

Instruction Manual  
for AC Generators  
English

QAS 150 John Deere



# **QAS 150 John Deere**

## **Instruction Manual for AC Generators**

Instruction manual .....	5
Circuit diagrams .....	43

Printed matter N°  
2954 3360 00  
12/2007



---

ATLAS COPCO - PORTABLE AIR DIVISION  
[www.atlascopco.com](http://www.atlascopco.com)

---

### **Warranty and Liability Limitation**

Use only authorized parts.

Any damage or malfunction caused by the use of unauthorized parts is not covered by Warranty or Product Liability.

The manufacturer does not accept any liability for any damage arising for modifications, additions or conversions made without the manufacturer's approval in writing.

Copyright 2007, Atlas Copco Airpower n.v., Antwerp, Belgium.

Any unauthorized use or copying of the contents or any part thereof is prohibited.

This applies in particular to trademarks, model denominations, part numbers and drawings.

*Congratulations on the purchase of your AC generator. It is a solid, safe and reliable machine, built according to the latest technology. Follow the instructions in this booklet and we guarantee you years of troublefree operation. Please read the following instructions carefully before starting to use your machine.*

*While every effort has been made to ensure that the information in this manual is correct, Atlas Copco does not assume responsibility for possible errors. Atlas Copco reserves the right to make changes without prior notice.*

## **Contents**

<b>Safety precautions for portable generators</b> .....	6	<b>Maintenance</b> .....	28	<b>Technical specifications for QAS 150 John Deere</b> .....	36
<b>Leading particulars</b> .....	12	Maintenance schedule .....	28	Readings on gauges .....	36
General description .....	12	Engine maintenance .....	30	Settings of switches .....	36
Bodywork .....	13	(*) Measuring the alternator insulation resistance .....	30	Specifications of the engine/ alternator/unit .....	36
Markings .....	13	Engine oil specifications .....	30	Conversion list of SI units into British units .....	41
Drain plugs and filler caps .....	14	Engine oil level check .....	31	Dataplate .....	41
Control and indicator panel Qc1002™ ..	14	Engine oil and oil filter change .....	31		
Output terminal board .....	22	Engine coolant specifications .....	31		
Triple voltage (3V) .....	23	Coolant check .....	32		
Battery switch .....	24	<b>Storage of the generator</b> .....	33		
Spillage free skid .....	24	Storage .....	33		
Engine coolant heater .....	24	Preparing for operation after storage ..	34		
COSMOS™ retrofit kit .....	24	<b>Checks and trouble shooting</b> .....	34		
<b>Operating instructions</b> .....	24	Checking voltmeter P4 .....	34		
Installation .....	24	Checking ammeters P1, P2 and P3 .....	34		
Connecting the generator .....	25	Alternator troubleshooting .....	35		
Before starting .....	26	Engine troubleshooting .....	34		
Operating Qc1002™ .....	26				

# ***Safety precautions for portable generators***

To be read attentively and acted accordingly before towing, lifting, operating, performing maintenance or repairing the generator.

## ***Introduction***

The policy of Atlas Copco is to provide the users of their equipment with safe, reliable and efficient products. Factors taken into account are among others:

- the intended and predictable future use of the products, and the environments in which they are expected to operate,
- applicable rules, codes and regulations,
- the expected useful product life, assuming proper service and maintenance,
- providing the manual with up-to-date information.

Before handling any product, take time to read the relevant instruction manual. Besides giving detailed operating instructions, it also gives specific information about safety, preventive maintenance, etc.

Keep the manual always at the unit location, easy accessible to the operating personnel.

See also the safety precautions of the engine and possible other equipment, which are separately sent along or are mentioned on the equipment or parts of the unit.

These safety precautions are general and some statements will therefore not always apply to a particular unit.

Only people that have the right skills should be allowed to operate, adjust, perform maintenance or repair on Atlas Copco equipment. It is the responsibility of management to appoint operators with the appropriate training and skill for each category of job.

### **Skill level 1: Operator**

An operator is trained in all aspects of operating the unit with the push-buttons, and is trained to know the safety aspects.

### **Skill level 2: Mechanical technician**

A mechanical technician is trained to operate the unit the same as the operator. In addition, the mechanical technician is also trained to perform maintenance and repair, as described in the instruction manual, and is allowed to change settings of the control and safety system. A mechanical technician does not work on live electrical components.

### **Skill level 3: Electrical technician**

An electrical technician is trained and has the same qualifications as both the operator and the mechanical technician. In addition, the electrical technician may carry out electrical repairs within the various enclosures of the unit. This includes work on live electrical components.

### **Skill level 4: Specialist from the manufacturer**

This is a skilled specialist sent by the manufacturer or its agent to perform complex repairs or modifications to the equipment.

In general it is recommended that not more than two people operate the unit, more operators could lead to unsafe operating conditions. Take necessary steps to keep unauthorized persons away from the unit and eliminate all possible sources of danger at the unit.

When handling, operating, overhauling and/or performing maintenance or repair on Atlas Copco equipment, the mechanics are expected to use safe engineering practices and to observe all relevant local

safety requirements and ordinances. The following list is a reminder of special safety directives and precautions mainly applicable to Atlas Copco equipment.

Neglecting the safety precautions may endanger people as well as environment and machinery:

- endanger people due to electrical, mechanical or chemical influences,
- endanger the environment due to leakage of oil, solvents or other substances,
- endanger the machinery due to function failures.

All responsibility for any damage or injury resulting from neglecting these precautions or by non-observance of ordinary caution and due care required in handling, operating, maintenance or repair, also if not expressly mentioned in this instruction manual, is disclaimed by Atlas Copco.

The manufacturer does not accept any liability for any damage arising from the use of non-original parts and for modifications, additions or conversions made without the manufacturer's approval in writing.

If any statement in this manual does not comply with local legislation, the stricter of the two shall be applied.

Statements in these safety precautions should not be interpreted as suggestions, recommendations or inducements that it should be used in violation of any applicable laws or regulations.

## **General safety precautions**

- 1 The owner is responsible for maintaining the unit in a safe operating condition. Unit parts and accessories must be replaced if missing or unsuitable for safe operation.
- 2 The supervisor, or the responsible person, shall at all times make sure that all instructions regarding machinery and equipment operation and maintenance are strictly followed and that the machines with all accessories and safety devices, as well as the consuming devices, are in good repair, free of abnormal wear or abuse, and are not tampered with.
- 3 Whenever there is an indication or any suspicion that an internal part of a machine is overheated, the machine shall be stopped but no inspection covers shall be opened before sufficient cooling time has elapsed; this to avoid the risk of spontaneous ignition of oil vapour when air is admitted.
- 4 Normal ratings (pressures, temperatures, speeds, etc.) shall be durably marked.
- 5 Operate the unit only for the intended purpose and within its rated limits (pressure, temperature, speeds, etc.).
- 6 The machinery and equipment shall be kept clean, i.e. as free as possible from oil, dust or other deposits.
- 7 To prevent an increase in working temperature, inspect and clean heat transfer surfaces (cooler fins, intercoolers, coolant jackets, etc.) regularly. See the maintenance schedule.
- 8 All regulating and safety devices shall be maintained with due care to ensure that they function properly. They may not be put out of action.

- 9 Pressure and temperature gauges shall be checked regularly with regard to their accuracy. They shall be replaced whenever outside acceptable tolerances.
  - 10 Safety devices shall be tested as described in the maintenance schedule of the instruction manual to determine that they are in good operating condition.
  - 11 Mind the markings and information labels on the unit.
  - 12 In the event the safety labels are damaged or destroyed, they must be replaced to ensure operator safety.
  - 13 Keep the work area neat. Lack of order will increase the risk of accidents.
  - 14 When working on the unit, wear safety clothing. Depending on the kind of activities these are: safety glasses, ear protection, safety helmet (including visor), safety gloves, protective clothing, safety shoes. Do not wear the hair long and loose (protect long hair with a hairnet), or wear loose clothing or jewellery.
  - 15 Take precautions against fire. Handle fuel, oil and anti-freeze with care because they are inflammable substances. Do not smoke or approach with naked flame when handling such substances. Keep a fire-extinguisher in the vicinity.
- 16a Portable generators (with earthing pin):**  
Earth the generator as well as the load properly.
- 16b Portable generators IT:**  
**Note:** This generator is built to supply a sheer alternating current IT network.  
Earth the load properly.

## **Safety during transport and installation**

To lift a unit, all loose or pivoting parts, e.g. doors and towbar, shall first be securely fastened.

Do not attach cables, chains or ropes directly to the lifting eye; apply a crane hook or lifting shackle meeting local safety regulations. Never allow sharp bends in lifting cables, chains or ropes.

Helicopter lifting is not allowed.

It is strictly forbidden to dwell or stay in the risk zone under a lifted load. Never lift the unit over people or residential areas. Lifting acceleration and retardation shall be kept within safe limits.

- 1 Before towing the unit:
  - check the towbar, the brake system and the towing eye. Also check the coupling of the towing vehicle,
  - check the towing and brake capability of the towing vehicle,
  - check that the towbar, jockey wheel or stand leg is safely locked in the raised position,
  - ascertain that the towing eye can swivel freely on the hook,
  - check that the wheels are secure and that the tyres are in good condition and inflated correctly,
  - connect the signalisation cable, check all lights and connect the pneumatic brake couplers,
  - attach the safety break-away cable or safety chain to the towing vehicle,
  - remove wheel chocks, if applied, and disengage the parking brake.
- 2 To tow a unit use a towing vehicle of ample capacity. Refer to the documentation of the towing vehicle.

- 3 If the unit is to be backed up by the towing vehicle, disengage the overrun brake mechanism (if it is not an automatic mechanism).
- 4 Never exceed the maximum towing speed of the unit (mind the local regulations).
- 5 Place the unit on level ground and apply the parking brake before disconnecting the unit from the towing vehicle. Unclip the safety break-away cable or safety chain. If the unit has no parking brake or jockey wheel, immobilize the unit by placing chocks in front of and/or behind the wheels. When the towbar can be positioned vertically, the locking device must be applied and kept in good order.
- 6 To lift heavy parts, a hoist of ample capacity, tested and approved according to local safety regulations, shall be used.
- 7 Lifting hooks, eyes, shackles, etc., shall never be bent and shall only have stress in line with their design load axis. The capacity of a lifting device diminishes when the lifting force is applied at an angle to its load axis.
- 8 For maximum safety and efficiency of the lifting apparatus all lifting members shall be applied as near to perpendicular as possible. If required, a lifting beam shall be applied between hoist and load.
- 9 Never leave a load hanging on a hoist.
- 10 A hoist has to be installed in such a way that the object will be lifted perpendicular. If that is not possible, the necessary precautions must be taken to prevent load-swinging, e.g. by using two hoists, each at approximately the same angle not exceeding 30° from the vertical.

- 11 Locate the unit away from walls. Take all precautions to ensure that hot air exhausted from the engine and driven machine cooling systems cannot be recirculated. If such hot air is taken in by the engine or driven machine cooling fan, this may cause overheating of the unit; if taken in for combustion, the engine power will be reduced.
- 12 Generators shall be stalled on an even, solid floor, in a clean location with sufficient ventilation. If the floor is not level or can vary in inclination, consult Atlas Copco.
- 13 The electrical connections shall correspond to local codes. The machines shall be earthed and protected against short circuits by fuses or circuit breakers.
- 14 Never connect the generator outlets to an installation which is also connected to a public mains.
- 15 Before connecting a load, switch off the corresponding circuit breaker, and check whether frequency, voltage, current and power factor comply with the ratings of the generator.

### ***Safety during use and operation***

- 1 When the unit has to operate in a fire-hazardous environment, each engine exhaust has to be provided with a spark arrestor to trap incendiary sparks.
- 2 The exhaust contains carbon monoxide which is a lethal gas. When the unit is used in a confined space, conduct the engine exhaust to the outside atmosphere by a pipe of sufficient diameter; do this in such a way that no extra back pressure is created for the engine. If necessary, install an extractor. Observe any existing local regulations.

Make sure that the unit has sufficient air intake for operation. If necessary, install extra air intake ducts.

- 3 When operating in a dust-laden atmosphere, place the unit so that dust is not carried towards it by the wind. Operation in clean surroundings considerably extends the intervals for cleaning the air intake filters and the cores of the coolers.
- 4 Never remove a filler cap of the coolant system of a hot engine. Wait until the engine has sufficiently cooled down.
- 5 Never refill fuel while the unit is running, unless otherwise stated in the Atlas Copco Instruction Book (AIB). Keep fuel away from hot parts such as air outlet pipes or the engine exhaust. Do not smoke when fuelling. When fuelling from an automatic pump, an earthing cable should be connected to the unit to discharge static electricity. Never spill nor leave oil, fuel, coolant or cleansing agent in or around the unit.
- 6 All doors shall be shut during operation so as not to disturb the cooling air flow inside the bodywork and/or render the silencing less effective. A door should be kept open for a short period only e.g. for inspection or adjustment.
- 7 Periodically carry out maintenance works according to the maintenance schedule.
- 8 Stationary housing guards are provided on all rotating or reciprocating parts not otherwise protected and which may be hazardous to personnel. Machinery shall never be put into operation, when such guards have been removed, before the guards are securely reinstalled.
- 9 Noise, even at reasonable levels, can cause irritation and disturbance which, over a long period of time, may cause severe injuries to the nervous system of human beings.  
When the sound pressure level, at any point where personnel normally has to attend, is:



- below 70 dB(A): no action needs to be taken,
  - above 70 dB(A): noise-protective devices should be provided for people continuously being present in the room,
  - below 85 dB(A): no action needs to be taken for occasional visitors staying a limited time only,
  - above 85 dB(A): room to be classified as a noise-hazardous area and an obvious warning shall be placed permanently at each entrance to alert people entering the room, for even relatively short times, about the need to wear ear protectors,
  - above 95 dB(A): the warning(s) at the entrance(s) shall be completed with the recommendation that also occasional visitors shall wear ear protectors,
  - above 105 dB(A): special ear protectors that are adequate for this noise level and the spectral composition of the noise shall be provided and a special warning to that effect shall be placed at each entrance.
- 10 Insulation or safety guards of parts the temperature of which can be in excess of 80°C (175°F) and which may be accidentally touched by personnel shall not be removed before the parts have cooled to room temperature.
  - 11 Never operate the unit in surroundings where there is a possibility of taking in flammable or toxic fumes.
  - 12 If the working process produces fumes, dust or vibration hazards, etc., take the necessary steps to eliminate the risk of personnel injury.
  - 13 When using compressed air or inert gas to clean down equipment, do so with caution and use the appropriate protection, at least safety glasses, for the operator as well as for any bystander. Do not apply compressed air or inert gas to your skin or direct an air or gas stream at people. Never use it to clean dirt from your clothes.
  - 14 When washing parts in or with a cleaning solvent, provide the required ventilation and use appropriate protection such as a breathing filter, safety glasses, rubber apron and gloves, etc.
  - 15 Safety shoes should be compulsory in any workshop and if there is a risk, however small, of falling objects, wearing of a safety helmet should be included.
  - 16 If there is a risk of inhaling hazardous gases, fumes or dust, the respiratory organs must be protected and depending on the nature of the hazard, so must the eyes and skin.
  - 17 Remember that where there is visible dust, the finer, invisible particles will almost certainly be present too; but the fact that no dust can be seen is not a reliable indication that dangerous, invisible dust is not present in the air.
  - 18 Never operate the generator in excess of its limits as indicated in the technical specifications and avoid long no-load sequences.
  - 19 Never operate the generator in a humid atmosphere. Excessive moisture causes worsening of the generator insulation.
  - 20 Do not open electrical cabinets, cubicles or other equipment while voltage is supplied. If such cannot be avoided, e.g. for measurements, tests or adjustments, have the action carried out by a qualified electrician only, with appropriate tools, and ascertain that the required bodily protection against electrical hazards is applied.
  - 21 Never touch the power terminals during operation of the machine.
  - 22 Whenever an abnormal condition arises, e.g. excessive vibration, noise, odour, etc., switch the circuit breakers to OFF and stop the engine. Correct the faulty condition before restarting.
  - 23 Check the electric cables regularly. Damaged cables and insufficient tightening of connections may cause electric shocks. Whenever damaged wires or dangerous conditions are observed, switch the circuit breakers to OFF and stop the engine. Replace the damaged wires or correct the dangerous condition before restarting. Make sure that all electric connections are securely tightened.
  - 24 Avoid overloading the generator. The generator is provided with circuit breakers for overload protection. When a breaker has tripped, reduce the concerned load before restarting.
  - 25 If the generator is used as stand-by for the mains supply, it must not be operated without control system which automatically disconnects the generator from the mains when the mains supply is restored.
  - 26 Never remove the cover of the output terminals during operation. Before connecting or disconnecting wires, switch off the load and the circuit breakers, stop the machine and make sure that the machine cannot be started inadvertently or there is any residual voltage on the power circuit.
  - 27 Running the generator at low load for long periods will reduce the lifetime of the engine.

## ***Safety during maintenance and repair***

Maintenance, overhaul and repair work shall only be carried out by adequately trained personnel; if required, under supervision of someone qualified for the job.

- 1 Use only the correct tools for maintenance and repair work, and only tools which are in good condition.
- 2 Parts shall only be replaced by genuine Atlas Copco replacement parts.
- 3 All maintenance work, other than routine attention, shall only be undertaken when the unit is stopped. Steps shall be taken to prevent inadvertent starting. In addition, a warning sign bearing a legend such as “work in progress; do not start” shall be attached to the starting equipment.  
On engine-driven units the battery shall be disconnected and removed or the terminals covered by insulating caps.  
On electrically driven units the main switch shall be locked in open position and the fuses shall be taken out. A warning sign bearing a legend such as “work in progress; do not supply voltage” shall be attached to the fuse box or main switch.
- 4 Prior to stripping an engine or other machine or undertaking major overhaul on it, prevent all movable parts from rolling over or moving.
- 5 Make sure that no tools, loose parts or rags are left in or on the machine. Never leave rags or loose clothing near the engine air intake.
- 6 Never use flammable solvents for cleaning (fire-risk).
- 7 Take safety precautions against toxic vapours of cleaning liquids.

- 8 Never use machine parts as a climbing aid.
- 9 Observe scrupulous cleanliness during maintenance and repair. Keep away dirt, cover the parts and exposed openings with a clean cloth, paper or tape.
- 10 Never weld on or perform any operation involving heat near the fuel or oil systems. Fuel and oil tanks must be completely purged, e.g. by steam-cleaning, before carrying out such operations. Never weld on, or in any way modify, pressure vessels. Disconnect the alternator cables during arc welding on the unit.
- 11 Support the towbar and the axle(s) securely if working underneath the unit or when removing a wheel. Do not rely on jacks.
- 12 Do not remove any of, or tamper with, the sound-damping material. Keep the material free of dirt and liquids such as fuel, oil and cleansing agents. If any sound-damping material is damaged, replace it to prevent the sound pressure level from increasing.
- 13 Use only lubricating oils and greases recommended or approved by Atlas Copco or the machine manufacturer. Ascertain that the selected lubricants comply with all applicable safety regulations, especially with regard to explosion or fire-risk and the possibility of decomposition or generation of hazardous gases. Never mix synthetic with mineral oil.
- 14 Protect the engine, alternator, air intake filter, electrical and regulating components, etc., to prevent moisture ingress, e.g. when steam-cleaning.
- 15 When performing any operation involving heat, flames or sparks on a machine, the surrounding components shall first be screened with non-flammable material.
- 16 Never use a light source with open flame for inspecting the interior of a machine.
- 17 When repair has been completed, the machine shall be barred over at least one revolution for reciprocating machines, several revolutions for rotary ones to ensure that there is no mechanical interference within the machine or driver. Check the direction of rotation of electric motors when starting up the machine initially and after any alteration to the electrical connection(s) or switch gear, to check that the oil pump and the fan function properly.
- 18 Maintenance and repair work should be recorded in an operator’s logbook for all machinery. Frequency and nature of repairs can reveal unsafe conditions.
- 19 When hot parts have to be handled, e.g. shrink fitting, special heat-resistant gloves shall be used and, if required, other body protection shall be applied.
- 20 When using cartridge type breathing filter equipment, ascertain that the correct type of cartridge is used and that its useful service life is not surpassed.
- 21 Make sure that oil, solvents and other substances likely to pollute the environment are properly disposed of.
- 22 Before clearing the generator for use after maintenance or overhaul, submit it to a testrun, check that the AC power performance is correct and that the control and shutdown devices function correctly.

## ***Tool applications safety***

Apply the proper tool for each job. With the knowledge of correct tool use and knowing the limitations of tools, along with some common sense, many accidents can be prevented.

Special service tools are available for specific jobs and should be used when recommended. The use of these tools will save time and prevent damage to parts.

## ***Battery safety precautions***

### **Batteries**

When servicing batteries, always wear protecting clothing and glasses.

- 1 The electrolyte in batteries is a sulphuric acid solution which is fatal if it hits your eyes, and which can cause burns if it contacts your skin. Therefore, be careful when handling batteries, e.g. when checking the charge condition.
- 2 Install a sign prohibiting fire, open flame and smoking at the post where batteries are being charged.
- 3 When batteries are being charged, an explosive gas mixture forms in the cells and might escape through the vent holes in the plugs.  
Thus an explosive atmosphere may form around the battery if ventilation is poor, and can remain in and around the battery for several hours after it has been charged. Therefore:
  - never smoke near batteries being, or having recently been, charged,
  - never break live circuits at battery terminals, because a spark usually occurs.

- 4 When connecting an auxiliary battery (AB) in parallel to the unit battery (CB) with booster cables: connect the + pole of AB to the + pole of CB, then connect the - pole of CB to the mass of the unit. Disconnect in the reverse order.

## Leading particulars

### General description

The QAS 150 John Deere is an AC generator, built for continuous running at sites where no electricity is available or as stand-by in cases of interruption of the mains. The generator can run in 3 different modes: 60 Hz, 480 V - 3 phase, 60 Hz, 208 V - 3 phase lower voltage and 60 Hz, 240 V - 1 phase. The QAS 150 John Deere generator is driven by a water-cooled diesel engine, manufactured by John Deere. An overview of the main parts is given in the diagram below.

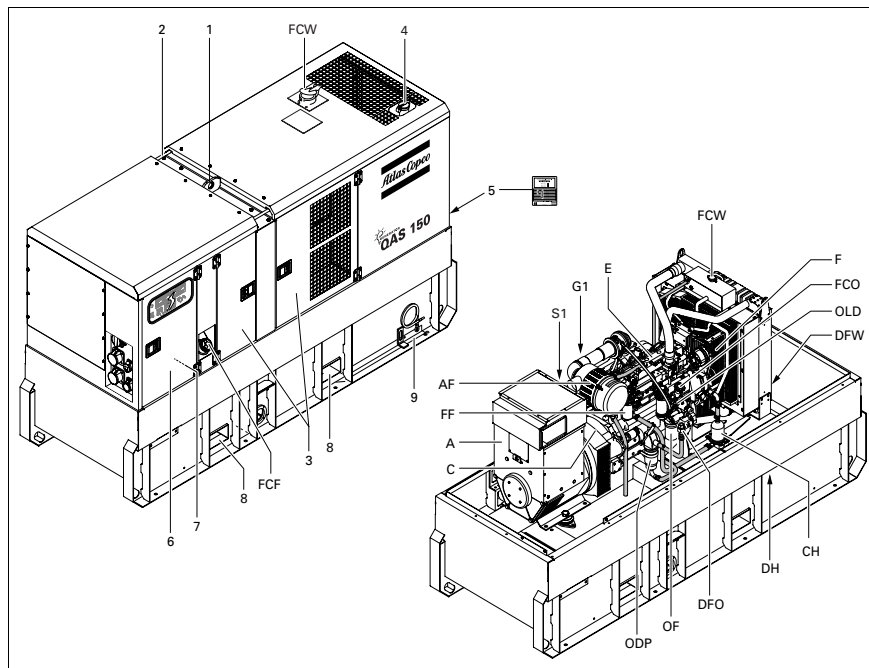

1	Lifting beam
2	Guiding rod
3	Side doors
4	Engine exhaust
5	Data plate
6	Side door, access to control and indicator panel
7	Output terminal board
8	Hole for forklift
9	Earthing rod
A	Alternator
AF	Air filter
C	Coupling
CH	Coolant heater
DFO	Drain flexible engine oil
DFW	Drain flexible cooling water
DH	Drain and access hole (in the frame)
E	Engine
F	Fan
FCF	Filler cap fuel
FCO	Filler cap engine oil
FCW	Filler cap cooling water
FF	Fuel filter
G1	Battery
ODP	Oil drain pump
OF	Oil filter
OLD	Engine oil level dipstick
S1	Battery switch

## Bodywork

The alternator, the engine, the cooling system, etc. are enclosed in a sound-insulated bodywork that can be opened by means of side doors (and service plates).

The generator's lifting eye is located in the middle of the roof. The recesses in the roof have guiding rods at both sides.



**Never use the guiding rods to lift the generator.**

To be able to lift the generator by means of a forklift, rectangular holes are provided in the frame.

The earthing rod, connected to the generator's earth terminal is located at the side of the frame.

## Markings

A brief description of all markings provided on the generator is given hereafter.



Indicates that an electric voltage, dangerous to life, is present. Never touch the electric terminals during operation.



Indicates that the engine exhaust is a hot and harmful gas, which is toxic in case of inhalation. Always make sure that the unit is operated outside or in a well-ventilated room.



Indicates that these parts can become very hot during operation (e.g. engine, cooler, etc.). Always make sure that these parts are cooled down before touching them.



Indicates that the guiding rods may not be used to lift the generator. Always use the lifting rod in the roof of the generator to lift it.



Indicates a lifting point of the generator.



Indicates that the generator may be refuelled with diesel fuel only.



Indicates the drain for the engine oil.



Indicates the drain for the coolant.



Indicates the drain plug for the engine fuel.



Use PAROIL 5W40 only.



Indicates the different earthing connections on the generator.



Indicates that the alternator should not be cleaned with high pressurised water.

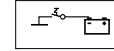

Indicates the battery switch.



Indicates that the unit may start automatically and that the instruction book has to be consulted prior to use.

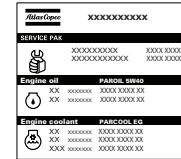

Indicates the partnumbers of the different service paks and of the engine oil. These parts can be ordered to the factory.

## ***Drain plugs and filler caps***

The drain holes for the engine oil, the coolant and the plug for the fuel, are located and labelled on the frame at the service side.

The drain flexible for engine oil can be brought to the outside of the generator through the drain hole.



**The drain hole can also be used to guide external fuel tank connections.**

## ***Control and indicator panel Qc1002™***

### **General description Qc1002™ control panel**

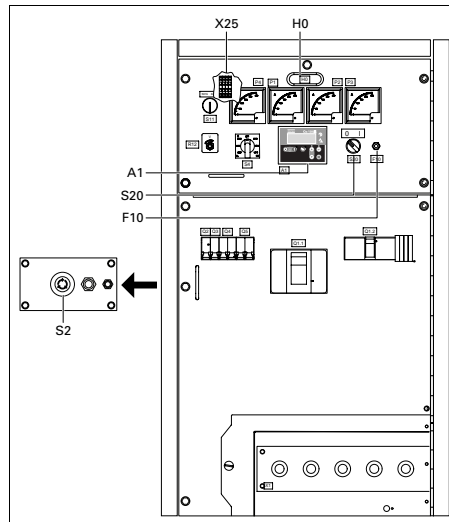

*A1 .....Qc1002™ display*

*F10.....Fuse*

The fuse activates when the current from the battery to the engine control circuit exceeds its setting. The fuse can be reset by pushing the button.

*H0 .....Panel light*

*S2.....Emergency stop button*

Push the button to stop the generator in case of an emergency. When the button is pressed, it must be unlocked, before the generator can be restarted. The emergency stop button can be secured in the locked position with the key, to avoid unauthorized use.

*S20.....ON/OFF switch*

Position O: No voltage is applied to the Qc1002™ module, the generator will not start.

Position I: Voltage is applied to the Qc1002™ module, it is possible to start up the generator.

*X25 .....Terminal strip*

## Qc1002™ Module

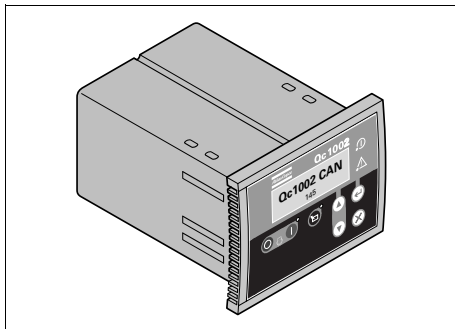

The Qc1002™ module is located inside the control panel. This control module will carry out all necessary tasks to control and protect a generator, regardless of the use of the generator.

This means that the Qc1002™ module can be used for several applications.

### Pushbutton and LED functions

#### **Following pushbuttons are used on the Qc1002™**



**ENTER:** Is used to select and confirm changed settings in the Parameter list.



**UP:** Is used to scroll through the display information and to adjust parameter value upwards.



**DOWN:** Is used to scroll through the display information and to adjust parameter value downwards.



**BACK:** Is used to leave the Alarm pop-up window, to leave the Parameter list and to leave menu's without change.



**REMOTE MODE:** Is used to activate the remote mode. The LED indicates if the gen-set is put in Remote Mode.



**START:** Is used to start the unit in Manual Mode.



**STOP:** Is used to stop the unit in Manual or Remote Mode (without cooldown). When the unit is stopped with the STOP button in Remote mode, it will automatically go to Manual Mode.

#### **Following LEDs are used on the Qc1002™**

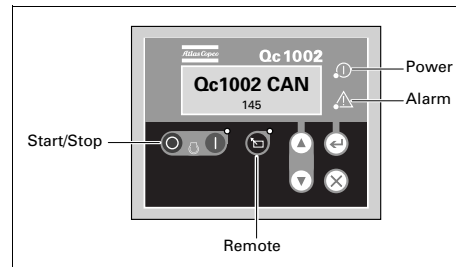

#### **Power**

Green LED indicates that the unit is powered up.

#### **Remote**

Green LED indicates that the Remote Mode is selected.

#### **Start/Stop**

Green LED indicates that the engine is running.

#### **Alarm**

Flashing red LED indicates that an alarm is present. A continuous red LED indicates that the alarm has been acknowledged by the user. The exact alarm is shown on the display.

## Qc1002™ Menu Overview

At Qc1002™, the LCD will show following information:

- in **Normal** condition (scroll through the information using **UP** and **DOWN**):
  - Status (eg: preheat, crank, cooldown, extended stop time, ...) (pop-up: this display is only shown when a Special status comes up)
  - Controller type & version
  - Parameter list
  - Alarm list
  - LOG list
  - Service Timer 1 & Service Timer 2
  - Battery Voltage
  - Coolant temperature
  - Oil pressure
  - RPM (speed)
  - Fuel level
  - Voltage - frequency - running hours
- in **Alarm** condition (scroll through the information using **UP** and **DOWN**):
  - a list of all active Alarms

It's possible to scroll through the views, using the **UP** and **DOWN** buttons. The scrolling is continuous.

If a Special status comes up, the Status Display is shown.

If an Alarm comes up, the Alarm Display is shown.

## Controller type and version display



This view shows the controller type and the ASW version number.

## Parameter display

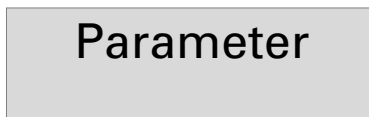

This view shows a number of Parameter settings and gives access to them.

An overview is given in "Parameter list" on page 18.

## Alarm list display

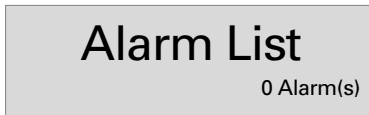

This view shows the number of active alarms and gives access to them.

An overview is given in "Alarm Display (pop-up window)" on page 20.

## LOG list display



This view shows the alarm memory and gives access to it.

An overview is given in "LOG list" on page 21.

## Service timer 1 & Service timer 2 display



This view shows both Service timers. The service timer indication is shown when service time has run out. It can be removed by resetting the timers or acknowledging the Service timer indication.

The service timer indications count upwards and give an alarm when the set value is reached.

Resetting the Service Timers can be done through the Parameter display.



### **Battery Voltage display**

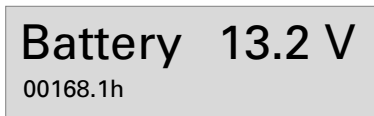

This view shows the Battery voltage and the running hours.

### **Coolant temperature display**

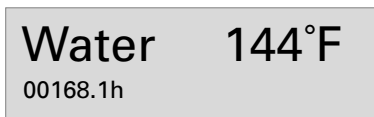

This view shows the Coolant temperature and the running hours.

See also “Parameter list” on page 18 for selection between °C and °F.

### **Oil pressure display**

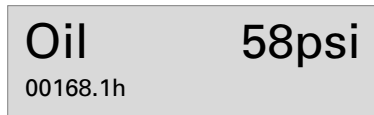

This view shows the Oil pressure and the running hours.

See also “Parameter list” on page 18 for selection between bar and psi.

### **Fuel level display**



This view shows the Fuel level and the running hours.

### **Voltage - frequency - running hours display**

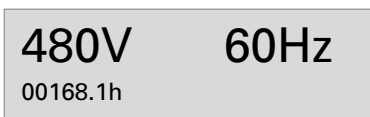

This view shows the voltage, frequency and running hours.

### **Engine speed display**

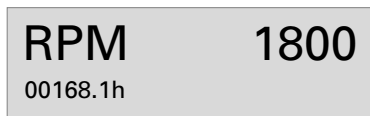

This view shows the engine speed and running hours.

### **Qc1002™ Menu Description**

#### **Status Display (pop-up window)**

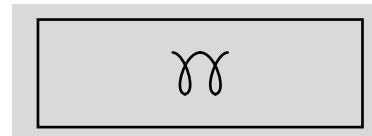

In case special statuses are entered, a pop-up window will automatically be entered for as long as the status is active.

The background screen is not updated when the status pop-up window is active.

*These special statuses are:*

PREHEAT



START OFF/  
EXTENDED  
STOP TIMER



COOLDOWN



## DIAGNOSTIC

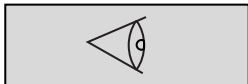

If a special status has elapsed, the active view will be entered again automatically.

If an Alarm comes up, the Alarm Display is shown.

### **Parameter list**

The Parameter Menu's are pre-programmed!

A password will be asked for when an attempt to change a setting is about to be done (user password = 2003).

By entering the parameter list, pushbutton REMOTE is disposed of its normal operations and will not perform any functionality.

Menu's shown on the Parameter list LCD:

- Running hours adjust

This menu is used to adjust the amount of running hours. The running hours can only be raised, not lowered.

- Unit Type



**Unit type 6 for QAS 150 John Deere!**

- Service Timer 2 reset

- Service Timer 1 reset

These menus are used to reset the service timers. When a service timer alarm occurs and is acknowledged, the service timer will be reset automatically.

- Diagnostics Menu

This menu is used to power up the engine electronics without starting the engine. When this setting is switched 'on', electric power will be supplied to the engine electronics after half a minute delay. The unit can not be started as long as this parameter is switched 'on'.

- Unit Menu

This menu is used to select whether temperature and pressure should appear in °C/bar or °F/psi.

- Language selection

Icons is the default factory set language, but 6 other languages can be selected: English, French, German, Italian, Spanish and Cyrillic (Russian). All information in the Parameter List display is always in English.

- Generator Underfrequency: failclass, enable, delay, setpoint

- Generator Overfrequency: failclass, enable, delay, setpoint

- Generator Undervoltage: failclass, enable, delay, setpoint

- Generator Overvoltage: failclass, enable, delay, setpoint

- Engine CAN communication

This menu is used to select the type of engine electronics, the Qc1002™ controller should communicate with via the Canbus.

It's possible to scroll between configuration menu's by using the pushbuttons UP and DOWN.

Pushing the ENTER button activates the configuration menu which is shown at the display.

This is the described menu flow for changing the unit type:

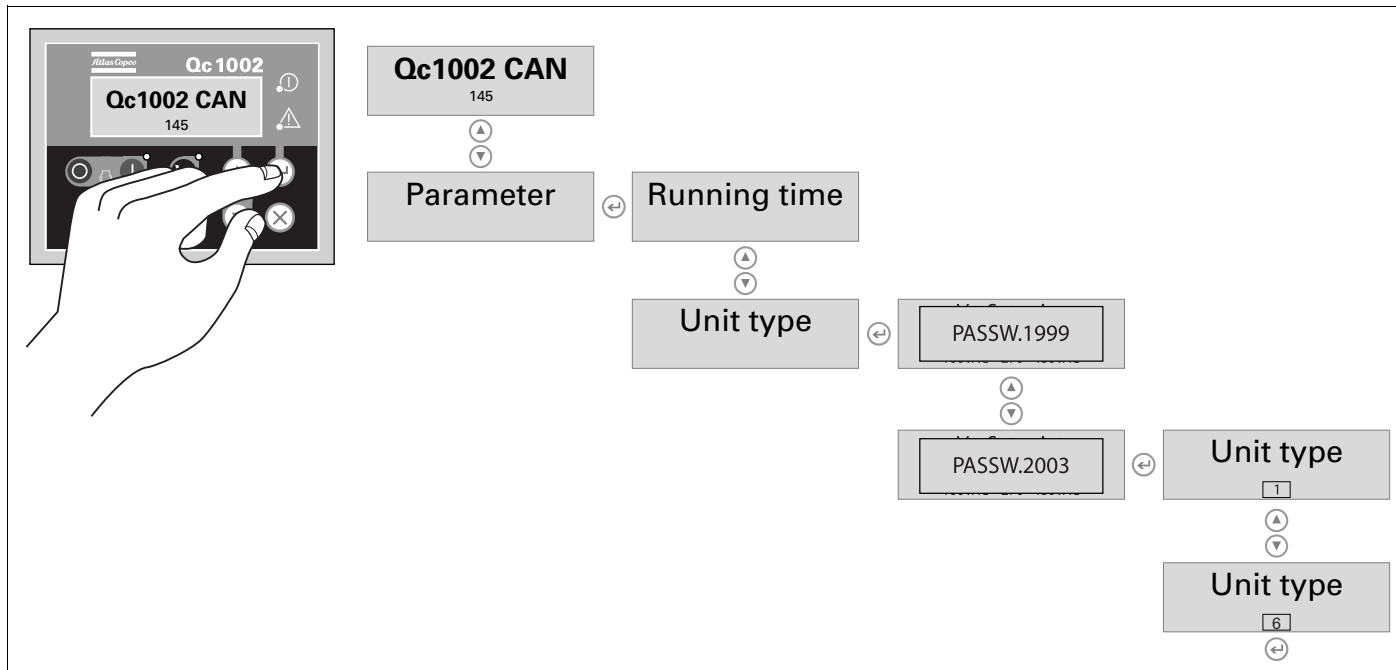

## Alarm Display (pop-up window)

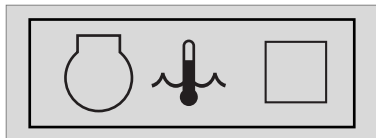

In case an Alarm occurs, a pop-up window will automatically be displayed for as long as the alarm is active, no matter which view is active. The flashing red alarm LED will light up. The alarm icons will be shown together with an acknowledgement check-box. Push the ENTER button to acknowledge the alarm. When the alarm has been acknowledged, a V-marking will appear in the check-box and the red alarm LED will light up continuously.



**An alarm should always be acknowledged before solving the problem that causes the alarm.**

The Alarm Display can always be left by pushing the BACK button.

If more than one alarm comes up, it's possible to scroll through the alarm messages with the UP and DOWN pushbuttons. The newest alarm will be placed at the bottom of the list (meaning that the older alarm stays at the display when a newer alarm comes up).

If one or more than one alarm is present, an arrow at the right of the display will be shown.

Following general groups of Alarms exist:

- Warning: Alarm LED lights up + Alarm pop-up appears on the display + Alarm relay is empowered (if configured)
- Trip of GB: 'Warning' actions + Generator Contactor opens
- Trip and Stop: 'Trip of GB' actions + unit stops after Cooldown
- Shutdown: 'Trip of GB' actions + unit stops immediately

*List of possible alarms:*

LOW OIL PRESSURE



HIGH COOLANT TEMPERATURE



CHARGING ALTERNATOR

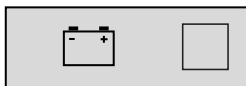

LOW FUEL LEVEL

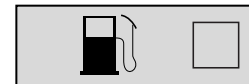

LOW COOLANT LEVEL



GENERATOR OVERVOLTAGE



GENERATOR UNDER-VOLTAGE



GENERATOR OVER-FREQUENCY

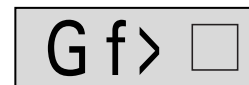

GENERATOR UNDER-FREQUENCY



SERVICE TIMER  
1

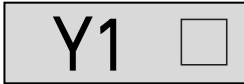

SERVICE TIMER  
2

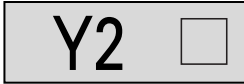

ENGINE ALARM



EMERGENCY  
STOP



START FAILURE



STOP FAILURE



### LOG list

The unit will keep an event log of the latest 30 events.

Events are:

- shutdowns
- service timer 1/2 reset
- unit type changes

Together with each event, the running hours at the time of the event will be stored.

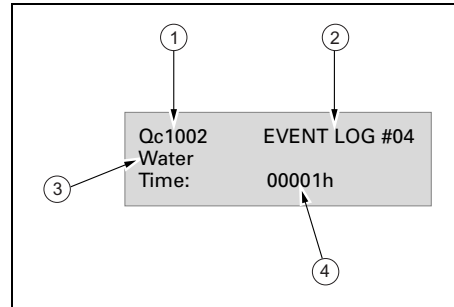

- |   |                 |
|---|-----------------|
| 1 | Controller type |
| 2 | Event number    |
| 3 | Event           |
| 4 | Running hours   |

### Remote start operation

Installation wirings:

- X25.1 & X25.2 to be wired for the remote start switch.
- X25.3 & X25.4 to be wired for the remote contactor (open/close).

### Fail classes

All the activated alarms of the Qc1002™ have their own pre-defined fail class.

All alarms are enabled according to one of these three statuses:

- disabled alarm, no supervision of alarm (OFF)
- enabled alarm, supervision of alarm all the time (ON)
- running alarm, only supervision when the machine is running (RUN)

## Output terminal board

The output terminal board is situated below the control and indicator panel.

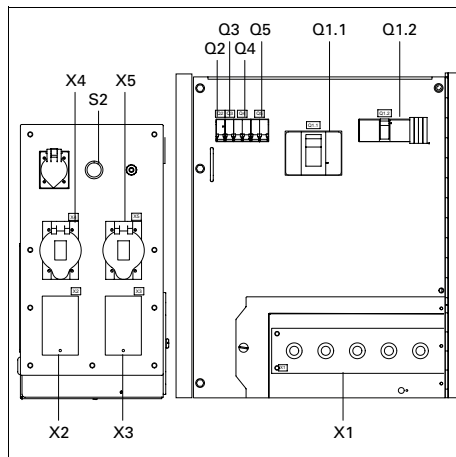

**S2** ..... Emergency stop button

**X1** ..... Terminal board

Provides a more easy connection of cables.

**X2** ..... 1-phase outlet socket (125 V)

Provides phase L2, neutral and earthing.

**X3** ..... 1-phase outlet socket (125 V)

Provides phase L1, neutral and earthing.

**X4** ..... 2-phase outlet socket (125/250 V)

Provides phases L1, L2, neutral and earthing.

**X5** ..... 2-phase outlet socket (125/250 V)

Provides phases L1, L2, neutral and earthing.

**Q1.1** ..... Circuit breaker for low voltage, high current

Interrupts the low voltage power supply towards X1 when a short-circuit occurs at the load side or when the overcurrent protection (364 A) is activated. It must be reset manually after eliminating the problem.

**Q1.2** ..... Circuit breaker for high voltage, low current

Interrupts the high voltage power supply towards X1 when a short-circuit occurs at the load side or when the overcurrent protection (172 A) is activated. It must be reset manually after eliminating the problem.

**Q2** ..... Circuit breaker for X2

Interrupts the power supply to X2 when a short-circuit occurs at the load side, or when the overcurrent protection (20 A) is activated. When activated, Q2 interrupts one phase towards X2. It can be activated again after eliminating the problem.

**Q3** ..... Circuit breaker for X3

Interrupts the power supply to X3 when a short-circuit occurs at the load side, or when the overcurrent protection (20 A) is activated. When activated, Q3 interrupts 2 phases towards X3. It can be activated again after eliminating the problem.

**Q4** ..... Circuit breaker for X4

Interrupts the power supply to X4 when a short-circuit occurs at the load side, or when the overcurrent protection (50 A) is activated. When activated, Q4 interrupts 2 phases towards X4. It can be activated again after eliminating the problem.

**Q5** ..... Circuit breaker for X5

Interrupts the power supply to X5 when a short-circuit occurs at the load side, or when the overcurrent protection (50 A) is activated. When activated, Q5 interrupts 2 phases towards X5. It can be activated again after eliminating the problem.



**Circuit breakers Q1.1 and Q1.2 do not only interrupt the power supply towards socket X1 but also towards X2, X3, X4 and X5.**

**Make sure to switch on circuit breakers Q1.1 or Q1.2, Q2, Q3, Q4 and Q5 after starting the generator when power supply is done by means of X2, X3, X4 or X5.**

## Triple voltage (3V)

The generator can run in three different modes:

### – 1 phase

When using this selection, the generator provides a 240/277 V output voltage.

### – 3 phase, lower voltage

When using this selection, the generator provides a 208/240 V output voltage.

### – 3 phase, higher voltage

When using this selection, the generator provides a 416/480 V output voltage.

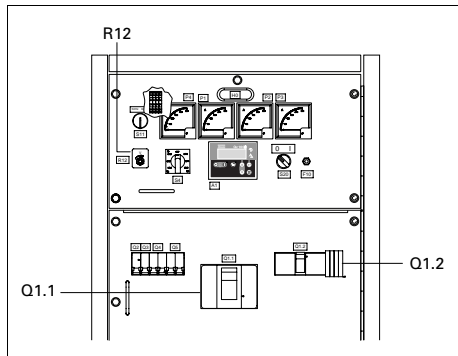

### Q1.1....Circuit breaker for low voltage, high current

Interrupts the low voltage power supply towards X1 when a short-circuit occurs at the load side or when the overcurrent protection (364 A) is activated. It must be reset manually after eliminating the problem.

### Q1.2....Circuit breaker for high voltage, low current

Interrupts the high voltage power supply towards X1 when a short-circuit occurs at the load side or when the overcurrent protection (172 A) is activated. It must be reset manually after eliminating the problem.

### R12 .....Output voltage adjust potentiometer

Allows to adjust the output voltage.

Depending on which mode the generator is running in, circuit breaker Q1.1 or Q1.2 will be operational.

Circuit breakers Q1.1 and Q1.2 cannot be switched on at the same time. This is prevented by means of the auxiliary voltage selection relays S10b and S10c (refer to the circuit diagram).

The selection between the three modes is done by means of S10.

### S10.....Output voltage selection switch

Allows to select a 1 phase output voltage, a 3 phase high output voltage or a 3 phase low output voltage. Selector switch S10 is located on the alternator.



**Changing the output voltage is only allowed after shutdown.**

**After changing the output voltage by means of the selection switch S10, adjust the output voltage by means of potentiometer R12 to the required value.**

## Battery switch

The battery switch is situated inside the sound-insulated bodywork. It allows to open or to close the electrical connection between the battery and the engine circuits.



**Never turn the battery switch to OFF during operation.**

## Spillage free skid

A spillage free skid with forklift slots allows the customer to transport the generator easily with a forklift.

It avoids accidental spilling of engine fluids.

## Engine coolant heater

To make sure that the engine can start and accept load immediately, an external cooling water heater (2000 W, 240 V) is provided which keeps the engine temperature between 38°C (100.40°F) and 49°C (120.20°F).

## COSMOS™ retrofit kit

COSMOS™ is a web-based global remote monitoring system that electronically tracks every aspect of equipment from its location to its operating parameters. The Cosmos system can send e-mails or SMS messages to the contractor or owner in real time, with all critical and non-critical events and data involving your compressors and generators. It allows optimal servicing.

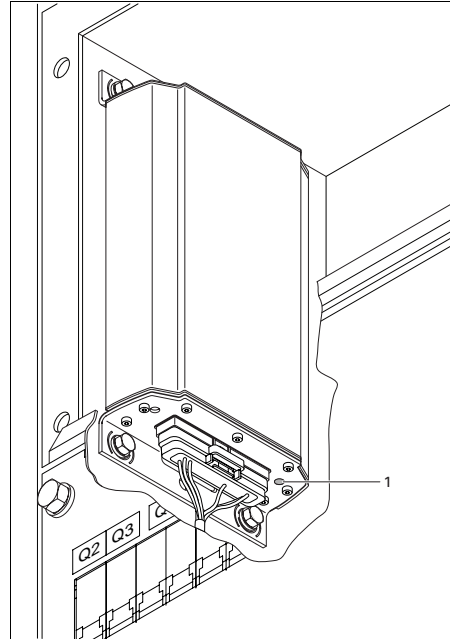

When starting up the generator, the green Power Led (1) of the Cosmos module will light up when the installation has been carried out correctly.

For information about COSMOS™, consult your local Atlas Copco dealer.

## Operating instructions



**In your own interest, always strictly observe all relevant safety instructions.**

**Do not operate the generator in excess of the limitations mentioned in the Technical Specifications.**

**Local rules concerning the setting up of low voltage power installations (below 1000 V) must be respected when connecting site distribution panels, switch gear or loads to the generator.**

## Installation



**For information about indoor installation, consult your local Atlas Copco dealer.**

- Place the generator on a horizontal, even and solid floor. The generator can operate in a slant position not exceeding 15° (in both senses: front/rear and left/right).
- The generator should be kept with the doors closed, in order to avoid the ingress of water and dust. Dust ingress reduces the lifetime of filters and may reduce your generator's performance.
- Check that the engine exhaust is not directed towards people. If the generator is operated indoors, install an exhaust pipe of sufficient diameter to duct the engine exhaust towards the outside. Check for sufficient ventilation so that the



cooling air is not recirculated. If necessary, consult Atlas Copco.

- Leave enough space for operation, inspection and maintenance (at least 1 meter at each side).
- Check that the inner earthing system is in compliance with the local legislation.
- Use coolant for the engine cooling system. Refer to the Engine instruction book for the proper coolant mixture.
- Check the tightness of the bolts and nuts.
- Install the earthing rod as near as possible to the generator and measure its diffusion resistance (max. 1 kΩ) in order not to have a contact voltage higher than 25 V at 30 mA leakage current.
- Check that the cable end of the earthing rod is connected to the earth terminal.

## Connecting the generator

### Precautions for non-linear and sensitive loads



**Non-linear loads draw currents with high contents in harmonics, causing distortion in the wave form of the voltage generated by the alternator.**

The most common non-linear, 3-phase loads are thyristor/rectifier-controlled loads, such as convertors supplying voltage to variable speed motors, uninterruptable power supplies and Telecom supplies. Gas-discharge lighting arranged in single-phase circuits generate high 3rd harmonics and risk for excessive neutral current.

Loads most sensitive to voltage distortion include incandescent lamps, discharge lamps, computers, X-ray equipment, audio amplifiers and elevators.

Consult Atlas Copco for measures against the adverse influence of non-linear loads.

### Quality, minimum section and maximum length of cables

The cable connected to the terminal board of the generator must be selected in accordance with local legislation. The type of cable, its rated voltage and current carrying capacity are determined by installation conditions, stress and ambient temperature. For flexible wiring, rubber-sheathed, flexible core conductors of the type H07 RN-F (Cenelec HD.22) or better must be used.

The following table indicates the maximum allowable 3-phase currents (in A), in an ambient temperature of 40°C (104°F), for cable types (multiple and single core PVC insulated conductors and H07 RN-F multiple core conductors) and wire sections as listed, in accordance with VDE 0298 installation method C3. Local regulations remain applicable if they are stricter than those proposed below.

Wire section (mm <sup>2</sup> )	Max. current (A)		
	Multiple core	Single core	H07 RN-F
25	94	101	88
35	114	123	110
50	138	155	138
70	176	191	170
95	212	228	205
120	245	273	239
150	282	314	275
185	323	358	313

Wire section (mm <sup>2</sup> )	Max. current (A)		
	Multiple core	Single core	H07 RN-F
240	379	421	371
300	429	477	428

The lowest acceptable wire section and the corresponding maximum cable or conductor length for multiple core cable or H07 RN-F, at rated current, for a voltage drop e lower than 5% and at a power factor of 0.80, are respectively 10 mm<sup>2</sup> (0.39 in<sup>2</sup>) and 146 m (179 ft). In case electric motors must be started, oversizing the cable is advisable.

The voltage drop across a cable can be determined as follows:

$$e = \frac{\sqrt{3} \cdot I \cdot L \cdot (R \cdot \cos \phi + X \cdot \sin \phi)}{1000}$$

e = Voltage drop (V)

I = Rated current (A)

L = Length of conductors (m)

R = Resistance (Ω/km to VDE 0102)

X = Reactance (Ω/km to VDE 0102)

### Connecting the load

#### Site distribution panel

If outlet sockets are required, they must be mounted on a site distribution panel supplied from the terminal board of the generator and in compliance with local regulations for power installations on building sites.

## Protection



For safety reasons, it is necessary to provide an isolating switch or circuit breaker in each load circuit. Local legislation may impose the use of isolating devices which can be locked.

- Check whether frequency, voltage and current comply with the ratings of the generator.
- Provide for the load cable, without excessive length, and lay it out in a safe way without forming coils.
- Open the door of the control and indicator panel and the transparent door in front of the terminal board X1.
- Provide the wire ends with cable lugs suited for the cable terminals.
- Loosen the cable clamp and push the wire ends of the load cable through the orifice and clamp.
- Connect the wires to the proper terminals (L1, L2, L3, N and PE) of X1 and tighten the bolts securely.
- Tighten the cable clamp.
- Close the transparent door in front of X1.

## Before starting

- With the generator standing level, check the engine oil level and top up if necessary. The oil level must be near to, but not exceed the high mark on the engine oil level dipstick.
- Check the coolant level in the expansion tank of the engine cooling system. The coolant level must be near to the FULL mark. Add coolant if necessary.
- Drain any coolant and sediment from the fuel pre-filter. Check the fuel level and top up if necessary. It is recommended to fill the tank after the day's operation to prevent coolant damp in a nearly empty tank from condensing.
- Check the vacuum indicator of the air filter. If the red part shows completely, replace the filter element.
- Press the vacuator valve of the air filter to remove dust.
- Check the generator for leakage, tightness of wire terminals, etc. Correct if necessary.
- Check that fuse F10 has not tripped and that the emergency stop is in the OUT position.
- Check that the load is switched off.
- Check that circuit breaker Q1.1/Q1.2 are switched off.

## Operating Qc1002™

### Starting Qc1002™

**To start up the unit locally, proceed as follows:**

- Switch on the battery switch.
- Switch off circuit breaker Q1.1/Q1.2. This is not necessary when a plant contactor is installed between Q1.1/Q1.2 and the load.
- Put the starter switch S20 in position I (ON). Voltage is applied to the Qc1002™ module.
- The unit can be started manually by pressing the START button on the Qc1002™ module.
- The unit starts a preheating cycle which takes 12 seconds.
- After the preheating period, the unit will start. The starting attempt will take maximum 12 seconds.
- Switch on circuit breaker Q1.1/Q1.2 in case no contactor is installed.

**To start up the unit from a remote location, proceed as follows:**

- Put the starter switch S20 in position I (ON). Voltage is applied to the Qc1002™ module.
- The unit can be started from a remote location by pressing the remote mode button  on the Qc1002™ module.

- Switch on circuit breaker Q1.1/Q1.2 .
- Put the remote start/stop switch in position start.
- The unit starts a preheating cycle which takes 12 seconds.
- After the preheating period, the unit will start. The starting attempt will take maximum 12 seconds.

### **During operation Qc1002™**

Following points should be carried out regularly:

- Check the engine gauges and the lamps for normal readings.



**Avoid to let the engine run out of fuel. If it happened, priming will speed up the starting.**

- Check for leakage of oil, fuel or coolant.
- Avoid long low-load periods (< 30%). In this case, an output drop and higher oil consumption of the engine could occur.
- Check, by means of the generator gauges, that the voltage between the phases is identical and that the rated current in the third phase (L3) is not exceeded.
- When single-phase loads are connected to the generator output terminals, keep all loads well-balanced.

If circuit breakers are activated during operation, switch off the load and stop the generator. Check and, if necessary, decrease the load.



**The generator's doors may only remain opened for short periods during operation, to carry out checks for example.**

### **Stopping Qc1002™**

**To stop the unit locally, proceed as follows:**

- Switch off the load.
- Switch off circuit breaker Q1.1/Q1.2 .
- Let the engine run for about 5 minutes.
- Stop the engine by using the STOP button on the Qc1002™ module.
- Put the starter switch S20 in position O (OFF) to shut down the voltage apply towards the Qc1002™ module.
- Lock the side doors and the door of the indicators and control panel to avoid unauthorized access.

**To stop the unit when the Qc1002™ module is in position , proceed as follows:**

- Switch off the load.
- Stop the engine by putting the remote start/stop switch in position stop or by using the STOP button on the Qc1002™ module. When the unit is stopped with the STOP button in Remote mode, it will automatically go to Manual Mode.
- Put the starter switch S20 in position O (OFF) to shut down the voltage apply towards the Qc1002™ module.
- Lock the side doors and the door of the indicators and control panel to avoid unauthorized access.

# Maintenance

## Maintenance schedule



Before carrying out any maintenance activity, check that the start switch is in position O and that no electrical power is present on the terminals.

Maintenance schedule	Daily	Every 250 hours	Every 500 hours or yearly	Every 2000 hours or 24 months
<b>Service pak</b>	-	<b>2912 6375 04</b>	<b>2912 6376 05</b>	<b>see 500 hours</b>
<i>For the most important subassemblies, Atlas Copco has developed service kits that combine all wear parts. These service kits offer you the benefits of genuine parts, save on administration costs and are offered at reduced price, compared to the loose components. Refer to the parts list for more information on the contents of the service kits.</i>				
Check for air, fuel, coolant and oil leakage	x	x	x	x
Check oil and coolant level	x	x	x	x
Check or drain water in fuelfilter/waterseparator	x	x	x	x
Clean air cleaner and dust bowl	x	x	x	x
Check vacuum indicator	x	x	x	x
Visual walk around the unit	x	x	x	x
Replace engine oil (1)		x	x	x
Replace engine oil filter (1)		x	x	x
Check/clean radiator/cooler fins		x	x	x
Check tension and condition of the drive belt (4)			x	x
Grease door hinges and locks			x	x
Replace fuel filter element			x	x
Replace fuel prefilter element			x	x
Check electrolyte level and terminals of battery			x	x

Check engine mounts			X	X
Check crankcase ventilation system			X	X
Check condition of cooling fan assembly			X	X
Pressure test cooling system			X	X
Check engine electrical ground connection			X	X
Replace air filter element			X	X
Replace safety cartridge			X	X
Measure alternator insulation resistance (*)			X	X
Check glycol level in coolant			X	X
Check PH level of engine coolant			X	X
Check and adjust engine inlet and outlet valves				X
Check alternator and starter motor				X
Check electrical system for security of cables and wear				X
Test thermostats				X
Test glow plugs				X
Check crankshaft vibration damper (3)				X
Inspection by Atlas Copco Service technician		<b>Generators in standby application have to be tested on a regular basis. At least once a month the engine should run for minimum 30 minutes at a high load ( 50% - 70% ) that the engine reaches its operating temperature.</b>		

**Notes:**

In highly dusty environments, these service intervals do not apply. Check and/or replace filters and clean radiator on a regular basis.

- (1) During engine break-in, change the oil and oil filter for the first time after max. 100 hours of operation. Use PAROIL 5W40 only.
- (2) Rocker cover gaskets can be re-used after valve clearance. (Rocker cover gasket: pn = 2914 9999 00 & O- ring ( 6# ): pn = 2914 9992 00)
- (3) Replace crankshaft damper every 4500 Hrs or 60 months, whichever occurs first.
- (4) V-belt can be ordered with pn = 2914 9998 00.

**Engine maintenance**

Refer to the engine's operator manual for full maintenance schedule.

**(\* ) Measuring the alternator insulation resistance**

A 500 V megger is required to measure the alternator insulation resistance.

If the N-terminal is connected to the earthing system, it must be disconnected from the earth terminal. Disconnect the AVR.

Connect the megger between the earth terminal and terminal L1 and generate a voltage of 500 V. The scale must indicate a resistance of at least 5 MΩ.

Refer to the alternator operating and maintenance instructions for more details.

**Engine oil specifications**

**It is strongly recommended to use Atlas Copco branded lubrication oils.**

High-quality, mineral, hydraulic or synthesized hydrocarbon oil with rust and oxidation inhibitors, anti-foam and anti-wear properties is recommended. The viscosity grade should correspond to the ambient temperature and ISO 3448, as follows.

Engine	Type of lubricant
between -25°C (-13°F) and 40°C (104°F)	PAROIL 5W40

**Specifications PAROIL**

PAROIL from Atlas Copco is the ONLY oil tested and approved for use in all engines built into Atlas Copco compressors and generators.

Extensive laboratory and field endurance tests on Atlas Copco equipment have proven PAROIL to match all lubrication demands in varied conditions. It meets stringent quality control specifications to ensure your equipment will run smoothly and reliably.

The quality lubricant additives in PAROIL allow for extended oil change intervals without any loss in performance or longevity.

PAROIL provides wear protection under extreme conditions. Powerful oxidation resistance, high chemical stability and rust- inhibiting additives help reduce corrosion, even within engines left idle for extended periods.

PAROIL contains high quality anti-oxidants to control deposits, sludge and contaminants that tend to build up under very high temperatures.

PAROIL's detergent additives keep sludge forming particles in a fine suspension instead of allowing them to clog your filter and accumulate in the valve/rocker cover area.

PAROIL releases excess heat efficiently, whilst maintaining excellent bore-polish protection to limit oil consumption.

PAROIL has an excellent Total Base Number (TBN) retention and more alkalinity to control acid formation.

PAROIL prevents Soot build-up.

PAROIL is optimized for the latest low emission EURO -3 & -2, EPA TIER II & III engines running on low sulphur diesel for lower oil and fuel consumption.

## PAROIL 5W40

PAROIL 5W40 is a Synthetic ultra high performance diesel engine oil with a high viscosity- index. Atlas Copco PAROIL 5W40 is designed to provide excellent lubrication from start-up in temperatures as low as -25°C (-13°F).

	Liter	US gal	Imp gal	cu.ft	Order number
can	5	1.3	1.1	0.175	1604 6060 01
barrel	210	55.2	46	7.35	1604 6059 01

## Engine oil level check

Consult the Engine Operation Manual for the oil specifications, viscosity recommendations and oil change intervals.

For intervals, see section “Maintenance schedule” on page 28.

Check engine oil level according to the instructions in the Engine Operation Manual and if necessary top up with oil.

## Engine oil and oil filter change

See section “Maintenance schedule” on page 28.

## Engine coolant specifications



Never remove the cooling system filler cap while coolant is hot.

The system may be under pressure. Remove the cap slowly and only when coolant is at ambient temperature. A sudden release of pressure from a heated cooling system can result in personal injury from the splash of hot coolant.

It is strongly recommended to use Atlas Copco branded coolant.

The use of the correct coolant is important for good heat transfer and protection of liquid-cooled engines. Coolants used in these engines must be mixtures of good quality water (distilled or de-ionised), special coolant additives and if necessary freeze protection. Coolant that is not to manufacturer's specification will result in mechanical damage of the engine.

The freezing point of the coolant must be lower than the freezing point that can occur in the area. The difference must be at least 5°C (41°F). If the coolant freezes, it may crack the cylinder block, radiator or coolant pump.

Consult the engine's operation manual and follow the manufacturer's directions.



Never mix different coolants and mix the coolant components outside the cooling system.

## Specifications PARCOOL EG

PARCOOL EG is the only coolant that has been tested and approved by all engine manufacturers currently in use in Atlas Copco compressors and generators.

Atlas Copco's PARCOOL EG extended life coolant is the new range of organic coolants purpose designed to meet the needs of modern engines. PARCOOL EG can help prevent leaks caused by corrosion. PARCOOL EG is also fully compatible with all sealants and gasket types developed to join different materials used within an engine.

PARCOOL EG is a ready to use Ethylene Glycol based coolant, premixed in an optimum 50/50 dilution ratio, for antifreeze protection guaranteed to -40°C (-40°F).

Because PARCOOL EG inhibits corrosion, deposit formation is minimized. This effectively eliminates the problem of restricted flow through the engine coolant ducts and the radiator, minimizing the risk for engine overheating and possible failure.

It reduces water pump seal wear and has excellent stability when subjected to sustained high operating temperatures.

PARCOOL EG is free of nitride and amines to protect your health and the environment. Longer service life reduces the amount of coolant produced and needing disposal to minimise environmental impact.

	<b>Liter</b>	<b>US gal</b>	<b>Imp gal</b>	<b>cu.ft</b>	<b>Order number</b>
can	5	1.3	1.1	0.175	1604 5308 00
can	20	5.3	4.4	0.7	1604 5307 01
barrel	210	55.2	46	7.35	1604 5306 00

To ensure protection against corrosion, cavitation and formation of deposits, the concentration of the additives in the coolant must be kept between certain limits, as stated by the manufacturer's guidelines. Topping up the coolant with water only, changes the concentration and is therefore not allowed.

Liquid-cooled engines are factory-filled with this type of coolant mixture.

## Coolant check

### Monitoring coolant condition

In order to guarantee the lifetime and quality of the product, thus to optimise engine protection, regular coolant-condition-analysis is advisable.

The quality of the product can be determined by three parameters.

### Visual check

- Verify the outlook of the coolant regarding colour and make sure that no loose particles are floating around.

### pH measurement

- Check the pH value of the coolant using a pH-measuring device.
- The pH-meter can be ordered from Atlas Copco with part number 2913 0029 00.
- Typical value for EG = 8.6.
- If the pH-level is below 7 or above 9.5, the coolant should be replaced.

### Glycol concentration measurement

- To optimise the unique engine protection features of the PARCOOL EG the concentration of the Glycol in the water should be always above 33 vol.%.  
- Mixtures with more than 68 vol.% mix ratio in water are not recommended, as this will lead to high engine operating temperatures.



- A refractometer can be ordered from Atlas Copco with part number 2913 0028 00.



**In case of a mix of different coolant products this type of measurement might provide incorrect values.**

### **Topping up of coolant**

- Verify if the engine cooling system is in a good condition (no leaks, clean,...).
- Check the condition of the coolant.
- If the condition of the coolant is outside the limits, the complete coolant should be replaced (see section "Replacing the coolant").
- Always top-up with PARCOOL EG.
- Topping up the coolant with water only, changes the concentration of additives and is therefore not allowed.

### **Replacing the coolant**

#### **Drain**

- Completely drain the entire cooling system.
- Used coolant must be disposed or recycled in accordance with laws and local regulations.

### **Flush**

- Flush twice with clean water. Used coolant must be disposed or recycled in accordance with laws and local regulations.
- From the Atlas Copco Instruction book, determine the amount of PARCOOL EG required and pour into the radiator top tank.
- It should be clearly understood that the risk for contamination is reduced in case of proper cleaning.
- In case a certain content of 'other' coolant remains in the system, the coolant with the lowest properties influences the quality of the 'mixed' coolant.

### **Fill**

- To assure proper operation and the release of trapped air, run the engine until normal engine operation temperature is reached. Turn off the engine and allow to cool.
- Recheck coolant level and add if necessary.

## **Storage of the generator**

### **Storage**

- Store the generator in a dry, frost-free room which is well ventilated.
- Run the engine regularly, e.g. once a week, until it is warmed up. If this is impossible, extra precautions must be taken:
  - Consult the engine's operator manual.
  - Remove the battery. Store it in a dry, frost-free room. Keep the battery clean and its terminals lightly covered with petroleum jelly. Recharge the battery regularly.
  - Clean the generator and protect all electrical components against moisture.
  - Place silica gel bags, VCI paper (Volatile Corrosion Inhibitor) or another drying agent inside the generator and close the doors.
  - Stick sheets of VCI paper with adhesive tape on the bodywork to close off all openings.
  - Wrap the generator, except the bottom, with a plastic bag.

## ***Preparing for operation after storage***

Before operating the generator again, remove the wrapping, VCI paper and silica gel bags and check the generator thoroughly (go through the checklist “Before starting” on page 26).

- Consult the engine’s operator manual.
- Check that the insulation resistance of the generator exceeds 5 MΩ.
- Replace the fuel filter and fill the fuel tank. Vent the fuel system.
- Reinstall and connect the battery, if necessary after being recharged.
- Submit the generator to a test run.

## ***Checks and trouble shooting***



**Never perform a test run with connected power cables. Never touch an electrical connector without a voltage check.**

**When a failure occurs, always report what you experienced before, during and after the failure. Information with regard to the load (type, size, power factor, etc.), vibrations, exhaust gas colour, insulation check, odours, output voltage, leaks and damaged parts, ambient temperature, daily and normal maintenance and altitude might be helpful to quickly locate the problem. Also report any information regarding the humidity and location of the generator (e.g. close to sea).**

## ***Checking voltmeter P4***

- Put a voltmeter in parallel with voltmeter P4 on the control panel.
- Check that the read-out of both voltmeters is the same.
- Stop the generator and disconnect one terminal.
- Check that the internal resistance of the voltmeter is high.

## ***Checking ammeters P1, P2 and P3***

- Measure by means of a clamp-on probe the outgoing current during the load.
- Compare the measured currents with the currents on the corresponding ammeters. Both readings should be the same.

## ***Engine troubleshooting***

Refer to the engine’s operator manual for the engine troubleshooting. An extensive Engine troubleshooting manual is available at John Deere. For more information contact John Deere.

## Alternator troubleshooting

<i>Symptom</i>	<i>Possible cause</i>	<i>Corrective action</i>
<i>Alternator gives 0 Volt</i>	Blown fuse. No residual voltage.	Replace fuse. Excite the alternator by applying a 12V battery voltage with a 30 W resistor in series on the + and - terminals of the electronic regulator, respecting the polarities.
<i>After being excited the alternator still gives 0 Volt.</i>	Connections are interrupted.	Check connection cables, measure winding resistances and compare with values mentioned in the alternator manual.
<i>Low voltage at no load</i>	Voltage potentiometer out of setting. Intervention of protection. Winding failure.	Reset voltage. Check frequency/voltage regulator. Check windings.
<i>High voltage at no load</i>	Voltage potentiometer out of setting. Failed regulator.	Reset voltage. Substitute regulator.
<i>Lower than rated voltage at load</i>	Voltage potentiometer out of setting. Intervention by protection.  Failed regulator. Rotating bridge failure.	Reset voltage potentiometer. Current too high, power factor lower than 0.8; speed lower than 10% of rated speed. Substitute regulator. Check diodes, disconnect cables.
<i>Higher than rated voltage at load</i>	Voltage potentiometer out of setting. Failed regulator.	Reset voltage potentiometer. Substitute regulator.
<i>Unstable voltage</i>	Speed variation in engine. Regulator out of setting.	Check regularity of rotation. Regulate stability of regulator by acting on STABILITY potentiometer.

## Technical specifications for QAS 150 John Deere

### Readings on gauges

Gauge	Reading	Unit
Ammeter L1-3 (P1-3)	Below max. rating	A
Voltmeter (P4)	Depends upon selector switch	V

### Settings of switches

Switch	Function	Activates at (US)	Activates at (Metric)
Engine oil pressure	Shut down	7.25 psi	0.5 bar
Engine coolant temperature	Shut down	217.40°F	103°C

### Specifications of the engine/alternator/unit

		US	Metric
<i>Reference values 1) 4)</i>	Rated frequency	60 Hz	60 Hz
	Rated speed	1800 rpm	1800 rpm
	Generator service duty	PRP	PRP
	Absolute air inlet pressure	100 kPa	100 kPa
	Relative air humidity	30%	30%
	Air inlet temperature	77°F	25°C
<i>Limitations 2)</i>	Maximum ambient temperature	122°F	50°C
	Altitude capability	13,124 ft	4000 m
	Relative air humidity maximum	85%	85%
	Minimum starting temperature unaided	5°F	-15°C
	Minimum starting temperature with heater (optional)	-13°F	-25°C
<i>Performance data 2) 3) 4) 5) 6)</i>	Rated active power (PRP) 3 phase	150.19 hp	112 kW
	Rated active power (PRP) 3 phase lower voltage	150.19 hp	112 kW
	Rated active power (PRP) 1 phase	113.3 hp	84.5 kW
	Rated power factor (lagging) 3 phase	0.8	0.8

*Application data*

Rated power factor (lagging) 1 phase	1.0	1.0
Rated apparent power (PRP) 3 phase	140 kVA	140 kVA
Rated apparent power (PRP) 3 phase, lower voltage	140 kVA	140 kVA
Rated apparent power (PRP) 1 phase	84.5 kVA	84.5 kVA
Rated voltage 3 phase line to line	480 V	480 V
Rated voltage 3 phase line to line, lower voltage	208 V	208 V
Rated voltage 1 phase line to line	240 V	240 V
Rated current 3 phase	168.4 A	168.4 A
Rated current 3 phase, lower voltage	336.8 A	336.8 A
Rated current 1 phase	336.8 A	336.8 A
Performance class (acc. to ISO 8528-5:1993)	G2	G2
Single step load acceptance (0-PRP)	70%	70%
Frequency droop	isochronous	isochronous
Fuel consumption at 0% load	10.96 lb/h	4.97 kg/h
Fuel consumption at 50% load	37.04 lb/h	16.80 kg/h
Fuel consumption at 75% load	50.27 lb/h	22.80 kg/h
Fuel consumption at full load (100%)	60.86 lb/h	27.60 kg/h
Specific fuel consumption at full load (100%)	0.53 lb/kWh	0.240 kg/kWh
Fuel autonomy at full load	25 h	25 h
Max. oil consumption at full load	18.22 US gal/h	69 l/h
Max. sound power level (LPA) measured according to Atlas Copco spec. 9822087700	71 dB(A)	71 dB(A)
Capacity of fuel tank	219.12 US gal	830 l
Single step load capability (0-PRP)	100%	100%
Mode of operation	PRP	PRP
Site	land use	land use
Operation	single/parallel	single/parallel
Start-up and control mode	manual/auto	manual/auto
Start-up time	unspecified	unspecified
Mobility/Config. acc. to ISO 8528-1:1993	transportable/D	transportable/D
optional	mobile/E	mobile/E
Mounting	fully resilient	fully resilient
Climatic exposure	open air	open air

<i>Alternator</i>	Degree of protection (cubicle)	IP54	IP54
	Status of neutral	earthed	earthed
	Standard	IEC 34-1	IEC 34-1
	Make	ISO 8528-3	ISO 8528-3
	Model	NEWAGE	NEWAGE
	Rated output, class H temp. rise	UCI 274 D	UCI 274 D
	Rating type acc. ISO 8528-3	146.3 kVA	146.3 kVA
	Degree of protection	“BR” 125/40°C	“BR” 125/40°C
	Insulation class stator	IP21	IP21
	Insulation class rotor	H	H
	Number of wires	H	H
<i>Engine</i>	Standard	12	12
	Standard	ISO 3046	ISO 3046
	Type JOHN DEERE	ISO 8528-2	ISO 8528-2
	Rated net output	6068HF285	6068HF285
	Rating type acc. ISO 3046-7	168.83 hp	125.9 kW
	Coolant	ICXN	ICXN
	Combustion system	water	water
	Aspiration	direct injection	direct injection
	Number of cylinders	turbocharged	turbocharged
	Swept volume	intercooled	intercooled
	Speed governing	6	6
	Capacity of oil sump	1.80 US gal	6.80 l
	Capacity of cooling system	electronic	electronic
	Electrical system	HPCR	HPCR
	Emission compliance	7.13 US gal	27 l
	6.34 US gal	24 l	
	12 Vdc	12 Vdc	
	USA TIER III	USA TIER III	

<i>Power circuit</i>	<b>Circuit-breaker, 3 phase</b>		
	Number of poles	3	3
	Thermal release $I_t$ (thermal release is higher at 25°C)	172 A	172 A
	Magnetic release $I_m$	3x $I_n$	3x $I_n$
	<b>Circuit-breaker, 3 phase, lower voltage</b>		
	Number of poles	3	3
	Thermal release $I_t$ (thermal release is higher at 25°C)	364 A	364 A
	Magnetic release $I_m$	3.5x $I_n$	3.5x $I_n$
	<b>Fault current protection</b>		
	Residual current release ( $I_{Dn}$ )	0.03-30 A	0.03-30 A
	Insulation resistance	10-100 kOhm	10-100 kOhm
	<b>Outlet sockets</b>		
	GFCI duplex (2x) 2p + E 20 A 125 V	GFCI duplex (2x) 2p + E 20 A 125 V	
	Temp power (2x) 2p + N + E 50 A 125/250 V	Temp power (2x) 2p + N + E 50 A 125/250 V	
<i>Unit</i>			
	Dimensions (L x W x H)	131.74 x 46.02 x 83.07 in	3378 x 1180 x 77.38 mm
	Weight net mass	5541.17 lb	2513 kg
	Weight wet mass	7239.02 lb	3283 kg

## Notes

- 1) Reference conditions for engine performance to ISO 3046-1.
- 2) See derating diagram or consult the factory for other conditions.
- 3) At reference conditions unless otherwise stated.
- 4) Rating definition (ISO 8528-1):  
 LTP: Limited Time Power is the maximum electrical power which a generating set is capable of delivering (at variable load), in the event of a utility power failure (for up to 500 hours per year of which a maximum of 300 hours is continuous running). No overload is permitted on these ratings. The alternator is peak continuous rated (as defined in ISO 8528-3) at 25°C.  
 PRP: Prime Power is the maximum power available during a variable power sequence, which may be run for an unlimited number of hours per year, between stated maintenance intervals and under the stated ambient conditions. A 10% overload is permitted for 1 hour in 12 hours. The permissible average power output during a 24h period shall not exceed the stated load factor of 70%.
- 5) Specific mass fuel used: 0.86 kg/l.

*Derating table (in %, 100% is declared power at "Performance data")*

Height (m)	Temperature (°C)										
	0	5	10	15	20	25	30	35	40	45	50
0	100	100	100	100	100	100	100	100	100	95	90
500	100	100	100	100	100	100	100	100	100	95	90
1000	100	100	100	100	100	100	100	100	100	95	90
1500	100	100	100	100	100	100	100	100	95	95	85
2000	95	95	95	95	95	95	95	95	95	90	85
2500	90	90	90	90	90	90	90	90	90	85	80
3000	90	90	90	90	90	90	90	90	90	85	80
3500	85	85	85	85	85	85	85	85	85	75	75
4000	85	85	85	85	85	85	85	85	85	75	75

*For use of generator outside these conditions, please contact Atlas Copco.*



## Conversion list of SI units into British units

1 bar	=	14.504 psi
1 g	=	0.035 oz
1 kg	=	2.205 lb
1 km/h	=	0.621 mile/h
1 kW	=	1.341 hp (UK and US)
1 l	=	0.264 US gal
1 l	=	0.220 lmp gal (UK)
1 l	=	0.035 cu.ft
1 m	=	3.281 ft
1 mm	=	0.039 in
1 m <sup>3</sup> /min	=	35.315 cfm
1 mbar	=	0.401 in wc
1 N	=	0.225 lbf
1 Nm	=	0.738 lbf.ft
$t_{°F}$	=	$32 + (1.8 \times t_{°C})$
$t_{°C}$	=	$(t_{°F} - 32)/1.8$

A temperature difference of 1°C = a temperature difference of 1.8°F.

## Dataplate

The diagram shows a rectangular dataplate with the following fields and markings:

- 1: Points to the top-left corner.
- 2: Points to the top-center.
- 3: Points to the top-right corner.
- 4: Points to the manufacturer name "ATLAS COPCO AIRPOWER n.v.".
- 5: Points to the product code "YA3-\*\*\*\*\*-\*\*\*\*\*".
- 6: Points to the unit serial number "A B C".
- 7: Points to the model number "Model/Modell/Modèle \*\*\*\*\*".
- 8: Points to the frequency field "f N LTP \* Hz \*\*".
- 9: Points to the active power field "P N LTP \* kVA \*\*\*".
- 10: Points to the apparent power field "P N \* kW \*\*\*".
- 11: Points to the nominal voltage field "U N \* V \*\*\*".
- 12: Points to the nominal current field "I N \* A \*\*\*".
- 13: Points to the power factor field "cos phi \*\*".
- 14: Points to the manufacturing year field "Manuf. year/Baujahr/Année de fabrication \*\*\*\*".
- 15: Points to the CE mark.
- 16: Points to the "MADE BY ATLAS COPCO AIRPOWER n.v. WILRIJK, BELGIUM" text.
- 17: Points to the "1 15 6945 00" and "Atlas Copco" logo.

A	XXXX
B	XXXX
C	XXXX
1	Company code
2	Product code
3	Unit serial number
4	Name of manufacturer
5	EEC or national type approved number
6	Vehicle identification number
7	Model number
8	Frequency
9	Apparant power - PRP
10	Active power - PRP
11	Nominal rated voltage
12	Nominal rated current
13	Power factor
14	Manufacturing year
15	EEC mark in accordance witt Machine Directive 89/392E
16	Mode of operation
17	Winding connections



**Circuit diagrams**

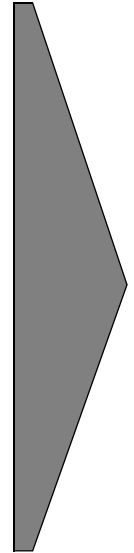

9822 0993 50/00

Applicable for QAS 150 John Deere - Power circuit

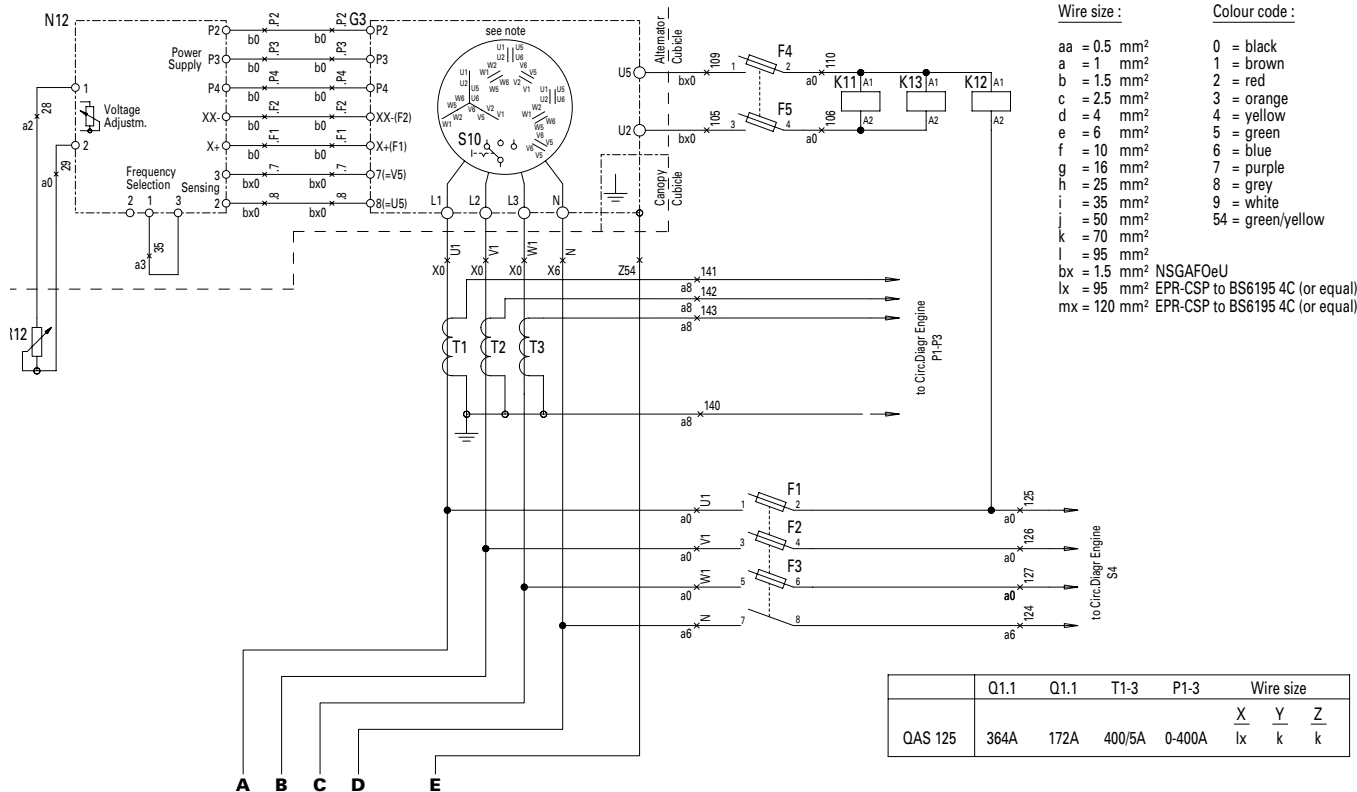

Legend

Wire size :

- aa = 0.5 mm<sup>2</sup>
- a = 1 mm<sup>2</sup>
- b = 1.5 mm<sup>2</sup>
- c = 2.5 mm<sup>2</sup>
- d = 4 mm<sup>2</sup>
- e = 6 mm<sup>2</sup>
- f = 10 mm<sup>2</sup>
- g = 16 mm<sup>2</sup>
- h = 25 mm<sup>2</sup>
- i = 35 mm<sup>2</sup>
- j = 50 mm<sup>2</sup>
- k = 70 mm<sup>2</sup>
- l = 95 mm<sup>2</sup>
- bx = 1.5 mm<sup>2</sup> NSGAFOeU
- lx = 95 mm<sup>2</sup> EPR-CSP to BS6195 4C (or equal)
- mx = 120 mm<sup>2</sup> EPR-CSP to BS6195 4C (or equal)

Colour code :

- 0 = black
- 1 = brown
- 2 = red
- 3 = orange
- 4 = yellow
- 5 = green
- 6 = blue
- 7 = purple
- 8 = grey
- 9 = white
- 54 = green/yellow

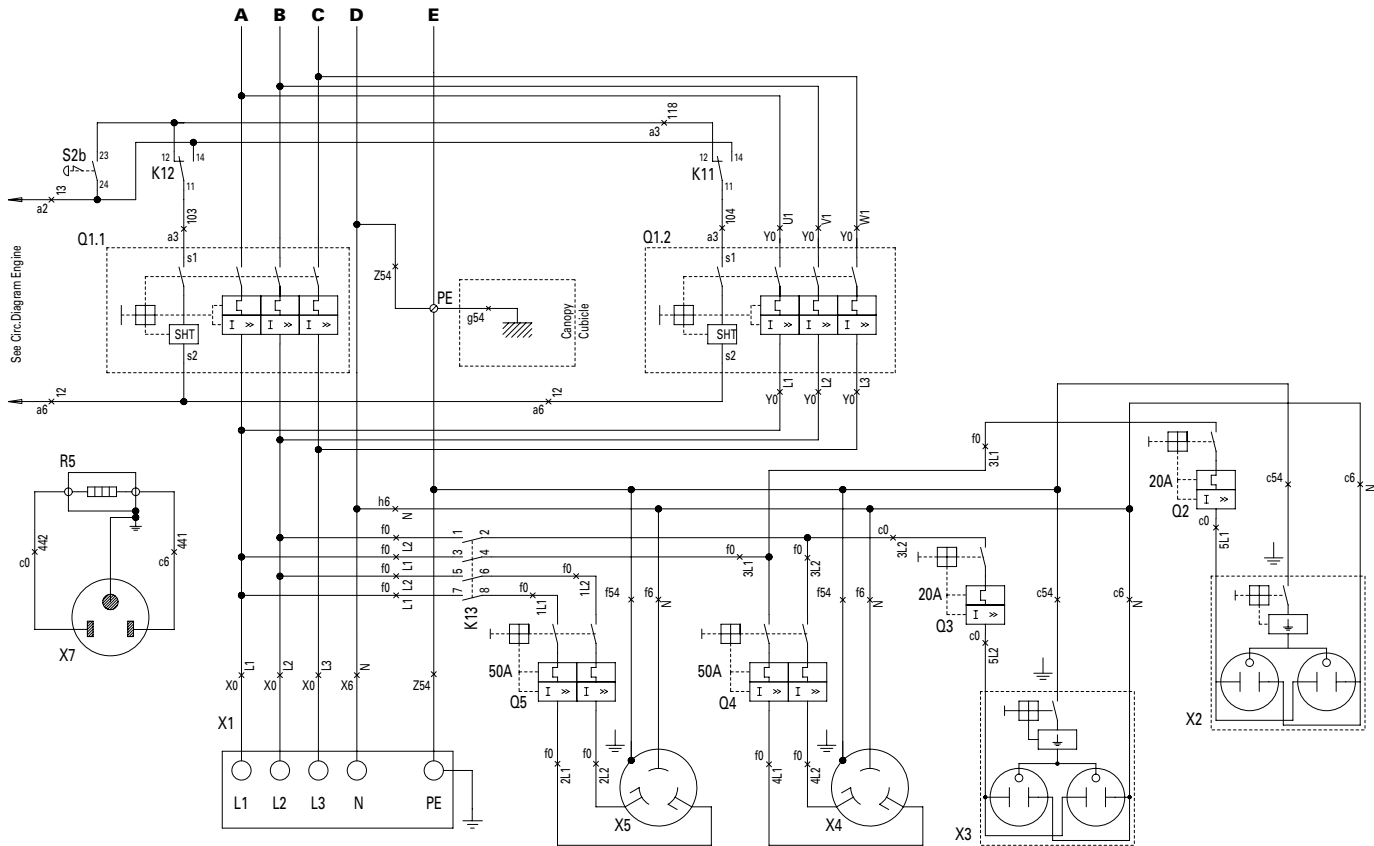

F1-5	Fuse 4 A
G3	Alternator
K11	Auxiliary relay (lower voltage)
K12	Auxiliary relay (higher voltage)
K13	Contactora
N12	Automatic voltage regulator
Q1.1	Circuit breaker (3 pole)
Q1.2	Circuit breaker (3 pole)
Q2	Circuit breaker (1 pole)
Q3	Circuit breaker (1 pole)
Q4	Circuit breaker (2 pole)
Q5	Circuit breaker (2 pole)
R5	Coolant heater
R12	Voltage adjustment potmeter
S2b	Emergency stop (S2a: see Engine circuit)
S10	Supply voltage switch
T1-3	Current transformer
X1	Terminal board
X2	Outlet socket
X3	Outlet socket
X4	Outlet socket
X5	Outlet socket
X7	Flanged inlet
X9	Terminal strip
X10	Terminal strip
X25	Terminal strip
Sx	Remote start/stop
Kx	Contactora generator ready (15s delayed)



9822 0993 55/00

Applicable for QAS 150 John Deere - Engine circuit Qc1002™

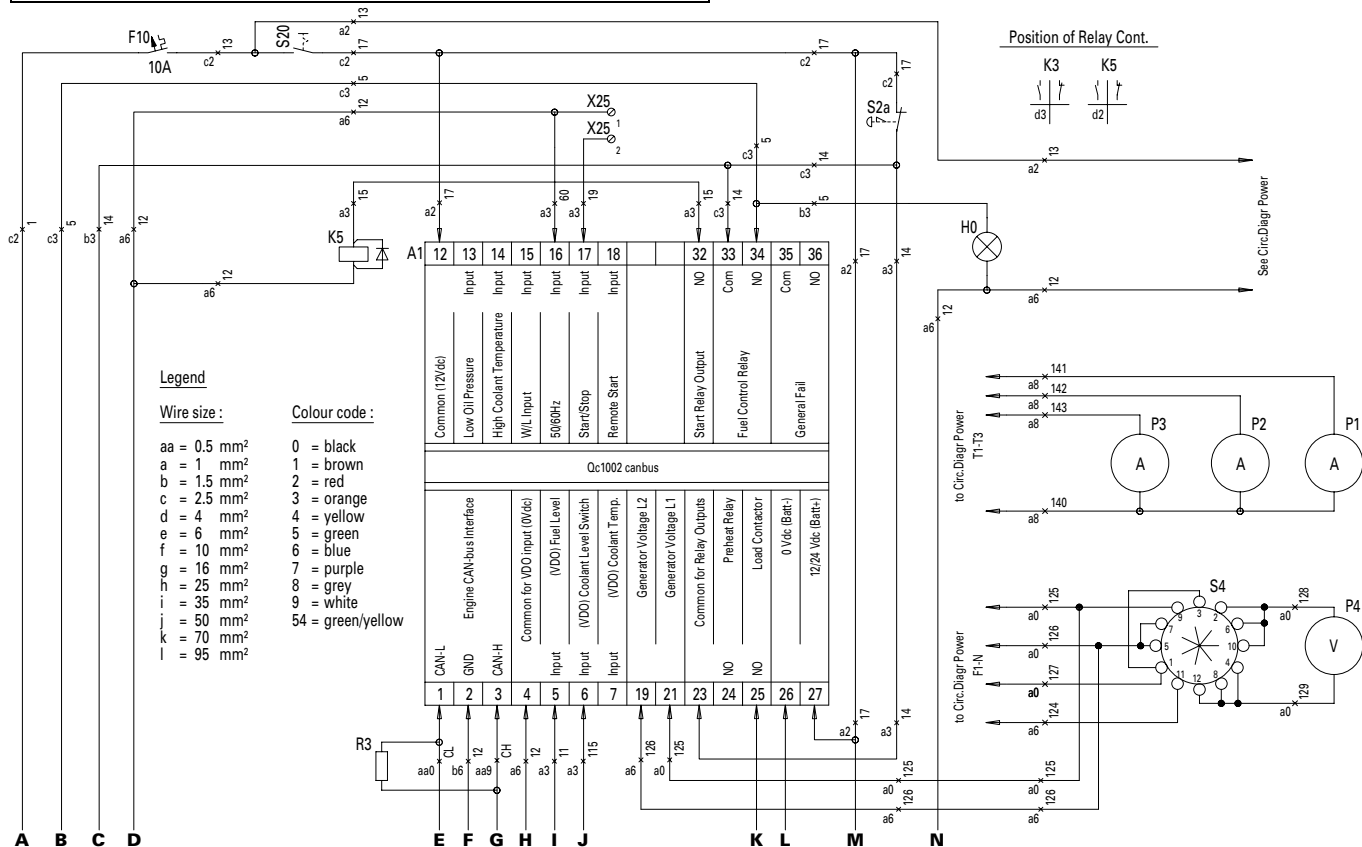



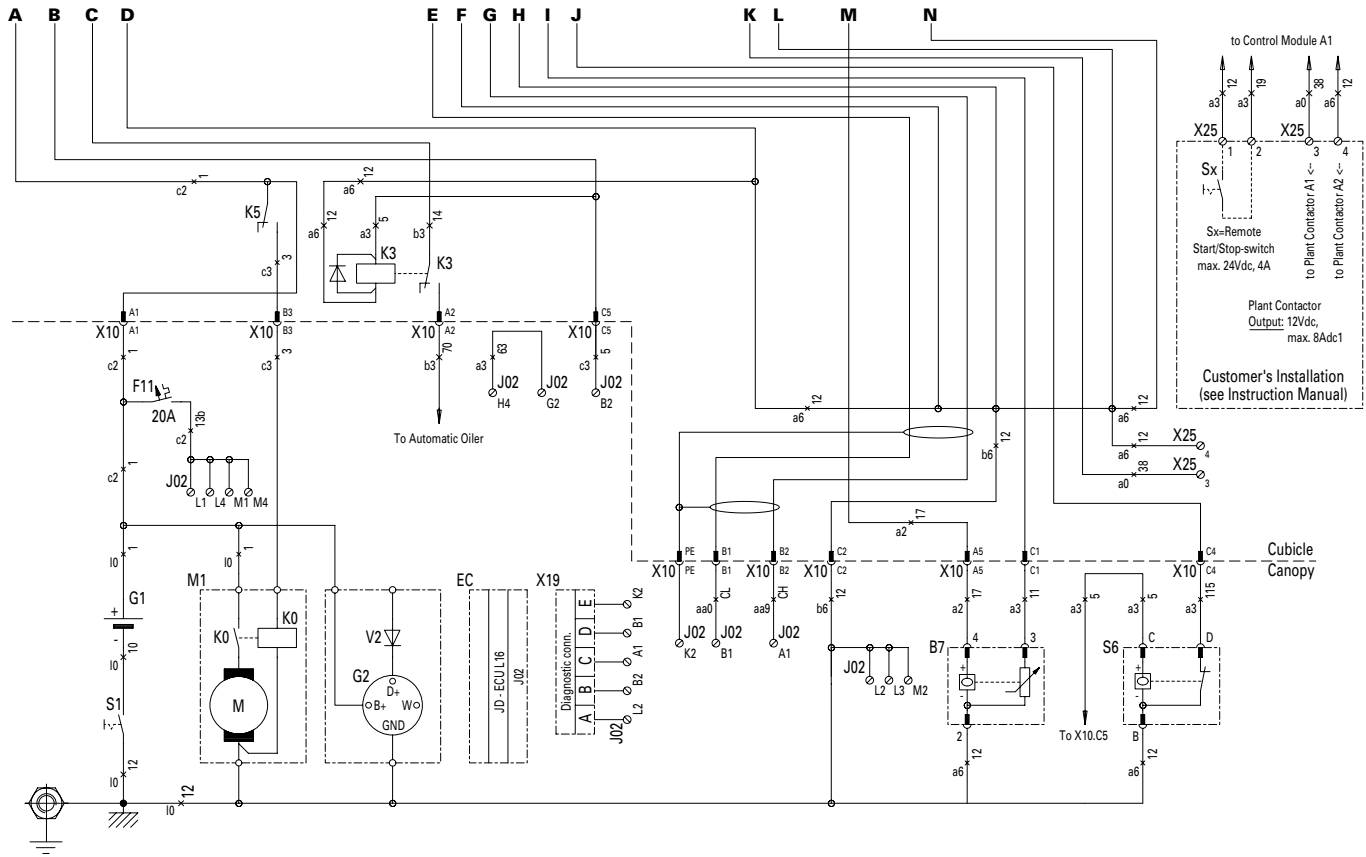

to Control Module A1

X25

Sx

Sx-Remote Start/Stop-switch max. 24Vdc, 4A

to Plant Contactor A1 <-

to Plant Contactor A2 <-

Plant Contactor Output: 12Vdc, max. 8Acd1

Customer's Installation (see Instruction Manual)

Cubicle Canopy

A1	Control module (configure in unit-type 6)
B7	Fuel level sensor
EC	Engine controller
F4	Fuse
F20	Fuse
G1	Battery 12 V
H1	Panel light
JO2	Engine connector
K3	Auxiliary relay automatic oiler (O)
K5	Starter relay
M1	Starter motor
P1-3	Amperemeter
P4	Voltmeter
R3	Resistor 120 Ohm
S1	Battery switch
S2a	Emergency stop button (S2b: see Power Circuit)
S4	Voltmeter change-over switch
S6	Coolant level switch
S7	Low fuel level switch
S7'	Low fuel level switch, warning
S20	On/Off switch
V2	Diode
X10	Terminal strip
X17	Fuel level unit connector
X19	Motor diagnostic plug
X25	Terminal strip
(O)	Optional equipment





[www.atlascopco.com](http://www.atlascopco.com)

Printed in Belgium 12/2007 - 2954 3360 00