

## BE1-32R, BE1-32 O/U DIRECTIONAL POWER RELAY

The BE1-32R Directional Overpower Relay and the BE1-32 O/U Directional Over/Underpower Relay are solid-state devices which provide versatility and control in protecting machines against reverse power flow, underpower and overpower conditions.

### ADVANTAGES

- Measures Real Power -  $EI \cos \theta$ .
- Wide variety of input configurations are available including single-phase and three phase, 3 and 4 wire systems.
- Sensing ranges available from 0.5 to 6000 watts secondary.
- Instantaneous, definite and inverse timing characteristics available.
- Low input sensing and supply burdens.
- Qualified to the requirements of
  - ANSI/IEEE C37.90.1-1989 and IEC 255 for fast transient and surge withstand capability;
  - IEC 255-5 for impulse.
- UL Recognized under Standard 508, UL File #E97033.

### ADDITIONAL INFORMATION

#### INSTRUCTION MANUAL

Request Publication 9-1711-00-990

#### SERVICE MANUAL

Request Publication 9-1711-00-620

**APPLICATION**  
Pages 2 - 4

**SPECIFICATIONS**  
Pages 4 - 8

**EXTERNAL  
CONNECTIONS**  
Pages 9 - 10

**ORDERING  
INFORMATION**  
Pages 11 - 12

**B Basler Electric**

P. O. BOX 269 HIGHLAND, ILLINOIS 62249, U.S.A. PHONE 618-654-2341 FAX 618-654-2351

UBU-5  
3-96

## APPLICATION

### PURPOSE

The BE1-32R Directional Overpower Relay and the BE1-32 O/U, Directional Over/Underpower Relays sense real power flow ( $EI \cos \theta$ ). These relays are solid-state devices designed for use in single-phase or three-phase systems to provide equipment protection for overpower and/or underpower or to be used for supervisory control of circuits. Both relay configurations may be used to monitor either forward or reverse power. In the following application examples, single-phase connections are shown for simplicity.

### APPLICATION EXAMPLES

The BE1-32 relays (R and O/U) are typically used in applications where excessive power flow in the tripping direction is indicative of undesirable situations. Typical examples are discussed below:

#### EXAMPLE 1 - ANTI MOTORING

In this example, the power relay is used to protect the prime mover rather than the generator. When an ac generator, operating in parallel with a power system, loses prime mover torque, it remains in synchronism with the system and continues to run as a synchronous motor drawing sufficient power from the system to drive

the prime mover. Sustained motoring can cause severe damage to the prime mover. The Directional Power Relay, with its wide sensitivity range, can detect levels of reverse real power flow as low as 0.5 Watts secondary and provide an alarm or trip the unit off line (See Figure 1). In this example, single phase sensing is usually considered sufficient, since motoring is a balanced condition.

#### EXAMPLE 2 - COGENERATOR CONTROL

Given that a co-generation system has automatic engine controls, auto synchronizer, and automatic kW and kVar controls, the system will virtually operate by itself. The only functions not readily apparent are the start/stop signals to the generators. Two system configurations using a Power Relay may be utilized to generate contact closures for start and/or stop signals.

The first configuration (Figure 2) shows a power relay connected to the utility to sense kW. The pickup point of the relay is set at the maximum desired utility power level. If the power relay contact closes, the generator will be started and automatically paralleled with the utility system. A time delay of 15 seconds or more is generally included in the "start" circuit to ignore transient over-load conditions.

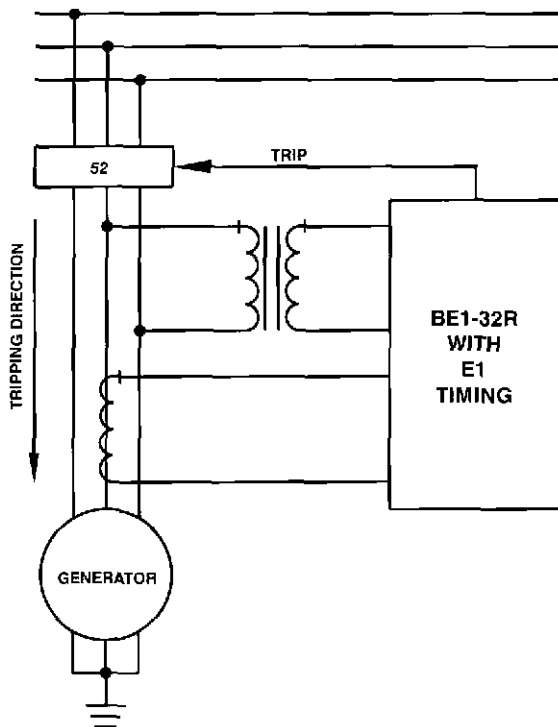

Figure 1 - Power Relay Motoring Protection

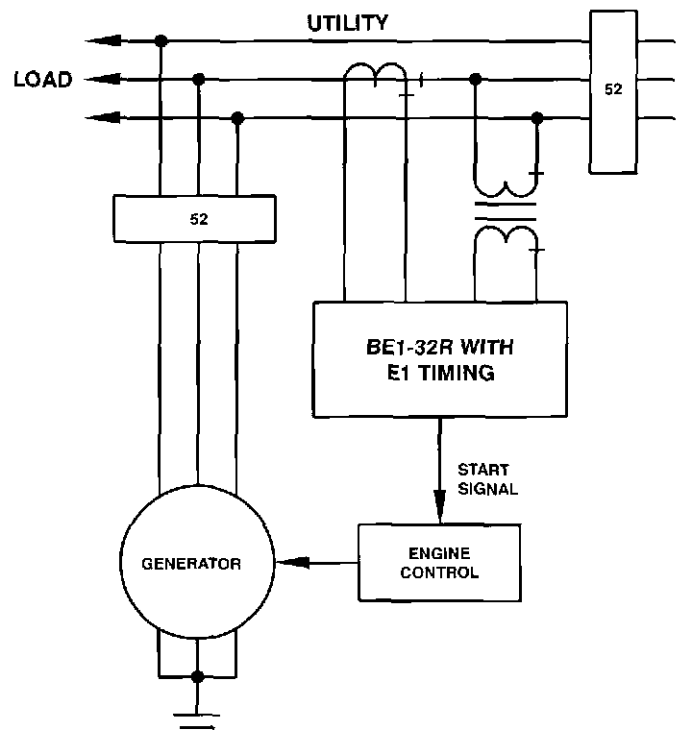

Figure 2 - Power Relay Start Control

## APPLICATION

(continued)

When the generator is paralleled and loaded, the kW signal will decrease by the amount of load the generator accepted. An underpower relay can measure utility power and generate a "stop" signal when utility power decreased below a selected level. A definite time delay will generally be provided for the "stop" signal of one minute or more. The Basler Model BE1-32 O/U Power Relay incorporates both over and under power sensing in one relay, which makes it ideal for this application.

In the second configuration (Figure 3) the "start" signal is generated as in that of Figure 2. The setpoint of the start signal should be above the import power setting. The "stop" signal will require an underpower relay on the generator output. This system is illustrated in Figure 3.

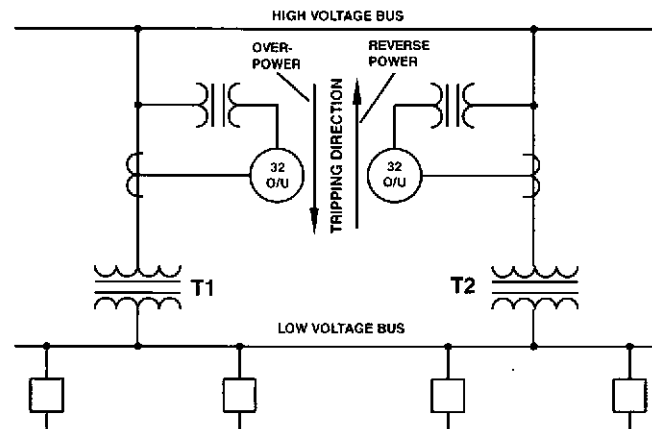

Figure 4 - Distribution Protection

### EXAMPLE 5 - REACTIVE POWER (VARs) DETECTION

This example deals with the Directional Power Relay's ability to measure real or reactive power.

Real power (watts) is supplied to the generator by the prime mover, and reactive power (vars) is supplied to the field by the exciter. When field excitation is significantly reduced and the connected system can provide sufficient reactive power to maintain the generator's terminal voltage, reactive power will flow into the machine and cause it to operate as an induction generator with essentially the same kW output. This situation causes problems; first, the additional reactive loading of the faulty generator must be redistributed to other synchronous generators on the system. Secondly, a synchronous generator is not designed to function as an induction generator. Excessive heating occurs in the damper (Amortisseur) windings, slot wedges, and in the surface iron of the rotor due to slip frequency current flow which results when a synchronous generator is operated as an induction generator. The Directional Power Relay can be applied to respond to this reactive power flow.

The Basler BE1-32 Directional Power Relay is designed to respond to true power as defined by the equation:

$$P = EI \cos \Theta$$

where: P = real power (watts)  
E = effective emf or system voltage  
I = effective current  
 $\Theta$  = the phase angle between E and I

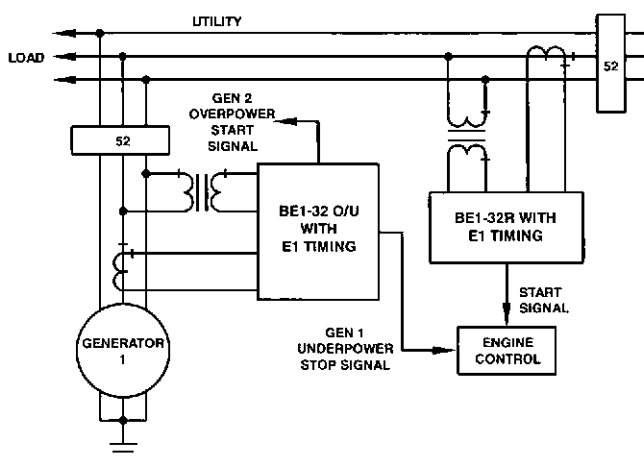

Figure 3 - Power Relay Start/Stop Control

### EXAMPLE 3 - GENERATOR OVERLOAD

Refer to Figure 3. Whenever excessive load has been connected to a generating system, the Power Relay will initiate the corrective action by energizing an alarm to alert the station operator or will initiate an automatic sequence to either shed non-critical load or start and parallel an in-house generator to assume the excess load.

### EXAMPLE 4 - DISTRIBUTION SYSTEM OVERLOAD

Another typical use, addressing excessive load, concerns distribution protection, see Figure 4. A high-voltage bus supplies two transformers. T1 and T2 together can supply all connected load. However, neither T1 or T2 is capable of supplying the total load. To provide adequate protection for the distribution system, the overpower function is used to sense overload conditions on each transformer and the underpower function is used to sense power flowing through the transformers in an undesired direction.

## APPLICATION (continued)

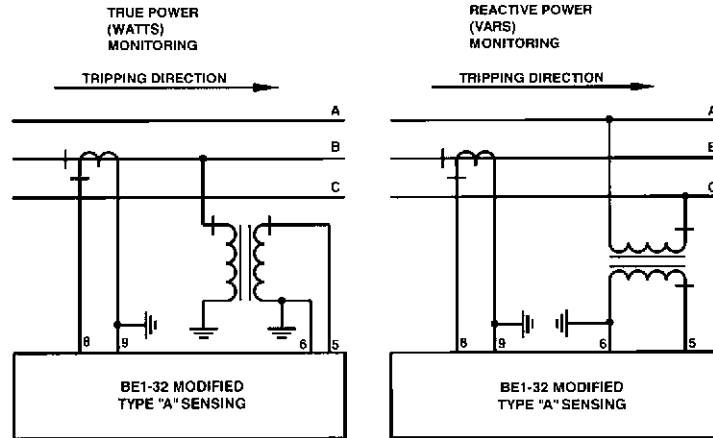

**Figure 5 - VARs Measuring**

However, reactive power is defined by the equation:

$$Q = EI \sin \Theta$$

Since the sine of Q equals the cosine of (Q - 90°) the relay can be connected to measure only reactive power by adding 90° in the connection of the PTs as shown in Figure 5. The relay is now capable of detecting the

inability of the excitation system to supply adequate reactive power.

With the many options and combinations of options available, the Basler Electric Directional Power Relays can be adapted to multitude of systems and situations to provide the utmost in overpower and underpower protection of system equipment.

## SPECIFICATIONS

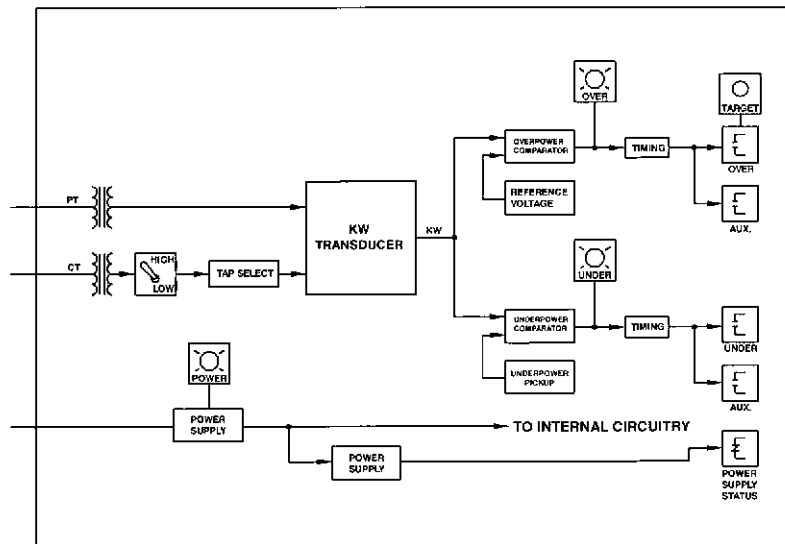

**Figure 6 - Functional Block Diagram**

### FUNCTIONAL DESCRIPTION

The specifications on these pages define the many features and options that can be combined to exactly satisfy a specific application requirement. The block diagram, Figure 6, illustrates how the various standard features, as well as the options, function together.

### INPUTS

#### Current Sensing

System current transformers (CTs) with nominal 5 A secondaries supply the Directional Power Relay's input transformers with one, two or three phase currents. If sensing input range 1, 4 or 7 is selected, the input transformers are capable of 7 A continuous current, 10 A for 1 minute and 140 A for 1 second.

# SPECIFICATIONS

(continued)

If sensing input range 2, 3, 5, 6, 8 or 9 is selected, the input transformers are capable of 10 A continuous current, 15 A for 1 minute and 200 A for 1 second.

Maximum burden for each current input (2 terminals) is 1 VA at threshold over the frequency range of 45 to 65 Hz.

### Voltage Sensing

System potential transformers (PTs) with 120 or 240V secondaries supply the Directional Power Relay's input transformers with single or three-phase voltages. The voltage sensing inputs are nominally rated at 100 or 220V (50 Hz) and 120 or 240V (60 Hz) with a maximum burden of 1 VA per input (2 terminals) over the frequency range of 45 to 65 Hz.

### SENSING INPUT TYPES

There are 6 sensing input types as defined by the Style Chart (page 12). The Directional Power Relay's input circuitry receives voltage and current signals from system PTs and CTs. The CT signal is adjusted in level by a front panel range switch before it is applied to the kW transducer circuitry. Several input circuit configurations are available, the selection of which is determined by the specific application. The following paragraphs provide a brief description of each input sensing type and their calibration

**Type A Sensing:** Single-Phase (Figure 7). The type A sensing configuration monitors line-to-neutral voltage and a single phase current of a three-phase, four-wire circuit and calculates the power flowing in the tripping direction. Relays with this sensing type are calibrated in single-phase watts.

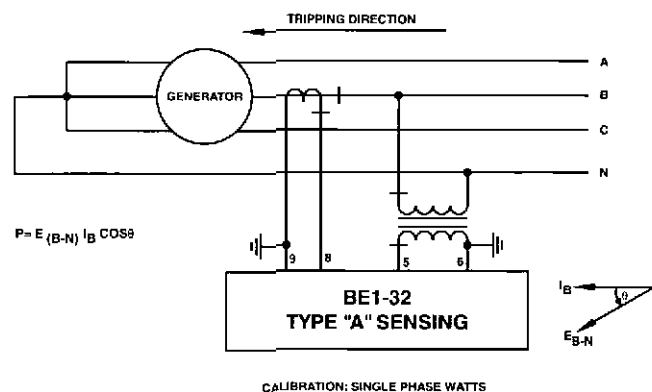

Figure 7 - Single Phase, Type A Sensing

**Type B (60 Hz) or Type V (50 Hz) Sensing:** Single-Phase (Figure 8) with 30° phase shift. This sensing configuration monitors a line-to-line voltage and a single phase current of a three-phase, three-wire circuit and calculates the power flowing in the tripping direction. Since the input voltage leads the input current by 30° (assuming unity power factor) a 30° lagging phase shift network is designed into the voltage input circuit. Relays with this sensing type are calibrated in single-phase watts. Note: Type B or V configurations are phase rotation sensitive.

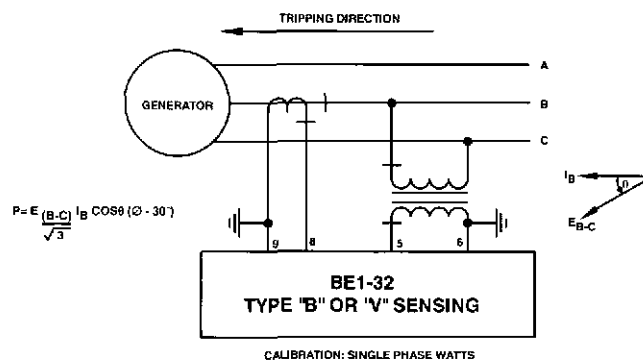

Figure 8 - Single Phase, Type B or V Sensing

**Type C Sensing:** Three-phase Scott Tee (Figure 9). The type C sensing configuration monitors three line-to-line voltages and a single phase current of a three-phase, three-wire circuit and calculates the power flowing in the tripping direction. The relay measures actual power even if the system voltages are not balanced. Relays with this sensing type are calibrated in three-phase watts.

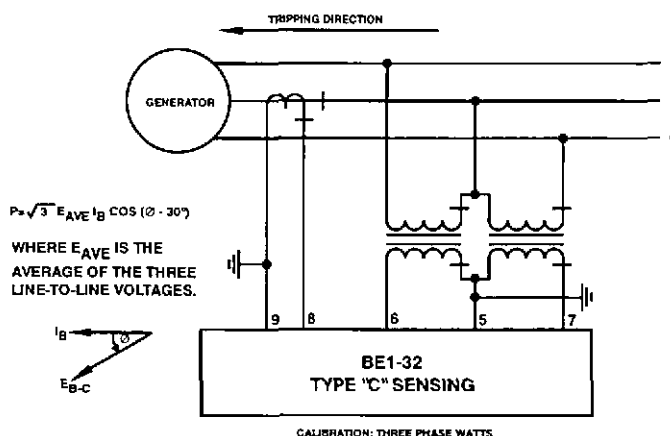

Figure 9 - Three Phase, Type C Sensing

# SPECIFICATIONS

(continued)

**Type D Sensing:** Three-Phase (Figure 10). The type D sensing configuration monitors three line-to-neutral voltages and three phase currents of a three-phase, four-wire circuit and calculates the power flowing in the tripping direction. Relays with this sensing type are calibrated in three-phase watts.

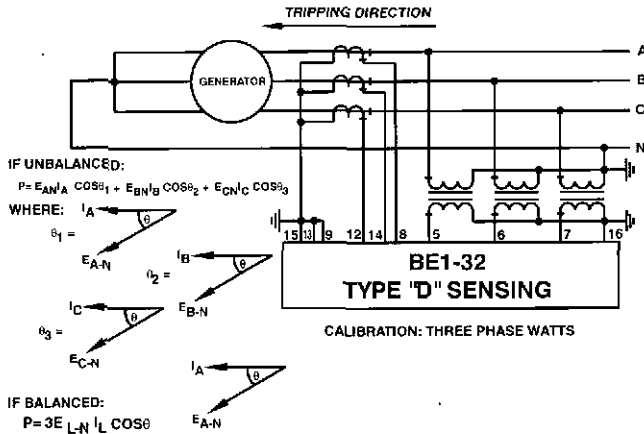

Figure 10 - Three Phase, Type D Sensing

**Type E Sensing:** Three-Phase (Figure 11). The type E sensing configuration monitors three line-to-line voltages and two of the phase currents of a three-phase, three-wire circuit and calculates the power flowing in the tripping direction. The power equation assumes that conditions are balanced. Relays with this sensing type are calibrated in three-phase watts. Note: Type E configurations are phase rotation sensitive.

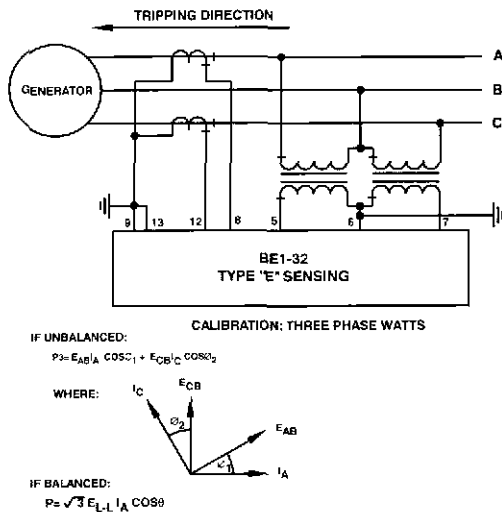

Figure 11 - Three Phase, Type E Sensing

### Power Supply

One of five power supply boxes may be selected to provide internal operating power. They are described in Table 1.

Type	Nominal Input Voltage	Input Voltage Range	Burden at Nominal
O	48 Vdc	24 to 60 Vdc	6.5 W
P	125 Vdc 120 Vac	62 to 150 Vdc 90 to 132 Vac	6.0 W 15.5 VA
†R	24 Vdc	12 to 32 Vdc	7.5W
‡S	48 Vdc 125 Vdc	24 to 60 Vdc 62 to 150 Vdc	6.5 W 6.0 W
T	250 Vdc 230 Vac	140 to 280 Vdc 190 to 270 Vac	9.5 W 27.0 VA

† Type R Power Supply may require 14 Vdc to begin operation. Once operating, the voltage may be reduced to 12 Vdc.

‡ Type S Power Supply is field selectable for 48 or 125 Vdc. Selection must be implemented at time of installation. This Power Supply option is factory set for 125 Vdc.

Table 1 - Power Supply Options

### POWER RANGE PICKUP

Overpower pickup of the relay is adjustable by means of a front panel 10 position rotary TAP select switch used in conjunction with the front panel HIGH/LOW switch over the defined ranges listed in Table 2. Underpower pickup is continuously adjustable from 10 to 95% of the selected overpower tap. Pickup accuracy is within 2% (or 0.05 watts) of the front panel setting for unity power factor. Pickup accuracy is within 5% of the front panel setting for all other power factors between 0.9 and 0.5. The range of voltage for proper operation is 40 to 150 percent of the nominal value.

When the calculated value for power exceeds the overpower pickup setting or falls below the underpower pickup setting and is in the tripping direction, the appropriate LED is illuminated and timing is initiated. One indicating LED is provided for each measuring function within the relay.

### KW TRANSDUCER

The kW Transducer samples the current and voltage of each phase on a continuous basis. The resulting signals representing current and voltage are multiplied and integrated to develop a dc voltage level that is representative of true kW.

### COMPARATOR CIRCUITS

The dc output of the kW Transducer is then compared to front panel settings for underpower and/or overpower. When the reference level of the comparator (or comparators if applicable) is crossed, the output of the comparator is used to either energize the appropriate output (if instantaneous timing has been specified) or to initiate the timing circuits (definite, or inverse).

### TIMING

Time delay is defined as the elapsed time between the application of the condition to the input terminals of the relay and the transition of the output contacts.

# SPECIFICATIONS

(continued)

Sensing Input Type	Nominal Volts	Range	Switch Positions (in Watts)										
			A	B	C	D	E	F	G	H	J	K	
A, B, or V 1∅	120	1	Hi	2.0	4.0	6.0	8.0	10.0	12.0	14.0	16.0	18.0	20.0
			Lo	0.5	1.0	1.5	2.0	2.5	3.0	3.5	4.0	4.5	5.0
		2	Hi	20	40	60	80	100	120	140	160	180	200
			Lo	5	10	15	20	25	30	35	40	45	50
		3	Hi	100	200	300	400	500	600	700	800	900	1000
			Lo	25	50	75	100	125	150	175	200	225	250
C, D, or E 3∅	120	1	Hi	6.0	12.0	18.0	24.0	30.0	36.0	42.0	48.0	54.0	60.0
			Lo	1.5	3.0	4.5	6.0	7.5	9.0	10.5	12.0	13.5	15.0
		2	Hi	60	120	180	240	300	360	420	480	540	600
			Lo	15	30	45	60	75	90	105	120	135	150
		3	Hi	300	600	900	1200	1500	1800	2100	2400	2700	3000
			Lo	75	150	225	300	375	450	525	600	675	750
A, B, or V 1∅	208 or 240	4, 7	Hi	4.0	8.0	12.0	16.0	20.0	24.0	28.0	32.0	36.0	40.0
			Lo	1.0	2.0	3.0	4.0	5.0	6.0	7.0	8.0	9.0	10.0
		5, 8	Hi	40	80	120	160	200	240	280	320	360	400
			Lo	10	20	30	40	50	60	70	80	90	100
		6, 9	Hi	200	400	600	800	1000	1200	1400	1600	1800	2000
			Lo	50	100	150	200	250	300	350	400	450	500
C, D, or E 3∅	208 or 240	4, 7	Hi	12.0	24.0	36.0	48.0	60.0	72.0	84.0	96.0	108.0	120.0
			Lo	3.0	6.0	9.0	12.0	15.0	18.0	21.0	24.0	27.0	30.0
		5, 8	Hi	120	240	360	480	600	720	840	960	1080	1200
			Lo	30	60	90	120	150	180	210	240	270	300
		6, 9	Hi	600	1200	1800	2400	3000	3600	4200	4800	5400	6000
			Lo	150	300	450	600	750	900	1050	1200	1350	1500

**Table 2 - Power Range Pickup Settings**

Each model, BE1-32R or BE1-32 O/U is capable of instantaneous trip, definite time delay trip, or an inverse time delayed trip as defined and selected by the Style Chart.

Instantaneous response time of the relay is within 80 ms (60 Hz) or 100 ms (50 Hz) for a real power magnitude of 2 times the setting.

The definite time delay is adjustable over the ranges of 0.1 to 9.9 seconds and 01 to 99 seconds. Selection of the ranges is accomplished by a front-panel multiplier switch which selects either 0.1 or 1.0 as a multiplier of the front panel Time Dial thumbwheel switch. (A Time Dial setting of 00 enables instantaneous operation.) Definite timing accuracy is  $\pm 5\%$  of the setting or 50 ms, whichever is greater.

Inverse time delayed trip is available for the overpower function only. The inverse time delay curve is adjustable from 01 to 99 by means of a front-panel thumbwheel switch. Incrementing the thumbwheel switch moves the inverse curve along the vertical axis. (See Figure 12 for Inverse Time Characteristics.) A Time Dial setting of 00 enables instantaneous operation. Inverse time is accurate to within  $\pm 5\%$  of the published curve or 50 ms, whichever is greater.

### POWER SUPPLY STATUS OUTPUT (OPTIONAL)

The power supply status output relay is energized and its NC output contact is opened when power is applied to the relay. Normal internal relay operating voltage maintains the power supply status output relay continuously energized with its output contact open. If the power supply output voltage falls below the requirements of proper operation, the power supply output relay is deenergized, closing the NC output contact.

## SPECIFICATIONS

(continued)

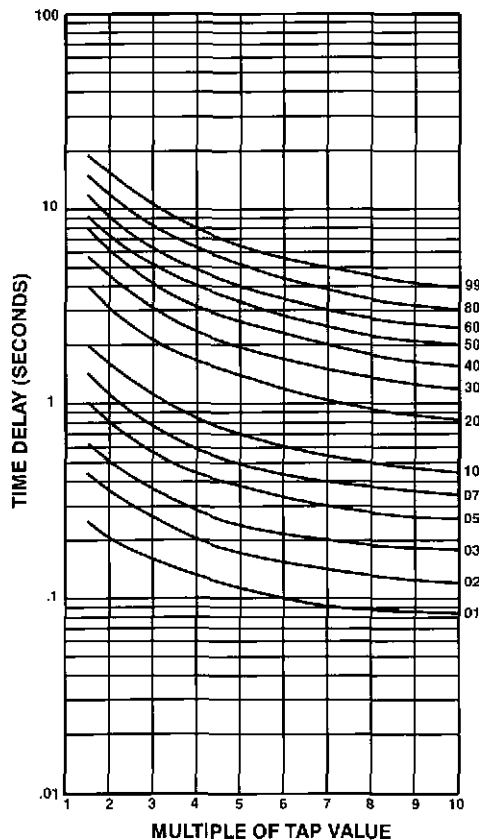

Figure 12 - Overpower Inverse Characteristics

### OUTPUTS

Output contacts are rated as follows:

#### Resistive

120/240 Vac - make 30 A for 0.2 seconds,  
carry 7 A continuously, break 7 A.

250 Vdc - make and carry 30 A for 0.2 seconds,  
carry 7 A continuously, break 0.3 A.

500 Vdc - make and carry 15 A for 0.2 seconds,  
carry 7 A continuously, break 0.1 A.

#### Inductive

120/240 Vac, 125 Vdc, 250 Vdc - break 0.3 A  
(L/R = 0.04).

### TARGETS

Magnetically latched, manually reset target indicators are optionally available to indicate that a trip output has energized. Either internally operated or current operated target may be specified. Current operated targets require 0.2 A in the output trip circuit to actuate, and trip current must not exceed 30 A for 0.2 seconds, 7 A for 2 minutes, and 3 A continuous. Current operated targets may be selected only when normally open (NO) output contacts have been specified.

### PUSH-TO-ENERGIZE-OUTPUT PUSHBUTTONS

Applying a thin non-conducting rod through a hole in the front panel energizes each output relay for testing the external trip circuits.

### SURGE WITHSTAND CAPABILITY

Qualified to ANSI/IEEE C37.90.1-1989 Surge Withstand Capability Test and IEC 255.

### FAST TRANSIENT

Qualified to ANSI/IEEE C37.90.1-1989 Fast Transient Test.

### IMPULSE TEST

Qualified to IEC 255-5.

### MECHANICAL

#### Operating Temperature

-40°C(-40°F) to +70°C(+158°F).

#### Storage Temperature

-65°C(-85°F) to +100°C(+212°F).

#### Weight

M1 - 18.5 pounds max.  
S1 - 13.5 pounds max.

#### Shock

In standard tests, the relay has withstood 15g in each of three mutually perpendicular axes without structural damage or degradation of performance.

#### Vibration

In standard tests, the relay has withstood 2g in each of three mutually perpendicular axes swept over the range of 10 to 500 Hz for a total of six sweeps, 15 minutes each sweep, without structural damage or degradation of performance.

### CONNECTIONS

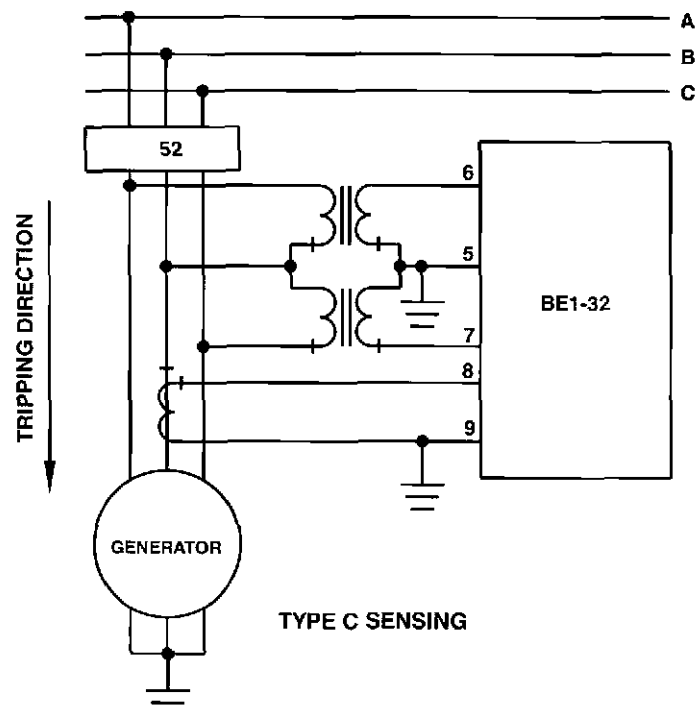
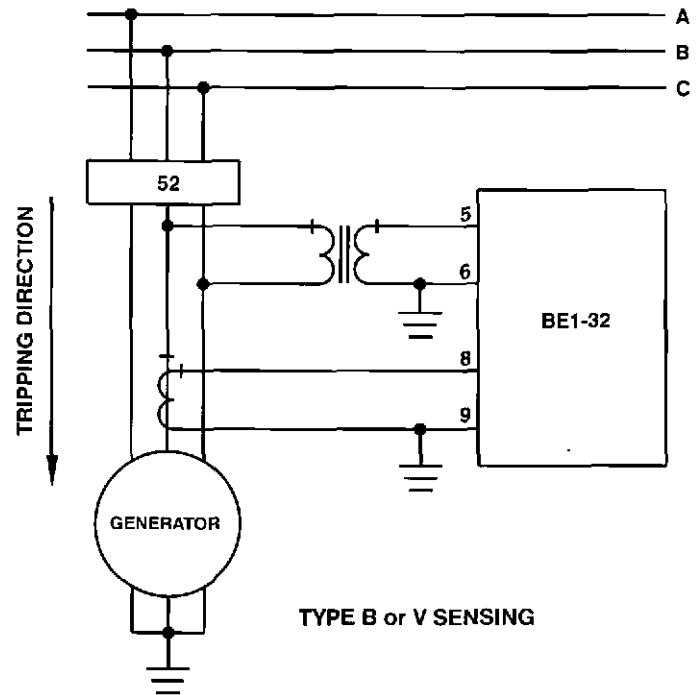
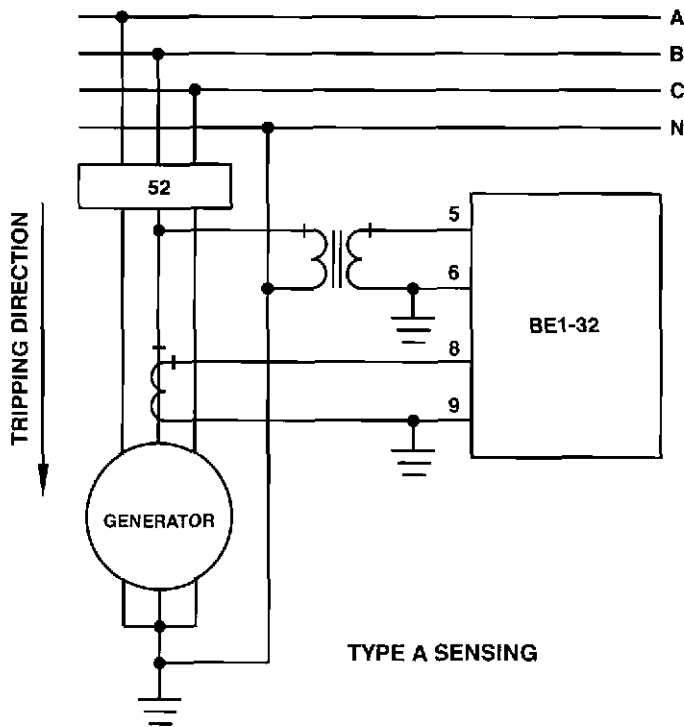

Figure 13 - Sensing Connections  
(Continued overpage.)

# CONNECTIONS

(continued)

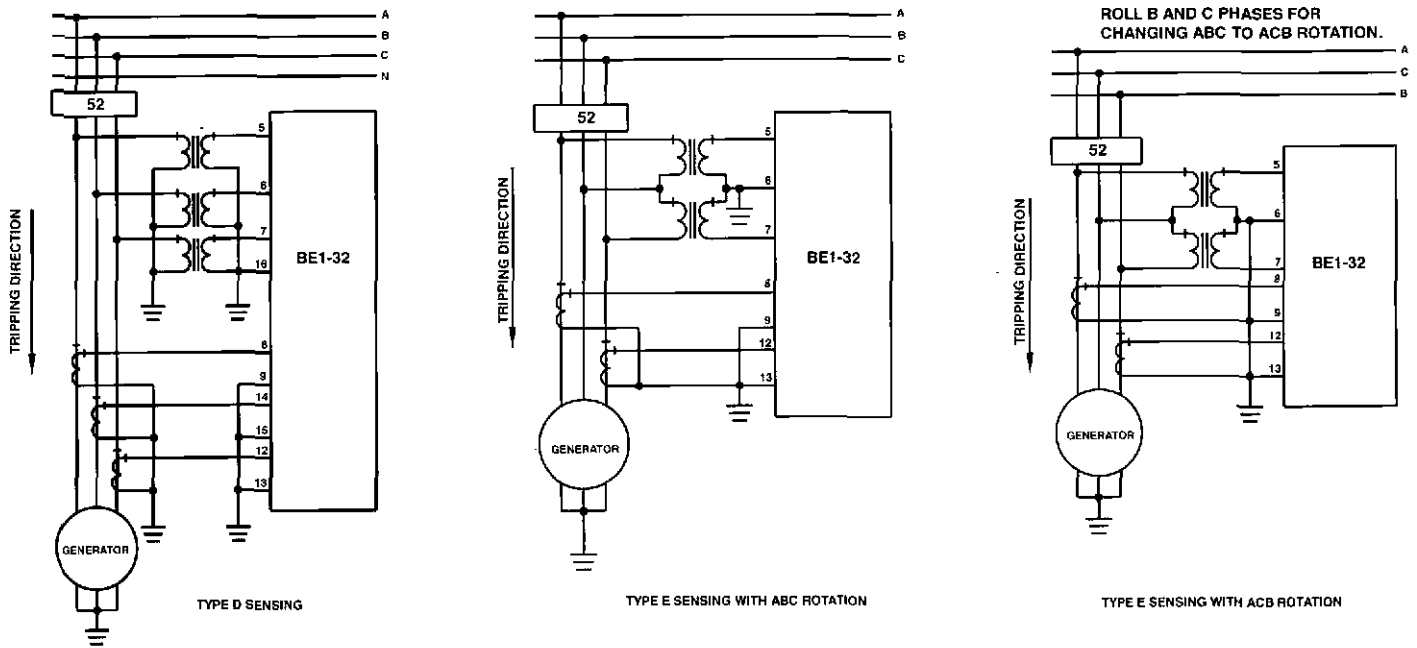

Figure 13 (continued) - Sensing Connections

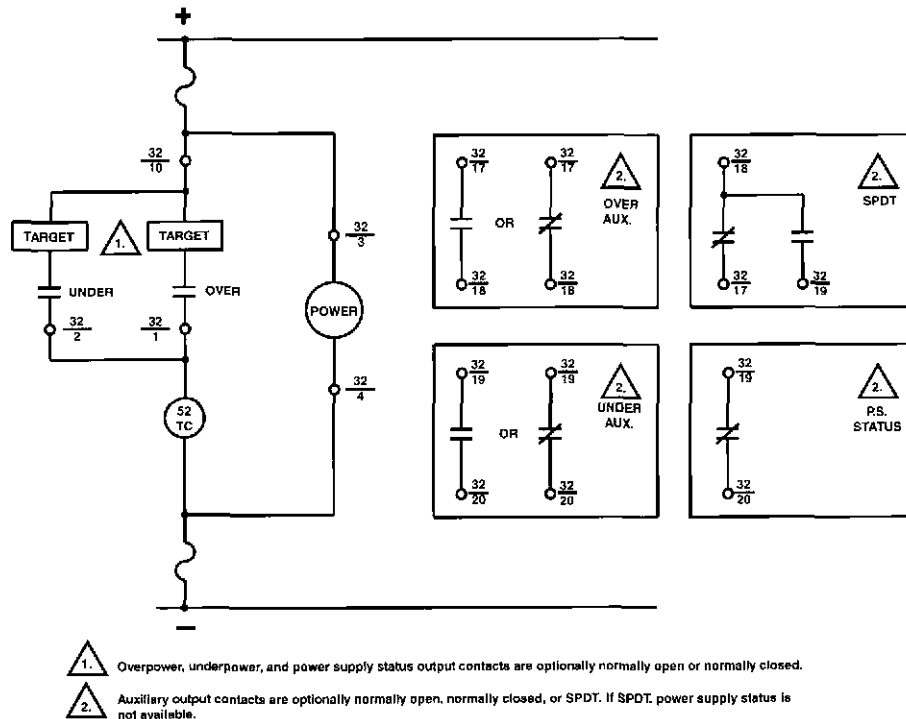

Figure 14 - Control Circuits

## ORDERING

### MODEL NUMBER

BE1-32R Directional Power Relay and BE1-32 O/U Directional Over/Underpower Relay.

### STYLE NUMBER

The style number appears on the front panel, drawout cradle, and inside the case assembly. This style number is an alphanumeric combination of characters identifying the features included in a particular unit. The sample style number below illustrates the manner in which the various features are designated. The Style Number Identification Chart (page 12) defines each of the options and characteristics available for this device.

#### SAMPLE STYLE NUMBER A1E-A1P-A0N2F

The style number above describes a BE1-32R Directional Power Relay having the following features.

Sensing Input Type (A) Single-phase current and L-N voltage sensing

Sensing Input Range (1) 120 Vac, 0.5-20W

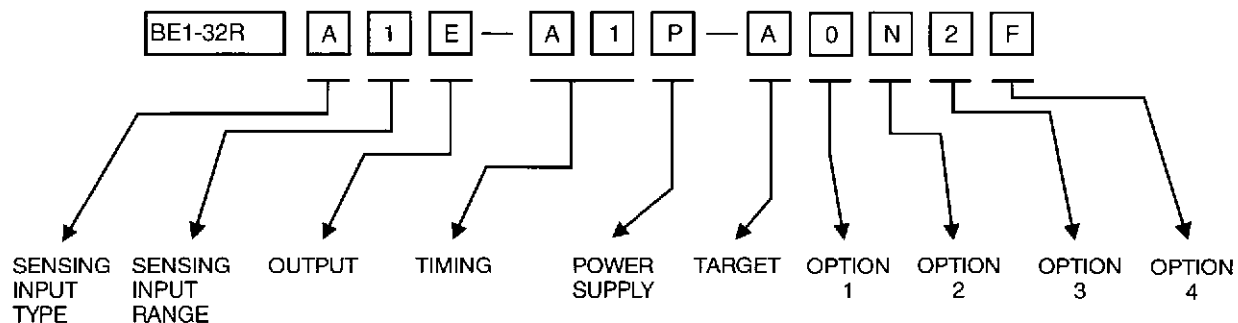

### HOW TO ORDER:

Designate the model number followed by the complete Style Number.

Complete the Style Number by selecting one feature from each column of the Style Number Identification Chart and entering its designation letter or number into the appropriate square. (Two squares are used to indicate time delay characteristics.) All squares must be completed.

Output	(E)	One Output relay with normally open contacts
Timing	(A1)	Instantaneous timing
Power Supply	(P)	125 Vdc/120 Vac input power supply
Target	(A)	One internally operated target
Option 1	(0)	None
Option 2	(N)	None
Option 3	(2)	One auxiliary output relay with normally closed contacts
Option 4	(F)	Semi-flush mounting

NOTE: The description of a complete relay must include both the model number and the style number.

### STANDARD ACCESSORIES:

The following accessories are available for the BE1-32R or BE1-32 O/U Directional Power Relays.

#### Test Plug

To allow testing of the relay without removing system wiring, order two test plugs, Basler Electric part number 10095.

#### Extender Board

The extender board permits troubleshooting of the printed circuit boards outside of the relay cradle. Order Basler Electric part number 9 1655 00 100.

# STYLE NUMBER IDENTIFICATION CHART

