

**BE1-47N
NEGATIVE SEQUENCE
VOLTAGE RELAY**

The BE1-47N Voltage Phase Sequence Relay provides protection for rotating equipment from the damaging effects of excessive negative sequence voltage resulting from phase failure, phase unbalance and reversed phase sequence.

ADVANTAGES

- Responds to true negative sequence voltage component.
- Unaffected by frequency variations of ± 5 Hz.
- Negative Sequence Voltage adjustment range of 2 - 32 percent.
- Optional Over and Undervoltage measuring elements.
- Low sensing and supply burdens.
- Instantaneous, Definite and Inverse time delay characteristics available for each measuring element.
- Qualified to the requirements of
 - ANSI/IEEE C37.90.1-1989 and IEC 255 for surge withstand capability;
 - IEC 255-5 for impulse.
- UL Recognized under Standard 508, UL File #E97033.

ADDITIONAL INFORMATION

INSTRUCTION MANUAL

Request publication 9-1704-00-990

SERVICE MANUAL

Request publication 9-1704-00-620

STANDARDS, DIMENSIONS & ACCESSORIES

Request bulletin SDA

APPLICATION Page 2
SPECIFICATIONS Page 2
EXTERNAL CONNECTIONS Page 6
ORDERING Page 7



APPLICATION

PURPOSE

The BE1-47N is designed to protect three-phase machines against damage caused by phase failure, reverse phase sequence, phase unbalance, undervoltage and overvoltage.

The BE1-47N responds to negative sequence voltage which results from a fault or misconnection on a balanced three-phase system.

The BE1-47N detects reverse phase connection of lines, transformers, motors, generators, and synchronous condensers and is often applied in automatic transfer schemes to assure connection of proper phase rotation as well as voltage conditions. The Negative Sequence Voltage Relay is recommended for all important busses supplying motor loads. When used in motor protection, the relay will provide protection by preventing start-up of the motor for open phase or reverse phase conditions and by tripping the motor off-line for phase unbalance, undervoltage or overvoltage conditions.

Negative sequence voltage is the result of any unequal phase condition. This can be due to unequal single-phase loads on the system or unequal transformer impedances between the phases. A 1% - 2% negative sequence level can normally be expected in an industrial supply. Any significant increase above this level is an indication of a power service problem that could lead to serious plant problems. The BE1-47N has the ability to detect negative sequence voltage levels of this magnitude.

Undervoltage and voltage balance relays have traditionally been applied for the protection of induction

motors from operating with one phase open. These relays may not reliably detect this condition due to the back emf of the motor on the open phase. However, an induction motor, with a starting current of 6 per unit, will generate a negative sequence voltage of 16% if fully loaded when a fuse blows. The negative sequence voltage will be somewhat reduced if the motor is not fully loaded. The sensitivity of the BE1-47N and its insensitivity to frequency will provide reliable protection for motors.

Motor losses and current unbalance increase with the negative sequence voltage level. The increased loss, due to negative sequence voltage, is not a function of motor load but is independent. A machine operating with 3.5% negative sequence voltage will have its stated losses increased by 25%. A blown fuse on a power factor correction capacitor bank can result in a negative sequence voltage increase. The increase in motor losses can be costly.

The BE1-47N should be applied to protect motor buses from a open phase. It can also be applied to protect critical individual motors, static and non-rotating loads from the effects of negative sequence voltage.

A choice of time delay characteristics allows the relay to respond in the desired manner for a wide variety of transient and fault conditions.

The BE1-47N may also be used to provide over/undervoltage protection as well. A separate time delay is utilized to prevent shutdown of equipment for minor voltage dips and to permit sequential operation when the relay is being used in a supervisory capacity.

SPECIFICATIONS

FUNCTIONAL DESCRIPTION

The specifications on these pages define the features and options that can be combined to satisfy an application requirement. The block diagram, Figure 1, illustrates how the various standard features, as well as the options function together.

INPUTS

Voltage Sensing

Standard potential transformer secondaries with 100/120 or 173/208V (50/60 HZ) nominal ratings supply the Negative Sequence Voltage Relay's input transformers with three phase voltages. The relay's sensing

SPECIFICATIONS (Continued)

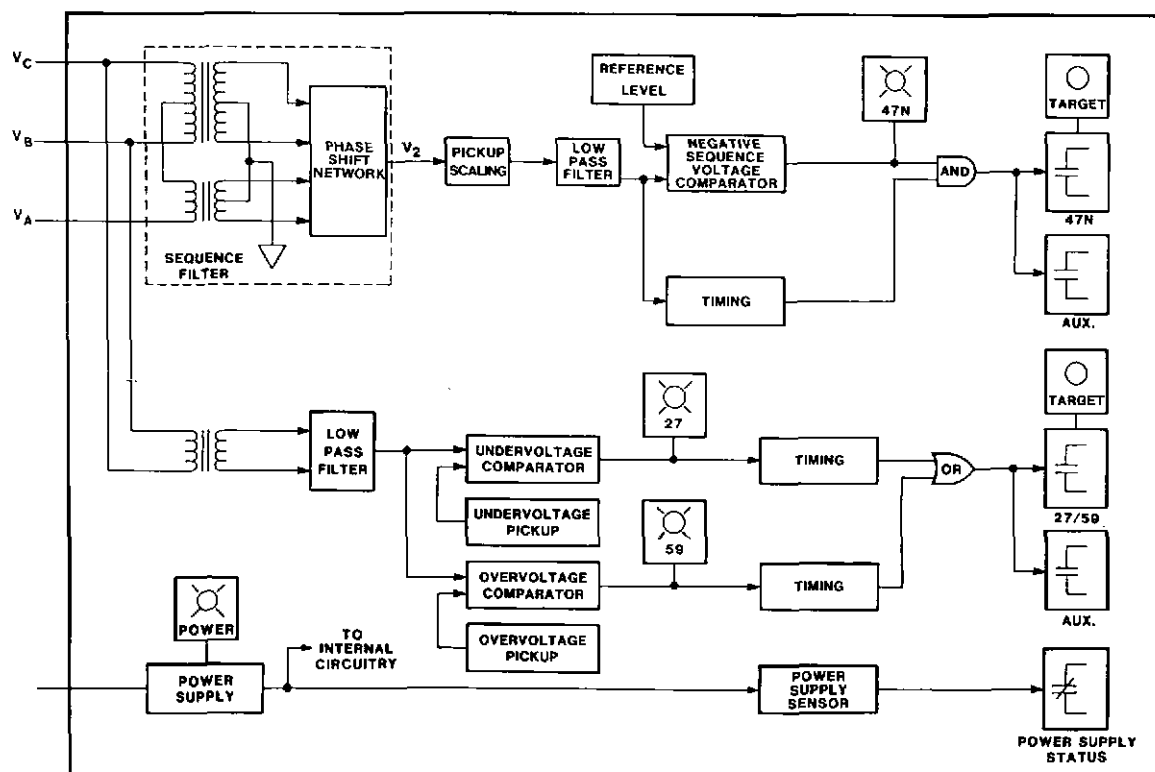

FIGURE 1. FUNCTIONAL BLOCK DIAGRAM

inputs are capable of withstanding 160% of the selected nominal continuously, with a maximum burden of 2 VA per phase.

Power Supply

One of five power supply types may be selected to provide internal operating power. They are described in Table 1.

TABLE 1. POWER SUPPLY OPTIONS

Type	O	P	R	S*	T
Nominal Voltage	48 Vdc	125 Vdc 120 Vac	24 Vdc	48 Vdc 125 Vdc	250 Vdc 230 Vac
Burden	7.0 W	7.0 W 18.0 VA	7.5 W	6.5 W 7.0 VA	10.0 W 28.0 VA

* The Type S power supply is field selectable for 48 Vdc or 125 Vdc. Selection must be implemented at the time of installation. This power supply option is factory set for 125 Vdc.

NEGATIVE SEQUENCE VOLTAGE (V_2) FILTER

The phase voltages are applied to a negative sequence

voltage filter which removes the positive sequence (V_1) and zero sequence (V_0) components of the voltage. The output of this filter is the true negative sequence voltage to be measured. The output of this filter is not affected by frequency variations of ± 5 Hz from system nominal (50 or 60 Hz).

NEGATIVE SEQUENCE VOLTAGE COMPARATOR

The voltage from the sequence filter is compared with the front panel pickup setting. When the level of V_2 exceeds the pickup setting, the 47N LED is illuminated and timing is initiated.

The range of the negative sequence voltage pickup setting is 2 to 32% in increments of 2%. Pickup accuracy is within ± 1 unit of the percent setting of the negative sequence voltage.

Over/Undervoltage Sensing

The relay has the optional capability to monitor the phase-to-phase voltage from the applied three phase voltage. This voltage is scaled and applied to the over/undervoltage comparator.

SPECIFICATIONS (Continued)

OVER/UNDERVOLTAGE COMPARATOR

The scaled, single-phase signal is compared with the respective front panel pickup setting. If the magnitude of the ac signal is above the overvoltage pickup setting or below the undervoltage pickup setting, the corresponding LED is illuminated and the selected time characteristic is initiated. The range of the overvoltage pickup setting is from 2 to 32% above the nominal rating of the relay. The range of the undervoltage pickup setting is from 2 to 32% below nominal. Both pickup settings are independently adjustable in increments of 2% with a pickup accuracy of $\pm 1\%$ of the expected voltage value.

TIMING

Each timing option (inverse, definite, and instantaneous) is completely independent for each relay function (47N - negative sequence voltage, 27 - undervoltage, 59 - overvoltage). Three timing characteristics are available:

Definite Time - adjustable over the range of 0.1 to 9.9 seconds in increments of 0.1 seconds

Inverse Time - adjustable over the range of 01 to 99 in increments of 1. Inverse time characteristics are illustrated in Figure 2.

Instantaneous Time - less than 50 milliseconds.

TARGETS

Magnetically latched, manually reset, target indicators are optionally available to indicate that an output has tripped. Either internally operated or current operated targets may be specified. Current operated targets require 0.2 A in the output trip circuit to actuate, and trip circuit current must not exceed 30 A for 0.2 seconds, 7 A for 2 minutes, and 3 A continuous. Current operated targets may be selected only when normally open (NO) output contacts have been specified.

OUTPUTS

Output contacts are rated as follows:

Resistive

120/240 Vac - make 30 A for 0.2 seconds, carry 7 A continuously, break 7 A.

250 Vdc - make and carry 30 A for 0.2 seconds, carry 7 A continuously, break 0.1 A.

500 Vdc - make and carry 15 A for 0.2 seconds, carry 7 A continuously, break 0.1 A.

Inductive

120/240 Vac, 125 Vdc, 250 Vdc - break 0.1 A (L/R = 0.04).

Push-to-Energize-Output Pushbuttons

Accessible with a thin non-conducting rod through the front panel, push-to-energize pushbuttons are available to energize each output for testing the external control/protective system wiring.

POWER SUPPLY STATUS OUTPUT

The power supply output relay is energized and its NC output contact is opened when power is applied to the relay. Normal internal relay operating voltage maintains the power supply status output relay in a continuously energized state with its output contact open. If the power supply output voltage falls below the requirements of proper operation, the power supply output relay is de-energized, closing the NC output contact.

SURGE WITHSTAND CAPABILITY

Qualified to ANSI C37.90a-1974, Surge Withstand Capability Test and IEC 255, Impulse Test and Dielectric Test.

MECHANICAL

Operating Temperature

-40°C (-40°F) to +70°C (+158°F)

Storage Temperature

-65°C (-85°F) to +100°C (+212°F)

Weight

14.0 pounds maximum

Shock

In standard tests, the relay has withstood 15g in each of three mutually perpendicular axes without structural damage or degradation of performance.

Vibration

In standard tests, the relay has withstood 2g in each of three mutually perpendicular axes swept over the range of 10 to 500 Hz for a total of six sweeps, 15 minutes each sweep, without structural damage or degradation of performance.

SPECIFICATIONS (Continued)

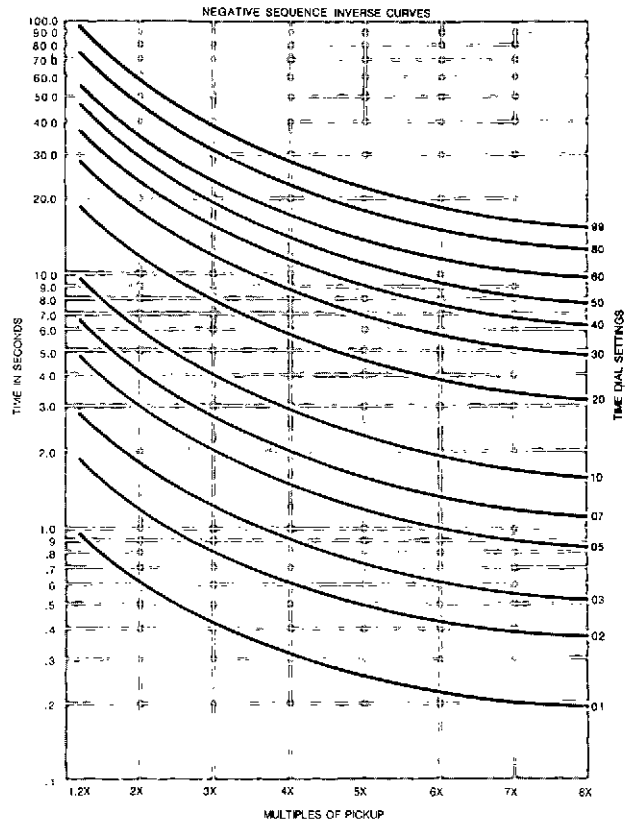

UNDERVOLTAGE-TIME INVERSE CURVES

OVERVOLTAGE-TIME INVERSE CURVES

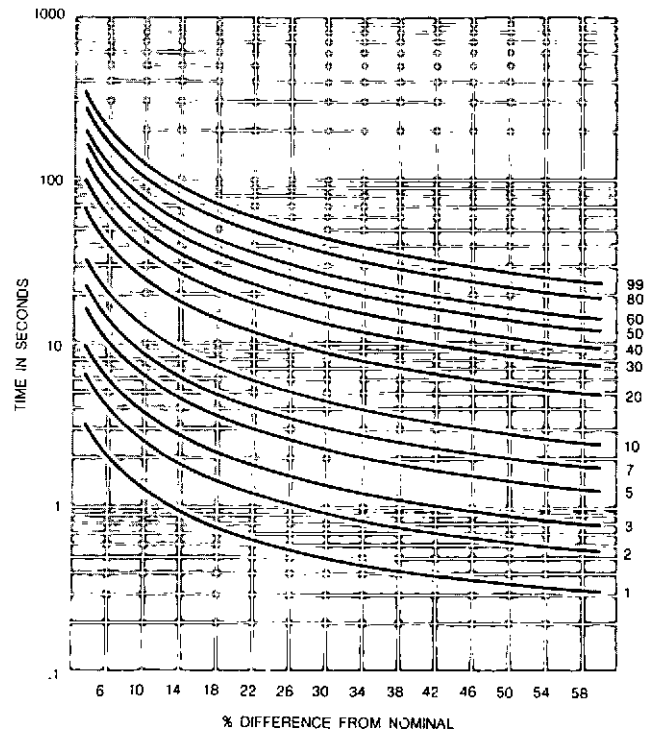
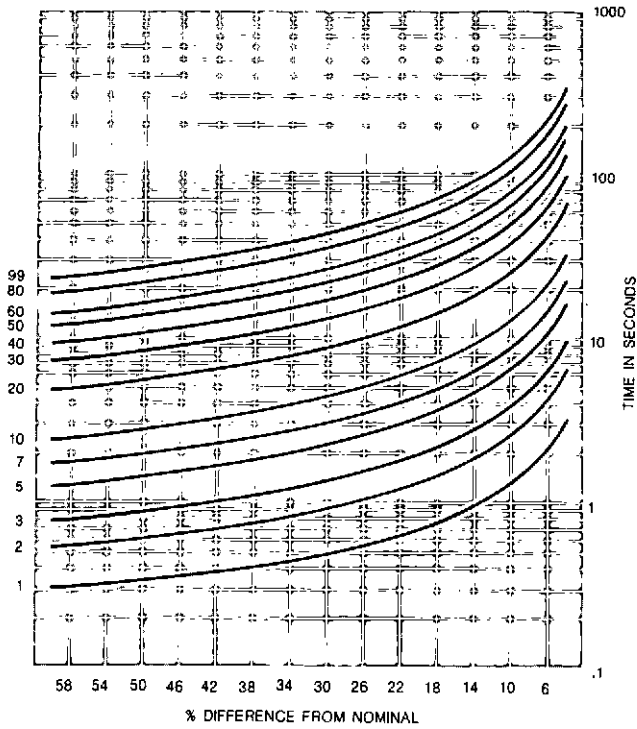

FIGURE 2. INVERSE TIME CHARACTERISTIC CURVES

CONNECTIONS

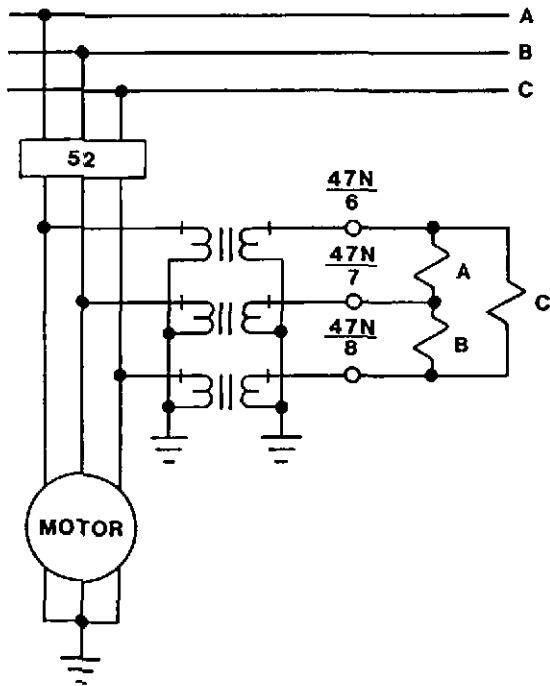

FIGURE 3. WYE VOLTAGE SENSING

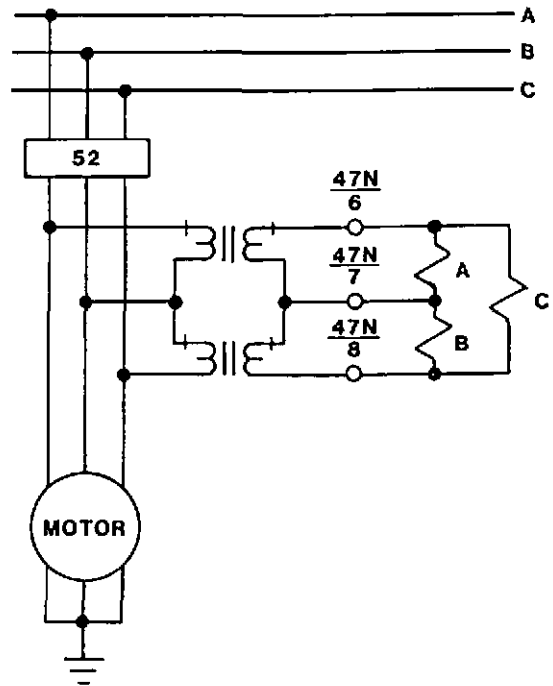
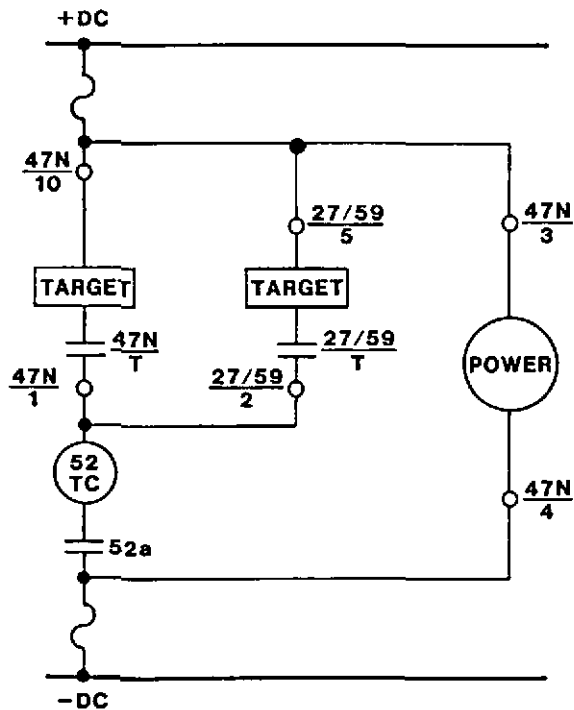

FIGURE 4. DELTA VOLTAGE SENSING



LEGEND:

- 47N VOLTAGE PHASE SEQUENCE
- 27/59 UNDER/OVERVOLTAGE
- 52a BREAKER AUXILIARY CONTACTS
- 52 TC BREAKER TRIP COIL
- T TIMED

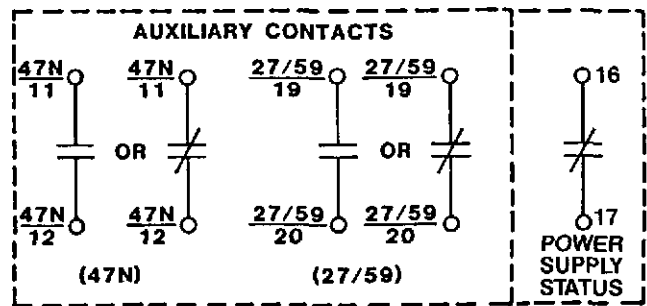

FIGURE 5. CONTROL CIRCUITS

ORDERING

MODEL NUMBER

BE1-47N Voltage Phase Sequence Relay.

STYLE NUMBER

The style number appears on the front panel, drawout cradle, and inside the case assembly. This style number is an alphanumeric combination of characters identifying the features included in a particular unit. The sample style number below illustrates the manner in which the various features are designated. The Style Number Identification Chart (page 8) defines each of the options and characteristics available for this device.

SAMPLE STYLE NUMBER: E3G-A1P-A2R2F

The style number above describes a BE1-4N Voltage Phase Sequence Relay having the following features.

Sensing Input Type (E) Three-phase voltage (L-L)

Sensing Input Range(3)	120V/60 Hz nominal
Output	(G) One relay, normally closed
Timing	(A1) Instantaneous
Power Supply	(P) 125 Vdc/120 Vac external power source
Target	(A) One internally operated target, 47N
Option 1 (undervoltage)	(2) Inverse time
Option 2 (overvoltage)	(R) Instantaneous time
Option 3	(2) One auxiliary output relay, 47N - normally closed
Option 4	(F) Semi-Flush mounting

NOTE: The description of a complete relay must include both the model number and the style number.

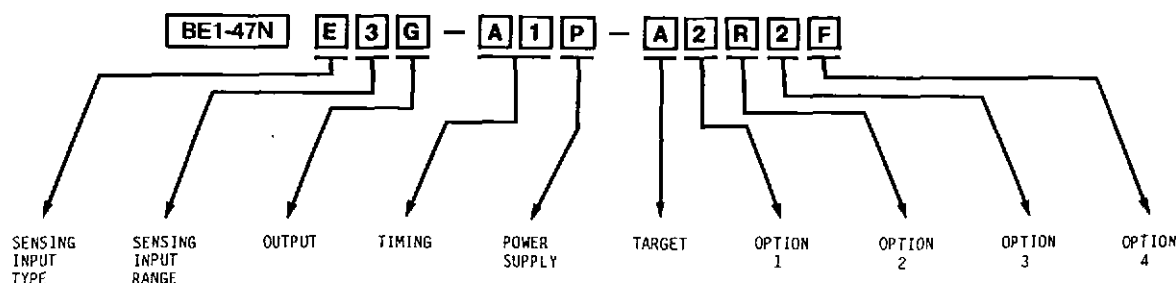

SAMPLE STYLE NUMBER ILLUSTRATED

HOW TO ORDER:

Designate the model number, followed by the complete style number.

BE1-47N Style No. - -

Complete the style number by selecting one feature from each column of the Style Number Identification Chart and entering its designation letter or number into the appropriate square. (Two squares are used to indicate time delay characteristics.) All squares must be completed.

STANDARD ACCESSORIES:

The following accessories are available for the BE1-47N, Voltage Phase Sequence Relay.

Test Plug

To allow testing of the relay without removing system wiring, order one test plug, Basler Electric part number 10095. If option 3-1 through 3-8 has been specified, order two test plugs.

Extender Board

The extender board permits troubleshooting of the printed circuit boards outside of the relay cradle. Order Basler Electric part number 9 1655 00 100.

