

**BE1-67
PHASE DIRECTIONAL
TIME OVERCURRENT
RELAY**

The BE1-67 Phase Directional Time Overcurrent Relay is a microprocessor-based relay to be used to protect transmission and distribution circuits where power can flow in either direction. The relay uses quadrature voltage polarization to determine the direction of fault current flow.

ADVANTAGES

- Single- or three-phase sensing.
- Time overcurrent range is continuously adjustable from 0.5 to 12A.
- Instantaneous range is adjustable from 1 to 40 times the time overcurrent element pickup.
- Polarized by line-to-line potential.
- Time-current characteristics are field selectable with optional switch.
- Time dial is adjustable in 100 incremental steps.
- A Limited Range of Operation option is available to provide additional protection against false tripping on mutually coupled lines.
- Optional directional or non-directional instantaneous elements.
- 2% pickup accuracy and timing repeatability.
- $\pm 5\%$ timing accuracy.
- UL recognized under Standard 508, UL File #E97033 for units having nominal power supply inputs of 120 Vac or less, and 125 Vdc or less.

ADDITIONAL INFORMATION

INSTRUCTION MANUAL

Request Publication 9-1709-00-990

SERVICE MANUAL

Request Publication 9-1709-00-620

STANDARDS, DIMENSIONS & ACCESSORIES

Request Bulletin SDA

APPLICATION Pages 2 & 3
SPECIFICATIONS Pages 3 - 8
EXTERNAL CONNECTIONS Pages 9 & 10
ORDERING INFORMATION Pages 11 & 12

APPLICATION

DESCRIPTION

The BE1-67 Phase Directional Overcurrent Relay is designed for the protection of transmission and distribution lines where the direction as well as the magnitude of the fault current (or power flow) are to be considered in the tripping decision.

The BE1-67 is a directionally controlled, microprocessor-based time overcurrent relay. The directional element is polarized by the phase-to-phase quadrature voltage of the power system. That is, the directional element monitoring phase A current uses the voltage between phases B and C to determine the direction of current (or power) flow into the fault. Then, if enough current flows in the tripping direction of the relay, the relay will pickup, time out, and trip. The angle of "maximum" sensitivity for the relay is also adjustable to allow the directional characteristic to be matched to the line and system conditions. Figure 1 illustrates the operation of the directional element and defines the terms that will be used in the following discussion.

Figure 1a shows the connections to the sensing circuits for a single phase BE1-67. Figure 1b illustrates the phasor quantities monitored by the relay for a unity power factor condition and for a single-phase fault. Figure 1c shows the protected line on an R-X diagram. The angle alpha (α) in Figure 1b and 1c is the characteristic angle setting for the relay.

The directional characteristic of the relay is adjustable to allow the relay to be sensitive for phase faults, and to maximize sensitivity at the characteristic angle representing a typical faulted line impedance.

Twelve standard time-current characteristics are available to aid in the coordination of this relay with other protective devices in the system (Table 1). These include seven characteristics that are standard in North America and five that are compatible with British or IEC Standard requirements. An internal switch is provided to select the desired characteristic.

Style Designation	Characteristic Shape	Special Characteristics
B1	Short Inverse	Relatively short time, desirable where preservation system stability is a critical factor.
B2, E2	Long Inverse	Provides protection for starting motors and overloads of short duration.
B3	Definite Time	Fixed time delay according to the time dial setting. Useful for sequential tripping schemes.
B4, E4	Moderately Inverse	Accommodates moderate load changes, as may occur on parallel lines where one line may occasionally have to carry both loads.
B5, E5	Inverse	Provide additional variations of the inverse characteristic, thereby allowing flexibility in meeting load variations, or in coordinating with other relays.
B6, E6	Very Inverse	
B7, E7	Extremely Inverse	

Table 1

If the supply to the protected portion of the system is constant, and if the magnitude of the fault current is determined primarily by the location of the fault on the line, the selection of a more inverse time characteristic may be more desirable to provide selective coordination with adjacent line protection. However, if the capacity of the supply varies significantly over a period (such as a day), a less inverse time, or even the Definite Time characteristic, may be preferred to provide smoother coordination.

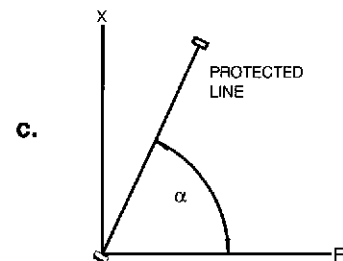
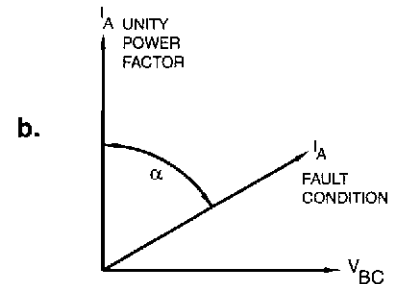
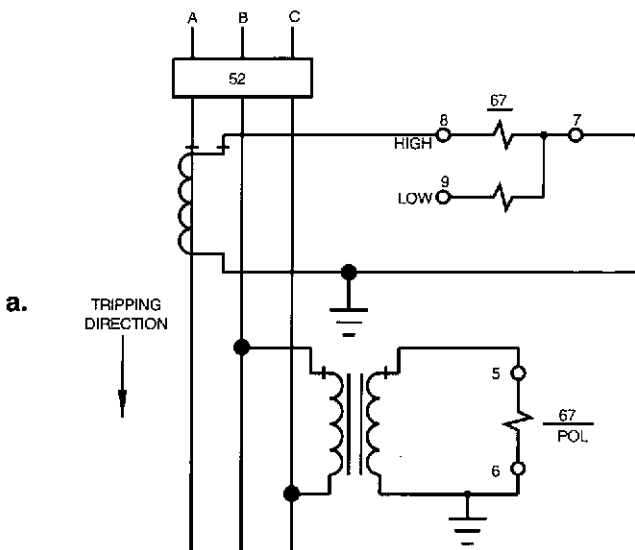

Figure 1 - Directional Overcurrent (Single-Phase)

APPLICATION

(continued)

COORDINATION

Without the ability to determine the direction of current flow, it is difficult to coordinate the settings of time overcurrent relays on lines that interconnect a series of substations. Without this capability, either the undesired tripping of adjacent lines may result, or a fault may go undetected because of the high settings required by the time overcurrent relays.

With directional time overcurrent relays, the settings and time delays can be decreased and the undesired tripping eliminated. Figure 2 illustrates the use of directional overcurrent relays on a group of interconnected distribution substations fed from a common station.

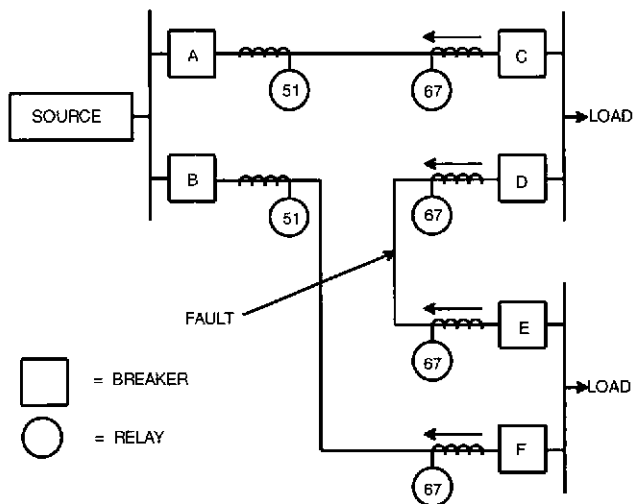

Figure 2. All Substations Fed From One Station

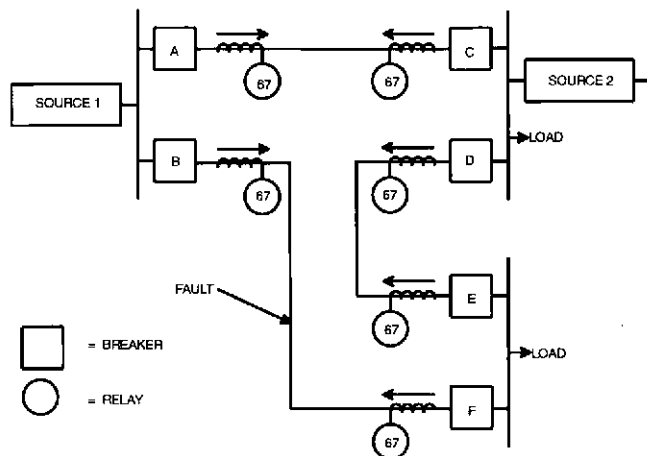

Figure 3. Substations Fed From Two Sources

In this example, non-directional overcurrent relays (51) are used to protect the lines leaving the source bus, inasmuch as there is only one source of fault current. However, the breakers at the load buses (C, D, E, and F) are protected by directional time overcurrent relays (67) to prevent overtripping in the event of a fault. This will remove the faulted line and retain service to the connected loads.

In the case where two sources of power can supply fault current, as shown in Figure 3, directional overcurrent relays will need to be applied to each end of the protected lines to prevent undesired tripping.

SPECIFICATIONS

FUNCTIONAL DESCRIPTION

The specifications on these pages define the features and options that can be combined to exactly satisfy an application requirement. The block diagram (Figure 4) illustrates how the various standard features, as well as the options, function together.

INPUTS

Current Sensing

Current sensing can be selected as either single-phase or three-phase as determined by the style chart. Each current sensing transformer of the relay (1 per phase) receives the output from the (5 A nominal) secondary of a standard system current transformer.

Each current sensing input has a sensing range of 0.5 to 12.0 A. The continuous current capability is rated at 20 A. The current sensing input burden is less than 0.01 ohm

per input. Two current sensing frequencies are offered: 50 Hz or 60 Hz.

The maximum 1-second current rating is 50 x the maximum tap current selected, or 500 A, whichever is less. For ratings other than those specified by the time curves, the rating is calculated as follows:

$$I = \frac{(50 \times \text{tap value or } 500 \text{ A, whichever is less})}{\sqrt{T}}$$

where I = Maximum current
T = Time of current flow in seconds

Voltage Sensing

The voltage sensing input transformers receive their input from 120 Volt nominal secondary, standard system voltage transformers.

SPECIFICATIONS

(continued)

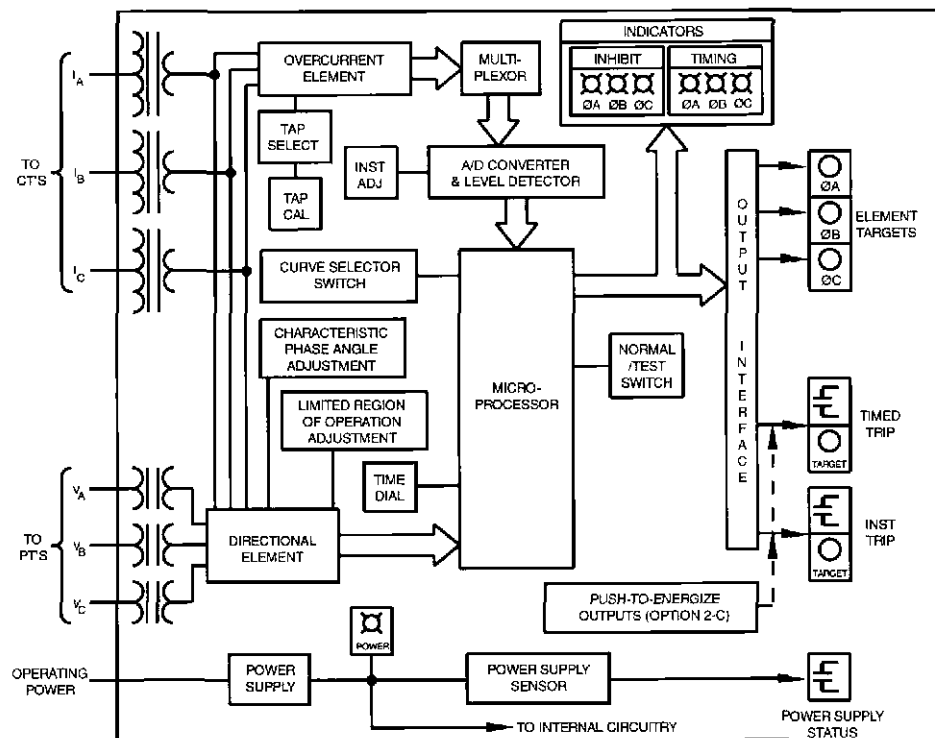

Figure 4. Functional Block Diagram

Each voltage sensing input has a continuous voltage rating of 240 Vac, and a sensing input burden greater than 25 K ohms at 120 Vac. Proper directional decisions are assured when the current applied to the relay exceeds 25% of TAP value and the voltage exceeds 1.0 Vac at the setting of the characteristic angle.

POWER SUPPLY

One of five power supply types may be selected to provide internal operating power. They are described in Table 2.

Type	Nominal Input Voltage	Input Voltage Range	Burden at Nominal
K	48 Vdc	24 to 60 Vdc	7.0 W
J	125 Vdc 120 Vac	62 to 150 Vdc 90 to 132 Vac	10.0 W 20.0 VA
L	24 Vdc	14 to 32 Vdc	7.0 W
Y	48 Vdc or 125 Vdc	24 to 60 Vdc 62 to 150 Vdc	7.0 W 7.5 W
Z	250 Vdc 230 Vac	140 to 280 Vdc 190 to 270 Vac	8.5 W 22.0 VA

Table 2

CURRENT SENSING INPUT

The BE1-67 Phase Directional Time Overcurrent Relay incorporates two basic measuring elements, the directional unit and overcurrent unit. The overcurrent tap is selected by a 10-position, rotary type, TAP SELECT switch. The available taps are shown in Table 3. Low range or high range is determined by selection of the input connections. (See Figures 19b and 20b).

The TAP CAL control sets the overcurrent pickup point between the discrete positions of the TAP SELECT switch to provide continuous pickup adjustability over the entire sensing input range (0.5 to 12.0A). A fully CW adjustment puts pickup within $\pm 5\%$ of the indicated TAP SELECT setting. Pickup repeatability is $\pm 2\%$.

DIRECTIONAL UNIT

The directional unit determines the direction of the current by analyzing the angular relationship between the operating current and a reference (polarizing) voltage. The operating current is the particular phase current under consideration and the polarizing voltage is the appropriate quadrature phase-to-phase voltage. Determination of direction requires less than 1 cycle.

TAP Range Plate	TAP Selector										Current Sensing Terminal			
	A	B	C	D	E	F	G	H	I	J	Single Phase	3 Phase		
												A	B	C
HIGH	2.25	3.0	4.5	5.25	6.75	7.5	9.0	9.75	11.25	12.0	8, 7	8, 7	14, 15	17, 18
LOW	0.75	1.0	1.5	1.75	2.25	2.5	3.0	3.25	3.75	4.0	9, 7	9, 7	13, 15	16, 18

Table 3. Sensing Input Ranges

SPECIFICATIONS

(continued)

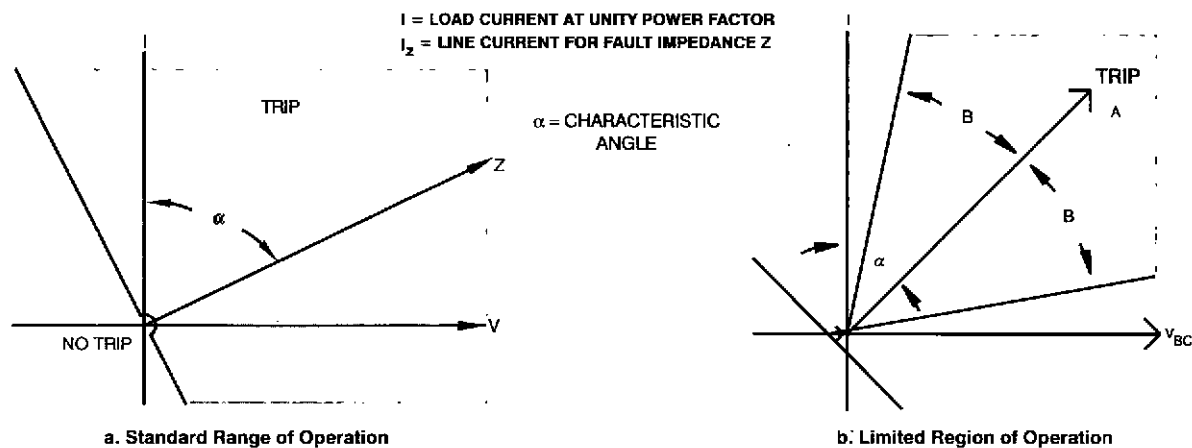

FIGURE 5. CHARACTERISTIC ANGLE (ALPHA)

The directional unit is front-panel adjustable by the CHARACTERISTIC PHASE ANGLE control and the (optional) LIMITED REGION OF OPERATION adjustment. Both are described below.

Characteristic Angle

The CHARACTERISTIC ANGLE control determines the characteristic angle (α) of Figure 5. This causes the characteristic of the directional unit to be rotated so that maximum sensitivity can match the impedance angle of the protected line. The tripping characteristic of the relay is then defined by a line that is normal to α . (The slight bow in the trip/no trip boundary at the origin is caused by the minimum sensitivity of the directional element: 0.02A and 1.0V.)

The CHARACTERISTIC ANGLE control may be a potentiometer (Options 3-1, 3-2, 3-5, and 3-6) or a 4-position switch (Options 3-2 and 3-4). Once established, angles are repeatable to within $\pm 5^\circ$ at nominal frequency. The potentiometer control has a range of 0-90°. When the control is a switch, the four discrete settings are 30°, 45°, 60°, and 75°.

When the phase relationship between current and voltage does not fall within the parameters of the directional element, an inhibit signal illuminates the appropriate PHASE INHIBIT indicator and prevents operation of the time overcurrent function. This signal also inhibits operation of the (optional) directional instantaneous overcurrent element. (Inhibit signals are generated independently for each sensed phase.)

Limited Region of Operation (Option)

Figure 5a indicates the region in which tripping is allowed: it is the shaded half-plane bounded by a line normal to I_2 at the origin.

The tripping region may be reduced (as illustrated in Figure 5b) by means of the front panel LIMITED REGION OF OPERATION control. This control is continuously adjustable (with reference to angle B) from $\pm 5^\circ$ to $\pm 90^\circ$.

TIMED TRIP

Timed trip is a standard feature of the relay. Pickup is determined by the TAP SELECT and the TAP CAL controls. When the overcurrent condition exceeds the pre-selected pickup point and the directional unit has removed its inhibit signal (indicating that direction is proper for tripping), timing is initiated. If these conditions persist for sufficient time, time-out will occur and the final output will energize.

Various timing characteristics are available and are defined by Figures 7 through 18. Individual curves of the designated set are selected by use of the front-panel time dial. The time dial is adjustable from 00 to 99 in increments of 01.

Timing accuracy is within $\pm 5\%$ of 50ms, whichever is greater, of the time indicated by the characteristic curve for any combination of time dial and pickup setting. Timings are repeatable to within $\pm 2\%$ or 50ms, whichever is greater.

INSTANTANEOUS TRIP (Option 1-1 or 1-3)

The instantaneous pickup point is front-panel adjustable from 1 to 40 times the selected pickup setting for timed trip. When the overcurrent condition exceeds the pickup point by the selected multiple, the instantaneous output relay energizes, assuming that:

1. The instantaneous option is non-directional (i.e., Option 1-1); or
2. The instantaneous option is directional (Option 1-3) and the sensed current is in the trip direction.

SPECIFICATIONS

(continued)

Pickup for the instantaneous element is accurate to within $\pm 2\%$ of the expected value. Dropout is greater than 92% of the established pickup level. Typical response time is shown in Figure 6.

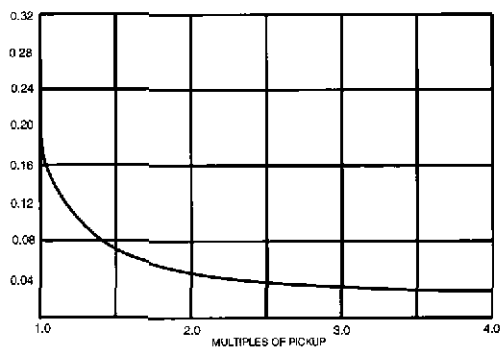

Figure 6. Typical Instantaneous Function Response Time

MICROPROCESSOR

The microprocessor is ultimately responsible for all timing functions, control functions, magnitude comparisons, and decision making within the relay. The BE1-67 utilizes an 8-bit CMOS microprocessor to accomplish these functions.

POWER SUPPLY STATUS OUTPUT (OPTION)

A normally closed (NC) output contact is provided to indicate the failure of the relay power supply. Under normal operating conditions, and with power applied to the relay, this output relay is energized and its contact is open. If the power supply ceases to provide proper operating voltages to the internal circuitry, the output relay de-energizes and the contact closes.

Removing the relay from its case will also give a closed (or out-of-service) indication.

OUTPUTS

Output tripping contacts are provided for each function incorporated in the relay (i.e. Time Trip and, if selected, Instantaneous Trip) and may be configured for normally open (NO) or normally closed (NC) operation.

All output contacts are rated as follows:

Resistive

120/240VAC	Make 30 A for 0.2 seconds, carry 7 A continuously, break 7 A.
250 Vdc	Make and carry 30 A for 0.2 seconds, carry 7 A continuously, break 0.3 A.
500 Vdc	Make and carry 15 A for 0.2 seconds, carry 7 A continuously, break 0.1 A.

Inductive

120/240 Vac, 125 Vdc, 250 Vdc - break 0.3A
(L/R = 0.04).

TARGETS (OPTION)

Magnetically latched, manually reset target indicators are optionally available to indicate that the respective output has tripped, and to further indicate (in multi-phase units) which particular phase or phases are involved.

Targets may be either internally operated or current operated. Current operated targets employ a 0.1 ohm current relay and require a minimum of 0.2 A flowing in the trip circuit to actuate.

Targets for this relay are further classified as either element targets or function targets. All element targets are internally operated and indicate the particular phase or phases causing the trip. Function targets, on the other hand, are associated with the primary tripping functions of relay. All function targets within a specific unit are of the same type, either all current operated or all internally operated.

PUSH-TO-ENERGIZE-OUTPUT PUSHBUTTONS

Accessible with a thin non-conducting rod through the front panel, push-to-energize pushbuttons are available to energize each output relay for testing the external control/protective system wiring.

SURGE WITHSTAND CAPABILITY

Qualified to ANSI/IEEE C37.90-1978 and C37.90a-1974 Surge Withstand Capability Test; IEC 255-5 Impulse Test and Dielectric Test.

MECHANICAL

Operating Temperature

-40°C (-40°F) to +70°C (+158°F).

Storage Temperature

-65°C (-85°C) to +100°C (+212°F).

Weight

18 pounds maximum.

Case Size

M1. (Case and mounting dimensions are defined in Bulletin SDA)

Shock

In standard tests, the relay has withstood 15g in each of three mutually perpendicular axes without structural damage or degradation of performance.

Vibration

In standard tests, the relay has withstood 2g in each of three mutually perpendicular axes, swept over the range of 10 to 500 Hz for a total of six sweeps, 15 minutes each sweep, without structural damage or degradation of performance.

SPECIFICATIONS

(continued)

TIME OVERCURRENT CHARACTERISTIC CURVES

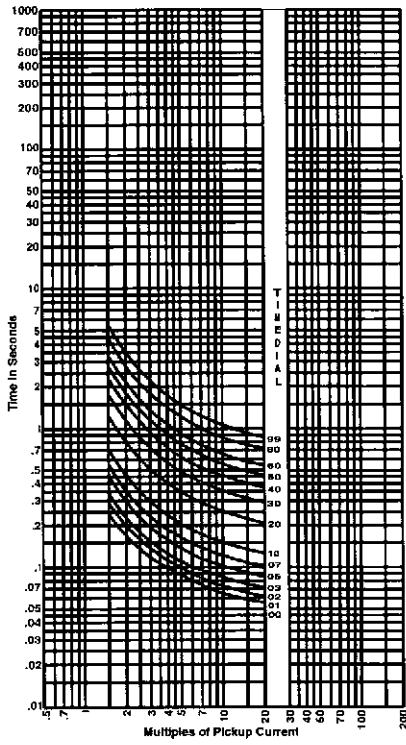

FIGURE 7. B1 - SHORT INVERSE

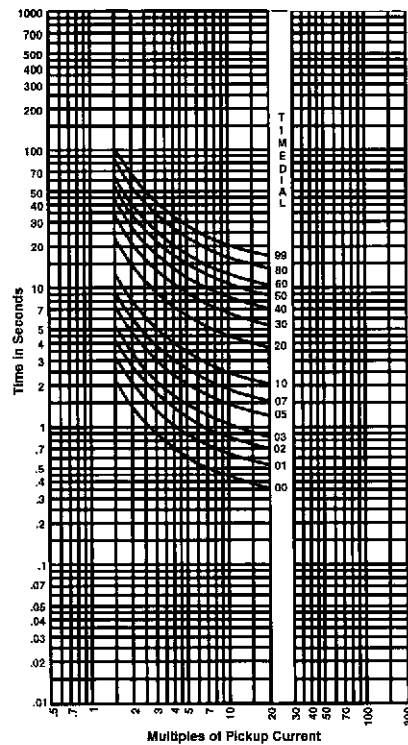

FIGURE 8. B2 - LONG INVERSE

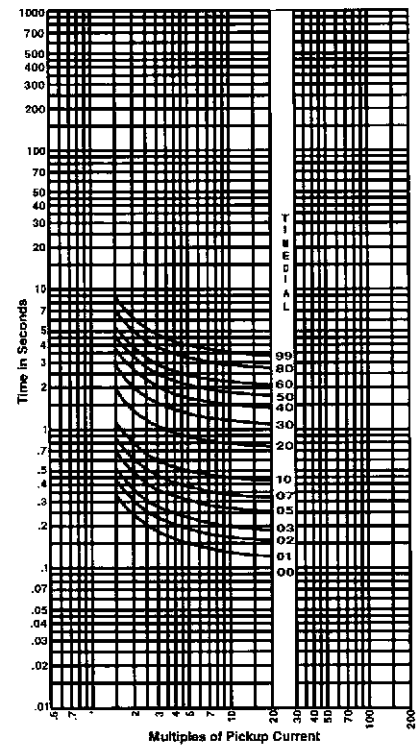

FIGURE 9. B3 - DEFINITE TIME

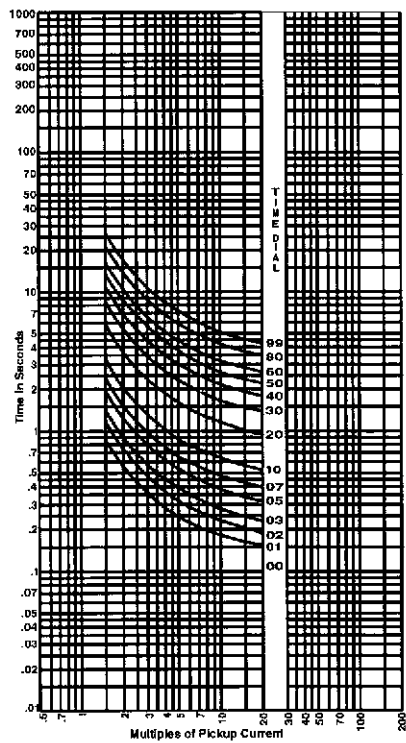

FIGURE 10. B4 - MODERATELY INVERSE

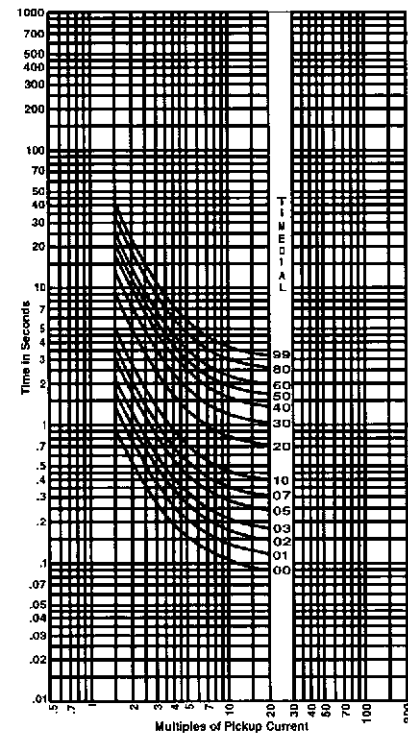

FIGURE 11. B5 - INVERSE

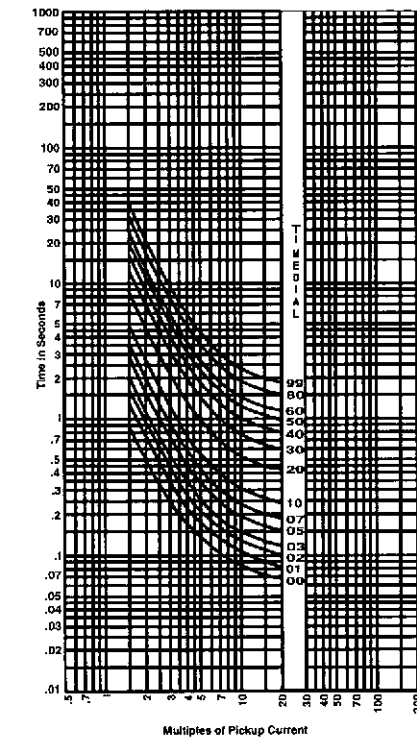

FIGURE 12. B6 - VERY INVERSE

SPECIFICATIONS

(continued)

TIME OVERCURRENT CHARACTERISTIC CURVES (continued)

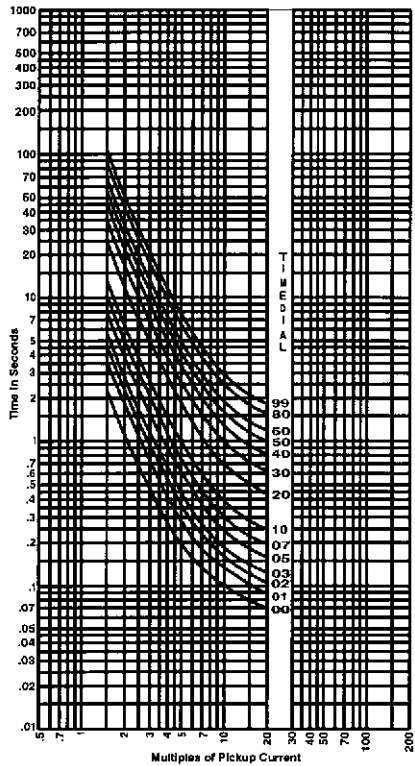

FIGURE 13. B7 - EXTREMELY INVERSE

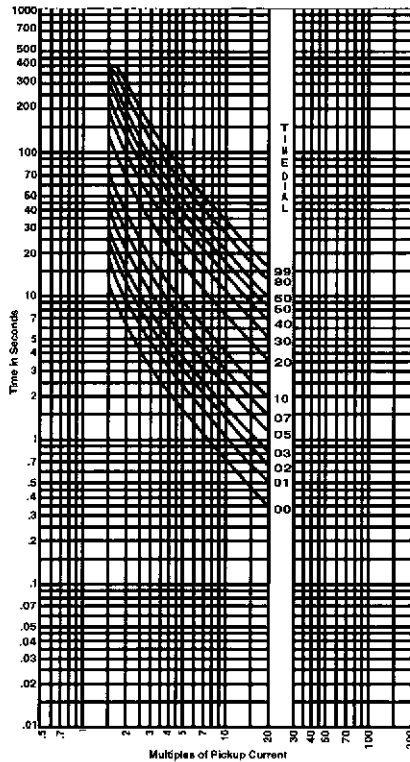

FIGURE 14. E2 - LONG INVERSE
BRITISH STANDARD 142 CURVE

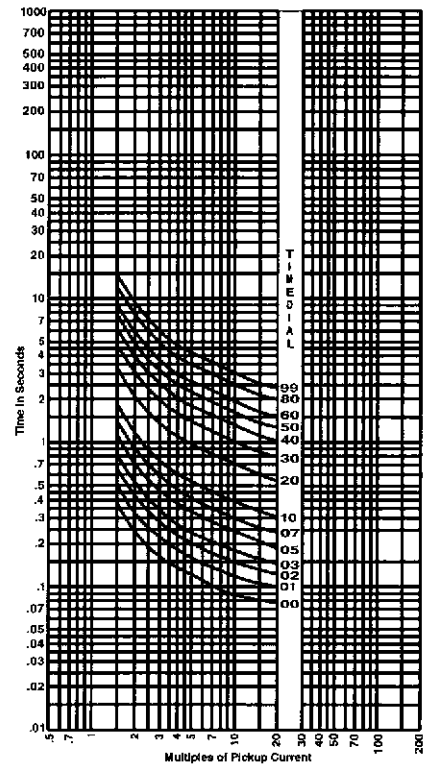

FIGURE 15. E4 - INVERSE (1.3)
BRITISH STANDARD 142 CURVE

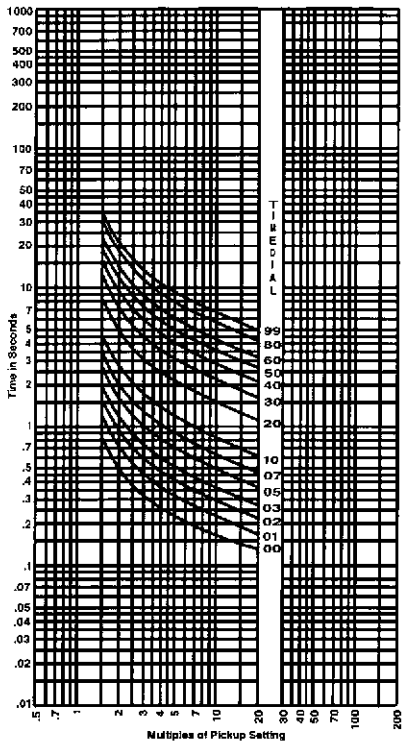

FIGURE 16. E5 - INVERSE (2.9)
BRITISH STANDARD 142 CURVE

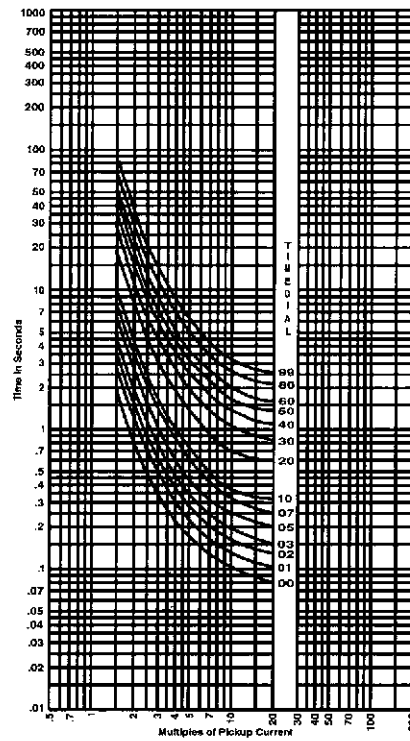

FIGURE 17. E6 - VERY INVERSE
BRITISH STANDARD 142 CURVE

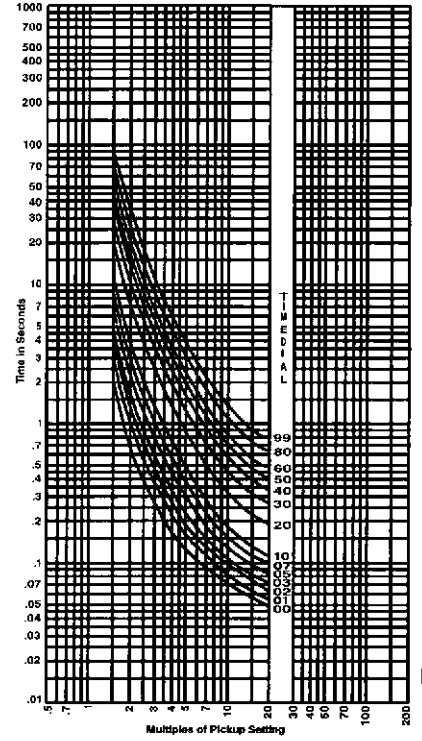
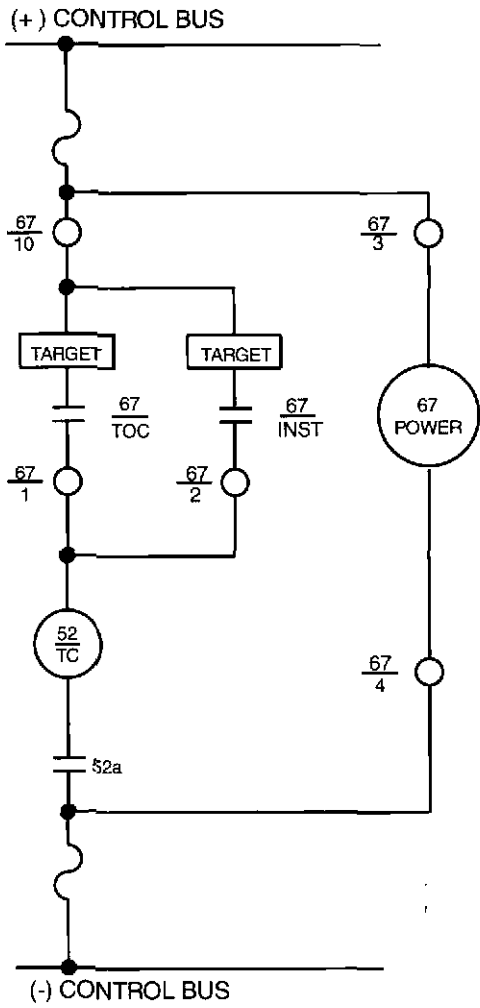



FIGURE 18. E7 - EXTREMELY INVERSE
BRITISH STANDARD 142 CURVE

CONNECTIONS



a.

LEGEND

- 67 PHASE DIRECTIONAL OVERCURRENT RELAY
- $\frac{52}{TC}$ BREAKER TRIP COIL
- 52a BREAKER AUXILIARY CONTACTS
- INST INSTANTANEOUS
- POL POLARIZING INPUT
- TOC TIME OVERCURRENT
-  FUSE

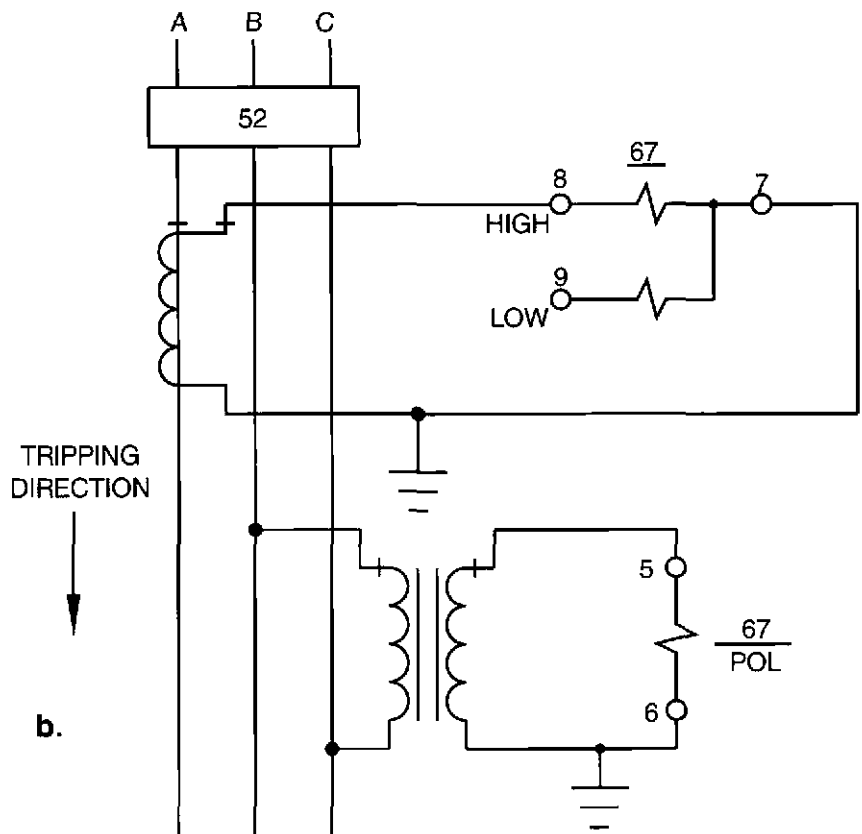
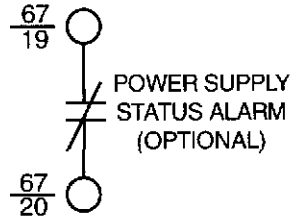

b.

FIGURE 19. SINGLE-PHASE CONNECTIONS

CONNECTIONS

(continued)

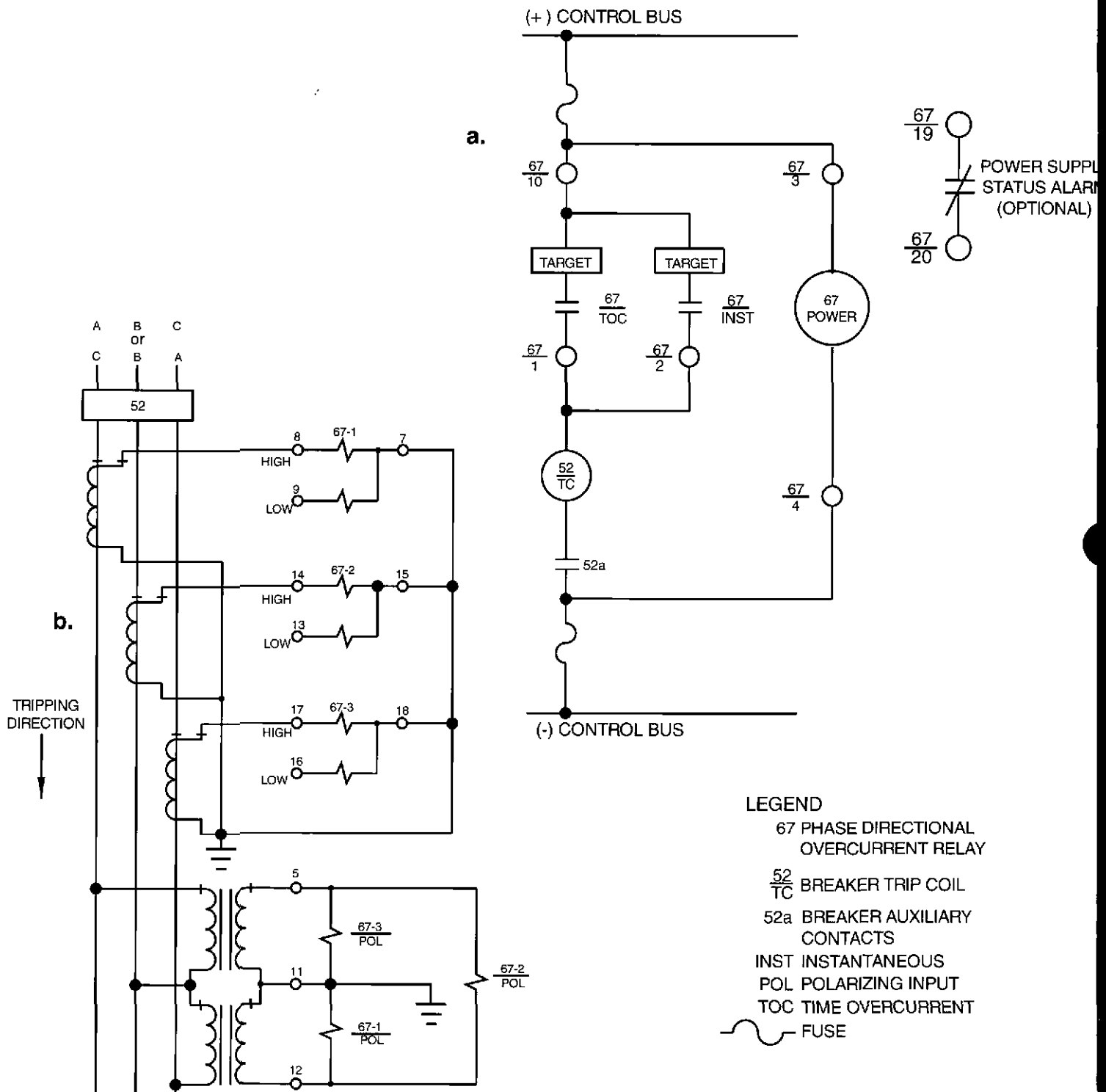

FIGURE 20. THREE-PHASE CONNECTIONS

ORDERING

MODEL NUMBER

BE1-67, Phase Directional Time Overcurrent Relay

STYLE NUMBER

The style number appears on the front panel, drawout cradle, and inside the case assembly. This style number is an alphanumeric combination of characters identifying the features included in a particular unit. The sample style number below illustrates the manner in which the various features are designated. The Style Number Identification Chart (page 12) defines each of the options and characteristics available for this device.

SAMPLE STYLE NUMBER: B1E-Z2J-B3C0F

The style number above describes a BE1-67, Phase Directional Time Overcurrent Relay having the following features.

Sensing Input Type (B) Three-phase

Sensing Input Range (1) 0.5 to 12.0 A, 60 Hz

Output	(E)	Normally open output contact
Timing	(Z2)	Switch selectable timing characteristics
Power Supply	(J)	125 Vdc/120 Vac nominal input power supply
Target	(B)	Current operated targets
Option 1	(3)	One directional instantaneous overcurrent element
Option 2	(C)	Push-to-energize-output pushbuttons
Option 3	(O)	None
Option 4	(F)	Semi-flush mounting

NOTE: The description of a complete relay must include both the model number and the style number as shown below.

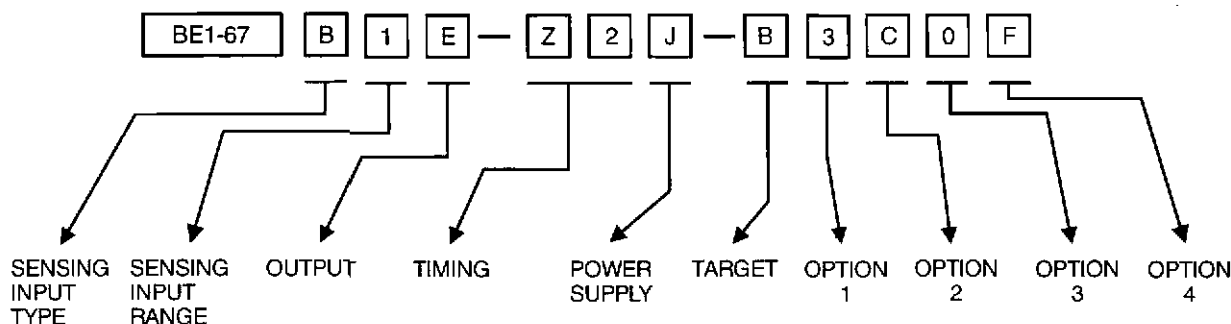

HOW TO ORDER

Designate the model number followed by the complete style number.

BE1-67 Style No. --

Complete the style number by selecting one feature from each column of the Style Number Identification Chart and entering its designation letter or number into the appropriate square. (Two squares are used to indicate time delay characteristics.) All squares must be completed.

STANDARD ACCESSORIES

The following accessories are available for the BE1-67, Phase Directional Time Overcurrent Relay.

Test Plug

To allow testing of the relay without removing system wiring, order two test plugs, Basler Electric part number 10095.

Extender Board

The extender board permits troubleshooting of the printed circuit boards outside of the relay cradle. Order Basler Electric part number 9 1655 00 100.

STYLE NUMBER IDENTIFICATION CHART

