

INSTRUCTION MANUAL

FOR

RDP-110

Remote Display Panel

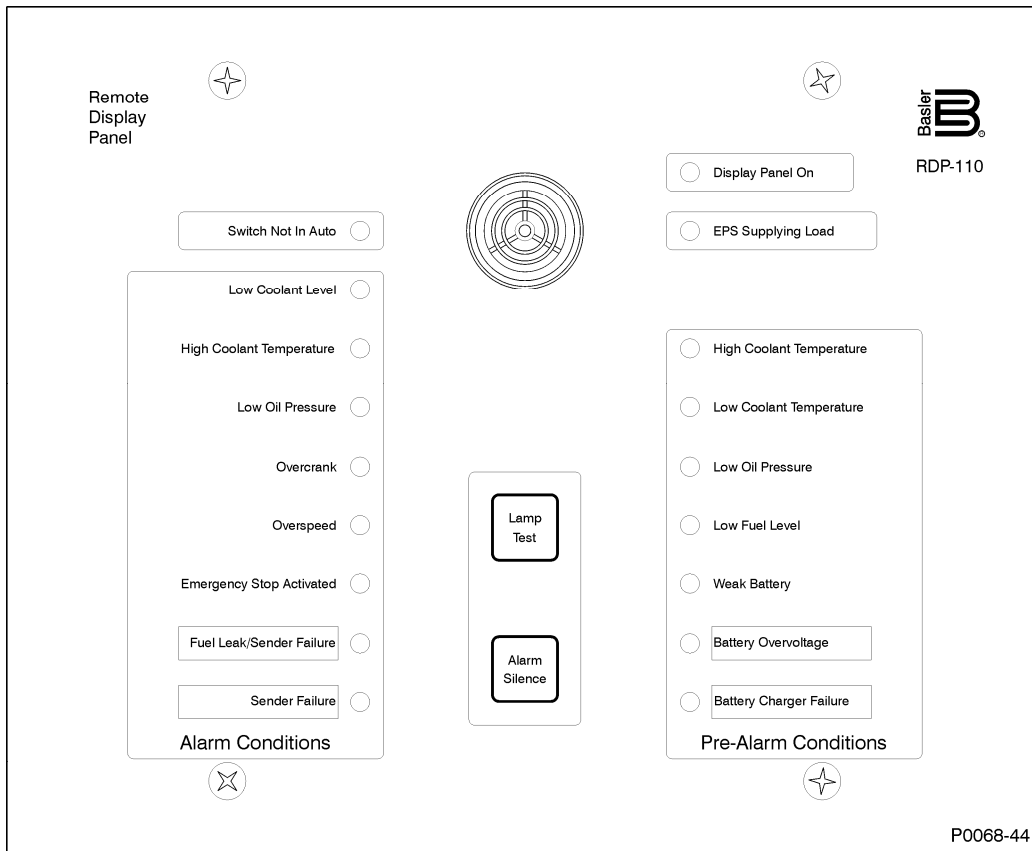

Publication: 9318100990
Revision: G 02/14

Preface

This instruction manual provides information about the installation and operation of the RDP-110 Remote Display Panel. To accomplish this, the following information is provided:

- Product specifications
- Functional description
- Mounting and wiring
- Testing

Conventions Used in this Manual

Important safety and procedural information is emphasized and presented in this manual through warning, caution, and note boxes. Each type is illustrated and defined as follows.

Warning!

Warning boxes call attention to conditions or actions that may cause personal injury or death.

Caution

Caution boxes call attention to operating conditions that may lead to equipment or property damage.

Note

Note boxes emphasize important information pertaining to Remote Display Panel installation or operation.



12570 State Route 143
Highland IL 62249-1074 USA

www.basler.com

info@basler.com

Tel: +1 618.654.2341

Fax: +1 618.654.2351

© 2014 by Basler Electric

All rights reserved

First printing: June 1998

Warning!

READ THIS MANUAL. Read this manual before installing, operating, or maintaining the RDP-110. Note all warnings, cautions, and notes in this manual as well as on the product. Keep this manual with the product for reference. Failure to follow warning and cautionary labels may result in personal injury or property damage. Exercise caution at all times.

To prevent personal injury or equipment damage, only qualified personnel should install, operate, or service this system.

Basler Electric does not assume any responsibility for compliance or noncompliance with national code, local code, or any other applicable code. This manual serves as reference material that must be well understood prior to installation, operation, or maintenance.

For terms of service relating to this product and software, see the *Commercial Terms of Products and Services* document available at www.basler.com/terms.

This publication contains confidential information of Basler Electric Company, an Illinois corporation. It is loaned for confidential use, subject to return on request, and with the mutual understanding that it will not be used in any manner detrimental to the interests of Basler Electric Company and used strictly for the purpose intended.

It is not the intention of this manual to cover all details and variations in equipment, nor does this manual provide data for every possible contingency regarding installation or operation. The availability and design of all features and options are subject to modification without notice. Over time, improvements and revisions may be made to this publication. Before performing any of the following procedures, contact Basler Electric for the latest revision of this manual.

The English-language version of this manual serves as the only approved manual version.

Revision History

The following information provides a historical summary of the changes made to the Remote Display Panel instruction manual (part number 9318100990 Rev G). Revisions are listed in chronological order.

Manual Revision and Date	Change
–, 06/1998	<ul style="list-style-type: none"> • Initial release
A, 10/1998	<ul style="list-style-type: none"> • Replaced part numbers for surface mount and semi-flush panels with style number designations • Added recommended maximum length for RS-485 wiring • Added manual revision information
B, 07/1999	<ul style="list-style-type: none"> • Added style chart and related information • Updated controls and indicators information to reflect style chart changes for styles RDP-110 X1 and RDP-110 X2 • Clarified the display functions for the Airbox Closed alarm
C, 01/2000	<ul style="list-style-type: none"> • Added DGC-1000 front panel illustration to existing DGC-2000 front panel illustration • Updated connections diagram to reflect DGC-1000 terminals
D, 04/2002	<ul style="list-style-type: none"> • Added UL and CSA agency compliance information • Updated illustrations to show UL and CSA agency logos
E, 06/2007	<ul style="list-style-type: none"> • Updated style chart to show DGC-2020 compatibility • Updated style of manual
F, 08/2012	<ul style="list-style-type: none"> • Added horn specifications • Added description of programmable pre-alarm and alarm functions • Added procedure for relabeling programmable pre-alarms and alarms • Added note stating that “240” terminal is not functional • Added illustration showing the location of the RS-485 terminating resistor • Added terminal numbers for the DGC-500, DGC-1000, and DGC-2020 to the typical connections illustration • Added numbered illustration showing annunciation sequence of test mode • Removed all references to the DGC-2000 • Updated the style of the manual
G, 02/2014	<ul style="list-style-type: none"> • Corrected RS-485 connection errors in all applicable illustrations



Contents

General Information	1
Features.....	1
Model and Style Number	1
Specifications.....	2
Controls and Indicators	3
Programmable Alarm and Pre-Alarm Indicator Configuration	4
Functional Description.....	7
Inputs	7
Microprocessor	8
Firmware.....	8
Installation	9
Mounting.....	9
Connections.....	9
Testing.....	13
Test Equipment and Setup	13
Test Procedure	13



General Information

The RDP-110 Remote Display Panel provides remote annunciation of engine/generator status. When used with Basler Electric Digital Genset Controllers DGC-2020, DGC-500, or DGC-1000, the RDP-110 provides compliance with NFPA 110 Level 1 and Level 2 requirements. The RDP-110 is suitable for use with isolated generators or paralleled generating systems.

Features

Features of the microprocessor-based RDP-110 are summarized below.

Comprehensive Annunciation Capabilities

The RDP-110 is equipped with the following LED (light emitting diode) indicator functions:

- RDP-110 control power applied
- Genset supplying load
- DGC not operating in Auto mode
- Six fixed-function alarms
- Two programmable alarms
- Five fixed-function pre-alarms
- Two programmable pre-alarms

An audible alarm annunciates the presence of alarms, pre-alarms, and when the DGC is taken out of Auto mode. An Alarm Silence pushbutton resets the audible alarm.

Operation of the audible alarm and all visual indicators can be verified with the Lamp Test pushbutton.

Rugged and Flexible Construction

A rugged metal case provides improved electromagnetic compatibility and makes the RDP-110 resistant to moisture, salt fog, dust, dirt, and chemical contaminants. Two available mounting configurations provide the option of semi-flush mounting or surface (projection) mounting. Conduit knockouts on the case enable the RDP-110 to be used as a “pass-through” or junction box for other site wiring.

Simple Connections

RDP-110 connections consist of control power wiring and wiring for communication between the DGC and RDP-110. Two-wire, RS-485 communication between the RDP-110 and DGC simplifies wiring and ensures noise immunity over long distances.

Model and Style Number

The model number together with the style number, describe the options in a specific device and appear on a label located on the right side of the case. The RDP-110 style number chart is shown in Figure 1.

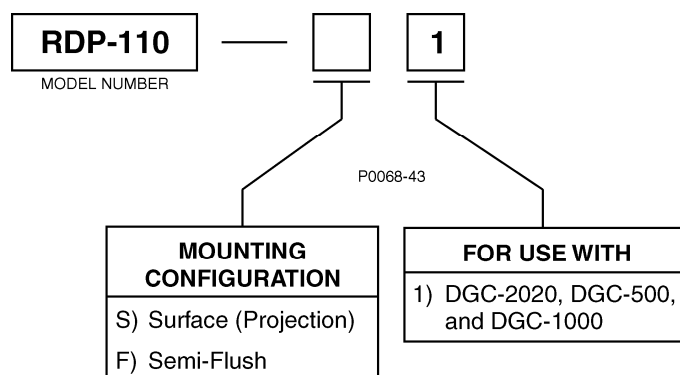

Figure 1. RDP-110 Style Chart

Specifications

RDP-110 electrical and physical characteristics are listed in the following paragraphs.

Control Power

DC Input

Range: 8 to 32 Vdc
Burden: 2 W maximum

AC Input

Range: 84 to 144 Vac
Burden: 5 VA maximum

Communication

The RDP-110 communicates through a serial, RS-485 port terminated with a 100 Ω resistor.

Audible Alarm

Frequency: 2,900 Hz, \pm 500 Hz
Sound Level: 90 dB(A) at 24 in (61 cm)

Temperature

Operating Temperature Range: -40 to 70°C (-40 to 158°F)
Storage Temperature Range: -40 to 85°C (-40 to 185°F)

Weight

3 kg (6.6 lb)

Type Test Data

Dielectric Strength

Withstood 1,800 Vdc for 1 minute between chassis ground and ac control power input. Withstood 700 Vdc for 1 minute between any combination of the following circuit groups:

- Chassis ground
- DC control power input and RS-485 terminals
- AC control power input

Radio Frequency Interference

Tested using a 5 W, handheld transceiver operating at random frequencies centered around 144 MHz and 440 MHz with the antenna located within 6 inches (15 centimeters) of the device in both the vertical and horizontal planes.

Vibration

Withstood 2 G in each of three mutually perpendicular planes, swept over the range of 10 to 500 Hz for a total of six sweeps, 15 minutes each sweep. No structural damage or degradation of performance was observed.

Shock

Withstood 15 G in all planes.

Agency Recognition

Underwriters Laboratory: Recognized per Standard 508, UL file number E97035

Canadian Standards Association: Certified per Standard CAN/CSA-C22.2 Number 14-95, CSA file number LR23-23131

Controls and Indicators

RDP-110 controls and indicators consist of pushbuttons, LED lamps, and an audible alarm (horn). These front panel elements are illustrated in Figure 2. Lettered locators in Figure 2 correspond to the lettered descriptions of Table 1.

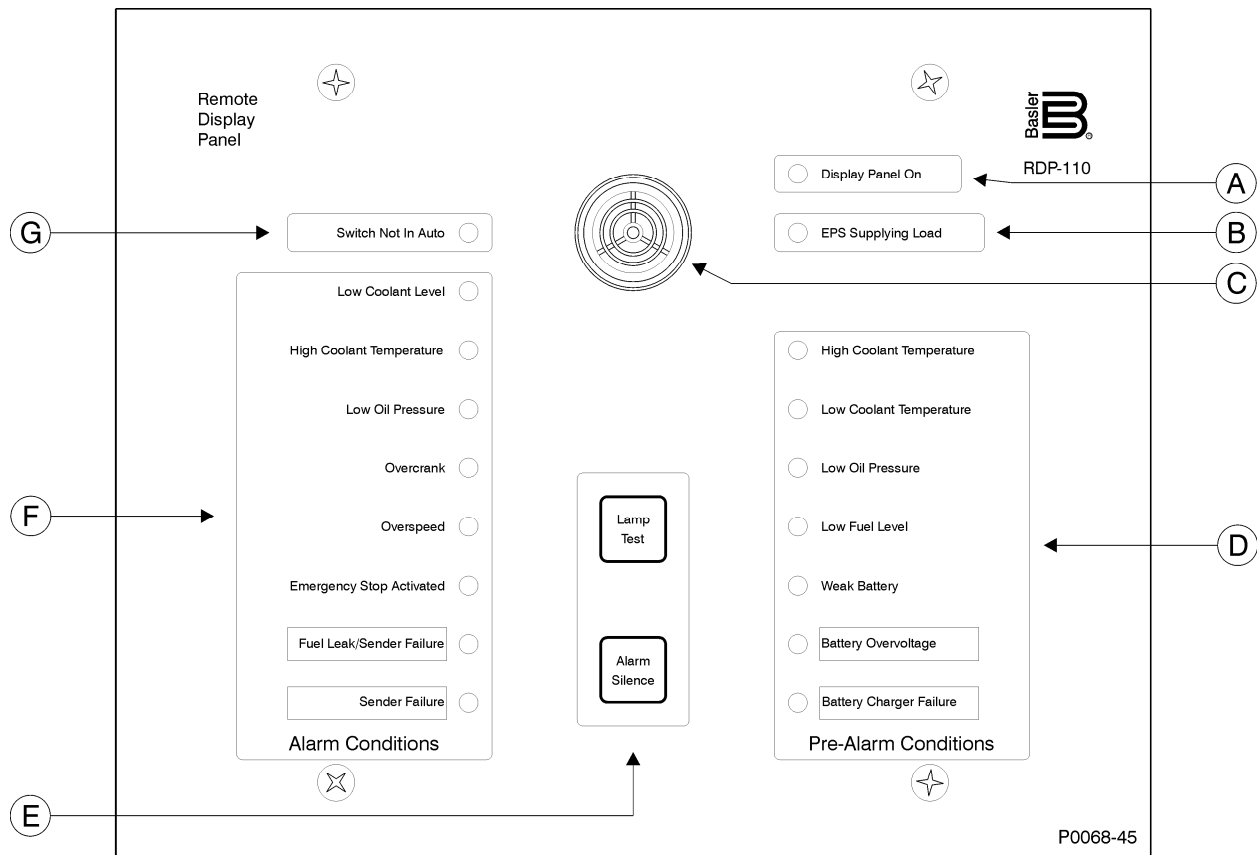

Figure 2. Controls and Indicators

Table 1. Control and Indicator Descriptions

Locator	Description
A	Green <i>Display Panel On</i> LED lights when control power is applied to the RDP-110.
B	Green <i>EPS Supplying Load</i> LED lights when the genset is supplying more than 2% of rated load.
C	The horn sounds when an alarm or pre-alarm exists or the connected DGC is not operating in Auto mode. The horn is silenced by pressing the <i>Alarm Silence</i> pushbutton (locator E).
D	The amber <i>Pre-Alarm</i> LEDs light when the corresponding pre-alarm setting is exceeded. Conditions annunciated by the pre-alarm LEDs include high coolant temperature, low coolant temperature, low oil pressure, low fuel level, weak battery, battery overvoltage, and battery charger failure. When the RDP-110 is used with a DGC-2020, the bottom two LEDs (Battery Overvoltage and Battery Charger Failure) can be reprogrammed to indicate other pre-alarm conditions. See <i>Programmable Alarm and Pre-Alarm Configuration</i> for information about configuring the two programmable pre-alarm indicators.
E	RDP-110 controls consist of two pushbuttons. The <i>Alarm Silence</i> pushbutton silences the horn (locator C). The <i>Lamp Test</i> pushbutton can be used to verify operation of all RDP-110 LEDs and the horn.

Locator	Description
F	The red <i>Alarm</i> LEDs light when the corresponding alarm setting is exceeded. Conditions annunciated by the alarm LEDs include low coolant level, high coolant temperature, low oil pressure, overcrank, overspeed, emergency stop activated, fuel leak/sender failure, and sender failure. When the RDP-110 is used with a DGC-2020, the bottom two LEDs (Fuel Leak/Sender Failure and Sender Failure) can be reprogrammed to indicate other alarm conditions. See <i>Programmable Alarm and Pre-Alarm Configuration</i> for information about configuring the two programmable alarm indicators.
G	Red <i>Switch Not In Auto</i> LED lights when the DGC is not operating in Auto mode.

Programmable Alarm and Pre-Alarm Indicator Configuration

When used with a DGC-2020, the RDP-110 has the added capability of programmable alarm and pre-alarm indicators. This ability applies only to the DGC-2020 and is not available when the RDP-110 is paired with the DGC-500 or DGC-1000.

Up to two alarm LEDs and two pre-alarm LEDs may be reprogrammed to suit the needs of a particular application. The two bottommost alarm LEDs are pre-configured in DGC-2020 logic to annunciate a fuel leak/sender failure and sender failure. The two bottommost pre-alarm LEDs are pre-configured in DGC-2020 logic to annunciate battery overvoltage and a battery charger failure. These LEDs are labeled as such with replaceable cards (Figure 3) that can be relabeled to match the function of each programmable indicator.

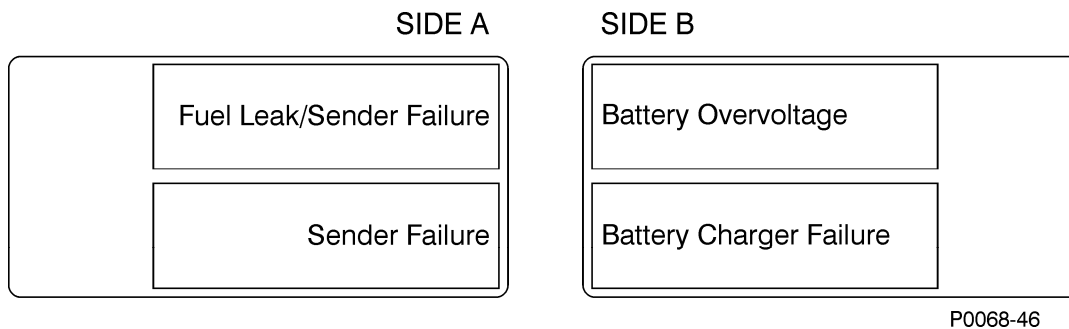

Figure 3. Programmable Alarm and Pre-Alarm Label Cards

Information about configuring DGC-2020 logic to provide other alarm and pre-alarm annunciations is available in Basler publication 9400200990. To re-label the RDP-110 programmable alarm and pre-alarm LEDs, perform the following steps.

1. Print the label text on readily-available address label sheets. The label cards accommodate adhesive-backed labels measuring 0.5 by 1.75 inches. Avery part number 18167 is suitable for this purpose.
2. Remove all control power from the RDP-110.
3. Remove the four Phillips screws from the front panel and separate the front panel from the conduit box. Disconnect the two connectors attached to the circuit board mounted to the front panel. When handling the front panel, avoid touching the circuit board.
4. Lay the front panel face-down on a suitable work surface.
5. Grasp the tab of the label card to be changed and pull free. The two label cards are located near the two lower corners of the circuit board. When facing the back of the panel, the pre-alarm label card is on the left and the alarm label card is on the right.
6. Apply the labels created in step 1 to the label cards. The rectangle outlines on each label card serve as guides for attaching the labels.

7. After applying the new labels, insert each label card into the appropriate panel slot. Ensure that each label card is oriented properly by viewing the custom labels through the label windows of the front panel.
8. Move the panel assembly adjacent to the conduit box and reconnect the cables to the two circuit board connectors.
9. Secure the front panel to the conduit box with the four Phillips screws removed in step 3. Maximum torque for these screws is 17 inch-pounds or 2 newton meters.
10. If desired, verify the function of the reprogrammed indicators before returning the RDP-110 to service.



Functional Description

The RDP-110 uses microprocessor-based technology to provide remote annunciation of engine and generator parameters. RDP-110 function blocks are illustrated in Figure 4 and described in the following paragraphs.

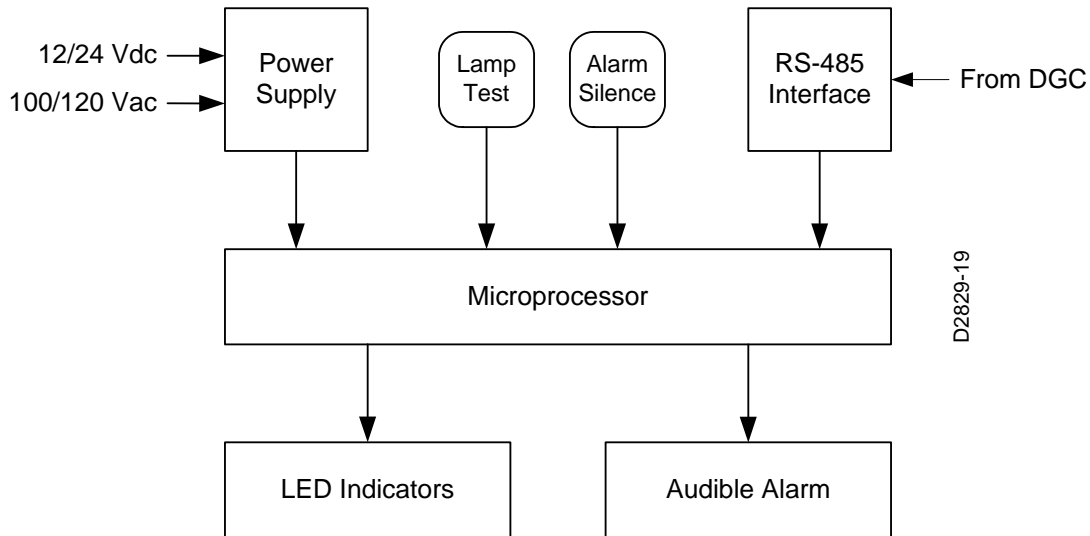

Figure 4. RDP-110 Function Blocks

Inputs

RDP-110 inputs consist of control power inputs, a communication interface, and pushbuttons. Control power and communication connections are made on the circuit board attached to the front panel.

Control Power

Redundant, isolated control power inputs enable continued RDP-110 operation if one power input is lost.

The dc control power input accepts nominal battery voltage of 12 Vdc or 24 Vdc. The acceptable range of dc control power is 8 to 32 Vdc.

The ac control power input is rated for a nominal voltage of 100 Vac or 120 Vac at 50 Hz or 60 Hz. The acceptable range of ac control power is 80 to 144 Vac.

Each control power input is applied to an internal switching power supply that provides filtered 5 Vdc operating power for the RDP-110 circuitry.

Communication Interface

RDP-110 annunciation commands are received from the DGC over an RS-485 serial communication bus. Received communication inputs are converted to signals suitable for use by the RDP-110 microprocessor.

Pushbuttons

Two front-panel pushbuttons accept local inputs: Lamp Test and Alarm Silence.

LED and horn operation can be verified by pressing the Lamp Test pushbutton.

An audible alarm is reset by pressing the Alarm Silence pushbutton. Once reset, the horn is reactivated only the occurrence of another, separate pre-alarm or alarm condition.

Microprocessor

The microprocessor executes embedded firmware which interprets commands received from the DGC and annunciates pre-alarm and alarm conditions by lighting the appropriate indicators and sounding the horn.

Firmware

Embedded firmware controls power-up initialization, annunciation element setup, and serial communication. When control power is applied to the RDP-110, the firmware initiates a power-up sequence, checks the onboard memory, activates all annunciation functions, and begins monitoring for inputs from the DGC.

Installation

A NEMA 1 enclosure makes the RDP-110 resistant to moisture and dust infiltration. Its metal construction improves immunity to electromagnetic interference. Conduit knockouts on the case enable the RDP-110 to be used as a “pass-through” or junction box for other site wiring. Two available mounting configurations provide the option of semi-flush mounting or surface (projection) mounting.

If the RDP-110 will not be installed immediately, store it in the original shipping package in a moisture- and dust-free environment.

Mounting

RDP-110 mounting dimensions are illustrated in Figure 5.

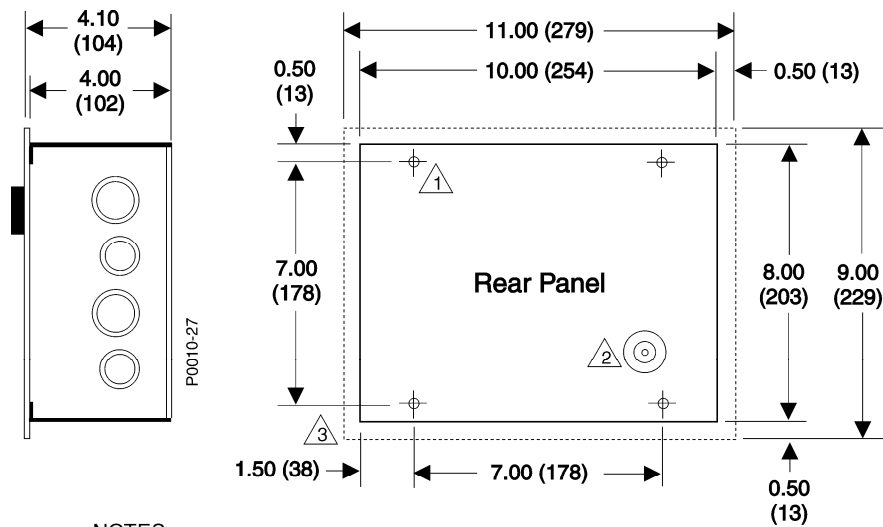

NOTES

- 1 Mounting hole diameter (4 places, on rear wall of enclosure) is 0.281 (7).
- 2 Grounding point is 10-31 threaded hole.
- 3 Dashed line indicates outline of flush-mount panel.
- 4 All dimensions are in inches (millimeters).

Figure 5. RDP-110 Mounting Dimensions

Connections

Display panel connections are made with two plug-in connectors that mate with headers on the lower edge of the RDP-110 circuit board. Keyed connectors prevent improper connections. These circuit board connections, illustrated in Figure 6, are accessed by removing the front panel from the conduit box.

Note

Ensure that the RDP-110 is hard-wired to earth ground with no smaller than 16 AWG (1.5 mm²) copper wire attached to the circuit board CHASSIS terminal. An additional ground connection is provided on the conduit box.

DC control power applied to the 12/24 (+) and DC COM (–) terminals must be of the correct polarity. Incorrect dc control power polarity will prevent the RDP-110 from functioning.

Note

The 240 terminal is not functional and cannot be used. For ac control power connections, only the 120 and AC COM terminals should be used for application of 100/120 Vac nominal voltage.

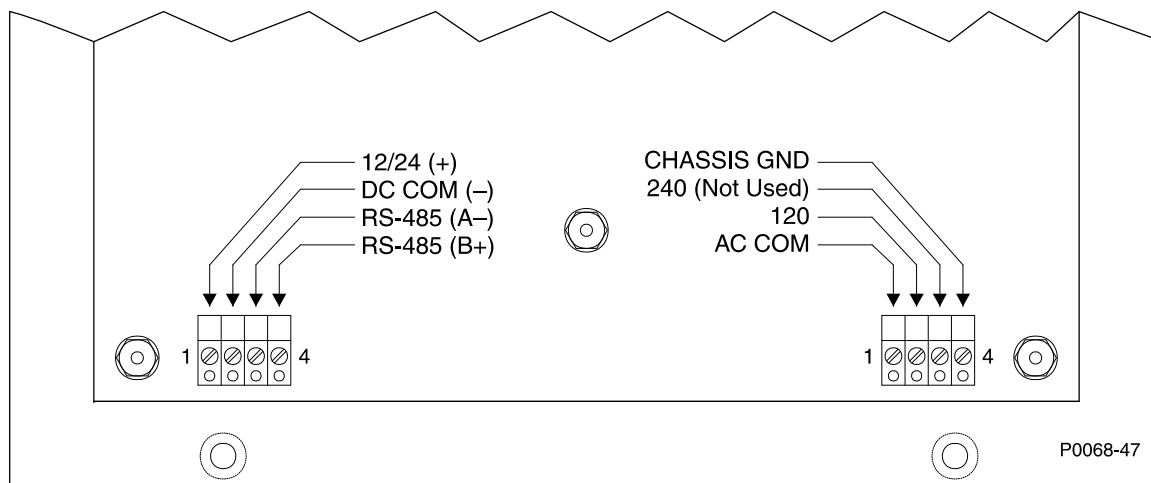

Figure 6. RDP-110 Circuit Board Connections

Connector Wiring

Note the following guidelines when wiring the two circuit board connections:

- The ground terminal connection should be made with wire no smaller than 16 AWG (1.5 mm²)
- Other than the ground terminal, connections should be made with wire no smaller than 20 AWG (0.5 mm²)
- Maximum conductor size for each terminal is 12 AWG (4 mm²)
- Strip the insulation from each wire to reveal 0.28 inches (7 millimeters) of exposed conductor
- Apply no more than 4.4 in-lb (0.5 N•m) of torque to each terminal screw

RS-485 Communication Connections

Twisted-pair conductors are recommended for the communication wiring between the DGC and RDP-110.

Overly long wiring runs may impair communication between the DGC and RDP-110 unreliable. Do not exceed an RS-485 conductor length of 4,000 feet (1,219 meters).

RS-485 Terminating Resistor

The RS-485 communication connection is internally terminated with a 100 Ω resistor. Connecting multiple display panels may necessitate removal of this terminating resistor (R65). R65 is located in the lower, left quadrant of the circuit board. The location of R65 is illustrated in Figure 7.

Consult standard TIA/EIA-485 for guidance on the electrical requirements of multipoint communication systems.

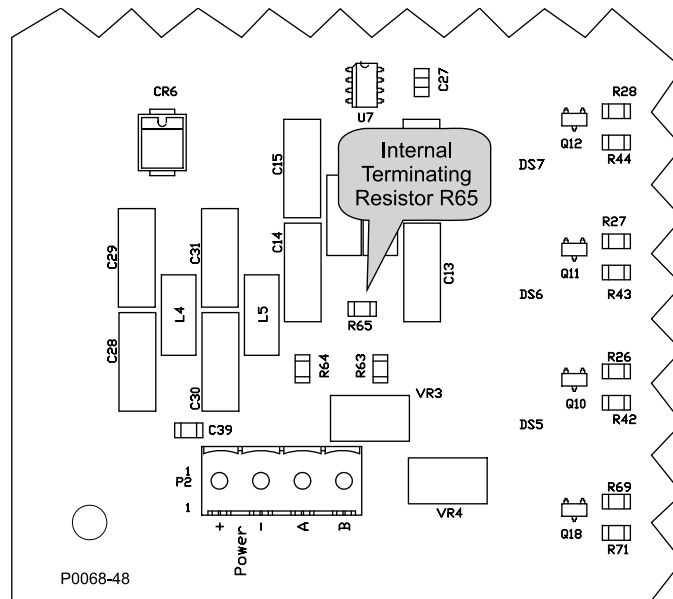

Figure 7. RS-485 Terminating Resistor Location

Typical Connections

Typical RDP-110 connections are shown in Figure 8.

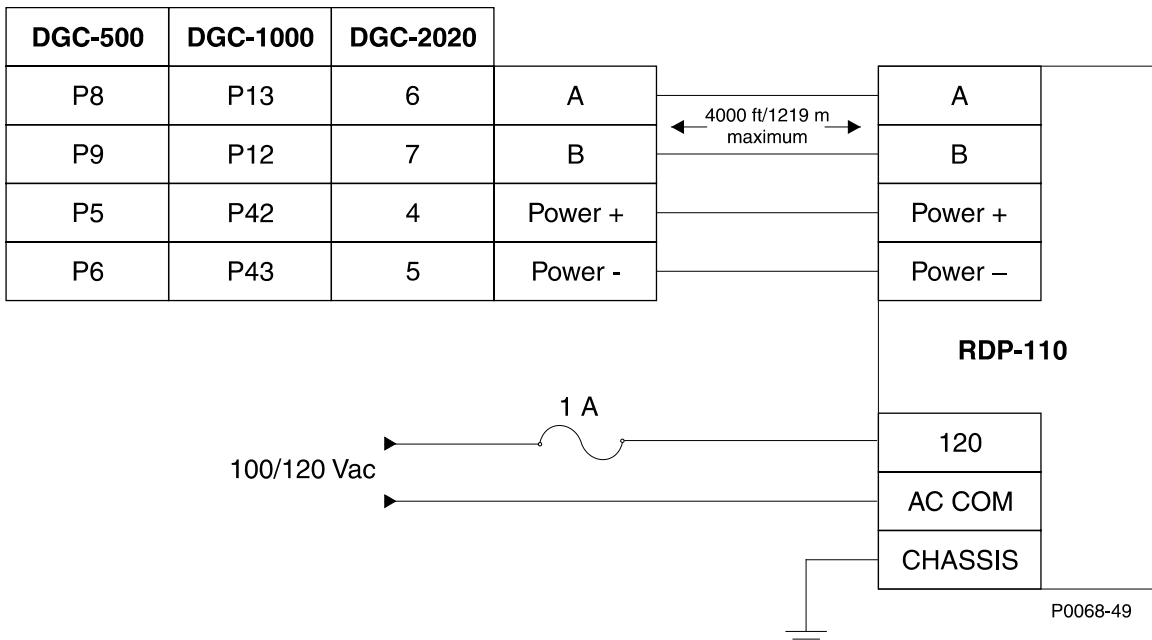

Figure 8. Typical RDP-110 Connections



Testing

A built-in test mode enables field testing of RDP-110 operation.

Test Equipment and Setup

Equipment needed for testing RDP-110 operation is listed below. Connections for the test are illustrated in Figure 9.

- Power supply, 24 Vdc
- Power source, 100/120 Vac, 50/60 Hz
- Fuse, 1 ampere (2)
- Signal generator, 10 Hz, square wave, 5 volts peak-to-peak

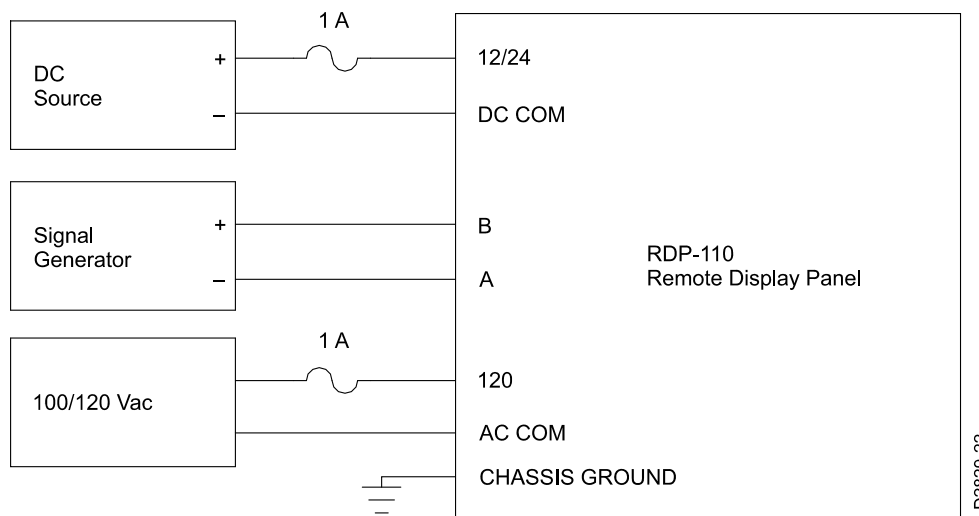

Figure 9. RDP-110 Test Setup

Test Procedure

1. Connect the RDP-110 test setup as shown in Figure 9.
2. Apply 24 Vdc control power. The Display Panel On LED should light.
3. Press and hold the Lamp Test pushbutton. All LEDs should light and the horn should sound.
4. Release the Lamp Test pushbutton to reset the indicators and horn.
5. Apply the 10 Hz signal.
6. Press and release the Lamp Test pushbutton. Observe that the LEDs and horn annunciate in the eighteen-step sequence indicated in Figure 10. This sequence will repeat until the Alarm Silence pushbutton is operated.
7. Press and release the Alarm Silence to end the annunciation sequence.
8. Remove the 10 Hz signal and 24 Vdc control power.
9. Repeat the test with 100/120 Vac control power applied instead of 24 Vdc control power.

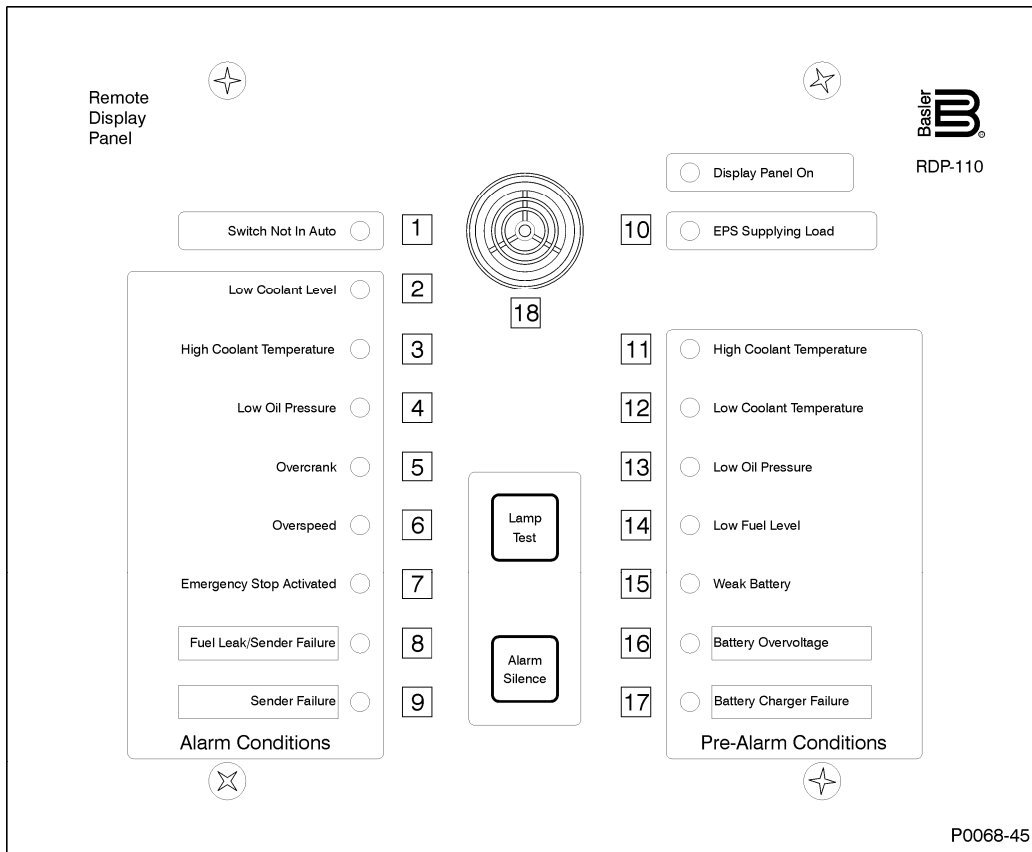

Figure 10. Test Mode Annunciation Sequence



12570 State Route 143
Highland IL 62249-1074 USA
Tel: +1 618.654.2341
Fax: +1 618.654.2351
email: info@basler.com

P.A.E. Les Pins
67319 Wasselonne Cedex
FRANCE
Tel: +33 3.88.87.1010
Fax: +33 3.88.87.0808
email: franceinfo@basler.com

No. 59 Heshun Road Loufeng District (N)
Suzhou Industrial Park
215122 Suzhou
P.R. CHINA
Tel: +86 512.8227.2888
Fax: +86 512.8227.2887
email: chinainfo@basler.com

111 North Bridge Road
15-06 Peninsula Plaza
Singapore 179098
Tel: +65 68.44.6445
Fax: +65 68.44.8902
email: singaporeinfo@basler.com