

INTRODUCTION

The Basler AVC63-7 Voltage Regulator is a potted unit contained in a plastic case. The regulator controls the dc exciter field power of conventional, 50 or 60 Hz brushless generators that have a 63 Vdc exciter field to regulate the generator output voltage.

Regulation is provided by sensing the generator output voltage, converting it to a dc signal and comparing the signal to a reference voltage signal. An error signal is developed and used to control the dc field power in order to maintain a constant generator output.

Models with P/N 9302800110 have adjustment potentiometers located on the reverse side of the unit. In generator paralleling applications, this model is compatible with other AVC63-7 regulators.

ELECTRICAL SPECIFICATIONS

DC Output Power

7 Adc at 63 Vdc maximum continuous with a 240 Vac input.

Exciter Field DC Resistance

9.0 ohms minimum.

AC Power Input

170 to 305 Vac, single-phase, 50/60 Hz.

Burden: 900 VA maximum at 240 Vac power.

AC Sensing Voltage

170 to 264 Vac, single-phase, 50/60 Hz.

Burden: 5 VA.

Voltage Adjust Range

170 to 264 Vac using the internal voltage adjust. The external voltage adjust provides a $\pm 10\%$ adjustment of the nominal value determined by the internal voltage adjust.

Regulation Accuracy

$\pm 0.25\%$

Voltage Drift

$< \pm 1\%$ voltage variation for a 50°C (122°F) change.

Response Time

< 16 ms

Frequency Compensation

Refer to Figure 1.

Voltage Buildup

Internal provisions for automatic buildup from generator residual voltage as low as 6 Vac at 25 Hz.

Power Dissipation

35 W maximum

Paralleling Provisions

CT input for customer supplied 5 A nominal CT. Adjustable droop from 0 to 6% with 5 A input at 0.8 power factor. CT input burden is 2.5 VA.

PHYSICAL SPECIFICATIONS

Temperature

Operating: -40 to 60°C (-40 to 140°F)

Storage: -65 to 85°C (-85 to 185°F)

Vibration

Withstands 1.2 G at 5 to 26 Hz; 0.036" double amplitude at 27 to 53 Hz; 5 G at 53 to 1,000 Hz.

Shock

Withstands up to 15 G in each of three mutually perpendicular axes.

Agency, Standards, and Directives

CSA

CSA Report: 1084382 (LR23131-1095)

CSA C22.2 No. 14

CSA C22.2 No. 0

EAC Mark (Eurasian Conformity)

Certificate: TC RU C-US.HO03.B.00211

- TP TC 004/2011
- TP TC 020/2011

Weight

17 oz (482 g) net.

INSTALLATION

Mounting

The regulator may be mounted in any position. Refer to the outline drawing (Figure 2) and drilling diagram (Figure 3). The regulator may be mounted directly on the generator set using $\frac{1}{4}$ " hardware. Select the proper hardware to withstand any expected shipping/transportation and operating conditions.

Interconnection

Refer to Figures 4 and 5.

1. Connect a jumper from COM to the 50 Hz terminal for 50 Hz operation, or leave the two terminals unconnected for 60 Hz operation.
2. If an external voltage adjust control is being used, connect the potentiometer to terminals 6 and 7 as shown. If not, connect a jumper between terminals 6 and 7.
3. Connect the exciter field to terminals F+ and F-. Be sure to observe polarity.
4. Connect the input power to the generator stator to provide power to terminals 3 and E3/4. Fuse both leads. Install the optional shutdown switch, if desired.
5. Connect the sensing input to E1 and E3/4. The sensing should be connected line-to-line.

Parallel Compensation

When it is required to operate the regulator in parallel with an isolated or utility bus, in addition to the regulator provisions, a 2.5 VA current transformer (CT) is required (See Figures 4 and 5). This CT is connected in a generator

line and should deliver from 3 to 5 amperes secondary current at rated load.

The phase relationship of the CT signal to the regulator sensing voltage must be correct or the system will not parallel properly. The CT must be installed in the line of the three-phase generator that does not supply sensing to the regulator.

Figures 4 and 5 show the correct CT polarity for ABC phase rotation sequence. If the phase rotation sequence is ACB, the CT secondary leads must be interchanged.

Reactive Droop Compensation

For reactive droop compensation, connect the CT to its respective regulator as shown on Figures 4 and 5.

A unit-parallel switch shorts the parallel CT secondary to prevent any droop signal from being injected into the regulating system during single unit operation. The switch may not be required on parallel droop compensation applications where a voltage drop is not objectionable.

Reactive Differential Compensation

On parallel reactive differential compensation applications, a contact should be used to short out the paralleling CT secondary when that generator is not paralleled to the bus. If the switch is not used, a voltage droop will be introduced into the system. This is due to the unloaded generator parallel CT not supplying its compensating signal, but allowing a voltage drop to occur across it. Lack of this shorting contact will also cause the voltage of the incoming generator to fluctuate prior to paralleling. Ideally, this contact is an auxiliary on the circuit breaker contactor that opens when the circuit breaker is closed.

For reactive differential compensation, connect each CT to its respective regulator. Then connect the finish of the first CT to the start of the second CT, the finish of the second CT to the start of the third CT, etc. Continue until all CT's are connected in series. The final step will be to connect the finish of the last CT to the start of the first CT. (See Figure 6).

Reactive differential compensation cannot be used when paralleled with the utility or any infinite bus. If this compensation system is used, a switching circuit must be used to convert the system to a reactive droop compensation system. Contact the factory for additional information.

OPERATION

The following procedures provide instructions for setting up, starting, operating, and adjusting the AVC63-7 Voltage Regulator. Figure 7 illustrates the locations of the potentiometer controls. Symptoms of problems occurring during startup that result from incorrect regulator adjustment and certain generator system problems that resemble faulty regulation are included together with possible solutions.

Preliminary Setup

To prevent damage to the regulator, complete the following steps before proceeding with system startup.

1. Verify that the voltage regulator specifications conform to the generator system requirements.
2. Ensure that the regulator has been installed and connected in accordance with the paragraphs on installation.

Operation at Reduced Speeds

During periods of prime mover idling, use the shutdown switch to remove power from the regulator.

System Startup

1. Perform preliminary setup as described in the above paragraphs.
2. Start the prime mover and bring up to rated speed.
Result: Voltage should build up. If not, perform field flashing.
3. Slowly adjust the VOLT control or external voltage adjust rheostat until the generator output voltage reaches the nominal value.
4. Apply and remove load to check stability.
5. Check the regulator under normal operating conditions.
Result: If regulation is not within range, verify the prime mover is at rated speed.
6. Reduce generator frequency to approximately 5 Hz below nominal.
Result: Generator output voltage should decrease at desired frequency.

Adjustments

Field Flashing

When the regulator is operated with the generator for the first time, the polarity of the residual magnetism may not be correct or of sufficient magnitude. If the residual voltage at terminals 3 and 4 is greater than 6 Vac, replace the regulator. If generator residual voltage is less than 6 Vac at terminals 3 and 4, shut down the prime mover and proceed with the following steps.

CAUTION

Do not flash the field with the generator in motion. Damage to the regulator may result.

1. With the prime mover at rest, apply a dc source (ungrounded), of not more than 48 Vdc, to terminals F+ (positive) and F- (negative) in series with a limiting resistor. Use one ohm of resistance for each volt from the dc power source with a power rating of least one watt per ohm.
EXAMPLE: If using a 24 Vdc source, use a 24 ohm, 24 watt resistor.
2. Allow the field to be flashed for approximately 10 seconds before removing the dc source.
3. If voltage buildup does not occur after performing steps 1 and 2, verify the polarity of the dc source used in steps 1 and 2 and perform again.

Frequency Roll-Off Adjustment

The AVC63-7 underfrequency (U/F) control is factory preset to cause an average 1 volt drop in the generator's line input voltage to the regulator when the frequency is between 54.5 and 55.5 Hz (for 60 Hz applications). For 50 Hz applications, the frequency roll-off is factory preset to between 44 and 46 Hz. To reset the frequency roll-off, proceed as follows:

1. Adjust the prime mover rpm to the desired frequency compensation (corner frequency roll-off) point.
2. Adjust the U/F control CW until the output voltage starts to drop off.
3. Bring the prime mover up to rated speed. The output voltage should return to normal.

Publication 9302800991	Revision D	Instructions	Date 05/19	Page 2 of 6
----------------------------------	----------------------	---------------------	----------------------	-----------------------

Stability Adjustment

An oscilloscope or other voltage recording device should be used if a stability setting is desired that will provide the fastest possible voltage response with good generator stability.

1. Rotation of the STAB control in the clockwise (CW) direction will slow response time.
2. Rotation of the STAB control in the counterclockwise (CCW) direction will speed response time. If rotated too far CCW, the generator voltage may oscillate (hunt).
3. Rotate the STAB control CCW until the system starts oscillating and then rotate CW just past the point where oscillation occurred.

Voltage Adjustment

1. Installation of a jumper across terminals 6 and 7 allows the internal VOLT control to vary the generator nominal voltage over the range shown in the Specifications.
2. A 1,500 ohm, 2 watt rheostat may be connected to terminals 6 and 7. This will allow approximately $\pm 10\%$ adjustment via the remote 1,500 ohm rheostat.

Drop Adjustment

The DROOP control adjusts the amount of droop that occurs in the generator output voltage for a given amount of reactive load current. A CT should be selected which will supply the AVC with 3 to 5 amperes of current with rated load and power factor on the generator. With 5 amperes of current supplied by the CT, at 0.8 power factor, the amount of droop can be adjusted from 0 to 6% of nominal generator voltage.

1. Determine the amount of droop desired; 3% to 5% is common. Adjust the DROOP control fully CCW.
2. Bring the generator up to rated speed and rated voltage. Apply full load at rated power factor.
3. Adjust the DROOP control until the desired amount of droop is achieved.

OPERATIONAL TEST

To operationally test any AVC63-7, refer to Figure 8 and perform the following steps.

1. Connect the voltage regulator as shown in Figure 8 and apply 240 Vac.
2. Adjust the VOLT control fully counterclockwise (CCW).
RESULT: Observe that the lamp does not light.
3. Adjust the VOLT control fully clockwise (CW).
RESULT: Observe that the lamp is now lit.
4. Adjust the VOLT control until the lamp just goes out.

Regulator operation is satisfactory if the above results are obtained. Stability, however, must be tested with the generator and regulator operating.

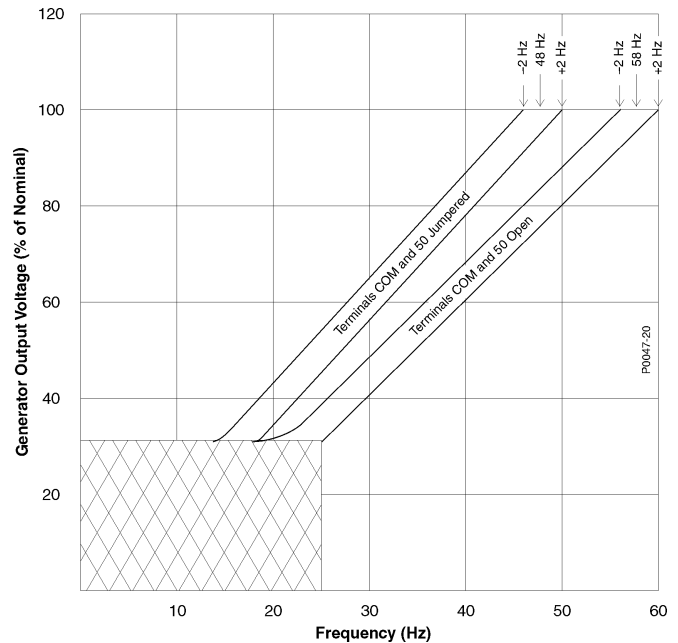
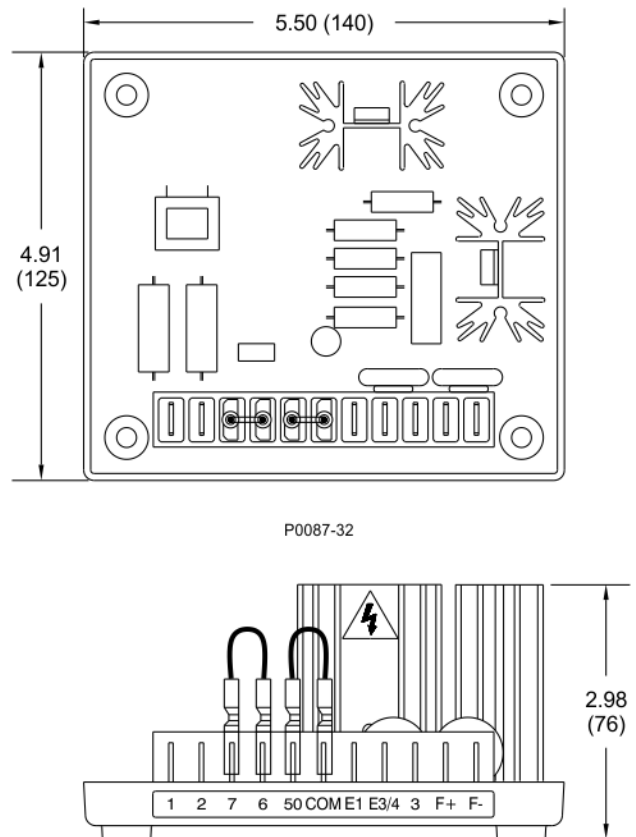
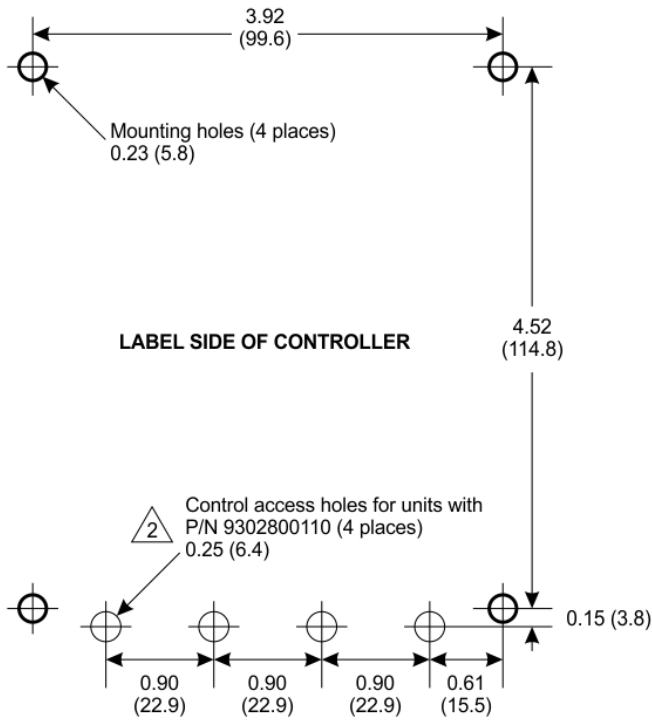

Figure 1. Typical AVC63-7 Frequency Compensation Curves



NOTE: All dimensions in inches (millimeters).

Figure 2. AVC63-7 Dimensions



NOTES:

1. All dimensions in inches (millimeters).

2. Omit control access holes for units with P/N 9302800103.

P0087-33

Figure 3. Drilling Dimensions

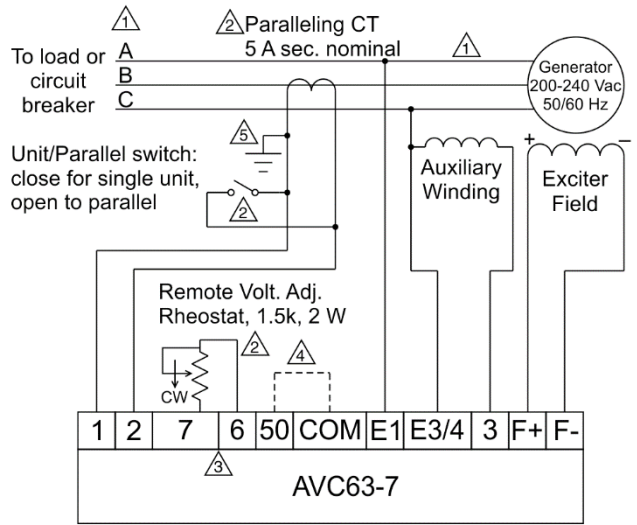

- 1 Phase rotation A-B-C
- 2 Item not supplied by Basler Electric Co.
- 3 If remote voltage adjust is not used, short terminals 6 and 7 together.
- 4 Short terminals 50 and COM together for 50 Hz operation. Leave unconnected for 60 Hz operation.
- 5 The secondary winding of a sensing transformer must be grounded as closely to the transformer as practical. When interconnecting more than one transformer, ensure that the secondary winding of only one transformer is grounded.

Figure 5. Interconnections, Typical Auxiliary Winding Powered

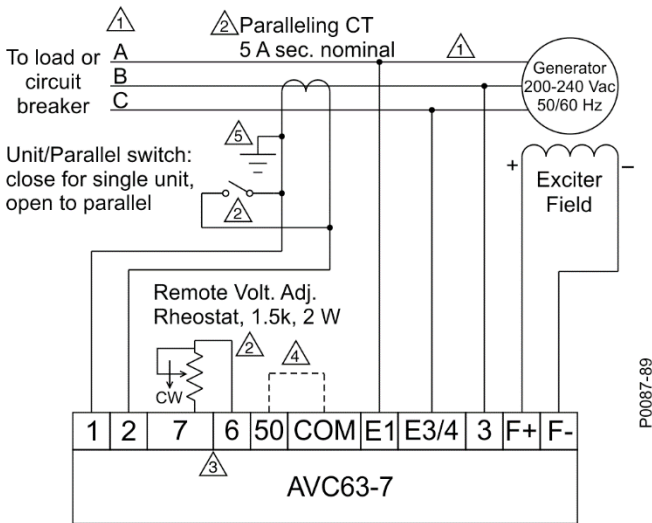

- 1 Phase rotation A-B-C
- 2 Item not supplied by Basler Electric Co.
- 3 If remote voltage adjust is not used, short terminals 6 and 7 together.
- 4 Short terminals 50 and COM together for 50 Hz operation. Leave unconnected for 60 Hz operation.
- 5 The secondary winding of a sensing transformer must be grounded as closely to the transformer as practical. When interconnecting more than one transformer, ensure that the secondary winding of only one transformer is grounded.

Figure 4. Interconnections, Typical Shunt-Powered

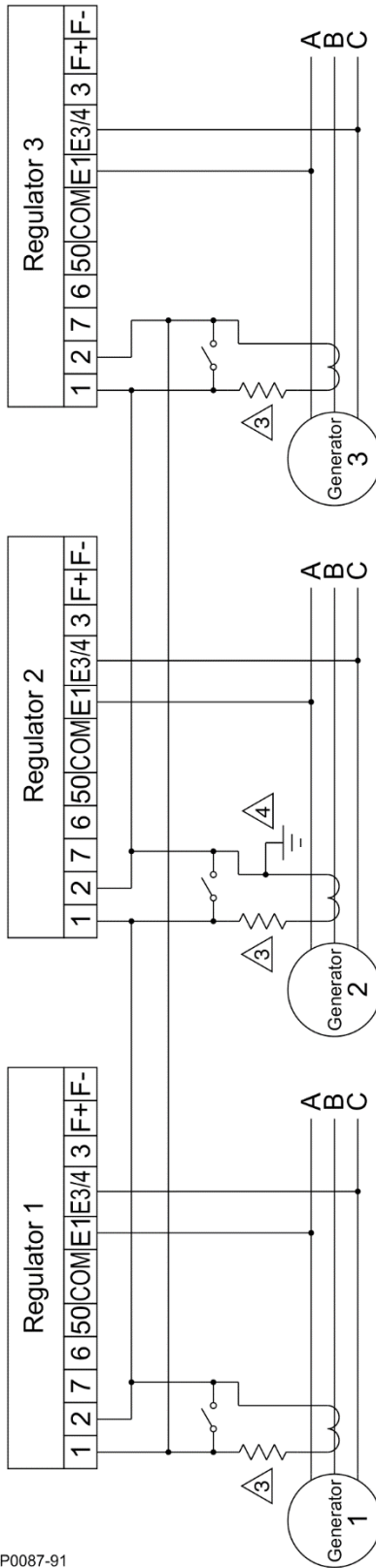

P0087-91

Figure 6. Interconnections, Reactive Differential (Cross-Current) Compensation

NOTES

- 1 When more than three generators are to be paralleled, continue connections as shown.
- 2 Paralleling CT polarities are shown with ABC phase rotation.
- 3 When connected in cross-current, external resistors may be required to improve load sharing among generators using regulators with dissimilar current input burdens. Use the following table as a guide.
- 4 The secondary winding of a sensing transformer must be grounded as closely to the transformer as practical. When interconnecting more than one transformer, ensure that the secondary winding of only one transformer is grounded.

Voltage Regulator CT Burden	External Resistor Value (not considering lead length)
2.5 VA	Not required
10 VA	0.3 ohms, 15 W
25 VA	0.9 ohms, 50 W

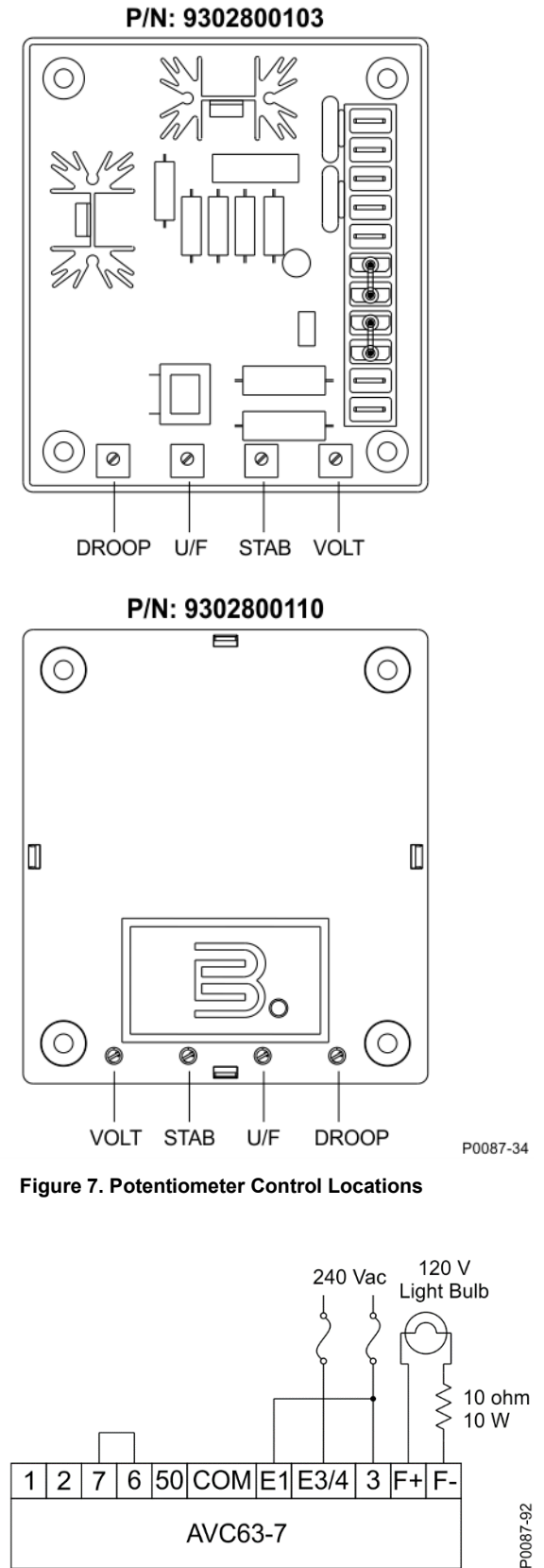

P0087-34

Figure 7. Potentiometer Control Locations

Figure 8. Interconnections, Operational Test

P0087-92



Publication 9302800991	Revision D	<i>Instructions</i>	Date 05/19	Page 6 of 6
----------------------------------	----------------------	----------------------------	----------------------	-----------------------