




# DECS-250

## Digital Excitation Control System

*Instruction Manual*



 **WARNING:** California's Proposition 65 requires special warnings for products that may contain chemicals known to the state of California to cause cancer, birth defects or other reproductive harm. Please note that by posting this Proposition 65 warning, we are notifying you that one or more of the Proposition 65 listed chemicals may be present in products we sell to you. For more information about the specific chemicals found in this product, please visit <https://www.basler.com/Prop65>.

# Preface

This instruction manual provides information about the installation and operation of the DECS-250 Digital Excitation Control System. To accomplish this, the following information is provided:

- General Information
- Human-machine interface
- Functional description
- Installation
- BESTCOMSPi<sup>us</sup>® software
- Setup
- Communication protocols
- Maintenance
- Specifications
- Expansion modules

## ***Conventions Used in this Manual***

---

Important safety and procedural information is emphasized and presented in this manual through warning, caution, and note boxes. Each type is illustrated and defined as follows.

### **Warning!**

Warning boxes call attention to conditions or actions that may cause personal injury or death.

### **Caution**

Caution boxes call attention to operating conditions that may lead to equipment or property damage.

### **Note**

Note boxes emphasize important information pertaining to installation or operation.

### **Note**

Be sure that the device is hard-wired to earth ground with no smaller than 12 AWG (3.3 mm<sup>2</sup>) copper wire attached to the case ground terminal. When the device is configured in a system with other devices, a separate lead should be connected from the ground bus to each device.

Current transformer (CT) grounding should be applied in accordance with local codes and conventions.



12570 State Route 143  
Highland IL 62249-1074 USA

[www.basler.com](http://www.basler.com)

[info@basler.com](mailto:info@basler.com)

Tel: +1 618.654.2341

Fax: +1 618.654.2351

© 2019 by Basler Electric

All rights reserved

First printing: October 2012

## Warning!

**READ THIS MANUAL.** Read this manual before installing, operating, or maintaining the DECS-250. Note all warnings, cautions, and notes in this manual as well as on the product. Keep this manual with the product for reference. Only qualified personnel should install, operate, or service this system. Failure to follow warning and cautionary labels may result in personal injury or property damage. Exercise caution at all times.

Basler Electric does not assume any responsibility to compliance or noncompliance with national code, local code, or any other applicable code. This manual serves as reference material that must be well understood prior to installation, operation, or maintenance.

For terms of service relating to this product and software, see the *Commercial Terms of Products and Services* document available at [www.basler.com/terms](http://www.basler.com/terms).

This publication contains confidential information of Basler Electric Company, an Illinois corporation. It is loaned for confidential use, subject to return on request, and with the mutual understanding that it will not be used in any manner detrimental to the interests of Basler Electric Company and used strictly for the purpose intended.

It is not the intention of this manual to cover all details and variations in equipment, nor does this manual provide data for every possible contingency regarding installation or operation. The availability and design of all features and options are subject to modification without notice. Over time, improvements and revisions may be made to this publication. Before performing any of the following procedures, contact Basler Electric for the latest revision of this manual.

The English-language version of this manual serves as the only approved manual version.

This product contains, in part, open source software (software licensed in a way that ensures freedom to run, copy, distribute, study, change, and improve the software) and you are granted a license to that software under the terms of either the GNU General Public License or GNU Lesser General Public License. The licenses, at the time of sale of the product, allow you to freely copy, modify, and redistribute that software and no other statement or documentation from us, including our End User License Agreement, places any additional restrictions on what you may do with that software.

For at least three (3) years from the date of distribution of this product, a machine-readable copy of the complete corresponding source code for the version of the programs distributed to you will be sent upon request (contact information is provided above). A fee of no more than our cost of physically performing the source code distribution is charged.

The source code is distributed in the hope that it will be useful, but WITHOUT ANY REPRESENTATION or WARRANTY or even the implied warranty of MERCHANTABILITY or FITNESS FOR A PARTICULAR PURPOSE. Refer to the source code distribution for additional restrictions regarding warranty and copyrights.

For a complete copy of GNU GENERAL PUBLIC LICENSE Version 2, June 1991 or GNU LESSER GENERAL PUBLIC LICENSE Version 2.1, February 1999 refer to [www.gnu.org](http://www.gnu.org) or contact Basler Electric. You, as a Basler Electric Company customer, agree to abide by the terms and conditions of GNU GENERAL PUBLIC LICENSE Version 2, June 1991 or GNU LESSER GENERAL PUBLIC LICENSE Version 2.1, February 1999, and as such hold Basler Electric Company harmless related to any open source software incorporated in this product. Basler Electric Company disclaims any and all liability associated with the open source software and the user agrees to defend and indemnify Basler Electric Company, its directors, officers, and employees from and against any and all losses, claims, attorneys' fees, and expenses arising from the use, sharing, or redistribution of the software.

Review the software website for the latest version of the software documentation.

Portions of this software are copyright © 2014 The Free Type Project ([www.freetype.org](http://www.freetype.org)). All rights reserved.



# Contents

<b>Introduction</b> .....	<b>1</b>
Features and Functions .....	1
Applications .....	2
Package .....	2
Optional Features and Capabilities .....	3
Storage .....	3
<b>Controls and Indicators</b> .....	<b>5</b>
Front Panel Illustration and Description .....	5
Menu Navigation .....	6
Adjusting Settings .....	7
Display Setup .....	7
<b>Power Inputs</b> .....	<b>9</b>
Control Power .....	9
Operating Power .....	9
<b>Power Stage</b> .....	<b>11</b>
<b>Voltage and Current Sensing</b> .....	<b>13</b>
Generator Voltage .....	13
Generator Current .....	13
Bus Voltage .....	15
<b>Synchronizer</b> .....	<b>17</b>
Generator Synchronization .....	17
Voltage Matching .....	19
Breaker Hardware Configuration .....	19
Generator and Bus Condition Detection .....	20
Generator Governor Control .....	23
<b>Regulation</b> .....	<b>25</b>
Regulation Modes .....	25
Pre-Position Setpoints .....	27
Transient Boost .....	28
Operation with Paralleled Generators .....	29
Autotracking .....	32
Setpoint Configure .....	33
<b>Auxiliary Control</b> .....	<b>35</b>
Auxiliary Control Input Type .....	35
Auxiliary Control Input Function .....	35
Auxiliary Control Gains .....	35
Summing Type .....	36
<b>Contact Inputs and Outputs</b> .....	<b>39</b>
Contact Inputs .....	39
Contact Outputs .....	40
<b>Protection</b> .....	<b>43</b>
Voltage Protection .....	43
Frequency Protection .....	47
Power Protection .....	48
Field Protection .....	50
Sync-Check Protection .....	55
Generator Frequency Less Than 10 Hertz .....	56
Configurable Protection .....	56
<b>Limiters</b> .....	<b>59</b>
Overexcitation Limiter .....	59

Underexcitation Limiter .....	63
Stator Current Limiter .....	65
Var Limiter .....	66
Limiter Scaling .....	67
Underfrequency Limiter .....	67
<b>Grid Code .....</b>	<b>71</b>
Configuration .....	71
Active Power Control (APC) .....	74
Reactive Power Control .....	78
Remote Communications .....	89
Setpoints .....	89
Grid Code Test .....	90
<b>Metering .....</b>	<b>91</b>
Metering Explorer .....	91
Metered Parameters .....	92
Status Indication .....	98
Auto Export Metering .....	106
<b>Event Recorder .....</b>	<b>107</b>
Sequence-of-Events Recording .....	107
Data Logging .....	107
Trending .....	111
<b>Power System Stabilizer .....</b>	<b>113</b>
Supervisory Function and Setting Groups .....	113
Theory of Operation .....	113
<b>Stability Tuning .....</b>	<b>123</b>
AVR Mode .....	123
FCR and FVR Modes .....	126
Other Modes and Functions .....	128
<b>Mounting .....</b>	<b>131</b>
Mounting Considerations .....	131
Projection Mounting .....	131
Behind-the-Panel Mounting .....	131
<b>Terminals and Connectors .....</b>	<b>135</b>
Overview .....	135
Terminal Types .....	139
<b>Typical Connections .....</b>	<b>141</b>
<b>BESTCOMSPlus® Software .....</b>	<b>145</b>
General Description .....	145
Installation .....	146
Activation of the DECS-250 Plugin for BESTCOMSPlus® .....	146
Menu Bars .....	150
Settings Explorer .....	152
Metering Explorer .....	153
Settings File Management .....	153
Automatic Metering Export .....	155
Firmware Updates .....	156
BESTCOMSPlus® Updates .....	159
<b>BESTlogic™ Plus .....</b>	<b>161</b>
Introduction .....	161
Overview of BESTlogic™ Plus .....	161
Logic Schemes .....	180
Programming BESTlogic™ Plus .....	184
Offline Logic Simulator .....	186

BESTlogic™Plus File Management .....	186
BESTlogic™Plus Examples .....	188
<b>Communication .....</b>	<b>189</b>
Local Communication .....	189
Communication with a Second DECS .....	189
Modbus Communication .....	190
CAN Communication .....	192
Ethernet Communication .....	193
PROFIBUS Communication .....	196
<b>Configuration .....</b>	<b>197</b>
Generator, Field, and Bus Ratings .....	197
Bridge .....	199
Sensing Transformer Ratings and Configuration .....	199
Startup Functions .....	200
Device Information .....	201
Display Units .....	202
<b>Security .....</b>	<b>205</b>
Password Access .....	205
Port Security .....	206
Login and Access Controls .....	207
<b>Timekeeping .....</b>	<b>209</b>
Time and Date Format .....	209
Daylight Saving Time Adjustments .....	209
Network Time Protocol (NTP) .....	209
IRIG .....	209
<b>Testing .....</b>	<b>213</b>
Real-Time Metering Analysis .....	213
Frequency Response .....	215
Time Response .....	216
Step Response Analysis .....	218
Analysis Options .....	219
<b>CAN Communication .....</b>	<b>221</b>
Introduction .....	221
CAN Parameters .....	221
<b>Modbus® Communication .....</b>	<b>225</b>
Introduction .....	225
Modbus Modes of Operation .....	226
Detailed Message Query and Response for RTU Transmission Mode .....	229
Data Formats .....	232
Secure DECS-250 Login via Modbus .....	234
Modbus Parameters .....	235
<b>PROFIBUS Communication .....</b>	<b>273</b>
Data Types .....	273
Setup .....	275
PROFIBUS Parameters .....	276
<b>Maintenance .....</b>	<b>323</b>
Storage .....	323
Preventive Maintenance .....	323
Cleaning the Front Panel .....	324
Troubleshooting .....	324
Support .....	325
<b>Specifications .....</b>	<b>327</b>
Operating Power .....	327

Control Power .....	327
Generator and Bus Voltage Sensing .....	328
Generator Current Sensing .....	328
Accessory Inputs .....	329
Metering Accuracy .....	329
Contact Inputs .....	329
Communication Ports .....	329
IRIG Time Synchronization Input .....	330
Contact Outputs.....	330
Field Power Output.....	331
Regulation .....	331
Parallel Compensation .....	332
Generator Protection Functions .....	332
Field Protection Functions .....	333
Synchronism Check (25) Protection.....	334
Startup .....	334
Voltage Matching.....	334
Power System Stabilizer (Style xPxxxxx).....	335
On-Line Overexcitation Limiting .....	335
Off-Line Overexcitation Limiting .....	335
Sequence of Events Recording (SER).....	336
Data Logging (Oscillography).....	336
Environment .....	336
Type Tests.....	336
Patent .....	337
Physical .....	337
Regulatory Certifications and Standards.....	337
<b>Analog Expansion Module .....</b>	<b>339</b>
General Information.....	339
Features .....	339
Specifications .....	339
Installation .....	341
Communications.....	349
Functional Description .....	349
Metering.....	353
Maintenance .....	356
Firmware Updates .....	356
<b>Contact Expansion Module .....</b>	<b>357</b>
General Information.....	357
Features .....	357
Specifications .....	357
Installation .....	359
Communications.....	366
Functional Description .....	366
Metering.....	368
Maintenance .....	368
Firmware Updates .....	368
<b>Revision History .....</b>	<b>369</b>

# Introduction

DECS-250 Digital Excitation Control Systems offer precise excitation control and machine protection in a compact package. DECS-250 adaptability to many applications is assured through configurable contact inputs and outputs, flexible communication capabilities, and programmable logic implemented with the provided BESTCOMSP<sup>Plus</sup>® software.

## Features and Functions

---

DECS-250 features and functions include:

- Precise excitation control for synchronous generator or synchronous motor applications
  - Power factor and var metering values will be opposite in motor mode
- Five excitation control modes:
  - Automatic Voltage Regulation (AVR)
  - Field Current Regulation (FCR)
  - Field Voltage Regulation (FVR)
  - Power Factor Regulation (PF)
  - Var Regulation (var)
- Three pre-position setpoints for each excitation control mode
- Internal tracking between operating mode setpoints and external tracking of a second DECS excitation setpoint
- Two PID stability groups with Auto Tune feature
- Remote setpoint control input accepts analog voltage or current control signal
- Grid code functions
  - Connect and disconnect
  - Active power control
  - Reactive power control
- Real-time metering
- Optional automatic synchronizer
- Optional integrated power system stabilizer (IEEE Std 421.5 type PSS2A/2B/2C)
  - Generator or motor control modes, accommodates phase rotation changes between modes
  - Speed and power sensing or speed-only sensing
  - Two wattmeter or three-wattmeter methods of power measurement
- Soft start and voltage buildup control
- Five limiting functions:
  - Overexcitation: summing point and takeover
  - Underexcitation
  - Stator current
  - Reactive power (var)
  - Underfrequency
- Twenty protection functions:
  - Generator undervoltage (27)
  - Generator overvoltage (59)
  - Loss of sensing (LOS)
  - Overfrequency (81O)
  - Underfrequency (81U)
  - Reverse power (32R)
  - Loss of excitation (40Q)
  - Field overvoltage
  - Field overcurrent
  - Loss of PMG
  - Exciter diode failure
  - Sync-check (25)
  - Eight configurable protection elements

- IRIG or network time synchronization
- Sixteen contact sensing inputs
  - Two fixed-function inputs: Start and Stop
  - Fourteen programmable inputs
- Twelve contact outputs
  - One, fixed-function output: Watchdog (SPDT configuration)
  - Eleven programmable outputs
- Flexible communication
  - Serial communication through front-panel USB port
  - Modbus communication through RS-485 port or Modbus TCP
  - Ethernet communication through an optional copper or fiber optic port
  - CAN communication with an ECU (engine control unit), optional AEM-2020 Analog Expansion Module, or optional CEM-2020 Contact Expansion Module
  - Optional PROFIBUS communication protocol
- Data logging, sequence of events recording, and trending
- Optional CEM-2020 Contact Expansion Module provides:
  - Ten contact inputs
  - Eighteen contact outputs (CEM-2020H) or 24 contact outputs (CEM-2020)
  - Customizable input and output functions assigned through BESTlogic™ *Plus* programmable logic
  - Communication via CAN protocol
- Optional AEM-2020 Analog Expansion Module provides:
  - Eight analog inputs
  - Eight resistive thermocouple device (RTD) inputs
  - Two thermocouple inputs
  - Four analog outputs
  - Customizable input and output functions assigned through BESTlogic *Plus* programmable logic
  - Communication via CAN protocol

## ***Applications***

---

The DECS-250 is intended for synchronous generator or synchronous motor applications. The DECS-250 controls the machine output through the application of regulated DC excitation power to the exciter field. The level of excitation power is based on the monitored voltage and current, and a regulation setpoint established by the user. The operating mode, generator or motor, is changed on the Operating Mode settings screen. Power factor and var metering values will be opposite in motor mode.

Excitation power is supplied from the DECS-250 by means of a filtered, switching power module that uses pulse-width modulation. It is capable of supplying 15 Adc (or 20 Adc up to 55°C (131°F)) continuously at a nominal voltage of 32, 63, or 125 Vdc. With nominal operating power applied, it has a forcing capability of 30 Adc for 10 seconds.

## ***Package***

---

A single, compact package contains all excitation control and power components.

A front panel HMI provides local annunciation and control through a backlit liquid crystal display (LCD), light-emitting diodes (LEDs), and pushbuttons. Remote annunciation and control is provided through a flexible communication interface which accommodates Ethernet, Modbus, optional PROFIBUS, and the optional Interactive Display Panel (IDP-801).

## Optional Features and Capabilities

DECS-250 optional features and capabilities are defined by a combination of letters and numbers that make up the style number. The model number and style number describe options and characteristics in a specific device and appear on a label affixed to the device.

### Style Number

The style number identification chart in Figure 1 defines the electrical characteristics and operational features available in the DECS-250.

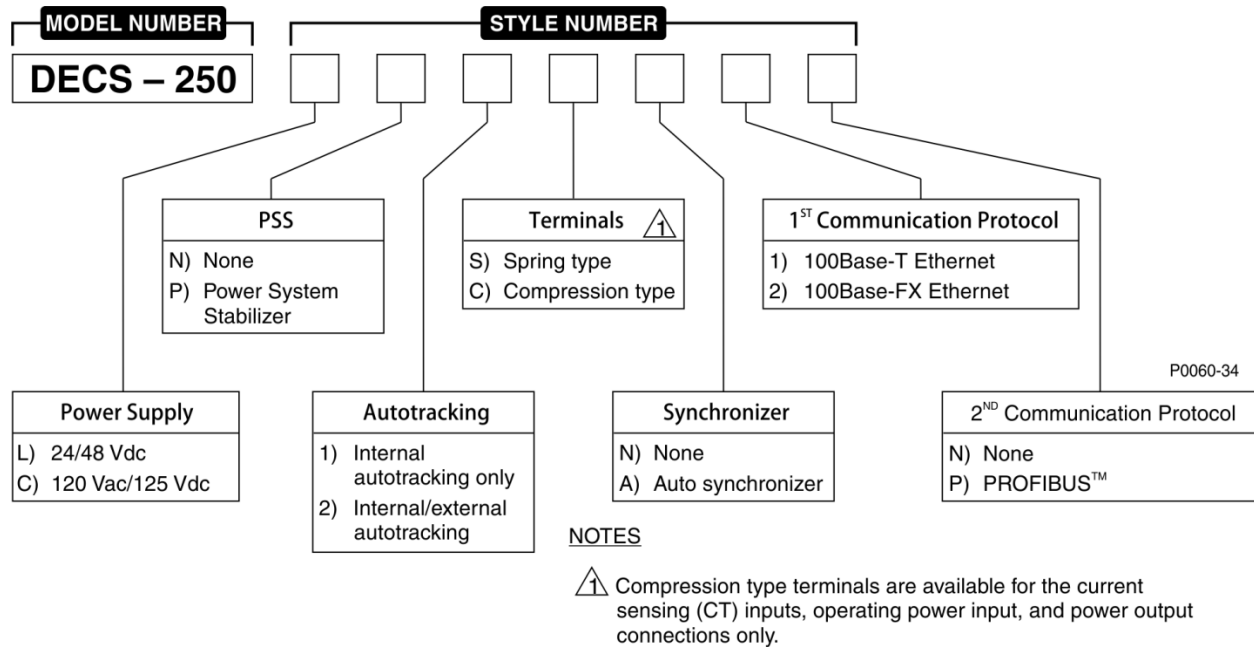


Figure 1. DECS-250 Style Chart

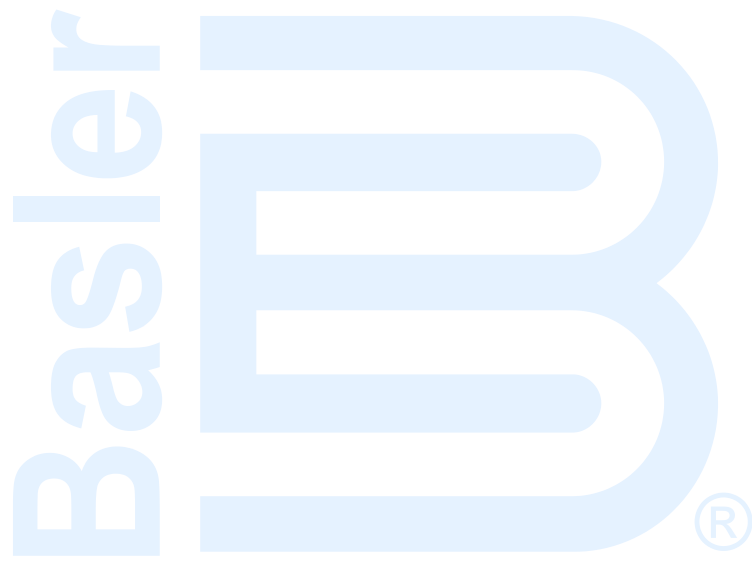
## Storage

If a DECS-250 will not be placed in service right away, store it in the original shipping carton in a moisture- and dust-free environment. The temperature of the storage environment must be within the range of –40 to 85°C (–40 to 185°F).

### Electrolytic Capacitor Considerations

The DECS-250 contains long-life aluminum electrolytic capacitors. For a DECS-250 kept in storage as a spare, the life of these capacitors can be maximized by energizing the device for 30 minutes once per year. Refer to the energizing procedures provided in *Maintenance*.

When energizing the DECS-250 from a low impedance source (such as a wall outlet), use of an Inrush Current Reduction Module (ICRM) is recommended to prevent damage to the DECS-250. For a detailed description of the Inrush Current Reduction Module, refer to Basler publication 9387900990. ICRM connections are illustrated in *Typical Connections*.



# Controls and Indicators

All controls and indicators are located on the front panel and consist of pushbuttons, LED indicators, and a liquid-crystal display (LCD).

## Front Panel Illustration and Description

DECS-250 controls and indicators are illustrated in Figure 2 and described in Table 1. The locators and descriptions of Table 1 correspond to the locators shown in Figure 2.

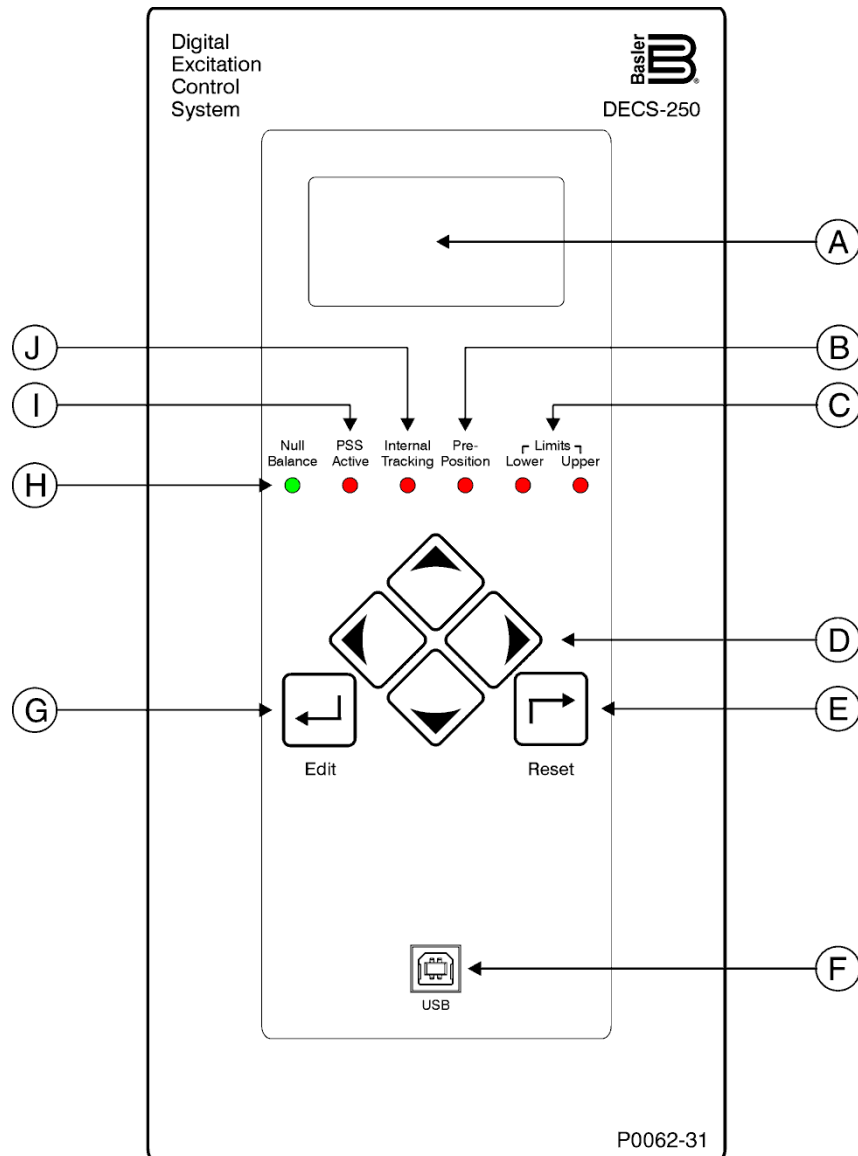


Figure 2. Front Panel Controls and Indicators

**Table 1. Front Panel Control and Indicators Descriptions**

Locator	Description
A	<i>Display.</i> The liquid crystal display (LCD) serves as a local source of information provided by the DECS-250. The LCD displays operating setpoints, loop gains, metering, protection functions, system parameters, and general settings. The 128 by 64 dot pixel, backlit LCD displays white characters on a blue background.
B	<i>Pre-Position Indicator.</i> This red light emitting diode (LED) lights when the active mode setpoint is at any of the three pre-position (predefined) settings.
C	<i>Limit Indicators.</i> Two red LEDs indicate when the active mode setpoint reaches the minimum or maximum value.
D	<i>Scrolling Pushbuttons.</i> These four buttons are used to scroll up, down, left, and right through the menus displayed on the LCD (locator A). During an editing session, the left and right scrolling pushbuttons select the variable to be changed and the up and down scrolling pushbuttons change the value of the variable.
E	<i>Reset Pushbutton.</i> This button cancels editing sessions, resets alarm annunciations and latched alarm relays, and can be used for quick access to the metering screen.
F	<i>Communication Port.</i> This type B USB jack connects the DECS-250 with a PC operating BESTCOMSP <sup>Plus</sup> ® for local communication. BESTCOMSP <sup>Plus</sup> is supplied with the DECS-250.
G	<i>Edit Pushbutton.</i> Pressing this button starts an editing session and enables changes to DECS-250 settings. At the conclusion of the editing session, the Edit pushbutton is pressed to save the settings changes.
H	<i>Null Balance Indicator.</i> This green LED lights when the setpoint of the inactive operating modes (AVR, FCR, FVR, var, and PF) match the setpoint of the active mode.
I	<i>PSS Active Indicator.</i> This red LED lights when the integrated power system stabilizer is enabled and can generate a stabilizing signal in response to a power system disturbance.
J	<i>Internal Tracking Indicator.</i> This red LED lights when any inactive mode (AVR, FCR, FVR, Var, or Power Factor) is tracking the setpoint of the active mode to achieve a “bumpless” transfer when changing active modes.

## Menu Navigation

The DECS-250 provides local access to DECS-250 settings and metering values through a menu structure displayed on the front panel LCD. An overview of the menu structure is illustrated in Figure 3. Movement through the menu structure is achieved by pressing the four scrolling pushbuttons.

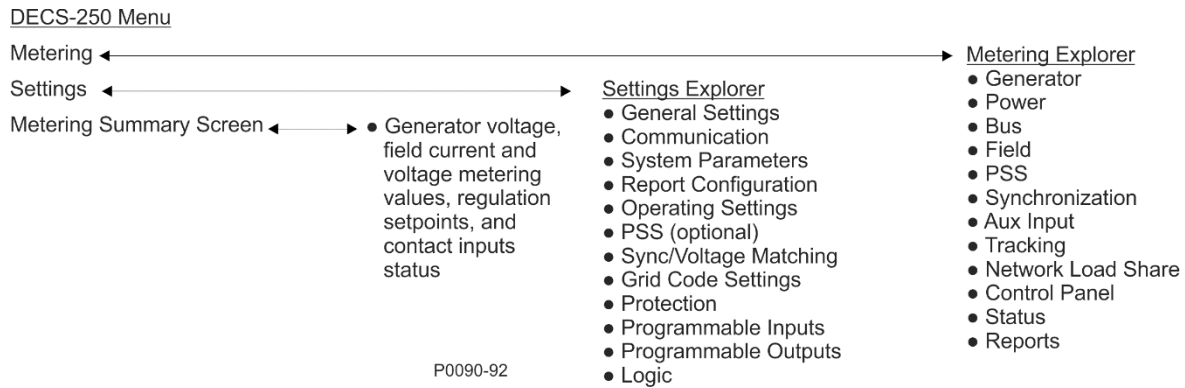


Figure 3. Menu Structure Overview

## Adjusting Settings

A setting adjustment is made at the front panel by performing the following steps.

1. Navigate to the screen listing the setting to be changed.
2. Press the Edit button and enter the appropriate username and password to gain the needed level of security access. (Information about implementing and using username and password protection is provided in the *Security* chapter of this manual.)
3. Highlight the desired setting and press the Edit button to view the setting editing screen. This screen lists the setting range or the permissible setting selection.
4. Use the scrolling pushbuttons to select the setting digits/selections and adjust/change the setting.
5. Press the Edit button to save the change.

## Display Setup

**BESTCOMSPi<sub>us</sub> Navigation Path:** Settings Explorer, General Settings, Front Panel HMI

**HMI Navigation Path:** Settings, General Settings, Front Panel HMI

Front panel display appearance and behavior can be customized to meet user preferences and site conditions. These BESTCOMSPi<sub>us</sub> settings are illustrated in Figure 4.

### LCD

LCD setup includes a contrast adjustment<sup>A</sup> to suit the viewing angle used or compensate for environmental conditions. The ability to reverse the display colors<sup>B</sup> is provided to accommodate lighting conditions and user preferences.

### Sleep Mode

Sleep mode<sup>C</sup> reduces the demand on control power by turning off the LCD backlight when no pushbutton activity is seen for the duration of the LCD Backlight Timeout setting<sup>D</sup>.

### Language

Language modules are available for the DECS-250. Once a language module is implemented it can be enabled via the Language Selection setting<sup>E</sup>.

### Screen Scrolling

The display can be set to automatically scroll through a user-selected list<sup>F</sup> of metered values. This feature is enabled and disabled with the Enable Scroll setting<sup>G</sup>. The rate at which scrolling occurs is configured with the Scroll Time Delay setting<sup>H</sup>.

### Front Panel HMI

**LCD Setup**

Contrast Value (%) A

75

Invert Display B

**Sleep Mode Setup**

Sleep Mode C

Enabled

LCD Backlight Timeout (s) D

60

**Language Setup**

Language Selection E

English

**Screen Scrolling Setup**

Enable Scroll G

Enabled

Scroll Time Delay (s) H

3.0

**Scrollable Metering Settings** F

- GV Primary
- GC Primary
- CC Primary
- Frequency
- Power Primary
- PF Primary
- Energy Primary
- BV Primary
- Field Primary
- PSS Primary
- Synchronization Primary
- Aux Input
- Tracking
- Real Time Clock
- Contact Inputs
- Contact Outputs
- Device ID

**Figure 4. Front Panel HMI Settings**

- <sup>A</sup> *Contrast Value (%)*: Adjustable from 0 to 100 in 1% increments.
- <sup>B</sup> *Invert display*: Deselect for white characters on a blue background. Select for blue characters on a white background.
- <sup>C</sup> *Sleep Mode*: Enable or disable.
- <sup>D</sup> *LCD Backlight Timeout*: Adjustable from 0 to 120 seconds in 1 second increments.
- <sup>E</sup> *Language Selection*: Select English, Chinese, Russian, French, Spanish, German, or Portuguese.
- <sup>F</sup> *Scrollable Metering Settings*: Select from main categories of GV Primary, GC Primary, CC Primary, Frequency, Power Primary, PF Primary, Energy Primary, BV Primary, Field Primary, PSS Primary, Synchronization Primary, Aux Input, Tracking, Real Time Clock, Contact Inputs, Contact Outputs, or Device ID. Follow this selection by the desired parameters within each category.
- <sup>G</sup> *Enable Scroll*: Enable or disable.
- <sup>H</sup> *Scroll Time Delay (s)*: Adjustable from 1 to 600 seconds in 1 second increments.

# Power Inputs

Power is applied to two separate inputs: control power and operating power. The control power input supplies power to an internal power supply that provides power for logic, protection, and control functions. The power stage uses the operating power input as the source for the converted excitation power that it applies to the field.

## Control Power

Two inputs supply the DECS-250 with control power. One input accepts dc control power and the other input accepts ac control power. The level of acceptable control power voltage is determined by the style number. One of two levels is possible. Style Lxxxxxx indicates a nominal voltage of 24 or 48 Vdc and accepts a voltage range of 16 to 60 Vdc. Style Cxxxxxx indicates a nominal voltage of 125 Vac/Vdc and accepts a voltage range of 90 to 150 Vdc and 82 to 132 Vac (50/60 Hz). One input (either dc or ac) is sufficient for operation but two inputs provide redundancy (for style Cxxxxxx only). When both control power inputs are used, an isolation transformer is required for the ac input. DC control power is applied at terminals BATT+ and BATT-. AC control power is applied at terminals L and N.

## Operating Power

### Caution

For redundant applications with a single-phase, 300 Hz Marathon® PMG, only one DECS-250 can be connected to the PMG at a time. In redundant applications, a contactor should be used for each DECS-250 power input or equipment damage may result.

If operating power exceeds 260 Vac, the connection must be configured as L-N single-phase or equipment damage may result.

Operating power is applied at terminals A, B, and C. To achieve the desired level of excitation, the appropriate operating power input voltage must be applied. Table 2 lists the acceptable operating power voltage ranges for the DECS-250. The operating power frequency range for the DECS-250 is 50 to 500 hertz for all voltages.

**Table 2. DECS-250 Operating Power Specifications**

Desired Nominal Excitation Power Voltage	Applied Operating Power Voltage Range
32 Vdc	56 to 70 Vac
63 Vdc	100 to 139 Vac, or 125 Vdc
125 Vdc	190 to 277 Vac, or 250 Vdc

## Inrush Current Reduction Module (ICRM)

During DECS-250 power-up, the optional ICRM prevents damage to the DECS-250 by limiting inrush current to a safe level. When operating power is applied to the DECS-250, the ICRM limits the inrush current by adding a high level of resistance between the DECS-250 and the power source. Once the inrush current subsides, the series resistance diminishes quickly to allow nominal, steady-state current flow.

**Caution**

To prevent damage to the DECS-250, the use of the ICRM is recommended when using a low impedance source, such as a wall outlet.

For a detailed description of the Inrush Current Reduction Module, refer to Basler publication 9387900990. ICRM connections are illustrated in the *Typical Connections* chapter.

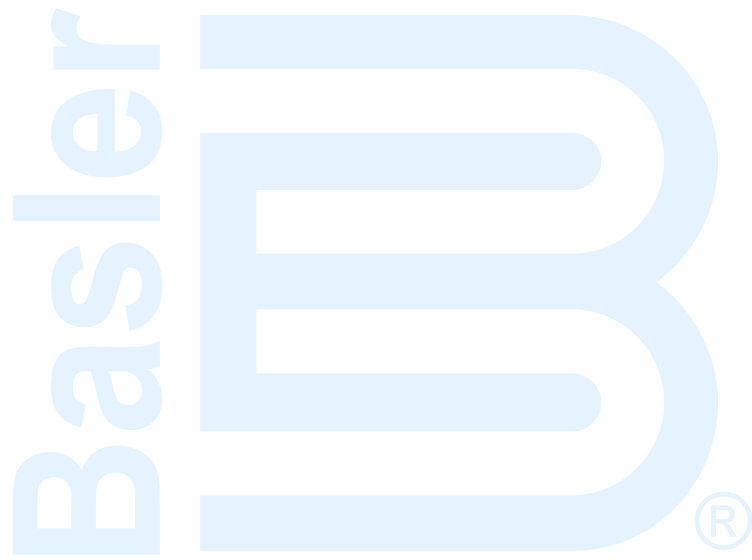
## Power Stage

The DECS-250 supplies regulated dc excitation power to the field of a brushless exciter. Excitation power is supplied at terminals F+ and F-.

DECS-250 power stage operating power accepts single- or three-phase ac power from a transformer or PMG. DC power from the station batteries or the armature of a dc exciter is also acceptable. Power stage operating power is applied at terminals A, B, and C. The GND terminal serves as a ground connection.

The DECS-250 power stage supplies excitation power by means of a filtered, switching power module that uses pulse-width modulation. It is capable of supplying 15 Adc continuously at nominal voltages of 32, 63, or 125 Vdc. With nominal operating voltage applied, it has a forcing capability of 30 Adc for 10 seconds.

Nominal DECS-250 operating power levels include 60 Vac for a 32 Vdc continuous exciter field requirement, 120 Vac or 125 Vdc for a 63 Vdc requirement, or 240 Vac or 250 Vdc for a 125 Vdc requirement.



# Voltage and Current Sensing

The DECS-250 senses generator voltage, generator current, and bus voltage through dedicated, isolated inputs.

## Generator Voltage

Three-phase generator sensing voltage is applied to DECS-250 terminals E1, E2, and E3. This sensing voltage is typically applied through a user-supplied voltage transformer, but may be applied directly. These terminals accept three-phase, three-wire connections at terminals E1 (A), E2 (B), and E3 (C) or single-phase connections at E1 (A) and E3 (C).

The generator voltage sensing input accepts a maximum voltage of 600 Vac and has a burden of less than 1 VA.

The transformer primary and secondary winding voltages are entered in settings that the DECS-250 uses to interpret the applied sensing voltage and calculate system parameters. The phase rotation of the generator sensing voltage can be configured as ABC or ACB. Information about configuring the DECS-250 for the generator sensing voltage is provided in the *Configuration* chapter of this manual.

Typical generator voltage sensing connections are illustrated in Figure 5.

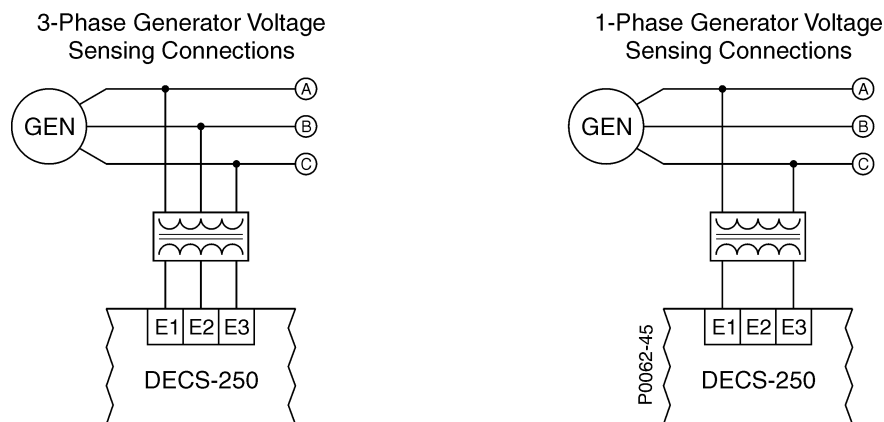


Figure 5. Typical Generator Voltage Sensing Connections

## Generator Current

Generator current sensing inputs consist of three phase-sensing inputs and a sensing input for cross-current compensation.

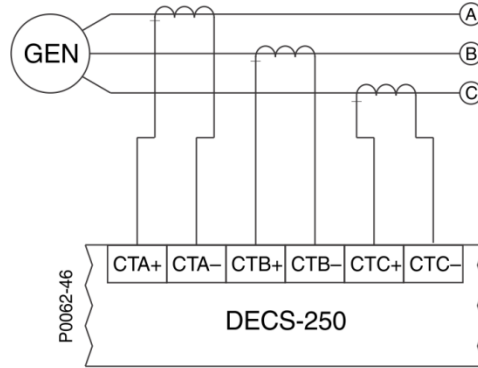
### Note

Current transformer (CT) grounding should be applied in accordance with local codes and conventions.

## Phase Sensing

Three-phase generator sensing current is applied to DECS-250 terminals CTA+ and CTA-, CTB+ and CTB-, and CTC+ and CTC- through user-supplied current transformers (CTs). Single-phase generator sensing current is applied to DECS-250 terminals CTB+ and CTB-. The DECS-250 is compatible with CTs having 5 Aac or 1 Aac nominal secondary ratings. The DECS-250 uses this secondary rating, along with the CT nominal primary ratings to interpret the sensed current and calculate system parameters. Information about configuring the DECS-250 for the generator sensing voltage is provided in the

Configuration chapter of this manual. Typical generator phase-current sensing connections are shown in Figure 6.



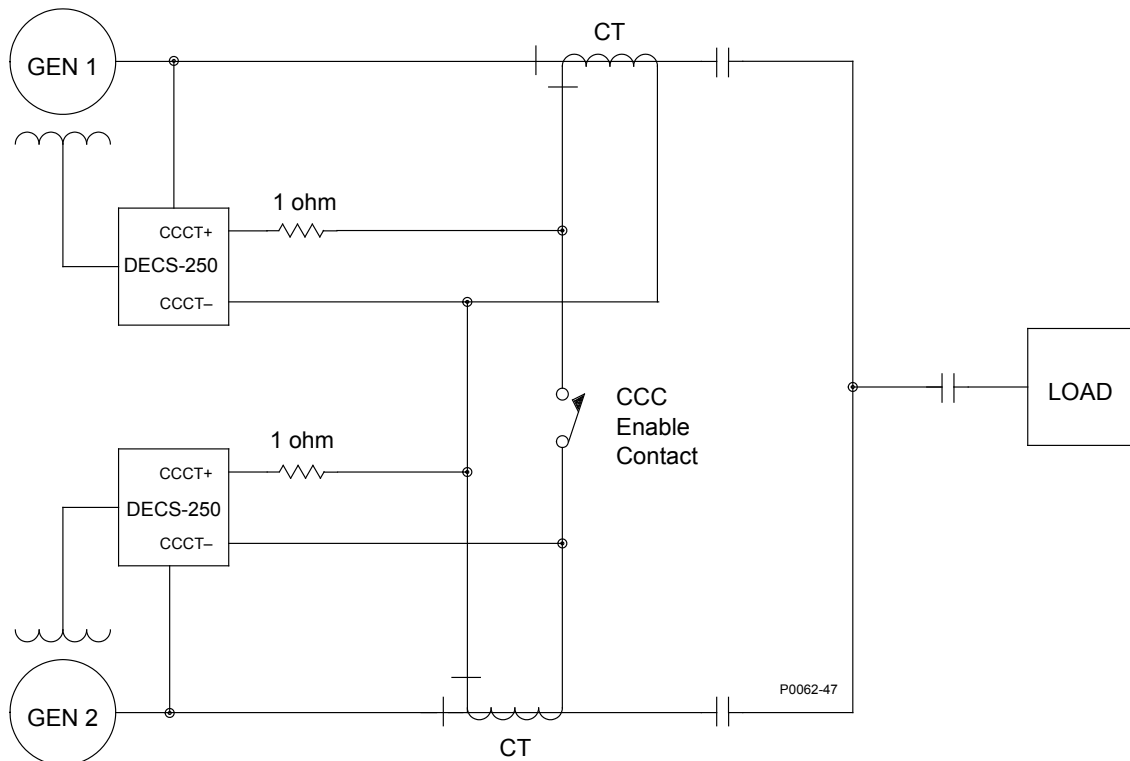
**NOTES**

1. If only one CT is used, connect it to the B-phase.
2. Three-phase current sensing is required for PSS applications.

**Figure 6. Typical Generator Current Sensing Connections**

**Cross-Current Compensation**

Cross-current compensation (reactive differential) mode allows two or more paralleled generators to share a common load. As shown in Figure 7, each generator is controlled by a DECS-250 using the DECS-250 cross-current compensation input (terminals CCCT+ and CCCT-) and a dedicated, external current transformer (CT) to sense generator current. The resistors shown in Figure 7 are used to set the burden and may be adjusted to suit the application. Ensure that the power rating of the resistors is adequate for the application.



**Figure 7. Connections for Cross-Current Compensation**

### Note

If a machine is taken offline, then the secondary winding of that machine's cross-current compensation CT must be shorted. Otherwise, the cross-current compensation scheme will not function.

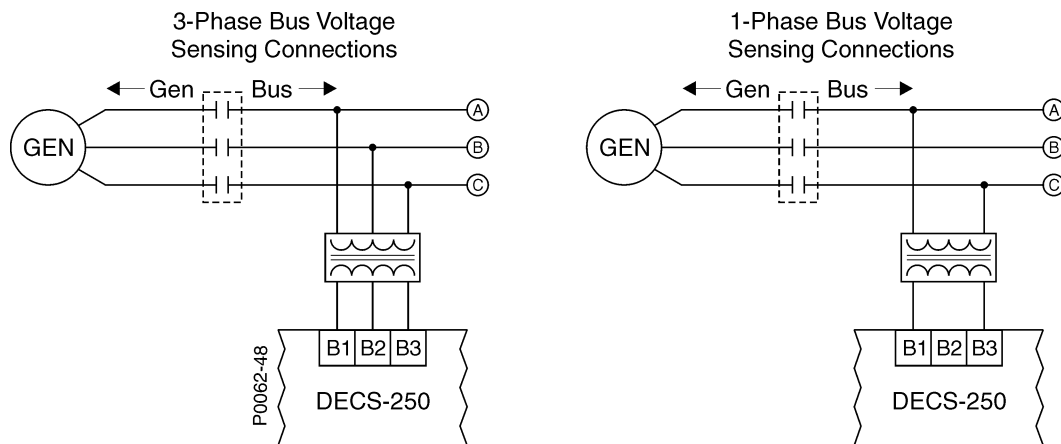
## Bus Voltage

Bus voltage monitoring enables bus failure detection, generator and bus voltage matching, and synchronization of the generator with the utility/bus. These features are discussed in the *Synchronizer* chapter of this manual. Three-phase bus sensing voltage is applied to DECS-250 terminals B1, B2, and B3. This sensing voltage is typically applied through a user-supplied voltage transformer, but may be applied directly. These terminals accept three-phase, three-wire connections at terminals B1 (A), B2 (B), and B3 (C) or single-phase connections at B3 (C) and B1 (A).

The bus voltage sensing input accepts a maximum voltage of 600 Vac and has a burden of less than 1 VA.

The transformer primary and secondary winding voltages are entered in settings that the DECS-250 uses to interpret the applied sensing voltage. Information about configuring the DECS-250 for the bus sensing voltage is provided in the *Configuration* chapter of this manual.

Typical bus voltage sensing connections are illustrated in Figure 8.



**Figure 8. Typical Bus Voltage Sensing Connections**



# Synchronizer

DECS-250 controllers with a style number of xxxxAxx are equipped with an automatic synchronizer that acts to align the voltage, phase angle, and frequency of the generator with the bus. The synchronizer function includes compensation settings for the generator breaker and bias control settings for the generator governor. Related synchronizer features include voltage matching and bus condition detection.

## Generator Synchronization

---

**BESTCOMSPlus Navigation Path:** Settings Explorer, Synchronizer/Voltage Matching, Synchronizer

**HMI Navigation Path:** Settings, Sync/Voltage Matching, Synchronizer

Two modes of automatic generator synchronization are available: phase lock loop (PLL) and anticipatory<sup>A</sup>. In PLL mode, the DECS-250 matches the voltage, phase angle, and frequency of the generator with the bus and then connects the generator to the bus by closing the generator breaker. In anticipatory mode, the DECS-250 drives the generator frequency close to the bus frequency and closes the breaker at a phase angle of zero by compensating for the breaker closing time. (Breaker closing time is the delay between the issuance of a breaker close command and closure of the breaker contacts.) The DECS-250 compensates for the breaker closing time by monitoring the slip frequency between the generator and bus and calculating the advance phase angle required to close the breaker at a zero-degree phase angle.

### Frequency Correction

The Slip Frequency setting<sup>B</sup> establishes the maximum slip allowed for breaker closure. When the measured slip frequency is less than the value of the Min Slip Control Limit setting<sup>C</sup>, the error output is set to zero. When the measured slip frequency is between the values of the Max Slip Control Limit<sup>D</sup> and Min Slip Control Limit settings, the error output is proportional to the difference between the measured slip frequency and the value of the Min Slip Control Limit setting with the opposite polarity. When the measured slip frequency is greater than the value of the Max Slip Control Limit setting, the error output is set to maximum with the opposite polarity.

To minimize the impact on the bus during synchronization, the generator frequency can be forced to exceed the bus frequency<sup>E</sup> at the moment of breaker closure. If this is the case, the DECS-250 will drive the generator frequency higher than the bus frequency before closing the breaker. The breaker closing angle setting<sup>F</sup> defines the maximum allowable phase angle difference between the generator and bus. To close the breaker, the slip angle must remain less than the value of this setting for the duration of the sync activation delay<sup>G</sup>.

The Min Slip Control Limit, Max Slip Control Limit, and Breaker Closing Angle settings are used only in the PLL mode.

### Voltage Correction

Voltage correction is initiated when the generator voltage is outside the defined voltage window. The voltage window setting<sup>H</sup> is expressed as a percentage of the bus voltage and determines the band of generator voltage surrounding the bus voltage where breaker closure will be considered. Enabling the Vgen>Vbus setting<sup>I</sup> causes the DECS-250 to drive the generator voltage higher than the bus voltage prior to synchronizing. A generator to bus PT matching level<sup>J</sup> setting is provided to compensate for step-up or step-down transformers in the system. The DECS-250 adjusts the sensed generator voltage by this percentage. This setting also appears on the Voltage Matching screen, below. When the value is changed, it is reflected in both places.

### Angle Compensation

An angle compensation<sup>K</sup> setting is provided to offset phase shift caused by transformers in the system. The angle compensation value is added only to the bus angle. For example, it is given that the generator and bus are synchronized but the DECS-250 metered slip angle reads  $-30^\circ$ . Equation 1, below, illustrates the DECS-250 slip angle calculation. This means that the generator angle is lagging behind the bus angle

by 30° due to transformer phase shift. To compensate for this phase shift, the angle compensation setting should contain a value of 330°. This value is added to the metered bus angle resulting in an adjusted slip angle of zero degrees. Only the metered bus angle is affected by the angle compensation setting, the metered generator angle is not biased by the DECS-250.

$$G - B + A = \text{Slip Angle}$$

**Equation 1. DECS-250 Metered Slip Angle**

Where:

- G = metered generator angle
- B = metered bus angle
- A = angle compensation value

## Failure of Synchronization

Generator synchronization is aborted if generator synchronization fails to occur within a timeframe<sup>L</sup> established by the user.

BESTCOMSP<sup>Plus</sup>® generator synchronization settings are illustrated in Figure 9.

**Figure 9. Generator Synchronizer Settings**

- <sup>A</sup> *Sync Type*: Select Anticipatory or Phase Lock Loop.
- <sup>B</sup> *Slip Frequency*: Adjustable from 0.1 to 0.5 Hz in 0.05 Hz increments.
- <sup>C</sup> *Min Slip Control Limit*: Adjustable from 0.0 to 2.0 Hz in 0.01 Hz increments.
- <sup>D</sup> *Max Slip Control Limit*: Adjustable from 0.0 to 2.0 Hz in 0.01 Hz increments.
- <sup>E</sup> *Fgen>Fbus*: Select Enable or Disable.
- <sup>F</sup> *Breaker Closing Angle*: Adjustable from 3 to 20° in 0.5° increments.
- <sup>G</sup> *Sync Activation Delay*: Adjustable from 0.1 to 0.8 s in 0.1 s increments.
- <sup>H</sup> *Voltage Window*: Adjustable from 2 to 15% in 0.5% increments.
- <sup>I</sup> *Vgen>Vbus*: Select Enable or Disable.
- <sup>J</sup> *Gen to Bus PT Match Level*: Adjustable from 0 to 700% in 0.1% increments.
- <sup>K</sup> *Angle Compensation (°)*: Adjustable from 0.0 to 359.9° in 0.1° increments.
- <sup>L</sup> *Sync Fail Activation Delay*: Adjustable from 0.1 to 600 s in 0.1 s increments.

## Voltage Matching

**BESTCOMSPPlus Navigation Path:** Settings Explorer, Synchronizer/Voltage Matching, Voltage Matching

**HMI Navigation Path:** Settings, Sync/Voltage Matching, Voltage Matching

When enabled<sup>A</sup>, voltage matching is active in AVR control mode and automatically adjusts the AVR mode setpoint to match the sensed bus voltage. Voltage matching is based on two parameters: band and matching level.

The voltage matching band<sup>B</sup> defines the window in which the generator voltage must be for voltage matching to occur.

A generator to bus PT matching level<sup>C</sup> setting is provided to compensate for step-up or step-down transformers in the system. The DECS-250 adjusts the sensed generator voltage by this percentage. This setting also appears on the Synchronizer screen, above. When the value is changed, it is reflected in both places.

Voltage matching settings are illustrated in Figure 10.

**Figure 10. Voltage Matching Settings**

<sup>A</sup> *Voltage Matching*: Select Enabled to enable function.

<sup>B</sup> *Band*: Adjustable from 0 to 20% in 0.1% increments.

<sup>C</sup> *Gen to Bus PT Match Level*: Adjustable from 0 to 700% in 0.1% increments.

## Breaker Hardware Configuration

**BESTCOMSPPlus Navigation Path:** Settings Explorer, Synchronizer/Voltage Matching, Breaker Hardware

**HMI Navigation Path:** Settings, Sync/Voltage Matching, Breaker Hardware

The DECS-250 can control and monitor a generator breaker. Breaker hardware settings are illustrated in Figure 11.

### Breaker Failure

When a close command is issued to the breaker, the DECS-250 monitors the breaker status and annunciates a breaker failure if the breaker does not close within the time defined by the breaker close wait delay<sup>A</sup>. Typically, the wait delay is set to be longer than the actual breaker closing time.

### Generator Breaker

The DECS-250 must be configured<sup>B</sup> with the generator breaker characteristics before the breaker can be controlled by the DECS-250. Breakers controlled by pulse or continuous control inputs<sup>C</sup> are supported. During anticipatory-mode synchronization, if the generator breaker is serving to tie the generator to the bus, the DECS-250 uses the breaker closing time<sup>D</sup> to calculate the optimum time to close the breaker. For a pulse-controlled generator breaker, the breaker open<sup>E</sup> and close<sup>F</sup> pulse times are used by the DECS-250 when issuing open and close commands to the breaker. When setting the pulse times, the open and close times should be set at or longer than the breaker closing time setting.

If desired, breaker closure is possible during a dead bus condition<sup>G</sup> and/or dead generator condition<sup>H</sup>.

### Caution

Use caution when connecting a “dead” generator to a “dead” bus. Undesired system damage can occur if the bus becomes energized while a “dead” generator is connected to it.

**Figure 11. Breaker Hardware Configuration Settings**

<sup>A</sup> *Breaker Close Wait Time*: Adjustable from 0.1 to 600 s in 0.1 s increments.

<sup>B</sup> *Gen Breaker*: Select Configured or NOT Configured.

<sup>C</sup> *Contact Type*: Select Pulse or Continuous.

<sup>D</sup> *Breaker Closing Time*: Adjustable from 0 to 800 ms in 5 ms increments.

<sup>E</sup> *Open Pulse Time*: Adjustable from 0.01 to 5 s in 0.01 s increments. Setting is available only when Contact Type is Pulse.

<sup>F</sup> *Close Pulse Time*: Adjustable from 0.01 to 5 s in 0.01 s increments. Setting is available only when Contact Type is Pulse.

<sup>G</sup> *Dead Bus Close*: Select Disabled or Enabled.

<sup>H</sup> *Dead Gen Close Enable*: Select Disabled or Enabled.

## Generator and Bus Condition Detection

**BESTCOMSPlus Navigation Path:** Settings Explorer, Synchronizer/Voltage Matching, Bus Condition Detection

**HMI Navigation Path:** Settings, Sync/Voltage Matching, Bus Condition Detection

The DECS-250 monitors the voltage and frequency of the generator and bus for determining when a breaker closure is appropriate. Generator and bus condition detection settings are illustrated in Figure 12.

### Generator Condition

A dead generator is recognized by the DECS-250 when the generator voltage decreases below the dead generator threshold<sup>A</sup> for the duration of the dead generator activation delay<sup>B</sup>.

A failed generator is recognized when the generator voltage or frequency does not meet the established generator stability criteria for the duration of the failed generator activation delay<sup>C</sup>. Generator stability parameters are described in *Generator Stability*.

## Generator Stability

Before initiating a breaker closure (tying the generator to a stable or dead bus), the generator voltage must be stable. Several settings are used to determine generator stability. These settings include pickup and dropout levels for overvoltage<sup>D</sup>, undervoltage<sup>E</sup>, overfrequency<sup>F</sup>, and under-frequency<sup>G</sup>. Recognition of generator stability is further controlled by a generator stability activation delay<sup>H</sup>. Breaker closure is not considered if the voltage conditions are not within the stability pickup and dropout settings for the duration of the stability activation delay.

## Bus Condition

A dead bus is recognized by the DECS-250 when the bus voltage decreases below the dead bus threshold<sup>I</sup> for the duration of the dead bus activation delay<sup>J</sup>.

A failed bus is recognized when the bus voltage or frequency does not meet the established stability criteria for the duration of the failed bus activation delay<sup>K</sup>. Bus stability parameters are described in *Bus Stability*.

## Bus Stability

Before initiating a breaker closure (tying the generator to a live bus), the bus voltage must be stable. Several settings are used to determine bus stability. These settings include pickup and dropout levels for overvoltage<sup>L</sup>, undervoltage<sup>M</sup>, overfrequency<sup>N</sup>, and underfrequency<sup>O</sup>. Recognition of bus stability is further controlled by a bus stability activation delay<sup>P</sup>. Breaker closure is not considered if the voltage conditions are not within the stability pickup and dropout settings for the duration of the stability activation delay.

### Bus Condition Detection

#### Generator Sensing

##### Generator Condition Settings

Dead Gen Threshold (Primary V)	Dead Gen Activation Delay (s)
<input type="text" value="30"/> <span style="border: 1px solid black; padding: 0 2px;">A</span>	<input type="text" value="0.1"/> <span style="border: 1px solid black; padding: 0 2px;">B</span>

Gen Failed Activation Delay (s)	
<input type="text" value="0.1"/> <span style="border: 1px solid black; padding: 0 2px;">C</span>	

##### Generator Stable

<h5 style="margin: 0;">Overvoltage Settings</h5> <table style="width: 100%; border: none;"> <tr> <td style="width: 50%;">Pickup (Primary V)</td> <td style="width: 50%;">Dropout (Primary V)</td> </tr> <tr> <td><input type="text" value="130"/> V L-L</td> <td><input type="text" value="127"/></td> </tr> </table>	Pickup (Primary V)	Dropout (Primary V)	<input type="text" value="130"/> V L-L	<input type="text" value="127"/>	<h5 style="margin: 0;">Undervoltage Settings</h5> <table style="width: 100%; border: none;"> <tr> <td style="width: 50%;">Pickup (Primary V)</td> <td style="width: 50%;">Dropout (Primary V)</td> </tr> <tr> <td><input type="text" value="115"/> V L-L</td> <td><input type="text" value="117"/></td> </tr> </table>	Pickup (Primary V)	Dropout (Primary V)	<input type="text" value="115"/> V L-L	<input type="text" value="117"/>
Pickup (Primary V)	Dropout (Primary V)								
<input type="text" value="130"/> V L-L	<input type="text" value="127"/>								
Pickup (Primary V)	Dropout (Primary V)								
<input type="text" value="115"/> V L-L	<input type="text" value="117"/>								
<h5 style="margin: 0;">Overfrequency Settings</h5> <table style="width: 100%; border: none;"> <tr> <td style="width: 50%;">Pickup (Hz)</td> <td style="width: 50%;">Dropout (Hz)</td> </tr> <tr> <td><input type="text" value="62.00"/></td> <td><input type="text" value="61.80"/></td> </tr> </table>	Pickup (Hz)	Dropout (Hz)	<input type="text" value="62.00"/>	<input type="text" value="61.80"/>	<h5 style="margin: 0;">Underfrequency Settings</h5> <table style="width: 100%; border: none;"> <tr> <td style="width: 50%;">Pickup (Hz)</td> <td style="width: 50%;">Dropout (Hz)</td> </tr> <tr> <td><input type="text" value="58.00"/></td> <td><input type="text" value="58.20"/></td> </tr> </table>	Pickup (Hz)	Dropout (Hz)	<input type="text" value="58.00"/>	<input type="text" value="58.20"/>
Pickup (Hz)	Dropout (Hz)								
<input type="text" value="62.00"/>	<input type="text" value="61.80"/>								
Pickup (Hz)	Dropout (Hz)								
<input type="text" value="58.00"/>	<input type="text" value="58.20"/>								
Gen Stable Activation Delay (s) <input type="text" value="0.1"/> <span style="border: 1px solid black; padding: 0 2px;">H</span>									

#### Bus Sensing

##### Bus Condition Settings

Dead Bus Threshold (Primary V)	Dead Bus Activation Delay (s)
<input type="text" value="30"/> <span style="border: 1px solid black; padding: 0 2px;">I</span>	<input type="text" value="0.1"/> <span style="border: 1px solid black; padding: 0 2px;">J</span>

Bus Failed Activation Delay (s)	
<input type="text" value="0.1"/> <span style="border: 1px solid black; padding: 0 2px;">K</span>	

##### Bus Stable

<h5 style="margin: 0;">Overvoltage Settings</h5> <table style="width: 100%; border: none;"> <tr> <td style="width: 50%;">Pickup (Primary V)</td> <td style="width: 50%;">Dropout (Primary V)</td> </tr> <tr> <td><input type="text" value="130"/> V L-L</td> <td><input type="text" value="127"/></td> </tr> </table>	Pickup (Primary V)	Dropout (Primary V)	<input type="text" value="130"/> V L-L	<input type="text" value="127"/>	<h5 style="margin: 0;">Undervoltage Settings</h5> <table style="width: 100%; border: none;"> <tr> <td style="width: 50%;">Pickup (Primary V)</td> <td style="width: 50%;">Dropout (Primary V)</td> </tr> <tr> <td><input type="text" value="115"/> V L-L</td> <td><input type="text" value="117"/></td> </tr> </table>	Pickup (Primary V)	Dropout (Primary V)	<input type="text" value="115"/> V L-L	<input type="text" value="117"/>
Pickup (Primary V)	Dropout (Primary V)								
<input type="text" value="130"/> V L-L	<input type="text" value="127"/>								
Pickup (Primary V)	Dropout (Primary V)								
<input type="text" value="115"/> V L-L	<input type="text" value="117"/>								
<h5 style="margin: 0;">Overfrequency Settings</h5> <table style="width: 100%; border: none;"> <tr> <td style="width: 50%;">Pickup (Hz)</td> <td style="width: 50%;">Dropout (Hz)</td> </tr> <tr> <td><input type="text" value="62.00"/></td> <td><input type="text" value="61.80"/></td> </tr> </table>	Pickup (Hz)	Dropout (Hz)	<input type="text" value="62.00"/>	<input type="text" value="61.80"/>	<h5 style="margin: 0;">Underfrequency Settings</h5> <table style="width: 100%; border: none;"> <tr> <td style="width: 50%;">Pickup (Hz)</td> <td style="width: 50%;">Dropout (Hz)</td> </tr> <tr> <td><input type="text" value="58.00"/></td> <td><input type="text" value="58.20"/></td> </tr> </table>	Pickup (Hz)	Dropout (Hz)	<input type="text" value="58.00"/>	<input type="text" value="58.20"/>
Pickup (Hz)	Dropout (Hz)								
<input type="text" value="62.00"/>	<input type="text" value="61.80"/>								
Pickup (Hz)	Dropout (Hz)								
<input type="text" value="58.00"/>	<input type="text" value="58.20"/>								
Bus Stable Activation Delay (s) <input type="text" value="0.1"/> <span style="border: 1px solid black; padding: 0 2px;">P</span>									

**Figure 12. Generator and Bus Condition Detection Settings**

- A** *Dead Gen Threshold*: Adjustable from 0 to 600,000 Vac in 1 Vac increments.
- B** *Dead Gen Activation Delay*: Adjustable from 0.1 to 600 s in 0.1 s increments.
- C** *Gen Failed Activation Delay*: Adjustable from 0.1 to 600 s in 0.1 s increments.
- D** *Generator Stability Overvoltage Pickup and Dropout*: Adjustable from 10 to 600,000 Vac in 1 Vac increments.
- E** *Generator Stability Undervoltage Pickup and Dropout*: Adjustable from 10 to 600,000 Vac in 1 Vac increments.
- F** *Generator Stability Overfrequency Pickup and Dropout*: Adjustable from 15 to 64 Hz in 0.05 Hz increments.
- G** *Generator Stability Underfrequency Pickup and Dropout*: Adjustable from 15 to 64 Hz in 0.05 Hz increments.
- H** *Generator Stability Activation Delay*: Adjustable from 0.1 to 600 s in 0.1 s increments.
- I** *Dead Bus Threshold*: Adjustable from 0 to 600,000 Vac in 1 Vac increments.
- J** *Dead Bus Activation Delay*: Adjustable from 0.1 to 600 s in 0.1 s increments.
- K** *Bus Failed Activation Delay*: Adjustable from 0.1 to 600 s in 0.1 s increments.
- L** *Bus Stability Overvoltage Pickup and Dropout*: Adjustable from 10 to 600,000 Vac in 1 Vac increments.
- M** *Bus Stability Undervoltage Pickup and Dropout*: Adjustable from 10 to 600,000 Vac in 1 Vac increments.

<sup>N</sup> *Bus Stability Overfrequency Pickup and Dropout*: Adjustable from 15 to 64 Hz in 0.05 Hz increments.

<sup>O</sup> *Bus Stability Underfrequency Pickup and Dropout*: Adjustable from 15 to 64 Hz in 0.05 Hz increments.

<sup>P</sup> *Bus Stable Activation Delay*: Adjustable from 0.1 to 600 s in 0.1 s increments.

## Generator Governor Control

**BESTCOMSPiplus Navigation Path:** Settings Explorer, Synchronizer/Voltage Matching, Governor Bias Control Settings

**HMI Navigation Path:** Settings, Sync/Voltage Matching, Governor Bias Control Settings

During synchronization, the DECS-250 adjusts the generator voltage and frequency by issuing speed correction signals to the speed governor. Correction signals are issued in the form of DECS-250 output contact closures. These correction signals may be either continuous, fixed, or proportional<sup>A</sup>. When fixed correction is selected, the correction pulses equal the Correction Pulse Width<sup>B</sup> and Correction Pulse Interval<sup>C</sup> settings. When proportional correction is selected, the correction pulse width varies in proportion to the error and the intervals equal the Correction Pulse Interval setting. Initially, long pulses are issued when the frequency difference between the generator and bus is large. As the correction pulses take effect and the frequency difference becomes smaller, the correction pulse widths are proportionally decreased.

Governor bias control settings are illustrated in Figure 13.

**Figure 13. Generator Governor Control Settings**

<sup>A</sup> *Bias Control Contact Type*: Select Continuous Pulse, Fixed Pulse, or Proportional Pulse.

<sup>B</sup> *Correction Pulse Width*: Adjustable from 0 to 99.9 s in 0.1 s increments.

<sup>C</sup> *Correction Pulse Interval*: Adjustable from 0 to 99.9 s in 0.1 s increments.



# Regulation

The DECS-250 precisely regulates the level of supplied excitation power in each of the five available regulation modes. Stable regulation is enhanced by the automatic tracking of the active-mode setpoint by the inactive regulation modes. Pre-position setpoints within each regulation mode enable the DECS-250 to be configured for multiple system and application needs.

**BESTCOMSPlus Navigation Path:** Settings Explorer, Operating Settings, AVR/FCR/FVR and VAR/PF  
**HMI Navigation Path:** Settings, Operating Settings, AVR/FCR/FVR and VAR/PF

## Regulation Modes

---

The DECS-250 provides five regulation modes: Automatic Voltage Regulation (AVR), Field Current Regulation (FCR), Field Voltage Regulation (FVR), var, and Power Factor (PF).

### AVR

When operating in AVR (Automatic Voltage Regulation) mode, the DECS-250 regulates the excitation level in order to maintain the generator terminal voltage setpoint<sup>A</sup> despite changes in load and operating conditions. AVR setpoint (or operating point) adjustment is made through:

- Application of contacts at DECS-250 contact inputs configured for raising and lowering the active setpoint
- Application of an analog control signal at the DECS-250 Auxiliary Control input.
- The BESTCOMSPlus<sup>®</sup> Control Panel screen (available in the BESTCOMSPlus Metering Explorer)
- A raise or lower command transmitted through the DECS-250 Modbus port

The range of adjustment is defined by Minimum<sup>B</sup> and Maximum<sup>C</sup> settings that are expressed as a percentage of the rated generator voltage. The length of time required to adjust the AVR setpoint from one limit to the other is controlled by a Traverse Rate setting<sup>D</sup>. These settings are illustrated in Figure 14.

### FCR

When operating in FCR (Field Current Regulation) mode, the DECS-250 regulates the level of current it supplies to the field based on the FCR setpoint<sup>E</sup>. The setting range of the FCR setpoint depends on the field rated data and other associated settings. FCR setpoint adjustment is made through:

- Application of contacts at DECS-250 contact inputs configured for raising and lowering the active setpoint
- Application of an analog control signal at the DECS-250 Auxiliary Control input
- The BESTCOMSPlus<sup>®</sup> Control Panel screen (available in the BESTCOMSPlus Metering Explorer)
- A raise or lower command transmitted through the DECS-250 Modbus port

The range of adjustment is defined by Minimum<sup>F</sup> and Maximum<sup>G</sup> settings that are expressed as a percentage of the rated field current. The length of time required to adjust the FCR setpoint from one limit to the other is controlled by a Traverse Rate setting<sup>H</sup>. These settings are illustrated in Figure 14.

### FVR

FVR (Field Voltage Regulation) mode enables generator modeling and validation testing in accordance with WECC testing requirements. FVR mode can also be used to smooth the transfer from the active DECS-250 to a secondary DECS.

When operating in FVR mode, the DECS-250 regulates the level of field voltage it supplies to the field based on the FVR setpoint<sup>I</sup>. The setting range of the FVR setpoint depends on the field rated data and other associated settings. FVR setpoint adjustment is made through:

- Application of contacts at DECS-250 contact inputs configured for raising and lowering the active setpoint

- Application of an analog control signal at the DECS-250 auxiliary Control input
- The BESTCOMSP<sup>Plus</sup> Control Panel screen (available in the BESTCOMSP<sup>Plus</sup> Metering Explorer)
- A raise or lower command transmitted through the DECS-250 Modbus port

The range of adjustment is defined by Minimum<sup>J</sup> and Maximum<sup>K</sup> settings that are expressed as a percentage of the rated field voltage. The length of time required to adjust the FVR setpoint from one limit to the other is controlled by a Traverse Rate<sup>L</sup> setting. These settings are illustrated in Figure 14.

AVR/FCR/FVR Setpoints		
<b>Automatic Voltage Regulator (AVR)</b>	<b>Field Current Regulator (FCR)</b>	<b>Field Voltage Regulator (FVR)</b>
Setpoint (Primary V) 120.00 [A]	Setpoint (Primary A) 0.10 [E]	Setpoint (Primary V) 10.00 [I]
Min (% of rated) 70.0 [B]	Min (% of rated) 0.0 [F]	Min (% of rated) 0.0 [J]
Max (% of rated) 120.0 [C]	Max (% of rated) 120.0 [G]	Max (% of rated) 150.0 [K]
Traverse Rate (s) 20 [D]	Traverse Rate (s) 20 [H]	Traverse Rate (s) 20 [L]

Figure 14. AVR, FCR, and FVR Regulation Settings

<sup>A</sup> *AVR Setpoint*: Range of adjustment is based on the rated generator voltage and limited by the AVR Min (B) and Max (C) settings.

<sup>B</sup> *Min (% of rated)*: Adjustable from 70 to 120% in 0.1% increments.

<sup>C</sup> *Max (% of rated)*: Adjustable from 71 to 120% in 0.1% increments.

<sup>D</sup> *Traverse Rate (s)*: Adjustable from 10 to 200 seconds in 1 second increments.

<sup>E</sup> *FCR Setpoint*: Range of adjustment is based on the rated field current and limited by the FCR Min (F) and Max (G) settings.

<sup>F</sup> *Min (% of rated)*: Adjustable from 0 to 120% in 0.1% increments.

<sup>G</sup> *Max (% of rated)*: Adjustable from 0 to 120% in 0.1% increments.

<sup>H</sup> *Traverse Rate (s)*: Adjustable from 10 to 200 seconds in 1 second increments.

<sup>I</sup> *FVR Setpoint*: Range of adjustment is based on the rated field voltage and limited by the FCR Min (J) and Max (K) settings.

<sup>J</sup> *Min (% of rated)*: Adjustable from 0 to 150% in 0.1% increments.

<sup>K</sup> *Max (% of rated)*: Adjustable from 0 to 150% in 0.1% increments.

<sup>L</sup> *Traverse Rate*: Adjustable from 10 to 200 seconds in 1 second increments.

## Var

When operating in var mode, the DECS-250 regulates the reactive power (var) output of the generator based on the var setpoint<sup>A</sup>. The setting range of the var setpoint depends on the generator ratings and other associated settings. Var setpoint adjustment is made through:

- Application of contacts at DECS-250 contact inputs configured for raising and lowering the active setpoint
- Application of an analog control signal at the DECS-250 Auxiliary Control input
- The BESTCOMSP<sup>Plus</sup> Control Panel screen (available in the BESTCOMSP<sup>Plus</sup> Metering Explorer)
- A raise or lower command transmitted through the DECS-250 Modbus port

The range of adjustment is defined by Minimum<sup>B</sup> and Maximum<sup>C</sup> settings that are expressed as a percentage of the generator rated kVA output. The length of time required to adjust the Var setpoint from one limit to the other is controlled by a Traverse Rate setting<sup>D</sup>. A Fine Voltage Adjustment Band setting<sup>E</sup> defines the upper and lower boundaries of voltage correction when operating in var or power factor regulation modes. Var mode settings are illustrated in Figure 15.

## Power Factor

When operating in Power Factor (PF) mode, the DECS-250 controls the var output of the generator to maintain the Power Factor setpoint<sup>F</sup> as the kW load on the generator varies. The setting range of the PF setpoint is determined by the PF – Leading<sup>G</sup> and PF – Lagging<sup>H</sup> settings. The length of time required to adjust the PF setpoint from one limit to the other is controlled by a Traverse Rate setting<sup>I</sup>. A Fine Voltage Adjustment Band setting<sup>E</sup> defines the upper and lower boundaries of voltage correction when the DECS-250 is operating in Var or Power Factor regulation modes. PF Active Power Level<sup>J</sup> establishes the level of generator output power (kW) where the DECS-250 switches to/from Droop Compensation/Power Factor mode. If the level of power decreases below the setting, the DECS-250 switches from Power Factor mode to Droop Compensation mode. Conversely, as the level of power increases above the setting, the DECS-250 switches from Droop Compensation mode to Power Factor mode. A setting of 0 to 30% may be entered in 0.1% increments.

Power Factor mode settings are illustrated in Figure 15.

var/PF Setpoints		
<b>Fine Voltage Adjustment Band</b>		
Fine Voltage Adjustment Band	20.00	E
<b>PF Active Power Level</b>		
PF Active Power Level	0.0	J
<b>Reactive Power Control (var)</b>		
Setpoint (Primary kvar)	0.00	A
Min (%)	0.0	B
Max (%)	100.0	C
Traverse Rate	20	D
Pre-position 1 Setpoint (Prim var)		
<b>Power Factor Control (PF)</b>		
Setpoint	1.000	F
PF - Leading	-0.800	G
PF - Lagging	0.800	H
Traverse Rate	20	I
Pre-position 1 Setpoint		

Figure 15. Var and Power Factor Regulation Settings

<sup>A</sup> **Setpoint**: Range of adjustment is based on the generator ratings and limited by the Var Minimum (B) and Var Maximum (C) settings.

<sup>B</sup> **Min (% of rated)**: Adjustable from –100 to 100% in 0.1% increments.

<sup>C</sup> **Max (% of rated)**: Adjustable from 0 to 100% in 0.1% increments.

<sup>D</sup> **Traverse Rate (s)**: Adjustable from 10 to 200 seconds in 1 second increments.

<sup>E</sup> **Fine Voltage Adjustment Band**: Adjustable from 0 to 30% in 0.01% increments.

<sup>F</sup> **PF Setpoint**: Range of adjustment is determined by the PF Leading (G) and Lagging (H) settings.

<sup>G</sup> **PF – Leading**: Adjustable from –1 to –0.5 in 0.005 increments.

<sup>H</sup> **PF – Lagging**: Adjustable from 0.5 to 1 in 0.005 increments.

<sup>I</sup> **Traverse Rate (s)**: Adjustable from 10 to 200 seconds in 1 second increments.

<sup>J</sup> **PF Active Power Level**: Adjustable from 0 to 30% in 0.1% increments.

## Pre-Position Setpoints

Each regulation mode has three pre-position setpoints which allow the DECS-250 to be configured for multiple system and application needs. Each pre-position setpoint can be assigned to a programmable contact input. When the appropriate contact input is closed, the setpoint is driven to the corresponding pre-position value. Each pre-position function has two settings: Setpoint and Mode. The setting range of each pre-position setpoint<sup>A</sup> is identical to that of the corresponding control mode setpoint. The Mode<sup>B</sup> setting determines whether or not the DECS-250 will respond to further setpoint change commands while the pre-position command is being asserted. If the pre-position mode is Release, setpoint change commands are accepted to raise and lower the setpoint while the pre-position command is being asserted. Additionally, if the inactive pre-position mode is Release and internal tracking is enabled, the pre-position value will respond to the tracking function. If the pre-position mode is Maintain, further setpoint change commands are ignored while the appropriate contact input is closed. Additionally, if the inactive pre-position mode is Maintain and internal tracking is enabled, the inactive mode will maintain the inactive setpoint at the pre-position value and override the tracking function. A portion of the pre-position

setpoints for var and PF modes are illustrated in Figure 16. (Pre-Position Setpoints for AVR, FCR, and FVR modes are similar and not shown here.)

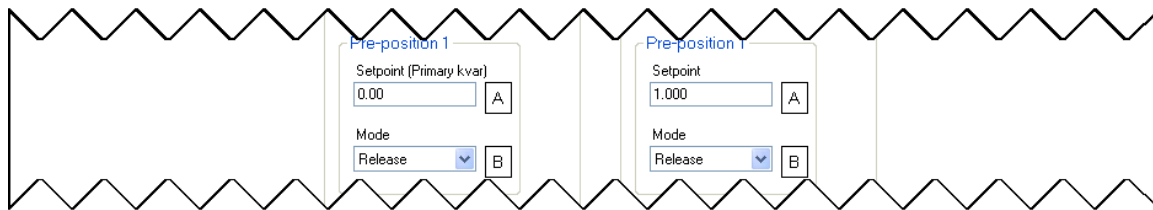


Figure 16. Pre-Position Setpoints

<sup>A</sup> *Setpoint*: Range of adjustment is based on the generator ratings and limited by the Var Minimum and Var Maximum settings.

<sup>B</sup> *Mode*: Select Release or Maintain

## Transient Boost

The transient excitation boosting function improves response to successive faults by providing increased excitation support. When a simultaneous line current increase and line voltage decrease occurs, the DECS-250 compensates by elevating the voltage setpoint above the nominal setpoint. When the line voltage recovers, the voltage setpoint is restored to the nominal value.

Fault detection is controlled by a voltage threshold<sup>A</sup> setting, a current threshold<sup>B</sup> setting, and a duration<sup>C</sup> setting. Fault voltage threshold is expressed as a percentage of the AVR setpoint and fault current threshold is expressed as a percentage of the rated field current. The duration setting determines how long a fault condition is tolerated before the setpoint is adjusted.

Setpoint adjustment is controlled by a voltage setpoint boosting level<sup>D</sup>, a clearing voltage threshold<sup>E</sup>, and a clearing voltage delay<sup>F</sup>. The setpoint boosting level is expressed as a percentage above the AVR setpoint. Transient boost is disabled once the line voltage recovers above the clearing voltage threshold. The clearing voltage threshold is expressed as a percentage below the AVR setpoint. The clearing voltage delay determines how long the line voltage must exceed the clearing voltage threshold before setpoint adjustment is terminated.

Figure 17. Transient Boost Settings

<sup>A</sup> *Fault Voltage Threshold (%)*: Adjustable from 0.0 to 100.0%, in 0.1% increments.

<sup>B</sup> *Fault Current Threshold (%)*: Adjustable from 0.0 to 400.0%, in 0.1% increments.

<sup>C</sup> *Minimum Fault Duration (ms)*: Adjustable from 0 to 1,000 ms, in 1 ms increments.

<sup>D</sup> *Voltage Setpoint Boosting Level (%)*: Adjustable from 0.0 to 100.0%, in 0.1% increments.

<sup>E</sup> *Clearing Voltage Threshold (%)*: Adjustable from 0.0 to 50.0%, in 0.1% increments.

<sup>F</sup> *Clearing Voltage Delay (ms)*: Adjustable from 0 to 1,000 ms, in increments of 1 ms.

## Operation with Paralleled Generators

**BESTCOMSPi<sup>us</sup> Navigation Path:** Settings Explorer, Operating Settings, Parallel/LineDrop Compensation

**HMI Navigation Path:** Settings, Operating Settings, Parallel/LineDrop Compensation

The DECS-250 can be used to control the excitation level of two or more generators operating in parallel so that the generators share the reactive load. The DECS-250 can employ either droop compensation or cross-current compensation (reactive differential) schemes for reactive load sharing. A separate load sharing function enables each machine to share the load proportionally without incurring a voltage and frequency droop.

Paralleled generator settings are illustrated in Figure 18 and described in the following paragraphs.

### Reactive Droop Compensation

Droop compensation serves as a method of controlling reactive current when the generator is connected in parallel with another energy source. Droop compensation utilizes the B-phase CT in single-phase applications. When droop compensation is enabled<sup>A</sup>, the generator voltage is adjusted in proportion to the measured generator reactive power. The reactive droop compensation setting<sup>B</sup> is expressed as a percentage of the generator rated terminal voltage.

#### Note

For droop compensation to operate, the PARALLEL\_EN\_LM logic block must be set true in BESTlogic™ *Plus* programmable logic.

### Cross-Current Compensation

Cross-current compensation (reactive differential) mode serves as a method of connecting multiple generators in parallel to share reactive load. When reactive load is shared properly, no current is fed into the DECS-250 cross-current compensation input (which is connected to the B-phase transformer). Improper sharing of reactive load causes a differential current to be fed into the cross-current compensation input. When cross-current compensation is enabled<sup>C</sup>, this input causes the DECS-250 to respond with the proper level of regulation. The response of the DECS-250 is controlled by the cross-current compensation gain setting<sup>D</sup> which is expressed as a percentage of the system nominal CT setting.

Application information about cross-current compensation is available in the *Voltage and Current* chapter of this manual.

### Network Load Sharing

In a multiple-generator application, the load sharing function ensures equal generator reactive-power sharing. It operates in a similar manner to cross-current compensation but without the external hardware requirements and distance limitations. Instead of sharing load based on the CT ratio, load is shared on a per-unit basis calculated from the generator rated data. Sharing of load information between DECS-250 controllers is accomplished through the Ethernet port of each DECS-250 communicating over a peer-to-peer network dedicated for the load sharing function. Each DECS-250 measures the reactive current of its associated generator and broadcasts its measurement to all other DECS-250 controllers on the network. Each DECS-250 compares its level of reactive current to the sum of all measured currents and adjusts its excitation level accordingly.

A Load Share ID setting identifies the DECS-250 as a load sharing unit in the network. Checking a Load Sharing Unit number box allows any DECS-250 load sharing units on the network with that Load Share ID number to share load with the currently connected DECS-250. It is not necessary for the Load Share ID to be unique for each unit. This allows for load sharing units to be grouped.

When the unit's configuration does not match the configuration of the other units with load sharing enabled, the Network Load Share Config Mismatch logic element becomes true. The Configuration Mismatch Delay setting adds a delay before the element becomes true.

Load sharing settings consist of an Enable checkbox<sup>E</sup> and Droop<sup>F</sup>, Kg<sup>G</sup>, Ki<sup>H</sup>, Max Vc<sup>I</sup>, Configuration Mismatch Delay<sup>J</sup>, and Load Share ID<sup>K</sup> settings.

### Line Drop Compensation

When enabled<sup>L</sup>, line drop compensation can be used to maintain voltage at a load located at a distance from the generator. The DECS-250 achieves this by measuring the line current and calculating the voltage for a specific point on the line. Line drop compensation is applied to both the real and reactive portion of the generator line current. It is expressed as a percentage of the generator terminal voltage<sup>M</sup>.

Equation 2 is used to calculate the Line Drop Value.

$$LD_{Value} = \sqrt{\left(V_{avg} - \left[LD \times I_{avg} \times \cos(I_{bang})\right]\right)^2 + \left(LD \times I_{avg} \times \sin(I_{bang})\right)^2}$$

#### Equation 2. Line Drop Value

LD <sub>Value</sub>	=	Line drop value (per unit)
V <sub>avg</sub>	=	Average voltage, metered value (per unit)
LD	=	Line Drop % / 100
I <sub>avg</sub>	=	Average Current, metered value (per unit)
I <sub>bang</sub>	=	Angle of phase B current (no compensation)

The LD<sub>Value</sub> is the per-unit value seen down the line from the synchronous machine. Equation 3 is used to determine the voltage needed to adjust for line drop.

$$V_{adjust,PU} = V_{rms,PU} - LD_{Value}$$

#### Equation 3. Voltage Needed to Adjust for Line Drop

Equation 4 is used to obtain primary units.

$$V_{adjust} = V_{adjust,PU} \times V_{rated}$$

#### Equation 4. Obtain Primary Units

The new line drop adjusted setpoint is calculated using Equation 5.

$$V_{Adjusted\ Setpoint} = V_{Setpoint} + V_{adjust}$$

#### Equation 5. Line Drop Adjusted Setpoint

Refer to Figure 18 for an illustration of the Line drop compensation settings.

### Parallel/Line Drop Compensation

**Droop Compensation**

Enable A

Reactive Droop Compensation (% of rated)

5.0 B

**Line Drop Compensation**

Enable L

Line Drop Compensation (% of rated)

5.0 M

**Cross Current Compensation**

Enable C

Cross Current Compensation Gain (% of rated)

0.00 D

**Network Load Share**

Enable E

Droop (%)

0.0 F

Kg

0.00 G

Ki

0.00 H

Max Vc

0.00 I

Configuration Mismatch Delay (s)

0.5 J

Load Share ID

1 K

<input checked="" type="checkbox"/> Load Sharing Unit 1	<input checked="" type="checkbox"/> Load Sharing Unit 9
<input checked="" type="checkbox"/> Load Sharing Unit 2	<input checked="" type="checkbox"/> Load Sharing Unit 10
<input checked="" type="checkbox"/> Load Sharing Unit 3	<input checked="" type="checkbox"/> Load Sharing Unit 11
<input checked="" type="checkbox"/> Load Sharing Unit 4	<input checked="" type="checkbox"/> Load Sharing Unit 12
<input checked="" type="checkbox"/> Load Sharing Unit 5	<input checked="" type="checkbox"/> Load Sharing Unit 13
<input checked="" type="checkbox"/> Load Sharing Unit 6	<input checked="" type="checkbox"/> Load Sharing Unit 14
<input checked="" type="checkbox"/> Load Sharing Unit 7	<input checked="" type="checkbox"/> Load Sharing Unit 15
<input checked="" type="checkbox"/> Load Sharing Unit 8	<input checked="" type="checkbox"/> Load Sharing Unit 16

**Figure 18. Paralleled Generators and Line Drop Compensation Settings**

- <sup>A</sup> *Droop Compensation Enable*: Place a check in the checkbox to enable droop compensation.
- <sup>B</sup> *Reactive Droop Compensation*: Adjustable from 0 to +30% in 0.1% increments.
- <sup>C</sup> *Cross-Current Compensation Enable*: Place a check in the checkbox to enable cross-current compensation.
- <sup>D</sup> *Cross-Current Compensation Gain*: Adjustable from –30 to +30% in 0.1% increments.
- <sup>E</sup> *Load Share Enable*: Place a check in the checkbox to enable load sharing.
- <sup>F</sup> *Droop*: Adjustable from 0 to +30% in 0.1% increments.
- <sup>G</sup> *Kg*: Adjustable from 0 to 1,000 in increments of 0.01.
- <sup>H</sup> *Ki*: Adjustable from 0 to 1,000 in increments of 0.01.
- <sup>I</sup> *Max Vc*: Adjustable from 0 to 1 in increments of 0.01.
- <sup>J</sup> *Configuration Mismatch Delay*: Adjustable from 0.2 to 10.0 s in increments of 0.1 s.
- <sup>K</sup> *Load Share ID*: Adjustable from 1 to 16 in increments of 1.
- <sup>L</sup> *Line Drop Compensation Enable*: Place a check in the checkbox to enable line drop compensation.
- <sup>M</sup> *Line Drop Compensation*: Adjustable from 0 to 30% in increments of 0.1%.

## Autotracking

**BESTCOMSPlus Navigation Path:** Settings Explorer, Operating Settings, Autotracking

**HMI Navigation Path:** Settings, Operating Settings, Autotracking.

Internal regulation mode setpoint tracking is a standard feature on the DECS-250. External setpoint tracking is optional (style xx2xxxx). Autotracking settings are illustrated in Figure 19.

## Internal Setpoint Tracking

In applications using a single DECS-250, internal tracking can be enabled<sup>A</sup> so that the inactive regulation modes track the active regulation mode.

The following examples demonstrate the advantages of internal tracking:

- If the excitation system is operating online with internal tracking enabled, a loss of sensing condition could trigger a transfer to FCR mode. Autotracking minimizes the impact that a loss of sensing condition has on the exciter's ability to maintain the proper excitation level.
- While performing routine testing of the DECS-250 in backup mode, the internal tracking feature allows a transfer to an inactive mode that will result in no disturbance to the system.

Two parameters control the behavior of internal tracking. A delay setting<sup>B</sup> determines the time delay between large system disturbance and the start of setpoint tracking. A traverse rate setting<sup>C</sup> configures the length of time for the inactive mode setpoints to traverse the full setting range of the active mode setpoint.

## External Setpoint Tracking

For critical applications, a second DECS-250 can provide backup excitation control. The DECS-250 (style xx2xxxx) allows for excitation redundancy by providing external tracking and transfer provisions between DECS-250 controllers. The secondary DECS-250 can be configured to track the primary DECS-250 setpoint. Proper redundant excitation system design allows for removal of the failed system.

### Note

Periodic testing of the backup system must be performed to ensure that it is operational and can be placed in service without warning.

Like internal tracking, external setpoint tracking uses enable/disable<sup>D</sup>, delay<sup>E</sup>, and traverse rate<sup>F</sup> settings.

Figure 19. Autotracking Settings

<sup>A</sup> **Internal Tracking Enabled:** Place a check in the checkbox to enable internal tracking.

<sup>B</sup> **Internal Tracking Delay:** Adjustable from 0 to 8 seconds in 0.1 second increments.

<sup>C</sup> **Internal Tracking Traverse Rate:** Adjustable from 1 to 80 seconds in 0.1 second increments.

<sup>D</sup> **External Tracking Enabled:** Place a check in the checkbox to enable external tracking.

<sup>E</sup> **External Tracking Delay:** Adjustable from 0 to 8 seconds in 0.1 second increments.

<sup>F</sup> **External Tracking Traverse Rate:** Adjustable from 1 to 80 seconds in 0.1 second increments.

## Setpoint Configure

When the Auto Save setting is enabled, the DECS-250 automatically saves the active setpoint in 10-minute intervals. Otherwise, the setpoint which was last sent to the DECS-250 is retained. Figure 20 illustrates the Setpoint Configure screen.

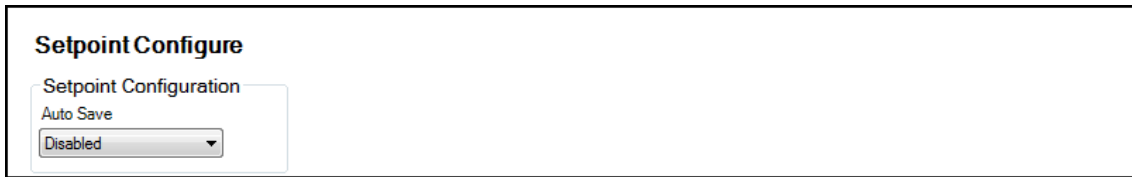


Figure 20. Setpoint Configure Setting



# Auxiliary Control

**BESTCOMSP<sup>Plus</sup> Navigation Path:** Settings Explorer, Operating Settings, Auxiliary Inputs

**HMI Navigation Path:** Settings, Operating Settings, Auxiliary Inputs

The DECS-250 accepts an external analog control signal for auxiliary control of the regulation setpoint. Auxiliary setpoint control is possible in all regulation modes: AVR, PF, Var, FCR, and FVR. The control signal can also be used for limiter scaling or power system stabilizer control. Auxiliary control settings are illustrated in Figure 21.

## ***Auxiliary Control Input Type<sup>A</sup>***

---

Either a voltage or current control signal may be used for auxiliary control. Terminals I+ and I– accept a 4 to 20 mAdc signal. Terminals V+ and V– accept a –10 to +10 Vdc signal. An adjacent terminal labeled GND provides the connection for a recommended cable shield. The input type is selected in BESTCOMSP<sup>Plus</sup>®.

## ***Auxiliary Control Input Function<sup>B</sup>***

---

The analog control input can be used for auxiliary control of the regulation setpoint, as a power system stabilizer test input, for limiter scaling, or for grid code input.

### **PSS Test Input**

The auxiliary control input can be used for control of the optional power system stabilizer function during testing and validation. More information is provided in the *Power System Stabilizer* chapter of this manual.

### **Limiter Scaling**

When the auxiliary control input is configured for limiter scaling, the stator current limiter (SCL) and overexcitation limiter (OEL) low-level values can be automatically adjusted. Automatic adjustment of the SCL and OEL is based on six parameters: signal and scale for three points. The signal value for each point represents the accessory input voltage. The scale value defines the limiter low level as a percentage of rated field current for the OEL and rated stator current for the SCL. For accessory input voltages between two of the three defined points, the low-level limiter setting is linearly adjusted between the two scale values. Limiter settings and limiter scaling are discussed in detail in the *Limiters* chapter of this manual.

### **Grid Code Input**

The grid code input must be selected when it is desired to use the auxiliary input as the adjustment source for active and reactive power control.

### **Setpoint Limits**

Minimum and maximum setpoint limits are observed when the With Limit box is checked.

## ***Auxiliary Control Gains***

---

When a current input type is selected, the input current is converted internally by the DECS-250 into a voltage signal in the range of –10 to +10 Vdc. The DECS-250 uses the following equation when converting the applied current into a voltage.

$$V_{aux} = (I_{aux} - 0.004) \times \left( \frac{20.0}{0.016} \right) - 10.0$$

#### Equation 6. Input Current to Voltage Signal Conversion

Where:  $V_{aux}$  is the calculated voltage signal and  $I_{aux}$  is the applied current in amperes.

For setpoint control,  $V_{aux}$  is multiplied by the appropriate regulation mode auxiliary gain setting.

If the auxiliary input is unused, all auxiliary control gains should be set to zero.

#### AVR Mode

In AVR mode, the auxiliary control signal is multiplied by the AVR gain setting<sup>C</sup>. The result defines the setpoint change as a percentage of the rated generator voltage.

$$\text{Generator Voltage Adjust} = V_{aux} \times 0.01 \times \text{AVR Gain} \times \text{Rated Voltage}$$

For example, applying +10 Vdc with an AVR gain of 1.0 raises the AVR setpoint 10% of rated generator voltage. This example also applies to the following modes.

#### FCR Mode

In FCR mode, the auxiliary control signal is multiplied by the FCR gain setting<sup>D</sup>. The resulting value relates to a percentage of the rated field current.

$$\text{FCR Adjust} = V_{aux} \times 0.01 \times \text{FCR Gain} \times \text{No Load Rated Field Current}$$

#### FVR Mode

In FVR mode, the auxiliary control signal is multiplied by the FVR gain setting<sup>E</sup>. The resulting value relates to a percentage of the rated field voltage.

$$\text{FVR Adjust} = V_{aux} \times 0.01 \times \text{FVR Gain} \times \text{No Load Rated Field Voltage}$$

#### Var Mode

In var mode, the auxiliary control signal is multiplied by the Var gain setting<sup>F</sup>. The resulting value relates to a percentage of the rated apparent power (kVA).

$$\text{var Adjust} = V_{aux} \times 0.01 \times \text{var Gain} \times 1.7321 \times \text{Rated Voltage} \times \text{Rated Current (Outerloop selected)}$$

#### Power Factor Mode

In Power Factor mode, the auxiliary control signal is multiplied by the PF gain setting<sup>G</sup> to define the PF setpoint change.

$$\text{PF Adjust} = V_{aux} \times 0.01 \times \text{PF Gain (Outerloop selected)}$$

### Summing Type<sup>H</sup>

The auxiliary control signal can be configured to control the inner or outer regulation control loop. Selecting the inner loop limits auxiliary control to AVR, FCR, and FVR modes. Selecting the outer loop limits auxiliary control to PF and Var modes.

Figure 21. Auxiliary Input Settings

- <sup>A</sup> *Input Type*: Select Voltage or Current.
- <sup>B</sup> *Input Function*: Select DECS Input, PSS Test Input, Limiter Scaling, or Grid Code Input.
- <sup>C</sup> *AVR (Mode) Gain*: Adjustable from –99 to +99 in 0.01 increments.
- <sup>D</sup> *FCR (Mode) Gain*: Adjustable from –99 to +99 in 0.01 increments.
- <sup>E</sup> *FVR (Mode) Gain*: Adjustable from –99 to +99 in 0.01 increments.
- <sup>F</sup> *Var (Mode) Gain*: Adjustable from –99 to +99 in 0.01 increments.
- <sup>G</sup> *PF (Mode) Gain*: Adjustable from –99 to +99 in 0.01 increments.
- <sup>H</sup> *Summing Type*: Select Inner Loop or Outer Loop.



# Contact Inputs and Outputs

Sixteen isolated, contact sensing inputs are available for initiating DECS-250 actions. Twelve sets of output contacts provide annunciation and control.

## Contact Inputs

**BESTCOMSPi<sup>us</sup> Navigation Path:** Settings Explorer, Programmable Inputs, Contact Inputs

**HMI Navigation Path:** Not available through HMI.

Sixteen contact inputs are provided for initiating DECS-250 actions. Two of the contact inputs are fixed-function inputs: Start and Stop. The remaining 14 contact inputs are programmable. An additional 10 contact inputs are available with the optional Contact Expansion Module (CEM-2020). Contact Basler Electric for ordering information.

All contact inputs are compatible with dry relay/switch contacts or open-collector outputs from a PLC. Each contact input has an isolated interrogation voltage and current of 12 Vdc at 4 mAdc. Appropriate switches/contacts should be selected for operation with this signal level.

### Note

The length of wiring connected to each contact input terminal must not exceed 150 feet (45.7 meters). Longer wiring lengths may allow induced electrical noise to interfere with the recognition of contact inputs.

## Start and Stop Inputs

The Start and Stop inputs accept a momentary contact closure that enables (Start) and disables (Stop) the DECS-250. If the DECS-250 receives Start and Stop contact inputs simultaneously, the Stop input takes priority. Start contact input connections are made at terminals START and COM A. Stop contact input connections are made at terminals STOP and COM A.

## Programmable Inputs

The 14 programmable inputs can be connected to monitor the status of excitation system contacts and switches. Then, using BESTlogic™ *Plus* programmable logic, these inputs can be used as part of a user-configured logic scheme to control and annunciate a variety of system conditions and contingencies. Information about using the programmable inputs in a logic scheme is provided in the *BESTlogicPlus* chapter.

To make the programmable contact inputs easier to identify, you can assign a custom name<sup>A</sup> that relates to the inputs/functions of your system. Figure 22 shows a portion of the BESTCOMSPi<sup>us</sup>® Contact Inputs screen where each of the 14 inputs can be assigned a custom name.

The screenshot displays a configuration interface titled "Contact Inputs". It contains 11 individual input configuration blocks, labeled "Input #1" through "Input #11". Each block includes a "Label Text" field. In the "Input #1" block, the label text is "INPUT 1" and there is a small box containing the letter "A". The other blocks show "INPUT 2" through "INPUT 11" in their respective label text fields. The interface has a jagged, sawtooth-style border on the right and bottom edges.

Figure 22. Contact Input Label Text

<sup>A</sup> *Label Text*: Enter a string of up to 64 alphanumeric characters.

See the *Terminals and Connectors* chapter for an illustration of the programmable input terminals.

## Contact Outputs

**BESTCOMSPiplus Navigation Path:** Settings Explorer, Programmable Outputs, Contact Outputs

**HMI Navigation Path:** Not available through HMI.

DECS-250 contact outputs consist of a dedicated watchdog output and 11 programmable outputs. An additional 18 contact outputs are available with the optional Contact Expansion Module (CEM-2020H). The optional CEM-2020 provides an additional 24 contact outputs. Contact Basler Electric for ordering information.

### Watchdog Output

This SPDT (Form C) output changes state during the following conditions:

- Control power is lost
- Normal firmware execution ceases
- Transfer Watchdog Trip is asserted in *BESTlogicPlus*.

Watchdog output connections are made at terminals WTCHD1 (normally open), WTCHD (common), and WTCHD2 (normally closed).

### Programmable Outputs

The 11 programmable, normally-open contact outputs can be configured to annunciate DECS-250 status, active alarms, active protection functions, and active limiter functions. Using *BESTlogicPlus* programmable logic, these outputs can be used as part of a user-configured logic scheme to control and annunciate a variety of system conditions and contingencies. Information about using the programmable outputs in a logic scheme is provided in the *BESTlogicPlus* chapter.

To make the programmable contact outputs easier to identify, you can assign a custom name<sup>A</sup> that relates to the functions of your system. Figure 23 shows the *BESTCOMSPiplus* Contact Outputs screen where each of the 12 outputs can be assigned a custom name.

The screenshot displays a configuration window titled "Contact Outputs". It contains 11 individual configuration boxes, each for a specific output. Each box has a title (e.g., "Output #1") and a "Label Text" field. The "Label Text" field for Output #1 contains the text "OUTPUT 1" and a small square icon with the letter "A" to its right. The other outputs (2 through 11) have their respective "Label Text" fields filled with "OUTPUT 2" through "OUTPUT 11".

Figure 23. Contact Output Label Text

<sup>A</sup> *Label Text*: Enter a string of up to 64 alphanumeric characters.

See the *Terminals and Connectors* chapter for an illustration of the programmable output terminals. Contact output electrical ratings are listed in the *Specifications* chapter.



# Protection

The DECS-250 offers protection relating to generator voltage, frequency, power, field parameters, rotating exciter diodes, power input failure, and generator-to-bus synchronism. Configurable protection elements supplement this protection with additional, user-defined system parameters that have multiple pickup thresholds per parameter. Most protection functions have two groups of settings labeled Primary and Secondary. Two setting groups enable independent protection coordination which is selectable in BESTlogic™ *Plus*.

## Voltage Protection

**BESTCOMSPlus Navigation Path:** Settings Explorer, Protection, Voltage

**HMI Navigation Path:** Settings, Protection, Voltage Protection

Voltage protection includes overexcitation, generator undervoltage, generator overvoltage, and loss of sensing voltage.

### Overexcitation (Volts per Hertz)

Volts per hertz protection is annunciated if the ratio of the per-unit voltage to the per-unit frequency (volts/hertz) exceeds one of the Volts per Hertz Pickup Level<sup>A</sup> settings for a definite amount of time<sup>B</sup>. If the Volts per Hertz Pickup level is exceeded, timing will continue until the volts per hertz ratio drops below the dropout ratio (95%). Volts per hertz protection also guards against other potentially damaging system conditions such as a change in system voltage and reduced frequency conditions that can exceed the system's excitation capability.

Several volts per hertz settings enable the DECS-250 to provide flexible generator and generator step-up transformer overexcitation protection. An inverse square timing characteristic is provided through the Inverse Time Pickup Setpoint<sup>C</sup> and Time Dial<sup>D</sup> settings. These settings enable the DECS-250 to approximate the heating characteristic of the generator and generator step-up transformer during overexcitation. A linear reset characteristic is provided through the Reset Dial<sup>E</sup> setting. Volts per hertz protection can be enabled and disabled<sup>F</sup> without altering the pickup and time delay settings.

Two sets of fixed-time, overexcitation pickup settings are available through the Definite Time Pickup #1, #2 and Definite Time Delay #1, #2 settings.

The following equations represent the trip time and reset time for a constant V/Hz level. Volts per hertz characteristic curves are illustrated in Figure 24 and Figure 25.

$$T_T = \frac{D_T}{\left( \frac{V / \text{Hz}_{\text{MEASURED}}}{V / \text{Hz}_{\text{NOMINAL}}} - 1 \right)^n}$$

Equation 7. Trip Time

$$T_R = D_R \times \frac{E_T}{FST} \times 100$$

Equation 8. Reset Time

Where:

- T<sub>T</sub> = time to trip
- T<sub>R</sub> = time to reset
- D<sub>T</sub> = time dial trip
- D<sub>R</sub> = time dial, reset
- E<sub>T</sub> = elapsed time
- n = curve exponent (0.5, 1, 2)<sup>G</sup>
- FST = full scale trip time (T<sub>T</sub>)
- E<sub>T</sub>/FST = fraction of total travel toward trip that integration had progressed to. (After a trip, this value will be equal to 1.)

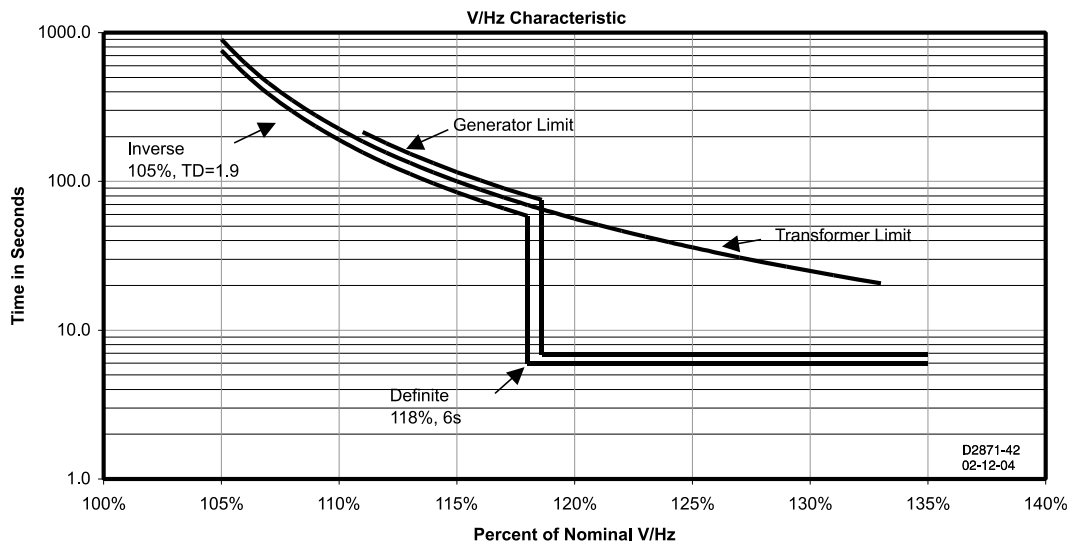


Figure 24. V/Hz Characteristic – Time Shown on Vertical Axis

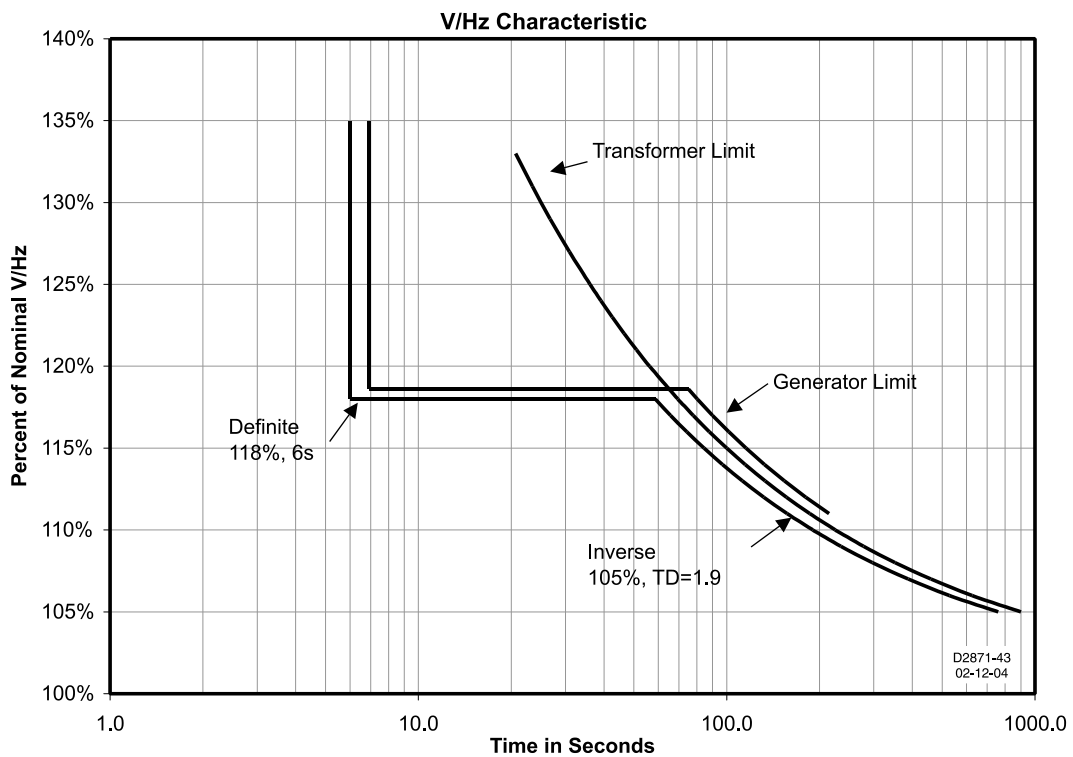


Figure 25. V/Hz Characteristic – Time Shown on Horizontal Axis

**Overexcitation (24)**

Primary	Secondary
Mode: Enabled (F)	Mode: Enabled (F)
Curve Exponent: 1 (G)	Curve Exponent: 1 (G)
Inverse Time Pickup (V/Hz): 0.00 (C)	Inverse Time Pickup (V/Hz): 0.00 (C)
Time Dial: 0.0 (D)	Time Dial: 0.0 (D)
Reset Dial: 0.0 (E)	Reset Dial: 0.0 (E)
Definite Time Pickup 1 (V/Hz): 0.00 (A)	Definite Time Pickup 1 (V/Hz): 0.00 (A)
Definite Time Delay 1 (s): 0.050 (B)	Definite Time Delay 1 (s): 0.050 (B)
Definite Time Pickup 2 (V/Hz): 0.00 (A)	Definite Time Pickup 2 (V/Hz): 0.00 (A)
Definite Time Delay 2 (s): 0.050 (B)	Definite Time Delay 2 (s): 0.050 (B)

**Figure 26. Overexcitation Protection Settings**

- <sup>A</sup> *Definite Time Pickup*: Adjustable from 0 or 0.5 to 6.00 in increments of 0.01.  
<sup>B</sup> *Definite Time Delay*: Adjustable from 0.05 to 600 seconds in increments of 0.001 seconds.  
<sup>C</sup> *Inverse Time Pickup*: Adjustable from 0 or 0.5 to 6.00 in increments of 0.01.  
<sup>D</sup> *Time Dial*: Adjustable from 0.0 to 9.9 in increments of 0.1.  
<sup>E</sup> *Reset Dial*: Adjustable from 0.0 to 9.9 in increments of 0.1.  
<sup>F</sup> *Mode*: Select Enabled or Disabled.  
<sup>G</sup> *Curve Exponent*: Select 0.5, 1, or 2

## Generator Undervoltage

An undervoltage pickup condition occurs when the sensed generator terminal voltage decreases below the pickup setting<sup>A</sup>. An undervoltage trip condition occurs if the generator voltage remains below the pickup threshold for the duration of the time delay setting<sup>B</sup>. Generator undervoltage protection can be enabled and disabled<sup>C</sup> without altering the pickup and time delay settings. Undervoltage pickup and trip elements in BESTLogicPlus can be used in a logic scheme to initiate corrective action in response to the condition. BESTCOMSPPlus<sup>®</sup> generator undervoltage settings are illustrated in Figure 27.

**Generator Undervoltage**

27 Element

Primary	Secondary
Mode: Enabled (C)	Mode: Enabled (C)
Pickup (Primary V): 0 (A)	Pickup (Primary V): 0 (A)
Time Delay (s): 0.1 (B)	Time Delay (s): 0.1 (B)

**Figure 27. Generator Undervoltage Protection Settings**

- <sup>A</sup> *Generator Undervoltage Pickup (V)*: Adjustable from 0 to 600,000 Vac in 1 Vac increments.  
<sup>B</sup> *Generator Undervoltage Time Delay (s)*: Adjustable from 0.1 to 60 seconds in 0.1 second increments.  
<sup>C</sup> *Generator Undervoltage Enable/Disable*: Select Enabled or Disabled.

## Generator Overvoltage

An overvoltage pickup condition occurs when the sensed generator terminal voltage increases above the pickup setting<sup>A</sup>. An overvoltage trip condition occurs if the generator voltage remains above the pickup threshold for the duration of the time delay setting<sup>B</sup>. Generator overvoltage protection can be enabled and disabled<sup>C</sup> without altering the pickup and time delay settings. Overvoltage pickup and trip elements in BESTlogicPlus can be used in a logic scheme to initiate corrective action in response to the condition. BESTCOMSPPlus<sup>®</sup> generator overvoltage settings are illustrated in Figure 28.

Figure 28. Generator Overvoltage Protection Settings

<sup>A</sup> *Generator Overvoltage Pickup (V)*: Adjustable from 0 to 600,000 Vac in 1 Vac increments.

<sup>B</sup> *Generator Overvoltage Time Delay (s)*: Adjustable from 0.1 to 60 seconds in 0.1 second increments.

<sup>C</sup> *Generator Overvoltage Enable/Disable*: Select Enabled or Disabled.

## Loss of Sensing

The generator voltage is monitored for a loss of sensing (LOS) condition. LOS protection settings are illustrated in Figure 29.

In the DECS-250, a loss of sensing (LOS) event is calculated using sequence components. LOS trip criteria is listed in Table 3.

Table 3. Loss of Sensing Trip Criteria

Loss of either 1 or 2 phases (3-phase sensing)	Loss of all 3 phases (3-phase sensing)	Loss of single-phase sensing
3-phase, 3-wire sensing selected	3-phase, 3-wire sensing selected	Single-phase sensing selected
$V1 > BV\%$ of AVR setpoint	$BV\%$ of AVR Setpoint $> V1$	$BV\%$ of AVR Setpoint $> VGEN$
$V2 > UV\%$ of $V1$	$200\%$ of $I_{rated} > I1$	$200\%$ of $I_{rated} > I1$
$17.7\%$ of $I1 > I2$ OR $1\%$ of $I_{rated} > I1$		$17.7\%$ of $I1 > I2$ OR $1\%$ of $I_{rated} > I1$

$V1$  = Positive sequence voltage

$V2$  = Negative sequence voltage

$I1$  = Positive sequence current

$I2$  = Negative sequence current

$I_{rated}$  = Rated current

$BV\%$  = Balanced voltage percent<sup>A</sup>

$UV\%$   $V1$  = Unbalanced voltage percent<sup>B</sup>

$VGEN$  = Average generator voltage

When all criteria in a column are true for the duration of the time delay<sup>C</sup> setting, a LOS trip condition occurs.

A LOS condition can be used to initiate a transfer to manual (FCR) control mode<sup>D</sup>. It also can be configured in BESTlogicPlus to initiate other actions. Protection can be enabled and disabled<sup>E</sup> without altering the individual loss of sensing settings.

LOS protection is automatically disabled when a short circuit exists. A short circuit is detected when the measured current is greater than twice the rated current for a single-phase CT connection and when the positive sequence current is greater than twice the rated current for a three-phase CT connection.

Figure 29. Loss of Sensing Protection Settings

<sup>A</sup> Voltage Balanced Level: Adjustable from 0 to 100% in 0.1% increments.

<sup>B</sup> Voltage Unbalanced Level: Adjustable from 0 to 100% in 0.1% increments.

<sup>C</sup> *Time Delay*: Adjustable from 0 to 30 seconds in 0.1 second increments.

<sup>D</sup> *Transfer to Manual*: Select Disabled or Enabled.

<sup>E</sup> *Mode*: Select Disabled or Enabled.

## Frequency Protection

**BESTCOMSPlus Navigation Path:** Settings Explorer, Protection, Frequency

**HMI Navigation Path:** Settings, Protection, Frequency Protection 81

The frequency of the generator terminal voltage is monitored for overfrequency and under-frequency conditions.

### Overfrequency

An overfrequency condition occurs when the frequency of the generator voltage exceeds the 81O pickup threshold<sup>A</sup> for the duration of the 81O time delay setting<sup>B</sup>. Overfrequency protection can be enabled and disabled<sup>C</sup> without altering the pickup and time delay settings. Overfrequency pickup and trip elements in BESTlogicPlus can be used in a logic scheme to initiate corrective action in response to the condition. BESTCOMSPlus overfrequency settings are illustrated in Figure 30.

Figure 30. Overfrequency Protection Settings

<sup>A</sup> *Overfrequency (81O) Pickup (Hz)*: Adjustable from 30 to 70 hertz in 0.01 hertz increments.

<sup>B</sup> *Overfrequency (81O) Time Delay (s)*: Adjustable from 0.1 to 300 seconds in 0.1 second increments.

<sup>C</sup> *Overfrequency (81O) Mode*: Select Disabled or Over.

## Underfrequency

An underfrequency condition occurs when the frequency of the generator voltage decreases below the 81U pickup threshold<sup>A</sup> for the duration of the 81U time delay setting<sup>B</sup>. A voltage inhibit setting<sup>C</sup>, expressed as a percentage of the rated generator voltage, can be implemented to prevent an underfrequency trip from occurring during startup when the generator voltage is rising toward the nominal level.

Underfrequency protection can be enabled and disabled<sup>D</sup> without altering the pickup, delay, and inhibit settings. Underfrequency pickup and trip elements in *BESTlogicPlus* can be used in a logic scheme to initiate corrective action in response to the condition. *BESTCOMSPlus* underfrequency settings are illustrated in Figure 31.

The screenshot shows the 'Frequency' settings for the '81U Element'. It is divided into 'Primary' and 'Secondary' sections. Each section has a 'Mode' dropdown menu (set to 'Under'), a 'Pickup (Hz)' text box (set to 30.00), a 'Time Delay (s)' text box (set to 0.1), and a 'Voltage Inhibit (%)' text box (set to 50). Small callout boxes labeled A, B, and C point to the Pickup, Time Delay, and Voltage Inhibit fields respectively. A callout box labeled D points to the Mode dropdown menu.

**Figure 31. Underfrequency Protection Settings**

<sup>A</sup> *Underfrequency (81U) Pickup (Hz)*: Adjustable from 30 to 70 hertz in 0.01 hertz increments.

<sup>B</sup> *Underfrequency (81U) Time Delay (s)*: Adjustable from 0.1 to 300 seconds in 0.1 second increments.

<sup>C</sup> *Underfrequency (81U) Voltage Inhibit (%)*: Adjustable from 50 to 100% in 1% increments.

<sup>D</sup> *Underfrequency (81U) Mode*: Select Disable or Under.

## Power Protection

**BESTCOMSPlus Navigation Path:** Settings Explorer, Protection, Power

**HMI Navigation Path:** Settings, Protection, Power

Generator power levels are monitored to protect against reverse power flow and loss of excitation.

### Caution

For optimal 40Q (loss of excitation) operation, set the rated PF to a value less than 1.0 on the *BESTCOMSPlus* Rated Data screen. When the rated PF value is changed, the rated kW is automatically recalculated and the 40Q and 32 (reverse power) element settings must be adjusted appropriately.

## Reverse Power

Reverse power protection guards against reverse power flow that may result from a loss of prime mover torque (and lead to generator motoring). A reverse power condition occurs when the flow of reverse power exceeds the 32R pickup threshold<sup>A</sup> for the duration of the 32R time delay<sup>B</sup>. Reverse power

protection can be enabled and disabled<sup>C</sup> without altering the pickup and time delay settings. Reverse power pickup and trip elements in BESTlogicPlus can be used in a logic scheme to initiate corrective action in response to the condition. BESTCOMSPlus reverse power protection settings are illustrated in Figure 32.

**Figure 32. Reverse Power Protection Settings**

<sup>A</sup> Reverse Power (32R) Pickup (%): Adjustable from 0 to 150% in 1% increments.

<sup>B</sup> Reverse Power (32R) Time Delay (s): Adjustable from 0 to 300 seconds in 0.1 second increments.

<sup>C</sup> Reverse Power (32R) Mode: Select Disabled or Enabled.

## Loss of Excitation

The loss of excitation element operates on excessive var flow into the machine, indicating abnormally low field excitation. This element protects controlled generators as well as motors. A diagram of the 40Q pickup response is illustrated in Figure 33. BESTCOMSPlus settings are described below and shown in Figure 34.

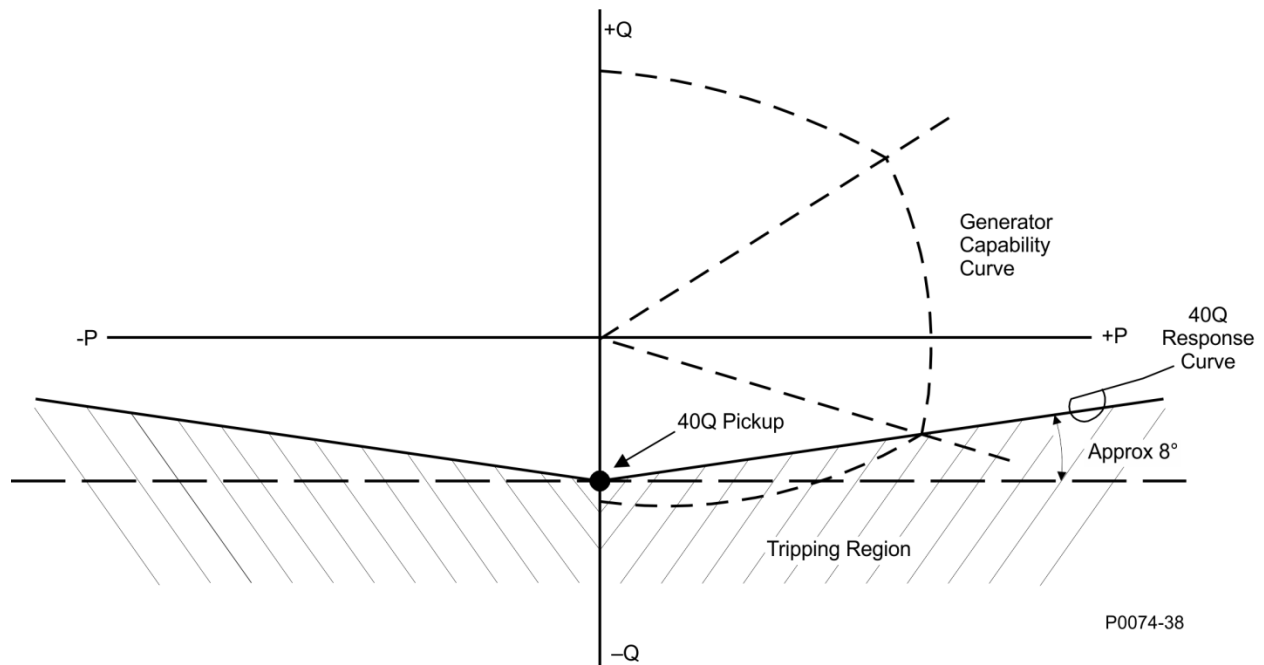
### Generator Protection

During loss of excitation, the generator absorbs reactive power from the power system which can overheat the stator windings. The loss of excitation element acts on the principal that if a generator begins to absorb vars outside its steady-state capability curve, it has likely lost its normal excitation supply. The element is always calibrated to the equivalent three-phase power even if the connection is single-phase.

The loss of excitation element compares the reactive power to a map of the allowed reactive power as defined by the Pickup setting. The loss of excitation element remains in a pickup condition until power flow falls below the dropout ratio of 95% of the actual pickup. A time delay is recommended for tripping. For settings well outside the generator capability curve, adding a 0.5 second time delay helps prevent transient fault conditions. However, recovery from power system swings after a major fault may take several seconds. Therefore, if the unit is to pick up near the steady-state capability curve of the generator, longer time delays are recommended. See Figure 33 for details.

### Motor Protection

The DECS-250 compares the real power (kW) flowing into the motor with the reactive power (kvar) being supplied. Operation of synchronous motors drawing reactive power from the system can result in overheating in parts of the rotor that do not normally carry current. The 40Q pickup response is shown in Figure 33.



**Figure 33. Generator Capability Curve vs. 40Q Response**

### Pickup and Trip

A loss of excitation condition exists when the level of absorbed vars exceeds the loss of excitation (40Q) threshold<sup>A</sup> for the duration of the 40Q time delay<sup>B</sup>. A time delay setting of zero makes the loss of excitation element instantaneous with no intentional time delay. If the pickup condition subsides before the time delay expires, the timer and pickup are reset, no corrective action is taken, and the element is rearmed for any further occurrences of loss of excitation.

The 40Q threshold is expressed as a percentage of the rated var flow for the machine. Loss of excitation protection can be enabled and disabled<sup>C</sup> without altering the pickup and time delay settings. BESTCOMSPlus loss of excitation settings are illustrated in Figure 34.

**Loss of Excitation**

40Q Element

<p><b>Primary</b></p> <p>Mode  <input type="button" value="Enabled"/> <input type="button" value="C"/></p> <p>Pickup (% of Rated vars)  <input type="text" value="0"/> <input type="button" value="A"/></p> <p>Time Delay (s)  <input type="text" value="0.0"/> <input type="button" value="B"/></p>	<p><b>Secondary</b></p> <p>Mode  <input type="button" value="Enabled"/> <input type="button" value="C"/></p> <p>Pickup (% of Rated vars)  <input type="text" value="0"/> <input type="button" value="A"/></p> <p>Time Delay (s)  <input type="text" value="0.0"/> <input type="button" value="B"/></p>
--	--

**Figure 34. Loss of Excitation Protection Settings**

<sup>A</sup> *Pickup (% of rated vars)*: Adjustable from 0 to 150% in 1% increments.

<sup>B</sup> *Time Delay*: Adjustable from 0 to 300 seconds in 0.1 second increments.

<sup>C</sup> *Mode*: Select Disabled or Enabled.

## **Field Protection**

**BESTCOMSPlus Navigation Path:** Settings Explorer, Protection, Field

**HMI Navigation Path:** Settings, Protection, Field

Field protection provided by the DECS-250 includes field overvoltage, field overcurrent, an exciter diode monitor, and power input failure.

## Field Overvoltage

A field overvoltage condition occurs when the field voltage exceeds the field overvoltage threshold<sup>A</sup> for the duration of the field overvoltage time delay<sup>B</sup>. Field overvoltage protection can be enabled and disabled<sup>C</sup> without altering the pickup and time delay settings. Field overvoltage pickup and trip elements in BESTlogicPlus can be used in a logic scheme to initiate corrective action in response to the condition. BESTlogicPlus field overvoltage settings are illustrated in Figure 35.

Figure 35. Field Overvoltage Protection Settings

<sup>A</sup> *Field Overvoltage Pickup (V)*: Adjustable from 0 to 325 Vdc in 1 Vdc increments.

<sup>B</sup> *Field Overvoltage Time Delay (s)*: Adjustable from 0.2 to 30 seconds in 0.1 second increments.

<sup>C</sup> *Field Overvoltage Mode*: Select Disabled or Enabled.

## Field Overcurrent

A field overcurrent condition is annunciated when the field current exceeds the field overcurrent pickup level<sup>A</sup> for the duration of the field overcurrent time delay. Depending on the selected timing mode<sup>B</sup>, the time delay can be fixed or related to an inverse function. Definite timing mode uses a fixed time delay<sup>C</sup>. In inverse timing mode, the time delay is shortened in relation to the level of field current above the pickup level. The time dial<sup>D</sup> setting acts as a linear multiplier for the time to an annunciation. This enables the DECS-250 to approximate the heating characteristic of the generator and generator step-up transformer during overexcitation. The field current must fall below the dropout ratio (95%) for the function to begin timing to reset. The following equations are used to calculate the field overcurrent pickup and reset time delays.

$$t_{pickup} = \frac{A \times TD}{B + \sqrt{C + D \times MOP}}$$

Equation 9. Inverse Field Overcurrent Pickup

Where:

$t_{pickup}$  = time to pick up in seconds

A = -95.908

B = -17.165

C = 490.864

D = -191.816

TD = time dial setting <0.1, 20>

MOP = multiple of pickup <1.03, 205>

$$Time_{reset} = \frac{0.36 \times TD}{(MOP_{reset})^2 - 1}$$

Equation 10. Inverse Field Overcurrent Reset

Where:

$\text{Time}_{\text{reset}}$  = maximum time to reset in seconds

TD = time dial setting <0.1, 20>

$\text{MOP}_{\text{reset}}$  = multiple of pickup <1.03, 205>

Primary and secondary setting groups provide additional control for two distinct machine operating conditions.

Field overcurrent protection can be enabled and disabled<sup>E</sup> without altering the pickup and time delay settings. Field overcurrent pickup and trip elements in *BESTlogicPlus* can be used in a logic scheme to initiate corrective action in response to the condition. *BESTCOMSPPlus* field overcurrent settings are illustrated in Figure 36. In *BESTCOMSPPlus*, a plot of the field overcurrent setting curve is displayed. The plot can display the primary or secondary setting curves.

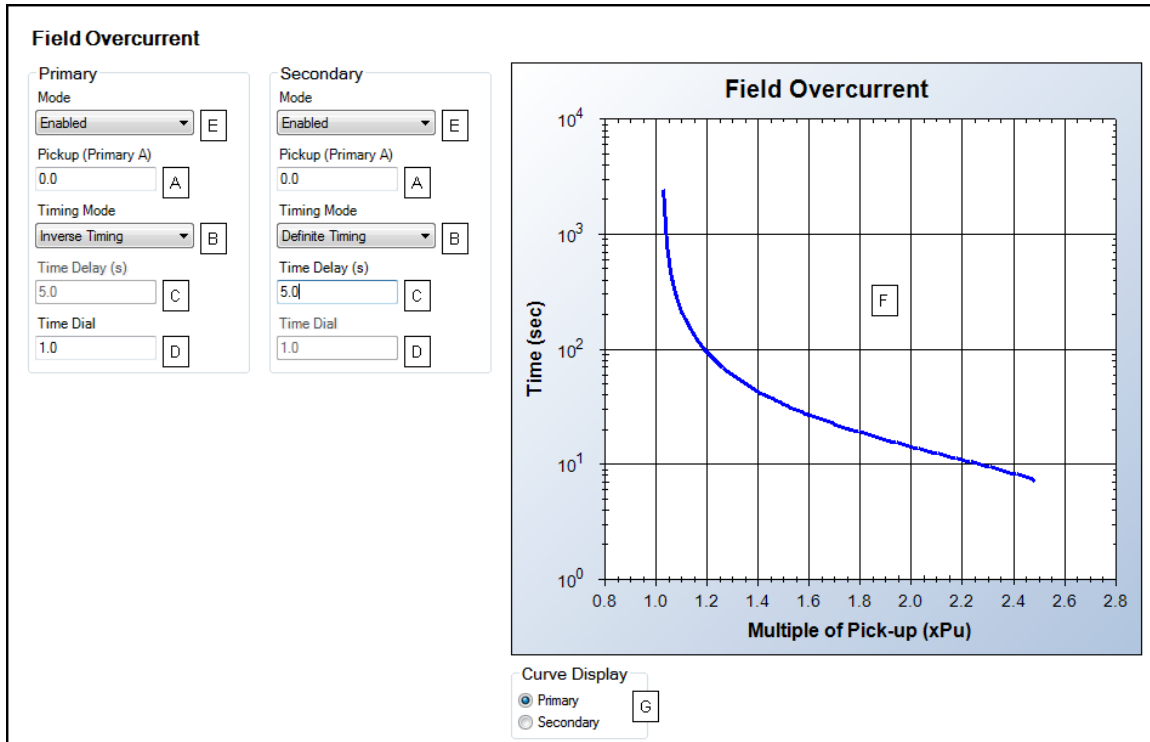


Figure 36. Field Overcurrent Protection Settings

<sup>A</sup> *Field Overcurrent Pickup (A)*: Adjustable from 0 to 22 Adc in 0.1 Adc increments.

<sup>B</sup> *Timing Mode*: Select Definite Timing or Inverse Timing

<sup>C</sup> *Field Overcurrent Time Delay (s)*: Adjustable from 0 or 5 to 60 seconds in 0.1 second increments.

<sup>D</sup> *Field Overcurrent Time Dial*: Adjustable from 0.1 to 20 in increments of 0.1.

<sup>E</sup> *Field Overcurrent Mode*: Select Disabled or Enabled.

<sup>F</sup> Inverse field overcurrent pickup curve.

<sup>G</sup> Curve display selections.

## Exciter Diode Monitor

The exciter diode monitor (EDM) monitors the condition of a brushless exciter's power semiconductors by monitoring the exciter field current. The EDM detects both open and shorted rotating diodes in the exciter bridge. EDM settings are illustrated in Figure 37. When implementing the EDM, it is imperative that the user know and specify the number of poles for the exciter armature and the generator rotor. For reliable open diode detection, the exciter to generator pole ratio<sup>A</sup> should be 1.5 or higher and the level of field current should be no less than 1.5 Adc. A pole ratio calculator, available in *BESTCOMSPPlus*, can be used to calculate the pole ratio from the number of exciter armature and generator rotor poles.

### Notes

If the number of poles for the exciter armature and the generator rotor is unknown, the EDM function will still operate. However, only a shorted diode can be detected. If the number of poles is not known, it is best to disable all exciter open diode protection parameters. In this situation, the generator and exciter pole parameters must be set to 1.0 to prevent false tripping.

All of the EDM setup guidelines presented here assume that the exciter diodes are not open or shorted at the time of setup and testing.

The EDM estimates the fundamental harmonic of the exciter field current using discrete Fourier transforms (DFTs). The harmonic, expressed as a percentage of the field current, is then compared to the pickup level for open diode detection<sup>B</sup> and shorted diode detection<sup>C</sup>. If the percentage of field current exceeds the open diode or shorted diode pickup level, then the appropriate time delay will begin. After the time delay for the open diode<sup>D</sup> or shorted diode<sup>E</sup> condition expires and if the percentage of field current continues to exceed the open or shorted diode pickup setting, the condition is annunciated. EDM pickup and trip elements in *BESTlogicPlus* can be used in a logic scheme to initiate corrective action in response to an open or shorted diode condition.

An EDM disable level setting prevents nuisance annunciations due to low excitation current or the generator frequency being out of range. A disable level setting<sup>F</sup> can be used to disable both open- and shorted-diode protection when the field current drops below the user-defined percentage of rated. EDM protection can be disabled and enabled<sup>G</sup> by the user without altering the individual protection settings.

#### Applying EDM Protection

It is especially difficult to detect open diode conditions when the number of generator and exciter poles is unknown. For this reason, the ratio of the number of brushless exciter armature poles to the number of generator rotor poles should be entered to ensure detection of both open and shorted diodes.

#### Finding the Maximum Field Ripple Current

To set the open diode pickup level and shorted diode pickup level, the maximum ripple current on the field must be known. This can be accomplished by running the generator unloaded and at rated speed. Vary the generator voltage from minimum to maximum while monitoring the EDM ripple level on the HMI display. Record the highest value.

#### Setting the Pickup Level—Number of Generator Poles Known

Multiply the highest EDM ripple value, obtained in the preceding paragraph, by 2. The result is the open diode pickup level setting. The multiplier can be varied between 1.5 and 5 to increase or decrease the trip margin. However, reducing the multiplier could result in nuisance open diode indications.

Multiply the highest EDM ripple value, obtained in the preceding paragraph by 50. The result is the shorted diode pickup level setting. The multiplier can be varied between 40 and 70 to increase or decrease the trip margin. However, reducing the multiplier could result in nuisance shorted diode indications.

The DECS-250 has fixed EDM inhibit levels to prevent nuisance failed-diode indications while the generator frequency is less than 40 hertz or greater than 70 hertz. EDM operation is also inhibited when the level of field current is below the disable level setting.

Figure 37. Exciter Diode Monitor Protection Settings

- <sup>A</sup> *EDM Pole Ratio*: Adjustable from 0 to 10 in 0.01 increments.
- <sup>B</sup> *Open Diode Pickup Level (%)*: Adjustable from 0 to 100% in 0.1% increments.
- <sup>C</sup> *Shorted Diode Pickup Level (%)*: Adjustable from 0 to 100% in 0.1% increments.
- <sup>D</sup> *Open Diode Delay (s)*: Adjustable from 10 to 60 seconds in 0.1 second increments.
- <sup>E</sup> *Shorted Diode Delay (s)*: Adjustable from 5 to 30 seconds in 0.1 second increments.
- <sup>F</sup> *Disable Level (%)*: Adjustable from 0 to 100% in 0.1% increments.
- <sup>G</sup> *Mode*: Select Disabled or Enabled.

#### Setting the Pickup Level—Number of Generator Poles Unknown

The DECS-250 can detect shorted diode conditions when the number of generator poles is not known. To provide this protection, disable open diode protection, set the pole ratio to 1.0, and enable shorted diode protection. Multiply the maximum EDM ripple level, obtained under *Finding the Maximum Field Ripple Current*, by 30. The multiplier can be varied between 20 and 40 to increase or decrease the pickup margin. However, reducing the multiplier could result in nuisance shorted diode indications.

#### Testing the EDM Settings

Start the generator from rest and increase the speed and voltage to the rated value. Load the machine to its rating and confirm that no failed diode annunciators occur. All of the EDM setup guidelines presented here assume that the exciter diodes were not opened or shorted at the time of setup and testing.

### Power Input Failure

A power input failure condition exists when any one of the following occurs:

#### 1-phase operating power

When operating power decreases below 30 Vac, a power input failure condition exists.

#### 3-phase operating power

- All three phases of operating power decrease below 30 Vac
- A phase-to-phase voltage imbalance greater than 20% exists at the operating power input

The DECS-250 settings must be properly set to match the active operating power configuration. For example, if the DECS-250 settings reflect a 3-phase power configuration but the actual operating power configuration is 1-phase then the DECS-250 will interpret the one phase as an imbalance and set an alarm/trip. For more information on 1- and 3-phase operating power settings see *Configuration and Specifications*.

Power input failure protection can be used for PMG applications, shunt-, or PMG-powered systems. This protection is only active in *Start* mode and after soft start. A time delay setting<sup>A</sup> delays power input failure annunciators to accommodate transient reductions/imbalance in the operating power input voltage. Power input failure protection can be enabled and disabled<sup>B</sup> without altering the time delay setting. The selected power input configuration<sup>C</sup> is shown as a read-only value. Power input failure pickup and trip elements in *BESTlogicPlus* can be used in a logic scheme to initiate corrective action in response to the condition. *BESTCOMSPPlus* power input failure settings are illustrated in Figure 38.

**Figure 38. Power Input Failure Protection Settings**

<sup>A</sup> *Time Delay (s)*: Adjustable from 0 to 10 seconds in 0.1 second increments.

<sup>B</sup> *Mode*: Select Disabled or Enabled.

<sup>C</sup> *Power Input Configuration*: Read-only value

## Sync-Check Protection

**BESTCOMSPPlus Navigation Path:** Settings Explorer, Protection, Sync Check (25)

**HMI Navigation Path:** Settings, Protection, Sync Check (25)

### Caution

Because the DECS-250 sync-check and automatic synchronizer functions share internal circuitry, the sync-check function is not available when the automatic synchronizer style option is selected.

When enabled<sup>A</sup>, the sync-check (25) function supervises the automatic or manual synchronism of the controlled generator with a bus/utility. During synchronizing, the 25 function compares the voltage<sup>B</sup>, slip angle<sup>C</sup>, and slip frequency<sup>D</sup> differences between the generator and bus. When the generator/bus differences fall within the setting for each parameter, the 25 status virtual output asserts. This virtual output can be configured (in *BESTlogicPlus*) to assert a DECS-250 contact output. This contact output can, in turn, enable the closure of a breaker tying the generator to the bus.

An angle compensation<sup>E</sup> setting is provided to offset phase shift caused by transformers in the system. For more details on the angle compensation setting, see the *Synchronizer* chapter.

When the Gen Freq > Bus Freq<sup>F</sup> setting box is checked, the 25 status virtual output will not assert unless the generator frequency is greater than the bus frequency. Sync-check protection settings are illustrated in Figure 39.

Figure 39. Sync-Check Protection Settings

<sup>A</sup> *Sync-Check Mode*: Select Disabled or Enabled.

<sup>B</sup> *Sync-Check Voltage Difference (%)*: Adjustable from 0 to 50% in 0.1% increments.

<sup>C</sup> *Sync-Check Slip Angle (Degrees)*: Adjustable from 1 to 99° in 0.1° increments.

<sup>D</sup> *Sync-Check Slip Freq (Hz)*: Adjustable from 0.01 to 0.5 Hz in 0.01 Hz increments.

<sup>E</sup> *Angle Compensation (°)*: Adjustable from 0.0 to 359.9° in 0.1° increments.

<sup>F</sup> *Gen Freq > Bus Freq*: Enable (checked) or Disable (unchecked)

## Generator Frequency Less Than 10 Hertz

A *Generator Below 10 Hz* condition is annunciated when the generator frequency decreases below 10 Hz or when residual voltage is low at 50/60 Hz. A *Generator Below 10 Hz* annunciation is automatically reset when the generator frequency increases above 10 Hz or the residual voltage increases above the threshold.

## Configurable Protection

**BESTCOMSPi<sub>us</sub> Navigation Path:** Settings Explorer, Protection, Configurable Protection

**HMI Navigation Path:** Settings, Protection, Configurable Protection

The DECS-250 has eight configurable protection elements which can be used to supplement the standard DECS-250 protection. BESTCOMSPi<sub>us</sub> configurable protection settings are illustrated in Figure 40. To make the protection elements easier to identify, each element can be given a user-assigned name<sup>A</sup>. A protection element is configured by selecting the parameter<sup>B</sup> to be monitored and then establishing the operating characteristics for the element. Any one of the following parameters may be selected.

- Analog Input 1, 2, 3, 4, 5, 6, 7, 8
- APC Output
- Auxiliary Input Current (mA)
- Auxiliary Input Voltage
- Bus Frequency
- Bus Voltage:  $V_{AB}$ ,  $V_{BC}$ , or  $V_{CA}$
- EDM Ripple
- Exciter Field Current
- Exciter Field Voltage
- Gen Current:  $I_A$ ,  $I_B$ ,  $I_C$ , or Average
- Gen Frequency
- Gen Power Factor
- Gen Voltage:  $V_{AB}$ ,  $V_{BC}$ ,  $V_{CA}$ , or Average

- Kilovarhours
- Kilowatthours
- LVRT Output
- Negative Sequence Current
- Negative Sequence Voltage
- NLS Error Percent
- Positive Sequence Current
- Positive Sequence Voltage
- Power Input
- PSS Output
- RTD Input 1, 2, 3, 4, 5, 6, 7, 8
- Setpoint Position
- Thermocouple 1, 2
- Total kVA
- Total kvar
- Total kW
- Tracking Error

If an optional Analog Expansion Module (AEM-2020) is used, any one of the following analog, RTD, and thermocouple inputs may be selected.

- Analog Input 1, 2, 3, 4, 5, 6, 7, or 8
- RTD Input 1, 2, 3, 4, 5, 6, 7, or 8
- Thermocouple 1 or 2

Protection can be always enabled or enabled only when the DECS-250 is enabled and supplying excitation<sup>C</sup>. When protection is enabled only in Start mode, an arming time delay<sup>D</sup> can be used to delay protection following the start of excitation.

A hysteresis function holds the protection function active for a user-defined percentage<sup>E</sup> above/below the pickup threshold. This prevents repeated pickups and dropouts where the monitored parameter is hovering around the pickup threshold. For example, with a hysteresis setting of 5% on a protection element configured to pick up at 100 Aac of A-phase generator overcurrent, the protection element would pick up when the current rises above 100 Aac and remain picked up until the current decreases below 95 Aac.

Each of the eight configurable protection elements has four individually-adjustable thresholds. Each threshold can be set for pickup when the monitored parameter increases above the pickup setting (Over), pickup when the monitored parameter decreases below the pickup setting (Under), or no pickup (Disabled)<sup>F</sup>. The pickup level for the monitored parameter is defined by a threshold setting<sup>G</sup>. While the threshold setting range is broad, you must use a value within the setting range limits for the monitored parameter. Using an out-of-limits threshold will prevent the protection element from functioning. An activation delay<sup>H</sup> serves to delay a protective trip after the threshold (pickup) level is exceeded.

### Configurable Protection #1

Label Text  
CONF PROT 1 A

Parameter Selection  
Gen VAB B

Stop Mode Inhibit  
No C

Arming Delay (s)  
0 D

Hysteresis (%)  
2.0 E

**Threshold #1**

Mode	Threshold	Activation Delay (s)
Disabled <span style="float: right;">F</span>	0.00 <span style="float: right;">G</span>	0 <span style="float: right;">H</span>

**Threshold #2**

Mode	Threshold	Activation Delay (s)
Disabled <span style="float: right;">F</span>	0.00 <span style="float: right;">G</span>	0 <span style="float: right;">H</span>

**Threshold #3**

Mode	Threshold	Activation Delay (s)
Disabled <span style="float: right;">F</span>	0.00 <span style="float: right;">G</span>	0 <span style="float: right;">H</span>

**Threshold #4**

Mode	Threshold	Activation Delay (s)
Disabled <span style="float: right;">F</span>	0.00 <span style="float: right;">G</span>	0 <span style="float: right;">H</span>

**Figure 40. Configurable Protection Settings**

<sup>A</sup> *Label Text*: Accepts a maximum of 16 alphanumeric characters.

<sup>B</sup> *Param Selection*: Select Gen VAB, Gen VBC, Gen VCA, Gen V Average, Bus Freq, Bus VAB, Bus VBC, Bus VCA, Gen Freq, Gen PF, KWH, kvarh, Gen IA, Gen IB, Gen IC, Gen I Average, KW Total, KVA Total, kvar Total, EDM Ripple, Exciter Field Voltage, Exciter Field Current, Auxiliary Input Voltage, Auxiliary Input Current (mA), Setpoint Position, Tracking Error, Negative Sequence Voltage, Negative Sequence Current, Positive Sequence Voltage, Positive Sequence Current, PSS Output, Analog Input 1, Analog Input 2, Analog Input 3, Analog Input 4, Analog Input 5, Analog Input 6, Analog Input 7, Analog Input 8, RTD Input 1, RTD Input 2, RTD Input 3, RTD Input 4, RTD Input 5, RTD Input 6, RTD Input 7, RTD Input 8, Thermocouple 1, Thermocouple 2, Power Input, NLS Error Percent, APC Output, or LVRT Output.

<sup>C</sup> *Stop Mode Inhibit*: Select Yes or No.

<sup>D</sup> *Arming Delay*: Adjustable from 0 to 300 seconds in 1 second increments.

<sup>E</sup> *Hysteresis*: Adjustable from 0 to 100% of the threshold setting in 0.1% increments.

<sup>F</sup> *Mode*: Select Over, Under, or Disabled.

<sup>G</sup> *Threshold*: Adjustable from -999,999 to +999,999 in 0.01 increments.

<sup>H</sup> *Activation Delay (s)*: Adjustable from 0 to 300 seconds in 1 second increments.

# Limiters

DECS-250 limiters ensure that the controlled machine does not exceed its capabilities. Overexcitation, underexcitation, stator current, and reactive power are limited by the DECS-250. It also limits the voltage during underfrequency conditions.

## Overexcitation Limiter

**BESTCOMSPlus Navigation Path:** Settings Explorer, Operating Settings, Limiters, OEL

**HMI Navigation Path:** Settings, Operating Settings, Limiters, OEL

Operating in the overexcited region of a generator's capability curve can cause excessive field current and field winding heating. The overexcitation limiter (OEL) monitors the level of field current supplied by the DECS-250 and limits it to prevent field overheating.

The OEL can be enabled<sup>A</sup> in all regulation modes. OEL behavior in manual mode can be configured to limit excitation or issue an alarm. This behavior is configured in BESTlogic™ Plus.

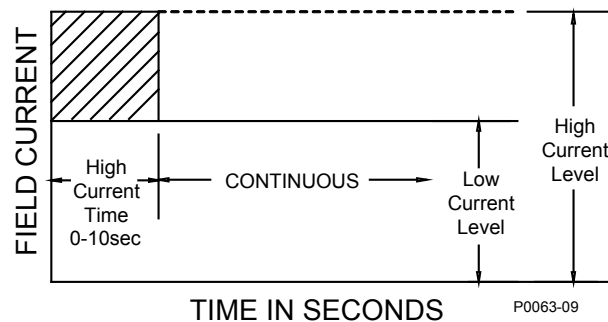
Two styles of overexcitation limiting are available in the DECS-250: summing point or takeover<sup>B</sup>. OEL settings are illustrated in Figure 43, Figure 44, and Figure 46.

### Summing Point OEL

Summing point overexcitation limiting compensates for field overcurrent conditions while the machine is offline or online. Offline and online OEL behavior is dictated by two separate groups of settings. Primary and secondary setting groups (selectable in configurable logic) provide additional control for two distinct machine operating conditions.

#### Offline Operation

For offline operation, there are two levels of summing-point overexcitation limiting: low and high. Figure 41 illustrates the relationship of the high-level and low-level OEL thresholds.



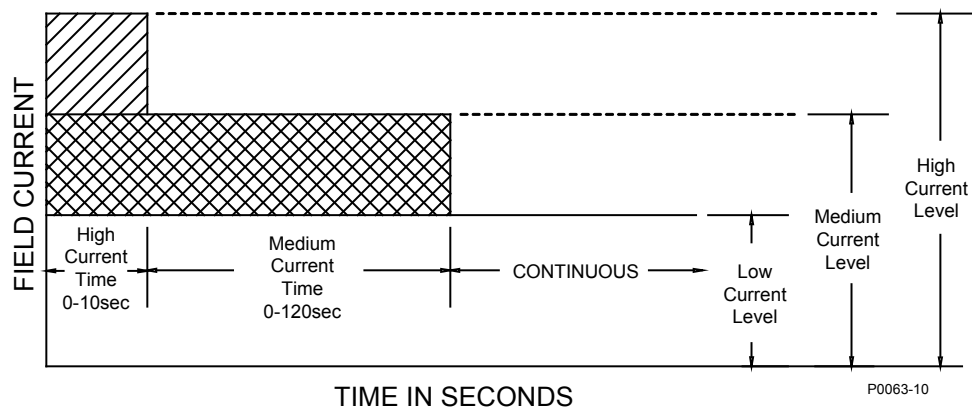
**Figure 41. Summing Point, Offline, Overexcitation Limiting**

The Offline, Low-Level OEL threshold is determined by the Low-Level setting<sup>C</sup>. When the OEL becomes inactive, the High Current Timer counts down from either the high time, if the High Current Timer has expired, or from the amount of time spent at high level, if the High Current Timer has not expired. The generator is permitted to operate indefinitely with this level of excitation.

The Offline, High-Level OEL threshold is determined by the High Level<sup>D</sup> and High Time<sup>E</sup> settings. When the excitation level exceeds the High Level setting, the DECS-250 acts to limit the excitation to the value of the High-Level setting and a High Level Timer is initiated. If this level of excitation persists until this timer reaches the High Time setting, the DECS-250 acts to limit the excitation to the value of the Low-Level setting.

### Online Operation

For online operation, there are three levels of summing-point overexcitation limiting: low, medium, and high. Figure 42 illustrates the relationship of the low-, medium-, and high-level OEL thresholds.



**Figure 42. Summing Point, Online, Overexcitation Limiting**

The online, low-level OEL threshold is determined by the low-level setting<sup>F</sup>. When the excitation level is below the low-level setting, no action is taken by the DECS-250. The generator is permitted to operate indefinitely with this level of excitation. When the excitation level exceeds the low-level setting for the duration of the medium and high time settings, the DECS-250 acts to limit the excitation to the value of the low-level setting.

The online, medium-level OEL threshold is determined by a medium level<sup>G</sup> and medium time<sup>H</sup> setting. When the excitation level exceeds the medium level setting for the duration of the high time setting, the DECS-250 acts to limit the excitation to the value of the medium-level setting.

The online, high-level OEL threshold is determined by a high level<sup>I</sup> and high time<sup>J</sup> setting. When the excitation level exceeds the high level setting, the DECS-250 instantaneously acts to limit the excitation to the value of the high-level setting.

### OEL Voltage Dependency

The OEL voltage dependency function<sup>K</sup> enables the OEL High-Level setting when a fault is present. The OEL High-Level setting is enabled when the  $dv/dt$  level is less than the setting<sup>L</sup>. Otherwise, only the Medium-Level and Low-Level settings are enabled.

**OEL Configure**

**OEL Configuration**

OEL Enable A

OEL Mode

Summing Point B

**OEL Voltage Dependency**

$dv/dt$  Enable K

$dv/dt$  Level

-5.00 L

**Figure 43. OEL Configuration Settings**

Figure 44. Summing Point OEL Settings

- <sup>A</sup> *OEL Enable*: Select checkbox to enable OEL.
- <sup>B</sup> *OEL Mode*: Select Summing Point or Takeover.
- <sup>C</sup> *Summing Point OEL Offline Low Level*: Adjustable from 0 to 20 Adc in increments of 0.01 Adc.
- <sup>D</sup> *Summing Point OEL Offline High Level*: Adjustable from 0 to 40 Adc in increments of 0.01 Adc.
- <sup>E</sup> *Summing Point OEL Offline High Time*: Adjustable from 0 to 10 s in 1 s increments.
- <sup>F</sup> *Summing Point OEL Online Low Level*: Adjustable from 0 to 20 Adc in increments of 0.01 Adc.
- <sup>G</sup> *Summing Point OEL Online Medium Level*: Adjustable from 0 to 30 Adc in increments of 0.01 Adc.
- <sup>H</sup> *Summing Point OEL Online Medium Time*: Adjustable from 0 to 120 s in 1 s increments.
- <sup>I</sup> *Summing Point OEL Online High Level*: Adjustable from 0 to 40 Adc for the DECS-250. The setting increment is 0.01 Adc.
- <sup>J</sup> *Summing Point OEL Online High Time*: Adjustable from 0 to 10 s in 1 s increments.
- <sup>K</sup> *dv/dt Enable*: Check box to enable OEL voltage dependency.
- <sup>L</sup> *dv/dt Level*: Adjustable from -10 to 0 in 0.1 increments (per unit).

### Takeover OEL

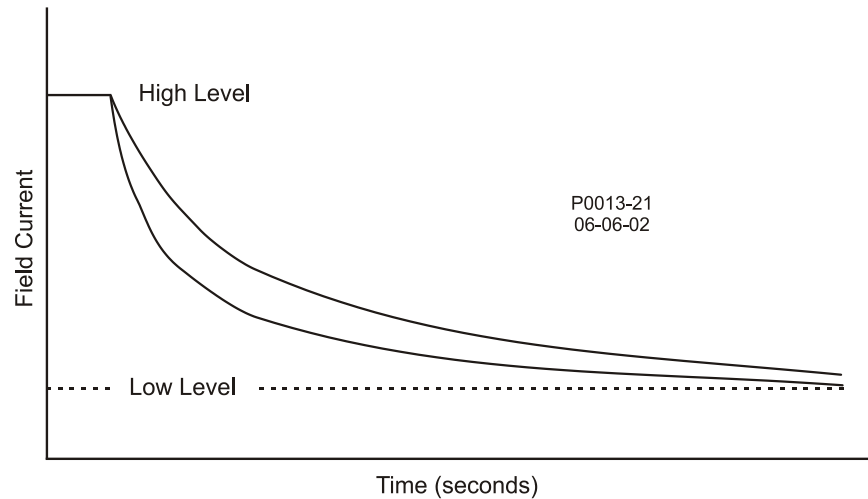
Takeover overexcitation limiting limits the field current level in relation to an inverse time characteristic similar to that shown in Figure 45. Separate curves may be selected for online and offline operation. If the system enters an overexcitation condition, the field current is limited and forced to follow the selected curve. The inverse time characteristic is defined by Equation 11.

$$t_{pickup} = \frac{A \times TD}{B + \sqrt{C + D \times MOP}}$$

Equation 11. Inverse Pickup Time Characteristic

Where:

- $t_{pickup}$  = time to pick up in seconds  
 A = -95.908  
 B = -17.165  
 C = 490.864  
 D = -191.816  
 TD = time dial setting <0.1, 20>  
 MOP = multiple of pickup <1.03, 205>



**Figure 45. Inverse Time Characteristic for Takeover OEL**

Primary and secondary setting groups provide additional control for two distinct machine operating conditions. Each mode of takeover OEL operation (offline and online) has a low-level<sup>A</sup>, high-level<sup>B</sup>, and time dial<sup>C</sup> setting.

Once the field current decreases below the dropout level (95% of pickup), the function is reset based on the selected reset method<sup>D</sup>. The available reset methods are inverse, integrating, and instantaneous.

Using the inverse method, the OEL is reset based on time versus multiple of pickup (MOP). The lower the field current level, the less time is required for reset. Inverse reset uses the following curve (Equation 12) to calculate maximum reset time.

$$\text{Reset Time Constant} = \frac{RC \times TD \times 0.05}{1 - (MOP \times 1.03)^2}$$

**Equation 12. Inverse Reset Time Characteristic**

Where:

Reset Time Constant = maximum time to reset in seconds

RC = reset coefficient setting<sup>E</sup> <0.01, 100>

TD = time dial setting <0.1, 20>

MOP = multiple of pickup

For the integrating reset method, the reset time is equal to the pickup time. In other words, the amount of time spent above the low level threshold is the amount of time required to reset.

Instantaneous reset has no intentional time delay.

In BESTCOMSPi<sup>us</sup>®, a plot of the takeover OEL setting curves is displayed. Settings enable selection of the displayed curves. The plot can display the primary or secondary setting curves, the offline or online settings curves, and the pick up or reset settings curves.

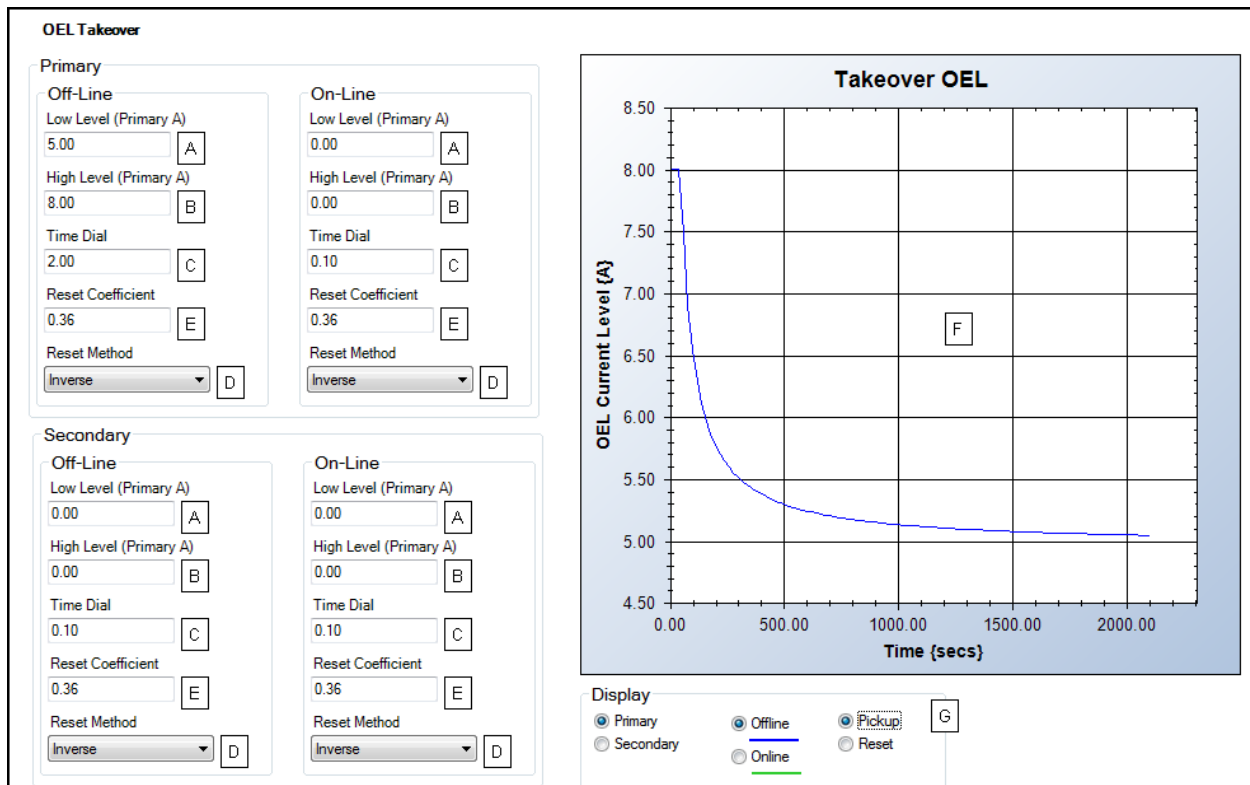


Figure 46. Takeover OEL Settings

- A *Takeover OEL Low Level*: Adjustable from 0 to 20 Adc in increments of 0.01 Adc.
- B *Takeover OEL High Level*: Adjustable range varies depending on value of *Low Level* setting.
- C *Takeover OEL Time Dial*: Adjustable from 0.1 to 20 in increments of 0.1.
- D *Reset Method*: Select Inverse, Integrating, or Instantaneous.
- E *Reset Coefficient*: Adjustable from 0.01 to 100 in increments of 0.01.
- F Takeover OEL curve.
- G Curve display selections/legend.

## Underexcitation Limiter

**BESTCOMSPlus Navigation Path:** Settings Explorer, Operating Settings, Limiters, UEL

**HMI Navigation Path:** Settings, Operating Settings, Limiters, UEL

Operating a generator in an underexcited condition can cause the stator end iron to overheat. Extreme underexcitation may lead to a loss of synchronism. The underexcitation limiter (UEL) senses the leading var level of the generator and limits decreases in excitation to limit end-iron heating. When enabled<sup>A</sup>, the UEL operates in all regulation modes. UEL behavior in manual mode can be configured to limit excitation or issue an alarm. This behavior is configured in *BESTlogicPlus*.

### Note

For UEL to operate, the PARALLEL\_EN\_LM logic block must be set true in *BESTlogicPlus* programmable logic.

UEL settings are illustrated in Figure 47 and Figure 48.

Underexcitation limiting is implemented through an internally-generated UEL curve or a user-defined UEL curve<sup>B</sup>. The internally-generated curve is based on the desired reactive power limit at zero real power with respect to the generator voltage and current rating. The absorbed reactive power axis of the curve on the UEL Custom Curve screen can be tailored<sup>C</sup> for your application.

A user-defined curve can have a maximum of five points<sup>D</sup>. This curve allows the user to match a specific generator characteristic by specifying the coordinates of the intended leading reactive power (kvar) limit at the appropriate real power (kW) level.

The levels entered for the user-defined curve are defined for operation at the rated generator voltage. The user-defined UEL curve can be automatically adjusted based on generator operating voltage by using the UEL voltage dependency real-power exponent<sup>E</sup>. The user-defined UEL curve is automatically adjusted based on the ratio of the generator operating voltage divided by the generator rated voltage raised to the power of the UEL voltage dependency real-power exponent. UEL voltage dependency is further defined by a real power filter time constant<sup>F</sup> that is applied to the low-pass filter for the real power output.



**UEL Configure**

**UEL Configuration**

Enable **A**

**UEL Voltage Dependency**

Real Power Exponent  
2.00 **E**

Real Power Filter Time Constant (s)  
5.0 **F**

Figure 47. UEL Configuration Settings

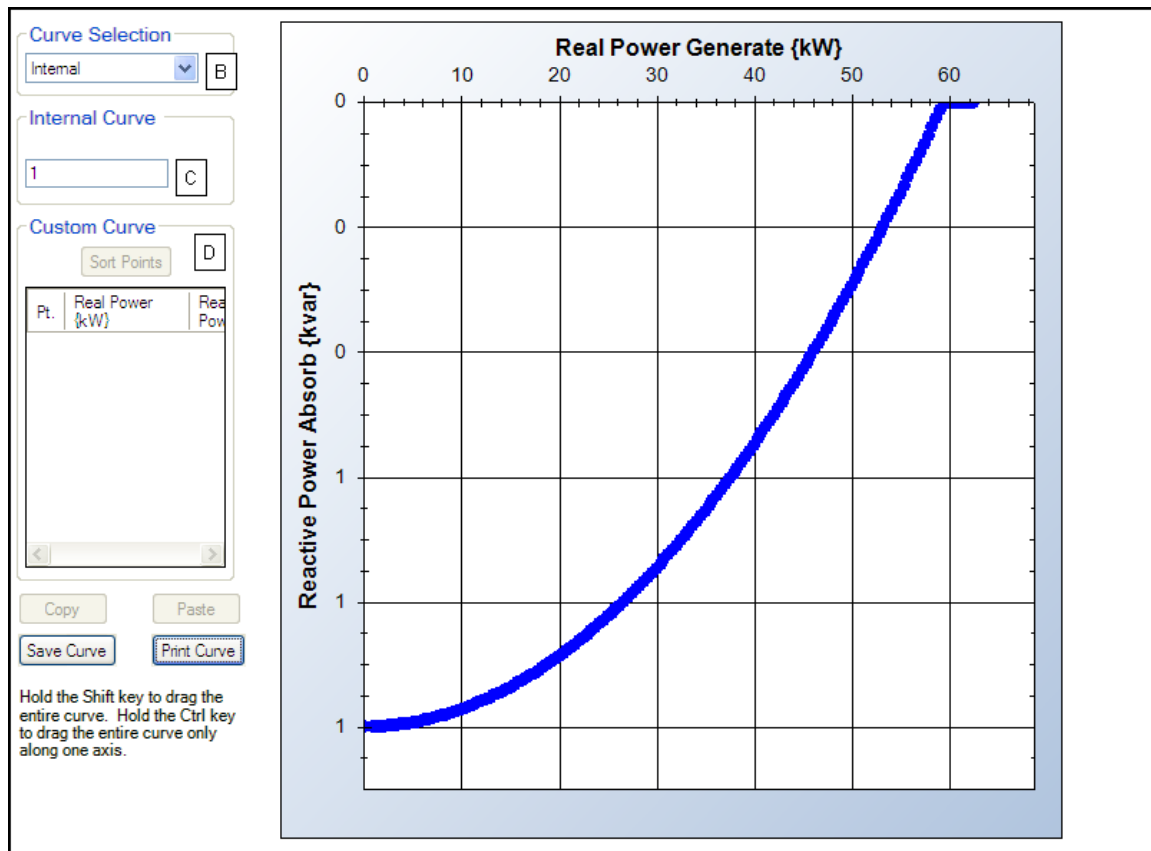


Figure 48. UEL Custom Curve Screen

<sup>A</sup> *UEL Configuration Enable*: Check box to enable underexcitation limiter.

<sup>B</sup> *Curve Selection*: Select Internal or Customized.

<sup>C</sup> *Internal Curve*: Enter number to adjust range of y axis.

<sup>D</sup> *Custom Curve*: Insert, enter, and delete curve data points as needed.

<sup>E</sup> *Real Power Exponent*: Enter a value of 0, 1, or 2.

<sup>F</sup> *Real Power Filter Time Constant*: Enter a value from 0 to 20 seconds in 0.1 second increments.

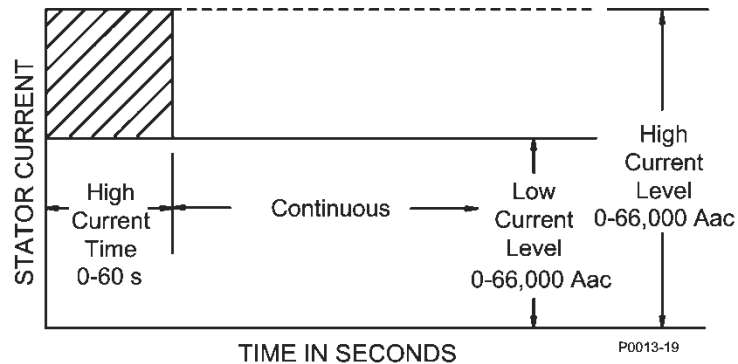
## Stator Current Limiter

**BESTCOMSPlus Navigation Path:** Settings Explorer, Operating Settings, Limiters, SCL

**HMI Navigation Path:** Settings, Operating Settings, Limiters, SCL

The stator current limiter (SCL) monitors the level of stator current and limits it to prevent stator overheating. To limit the stator current, the SCL modifies the excitation level according to the direction of var flow into or out of the generator. Excessive stator current with leading power factor calls for increased excitation. Excessive stator current with lagging power factor calls for reduced excitation.

The SCL can be enabled<sup>A</sup> in all regulation modes. When operating in Manual mode, the DECS-250 will announce high stator current but will not act to limit it. Primary and secondary SCL setting groups provide additional control for two distinct machine operating conditions. Stator current limiting is provided at two levels: low and high (see Figure 49). SCL settings are illustrated in Figure 50.



**Figure 49. Stator Current Limiting**

### Low-Level Limiting

When the stator current exceeds the low-level setting<sup>B</sup>, the DECS-250 annunciates the elevated level. If this condition persists for the duration of the High SCL Time setting, the DECS-250 acts to limit the current to the low-level SCL Setting. When the stator current is below the Low-Level SCL setting, no SCL limiting action is taken by the DECS-250. The High Current Timer counts down either from the high time, if the High Current Timer has expired, or from the amount of time spent at high level, if the High Current Timer has not expired. The generator is permitted to operate indefinitely at or below the low-level threshold.

### High-Level Limiting

When the stator current exceeds the High-Level setting<sup>C</sup>, the DECS-250 acts to limit the current to the value of the High-Level setting and a High Level Timer is initiated. If this level of current persists until this timer reaches the High-Level Time setting<sup>D</sup>, the DECS-250 acts to limit the current to the value of the Low-level SCL setting.

### Initial Delay

In the case of low- or high-level stator current limiting, the limiting function will not respond until an initial time delay<sup>F</sup> expires.

Figure 50. Stator Current Limiter Settings

- <sup>A</sup> *Stator Current Limiter Enable*: Check box to enable.
- <sup>B</sup> *Low SCL Level*: Adjustable from 0 to 66,000 Aac in 0.1 Aac increments.
- <sup>C</sup> *High SCL Level*: Adjustable from 0 to 66,000 Aac in 0.1 Aac increments.
- <sup>D</sup> *High SCL Time*: Adjustable from 0 to 60 s in 0.1 s increments.
- <sup>E</sup> *Initial Delay*: Adjustable from 0 to 10 s in 0.1 s increments.

## Var Limiter

**BESTCOMSPlus Navigation Path:** Settings Explorer, Operating Settings, Limiters, var

**HMI Navigation Path:** Settings, Operating Settings, Limiters, VAR

The var limiter can be enabled<sup>A</sup> to limit the level of reactive power exported from the generator. Primary and secondary setting groups provide additional control for two distinct machine operating conditions. The var limiter setpoint<sup>B</sup> is expressed as a percentage of the calculated, maximum VA rating for the machine. A delay setting<sup>C</sup> establishes a time delay between when the var threshold is exceeded and the DECS-250 acts to limit the var flow.

Var limiter settings are illustrated in Figure 51.

Figure 51. Var Limiter Settings

- <sup>A</sup> *Var Limiter Enable*: Select checkbox to enable var limiter.
- <sup>B</sup> *Var Limiter Setpoint*: Adjustable from 0 to 200% in 0.1% increments.
- <sup>C</sup> *Var Limiter Delay*: Adjustable from 0 to 300 s in 0.1 s increments.

## Limiter Scaling

**BESTCOMSPPlus Navigation Path:** Settings Explorer, Operating Settings, Limiters, Scaling

**HMI Navigation Path:** Settings, Operating Settings, Limiters, Scaling

Automatic adjustment (scaling) of the overexcitation limiter and stator current limiter is possible through the DECS-250 auxiliary control input. Limiter scaling settings are illustrated in Figure 52. OEL and SCL scaling may be independently enabled and disabled<sup>A</sup>. Automatic adjustment of the OEL and SCL is based on six parameters: signal and scale for three points (levels).

With the scaling input set to *Auxiliary Input*, the signal value<sup>B</sup> for each point represents the auxiliary control input. This input can be a 4 to 20 mA<sub>dc</sub> signal applied to terminals I+ and I– or a –10 to +10 V<sub>dc</sub> signal applied to terminals V+ and V–. (The input type is selected in *BESTCOMSPPlus*). See the *Auxiliary Control* chapter of this manual for details.

With the scaling input set to *AEM RTD #*, the signal value for each point represents an AEM RTD input in degrees Fahrenheit. See the *Analog Expansion Module* chapter of the manual for details.

The scale value<sup>C</sup> for each point defines the limiter low level as a percent of rated field current for the OEL and rated stator current for the SCL.

Section	Input Type	Point	Signal (Degrees F)	Scale
Oel Scale Enable	AEM RTD 1	Point 1	77	80.0
		Point 2	212	100.0
Scl Scale Enable	Disabled	Point 1	77	80.0
		Point 2	212	100.0
Summing Point OEL Scaling	AEM RTD 1	Point 1	77	80.0
		Point 2	212	100.0
Takeover OEL Scaling	AEM RTD 1	Point 1	77	80.0
		Point 2	212	100.0
SCL Scaling	AEM RTD 1	Point 1	77	80.0
		Point 2	212	100.0

**Figure 52. Limiter Scaling Settings**

<sup>A</sup> *OEL and SCL Scale Enable:* Select Auxiliary Input, AEM RTD 1 to AEM RTD 8, or Disabled.

<sup>B</sup> *Signal:* Adjustable from –10 to +10 in 0.01 increments when *Auxiliary Input* is selected.

Adjustable from –58 to +482 in increments of 1 when any *AEM RTD* input is selected.

<sup>C</sup> *Scale:* Adjustable from 0 to 200 in increments of 0.1.

## Underfrequency Limiter

**BESTCOMSPPlus Navigation Path:** Settings Explorer, Operating Settings, Limiters, Underfrequency

**HMI Navigation Path:** Settings, Operating Settings, Limiters, UEL

The underfrequency limiter is selectable for underfrequency limiting or volts per hertz limiting<sup>A</sup>. These limiters protect the generator from damage due to excessive magnetic flux resulting from low frequency and/or overvoltage.

Underfrequency and volts per hertz limiter settings are illustrated in Figure 55.

If the generator frequency decreases below the corner frequency<sup>B</sup> for the selected underfrequency slope<sup>C</sup> (Figure 53), the DECS-250 adjusts the voltage setpoint so that the generator voltage follows the underfrequency slope. The adjustment range of the corner frequency and slope settings enables the

DECS-250 to precisely match the operating characteristics of the prime mover and the loads being applied to the generator.

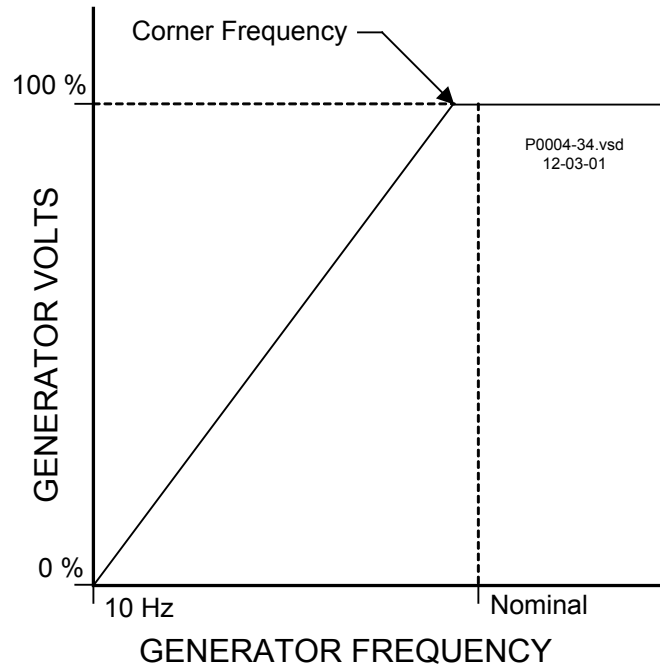


Figure 53. Typical Underfrequency Compensation Curve

### Volts per Hertz

The volts per hertz limiter prevents the regulation setpoint from exceeding the volts per hertz ratio defined by the V/Hz High Limiter<sup>D</sup> and V/Hz Low Limiter<sup>E</sup> settings. A typical volts per hertz limiter curve is illustrated in Figure 54.

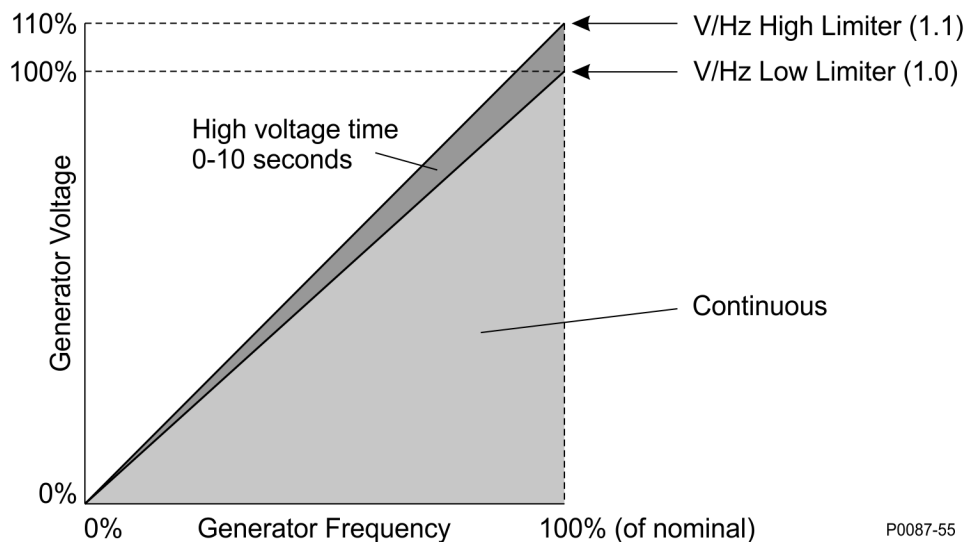


Figure 54. Typical 1.1 PU Volts per Hertz Limiter Curve

Volts per hertz limiter operation is established by the V/Hz High Limiter<sup>D</sup>, V/Hz Low Limiter<sup>E</sup>, and V/Hz Time Limiter<sup>F</sup> settings. The generator may operate continuously at setpoints below the low limit threshold. When the regulation setpoint is greater than the low limit threshold for the duration of the time delay, the setpoint is reduced to the low limit threshold and is prevented from exceeding the low limit threshold. The regulation setpoint is prevented from exceeding the value of the high limit threshold at all times.

**Underfrequency**

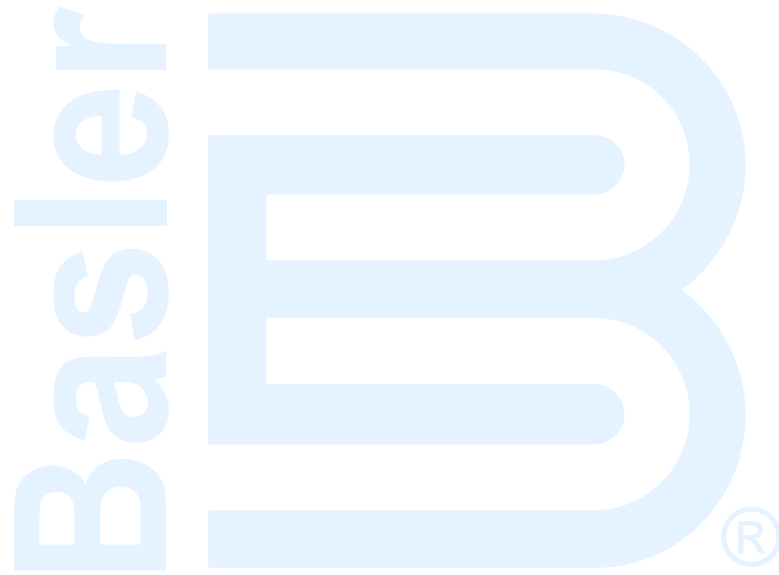
**Limiter Mode**  
Mode  
UF Limiter  A

**Underfrequency Limiter**  
Corner Frequency (Hz)  
57.0  B  
Slope  
1.00  C

**Volts/Hz Limiter**  
V/Hz High Limiter  
1.00  D  
V/Hz Low Limiter  
1.00  E  
V/Hz Time Limiter (s)  
10.0  F

**Figure 55. Underfrequency/Volts per Hertz Limiter Settings**

- <sup>A</sup> *Limiter Mode*: Select UF Limiter or V/Hz Limiter.
- <sup>B</sup> *Underfrequency Limiter Corner Frequency*: Adjustable from 10 to 75 Hz in 0.1 Hz increments.
- <sup>C</sup> *Underfrequency Limiter Slope*: Adjustable from 0 to 3 in increments of 0.01.
- <sup>D</sup> *V/Hz High Limiter*: Adjustable from 0 to 3 in increments of 0.01.
- <sup>E</sup> *V/Hz Low Limiter*: Adjustable from 0 to 3 in increments of 0.01.
- <sup>F</sup> *V/Hz Time Limiter*: Adjustable from 0 to 10 s in 0.2 s increments.



# Grid Code

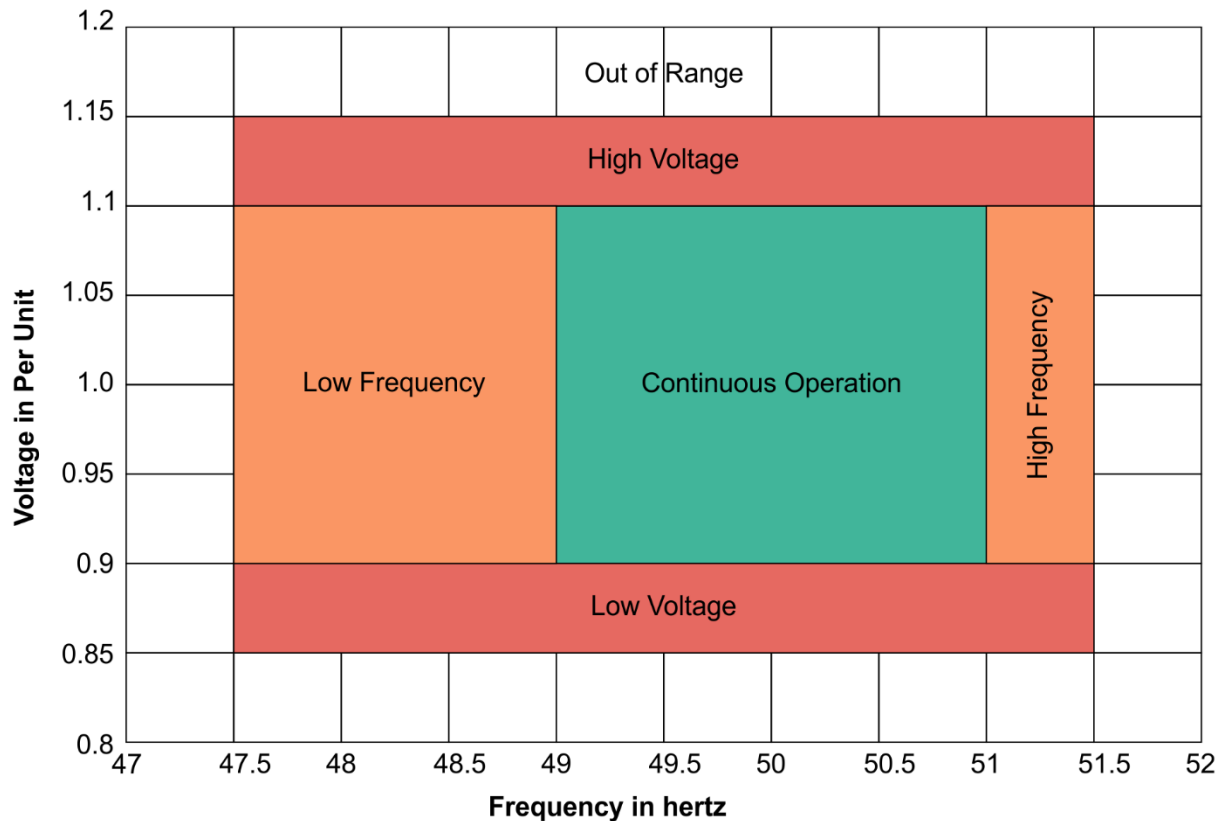
Grid Code settings make the DECS compatible with grid code compliant systems. Grid Code mode settings consist of grid connectivity parameters, active power control parameters, and reactive power control parameters. These settings are defined in the following paragraphs.

## Configuration

**BESTCOMSPlus Navigation Path:** Settings Explorer, Grid Code Settings, Configure

**HMI Navigation Path:** Settings, Operating Settings, Grid Code Settings, Grid Code Configure

Grid Code compliant generating units must remain connected to the grid during grid instability for a set amount of time within certain voltage and frequency limits. See Figure 56.



P0087-76

**Figure 56. Generator Operation Regions**

The Continuous Operation region in Figure 56 is defined by four settings: Max Frequency for Continuous Operation, Min Frequency for Continuous Operation, Max Voltage for Continuous Operation, and Min Voltage for Continuous Operation.

### High and Low Frequency

The High Frequency region in Figure 56 is defined by two settings: Max Frequency for Disconnect and Max Frequency for Continuous Operation. When grid frequency is within the range defined by these two settings, the Frequency Disconnect timer is active.

The Low Frequency region in Figure 56 is defined by two settings: Min Frequency for Disconnect and Min Frequency for Continuous Operation. When grid frequency is within the range defined by these two settings, the Frequency Disconnect timer is active.

## High and Low Voltage

The High Voltage region in Figure 56 is defined by two settings: Max Voltage for Disconnect and Max Voltage for Continuous Operation. When grid voltage is within the range defined by these two settings, the Voltage Disconnect timer is active.

The Low Voltage region in Figure 56 is defined by two settings: Min Voltage for Disconnect and Min Voltage for Continuous Operation. When grid voltage is within the range defined by these two settings, the Voltage Disconnect timer is active.

## Out of Range

When grid voltage or frequency are outside of the regions shown in Figure 56, the Grid Disconnect timer is active.

## Disconnection Timers

When the Frequency Disconnect Timer, Voltage Disconnect Timer, or the Grid Disconnect Timer expires, the generating unit is permitted to disconnect from the grid.

Note
Rather than performing the disconnection, the DECS-250 issues a logic indication which can be used to energize a physical output. See the BESTlogic™ Plus chapter for details on the GCC Disconnected status input.

The duration of the Frequency Disconnect timer is defined by the Frequency Disconnect Time Delay setting, the Voltage Disconnect timer is defined by the Voltage Disconnect Time Delay setting, and the Grid Disconnect timer is defined by the Grid Disconnect Time Delay setting. The Grid Disconnect timer may be set to 0 for immediate disconnection.

## Grid Recovery Mode

Once the generating unit has disconnected from the grid due to expiration of the Grid Disconnect timer, the DECS enters Grid Recovery Mode. In this mode, grid voltage and frequency are monitored and must remain within certain limits for a period of time to ensure stability. The grid recovery frequency limits are defined by the Max Frequency for Reconnect and Min Frequency for Reconnect settings. The grid recovery voltage limits are defined by the Max Voltage for Reconnect and Min Voltage for Reconnect settings. The grid recovery stability time is defined by the Grid Reconnect Stability Timer setting.

### Configure

**Configure**

Grid Code Enable

A

**Grid Connection**

**Steady State Operation**

Max Frequency For Continuous Operation (Hz)  
51.000 B

Min Frequency For Continuous Operation (Hz)  
49.000 C

Max Voltage For Continuous Operation (pu)  
1.100 D

Min Voltage For Continuous Operation (pu)  
0.900 E

Max Frequency For Disconnect (Hz)  
51.500 F

Min Frequency For Disconnect (Hz)  
47.500 G

Frequency Disconnect Time Delay (min)  
30.0 H

Max Voltage For Disconnect (pu)  
1.150 I

Min Voltage For Disconnect (pu)  
0.850 J

Voltage Disconnect Time Delay (s)  
30.000 K

Grid Disconnect Time Delay (s)  
0.000 L

**Reconnect**

Max Frequency for Reconnect (Hz)  
50.100 M

Min Frequency for Reconnect (Hz)  
49.900 N

Max Voltage for Reconnect (pu)  
1.100 O

Min Voltage for Reconnect (pu)  
0.950 P

Grid Reconnect Stability Timer (min)  
10.0 Q

**Figure 57. Configure Screen**

- A. Grid Code Enable: Check box to enable.
- B. Max Frequency for Continuous Operation: Adjustable from 40 to 70 in 0.001 Hz increments.
- C. Min Frequency for Continuous Operation: Adjustable from 40 to 70 in 0.001 Hz increments.
- D. Max Voltage for Continuous Operation: Adjustable from 1.0 to 1.3 in 0.001 pu increments.
- E. Min Voltage for Continuous Operation: Adjustable from 0.1 to 1.0 in 0.001 pu increments.
- F. Max Frequency for Disconnect: Adjustable from 40 to 70 in 0.001 Hz increments.
- G. Min Frequency for Disconnect: Adjustable from 40 to 70 in 0.001 Hz increments.
- H. Frequency Disconnect Time Delay: Adjustable from 1 to 60 in 0.5 minute increments.
- I. Max Voltage for Disconnect: Adjustable from 1.0 to 1.3 in 0.001 pu increments.
- J. Min Voltage for Disconnect: Adjustable from 0.1 to 1.0 in 0.001 pu increments.
- K. Voltage Disconnect Time Delay: Adjustable from 1 to 3600 in 0.001 second increments.
- L. Grid Disconnect Time Delay: Adjustable from 0 to 3600 in 0.001 second increments.
- M. Max Frequency for Reconnect: Adjustable from 40 to 70 in 0.001 Hz increments.
- N. Min Frequency for Reconnect: Adjustable from 40 to 70 in 0.001 Hz increments.
- O. Max Voltage for Reconnect: Adjustable from 1.0 to 1.3 in 0.001 pu increments.
- P. Min Voltage for Reconnect: Adjustable from 0.1 to 1.0 in 0.001 pu increments.
- Q. Grid Reconnect Stability Timer: Adjustable from 0 to 30 in 0.5 minute increments.

## Active Power Control (APC)

**BESTCOMSPi+ Navigation Path:** Settings Explorer, Grid Code Settings, Active Power Control

**HMI Navigation Path:** Settings, Operating Settings, Grid Code Settings, Active Power Control

The DECS-250 runs in Active Power Control mode continuously when grid frequency is normal (within the dead band). It shifts into Limited Frequency Sensitive Mode (LFSM) when grid frequency is outside the dead band. Then it shifts into Grid Recovery mode for a set period of time once grid frequency returns to within the dead band.

### APC Mode

When enabled, APC mode limits the generating unit's ramp rates for increasing and decreasing output. The active power setpoint can be adjusted through analog inputs or remote communication protocols. Alternatively, one of four active power levels can be selected through logic.

#### Active Power Control Settings

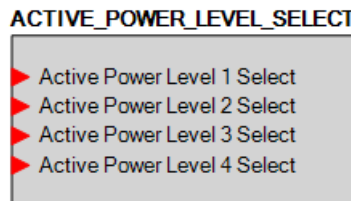
The active power setpoint, the maximum setpoint limit, and the minimum setpoint limit are established by the Active Power Setpoint, Max Active Power Setpoint, and Min Active Power Setpoint settings, respectively.

Power output ramp rates are established by the Normal Power Increase Rate and Normal Power Decrease Rate settings. These rates are used when Active Power Control mode is active.

#### Active Power Level Selection Settings

When the Active Power Input Source setting is set to Active Power Level Selection, the Active Power Setpoint setting is not used.

Each of the four Active Power Level settings corresponds to an input on the Active Power Level Select logic element (Figure 58). See the *BESTlogicPi+* chapter for details.



**Figure 58. Active Power Level Select Logic Element**

#### Adjustment Sources

The active power setpoint may be adjusted by the DECS-250 auxiliary input, an Analog Expansion Module AEM-2020 analog input, or via remote communication (Modbus® or CAN bus). For all adjustment sources, the value of the APC Gain setting is applied to the value read from the selected input. Refer to the *CAN Communication* and *Modbus Communication* chapters for more information on adjusting the setpoint via remote communication.

#### Auxiliary Input

To use the DECS-250 auxiliary input as the grid code Active Power Control adjustment source, make the following settings:

- On the Auxiliary Input screen, set the Input Function setting to Grid Code Input. Refer to the *Auxiliary Control* chapter for details.
- On the Active Power Control screen, set the Adjust Source setting to Auxiliary Input.

Refer to the *Auxiliary Control* chapter for details on how the auxiliary voltage ( $V_{aux}$ ) is calculated.

$V_{aux}$  is multiplied by 0.01 and the value of the APC Gain setting:  
( $APC\ Adjust = V_{aux} \times 0.01 \times APC\ Gain$ ).

### Active Power PI Controller Settings

Gains are established by the Loop Gain (Kg) and Integral Gain (Ki) settings. Maximum and minimum power output is established by the Max Power Output and Min Power Output settings.

### **APC Bridging**

When APC Bridging is enabled, a third party active power setpoint is inserted directly into the normalized governor bias where it is scaled by the AEM Gain before going into the speed governor bias input. This bypasses the DECS-250's active power control modes.

### **LFSM**

When grid frequency exceeds the dead band threshold, LFSM becomes the active control mode, if enabled. During over or underfrequency conditions, output power should change as fast as possible to respond to the change requested by the curve illustrated in Figure 59. When frequency is low, the generating units increase their output power to support the grid. When frequency is high, the generating units decrease their output power to help prevent grid frequency from rising further.

### LFSM Dead Band Settings

The LFSM-U Dead Band setting establishes the deadband minimum frequency and the LFSM-O Dead Band setting establishes the deadband maximum frequency.

### LFSM Droop Settings

The LFSM-U Droop setting establishes the underfrequency droop curve and the LFSM-O establishes the overfrequency droop curve. These curves, represented by the green lines in Figure 59, do not necessarily have to be the same.

### LFSM Max Power Limit Settings

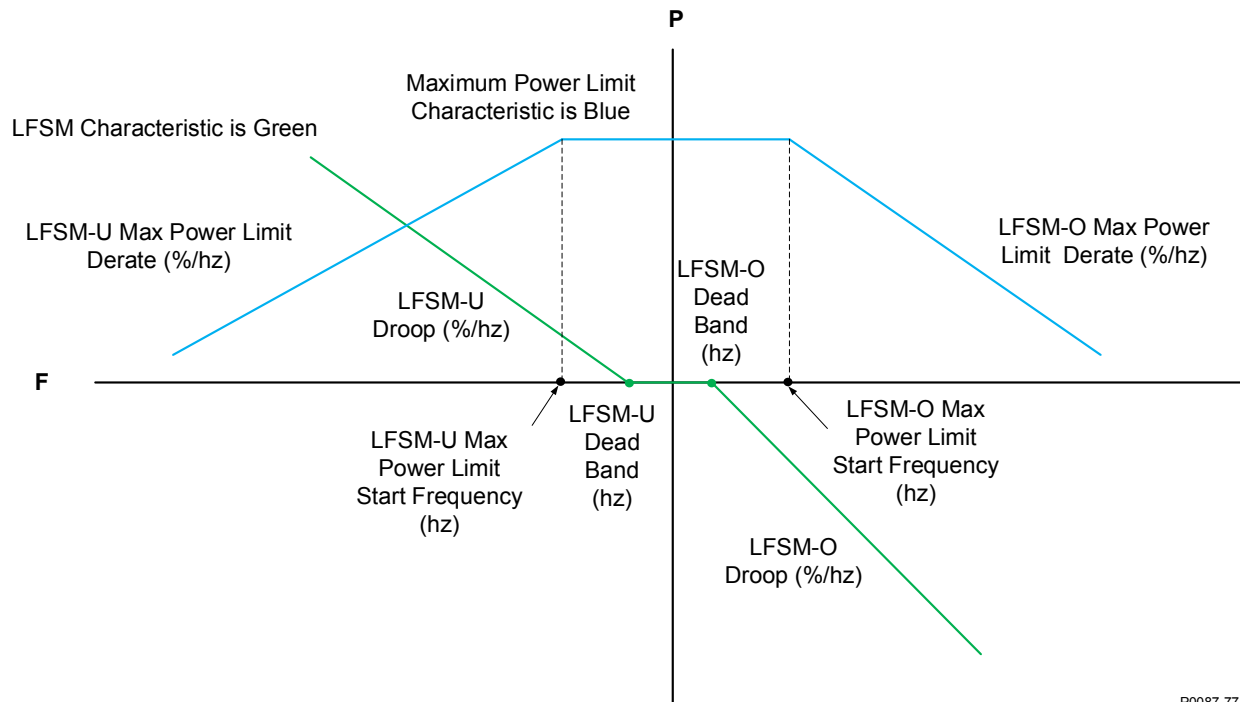
The LFSM-U Max Power Limit Start Frequency setting establishes the frequency at which the generating unit can limit maximum output power during underfrequency conditions. The LFSM-O Max Power Limit Start Frequency setting establishes the frequency at which the generating unit can limit maximum output power during overfrequency conditions.

The LFSM-U Max Power Limit Derate setting establishes the power output derating curve for an underfrequency condition. The LFSM-O Max Power Limit Derate setting establishes the power output derating curve for an overfrequency condition. These curves, represented by the blue lines in Figure 59, do not necessarily have to be the same.

### LFSM Power Ramp Rate Settings

Power output ramp rates are established by the LFSM Power Increase Rate and LFSM Power Decrease Rate settings. These rates are used when LFSM is active.

### Limited Frequency Sensitive Mode Characteristic and Maximum Power Limit Characteristic



P0087-77

**Figure 59. LFSM Characteristic and Maximum Power Limit Characteristic**

### Grid Recovery Mode

When the DECS-250 is operating in LFSM and the grid frequency returns to normal (within the dead band), Grid Recovery mode becomes the active control mode. In this mode, grid recovery ramp rates are used and grid frequency must remain within the dead band for the duration for the grid recovery timer before returning to Active Power Control mode.

#### Grid Recovery Settings

The Recovery Time setting establishes the amount of time the grid frequency must remain within the dead band before the grid is deemed stable and the DECS-250 can return to Active Power Control mode.

Power output ramp rates are established by the Recovery Power Increase Rate and Recovery Power Decrease Rate settings. These rates are used when Grid Recovery mode is active.

### Active Power Control

**Configure**  
 Active Power Control Enable A  
 LFSM Enable B  
 APC Bridging Enable C  

Active Power Input Source  
 Active Power Setpoint D

Adjust Source  
 None E

Gain  
 1.000 F

**Active Power Control**  
 Active Power Setpoint (pu)  
 0.000 G  
 Maximum Active Power Setpoint (pu)  
 0.000 H  
 Minimum Active Power Setpoint (pu)  
 0.000 I  
 Normal Power Increase Rate (%/sec)  
 0.660 J  
 Normal Power Decrease Rate (%/sec)  
 0.660 K

**Active Power Level Selection**  
 Active Power Level 1 (pu)  
 0.000 L  
 Active Power Level 2 (pu)  
 0.300 L  
 Active Power Level 3 (pu)  
 0.600 L  
 Active Power Level 4 (pu)  
 1.000 L

**Limited Frequency Sensitivity Mode**  
 LFSM-U Dead Band (Hz)  
 49.800 M  
 LFSM-O Dead Band (Hz)  
 50.200 N  
 LFSM-U Droop (%/Hz)  
 40.000 O  
 LFSM-O Droop (%/Hz)  
 40.000 P  
 LFSM-U Max Power Limit Start Frequency (Hz)  
 49.500 Q  
 LFSM-O Max Power Limit Start Frequency (Hz)  
 50.500 R  
 LFSM-U Max Power Limit Derate (%/Hz)  
 10.000 S  
 LFSM-O Max Power Limit Derate (%/Hz)  
 0.000 T  
 LFSM Power Increase Rate (%/sec)  
 0.660 U  
 LFSM Power Decrease Rate (%/sec)  
 0.660 V

**Grid Recovery**  
 Recovery Time (min)  
 10.0 W  
 Recovery Power Increase Rate (%/sec)  
 0.167 X  
 Recovery Power Decrease Rate (%/sec)  
 0.167 Y

**Active Power PI Controller**  
 Loop Gain (Kg)  
 1.000 Z  
 Integral Gain (Kj)  
 0.000 AA  
 Max Power Output (pu)  
 1.000 BB  
 Min Power Output (pu)  
 -1.000 CC

**Figure 60. Active Power Control**

- A. Active Power Control Enable: Check box to enable.
- B. LFSM Enable: Check box to enable.
- C. APC Bridging Enable: Check box to enable.
- D. Active Power Input Source: Select Active Power Setpoint or Active Power Level Selection
- E. Adjust Source: Select None, Auxiliary Input, Modbus, CAN bus, AEM Input Config 1-8
- F. Gain: Adjustable from -100 to 100 in 0.001 increments.
- G. Active Power Setpoint: Adjustable from -2.0 to 2.0 in 0.001 pu increments.
- H. Maximum Active Power Setpoint: Adjustable from -2.0 to 2.0 in 0.001 pu increments.
- I. Minimum Active Power Setpoint: Adjustable from -2.0 to 2.0 in 0.001 pu increments.
- J. Normal Power Increase Rate: Adjustable from 0.07 to 10.00 in 0.001 %/second increments
- K. Normal Power Decrease Rate: Adjustable from 0.07 to 10.00 in 0.001 %/second increments
- L. Active Power Level 1-4: Adjustable from -2.0 to 2.0 in 0.001 pu increments.
- M. LFSM-U Dead Band: Adjustable from 40 to 70 in 0.001 Hz increments.
- N. LFSM-O Dead Band: Adjustable from 40 to 70 in 0.001 Hz increments.
- O. LFSM-U Droop: Adjustable from 16.670 to 100.000 in 0.001 %/Hz increments.
- P. LFSM-O Droop: Adjustable from 16.670 to 100.000 in 0.001 %/Hz increments.
- Q. LFSM-U Max Power Limit Start Frequency: Adjustable from 40 to 70 in 0.001 Hz increments.
- R. LFSM-O Max Power Limit Start Frequency: Adjustable from 40 to 70 in 0.001 Hz increments.
- S. LFSM-U Max Power Limit Derate: Adjustable from 0 to 20 in 0.001 %/Hz increments.
- T. LFSM-O Max Power Limit Derate: Adjustable from 0 to 20 in 0.001 %/Hz increments.
- U. LFSM Power Increase Rate: Adjustable from 0.33 to 10.00 in 0.001 %/second increments.
- V. LFSM Power Decrease Rate: Adjustable from 0.33 to 10.00 in 0.001 %/second increments.
- W. Recovery Time: Adjustable from 0.1 to 90.0 in 0.1 minute increments.
- X. Recovery Power Increase Rate: Adjustable from 0.001 to 10.000 in 0.001 %/second increments.
- Y. Recovery Power Decrease Rate: Adjustable from 0.001 to 10.000 in 0.001 %/second increments.
- Z. Loop Gain: Adjustable from 0 to 100 in 0.001 increments.
- AA. Integral Gain: Adjustable from 0 to 100 in 0.001 increments.
- BB. Max Power Output: Adjustable from -2.0 to 2.0 in 0.001 pu increments.
- CC. Min Power Output: Adjustable from -2.0 to 2.0 in 0.001 pu increments.

## Reactive Power Control

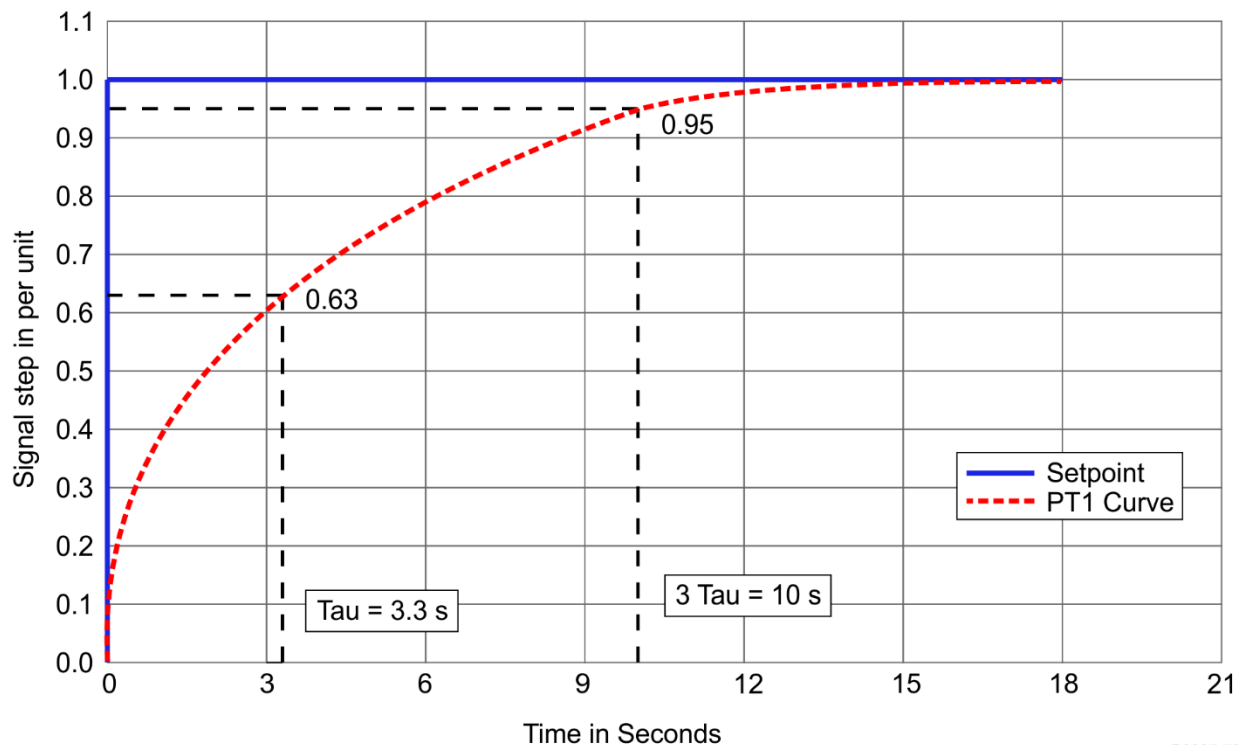
Five reactive power control modes are provided:

1. Reactive power, voltage characteristic – Q(U)
2. Characteristic curve reactive power as a function of the active power – Q(P)
3. Reactive power with voltage limiting function – Q(Voltage Limit)
4. Displacement factor cos. (power factor) – Q(PF)
5. Fixed W reactive power – Q(third party)

If not specified, the default control mode is power factor with a value of 1.0.

### Reactive Power Control Time Response

Responses to setpoint changes in LVRT modes Q(U), Q(P), and Q(Voltage Limit) must follow the characteristic curve illustrated in Figure 61. The time constant is established by the PT1 Time Constant setting. When in Power Factor mode, the time can take up to 60 seconds for settling into the 5% tolerance band. The Vbus Time Constant setting establishes the time constant for the low-pass filter on the bus voltage measurement.



P0087-78

Figure 61. Reactive Power Control Time Response Characteristic Curve

### Control Mode Changes

**BESTCOMSPlus Navigation Path:** Settings Explorer, Grid Code Settings, Reactive Power Control, LVRT Configure

**HMI Navigation Path:** Settings, Operating Settings, Grid Code Settings, Reactive Power Control, Configure

Control modes can be changed through a setpoint change, remote communications, or switch inputs. When switching between modes Q(U), Q(P), and Q (Voltage Limited), the new setpoint must not be faster than the PT1 curve indicated above and must not be slower than four minutes.

LVRT reactive power control functionality is enabled by the LVRT Enable setting. When the input on the LVRT\_DISABLE logic element is held true, LVRT functionality is disabled, even if LVRT functionality is enabled by the LVRT enable setting.

The Mode Selection setting establishes the active LVRT reactive power control mode. When an input on the LVRT\_MODE\_SELECT logic element is held true, the corresponding LVRT reactive power control mode becomes the active mode, overriding the mode specified by the Mode Selection setting.

The screenshot shows the 'LVRT Configure' screen with two main sections. The top section, 'Remote Control Failure', includes a 'Failure Time Delay (s)' input field set to 15.0 (labeled A) and a 'Fail Mode' dropdown menu set to 'Q(PF) Control' (labeled B). The bottom section, 'LVRT Configure', includes a 'LVRT Enable' checkbox (labeled C), a 'Mode Selection' dropdown menu set to 'Q(PF) Control' (labeled D), a 'PT1 Time Constant (s)' input field set to 10.000 (labeled E), and a 'Vbus Time Constant (s)' input field set to 10.000 (labeled F).

**Figure 62. Reactive Power Control, LVRT Configure Screen**

- A. Failure Time Delay: Adjustable from 0 to 600 in 0.1 second increments.
- B. Fail Mode: Select Q(PF) Control or Hold Value
- C. LVRT Enable: Check box to enable.
- D. Mode Selection: Select Disabled, Q(PF) Control, Q(Voltage Limit) Control, Q(U) Control, Q(P) Control, or Q(Third Party) Control
- E. PT1 Time Constant: Adjustable from 0.01 to 60.00 in 0.001 second increments.
- F. Vbus Time Constant: Adjustable from 0.01 to 60.00 in 0.001 second increments.

## Reactive Power as a Function of Voltage - Q(U)

**BESTCOMSPiplus Navigation Path:** Settings Explorer, Grid Code Settings, Reactive Power Control, Q(U)

**HMI Navigation Path:** Settings, Operating Settings, Grid Code Settings, Reactive Power Control, Q(U) Settings

In this mode the reactive power output of the machine is adjusted as Grid Voltage fluctuates. The curve is specified by a slope which goes through the point  $U = 1.00$  along with a Maximum Reactive Power setting and a Minimum Reactive Power settings both of which are in per unit.

The slope is derived from two points determined by the grid operator at the time of commissioning. The first point is the reference voltage  $U_{Q0, ref} / U_C$ , at which reactive power output is 0. The second point is  $(U_{MAX} / U_C, Q_{MAX} \text{ under-excited} / P_{b inst})$ . The slope of the characteristic  $m$  is calculated according to:

$$\text{Slope } m = (Q_{MAX} \text{ underexcited} / P_{inst b}) / (U_{MAX} / U_C - U_{Q0, ref} / U_C)$$

**Equation 13. Slope**

The slope of the characteristic must be in a range of 5 to 16.5. Unless specified, the default values for these parameters are:

$$(U_{MAX} / U_C, Q_{MAX} \text{ under-excited} / P_{b inst}) = (1.04, 0.33) \text{ and } U_{Q0, ref} / U_C = 1.00$$

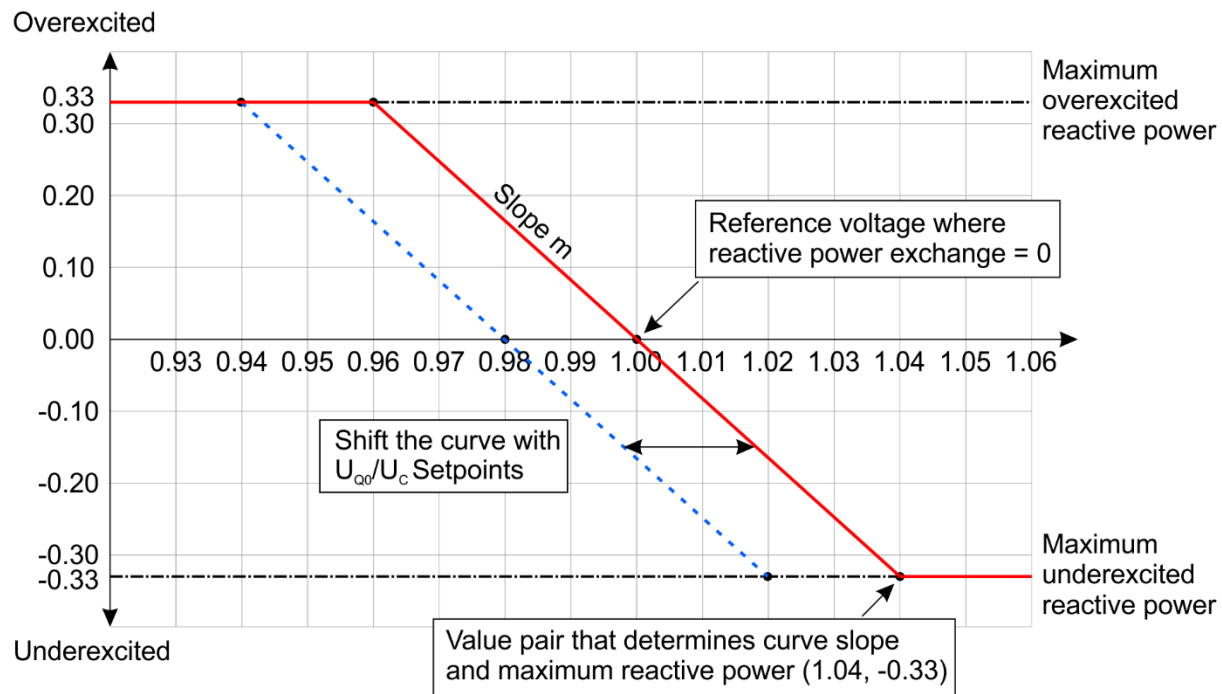
**Equation 14. Default Values for Slope Equation**

The value for the Max Reactive Power setting is equal to  $Q_{MAX} \text{ under-excited} / P_{b inst}$  from the point  $(U_{MAX} / U_C, Q_{MAX} \text{ under-excited} / P_{b inst})$ . The value of the Min Reactive Power setting is equal to the negative of the Max Reactive Power setting.

The voltage at the grid connection point may be averaged or filtered.

There is a voltage dead band adjustable from 0.00 to 0.05 per unit in increments of 0.001 per unit. The default is zero. When the voltage goes outside the dead band, a new setpoint is calculated from the characteristic itself or the intersection of the measured mains voltage and the exceeded dead band limit.

There is also an operating setpoint ( $U_{Q0} / U_C$ ) which is the operating voltage at which reactive power output will be zero. The operating setpoint is typically a fixed value but may be remotely adjusted in steps of 0.5%  $U_C$ . Such adjustment results in a horizontal shift of the characteristic (see Figure 63). The ability to remotely modify the setpoint is specified by the network operator at the time of system planning.



P0087-79

**Figure 63. Reactive Power  $Q(U)$  Characteristic Curve**

In the event of a remote communications failure while in  $Q(U)$  mode, the controller may continue operating in  $Q(U)$  mode using the last valid value for  $U_{Q0} / U_C$  received over communications, or switch to  $Q(PF)$  operation with a PF of 1.0. The network operator may also arrange a switch to one of the other Reactive Power control modes instead.

#### Adjustment Sources

The  $Q(U)$  setpoint may be adjusted by the DECS-250 auxiliary input, an Analog Expansion Module AEM-2020 analog input, or via remote communication (Modbus® or CAN bus). For all adjustment sources, the value of the  $Q(U)$  Gain setting is applied to the value read from the selected input. Refer to the *CAN Communication* and *Modbus Communication* chapters for more information on adjusting the setpoint via remote communication.

#### Auxiliary Input

To use the DECS-250 auxiliary input as the  $Q(U)$  adjustment source, make the following settings:

- On the Auxiliary Input screen, set the Input Function setting to Grid Code Input. Refer to the *Auxiliary Control* chapter for details.
- On the Active Power Control screen, set the Adjust Source setting to Auxiliary Input.

Refer to the *Auxiliary Control* chapter for details on how the auxiliary voltage ( $V_{aux}$ ) is calculated.

$V_{aux}$  is multiplied by 0.01 and the value of the  $Q(U)$  Gain setting:  
 $(APC\ Adjust = V_{aux} \times 0.01 \times Q(U)\ Gain)$ .

**Figure 64. Reactive Power Control, Q(U) Screen**

- A. Reference Voltage: Adjustable from 0.9 to 1.1 in 0.001 pu increments.
- B. Adjust Source: Select None, Auxiliary Input, Modbus, CAN bus, AEM Input Config 1-8
- C. Gain: Adjustable from -100 to 100 in 0.001 increments.
- D. Voltage Band: Adjustable from 0.0 to 0.1 in 0.001 pu increments.
- E. Q(U) Slope: Adjustable from 0 to 20 in 0.001 increments.
- F. Q(U) Maximum Reactive Power: Adjustable from -0.4 to 0.4 in 0.001 pu increments.
- G. Q(U) Minimum Reactive Power: Adjustable from -0.4 to 0.4 in 0.001 pu increments.

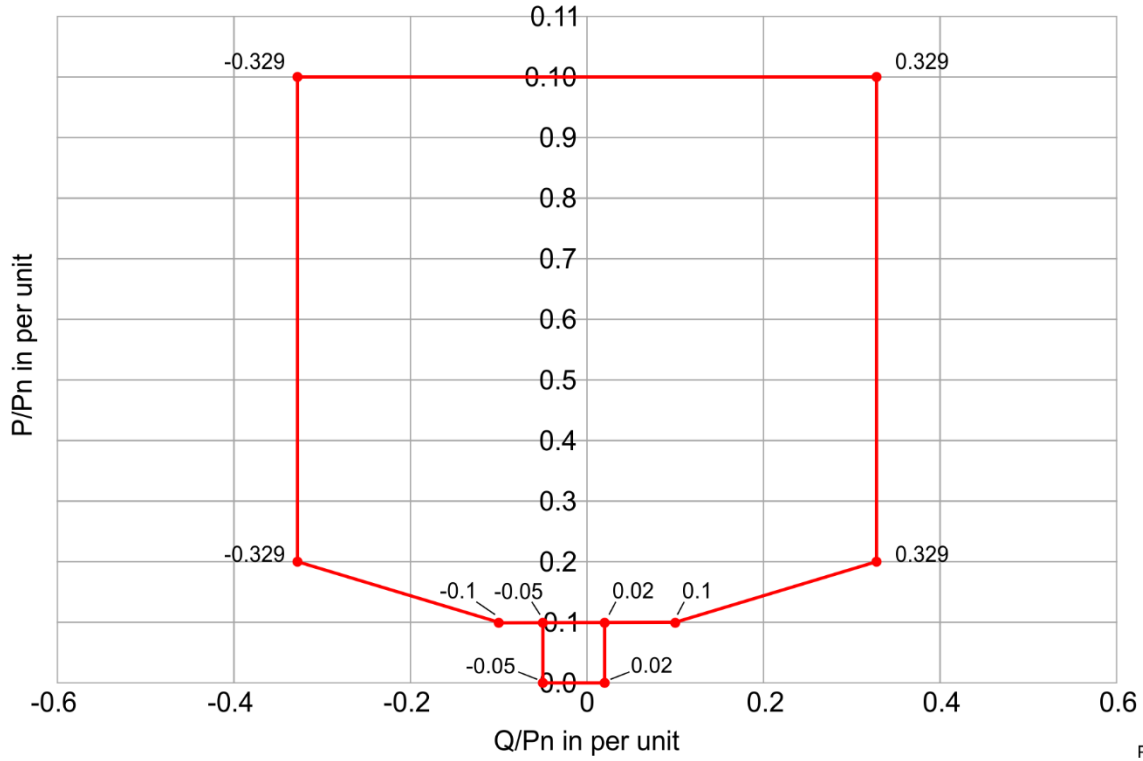
### Reactive Power as a Function of Active Power – Q(P)

**BESTCOMSPPlus Navigation Path:** Settings Explorer, Grid Code Settings, Reactive Power Control, Q(P)

**HMI Navigation Path:** Settings, Operating Settings, Grid Code Settings, Reactive Power Control, Q(P) Settings

In this mode the reactive power output of the machine is adjusted as the real power output fluctuates ( $Q = f(P)$ ).

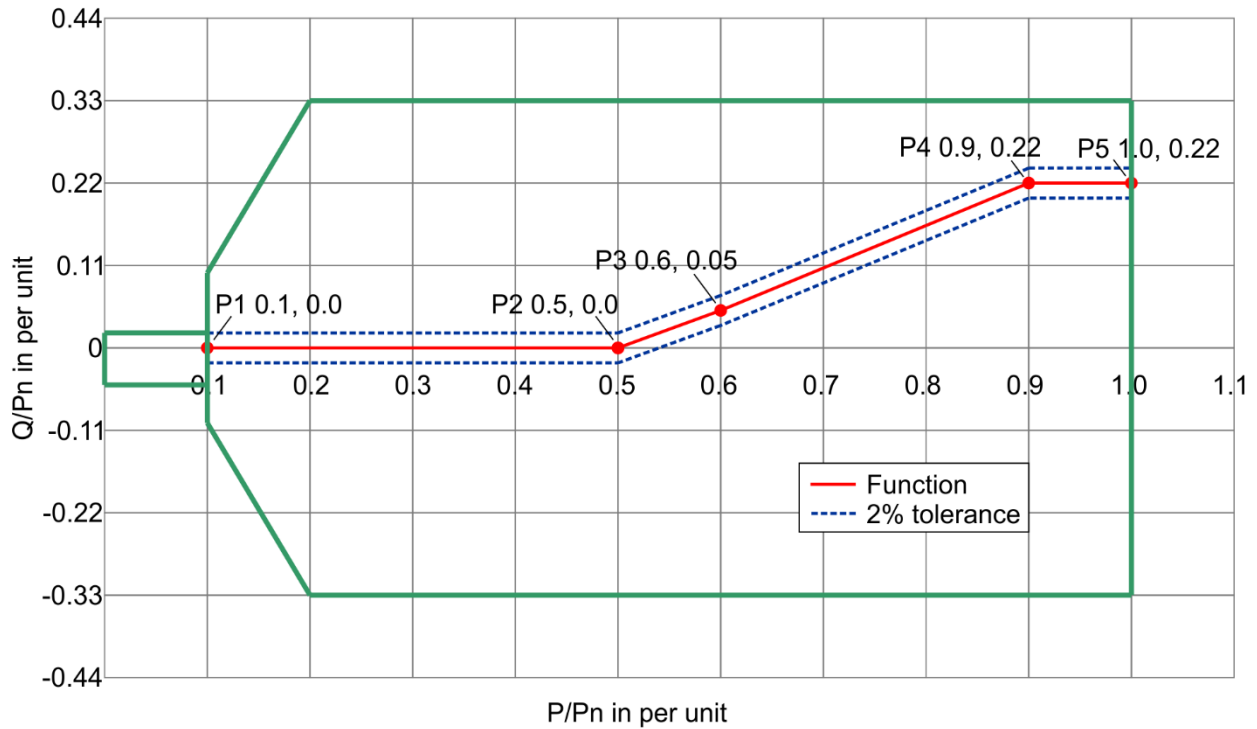
A filter time constant setting is available for the measured power level. The characteristic curve is specified by up to 10 points relating desired Q output to exported power. Perform linear interpolation between the points. The active power coordinate for each point may range from 10% to 100% active power and the range for the reactive power level must conform to Figure 65, below. Above 20% active power, the reactive power range should be -0.33 to 0.33 per unit reactive power.



P0087-80

Figure 65. Q(P) Characteristic Curve

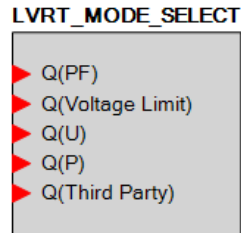
Figure 66 illustrates an example characteristic with five plotted points.



P0087-81

Figure 66. Q(P) Characteristic Curve Example

The network operator defines the characteristic curve during network planning. Remote setpoint adjustment is not provided. However, it is possible to switch from this mode to another reactive power control mode at any time through logic. Logic can also be set to switch reactive power control modes upon a remote communications failure. Figure 67 illustrates the LVRT Mode Select logic element. See the *BESTlogicPlus* chapter for details.



**Figure 67. LVRT Mode Select Logic Element**

If LVRT Mode is enabled, but no operating mode is specified, the default operating mode will be Power Factor with a power factor setting of 1.0.

**Q(P)**

<p><b>Q(P)</b></p> <p><b>P(k)</b></p> <p>Point 1 (pu) <span style="float: right;">A</span></p> <input style="width: 100%;" type="text" value="0.000"/> <p>Point 2 (pu)</p> <input style="width: 100%;" type="text" value="0.500"/> <p>Point 3 (pu)</p> <input style="width: 100%;" type="text" value="0.600"/> <p>Point 4 (pu)</p> <input style="width: 100%;" type="text" value="0.900"/> <p>Point 5 (pu)</p> <input style="width: 100%;" type="text" value="1.000"/> <p>Point 6 (pu)</p> <input style="width: 100%;" type="text" value="1.000"/> <p>Point 7 (pu)</p> <input style="width: 100%;" type="text" value="1.000"/> <p>Point 8 (pu)</p> <input style="width: 100%;" type="text" value="1.000"/> <p>Point 9 (pu)</p> <input style="width: 100%;" type="text" value="1.000"/> <p>Point 10 (pu)</p> <input style="width: 100%;" type="text" value="1.000"/>	<p><b>Q(k)</b></p> <p>Point 1 (pu) <span style="float: right;">B</span></p> <input style="width: 100%;" type="text" value="0.000"/> <p>Point 2 (pu)</p> <input style="width: 100%;" type="text" value="0.000"/> <p>Point 3 (pu)</p> <input style="width: 100%;" type="text" value="0.050"/> <p>Point 4 (pu)</p> <input style="width: 100%;" type="text" value="0.330"/> <p>Point 5 (pu)</p> <input style="width: 100%;" type="text" value="0.330"/> <p>Point 6 (pu)</p> <input style="width: 100%;" type="text" value="0.330"/> <p>Point 7 (pu)</p> <input style="width: 100%;" type="text" value="0.330"/> <p>Point 8 (pu)</p> <input style="width: 100%;" type="text" value="0.330"/> <p>Point 9 (pu)</p> <input style="width: 100%;" type="text" value="0.330"/> <p>Point 10 (pu)</p> <input style="width: 100%;" type="text" value="0.330"/>	<p><b>Q(P) Time Constant (s)</b></p> <p>10.000 <span style="float: right;">C</span></p> <input style="width: 100%;" type="text"/>
--	---	---

**Figure 68. Reactive Power Control, Q(P) Screen**

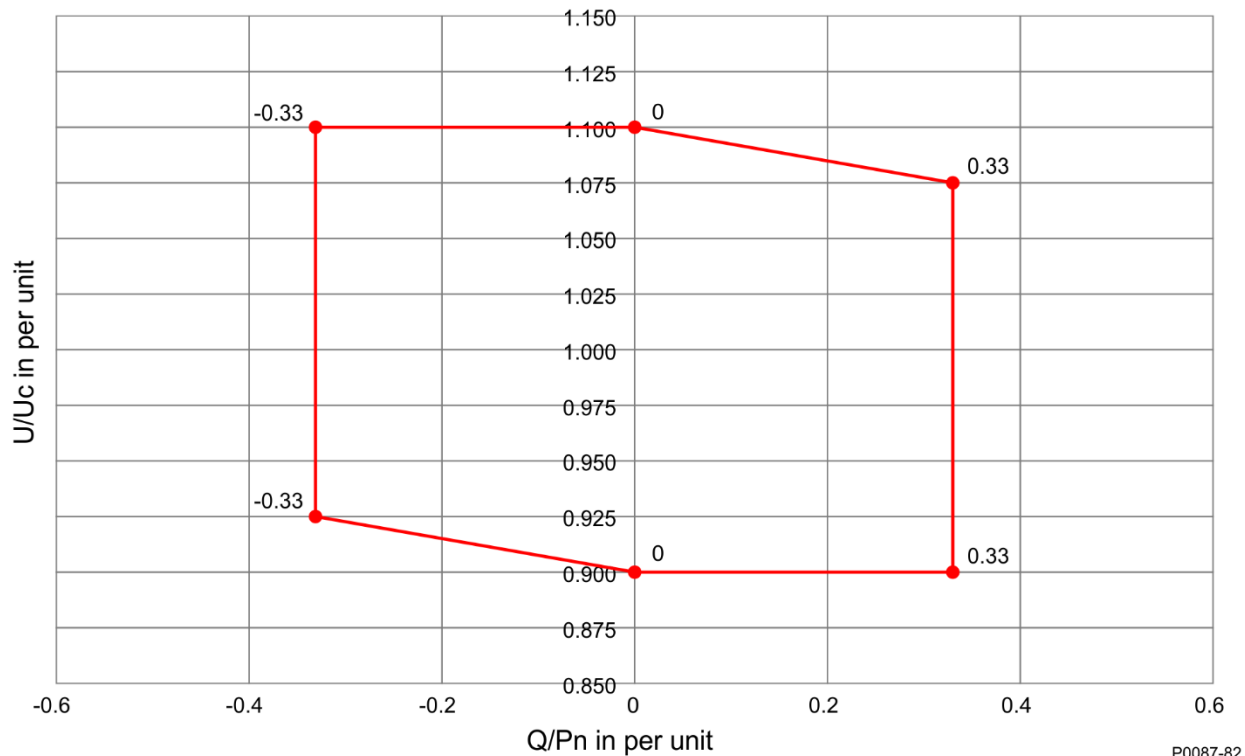
- A. P(k) Point 1-10: Adjustable from 0.0 to 1.5 in 0.001 pu increments.
- B. Q(k) Point 1-10: Adjustable from -0.7 to 0.7 in 0.001 pu increments.
- C. Q(P) Time Constants: Adjustable from 0.01 to 60.00 in 0.001 second increments.

## Reactive Power Control with Fixed Q and Voltage Limits – Q(Voltage Limit)

**BESTCOMSPlus Navigation Path:** Settings Explorer, Grid Code Settings, Reactive Power Control, Q(Voltage Limit)

**HMI Navigation Path:** Settings, Operating Settings, Grid Code Settings, Reactive Power Control, Q Limited Settings

In Q(Voltage Limit) mode, the reactive power output of the generating unit is a constant. However, it is required that the voltage and reactive power stay within the limits of the voltage dependent provision of reactive power as illustrated in Figure 69. This is accomplished by imposing voltage dependent limits on the reactive power output that can be achieved.



**Figure 69. Q(Voltage Limit) Voltage Dependent Provision of Reactive Power**

The characteristic curve consists of four points (denoted P1, P2, P3, and P4) with coordinates of per unit voltage and per unit reactive power. The points and slopes of the characteristic are as follows:

P1: ( $U_{p1}/U_c$ ;  $Q_{p1}/P_{binst}$ )

P2: ( $U_{p2}/U_c$ ;  $Q_{ref}/P_{binst}$ )

The slope of the characteristic curve section  $m_A = (Q_{p1}/P_{binst} - Q_{ref}/P_{binst}) / (U_{p1}/U_c - U_{p2}/U_c)$ ;

P3: ( $U_{p3}/U_c$ ;  $Q_{ref}/P_{binst}$ ),

P4: ( $U_{p4}/U_c$ ;  $Q_{p4}/P_{binst}$ )

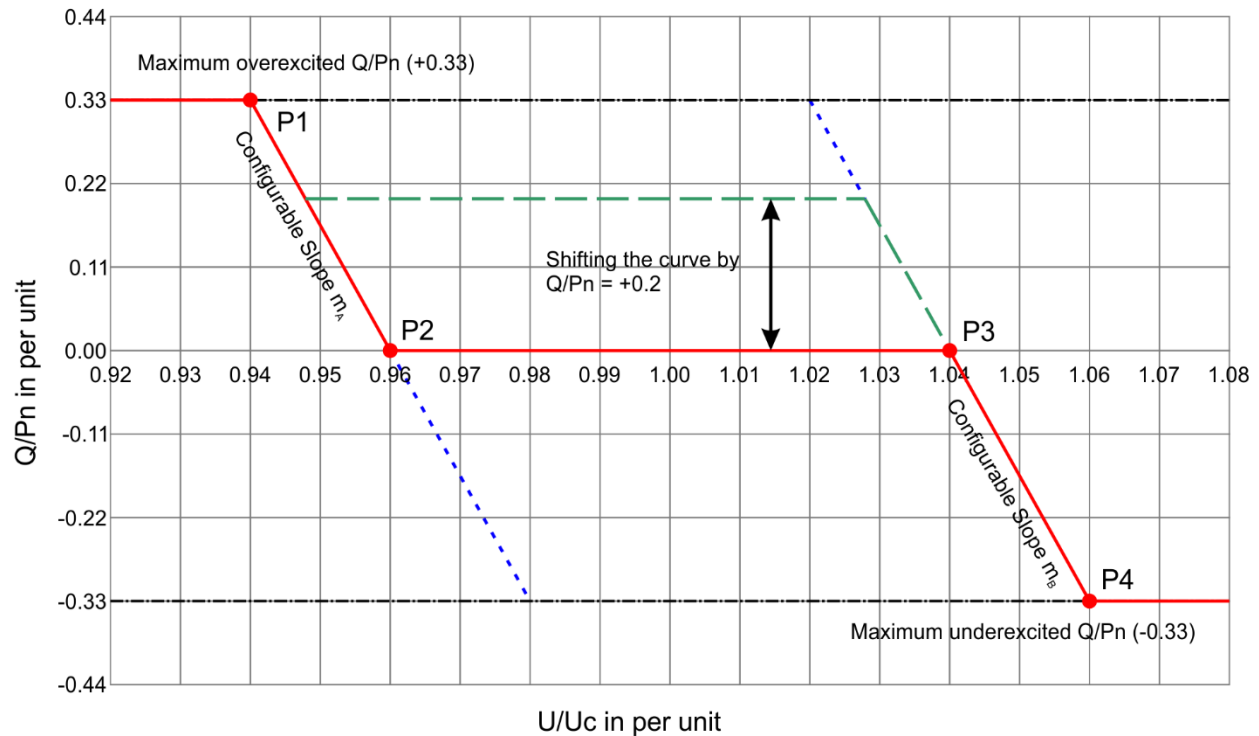
The slope of the characteristic curve section  $m_B = (Q_{ref}/P_{binst} - Q_{p4}/P_{binst}) / (U_{p3}/U_c - U_{p2}/U_c)$ ;

To help ensure stability, gradients greater than  $m=24$  are not permitted.

The network operator specifies the four points when the installation is planned. Unless specified by the network operator, the following value pairs apply:

P1 (0.94; 0.33), P2 (0.96;0), P3( 1.04; 0), P4 (1.06, -0.33)

An example characteristic is shown in Figure 70.



P0087-83

**Figure 70. Q(Voltage Limit) Curve Example**

The reactive power value ( $Q_{ref}/P_b \text{ inst}$ ) can be adjusted in steps of 1% ( $P_b \text{ inst}$ ) but the range of the characteristic curve between P2 and P3 must take into account the gradients  $m_A$  and  $m_B$ . The parameter may be modified by a setting change or through remote communication. The network operator determines the availability of remote setpoint adjustment in the planning phase.

After modification of the value ( $Q_{ref}/P_b \text{ inst}$ ), the machine output must achieve the specified output level within a maximum of four minutes.

#### Adjustment Sources

The Q(Voltage Limit) setpoint may be adjusted by the DECS-250 auxiliary input, an Analog Expansion Module AEM-2020 analog input, or via remote communication (Modbus® or CAN bus). For all adjustment sources, the value of the Q(Voltage Limit) Gain setting is applied to the value read from the selected input. Refer to the *CAN Communication* and *Modbus Communication* chapters for more information on adjusting the setpoint via remote communication.

#### Auxiliary Input

To use the DECS-250 auxiliary input as the Q(Voltage Limit) adjustment source, make the following settings:

- On the Auxiliary Input screen, set the Input Function setting to Grid Code Input. Refer to the *Auxiliary Control* chapter for details.
- On the Active Power Control screen, set the Adjust Source setting to Auxiliary Input.

Refer to the *Auxiliary Control* chapter for details on how the auxiliary voltage ( $V_{aux}$ ) is calculated.

$V_{aux}$  is multiplied by 0.01 and the value of the Q(Voltage Limit) Gain setting:  
 $(APC \text{ Adjust} = V_{aux} \times 0.01 \times Q(\text{Voltage Limit}) \text{ Gain})$ .

**Figure 71. Reactive Power Control, Q(Voltage Limit) Screen**

- A. Q Bias: Adjustable from -0.45 to 0.45 in 0.001 pu increments.
- B. Adjust Source: Select None, Auxiliary Input, Modbus, CAN bus, AEM Input Config 1-8
- C. Gain: Adjustable from -100 to 100 in 0.001 increments.
- D. U(k) Point 1-4: Adjustable from 0.8 to 1.2 in 0.001 pu increments.
- E. Q(k) Points 1 and 4: Adjustable from -0.4 to 0.4 in 0.001 pu increments (points 2 and 3 are fixed).

### Reactive Power Control with Fixed Power Factor – Q(PF)

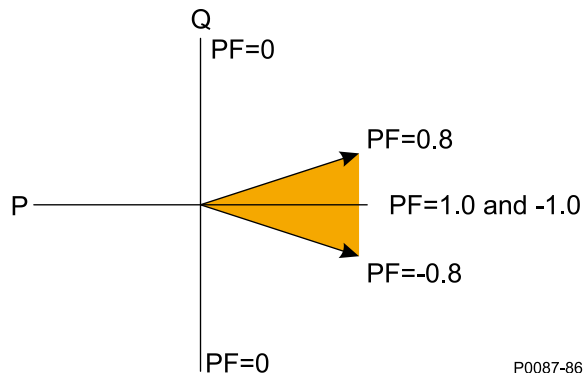
**BESTCOMSPlus Navigation Path:** Settings Explorer, Grid Code Settings, Reactive Power Control, Q(PF)

**HMI Navigation Path:** Settings, Operating Settings, Grid Code Settings, Reactive Power Control, Q(PF) Settings

In Q(PF) mode, the reactive power output must be controlled to a level that maintains a constant ratio of reactive power to apparent power to be fed to the grid. In other words, power factor at the grid connection point must be constant. The grid operator specifies the power factor setpoint. If no setpoint is specified, the default power factor shall be 1.0. This setting has a step width of 0.005. The required regulation accuracy is 2% for plants with less than 2 MW output and 4% for plants with greater than 4 MW output.

#### Q(PF) Adjustment.

In the DECS-250, power factor is defined such that it is positive when reactive power is exported and negative when reactive power is imported. When PF = 1.0, or -1.0, the power is pure real power so Reactive Power = 0. A positive adjustment increases reactive power export and/or reduces reactive power input. A negative adjustment reduces reactive power export and/or increases reactive power export. See Figure 72.



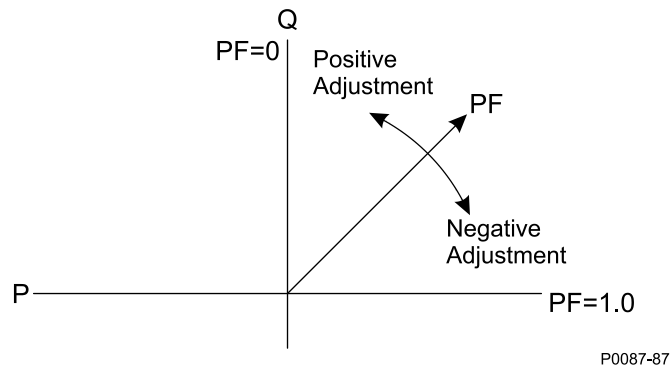
P0087-86

**Figure 72. Preferable PF Region for Operating Machines**

When the power factor is positive, reactive power is being exported. Applying an adjustment results in the following:

1. Application of a positive adjustment results in an increase of exported reactive power. Thus, the power factor value will decrease or move away from  $PF = 1.0$ .
2. Application of a negative adjustment results in a decrease of exported reactive power. Thus, the power factor value will increase or move toward  $PF = 1.0$ .

See Figure 73.

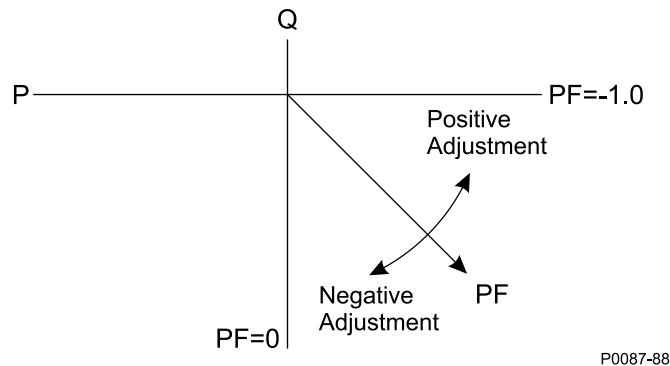


**Figure 73. Power Factor: Positive**

When the power factor is negative, reactive power is being imported. Applying an adjustment results in the following:

1. Application of a positive adjustment results in a decrease of imported reactive power. Thus, the power factor value will decrease (become more negative) or move toward  $PF = -1.0$ .
2. Application of a negative adjustment results in an increase of imported reactive power. Thus, the power factor value will increase (become less negative) or move away from  $PF = -1.0$ .

See Figure 74.



**Figure 74. Power Factor: Negative**

### Adjustment Sources

The  $Q(PF)$  setpoint may be adjusted by the DECS-250 auxiliary input, an Analog Expansion Module AEM-2020 analog input, or via remote communication (Modbus® or CAN bus). For all adjustment sources, the value of the  $Q(PF)$  Gain setting is applied to the value read from the selected input. Refer to the *CAN Communication* and *Modbus Communication* chapters for more information on adjusting the setpoint via remote communication.

### Auxiliary Input

To use the DECS-250 auxiliary input as the Q(PF) adjustment source, make the following settings:

- On the Auxiliary Input screen, set the Input Function setting to Grid Code Input. Refer to the *Auxiliary Control* chapter for details.
- On the Active Power Control screen, set the Adjust Source setting to Auxiliary Input.

Refer to the *Auxiliary Control* chapter for details on how the auxiliary voltage ( $V_{aux}$ ) is calculated.

$V_{aux}$  is multiplied by 0.01 and the value of the Q(PF) Gain setting:  
( $APC\ Adjust = V_{aux} \times 0.01 \times Q(PF)\ Gain$ ).

The screenshot shows the Q(PF) control screen with the following settings:

- Q(PF) PF Setpoint:** 0.000 (labeled A)
- Adjust Source:** None (labeled B)
- Gain:** 1.000 (labeled C)
- PF Active Power Level (pu):** 0.100 (labeled D)

**Figure 75. Reactive Power Control, Q(PF) Screen**

- A. PF Setpoint: Adjustable from -1 to 1 in 0.001 increments.
- B. Adjust Source: Select None, Auxiliary Input, Modbus, CAN bus, AEM Input Config 1-8
- C. Gain: Adjustable from -100 to 100 in 0.001 increments.
- D. PF Active Power Level: Adjustable from 0 to 1 in 0.001 pu increments.

### Reactive Power Control with Fixed Q – Q(Third Party)

**BESTCOMSPiplus Navigation Path:** Settings Explorer, Grid Code Settings, Reactive Power Control, Q(Third Party)

**HMI Navigation Path:** Settings, Operating Settings, Grid Code Settings, Reactive Power Control, Q Third Party

This mode provides fixed reactive power output for instances where an external controller, outside of the DECS-250, performs the reactive power control and feeds a reactive power setpoint to the DECS-250. The PT1 time characteristic is applied in this mode, as it is in all the other modes.

#### Adjustment Sources

The Q(Third Party) setpoint may be adjusted by the DECS-250 auxiliary input, an Analog Expansion Module AEM-2020 analog input, or via remote communication (Modbus® or CAN bus). For all adjustment sources, the value of the Q(Third Party) Gain setting is applied to the value read from the selected input. Refer to the *CAN Communication* and *Modbus Communication* chapters for more information on adjusting the setpoint via remote communication.

### Auxiliary Input

To use the DECS-250 auxiliary input as the Q(Third Party) adjustment source, make the following settings:

- On the Auxiliary Input screen, set the Input Function setting to Grid Code Input. Refer to the *Auxiliary Control* chapter for details.
- On the Active Power Control screen, set the Adjust Source setting to Auxiliary Input.

Refer to the *Auxiliary Control* chapter for details on how the auxiliary voltage ( $V_{aux}$ ) is calculated.

Vaux is multiplied by 0.01 and the value of the Q(Third Party) Gain setting:  
 (APC Adjust = Vaux x 0.01 x Q(Third Party) Gain).

**Figure 76. Reactive Power Control, Q(Third Party) Screen**

- A. Q Reference: Adjustable from -0.45 to 0.45 in 0.001 pu increments.
- B. Adjust Source: Select None, Auxiliary Input, Modbus, CAN bus, AEM Input Config 1-8
- C. Gain: Adjustable from -100 to 100 in 0.001 increments.
- D. Bridge Enable: Check box to enable.

## Remote Communications

Communication timers are used to assess whether Modbus or CAN bus communications has failed. There is one timer for Modbus and a separate timer for CAN bus. The timers constantly count and any time the adjust setting is written, the associated timer is reset to zero. The Failure Time Delay setting is located on LVRT Configure screen.

If the Modbus timer counts up to the value of the Failure Time Delay setting and the Adjust Source is set to Modbus, an Active Power Control Remote Communications Failure occurs. The same is true for CAN bus communication.

If an AEM Comms Failure is detected by the DECS-250 and the Adjust Source is set to an AEM analog input, an Active Power Control Remote Communications Failure occurs.

### Remote Communication Failure

Remote communications failures are recorded in the logs and made available in *BESTlogicPlus* via the appropriate APC or LVRT Comm Fail status input. Refer to the *BESTlogicPlus* chapter for details. A remote communications failure has no preset effect on APC or LVRT operation. However, the APC or LVRT Comm Fail status inputs may be used with the Freeze APC Output or Freeze LVRT Output logic elements to freeze the output of the APC or LVRT PID controllers if desired.

In the event of an LVRT remote communications failure, system behavior is determined by the LVRT Failure Mode setting. The two modes of operation are:

1. Hold Q Value: When selected, the desired reactive power (Q) level determined by LVRT is frozen.
2. Q(PF): When selected, the system switches to fixed power factor operation.

## Setpoints

### Reactive Power Control Mode

In any reactive power control mode, other than Q(P), each setpoint is programmable through a setting or remote communication. The setpoint can be set through *BESTCOMSPPlus*, the front panel, Modbus, or CAN bus. In addition, each setpoint may be biased through an analog input in the DECS-250 and in the AEM-2020 Analog Expansion Module. Loss of remote communications is detected by the DECS-250.

Setpoints are calculated as the sum of the user setting value and an adjustment offset received from remote communications. In modes Q(U), Q(Voltage Limit), Q(PF), and Q(Third Party), the Adjust Source setting allows selection of the adjustment source. The selections are: None, Auxiliary Input, Modbus, CAN bus, or one of eight AEM analog inputs. A Gain setting specifies the gain to be applied to the DECS-250 auxiliary analog input or AEM analog input value to achieve the desired adjustment value.

## Grid Code Test

**BESTCOMSPiplus Navigation Path:** Settings Explorer, Grid Code Settings, Grid Code Test

**HMI Navigation Path:** Not available via HMI

Grid Code Test settings provide a means to artificially bias measured grid voltage and frequency for testing grid code functionality.

The values of the Frequency Bias and Voltage Bias settings bias the measured grid frequency and voltage. These biases become active when the Send to Device button is clicked.

The Test Meter setting establishes which signal will be recorded in the Analysis (real time monitor) screen when Grid Code Test Signal is the selected test parameter.

The duration of the grid code test is established by the Max Time For Testing setting. This timer begins when the Send to Device button is clicked. When the timer expires, the frequency and voltage biases are no longer applied.

**Grid Code Test**

Max Time For Testing (s)  
 A

Frequency Bias for Test (Hz)  
 B

Voltage Bias for Test (pu)  
 C

Test Meter  
 Disabled ▼ D

Send To Device E

**Figure 77. Grid Code Test Screen**

- A. Max Time for Testing: Adjustable from 0 to 3,600 in 1 second increments.
- B. Frequency Bias for LFSM Test: Adjustable from -15 to 65 in 0.001 Hz increments.
- C. Voltage Bias for Q(U) Test: Adjustable from -0.2 to 1.2 in 0.001 pu increments.
- D. Test Meter: Select Disabled, Grid Code State, Grid Connect State, Grid Disconnect Flag, LVRT Mode, LFSM Mode, Remote LVRT Status, APC Mode, Q Ref, P Ref, Q(U) Ref, Q(Voltage Limit) Ref, Q(Third Party) Ref, FbusFLT: Filtered Bus Frequency, VbusFlt: Filtered Bus Voltage, BusVminFlt: Filtered Bus MinV, pfgcn: Generator Power Factor, PrefBias for LFSM, LFSM Sim Timer, PgenFlt: Filtered Generator Power, GCC Voltage Timer, GCC Frequency Timer, GCC Disconnect Timer, or GCC Reconnect Timer.
- E. Send to Device Button: Click to send current Grid Code Test settings to the connected DECS-250.

# Metering

The DECS-250 provides comprehensive metering of internal and system conditions. These capabilities include extensive parameter metering, status indication, reporting, and real-time metering analysis.

## Metering Explorer

DECS-250 metering is accessed through the metering explorer menu on the front panel HMI or the BESTCOMSPi<sup>us</sup>® metering explorer.

### HMI

On the front panel HMI, the metering explorer is accessed through the Metering branch of the HMI menu.

### BESTCOMSPi<sup>us</sup>®

In BESTCOMSPi<sup>us</sup>, the metering explorer is located in the upper left portion of the application window.

### Metering Screen Docking

A docking feature within the metering explorer allows arrangement and docking of multiple metering screens. Clicking and dragging a metering screen tab displays a blue, transparent square, several arrow boxes, and a tab box. These docking elements are illustrated in Figure 78.

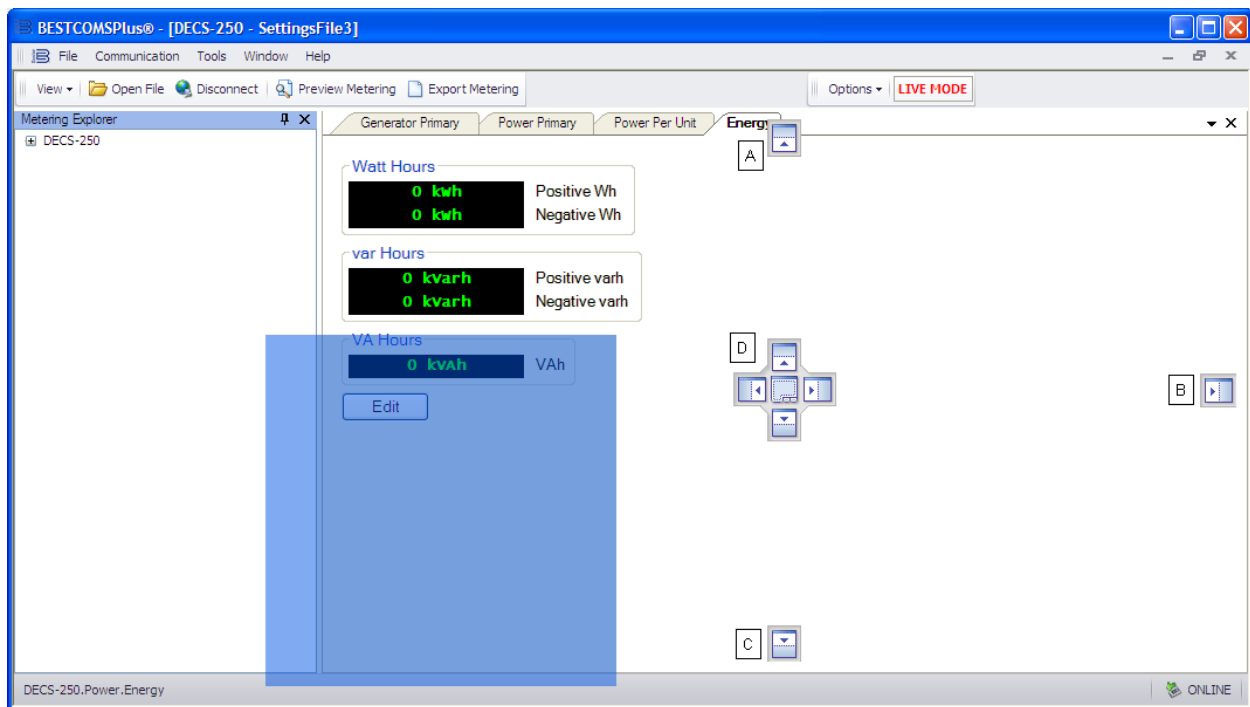


Figure 78. Metering Screen Docking Controls

Dragging the blue square to the “up” (locator A), “right” (locator B), or “down” (locator C) arrow box places the selected metering screen across the top, along the side, or at the bottom of the window. Once placed, the screen’s thumbtack icon can be clicked to dock the screen on the corresponding top, right, or lower bar. A docked screen is viewed by hovering the mouse pointer over the docked screen.

Dragging the blue square to one of the four arrow boxes (locator D) places the screen inside the selected window according to the arrow box selected. A metering screen can be placed as a tab inside the selected window by dropping the screen on the tab box at the center of the four arrow boxes.

Dragging the blue square anywhere other than one of the arrow/tab boxes places the selected metering screen as a floating window.

## Metered Parameters

DECS-250 metering categories include generator, power, bus, field, power system stabilizer (PSS), and generator synchronization parameters.

### Generator

**BESTCOMSPlus Navigation Path:** Metering Explorer, Generator

**HMI Navigation Path:** Metering Explorer, Generator

Metered generator parameters include the voltage (magnitude and angle), current (magnitude and angle), and frequency. Primary- and per-unit values are available. Figure 79 illustrates the generator primary-values metering screen.



Figure 79. Generator Primary-Values Metering

### Power

**BESTCOMSPlus Navigation Path:** Metering Explorer, Power

**HMI Navigation Path:** Metering Explorer, Power

Metered power parameters include true power (kW), apparent power (kVA), reactive power (kvar), and machine power factor. Primary- and per-unit values are available. Accumulated watt-hours (positive and negative kWh), var-hours (positive and negative kvarh), and voltampere hours (kVAh) are also metered. Figure 80 illustrates the power primary-values screen and Figure 81 illustrates the energy screen.



Figure 80. Power Primary-Values



Figure 81. Energy

When operating in motor mode, values for var and power factor will be opposite in BESTCOMSPi.us and on the front-panel HMI.

## Bus

**BESTCOMSPi.us Navigation Path:** Metering Explorer, Bus

**HMI Navigation Path:** Metering Explorer, Bus

Metered bus parameters include the voltage across phases A and B (Vab), phases B and C (Vbc), phases A and C (Vca), and the average bus voltage. The frequency of the bus voltage is also metered. Primary- and per-unit values are available. Figure 82 illustrates the bus primary-values metering screen.

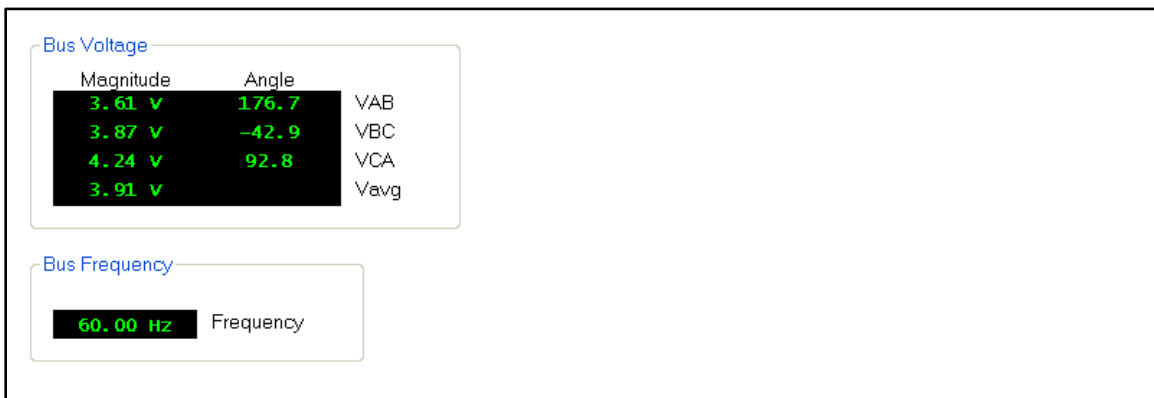


Figure 82. Bus Primary-Values Metering

## Field

**BESTCOMSPlus Navigation Path:** Metering Explorer, Field

**HMI Navigation Path:** Metering Explorer, DECS Output

Metered field parameters include the field voltage (Vfd), current (Ifd), and exciter diode ripple. The exciter diode ripple is reported by the exciter diode monitor (EDM) and is reported as a percentage of the induced ripple in the exciter field current.

To achieve the desired level of excitation, the appropriate level of operating power input voltage must be applied. This value is displayed as the power input voltage.

The level of excitation power supplied to the field is displayed as a percentage, with 0% being the minimum and 100% being the maximum.

Primary- and per-unit values are available. Figure 83 illustrates the field primary-values metering screen.



Figure 83. Field Primary-Values Metering

## PSS

**BESTCOMSPlus Navigation Path:** Metering Explorer, PSS (Power System Stabilizer)

**HMI Navigation Path:** Metering Explorer, PSS

Values metered by the power system stabilizer function display positive sequence voltage and current, negative sequence voltage and current, terminal frequency deviation, compensated frequency deviation, and the per-unit PSS output level. The PSS function on/off status is also reported. Primary- and per-unit values are available. Figure 84 illustrates the PSS primary-values metering screen.

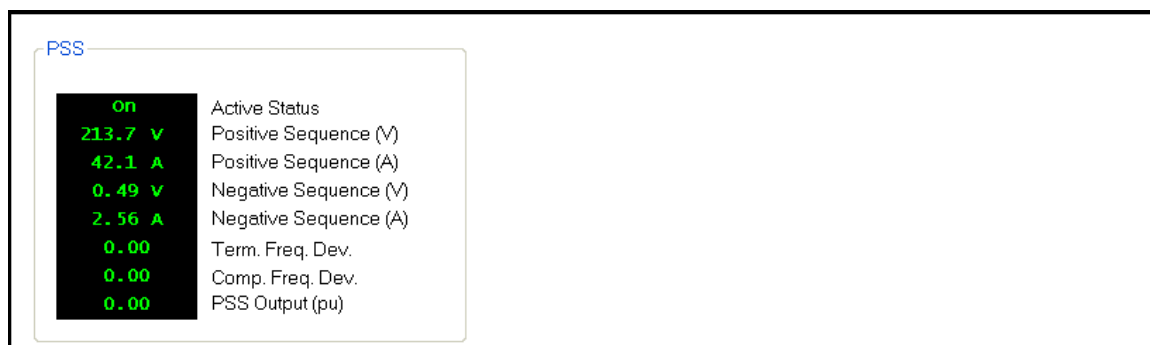


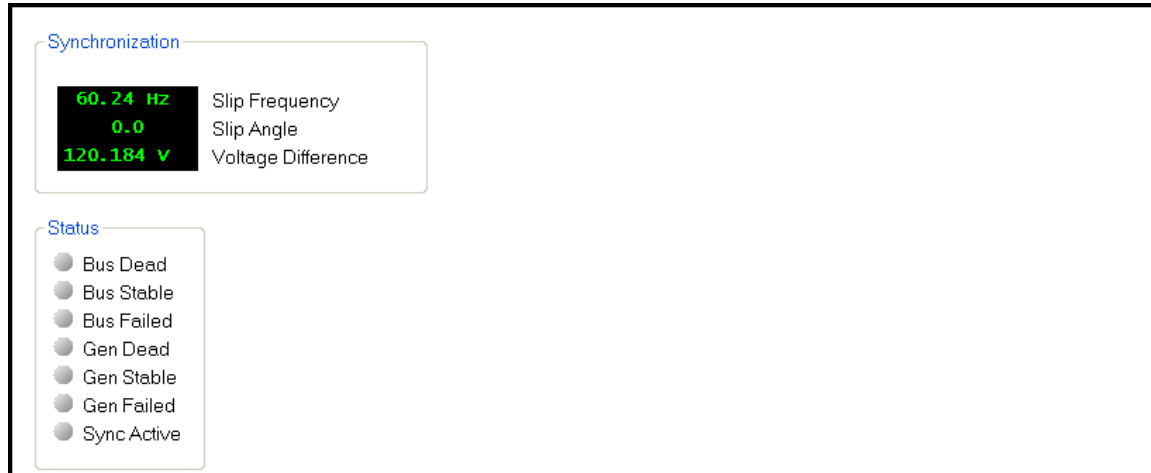
Figure 84. PSS Primary-Values Metering

## Synchronization

**BESTCOMSPi<sub>us</sub> Navigation Path:** Metering Explorer, Synchronization

**HMI Navigation Path:** Metering Explorer, Synchronization

Metered generator-to-bus synchronization parameters include the slip frequency, slip angle, and voltage difference. Primary- and per-unit values are available. Figure 85 illustrates the synchronization primary-values metering screen.



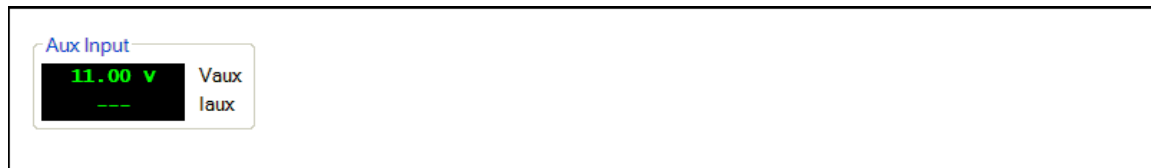
**Figure 85. Synchronization Primary Values Metering**

## Auxiliary Control Input

**BESTCOMSPi<sub>us</sub> Navigation Path:** Metering Explorer, Aux Input

**HMI Navigation Path:** Metering Explorer, Aux Input

The control signal applied at the DECS-250 auxiliary control input is indicated on the Aux Input metering screen (Figure 86). As configured in BESTCOMSPi<sub>us</sub>, a dc voltage or dc current signal may be applied.



**Figure 86. Auxiliary Control Input Metering**

## Tracking

**BESTCOMSPi<sub>us</sub> Navigation Path:** Metering Explorer, Tracking

**HMI Navigation Path:** Metering Explorer, Tracking

The metered setpoint tracking error between DECS-250 operating modes is displayed on the Tracking metering screen (Figure 87). Status fields are also provided for the on/off status for internal and external setpoint tracking. An additional status field indicates when the setpoint of an inactive operating mode matches the metered value.



**Figure 87. Tracking Metering**

## Control Panel

**BESTCOMSPlus Navigation Path:** Metering Explorer, Control Panel

**HMI Navigation Path:** Metering Explorer, Control Panel

The Control Panel (Figure 88) provides options for changing operating modes, selecting setpoint pre-positions, fine tuning setpoints, and toggling virtual switches. The setpoints for AVR, FCR, FVR, var, and PF are displayed, as well as Alarm status, PSS status, Null Balance status, and Grid Code Mode.



**Figure 88. Control Panel**

**Start/Stop Mode:** Two indicators show the start/stop mode of the DECS-250. When a mode is active, its corresponding indicator changes from gray to green. To select the DECS-250 Start status, click the Start button. Click the Stop button to select DECS-250 Stop status.

**AVR/Manual Mode:** AVR and Manual Mode status is reported by two indicators. When a mode is active, its corresponding indicator changes from gray to green. AVR mode is selected by clicking the *AVR* button and manual mode is selected by clicking the *Manual* button.

**FCR/FVR Mode:** FCR and FVR mode status is reported by two indicators. When a mode is active, its corresponding indicator changes from gray to green. FCR mode is selected by clicking the *FCR* button and FVR mode is selected by clicking the *FVR* button.

**Var/PF Mode:** Three indicators report whether Var mode, Power Factor mode, or neither mode is active. When a mode is active, its corresponding indicator changes from gray to green. When neither mode is active, the Off indicator changes from gray to green. Var mode is enabled by clicking the *var* button and Power Factor mode is enabled by clicking the *PF* button. Neither mode is enabled by clicking the *Off* button. Only one mode can be enabled at any time.

**Setpoint Pre-position:** A control button and indicator is provided for the three setpoint pre-positions. Clicking the *Set 1* button adjusts the excitation setpoint to the Pre-position 1 value and changes the Pre-position 1 indicator to green. Pre-positions 2 and 3 are selected by clicking either the *Set 2* or *Set 3* button.

**Grid Code Mode:** These eight indicators change from gray to green to indicate various grid code status.

**Setpoints:** Five status fields display the active setpoints for AVR mode, FCR mode, FVR mode, var mode, and Power Factor mode. These active setpoints, represented by a yellow font, are not to be confused with metered analog values which are represented by a green font throughout BESTCOMS*Plus*. For details on operating setpoint settings, see the *Regulation* chapter.

**Setpoint Fine Adjust:** Clicking the *Raise* button increases the active operating setpoint. Clicking the *Lower* button decreases the active operating setpoint. The raise and lower increment is directly proportional to the adjustment range and inversely proportional to the traverse rate.

**Setpoint Return:** Clicking the Return button changes the active operating setpoint back to the original value before it was adjusted.

**Setpoint Limits:** The Upper indicator changes from gray to green when the upper setpoint limit threshold has been exceeded. The Lower indicator changes from gray to green when the lower setpoint limit threshold has been exceeded.

**Alarm Status:** The Alarm Status indicator changes from gray to green when there is an active alarm.

**PSS Status:** The PSS Status indicator changes from gray to green when the PSS is active.

**Null Balance:** The Null Balance indicator changes from gray to green when the setpoint of the inactive operating modes (AVR, FCR, FVR, var, and PF) match the setpoint of the active mode.

**Virtual Switches:** These buttons control the open or closed status of the six virtual switches. Clicking the Open button sets the switch to the open position and changes the switch indicator to gray. Clicking the Close button sets the switch to the closed position and changes the switch indicator to red. A dialog will appear asking if you are sure you want to open or close the switch.

## Metering Summary

**BESTCOMS*Plus* Navigation Path:** [Metering Explorer, Summary](#)  
**HMI Navigation Path:** Not available via HMI

All of the metering values displayed on the individual, previously-described metering screens are consolidated on the metering summary screen. Primary- and per-unit values are available. Figure 89 illustrates the primary-values metering summary screen. The primary- and per-unit metering summary screens are available only in BESTCOMS*Plus*.

Summary			
208.52 V	VAB	117.069 V	Vfd
207.15 V	VBC	0.14 A	I <sub>fd</sub>
208.17 V	VCA	0.0 %	EDM Ripple
207.95 V	Vavg	158.01 V	Power Input Voltage
0.31 A	I <sub>A</sub>	0.51	Control Out
0.00 A	I <sub>B</sub>	off	PSS Active Status
0.00 A	I <sub>C</sub>	207.98 V	Positive Sequence(V)
0.10 A	I <sub>avg</sub>	0.00 A	Positive Sequence(A)
0.00 A	I <sub>cc</sub>	0.70 V	Negative Sequence(V)
60.0 Hz	Frequency	0.00 A	Negative Sequence(A)
-0.002 kW	KW	0.00	Term. Freq. Dev.
0.002 kVA	kVA	0.00	Comp. Freq. Dev.
0.000 kVar	kVar	0.00	PSS Output
-0.994	PF	0.00 Hz	Slip Frequency
39 kWh	Positive kWh	0.2	Slip Angle
-1 kWh	Negative kWh	-139.1 V	Voltage Difference
0 varh	Positive kvarh	0.00 V	V <sub>aux</sub>
-1 kvarh	Negative kvarh	-0.04 mA	I <sub>aux</sub>
40 kVAh	kVAh	-86.6 %	Tracking Error
69.20 V	Bus VAB	off	Internal Track Status
68.73 V	Bus VBC	off	External Track Status
69.11 V	Bus VCA	off	Null Balance Status
69.01 V	Bus Vavg		
60.01 Hz	Bus Frequency		

Figure 89. Metering Summary Screen

## Status Indication

Status indication is provided for DECS-250 system functions, inputs, outputs, network load share, grid code, configurable protection, alarms, and the real-time clock.

### System Status

**BESTCOMSPlus Navigation Path:** Metering Explorer, Status, System Status

**HMI Navigation Path:** Metering Explorer, Status, System Status

When any of the system functions illustrated in Figure 90 are active, the corresponding indicator changes from gray to green. An inactive function is represented by a gray indicator.

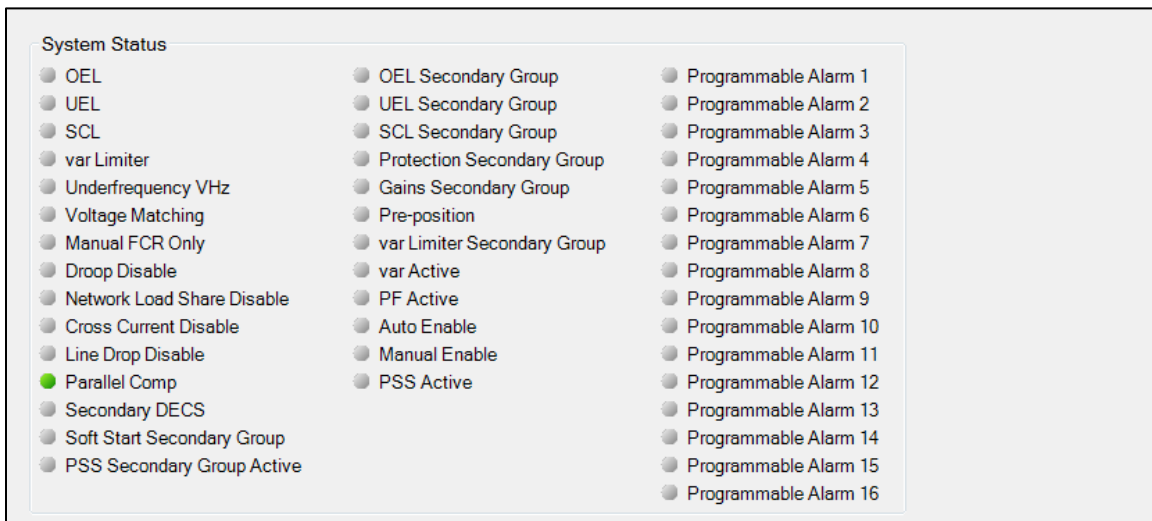


Figure 90. System Status Indication Screen

## Inputs

**BESTCOMSPlus Navigation Path:** Metering Explorer, Status, Inputs

**HMI Navigation Path:** Metering Explorer, Status, Inputs

Status annunciation is provided for the DECS-250 and optional Contact Expansion Module (CEM-2020) inputs. Annunciation is also provided for the optional Analog Expansion Module (AEM-2020) inputs.

### DECS-250 Contact Inputs

Status indication for the DECS-250's 16 contact sensing inputs is provided on the BESTCOMSPlus contact inputs screen illustrated in Figure 91. An indicator changes from gray to red when a closed contact is sensed at the corresponding input.



Figure 91. DECS-250 Contact Inputs Status Indication Screen

### CEM-2020 Contact Inputs

The status of the 10 contact sensing inputs of the optional CEM-2020 Contact Expansion Module is provided on the BESTCOMSPlus remote contact inputs screen. See the *Contact Expansion Module* chapter of this manual for a description and illustration of this screen.

### AEM-2020 Inputs

Status annunciations for the optional AEM-2020 Analog Expansion Module's analog, RTD, thermocouple, and analog metering inputs are provided on the BESTCOMSP*Plus* remote analog inputs, remote RTD inputs, remote thermocouple inputs, and remote analog input values screens. These screens are described and illustrated in the *Analog Expansion Module* chapter of this manual.

## Outputs

**BESTCOMSP*Plus* Navigation Path:** Metering Explorer, Status, Outputs

**HMI Navigation Path:** Metering Explorer, Status, Outputs

Status annunciation is provided for the DECS-250 contact outputs and optional Contact Expansion Module (CEM-2020) contact outputs. Annunciation is also provided for the optional Analog Expansion Module (AEM-2020) analog outputs.

### DECS-250 Contact Outputs

Status indication for the DECS-250's Watchdog and 11 contact outputs is provided on the BESTCOMSP*Plus* contact outputs screen illustrated in Figure 92. An indicator changes from gray to green when the corresponding output changes state (Watchdog output) or closes (Output 1 through 11).

### CEM-2020 Contact Outputs

The status of the 24 contact outputs of the optional CEM-2020 Contact Expansion Module is provided on the BESTCOMSP*Plus* remote contact inputs screen. See the *Contact Expansion Module* chapter of this manual for a description and illustration of this screen.

### AEM-2020 Analog Outputs

Metering and status indications provided by the optional AEM-2020 Analog Expansion Module are shown on the BESTCOMSP*Plus* remote analog outputs screen. This screen is described and illustrated in the *Analog Expansion Module* chapter of this manual.



**Figure 92. DECS-250 Contact Outputs Status Indication Screen**

## Network Load Share

The screen shown in Figure 93 reports the error percent, reactive current, NLS average reactive current, and number of generators online. The status indicators change from gray to green when a status is active.

The Error percent is the deviation of the unit's reactive current from the system average. The NLS Average Reactive Current is the average of the reactive current of every unit in the system. Generators Online is the number of units actively load sharing.

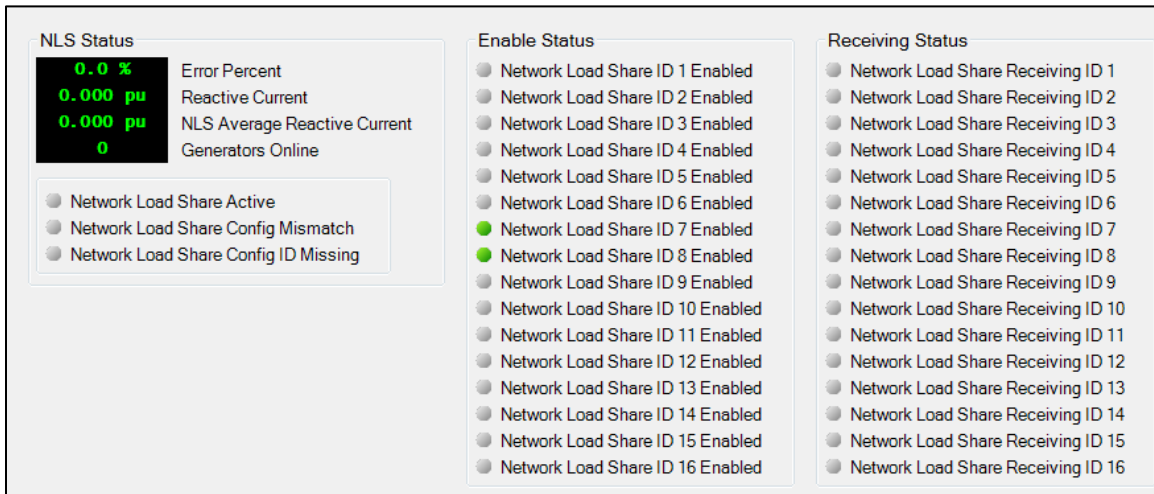


Figure 93. NLS Status Screen

### Grid Code

**BESTCOMSPPlus Navigation Path:** Metering Explorer, Status, Grid Code

**HMI Navigation Path:** Metering Explorer, Status, Grid Code

Metering and status related to grid code is shown on this screen (Figure 94). Indicators change from gray to green when the status is true.

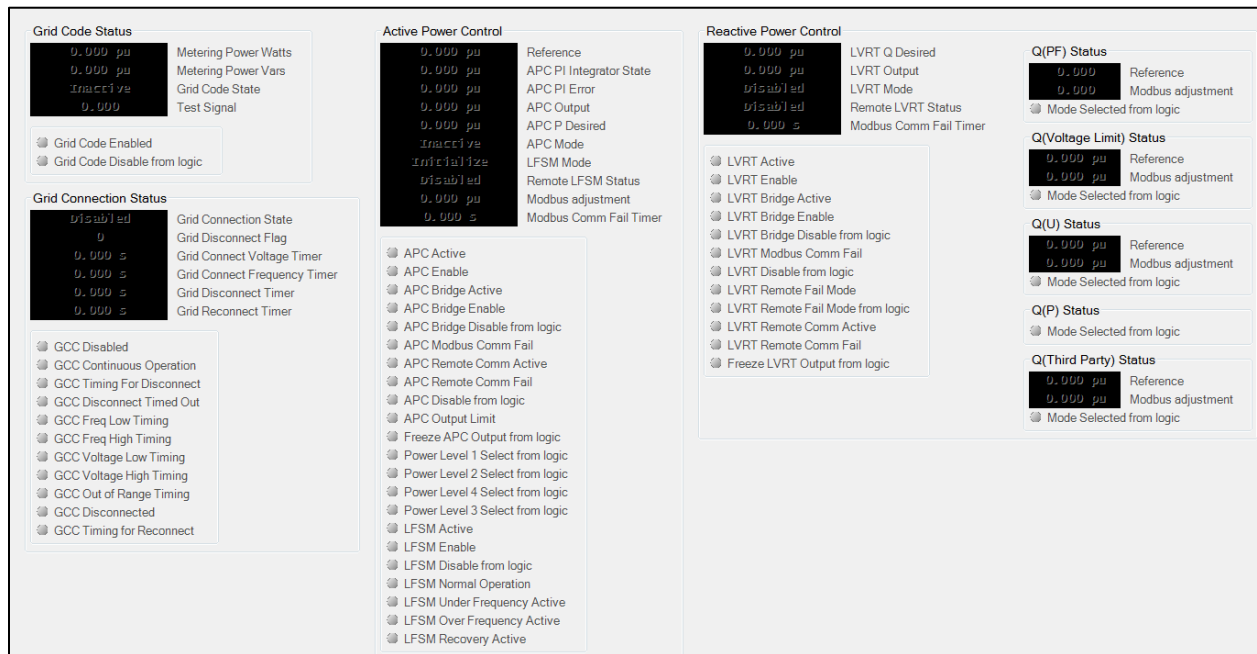


Figure 94. Grid Code Status Screen

### Configurable Protection

**BESTCOMSPPlus Navigation Path:** Metering Explorer, Status, Configurable Protection

**HMI Navigation Path:** Metering Explorer, Status, Configurable Protection

Trip status for the eight configurable, supplemental protection elements is annunciated on the BESTCOMSPPlus configurable protection screen (Figure 95). An indicator for each protection element's four trip thresholds changes from gray to green when the corresponding trip threshold is exceeded.

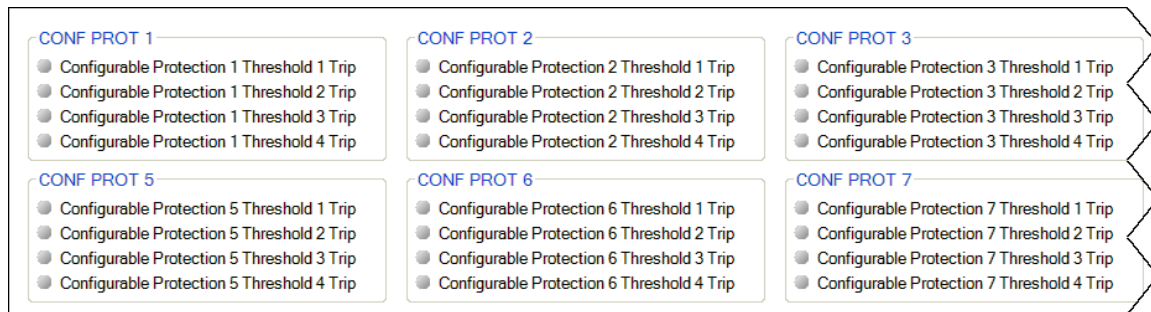


Figure 95. Configurable Protection Indication Status Screen

## Alarms

**BESTCOMSPPlus Navigation Path:** Metering Explorer, Status, Alarms

**HMI Navigation Path:** Alarms automatically displayed when active

System parameters, communication links, protection functions, and remote inputs/outputs are constantly monitored for alarm conditions. Active and previously latched alarms are listed on the front panel display and the Alarms screen of BESTCOMSPPlus. At the front panel, an inactive alarm is reset by selecting the alarm and then pressing the Reset pushbutton. A Reset Alarms button on the Alarms screen is clicked to clear all inactive alarms in BESTCOMSPPlus. The BESTCOMSPPlus Alarms screen is illustrated in Figure 96. All possible DECS-250 alarms are listed below.



Figure 96. DECS-250 Alarm Annunciation and Reset Screen

27P Protection	AEM Input 3 Threshold 1 Trip
32 Protection	AEM Input 3 Threshold 2 Trip
40Q	AEM Input 3 Threshold 3 Trip
59P Protection	AEM Input 3 Threshold 4 Trip
81O Protection	AEM Input 4 Out of Range
81U Protection	AEM Input 4 Threshold 1 Trip
AEM Communication Failure	AEM Input 4 Threshold 2 Trip
AEM Input 1 Out of Range	AEM Input 4 Threshold 3 Trip
AEM Input 1 Threshold 1 Trip	AEM Input 4 Threshold 4 Trip
AEM Input 1 Threshold 2 Trip	AEM Input 5 Out of Range
AEM Input 1 Threshold 3 Trip	AEM Input 5 Threshold 1 Trip
AEM Input 1 Threshold 4 Trip	AEM Input 5 Threshold 2 Trip
AEM Input 2 Out of Range	AEM Input 5 Threshold 3 Trip
AEM Input 2 Threshold 1 Trip	AEM Input 5 Threshold 4 Trip
AEM Input 2 Threshold 2 Trip	AEM Input 6 Out of Range
AEM Input 2 Threshold 3 Trip	AEM Input 6 Threshold 1 Trip
AEM Input 2 Threshold 4 Trip	AEM Input 6 Threshold 2 Trip
AEM Input 3 Out of Range	AEM Input 6 Threshold 3 Trip

AEM Input 6 Threshold 4 Trip	Exciter Shorted Diode
AEM Input 7 Out of Range	Failed to Build Up Alarm
AEM Input 7 Threshold 1 Trip	Field Short Circuit Status
AEM Input 7 Threshold 2 Trip	Field Short Circuit Status
AEM Input 7 Threshold 3 Trip	Firmware Change
AEM Input 7 Threshold 4 Trip	GCC Disconnect Timed Out
AEM Input 8 Out of Range	GCC Timing for Disconnect
AEM Input 8 Threshold 1 Trip	Generator Below 10Hz
AEM Input 8 Threshold 2 Trip	IRIG Lost Sync
AEM Input 8 Threshold 3 Trip	Loss of Sensing
AEM Input 8 Threshold 4 Trip	LVRT Bridge Active
AEM Output 1 Out of Range	LVRT Remote Comm Fail
AEM Output 2 Out of Range	No Logic
AEM Output 3 Out of Range	NTP Sync Lost
AEM Output 4 Out of Range	OEL
APC Bridge Active	Phase Rotation Mismatch
APC Output Limit	Power Input Failure
APC Remote Comm Fail	Programmable Alarm 1 Name
CEM Communications Failure	Programmable Alarm 10 Name
CEM Communications Failure	Programmable Alarm 11 Name
CEM Hardware Mismatch	Programmable Alarm 12 Name
Configurable Protection 1 Threshold 1 Trip	Programmable Alarm 13 Name
Configurable Protection 1 Threshold 2 Trip	Programmable Alarm 14 Name
Configurable Protection 1 Threshold 3 Trip	Programmable Alarm 15 Name
Configurable Protection 1 Threshold 4 Trip	Programmable Alarm 16 Name
Configurable Protection 2 Threshold 1 Trip	Programmable Alarm 2 Name
Configurable Protection 2 Threshold 2 Trip	Programmable Alarm 3 Name
Configurable Protection 2 Threshold 3 Trip	Programmable Alarm 4 Name
Configurable Protection 2 Threshold 4 Trip	Programmable Alarm 5 Name
Configurable Protection 3 Threshold 1 Trip	Programmable Alarm 6 Name
Configurable Protection 3 Threshold 2 Trip	Programmable Alarm 7 Name
Configurable Protection 3 Threshold 3 Trip	Programmable Alarm 8 Name
Configurable Protection 3 Threshold 4 Trip	Programmable Alarm 9 Name
Configurable Protection 4 Threshold 1 Trip	Protection Field Over Current
Configurable Protection 4 Threshold 2 Trip	Protection Field Over Voltage
Configurable Protection 4 Threshold 3 Trip	RTD Input 1 Out of Range
Configurable Protection 4 Threshold 4 Trip	RTD Input 1 Threshold 1 Trip
Configurable Protection 5 Threshold 1 Trip	RTD Input 1 Threshold 2 Trip
Configurable Protection 5 Threshold 2 Trip	RTD Input 1 Threshold 3 Trip
Configurable Protection 5 Threshold 3 Trip	RTD Input 1 Threshold 4 Trip
Configurable Protection 5 Threshold 4 Trip	RTD Input 2 Out of Range
Configurable Protection 6 Threshold 1 Trip	RTD Input 2 Threshold 1 Trip
Configurable Protection 6 Threshold 2 Trip	RTD Input 2 Threshold 2 Trip
Configurable Protection 6 Threshold 2 Trip	RTD Input 2 Threshold 3 Trip
Configurable Protection 6 Threshold 3 Trip	RTD Input 2 Threshold 4 Trip
Configurable Protection 6 Threshold 4 Trip	RTD Input 3 Out of Range
Configurable Protection 7 Threshold 1 Trip	RTD Input 3 Threshold 1 Trip
Configurable Protection 7 Threshold 2 Trip	RTD Input 3 Threshold 2 Trip
Configurable Protection 7 Threshold 3 Trip	RTD Input 3 Threshold 3 Trip
Configurable Protection 7 Threshold 4 Trip	RTD Input 3 Threshold 4 Trip
Configurable Protection 8 Threshold 1 Trip	RTD Input 4 Out of Range
Configurable Protection 8 Threshold 2 Trip	RTD Input 4 Threshold 1 Trip
Configurable Protection 8 Threshold 3 Trip	RTD Input 4 Threshold 2 Trip
Configurable Protection 8 Threshold 4 Trip	RTD Input 4 Threshold 3 Trip
Duplicate AEM	RTD Input 4 Threshold 4 Trip
Duplicate CEM	RTD Input 5 Out of Range
Ethernet Link Lost	RTD Input 5 Threshold 1 Trip
Exciter Open Diode	RTD Input 5 Threshold 2 Trip

RTD Input 5 Threshold 3 Trip  
 RTD Input 5 Threshold 4 Trip  
 RTD Input 6 Out of Range  
 RTD Input 6 Threshold 1 Trip  
 RTD Input 6 Threshold 2 Trip  
 RTD Input 6 Threshold 3 Trip  
 RTD Input 6 Threshold 4 Trip  
 RTD Input 7 Out of Range  
 RTD Input 7 Threshold 1 Trip  
 RTD Input 7 Threshold 2 Trip  
 RTD Input 7 Threshold 3 Trip  
 RTD Input 7 Threshold 4 Trip  
 RTD Input 8 Out of Range  
 RTD Input 8 Threshold 1 Trip  
 RTD Input 8 Threshold 2 Trip  
 RTD Input 8 Threshold 3 Trip

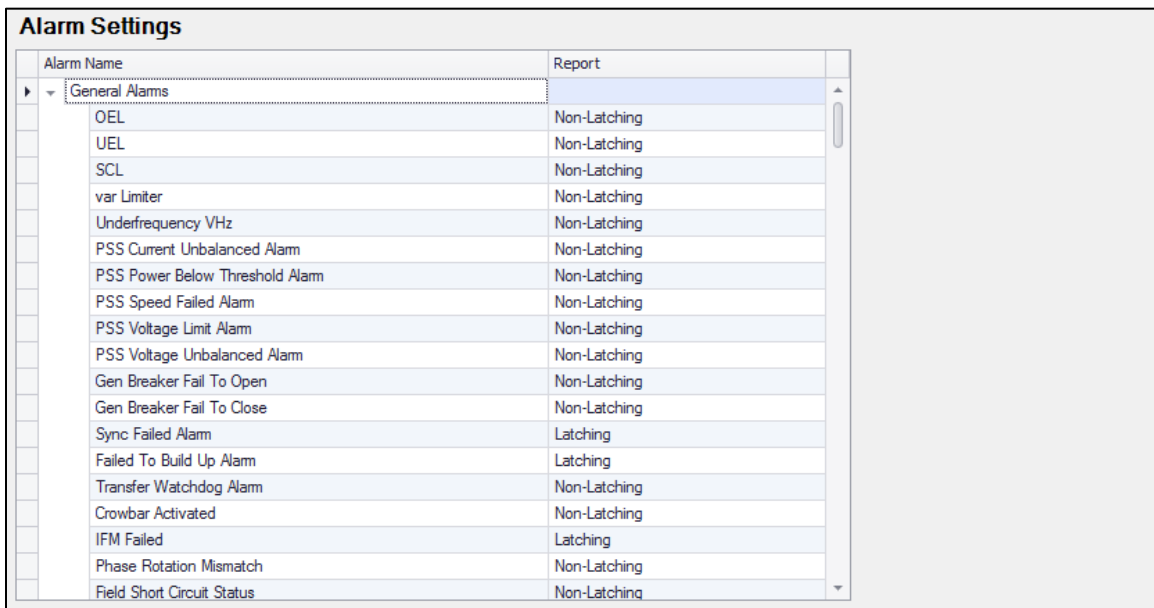
RTD Input 8 Threshold 4 Trip  
 SCL  
 Thermocouple 1 Threshold 1 Trip  
 Thermocouple 1 Threshold 2 Trip  
 Thermocouple 1 Threshold 3 Trip  
 Thermocouple 1 Threshold 4 Trip  
 Thermocouple 2 Threshold 1 Trip  
 Thermocouple 2 Threshold 2 Trip  
 Thermocouple 2 Threshold 3 Trip  
 Thermocouple 2 Threshold 4 Trip  
 Transfer Watchdog Alarm  
 UEL  
 Underfrequency VHz  
 Unknown NLS Protocol Version  
 Var Limiter

Alarm Configuration

**BESTCOMSPPlus Navigation Path:** Settings Explorer, Alarm Configuration, Alarms

Alarms are configured using BESTCOMSPPlus. Customize the reporting style of each alarm by choosing *Disabled*, *Latching*, or *Non-Latching*. Latching alarms are stored in nonvolatile memory and are retained even when control power to the DECS-250 is lost. Active alarms are shown on the front panel LCD and in BESTCOMSPPlus until they are cleared. Non-latching alarms are cleared when control power is removed. Disabling an alarm affects only the annunciation of the alarm and not the actual operation of the alarm. This means that the alarm will still trip when trip conditions are met and the occurrence will appear on the sequence of events reports.

The BESTCOMSPPlus Alarm Settings screen is illustrated in Figure 97 below.



**Figure 97. Alarm Settings Screen**

User-Programmable Alarms

**BESTCOMSPPlus Navigation Path:** Settings Explorer, Alarm Configuration, User Programmable Alarms

Sixteen user programmable alarms are available. User alarm labels<sup>A</sup> are entered on the User Programmable Alarms screen (Figure 98). If the trip condition exists for the duration of the Activation Delay<sup>B</sup>, the alarm is tripped. When active, the label of a user programmable alarm is displayed on the BESTCOMSPPlus Alarms screen, on the front panel display, and in the sequence of events reports.

Each alarm provides a logic output that can be connected to a physical output or other logic input using BESTlogic™ *Plus* Programmable Logic. Refer to the *BESTlogicPlus* chapter for more information on setting up alarm logic.

The screenshot displays a screen titled "User Programmable Alarms" containing 15 individual alarm configuration panels. The panels are arranged in a grid:

- Row 1:** Alarm #1, #2, #3
- Row 2:** Alarm #5, #6, #7
- Row 3:** Alarm #9, #10, #11
- Row 4:** Alarm #13, #14, #15

Each panel includes:

- Title:** "User Programmable Alarm #X"
- Label Text:** A text input field with a placeholder "Programmable Alarm X Name".
- Activation Delay (s):** A numeric input field with a placeholder "0".

Annotations in the image:

- A:** A small box next to the "Label Text" field of Alarm #1.
- B:** A small box next to the "Activation Delay (s)" field of Alarm #1.

**Figure 98. User Programmable Alarms Screen**

<sup>A</sup> *Label Text*: Enter a string of alphanumeric characters.

<sup>B</sup> *Activation Delay*: Adjustable from 0 to 300 in 1 second increments.

### Retrieving Alarm Information

Alarms are displayed in the sequence of events reports. Alarms are automatically shown on the front panel display when active. To view active alarms using BESTCOMS*Plus*, use the Metering Explorer to open the Status, Alarms screen. See the *Metering* chapter for more information.

### Resetting Alarms

A BESTlogic*Plus* expression can be used to reset the alarms. Use the Settings Explorer within BESTCOMS*Plus* to open the BESTlogic*Plus* Programmable Logic screen. Select the ALARM\_RESET logic block from the list of *Elements*. Use the drag and drop method to connect a variable or series of variables to the *Reset* input. When this input is set TRUE, this element resets all active alarms. Refer to the *BESTlogicPlus* chapter for more information.

## Real-Time Clock

**BESTCOMS*Plus* Navigation Path:** Metering Explorer, Status, Real Time Clock

**HMI Navigation Path:** Metering Explorer, Status, Real Time Clock

The DECS-250 time and date is displayed and adjusted on the BESTCOMS*Plus* Real-Time Clock screen (Figure 99). Manual adjustment of the DECS-250 clock is made by clicking the Edit button. This displays a window where the DECS-250 time and date can be adjusted manually or according to the connected PC clock's date and time.

Advanced clock settings such as time and date format, daylight saving time, network time protocol, and IRIG are described in the *Timekeeping* chapter of this manual.



Figure 99. Real-Time Clock Screen

## Auto Export Metering

Found under the *Tools* menu, the auto export metering function is an automated method for saving multiple metering data files at specific intervals over a period of time while connected to a DECS-250. The user specifies the *Number of Exports* and the *Interval* between each export. Enter a base filename for the metering data and a folder in which to save. The exports are counted and the count number will be appended to the base filename, making each filename unique. The first export is performed immediately after clicking the *Start* button. Figure 100 illustrates the *Auto Export Metering* screen.

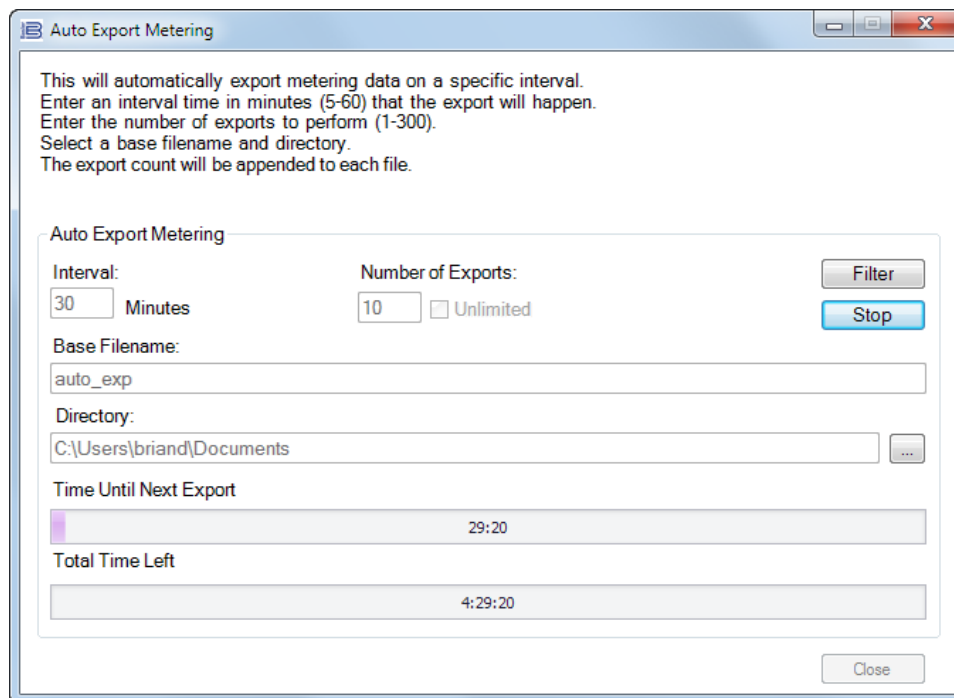


Figure 100. Auto Export Metering

# Event Recorder

DECS-250 event recorder functions include sequence-of-events recording (SER), data logging (oscillography), and trending.

## Sequence-of-Events Recording

**BESTCOMSPi<sup>us</sup> Navigation Path:** Metering Explorer, Reports, Sequence of Events

**HMI Navigation Path:** Metering Explorer, Reports, Sequence of Events

A sequence of events recorder monitors the internal and external status of the DECS-250. Events are scanned at four millisecond intervals with 1,023 events stored per record. All changes of state that occur during each scan are time- and date-stamped. Sequence of events reports are available through BESTCOMSPi<sup>us</sup>®.

Any one of over 400 monitored data/status points can be recorded in the sequence of events. All points are enabled by default. Sequence of Events Setup is illustrated in Figure 101.



Figure 101. Sequence of Events Setup

## Data Logging

**BESTCOMSPi<sup>us</sup> Navigation Path:** Settings Explorer, Report Configuration, Data Log

**HMI Navigation Path:** Settings, Configuration Settings, Data Log

The data logging function of the DECS-250 can record up to 6 oscillography records. DECS-250 oscillography records use the IEEE Standard Common Format for Transient Data Exchange (COMTRADE). Each record is time- and date-stamped. After 6 records have been recorded, the DECS-250 begins recording the next record over the oldest record. Because oscillography records are stored in nonvolatile memory, interruptions in DECS-250 control power will not affect the integrity of the records. Data log settings are configured in BESTCOMSPi<sup>us</sup> and illustrated in Figure 102 through Figure 105.

## Setup

When oscillography is enabled<sup>A</sup>, the records consist of up to six user-selectable parameters<sup>B</sup> with up to 1,200 data points recorded for each parameter. Data log setup settings are illustrated in Figure 102.

A pre-trigger-points setting<sup>C</sup> enables a user-defined number of data points recorded prior to the event trigger to be included in a data log. The value of this setting affects the duration<sup>D</sup> of the recorded pre-trigger points, the recorded post-trigger points<sup>E</sup>, and the duration of the post-trigger points<sup>F</sup>. A sample interval setting<sup>G</sup> establishes the sample rate of the data points recorded. The value of this setting affects the pre- and post-trigger duration values and the total recording duration<sup>H</sup> for a data log.

Figure 102. Data Log Setup

<sup>A</sup> **Enable:** Select Enabled or Disabled.

<sup>B</sup> **Log Parameters:** For each of the six parameters, select No Level Trigger, Vab, Vbc, Vca, Vbus, Ia, Ib, Ic, Vavg, Iavg, Iaux, Vfd, lfd, Vaux, kW, kvar, kVA, PF, V1, V2, I1, I2, G Hz, B Hz, Test, Ptest, TermF, CompF, PsskW, Vtmag, x2, WashW, x5, WashP, x7, x8, x9, x10, x11, MechP, Synth, Tftl, x29, x15, x16, x17, x31, Prelim, Post, POut, CntOp, TrnOp, ErrIn, Oel Output, Uel Output, Scl Output, varLimOutput, Null Balance, PositionInd, AvrOut, FcrErr, FcrState, FcrOut, FvrErr, FvrState, FvrOut, var/PfErr, var/PfState, var/PfOut, Oel State, Uel State, Scl State, VarLimState, Droop, Network Load Share, Oel Ref, Uel Ref, Scl Ref, Scl PfRef, VarLimRef, Power In, Grid Connect State, APCDes, APCOut, APCErr, APCState, LVRTref, LVRTDes, Grid Code Test Signal, Logic Status Points 1–6. (Selecting “No Level Trigger” excludes a parameter from data logging.)

<sup>C</sup> **Pre-Trigger Points:** Adjustable from 0 to 1,199 in increments of 1.

<sup>D</sup> **Pre-Trigger Duration:** Read-only value based on the Pre-Trigger Points and Sample Interval settings.

<sup>E</sup> **Post-Trigger Points:** Read-only value based on the Pre-Trigger Points setting.

<sup>F</sup> **Post-Trigger Duration:** Read-only value based on the Pre-Trigger Points and Sample Interval settings.

<sup>G</sup> **Sample Interval:** Adjustable from 4 to 10,000 milliseconds in 4 millisecond increments for 60 Hz nominal generator frequency. Adjustable from 5 to 12,500 milliseconds in 5 millisecond increments for 50 Hz nominal generator frequency.

<sup>H</sup> **Total Duration:** Read-only value is the sum of the pre- and post-trigger duration values.

## Triggers

**BESTCOMSPlus Navigation Path:** Settings Explorer, Report Configuration, DataLog

**HMI Navigation Path:** Settings, Configuration Settings, Data Log

Data logging may be triggered by mode triggers, logic triggers, level triggers, or manually through BESTCOMSPlus.

### Mode Triggers

Mode triggers initiate data logging as a result of an internal or external DECS-250 status change. A data log can be triggered by any of the following status changes:

- Start or Stop mode selected<sup>A</sup>
- Soft Start mode enabled or disabled<sup>B</sup>
- Underfrequency condition<sup>C</sup>
- Manual or AVR mode selected<sup>D</sup>
- Power Factor or Var mode selected<sup>E</sup>
- Limiter active<sup>F</sup>
- Voltage matching enabled or disabled<sup>G</sup>
- Primary or secondary DECS selected<sup>H</sup>
- PSS enabled or disabled<sup>I</sup>
- Auto Sync enabled or disabled<sup>J</sup>
- FCR or FVR mode selected<sup>K</sup>
- Droop mode enabled or disabled<sup>L</sup>
- Network Load Share enabled or disabled<sup>M</sup>
- Line drop compensation enabled or disabled<sup>N</sup>
- Cross-current compensation enabled or disabled<sup>O</sup>
- Grid Code enabled or disabled<sup>P</sup>
- APC enabled or disabled<sup>Q</sup>
- LFSM enabled or disabled<sup>R</sup>
- LVRT mode enabled or disabled<sup>S</sup>
- Test mode enabled or disabled<sup>T</sup>

Mode trigger settings are illustrated in Figure 103.

Mode Triggers				
Data Log Mode Triggers				
Start/Stop No Trigger A	Power Factor/var No Trigger E	PSS No Trigger I	Network Load Share No Trigger M	APC Enable No Trigger Q
Soft Start No Trigger B	Limiters No Trigger F	Auto Sync No Trigger J	Line Drop No Trigger N	LFSM Enable No Trigger R
Underfrequency No Trigger C	Voltage Matching No Trigger G	FCR/FVR No Trigger K	Cross Current Comp. No Trigger O	LVRT Mode No Trigger S
Auto/Manual No Trigger D	Pri/Sec DECS No Trigger H	Droop No Trigger L	Grid Code Enable No Trigger P	Test No Trigger T

Figure 103. Data Log Mode Triggers

<sup>A</sup> **Start/Stop**: Select Trigger on stop mode, Trigger on start mode, or No Trigger.

<sup>B</sup> **Soft Start**: Select Soft Start Mode Off, Soft Start Mode Active, or No Trigger.

<sup>C</sup> **Underfrequency**: Select Inactive Trigger, Active Trigger, or No Trigger.

<sup>D</sup> **Auto/Manual**: Select Manual Control Trigger, AVR Control Trigger, or No Trigger.

<sup>E</sup> **Var/Power Factor**: Select Operating Mode Off Trigger, Operating Mode PF Trigger, Operating Mode VAR Trigger, or No Trigger.

<sup>F</sup> **Limiters**: Select Limiter Off Trigger, Limiter UEL Trigger, Limiter OEL Trigger, Limiter UEL OEL Trigger, Limiter SCL Trigger, Limiter UEL SCL Trigger, Limiter OEL SCL Trigger, Limiter UEL OEL SCL Trigger, or No Trigger.

<sup>G</sup> **Voltage Matching**: Select VMM Off Trigger, VMM On Trigger, or No Trigger.

<sup>H</sup> **Pri/Sec DECS**: Select Primary Trigger, Secondary Trigger, or No Trigger.

<sup>I</sup> **PSS**: Select Disabled Trigger, Enabled Trigger, or No Trigger.

<sup>J</sup> **Auto Sync**: Select Disabled Trigger, Enabled Trigger, or No Trigger.

<sup>K</sup> **FCR/FVR**: Select FVR Trigger, FCR Trigger, or No Trigger.

<sup>L</sup> **Droop**: Select Disabled Trigger, Enabled Trigger, or No Trigger.

<sup>M</sup> **Network Load Share**: Disabled Trigger, Enabled Trigger, or No Trigger.

<sup>N</sup> **Line Drop Comp.**: Select Disabled Trigger, Enabled Trigger, or No Trigger.

<sup>O</sup> **Cross-Current Comp.**: Select Disabled Trigger, Enabled Trigger, or No Trigger.

<sup>P</sup> **Grid Code Enable**: Select Disabled Trigger, Enabled Trigger, or No Trigger.

<sup>Q</sup> **APC Enable**: Select Disabled Trigger, Enabled Trigger, or No Trigger.

<sup>R</sup> **LFSM Enable**: Select Disabled Trigger, Enabled Trigger, or No Trigger.

<sup>S</sup> *LVRT Mode*: Select Disabled Trigger, Enabled Trigger, or No Trigger.

<sup>T</sup> *Test*: Select Disabled Trigger, Enabled Trigger, or No Trigger.

### Level Triggers

Level triggering initiates a data log based on the value of an internal variable. The variable can be a minimum or maximum value and can be specified to trigger a record when the monitored variable crosses a minimum threshold from above, or a maximum threshold from below. A minimum and maximum threshold may also be selected for the monitored variable, causing the monitored value to trigger a record when it rises above its maximum threshold or decreases below its minimum threshold.

Level triggers are configured in BESTCOMS*Plus* on the Level Triggers tab (Figure 104) in the Data Log area of the Report Configuration. The Level Triggers tab consists of a list of parameters that can be selected to trigger a data log. Each parameter has a level trigger enable setting which configures triggering of a data log when the parameter increases above the upper threshold setting or decreases below the lower threshold setting. The parameters available to trigger a data log are listed below.

**Level Triggers**

**Auxiliary Voltage Input**  
 Lower Threshold: 0.00    Upper Threshold: 0.00    Level Trigger Enable: No Trigger

**AVR Output**  
 Lower Threshold: 0.00    Upper Threshold: 0.00    Level Trigger Enable: No Trigger

**AVR PID Error Signal Input**  
 Lower Threshold: 0.00    Upper Threshold: 0.00    Level Trigger Enable: No Trigger

**Figure 104. Data Log Level Triggers**

- APC desired reference
- APC error
- APC output
- APC state
- Auxiliary voltage input
- AVR output
- AVR PID error signal input
- Bus frequency
- Bus voltage
- Comp. frequency deviation
- Control output
- Cross current input
- Droop
- FCR error
- FCR output
- FCR state
- Field current
- Field voltage
- Frequency response
- FVR error
- FVR output
- FVR state
- Generator apparent power
- Generator average current
- Generator average voltage
- Generator current Ia
- Generator current Ib
- Generator current Ic
- Generator frequency
- Generator power factor
- Generator reactive power
- Generator real power
- Generator voltage Vab
- Generator voltage Vbc
- Generator voltage Vca
- LVRT desired reference
- LVRT reference
- Negative sequence current
- Negative sequence voltage
- Null balance level
- OEL controller output
- OEL ref.
- OEL state
- Internal State
- Position Indication
- Positive sequence current
- Positive sequence voltage
- Power in
- PSS electrical power
- PSS filtered mech. Power

- PSS final output
- PSS lead/lag #1
- PSS lead/lag #2
- PSS lead/lag #3
- PSS lead/lag #4
- PSS mechanical power
- PSS mechanical power LP #1
- PSS mechanical power LP #2
- PSS mechanical power LP #3
- PSS mechanical power LP #4
- PSS post-limit output
- PSS power HP #1
- PSS pre-limit output
- PSS speed HP #1
- PSS synthesized speed
- PSS terminal voltage
- PSS torsional filter #1
- PSS torsional filter #2
- PSS washed out power
- PSS washed out speed
- Network Load Share
- SCL controller output
- SCL PF ref.
- SCL ref.
- SCL state
- Terminal frequency deviation
- Time response
- UEL controller output
- UEL ref.
- UEL state
- Var limit output
- Var limit ref
- Var limit state
- Var/PF error
- Var/PF output
- Var/PF state

### Logic Triggers

Logic triggering initiates a data log as a result of an internal or external status change. A data log can be triggered by any combination of alarm, contact output, or contact input state changes. The available logic triggers are illustrated in Figure 105.

Alarm States		Relay Outputs	Contact Inputs
<input type="checkbox"/> Generator Overvolt	<input type="checkbox"/> EDM Open Diode	<input type="checkbox"/> Watchdog Output	<input type="checkbox"/> Start Input
<input type="checkbox"/> Generator Undervolt	<input type="checkbox"/> EDM Shorted Diode	<input type="checkbox"/> Relay1 Output	<input type="checkbox"/> Stop Input
<input type="checkbox"/> Excess Volts Per Hz	<input type="checkbox"/> PSS Power Below Threshold	<input type="checkbox"/> Relay2 Output	<input type="checkbox"/> Switch1 Input
<input type="checkbox"/> Loss Of Field	<input type="checkbox"/> PSS Volt Unbalanced	<input type="checkbox"/> Relay3 Output	<input type="checkbox"/> Switch2 Input
<input type="checkbox"/> Loss Of Sensing Voltage	<input type="checkbox"/> PSS Current Unbalanced	<input type="checkbox"/> Relay4 Output	<input type="checkbox"/> Switch3 Input
<input type="checkbox"/> Below 10 Hz	<input type="checkbox"/> PSS Speed Failure	<input type="checkbox"/> Relay5 Output	<input type="checkbox"/> Switch4 Input
<input type="checkbox"/> Failed To Build Up	<input type="checkbox"/> PSS Voltage Limit Alarm	<input type="checkbox"/> Relay6 Output	<input type="checkbox"/> Switch5 Input
<input type="checkbox"/> Field Over Voltage	<input type="checkbox"/> GCC Disconnect Timed Out	<input type="checkbox"/> Relay7 Output	<input type="checkbox"/> Switch6 Input
<input type="checkbox"/> Field Over Current	<input type="checkbox"/> APC Remote Trip	<input type="checkbox"/> Relay8 Output	<input type="checkbox"/> Switch7 Input
<input type="checkbox"/> OEL	<input type="checkbox"/> LFSM Active	<input type="checkbox"/> Relay9 Output	<input type="checkbox"/> Switch8 Input
<input type="checkbox"/> UEL	<input type="checkbox"/> LVRT Active	<input type="checkbox"/> Relay 10 Output	<input type="checkbox"/> Switch9 Input
<input type="checkbox"/> SCL	<input type="checkbox"/> LVRT Remote Trip	<input type="checkbox"/> Relay11 Output	<input type="checkbox"/> Switch10 Input
<input type="checkbox"/> Under Freq Limiter			<input type="checkbox"/> Switch11 Input
<input type="checkbox"/> Set Point Upper Limit			<input type="checkbox"/> Switch12 Input
<input type="checkbox"/> Set Point Lower Limit			<input type="checkbox"/> Switch13 Input
			<input type="checkbox"/> Switch14 Input

Figure 105. Data Log Logic Triggers

## **Trending**

**BESTCOMSPi<sup>us</sup> Navigation Path:** Settings Explorer, Report Configuration, Trending

**HMI Navigation Path:** Settings, Configuration Settings, Trending

The trend log records the activity of DECS-250 parameters over an extended period of time. When enabled<sup>A</sup>, up to six selectable parameters<sup>B</sup> can be monitored over a user-defined duration<sup>C</sup> ranging from one to 720 hours. Trend log settings are illustrated in Figure 106.

Figure 106. Trend Log Setup

<sup>A</sup> *Trending Enable*: Select Enabled or Disabled.

<sup>B</sup> *Trending Log Parameters*: Select NO Level Trigger, Vab: PhA-PhB L-L Voltage {p.u}, Vbc: PhB-PhC L-L Voltage {p.u}, Vca: PhC-PhA L-L Voltage {p.u}, Vbus: Bus Voltage {p.u}, Ia : Phase A Current {p.u}, Ib: Phase B Current {p.u}, Ic: Phase C Current {p.u}, Vavg: Avg L-L Voltage {p.u}, Iavg: Avg Line Current {p.u}, Iaux: Cross Current Input {p.u}, Vfd: Field Voltage {p.u}, Ifd: Field Current {p.u}, Vaux: Aux Voltage Input {p.u}, kW: Real Power {p.u}, kvar: Reactive Power {p.u}, kVA: Total Power {p.u}, PF: Power Factor, V1: Positive Sequence Voltage {p.u}, V2: Negative Sequence Voltage {p.u}, I1: Positive Sequence Current {p.u}, I2: Negative Sequence Current {p.u}, G Hz: Generator Frequency (Hz), B Hz: Bus Frequency {Hz}, Test: Frequency Response Signal {p.u}, or Ptest: Time Response Signal {p.u}, TermF: Terminal Frequency Deviation {%), CompF: Compensated Frequency Deviation, PssKW: Pss Electric Power {p.u}, Vtmag: PSS Term Voltage, x2 : Speed HP #1, WashW : Washed Out Speed {p.u}, x5 : Power HP #1 {p.u}, WashP: Washed Out Power {p.u}, x7: Mechanical Power {p.u}, x8: Mechanical Power LP #1, x9: Mechanical Power LP #2, x10: Mechanical Power LP #3, x11: Mechanical Power LP #4, MechP: Filtered Mechanical Power {p.u}, Synth: Synthesized Speed {p.u}, Tflt1: Torsional Filter #1 {p.u}, x29: Torsional Filter #2 {p.u}, x15: Lead-Lag #1 {p.u}, x16: Lead-Lag #2 {p.u}, x17: Lead-Lag #3 {p.u}, x31: Lead-Lag #4 {p.u}, Prelim: Pre-Limit Output {p.u}, Post: Post-Limit Output {p.u}, POut: Final PSS Output {p.u}, CntOp: Control Output {p.u}, TrnOp: Internal State {p.u}, ErrIn: Avr Error Signal, OelOutput: OEL Controller Output, UelOutput: UEL Controller Output, SclOutput: SCL Controller Output, varLimOutput: var Limiter Output, NullBalance: Null Balance Level {p.u}, PositionInd: Position Indication {p.u}, AvrOut, FcrErr, FcrState, FcrOut, FvrErr, FvrState, FvrOut, var/PfErr, var/PfState, var/PfOut, OelState, UelState, SclState, varLimState, Droop,Rcc, OelRef, UelRef, SclIRef, SclPfRef, varLimRef, Power In, Grid Connect State, APCDes, APCOut, APCErr, APCState, LVRTref, LVRTDes, Grid Code Test Signal, Logic Status Points 1–6.

<sup>C</sup> *Trending Duration*: Adjustable from 1 to 720 hours in 1 hour increments.

# Power System Stabilizer

The optional (style xPxxxxx), integrated power system stabilizer (PSS) is an IEEE Std 421.5 type PSS2A/2B/2C, dual-input, “integral of accelerating power” stabilizer that provides supplementary damping for low-frequency, local-mode oscillations and power system oscillations.

PSS features include user-selectable, speed-only sensing, two- or three-wattmeter power measurement, optional frequency-based operation, and generator and motor control modes.

PSS settings are configured exclusively through the BESTCOMSP<sup>Plus</sup>® interface. These settings are illustrated in Figure 116, Figure 117, Figure 118, and Figure 119.

**BESTCOMSP<sup>Plus</sup> Navigation Path:** Settings Explorer, PSS

**HMI Navigation Path:** Settings, PSS

## ***Supervisory Function and Setting Groups***

---

A supervisory function enables PSS operation only when a sufficient load is applied to the generator. Two separate groups of PSS settings enable stabilizer operation tailored for two distinct load conditions.

### **Supervisory Function**

When PSS control is enabled<sup>A</sup>, a power-on threshold setting<sup>B</sup> determines the level of power (watts) where PSS operation is automatically enabled. This threshold is a per-unit setting based on the generator ratings. (The *Configuration* chapter of this manual provides information about entering the generator and system ratings.) A hysteresis setting<sup>C</sup> provides a margin below the power-on threshold so that transient dips in power (watts) will not disable stabilizer operation. This hysteresis is a per-unit setting based on the generator ratings.

### **Setting Groups**

When setting group selection is enabled<sup>D</sup>, a threshold setting<sup>E</sup> establishes the power level where the PSS gain settings are switched from the primary group to the secondary group. After a transfer to the secondary gain settings, a hysteresis setting<sup>F</sup> determines the level of (decreasing) power where a transfer back to the primary gain settings will occur.

## ***Theory of Operation***

---

The PSS uses an indirect method of power system stabilization that employs two signals: shaft speed and electrical power. This method eliminates the undesirable components from the speed signal (such as noise, lateral shaft run-out, or torsional oscillations) while avoiding a reliance on the difficult-to-measure mechanical power signal.

PSS function is illustrated by the function blocks and software switches shown in Figure 107. This illustration is also available in BESTCOMSP<sup>Plus</sup> by clicking the PSS Model Info button located on the Control tab.

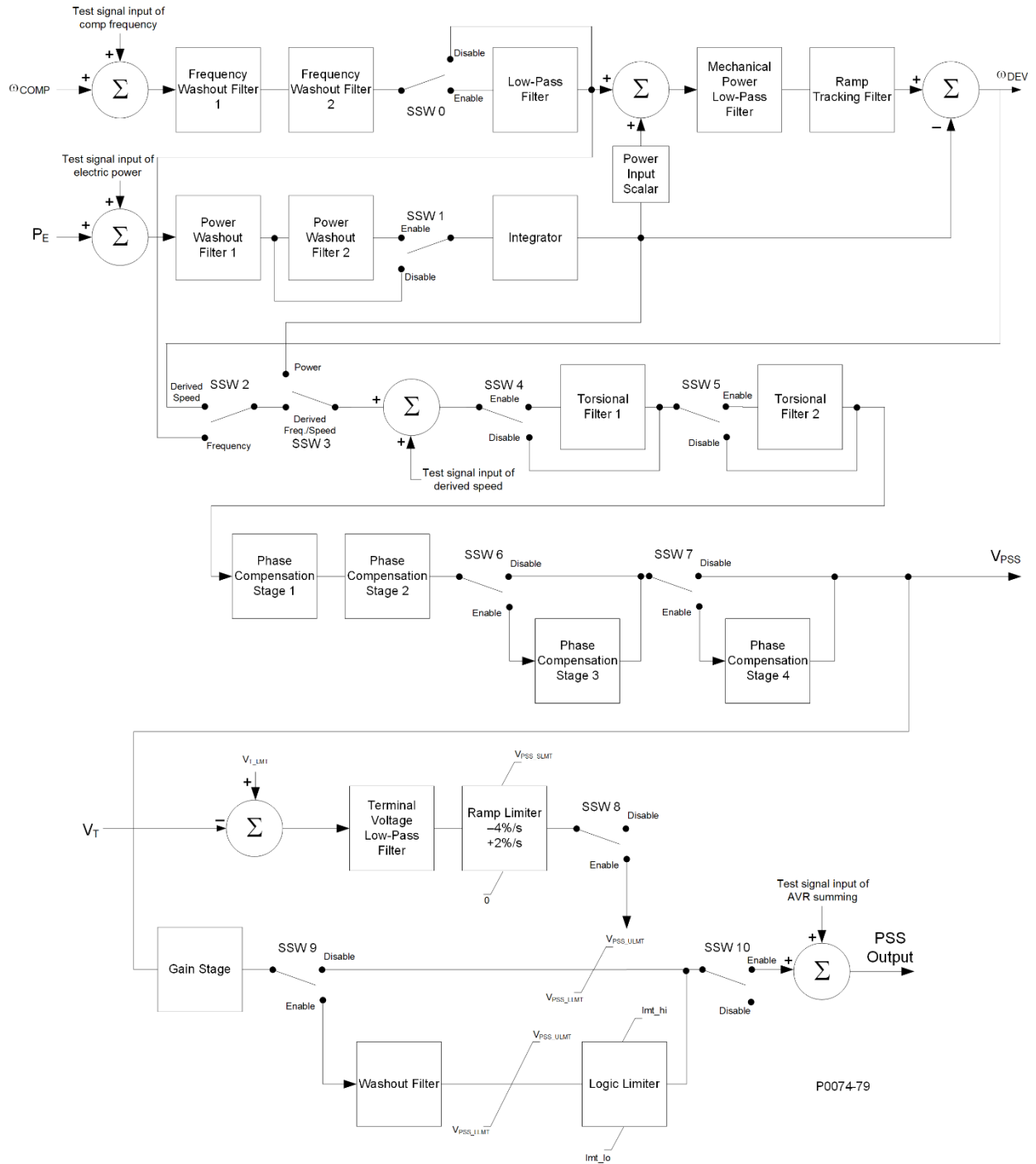


Figure 107. PSS Function Blocks and Software Switches

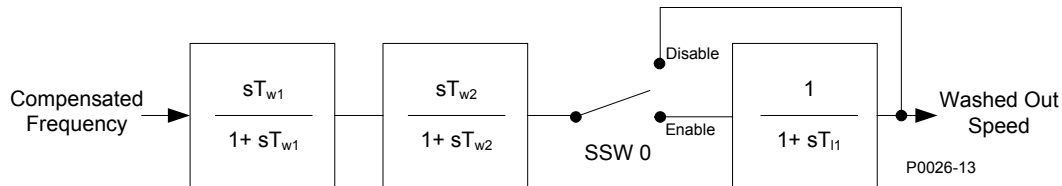
## Speed Signal

The speed signal is converted to a constant level that is proportional to the shaft speed (frequency).

Two high-pass (frequency washout) filter stages are applied to the resulting signal to remove the average speed level and produce a speed deviation signal. This ensures that the stabilizer reacts only to changes in speed and does not permanently alter the generator terminal voltage reference.

The frequency washout filter stages are controlled by time constant settings  $T_{w1}^G$  and  $T_{w2}^H$ . Low-pass filtering of the speed deviation signal can be enabled or disabled through software switch  $SSW 0^I$ . The low-pass filter time constant is adjusted by the  $T_{I1}$  setting<sup>J</sup>.

Figure 108 shows the high-pass and low-pass filter transfer function blocks in frequency domain form. (The letter  $s$  is used to represent the complex frequency of Laplace operator.)



PSS Frequency Input Signal

Figure 108. Speed Signal

## Rotor Frequency Calculation

During steady-state conditions, the terminal frequency of the generator is a good measure of rotor speed. However, this may not be the case during low frequency transients, due to the voltage drop across the machine reactance. To compensate for this effect, the DECS-250 first calculates the terminal voltages and currents. It then adds the voltage drop across the quadrature reactance to the terminal voltages to obtain internal machine voltages. These voltages are then used to calculate the rotor frequency. This gives a more accurate measure of rotor speed during low frequency transients when stabilizing action is required.

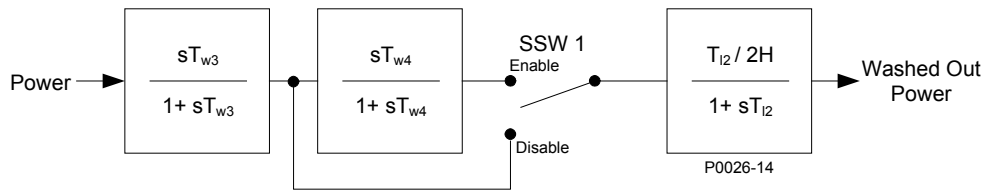
The quadrature axis compensation used in the rotor frequency calculation is entered through the Quadrature  $X_q$  setting<sup>K</sup>.

## Generator Electrical Power Signal

Figure 109 illustrates the operations performed on the power input signal to produce the integral of electrical power deviation signal.

The generator electrical power output is derived from the generator VT secondary voltages and generator CT secondary currents applied to the DECS-250.

The power output is high-pass (washout) filtered to produce the required power deviation signal. If additional washout filtering is desired, a second high-pass filter can be enabled by software switch  $SSW 1^L$ . The first high-pass filter is controlled by time constant setting  $T_{w3}^M$  and the second high-pass filter is controlled by time constant setting  $T_{w4}^N$ .



PSS Power Input Signal

Figure 109. Generator Electrical Power Signal

After high-pass filtering, the electrical power signal is integrated and scaled, combining the generator inertia constant<sup>O</sup> (2H) with the speed signal. Low-pass filtering within the integrator is controlled by time constant T12<sup>P</sup>.

**Derived Mechanical Power Signal**

The speed deviation signal and integral of electrical power deviation signal are combined to produce a derived, integral of mechanical power signal.

An adjustable gain stage, Kpe<sup>Q</sup>, establishes the amplitude of the electrical power input used by the PSS function.

The derived integral of mechanical power signal is then passed through a mechanical-power, low-pass filter and ramp tracking filter. The low-pass filter is controlled by time constant TI3<sup>R</sup> and provides attenuation of torsional components appearing in the speed input path. The ramp tracking filter produces a zero, steady-state error to ramp changes in the integral of electric power input signal. This limits the stabilizer output variation to very low levels for the mechanical power rates of change that are normally encountered during operation of utility-scale generators. The ramp tracking filter is controlled by time constant Tr<sup>S</sup>. An exponent consisting of a numerator<sup>T</sup> and denominator<sup>U</sup> is applied to the mechanical power filter.

Processing of the derived integral of mechanical power signal is illustrated in Figure 110.

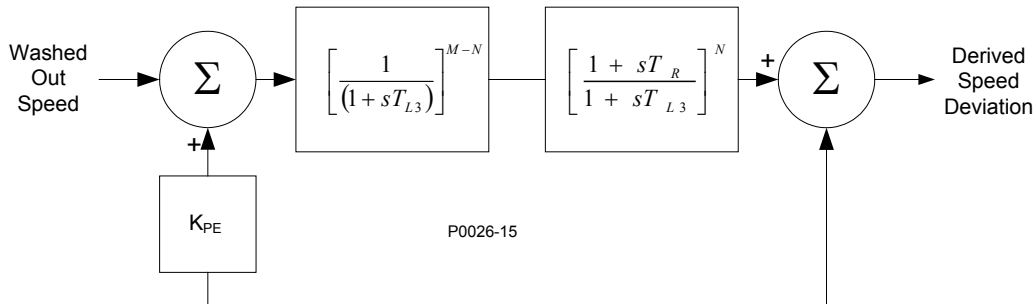


Figure 110. Derived Mechanical Power Signal

**Stabilizing Signal Selection**

Figure 111 illustrates how software switches SSW 2<sup>V</sup> and SSW 3<sup>W</sup> are used to select the stabilizing signal. Derived speed deviation is selected as the stabilizing signal when the SSW 2 setting is Derived Speed and the SSW 3 setting is Derived Frequency/Speed. Washed out speed is selected as the stabilizing signal when the SSW 2 setting is Frequency and the SSW 3 setting is Derived Frequency/Speed. Washed out power is selected as the stabilizing signal when the SSW 3 setting is Power. (When the SSW 3 setting is Power, the SSW 2 setting has no effect.)

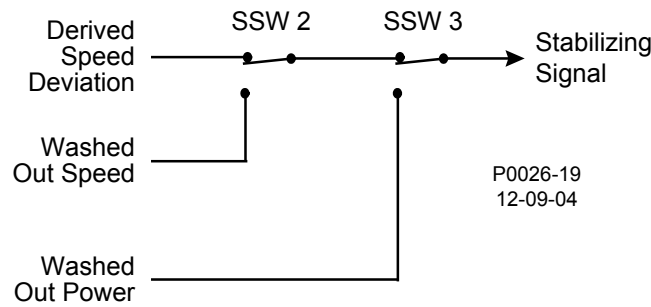


Figure 111. Stabilizing Signal Selection

### Torsional Filters

Two torsional filters, shown in Figure 112, are available after the stabilizing signal and before the phase compensation blocks. The torsional filters provide the desired gain reduction at a specified frequency. The filters compensate the torsional frequency components present in the input signal.

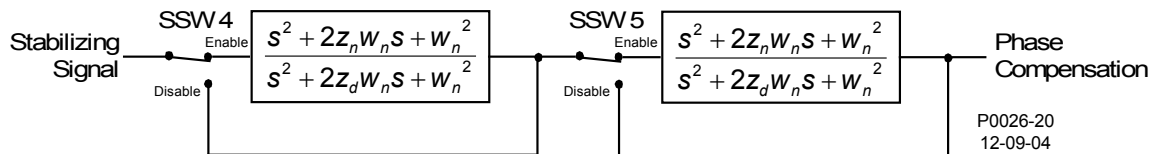


Figure 112. Torsional Filters

Software switch SSW 4<sup>X</sup> enables and disables torsional filter 1 and SSW 5<sup>Y</sup> enables and disables torsional filter 2.

Torsional filters 1 and 2 are controlled by a zeta numerator<sup>Z</sup> (Zeta Num), zeta denominator<sup>AA</sup> (Zeta Den), and a frequency response parameter<sup>BB</sup> (Wn).

### Phase Compensation

The derived speed signal is modified before it is applied to the voltage regulator input. Filtering of the signal provides phase lead at the electromechanical frequencies of interest (0.1 to 5 Hz). The phase lead requirement is site-specific and is required to compensate for phase lag introduced by the closed-loop voltage regulator.

Four phase compensation stages are available. Each phase compensation stage has a phase lead time constant<sup>CC</sup> (T1, T3, T5, T7) and a phase lag time constant<sup>DD</sup> (T2, T4, T6, T8). Normally, the first two lead-lag stages are adequate to match the phase compensation requirements of a unit. If needed, the third and fourth stages may be added through the settings of software switches SSW 6<sup>EE</sup> and SSW 7<sup>FF</sup>. Figure 113 illustrates the phase compensation stages and associates software switches.

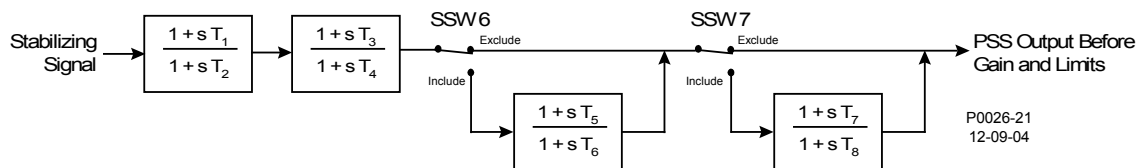


Figure 113. Phase Compensation

### Washout Filter and Logic Limiter

The output of the phase compensation stages is connected, through a stabilizer gain stage, to the washout filter and logic limiter.

Software switch SSW 9<sup>GG</sup> enables and bypasses the washout filter and logic limiter. The washout filter has two time constants: normal<sup>HH</sup> and limit<sup>II</sup> (less than normal).

The logic limiter compares the signal from the washout filter with the logic limiter upper<sup>JJ</sup> and lower<sup>KK</sup> limit settings. If the counter reaches the set delay time<sup>LL</sup>, the time constant for the washout filter changes from the normal time constant to the limit time constant. When the signal returns to within the specified limits, the counter resets and the washout filter time constant changes back to the normal time constant.

Figure 114 illustrates the washout filter and logic limiter.

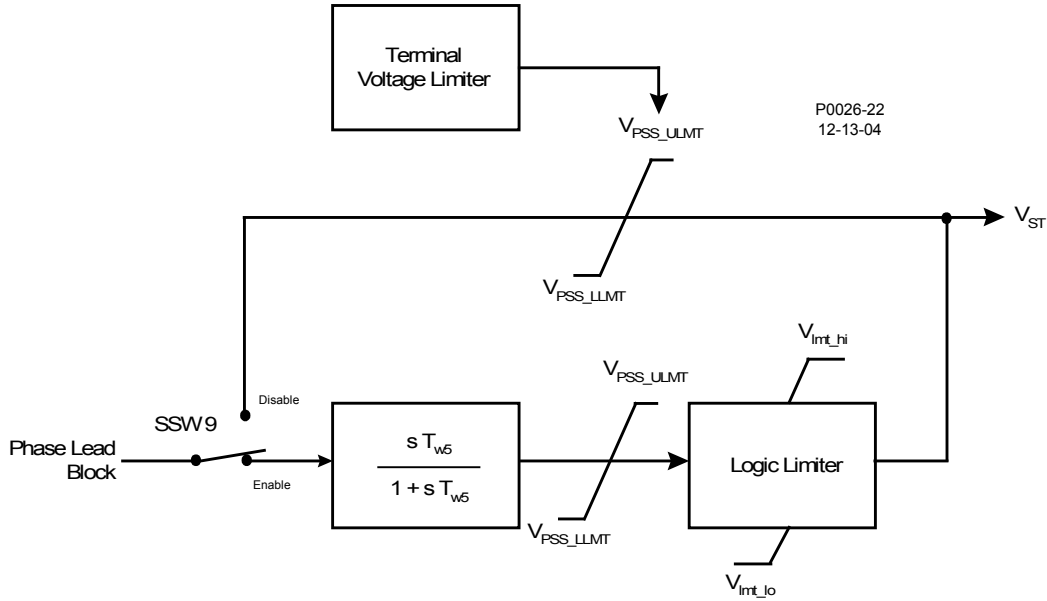


Figure 114. Washout Filter and Logic Limiter

**Output Stage**

Prior to connecting the stabilizer output signal to the voltage regulator input, adjustable gain<sup>MM</sup> and upper<sup>NN</sup> and lower<sup>OO</sup> limits are applied. The stabilizer output is connected to the voltage regulator input when the software switch SSW 10<sup>PP</sup> setting is On. Processing of the stabilizer output signal is illustrated in Figure 115.

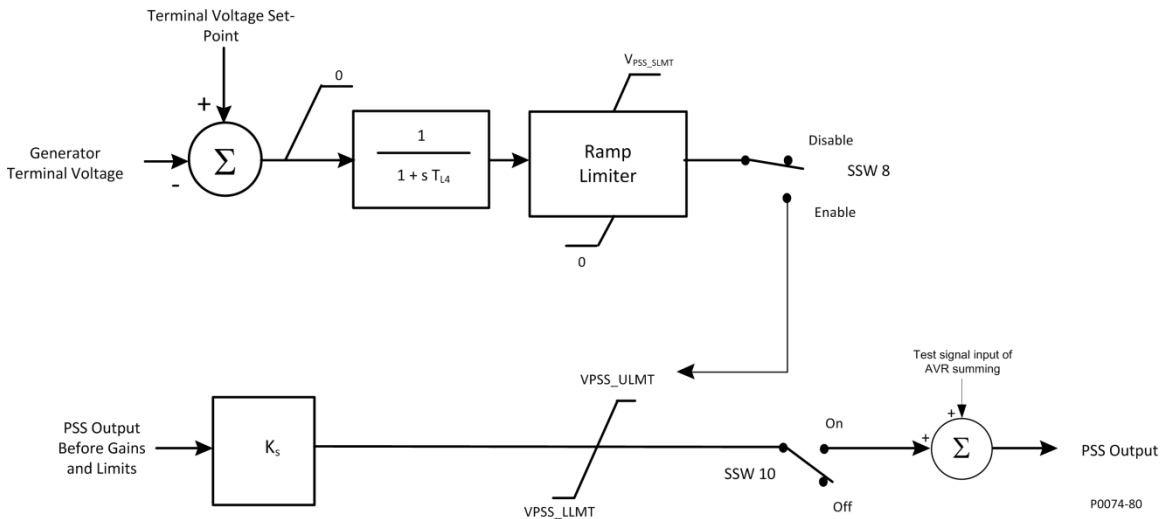


Figure 115. Output Stage

**Terminal Voltage Limiter**

Since the PSS operates by modulating the excitation, it may counteract the voltage regulator’s attempts to maintain terminal voltage within a tolerance band. To avoid creating an overvoltage condition, the PSS has a terminal voltage limiter (shown in Figure 114) that reduces the upper output limit to zero when the

generator voltage exceeds the terminal voltage setpoint<sup>QQ</sup>. The terminal voltage limiter is enabled and disabled by software switch SSW 8<sup>RR</sup>. The limit setpoint is normally selected such that the limiter will eliminate any contribution from the PSS before the timed overvoltage or volts per hertz protection operates.

The limiter reduces the stabilizer's upper limit,  $V_{PSS\_ULMT}$ , at a fixed rate until zero is reached or overvoltage is no longer present. The limiter does not reduce the AVR reference below its normal level; it will not interfere with system voltage control during disturbance conditions. The error signal (terminal voltage minus the limit start point) is processed through a conventional low-pass filter to reduce the effect of measurement noise. The low-pass filter is controlled by a time constant<sup>SS</sup>.



Figure 116. PSS Configuration Settings

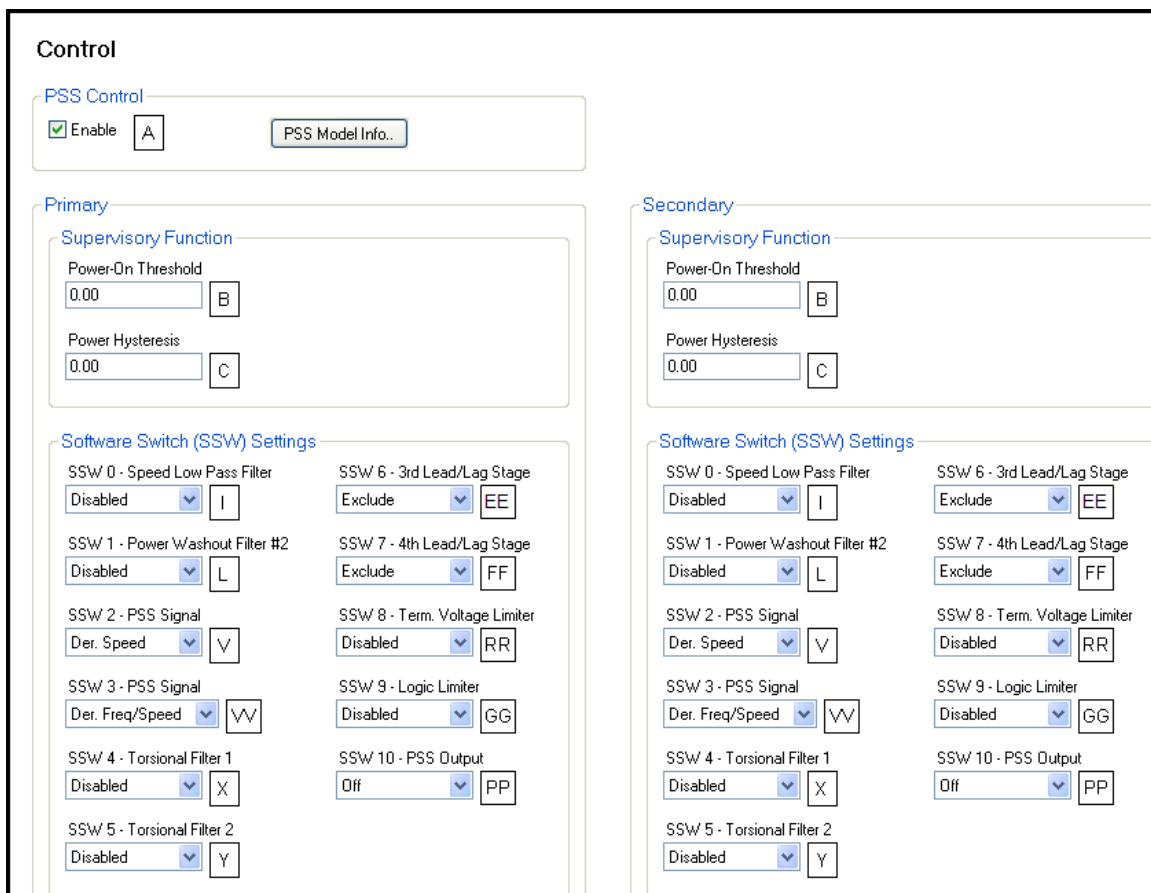


Figure 117. PSS Control Settings

Parameter	
<b>Primary</b>	
<b>Low-Pass/Ramp Tracking</b>	
TI1 - Time Const. <input type="text" value="0.00"/> <input type="button" value="J"/>	Tr - Time Const. <input type="text" value="0.50"/> <input type="button" value="S"/>
TI2 - Time Const. <input type="text" value="1.00"/> <input type="button" value="P"/>	N - Num Exp. <input type="text" value="1"/> <input type="button" value="T"/>
TI3 - Time Const. <input type="text" value="0.10"/> <input type="button" value="R"/>	M - Den Exp. <input type="text" value="5"/> <input type="button" value="U"/>
<b>High-Pass Filtering/Integration</b>	
Tw1 - Time Const. <input type="text" value="1.00"/> <input type="button" value="G"/>	Tw4 - Time Const. <input type="text" value="1.00"/> <input type="button" value="N"/>
Tw2 - Time Const. <input type="text" value="1.00"/> <input type="button" value="H"/>	H - Inertia <input type="text" value="1.00"/> <input type="button" value="O"/>
Tw3 - Time Const. <input type="text" value="1.00"/> <input type="button" value="M"/>	
<b>Torsional Filters</b>	
Zeta Num 1 <input type="text" value="0.50"/> <input type="button" value="Z"/>	Zeta Num 2 <input type="text" value="0.50"/> <input type="button" value="Z"/>
Zeta Den 1 <input type="text" value="0.25"/> <input type="button" value="AA"/>	Zeta Den 2 <input type="text" value="0.25"/> <input type="button" value="AA"/>
Wn 1 <input type="text" value="42.05"/> <input type="button" value="BB"/>	Wn 2 <input type="text" value="42.05"/> <input type="button" value="BB"/>
<b>Rotor Freq Calculation</b>	
Quadrature Xq <input type="text" value="0.000"/> <input type="button" value="K"/>	
<b>Power Input</b>	
Kpe <input type="text" value="1.00"/> <input type="button" value="Q"/>	
<b>Phase Comp - Time Constants</b>	
T1 - 1st Phase Lead <input type="text" value="1.000"/> <input type="button" value="CC"/>	T5 - 3rd Phase Lead <input type="text" value="1.000"/> <input type="button" value="CC"/>
T2 - 1st Phase Lag <input type="text" value="1.000"/> <input type="button" value="DD"/>	T6 - 3rd Phase Lag <input type="text" value="1.000"/> <input type="button" value="DD"/>
T3 - 2nd Phase Lead <input type="text" value="1.000"/> <input type="button" value="CC"/>	T7 - 4th Phase Lead <input type="text" value="1.000"/> <input type="button" value="CC"/>
T4 - 2nd Phase Lag <input type="text" value="1.000"/> <input type="button" value="DD"/>	T8 - 4th Phase Lag <input type="text" value="1.000"/> <input type="button" value="DD"/>
<b>Secondary</b>	
<b>Low-Pass/Ramp Tracking</b>	
TI1 - Time Const. <input type="text" value="0.00"/> <input type="button" value="J"/>	Tr - Time Const. <input type="text" value="0.50"/> <input type="button" value="S"/>
TI2 - Time Const. <input type="text" value="1.00"/> <input type="button" value="P"/>	N - Num Exp. <input type="text" value="1"/> <input type="button" value="T"/>
TI3 - Time Const. <input type="text" value="0.10"/> <input type="button" value="R"/>	M - Den Exp. <input type="text" value="5"/> <input type="button" value="U"/>
<b>High-Pass Filtering/Integration</b>	
Tw1 - Time Const. <input type="text" value="1.00"/> <input type="button" value="G"/>	Tw4 - Time Const. <input type="text" value="1.00"/> <input type="button" value="N"/>
Tw2 - Time Const. <input type="text" value="1.00"/> <input type="button" value="H"/>	H - Inertia <input type="text" value="1.00"/> <input type="button" value="O"/>
Tw3 - Time Const. <input type="text" value="1.00"/> <input type="button" value="M"/>	
<b>Torsional Filters</b>	
Zeta Num 1 <input type="text" value="0.50"/> <input type="button" value="Z"/>	Zeta Num 2 <input type="text" value="0.50"/> <input type="button" value="Z"/>
Zeta Den 1 <input type="text" value="0.25"/> <input type="button" value="AA"/>	Zeta Den 2 <input type="text" value="0.25"/> <input type="button" value="AA"/>
Wn 1 <input type="text" value="42.05"/> <input type="button" value="BB"/>	Wn 2 <input type="text" value="42.05"/> <input type="button" value="BB"/>
<b>Rotor Freq Calculation</b>	
Quadrature Xq <input type="text" value="0.000"/> <input type="button" value="K"/>	
<b>Power Input</b>	
Kpe <input type="text" value="1.00"/> <input type="button" value="Q"/>	
<b>Phase Comp - Time Constants</b>	
T1 - 1st Phase Lead <input type="text" value="1.000"/> <input type="button" value="CC"/>	T5 - 3rd Phase Lead <input type="text" value="1.000"/> <input type="button" value="CC"/>
T2 - 1st Phase Lag <input type="text" value="1.000"/> <input type="button" value="DD"/>	T6 - 3rd Phase Lag <input type="text" value="1.000"/> <input type="button" value="DD"/>
T3 - 2nd Phase Lead <input type="text" value="1.000"/> <input type="button" value="CC"/>	T7 - 4th Phase Lead <input type="text" value="1.000"/> <input type="button" value="CC"/>
T4 - 2nd Phase Lag <input type="text" value="1.000"/> <input type="button" value="DD"/>	T8 - 4th Phase Lag <input type="text" value="1.000"/> <input type="button" value="DD"/>

Figure 118. PSS Parameter Settings

Output Limiter	
Primary	Secondary
<b>PSS Output Limiting</b>	
Upper Limit 0.000 <input type="text"/> NN	Upper Limit 0.000 <input type="text"/> NN
Lower Limit 0.000 <input type="text"/> OO	Lower Limit 0.000 <input type="text"/> OO
<b>Stabilizer Gain</b>	
Ks 0.00 <input type="text"/> MM	Ks 0.00 <input type="text"/> MM
<b>Terminal Voltage Limiter</b>	
Time Constant 1.000 <input type="text"/> SS	Time Constant 1.000 <input type="text"/> SS
Setpoint 1.000 <input type="text"/> QQ	Setpoint 1.000 <input type="text"/> QQ
<b>Logic Limiter Washout Filter</b>	
Normal Time 10.0 <input type="text"/> HH	Normal Time 10.0 <input type="text"/> HH
Limit Time 0.30 <input type="text"/> II	Limit Time 0.30 <input type="text"/> II
<b>Logic Output Limiter</b>	
Upper Limit 0.020 <input type="text"/> JJ	Upper Limit 0.020 <input type="text"/> JJ
Lower Limit -0.020 <input type="text"/> KK	Lower Limit -0.020 <input type="text"/> KK
Time Delay 0.50 <input type="text"/> LL	Time Delay 0.50 <input type="text"/> LL

Figure 119. PSS Output Limiter Settings

- A *PSS Control*: Check box to enable.
- B *Supervisory Function Power-On Threshold*: Adjustable from 0 to 1 in 0.01 increments.
- C *Supervisory Function Power Hysteresis*: Adjustable from 0 to 1 in 0.01 increments.
- D *Setting Group Logic*: Check box to enable.
- E *Power Level Threshold*: Adjustable from 0 to 1 in 0.01 increments.
- F *Power Level Hysteresis*: Adjustable from 0 to 1 in 0.01 increments.
- G *High-Pass Filtering/Integration Time Constant Tw1*: Adjustable from 1 to 20 in 0.01 increments.
- H *High-Pass Filtering/Integration Time Constant Tw2*: Adjustable from 1 to 20 in 0.01 increments.
- I *Speed Low-Pass Filter Switch SSW 0*: Select Enabled or Disabled.
- J *Low-Pass/Ramp Tracking Time Constant TI1*: Adjustable from 1 to 20 in 0.01 increments.
- K *Rotor Frequency Calculation – Quadrature Xq*: Adjustable from 0 to 5 in 0.001 increments.
- L *Power Washout Filter #2 Software Switch SSW 1*: Select Enabled or Disabled.
- M *High-Pass Filtering/Integration Time Constant Tw3*: Adjustable from 1 to 20 in 0.01 increments.
- N *High-Pass Filtering/Integration Time Constant Tw4*: Adjustable from 1 to 20 in 0.01 increments.
- O *High-Pass Filtering/Integration Inertia (H)*: Adjustable from 0.01 to 25 in 0.01 increments.
- P *Low-Pass/Ramp Tracking Time Constant TI2*: Adjustable from 1 to 20 in 0.01 increments.
- Q *Power Input Gain Stage Kpe*: Adjustable from 0 to 2 in 0.01 increments.
- R *Low-Pass/Ramp Tracking Time Constant TI3*: Adjustable from 0.05 to 0.2 in 0.01 increments.
- S *Low-Pass/Ramp Tracking Time Constant Tr*: Adjustable from 0.05 to 1 in 0.01 increments.
- T *Low-Pass/Ramp Tracking Exponent Numerator*: Adjustable from 0 to 1 in increments of 1.
- U *Low-Pass/Ramp Tracking Exponent Denominator*: Adjustable from 1 to 5 in increments of 1.
- V *PSS Signal Software Switch SSW 2*: Select Frequency or Der. Speed.
- W *PSS Signal Software Switch SSW 3*: Select Power or Der. Freq/Speed.
- X *Torsional Filter 1 Software Switch SSW 4*: Select Disabled or Enabled.

- 
- Y *Torsional Filter 2 Software Switch SSW 5*: Select Disabled or Enabled.
- Z *Torsional Filter Zeta Numerator*: Adjustable from 0 to 1 in 0.01 increments.
- AA *Torsional Filter Zeta Denominator*: Adjustable from 0 to 1 in 0.01 increments.
- BB *Torsional Filter Frequency Response Parameter (Wn)*: Adjustable from 10 to 150 in 0.05 increments.
- CC *Phase Compensation Phase Lead Time Constant*: Adjustable from 0.001 to 6 in 0.001 increments.
- DD *Phase Compensation Phase Lag Time Constant*: Adjustable from 0.001 to 6 in 0.001 increments.
- EE *3<sup>rd</sup> Lead/Lag Stage Software Switch SSW 6*: Select Include or Exclude.
- FF *4<sup>th</sup> Lead/Lag Stage Software Switch SSW 7*: Select Include or Exclude.
- GG *Logic Limiter Software Switch SSW 9*: Select Enabled or Disabled.
- HH *Logic Limiter Washout Filter Normal Time Constant*: Adjustable from 5 to 30 in 0.1 increments.
- II *Logic Limiter Washout Filter Limit Time Constant*: Adjustable from 0 to 1 in 0.01 increments.
- JJ *Logic Output Limiter Upper Limit*: Adjustable from 0.01 to 0.04 in 0.01 increments.
- KK *Logic Output Limiter Lower Limit*: Adjustable from -0.04 to -0.01 in 0.01 increments.
- LL *Logic Output Limiter Time Delay*: Adjustable from 0 to 2 in 0.01 increments.
- MM *Stabilizer Gain (Ks)*: Adjustable from -100 to 100 in 0.01 increments.
- NN *PSS Output Limiting Upper Limit*: Adjustable from 0 to 0.5 in 0.01 increments.
- OO *PSS Output Limiting Lower Limit*: Adjustable from -0.5 to 0 in 0.01 increments.
- PP *PSS Output Software Switch SSW 10*: Select On or Off.
- QQ *Terminal Voltage Limiter Setpoint*: Adjustable from 0 to 10 in 0.001 increments.
- RR *Terminal Voltage Limiter Software Switch SSW 8*: Select Enabled or Disabled.
- SS *Terminal Voltage Limiter Time Constant*: Adjustable from 0.02 to 5 in 0.01 increments.

# Stability Tuning

Generator stability tuning in the DECS-250 is achieved through the calculation of PID parameters. PID stands for Proportional, Integral, Derivative. The word proportional indicates that the response of the DECS-250 output is proportional or relative to the amount of difference observed. Integral means that the DECS-250 output is proportional to the amount of time that a difference is observed. Integral action eliminates offset. Derivative means that the DECS-250 output is proportional to the required rate of excitation change. Derivative action avoids excitation overshoot.

## Caution

All stability tuning must be performed with no load on the system or equipment damage may occur.

## AVR Mode

**BESTCOMSPlus Navigation Path:** Settings Explorer, Operating Settings, Gain, AVR

**HMI Navigation Path:** Settings, Operating Settings, Gains, AVR Gains

Two sets of PID settings are provided to optimize performance under two distinct operating conditions, such as with the power system stabilizer (PSS) in or out of service. A fast controller provides optimum transient performance with the PSS in service while a slower controller can provide improved damping of first swing oscillations when the PSS is offline. BESTCOMSPlus® primary and secondary AVR stability settings are shown in Figure 120.

### Predefined Stability Settings

Twenty predefined sets<sup>A</sup> of stability settings are available with the DECS-250. Appropriate PID values are implemented based on the nominal generator frequency selected (see the *Configuration* chapter of this manual) and the combination of generator (T'do) and exciter (Texc) time constants selected from the gain option list. (The default value for the exciter time constant is the generator time constant divided by six.)

Additional settings are available to remove the effects of noise on numerical differentiation (AVR derivative time constant T<sub>d</sub>)<sup>B</sup> and set the voltage regulator gain level of the PID algorithm (K<sub>a</sub>)<sup>C</sup>.

### Custom Stability Settings

Stability tuning can be tailored for optimum generator transient performance. Selecting a primary gain option of "custom" enables entry of custom proportional (K<sub>p</sub>)<sup>D</sup>, integral (K<sub>i</sub>)<sup>E</sup>, and derivative (K<sub>d</sub>)<sup>F</sup> gains.

When tuning the stability gain settings, consider the following guidelines

- If the transient response has too much overshoot, decrease K<sub>p</sub>. If the transient response is too slow, with little or no overshoot, increase K<sub>p</sub>.
- If the time to reach steady-state is too long, increase K<sub>i</sub>.
- If the transient response has too much ringing, increase K<sub>d</sub>.

**AVR**

**Primary**

AVR

Kp - Proportional Gain  
10.000 D

Ki - Integral Gain  
30.000 E

Kd - Derivative Gain  
1.000 F

Td - Derivative Time Constant  
0.00 B

Ka - Voltage Regulator Gain (Recommended Ka)  
0.100 C 0.099 I

PID Pre-Settings

Primary Gain Option  
Custom A

Primary PID Calculator G

**Secondary**

AVR

Kp - Proportional Gain  
10.000 D

Ki - Integral Gain  
30.000 E

Kd - Derivative Gain  
1.000 F

Td - Derivative Time Constant  
0.00 B

Ka - Voltage Regulator Gain (Recommended Ka)  
0.100 C 0.099 I

PID Pre-Settings

Secondary Gain Option  
Custom A

Secondary PID Calculator G

Auto Tuning

AutoTune H

Figure 120. AVR Stability Settings

<sup>A</sup> *Gain Option*: Select T'do=1.0 Te=0.17, T'do=1.5 Te=0.25, T'do=2.0 Te=0.33, T'do=2.5 Te=0.42, T'do=3.0 Te=0.50, T'do=3.5 Te=0.58, T'do=4.0 Te=0.67, T'do=4.5 Te=0.75, T'do=5.0 Te=0.83, T'do=5.5 Te=0.92, T'do=6.0 Te=1.00, T'do=6.5 Te=1.08, T'do=7.0 Te=1.17, T'do=7.5 Te=1.25, T'do=8.0 Te=1.33, T'do=8.5 Te=1.42, T'do=9.0 Te=1.50, T'do=9.5 Te=1.58, T'do=10.0 Te=1.67, T'do=10.5 Te=1.75, or Custom.

<sup>B</sup> *T<sub>d</sub>* – *AVR Derivative Time Constant*: Adjustable from 0 to 1 in 0.01 increments.

<sup>C</sup> *K<sub>a</sub>* – *Voltage Regulator Gain*: Adjustable from 0 to 1 in 0.001 increments.

<sup>D</sup> *K<sub>p</sub>* – *Proportional Gain*: Adjustable from 0 to 1,000 in 0.001 increments.

<sup>E</sup> *K<sub>i</sub>* – *Integral Gain*: Adjustable from 0 to 1,000 in 0.001 increments.

<sup>F</sup> *K<sub>d</sub>* – *Derivative Gain*: Adjustable from 0 to 1,000 in 0.001 increments.

### PID Calculator

The PID calculator is accessed by clicking the PID calculator button (Figure 120, locator G) and is available only when the primary gain option is “Custom”. The PID calculator (Figure 121) calculates the gain parameters  $K_p^A$ ,  $K_i^B$ , and  $K_d^C$  based on the generator time constants ( $T'do^D$ ) and exciter time constant ( $T_e^E$ ). If the exciter time constant is not known, it can be forced to the default value<sup>F</sup> which is the generator time constant divided by six. A derivative time constant ( $T_d^G$ ) setting field enables the removal of noise effects on numerical differentiation. A voltage regulator gain ( $K_a^H$ ) setting field sets the voltage regulator gain level of the PID algorithm. Calculated and entered parameters can be applied<sup>I</sup> upon closure<sup>J</sup> of the PID calculator.

Generator information<sup>K</sup> appears in the PID Record List where records can be added<sup>L</sup> or removed<sup>M</sup>.

A group of settings can be saved with a unique name and added to a list of gain setting records available for application. Upon completion of stability tuning, undesired records can be removed from the record list.

### Caution

Calculated or user-defined PID values are to be implemented only after their suitability for the application has been verified by the user. Incorrect PID numbers can result in poor system performance or equipment damage.

Figure 121. PID Calculator

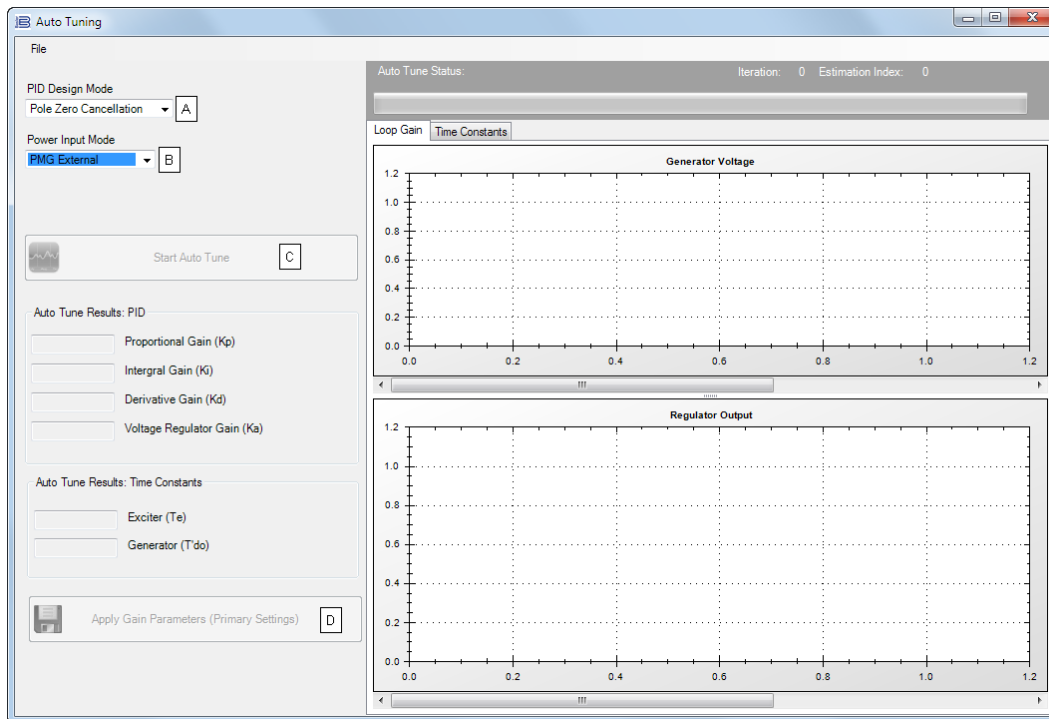
- A  $K_p$  – Proportional Gain: Read-only, calculated gain value.  
 B  $K_i$  – Integral Gain: Read-only, calculated gain value.  
 C  $K_d$  – Derivative Gain: Read-only, calculated gain value.  
 D  $T'do$  – Gen. Time Constant: Select a value within the range of 1 to 15 seconds.  
 E  $T_e$  – Exciter Time Constant: Select a value within the range of 0.04 to 1.0 seconds.  
 F Use Default Exciter Time Constant: Select or deselect.  
 G  $T_d$  – Derivative Time Constant: Adjustable from 0 to 1 in 0.01 increments.  
 H  $K_a$  – Voltage Regulator Gain: Adjustable from 0 to 1 in 0.001 increments.  
 I Apply Gain Parameters Button: Click button to apply gain parameters.  
 J Close Button: Click button to close PID calculator.  
 K Generator Information: Enter up to 30 alphanumeric characters.  
 L Add Record: Adds a PID record.  
 M Remove Record: Removes a PID record.

## Auto Tuning

During commissioning, excitation system parameters may not be known. These unknown variables traditionally cause the commissioning process to consume large amounts of time and fuel. With the development of auto tuning, the excitation system parameters are now automatically identified and the PID gains are calculated using well-developed algorithms. Automatically tuning the PID controller greatly reduces commissioning time and cost. The auto tuning function is accessed by clicking the *Auto Tune* button (Figure 120, Locator H). BESTCOMSP<sup>Plus</sup> must be in Live Mode in order to begin the auto tuning process. The auto tuning window (Figure 122) provides options for choosing the PID Design Mode<sup>A</sup> and the Power Input Mode<sup>B</sup>. When the desired settings are selected, the *Start Auto Tune*<sup>C</sup> button is clicked to start the process. After the process is complete, click the *Save PID Gains (Primary)*<sup>D</sup> button to save the data.

### Caution

PID values calculated by the Auto Tuning function are to be implemented only after their suitability for the application has been verified by the user. Incorrect PID numbers can result in poor system performance or equipment damage.



**Figure 122. Auto Tuning Window**

<sup>A</sup> *PID Design Mode*: Set to either Pole Zero Cancellation or Pole Placement.

<sup>B</sup> *Power Input Mode*: Set to either PMG External or Shunt.

<sup>C</sup> *Start Auto Tune Button*: Begins the auto tuning process.

<sup>D</sup> *Save PID Gains Button*: Saves the calculated PID gains.

The File menu contains options for importing, exporting, and printing a graph (.gph) file.

## FCR and FVR Modes

**BESTCOMSPiplus Navigation Path:** Settings Explorer, Operating Settings, Gain, FCR/FVR

**HMI Navigation Path:** Settings, Operating Settings, Gains, FCR Gains or FVR Gains

Stability tuning can be tailored for optimum performance when operating in field current regulation or field voltage regulation mode. BESTCOMSPiplus FCR stability settings and FVR stability settings are illustrated in Figure 123.

### FCR Mode Stability Settings

The DECS-250 bases its field current output upon the following settings.

The proportional gain ( $K_p$ )<sup>A</sup> is multiplied by the error between the field current setpoint and the actual field current value. Decreasing  $K_p$  reduces overshoot in the transient response. Increasing  $K_p$  speeds the transient response.

The integral gain ( $K_i$ )<sup>B</sup> is multiplied by the integral of the error between the current setpoint and the actual field current value. Increasing  $K_i$  reduces the time to reach a steady state.

The derivative gain ( $K_d$ )<sup>C</sup> is multiplied by the derivative of the error between the current setpoint and the actual field current value. Increasing  $K_d$  reduces ringing in the transient response.

Additional FCR stability settings remove the noise effect on numerical differentiation (derivative time constant  $T_d$ )<sup>D</sup> and set the voltage regulator gain level of the PID algorithm ( $K_a$ )<sup>E</sup> with recommended gain calculation<sup>F</sup>.

### FVR Mode Stability Settings

The DECS-250 bases its field voltage output upon the following settings.

The proportional gain ( $K_p$ )<sup>G</sup> is multiplied by the error between the field voltage setpoint and the actual field voltage value. Decreasing  $K_p$  reduces overshoot in the transient response. Increasing  $K_p$  speeds the transient response.

The integral gain ( $K_i$ )<sup>H</sup> is multiplied by the integral of the error between the voltage setpoint and the actual field voltage value. Increasing  $K_i$  reduces the time to reach a steady state.

The derivative gain ( $K_d$ )<sup>I</sup> is multiplied by the derivative of the error between the voltage setpoint and the actual field voltage value. Increasing  $K_d$  reduces ringing in the transient response.

Additional FVR stability settings remove the noise effect on numerical differentiation (derivative time constant  $T_d$ )<sup>J</sup> and set the voltage regulator gain level of the PID algorithm ( $K_a$ )<sup>K</sup> with recommended gain calculation<sup>L</sup>.

Parameter	FCR Value	FVR Value	Recommended Value
Kp - Proportional Gain	80.000 (A)	80.000 (F)	0.099 (K)
Ki - Integral Gain	20.000 (B)	20.000 (G)	0.099 (L)
Kd - Derivative Gain	0.000 (C)	0.000 (H)	0.099 (K)
Td - Derivative Time Constant	0.00 (D)	0.00 (I)	0.099 (L)
Ka - Voltage Regulator Gain	0.100 (E)	0.100 (J)	0.099 (K)

Figure 123. FCR and FVR Gain Settings

<sup>A</sup>  $K_p$  – Proportional Gain: Adjustable from 0 to 1,000 in 0.001 increments.

<sup>B</sup>  $K_i$  – Integral Gain: Adjustable from 0 to 1,000 in 0.001 increments.

<sup>C</sup>  $K_d$  – Derivative Gain: Adjustable from 0 to 1,000 in 0.001 increments.

<sup>D</sup>  $T_d$  – Derivative Time Constant: Adjustable from 0 to 1,000 in 0.01 increments.

<sup>E</sup>  $K_a$  – Voltage Regulator Gain: Adjustable from 0 to 1 in 0.001 increments.

<sup>F</sup>  $K_p$  – Proportional Gain: Adjustable from 0 to 1,000 in 0.1 increments.

<sup>G</sup>  $K_i$  – Integral Gain: Adjustable from 0 to 1,000 in 0.1 increments.

<sup>H</sup>  $K_d$  – Derivative Gain: Adjustable from 0 to 1,000 in 0.1 increments.

<sup>I</sup>  $T_d$  – Derivative Time Constant: Adjustable from 0 to 1,000 in 0.1 increments.

<sup>J</sup>  $K_a$  – Voltage Regulator Gain: Adjustable from 0 to 1 in 0.001 increments.

<sup>K</sup> FCR Recommended  $K_a$ : Recommended  $K_a$  based on calculation using no load field voltage and operating power input voltage.

<sup>L</sup> FVR Recommended  $K_a$ : Recommended  $K_a$  based on calculation using no load field voltage and operating power input voltage.

## Other Modes and Functions

---

**BESTCOMSPi.us Navigation Path:** Settings Explorer, Operating Settings, Gain, var, PF, OEL, UEL, SCL, VAR Limiter

**HMI Navigation Path:** Settings, Operating Settings, Gains, Other Gains

Settings for stability tuning of the Var and Power Factor modes are provided in the DECS-250 along with settings for stability tuning of limiters, the voltage matching function, and main field voltage response. Figure 124 illustrates these settings as they appear in BESTCOMSPi.us.

### Var Mode

The integral gain ( $K_i$ )<sup>A</sup> adjusts the Var mode integral gain which determines the characteristic of the DECS-250 dynamic response to a changed var setpoint.

The loop gain ( $K_g$ )<sup>B</sup> adjusts the coarse loop-gain level of the PI algorithm for var control.

### Power Factor Mode

The integral gain ( $K_i$ )<sup>C</sup> adjusts the integral gain which determines the characteristic of the DECS-250 dynamic response to a changed power factor setpoint.

The loop gain ( $K_g$ )<sup>D</sup> adjusts the coarse loop-gain level of the PI algorithm for power factor control.

### Overexcitation Limiter (OEL)

The integral gain ( $K_i$ )<sup>E</sup> adjusts the rate at which the DECS-250 responds during an overexcitation condition.

The integral loop gain ( $K_g$ )<sup>F</sup> adjusts the coarse loop-gain level of the PI algorithm for the overexcitation limiter function.

### Underexcitation Limiter (UEL)

The integral gain ( $K_i$ )<sup>G</sup> adjusts the rate at which the DECS-250 responds during an underexcitation condition.

The loop gain ( $K_g$ )<sup>H</sup> adjusts the coarse loop-gain level of the PI algorithm for the underexcitation limiter function.

### Stator Current Limiter (SCL)

The integral gain ( $K_i$ )<sup>I</sup> adjusts the rate at which the DECS-250 limits stator current.

The loop gain ( $K_g$ )<sup>J</sup> adjusts the coarse loop-gain level of the PI algorithm for the stator current limiter function.

### Var Limiter

The integral gain ( $K_i$ )<sup>K</sup> adjusts the rate at which the DECS-250 limits reactive power.

The loop gain ( $K_g$ )<sup>L</sup> adjusts the coarse loop-gain level of the PID algorithm for the reactive power limiter function.

### Voltage Matching

The integral gain ( $K_i$ )<sup>M</sup> adjusts the rate at which the DECS-250 matches the generator voltage to the bus voltage.

**var, PF, OEL, UEL, SCL, VAR Limiter**

<p><b>var</b></p> <p>Ki - Integral Gain 0.050 <input type="text"/> <b>A</b></p> <p>Kg - Loop Gain 0.050 <input type="text"/> <b>B</b></p>	<p><b>OEL</b></p> <p>Ki - Integral Gain 0.050 <input type="text"/> <b>E</b></p> <p>Kg - Loop Gain 0.050 <input type="text"/> <b>F</b></p>	<p><b>SCL</b></p> <p>Ki - Integral Gain 0.050 <input type="text"/> <b>I</b></p> <p>Kg - Loop Gain 0.050 <input type="text"/> <b>J</b></p>	<p><b>Voltage Matching</b></p> <p>Kg - Loop Gain 0.050 <input type="text"/> <b>M</b></p>
<p><b>PF</b></p> <p>Ki - Integral Gain 0.050 <input type="text"/> <b>C</b></p> <p>Kg - Loop Gain 0.050 <input type="text"/> <b>D</b></p>	<p><b>UEL</b></p> <p>Ki - Integral Gain 0.050 <input type="text"/> <b>G</b></p> <p>Kg - Loop Gain 0.050 <input type="text"/> <b>H</b></p>	<p><b>varL</b></p> <p>Ki - Integral Gain 10.000 <input type="text"/> <b>K</b></p> <p>Kg - Loop Gain 1.000 <input type="text"/> <b>L</b></p>	

**Figure 124. Other Mode and Function Gain Settings**

- <sup>A</sup> *Var*  $K_i$  – *Integral Gain*: Adjustable from 0 to 1,000 in 0.001 increments.
- <sup>B</sup> *Var*  $K_g$  – *Loop Gain*: Adjustable from 0 to 1,000 in 0.001 increments.
- <sup>C</sup> *PF*  $K_i$  – *Integral Gain*: Adjustable from 0 to 1,000 in 0.001 increments.
- <sup>D</sup> *PF*  $K_g$  – *Loop Gain*: Adjustable from 0 to 1,000 in 0.001 increments.
- <sup>E</sup> *OEL*  $K_i$  – *Integral Gain*: Adjustable from 0 to 1,000 in 0.001 increments.
- <sup>F</sup> *OEL*  $K_g$  – *Loop Gain*: Adjustable from 0 to 1,000 in 0.001 increments.
- <sup>G</sup> *UEL*  $K_i$  – *Integral Gain*: Adjustable from 0 to 1,000 in 0.001 increments.
- <sup>H</sup> *UEL*  $K_g$  – *Loop Gain*: Adjustable from 0 to 1,000 in 0.001 increments.
- <sup>I</sup> *SCL*  $K_i$  – *Integral Gain*: Adjustable from 0 to 1,000 in 0.001 increments.
- <sup>J</sup> *SCL*  $K_g$  – *Loop Gain*: Adjustable from 0 to 1,000 in 0.001 increments.
- <sup>K</sup> *VARL*  $K_i$  – *Integral Gain*: Adjustable from 0 to 1,000 in 0.1 increments.
- <sup>L</sup> *VARL*  $K_g$  – *Loop Gain*: Adjustable from 0 to 1,000 in 0.1 increments.
- <sup>M</sup> *Voltage Matching*  $K_i$  – *Integral Gain*: Adjustable from 0 to 1,000 in 0.001 increments.



# Mounting

As delivered, the DECS-250 is configured for projection (wall) mounting. Front panel mounting is possible with an optional escutcheon kit. Kits are supplied with an escutcheon and screws for securing the escutcheon to the DECS-250. Request part number 9440311101. This kit is suitable for new installations and when replacing a DECS-200 with the DECS-250.

## ***Mounting Considerations***

---

DECS-250 heat sink orientation necessitates vertical mounting for maximum cooling. Any other mounting angle will reduce heat dissipation and possibly lead to premature failure of critical components.

The DECS-250 may be mounted anywhere the ambient temperature does not exceed the maximum operating temperature as listed in the *Specifications* chapter.

### **Caution**

This device is not intended for exposure to caustic environments. If operated in such an environment, the device must be housed in an enclosure that shields it from exposure to all caustic elements.

## ***Projection Mounting***

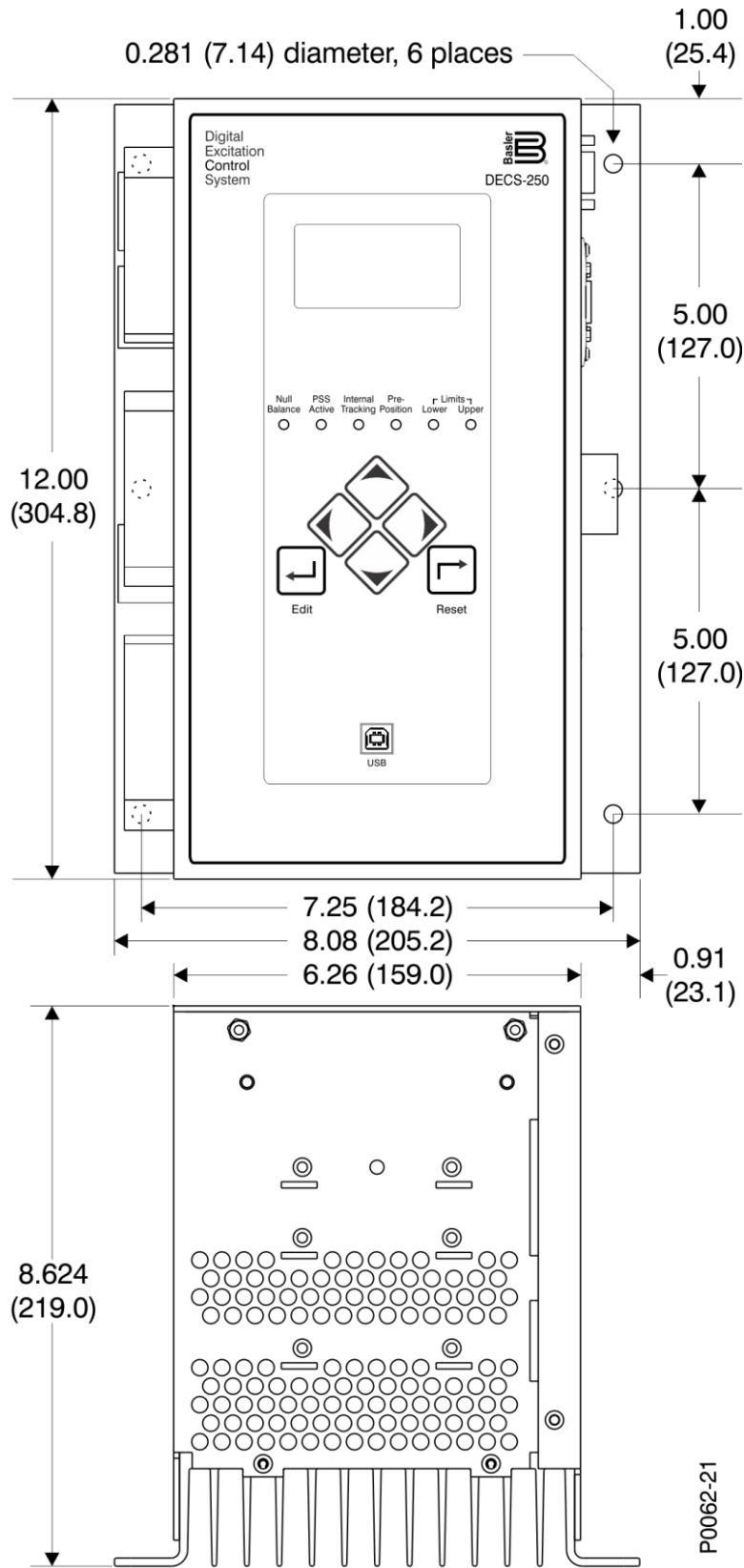
---

Figure 125 illustrates the mounting dimensions for projection (wall) mounting of the DECS-250.

## ***Behind-the-Panel Mounting***

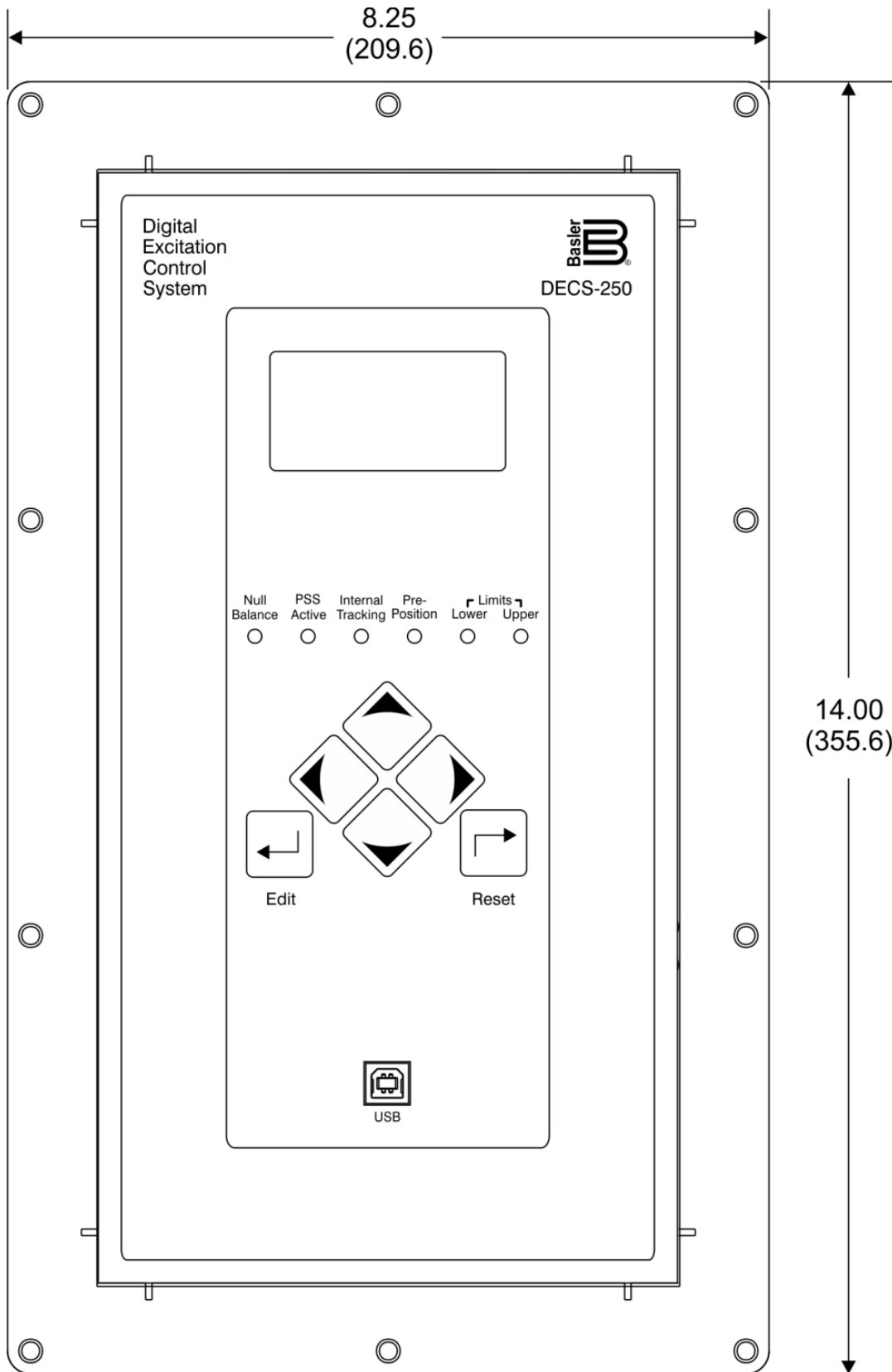
---

Figure 126 shows the front dimensions of the optional escutcheon mounting plate for the DECS-250. Panel cutting and drilling dimensions for panel mounting are shown in Figure 127.



Note: All dimensions are in inches (millimeters).

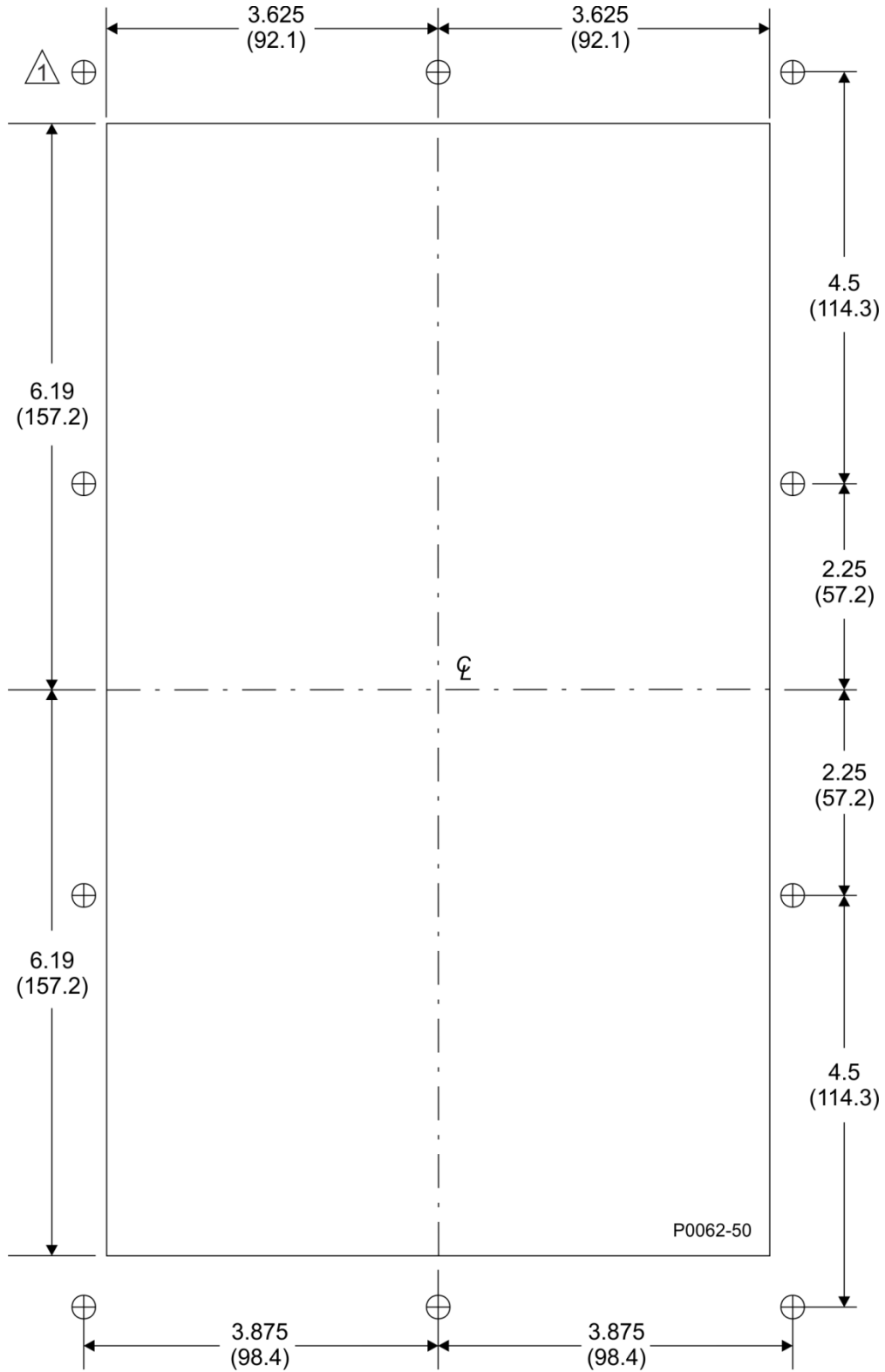
Figure 125. Overall and Projection Mounting Dimensions



Note: All dimensions are in inches (millimeters).

P0074-91

Figure 126. DECS-250 Escutcheon Plate Dimensions



- 1 Mounting holes (10 places) are 0.218 (5.54) diameter.
- 2 Use provided hardware when attaching escutcheon plate to DECS-250.
- 3 All dimensions are in inches (millimeters).

**Figure 127. Panel Cutting and Drilling Dimensions for DECS-250 Panel Mounting**

# Terminals and Connectors

DECS-250 terminals and connectors are located on the left side panel, front panel, and right side panel. DECS-250 terminals consist of single-row, multiple-pin headers that mate with removable connectors wired by the user. DECS-250 connectors vary according to their function and the specified options.

## Overview

---

Figure 128 illustrates the left side panel terminals and Figure 129 illustrates the right side connectors and terminals. For clarity, these illustrations do not show the connectors plugged into the terminals. Locator letters in each illustration correspond to the terminal block and connector descriptions in Table 4 and Table 5. The front-panel USB jack is illustrated and described in the *Controls and Indicators* chapter of this manual.

Note
DECS-250 units with hardware versions prior to Rev K are not equipped with the ground terminal on the power connector (locator D in Figure 108). As a result, the numbering of terminals from 84 to 95 on the left side panel and 96 to 103 on the right side panel are decremented by 1 on these units.

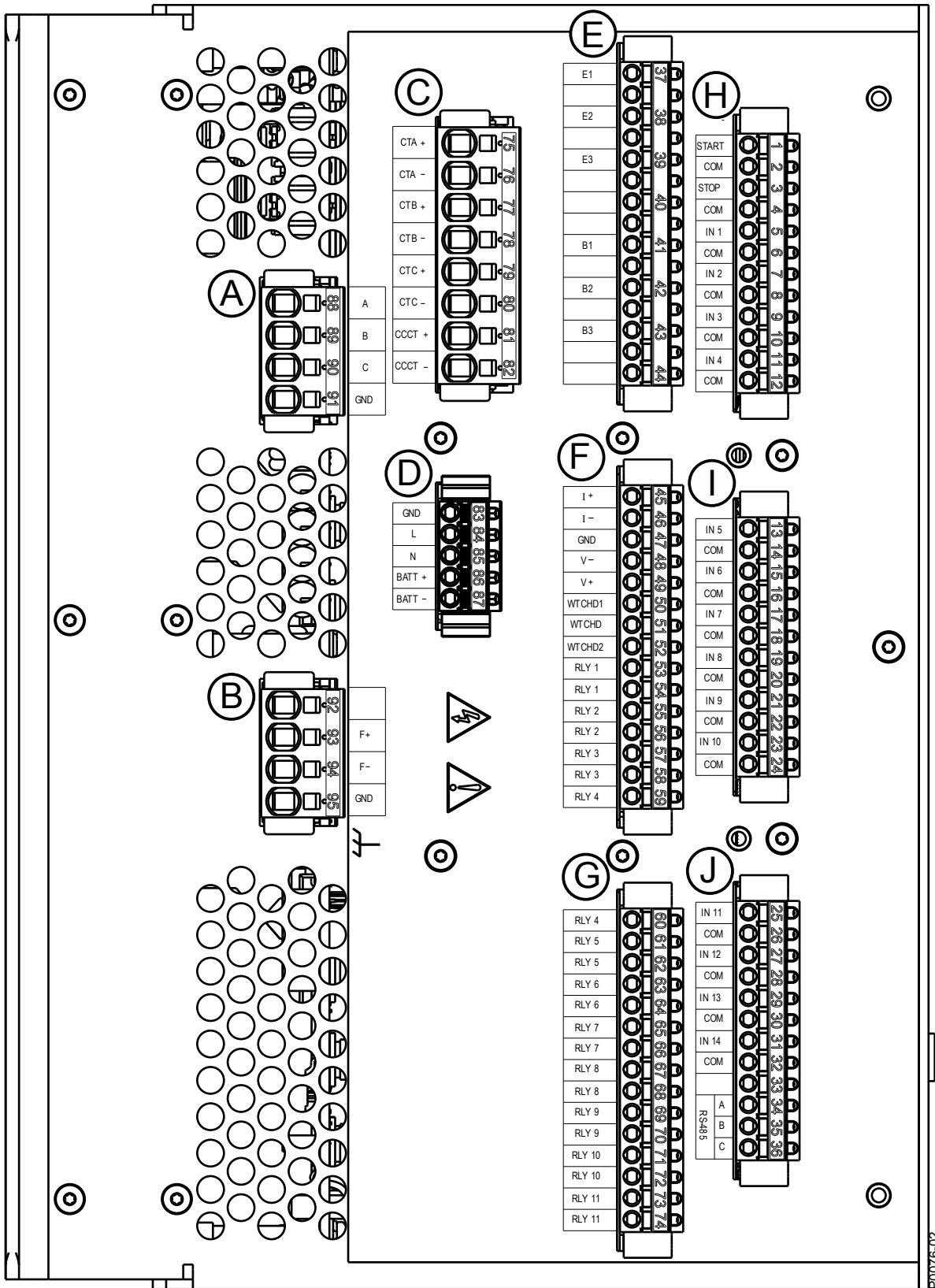


Figure 128. Left Side Panel Terminals

**Table 4. Left Side Terminal and Connector Descriptions**

<b>Locator</b>	<b>Description</b>
A	These terminals accept three-phase operating power for the excitation power stage of the DECS-250. A ground for the operating power connections is provided at terminal GND.
B	Excitation power is supplied to the field through the terminals labeled F+ and F-. The GND terminal serves as the chassis ground for the DECS-250.
C	These terminals connect to user-supplied current transformers (CTs) providing three phases of generator sensing current and a cross-current compensation signal.
D	These terminals accept ac and/or dc control power to enable DECS-250 operation. A ground terminal is also provided.
E	Three-phase generator and bus sensing voltage, obtained from user-supplied voltage transformers (VTs), connect to these terminals.
F	A portion of this terminal block accepts an external analog control signal for auxiliary control of the regulation setpoint. Terminals I+, I-, V+, and V- are used for external control of the regulation setpoint with the GND terminal serving as a cable shield connection. The remaining terminal block pins serve as connections for the Watchdog and programmable relay outputs 1 through 4.
G	Relay contact outputs for programmable relay outputs 4 through 11 connect to these terminals.
H	Contact inputs for the Start and Stop functions and programmable contact inputs 1 through 4 are applied to these terminals.
I	Programmable contact inputs 5 through 10 are applied to these terminals.
J	A portion of these terminal block pins accept connections for programmable contact inputs 11 through 14. The remaining terminal block pins serve as connections for RS-485 communication.

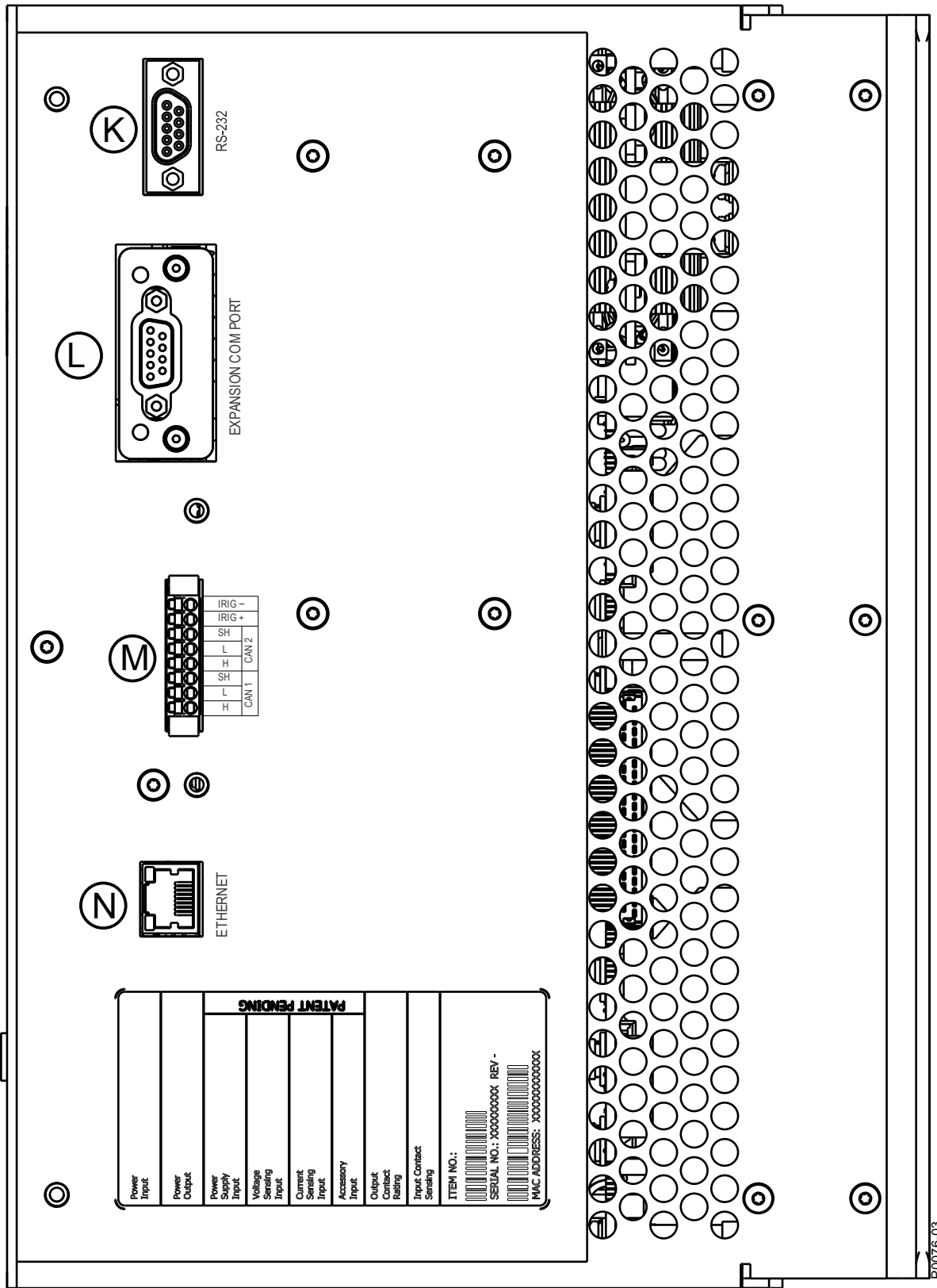


Figure 129. Right Side Connectors and Terminals

**Table 5. Right Side Terminal and Connector Descriptions**

Locator	Description
K	A second DECS-250 connects through a standard serial cable to this DB-9 connector for the purpose of setpoint tracking. Setpoint tracking between a DECS-250 and DECS-200 is possible.
L	This DB-9 connector is provided for PROFIBUS communication (style xxxxxxP) and the future implementation of other communication protocols. Contact Basler Electric for protocol availability.
M	<p>Three terminal sets within this block include two CAN communication ports and an IRIG input. The IRIG terminals connect to an IRIG source for synchronization of DECS-250 timekeeping with the IRIG source. Both CAN ports are SAE J1939 compliant. CAN 1 is used to connect add-on modules such as the Basler Electric CEM-2020 and AEM-2020. CAN 2 is used to communicate with a genset engine controller.</p> <p>The terminal numbers (shown below) are located on the mating side of the connector.</p> <ul style="list-style-type: none"> <li>• 96 - CAN 1 High</li> <li>• 97 - CAN 1 Low</li> <li>• 98 - CAN 1 Shield</li> <li>• 99 - CAN 2 High</li> <li>• 100 - CAN 2 Low</li> <li>• 101 - CAN 2 Shield</li> <li>• 102 - IRIG +</li> <li>• 103 - IRIG –</li> </ul>
N	This optional Ethernet communication port uses the Modbus TCP protocol to provide remote metering, annunciation, and control. A copper (100Base-T) port (style xxxxx1x) uses a standard RJ45 jack while a fiber optic (100Base-FX) port (style xxxxx2x) uses two fiber optic connectors (not shown).

## Terminal Types

Spring terminals are supplied on DECS-250 controllers with a style number of xxxSxxx. These removable connectors secure each wire with a spring-loaded contact.

Compression terminals are supplied for the operating power terminals (locator A), field power output terminals (locator B), and current sensing terminals (locator C) when a style number of xxxCxxx is specified. The remaining connectors use spring terminals.

Table 6 lists the acceptable wire sizes, strip lengths, and screw torques (compression terminals only) for each terminal block. The locator letters used in Table 6 correspond to the locator letters shown in Figure 128 and Figure 129.

**Table 6. Connector Wiring Specifications**

Terminal Block	Maximum Wire Size	Compression Terminals		Spring Terminals
		Strip Length	Maximum Screw Torque	Strip Length
A, B, C	10 AWG 10 mm <sup>2</sup> (solid) 6 mm <sup>2</sup> (stranded)	0.4 in (10 mm)	6.64 in-lb (0.75 N•m)	0.6 in (15 mm)
D, E, F, G, H, I, J	12 AWG 2.5 mm <sup>2</sup> (solid and stranded)	N/A	N/A	0.4 in (10 mm)

Terminal Block	Maximum Wire Size	Compression Terminals		Spring Terminals
		Strip Length	Maximum Screw Torque	Strip Length
M	16 AWG 1.5 mm <sup>2</sup> (solid and stranded)	N/A	N/A	0.35 in (9 mm)

Spring terminal connector blocks identified by locators A through J and M are held in place by retaining clips.

Connectors identified by locators A, B, E, F, G, H, I, and J are keyed to avoid misconnections.

# Typical Connections

Typical connection diagrams are provided in this chapter as a guide when wiring the DECS-250 for communication, contact inputs, contact outputs, sensing, and operating power.

Typical connections for shunt powered applications are shown in Figure 130. Typical connections for PMG powered applications are shown in Figure 131. Typical connections for station powered applications are shown in Figure 132. Three-phase-delta voltage sensing connections are shown. The drawing notes in Figures 130, 131, and 132 correspond to the descriptions found in Table 7. The Machine in Figures 130, 131, and 132 represents a generator when in generator mode and a motor when in motor mode.

## Note

Field wires, connected to terminals F+ and F–, must be twisted pair with approximately one turn per inch for an EMC compliant installation.

**Table 7. Typical Connection Drawing Descriptions**

Locator	Description
1	Optional - ICRM (Inrush Current Reduction Module), Basler part number 9387900104.
2	Operating (bridge) power input. For single-phase power, omit one phase connection. See <i>Power Inputs</i> or <i>Specifications</i> for operating power ratings. <div style="border: 1px solid black; padding: 5px; margin: 10px 0;"> <p style="text-align: center;"><b>Caution</b></p> <p>For redundant applications with a single-phase, 300 Hz Marathon PMG, only one DECS-250 can be connected to the PMG at a time. In redundant applications, a contactor should be used for each DECS-250 power input or equipment damage may occur.</p> </div>
3	Generator voltage sensing input. Potential transformer required if line voltage exceeds 600 Vac.
4	Cross-current compensation input, 1 Aac or 5 Aac.
5	Connections required only if voltage matching, sync-check, or auto synchronizer functions are used.
6	Labels indicate the functions assigned by the default programmable logic to the contact inputs and output contacts.
7	See <i>Power Inputs</i> or <i>Specifications</i> for control power input ratings.
8	RS-232 port used for communication with another DECS in a redundant DECS system.
9	Optional communication port (style xxxxxxP) uses PROFIBUS protocol.
10	IRIG time synchronization input.
11	Ethernet communication port can be copper (style xxxxx1x) or fiber optic (style xxxxx2x) and uses Modbus communication protocol.
12	Type B USB jack for temporary, local communication.
13	This input/output is unassigned by default if the DECS-250 is not equipped with the optional PSS (style number xPxxxx).
14	If the DECS-250 is providing one end of the J1939 bus, a 120-ohm, 0.5-watt terminating resistor must be installed across terminals 96 (H) and 97 (L) for CAN 1 and 99 (H) and 100 (L) for CAN 2.

Locator	Description
15	RS-485 port uses the Modbus RTU protocol for communication with other networked devices.

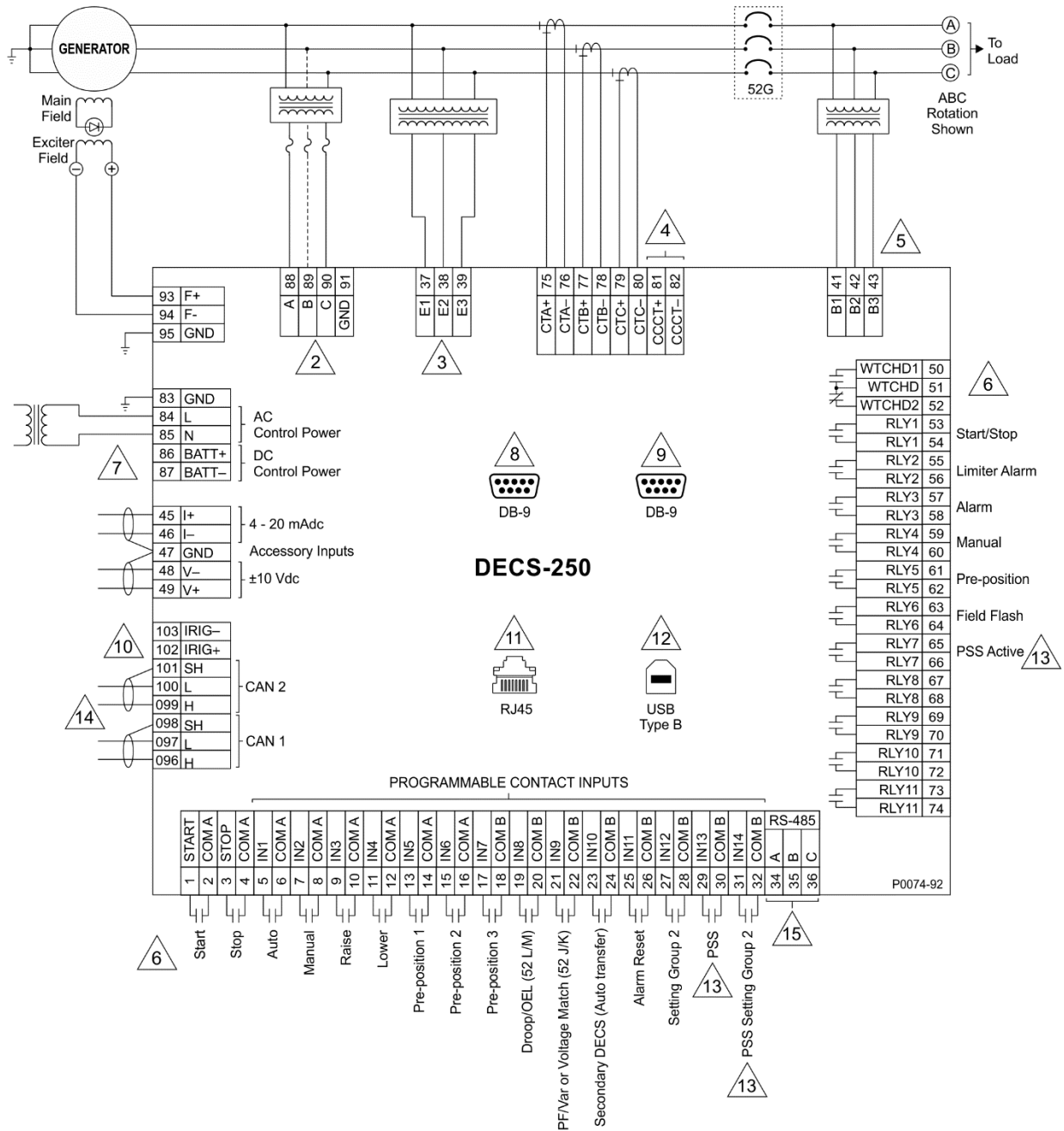


Figure 130. Typical DECS-250 Connections for Shunt Powered Applications

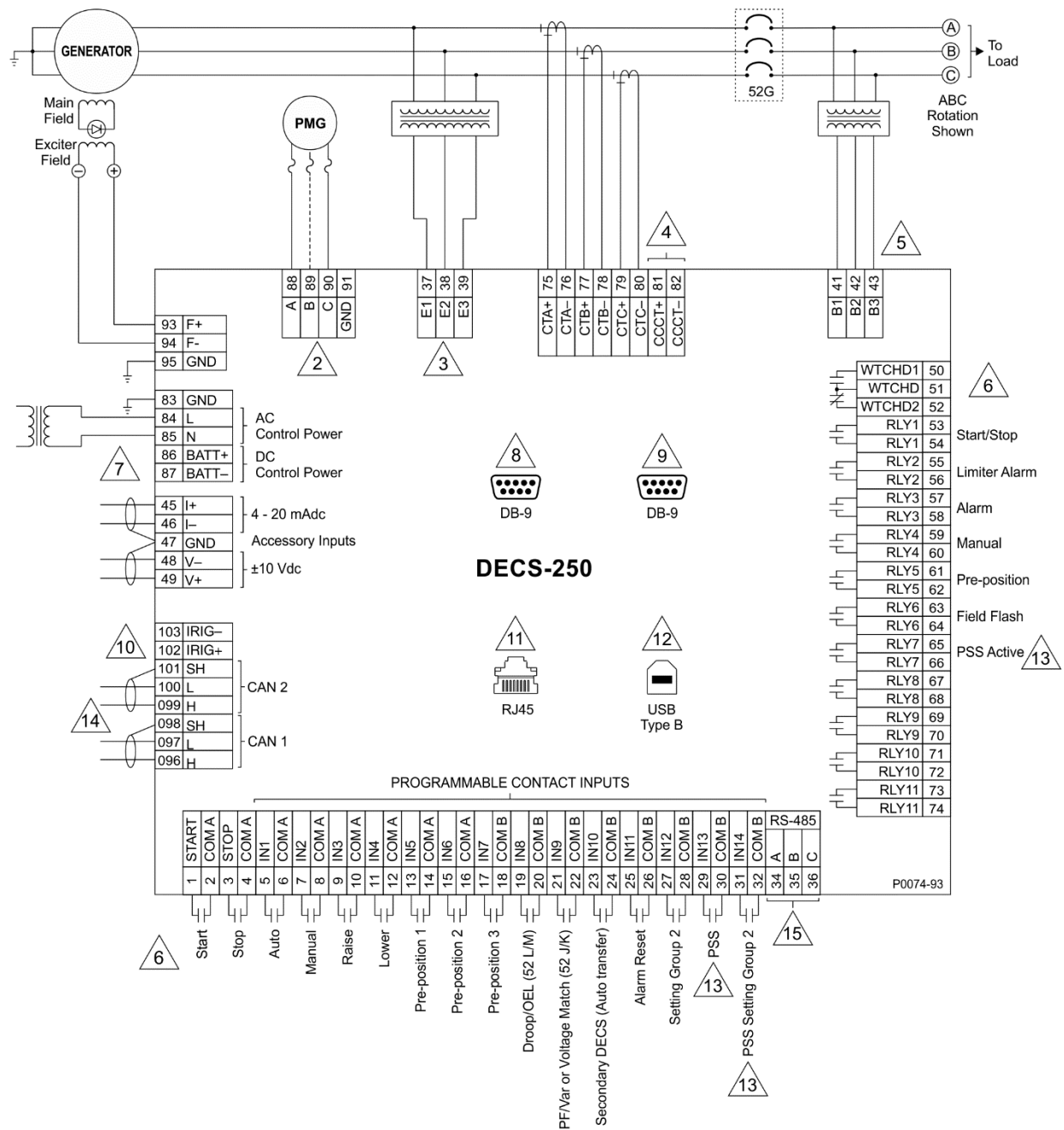


Figure 131. Typical DECS-250 Connections for PMG Powered Applications

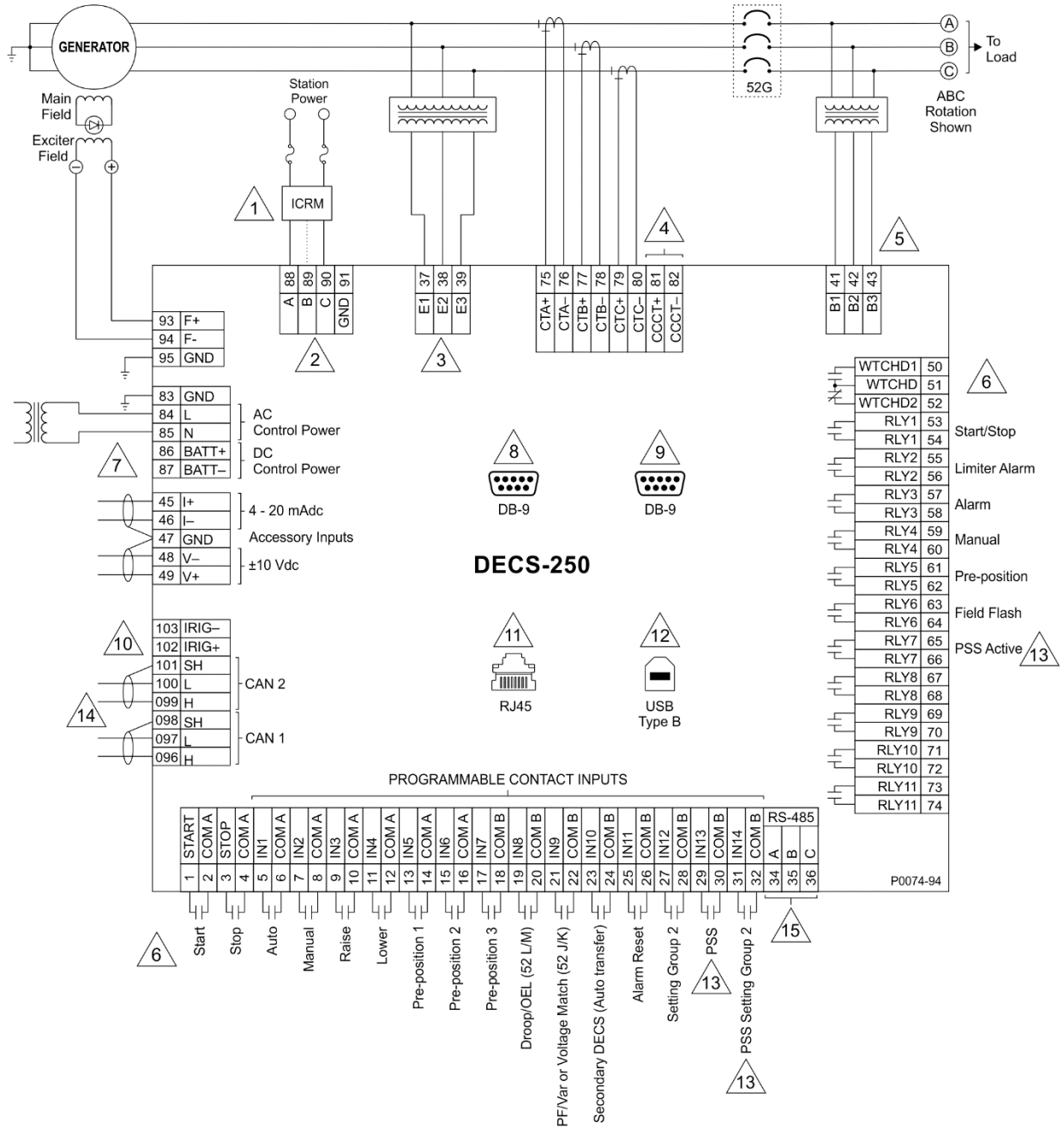


Figure 132. Typical DECS-250 Connections for Station Powered Applications

# BESTCOMSP<sup>Plus</sup>® Software

## General Description

BESTCOMSP<sup>Plus</sup>® is a Windows®-based, PC application that provides a user-friendly, graphical user interface (GUI) for use with Basler Electric communicating products. The name BESTCOMSPlus is an acronym that stands for Basler Electric Software Tool for Communications, Operations, Maintenance, and Settings.

BESTCOMSP<sup>Plus</sup> provides the user with a point-and-click means to set and monitor the DECS-250. The capabilities of BESTCOMSP<sup>Plus</sup> make the configuration of one or several DECS-250 controllers fast and efficient. A primary advantage of BESTCOMSP<sup>Plus</sup> is that a settings scheme can be created, saved as a file, and then uploaded to the DECS-250 at the user's convenience.

BESTCOMSP<sup>Plus</sup> uses plugins allowing the user to manage several different Basler Electric products. The DECS-250 plugin must be activated before use. The plugin can be activated automatically by connecting to a DECS-250 or activated manually by requesting an activation key from Basler Electric.

The DECS-250 plugin opens inside the BESTCOMSP<sup>Plus</sup> main shell. The same default logic scheme that is shipped with the DECS-250 is brought into BESTCOMSP<sup>Plus</sup> by downloading settings and logic from the DECS-250. This gives the user the option of developing a custom setting file by modifying the default logic scheme or by building a unique scheme from scratch.

BESTlogic™ *Plus* Programmable Logic is used to program DECS-250 logic for protection elements, inputs, outputs, alarms, etc. This is accomplished by the drag-and-drop method. The user can drag elements, components, inputs, and outputs onto the program grid and make connections between them to create the desired logic scheme.

BESTCOMSP<sup>Plus</sup> also allows for downloading industry-standard COMTRADE files for analysis of stored oscillography data. Detailed analysis of the oscillography files can be accomplished using BESTwave™ software.

Figure 133 illustrates the typical user interface components of the DECS-250 plugin with BESTCOMSP<sup>Plus</sup>.

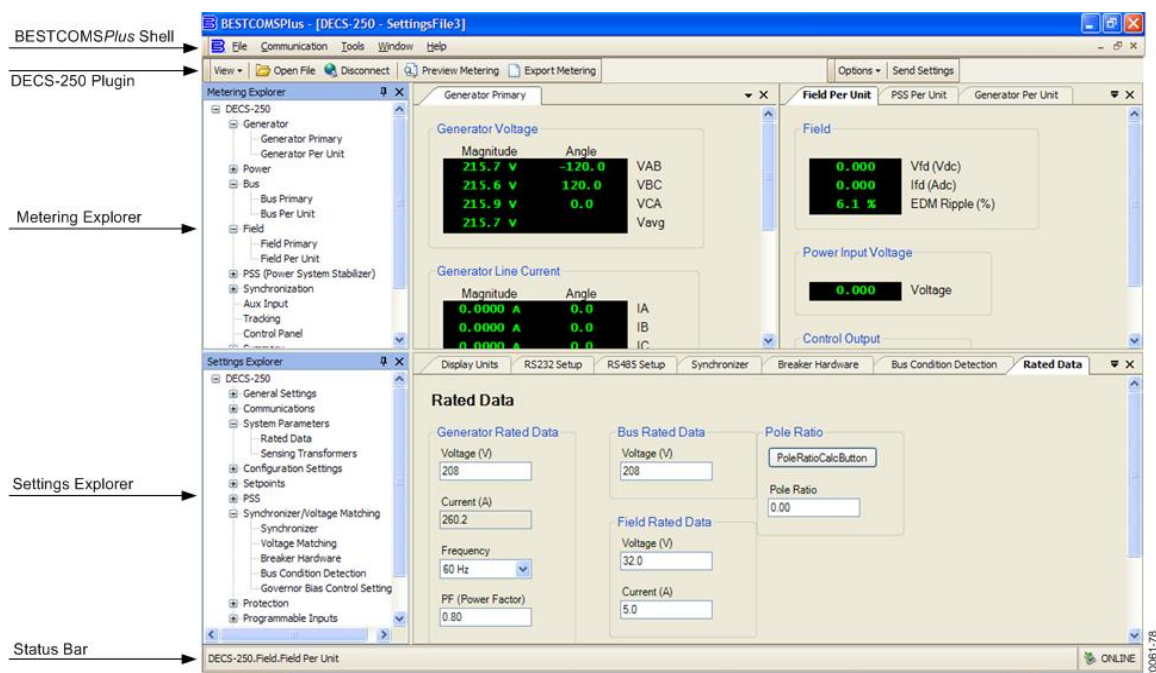


Figure 133. Typical User Interface Components

## Installation

BESTCOMSPi<sup>®</sup> software is built on the Microsoft<sup>®</sup> .NET Framework. The setup utility that installs BESTCOMSPi on your PC also installs the DECS-250 plugin and the required version of .NET Framework (if not already installed). BESTCOMSPi operates with systems using Windows<sup>®</sup> XP 32-bit SP3, Windows Vista 32-bit SP1 (all editions), Windows 7 32-bit (all editions), Windows 7 64-bit (all editions), Windows 8, and Windows 10. Microsoft Internet Explorer 5.01 or later must be installed on your PC before installing BESTCOMSPi. System recommendations for the .NET Framework and BESTCOMSPi are listed in Table 8.

**Table 8. System Recommendations for BESTCOMSPi and the .NET Framework**

System Type	Component	Recommendation
32/64 bit	Processor	2.0 GHz
32/64 bit	RAM	1 GB minimum, 2 GB recommended
32 bit	Hard Drive	100 MB (if .NET Framework is already installed on PC.)
		950 MB (if .NET Framework is not already installed on PC.)
64 bit	Hard Drive	100 MB (if .NET Framework is already installed on PC.)
		2.1 GB (if .NET Framework is not already installed on PC.)

To install and run BESTCOMSPi, a Windows user must have Administrator rights. A Windows user with limited rights might not be permitted to save files in certain folders.

### Install BESTCOMSPi<sup>®</sup>

#### Note

Do not connect a USB cable until setup completes successfully. Connecting a USB cable before setup is complete may result in unwanted or unexpected errors.

1. Insert the BESTCOMSPi CD-ROM into the PC CD-ROM drive.
2. When the BESTCOMSPi Setup and Documentation CD menu appears, click the *Install* button for the BESTCOMSPi application. The setup utility installs BESTCOMSPi, the .NET Framework (if not already installed), the USB driver, and the DECS-250 plugin for BESTCOMSPi on your PC.

When BESTCOMSPi installation is complete, a Basler Electric folder is added to the Windows programs menu. This folder is accessed by clicking the Windows *Start* button and then accessing the Basler Electric folder in the *Programs* menu. The Basler Electric folder contains an icon that starts BESTCOMSPi when clicked.

### Activation of the DECS-250 Plugin for BESTCOMSPi<sup>®</sup>

The DECS-250 plugin is a module that runs inside the BESTCOMSPi shell. The DECS-250 plugin contains specific operational and logic settings for only the DECS-250. Uploading settings to the DECS-250 is possible only after activating the DECS-250 plugin.

The DECS-250 plugin can be activated automatically or manually. Automatic activation is achieved by using a USB cable to establish communication between the DECS-250 and BESTCOMSPi. Manual activation is initiated by contacting Basler Electric for an activation key and entering the key into BESTCOMSPi. Manual activation is useful if you want to create a settings file prior to receiving your digital excitation system. Note that if a DECS-250 is not connected, you will not be able to configure certain Ethernet settings. Ethernet settings can be changed only when an active USB or Ethernet connection is present. Refer to *Manual Activation of DECS-250 Plugin*.

## Connect a USB Cable

The USB driver was copied to your PC during BESTCOMSP<sup>l</sup>us<sup>®</sup> installation and is installed automatically after powering the DECS-250. USB driver installation progress is shown in the Windows Taskbar area. Windows will notify you when installation is complete.

### Note

In some instances, the Found New Hardware Wizard will prompt you for the USB driver. If this happens, direct the wizard to the following folder:

C:\Program Files\Basler Electric\USB Device Drivers\

If the USB driver does not install properly, refer to the *Maintenance* chapter for a troubleshooting procedure.

Connect a USB cable between the PC and your DECS-250. Apply operating power (per style chart in the *Introduction* chapter) to the DECS-250 at rear terminals A, B, and C. Wait until the boot sequence is complete.

## Start BESTCOMSP<sup>l</sup>us<sup>®</sup> and Activate DECS-250 Plugin Automatically

To start BESTCOMSP<sup>l</sup>us<sup>®</sup>, click the *Start* button, point to *Programs, Basler Electric*, and then click the BESTCOMSP<sup>l</sup>us<sup>®</sup> icon. During initial startup, the BESTCOMSP<sup>l</sup>us<sup>®</sup> *Select Language* screen is displayed (Figure 134). You can choose to have this screen displayed each time BESTCOMSP<sup>l</sup>us<sup>®</sup> is started, or you can select a preferred language and this screen will be bypassed in the future. Click *OK* to continue. This screen can be accessed later by selecting *Tools* and *Select Language* from the menu bar.

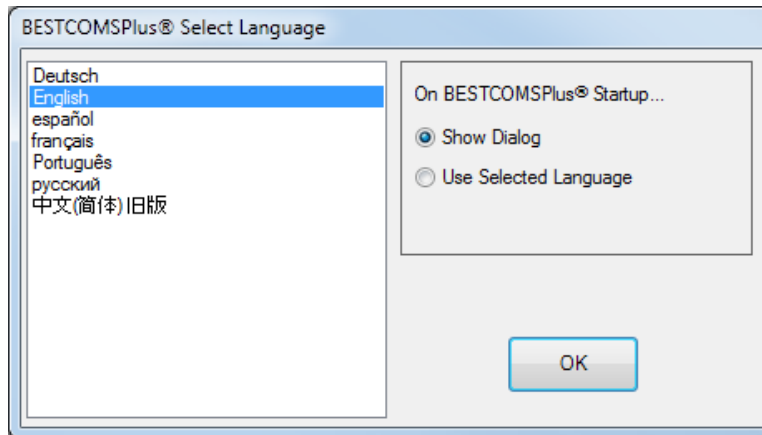


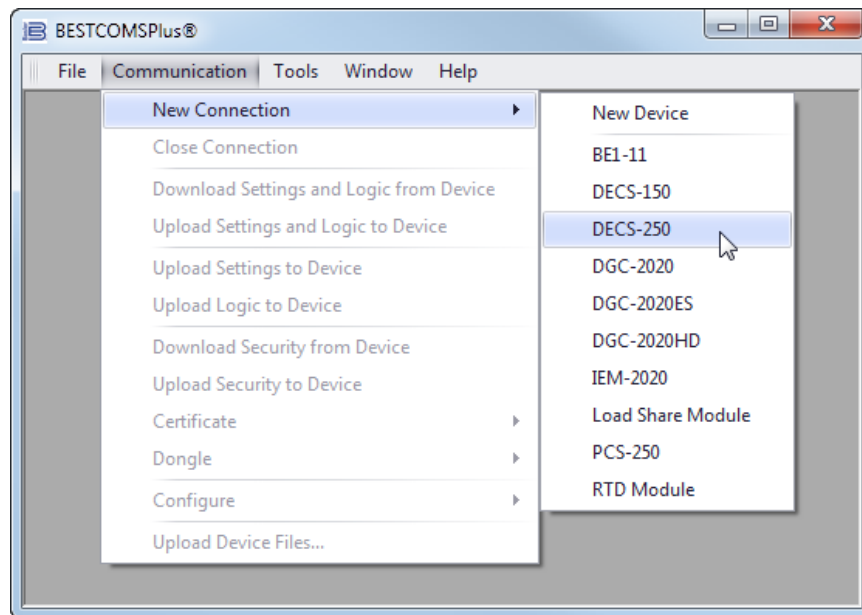
Figure 134. BESTCOMSP<sup>l</sup>us<sup>®</sup> Select Language Screen

The BESTCOMSP<sup>l</sup>us splash screen is shown for a brief time. See Figure 135.



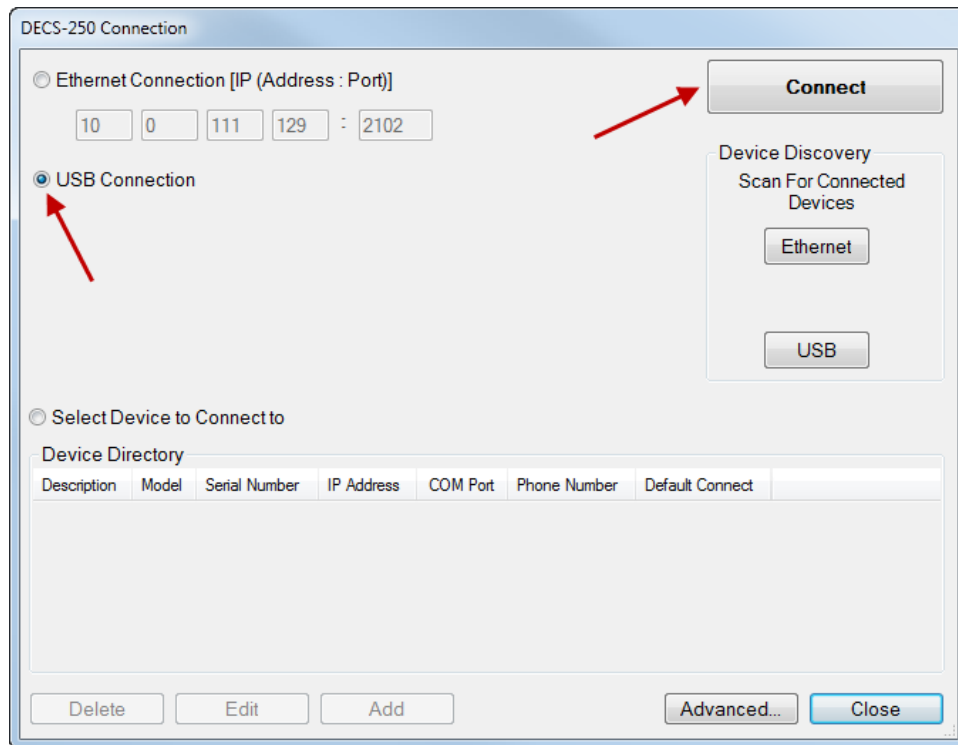
**Figure 135. BESTCOMSPlus Splash Screen**

The BESTCOMSPlus® platform window opens. Select *New Connection* from the *Communication* pull-down menu and select *DECS-250*. See Figure 136. The DECS-250 plugin is activated automatically after connecting to a DECS-250.



**Figure 136. Communication Pull-Down Menu**

The *DECS-250 Connection* screen shown in Figure 137 appears. Select *USB Connection* and click *Connect*.



**Figure 137. DECS-250 Connection Screen**

The DECS-250 plugin opens indicating that activation was successful. You can now configure the DECS-250 communication ports and other DECS-250 settings.

### Manual Activation of the DECS-250 Plugin

Manual activation of the DECS-250 plugin is required only if your initial use of BESTCOMSP<sup>Plus</sup>® will be on a PC that is not connected to a DECS-250. Manual activation is described in the following paragraphs.

#### Requesting an Activation Key

When initially running the DECS-250 plugin, the *Activate Device Plugin* pop-up appears. You must contact Basler Electric for an activation key before you can activate the DECS-250 plugin. You can request an activation key through email or the Basler Electric website. Click either the *Website* or *Email* button. Click the *Activate* button when you are ready to enter the activation key you received from Basler Electric. The *Activate Device Plugin* pop-up appears. Refer to Figure 138.

Figure 138. Activate Device Plugin Screen

### Entering an Activation Key

Select DECS-250 from the *Device* pull-down menu. Enter your *Email Address* and *Activation Key* provided by Basler Electric. If you received an email containing the *Activation Key*, you can select all of the text in the email and copy it to the Windows clipboard using normal Windows techniques. The *Get Data* button extracts the *Device*, *Email Address*, and *Activation Key* from the Windows clipboard and pastes it into the appropriate fields. Click the *Activate* button to continue. The *Activate Device Plugin* screen is also found by selecting *Activate Device* from the *Tools* pull-down menu of the BESTCOMSPUs main screen.

### Establishing Communication

Communication between BESTCOMSPUs and the DECS-250 is established by clicking the *Connect* button on the *DECS-250 Connection* screen (see Figure 137) or by clicking the *Connect* button on the lower menu bar of the main BESTCOMSPUs screen (Figure 133). If you receive an "Unable to Connect to Device" error message, verify that communications are configured properly. Only one Ethernet connection is allowed at one time. Download all settings and logic from the relay by selecting *Download Settings and Logic* from the *Communication* pull-down menu. BESTCOMSPUs will read all settings and logic from the DECS-250 and load them into BESTCOMSPUs memory. See Figure 139.

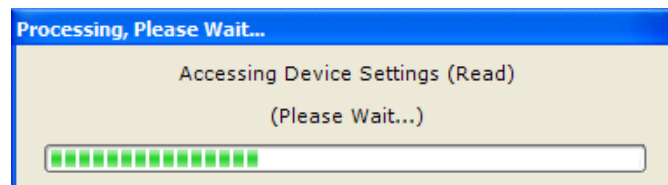


Figure 139. Processing, Please Wait...

### Menu Bars

The menu bars are located near the top of the BESTCOMSPUs® screen (see Figure 133). The upper menu bar has five pull-down menus. With the upper menu bar, it is possible to manage settings files, configure communication settings, upload and download settings and security files, and compare settings files. The lower menu bar consists of clickable icons. The lower menu bar is used to change BESTCOMSPUs views, open a settings file, connect/disconnect, preview metering printout, switch to live mode, and send settings after a change is made when not in live mode.

## Upper Menu Bar (BESTCOMSPPlus® Shell)

Upper menu bar functions are listed and described in Table 9.

**Table 9. Upper Menu Bar (BESTCOMSPPlus® Shell)**

Menu Item	Description
<u><i>File</i></u>	
New	Create a new settings file
Open	Open an existing settings file
Open File As Text	Generic file viewer for *.csv, *.txt, etc. files
Close	Close settings file
Save	Save settings file
Save As	Save settings file with a different name
Export To File	Save settings as a *.csv file
Print	Open the print menu
Properties	View properties of a settings file
History	View history of a settings file
Recent Files	Open a previously opened file
Exit	Close BESTCOMSPPlus program
<u><i>Communication</i></u>	
New Connection	Choose new device or DECS-250
Close Connection	Close communication between BESTCOMSPPlus and DECS-250
Download Settings and Logic from Device	Download operational and logic settings from the device
Upload Settings and Logic to Device	Upload operational and logic settings to the device
Upload Settings to Device	Upload operational settings to the device
Upload Logic to Device	Upload logic settings to the device
Download Security from Device	Download security settings from the device
Upload Security to Device	Upload security settings to the device
Configure	Ethernet settings
Upload Device Files	Upload firmware to the device
<u><i>Tools</i></u>	
Check for Updates	Check for BESTCOMSPPlus® updates via the internet
Select Language	Select BESTCOMSPPlus language
Activate Device	Activate the DECS-250 plugin
Set File Password	Password protect a settings file
Compare Settings Files	Compare two settings files
Auto Export Metering	Exports metering data on a user-defined interval
Event Log - View	View the BESTCOMSPPlus event log
Event Log - Verbose Logging	Enable/disable verbose logging
Event Log - Verbose Communication Logging	Enable/disable verbose communication logging
Generate Certificate (this function is not applicable to the DECS-250)	Generate a certificate
Accepted Devices (this function is not applicable to the DECS-250)	View and delete accepted devices

Menu Item	Description
<i>Window</i>	
Cascade All	Cascade all windows
Tile	Tile horizontally or vertically
Maximize All	Maximize all windows
<i>Help</i>	
Check for Updates	Check for BESTCOMSPi <sup>®</sup> updates via the internet
Check for Update Settings	Enable or change automatic checking for update
About	View general, detailed build, and system information

### Lower Menu Bar (DECS-250 Plugin)

Lower menu bar functions are listed and described in Table 10.

**Table 10. Lower Menu Bar (DECS-250 Plugin)**

Menu Button	Description
<i>View</i>	Enables you to view the Metering Panel, Settings Panel, or Show Settings Information. Opens and saves workspaces. Customized workspaces make switching between tasks easier and more efficient.
<i>Open File</i>	Opens a saved settings file.
<i>Connect/Disconnect</i>	Opens the <i>DECS-250 Connection</i> screen which enables you to connect to the DECS-250 via USB or Ethernet. Also used to disconnect a connected DECS-250.
<i>Preview Metering</i>	Displays the <i>Print Preview</i> screen where a preview of the Metering printout is shown. Click on the printer button to send to a printer.
<i>Export Metering</i>	Enables all metering values to be exported into a *.csv file.
<i>Options</i>	Displays a drop-down list entitled <i>Live Mode Settings</i> which enables <i>Live mode</i> where settings are automatically sent to the device in real time as they are changed.
<i>Send Settings</i>	Sends settings to the DECS-250 when BESTCOMSPi <sup>®</sup> is not operating in Live Mode. Click on this button after making a setting change to send the modified setting to the DECS-250.

## Settings Explorer

The Settings Explorer is a convenient tool within BESTCOMSPi<sup>®</sup> used to navigate through the various settings screens of the DECS-250 plugin. Descriptions of these configuration settings are organized as follows:

- General Settings
- Communications
- System Parameters
- Report Configuration
- Operating Settings
- PSS
- Synchronizer/Voltage Matching
- Grid Code Settings
- Protection

- Programmable Inputs
- Programmable Outputs
- Alarm Configuration
- BESTlogicPlus Programmable Logic

Logic setup will be necessary after making certain setting changes. For more information, refer to the *BESTlogicPlus* chapter.

---

## ***Metering Explorer***

The Metering Explorer is used to view real-time system data including generator voltages and currents, input/output status, alarms, reports, and other parameters. Refer to the *Metering* chapter for full details about the Metering Explorer.

---

## ***Settings File Management***

A settings file contains all DECS-250 settings including logic. A settings file assumes a file extension of “\*.bstx”. It is possible to save the logic only as a separate logic library file on the *BESTlogicPlus Programmable Logic* screen. This function is helpful when similar logic is required for several devices. A logic library file assumes a file extension of “\*.bslx”. It is important to note that settings and logic can be uploaded to the device separately or together, but are always downloaded together. For more information on logic files, refer to the *BESTlogicPlus* chapter.

### **Opening a Settings File**

To open a DECS-250 settings file with *BESTCOMSPlus*, pull down the *File* menu and choose *Open*. The *Open* dialog box appears. This dialog box allows you to use normal Windows techniques to select the file that you want to open. Select the file and choose *Open*. You can also open a file by clicking on the *Open File* button on the lower menu bar. If connected to a device, you will be asked to upload the settings and logic from the file to the current device. If you choose *Yes*, the settings displayed in *BESTCOMSPlus* instance will be overwritten with the settings of the opened file.

### **Saving a Settings File**

Select *Save* or *Save As* from the *File* pull-down menu. A dialog box pops up allowing you to enter a filename and location to save the file. Select the *Save* button to complete the save.

### **Upload Settings and/or Logic to Device**

To upload a settings file to the DECS-250, open the file or create a new file through *BESTCOMSPlus*. Then pull down the *Communication* menu and select *Upload Settings and Logic to Device*. If you want to upload operational settings without logic, select *Upload Settings to Device*. If you want to upload logic without operational settings, select *Upload Logic to Device*. You are prompted to enter the username and password. The default username is “**A**” and the default password is “**A**”. If the username and password are correct, the upload begins and the progress bar is shown.

### **Download Settings and Logic from Device**

To download settings and logic from the DECS-250, pull down the *Communication* menu and select *Download Settings and Logic from Device*. If the settings in *BESTCOMSPlus*<sup>®</sup> have changed, a dialog box will open asking if you want to save the current settings changes. You can choose *Yes* or *No*. After you have taken the required action to save or discard the current settings, downloading begins. *BESTCOMSPlus* reads all settings and logic from the DECS-250 and loads them into *BESTCOMSPlus* memory. See Figure 140.

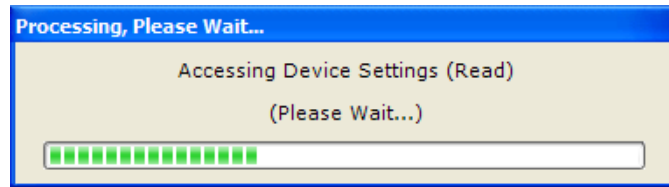


Figure 140. Processing, Please Wait...

## Printing a Settings File

To view a preview of the settings printout, select *Print* from the *File* pull-down menu. To print the settings, select the printer icon in the upper left corner of the *Print Preview* screen.

## Comparing Settings Files

BESTCOMSPPlus has the ability to compare two settings files. To compare files, pull down the *Tools* menu and select *Compare Settings Files*. The *BESTCOMSPPlus Settings Compare Setup* dialog box appears (Figure 141). Select the location of the first file under *Left Settings Source* and select the location of the second file under *Right Settings Source*. If you are comparing a settings file located on your PC hard drive or portable media, click the folder button and navigate to the file. If you want to compare settings downloaded from a unit, click the *Select Unit* button to set up the communication port. Click the *Compare* button to compare the selected settings files.

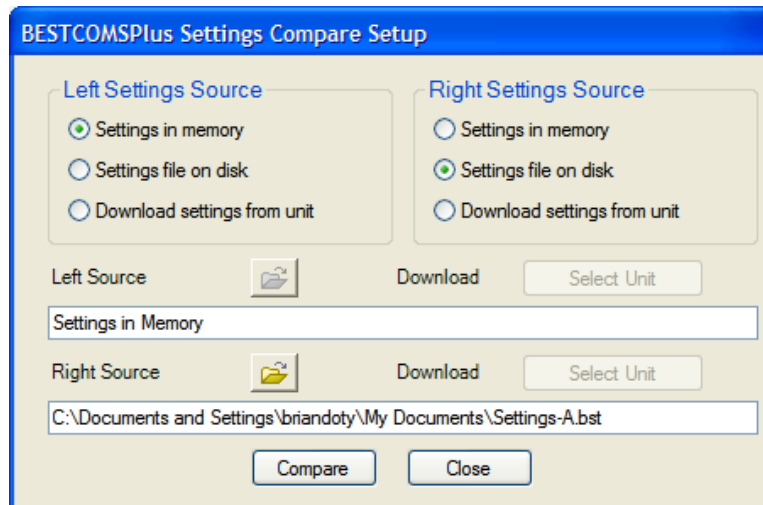


Figure 141. BESTCOMSPPlus Settings Compare Setup

A dialog box will appear and notify you if any differences were found. The *BESTCOMSPPlus® Settings Compare* dialog box (Figure 142) is displayed where you can view all settings (*Show All Settings*), view only the differences (*Show Settings Differences*), view all logic (*Show All Logic Paths*), or view only logic differences (*Show Logic Path Differences*). Select *Close* when finished.

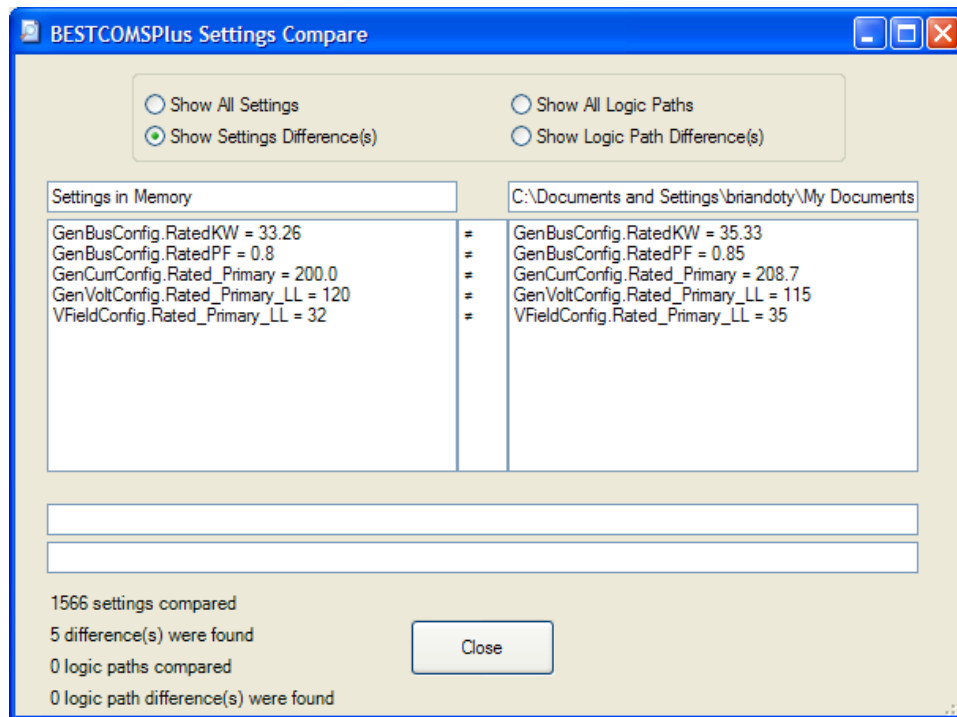


Figure 142. BESTCOMSPPlus® Settings Compare

## Automatic Metering Export

The auto export metering function automatically exports metering data over a user-defined period when a DECS-250 connection is active. The user specifies the *Number of Exports* and the *Interval* between each export. Enter a filename for the metering data and a folder in which to save. The first export is performed immediately after clicking the *Start* button. Click the *Filter* button to select specific metering screens. Figure 143 illustrates the *Auto Export Metering* screen.

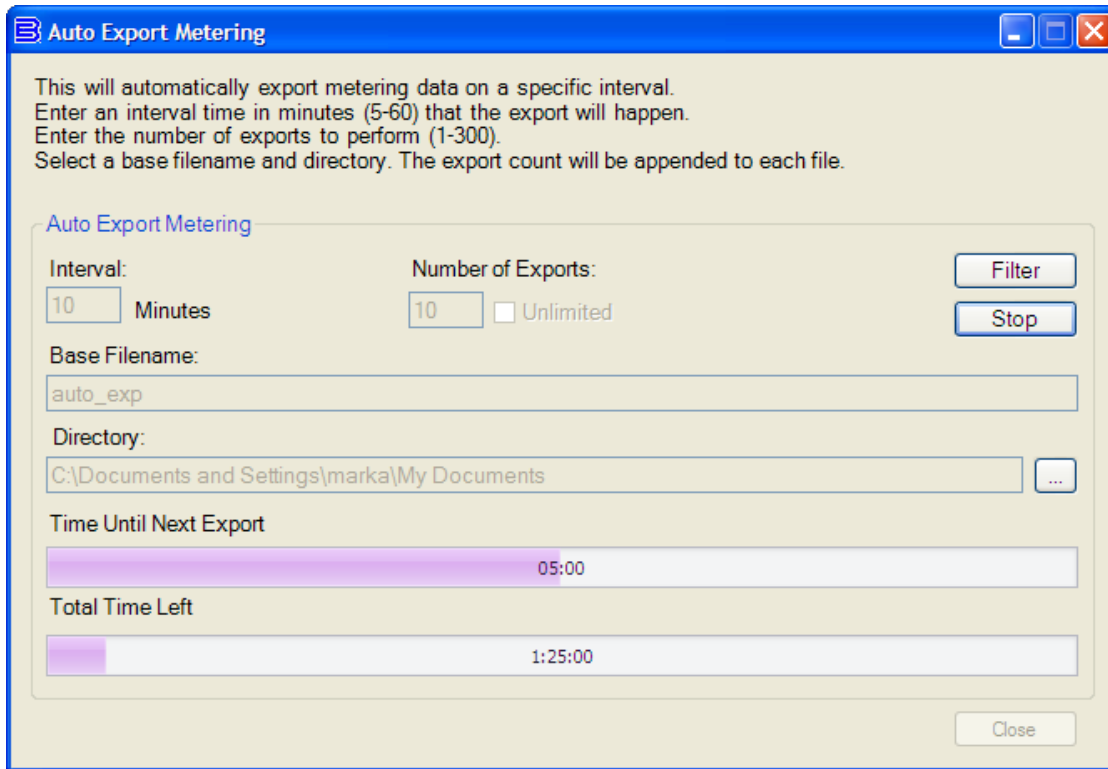


Figure 143. Auto Export Metering Screen

## Firmware Updates

Future enhancements to the DECS-250 functionality may require a firmware update. Because default settings are loaded when DECS-250 firmware is updated, your settings should be saved in a file prior to upgrading firmware.

### Warning!

Before performing any maintenance procedures, remove the DECS-250 from service. Refer to the appropriate site schematics to ensure that all steps have been taken to properly and completely de-energize the DECS-250.

### Caution – Settings will be lost!

Default settings will be loaded into the DECS-250, reports and events will be cleared, and the DECS-250 will reboot when firmware is updated. BESTCOMSP<sup>l</sup>us<sup>®</sup> can be used to download settings and save the settings in a file so that they can be restored after updating firmware. Refer to *Settings File Management* for help with saving a settings file.

### Note

The latest version of BESTCOMSP<sup>l</sup>us<sup>®</sup> software should be downloaded from the Basler Electric website and installed before performing a firmware upgrade.

A device package contains firmware for the DECS-250, the optional Contact Expansion Module (CEM-2020), and the optional Analog Expansion Module (AEM-2020). Embedded firmware is the operating program that controls the actions of the DECS-250. The DECS-250 stores firmware in nonvolatile flash memory that can be reprogrammed through the communication ports. It is not necessary to replace EPROM chips when updating the firmware with a newer version.

The DECS-250 can be used in conjunction with CEM-2020 or AEM-2020 expansion modules which expand the DECS-250 capabilities. When upgrading the firmware in any component of this system, the firmware in ALL of the components of the system should be upgraded to ensure compatibility of communications between the components.

### Caution

The order in which the components are upgraded is critical. Assuming a system of a DECS-250 and expansion module(s) is in a state where the DECS-250 is communicating with the system expansion module(s), **the expansion module must be upgraded before the DECS-250**. This is necessary because the DECS-250 must be able to communicate with the expansion module(s) before the DECS-250 can send firmware to it. If the DECS-250 were upgraded first, and the new firmware included a change to the expansion module communication protocol, it is possible that the expansion module(s) could no longer communicate with the upgraded DECS-250. Without communications between the DECS-250 and the expansion module(s), upgrading the expansion module(s) is not possible.

### Note

If power is lost or communication is interrupted during file transfer to the DECS-250, the firmware upload will fail. The device will continue to use the previous firmware. Once communication has been restored, the user must start the firmware upload again. Select Upload Device Files from the Communication pull-down menu and proceed normally.

## Upgrading Firmware in Expansion Modules

The following procedure is used to upgrade firmware in the expansion modules. This must be completed before upgrading firmware in the DECS-250. If no expansion module is present, proceed to *Upgrading Firmware in the DECS-250*.

1. Remove the DECS-250 from service. Refer to the appropriate site schematics to ensure that all steps have been taken to properly and completely de-energize the DECS-250.
2. Apply only control power to the DECS-250.
3. Enable the expansion modules that are present in the system. If they have not already been enabled, enable the expansion modules in the BESTCOMS*Plus* Settings Explorer, Communications, CAN Bus, Remote Module Setup screen.
4. Verify that the DECS-250 and the associated expansion modules are communicating. This can be verified by examining the alarm status using the Metering Explorer in BESTCOMS*Plus* or from the front panel by navigating to Metering > Status > Alarms. When communications are functioning properly, there should be no active AEM or CEM Communications Failure alarms.
5. Connect to the DECS-250 through the USB or Ethernet port if not already connected.
6. Select Upload Device Files from the Communication pull-down menu.
7. You will be asked to save the current settings file. Select Yes or No.
8. When the Basler Electric Device Package Uploader screen (Figure 144) appears, click on the Open button to browse for the device package you have received from Basler Electric. The Package Files along with File Details are listed. Place a check in the boxes next to the individual files you want to upload.

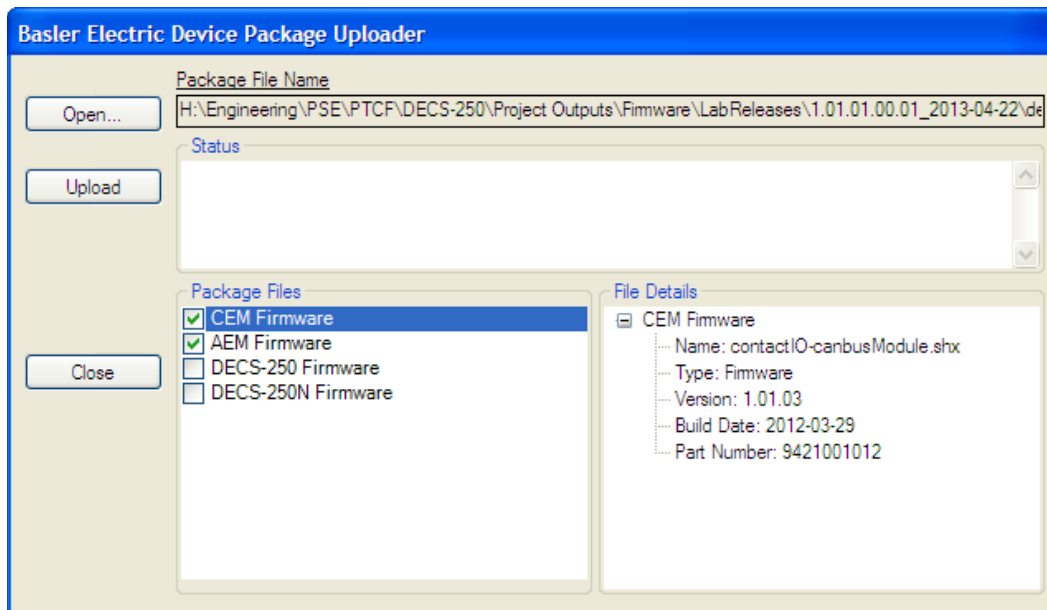


Figure 144. Basler Electric Device Package Uploader

9. Click on the Upload button and the Proceed with Device Upload screen will appear. Select Yes or No.
10. After selecting Yes, the DECS-250 Selection screen will appear. Select either USB or Ethernet.
11. After file(s) have been uploaded, click the *Close* button on the Basler Electric Device Package Uploader screen and disconnect communication to the DECS-250.

### Upgrading Firmware in the DECS-250

The following procedure is used to upgrade firmware in the DECS-250. This must be completed after upgrading firmware in any expansion modules.

1. Remove the DECS-250 from service. Refer to the appropriate site schematics to ensure that all steps have been taken to properly and completely de-energize the DECS-250.
2. Apply only control power to the DECS-250.

3. Connect to the DECS-250 with BESTCOMSP*lus*. Check the firmware Application Version on the General Settings > Device Info screen.
4. Select Upload Device Files from the Communication pull-down menu. You do not have to be connected to the DECS-250 at this time. Save settings when prompted, if desired.
5. Open the desired device package file (decs-250.bef).
6. Check the box for DECS-250 Firmware. Note the version number of the DECS-250 firmware; this is the version that will be used to set the Application Version in the settings file in a later step.
7. Click the Upload button and follow the instructions that appear to begin the upgrade process.
8. After the upload is complete, disconnect communication to the DECS-250.
9. Load the saved settings file into the DECS-250.
  - a. Close all settings files.
  - b. From the File pull-down menu, select New, DECS-250.
  - c. Connect to the DECS-250.
  - d. Once all settings have been read from the DECS-250, open the saved settings file by selecting File, Open File in the BESTCOMSP*lus* menu. Then browse for the file to upload.
  - e. When BESTCOMSP*lus* asks if you wish to upload settings and logic to the device, click Yes.
  - f. If you are receiving upload failures and indications that the logic is incompatible with the firmware version, check that the DECS-250 style number in the saved file matches that of the DECS-250 into which the file is being uploaded. The style number in the settings file is found under General Settings > Style Number in BESTCOMSP*lus*.
  - g. If the style number of the settings file does not match that of the DECS-250 into which it is to be loaded, disconnect from the DECS-250, then modify the style number in the settings file. Then repeat the steps titled *Load the Saved Settings File into the DECS-250*.

## **BESTCOMSP*lus*® Updates**

---

Enhancements to DECS-250 firmware typically coincide with enhancements to the DECS-250 plugin for BESTCOMSP*lus*®. When a DECS-250 is updated with the latest version of firmware, the latest version of BESTCOMSP*lus* should also be obtained.

- If you obtained a CD-ROM containing a firmware update from Basler Electric, then that CD-ROM will also contain the corresponding version of BESTCOMSP*lus* software.
- You can download the latest version of BESTCOMSP*lus* by visiting [www.basler.com](http://www.basler.com).
- BESTCOMSP*lus* automatically checks for updates when Check Automatically is selected on the Check for Updates User Settings screen. This screen is accessed under the Help drop-down menu. (An internet connection is required.)
- You can use the manual “check for updates” function in BESTCOMSP*lus* to ensure that the latest version is installed by selecting Check for Updates in the Help drop-down menu. (An internet connection is required.)



# BESTlogic™ Plus

## Introduction

BESTlogic™ Plus Programmable Logic is a programming method used for managing the input, output, protection, control, monitoring, and reporting capabilities of Basler Electric's DECS-250 Digital Excitation Control System. Each DECS-250 has multiple, self-contained logic blocks that have all of the inputs and outputs of its discrete component counterpart. Each independent logic block interacts with control inputs and hardware outputs based on logic variables defined in equation form with BESTlogicPlus.

BESTlogicPlus equations entered and saved in the DECS-250 system's nonvolatile memory integrate (electronically wire) the selected or enabled protection and control blocks with control inputs and hardware outputs. A group of logic equations defining the logic of the DECS-250 is called a logic scheme.

Two default active logic schemes are preloaded into the DECS-250. One default logic scheme is tailored for a system with the PSS option disabled and the other is for a system with PSS enabled. The proper default logic scheme is loaded depending on the PSS option selected in the system style number. These schemes are configured for a typical protection and control application of a synchronous generator and virtually eliminate the need for "start-from-scratch" programming. The default logic schemes are similar to that of a DECS-200. BESTCOMSPPlus® can be used to open a logic scheme that was previously saved as a file and upload it to the DECS-250. The default logic schemes can also be customized to suit your application. Detailed information about logic schemes is provided later in this chapter.

BESTlogicPlus is not used to define the operating settings (modes, pickup thresholds, and time delays) of the individual protection and control functions. Operating settings and logic settings are interdependent but separately programmed functions. Changing logic settings is similar to rewiring a panel and is separate and distinct from making the operating settings that control the pickup thresholds and time delays of a DECS-250. Detailed information about operating settings is provided in other chapters of this instruction manual.

### Caution

This product contains one or more *nonvolatile memory* devices. Nonvolatile memory is used to store information (such as settings) that needs to be preserved when the product is power-cycled or otherwise restarted. Established nonvolatile memory technologies have a physical limit on the number of times they can be erased and written. In this product, the limit is 100,000 erase/write cycles. During product application, consideration should be given to communications, logic, and other factors that may cause frequent/repeated writes of settings or other information that is retained by the product. Applications that result in such frequent/repeated writes may reduce the useable product life and result in loss of information and/or product inoperability.

## Overview of BESTlogic™ Plus

Use BESTCOMSPPlus to make BESTlogicPlus settings. Use the Settings Explorer to open the *BESTlogicPlus Programmable Logic* tree branch as shown in Figure 145.

The *BESTlogicPlus Programmable Logic* screen contains a logic library for opening and saving logic files, tools for creating and editing logic documents, and protection settings.

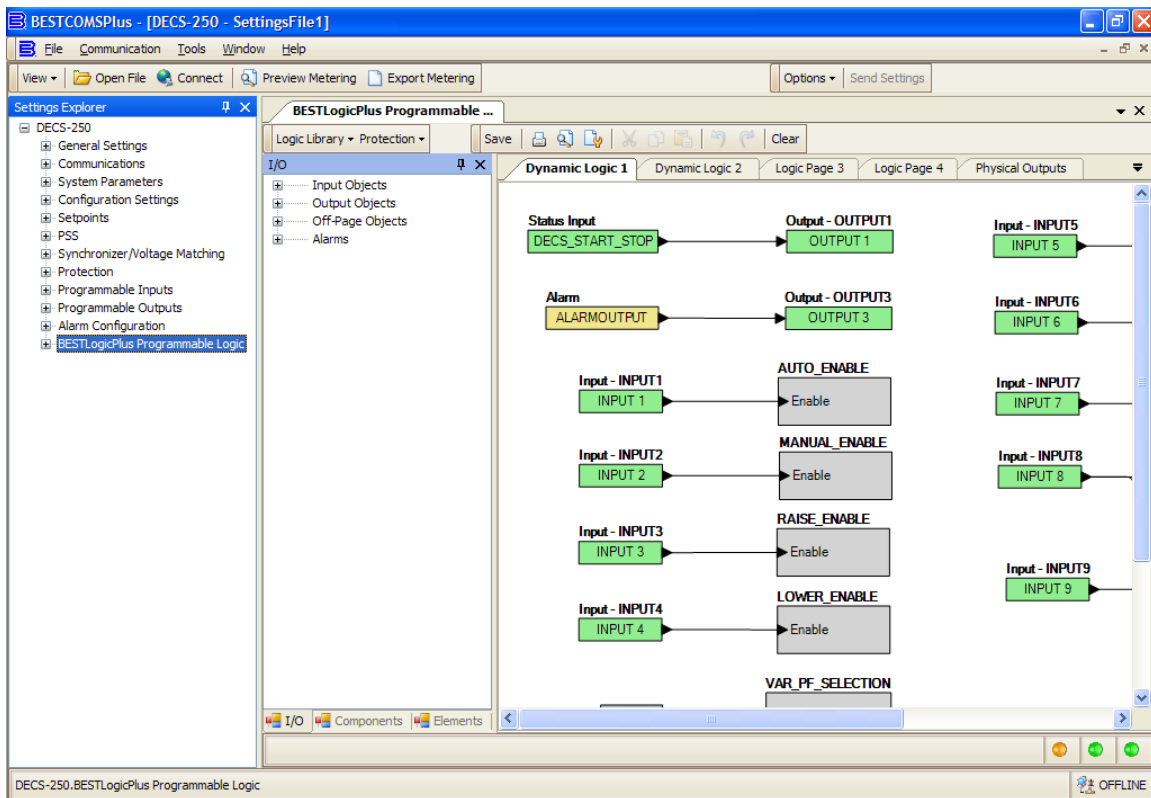


Figure 145. BESTlogicPlus Programmable Logic Tree Branch

### BESTlogic™ Plus Composition


















There are three main groups of objects used for programming BESTlogicPlus. These groups are *I/O*, *Components*, and *Elements*. For details on how these objects are used to program BESTlogicPlus, see the paragraphs on *Programming BESTlogicPlus*.

#### I/O


















This group contains Input Objects, Output Objects, Off-Page Objects, and Alarms. Table 11 lists the names and descriptions of the objects in the *I/O* group.

Table 11. I/O Group, Names and Descriptions

Name	Description	Symbol
<b>Input Objects</b>		
Logic 0	Always false (Low).	
Logic 1	Always true (High).	
<b>Front Panel Buttons</b>		
Down Button	True while the front panel Down arrow button is pressed.	<b>Status Input</b> 
Edit Button	True while the front panel Edit button is pressed.	<b>Status Input</b> 
Left Button	True while the front panel Left arrow button is pressed.	<b>Status Input</b> 

Name	Description	Symbol
Reset Button	True while the front panel Reset button is pressed.	<b>Status Input</b> ResetButton 
Right Button	True while the front panel Right arrow button is pressed.	<b>Status Input</b> RightButton 
Up Button	True while the front panel Up arrow button is pressed.	<b>Status Input</b> UpButton 
<i>Physical Inputs</i>		
Start Input	True when the physical Start input is active.	<b>Input - STARTINPUT</b> STARTINPUT 
Stop Input	True when the physical Stop input is active.	<b>Input - STOPINPUT</b> STOPINPUT 
IN1 - IN14	True when Physical Input x is active.	<b>Input - INPUT1</b> INPUT 1 
<i>Remote Inputs</i>		
IN15 - IN24	True when Remote Input x is active. (Available when an optional CEM-2020 is connected.)	<b>Input - IN15</b> INPUT 15 
<i>Virtual Inputs</i>		
VIN1 - VIN6	True when Virtual Input x is active.	<b>Input - VIRTUALSEWITCH1</b> VIRTUALSEWITCH1 
<i>Status Inputs</i>		
APC Active	True when Active Power Control (APC) mode is active.	<b>Status Input</b> APC_ACTIVE 
APC AEM Comm Fail	True when the APC Adjust Source setting is set to an AEM Analog Input and the Remote Control Failure Timer has expired.	<b>Status Input</b> APC_AEM_COMM_FAIL 
APC Bridge Active	True when APC Bridge mode is active.	<b>Status Input</b> APC_BRIDGE_ACTME 
APC Bridge Enable	True when APC Bridge mode is enabled.	<b>Status Input</b> APC_BRIDGE_ENABLE 
APC CANBus Comm Fail	True when the APC Adjust Source setting is set to CANBus and the Remote Control Failure Timer has expired.	<b>Status Input</b> APC_CANBUS_COMM_FAIL 
APC Enable	True when APC mode is enabled.	<b>Status Input</b> APC_ENABLE 
APC Modbus Comm Fail	True when the APC Adjust Source setting is set to Modbus and the Remote Control Failure Timer has expired.	<b>Status Input</b> APC_MODBUS_COMM_FAIL 
APC Output Limit	True when the Active Power PI controller is at either its maximum or minimum output limit.	<b>Status Input</b> APC_OUTPUT_LIMIT 
APC Remote Comm Active	True while the Remote Control Failure Timer is active. The Remote Control Failure Timer is always active and resets frequently, during good communications.	<b>Status Input</b> APC_REMOTE_COMM_ACTME 

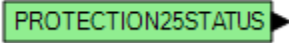
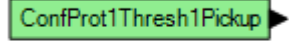
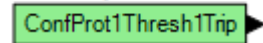
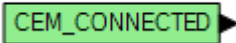
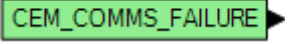
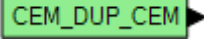
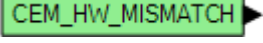
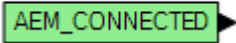
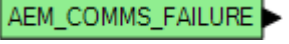
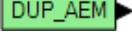
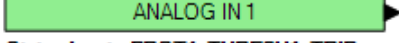

Name	Description	Symbol
APC Remote Comm Fail	True when the Remote Control Failure Timer has expired for any communication protocol (defined by the Adjust Source setting).	<b>Status Input</b> APC_REMOTE_COMM_FAIL
Anticipatory Sync Selected	True when Anticipatory is selected. (Synchronizer screen)	<b>Status Input</b> ANTICIPATORY_SYNC_SELECT
Auto Mode Active	True when the unit is in Auto mode (AVR).	<b>Status Input</b> AUTO_ACTIVE
Bus Dead	True when the Bus Dead condition settings have been exceeded. (Available when the controller is equipped with the optional Auto synchronizer, style number xxxxAxx)	<b>Status Input</b> BUS_DEAD
Bus Failed	True when the Bus Stable condition settings are not met. (Available when the controller is equipped with the optional Auto synchronizer, style number xxxxAxx)	<b>Status Input</b> BUS_FAILED
Bus Stable	True when the Bus Stable condition settings have been exceeded. (Available when the controller is equipped with the optional Auto synchronizer, style number xxxxAxx)	<b>Status Input</b> BUS_STABLE_COND
Auto Sync Enabled	True when DECS auto-sync is enabled. (Available when the controller is equipped with the optional Auto synchronizer, style number xxxxAxx)	<b>Status Input</b> DECS_AUTOSYNC_ENABLE
Dead Bus Close Request	True when this option is user-enabled; a dead bus is closed automatically upon detection. False when this option is disabled; a dead bus will remain open. (Available when the controller is equipped with the optional Auto synchronizer, style number xxxxAxx)	<b>Status Input</b> DEAD_BUS_CLOSE_REQUEST
External Tracking Active	True when external tracking is running.	<b>Status Input</b> EXT_TRACKING_ACTIVE
Failed To Buildup	True when the Failed to Buildup alarm is active.	<b>Status Input</b> FAILEDTOBUILDUP
FCR Active	True when the unit is in FCR mode.	<b>Status Input</b> FCR_Active
Field Flash Active	True when field flash is active.	<b>Status Input</b> FIELD_FLASH_ACTIVE
Field Short Circuit Status	True when a field short circuit condition is detected.	<b>Status Input</b> FIELDSHORTCIRCUITSTATUS
FVR Active	True when the unit is in FVR mode.	<b>Status Input</b> FVR_Active
GCC Continuous Operation	True when the controlled generator's frequency and voltage are within the Continuous Operation region for Grid Code Connectivity (GCC).	<b>Status Input</b> GCC_CONTINUOUS_OPERATION
GCC Disabled	True when the GCC function is disabled.	<b>Status Input</b> GCC_DISABLED
GCC Disconnect Timed Out	True when any Grid Code disconnection timer has expired. Remains true until the GCC reconnect timer becomes active.	<b>Status Input</b> GCC_DISCONNECT_TIMED_OUT


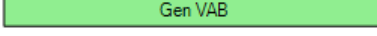
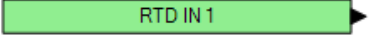
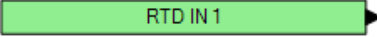
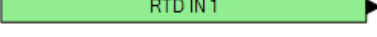
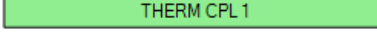
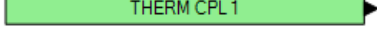
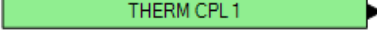
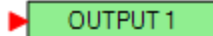
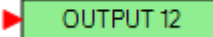
Name	Description	Symbol
GCC Disconnected	True when disconnection criteria for GCC has been met and remains true until the GCC reconnect timer expires.	<b>Status Input</b> GCC_DISCONNECTED 
GCC Freq High Timing	True when the controlled generator's frequency is in the high frequency region for GCC and the timer is active.	<b>Status Input</b> GCC_FREQ_HI_TIMING 
GCC Freq Low Timing	True when the controlled generator's frequency is in the low frequency region for GCC and the timer is active.	<b>Status Input</b> GCC_FREQ_LOW_TIMING 
GCC Out of Range Timing	True when the controlled generator's frequency or voltage are in the Out of Range region for GCC and the timer is active.	<b>Status Input</b> GCC_OUT_OF_RANGE_TIMING 
GCC Timing For Disconnect	True when any of the GCC timers is active.	<b>Status Input</b> GCC_DISCONNECT_TIMING 
GCC Timing for Reconnect	True when the GCC reconnect timer is active.	<b>Status Input</b> GCC_RECONNECT_TIMING 
GCC Voltage High Timing	True when the controlled generator's voltage is in the high voltage region for GCC and the timer is active.	<b>Status Input</b> GCC_VOLTS_HIGH_TIMING 
GCC Voltage Low Timing	True when the controlled generator's voltage is in the low voltage region for GCC and the timer is active.	<b>Status Input</b> GCC_VOLTS_LOW_TIMING 
Gen Breaker Fail to Open	The generator breaker did not open in the close wait time period. (Available when the controller is equipped with the optional Auto synchronizer, style number xxxxAxx)	<b>Status Input</b> GEN_BREAKER_FAIL_TO_OPEN 
Gen Breaker Fail to Close	The generator breaker did not close in the close wait time period. (Available when the controller is equipped with the optional Auto synchronizer, style number xxxxAxx)	<b>Status Input</b> GEN_BREAKER_FAIL_TO_CLOSE 
Gen Breaker Sync Fail	True when generator breaker sync has failed. (Available when the controller is equipped with the optional Auto synchronizer, style number xxxxAxx)	<b>Status Input</b> GEN_BREAKER_SYNC_FAIL 
Gen Dead	True when the Generator Breaker Dead condition settings have been exceeded. (Available when the controller is equipped with the optional Auto synchronizer, style number xxxxAxx)	<b>Status Input</b> GEN_DEAD 
Gen Failed	True when the Generator Breaker Stable condition settings are not met. (Available when the controller is equipped with the optional Auto synchronizer, style number xxxxAxx)	<b>Status Input</b> GEN_FAILED 
Gen Stable	True when the Generator Breaker Stable condition settings have been exceeded. (Available when the controller is equipped with the optional Auto synchronizer, style number xxxxAxx)	<b>Status Input</b> GEN_STABLE 
GOV Contact Type Proportional	True when this option is selected. (Governor Bias Control Settings screen)	<b>Status Input</b> CONTACT_TYPE_PROPORTIONAL 
Grid Code Enabled	True when overall Grid Code functionality is enabled.	<b>Status Input</b> GRIDCODE_ENABLED 
KW Threshold	True when kW output is below the standard (non-Grid Code) PF Active Power Level.	<b>Status Input</b> KW_THRESHOLD_STATUS 

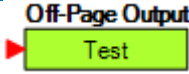
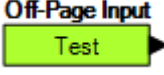
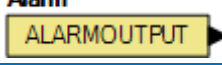
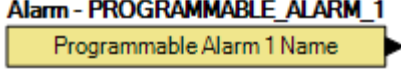
Name	Description	Symbol
LFSM Active	True when Limited Frequency Sensitive Mode (LFSM) is active.	Status Input LFSM_ACTIVE
LFSM Enable	True when LFSM is enabled.	Status Input LFSM_ENABLE
LFSM Normal Operation	True when LFSM is enabled and grid frequency is within the dead band.	Status Input LFSM_NORMAL_OPERATION
LFSM Over Frequency Active	True when LFSM is enabled and grid frequency is greater than the LFSM-O Dead Band setting value.	Status Input LFSM_O_ACTIVE
LFSM Recovery Active	True when LFSM is enabled and the Grid Recovery timer is active.	Status Input LFSM_RECOVERY_ACTIVE
LFSM Under Frequency Active	True when LFSM is enabled and grid frequency is less than the LFSM-U Dead Band setting value.	Status Input LFSM_U_ACTIVE
LVRT Active	True when Low Voltage Ride Through (LVRT) mode is active.	Status Input LVRT_ACTIVE
LVRT AEM Comm Fail	True when the LVRT Adjust Source setting is set to an AEM Analog Input and the Remote Control Failure Timer has expired.	Status Input LVRT_AEM_COMM_FAIL
LVRT Bridge Active	True when LVRT Bridge mode is active.	Status Input LVRT_BRIDGE_ACTIVE
LVRT Bridge Enable	True when LVRT Bridge mode is enabled.	Status Input LVRT_BRIDGE_ENABLE
LVRT CANBus Comm Fail	True when the LVRT Adjust Source setting is set to CANBus and the Remote Control Failure Timer has expired.	Status Input LVRT_CANBUS_COMM_FAIL
LVRT Enable	True when LVRT mode is enabled.	Status Input LVRT_ENABLE
LVRT Modbus Comm Fail	True when the LVRT Adjust Source setting is set to Modbus and the Remote Control Failure Timer has expired.	Status Input LVRT_MODBUS_COMM_FAIL
LVRT Remote Comm Active	True when the Remote Control Failure Timer is active. The Remote Control Failure Timer is always active and resets frequently, during good communications.	Status Input LVRT_REMOTE_COMM_ACTIVE
LVRT Remote Comm Fail	True when the Remote Control Failure Timer has expired for any communication protocol (defined by the Adjust Source setting).	Status Input LVRT_REMOTE_COMM_FAIL
LVRT Remote Failmode	True when LVRT remote communication has failed.	Status Input REMOTE_LVRT_FAILMODE
Internal Tracking Active	True when internal tracking is running.	Status Input INT_TRACKING_ACTME
IRIG Sync Lost	True when IRIG signal is not being received.	Status Input IRIG_SYNC_LOST_ALM
Manual Mode Active	True when the unit is in Manual mode (FCR/FVR).	Status Input MANUAL_ACTIVE

Name	Description	Symbol
Network Load Share Active	True when network load sharing is active.	Status Input NLS_ACTIVE
Network Load Share Config Mismatch	True when the unit's configuration does not match the configuration of the other units with load sharing enabled.	Status Input NLS_CONFIG_MISMATCH
Network Load Share ID Missing	True when any of the load sharing enabled units are not detected on the network.	Status Input NLS_ID_MISSING
Network Load Share Receiving ID 1 - 16	True when data is being received from a specific unit on the load share network.	Status Input RCC_RECEIVING_ID_1
No Network Load Share Data Received	True when Network Load Sharing is enabled but there is no data being received from other network load sharing devices.	Status Input NO_NETWORK_LOADSHARE_DATA
Network Load Share Status 1-4	This element functions in conjunction with the Network Load Share Broadcast elements on all units on the network. True when the corresponding Network Load Share Broadcast element input is true on another unit on the network.	Status Input NLS_STATUS_1
NTP Sync Lost	True when NTP server has lost communications.	Status Input NTP_SYNC_LOST_ALM
Null Balance	True when Null Balance is achieved in both external and internal tracking.	Status Input NULL_BALANCE
OEL	True when the Overexcitation Limiter is active.	Status Input OEL
PF Controller Active	True when the unit is in PF mode.	Status Input PF_Active
PLL Sync Selected	True when phase locked loop (PLL) is selected. (Synchronizer screen)	Status Input PLL_SYNC_SELECTED
Preposition Active	True when any preposition is active.	Status Input DECS_PREPOSITION
Preposition 1 Active	True when Preposition 1 is active.	Status Input PREPOSITION_1_ACTME
Preposition 2 Active	True when Preposition 2 is active.	Status Input PREPOSITION_2_ACTME
Preposition 3 Active	True when Preposition 3 is active.	Status Input PREPOSITION_3_ACTME
PSS Active (Optional)	True when the power system stabilizer (PSS) is turned on and running.	Status Input PSS_ACTIVE
PSS Current Unbalanced (Optional)	True when the phase current is unbalanced and the PSS is active.	Status Input PSSCURRENTUNBALANCED
PSS Power Below Threshold (Optional)	True when the input power is below the Power Level threshold and the PSS is active.	Status Input PSSPOWERBELOWTHRESHOLD

Name	Description	Symbol
PSS Secondary Group (Optional)	True when the PSS is using secondary settings.	Status Input PSS_USING_SEC_SETTINGS
PSS Speed Failed (Optional)	True when the frequency is out of range for a length of time calculated internally by the DECS-250 and the PSS is active.	Status Input PSSSPEEDFAILED
PSS Test On (Optional)	True when the power system stabilizer test signal (Frequency Response) is active.	Status Input PSS_TEST_MODE
PSS Voltage Limit (Optional)	True when the calculated terminal voltage upper or lower limit is reached and the PSS is active.	Status Input PSSVOLTAGELIMIT
PSS Voltage Unbalanced (Optional)	True when the phase voltage is unbalanced and the PSS is active.	Status Input PSSVOLTAGEUNBALANCED
SCL	True when the Stator Current Limiter is active.	Status Input SCL
Setpoint at Lower Limit	True when the active modes setpoint is at the lower limit.	Status Input Setpoint_At_Lower_Limit
Setpoint at Upper Limit	True when the active modes setpoint is at the upper limit.	Status Input Setpoint_At_Upper_Limit
Soft Start Active	True during softstart.	Status Input SOFTSTART_ACTME
Start Status	True when the unit is in Start mode.	Status Input DECS_START_STOP
Sync Active	True when synchronization is active.	Status Input SYNC_ACTIVE
Transfer Watchdog	True when watchdog has timed out and system control will switch to an alternate redundant DECS-250.	Status Input TRANSFERWATCHDOG
Transient Boost Active	True when transient boost is active.	Status Input TRANSIENT_BOOST_ACTME
UEL	True when the Under Excitation Limiter is active.	Status Input UEL
Under Frequency V/Hz	True when the Under Frequency or the Volts/Hz Limiter is active.	Status Input UNDERFREQUENCYVHZ
Unknown Network Load Share Protocol Version	True when there is another unit on the network whose load share protocol version is not the same as this units load share protocol version.	Status Input UNKNOWN_LOAD_SHARE_VER
VAR Controller Active	True when the unit is in VAR mode.	Status Input VAR_Active
VAR Limiter Active	True when the Var Limiter is active.	Status Input VAR_LIMITER_ACTIVE
Voltage Matching Active	True when Voltage Matching is active.	Status Input VOLTAGE_MATCHING_ACTME

Name	Description	Symbol
Protection	Several protection status alarms are available. The 25 Sync-Check Status Alarm input is shown to the right. These elements are true when the pickup threshold is exceeded for the duration of the time delay.	<b>Status Input</b> 
Configurable Protection 1-8	There are four thresholds for each of the eight Configurable Protection blocks. Each threshold can be set to Over or Under mode and the threshold limit and activation delay can each be set. See the <i>Protection</i> chapter in this manual for more details. Each threshold has a separate logic block for the pickup and the trip. Configurable Protection #1 with its Threshold #1 Pickup and Trip blocks is shown to the right. The pickup block is true when the threshold is exceeded. The trip block is true when the corresponding pickup block threshold is exceeded for the duration of the time delay.	<b>Status Input</b>  <b>Status Input</b> 
Contact Expansion Module, CEM Connected	Contact Expansion Module Connected. True when an optional CEM-2020 is connected to the DECS-250.	<b>Status Input</b> 
Contact Expansion Module, Comms Failure	True when there is no communication from the CEM.	<b>Status Input</b> 
Contact Expansion Module, Duplicate CEM	True when more than one CEM is detected. Only one CEM is supported at a time.	<b>Status Input</b> 
Contact Expansion Module, Hardware Mismatch	True when selected CEM type differs from detected CEM type. Go to <i>Settings Explorer, Communications, CAN Bus, Remote Module Setup</i> to select the CEM type (18 or 24 contacts).	<b>Status Input</b> 
Analog Expansion Module, Connected	Analog Expansion Module Connected. True when an optional AEM-2020 is connected to the DECS-250.	<b>Status Input</b> 
Analog Expansion Module, Comms Failure	True when there is no communication from the AEM.	<b>Status Input</b> 
Analog Expansion Module, Duplicate AEM	True when more than one AEM is detected. Only one AEM is supported at a time.	<b>Status Input</b> 
Analog Expansion Module, Remote Analog Inputs 1-8	There are four thresholds for each of the eight Remote Analog Input blocks. Each threshold has a separate logic block for the pickup and the trip. Remote Analog Input #1 with its Threshold #1 Pickup and Trip blocks is shown to the right. For more details on configuring the Remote Analog Inputs, see the <i>Analog Expansion Module</i> chapter in this manual. The pickup block is true when the threshold is exceeded. The trip block is true when the corresponding pickup block threshold is exceeded for the duration of the time delay.	<b>Status Input - PROT1_THRESH1_PICKUP</b>  <b>Status Input - PROT1_THRESH1_TRIP</b> 

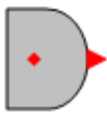
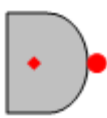


Name	Description	Symbol
Analog Expansion Module Remote Analog Inputs, Out of Range 1-8	Each Remote Analog Input has one Out of Range Block. True when parameters exceed out of range threshold. This function alerts the user of an open or damaged analog input wire.	<b>Status Input - PROT1_OUT_OF_RANGE</b> 
Analog Expansion Module Remote Analog Outputs 1-4	True when the analog output connection is open.	<b>Status Input - AEM_OUTPUT_1_OUT_OF_RANGE</b> 
Analog Expansion Module Remote RTD Inputs 1-8	There are four thresholds for each of the eight Remote RTD Input blocks. Each threshold has a separate logic block for the pickup and the trip. Remote RTD Input #1 with its Threshold #1 Pickup and Trip blocks is shown to the right. For more details on configuring the Remote RTD Inputs, see the <i>Analog Expansion Module</i> chapter in this manual. The pickup block is true when the threshold is exceeded. The trip block is true when the corresponding pickup block threshold is exceeded for the duration of the time delay.	<b>Status Input - RTDPROT1_THRESH1_PU</b>  <b>Status Input - RTDPROT1_THRESH1_TRIP</b> 
Analog Expansion Module Remote RTD Inputs, Out of Range 1-8	Each Remote RTD Input has one Out of Range Block. True when parameters exceed out of range threshold. This function alerts the user of an open or damaged analog input wire.	<b>Status Input - RTD_INPUT_1_OUT_OF_RANGE</b> 
Analog Expansion Module Remote Thermocouple Inputs 1-2	There are four thresholds for both of the Remote Thermocouple Input blocks. Each threshold has a separate logic block for the pickup and the trip. Remote Thermocouple Input #1 with its Threshold #1 Pickup and Trip blocks is shown to the right. For more details on configuring the Remote Thermocouple Inputs, see the <i>Analog Expansion Module</i> chapter in this manual. The pickup block is true when the threshold is exceeded. The trip block is true when the corresponding pickup block threshold is exceeded for the duration of the time delay.	<b>Status Input - THERMPROT1_THRESH1_PICKUP</b>  <b>Status Input - THERMPROT1_THRESH1_TRIP</b> 
Analog Expansion Module Remote Thermocouple Inputs, Out of Range 1-2	Each Remote Thermocouple Input has one Out of Range Block. True when parameters exceed out of range threshold. This function alerts the user of an open or damaged analog input wire.	<b>Status Input - THERMAL_1_OUT_OF_RANGE</b> 
<b>Output Objects</b>		
<i>Physical Outputs</i> OUT1 - OUT11	Physical Outputs 1 through 11.	<b>Output - OUTPUT1</b> 
<i>Remote Outputs</i> OUT12 - OUT35	Remote Outputs 12 through 35. (Available when an optional CEM-2020 is connected.)	<b>Output - OUTPUT12</b> 
<b>Off-Page Objects</b>		

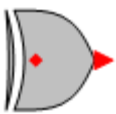
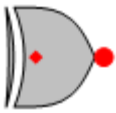

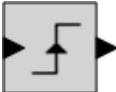
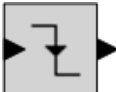
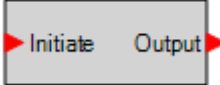
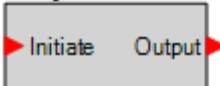
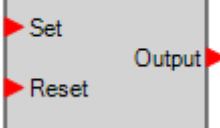
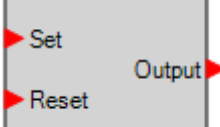
Name	Description	Symbol
Off-Page Output	Used in conjunction with the Off-Page Input to transform an output on one logic page into an input on another logic page. Outputs can be renamed by right-clicking and selecting Rename Output. Right-clicking will also show pages that the corresponding inputs can be found on. Selecting the page will take you to that page.	
Off-Page Input	Used in conjunction with the Off-Page Output to transform an output on one logic page into an input on another logic page. Inputs can be renamed by right-clicking and selecting Rename Input. Right-clicking will also show pages that the corresponding outputs can be found on. Selecting the page will take you to that page.	
<b>Alarms</b>		
Global Alarm	True when one or more alarms are set.	
Programmable Alarms 1 - 16	True when a programmable alarm is set.	

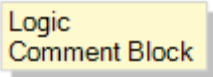
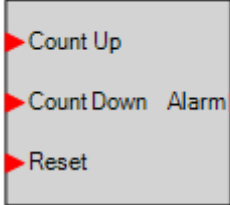
Components

This group contains Logic Gates, Pickup and Dropout Timers, Latches, and Comment Blocks. Table 12 lists the names and descriptions of the objects in the *Components* group.

**Table 12. Components Group, Names and Descriptions**

Name	Description	Symbol										
<b>Logic Gates</b>												
AND	<table border="1"> <thead> <tr> <th>Input</th> <th>Output</th> </tr> </thead> <tbody> <tr> <td>0   0</td> <td>0</td> </tr> <tr> <td>0   1</td> <td>0</td> </tr> <tr> <td>1   0</td> <td>0</td> </tr> <tr> <td>1   1</td> <td>1</td> </tr> </tbody> </table>	Input	Output	0   0	0	0   1	0	1   0	0	1   1	1	
Input	Output											
0   0	0											
0   1	0											
1   0	0											
1   1	1											
NAND	<table border="1"> <thead> <tr> <th>Input</th> <th>Output</th> </tr> </thead> <tbody> <tr> <td>0   0</td> <td>1</td> </tr> <tr> <td>0   1</td> <td>1</td> </tr> <tr> <td>1   0</td> <td>1</td> </tr> <tr> <td>1   1</td> <td>0</td> </tr> </tbody> </table>	Input	Output	0   0	1	0   1	1	1   0	1	1   1	0	
Input	Output											
0   0	1											
0   1	1											
1   0	1											
1   1	0											
OR	<table border="1"> <thead> <tr> <th>Input</th> <th>Output</th> </tr> </thead> <tbody> <tr> <td>0   0</td> <td>0</td> </tr> <tr> <td>0   1</td> <td>1</td> </tr> <tr> <td>1   0</td> <td>1</td> </tr> <tr> <td>1   1</td> <td>1</td> </tr> </tbody> </table>	Input	Output	0   0	0	0   1	1	1   0	1	1   1	1	
Input	Output											
0   0	0											
0   1	1											
1   0	1											
1   1	1											
NOR	<table border="1"> <thead> <tr> <th>Input</th> <th>Output</th> </tr> </thead> <tbody> <tr> <td>0   0</td> <td>1</td> </tr> <tr> <td>0   1</td> <td>0</td> </tr> <tr> <td>1   0</td> <td>0</td> </tr> <tr> <td>1   1</td> <td>0</td> </tr> </tbody> </table>	Input	Output	0   0	1	0   1	0	1   0	0	1   1	0	
Input	Output											
0   0	1											
0   1	0											
1   0	0											
1   1	0											

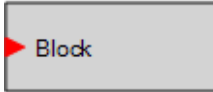
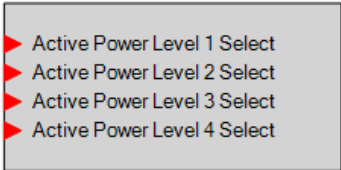
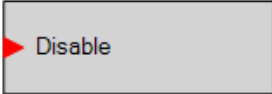
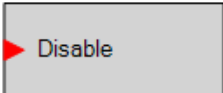

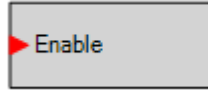
Name	Description	Symbol															
XOR	<table border="1"> <thead> <tr> <th colspan="2">Input</th> <th>Output</th> </tr> </thead> <tbody> <tr> <td>0</td> <td>0</td> <td>0</td> </tr> <tr> <td>0</td> <td>1</td> <td>1</td> </tr> <tr> <td>1</td> <td>0</td> <td>1</td> </tr> <tr> <td>1</td> <td>1</td> <td>0</td> </tr> </tbody> </table>	Input		Output	0	0	0	0	1	1	1	0	1	1	1	0	
Input		Output															
0	0	0															
0	1	1															
1	0	1															
1	1	0															
XNOR	<table border="1"> <thead> <tr> <th colspan="2">Input</th> <th>Output</th> </tr> </thead> <tbody> <tr> <td>0</td> <td>0</td> <td>1</td> </tr> <tr> <td>0</td> <td>1</td> <td>0</td> </tr> <tr> <td>1</td> <td>0</td> <td>0</td> </tr> <tr> <td>1</td> <td>1</td> <td>1</td> </tr> </tbody> </table>	Input		Output	0	0	1	0	1	0	1	0	0	1	1	1	
Input		Output															
0	0	1															
0	1	0															
1	0	0															
1	1	1															
NOT (INVERTER)	<table border="1"> <thead> <tr> <th>Input</th> <th>Output</th> </tr> </thead> <tbody> <tr> <td>0</td> <td>1</td> </tr> <tr> <td>1</td> <td>0</td> </tr> </tbody> </table>	Input	Output	0	1	1	0										
Input	Output																
0	1																
1	0																
Rising Edge	The output is true when the rising edge of a pulse is detected on the input signal.																
Falling Edge	The output is true when the falling edge of a pulse is detected on the input signal.																
<b>Pickup and Dropout Timers</b>																	
Drop Out Timer	Used to set a delay in the logic. For more information, refer to <i>Programming BESTlogicPlus, Pickup and Dropout Timers</i> , later in this chapter.	<b>Drop Out Timer (1)</b> <b>TIMER_1</b> <b>Delay = 1</b> 															
Pick Up Timer	Used to set a delay in the logic. For more information, refer to <i>Programming BESTlogicPlus, Pickup and Dropout Timers</i> , later in this chapter.	<b>Pick Up Timer (1)</b> <b>TIMER_1</b> <b>Delay = 1</b> 															
<b>Latches</b>																	
Reset Priority Latch	When the Set input is on and the Reset input is off, the latch will go to the SET (ON) state. When the Reset input is on and the Set input is off, the latch will go to the RESET (OFF) state. If both the Set and Reset inputs are on at the same time, a reset priority latch will go to the RESET (OFF) state.	<b>Reset Priority Latch</b> 															
Set Priority Latch	When the Set input is on and the Reset input is off, the latch will go to the SET (ON) state. When the Reset input is on and the Set input is off, the latch will go to the RESET (OFF) state. If both the Set and Reset inputs are on at the same time, a set priority latch will go to the SET (ON) state.	<b>Set Priority Latch</b> 															

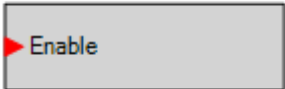
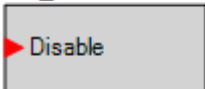
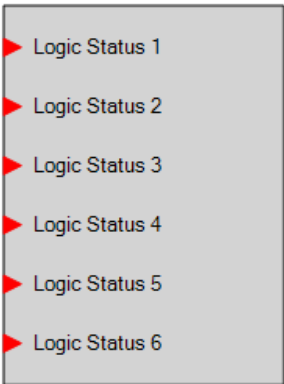
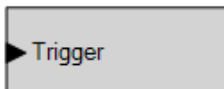
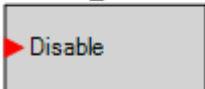
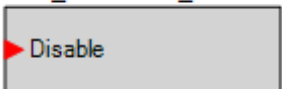
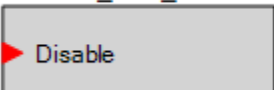
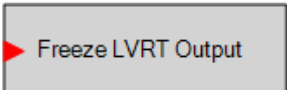
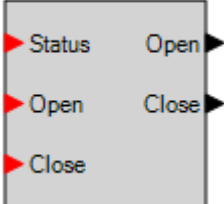
Name	Description	Symbol
<b>Other</b>		
Comment Block	Enter user comments.	
Counter	<p>True when the count reaches a user-selected number. COUNT_UP increments the count when a true is received. COUNT_DOWN decrements the count when a true is received. RESET resets the count to zero when a true is received. OUTPUT is true when the count reaches the trigger count. The trigger count is set by the user and is found in <i>Settings Explorer, BESTlogicPlus Programmable Logic, Logic Counters</i>.</p>	<p><b>Counter (1)</b>  <b>Counter 1</b>  <b>Trigger Count = 1</b></p> 

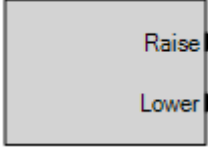
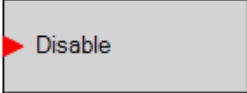

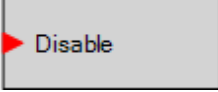
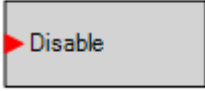
Elements

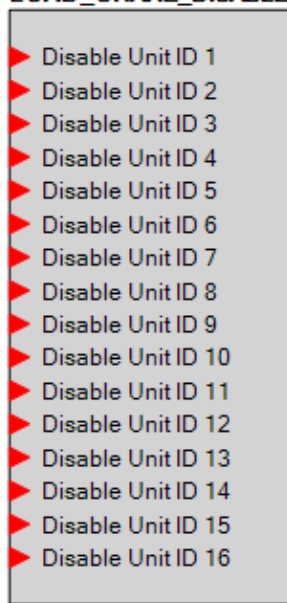
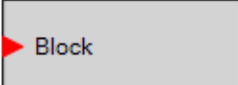
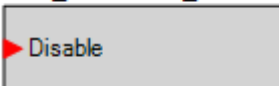
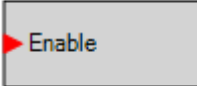
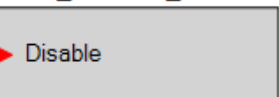
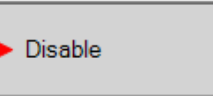
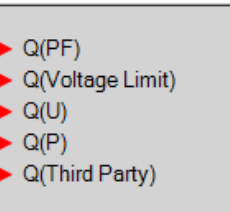
Table 13 lists the names and descriptions of the elements in the *Elements* group.

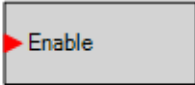


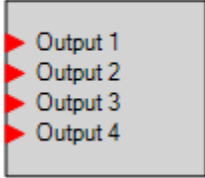

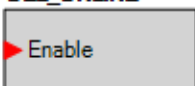
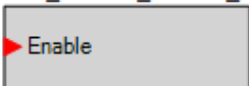
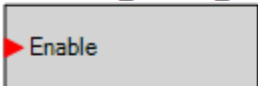
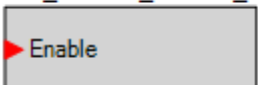
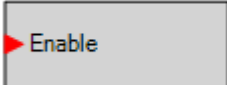

**Table 13. Elements Group, Names and Descriptions**


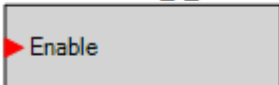
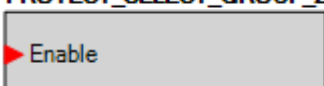
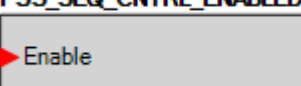
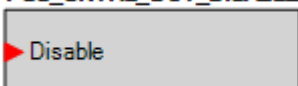
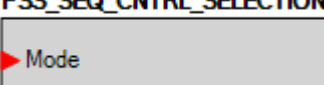
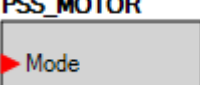
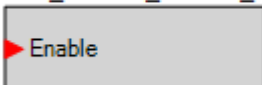
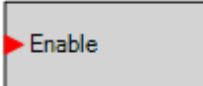

Name	Description	Symbol
27	When true, this element blocks, or disables, the 27 undervoltage protection function.	<p><b>27</b></p> 
ACTIVE POWER LEVEL SELECT	<p>This element allows selection of the active power level. When an input is true, the corresponding active power level is selected. When no inputs are true, the active power level is 0.0. When multiple inputs are true, the active power level is selected in the following priority order: 4 &gt; 3 &gt; 2 &gt; 1. For example, if inputs 2 and 3 are true, active power level 3 is selected.</p>	<p><b>ACTIVE_POWER_LEVEL_SELECT</b></p> 
APC BRIDGE DISABLE	When true, this element disables APC Bridge mode.	<p><b>APC_BRIDGE_DISABLE</b></p> 
APC DISABLE	When true, this element disables Grid Code APC mode.	<p><b>APC_DISABLE</b></p> 
ALARM RESET	When true, this element resets all active alarms.	<p><b>ALARM_RESET</b></p> 
AUTO ENABLE	When true, this element sets the unit in Auto mode (AVR).	<p><b>AUTO_ENABLE</b></p> 



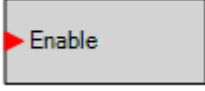
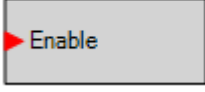
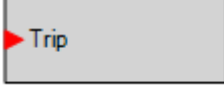

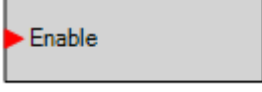

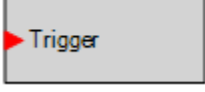

Name	Description	Symbol
AUTO TRANSFER ENABLE	When true, this element sets the unit as secondary. When false, the unit is primary.	<b>AUTOTRANSFER_ENABLE</b> 
CROSS CURRENT COMPENSATION DISABLE	When true, this element disables cross current compensation.	<b>CC_DISABLE</b> 
DATALOG LOGIC STATUS	When true, Logic Status x can be selected and displayed in the data log and the real-time monitor.	<b>DATALOG_LOGIC_STATUS</b> 
DATALOG TRIGGER	When true, this element triggers the datalog to begin recording data.	<b>DATALOGTRIGGER</b> 
DROOP DISABLE	When true, this element disables droop when the unit is operating in AVR mode.	<b>DROOP_DISABLE</b> 
EXTERNAL TRACKING DISABLE	When true, this element disables external tracking.	<b>EXT_TRACKING_DISABLE</b> 
FREEZE APC OUTPUT	When true, the output of the APC PI controller is frozen. This can be used with the APC REMOTE COMM FAIL status input to freeze APC output when remote communication fails.	<b>FREEZE_APC_OUTPUT</b> 
FREEZE LVRT OUTPUT	When true, the output of the LVRT controller is frozen. This can be used with the LVRT REMOTE COMM FAIL status input to freeze LVRT output when remote communication fails.	<b>FREEZE_LVRT_OUTPUT</b> 
GENERATOR BREAKER	This element is used to connect the breaker open and close output signals from the DECS-250 to physical output contacts to open and close the generator breaker, and map breaker status feedback to a contact input. In addition, contact inputs can be mapped to allow switches to be implemented to manually initiate breaker open and close requests. (Available when the controller is	<b>GENBRK</b> 

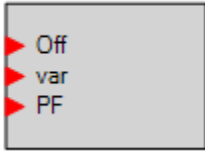

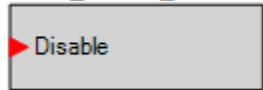
Name	Description	Symbol
	equipped with the optional Auto synchronizer, style number xxxxAxx)	
<p><b>GENERATOR BREAKER Inputs</b></p> <p><i>Status:</i> This input allows a contact input to be mapped that will provide breaker status feedback to the DECS-250. When the contact input is closed, the breaker is indicated to be closed. When the contact input is open, the breaker is indicated to be open.</p> <p><i>Open:</i> This input allows a contact input to be mapped that can be used to initiate a manual breaker open request. When this input is pulsed closed, the breaker opens.</p> <p><i>Close:</i> This input allows a contact input to be mapped that can be used to initiate a manual breaker close request. When this input is pulsed and the generator is stable, a close request is initiated. If the Dead Bus Close Enable parameter is TRUE, and the bus is dead, the breaker will close. If the bus is stable, the DECS-250 will synchronize the generator to the bus, and then close the breaker.</p>	<p><b>GENERATOR BREAKER Outputs</b></p> <p>The outputs must be mapped to the contact outputs of the DECS-250 that will be used to drive the breaker.</p> <p><i>Open:</i> This output is pulsed TRUE (closes the output contact it is mapped to) when the DECS-250 is providing a signal to the breaker to open. It will be a pulse if the Breaker Output Contact Type is set to Pulse on the Breaker Hardware screen under Synchronizer/Voltage Matching in the Settings Explorer, and the length is determined by the Open Pulse Time. It will be a constant output if the Generator Breaker Hardware Contact Type is set to continuous. Note the pulse time must be set long enough for the breaker to actually open before the pulse is removed.</p> <p><i>Close:</i> This output is pulsed TRUE (closes the output contact it is mapped to) when the DECS-250 is providing a signal to the breaker to close. It will be a pulse if the Breaker Output Contact Type is set to Pulse on the Breaker Hardware screen under Synchronizer/Voltage Matching in the Settings Explorer, and the length is determined by the Open Pulse Time. It will be a constant output if the Generator Breaker Hardware Contact Type is set to continuous. Note the pulse time must be set long enough for the breaker to actually open before the pulse is removed.</p>	
GOVERNOR	Can be connected to inputs of other logic blocks. When the Governor is being raised, the Raise output is true. When being lowered, the Lower output is true. (Available when the controller is equipped with the optional Auto synchronizer, style number xxxxAxx)	<p><b>GOVR</b></p> 
GRID CODE DISABLE	When true, overall Grid Code functionality is disabled.	<p><b>GRIDCODE_DISABLE</b></p> 
INTERNAL TRACKING DISABLE	When true, this element disables internal tracking.	<p><b>INT_TRACKING_DISABLE</b></p> 
LFSM DISABLE	When true, Grid Code LFSM is disabled.	<p><b>LFSM_DISABLE</b></p> 
LINE DROP DISABLE	When true, this element disables line drop when the unit is operating in AVR mode.	<p><b>LDROP_DISABLE</b></p> 

Name	Description	Symbol
LOAD SHARE DISABLE	<p>This element allows load sharing with specific units on the network to be disabled.</p> <p>When an input to this block is true, load share data received from that unit is ignored by the DECS-250.</p>	<p><b>LOAD_SHARE_DISABLE</b></p> 
LOSS OF SENSING DISABLE	<p>When true, this element disables the Loss of Sensing function.</p>	<p><b>LOSS_OF_SENSING</b></p> 
LOSS OF SENSING TRANSFER DISABLE	<p>When true, this element disables the transfer to Manual mode during a Loss of Sensing condition.</p>	<p><b>LOS_TRANSFER_DISABLE</b></p> 
LOWER ENABLE	<p>When true, this element lowers the active setpoint.</p>	<p><b>LOWER_ENABLE</b></p> 
LVRT BRIDGE DISABLE	<p>When true, LVRT Bridge mode is disabled.</p>	<p><b>LVRT_BRIDGE_DISABLE</b></p> 
LVRT DISABLE	<p>When true, LVRT mode is disabled.</p>	<p><b>LVRT_DISABLE</b></p> 
LVRT MODE SELECT	<p>When an input is true, the corresponding LVRT control mode is active.</p> <p>When no inputs are true, the default operating mode is Power Factor.</p> <p>When multiple inputs are true, the active control mode is selected in the following priority order: Q(PF) &gt; Q(Voltage Limit) &gt; Q(U) &gt; Q(P) &gt; Q(Third Party). For example, if inputs Q(Voltage Limit) and Q(P) are true, Q(Voltage Limit) becomes the active control mode. See the <i>Grid Code</i> chapter for details.</p>	<p><b>LVRT_MODE_SELECT</b></p> 

Name	Description	Symbol
MANUAL ENABLE	When true, this element switches the unit to Manual mode.	<b>MANUAL_ENABLE</b> 
MANUAL MODE FCR ONLY	When true, this element switches the Manual mode to FCR.	<b>MANUAL_MODE_FCR_ONLY</b> 
NETWORK LOAD SHARE DISABLE	When true, this element disables network load sharing.	<b>NETWORK_LOAD_SHARE_DISABLE</b> 
NLS BROADCAST	This element functions in conjunction with the Network Load Share Status inputs on all units on the network. When an input is true, the corresponding Network Load Share Status input on all units on the network is true.	<b>NLS_BROADCAST</b> 
OEL DISABLED IN MANUAL MODE	When true, this element disables OEL when the unit is operating in Manual mode.	<b>OEL_DISABLED_IN_MAN_MODE</b> 
OEL ONLINE	When true, this element enables the use of OEL when the unit is considered online.	<b>OEL_ONLINE</b> 
OEL SELECT SECONDARY SETTINGS	When true, this element selects the secondary settings for OEL.	<b>OEL_SELECT_GROUP_2</b> 
PARALLEL ENABLE LM	When true, this element informs the unit that it is online. The element should be enabled when the 52LM is closed. This element also allows UEL and droop compensation to operate when true.	<b>PARALLEL_ENABLE_LM</b> 
PID SELECT SECONDARY SETTINGS	When true, this element selects secondary settings on the PID.	<b>PID_SELECT_GROUP_2</b> 
PF/VAR ENABLE	When true, this element enables the PF and Var controller, and informs the unit that it is online. The Var/PF Selection element must be set to true to use var or PF mode. This element should be enabled when the 52JK is closed.	<b>PF_VAR_ENABLE_JK</b> 
PREPOSITION 1 ENABLE	When true, this element informs the unit to use setpoints for Preposition 1.	<b>PREPOSITION_1_ENABLE</b> 

Name	Description	Symbol
PREPOSITION 2 ENABLE	When true, this element informs the unit to use setpoints for Preposition 2.	<b>PREPOSITION_2_ENABLE</b> 
PREPOSITION 3 ENABLE	When true, this element informs the unit to use setpoints for Preposition 3.	<b>PREPOSITION_3_ENABLE</b> 
PROTECTION SELECT SECONDARY SETTINGS	When true, this element informs the unit to use secondary values for protection.	<b>PROTECT_SELECT_GROUP_2</b> 
PSS SEQ CNTRL ENABLED	When true, PSS sequence (phase rotation) control is enabled. (Available when the controller is equipped with the optional Power System Stabilizer, style number xPxxxxx)	<b>PSS_SEQ_CNTRL_ENABLED</b> 
PSS OUTPUT DISABLE	When true, this element disables the output of the PSS. The PSS continues to run, but the output is not used. (Available when the controller is equipped with the optional Power System Stabilizer, style number xPxxxxx)	<b>PSS_CNTRL_OUT_DISABLE</b> 
PSS SEQ CNTRL SELECTION	When true, phase rotation is selected to be ACB. False when phase rotation is selected to be ABC. (Available when the controller is equipped with the optional Power System Stabilizer, style number xPxxxxx)	<b>PSS_SEQ_CNTRL_SELECTION</b> 
PSS MOTOR	When true, the PSS is in motor mode. False when in generator mode. (Available when the controller is equipped with the optional Power System Stabilizer, style number xPxxxxx)	<b>PSS_MOTOR</b> 
PSS SELECT SECONDARY SETTINGS	When true, this element selects secondary settings for the PSS. (Available when the controller is equipped with the optional Power System Stabilizer, style number xPxxxxx)	<b>PSS_SELECT_GROUP_2</b> 
RAISE ENABLE	When true, this element raises the active setpoint.	<b>RAISE_ENABLE</b> 
REMOTE LVRT FAIL MODE	This element can be used to toggle the operating mode (Q(PF) or Hold Value) when an LVRT Remote Communications Failure has occurred. When an LVRT Remote Communications Failure has been detected, the LVRT Mode during the failure will be controlled by the Fail Mode Setting and this logic element. When the LVRT Remote Control Fail Mode is set to Q(PF), the operating mode will be Q(PF) and this logic element has no effect. When the LVRT Remote Control Fail Mode is set to Hold Value, this logic element can be used to set the operating mode during an LVRT Remote Communications Failure as indicated below:	<b>REMOTE_LVRT_FAILMODE</b> 

Name	Description	Symbol
	<ul style="list-style-type: none"> <li>When true, the LVRT Remote Control Failure Mode is set to Hold Output.</li> <li>When false, the LVRT Remote Control Failure Mode is set to Q(PF).</li> </ul>	
SCL SELECT SECONDARY SETTINGS	When true, this element selects the secondary settings for SCL.	<b>SCL_SELECT_GROUP_2</b> 
SOFT START SELECT SECONDARY SETTINGS	When true, this element selects the secondary settings for softstart.	<b>SOFT_START_SELECT_GROUP_2</b> 
START ENABLE	When true, this element starts the unit.	<b>START_ENABLE</b> 
STOP ENABLE	When true, this element stops the unit.	<b>STOP_ENABLE</b> 
Transfer Watchdog Trip	When true, this element opens the transfer watchdog output.	<b>TransferWatchdogTrip</b> 
UEL DISABLED IN MANUAL MODE	When true, this element disables UEL when the unit is operating in Manual mode.	<b>UEL_DISABLED_IN_MAN_MODE</b> 
UEL SELECT SECONDARY SETTINGS	When true, this element selects secondary settings for UEL.	<b>UEL_SELECT_GROUP_2</b> 
UNDERFREQUENCY V/Hz DISABLE	When true, this element disables the V/Hz Underfrequency limiter.	<b>UNDERFREQUENCYVHZ_DISABLE</b> 
USER PROGRAMMABLE ALARM 1 - 16	When true, this element triggers a programmable alarm.	<b>USERALM1</b> <b>Programmable Alarm 1 Name</b> 
VAR LIMITER SELECT SECONDARY SETTINGS	When true, this element selects the secondary settings on the Var limiter.	<b>VAR_LIM_SELECT_GROUP_2</b> 

Name	Description	Symbol
VAR/PF MODE	The var input selects var control and the PF input selects power factor control.	<b>VAR_PF_MODE</b> 
VAR/PF SELECT ENABLE	When true, this element allows the selection of Var and PF.	<b>VAR_PF_SELECT_ENABLE</b> 
VOLTAGE MATCHING DISABLE	When true, this element disables voltage matching when the unit is operating in AVR mode.	<b>VOLT_MATCH_DISABLE</b> 

## Logic Schemes

A logic scheme is a group of logic variables written in equation form that defines the operation of a DECS-250 Digital Excitation System. Each logic scheme is given a unique name. This gives you the ability to select a specific scheme and be confident that the selected scheme is in operation. One logic scheme is configured for a typical protection and control application of a synchronous generator and is the default active logic scheme. Only one logic scheme can be active at a given time. In most applications, preprogrammed logic schemes eliminate the need for custom programming. Preprogrammed logic schemes may provide more inputs, outputs, or features than are needed for a particular application. This is because a preprogrammed scheme is designed for a large number of applications with no special programming required. Unneeded logic block outputs may be left open to disable a function or a function block can be disabled through operating settings.

When a custom logic scheme is required, programming time is reduced by modifying the default logic scheme.

### The Active Logic Scheme

The DECS-250 must have an active logic scheme in order to function. All DECS-250 controllers are delivered with a default, active logic scheme preloaded in memory. The functionality of this logic scheme is similar to the scheme provided with the DECS-200. If the function block configuration and output logic of the default logic scheme meet the requirements of your application, then only the operating settings (system parameters and threshold settings) need to be adjusted before placing the DECS-250 in service.

### Sending and Retrieving Logic Schemes

#### Retrieving a Logic Scheme from the DECS-250

To retrieve settings from the DECS-250, the DECS-250 must be connected to a computer through a communications port. Once the necessary connections are made, settings can be downloaded from the DECS-250 by selecting *Download Settings and Logic* on the Communication pull-down menu.

#### Sending a Logic Scheme to the DECS-250

To send settings to the DECS-250, the DECS-250 must be connected to a computer through a communications port. Once the necessary connections are made, settings can be uploaded to the DECS-250 by selecting *Upload Settings and Logic* on the Communication pull-down menu.

**Caution**

Always remove the DECS-250 from service prior to changing or modifying the active logic scheme. Attempting to modify a logic scheme while the DECS-250 is in service could generate unexpected or unwanted outputs.

Modifying a logic scheme in BESTCOMSPi<sup>us</sup>® does not automatically make that scheme active in the DECS-250. The modified scheme must be uploaded into the DECS-250. See the paragraphs on *Sending and Retrieving Logic Schemes* above.

**Default Logic Schemes**

The default logic scheme for PSS-disabled systems is shown in Figure 146 through Figure 148 and the default logic scheme for PSS-enabled systems is shown in Figure 149 through Figure 152.

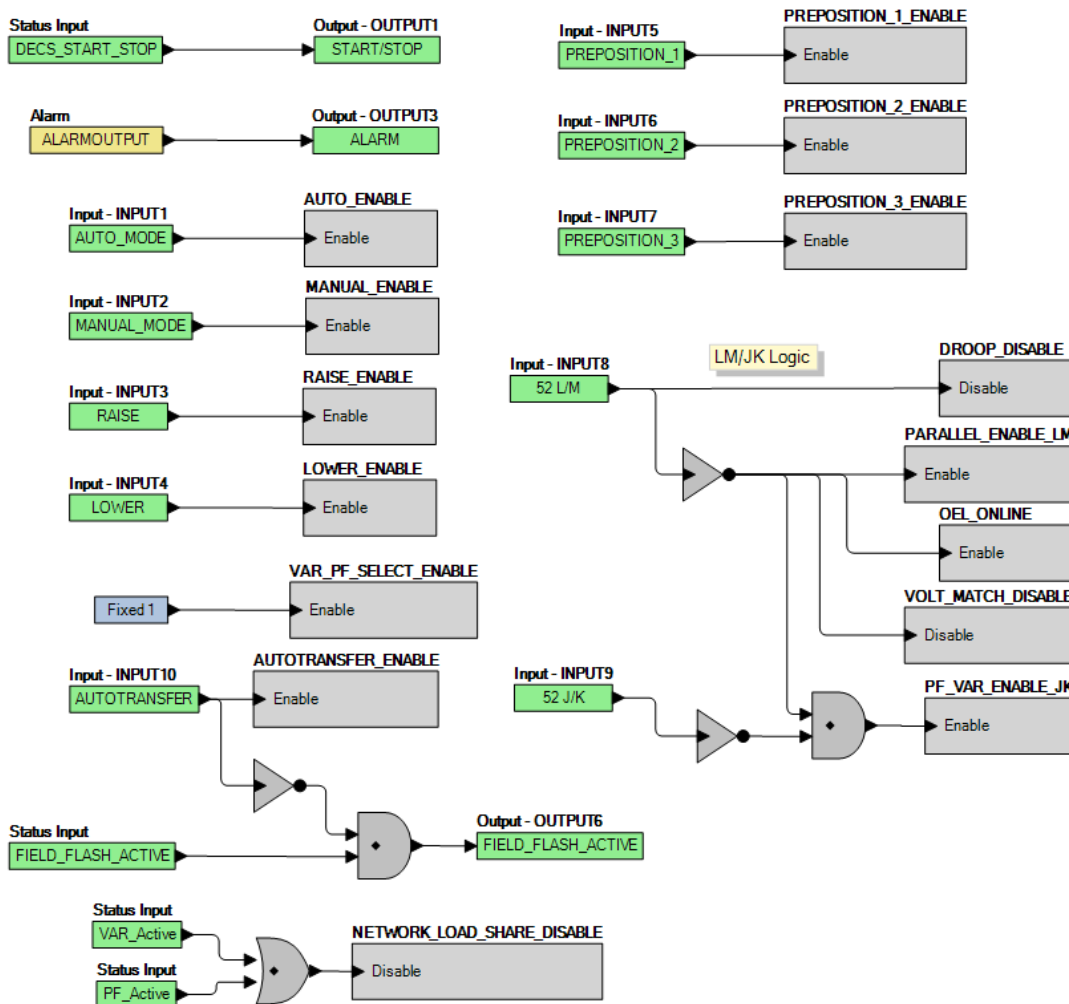


Figure 146. PSS-Disabled Default Logic – Logic Page 1 Tab

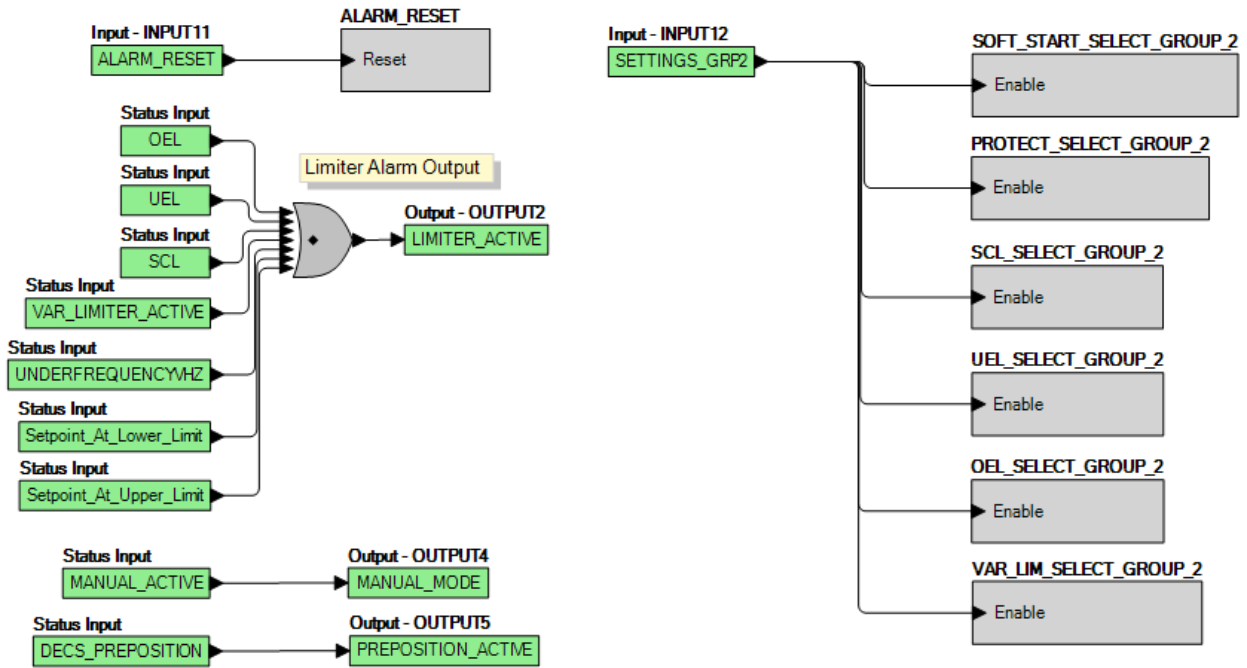


Figure 147. PSS-Disabled Default Logic - Logic Page 2 Tab

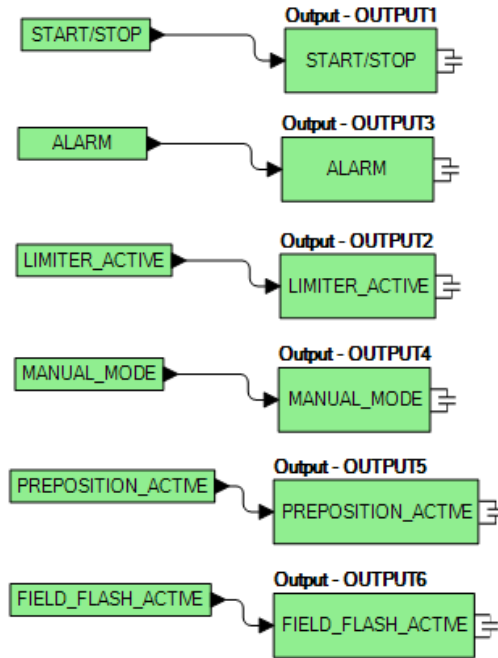


Figure 148. PSS-Disabled Default Logic - Physical Outputs Tab

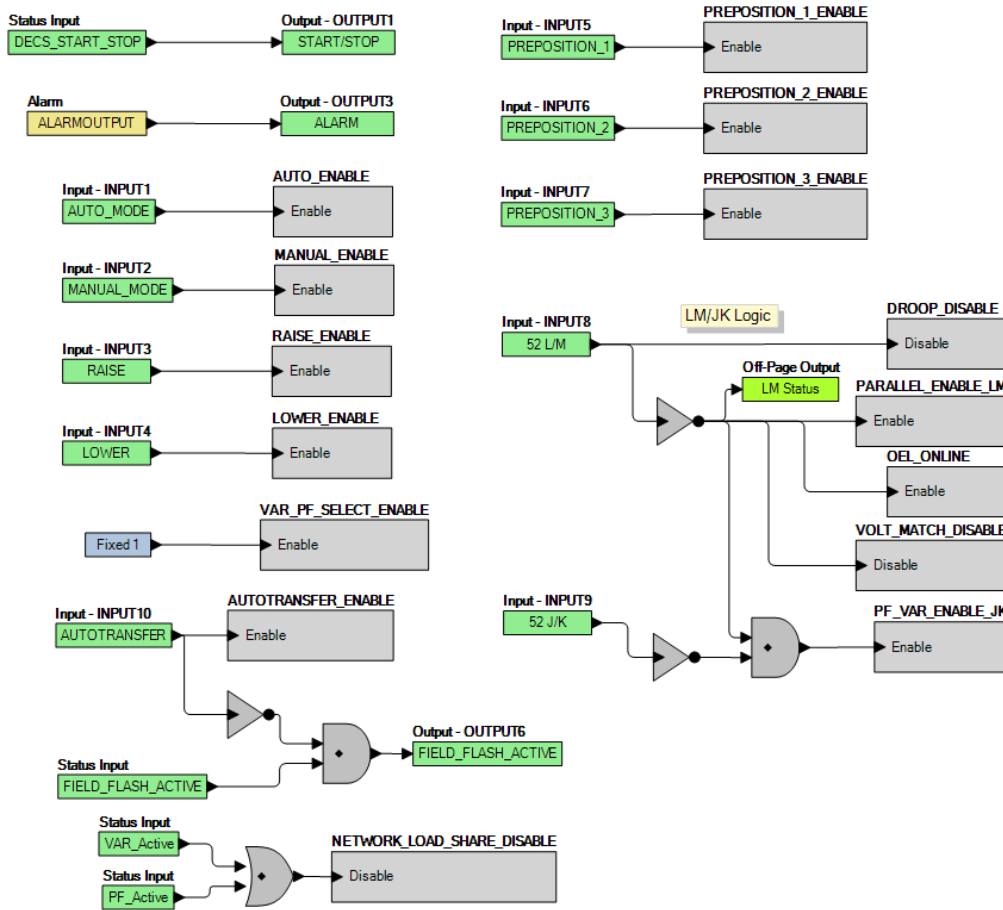


Figure 149. PSS-Enabled Default Logic - Logic Page 1 Tab

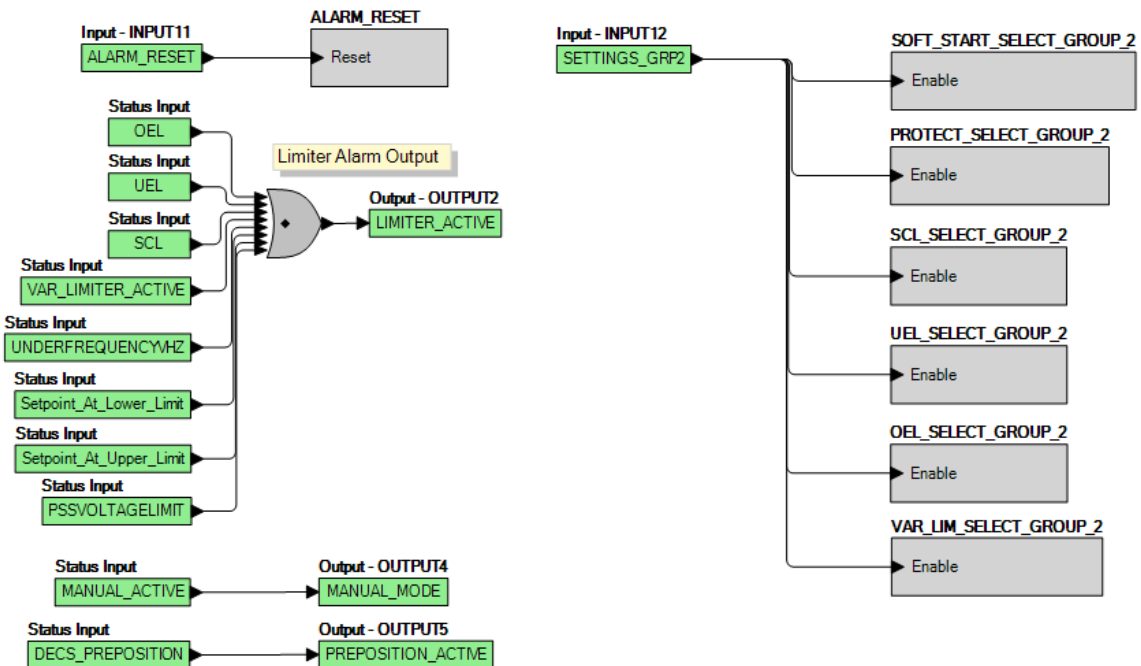


Figure 150. PSS-Enabled Default Logic - Logic Page 2 Tab

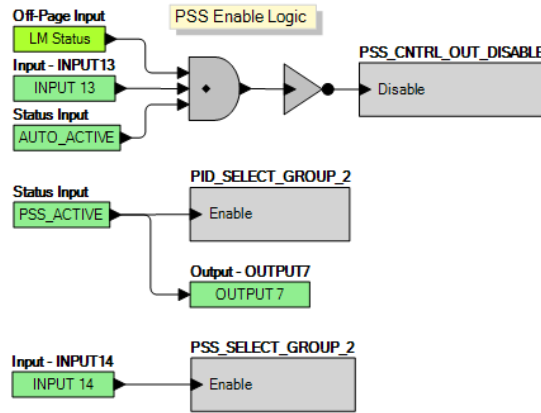


Figure 151. PSS-Enabled Default Logic – Logic Page 3 Tab

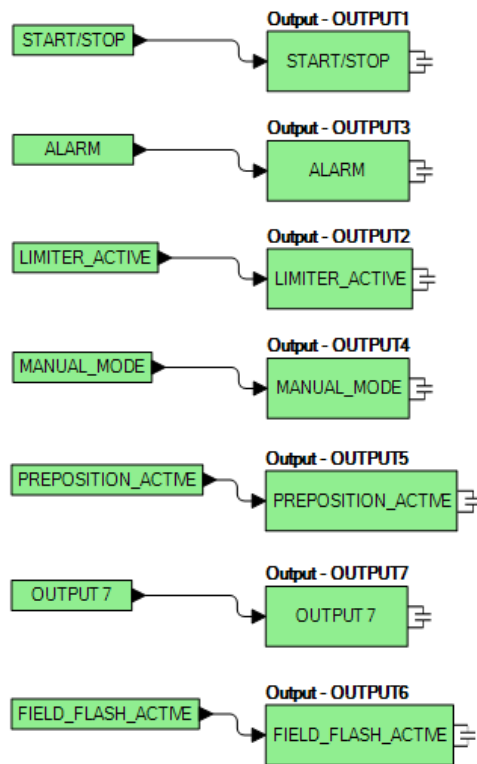


Figure 152. PSS-Enabled Default Logic - Physical Outputs Tab

## Programming BESTlogic™ Plus

Use BESTCOMSPlus® to program BESTlogicPlus. Using BESTlogicPlus is analogous to physically attaching wire between discrete DECS-250 terminals. To program BESTlogicPlus, use the Settings Explorer within BESTCOMSPlus to open the *BESTlogicPlus Programmable Logic* tree branch as shown in Figure 145.

The drag and drop method is used to connect a variable or series of variables to the logic inputs, outputs, components, and elements. To draw a wire/link from port to port (triangles), click the left mouse button on a port, pull the wire onto another port, and release the left mouse button. A red port indicates that a connection to the port is required or missing. A black port indicates that a connection to the port is not required. Drawing wires/links from input to input or output to output is not allowed. Only one wire/link can be connected to any one output. If the proximity of the endpoint of the wire/link is not exact, it may attach to an unintended port.

If an object or element is disabled, it will have a yellow X on it. To enable the element, navigate to the settings page for that element. A red X indicates that an object or element is not available per the style number of the DECS-250.

The view of the Main Logic and Physical Outputs can be automatically arranged by clicking the right mouse button on the window and selecting *Auto-Layout*.

The following must be met before BESTCOMSP*Plus* will allow logic to be uploaded to the DECS-250:

- A minimum of two inputs and a maximum of 32 inputs on any multi-port (AND, OR, NAND, NOR, XOR, and XNOR) gate.
- A maximum of 32 logic levels for any particular path. A path being an input block or an output side of an element block through gates to an output block or an input side of an element block. This is to include any OR gates on the Physical Outputs page, but not the matched pairs of Physical Outputs blocks.
- A maximum of 256 gates per logic level with a maximum of 256 gates allowed per diagram. All output blocks and input sides of element blocks are at the maximum logic level of the diagram. All gates are pushed forward/upwards in logic levels and buffered to reach the final output block or element block if needed.

Three status LEDs are located in the lower right corner of the BESTlogic*Plus* window. These LEDs show the *Logic Save Status*, *Logic Diagram Status*, and *Logic Layer Status*. Table 14 defines the colors for each LED.

**Table 14. Status LEDs**

LED	Color	Definition
Logic Save Status (Left LED)	● Orange	Logic has changed since last save.
	● Green	Logic has NOT changed since last save.
Logic Diagram Status (Center LED)	● Red	Requirements NOT met as listed above.
	● Green	Requirements met as listed above.
Logic Layer Status (Right LED)	● Red	Requirements NOT met as listed above.
	● Green	Requirements met as listed above.

### Pickup and Dropout Timers

A pickup timer produces a TRUE output when the elapsed time is greater than or equal to the Pickup Time setting after a FALSE to TRUE transition occurs on the Initiate input from the connected logic. Whenever the Initiate input status transitions to FALSE, the output transitions to FALSE immediately.

A drop out timer produces a TRUE output when the elapsed time is greater than or equal to the Dropout Time setting after a TRUE to FALSE transition occurs on the Initiate input from the connected logic. Whenever the Initiate input transitions to TRUE, the output transitions to FALSE immediately.

Refer to Figure 153, *Pickup and Dropout Logic Timer Blocks*.

To program logic timer settings, use the Settings Explorer within BESTCOMSP*Plus* to open the *BESTlogicPlus Programmable Logic/Logic Timers* tree branch. Enter a *Name* label that you want to appear on the timer logic block. The *Time Delay* value range is 0 to 250 hours in 1 hour increments, 0 to 250 minutes in 1 minute increments, or 0 to 1,800 seconds in 0.1 second increments.

Next, open the *Components* tab inside the BESTlogic*Plus* window and drag a timer onto the program grid. Right click on the timer to select the timer you want to use that was previously set on the *Logic Timers* tree branch. The *Logic Timer Properties Dialog Box* will appear. Select the timer you want to use.

Timing accuracy is  $\pm 15$  milliseconds.

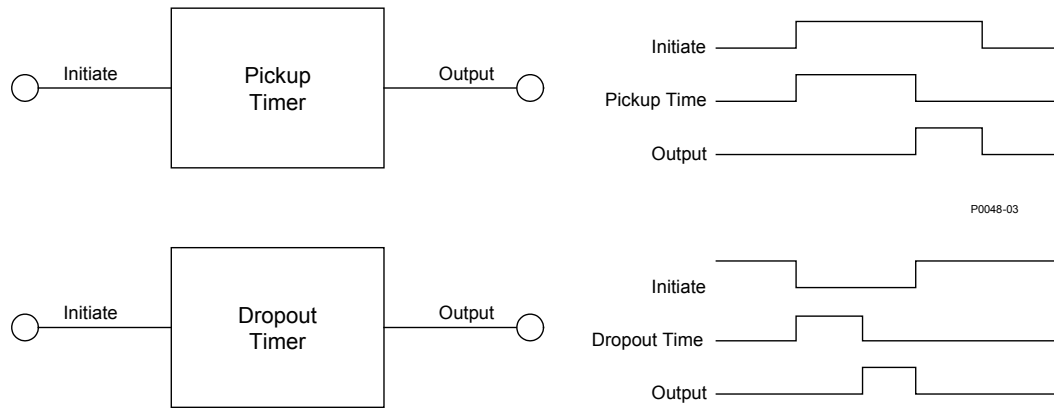


Figure 153. Pickup and Dropout Timer Logic Blocks

## Offline Logic Simulator

You can use the offline logic simulator to test your custom logic before placing it in operation. The state of various logic elements can be toggled to verify that the logic states travel through the system as expected.

The offline logic simulator allows you to change the state of various logic elements to illustrate how that state travels through the system. Before running the logic simulator, you must click the Save button on the BESTlogicPlus toolbar to save the logic to memory. Changes to the logic (other than changing the state) are disabled when the simulator is enabled. Colors are selected by clicking the Options button on the BESTlogicPlus toolbar. By default, Logic 0 is red and Logic 1 is green. Using your mouse, double-click on a logic element to change its state.

An example of the offline logic simulator is shown in Figure 154. STOP\_ENABLE is Logic 0 (red) when Input 1 is Logic 1 (green), Input 2 is Logic 0 (red), and the inverter is Logic 1 (green).

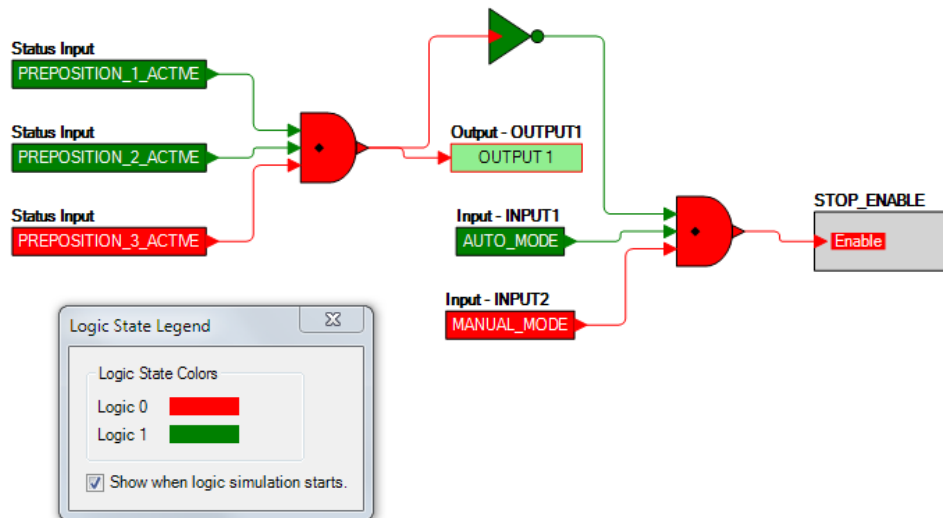


Figure 154. Offline Logic Simulator Example

## BESTlogic™ Plus File Management

To manage BESTlogicPlus files, use the Settings Explorer to open the *BESTlogicPlus Programmable Logic* tree branch. Use the BESTlogicPlus Programmable Logic toolbar to manage BESTlogicPlus files. Refer to Figure 155. For information on Settings Files management, refer to the *BESTCOMSPPlus Software* chapter.



Figure 155. BESTlogicPlus Programmable Logic Toolbar

### Saving a BESTlogicPlus File

After programming BESTlogicPlus settings, click on the *Save* button to save the settings to memory.

Before the new BESTlogicPlus settings can be uploaded to the DECS-250, you must select *Save* from the *File* pull-down menu located at the top of the BESTCOMSPlus main shell. This step will save both the BESTlogicPlus settings and the operating settings to a file.

The user also has the option to save the BESTlogicPlus settings to a unique file that contains only BESTlogicPlus settings. Click on the *Logic Library* drop-down button and select *Save Logic Library File*. Use normal Windows® techniques to browse to the folder where you want to save the file and enter a filename to save as.

### Opening a BESTlogicPlus File

To open a saved BESTlogicPlus file, click on the *Logic Library* drop-down button on the BESTlogicPlus Programmable Logic toolbar and select *Open Logic Library File*. Use normal Windows techniques to browse to the folder where the file is located.

### Protecting a BESTlogicPlus File

Objects in a logic diagram can be locked so that when the logic document is protected these objects cannot be changed. Locking and protecting is useful when sending logic files to other personnel to be modified. The locked object(s) cannot be changed. To view the lock status of the object(s), select *Show Lock Status* from the *Protection* drop-down menu. To lock object(s), use the mouse to select object(s) to be locked. Right click on the selected object(s) and select *Lock Object(s)*. The gold colored padlock next to the object(s) will change from an open to a locked state. To protect a logic document, select *Protect Logic Document* from the *Protection* drop-down button. Establishing a password is optional.

### Uploading a BESTlogicPlus File

To upload a BESTlogicPlus file to the DECS-250, you must first open the file through BESTCOMSPlus or create the file using BESTCOMSPlus. Then pull down the *Communication* menu and select *Upload Logic*.

### Downloading a BESTlogicPlus File

To download a BESTlogicPlus file from the DECS-250, you must pull down the *Communication* menu and select *Download Settings and Logic from Device*. If the logic in your BESTCOMSPlus has changed, a dialog box will open asking you if want to save the current logic changes. You may choose *Yes* or *No*. After you have taken the required action to save or not save the current logic, the downloading is executed.

### Copying and Renaming Preprogrammed Logic Schemes

Copying a saved logic scheme and assigning a unique name is accomplished by first loading the saved logic scheme into BESTCOMSPlus. Click on the *Logic Library* drop-down button and select *Save Logic Library File*. Use normal Windows® techniques to browse to the folder where you want to save the new file and enter a filename to save as. Changes are not activated until the new settings have been saved and uploaded to the device.

### Printing a BESTlogicPlus File

To view a preview of the printout, click on the *Print Preview* icon located on the BESTlogicPlus Programmable Logic toolbar. If you wish to print to a printer, select the printer icon in the upper left corner of the *Print Preview* screen.

You may skip the print preview and go directly to print by clicking on the *Printer* icon on the BESTlogicPlus Programmable Logic toolbar. A dialog box, *Select Views to Print* opens allowing you to

check which views you would like to print. Next, the *Print* dialog box opens with the typical Windows choice to setup the properties of printer. Execute this command, as necessary, and then select *Print*.

A *Page Setup* icon is also provided on the BESTlogicPlus Programmable Logic toolbar allowing you to select *Paper Size*, *Paper Source*, *Orientation*, and *Margins*.

### Clearing the On-Screen Logic Diagram

Click on the *Clear* button to clear the on-screen logic diagram and start over.

## BESTlogic™ Plus Examples

### Example 1 - GOVR Logic Block Connections

Figure 156 illustrates the GOVR logic block and two output logic blocks. Output 6 is active while the governor is being raised and Output 9 is active while the governor is being lowered.

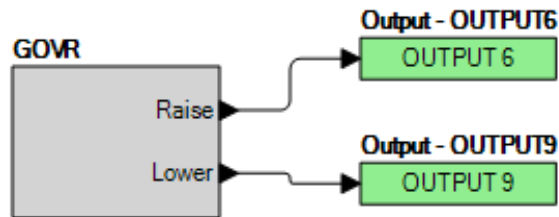


Figure 156. Example 1 - GOVR Logic Block Connections

### Example 2 - AND Gate Connections

Figure 157 illustrates a typical AND gate connection. In this example, Output 11 will become active when the bus and the generator are dead.

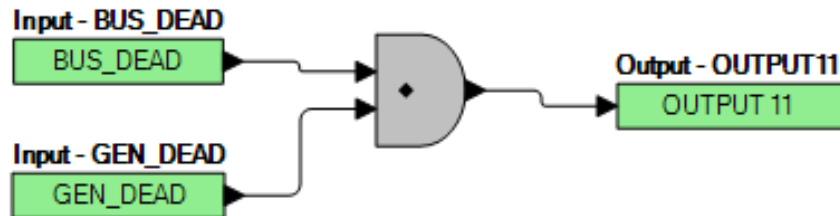


Figure 157. Example 2 - AND Gate Connections

# Communication

## Local Communication

A type B, USB port connects the DECS-250 with a PC operating BESTCOMSPPlus® for local, short-term communication. This mode of communication is useful for settings configuration and system commissioning. The USB port is located on the front panel and illustrated in the *Controls and Indicators* chapter of this manual. A USB device driver for the DECS-250 is automatically installed on your PC during the installation of BESTCOMSPPlus. Information about establishing communication between BESTCOMSPPlus and the DECS-250 is provided in the *BESTCOMSPPlus Software* chapter of this manual.

### Caution

This product contains one or more *nonvolatile memory* devices. Nonvolatile memory is used to store information (such as settings) that needs to be preserved when the product is power-cycled or otherwise restarted. Established nonvolatile memory technologies have a physical limit on the number of times they can be erased and written. In this product, the limit is 100,000 erase/write cycles. During product application, consideration should be given to communications, logic, and other factors that may cause frequent/repeated writes of settings or other information that is retained by the product. Applications that result in such frequent/repeated writes may reduce the useable product life and result in loss of information and/or product inoperability.

## Communication with a Second DECS

**BESTCOMSPPlus Navigation Path:** Settings Explorer, Communications, RS232 Setup

**HMI Navigation Path:** Settings, Communications, RS232 Setup.

Communication with a second DECS enables regulation setpoint tracking to occur in a dual, or redundant, DECS application. External setpoint tracking is possible between a DECS-250 and second DECS-250 or a DECS-250 and DECS-200.

All DECS controllers mentioned here use a female DB-9 (RS-232) connector for communication with a second DECS. On the DECS-250, this connector is located on the right side panel and is illustrated in the *Terminals and Connectors* chapter of this manual. A five-foot (1.5 meter) cable, part number 9310300032, is available for interconnecting two DECS controllers.

RS-232 port communication settings are illustrated in Figure 158 and consist of the baud rate<sup>A</sup>, number of bits per character<sup>B</sup>, parity<sup>C</sup>, and the number of stop bits<sup>D</sup>. When connecting the DECS-250 to a DECS-200, you must ensure that the communication settings of the DECS-200 match those of the DECS-250.

The screenshot shows a dialog box titled "RS232 Setup" with a sub-section "Communication Settings". It contains four dropdown menus, each with a corresponding letter in a box to its right:

- Baud Rate:** 19200 Baud (A)
- Bits Per Char:** 8 bits/character (B)
- Parity:** No Parity (C)
- Stop Bits:** 1 stop bit (D)

Figure 158. RS232 Setup

- <sup>A</sup> *Baud Rate*: Select 4800, 9600, 19200, 38400, 57600, or 115200.  
<sup>B</sup> *Bits Per Char*: Select 7 or 8 bits/character.  
<sup>C</sup> *Parity*: Select Even, Odd, or No parity.  
<sup>D</sup> *Stop Bits*: Select 1 or 2 stop bits.

## Modbus<sup>®</sup> Communication

**BESTCOMSPlus Navigation Path:** Settings Explorer, Communications, Modbus Setup

**HMI Navigation Path:** Not available through HMI.

DECS-250 systems support the RS-485 mode and Modbus TCP (Ethernet) mode at the same time. DECS-250 Modbus communication registers are listed and defined in the *Modbus Communication* chapter of this manual.

Modbus settings for RS-485 and Ethernet are illustrated in Figure 159 and consist of RS-485 Unit ID<sup>A</sup>, RS-485 Response Delay<sup>B</sup>, and Ethernet Unit ID<sup>C</sup>.

Figure 159. Modbus Setup

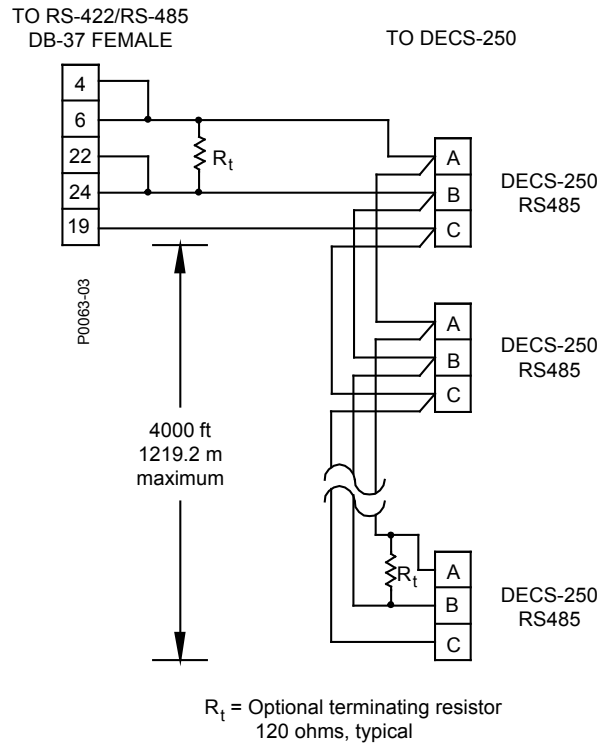
- <sup>A</sup> *RS-485 Unit ID*: Adjustable from 1 to 247 in increments of 1.  
<sup>B</sup> *RS-485 Response Delay*: Adjustable from 10 to 10,000 milliseconds in 10 millisecond increments.  
<sup>C</sup> *Ethernet Unit ID*: Adjustable from 1 to 247 in increments of 1.

### RS-485 Port

**BESTCOMSPlus Navigation Path:** Settings Explorer, Communications, RS-485 Setup

**HMI Navigation Path:** Settings, Communications, RS-485 Setup

An RS-485 port uses the Modbus RTU (remote terminal unit) protocol for polled communication with other networked devices or remote annunciation and control with an IDP-801 Interactive Display Panel. RS-485 port terminals are located on the left side panel and are identified as RS-485 A, B, and C. Terminal A serves as the send/receive A terminal, terminal B serves as the send/receive B terminal, and terminal C serves as the signal ground terminal. Figure 160 illustrates typical RS-485 connections for multiple DECS-250 controllers communicating over a Modbus network.



**Figure 160. Typical RS-485 Connections**

RS-485 port communication settings are illustrated in Figure 161 and consist of the baud rate<sup>A</sup>, number of bits per character<sup>B</sup>, parity<sup>C</sup>, and the number of stop bits<sup>D</sup>.

**RS485 Setup**

**Communication Settings**

Baud Rate: 19200 Baud A

Bits Per Char: 8 bits/character B

Parity: No Parity C

Stop Bits: 1 stop bit D

**Figure 161. RS-485 Port Communication Settings**

<sup>A</sup> **Baud Rate:** Select 1200, 2400, 4800, 9600, 19200, 38400, 57600, or 115200.

<sup>B</sup> **Bits Per Char:** Select 7 or 8 bits/character.

<sup>C</sup> **Parity:** Select Even, Odd, or No parity.

<sup>D</sup> **Stop Bits:** Select 1 or 2 stop bits.

### Ethernet Port

An Ethernet port uses the Modbus TCP protocol for polled communication with other networked devices or remote annunciation and control with an IDP-801 Interactive Display Panel.

## CAN Communication

**BESTCOMSPi+ Navigation Path:** Settings Explorer, Communications, CAN Bus, CAN Bus Setup

**HMI Navigation Path:** Settings, Communications, CAN Bus, CAN Bus Setup

One CAN (controller area network) interface (CAN 1) facilitates communication between the DECS-250 and optional modules such as the contact expansion module (CEM-2020) and analog expansion module (AEM-2020).

A second CAN interface (CAN 2) enables the DECS-250 to provide generator and system parameters to a generator controller such as the Basler DGC-2020. CAN 2 also permits DECS-250 setpoint and mode control from an external device connected to the CAN.

Both CAN bus interfaces utilize the SAE J1939 messaging protocol.

DECS-250 CAN parameters are listed and defined in the *CAN Communication* chapter of this manual.

### Connections

DECS-250 CAN connections should be made with twisted-pair, shielded cable. Each CAN port (designated CAN 1 and CAN 2) has a CAN high (H) terminal, a CAN low (L) terminal, and a CAN drain (SH) terminal. CAN port terminals are illustrated in the *Terminals and Connectors* chapter of this manual.

### Port Configuration

Each DECS-250 CAN port must be identified by a unique address number<sup>A</sup>. The baud rate<sup>B</sup> of each port can be configured for 125 kbps or 250 kbps.

The Allowed Command Address<sup>C</sup> is the J1939 address from which the DECS-250 will accept broadcast data. If the address is set to 255 or the same as the DECS-250 CAN Bus Interface address, then broadcast data is accepted from any address. Otherwise, broadcast data is accepted from only the specified address. Port configuration settings are illustrated in Figure 162.

**Figure 162. CAN Port Configuration Settings**

<sup>A</sup> *CAN bus Address:* Adjustable from 1 to 253.

<sup>B</sup> *Baud Rate:* Select 125 kbps or 250 kbps.

<sup>C</sup> *Allowed Command Address:* Adjustable from 0 to 255.

### Remote Module Setup

**BESTCOMSPi+ Navigation Path:** Settings Explorer, Communications, CAN Bus, Remote Module Setup

**HMI Navigation Path:** Settings, Communications, CAN Bus, Remote Module Setup

Optional, external modules, such as the contact expansion module (CEM-2020) and analog expansion module (AEM-2020), communicate via the DECS-250 CAN 1 interface and are configured through the DECS-250 BESTCOMSPi+ interface. These settings are illustrated in Figure 163.

#### Contact Expansion Module

When enabled<sup>A</sup> for operation, the CEM-2020 CAN address<sup>B</sup> is assigned a unique number and the number of outputs<sup>C</sup> is selected. Standard module (CEM-2020) provides 24 output contacts and high-current module (CEM-2020H) provides 18 output contacts.

### Analog Expansion Module

When enabled<sup>D</sup> for operation, the AEM-2020 CAN address<sup>E</sup> is assigned a unique address for communication on the network.

Figure 163. Remote Module Setup

- <sup>A</sup> *Contact Expansion Module Enable/Disable*: Select Enabled or Disabled.  
<sup>B</sup> *CEM J1939 Address*: Adjustable from 1 to 253.  
<sup>C</sup> *CEM Outputs*: Select 18 Outputs (CEM-2020H) or 24 Outputs (CEM-2020).  
<sup>D</sup> *Analog Expansion Module Enable/Disable*: Select Enabled or Disabled.  
<sup>E</sup> *AEM J1939 Address*: Adjustable from 1 to 253.

## Ethernet Communication

Depending upon the style number, each DECS-250 is equipped with a copper (100Base-T) Ethernet communication port (style xxxxx1x) or a fiber optic (100Base-FX) Ethernet communication port (style xxxxx2x). The ST type fiber optic port uses a 1300 nanometer, near-infrared (NIR) light wavelength transmitted via two strands of multimode optical fiber, one for receive (RX) and the other for transmit (TX). The copper or fiber optic Ethernet connector is located on the right side panel. DECS-250 metering, annunciation, and control is provided through the Ethernet port using the Modbus TCP protocol. DECS-250 Modbus communication registers are listed and defined in the *Modbus Communication* chapter of this manual.

### Note

Industrial Ethernet devices designed to comply with IEC 61000-4 series of specifications are recommended.

### Ethernet Connection

1. Connect the DECS-250 to the PC using a standard Ethernet cable.
2. In BESTCOMSPPlus, click *Communication, New Connection, DECS-250*, or click the *Connection* button on the lower menu bar. The DECS-250 Connection window appears. (Figure 164)
3. If you know the IP address of the DECS-250, click the radio button for the Ethernet Connection IP at the top of the DECS-250 Connection window, enter the address into the fields and click the *Connect* button.
4. If you don't know the IP address, you can perform a scan (Figure 165) to search for all connected devices by clicking the *Ethernet* button in the Device Discovery box. After the scan is complete, a window containing the connected devices will be displayed. (Figure 166)

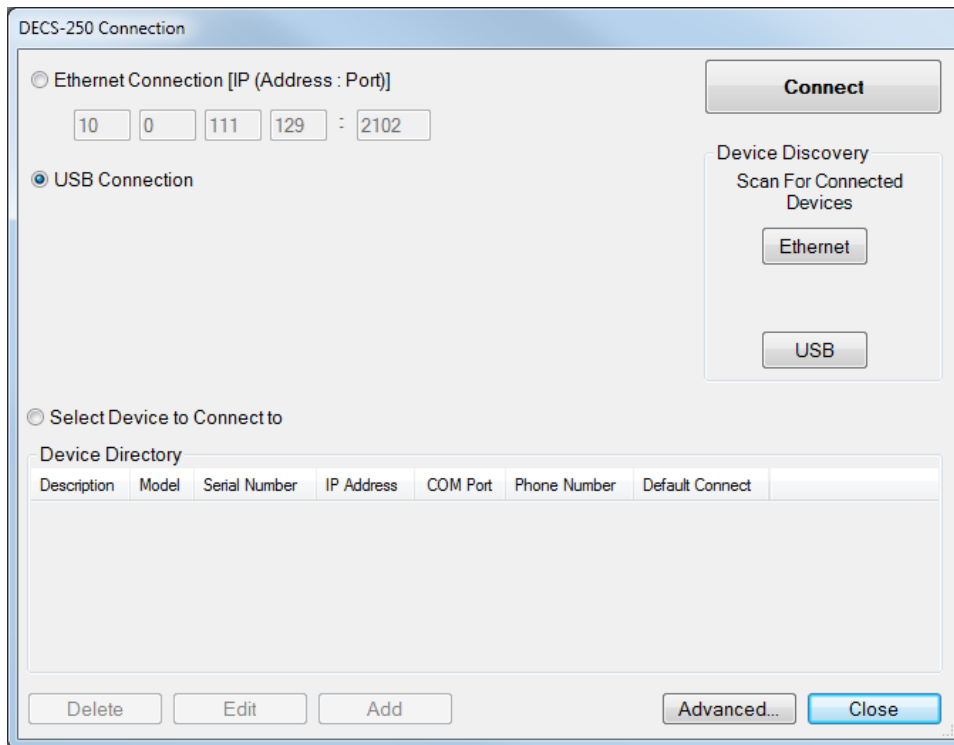


Figure 164. DECS-250 Connection Window

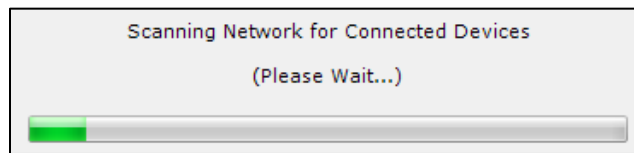


Figure 165. Scanning for Connected Devices

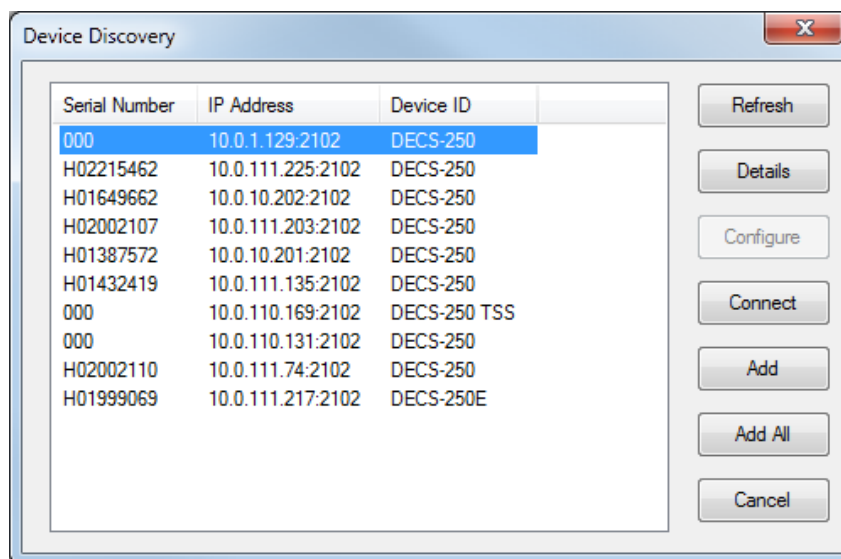


Figure 166. Device Discovery Window

- At this point you can also add any or all of the detected devices to the Device Directory. This prevents the need to scan for connected devices each time a connection is desired. Simply select a device from the list and click *Add*. Clicking *Add All* will add all detected devices from the list to the Device Directory. The Device Directory stores the name, model, and address of devices you have added. Click the radio button for *Select Device to Connect to*, select the device from the Device Directory list, and click the *Connect* button at the top of the DECS-250 Connection window.
- Choose the desired device from the list and click *Connect*. Wait for connection to complete (Figure 167).

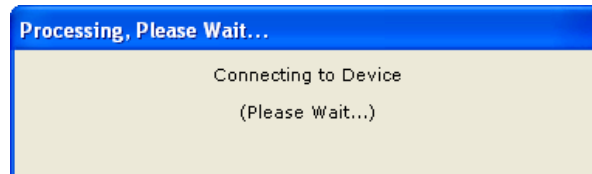


Figure 167. Waiting for Connection

- The *Advanced* button displays the following window. It contains options for enabling Auto Reconnect, downloading settings after reconnect, the delay between retries (in milliseconds), and the maximum number of attempts (Figure 168).

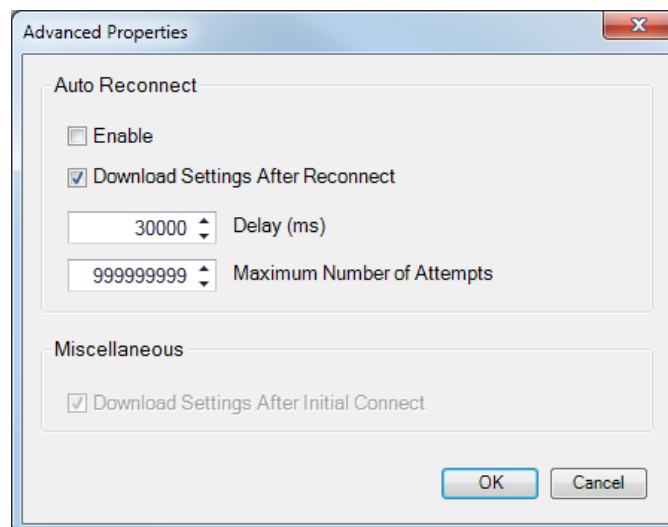


Figure 168. Advanced Properties, Auto Reconnect

### Note

The PC running BESTCOMSP<sup>Plus</sup> software must be configured correctly to communicate with the DECS-250. The PC must have an IP address in the same subnet range as the DECS-250 if the DECS-250 is operating on a private, local network.

Otherwise, the PC must have a valid IP address with access to the network and the DECS-250 must be connected to a properly configured router. The network settings of the PC depend on the operating system installed. Refer to the operating system manual for instructions.

On most Microsoft Windows based PCs, the network settings can be accessed through the *Network Connections* icon located inside the Control Panel.

## PROFIBUS Communication

**BESTCOMSP<sup>Plus</sup> Navigation Path:** Settings Explorer, Communications, Profibus Setup

**HMI Navigation Path:** Settings, Communications, Profibus

On units equipped with the PROFIBUS communication protocol (style xxxxxxP), the DECS-250 sends and receives PROFIBUS data through a DB-9 port located on the right side panel. DECS-250 PROFIBUS communication parameters are listed and defined in the *PROFIBUS Communication* chapter of this manual.

DB-9 port communication settings are illustrated in Figure 169 and consist of the address<sup>A</sup> and network byte order<sup>B</sup>.

Figure 169. Profibus Setup

<sup>A</sup> *Address*: Adjustable from 0 to 126 in increments of 1.

<sup>B</sup> *Network Byte Order*: MSB First or LSB First.

# Configuration

Before the DECS-250 is placed in service, it must be configured for the controlled equipment and application.

## **Generator, Field, and Bus Ratings**

**BESTCOMSPlus Navigation Path:** Settings Explorer, System Parameters, Rated Data

**HMI Navigation Path:** Settings, System Parameters, Rated Data

Generator, field, and bus rating settings are illustrated in Figure 170.

For proper excitation control and protection, the DECS-250 must be configured with the ratings of the controlled generator and field. These ratings are typically shown on the generator nameplate or can be obtained from the generator manufacturer. Required generator ratings include the voltage<sup>A</sup>, frequency<sup>B</sup>, power factor<sup>C</sup>, and apparent power<sup>D</sup> (kVA). Generator current<sup>E</sup>, real power<sup>F</sup> (kW), and reactive power (kvar)<sup>G</sup> are listed with the other generator ratings as read-only settings. These values are automatically calculated from the other generator ratings entered by the user. Required field ratings include the no load dc voltage<sup>H</sup> and current<sup>I</sup> and full load voltage<sup>J</sup> and current<sup>K</sup>.

The ratio<sup>L</sup> of exciter poles to generator poles is used by the exciter diode monitor (EDM) function to detect open and shorted exciter diodes. The calculated value can be entered directly or calculated using the pole calculator<sup>M</sup>. A minimum ratio of 1.5 is recommended to ensure consistent EDM operation.

In applications where the generator will be synchronized/paralleled with a bus, the DECS-250 must be configured with the rated bus voltage<sup>N</sup>.

The nominal operating power input voltage<sup>O</sup> is used to calculate the recommended Ka (Loop Gain) value. This value is also used in metering calculations.

When using the DECS-250 with an exciter requiring an inverted output, check this box<sup>P</sup> to enable the inverting of the DECS-250 control output.

### **Caution**

- Enabling inverted bridge output with an exciter which does not require inverted bridge output will result in equipment damage.
- For optimal 40Q (loss of excitation) operation, set the rated PF to a value less than 1.0 on the BESTCOMSPlus Rated Data screen. When the rated PF value is changed, the rated kW is automatically recalculated and the 40Q and 32 (reverse power) element settings must be adjusted appropriately.

Rated Data		
<b>Generator Rated Data</b>		
Voltage (V)	120	A
Current (A)	200.0	E
Frequency	60 Hz	B
PF (Power Factor)	0.80	C
Rating (kVA)	41.57	D
Rating (kW)	33.26	F
Rating (kvar)	24.94	G
<b>Field Rated Data</b>		
Voltage - Full Load (V)	63.0	J
Current - Full Load (A)	5.0	K
Voltage - No Load (V)	32.0	H
Current - No Load (A)	5.0	I
<b>Bridge Output</b>		
<input type="checkbox"/> Inverter for SCT/PPT P		
<b>Pole Ratio</b>		
Pole Ratio	0.00	L
Calculator M		
<b>Bus Rated Data</b>		
Voltage (V)	120	N
<b>Operating Power Input</b>		
Power Input Voltage (V)	240.0	O

**Figure 170. Generator, Bus, Field, and Pole Ratio Ratings**

- A **Generator Voltage Rating**: Adjustable from 1 to 500,000 Vac in 1 Vac increments.
- B **Generator Frequency Rating**: Select 50 or 60 Hz.
- C **Generator PF (Power Factor)**: Adjustable from -0.5 to 0.5 in 0.001 increments.
- D **Generator Voltamperes**: Adjustable from 0 to 1,000,000 kVA in 0.01 kVA increments.
- E **Generator Current**: Read-only value calculated from the generator VA and voltage.
- F **Generator Power**: Read-only value calculated from the generator voltage, current, and PF.
- G **Generator Reactive Power**: Read-only value calculated from the generator VA and PF.
- H **Field Voltage No Load**: Adjustable from 1 to 264 Vdc in 0.1 Vdc increments.
- I **Field Current No Load**: Adjustable from 0.1 to 15 Adc in 0.1 Adc increments.
- J **Field Voltage Full Load**: Adjustable from 1 to 264 Vdc in 0.1 Vdc increments.
- K **Field Current Full Load**: Adjustable from 0.1 to 15 Adc in 0.1 Adc increments.
- L **Pole Ratio**: Adjustable from 0 to 10 in 0.01 increments.
- M **Calculator**: Choose number of exciter and generator poles to calculate pole ratio.
- N **Bus Voltage**: Adjustable from 1 to 500,000 Vac in 1 Vac increments.
- O **Power Input Voltage**: Adjustable from 1 to 480 V in .01 increments.
- P **Bridge (Inverted) Output**: Check box to enable inversion, uncheck to disable inversion.

## Bridge

A Power Input Configuration<sup>A</sup> setting establishes the DECS-250 operating power configuration. All other settings on this screen are disabled and used only by the DECS-250N Digital Excitation Control System.

The screenshot shows the 'Bridge' configuration screen with the following settings:

- Operating Power Input**
  - Voltage: 190 - 277
- Modes of Operation**
  - Power Input Configuration: Three Phase (with a button labeled 'A')
  - Single Phase Selection: A-C
- Rated Frequency**
  - Frequency (Hz): 60
- Maximum Over Speed**
  - Maximum Over Speed (%): 150

Figure 171. Power Input Configuration

<sup>A</sup> Power Input Configuration: Select Single Phase or Three Phase.

## Sensing Transformer Ratings and Configuration

**BESTCOMSPlus Navigation Path:** Settings Explorer, System Parameters, Sensing Transformers

**HMI Navigation Path:** Settings, System Parameters, Sensing Transformers

DECS-250 configuration includes entry of the primary and secondary values for the transformers that supply generator and bus sensing values to the DECS-250. These configuration settings are illustrated in Figure 172.

### Generator PT

Voltage settings for the generator PT primary<sup>A</sup> and secondary<sup>B</sup> windings establish the nominal PT voltages expected by the DECS-250. ABC or ACB phase rotation<sup>C</sup> can be accommodated. Options for the generator voltage sensing connections<sup>D</sup> include single-phase (across phases C and A) and three-phase sensing using three-wire connections.

### Generator CTs

Current settings for the generator CT primary<sup>E</sup> and secondary<sup>F</sup> windings establish the nominal CT current values expected by the DECS-250. DECS-250 sensing current can be obtained from a single phase or all three generator phases<sup>G</sup>.

### Bus PT

Voltage settings for the bus PT primary<sup>H</sup> and secondary<sup>I</sup> windings establish the nominal bus PT voltages expected by the DECS-250. Options for the bus voltage sensing connections<sup>J</sup> include single-phase (across phases A and C) and three-phase sensing using three-wire delta connections.

**Figure 172. Sensing Transformer Ratings and Configuration**

- A *Generator PT Primary Voltage*: Adjustable from 1 to 500,000 Vac in 1 Vac increments.  
 B *Generator PT Secondary Voltage*: Adjustable from 1 to 600 Vac in 1 Vac increments.  
 C *Generator PT Phase Rotation*: Select ABC or ACB rotation.  
 D *Generator Voltage Connections*: Select CA or 3W-D.  
 E *Generator CT Primary Current*: Adjustable from 1 to 99,999 Aac in 1 Aac increments.  
 F *Generator CT Secondary Current*: Select 1 or 5 Aac.  
 G *Generator CT Configuration*: Select B or CT\_ABC.  
 H *Bus PT Primary Voltage*: Adjustable from 1 to 500,000 Vac in 1 Vac increments.  
 I *Bus PT Secondary Voltage*: Adjustable from 1 to 600 Vac in 1 Vac increments.  
 J *Bus Voltage Sensing Connections*: Select CA or 3W-D.

## Startup Functions

**BESTCOMSPPlus Navigation Path:** Settings Explorer, Operating Settings, Startup

**HMI Navigation Path:** Settings, Operating Settings, Startup

DECS-250 startup functions consist of soft start and field flashing. These settings are illustrated in Figure 173.

### Soft Start

During startup, the soft start function prevents voltage overshoot by controlling the rate of generator terminal voltage buildup (toward the setpoint). Soft start is active in AVR, FCR, and FVR regulation modes. Soft start behavior is based on two parameters: level and time. The soft start level<sup>A</sup> is expressed as a percentage of the nominal generator terminal voltage and determines the starting point for generator voltage buildup during startup. The soft start time<sup>B</sup> defines the amount of time allowed for the buildup of generator voltage during startup. Two groups of soft start settings (primary and secondary) provide for independent startup behavior which is selectable through BESTlogic™ Plus.

### Field Flashing

To ensure generator voltage buildup, the field flashing function applies and removes flashing power from an external field flashing source. Field flashing is active in AVR, FCR, and FVR control modes. During system startup, the application of field flashing is based on two parameters: level and time.

The field flash dropout level<sup>C</sup> determines the level of generator voltage where field flashing is withdrawn. In AVR mode, the field flash dropout level is expressed as a percentage of the generator terminal voltage.

In FCR mode, the level is expressed as a percentage of the field current. And in FVR mode, the level is expressed as a percentage of the field voltage.

The field flash time<sup>D</sup> defines the maximum length of time that field flashing may be applied during startup.

To use the field flashing function, one of the DECS-250 programmable contact outputs must be configured as a field flashing output.

**Startup**

**Soft Start**

**Primary**

Soft Start Level (%)  A

Soft Start Time (s)  B

**Secondary**

Soft Start Level (%)  A

Soft Start Time (s)  B

**Startup Control**

Field Flash Dropout Level (%)  C

Maximum Field Flash Time (s)  D

**Figure 173. Startup Function Settings**

<sup>A</sup> *Soft Start Level (%)*: Adjustable from 0 to 90% in 1% increments.

<sup>B</sup> *Soft Start Time (s)*: Adjustable from 1 to 7,200 seconds in 1 second increments.

<sup>C</sup> *Field Flash Dropout Level*: Adjustable from 0 to 100% in 1% increments.

<sup>D</sup> *Maximum Field Flash Time*: Adjustable from 1 to 50 seconds in 1 second increments.

## Device Information

**BESTCOMSPi<sup>us</sup> Navigation Path:** Settings Explorer, General Settings, Device Info

**HMI Navigation Path:** Settings, General Settings, Device Information, DECS-250

Device information includes user-assigned identification labeling and read-only firmware version information and product information. Device information (Figure 174) is provided for the DECS-250, CEM-2020 Contact Expansion Module, and AEM-2020 Analog Expansion Module.

### Firmware and Product Information

Firmware and product information can be viewed on the HMI display and Device Info tab of BESTCOMSPi<sup>us</sup>.

#### Firmware Information

Firmware information is provided for the DECS-250, optional CEM-2020, and optional AEM-2020. This information includes the application part number<sup>A</sup>, version number<sup>B</sup>, and build date<sup>C</sup>. Also included is the version of the boot code<sup>D</sup>. When configuring settings in BESTCOMSPi<sup>us</sup> while disconnected from a DECS-250, an Application Version Number setting<sup>E</sup> is available to ensure compatibility between the selected settings and the actual settings available in the DECS-250.

#### Product Information

Product information for the DECS-250, CEM-2020, and AEM-2020 includes the device model number<sup>F</sup> and serial number<sup>G</sup>.

### Device Identification

The user-assigned *Device ID*<sup>H</sup> can be used to identify DECS-250 controllers in reports and during polling.

### Device Info

Application Version Number <input type="text" value="≥1.01.00"/> <span style="float: right;">E</span>	Application Part Number <input type="text" value="....."/> <span style="float: right;">A</span>
Application Version <input type="text" value="...-"/> <span style="float: right;">B</span>	Model Number <input type="text" value="....."/> <span style="float: right;">F</span>
Boot Code Version <input type="text" value="...-"/> <span style="float: right;">D</span>	
Application Build Date <input type="text" value="YYYY-MM-DD"/> <span style="float: right;">C</span>	
Serial Number <input type="text" value="....."/> <span style="float: right;">G</span>	

**Identification**

Device ID  
 H

**Contact Expansion Module**

Application Version <input type="text" value="...-"/> <span style="float: right;">B</span>	Serial Number <input type="text" value="....."/> <span style="float: right;">G</span>
Boot Code Version <input type="text" value="...-"/> <span style="float: right;">D</span>	Application Part Number <input type="text" value="....."/> <span style="float: right;">A</span>
Application Build Date <input type="text" value="YYYY-MM-DD"/> <span style="float: right;">C</span>	Model Number <input type="text" value="....."/> <span style="float: right;">F</span>

**Analog Expansion Module**

Application Version <input type="text" value="...-"/> <span style="float: right;">B</span>	Serial Number <input type="text" value="....."/> <span style="float: right;">G</span>
Boot Code Version <input type="text" value="...-"/> <span style="float: right;">D</span>	Application Part Number <input type="text" value="....."/> <span style="float: right;">A</span>
Application Build Date <input type="text" value="YYYY-MM-DD"/> <span style="float: right;">C</span>	Model Number <input type="text" value="....."/> <span style="float: right;">F</span>

**Figure 174. Device Information**

- <sup>A</sup> *Application Part Number*: Read-only field indicates the firmware file part number.
- <sup>B</sup> *Application Version*: Read-only field indicates the firmware version number.
- <sup>C</sup> *Application Build Date*: Read-only field indicates the release date of the device firmware.
- <sup>D</sup> *Boot Code Version*: Read-only field indicates the version of hardware boot code.
- <sup>E</sup> *Application Version Number*: When configuring settings offline, select the appropriate firmware version to ensure settings/features compatibility with the DECS-250.
- <sup>F</sup> *Model Number*: Read-only field displays the product model number.
- <sup>G</sup> *Serial Number*: Read-only field displays the serial number of the product.
- <sup>H</sup> *Device ID*: Enter up to 60 alphanumeric characters.

## Display Units

**BESTCOMSPi+ Navigation Path:** General Settings, Display Units

**HMI Navigation Path:** N/A

When working with DECS-250 settings in BESTCOMSPi+, you have the option of viewing the settings in English or Metric<sup>A</sup> units and as primary units or per-unit values<sup>B</sup>. When per-unit values are selected, settings are entered as per-unit values and BESTCOMSPi+ converts the per-unit inputs to high-side values based on the generator rated data. The *display units* setting is illustrated in Figure 175 and is not available for settings shown on the front panel display.

**Display Units**

**System Units**

System Units

English

A

**Settings Display Modes**

Thresholds

Primary Units

B

\* BESTCOMSPlus® Only

Figure 175. Display Units

<sup>A</sup> *System Units*: Select English or Metric

<sup>B</sup> *Thresholds*: Select Primary Units or Per Unit.



# Security

DECS-250 security is provided in the form of passwords which control the type of operations allowed by a particular user. Passwords can be tailored to provide access to specific operations. Additional security is available by controlling the type of operations allowed through certain DECS-250 communication ports.

Security settings are uploaded and downloaded separately from the settings and logic. See the *BESTCOMSPiplus*<sup>®</sup> chapter for more information on uploading and downloading security.

## Password Access

**BESTCOMSPiplus Navigation Path:** Settings Explorer, General Settings, Device Security Setup, User Name Setup

A username and password can be established for one of six functional access areas within the DECS-250. These access areas are listed in Table 15 according to rank. A username and password with higher access can be used to gain access to operations controlled by a password with lower access. For example, a settings-level username and password has access to operations protected by the settings-, operator-, control-, and read-level usernames and passwords. This screen cannot be accessed when in Live Mode.

**Table 15. Password Access Levels and Descriptions**

Access Level	Description
Admin (1)	Access to security setup, communications settings, and software upgrades. Includes levels 2, 3, 4, 5, and 6 below.
Design (2)	Access to create and edit programmable logic. Includes levels 3, 4, 5, and 6 below.
Settings (3)	Access to edit settings. Does <u>not</u> include logic settings, security setup, communications settings, and software upgrades. Includes levels 4, 5, and 6 below.
Operator (4)	Access to set date and time, trigger and clear logs, and edit energy values. Includes levels 5 and 6 below.
Control (5)	Access to change setpoints, raise and lower, reset alarms, and preposition. Includes level 6 below.
Read (6)	Access to read all system parameters, metering, and logs. No write access.
None (7)	Lowest access level. All access is denied.

## Password Creation and Configuration

Usernames and passwords are created and configured in *BESTCOMSPiplus* on the Username Setup tab (Figure 176) of the Device Security Setup area. To create and configure a username and password, perform the following steps.

1. In the *BESTCOMSPiplus* settings explorer, select *User Name Setup*. This selection is located under *General Settings, Device Security Setup*. When prompted, enter a username of "A" and a password of "A" and log on. This factory-default username and password allows administrator-level access. It is highly recommended that this factory-default password be changed immediately to prevent undesired access.
2. Highlight an "UNASSIGNED" entry in the user list<sup>A</sup>. (Highlighting a previously-established username will display the password and access level for the user. This enables the password and access level for an existing user to be changed.)
3. Enter the desired username<sup>B</sup>.
4. Enter the desired password for the user<sup>C</sup>.

5. Reenter the password created in step 4 to verify the password<sup>D</sup>.
6. Select the maximum allowed access level<sup>E</sup> for the user.
7. If a maximum duration is desired for the user's access, enter the limit<sup>F</sup> (in days). Otherwise, leave the expiration value at zero.
8. Click the Save User button<sup>G</sup> to save the user settings.
9. Open the *Communication* menu, and click *Upload Security to Device*.
10. BESTCOMSPi<sup>us</sup> notifies you when the security upload is successful.

The screenshot displays the 'User List' and 'Selected User Information' sections of the BESTCOMSPi user management interface.

**User List:** A table with two columns: 'User Name' and 'Max Access Level'. The table contains 26 rows of users. The user 'SUSANT188' is highlighted, and a callout box 'A' points to the 'Max Access Level' column.

User Name	Max Access Level
A	Admin
ADMINISTRATOR	Admin
ANDREA221	Control
BRIANH149	Design
JEFFD331	Admin
SUSANT188	Operator
UNASSIGNED	Read
UNASSIGNED	Read
UNASSIGNED	Read
UNASSIGNED	Read
UNASSIGNED	Read
UNASSIGNED	Read
UNASSIGNED	Read
UNASSIGNED	Read
UNASSIGNED	Read
UNASSIGNED	Read
UNASSIGNED	Read
UNASSIGNED	Read
UNASSIGNED	Read
UNASSIGNED	Read
UNASSIGNED	Read
UNASSIGNED	Read
UNASSIGNED	Read
UNASSIGNED	Read
UNASSIGNED	Read
UNASSIGNED	Read
UNASSIGNED	Read
UNASSIGNED	Read
UNASSIGNED	Read
UNASSIGNED	Read
UNASSIGNED	Read
UNASSIGNED	Read

**Selected User Information:** A form for editing user details for 'SUSANT188'. Fields include:

- User Name:** SUSANT188 (callout B)
- Password:** 7077FT (callout C)
- Verify Password:** 7077FT (callout D)
- Maximum Access Level Allowed:** Operator (callout E)
- Days to Expiration (0 - No Password Expiration):** 0 (callout F)

Buttons for 'Save User' (callout G) and 'Delete User' are located at the bottom.

**Figure 176. Password Access Settings**

- <sup>A</sup> *User List:* Displays 26 usernames and the corresponding maximum access levels.
- <sup>B</sup> *User Name:* Accepts up to a 16 character label that may include upper and lowercase letters, numbers, and special characters.
- <sup>C</sup> *Password:* Accepts up to a 16 character label that may include upper and lowercase letters, numbers, and special characters.
- <sup>D</sup> *Verify Password:* Accepts up to a 16 character label that may include upper and lowercase letters, numbers, and special characters.
- <sup>E</sup> *Maximum Access Level Allowed:* Select Read, Control, Operator, Settings, Design, or Admin.
- <sup>F</sup> *Days to Expiration:* Adjustable from 0 to 50,000 days in 1 day increments. 0 disables setting.
- <sup>G</sup> *Save User:* Click button to save username and password settings.

## Port Security

**BESTCOMSPi<sup>us</sup> Navigation Path:** Settings Explorer, General Settings, Device Security Setup, Port Access Setup

An additional dimension of security is provided by the ability to restrict the control available through the DECS-250 communication ports. At any given time, only one port can be in use with read or higher access. For example, if a user gains settings access at one port, users at other ports will be able to gain no higher than read access until the user with settings access logs off. This screen cannot be accessed when in Live Mode.

### Port Access Configuration

Communication port access is configured in BESTCOMSPi<sup>us</sup> on the Port Access Setup tab (Figure 177) of the Device Security Setup area. To configure communication port access, perform the following steps.

1. In the BESTCOMSP*Plus* settings explorer, select *Port Access Setup*. This selection is located under *General Settings, Device Security Setup*. When prompted, enter a username of “A” and a password of “A” and log on. This factory-default username and password allows administrator-level access. It is highly recommended that this factory-default password be changed immediately to prevent undesired access.
2. Highlight the desired communication port in the port list<sup>A</sup>.
3. Select the unsecured access level<sup>B</sup> for the port.
4. Select the secured access level<sup>C</sup> for the port.
5. Save the configuration by clicking the Save port button<sup>D</sup>.
6. Open the *Communication* menu, and click *Upload Security to Device*.
7. BESTCOMSP*Plus* notifies you when the security upload is successful.

Port	Unsecured Access	Secured Access
BESTCOMSP <i>Plus</i> ® via Ethernet	Read	Admin
BESTCOMSP <i>Plus</i> ® via USB	Read	Admin
CAN Bus	Read	Admin
HMI	Read	Admin
Modbus via Ethernet	Read	Admin
Modbus via Serial	Read	Admin
Profibus via Serial	Read	Admin

A

**Selected Port Information**

Unsecured Access Level  
 Read [B]

Secured Access Level  
 Admin [C]

Save Port [D]

**Figure 177. Port Access Configuration Settings**

<sup>A</sup> *Port List*: Displays available communication ports and the corresponding access levels.

<sup>B</sup> *Unsecured Access Level*: Select None, Read, Control, Operator, Settings, Design, or Admin.

<sup>C</sup> *Secured Access Level*: Select None, Read, Control, Operator, Settings, Design, or Admin.

<sup>D</sup> *Save Port*: Click button to save port access settings.

## Login and Access Controls

**BESTCOMSP*Plus* Navigation Path:** Settings Explorer, General Settings, Device Security Setup, Access Control

Additional controls are available to limit login time and login attempts. These control settings are illustrated in Figure 178.

### Access Timeout

The access timeout setting<sup>A</sup> maintains security by automatically withdrawing password access if a user neglects to log out. If no activity is seen for the duration of the access timeout setting, password access is automatically withdrawn.

### Login Failure

A login attempts setting<sup>B</sup> limits the number of times that login can be attempted. A login time window<sup>C</sup> limits the length of time permitted during the login process. If login is unsuccessful, access is blocked for the duration of the login lockout time setting<sup>D</sup>.

**Access Control**

**Access Timeout**

Delay (s)

300 A

**Login Failure**

Login Attempts

1 B

Login Time Window (s)

1 C

Login Lockout Time (s)

1 D

**Figure 178. Login and Access Control Settings**

<sup>A</sup> *Access Timeout*: Adjustable from 10 to 3,600 s in 1 s increments.

<sup>B</sup> *Login Attempts*: Adjustable from 1 to 10 in increments of 1.

<sup>C</sup> *Login Time Window*: Adjustable from 1 to 99,999 s in 1 s increments.

<sup>D</sup> *Login Lockout Time*: Adjustable from 1 to 99,999 s in 1 s increments.

# Timekeeping

The DECS-250 clock is used by the logging functions to timestamp events. DECS-250 timekeeping can be self-managed by the internal clock or coordinated with an external source through a network or IRIG device.

BESTCOMS*Plus*® Timekeeping settings are shown in Figure 179.

**BESTCOMS*Plus* Navigation Path:** Settings Explorer, General Settings, Clock Setup

**HMI Navigation Path:** Settings, General Settings, Clock Setup

## ***Time and Date Format***

---

Clock display settings enable you to configure the time and date reported by the DECS-250 to match the conventions used in your organization/facility. The reported time can be configured for either the 12- or 24-hour format<sup>A</sup> with the Time Format setting. The Date Format setting<sup>A</sup> configures the reported date for one of three available formats: MM-DD-YYYY, DD-MM-YYYY, or YYYY-MM-DD.

## ***Daylight Saving Time Adjustments***

---

The DECS-250 can automatically compensate for the start and end of daylight saving time (DST) on a fixed- or floating-date basis<sup>B</sup>. A fixed-date, for example, is March 2, and an example of a floating-date is, “Second Sunday of March”. DST compensation can be made in respect to your local time or coordinated universal time (UTC)<sup>C</sup>. DST start<sup>D</sup> and end<sup>E</sup> points are fully configurable and include a bias adjustment<sup>F</sup>.

## ***Network Time Protocol (NTP)***

---

When connected to an Ethernet network, the DECS-250 can use NTP to assure accurate, synchronized timekeeping. By synchronizing with a radio, atomic, or other clock located on the internet/intranet, each DECS-250 maintains accurate timekeeping that is coordinated with the time source.

### **NTP Settings**

NTP is enabled in the DECS-250 by entering the internet protocol (IP) address of the network timeserver in the four decimal-separated fields of the NTP Address setting<sup>G</sup>. Time zone offset settings<sup>H</sup> provide the necessary offset from the coordinated universal time (UTC) standard. Central standard time is six hours and zero minutes behind (–6, 0) UTC and is the default setting.

The Time Priority Setup must be used to enable a connected time source. When multiple time sources are connected, the Time Priority Setup<sup>I</sup> can be used to rank the sources according to their priority.

## ***IRIG***

---

When the IRIG source is enabled, through the Time Priority Setup, it begins synchronizing the DECS-250 internal clock with the time code signal.

Some older IRIG receivers may use a time code signal compatible with IRIG standard 200-98, format B002, which does not contain year information. To use this standard, select the *IRIG without Year* radio button in the *IRIG Decoding* box<sup>J</sup>. Year information is stored in nonvolatile memory so the year is retained during a control power interruption.

The IRIG input accepts a demodulated (dc level-shifted) signal. For proper recognition, the applied IRIG signal must have a logic high level of no less than 3.5 Vdc and a logic low level that is no higher than 0.5 Vdc. The input signal voltage range is –10 Vdc to +10 Vdc. Input resistance is nonlinear and approximately 4 kΩ at 3.5 Vdc and 3 kΩ at 20 Vdc. IRIG signal connections are made at terminals IRIG+ and IRIG– which are located on the right side panel.

The Time Priority Setup must be used to enable a connected time source. When multiple, time sources are connected, the Time Priority Setup<sup>1</sup> can be used to rank the sources according to their priority.

Figure 179. Clock Setup

<sup>A</sup> *Time Format and Date Format:* Time format is 12- or 24-hour mode. Date format is MM-DD-YYYY, DD-MM-YYYY, or YYYY-MM-DD.

<sup>B</sup> *DST Config:* Select Disabled, Floating Dates, or Fixed Dates.

<sup>C</sup> *Start/End Time Reference:* Select “Respective to Local Time” or “Respective to UTC Time”.

<sup>D</sup> For Floating Date DST Configuration:

*DST Start Month:* Select desired month for DST start.

*DST Start Week of Month:* Select First, Second, Third, Fourth, or Last.

*DST Start Day of Week:* Select desired day of the week for DST start.

*DST Start Hour:* Adjustable from hour 0 to 23 in 1 hour increments.

*DST Start Minutes:* Adjustable from minute 0 to 59 in 1 minute increments.

For Fixed Date DST Configuration:

*DST Start Month:* Select desired month for DST start.

*<Day>:* Select desired day (number) of month.

*DST Start Hour:* Adjustable from hour 0 to 23 in 1 hour increments.

*DST Start Minutes:* Adjustable from minute 0 to 59 in 1 minute increments.

<sup>E</sup> For Floating Date DST Configuration:

*DST Stop Month:* Select desired month for DST stop.

*DST Stop Week of Month:* Select First, Second, Third, Fourth, or Last.

*DST Stop Day of Week:* Select desired day of the week for DST stop.

*DST Stop Hour:* Adjustable from hour 0 to 23 in 1 hour increments.

*DST Stop Minutes:* Adjustable from minute 0 to 59 in 1 minute increments.

---

For Fixed Date DST Configuration:

*DST Stop Month*: Select desired month for DST stop.

*<Day>*: Select desired day (number) of month.

*DST Stop Hour*: Adjustable from hour 0 to 23 in 1 hour increments.

*DST Stop Minutes*: Adjustable from minute 0 to 59 in 1 minute increments.

<sup>F</sup> *DST Bias Hours*: Adjustable from –12 to 12 hours in 1 hour increments.

*DST Bias Minutes*: Adjustable from –59 to 59 minutes in 1 minute increments.

<sup>G</sup> *NTP Address*: Four decimal-separated numbers determined by the IP address of the networked time source.

<sup>H</sup> *Time Zone hour and Minute Offset*: Hour offset is adjustable over the range of –12 to 12 hours in 1 hour increments. Minute offset is adjustable over the range of –59 to 59 minutes in 1 minute increments.

<sup>I</sup> *Time Priority Setup*: Sort available time sources using the two arrow buttons.

<sup>J</sup> *IRIG Decoding*: Select IRIG without Year or IRIG with Year.



# Testing

Testing of the DECS-250's regulation and optional power system stabilizer (style XPXXXXX) performance is possible through the integrated analysis tools of BESTCOMSPlus®.

## Real-Time Metering Analysis

**BESTCOMSPlus Navigation Path:** Metering Explorer, Analysis

**HMI Navigation Path:** Analysis functions are not available through front panel HMI.

Proper voltage regulator performance is critical to power system stabilizer performance. Step response measurements of the voltage regulator should be performed to confirm the AVR gain and other critical parameters. A transfer function measurement between terminal voltage reference and terminal voltage should be performed with the machine operating at very low load. This test provides an indirect measurement of the PSS phase requirement. As long as the machine is operating at very low load, the terminal voltage modulation does not produce significant speed and power changes.

The BESTCOMSPlus Real-Time Metering Analysis screen can be used to perform and monitor on-line AVR and PSS testing. Six plots of user-selected data can be generated and the logged data can be stored in a file for later examination. BESTCOMSPlus must be in *Live Mode* in order to start plotting. Live Mode is found under the *Options* menu on the lower menu bar. RTM Analysis screen controls and indications are illustrated in Figure 180.

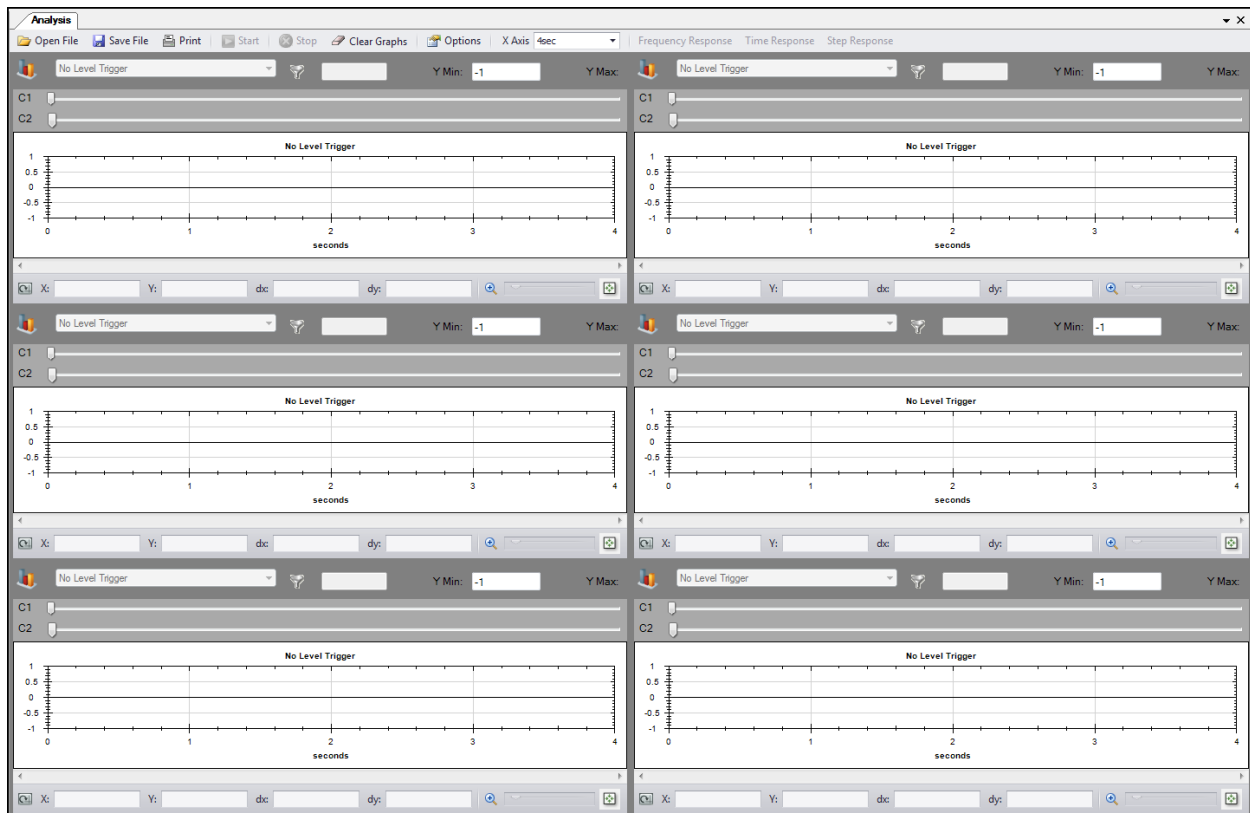


Figure 180. RTM Analysis Screen

With the RTM Analysis screen controls, you can:

- Select the parameters to be graphed
- Adjust the resolution of the graph x axis and the range of the graph y axis
- Start and stop plot captures
- Open an existing graph file, save a captured plot in a graph file, and print a captured graph

## Graph Parameters

Any four of the following parameters may be selected for plotting in the graph areas.

- APC Error to PI
- APC Integrator state
- APC PI output
- Auxiliary voltage input (Vaux)
- Average line current (Iavg)
- Average line-to-line voltage (Vavg)
- AVR error signal (ErrIn)
- AVR output
- Bus frequency (B Hz)
- Bus voltage (Vbus)
- Compensated frequency deviation (CompF)
- Control output (CntOp)
- Cross-current input (Iaux)
- Desired APC Reference
- Droop
- FCR error
- FCR state
- FCR output
- Field current (Ifd)
- Field voltage (Vfd)
- Filtered mechanical power (MechP)
- Final PSS output (Pout)
- Frequency response signal (Test)
- FVR error
- FVR state
- FVR output
- Generator frequency (G Hz)
- Grid connect state
- Grid code test signal
- Internal state (TrnOp)
- Lead-lag #1 (x15)
- Lead-lag #2 (x16)
- Lead-lag #3 (x17)
- Lead-lag #4 (x31)
- LVRT Desired var Reference
- LVRT var Reference
- Mechanical power (x10)
- Mechanical power (x11)
- Mechanical power (x7)
- Mechanical power (x8)
- Mechanical power (x9)
- Negative sequence current (I2)
- Negative sequence voltage (V2)
- Network Load Share
- Null Balance Level (Null Balance)
- Null Balance State (Null State)
- OEL controller output (OelOutput)
- OEL reference
- OEL state
- Phase A current (Ia)
- Phase A to B, line-to-line voltage (Vab)
- Phase B current (Ib)
- Phase B to C, line-to-line voltage (Vbc)
- Phase C current (Ic)
- Phase C to A, line-to-line voltage Vca
- Position Indication (PositionInd)
- Positive sequence current (I1)
- Positive sequence voltage (V1)
- Post-limit output (Post)
- Power factor (PF)
- Power HP #1 (x5)
- Pre-limit output (Prelim)
- PSS electrical power (PSSkW)
- PSS terminal voltage (Vtmag)
- Reactive power (kvar)
- Real power (kW)
- SCL controller output (SclOutput)
- SCL reference
- SCL state
- SCL PF reference
- Speed HP #1 (x2)
- Synthesized speed (Synth)
- Terminal frequency deviation (TermF)
- Time response signal (Ptest)
- Torsional filter #1 (Tflt1)
- Torsional filter #2 (x29)
- Total power (kVA)
- UEL controller output (UelOutput)
- UEL reference
- UEL state
- Var limiter output (VArLimOutput)
- Var limiter reference
- Var limiter state
- Var/PF error
- Var/PF state
- Var/PF output
- Washed out power (WashP)
- Washed out speed (WashW)

## Frequency Response

Frequency response testing functions are available by clicking the RTM Analysis screen Frequency Response button. Frequency Response screen functions are illustrated in Figure 181 and described as follows.

### Test Mode

Frequency response testing may be performed in Manual or Auto mode. In Manual mode, a single frequency can be specified to obtain the corresponding magnitude and phase responses. In Auto mode, BESTCOMSP<sup>Plus</sup>® will sweep the range of frequencies and obtain the corresponding magnitude and phase responses.

### Manual Test Mode Options

Manual test mode options include settings to select the frequency and magnitude of the applied test signal. A time delay setting selects the time after which the magnitude and phase response corresponding to the specified frequency is computed. This delay allows transients to settle before computations are made.

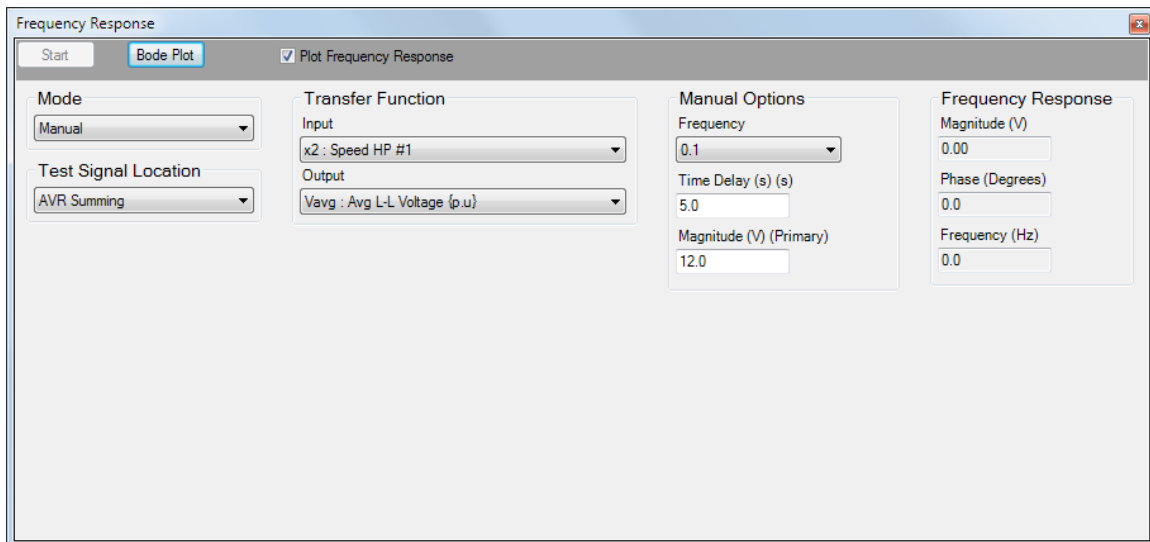


Figure 181. Frequency Response Screen

### Auto Test Mode Options

Automatic test mode options include settings to select the minimum frequency, maximum frequency, and magnitude of the sinusoidal wave that is applied during a frequency response test.

### Bode Plotting

A Bode plot can be printed, opened, and saved in graph (.gph) format.

### Transfer Function

The point in the DECS-250 logic circuitry where a signal is injected for analysis of magnitude and phase responses is selectable. Signal points include PSS Comp Frequency, PSS Electric Power, AVR Summing, AVR PID Input, and Manual PID Input.

The type of input signal to be injected and output point are selectable, and include:

- AvrOut
- B Hz: Bus Frequency {Hz}
- CntOp: Control Output {pu}
- CompF: Compensated Frequency Deviation
- Droop
- ErrIn: AVR Error Signal
- FcrErr
- FcrOut

- FcrState
- FvrErr
- FvrOut
- FvrState
- G Hz: Generator Frequency {Hz}
- I1: Positive Sequence Current {pu}
- I2: Negative Sequence Current {pu}
- Ia: Phase A Current {pu}
- Iaux: Cross Current Input {pu}
- Iavg: Ave Line Current {pu}
- Ib: Phase B Current {pu}
- Ic: Phase C Current {pu}
- Ifd: Field Current {pu}
- kVA: Total Power {pu}
- kvar: Reactive Power {pu}
- kW: Real Power {pu}
- MechP: Filtered Mechanical Power
- Network Load Share
- NullBalance: Null Balance Level
- OelOutput: OEL Controller Output
- OelRef
- OelState
- PF: Power Factor
- PositionInd: Position Indication {pu}
- Post: Post-Limit Output {pu}
- POut: Final PSS Output {pu}
- Prelim: Pre-Limit Output {pu}
- PsskW: PSS Electric Power {pu}
- Ptest: Time Response Signal {pu}
- SclOutput: SCL Controller Output
- SclRef
- SclPfRef
- SclState
- Synth: Synthesized Speed {pu}
- TermF: Terminal Frequency Deviation
- Test: Frequency Response Signal {pu}
- Tflt1: Torsional Filter #1 {pu}
- TrnOp: Internal State {pu}
- UelOutput: UEL Controller Output
- UelRef
- UelState
- V1: Positive Sequence Voltage {pu}
- V2: Negative Sequence Voltage {pu}
- Vab: PhA-PhB L-L Voltage {pu}
- Var/PfErr
- Var/PfOut
- Var/PfState
- VarLimOutput: Var Limiter Output
- VarLimRef
- VarLimState
- Vaux: Aux Voltage Input {pu}
- Vavg: Ave L-L Voltage {pu}
- Vbc: PhB-PhC L-L Voltage {pu}
- Vbus: Bus Voltage {pu}
- Vca: PhC-PhA L-L Voltage {pu}
- Vfd: Field Voltage {pu}
- Vtmag: PSS Term Voltage
- WashP: Washed Out Power
- WashW: Washed Out Speed {pu}
- x10: Mechanical Power LP #3
- x11: Mechanical Power LP #4
- x15: Lead-Lag #1 {pu}
- x16: Lead-Lag #2 {pu}
- x17: Lead-Lag #3 {pu}
- x2: Speed HP #1
- x29: Torsional Filter #2 {pu}
- x31: Lead-Lag #4 {pu}
- x5: Power HP #1 {pu}
- x7: Mechanical Power {pu}
- x8: Mechanical Power LP #1
- x9: Mechanical Power LP #2

## Frequency Response

Read-only frequency response fields indicate the magnitude response, phase response, and test signal frequency. The magnitude response and phase response corresponds to the test signal previously applied. The test frequency value reflects the frequency of the test signal currently being applied.

### Caution

Exercise caution when performing frequency response testing on a generator connected to the grid. Frequencies that are close to the resonant frequency of the machine or neighboring machines are to be avoided. Frequencies above 3 Hz may correspond to the lowest shaft torsional frequencies of a generator. A torsional profile for the machine should be obtained from the manufacturer and consulted before conducting any frequency response tests.

## Time Response

Tests should be performed at various load levels to confirm that the input signals are calculated or measured correctly. Since the PSS function uses compensated terminal frequency in place of speed, the derived mechanical power signal should be examined carefully to ensure that it does not contain any

components at the electromechanical oscillation frequencies. If such components are present, it indicates that the frequency compensation is less than ideal, or that the machine inertia value is incorrect.

PSS test signal configuration settings are provided on the Time Response screen shown in Figure 182. Click the RTM Analysis screen's Time Response button to access this screen.

## Signal Input

Signal input selections determine the point in the PSS circuitry where the test signal is applied. Test points include AVR Summing, PSS Comp Frequency, PSS Electric Power, PSS Derived Speed, Manual Summing, and var/PF.

A time delay is provided to delay the start of a PSS test after the Time Response screen Start button is clicked.

Figure 182. Time Response Screen

## Test Signal Characteristics

Test signal characteristics (magnitude, offset, frequency, and duration) can be adjusted according to the type of test signal selected.

### Magnitude

The test signal magnitude is expressed as a percentage and excludes the gain of externally-applied signals.

### Offset

A dc offset can be applied to the PSS test signal. The offset is expressed as a per-unit value used in proper context wherever the test signal is applied. A dc offset cannot be applied to a Step test signal.

### Frequency

The test signal frequency can be adjusted as desired for Step and Sine test signals. See *Swept Sine Test Signal* for information about configuring the frequency attributes of swept sine test signals.

### Duration

A duration setting controls the total test duration for Sine and External test signals. For Step test signals, the duration setting determines the “on” period of the signal. The duration setting does not apply to Swept Sine signals.

### Swept Sine Test Signals

Swept Sine test signals employ a unique set of characteristics that include the sweep style, frequency step, and start/stop frequencies.

### Sweep Type

A Swept Sine test signal can be configured as linear or logarithmic.

## Start and Stop Frequencies

The range of a Swept Sine test signal is determined by Start Frequency and Stop Frequency settings.

### Frequency Step

The frequency of a Swept Sine test signal is incremented according to the sweep type used. For linear sweeps, the test signal frequency is incremented by “step” every half-cycle of the system frequency. For logarithmic sweeps, the test signal frequency is multiplied by  $1.0 + \text{step}$  every half-cycle of the system frequency.

## Step Response Analysis

A standard technique for verifying overall system response is through step response measurements. This involves exciting the local electromechanical oscillation modes through a fixed step change in the AVR reference. Damping and frequency of oscillation can be measured directly from recordings of generator speed and power for different operating conditions and settings. Normally this test is performed with variations of the following:

- Generator active and reactive power loading
- Stabilizer gain
- System configuration (e.g., lines out of service)
- Stabilizer parameters (e.g., phase lead, frequency compensation)

As the stabilizer gain is increased, the damping should increase continuously while the natural frequency of oscillation should remain relatively constant. Large changes in the frequency of oscillation, a lack of improvement in damping, or the emergence of new modes of oscillation are all indications of problems with the selected settings.

Step response testing is performed using the Step Response Analysis screen. This screen (Figure 183) is accessed by clicking the Step Response button in the RTM Analysis window. The Step Response Analysis screen consists of:

- Metering fields: generator VA, total vars and PF, field voltage, and field current
- An alarms window that displays any active alarms triggered by a step change
- Control buttons to start and stop step response analysis and a button to close the screen
- A checkbox to select triggering of a data record when a setpoint step change is performed
- Tabs for controlling the application of step changes to the AVR, FCR, FVR, var, and PF setpoints. Tab functions are described in the following paragraphs.

### Note

If logging is in progress, another log cannot be triggered.

Response characteristics displayed on the Step Response Analysis screen are not automatically updated when the DECS-250 operating mode is switched externally. The screen must be manually updated by exiting and then reopening the screen.

## AVR, FCR, and FVR Tabs

The AVR, FCR, and FVR tabs are similar in their controls that enable the application of step changes to their respective setpoints. AVR tab controls are illustrated in Figure 183. AVR, FCR, and FVR tab controls operate as follows.

Step changes that increase or decrease the setpoint are applied by clicking the increment (up arrow) or decrement (down arrow) button. Step-change setting fields (one for increase and one for decrease) establish the percent change in the setpoint that occurs when the increment or decrement button is clicked. A read-only setpoint field indicates the current setpoint and what the setpoint will be when a step change occurs. A button is provided to return the setpoint to its original value. This original value is the setpoint established in the Setpoints section of the BESTCOMSPi<sup>®</sup> settings explorer and is displayed in the read-only field adjacent to the button.

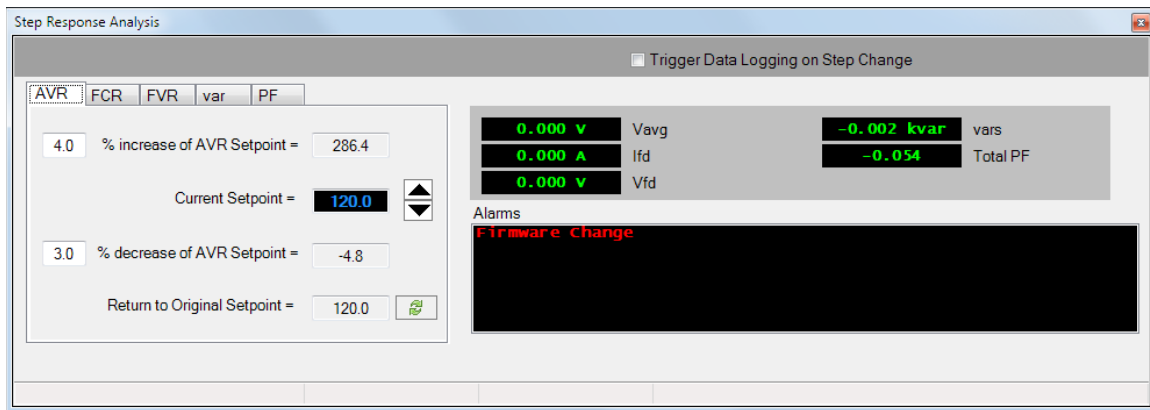


Figure 183. Step Response Analysis - AVR Tab

## Var and PF Tabs

The var and PF tabs are similar in their controls that enable the application of step changes to their respective setpoints. PF tab controls are illustrated in Figure 184. Var and PF tab controls operate as follows.

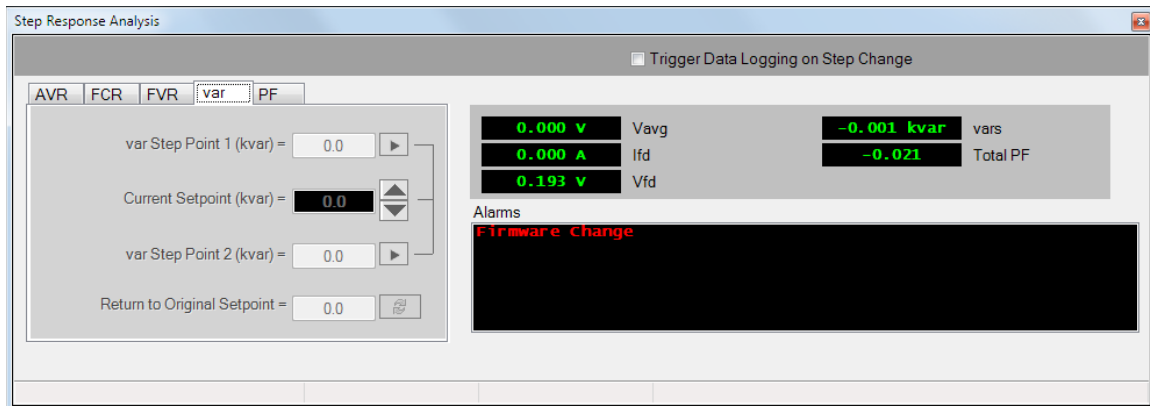


Figure 184. Step Response Analysis - PF Tab

Step changes that increase or decrease the setpoint can be applied by clicking the increment (up arrow) or decrement (down arrow) button. Step-change setpoints can be entered in two setting fields. Clicking the right-arrow button beside one of the two fields initiates a step change to the corresponding setpoint value. A button is provided to return the setpoint to its original value before any step changes were invoked. This original value is the setpoint established in the Setpoints section of the BESTCOMSP<sup>®</sup> settings explorer and is displayed in the read-only field adjacent to the button.

## Analysis Options

Options are provided to arrange the layout of plots and adjust graph display.

### Layout Tab

Up to six data plots may be displayed in three different layouts on the RTM screen. Place a check in the Cursors Enabled box to enable cursors used for measuring between two horizontal points. See Figure 185.

### Graph Display Tab

Options are provided to adjust graph history and poll rate. Graph height sets the displayed graphs to a fixed height in pixels. When the Auto Size box is checked, all displayed graphs are automatically sized to equally fit the available space. History length is selectable from 1 to 30 minutes. Poll rate is adjustable

between 100 to 500 milliseconds. Lowering the history and poll rate may also result in improved PC performance while plotting.

Place a check in the Sync Graph Scrolling box to sync scrolling between all graphs when any horizontal scroll bar is moved. See Figure 186.

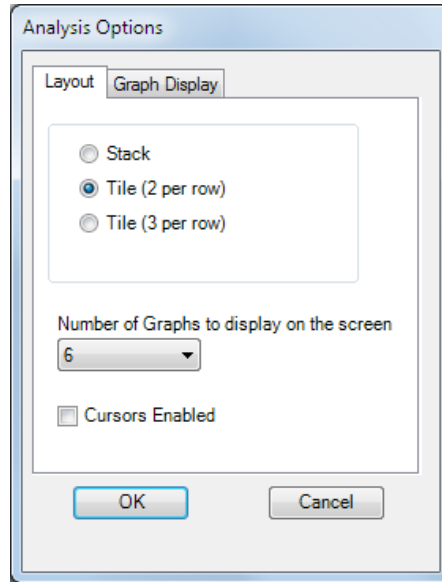


Figure 185. Analysis Options Screen, Layout Tab

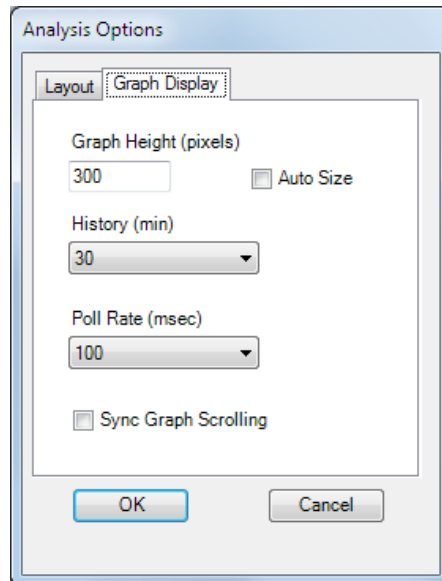


Figure 186. Analysis Options Screen, Graph Display Tab

# CAN Communication

## Introduction

CAN Bus interface 1 facilitates communication between the DECS-250 and optional modules such as the Contact Expansion Module (CEM-2020) and Analog Expansion Module (AEM-2020). Refer to the chapters *Contact Expansion Module* and *Analog Expansion Module* for more information.

CAN Bus interface 2 enables the DECS-250 to provide generator and system parameters to a generator controller such as the Basler DGC-2020. CAN 2 also permits DECS-250 setpoint and mode control from an external device connected to the CAN. The parameters sent over CAN 2 are listed in this chapter.

Both CAN Bus interfaces utilize the SAE J1939 messaging protocol.

Refer to the *Communication* chapter for CAN port configuration and the *Terminals and Connectors* chapter for wiring.

## CAN Parameters

Supported CAN parameters are listed in Table 16. The first column contains the parameter group number (PGN), the second column contains the parameter name, the third column contains the unit of measurement for a parameter, the fourth column contains the suspect parameter number (SPN), and the fifth column contains the broadcast rate for a parameter.

**Table 16. CAN Parameters**

PGN	Name	Units	SPN	Broadcast Rate
0xFDA6	Generator Excitation Field Voltage	Volts	3380	100 ms
	Generator Excitation Field Current	Amps	3381	
	Generator Output Voltage Bias Percentage	Percent	3382	
0xFDA7	Voltage Regulator Load Compensation Mode	n/a	3375	1 s
	Voltage Regulator var/PF Operating Mode	n/a	3376	
	Voltage Regulator Underfrequency Compensation Enabled	n/a	3377	
	Voltage Regulator Soft Start State	n/a	3378	
	Voltage Regulator Enabled	n/a	3379	
0xFDFD	Generator Phase CA L-L AC RMS Voltage	Volts	2443	100 ms
	(Unsupported)	n/a	2247	
	Generator Phase C AC RMS Current	Amps	2451	
0xFE00	Generator Phase BC L-L AC RMS Voltage	Volts	2442	100 ms
	(Unsupported)	n/a	2446	
	Generator Phase B AC RMS Current	Amps	2450	
0xFE03	Generator Phase AB L-L AC RMS Voltage	Volts	2441	100 ms
	(Unsupported)	n/a	2445	
	Generator Phase A AC RMS Current	Amps	2249	
0xFE06	Generator Average L-L AC RMS Voltage	Volts	2440	100 ms
	(Unsupported)	n/a	2444	
	Generator Average AC Frequency	Hertz	2436	
	Generator Average AC RMS Current	Amps	2448	
0xFE04	Generator Total Reactive Power	var	2456	100 ms
	Generator Overall PF	n/a	2464	
	Generator Overall PF Lagging	n/a	2518	
0xFE05	Generator Total Real Power	Watts	2452	100 ms

PGN	Name	Units	SPN	Broadcast Rate
	Generator Total Apparent Power	VA	2460	
0xFF00	<u>Contact I/O Status</u> Start Input - Byte 0, bits 0,1 Stop Input - Byte 0, bits 2,3 Input 1 - Byte 0, bits 4,5 Input 2 - Byte 0, bits 6,7 Input 3 - Byte 1, bits 0,1 Input 4 - Byte 1, bits 2,3 Input 5 - Byte 1, bits 4,5 Input 6 - Byte 1, bits 6,7 Input 7 - Byte 2, bits 0,1 Input 8 - Byte 2, bits 2,3 Input 9 - Byte 2, bits 4,5 Input 10 - Byte 2, bits 6,7 Input 11 - Byte 3, bits 0,1 Input 12 - Byte 3, bits 2,3 Input 13 - Byte 3, bits 4,5 Input 14 - Byte 3, bits 6,7 Watchdog Output - Byte 4, bits 0,1 Output 1 - Byte 4, bits 2,3 Output 2 - Byte 4, bits 4,5 Output 3 - Byte 4, bits 6,7 Output 4 - Byte 5, bits 0,1 Output 5 - Byte 5, bits 2,3 Output 6 - Byte 5, bits 4,5 Output 7 - Byte 5, bits 6,7 Output 8 - Byte 6, bits 0,1 Output 9 - Byte 6, bits 2,3 Output 10 - Byte 6, bits 4,5 Output 11 - Byte 6, bits 6,7 <u>Notes</u> 0 = Open 1 = Closed 2 = Reserved 3 = Reserved	n/a	n/a	100 ms
0xFF01	Requested Generator Excitation Field Voltage (FVR Setpoint)	Volts	3380	n/a
	Requested Generator Excitation Field Current (FCR Setpoint)	Amps	3381	n/a
0xFF02	<u>Requested Operating Mode</u> Byte 0, Bits 0-2 <u>Notes</u> 1 = FCR 2 = AVR 3 = VAR 4 = PF 5 = FVR Will not override if held by logic. Byte 0, Bits 3–7 unused Bytes 1–7 unused	n/a	n/a	100 ms

PGN	Name	Units	SPN	Broadcast Rate
0xFF03	Data Bytes 1–2 Power Factor Setpoint Adjust Operating Range: -1.0 to +1.0 Scaling: 0.0001/bit Offset: -1.0 Scaled Data Range: 0 to 20,000 Scaled Data Offset: 10,000 Data Bytes 3–4 Q(Voltage Limit) Bias Adjust Operating Range: -0.45 to +0.45 Scaling: 0.0001/bit Offset: -0.45 Scaled Data Range: 0 to 9,000 Scaled Data Offset: 4,500 Data Bytes 5–6 Q(U) Reference Voltage Adjust Operating Range: -0.1 to +0.1 Scaling: 0.0001/bit Offset: -0.1 Scaled Data Range: 0 to 1,000 Scaled Data Offset: 1,000 Data Bytes 7–8 Q(Third Party) Q Reference Adjust Operating Range: -0.45 to +0.45 Scaling: 0.0001/bit Offset: -0.45 Scaled Data Range: 0 to 9,000 Scaled Data Offset: 4,500	n/a	n/a	100 ms
0xFF04	Data Bytes 1–2 Active Power Reference Adjust Operating Range: -1.00 to +1.00 Scaling: 0.0001/bit Offset: -1.0 Scaled Data Range: 0 to 20,000 Scaled Data Offset: 10,000 Data Bytes 3–8 Reserved	n/a	n/a	100 ms
0xF015	Requested Generator Total AC Reactive Power (var Setpoint)	var	3383	n/a
	Requested Generator Overall PF (PF Setpoint)	n/a	3384	n/a
	Requested Generator Overall PF Lagging (PF Setpoint)	n/a	3385	n/a
0xF01C	Requested Generator Average L-L AC RMS Voltage (AVR Setpoint)	Volts	3386	n/a

### Diagnostic Trouble Codes (DTCs)

The DECS-250 will send an unsolicited message of a currently active diagnostic trouble code (DTC). Previously active DTCs are available upon request. Active and previously active DTCs can be cleared on request. Table 17 lists the diagnostic information that the DECS-250 obtains over the CAN Bus interface.

DTCs are reported in coded diagnostic information that includes the Suspect Parameter Number (SPN), Failure Mode Identifier (FMI), and Occurrence Count (OC) as listed in Table 3. All parameters have an SPN and are used to display or identify the items for which diagnostics are being reported. The FMI defines the type of failure detected in the subsystem identified by an SPN. The reported problem may not be an electrical failure but a subsystem condition needing to be reported to an operator or technician. The OC contains the number of times that a fault has gone from active to previously active.

**Table 17. Diagnostic Information Obtained Over CAN Bus Interface 2**

<b>PGN</b>	<b>Name</b>
0xEA00	Request DTCs
0xFECA	Currently Active DTCs
0xFECEB	Previously Active DTCs
0xFECC	Clear Previously Active DTCs
0xFED3	Clear Active DTCs

**Table 18. Reported DTCs**

<b>SPN hex (decimal)</b>	<b>Name</b>	<b>FMI hex (decimal) *</b>
0x263 (611)	Loss of Sensing Fault	0x00 (0)
0x264 (612)	EDM Fault	0x0E (14)
0xD34 (3380)	Field Overvoltage Fault	0x00 (0)
0xD35 (3381)	Field Overcurrent Fault	0x00 (0)
0x988 (2440)	Overvoltage Fault	0x0F (15)
0x988 (2440)	Undervoltage Fault	0x11 (17)
0x998 (2456)	Loss of Excitation Fault	0x11 (17)

- \* 0 = Data valid but above normal range, most severe.  
 14 = Special instructions.  
 15 = Data valid but above normal range, least severe.  
 17 = Data valid but below normal range, least severe.

# Modbus® Communication

## Introduction

This document describes the Modbus® communications protocol employed by DECS-250 systems and how to exchange information with DECS-250 systems over a Modbus network. DECS-250 systems communicate by emulating a subset of the Modicon 984 Programmable Controller.

### Caution

This product contains one or more *nonvolatile memory* devices. Nonvolatile memory is used to store information (such as settings) that needs to be preserved when the product is power-cycled or otherwise restarted. Established nonvolatile memory technologies have a physical limit on the number of times they can be erased and written. In this product, the limit is 100,000 erase/write cycles. During product application, consideration should be given to communications, logic, and other factors that may cause frequent/repeated writes of settings or other information that is retained by the product. Applications that result in such frequent/repeated writes may reduce the useable product life and result in loss of information and/or product inoperability.

Modbus communications use a master-slave technique in which only the master can initiate a transaction. This transaction is called a query. When appropriate, a slave (DECS-250) responds to the query. When a Modbus master communicates with a slave, information is provided or requested by the master. Information residing in the DECS-250 is grouped categorically as follows:

- General
- Binary Points
- Metering
- Limiters
- Setpoints
- Global Settings
- Relay Settings
- Protection Settings
- Gains
- Legacy Modbus

All supported data can be read as specified in the Register Table. Abbreviations are used in the Register Table to indicate the register type. Register types are:

- Read/Write = RW
- Read Only = R

When a slave receives a query, the slave responds by either supplying the requested data to the master or performing the requested action. A slave device never initiates communications on the Modbus and will always generate a response to the query unless certain error conditions occur. The DECS-250 is designed to communicate on the Modbus network only as slave devices.

Refer to the *Communication* chapter for Modbus communication setup and the *Terminals and Connectors* chapter for wiring.

## Message Structure

### Device Address Field

The device address field contains the unique Modbus address of the slave being queried. The addressed slave repeats the address in the device address field of the response message. This field is 1 byte.

Although Modbus protocol limits a device address from 1 - 247. The address is user-selectable at installation and can be altered during real-time operation.

### Function Code Field

The function code field in the query message defines the action to be taken by the addressed slave. This field is echoed in the response message and is altered by setting the most significant bit (MSB) of the field to 1 if the response is an error response. This field is 1 byte in length.

The DECS-250 maps all available data into the Modicon 984 holding register address space supports the following function codes:

- Function 03 (03 hex) - read holding registers
- Function 06 (06 hex) - preset single register
- Function 08 (08 hex), subfunction 00 - diagnostics: return query data
- Function 08 (08 hex), subfunction 01 - diagnostics: restart communications option
- Function 08 (08 hex), subfunction 04 - diagnostics: force listen only mode
- Function 16 (10 hex) - preset multiple registers

### Data Block Field

The query data block contains additional information needed by the slave to perform the requested function. The response data block contains data collected by the slave for the queried function. An error response will substitute an exception response code for the data block. The length of this field varies with each query.

### Error Check Field

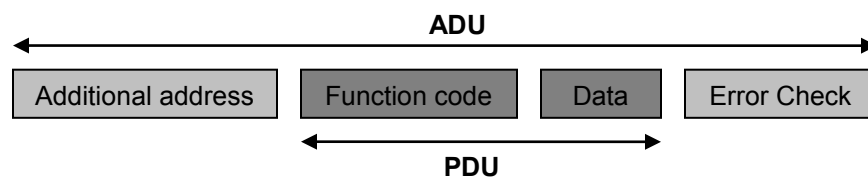
The error check field provides a method for the slave to validate the integrity of the query message contents and allows the master to confirm the validity of response message contents. This field is 2 bytes.

## ***Modbus Modes of Operation***

A standard Modbus network offers the remote terminal unit (RTU) transmission mode and Modbus TCP mode for communication. DECS-250 systems support the Modbus TCP mode and RS-485 mode at the same time. To enable editing over Modbus TCP, or RS-485, the unsecured access level for the port must be configured to the appropriate access level. See the *Security* chapter of this manual for more information on security and access levels. These two modes of operation are described below.

A master can query slaves individually or universally. A universal ("broadcast") query, when allowed, evokes no response from any slave device. If a query to an individual slave device requests actions unable to be performed by the slave, the slave response message contains an exception response code defining the error detected. Exception response codes are quite often enhanced by the information found in the "Error Details" block of holding registers.

The Modbus protocol defines a simple Protocol Data Unit (PDU) independent of the underlying communication layers. The mapping of the Modbus protocol on specific buses or networks can introduce some additional fields on the Application Data Unit (ADU). See Figure 187.



**Figure 187. General Modbus Frame**

The client that initiates a Modbus transaction builds the Modbus Application Data Unit. The function code indicates to the server which kind of action to perform.

## Modbus® Over Serial Line

### Message Structure

Master initiated queries and DECS-250 responses share the same message structure. Each message is comprised of four message fields. They are:

- Device Address (1 byte)
- Function Code (1 byte)
- Data Block (n bytes)
- Error Check field (2 bytes)

Each 8-bit byte in a message contains two 4-bit hexadecimal characters. The message is transmitted in a continuous stream with the LSB of each byte of data transmitted first. Transmission of each 8-bit data byte occurs with one start bit and either one or two stop bits. Parity checking is performed, when enabled, and can be either odd or even. The transmission baud rate is user-selectable, and can be set at installation and altered during real-time operation. The DECS-250 Modbus supports baud rates up to 115200. The factory default baud rate is 19200.

DECS-250 systems support RS-485 compatible serial interfaces. This interface is accessible from the left side panel of the DECS-250.

### Message Framing and Timing Considerations

When receiving a message via the RS-485 communication port, the DECS-250 requires an inter-byte latency of 3.5 character times before considering the message complete.

Once a valid query is received, the DECS-250 waits a specified amount of time before responding. This time delay is set on the Modbus Setup screen under Communications in BESTCOMSPlus®. This parameter contains a value from 10 - 10,000 milliseconds. The default value is 10 milliseconds.

Table 19 provides the response message transmission time (in seconds) and 3.5 character times (in milliseconds) for various message lengths and baud rates.

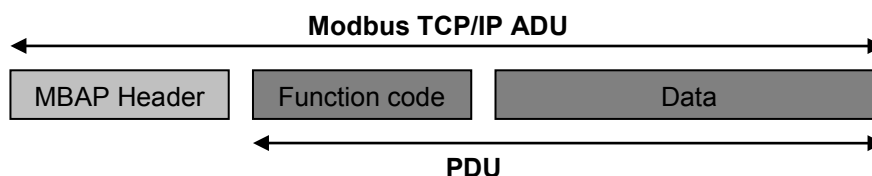
**Table 19. Timing Considerations**

Baud Rate	3.5 Character Time (ms)	Message Tx Time (s)	
		128 Bytes	256 Bytes
1200	32.08	1.17	2.34
2400	16.04	0.59	1.17
4800	8.021	0.29	0.59
9600	4.0104	0.15	0.29
19200	2.0052	0.07	0.15
38400	1.0026	0.04	0.07
57600	0.6684	0.02	0.04
115200	0.3342	0.01	0.02

## Modbus on TCP/IP

### Application Data Unit

The following describes the encapsulation of a Modbus request or response when it is carried on a Modbus TCP/IP network. See Figure 188.



**Figure 188. Modbus Request/Response Over TCP/IP**

A dedicated header is used on TCP/IP to identify the Modbus Application Data Unit. It is called the MBAP header (Modbus Application Protocol header).

This header provides some differences compared to the Modbus RTU application data unit used on a serial line:

- The Modbus 'slave address' field usually used on Modbus Serial Line is replaced by a single byte 'Unit Identifier' within the MBAP header. The 'Unit Identifier' is used to communicate via devices such as bridges, routers, and gateways that use a single IP address to support multiple independent Modbus end units.
- All Modbus requests and responses are designed in such a way that the recipient can verify that a message is finished. For function codes where the Modbus PDU has a fixed length, the function code alone is sufficient. For function codes carrying a variable amount of data in the request or response, the data field includes a byte count.
- When Modbus is carried over TCP, additional length information is carried in the MBAP header to allow the recipient to recognize message boundaries even if the message has been split into multiple packets for transmission. The existence of explicit and implicit length rules and use of a CRC-32 error check code (on Ethernet) results in an infinitesimal chance of undetected corruption to a request or response message.

#### MBAP Header Description

The MBAP Header contains the fields listed in Table 20.

**Table 20. MBAP Header Fields**

Fields	Length	Description	Client	Server
Transaction Identifier	2 Bytes	Identification of a Modbus request/response transaction.	Initialized by the client.	Recopied by the server from the received request.
Protocol Identifier	2 Bytes	0 = Modbus protocol.	Initialized by the client.	Recopied by the server from the received request.
Length	2 Bytes	Number of following bytes.	Initialized by the client (request).	Initialized by the server (response).
Unit Identifier	1 Byte	Identification of a remote slave connected on a serial line or on other buses.	Initialized by the client.	Recopied by the server from the received request.

The header is 7 bytes long:

- *Transaction Identifier* – Used for transaction pairing, the Modbus server copies in the response the transaction identifier of the request.
- *Protocol Identifier* – Used for intra-system multiplexing. The Modbus protocol is identified by the value 0.
- *Length* – A byte count of the following fields, including the Unit Identifier and data fields.
- *Unit Identifier* – Used for intra-system routing purpose. It is typically used to communicate to a Modbus or a Modbus serial line slave through a gateway between an Ethernet TCP/IP network and a Modbus serial line. This field is set by the Modbus Client in the request and must be returned with the same value in the response by the server.

Note: All Modbus TCP ADU are sent via TCP on registered port 502.

### **Error Handling and Exception Responses**

Any query received that contains a non-existent device address, a framing error, or CRC error is ignored. No response is transmitted. Queries addressed to the DECS-250 with an unsupported function or illegal

values in the data block result in an error response message with an exception response code. The exception response codes supported by the DECS-250 are provided in Table 21.

**Table 21. Supported Exception Response Codes**

Code	Name	Description
01	Illegal Function	The query Function/Subfunction Code is unsupported; query read of more than 125 registers; query preset of more than 100 registers.
02	Illegal Data Address	A register referenced in the data block does not support queried read/write; query preset of a subset of a numerical register group.
03	Illegal Data Value	A preset register data block contains an incorrect number of bytes or one or more data values out of range.

### DECS-250 Modbus® via Ethernet

Modbus can communicate through Ethernet if the IP address of the DECS-250 is configured as described in the *Communications* chapter of this manual.

## Detailed Message Query and Response for RTU Transmission Mode

A detailed description of DECS-250 supported message queries and responses is provided in the following paragraphs.

### Read Holding Registers

#### Query

This query message requests a register or block of registers to be read. The data block contains the starting register address and the quantity of registers to be read. A register address of N will read holding register N+1. If the query is a broadcast (device address = 0), no response message is returned.

Device Address  
 Function Code = 03 (hex)  
 Starting Address Hi  
 Starting Address Lo  
 No. of Registers Hi  
 No. of Registers Lo  
 CRC Hi error check  
 CRC Lo error check

The number of registers cannot exceed 125 without causing an error response with the exception code for an illegal function.

#### Response

The response message contains the data queried. The data block contains the block length in bytes followed by the data (one Data Hi byte and one Data Lo byte) for each requested register.

Reading an unassigned holding register returns a value of zero.

Device Address  
 Function Code = 03 (hex)  
 Byte Count  
 Data Hi (For each requested register, there is one Data Hi and one Data Lo.)  
 Data Lo  
 .  
 .  
 Data Hi  
 Data Lo

CRC Hi error check  
CRC Lo error check

### Return Query Data

This query contains data to be returned (looped back) in the response. The response and query messages should be identical. If the query is a broadcast (device address = 0), no response message is returned.

Device Address  
Function Code = 08 (hex)  
Subfunction Hi = 00 (hex)  
Subfunction Lo = 00 (hex)  
Data Hi = xx (don't care)  
Data Lo = xx (don't care)  
CRC Hi error check  
CRC Lo error check

### Restart Communications Option

This query causes the remote communications function of the DECS-250 to restart, terminating an active listen only mode of operation. No effect is made upon primary relay operations. Only the remote communications function is affected. If the query is a broadcast (device address = 0), no response message is returned.

If the DECS-250 receives this query while in the listen only mode, no response message is generated. Otherwise, a response message identical to the query message is transmitted prior to the communications restart.

Device Address  
Function Code = 08 (hex)  
Subfunction Hi = 00 (hex)  
Subfunction Lo = 01 (hex)  
Data Hi = xx (don't care)  
Data Lo = xx (don't care)  
CRC Hi error check  
CRC Lo error check

### Listen Only Mode

This query forces the addressed DECS-250 to the listen only mode for Modbus communications, isolating it from other devices on the network. No responses are returned.

While in the listen only mode, the DECS-250 continues to monitor all queries. The DECS-250 does not respond to any other query until the listen only mode is removed. All write requests with a query to Preset Multiple Registers (Function Code = 16) are also ignored. When the DECS-250 receives the restart communications query, the listen only mode is removed.

Device Address  
Function Code = 08 (hex)  
Subfunction Hi = 00 (hex)  
Subfunction Lo = 04 (hex)  
Data Hi = xx (don't care)  
Data Lo = xx (don't care)  
CRC Hi error check  
CRC Lo error check

### Preset Multiple Registers

A preset multiple registers query could address multiple registers in one slave or multiple slaves. If the query is a broadcast (device address = 0), no response message is returned.

Query

A Preset Multiple Register query message requests a register or block of registers to be written. The data block contains the starting address and the quantity of registers to be written, followed by the Data Block byte count and data. The DECS-250 will perform the write when the device address in query is a broadcast address or the same as the DECS-250 Modbus Unit ID (device address).

A register address of N will write Holding Register N+1.

Data will cease to be written if any of the following exceptions occur.

- Queries to write to Read Only registers result in an error response with Exception Code of “Illegal Data Address”.
- Queries attempting to write more than 100 registers cause an error response with Exception Code “Illegal Function”.
- An incorrect Byte Count will result in an error response with Exception Code of “Illegal Data Value”.
- There are several instances of registers that are grouped together to collectively represent a single numerical DECS-250 data value (i.e. - floating point data, 32-bit integer data, and strings). A query to write a subset of such a register group will result in an error response with Exception Code “Illegal Data Address”.
- A query to write a not allowed value (out of range) to a register results in an error response with Exception Code of “Illegal Data Value”.

Device Address  
 Function Code =           10 (hex)  
 Starting Address Hi  
 Starting Address Lo  
 No. of Registers Hi  
 No. of Registers Lo  
 Byte Count  
 Data Hi  
 Data Lo  
 .  
 .  
 Data Hi  
 Data Lo  
 CRC Hi error check  
 CRC Lo error check

Response

The response message echoes the starting address and the number of registers. There is no response message when the query is a broadcast (device address = 0).

Device Address  
 Function Code =           10 (hex)  
 Starting Address Hi  
 Starting Address Lo  
 No. of Registers Hi  
 No. of Registers Lo  
 CRC Hi Error Check  
 CRC Lo Error Check

**Preset Single Register**

A Preset Single Register query message requests a single register to be written. If the query is a broadcast (device address = 0), no response message is returned.

Note: Only data types INT16, INT8, UINT16, UINT8, and String (not longer than 2 bytes), can be preset by this function.

### Query

Data will cease to be written if any of the following exceptions occur.

- Queries to write to Read Only registers result in an error response with Exception Code of “Illegal Data Address”.
- A query to write an unallowed value (out of range) to a register results in an error response with Exception Code of “Illegal Data Value”.

Device Address  
 Function Code =           06 (hex)  
 Address Hi  
 Address Lo  
 Data Hi  
 Data Lo  
 CRC Hi error check  
 CRC Lo error check

### Response

The response message echoes the Query message after the register has been altered.

## **Data Formats**

DECS-250 systems support the following data types:

- Data types mapped to 2 registers
  - Unsigned Integer 32 (Uint32)
  - Floating Point (Float)
  - Strings maximum 4 characters long (String)
- Data types mapped to 1 register
  - Unsigned Integer 16 (Uint16)
  - Unsigned Integer 8 (Uint8)
  - Strings maximum 2 characters long (String)
- Data types mapped to more than 2 registers
  - Strings longer than 4 characters (String)

### **Floating Point Data Format (Float)**

The Modbus floating point data format uses two consecutive holding registers to represent a data value. The first register contains the low-order 16 bits of the following 32-bit format:

- MSB is the sign bit for the floating-point value (0 = positive).
- The next 8 bits are the exponent biased by 127 decimal.
- The 23 LSBs comprise the normalized mantissa. The most-significant bit of the mantissa is always assumed to be 1 and is not explicitly stored, yielding an effective precision of 24 bits.

The value of the floating-point number is obtained by multiplying the binary mantissa times two raised to the power of the unbiased exponent. The assumed bit of the binary mantissa has the value of 1.0, with the remaining 23 bits providing a fractional value. Table 22 shows the floating-point format.

**Table 22. Floating Point Format**

<b>Sign</b>	<b>Exponent + 127</b>	<b>Mantissa</b>
1 Bit	8 Bits	23 Bits

The floating-point format allows for values ranging from approximately  $8.43 \times 10^{-37}$  to  $3.38 \times 10^{38}$ . A floating-point value of all zeroes is the value zero. A floating-point value of all ones (not a number) signifies a value currently not applicable or disabled.

Example: The value 95,800 represented in floating-point format is hexadecimal 47BB1C00. This number will read from two consecutive holding registers as follows:

<u>Holding Register</u>	<u>Value</u>
K (Hi Byte)	hex 1C
K (Lo Byte)	hex 00
K+1(Hi Byte)	hex 47
K+1(Lo Byte)	hex BB

The same byte alignments are required to write.

### Long Integer Data Format (Uint32)

The Modbus long integer data format uses two consecutive holding registers to represent a 32-bit data value. The first register contains the low-order 16 bits and the second register contains the high-order 16 bits.

Example: The value 95,800 represented in long integer format is hexadecimal 0x00017638. This number will read from two consecutive holding registers as follows:

<u>Holding Register</u>	<u>Value</u>
K (Hi Byte)	hex 76
K (Lo Byte)	hex 38
K+1(Hi Byte)	hex 00
K+1(Lo Byte)	hex 01

The same byte alignments are required to write.

### Integer Data Format (Uint16) or Bit-Mapped Variables in Uint16 Format

The Modbus integer data format uses a single holding register to represent a 16-bit data value.

Example: The value 4660 represented in integer format is hexadecimal 0x1234. This number will read from a holding register as follows:

<u>Holding Register</u>	<u>Value</u>
K (Hi Byte)	hex 12
K (Lo Byte)	hex 34

The same byte alignments are required to write.

The Uint16 Data Format is listed in *Binary Points* (Table 25), below.

Example: Register 900 occupies 16 rows in the Register Table where each row gives the name of specific bit-mapped data such as 900-0 indicates bit 0 of register 900 is mapped to RF-TRIG.

### Short Integer Data Format/Byte Character Data Format (Uint8)

The Modbus short integer data format uses a single holding register to represent an 8-bit data value. The holding register high byte will always be zero.

Example: The value 132 represented in short integer format is hexadecimal 0x84. This number will read from a holding register as follows:

<u>Holding Register</u>	<u>Value</u>
K (Hi Byte)	hex 00
K (Lo Byte)	hex 84

The same byte alignments are required to write.

### String Data Format (String)

The Modbus string data format uses one or more holding registers to represent a sequence, or string, of character values. If the string contains a single character, the holding register high byte will contain the ASCII character code and the low byte will be zero.

Example: The string “PASSWORD” represented in string format will read as follows:

Holding Register	Value
K (Hi Byte)	'P'
K (Lo Byte)	'A'
K+1(Hi Byte)	'S'
K+1(Lo Byte)	'S'
K+2(Hi Byte)	'W'
K+2(Lo Byte)	'O'
K+3(Hi Byte)	'R'
K+3(Lo Byte)	'D'

Example: If the above string is changed to “P”, the new string will read as follows:

Holding Register	Value
K (Hi Byte)	'P'
K (Lo Byte)	hex 00
K+1(Hi Byte)	hex 00
K+1(Lo Byte)	hex 00
K+2(Hi Byte)	hex 00
K+2(Lo Byte)	hex 00
K+3(Hi Byte)	hex 00
K+3(Lo Byte)	hex 00

The same byte alignments are required to write.

### CRC Error Check

This field contains a two-byte CRC value for transmission error detection. The master first calculates the CRC and appends it to the query message. The DECS-250 system recalculates the CRC value for the received query and performs a comparison to the query CRC value to determine if a transmission error has occurred. If so, no response message is generated. If no transmission error has occurred, the slave calculates a new CRC value for the response message and appends it to the message for transmission.

The CRC calculation is performed using all bytes of the device address, function code, and data block fields. A 16-bit CRC-register is initialized to all 1's. Then each eight-bit byte of the message is used in the following algorithm:

First, exclusive-OR the message byte with the low-order byte of the CRC-register. The result, stored in the CRC-register, will then be right-shifted eight times. The CRC-register MSB is zero-filled with each shift. After each shift, the CRC-register LSB is examined. If the LSB is a 1, the CRC-register is exclusive-ORed with the fixed polynomial value A001 (hex) prior to the next shift. Once all bytes of the message have undergone the above algorithm, the CRC-register will contain the message CRC value to be placed in the error check field.

### Secure DECS-250 Login via Modbus

To login to the DECS-250 via Modbus, write the string *username|password* to the Secure Login register (40500). Substitute “username” with the user name of the desired access level, include the pipe “|” symbol, and substitute “password” with the password of the chosen access level. To view the current access level, read the Current Access register (40520). Write any value to the Logout register (40517) to log out of the DECS-250. Upon disconnecting from Modbus over TCP/IP, the user is automatically logged out of the DECS-250. However, upon disconnecting from Modbus over serial line, the user remains logged in.

## Modbus Parameters

### General

General parameters are listed in Table 23.

**Table 23. General Group Parameters**

Group	Name	Register	Type	Bytes	R/W	Range
System Data	Model Number	40001	String	64	R	0–64
System Data	App Version Information	40033	String	64	R	0–64
System Data	App Sub-version Version	40065	String	64	R	0–64
System Data	Boot Version Information	40097	String	64	R	0–64
System Data	Firmware Part Number	40129	String	64	R	0–64
Time	Date	40161	String	16	R	0–16
Time	Time	40169	String	16	R	0–16
Unit Information	Style Number	40177	String	32	R	0–32
Unit Information	Serial Number	40193	String	32	R	0–32
DECS Control	Control Output Var PF	40209	Float	4	R	n/a
DECS Control	Control Output OEL	40211	Float	4	R	n/a
DECS Control	Control Output UEL	40213	Float	4	R	n/a
DECS Control	Control Output SCL	40215	Float	4	R	n/a
DECS Control	Control Output AVR	40217	Float	4	R	n/a
DECS Control	Control Output FCR	40219	Float	4	R	n/a
DECS Control	Control Output FVR	40221	Float	4	R	n/a
DECS Control	Invert Output (SCT/PPT)	40223	Uint	4	RW	Disabled=0 Enabled=1

### Security

**Table 24. Security Group Parameters**

Group	Name	Register	Type	Bytes	R/W	Range
Security	Secure Login	40500	String	34	RW	0–34
Security	Logout	40517	String	5	RW	0–5
Security	Current Access	40520	Uint32	4	R	No Access=0, Read Access=1 Control Access=2 Operator Access=3 Setting Access=4 Design Access=5 Administrator Access=6

### Binary Points

**Table 25. Binary Point Group Parameters**

Group	Name	Register	Type	Bytes	R/W	Range
System Data	RF trig	40900 bit 0	Uint16	2	R	True=1 False=0
System Data	PU logic	40900 bit 1	Uint16	2	R	True=1 False=0
System Data	Trip logic	40900 bit 2	Uint16	2	R	True=1 False=0
System Data	Logic trig	40900 bit 3	Uint16	2	R	True=1 False=0
System Data	Breaker Status	40900 bit 4	Uint16	2	R	True=1 False=0
Alarms	Real Time Clock Alarm	40900 bit 5	Uint16	2	R	True=1 False=0
Alarms	Date Time Set Alarm	40900 bit 6	Uint16	2	R	True=1 False=0
Alarms	Firmware Change Alarm	40900 bit 7	Uint16	2	R	True=1 False=0
Alarms	Frequency out of range alarm	40900 bit 8	Uint16	2	R	True=1 False=0
Alarms	Ethernet link lost alarm	40900 bit 9	Uint16	2	R	True=1 False=0
Alarms	USB com alarm	40900 bit 10	Uint16	2	R	True=1 False=0
Alarms	IRIG sync lost alarm	40900 bit 11	Uint16	2	R	True=1 False=0

Group	Name	Register	Type	Bytes	R/W	Range
Alarms	Logic equal none alarm	40900 bit 12	Uint16	2	R	True=1 False=0
Alarms	No user setting alarm	40900 bit 13	Uint16	2	R	True=1 False=0
Alarms	NTP sync lost alarm	40900 bit 14	Uint16	2	R	True=1 False=0
Alarms	Microprocessor Reset Alarm	40900 bit 15	Uint16	2	R	True=1 False=0
Alarms	Programmable Alarm 1	40901 bit 0	Uint16	2	R	True=1 False=0
Alarms	Programmable Alarm 2	40901 bit 1	Uint16	2	R	True=1 False=0
Alarms	Programmable Alarm 3	40901 bit 2	Uint16	2	R	True=1 False=0
Alarms	Programmable Alarm 4	40901 bit 3	Uint16	2	R	True=1 False=0
Alarms	Programmable Alarm 5	40901 bit 4	Uint16	2	R	True=1 False=0
Alarms	Programmable Alarm 6	40901 bit 5	Uint16	2	R	True=1 False=0
Alarms	Programmable Alarm 7	40901 bit 6	Uint16	2	R	True=1 False=0
Alarms	Programmable Alarm 8	40901 bit 7	Uint16	2	R	True=1 False=0
Alarms	Programmable Alarm 9	40901 bit 8	Uint16	2	R	True=1 False=0
Alarms	Programmable Alarm 10	40901 bit 9	Uint16	2	R	True=1 False=0
Alarms	Programmable Alarm 11	40901 bit 10	Uint16	2	R	True=1 False=0
Alarms	Programmable Alarm 12	40901 bit 11	Uint16	2	R	True=1 False=0
Alarms	Programmable Alarm 13	40901 bit 12	Uint16	2	R	True=1 False=0
Alarms	Programmable Alarm 14	40901 bit 13	Uint16	2	R	True=1 False=0
Alarms	Programmable Alarm 15	40901 bit 14	Uint16	2	R	True=1 False=0
Alarms	Programmable Alarm 16	40901 bit 15	Uint16	2	R	True=1 False=0
Alarms	Underfrequency V/Hz Alarm	40902 bit 0	Uint16	2	R	True=1 False=0
Alarms	OEL alarm	40902 bit 1	Uint16	2	R	True=1 False=0
Alarms	UEL alarm	40902 bit 2	Uint16	2	R	True=1 False=0
Alarms	Failed to build up alarm	40902 bit 3	Uint16	2	R	True=1 False=0
Alarms	SCL alarm	40902 bit 4	Uint16	2	R	True=1 False=0
Alarms	PSS voltage unbalanced alarm	40902 bit 5	Uint16	2	R	True=1 False=0
Alarms	PSS current unbalanced alarm	40902 bit 6	Uint16	2	R	True=1 False=0
Alarms	PSS power below threshold alarm	40902 bit 7	Uint16	2	R	True=1 False=0
Alarms	PSS speed failed alarm	40902 bit 8	Uint16	2	R	True=1 False=0
Alarms	PSS voltage limit alarm	40902 bit 9	Uint16	2	R	True=1 False=0
Alarms	Transfer watchdog alarm	40902 bit 10	Uint16	2	R	True=1 False=0
Alarms	Crowbar activated	40902 bit 11	Uint16	2	R	True=1 False=0
Alarms	Var limiter active alarm	40902 bit 12	Uint16	2	R	True=1 False=0
Alarm Report	Alarm Output	40902 bit 13	Uint16	2	R	True=1 False=0
Hardware Ports	Field Short Circuit Status	40902 bit 14	Uint16	2	R	True=1 False=0
DECS Control	Auto transfer enable	40902 bit 15	Uint16	2	R	True=1 False=0
DECS Control	Var PF selection	40903 bit 0	Uint16	2	R	True=1 False=0
DECS Control	DECS start stop (external)	40903 bit 1	Uint16	2	R	True=1 False=0
DECS Control	Pre-position 1 active	40903 bit 2	Uint16	2	R	True=1 False=0
DECS Control	Pre-position 2 active	40903 bit 3	Uint16	2	R	True=1 False=0
DECS Control	Pre-position 3 active	40903 bit 4	Uint16	2	R	True=1 False=0
DECS Control	Auto active	40903 bit 5	Uint16	2	R	True=1 False=0
Field Overvoltage	Block	40903 bit 6	Uint16	2	R	True=1 False=0
Field Overvoltage	Pickup	40903 bit 7	Uint16	2	R	True=1 False=0
Field Overvoltage	Trip	40903 bit 8	Uint16	2	R	True=1 False=0
Field Overcurrent	Block	40903 bit 9	Uint16	2	R	True=1 False=0
Field Overcurrent	Pickup	40903 bit 10	Uint16	2	R	True=1 False=0
Field Overcurrent	Trip	40903 bit 11	Uint16	2	R	True=1 False=0
Exciter Diode Monitor	Block open diode	40903 bit 12	Uint16	2	R	True=1 False=0
Exciter Diode Monitor	Pickup open diode	40903 bit 13	Uint16	2	R	True=1 False=0
Exciter Diode Monitor	Trip open diode	40903 bit 14	Uint16	2	R	True=1 False=0

Group	Name	Register	Type	Bytes	R/W	Range
Exciter Diode Monitor	Block shorted diode	40903 bit 15	Uint16	2	R	True=1 False=0
Exciter Diode Monitor	Pickup shorted diode	40904 bit 0	Uint16	2	R	True=1 False=0
Exciter Diode Monitor	Trip shorted diode	40904 bit 1	Uint16	2	R	True=1 False=0
Power Input Failure	Block	40904 bit 2	Uint16	2	R	True=1 False=0
Power Input Failure	Pickup	40904 bit 3	Uint16	2	R	True=1 False=0
Power Input Failure	Trip	40904 bit 4	Uint16	2	R	True=1 False=0
Loss of Sensing	Block	40904 bit 5	Uint16	2	R	True=1 False=0
Loss of Sensing	Pickup	40904 bit 6	Uint16	2	R	True=1 False=0
Loss of Sensing	Trip	40904 bit 7	Uint16	2	R	True=1 False=0
25	Block	40904 bit 8	Uint16	2	R	True=1 False=0
25	Status	40904 bit 9	Uint16	2	R	True=1 False=0
25	VM1 status	40904 bit 10	Uint16	2	R	True=1 False=0
27P	Block	40904 bit 11	Uint16	2	R	True=1 False=0
27P	Pickup	40904 bit 12	Uint16	2	R	True=1 False=0
27P	Trip	40904 bit 13	Uint16	2	R	True=1 False=0
59P	Block	40904 bit 14	Uint16	2	R	True=1 False=0
59P	Pickup	40904 bit 15	Uint16	2	R	True=1 False=0
59P	Trip	40905 bit 0	Uint16	2	R	True=1 False=0
81O	Block	40905 bit 1	Uint16	2	R	True=1 False=0
81O	Pickup	40905 bit 2	Uint16	2	R	True=1 False=0
81O	Trip	40905 bit 3	Uint16	2	R	True=1 False=0
81U	Block	40905 bit 4	Uint16	2	R	True=1 False=0
81U	Pickup	40905 bit 5	Uint16	2	R	True=1 False=0
81U	Trip	40905 bit 6	Uint16	2	R	True=1 False=0
Gen Below 10 Hz	Block	40905 bit 7	Uint16	2	R	True=1 False=0
Gen Below 10 Hz	Pickup	40905 bit 8	Uint16	2	R	True=1 False=0
Gen Below 10 Hz	Trip	40905 bit 9	Uint16	2	R	True=1 False=0
40Q	Block	40905 bit 10	Uint16	2	R	True=1 False=0
40Q	Pickup	40905 bit 11	Uint16	2	R	True=1 False=0
40Q	Trip	40905 bit 12	Uint16	2	R	True=1 False=0
32R	Block	40905 bit 13	Uint16	2	R	True=1 False=0
32R	Pickup	40905 bit 14	Uint16	2	R	True=1 False=0
32R	Trip	40905 bit 15	Uint16	2	R	True=1 False=0
Configurable Protection 1	Configurable Protection Threshold 1 Pickup	40906 bit 0	Uint16	2	R	True=1 False=0
Configurable Protection 1	Configurable Protection Threshold 1 Trip	40906 bit 1	Uint16	2	R	True=1 False=0
Configurable Protection 1	Configurable Protection Threshold 2 Pickup	40906 bit 2	Uint16	2	R	True=1 False=0
Configurable Protection 1	Configurable Protection Threshold 2 Trip	40906 bit 3	Uint16	2	R	True=1 False=0
Configurable Protection 1	Configurable Protection Threshold 3 Pickup	40906 bit 4	Uint16	2	R	True=1 False=0
Configurable Protection 1	Configurable Protection Threshold 3 Trip	40906 bit 5	Uint16	2	R	True=1 False=0
Configurable Protection 1	Configurable Protection Threshold 4 Pickup	40906 bit 6	Uint16	2	R	True=1 False=0
Configurable Protection 1	Configurable Protection Threshold 4 Trip	40906 bit 7	Uint16	2	R	True=1 False=0
Configurable Protection 2	Configurable Protection Threshold 1 Pickup	40906 bit 8	Uint16	2	R	True=1 False=0
Configurable Protection 2	Configurable Protection Threshold 1 Trip	40906 bit 9	Uint16	2	R	True=1 False=0
Configurable Protection 2	Configurable Protection Threshold 2 Pickup	40906 bit 10	Uint16	2	R	True=1 False=0
Configurable Protection 2	Configurable Protection Threshold 2 Trip	40906 bit 11	Uint16	2	R	True=1 False=0
Configurable Protection 2	Configurable Protection Threshold 3 Pickup	40906 bit 12	Uint16	2	R	True=1 False=0
Configurable Protection 2	Configurable Protection Threshold 3 Trip	40906 bit 13	Uint16	2	R	True=1 False=0
Configurable Protection 2	Configurable Protection Threshold 4 Pickup	40906 bit 14	Uint16	2	R	True=1 False=0
Configurable Protection 2	Configurable Protection Threshold 4 Trip	40906 bit 15	Uint16	2	R	True=1 False=0
Configurable Protection 3	Configurable Protection Threshold 1 Pickup	40907 bit 0	Uint16	2	R	True=1 False=0
Configurable Protection 3	Configurable Protection Threshold 1 Trip	40907 bit 1	Uint16	2	R	True=1 False=0

Group	Name	Register	Type	Bytes	R/W	Range
Configurable Protection 3	Configurable Protection Threshold 2 Pickup	40907 bit 2	Uint16	2	R	True=1 False=0
Configurable Protection 3	Configurable Protection Threshold 2 Trip	40907 bit 3	Uint16	2	R	True=1 False=0
Configurable Protection 3	Configurable Protection Threshold 3 Pickup	40907 bit 4	Uint16	2	R	True=1 False=0
Configurable Protection 3	Configurable Protection Threshold 3 Trip	40907 bit 5	Uint16	2	R	True=1 False=0
Configurable Protection 3	Configurable Protection Threshold 4 Pickup	40907 bit 6	Uint16	2	R	True=1 False=0
Configurable Protection 3	Configurable Protection Threshold 4 Trip	40907 bit 7	Uint16	2	R	True=1 False=0
Configurable Protection 4	Configurable Protection Threshold 1 Pickup	40907 bit 8	Uint16	2	R	True=1 False=0
Configurable Protection 4	Configurable Protection Threshold 1 Trip	40907 bit 9	Uint16	2	R	True=1 False=0
Configurable Protection 4	Configurable Protection Threshold 2 Pickup	40907 bit 10	Uint16	2	R	True=1 False=0
Configurable Protection 4	Configurable Protection Threshold 2 Trip	40907 bit 11	Uint16	2	R	True=1 False=0
Configurable Protection 4	Configurable Protection Threshold 3 Pickup	40907 bit 12	Uint16	2	R	True=1 False=0
Configurable Protection 4	Configurable Protection Threshold 3 Trip	40907 bit 13	Uint16	2	R	True=1 False=0
Configurable Protection 4	Configurable Protection Threshold 4 Pickup	40907 bit 14	Uint16	2	R	True=1 False=0
Configurable Protection 4	Configurable Protection Threshold 4 Trip	40907 bit 15	Uint16	2	R	True=1 False=0
Configurable Protection 5	Configurable Protection Threshold 1 Pickup	40908 bit 0	Uint16	2	R	True=1 False=0
Configurable Protection 5	Configurable Protection Threshold 1 Trip	40908 bit 1	Uint16	2	R	True=1 False=0
Configurable Protection 5	Configurable Protection Threshold 2 Pickup	40908 bit 2	Uint16	2	R	True=1 False=0
Configurable Protection 5	Configurable Protection Threshold 2 Trip	40908 bit 3	Uint16	2	R	True=1 False=0
Configurable Protection 5	Configurable Protection Threshold 3 Pickup	40908 bit 4	Uint16	2	R	True=1 False=0
Configurable Protection 5	Configurable Protection Threshold 3 Trip	40908 bit 5	Uint16	2	R	True=1 False=0
Configurable Protection 5	Configurable Protection Threshold 4 Pickup	40908 bit 6	Uint16	2	R	True=1 False=0
Configurable Protection 5	Configurable Protection Threshold 4 Trip	40908 bit 7	Uint16	2	R	True=1 False=0
Configurable Protection 6	Configurable Protection Threshold 1 Pickup	40908 bit 8	Uint16	2	R	True=1 False=0
Configurable Protection 6	Configurable Protection Threshold 1 Trip	40908 bit 9	Uint16	2	R	True=1 False=0
Configurable Protection 6	Configurable Protection Threshold 2 Pickup	40908 bit 10	Uint16	2	R	True=1 False=0
Configurable Protection 6	Configurable Protection Threshold 2 Trip	40908 bit 11	Uint16	2	R	True=1 False=0
Configurable Protection 6	Configurable Protection Threshold 3 Pickup	40908 bit 12	Uint16	2	R	True=1 False=0
Configurable Protection 6	Configurable Protection Threshold 3 Trip	40908 bit 13	Uint16	2	R	True=1 False=0
Configurable Protection 6	Configurable Protection Threshold 4 Pickup	40908 bit 14	Uint16	2	R	True=1 False=0
Configurable Protection 6	Configurable Protection Threshold 4 Trip	40908 bit 15	Uint16	2	R	True=1 False=0
Configurable Protection 7	Configurable Protection Threshold 1 Pickup	40909 bit 0	Uint16	2	R	True=1 False=0
Configurable Protection 7	Configurable Protection Threshold 1 Trip	40909 bit 1	Uint16	2	R	True=1 False=0
Configurable Protection 7	Configurable Protection Threshold 2 Pickup	40909 bit 2	Uint16	2	R	True=1 False=0
Configurable Protection 7	Configurable Protection Threshold 2 Trip	40909 bit 3	Uint16	2	R	True=1 False=0
Configurable Protection 7	Configurable Protection Threshold 3 Pickup	40909 bit 4	Uint16	2	R	True=1 False=0
Configurable Protection 7	Configurable Protection Threshold 3 Trip	40909 bit 5	Uint16	2	R	True=1 False=0
Configurable Protection 7	Configurable Protection Threshold 4 Pickup	40909 bit 6	Uint16	2	R	True=1 False=0
Configurable Protection 7	Configurable Protection Threshold 4 Trip	40909 bit 7	Uint16	2	R	True=1 False=0
Configurable Protection 8	Configurable Protection Threshold 1 Pickup	40909 bit 8	Uint16	2	R	True=1 False=0
Configurable Protection 8	Configurable Protection Threshold 1 Trip	40909 bit 9	Uint16	2	R	True=1 False=0
Configurable Protection 8	Configurable Protection Threshold 2 Pickup	40909 bit 10	Uint16	2	R	True=1 False=0
Configurable Protection 8	Configurable Protection Threshold 2 Trip	40909 bit 11	Uint16	2	R	True=1 False=0
Configurable Protection 8	Configurable Protection Threshold 3 Pickup	40909 bit 12	Uint16	2	R	True=1 False=0
Configurable Protection 8	Configurable Protection Threshold 3 Trip	40909 bit 13	Uint16	2	R	True=1 False=0
Configurable Protection 8	Configurable Protection Threshold 4 Pickup	40909 bit 14	Uint16	2	R	True=1 False=0
Configurable Protection 8	Configurable Protection Threshold 4 Trip	40909 bit 15	Uint16	2	R	True=1 False=0
Synchronizer	Sync Failed Alarm	40910 bit 0	Uint16	2	R	True=1 False=0
Network Load Share	Unknown Network Load Share Protocol Version	40910 bit 1	Uint16	2	R	True=1 False=0
Alarms	Voltage Matching Active	40910 bit 2	Uint16	2	R	True=1 False=0
Contact Inputs	Start Input	40910 bit 3	Uint16	2	R	True=1 False=0

Group	Name	Register	Type	Bytes	R/W	Range
Contact Inputs	Stop Input	40910 bit 4	Uint16	2	R	True=1 False=0
Contact Inputs	Input 1	40910 bit 5	Uint16	2	R	True=1 False=0
Contact Inputs	Input 2	40910 bit 6	Uint16	2	R	True=1 False=0
Contact Inputs	Input 3	40910 bit 7	Uint16	2	R	True=1 False=0
Contact Inputs	Input 4	40910 bit 8	Uint16	2	R	True=1 False=0
Contact Inputs	Input 5	40910 bit 9	Uint16	2	R	True=1 False=0
Contact Inputs	Input 6	40910 bit 10	Uint16	2	R	True=1 False=0
Contact Inputs	Input 7	40910 bit 11	Uint16	2	R	True=1 False=0
Contact Inputs	Input 8	40910 bit 12	Uint16	2	R	True=1 False=0
Contact Inputs	Input 9	40910 bit 13	Uint16	2	R	True=1 False=0
Contact Inputs	Input 10	40910 bit 14	Uint16	2	R	True=1 False=0
Contact Inputs	Input 11	40910 bit 15	Uint16	2	R	True=1 False=0
Contact Inputs	Input 12	40911 bit 0	Uint16	2	R	True=1 False=0
Contact Inputs	Input 13	40911 bit 1	Uint16	2	R	True=1 False=0
Contact Inputs	Input 14	40911 bit 2	Uint16	2	R	True=1 False=0
Contact Outputs	Watchdog Output	40911 bit 3	Uint16	2	R	True=1 False=0
Contact Outputs	Output 1	40911 bit 4	Uint16	2	R	True=1 False=0
Contact Outputs	Output 2	40911 bit 5	Uint16	2	R	True=1 False=0
Contact Outputs	Output 3	40911 bit 6	Uint16	2	R	True=1 False=0
Contact Outputs	Output 4	40911 bit 7	Uint16	2	R	True=1 False=0
Contact Outputs	Output 5	40911 bit 8	Uint16	2	R	True=1 False=0
Contact Outputs	Output 6	40911 bit 9	Uint16	2	R	True=1 False=0
Contact Outputs	Output 7	40911 bit 10	Uint16	2	R	True=1 False=0
Contact Outputs	Output 8	40911 bit 11	Uint16	2	R	True=1 False=0
Contact Outputs	Output 9	40911 bit 12	Uint16	2	R	True=1 False=0
Contact Outputs	Output 10	40911 bit 13	Uint16	2	R	True=1 False=0
Contact Outputs	Output 11	40911 bit 14	Uint16	2	R	True=1 False=0
Virtual Switch	Virtual Switch 1	40911 bit 15	Uint16	2	R	True=1 False=0
Virtual Switch	Virtual Switch 2	40912 bit 0	Uint16	2	R	True=1 False=0
Virtual Switch	Virtual Switch 3	40912 bit 1	Uint16	2	R	True=1 False=0
Virtual Switch	Virtual Switch 4	40912 bit 2	Uint16	2	R	True=1 False=0
Virtual Switch	Virtual Switch 5	40912 bit 3	Uint16	2	R	True=1 False=0
Virtual Switch	Virtual Switch 6	40912 bit 4	Uint16	2	R	True=1 False=0
DECS Control	Manual FCR Only	40912 bit 5	Uint16	2	R	True=1 False=0
DECS Control	Droop Disable	40912 bit 6	Uint16	2	R	True=1 False=0
DECS Control	CC Disable	40912 bit 7	Uint16	2	R	True=1 False=0
DECS Control	Line Drop Disable	40912 bit 8	Uint16	2	R	True=1 False=0
DECS Control	Parallel Enable	40912 bit 9	Uint16	2	R	True=1 False=0
DECS Control	Soft Start Select Group 2	40912 bit 10	Uint16	2	R	True=1 False=0
DECS Control	PSS Select Group 2	40912 bit 11	Uint16	2	R	True=1 False=0
DECS Control	OEL Select Group 2	40912 bit 12	Uint16	2	R	True=1 False=0
DECS Control	UEL Select Group 2	40912 bit 13	Uint16	2	R	True=1 False=0
DECS Control	SCL Select Group 2	40912 bit 14	Uint16	2	R	True=1 False=0
DECS Control	Protect Select Group 2	40912 bit 15	Uint16	2	R	True=1 False=0
DECS Control	PID Select Group 2	40913 bit 0	Uint16	2	R	True=1 False=0
DECS Control	DECS Manual Auto	40913 bit 1	Uint16	2	R	True=1 False=0
DECS Control	Null Balance	40913 bit 2	Uint16	2	R	True=1 False=0
DECS Control	DECS Pre-position	40913 bit 3	Uint16	2	R	True=1 False=0
DECS Control	Var Limiter Select Group 2	40913 bit 4	Uint16	2	R	True=1 False=0
DECS Control	Var Active	40913 bit 5	Uint16	2	R	True=1 False=0
DECS Control	PF Active	40913 bit 6	Uint16	2	R	True=1 False=0

Group	Name	Register	Type	Bytes	R/W	Range
DECS Control	FVR Active	40913 bit 7	Uint16	2	R	True=1 False=0
DECS Control	FCR Active	40913 bit 8	Uint16	2	R	True=1 False=0
DECS Control	Manual Active	40913 bit 9	Uint16	2	R	True=1 False=0
DECS PSS Meter	PSS Active	40913 bit 10	Uint16	2	R	True=1 False=0
DECS Regulator Meter	Setpoint at Lower Limit	40913 bit 11	Uint16	2	R	True=1 False=0
DECS Regulator Meter	Setpoint at Upper Limit	40913 bit 12	Uint16	2	R	True=1 False=0
Exciter Diode Monitor	Trip Open or Shorted Diode	40913 bit 13	Uint16	2	R	True=1 False=0
Contact Expansion Module	Input 1	40913 bit 14	Uint16	2	R	True=1 False=0
Contact Expansion Module	Input 2	40913 bit 15	Uint16	2	R	True=1 False=0
Contact Expansion Module	Input 3	40914 bit 0	Uint16	2	R	True=1 False=0
Contact Expansion Module	Input 4	40914 bit 1	Uint16	2	R	True=1 False=0
Contact Expansion Module	Input 5	40914 bit 2	Uint16	2	R	True=1 False=0
Contact Expansion Module	Input 6	40914 bit 3	Uint16	2	R	True=1 False=0
Contact Expansion Module	Input 7	40914 bit 4	Uint16	2	R	True=1 False=0
Contact Expansion Module	Input 8	40914 bit 5	Uint16	2	R	True=1 False=0
Contact Expansion Module	Input 9	40914 bit 6	Uint16	2	R	True=1 False=0
Contact Expansion Module	Input 10	40914 bit 7	Uint16	2	R	True=1 False=0
Contact Expansion Module	Output 1	40914 bit 8	Uint16	2	R	True=1 False=0
Contact Expansion Module	Output 2	40914 bit 9	Uint16	2	R	True=1 False=0
Contact Expansion Module	Output 3	40914 bit 10	Uint16	2	R	True=1 False=0
Contact Expansion Module	Output 4	40914 bit 11	Uint16	2	R	True=1 False=0
Contact Expansion Module	Output 5	40914 bit 12	Uint16	2	R	True=1 False=0
Contact Expansion Module	Output 6	40914 bit 13	Uint16	2	R	True=1 False=0
Contact Expansion Module	Output 7	40914 bit 14	Uint16	2	R	True=1 False=0
Contact Expansion Module	Output 8	40914 bit 15	Uint16	2	R	True=1 False=0
Contact Expansion Module	Output 9	40915 bit 0	Uint16	2	R	True=1 False=0
Contact Expansion Module	Output 10	40915 bit 1	Uint16	2	R	True=1 False=0
Contact Expansion Module	Output 11	40915 bit 2	Uint16	2	R	True=1 False=0
Contact Expansion Module	Output 12	40915 bit 3	Uint16	2	R	True=1 False=0
Contact Expansion Module	Output 13	40915 bit 4	Uint16	2	R	True=1 False=0
Contact Expansion Module	Output 14	40915 bit 5	Uint16	2	R	True=1 False=0
Contact Expansion Module	Output 15	40915 bit 6	Uint16	2	R	True=1 False=0
Contact Expansion Module	Output 16	40915 bit 7	Uint16	2	R	True=1 False=0
Contact Expansion Module	Output 17	40915 bit 8	Uint16	2	R	True=1 False=0
Contact Expansion Module	Output 18	40915 bit 9	Uint16	2	R	True=1 False=0
Contact Expansion Module	Output 19	40915 bit 10	Uint16	2	R	True=1 False=0
Contact Expansion Module	Output 20	40915 bit 11	Uint16	2	R	True=1 False=0
Contact Expansion Module	Output 21	40915 bit 12	Uint16	2	R	True=1 False=0
Contact Expansion Module	Output 22	40915 bit 13	Uint16	2	R	True=1 False=0
Contact Expansion Module	Output 23	40915 bit 14	Uint16	2	R	True=1 False=0
Contact Expansion Module	Output 24	40915 bit 15	Uint16	2	R	True=1 False=0
Network Load Share	Network Load Share Disable	40916 bit 0	Uint16	2	R	True=1 False=0
Alarms	Invalid Logic Alarm	40916 bit 1	Uint16	2	R	True=1 False=0
24	Block	40916 bit 2	Uint16	2	R	True=1 False=0
24	Pickup	40916 bit 3	Uint16	2	R	True=1 False=0
24	Trip	40916 bit 4	Uint16	2	R	True=1 False=0
24	Reserved	40916 bit 5	Uint16	2	R	True=1 False=0
DECS Control	Transient Boost Active	40916 bit 6	Uint16	2	R	True=1 False=0
AEM Configuration	AEM Communication Failure	40916 bit 7	Uint16	2	R	True=1 False=0
AEM Configuration	Duplicate AEM	40916 bit 8	Uint16	2	R	True=1 False=0
AEM Configuration	AEM Input 1 Out of Range	40916 bit 9	Uint16	2	R	True=1 False=0

Group	Name	Register	Type	Bytes	R/W	Range
AEM Configuration	AEM Input 2 Out of Range	40916 bit 10	Uint16	2	R	True=1 False=0
AEM Configuration	AEM Input 3 Out of Range	40916 bit 11	Uint16	2	R	True=1 False=0
AEM Configuration	AEM Input 4 Out of Range	40916 bit 12	Uint16	2	R	True=1 False=0
AEM Configuration	AEM Input 5 Out of Range	40916 bit 13	Uint16	2	R	True=1 False=0
AEM Configuration	AEM Input 6 Out of Range	40916 bit 14	Uint16	2	R	True=1 False=0
AEM Configuration	AEM Input 7 Out of Range	40916 bit 15	Uint16	2	R	True=1 False=0
AEM Configuration	AEM Input 8 Out of Range	40917 bit 0	Uint16	2	R	True=1 False=0
AEM Configuration	RTD Input 1 Out of Range	40917 bit 1	Uint16	2	R	True=1 False=0
AEM Configuration	RTD Input 2 Out of Range	40917 bit 2	Uint16	2	R	True=1 False=0
AEM Configuration	RTD Input 3 Out of Range	40917 bit 3	Uint16	2	R	True=1 False=0
AEM Configuration	RTD Input 4 Out of Range	40917 bit 4	Uint16	2	R	True=1 False=0
AEM Configuration	RTD Input 5 Out of Range	40917 bit 5	Uint16	2	R	True=1 False=0
AEM Configuration	RTD Input 6 Out of Range	40917 bit 6	Uint16	2	R	True=1 False=0
AEM Configuration	RTD Input 7 Out of Range	40917 bit 7	Uint16	2	R	True=1 False=0
AEM Configuration	RTD Input 8 Out of Range	40917 bit 8	Uint16	2	R	True=1 False=0
AEM Configuration	AEM Output 1 Out of Range	40917 bit 9	Uint16	2	R	True=1 False=0
AEM Configuration	AEM Output 2 Out of Range	40917 bit 10	Uint16	2	R	True=1 False=0
AEM Configuration	AEM Output 3 Out of Range	40917 bit 11	Uint16	2	R	True=1 False=0
AEM Configuration	AEM Output 4 Out of Range	40917 bit 12	Uint16	2	R	True=1 False=0
AEM Protection 1	Threshold 1 Pickup	40917 bit 13	Uint16	2	R	True=1 False=0
AEM Protection 1	Threshold 1 Trip	40917 bit 14	Uint16	2	R	True=1 False=0
AEM Protection 1	Threshold 2 Pickup	40917 bit 15	Uint16	2	R	True=1 False=0
AEM Protection 1	Threshold 2 Trip	40918 bit 0	Uint16	2	R	True=1 False=0
AEM Protection 1	Threshold 3 Pickup	40918 bit 1	Uint16	2	R	True=1 False=0
AEM Protection 1	Threshold 3 Trip	40918 bit 2	Uint16	2	R	True=1 False=0
AEM Protection 1	Threshold 4 Pickup	40918 bit 3	Uint16	2	R	True=1 False=0
AEM Protection 1	Threshold 4 Trip	40918 bit 4	Uint16	2	R	True=1 False=0
AEM Protection 2	Threshold 1 Pickup	40918 bit 5	Uint16	2	R	True=1 False=0
AEM Protection 2	Threshold 1 Trip	40918 bit 6	Uint16	2	R	True=1 False=0
AEM Protection 2	Threshold 2 Pickup	40918 bit 7	Uint16	2	R	True=1 False=0
AEM Protection 2	Threshold 2 Trip	40918 bit 8	Uint16	2	R	True=1 False=0
AEM Protection 2	Threshold 3 Pickup	40918 bit 9	Uint16	2	R	True=1 False=0
AEM Protection 2	Threshold 3 Trip	40918 bit 10	Uint16	2	R	True=1 False=0
AEM Protection 2	Threshold 4 Pickup	40918 bit 11	Uint16	2	R	True=1 False=0
AEM Protection 2	Threshold 4 Trip	40918 bit 12	Uint16	2	R	True=1 False=0
AEM Protection 3	Threshold 1 Pickup	40918 bit 13	Uint16	2	R	True=1 False=0
AEM Protection 3	Threshold 1 Trip	40918 bit 14	Uint16	2	R	True=1 False=0
AEM Protection 3	Threshold 2 Pickup	40918 bit 15	Uint16	2	R	True=1 False=0
AEM Protection 3	Threshold 2 Trip	40919 bit 0	Uint16	2	R	True=1 False=0
AEM Protection 3	Threshold 3 Pickup	40919 bit 1	Uint16	2	R	True=1 False=0
AEM Protection 3	Threshold 3 Trip	40919 bit 2	Uint16	2	R	True=1 False=0
AEM Protection 3	Threshold 4 Pickup	40919 bit 3	Uint16	2	R	True=1 False=0
AEM Protection 3	Threshold 4 Trip	40919 bit 4	Uint16	2	R	True=1 False=0
AEM Protection 4	Threshold 1 Pickup	40919 bit 5	Uint16	2	R	True=1 False=0
AEM Protection 4	Threshold 1 Trip	40919 bit 6	Uint16	2	R	True=1 False=0
AEM Protection 4	Threshold 2 Pickup	40919 bit 7	Uint16	2	R	True=1 False=0
AEM Protection 4	Threshold 2 Trip	40919 bit 8	Uint16	2	R	True=1 False=0
AEM Protection 4	Threshold 3 Pickup	40919 bit 9	Uint16	2	R	True=1 False=0
AEM Protection 4	Threshold 3 Trip	40919 bit 10	Uint16	2	R	True=1 False=0
AEM Protection 4	Threshold 4 Pickup	40919 bit 11	Uint16	2	R	True=1 False=0
AEM Protection 4	Threshold 4 Trip	40919 bit 12	Uint16	2	R	True=1 False=0

Group	Name	Register	Type	Bytes	R/W	Range
AEM Protection 5	Threshold 1 Pickup	40919 bit 13	Uint16	2	R	True=1 False=0
AEM Protection 5	Threshold 1 Trip	40919 bit 14	Uint16	2	R	True=1 False=0
AEM Protection 5	Threshold 2 Pickup	40919 bit 15	Uint16	2	R	True=1 False=0
AEM Protection 5	Threshold 2 Trip	40920 bit 0	Uint16	2	R	True=1 False=0
AEM Protection 5	Threshold 3 Pickup	40920 bit 1	Uint16	2	R	True=1 False=0
AEM Protection 5	Threshold 3 Trip	40920 bit 2	Uint16	2	R	True=1 False=0
AEM Protection 5	Threshold 4 Pickup	40920 bit 3	Uint16	2	R	True=1 False=0
AEM Protection 5	Threshold 4 Trip	40920 bit 4	Uint16	2	R	True=1 False=0
AEM Protection 6	Threshold 1 Pickup	40920 bit 5	Uint16	2	R	True=1 False=0
AEM Protection 6	Threshold 1 Trip	40920 bit 6	Uint16	2	R	True=1 False=0
AEM Protection 6	Threshold 2 Pickup	40920 bit 7	Uint16	2	R	True=1 False=0
AEM Protection 6	Threshold 2 Trip	40920 bit 8	Uint16	2	R	True=1 False=0
AEM Protection 6	Threshold 3 Pickup	40920 bit 9	Uint16	2	R	True=1 False=0
AEM Protection 6	Threshold 3 Trip	40920 bit 10	Uint16	2	R	True=1 False=0
AEM Protection 6	Threshold 4 Pickup	40920 bit 11	Uint16	2	R	True=1 False=0
AEM Protection 6	Threshold 4 Trip	40920 bit 12	Uint16	2	R	True=1 False=0
AEM Protection 7	Threshold 1 Pickup	40920 bit 13	Uint16	2	R	True=1 False=0
AEM Protection 7	Threshold 1 Trip	40920 bit 14	Uint16	2	R	True=1 False=0
AEM Protection 7	Threshold 2 Pickup	40920 bit 15	Uint16	2	R	True=1 False=0
AEM Protection 7	Threshold 2 Trip	40921 bit 0	Uint16	2	R	True=1 False=0
AEM Protection 7	Threshold 3 Pickup	40921 bit 1	Uint16	2	R	True=1 False=0
AEM Protection 7	Threshold 3 Trip	40921 bit 2	Uint16	2	R	True=1 False=0
AEM Protection 7	Threshold 4 Pickup	40921 bit 3	Uint16	2	R	True=1 False=0
AEM Protection 7	Threshold 4 Trip	40921 bit 4	Uint16	2	R	True=1 False=0
AEM Protection 8	Threshold 1 Pickup	40921 bit 5	Uint16	2	R	True=1 False=0
AEM Protection 8	Threshold 1 Trip	40921 bit 6	Uint16	2	R	True=1 False=0
AEM Protection 8	Threshold 2 Pickup	40921 bit 7	Uint16	2	R	True=1 False=0
AEM Protection 8	Threshold 2 Trip	40921 bit 8	Uint16	2	R	True=1 False=0
AEM Protection 8	Threshold 3 Pickup	40921 bit 9	Uint16	2	R	True=1 False=0
AEM Protection 8	Threshold 3 Trip	40921 bit 10	Uint16	2	R	True=1 False=0
AEM Protection 8	Threshold 4 Pickup	40921 bit 11	Uint16	2	R	True=1 False=0
AEM Protection 8	Threshold 4 Trip	40921 bit 12	Uint16	2	R	True=1 False=0
RTD Protection 1	Threshold 1 Pickup	40921 bit 13	Uint16	2	R	True=1 False=0
RTD Protection 1	Threshold 1 Trip	40921 bit 14	Uint16	2	R	True=1 False=0
RTD Protection 1	Threshold 2 Pickup	40921 bit 15	Uint16	2	R	True=1 False=0
RTD Protection 1	Threshold 2 Trip	40922 bit 0	Uint16	2	R	True=1 False=0
RTD Protection 1	Threshold 3 Pickup	40922 bit 1	Uint16	2	R	True=1 False=0
RTD Protection 1	Threshold 3 Trip	40922 bit 2	Uint16	2	R	True=1 False=0
RTD Protection 1	Threshold 4 Pickup	40922 bit 3	Uint16	2	R	True=1 False=0
RTD Protection 1	Threshold 4 Trip	40922 bit 4	Uint16	2	R	True=1 False=0
RTD Protection 2	Threshold 1 Pickup	40922 bit 5	Uint16	2	R	True=1 False=0
RTD Protection 2	Threshold 1 Trip	40922 bit 6	Uint16	2	R	True=1 False=0
RTD Protection 2	Threshold 2 Pickup	40922 bit 7	Uint16	2	R	True=1 False=0
RTD Protection 2	Threshold 2 Trip	40922 bit 8	Uint16	2	R	True=1 False=0
RTD Protection 2	Threshold 3 Pickup	40922 bit 9	Uint16	2	R	True=1 False=0
RTD Protection 2	Threshold 3 Trip	40922 bit 10	Uint16	2	R	True=1 False=0
RTD Protection 2	Threshold 4 Pickup	40922 bit 11	Uint16	2	R	True=1 False=0
RTD Protection 2	Threshold 4 Trip	40922 bit 12	Uint16	2	R	True=1 False=0
RTD Protection 3	Threshold 1 Pickup	40922 bit 13	Uint16	2	R	True=1 False=0
RTD Protection 3	Threshold 1 Trip	40922 bit 14	Uint16	2	R	True=1 False=0
RTD Protection 3	Threshold 2 Pickup	40922 bit 15	Uint16	2	R	True=1 False=0

Group	Name	Register	Type	Bytes	R/W	Range
RTD Protection 3	Threshold 2 Trip	40923 bit 0	Uint16	2	R	True=1 False=0
RTD Protection 3	Threshold 3 Pickup	40923 bit 1	Uint16	2	R	True=1 False=0
RTD Protection 3	Threshold 3 Trip	40923 bit 2	Uint16	2	R	True=1 False=0
RTD Protection 3	Threshold 4 Pickup	40923 bit 3	Uint16	2	R	True=1 False=0
RTD Protection 3	Threshold 4 Trip	40923 bit 4	Uint16	2	R	True=1 False=0
RTD Protection 4	Threshold 1 Pickup	40923 bit 5	Uint16	2	R	True=1 False=0
RTD Protection 4	Threshold 1 Trip	40923 bit 6	Uint16	2	R	True=1 False=0
RTD Protection 4	Threshold 2 Pickup	40923 bit 7	Uint16	2	R	True=1 False=0
RTD Protection 4	Threshold 2 Trip	40923 bit 8	Uint16	2	R	True=1 False=0
RTD Protection 4	Threshold 3 Pickup	40923 bit 9	Uint16	2	R	True=1 False=0
RTD Protection 4	Threshold 3 Trip	40923 bit 10	Uint16	2	R	True=1 False=0
RTD Protection 4	Threshold 4 Pickup	40923 bit 11	Uint16	2	R	True=1 False=0
RTD Protection 4	Threshold 4 Trip	40923 bit 12	Uint16	2	R	True=1 False=0
RTD Protection 5	Threshold 1 Pickup	40923 bit 13	Uint16	2	R	True=1 False=0
RTD Protection 5	Threshold 1 Trip	40923 bit 14	Uint16	2	R	True=1 False=0
RTD Protection 5	Threshold 2 Pickup	40923 bit 15	Uint16	2	R	True=1 False=0
RTD Protection 5	Threshold 2 Trip	40924 bit 0	Uint16	2	R	True=1 False=0
RTD Protection 5	Threshold 3 Pickup	40924 bit 1	Uint16	2	R	True=1 False=0
RTD Protection 5	Threshold 3 Trip	40924 bit 2	Uint16	2	R	True=1 False=0
RTD Protection 5	Threshold 4 Pickup	40924 bit 3	Uint16	2	R	True=1 False=0
RTD Protection 5	Threshold 4 Trip	40924 bit 4	Uint16	2	R	True=1 False=0
RTD Protection 6	Threshold 1 Pickup	40924 bit 5	Uint16	2	R	True=1 False=0
RTD Protection 6	Threshold 1 Trip	40924 bit 6	Uint16	2	R	True=1 False=0
RTD Protection 6	Threshold 2 Pickup	40924 bit 7	Uint16	2	R	True=1 False=0
RTD Protection 6	Threshold 2 Trip	40924 bit 8	Uint16	2	R	True=1 False=0
RTD Protection 6	Threshold 3 Pickup	40924 bit 9	Uint16	2	R	True=1 False=0
RTD Protection 6	Threshold 3 Trip	40924 bit 10	Uint16	2	R	True=1 False=0
RTD Protection 6	Threshold 4 Pickup	40924 bit 11	Uint16	2	R	True=1 False=0
RTD Protection 6	Threshold 4 Trip	40924 bit 12	Uint16	2	R	True=1 False=0
RTD Protection 7	Threshold 1 Pickup	40924 bit 13	Uint16	2	R	True=1 False=0
RTD Protection 7	Threshold 1 Trip	40924 bit 14	Uint16	2	R	True=1 False=0
RTD Protection 7	Threshold 2 Pickup	40924 bit 15	Uint16	2	R	True=1 False=0
RTD Protection 7	Threshold 2 Trip	40925 bit 0	Uint16	2	R	True=1 False=0
RTD Protection 7	Threshold 3 Pickup	40925 bit 1	Uint16	2	R	True=1 False=0
RTD Protection 7	Threshold 3 Trip	40925 bit 2	Uint16	2	R	True=1 False=0
RTD Protection 7	Threshold 4 Pickup	40925 bit 3	Uint16	2	R	True=1 False=0
RTD Protection 7	Threshold 4 Trip	40925 bit 4	Uint16	2	R	True=1 False=0
RTD Protection 8	Threshold 1 Pickup	40925 bit 5	Uint16	2	R	True=1 False=0
RTD Protection 8	Threshold 1 Trip	40925 bit 6	Uint16	2	R	True=1 False=0
RTD Protection 8	Threshold 2 Pickup	40925 bit 7	Uint16	2	R	True=1 False=0
RTD Protection 8	Threshold 2 Trip	40925 bit 8	Uint16	2	R	True=1 False=0
RTD Protection 8	Threshold 3 Pickup	40925 bit 9	Uint16	2	R	True=1 False=0
RTD Protection 8	Threshold 3 Trip	40925 bit 10	Uint16	2	R	True=1 False=0
RTD Protection 8	Threshold 4 Pickup	40925 bit 11	Uint16	2	R	True=1 False=0
RTD Protection 8	Threshold 4 Trip	40925 bit 12	Uint16	2	R	True=1 False=0
Thermocouple Protection 1	Threshold 1 Pickup	40925 bit 13	Uint16	2	R	True=1 False=0
Thermocouple Protection 1	Threshold 1 Trip	40925 bit 14	Uint16	2	R	True=1 False=0
Thermocouple Protection 1	Threshold 2 Pickup	40925 bit 15	Uint16	2	R	True=1 False=0
Thermocouple Protection 1	Threshold 2 Trip	40926 bit 0	Uint16	2	R	True=1 False=0
Thermocouple Protection 1	Threshold 3 Pickup	40926 bit 1	Uint16	2	R	True=1 False=0
Thermocouple Protection 1	Threshold 3 Trip	40926 bit 2	Uint16	2	R	True=1 False=0

Group	Name	Register	Type	Bytes	R/W	Range
Thermocouple Protection 1	Threshold 4 Pickup	40926 bit 3	Uint16	2	R	True=1 False=0
Thermocouple Protection 1	Threshold 4 Trip	40926 bit 4	Uint16	2	R	True=1 False=0
Thermocouple Protection 2	Threshold 1 Pickup	40926 bit 5	Uint16	2	R	True=1 False=0
Thermocouple Protection 2	Threshold 1 Trip	40926 bit 6	Uint16	2	R	True=1 False=0
Thermocouple Protection 2	Threshold 2 Pickup	40926 bit 7	Uint16	2	R	True=1 False=0
Thermocouple Protection 2	Threshold 2 Trip	40926 bit 8	Uint16	2	R	True=1 False=0
Thermocouple Protection 2	Threshold 3 Pickup	40926 bit 9	Uint16	2	R	True=1 False=0
Thermocouple Protection 2	Threshold 3 Trip	40926 bit 10	Uint16	2	R	True=1 False=0
Thermocouple Protection 2	Threshold 4 Pickup	40926 bit 11	Uint16	2	R	True=1 False=0
Thermocouple Protection 2	Threshold 4 Trip	40926 bit 12	Uint16	2	R	True=1 False=0
Network Load Share	NLS Active	40926 bit 13	Uint16	2	R	True=1 False=0
Network Load Share	Receiving ID 1	40926 bit 14	Uint16	2	R	True=1 False=0
Network Load Share	Receiving ID 2	40926 bit 15	Uint16	2	R	True=1 False=0
Network Load Share	Receiving ID 3	40927 bit 0	Uint16	2	R	True=1 False=0
Network Load Share	Receiving ID 4	40927 bit 1	Uint16	2	R	True=1 False=0
Network Load Share	Receiving ID 5	40927 bit 2	Uint16	2	R	True=1 False=0
Network Load Share	Receiving ID 6	40927 bit 3	Uint16	2	R	True=1 False=0
Network Load Share	Receiving ID 7	40927 bit 4	Uint16	2	R	True=1 False=0
Network Load Share	Receiving ID 8	40927 bit 5	Uint16	2	R	True=1 False=0
Network Load Share	Receiving ID 9	40927 bit 6	Uint16	2	R	True=1 False=0
Network Load Share	Receiving ID 10	40927 bit 7	Uint16	2	R	True=1 False=0
Network Load Share	Receiving ID 11	40927 bit 8	Uint16	2	R	True=1 False=0
Network Load Share	Receiving ID 12	40927 bit 9	Uint16	2	R	True=1 False=0
Network Load Share	Receiving ID 13	40927 bit 10	Uint16	2	R	True=1 False=0
Network Load Share	Receiving ID 14	40927 bit 11	Uint16	2	R	True=1 False=0
Network Load Share	Receiving ID 15	40927 bit 12	Uint16	2	R	True=1 False=0
Network Load Share	Receiving ID 16	40927 bit 13	Uint16	2	R	True=1 False=0
Network Load Share	NLS Configuration Mismatch	40927 bit 14	Uint16	2	R	True=1 False=0
Network Load Share	NLS ID Missing	40927 bit 15	Uint16	2	R	True=1 False=0
Network Load Share	ID 1 Enabled	40928 bit 0	Uint16	2	R	True=1 False=0
Network Load Share	ID 2 Enabled	40928 bit 1	Uint16	2	R	True=1 False=0
Network Load Share	ID 3 Enabled	40928 bit 2	Uint16	2	R	True=1 False=0
Network Load Share	ID 4 Enabled	40928 bit 3	Uint16	2	R	True=1 False=0
Network Load Share	ID 5 Enabled	40928 bit 4	Uint16	2	R	True=1 False=0
Network Load Share	ID 6 Enabled	40928 bit 5	Uint16	2	R	True=1 False=0
Network Load Share	ID 7 Enabled	40928 bit 6	Uint16	2	R	True=1 False=0
Network Load Share	ID 8 Enabled	40928 bit 7	Uint16	2	R	True=1 False=0
Network Load Share	ID 9 Enabled	40928 bit 8	Uint16	2	R	True=1 False=0
Network Load Share	ID 10 Enabled	40928 bit 9	Uint16	2	R	True=1 False=0
Network Load Share	ID 11 Enabled	40928 bit 10	Uint16	2	R	True=1 False=0
Network Load Share	ID 12 Enabled	40928 bit 11	Uint16	2	R	True=1 False=0
Network Load Share	ID 13 Enabled	40928 bit 12	Uint16	2	R	True=1 False=0
Network Load Share	ID 14 Enabled	40928 bit 13	Uint16	2	R	True=1 False=0
Network Load Share	ID 15 Enabled	40928 bit 14	Uint16	2	R	True=1 False=0
Network Load Share	ID 16 Enabled	40928 bit 15	Uint16	2	R	True=1 False=0
Network Load Share	NLS Status 1	40929 bit 0	Uint16	2	R	True=1 False=0
Network Load Share	NLS Status 2	40929 bit 1	Uint16	2	R	True=1 False=0
Network Load Share	NLS Status 3	40929 bit 2	Uint16	2	R	True=1 False=0
Network Load Share	NLS Status 4	40929 bit 3	Uint16	2	R	True=1 False=0
Reserved		40929 bit 4				
Reserved		40929 bit 5				

Group	Name	Register	Type	Bytes	R/W	Range
Reserved		40929 bit 6				
Grid Code Parameters	LFSM Enable	40929 bit 7	Uint16	2	R	True=1 False=0
Grid Code Parameters	LFSM Active	40929 bit 8	Uint16	2	R	True=1 False=0
Grid Code Parameters	LVRT Enable	40929 bit 9	Uint16	2	R	True=1 False=0
Grid Code Parameters	LVRT Active	40929 bit 10	Uint16	2	R	True=1 False=0
Grid Code Parameters	Grid Code Enabled	40929 bit 11	Uint16	2	R	True=1 False=0
Grid Code Parameters	APC Enable	40929 bit 12	Uint16	2	R	True=1 False=0
Grid Code Parameters	GCC Disconnect Timing	40929 bit 13	Uint16	2	R	True=1 False=0
Grid Code Parameters	GCC Disconnect Timed Out	40929 bit 14	Uint16	2	R	True=1 False=0
Grid Code Parameters	LVRT Remote Communications Active	40929 bit 15	Uint16	2	R	True=1 False=0
Grid Code Parameters	APC Active	40930 bit 0	Uint16	2	R	True=1 False=0
Grid Code Parameters	LVRT Remote Communications Fail	40930 bit 1	Uint16	2	R	True=1 False=0
Grid Code Parameters	APC Remote Communications Fail	40930 bit 2	Uint16	2	R	True=1 False=0
Grid Code Parameters	APC Output Limit	40930 bit 3	Uint16	2	R	True=1 False=0
Grid Code Parameters	LFSM Recovery Active	40930 bit 4	Uint16	2	R	True=1 False=0
Grid Code Parameters	GCC Disabled	40930 bit 5	Uint16	2	R	True=1 False=0
Grid Code Parameters	GCC Continuous Operation	40930 bit 6	Uint16	2	R	True=1 False=0
Grid Code Parameters	GCC Frequency Low Timing	40930 bit 7	Uint16	2	R	True=1 False=0
Grid Code Parameters	GCC Frequency High Timing	40930 bit 8	Uint16	2	R	True=1 False=0
Grid Code Parameters	GCC Voltage Low Timing	40930 bit 9	Uint16	2	R	True=1 False=0
Grid Code Parameters	GCC Voltage High Timing	40930 bit 10	Uint16	2	R	True=1 False=0
Grid Code Parameters	GCC Out of Range Timing	40930 bit 11	Uint16	2	R	True=1 False=0
Grid Code Parameters	GCC Disconnected	40930 bit 12	Uint16	2	R	True=1 False=0
Grid Code Parameters	GCC Reconnect Timing	40930 bit 13	Uint16	2	R	True=1 False=0
Grid Code Parameters	LFSM O Active	40930 bit 14	Uint16	2	R	True=1 False=0
Grid Code Parameters	LFSM U Active	40930 bit 15	Uint16	2	R	True=1 False=0
Grid Code Parameters	LFSM Normal Operation	40931 bit 0	Uint16	2	R	True=1 False=0
Grid Code Parameters	LVRT Modbus Communications Fail	40931 bit 1	Uint16	2	R	True=1 False=0
Grid Code Parameters	LVRT CAN Bus Communications Fail	40931 bit 2	Uint16	2	R	True=1 False=0
Grid Code Parameters	LVRT AEM Comm Fail	40931 bit 3	Uint16	2	R	True=1 False=0
Grid Code Parameters	APC Modbus Communications Fail	40931 bit 4	Uint16	2	R	True=1 False=0
Grid Code Parameters	APC CAN Bus Communications Fail	40931 bit 5	Uint16	2	R	True=1 False=0
Grid Code Parameters	APC AEM Comm Fail	40931 bit 6	Uint16	2	R	True=1 False=0
Grid Code Parameters	APC Remote Communications Active	40931 bit 7	Uint16	2	R	True=1 False=0
Grid Code Parameters	APC Bridge Enable	40931 bit 8	Uint16	2	R	True=1 False=0
Grid Code Parameters	APC Bridge Active	40931 bit 9	Uint16	2	R	True=1 False=0
Grid Code Parameters	LVRT Bridge Enable	40931 bit 10	Uint16	2	R	True=1 False=0
Grid Code Parameters	LVRT Bridge Active	40931 bit 11	Uint16	2	R	True=1 False=0
Grid Code Parameters	kW Threshold Status	40931 bit 12	Uint16	2	R	True=1 False=0

## Metering

**Table 26. Metering Group Parameters**

Group	Name	Register	Type	Bytes	R/W	Unit	Range
Field Voltage Meter	V <sub>x</sub>	41000	Float	4	R	Volt	-1000 – 1000
Field Current Meter	I <sub>x</sub>	41002	Float	4	R	Amp	0–2000000000
DECS PSS Meter	Terminal Frequency Deviation	41004	Float	4	R	Percent	n/a
DECS PSS Meter	Compensated Frequency Deviation	41006	Float	4	R	Percent	n/a
DECS PSS Meter	PSS output	41008	Float	4	R	n/a	n/a
DECS Regulator Meter	Tracking error	41010	Float	4	R	Percent	n/a
DECS Regulator Meter	Control output PU	41012	Float	4	R	Per Unit	-10 – 10

Group	Name	Register	Type	Bytes	R/W	Unit	Range
DECS Regulator Meter	Exciter Diode Monitor Ripple Percent	41014	Float	4	R	Percent	n/a
DECS Regulator Meter	Power Input	41016	Float	4	R	Volt	0-2000000000
Generator Voltage Meter Magnitude 1	V <sub>AB</sub>	41018	Float	4	R	Volt	0-2000000000
Generator Voltage Meter Magnitude 1	V <sub>BC</sub>	41020	Float	4	R	Volt	0-2000000000
Generator Voltage Meter Magnitude 1	V <sub>CA</sub>	41022	Float	4	R	Volt	0-2000000000
Generator Voltage Meter Magnitude 1	V <sub>AVG LL</sub>	41024	Float	4	R	Volt	0-2000000000
Generator Voltage Meter Primary 1	V <sub>AB</sub>	41026	Float	4	R	Volt	0-2000000000
Generator Voltage Meter Primary 1	V <sub>BC</sub>	41028	Float	4	R	Volt	0-2000000000
Generator Voltage Meter Primary 1	V <sub>CA</sub>	41030	Float	4	R	Volt	0-2000000000
Generator Voltage Meter Primary 1	V <sub>AVG LL</sub>	41032	Float	4	R	Volt	0-2000000000
Generator Voltage Meter Angle 1	V <sub>AB</sub>	41034	Float	4	R	Degree	0-360
Generator Voltage Meter Angle 1	V <sub>BC</sub>	41036	Float	4	R	Degree	0-360
Generator Voltage Meter Angle 1	V <sub>CA</sub>	41038	Float	4	R	Degree	0-360
Generator Voltage Meter Angle 1	V <sub>AB</sub>	41040	String	24	R	n/a	0-24
Generator Voltage Meter Angle 1	V <sub>BC</sub>	41052	String	24	R	n/a	0-24
Generator Voltage Meter Angle 1	V <sub>CA</sub>	41064	String	24	R	n/a	0-24
Gen Voltage Meter Primary Angle 1	V <sub>AB</sub>	41076	String	24	R	n/a	0-24
Gen Voltage Meter Primary Angle 1	V <sub>BC</sub>	41088	String	24	R	n/a	0-24
Gen Voltage Meter Primary Angle 1	V <sub>CA</sub>	41100	String	24	R	n/a	0-24
Bus Voltage Meter Magnitude 1	V <sub>AB</sub>	41112	Float	4	R	Volt	0-2000000000
Bus Voltage Meter Magnitude 1	V <sub>BC</sub>	41114	Float	4	R	Volt	0-2000000000
Bus Voltage Meter Magnitude 1	V <sub>CA</sub>	41116	Float	4	R	Volt	0-2000000000
Bus Voltage Meter Magnitude 1	V <sub>AVG LL</sub>	41118	Float	4	R	Volt	0-2000000000
Bus Voltage Meter Primary 1	V <sub>AB</sub>	41120	Float	4	R	Volt	0-2000000000
Bus Voltage Meter Primary 1	V <sub>BC</sub>	41122	Float	4	R	Volt	0-2000000000
Bus Voltage Meter Primary 1	V <sub>CA</sub>	41124	Float	4	R	Volt	0-2000000000
Bus Voltage Meter Primary 1	V <sub>AVG LL</sub>	41126	Float	4	R	Volt	0-2000000000
Bus Voltage Meter Angle 1	V <sub>AB</sub>	41128	Float	4	R	Degree	0-360
Bus Voltage Meter Angle 1	V <sub>BC</sub>	41130	Float	4	R	Degree	0-360
Bus Voltage Meter Angle 1	V <sub>CA</sub>	41132	Float	4	R	Degree	0-360
Bus Voltage Meter Angle 1	V <sub>AB</sub>	41134	String	24	R	n/a	0-24
Bus Voltage Meter Magnitude Angle 1	V <sub>BC</sub>	41146	String	24	R	n/a	0-24
Bus Voltage Meter Magnitude Angle 1	V <sub>CA</sub>	41158	String	24	R	n/a	0-24
Bus Voltage Meter Primary Angle 1	V <sub>AB</sub>	41170	String	24	R	n/a	0-24
Bus Voltage Meter Primary Angle 1	V <sub>BC</sub>	41182	String	24	R	n/a	0-24

Group	Name	Register	Type	Bytes	R/W	Unit	Range
Bus Voltage Meter Primary Angle 1	V <sub>CA</sub>	41194	String	24	R	n/a	0-24
Generator Current Meter Magnitude 1	I <sub>A</sub>	41206	Float	4	R	Amp	0-2000000000
Generator Current Meter Magnitude 1	I <sub>B</sub>	41208	Float	4	R	Amp	0-2000000000
Generator Current Meter Magnitude 1	I <sub>C</sub>	41210	Float	4	R	Amp	0-2000000000
Generator Current Meter Magnitude 1	I <sub>AVG</sub>	41212	Float	4	R	Amp	0-2000000000
Generator Current Meter Primary 1	I <sub>A</sub>	41214	Float	4	R	Amp	0-2000000000
Generator Current Meter Primary 1	I <sub>B</sub>	41216	Float	4	R	Amp	0-2000000000
Generator Current Meter Primary 1	I <sub>C</sub>	41218	Float	4	R	Amp	0-2000000000
Generator Current Meter Primary 1	I <sub>AVG</sub>	41220	Float	4	R	Amp	0-2000000000
Generator Current Meter Angle 1	I <sub>A</sub>	41222	Float	4	R	Degree	0-360
Generator Current Meter Angle 1	I <sub>B</sub>	41224	Float	4	R	Degree	0-360
Generator Current Meter Angle 1	I <sub>C</sub>	41226	Float	4	R	Degree	0-360
Generator Current Meter Magnitude Angle 1	I <sub>A</sub>	41228	String	24	R	n/a	0-24
Generator Current Meter Magnitude Angle 1	I <sub>B</sub>	41240	String	24	R	n/a	0-24
Generator Current Meter Magnitude Angle 1	I <sub>C</sub>	41252	String	24	R	n/a	0-24
Generator Current Meter Primary Angle 1	I <sub>A</sub>	41264	String	24	R	n/a	0-24
Generator Current Meter Primary Angle 1	I <sub>B</sub>	41276	String	24	R	n/a	0-24
Generator Current Meter Primary Angle 1	I <sub>C</sub>	41288	String	24	R	n/a	0-24
Icc Current Meter Magnitude 1	I <sub>X</sub>	41300	Float	4	R	Amp	0-2000000000
Icc Current Meter Primary 1	I <sub>X</sub>	41302	Float	4	R	Amp	0-2000000000
Power Meter	Total watts secondary	41304	Float	4	R	Watt	n/a
Power Meter	Total watts primary	41306	Float	4	R	Watt	n/a
Power Meter	Total vars secondary	41308	Float	4	R	Var	n/a
Power Meter	Total vars primary	41310	Float	4	R	var	n/a
Power Meter	Total S secondary	41312	Float	4	R	VA	n/a
Power Meter	Total S primary	41314	Float	4	R	VA	n/a
Power Meter	Total PF secondary	41316	Float	4	R	PF	-1 - 1
Power Meter	Total PF primary	41318	Float	4	R	PF	-1 - 1
Power Meter	Positive watthour total	41320	Float	4	RW	Watthour	0.00E+00-1.00E+09
Power Meter	Positive varhour total	41322	Float	4	RW	Varhour	0.00E+00-1.00E+09
Power Meter	Negative watthour total	41324	Float	4	RW	Watthour	0.00E+00-1.00E+09
Power Meter	Negative varhour total	41326	Float	4	RW	Varhour	0.00E+00-1.00E+09
Power Meter	VA hour total	41328	Float	4	RW	Varhour	0.00E+00-1.00E+09
Energy Meter	Positive watthour total	41330	Float	4	RW	Watthour	0.00E+00-1.00E+09
Energy Meter	Positive varhour total	41332	Float	4	RW	Varhour	0.00E+00-1.00E+09

Group	Name	Register	Type	Bytes	R/W	Unit	Range
Energy Meter	Negative watthour total	41334	Float	4	RW	Watthour	0.00E+00– 1.00E+09
Energy Meter	Negative varhour total	41336	Float	4	RW	Varhour	0.00E+00– 1.00E+09
Energy Meter	VA hour total	41338	Float	4	RW	Varhour	0.00E+00– 1.00E+09
Sync Meter 1	Slip Angle	41340	Float	4	R	Degree	-359.9 – 359.9
Sync Meter 1	Slip Frequency	41342	Float	4	R	Hertz	n/a
Sync Meter 1	Voltage Difference	41344	Float	4	R	Volt	n/a
Generator Frequency Meter 1	Frequency	41346	Float	4	R	Hertz	10–180
Bus Frequency Meter 1	Frequency	41348	Float	4	R	Hertz	10–180
Auxiliary Input Voltage 1	Value	41350	Float	4	R	Volt	-9999999 – 9999999
Auxiliary Input Current 1	Value	41352	Float	4	R	Amp	-9999999 – 9999999
AEM Metering	RTD Input 1 Raw Value	41354	Float	4	R	Ohm	n/a
AEM Metering	RTD Input 2 Raw Value	41356	Float	4	R	Ohm	n/a
AEM Metering	RTD Input 3 Raw Value	41358	Float	4	R	Ohm	n/a
AEM Metering	RTD Input 4 Raw Value	41360	Float	4	R	Ohm	n/a
AEM Metering	RTD Input 5 Raw Value	41362	Float	4	R	Ohm	n/a
AEM Metering	RTD Input 6 Raw Value	41364	Float	4	R	Ohm	n/a
AEM Metering	RTD Input 7 Raw Value	41366	Float	4	R	Ohm	n/a
AEM Metering	RTD Input 8 Raw Value	41368	Float	4	R	Ohm	n/a
AEM Metering	RTD Input 1 Scaled Value	41370	Float	4	R	Deg F	-40000 – 9999999
AEM Metering	RTD Input 2 Scaled Value	41372	Float	4	R	Deg F	-40000 – 9999999
AEM Metering	RTD Input 3 Scaled Value	41374	Float	4	R	Deg F	-40000 – 9999999
AEM Metering	RTD Input 4 Scaled Value	41376	Float	4	R	Deg F	-40000 – 9999999
AEM Metering	RTD Input 5 Scaled Value	41378	Float	4	R	Deg F	-40000 – 9999999
AEM Metering	RTD Input 6 Scaled Value	41380	Float	4	R	Deg F	-40000 – 9999999
AEM Metering	RTD Input 7 Scaled Value	41382	Float	4	R	Deg F	-40000 – 9999999
AEM Metering	RTD Input 8 Scaled Value	41384	Float	4	R	Deg F	-40000 – 9999999
DECS Regulator Meter	Control Output	41386	Float	4	R	Percent	n/a
AEM Metering	RTD Input 1 Metric Value	41388	Float	4	R	Deg C	n/a
AEM Metering	RTD Input 2 Metric Value	41390	Float	4	R	Deg C	n/a
AEM Metering	RTD Input 3 Metric Value	41392	Float	4	R	Deg C	n/a
AEM Metering	RTD Input 4 Metric Value	41394	Float	4	R	Deg C	n/a
AEM Metering	RTD Input 5 Metric Value	41396	Float	4	R	Deg C	n/a
AEM Metering	RTD Input 6 Metric Value	41398	Float	4	R	Deg C	n/a
AEM Metering	RTD Input 7 Metric Value	41400	Float	4	R	Deg C	n/a
AEM Metering	RTD Input 8 Metric Value	41402	Float	4	R	Deg C	n/a
AEM Metering	Thermocouple Input 1 Metric Value	41404	Float	4	R	Deg C	n/a
AEM Metering	Thermocouple Input 2 Metric Value	41406	Float	4	R	Deg C	n/a
DECS Regulator Meter	NLS Error Percent	41408	Float	4	R	Percent	n/a
DECS Regulator Meter	Current Magnitude Pickup	41410	Float	4	R	Per Unit	-10 – 10
DECS Regulator Meter	NLS Current Magnitude Average Pickup	41412	Float	4	R	Per Unit	-10 – 10
DECS Regulator Meter	NLS Number of Generators Online	41414	Int32	4	R	n/a	n/a
Per Unit Meter	Vab Pickup	41416	Float	4	R	Per Unit	-10 – 10
Per Unit Meter	Vbc Pickup	41418	Float	4	R	Per Unit	-10 – 10
Per Unit Meter	Vca Pickup	41420	Float	4	R	Per Unit	-10 – 10
Per Unit Meter	V Average Pickup	41422	Float	4	R	Per Unit	-10 – 10

Group	Name	Register	Type	Bytes	R/W	Unit	Range
Per Unit Meter	Ia Pickup	41424	Float	4	R	Per Unit	-10 – 10
Per Unit Meter	Ib Pickup	41426	Float	4	R	Per Unit	-10 – 10
Per Unit Meter	Ic Pickup	41428	Float	4	R	Per Unit	-10 – 10
Per Unit Meter	I Average Pickup	41430	Float	4	R	Per Unit	-10 – 10
Per Unit Meter	kW Pickup	41432	Float	4	R	Per Unit	-10 – 10
Per Unit Meter	kVA Pickup	41434	Float	4	R	Per Unit	-10 – 10
Per Unit Meter	Kvar Pickup	41436	Float	4	R	Per Unit	-10 – 10
Per Unit Meter	Positive Sequence Voltage Pickup	41438	Float	4	R	Per Unit	-10 – 10
Per Unit Meter	Negative Sequence Voltage Pickup	41440	Float	4	R	Per Unit	-10 – 10
Per Unit Meter	Positive Sequence Current Pickup	41442	Float	4	R	Per Unit	-10 – 10
Per Unit Meter	Negative Sequence Current Pickup	41444	Float	4	R	Per Unit	-10 – 10
Per Unit Meter	Bus Vab Pickup	41446	Float	4	R	Per Unit	-10 – 10
Per Unit Meter	Bus Vbc Pickup	41448	Float	4	R	Per Unit	-10 – 10
Per Unit Meter	Bus Vca Pickup	41450	Float	4	R	Per Unit	-10 – 10
Per Unit Meter	Bus V Average Pickup	41452	Float	4	R	Per Unit	-10 – 10
Per Unit Meter	Voltage Difference Pickup	41454	Float	4	R	Per Unit	-10 – 10
Per Unit Meter	Power in Voltage Pickup	41456	Float	4	R	Per Unit	-10 – 10
Per Unit Meter	Generator Frequency Pickup	41458	Float	4	R	Per Unit	-10 – 10
Per Unit Meter	Bus Frequency Pickup	41460	Float	4	R	Per Unit	-10 – 10
Per Unit Meter	I <sub>fd</sub> Pickup	41462	Float	4	R	Per Unit	-10 – 10
Per Unit Meter	V <sub>fd</sub> Pickup	41464	Float	4	R	Per Unit	-10 – 10
Per Unit Meter	Slip Frequency Pickup	41466	Float	4	R	Per Unit	-10 – 10
Per Unit Meter	I <sub>cc</sub> Pickup	41468	Float	4	R	Per Unit	-10 – 10
Per Unit Meter	AVR Setpoint Pickup	41470	Float	4	R	Per Unit	-10 – 10
Per Unit Meter	FCR Setpoint Pickup	41472	Float	4	R	Per Unit	-10 – 10
Per Unit Meter	FVR Setpoint Pickup	41474	Float	4	R	Per Unit	-10 – 10
Per Unit Meter	Var Setpoint Pickup	41476	Float	4	R	Per Unit	-10 – 10
Power Meter	Scaled PF	41478	Float	4	R	Power Factor	-1 – 1
AEM Metering	Analog Input 1 Raw Value	41480	Float	4	R	Milliamp	n/a
AEM Metering	Analog Input 2 Raw Value	41482	Float	4	R	Milliamp	n/a
AEM Metering	Analog Input 3 Raw Value	41484	Float	4	R	Milliamp	n/a
AEM Metering	Analog Input 4 Raw Value	41486	Float	4	R	Milliamp	n/a
AEM Metering	Analog Input 5 Raw Value	41488	Float	4	R	Milliamp	n/a
AEM Metering	Analog Input 6 Raw Value	41490	Float	4	R	Milliamp	n/a
AEM Metering	Analog Input 7 Raw Value	41492	Float	4	R	Milliamp	n/a
AEM Metering	Analog Input 8 Raw Value	41494	Float	4	R	Milliamp	n/a
AEM Metering	Analog Input 1 Scaled Value	41496	Float	4	R	n/a	n/a
AEM Metering	Analog Input 2 Scaled Value	41498	Float	4	R	n/a	n/a
AEM Metering	Analog Input 3 Scaled Value	41500	Float	4	R	n/a	n/a
AEM Metering	Analog Input 4 Scaled Value	41502	Float	4	R	n/a	n/a
AEM Metering	Analog Input 5 Scaled Value	41504	Float	4	R	n/a	n/a
AEM Metering	Analog Input 6 Scaled Value	41506	Float	4	R	n/a	n/a
AEM Metering	Analog Input 7 Scaled Value	41508	Float	4	R	n/a	n/a
AEM Metering	Analog Input 8 Scaled Value	41510	Float	4	R	n/a	n/a
AEM Metering	Thermocouple 1 Raw Value	41512	Float	4	R	Millivolt	n/a
AEM Metering	Thermocouple 2 Raw Value	41514	Float	4	R	Millivolt	n/a
AEM Metering	Analog Output 1 Raw Value	41516	Float	4	R	n/a	n/a
AEM Metering	Analog Output 2 Raw Value	41518	Float	4	R	n/a	n/a

Group	Name	Register	Type	Bytes	R/W	Unit	Range
AEM Metering	Analog Output 3 Raw Value	41520	Float	4	R	n/a	n/a
AEM Metering	Analog Output 4 Raw Value	41522	Float	4	R	n/a	n/a
AEM Metering	Analog Output 1 Scaled Value	41524	Float	4	R	n/a	n/a
AEM Metering	Analog Output 2 Scaled Value	41526	Float	4	R	n/a	n/a
AEM Metering	Analog Output 3 Scaled Value	41528	Float	4	R	n/a	n/a
AEM Metering	Analog Output 4 Scaled Value	41530	Float	4	R	n/a	n/a
AEM Metering	Thermocouple Input 1 Scaled Value	41532	Float	4	R	Deg F	n/a
AEM Metering	Thermocouple Input 2 Scaled Value	41534	Float	4	R	Deg F	n/a
Reserved		41536-51					
Grid Code	Q Reference	41552	Float	4	R	Per Unit	-10 – 10
Grid Code	P Reference	41554	Float	4	R	Per Unit	-10 – 10
Grid Code	State	41556	Uint32	4	R	n/a	Inactive=0 Active=1
Grid Code	Grid Connect State	41558	Uint32	4	R	n/a	Disabled=0 Continuous Operation=1 Low Frequency Timing=2 High Frequency Timing=3 Low Voltage Timing=4 High Voltage Timing=5 Out of Range Timing=6 Disconnected=7 Reconnect Timing=8
Grid Code	Grid Disconnect Flag	41560	Int32	4	R	n/a	n/a
Grid Code	LVRT Mode	41562	Uint32	4	R	n/a	Disabled=0 Q(PF)=1 Q(Voltage Limit)=2 Q(U)=3 Q(P)=4 Q(Third Party)=5 Freeze Output=6
Grid Code	LFSM Mode	41564	Uint32	4	R	n/a	Initialize=0 Nominal=1 Underfrequency=2 Overfrequency=3 Recovery=4
Grid Code	Remote LVRT Status	41566	Uint32	4	R	n/a	Disabled=0 Active=1 Failed=2
Grid Code	Remote LFSM Status	41568	Uint32	4	R	n/a	Disabled=0 Active=1 Failed=2
Grid Code	PF Mode Reference	41570	Float	4	R	n/a	n/a
Grid Code	Q U Mode Reference	41572	Float	4	R	Per Unit	-10 – 10
Grid Code	Q Voltage Limit Mode Reference	41574	Float	4	R	Per Unit	-10 – 10
Grid Code	Q Third Party Mode Reference	41576	Float	4	R	Per Unit	-10 – 10
Grid Code	APC Reference	41578	Float	4	R	Per Unit	-10 – 10
Grid Code	LVRT Modbus Comm Fail Timer	41580	Float	4	R	Second	0–600
Grid Code	LVRT CAN Bus Comm Fail Timer	41582	Float	4	R	Second	0–600
Grid Code	APC Modbus Comm Fail Timer	41584	Float	4	R	Second	0–600
Grid Code	APC CAN Bus Comm Fail Timer	41586	Float	4	R	Second	0–600
Grid Code	APC Integrator State	41588	Float	4	R	Per Unit	-10 – 10
Grid Code	APC Error	41590	Float	4	R	Per Unit	-10 – 10
Grid Code	APC P Desired	41592	Float	4	R	Per Unit	-10 – 10

Group	Name	Register	Type	Bytes	R/W	Unit	Range
Grid Code	APC Bias Voltage	41594	Float	4	R	n/a	n/a
Grid Code	LVRT Q Desired	41596	Float	4	R	Per Unit	-10 – 10
Grid Code	LVRT Bias Voltage	41598	Float	4	R	n/a	n/a
Grid Code	Test Signal	41600	Float	4	R	n/a	n/a
Grid Code	Active Power Adjust CAN Bus	41602	Float	4	R	Per Unit	-10 – 10
Grid Code	PF Reference Adjust CAN Bus	41604	Float	4	R	n/a	n/a
Grid Code	Q Voltage Limit Adjust CAN Bus	41606	Float	4	R	Per Unit	-10 – 10
Grid Code	Q U Voltage Bus for Zero Q Adjust CAN Bus	41608	Float	4	R	Per Unit	-10 – 10
Grid Code	Q Third Party Adjust CAN Bus	41610	Float	4	R	Per Unit	-10 – 10
Grid Code	Active Power Adjust Modbus	41612	Float	4	R	Per Unit	-10 – 10
Grid Code	PF Reference Adjust Modbus	41614	Float	4	R	n/a	n/a
Grid Code	Q Voltage Limit Adjust Modbus	41616	Float	4	R	Per Unit	-10 – 10
Grid Code	Q U Voltage Bus for Zero Q Adjust Modbus	41618	Float	4	R	Per Unit	-10 – 10
Grid Code	Q Third Party Adjust Modbus	41620	Float	4	R	Per Unit	-10 – 10
Grid Code	APC Mode	41622	Uint32	4	R	n/a	Inactive=0 Active=1 LFSM Override=2
Grid Code	Grid Connect Voltage Timer	41624	Float	4	R	Second	0–2000
Grid Code	Grid Connect Frequency Timer	41626	Float	4	R	Second	0–2000
Grid Code	Grid Connect Disconnect Timer	41628	Float	4	R	Second	0–2000
Grid Code	Grid Connect Reconnect Timer	41630	Float	4	R	Second	0–2000

## Limiters

Table 27. Limiter Group Parameters

Name	Register	Type	Bytes	R/W	Unit	Range
OEL Primary Current Hi	41700	Float	4	R W	Amp	0–40
OEL Primary Current Mid	41702	Float	4	R W	Amp	0–30
OEL Primary Current Lo	41704	Float	4	R W	Amp	0–20
OEL Primary Time Hi	41706	Float	4	R W	Second	0–10
OEL Primary Time Mid	41708	Float	4	R W	Second	0–120
OEL Primary Current Hi Off	41710	Float	4	R W	Amp	0–40
OEL Primary Current Lo Off	41712	Float	4	R W	Amp	0–20
OEL Primary Current Time Off	41714	Float	4	R W	Second	0–10
OEL Primary Takeover Current Max Off	41716	Float	4	R W	Amp	0–40
OEL Primary Takeover Current Min Off	41718	Float	4	R W	Amp	0–20
OEL Primary Takeover Time Dial Off	41720	Float	4	R W	n/a	0.1–20
OEL Primary Takeover Current Max On	41722	Float	4	R W	Amp	0–40
OEL Primary Takeover Current Min On	41724	Float	4	R W	Amp	0–20
OEL Primary Takeover Time Dial On	41726	Float	4	R W	n/a	0.1–20
OEL Primary Dvdt Enable	41728	Uint32	4	R W	n/a	Disabled=0 Enabled=1
OEL Primary Dvdt Ref	41730	Float	4	R W	n/a	-10 – 0
OEL Secondary Current Hi	41732	Float	4	R W	Amp	0–40
OEL Secondary Current Mid	41734	Float	4	R W	Amp	0–30
OEL Secondary Current Lo	41736	Float	4	R W	Amp	0–20
OEL Secondary Time Hi	41738	Float	4	R W	Second	0–10
OEL Secondary Time Mid	41740	Float	4	R W	Second	0–120
OEL Secondary Current Hi Off	41742	Float	4	R W	Amp	0–40
OEL Secondary Current Lo Off	41744	Float	4	R W	Amp	0–20
OEL Secondary Current Time Off	41746	Float	4	R W	Second	0–10
OEL Secondary Takeover Current Max Off	41748	Float	4	R W	Amp	0–40

Name	Register	Type	Bytes	R/W	Unit	Range
OEL Secondary Takeover Current Min Off	41750	Float	4	R W	Amp	0–20
OEL Secondary Takeover Time Dial Off	41752	Float	4	R W	n/a	0.1–20
OEL Secondary Takeover Current Max On	41754	Float	4	R W	Amp	0–40
OEL Secondary Takeover Current Min On	41756	Float	4	R W	Amp	0–20
OEL Secondary Takeover Time Dial On	41758	Float	4	R W	n/a	0.1–20
OEL Scale Enable	41760	Uint32	4	R W	n/a	Disabled=0 Auxiliary Input=1 AEM RTD 1=2 AEM RTD 2=3 AEM RTD 3=4 AEM RTD 4=5 AEM RTD 5=6 AEM RTD 6=7 AEM RTD 7=8 AEM RTD 8=9
OEL Scale Takeover Signal 1	41762	Float	4	R W	Limiter Scale Volt or Deg F	Adjustment range is determined by register 41760. -10 – 10 V when 41760 = 1 -58 – 482°F when 41760 = 2-8
OEL Scale Takeover Signal 2	41764	Float	4	R W	Limiter Scale Volt or Deg F	Adjustment range is determined by register 41760. -10 – 10 V when 41760 = 1 -58 – 482°F when 41760 = 2-8
OEL Scale Takeover Signal 3	41766	Float	4	R W	Limiter Scale Volt or Deg F	Adjustment range is determined by register 41760. -10 – 10 V when 41760 = 1 -58 – 482°F when 41760 = 2-8
OEL Scale Takeover Scale 1	41768	Float	4	R W	Percent	0–200
OEL Scale Takeover Scale 2	41770	Float	4	R W	Percent	0–200
OEL Scale Takeover Scale 3	41772	Float	4	R W	Percent	0–200
OEL Scale Summing Signal 1	41774	Float	4	R W	Limiter Scale Volt or Deg F	Adjustment range is determined by register 41760. -10 – 10 V when 41760 = 1 -58 – 482°F when 41760 = 2-8
OEL Scale Summing Signal 2	41776	Float	4	R W	Limiter Scale Volt or Deg F	Adjustment range is determined by register 41760. -10 – 10 V when 41760 = 1 -58 – 482°F when 41760 = 2-8
OEL Scale Summing Signal 3	41778	Float	4	R W	Limiter Scale Volt or Deg F	Adjustment range is determined by register 41760. -10 – 10 V when 41760 = 1 -58 – 482°F when 41760 = 2-8
OEL Scale Summing Scale 1	41780	Float	4	R W	Percent	0–200
OEL Scale Summing Scale 2	41782	Float	4	R W	Percent	0–200
OEL Scale Summing Scale 3	41784	Float	4	R W	Percent	0–200
UEL Primary Curve X1	41786	Float	4	R W	kilowatt	0–1.5 • Rated kVA
UEL Primary Curve X2	41788	Float	4	R W	kilowatt	0–1.5 • Rated kVA
UEL Primary Curve X3	41790	Float	4	R W	kilowatt	0–1.5 • Rated kVA
UEL Primary Curve X4	41792	Float	4	R W	kilowatt	0–1.5 • Rated kVA
UEL Primary Curve X5	41794	Float	4	R W	kilowatt	0–1.5 • Rated kVA
UEL Primary Curve Y1	41796	Float	4	R W	kilovar	0–1.5 • Rated kVA
UEL Primary Curve Y2	41798	Float	4	R W	kilovar	0–1.5 • Rated kVA
UEL Primary Curve Y3	41800	Float	4	R W	kilovar	0–1.5 • Rated kVA
UEL Primary Curve Y4	41802	Float	4	R W	kilovar	0–1.5 • Rated kVA
UEL Primary Curve Y5	41804	Float	4	R W	kilovar	0–1.5 • Rated kVA
UEL Primary Power Filter TC	41806	Float	4	R W	Second	0–20
UEL Primary Voltage Dependent Exponent	41808	Float	4	R W	n/a	0–2
UEL Secondary Curve X1	41810	Float	4	R W	kilowatt	0–1.5 • Rated kVA
UEL Secondary Curve X2	41812	Float	4	R W	kilowatt	0–1.5 • Rated kVA
UEL Secondary Curve X3	41814	Float	4	R W	kilowatt	0–1.5 • Rated kVA
UEL Secondary Curve X4	41816	Float	4	R W	kilowatt	0–1.5 • Rated kVA

Name	Register	Type	Bytes	R/W	Unit	Range
UEL Secondary Curve X5	41818	Float	4	R W	kilowatt	0–1.5 • Rated kVA
UEL Secondary Curve Y1	41820	Float	4	R W	kilovar	0–1.5 • Rated kVA
UEL Secondary Curve Y2	41822	Float	4	R W	kilovar	0–1.5 • Rated kVA
UEL Secondary Curve Y3	41824	Float	4	R W	kilovar	0–1.5 • Rated kVA
UEL Secondary Curve Y4	41826	Float	4	R W	kilovar	0–1.5 • Rated kVA
UEL Secondary Curve Y5	41828	Float	4	R W	kilovar	0–1.5 • Rated kVA
SCL Primary Reference Hi	41830	Float	4	R W	Amp	0–66000
SCL Primary Reference Lo	41832	Float	4	R W	Amp	0–66000
SCL Primary Time Hi	41834	Float	4	R W	Second	0–60
SCL Primary No Response Time	41836	Float	4	R W	Second	0–10
SCL Secondary Reference Hi	41838	Float	4	R W	Amp	0–66000
SCL Secondary Reference Lo	41840	Float	4	R W	Amp	0–66000
SCL Secondary Time Hi	41842	Float	4	R W	Second	0–60
SCL Secondary No Response Time	41844	Float	4	R W	Second	0–10
SCL Scale Enable	41846	Uint32	4	R W	n/a	Disabled=0 Auxiliary Input=1 AEM RTD 1=2 AEM RTD 2=3 AEM RTD 3=4 AEM RTD 4=5 AEM RTD 5=6 AEM RTD 6=7 AEM RTD 7=8 AEM RTD 8=9
SCL Scale Signal 1	41848	Float	4	R W	Limiter Scale Volt or Deg F	Adjustment range is determined by register 41846. -10 – 10 V when 41846 = 1 -58 – 482°F when 41846 = 2-8
SCL Scale Signal 2	41850	Float	4	R W	Limiter Scale Volt or Deg F	Adjustment range is determined by register 41846. -10 – 10 V when 41846 = 1 -58 – 482°F when 41846 = 2-8
SCL Scale Signal 3	41852	Float	4	R W	Limiter Scale Volt or Deg F	Adjustment range is determined by register 41846. -10 – 10 V when 41846 = 1 -58 – 482°F when 41846 = 2-8
SCL Scale Point 1	41854	Float	4	R W	Percent	0–200
SCL Scale Point 2	41856	Float	4	R W	Percent	0–200
SCL Scale Point 3	41858	Float	4	R W	Percent	0–200
Var Limit Enable	41860	Uint32	4	R W	n/a	Disabled=0 Enabled=1
Var Limit Primary Delay	41862	Float	4	R W	Second	0–300
Var Limit Primary Setpoint	41864	Float	4	R W	Percent	0–200
Var Limit Secondary Delay	41866	Float	4	R W	Second	0–300
Var Limit Secondary Setpoint	41868	Float	4	R W	Percent	0–200
Var Limit Enable Status	41870	Uint32	4	R	n/a	Off=0 On=1
OEL Primary Takeover Reset Time Coefficient Off	41872	Float	4	R W	n/a	0.01–100
OEL Primary Takeover Reset Time Coefficient On	41874	Float	4	R W	n/a	0.01–100
OEL Secondary Takeover Reset Time Coefficient Off	41876	Float	4	R W	n/a	0.01–100
OEL Secondary Takeover Reset Time Coefficient On	41878	Float	4	R W	n/a	0.01–100
OEL Primary Takeover Reset Type Off	41880	Uint32	4	R W	n/a	Inverse=0 Integrating=1 Instantaneous=2
OEL Primary Takeover Reset Type On	41882	Uint32	4	R W	n/a	Inverse=0 Integrating=1 Instantaneous=2
OEL Secondary Takeover Reset Type Off	41884	Uint32	4	R W	n/a	Inverse=0 Integrating=1 Instantaneous=2

Name	Register	Type	Bytes	R/W	Unit	Range
OEL Secondary Takeover Reset Type On	41886	Uint32	4	R W	n/a	Inverse=0 Integrating=1 Instantaneous=2

## Setpoints

**Table 28. Setpoint Group Parameters**

Name	Register	Type	Bytes	R/W	Unit	Range
Field Current Regulation Setpoint	42200	Float	4	R W	Amp	Setpoint adjustment range determined by registers 42212 and 42214.
Field Current Regulation Traverse Rate	42202	Float	4	R W	Second	10–200
Field Current Regulation Pre-position Mode 1	42204	Uint32	4	R W	n/a	Maintain=0 Release=1
Field Current Regulation Pre-position 1	42206	Float	4	R W	Amp	Setpoint adjustment range determined by registers 42212 and 42214.
Field Current Regulation Pre-position Mode 2	42208	Uint32	4	R W	n/a	Maintain=0 Release=1
Field Current Regulation Pre-position 2	42210	Float	4	R W	Amp	Setpoint adjustment range determined by registers 42212 and 42214.
Field Current Regulation Minimum Setpoint Limit	42212	Float	4	R W	Percent	0–120
Field Current Regulation Maximum Setpoint Limit	42214	Float	4	R W	Percent	0–120
Generator Voltage Setpoint	42216	Float	4	R W	Volt	Setpoint adjustment range determined by registers 42228 and 42230.
Generator Voltage Traverse Rate	42218	Float	4	R W	Second	10–200
Generator Voltage Pre-position Mode 1	42220	Uint32	4	R W	n/a	Maintain=0 Release=1
Generator Voltage Pre-position 1	42222	Float	4	R W	Volt	Setpoint adjustment range determined by registers 42228 and 42230.
Generator Voltage Pre-position Mode 2	42224	Uint32	4	R W	n/a	Maintain=0 Release=1
Generator Voltage Pre-position 2	42226	Float	4	R W	Volt	Setpoint adjustment range determined by registers 42228 and 42230.
Generator Voltage Minimum Setpoint Limit	42228	Float	4	R W	Percent	70–120
Generator Voltage Maximum Setpoint Limit	42230	Float	4	R W	Percent	70–120
Generator var Setpoint	42232	Float	4	R W	kilovar	Setpoint adjustment range determined by registers 42244 and 42246.
Generator var Traverse Rate	42234	Float	4	R W	Second	10–200
Generator var Pre-position Mode 1	42236	Uint32	4	R W	n/a	Maintain=0 Release=1
Generator var Pre-position 1	42238	Float	4	R W	kilovar	Setpoint adjustment range determined by registers 42244 and 42246.
Generator var Pre-position Mode 2	42240	Uint32	4	R W	n/a	Maintain=0 Release=1
Generator var Pre-position 2	42242	Float	4	R W	kilovar	Setpoint adjustment range determined by registers 42244 and 42246.
Generator var Minimum Setpoint Limit	42244	Float	4	R W	Percent	-100 – 100
Generator var Maximum Setpoint Limit	42246	Float	4	R W	Percent	-100 – 100
Generator PF Setpoint	42248	Float	4	R W	Power Factor	Setpoint adjustment range determined by registers 42260 and 42262.
Generator PF Traverse Rate	42250	Float	4	R W	Second	10–200
Generator PF Pre-position Mode 1	42252	Uint32	4	R W	n/a	Maintain=0 Release=1
Generator PF Pre-position 1	42254	Float	4	R W	Power Factor	Setpoint adjustment range determined by registers 42260 and 42262.
Generator PF Pre-position Mode 2	42256	Uint32	4	R W	n/a	Maintain=0 Release=1
Generator PF Pre-position 2	42258	Float	4	R W	Power Factor	Setpoint adjustment range determined by registers 42260 and 42262.
Generator PF Minimum Setpoint Limit	42260	Float	4	R W	Power Factor	0.5–1
Generator PF Maximum Setpoint Limit	42262	Float	4	R W	Power Factor	-1 – -0.5
FVR Setpoint	42264	Float	4	R W	Volt	Setpoint adjustment range determined by registers 42276 and 42278.

Name	Register	Type	Bytes	R/W	Unit	Range
FVR Traverse Rate	42266	Float	4	R W	Second	10–200
FVR Pre-position Mode 1	42268	Uint32	4	R W	n/a	Maintain=0 Release=1
FVR Pre-position 1	42270	Float	4	R W	Volt	Setpoint adjustment range determined by registers 42276 and 42278.
FVR Pre-position Mode 2	42272	Uint32	4	R W	n/a	Maintain=0 Release=1
FVR Pre-position 2	42274	Float	4	R W	Volt	Setpoint adjustment range determined by registers 42276 and 42278.
FVR Minimum Setpoint Limit	42276	Float	4	R W	Percent	0–150
FVR Maximum Setpoint Limit	42278	Float	4	R W	Percent	0–150
Drop Value	42280	Float	4	R W	Percent	0–30
L-Drop Value	42282	Float	4	R W	Percent	0–30
Auxiliary Limit Enable	42284	Int32	4	R W	n/a	Disabled=0 Enabled=1
Field Current Regulation Pre-position Mode 3	42286	Uint32	4	R W	n/a	Maintain=0 Release=1
Field Current Regulation Pre-position 3	42288	Float	4	R W	Amp	Setpoint adjustment range determined by registers 42212 and 42214.
Generator Voltage Pre-position Mode 3	42290	Uint32	4	R W	n/a	Maintain=0 Release=1
Generator Voltage Pre-position 3	42292	Float	4	R W	Volt	Setpoint adjustment range determined by registers 42228 and 42230.
Generator var Pre-position Mode 3	42294	Uint32	4	R W	n/a	Maintain=0 Release=1
Generator var Pre-position 3	42296	Float	4	R W	kilovar	Setpoint adjustment range determined by registers 42244 and 42246.
Generator PF Pre-position Mode 3	42298	Uint32	4	R W	n/a	Maintain=0 Release=1
Generator PF Pre-position 3	42300	Float	4	R W	Power Factor	Setpoint adjustment range determined by registers 42260 and 42262.
FVR Pre-position Mode 3	42302	Uint32	4	R W	n/a	Maintain=0 Release=1
FVR Pre-position 3	42304	Float	4	R W	Volt	Setpoint adjustment range determined by registers 42276 and 42278.
Active Field Current Regulation Setpoint	42306	Float	4	R W	Amp	Setpoint adjustment range determined by registers 42212 and 42214.
Active Generator Voltage Setpoint	42308	Float	4	R W	Volt	Setpoint adjustment range determined by registers 42228 and 42230. When the With Limits box is checked on the Auxiliary Input screen in BESTCOMSP/us, register 42308 equals register 42216 plus the Aux input. When the With Limits box is not checked on the Auxiliary Input screen in BESTCOMSP/us, register 42308 equals register 42216.
Active Generator var Setpoint	42310	Float	4	R W	kilovar	Setpoint adjustment range determined by registers 42244 and 42246.
Active Generator PF Setpoint	42312	Float	4	R W	Power Factor	Setpoint adjustment range determined by registers 42260 and 42262.
Active FVR Setpoint	42314	Float	4	R W	Volt	Setpoint adjustment range determined by registers 42276 and 42278.
Transient Boost Enable	42316	Int32	4	R W	n/a	Disabled=0 Enabled=1
Transient Boost, Fault Voltage Threshold	42318	Float	4	R W	Percent	0–100
Transient Boost, Fault Current Threshold	42320	Float	4	R W	Percent	0–400
Transient Boost, Minimum Fault Duration	42322	Float	4	R W	Second	0–1
Transient Boost, Voltage Setpoint Boosting Level	42324	Float	4	R W	Percent	0–100
Transient Boost, Clearing Voltage Threshold	42326	Float	4	R W	Percent	0–50
Transient Boost, Clearing Voltage Delay	42328	Float	4	R W	Second	0–1

## Global Settings

Table 29. Global Settings Group Parameters

Group	Name	Register	Type	Bytes	R/W	Unit	Range
PLC Timed Element Settings	Logic Timer 1 Output Timeout	42400	Float	4	R W	Sec	0–1800
PLC Timed Element Settings	Logic Timer 2 Output Timeout	42402	Float	4	R W	Sec	0–1800
PLC Timed Element Settings	Logic Timer 3 Output Timeout	42404	Float	4	R W	Sec	0–1800
PLC Timed Element Settings	Logic Timer 4 Output Timeout	42406	Float	4	R W	Sec	0–1800
PLC Timed Element Settings	Logic Timer 5 Output Timeout	42408	Float	4	R W	Sec	0–1800
PLC Timed Element Settings	Logic Timer 6 Output Timeout	42410	Float	4	R W	Sec	0–1800
PLC Timed Element Settings	Logic Timer 7 Output Timeout	42412	Float	4	R W	Sec	0–1800
PLC Timed Element Settings	Logic Timer 8 Output Timeout	42414	Float	4	R W	Sec	0–1800
PLC Timed Element Settings	Logic Timer 9 Output Timeout	42416	Float	4	R W	Sec	0–1800
PLC Timed Element Settings	Logic Timer 10 Output Timeout	42418	Float	4	R W	Sec	0–1800
PLC Timed Element Settings	Logic Timer 11 Output Timeout	42420	Float	4	R W	Sec	0–1800
PLC Timed Element Settings	Logic Timer 12 Output Timeout	42422	Float	4	R W	Sec	0–1800
PLC Timed Element Settings	Logic Timer 13 Output Timeout	42424	Float	4	R W	Sec	0–1800
PLC Timed Element Settings	Logic Timer 14 Output Timeout	42426	Float	4	R W	Sec	0–1800
PLC Timed Element Settings	Logic Timer 15 Output Timeout	42428	Float	4	R W	Sec	0–1800
PLC Timed Element Settings	Logic Timer 16 Output Timeout	42430	Float	4	R W	Sec	0–1800
PLC Timed Element Settings	Counter 1 Output Timeout	42432	Float	4	R W	n/a	0–1800
PLC Timed Element Settings	Counter 2 Output Timeout	42434	Float	4	R W	n/a	0–1800
PLC Timed Element Settings	Counter 3 Output Timeout	42436	Float	4	R W	n/a	0–1800
PLC Timed Element Settings	Counter 4 Output Timeout	42438	Float	4	R W	n/a	0–1800
PLC Timed Element Settings	Counter 5 Output Timeout	42440	Float	4	R W	n/a	0–1800
PLC Timed Element Settings	Counter 6 Output Timeout	42442	Float	4	R W	n/a	0–1800
PLC Timed Element Settings	Counter 7 Output Timeout	42444	Float	4	R W	n/a	0–1800
PLC Timed Element Settings	Counter 8 Output Timeout	42446	Float	4	R W	n/a	0–1800
DECS PSS	PSS Enable	42448	Uint32	4	R W	n/a	Disabled=0 Enabled=1
DECS PSS	PSS Enable Status	42450	Uint32	4	R	n/a	Off=0 On=1
Synchronizer	Sync Type	42452	Uint32	4	R W	n/a	Anticipatory=0 Phase Lock Loop=1
Synchronizer	Slip Frequency	42454	Float	4	R W	Hz	0.1–0.5
Synchronizer	Generator Frequency Greater Than Bus Frequency	42456	Uint32	4	R W	n/a	Disabled=0 Enabled=1
Synchronizer	Breaker Closing Angle	42458	Float	4	R W	Deg	3–20
Synchronizer	Sync Activation Delay	42460	Float	4	R W	Sec	0.1–0.8
Synchronizer	Generator Voltage Greater Than Bus Voltage	42462	Uint32	4	R W	n/a	Disabled=0 Enabled=1
Synchronizer	Sync Fail Activation Delay	42464	Float	4	R W	Sec	0.1–600
Synchronizer	Sync Speed Gain	42466	Float	4	R W	n/a	0.001–1000
Synchronizer	Sync Voltage Gain	42468	Float	4	R W	n/a	0.001–1000
Synchronizer	Voltage Window	42470	Float	4	R W	%	2–15
Synchronizer	Sys Option Input Auto Sync Enabled	42472	Uint32	4	R W	n/a	Disabled=0 Enabled=1
Synchronizer	Max Slip Control Limit Hz	42474	Float	4	R W	Hz	0–2
Synchronizer	Min Slip Control Limit Hz	42476	Float	4	R W	Hz	0–2
Network Load Share	Load Share Enable	42478	Uint32	4	R W	n/a	Disabled=0 Enabled=1
Network Load Share	Load Share Droop Percent	42480	Float	4	R W	%	0–30
Network Load Share	Load Share Gain	42482	Float	4	R W	n/a	0–1000
Reserved		42484–87					
Generator Current Configuration	Rotation	42488	Uint32	4	R W	n/a	Forward=0 Reverse=1

Group	Name	Register	Type	Bytes	R/W	Unit	Range
Synchronizer	Angle Compensation	42490	Float	4	R W	Degree	0–359.9
System Configuration	Operating Mode	42492	Int32	4	R W	n/a	Generator=0 Motor=1
Reserved		42494					
Network Load Share	Ki Gain	42496	Float	4	R W	No Unit	0–1000
Network Load Share	Max Vc	42498	Float	4	R W	No Unit	0–1
Reserved		42500					

## Relay Settings

**Table 30. Relay Settings Group Parameters**

Group	Name	Register	Type	Bytes	R/W	Unit	Range
System Configuration	Nominal Frequency	42600	Uint32	4	R W	n/a	50 Hz=50 60 Hz=60
System Configuration	DECS Auxiliary Summing Mode	42602	Uint32	4	R W	n/a	Voltage=0 Var=1
System Configuration	DECS Auxiliary Input Mode	42604	Uint32	4	R W	n/a	Voltage=0 Current=1
System Configuration	DECS Auxiliary Input Function	42606	Uint32	4	R W	n/a	DECS Input=0 PSS Test Input=1 Limiter Selection=2 Grid Code Input=3
System Configuration	DECS Auxiliary Voltage Gain	42608	Float	4	R W	n/a	-99 – 99
System Configuration	DECS Auto Track Time Delay	42610	Float	4	R W	Second	0–8
System Configuration	DECS Auto Track Traverse Rate	42612	Float	4	R W	Second	1–80
System Configuration	DECS Null Balance Level	42614	Float	4	R W	Percent	0–9999
System Configuration	DECS Auto Trans Time Delay	42616	Float	4	R W	Second	0–8
System Configuration	DECS Auto Trans Traverse Rate	42618	Float	4	R W	Second	1–80
Gen Volt Configuration	Ratio Primary	42620	Float	4	R W	n/a	1–500000
Gen Volt Configuration	Ratio Secondary	42622	Float	4	R W	n/a	1–600
Gen Volt Configuration	Rated Primary LL	42624	Float	4	R W	Volt	1–500000
Bus Volt Configuration	Ratio Primary	42626	Float	4	R W	n/a	1–500000
Bus Volt Configuration	Ratio Secondary	42628	Float	4	R W	n/a	1–600
Bus Volt Configuration	Rated Primary LL	42630	Float	4	R W	Volt	1–500000
Gen Current Configuration	Ratio Primary	42632	Float	4	R W	n/a	1–99999
Gen Current Configuration	Ratio Secondary	42634	Int32	4	R W	n/a	1=1 5=5
Gen Current Configuration	Rated Primary	42636	Float	4	R	Amp	0–180000
DECS Control	Start Stop Request	42638	Uint32	4	R W	n/a	Stop=0 =1 Start =2
DECS Control	System Option Underfrequency Hz	42640	Float	4	R W	Hertz	10–75
DECS Control	System Input COM Port Manual Enabled	42642	Uint32	4	R W	n/a	Manual=1 Automatic=2
DECS Control	System Input COM Port PF var Enabled	42644	Uint32	4	R W	n/a	Off=0 PF=1 Var=2
DECS Control	System Input COM Port External Tracking Enabled	42646	Uint32	4	R W	n/a	Disabled=0 Enabled=1
DECS Control	System Input COM Port Pre-position Enabled	42648	Uint32	4	R W	n/a	NOT SET=0 SET=1

Group	Name	Register	Type	Bytes	R/W	Unit	Range
DECS Control	System Input COM Port Pre-position Enabled 2	42650	Uint32	4	R W	n/a	NOT SET=0 SET=1
DECS Control	System Input COM Port Raise Enabled	42652	Uint32	4	R W	n/a	NOT SET=0 Raise=1
DECS Control	System Input COM Port Lower Enabled	42654	Uint32	4	R W	n/a	NOT SET=0 Lower=1
DECS Control	System Option Input Voltage Match Enabled	42656	Uint32	4	R W	n/a	Disabled=0 Enabled=1
DECS Control	System Option Underfrequency Mode	42658	Uint32	4	R W	n/a	UF Limiter=0 V/Hz Limiter=1
DECS Control	System Option Limiter Mode	42660	Uint32	4	R W	n/a	Off=0 UEL=1 OEL=2 UEL & OEL=3 SCL=4 UEL & SCL=5 OEL & SCL=6 UEL & OEL & SCL=7
DECS Control	System Option Voltage Match Band	42662	Float	4	R W	Percent	0–20
DECS Control	System Option Voltage Match Reference	42664	Float	4	R W	Percent	0–700
DECS Control	System Option Underfrequency Slope	42666	Float	4	R W	n/a	0–3
DECS Control	Startup Primary Soft-start Bias	42668	Float	4	R W	Percent	0–90
DECS Control	Startup Primary Soft-start Time	42670	Float	4	R W	Second	1–7200
DECS Control	Startup Secondary Soft-start Bias	42672	Float	4	R W	Percent	0–90
DECS Control	Startup Secondary Soft-start Time	42674	Float	4	R W	Second	1–7200
DECS Control	System Option PF to Droop kW Threshold	42676	Float	4	R W	Percent	0–30

## Protection Settings

Table 31. Protection Settings Group Parameters

Group	Name	Register	Type	Sz	R/W	Unit	Range
Field Overvoltage	Primary Mode	43100	Uint32	4	R W	n/a	Disabled=0 Enabled=1
Field Overvoltage	Primary Pickup	43102	Float	4	R W	V	Disabled=0, 1–325
Field Overvoltage	Primary Time Delay	43104	Float	4	R W	ms	Instantaneous=0, 200–30000
Field Overvoltage	Secondary Mode	43106	Uint32	4	R W	n/a	Disabled=0 Enabled=1
Field Overvoltage	Secondary Pickup	43108	Float	4	R W	V	Disabled=0, 1–325
Field Overvoltage	Secondary Time Delay	43110	Float	4	R W	ms	Instantaneous=0, 200–30000
Field Overcurrent	Primary Mode	43112	Uint32	4	R W	n/a	Disabled=0 Enabled=1
Field Overcurrent	Primary Pickup	43114	Float	4	R W	Amp	Disabled=0, 0–22
Field Overcurrent	Primary Time Delay	43116	Float	4	R W	ms	Instantaneous=0, 5000–60000
Field Overcurrent	Secondary Mode	43118	Uint32	4	R W	n/a	Disabled=0 Enabled=1
Field Overcurrent	Secondary Pickup	43120	Float	4	R W	Amp	Disabled=0, 0–22
Field Overcurrent	Secondary Time Delay	43122	Float	4	R W	ms	Instantaneous=0, 5000–60000
Exciter Diode Monitor	Exciter Open Diode Enable	43124	Uint32	4	R W	n/a	Disabled=0 Enabled=1
Exciter Diode Monitor	Exciter Shorted Diode Enable	43126	Uint32	4	R W	n/a	Disabled=0 Enabled=1
Exciter Diode Monitor	Exciter Diode Disable Level	43128	Float	4	R W	%	0–100
Exciter Diode Monitor	Exciter Open Diode Pickup	43130	Float	4	R W	%	0–100
Exciter Diode Monitor	Exciter Open Diode Time Delay	43132	Float	4	R W	Sec	10–60
Exciter Diode Monitor	Exciter Shorted Diode Pickup	43134	Float	4	R W	%	0–100
Exciter Diode Monitor	Exciter Shorted Diode Time Delay	43136	Float	4	R W	Sec	5–30
Exciter Diode Monitor	Exciter Pole Ratio	43138	Float	4	R W	n/a	Disabled=0, 1–10
Power Input Failure	Mode	43140	Uint32	4	R W	n/a	Disabled=0 Enabled=1
Power Input Failure	Time Delay	43142	Float	4	R W	Sec	0–10
Loss Of Sensing	Mode	43144	Uint32	4	R W	n/a	Disabled=0 Enabled=1
Loss Of Sensing	Time Delay	43146	Float	4	R W	Sec	0–30

Group	Name	Register	Type	Sz	R/W	Unit	Range
Loss Of Sensing	Voltage Balanced Level	43148	Float	4	R W	%	0–100
Loss Of Sensing	Voltage Unbalanced Level	43150	Float	4	R W	%	0–100
25	Mode	43152	Uint32	4	R W	n/a	Disabled=0 Enabled=1
25	Slip Angle	43156	Float	4	R W	Deg	1–99
25	Slip Frequency	43158	Float	4	R W	Hz	0.01–0.5
25	Voltage Difference	43160	Float	4	R W	%	0.1–50
25	Generator Frequency Greater Than Bus Frequency	43162	Uint32	4	R W	n/a	Disabled=0 Enabled=1
25	Dead Voltage	43164	Float	4	R W	%	Disabled=0, 10–90
25	Live Voltage	43166	Float	4	R W	%	Disabled=0, 10–90
25	Dropout Delay	43168	Float	4	R W	ms	50–60000
25	Angle Compensation	43170	Float	4	R W	Deg	0–359.9
25	VMM Dead Line, Dead Aux	43172	Uint32	4	R W	n/a	Disabled=0 Enabled=1
25	VMM Dead Line, Live Aux	43174	Uint32	4	R W	n/a	Disabled=0 Enabled=1
25	VMM Live Line, Dead Aux	43176	Uint32	4	R W	n/a	Disabled=0 Enabled=1
27P	Primary Mode	43178	Uint32	4	R W	n/a	Disabled=0 Enabled=1
27P	Primary Pickup	43180	Float	4	R W	V	Disabled=0, 1–600000
27P	Primary Time Delay	43182	Float	4	R W	ms	100–60000
27P	Secondary Mode	43184	Uint32	4	R W	n/a	Disabled=0 Enabled=1
27P	Secondary Pickup	43186	Float	4	R W	V	Disabled=0, 1 - 600000
27P	Secondary Time Delay	43188	Float	4	R W	ms	100–60000
59P	Primary Mode	43190	Uint32	4	R W	n/a	Disabled=0 Enabled=1
59P	Primary Pickup	43192	Float	4	R W	V	Disabled=0, 0–600000
59P	Primary Time Delay	43194	Float	4	R W	ms	100–60000
59P	Secondary Mode	43196	Uint32	4	R W	n/a	Disabled=0 Enabled=1
59P	Secondary Pickup	43198	Float	4	R W	V	Disabled=0, 0–600000
59P	Secondary Time Delay	43200	Float	4	R W	ms	100–60000
81O	Primary Mode	43202	Uint32	4	R W	n/a	Disabled=0 Over=1
81O	Primary Pickup	43204	Float	4	R W	Hz	Disabled=0, 30–70
81O	Primary Time Delay	43206	Float	4	R W	ms	100–300000
81O	Secondary Mode	43208	Uint32	4	R W	n/a	Disabled=0 Over=1
81O	Secondary Pickup	43210	Float	4	R W	Hz	Disabled=0, 30–70
81O	Secondary Time Delay	43212	Float	4	R W	ms	100–300000
81U	Primary Mode	43214	Uint32	4	R W	n/a	Disabled=0 Under=2
81U	Primary Pickup	43216	Float	4	R W	Hz	Disabled=0, 30–70
81U	Primary Time Delay	43218	Float	4	R W	ms	100–300000
81U	Primary Voltage Inhibit	43220	Float	4	R W	%	Disabled=0, 50–100
81U	Secondary Mode	43222	Uint32	4	R W	n/a	Disabled=0 Under=2
81U	Secondary Pickup	43224	Float	4	R W	Hz	Disabled=0, 30–70
81U	Secondary Time Delay	43226	Float	4	R W	ms	100–300000
81U	Secondary Voltage Inhibit	43228	Float	4	R W	%	Disabled=0, 50–100
40Q	Primary Mode	43230	Uint32	4	R W	n/a	Disabled=0 Enabled=1
40Q	Primary Pickup	43232	Float	4	R W	%	Disabled=0, 0–150
40Q	Primary Time Delay	43234	Float	4	R W	ms	Instantaneous=0, 0–300000
40Q	Secondary Mode	43236	Uint32	4	R W	n/a	Disabled=0 Enabled=1
40Q	Secondary Pickup	43238	Float	4	R W	%	Disabled=0, 0–150
40Q	Secondary Time Delay	43240	Float	4	R W	ms	Instantaneous=0, 0–300000
32R	Primary Mode	43242	Uint32	4	R W	n/a	Disabled=0 Enabled=4
32R	Primary Pickup	43244	Float	4	R W	%	Disabled=0, 0–150
32R	Primary Time Delay	43246	Float	4	R W	ms	Instantaneous =0, 0–300000
32R	Secondary Mode	43248	Uint32	4	R W	n/a	Disabled=0 Enabled=4

Group	Name	Register	Type	Sz	R/W	Unit	Range
32R	Secondary Pickup	43250	Float	4	R W	%	Disabled=0, 0–150
32R	Secondary Time Delay	43252	Float	4	R W	ms	Instantaneous=0, 0–300000
Field Overcurrent	Timing Mode, Protection Primary	43254	Uint32	4	R W	n/a	Definite Timing=0 Inverse Timing=1
Field Overcurrent	Time Dial, Protection Primary	43256	Float	4	R W	n/a	0.1–20
Field Overcurrent	Timing Mode, Protection Secondary	43258	Uint32	4	R W	n/a	Definite Timing=0 Inverse Timing=1
Field Overcurrent	Time Dial, Protection Secondary	43260	Float	4	R W	n/a	0.1–20
24	Primary Mode	43262	Uint32	4	R W	n/a	Disabled=0, Enabled=1
24	Primary Definite Time Pickup 1	43264	Float	4	R W	n/a	0.5–6
24	Primary Definite Time Pickup 2	43266	Float	4	R W	n/a	0.5–6
24	Primary Definite Time Delay 1	43268	Float	4	R W	ms	50–600000
24	Primary Definite Time Delay 2	43270	Float	4	R W	ms	50–600000
24	Primary Inverse Time Pickup	43272	Float	4	R W	n/a	0.5–6
24	Primary Time Dial Trip	43274	Float	4	R W	n/a	0–9.9
24	Primary Time Dial Reset	43276	Float	4	R W	n/a	0–9.9
24	Primary Curve Exponent	43278	Uint32	4	R W	n/a	0.5=0, 1=1, 2=2
24	Secondary Mode	43280	Uint32	4	R W	n/a	Disabled=0, Enabled=1
24	Secondary Definite Time Pickup 1	43282	Float	4	R W	n/a	0.5–6
24	Secondary Definite Time Pickup 2	43284	Float	4	R W	n/a	0.5–6
24	Secondary Definite Time Delay 1	43286	Float	4	R W	ms	50–600000
24	Secondary Definite Time Delay 2	43288	Float	4	R W	ms	50–600000
24	Secondary Inverse Time Pickup	43290	Float	4	R W	n/a	0.5–6
24	Secondary Time Dial Trip	43292	Float	4	R W	n/a	0–9.9
24	Secondary Time Dial Reset	43294	Float	4	R W	n/a	0–9.9
24	Curve Exponent	43296	Uint32	4	R W	n/a	0.5=0, 1=1, 2=2

## Gains Settings

Table 32. Gains Settings Group Parameters

Name	Register	Type	Bytes	R/W	Unit	Range
Primary Gain Option	43800	Uint32	4	R W		T'do=1.0 Te=0.17=1 T'do=1.5 Te=0.25=2 T'do=2.0 Te=0.33=3 T'do=2.5 Te=0.42=4 T'do=3.0 Te=0.50=5 T'do=3.5 Te=0.58=6 T'do=4.0 Te=0.67=7 T'do=4.5 Te=0.75=8 T'do=5.0 Te=0.83=9 T'do=5.5 Te=0.92=10 T'do=6.0 Te=1.00=11 T'do=6.5 Te=1.08=12 T'do=7.0 Te=1.17=13 T'do=7.5 Te=1.25=14 T'do=8.0 Te=1.33=15 T'do=8.5 Te=1.42=16 T'do=9.0 Te=1.50=17 T'do=9.5 Te=1.58=18 T'do=10.0 Te=1.67=19 T'do=10.5 Te=1.75=20 Custom=21
Secondary Gain Option	43802	Uint32	4	R W		T'do=1.0 Te=0.17=1 T'do=1.5 Te=0.25=2 T'do=2.0 Te=0.33=3 T'do=2.5 Te=0.42=4 T'do=3.0 Te=0.50=5 T'do=3.5 Te=0.58=6 T'do=4.0 Te=0.67=7 T'do=4.5 Te=0.75=8 T'do=5.0 Te=0.83=9 T'do=5.5 Te=0.92=10 T'do=6.0 Te=1.00=11 T'do=6.5 Te=1.08=12 T'do=7.0 Te=1.17=13 T'do=7.5 Te=1.25=14 T'do=8.0 Te=1.33=15 T'do=8.5 Te=1.42=16 T'do=9.0 Te=1.50=17 T'do=9.5 Te=1.58=18 T'do=10.0 Te=1.67=19 T'do=10.5 Te=1.75=20 Custom=21
AVR Kp Primary	43804	Float	4	R W	n/a	0–1000
AVR Ki Primary	43806	Float	4	R W	n/a	0–1000
AVR Kd Primary	43808	Float	4	R W	n/a	0–1000
AVR Td Primary	43810	Float	4	R W	n/a	0–1
FCR Kp	43812	Float	4	R W	n/a	0–1000
FCR Ki	43814	Float	4	R W	n/a	0–1000
FCR Kd	43816	Float	4	R W	n/a	0–1000
FCR Td	43818	Float	4	R W	n/a	0–1
FVR Kp	43820	Float	4	R W	n/a	0–1000

Name	Register	Type	Bytes	R/W	Unit	Range
FVR Ki	43822	Float	4	R W	n/a	0–1000
FVR Kd	43824	Float	4	R W	n/a	0–1000
FVR Td	43826	Float	4	R W	n/a	0–1
PF Ki	43828	Float	4	R W	n/a	0–1000
PF Kg	43830	Float	4	R W	n/a	0–1000
Var Ki	43832	Float	4	R W	n/a	0–1000
Var Kg	43834	Float	4	R W	n/a	0–1000
OEL Ki	43836	Float	4	R W	n/a	0–1000
OEL Kg	43838	Float	4	R W	n/a	0–1000
UEL Ki	43840	Float	4	R W	n/a	0–1000
UEL Kg	43842	Float	4	R W	n/a	0–1000
SCL Ki	43844	Float	4	R W	n/a	0–1000
SCL Kg	43846	Float	4	R W	n/a	0–1000
Vm Kg	43848	Float	4	R W	n/a	0–1000
Inner Loop Kp	43850	Float	4	R W	n/a	0–1000
Inner Loop Ki	43852	Float	4	R W	n/a	0–1000
AVR Kp Secondary	43854	Float	4	R W	n/a	0–1000
AVR Ki Secondary	43856	Float	4	R W	n/a	0–1000
AVR Kd Secondary	43858	Float	4	R W	n/a	0–1000
AVR Td Secondary	43860	Float	4	R W	n/a	0–1
Var Limit Ki	43862	Float	4	R W	n/a	0–1000
Var Limit Kg	43864	Float	4	R W	n/a	0–1000
AVR Primary Ka	43866	Float	4	R W	n/a	0–1
AVR Secondary Ka	43868	Float	4	R W	n/a	0–1
FCR Ka	43870	Float	4	R W	n/a	0–1
FVR Ka	43872	Float	4	R W	n/a	0–1

## Grid Code Settings

Table 33. Grid Code Settings Group Parameters

Name	Register	Type	Bytes	R/W	Unit	Range
Grid Code Enable	44800	Uint32	4	R W	n/a	Disabled=0 Enabled=1
Grid Disconnect Time Delay	44802	Float	4	R W	Second	0–3600
Min Freq Normal	44804	Float	4	R W	Hertz	40–70
Max Freq Normal	44806	Float	4	R W	Hertz	40–70
Min V Bus Normal	44808	Float	4	R W	Per Unit	0.1–1
Max V Bus Normal	44810	Float	4	R W	Per Unit	1–1.3
Min Freq Disconnect	44812	Float	4	R W	Hertz	40–70
Max Freq Disconnect	44814	Float	4	R W	Hertz	40–70
Min V Bus Disconnect	44816	Float	4	R W	Per Unit	0.1–1
Max V Bus Disconnect	44818	Float	4	R W	Per Unit	1–1.3
PF Reference	44820	Float	4	R W	Power Factor	-1 – 1
Q Limit U Point 1	44822	Float	4	R W	Per Unit	0.8–1.2
Q Limit U Point 2	44824	Float	4	R W	Per Unit	0.8–1.2
Q Limit U Point 3	44826	Float	4	R W	Per Unit	0.8–1.2
Q Limit U Point 4	44828	Float	4	R W	Per Unit	0.8–1.2
Q Limit Q Point 1	44830	Float	4	R W	Per Unit	-0.4 – 0.4
Q Limit Q Point 2	44832	Float	4	R W	Per Unit	-0.4 – 0.4
Q Limit Q Point 3	44834	Float	4	R W	Per Unit	-0.4 – 0.4
Q Limit Q Point 4	44836	Float	4	R W	Per Unit	-0.4 – 0.4
Q(U) Slope	44838	Float	4	R W	Per Unit	0–20

Name	Register	Type	Bytes	R/W	Unit	Range
Q(U) V Bus for Zero Q	44840	Float	4	R W	Per Unit	0.9–1.1
Q(U) Deadband	44842	Float	4	R W	Per Unit	0–0.1
Q(U) Max	44844	Float	4	R W	Per Unit	-0.4 – 0.4
Q(U) Min	44846	Float	4	R W	Per Unit	-0.4 – 0.4
Q(P) Point P01	44848	Float	4	R W	Per Unit	0–1.5
Q(P) Point P02	44850	Float	4	R W	Per Unit	0–1.5
Q(P) Point P03	44852	Float	4	R W	Per Unit	0–1.5
Q(P) Point P04	44854	Float	4	R W	Per Unit	0–1.5
Q(P) Point P05	44856	Float	4	R W	Per Unit	0–1.5
Q(P) Point P06	44858	Float	4	R W	Per Unit	0–1.5
Q(P) Point P07	44860	Float	4	R W	Per Unit	0–1.5
Q(P) Point P08	44862	Float	4	R W	Per Unit	0–1.5
Q(P) Point P09	44864	Float	4	R W	Per Unit	0–1.5
Q(P) Point P10	44866	Float	4	R W	Per Unit	0–1.5
Q(P) Point Q01	44868	Float	4	R W	Per Unit	-0.7 – 0.7
Q(P) Point Q02	44870	Float	4	R W	Per Unit	-0.7 – 0.7
Q(P) Point Q03	44872	Float	4	R W	Per Unit	-0.7 – 0.7
Q(P) Point Q04	44874	Float	4	R W	Per Unit	-0.7 – 0.7
Q(P) Point Q05	44876	Float	4	R W	Per Unit	-0.7 – 0.7
Q(P) Point Q06	44878	Float	4	R W	Per Unit	-0.7 – 0.7
Q(P) Point Q07	44880	Float	4	R W	Per Unit	-0.7 – 0.7
Q(P) Point Q08	44882	Float	4	R W	Per Unit	-0.7 – 0.7
Q(P) Point Q09	44884	Float	4	R W	Per Unit	-0.7 – 0.7
Q(P) Point Q10	44886	Float	4	R W	Per Unit	-0.7 – 0.7
Remote Control Fail Mode	44888	Uint32	4	R W	n/a	Q(PF) Control=0 Hold Value=1
Remote Failure Time Delay	44890	Float	4	R W	Second	0–600
APC Enabled	44892	Uint32	4	R W	n/a	Disabled=0 Enabled=1
Active Power Input Source	44894	Uint32	4	R W	n/a	Active Power Setpoint=0 Active Power Selection=1
Active Power Setpoint	44896	Float	4	R W	Per Unit	-2 – 2
APC Normal Power Increase Rate Percent	44898	Float	4	R W	Percent Per Second	0.07–10
APC Normal Power Decrease Rate Percent	44900	Float	4	R W	Percent Per Second	0.07–10
LVRT Option	44902	Uint32	4	R W	n/a	Disabled=0 Q(PF) Control=1 Q(Voltage Limit) Control=2 Q(U) Control=3 Q(P) Control=4 Q (Third Party)=5
LVRT Enabled	44904	Uint32	4	R W	n/a	Disabled=0 Enabled=1
Time Constant for PT1	44906	Float	4	R W	Second	0.01–60
LFSM Enabled	44908	Uint32	4	R W	n/a	Disabled=0 Enabled=1
LFSM U Deadband	44910	Float	4	R W	Hertz	40–70
LFSM O Deadband	44912	Float	4	R W	Hertz	40–70
LFSM U Max Power Limit Derate Percent	44914	Float	4	R W	Percent Per Hertz	0–20
LFSM O Max Power Limit Derate Percent	44916	Float	4	R W	Percent Per Hertz	0–20
LFSM U Droop Percent	44918	Float	4	R W	Percent Per Hertz	16.67–100
LFSM O Droop Percent	44920	Float	4	R W	Percent Per Hertz	16.67–100
APC Kg	44922	Float	4	R W	n/a	0–100

Name	Register	Type	Bytes	R/W	Unit	Range
APC Ki	44924	Float	4	R W	n/a	0–100
APC PI Controller Max Limit	44926	Float	4	R W	Per Unit	-2 – 2
APC PI Controller Min Limit	44928	Float	4	R W	Per Unit	-2 – 2
Q(Third Party) Reference	44930	Float	4	R W	n/a	-0.45 – 0.45
Voltage Disconnect Time Delay	44932	Float	4	R W	Second	1–3600
Frequency Disconnect Time Delay	44934	Float	4	R W	Minute	1–60
Voltage Bus Time Constant	44936	Float	4	R W	Second	0.01–60
Q P Time Constant	44938	Float	4	R W	Second	0.01–60
Min Active Power Setpoint	44940	Float	4	R W	Per Unit	-2 – 2
Max Active Power Setpoint	44942	Float	4	R W	Per Unit	-2 – 2
PF Gain	44944	Float	4	R W	n/a	-100 – 100
Q Limit Gain	44946	Float	4	R W	n/a	-100 – 100
Q U Gain	44948	Float	4	R W	n/a	-100 – 100
Q Remote Gain	44950	Float	4	R W	n/a	-100 – 100
Q Limit Q Reference	44952	Float	4	R W	Per Unit	-0.45 – 0.45
Grid Reconnect Stability Timer	44954	Float	4	R W	Minute	0–30
Min Frequency Reconnect	44956	Float	4	R W	Hertz	40–70
Max Frequency Reconnect	44958	Float	4	R W	Hertz	40–70
Min V Bus Reconnect	44960	Float	4	R W	Per Unit	0.1–1
Max V Bus Reconnect	44962	Float	4	R W	Per Unit	1–1.3
Recovery Time LFSM	44964	Float	4	R W	Minute	0.1–90
Recovery Power Increase Rate Percent	44966	Float	4	R W	Percent Per Second	0.001–10
Recovery Power Decrease Rate Percent	44968	Float	4	R W	Percent Per Second	0.001–10
Reserved	44970-74					
Active Power Level 1	44976	Float	4	R W	Per Unit	-2 – 2
Active Power Level 2	44978	Float	4	R W	Per Unit	-2 – 2
Active Power Level 3	44980	Float	4	R W	Per Unit	-2 – 2
Active Power Level 4	44982	Float	4	R W	Per Unit	-2 – 2
LFSM U Max Power Limit Start Frequency	44984	Float	4	R W	Hertz	40–70
LFSM O Max Power Limit Start Frequency	44986	Float	4	R W	Hertz	40–70
LFSM Power Increase Rate Percent	44988	Float	4	R W	Percent Per Second	0.33–10
LFSM Power Decrease Rate Percent	44990	Float	4	R W	Percent Per Second	0.33–10
APC Gain	44992	Float	4	R W	n/a	-100 – 100
Q Volt Limit Adjust Source	44994	UInt32	4	R W	n/a	None=0 Auxiliary Input=1 Modbus=2
Q U Adjust Source	44996	UInt32	4	R W	n/a	None=0 Auxiliary Input=1 Modbus=2
PF Adjust Source	44998	UInt32	4	R W	n/a	None=0 Auxiliary Input=1 Modbus=2
Q Third Party Adjust Source	45000	UInt32	4	R W	n/a	None=0 Auxiliary Input=1 Modbus=2
Active Power Adjust Source	45002	UInt32	4	R W	n/a	None=0 Auxiliary Input=1 Modbus=2
Reserved	45004					
Q Volt Limit Adjust Modbus	45006	Float	4	R W	Per Unit	-0.45 – 0.45
Q U Volt Bus for Zero Q Adjust Modbus	45008	Float	4	R W	n/a	-0.5 – 0.5

Name	Register	Type	Bytes	R/W	Unit	Range
PF Reference Adjust Modbus	45010	Float	4	R W	Power Factor	-1 – 1
Q Third Party Adjust Modbus	45012	Float	4	R W	Per Unit	-0.45 – 0.45
Active Power Adjust Modbus	45014	Float	4	R W	Per Unit	-2 – 2
APC Bridge Enable	45016	Uint32	4	R W	n/a	Disabled=0 Enabled=1
LVRT Bridge Enable	45018	Float	4	R W	n/a	Disabled=0 Enabled=1
PF Active Power Level	45020	Float	4	R W	Per Unit	0–1

## Legacy Modbus

**Table 34. Legacy Modbus Parameters**

Name	Register	Type	Bytes	R/W	Unit	Range
Model Information Character 1	47001	Uint8	1	R	n/a	n/a
Model Information Character 2	47002	Uint8	1	R	n/a	n/a
Model Information Character 3	47003	Uint8	1	R	n/a	n/a
Model Information Character 4	47004	Uint8	1	R	n/a	n/a
Model Information Character 5	47005	Uint8	1	R	n/a	n/a
Model Information Character 6	47006	Uint8	1	R	n/a	n/a
Model Information Character 7	47007	Uint8	1	R	n/a	n/a
Model Information Character 8	47008	Uint8	1	R	n/a	n/a
Model Information Character 9	47009	Uint8	1	R	n/a	n/a
Application Program Version Character 1	47010	Uint8	1	R	n/a	n/a
Application Program Version Character 2	47011	Uint8	1	R	n/a	n/a
Application Program Version Character 3	47012	Uint8	1	R	n/a	n/a
Application Program Version Character 4	47013	Uint8	1	R	n/a	n/a
Application Program Version Character 5	47014	Uint8	1	R	n/a	n/a
Application Program Version Character 6	47015	Uint8	1	R	n/a	n/a
Application Program Version Character 7	47016	Uint8	1	R	n/a	n/a
Application Program Version Character 8	47017	Uint8	1	R	n/a	n/a
Application Version Date Character 1	47018	Uint8	1	R	n/a	n/a
Application Version Date Character 2	47019	Uint8	1	R	n/a	n/a
Application Version Date Character 3	47020	Uint8	1	R	n/a	n/a
Application Version Date Character 4	47021	Uint8	1	R	n/a	n/a
Application Version Date Character 5	47022	Uint8	1	R	n/a	n/a
Application Version Date Character 6	47023	Uint8	1	R	n/a	n/a
Application Version Date Character 7	47024	Uint8	1	R	n/a	n/a
Application Version Date Character 8	47025	Uint8	1	R	n/a	n/a
Application Version Date Character 9	47026	Uint8	1	R	n/a	n/a
Reserved	47027-43	Uint8	1	R	n/a	0–255
Boot Program Version Character 1	47044	Uint8	1	R	n/a	n/a
Boot Program Version Character 2	47045	Uint8	1	R	n/a	n/a
Boot Program Version Character 3	47046	Uint8	1	R	n/a	n/a
Boot Program Version Character 4	47047	Uint8	1	R	n/a	n/a
Boot Program Version Character 5	47048	Uint8	1	R	n/a	n/a
Boot Program Version Character 6	47049	Uint8	1	R	n/a	n/a
Boot Program Version Character 7	47050	Uint8	1	R	n/a	n/a
Boot Program Version Character 8	47051	Uint8	1	R	n/a	n/a
Reserved	47052-64	Uint8	1	R	n/a	0–255
RMS Generator Volts Phase A to B	47251	Float	4	R	n/a	n/a
RMS Generator Volts Phase B to C	47253	Float	4	R	n/a	n/a
RMS Generator Volts Phase C to A	47255	Float	4	R	n/a	n/a

Name	Register	Type	Bytes	R/W	Unit	Range
Average RMS L-L Volts	47257	Float	4	R	n/a	n/a
Generator Current IB in amps	47259	Float	4	R	n/a	n/a
Generator Apparent Power in kVA	47261	Float	4	R	n/a	n/a
Generator Real Power in kW	47263	Float	4	R	n/a	n/a
Generator Reactive Power in kvar	47265	Float	4	R	n/a	n/a
Power Factor	47267	Float	4	R	n/a	n/a
Generator Frequency in Hertz	47269	Float	4	R	n/a	n/a
Bus Frequency in Hertz	47271	Float	4	R	n/a	n/a
RMS Bus Voltage in Volts	47273	Float	4	R	n/a	n/a
Field Voltage in Volts	47275	Float	4	R	n/a	n/a
Field Current in Amps	47277	Float	4	R	n/a	n/a
Var/PF Controller Output in Volts	47279	Float	4	R	Per Unit	n/a
Phase Angle Between Phase B Voltage and Current	47281	Float	4	R	n/a	n/a
Auxiliary Input in Volts	47283	Float	4	R	n/a	n/a
Current Input for Load Compensation	47285	Float	4	R	n/a	n/a
Null Balance in Percent	47287	Float	4	R	n/a	n/a
Error Signal to Autotracking Loop	47289	Float	4	R	n/a	n/a
Active Controller Output	47291	Float	4	R	n/a	n/a
PF State	47293	Uint16	2	R	n/a	n/a
Generator State	47294	Uint16	2	R	n/a	n/a
Status of Front Panel LEDs	47295	Uint16	2	R	n/a	(bit flags, 0 = off, 1 = on for all LEDs except Null Balance and Internal Tracking, which are reversed): b0 = Null Balance, b1 = Tracking, b2 = Pre-position, b3 = Upper Limit, b4 = Lower Limit, b5 = Edit, b6-b15 = unassigned
Voltage Matching Status	47296	Uint16	2	R	n/a	n/a
Protection Status Bit Flags 1	47297	Uint16	2	R	n/a	(0 = clear, 1 = condition present): b0 = field overvoltage, b1 = field overcurrent, b2 = gen. Undervoltage, b3 = gen. overvoltage, b4 = underfrequency, b5 = in OEL, b6 = in UEL, b7 = in FCR mode, b8 = loss of sensing voltage, b9 = setpoint at lower limit, b10 = setpoint at upper limit, b11 = gen. failed to build up, b12 = gen. below 10Hz, b13 = unassigned, b14 = exciter diode open, b15 = exciter diode shorted.
Reserved	47298	Float	4	R	n/a	n/a
Active Operating Setpoint in Percent	47300	Float	4	R	n/a	n/a
Contact Input States	47302	Uint16	2	R	n/a	n/a
Annunciation Status Bit Flags 1	47303	Uint16	2	R	n/a	(0 = clear, 1 = annunciation present): b0 = field overvoltage, b1 = field overcurrent, b2 = gen. undervoltage, b3 = gen. overvoltage, b4 = underfrequency, b5 = in OEL, b6 = in UEL, b7 = in FCR, b8 = loss of sensing voltage, b9 = setpoint at lower limit, b10 = setpoint at upper limit, b11 = gen. failed to build up, b12 = gen. below 10Hz, b13 = unassigned, b14 = exciter diode open, b15 = exciter diode shorted
Reserved 3	47304	Float	4	R	n/a	n/a
Protection Status Bit Flags 2	47306	Uint16	2	R	n/a	(0 = clear, 1 = condition present) b0 = loss of field, b1 = in SCL, b2 – b15 are unassigned
Annunciation Status Bit Flags 2	47307	Uint16	2	R	n/a	(0 = clear, 1 = condition present) b0 = loss of field, b1 = in SCL, b2 – b15 are unassigned
Reserved 4	47308-375	C2 Filler	136	n/a	n/a	n/a

Name	Register	Type	Bytes	R/W	Unit	Range
Reserved 5	47376-499	C3 Filler	248	n/a	n/a	n/a
Auxiliary Input Function	47500	Uint16	2	n/a	n/a	DECS Input=0 PSS Test Input=1 Limiter Selection=2 Grid Code Input=3
Generator Rated Frequency	47501	Uint32	4	R W	n/a	50 Hz=50 60 Hz=60
Generator PT Primary Voltage Rating	47503	Float	4	R W	n/a	1-500000
Generator PT Secondary Voltage Rating	47505	Float	4	R W	n/a	1-600
Generator CT Primary Current Rating	47507	Float	4	R W	n/a	1-99999
Generator CT Secondary Current Rating	47509	Int32	4	R W	n/a	1=1 5=5
Not used in DECS-250	47511	Float	4	R W	n/a	
Reserved Float 1	47513	Float	4	R	n/a	0-10000
Bus Sensing PT Primary Rating	47515	Float	4	R W	n/a	1-500000
Bus Sensing PT Secondary Rating	47517	Float	4	R W	n/a	1-600
Reserved 6	47519	Float	4	R	n/a	n/a
Reserved 7	47521	Float	4	R	n/a	n/a
Generator Rated Voltage	47523	Float	4	R W	Volt	1-500000
Generator Rated Current	47525	Float	4	R	Amp	0-180000
Generator Rated Field Voltage	47527	Float	4	R W	Volt	1-125
Generator Rated Field Current	47529	Float	4	R W	Amp	0.1-20
Nominal Bus Voltage	47531	Float	4	R W	Volt	1-500000
Auxiliary Input Gain for AVR Mode	47533	Float	4	R W	n/a	-99 - 99
Time Delay Before Autotracking	47535	Float	4	R W	Second	0-8
Traverse Rate of Autotracking	47537	Float	4	R W	Second	1-80
Not used in DECS-250	47539	Float	4	R W	n/a	
Gain for Cross Current Compensation	47541	Float	4	R W	Percent	-30 - 30
Sensing Mode	47543	Uint16	2	R W	n/a	1-phase (A-C)=0 3-phase=1
Auxiliary Input Summing Mode	47544	Uint16	2	R W	n/a	Voltage=0 Var=1
Not used in DECS-250	47545	Uint16	2	R	n/a	n/a
Reserved 8	47546	Uint16	2	R	n/a	n/a
Auxiliary Input Mode	47547	Uint16	2	R W	n/a	Voltage=0 Current=1
For Future Use	47548	Uint16	2	R	n/a	n/a
External Tracking Time Delay	47549	Float	4	R W	Second	0-8
External Tracking Traverse Rate	47551	Float	4	R W	Second	1-80
Reserved 29	47553	Uint16	2	R	n/a	n/a
Auxiliary Input Gain for FCR Mode	47554	Float	4	R W	n/a	-99 - 99
Auxiliary Input Gain for VAR Mode	47556	Float	4	R W	n/a	-99 - 99
Auxiliary Input Gain for PF Mode	47558	Float	4	R W	n/a	-99 - 99
Reserved 9	47560	Uint16	2	R	n/a	n/a
Unit Mode Virtual Toggle	47561	Uint16	2	R W	n/a	An entry of '1' toggles through the following modes: Stop, Start
Control Mode Virtual Toggle	47562	Uint16	2	R W	n/a	An entry of '1' toggles through the following modes: Manual, Automatic
Operating Mode Virtual Switch	47563	Uint16	2	R W	n/a	Off=0 PF=1 Var=2
Auto Track Enabled Status	47564	Uint16	2	R W	n/a	Disabled=0 Enabled=1
Pre-position Enable	47565	Uint16	2	R W	n/a	=0 SET=1
Raise Enabled Status	47566	Uint16	2	R W	n/a	=0 Raise=1
Lower Enabled Status	47567	Uint16	2	R W	n/a	=0 Lower=1
External Tracking Enable Status	47568	Uint16	2	R	n/a	Off=0 Enabled=1
Limiter Mode Options	47569	Uint16	2	R W	n/a	Off=0 UEL=1 OEL=2 UEL & OEL=3 SCL=4 UEL & SCL=5 OEL & SCL=6 UEL & OEL & SCL=7
Voltage Match Mode	47570	Uint16	2	R W	n/a	Disabled=0 Enabled=1
Operating Mode Status	47571	Uint16	2	R	n/a	n/a

Name	Register	Type	Bytes	R/W	Unit	Range
Unit Mode Status	47572	Uint16	2	R	n/a	n/a
Control Mode Status	47573	Uint16	2	R	n/a	FCR=1 AVR=2
Internal Tracking Status	47574	Uint16	2	R	n/a	Off=0 Enabled=1
Pre-position Enable Status	47575	Uint16	2	R	n/a	n/a
Autotransfer Status	47576	Uint16	2	R	n/a	Primary=0 Secondary=1
Load Compensation Mode Status	47577	Uint16	2	R	n/a	Off=0 Droop=1 Line Drop=2
Load Compensation Mode Select	47578	Uint16	2	R W	n/a	Disabled=0 Enabled=1
Alarm Reset Enable	47579	Uint16	2	R W	n/a	Disabled=0 Enabled=1
Loss-of-Sensing Detection Enable	47580	Uint16	2	R W	n/a	Disabled=0 Enabled=1
Loss-of-Sensing Triggered Transfer-to-FCR-mode Enable	47581	Uint16	2	R W	n/a	Disabled=0 Enabled=1
Underfrequency or V/Hz Mode Enable	47582	Uint16	2	R W	n/a	UF Limiter=0 V/Hz Limiter=1
External Tracking Enabled	47583	Uint16	2	R W	n/a	Disabled=0 Enabled=1
OEL Style Virtual Toggle	47584	Uint16	2	R W	n/a	Summing=0 Takeover=1
Reserved 16bit 32	47585	Uint16	2	R W	n/a	0-65535
PF/var Option Status	47586	Uint16	2	R	n/a	Off=0 PF=1 var=2
Reserved 10	47587-620	C5 Filler	68	n/a	n/a	n/a
FCR Mode Setpoint	47621	Float	4	R W	Amp	Setpoint adjustment range determined by registers 47655 and 47663.
AVR Mode Setpoint	47623	Float	4	R W	Volt	Setpoint adjustment range determined by registers 47657 and 47665.
Var Mode Setpoint in kvar	47625	Float	4	R W	kilovar	Setpoint adjustment range determined by registers 47659 and 47667.
PF Mode Setpoint	47627	Float	4	R W	Power Factor	Setpoint adjustment range determined by registers 47661 and 47669.
Droop Setting in Percent	47629	Float	4	R W	Percent	0-30
FCR Mode Traverse Rate	47631	Float	4	R W	Second	10-200
AVR Mode Traverse Rate	47633	Float	4	R W	Second	10-200
Var Mode Traverse Rate	47635	Float	4	R W	Second	10-200
PF Mode Traverse Rate	47637	Float	4	R W	Second	10-200
FCR Mode Setpoint Pre-Position	47639	Float	4	R W	Amp	Setpoint adjustment range determined by registers 47655 and 47663.
AVR Mode Setpoint Pre-Position	47641	Float	4	R W	Volt	Setpoint adjustment range determined by registers 47657 and 47665.
Var Mode Setpoint Pre-Position in kvar	47643	Float	4	R W	kilovar	Setpoint adjustment range determined by registers 47659 and 47667.
PF Mode Setpoint Pre-Position	47645	Float	4	R W	Power Factor	Setpoint adjustment range determined by registers 47661 and 47669.
FCR Mode Setpoint Step Size	47647	Float	4	R	n/a	n/a
AVR Mode Setpoint Step Size	47649	Float	4	R	n/a	n/a
Var Mode Setpoint Step Size	47651	Float	4	R	n/a	n/a
PF Mode Setpoint Step Size	47653	Float	4	R	n/a	n/a
FCR Mode Setpoint Adjustable Minimum	47655	Float	4	R W	Percent	0-120
AVR Mode Setpoint Adjustable Minimum	47657	Float	4	R W	Percent	70-120
Var Mode Setpoint Adjustable Minimum	47659	Float	4	R W	Percent	-100 - 100
PF Mode Setpoint Adjustable Minimum	47661	Float	4	R W	Power Factor	0.5-1
FCR Mode Setpoint Adjustable Maximum	47663	Float	4	R W	Percent	0-120
AVR Mode Setpoint Adjustable Maximum	47665	Float	4	R W	Percent	70-120
Var Mode Setpoint Adjustable Maximum	47667	Float	4	R W	Percent	-100 - 100
PF Mode Setpoint Adjustable Maximum	47669	Float	4	R W	Power Factor	-1 - -0.5
Minimum Value for FCR Adjustable Maximum	47671	Float	4	R	n/a	n/a

Name	Register	Type	Bytes	R/W	Unit	Range
Minimum Value for AVR Adjustable Maximum	47673	Float	4	R	n/a	n/a
Minimum Value for Var Adjustable Maximum	47675	Float	4	R	n/a	n/a
Mini Value for PF Adjustable Max	47677	Float	4	R	n/a	n/a
Max Value for FCR Adjustable Max	47679	Float	4	R	n/a	n/a
Max Value for AVR Adjustable Max	47681	Float	4	R	n/a	n/a
Max Value for Var Adjustable Max	47683	Float	4	R	n/a	n/a
Max Value for PF Adjustable Max	47685	Float	4	R	n/a	n/a
Step Size for FCR Adjustable Max	47687	Float	4	R	n/a	n/a
Step Size for AVR Adjustable Max	47689	Float	4	R	n/a	n/a
Step Size for Var Adjustable Max	47691	Float	4	R	n/a	n/a
Step Size for PF Adjustable Max	47693	Float	4	R	n/a	n/a
FCR Pre-Position Mode	47695	Uint16	2	R W	n/a	Maintain=0 Release=1
AVR Pre-Position Mode	47696	Uint16	2	R W	n/a	Maintain=0 Release=1
Var Pre-Position Mode	47697	Uint16	2	R W	n/a	Maintain=0 Release=1
PF Pre-Position Mode	47698	Uint16	2	R W	n/a	Maintain=0 Release=1
FCR Minimum Setpoint	47699	Float	4	R	n/a	Setpoint adjustment range determined by registers 47655 and 47529.
AVR Minimum Setpoint	47701	Float	4	R	n/a	Setpoint adjustment range determined by registers 47657 and 47525.
Var Minimum Setpoint	47703	Float	4	R	n/a	Setpoint adjustment range determined by registers 47659 and Rated VA.
PF Minimum Setpoint	47705	Float	4	R	n/a	Range determined by register 47661.
FCR Maximum Setpoint	47707	Float	4	R	n/a	Setpoint adjustment range determined by registers 47663 and 47529.
AVR Maximum Setpoint	47709	Float	4	R	n/a	Setpoint adjustment range determined by registers 47665 and 47525.
Var Maximum Setpoint	47711	Float	4	R	n/a	Setpoint adjustment range determined by registers 47667 and Rated VA.
PF Maximum Setpoint	47713	Float	4	R	n/a	Range determined by register 47669.
Reserved 11	47715-740	C6 Filler	52	n/a	n/a	n/a
Soft Start Threshold	47741	Float	4	R W	Percent	0-90
Soft Start Duration	47743	Float	4	R W	Second	1-7200
Underfrequency Corner Frequency	47745	Float	4	R W	Hertz	40-75
Slope of Underfrequency Curve	47747	Float	4	R W	n/a	0-3
Width of Voltage Matching Window	47749	Float	4	R W	Percent	0-20
Voltage Matching Reference	47751	Float	4	R W	Percent	0-700
Fine Voltage Adjust Band	47753	Float	4	R W	Percent	0-30
Time Required for Loss of Sensing	47755	Float	4	R W	Second	0-30
Loss of Sensing Level Under Balanced Conditions	47757	Float	4	R W	Percent	0-100
Loss of Sensing Level Under Unbalanced Conditions	47759	Float	4	R W	Percent	0-100
Reserved 12	47761-800	C7 Filler	80	n/a	n/a	n/a
On-line High OEL Level	47801	Float	4	R W	Amp	0-40
Time Allowed for On-line High OEL Level	47803	Float	4	R W	Second	0-10
On-line Medium OEL Level	47805	Float	4	R W	Amp	0-30
Time Allowed for On-line Medium OEL Level	47807	Float	4	R W	Second	0-120
On-line Low OEL Level	47809	Float	4	R W	Amp	0-20
Reserved 13	47811	Float	4	R W	var	0-99
Time Allowed for Off-line High OEL	47813	Float	4	R W	Second	0 - 10

Name	Register	Type	Bytes	R/W	Unit	Range
Off-line High OEL Level	47815	Float	4	R W	Amp	0 - 40
Off-line Low OEL Level	47817	Float	4	R W	Amp	0 - 20
First UEL Point kW Value	47819	Float	4	R W	kilowatt	0-1.5 • Rated kVA
Second UEL Point kW Value	47821	Float	4	R W	kilowatt	0-1.5 • Rated kVA
Third UEL Point kW Value	47823	Float	4	R W	kilowatt	0-1.5 • Rated kVA
Fourth UEL Point kW Value	47825	Float	4	R W	kilowatt	0-1.5 • Rated kVA
Fifth UEL Point kW Value	47827	Float	4	R W	kilowatt	0-1.5 • Rated kVA
First UEL Point kvar Value	47829	Float	4	R W	kilovar	0-1.5 • Rated kVA
Second UEL Point kvar Value	47831	Float	4	R W	kilovar	0-1.5 • Rated kVA
Third UEL Point kvar Value	47833	Float	4	R W	kilovar	0-1.5 • Rated kVA
Fourth UEL Point kvar Value	47835	Float	4	R W	kilovar	0-1.5 • Rated kVA
Fifth UEL Point kvar Value	47837	Float	4	R W	kilovar	0-1.5 • Rated kVA
SCL High Limit Level	47839	Float	4	R W	Amp	0-66000
Time Allowed at SCL High Limit Level	47841	Float	4	R W	Second	0-60
SCL Low Limit Level	47843	Float	4	R W	Amp	0-66000
Takeover OEL Offline High Limit Level	47845	Float	4	R W	Amp	0-40
Takeover OEL Offline Low Limit Level	47847	Float	4	R W	Amp	0-20
Takeover OEL Offline Time Dial	47849	Float	4	R W	n/a	0.1-20
Takeover OEL Online High Limit Level	47851	Float	4	R W	Amp	0-40
Takeover OEL Online Low Limit Level	47853	Float	4	R W	Amp	0-20
Takeover OEL Online Time Dial	47855	Float	4	R W	n/a	0.1-20
Reserved 14	47857-860	C8 Filler	8	n/a	n/a	n/a
Index into Table of Gain Constants	47861	Float	4	R W	n/a	1-21
Primary AVR Mode Proportional Gain	47863	Float	4	R W	n/a	0-1000
Primary AVR Mode Integral Gain	47865	Float	4	R W	n/a	0-1000
Primary AVR Mode Derivative Gain	47867	Float	4	R W	n/a	0-1000
OEL Integral Gain: Ki	47869	Float	4	R W	n/a	0-1000
PF Mode Integral Gain: Ki	47871	Float	4	R W	n/a	0-1000
Var Mode Integral Gain: Ki	47873	Float	4	R W	n/a	0-1000
FCR Mode Loop Gain: Ka	47875	Float	4	R W	n/a	0-1000
Primary AVR Mode Loop Gain: Ka	47877	Float	4	R W	n/a	0-1000
Var Mode Loop Gain: Kg	47879	Float	4	R W	n/a	0-1000
PF Mode Loop Gain: Kg	47881	Float	4	R W	n/a	0-1000
OEL Loop Gain: Kg	47883	Float	4	R W	n/a	0-1000
UEL Loop Gain: Kg	47885	Float	4	R W	n/a	0-1000
UEL Integral Gain: Ki	47887	Float	4	R W	n/a	0-1000
Voltage Matching Loop Gain: Kg	47889	Float	4	R W	n/a	0-1000
Primary AVR Mode Derivative Time Constant: Td	47891	Float	4	R W	n/a	0-1
Secondary Gain Option Index	47893	Uint32	4	R W	n/a	T'do=1.0 Te=0.17=1 T'do=1.5 Te=0.25=2 T'do=2.0 Te=0.33=3 T'do=2.5 Te=0.42=4 T'do=3.0 Te=0.50=5 T'do=3.5 Te=0.58=6 T'do=4.0 Te=0.67=7 T'do=4.5 Te=0.75=8 T'do=5.0 Te=0.83=9 T'do=5.5 Te=0.92=10 T'do=6.0 Te=1.00=11 T'do=6.5 Te=1.08=12 T'do=7.0 Te=1.17=13 T'do=7.5 Te=1.25=14 T'do=8.0 Te=1.33=15 T'do=8.5 Te=1.42=16 T'do=9.0 Te=1.50=17 T'do=9.5 Te=1.58=18 T'do=10.0 Te=1.67=19 T'do=10.5 Te=1.75=20 Custom=21
Secondary AVR Mode Proportional Gain - Kp	47895	Float	4	R W	n/a	0-1000
Secondary AVR Mode Integral Gain - Ki	47897	Float	4	R W	n/a	0-1000

Name	Register	Type	Bytes	R/W	Unit	Range
Secondary AVR Mode Derivative Gain - Kd	47899	Float	4	R W	n/a	0-1000
Secondary AVR Mode Loop Gain - Kg	47901	Float	4	R W	n/a	0-1000
Secondary AVR Derivative Time Constant - Td	47903	Float	4	R W	n/a	0-1
Active Gain Setting Group	47905	Uint16	2	R	n/a	n/a
SCL Loop Gain - Kg	47906	Float	4	R W	n/a	0-1000
SCL Integral Gain - Ki	47908	Float	4	R W	n/a	0-1000
Reserved 14	47910-920	C9 Filler	22	n/a	n/a	n/a
Field Overvoltage Level	47921	Float	4	R W	Volt	Disabled=0, 1-325
Field Overcurrent Base Level	47923	Float	4	R W	Amp	Disabled=0, 0-22
Stator Undervoltage Level	47925	Float	4	R W	Volt	Disabled=0, 1-600000
Stator Overvoltage Level	47927	Float	4	R W	Volt	Disabled=0, 0-600000
Field Overvoltage Delay	47929	Float	4	R W	Millisecond	Disabled=0, 200-30000
Overcurrent Delay	47931	Float	4	R W	Millisecond	Disabled=0, 5000-60000
Stator Undervoltage Delay	47933	Float	4	R W	Millisecond	100-60000
Stator Overvoltage Delay	47935	Float	4	R W	Millisecond	100-60000
Field Overvoltage Alarm Enable	47937	Uint16	2	R W	n/a	Disabled=0 Enabled=1
Field Overcurrent Alarm Enable	47938	Uint16	2	R W	n/a	Disabled=0 Enabled=1
Stator Undervoltage Alarm Enable	47939	Uint16	2	R W	n/a	Disabled=0 Enabled=1
Stator Overvoltage Alarm Enable	47940	Uint16	2	R W	n/a	Disabled=0 Enabled=1
Reserved 15	47941	Float	4	R	n/a	n/a
Reserved 16	47943	Float	4	R	n/a	n/a
Reserved 17	47945	Uint16	2	R	n/a	n/a
Exciter Open Diode Ripple Pickup Level	47946	Float	4	R W	Percent	0 - 100
Exciter Open Diode Time Delay	47948	Float	4	R W	Second	10-60
Exciter Open Diode Protection Enable	47950	Uint16	2	R W	n/a	Disabled=0 Enabled=1
Exciter Shorted Diode Ripple Pickup Level	47951	Float	4	R W	Percent	0-100
Exciter Shorted Diode Time Delay	47953	Float	4	R W	Second	5-30
Exciter Shorted Diode Protection Enable	47955	Uint16	2	R W	n/a	Disabled=0 Enabled=1
EDM Protection Disable Level	47956	Float	4	R W	Percent	0-100
Loss of Field Alarm Enable	47958	Uint16	2	R W	n/a	Disabled=0 Enabled=1
Loss of Field Pickup Level	47959	Float	4	R W	Percent	Disabled=0, 0-150
Loss of Field Time Delay	47961	Float	4	R W	Millisecond	Instantaneous=0, 0-300000
Reserved 18	47963-980	C10 Filler	36	n/a	n/a	n/a
Reserved 19	47981-8040	C11 Filler	120	n/a	n/a	n/a
Reserved 16 bit 1	48041	Uint16	2	R W	n/a	0-65535
Reserved 16 bit 2	48042	Uint16	2	R W	n/a	0-65535
Reserved 20	48043-056	Annu Filler	28	R	n/a	n/a
Output for Relay 1	48057	Uint16	2	R	n/a	n/a
Reserved	48058-76	Uint16	2	R W	n/a	0-65535
Output for Relay 2	48077	Uint16	2	R	n/a	n/a
Reserved	48078-96	Uint16	2	R W	n/a	0-65535
Output for Relay 3	48097	Uint16	2	R	n/a	n/a
Reserved 16 bit 13	48098-116	Uint16	2	R W	n/a	0-65535
Output for Relay 4	48117	Uint16	2	R	n/a	n/a
Reserved 16 bit 18	48118-136	Uint16	2	R W	n/a	0-65535
Output for Relay 5	48137	Uint16	2	R	n/a	n/a
Reserved 16 bit 23	48138-141	Uint16	2	R W	n/a	0-65535

Name	Register	Type	Bytes	R/W	Unit	Range
Reserved 16 bit 26	48161	Uint16	2	R	n/a	0-65535
Reserved 16 bit 27	48162	Uint16	2	R	n/a	0-65535
RS-232 Baud Rate	48163	Uint16	2	R W	n/a	1200 Baud=1200 2400 Baud=2400 4800 Baud=4800 9600 Baud=9600 19200 Baud=19200 38400 Baud=38400 57600 Baud=57600
RS-485 Baud Rate	48164	Uint16	2	R W	n/a	1200 Baud=1200 2400 Baud=2400 4800 Baud=4800 9600 Baud=9600 19200 Baud=19200 38400 Baud=38400 57600 Baud=57600
RS485 Parity	48165	Uint16	2	R W	n/a	Even Parity=0 Odd Parity=1 No Parity=2
RS485 Stop Bits	48166	Uint16	2	R W	n/a	1 Stop Bit=1 2 Stop Bits=2
DECS-250 Polling Address	48167	Uint16	2	R W	n/a	1-247
Modbus Response Time Delay	48168	Uint16	2	R W	Millisecond	10-10000
Reserved 26	48169-220	C13 Filler	104	n/a	n/a	n/a
Reserved 16 bit 29	48221-223	Uint16	2	R W	n/a	0-65535
Reserved	48224-250	C14 Filler		n/a	n/a	n/a
Reserved	48251-508	C15 Filler		n/a	n/a	n/a
Pole Ratio	48509-510	Float	4	R W	n/a	Disabled=0, 1-10



# PROFIBUS Communication

On units equipped with the PROFIBUS communication protocol (style xxxxxxP), the DECS-250 sends and receives PROFIBUS data through a DB-9 port located on the right side panel.

## Caution

This product contains one or more *nonvolatile memory* devices. Nonvolatile memory is used to store information (such as settings) that needs to be preserved when the product is power-cycled or otherwise restarted. Established nonvolatile memory technologies have a physical limit on the number of times they can be erased and written. In this product, the limit is 100,000 erase/write cycles. During product application, consideration should be given to communications, logic, and other factors that may cause frequent/repeated writes of settings or other information that is retained by the product. Applications that result in such frequent/repeated writes may reduce the useable product life and result in loss of information and/or product inoperability.

Refer to the *Communication* chapter for PROFIBUS communication settings in BESTCOMSPlus® and the *Terminals and Connectors* chapter for wiring.

The DECS-250 utilizes PROFIBUS DP (Decentralized Peripherals) to operate sensors and actuators via a centralized controller in production (factory) automation applications.

Per IEC 61158, PROFIBUS, consists of digitized signals transmitted over a simple, two-wire bus. It is intended to replace the industry-standard, 4 to 20 mA signal used in the transmission of system parameters. PROFIBUS expands the amount of information shared by system devices and makes the exchange of data faster and more efficient.

## Data Types

### Float/UINT32

Parameters listed in Table 40 as Float or UINT32 types are “Input 2 word” (4 byte) parameters. The Network Byte Order setting allows the byte order of these parameters to be set to MSB first or LSB first. This setting can be found by using the following navigation paths.

**BESTCOMSPlus® Navigation Path:** Settings Explorer, Communications, Profibus Setup

**HMI Navigation Path:** Settings, Communications, Profibus Setup

### UINT8

Parameters listed in Table 40 as UINT8 types are bit-packed binary data. This allows transmission of up to eight single-bit parameters in each byte of data. When configuring an instance of UINT8 type parameters, the data type is “Input 1 byte” and the size is determined by the number of parameters in the instance divided by eight, rounding up to the next integer. Table 35 illustrates the sizes of the UINT8 cyclic data instances.

**Table 35. Instance Data Size Calculation**

Instance Number	Number of Parameters in the Instance	Number of Parameters Divided by Eight	Total Data Size
6	5	0.625	1 byte
7	7	0.875	1 byte
8	5	0.625	1 byte

Instance Number	Number of Parameters in the Instance	Number of Parameters Divided by Eight	Total Data Size
9	6	0.75	1 byte
10	16	2	2 bytes
11	12	1.5	2 bytes
12	8	1	1 byte

Within these instances, the data is packed in the order listed in Table 40. The first item is the lowest bit of the first byte. If there are unused bits, they are filled with a value of zero. Parameters of UINT8 type are not affected by the DECS-250 Network Byte Order setting. The examples, below, show the bit packing order for instances 8 (Controller Status Cyclic) and 11 (Local Contact Outputs Cyclic).

*Example 1: Bit Packing Order for Instance 8*

The total data size of Instance 8 is one byte. Table 36 shows the parameters of instance 8 as they appear in Table 40. The first parameter in instance 8, with key name DECSCONTROL IN AVR MODE, is represented by the lowest bit in the byte (bit 0). Bit 1 represents the next parameter with key name DECSCONTROL IN FCR MODE and so on. The three highest bits in this instance are unused and thus always return a value of zero.

**Table 36. Instance 8 Parameters**

Instance Name	Inst. #	Type	RW	Key Name	Range
Controller Status Cyclic	8	UINT8	R	DECSCONTROL IN AVR MODE	Not in AVR mode=0, In AVR mode=1
Controller Status Cyclic	8	UINT8	R	DECSCONTROL IN FCR MODE	Not in FCR mode=0, In FCR mode=1
Controller Status Cyclic	8	UINT8	R	DECSCONTROL IN FVR MODE	Not in FVR mode=0, In FVR mode=1
Controller Status Cyclic	8	UINT8	R	DECSCONTROL IN PF MODE	Not in PF mode=0, In PF mode=1
Controller Status Cyclic	8	UINT8	R	DECSCONTROL IN VAR MODE	Not in var mode=0, In var mode=1

Table 37 shows the bit number of each parameter in instance 8 and an example packet returned from a DECS-250. Reading a value of 0x02 (0000 0010) for instance 8 indicates that the device is operating in FCR mode.

**Table 37. Instance 8 Bit Order**

Instance Number	Bit Number	Key Name	Packet Returned from DECS-250
8	0	DECSCONTROL IN AVR MODE	0
	1	DECSCONTROL IN FCR MODE	1
	2	DECSCONTROL IN FVR MODE	0
	3	DECSCONTROL IN PF MODE	0
	4	DECSCONTROL IN VAR MODE	0
	5	0 (unused)	0
	6	0 (unused)	0
	7	0 (unused)	0

*Example 2: Bit Packing Order for Instance 11*

The total size of Instance 11 is two bytes. Table 38 shows the parameters of instance 11 as they appear in Table 40. The first parameter in instance 11, with key name CONTACTOUTPUTS WATCHDOGOUTPUT, is represented by the lowest bit in the first byte (bit 0). The ninth parameter, with key name CONTACTOUTPUTS OUTPUT8, is represented by the lowest bit in the second byte (bit 0). The four highest bits in the second byte are unused and thus always return a value of zero.

**Table 38. Instance 11 Parameters**

Instance Name	Inst. #	Type	RW	Key Name	Range
Local Contact Outputs Cyclic	11	UINT8	R	CONTACTOUTPUTS WATCHDOGOUTPUT	Open=0, Closed=1

Instance Name	Inst. #	Type	RW	Key Name	Range
Local Contact Outputs Cyclic	11	UINT8	R	CONTACTOUTPUTS OUTPUT1	Open=0, Closed=1
Local Contact Outputs Cyclic	11	UINT8	R	CONTACTOUTPUTS OUTPUT2	Open=0, Closed=1
Local Contact Outputs Cyclic	11	UINT8	R	CONTACTOUTPUTS OUTPUT3	Open=0, Closed=1
Local Contact Outputs Cyclic	11	UINT8	R	CONTACTOUTPUTS OUTPUT4	Open=0, Closed=1
Local Contact Outputs Cyclic	11	UINT8	R	CONTACTOUTPUTS OUTPUT5	Open=0, Closed=1
Local Contact Outputs Cyclic	11	UINT8	R	CONTACTOUTPUTS OUTPUT6	Open=0, Closed=1
Local Contact Outputs Cyclic	11	UINT8	R	CONTACTOUTPUTS OUTPUT7	Open=0, Closed=1
Local Contact Outputs Cyclic	11	UINT8	R	CONTACTOUTPUTS OUTPUT8	Open=0, Closed=1
Local Contact Outputs Cyclic	11	UINT8	R	CONTACTOUTPUTS OUTPUT9	Open=0, Closed=1
Local Contact Outputs Cyclic	11	UINT8	R	CONTACTOUTPUTS OUTPUT10	Open=0, Closed=1
Local Contact Outputs Cyclic	11	UINT8	R	CONTACTOUTPUTS OUTPUT11	Open=0, Closed=1

Table 39 shows the bit number of each parameter in instance 11 and an example packet returned from a DECS-250. Reading a value of 0xA4 06 (1010 0100 0000 0110) for instance 11 indicates that contact outputs 2, 5, 7, 9, and 10 are closed. The first byte is 1010 0100 and the second is 0000 0110.

**Table 39. Instance 11 Bit Order**

Instance Number	Byte Number	Bit Number	Key Name	Packet Returned from DECS-250
11	1	0	CONTACTOUTPUTS WATCHDOG	0
		1	CONTACTOUTPUTS OUTPUT1	0
		2	CONTACTOUTPUTS OUTPUT2	1
		3	CONTACTOUTPUTS OUTPUT3	0
		4	CONTACTOUTPUTS OUTPUT4	0
		5	CONTACTOUTPUTS OUTPUT5	1
		6	CONTACTOUTPUTS OUTPUT6	0
	2	7	CONTACTOUTPUTS OUTPUT7	1
		0	CONTACTOUTPUTS OUTPUT8	0
		1	CONTACTOUTPUTS OUTPUT9	1
		2	CONTACTOUTPUTS OUTPUT10	1
		3	CONTACTOUTPUTS OUTPUT11	0
		4	0 (unused)	0
		5	0 (unused)	0
		6	0 (unused)	0
7	0 (unused)	0		

## Setup

The following steps are provided to assist in setting up the DECS-250 as a slave on a PROFIBUS network. Please refer to the documentation included with your PLC configuration software for installation and operation instructions.

1. Download the DECS-250 GSD file from the Basler website: [www.basler.com](http://www.basler.com)
2. Using PLC configuration software, import the GSD file. This allows the DECS-250 to be included in the bus configuration as a slave.
3. Assign a unique PROFIBUS address to the DECS-250. This allows the master to exchange data with the DECS-250.

4. Select modules from the GSD file to be part of the data exchange. Selecting the cyclic parameters is recommended. The cyclic parameters are comprised of the first 12 instances in the PROFIBUS parameters table (Table 40). Instances 1 through 5 consist of 25 float types. Instances 6 through 12 consist of 9 UINT8 types.
5. Set each selected module to an address in the master's memory bank.
6. Compile and download the configuration to the master before going online.

When the PROFIBUS network is initialized, the master connects to each slave checking for address mismatches and sending configuration data. The configuration data is sent so that the master and slave agree on the data exchange to occur. Then, the master begins polling each slave in a cyclic order.

### Note

It is not possible to write a portion of an instance by specifying a length smaller than the size of the instance. To modify a single parameter, read the entire instance, update the desired parameter, and write the entire instance back to the device.

## PROFIBUS Parameters

PROFIBUS parameters are listed in Table 40. Instances with names ending in “cyclic” are automatically transmitted at a periodic rate. All other instances are acyclic and transmitted only when requested by the PLC.

**Table 40. PROFIBUS Parameters**

Instance Name	Inst. #	Type	RW	Key Name	Unit	Range
Gen Metering Cyclic	1	Float	R	VAB GG	V	0 - 2000000000
Gen Metering Cyclic	1	Float	R	VBC GG	V	0 - 2000000000
Gen Metering Cyclic	1	Float	R	VCA GG	V	0 - 2000000000
Gen Metering Cyclic	1	Float	R	IA GG	Amp	0 - 2000000000
Gen Metering Cyclic	1	Float	R	IB GG	Amp	0 - 2000000000
Gen Metering Cyclic	1	Float	R	IC GG	Amp	0 - 2000000000
Gen Metering Cyclic	1	Float	R	Freq GG	Hz	10 - 180
Gen Metering Cyclic	1	Float	R	Total Watts AVG GG	Watt	-3.00E+14 - 3.00E+14
Gen Metering Cyclic	1	Float	R	Total VARS AVG GG	Var	-3.00E+14 - 3.00E+14
Gen Metering Cyclic	1	Float	R	Total S GG	VA	-3.00E+14 - 3.00E+14
Gen Metering Cyclic	1	Float	R	Total PF GG	PF	-1 - 1
Bus Metering Cyclic	2	Float	R	VAB GG	V	0 - 2000000000
Bus Metering Cyclic	2	Float	R	VBC GG	V	0 - 2000000000
Bus Metering Cyclic	2	Float	R	VCA GG	V	0 - 2000000000
Bus Metering Cyclic	2	Float	R	Freq GG	Hz	10 - 180
Field Metering Cyclic	3	Float	R	VX GG	V	-1000 - 1000
Field Metering Cyclic	3	Float	R	IX GG	Amp	0 - 2000000000
Setpoint Metering Cyclic	4	Float	R	Gen Voltage Setpoint GG	V	84 - 144
Setpoint Metering Cyclic	4	Float	R	Excitation Current Setpoint GG	Amp	0 - 12
Setpoint Metering Cyclic	4	Float	R	Excitation Voltage Setpoint GG	V	0 - 75
Setpoint Metering Cyclic	4	Float	R	Gen Var Setpoint GG	kvar	0 - 41.57
Setpoint Metering Cyclic	4	Float	R	Gen Pf Setpoint GG	PF	0.5 - -0.5
Synchronizer Metering Cyclic	5	Float	R	Slip Angle GG	Deg	-359.9 - 359.9

Instance Name	Inst. #	Type	RW	Key Name	Unit	Range
Synchronizer Metering Cyclic	5	Float	R	Slip Freq GG	Hz	n/a
Synchronizer Metering Cyclic	5	Float	R	Voltage Diff GG	V	n/a
Limiter Status Cyclic	6	UINT8	R	Alarms OEL ALM	No Unit	Not Active=0, Active=1
Limiter Status Cyclic	6	UINT8	R	Alarms UEL ALM	No Unit	Not Active=0, Active=1
Limiter Status Cyclic	6	UINT8	R	Alarms SCL ALM	No Unit	Not Active=0, Active=1
Limiter Status Cyclic	6	UINT8	R	Alarms VAR Limiter Active	No Unit	Not Active=0, Active=1
Limiter Status Cyclic	6	UINT8	R	Alarms Underfrequency V/Hz ALM	No Unit	Not Active=0, Active=1
HMI Indicators Cyclic	7	UINT8	R	DECSCONTROL DECS NULL BALANCE	No Unit	Not Active=0, Active=1
HMI Indicators Cyclic	7	UINT8	R	DECSPSSMETER DECS PSS ACTIVE	No Unit	Not Active=0, Active=1
HMI Indicators Cyclic	7	UINT8	R	DECSREGULATORMETER DECS INTERNAL TRACKING ACTIVE	No Unit	Not Active=0, Active=1
HMI Indicators Cyclic	7	UINT8	R	DECSCONTROL DECS PREPOSITION	No Unit	Active setpoint is not at a pre-position value=0, Active setpoint is at a pre-position value=1
HMI Indicators Cyclic	7	UINT8	R	DECSREGULATORMETER SETPOINT AT LOWER LIMIT	No Unit	Active setpoint is not at minimum value=0, Active setpoint is at minimum value=1
HMI Indicators Cyclic	7	UINT8	R	DECSREGULATORMETER SETPOINT AT UPPER LIMIT	No Unit	Active setpoint is not at maximum value=0, Active setpoint is at maximum value=1
Controller Status Cyclic	8	UINT8	R	DECSCONTROL IN AVR MODE	No Unit	Not in AVR mode=0, In AVR mode=1
Controller Status Cyclic	8	UINT8	R	DECSCONTROL IN FCR MODE	No Unit	Not in FCR mode=0, In FCR mode=1
Controller Status Cyclic	8	UINT8	R	DECSCONTROL IN FVR MODE	No Unit	Not in FVR mode=0, In FVR mode=1
Controller Status Cyclic	8	UINT8	R	DECSCONTROL IN PF MODE	No Unit	Not in PF mode=0, In PF mode=1
Controller Status Cyclic	8	UINT8	R	DECSCONTROL IN VAR MODE	No Unit	Not in var mode=0, In var mode=1
System Status Cyclic	9	UINT8	R	DECSCONTROL DECS START STOP	No Unit	Stopped=0, Started=1
System Status Cyclic	9	UINT8	R	ALARMS IFLIMIT	No Unit	No field short circuit condition=0, Field short circuit condition=1
System Status Cyclic	9	UINT8	R	DECSCONTROL DECS SOFT START ACTIVE	No Unit	Not in soft start=0, In soft start=1
System Status Cyclic	9	UINT8	R	ALARMREPORT ALARMOUTPUT	No Unit	No active alarms=0, Active alarms=1
System Status Cyclic	9	UINT8	R	DECSCONTROL DECS PF VAR ENABLE 52 J K	No Unit	PF/var not enabled via PLC=0, PF/var enabled via PLC=1
System Status Cyclic	9	UINT8	R	DECSCONTROL DECS PARALLEL ENABLE 52 L M	No Unit	Parallel not enabled via PLC=0, Parallel enabled via PLC=1
Local Contact Inputs Cyclic	10	UINT8	R	CONTACTINPUTS STARTINPUT	No Unit	Open=0, Closed=1
Local Contact Inputs Cyclic	10	UINT8	R	CONTACTINPUTS STOPINPUT	No Unit	Open=0, Closed=1
Local Contact Inputs Cyclic	10	UINT8	R	Contact Inputs Input 1	No Unit	Open=0, Closed=1
Local Contact Inputs Cyclic	10	UINT8	R	Contact Inputs Input 2	No Unit	Open=0, Closed=1
Local Contact Inputs Cyclic	10	UINT8	R	Contact Inputs Input 3	No Unit	Open=0, Closed=1
Local Contact Inputs Cyclic	10	UINT8	R	Contact Inputs Input 4	No Unit	Open=0, Closed=1
Local Contact Inputs Cyclic	10	UINT8	R	Contact Inputs Input 5	No Unit	Open=0, Closed=1

Instance Name	Inst. #	Type	RW	Key Name	Unit	Range
Local Contact Inputs Cyclic	10	UINT8	R	Contact Inputs Input 6	No Unit	Open=0, Closed=1
Local Contact Inputs Cyclic	10	UINT8	R	Contact Inputs Input 7	No Unit	Open=0, Closed=1
Local Contact Inputs Cyclic	10	UINT8	R	Contact Inputs Input 8	No Unit	Open=0, Closed=1
Local Contact Inputs Cyclic	10	UINT8	R	Contact Inputs Input 9	No Unit	Open=0, Closed=1
Local Contact Inputs Cyclic	10	UINT8	R	Contact Inputs Input 10	No Unit	Open=0, Closed=1
Local Contact Inputs Cyclic	10	UINT8	R	Contact Inputs Input 11	No Unit	Open=0, Closed=1
Local Contact Inputs Cyclic	10	UINT8	R	Contact Inputs Input 12	No Unit	Open=0, Closed=1
Local Contact Inputs Cyclic	10	UINT8	R	Contact Inputs Input 13	No Unit	Open=0, Closed=1
Local Contact Inputs Cyclic	10	UINT8	R	Contact Inputs Input 14	No Unit	Open=0, Closed=1
Local Contact Outputs Cyclic	11	UINT8	R	Contact Outputs Watchdog Output	No Unit	Open=0, Closed=1
Local Contact Outputs Cyclic	11	UINT8	R	Contact Outputs Output 1	No Unit	Open=0, Closed=1
Local Contact Outputs Cyclic	11	UINT8	R	Contact Outputs Output 2	No Unit	Open=0, Closed=1
Local Contact Outputs Cyclic	11	UINT8	R	Contact Outputs Output 3	No Unit	Open=0, Closed=1
Local Contact Outputs Cyclic	11	UINT8	R	Contact Outputs Output 4	No Unit	Open=0, Closed=1
Local Contact Outputs Cyclic	11	UINT8	R	Contact Outputs Output 5	No Unit	Open=0, Closed=1
Local Contact Outputs Cyclic	11	UINT8	R	Contact Outputs Output 6	No Unit	Open=0, Closed=1
Local Contact Outputs Cyclic	11	UINT8	R	Contact Outputs Output 7	No Unit	Open=0, Closed=1
Local Contact Outputs Cyclic	11	UINT8	R	Contact Outputs Output 8	No Unit	Open=0, Closed=1
Local Contact Outputs Cyclic	11	UINT8	R	Contact Outputs Output 9	No Unit	Open=0, Closed=1
Local Contact Outputs Cyclic	11	UINT8	R	Contact Outputs Output 10	No Unit	Open=0, Closed=1
Local Contact Outputs Cyclic	11	UINT8	R	Contact Outputs Output 11	No Unit	Open=0, Closed=1
Settings Group Indication Cyclic	12	UINT8	R	DECSCONTROL DECS SOFT START SELECT SECONDARY SETTINGS	No Unit	Primary settings active=0, Secondary settings active=1
Settings Group Indication Cyclic	12	UINT8	R	DECSCONTROL DECS PSS SELECT SECONDARY SETTINGS	No Unit	Primary settings active=0, Secondary settings active=1
Settings Group Indication Cyclic	12	UINT8	R	DECSCONTROL DECS OEL SELECT SECONDARY SETTINGS	No Unit	Primary settings active=0, Secondary settings active=1
Settings Group Indication Cyclic	12	UINT8	R	DECSCONTROL DECS UEL SELECT SECONDARY SETTINGS	No Unit	Primary settings active=0, Secondary settings active=1
Settings Group Indication Cyclic	12	UINT8	R	DECSCONTROL DECS SCL SELECT SECONDARY SETTINGS	No Unit	Primary settings active=0, Secondary settings active=1
Settings Group Indication Cyclic	12	UINT8	R	DECSCONTROL DECS PROTECT SELECT SECONDARY SETTINGS	No Unit	Primary settings active=0, Secondary settings active=1
Settings Group Indication Cyclic	12	UINT8	R	DECSCONTROL DECS PID SELECT SECONDARY SETTINGS	No Unit	Primary settings active=0, Secondary settings active=1
Settings Group Indication Cyclic	12	UINT8	R	DECSCONTROL DECS VAR LIMITER SELECT SECONDARY SETTINGS	No Unit	Primary settings active=0, Secondary settings active=1
Gen Metering	16	Float	R	VAB GG (Gen Voltage Magnitude)	V	0 - 2000000000

Instance Name	Inst. #	Type	RW	Key Name	Unit	Range
Gen Metering	16	Float	R	VBC GG (Gen Voltage Magnitude)	V	0 - 2000000000
Gen Metering	16	Float	R	VCA GG (Gen Voltage Magnitude)	V	0 - 2000000000
Gen Metering	16	Float	R	VAB GG (Gen Voltage Angle)	Deg	0 - 360
Gen Metering	16	Float	R	VBC GG (Gen Voltage Angle)	Deg	0 - 360
Gen Metering	16	Float	R	VCA GG (Gen Voltage Angle)	Deg	0 - 360
Gen Metering	16	Float	R	IA GG (Gen Current Magnitude)	Amp	0 - 2000000000
Gen Metering	16	Float	R	IB GG (Gen Current Magnitude)	Amp	0 - 2000000000
Gen Metering	16	Float	R	IC GG (Gen Current Magnitude)	Amp	0 - 2000000000
Gen Metering	16	Float	R	IA GG (Gen Current Angle)	Deg	0 - 360
Gen Metering	16	Float	R	IB GG (Gen Current Angle)	Deg	0 - 360
Gen Metering	16	Float	R	IC GG (Gen Current Angle)	Deg	0 - 360
Gen Metering	16	Float	R	Iavg GG	Amp	0 - 2000000000
Gen Metering	16	Float	R	Freq GG	Hz	10 - 180
Gen Metering Per Unit	17	Float	R	Vab pu GG	Per Unit	-10 - 10
Gen Metering Per Unit	17	Float	R	Vbc pu GG	Per Unit	-10 - 10
Gen Metering Per Unit	17	Float	R	Vca pu GG	Per Unit	-10 - 10
Gen Metering Per Unit	17	Float	R	Vavg pu GG	Per Unit	-10 - 10
Gen Metering Per Unit	17	Float	R	Ia pu GG	Per Unit	-10 - 10
Gen Metering Per Unit	17	Float	R	Ib pu GG	Per Unit	-10 - 10
Gen Metering Per Unit	17	Float	R	Ic pu GG	Per Unit	-10 - 10
Gen Metering Per Unit	17	Float	R	Iavg pu GG	Per Unit	-10 - 10
Power Metering	18	Float	R	Total Watts AVG GG	Watt	-3.00E+14 - 3.00E+14
Power Metering	18	Float	R	Total VARS AVG GG	var	-3.00E+14 - 3.00E+14
Power Metering	18	Float	R	Total S GG	VA	-3.00E+14 - 3.00E+14
Power Metering	18	Float	R	Total PF GG	PF	-1 - 1
Power Metering	18	Float	R	POS Watthour Total GG	watthour	0.00E+00 - 1.00E+09
Power Metering	18	Float	R	POS varhour Total GG	varhour	0.00E+00 - 1.00E+09
Power Metering	18	Float	R	NEG Watthour Total GG	watthour	-1.00E+09 - 0.00E+00
Power Metering	18	Float	R	NEG varhour Total GG	varhour	-1.00E+09 - 0.00E+00
Power Metering Per Unit	19	Float	R	kW pu GG	Per Unit	-10 - 10
Power Metering Per Unit	19	Float	R	kVA pu GG	Per Unit	-10 - 10
Power Metering Per Unit	19	Float	R	kvar pu GG	Per Unit	-10 - 10
Bus Metering	20	Float	R	VAB GG (Bus Voltage Magnitude)	V	0 - 2000000000
Bus Metering	20	Float	R	VBC GG (Bus Voltage Magnitude)	V	0 - 2000000000
Bus Metering	20	Float	R	VCA GG (Bus Voltage Magnitude)	V	0 - 2000000000
Bus Metering	20	Float	R	VAB GG (Bus Voltage Angle)	Deg	0 - 360
Bus Metering	20	Float	R	VBC GG (Bus Voltage Angle)	Deg	0 - 360
Bus Metering	20	Float	R	VCA GG (Bus Voltage Angle)	Deg	0 - 360
Bus Metering	20	Float	R	Freq GG	Hz	10 - 180
Bus Metering Per Unit	21	Float	R	Bus Vab pu GG	Per Unit	-10 - 10
Bus Metering Per Unit	21	Float	R	Bus Vbc pu GG	Per Unit	-10 - 10

Instance Name	Inst. #	Type	RW	Key Name	Unit	Range
Bus Metering Per Unit	21	Float	R	Bus Vca pu GG	Per Unit	-10 - 10
Bus Metering Per Unit	21	Float	R	Bus Vavg pu GG	Per Unit	-10 - 10
Field Metering	22	Float	R	VX GG	V	-1000 - 1000
Field Metering	22	Float	R	IX GG	Amp	0 - 2000000000
Field Metering	22	Float	R	EDM Ripple Percent GG	%	n/a
PSS Metering	23	Float	R	V1 GG	V	0 - 2000000000
PSS Metering	23	Float	R	V2 GG	V	0 - 2000000000
PSS Metering	23	Float	R	I1 GG	Amp	0 - 2000000000
PSS Metering	23	Float	R	I2 GG	Amp	0 - 2000000000
PSS Metering	23	Float	R	Term Freq DEV GG	Percent	n/a
PSS Metering	23	Float	R	Comp Freq DEV GG	Percent	n/a
PSS Metering	23	Float	R	PSS Output GG	No Unit	n/a
PSS Metering Per Unit	24	Float	R	Pos Seq V pu GG	Per Unit	-10 - 10
PSS Metering Per Unit	24	Float	R	Neq Seq V pu GG	Per Unit	-10 - 10
PSS Metering Per Unit	24	Float	R	Pos Seq I pu GG	Per Unit	-10 - 10
PSS Metering Per Unit	24	Float	R	Neq Seq I pu GG	Per Unit	-10 - 10
Synchronization	25	Float	R	Slip Angle GG	Deg	-359.9 - 359.9
Synchronization	25	Float	R	Slip Freq GG	Hz	n/a
Synchronization	25	Float	R	Voltage Diff GG	V	n/a
Aux Input Metering	26	Float	R	Value GG (Aux Input Voltage)	V	-9999999 - 9999999
Aux Input Metering	26	Float	R	Value GG (Aux Input Current)	Amp	-9999999 - 9999999
Tracking	27	Float	R	Tracking Error GG	%	n/a
Tracking Status	28	UINT8	R	DECS Regulator Meter DECS Internal Tracking Active	No Unit	Not active=0, Active=1
Tracking Status	28	UINT8	R	DECS Regulator Meter DECS External Tracking Active	No Unit	Not active=0, Active=1
Tracking Status	28	UINT8	R	DECS Control DECS Null Balance	No Unit	Not active=0, Active=1
Control Panel Setpoint Metering	29	Float	R	Gen Voltage Setpoint GG	No Unit	84 - 144
Control Panel Setpoint Metering	29	Float	R	Excitation Current Setpoint GG	No Unit	0 - 12
Control Panel Setpoint Metering	29	Float	R	Excitation Voltage Setpoint GG	No Unit	0 - 75
Control Panel Setpoint Metering	29	Float	R	Gen Var Setpoint GG	No Unit	0 - 41.57
Control Panel Setpoint Metering	29	Float	R	Gen Pf Setpoint GG	No Unit	0.5 - -0.5
Control Panel Status	30	UINT8	R	DECS Control DECS Start Stop	No Unit	Stopped=0, Started=1
Control Panel Status	30	UINT8	R	DECS Control DECS is in Automatic Mode	No Unit	Not in automatic=0, In automatic=1
Control Panel Status	30	UINT8	R	DECS Control DECS is in Manual Mode	No Unit	Not in manual=0, In manual=1
Control Panel Status	30	UINT8	R	DECS Control DECS FCR Controller Active	No Unit	FCR not active=0, FCR active=1
Control Panel Status	30	UINT8	R	DECS Control DECS FVR Controller Active	No Unit	FVR not active=0, FVR active=1
Control Panel Status	30	UINT8	R	DECS Control DECS VAR Controller Active	No Unit	VAR not active=0, VAR active=1
Control Panel Status	30	UINT8	R	DECS Control DECS PF Controller Active	No Unit	PF not active=0, PF active=1

Instance Name	Inst. #	Type	RW	Key Name	Unit	Range
Control Panel Status	30	UINT8	R	DECS Control DECS Preposition 1 Active	No Unit	Active setpoint is not at pre-position 1 value=0, Active setpoint is at pre-position 1 value=1
Control Panel Status	30	UINT8	R	DECS Control DECS Preposition 2 Active	No Unit	Active setpoint is not at pre-position 2 value=0, Active setpoint is at pre-position 2 value=1
Control Panel Status	30	UINT8	R	DECS Control DECS Preposition 3 Active	No Unit	Active setpoint is not at pre-position 3 value=0, Active setpoint is at pre-position 3 value=1
Control Panel Status	30	UINT8	R	Virtual Switch 1	No Unit	Open=0, Closed=1
Control Panel Status	30	UINT8	R	Virtual Switch 2	No Unit	Open=0, Closed=1
Control Panel Status	30	UINT8	R	Virtual Switch 3	No Unit	Open=0, Closed=1
Control Panel Status	30	UINT8	R	Virtual Switch 4	No Unit	Open=0, Closed=1
Control Panel Status	30	UINT8	R	Virtual Switch 5	No Unit	Open=0, Closed=1
Control Panel Status	30	UINT8	R	Virtual Switch 6	No Unit	Open=0, Closed=1
Control Panel Status	30	UINT8	R	Alarm Report Alarm Output	No Unit	No active alarms=0, Active alarms=1
Control Panel Status	30	UINT8	R	DECS PSS Meter DECS PSS Active	No Unit	PSS not active=0, PSS active=1
Control Panel Status	30	UINT8	R	DECS Control DECS Null Balance	No Unit	Not active=0, Active=1
System Status	31	UINT8	R	Alarms OEL ALM	No Unit	Not active=0, Active=1
System Status	31	UINT8	R	Alarms UEL ALM	No Unit	Not active=0, Active=1
System Status	31	UINT8	R	Alarms SCL ALM	No Unit	Not active=0, Active=1
System Status	31	UINT8	R	Alarms VAR LIMITER ACTIVE	No Unit	Not active=0, Active=1
System Status	31	UINT8	R	Alarms VOLTAGE MATCHING ACTIVE	No Unit	Not active=0, Active=1
System Status	31	UINT8	R	DECS Control DECS Soft Start Select Secondary Settings	No Unit	Primary settings active=0, Secondary settings active=1
System Status	31	UINT8	R	DECS CONTROL DECS PSS Select Secondary Settings	No Unit	Primary settings active=0, Secondary settings active=1
System Status	31	UINT8	R	DECS Control DECS OEL Select Secondary Settings	No Unit	Primary settings active=0, Secondary settings active=1
System Status	31	UINT8	R	DECS Control DECS UEL Select Secondary Settings	No Unit	Primary settings active=0, Secondary settings active=1
System Status	31	UINT8	R	DECS Control DECS SCL Select Secondary Settings	No Unit	Primary settings active=0, Secondary settings active=1
System Status	31	UINT8	R	DECS Control DECS Protect Select Secondary Settings	No Unit	Primary settings active=0, Secondary settings active=1
System Status	31	UINT8	R	DECS Control DECS PID Select Secondary Settings	No Unit	Primary settings active=0, Secondary settings active=1
System Status	31	UINT8	R	DECS Control DECS VAR Limiter Select Secondary Settings	No Unit	Primary settings active=0, Secondary settings active=1
System Status	31	UINT8	R	DECS Control DECS Preposition	No Unit	Active setpoint is not at a pre-position value=0, Active setpoint is at a pre-position value=1
System Status	31	UINT8	R	DECS Control DECS VAR Controller Active	No Unit	VAR not active=0, VAR active=1
System Status	31	UINT8	R	DECS Control DECS PF Controller Active	No Unit	PF not active=0, PF active=1
System Status	31	UINT8	R	DECS Control DECS Auto Mode Enable	No Unit	Auto mode not enabled via PLC=0, Auto mode enabled via PLC=1
System Status	31	UINT8	R	DECS Control DECS Manual Mode Enable	No Unit	Manual mode not enabled via PLC=0, Manual mode enabled via PLC=1
System Status	31	UINT8	R	DECS Control DECS FVR Controller Active	No Unit	FVR not active=0, FVR active=1

Instance Name	Inst. #	Type	RW	Key Name	Unit	Range
System Status	31	UINT8	R	DECS Control DECS FCR Controller Active	No Unit	FCR not active=0, FCR active=1
System Status	31	UINT8	R	DECS Control DECS Field Flashing in Progress	No Unit	Field flashing not in progress=0, Field flashing in progress=1
System Status	31	UINT8	R	DECS Control DECS IS in Manual Mode	No Unit	Not in manual=0, In manual=1
System Status	31	UINT8	R	DECS Control DECS is in Automatic Mode	No Unit	Not in automatic=0, In automatic=1
System Status	31	UINT8	R	DECS Control DECS PSS Output Disable	No Unit	PSS not disabled via PLC=0, PSS disabled via PLC=1
Contact Input Status	32	UINT8	R	CONTACT Inputs Start Input	No Unit	Open=0, Closed=1
Contact Input Status	32	UINT8	R	Contact Inputs Stop Input	No Unit	Open=0, Closed=1
Contact Input Status	32	UINT8	R	Contact Inputs Input 1	No Unit	Open=0, Closed=1
Contact Input Status	32	UINT8	R	Contact Inputs Input 2	No Unit	Open=0, Closed=1
Contact Input Status	32	UINT8	R	Contact Inputs Input 3	No Unit	Open=0, Closed=1
Contact Input Status	32	UINT8	R	Contact Inputs Input 4	No Unit	Open=0, Closed=1
Contact Input Status	32	UINT8	R	Contact Inputs Input 5	No Unit	Open=0, Closed=1
Contact Input Status	32	UINT8	R	Contact Inputs Input 6	No Unit	Open=0, Closed=1
Contact Input Status	32	UINT8	R	Contact Inputs Input 7	No Unit	Open=0, Closed=1
Contact Input Status	32	UINT8	R	Contact Inputs Input 8	No Unit	Open=0, Closed=1
Contact Input Status	32	UINT8	R	Contact Inputs Input 9	No Unit	Open=0, Closed=1
Contact Input Status	32	UINT8	R	Contact Inputs Input 10	No Unit	Open=0, Closed=1
Contact Input Status	32	UINT8	R	Contact Inputs Input 11	No Unit	Open=0, Closed=1
Contact Input Status	32	UINT8	R	Contact Inputs Input 12	No Unit	Open=0, Closed=1
Contact Input Status	32	UINT8	R	Contact Inputs Input 13	No Unit	Open=0, Closed=1
Contact Input Status	32	UINT8	R	Contact Inputs Input 14	No Unit	Open=0, Closed=1
CEM Input Status	33	UINT8	R	CEM Input 1	No Unit	Open=0, Closed=1
CEM Input Status	33	UINT8	R	CEM Input 2	No Unit	Open=0, Closed=1
CEM Input Status	33	UINT8	R	CEM Input 3	No Unit	Open=0, Closed=1
CEM Input Status	33	UINT8	R	CEM Input 4	No Unit	Open=0, Closed=1
CEM Input Status	33	UINT8	R	CEM Input 5	No Unit	Open=0, Closed=1
CEM Input Status	33	UINT8	R	CEM Input 6	No Unit	Open=0, Closed=1
CEM Input Status	33	UINT8	R	CEM Input 7	No Unit	Open=0, Closed=1
CEM Input Status	33	UINT8	R	CEM Input 8	No Unit	Open=0, Closed=1
CEM Input Status	33	UINT8	R	CEM Input 9	No Unit	Open=0, Closed=1
CEM Input Status	33	UINT8	R	CEM Input 10	No Unit	Open=0, Closed=1
AEM Analog Input Meter	34	Float	R	Analog Input 1 Raw Value GG	V / mA	0 - 10 V or 4 - 20 mA
AEM Analog Input Meter	34	Float	R	Analog Input 2 Raw Value GG	V / mA	0 - 10 V or 4 - 20 mA
AEM Analog Input Meter	34	Float	R	Analog Input 3 Raw Value GG	V / mA	0 - 10 V or 4 - 20 mA
AEM Analog Input Meter	34	Float	R	Analog Input 4 Raw Value GG	V / mA	0 - 10 V or 4 - 20 mA
AEM Analog Input Meter	34	Float	R	Analog Input 5 Raw Value GG	V / mA	0 - 10 V or 4 - 20 mA
AEM Analog Input Meter	34	Float	R	Analog Input 6 Raw Value GG	V / mA	0 - 10 V or 4 - 20 mA
AEM Analog Input Meter	34	Float	R	Analog Input 7 Raw Value GG	V / mA	0 - 10 V or 4 - 20 mA
AEM Analog Input Meter	34	Float	R	Analog Input 8 Raw Value GG	V / mA	0 - 10 V or 4 - 20 mA
AEM Analog Input Meter	34	Float	R	Analog Input 1 Scaled Value GG	No Unit	-9999 - 9999

Instance Name	Inst. #	Type	RW	Key Name	Unit	Range
AEM Analog Input Meter	34	Float	R	Analog Input 2 Scaled Value GG	No Unit	-9999 – 9999
AEM Analog Input Meter	34	Float	R	Analog Input 3 Scaled Value GG	No Unit	-9999 – 9999
AEM Analog Input Meter	34	Float	R	Analog Input 4 Scaled Value GG	No Unit	-9999 – 9999
AEM Analog Input Meter	34	Float	R	Analog Input 5 Scaled Value GG	No Unit	-9999 – 9999
AEM Analog Input Meter	34	Float	R	Analog Input 6 Scaled Value GG	No Unit	-9999 – 9999
AEM Analog Input Meter	34	Float	R	Analog Input 7 Scaled Value GG	No Unit	-9999 – 9999
AEM Analog Input Meter	34	Float	R	Analog Input 8 Scaled Value GG	No Unit	-9999 – 9999
AEM Analog Input Status	35	UINT8	R	AEM Config AEM Input 1 Out of Range	No Unit	Value in range=0, Value out of range=1
AEM Analog Input Status	35	UINT8	R	AEM Config AEM Input 2 Out of Range	No Unit	Value in range=0, Value out of range=1
AEM Analog Input Status	35	UINT8	R	AEM Config AEM Input 3 Out of Range	No Unit	Value in range=0, Value out of range=1
AEM Analog Input Status	35	UINT8	R	AEM Config AEM Input 4 Out of Range	No Unit	Value in range=0, Value out of range=1
AEM Analog Input Status	35	UINT8	R	AEM Config AEM Input 5 Out of Range	No Unit	Value in range=0, Value out of range=1
AEM Analog Input Status	35	UINT8	R	AEM Config AEM Input 6 Out of Range	No Unit	Value in range=0, Value out of range=1
AEM Analog Input Status	35	UINT8	R	AEM Config AEM Input 7 Out of Range	No Unit	Value in range=0, Value out of range=1
AEM Analog Input Status	35	UINT8	R	AEM Config AEM Input 8 Out of Range	No Unit	Value in range=0, Value out of range=1
AEM Analog Input Status	35	UINT8	R	AEM Protection 1 Thresh 1 Trip	No Unit	Not tripped=0, Tripped=1
AEM Analog Input Status	35	UINT8	R	AEM Protection 1 Thresh 2 Trip	No Unit	Not tripped=0, Tripped=1
AEM Analog Input Status	35	UINT8	R	AEM Protection 1 Thresh 3 Trip	No Unit	Not tripped=0, Tripped=1
AEM Analog Input Status	35	UINT8	R	AEM Protection 1 Thresh 4 Trip	No Unit	Not tripped=0, Tripped=1
AEM Analog Input Status	35	UINT8	R	AEM Protection 2 Thresh 1 Trip	No Unit	Not tripped=0, Tripped=1
AEM Analog Input Status	35	UINT8	R	AEM Protection 2 Thresh 2 Trip	No Unit	Not tripped=0, Tripped=1
AEM Analog Input Status	35	UINT8	R	AEM Protection 2 Thresh 3 Trip	No Unit	Not tripped=0, Tripped=1
AEM Analog Input Status	35	UINT8	R	AEM Protection 2 Thresh 4 Trip	No Unit	Not tripped=0, Tripped=1
AEM Analog Input Status	35	UINT8	R	AEM Protection 3 Thresh 1 Trip	No Unit	Not tripped=0, Tripped=1
AEM Analog Input Status	35	UINT8	R	AEM Protection 3 Thresh 2 Trip	No Unit	Not tripped=0, Tripped=1
AEM Analog Input Status	35	UINT8	R	AEM Protection 3 Thresh 3 Trip	No Unit	Not tripped=0, Tripped=1
AEM Analog Input Status	35	UINT8	R	AEM Protection 3 Thresh 4 Trip	No Unit	Not tripped=0, Tripped=1
AEM Analog Input Status	35	UINT8	R	AEM Protection 4 Thresh 1 Trip	No Unit	Not tripped=0, Tripped=1
AEM Analog Input Status	35	UINT8	R	AEM Protection 4 Thresh 2 Trip	No Unit	Not tripped=0, Tripped=1
AEM Analog Input Status	35	UINT8	R	AEM Protection 4 Thresh 3 Trip	No Unit	Not tripped=0, Tripped=1
AEM Analog Input Status	35	UINT8	R	AEM Protection 4 Thresh 4 Trip	No Unit	Not tripped=0, Tripped=1

Instance Name	Inst. #	Type	RW	Key Name	Unit	Range
AEM Analog Input Status	35	UINT8	R	AEM Protection 5 Thresh 1 Trip	No Unit	Not tripped=0, Tripped=1
AEM Analog Input Status	35	UINT8	R	AEM Protection 5 Thresh 2 Trip	No Unit	Not tripped=0, Tripped=1
AEM Analog Input Status	35	UINT8	R	AEM Protection 5 Thresh 3 Trip	No Unit	Not tripped=0, Tripped=1
AEM Analog Input Status	35	UINT8	R	AEM Protection 5 Thresh 4 Trip	No Unit	Not tripped=0, Tripped=1
AEM Analog Input Status	35	UINT8	R	AEM Protection 6 Thresh 1 Trip	No Unit	Not tripped=0, Tripped=1
AEM Analog Input Status	35	UINT8	R	AEM Protection 6 Thresh 2 Trip	No Unit	Not tripped=0, Tripped=1
AEM Analog Input Status	35	UINT8	R	AEM Protection 6 Thresh 3 Trip	No Unit	Not tripped=0, Tripped=1
AEM Analog Input Status	35	UINT8	R	AEM Protection 6 Thresh Trip	No Unit	Not tripped=0, Tripped=1
AEM Analog Input Status	35	UINT8	R	AEM Protection 7 Thresh 1 Trip	No Unit	Not tripped=0, Tripped=1
AEM Analog Input Status	35	UINT8	R	AEM Protection 7 Thresh 2 Trip	No Unit	Not tripped=0, Tripped=1
AEM Analog Input Status	35	UINT8	R	AEM Protection 7 Thresh 3 Trip	No Unit	Not tripped=0, Tripped=1
AEM Analog Input Status	35	UINT8	R	AEM Protection 7 Thresh 4 Trip	No Unit	Not tripped=0, Tripped=1
AEM Analog Input Status	35	UINT8	R	AEM Protection 8 Thresh 1 Trip	No Unit	Not tripped=0, Tripped=1
AEM Analog Input Status	35	UINT8	R	AEM Protection 8 Thresh 2 Trip	No Unit	Not tripped=0, Tripped=1
AEM Analog Input Status	35	UINT8	R	AEM Protection 8 Thresh 3 Trip	No Unit	Not tripped=0, Tripped=1
AEM Analog Input Status	35	UINT8	R	AEM Protection 8 Thresh 4 Trip	No Unit	Not tripped=0, Tripped=1
AEM RTD Input Meter	36	Float	R	RTD Input 1 Raw Value GG	Ohm	7.1 – 18.73 or 80.31 – 194.1 (cu or pt)
AEM RTD Input Meter	36	Float	R	RTD Input 2 Raw Value GG	Ohm	7.1 – 18.73 or 80.31 – 194.1 (cu or pt)
AEM RTD Input Meter	36	Float	R	RTD Input 3 Raw Value GG	Ohm	7.1 – 18.73 or 80.31 – 194.1 (cu or pt)
AEM RTD Input Meter	36	Float	R	RTD Input 4 Raw Value GG	Ohm	7.1 – 18.73 or 80.31 – 194.1 (cu or pt)
AEM RTD Input Meter	36	Float	R	RTD Input 5 Raw Value GG	Ohm	7.1 – 18.73 or 80.31 – 194.1 ohms (cu or pt)
AEM RTD Input Meter	36	Float	R	RTD Input 6 Raw Value GG	Ohm	7.1 – 18.73 or 80.31 – 194.1 (cu or pt)
AEM RTD Input Meter	36	Float	R	RTD Input 7 Raw Value GG	Ohm	7.1 – 18.73 or 80.31 – 194.1 ohms (cu or pt)
AEM RTD Input Meter	36	Float	R	RTD Input 8 Raw Value GG	Ohm	7.1 – 18.73 or 80.31 – 194.1 (cu or pt)
AEM RTD Input Meter	36	Float	R	RTD Input 1 Scaled Value GG	Deg F	n/a
AEM RTD Input Meter	36	Float	R	RTD Input 2 Scaled Value GG	Deg F	n/a
AEM RTD Input Meter	36	Float	R	RTD Input 3 Scaled Value GG	Deg F	n/a
AEM RTD Input Meter	36	Float	R	RTD Input 4 Scaled Value GG	Deg F	n/a
AEM RTD Input Meter	36	Float	R	RTD Input 5 Scaled Value GG	Deg F	n/a
AEM RTD Input Meter	36	Float	R	RTD Input 6 Scaled Value GG	Deg F	n/a
AEM RTD Input Meter	36	Float	R	RTD Input 7 Scaled Value GG	Deg F	n/a

Instance Name	Inst. #	Type	RW	Key Name	Unit	Range
AEM RTD Input Meter	36	Float	R	RTD Input 8 Scaled Value GG	Deg F	n/a
AEM RTD Input Status	37	UINT8	R	AEM Config RTD Input 1 Out of Range	No Unit	Value in range=0, Value out of range=1
AEM RTD Input Status	37	UINT8	R	AEM Config RTD Input 2 Out of Range	No Unit	Value in range=0, Value out of range=1
AEM RTD Input Status	37	UINT8	R	AEM Config RTD Input 3 Out of Range	No Unit	Value in range=0, Value out of range=1
AEM RTD Input Status	37	UINT8	R	AEM Config RTD Input 4 Out of Range	No Unit	Value in range=0, Value out of range=1
AEM RTD Input Status	37	UINT8	R	AEM Config RTD Input 5 Out of Range	No Unit	Value in range=0, Value out of range=1
AEM RTD Input Status	37	UINT8	R	AEM Config RTD Input 6 Out of Range	No Unit	Value in range=0, Value out of range=1
AEM RTD Input Status	37	UINT8	R	AEM Config RTD Input 7 Out of Range	No Unit	Value in range=0, Value out of range=1
AEM RTD Input Status	37	UINT8	R	AEM Config RTD Input 8 Out of Range	No Unit	Value in range=0, Value out of range=1
AEM RTD Input Status	37	UINT8	R	RTD Protection 1 Thresh 1 Trip	No Unit	Not tripped=0, Tripped=1
AEM RTD Input Status	37	UINT8	R	RTD Protection 1 Thresh 2 Trip	No Unit	Not tripped=0, Tripped=1
AEM RTD Input Status	37	UINT8	R	RTD Protection 1 Thresh 3 Trip	No Unit	Not tripped=0, Tripped=1
AEM RTD Input Status	37	UINT8	R	RTD Protection 1 Thresh 4 Trip	No Unit	Not tripped=0, Tripped=1
AEM RTD Input Status	37	UINT8	R	RTD Protection 2 Thresh 1 Trip	No Unit	Not tripped=0, Tripped=1
AEM RTD Input Status	37	UINT8	R	RTD Protection 2 Thresh 2 Trip	No Unit	Not tripped=0, Tripped=1
AEM RTD Input Status	37	UINT8	R	RTD Protection 2 Thresh 3 Trip	No Unit	Not tripped=0, Tripped=1
AEM RTD Input Status	37	UINT8	R	RTD Protection 2 Thresh 4 Trip	No Unit	Not tripped=0, Tripped=1
AEM RTD Input Status	37	UINT8	R	RTD Protection 3 Thresh 1 Trip	No Unit	Not tripped=0, Tripped=1
AEM RTD Input Status	37	UINT8	R	RTD Protection 3 Thresh 2 Trip	No Unit	Not tripped=0, Tripped=1
AEM RTD Input Status	37	UINT8	R	RTD Protection 3 Thresh 3 Trip	No Unit	Not tripped=0, Tripped=1
AEM RTD Input Status	37	UINT8	R	RTD Protection 3 Thresh 4 Trip	No Unit	Not tripped=0, Tripped=1
AEM RTD Input Status	37	UINT8	R	RTD Protection 4 Thresh 1 Trip	No Unit	Not tripped=0, Tripped=1
AEM RTD Input Status	37	UINT8	R	RTD Protection 4 Thresh 2 Trip	No Unit	Not tripped=0, Tripped=1
AEM RTD Input Status	37	UINT8	R	RTD Protection 4 Thresh 3 Trip	No Unit	Not tripped=0, Tripped=1
AEM RTD Input Status	37	UINT8	R	RTD Protection 4 Thresh 4 Trip	No Unit	Not tripped=0, Tripped=1
AEM RTD Input Status	37	UINT8	R	RTD Protection 5 Thresh 1 Trip	No Unit	Not tripped=0, Tripped=1
AEM RTD Input Status	37	UINT8	R	RTD Protection 5 Thresh 2 Trip	No Unit	Not tripped=0, Tripped=1
AEM RTD Input Status	37	UINT8	R	RTD Protection 5 Thresh 3 Trip	No Unit	Not tripped=0, Tripped=1
AEM RTD Input Status	37	UINT8	R	RTD Protection 5 Thresh 4 Trip	No Unit	Not tripped=0, Tripped=1
AEM RTD Input Status	37	UINT8	R	RTD Protection 6 Thresh 1 Trip	No Unit	Not tripped=0, Tripped=1
AEM RTD Input Status	37	UINT8	R	RTD Protection 6 Thresh 2 Trip	No Unit	Not tripped=0, Tripped=1

Instance Name	Inst. #	Type	RW	Key Name	Unit	Range
AEM RTD Input Status	37	UINT8	R	RTD Protection 6 Thresh 3 Trip	No Unit	Not tripped=0, Tripped=1
AEM RTD Input Status	37	UINT8	R	RTD Protection 6 Thresh 4 Trip	No Unit	Not tripped=0, Tripped=1
AEM RTD Input Status	37	UINT8	R	RTD Protection 7 Thresh 1 Trip	No Unit	Not tripped=0, Tripped=1
AEM RTD Input Status	37	UINT8	R	RTD Protection 7 Thresh 2 Trip	No Unit	Not tripped=0, Tripped=1
AEM RTD Input Status	37	UINT8	R	RTD Protection 7 Thresh 3 Trip	No Unit	Not tripped=0, Tripped=1
AEM RTD Input Status	37	UINT8	R	RTD Protection 7 Thresh 4 Trip	No Unit	Not tripped=0, Tripped=1
AEM RTD Input Status	37	UINT8	R	RTD Protection 8 Thresh 1 Trip	No Unit	Not tripped=0, Tripped=1
AEM RTD Input Status	37	UINT8	R	RTD Protection 8 Thresh 2 Trip	No Unit	Not tripped=0, Tripped=1
AEM RTD Input Status	37	UINT8	R	RTD Protection 8 Thresh 3 Trip	No Unit	Not tripped=0, Tripped=1
AEM RTD Input Status	37	UINT8	R	RTD Protection 8 Thresh 4 Trip	No Unit	Not tripped=0, Tripped=1
AEM TC Input Meter	38	Float	R	Thermocouple Input 1 Raw Value GG	mV	n/a
AEM TC Input Meter	38	Float	R	Thermocouple Input 2 Raw Value GG	mV	n/a
AEM TC Input Meter	38	Float	R	Thermocouple Input 1 Scaled Value GG	Deg F	n/a
AEM TC Input Meter	38	Float	R	Thermocouple Input 2 Scaled Value GG	Deg F	n/a
AEM TC Input Status	39	UINT8	R	AEM Config Thermocouple 1 Out of Range	No Unit	Value in range=0, Value out of range=1
AEM TC Input Status	39	UINT8	R	AEM Config Thermocouple 2 Out of Range	No Unit	Value in range=0, Value out of range=1
AEM TC Input Status	39	UINT8	R	Thermocouple Protection 1 Thresh 1 Trip	No Unit	Not tripped=0, Tripped=1
AEM TC Input Status	39	UINT8	R	Thermocouple Protection 1 Thresh 2 Trip	No Unit	Not tripped=0, Tripped=1
AEM TC Input Status	39	UINT8	R	Thermocouple Protection 1 Thresh 3 Trip	No Unit	Not tripped=0, Tripped=1
AEM TC Input Status	39	UINT8	R	Thermocouple Protection 1 Thresh 4 Trip	No Unit	Not tripped=0, Tripped=1
AEM TC Input Status	39	UINT8	R	Thermocouple Protection 2 Thresh 1 Trip	No Unit	Not tripped=0, Tripped=1
AEM TC Input Status	39	UINT8	R	Thermocouple Protection 2 Thresh 2 Trip	No Unit	Not tripped=0, Tripped=1
AEM TC Input Status	39	UINT8	R	Thermocouple Protection 2 Thresh 3 Trip	No Unit	Not tripped=0, Tripped=1
AEM TC Input Status	39	UINT8	R	Thermocouple Protection 2 Thresh 4 Trip	No Unit	Not tripped=0, Tripped=1
Contact Output Status	40	UINT8	R	Contact Outputs Watchdog Output	No Unit	Open=0, Closed=1
Contact Output Status	40	UINT8	R	Contact Outputs Output 1	No Unit	Open=0, Closed=1
Contact Output Status	40	UINT8	R	Contact Outputs Output 2	No Unit	Open=0, Closed=1
Contact Output Status	40	UINT8	R	Contact Outputs Output 3	No Unit	Open=0, Closed=1
Contact Output Status	40	UINT8	R	Contact Outputs Output 4	No Unit	Open=0, Closed=1
Contact Output Status	40	UINT8	R	Contact Outputs Output 5	No Unit	Open=0, Closed=1
Contact Output Status	40	UINT8	R	Contact Outputs Output 6	No Unit	Open=0, Closed=1
Contact Output Status	40	UINT8	R	Contact Outputs Output 7	No Unit	Open=0, Closed=1
Contact Output Status	40	UINT8	R	Contact Outputs Output 8	No Unit	Open=0, Closed=1

Instance Name	Inst. #	Type	RW	Key Name	Unit	Range
Contact Output Status	40	UINT8	R	Contact Outputs Output 9	No Unit	Open=0, Closed=1
Contact Output Status	40	UINT8	R	Contact Outputs Output 10	No Unit	Open=0, Closed=1
Contact Output Status	40	UINT8	R	Contact Outputs Output 11	No Unit	Open=0, Closed=1
CEM Output Status	41	UINT8	R	CEM Output 1	No Unit	Open=0, Closed=1
CEM Output Status	41	UINT8	R	CEM Output 2	No Unit	Open=0, Closed=1
CEM Output Status	41	UINT8	R	CEM Output 3	No Unit	Open=0, Closed=1
CEM Output Status	41	UINT8	R	CEM Output 4	No Unit	Open=0, Closed=1
CEM Output Status	41	UINT8	R	CEM Output 5	No Unit	Open=0, Closed=1
CEM Output Status	41	UINT8	R	CEM Output 6	No Unit	Open=0, Closed=1
CEM Output Status	41	UINT8	R	CEM Output 7	No Unit	Open=0, Closed=1
CEM Output Status	41	UINT8	R	CEM Output 8	No Unit	Open=0, Closed=1
CEM Output Status	41	UINT8	R	CEM Output 9	No Unit	Open=0, Closed=1
CEM Output Status	41	UINT8	R	CEM Output 10	No Unit	Open=0, Closed=1
CEM Output Status	41	UINT8	R	CEM Output 11	No Unit	Open=0, Closed=1
CEM Output Status	41	UINT8	R	CEM Output 12	No Unit	Open=0, Closed=1
CEM Output Status	41	UINT8	R	CEM Output 13	No Unit	Open=0, Closed=1
CEM Output Status	41	UINT8	R	CEM Output 14	No Unit	Open=0, Closed=1
CEM Output Status	41	UINT8	R	CEM Output 15	No Unit	Open=0, Closed=1
CEM Output Status	41	UINT8	R	CEM Output 16	No Unit	Open=0, Closed=1
CEM Output Status	41	UINT8	R	CEM Output 17	No Unit	Open=0, Closed=1
CEM Output Status	41	UINT8	R	CEM Output 18	No Unit	Open=0, Closed=1
CEM Output Status	41	UINT8	R	CEM Output 19	No Unit	Open=0, Closed=1
CEM Output Status	41	UINT8	R	CEM Output 20	No Unit	Open=0, Closed=1
CEM Output Status	41	UINT8	R	CEM Output 21	No Unit	Open=0, Closed=1
CEM Output Status	41	UINT8	R	CEM Output 22	No Unit	Open=0, Closed=1
CEM Output Status	41	UINT8	R	CEM Output 23	No Unit	Open=0, Closed=1
CEM Output Status	41	UINT8	R	CEM Output 24	No Unit	Open=0, Closed=1
AEM Analog Output Meter	42	Float	R	Analog Output 1 Raw Value GG	No Unit	0 – 10 V or 4 – 20 mA
AEM Analog Output Meter	42	Float	R	Analog Output 2 Raw Value GG	No Unit	0 – 10 V or 4 – 20 mA
AEM Analog Output Meter	42	Float	R	Analog Output 3 Raw Value GG	No Unit	0 – 10 V or 4 – 20 mA
AEM Analog Output Meter	42	Float	R	Analog Output 4 Raw Value GG	No Unit	0 – 10 V or 4 – 20 mA
AEM Analog Output Meter	42	Float	R	Analog Output 1 Scaled Value GG	No Unit	n/a
AEM Analog Output Meter	42	Float	R	Analog Output 2 Scaled Value GG	No Unit	n/a
AEM Analog Output Meter	42	Float	R	Analog Output 3 Scaled Value GG	No Unit	n/a
AEM Analog Output Meter	42	Float	R	Analog Output 4 Scaled Value GG	No Unit	n/a
AEM Analog Output Status	43	UINT8	R	Remote Analog Output 1 Out of Range	No Unit	Value in range=0, Value out of range=1
AEM Analog Output Status	43	UINT8	R	Remote Analog Output 2 Out of Range	No Unit	Value in range=0, Value out of range=1
AEM Analog Output Status	43	UINT8	R	Remote Analog Output 3 Out of Range	No Unit	Value in range=0, Value out of range=1
AEM Analog Output Status	43	UINT8	R	Remote Analog Output 4 Out of Range	No Unit	Value in range=0, Value out of range=1
Config. Prot. Status	44	UINT8	R	Configurable Protection 1 Configurable Protection Threshold 1 Trip	No Unit	Not tripped=0, Tripped=1



Instance Name	Inst. #	Type	RW	Key Name	Unit	Range
Config. Prot. Status	44	UINT8	R	Configurable Protection 6 Configurable Protection Threshold 4 Trip	No Unit	Not tripped=0, Tripped=1
Config. Prot. Status	44	UINT8	R	Configurable Protection 7 Configurable Protection Threshold 1 Trip	No Unit	Not tripped=0, Tripped=1
Config. Prot. Status	44	UINT8	R	Configurable Protection 7 Configurable Protection Threshold 2 Trip	No Unit	Not tripped=0, Tripped=1
Config. Prot. Status	44	UINT8	R	Configurable Protection 7 Configurable Protection Threshold 3 Trip	No Unit	Not tripped=0, Tripped=1
Config. Prot. Status	44	UINT8	R	Configurable Protection 7 Configurable Protection Threshold 4 Trip	No Unit	Not tripped=0, Tripped=1
Config. Prot. Status	44	UINT8	R	Configurable Protection 8 Configurable Protection Threshold 1 Trip	No Unit	Not tripped=0, Tripped=1
Config. Prot. Status	44	UINT8	R	Configurable Protection 8 Configurable Protection Threshold 2 Trip	No Unit	Not tripped=0, Tripped=1
Config. Prot. Status	44	UINT8	R	Configurable Protection 8 Configurable Protection Threshold 3 Trip	No Unit	Not tripped=0, Tripped=1
Config. Prot. Status	44	UINT8	R	Configurable Protection 8 Configurable Protection Threshold 4 Trip	No Unit	Not tripped=0, Tripped=1
Real Time Clock	45	String	R	Date GG	No Unit	0 – 25 characters
Real Time Clock	45	String	R	Time GG	No Unit	0 – 25 characters
Front Panel Settings	46	UINT32	R	LCD Contrast GG	%	0 - 100
Front Panel Settings	46	UINT32	R	LCD Invert Display GG	No Unit	No=0 Yes=1
Front Panel Settings	46	UINT32	R	LCD Sleep Mode GG	No Unit	Disabled=0 Enabled=1
Front Panel Settings	46	UINT32	R	LCD Backlight Timeout GG	Sec	1 - 120
Front Panel Settings	46	UINT32	R	LCD Language Selection GG	No Unit	English=0 Chinese=1 Russian=2 Spanish=4 German=5
Front Panel Settings	46	UINT32	R	Enable Scroll GG	No Unit	Disabled=0 Enabled=1
Front Panel Settings	46	UINT32	R	Scroll Time Delay GG	Sec	1 - 600
250 Device Info App Version	47	String	R	External Version GG	No Unit	0 - 25 characters
250 Device Info Boot Version	48	String	R	External Boot Version GG	No Unit	0 - 25 characters
250 Device Info App Build Date	49	String	R	App Build Date GG	No Unit	0 - 25 characters
250 Device Info Serial	50	String	R	Serial Number GG	No Unit	0 - 25 characters
250 Device Info App Part Number	51	String	R	Firmware Part Number GG	No Unit	0 - 25 characters
250 Device Info Model	52	String	R	Model Number GG	No Unit	0 - 25 characters
AEM Device Info App Version	53	String	R	App Version Number GG	No Unit	0 - 25 characters
AEM Device Info Boot Version	54	String	R	Boot Version Number GG	No Unit	0 - 25 characters
AEM Device Info Build Date	55	String	R	App Build Date GG	No Unit	0 - 25 characters
AEM Device Info Serial	56	String	R	Serial Number GG	No Unit	0 - 25 characters
AEM Device Info App Part Number	57	String	R	App Part Number GG	No Unit	0 - 25 characters
AEM Device Info Model	58	String	R	Model Number GG	No Unit	0 - 25 characters
CEM Device Info App Version	59	String	R	App Version Number GG	No Unit	0 - 25 characters
CEM Device Info Boot Version	60	String	R	Boot Version Number GG	No Unit	0 - 25 characters
CEM Device Info App Build Date	61	String	R	App Build Date GG	No Unit	0 - 25 characters

Instance Name	Inst. #	Type	RW	Key Name	Unit	Range
CEM Device Info Serial	62	String	R	Serial Number GG	No Unit	0 - 25 characters
CEM Device Info App Part Number	63	String	R	App Part Number GG	No Unit	0 - 25 characters
CEM Device Info Model	64	String	R	Model Number GG	No Unit	0 - 25 characters
System Param	65	UINT32	R/W	Nominal Freq GG	No Unit	50 Hz=50 60 Hz=60
System Param	66	Float	R/W	Rated Primary LL GG (Gen Voltage Config)	V	1 - 500000
System Param	66	Float	R/W	Rated Primary LL GG (Bus Voltage Config)	V	1 - 500000
System Param	66	Float	R/W	Rated PF GG	PF	0.5 - -0.5
System Param	66	Float	R/W	Rated KVA GG	KVA	1 - 1000000
System Param	66	Float	R/W	Rated Field Volt Full Load GG	V	1 - 250
System Param	66	Float	R/W	Rated Field Volt No Load GG	V	1 - 250
System Param	66	Float	R/W	Rated Field Current Full Load GG	Amp	0.1 - 20
System Param	66	Float	R/W	Rated Field Current No Load GG	Amp	0.1 - 20
System Param	66	Float	R/W	Exciter Pole Ratio GG	No Unit	1 - 10
AVR Setpoints	67	UINT32	R/W	Gen Voltage Preposition Mode 1 GG	No Unit	Maintain=0 Release=1
AVR Setpoints	67	UINT32	R/W	Gen Voltage Preposition Mode 2 GG	No Unit	Maintain=0 Release=1
AVR Setpoints	67	UINT32	R/W	Gen Voltage Preposition Mode 3 GG	No Unit	Maintain=0 Release=1
AVR Setpoints	68	Float	R/W	Gen Voltage Traverse Rate GG	Sec	10 - 200
AVR Setpoints	68	Float	R/W	Gen Voltage Setpoint GG	V	84 - 144
AVR Setpoints	68	Float	R/W	Gen Voltage Min Setpoint Limit GG	%	70 - 120
AVR Setpoints	68	Float	R/W	Gen Voltage Max Setpoint Limit GG	%	70 - 120
AVR Setpoints	68	Float	R/W	Gen Voltage Preposition1 GG	V	84 - 144
AVR Setpoints	68	Float	R/W	Gen Voltage Preposition2 GG	V	84 - 144
AVR Setpoints	68	Float	R/W	Gen Voltage Preposition3 GG	V	84 - 144
FCR Setpoints	69	UINT32	R/W	Excitation Current Preposition Mode 1 GG	No Unit	Maintain=0 Release=1
FCR Setpoints	69	UINT32	R/W	Excitation Current Preposition Mode 2 GG	No Unit	Maintain=0 Release=1
FCR Setpoints	69	UINT32	R/W	Excitation Current Preposition Mode 3 GG	No Unit	Maintain=0 Release=1
FCR Setpoints	70	Float	R/W	Excitation Current Traverse Rate GG	Sec	10 - 200
FCR Setpoints	70	Float	R/W	Excitation Current Setpoint GG	Amp	0 - 12
FCR Setpoints	70	Float	R/W	Excitation Current Min Setpoint Limit GG	%	0 - 120
FCR Setpoints	70	Float	R/W	Excitation Current Max Setpoint Limit GG	%	0 - 120
FCR Setpoints	70	Float	R/W	Excitation Current Preposition 1 GG	Amp	0 - 12
FCR Setpoints	70	Float	R/W	Excitation Current Preposition 2 GG	Amp	0 - 12

Instance Name	Inst. #	Type	RW	Key Name	Unit	Range
FCR Setpoints	70	Float	R/W	Excitation Current Preposition 3 GG	Amp	0 - 12
FVR Setpoints	71	UINT32	R/W	Excitation Voltage Preposition Mode 1 GG	No Unit	Maintain=0 Release=1
FVR Setpoints	71	UINT32	R/W	Excitation Voltage Preposition Mode 2 GG	No Unit	Maintain=0 Release=1
FVR Setpoints	71	UINT32	R/W	Excitation Voltage Preposition Mode 3 GG	No Unit	Maintain=0 Release=1
FVR Setpoints	72	Float	R/W	Excitation Voltage Traverse Rate GG	Sec	10 - 200
FVR Setpoints	72	Float	R/W	Excitation Voltage Setpoint GG	V	0 - 75
FVR Setpoints	72	Float	R/W	Excitation Voltage Min Setpoint Limit GG	%	0 - 150
FVR Setpoints	72	Float	R/W	Excitation Voltage Max Setpoint Limit GG	%	0 - 150
FVR Setpoints	72	Float	R/W	Excitation Voltage Preposition 1 GG	V	0 - 75
FVR Setpoints	72	Float	R/W	Excitation Voltage Preposition 2 GG	V	0 - 75
FVR Setpoints	72	Float	R/W	Excitation Voltage Preposition 3 GG	V	0 - 75
VAR Setpoints	73	UINT32	R/W	Gen Var Preposition Mode1 GG	No Unit	Maintain=0 Release=1
VAR Setpoints	73	UINT32	R/W	Gen Var Preposition Mode2 GG	No Unit	Maintain=0 Release=1
VAR Setpoints	73	UINT32	R/W	Gen Var Preposition Mode 3 GG	No Unit	Maintain=0 Release=1
VAR Setpoints	74	Float	R/W	Sys Option Fine Adjust Band GG	%	0 - 30
VAR Setpoints	74	Float	R/W	Gen Var Traverse Rate GG	Sec	10 - 200
VAR Setpoints	74	Float	R/W	Gen Var Setpoint GG	kvar	0 – 41.57
VAR Setpoints	74	Float	R/W	Gen Var Min Setpoint Limit GG	%	-100 - 100
VAR Setpoints	74	Float	R/W	Gen Var Max Setpoint Limit GG	%	-100 - 100
VAR Setpoints	74	Float	R/W	Gen var Preposition 1 GG	kvar	0 – 41.57
VAR Setpoints	74	Float	R/W	Gen var Preposition 2 GG	kvar	0 – 41.57
VAR Setpoints	74	Float	R/W	Gen var Preposition 3 GG	kvar	0 – 41.57
PF Setpoints	75	UINT32	R/W	Gen PF Preposition Mode 1 GG	No Unit	Maintain=0 Release=1
PF Setpoints	75	UINT32	R/W	Gen PF Preposition Mode 2 GG	No Unit	Maintain=0 Release=1
PF Setpoints	75	UINT32	R/W	Gen PF Preposition Mode 3 GG	No Unit	Maintain=0 Release=1
PF Setpoints	76	Float	R/W	Gen PF Traverse Rate GG	Sec	10 - 200
PF Setpoints	76	Float	R/W	Gen PF Setpoint GG	PF	0.5 – -0.5
PF Setpoints	76	Float	R/W	Gen PF Min Setpoint Limit GG	PF	0.5 – 1
PF Setpoints	76	Float	R/W	Gen Pf Max Setpoint Limit GG	PF	-1 - -0.5
PF Setpoints	76	Float	R/W	Gen PF Preposition 1 GG	PF	0.5 – -0.5
PF Setpoints	76	Float	R/W	Gen PF preposition 2 GG	PF	0.5 – -0.5

Instance Name	Inst. #	Type	RW	Key Name	Unit	Range
PF Setpoints	76	Float	R/W	Gen PF Preposition 3 GG	PF	0.5 - -0.5
Aux Input Settings	77	UINT32	R/W	DECS Aux Input Mode GG	No Unit	Voltage=0 Current=1
Aux Input Settings	77	UINT32	R/W	DECS Aux Summing Mode GG	No Unit	Voltage=0 Var=1
Aux Input Settings	77	UINT32	R/W	DECS Aux Input Function GG	No Unit	DECS Input=0 PSS Test Input=1 Limiter Selection=2 Grid Code Input=3
Aux Input Settings	78	Float	R/W	DECS Aux Voltage Gain GG	No Unit	-99 - 99
Aux Input Settings	78	Float	R/W	DECS Aux FCR Gain GG	No Unit	-99 - 99
Aux Input Settings	78	Float	R/W	DECS Aux FVR Gain GG	No Unit	-99 - 99
Aux Input Settings	78	Float	R/W	DECS Aux var Gain GG	No Unit	-99 - 99
Aux Input Settings	78	Float	R/W	DECS Aux PF Gain GG	No Unit	-99 - 99
Parallel/Line Drop	79	UINT32	R/W	Sys Option Input Droop Enabled GG	No Unit	Disabled=0 Enabled=1
Parallel/Line Drop	79	UINT32	R/W	Sys Option Input L Drop Enabled GG	No Unit	Disabled=0 Enabled=1
Parallel/Line Drop	79	UINT32	R/W	Sys Option Input CC Enabled GG	No Unit	Disabled=0 Enabled=1
Parallel/Line Drop	80	Float	R/W	Droop Value GG	%	0 - 30
Parallel/Line Drop	80	Float	R/W	L Drop Value GG	%	0 - 30
Parallel/Line Drop	80	Float	R/W	DECS Aux Amp Gain GG	%	-30 - 30
Load Share	81	UINT32	R/W	LS Enable GG	No Unit	Disabled=0 Enabled=1
Load Share	82	Float	R/W	LS Droop Percent GG	%	0 - 30
Load Share	82	Float	R/W	LS Gain GG	No Unit	0 - 1000
Load Share	82	Float	R/W	Washout Filter Time Constant GG	No Unit	0 - 1
Load Share	82	Float	R/W	Washout Filter Gain GG	No Unit	0 - 1000
Load Share	82	Float	R/W	LS Ki Gain GG	No Unit	0 - 1000
Load Share	82	Float	R/W	LS Max Vc GG	No Unit	0 - 1
Auto Tracking	83	UINT32	R/W	Sys Input Comport Int Track Enabled GG	No Unit	Disabled=0 Enabled=1
Auto Tracking	83	UINT32	R/W	Sys Input Comport Ext Track Enabled GG	No Unit	Disabled=0 Enabled=1
Auto Tracking	84	Float	R/W	DECS Auto Track T Delay GG	Sec	0 - 8
Auto Tracking	84	Float	R/W	DECS Auto Track T Rate GG	Sec	1 - 80
Auto Tracking	84	Float	R/W	DECS Auto Trans T Delay GG	Sec	0 - 8
Auto Tracking	84	Float	R/W	DECS Auto Trans T Rate GG	Sec	1 - 80
Startup	86	Float	R/W	Startup Primary Soft Start Bias GG	%	0 - 90
Startup	86	Float	R/W	Startup Primary Soft Start Time GG	Sec	1 - 7200
Startup	86	Float	R/W	Startup Sec Soft Start Bias GG	%	0 - 90
Startup	86	Float	R/W	Startup Sec Soft Start Time GG	Sec	1 - 7200
Startup	86	Float	R/W	DECS Field Flash Level GG	No Unit	0 - 100
Startup	86	Float	R/W	DECS Field Flash Time GG	No Unit	1 - 50

Instance Name	Inst. #	Type	RW	Key Name	Unit	Range
AVR Gains	87	UINT32	R/W	Primary Gain Option GG	No Unit	TpdoEQ1pt0 TeEQ0pt17=1 TpdoEQ1pt5 TeEQ0pt25=2 TpdoEQ2pt0 TeEQ0pt33=3 TpdoEQ2pt5 TeEQ0pt42=4 TpdoEQ3pt0 TeEQ0pt50=5 TpdoEQ3pt5 TeEQ0pt58=6 TpdoEQ4pt0 TeEQ0pt67=7 TpdoEQ4pt5 TeEQ0pt75=8 TpdoEQ5pt0 TeEQ0pt83=9 TpdoEQ5pt5 TeEQ0pt92=10 TpdoEQ6pt0 TeEQ1pt00=11 TpdoEQ6pt5 TeEQ1pt08=12 TpdoEQ7pt0 TeEQ1pt17=13 TpdoEQ7pt5 TeEQ1pt25=14 TpdoEQ8pt0 TeEQ1pt33=15 TpdoEQ8pt5 TeEQ1pt42=16 TpdoEQ9pt0 TeEQ1pt50=17 TpdoEQ9pt5 TeEQ1pt58=18 TpdoEQ10pt0 TeEQ1pt67=19 TpdoEQ10pt5 TeEQ1pt75=20 Custom=21
AVR Gains	87	UINT32	R/W	Secondary Gain Option GG	No Unit	TpdoEQ1pt0 TeEQ0pt17=1 TpdoEQ1pt5 TeEQ0pt25=2 TpdoEQ2pt0 TeEQ0pt33=3 TpdoEQ2pt5 TeEQ0pt42=4 TpdoEQ3pt0 TeEQ0pt50=5 TpdoEQ3pt5 TeEQ0pt58=6 TpdoEQ4pt0 TeEQ0pt67=7 TpdoEQ4pt5 TeEQ0pt75=8 TpdoEQ5pt0 TeEQ0pt83=9 TpdoEQ5pt5 TeEQ0pt92=10 TpdoEQ6pt0 TeEQ1pt00=11 TpdoEQ6pt5 TeEQ1pt08=12 TpdoEQ7pt0 TeEQ1pt17=13 TpdoEQ7pt5 TeEQ1pt25=14 TpdoEQ8pt0 TeEQ1pt33=15 TpdoEQ8pt5 TeEQ1pt42=16 TpdoEQ9pt0 TeEQ1pt50=17 TpdoEQ9pt5 TeEQ1pt58=18 TpdoEQ10pt0 TeEQ1pt67=19 TpdoEQ10pt5 TeEQ1pt75=20 Custom=21
AVR Gains	88	Float	R/W	AVR Kp Primary GG	No Unit	0 - 1000
AVR Gains	88	Float	R/W	AVR Ki Primary GG	No Unit	0 - 1000
AVR Gains	88	Float	R/W	AVR Kd Primary GG	No Unit	0 - 1000
AVR Gains	88	Float	R/W	AVR Td Primary GG	No Unit	0 - 1
AVR Gains	88	Float	R/W	AVR Kg Primary GG	No Unit	0 - 1000
AVR Gains	88	Float	R/W	AVR Kp Sec GG	No Unit	0 - 1000
AVR Gains	88	Float	R/W	AVR Ki Sec GG	No Unit	0 - 1000
AVR Gains	88	Float	R/W	AVR Kd Sec GG	No Unit	0 - 1000
AVR Gains	88	Float	R/W	AVR Td Sec GG	No Unit	0 - 1
AVR Gains	88	Float	R/W	AVR Kg Sec GG	No Unit	0 - 1000
FCR Gains	90	Float	R/W	FCR Kp GG	No Unit	0 - 1000
FCR Gains	90	Float	R/W	FCR Ki GG	No Unit	0 - 1000
FCR Gains	90	Float	R/W	FCR Kd GG	No Unit	0 - 1000
FCR Gains	90	Float	R/W	FCR Td GG	No Unit	0 - 1
FCR Gains	90	Float	R/W	FCR Kg GG	No Unit	0 - 1000
FVR Gains	92	Float	R/W	FVR Kp GG	No Unit	0 - 1000
FVR Gains	92	Float	R/W	FVR Ki GG	No Unit	0 - 1000
FVR Gains	92	Float	R/W	FVR Kd GG	No Unit	0 - 1000
FVR Gains	92	Float	R/W	FVR Td GG	No Unit	0 - 1
FVR Gains	92	Float	R/W	FVR Kg GG	No Unit	0 - 1000
VAR Gains	94	Float	R/W	Var Ki GG	No Unit	0 - 1000
VAR Gains	94	Float	R/W	Var Kg GG	No Unit	0 - 1000
PF Gains	96	Float	R/W	PF Ki GG	No Unit	0 - 1000

Instance Name	Inst. #	Type	RW	Key Name	Unit	Range
PF Gains	96	Float	R/W	PF Kg GG	No Unit	0 - 1000
OEL Gains	98	Float	R/W	OEL Ki GG	No Unit	0 - 1000
OEL Gains	98	Float	R/W	OEL Kg GG	No Unit	0 - 1000
UEL Gains	100	Float	R/W	UEL Ki GG	No Unit	0 - 1000
UEL Gains	100	Float	R/W	UEL Kg GG	No Unit	0 - 1000
SCL Gains	102	Float	R/W	SCL Ki GG	No Unit	0 - 1000
SCL Gains	102	Float	R/W	SCL Kg GG	No Unit	0 - 1000
VAR Limiter Gains	104	Float	R/W	Var Limit Ki GG	No Unit	0 - 1000
VAR Limiter Gains	104	Float	R/W	Var Limit Kg GG	No Unit	0 - 1000
Voltage Match Gains	106	Float	R/W	Vm Ki GG	No Unit	0 - 1000
Voltage Match Gains	106	Float	R/W	Vm Kg GG	No Unit	0 - 1000
OEL Configure	107	UINT32	R/W	Sys Option Input OEL Enabled GG	No Unit	Disabled=0 Enabled=1
OEL Configure	107	UINT32	R/W	Sys Option Input OEL Style Enabled GG	No Unit	Summing=0 Takeover=1
OEL Configure	107	UINT32	R/W	OEL Pri Dvdt Enable GG	No Unit	Disabled=0 Enabled=1
OEL Configure	108	Float	R/W	OEL Pri Dvdt Ref GG	No Unit	-10 - 0
OEL Summing Point	110	Float	R/W	OEL Pri Cur Hi GG	Amp	0 - 40
OEL Summing Point	110	Float	R/W	OEL Pri Cur Mid GG	Amp	0 - 30
OEL Summing Point	110	Float	R/W	OEL Pri Cur Lo GG	Amp	0 - 20
OEL Summing Point	110	Float	R/W	OEL Pri Time Hi GG	Sec	0 - 10
OEL Summing Point	110	Float	R/W	OEL Pri Time Mid GG	Sec	0 - 120
OEL Summing Point	110	Float	R/W	OEL Pri Cur Hi Off GG	Amp	0 - 40
OEL Summing Point	110	Float	R/W	OEL Pri Cur Lo Off GG	Amp	0 - 20
OEL Summing Point	110	Float	R/W	OEL Pri Cur Time Off GG	Sec	0 - 10
OEL Summing Point	110	Float	R/W	OEL Sec Cur Hi GG	Amp	0 - 40
OEL Summing Point	110	Float	R/W	OEL Sec Cur Mid GG	Amp	0 - 30
OEL Summing Point	110	Float	R/W	OEL Sec Cur Lo GG	Amp	0 - 20
OEL Summing Point	110	Float	R/W	OEL Sec Time Hi GG	Sec	0 - 10
OEL Summing Point	110	Float	R/W	OEL Sec Time Mid GG	Sec	0 - 120
OEL Summing Point	110	Float	R/W	OEL Sec Cur Hi Off GG	Amp	0 - 40
OEL Summing Point	110	Float	R/W	OEL Sec Cur Lo Off GG	Amp	0 - 20
OEL Summing Point	110	Float	R/W	OEL Sec Cur Time Off GG	Sec	0 - 10
OEL Takeover	112	Float	R/W	OEL Pri Takeover Cur Max Off GG	Amp	0 - 40
OEL Takeover	112	Float	R/W	OEL Pri Takeover Cur Min Off GG	Amp	0 - 20
OEL Takeover	112	Float	R/W	OEL Pri Takeover Time Dial Off GG	No Unit	0.1 - 20
OEL Takeover	112	Float	R/W	OEL Pri Takeover Cur Max On GG	Amp	0 - 40
OEL Takeover	112	Float	R/W	OEL Pri Takeover Cur Min On GG	Amp	0 - 20
OEL Takeover	112	Float	R/W	OEL Pri Takeover Time Dial On GG	No Unit	0.1 - 20
OEL Takeover	112	Float	R/W	OEL Sec Takeover Cur Max Off GG	Amp	0 - 40
OEL Takeover	112	Float	R/W	OEL Sec Takeover Cur Min Off GG	Amp	0 - 20
OEL Takeover	112	Float	R/W	OEL Sec Takeover Time Dial Off GG	No Unit	0.1 - 20
OEL Takeover	112	Float	R/W	OEL Sec Takeover Cur Max On GG	Amp	0 - 40
OEL Takeover	112	Float	R/W	OEL Sec Takeover Cur Min On GG	Amp	0 - 20

Instance Name	Inst. #	Type	RW	Key Name	Unit	Range
OEL Takeover	112	Float	R/W	OEL Sec Takeover Time Dial On GG	No Unit	0.1 - 20
UEL Configure	113	UINT32	R/W	Sys Option Input UEL Enabled GG	No Unit	Disabled=0 Enabled=1
UEL Configure	114	Float	R/W	UEL Pri Pow Filter TC GG	Sec	0 - 20
UEL Configure	114	Float	R/W	UEL Pri Volt Dep Exponent GG	No Unit	0 - 2
UEL Curve Float Primary	116	Float	R/W	UEL Pri Curve X1 GG	KW	0 - 62
UEL Curve Float Primary	116	Float	R/W	Uel Pri Curve X2 GG	KW	0 - 62
UEL Curve Float Primary	116	Float	R/W	UEL Pri Curve X3 GG	KW	0 - 62
UEL Curve Float Primary	116	Float	R/W	UEL Pri Curve X4 GG	KW	0 - 62
UEL Curve Float Primary	116	Float	R/W	UEL Pri Curve X5 GG	KW	0 - 62
UEL Curve Float Primary	116	Float	R/W	UEL Pri Curve Y1 GG	kvar	0 - 62
UEL Curve Float Primary	116	Float	R/W	UEL Pri Curve Y2 GG	kvar	0 - 62
UEL Curve Float Primary	116	Float	R/W	UEL Pri Curve Y3 GG	kvar	0 - 62
UEL Curve Float Primary	116	Float	R/W	UEL Pri Curve Y4 GG	kvar	0 - 62
UEL Curve Float Primary	116	Float	R/W	UEL Pri Curve Y5 GG	kvar	0 - 62
UEL Curve Float Secondary	118	Float	R/W	UEL Sec Curve X1 GG	KW	0 - 62
UEL Curve Float Secondary	118	Float	R/W	UEL Sec Curve X2 GG	KW	0 - 62
UEL Curve Float Secondary	118	Float	R/W	UEL Sec Curve X3 GG	KW	0 - 62
UEL Curve Float Secondary	118	Float	R/W	UEL Sec Curve X4 GG	KW	0 - 62
UEL Curve Float Secondary	118	Float	R/W	UEL Sec Curve X5 GG	KW	0 - 62
UEL Curve Float Secondary	118	Float	R/W	UEL Sec Curve Y1 GG	kvar	0 - 62
UEL Curve Float Secondary	118	Float	R/W	UEL Sec Curve Y2 GG	kvar	0 - 62
UEL Curve Float Secondary	118	Float	R/W	UEL Sec Curve Y3 GG	kvar	0 - 62
UEL Curve Float Secondary	118	Float	R/W	UEL Sec Curve Y4 GG	kvar	0 - 62
UEL Curve Float Secondary	118	Float	R/W	UEL Sec Curve Y5 GG	kvar	0 - 62
SCL Settings	119	UINT32	R/W	Sys Option Input SCL Enabled GG	No Unit	Disabled=0 Enabled=1
SCL Settings	120	Float	R/W	SCL Pri Ref Hi GG	Amp	0 - 66000
SCL Settings	120	Float	R/W	SCL Pri Ref Lo GG	Amp	0 - 66000
SCL Settings	120	Float	R/W	SCL Pri Time Hi GG	Sec	0 - 60
SCL Settings	120	Float	R/W	SCL Pri No Response Time GG	Sec	0 - 10
SCL Settings	120	Float	R/W	SCL Sec Ref Hi GG	Amp	0 - 66000
SCL Settings	120	Float	R/W	SCL Sec Ref Lo GG	Amp	0 - 66000
SCL Settings	120	Float	R/W	SCL Sec Time Hi GG	Sec	0 - 60
SCL Settings	120	Float	R/W	SCL Sec No Response Time GG	Sec	0 - 10
SCL Settings	120	Float	R/W	Reserved	n/a	n/a
SCL Settings	120	Float	R/W	Reserved	n/a	n/a
SCL Settings	120	Float	R/W	Reserved	n/a	n/a
SCL Settings	120	Float	R/W	Reserved	n/a	n/a
SCL Settings	120	Float	R/W	Reserved	n/a	n/a
VAR Limiter Settings	121	UINT32	R/W	Var Limit Enable GG	No Unit	Disabled=0 Enabled=1
VAR Limiter Settings	122	Float	R/W	Var Limit Pri Delay GG	Sec	0 - 300
VAR Limiter Settings	122	Float	R/W	Var Limit Pri Setpoint GG	%	0 - 200
VAR Limiter Settings	122	Float	R/W	Var Limit Sec Delay GG	Sec	0 - 300
VAR Limiter Settings	122	Float	R/W	Var Limit Sec Setpoint GG	%	0 - 200

Instance Name	Inst. #	Type	RW	Key Name	Unit	Range
OEL Scaling	123	UINT32	R/W	OEL Scale Enable GG	No Unit	DISABLED=0 Auxiliary Input=1 AEM RTD 1=2 AEM RTD 2=3 AEM RTD 3=4 AEM RTD 4=5 AEM RTD 5=6 AEM RTD 6=7 AEM RTD 7=8 AEM RTD 8=9
OEL Scaling	124	Float	R/W	OEL Scale Summing Signal1 GG	V	-10 - 10
OEL Scaling	124	Float	R/W	OEL Scale Summing Signal2 GG	V	-10 - 10
OEL Scaling	124	Float	R/W	OEL Scale Summing Signal3 GG	V	-10 - 10
OEL Scaling	124	Float	R/W	OEL Scale Summing Scale1 GG	%	0 - 200
OEL Scaling	124	Float	R/W	OEL Scale Summing Scale2 GG	%	0 - 200
OEL Scaling	124	Float	R/W	OEL Scale Summing Scale3 GG	%	0 - 200
OEL Scaling	124	Float	R/W	OEL Scale Takeover SIGNAL1 GG	V	-10 - 10
OEL Scaling	124	Float	R/W	OEL Scale Takeover Signal2 GG	V	-10 - 10
OEL Scaling	124	Float	R/W	OEL Scale Takeover Signal3 GG	V	-10 - 10
OEL Scaling	124	Float	R/W	OEL Scale Takeover Scale1 GG	%	0 - 200
OEL Scaling	124	Float	R/W	OEL Scale Takeover Scale2 GG	%	0 - 200
OEL Scaling	124	Float	R/W	OEL Scale Takeover Scale3 GG	%	0 - 200
SCL Scaling	125	UINT32	R/W	SCL Scale Enable GG	No Unit	DISABLED=0 Auxiliary Input=1 AEM RTD 1=2 AEM RTD 2=3 AEM RTD 3=4 AEM RTD 4=5 AEM RTD 5=6 AEM RTD 6=7 AEM RTD 7=8 AEM RTD 8=9
SCL Scaling	126	Float	R/W	ScIScaleSignal1 GG	V	-10 - 10
SCL Scaling	126	Float	R/W	ScIScaleSignal2 GG	V	-10 - 10
SCL Scaling	126	Float	R/W	ScIScaleSignal3 GG	V	-10 - 10
SCL Scaling	126	Float	R/W	ScIScalePoint1 GG	%	0 - 200
SCL Scaling	126	Float	R/W	ScIScalePoint2 GG	%	0 - 200
SCL Scaling	126	Float	R/W	ScIScalePoint3 GG	%	0 - 200
Underfrequency/Volts per hertz	127	UINT32	R/W	Sys Option Under Freq Mode GG	No Unit	UF Limiter=0 V2H Limiter=1
Underfrequency /Volts per Hertz	128	Float	R/W	Sys Option Under Freq Hz GG	Hz	40 - 75
Underfrequency /Volts per Hertz	128	Float	R/W	Sys Option Under Freq Slope GG	No Unit	0 - 3
Underfrequency /Volts per Hertz	128	Float	R/W	Sys Option Voltage Per Hz Slope Hi GG	No Unit	0 - 3
Underfrequency /Volts per Hertz	128	Float	R/W	Sys Option Voltage Per Hz Slope Lo GG	No Unit	0 - 3
Underfrequency /Volts per Hertz	128	Float	R/W	Sys Option Voltage Per Hz Slope Time GG	Sec	0 - 10
PSS Configure	129	UINT32	R/W	Sys Option PSS Power Level Enable GG	No Unit	Disabled=0 Enabled=1

Instance Name	Inst. #	Type	RW	Key Name	Unit	Range
PSS Configure	130	Float	R/W	PSS Primary Power Level Percentage GG	No Unit	0 - 1
PSS Configure	130	Float	R/W	PSS Primary Power Level Hysteresis GG	No Unit	0 - 1
PSS Control Primary	131	UINT32	R/W	PSS Enable GG	No Unit	Disabled=0 Enabled=1
PSS Control Primary	131	UINT32	R/W	PSS Primary Switch 10 GG	No Unit	Disabled=0 Enabled=1
PSS Control Primary	131	UINT32	R/W	PSS Primary Switch 11 GG	No Unit	Disabled=0 Enabled=1
PSS Control Primary	131	UINT32	R/W	PSS Primary Switch 3 GG	No Unit	Frequency=0 Der. Speed=1
PSS Control Primary	131	UINT32	R/W	PSS Primary Switch 4 GG	No Unit	Power=0 Der. Freq/Speed=1
PSS Control Primary	131	UINT32	R/W	PSS Primary Switch 0 GG	No Unit	Disabled=0 Enabled=1
PSS Control Primary	131	UINT32	R/W	PSS Primary Switch 1 GG	No Unit	Disabled=0 Enabled=1
PSS Control Primary	131	UINT32	R/W	PSS Primary Switch 5 GG	No Unit	Exclude=0 Include=1
PSS Control Primary	131	UINT32	R/W	PSS Primary Switch GG	No Unit	Exclude=0 Include=1
PSS Control Primary	131	UINT32	R/W	PSS Primary Switch 6 GG	No Unit	Disabled=0 Enabled=1
PSS Control Primary	131	UINT32	R/W	PSS Primary Switch 8 GG	No Unit	Disabled=0 Enabled=1
PSS Control Primary	131	UINT32	R/W	PSS Primary Switch 7 GG	No Unit	OFF=0 ON=1
PSS Control Primary	131	UINT32	R/W	PSS Primary Switch 2 GG	No Unit	Disabled=0 Enabled=1
PSS Control Primary	132	Float	R/W	PSS Primary Power On Threshold GG	No Unit	0 - 1
PSS Control Primary	132	Float	R/W	PSS Primary Power Hysteresis GG	No Unit	0 - 1
PSS Control Secondary	133	UINT32	R/W	PSS Sec Switch 10 GG	No Unit	Disabled=0 Enabled=1
PSS Control Secondary	133	UINT32	R/W	PSS Sec Switch 11 GG	No Unit	Disabled=0 Enabled=1
PSS Control Secondary	133	UINT32	R/W	PSS Sec Switch 3 GG	No Unit	Frequency=0 Der. Speed=1
PSS Control Secondary	133	UINT32	R/W	PSS Sec Switch 4 GG	No Unit	Power=0 Der. Freq/Speed=1
PSS Control Secondary	133	UINT32	R/W	PSS Sec Switch 0 GG	No Unit	Disabled=0 Enabled=1
PSS Control Secondary	133	UINT32	R/W	PSS Sec Switch 1 GG	No Unit	Disabled=0 Enabled=1
PSS Control Secondary	133	UINT32	R/W	PSS Sec Switch 5 GG	No Unit	Exclude=0 Include=1
PSS Control Secondary	133	UINT32	R/W	PSS Sec Switch 9 GG	No Unit	Exclude=0 Include=1
PSS Control Secondary	133	UINT32	R/W	PSS Sec Switch 6 GG	No Unit	Disabled=0 Enabled=1
PSS Control Secondary	133	UINT32	R/W	PSS Sec Switch 8 GG	No Unit	Disabled=0 Enabled=1
PSS Control Secondary	133	UINT32	R/W	PSS Sec Switch 7 GG	No Unit	OFF=0 ON=1
PSS Control Secondary	133	UINT32	R/W	PSS Sec Switch 2 GG	No Unit	Disabled=0 Enabled=1
PSS Control Secondary	134	Float	R/W	PSS Sec Power On Threshold GG	No Unit	0 - 1
PSS Control Secondary	134	Float	R/W	PSS Sec Power Hysteresis GG	No Unit	0 - 1
PSS Filter Parameter Primary Int	135	UINT32	R/W	PSS Primary Ramp Fit M GG	No Unit	1 - 5
PSS Filter Parameter Primary Int	135	UINT32	R/W	PSS Primary Ramp Fit N GG	No Unit	0 - 1
PSS Filter Parameter Primary Float	136	Float	R/W	PSS Primary Tlpf 1 GG	Sec	0 - 20
PSS Filter Parameter Primary Float	136	Float	R/W	PSS Primary Tlpf 2 GG	Sec	1 - 20
PSS Filter Parameter Primary Float	136	Float	R/W	PSS Primary Tlpf 3 GG	Sec	0.05 - 0.2
PSS Filter Parameter Primary Float	136	Float	R/W	PSS Primary Tr GG	Sec	0.05 - 1
PSS Filter Parameter Primary Float	136	Float	R/W	PSS Primary Tw 1 GG	Sec	1 - 20
PSS Filter Parameter Primary Float	136	Float	R/W	PSS Primary Tw 2 GG	Sec	1 - 20
PSS Filter Parameter Primary Float	136	Float	R/W	PSS Primary Tw 3 GG	Sec	1 - 20

Instance Name	Inst. #	Type	RW	Key Name	Unit	Range
PSS Filter Parameter Primary Float	136	Float	R/W	PSS Primary Tw 4 GG	Sec	1 - 20
PSS Filter Parameter Primary Float	136	Float	R/W	PSS Primary H GG	No Unit	0.01 - 25
PSS Parameter Primary Float	138	Float	R/W	PSS Primary Zn 1 GG	No Unit	0 - 1
PSS Parameter Primary Float	138	Float	R/W	PSS Primary Zn 2 GG	No Unit	0 - 1
PSS Parameter Primary Float	138	Float	R/W	PSS Primary Zd 1 GG	No Unit	0 - 1
PSS Parameter Primary Float	138	Float	R/W	PSS Primary Zd 2 GG	No Unit	0 - 1
PSS Parameter Primary Float	138	Float	R/W	PSS Primary Wn 1 GG	No Unit	10 - 150
PSS Parameter Primary Float	138	Float	R/W	PSS Primary Wn 2 GG	No Unit	10 - 150
PSS Parameter Primary Float	138	Float	R/W	PSS Primary Xq GG	No Unit	0 - 5
PSS Parameter Primary Float	138	Float	R/W	PSS Primary Kpe GG	No Unit	0 - 2
PSS Parameter Primary Phase Comp Float	140	Float	R/W	PSS Primary T1 GG	Sec	0.001 - 6
PSS Parameter Primary Phase Comp Float	140	Float	R/W	PSS Primary T2 GG	Sec	0.001 - 6
PSS Parameter Primary Phase Comp Float	140	Float	R/W	PSS Primary T3 GG	Sec	0.001 - 6
PSS Parameter Primary Phase Comp Float	140	Float	R/W	PSS Primary T4 GG	Sec	0.001 - 6
PSS Parameter Primary Phase Comp Float	140	Float	R/W	PSS Primary T5 GG	Sec	0.001 - 6
PSS Parameter Primary Phase Comp Float	140	Float	R/W	PSS Primary T6 GG	Sec	0.001 - 6
PSS Parameter Primary Phase Comp Float	140	Float	R/W	PSS Primary T7 GG	Sec	0.001 - 6
PSS Parameter Primary Phase Comp Float	140	Float	R/W	PSS Primary T8 GG	Sec	0.001 - 6
PSS Parameter Secondary Filters Int	141	UINT32	R/W	PSS Secondary Ramp Flt M GG	No Unit	1 - 5
PSS Parameter Secondary Filters Int	141	UINT32	R/W	PSS Secondary Ramp Flt N GG	No Unit	0 - 1
PSS Parameter Secondary Filters Float	142	Float	R/W	PSS Secondary Tlpf 1 GG	Sec	0 - 20
PSS Parameter Secondary Filters Float	142	Float	R/W	PSS Secondary Tlpf 2 GG	Sec	1 - 20
PSS Parameter Secondary Filters Float	142	Float	R/W	PSS Secondary Tlpf 3 GG	Sec	0.05 - 0.2
PSS Parameter Secondary Filters Float	142	Float	R/W	PSS Secondary Tr GG	Sec	0.05 - 1
PSS Parameter Secondary Filters Float	142	Float	R/W	PSS Secondary Tw1 GG	Sec	1 - 20
PSS Parameter Secondary Filters Float	142	Float	R/W	PSS Secondary Tw2 GG	Sec	1 - 20
PSS Parameter Secondary Filters Float	142	Float	R/W	PSS Secondary Tw3 GG	Sec	1 - 20
PSS Parameter Secondary Filters Float	142	Float	R/W	PSS Secondary Tw4 GG	Sec	1 - 20
PSS Parameter Secondary Float	144	Float	R/W	PSS Secondary Zn1 GG	No Unit	0 - 1
PSS Parameter Secondary Float	144	Float	R/W	PSS Secondary Zn2 GG	No Unit	0 - 1
PSS Parameter Secondary Float	144	Float	R/W	PSS Secondary Zd1 GG	No Unit	0 - 1

Instance Name	Inst. #	Type	RW	Key Name	Unit	Range
PSS Parameter Secondary Float	144	Float	R/W	PSS Secondary Zd2 GG	No Unit	0 - 1
PSS Parameter Secondary Float	144	Float	R/W	PSS Secondary Wn1 GG	No Unit	10 - 150
PSS Parameter Secondary Float	144	Float	R/W	PSS Secondary Wn2 GG	No Unit	10 - 150
PSS Parameter Secondary Float	144	Float	R/W	PSS Secondary Xq GG	No Unit	0 - 5
PSS Parameter Secondary Float	144	Float	R/W	PSS Secondary Kpe GG	No Unit	0 - 2
PSS Parameter Secondary Phase Comp Float	146	Float	R/W	PSS Secondary T1 GG	Sec	0.001 - 6
PSS Parameter Secondary Phase Comp Float	146	Float	R/W	PSS Secondary T2 GG	Sec	0.001 - 6
PSS Parameter Secondary Phase Comp Float	146	Float	R/W	PSS Secondary T3 GG	Sec	0.001 - 6
PSS Parameter Secondary Phase Comp Float	146	Float	R/W	PSS Secondary T4 GG	Sec	0.001 - 6
PSS Parameter Secondary Phase Comp Float	146	Float	R/W	PSS Secondary T5 GG	Sec	0.001 - 6
PSS Parameter Secondary Phase Comp Float	146	Float	R/W	PSS Secondary T6 GG	Sec	0.001 - 6
PSS Parameter Secondary Phase Comp Float	146	Float	R/W	PSS Secondary T7 GG	Sec	0.001 - 6
PSS Parameter Secondary Phase Comp Float	146	Float	R/W	PSS Secondary T8 GG	Sec	0.001 - 6
PSS Output Limiter Primary	148	Float	R/W	PSS Primary Limit Plus GG	No Unit	0 - 0.5
PSS Output Limiter Primary	148	Float	R/W	PSS Primary Limit Minus GG	No Unit	-0.5 - 0
PSS Output Limiter Primary	148	Float	R/W	PSS Primary Ks GG	No Unit	-100 - 100
PSS Output Limiter Primary	148	Float	R/W	PSS Primary Et Lmt Tlpf GG	Sec	0.02 - 5
PSS Output Limiter Primary	148	Float	R/W	PSS Primary Et Lmt Vref GG	No Unit	0 - 10
PSS Output Limiter Primary	148	Float	R/W	PSS Primary Tw5 Normal GG	No Unit	5 - 30
PSS Output Limiter Primary	148	Float	R/W	PSS Primary Tw5 Limit GG	No Unit	0 - 1
PSS Output Limiter Primary	148	Float	R/W	PSS Primary Lmt Vhi GG	No Unit	0.01 - 0.04
PSS Output Limiter Primary	148	Float	R/W	PSS Primary Lmt Vlo GG	No Unit	-0.04 - -0.01
PSS Output Limiter Primary	148	Float	R/W	PSS Primary Lmt T Delay GG	No Unit	0 - 2
PSS Output Limiter Secondary	150	Float	R/W	PSS Secondary Limit Plus GG	No Unit	0 - 0.5
PSS Output Limiter Secondary	150	Float	R/W	PSS Secondary Limit Minus GG	No Unit	-0.5 - 0
PSS Output Limiter Secondary	150	Float	R/W	PSS Secondary Ks GG	No Unit	-100 - 100
PSS Output Limiter Secondary	150	Float	R/W	PSS Secondary Et Lmt Tlpf GG	Sec	0.02 - 5
PSS Output Limiter Secondary	150	Float	R/W	PSS Secondary Et Lmt Vref GG	No Unit	0 - 10
PSS Output Limiter Secondary	150	Float	R/W	PSS Secondary Tw5 Normal GG	No Unit	5 - 30
PSS Output Limiter Secondary	150	Float	R/W	PSS Secondary Tw5 Limit GG	No Unit	0 - 1
PSS Output Limiter Secondary	150	Float	R/W	PSS Secondary Lmt Vhi GG	No Unit	0.01 - 0.04
PSS Output Limiter Secondary	150	Float	R/W	PSS Secondary LmtVlo GG	No Unit	-0.04 - -0.01
PSS Output Limiter Secondary	150	Float	R/W	PSS Secondary Lmt T Delay GG	No Unit	0 - 2

Instance Name	Inst. #	Type	RW	Key Name	Unit	Range
Synchronizer	151	UINT32	R/W	Sync Type GG	No Unit	Anticipatory=0 Phase Lock Loop=1
Synchronizer	151	UINT32	R/W	Fgen GT Fbus GG	No Unit	Disabled=0 Enabled=1
Synchronizer	151	UINT32	R/W	Vgen GT Vbus GG	No Unit	Disabled=0 Enabled=1
Synchronizer	152	Float	R/W	Slip Frequency GG	Hz	0.1 - 0.5
Synchronizer	152	Float	R/W	Voltage Window GG	%	2 - 15
Synchronizer	152	Float	R/W	Breaker Closing Angle GG	Deg	3 - 20
Synchronizer	152	Float	R/W	Sync Activation Delay GG	Sec	0.1 - 0.8
Synchronizer	152	Float	R/W	Sync Fail Activation Delay GG	Sec	0.1 - 600
Synchronizer	152	Float	R/W	Sync Speed Gain GG	No Unit	0.001 - 1000
Synchronizer	152	Float	R/W	Sync Voltage Gain GG	No Unit	0.001 - 1000
Voltage Matching	153	UINT32	R/W	Sys Option Input Volt Match Enabled GG	No Unit	Disabled=0 Enabled=1
Voltage Matching	154	Float	R/W	Sys Option Voltage Match Band GG	%	0 - 20
Voltage Matching	154	Float	R/W	Sys Option Voltage Match Ref GG	%	0 - 700
Breaker Hardware	155	UINT32	R/W	Gen Breaker GG	No Unit	Not Configured=0 Configured=1
Breaker Hardware	155	UINT32	R/W	Gen Contact Type GG	No Unit	Pulse=0 Continuous=1
Breaker Hardware	155	UINT32	R/W	Dead Bus Close Enable GG	No Unit	Disabled=0 Enabled=1
Breaker Hardware	155	UINT32	R/W	Dead Gen Close Enable GG	No Unit	Disabled=0 Enabled=1
Breaker Hardware	156	Float	R/W	Breaker Close Wait Time GG	Sec	0.1 - 600
Breaker Hardware	156	Float	R/W	Gen Open Pulse Time GG	Sec	0.01 - 5
Breaker Hardware	156	Float	R/W	Gen Close Pulse Time GG	Sec	0.01 - 5
Bus Condition Detection (Gen Sensing)	158	Float	R/W	Dead Gen Threshold GG	V	0 - 600000
Bus Condition Detection (Gen Sensing)	158	Float	R/W	Dead Gen Time Delay GG	Sec	0.1 - 600
Bus Condition Detection (Gen Sensing)	158	Float	R/W	Gen Stable Over Voltage Pickup GG	V	10 - 600000
Bus Condition Detection (Gen Sensing)	158	Float	R/W	Gen Stable Over Voltage Dropout GG	V	10 - 600000
Bus Condition Detection (Gen Sensing)	158	Float	R/W	Gen Stable Under Voltage Pickup GG	V	10 - 600000
Bus Condition Detection (Gen Sensing)	158	Float	R/W	Gen Stable Under Voltage Dropout GG	V	10 - 600000
Bus Condition Detection (Gen Sensing)	158	Float	R/W	Gen Stable Over Frequency Pickup GG	Hz	46 - 64
Bus Condition Detection (Gen Sensing)	158	Float	R/W	Gen Stable Over Frequency Dropout GG	Hz	46 - 64
Bus Condition Detection (Gen Sensing)	158	Float	R/W	Gen Stable Under Frequency Pickup GG	Hz	46 - 64
Bus Condition Detection (Gen Sensing)	158	Float	R/W	Gen Stable Under Frequency Dropout GG	Hz	46 - 64
Bus Condition Detection (Gen Sensing)	158	Float	R/W	Gen Stable Activation Delay GG	Sec	0.1 - 600
Bus Condition Detection (Gen Sensing)	158	Float	R/W	Gen Failed Activation Delay GG	Sec	0.1 - 600
Bus Condition Detection (Gen Sensing)	158	Float	R/W	Gen Stable Low Line Scale Factor GG	No Unit	0.001 - 3

Instance Name	Inst. #	Type	R/W	Key Name	Unit	Range
Bus Condition Detection (Gen Sensing)	158	Float	R/W	Gen Stable Alternate Frequency Scale Factor GG	No Unit	0.001 - 100
Bus Condition Detection (Bus Sensing)	160	Float	R/W	Dead Bus Threshold GG	V	0 - 600000
Bus Condition Detection (Bus Sensing)	160	Float	R/W	Dead Bus Time Delay GG	Sec	0.1 - 600
Bus Condition Detection (Bus Sensing)	160	Float	R/W	Bus S table Over Voltage Pickup GG	V	10 - 600000
Bus Condition Detection (Bus Sensing)	160	Float	R/W	Bus Stable Over Voltage Dropout GG	V	10 - 600000
Bus Condition Detection (Bus Sensing)	160	Float	R/W	Bus Stable Under Voltage Pickup GG	V	10 - 600000
Bus Condition Detection (Bus Sensing)	160	Float	R/W	Bus Stable Under Voltage Dropout GG	V	10 - 600000
Bus Condition Detection (Bus Sensing)	160	Float	R/W	Bus Stable Over Frequency Pickup GG	Hz	46 - 64
Bus Condition Detection (Bus Sensing)	160	Float	R/W	Bus Stable Over Frequency Dropout GG	Hz	46 - 64
Bus Condition Detection (Bus Sensing)	160	Float	R/W	Bus Stable Under Frequency Pickup GG	Hz	46 - 64
Bus Condition Detection (Bus Sensing)	160	Float	R/W	Bus Stable Under Frequency Dropout GG	Hz	46 - 64
Bus Condition Detection (Bus Sensing)	160	Float	R/W	Bus Stable Activation Delay GG	Sec	0.1 - 600
Bus Condition Detection (Bus Sensing)	160	Float	R/W	Bus Failed Activation Delay GG	Sec	0.1 - 600
Bus Condition Detection (Bus Sensing)	160	Float	R/W	Bus Stable Low Line Scale Factor GG	No Unit	0.001 - 3
Bus Condition Detection (Bus Sensing)	160	Float	R/W	Bus Stable Alternate Frequency Scale Factor GG	No Unit	0.001 - 100
Governor Bias Control	161	UINT32	R/W	Control Contact Type GG	No Unit	Continuous=0 Proportional=1
Governor Bias Control	162	Float	R/W	Correction Pulse Width GG	Sec	0 - 99.9
Governor Bias Control	162	Float	R/W	Correction Pulse Interval GG	Sec	0 - 99.9
Gen Undervoltage	163	UINT32	R/W	Mode PP	No Unit	Disabled=0 Enabled=1
Gen Undervoltage	163	UINT32	R/W	Mode PS	No Unit	Disabled=0 Enabled=1
Gen Undervoltage	164	Float	R/W	Pickup PP	V	1 - 600000
Gen Undervoltage	164	Float	R/W	Time Delay PP	ms	100 - 60000
Gen Undervoltage	164	Float	R/W	Pickup PS	V	1 - 600000
Gen Undervoltage	164	Float	R/W	Time Delay PS	ms	100 - 60000
Gen Undervoltage	165	UINT32	R/W	Mode PP	No Unit	Disabled=0 Enabled=1
Gen Undervoltage	165	UINT32	R/W	Mode PS	No Unit	Disabled=0 Enabled=1
Gen Undervoltage	166	Float	R/W	Pickup PP	V	0 - 600000
Gen Undervoltage	166	Float	R/W	Time Delay PP	ms	100 - 60000
Gen Undervoltage	166	Float	R/W	Pickup PS	V	0 - 600000
Gen Undervoltage	166	Float	R/W	Time Delay PS	ms	100 - 60000
Loss of Sensing	167	UINT32	R/W	Mode GG	No Unit	Disabled=0 Enabled=1
Loss of Sensing	167	UINT32	R/W	Sys Option No Sense To Manual Mode GG	No Unit	Disabled=0 Enabled=1

Instance Name	Inst. #	Type	RW	Key Name	Unit	Range
Loss of Sensing	168	Float	R/W	Time Delay GG	Sec	0 - 30
Loss of Sensing	168	Float	R/W	Voltage Balanced Level GG	%	0 - 100
Loss of Sensing	168	Float	R/W	Voltage Unbalanced Level GG	%	0 - 100
81O	169	UINT32	R/W	Mode PP	No Unit	Disabled=0 Over=1
81O	169	UINT32	R/W	Mode PS	No Unit	Disabled=0 Over=1
81O	170	Float	R/W	Pickup PP	Hz	30 - 70
81O	170	Float	R/W	Time Delay PP	ms	100 - 300000
81O	170	Float	R/W	Pickup PS	Hz	30 - 70
81O	170	Float	R/W	Time Delay PS	ms	100 - 300000
81O	170	Float	R/W	Voltage Inhibit PP	%	5 - 100
81O	170	Float	R/W	Voltage Inhibit PS	%	5 - 100
81U	171	UINT32	R/W	Mode PP	No Unit	Disabled=0 Under=2
81U	171	UINT32	R/W	Mode PS	No Unit	Disabled=0 Under=2
81U	172	Float	R/W	Pickup PP	Hz	30 - 70
81U	172	Float	R/W	Time Delay PP	ms	100 - 300000
81U	172	Float	R/W	Voltage Inhibit PP	%	5 - 100
81U	172	Float	R/W	Pickup PS	Hz	30 - 70
81U	172	Float	R/W	Time Delay PS	ms	5 - 300000
81U	172	Float	R/W	Voltage Inhibit PS	%	50 - 100
Reverse Power	173	UINT32	R/W	Mode PP	No Unit	Disabled=0 Enabled=4
Reverse Power	173	UINT32	R/W	Mode PS	No Unit	Disabled=0 Enabled=4
Reverse Power	174	Float	R/W	Pickup PP	%	0 - 150
Reverse Power	174	Float	R/W	Pickup PS	%	0 - 150
Reverse Power	174	Float	R/W	Time Delay PP	ms	0 - 300000
Reverse Power	174	Float	R/W	Time Delay PS	ms	0 - 300000
Loss of Excitation	175	UINT32	R/W	Mode PP	No Unit	Disabled=0 Enabled=1
Loss of Excitation	175	UINT32	R/W	Mode PS	No Unit	Disabled=0 Enabled=1
Loss of Excitation	176	Float	R/W	Pickup PP	%	0 - 150
Loss of Excitation	176	Float	R/W	Time Delay PP	ms	0 - 300000
Loss of Excitation	176	Float	R/W	Pickup PS	%	0 - 150
Loss of Excitation	176	Float	R/W	Time Delay PS	ms	0 - 300000
Field Overvoltage	177	UINT32	R/W	Mode PP	No Unit	Disabled=0 Enabled=1
Field Overvoltage	177	UINT32	R/W	Mode PS	No Unit	Disabled=0 Enabled=1
Field Overvoltage	178	Float	R/W	Pickup PP	V	1 - 325
Field Overvoltage	178	Float	R/W	Time Delay PP	ms	200 - 30000
Field Overvoltage	178	Float	R/W	Pickup PS	V	1 - 325
Field Overvoltage	178	Float	R/W	Time Delay PS	ms	200 - 30000
Field Overcurrent	179	UINT32	R/W	Mode PP	No Unit	Disabled=0 Enabled=1
Field Overcurrent	179	UINT32	R/W	Mode PS	No Unit	Disabled=0 Enabled=1
Field Overcurrent	180	Float	R/W	Pickup PP	Amp	0 - 22
Field Overcurrent	180	Float	R/W	Time Delay PP	ms	5000 - 60000
Field Overcurrent	180	Float	R/W	Pickup PS	Amp	0 - 22
Field Overcurrent	180	Float	R/W	Time Delay PS	ms	5000 - 60000
Power Input Failure	181	UINT32	R/W	Mode GG	No Unit	Disabled=0 Enabled=1
Power Input Failure	182	Float	R/W	Time Delay GG	Sec	0 - 10
Exciter Diode Monitor	183	UINT32	R/W	Exciter Open Diode Enable GG	No Unit	Disabled=0 Enabled=1
Exciter Diode Monitor	183	UINT32	R/W	Exciter Shorted Diode Enable GG	No Unit	Disabled=0 Enabled=1

Instance Name	Inst. #	Type	RW	Key Name	Unit	Range
Exciter Diode Monitor	184	Float	R/W	Exciter Diode Inhibit Threshold GG	%	0 - 100
Exciter Diode Monitor	184	Float	R/W	Exciter Open Diode Pickup GG	%	0 - 100
Exciter Diode Monitor	184	Float	R/W	Exciter Open Diode Time Delay GG	Sec	10 - 60
Exciter Diode Monitor	184	Float	R/W	Exciter Shorted Diode Pickup GG	%	0 - 100
Exciter Diode Monitor	184	Float	R/W	Exciter Shorted Diode Time Delay GG	Sec	5 - 30
Exciter Diode Monitor	184	Float	R/W	Exciter Pole Ratio GG	No Unit	1 - 10
Sync Check	185	UINT32	R/W	Mode GG	No Unit	Disabled=0 Enabled=1
Sync Check	186	Float	R/W	Phase Angle GG	Deg	1 - 99
Sync Check	186	Float	R/W	Slip Freq GG	Hz	0.01 - 0.5
Sync Check	186	Float	R/W	Volt Mag Error Percent GG	%	0.1 - 50
Config Protection 1	187	UINT32	R/W	Param Selection GG	No Unit	Gen VAB=0 Gen VBC=1 Gen VCA=2 Gen V Average=3 Bus Freq=4 Bus VAB=5 Bus VBC=6 Bus VCA=7 Gen Freq=8 Gen PF=9 KWH=10 KVARH=11 Gen IA=12 Gen IB=13 Gen IC=14 Gen I Average=15 KW Total=16 KVA Total=17 KVAR Total=18 EDM Ripple=19 Exciter Field Voltage=20 Exciter Field Current=21 Auxiliary Input Voltage=22 Auxiliary Input Current (mA)=23 Setpoint Position=24 Tracking Error=25 Neg Seq V=26 Neg Seq I=27 Pos Seq V=28 Pos Seq I=29 PSS Output=30 Analog Input 1=31 Analog Input 2=32 Analog Input 3=33 Analog Input 4=34 Analog Input 5=35 Analog Input 6=36 Analog Input 7=37 Analog Input 8=38 RTD Input 1=39 RTD Input 2=40 RTD Input 3=41 RTD Input 4=42 RTD Input 5=43 RTD Input 6=44 RTD Input 7=45 RTD Input 8=46 Thermocouple 1=47 Thermocouple 2=48 Power Input=49 Network Load Share Error Percent=50 Gen Scaled PF=51 APC Output=52 LVRT Output=53
Config Protection 1	187	UINT32	R/W	Stop Mode Inhibit GG	No Unit	NO=0 YES=1
Config Protection 1	187	UINT32	R/W	Threshold 1 Type GG	No Unit	Disabled=0 Over=1 Under=2
Config Protection 1	187	UINT32	R/W	Threshold 2 Type GG	No Unit	Disabled=0 Over=1 Under=2
Config Protection 1	187	UINT32	R/W	Threshold 3 Type GG	No Unit	Disabled=0 Over=1 Under=2
Config Protection 1	187	UINT32	R/W	Threshold 4 Type GG	No Unit	Disabled=0 Over=1 Under=2
Config Protection 1	188	Float	R/W	Hysteresis GG	%	0 - 100
Config Protection 1	188	Float	R/W	Arming Delay GG	Sec	0 - 300
Config Protection 1	188	Float	R/W	Threshold 1 Pickup GG	No Unit	-999999 - 999999
Config Protection 1	188	Float	R/W	Threshold 1 Activation Delay GG	Sec	0 - 300
Config Protection 1	188	Float	R/W	Threshold 2 Pickup GG	No Unit	-999999 - 999999
Config Protection 1	188	Float	R/W	Threshold 2 Activation Delay GG	Sec	0 - 300
Config Protection 1	188	Float	R/W	Threshold 3 Pickup GG	No Unit	-999999 - 999999
Config Protection 1	188	Float	R/W	Threshold 3 Activation Delay GG	Sec	0 - 300
Config Protection 1	188	Float	R/W	Threshold 4 Pickup GG	No Unit	-999999 - 999999
Config Protection 1	188	Float	R/W	Threshold 4 Activation Delay GG	Sec	0 - 300

Instance Name	Inst. #	Type	RW	Key Name	Unit	Range
Config Protection 2	189	UINT32	R/W	Param Selection GG	No Unit	Gen VAB=0 Gen VBC=1 Gen VCA=2 Gen V Average=3 Bus Freq=4 Bus VAB=5 Bus VBC=6 Bus VCA=7 Gen Freq=8 Gen PF=9 KWH=10 KVARH=11 Gen IA=12 Gen IB=13 Gen IC=14 Gen I Average=15 KW Total=16 KVA Total=17 KVAR Total=18 EDM Ripple=19 Exciter Field Voltage=20 Exciter Field Current=21 Auxiliary Input Voltage=22 Auxiliary Input Current (mA)=23 Setpoint Position=24 Tracking Error=25 Neg Seq V=26 Neg Seq I=27 Pos Seq V=28 Pos Seq I=29 PSS Output=30 Analog Input 1=31 Analog Input 2=32 Analog Input 3=33 Analog Input 4=34 Analog Input 5=35 Analog Input 6=36 Analog Input 7=37 Analog Input 8=38 RTD Input 1=39 RTD Input 2=40 RTD Input 3=41 RTD Input 4=42 RTD Input 5=43 RTD Input 6=44 RTD Input 7=45 RTD Input 8=46 Thermocouple 1=47 Thermocouple 2=48 Power Input=49 Network Load Share Error Percent=50 Gen Scaled PF=51 APC Output=52 LVRT Output=53
Config Protection 2	189	UINT32	R/W	Stop Mode Inhibit GG	No Unit	NO=0 YES=1
Config Protection 2	189	UINT32	R/W	Threshold 1Type GG	No Unit	Disabled=0 Over=1 Under=2
Config Protection 2	189	UINT32	R/W	Threshold 2Type GG	No Unit	Disabled=0 Over=1 Under=2
Config Protection 2	189	UINT32	R/W	Threshold 3Type GG	No Unit	Disabled=0 Over=1 Under=2
Config Protection 2	189	UINT32	R/W	Threshold 4Type GG	No Unit	Disabled=0 Over=1 Under=2
Config Protection 2	190	Float	R/W	Hysteresis GG	%	0 - 100
Config Protection 2	190	Float	R/W	Arming Delay GG	Sec	0 - 300
Config Protection 2	190	Float	R/W	Threshold1Pickup GG	No Unit	-999999 - 999999
Config Protection 2	190	Float	R/W	Threshold 1 Activation Delay GG	Sec	0 - 300
Config Protection 2	190	Float	R/W	Threshold 2 Pickup GG	No Unit	-999999 - 999999
Config Protection 2	190	Float	R/W	Threshold 2 Activation Delay GG	Sec	0 - 300
Config Protection 2	190	Float	R/W	Threshold 3 Pickup GG	No Unit	-999999 - 999999
Config Protection 2	190	Float	R/W	Threshold 3 Activation Delay GG	Sec	0 - 300
Config Protection 2	190	Float	R/W	Threshold 4 Pickup GG	No Unit	-999999 - 999999
Config Protection 2	190	Float	R/W	Threshold 4 Activation Delay GG	Sec	0 - 300

Instance Name	Inst. #	Type	RW	Key Name	Unit	Range
Config Protection 3	191	UINT32	R/W	Param Selection GG	No Unit	Gen VAB=0 Gen VBC=1 Gen VCA=2 Gen V Average=3 Bus Freq=4 Bus VAB=5 Bus VBC=6 Bus VCA=7 Gen Freq=8 Gen PF=9 KWH=10 KVARH=11 Gen IA=12 Gen IB=13 Gen IC=14 Gen I Average=15 KW Total=16 KVA Total=17 KVAR Total=18 EDM Ripple=19 Exciter Field Voltage=20 Exciter Field Current=21 Auxiliary Input Voltage=22 Auxiliary Input Current (mA)=23 Setpoint Position=24 Tracking Error=25 Neg Seq V=26 Neg Seq I=27 Pos Seq V=28 Pos Seq I=29 PSS Output=30 Analog Input 1=31 Analog Input 2=32 Analog Input 3=33 Analog Input 4=34 Analog Input 5=35 Analog Input 6=36 Analog Input 7=37 Analog Input 8=38 RTD Input 1=39 RTD Input 2=40 RTD Input 3=41 RTD Input 4=42 RTD Input 5=43 RTD Input 6=44 RTD Input 7=45 RTD Input 8=46 Thermocouple 1=47 Thermocouple 2=48 Power Input=49 Network Load Share Error Percent=50 Gen Scaled PF=51 APC Output=52 LVRT Output=53
Config Protection 3	191	UINT32	R/W	Stop Mode Inhibit GG	No Unit	No=0 Yes=1
Config Protection 3	191	UINT32	R/W	Threshold 1 Type GG	No Unit	Disabled=0 Over=1 Under=2
Config Protection 3	191	UINT32	R/W	Threshold 2 Type GG	No Unit	Disabled=0 Over=1 Under=2
Config Protection 3	191	UINT32	R/W	Threshold 3 Type GG	No Unit	Disabled=0 Over=1 Under=2
Config Protection 3	191	UINT32	R/W	Threshold 4 Type GG	No Unit	Disabled=0 Over=1 Under=2
Config Protection 3	192	Float	R/W	Hysteresis GG	%	0 - 100
Config Protection 3	192	Float	R/W	Arming Delay GG	Sec	0 - 300
Config Protection 3	192	Float	R/W	Threshold 1 Pickup GG	No Unit	-999999 - 999999
Config Protection 3	192	Float	R/W	Threshold 1 Activation Delay GG	Sec	0 - 300
Config Protection 3	192	Float	R/W	Threshold 2 Pickup GG	No Unit	-999999 - 999999
Config Protection 3	192	Float	R/W	Threshold 2 Activation Delay GG	Sec	0 - 300
Config Protection 3	192	Float	R/W	Threshold 3 Pickup GG	No Unit	-999999 - 999999
Config Protection 3	192	Float	R/W	Threshold 3 Activation Delay GG	Sec	0 - 300
Config Protection 3	192	Float	R/W	Threshold 4 Pickup GG	No Unit	-999999 - 999999
Config Protection 3	192	Float	R/W	Threshold 4 Activation Delay GG	Sec	0 - 300

Instance Name	Inst. #	Type	RW	Key Name	Unit	Range
Config Protection 4	193	UINT32	R/W	Param Selection GG	No Unit	Gen VAB=0 Gen VBC=1 Gen VCA=2 Gen V Average=3 Bus Freq=4 Bus VAB=5 Bus VBC=6 Bus VCA=7 Gen Freq=8 Gen PF=9 KWH=10 KVARH=11 Gen IA=12 Gen IB=13 Gen IC=14 Gen I Average=15 KW Total=16 KVA Total=17 KVAR Total=18 EDM Ripple=19 Exciter Field Voltage=20 Exciter Field Current=21 Auxiliary Input Voltage=22 Auxiliary Input Current (mA)=23 Setpoint Position=24 Tracking Error=25 Neg Seq V=26 Neg Seq I=27 Pos Seq V=28 Pos Seq I=29 PSS Output=30 Analog Input 1=31 Analog Input 2=32 Analog Input 3=33 Analog Input 4=34 Analog Input 5=35 Analog Input 6=36 Analog Input 7=37 Analog Input 8=38 RTD Input 1=39 RTD Input 2=40 RTD Input 3=41 RTD Input 4=42 RTD Input 5=43 RTD Input 6=44 RTD Input 7=45 RTD Input 8=46 Thermocouple 1=47 Thermocouple 2=48 Power Input=49 Network Load Share Error Percent=50 Gen Scaled PF=51 APC Output=52 LVRT Output=53
Config Protection 4	193	UINT32	R/W	Stop Mode Inhibit GG	No Unit	No=0 Yes=1
Config Protection 4	193	UINT32	R/W	Threshold 1 Type GG	No Unit	Disabled=0 Over=1 Under=2
Config Protection 4	193	UINT32	R/W	Threshold 2 Type GG	No Unit	Disabled=0 Over=1 Under=2
Config Protection 4	193	UINT32	R/W	Threshold 3 Type GG	No Unit	Disabled=0 Over=1 Under=2
Config Protection 4	193	UINT32	R/W	Threshold4 Type GG	No Unit	Disabled=0 Over=1 Under=2
Config Protection 4	194	Float	R/W	Hysteresis GG	%	0 - 100
Config Protection 4	194	Float	R/W	Arming Delay GG	Sec	0 - 300
Config Protection 4	194	Float	R/W	Threshold 1 Pickup GG	No Unit	-999999 - 999999
Config Protection 4	194	Float	R/W	Threshold 1 Activation Delay GG	Sec	0 - 300
Config Protection 4	194	Float	R/W	Threshold 2 Pickup GG	No Unit	-999999 - 999999
Config Protection 4	194	Float	R/W	Threshold 2 Activation Delay GG	Sec	0 - 300
Config Protection 4	194	Float	R/W	Threshold 3 Pickup GG	No Unit	-999999 - 999999
Config Protection 4	194	Float	R/W	Threshold 3 Activation Delay GG	Sec	0 - 300
Config Protection 4	194	Float	R/W	Threshold 4 Pickup GG	No Unit	-999999 - 999999
Config Protection 4	194	Float	R/W	Threshold 4 Activation Delay GG	Sec	0 - 300

Instance Name	Inst. #	Type	RW	Key Name	Unit	Range
Config Protection 5	195	UINT32	R/W	Param Selection GG	No Unit	Gen VAB=0 Gen VBC=1 Gen VCA=2 Gen V Average=3 Bus Freq=4 Bus VAB=5 Bus VBC=6 Bus VCA=7 Gen Freq=8 Gen PF=9 KWH=10 KVARH=11 Gen IA=12 Gen IB=13 Gen IC=14 Gen I Average=15 KW Total=16 KVA Total=17 KVAR Total=18 EDM Ripple=19 Exciter Field Voltage=20 Exciter Field Current=21 Auxiliary Input Voltage=22 Auxiliary Input Current (mA)=23 Setpoint Position=24 Tracking Error=25 Neg Seq V=26 Neg Seq I=27 Pos Seq V=28 Pos Seq I=29 PSS Output=30 Analog Input 1=31 Analog Input 2=32 Analog Input 3=33 Analog Input 4=34 Analog Input 5=35 Analog Input 6=36 Analog Input 7=37 Analog Input 8=38 RTD Input 1=39 RTD Input 2=40 RTD Input 3=41 RTD Input 4=42 RTD Input 5=43 RTD Input 6=44 RTD Input 7=45 RTD Input 8=46 Thermocouple 1=47 Thermocouple 2=48 Power Input=49 Network Load Share Error Percent=50 Gen Scaled PF=51 APC Output=52 LVRT Output=53
Config Protection 5	195	UINT32	R/W	Stop Mode Inhibit GG	No Unit	No=0 Yes=1
Config Protection 5	195	UINT32	R/W	Threshold 1 Type GG	No Unit	Disabled=0 Over=1 Under=2
Config Protection 5	195	UINT32	R/W	Threshold 2 Type GG	No Unit	Disabled=0 Over=1 Under=2
Config Protection 5	195	UINT32	R/W	Threshold 3 Type GG	No Unit	Disabled=0 Over=1 Under=2
Config Protection 5	195	UINT32	R/W	Threshold 4 Type GG	No Unit	Disabled=0 Over=1 Under=2
Config Protection 5	196	Float	R/W	Hysteresis GG	%	0 - 100
Config Protection 5	196	Float	R/W	Arming Delay GG	Sec	0 - 300
Config Protection 5	196	Float	R/W	Threshold 1 Pickup GG	No Unit	-999999 - 999999
Config Protection 5	196	Float	R/W	Threshold 1 Activation Delay GG	Sec	0 - 300
Config Protection 5	196	Float	R/W	Threshold 2 Pickup GG	No Unit	-999999 - 999999
Config Protection 5	196	Float	R/W	Threshold 2 Activation Delay GG	Sec	0 - 300
Config Protection 5	196	Float	R/W	Threshold 3 Pickup GG	No Unit	-999999 - 999999
Config Protection 5	196	Float	R/W	Threshold 3 Activation Delay GG	Sec	0 - 300
Config Protection 5	196	Float	R/W	Threshold 4 Pickup GG	No Unit	-999999 - 999999
Config Protection 5	196	Float	R/W	Threshold 4 Activation Delay GG	Sec	0 - 300

Instance Name	Inst. #	Type	RW	Key Name	Unit	Range
Config Protection 6	197	UINT32	R/W	Param Selection GG	No Unit	Gen VAB=0 Gen VBC=1 Gen VCA=2 Gen V Average=3 Bus Freq=4 Bus VAB=5 Bus VBC=6 Bus VCA=7 Gen Freq=8 Gen PF=9 KWH=10 KVARH=11 Gen IA=12 Gen IB=13 Gen IC=14 Gen I Average=15 KW Total=16 KVA Total=17 KVAR Total=18 EDM Ripple=19 Exciter Field Voltage=20 Exciter Field Current=21 Auxiliary Input Voltage=22 Auxiliary Input Current (mA)=23 Setpoint Position=24 Tracking Error=25 Neg Seq V=26 Neg Seq I=27 Pos Seq V=28 Pos Seq I=29 PSS Output=30 Analog Input 1=31 Analog Input 2=32 Analog Input 3=33 Analog Input 4=34 Analog Input 5=35 Analog Input 6=36 Analog Input 7=37 Analog Input 8=38 RTD Input 1=39 RTD Input 2=40 RTD Input 3=41 RTD Input 4=42 RTD Input 5=43 RTD Input 6=44 RTD Input 7=45 RTD Input 8=46 Thermocouple 1=47 Thermocouple 2=48 Power Input=49 Network Load Share Error Percent=50 Gen Scaled PF=51 APC Output=52 LVRT Output=53
Config Protection 6	197	UINT32	R/W	Stop Mode Inhibit GG	No Unit	No=0 Yes=1
Config Protection 6	197	UINT32	R/W	Threshold 1 Type GG	No Unit	Disabled=0 Over=1 Under=2
Config Protection 6	197	UINT32	R/W	Threshold 2Type GG	No Unit	Disabled=0 Over=1 Under=2
Config Protection 6	197	UINT32	R/W	Threshold 3 Type GG	No Unit	Disabled=0 Over=1 Under=2
Config Protection 6	197	UINT32	R/W	Threshold 4 Type GG	No Unit	Disabled=0 Over=1 Under=2
Config Protection 6	198	Float	R/W	Hysteresis GG	%	0 - 100
Config Protection 6	198	Float	R/W	Arming Delay GG	Sec	0 - 300
Config Protection 6	198	Float	R/W	Threshold 1 Pickup GG	No Unit	-999999 - 999999
Config Protection 6	198	Float	R/W	Threshold 1 Activation Delay GG	Sec	0 - 300
Config Protection 6	198	Float	R/W	Threshold 2 Pickup GG	No Unit	-999999 - 999999
Config Protection 6	198	Float	R/W	Threshold 2 Activation Delay GG	Sec	0 - 300
Config Protection 6	198	Float	R/W	Threshold 3 Pickup GG	No Unit	-999999 - 999999
Config Protection 6	198	Float	R/W	Threshold 3 Activation Delay GG	Sec	0 - 300
Config Protection 6	198	Float	R/W	Threshold 4 Pickup GG	No Unit	-999999 - 999999
Config Protection 6	198	Float	R/W	Threshold 4 Activation Delay GG	Sec	0 - 300

Instance Name	Inst. #	Type	RW	Key Name	Unit	Range
Config Protection 7	199	UINT32	R/W	Param Selection GG	No Unit	Gen VAB=0 Gen VBC=1 Gen VCA=2 Gen V Average=3 Bus Freq=4 Bus VAB=5 Bus VBC=6 Bus VCA=7 Gen Freq=8 Gen PF=9 KWH=10 KVARH=11 Gen IA=12 Gen IB=13 Gen IC=14 Gen I Average=15 KW Total=16 KVA Total=17 KVAR Total=18 EDM Ripple=19 Exciter Field Voltage=20 Exciter Field Current=21 Auxiliary Input Voltage=22 Auxiliary Input Current (mA)=23 Setpoint Position=24 Tracking Error=25 Neg Seq V=26 Neg Seq I=27 Pos Seq V=28 Pos Seq I=29 PSS Output=30 Analog Input 1=31 Analog Input 2=32 Analog Input 3=33 Analog Input 4=34 Analog Input 5=35 Analog Input 6=36 Analog Input 7=37 Analog Input 8=38 RTD Input 1=39 RTD Input 2=40 RTD Input 3=41 RTD Input 4=42 RTD Input 5=43 RTD Input 6=44 RTD Input 7=45 RTD Input 8=46 Thermocouple 1=47 Thermocouple 2=48 Power Input=49 Network Load Share Error Percent=50 Gen Scaled PF=51 APC Output=52 LVRT Output=53
Config Protection 7	199	UINT32	R/W	Stop Mode Inhibit GG	No Unit	No=0 Yes=1
Config Protection 7	199	UINT32	R/W	Threshold1 Type GG	No Unit	Disabled=0 Over=1 Under=2
Config Protection 7	199	UINT32	R/W	Threshold 2 Type GG	No Unit	Disabled=0 Over=1 Under=2
Config Protection 7	199	UINT32	R/W	Threshold 3 Type GG	No Unit	Disabled=0 Over=1 Under=2
Config Protection 7	199	UINT32	R/W	Threshold 4Type GG	No Unit	Disabled=0 Over=1 Under=2
Config Protection 7	200	Float	R/W	Hysteresis GG	%	0 - 100
Config Protection 7	200	Float	R/W	Arming Delay GG	Sec	0 - 300
Config Protection 7	200	Float	R/W	Threshold 1 Pickup GG	No Unit	-999999 - 999999
Config Protection 7	200	Float	R/W	Threshold 1 Activation Delay GG	Sec	0 - 300
Config Protection 7	200	Float	R/W	Threshold 2 Pickup GG	No Unit	-999999 - 999999
Config Protection 7	200	Float	R/W	Threshold 2 Activation Delay GG	Sec	0 - 300
Config Protection 7	200	Float	R/W	Threshold 3 Pickup GG	No Unit	-999999 - 999999
Config Protection 7	200	Float	R/W	Threshold 3 Activation Delay GG	Sec	0 - 300
Config Protection 7	200	Float	R/W	Threshold 4 Pickup GG	No Unit	-999999 - 999999
Config Protection 7	200	Float	R/W	Threshold 4 Activation Delay GG	Sec	0 - 300

Instance Name	Inst. #	Type	RW	Key Name	Unit	Range
Config Protection 8	201	UINT32	R/W	Param Selection GG	No Unit	Gen VAB=0 Gen VBC=1 Gen VCA=2 Gen V Average=3 Bus Freq=4 Bus VAB=5 Bus VBC=6 Bus VCA=7 Gen Freq=8 Gen PF=9 KWH=10 KVARH=11 Gen IA=12 Gen IB=13 Gen IC=14 Gen I Average=15 KW Total=16 KVA Total=17 KVAR Total=18 EDM Ripple=19 Exciter Field Voltage=20 Exciter Field Current=21 Auxiliary Input Voltage=22 Auxiliary Input Current (mA)=23 Setpoint Position=24 Tracking Error=25 Neg Seq V=26 Neg Seq I=27 Pos Seq V=28 Pos Seq I=29 PSS Output=30 Analog Input 1=31 Analog Input 2=32 Analog Input 3=33 Analog Input 4=34 Analog Input 5=35 Analog Input 6=36 Analog Input 7=37 Analog Input 8=38 RTD Input 1=39 RTD Input 2=40 RTD Input 3=41 RTD Input 4=42 RTD Input 5=43 RTD Input 6=44 RTD Input 7=45 RTD Input 8=46 Thermocouple 1=47 Thermocouple 2=48 Power Input=49 Network Load Share Error Percent=50 Gen Scaled PF=51 APC Output=52 LVRT Output=53
Config Protection 8	201	UINT32	R/W	Stop Mode Inhibit GG	No Unit	No=0 Yes=1
Config Protection 8	201	UINT32	R/W	Threshold 1 Type GG	No Unit	Disabled=0 Over=1 Under=2
Config Protection 8	201	UINT32	R/W	Threshold Type GG	No Unit	Disabled=0 Over=1 Under=2
Config Protection 8	201	UINT32	R/W	Threshold Type GG	No Unit	Disabled=0 Over=1 Under=2
Config Protection 8	201	UINT32	R/W	Threshold Type GG	No Unit	Disabled=0 Over=1 Under=2
Config Protection 8	202	Float	R/W	Hysteresis GG	%	0 - 100
Config Protection 8	202	Float	R/W	Arming Delay GG	Sec	0 - 300
Config Protection 8	202	Float	R/W	Threshold 1 Pickup GG	No Unit	-999999 - 999999
Config Protection 8	202	Float	R/W	Threshold 1 Activation Delay GG	Sec	0 - 300
Config Protection 8	202	Float	R/W	Threshold 2 Pickup GG	No Unit	-999999 - 999999
Config Protection 8	202	Float	R/W	Threshold 2 Activation Delay	Sec	0 - 300
Config Protection 8	202	Float	R/W	Threshold 3 Pickup GG	No Unit	-999999 - 999999
Config Protection 8	202	Float	R/W	Threshold 3 Activation Delay GG	Sec	0 - 300
Config Protection 8	202	Float	R/W	Threshold 4 Pickup GG	No Unit	-999999 - 999999
Config Protection 8	202	Float	R/W	Threshold Activation Delay GG	Sec	0 - 300
Remote Analog In 1	203	UINT32	R/W	Stop Mode Inhibit GG	No Unit	NO=0 YES=1
Remote Analog In 1	203	UINT32	R/W	Threshold 1 Type GG	No Unit	Disabled=0 Over=1 Under=2
Remote Analog In 1	203	UINT32	R/W	Threshold 2 Type GG	No Unit	Disabled=0 Over=1 Under=2
Remote Analog In 1	203	UINT32	R/W	Threshold 3 Type GG	No Unit	Disabled=0 Over=1 Under=2
Remote Analog In 1	203	UINT32	R/W	Threshold 4 Type GG	No Unit	Disabled=0 Over=1 Under=2
Remote Analog In 1	203	UINT32	R/W	Type GG	No Unit	Voltage=0 Current=1
Remote Analog In 1	204	Float	R/W	Hysteresis GG	%	0 - 100
Remote Analog In 1	204	Float	R/W	Arming Delay GG	Sec	0 - 300
Remote Analog In 1	204	Float	R/W	Threshold 1 Pickup GG	No Unit	-9999 - 9999
Remote Analog In 1	204	Float	R/W	Threshold 1 Activation Delay GG	Sec	0 - 300
Remote Analog In 1	204	Float	R/W	Threshold 2 Pickup GG	No Unit	-9999 - 9999
Remote Analog In 1	204	Float	R/W	Threshold 2 Activation Delay GG	Sec	0 - 300
Remote Analog In 1	204	Float	R/W	Threshold 3 Pickup GG	No Unit	-9999 - 9999

Instance Name	Inst. #	Type	RW	Key Name	Unit	Range
Remote Analog In 1	204	Float	R/W	Threshold 3 Activation Delay GG	Sec	0 - 300
Remote Analog In 1	204	Float	R/W	Threshold 4 Pickup GG	No Unit	-9999 - 9999
Remote Analog In 1	204	Float	R/W	Threshold 4 Activation Delay GG	Sec	0 - 300
Remote Analog In 1	204	Float	R/W	Param Min GG	No Unit	-9999 - 9999
Remote Analog In 1	204	Float	R/W	Param Max GG	No Unit	-9999 - 9999
Remote Analog In 1	204	Float	R/W	Current Min GG	mA	4 - 20
Remote Analog In 1	204	Float	R/W	Current Max GG	mA	4 - 20
Remote Analog In 1	204	Float	R/W	Voltage Min GG	V	0 - 10
Remote Analog In 1	204	Float	R/W	Voltage Max GG	V	0 - 10
Remote Analog In 2	205	UINT32	R/W	Stop Mode Inhibit GG	No Unit	No=0 Yes=1
Remote Analog In 2	205	UINT32	R/W	Threshold1Type GG	No Unit	Disabled=0 Over=1 Under=2
Remote Analog In 2	205	UINT32	R/W	Threshold2Type GG	No Unit	Disabled=0 Over=1 Under=2
Remote Analog In 2	205	UINT32	R/W	Threshold3Type GG	No Unit	Disabled=0 Over=1 Under=2
Remote Analog In 2	205	UINT32	R/W	Threshold4Type GG	No Unit	Disabled=0 Over=1 Under=2
Remote Analog In 2	205	UINT32	R/W	Type GG	No Unit	Voltage=0 Current=1
Remote Analog In 2	206	Float	R/W	Hysteresis GG	%	0 - 100
Remote Analog In 2	206	Float	R/W	Arming Delay GG	Sec	0 - 300
Remote Analog In 2	206	Float	R/W	Threshold 1 Pickup GG	No Unit	-9999 - 9999
Remote Analog In 2	206	Float	R/W	Threshold 1 Activation Delay GG	Sec	0 - 300
Remote Analog In 2	206	Float	R/W	Threshold 2 Pickup GG	No Unit	-9999 - 9999
Remote Analog In 2	206	Float	R/W	Threshold 2 Activation Delay GG	Sec	0 - 300
Remote Analog In 2	206	Float	R/W	Threshold 3 Pickup GG	No Unit	-9999 - 9999
Remote Analog In 2	206	Float	R/W	Threshold 3 Activation Delay GG	Sec	0 - 300
Remote Analog In 2	206	Float	R/W	Threshold 4 Pickup GG	No Unit	-9999 - 9999
Remote Analog In 2	206	Float	R/W	Threshold 4 Activation Delay GG	Sec	0 - 300
Remote Analog In 2	206	Float	R/W	Param Min GG	No Unit	-9999 - 9999
Remote Analog In 2	206	Float	R/W	Param Max GG	No Unit	-9999 - 9999
Remote Analog In 2	206	Float	R/W	Current Min GG	mA	4 - 20
Remote Analog In 2	206	Float	R/W	Current Max GG	mA	4 - 20
Remote Analog In 2	206	Float	R/W	Voltage Min GG	V	0 - 10
Remote Analog In 2	206	Float	R/W	Voltage Max GG	V	0 - 10
Remote Analog In 3	207	UINT32	R/W	Stop Mode Inhibit GG	No Unit	No=0 Yes=1
Remote Analog In 3	207	UINT32	R/W	Threshold 1 Type GG	No Unit	Disabled=0 Over=1 Under=2
Remote Analog In 3	207	UINT32	R/W	Threshold 2 Type GG	No Unit	Disabled=0 Over=1 Under=2
Remote Analog In 3	207	UINT32	R/W	Threshold 3 Type GG	No Unit	Disabled=0 Over=1 Under=2
Remote Analog In 3	207	UINT32	R/W	Threshold 4 Type GG	No Unit	Disabled=0 Over=1 Under=2
Remote Analog In 3	207	UINT32	R/W	Type GG	No Unit	Voltage=0 Current=1
Remote Analog In 3	208	Float	R/W	Hysteresis GG	%	0 - 100
Remote Analog In 3	208	Float	R/W	Arming Delay GG	Sec	0 - 300
Remote Analog In 3	208	Float	R/W	Threshold 1 Pickup GG	No Unit	-9999 - 9999
Remote Analog In 3	208	Float	R/W	Threshold 1 Activation Delay GG	Sec	0 - 300
Remote Analog In 3	208	Float	R/W	Threshold 2 Pickup GG	No Unit	-9999 - 9999
Remote Analog In 3	208	Float	R/W	Threshold 2 Activation Delay GG	Sec	0 - 300
Remote Analog In 3	208	Float	R/W	Threshold 3 Pickup GG	No Unit	-9999 - 9999

Instance Name	Inst. #	Type	RW	Key Name	Unit	Range
Remote Analog In 3	208	Float	R/W	Threshold 3 Activation Delay GG	Sec	0 - 300
Remote Analog In 3	208	Float	R/W	Threshold 4 Pickup GG	No Unit	-9999 - 9999
Remote Analog In 3	208	Float	R/W	Threshold 4 Activation Delay GG	Sec	0 - 300
Remote Analog In 3	208	Float	R/W	Param Min GG	No Unit	-9999 - 9999
Remote Analog In 3	208	Float	R/W	Param Max GG	No Unit	-9999 - 9999
Remote Analog In 3	208	Float	R/W	Current Min GG	mA	4 - 20
Remote Analog In 3	208	Float	R/W	Current Max GG	mA	4 - 20
Remote Analog In 3	208	Float	R/W	Voltage Min GG	V	0 - 10
Remote Analog In 3	208	Float	R/W	Voltage Max GG	V	0 - 10
Remote Analog In 4	209	UINT32	R/W	Stop Mode Inhibit GG	No Unit	No=0 Yes=1
Remote Analog In 4	209	UINT32	R/W	Threshold 1Type GG	No Unit	Disabled=0 Over=1 Under=2
Remote Analog In 4	209	UINT32	R/W	Threshold 2Type GG	No Unit	Disabled=0 Over=1 Under=2
Remote Analog In 4	209	UINT32	R/W	Threshold 3Type GG	No Unit	Disabled=0 Over=1 Under=2
Remote Analog In 4	209	UINT32	R/W	Threshold 4Type GG	No Unit	Disabled=0 Over=1 Under=2
Remote Analog In 4	209	UINT32	R/W	Type GG	No Unit	Voltage=0 Current=1
Remote Analog In 4	210	Float	R/W	Hysteresis GG	%	0 - 100
Remote Analog In 4	210	Float	R/W	Arming Delay GG	Sec	0 - 300
Remote Analog In 4	210	Float	R/W	Threshold 1 Pickup GG	No Unit	-9999 - 9999
Remote Analog In 4	210	Float	R/W	Threshold 1 Activation Delay GG	Sec	0 - 300
Remote Analog In 4	210	Float	R/W	Threshold 2 Pickup GG	No Unit	-9999 - 9999
Remote Analog In 4	210	Float	R/W	Threshold 2 Activation Delay GG	Sec	0 - 300
Remote Analog In 4	210	Float	R/W	Threshold 3 Pickup GG	No Unit	-9999 - 9999
Remote Analog In 4	210	Float	R/W	Threshold 3 Activation Delay GG	Sec	0 - 300
Remote Analog In 4	210	Float	R/W	Threshold 4 Pickup GG	No Unit	-9999 - 9999
Remote Analog In 4	210	Float	R/W	Threshold 4 Activation Delay GG	Sec	0 - 300
Remote Analog In 4	210	Float	R/W	Param Min GG	No Unit	-9999 - 9999
Remote Analog In 4	210	Float	R/W	Param Max GG	No Unit	-9999 - 9999
Remote Analog In 4	210	Float	R/W	Current Min GG	mA	4 - 20
Remote Analog In 4	210	Float	R/W	Current Max GG	mA	4 - 20
Remote Analog In 4	210	Float	R/W	Voltage Min GG	V	0 - 10
Remote Analog In 4	210	Float	R/W	Voltage Max GG	V	0 - 10
Remote Analog In 5	211	UINT32	R/W	Stop Mode Inhibit GG	No Unit	No=0 Yes=1
Remote Analog In 5	211	UINT32	R/W	Threshold 1 Type GG	No Unit	Disabled=0 Over=1 Under=2
Remote Analog In 5	211	UINT32	R/W	Threshold 2 Type GG	No Unit	Disabled=0 Over=1 Under=2
Remote Analog In 5	211	UINT32	R/W	Threshold 3 Type GG	No Unit	Disabled=0 Over=1 Under=2
Remote Analog In 5	211	UINT32	R/W	Threshold 4 Type GG	No Unit	Disabled=0 Over=1 Under=2
Remote Analog In 5	211	UINT32	R/W	Type GG	No Unit	Voltage=0 Current=1
Remote Analog In 5	212	Float	R/W	Hysteresis GG	%	0 - 100
Remote Analog In 5	212	Float	R/W	Arming Delay GG	Sec	0 - 300
Remote Analog In 5	212	Float	R/W	Threshold 1 Pickup GG	No Unit	-9999 - 9999
Remote Analog In 5	212	Float	R/W	Threshold 1 Activation Delay GG	Sec	0 - 300
Remote Analog In 5	212	Float	R/W	Threshold 2 Pickup GG	No Unit	-9999 - 9999
Remote Analog In 5	212	Float	R/W	Threshold 2 Activation Delay GG	Sec	0 - 300
Remote Analog In 5	212	Float	R/W	Threshold 3 Pickup GG	No Unit	-9999 - 9999

Instance Name	Inst. #	Type	RW	Key Name	Unit	Range
Remote Analog In 5	212	Float	R/W	Threshold 3 Activation Delay GG	Sec	0 - 300
Remote Analog In 5	212	Float	R/W	Threshold4 GG Pickup	No Unit	-9999 - 9999
Remote Analog In 5	212	Float	R/W	Threshold 4 Activation Delay GG	Sec	0 - 300
Remote Analog In 5	212	Float	R/W	Param Min GG	No Unit	-9999 - 9999
Remote Analog In 5	212	Float	R/W	Param Max GG	No Unit	-9999 - 9999
Remote Analog In 5	212	Float	R/W	Current Min GG	mA	4 - 20
Remote Analog In 5	212	Float	R/W	Current Max GG	mA	4 - 20
Remote Analog In 5	212	Float	R/W	Voltage Min GG	V	0 - 10
Remote Analog In 5	212	Float	R/W	Voltage Max GG	V	0 - 10
Remote Analog In 6	213	UINT32	R/W	Stop Mode Inhibit GG	No Unit	No=0 Yes=1
Remote Analog In 6	213	UINT32	R/W	Threshold 1 Type GG	No Unit	Disabled=0 Over=1 Under=2
Remote Analog In 6	213	UINT32	R/W	Threshold 2 Type GG	No Unit	Disabled=0 Over=1 Under=2
Remote Analog In 6	213	UINT32	R/W	Threshold 3 Type GG	No Unit	Disabled=0 Over=1 Under=2
Remote Analog In 6	213	UINT32	R/W	Threshold 4 Type GG	No Unit	Disabled=0 Over=1 Under=2
Remote Analog In 6	213	UINT32	R/W	Type GG	No Unit	Voltage=0 Current=1
Remote Analog In 6	214	Float	R/W	Hysteresis GG	%	0 - 100
Remote Analog In 6	214	Float	R/W	Arming Delay GG	Sec	0 - 300
Remote Analog In 6	214	Float	R/W	Threshold 1 Pickup GG	No Unit	-9999 - 9999
Remote Analog In 6	214	Float	R/W	Threshold 1 Activation Delay GG	Sec	0 - 300
Remote Analog In 6	214	Float	R/W	Threshold 2 Pickup GG	No Unit	-9999 - 9999
Remote Analog In 6	214	Float	R/W	Threshold 2 Activation Delay GG	Sec	0 - 300
Remote Analog In 6	214	Float	R/W	Threshold 3 Pickup GG	No Unit	-9999 - 9999
Remote Analog In 6	214	Float	R/W	Threshold 3 Activation Delay GG	Sec	0 - 300
Remote Analog In 6	214	Float	R/W	Threshold 4 Pickup GG	No Unit	-9999 - 9999
Remote Analog In 6	214	Float	R/W	Threshold 4 Activation Delay GG	Sec	0 - 300
Remote Analog In 6	214	Float	R/W	Param Min GG	No Unit	-9999 - 9999
Remote Analog In 6	214	Float	R/W	Param Max GG	No Unit	-9999 - 9999
Remote Analog In 6	214	Float	R/W	Current Min GG	mA	4 - 20
Remote Analog In 6	214	Float	R/W	Current Max GG	mA	4 - 20
Remote Analog In 6	214	Float	R/W	Voltage Min GG	V	0 - 10
Remote Analog In 6	214	Float	R/W	Voltage Max GG	V	0 - 10
Remote Analog In 7	215	UINT32	R/W	Stop Mode Inhibit GG	No Unit	No=0 Yes=1
Remote Analog In 7	215	UINT32	R/W	Threshold 1 Type GG	No Unit	Disabled=0 Over=1 Under=2
Remote Analog In 7	215	UINT32	R/W	Threshold 2 Type GG	No Unit	Disabled=0 Over=1 Under=2
Remote Analog In 7	215	UINT32	R/W	Threshold 3 Type GG	No Unit	Disabled=0 Over=1 Under=2
Remote Analog In 7	215	UINT32	R/W	Threshold 4 Type GG	No Unit	Disabled=0 Over=1 Under=2
Remote Analog In 7	215	UINT32	R/W	Type GG	No Unit	Voltage=0 Current=1
Remote Analog In 7	216	Float	R/W	Hysteresis GG	%	0 - 100
Remote Analog In 7	216	Float	R/W	Arming Delay GG	Sec	0 - 300
Remote Analog In 7	216	Float	R/W	Threshold 1 Pickup GG	No Unit	-9999 - 9999
Remote Analog In 7	216	Float	R/W	Threshold 1 Activation Delay GG	Sec	0 - 300
Remote Analog In 7	216	Float	R/W	Threshold 2 Pickup GG	No Unit	-9999 - 9999
Remote Analog In 7	216	Float	R/W	Threshold 2 Activation Delay GG	Sec	0 - 300
Remote Analog In 7	216	Float	R/W	Threshold 3 Pickup GG	No Unit	-9999 - 9999

Instance Name	Inst. #	Type	RW	Key Name	Unit	Range
Remote Analog In 7	216	Float	R/W	Threshold 3 Activation Delay GG	Sec	0 - 300
Remote Analog In 7	216	Float	R/W	Threshold 4 Pickup GG	No Unit	-9999 - 9999
Remote Analog In 7	216	Float	R/W	Threshold 4 Activation Delay GG	Sec	0 - 300
Remote Analog In 7	216	Float	R/W	Param Min GG	No Unit	-9999 - 9999
Remote Analog In 7	216	Float	R/W	Param Max GG	No Unit	-9999 - 9999
Remote Analog In 7	216	Float	R/W	Current Min GG	mA	4 - 20
Remote Analog In 7	216	Float	R/W	Current Max GG	mA	4 - 20
Remote Analog In 7	216	Float	R/W	Voltage Min GG	V	0 - 10
Remote Analog In 7	216	Float	R/W	Voltage Max GG	V	0 - 10
Remote Analog In 8	217	UINT32	R/W	Stop Mode Inhibit GG	No Unit	No=0 Yes=1
Remote Analog In 8	217	UINT32	R/W	Threshold 1 Type GG	No Unit	Disabled=0 Over=1 Under=2
Remote Analog In 8	217	UINT32	R/W	Threshold 2 Type GG	No Unit	Disabled=0 Over=1 Under=2
Remote Analog In 8	217	UINT32	R/W	Threshold 3 Type GG	No Unit	Disabled=0 Over=1 Under=2
Remote Analog In 8	217	UINT32	R/W	Threshold 4 Type GG	No Unit	Disabled=0 Over=1 Under=2
Remote Analog In 8	217	UINT32	R/W	Type GG	No Unit	Voltage=0 Current=1
Remote Analog In 8	218	Float	R/W	Hysteresis GG	%	0 - 100
Remote Analog In 8	218	Float	R/W	Arming Delay GG	Sec	0 - 300
Remote Analog In 8	218	Float	R/W	Threshold 1 Pickup GG	No Unit	-9999 - 9999
Remote Analog In 8	218	Float	R/W	Threshold 1 Activation Delay GG	Sec	0 - 300
Remote Analog In 8	218	Float	R/W	Threshold 2 Pickup GG	No Unit	-9999 - 9999
Remote Analog In 8	218	Float	R/W	Threshold 2 Activation Delay GG	Sec	0 - 300
Remote Analog In 8	218	Float	R/W	Threshold 3 Pickup GG	No Unit	-9999 - 9999
Remote Analog In 8	218	Float	R/W	Threshold 3 Activation Delay GG	Sec	0 - 300
Remote Analog In 8	218	Float	R/W	Threshold 4 Pickup GG	No Unit	-9999 - 9999
Remote Analog In 8	218	Float	R/W	Threshold 4 Activation Delay GG	Sec	0 - 300
Remote Analog In 8	218	Float	R/W	Param Min GG	No Unit	-9999 - 9999
Remote Analog In 8	218	Float	R/W	Param Max GG	No Unit	-9999 - 9999
Remote Analog In 8	218	Float	R/W	Current Min GG	mA	4 - 20
Remote Analog In 8	218	Float	R/W	Current Max GG	mA	4 - 20
Remote Analog In 8	218	Float	R/W	Voltage Min GG	V	0 - 10
Remote Analog In 8	218	Float	R/W	Voltage Max GG	V	0 - 10
Remote RTD In 1	219	UINT32	R/W	Type GG	No Unit	10 Ohm Cu=0 100 Ohm Pt=1
Remote RTD In 1	219	UINT32	R/W	Stop Mode Inhibit GG	No Unit	No=0 Yes=1
Remote RTD In 1	219	UINT32	R/W	Threshold 1 Type GG	No Unit	Disabled=0 Over=1 Under=2
Remote RTD In 1	219	UINT32	R/W	Threshold 2 Type GG	No Unit	Disabled=0 Over=1 Under=2
Remote RTD In 1	219	UINT32	R/W	Threshold 3 Type GG	No Unit	Disabled=0 Over=1 Under=2
Remote RTD In 1	219	UINT32	R/W	Threshold 4 Type GG	No Unit	Disabled=0 Over=1 Under=2
Remote RTD In 1	220	Float	R/W	Cal Offset GG	Deg F	-99999 - 99999
Remote RTD In 1	220	Float	R/W	Hysteresis GG	%	0 - 100
Remote RTD In 1	220	Float	R/W	Arming Delay GG	Sec	0 - 300
Remote RTD In 1	220	Float	R/W	Threshold 1 Pickup GG	Deg F	-58 - 482
Remote RTD In 1	220	Float	R/W	Threshold 1 Activation Delay GG	Sec	0 - 300
Remote RTD In 1	220	Float	R/W	Threshold 2 Pickup GG	Deg F	-58 - 482
Remote RTD In 1	220	Float	R/W	Threshold 2 Activation Delay GG	Sec	0 - 300
Remote RTD In 1	220	Float	R/W	Threshold 3 Pickup GG	Deg F	-58 - 482

Instance Name	Inst. #	Type	RW	Key Name	Unit	Range
Remote RTD In 1	220	Float	R/W	Threshold 3 Activation Delay GG	Sec	0 - 300
Remote RTD In 1	220	Float	R/W	Threshold 4 Pickup GG	Deg F	-58 - 482
Remote RTD In 1	220	Float	R/W	Threshold 4 Activation Delay GG	Sec	0 - 300
Remote RTD In 2	221	UINT32	R/W	Type GG	No Unit	10 Ohm Cu=0 100 Ohm Pt=1
Remote RTD In 2	221	UINT32	R/W	Stop Mode Inhibit GG	No Unit	No=0 Yes=1
Remote RTD In 2	221	UINT32	R/W	Threshold 1 Type GG	No Unit	Disabled=0 Over=1 Under=2
Remote RTD In 2	221	UINT32	R/W	Threshold 2 Type GG	No Unit	Disabled=0 Over=1 Under=2
Remote RTD In 2	221	UINT32	R/W	Threshold 3 Type GG	No Unit	Disabled=0 Over=1 Under=2
Remote RTD In 2	221	UINT32	R/W	Threshold 4 Type GG	No Unit	Disabled=0 Over=1 Under=2
Remote RTD In 2	222	Float	R/W	Cal Offset GG	Deg F	-99999 - 99999
Remote RTD In 2	222	Float	R/W	Hysteresis GG	%	0 - 100
Remote RTD In 2	222	Float	R/W	Arming Delay GG	Sec	0 - 300
Remote RTD In 2	222	Float	R/W	Threshold 1 Pickup GG	Deg F	-58 - 482
Remote RTD In 2	222	Float	R/W	Threshold 1 Activation Delay GG	Sec	0 - 300
Remote RTD In 2	222	Float	R/W	Threshold 2 Pickup GG	Deg F	-58 - 482
Remote RTD In 2	222	Float	R/W	Threshold 2 Activation Delay GG	Sec	0 - 300
Remote RTD In 2	222	Float	R/W	Threshold 3 Pickup GG	Deg F	-58 - 482
Remote RTD In 2	222	Float	R/W	Threshold 3 Activation Delay GG	Sec	0 - 300
Remote RTD In 2	222	Float	R/W	Threshold 4 Pickup GG	Deg F	-58 - 482
Remote RTD In 2	222	Float	R/W	Threshold 4 Activation Delay GG	Sec	0 - 300
Remote RTD In 3	223	UINT32	R/W	Type GG	No Unit	10 Ohm Cu=0 100 Ohm Pt=1
Remote RTD In 3	223	UINT32	R/W	Stop Mode Inhibit GG	No Unit	No=0 Yes=1
Remote RTD In 3	223	UINT32	R/W	Threshold 1 Type GG	No Unit	Disabled=0 Over=1 Under=2
Remote RTD In 3	223	UINT32	R/W	Threshold 2 Type GG	No Unit	Disabled=0 Over=1 Under=2
Remote RTD In 3	223	UINT32	R/W	Threshold 3 Type GG	No Unit	Disabled=0 Over=1 Under=2
Remote RTD In 3	223	UINT32	R/W	Threshold 4 Type GG	No Unit	Disabled=0 Over=1 Under=2
Remote RTD In 3	224	Float	R/W	Cal Offset GG	Deg F	-99999 - 99999
Remote RTD In 3	224	Float	R/W	Hysteresis GG	%	0 - 100
Remote RTD In 3	224	Float	R/W	Arming Delay GG	Sec	0 - 300
Remote RTD In 3	224	Float	R/W	Threshold 1 Pickup GG	Deg F	-58 - 482
Remote RTD In 3	224	Float	R/W	Threshold 1 Activation Delay GG	Sec	0 - 300
Remote RTD In 3	224	Float	R/W	Threshold 2 Pickup GG	Deg F	-58 - 482
Remote RTD In 3	224	Float	R/W	Threshold 2 Activation Delay GG	Sec	0 - 300
Remote RTD In 3	224	Float	R/W	Threshold 3 Pickup GG	Deg F	-58 - 482
Remote RTD In 3	224	Float	R/W	Threshold 3 Activation Delay GG	Sec	0 - 300
Remote RTD In 3	224	Float	R/W	Threshold 4 Pickup GG	Deg F	-58 - 482
Remote RTD In 3	224	Float	R/W	Threshold 4 Activation Delay GG	Sec	0 - 300
Remote RTD In 4	225	UINT32	R/W	Type GG	No Unit	10 Ohm Cu=0 100 Ohm Pt=1
Remote RTD In 4	225	UINT32	R/W	Stop Mode Inhibit GG	No Unit	No=0 Yes=1
Remote RTD In 4	225	UINT32	R/W	Threshold 1 Type GG	No Unit	Disabled=0 Over=1 Under=2
Remote RTD In 4	225	UINT32	R/W	Threshold 2 Type GG	No Unit	Disabled=0 Over=1 Under=2
Remote RTD In 4	225	UINT32	R/W	Threshold 3 Type GG	No Unit	Disabled=0 Over=1 Under=2
Remote RTD In 4	225	UINT32	R/W	Threshold 4 Type GG	No Unit	Disabled=0 Over=1 Under=2
Remote RTD In 4	226	Float	R/W	Cal Offset GG	Deg F	-99999 - 99999

Instance Name	Inst. #	Type	RW	Key Name	Unit	Range
Remote RTD In 4	226	Float	R/W	Hysteresis GG	%	0 - 100
Remote RTD In 4	226	Float	R/W	Arming Delay GG	Sec	0 - 300
Remote RTD In 4	226	Float	R/W	Threshold 1 Pickup GG	Deg F	-58 - 482
Remote RTD In 4	226	Float	R/W	Threshold 1 Activation Delay GG	Sec	0 - 300
Remote RTD In 4	226	Float	R/W	Threshold 2 Pickup GG	Deg F	-58 - 482
Remote RTD In 4	226	Float	R/W	Threshold 2 Activation Delay GG	Sec	0 - 300
Remote RTD In 4	226	Float	R/W	Threshold 3 Pickup GG	Deg F	-58 - 482
Remote RTD In 4	226	Float	R/W	Threshold 3 Activation Delay GG	Sec	0 - 300
Remote RTD In 4	226	Float	R/W	Threshold 4 Pickup GG	Deg F	-58 - 482
Remote RTD In 4	226	Float	R/W	Threshold 4 Activation Delay GG	Sec	0 - 300
Remote RTD In 5	227	UINT32	R/W	Type GG	No Unit	10 Ohm Cu=0 100 Ohm Pt=1
Remote RTD In 5	227	UINT32	R/W	Stop Mode Inhibit GG	No Unit	No=0 Yes=1
Remote RTD In 5	227	UINT32	R/W	Threshold 1 Type GG	No Unit	Disabled=0 Over=1 Under=2
Remote RTD In 5	227	UINT32	R/W	Threshold 2 Type GG	No Unit	Disabled=0 Over=1 Under=2
Remote RTD In 5	227	UINT32	R/W	Threshold 3 Type GG	No Unit	Disabled=0 Over=1 Under=2
Remote RTD In 5	227	UINT32	R/W	Threshold 4 Type GG	No Unit	Disabled=0 Over=1 Under=2
Remote RTD In 5	228	Float	R/W	Cal Offset GG	Deg F	-99999 - 99999
Remote RTD In 5	228	Float	R/W	Hysteresis GG	%	0 - 100
Remote RTD In 5	228	Float	R/W	Arming Delay GG	Sec	0 - 300
Remote RTD In 5	228	Float	R/W	Threshold 1 Pickup GG	Deg F	-58 - 482
Remote RTD In 5	228	Float	R/W	Threshold 1 Activation Delay GG	Sec	0 - 300
Remote RTD In 5	228	Float	R/W	Threshold 2 Pickup GG	Deg F	-58 - 482
Remote RTD In 5	228	Float	R/W	Threshold 2 Activation Delay GG	Sec	0 - 300
Remote RTD In 5	228	Float	R/W	Threshold 3 Pickup GG	Deg F	-58 - 482
Remote RTD In 5	228	Float	R/W	Threshold 3 Activation Delay GG	Sec	0 - 300
Remote RTD In 5	228	Float	R/W	Threshold 4 Pickup GG	Deg F	-58 - 482
Remote RTD In 5	228	Float	R/W	Threshold 4 Activation Delay GG	Sec	0 - 300
Remote RTD In 6	229	UINT32	R/W	Type GG	No Unit	10 Ohm Cu=0 100 Ohm Pt=1
Remote RTD In 6	229	UINT32	R/W	Stop Mode Inhibit GG	No Unit	No=0 Yes=1
Remote RTD In 6	229	UINT32	R/W	Threshold 1 Type GG	No Unit	Disabled=0 Over=1 Under=2
Remote RTD In 6	229	UINT32	R/W	Threshold 2 Type GG	No Unit	Disabled=0 Over=1 Under=2
Remote RTD In 6	229	UINT32	R/W	Threshold 3 Type GG	No Unit	Disabled=0 Over=1 Under=2
Remote RTD In 6	229	UINT32	R/W	Threshold 4 Type GG	No Unit	Disabled=0 Over=1 Under=2
Remote RTD In 6	230	Float	R/W	Cal Off set GG	Deg F	-99999 - 99999
Remote RTD In 6	230	Float	R/W	Hysteresis GG	%	0 - 100
Remote RTD In 6	230	Float	R/W	Arming Delay GG	Sec	0 - 300
Remote RTD In 6	230	Float	R/W	Threshold 1 Pickup GG	Deg F	-58 - 482
Remote RTD In 6	230	Float	R/W	Threshold 1 Activation Delay GG	Sec	0 - 300
Remote RTD In 6	230	Float	R/W	Threshold 2 Pickup GG	Deg F	-58 - 482
Remote RTD In 6	230	Float	R/W	Threshold 2 Activation Delay GG	Sec	0 - 300
Remote RTD In 6	230	Float	R/W	Threshold 3 Pickup GG	Deg F	-58 - 482
Remote RTD In 6	230	Float	R/W	Threshold 3 Activation Delay GG	Sec	0 - 300
Remote RTD In 6	230	Float	R/W	Threshold 4 Pickup GG	Deg F	-58 - 482

Instance Name	Inst. #	Type	RW	Key Name	Unit	Range
Remote RTD In 6	230	Float	R/W	Threshold 4 Activation Delay GG	Sec	0 - 300
Remote RTD In 7	231	UINT32	R/W	Type GG	No Unit	10 Ohm Cu=0 100 Ohm Pt=1
Remote RTD In 7	231	UINT32	R/W	Stop Mode Inhibit GG	No Unit	No=0 Yes=1
Remote RTD In 7	231	UINT32	R/W	Threshold 1 Type GG	No Unit	Disabled=0 Over=1 Under=2
Remote RTD In 7	231	UINT32	R/W	Threshold 2 Type GG	No Unit	Disabled=0 Over=1 Under=2
Remote RTD In 7	231	UINT32	R/W	Threshold 3 Type GG	No Unit	Disabled=0 Over=1 Under=2
Remote RTD In 7	231	UINT32	R/W	Threshold 4 Type GG	No Unit	Disabled=0 Over=1 Under=2
Remote RTD In 7	232	Float	R/W	Cal Offset GG	Deg F	-99999 - 99999
Remote RTD In 7	232	Float	R/W	Hysteresis GG	%	0 - 100
Remote RTD In 7	232	Float	R/W	Arming Delay GG	Sec	0 - 300
Remote RTD In 7	232	Float	R/W	Threshold 1 Pickup GG	Deg F	-58 - 482
Remote RTD In 7	232	Float	R/W	Threshold 1 Activation Delay GG	Sec	0 - 300
Remote RTD In 7	232	Float	R/W	Threshold 2 Pickup GG	Deg F	-58 - 482
Remote RTD In 7	232	Float	R/W	Threshold 2 Activation Delay GG	Sec	0 - 300
Remote RTD In 7	232	Float	R/W	Threshold 3 Pickup GG	Deg F	-58 - 482
Remote RTD In 7	232	Float	R/W	Threshold 3 Activation Delay GG	Sec	0 - 300
Remote RTD In 7	232	Float	R/W	Threshold 4 Pickup GG	Deg F	-58 - 482
Remote RTD In 7	232	Float	R/W	Threshold 4 Activation Delay GG	Sec	0 - 300
Remote RTD In 8	233	UINT32	R/W	Type GG	No Unit	10 Ohm Cu=0 100 Ohm Pt=1
Remote RTD In 8	233	UINT32	R/W	Stop Mode Inhibit GG	No Unit	No=0 Yes=1
Remote RTD In 8	233	UINT32	R/W	Threshold 1 Type GG	No Unit	Disabled=0 Over=1 Under=2
Remote RTD In 8	233	UINT32	R/W	Threshold 2 Type GG	No Unit	Disabled=0 Over=1 Under=2
Remote RTD In 8	233	UINT32	R/W	Threshold 3 Type GG	No Unit	Disabled=0 Over=1 Under=2
Remote RTD In 8	233	UINT32	R/W	Threshold 4 Type GG	No Unit	Disabled=0 Over=1 Under=2
Remote RTD In 8	234	Float	R/W	Cal Offset GG	Deg F	-99999 - 99999
Remote RTD In 8	234	Float	R/W	Hysteresis GG	%	0 - 100
Remote RTD In 8	234	Float	R/W	Arming Delay GG	Sec	0 - 300
Remote RTD In 8	234	Float	R/W	Threshold 1 Pickup GG	Deg F	-58 - 482
Remote RTD In 8	234	Float	R/W	Threshold 1 Activation Delay GG	Sec	0 - 300
Remote RTD In 8	234	Float	R/W	Threshold 2 Pickup GG	Deg F	-58 - 482
Remote RTD In 8	234	Float	R/W	Threshold 2 Activation Delay GG	Sec	0 - 300
Remote RTD In 8	234	Float	R/W	Threshold 3 Pickup GG	Deg F	-58 - 482
Remote RTD In 8	234	Float	R/W	Threshold 3 Activation Delay GG	Sec	0 - 300
Remote RTD In 8	234	Float	R/W	Threshold 4 Pickup GG	Deg F	-58 - 482
Remote RTD In 8	234	Float	R/W	Threshold 4 Activation Delay GG	Sec	0 - 300
Remote TC In 1	235	UINT32	R/W	Stop Mode Inhibit GG	No Unit	No=0 Yes=1
Remote TC In 1	235	UINT32	R/W	Threshold 1 Type GG	No Unit	Disabled=0 Over=1 Under=2
Remote TC In 1	235	UINT32	R/W	Threshold 2 Type GG	No Unit	Disabled=0 Over=1 Under=2
Remote TC In 1	235	UINT32	R/W	Threshold 3 Type GG	No Unit	Disabled=0 Over=1 Under=2
Remote TC In 1	235	UINT32	R/W	Threshold 4 Type GG	No Unit	Disabled=0 Over=1 Under=2
Remote TC In 1	236	Float	R/W	Cal Offset GG	Deg F	-99999 - 99999
Remote TC In 1	236	Float	R/W	Hysteresis GG	%	0 - 100
Remote TC In 1	236	Float	R/W	Arming Delay GG	Sec	0 - 300
Remote TC In 1	236	Float	R/W	Threshold 1 Pickup GG	Deg F	32 - 2507

Instance Name	Inst. #	Type	RW	Key Name	Unit	Range
Remote TC In 1	236	Float	R/W	Threshold 1 Activation Delay GG	Sec	0 - 300
Remote TC In 1	236	Float	R/W	Threshold 2 Pickup GG	Deg F	32 - 2507
Remote TC In 1	236	Float	R/W	Threshold 2 Activation Delay GG	Sec	0 - 300
Remote TC In 1	236	Float	R/W	Threshold 3 Pickup GG	Deg F	32 - 2507
Remote TC In 1	236	Float	R/W	Threshold 3 Activation Delay GG	Sec	0 - 300
Remote TC In 1	236	Float	R/W	Threshold 4 Pickup GG	Deg F	32 - 2507
Remote TC In 1	236	Float	R/W	Threshold 4 Activation Delay GG	Sec	0 - 300
Remote TC In 2	237	UINT32	R/W	Stop Mode Inhibit GG	No Unit	No=0 Yes=1
Remote TC In 2	237	UINT32	R/W	Threshold 1 Type GG	No Unit	Disabled=0 Over=1 Under=2
Remote TC In 2	237	UINT32	R/W	Threshold 2 Type GG	No Unit	Disabled=0 Over=1 Under=2
Remote TC In 2	237	UINT32	R/W	Threshold 3 Type GG	No Unit	Disabled=0 Over=1 Under=2
Remote TC In 2	237	UINT32	R/W	Threshold 4 Type GG	No Unit	Disabled=0 Over=1 Under=2
Remote TC In 2	238	Float	R/W	Cal Offset GG	Deg F	-99999 - 99999
Remote TC In 2	238	Float	R/W	Hysteresis GG	%	0 - 100
Remote TC In 2	238	Float	R/W	Arming Delay GG	Sec	0 - 300
Remote TC In 2	238	Float	R/W	Threshold 1 Pickup GG	Deg F	32 - 2507
Remote TC In 2	238	Float	R/W	Threshold 1 Activation Delay GG	Sec	0 - 300
Remote TC In 2	238	Float	R/W	Threshold 2 Pickup GG	Deg F	32 - 2507
Remote TC In 2	238	Float	R/W	Threshold 2 Activation Delay GG	Sec	0 - 300
Remote TC In 2	238	Float	R/W	Threshold 3 Pickup GG	Deg F	32 - 2507
Remote TC In 2	238	Float	R/W	Threshold 3 Activation Delay GG	Sec	0 - 300
Remote TC In 2	238	Float	R/W	Threshold 4 Pickup GG	Deg F	32 - 2507
Remote TC In 2	238	Float	R/W	Threshold 4 Activation Delay GG	Sec	0 - 300
Remote Analog Out 1	239	UINT32	R/W	Param Selection GG	No Unit	Gen VAB=0 Gen VBC=1 Gen VCA=2 Gen V Average=3 Bus Freq=4 Bus VAB=5 Bus VBC=6 Bus VCA=7 Gen Freq=8 Gen PF=9 KWH=10 KVARH=11 Gen IA=12 Gen IB=13 Gen IC=14 Gen I Average=15 KW Total=16 KVA Total=17 KVAR Total=18 EDM Ripple=19 Exciter Field Voltage=20 Exciter Field Current=21 Auxiliary Input Voltage=22 Auxiliary Input Current (mA)=23 Setpoint Position=24 Tracking Error=25 Neg Seq V=26 Neg Seq I=27 Pos Seq V=28 Pos Seq I=29 PSS Output=30 Analog Input 1=31 Analog Input 2=32 Analog Input 3=33 Analog Input 4=34 Analog Input 5=35 Analog Input 6=36 Analog Input 7=37 Analog Input 8=38 RTD Input 1=39 RTD Input 2=40 RTD Input 3=41 RTD Input 4=42 RTD Input 5=43 RTD Input 6=44 RTD Input 7=45 RTD Input 8=46 Thermocouple 1=47 Thermocouple 2=48
Remote Analog Out 1	239	UINT32	R/W	Output Type GG	No Unit	Voltage=0 Current=1
Remote Analog Out 1	240	Float	R/W	Out of Range Activation Delay GG	Sec	0 - 300
Remote Analog Out 1	240	Float	R/W	Param Min GG	No Unit	-99999 - 99999
Remote Analog Out 1	240	Float	R/W	Param Max GG	No Unit	-99999 - 99999
Remote Analog Out 1	240	Float	R/W	Current Min GG	mA	4 - 20

Instance Name	Inst. #	Type	RW	Key Name	Unit	Range
Remote Analog Out 1	240	Float	R/W	Current Max GG	mA	4 - 20
Remote Analog Out 1	240	Float	R/W	Voltage Min GG	V	0 - 10
Remote Analog Out 1	240	Float	R/W	Voltage Max GG	V	0 - 10
Remote Analog Out 2	241	UINT32	R/W	Param Selection GG	No Unit	Gen VAB=0 Gen VBC=1 Gen VCA=2 Gen V Average=3 Bus Freq=4 Bus VAB=5 Bus VBC=6 Bus VCA=7 Gen Freq=8 Gen PF=9 KWH=10 KVARH=11 Gen IA=12 Gen IB=13 Gen IC=14 Gen I Average=15 KW Total=16 KVA Total=17 KVAR Total=18 EDM Ripple=19 Exciter Field Voltage=20 Exciter Field Current=21 Auxiliary Input Voltage=22 Auxiliary Input Current (mA)=23 Setpoint Position=24 Tracking Error=25 Neg Seq V=26 Neg Seq I=27 Pos Seq V=28 Pos Seq I=29 PSS Output=30 Analog Input 1=31 Analog Input 2=32 Analog Input 3=33 Analog Input 4=34 Analog Input 5=35 Analog Input 6=36 Analog Input 7=37 Analog Input 8=38 RTD Input 1=39 RTD Input 2=40 RTD Input 3=41 RTD Input 4=42 RTD Input 5=43 RTD Input 6=44 RTD Input 7=45 RTD Input 8=46 Thermocouple 1=47 Thermocouple 2=48
Remote Analog Out 2	241	UINT32	R/W	Output Type GG	No Unit	Voltage=0 Current=1
Remote Analog Out 2	242	Float	R/W	Out of Range Activation Delay GG	Sec	0 - 300
Remote Analog Out 2	242	Float	R/W	Param Min GG	No Unit	-99999 - 99999
Remote Analog Out 2	242	Float	R/W	Param Max GG	No Unit	-99999 - 99999
Remote Analog Out 2	242	Float	R/W	Current Min GG	mA	4 - 20
Remote Analog Out 2	242	Float	R/W	Current Max GG	mA	4 - 20
Remote Analog Out 2	242	Float	R/W	Voltage Min GG	V	0 - 10
Remote Analog Out 2	242	Float	R/W	Voltage Max GG	V	0 - 10
Remote Analog Out 3	243	UINT32	R/W	Param Selection GG	No Unit	Gen VAB=0 Gen VBC=1 Gen VCA=2 Gen V Average=3 Bus Freq=4 Bus VAB=5 Bus VBC=6 Bus VCA=7 Gen Freq=8 Gen PF=9 KWH=10 KVARH=11 Gen IA=12 Gen IB=13 Gen IC=14 Gen I Average=15 KW Total=16 KVA Total=17 KVAR Total=18 EDM Ripple=19 Exciter Field Voltage=20 Exciter Field Current=21 Auxiliary Input Voltage=22 Auxiliary Input Current (mA)=23 Setpoint Position=24 Tracking Error=25 Neg Seq V=26 Neg Seq I=27 Pos Seq V=28 Pos Seq I=29 PSS Output=30 Analog Input 1=31 Analog Input 2=32 Analog Input 3=33 Analog Input 4=34 Analog Input 5=35 Analog Input 6=36 Analog Input 7=37 Analog Input 8=38 RTD Input 1=39 RTD Input 2=40 RTD Input 3=41 RTD Input 4=42 RTD Input 5=43 RTD Input 6=44 RTD Input 7=45 RTD Input 8=46 Thermocouple 1=47 Thermocouple 2=48
Remote Analog Out 3	243	UINT32	R/W	Output Type GG	No Unit	Voltage=0 Current=1
Remote Analog Out 3	244	Float	R/W	Out of Range Activation Delay GG	Sec	0 - 300
Remote Analog Out 3	244	Float	R/W	Param Min GG	No Unit	-99999 - 99999
Remote Analog Out 3	244	Float	R/W	Param Max GG	No Unit	-99999 - 99999
Remote Analog Out 3	244	Float	R/W	Current Min GG	mA	4 - 20

Instance Name	Inst. #	Type	RW	Key Name	Unit	Range
Remote Analog Out 3	244	Float	R/W	Current Max GG	mA	4 - 20
Remote Analog Out 3	244	Float	R/W	Voltage Min GG	V	0 - 10
Remote Analog Out 3	244	Float	R/W	Voltage Max GG	V	0 - 10
Remote Analog Out 4	245	UINT32	R/W	Param Selection GG	No Unit	Gen VAB=0 Gen VBC=1 Gen VCA=2 Gen V Average=3 Bus Freq=4 Bus VAB=5 Bus VBC=6 Bus VCA=7 Gen Freq=8 Gen PF=9 KWH=10 KVARH=11 Gen IA=12 Gen IB=13 Gen IC=14 Gen I Average=15 KW Total=16 KVA Total=17 KVAR Total=18 EDM Ripple=19 Exciter Field Voltage=20 Exciter Field Current=21 Auxiliary Input Voltage=22 Auxiliary Input Current (mA)=23 Setpoint Position=24 Tracking Error=25 Neg Seq V=26 Neg Seq I=27 Pos Seq V=28 Pos Seq I=29 PSS Output=30 Analog Input 1=31 Analog Input 2=32 Analog Input 3=33 Analog Input 4=34 Analog Input 5=35 Analog Input 6=36 Analog Input 7=37 Analog Input 8=38 RTD Input 1=39 RTD Input 2=40 RTD Input 3=41 RTD Input 4=42 RTD Input 5=43 RTD Input 6=44 RTD Input 7=45 RTD Input 8=46 Thermocouple 1=47 Thermocouple 2=48
Remote Analog Out 4	245	UINT32	R/W	Output Type GG	No Unit	Voltage=0 Current=1
Remote Analog Out 4	246	Float	R/W	Out of Range Activation Delay GG	Sec	0 - 300
Remote Analog Out 4	246	Float	R/W	Param Min GG	No Unit	-99999 - 99999
Remote Analog Out 4	246	Float	R/W	Param Max GG	No Unit	-99999 - 99999
Remote Analog Out 4	246	Float	R/W	Current Min GG	mA	4 - 20
Remote Analog Out 4	246	Float	R/W	Current Max GG	mA	4 - 20
Remote Analog Out 4	246	Float	R/W	Voltage Min GG	V	0 - 10
Remote Analog Out 4	246	Float	R/W	Voltage Max GG	V	0 - 10
User Programmable Alarms	248	Float	R/W	Programmable Alarm 1 Delay GG	Sec	0 - 300
User Programmable Alarms	248	Float	R/W	Programmable Alarm 2 Delay GG	Sec	0 - 300
User Programmable Alarms	248	Float	R/W	Programmable Alarm 3 Delay GG	Sec	0 - 300
User Programmable Alarms	248	Float	R/W	Programmable Alarm 4 Delay GG	Sec	0 - 300
User Programmable Alarms	248	Float	R/W	Programmable Alarm 5 Delay GG	Sec	0 - 300
User Programmable Alarms	248	Float	R/W	Programmable Alarm 6 Delay GG	Sec	0 - 300
User Programmable Alarms	248	Float	R/W	Programmable Alarm 7 Delay GG	Sec	0 - 300
User Programmable Alarms	248	Float	R/W	Programmable Alarm 8 Delay GG	Sec	0 - 300
User Programmable Alarms	248	Float	R/W	Programmable Alarm 9 Delay GG	Sec	0 - 300
User Programmable Alarms	248	Float	R/W	Programmable Alarm 10 Delay GG	Sec	0 - 300
User Programmable Alarms	248	Float	R/W	Programmable Alarm 11 Delay GG	Sec	0 - 300

Instance Name	Inst. #	Type	RW	Key Name	Unit	Range
User Programmable Alarms	248	Float	R/W	Programmable Alarm 12 Delay GG	Sec	0 - 300
User Programmable Alarms	248	Float	R/W	Programmable Alarm 13 Delay GG	Sec	0 - 300
User Programmable Alarms	248	Float	R/W	Programmable Alarm 14 Delay GG	Sec	0 - 300
User Programmable Alarms	248	Float	R/W	Programmable Alarm 15 Delay GG	Sec	0 - 300
User Programmable Alarms	248	Float	R/W	Programmable Alarm 16 Delay GG	Sec	0 - 300
Logic Timers	250	Float	R/W	Logic Timer 1 Output Timeout GG	Sec	0 - 1800
Logic Timers	250	Float	R/W	Logic Timer 2 Output Timeout GG	Sec	0 - 1800
Logic Timers	250	Float	R/W	Logic Timer 3 Output Timeout GG	Sec	0 - 1800
Logic Timers	250	Float	R/W	Logic Timer 4 Output Timeout GG	Sec	0 - 1800
Logic Timers	250	Float	R/W	Logic Timer 5 Output Timeout GG	Sec	0 - 1800
Logic Timers	250	Float	R/W	Logic Timer 6 Output Timeout GG	Sec	0 - 1800
Logic Timers	250	Float	R/W	Logic Timer 7 Output Timeout GG	Sec	0 - 1800
Logic Timers	250	Float	R/W	Logic Timer 8 Output Timeout GG	Sec	0 - 1800
Logic Timers	250	Float	R/W	Logic Timer 9 Output Timeout GG	Sec	0 - 1800
Logic Timers	250	Float	R/W	Logic Timer 10 Output Timeout GG	Sec	0 - 1800
Logic Timers	250	Float	R/W	Logic Timer 11 Output Timeout GG	Sec	0 - 1800
Logic Timers	250	Float	R/W	Logic Timer 12 Output Timeout GG	Sec	0 - 1800
Logic Timers	250	Float	R/W	Logic Timer 13 Output Timeout GG	Sec	0 - 1800
Logic Timers	250	Float	R/W	Logic Timer 14 Output Timeout GG	Sec	0 - 1800
Logic Timers	250	Float	R/W	Logic Timer 15 Output Timeout GG	Sec	0 - 1800
Logic Timers	250	Float	R/W	Logic Timer 16 Output Timeout GG	Sec	0 - 1800
Logic Counters	252	Float	R/W	Counter 1 Output Timeout GG	No Unit	0 - 1800
Logic Counters	252	Float	R/W	Counter 2 Output Timeout GG	No Unit	0 - 1800
Logic Counters	252	Float	R/W	Counter 3 Output Timeout GG	No Unit	0 - 1800
Logic Counters	252	Float	R/W	Counter 4 Output Timeout GG	No Unit	0 - 1800
Logic Counters	252	Float	R/W	Counter 5 Output Timeout GG	No Unit	0 - 1800
Logic Counters	252	Float	R/W	Counter 6 Output Timeout GG	No Unit	0 - 1800
Logic Counters	252	Float	R/W	Counter 7 Output Timeout GG	No Unit	0 - 1800
Logic Counters	252	Float	R/W	Counter 8 Output Timeout GG	No Unit	0 - 1800
AEM RTD TC Metric Meter	253	Float	R	RTD Input 1 Metric Value GG	Deg C	n/a
AEM RTD TC Metric Meter	253	Float	R	RTD Input 2 Metric Value GG	Deg C	n/a

Instance Name	Inst. #	Type	RW	Key Name	Unit	Range
AEM RTD TC Metric Meter	253	Float	R	RTD Input 3 Metric Value GG	Deg C	n/a
AEM RTD TC Metric Meter	253	Float	R	RTD Input 4 Metric Value GG	Deg C	n/a
AEM RTD TC Metric Meter	253	Float	R	RTD Input 5 Metric Value GG	Deg C	n/a
AEM RTD TC Metric Meter	253	Float	R	RTD Input 6 Metric Value GG	Deg C	n/a
AEM RTD TC Metric Meter	253	Float	R	RTD Input 7 Metric Value GG	Deg C	n/a
AEM RTD TC Metric Meter	253	Float	R	RTD Input 8 Metric Value GG	Deg C	n/a
AEM RTD TC Metric Meter	253	Float	R	Thermocouple Input 1 Metric Value GG	Deg C	n/a
AEM RTD TC Metric Meter	253	Float	R	Thermocouple Input 2 Metric Value GG	Deg C	n/a
Active Setpoint Meter	254	Float	R	Active AVR Setpoint	V	Configured
Active Setpoint Meter	254	Float	R	Active FCR Setpoint	Amp	Configured
Active Setpoint Meter	254	Float	R	Active FVR Setpoint	V	Configured
Active Setpoint Meter	254	Float	R	Active kvar Setpoint	kvar	Configured
Active Setpoint Meter	254	Float	R	Active PF Setpoint	PF	Configured

# Maintenance

## Warning!

These servicing instructions are for use by qualified personnel only. To reduce the risk of electric shock, do not perform any servicing other than that specified in the operating instructions unless you are qualified to do so.

Before performing any maintenance procedures, remove the DECS-250 from service. Refer to the appropriate site schematics to ensure that all steps have been taken to properly and completely de-energize the DECS-250.

## Storage

If the unit is not installed immediately DECS-250, store it in the original shipping package in a moisture- and dust-free environment.

## Preventive Maintenance

### Connections

Periodically check the connections of the DECS-250 to ensure they are clean and tight and remove any accumulation of dust.

### Electrolytic Capacitors

The DECS-250 contains long-life aluminum electrolytic capacitors. For a DECS-250 kept in storage as a spare, the life of these capacitors can be maximized by energizing the device for 30 minutes once per year. The energizing procedure for the DECS-250 is shown below.

#### DECS-250

1. Apply control power as indicated by the device style number. For this maintenance procedure, it is recommended that the applied voltage not exceed the nominal value.
  - Style Lxxxxxx: 24/48 Vdc (16 to 48 Vdc)
  - Style Cxxxxxx: 120 Vac (82 to 120 Vac at 50/60 Hz) or 125 Vdc (90 to 125 Vdc)
2. Apply operating power within one of the following ranges.
  - 56 to 70 Vac
  - 100 to 139 Vac, or 125 Vdc
  - 190 to 277 Vac, or 250 Vdc

## Caution

When energizing the DECS-250 from a low impedance source (such as a wall outlet), use of an Inrush Current Reduction Module (ICRM) is recommended to prevent damage to the DECS-250. For a detailed description of the Inrush Current Reduction Module, refer to Basler publication 9387900990. ICRM connections are illustrated in *Typical Connections*.

---

## ***Cleaning the Front Panel***

---

Only a soft cloth and water-based solutions should be used to clean the front panel. Do not use solvents.

## ***Troubleshooting***

---

The following troubleshooting procedures assume the excitation system components are properly matched, fully operational, and correctly connected. If you do not obtain the results that you expect from the DECS-250, first check the programmable settings for the appropriate function.

### **The DECS-250 Appears Inoperative**

If the DECS-250 does not power up (no backlighting on front panel display), ensure that the control power applied to the unit (AC input terminals L and N, DC input terminals BATT+ and BATT-) is at the correct level. If dc control power is being used, verify that the polarity is correct. Units with style number Lxxxxxx have an input voltage range of 16 to 60 Vdc. Units with style number Cxxxxxx have an input voltage range of 90 to 150 Vdc or 82 to 132 Vac (50/60 Hz).

<b>Note</b>
When both ac and dc control power is used, an isolation transformer must be connected between the ac voltage source and the ac control power terminals of the DECS-250.

### **Display Blank or Frozen**

If the front panel display (LCD) is blank or frozen (does not scroll), remove control power for about 60 seconds and then reapply control power. If the problem occurred during software uploading, repeat the upload procedures as described in the associated instructions.

### **Generator Voltage Does Not Build**

Check the DECS-250 settings and system voltages for the following:

- a. Generator potential transformer (PT) primary voltage
- b. Generator PT secondary voltage
- c. AC voltage on the DECS-250 operating (bridge) power terminals (C5 (A), C6 (B), and C7 (C))

Check the DECS-250 soft start bias and soft start time settings. If necessary, increase the generator soft start bias and decrease the generator soft start time.

If the generator voltage still does not build, increase the value of Kg.

Temporarily disable the overexcitation limiter.

### **Low Generator Voltage in AVR Mode**

Check the following DECS-250 settings and system parameters:

- a. AVR voltage setpoint
- b. Generator potential transformer (PT) primary voltage
- c. Generator PT secondary voltage
- d. Overexcitation limiter (not activated)
- e. Accessory inputs (should be zero)
- f. Var/PF and droop (should be disabled)
- g. Cut-in underfrequency setting (should be below the generator operating frequency)

If the problem persists, contact the Basler Electric Technical Sales Support department for advice.

## High Generator Voltage in AVR Mode

Check the following DECS-250 settings and system parameters:

- a. AVR voltage setpoint
- b. Generator potential transformer (PT) primary voltage
- c. Generator PT secondary voltage
- d. Accessory inputs (should be zero)
- e. Var/PF and droop (should be disabled)

If the problem persists, contact the Basler Electric Technical Sales Support department for advice.

## Generator Voltage Unstable (Hunting)

Verify that the exciter power converter is working correctly by substituting the appropriate battery voltage in place of the DECS-250 drive voltage. If the problem is caused by the DECS-250, check the gain settings for the specific mode of operation selected.

If the problem persists, contact the Basler Electric Technical Sales Support department for advice.

## Protection or Limit Annunciation

If a protection function or limiting function is annunciated, check the associated setting values.

If the problem persists, contact the Basler Electric Technical Sales Support department for advice.

## HMI Meter Readings Incorrect

If your PF, var, or watt readings are significantly different from the expected readings for a known load, verify that the B-phase current sensing input of the DECS-250 is connected to a CT on phase B and not phases A or C.

## No Communication

If communication with the DECS-250 cannot be initiated, check the connections at the communication ports, the baud rate, and supporting software.

## The DECS-250 Reboots Frequently

If a single DECS-250 control power source is used and the power source is supplying less than the minimum required voltage or is fluctuating below the minimum required voltage, the DECS-250 will reboot. Increase the control power source voltage so that it is within the specified operating range. Units with style number Lxxxxxx have an input voltage range of 16 to 60 Vdc. Units with style number Cxxxxxx have an input voltage range of 90 to 150 Vdc or 82 to 132 Vac (50/60 Hz).

## USB Drivers Failed to Install Automatically

Perform the following steps to manually install the DECS-250 USB drivers.

1. In the Windows Device Manager, under Other Devices, right-click on DECS-250 and select Properties. The Properties window will appear. (If DECS-250 is displayed as an "Unknown Device", restart the PC and repeat this step.)
2. In the Properties window, click the Update Driver button on the Driver tab.
3. Select "Browse my computer for driver software".
4. Click Browse and navigate to the following directory: C:\Program Files\Basler Electric\USB Device Drivers\USBIO
5. Click Next to install the drivers.

## Support

---

Contact the Basler Electric Technical Services Department at 1-(618)-654-2341 for troubleshooting support or to receive a return authorization number.



# Specifications

DECS-250 electrical and physical characteristics are listed in the following paragraphs.

## Operating Power

### Voltage Range

For 32 Vdc Excitation Power ..... 56 to 70 Vac

For 63 Vdc Excitation Power ..... 100 to 139 Vac or 125 Vdc

For 125 Vdc Excitation Power ... 190 to 277 Vac single-phase, 190 to 260 Vac three-phase,  
or 250 Vdc

Frequency Range..... dc, 50 to 500 Hz

### Caution

For redundant applications with a single-phase, 300 Hz Marathon® PMG, only one DECS-250 can be connected to the PMG at a time. In redundant applications, a contactor should be used for each DECS-250 power input or equipment damage may result.

If operating power exceeds 260 Vac, the connection must be configured as L-N single-phase or equipment damage may result.

Table 41 lists the required nominal operating power voltage and configuration required to obtain 32, 63, and 125 Vdc continuous field power for the DECS-250.

**Table 41. Operating Power Requirements**

Excitation Power	32 Vdc	63 Vdc	125 Vdc
Input Power Configuration	1- or 3-phase	1- or 3-phase	1- or 3-phase
Nominal Input Voltage	60 Vac	120 Vac	240 Vac
Full Load Continuous Voltage	32 Vdc	63 Vdc	125 Vdc
Full Load Continuous Current	15 Adc (20 Adc up to 55°C (131°F))		
Minimum Residual Voltage for Buildup	6 Vac		
Operating Power Input Burden at 15 Adc Excitation Output	780 VA	1,570 VA	3,070 VA
Operating Temperature at 15 Adc Excitation Output	-40 to +70°C (-40 to +158°F)		
Operating Power Input Burden at 20 Adc Excitation Output	1,070 VA	2,100 VA	4,170 VA
Operating Temperature at 20 Adc Excitation Output	-40 to +55°C (-40 to +131°F)		

## Control Power

Two control power inputs enable continued operation if one of the two inputs is lost. The control power voltage rating is determined by the device style number.

**Style LXXXXXX**DC Input

Nominal Input .....	24 or 48 Vdc
Input Range.....	16 to 60 Vdc
Burden.....	30 W

**Style CXXXXXX**AC Input

Nominal Input .....	120 Vac, 50/60 Hz
Input Range.....	82 to 132 Vac, 50/60 Hz
Burden.....	50 VA

DC Input

Nominal Input .....	125 Vdc
Input Range.....	90 to 150 Vdc
Burden.....	30 W

**Terminals**

AC Input .....	L, N
DC Input .....	BATT+, BATT-

***Generator and Bus Voltage Sensing***

Type .....	1-phase or 3-phase-3-wire
Burden.....	<1 VA per phase

**Terminals**

Generator Voltage Sensing.....	E1, E2, E3
Bus Voltage Sensing.....	B1, B2, B3

**50/60 Hz Sensing Voltage Nominal Input Range**

100 to 600 Vac,  $\pm 10\%$

***Generator Current Sensing***

Configuration.....	4 inputs: A-, B-, C-phase, and cross-current compensation CT input
Type .....	1-phase (B-phase), 1-phase with cross-current compensation, 3-phase, 3-phase with cross-current compensation
Range.....	1 Aac or 5 Aac nominal
Frequency .....	50/60 Hz
Burden	
1 Aac Sensing.....	<5 VA
5 Aac Sensing.....	<10 VA

**Terminals**

A-Phase.....	CTA+, CTA-
B-Phase.....	CTB+, CTB-
C-Phase .....	CTC+, CTC-
Cross-Current Compensation .....	CCCT+, CCCT-

## Accessory Inputs

---

### Current Input

Range.....	4 to 20 mAdc
Burden.....	Approximately 500 $\Omega$
Terminals.....	I+, I-

### Voltage Input

Range.....	-10 to +10 Vdc
Burden.....	>20 k $\Omega$
Terminals.....	V+, V-

## Metering Accuracy

---

Generator Voltage (each phase and average) .....	$\pm 1\%$ of rated
Bus Voltage.....	$\pm 1\%$ of rated
Generator and Bus Frequency.....	$\pm 0.1$ Hz of rated
Generator Line Current .....	$\pm 1\%$ of rated
Generator Apparent, Active, and Reactive Power .....	$\pm 1\%$ of rated
Power Factor.....	$\pm 0.02$
Field Current and Voltage .....	$\pm 1\%$ of rated
Accessory Input.....	$\pm 1\%$ of rated

## Contact Inputs

---

Type .....	Dry contact, accept PLC open-collector outputs
Interrogation Voltage.....	12 Vdc

### Terminals

Start.....	START, COM A
Stop .....	STOP, COM A
Programmable Input 1.....	IN 1, COM A
Programmable Input 2.....	IN 2, COM A
Programmable Input 3.....	IN 3, COM A
Programmable Input 4.....	IN 4, COM A
Programmable Input 5.....	IN 5, COM A
Programmable Input 6.....	IN 6, COM A
Programmable Input 7.....	IN 7, COM B
Programmable Input 8.....	IN 8, COM B
Programmable Input 9.....	IN 9, COM B
Programmable Input 10.....	IN 10, COM B
Programmable Input 11.....	IN 11, COM B
Programmable Input 12.....	IN 12, COM B
Programmable Input 13.....	IN 13, COM B
Programmable Input 14.....	IN 14, COM B

## Communication Ports

---

### Universal Serial Bus (USB)

Interface .....	USB type B port
Location.....	Front panel



120/240 Vac.....	7.0 Aac
<b>Terminal Assignments</b>	
Watchdog.....	WTCHD1, WTCHD, WTCHD2
Relay Output 1.....	RLY 1, RLY 1
Relay Output 2.....	RLY 2, RLY 2
Relay Output 3.....	RLY 3, RLY 3
Relay Output 4.....	RLY 4, RLY 4
Relay Output 5.....	RLY 5, RLY 5
Relay Output 6.....	RLY 6, RLY 6
Relay Output 7.....	RLY 7, RLY 7
Relay Output 8.....	RLY 8, RLY 8
Relay Output 9.....	RLY 9, RLY 9
Relay Output 10.....	RLY 10, RLY 10
Relay Output 11.....	RLY 11, RLY 11

## ***Field Power Output***

---

Continuous Rating.....	15 Adc (20 Adc up to 55°C (131°F))
Terminals.....	F+, F–

### **Minimum 10-Second Forcing Output Rating**

60 Vac Input .....	50 Vdc, 30 Adc
120 Vac Input .....	100 Vdc, 30 Adc
240 Vac Input .....	200 Vdc, 30 Adc

### **Minimum Field Resistance**

32 Vdc Application .....	2.13 $\Omega$ (1.6 $\Omega$ for 20 Adc up to 55°C (131°F))
63 Vdc Application .....	4.20 $\Omega$ (3.15 $\Omega$ for 20 Adc up to 55°C (131°F))
125 Vdc Application .....	8.33 $\Omega$ (6.25 $\Omega$ for 20 Adc up to 55°C (131°F))

## ***Regulation***

---

### **FCR Operating Mode**

Setpoint Range .....	0 to 18 Adc, in increments of 0.1%
Regulation Accuracy .....	$\pm 1.0\%$ of the nominal value for 10% of the power input voltage change or 20% of the field resistance change. Otherwise, $\pm 5.0\%$

### **FVR Operating Mode**

Setpoint Range .....	0 to 270 Vdc, in increments of 0.1%
Regulation Accuracy .....	$\pm 1.0\%$ of the nominal value for 10% of the power input voltage change or 20% of the field resistance change. Otherwise, $\pm 5.0\%$

### **AVR Operating Mode**

Setpoint Range .....	70 to 120% of rated generator voltage, in increments of 0.1%
Regulation Accuracy .....	$\pm 0.25\%$ over load range at rated PF with constant generator frequency and ambient temperature
Steady-State Stability.....	$\pm 0.25\%$ at rated PF with constant generator frequency and ambient temperature
Temperature Drift.....	$\pm 0.5\%$ between 0 and 40°C at constant load and generator frequency

### **Var Operating Mode**

Setpoint Range .....	–100% (leading) to +100% (lagging) of the generator nominal apparent power in increments of 0.1%
----------------------	--

Regulation Accuracy .....  $\pm 2.0\%$  of the nominal generator apparent power rating at the rated generator frequency

### Power Factor Operating Mode

Setpoint Range ..... 0.5 to 1.0 (lagging) and  $-0.5$  to  $-1.0$  (leading), in increments of 0.005  
 Regulation Accuracy .....  $\pm 0.02$  PF of the PF setpoint for the real power between 10 and 100% at the rated frequency

## Parallel Compensation

---

Modes ..... Reactive Droop, Line Drop, and Reactive Differential (Cross-Current)  
 Cross-Current Input Burden ..... Can exceed 1 VA if external resistors are added to the CT circuit for cross-current compensation  
 Cross-Current Input Terminals ..... CCCT+, CCCT–

### Setpoint Range

Reactive Droop ..... 0 to  $+30\%$  of Rated Voltage  
 Line Drop ..... 0 to  $30\%$  of Rated Voltage  
 Cross-Current .....  $-30$  to  $+30\%$  of Primary CT Current

## Generator Protection Functions

---

### Overvoltage (59) and Undervoltage (27)

#### Pickup

Range ..... 1 to 600,000 Vac  
 Increment ..... 1 Vac

#### Time Delay

Range ..... 0.1 to 60 s  
 Increment ..... 0.1 s

### Loss of Sensing

#### Time Delay

Range ..... 0 to 30 s  
 Increment ..... 0.1 s

#### Voltage Balanced Level

Range ..... 0 to  $100\%$  of Positive Sequence Voltage  
 Increment .....  $0.1\%$

#### Voltage Unbalanced Level

Range ..... 0 to  $100\%$  of Positive Sequence Voltage  
 Increment .....  $0.1\%$

### Overfrequency (81O) and Underfrequency (81U)

#### Pickup

Range ..... 30 to 70 Hz  
 Increment ..... 0.01 Hz

#### Time Delay

Time Delay Range ..... 0 to 300 s  
 Increment ..... 0.1 s

Voltage Inhibit (81U only)

Range..... 50 to 100% of Rated Voltage  
 Increment ..... 1%

**Reverse Power (32R)**Pickup

Range..... 0 to 150% of Rated Watts  
 Increment ..... 1%

Time Delay

Range..... 0 to 300 s  
 Increment ..... 0.1 s

**Loss of Excitation (40Q)**Pickup

Range..... 0 to 150% of Rated kvars  
 Increment ..... 1%

Time Delay

Range..... 0 to 300 s  
 Increment ..... 0.1 s

**Field Protection Functions****Field Overvoltage**Pickup

Range..... 1 to 325 Vdc  
 Increment ..... 1 Vdc

Time Delay

Range..... 0.2 to 30 s  
 Increment ..... 0.1 s

**Field Overcurrent**Pickup

Range..... 0 to 22 Adc  
 Increment ..... 0.1 Adc

Time Delay

Range..... 5 to 60 s  
 Increment ..... 0.1 s

**Loss of PMG**Pickup

Single-Phase Source ..... <10 Vac  
 Three-Phase Source ..... <50 Vac or a phase-to-phase imbalance >20%

Time Delay

Range..... 0 to 10 s  
 Increment ..... 0.1 s

## Exciter Diode Monitor (EDM)

### Pole Ratio

Range..... 0 to 10  
Increment ..... 0.01

### Pickup Level

Open and Shorted Diode ..... 0 to 100% of Metered Field Current  
Increment ..... 0.1%

### Delay

Open Diode Protection..... 10 to 60 s  
Shorted Diode Protection ..... 5 to 30 s  
Increment ..... 0.1 s

## **Synchronism Check (25) Protection**

---

### **Voltage Difference**

Range..... 1 to 50%  
Increment ..... 1%

### **Slip Angle**

Range..... 1 to 99°  
Increment ..... 0.1°

### **Slip Frequency**

Range..... 0.01 to 0.5 Hz  
Increment ..... 0.01 Hz

## **Startup**

---

### **Soft Start Level**

Range..... 0 to 90% of Rated Gen Voltage  
Increment ..... 1%

### **Soft Start Time**

Range..... 1 to 7,200 s  
Increment ..... 1 s

### **Field Flash Dropout Level**

Range..... 0 to 100% of Rated Gen Voltage  
Increment ..... 1%

### **Maximum Field Flash Time**

Range..... 1 to 50 s  
Increment ..... 1 s

## **Voltage Matching**

---

Accuracy..... Generator rms voltage is matched with the bus rms voltage to within  $\pm 0.5\%$  of the generator voltage.

## ***Power System Stabilizer (Style xPxxxxx)***

---

Model..... IEEE Std 421.5 type PSS2A/2B/2C  
 Operating Mode ..... Generator or Motor, ABC or ACB phase sequence  
 Sensing Configuration ..... Power and Speed or Speed only  
 Power Measurement ..... Two Wattmeter method or Three Wattmeter method

### ***On-Line Overexcitation Limiting***

---

#### **High Current Level**

##### Pickup

Range..... 0 to 40 Adc  
 Increment ..... 0.1 Adc

##### Time

Range..... 0 to 10 s  
 Increment ..... 1 s

#### **Medium Current Level**

##### Pickup

Range..... 0 to 30 Adc  
 Increment ..... 0.1 Adc

##### Time

Range..... 0 to 120 s  
 Increment ..... 1 s

#### **Low Current Level**

##### Pickup

Range..... 0 to 20 Adc  
 Increment ..... 0.1 Adc

### ***Off-Line Overexcitation Limiting***

---

#### **High Current Level**

##### Pickup

Range..... 0 to 40 Adc  
 Increment ..... 0.1 Adc

##### Time

Range: ..... 0 to 10 s  
 Increment: ..... 1 s

#### **Low Current Level**

##### Pickup

Range..... 0 to 20 Adc  
 Increment ..... 0.1 Adc

---

## ***Sequence of Events Recording (SER)***

---

Over 1,000 records are stored in nonvolatile memory (retrievable via BESTCOMSPi<sup>us</sup>®). The SER can be triggered by: Input/Output status changes, system operating status changes, or alarm annunciations.

---

## ***Data Logging (Oscillography)***

---

Up to 6 variables can be logged. The sampling rate is 1,200 data points per log, up to 1,199 pre-trigger, 4 ms to 10 s intervals, (4.8 s to 12,000 s total log duration).

---

## ***Environment***

---

### **Temperature**

Operating Range ..... –40 to +70°C (–40 to +158°F)

Storage Range ..... –40 to +85°C (–40 to +185°F)

### **Humidity**

MIL-STD-705B, Method 711-1C

### **Salt Fog**

MIL-STD-810E, Method 509.3

---

## ***Type Tests***

---

### **Shock**

Withstands 15 G in 3 perpendicular planes.

### **Vibration**

18 to 2,000 Hz ..... 5 G for 8 hours

### **Impulse**

IEC 60255-5

### **Transients**

EN61000-4-4

### **Static Discharge**

EN61000-4-2

### **Radio Interference**

Type tested using a 5 W, hand-held transceiver operating at random frequencies centered around 144 MHz and 440 MHz with the antenna located within 150 mm (6 inches) of the device in both vertical and horizontal planes.

### **HALT (Highly Accelerated Life Testing)**

HALT is used by Basler Electric to prove that our products will provide the user with many years of reliable service. HALT subjects the device to extremes in temperature, shock, and vibration to simulate years of operation, but in a much shorter period. HALT allows Basler Electric to evaluate all possible design elements that will add to the life of this device. As an example of some of the extreme testing conditions, the DECS-250 was subjected to temperature tests (tested over a temperature range of –100

to +120°C (–148 to +248°F)), vibration tests (of 5 to 45 G at +20°C (68°F)), and temperature/vibration tests (tested at 40 G over a temperature range of –100 to +120°C (–148 to +248°F)). Combined temperature and vibration testing at these extremes proves that the DECS-250 is expected to provide long-term operation in a rugged environment. Note that the vibration and temperature extremes listed in this paragraph are specific to HALT and do not reflect recommended operation levels.

## **Patent**

---

Self-Tuning Patent Number: ..... US 2009/0195224 A1

## **Physical**

---

Dimensions..... Refer to the *Mounting* chapter.  
Weight ..... 6.62 kg (14.6 lb)

## **Regulatory Certifications and Standards**

---

### **Maritime Recognition**

Recognized per standard IACS UR (sections E10 and E22) by the following:

- Bureau Veritas (BV)
- Det Norske Veritas - Germanischer Lloyd (DNV•GL)
- American Bureau of Shipping (ABS)

IEC 60092-504 used for evaluation.

For current certificates, see [www.basler.com](http://www.basler.com).

### **UL Certification**

This product is a Recognized Component (cURus) covering the US and Canadian.

UL File (E97035-FPTM2/FPTM8)

Standards used for evaluation:

- UL 6200
- CSA C22.2 No. 14

### **CSA Certification**

This product was tested and has met the certification requirements for electrical, plumbing, and/or mechanical products. CSA Report (2385480)

Standards used for evaluation:

- UL 508
- CSA C22.2 No. 0
- CSA C22.2 No. 14

### **CE Compliance**

This product has been evaluated and complies with the relevant essential requirements set forth by the EU legislation.

EC Directives:

- LVD 2014/35/EU
- EMC 2014/30/EU
- ROHS 2 2011/65/EU

Harmonized standards used for evaluation:

- EN 50178 – Electronic Equipment for use in Power Installations

- EN 50581 – Technical Documentation for the Assessment of Electrical and Electronic Products with Respect to the Restriction of Hazardous Substances.
- EN 61000-6-4 – Electromagnetic Compatibility (EMC), Generic Standards, Emission Standard for Industrial Environments
- EN 61000-6-2 – Electromagnetic Compatibility (EMC), Generic Standards, Immunity for Industrial Environments

**EAC Mark (Eurasian Conformity)**

- TP TC 004/2011
- TP TC 020/2011

For current certificate, see [www.basler.com](http://www.basler.com).

# Analog Expansion Module

## General Information

---

The optional AEM-2020 is a remote auxiliary device that provides additional DECS-250 analog inputs and outputs.

## Features

---

The AEM-2020 has the following features:

- Eight Analog Inputs
- Eight RTD Inputs
- Two Thermocouple Inputs
- Four Analog Outputs
- Functionality of Inputs and Outputs assigned by BESTlogic™ *Plus* programmable logic
- Communications via CAN Bus

## Specifications

---

### Operating Power

Nominal ..... 12 or 24 Vdc  
 Range ..... 8 to 32 Vdc (Withstands ride-through down to 6 Vdc for 500 ms.)  
 Maximum Consumption ..... 5.1 W

### Analog Inputs

The AEM-2020 contains eight programmable analog inputs.

Rating ..... 4 to 20 mA or 0 to 10 Vdc (user-selectable)  
 Burden  
   4 to 20 mA ..... 470  $\Omega$  maximum  
   0 to 10 Vdc ..... 9.65k  $\Omega$  minimum

### RTD Inputs

The AEM-2020 contains eight programmable RTD inputs.

Rating ..... 100  $\Omega$  Platinum or 10  $\Omega$  Copper (user-selectable)  
 Setting Range ..... -50 to +250°C or -58 to +482°F  
 Accuracy (10  $\Omega$  Copper) .....  $\pm 0.044 \Omega @ 25^\circ\text{C}$ ,  $\pm 0.005 \Omega/^\circ\text{C}$  drift over ambient temperature  
 Accuracy (100  $\Omega$  Platinum) .....  $\pm 0.39 \Omega @ 25^\circ\text{C}$ ,  $\pm 0.047 \Omega/^\circ\text{C}$  drift over ambient temperature

### Thermocouple Inputs

The AEM-2020 contains two thermocouple inputs.

Rating ..... 2 K Type Thermocouples  
 Setting Range ..... 0 to 1,375°C or 0 to 2,507°F  
 Display Range ..... Ambient to 1,375°C or Ambient to 2,507°F  
 Accuracy .....  $\pm 40 \mu\text{V} @ 25^\circ\text{C}$ ,  $\pm 5 \mu\text{V}/^\circ\text{C}$  drift over ambient temperature

### Analog Outputs

The AEM-2020 contains four programmable analog outputs.

Rating ..... 4 to 20 mA or 0 to 10 Vdc (user-selectable)

## Communication Interface

The AEM-2020 communicates with the through CAN1.

### CAN Bus

Differential Bus Voltage..... 1.5 to 3 Vdc  
 Maximum Voltage .....-32 to +32 Vdc with respect to negative battery terminal  
 Communication Rate..... 125 or 250 kb/s

## Type Tests

### Shock

Withstands 15 G in 3 perpendicular planes.

### Vibration

Swept over the following ranges for 12 sweeps in each of three mutually perpendicular planes with each 15-minute sweep consisting of the following:

5 to 29 to 5 Hz..... 1.5 G peak for 5 min.  
 29 to 52 to 29 Hz..... 0.036" Double Amplitude for 2.5 min.  
 52 to 500 to 52 Hz..... 5 G peak for 7.5 min.

### HALT (Highly Accelerated Life Testing)

HALT is used by Basler Electric to prove that our products will provide the user with many years of reliable service. HALT subjects the device to extremes in temperature, shock, and vibration to simulate years of operation, but in a much shorter period span. HALT allows Basler Electric to evaluate all possible design elements that will add to the life of this device. As an example of some of the extreme testing conditions, the AEM-2020 was subjected to temperature tests (tested over a temperature range of -80°C to +130°C), vibration tests (of 5 to 50 G at +25°C), and temperature/vibration tests (tested at 10 to 20 G over a temperature range of -60°C to +100°C). Combined temperature and vibration testing at these extremes proves that the AEM-2020 is expected to provide long-term operation in a rugged environment. Note that the vibration and temperature extremes listed in this paragraph are specific to HALT and do not reflect recommended operation levels. These operational ratings are included in the *Specifications* chapter of this manual.

## Environment

### Temperature

Operating .....-40 to +70°C (-40 to +158°F)  
 Storage .....-40 to +85°C (-40 to +185°F)  
 Humidity ..... IEC 68-2-38

## Agency, Standards, and Directives

### UL Approval

The AEM-2020 is a Recognized Component for the US and Canada under UL file E97035 (CCN-FTPM2/FTPM8) covered under the Standards below:

- UL 6200
- CSA C22.2 No.14-13

The AEM-2020 is a Recognized Component for the US and Canada under UL file E470837 (CCN-FTWD2/FTWD8) for use in Hazardous Locations:

- Class I Division 2
- Groups A, B, C & D

### CSA Approval

The AEM-2020 is covered under CSA file 1042505 (LR23131-138S).

- CSA C22.2 No. 14-13

### CE Compliance

This product complies with the requirements of the following EC Directives:

- Low Voltage Directive (LVD) 2014/35/EU
- Electromagnetic Compatibility (EMC) 2014/30/EU
- Hazardous Substances (RoHS 2) 2011/65/EU

This product conforms to the following Harmonized Standards:

- EN 50178:1997 - *Electronic Equipment for use in Power Installations*
- EN 61000-6-4:2001 - *Electromagnetic Compatibility (EMC), Generic Standards, Emission Standard for Industrial Environments*
- EN 61000-6-2:2001 - *Electromagnetic Compatibility (EMC), Generic Standards, Immunity for Industrial Environments*
- EN 50581:2012, Ed. 12 - *Technical Documentation for the Assessment of Electrical and Electronic Products with respect to the Restriction of Hazardous Substances.*

### EAC Mark (Eurasian Conformity)

- TP TC 004/2011
- TP TC 020/2011

### **Physical**

Weight ..... 1.80 lb (816 g)

Dimensions..... See *Installation* later in this chapter.

## ***Installation***

Analog Expansion Modules are delivered in sturdy cartons to prevent shipping damage. Upon receipt of a module, check the part number against the requisition and packing list for agreement. Inspect for damage, and if there is evidence of such, immediately file a claim with the carrier and notify the Basler Electric regional sales office, your sales representative, or a sales representative at Basler Electric, Highland, Illinois USA.

If the device is not installed immediately, store it in the original shipping package in a moisture- and dust-free environment.

### **Mounting**

Analog Expansion Modules are contained in a potted plastic case and may be mounted in any convenient position. The construction of an Analog Expansion Module is durable enough to mount directly on a gasket using ¼-inch hardware. Hardware selection should be based on any expected shipping/transportation and operating conditions. The torque applied to the mounting hardware should not exceed 65 in-lb (7.34 N•m).

See Figure 189 for AEM-2020 overall dimensions. All dimensions are shown in inches with millimeters in parenthesis.

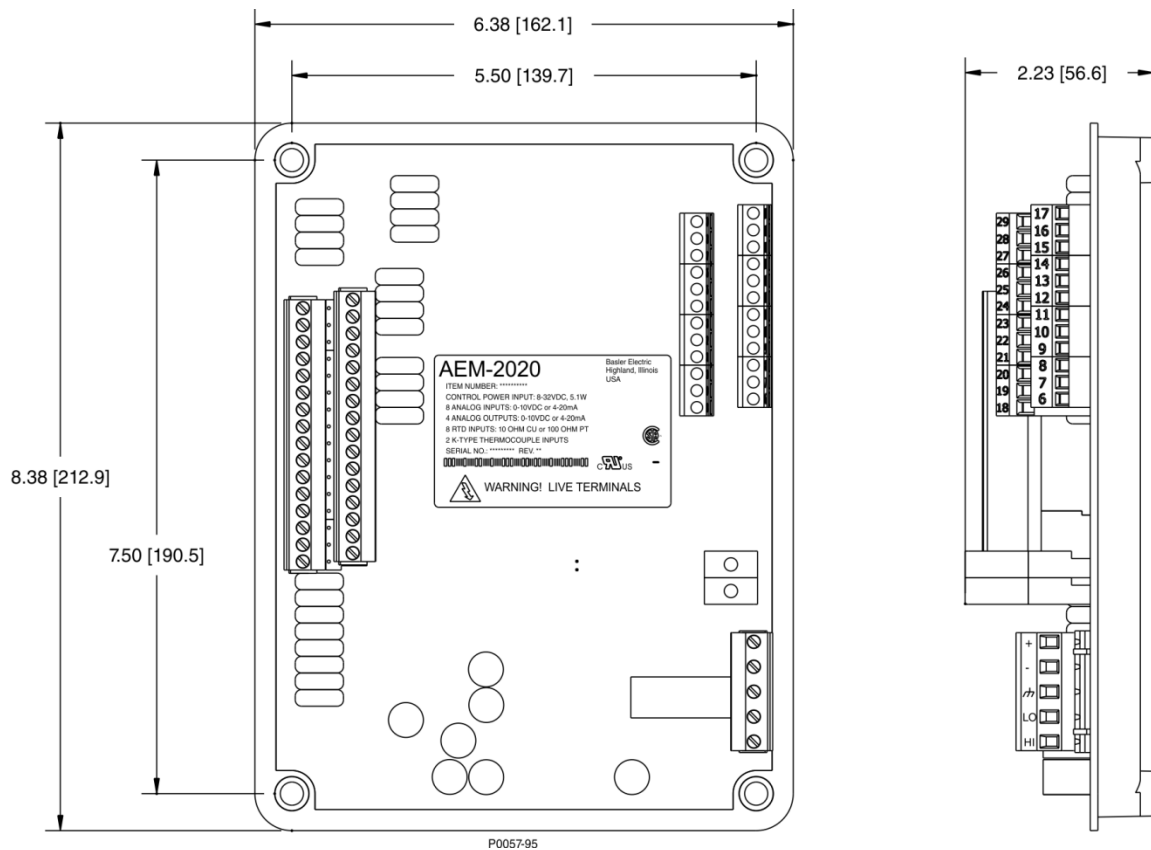


Figure 189. AEM-200 Overall Dimensions

## Connections

Analog Expansion Module connections are dependent on the application. Incorrect wiring may result in damage to the module.

### Note

Operating power from the battery must be of the correct polarity. Although reverse polarity will not cause damage, the AEM-200 will not operate.

Be sure that the AEM-200 is hard-wired to earth ground with no smaller than 12 AWG copper wire attached to the chassis ground terminal on the module.

### Terminations

The terminal interface consists of both plug-in connectors and a permanently mounted connector with screw-down compression terminals.

AEM-200 connections are made with one 5-position connector, two 12-position connectors, two 16-position connectors, and two 2-position thermocouple connectors. The 16, 5, and 2-position connectors plug into headers on the AEM-200. The connectors and headers have dovetailed edges that ensure proper connector orientation. Also, the connectors and headers are uniquely keyed to ensure that the connectors mate only with the correct headers. The 12-position connector is not a plug-in connector and is mounted permanently to the board.

Connectors and headers may contain tin- or gold-plated conductors. Tin-plated conductors are housed in a black plastic casing and gold-plated conductors are housed in an orange plastic casing. Mate connectors to headers of the same color only.

### Caution

By mating conductors of dissimilar metals, galvanic corrosion could occur which deteriorates connections and leads to signal loss.

Connector screw terminals accept a maximum wire size of 12 AWG. Thermocouple connectors accept a maximum thermocouple wire diameter of 0.177 inches (4.5 mm). Maximum screw torque is 5 in-lb (0.56 N•m).

#### Operating Power

The Analog Expansion Module operating power input accepts either 12 Vdc or 24 Vdc and tolerates voltage over the range of 6 to 32 Vdc. Operating power must be of the correct polarity. Although reverse polarity will not cause damage, the AEM-2020 will not operate. Operating power terminals are listed in Table 42.

It is recommended that a fuse be added for additional protection for the wiring to the battery input of the Analog Expansion Module. A Bussmann ABC-7 fuse or equivalent is recommended.

**Table 42. Operating Power Terminals**

Terminal	Description
P1- ↗ (SHIELD)	Chassis ground connection
P1- – (BATT–)	Negative side of operating power input
P1- + (BATT+)	Positive side of operating power input

#### AEM-2020 Inputs and Outputs

Input and output terminals are shown in Figure 190 and listed in Table 43.

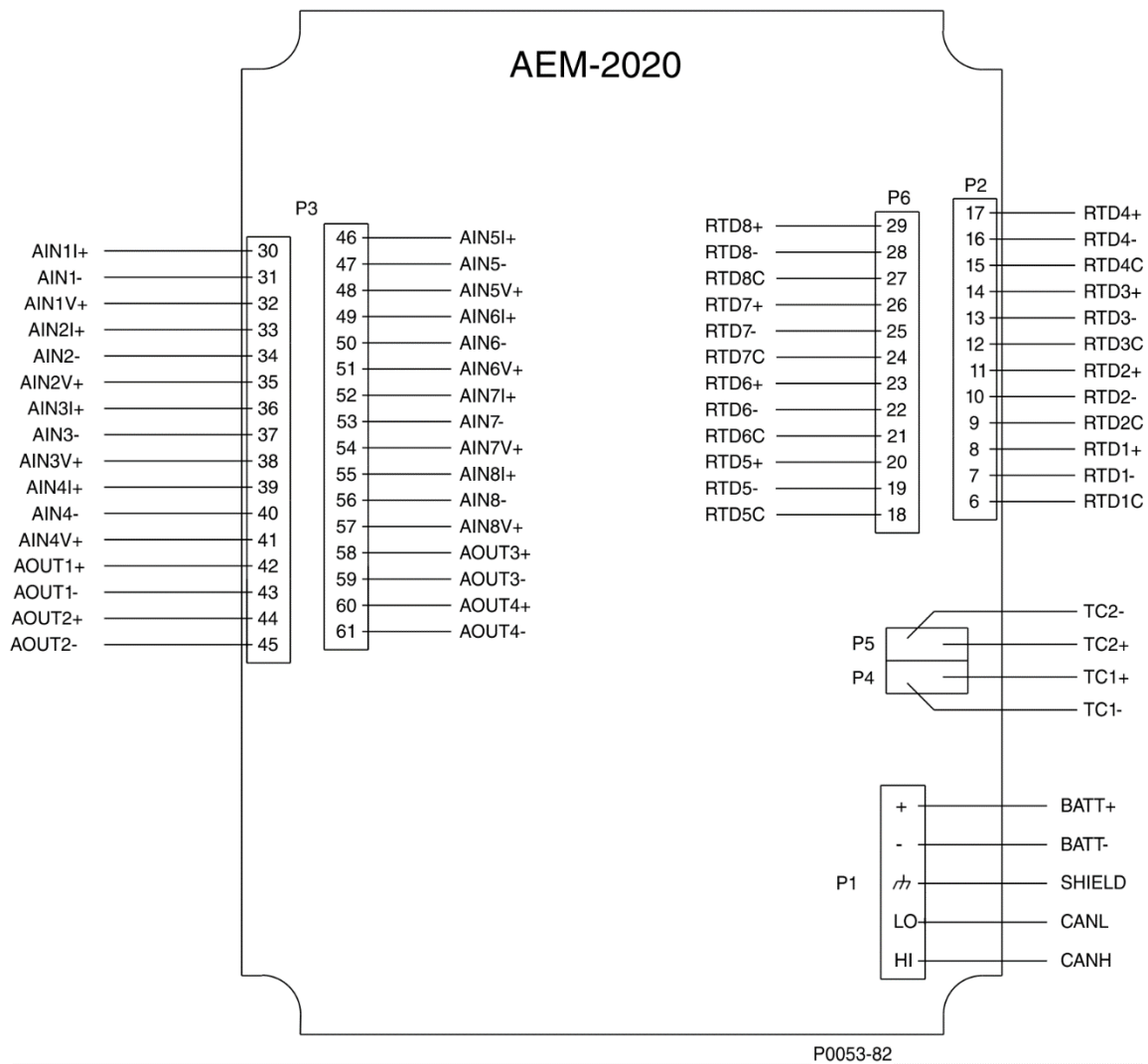


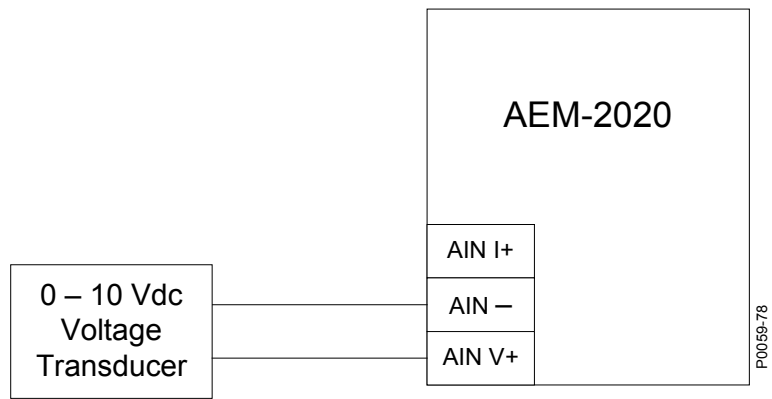
Figure 190. Input and Output Terminals

Table 43. Input and Output Terminals

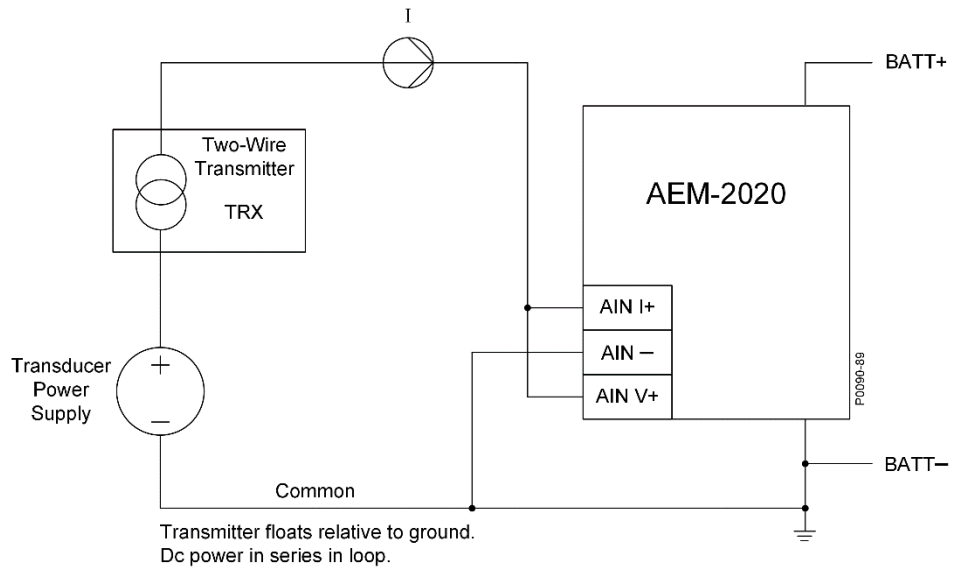
Connector	Description
P1	Operating Power and CAN bus
P2	RTD Inputs 1 - 4
P3	Analog Inputs 1 - 8 and Analog Outputs 1 - 4
P4	Thermocouple 1 Input
P5	Thermocouple 2 Input
P6	RTD Inputs 5 - 8

### External Analog Input Connections

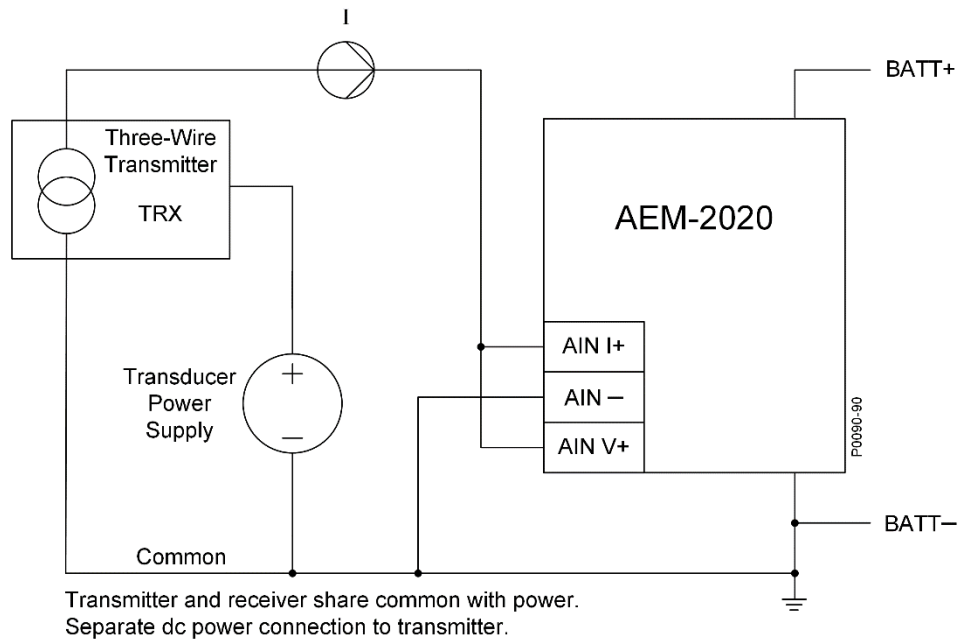
Voltage input connections are shown in Figure 191 and current input connections are shown in Figures 192 through 194. When using the current input, AIN V+ and AIN I+ must be tied together.



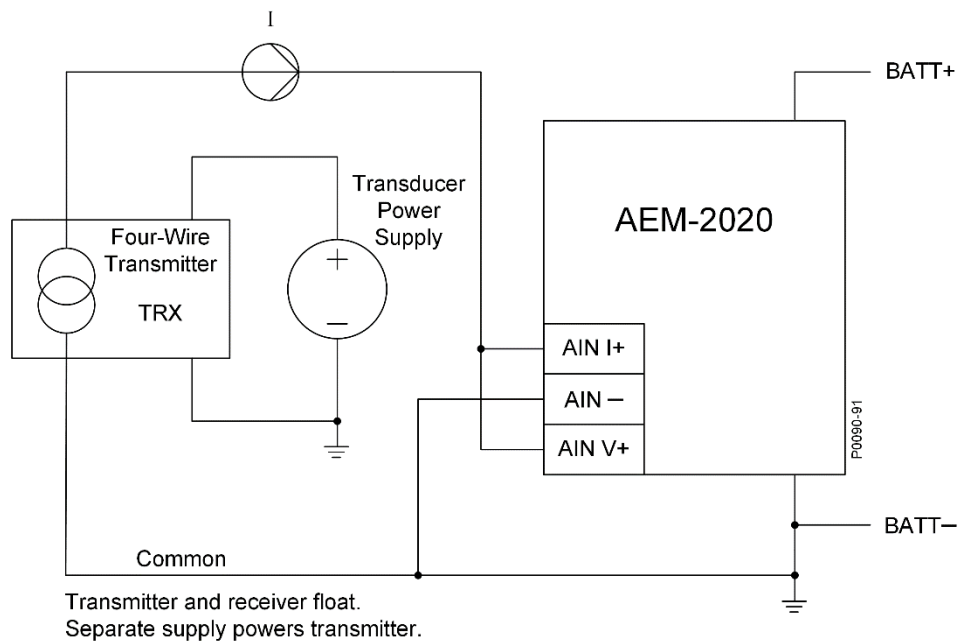
**Figure 191. Analog Inputs - Voltage Input Connections**



**Figure 192. Analog Inputs - Current Input Connections, Type II 2-Wire Circuit**



**Figure 193. Analog Inputs - Current Input Connections, Type III 2-Wire Circuit**



**Figure 194. Analog Inputs - Current Input Connections, Type IV 2-Wire Circuit**

### External RTD Input Connections

External 2-wire RTD input connections are shown in Figure 195. Figure 196 shows external 3-wire RTD input connections.

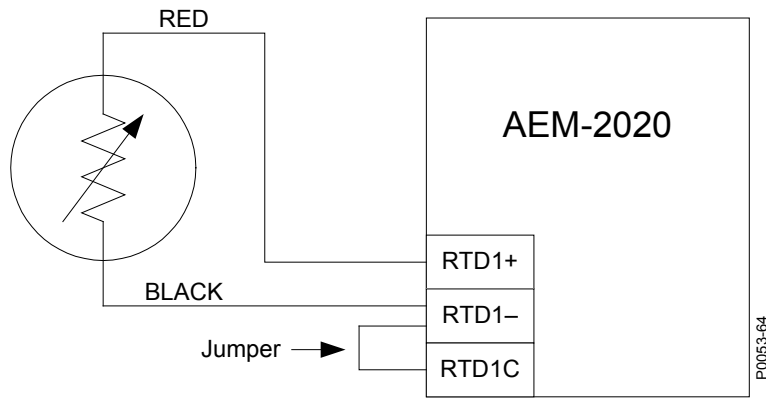


Figure 195. External Two-Wire RTD Input Connections

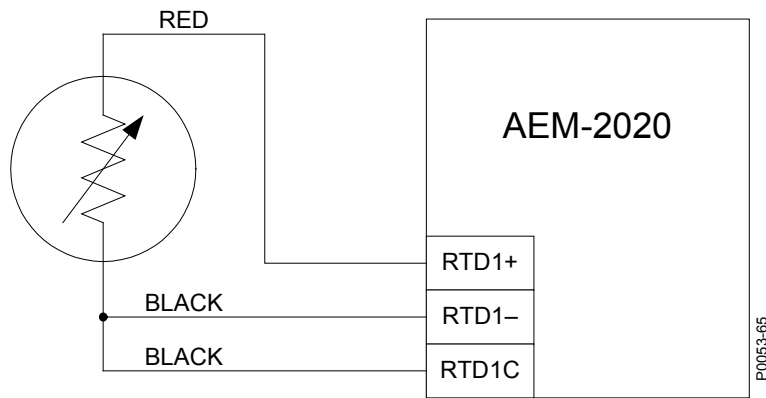


Figure 196. External Three-Wire RTD Input Connections

CAN Bus Interface

These terminals provide communication using the SAE J1939 protocol and provide high-speed communication between the Analog Expansion Module and the DECS-250. Connections between the AEM-2020 and DECS-250 should be made with twisted-pair, shielded cable. CAN Bus interface terminals are listed in Table 44. Refer to Figure 197 and Figure 198.

Table 44. CAN bus Interface Terminals

Terminal	Description
P1- HI (CAN H)	CAN high connection (yellow wire)
P1- LO (CAN L)	CAN low connection (green wire)
P1- ⚡ (SHIELD)	CAN drain connection

### Notes

1. If the AEM-2020 is providing one end of the J1939 bus, a 120  $\Omega$ , ½ watt terminating resistor should be installed across terminals P1- LO (CANL) and P1- HI (CANH).
2. If the AEM-2020 is not part of the J1939 bus, the stub connecting the AEM-2020 to the bus should not exceed 914 mm (3 ft) in length.
3. The maximum bus length, not including stubs, is 40 m (131 ft).
4. The J1939 drain (shield) should be grounded at one point only. If grounded elsewhere, do not connect the drain to the AEM-2020.

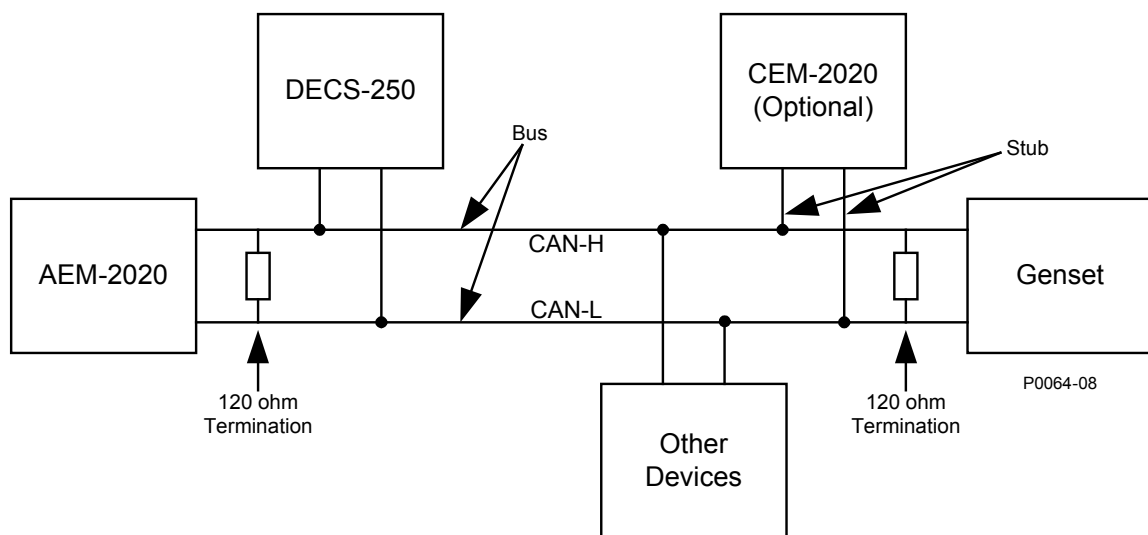


Figure 197. CAN Bus Interface with AEM-2020 providing One End of the Bus

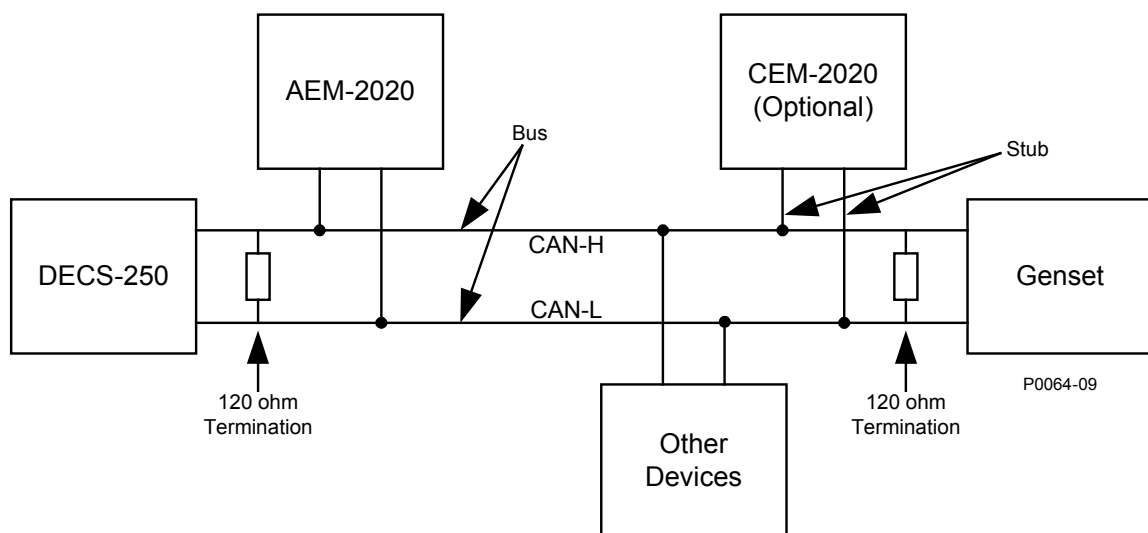


Figure 198. CAN Bus Interface with DECS-250 providing One End of the Bus

## Communications

**BESTCOMSPi<sup>®</sup> Navigation Path:** Settings, Communications, CAN bus, Remote Module Setup

**HMI Navigation Path:** Settings, Communication, CAN bus, Remote Module Setup, Analog Expansion Module

The analog expansion module must be enabled with the correct J1939 address. A Control Area Network (CAN) is a standard interface that enables communication between the AEM-2020 and the DECS-250. The Remote Module Setup screen is illustrated in Figure 199.

Figure 199. Remote Module Setup

## Functional Description

### Analog Inputs

**BESTCOMSPi<sup>®</sup> Navigation Path:** Settings, Programmable Inputs, Remote Analog Inputs

**HMI Navigation Path:** Settings, Programmable Inputs, Remote Analog Inputs

The AEM-2020 provides eight analog inputs that can annunciate a latching or non-latching alarm. The analog inputs are always monitored and their status is displayed on the appropriate metering screens. To make identifying the analog inputs easier, a user-assigned name<sup>A</sup> can be given to each input.

Select the input type<sup>B</sup>. Select the amount of hysteresis<sup>C</sup> needed to prevent rapid switching of the alarm. A user-adjustable arming delay<sup>D</sup> allows configuration of the analog input threshold monitoring in one of two ways. (1) When the arming delay is set to zero, threshold monitoring is performed all the time, whether or not excitation is enabled. (2) When the arming delay is set to a non-zero value, threshold monitoring begins when the arming delay time has expired after system startup is complete. An out-of-range alarm, configured on the *Alarm Configuration, Alarms* screen in BESTCOMSPi<sup>®</sup>, alerts the user of an open or damaged analog input wire. When enabled, Stop Mode Inhibit<sup>E</sup> turns off analog input protection when excitation is stopped.

Ranges must be set for the selected input type. Param Min<sup>F</sup> correlates to Min Input Current<sup>G</sup> or Min Input Voltage<sup>H</sup> and Param Max<sup>I</sup> correlates to Max Input Current<sup>J</sup> or Max Input Voltage<sup>K</sup>.

Each analog input can be independently configured for over or under mode<sup>L</sup> to annunciate an alarm when the analog input signal falls beyond the threshold<sup>M</sup>. Alarms are configured on the *Alarm Configuration, Alarms* screen in BESTCOMSPi<sup>®</sup>. A user-adjustable activation delay<sup>N</sup> setting delays alarm annunciation after the threshold has been exceeded.

The remote analog inputs are incorporated into a BESTlogicPi<sup>®</sup> programmable logic scheme by selecting them from the I/O group in BESTlogicPi<sup>®</sup>. For more details, refer to the BESTlogicPi<sup>®</sup> chapter.

BESTCOMSPi<sup>®</sup> settings for remote analog inputs are illustrated in Figure 200. Remote Analog Input #1 is shown.

**Remote Analog Input #1**

Label Text: ANALOG IN 1 A

Arming Delay (s): 0 D

Hysteresis (%): 2.0 C

Stop Mode Inhibit: No E

Input Type: Voltage B

**Ranges**

Param Min: -9999.0 F

Min Input Current (mA): 4.0 G

Min Input Voltage (V): 0.0 H

Param Max: 9999.0 I

Max Input Current (mA): 20.0 J

Max Input Voltage (V): 10.0 K

**Threshold #1**

Mode: Disabled L

Threshold: -9999.0 M

Activation Delay (s): 0 N

**Figure 200. Remote Analog Input Settings**

<sup>A</sup> **Label Text:** An alphanumeric character string with a maximum of 64 characters.

<sup>B</sup> **Input Type:** Voltage or Current.

<sup>C</sup> **Hysteresis:** Adjustable from 0 to 100% in 0.1% increments.

<sup>D</sup> **Arming Delay:** Adjustable from 0 to 300 s in 1 s increments.

<sup>E</sup> **Stop Mode Inhibit:** Yes or No.

<sup>F</sup> **Param Min:** Adjustable from -9999.0 to +9999.0 in increments of 0.1

<sup>G</sup> **Min Input Current:** Adjustable from 4 to 20 mA in 0.1 mA increments.

<sup>H</sup> **Min Input Voltage:** Adjustable from 0 to 10 V in 0.1 V increments.

<sup>I</sup> **Param Max:** Adjustable from -9999.0 to +9999.0 in increments of 0.1.

<sup>J</sup> **Max Input Current:** Adjustable from 4 to 20 mA in 0.1 mA increments.

<sup>K</sup> **Max Input Voltage:** Adjustable from 0 to 10 V in 0.1 V increments.

<sup>L</sup> **Mode:** Disabled, Over, or Under.

<sup>M</sup> **Threshold:** Adjustable from -9999.0 to +9999.0 in increments of 0.1.

<sup>N</sup> **Activation Delay:** Adjustable from 0 to 300 s in 1 s increments.

## RTD Inputs

**BESTCOMSPlus® Navigation Path:** Settings, Programmable Inputs, Remote RTD Inputs

**HMI Navigation Path:** Settings, Programmable Inputs, Remote RTD Inputs

The AEM-2020 provides eight user-configurable RTD inputs that can annunciate a latching or non-latching alarm. The RTD inputs are always monitored and their status is displayed on the appropriate metering screens. To make identifying the RTD inputs easier, a user-assigned name<sup>A</sup> can be given to each input.

Select the amount of hysteresis<sup>B</sup> needed to prevent rapid switching of the alarm. Select the RTD type<sup>C</sup>. A user-adjustable arming delay<sup>D</sup> allows configuration of the RTD input threshold monitoring in one of two ways. (1) When the arming delay is set to zero, threshold monitoring is performed all the time, whether or not excitation is enabled. (2) When the arming delay is set to a non-zero value, threshold monitoring begins when the arming delay time has expired after system startup is complete. An out-of-range alarm, configured on the *Alarm Configuration, Alarms* screen in BESTCOMSPlus, alerts the user of an open or

damaged RTD input wire. When enabled, Stop Mode Inhibit<sup>E</sup> turns off RTD input protection when excitation is stopped.

Each RTD input can be independently configured for over or under mode<sup>F</sup> to announce an alarm when the RTD input signal falls beyond the threshold<sup>G</sup>. Alarms are configured on the *Alarm Configuration, Alarms* screen in *BESTCOMSPPlus*. A user-adjustable activation delay<sup>H</sup> setting delays alarm annunciation after the threshold has been exceeded.

The remote RTD inputs are incorporated into a *BESTlogicPlus* programmable logic scheme by selecting them from the *I/O* group in *BESTlogicPlus*. For more details, refer to the *BESTlogicPlus* chapter.

*BESTCOMSPPlus*<sup>®</sup> settings for remote RTD inputs are illustrated in Figure 201. Remote RTD Input #1 is shown.

Figure 201. Remote RTD Input Settings

<sup>A</sup> *Label Text*: An alphanumeric character string with a maximum of 64 characters.

<sup>B</sup> *Hysteresis*: Adjustable from 0 to 100% in 0.1% increments.

<sup>C</sup> *RTD Type*: 100 Ohm Platinum or 10 Ohm Copper.

<sup>D</sup> *Arming Delay*: Adjustable from 0 to 300 s in 1 s increments.

<sup>E</sup> *Stop Mode Inhibit*: Yes or No.

<sup>F</sup> *Mode*: Disabled, Over, or Under.

<sup>G</sup> *Threshold*: -58 to +482°F in 1°F increments.

<sup>H</sup> *Activation Delay*: Adjustable from 0 to 300 s in 1 s increments.

## Thermocouple Inputs

**BESTCOMSPPlus Navigation Path:** Settings, Programmable Inputs, Remote Thermocouple Inputs

**HMI Navigation Path:** Settings, Programmable Inputs, Remote Thermocouple Inputs

The AEM-2020 provides two thermocouple inputs. The thermocouple inputs are always monitored and their status is displayed on the appropriate metering screens. To make identifying the thermocouple inputs easier, a user-assigned name<sup>A</sup> can be given to each input.

Select the amount of hysteresis<sup>B</sup> needed to prevent rapid switching of the alarm. A user-adjustable arming delay<sup>C</sup> allows configuration of the thermocouple input threshold monitoring in one of two ways. (1) When the arming delay is set to zero, threshold monitoring is performed all the time, whether or not excitation is enabled. (2) When the arming delay is set to a non-zero value, threshold monitoring begins when the arming delay time has expired after system startup is complete. An out-of-range alarm, configured on the *Alarm Configuration, Alarms* screen in *BESTCOMSPPlus*, alerts the user of an open or damaged thermocouple input wire. When enabled, Stop Mode Inhibit<sup>D</sup> turns off thermocouple input protection when excitation is stopped.

Each thermocouple input can be independently configured for over or under mode<sup>E</sup> to announce an alarm when the thermocouple input signal falls beyond the threshold<sup>F</sup>. Alarms are configured on the *Alarm Configuration, Alarms* screen in *BESTCOMSPPlus*. A user-adjustable activation delay<sup>G</sup> setting delays alarm annunciation after the threshold has been exceeded.

The remote thermocouple inputs are incorporated into a *BESTlogicPlus* programmable logic scheme by selecting them from the *I/O* group in *BESTlogicPlus*. For more details, refer to the *BESTlogicPlus* chapter.

*BESTCOMSPPlus*<sup>®</sup> settings for remote thermocouple inputs are illustrated in Figure 202. Remote Thermocouple Input #1 is shown.

**Figure 202. Remote Thermocouple Input Settings**

<sup>A</sup> *Label Text*: An alphanumeric character string with a maximum of 64 characters.

<sup>B</sup> *Hysteresis*: Adjustable from 0 to 100% in 0.1% increments.

<sup>C</sup> *Arming Delay*: Adjustable from 0 to 300 s in 1 s increments.

<sup>D</sup> *Stop Mode Inhibit*: Yes or No.

<sup>E</sup> *Mode*: Disabled, Over, or Under.

<sup>F</sup> *Threshold*: Adjustable from 32 to 2,507°F in 1°F increments.

<sup>G</sup> *Activation Delay*: Adjustable from 0 to 300 s in 1 s increments.

## Analog Outputs

**BESTCOMSPPlus Navigation Path:** Settings, Programmable Outputs, Remote Analog Outputs

**HMI Navigation Path:** Settings, Programmable Outputs, Remote Analog Outputs

The AEM-2020 provides four analog outputs.

Make a parameter selection<sup>A</sup> and select the output type<sup>B</sup>. An out-of-range alarm configured on the *Alarm Configuration, Alarms* screen in *BESTCOMSPPlus*, alerts the user of an open or damaged analog output wire. An out-of-range activation delay<sup>C</sup> setting delays alarm annunciation.

Ranges must be set for the selected output type. Param Min<sup>D</sup> correlates to Min Output Current<sup>E</sup> or Min Output Voltage<sup>F</sup> and Param Max<sup>G</sup> correlates to Max Output Current<sup>H</sup> or Max Output Voltage<sup>I</sup>.

The remote analog outputs are incorporated into a *BESTlogicPlus* programmable logic scheme by selecting them from the *I/O* group in *BESTlogicPlus*. For more details, refer to the *BESTlogicPlus* chapter.

*BESTCOMSPPlus* settings for remote analog outputs are illustrated in Figure 203. Remote Analog Output #1 is shown.

**Figure 203. Remote Analog Output Settings**

<sup>A</sup> *Parameter Selection:* Gen VAB, Gen VBC, Gen VCA, Gen V Average, Bus Freq, Bus VAB, Bus VBC, Bus VCA, Gen Freq, Gen PF, kWh, kvarh, Gen IA, Gen IB, Gen IC, Gen I Average, kW Total, kVA Total, kvar Total, EDM Ripple, Exciter Field Voltage, Exciter Field Current, Auxiliary Input Voltage, Auxiliary Input Current, Setpoint Position, Tracking Error, Negative Sequence Voltage, Negative Sequence Current, Positive Sequence Voltage, Positive Sequence Current, PSS Output, Analog Input 1-8, RTD Input 1-8, Thermocouple 1-2, Power Input, or NLS Error Percent.

<sup>B</sup> *Output Type:* Voltage or Current.

<sup>C</sup> *Out of Range Activation Delay:* Adjustable from 0 to 300 s in 1 s increments.

<sup>D</sup> *Param Min:* Adjustable from -999,999.0 to +999,999.0 in increments of 0.1.

<sup>E</sup> *Min Output Current:* Adjustable from 4 to 20 mA in 0.1 mA increments.

<sup>F</sup> *Min Output Voltage:* Adjustable from 0 to 10 V in 0.1 V increments.

<sup>G</sup> *Param Max:* Adjustable from -999,999.0 to +999,999.0 in increments of 0.1.

<sup>H</sup> *Max Output Current:* Adjustable from 4 to 20 mA in 0.1 mA increments.

<sup>I</sup> *Max Output Voltage:* Adjustable from 0 to 10 V in 0.1 V increments.

## Status LED

This red LED flashes to indicate that the AEM-2020 is powered up and functioning properly. The LED lights solid during power up. When the power-up sequence is complete, this LED flashes. If the LED does not flash after power up, contact Basler Electric.

## Metering

### Analog Inputs

**BESTCOMSPPlus® Navigation Path:** Metering, Status, Inputs, Remote Analog Inputs

**HMI Navigation Path:** Metering, Status, Inputs, Remote Analog Input Values

The value and status of the remote analog inputs are shown on this screen. The status is TRUE when the corresponding LED is green. Refer to Figure 204. Remote Analog Input #1 is shown.

**Figure 204. Remote Analog Inputs Metering**

## RTD Inputs

**BESTCOMSPlus Navigation Path:** Metering, Status, Inputs, Remote RTD Inputs

**HMI Navigation Path:** Metering, Status, Inputs, Remote Analog Input Values

The value and status of the remote RTD inputs are shown on this screen. The status is TRUE when the corresponding LED is green. Refer to Figure 205. Remote RTD Input #1 is shown.

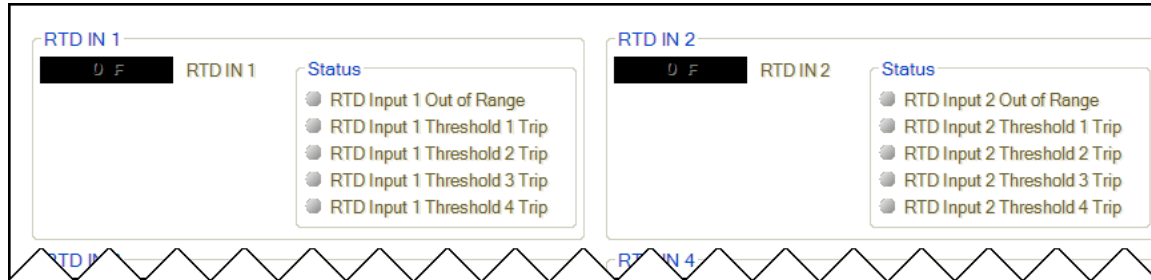


Figure 205. Remote RTD Inputs Metering

## Thermocouple Inputs

**BESTCOMSPlus Navigation Path:** Metering, Status, Inputs, Remote Thermocouple Inputs

**HMI Navigation Path:** Metering, Status, Inputs, Remote Analog Input Values

The value and status of the remote thermocouple inputs are shown on this screen. The status is TRUE when the corresponding LED is green. Refer to Figure 206. Remote Thermocouple Input #1 is shown.

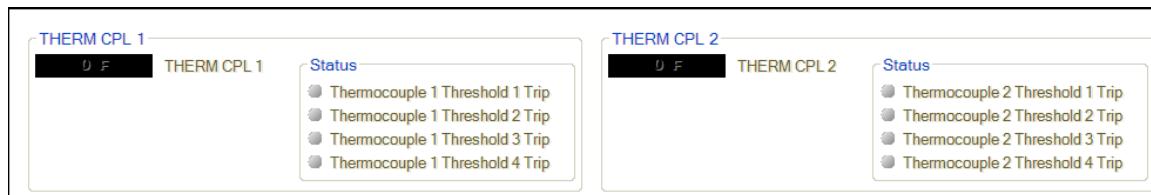


Figure 206. Remote Thermocouple Inputs Metering

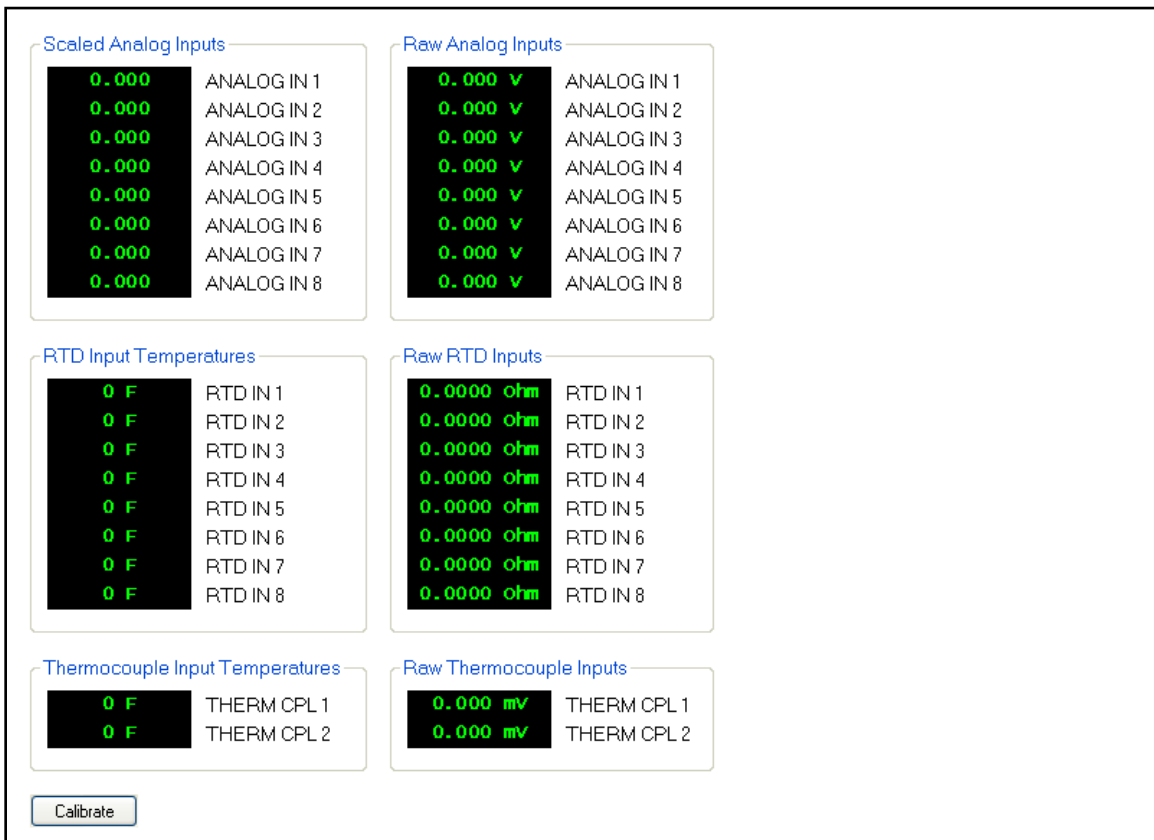
## Analog Input Values

**BESTCOMSPlus Navigation Path:** Metering, Status, Inputs, Remote Analog Input Values

**HMI Navigation Path:** Metering, Status, Inputs, Remote Analog Input Values

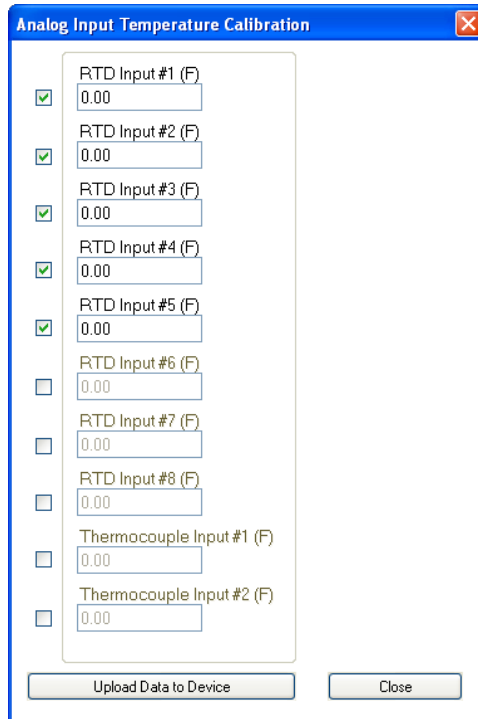
The values of the scaled analog inputs, raw analog inputs, RTD input temperatures, raw RTD inputs, thermocouple input temperatures, and raw thermocouple inputs are shown on this screen.

For each analog input, the raw metered input value is displayed, and the scaled metered input value. This is useful to check if the AEM-2020 is seeing a valid raw input value (i.e. the raw 0 to 10 volt voltage input or 4 to 20 mA current input). The scaled value is the raw input scaled up to the range specified by the Parameter Minimum and Parameter Maximum value parameters in the Remote Analog Input settings. Refer to Figure 207.



**Figure 207. Remote Analog Input Values Metering**

When connected to a , the *Calibrate* button shown on the Remote Analog Input Values screen opens the Analog Input Temperature Calibration screen shown in Figure 208. This screen is used to calibrate RTD inputs 1 through 8 and thermocouple inputs 1 and 2.



**Figure 208. Remote Analog Input Temperature Calibration**

## Analog Outputs

**BESTCOMSPlus® Navigation Path:** Metering, Status, Outputs, Remote Analog Outputs

**HMI Navigation Path:** Metering, Status, Outputs, Remote Analog Outputs

The status of the remote analog outputs, scaled analog output values, and raw analog output values are shown on this screen. Parameter selections are made on the Remote Analog Outputs screen under settings in BESTCOMSPlus. The status is TRUE when the corresponding LED is green. Refer to Figure 209.

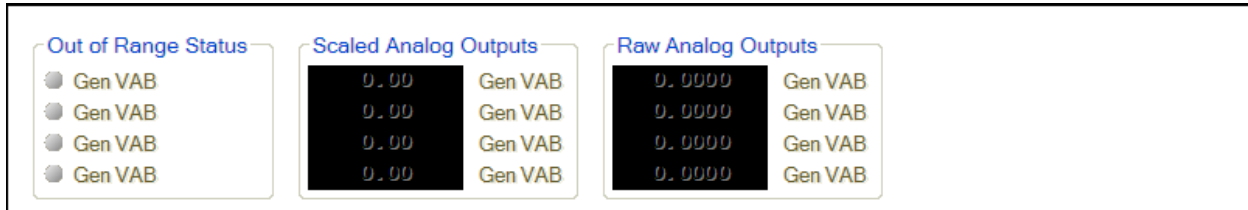


Figure 209. Remote Analog Outputs Metering

## Maintenance

Preventive maintenance consists of periodically checking that the connections between the AEM-2020 and the system are clean and tight. Analog Expansion Modules are manufactured using state-of-the-art surface-mount technology. As such, Basler Electric recommends that no repair procedures be attempted by anyone other than Basler Electric personnel.

## Firmware Updates

Refer to the BESTCOMSPlus® chapter for instructions on updating firmware in the AEM-2020.

# Contact Expansion Module

## General Information

The optional CEM-2020 is a remote auxiliary device that provides additional DECS-250 contact inputs and outputs. Two types of modules are available. A standard module (CEM-2020) provides 24 contact outputs and a high current module (CEM-2020H) provides 18 contact outputs.

## Features

CEM-2020s have the following features:

- 10 Contact Inputs
- 18 Contact Outputs (CEM-2020H) or 24 Contact Outputs (CEM-2020)
- Functionality of Inputs and Outputs assigned by BESTlogic™ *Plus* programmable logic
- Communications via CAN Bus

## Specifications

### Operating Power

Nominal ..... 12 or 24 Vdc  
 Range ..... 8 to 32 Vdc (Withstands ride-through down to 6 Vdc for 500 ms.)

### Maximum Consumption

CEM-2020 ..... 14 W  
 CEM-2020H ..... 8 W

### Contact Inputs

The CEM-2020 contains 10 programmable inputs that accept normally open and normally closed, dry contacts.

### Contact Outputs

#### Ratings

#### CEM-2020

Outputs 12 through 23 .. 1 Adc at 30 Vdc, Form C, gold contacts\*  
 Outputs 24 through 35 .. 4 Adc at 30 Vdc, Form C, 1.2 A pilot duty†

#### CEM-2020H

Outputs 12 through 23 .. 2 Adc at 30 Vdc, Form C, gold contacts\*  
 Outputs 24 through 29 .. 10 Adc at 30 Vdc, Form C, 1.2 A pilot duty†

\* Gold contacts intended for low voltage signaling to dry circuits. Not rated for inductive loads or pilot duty.

† For pilot duty, the load must be in parallel with a diode rated at least 3 times the coil current and 3 times the coil voltage.

### Communication Interface

The CEM-2020 communicates with the DECS-250 through CAN1.

#### CAN Bus

Differential Bus Voltage ..... 1.5 to 3 Vdc  
 Maximum Voltage ..... -32 to +32 Vdc with respect to negative battery terminal  
 Communication Rate ..... 125 or 250 kb/s

## Type Tests

### Shock

Withstands 15 G in 3 perpendicular planes.

### Vibration

Swept over the following ranges for 12 sweeps in each of three mutually perpendicular planes with each 15-minute sweep consisting of the following:

5 to 29 to 5 Hz..... 1.5 G peak for 5 min.  
 29 to 52 to 29 Hz..... 0.036" Double Amplitude for 2.5 min.  
 52 to 500 to 52 Hz..... 5 G peak for 7.5 min.

### HALT (Highly Accelerated Life Testing)

HALT is used by Basler Electric to prove that our products will provide the user with many years of reliable service. HALT subjects the device to extremes in temperature, shock, and vibration to simulate years of operation, but in a much shorter period span. HALT allows Basler Electric to evaluate all possible design elements that will add to the life of this device. As an example of some of the extreme testing conditions, the CEM-2020 was subjected to temperature tests (tested over a temperature range of  $-80^{\circ}\text{C}$  to  $+130^{\circ}\text{C}$ ), vibration tests (of 5 to 50 G at  $+25^{\circ}\text{C}$ ), and temperature/vibration tests (tested at 10 to 20 G over a temperature range of  $-60^{\circ}\text{C}$  to  $+100^{\circ}\text{C}$ ). Combined temperature and vibration testing at these extremes proves that the CEM-2020 is expected to provide long-term operation in a rugged environment. Note that the vibration and temperature extremes listed in this paragraph are specific to HALT and do not reflect recommended operation levels. These operational ratings are included in the *Specifications* chapter of this manual.

## Environment

### Temperature

Operating .....  $-40$  to  $+70^{\circ}\text{C}$  ( $-40$  to  $+158^{\circ}\text{F}$ )

Storage .....  $-40$  to  $+85^{\circ}\text{C}$  ( $-40$  to  $+185^{\circ}\text{F}$ )

Humidity ..... IEC 68-2-38

## Agency, Standards, and Directives

### UL Approval

The CEM-2020 is a Recognized Component for the US and Canada under UL file E97035

(CCN-FTPM2/FTPM8) covered under the Standards below:

- UL 6200
- CSA C22.2 No.14-13

The CEM-2020 is a Recognized Component for the US and Canada under UL file E470837

(CCN-FTWD2/FTWD8) for use in Hazardous Locations:

- Class I Division 2
- Groups A, B, C & D

### CSA Approval

The CEM-2020 is covered under CSA file 1042505 (LR23131-138S).

- CSA C22.2 No. 14-13

### CE Compliance

This product complies with the requirements of the following EC Directives:

- Low Voltage Directive (LVD) 2014/35/EU
- Electromagnetic Compatibility (EMC) 2014/30/EU
- Hazardous Substances (RoHS 2) - 2011/65/EU

This product conforms to the following Harmonized Standards:

- EN 50178:1997 - *Electronic Equipment for use in Power Installations*
- EN 61000-6-4:2001 - *Electromagnetic Compatibility (EMC), Generic Standards, Emission Standard for Industrial Environments*
- EN 61000-6-2:2001 - *Electromagnetic Compatibility (EMC), Generic Standards, Immunity for Industrial Environments*
- EN 50581:2012, Ed. 12 - *Technical Documentation for the Assessment of Electrical and Electronic Products with respect to the Restriction of Hazardous Substances.*

EAC Mark (Eurasian Conformity)

- TP TC 004/2011
- TP TC 020/2011

## Physical

Weight

CEM-2020.....	2.25 lb (1.02 kg)
CEM-2020H.....	1.90 lb (0.86 kg)

Dimensions..... See *Installation* later in this chapter.

## Installation

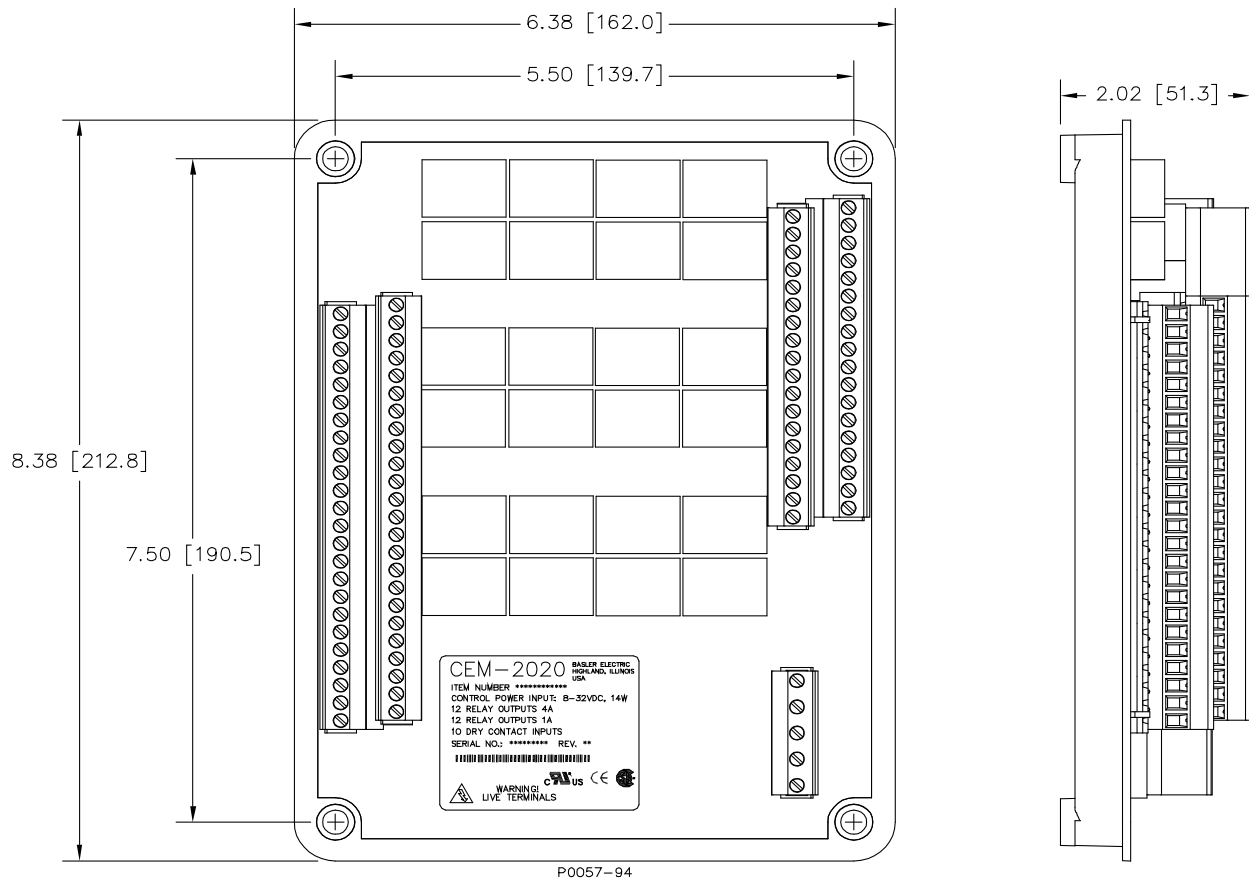
Contact Expansion Modules are delivered in sturdy cartons to prevent shipping damage. Upon receipt of a module, check the part number against the requisition and packing list for agreement. Inspect for damage, and if there is evidence of such, immediately file a claim with the carrier and notify the Basler Electric regional sales office, your sales representative, or a sales representative at Basler Electric, Highland, Illinois USA.

If the device is not installed immediately, store it in the original shipping package in a moisture- and dust-free environment.

## Mounting

Contact Expansion Modules are contained in a potted plastic case and may be mounted in any convenient position. The construction of a Contact Expansion Module is durable enough to mount directly on a genset using ¼-inch hardware. Hardware selection should be based on any expected shipping/transportation and operating conditions. The torque applied to the mounting hardware should not exceed 65 in-lb (7.34 N•m).

See Figure 210 for CEM-2020 overall dimensions. All dimensions are shown in inches with millimeters in parenthesis.



**Figure 210. CEM-2020 Overall Dimensions**

See Figure 211 for CEM-2020H overall dimensions. All dimensions are shown in inches with millimeters in parenthesis.

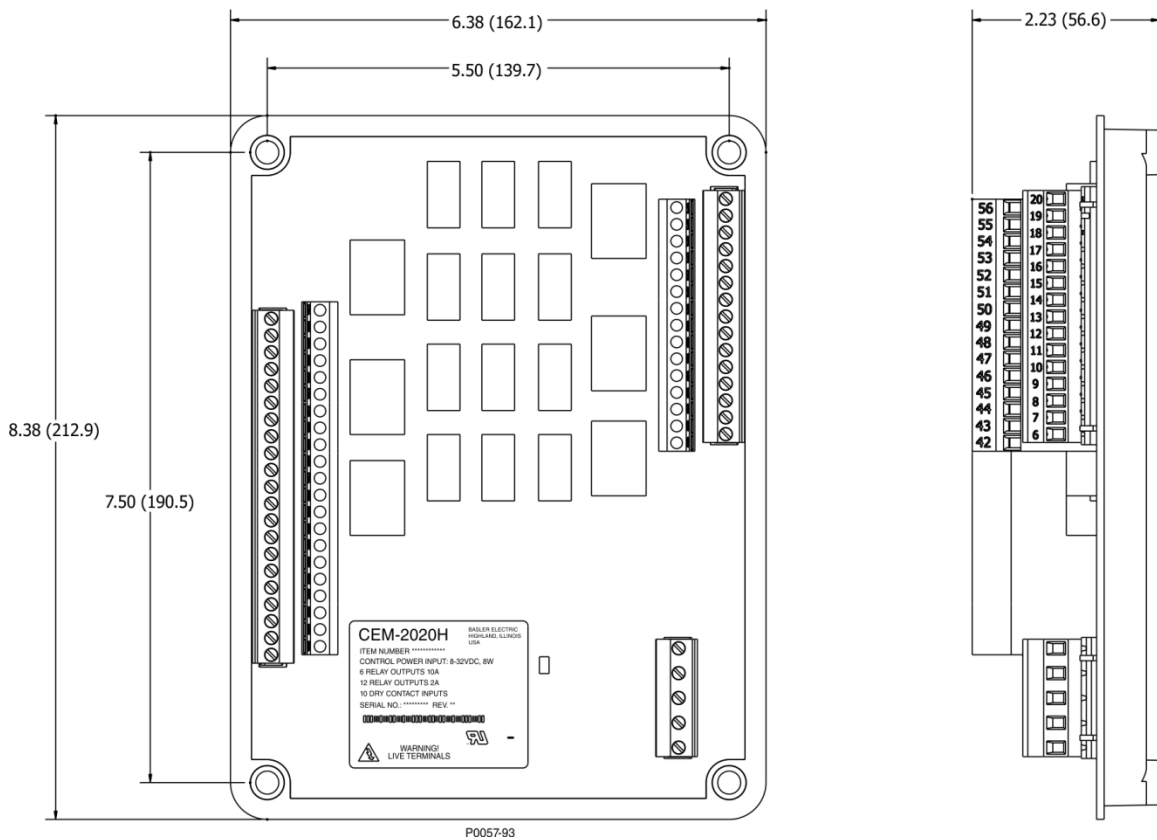


Figure 211. CEM-2020H Overall Dimensions

## Connections

Contact Expansion Module connections are dependent on the application. Incorrect wiring may result in damage to the module.

### Notes

Operating power from the battery must be of the correct polarity. Although reverse polarity will not cause damage, the CEM-2020 will not operate.

Be sure that the CEM-2020 is hard-wired to earth ground with no smaller than 12 AWG copper wire attached to the chassis ground terminal on the module.

### Terminations

The terminal interface consists of plug-in connectors with screw-down compression terminals.

CEM-2020 connections are made with one 5-position connector, two 18-position connectors, and two 24-position connectors with screw-down compression terminals. These connectors plug into headers on the CEM-2020. The connectors and headers have dovetailed edges that ensure proper connector orientation. Also, the connectors and headers are uniquely keyed to ensure that the connectors mate only with the correct headers.

Connectors and headers may contain tin- or gold-plated conductors. Tin-plated conductors are housed in a black plastic casing and gold-plated conductors are housed in an orange plastic casing. Mate connectors to headers of the same color only.

### Caution

By mating conductors of dissimilar metals, galvanic corrosion could occur which deteriorates connections and leads to signal loss.

Connector screw terminals accept a maximum wire size of 12 AWG. Maximum screw torque is 5 in-lb (0.56 N•m).

#### Operating Power

The Contact Expansion Module operating power input accepts either 12 Vdc or 24 Vdc and tolerates voltage over the range of 6 to 32 Vdc. Operating power must be of the correct polarity. Although reverse polarity will not cause damage, the CEM-2020 will not operate. Operating power terminals are listed in Table 45.

It is recommended that a fuse be added for additional protection for the wiring to the battery input of the Contact Expansion Module. A Bussmann ABC-7 fuse or equivalent is recommended.

**Table 45. Operating Power Terminals**

Terminal	Description
P1-  (SHIELD)	Chassis ground connection
P1- - (BATT-)	Negative side of operating power input
P1- + (BATT+)	Positive side of operating power input

#### Contact Inputs and Contact Outputs

The CEM-2020 (Figure 212) has 10 contact inputs and 24 contact outputs. The CEM-2020H (Figure 213) has 10 contact inputs and 18 contact outputs.

### Note

To follow UL guidelines, a fuse must be implemented in the 2Adc contact circuits (Outputs 12 through 23) of the CEM-2020H used in hazardous locations. The suggested fuse size in Adc = (100/Contact Voltage) with a maximum fuse size of 5Adc.

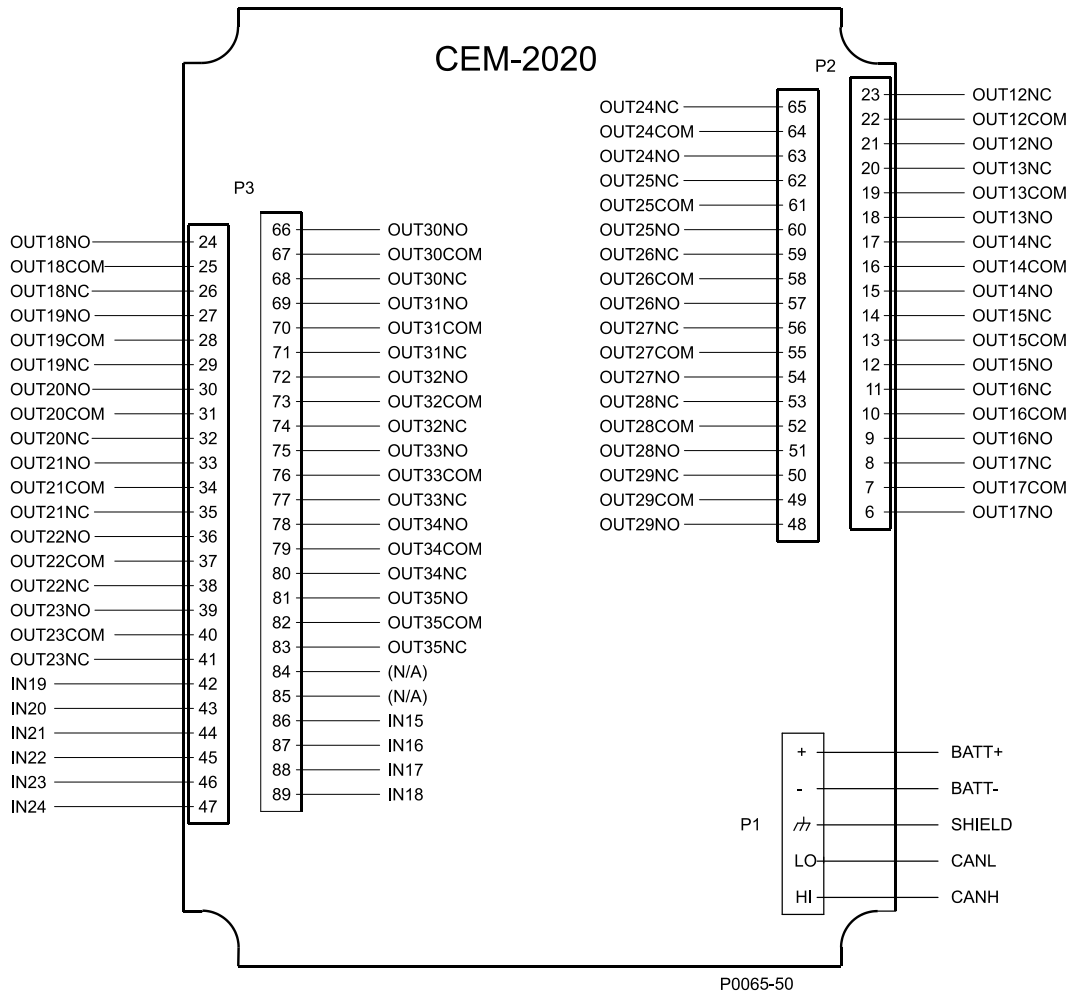
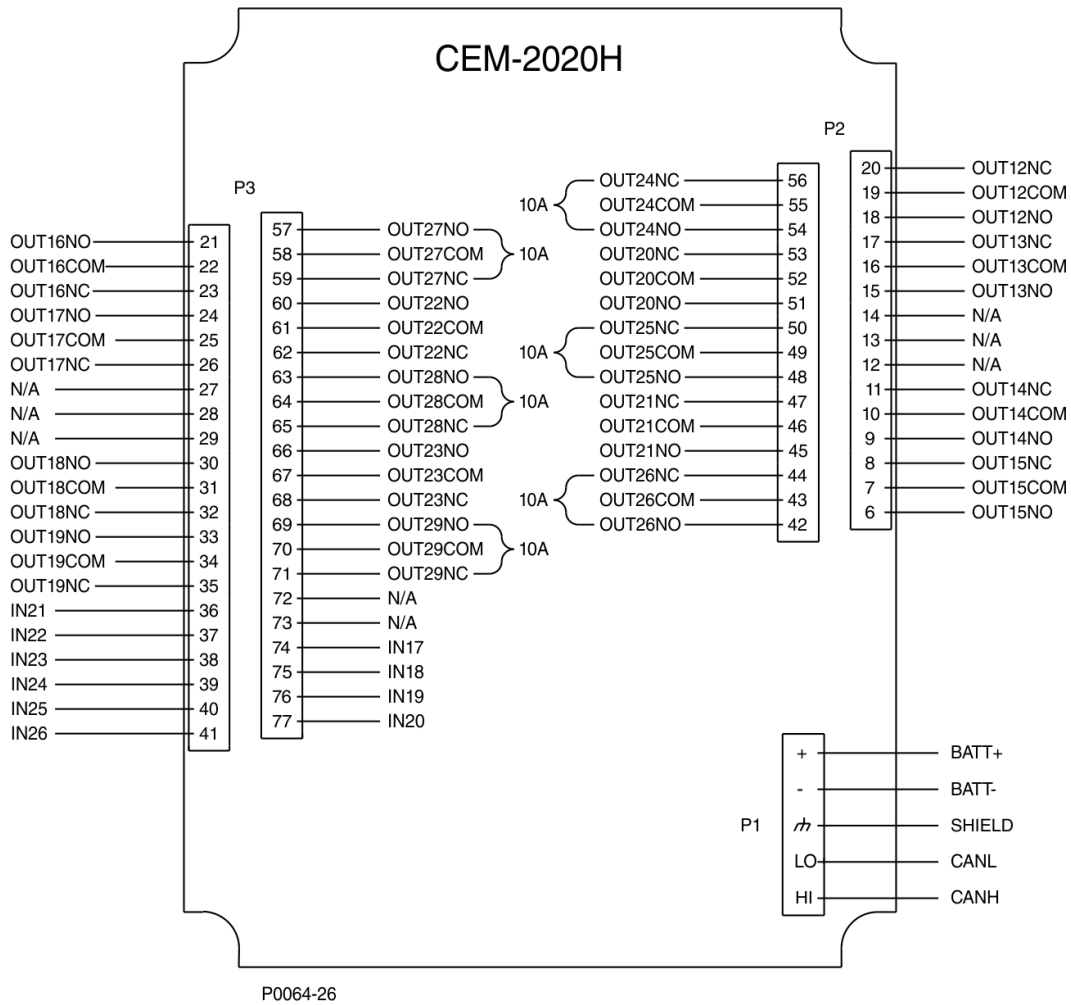


Figure 212. CEM-200 Input Contact and Output Contact Terminals



**Figure 213. CEM-2020H Input Contact and Output Contact Terminals**

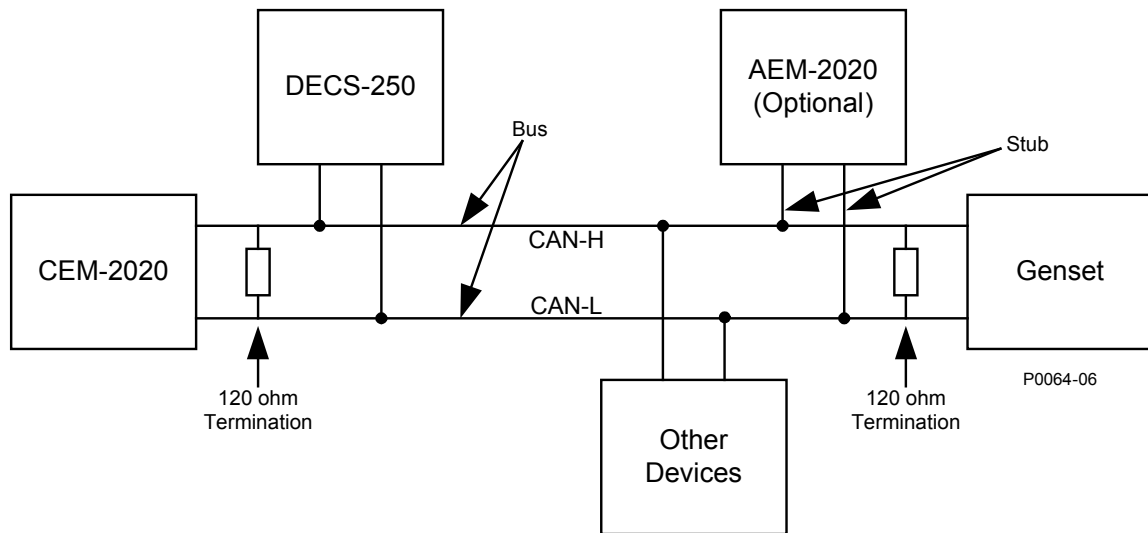
**CAN Bus Interface**

These terminals provide communication using the SAE J1939 protocol and provide high-speed communication between the Contact Expansion Module and the DECS-250. Connections between the CEM-2020 and DECS-250 should be made with twisted-pair, shielded cable. CAN Bus interface terminals are listed in Table 46. Refer to Figure 214 and Figure 215.

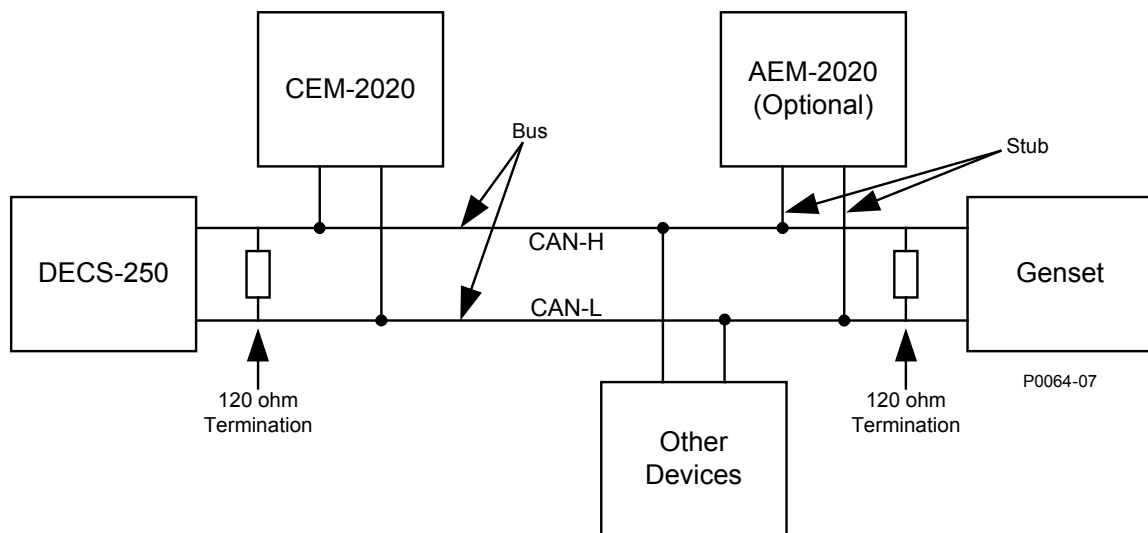
**Table 46. CAN Bus Interface Terminals**

Terminal	Description
P1- HI (CAN H)	CAN high connection (yellow wire)
P1- LO (CAN L)	CAN low connection (green wire)
P1- ⚡ (SHIELD)	CAN drain connection

- Note**
1. If the CEM-2020 is providing one end of the J1939 bus, a 120 Ω, ½ watt terminating resistor should be installed across terminals P1- LO (CANL) and P1- HI (CANH).
  2. If the CEM-2020 is not part of the J1939 bus, the stub connecting the CEM-2020 to the bus should not exceed 914 mm (3 ft) in length.
  3. The maximum bus length, not including stubs, is 40 m (131 ft).
  4. The J1939 drain (shield) should be grounded at one point only. If grounded elsewhere, do not connect the drain to the CEM-2020.



**Figure 214. CAN Bus Interface with CEM-2020 providing One End of the Bus**



**Figure 215. CAN Bus Interface with DECS-250 providing One End of the Bus**

## Communications

**BESTCOMSPi<sup>us</sup>® Navigation Path:** Settings, Communications, CAN bus, Remote Module Setup

**HMI Navigation Path:** Settings, Communication, CAN bus, Remote Module Setup, Contact Expansion Module

The contact expansion module must be enabled with the correct J1939 address. A Control Area Network (CAN) is a standard interface that enables communication between the CEM-2020 and the DECS-250. The Remote Module Setup screen is illustrated in Figure 216.

Figure 216. Remote Module Setup

## Functional Description

### Contact Inputs

**BESTCOMSPi<sup>us</sup> Navigation Path:** Settings, Programmable Inputs, Remote Contact Inputs

**HMI Navigation Path:** Settings, Programmable Inputs, Remote Contact Inputs

The CEM-2020 provides 10 programmable contact inputs with the same functionality as the contact inputs on the DECS-250. The label text of each contact input is customizable and accepts an alphanumeric character string with a maximum of 64 characters.

The remote contact inputs are incorporated into a BESTlogicPi<sup>us</sup> programmable logic scheme by selecting them from the I/O group in BESTlogicPi<sup>us</sup>. For more details, refer to the BESTlogicPi<sup>us</sup> chapter.

BESTCOMSPi<sup>us</sup> settings for remote contact inputs are illustrated in Figure 217.

**Remote Contact Inputs**

Input #15 Label Text INPUT 15	Input #16 Label Text INPUT 16	Input #17 Label Text INPUT 17
Input #18 Label Text INPUT 18	Input #19 Label Text INPUT 19	Input #20 Label Text INPUT 20
Input #21 Label Text INPUT 21	Input #22 Label Text INPUT 22	Input #23 Label Text INPUT 23
Input #24 Label Text INPUT 24		

**Figure 217. Remote Contact Inputs Settings**

## Contact Outputs

**BESTCOMSPiplus Navigation Path:** Settings, Programmable Outputs, Remote Contact Outputs

**HMI Navigation Path:** Settings, Programmable Outputs, Remote Contact Outputs

The CEM-2020 provides 24 programmable contact outputs with the same functionality as the contact outputs on the DECS-250. Outputs 12 through 23 can carry 1 A. Outputs 24 through 35 can carry 4 A.

The CEM-2020H provides 18 programmable contact outputs with the same functionality as the contact outputs on the DECS-250. Outputs 12 through 23 can carry 2 A. Outputs 24 through 29 can carry 10 A.

The label text of each contact output is customizable and accepts an alphanumeric character string with a maximum of 64 characters.

The remote analog outputs are incorporated into a BESTlogicPiplus programmable logic scheme by selecting them from the I/O group in BESTlogicPiplus. For more details, refer to the BESTlogicPiplus chapter.

BESTCOMSPiplus settings for remote contact outputs are illustrated in Figure 218.

**Remote Contact Outputs**

Output #12 Label Text OUTPUT 12	Output #13 Label Text OUTPUT 13	Output #14 Label Text OUTPUT 14
Output #15 Label Text OUTPUT 15	Output #16 Label Text OUTPUT 16	Output #17 Label Text OUTPUT 17

**Figure 218. Remote Contact Outputs Settings**

## Status LED

This red LED flashes to indicate that the CEM-2020 is powered up and functioning properly. The LED lights solid during power up. When the power-up sequence is complete, this LED flashes. If the LED does not flash after power up, contact Basler Electric.

## Metering

### Contact Inputs

**BESTCOMSPlus Navigation Path:** Metering, Status, Inputs, Remote Contact Inputs

**HMI Navigation Path:** Metering, Status, Inputs, Remote Contact Input Values

The value and status of the remote contact inputs are shown on this screen. The status is TRUE when the corresponding LED is green. Refer to Figure 219.



Figure 219. Remote Contact Inputs Metering

### Contact Outputs

**BESTCOMSPlus® Navigation Path:** Metering, Programmable Outputs, Remote Contact Outputs

**HMI Navigation Path:** Metering, Status, Outputs, Remote Contact Outputs

The value and status of the remote contact outputs are shown on this screen. The status is TRUE when the corresponding LED is green. Refer to Figure 220.

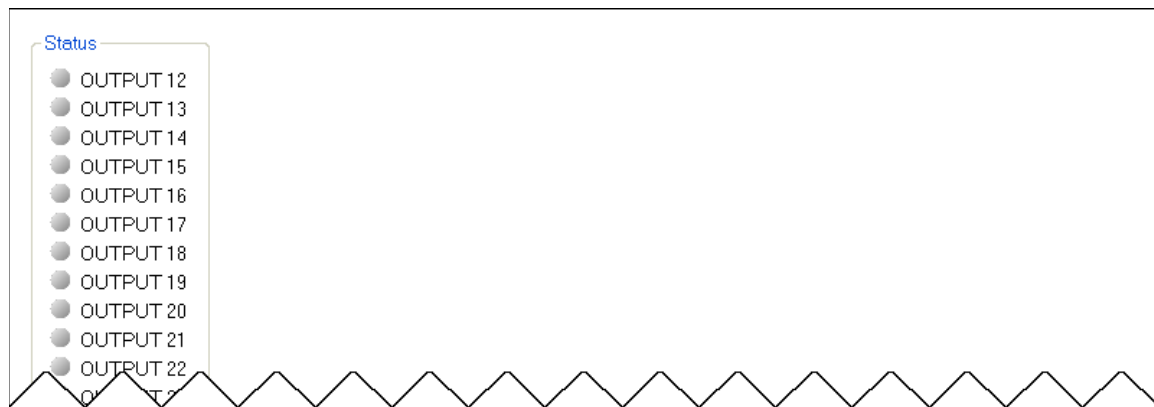


Figure 220. Remote Contact Outputs Metering

## Maintenance

Preventive maintenance consists of periodically checking that the connections between the CEM-2020 and the system are clean and tight. Contact Expansion Modules are manufactured using state-of-the-art surface-mount technology. As such, Basler Electric recommends that no repair procedures be attempted by anyone other than Basler Electric personnel.

### Firmware Updates

Refer to the BESTCOMSPlus® chapter for instructions on updating firmware in the CEM-2020.

# Revision History

Table 47 provides a historical summary of the changes made to the DECS-250 hardware. Firmware changes are listed in Table 48 and software changes are listed in Table 49. The corresponding revisions made to this instruction manual are summarized in Table 50. Revisions are listed in chronological order.

**Table 47. Hardware Revision History**

Hardware Version and Date	Change
A, Jan-12	<ul style="list-style-type: none"> <li>Initial release</li> </ul>
B, May-13	<ul style="list-style-type: none"> <li>Improved mechanical design of analog board</li> </ul>
C, May-13	<ul style="list-style-type: none"> <li>Improved alignment of terminal labeling</li> </ul>
D, Jul-13	<ul style="list-style-type: none"> <li>Improved escutcheon plate rigidity</li> </ul>
E, Jul-13	<ul style="list-style-type: none"> <li>Improved power supply isolation</li> <li>Added RoHS compliance</li> </ul>
F, Oct-13	<ul style="list-style-type: none"> <li>RoHS updates to documentation</li> </ul>
G, Mar-14	<ul style="list-style-type: none"> <li>Released firmware version 1.01.05</li> </ul>
H, May-14	<ul style="list-style-type: none"> <li>Improved components on digital boards</li> </ul>
J, Jun-14	<ul style="list-style-type: none"> <li>Released firmware version 1.02.00</li> </ul>
K, Aug-14	<ul style="list-style-type: none"> <li>Increased maximum operating temperature to +70°C</li> <li>Added GND terminal to power connector</li> </ul>
L, Sep-14	<ul style="list-style-type: none"> <li>Improved hardware on the PowerPC board</li> </ul>
M, Oct-14	<ul style="list-style-type: none"> <li>Re-designed analog board to provide clearance for chassis screws</li> </ul>
N, Feb-15	<ul style="list-style-type: none"> <li>Released firmware version 1.03.00 and BESTCOMSPi.us version 3.08.00</li> </ul>
O	<ul style="list-style-type: none"> <li>This revision letter not used</li> </ul>
P, Feb-15	<ul style="list-style-type: none"> <li>Released firmware version 1.03.00 and BESTCOMSPi.us version 3.08.00</li> </ul>
Q	<ul style="list-style-type: none"> <li>This revision letter not used.</li> </ul>
R, Mar-15	<ul style="list-style-type: none"> <li>Modified case for easier assembly.</li> </ul>
T, Jul-15	<ul style="list-style-type: none"> <li>Released firmware version 1.03.01.</li> </ul>
U, Oct-15	<ul style="list-style-type: none"> <li>Updated PCB.</li> </ul>
V, Dec-15	<ul style="list-style-type: none"> <li>Released firmware version 1.03.02 and BESTCOMSPi.us version 3.11.00.</li> </ul>
W, Jun-16	<ul style="list-style-type: none"> <li>Released firmware version 1.05.00 and BESTCOMSPi.us version 3.14.00.</li> </ul>
X, Aug-16	<ul style="list-style-type: none"> <li>Released RoHS compliant PCBs.</li> </ul>
Y, Dec-16	<ul style="list-style-type: none"> <li>Replaced internal cable with improved version.</li> </ul>
AA, Apr-18	<ul style="list-style-type: none"> <li>Changed Digital circuit board and Power PC circuit board</li> </ul>
AB, Sep-18	<ul style="list-style-type: none"> <li>Updated Analog circuit board</li> </ul>

**Table 48. Firmware Revision History**

Firmware Version and Date	Change
1.01.00, Jul-12	<ul style="list-style-type: none"> <li>Initial release</li> </ul>
1.01.01, May-13	<ul style="list-style-type: none"> <li>Miscellaneous Modbus™ enhancements</li> </ul>

Firmware Version and Date	Change
1.01.05, Mar-14	<ul style="list-style-type: none"> <li>• Added PF Active Power Level setting for var/PF regulation</li> <li>• Added Network Load Share ID settings</li> <li>• Added secure login via Modbus™ communication settings</li> <li>• Added Modbus registers for Binary Points and Metering</li> </ul>
1.02.00, May-14	<ul style="list-style-type: none"> <li>• Added Russian language support</li> <li>• Added overexcitation (24) protection</li> <li>• Added transient excitation boosting function</li> <li>• Added loss of excitation (40Q) protection for motors</li> <li>• Added integrating reset method to takeover OEL</li> <li>• Added angle compensation to synchronizer and sync check (25)</li> <li>• Increased available real-time monitoring plots from two to six</li> </ul>
1.03.00, Feb-15	<ul style="list-style-type: none"> <li>• Added Chinese language</li> <li>• Added Generator/Motor operating mode selection</li> <li>• Enhanced network load sharing <ul style="list-style-type: none"> <li>○ Added Network Load Share metering screen</li> <li>○ Added Power Input and NLS Error Percent parameter selections for configurable protection</li> <li>○ Added status logic elements for Config Mismatch, ID Missing, and Network Load Share Active</li> <li>○ Added NLS Broadcast logic element to broadcast alarms to selected units actively sharing load</li> </ul> </li> <li>• Added VAR/PF MODE logic element</li> <li>• Changed the default value of auxiliary control gains to zero</li> <li>• Modified datalog triggering by watchdog</li> <li>• Modified the way PF is scaled when used for an analog output</li> <li>• Modified display of setpoints</li> <li>• Modified datalog to trigger on contact input open</li> <li>• Added PF Active Power Level % to Modbus</li> <li>• Expanded the range for analog outputs to –999,999 to 999,999</li> <li>• Added Modbus registers for AEM-2020 alarms</li> <li>• Modified unsecured access level security</li> <li>• Modified communication with IDP-800</li> <li>• Modified total VA and total PF calculations</li> <li>• Modified frequency display in Comtrade files</li> <li>• Modified scaling of RTD values</li> <li>• Modified operation of SCL limiter</li> </ul>
1.03.01, Dec-15	<ul style="list-style-type: none"> <li>• Enhanced auto synchronizer function</li> </ul>
1.03.02, Jun-16	<ul style="list-style-type: none"> <li>• New ranges for PSS parameters, changed default option or PID Design Mode in Auto Tune function.</li> </ul>
1.05.00, Dec-16	<ul style="list-style-type: none"> <li>• Maintenance release for DECS-250N</li> </ul>
1.05.01, Dec-16	<ul style="list-style-type: none"> <li>• Added active setpoints to acyclic Profibus points.</li> </ul>
1.05.02, Apr-17	<ul style="list-style-type: none"> <li>• Improved Auto Tuning on high gain systems</li> <li>• Improved Synchronizer breaker close timing accuracy</li> <li>• Modified time display for 12:00 am and pm.</li> <li>• Improved indication of CAN Bus baud rate selection.</li> <li>• Improved display of RTD value when no RTD is connected.</li> </ul>

<b>Firmware Version and Date</b>	<b>Change</b>
1.05.03, May-17	<ul style="list-style-type: none"> <li>• Added support for synchronizing at 25 Hz</li> <li>• Improved Governor Bias Control Proportional Pulse scaling.</li> <li>• Added time delay setting for Network Load Share Config Mismatch</li> <li>• Updated Default Logic for PSS and Network Load Sharing</li> <li>• Added support for metering DC power input</li> <li>• Modified behavior of tracking error in stop mode.</li> </ul>
1.05.05, Jun-17	<ul style="list-style-type: none"> <li>• Maintenance release for DECS-250N</li> </ul>
1.05.06, May-18	<ul style="list-style-type: none"> <li>• Maintenance release</li> </ul>
1.06.00, Apr-19	<ul style="list-style-type: none"> <li>• Added grid code settings, which makes the DECS-250 compatible with grid code compliant systems</li> <li>• Metering labels updated</li> <li>• Added Power Input parameter in data log and real-time monitoring</li> <li>• Corrected Scale Factors for the Terminal Frequency and Compensated Frequency so they are in units of percent in datalogs and analysis charts</li> <li>• Improved Network Load Share algorithm</li> <li>• Improved anti reset windup for the PI controller</li> <li>• Changed low end range of High-Pass Filtering/Integration Inertia (H) PSS Parameter setting to 0.01</li> <li>• Fixed error in the discrete proportional gain of the PID controller</li> <li>• Increased current ranges for Summing Point OEL and Takeover OEL to allow for proper operation at 20 Adc</li> </ul>

**Table 49. BESTCOMSPi<sup>us</sup>® Software Revision History**

<b>Software Version and Date</b>	<b>Change</b>
3.00.02, Sep-12	<ul style="list-style-type: none"> <li>• Initial release</li> </ul>
3.01.01, Nov-12	<ul style="list-style-type: none"> <li>• Added English/Metric unit display</li> </ul>
3.02.00, Dec-12	<ul style="list-style-type: none"> <li>• Added Windows® 8 compatibility</li> </ul>
3.05.02, Jan-14	<ul style="list-style-type: none"> <li>• Updated to support firmware version 1.01.05</li> </ul>
3.05.03, Feb-14	<ul style="list-style-type: none"> <li>• Maintenance release</li> </ul>
3.06.00, Apr-14	<ul style="list-style-type: none"> <li>• Updated to support firmware version 1.02.00</li> </ul>
3.07.00, Oct-14	<ul style="list-style-type: none"> <li>• Improved graphing of UEL curve</li> <li>• Changed UEL Primary Curve screen to allow decimal points when in per unit mode</li> <li>• Removed duplicate results in the device discovery list</li> <li>• Improvements to device directory on Connection screen</li> <li>• Changed to allow a comma in the Device ID</li> <li>• Changed to announce a connection failure message when a device is not present on a selected port</li> <li>• Improved prompts to save settings when choosing to close all open views</li> <li>• Changed to allow the middle mouse button to close the security view</li> <li>• Improved display of raw analog input currents</li> <li>• Changed to make BESTlogicPlus status LEDs report all logic errors</li> </ul>
3.07.03, Jan-15	<ul style="list-style-type: none"> <li>• Modified autotuning</li> </ul>

Software Version and Date	Change
3.08.00, Feb-15	<ul style="list-style-type: none"> <li>Added support for DECS-250 firmware version 1.03.00</li> <li>Added pre-defined logic schemes with PSS</li> </ul>
3.08.02, Mar-15	<ul style="list-style-type: none"> <li>Maintenance release (DGC-2020HD changes)</li> </ul>
3.09.00, Apr-15	<ul style="list-style-type: none"> <li>Maintenance release (DGC-2020HD)</li> </ul>
3.10.00, Oct-15	<ul style="list-style-type: none"> <li>Maintenance release (DECS-150)</li> </ul>
3.11.00, Dec-15	<ul style="list-style-type: none"> <li>Added support for DECS-250 firmware version 1.03.02</li> </ul>
3.12.00, Apr-16	<ul style="list-style-type: none"> <li>Added Windows® 10 compatibility</li> </ul>
3.14.00, Jul-16	<ul style="list-style-type: none"> <li>Added support for DECS-250 firmware version 1.05.00</li> </ul>
3.15.00, Nov-16	<ul style="list-style-type: none"> <li>Maintenance release (DGC-2020HD)</li> </ul>
3.17.00, May-17	<ul style="list-style-type: none"> <li>Added support for DECS-250 firmware version 1.05.03</li> </ul>
3.17.01, Jul-17	<ul style="list-style-type: none"> <li>Updated USB driver installer to improve Windows 10 compatibility.</li> </ul>
3.18.00, Jan-18	<ul style="list-style-type: none"> <li>Maintenance release (DECS-150)</li> </ul>
3.19.00, Jul-18	<ul style="list-style-type: none"> <li>Improved user experience when changing style number.</li> </ul>
3.20.00, Feb-19	<ul style="list-style-type: none"> <li>Maintenance release (BE1-11 changes)</li> </ul>
3.21.00, Apr-19	<ul style="list-style-type: none"> <li>Added support for firmware version 1.06.00</li> </ul>

Table 50. Instruction Manual Revision History

Manual Revision and Date	Change
B, Oct-12	<ul style="list-style-type: none"> <li>Initial release</li> </ul>
C, Nov-12	<ul style="list-style-type: none"> <li>Updated operating temperature and frequency specifications</li> </ul>
D, Jul-13	<ul style="list-style-type: none"> <li>Added maritime agency recognitions (BV, DNV, GL)</li> <li>Clarified online OEL and low-level SCL limiting conditions</li> <li>Improved the description of the BESTCOM<i>Plus</i>® control panel setpoint window</li> <li>Added field wiring requirement for EMC compliance</li> <li>Improved typical connection diagrams</li> <li>Improved firmware upgrading procedures</li> <li>Added BESTlogic™ <i>Plus</i> logic element “27”</li> <li>Added clarification stating that the PARALLEL_EN logic input must be true in order for UEL and droop compensation to operate</li> <li>Expanded description of the Loss of Excitation (40Q) protection element</li> <li>Expanded description of the IRIG decoding setting in Clock Setup</li> <li>Minor edits to Modbus™ communication legacy register table</li> <li>Added caution statements in several places recommending proper grounding of the DECS-250 when using the non-isolated USB port</li> </ul>
E, DEC-13	<ul style="list-style-type: none"> <li>Improved description of Profibus communication setup</li> <li>Expansion modules, AEM-2020 and CEM-2020, now have connectors with gold-plated pins to better protect communication signal integrity</li> <li>Added PF Active Power Level setting for var/PF regulation</li> <li>Added Network Load Share ID settings</li> <li>Added secure login via Modbus™ communication settings</li> <li>Added Binary Points and Metering Modbus registers</li> <li>Minor text edits throughout manual</li> </ul>

Manual Revision and Date	Change
F, Apr-14	<ul style="list-style-type: none"> <li>• Added Russian language support</li> <li>• Added overexcitation (24) protection</li> <li>• Added transient excitation boosting function</li> <li>• Added loss of excitation (40Q) protection for motors</li> <li>• Added integrating reset method to takeover OEL</li> <li>• Added angle compensation to synchronizer and sync check (25)</li> <li>• Increased available real-time monitoring plots from two to six</li> <li>• Minor text edits throughout manual</li> </ul>
G, Aug-14	<ul style="list-style-type: none"> <li>• Increased maximum operating temperature to +70°C</li> <li>• Added GND terminal to power connector and vent holes to chassis</li> </ul>
H, Feb-15	<ul style="list-style-type: none"> <li>• Added support for DECS-250 firmware version 1.03.00 and BESTCOMS<i>Plus</i> version 3.08.00</li> <li>• Changed layout of Auxiliary Control Gains section and added equations in the <i>Auxiliary Control</i> chapter</li> <li>• Added Off-Page Objects description in the <i>BESTlogicPlus</i> chapter</li> <li>• Cleaned up various Modbus register names and descriptions in the <i>Modbus</i> chapter</li> <li>• Added Modbus registers for AEM Configuration, AEM Protection, RTD Protection, and Thermocouple Protection in the <i>Modbus</i> chapter</li> <li>• Expanded IRIG specifications in the <i>Specifications</i> chapter</li> <li>• Added Maritime Recognition to the <i>Specifications</i> chapter</li> <li>• Minor text edits throughout manual</li> </ul>
I	<ul style="list-style-type: none"> <li>• This revision letter not used</li> </ul>
J, May-15	<ul style="list-style-type: none"> <li>• Improved description of optional escutcheon plate in the <i>Mounting</i> chapter</li> <li>• Added a figure for station-powered applications in the <i>Typical Connections</i> chapter.</li> <li>• Updated manual to reflect BESTCOMS<i>Plus</i> screen layout changes</li> <li>• Added Offline Logic Simulator description in the <i>BESTlogicPlus</i> chapter</li> <li>• Added descriptions for Cursors Enabled and Sync Graph Scrolling settings on the Analysis Options screen in the <i>Testing</i> chapter</li> <li>• Added EAC certification in the <i>Specifications</i> chapter</li> <li>• Minor text edits throughout manual</li> </ul>

Manual Revision and Date	Change
K, May-17	<ul style="list-style-type: none"> <li>• Changed the Auto Save interval to 10 minutes in the <i>Regulation</i> chapter.</li> <li>• Added Loss of Sensing Trip Criteria table to the <i>Protection</i> chapter.</li> <li>• Clarified description of Summing Point OEL online operation in the <i>Limiters</i> chapter.</li> <li>• Added support for synchronizing at 25 Hz.</li> <li>• Added caution statement for operation in caustic environments to the <i>Mounting</i> chapter.</li> <li>• Noted the location of the USB driver directory in the <i>BESTCOMSPPlus Software</i> chapter.</li> <li>• Added nonvolatile memory caution statement to the <i>BESTlogicPlus, Communication, Modbus Communication, and Profibus Communication</i> chapters.</li> <li>• Clarified Step 4 under Setup in <i>Profibus Communication</i> chapter.</li> <li>• Added Active Setpoint registers (instance 254) to the <i>Profibus Communication</i> chapter.</li> <li>• Added USB driver installation troubleshooting material to the <i>Maintenance</i> chapter.</li> <li>• Simplified the presentation of the sensing voltage nominal input ranges, added metering accuracy values, and added self-tuning patent number to the <i>Specifications</i> chapter.</li> <li>• Added description of the status LED on the AEM-2020 and CEM-2020 to their respective chapters.</li> <li>• Updated CE Compliance and UL Certification sections in <i>Specifications, Analog Expansion Module, and Contact Expansion Module</i> chapters.</li> <li>• Minor text edits throughout manual</li> </ul>
L, Sept-17	<ul style="list-style-type: none"> <li>• Added support for BESTCOMSPPlus version 3.17.01.</li> </ul>
M, May-18	<ul style="list-style-type: none"> <li>• Maintenance release</li> </ul>
N, Jun-18	<ul style="list-style-type: none"> <li>• Added Configuration Mismatch Delay setting in <i>Regulation</i> chapter.</li> <li>• Corrected caution box in <i>Power Inputs</i> chapter.</li> <li>• Added UL, Class I, Div. 2 for AEM-2020 and CEM-2020.</li> <li>• Improved description of CEM-2020 output contact ratings.</li> <li>• Added caution statement about using the 40Q function with a rated PF of 1.0.</li> <li>• Removed Table 4. Lead/Lag labels remain the same in generator and motor modes.</li> <li>• Corrected description of settings under Frequency Correction section in <i>Synchronizer</i> chapter.</li> <li>• Corrected V/Hz Limiter description and Figure 55 (Typical 1.1 pu Volts per Hertz Limiter Curve) in <i>Limiters</i> chapter.</li> <li>• Corrected UEL, Real Power Exponent setting range in <i>Limiters</i> chapter.</li> <li>• Added notes in <i>Typical Connections</i> chapter about the terminating resistor requirement for CAN terminals.</li> </ul>
O	<ul style="list-style-type: none"> <li>• This revision letter not used</li> </ul>

<b>Manual Revision and Date</b>	<b>Change</b>
P, Nov-18	<ul style="list-style-type: none"><li>• Added California Proposition 65 warning statement</li><li>• Clarified power system stabilizer type</li></ul>
Q	<ul style="list-style-type: none"><li>• This revision letter not used</li></ul>
R, Apr-19	<ul style="list-style-type: none"><li>• Added support for firmware version 1.06.00 and BESTCOMSPlus version 3.21.00</li><li>• Added drawings for Analog Inputs – Current Input Connections in the Analog Expansion Module chapter</li><li>• Minor text edits throughout manual</li></ul>







12570 Route 143  
Highland IL 62249-1074 USA  
Tel: +1 618.654.2341  
Fax: +1 618.654.2351  
email: [info@basler.com](mailto:info@basler.com)

No. 59 Heshun Road Loufeng District (N)  
Suzhou Industrial Park  
215122 Suzhou  
P.R. CHINA  
Tel: +86 512.8227.2888  
Fax: +86 512.8227.2887  
email: [chinainfo@basler.com](mailto:chinainfo@basler.com)

111 North Bridge Road  
15-06 Peninsula Plaza  
Singapore 179098  
Tel: +65 68.44.6445  
Fax: +65 68.44.8902  
email: [singaporeinfo@basler.com](mailto:singaporeinfo@basler.com)