

Extension modules for ID-DCU, IGS-NT gen-set or engine controllers



Accessory Modules

May 2014

Reference Guide

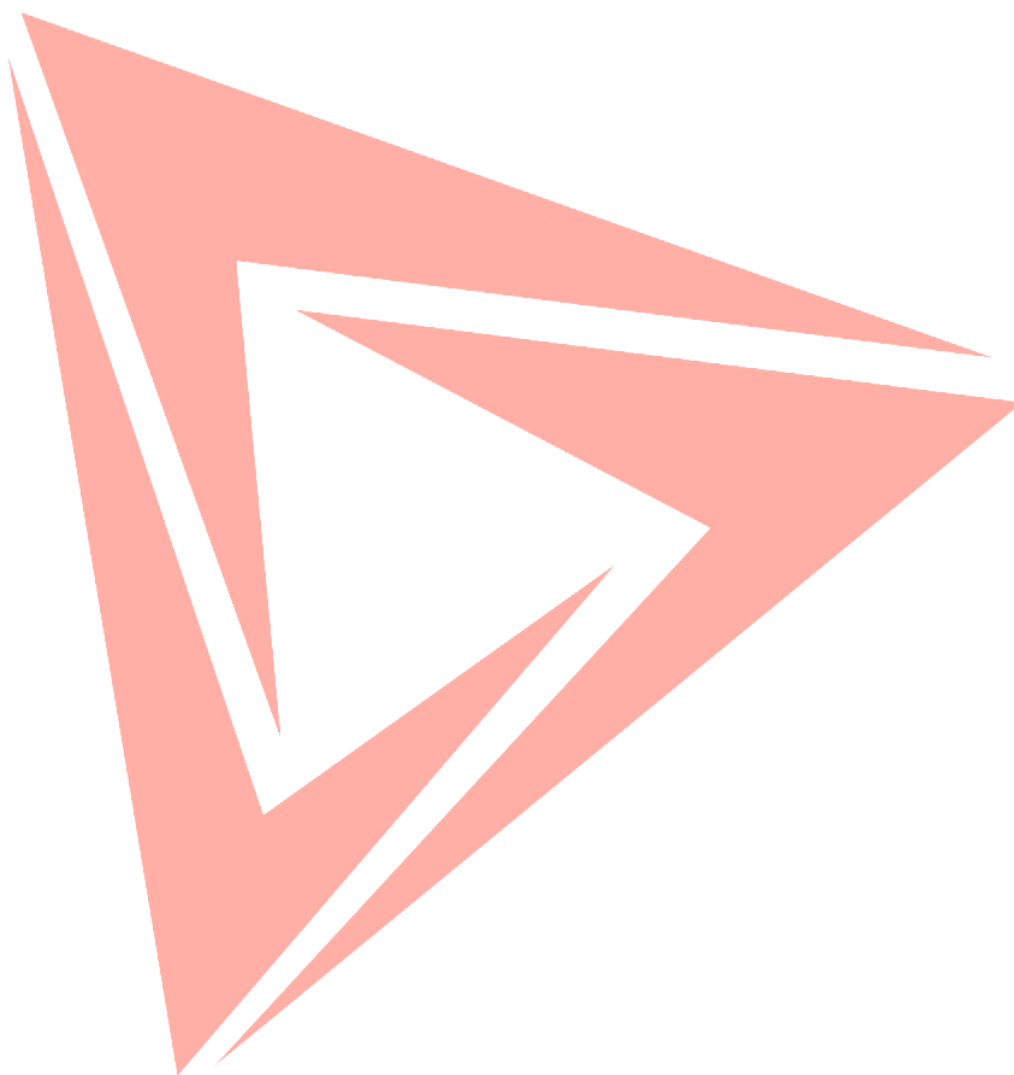

ComAp, a.s.

Kundratka 2359/17, 180 00 Praha 8, Czech Republic
Tel: +420 246 012 111, Fax: +420 266 316 647
E-mail : info@comap.cz, www.comap.cz

Support : support@comap.cz

Copyright © 2008-2014 ComAp a.s.
Written by: R. Taragel, Ladislav Szetei



Table of Contents

Table of Contents	2
Table of Modules	3
Modules	4
Intel IO8/8 (I-IO8/8)	4
Intel AIN8 (I-AIN8)	12
Intel AIN8TC (I-AIN8TC)	22
I-AOUT8	27
I-LB+	31
I-LBA	41
I-RB8 / I-RB16	43
I-RD-CAN / I-RD-CAN-ID-DCU-MARINE	45
ID-COM	50
ID-RPU	52
ID-SCM	59
IGS-PTM	63
IG-MTU/IG-MTU-C/MTU-2-1	68
IS-AIN8	70
IS-AIN8TC	78
IS-BIN16/8	82
IG-AVRi	88
Theory of binary inputs and outputs	91
Table of symbols	93

Table of Modules

Module	Controller type		Related documentation
	IGS-NT	ID-DCU	
Intel IO8/8 (I-IO8/8)	✓	✓	
Intel AIN8 (I-AIN8)	✓	✓	
Intel AIN8TC (I-AIN8TC)	✓	✓	
I-AOUT8	✓	✓	
I-CB/MTU	✓	✓	I-CB-ICBEdit-1.1
I-CB/CAT diesel/gas	✓	✓	
I-CB/DeutzTEME	✓	✓	
I-LB / I-LB+	✓	✓	
I-LBA	✓	✓	
I-RB8	✓	✓	
I-RB16	✓	✓	
I-RB8-231	✓	✓	
I-RB16-231	✓	✓	
I-RD-CAN	✗	✓	
I-RD-CAN-ID-DCU-MARINE	✗	✓	
ID-COM	✗	✓	
ID-RPU	✗	✓	
ID-SCM	✗	✓	
ID-SCM1	✗	✓	
IG-AVRi with IG-AVRI TRANS/LV	✓	✗	
IG-AVRi with IG-AVRI TRANS/100	✓	✗	
IG-IB	✓	✓	IG-6.1-IS-3.1-CommunicationGuide
IGL-RA15	✓	✓	IGL-RA15-1.2
IG-MTU / IG-MTU-C/ MTU-2-1	✓	✗	
IGS-PTM	✓	✓	
IS-AIN8	✓	✓	
IS-AIN8TC	✓	✓	
IS-BIN16/8	✓	✓	

Note:

For connecting with controller and unit reprogramming, see **Proprietary controller guide**.

You can download these manuals from <http://www.comap.cz>

Modules

Inteli IO8/8 (I-IO8/8)

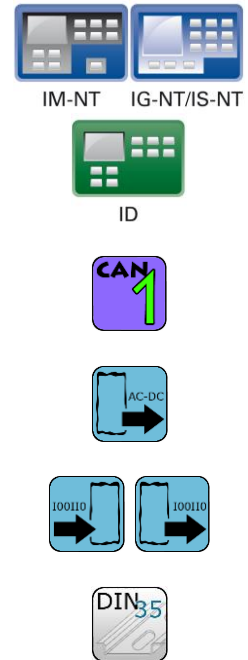
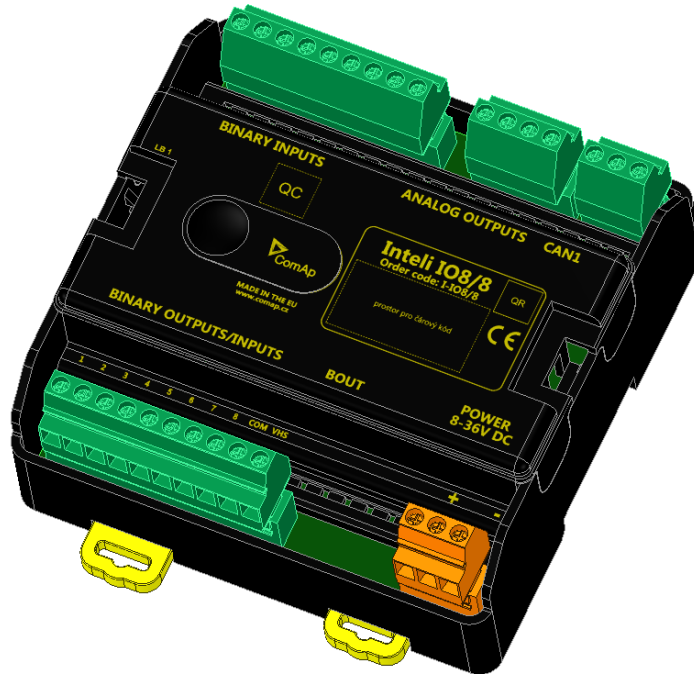

Description

Inteli IO8/8 module is an extension module equipped with binary inputs, binary outputs and analog outputs.

The module can be used for ID-DCU, InteliMains-NT, InteliGen-NT and InteliSys-NT controllers.

“Inteli IO8/8” is the name of the module, but it is possible to configure the module (by internal switch) to two configurations:

- 1) Inteli IO8/8 (8 binary inputs, 8 binary outputs and 2 analog outputs)
- 2) Inteli IO16/0 (16 binary inputs, 0 binary outputs and 2 analog outputs)

Available inputs/outputs:

Binary inputs

- 8 channels
- can be configured as:

- pull up
- pull down

All 8 inputs are configured to one type together.

Binary outputs

- 8 channels
- can be configured as:

- High side switch
- Low side switch

Always all 8 inputs are configured to one type (HSS/LSS) together.

All 8 outputs can be modified to inputs by switch on the PCB (IO 8/8 to IO 16/0).

New function “output state check” can be switched on for all 8 binary outputs.

Hint:

[Theory of Binary inputs/outputs \(Pull Up, Pull Down, High side switch, Low side switch\)](#)

“**Output state check**” function evaluates in real time the state of binary outputs and adjusted (required) state. In case of failure (different state of required state and real state) history record and alarm are issued (type of the alarm is set by “Protection upon module failure” - (no alarm/warning/SD)).

This function is designed for short-circuit or other failure, which causes change of set state of binary output.

Module type	IntelIIO8/8
Module index	IntelIIO8/8(1) ▼
Protection upon module failure	SHUTDOWN (RED) ▼
Module failure prefix	IIO8/8(1)
Add screens	Yes ▼
Output type	High side ▼
Output state check	Activated ▼
Input type	Pull up ▼

Analog outputs

- 2 channels

- can be configured as:

- voltage 0-10V
- current 0-20mA
- PWM (level 5V, with adjustable frequency from 200Hz to 2400Hz, with step 1Hz)

All inputs/outputs can be configured to any logical function or protection.

It is possible to connect up to 12 modules (in configuration 8inputs/8outputs) to the Inteligen-NT, Intelisys-NT or Intelimains-NT controllers or up to 4 modules to the ID-DCU.

Intel IO8/8 module is connected to controller CAN1 bus.

Default configuration of module:

If the software of the controller supports this module, then you can configure inputs/output to all options.

In case that the software of the controller doesn't support this module, you can add this module to the configuration by generic extension (as group of 8 signals).

In this case you cannot define the type of Inputs/outputs, all inputs/outputs are configured as:

- Binary inputs – pull up
- Binary outputs – Low side
- Analog output – current, range 0-20mA

Dimensions:

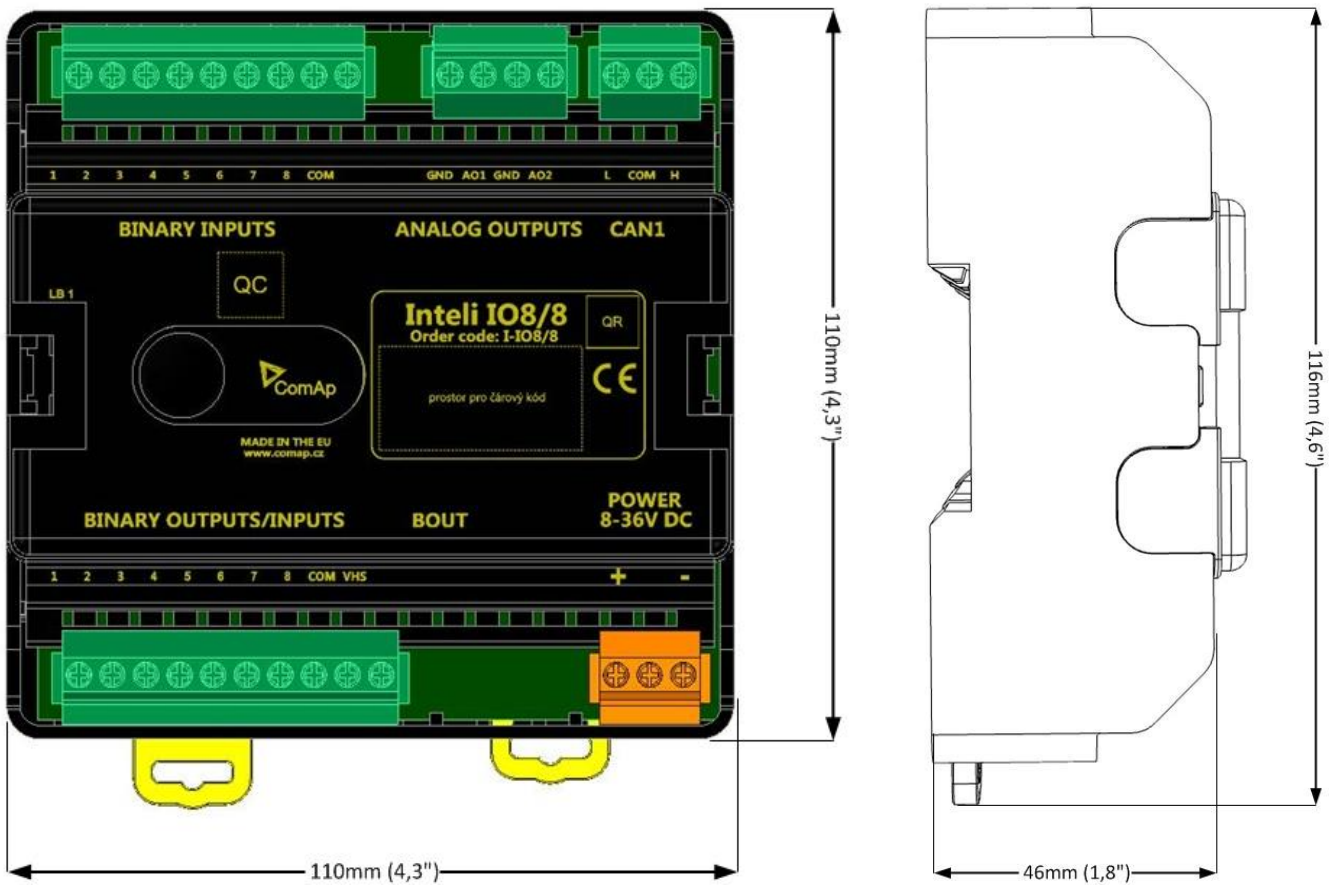

Unit is 35 mm DIN rail mounted.

Terminals

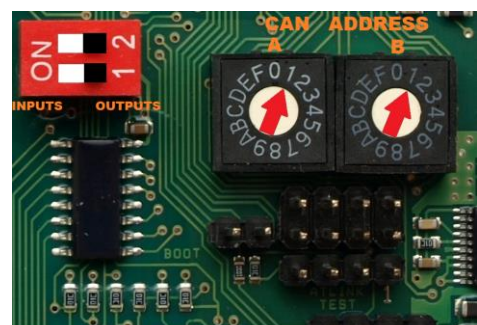
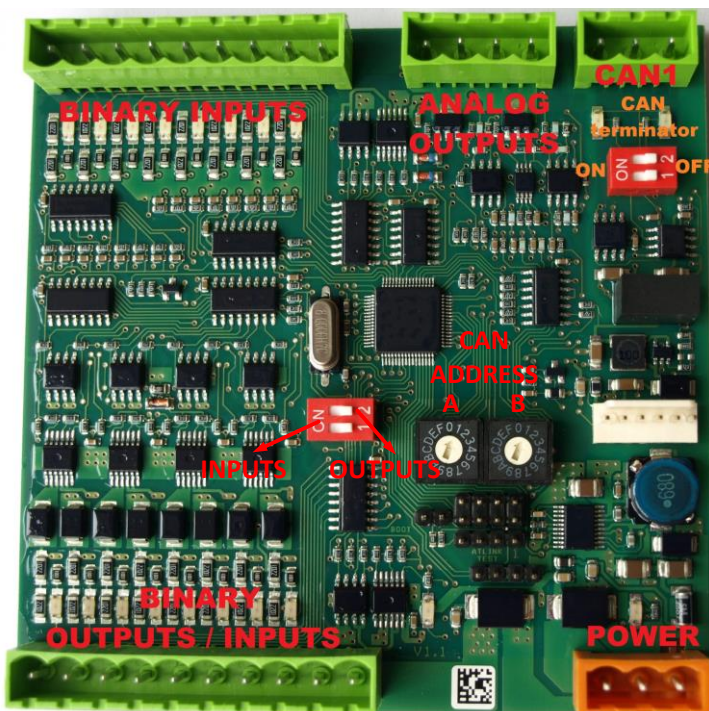

BINARY INPUTS	8 binary inputs
BINARY OUTPUT	8 binary outputs (8 binary inputs)
ANALOG OUTPUT	2 analog outputs
CAN	CAN1 line
POWER	Power supply
BINARY INPUTS LED	8 LEDs for binary input indication
BINARY OUTPUT LED	8 LEDs for binary output indication
CAN LED Tx, Rx	Indication transmitted or received data
Status LED	LED indication of correct function
Bout LED	Indicate binary outputs active (non-active = 16 binary inputs are active)
CAN terminator	Terminating CAN resistor (active in position "ON")
TEST jumper	Upgrade of sw
AT-LINK	Connector for AT-LINK

Address and DIP switches setting

Configuration as Intel I/O8/8:

CAN address for binary inputs is determined by DIP switch A, CAN address for binary output and analog outputs is determined by DIP switch B.

Configuration as Intel I/O16/0:

CAN address for binary inputs is determined by DIP switch A, first group of 8 input has address A, second group of 8 inputs has address A+1. CAN address of analog outputs is set by DIP switch B.

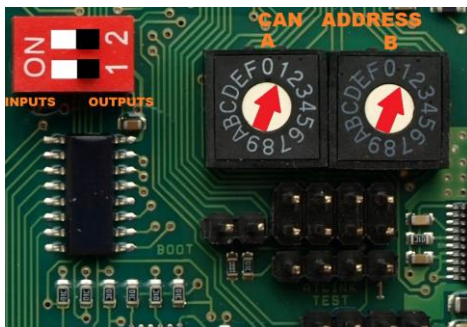

In case of setting the CAN address to zero, the appropriate group of signals is deactivated.

Programming Firmware

Firmware upgrade is via AT-link (TTL). For programming is necessary to close jumper TEST. For programming FlashProg PC tool version 4.2 or higher must be used.

LED indication

Binary input

Each binary input has LED which indicates input signal. LED is shining when input signal is set, and LED is dark while input signal has other state.

Binary output

Each binary output has LED which indicates output signal. Binary output LED is shining when binary output is set.

Binary output status LED

When this LED is shining, then module is configured as 8 binary inputs and 8 binary outputs. When this LED is dark, then the module is configured as 16 binary inputs.

LED at power connector – status LED:

LED status	Description
Dark	Fw in module does not work correctly.
flashing	At least one “group of signals” (binary inputs, binary outputs, analog outputs) with a non-zero address does not communicated.
Lights	Power supply is in the range and communication between Intel IO8/8 and controller properly works.

Wiring:

Binary inputs:

- 1) Pull up

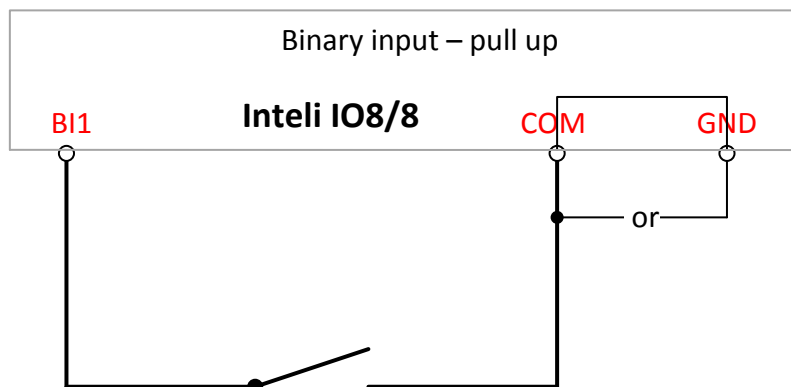

Terminator COM and GND are connected together internally in case activation of pull up inputs.

2) Pull down

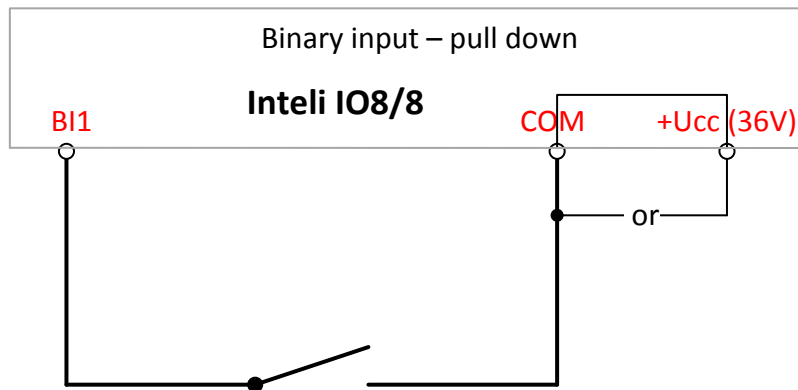

Terminator COM and +Ucc are connected together internally in case activation of pull down inputs.

There is an interconnection between COM terminal and GND terminal (+Ucc terminal) in the module, but it is possible to realize this by directly connecting to the terminal GND (+Ucc terminal). COM terminator is internally switched based on type of inputs (pull up or pull down).

Binary outputs:

1) High side

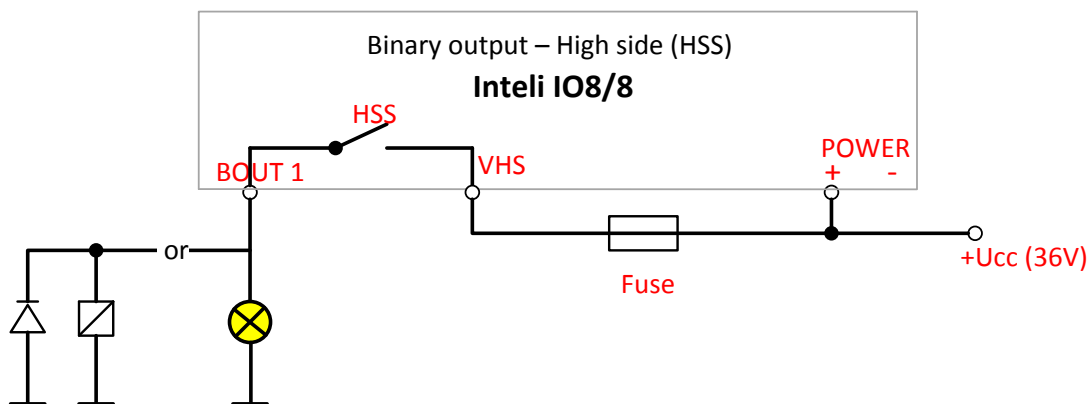

When High side setting of outputs is chosen - binary output must be connected to the plus potential (+Ucc) of power supply connect directly to terminal VHS (voltage High side). Maximal current of each binary output is 500mA.

Size of fuse depends on load.

2) Low side

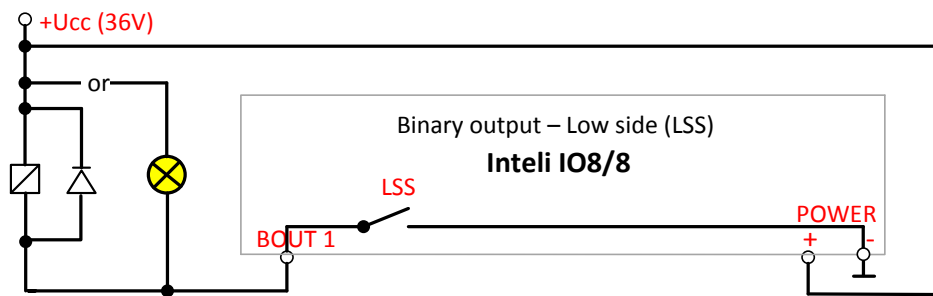

o

Analog outputs:

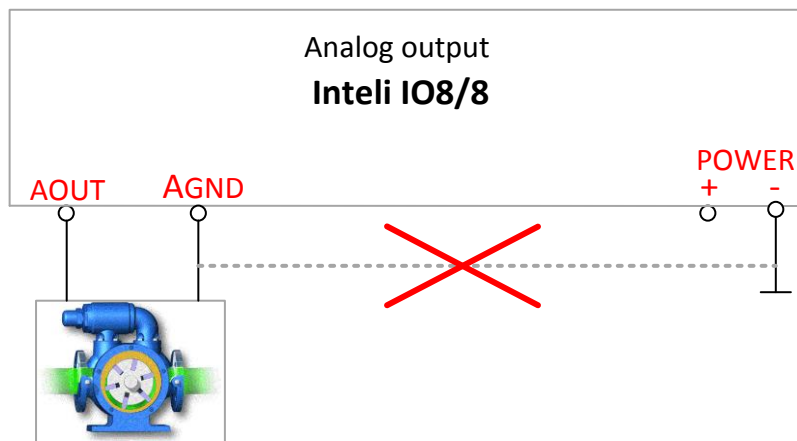

Terminator for analog output has special analog ground (AGND), which must not be connected to the GND. **Limit of analog ground (AGND) is 100mA.**

Technical data

Dimension (WxHxD)	110x110x46 mm (4,3"x4,3"x1,8")
Interface to controller	CAN 1
Binary inputs	<i>Input resistance</i> 4400 ohm
	<i>Input range</i> 0 to 36V DC
	<i>Switching voltage level for open contact indication</i> 0 to 2V
	<i>Max voltage level for close contact indication</i> 6 to 36V
Binary output (Open collector output)	<i>Max current</i> 500mA
	<i>Max switching voltage</i> 36V DC
Analog output (not electric separated)	current Range 0 - 20mA accuracy: $\pm 100 \mu\text{A} + \pm 0,5 \%$ of actual value (Rmax 500 Ω)
	voltage range 0 – 10V accuracy: $\pm 20\text{mV} + \pm 0,5 \%$ of actual value (Imax 5mA)
	PWM Level 5V, adjustable freq 200÷2400Hz (Imax 20mA) (minimal step of pulse is 2 μs)
	Max current of AGND 100mA
Galvanic separation	CAN bus is galvanic separated from the measurement and power supply All Inputs/outputs are not galvanic separated from power supply
Power supply	8 to 36 V DC
Protection	IP20
Current consumption	35 mA at 24V ÷ 100 mA at 8V
Storage temperature	- 40C to + 80°C
Operating temperature	- 30°C to + 70°C

The product is fully supported in fw IGS-NT 3.0 or higher and in IGS-NT-branches based on this fw.

Inteli AIN8 (I-AIN8)

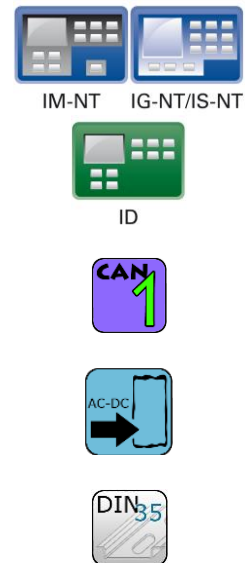
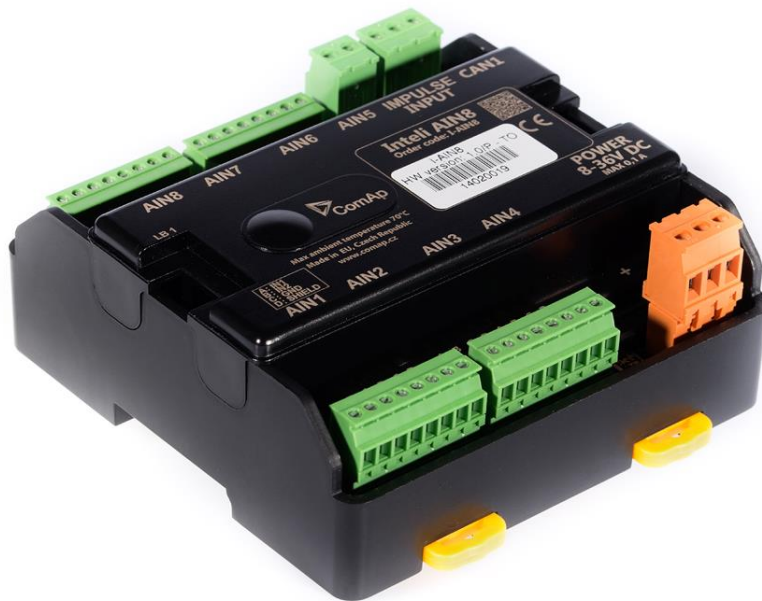

Description

Inteli AIN8 module is extension module equipped with analog inputs and impulse input. The module can be used for ID-DCU, InteliMains-NT, InteliGen-NT and InteliSys-NT controllers.

Available inputs/outputs:

Analog inputs

- 8 channels
- can be configured as:
 - resistor three wire input
 - current input
 - voltage input

Impulse input:

- 1 channel
- can be configured as:
 - Impulse
 - Impulse/time
 - RPM

All inputs can be configured to any logical function or protection. It is possible to connect up to 10 modules to the InteliGen-NT, InteliSys-NT or InteliMains-NT controllers or up to 4 modules to the ID-DCU. Inteli AIN8 module is connected to controller CAN1 bus.

Supported sensors:

Sensors
user curves
PT100 [°C] (fix)
PT1000 [°C] (fix)
NI100 [°C] (fix)
NI1000 [°C] (fix)
PT100 [°F] (fix)
PT1000 [°F] (fix)
NI100 [°F] (fix)
NI1000 [°F] (fix)
0-250ohm (fix linear)
0-2400ohm (fix linear)
0-10k ohm (fix linear)
+/-1V (fix linear)
0-2.4V (fix linear)
0-5V (fix linear)
0-10V (fix linear)
4-20mA passive (fix linear)
4-20mA active (fix linear)
0-20mA passive (fix linear)
+/-20mA active (fix linear)

Dimensions:

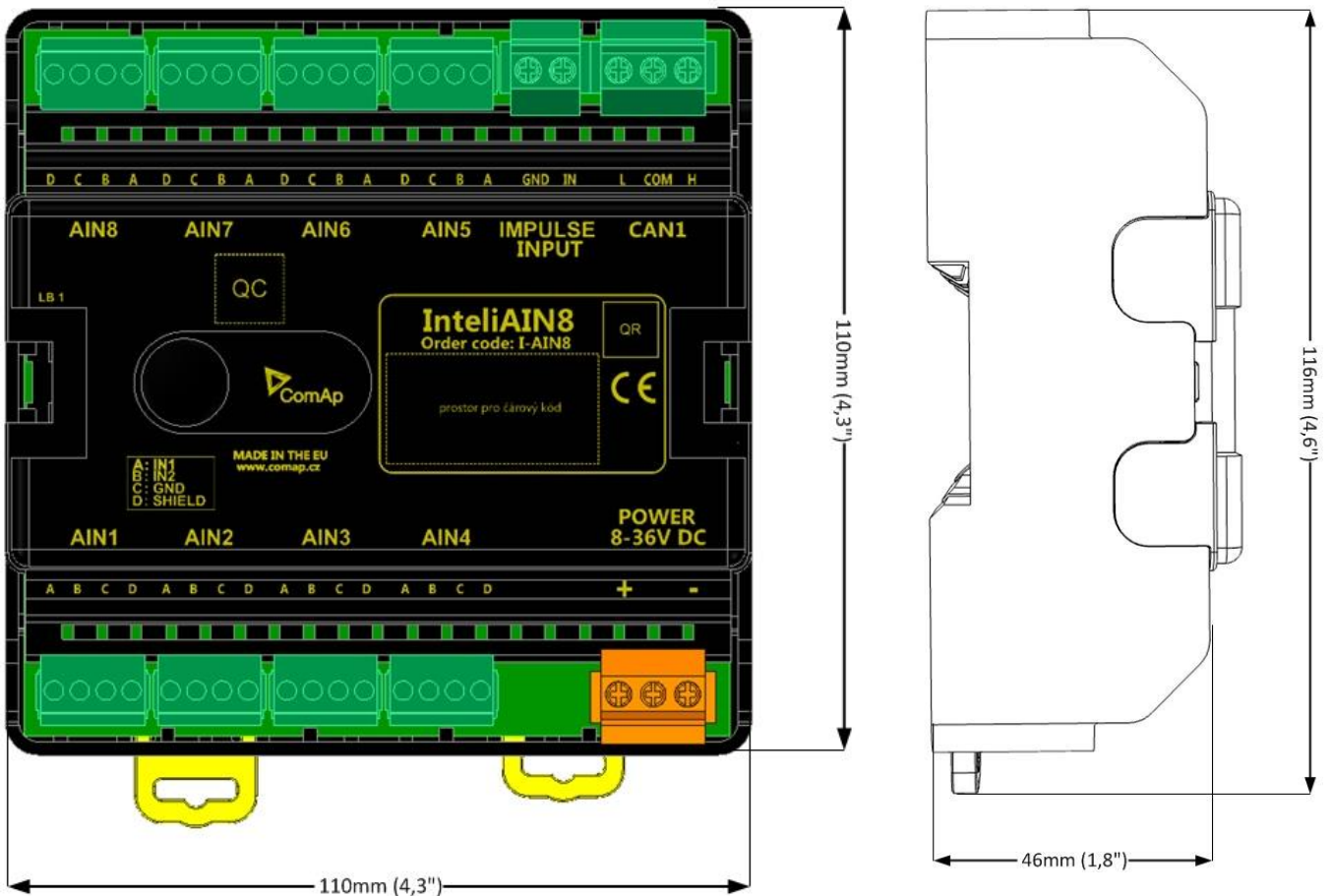

Unit is 35 mm DIN rail mounted.

Terminals

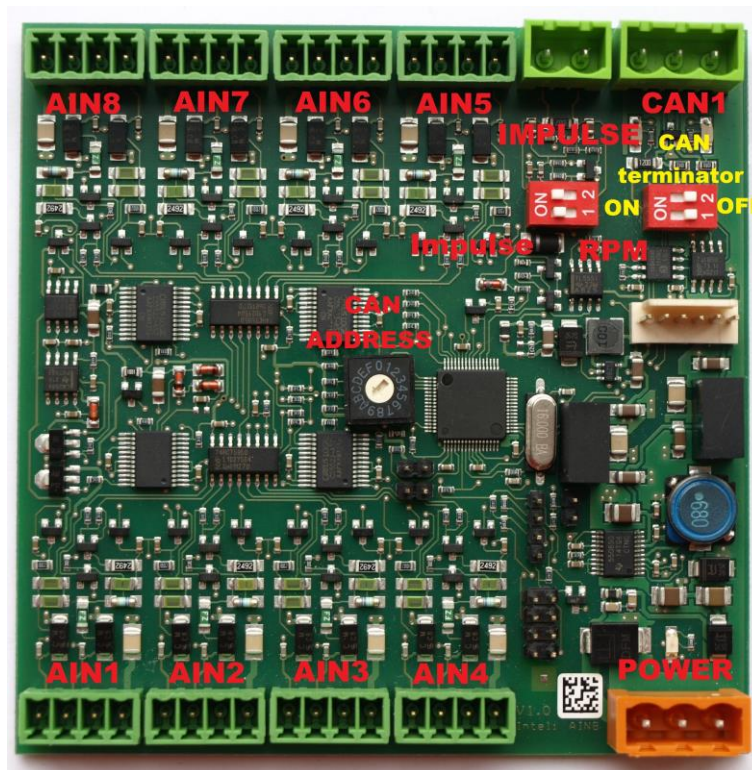

ANALOG INPUT	<i>8 analog Inputs</i>
IMPULSE INPUT	<i>1 impulse input</i>
CAN	<i>CAN1 line</i>
POWER	<i>Power supply</i>
CAN LED Tx, Rx	<i>Indication transmitted or received data</i>
Status LED	<i>LED indication of correct function</i>
CAN terminator	<i>Terminating CAN resistor (active in position "ON")</i>
TEST jumper	<i>Upgrade of sw</i>
AT-LINK	<i>Connector for AT-LINK</i>

Address and DIP switch setting

Address configuration

DIP switch determinates CAN address for analog inputs and impulse input too.

Programming Firmware

Firmware upgrade is via AT-link (TTL). For programming it is necessary to close jumper TEST. For programming use FlashProg PC tool version 4.2 or higher.

LED indication

LED at power connector – status LED:

LED status	Description
Dark	Fw in module does not work correctly.
flashing	Module does not communicate with controller (in case non-zero CAN address)
Lights	Power supply is in the range and the communication between Inteli AIN8TC and controller works properly. Or power supply is in range and zero CAN address is set. (in case zero CAN address module doesn't communicate with the controller)

Impulse input configuration:

(This input is supported in sw IGS-NT3.0 and higher)

(InteliGen-NT and InteliSys-NT support 1 impulse input (type Impulse or Impulse/time or Impulse+Impulse/time) and 1 RPM input or 2 RPM inputs)

After adding Inteli AIN8 module to configuration in GenConfig/ card Modules, you choose type of impulse input:

Module type	InteliAIN8
Module index	InteliAIN8 (1) ▼
Protection upon module failure	SHUTDOWN (RED) ▼
Module failure prefix	IAIN8(1)
Add screens	Yes ▼
Display data as	Number ▼
Impulse input type	None ▼
	None Impulse Impulse/time Impulse+Impulse/time RPM

After selection you configure input - in card "I/O", group "Impulse input"

1) RPM

In this case you can set name of this input and set the number of gear teeth. Value of RPM is placed in value group: "RPM & Imp/time"

2) Impulse

This setting is designed for reading of pulses from electricity meter or flow meter.

Configuration:

Property	Value
Conversion	1000 pulses = 1 kWh ...
Impulse input name	Imp 1
Impulse output format	0,001 MWh ...
Type of pulses	Electric meter ▼
Ton min [ms]	30
Toff min [ms]	30

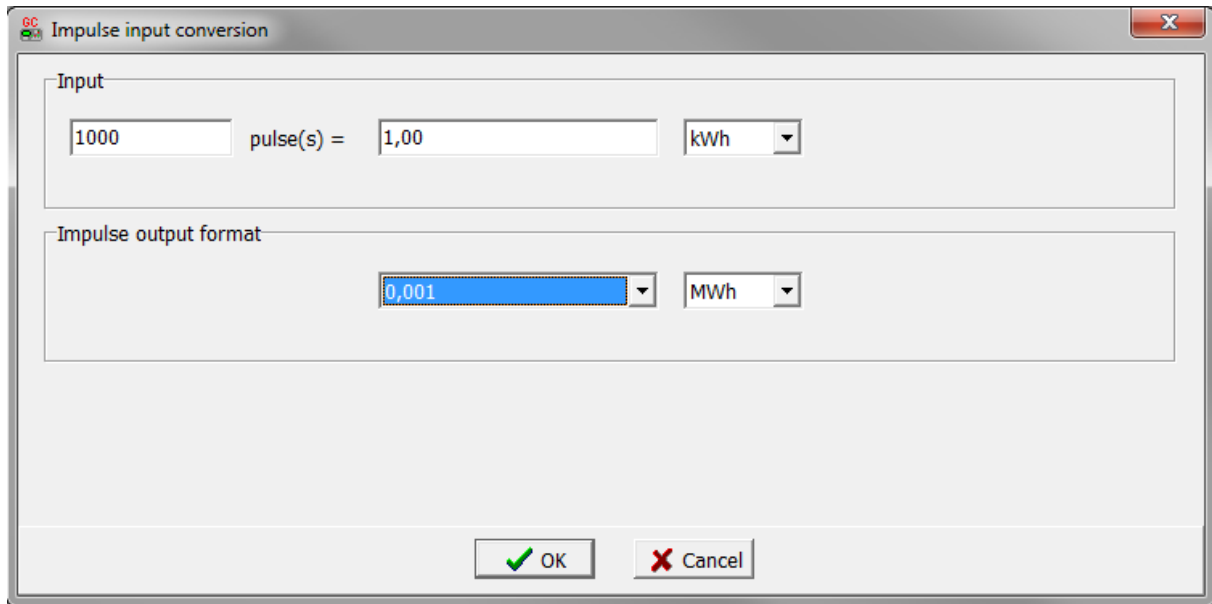

Example:

We have electric meter, which gives 1000 pulses/ 1kWh.
 Value, which is saved to statistic will be calculate to three decimal places and will be in MWh value.
 In case electricity meter is used, the valid pulse from electricity meter is defined by norm DIN 43864 and norm IEC 62053-31 – for equipment class A. In these norms the valid pulses are defined with these parameters: minimal $T_{on} \geq 30ms$, min $T_{off} \geq 30ms$.

In case flow meters you can use $T_{on} \geq 10ms$, min $T_{off} \geq 10ms$, or you can use option “Custom meter” where you can define any T_{on} and T_{off} .

Value is placed in value group: “Statistic“

This type of impulse input is designed for measurement of total electricity consumption – in this case.

Internal counter for this value:

Example:

100pulses=0,01kWh , output format to statistic is 0,001MWh.

Property	Value
Conversion	1 pulse = 0,01 kWh
Impulse input name	Imp 1
Impulse output format	0,001 MWh
Type of pulses	Electric meter
Ton min [ms]	30
Toff min [ms]	30

Counter value for counting of value from input is with range **4 294 967 295**.

So, 100pulses=0,01kWh => range is 4 294 967 2,95 kWh.

Output value is in MWh, so range is 4 294 9,67 295 MWh. [kWh ->MWh]

If counter value achieves this number (4 294 9,67 295 MWh), then it is cleared and count from 0 value again.

3) Impulse/time

This option counts pulses for any period and value says, how many pulses came in last defined period.

Property	Value
Conversion	1000 pulses = 1,00 l
Imp/time input name	Imp/time 1
Imp/time output format	0,1 hl/h
Type of pulses	Flowmeter
Ton min [ms]	10
Toff min [ms]	10

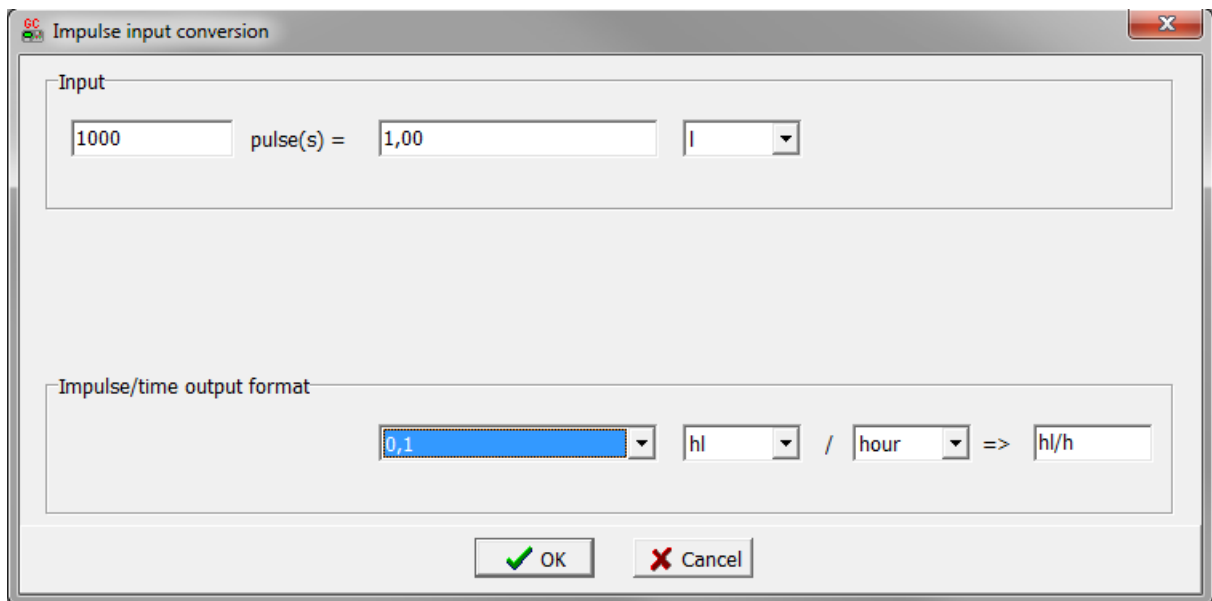

Example:

We connected output from the flow meter to the impulse input and we want to measure volume of cooling water.

Flow meter gives 1000 pulses per 1 litre.

Our resulting value will be calculated to one decimal place and will be in hectoliters.

This value is placed in group value "RPM & Imp/time".

The value shows the flow of the cooling water in the last hour. Value is perpetually recounted.

4) Impulse+Impulse/time

In this option you can choose the combination of Impuls and Impuls/Time inputs.

There are two value – total number of "pulses" and number of "pulses" per last period.

Description of both you can see higher.

Wiring:

The following diagrams show the correct connection of sensors.

Terminator:

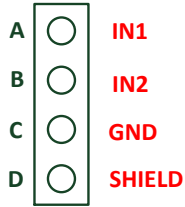

Measuring resistance:

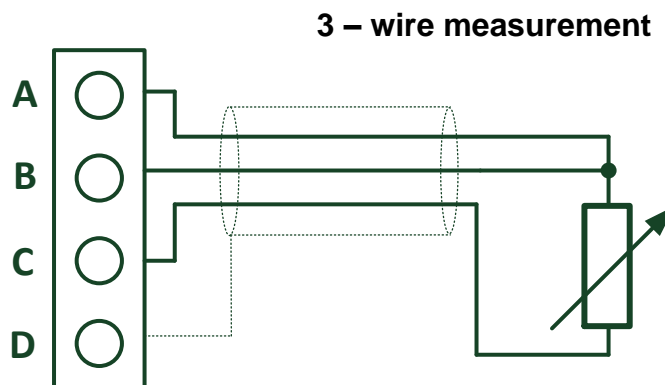

Ranges: Pt100, Pt1000, Ni100, Ni1000, 0 – 250Ω, 0 – 2400Ω, 0 – 10kΩ

Measuring current:

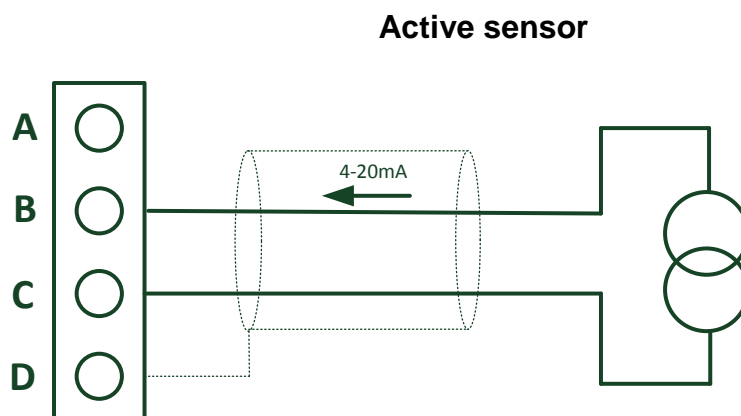

Ranges: ±20mA, 4 – 20mA

Passive sensor:

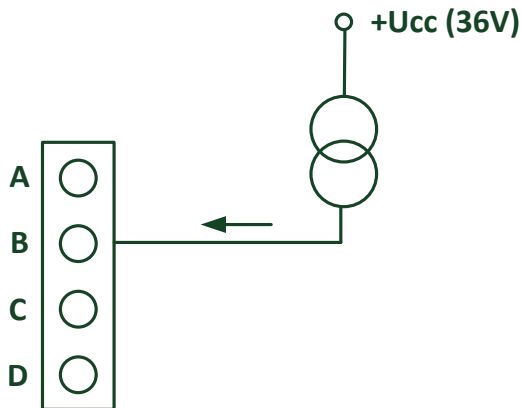

Ranges: 0 – 20mA, 4 – 20mA

Measuring voltage:

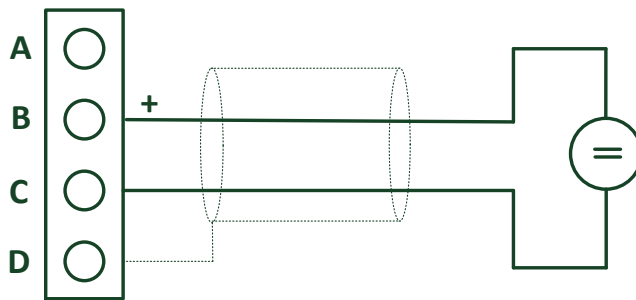

Ranges: ±1V, 0 – 2,5V, 0 – 5V, 0 – 10V

Impulse input:



Two options: measuring RPM or pulses – selection is realized by switch on the board. Parameters for valid pulse is configured in configuration.



Technical data

Dimension (WxHxD)	110x110x46 mm (4,3"x4,3"x1,8")
Interface to controller	CAN 1
Analog inputs <i>(not electric separated)</i>	8 channels *Voltage range 0-10V accuracy: $\pm 0,25\%$ of actual value + ± 25 mV current range: ± 20 mA accuracy: $\pm 0,25\%$ of actual value + ± 50 μ A resistance range: 0- 10k Ω accuracy: resistance: $\pm 0,5\%$ of actual value + ± 2 Ω Pt100, Pt1000, Ni100, Ni1000 $\pm 2,5$ $^{\circ}$ C
Impulse input	RPM:* level of signal: 2 Vpk-pk \div 70 Vpk-pk frequency range 4 Hz \div 10 kHz Impulse: Measurement of pulses by norm DIN 43864 and norm IEC 62053-31– equipment class A. for flow meter pulses: UH=30V, I _{max} =30mA, Ton min =10ms, Toff min = 10ms , OC
Galvanic separation	CAN bus is galvanic separated from the measurement and power supply All analog inputs are galvanic separated from power supply Analog inputs are not galvanic separated between channels
Power supply	8 to 36 V DC
Protection	IP20
Current consumption	35 mA at 24V \div 100 mA at 8V
Storage temperature	- 40C to + 80 $^{\circ}$ C
Operating temperature	- 30 $^{\circ}$ C to + 70 $^{\circ}$ C

*RPM input – required level of signal for correct sensing:

- Minimum input voltage 2 Vpk-pk (from 4 Hz to 4 kHz)
- Minimum input voltage 6 Vpk-pk (from 4 kHz to 10 kHz)

*Voltage measurement circuit was designed for lambda probe, for measurement thermocouples please use Inteli AIN8TC.

The product is fully supported in fw IGS-NT 3.0 or higher and in IGS-NT-branches based on this fw.

Inteli AIN8TC (I-AIN8TC)

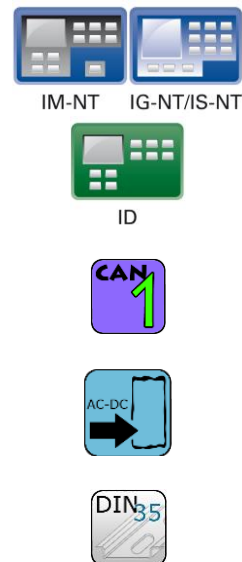
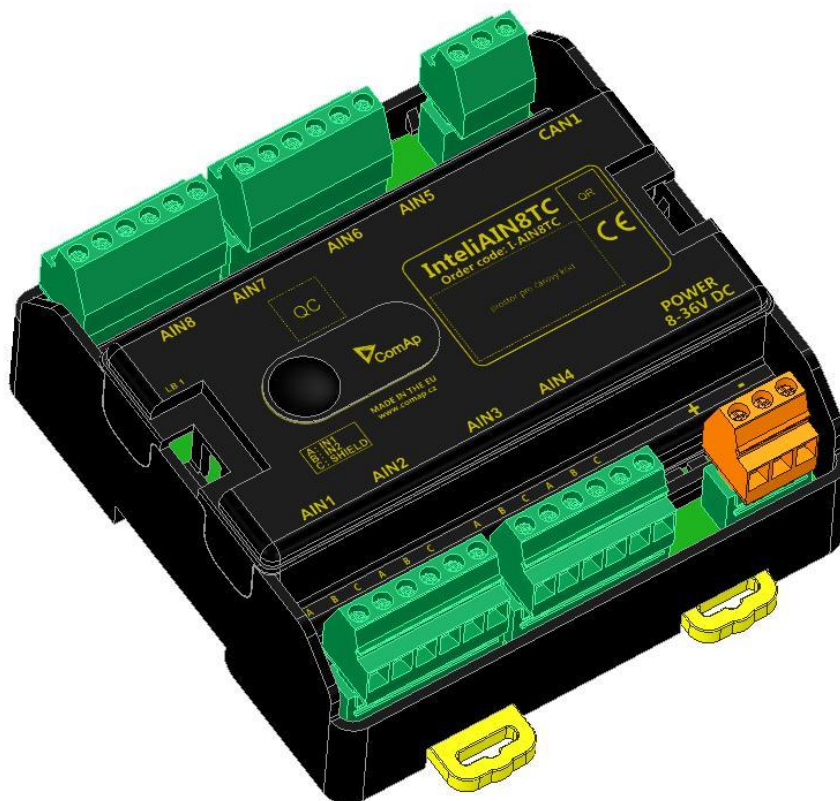

Description

Inteli AIN8TC module is extension module equipped with 8 analog inputs dedicated for thermocouple sensors only.

The module can be used for ID-DCU, InteliMains-NT, InteliGen-NT and InteliSys-NT controllers.

Available inputs

Analog inputs

- 8 channels
- can be configured as thermocouple sensors only.

All inputs can be configured to any logical function or protection.

It is possible to connect up to 10 modules to the InteliGen-NT, InteliSys-NT or InteliMains-NT controllers or up to 4 modules to the ID-DCU.

Inteli AIN8TC module is connected to controller CAN1 bus.

Supported sensors:

Sensors
Thermocpl J [°C] (fix)
Thermocpl K [°C] (fix)
Thermocpl L [°C] (fix)
Thermocpl J [°F] (fix)
Thermocpl K [°F] (fix)
Thermocpl L [°F] (fix)
Thermocpl (nc) J [°C] (fix)
Thermocpl (nc) K [°C] (fix)
Thermocpl (nc) L [°C] (fix)
Thermocpl (nc) J [°F] (fix)
Thermocpl (nc) K [°F] (fix)
Thermocpl (nc) L [°F] (fix)

Note: “nc” means “not cold junction compensation (by external sensor). In this case is used internal temperature sensor on the PCB .

Dimensions:

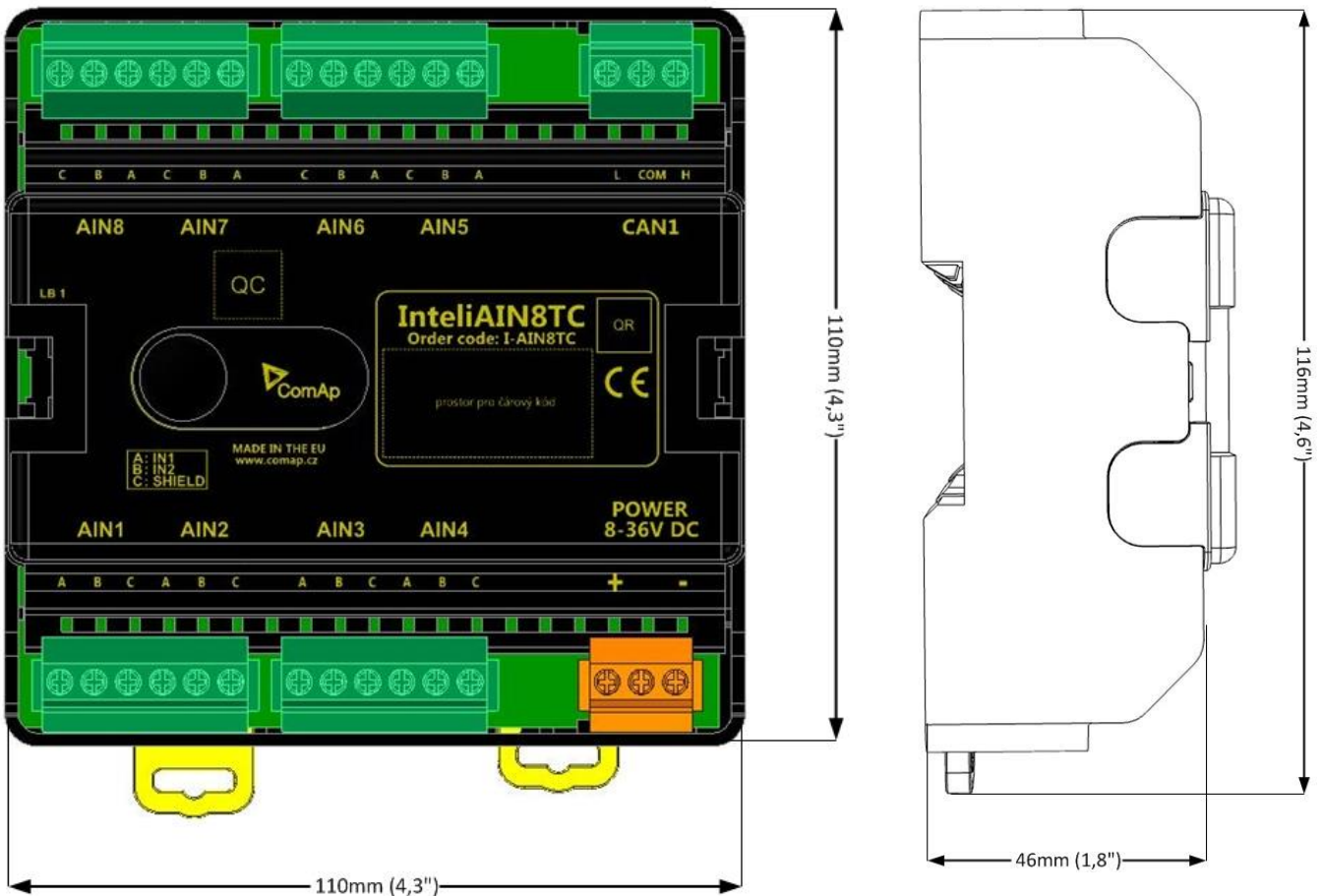

Unit is 35 mm DIN rail mounted.

Terminals

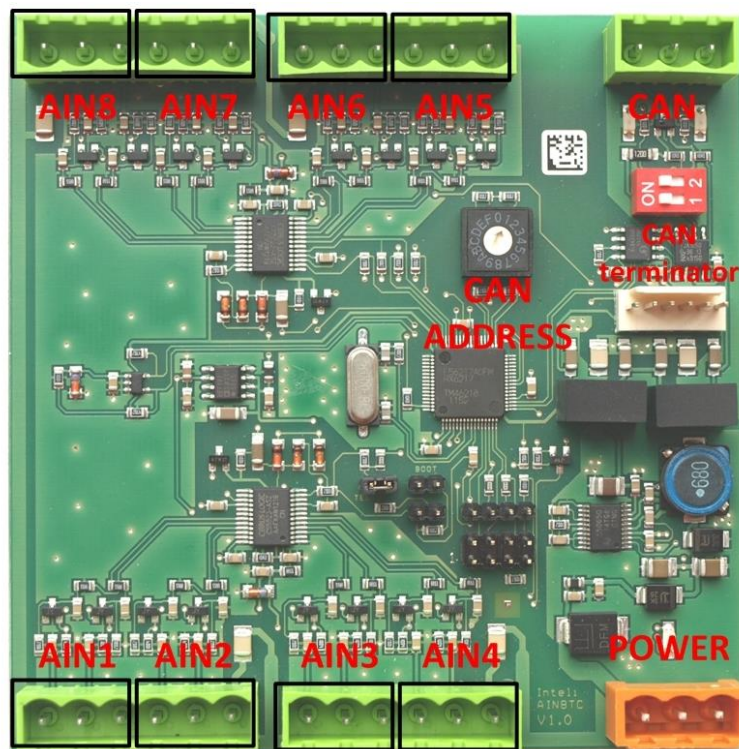

ANALOG INPUT	8 analog Inputs
CAN	CAN1 line
POWER	Power supply
CAN LED Tx, Rx	Indication transmitted or received data
Status LED	LED indication of correct function
CAN terminator	Terminating CAN resistor (active in position "ON")
TEST jumper	Upgrade of sw
AT-LINK	Connector for AT-LINK

Address and DIP switch setting

Address configuration

DIP switch determinates CAN address for analog inputs.

Programming Firmware

Firmware is upgraded via AT-link (TTL). For programming it is necessary to close jumper TEST. For programming FlashProg PC tool version 4.2 or higher must be used.

LED indication

LED at power connector – status LED:

LED status	Description
Dark	Fw in module does not work correctly.
flashing	Module does not communicate with controller (in case non-zero CAN address)
Lights	Power supply is in the range and communication between Inteli AIN8TC and controller works properly. Or power supply is in range and zero CAN address is set. (in case zero CAN address module doesn't communicate with controller)

Wiring:

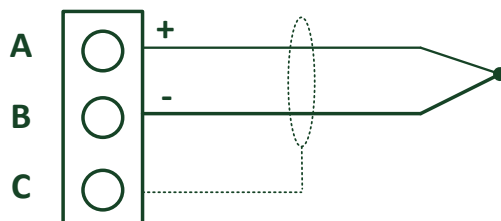

Terminator:

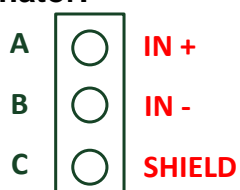

Cold Junction Compensation (CJC) settings

Please have a look at [Cold junction compensation](#) in IS-AIN8 chapter.

Technical data

Dimension (WxHxD)	110x110x46 mm (4,3"x4,3"x1,8")
Interface to controller	CAN 1
Analog inputs <i>(not electric separated)</i>	8, no galvanic separated Measuring: Voltage range ± 100 mV Accuracy: $\pm 0,1$ % of actual value + ± 100 μ V (± 3 °C) Internal sensor for measuring cold junction: Accuracy: ± 1 °C in temperature range -20 °C ÷ $+70$ °C
Galvanic separation	CAN bus is galvanic separated from the measurement and power supply All analog inputs are galvanic separated from power supply Analog inputs are not galvanic separated between channels
Power supply	8 to 36 V DC
Protection	IP20
Current consumption	35 mA at 24V ÷ 100 mA at 8V
Storage temperature	- 40C to + 80°C
Operating temperature	- 30°C to + 70°C

Thermocouples galvanically separated and galvanically non-separated are supported.

I-AOUT8

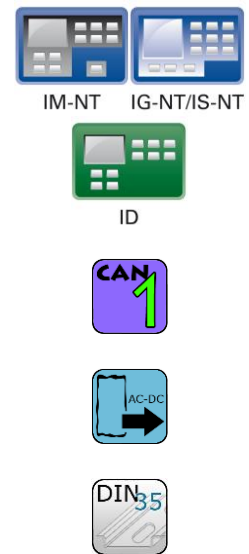
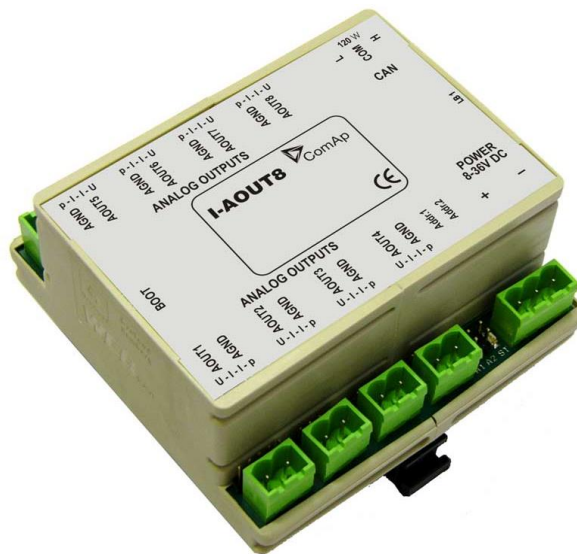

Description

I-AOUT8 is an extension unit with 8 analog outputs. Each analog output can be switched to:

- 0 to 20 mA DC
- 0 to 10 V DC
- PWM (Pulse With Modulation on 1,2 kHz)

I-AOUT8 module is connected on IGS-NT or ID CAN1 (peripheral) bus. The corresponding module Address 1 to 4 (default 1) must be set on module (by Adr.1 and Adr.2 jumpers) and in controller configuration. Communication fail is indicated in controller Alarm list and by binary output. Use GenConfig PC tool for controller configuration.

It is possible to connect up to four I-AOUT8 units to one controller. CAN1 terminating 120 ohm resistor jumper is connected as default. AGND terminals are on the same potential.

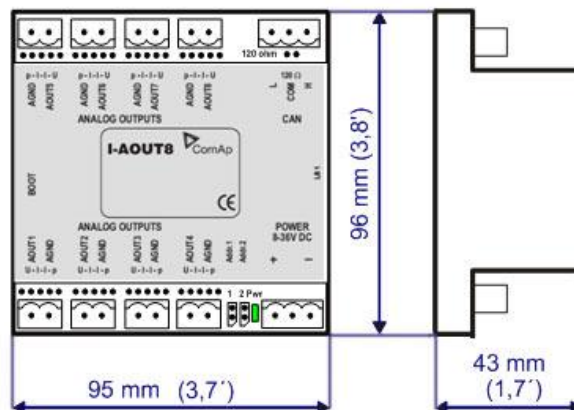

Unit is 35 mm DIN rail mounted.

Connectors

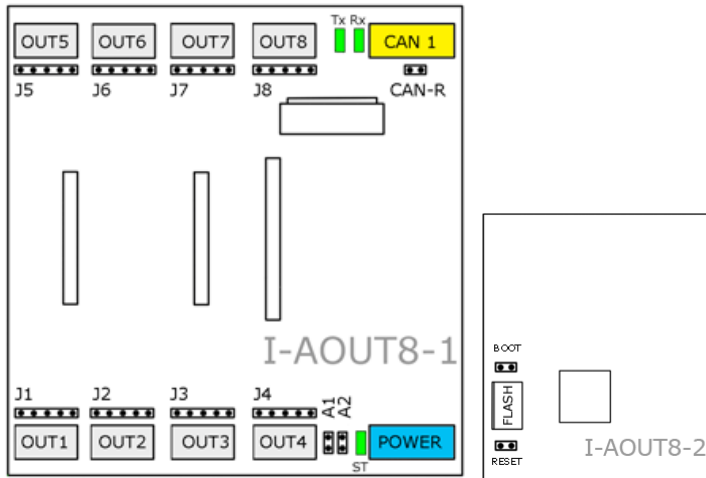

POWER	Power supply
CAN 1	CAN 1 line
OUT1 – OUT8	Analog output
FLASH	AT-link
J1 – J8	Output mode
A1, A2	CAN 1 address
CAN-R	Terminating resistor
BOOT	Programming
RESET	Programming / reset
Tx, Rx	CAN 1 data
ST	Power / module state

Address and jumpers setting

CAN Address

The module CAN address is set by jumpers A1 and A2. Set module CAN address correspondingly to configuration according table below.



Setting CAN Address

CAN Address	A1	A2
1	Open	Open
2	Close	Open
3	Open	Close
4	Close	Close

Output mode

Follow the p – I – U symbols on the module sticker. There are two equivalent positions for current output.

Setting output mode

AOUT	Symbol	Function
	p	PWM Pulse-Width-Modulation
	I	0 to 20 mA DC
	U	0 to 10 V DC

Programming Firmware

Firmware upgrade is via AT-link (TTL). For programming it is necessary to close jumper BOOT. RESET jumper is used to reset the device. Close jumper to reset the device. For programming is used FlashProg PC tool.

CAN1 termination

I-AOUT8 has own CAN terminating resistor (120 ohm). Close jumper CAN-R to connect terminating resistor to CAN bus, open jumper CAN-R disconnecting terminating resistor.

LED indication

Power LED (ST)

Red LED is located near the power supply connector.

Power LED indication

module state	Power LED
No power supply	Dark
Memory fail	Fast blink (100/100 ms)
Communication fail	Slow blink (300/300 ms)
OK	Continuous light

Communication LED

Red LEDs are located near the CAN1 connector.

Communication LEDs indication

communication state	Rx	Tx
No communication	Dark	Dark
Data transmitted	Dark	Blink
Data received	Blink	Dark

Wiring

Possible output modes

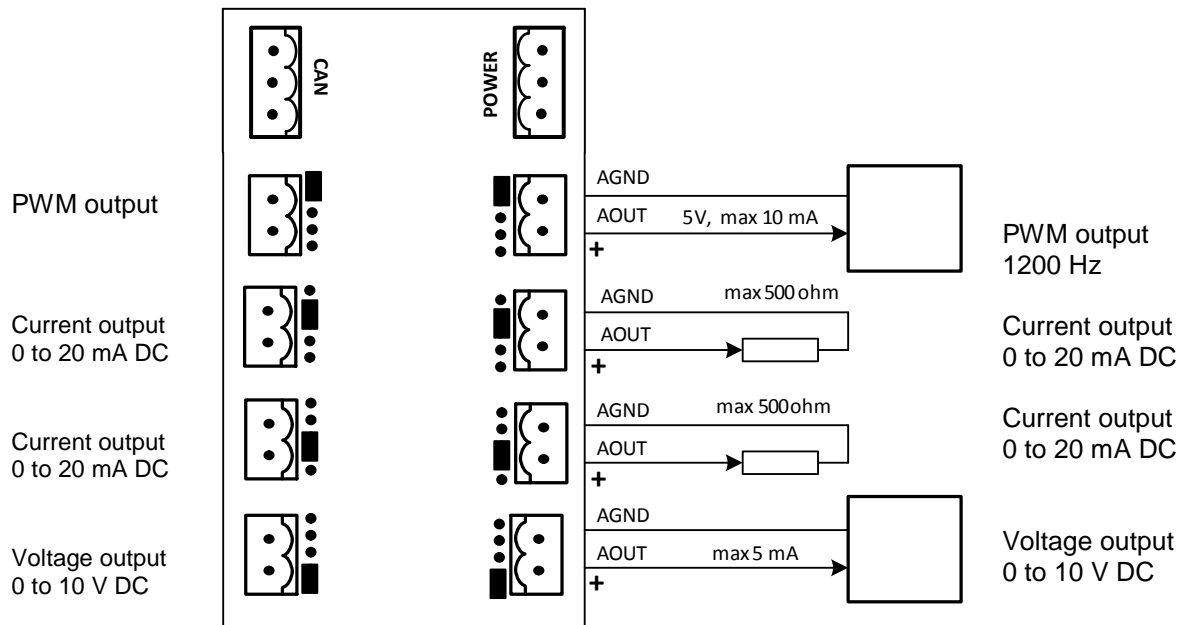

Technical data

Dimension (WxHxD)	95x96x43 mm (3.7'x3.8'x1.7')
Interface to controller	CAN
Output	8 analog, no galvanic separation
Type of analog output	0 to 10V DC \pm 1% , max 5 mA DC 0 to 20 mA DC \pm 1% , max 500 ohms PWM 1200 Hz, 5V DC level, max 10 mA DC
Power supply	8 to 36 V DC
Analog output refreshment	See the example below this table
Current consumption	100 mA at 24V \pm 300 mA
Communication interface	CAN1, address 1 to 4, terminating resistor 120 ohms.
RS232 interface	TTL, firmware upgrade via AT-link.
Storage temperature	- 40C to + 80°C
Operating temperature	- 30°C to + 70°C

Analog output refresh rate is 320ms.

I-LB+

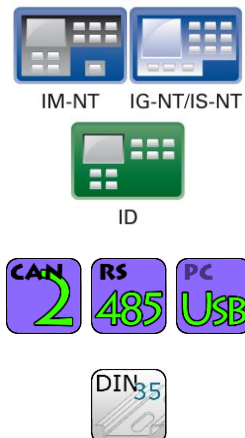

Description

I-LB+ is communication modules for communication with all devices connected to CAN2 bus. I-LB+ is successors of the IG-MU unit designed to be used with IG/IS controllers. It therefore provides additional communication port and higher communication speed. Speed for direct/modem connection can be up to 57600 bps (IG-MU only 19200 bps). I-LB / I-LB+ can be connected with PC via USB, RS232 or RS485. I-LB is without USB port, I-LB+ is with USB port (speed \approx 115200 bps).

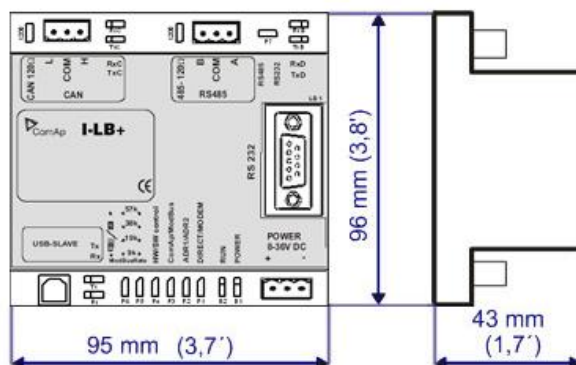

Unit is 35 mm DIN rail mounted.

Connectors

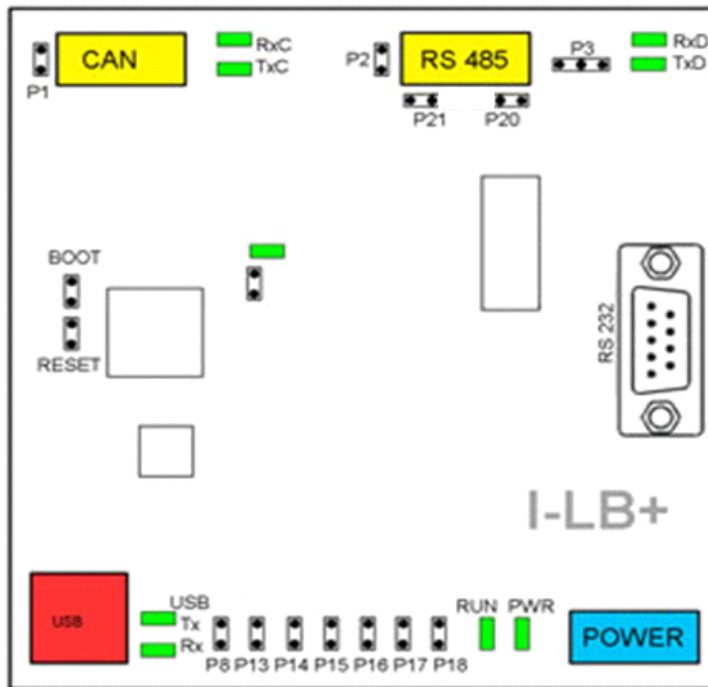

POWER	Power supply
CAN	CAN 1 line
USB	USB line
RS232	RS485 line
J13 – J18	SW / HW control
BOOT	Programming
RESET	Programming / reset
P1	Terminating resistor
P2	Terminating resistor
P3	RS232 or RS485
P8	USB enable/disable
P13	Communication speed
P14	Communication speed
P15	Modem control (HW / SW)
P16	Protocol (Modbus/ComAp)
P17	CAN address
P18	Connection (direct/modem)
P20	Bias –A
P21	Bias –B
RxC,TxC	CAN data
RxD, TxD	RSxxx data
Tx,Rx USB	USB data
RUN	Power
PWR	Module state

Address and jumpers settings

CAN1 termination (P1)

I-LB+ has included CAN terminating resistor (120 ohm). Close jumper P1 to connect terminating resistor to CAN bus, open jumper P1 to disconnect terminating resistor.

RS232 or RS485 termination (P2)

I-LB+ has included RS232/RS485 terminating resistor (120 ohm). Close jumper P2 to connect terminating resistor to RS485 bus, open jumper P2 to disconnect terminating resistor.

Select RS mode (P3)

Jumper P3 selecting RS mode. When jumper P3 is connected to 1-2, RS485 mode is activated. When jumper P3 is connected to 2-3, RS232 mode is active.

ComAp / Modbus (P16)

Jumper P16 selects between ComAp PC tools (IntelIMonitor, WinScope, et al.) and third party PC SW for monitoring with Modbus interface. ComAp PC tools are selected when P16 is opened; Modbus is selected when P16 is closed.

Modbus rate (P13 and P14)

Modbus rate is set by jumpers P13 and P14; description is in the table below.

Modbus rate		
Modbus rate	P13	P14
9600 bps	Open	Open
19200 bps	Close	Open
38400 bps	Open	Close
57600 bps	Close	Close

Direct / Modem (P18)

Select between direct connection via RS232 or RS 485 and modem connection type. For modem connection is jumper P18 closed, for direct connection is jumper P18 opened.

ADR1 / ADR2 (P17)

Select device address. ADR1 is selected if P17 is opened and ADR2 is selected if P17 is closed.

SW / HW control (P15)

Select SW or HW modem control. Jumper P15 is opened for HW modem control and closed for SW modem control.

RS485 bias resistor (P20 and P21)

Jumpers P20 and P21 are opened if the bias resistors (560R) are not requested. Closed jumper connects bias resistor to the line A (P20) or B (P21).

USB interface enable/disable (P8) missing on HW 1.0

Jumper P8 has to be set to enable USB interface. Opened jumper disables USB interface (disabled USB doesn't occupy a communication channel on the CAN bus i.e. there are still 3 free communication channels on the CAN bus).

USB interface allows only local communication (**modbus is not implemented in this interface!**).

Default jumpers settings

Jumper	Description	State
P1	CAN terminating resistor	Opened – not connect
P2	RS485 terminating resistor	Opened – not connect
P3	RS232 or RS485	1–2 – active RS232
P8	USB enable/disable	Opened – disabled
P13	Modbus rate	Opened
P14	Modbus rate	Opened – 9600 bps
P15	HW or SW modem control	Opened – HW control
P16	ComAp or Modbus	Opened – ComAp protocol
P17	ADR1 or ADR2	Opened – ADR1
P18	Direct or Modem	Opened – Direct

Jumper tree:

- **ComAp**
 - **DIRECT**
 - **RS232 / RS485** – selection of serial communication type
 - **ADR1 / ADR2** – selection between two available local communication channels
 - **MODEM**
 - **HW / SW control** – selection between modems with full interface
 - **ADR1 / ADR2** – selection between two available modem communication channels; IG/IS-NT controllers only, in ID the secondary modem channel not available
 - Setting **RS232 / RS485** jumper to RS232 position is obligatory
- **Modbus (not available at USB port of I-LB+, USB port always works in ComAp mode)**
 - **DIRECT**
 - **RS232 / RS485** – selection of serial communication type
 - **ADR1 / ADR2** – selection between two available local communication channels
 - **MODEM**
 - **ADR1 / ADR2** – selection between two available modem communication channels; IG/IS-NT controllers only, in ID the secondary modem channel not available
 - Setting **HW / SW control** has no influence; a modem with HW control is always expected in this mode
 - **Modbus Rate** (9600 / 19200 / 38400 / 57600 bps) – selects the communication speed when Modbus protocol is selected, no matter if in Direct or Modem mode

Programming

For programming is necessary to close BOOT jumper. RESET jumper is used to reset the device. Close jumper to reset the device. For programming is used FlashProg PC tool. Check if jumper P3 is set according to your communication interface (mostly RS232 – position 1-2).

LEDs indication

LEDs indication

LED	Description	State
RxC	No data are received on the CAN line	Dark
	Data are received on the CAN line	Blink
TxC	No data are transmitted on the CAN line	Dark
	Data are transmitted on the CAN line	Blink
RxD	No data are received on the RS232 or RS485 line	Dark
	Data are received on the RS232 or RS485 line	Blink
TxD	No data are transmitted on the RS232 or RS485 line	Dark
	Data are transmitted on the RS232 or RS485 line	Blink
TxUSB	No data are received on USB	Dark
	Data are received on USB	Blink
RxUSB	No data are transmitted on USB	Dark
	Data are transmitted on USB	Blink
RUN	No power supply	Dark
	Power supply OK	Continuous light
PWR	When at least one controller is active on the CAN bus	Continuous light
	After connection power supply - no controller detected on the CAN bus (during communication speed detection).	Blink

Wiring

I-LB+ has to be connected to modem via standard modem cable (full RS232) where the DSR (Data Set Ready) signal detects modem presence (when MODEM (HW) type selected). Three-wire RS232 cable (TxD, RxD, GND) can be used (e.g. for GSM modems) when MODEM (SW) type is selected.

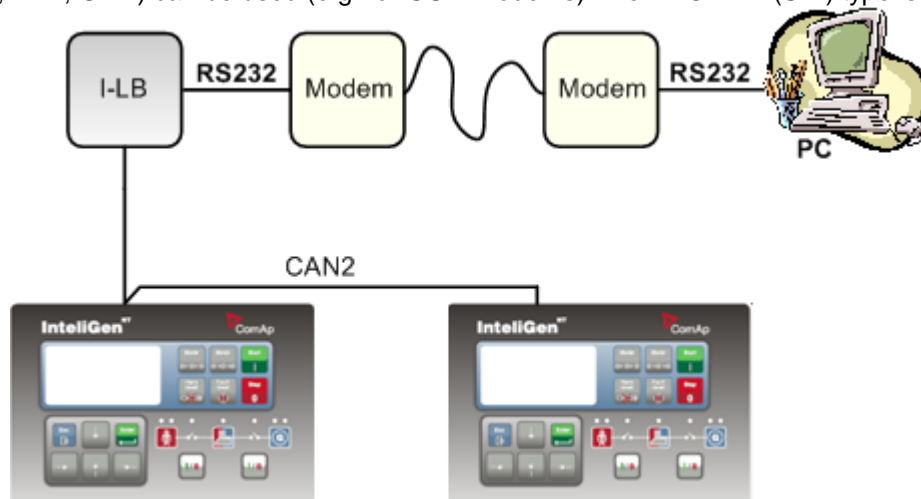

Hint:

The IG-MU module can be used to cover most of the I-LB+ functionality but with slower performance. Otherwise the I-LB+ module is also compatible with the classic line controllers IntelliSys and IntelliGen but the installation package IGS-ClassicLine-Install-6.2 must be installed (available since March 2007).

Combined communication – remote and modem
Option 1:

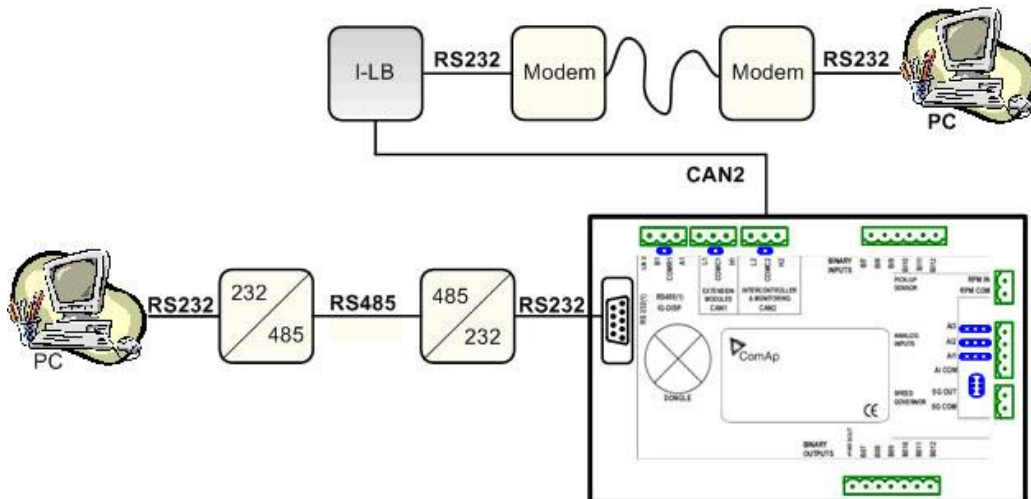

Option 2:

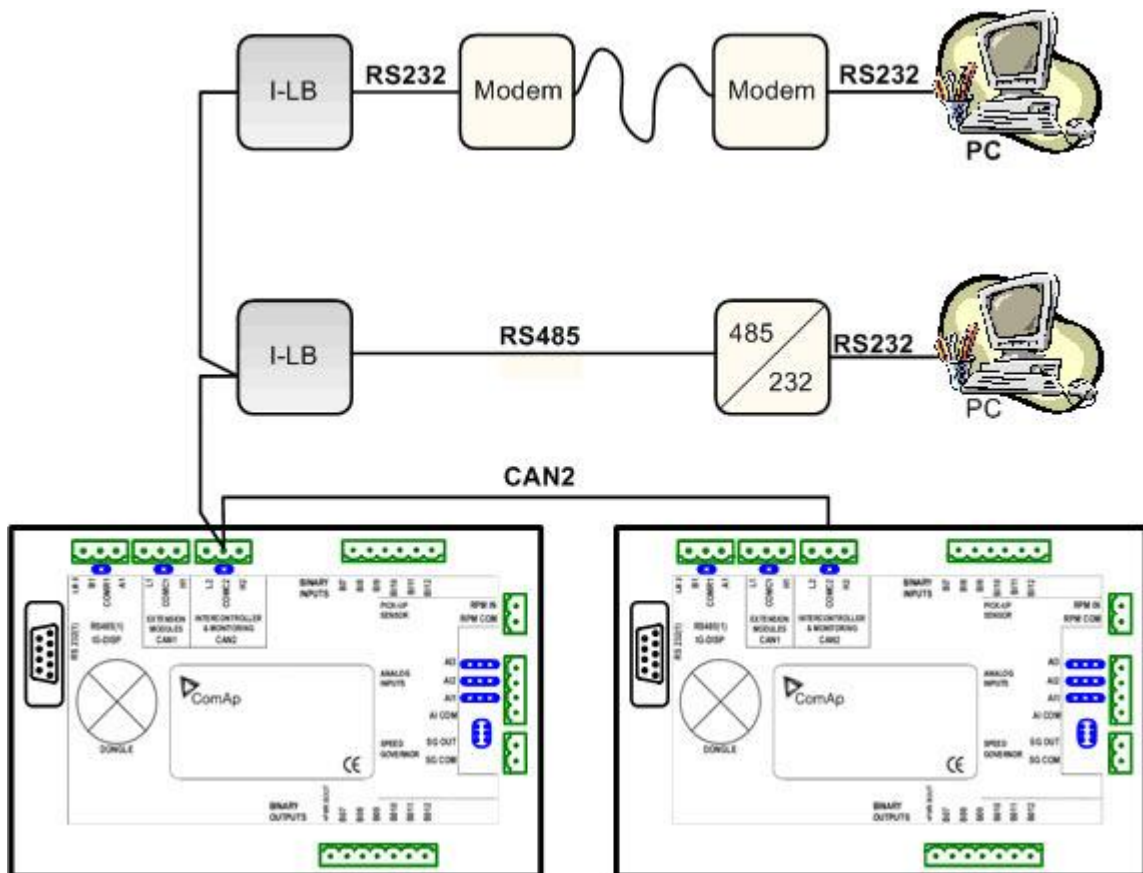

Important setpoint in the controller

Basic settings: *Contr addr* [1 to 32]

Controller identification number. Each gen-set in the group has to have its own unique number. Default value is 1.

Hint:

When opening Direct or Modem connection to single controller, the *Controller address* has to correspond to PC SW communication setup setting.

Combined communication I-LB+ with maximum configuration

There are more separate internal channels for NT controller connection which can operate at once (all via CAN2):

- Local connection 1 (I-LB+ local address 1)
- Local connection 2 (I-LB+ local address 2)
- Modem connection 1 (I-LB+ modem address 1)
- Modem connection 2 (I-LB+ modem address 2)

It is necessary to select which connection type(s) particular I-LB+ is using.

Available combinations of I-LB+ modules

There are four of communication channels available on the CAN2 link at the same time. See the connection possibilities in the table on next side:

Table of I-LB+ connection

I-LB+ module	DIRECT/ MODEM jumper	ADR1/ ADR2 jumper	channel 1 (local con. 1)	channel 2 (local con. 2)	channel 3 (modem con. 1)	channel 4 (***) (modem con. 2)
<i>Connection possibilities of only I-LB+ in following eight examples</i>						
1.	I-LB+ (*)	DIRECT	ADR1	RS232/485	-	-
2.	I-LB+ (*)	DIRECT	ADR2	-	RS232/485	-
3.	I-LB+ (*)	MODEM	ADR1	-	-	RS232-modem
4.	I-LB+ (*)	MODEM	ADR2	-	-	RS232-modem
5.	I-LB+	DIRECT	ADR1	RS232/485	USB	-
6.	I-LB+	DIRECT	ADR2	USB	RS232/485	-
7.	I-LB+	MODEM	ADR1	-	USB	RS232-modem
8.	I-LB+	MODEM	ADR2	USB	-	RS232-modem
<i>Connection possibilities of both I-LB+ (**) in following four examples</i>						
9.	I-LB+ (*)	DIRECT	ADR1	RS232/485	-	-
	I-LB+	MODEM	ADR1	-	USB	RS232-modem
10.	I-LB+ (*)	MODEM	ADR1	-	-	RS232-modem
	I-LB+	DIRECT	ADR1	RS232/485	USB	-
11.	I-LB+ (*)	MODEM	ADR1	-	-	RS232-modem
	I-LB+	MODEM	ADR2	USB	-	RS232-modem
12.	I-LB+	MODEM	ADR1	-	USB	RS232-modem
	I-LB+	MODEM	ADR2	USB	-	RS232-modem

(*) – USB interface is disabled

(**) – there can be max. two of I-LB+ on the CAN2 link.

(***) – available for IG-NT, IS-NT controllers only, not for ID, IG, IS, IL-NT

Hint:

The IG-MU module can be used to cover most of the I-LB+ functionality but with slower performance. Otherwise the I-LB+ module is also compatible with the classic line controllers IntelliSys and IntelliGen but the installation package IGS-ClassicLine-Install-6.2 must be installed (available since March 2007).

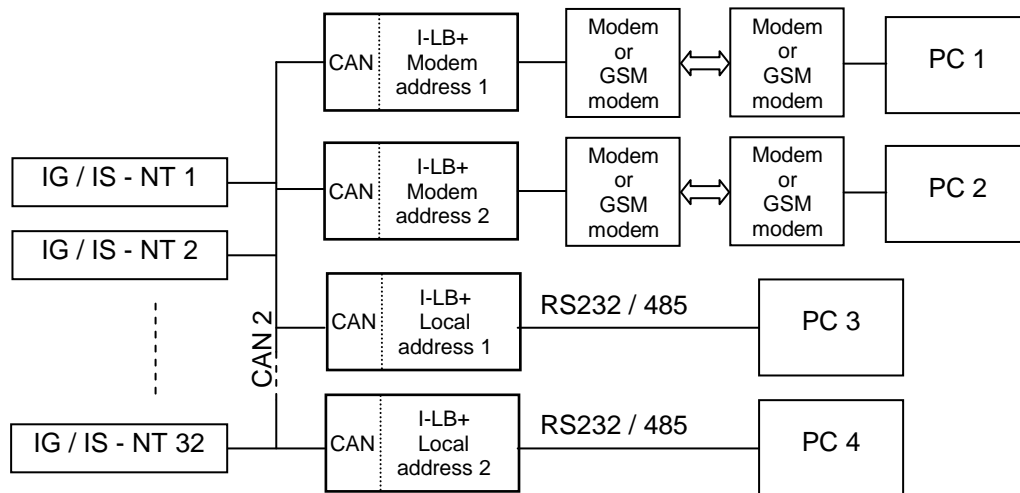

Addresses of modules on CAN2 (IG/IS-NT, ID)

Following CAN addresses are used for modules connected to CAN2 (intercontroller CAN bus). There cannot be more modules using the same address connected at the same time.

Addresses can be changed using jumpers, configuration program or from the display - refer to the corresponding chapter or reference guide for detailed description.

Table address settings

Real CAN2 Address	IG-MU	I-LB (local)	I-LB (modem)	I-LB+ (RS232)	I-LB+ (USB)	IG-IB (IBConfig ≤ 1.5)	IG-IB (IBConfig ≥ 1.6)	IV	I-RD-CAN
122			addr. 2						
123	addr. 2	addr. 2		addr. 1	addr. 1	addr. 1	addr. 2	Addr. 2	addr. 2
124	addr. 1	addr. 1		addr. 2	or 2	addr. 2	addr. 1	Addr. 1	addr. 1
125	modem		addr. 1						

Hint:

Make sure that other device (e.g. IG-IB) is not using the same CAN address as USB port of an I-LB+, because using USB port could interrupt CAN communication.

Hint:

Please note that addresses 1 and 2 (123, 124) are exchanged in versions IBConfig ≤ 1.5 and IBConfig ≥ 1.6 (see the table above).

IG-MU

Address 1 => CAN-address 124
 Address 2 => CAN-address 123
 When switched to modem mode it uses CAN-address 125.

I-LB Direct connection

Address 1 => CAN-address 124
 Address 2 => CAN-address 123

I-LB Modem connection

Address 1 => CAN-address 125
 Address 2 => CAN-address 122

I-LB+ when USB terminal is connected

Address 1 => CAN-address 123
 Address 2 => CAN-address 124

IG-IB

Address 1 => CAN-address 124
 Address 2 => CAN-address 123

Hint:

These addresses are valid for IBConfig ≥ 1.6.

IV

Address 1 => CAN-address 124

Address 2 => CAN-address 123

I-RD-CAN

Address 1 => CAN-address 124

Address 2 => CAN-address 123

Example 1:

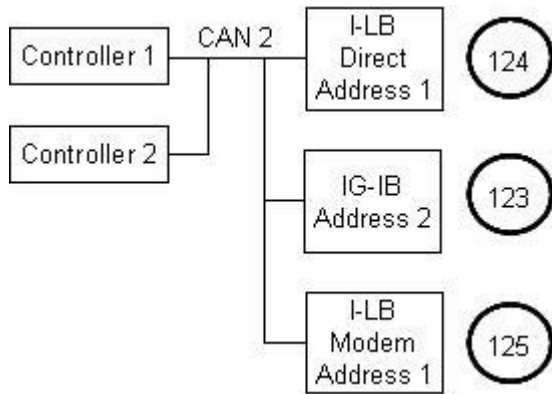

Example 2:

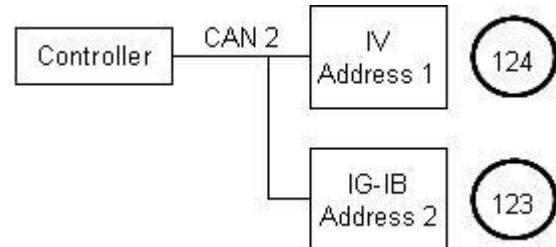

Example 3: Wrong connection:

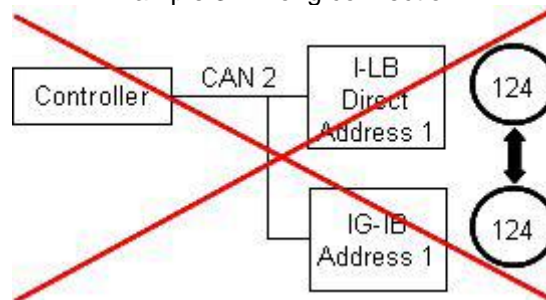

Hint:

In this example IBConfig \geq 1.6 is used for programming IG-IB.

Two modem types connection

It is possible to connect two modems (e.g. Analog and GSM) to one controller at once to have two independent modem channels for DATA and GSM messages.

One modem is connected via I-LB+ – CAN bus, the second is connected directly to RS 232 controller interface.

When an active call is activated in the controller, the modem connected directly to the controller tries to call/send an SMS. If this is not successful, the Active call fail alarm appears. The second modem doesn't then try to substitute the first one.

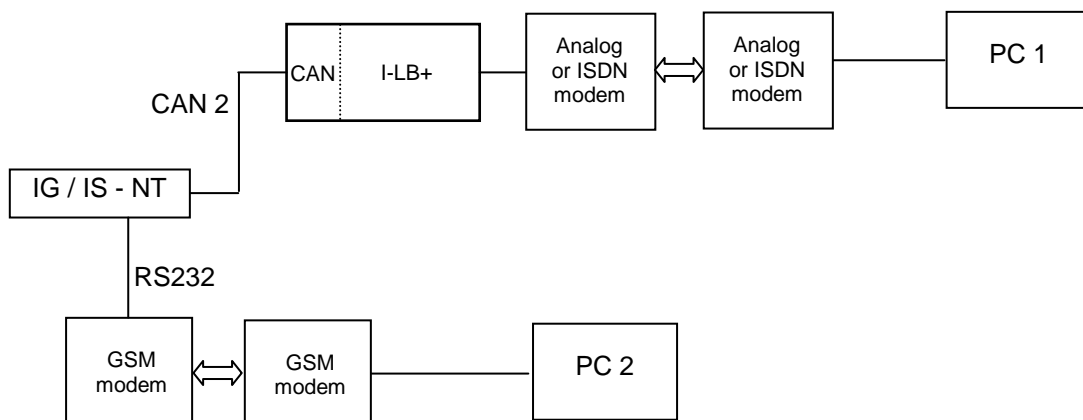

Modbus communication via I-LB+

To use I-LB+ modbus communication connect Modbus jumper in I-LB+ unit. Additionally, you can choose the communication speed using the speed selection jumpers. Their combination allows the speed selection of 9600 / 19200 / 38400 / 57600 bps. Modbus is not supported via USB interface.

Technical data

Dimension (WxHxD)	95x96x43 mm (3.7'x3.8'x1.7')
Interface to controller	CAN
Interface to modem or PC	RS232, RS422, RS485, USB only I-LB+
Power supply	8 to 36 V DC
Analog outputs refreshment	Max. 300 ms
Current consumption	100mA at 24 V
Storage temperature	- 40C to + 80°C
Operating temperature	- 30°C to + 70°C

I-LBA

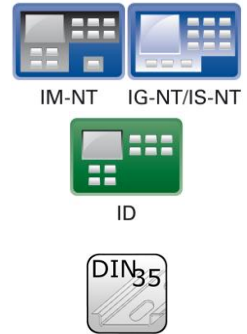

Description

For the connections with power supply an I-LBA module can be connected to controller power terminals in order to allow the controller to continue operation during cranking if the battery voltage dip occurs.

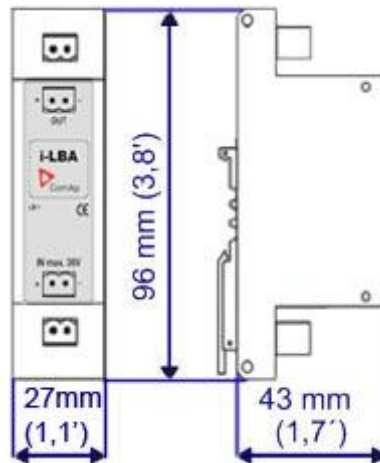

Unit is 35 mm DIN rail mounted.

Connectors



POWER in	Power supply from battery
POWER out	Power supply to controller

Wiring

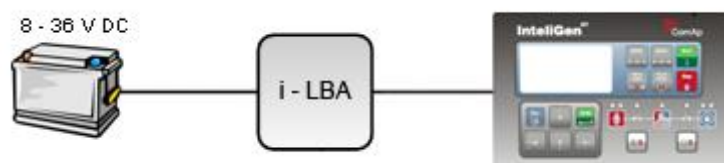

Technical data

Dimension (WxHxD)	27x96x43 mm (1.1'x3.8'x1.7')
Output	8 to 36 V DC, no galvanic separation
Internal resistance	Under 0.2 ohm
Power supply	8 to 36 V DC
Storage temperature	- 40°C to + 80°C
Operating temperature	- 30°C to + 70°C

Voltage dip recovery

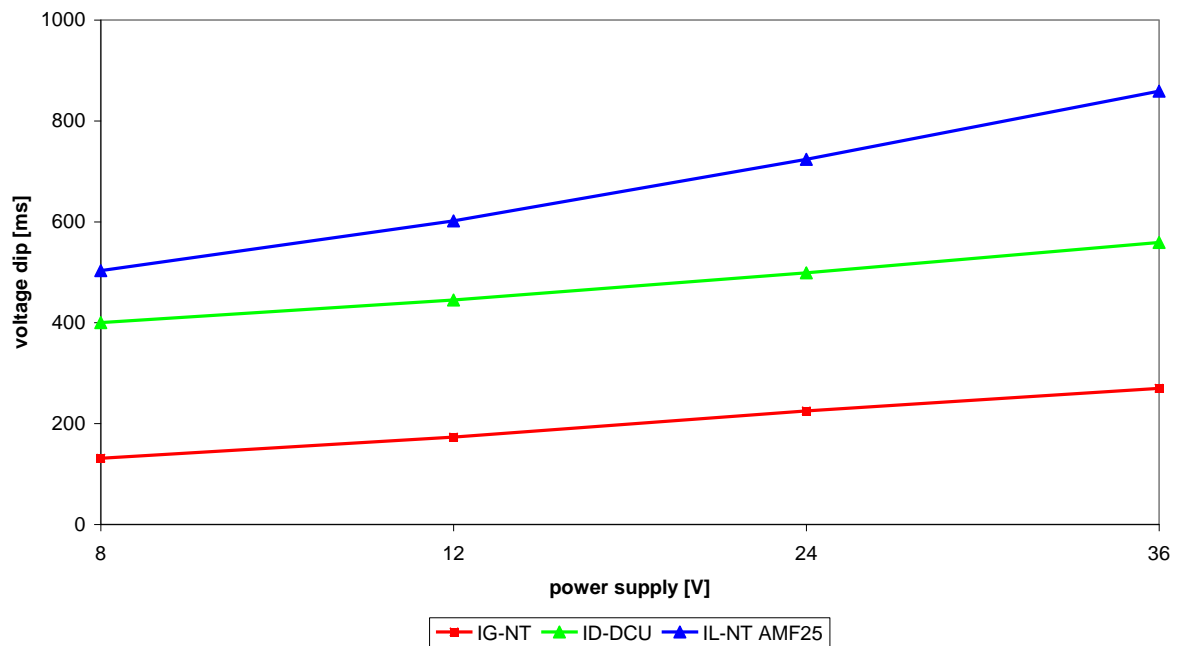

I-RB8 / I-RB16

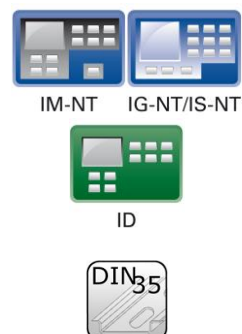

Description

Relay board contains 8 or 16 relays for binary (open collector) output separation. All relays are placed in sockets.

Table of device difference

	I-RB8	I-RB16
Number of relays	8	16
Nominal voltage [V] DC	24	24
Maximal load	16A resistive load, 4A inductive load	

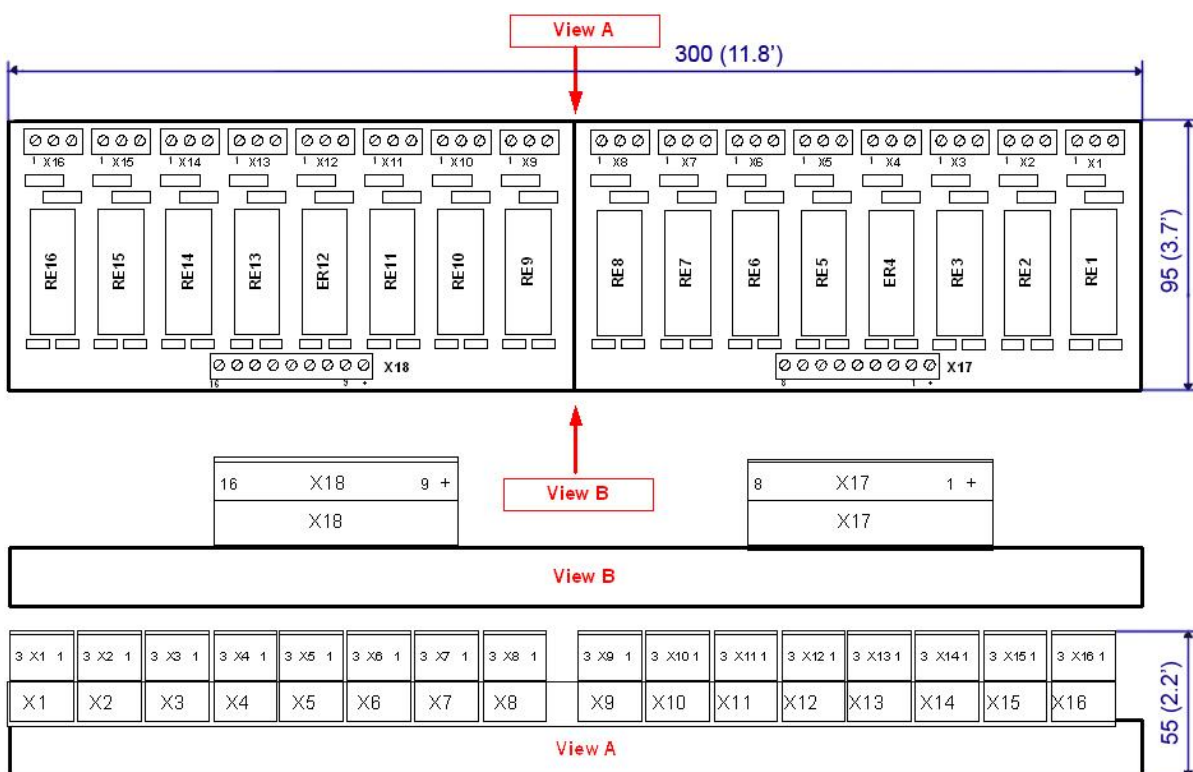

Unit is 35 mm DIN rail mounted.

Connectors



O1-O16	Relay connector
INPUT1, INPUT2	Input signals

LEDs indication

Each relay has LED which lights when n.o. relay's connector is closed. This LED is dark when n.o. relay's connector is open. I-RB8, I-RB8-231 has 8 LEDs and I-RB16, I-RB16-231 has 16 LEDs.

Wiring

Relay-connector connection

1 – 2 **n.o.**
1 – 3 **n.c.**

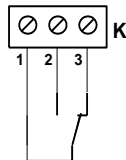

Technical data

Dimension (WxHxD)	300x95x55 mm (11.8'x3.7'x2.2')
Output	Max. switched current 16A DC, 4A AC Max. switched voltage 24V DC
Voltage range	16.8 – 36V DC
Relay opens	At 10% of nominal voltage
Electric / mechanic cycles	100 000 (when switching 16A) / 10 000 000
Contacts protection	varistor 14DK390
Storage temperature	- 40°C to + 80°C
Operating temperature	- 30°C to + 70°C

I-RD-CAN / I-RD-CAN-ID-DCU-MARINE



ID



Description

Remote Display I-RD-CAN (Remote Panel) works as “a remote control panel” for the ID-DCU master controller. All panel buttons work the same way as corresponding buttons on master controller. All LEDs display the same state as corresponding LEDs on master controller.

- Remote Display I-RD-CAN of version 1.3 is compatible with ID-DCU Industrial (not version 1.2).
- Start, Stop buttons and setpoint changes are not active when master ID-DCU controller is in Local mode.
- I-RD-CAN screen listing does not influence screen on master controller.
- Interruption of the serial line between master device and I-RD-CAN will have no effect to the engine.
- Master device will always be able to work without connected Remote display.
- I-RD-CAN displays the same screens as its master controller and can be switched to the same languages. The user interface is identical as the master controller.
- I-RD-CAN is the same mechanical and electronic design (the same box but some electronic components were removed). No inputs and output are available on I-RD-CAN only.
- It is possible to connect I-RD-CAN to ID-DCU via RS232 (38,4kbps) or via CAN bus (50 or 250 kbps).
- I-RD-CAN automatically downloads new configuration table from master controller if the CRC doesn't match the CRC of the stored configuration table.
- I-RD-CAN uses separate mhx firmware different from controller firmware compatible with both ID-DCU and ID-DCU-Marine.
- I-RD-CAN firmware can be reprogrammed via Boot load procedure only.
- I-RD-CAN backlight can be switched to full intensity when middle power supply terminal (D+ in DCU) is closed to + power supply.

I-RD-CAN-ID-DCU-MARINE has to same function as I-RD-CAN, and it has **Marine certification**.

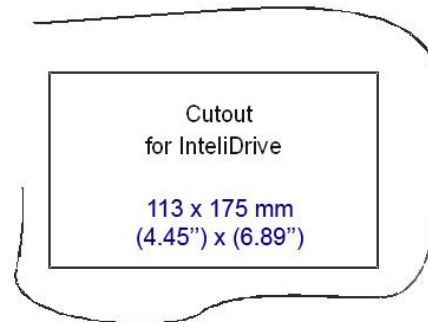
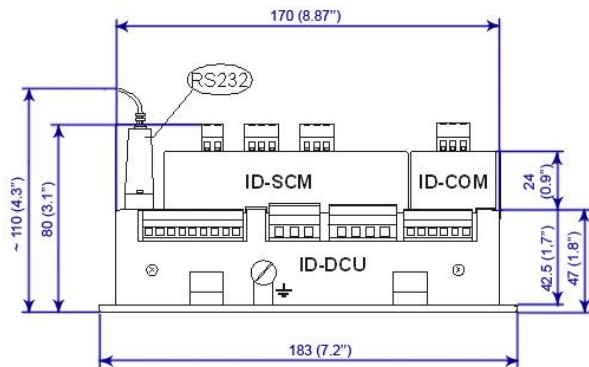
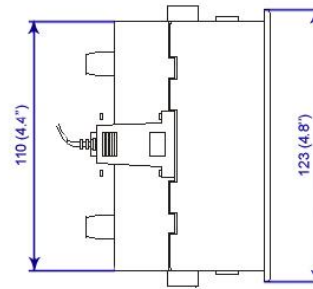
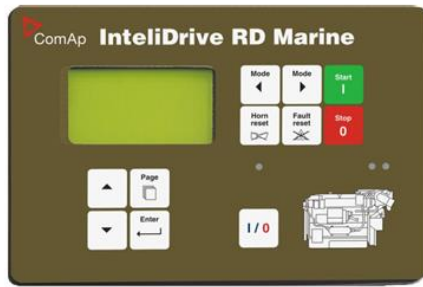

Connectors

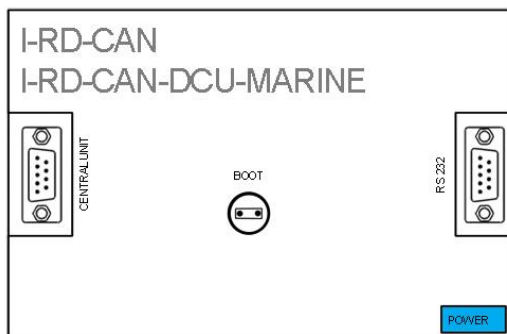

POWER	Power supply
RS232	RS232 line
CENTRAL UNIT	Line to central unit
BOOT	Programming

Address and jumpers setting

There are only 2 addresses on the CAN2 bus that are shared between ID, I-RD-CAN and IG-MU (when used for direct cable connection). That means only two of these modules can be used at the same time on the same bus. If the IG-MU is used for modem connection, then it has other address and is not included to the address sharing described above. Following table shows the allowed combinations: See table on page 15.

Programming Firmware

Firmware upgrade is via RS232 link and FlashProg PC tool. For programming is necessary to close BOOT jumper.

Establish ID-DCU to I-RD-CAN connection

Following screen appears after I-RD-CAN power supply is switched on and there is no connection to ID-DCU established.

ID-DCU to I-RD-CAN connection

Screen rows	Meaning / selection range	I-RD front panel button to change
I-RD-Industrial 1.x	I-RD firmware branch and version	
ComAp 2004	Copyright	
SN: xxxxxxxx	Controller serial number	
Contr. Addr: 1	Controller address: 1 to 32 and AUTO	Up, Down
Connection: CAN ADR1	Connection: CAN ADR1, CAN ADR2, RS232	Page
NO CONNECTION	TRYING.... , PROGRAMMING	I-RD status during Init state.

1. Connect selected communication line between ID-DCU controller and I-RD-CAN panel.
2. Switch ID-DCU and I-RD-CAN power supply on.
3. After I-RD-CAN Initialization screen appears: Use front panel Up/Down buttons to change Controller address in the range 1 to 32 or AUTO. I-RD-CAN automatically increases the controller address and tries to open connection. This I-RD-CAN Controller address must correspond to connect ID-DCU Basic setting: *Controller address* setpoint.
4. Use Page button to set I-RD-CAN connection: CAN ADR1, CAN ADR2 or RS232.
5. Then press Enter button to start data download. Message TRAYING ... appears on the I-RD-CAN screen. Unsuccessful attempt to read data is repeated each 15 sec.
6. The Programming bargraph appears on I-RD-CAN screen after connection is opened.
7. Standard ID-DCU screen appears after complete configuration is loaded to I-RD-CAN.

Hint:

To switch to Init screen press Page button for more than 2 sec when CFG table error message appears on the I-RD-CAN screen.

Setting I-RD-CAN backlight-brightness

The same procedure is for ID-DCU and I-RD-CAN.

1. Enter+Page buttons = switch to Info screen
2. Enter+Up / Down button increases or decreases the display backlight (it is stored - until the next change).
3. The setpoint **Basic setting: LightTimeOff** in I-RD works locally for I-RD (this is only exception) and it is not transferred to the central unit. Backlight is after this time switched off from current level. Any key touch activates the backlight. That means it is possible to set I-RD backlight level and *LightTimeOff* independent to ID-DCU.

From I-RD firmware version 1.2 and hardware version 2.0 (from s.n. xxxx0006) is possible to change Remote panel display backlight between adjustable and full level via external switch – see drawing below.

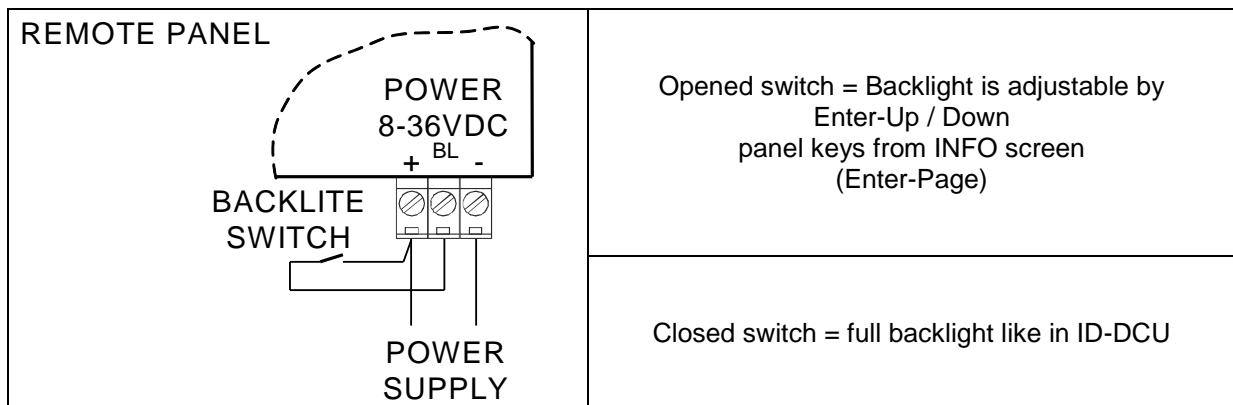

Hint:

It is not possible to control I-RD backlight continuously via analog input like on ID-DCU.

Wiring

RS232 interface: three wire cable (2-3, 3-2, 5-5), max. cable length up to 10 meters.

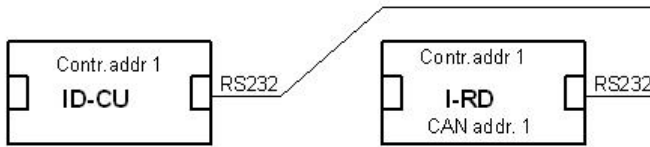

Using converters to RS485 or RS422 increases distance up to 1000 meters. *Recommend external converter: ADVANTECH – ADAM 4520: RS232 to RS422/485 converter, DIN rail, automatic RS485 bus supervision, no external data flow control signals, galvanic isolated, baud rate 38400bps.*

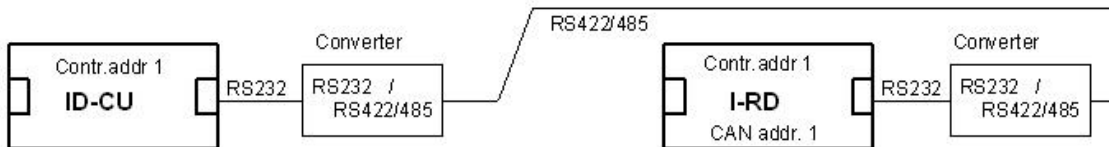

CAN bus connection requires ID-COM module on ID-DCU. Use I-RD-CAN Central unit 9-pin connector (5=CAN H, 9=CAN L) to connect CAN bus. Put jumper to connect I-RD-CAN internal 120 ohm resistor for CAN bus line terminating.

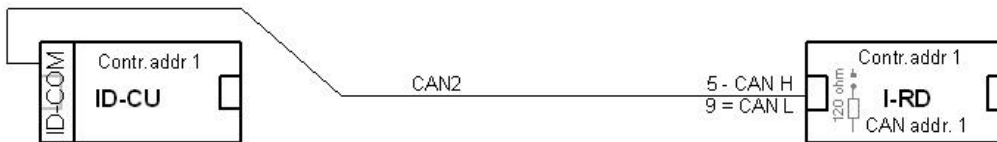

I-RD-CAN can monitor any ID-DCU controller on the CAN2 bus based on I-RD-CAN Contr. address setting.

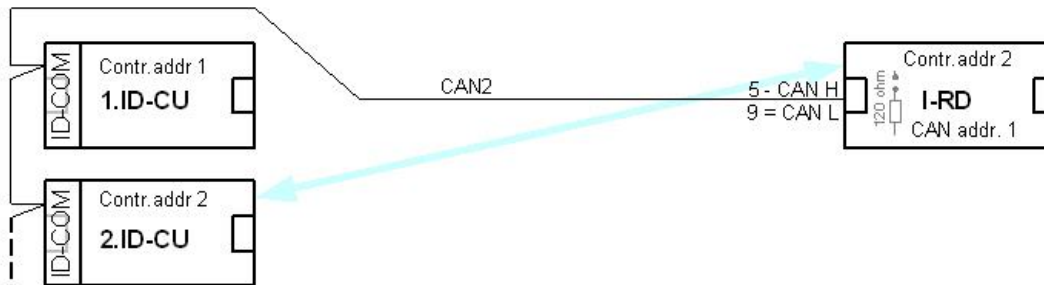

It is possible to connect up to two I-RD-CAN to common CAN2 bus. The I-RD-CAN address must be different in this case.

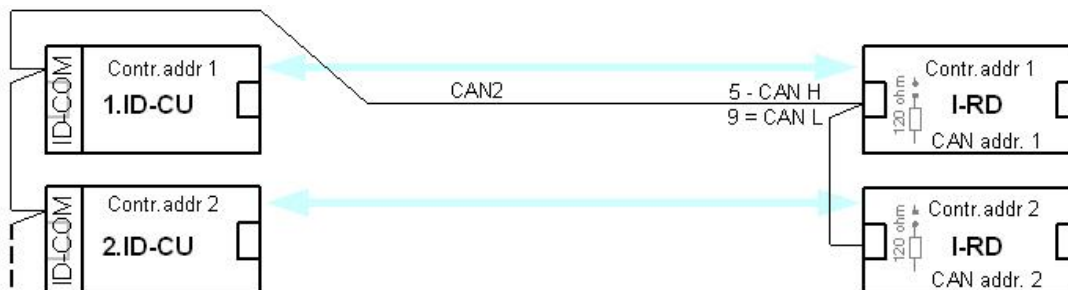

Hint:

There is no connection between ID-DCU and Remote panel during ID-DCU controller programming and in INIT state.

Technical data

Dimension (WxHxD)	183x123x47 mm (7.2'x4.8'x1.8')
Weight	950 g
Interface to controller	CAN, RS232
Power supply	8 to 36 V DC
Current consumption	100 mA at 24V ÷ 350 mA
Protection front panel	IP 65
Storage temperature	- 30°C to + 80°C
Operating temperature	- 20°C to + 70°C
Humidity	85%
Low Voltage Directive	EN 61010-1:95 +A1:97
Electromagnetic Compatibility	EN 50081-1:94, EN 50081-2:96 EN 50082-1:99, EN 50082-2:97
Vibration	5 - 25 Hz, ±1,6mm 25 - 100 Hz, a = 4 g
Shocks	a = 200 m/s ²

ID-COM

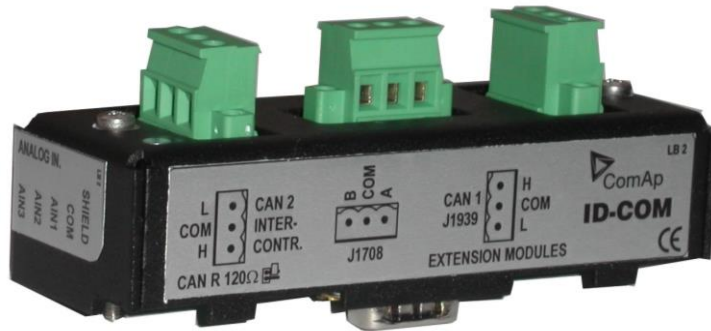

ID



Description

InteliDrive Communication interface for inter-controller or Remote display CAN2 line and for Redundancy synchronous J1708/1587 data line. ID-COM is mounted directly to ID-DCU box.

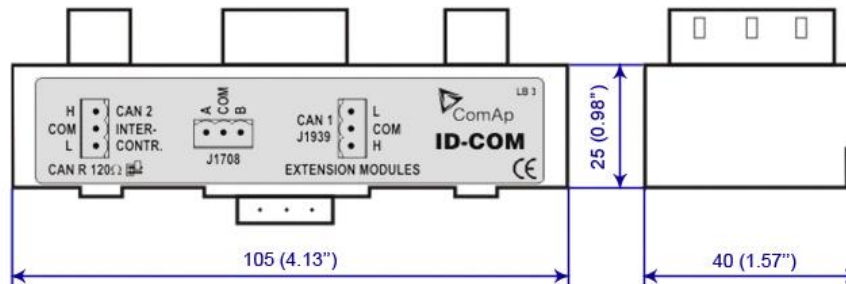

Connectors

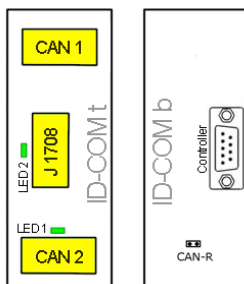

CAN1	CAN1 line
CAN2	CAN2 line
J1708	SAE J1708 line
CONTROLLER	Connection to controller
LED1	Communication on J1708
LED2	Communication on CAN2

Address and jumper settings

CAN1 termination

I-AOUT8 has own CAN terminating resistor (120 ohm). Close jumper CAN R connecting terminating resistor to CAN bus, open jumper CAN-R disconnecting terminating resistor.

LED indication

LED	Description
LED1	Blink when data are transmitted on the CAN2 line
LED2	Blink when data are transmitted on the J1708 line

Wiring

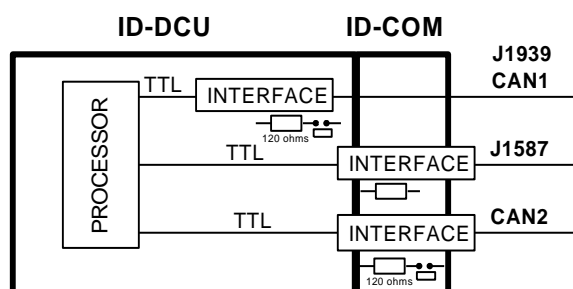

Technical data

Dimension (WxHxD)	105x25x40 mm (4.13'x0.98'x1.57')
Interface	CAN 2, J1587 (J1708), J1939
Storage temperature	- 40°C to + 80°C
Operating temperature	- 30°C to + 70°C

Hint:

ID-COM module is not required when inter-controller CAN2 and J1587 lines are not used. In this case connect Extension modules CAN1 directly to Extension modules port ID-COM on ID-DCU (9-pin connector: 5=H, 9=L).

ID-RPU



ID



Description

Redundant Protection Unit. ID-RPU is mounted directly to ID-DCU box. Unit is designed for marine applications only. This no microprocessor unit provides redundant engine protection, RPM measuring and back-up power supply switching for the control system. ID-RPU monitors IntelliDrive central unit and in the case of fail switches itself to the backup mode or Emergency backup mode and protects the engine using its own binary EMERGENCY STOP and SHUT DOWN inputs and FUEL and STOP SOLENOID output.

The ID-RPU unit has three operational modes:

- **Normal** – ID-DCU is working and periodically sends the watchdog impulses to the ID-RPU. All ID-RPU inputs and output are processed via ID-DCU.
- **Backup** – ID-RPU unit doesn't receive watchdog impulses from the ID-DCU. The Shut down (Sd1 to Sd5), Emergency stop inputs (fix 0,5 sec delay) and Over speed protection are processed via RPU only. ID-RPU stays in the mode that was before ID-DCU fail.
- **Emergency backup** – ID-DCU was in EME mode (or Sd override function was active) before fail (or Sd override was active) before ID-DCU fail. The only Emergency stop and Over speed protection is active in this mode. Shut down Sd1 to Sd5 inputs are inactive. ID-RPU starts to Emergency backup mode after power on without active ID-DCU.

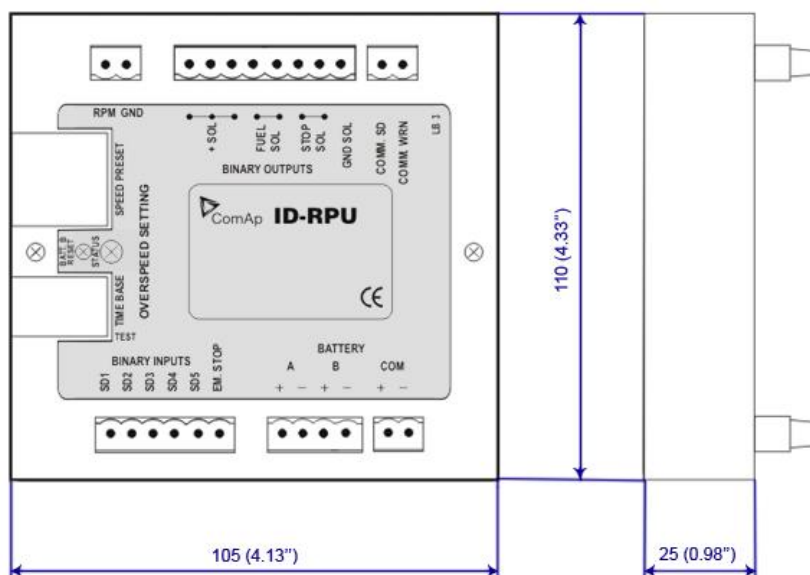

Connectors

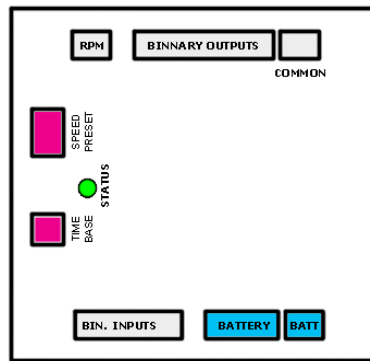

RPM	Secondary RPM
+SOL	Common power supply for galvanic separated Fuel solenoid and Stop solenoid output.
FUEL SOL	Fuel solenoid output, High side switch (8 Amps), BW detection in open state or above 1 amp load
STOP SOL	Stop solenoid output, High side switch (8 Amps), BW detection in open state or above 1 amp load
GND SOL	Common GND for Fuel and Stop solenoid output
COMM.SD	Common Shut down output, Low side switch (0,5 Amps)
COMM.WRN	Common Warning output, Low side switch (0,5 Amps)
SD1 to SD5	Shut down inputs, BW detection, Normally open
EM.STOP	Emergency stop input, Normally closed
A+, A-	Primary battery
B+, B-	Secondary battery
COM+, COM-	Battery A, B output to ID-DCU

Hint:

10k ohm resistor must be connected in parallel to SD1 to SD5 inputs.

Detail description

Binary inputs SD1-SD5 – shutdown channels

Include broken wire detection. The input logic is Normally Opened. Inputs are active only if ID-DCU unit is in AUX mode (and Sd **override is not closed**). No LED indication.

Hint:

There is no I/O state or broken wire LED indication on ID-RPU module. All indications are visible on ID-DCU screen including Alarm list and History record.

Binary input Emergency stop

No Broken wire detection. The input logic is Normally Closed. Input is active in both ID-DCU EME and AUX modes. No LED indication.

Binary output COMM SD

Output indicates any shutdown Alarm.

Normal mode: the output is controlled from ID-DCU (Binary output Comm Sd)

Backup mode: the output is activated if RPU emergency stop or SD1 – SD5 become active.

Binary output COMM WRN

Common warning indication.

Normal mode: the output is controlled from ID-DCU (Binary output Comm Wrn)

Backup mode: the output is ACTIVE.

Binary output **STOP SOL**

Stop solenoid output (high side switch) with broken wire (BW) detection active on opened output.
Normal mode: the output is controlled from the ID-DCU. The logical output Stop solenoid must be configured to this output in the configuration of ID-DCU. In case the stop solenoid is not used, the output must be configured as not used; otherwise broken wire protection will be detected.
Backup mode: the output is activated in case of any shutdown and released 30s after zero RPM reached.

Binary output **FUEL SOL**

Fuel solenoid output (high side switch) with broken wire (BW) detection active on opened output.
Normal mode: the output is controlled from the ID-DCU. The logical output Fuel solenoid must be configured to this output in the configuration of ID-DCU. In case the fuel solenoid is not used, the output must be configured as not used; otherwise broken wire protection will be detected.
Backup mode: If no shutdown protection active, the output is closed.

SEC RPM IN, SEC RPM GND

Terminals for the secondary RPM pickup. It is possible to connect two redundancy pickups or one pickup to ID-DCU and to the ID-RPU in parallel. The ID-RPU will detect over speed failure on running engine.

Address and jumpers setting

Over speed setting

ID-RPU Over speed limit is set via two DIP switches: Prefix and Speed preset. OT switch in On (1) position activates Over speed Test = Reduce Over speed limit to 50%.

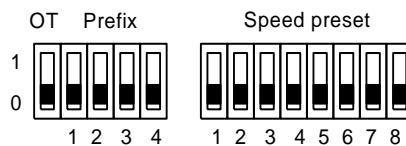

Example of prefix and speed preset calculation:

Required over-speed limit: RPMover = 1600 RPM
 Basic settings: Gear teeth = 120
 Speed preset formula:

$$N = \{ [(\text{RPMover} \times \text{Gear teeth}) / 60] / C \} + 1$$

1. $X = (\text{RPMover} \times \text{Gear teeth}) / 60 = 3200$,
2. select coefficient C according table and corresponding DIP Prefix,

Prefix table

X range	C	Prefix
2016 to 8128	32	1000
504 to 2032	8	0100
126 to 508	2	0010
1 to 127	0,5	0001

$X = 3200$ is in the range 2016 to 8128 -> $C = 32$, Prefix = 1000

3. Speed preset = $3200 / 32 + 1 = 101$; -> 01100101 in binary format,
4. set Prefix = 1000 and Speed preset = 01100101.

Another example of over speed setting

RPMover	Gear teeth	Prefix	Speed preset	DIP8
1800	150	1000	141	10001101
1800	120	1000	113	01110001
1800	60	0100	226	11100010
1000	30	0010	251	11111011

Speed preset binary conversion examples

Speed preset	DIP8
0	00000000
1	00000001
2	00000010
4	00000100
8	00001000
16	00010000
32	00100000
64	01000000
128	10000000
255	11111111

Wiring

Power supply terminals **A+, A-, B+, B-, COM+, COM-**

The ID-RPU module has two independent power input terminals and one power output terminals. The power output is supplied from battery A and if this voltage drops under 8V, the relay switches to the power supply B.

Battery B is switched to A when: Batt A > 10VDC and Fault reset button is pressed on ID-DCU or Batt reset button is pressed on ID-RPU when ID-DCU is out of order. The voltage switching levels is fix set in the ID-RPU.

Hint:

Short supply drop out occurs during battery A to B or B to A switching. Connect B terminals in parallel to A when redundant battery B is not used.

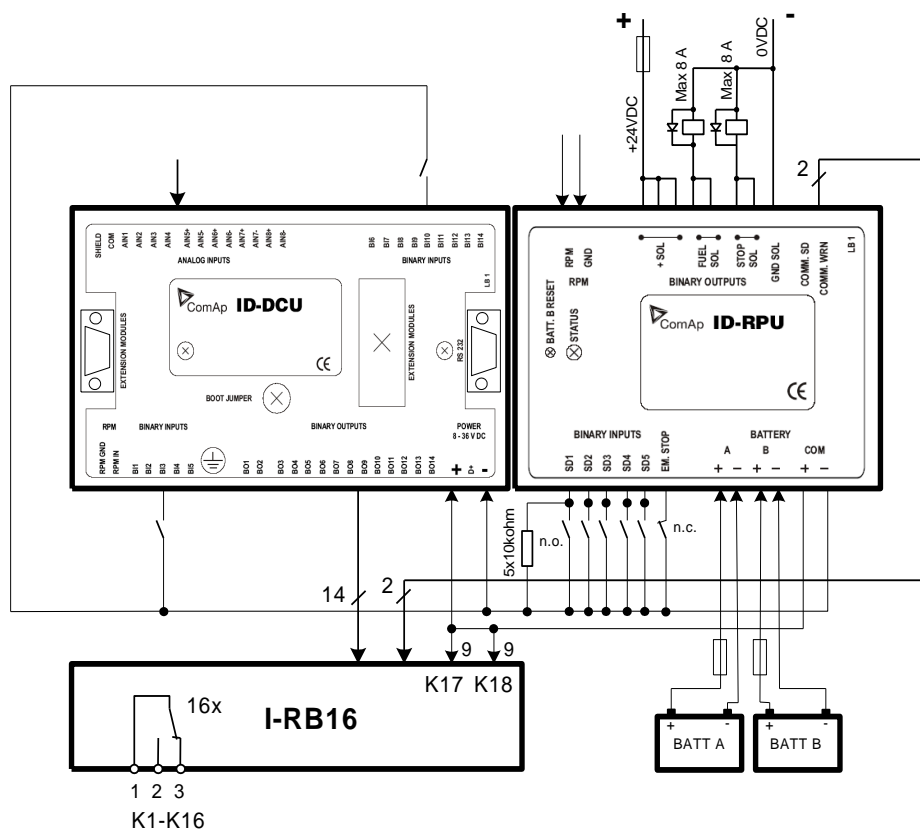

Hint:

BW protection of the ID-RPU output Fuel solenoid and Stop solenoid is active in open state only. To avoid BW detection configures not wired inputs or output of ID-RPU as not used by DriveConfig sw.

Battery minus terminals are separated.

Other information

Battery voltage measuring

ID-RPU senses battery voltage on both power supply inputs. Those values are connected to the ID-DCU through the CANNON connector. There is one common Battery V>, V< and delay limit for all three batteries.

Watchdog

ID-DCU periodically (~0.2s) sends an impulse to the ID-RPU. ID-RPU backup mode is activated after 1s without watchdog pulse.

Over speed protection

The ID-RPU over speed protection is active in the case of ID-DCU fail only (backup mode). Over speed limit can be set by DIP switch (accessible after cover removal).

ID-RPU Emergency / Auxiliary mode operation

ID-RPU only reflects ID-DCU setting following way. ID-DCU controller modes are selected on ID-DCU only.

Operation mode

ID-RPU binary inputs	Emergency mode	Auxiliary mode
Emergency stop	Active	Active
Shut down Sd1 – Sd5	Inactive	Active

ID-RPU is switched to Emergency mode after power-on reset without ID-DCU.

ID-RPU operation in the case of ID-DCU fails

The ID-RPU itself can never start the engine because of the engine starter is controlled from ID-DCU. ID-RPU will leave all own binary output in the last state when ID-DCU fail is detected (engine stays running after ID-DCU fail). ID-RPU activates corresponding binary output when Emergency stop, Engine over speed protection or some Shutdown input (in AUX mode only), is activated.

Binary information from ID-RPU to ID-DCU

Symbol	Meaning
SD1 ... SD5	State of all binary inputs SD1-SD5
BW1 ... BW5	State of all BW protections
PRIFAIL	Primary A battery fail = switched to B battery
ESTOP	Binary input Emergency stop state
BWSS	Stop solenoid output BW indication
BWFS	Fuel solenoid output BW indication

Binary information from ID-DCU to ID-RPU

Symbol	Meaning
COMMWRN	Binary output Common warning
COMMSD	Binary output Common shut down
FUELSOL	Binary output Fuel solenoid
STOPSOL	Binary output Stop solenoid
MODE	Controller application AUX – EME (or Sd override active)

Complete system example

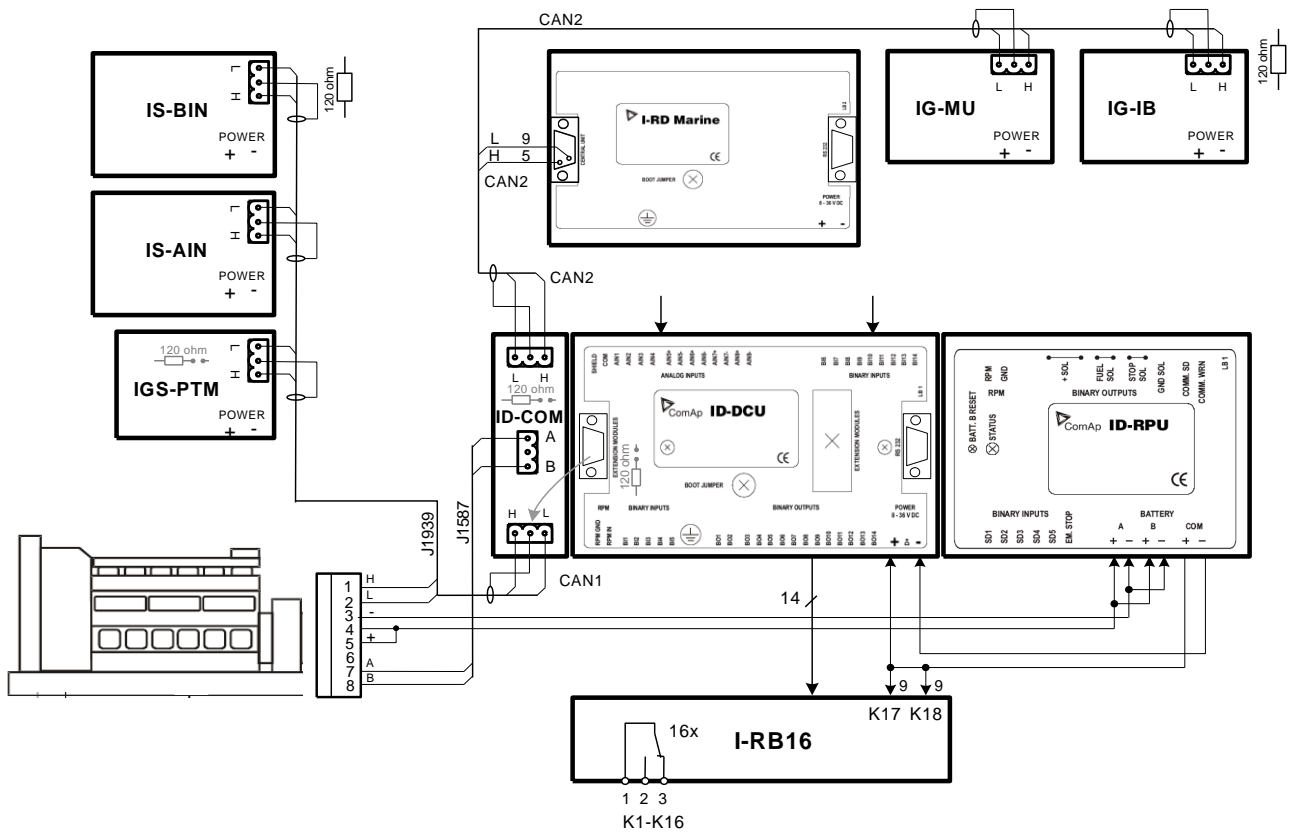

Technical data

Dimension (WxHxD)	105x110x25 mm (4.13'x4.33'x0.98')		
Binary inputs Sd1 – Sd5	Broken wire detection, 10 ³ ohm required		
	Input resistance	1000 ohm	
	Input range	0 – 5V DC	
	Switching voltage level for close contact indication	0 - 1,5V	
	Max voltage level for open contact indication	3 - 4,5V	
	Voltage range for broken wire indication	4,5 - 5V	
	Resistance limit for broken wire detection	20 ³ ohm	
	Emergency stop input (normally closed)	1 (no BW detection)	
	Binary output	Fix function – warning and shutdown	
Maximum switching voltage		36V DC	
Maximum switching current		0,5A	
Speed pick-up input	Type of sensor	magnetic pick-up (connection by shielded cable is recommended)	
	Input impedance	10 ³ ohm	
	Minimum input voltage	2 Vpk-pk (from 4 Hz to 4 kHz)	
	Maximum input voltage	50 Veff	
	Minimum measured frequency	4 Hz	
	Maximum measured frequency	10 kHz (min. input voltage 6Vpk-pk)	
	Frequency measurement tolerance	1,5 %	
Solenoid driver (power) output	Galvanic separated	Separate terminals for ± supply	
	Number of output	2 (Fuel solenoid, Stop solenoid)	
	Maximum current	8A DC (one channel only)	
	Maximum current	12A DC (both channels together)	
	Supply voltage range	8 - 36V DC	
	Protections	OFF – state	Broken wire (open circuit) detection Short circuit
		ON – state	Overload (switch-overheat detection) Lost of power supply indication
Voltage range	8 – 36V DC		
Storage temperature	- 40C to + 80°C		
Operating temperature	- 30°C to + 70°C		

Time sequence of binary output "FUEL SOLENOID"

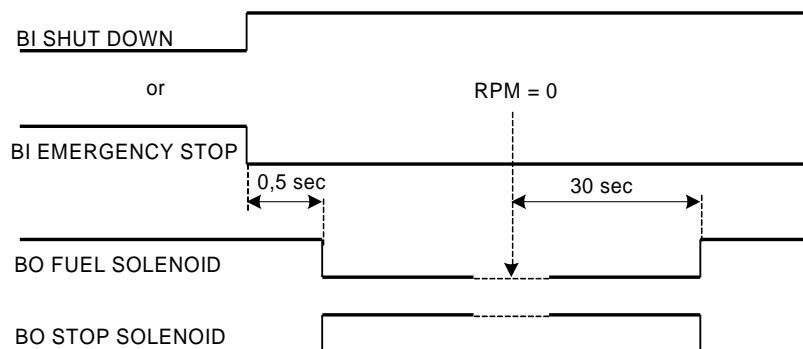

ID-SCM



ID



Description

ID-SCM (speed control module) is extension module for IntelliDrive industrial, marine and CCU application. It is compatible with ID-DCU-Industrial firmware (not compatible with Marine firmware).

- 2 inputs (RPMx) for frequency measuring up to 8kHz, not configurable, corresponding setpoints (FlowRate1, FlowRate2)
- 2 inputs (IMPx) for integral measuring (pulse counter) up to 60 Hz, not configurable, corresponding setpoint (TransferRate1, TransferRate2)
- Speed governor output
- 2 analog output (AOUTx) 0-20mA or 0-10V
- AOUTs values, names and range are configurable.

Module is mounted directly to ID-DCU controller case. Speed governor output only is supported with the ID-DCU Industrial-2.0. Complete ID-SCU functionality will be supported from ID-DCU-Industrial 2.1 and higher (not available now).

Hint:

It is possible to use standard IG-PCM module with ID-DCU-Industrial-2.0 firmware. In this case only the Speed governor output is active (IG-PCM case must be mechanically modified).

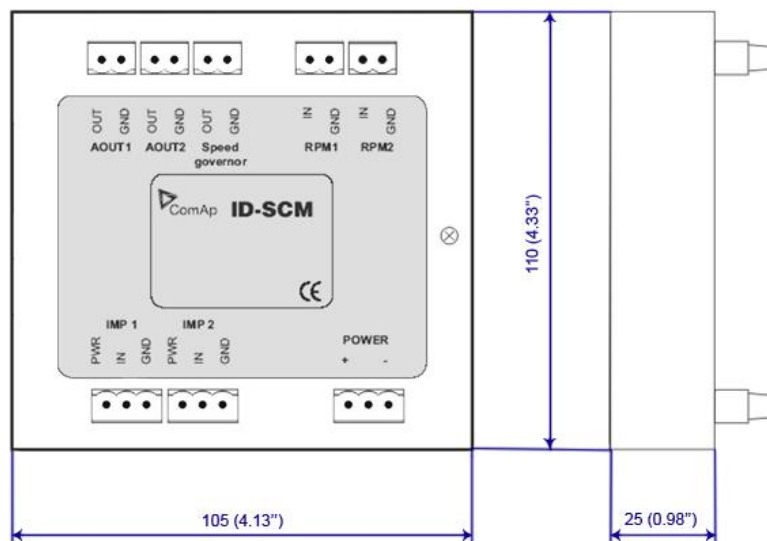

Connectors and Wiring

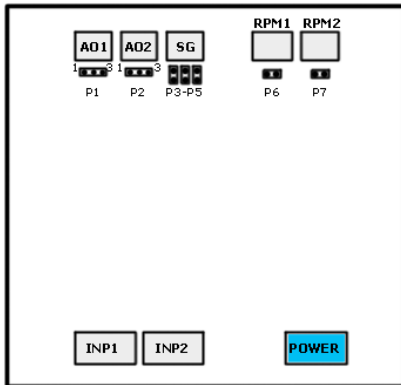

AO1	Analog output
AO2	Analog output
SG	Speed governor
RPM1	Input for RPM measuring
RPM2	Input for RPM measuring
INP1	Pulse input
INP2	Pulse input
POWER	Power supply

Inputs

RPM1, RPM2: Inputs for two RPM measuring. Expected sensor is magnetic pickup – with maximal frequency range up to 8 kHz. Closed jumper divides input frequency by 16.

IMP1, IMP2: Inputs for integral (e.g. consumption) measuring. It is expected NPN – open collector (active) impulse sensor with maximal frequency range up to 60 Hz. Minimal pulse duration is 1ms. PWR terminal can be used for sensor power supply - 24VDC.

ID-SCM inputs wiring example

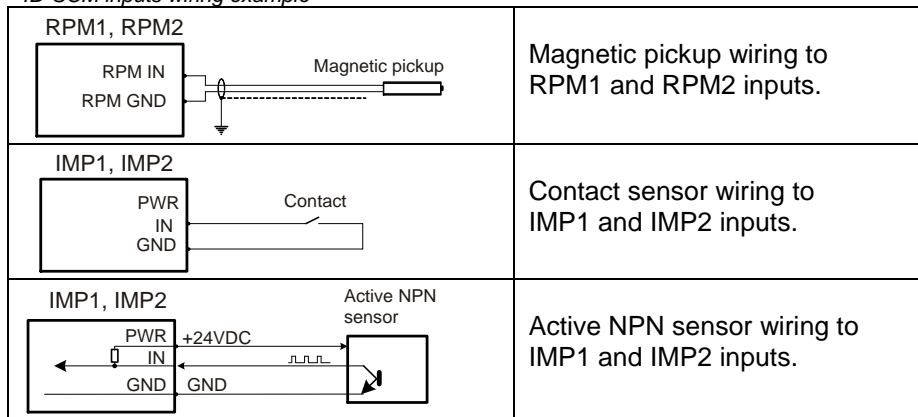

Output

AOUT1, AOUT2: General-configurable analog output for indication or any control loop output. Outputs are jumper adjustable between 0 to 10VDC or 0 to 20 mA.

Speed governor: Analog interface to engine speed governor for engine speed control by voltage (engine without ECU). Output is jumper selectable between ± 10 VDC or ± 10 VDC via 10^3 ohms or PWM (1200Hz / 5Volts, 10 mA max).

Address and jumpers settings

AOUT jumper settings

Jumper	Description
P1	1-2 Set output 0 – 20mA DC
	2-3 Set output 0 – 10V DC
P2	1-2 Set output 0 – 20mA DC
	2-3 Set output 0 – 10V DC

RPM jumper settings I

Jumper	Description
P6	Open divides input frequency by 1
	Close divides input frequency by 16
P7	Open divides input frequency by 1
	Close divides input frequency by 16

RPM jumper settings II (P6,P7 jumper)

Jumper	RPM input nominal frequency range
Closed	> 1000 Hz
Closed or Opened	500 – 1000 Hz
Opened	< 500 Hz

Speed governor jumper settings

Jumper	Description	
P3	Open	-
	Close	Set output $\pm 10V$ DC
P4	Open	-
	Close	Set output $\pm 10V$ DC via 10^3 ohms
P5	Open	-
	Close	Set output PWM

Other settings – DriveConfig

These setpoint are available when the SCM module is configured in DriveConfig / Modules window.

FreqRate1 []

Conversion constant (number of pulses for one RPM) for ID-SCM RPM1 frequency input - SCM Freq1 value. Frequency range max 8 kHz

Step: 1

Range: 0 to 500

FreqRate2 []

Conversion constant (number of pulses for one RPM) for ID-SCM RPM2 frequency input - SCM Freq2 value. Frequency range max 8 kHz

Step: 1

Range: 0 to 500

TransferRate1 []

Conversion constant (number of pulses is for increment 1) for ID-SCM IMP 1 impulse input / SCM Imp1 value. Frequency range max 60 Hz.

Step: 1

Range: 0 to 500

TransferRate2 []

Conversion constant (number of pulses is for increment 1) for ID-SCM IMP 2 impulse input / SCM Imp2 value. Frequency range max 60 Hz.

Step: 1

Range: 0 to 500

ID-SCM input – Setpoint – Values name overview

Input	Setpoint	Value
RPM1	FreqRate1	SCM Freq1
RPM2	FreqRate2	SCM Freq2
IMP1	TransferRate1	SCM Imp1
IMP2	TransferRate2	SCM Imp2

Example 1:

To measure actual water flow in liters (or cubic meter) per minute set *FreqRate* = 10 [] when sensor gives 10 pulses per liter (or cubic meter).

Example 2:

To measure total water consumption in liters (or cubic meter) set *TransferRate* = 100 [] when sensor gives 100 pulses per 1liter (or cubic meter).

Technical data

Dimension (WxHxD)	105x110x25 mm (4.13'x4.33'x0.98')
Interface to controller	Direct mounted (SUB25)
Analog output	0 to 20mA DC \pm 0,33 mA 0 to 10V DC (<i>AOUT</i>)
	\pm 10V DC, \pm 10VDC via 10^3 ohm PWM (1200Hz / 5V, 10 mA max) (<i>speed governor</i>)
Frequency / Impulse inputs (no electric separated)	Measuring pulse up to 60 Hz (<i>IMP</i>)
	Measuring pulse up to 8kHz (<i>RPM</i>)
Power supply	8 to 36 V DC
Current consumption	100 mA at 24V \div 300 mA
Storage temperature	- 40C to + 80°C
Operating temperature	- 30°C to + 70°C
Frequency inputs	
Input impedance	10 k Ω
Minimum input voltage	2 Vpk-pk (from 4 Hz to 4 kHz)
Maximum input voltage	50 Veff
Impulse inputs	
Min pulse duration	1 ms
Input impedance	4000 ohm
ON input voltage	< 0,8 V
OFF input voltage	4,2 V
R _{ON} max	1000 ohm
Maximum input voltage	40 V

IGS-PTM

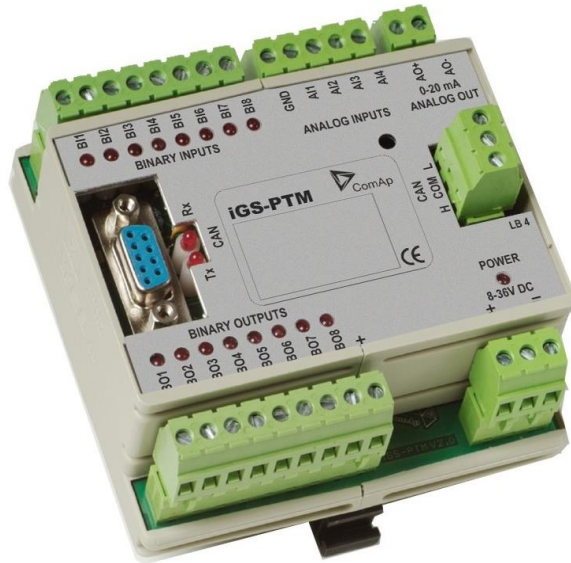

IM-NT IG-NT/IS-NT



ID

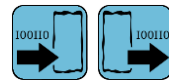
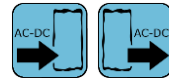

Description

IGS-PTM is modification of standard IG-IOM module with four analog inputs, which can be configured for range:

- 0 – 250 Ω (suitable for Pt100, Ni100),
- 0 – 100 mV,
- 0/4 – 20 mA.

Dimensions

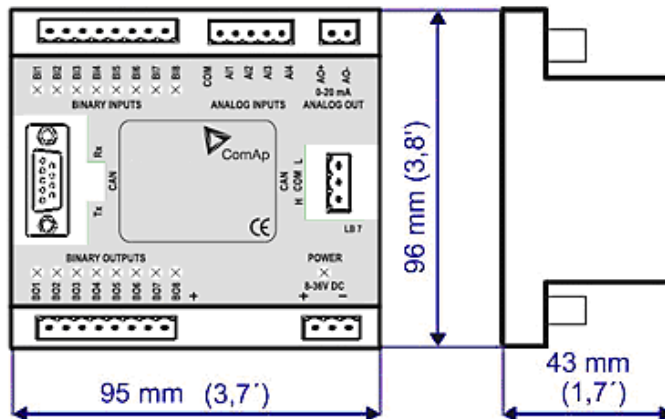

Unit is 35 mm DIN rail mounted.

Terminals

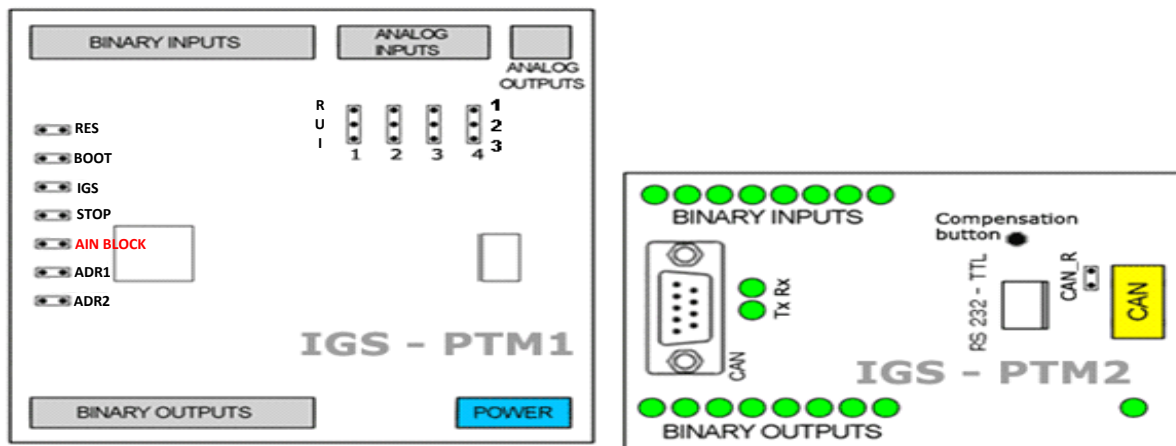

BINARY INPUTS	8 binary input
ANALOG INPUTS	4 analog input
ANALOG OUTPUT	1 analog output
BINARY OUTPUT	8 binary output
CAN	CAN1 line
RS232-TTL	Interface for programming
POWER	Power supply
BINARY INPUTS	8 LEDs for binary input indication
BINARY OUTPUT	8 LEDs for binary output indication
Tx, Rx	Indication transmitted or received data
POWER	Power supply LED indication
CAN_R	Terminating CAN resistor
RUI	Analog inputs configuration
RESET	Programming / reset
BOOT	Programming
IGS	Controller type selection
AIN BLOCK	Block of all Analog inputs
STOP	Service jumper
ADR1	Module's address offset 1,2
ADR2	
Compensation button	Long wires resistance compensation

Hint:

Configuration jumpers IGS, ADR1, ADR2 are OPEN by default.
 CAN_R jumper is CLOSE by default (IG-IOM mode).
 Analog inputs are configured for resistance measurement by default.

Address and jumpers setting

Controller type selection

The type of controller to be used with IGS-PTM must be selected via jumper labeled IGS accessible at the lower PCB.

IGS jumper description	
IGS jumper	controller type
OPEN	IL-NT, IC-NT
CLOSE	IG-NT, IS-NT, IM-NT, ID

Address configuration

If IS-NT controller type is selected (by IGS jumper), address of IGS-PTM could be modified via jumpers labeled ADR1 and ADR2.

CAN address settings

ADR1	ADR2	BIN module	BOUT module	AOUT module	AIN module
Open	Open	1	1	1	1
close	Open	2	2	2	2
Open	Close	3	3	3	3
close	close	4	4	4	4

Analog inputs hardware configuration

Analog inputs can be configured for:

- Resistance measurement
- Current measurement
- Voltage measurement

The type of analog inputs is configured via jumpers RUI located on lower PCB.

Analog input settings

RUI	Analog input configuration
1 – 2	Resistance measuring
2 – 3	Current measuring
no jumper	Voltage measuring

Programming Firmware

Firmware upgrade is via AT-link (TTL). For programming is necessary to close jumper BOOT. RESET jumper is used to reset the device. Close jumper to reset the device. For programming is used FlashProg PC tool.

LED indication

Binary inputs

Each binary input has LED which indicates input signal. LED is shining when input signal is set, and LED is dark while input signal has other state.

Binary output

Binary output LED shining when binary output is set.

Power

Table of power LED description

LED status	Description
Dark	No required power connected
Quick flashing	Program check failure
One flash and pause	Compensation fail
Three flashes and pause	Compensation successful
Flashes	there is no communication between IGS-PTM and the controller.
Lights	Power supply is in the range and communication between IGS-PTM and controller properly works.

Wiring

Analog inputs connection

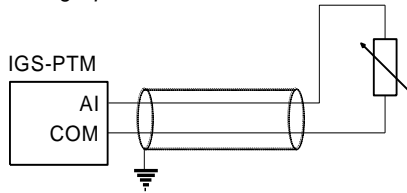

Two wire resistor sensor

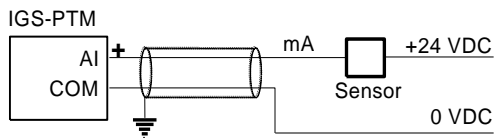

Two wire current sensor.

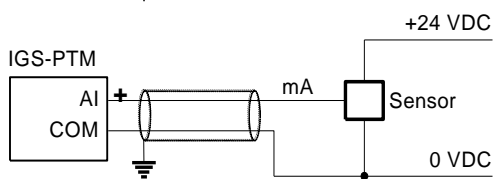

Three wire current sensor.

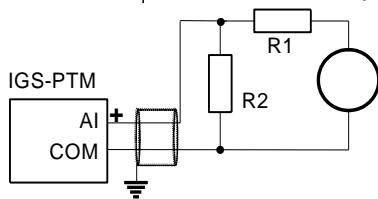

Extension of voltage measuring range.

Hint:

It is not necessary to connect analog inputs COM terminal to negative power supply.

Long wires resistance compensation

Process of compensation:

1. Short all wires to analog sensors at the end (replace sensors with shorting links).
2. Hold the compensation button on IGS-PTM through the hole in upper cover when switching IGS-PTM on.
3. Result of compensation will be shown in 2 seconds by flashing of POWER LED.
 - o One flash and pause – compensation fail.
 - o Three flashes and pause – compensation success.
4. Measured lead's resistance is stored in EEPROM memory (separate value for each input) and is subtracted from measured value when resistance measuring.

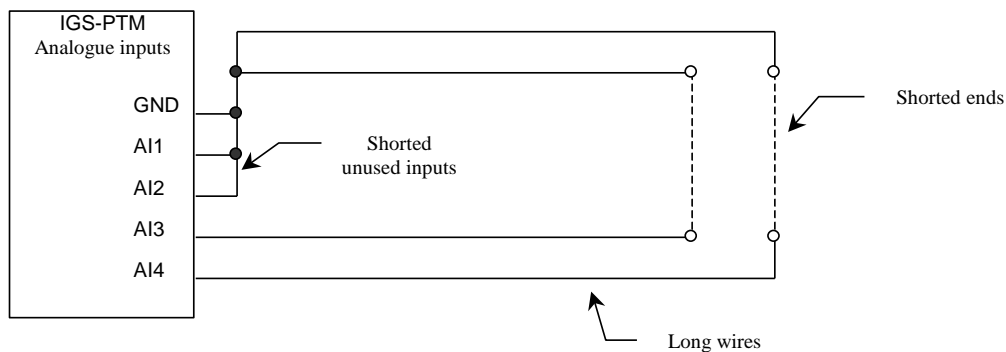

Hint:

Maximum resistance of two leads (from IGS-PTM to sensor and back) can be 20Ω. Otherwise the compensation fails. Unused analog inputs must be shorted at the IGS-PTM.

Technical data

Dimension (WxHxD)	95x96x43 mm (3.7'x3.8'x1.7')	
Interface to controller	CAN1	
Binary inputs	<i>Input resistance</i>	4700 ohm
	<i>Input range</i>	0 to 36V DC
	<i>Switching voltage level for open contact indication</i>	0 to 2V
	<i>Max voltage level for open contact indication</i>	8 to 36V
Binary output <i>(Open collector output)</i>	<i>Max current</i>	500mA
	<i>Max switching voltage</i>	36V DC
Analog inputs <i>(Not electric separated)</i>	Resolution	10 bits
	Sensor resistance range	0 to 250 ohm
	Maximal voltage range	0 to 100 mV
	Maximal current range	0 to 20 mA
	Resistance measurement tolerance	1 % ± 2 ohm out of measured value
	Voltage measurement tolerance	1.5 % ± 1 mV out of measured value
	Current measurement tolerance	2.5 % ± 0.5 ohm out of measured value
	Input impedance for measuring current	3,9 ohm
	Input impedance for measuring voltage	100k ohm
Analog output <i>(not electric separated)</i>	Output current	0 to 20 mA ± 0.33mA
	resolution	10 bit
Power supply	8 to 36 V DC	
Protection	IP20	
Current consumption	100 mA at 24V ÷ 500 mA	
Storage temperature	- 40C to + 80°C	
Operating temperature	- 30°C to + 70°C	

Analog output refresh rate is 320ms.

IG-MTU/IG-MTU-C/MTU-2-1

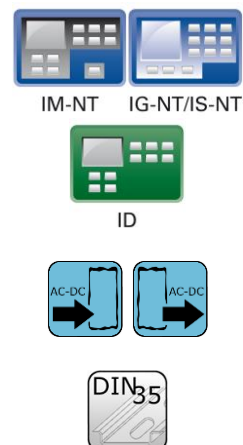

Description

Voltage transformer unit, for three wire system, system with separated Neutral or when galvanic separation between generator or mains voltage and controller is required.

- IG-MTU with voltage ratio 1 : 1, conversion accuracy $\pm 1.5\%$, phase shift $\pm 2^\circ$
- IG-MTU-2-1 with voltage ratio 2 : 1, conversion accuracy $\pm 1.5\%$, phase shift $\pm 2^\circ$
- IG-MTU-C with voltage ratio 1 : 1, conversion accuracy $\pm 3\%$, phase shift $\pm 3^\circ$. Additional filter for the cases of extreme distortion of generator voltage by higher harmonics due to inverters etc.

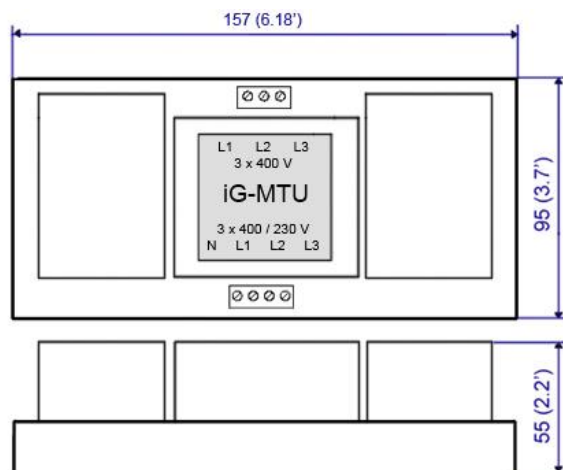

Unit is 35 mm DIN rail mounted.

Connectors

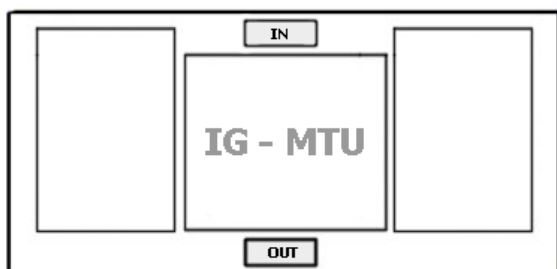

IN	Input voltage
OUT	Output voltage

Wiring

Connect one or two IG-MTU units to separate generator and Mains/bus voltage from controller.

Three wire mains

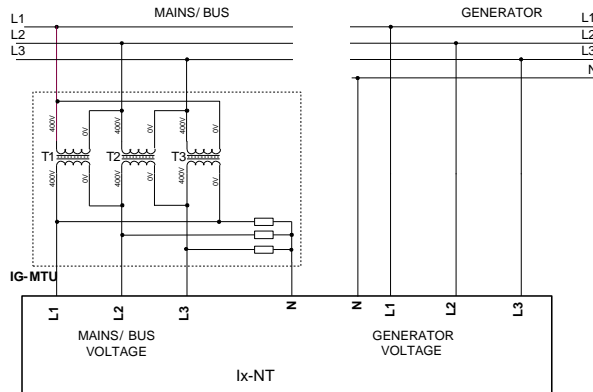

Three wire mains and three wire genset or electric separation

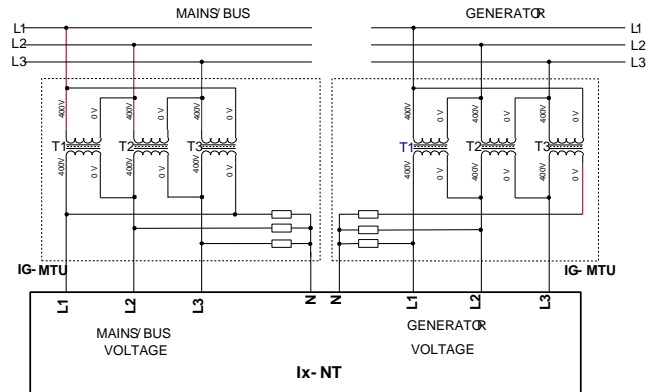

Hint:

IG-MTU-C can be connected **only with classical line controllers!**

We recommend connect IG-MTU and IG-MTU-2-1 only when is needed separated neutral or when is necessary galvanic separate mains/generator and controller.

Technical data

Dimension (WxHxD)	157x55x95 mm (6.18'x2.2'x3.7')
Interface to controller	Direct mounted (SUB25)
Primary voltage Ph-Ph	3x400 VAC / 50Hz (3x480 VAC / 60 Hz) <i>IG-MTU, IG-MTU-C</i> 3x600 VAC / 50Hz (3x720 VAC / 60 Hz) <i>IG-MTU-2-1</i>
Secondary voltage Ph-N	3x 230 V AC (3x277 VAC / 60 Hz) , 5 VA <i>IG-MTU, IG-MTU-C</i> 3x 173 V AC (3x208 VAC / 60 Hz) , 5 VA <i>IG-MTU-2-1</i>
Primary/secondary Phase shift	$\pm 2^\circ$ <i>IG-MTU, IG-MTU-2-1</i> $\pm 3^\circ$ <i>IG-MTU-C</i>
Conversion accuracy	$\pm 1.5\%$ at 50Hz <i>IG-MTU, IG-MTU-2-1</i> $\pm 3.0\%$ at 50Hz <i>IG-MTU-C</i>
Storage temperature	- 40°C to + 80°C
Operating temperature	- 30°C to + 70°C

IS-AIN8



IM-NT IG-NT/IS-NT ID



Description

IS-AIN8 is input extension module equipped with 8 analog inputs. The module can be used for ID, IGS-NT controller. IS-AIN8 can be configured to:

- Resistor two wire input
- Resistor three wire input
- Current input
- Thermocouple input
- Voltage input

All inputs can be configured to any logical function or protection. It is possible to connect up to 10 IS-AIN8 (with IGS-NT) or up to 4 (with ID) external units to one controller. IS-AIN8 is connected to controller CAN1 bus.

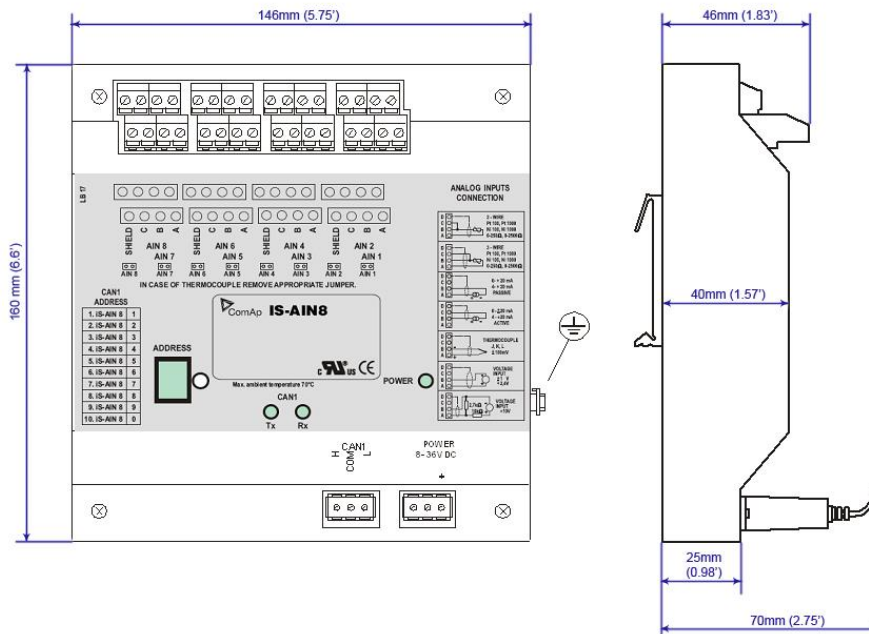

Unit is 35 mm DIN rail mounted.

Connectors

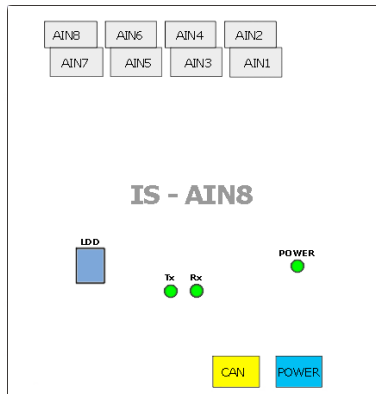

AIN1 – AIN8	8 analog inputs
CAN	CAN1 line
POWER	Power supply
POWER	State indication
Rx, Tx	Data transmitted and received on CAN1 line
LDD	CAN1 address

Address and jumper settings

CAN 1 address is set by following procedure:

1. Press Address button during IS-AIN8 power supply on to switch to addressing mode.
2. Then repeatedly press or keep pressed address button to adjust required address according to controller configuration.
3. After setting requested address, release the buttons and wait until the digits blink – it indicates writing of the change address to EEPROM memory.

Table of recommended CAN1 address setting

	CAN 1 Address
1. IS-AIN8	1
2. IS-AIN8	2
3. IS-AIN8	3
4. IS-AIN8	4
5. IS-AIN8	5
6. IS-AIN8	6
7. IS-AIN8	7
8. IS-AIN8	8
9. IS-AIN8	9
10. IS-AIN8	0

SW version check

Let suppose IS-AIN8 of SW version 1.4. Shortly press address button. Following sequence appears on the display: number “1”, one second pause, number “4”, two second pause, number “1”, one second pause, number “4”, two second pause and finally IS-AIN8 actual address.

Error message (e.g. SD BOUT2) appears on Controller screen when Binary input or output Address x is configured but corresponding unit is not recognized (no message is received from CAN bus). Check IS configuration and corresponding external IS-AIN8, IS-BIN8/16 unit address setting.

LED indication

LED / LDD status

Power LED		Address LDD	
Lighting	Blink	Lighting	Blink
Power supply and CAN address are with no problems	CAN1 address is adjusted different in IS-AIN8 and in controller	Displaying current CAN1 address	Displaying current SW version

Tx / Rx LED status

Tx		Rx	
Dark	Blink	Dark	Blink
Any data are transmitted on the CAN1 line	Data are transmitted on the CAN1 line	Any data are received on the CAN1 line	Data are received on the CAN1 line

Wiring

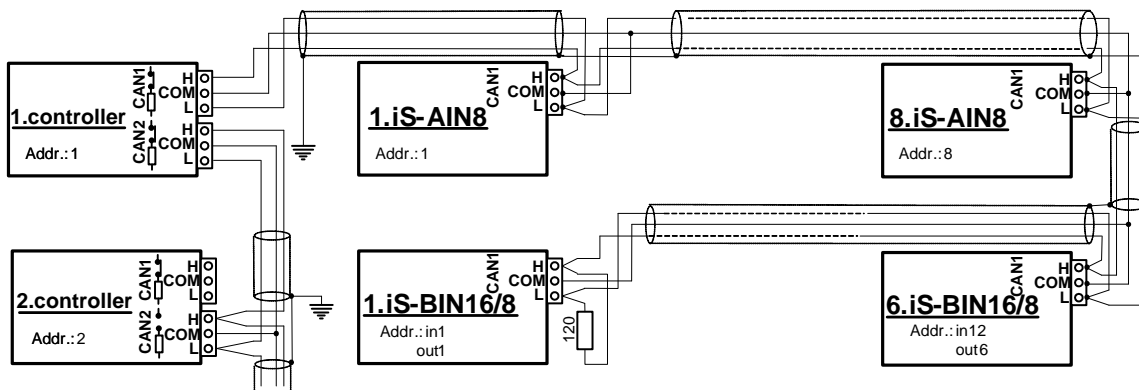

Hint:

CAN bus line has to be terminated by 120 ohm resistors on the both ends.

For longer distances is recommended to connect CAN COM terminals between all controllers and cable shielding to the **ground in one point!**

External units can be connected on the CAN bus line in any order, but line arrangement (no tails no star) is necessary.

Recommended CAN bus data cables see in Chapter Technical data.

IG-MU and IG-IB units are connected to CONTROLLER CAN2 bus.

Select sensor characteristic from the list or define user sensor characteristic in PC configuration tool.

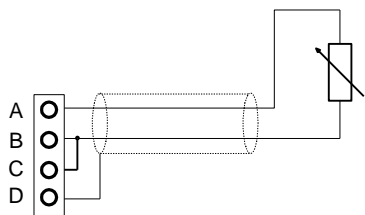

Resistor sensor input – two wire connection.

Range 0 to 2400 ohms.

Pt100, Pt1000, Ni100, Ni1000

D terminal is shielding

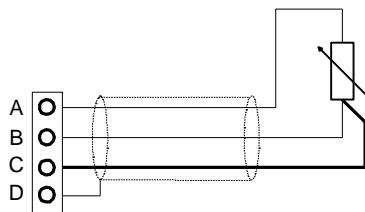

Resistor sensor input – three wire connection.

Range 0 to 2400 ohms.

Pt100, Pt1000, Ni100, Ni1000 – recommended.

D terminal is shielding

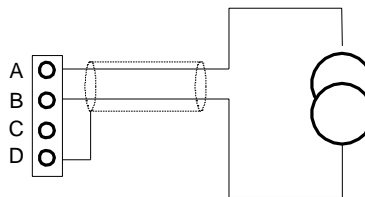

Passive current sensor (current source is in IS-AIN8)

Range 0 to + 20 mA or 4 to + 20 mA

D terminal is shielding

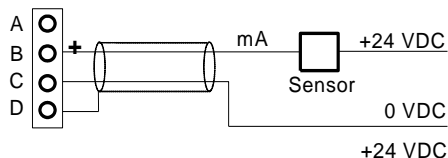

Active current sensor (current source is in sensor)

Range -20mA to +20 mA or 4 to + 20 mA

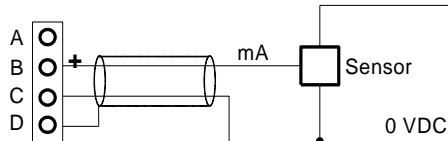

D terminal is shielding

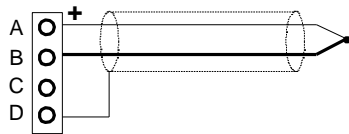

Thermocouple J, K, L
D terminal is shielding

From IS-AIN8 hardware version 5.1 can be B terminal grounded to frame

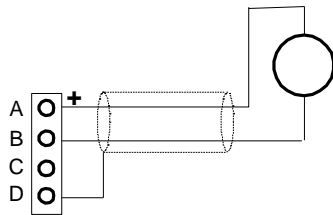

Voltage input
Range 0 to + 2500 mV.
Voltage range is 0 to ± 1000 mV.

D terminal is shielding

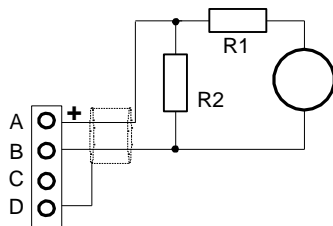

For 10V input voltage range connects external resistors R1, R2 and select sensor characteristic 10V.

R1=10 kohm, R2=2,7 kohm.



D terminal is shielding

Hint

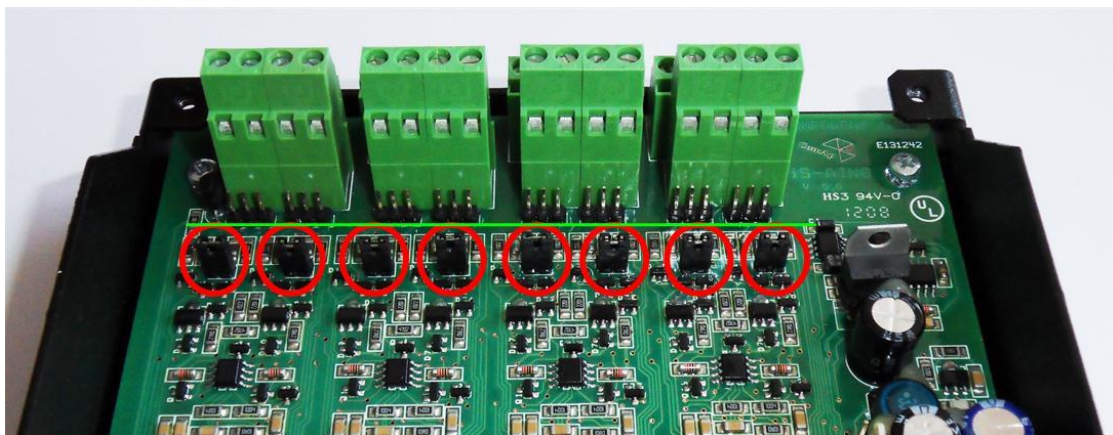
If the thermocouples are connected to IS-AIN8, appropriate jumpers must be removed (see rear sticker). (jumpers are placed under the cover)



Supported sensors

<p>Sensor IS-AIN8</p>	<p>None I-CB analog Pt100/°C Pt1000/°C Ni100/°C Ni1000/°C Thermocouple J/°C Thermocouple K/°C Thermocouple L/°C 4 to 20 mA passive 4 to 20 mA active 0 to 20 mA passive 0 ± 20 mA active 0-250 ohm 0-2400 ohm 0 – 2,4 V ±1 V 0 - 10 V 0 - 100mV Pt100/°F Pt1000/°F Ni100/°F Ni1000/°F Thermocouple J/°F Thermocouple K/°F Thermocouple L/°F</p>	<p>Value is received from I-CB</p>  <p>Use  button to create new sensor characteristic.</p> <p>Adjust Range = maximal measured value Adjust Range Adjust Range Adjust Range Adjust Range Adjust Range Adjust Range</p>
---------------------------	---	--

Cold Junction Compensation (CJC)

Cold junction compensation is also called reference junction compensation. When measuring temperature using thermocouples, the reference terminal may not be held at 0°C, but at the surrounding temperature of T1°C instead. Without any compensation, the thermocouple output will be changed (reduced) by T1°C. This is compensated by adding potential difference to the IS-AIN8 corresponding to T1°C.

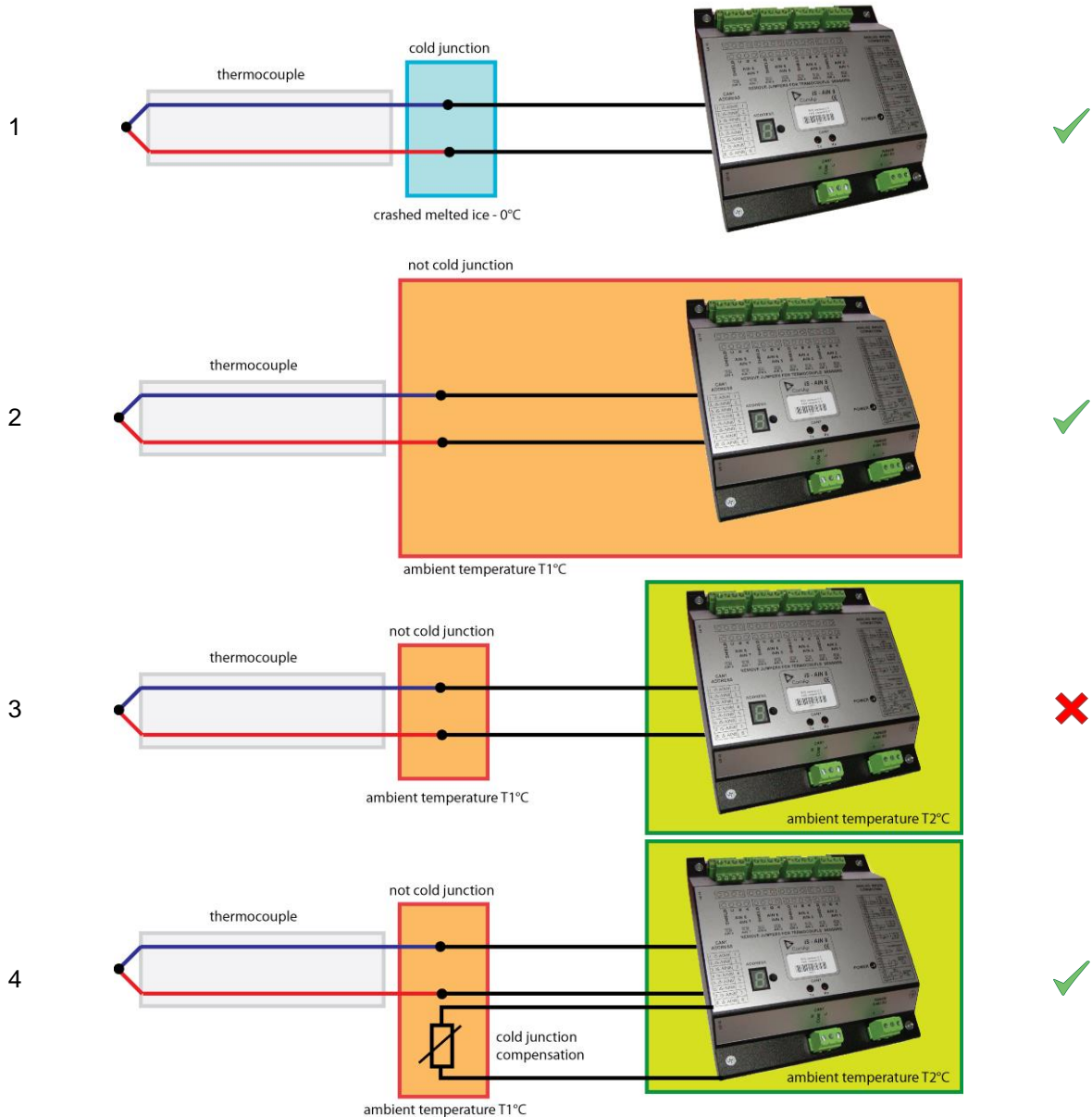

Example 1 shows the correct temperature measurement. The 3rd metal (the cable between IS-AIN8 and thermocouple) is connected in cold bath which temperature is 0°C. This is very difficult to provide in real application.

Example 2 shows the correct temperature measurement. The 3rd metal (the cable between IS-AIN8 and thermocouple) is connected in ambient environment which temperature is not 0°C, but T1°C. Resultant temperature is correct, because is compensated by internal IS-AIN8 temperature sensor. The temperature of IS-AIN8 and junction is the same T-T1+T1 (reduced and compensated by T1).

Example 3 shows the incorrect temperature measurement. The 3rd metal (the cable between IS-AIN8 and thermocouple) is connected in ambient environment which temperature is not 0°C, but T1°C. Resultant temperature is T-T1 (reduced by T1). Internal IS-AIN8 compensation should not be used because measures T2 temperature, not T1!

Example 4 shows the correct temperature measurement. The 3rd metal (the cable between IS-AIN8 and thermocouple) is connected in ambient environment which temperature is not 0°C, but T1°C. Resultant temperature is correct, because is compensated by external temperature sensor, T+T1 (reduced and compensated by T1).

Cold Junction Compensation (CJC) settings

Example 1 is not a practical in regard of ice bath. In this case should any of not compensated (nc) sensors for analog input be selected base on used thermocouple.

Property	Value
Function	<input type="checkbox"/>
Protection	<input type="checkbox"/>
Name	AIN-1 1
Dim	-
Sensor	None
Resolution	Thermocpl L°F
Sensor range	Thermo(nc) J°C Thermo(nc) K°C
Bargraph 0%	Thermo(nc) L°C
Bargraph 100%	Thermo(nc) J°F Thermo(nc) K°F
Offset	Thermo(nc) L°F 4-20mA, passive

Example 2 is a standard wiring between thermocouple sensor and IS-AIN8. IS-AIN8 is placed in the same ambient temperature as thermocouple terminal; it means IS-AIN8's internal temperature sensor measures the same temperature as is on thermocouple terminal. In this case, cold junction compensation is done by IS-AIN8 itself. Any of standard (compensated) sensors should be selected.

Function	<input type="checkbox"/>
Protection	<input type="checkbox"/>
Name	AIN-1 1
Dim	-
Sensor	None
Resolution	NI1000°F
Sensor range	Thermocpl J°C Thermocpl K°C
Bargraph 0%	Thermocpl L°C
Bargraph 100%	Thermocpl J°F Thermocpl K°F
Offset	Thermocpl L°F Thermo(nc) J°C

Example 3 is a standard wiring between thermocouple sensor and IS-AIN8. Regardless selected type of sensor the resultant temperature will be incorrect

- not compensated sensor – temperature T1 is not calculated
- compensated sensor – IS-AIN8 measures different T2 temperature, not T1

Example 4 External temperature T1 sensor is included. Resultant temperature is correct if

- any of **not compensated sensors** (nc) is selected
- external sensor **has a function Cold Temp 1**

Property	Value	Logical function	Used
Function	<input checked="" type="checkbox"/>	Cold Temp 1	<input checked="" type="checkbox"/>
Protection	<input type="checkbox"/>	Cold Temp 2	<input type="checkbox"/>
Name	CJC of IS-AIN8	Cold Temp 3	<input type="checkbox"/>
Dim	°C	Cold Temp 4	<input type="checkbox"/>
Sensor	PT100/°C		
Resolution	0,1		
Sensor range	0,0		
Bargraph 0%	0,0		
Bargraph 100%	100,0		
Function	Cold Temp 1		
Offset	0,0		

Hint:

LAI (logical analog input) Cold Temp 1 compensates every of 8 thermocouples inputs of IS-AIN8 on address 1,

- any of non thermocouple configured input is not compensated anyway
- any of non thermocouple input with sensor adjusted as compensated is not compensated by external compensation (IS-AIN8 compensates it itself)
- IS-AIN8 on address 2 – 10 is not compensated by this LAI Cold Temp1.

LAI Cold Temp 2 compensates every of 8 thermocouples inputs of IS-AIN8 on address 2, etc.

Up to 32 (Cold Temp 1-4 times 8 analog input of IS-AIN8) may be compensated by external sensor.

Even only one external sensor may be configured for more than one LAI Cold Temp.

Technical data

Dimension (WxHxD)	146x160x46 mm (5.79'x6.6'x1.83')
Interface to controller	CAN1
Analog inputs	8, galvanic separated from power supply, 16bit *
Power supply	8 to 36 V DC
Current consumption	250mA at 24 V
Protection front panel	IP20
Humidity	95% without condensation
Storage temperature	- 40C to + 80°C
Operating temperature	- 30°C to + 70°C
Standard conformity	
Low Voltage Directive	EN 61010-1:95 +A1:97
Electromagnetic Compatibility	EN 50081-1:94, EN 50081-2:96 EN 50082-1:99, EN 50082-2:97

* each analog input can be software configured to:

		Measuring range		Accuracy
		From	to	
Resistance		0 Ω	2400 Ω	± 0,5 %
		0 Ω	250 Ω	± 1,0 %
Current	Passive	0 / 4 mA	20 mA	± 0,5 %
	Active	4 mA	20 mA	± 0,5 %
	Active	0 mA	± 20 mA	± 0,5 %
Voltage	Thermocouples J, K, L type			± 0,2 %
				± 0,2 %
		- 1000 mV	+ 1000 mV	± 0,5 %
		0 mV	2500 mV	± 0,5 %

IS-AIN8TC



IM-NT IG-NT/IS-NT ID



Description

IS-AIN8 is input extension module equipped with 8 analog inputs dedicated for thermocouple sensors only. The module can be used for ID, IGS-NT controller. IS-AIN8TC can be configured to:

- Thermocouple input

All inputs can be configured to any logical function or protection. It is possible to connect up to 10 IS-AIN8TC (with IGS-NT) or up to 4 (with ID) external units to one controller. IS-AIN8TC is connected to controller CAN1 bus.

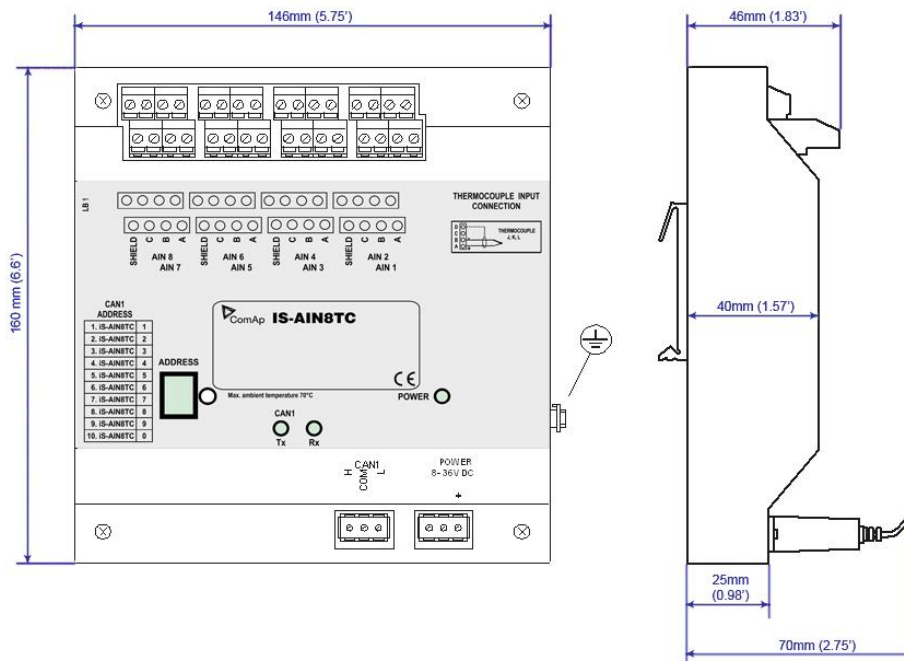

Unit is 35 mm DIN rail mounted.

Connectors

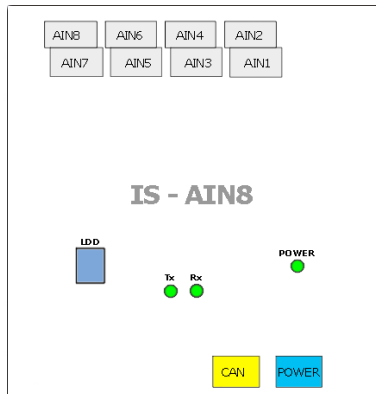

AIN1 – AIN8	8 analog inputs
CAN	CAN1 line
POWER	Power supply
POWER	State indication
Rx, Tx	Data transmitted and received on CAN1 line
LDD	CAN1 address

Address and jumper settings

CAN 1 address is set by following procedure:

4. Press Address button during IS-AIN8TC power supply on to switch to addressing mode.
5. Then repeatedly press or keep pressed address button to adjust required address according to controller configuration.
6. After setting requested address, release the buttons and wait until the digits blink – it indicates writing of the change address to EEPROM memory.

Table of recommended CAN1 address setting

	CAN 1 Address
1. IS-AIN8TC	1
2. IS-AIN8TC	2
3. IS-AIN8TC	3
4. IS-AIN8TC	4
5. IS-AIN8TC	5
6. IS-AIN8TC	6
7. IS-AIN8TC	7
8. IS-AIN8TC	8
9. IS-AIN8TC	9
10. IS-AIN8TC	0

SW version check

Shortly press address button. Following sequence appears on the display: number “1”, one second pause, number “4”, two second pause, number “1”, one second pause, number “4”, two second pause and finally IS-AIN8TC actual address.

Error message (e.g. SD BOUT2) appears on Controller screen when Binary input or output Address x is configured but corresponding unit is not recognized (no message is received from CAN bus). Check IS configuration and corresponding external IS-AIN8TC, IS-BIN8/16 unit address setting.

LED indication

LED / LDD status

Power LED		Address LDD	
Lighting	Blink	Lighting	Blink
Power supply and CAN address are with no problems	CAN1 address is adjusted different in IS-AIN8TC and in controller	Displaying current CAN1 address	Displaying current SW version

Tx / Rx LED status

Tx		Rx	
Dark	Blink	Dark	Blink
Any data are transmitted on the CAN1 line	Data are transmitted on the CAN1 line	Any data are received on the CAN1 line	Data are received on the CAN1 line

Wiring

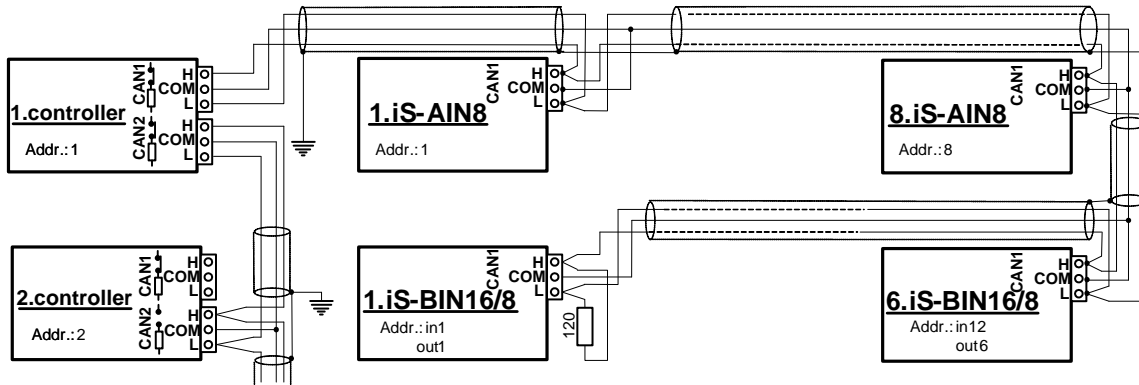

Hint:

CAN bus line has to be terminated by 120 ohm resistors on the both ends.
 For longer distances is recommended to connect CAN COM terminals between all controllers and cable shielding to the **ground in one point!**
 External units can be connected on the CAN bus line in any order, but line arrangement (no tails no star) is necessary.
 Recommended CAN bus data cables see in Chapter Technical data.
 IG-MU and IG-IB units are connected to CONTROLLER CAN2 bus.

Select sensor characteristic from the list or define user sensor characteristic in PC configuration tool.

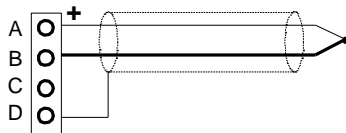

Thermocouple J, K, L
 D terminal is shielding

Supported sensors

Sensor IS-AIN8TC	None Thermocouple J/°C Thermocouple K/°C Thermocouple L/°C Thermocouple J/°F Thermocouple K/°F Thermocouple L/°F
------------------	--

Cold Junction Compensation (CJC) settings

Please have a look at [Cold junction compensation](#) in IS-AIN8 chapter.

Technical data

Dimension (WxHxD)	146x160x46 mm (5.79'x6.6'x1.83')
Interface to controller	CAN1
Analog inputs	8, galvanic separated from power supply, 16bit *
Power supply	8 to 36 V DC
Current consumption	250mA at 24 V
Protection front panel	IP20
Humidity	95% without condensation
Storage temperature	- 40C to + 80°C
Operating temperature	- 30°C to + 70°C
Standard conformity	
Low Voltage Directive	EN 61010-1:95 +A1:97
Electromagnetic Compatibility	EN 50081-1:94, EN 50081-2:96 EN 50082-1:99, EN 50082-2:97

* each analog input can be software configured to:

		Measuring range		Accuracy
		From	to	
Voltage	Thermocouples J, K, L type			± 0,2 %

IS-BIN16/8

IS-BIN16/8 becomes an obsolete product from first January 2014.

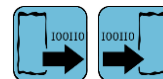
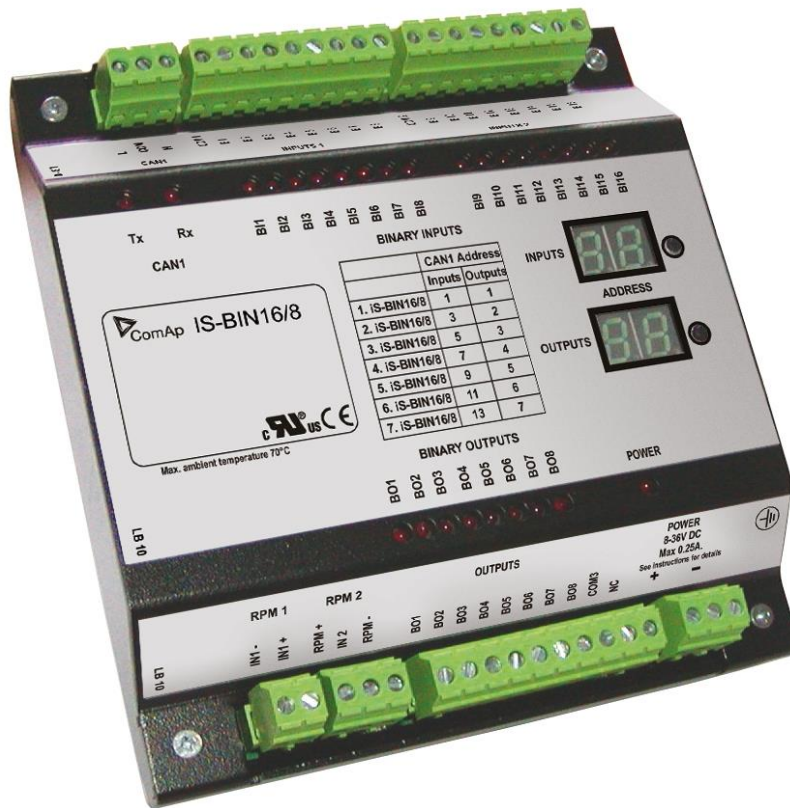

Description

IS-BIN16/8 is an extension module with 16 binary inputs (galvanic separated) and 8 binary output (galvanic separated), 2 pulse inputs (frequency measurement or pulse counting). All I/O can be configured to any logical function or protection. It is possible to connect up to 6 IS-BIN16/8 external units to one controller. External modules IS-BIN16/8 is connected to controller CAN1 bus. To operate external modules:

- Connect all external modules to CAN1 bus line
- On each module adjust I/O CAN1 address in the range of 1 to 7 for IS-BIN16/8 output, 1,3,5,7,9,11,13 for IS-BIN18/8 inputs
- In case of use generic module in configuration you can set CAN address from 1 – 12
- In case of set 0 CAN address - inputs/ outputs are deactivated
- Input output address is displayed on the front panel LCD's
- Use PC configuration tool to configure controller according external modules setting

IS-BIN16/8 module has two separate CAN1 addresses for binary inputs Group 1, Group 2 and binary output Group (total three addresses). The CAN1 address for BI Group 1 and for BO Group 2 can be adjusted on the IS-BIN16/8. The address for BI Group 2 is set automatically to the address following BI Group 1.

Hint:

CAN address 0 disables corresponding CAN message (Group data are not send).

Dimensions

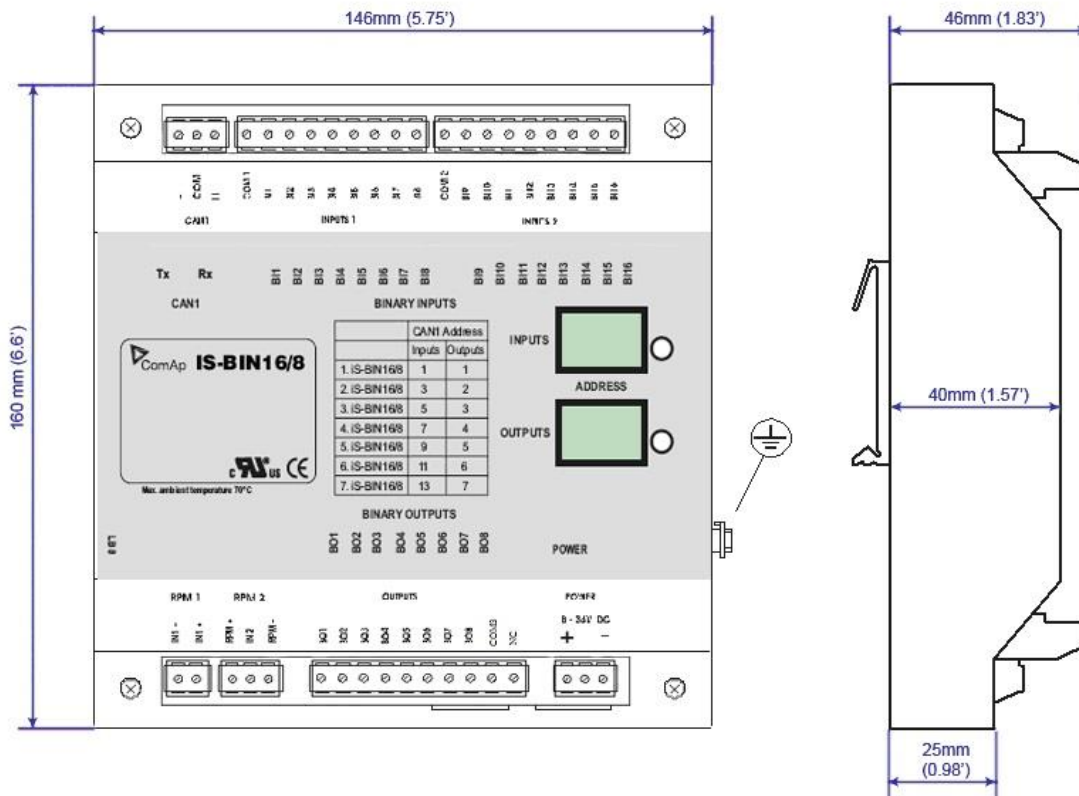

Unit is 35 mm DIN rail mounted.

Connectors

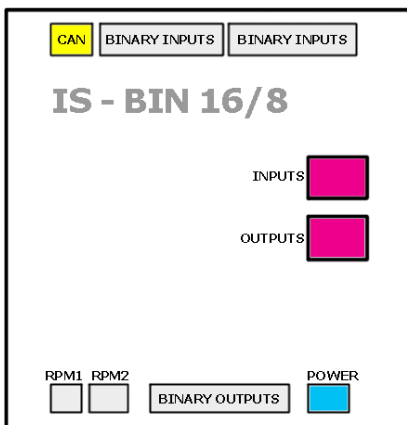

CAN	CAN1 line
BINARY INPUTS	16 binary inputs
BINARY OUTPUT	8 binary output
RPM1, RPM2	2 frequency inputs
POWER	Power supply
INPUTS	LDD CAN address
OUTPUT	LDD CAN address

Address and jumpers settings

CAN 1 address is setting by following procedure:

- Press Address buttons (for INPUTS address and OUTPUT address) during IS-BIN8 power supply on to switch to addressing mode.
- Then repeatedly press or keep pressed address button to adjust required address according to CONTROLLER configuration.
- After setting requested address, release the buttons and wait until the digits blink – it indicates write the changed address to EEPROM memory.

Table of recommended CAN1 address setting

	CAN 1 Address	
	Inputs	Output
1. IS-BIN16/8	1	1
2. IS-BIN16/8	3	2
3. IS-BIN16/8	5	3
4. IS-BIN16/8	7	4
5. IS-BIN16/8	9	5
6. IS-BIN16/8	11	6
7. IS-BIN16/8	13	7

SW version check

Let suppose IS-AIN8 of SW version 1.4. Shortly press address button. Following sequence appears on the display: number “1”, one second pause, number “4”, two second pause, number “1”, one second pause, number “4”, two second pause and finally IS-AIN8 actual address.

Error message (e.g. SD BOUT2) appears on Controller screen when Binary input or output Address x is configured but corresponding unit is not recognized (no message is received from CAN bus). Check IS configuration and corresponding external IS-AIN, IS-BIN unit address setting.

LED indication

Tx / Rx LED status

Tx			Rx		
Dark	Blink	Light	Dark	Blink	Light
Any data are transmitted on the CAN1 line	Data are transmitted on the CAN1 line		Any data are received on the CAN1 line	Data are received on the CAN1 line	

Wiring

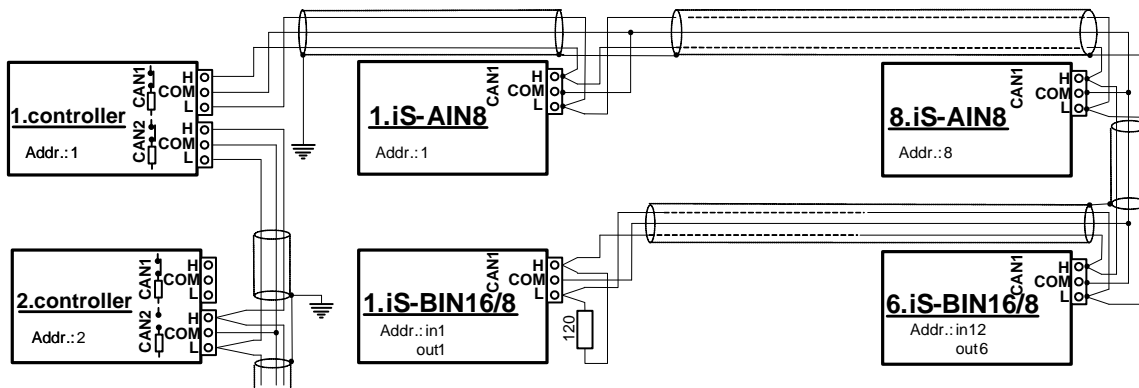

Hint:

CAN bus line has to be terminated by 120 ohm resistors on the both ends. For longer distances is recommended to connect CAN COM terminals between all controllers and cable shielding to the **ground in one point!** External units can be connected on the CAN bus line in any order, but line arrangement (no tails no star) is necessary. Recommended CAN bus data cables see in Chapter Technical data.

Binary inputs

There are two groups of eight Binary inputs BI1 to BI8 and BI9 to BI16. Each group has a separate Common terminal COM1 and COM2. The Common terminal can be connected to positive or negative pole – see following drawing. Binary inputs are galvanically separated from IS-BIN16/8 power supply.

Hint:

[Theory of Binary inputs/outputs \(Pull Up, Pull Down, High side switch, Low side switch\)](#)

Binary inputs Common terminal is connected to **positive** supply terminal, Binary inputs contacts are closed to **negative** supply terminals.

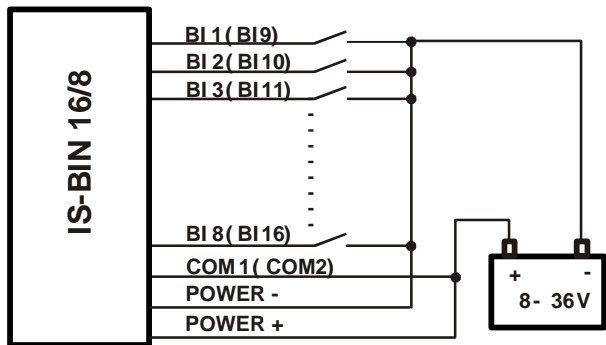

Binary inputs common terminal is connected to **negative** supply terminal, Binary inputs contacts are closed to **positive** supply terminals.

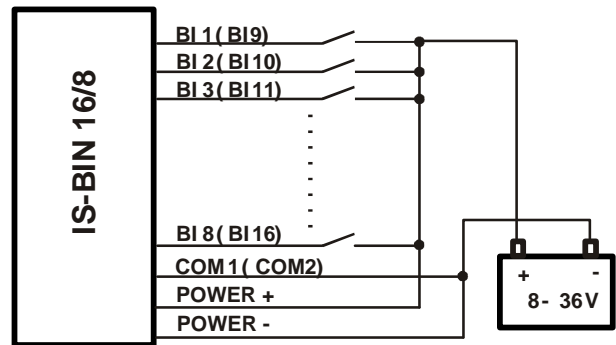

Input voltage range for opened contact is from 8 VDC to Power supply VDC. Input voltage range for closed contact is from 0 to 2 VDC. Voltage level is defined between Binary input and Binary input COM terminal and does not depend on “positive” or “negative” connection. Impulse inputs do not work with IGS-NT controller.

Binary output

The Common terminal can be connected to positive or negative pole (HW3.0 only) – see following drawing. Binary outputs are galvanic separated from IS-BIN16/8 power supply (have a look at technical data). The maximum load values are 0.5 A / 36V for one output.

Binary output common terminal is connected to **negative** supply terminal, Binary output contacts are closed to **positive** supply terminals.

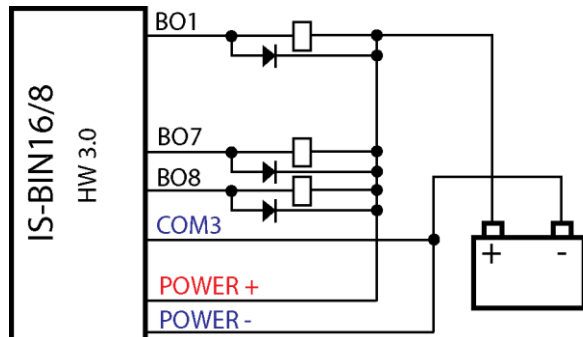

Binary output common terminal is connected to **positive** supply terminal, Binary output contacts are closed to **negative** supply terminals.

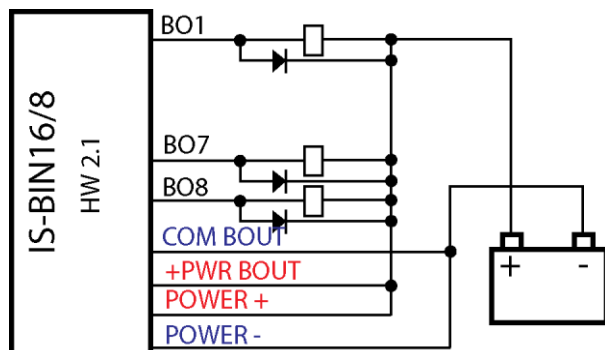
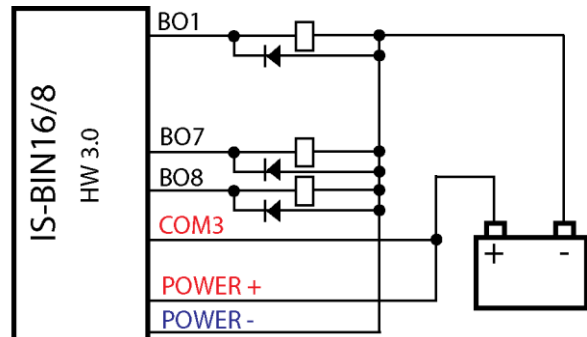

Power supply fusing

A (2) respectively (1) amp fuse should be connected in-line with the power to the controller and modules, these items should never be connected directly to the starting battery.

Take care for proper controller, extension units and relays power supply fusing. Fuse value and type depends on number of connected devices and wire length.

Recommended fuse (not fast) types:

Controller or unit	Fuse
Controller	T1A or T2A
IS-AIN8	T2A
IS-BIN16/8	T1A

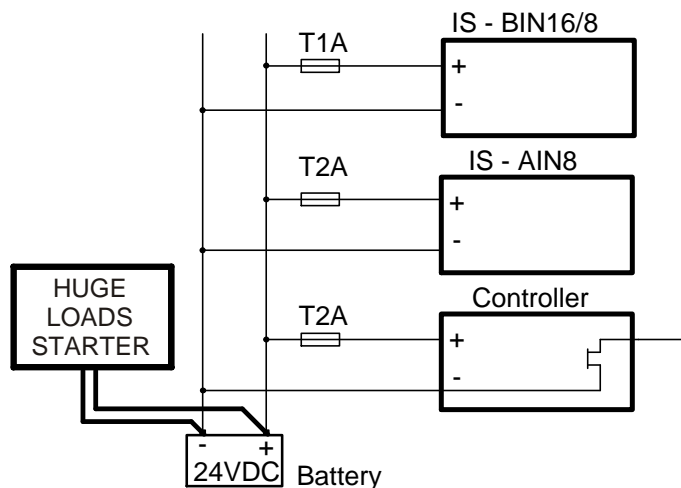

For more extension units use separate fusing according to the table above. Controller power supply should never be connected to starter terminals.

Technical data

Dimension (WxHxD)	146x160x46 mm (5.79'x6.6'x1.83')	
Interface to controller	CAN1	
Binary inputs <i>(galvanic separated)</i> <i>Voltage level is defined between binary input and binary input COM terminal</i>	Number of inputs	8 + 8
	Input resistance	3000ohm
	Input voltage range	0-36V DC
	Input voltage level for open contact	8 to Power supply VDC
	Input voltage level for close contact	0 to 2 VDC
Frequency inputs * <i>(for IS-CU only)</i>	RPM1	
	Type of sensor	magnetic pick-up
	Minimum input voltage	2 Vpk-pk (from 4 Hz to 4 kHz)
	Maximum input voltage	50 Veff
	Maximum measured frequency	8 kHz (min. input voltage 6Vpk-pk), frequency mode
	RPM2	
Type of sensor	Contact or Active sensor	
Minimal pulse width	10 ms, integration mode	
Maximum measured frequency	60 Hz, integration mode	
Relays outputs <i>(galvanic separated) only HW 3.0</i> <i>(non galvanic separated) HW 2.1</i>	Number of output	8
	Maximum current	0,5A DC
	Maximum switching voltage	36V DC
Power supply	8 to 36 V DC	
Current consumption	250mA** at 24 V	
Protection front panel	IP20	
Humidity	95% without condensation	
Storage temperature	- 40C to + 80°C	
Operating temperature	- 30°C to + 70°C	
Standard conformity		
Low Voltage Directive	EN 61010-1:95 +A1:97	
Electromagnetic Compatibility	EN 50081-1:94, EN 50081-2:96 EN 50082-1:99, EN 50082-2:97	

* RPM1, RPM2 are available in IS-CU only
 ** During powering up current can be up to 1,5A.

IG-AVRi



IG-NT/IS-NT



Description

Automatic voltage Regulator interface is used for volt / PF control adjustment with galvanic separate input – output.

Every time refer to corresponding AVR manual before interface connecting. Use no droop AVR.

IG-AVRi-TRANS (AC power supply for AVRi) has to be supplied from gen-set voltage.

AVRi output can be connected as symmetrical: OUT1-OUT2 or unsymmetrical OUT1-GND or OUT2-GND.

- Potentiometer on the AVRi defines maximal OUT1, OUT2 voltage range.
- Use symmetrical (OUT1,OUT2) AVRi output to connect the AVRi to AVR auxiliary voltage input.
- Use unsymmetrical output if an external AVR potentiometer has to be replaced with AVRi.
- AVRi output voltage should change generator voltage typically in range $\pm 10\%$ of Nominal voltage.
- For more details please refer to Application guide – chapter AVR interface examples.

IG-AVRi TRANS/LV is power supply unit for IG-AVRi, it is not included in package with IG-AVRi.

Dimensions

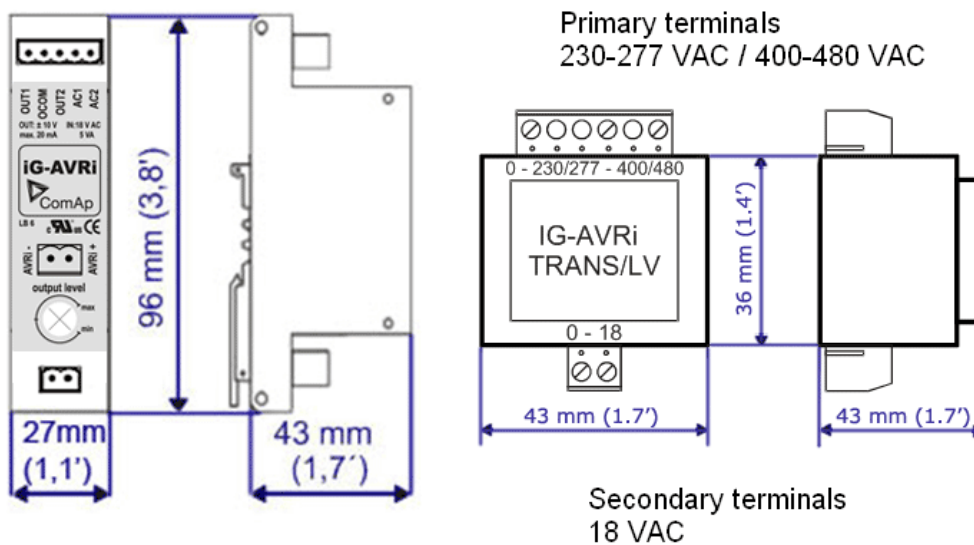

IG-AVRi unit is DIN rail mount (35mm)

IG-AVRi TRANS are DIN rail mount (35mm)

Connectors



output	OUT1	Output terminals for alternator AVR
	GND	
	OUT2	
input	AC1	Power supply from IG-AVRi TRANS/LV
	AC2	
	AVRi+	Input signals from the controller
	AVRi-	
	Output level	Set output voltage bias

Wiring

Example of iG-AVRi wiring:

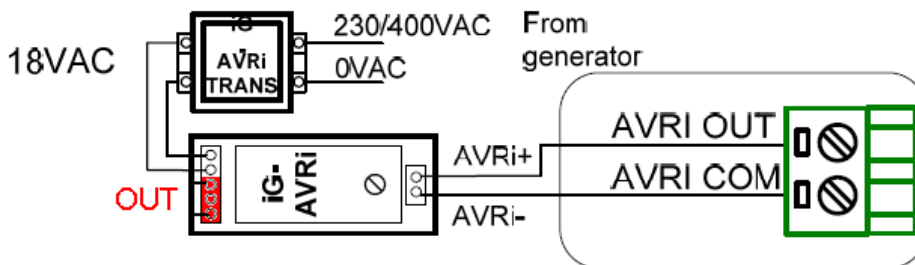

For more details about wiring see Installation guide.

Technical data

Dimension (WxHxD)	96x27x43 mm (3.77'x1.06'x1.69')
Output <i>potentiometer adjustable from +- 1V to +-10V DC, max 15mA</i>	OUT1, OUT2 floating (potential free) voltage source
Inputs	+AVR, -AVR (two wires, PWM from IG-CU)
Power supply	18V AC from IG-AVRi Trans/LV or IG-AVRi Trans/100
Storage temperature	- 40C to + 80°C
Operating temperature	- 30°C to + 70°C

IG-AVRi TRANS/LV – power supply unit

Dimension (WxHxD)	43x36x43 mm (1.7'x1.4'x1.7')
Output	18V AC, max 5VA
Inputs	230 to 277V AC, frequency 50 to 60Hz 400 to 480V AC, frequency 50 to 60Hz
Storage temperature	- 40C to + 80°C
Operating temperature	- 30°C to + 70°C

IG-AVRI TRANS/100 – power supply unit

Dimension (WxHxD)	43x36x43 mm (1.7'x1.4'x1.7')
Output	18V AC, max 5VA
Inputs	100 to 120V AC, frequency 50 to 60Hz
Storage temperature	- 40C to + 80°C
Operating temperature	- 30°C to + 70°C

Theory of binary inputs and outputs

Binary inputs:

Pull Up

Principle of internal connection is showed on picture below.

The bulb presents internal state of binary input.

In case of connection terminal "BIN" with terminal "COM" (GND) then the internal state is logical 1.

In case of connection +Ucc polarity to the "BIN" terminal is internal state logical 0.

Binary input : Pull Up

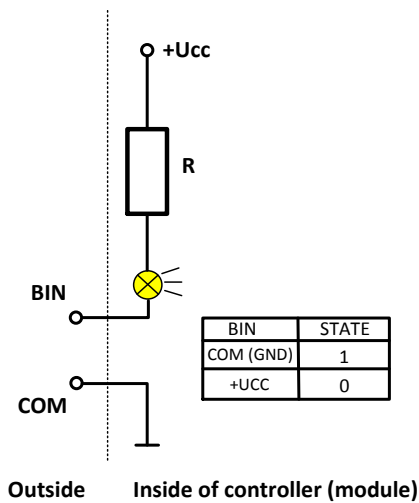

Pull Down

Principle of internal connection is showed on picture below.

The bulb presents internal state of binary input.

In case of connection terminal "BIN" with terminal "COM" (+Ucc) then the internal state is logical 1.

In case of connection GND to the "BIN" terminal is internal state logical 0.

Binary input : Pull Down

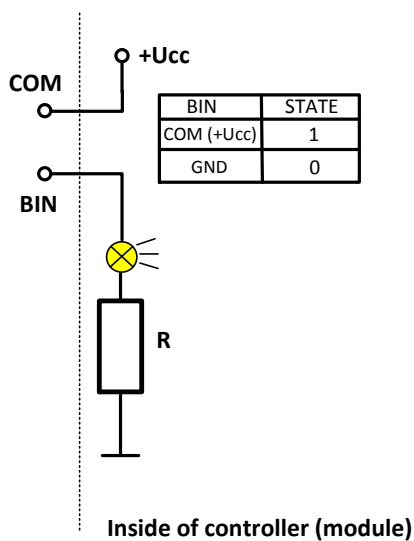

Binary outputs:

High side switch - HSS

Principle of internal connection is showed on picture below.

High side switch connection is for case, where load is permanently connected to the ground (GND). By activating of Binary output (Bout=1) is closed switch which causes connection of load to the VHS (Voltage High side) and +Ucc.

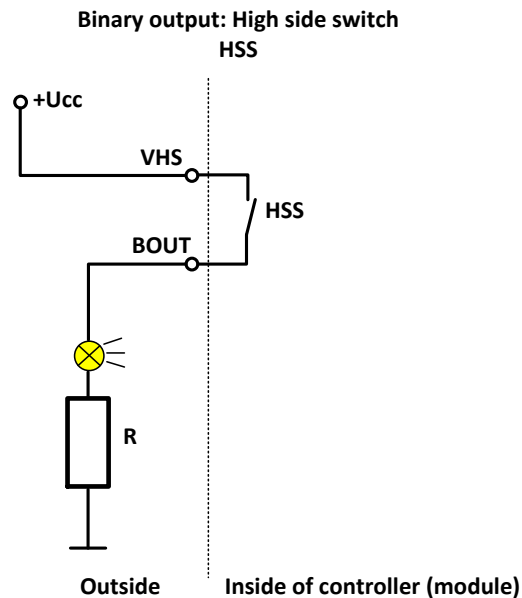

Low side switch - LSS

Principle of internal connection is showed on picture below.

Low side switch connection is for case, where load is permanently connected to the voltage (+Ucc). By activating of Binary output (Bout=1) is closed switch which causes connection of load to the ground (GND).

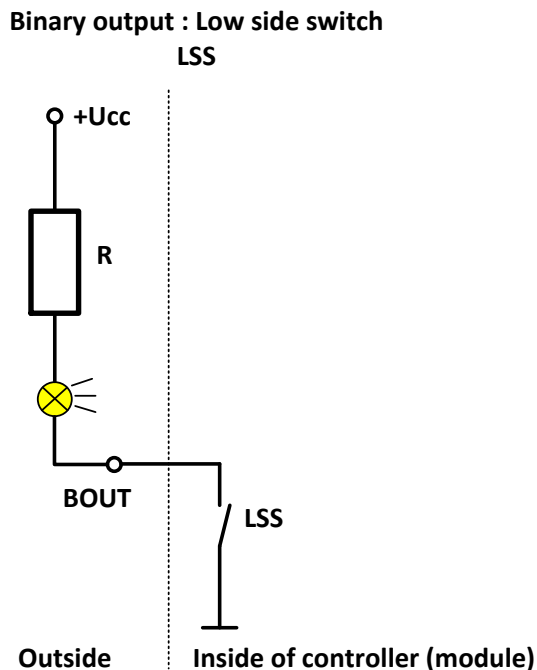



















Table of symbols

	Supported IntelliDrive controller
ID	
	Supported IntelliSys-NT controller
IS-NT	
	Supported IntelliGen-NT controller
IG-NT	
	Supported IntelliGen-NT controller
IM-NT	
<hr/>	
	Supported IntelliGen-NT and IntelliSys-NT controller
IG-NT/IS-NT	
<hr/>	
	Supported CAN1 line
	Supported CAN2 line
	Supported CAN1 and CAN2 line
	Supported USB
	Supported Ethernet
	Supported RS232 line
	Supported RS485 line
<hr/>	
	Module has analog inputs
	Module has digital inputs
	Module has analog output
	Module has digital output
<hr/>	
	Unit is 35 mm DIN rail mounted
	Unit is direct to controller mounted