

InteliLite^{NT}

InteliLite NT[®] MRS

Modular Gen-set Controller

Compact Controller for Single Operating Gen-sets

(IL-NT MRS10/11/15/16 unit)

SW version 1.5, September 2009



Reference Guide



Table of Contents

Table of Contents	2
General Guidelines	4
What describes this manual?	4
!! Warnings !!	4
Symbols	4
Text	5
General Description	6
Description of the controller system (with all options)	6
What is in the package?	6
IL-NT RS232 Communication plug-in card	6
IL-NT RS232-485 Communication plug-in card	10
IL-NT S-USB Service USB communication plug-in card	11
IB-Lite Ethernet communication plug-in card	11
IL-NT AOOUT8 Gauge driver module	12
IL-NT BIO8 Hybrid binary input/output module	14
IL-NT RD Remote display software	15
Remote annunciator IGL - RA15	15
IG IOM/PTM module	16
IG-IB Internet bridge	17
IL-NT Terminals	18
IL-NT terminals and face	18
Installation	19
Mounting	19
Recommended Wiring	20
MRS – Wiring Diagram	20
Getting Started	21
How to install	21
Current measurement	24
Voltage measurement and generator connection types	25
Analog inputs	28
RS485 connection	34
Extension modules (CAN bus) connection	35
Inputs and Outputs	37
Binary inputs IL-NT - default	37
Binary inputs – list	37
Binary outputs - list	40
Analog inputs	49
Analog outputs	50
Setpoints	51
Password	51
Basic Settings	51
Engine Params	54
Engine Protect	58
Gener Protect	60
Date/Time	62
Sensors spec	64
*Extension I/O	64
SMS/E-Mail	64
*ECU-controlled engine support	66
Identifying configured ECU	67
Values read from ECU	67
Diagnostic messages read from ECU	68
Analog inputs	68
Connection description	69
Sensor Specification	72

Background of the sensor calibration.....	72
Default sensor curves	72
Function Description.....	73
OFF Mode	73
MAN Mode	73
AUT mode	74
Alarm Management	75
Sensor Fail (FLS).....	75
Warning (WRN).....	75
Shut down (SD).....	75
Voltage phase sequence detection.....	76
Gen-set Operation States.....	78
List of possible events.....	78
History file.....	80
Init Screens.....	81
Customer Logo screen.....	81
Firmware Init screen.....	81
Language screen	81
User Interface screen.....	81
Remote Control and Data Logging.....	82
Direct connection to the PC	82
PC software - LiteEdit	83
Modbus protocol.....	83
Remote Communication	90
Internet connection.....	90
Recommended ISDN modem	90
Recommended GSM modem.....	90
Mobile SIM card setting.....	90
IL-NT-RD Remote display software.....	92
General description	92
Warning !.....	92
IL-NT-RD Software installation.....	92
IL-NT-RD Wiring.....	93
Function description	96
SW compatibility.....	96
Maintenance	97
Backup battery replacement	97
Technical Data.....	99
Inputs/Outputs overview.....	99
Generator protections	99
Language support	99
Power supply.....	100
Operating conditions	100
#Low Temperature modification	100
Dimensions and weight	101
Generator	101
Binary inputs and outputs.....	101
Analog inputs.....	101
Speed pick-up input	102
D+ Terminal.....	102
*CAN bus interface.....	102
IL-NT RS232 interface (optional card)	102
IL-NT RS232-485 interface (optional card).....	103
IL-NT S-USB interface (optional card)	103
IL-NT AOUI8 interface (optional card)	103
IL-NT BIO8 interface (optional card).....	104
IGS-PTM	104
IGL-RA15	104
IG-IB.....	105

General Guidelines

What describes this manual?

IMPORTANT SAFETY INSTRUCTIONS

SAVE THESE INSTRUCTION - This manual contains important instructions for IL-NT controllers family that shall be followed during installation and maintenance of the Intelli NT genset controllers.

It is intended for use by gen-set control panel builders and for everybody who is concerned with installation, operation and maintenance of the gen-set.

This manual describes „MRS 10/11/15/16“ software, which is designed for single set applications. What is the purpose of the manual?

This manual provides general information how to install and operate IntelliLite-NT MRS controller. *This manual is dedicated for*

- Operators of gen-sets

- Gen-set control panel builders

- For everybody who is concerned with installation, operation and maintenance of the gen-set

!! Warnings !!

Remote control

IntelliLite^{NT} controller can be remotely controlled. In case of the work on the gen-set check, that nobody can remotely start the engine.

To be sure:

- Disconnect remote control via RS232 line

- Disconnect input REM START/STOP

or

- Disconnect output STARTER and outputs GCB CLOSE/OPEN

Because of large variety of IntelliLite^{NT} parameters settings, it is not possible to describe any combination. Some of IntelliLite^{NT} functions are subject of changes depend on SW version. The data in this manual only describes the product and are not warranty of performance or characteristic.

IntelliLite controller SW and HW versions compatibility

Be aware that IL-NT SW version 1.2.1 and older is not possible to use with IL-NT HW version 1.3 and newer!!! Software IL-NT 1.3 is compatible with IL-NT hardware version 1.3 and older.

Symbols

Symbols used in this manual:



Grounding point symbol



AC voltage symbol



DC voltage symbol

Text

PAGE	(Capital letters in the frame) buttons on the front panel
<i>Break Return</i>	(Italic) set points
Generator protections	(Bold) Set point group
REMOTE START/STOP	(Capital letters) binary inputs and outputs
*Something	(Symbol * before text) valid only for IL-NT MRS15/16
^Something	(Symbol ^ before text) valid only for IL-NT MRS11/16

Note:

ComAp believes that all information provided herein is correct and reliable and reserves the right to update at any time. ComAp does not assume any responsibility for its use unless otherwise expressly undertaken.

Note:

SW and HW must be compatible (e.g. IL-NT-MRS10 firmware and IL-NT MRS10 HW) otherwise the function will be disabled. If wrong software is downloaded, message HARDWARE INCOMPATIBLE appears on controller screen. In this case download correct software and use Boot jumper programming – close Boot jumper and follow instructions in LiteEdit or follow video guide “**Boot Jumper Programming**” at <http://www.comap.cz/support/training/training-videos/>.

!!! CAUTION !!!

Dangerous voltage

In no case touch the terminals for voltage and current measurement!
 Always connect grounding terminals!
 In any case do not disconnect Intelilite^{NT} CT terminals !

Adjust set points

All parameters are preadjusted to their typical values. But the set points in the “**Basic Settings**” settings group **!!must!!** be adjusted before the first startup of the gen-set.

**!!! WRONG ADJUSTMENT OF BASIC PARAMETERS
 CAN DESTROY THE GEN-SET !!!**

The following instructions are for qualified personnel only. To avoid personal injury do not perform any action not specified in this User guide !!!

General Description

Description of the controller system (with all options)

InteliLite^{NT}-MRS is a comprehensive controller for single generating sets. IL-NT MRS 15/16 features extended support of electronic engines and extension modules.

InteliLite^{NT} controllers are equipped with a powerful graphic display showing icons, symbols and bar-graphs for intuitive operation, which sets, together with high functionality, new standards in Gen-set controls.

InteliLite automatically starts the Gen-set, closes the Gen-set C.B. when all conditions are met, then stops the engine on external signal or by pressing push buttons.

InteliLite^{NT} provides gas engine support without ventilation.

The key feature of InteliLite^{NT} is its easy-to-use operation and installation. Predefined configurations for typical applications are available as well as user-defined configurations for special applications.

What is in the package?

Accessories	Description	Optional / Obligatory
IL-NT MRS	InteliLite ^{NT} central unit	Obligatory
IL-NT RS232	RS232 communication card	Optional for MRS
IL-NT-RS232-485	RS232 and RS485 communication card	Optional for MRS
IL-NT-S-USB	Service USB communication card	Optional for MRS
IB-Lite	Ethernet communication card	Optional for MRS
IL-NT AOUT8	Gauge driver card	Optional for MRS
IL-NT-BIO8	Configurable I/O plug-in card	Optional for MRS
*IL-NT RD	Remoted display software	Optional for MRS
IGL-RA15	Remote annunciator	Optional for MRS15/16
IG-IOM/PTM	I/O extension module	Optional for MRS15/16
IG-IB	Internet communication bridge	Optional for MRS
AT -LINK-CONV	Service programming RS232 interface	Optional for MRS
AT-LINK-CABLE	Serial RS232 communication cable 1,8m	Optional for MRS

*Remote display for IL-NT controllers uses standard IL-NT controller with Remote display software

Hint:

For detailed information about extension modules used with IL-NT controllers, please see the IL-NT-Accessory Modules manual.

IL-NT RS232 Communication plug-in card

IL-NT RS232 is optional plug-in card to enable InteliLite^{NT} for RS232 communication. This is required for computer or Modbus connectin. Card inserts into expansion slot back on the controller.

To insert the module, you must open the cover first (use screwdriver to open) and then insert the module into slot. Once you have insert it, the module will snap under plastic teeth. It is supposed to be installed permanently. Should you need to remove it, the safest way is to remove whole back cover and than remove module manually.

How to install RS 232 communication module:

1. Insert a screwdriver into the slot of the cover.



2. Move the screwdriver to set apart the small cover. **Be careful!**

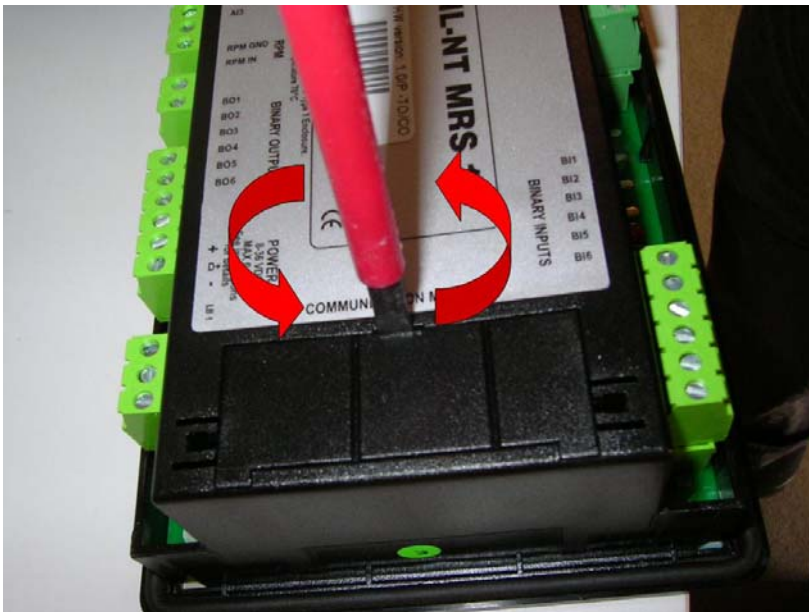

3. Remove the small cover.

4. Break apart the small cover into two pieces. **Do not throw away the smaller part!**

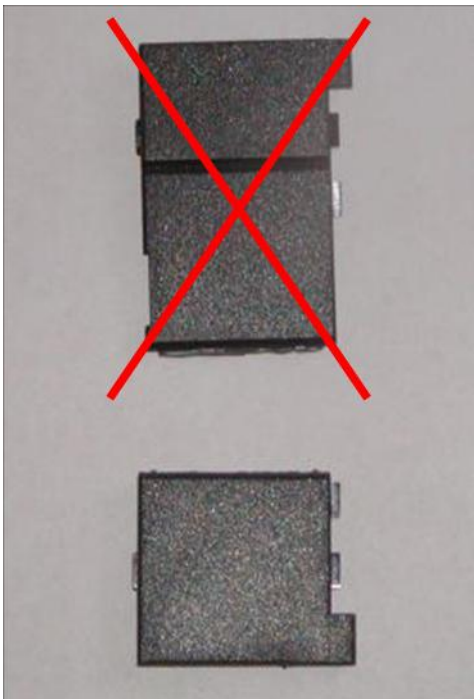
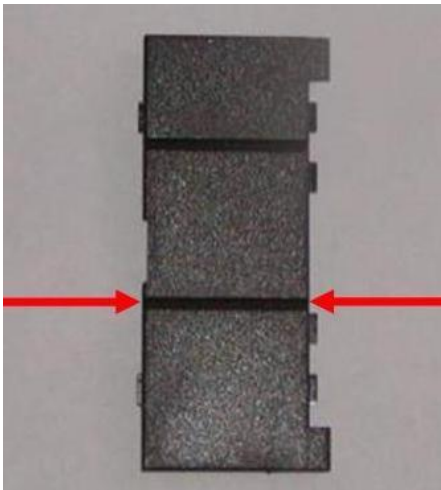

5. Take RS 232 communication module.



6. Plug RS 232 communication module into the slot of the controller.
7. Put back the small cover.



Hint:

When you insert RS 232 communication module, the boot jumper is hidden. For that reason we recommend to use RS 232 communication module with the boot jumper placed on it. See pictures below:

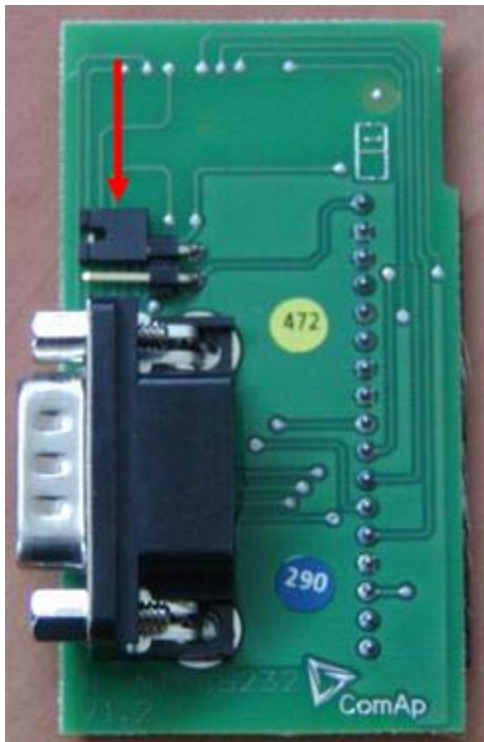

RS 232 communication module with the boot jumper.

Hint:

Boot jumper programming – In case of interrupted programming or other software failure is possible to use the boot jumper programming to restore controller to working order. Connect controller to PC, run LiteEdit and wait until connection bar at bottom turns red. Then run programming process via menu Controller -> Programming and cloning – Programming. Select correct firmware and confirm dialog. Than follow instructions in LiteEdit.

Or follow video guide “**Boot Jumper Programming**“ at <http://www.comap.cz/support/training/training-videos/>.

- Please see chapter [IL-NT RS232 interface \(optional card\)](#) for technical details.

IL-NT RS232-485 Communication plug-in card

IL-NT RS232-485 is optional plug-in card to enable IntelliLite^{NT} the RS232 and RS485 communication. This is required for computer or Modbus connection. Card inserts into expansion slot back on the controller. The IL-NT RS232-485 is a dual port module with RS232 and RS485 interfaces at independent COM channels. The RS232 is connected to COM1 and RS485 to COM2.

To insert the module, please follow the instructions for IL-NT RS232 module, procedure is analogous. You must open the cover first (use screwdriver to open) and then insert the module into slot. Once you have insert it, the module will snap under plastic teeth. It is supposed to be installed permanently. Should you need to remove it, the safest way is to remove whole back cover and than remove module manually.

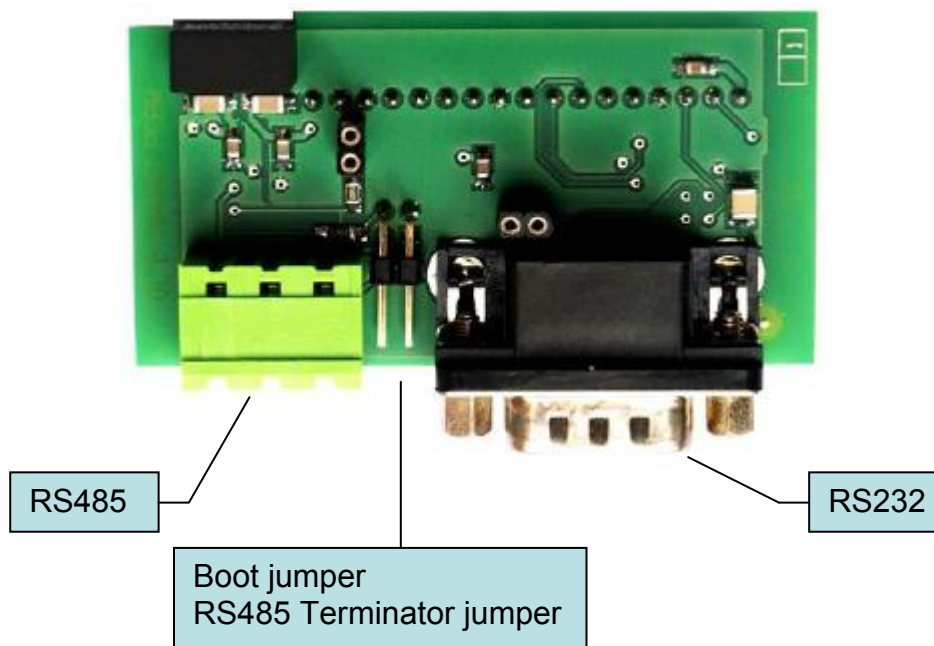

Hint:

- Boot jumper programming – In case of interrupted programming or other software failure is possible to use the boot jumper programming to restore controller to working order. Connect controller to PC, run LiteEdit and wait until connection bar at bottom turns red. Then run programming process via menu Controller -> Programming and cloning – Programming. Select correct firmware and confirm dialog. Than follow instructions in LiteEdit.

Or follow video guide “**Boot Jumper Programming**“ at <http://www.comap.cz/support/training/training-videos/>.

- Please see chapter [IL-NT RS232-485 interface \(optional card\)](#) for technical details.

IL-NT S-USB Service USB communication plug-in card

IL-NT S-USB is optional plug-in card to enable IntelliLite^{NT} for communication via USB port. This is required for computer or Modbus connecting. Card inserts into expansion slot back on the controller. To insert the module, you must open the cover first (use screwdriver to open) and then insert the module into slot. Once you have inserted it, part of the module will remain over plastic box. It is supposed to be used as a service tool. When you need to remove it, grab module in cutouts and pull it up manually.

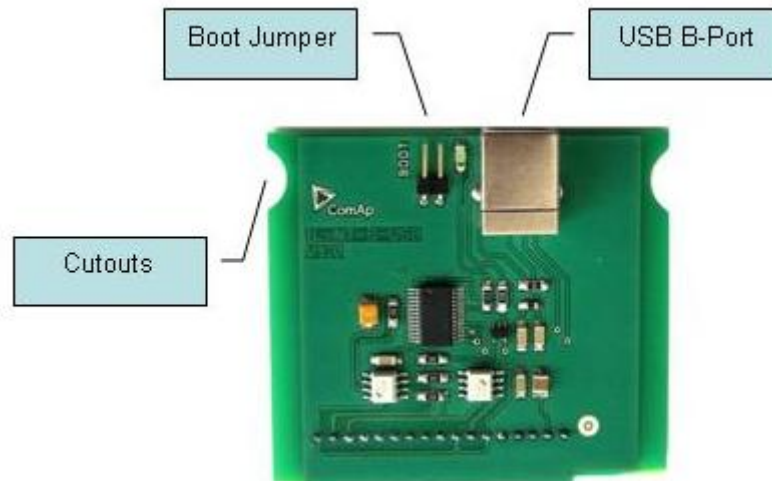

Hint:

- Use the shielded USB A-B cable with this module! Recommended is ComAp cable – Order code: “USB-LINK CABLE 1.8M”.
- Please see chapter [IL-NT S-USB interface \(optional card\)](#) for technical details.

Hint:

Boot jumper programming – In case of interrupted programming or other software failure is possible to use the boot jumper programming to restore controller to working order. Connect controller to PC, run LiteEdit and wait until connection bar at bottom turns red. Then run programming process via menu Controller -> Programming and cloning – Programming. Select correct firmware and confirm dialog. Than follow instructions in LiteEdit.

Or follow video guide “**Boot Jumper Programming**“ at <http://www.comap.cz/support/training/training-videos/>.

IB-Lite Ethernet communication plug-in card

IB-Lite is a plug-in card with Ethernet 10/100 Mbit interface in RJ45 connector. The card is internally connected to both COM1 and COM2 serial channels and provides an interface for connecting a PC with LiteEdit or IntelliMonitor through ethernet/internet network, for sending active e-mails and for integration of the controller into a building management (Modbus TCP protocol).

This card also enables to monitor and control the genset over web browser from any location with internet access using appropriate security measures.

Card inserts into expansion slot back on the controller. To insert the module, please follow the instructions for IL-NT RS232 module, procedure is analogous.

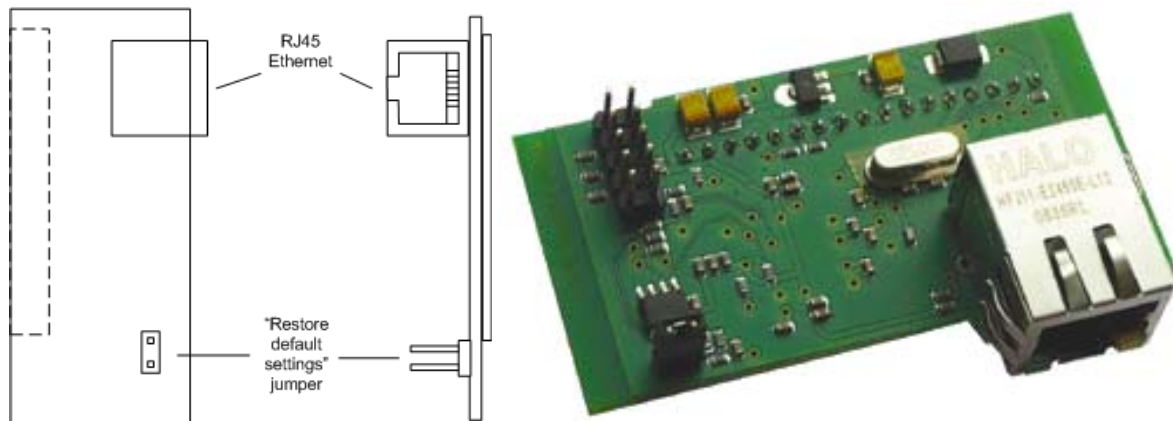

Use Ethernet UTP cable with RJ45 connector for connection of the module into your ethernet network. The module can be also connected directly to a PC using cross-wired UTP cable.

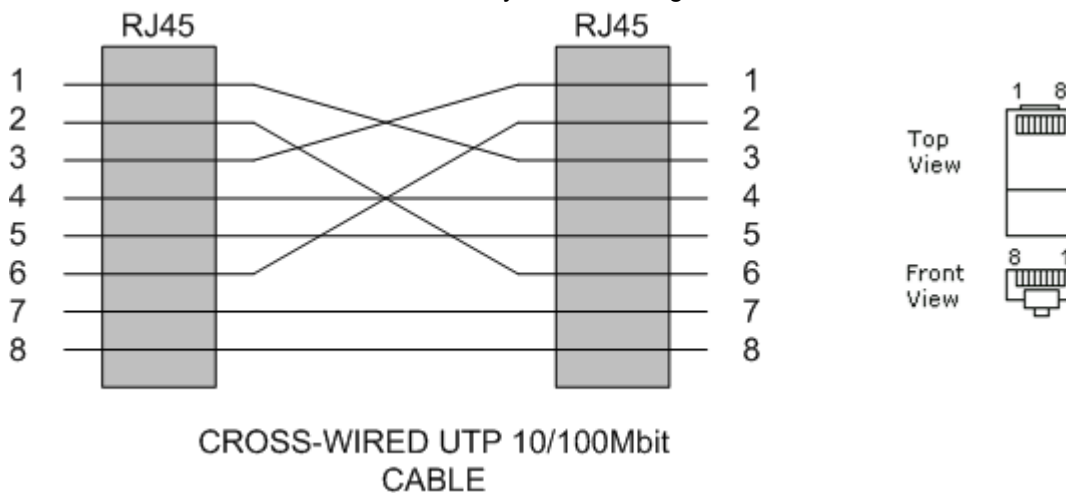

Hint:

Modbus TCP protocol using IB-Lite communication module requires setting [COM1 Mode](#) = DIRECT and [COM2 Mode](#) = MODBUS.

Hint:

The module requires some settings before initial usage. See IB-Lite-1.0 Reference Guide.

IL-NT AOUT8 Gauge driver module

IL-NT AOUT8 is optional plug-in card. Through this card controller can drive up to 8 VDO style industrial/automotive gauges. Noncompensated gauges like 0-10V or 0-20mA are not supported. Gauge type and value are configured in LiteEdit software. Any analog value from controller may be shown in that way.

To insert the module, you must open the cover first (use screwdriver to open) and then insert the module into slot. Once you have insert it, the module will snap under plastic teeth. It is supposed to be installed permanently. Should you need to remove it, the safest way is to remove whole back cover and than remove module manually.

Installing IL-NT AOUT8 module is similar to installing RS 232 module. The difference is that module fits to "extension module" slot and after installing IL-NT AOUT8 you do not put back the small cover.

PC Installation Suite consist a set of prepared converting curves for basic usage of PWM outputs with automotove gauges.

Installing IL-NT AOUT8 module is similar to installing RS 232 module. The difference is that module fits to “extension module” slot and after installing IL-NT AOUT8 you do not put back the small cover.

IL-NT AOUT8 module:

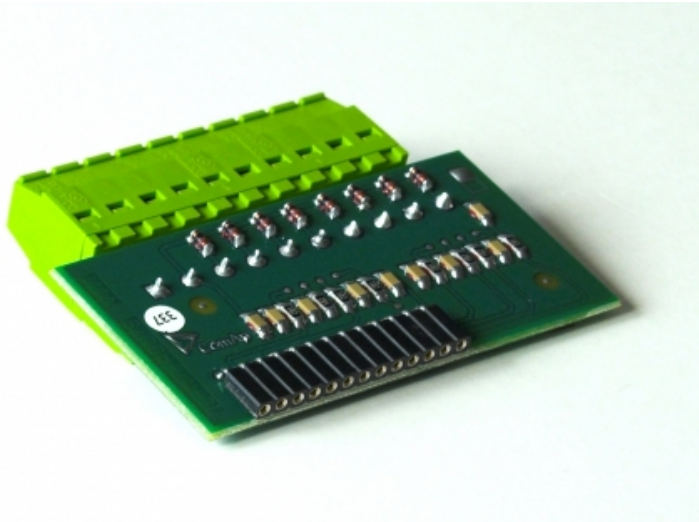

Typical wiring

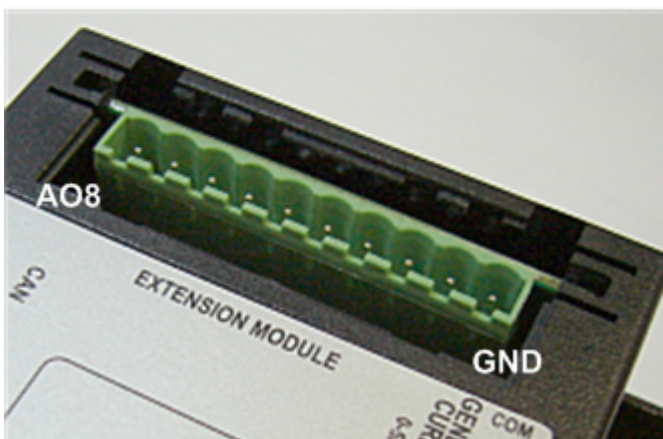
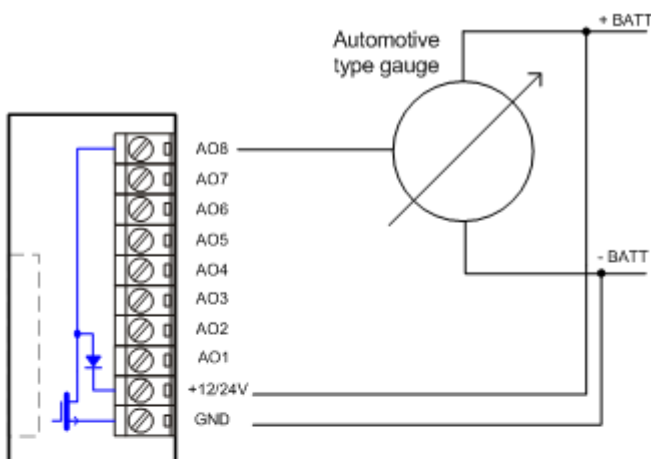

Hint:

Please see chapter [IL-NT AOUT8 interface \(optional card\)](#) for technical details.

IL-NT BIO8 Hybrid binary input/output module

IL-NT BIO8 is optional plug-in card. Through this card controller can accommodate up to 8 binary inputs or outputs. In LiteEdit configuration is possible to easily choose if particular I/O will be binary input or output.

To insert the module, you must open the cover first (use screwdriver to open) and then insert the module into slot. Once you have insert it, the module will snap under plastic teeth. It is supposed to be installed permanently. Should you need to remove it, the safest way is to remove whole back cover and than remove module manually.

Installing IL-NT BIO8 module is similar to installing RS 232 module. The difference is that module fits to "extension module" slot and after installing IL-NT AOUT8 you do not put back the small cover.

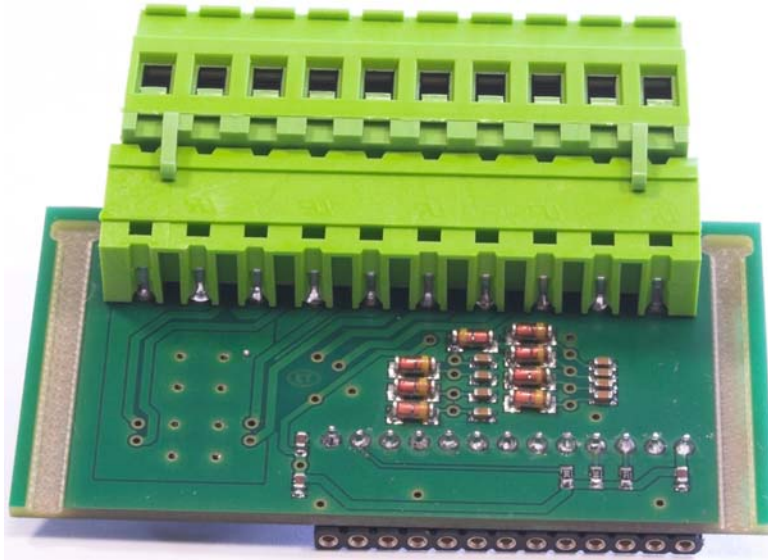

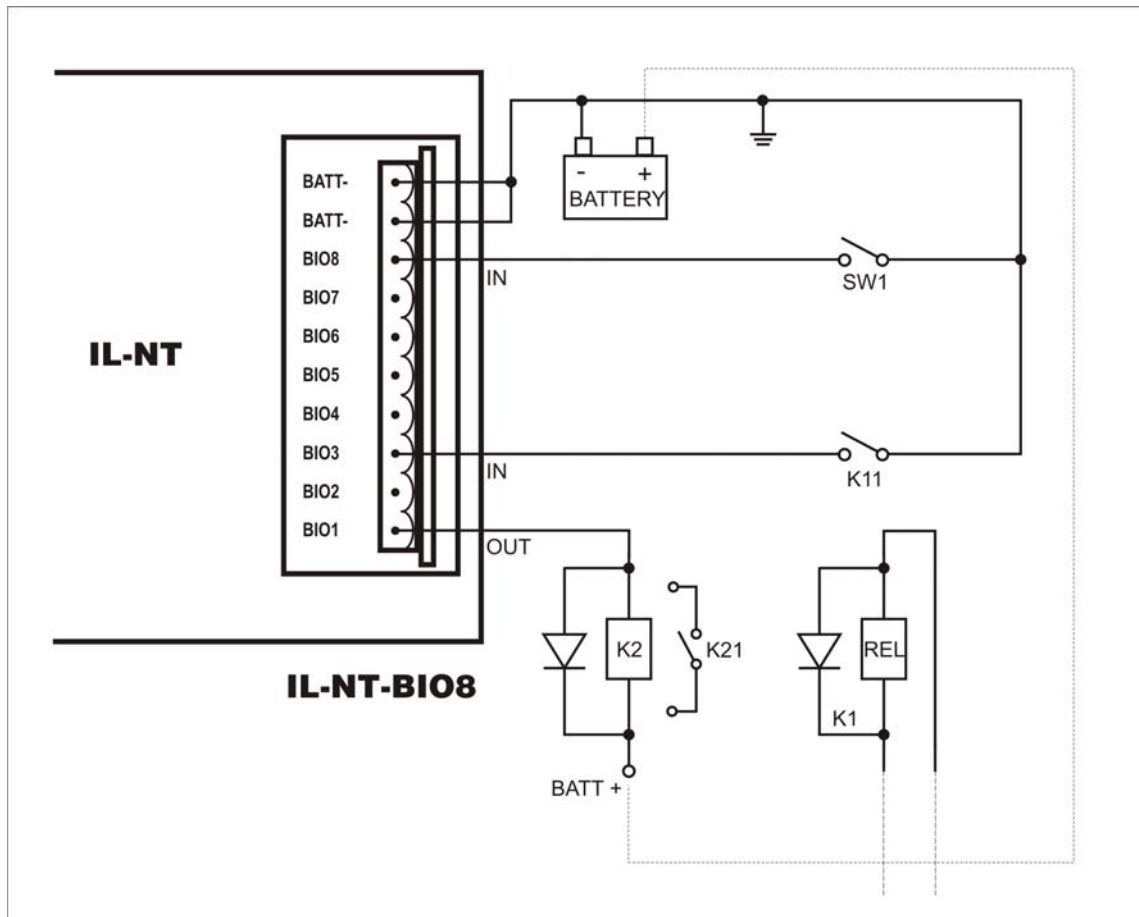

Hint:

Please see chapter [IL-NT BIO8 interface \(optional card\)](#) for technical details.

IL-NT RD Remote display software

IL-NT RD is remote display software for a controller. Remote display provides the same control and monitoring functions as controller itself. Remote display for IL-NT controllers uses standard IL-NT controller with Remote display software. No further programming of the display is required – unit is self configurable from the main controller. It is connected with the controller via IL-NT-RS232 communication modules using RS232 line. Longer distances (up to 1200m) are possible using IL-NT-RS232-485 communication module or when RS232/RS485 converters are used.

The IL-NT RD hardware type should fit to the master IL-NT.

Hint:

Please see the [IL-NT-RD Remote display software](#) chapter for more details.

Remote annunciator IGL - RA15

The remote annunciator IGL-RA15 can be connected to the IL-NT unit via CAN bus. Any of the binary outputs can be configured (using LiteEdit software) to each LED diode on the RA15. The module can be also enabled or disabled using LiteEdit software.

If IGL-RA15 remote annunciator is not communicating with a controller via CAN bus, it activates a warning.

See the documentation of RA15 for the technical and function description.

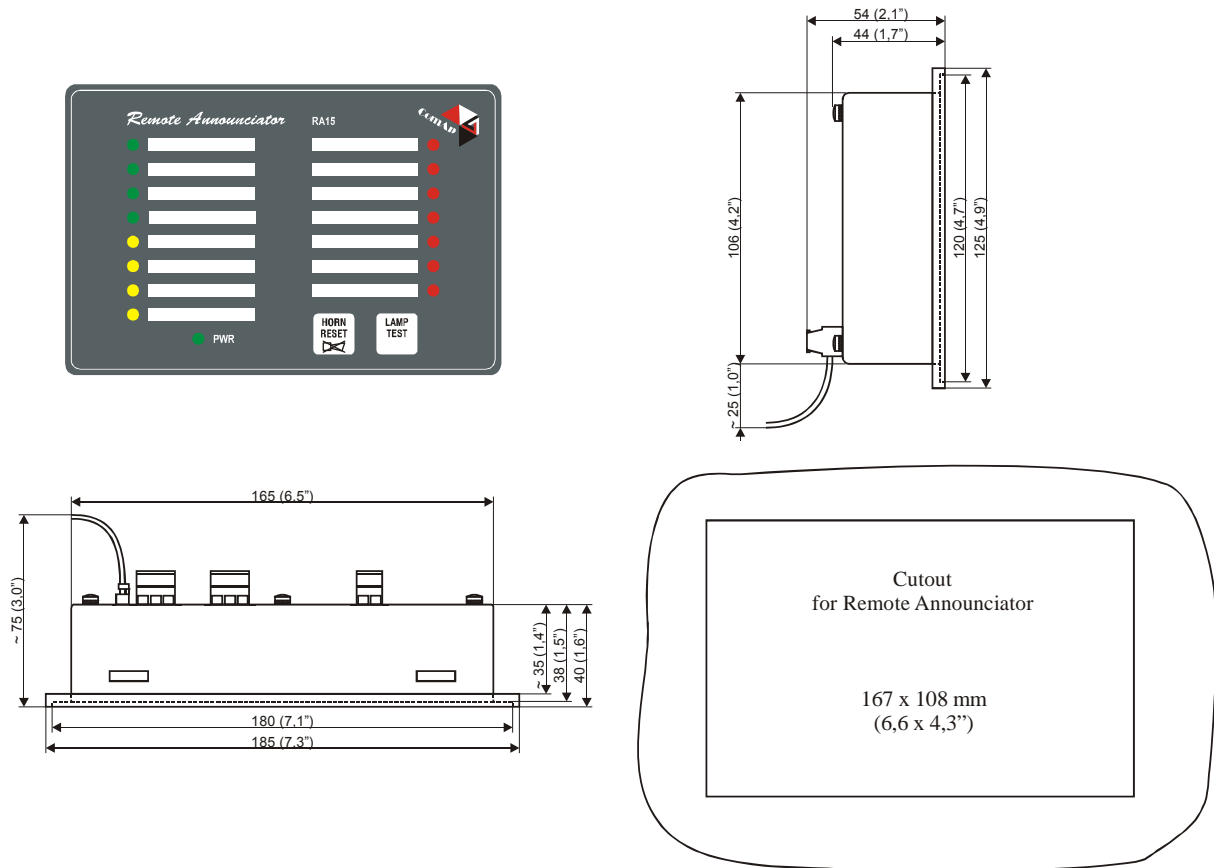

IG IOM/PTM module

IG-IOM and IGS-PTM modules are I/O extension modules equipped with 8 binary inputs, 8 binary outputs, 4 analogue inputs and one analogue output. The module can be used for AMF25, MRS15, 16, 19 only.

- Binary inputs and outputs are configurable the same way like inputs and outputs on iL.
- Analogue inputs are configurable like iL with the limitation that the binary and tristate mode can not be used on PTM module.
- The protection of analogue IOM/PTM inputs is activated by overcrossing the limits, active only when the engine is running.
- IG-IOM analogue inputs are resistive (the same parameters like IL-NT) $0\ \Omega$ -2,4 k Ω . The module IOM is designed for especially VDO resistive sensors.
- IGS-PTM analogue inputs are configurable by jumpers to ranges 0-250 Ω , 0-100mV, 0-20mA. The module can be used especially for Pt100 sensors and current sensors. The module PTM is not suitable for VDO temperature sensor.

Hint:

- For a description of setting IGS-PTM module with current/voltage sensors please see the Extension modules manual.
- When module is not configured by LiteEdit SW, controller does not show related values and setpoints

Hint:

If IGS-PTM is not communicating to a controller, ShutDown protection on controller is activated.

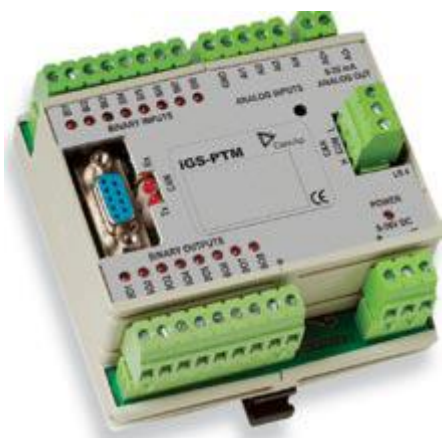

See the documentation of IGS-PTM for the technical and function description.

IG-IB Internet bridge

IG-IB Internet bridge enables IntelliLite^{NT} for Ethernet/Internet communications. It is connected to controller via RS232 line.

See the IntelliCommunication guide for further details.



IL-NT Terminals

IL-NT terminals and face

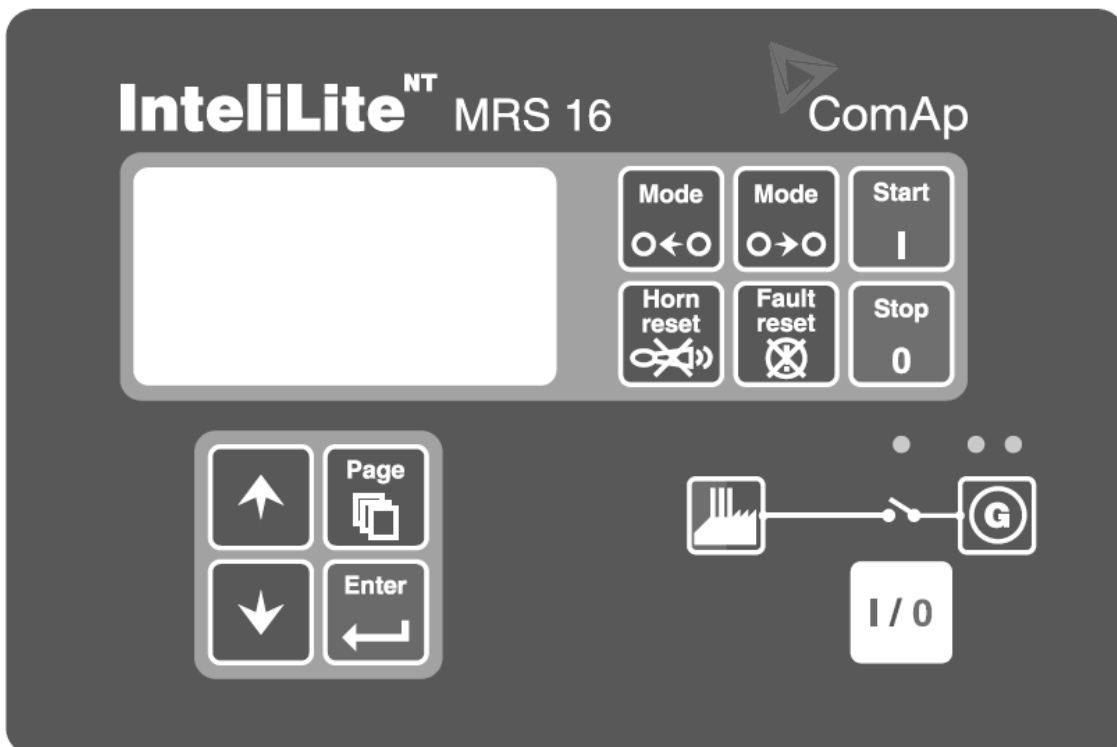
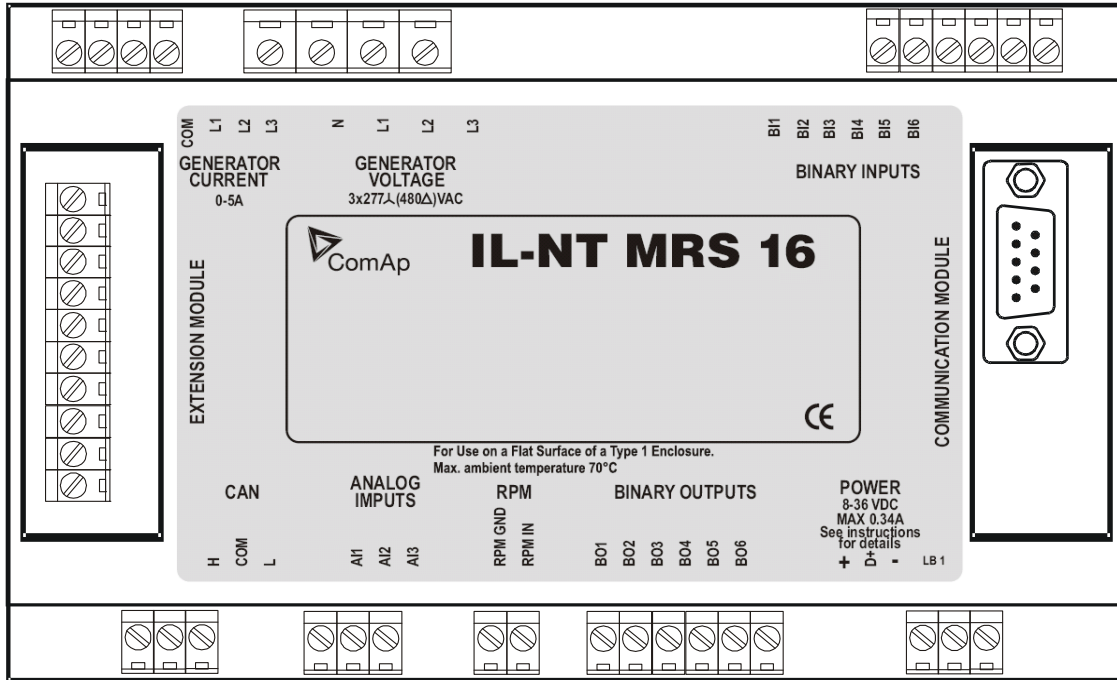

Installation

Mounting

The controller is to be mounted onto the switchboard door. Requested cutout size is 175x115mm. Use the screw holders delivered with the controller to fix the controller into the door as described on pictures below.



Recommended Wiring

MRS – Wiring Diagram

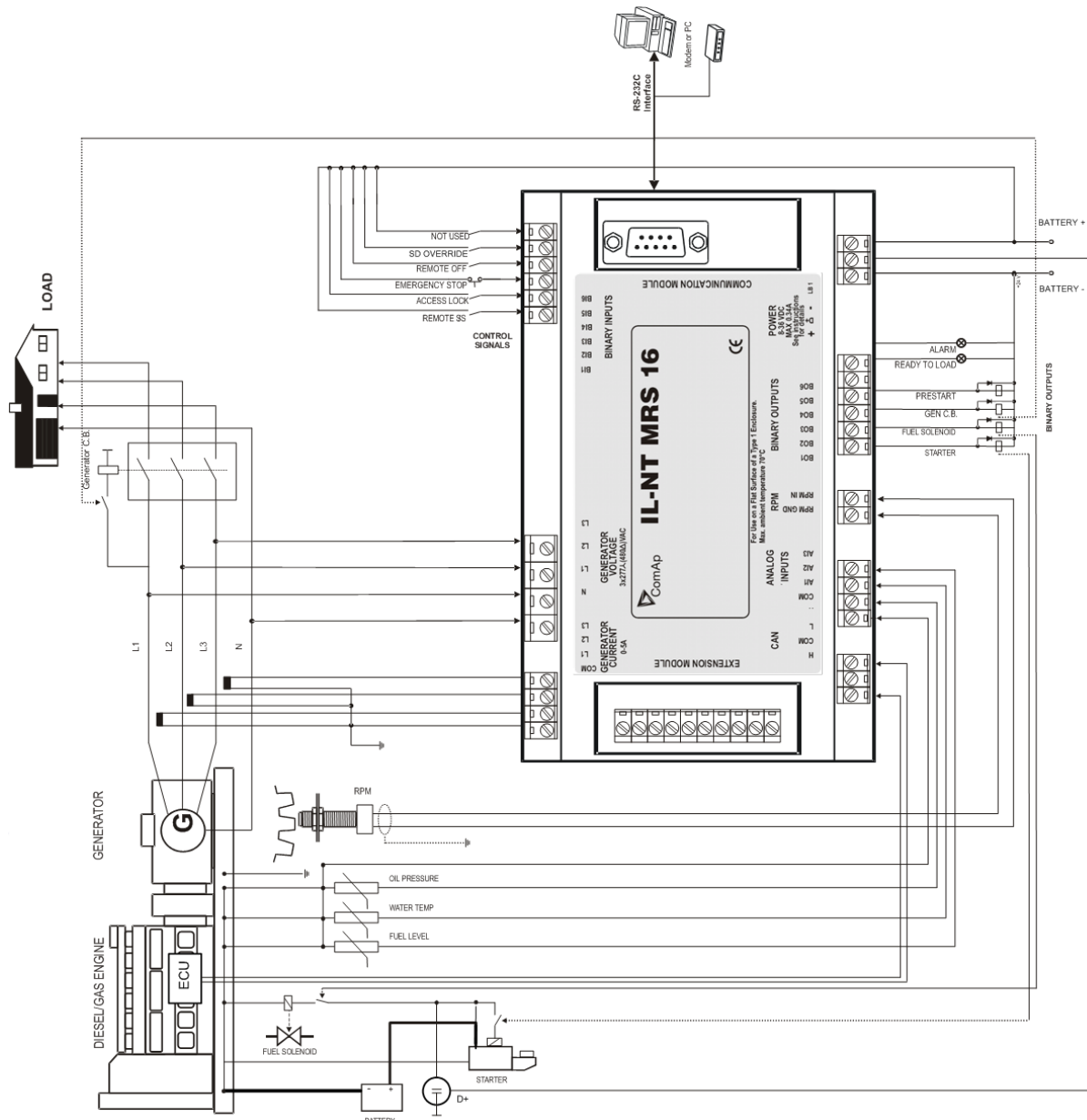

Hint:

It is possible to start Volvo and Scania engines via CAN bus. See [Engines started via CAN bus](#)

Getting Started

How to install

During the configuration of controller or setpoints changes is required a password to the controller. The default password from ComAp is "0".

General

To ensure proper function:

Use grounding terminals.

Wiring for binary inputs and analog inputs must not be run with power cables.

Analog and binary inputs should use shielded cables, especially when length >3m.

Wiring

Tightening torque, allowable wire size and type, for the Field-Wiring Terminals:

Based on terminal type:

PA256:



Specified tightening torque 0,5Nm (4,4 In-lb)

2EDGK:



Specified tightening torque 0,4Nm (3,5 In-lb)

For field type terminals:

Use only diameter 2,0-0,5mm (12-26AWG) conductor, rated for 75°C minimum.

For Generator Voltage terminals

Use only diameter 2,0-0,5mm (12-26AWG) conductor, rated for 90°C minimum.

Use copper conductors only.

Grounding

The shortest possible piece of wire should be used for controller grounding.

Use cable min. 2,5mm²

Brass M4x10 screw with star washer securing ring type grounding terminal shall be used.

The negative "-" battery terminal has to be properly grounded.

Switchboard and engine has to be grounded in common spot. Use as short as possible cable to the grounding point.

Power supply

To ensure proper function:

Use min. power supply cable of 1.5mm²

Maximum continuous DC power supply voltage is 36VDC. Maximum allowable power supply voltage is 39VDC. The IntelliLite's power supply terminals are protected against large pulse power disturbances. When there is a potential risk of the controller being subjected to conditions outside its capabilities, an outside protection devise should be used.

It is necessary to ensure that potential difference between generator current COM terminal and battery “-” terminal is maximally $\pm 2V$. Therefore is strongly recommended to interconnect these two terminals together.

Hint:

The IntelliLite^{NT} controller should be grounded properly in order to protect against lightning strikes!! The maximum allowable current through the controller’s negative terminal is 4A (this is dependent on binary output load).

For the connections with 12VDC power supply, the IntelliLite^{NT} includes internal capacitors that allow the controller to continue operation during cranking if the battery voltage dip occurs. If the voltage before dip is 10V, after 100ms the voltage recovers to 7 V, the controller continues operating. During this voltage dip the controller screen backlight can turn off and on but the controller keeps operating. It is possible to further support the controller by connecting the external capacitor and separating diode or I-LBA module.

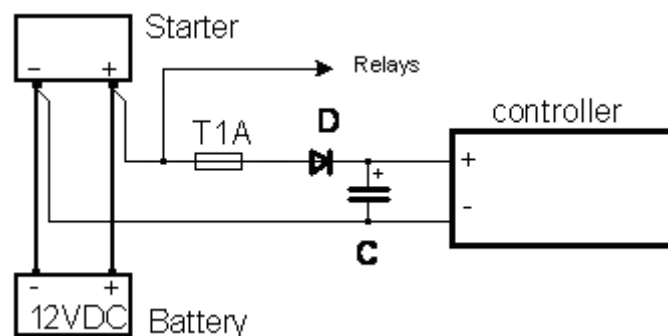

The capacitor size depends on required time. It shall be approximately thousands of microFarads. The capacitor size should be 5 000 microFarad to withstand 150ms voltage dip under following conditions:

Voltage before dip is 12V, after 150ms the voltage recovers to min. allowed voltage, i.e. 8V

Hint:

Before the battery is discharged the message "Low BackupBatt" appears.

Or by connecting special I-LBA Low Battery Adaptor module:

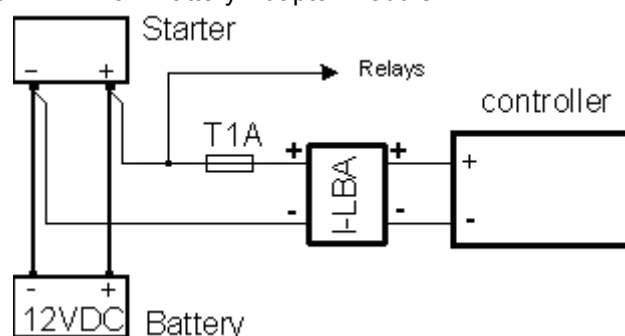

The I-LBA module ensures min. 350ms voltage dip under following conditions: RS232 and other plug-in module is connected.

Voltage before dip is 12V and after 350ms the voltage recovers to min. allowed voltage 5V.

The I-LBA enables controller operation from 5VDC (for 10 to 30 sec).

The wiring resistance from battery should be up to 0.1 Ohm for I-LBA proper function.

Hint:

I-LBA may not eliminate voltage drop when used with low temperature ($-40^{\circ}C$) version of controller and display heating element is on (below $5^{\circ}C$). Current drain of heating element exhausts LBA capacitors very fast .

Power supply fusing

A one-amp fuse should be connected in-line with the battery positive terminal to the controller and modules. These items should never be connected directly to the starting battery. Fuse value and type depends on number of connected devices and wire length. Recommended fuse (not fast) type - T1A. Not fast due to internal capacitors charging during power up.

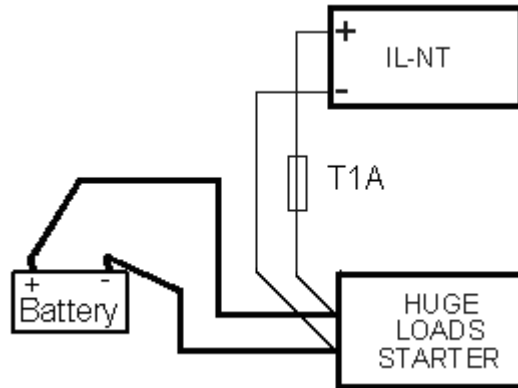

Binary output protections

Hint

Do not connect binary outputs directly to DC relays without protection diodes, even if they are not connected directly to controller outputs.

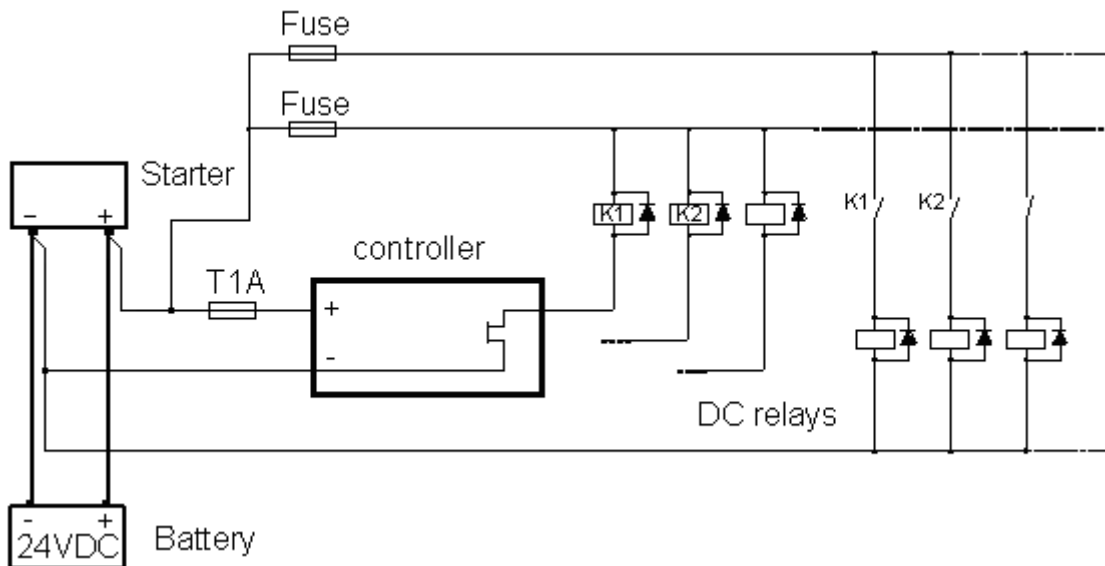

Magnetic pick-up

To ensure proper function:
Use a shielded cable

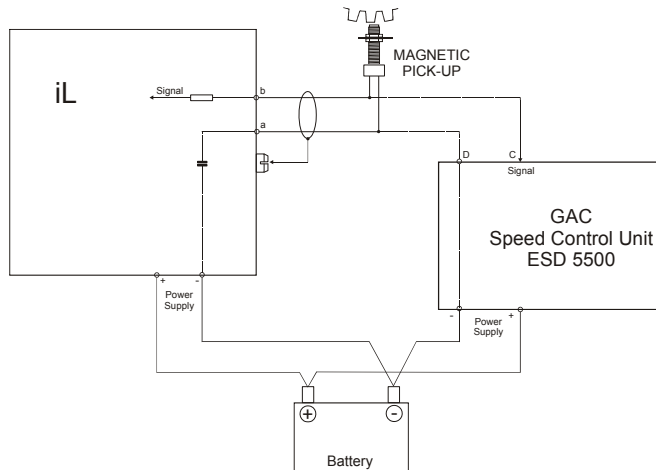

Be aware of interference signal from Speed governor when one speed pick-up is used.

If engine will not start:

- Check ground connection from pick-up to controllers, eventually disconnect ground connection to one of them
- Galvanically separate IntelliLite RPM input using ComAp separation transformer RPM-ISO (1:1)
- Use separate pick-up for Speed governor and IntelliLite^{NT}

Hint:

In some cases the controller will measure a RPM value even though the gen-set is not running: RPM is measured from the generator voltage (Gear teeth = 0)

IL-NT is measuring some voltage value on input terminals due to open fusing.

If RPM > 0 the controller will be put into a Not ready state and the engine will not be allowed to start.

Current measurement

The number of CT's is automatically selected based on selected value of setpoint [ConnectionType](#) [[3Ph4Wire](#) / [3Ph3Wire](#) / [Split Ph](#) / [Mono Ph](#)].

To ensure proper function:

Use cables of 2,5mm²

Use transformers to 5A

Connect CT according to following drawings:

Three phase application:

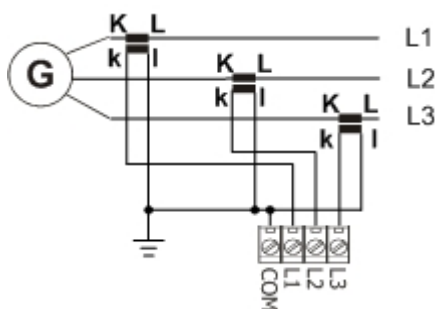

It is necessary to ensure that potential difference between generator current COM terminal and battery “-” terminal is maximally $\pm 2V$. Therefore is strongly recommended to interconnect these two terminals together.

Single phase application:

Connect CT according to following drawings. Terminals L2I and L3I are opened.

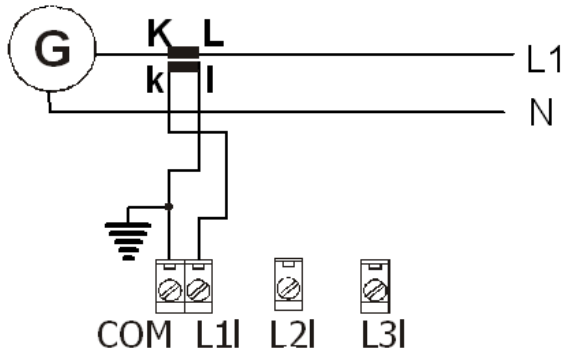

Voltage measurement and generator connection types

There are 4 voltage measurement **ConnectionType** (setpoint [ConnectionType \[3Ph4Wire / 3Ph3Wire / Split Ph / Mono Ph\]](#)) options, every type matches to corresponding generator connection type.

ConnectionType: 3 Phase 4 Wires

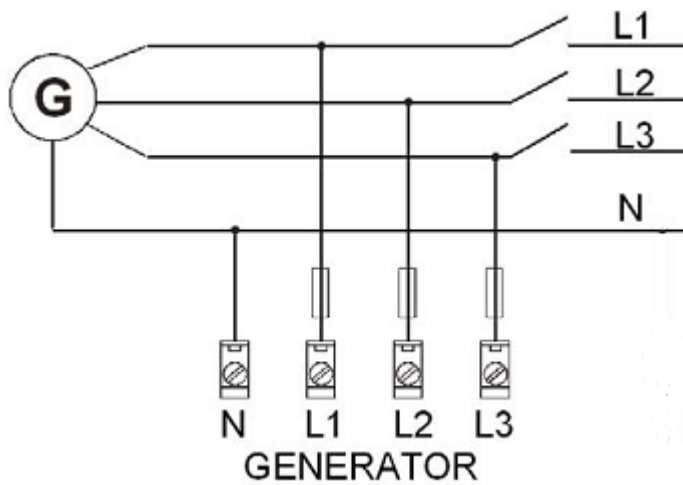

Three phase “wye” measurement – 3PY

3 Phase 4 Wires - STAR Connection

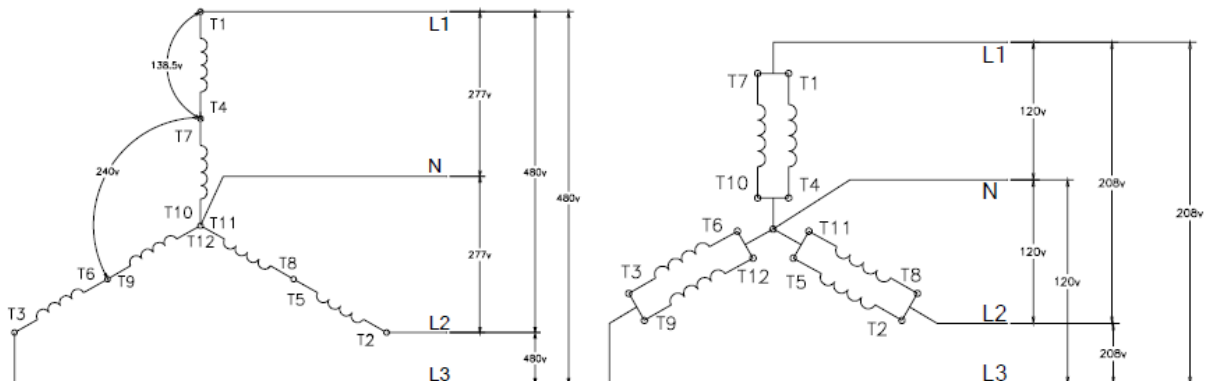

ConnectionType: 3 Phase 3 Wires

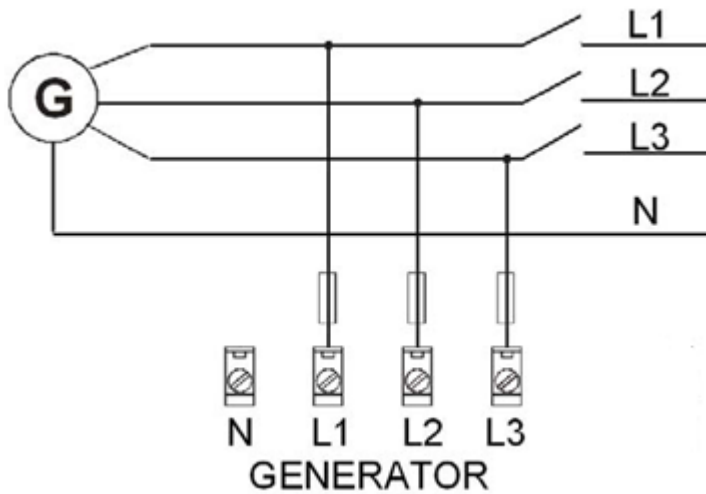

Three phase “delta” measurement – 3PD

3 Phase 3 Wires

– DELTA Connection

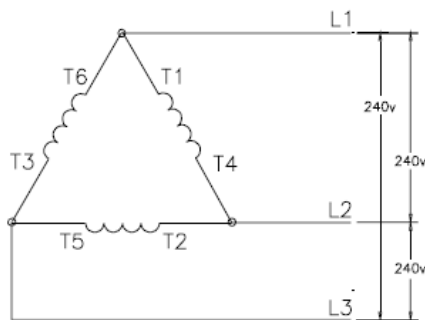

– EDISON DELTA Connection

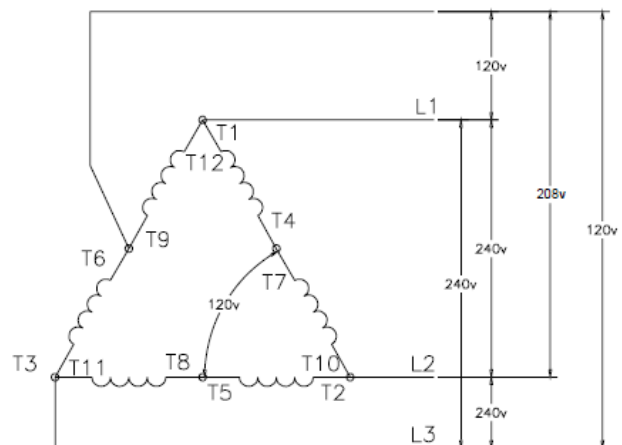

Hint:

Only L1, L2 and L3 wires should be connected. In case of EDISON DELTA connection the N (neutral) wire (in the diagram connected between T6 and T9) has to be disconnected.

No separation transformers for three wires voltage connection (without N) are needed.

ConnectionType: Split Phase

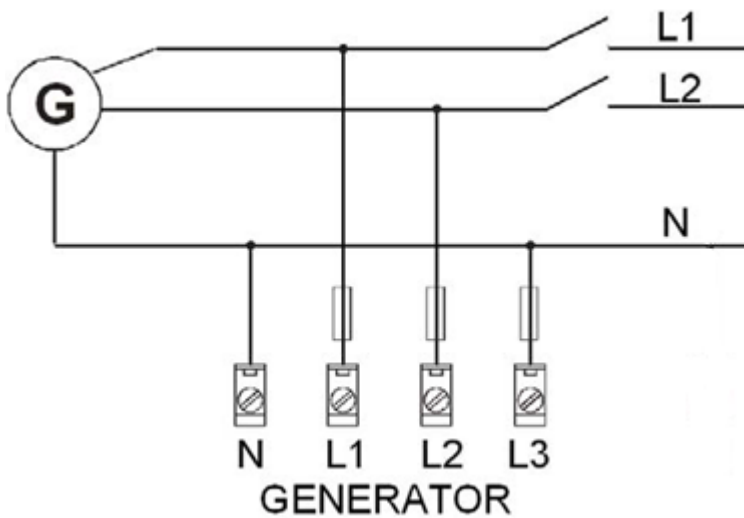

Single-phase measurement – 1PH

Split Phase

– DOUBLE DELTA Connection

– ZIG ZAG (DOG LEG) Connection

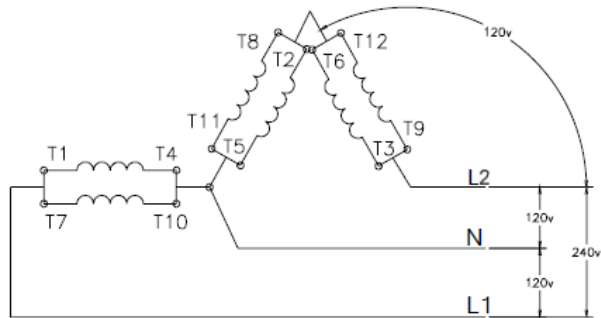
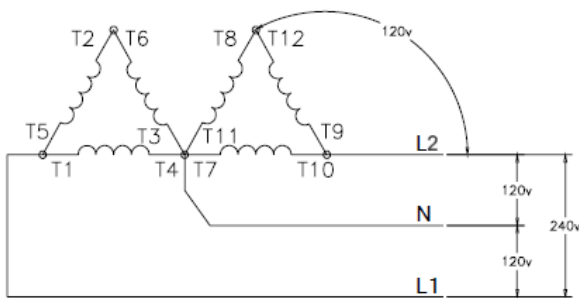

ConnectionType: Mono Phase

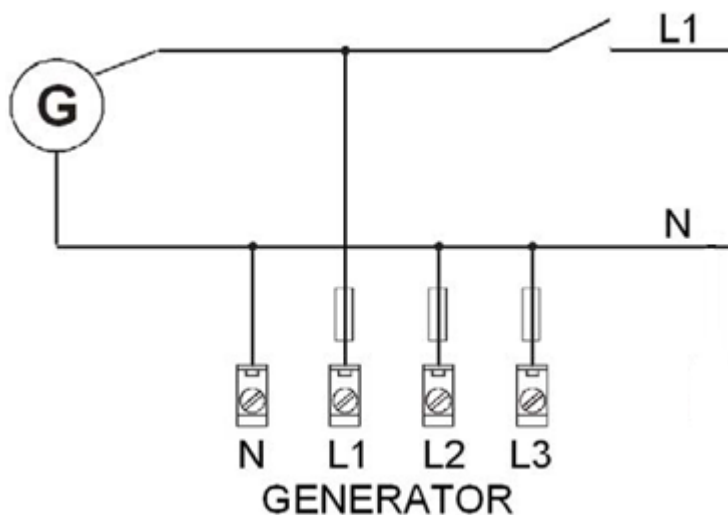

Single-phase measurement – 1PH

Hint:

There has been a change in wiring of monophase at voltage terminals between firmwares IL-NT1.4 and IL-NT1.5! Picture above shows connection for IL-NT 1.5. Wiring for older firmwares is described in older IL-NT manuals, line L1 was connected to all three terminals L1,L2 and L3.

Mono Phase – MONOPHASE Connection

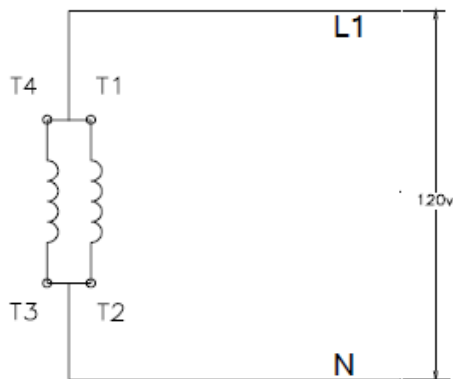

Hint:

Switchboard lighting strike protection according standard regulation is expected **for all 4 connection types!!!**

Hint:

Phase sequence check is not possible to evaluate under voltage 50V what causes that if measured voltage 50V is within the allowed range, controller will not allow to close the GCB, even if relevant LED diod on front panel of IL-NT lits.

Analog inputs

Three analog inputs are available on the IL-NT. First analog input is fixed to be used for engine Oil Pressure.

Configuration

Each analog input can be configured by LiteEdit software following way. (First analog input is dedicated to engine Oil pressure).

Analog input item	LiteEdit		Possibility
Type	Type	Not used Alarm	Analog input isn't used
Analog input name	Name		Up to 14 ASCII characters
Config of input	Config	Analog Binary (not supp. by PTM) Tri-state (not supp. by PTM)	Analog measuring in specified range. Binary: open/close - threshold 750 Ω. Three-state: open/close - threshold 750 Ω, Failure <10 Ω or > 2400 Ω
Physical dimension	Dim	bar,%, °C, ...	Up to 4 ASCII characters (Valid only for analog inputs)
Polarity	Contact type	NC NO	Valid only for binary and three-state inputs Valid only for binary and three-state inputs
Protection direction	Protection	Over	Overstep. Sensor Fail does not activate protection.
		Over+FIs	Overstep and Sensor Fail activates protection.
		Under	Under step. Sensor Fail does not activate protection.
		Under+FIs	Under step and Sensor Fail activates protection.
Sensor characteristic	Sensor	Predefined user curves	User changeable and

			configurable
Resolution	Resolution	0 – 0,00001	Sensor resolution (Valid only for analog inputs)

Each Analog input has separate set points for two level alarm setting. Analog input alarm levels and delay adjust in **Extension I/O** and **Engine Protect** group.

Hint:

Description of Sensor fail evaluation can be found in chapter [Alarm Management](#), article [Sensor Fail \(FLS\)](#).

Connection of IL-NT analog inputs

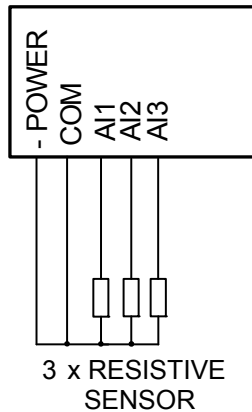

Standard connection of three resistive sensors to analog inputs.

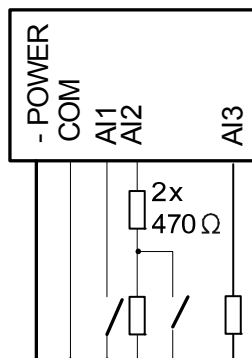

Mixed connection of IntelliLite analog inputs:

- AI1 – binary input
- AI2 – three state input
- AI3 – analog resistive input

Hint:

Description of analog inputs with COM terminal and 4 pins relates to units with HW version 1.3. Older HW versions do not have “COM” terminal and use only 3 pins AI1, AI2 and AI3.

Wiring

Wiring diagrams of analog inputs for IL-NT HW 1.3:

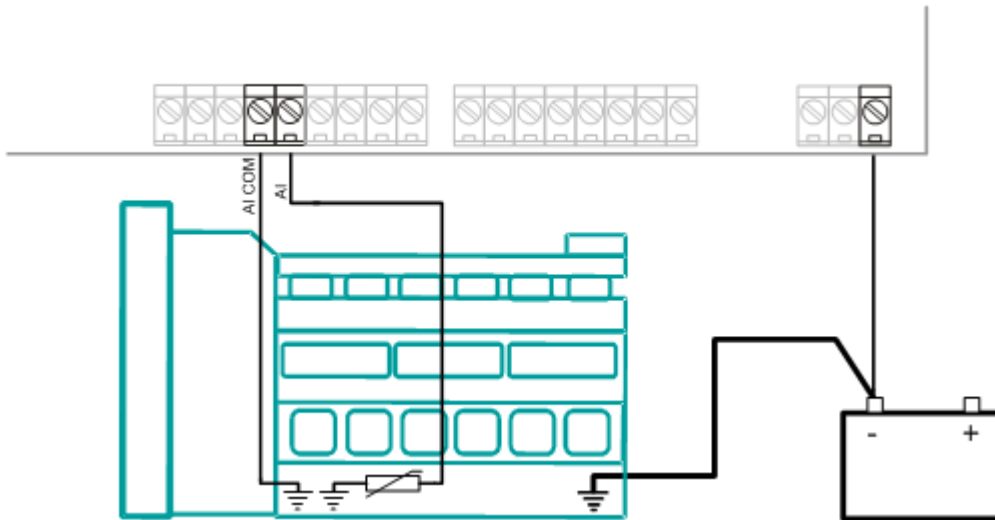

WIRING OF ANALOG INPUTS-GROUNDED SENSORS

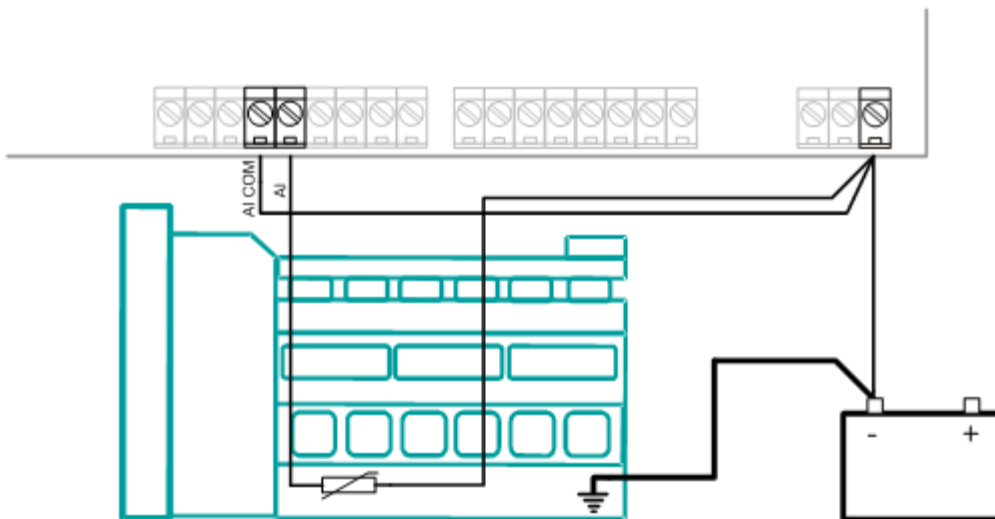

WIRING OF ANALOG INPUTS-ISOLATED SENSORS

Wiring diagrams of analog inputs for IL-NT HW 1.1 and older:

WIRING OF ANALOG INPUTS FOR CONTROLLERS WHERE COM TERMINAL IS NOT PROVIDED

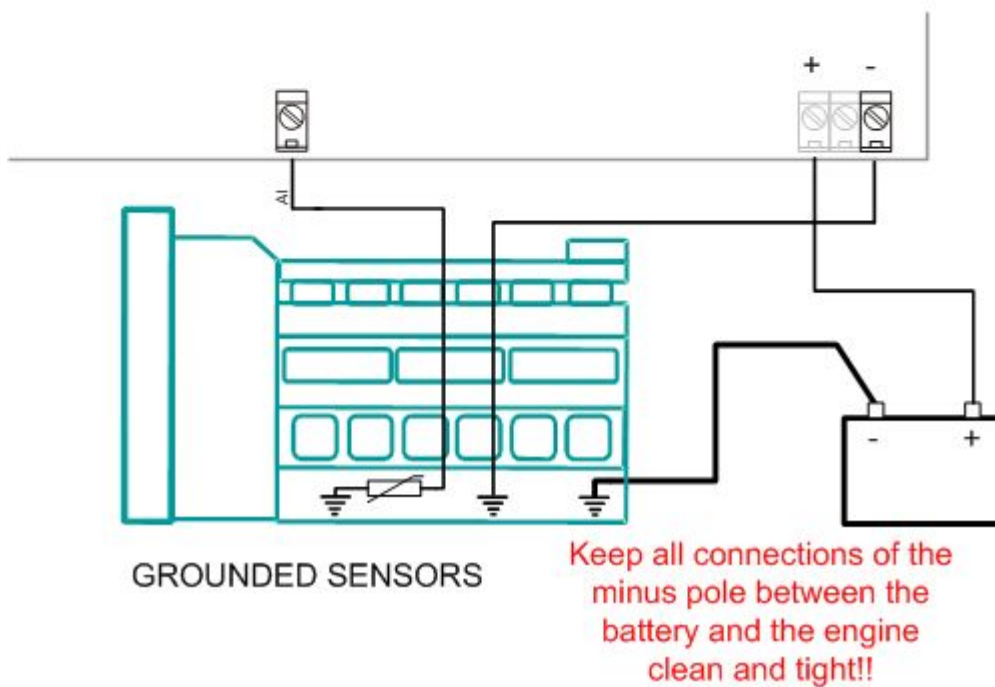
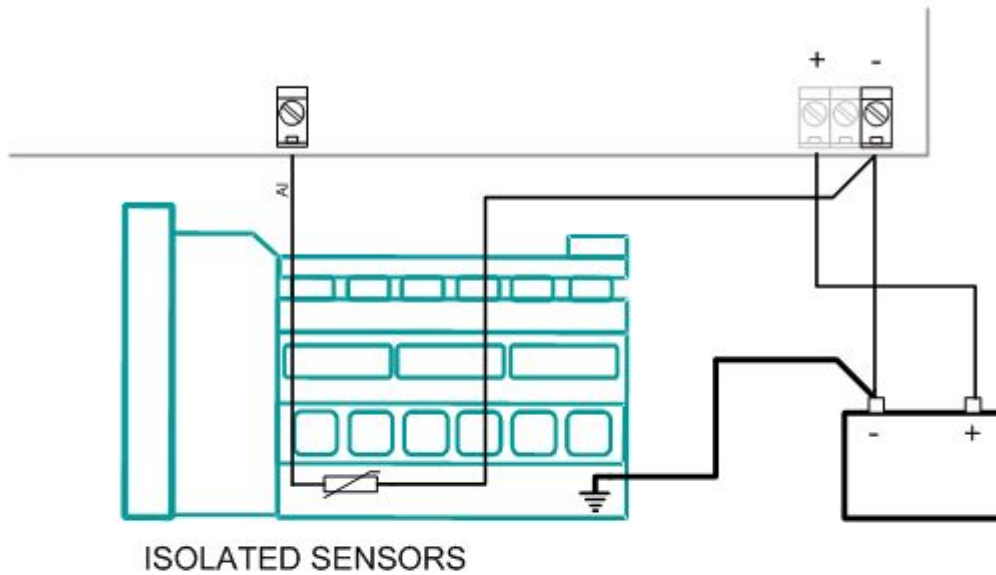

Analog inputs are designed for resistive sensors with resistance in range of 0Ω to $2,4k\Omega$. To ensure a proper function use shielded cables, especially for length over $>3m$.

COM terminal is dedicated to measure ground voltage potential difference between engine and controller.

As binary input

Open, close state are detected, threshold level is 750Ω .

As three state input

Open, close and failure state are detected. Threshold level is 750 Ω , failure is detected when circuit resistance is $<10 \Omega$ or $> 2400 \Omega$.

Hint:

Protections on binary and three state inputs are following:

<i>IL-NT:</i>	A1	Shutdown	<i>IG-IOM:</i>	A1	Shutdown
	A2	Shutdown		A2	Shutdown
	A3	Warning		A3	Shutdown
				A4	Shutdown

Unused analog inputs

Configure Type = Not used

Example of analog input configuration

Configure Engine Temp input for measuring in $^{\circ}\text{C}$, VDO 40-120 $^{\circ}\text{C}$ sensor, range -16 to 120 $^{\circ}\text{C}$. Alarm protection level set to 90 $^{\circ}\text{C}$, shut down level 110 $^{\circ}\text{C}$.

Start LiteEdit and select – Controller - Configuration – Modify – Engine Temp.

Set configuration for Engine temp analog input:

Type: Selection between Not used and Alarm

“Not used” – analog input isn’t used

”Alarm” – analog input is used

Set to: Alarm

Name: Name of the analog input. Maximally 14 letters.

Set to: Engine Temp

Config: Selection between Analog, Binary Tri-state input.

“Analog” – resistor sensor is connected to Analog input.

“Binary” – open/close contact is connected between Analog input and COM terminal of Analog inputs.

Analog input detects only open/close state.

“Tri-state” – open/close contact is connected parallel to one of two serial resistors between Analog input and COM terminal of Analog inputs.

Set to: Analog

Alarm Properties: Selection between different direction of protection – Under Limit, Over Limit or combination with Fail sensor.

“Engine running only” – check this setting if you wish to active protection on analog input only while engine is running, not, when it stops.

Set to: Over Limit

Contact type: selection of polarity only when analog input is configured as Binary or Tri-state. When is analog input configured as analog this setting has no sense.

„NC” – polarity of binary or tri-state input

„NO” – polarity of binary or tri-state input

Sensor: selection of sensor characteristic

„Unused input” - when Analog input is not used. On the IntelliLite screen is displayed „####” value, no alarm is detected.

Default user curves predefined on A11 – A13:

„VDO 10 Bar” – VDO pressure sensor

„VDO 40-120 $^{\circ}\text{C}$ ” – VDO temperature sensor

„VDO level %” – VDO level sensor

Set to: VDO 40-120 $^{\circ}\text{C}$

When you choose the predefined or user curve the Sensor Name, Dim and Resolution are setted automatically according to curve, user modification is possible.

Sensor Name: Name of used sensor, up to 14 letters can be used.

Dim: Name of measured unit (Bar, °C, %, ...), up to 4 letters can be used.

Resolution: setting of resolution of measured value.

„0“ - e.g. 360 kPa, 100%, 50 °C

„1“ - e.g. 360.0 kPa

„2“ - e.g. 360.00 kPa

„3“ - e.g. 360.000 kPa

Set to: 1

When Analog input configuration is finished set the setpoints *AI1 Wrn*, *AI1 Sd*, *AI1 Del* in **Engine Protect** group.

Each Analog input has separate triplet of setpoints: *Wrn level*, *Sd level*, *AI del*. Names of these setpoints are fix defined

Number of decimal points of *Wrn level* and *Sd level* is the same as the configured number of decimal points of measured value.

Binary inputs

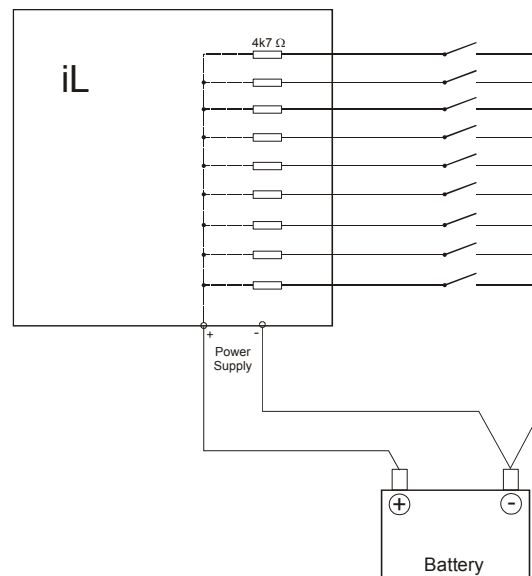

Binary outputs

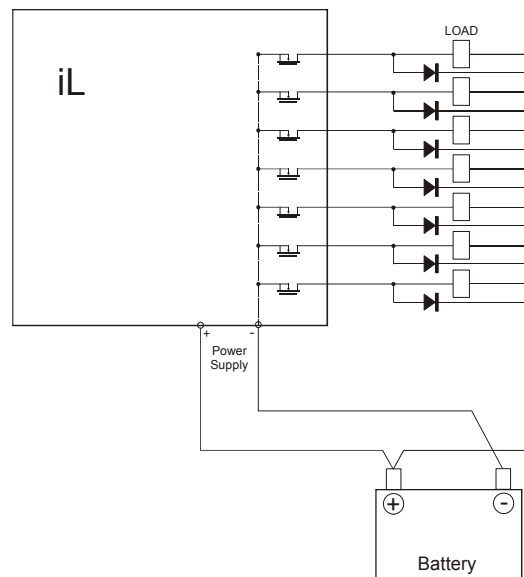

RS485 connection

The line has to be terminated by 120 Ohm resistors at both ends.
 External units can be connected on the RS485 line in any order, but keeping line arrangement (no tails, no star) is necessary.
 Standard maximum link length is 1000m.
 Shielded cable has to be used, shielding has to be connected to PE on one side (controller side).

- A) For shorter distances** (all network components within one room) – **picture 1**
interconnect A and B; shielding connect to PE on controller side
- B) For longer distances** (connection between rooms within one building) – **picture 2**
interconnect A, B, COM; shielding connect to PE in one point
- C) In case of surge hazard** (connection out of building in case of storm etc.) – **picture 3**

We recommend to use following protections:

- Phoenix Contact (<http://www.phoenixcontact.com>):
PT 5-HF-5DC-ST with PT2x2-BE (base element)
(or MT-RS485-TTL)
- Saltek (<http://www.saltek.cz>):
DM-006/2 R DJ

Recommended data cables: BELDEN (<http://www.belden.com>)

- A) For shorter distances: 3105A Paired - EIA Industrial RS-485 PLTC/CM (1x2 conductors)
- B) For longer distances: 3106A Paired - EIA Industrial RS-485 PLTC/CM (1x2+1 conductors)
- C) In case of surge hazard: 3106A Paired - EIA Industrial RS-485 PLTC/CM (1x2+1 conductors)

Picture 1 - shorter distances (all network components within one room)

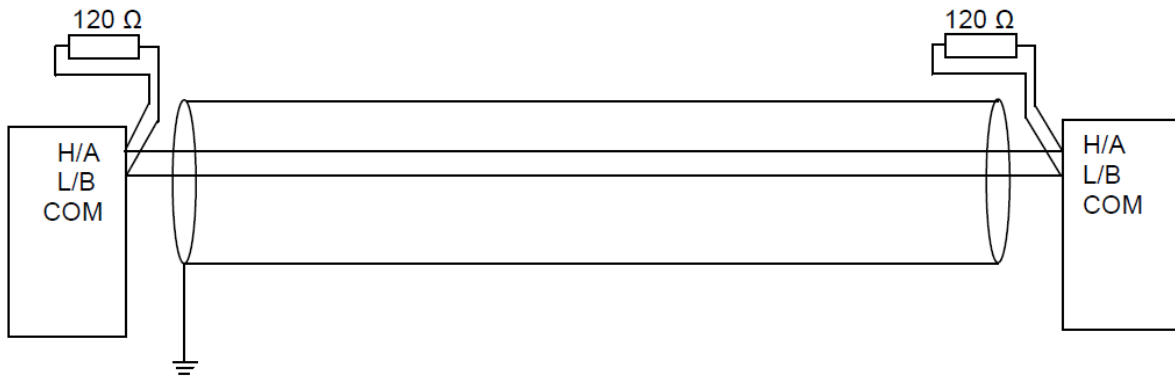

Picture 2 - longer distances (connection between rooms within one building)

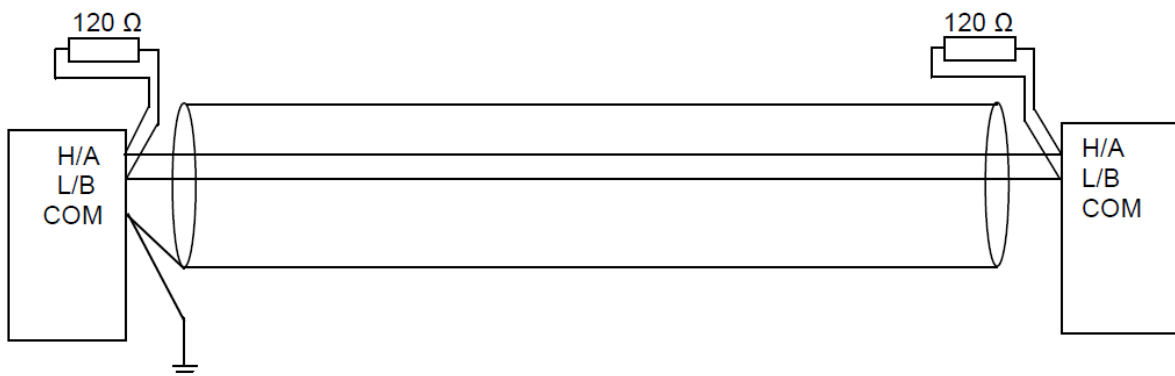

Picture 3 - surge hazard (connection out of building in case of storm etc.)

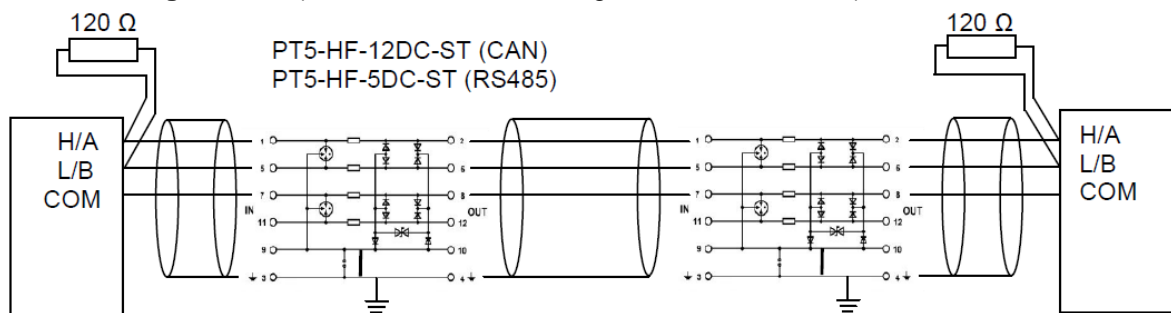

Extension modules (CAN bus) connection

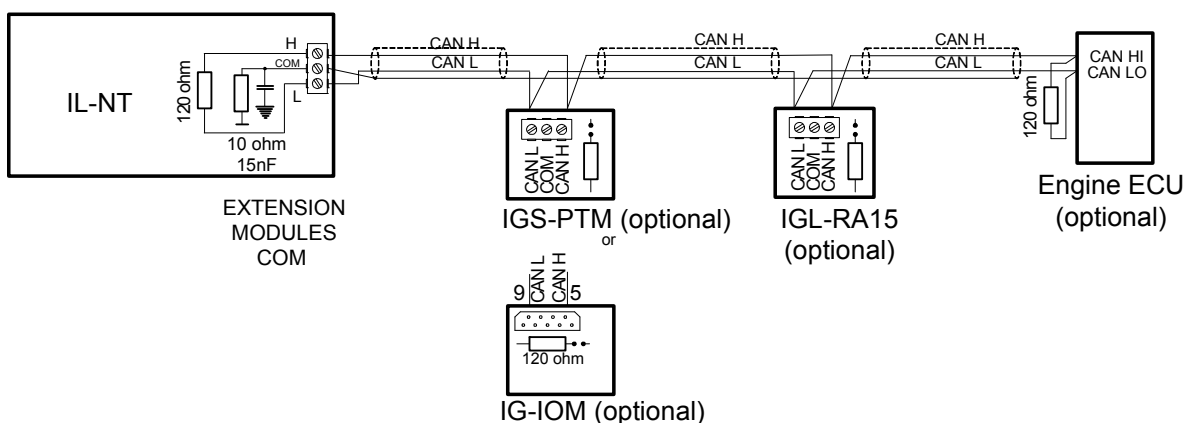

Connection rules

CAN bus line must be connected in series, from one unit to the next (no star, no cable stubs, no branches) both ends must be by the 120-ohm (internal or external) resistor terminated. Maximal CAN bus length is up to 200 meters.

For CAN data cables details see chapter [Technical data – Communication interface](#). CAN cable shielding connect to IL-NT COM terminal.

IL-NT contains internal fix 120-ohm resistor and must be located on the CAN bus end. New units with HW version 1.3 have terminating resistor jumper located at CAN terminal.

New IG-IOM and IGS-PTM units contain internal jumper removable 120-ohm resistor (in older IOM types are fix resistors). To be sure check resistor presence by ohmmeter. Unit with internal resistor connect to the end of CAN line.

Following connections are supported (IOM, PTM, ECU order is not important).

IL- NT – IG-IOM – IGL-RA15 – ECU
IL- NT – IGS-PTM – IGL-RA15 – ECU

It is possible to connect only one IG-IOM or IGS-PTM and one IGL-RA15 to IL-NT.



Use  button in LiteEdit configuration window to activate CAN (J1939) interface.

Inputs and Outputs

For Inputs/Outputs overview table see chapter Technical Data.

Hint:

Any Binary input or output can be configured to any IL-NT controller terminal or changed to different function by LiteEdit software. There is fix 1 sec delay when any binary input is configured as protection.

Binary inputs IL-NT - default

- BI1 Rem Start/Stop**
- BI2 Access Lock**
- BI3 Emergency Stop**
- BI4 Remote OFF**
- BI5 Sd Override**
- BI6 RemControlLock**

Binary inputs – list

Not used

Binary input has no function. Use this configuration when Binary input is not connected.

Alarm

If the input is closed (or opened) selected alarm is activated.

Binary Alarm configuration items

Name		14 characters ASCII string
Contact type	NC	Normally closed
	NO	Normally opened
Alarm type	Warning	
	Shut down	
Alarm active	All the time	Valid if checkbox "Engine running only" is not checked
	Engine running only	Valid if checkbox "Engine running only" is checked

Rem Start/Stop

External request for engine run. AUT mode only.

Emergency Stop

If the input is opened, shut down is immediately activated. Input is inverted (normally closed) in default configuration.

Hint:

In case of controller hardware or software fail, safe stop of the engine doesn't have to be ensured. To back-up the Emergency Stop function it is recommended to connect separate circuit for disconnection of Fuel Solenoid and Starter signals.

Sd Override

If the input is closed all alarms are disabled except the binary input EMERGENCY STOP and "engine overspeed protection".

- all IL alarms are detected,
- IL front panel gen-set RED LED blinks or lights,
- alarm is recorded on the IL alarm list screen,
- BUT gen-set remains running.

Hint:

Alarm *Sd Override* is indicated in the AlarmList if Sd Override mode active to inform the operator that the engine is not protected.

Access Lock

If the input is closed, no setpoints can be adjusted from controller front panel and gen-set mode (OFF-MAN-AUT) cannot be changed.

Hint:

Access lock does not protect setpoints and mode changing from LiteEdit. To avoid unqualified changes the selected setpoints can be password protected. Also the buttons Fault reset, Horn reset are not blocked at all and buttons Start and Stop in MAN mode are not blocked.

Remote OFF

If closed, iL is switched to OFF mode (there are four modes OFF-MAN-AUT-TEST). When opens controller is switched back to previous mode.

Hint:

This binary input should be connected to schedule timer switch, to avoid start of engine.

Remote MAN

If the input is active, MAN mode is forced to the controller independently on the position of the MODE selector.

Remote AUT

If the input is active, AUT mode is forced to the controller independently on the position of the MODE selector. If another of „remote“ inputs is active, then the REMOTE AUT input has the lowest priority.

RemControlLock

If the input is active, setpoints writing or command sending from the external terminal is disabled.

Emergency MAN

If the input is activated the controller behaves like when switched to OFF Mode. Opens all binary outputs. There is one exception – STOP SOLENOID doesn't activate on this transition.

Detection of "running" engine and subsequent alarm message "Sd Stop Fail" is blocked.

The controller shows "Emerg Man" state and the engine can not be started.

Generator current and power measurement is active in this mode, regardless of the actual state of the engine.

After the input is open again, the controller recovers to previous state and behaves according to the actual situation .

Function is active in any controller mode.

Start Button

Binary input has the same function as **Start** button on the IntelliLite front panel. It is active in MAN mode only.

Stop Button

Binary input has the same function as **Stop** button on the IntelliLite front panel. It is active in MAN Mode only.

Hint:

Changed function of Stop Button. After the first pressing from running state, there is a standard delay and controller change state to cooling. After holding the button down for 2 seconds controller goes to stop state. The same holds true for BI “Stop Button”.

FaultResButton

Binary input has the same function as **Fault reset** button on the IntelliLite front panel.

HornResButton

Binary input has the same function as **Horn reset** button on the IntelliLite front panel.

^GCB button

Binary input has the same function as **GCB** button on the IntelliLite front panel. It is active in MAN mode only.

Lang Selection

Not configured

Language selection is done only through the controller display. Pressing **ENTER** and **PAGE** buttons concurrently and then only **PAGE** button separately.

Configured on any binary input

If the output is opened the first (default) language is active and if the input is closed then the second language is active. In case there is more languages available in the controller it is not possible to select any other language even through the controller display.

Binary outputs IL-NT MRS16 - default

BO1	Starter
BO2	Fuel Solenoid
BO3	GCB Close/Open
BO4	Prestart
BO5	Ready To Load
BO6	Alarm

Hint:

The description of binary outputs of a controller relates also to IOM/PTM modules.

Binary outputs - list

Not used

Output has no function.

Starter

The closed relay energizes the starter motor.

The relay opens if:

- the “firing” speed is reached or
- maximum time of cranking is exceeded or
- request to stop comes up

Fuel Solenoid

Closed output opens the fuel solenoid and enables the engine start.

The output opens if:

- EMERGENCY STOP comes or
- Cooled gen-set is stopped or
- in pause between repeated starts

Stop Solenoid

The closed output energizes stop solenoid to stop the engine.

The output is active at least for *Stop Time*, if the stop lasts longer, it stays active until all symptoms say the engine is stopped.

The engine is stopped if:

- RPM < 2 and
- Generator voltage < 10V and
- Oil pressure < **Engine Params: Starting Oil P.**

Hint:

The engine can be started anytime, if all symptoms say the engine is steady regardless of the fact the *Stop Solenoid* can still be active (in that case it is deactivated before cranking).

Stop Pulse

Output is active for 1 second after *Stop Solenoid* output activation. This signal is sent to ECU in case of engine stop request.

Ignition

The output closes after reaching value of CrankRPM, fixed 30RPM. Opens after stopping of the engine or in pause during repeated start.

Prestart

The output closes prior to the engine start (*Prestart*) and opens when *Starting RPM* speed is reached. During crank attempts the output is closed too. The output could be used for pre-glow, pre-heat or prelubrication.

Cooling Pump

The output closes when gen-set starts and opens after stop of the engine.

Idle/Nominal

The output *Idle/Nominal* closes after the timer *Idle Time* elapses. The *Idle Time* counter starts to countdown when *Starting RPM* reached. The *Underspeed* protection is not evaluated during fixed 5 seconds period after reaching *Starting RPM*. A *Start Fail* protection occurs if the RPM drop below 2RPM during idle.

Hint:

Connect Binary output Idle/Nominal to speed governor to switch the speed: opened = IDLE, closed=NOMINAL. If the IDLE contact is not supported on the governor, set the *Idle Time* nevertheless to minimum 5s to avoid *Underspeed* possibly caused by instability of the engine short after start.

Air Valves

Closes together with *Prestart*. Opens after the engine is stopped. Stopped engine conditions: RPM = 0, **Engine Params:** *Starting Oil P, D+* (when enabled).

Alarm

The output closes if :

- any warning or shutdown comes up or
- the gen-set malfunctions

The output opens if

- **FAULT RESET** is pressed

The output closes again if a new fault comes up.

Horn

The output closes if:

- any warning or shutdown comes up or
- the gen-set malfunctions

The output opens if:

- **FAULT RESET** is pressed or
- **HORN RESET** is pressed or
- Max time of HORN is exceeded (*Horn Timeout*)

The output closes again if a new fault comes up.

GCB Close/Open

MRS11, 16: The output controls the generator circuit breaker.

MRS10, 15 (GCB no GCB button):

The output closes automatically (in MAN or AUT mode) after engine is started, *Min Stab Time* elapsed, and generator voltage and frequency is in limits.

GCB ON Coil

The output activates Generator Circuit Breaker coil.

GCB OFF Coil

The output deactivates Generator Circuit Breaker coil.

GCB UV Coil

The output controls Generator Circuit Breaker coil after voltage drop-out.

*AL IOM AI1..4 Wrn

Output closes if warning alarm on the appropriate IOM/PTM analog input activates.

The output opens, if

- alarm is not active and
- **FAULT RESET** is pressed

Ready

The output is closed if following conditions are fulfilled:

- Gen-set is not running and
- No Shut down is active
- Controller is not in OFF Mode

Ready To Load

The output is closed if genset is running and all electric values are in limits no alarm is active - it is possible to close GCB or it is already closed. The output opens during cooling state.

Running

Output closes if the engine is in Running state.

Cooling

The output closes when gen-set is in Cooling state.

Supplying Load

Closed when the generator current is $> 0,5\%$ of the CT ratio.

Exact formulas:

Output is closed when the current at least in one phase is for 1 sec over $CT\ ratio/200+2$

Output is opened when the current in all three phases is for 1 sec below $CT\ ratio/200+2$

Hint:

Values are truncated after division, not rounded.

Fault Reset

The output is a copy of Fault Reset button on controller and binary input *FaultResButton*.

Gen Healthy

The output is copy of generator status LED on iL front panel. The output is closed if genset is running and all genset electric values are in limits.

AL D+ Fail

Output closes if gen-set is running and D+ input not energized.

The output opens, if

- alarm is not active and
- **FAULT RESET** is pressed

Hint:

Threshold level for D+ input is 80% supply voltage.

AL Gen >V

The output closes if the generator overvoltage shutdown alarm activates.

The output opens, if

- alarm is not active and
- **FAULT RESET** is pressed

AL Gen <V

The output closes if the generator undervoltage shutdown alarm activates.
The output opens, if

- alarm is not active and
- **FAULT RESET** is pressed

AL Gen Volts

The output closes if the generator over/under voltage shutdown alarm or voltage asymmetry shutdown alarm activates.

The output opens, if

- alarm is not active and
- **FAULT RESET** is pressed

AL Gen Freq

Output closes if the generator over/under frequency shutdown alarm activates.

The output opens, if

- alarm is not active and
- **FAULT RESET** is pressed

Hint:

Devised LBO <>fgen to <fgen and >fgen, and <>Vgen to >Vgen and <Vgen.

AL Gen >Freq

Output closes if the generator over frequency alarm activates.

The output opens, if

- alarm is not active and
- **FAULT RESET** is pressed

AL Gen <Freq

Output closes if the generator under frequency alarm activates.

The output opens, if

- alarm is not active and
- **FAULT RESET** is pressed

AL Overload Sd

Output closes if the generator overload shutdown alarm activates.

The output opens, if

- alarm is not active and
- **FAULT RESET** is pressed

AL Stop Fail

Output closes when the engine has to be stopped, but speed or frequency or voltage or oil pressure is detected. This protection goes active 60s after stop command.

The output opens, if

- alarm is not active and
- **FAULT RESET** is pressed

AL Overspeed

Output closes if the gen-set over speed alarm activates.

The output opens, if

- alarm is not active and
- **FAULT RESET** is pressed

AL Underspeed

Output closes if the gen-set under speed alarm activates.

The output opens, if

- alarm is not active and
- **FAULT RESET** is pressed

AL Start Fail

Output closes after the gen-set start-up fails.

The output opens, if

- alarm is not active and
- **FAULT RESET** is pressed

AL Overcurrent

Output closes if the generator

*IDMT over current or
current unbalance or
short current alarm activates.

The output opens, if Alarm is not active and **FAULT RESET** is pressed

AL BatteryFail

Output closes when IL-NT performs reset during start procedure (probably due to weak battery) or when battery under/over voltage warning appears.

The output opens, if

- alarm is not active and
- **FAULT RESET** is pressed

AL Common Wrn

Output closes when any warning alarm appears.

The output opens, if

- No warning alarm is active and
- **FAULT RESET** is pressed

AL Common Sd

Output closes when any shut-down alarm appears.

The output opens, if

- No sd alarm is active and
- **FAULT RESET** is pressed

AL Common Fls

Output closes when any Sensor Fail alarm appears.

The output opens, if

- No warning alarm is active and
- **FAULT RESET** is pressed

AL AI1 Sd

Output closes if the oil pressure (configured to the first analog input) shutdown alarm activates.

The output opens, if

- alarm is not active and
- **FAULT RESET** is pressed

AL AI1 Wrn

Output closes if the oil pressure (configured to the first analog input) warning alarm activates.

The output opens, if

- alarm is not active and
- **FAULT RESET** is pressed

AL AI2 Sd

Output closes if the water temperature (configured to the second analog input) shutdown alarm activates.

The output opens, if

- alarm is not active and
- **FAULT RESET** is pressed

AL AI2 Wrn

Output closes if the water temperature (configured to the second analog input) warning alarm activates.

The output opens, if

- alarm is not active and
- **FAULT RESET** is pressed

AL AI3 Sd

Output closes if the Fuel Level (configured to the third analog input) shutdown alarm activates.

AL AI3 Wrn

Output closes if the Fuel Level (configured to the third analog input) warning alarm activates.

Mode OFF

The output is closed, if OFF Mode is selected.

Mode MAN

The output is closed, if MAN Mode is selected.

Mode AUT

The output is closed, if AUT Mode is selected.

Maintenance

Output closes if the Maintenance alarm activates, i.e. the gen-set has been running for more than **Engine Protect: WrnMaintenance**.

The output opens, if

- alarm is not active and
- **FAULT RESET** is pressed

Ctrl HeartBeat

Output signalizes Watchdog Reset. In a healthy state it blinks at 500ms : 500ms rate. When Watchdog Reset occurs, it stops blinking.

BI1..6 Status

* IOM BI1..7 Status

The outputs give an information about the assigned binary input.

In case the assigned binary input is configured to alarm type, then the output closes when the alarm activates. It opens if

- alarm is not active and
- **FAULT RESET** is pressed

In case the assigned binary input is configured to any control function, the output propagates the state of the input.

* AL IOM AI1..4 Sd

Output closes if shutdown alarm on the appropriate IOM/PTM analog input activates.

The output opens, if

- alarm is not active and
- **FAULT RESET** is pressed

* AL IOM AI1..4 Wrn

Output closes if warning alarm on the appropriate IOM/PTM analog input activates. The output opens, if

- alarm is not active and
- **FAULT RESET** is pressed

ECU Comm OK

If the ECU is not communicating and all values from ECU show ##### the output is not active. If the ECU communicates the output is active.

ECU Comm Error

The output is an inversion of binary output *ECU Comm OK*, i.e. the output is closed when ECU is not communicating and all values from ECU show #####. Communication error causes stop of the engine.

ECU YellowLamp

The output copies warning information from ECU.

ECU Red Lamp

The output copies shutdown information from ECU.

ECU PowerRelay

The output closes at the beginning of prestart and opens if the engine shall be stopped.

This output can be used to indicate when the ECU should be powered up i.e. only while the engine is running.

This output also influences evaluation of communication failure with ECU and related FLS alarms from analog inputs read from the ECU. If the output is configured (which means configured on physical binary output or VPIO output), the issuing of communication error is blocked during Prestart and Stopping procedure as shown in the picture.

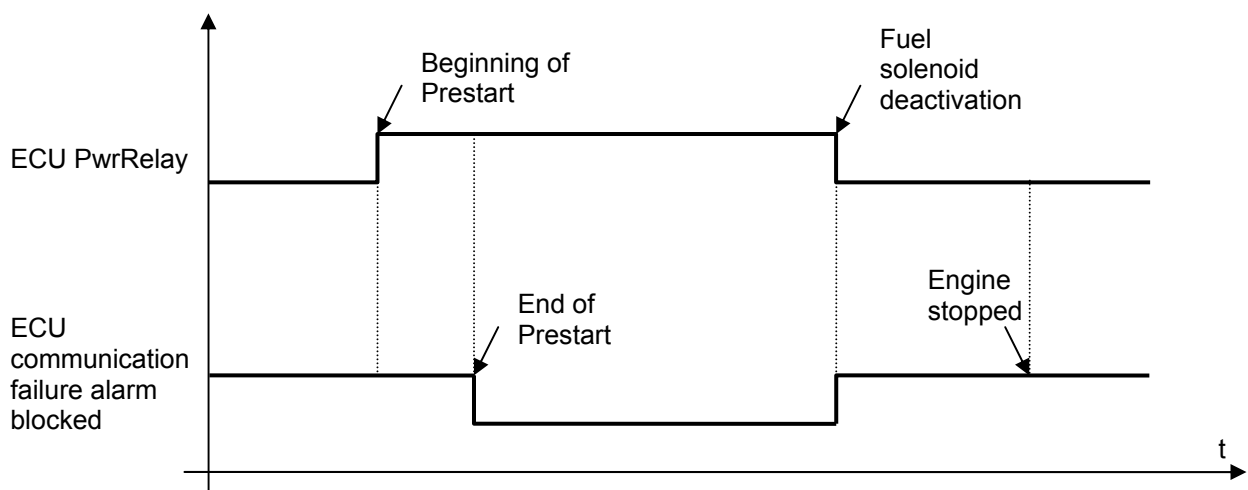

Exerc Timer 1

Output activates when Timer 1 is active. Simultaneously, gen-set is started when it is in AUT mode.

Exerc Timer 2

Output activates when Timer 2 is active

Glow Plugs

The output closes prior to the engine start (by Prestart Time) and opens at the beginning of cranking time. In case of repeated crank attempts the output closes always prior to the other engine start attempts (by Prestart Time) and is opened during crank attempts.

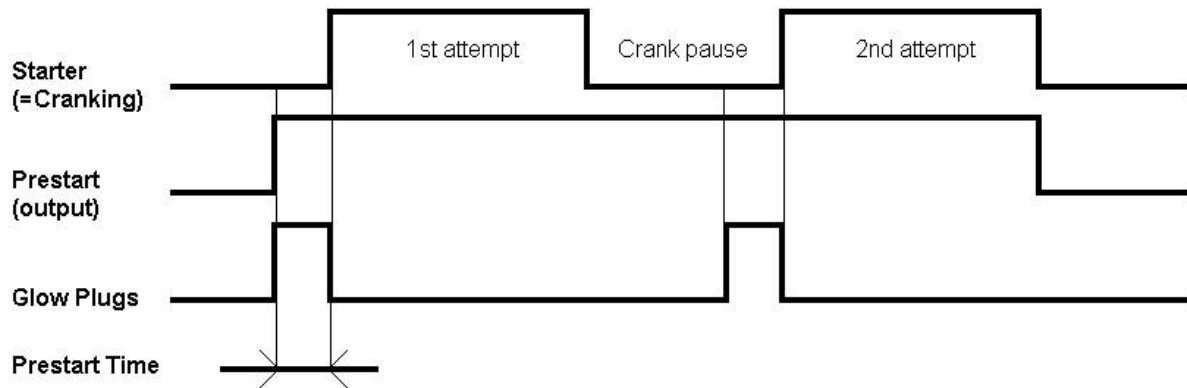

Fuel Pump

Output closes when the value of Fuel Level lies under the value of Fuel Pump ON setpoint and opens when value of Fuel Pump OFF is reached.

Hint:

Fuel pump function is internally connected to analog input 3 to monitor the actual fuel level in tank. It is a prerequisite for this function to use a fuel level sensor at this analog input.

Temp Switch

This switch is assigned to the controller's analog input 2 – commonly used for water temperature sensing. The setpoints [TempSwitch ON](#) and [TempSwitchOFF](#) for on and off level adjustment are located in the setpoint group [Engine Params](#). Typical usage for this binary output can be activation of fans or heaters. The output behaves based on the setpoint adjustment as described on picture lower:

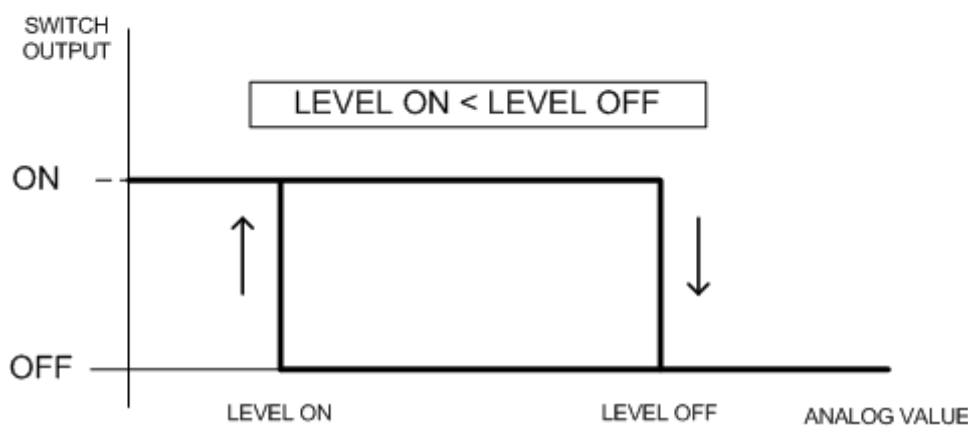
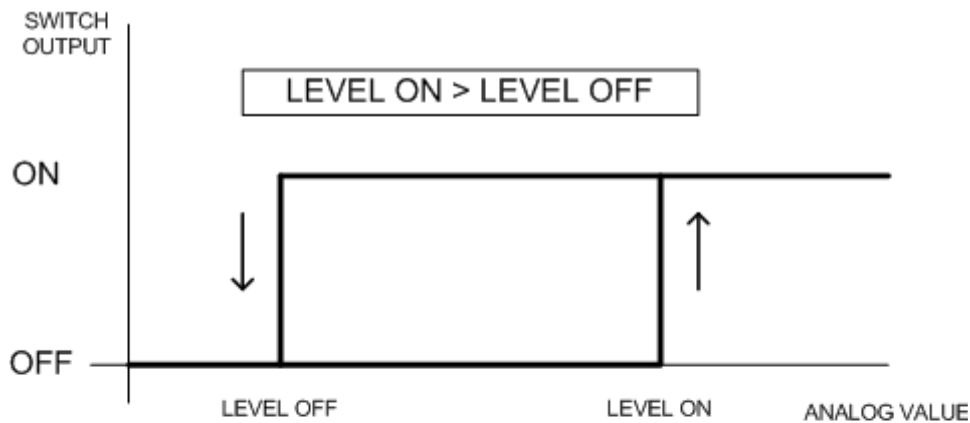

Power Switch

This switch is assigned to the gen-set active power. The setpoints [PowerSwitch ON \[kW\]](#) and [PowerSwitch OFF \[kW\]](#) for on and off level adjustment are located in the setpoint group [Engine Params](#). Typical usage for this binary output can be switching of dummy load. The output behaves

based on the setpoint adjustment as described on picture lower:

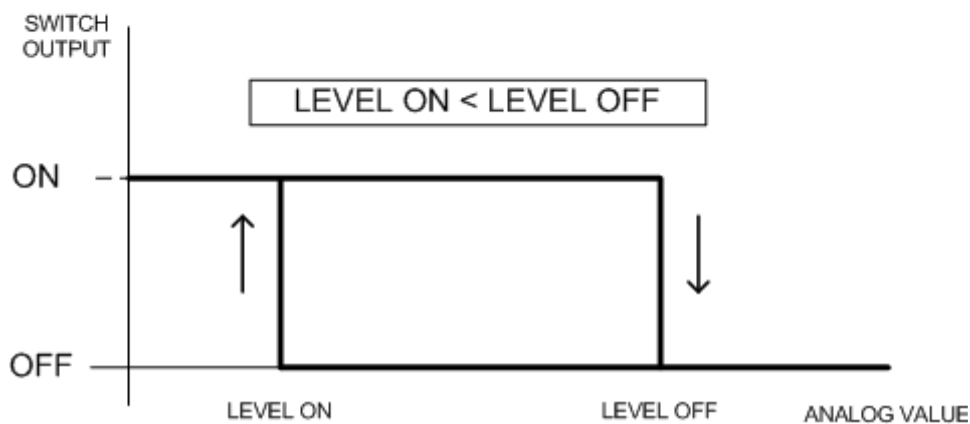
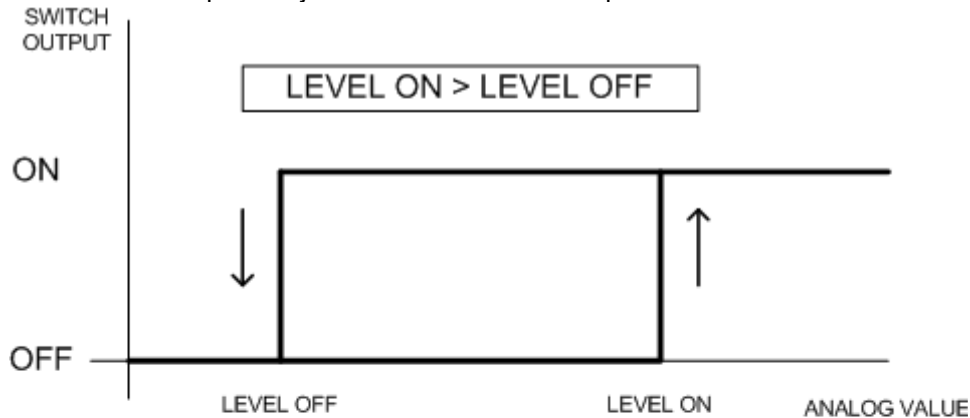

Analog inputs

It is possible to configure on each Analog input:

- Reading from IL Analog inputs or from Engine Control Unit via CAN bus (J1939)
- Sensor characteristics – from the list, or custom sensor curve
- Value dimension (e.g. psi - bars, °F - °C, % - l)
- Sensor resolution

Warning and shut-down limits are adjusted in **Engine Protect** group.

The analog inputs are configurable. Use LiteEdit software to modify configuration. Default configuration is:

Oil Press

Oil pressure analog input. Default VDO sensor in range 0 to 10.0 bars.

Water Temp

Water temperature analog input. Default VDO sensor in range 40 to 120 °C.

Fuel Level

Fuel Level analog input. Default VDO sensor 0-180R = 0-100%

Hint:

For further information about analog inputs configuration see [Analog inputs](#).

CAN J1939 interface

Following values can be received from Engine Control Unit via CAN bus instead of measuring on IL-NT terminals when J1939 interface is enabled.

Value	Value is received from	
	J1939 enabled	J1939 disabled
RPM	ECU	IL-NT – RPM terminals
Oil pressure	ECU or IL-NT AI1	IL-NT AI1 terminals
Water temperature	ECU or IL-NT AI2	IL-NT AI2 terminals
Fuel Level	ECU or IL-NT AI3	IL-NT AI3 terminals
ECU State	ECU	
Fuel Rate	ECU	
Manifold temp	ECU	
Boost Pressure	ECU	
Percent Load	ECU	

Use LiteEdit to enable/disable J1939 interface and to configure IL-NT analog inputs.

Hint:

RPM reading is automatically switched to pickup or generator voltage measuring (depends on **Basic setting**: *Gear Teeth* value) if J1939 fails.

Analog outputs



Optional plug in card IL-NT AOUT8 provides eighth Pulse-With-Modulation (PWM) outputs. These are intended to drive VDO style analog gauges. This is to provide visual indication of typically ECU values without installing additional sensors on the engine. PWM signal emulates sensor which would be typically mounted on the engine.

Any value from controller may be configured to the outputs. Use LiteEdit PC SW to configure corresponding sensor/gauge curve and value selection.

Setpoints

Password

EnterPassword

Password is a four-digit number. Password enables change of relevant protected setpoints. Use  or  keys to set and  key to enter the password.

Hint:

There is only 1 level of a password.

ChangePassword

Use  or  keys to set and  key to change the password.

Hint:

At first the password has to be entered before the new password can be changed.

During the configuration of controller or setpoints changes is required a password to the controller. The default password from manufacturer is "0". Maximum value of password is "9999".

Controller has following functions:

- Automatic checking of password during change to be maximally 9999, if it is bigger value it will be automatically changed to 0. LE will prevent to write bigger value than 9999.
- Cyclic rotation of value of password in case of using arrows on controller

Basic Settings

Gen-set Name

User defined name, used for IntelliLite identification at remote phone or mobile connection. *Gen-set Name* is max 14 characters long and have to be entered using LiteEdit software.

Nomin Power [kW]

Nominal power of the generator
 Step: 1kW
 Range: 1 – 5000 kW

Nomin Current [A]

It is current limit for generator *IDMT over current and short current protection and means maximal continuous generator current. See **Gener Protect**: *Amps IDMT Del, Short Crct Sd setpoints. *Nominal Current* can be different from generator rated current value.

Step: 1 A
 Range: 1 - 10000 A

CT Ratio [/5A]

Gen-set phases current transformers ratio.
 Step: 1 A
 Range: 1 – 5000 A / 5A

Hint:

For firmware versions <= 1.4:

For CT Ratio ≤ 250 the values of power and current are displayed in a controller with one decimal.
 For CT Ratio > 250 the values of power and current are displayed in a controller with integral numbers. If you change CT Ratio in LiteEdit or directly in the controller, decimal numbers will not be changed immediately. The change will be executed only by reconfiguring in LiteEdit. The statistics of power will be recounted at this time with regards to decimal numbers of power.

WARNING! When you change the firmware, statistics can be invalid!

WARNING! Change of CT ratio over value 250 without reconfiguring in LiteEdit can cause overflow of current measurement and improper function of controller!

For firmware version 1.5:

Decimal switching is not done via value of "CT ratio" setpoint, but in configuration window of LiteEdit software via icon „Units/Formats“:

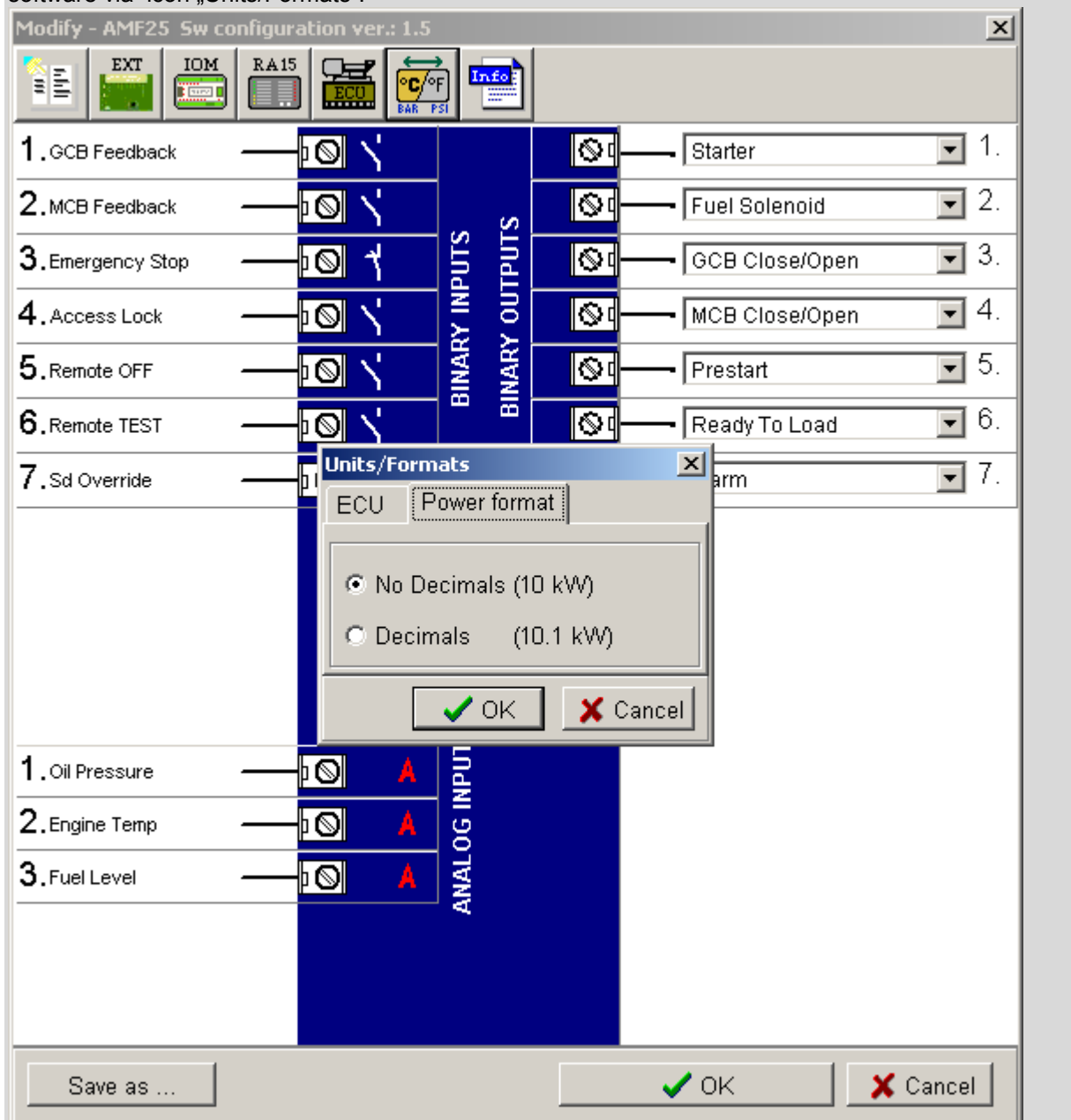

PT Ratio

[/1]

Gen-set potential transformers ratio.

Step: 0,1 V / V

Range: 0,1 – 500,0 V / V

NomVolts Ph-N [V]

Nominal generator voltage (phase to neutral)

Step: 1V

Range: 80 – 20000 V

Hint:

Phase sequence check is not possible to evaluate under voltage 50V what causes that if measured voltage 50V is within the allowed range, controller will not allow to close the GCB, even if relevant LED diod on front panel of IL-NT lits.

NomVolts Ph-Ph [V]

Nominal generator voltage (phase to phase)

Step: 1V

Range: 138 – 35000 V

Nominal Freq [Hz]

Nominal generator frequency (usually 50 or 60 Hz)

Step: 1Hz

Range: 45 – 65 Hz

Gear Teeth [-]

Number of teeth on the engine gear for the pick-up.

Set to zero, if no pick-up is used. Engine speed is counted from the generator frequency.

Step: 1

Range: 0 – 500

Hint:

Generator frequency can be used only when generator voltage (min 5V) is present before reaching of the firing speed (*Starting RPM*) after start.

Nominal RPM [RPM]

Nominal engine speed.

Step: 1RPM

Range: 100 – 4000 RPM

ControllerMode [OFF, MAN, AUT]

Equivalent to Controller mode changes by or buttons.

Hint:

Controller Mode change can be separately password protected.

Reset To MAN [ENABLED/DISABLED]

DISABLED: Controller stays in AUT mode after Fault reset .

ENABLED: Automatic switch from AUT (or TEST) to MAN Mode after Fault reset to avoid automatic engine start. This function is active for Shut down protection only.

ControllerAddr (1 .. 32) [-]

Controller identification number. It is possible to set controller address different from the default value (1) so that more IL controllers can be interconnected (via RS485) and accessed e.g. from Modbus terminal.

Hint:

When opening connection to the controller it's address has to correspond with the setting in PC tool. From LiteEdit it is only possible to connect to controllers with address 1.

COM1 Mode [DIRECT/MODEM/MODBUS/ECU LINK]

Communication protocol switch for the COM1 channel.

- DIRECT: LiteEdit communication protocol via direct cable.
 MODEM: LiteEdit communication protocol via modem.
 MODBUS: Modbus protocol. See detailed description in IntelliCommunication guide.
 ECU LINK: Protocol for communication with Cummins engines via Modbus.

Hint:

For details on communication speed and other technical parameters please see chapter [Technical Data](#).

For detail description see chapter [Modbus protocol](#). Since IL-NT version 1.3 controller supports register oriented modbus.

COM2 Mode [DIRECT/MODBUS/ECU LINK]

Communication protocol switch for the COM2 channel, if dual communication module is plugged in.

- DIRECT: LiteEdit communication protocol via direct cable.
 MODBUS: Modbus protocol. See detailed description in IntelliCommunication guide.
 ECU LINK: Protocol for communication with Cummins engines via Modbus.

Hint:

For details on communication speed and other technical parameters please see chapter [Technical Data](#).

For detail description see chapter [Modbus protocol](#). Since IL-NT version 1.3 controller supports register oriented modbus.

Hint:

Modbus TCP protocol using IB-Lite communication module requires setting [COM1 Mode](#) = DIRECT and [COM2 Mode](#) = MODBUS.

ModemIniString

If your modem needs some additional initialization AT commands (i.e. because of national telephony network differences), it can be entered here. Otherwise leave this setpoint blank.

ModbusComSpeed [9600,19200, 38400, 57600]

If the Modbus mode is selected on COM1 or COM2 channels, the Modbus communication speed in *bps* can be adjusted here.

ConnectionType [3Ph4Wire / 3Ph3Wire / Split Ph / Mono Ph]

- 3Ph4Wire: STAR Connection, 3 phases and neutral - 4 wires,
 Three phase "wye" measurement – 3PY, 3x CT's
 3Ph3Wire: DELTA Connection, 3 Phase without neutral - 3 Wires,
 Three phase "delta" measurement – 3PD, 3x CT's
 Split Phase: DOUBLE DELTA Connection, Split Phase,
 Single-phase measurement – 1PH, 1xCT
 Mono Phase: MONOPHASE,
 Single-phase measurement – 1PH, 1x CT

Hint:

For more details about connection types see [Voltage measurement and generator connection types](#)

Engine Params

Starting RPM [%]

"Firing" speed when IL controller stops cranking (starter goes OFF).

- Step: 1% of nominal RPM
 Range: 5 – 50 %

Starting Oil P [Bar]

When reached controller stops cranking (starter goes OFF).

Step: 0,1 bar
Range: 0,0 – 10,0

Hint:

There are three conditions for stop cranking: *Starting RPM*, *Starting Oil P* and *D+* (when enabled). Starter goes off when any of these conditions is void.

Prestart Time [s]

Time of closing of the PRE-START output prior to the engine start. Set to zero if you want to leave the output PRE-START open.

Step: 1s
Range: 0 – 600 s

MaxCrank Time [s]

Maximum time limit of cranking.

Step: 1s
Range: 1 – 60 s

CrnkFail Pause [s]

Pause between crank attempts.

Step: 1s
Range: 5 – 60 s

Crank Attempts [-]

Max number of crank attempts.

Step: 1
Range: 1 – 10

Idle Time [s]

Idle time delay starts when RPM exceeds *Starting RPM*. Start fail is detected when during Idle state RPM decreases below 2.

During the *Idle time* timer running the binary output *Idle/Nominal* is opened when it elapses the *Idle/Nominal* output closes. Binary output *Idle/Nominal* opens during Cooling period again.

Step: 1 s
Range: 0 – 600 s

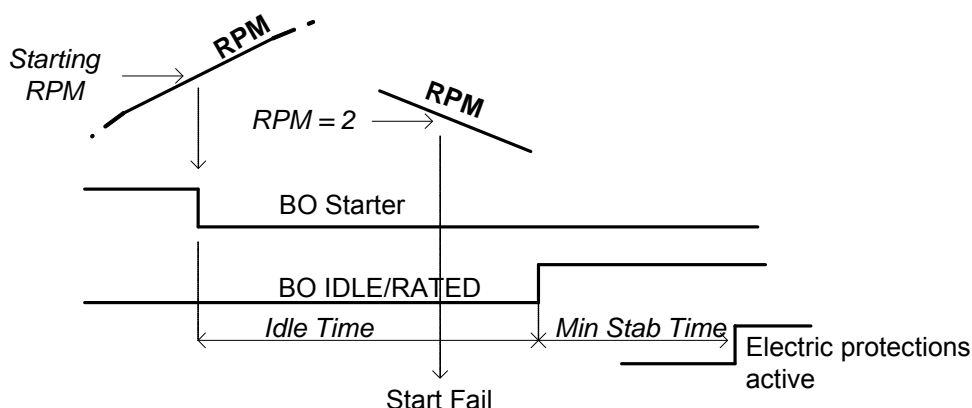

Hint:

If the IDLE function not supported on the governor, set the *Idle Time* nevertheless to minimum 5s to avoid *Underspeed* possibly caused by instability of the engine short after start.

Min Stab Time [s]

Minimum time after reaching of defined level of RPM to the closing GCB.

Step: 1s
Range: 1 – 300 (Max stab time) s

Max Stab Time [s]

Maximum time after start to get proper voltage level of the generator.

Step: 1s
Range: 1 (Min stab time) – 300 s

Hint:

When generator voltage within *Max Stab Time* does not reach defined limits (Generator protection group), an alarm occurs and the genset will shut down

Cooling Speed [IDLE/NOMINAL]

Selects the function of the Binary output IDLE/NOMINAL during engine Cooling state.

NOMINAL : Cooling is executed at Nominal speed and generator protections are active.

IDLE: Cooling is executed at Idle speed and generator protections are switched off.

Hint:

Binary output IDLE/NOMINAL must be configured and connected to speed governor. Engine Idle speed must be adjusted on speed governor

Cooling Time [s]

Runtime of the unloaded gen-set to cool the engine before stop.

Step: 1s
Range: 0 – 3600 s

Hint:

Cooling is executed at nominal speed and generator protections are active.

Stop Time [s]

Under normal conditions the engine must certainly stop within this period. The period starts by issuing stop command.

Step: 1s
Range: 0 – 240 s

Hint:

Stop of engine is detected when all following conditions are met: RPM <2, Oil pressure < *Starting Oil P*
Generator voltage < 10 VAC and D+ input isn't active.

Stop fail is detected when there is difference between those conditions, e.g RPM<2 and Generator voltage > 10V.

Fuel Solenoid [DIESEL / GAS]

Determines behavior of the Binary output FUEL SOLENOID.

DIESEL: Output closes 1 sec before Binary output STARTER.

The output opens if Emergency stop comes or Cooled gen-set is stopped and in pause between repeated starts.

GAS: Output closes together with Binary output IGNITION if RPM is over the *30 RPM (fix value)*.

Output opens after stop command or in pause between repeated start.

D+ Function [ENABLED/CHRGFAIL/DISABLED]

ENABLED: The D+ terminal is used for both functions – “running engine” detection and charge fail detection.

CHRGFAIL: The D+ terminal is used for charge fail detection only

DISABLED: The D+ terminal is not used.

Hint:

The magnetization current is provided independently on this setpoint value.
The D+ charge fail protection becomes active after **Engine Params: Idle Time** reaches zero.

ECU FreqSelect [PRIMARY/SECONDARY/DEFAULT]

This setpoint should be used only for Volvo and Scania engines.

Volvo – “Volvo Aux” is selected in ECU configuration:

Primary or secondary engine speed is set by *Frequency select* bits in **VP Status** frame.

Scania – “Scania S6 Singlespeed” is selected in ECU configuration:

Nominal engine speed is chosen by *Nominal speed switch 1* and *2* from **DLN1** frame when the engine is running on nominal speed, i.e. binary output *Idle/Nominal* is active. When the output is not active (engine is running on Idle speed), the setpoint *ECU FreqSelect* is not taken into account.

Frequency change for Volvo Penta engines with EMS2

This description refers to the Volvo Penta Application bulletin 30-0-003.

The procedure for changing engine speed on the D9 and D16 engines is different from the D12 engine.

There is no system reset on the EMS2 unit; therefore the procedure is changed.

Procedure if ECU not energized:

1. Switch the IL controller to MAN Mode.
2. Power up the ECU.
3. Change the setpoint *ECU FreqSelect* and confirm it by pressing Enter
4. Press the Stop button on the IL controller.

The whole procedure (step 2 to 4) must not exceed **10 seconds**.

Procedure with ECU powered on:

1. Switch the IL controller to MAN Mode.
2. Press the Stop button on the IL controller.
3. Change the setpoint *ECU FreqSelect* and confirm it by pressing Enter
4. Press the Stop button on the IL controller.

The whole procedure (step 2 to 4) must not exceed **10 seconds**.

ECU SpeedAdj [%]

Enables to adjust engine speed in ECU via CAN bus. Nominal speed corresponds to 50%.

Step: 1%

Range: 0 – 100%

Hint:

The minimum value 0% is equal to 90% of nominal speed. Maximum value 100% is equal to 110% of nominal speed.

Fuel Pump ON [%]

When the actual value of Fuel Level is lower or equals to this value then the binary output Fuel Pump is activated.

Step: 1

Range: 0 – 100 %

Fuel Pump OFF [%]

When the actual value of Fuel Level is higher or equals to this value then the binary output Fuel Pump is deactivated.

Step: 1

Range: 0 – 100 %

Hint:

The two setpoints above are compared to Analog Input 3 (usually used for Fuel Level)
It is a prerequisite for this function to use a fuel level sensor at this analog input.

TempSwitch ON [-]

Threshold level for switching on the binary output TempSwitch. This function is connected with controller's analog input 2.

Step: 1
Range: -100 .. 10000 [-]

TempSwitchOFF [-]

Threshold level for switching off the binary output TempSwitch. This function is connected with controller's analog input 2.

Step: 1
Range: -100 .. 10000 [-]

Hint:

The description of Power Switch function is in chapter [Binary outputs - list](#) at [Temp Switch](#).

PowerSwitch ON [kW]

Threshold level for switching the binary output "Power Switch" on.

Step: 1
Range: 0 – 32000 kW

PowerSwitchOFF [kW]

Threshold level for switching the binary output "Power Switch" off.

Step: 1
Range: 0 – 32000 kW

Hint:

The description of Power Switch function is in chapter [Binary outputs - list](#) at [Power Switch](#).

Engine Protect

ProtectHoldOff [s]

During the start of the gen-set, some Engine Protections have to be blocked (e.g. Oil pressure). The protections are unblocked after the *ProtectHoldOff* time. The time starts after reaching *Starting RPM*.

Step: 1s
Range: 0 – 300 s

Hint:

The protections sequence diagram can be found in [Alarm time chart](#) in chapter [Alarm Management](#). It displays when and what protections are active.

Horn Timeout [s]

Max time limit of horn sounding. Set to zero if you want to leave the output HORN open. Horn timeout starts again from the beginning if a new alarm appears before previous Horn timeout has elapsed.

Step: 1s
Range: 0 – 600 s

Overspeed [%]

Threshold for over speed protection

Step: 1% of nominal RPM
Range: 100 – 150%

Hint:

The Overspeed protection value is increasing from 115 % to 125% of nominal RPM for the duration of 5sec (ProtectHoldOff delay). ProtectHoldOff delay takes place during the start of the gen-set when some engine protections have to be blocked. This delay starts after reaching 25% of nominal RPM. It holds true if the value GeerTeeth = 0.

AI1 Wrn [Bar]

Warning threshold level for ANALOG INPUT 1

Step: 0,1 bar

Range: -10 – 1000

AI1 Sd [Bar]

Shutdown threshold level for ANALOG INPUT 1

Step: 0,1 bar

Range: -10 – 1000

AI1 Del [s]

Delay for ANALOG INPUT 1

Step: 1 s

Range: 0 – 900 s

Hint:

First analog input is dedicated to Oil Pressure measurement. It is not supposed to be used for measurement of other values.

AI2 Wrn []

Warning threshold level for ANALOG INPUT 2

Step: 1 °C

Range: -100 – 10000

AI2 Sd []

Shutdown threshold level for ANALOG INPUT 2

Step: 1 °C

Range: -100 – 10000

AI2 Del [s]

Delay for ANALOG INPUT 2 alarm.

Step: 1 s

Range: 0 – 900 s

AI3 Wrn []

Warning threshold level for ANALOG INPUT 3

Step: 1 %

Range: -100 – 10000

AI3 Sd []

Shutdown threshold level for ANALOG INPUT 3

Step: 1 %

Range: -100 – 10000

AI3 Del [s]

Delay for ANALOG INPUT 3

Step: 1 s

Range: 0 – 900 s

Batt Undervolt [V]

Warning threshold for low battery voltage.

Step: 0,1 V
Range: 8V – 40 (Battery >Volts)

Batt Overvolt [V]

Warning threshold for hi battery voltage.

Step: 0,1 V
Range: 8V – 40 (Battery <Volts)

Batt Volt Del [s]

Delay for low battery voltage alarm.

Step: 1s
Range: 0 – 600 s

WrnMaintenance [h]

Counts down when engine running. If reaches zero, an alarm appears. When the value 10000 is set, than the Maintenance function is disabled and counter does not count. Counter value disappear in controllers statistics. Maximum value for running countdown is 9999.

Step: 1h
Range: 0 – 10000 h

Gener Protect

Hint:

All electric protections when activated result in shutdown.

Overload [%]

Threshold for generator overload (in % of Nominal power)

Step: 1% of Nominal power
Range: 0 – 200%

Overload Del [s]

Delay for generator overload alarm.

Step: 0.1s
Range: 0 – 600.0 s

Short Crct Sd [%]

Shutdown occurs when generator current reaches *Short Crct Sd* limit.

Step: 1 % of Nominal current
Range: 100 - 500 %

Short Crct Del [s]

Delay for generator shorcurrent alarm.

Step: 0.01s
Range: 0.00 – 10.00 s

***Amps IDMT Del [s]**

IDMT curve shape selection. *Amps IDMT Del* is Reaction time of IDMT protection for 200% overcurrent $I_{gen} = 2 * Nomin Current$.

Step: 0,1 s
Range: 0,1 - 60,0 s

IDMT is "very inverse" generator over current protection. Reaction time is not constant but depends on generator over current level according following formula.

$$\text{Reaction time} = \frac{\text{Amps IDMT Del} * \text{Nomin Current}}{\text{Igen} - \text{Nomin Current}}$$

Hint:

Reaction time is limited up to 900 sec = 15 minutes. IDMT protection is not active for Reaction time values longer than 15 minutes.

Igen is maximal value of all measured phases of generator current.

EXAMPLE of Reaction time for different over current levels. Values in column 200% are *IDMT Curr Del*.

	Overcurrent			
	200 % = IDMT Curr Del	≤ 100 %	101 %	110 %
Reaction time	0,2 s	No action	20 s	2 s
	2 s	No action	200 s	20 s
	20 s	No action	No action (time > 900 s)	200 s

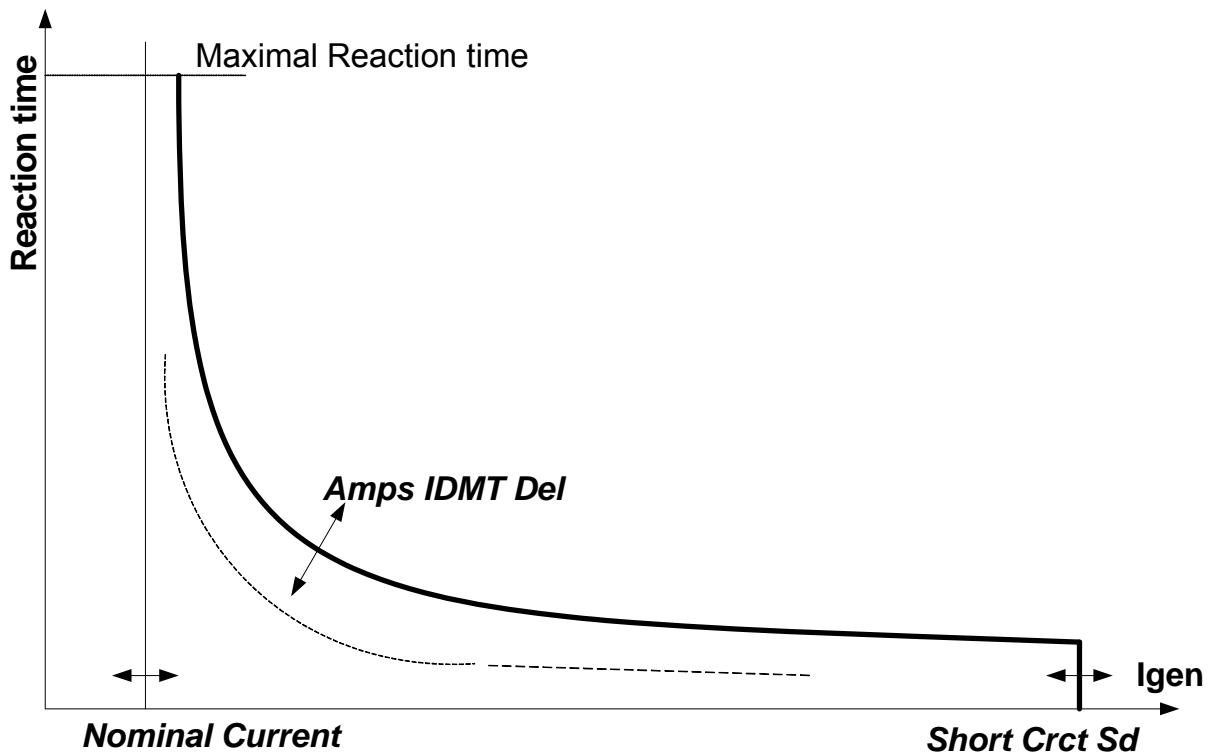

Amps Unbal Sd [%]

Threshold for generator current asymmetry (unbalance).

Step: 1% of Nominal current

Range: 1 – 200% of Nominal current

Amps Unbal Del [s]

Delay for generator current unbalance

Step: 0.1 s

Range: 0.0 – 600.0 s

Gen >V Sd [%]

Threshold for generator overvoltage. All three phases are checked. Maximum out of three is used.

Step: 1% of Nominal voltage

Range: 0(Gen <V Sd) – 200%

Gen <V Sd [%]

Threshold for generator undervoltage. All three phases are checked. Minimum out of three is used.

Step: 1% of Nominal voltage

Range: 0% – 200 (Gen >V Sd)%

Gen V Del [s]

Delay for generator undervoltage and overvoltage alarm

Step: 0.1s

Range: 0.0 – 600.0 s

Volt Unbal Sd [%]

Threshold for generator voltage unbalance alarm.

Step: 1% of Nominal voltage

Range: 0 – 200% of Nominal voltage

Volt Unbal Del [s]

Delay for generator voltage unbalance alarm.

Step: 0.1s

Range: 0.0 – 600.0 s

Gen >Freq Sd [%]

Threshold for generator phase L3 overfrequency.

Step: 0.1% of Nominal frequency

Range: 0 (Gen <Freq Sd) – 200.0% of Nominal frequency

Gen <Freq Sd [%]

Threshold for generator phase L3 underfrequency.

Step: 0.1% of Nominal frequency

Range: 0.0 – 200 (Gen >Freq Sd) % of Nominal frequency

Gen Freq Del [s]

Delay for generator underfrequency and overfrequency alarm.

Step: 0.1s

Range: 0.0 – 600.0 s

Date/Time

Some of parameters in this group are only available at specific models of IL-NT.

***Time Stamp Per** [min]

Time interval for periodic history records.

Step: 1 min

Range: 0 – 200min

Hint:

Time stamps are only recorded into history while gen-set is running. When is engine stopped there are no time stamps records made.

***#SummerTimeMod [DISABLED / WINTER / SUMMER, WINTER-S, SUMMER-S]**

DISABLED: Automatic switching between summer and wintertime is disabled.

WINTER (SUMMER) : Automatic switching between summer and wintertime is enabled and it is set to winter (summer) season.

WINTER-S (SUMMER-S) : Modification for southern hemisphere.

***#Time [HHMMSS]**

Actual real time

***#Date [DDMMYYYY]**

Actual date.

***Timer1..2Function [No Func/TEST/TEST OnLd/MFail Bk/Mode OFF]**

It is possible to choose out of 3 following Timer functions. Binary output Exerc Timer X is always activated when Timer is active regardless of chosen Timer function. Timer functions require controller running in AUT mode.

No Func: There is no any other function, but binary output Timer1..2 activation.

Auto Run: When this option is chosen then the Timer output is also internally connected to the Remote start binary input.

Mode OFF: When this option is chosen then the Timer output is also internally connected to the Remote OFF binary input.

***Timer 1..2 Repeat**

[NONE/MONDAY/TUESDAY/WEDNESDAY/THURSDAY/WEDNESDAY/FRIDAY/SATURDAY/SUNDAY/MON-FRI/MON-SAT/MON-SUN/SAT-SUN]

Defines TIMER 1 activation. Binary output TIMER 1 is internally linked with Rem Start/Stop binary input. Refer to binary inputs for details.

NONE: Timer function is disabled

MONDAY, TUESDAY, WEDNESDAY, THURSDAY, WEDNESDAY, FRIDAY, SATURDAY, SUNDAY: Timer is activated on daily basis.

MON-FRI, MON-SAT, SAT-SUN: Timer is activated on selected day interval.

***Timer1..2 ON Time**

Day time when Timer output activates.

***Timer1..2Duration**

Duration of Timer output is active.

Step: 1 min

Range: 1 – 1440 s

Test Period

Duration of testing run timer. This timer will run the engine with specified period for specified time duration. Timer starts at time of restarting the controller, or during start of engine with transition from Idle to Running state.

This setpoint is only available at models IL-NT MRS10 and MRS11.

Step: 1 day

Range: 1 – 240 days

Test Duration

Duration of testing run of engine.

This setpoint is only available at models IL-NT MRS10 and MRS11.

Step: 1 min
Range: 1 – 240 min

Sensors spec

AI1,AI2,AI3Calibration [...]

Calibrating constant to adjust the measured value of IL analog inputs. Physical dimension of calibrating constant is corresponding to Analog input.

Step: 1
Range: -1000 – +1000

Hint:

Calibration constants have to be adjusted when measured value is near the alarm level. User curves can be defined by LiteEdit software.

*Extension I/O

IOM AI1..4 Wrn []

The warning level for IOM ANALOG INPUT 1..4 alarm detection.

Step: 1
Range: -100 - +10000

IOM AI1..4 Sd []

The shutdown level for IOM ANALOG INPUT 1..4 alarm detection.

Step: 1
Range: -100 - +10000

IOM AI1..4 Del [s]

Delay for IOM ANALOG INPUT 1..4 alarm.

Step: 1 s
Range: 0 - 900 s

Hint:

IG-IOM/IGS-PTM analog inputs protection alarms can be configured following way

Configuration	Protection
Under	Protection is activated only when measured value is under measured level.
Over	Protection is activated only when measured value is over measured level.
Under+fls	Level 2 protection is activated by Sensor Fail as well.
Over+fls	Level 2 protection is activated by Sensor Fail as well.

IOM AI1..4 Calibr [...]

Calibrating constant to adjust the measured value of IOM/PTM analog inputs. Physical dimension of calibrating constant is corresponding to Analog input.

Step: 1
Range: -1000 – +1000

SMS/E-Mail

Remote alarm messaging

If a GSM modem and/or Internet bridge is connected to the controller, the controller can send SMS messages and/or emails in the moment when a new alarm appears in the Alarm list. The message will contain a copy of the Alarm list.

To enable this function, you should select with setpoints Yel Alarm Msg and Red Alarm Msg, which levels of alarms shall be announced (red/yellow/both) and also enter valid GSM phone number and/or e-mail address to the setpoints TelNo/Addr Ch1 and TelNo/Addr Ch2. It is possible to put either a GSM number or e-mail to both setpoints.

NOTE:

An internet module must be available for sending of e-mails. Similarly, a GSM modem is necessary for sending of SMS.

Hint:

There are 5 attempts for any active call (SMS/E-Mail). Timeout for connection is 90 sec and after 120 sec controller starts the next attempt. During the time the IL-NT is trying to send an active call type, incoming calls are blocked.

Yel Alarm Msg [DISABLED, ENABLED]

Set this setpoint to YES if you want to get messages when a **yellow** (warning) alarm occurs.

Hint:

The target address (GSM phone number or e-mail address) must be set correctly to the setpoint(s) TelNo/Addr Ch1 resp. TelNo/Addr Ch2.

Red Alarm Msg [DISABLED, ENABLED]

Set this setpoint to YES if you want to get messages when a **red** (shutdown) alarm occurs.

Hint:

The target address (GSM phone number or e-mail address) must be set correctly to the setpoint(s) TelNo/Addr Ch1 resp. TelNo/Addr Ch2.

TelNo/Addr Ch1, 2

Enter either a valid GSM phone number or e-mail address to this setpoint, where the alarm messages shall be sent. Type of active call is considered from the value of this parameter. If it consist „@“ it is supposed to be e-mail address and active e-mail is sent. If the value is number, without „@“, it is supposed to be the telephone number and active SMS is sent.

Hint:

For GSM numbers use either national format (i.e. like number you will dial if you want to make a local call) or full international format with "+" character followed by international prefix in the begin.

This setpoint can be modified from PC only!

*ECU-controlled engine support

There exists only one firmware branch for both standard and electronic controlled (monitored) engines.

Presence of the ECU on the CAN bus/RS232 is configured via LiteEdit like other peripherals (IG-IOM,



IGL-RA15). Pressing the  button in Configuration window of LiteEdit opens ECU dialog window where the appropriate engine/ECU type should be selected. The actual list of ECU types is available on ComAp website in "ECU list - x.y.iwe" package. Download this package and import it into LiteEdit in the same way as standard firmware IWE package.

More information about ECU list packages, configuration and wiring recommendations can be found in *Comap Electronic Engines Support* manual.

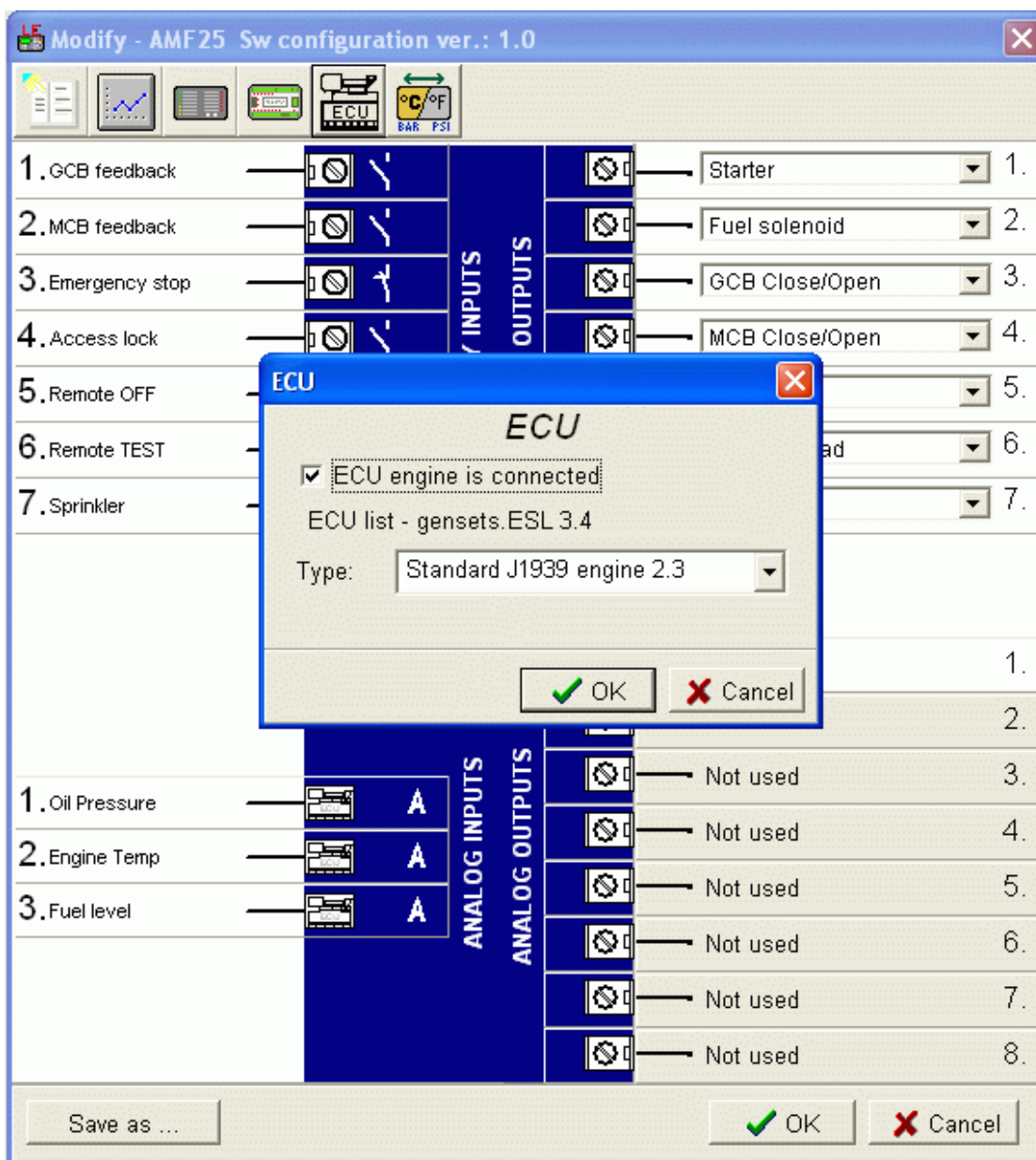

If the connected engine is Cummins with GCS engine control unit communicating via Modbus it is

necessary to set the setpoint **Basic settings**: *COM1 Mode* = ECU LINK or *COM2 Mode* = ECU LINK.

Loss of communication causes a warning alarm. On the contrary the ECU can be switched off at quiescent engine that means not-communicating ECU is in that moment normal situation. All values from ECU shall show ####, but no alarm is displayed. The output *ECU Comm OK* follows the real situation which means it is not active anytime when the ECU does not communicate.

The output *ECU PowerRelay* closes at the beginning of prestart and opens if the engine shall be stopped. It can be used to switch the ECU on and off. If the putput is configured but not active the ECU communication alarm is blocked.

The engine is started via standard contact output or via CAN bus depending on ECU capabilities.

Identifying configured ECU

It is possible to identify what ECU is currently configured in IL-NT (FW version ≥ 1.5) controller on init screens. Navigate to default screen with gauge and press buttons **PAGE** and **ENTER** at the same time. Than browse through inits screen by button **PAGE** until you find value "ESF:xx.y - (zzz)", where xx.y = ESF version number, zzz= Motor ID.

Explanation of Motor ID is in table below:

Motor ID	ESF - Electronic Engine
1	Volvo EMSI Singlespeed / EMSII
3	Scania S6 Singlespeed
4	Cummins CM570
5	Cummins MODBUS
7	John Deere
8	Deutz EMR2
9	DDC DDEC IV/V
10	Caterpillar J1939
12	Perkins ECM
14	Iveco NEF&Cursor
16	Scania S6 Singlespeed from ver.1794335
18	SISU EEM3 Gen-set
20	MTU ADEC J1939
25	Deutz EMR3
26	Cummins CM850
28	Iveco Vector
29	MAN MFR
31	VM Marine
32	VM Industrial
35	GM SECM
36	ISUZU ECM
44	E-control ECU
255	Standard J1939 engine

Values read from ECU

There is fixed set of values read from J1939 ECU by IL-NT controller:

- Engine speed (frame EEC1)
- Engine oil pressure (frame Engine Fluid Level/Pressure)
- Engine coolant temperature (frame Engine Temperature)
- Total engine hours (frame Engine Hours, Revolutions)
- Fuel rate (frame Fuel Economy)
- Boost pressure (frame Inlet/Exhaust Conditions)

- Intake manifold 1 temperature (frame Inlet/Exhaust Conditions)
- Engine oil temperature 1 (frame Engine Temperature 1)

When “ECU LINK”-Modbus option is selected, following values are read from Modbus Register Data (for QSK15, QSK45, QSK60):

- Engine Speed (Register Address:30001)
- Oil Pressure (Register Address:30003)
- Coolant Temperature (Register Address:30002)
- Engine Running Time (Register Address:30008-30009)
- Fuel Consumption Rate (Register Address:30018)
- Intake Manifold Absolute Pressure (Register Address:30530 (QSK45, QSK60 only))
- Intake Manifold Temperature (Register Address:30531 (QSK45, QSK60 only))

Hint:

Values read from ECU are not written to history besides the fault codes.

Diagnostic messages read from ECU

Diagnostic messages are read and displayed in extra ECU Alarm list. For Standard J1939 SPN (Suspect Parameter Number), FMI (Failure Mode Identifier) and OC (Occurrence Counter) are shown together with text description if available.

One SPN (Suspect Parameter Number) / FMI (Failure Mode Identify) couple describes one fail information. If FMI is equal to 0 or 1, WRN is displayed in the ECU Alarm list. For any other FMI values, FLS is displayed.

Detail SPN/FMI code specification see in:

- SAE Truck and Bus Control and Communications Network Standards Manual, SAE HS-1939 Publication
- Or refer to corresponding engine manufacturer’s ECU error codes list.

Complete list of text diagnostic messages for each ECU can be found in *Comap Electronic Engines Support* manual.

Hint:

InteliLite controller doesn’t support J1587 diagnostic line on Volvo engines. This can cause in some cases a J1939 alarm message FC:000608 due to missing J1587 bus. Contact your Volvo distributor to update ECU firmware.

For Scania engines the fault codes are displayed in hexadecimal format.

Analog inputs

Reading of mentioned values from ECU enables to use analog inputs of the unit for other purposes, e.g. measuring, displaying and alarm activation related to various quantities. The configuration thus allows to use three analog inputs on the central unit and four analog inputs on IG-IOM/IGS-PTM module if connected.

Connection description

The following diagrams show how to connect the engine control unit to the IntelliLite controller:

Engines with J1939 support started via CAN bus

VOLVO PENTA engines (EMS II, EDC III units)

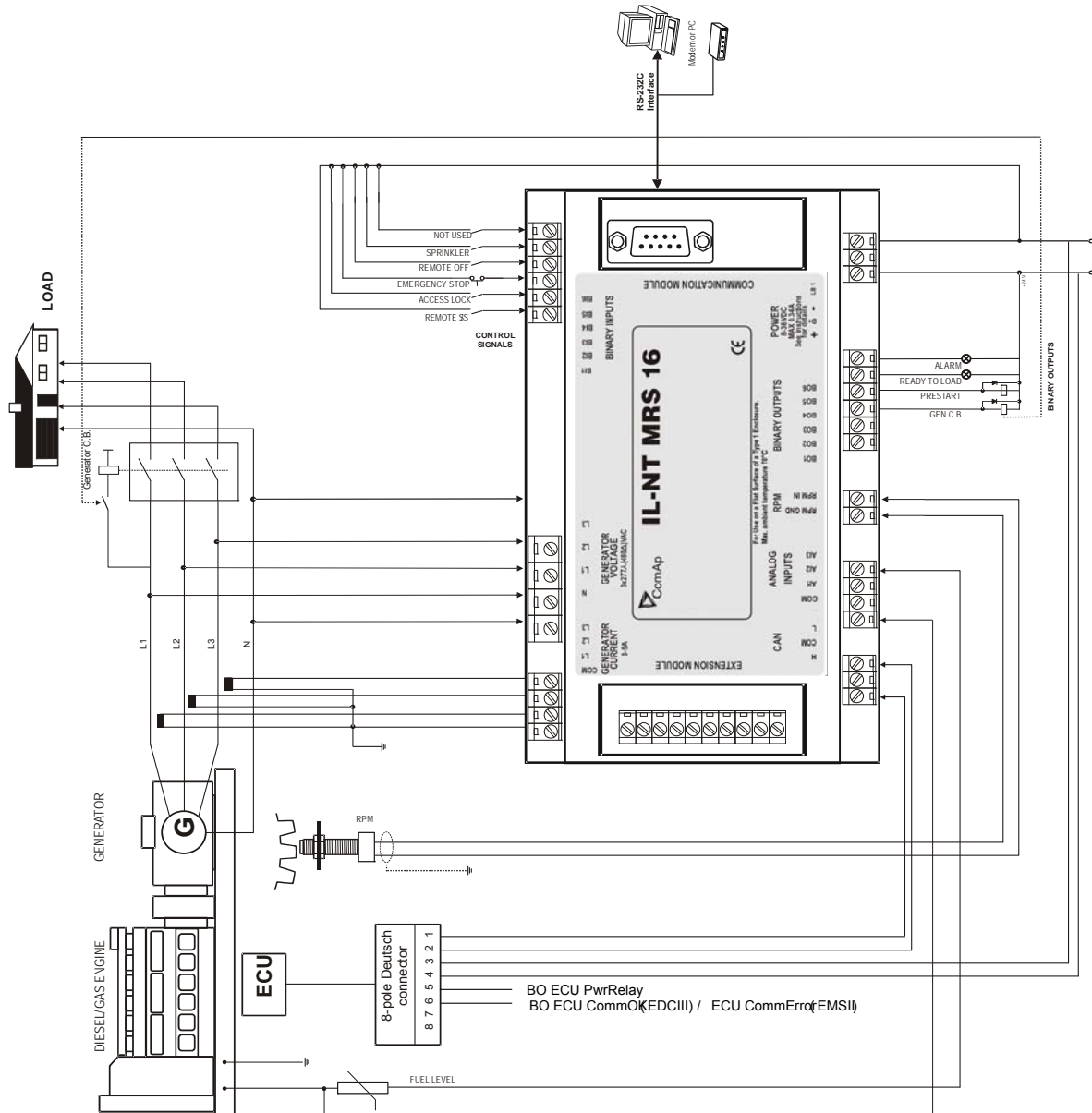

SCANIA S6

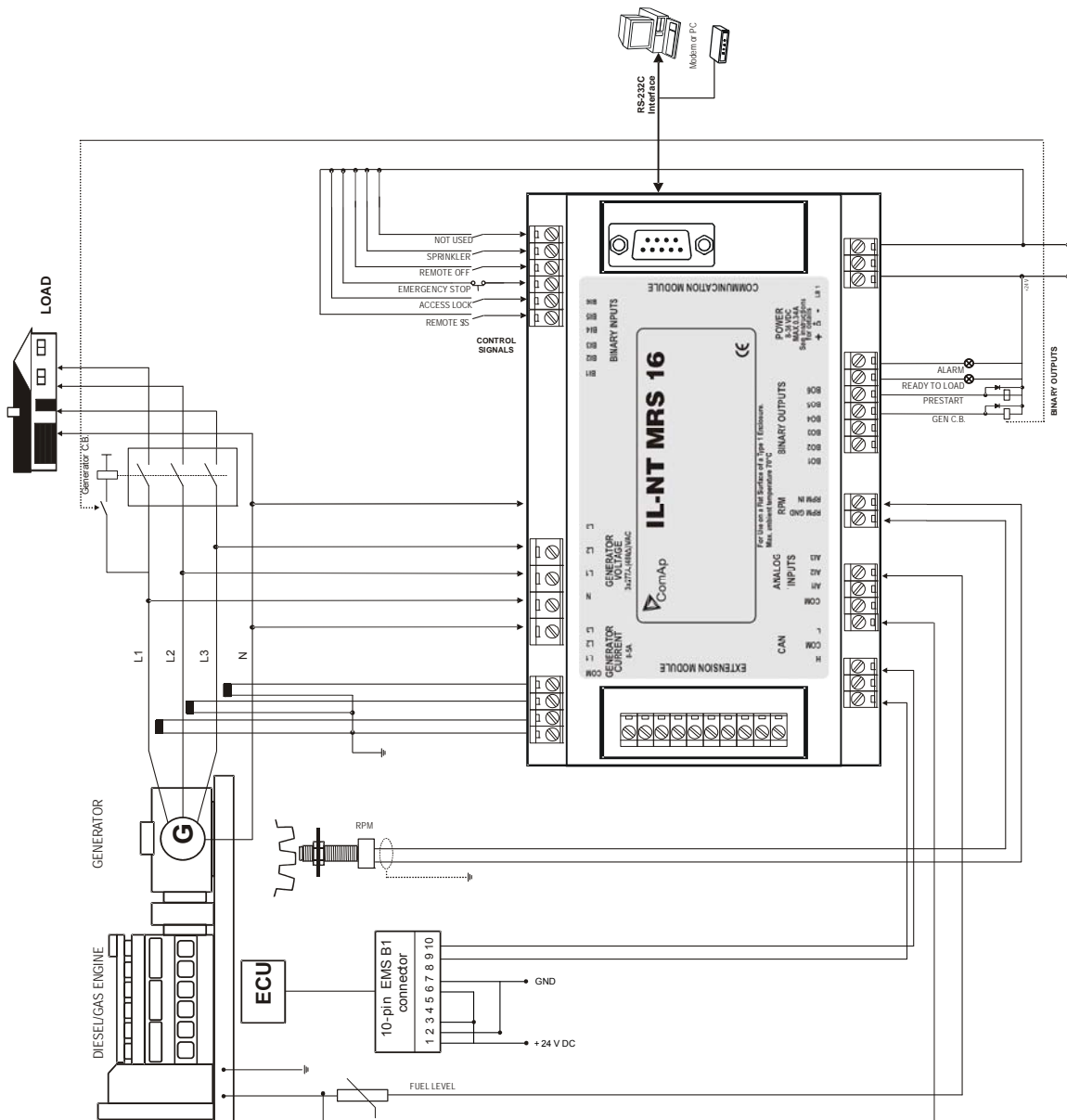

Cummins engines with MODBUS communication

InteliLite set up:

Basic settings: COM1 Mode = ECU LINK or COM2 Mode = ECU LINK

Software configuration: ECU → ECU engine is connected → Type: Cummins MODBUS

RS232/RS485 converter (see following diagram) set up:

Data format settings (SW1) 11 bits (1 start bit, 8 data bits, 2 stop bits)

Baud rate settings (SW2) 9600 bps

(more info available on http://www.advantech.com/products/Model_Detail.asp?model_id=1-D6FLH)

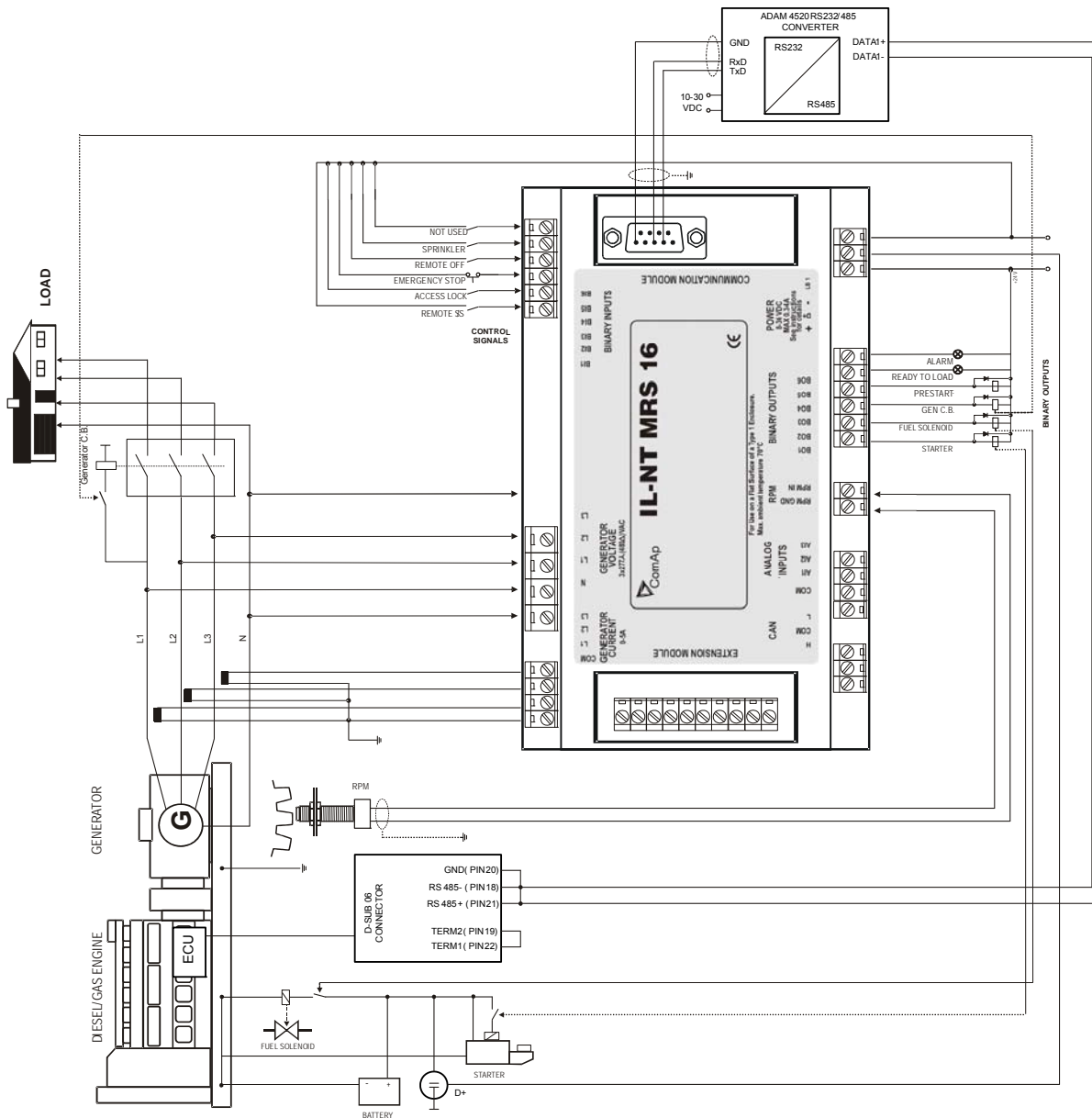

Sensor Specification

Background of the sensor calibration

To correct measuring error of each analog input (pressure, temperature, level) calibrating constants within 10 % of measure range should be set. Two calibrating constants are set in physical units - bar, °C, % .Calibration is made by adding the value of setpoint *AlxCalibration* directly to the calculated value at analog input.

Hint:

The calibration must be done at the operational point of the analog input (e.g. 80°C, 4.0Bar etc..)

Default sensor curves

There are 20 resistive curves available. The following table provides information on minimum/maximum values of respective sensors. Actual values especially of temperature curves may differ. Meaning is to prolong curve to the lower temperature values, so the cold engine will not raise alarm fail sensor.

Curve	Min Value	Max Value	Unit
Datcon 5 Bar	0	5	Bar
Datcon 7 Bar	0	7	Bar
Datcon 10 Bar	0	10	Bar
Datcon 80 Psi	0	80	Psi
Datcon 100 Psi	0	100	Psi
Datcon 150 Psi	0	150	Psi
Datcon Low °C	25	150	°C
Datcon High °C	25	160	°C
Datcon Low °F	80	300	°F
Datcon High °F	80	320	°F
Datcon Fuel %	0	100	%
VDO 5 Bar	0	5	Bar
VDO 10 Bar	0	10	Bar
VDO 72 Psi	0	72	Psi
VDO 145 Psi	0	145	Psi
VDO 40-120 °C	40	120	°C
VDO 50-150 °C	50	150	°C
VDO 100-250 °F	100	250	°F
VDO 120-300°F	120	300	°F
VDO Fuel %	0	100	%

Hint:

When measured value is 6% out of range the Sensor Fail FLS is detected. You can find detail information on sensors in LiteEdit Reference Guide.

Function Description

OFF Mode

No start of the gen-set is possible. Outputs STARTER, GCB CLOSE/OPEN and FUEL SOLENOID are not energized.

No reaction if buttons **START**, **STOP**, **GCB ON/OFF** are pressed.

MAN Mode

START - starts the gen-set.

GCB ON/OFF

- The controller closes GCB.
- The controller opens GCB when closed.
- If the generator voltage is out of the limits, the controller does not to respond to the **GCB ON/OFF**

STOP stops the gen-set.

Hint:

The engine can run without load unlimited time.

The controller does not automatically stop the running gen-set in MAN Mode.

The controller does not start the gen-set when binary input REM START/STOP is closed.

Start-stop sequence (simplified)

MODE = MAN (Engine start/stop request is given by pressing buttons **START** and **STOP**)

MODE = AUT (Engine start/stop request is evaluated form Mains failure/return)

State	Condition of the transition	Action	Next state
Ready	Start request	PRESTART on <i>Prestart Time</i> counter started	<i>Prestart</i>
	RPM > 2 or Oil pressure detected or Gen voltage > 10V or D+ active		<i>Stop (Stop fail)</i>
	OFF Mode selected or Shut down alarm active		<i>Not Ready</i>
Not Ready	RPM < 2, Oil pressure not detected, Vgen < 10V, D+ not Active no shutdown alarm active, other than OFF Mode selected		<i>Ready</i>
Prestart ³	<i>Prestart time elapsed</i>	STARTER on FUEL SOLENOID on ⁴ <i>MaxCrank Time</i> counter started	<i>Cranking</i>
Cranking ³	RPM > Starting RPM	STARTER off PRESTART off	<i>Starting</i>
	D+ input activated or oil pressure detected or Gen voltage > 25% Vgnom or D+ active for 1s	STARTER off PRESTART off	<i>Cranking</i>

State	Condition of the transition	Action	Next state
	MaxCrank Time <i>elapsed, 1st attempt</i>	STARTER off FUEL SOLENOID off STOP SOLENOID on CrankFail Pause timer started	Crank pause
	MaxCrank Time <i>elapsed, last attempt</i>	STARTER off PRESTART off	Shutdown (Start fail)
Crank pause ³	CrankFail Pause <i>elapsed</i>	STARTER on FUEL SOLENOID on ⁴ STOP SOLENOID off MaxCrank Time counter started	Cranking
Starting ³	80% Nominal RPM <i>reached</i>	READY TO LOAD on ¹ Min, Max Stab Time counter started	Running
	RPM = 0 or any other shutdown condition	FUEL SOLENOID off STOP SOLENOID on	Shutdown
	60 sec. <i>Elapsed</i>	FUEL SOLENOID off STOP SOLENOID on	Shutdown (Start fail)
Running	Stop request	READY TO LOAD off Cooling Time timer started	Cooling
	RPM = 0 or any other shutdown condition	READY TO LOAD off ² FUEL SOLENOID off	Shutdown
	GCB CLOSE/OPEN <i>closed</i>		Loaded
Loaded	GCB CLOSE/OPEN <i>opened</i>		Running
	RPM = 0 or any other shutdown condition	FUEL SOLENOID off STOP SOLENOID on READY TO LOAD off	Shutdown
Cooling	Cooling Time <i>elapsed</i>	FUEL SOLENOID off STOP SOLENOID on	Stop
	RPM = 0 or any other shutdown condition	FUEL SOLENOID off STOP SOLENOID on	Shutdown
	Start request	READY TO LOAD on ¹	Running
Stop	RPM = 0, Oil pressure not detected, Vgen < 10V, D+ not active		Ready
	60 sec. <i>Elapsed</i>		Stop (Stop fail)

¹ if all generator parameters OK and Min Stab Time elapsed, indicates that GCB is possible to close. In AUTO Mode closes in this moment GCB automatically.

² If GCB output used GCB opens automatically

³ The start-up sequence can be interrupted in any time by comming stop request

⁴ Fuel solenoid is switched on with time advance of 1s fixed before starter motor is switched on.

Hint:

Threshold level for D+ input is 80% supply voltage, activation delay is 1s (to override short firings during cranking – for example in cold conditions).

AUT mode

The controller does not respond to buttons **START**, **STOP**, **GCB ON/OFF**. Engine start/stop request is given by binary input REM START/STOP.

Alarm Management

Following alarms are available:

- Sensor Fail
- Warning
- Shut down

Sensor Fail (FLS)

Sensor Fail of analog inputs is detected in three ways. First when measured resistance value is lower than half of the lowest point of sensor characteristics. Second when measured resistance value is higher than 112,5% of highest point of sensor characteristics. Or when data from ECU are missing.

Sensor Fail is indicated by ##### symbol instead measured value.

Sensor Fail is only evaluated for values of sensor curve within range 1..14999Ohm.

When the sensor characteristic curve consists values “0” or “15000”, the sensor fault for shortcircuit/sensor fail is not evaluated.

Maximum allowable resistance value for sensor characteristics is 15000 Ohms.

Warning (WRN)

When warning comes up, only alarm outputs and common warning output are closed.

Possible warnings:

See [List of possible events](#)

Shut down (SD)

When the shut-down alarm comes up, IntelliLite opens outputs GCB CLOSE/OPEN, FUEL SOLENOID, STARTER and PRESTART to stop the engine immediately. Alarm outputs and common shutdown output are closed. Active or not reset protection disables start.

Possible shut-down alarms:

See [List of possible events](#)

Alarm time chart

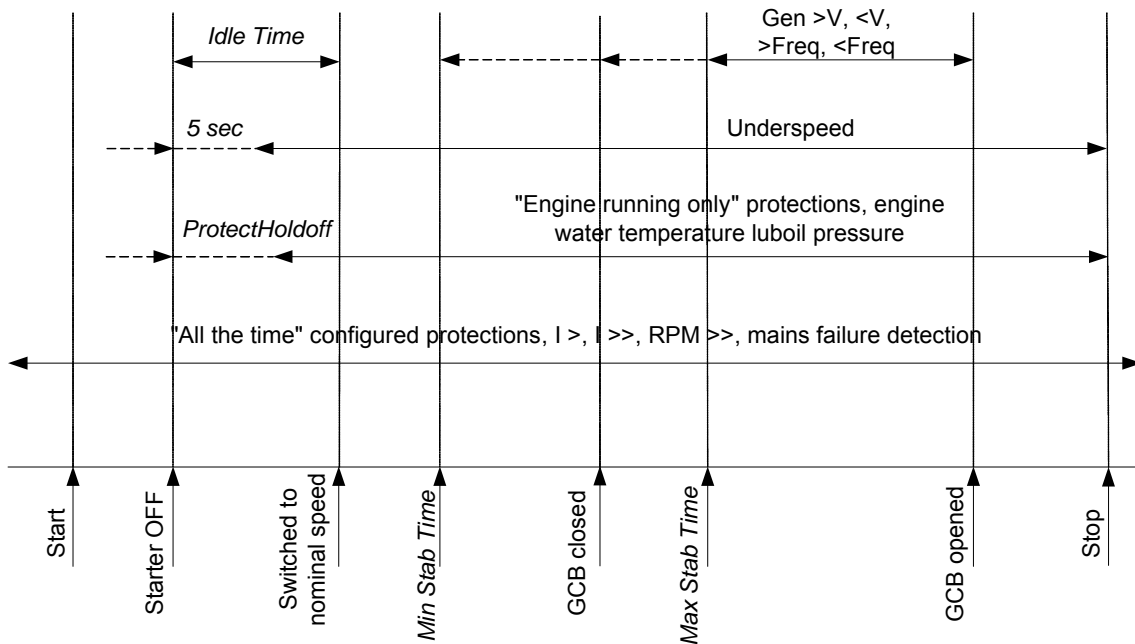

Voltage phase sequence detection

InteliLite controller detects phase sequence on generator voltage terminals. This protection is important after controller installation to avoid wrong voltage phases phase connection. Following alarms can be detected:

Wrong phase sequence

There is fix defined phase sequence in InteliLite controller L1, L2, L3. When the phases are connected in different order (e.g. L1,L3,L2 or L2,L1,L3) following alarms are detected:

Gen CCW Rot = wrong generator phase sequence

Hint:

Phase sequence detection is active when voltage in all three phases is >50VAC and all phases angles are in the range $120^\circ \pm 20$.

Phase sequence alarm detection is 1 sec delayed to avoid transient effects.

Sensor Fail detection

Sensor Fail FI is detected when measured value is 6 percent out of range. Controller screen displays in this case string ##### instead measured value.

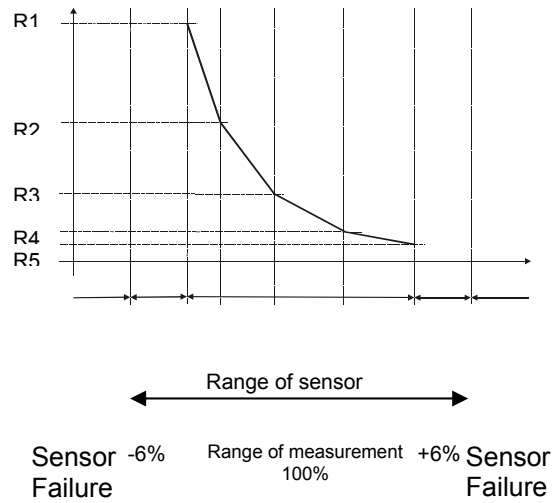

Gen-set Operation States

Engine state machine

Init	Autotest during controller power on
Not ready	Genset is not ready to start
Prestart	Prestart sequence in process, Prestart output is closed
Cranking	Engine is cranking
Pause	Pause between start attempts
Starting	Starting speed is reached and the <i>Idle timer</i> is running
Running	Genset is running at nominal speed
Loaded	Genset is running at nominal speed and GCB OPEN/CLOSE is closed
Stop	Stop
ShutDowns	Shut-down alarm activated
Ready	Genset is ready to run
Cooling	Genset is cooling before stop
EmergMan	Emergency Manual gen-set operation

Electric state machine

MinStabTO	Minimal Stabilization Timeout
MaxStabTO	Maximal Stabilization Timeout
Trans Del	Forward return break delay. Delay between GCB opening and MCB closing

List of possible events

Events specification	Protection type	Information on binary output available (See list of Binary outputs)	Description
A11 Wrn	WRN	YES	Value measured on analog input 1 is lower than <i>A11 Wrn</i> setpoint.
A11 Sd	SD	YES	Value measured on analog input 1 is lower than <i>A11 Sd</i> setpoint.
A12 Wrn	WRN	YES	Value measured on analog input 2 is greater than <i>A12 Wrn</i> setpoint.
A12 Sd	SD	YES	Value measured on analog input 2 is greater than <i>A12 Sd</i> setpoint.
A13 Wrn	WRN	YES	Value measured on analog input 3 is greater than <i>A13 Wrn</i> setpoint.
A13 Sd	SD	YES	Value measured on analog input 3 is greater than <i>A13 Sd</i> setpoint.
Wrn Batt Volt	WRN	YES	Battery voltage is out of limits given by <i>Batt Undervolt/Batt OverVolt</i> setpoints.
IOM Alx Wrn	WRN	YES	Warning alarm configurable on the input of IG-IOM/IGS-PTM.
IOM Alx Sd	SD	YES	Shutdown alarm configurable on the input of IG-IOM/IGS-PTM.
Binary input	Configurable	YES	Configurable Warning/Shutdown alarms on the inputs of IL-NT.
Sd BatteryFlat	SD	YES	If the controller switches off during starting sequence due to bad battery condition it doesn't try to start again and activates this protection.
Sd Start Fail	SD	YES	Gen-set start failed.

Events specification	Protection type	Information on binary output available (See list of Binary outputs)	Description
ParamFail	NONE	NO	Wrong checksum of parameters. Happends typically after downloading new firmware or changing of the parameter. The controller stays in INIT mode. Check all parameters, write at least one new parameter.
Sd Gen Lx >,<V	SD	YES	The generator voltage is out of limits given by <i>Gen <V Sd</i> and <i>Gen >V Sd</i> setpoints.
Sd Gen V Unbal	SD	YES	The generator voltage is unbalanced more than the value of <i>Volt Unbal Sd</i> setpoint.
Sd Gen >Freq	SD	YES	The generator frequency is out of limits given by <i>Gen >Freq Sd</i> and <i>Gen <Freq Sd</i> setpoints.
Wrn Amps Unbal	SD	NO	The generator current is unbalanced.
Sd Overload	SD	YES	The load is greater than the value given by <i>Overload</i> setpoint.
Sd Overspeed	SD	YES	The protection comes active if the speed is greater than <i>Overspeed</i> setpoint.
Sd Underspeed	SD	YES	During starting of the engine when the RPM reach the value of <i>Starting RPM</i> setpoint the starter is switched off and the speed of the engine can drop under <i>Starting RPM</i> again. Then the Underspeed protection becomes active. Protection evaluation starts 5 seconds after reaching <i>StartingRPM</i> .
EmergencyStop	SD	NO	If the input <i>Emergency Stop</i> is opened shutdown is immediately activated.
GCB Fail	SD	NO	Failure of generator circuit breaker.
MCB Fail	MF	NO	Failure of mains circuit breaker.
Sd RPMMeasFail	SD	NO	Failure of magnetic pick-up sensor for speed measurement.
Sd Stop Fail	SD	YES	Gen-set stop failed.
WrnMaintenance	WRN	NO	The period for servicing is set by the <i>WrnMaintenance</i> setpoint. The protection comes active if the running hours of the engine reach this value.
ChargeAlt Fail	WRN	YES	Failure of alternator for charging the battery.
Sd Override	WRN	NO	The protection is active if the output <i>Sd Override</i> is closed.
*Wrn RA15 Fail	WRN	NO	Warning alarm in case of lost connection to IGL-RA15 module.
*Sd IOM Fail	SD	NO	Shutdown alarm in case of lost connection to IG-IOM/IGS-PTM module.
Wrn ECU Alarm	WRN	NO	ECU alarm list is not empty
Wrn MainV Det	WRN	NO	GCB can't be closed due to detected Mains voltage >5% of nominal voltage. In case that MRS application run runned in IL-NT AMF hardware
Low BackupBatt	WRN	NO	RTC backup battery is flat

History file

InteliLite NT stores a record of each important event into the history file. The history file seats 117 records. When the history file is full, the oldest records are removed. Number of history records varies with number of configured modules.

Hint:

To force history download in LiteEdit (direct,,modem or Internet) open History window and select History | Read history command.

Hint:

The first history record after the controller is switched on, programmed or watchdog reset occurs contains diagnostic vlaues instead of operational. Some fields in these records seem to have nonsense values. Do not take these values into account.

Record structure

Abbreviation	Historical value
Num	Number of historical event
Reason	Event specification
Date	Date of historical event in format DD/MM/YY
Time	Time of historical event in format HH:MM:SS
Mode	Controller's mode
RPM	Engine speed
Pwr	Generator active power
PF	Generator PF
LChr	Character of the load
Gfrq	Generator frequency
Vg1	Generator voltage L1
Vg2	Generator voltage L2
Vg3	Generator voltage L3
Ig1	Generator current L1
Ig2	Generator current L2
Ig3	Generator current L3
UBat	Battery voltage
OilP	IL-NT Analog input 1 value (default Oil pressure)
EngT	IL-NT Analog input 2 value (default Water temperature)
FLvl	IL-NT Analog input 3 value (default Fuel Level)
BIN	Binary inputs IL-NT
BOU	Binary inputs IL-NT
BIOE	Binary inputs/outputs plug-in module (when IL-NT-BIO8 module is configured)
FC	ECU alarm FailureCode (when ECU is configured)
FMI	ECUalarm Failure Mode Identifier (when ECU is configured)
AIM1	IG-IOM, IGS-PTM Analog input 1 value (when configured IG-IOM, IGS-PTM)
AIM2	IG-IOM, IGS-PTM Analog input 2 value (when configured IG-IOM, IGS-PTM)
AIM3	IG-IOM, IGS-PTM Analog input 3 value (when configured IG-IOM, IGS-PTM)
AIM4	IG-IOM, IGS-PTM Analog input 4 value (when configured IG-IOM, IGS-PTM)
BIM	IG-IOM, IGS-PTM Binary inputs (when configured IG-IOM, IGS-PTM)
BOM	IG-IOM, IGS-PTM Binary outputs (when configured IG-IOM, IGS-PTM)

Init Screens

Each IntelliLite NT controller holds informations about serial number, uploaded firmware version and others. These informations are displayed on so called “Init Screens”. It is possible to call this screens from any measurement screen by pressing **ENTER** and **PAGE** buttons concurrently and then only **PAGE** button separately.

Init screens consists of:

Customer Logo screen

This is a first screen which is dedicated for informations provided by customers such as contact numbers, service technician contact and customer message for end users of gen-set. Configuration of this screen is only done by LiteEdit PC software.

Firmware Init screen

This screen consists informations about type of controller, controller manufacturer ComAp, uploaded firmware branch, used application and version of firmware. There is also information about currently configured electronic engine, respectively used ESF file.

Details on recognition of configured electronic engine are in chapter [Identifying configured ECU](#).

Language screen

IL-NT controller offers configurable language support. On this screen si possible to switch between languages configured in controller.

Other way to change language is by binary input [Lang Selection](#).

User Interface screen

IntelliLite NT controller since IL-NT 1.3 SW enables to choose the user interface as customer prefers. There are two choices available: USER or ENGINEER interface.

USER interface is ment for customers, who prefer simple and easy menu and don't wish to list in complex menu or change the settings of controller. In USER interface controller displayes measuring, alarm and init screens.

ENGINEER interface is dedicated for engineers and allow changing the settings of controller, reviewing the history, measurement, alarms and grant the full access to all controllers screens with are available. This mode is default.

This screen also consists information about controller's Serial number and Password decode number which can be useful in case of lost password to controller. For this situations please contact your distributor for help and these two numbers will be needed to recover the password.

Last value displayed on screen is DiagData, which is internal ComAp information is case of FW or unit problems, which helps ComAp to analyze the root cause and find a proper solution.

Please see latest IL-NT Operator Guide for detailed description.

Remote Control and Data Logging

Direct connection to the PC

InteliLite can be connected directly with PC via optional IL-NT RS232 interface. Use the recommended ComAp AT-LINK CABLE 1.8M or cross-wired serial communication cable with DB9 female connectors and signals Rx, Tx, GND for RS232 connection.

Hint:

Make sure the grounding system on controller and PC – COM port (negative of the PC DC supply) are identical – before the first direct connection. There must not be any voltage between these two points otherwise the internal reversible fuse in controller burns out. The simple solution is to assure, that the PC supply 240/20V is ground free (GND terminal is not connected).

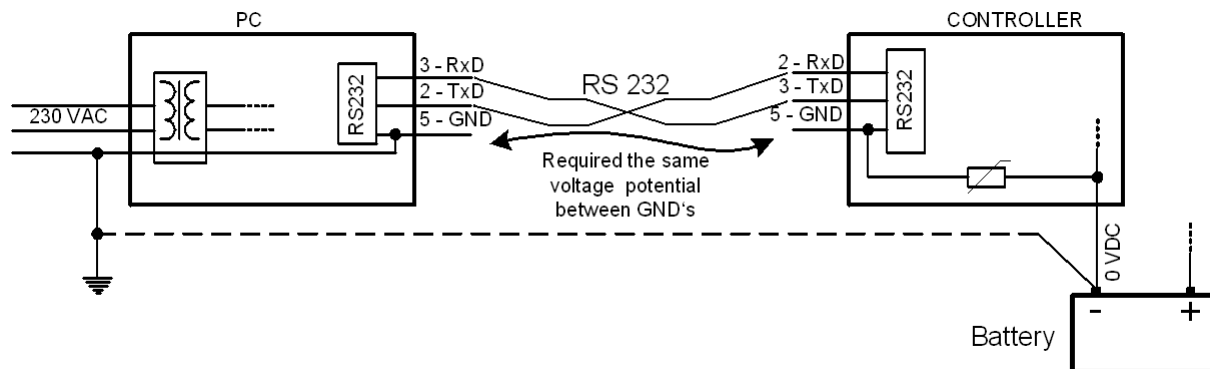

RS232, USB or RS485 interface can be used for direct cable connection to a PC. The setpoint [COM1 Mode](#) or [COM2 Mode](#) (according to the interface used) must be set to DIRECT position for this kind of connection.

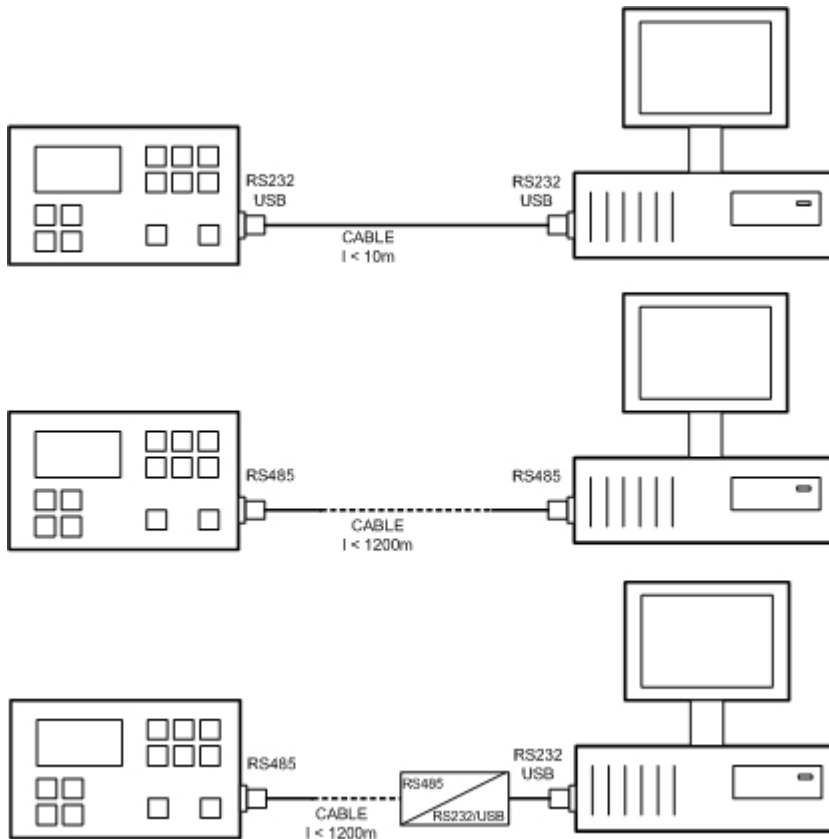

DIRECT CABLE CONNECTION TYPES

Following modules are available for direct connection to a PC:

1. IL-NT-232
2. IL-NT-RS232-485
3. IL-NT-S-USB (USB easy removable service module)

The RS232 or USB interface uses COM1 port of the controller. The RS485 uses COM2.

PC software - LiteEdit

On the PC (for direct or modem connection) has to be installed the ComAp's software package LiteEdit. (based on Windows 95 or newer platform)

LiteEdit enables:

read the quantities
adjust all set points
control the engine
configure the controller
select software configuration
modify alarm inputs and outputs
modify password, commands protections
direct, modem or Internet communication

Modbus protocol

The selection of the function of IL serial port is done via the setpoint *COMx Mode* in *Basic settings*

- 57600 bps, 8 data bits, 1 stop bit, no parity

- Transfer mode RTU
- Function 3 (Read Multiply Registers)
- Function 6 (Write Single Register)
- Function 16 (Write Multiply Registers)
- The response to an incoming message is sent with minimum 4.096 ms delay after message reception

The complete description of Modbus communication protocol can be found in *Modbus Protocol Reference Guide PI-MBUS-300* and *Open Modbus Specification Release 1.0*. Both documents are available from web site at <http://www.modicon.com/openmbus/>.

Communication object vs. Register

All the data intended for communication has its representation as communication objects in the controller. The communication object is represented by the n-byte array in the controller memory and identified by the unique 16-bit communication object number. The register, according to Modbus communication protocol, represents a two-byte data and in communication functions is referenced by 16-bit register address. Further in the description of communication functions **the communication object number will always be used as a register address** and length of the communication object will be expressed by number of registers. **Just one communication object can be read or written by one communication function.**

Hint:

To obtain communication object numbers it is possible to download the actual controller description on-line from controller or from (ail) archive and use “export data” function from LiteEdit software.

Communication object list (exported from default IL-NT-MRS16 archive)

Setpoints of MRS16:

Name	Firmware ver.	Application	Date	App. ver.	Ser. num.	Filename
IL-NT	IL-NT-1.5 R:22.10.2009	MRS16	22.10.2009	1,5	12345678	IL-NT-MRS16-1.5.AIL

Group	Name	Value	Dimension	Password	Com. obj.	Low limit	High limit	Data type
Basic Settings	Gen-set Name	IL-NT		No	8637			Short string
Basic Settings	Nominal Power	200 kW		No	8276	1	5000	Unsigned 16
Basic Settings	Nomin Current	350 A		No	8275	1	10000	Unsigned 16
Basic Settings	CT Ratio	2000 /5A		No	8274	1	5000	Unsigned 16
Basic Settings	PT Ratio	1,0 /1		No	9579	0,1	500,0	Unsigned 16
Basic Settings	NomVolts Ph-N	231 V		No	8277	80	20000	Unsigned 16
Basic Settings	NomVolts Ph-Ph	400 V		No	11657	138	35000	Unsigned 16
Basic Settings	Nominal Freq	50 Hz		No	8278	45	65	Unsigned 16
Basic Settings	Gear Teeth	120		No	8252	0	500	Unsigned 16
Basic Settings	Nominal RPM	1500 RPM		No	8253	100	4000	Unsigned 16
Basic Settings	ControllerMode	OFF		No	8315			String list
Basic Settings	Reset To MAN	DISABLED		No	9983			String list
Basic Settings	ControllerAddr	1		Yes	24537	1	32	Unsigned 8
Basic Settings	COM1 Mode	DIRECT		Yes	24522			String list
Basic Settings	COM2 Mode	DIRECT		Yes	24451			String list
Basic Settings	ModemIniString			No	24436			Long string
Basic Settings	ModbusComSpeed	9600 bps		No	24477			String list

Basic Settings	ConnectionType	3Ph4Wire	No	11628		String list
Engine Params	Starting RPM	25 %	No	8254	5	50 Unsigned 8
Engine Params	Starting Oil P	4,5 Bar	No	9681	0,0	10,0 Integer 16
Engine Params	Prestart Time	2 s	No	8394	0	600 Unsigned 16
Engine Params	MaxCrank Time	5 s	No	8256	1	60 Unsigned 8
Engine Params	CrnkFail Pause	8 s	No	8257	5	60 Unsigned 8
Engine Params	Crank Attempts	3	No	8255	1	10 Unsigned 8
Engine Params	Idle Time	12 s	No	9097	0	600 Unsigned 16
Engine Params	Min Stab Time	2 s	No	8259	1	10 Unsigned 16
Engine Params	Max Stab Time	10 s	No	8313	2	300 Unsigned 16
Engine Params	Cooling Speed	NOMINAL	No	10046		String list
Engine Params	Cooling Time	30 s	No	8258	0	3600 Unsigned 16
Engine Params	Stop Time	60 s	No	9815	0	240 Unsigned 16
Engine Params	Fuel Solenoid	DIESEL	No	9100		String list
Engine Params	D+ Function	DISABLED	No	9683		String list
Engine Params	ECU FreqSelect	DEFAULT	No	10266		String list
Engine Params	ECU SpeedAdj	50 %	No	9948	0	100 Unsigned 16
Engine Params	Fuel Pump ON	20 %	No	10100	-100	90 Integer 16
Engine Params	Fuel Pump OFF	90 %	No	10101	20	10000 Integer 16
Engine Params	TempSwitch ON	90 -	No	8688	-100	10000 Integer 16
Engine Params	TempSwitch OFF	75 -	No	8689	-100	10000 Integer 16
Engine Params	PowerSwitch ON	100 kW	No	11658	0	32000 Integer 16
Engine Params	PowerSwitchOFF	50 kW	No	11659	0	32000 Integer 16
Engine Protect	ProtectHoldOff	5 s	No	8262	0	300 Unsigned 16
Engine Protect	Horn Timeout	10 s	No	8264	0	600 Unsigned 16
Engine Protect	Overspeed Sd	115 %	No	8263	50	150 Unsigned 16
Engine Protect	AI1 Wrn	2,0 Bar	No	8369	-10,0	1000,0 Integer 16
Engine Protect	AI1 Sd	1,0 Bar	No	8370	-10,0	1000,0 Integer 16
Engine Protect	AI1 Del	3 s	No	8365	0	900 Unsigned 16
Engine Protect	AI2 Wrn	80 °C	No	8375	-100	10000 Integer 16
Engine Protect	AI2 Sd	90 °C	No	8376	-100	10000 Integer 16
Engine Protect	AI2 Del	5 s	No	8371	0	900 Unsigned 16
Engine Protect	AI3 Wrn	20 %	No	8381	-100	10000 Integer 16
Engine Protect	AI3 Sd	10 %	No	8382	-100	10000 Integer 16
Engine Protect	AI3 Del	10 s	No	8377	0	900 Unsigned 16
Engine Protect	Batt Overvolt	36,0 V	No	9587	18,0	40,0 Integer 16
Engine Protect	Batt Undervolt	18,0 V	No	8387	8,0	40,0 Integer 16
Engine Protect	Batt Volt Del	5 s	No	8383	0	600 Unsigned 16
Engine Protect	WrnMaintenance	9999 h	No	9648	0	10000 Unsigned 16

Gener Protect	Overload Sd	120 %	No	8280	0	200 Unsigned 16
Gener Protect	Overload Del	5,0 s	No	8281	0,0	600,0 Unsigned 16
Gener Protect	Short Crct Sd	250 %	No	8282	100	500 Unsigned 16
Gener Protect	Short Crct Del	0,00 s	No	9991	0,00	10,00 Unsigned 16
Gener Protect	Amps IDMT Del	4,0 s	No	8283	1,0	60,0 Unsigned 16
Gener Protect	Amps Unbal Sd	50 %	No	8284	1	200 Unsigned 16
Gener Protect	Amps Unbal Del	5,0 s	No	8285	0,0	600,0 Unsigned 16
Gener Protect	Gen >V Sd	110 %	No	8291	70	200 Unsigned 16
Gener Protect	Gen <V Sd	70 %	No	8293	0	110 Unsigned 16
Gener Protect	Gen V Del	3,0 s	No	8292	0,0	600,0 Unsigned 16
Gener Protect	Volt Unbal Sd	10 %	No	8288	1	200 Unsigned 16
Gener Protect	Volt Unbal Del	3,0 s	No	8289	0,0	600,0 Unsigned 16
Gener Protect	Gen >Freq Sd	110,0 %	No	8296	85,0	200,0 Unsigned 16
Gener Protect	Gen <Freq Sd	85,0 %	No	8298	0,0	110,0 Unsigned 16
Gener Protect	Gen Freq Del	3,0 s	No	8297	0,0	600,0 Unsigned 16
Extension I/O	IOM AI1 Wrn	0 U4	No	8762	-100	10000 Integer 16
Extension I/O	IOM AI1 Sd	0 U4	No	8766	-100	10000 Integer 16
Extension I/O	IOM AI1 Del	5 s	No	8770	0	900 Unsigned 16
Extension I/O	IOM AI2 Wrn	0 U5	No	8763	-100	10000 Integer 16
Extension I/O	IOM AI2 Sd	0 U5	No	8767	-100	10000 Integer 16
Extension I/O	IOM AI2 Del	5 s	No	8771	0	900 Unsigned 16
Extension I/O	IOM AI3 Wrn	0 U6	No	8764	-100	10000 Integer 16
Extension I/O	IOM AI3 Sd	0 U6	No	8768	-100	10000 Integer 16
Extension I/O	IOM AI3 Del	5 s	No	8772	0	900 Unsigned 16
Extension I/O	IOM AI4 Wrn	0 U7	No	8765	-100	10000 Integer 16
Extension I/O	IOM AI4 Sd	0 U7	No	8769	-100	10000 Integer 16
Extension I/O	IOM AI4 Del	5 s	No	8773	0	900 Unsigned 16
Extension I/O	IOM AI1 Calibr	0 U4	No	8793	-1000	1000 Integer 16
Extension I/O	IOM AI2 Calibr	0 U5	No	8794	-1000	1000 Integer 16
Extension I/O	IOM AI3 Calibr	0 U6	No	8795	-1000	1000 Integer 16
Extension I/O	IOM AI4 Calibr	0 U7	No	8796	-1000	1000 Integer 16
Date/Time	Time Stamp Per	60 min	No	8979	0	240 Unsigned 8
Date/Time	SummerTimeMod	DISABLED	No	8727		String list
Date/Time	Time	0:00:00	No	24554		Time
Date/Time	Date	1.1.2006	No	24553		Date
Date/Time	Timer1Function	No Func	No	11660		String list
Date/Time	Timer1 Repeat	NONE	No	10045		String list
Date/Time	Timer1 ON Time	5:00:00	No	10042		Time
Date/Time	Timer1Duration	5 min	No	10044	1	1440 Unsigned 16
Date/Time	Timer2Function	No Func	No	11661		String list

Date/Time	Timer2 Repeat	NONE	No	10202		String list
Date/Time	Timer2 ON Time	5:00:00	No	10199		Time
Date/Time	Timer2Duration	5 min	No	10201	1	1440 Unsigned 16
Sensors Spec	AI1Calibration	0,0 Bar	No	8431	-100,0	100,0 Integer 16
Sensors Spec	AI2Calibration	0 °C	No	8407	-1000	1000 Integer 16
Sensors Spec	AI3Calibration	0 %	No	8467	-1000	1000 Integer 16
SMS/E-Mail	Yel Alarm Msg	OFF	No	8482		String list
SMS/E-Mail	Red Alarm Msg	OFF	No	8484		String list
SMS/E-Mail	TelNo/Addr Ch1		No	9597		Long string
SMS/E-Mail	TelNo/Addr Ch2		No	9598		Long string

Values of MRS16:

Name	Firmware ver.	Application	Date	App. ver.	Ser. num.	Filename
IL-NT	IL-NT-1.5 R:22.10.2009	MRS16	22.10.2009	1,5	12345678	IL-NT-MRS16-1.5.AIL

Group	Name	Value Dimension	Com. obj. Data type
Engine	RPM	1500 RPM	8209 Unsigned 16
Engine	ECU State	[010]	10034 Binary 8
Engine	Fuel Rate ECU	0,0 L/h	9860 Unsigned 16
Engine	Cool Temp ECU	22 °C	9855 Integer 16
Engine	IntakeTemp ECU	20 °C	9878 Integer 16
Engine	Oil Press ECU	0,0 Bar	10354 Integer 16
Engine	BoostPress ECU	0,0 Bar	9877 Unsigned 8
Engine	Oil Temp ECU	22 °C	9857 Integer 16
Generator	Gen kW	150 kW	8202 Integer 16
Generator	Gen kW L1	50 kW	8524 Integer 16
Generator	Gen kW L2	50 kW	8525 Integer 16
Generator	Gen kW L3	50 kW	8526 Integer 16
Generator	Gen kVAr	15 kVAr	8203 Integer 16
Generator	Gen kVAr L1	5 kVAr	8527 Integer 16
Generator	Gen kVAr L2	5 kVAr	8528 Integer 16
Generator	Gen kVAr L3	5 kVAr	8529 Integer 16
Generator	Gen kVA	153 kVA	8565 Integer 16
Generator	Gen kVA L1	51 kVA	8530 Integer 16
Generator	Gen kVA L2	51 kVA	8531 Integer 16
Generator	Gen kVA L3	51 kVA	8532 Integer 16
Generator	Gen PF	1,00	8204 Integer 8
Generator	Gen Load Char	R	8395 Char
Generator	Gen PF L1	1,00	8533 Integer 8

Generator	Gen Ld Char L1	R	8626 Char
Generator	Gen PF L2	1,00	8534 Integer 8
Generator	Gen Ld Char L2	R	8627 Char
Generator	Gen PF L3	1,00	8535 Integer 8
Generator	Gen Ld Char L3	R	8628 Char
Generator	Gen Freq	50,0 Hz	8210 Unsigned 16
Generator	Gen V L1-N	230 V	8192 Unsigned 16
Generator	Gen V L2-N	230 V	8193 Unsigned 16
Generator	Gen V L3-N	230 V	8194 Unsigned 16
Generator	Gen V L1-L2	398 V	9628 Unsigned 16
Generator	Gen V L2-L3	398 V	9629 Unsigned 16
Generator	Gen V L3-L1	398 V	9630 Unsigned 16
Generator	Gen A L1	41 A	8198 Unsigned 16
Generator	Gen A L2	41 A	8199 Unsigned 16
Generator	Gen A L3	41 A	8200 Unsigned 16
Controller I/O	Battery Volts	24,3 V	8213 Integer 16
Controller I/O	D+	5,7 V	10603 Integer 16
Controller I/O	Oil Pressure	15,6 Bar	8227 Integer 16
Controller I/O	Engine Temp	50 °C	8228 Integer 16
Controller I/O	Fuel Level	99 %	8229 Integer 16
Controller I/O	Bin Inputs	[111100]	8235 Binary 16
Controller I/O	Bin Outputs	[111100]	8239 Binary 16
Extension I/O	IOM AI1	10 U4	8978 Integer 16
Extension I/O	IOM AI2	20 U5	8759 Integer 16
Extension I/O	IOM AI3	30 U6	8760 Integer 16
Extension I/O	IOM AI4	40 U7	8761 Integer 16
Extension I/O	IOM Bin Inp	[01000110]	8602 Binary 16
Extension I/O	IOM Bin Out	[11011001]	8604 Binary 16
Extension I/O	RA Bin Out	[100010010000000]	9849 Binary 16
Extension I/O	IL-NT-BIO8	[xxxxxxx]	11635 Binary 8
Statistics	Energy kWh	0	8205 Integer 32
Statistics	Energy kVAh	0	8539 Integer 32
Statistics	Run Hours	0,0 h	8206 Integer 32
Statistics	Num Starts	0	8207 Unsigned 16
Statistics	Maintenance	9999 h	9648 Unsigned 16
Statistics	Num E-Stops	0	11195 Unsigned 32
Statistics	Shutdowns	0	11196 Unsigned 32
IL Info	Engine State	#####	8330 Unsigned 16

IL Info	Breaker State	#####	8455 Unsigned 16
IL Info	Timer Text	#####	8954 Unsigned 16
IL Info	Timer Value	0 s	8955 Unsigned 16
IL Info	FW Version	0,0	8393 Unsigned 8
IL Info	Application	4	8480 Unsigned 8
IL Info	FW Branch	1	8707 Unsigned 8
IL Info	PasswordDecode	#####	9090 Unsigned 32
IL Info	DiagData	#####	10050 Unsigned 32
Date/Time	Time	#####	24554 Time
Date/Time	Date	#####	24553 Date

Remote Communication

Internet connection

IL-NT controllers can be monitored from LiteEdit over the Internet using Internet Bridge (IG-IB) connected to the controller RS232 port. Or via plug-in card IB-Lite directly plugged in communication slot on back side of the controller.

Recommended ISDN modem

- Askey TAS-200E
- ASUScom TA-220ST
- Develo Microlink ISDN i

Recommended GSM modem

- Siemens M20, TC35, TC35i, ES75, MC39
- Wavecom M1200/WMOD2
- Wavecom - Maestro 20, dual 900/1800MHz.
- Wavecom – Fastrack M1306B, dual 900/1800 MHz (Fastrack M1206B is NOT recommended)
- FALCOM A2D, dual 900/1800MHz.

GSM Modem setup

Prior to start work with GSM modem run following program for GSM proper setup.

Program writes all the necessary AT commands to configure the GSM modem properly for use with IL-NT.

This program runs independent on LiteEdit:

- Start MS Windows-Start-Program files - LiteEdit –Gm_setup.exe.
- Select COM port
- Select iG-CU (=IS-CU) or iG-MU unit
- Press Setup button
- Follow commands in GSM Modem Setup window

Typical real baud rate for GSM data communication is 80 to 90 Bps.

Hint:

It is strongly recommended to use the same type of modem on the both sides (IL and PC) of connection.

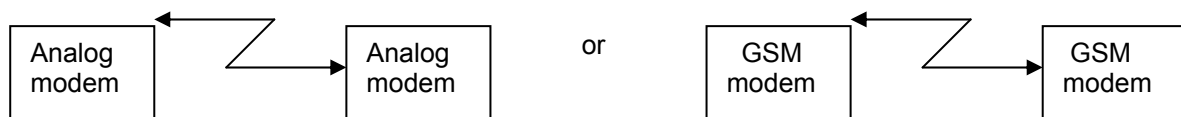

Mobile SIM card setting

- Adjust SIM card in GSM modem following way:
- enable data connection (when required)
- no PIN code

Hint:

Refer to IntelliCommunication guide for all additional information.

IL-NT-RD Remote display software

This chapter describes Remote display software IL-NT-RD, which is designed as an remote signalling and control software for IntelliLite-NT and IntelliDrive Lite controllers. **It is the optional software which is possible to upload into controller instead of standard controller's firmware.**

General description

Remote display software works as “remote display and control” for the master IntelliLite-NT or IntelliDrive Lite controller. Genset/Engines can be controlled from remote display as well as from master controller. All remote display screens (Measure, Setpoints and History) displays the same data like master controller. Front panel buttons on both controllers work the same way. All remote display LED's shows the same state as corresponding LED's on master controller.

Warning !

It is highly recommended to use the same type and model of controller for master and remote display. Only in such case is assured the proper function of all buttons, LED diods and display. Another combinations of HW types and models from Master controller and remote display are not supported nor tested!

IL-NT-RD Software installation

The IL-NT-RD remote display firmware is installed in the same way as any other IL-NT firmware using LiteEdit software. Please see LiteEdit Reference guide for details about upgrading firmware. IL-NT-RD consists only firmware, not an archive.

However when there is IL-NT-RD firmware installed in the controller the procedure to install back the original standard firmware is following:

- Open any type of online connection.
- DDE server will try to open the connection, but it will fail and write red error message in the status bar.
- In this moment go to **CONTROLLER -> PROGRAMMING AND CLONING -> PROGRAMMING** and select **proper!** firmware you want program to the controller. Choosing the wrong type of firmware

may result in non-functional controller.

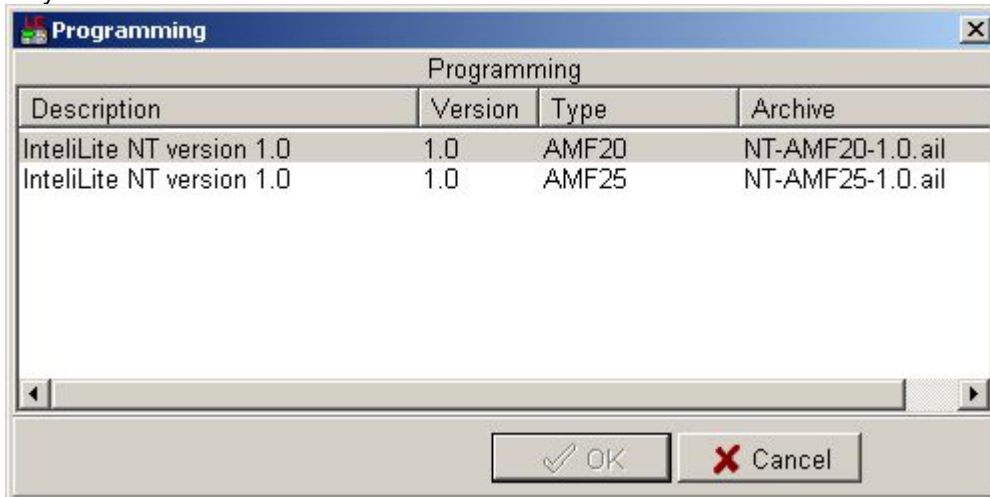

- Press "OK" button to programm the firmware to the controller.
- It may be required to switch off power supply of controller, close the boot jumper and switch on controller again. Follow the information windows accordingly.
- After programming is finished (it may be required to power off controller, open the boot jumper and power it on again) open configuration window and perform the configuration process manually. There is no compatibility of the configuration between different firmware versions.
- In some cases the "wrong setpoints" message can occur in the DDE server status line and the controller is blocked showing "Init" state. Use **CONTROLLER -> RESET FROM INIT STATE** menu item to put the controller to normal operation. Be sure you have checked all setpoints before.

CAUTION!

Check the statistic value "Engine hours" after firmware upgrade. Readjust the value if necessary.

IL-NT-RD Wiring

IL-NT-RD can be connected to InteliLite-NT or InteliDrive Lite controller via RS232 or RS485 communication line. It is possible to connect only up to two remote displays to one master controller, if they are using different communication COMs. It is not supported to connect two or more remote displays to one communication line, eg. RS485. It is possible to monitor only one master controller from one remote display at the time.

Connection process

Remote display after power on automatically starts to search for any master controller connected. It starts to search on COM1 from master controllers address 1 to 32 and later on COM2 from address 1 to 32. Remote display tries two communication speeds 38400 bps and 56000bps.

During this process is displayed text "Detecting..." on screen and progress bar below counts from 0 to 100%. This process takes approx. 10-15 seconds. Than is 5 seconds pause and process continues again until compatible master controller is found.

Not supported types of controllers, not supported application, or controllers that are not properly communicating are skipped during the search.

Controller type selection

IL-NT-RD automatically detects controller type.

Troubles with connection

There are few reasons why remote display can not connect with master controller:

1. Not supported type of controller connected (Eg. IGS-NT, ID-DCU, IC-NT, IGS-CU, etc.)

2. Not supported firmware in master controller
3. Configuration table error in master controller
4. Wrong settings of setpoint COMx Mode in master controller
5. Wrong connection, wiring, communication fail

Direct RS232 connection

HW module:
IL-NT-RS232

Master controller settings:
ControllerAddr = 1..32
COM1 Mode = DIRECT

Up to 2 meters:
It is recommended to use our standard AT-LINK cable.

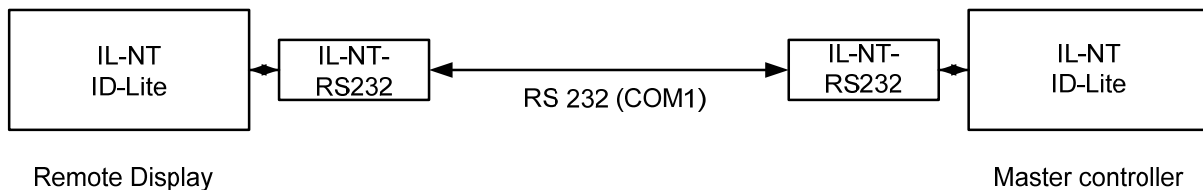

Up to 10 meters:
It is recommended to use standard Null-modem cable for local connection between controller and remote display, although the three wires (TxD, RxD, GND) RS 232 connection is enough for direct communication:

IL-NT/ID-Lite connector D-SUB9 female	IL-NT-RD connector D-SUB9 female
RxD 2	3 TxD
TxD 3	2 RxD
GND 5	5 GND

Remote RS485 and/or direct RS232 connection

HW module:
IL-NT-RS232-485

Up to 1000 meters (only with RS485):

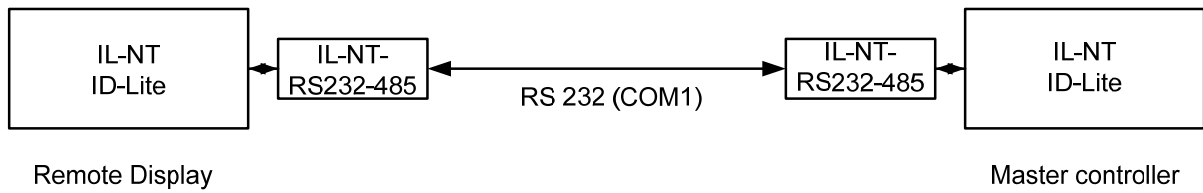

OR

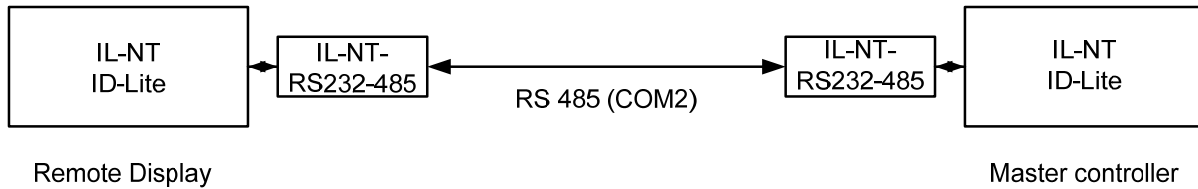

OR

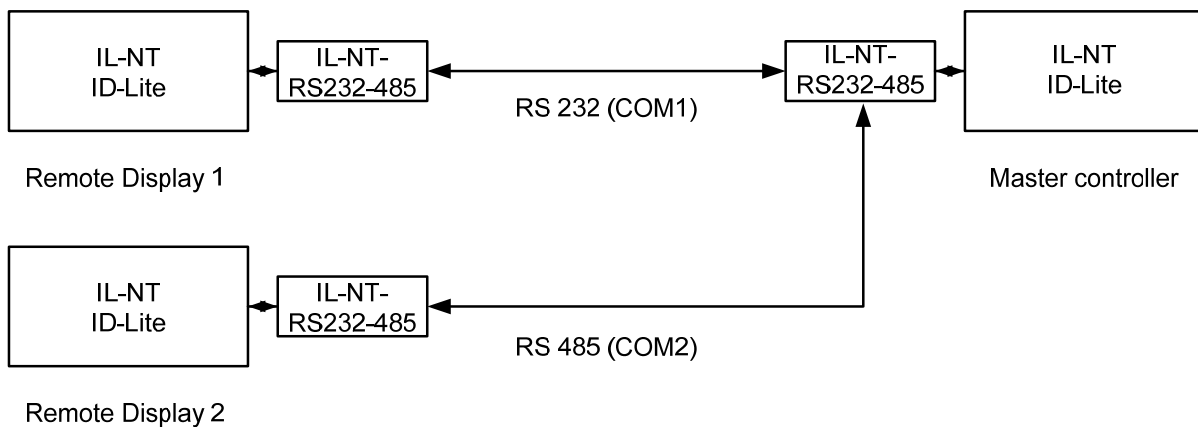

Case 1) RS232

Master controller settings:
ControllerAddr = 1..32
COM1 Mode = DIRECT

Case 2) RS485

Master controller settings:
ControllerAddr = 1..32
COM2 Mode = DIRECT

Case 3) RS232 +RS485

Master controller settings:
ControllerAddr = 1..32
COM1 Mode = DIRECT
COM2 Mode = DIRECT

It is possible to make a RS232 direct connection with IL-NT-RS232 module on one side and IL-NT-RS232-485 module on the other side.

Alternative connection using external RS232-RS422/485 converter:

Recommend external converter:

ADVANTECH – ADAM 4520: RS232 to RS422/485 converter, DIN rail, automatic RS485 bus supervision, no external data flow control signals, galvanic isolated, baud rate 38400 or 56000 bps.

Any connected RS 232 to RS 422/485 converter has to be set to passive DSR signal (when DSR connected) after switch on.

Function description

Remote display IL-NT-RD works as remote display and control of the master IntelliLite-NT or IntelliDrive Lite controller. It is supposed and highly recommended that both, remote display and master are using the same HW type and model of controller. Another types and models of master and remote display are not supported nor tested. All remote display's LEDs shows the same state as corresponding LEDs on master controller. Front panel buttons on both controllers work in the same way. Genset/Engine can be controlled from remote display as well as from master controller. User can switch screens, set password, change setpoints and view history records.

All IL-NT-RD screens Init, Measure, Setpoints and History display the same data like in the master controller.

Master device is always able to work without connected Remote display.

Interruption of the serial line between master device and Remote display has no effect to the master controller.

If the serial line between master device and remote display is interrupted, or communication cannot be established, remote display shows it's Init screen and message "Trying" and all LED's are off.

Once remote display finds compatible master it shows "Preparing" and downloads configuration table from master controller.

After the configuration from master is downloaded remote display jump to master controllers Init screen and all LEDs and blinking.

It is possible to switch to remote displays Init screen to check it's version and serial number of used controller and communication status by pressing PAGE button for 3 seconds.

SW compatibility

IL-NT-RD sw. version 1.1 is compatible with masters SW:

- All IntelliLite-NT standard software from ver. 1.1
- All ID-Lite standard software from ver. 1.0
- Chosen IL-NT and ID-Lite customer branches

Some of the future IL-NT, ID-Lite versions may require upgrade of the IL-NT-RD software.

Maintenance

Backup battery replacement

The internal backup battery should be replaced approx. every 5-7 years. Replace the battery, if the alarm *Low BackupBatt* occurs. Follow these instructions:

1. Disconnect all terminals from the controller and remove the controller from the switchboard.
2. Release the rear cover using a flat screwdriver or another suitable tool.



3. Remove all plug-in modules.
4. The battery is located in a holder on the circuit board. Remove the old battery with a small sharp screwdriver and push with a finger the new battery into the holder. Use only CR1225 lithium battery.



5. Put the rear cover back. Use slight pressure to lock the snaps into the housing. **Pay attention that the cover is in correct position and not upside down!**
6. Plug the modules back into the slots.
7. Power the controller on, adjust date and time and check all setpoints.

Technical Data

Inputs/Outputs overview

Model	BIN	BOUT	AI	AOUT	COM1	COM2	CAN	RPM	Gen. Voltage	Mains Voltage	Gen. Current
IL-NT MRS10	6	6	3	8*	Y*	Y*	N	Y	Y	N	Y
IL-NT MRS11	6	6	3	8*	Y*	Y*	N	Y	Y	N	Y
IL-NT MRS15	6	6	3	8*	Y*	Y*	Y	Y	Y	N	Y
IL-NT MRS16	6	6	3	8*	Y*	Y*	Y	Y	Y	N	Y

Note:

* With optional plug-in module

Y -Available

N -Not available

Generator protections

ComAp gen-set controllers provide following range of generator protections. For each protection adjustable limit and time delay are available.

Comparison table with ANSI codes:

ANSI code	Protection	IL-NT MRS10	IL-NT MRS11	IL-NT MRS15	IL-NT MRS16
59	Overvoltage	•	•	•	•
27	Undervoltage	•	•	•	•
47	Voltage Assymetry	•	•	•	•
81H	Overfrequency	•	•	•	•
81L	Underfrequency	•	•	•	•
50+51	Overcurrent	***	***	•	•
46	Current Unbalance	•	•	•	•
32	Overload	•	•	•	•
51N+64	Earth Fault	-	-	-	-
32R	Reverse Power	-	-	-	-
25	Synchronism Check	-	-	-	-
47	Phase Rotation	**	**	**	**
37	Undercurrent	-	-	-	-
55	Power Factor	-	-	-	-
71	Gas (Fuel) Level	•	•	•	•

Note:

- Not available

• Available

** Fixed setting

*** Shortcurrent only

Language support

IL-NT in firmware version 1.5 supports following language code pages:

Code page	Language	Windows code
0	West European languages	Windows 1252
134	Chinese	GB 2312
162	Turkish	Windows 1254
177	Hebrew	Windows 1255
204	Russian	Windows 1251
238	East European languages	Windows 1250

Power supply

Voltage supply 8-36V DC
Consumption 40-430mA depend on supply voltage and temperature

Consumption depends on supply voltage 0,104A at 8VDC
0,080A at 12VDC
0,051A at 24VDC
0,044A at 30VDC
0,040A at 36VDC

Allowed supply voltage drop-out: 100ms from min. 10V, return to min. 8V
Battery voltage measurement tolerance 2 % at 24V

Hint:

For the supply voltage less than 7V the backlight of the display is switched off.
Short-term voltage drops (e.g. during the engine cranking) do not affect the operation at all.

Operating conditions

Operating temperature IL-NT -20..+70°C
Operating temperature IL-NT LT# -40..+70°C
Storage temperature -30..+80°C
Protection front panel IP65
Humidity 95% without condensation
Standard conformity EN 61010-1:95 +A1:97
Low Voltage Directive EN 50081-1:94, EN 50081-2:96
Electromagnetic Compatibility EN 50082-1:99, EN 50082-2:97
Vibration 5 - 25 Hz, ±1,6mm
25 - 100 Hz, a = 4 g
Shocks a = 200 m/s²

#Low Temperature modification

LCD display limits controller operating temperature range to -20 °C - + 70 °C even if the other electronic components work in wider temperature range.

Internal preheating foil is mounted in IntelliLite^{NT} LT to extend display operational temperature range. Preheating starts at temperature below 5 °C and preheating power depends on temperature and power supply voltage.

Technical data

	IL-NT Standard	Order code:IL-NT-xxxxx LT
Operating temperature	-20 °C..+70°C	-40 °C..+70°C
Storage temperature	-30 °C..+80°C	-30 °C..+80°C

Preheating foil increases controller current consumption

Controller consumption at	No preheating	Preheating at ambient temperature		
		0 °C	-20 °C	-40 °C
12VDC	80 mA	+75 mA	+210 mA	+325 mA
24VDC	51 mA	+31 mA	+100 mA	+175 mA

InteliLite LT works immediately after switch on at -30 °C and display becomes visible after a few minutes.

Dimensions and weight

Dimensions	180x120x55mm
Weight	450g

Generator

Nominal frequency	50-60Hz
Frequency measurement tolerance	0,2Hz

Current inputs

Nominal input current (from CT)	5 A
Load (CT output impedance)	< 0,1 Ω
CT input burden	< 0,2 VA per phase (In=5A)
Max. measured current from CT	10 A
Current measurement tolerance	2% from the Nominal current
Max. peak current from CT	150 A / 1s
Max. continuous current	12 A

Voltage inputs

Measuring voltage range	0 – 277 VAC phase to neutral 0 – 480 VAC phase to phase
Maximal measured voltage	340 VAC phase to neutral 600 VAC phase to phase
Input resistance	0.6 MΩ phase to phase 0.3 MΩ phase to neutral
Voltage measurement tolerance	2 % from the Nominal voltage
Overvoltage class	III / 2 (EN61010)

Binary inputs and outputs

Binary inputs

Number of inputs	6
Input resistance	4,2 kΩ
Input range	0-36 VDC
Voltage level for close contact indication (Logical 1)	<0,8 VDC
Voltage level for open contact indication (Logical 0)	>2 VDC
Max voltage level for open contact indication	8-36 VDC

Binary open collector outputs

Number of outputs	6
Maximum current	0,5 A
Maximum switching voltage	36 VDC

Analog inputs

Not electrically separated	
Number of inputs	3
Resolution	10 bits
Maximal resistance range	2500 Ω
Resistance measurement tolerance	± 2 % ± 2 Ω out of measured value

Speed pick-up input

Type of sensor	magnetic pick-up (connection by shielded cable is recommended)
Minimum input voltage	2 Vpk-pk (from 4 Hz to 4 kHz)
Maximum input voltage	50 Veff
Minimum measured frequency	4 Hz
Maximum measured frequency	10 kHz (min. input voltage 6Vpk-pk)
Frequency measurement tolerance	0,2 %

D+ Terminal

CHARGE ALT D+ Function:	
Max. CHARGE ALT D+ output current	300 mA
Guaranteed level for signal Charging OK	80% of supply voltage

****CAN bus interface***

Galvanically separated	
Maximal CAN bus length	200m
Speed	250kBd
Nominal impedance	120Ω
Cable type	twisted pair (shielded)

Following dynamic cable parameters are important especially for maximal 200 meters CAN bus length and 32 iS-COM units connected:

Nominal Velocity of Propagation	min. 75% (max. 4,4 ns/m)
Wire crosscut	min. 0,25 mm ²
Maximal attenuation (at 1 MHz)	2 dB / 100m

Recommended Industrial Automation & Process Control Cables:
BELDEN (see <http://www.belden.com>):

- 3082A DeviceBus for Allen-Bradley DeviceNet
- 3083A DeviceBus for Allen-Bradley DeviceNet
- 3086A DeviceBus for Honeywell SDS
- 3087A DeviceBus for Honeywell SDS
- 3084A DeviceBus for Allen-Bradley DeviceNet
- 3085A DeviceBus for Allen-Bradley DeviceNet
- 3105A Paired EIA Industrial RS485 cable

LAPP CABLE

- Unitronic BUS DeviceNet Trunk Cable
- Unitronic BUS DeviceNet Drop Cable
- Unitronic BUS CAN
- Unitronic-FD BUS P CAN UL/CSA

IL-NT RS232 interface (optional card)

Plugs into IL-NT controller COMMUNICATION MODULE port.

Maximal distance	10m
Maximum Speed	Up to 57.6 kBd (DIRECT), 38.4kBd Analog modem, 9.6 kBd digital modem, 57.6 kBd (MODBUS)

Recommend external converter:

ADVANTECH – ADAM 4520: RS232 to RS422/485 converter, DIN rail, automatic RS485 bus supervision, no external data flow control signals, galvanic isolated.

Recommended internal converter:

ADVANTECH – PCL-745B or PCL745S : Dual port RS422/485 Interface card, automatic RS485 bus supervision, no external data flow control signals, galvanic isolated

Hint:

For details on all IL-NT extension and communication modules see IL-NT, IC-NT-Accessory Modules manual.

With SW version IL-NT 1.2 and older, the communication speeds are 19.2kBd (STD/DIRECT), 19.2kBd Analog modem, 9.6 kBd digital modem, 9.6kBd (MODBUS)

IL-NT RS232-485 interface (optional card)

Plugs into IL-NT controller COMMUNICATION MODULE port.

Maximal distance	10m (RS232), 1200m (RS485)
Maximum Speed	Up to 57.6 kBd (DIRECT), 38.4kBd Analog modem, 9.6 kBd digital modem, 57.6 kBd (MODBUS)

Hint:

This module is supported with SW version IL-NT 1.3 and newer.

IL-NT S-USB interface (optional card)

Plugs into IL-NT controller COMMUNICATION MODULE port.

Maximal distance	5m
Maximum Speed	Up to 57.6 kBd (DIRECT), 38.4kBd Analog modem, 9.6 kBd digital modem, 57.6 kBd (MODBUS)

Use only shielded A-B USB cables up to 5m length.

Recommend USB cable:

USB-LINK CABLE 1.8M – ComAp A-B USB cable.

Hint:

With SW version IL-NT 1.2 and older, the communication speeds are 19.2kBd (STD/DIRECT), 19.2kBd Analog modem, 9.6 kBd digital modem, 9.6kBd (MODBUS)

IL-NT AOUT8 interface (optional card)

Plugs into IL-NT controller EXTENSION MODULE port.

Number of PWM outputs	8
PWM frequency	250Hz
Maximum current	0.5 A

Maximum switching voltage	36 VDC
Output resistance	1Ω
Resolution	10 bits

IL-NT BIO8 interface (optional card)

Plugs into IL-NT controller EXTENSION MODULE port.

8 dedicated pins of the plug-in card's terminal can be configured as binary inputs or outputs.

Binary inputs

Number of inputs	8
Input resistance	4,7kΩ
Input range	0-36 VDC
Voltage level for close contact indication (Logical 1)	<0,8 VDC
Voltage level for open contact indication (Logical 0)	>2 VDC
Max voltage level for open contact indication	8-36 VDC

Binary open collector outputs

Number of outputs	8
Maximum current per pin	0,5 A
Maximum switching common current	2 A
Maximum switching voltage	36V

Hint:

Binary inputs are not galvanically isolated.

Please see detail about wiring and description at chapter [IL-NT BIO8 Hybrid binary input/output module](#).

IGS-PTM

Voltage supply	8-36V DC
Consumption	0,1A depend on supply voltage
Mechanical dimensions:	40 x 95 x 45 mm , DIN rail (35 mm) mounted
Interface to controller	CAN
Binary inputs and outputs	see IG-IOM
Analog output	see IG-IOM

Analog inputs

Not electrically separated	
Number of inputs	4
Resolution	10 bits
Maximal resistance range	0 – 250 Ω
Maximal voltage range	0 – 100 mV
Maximal current range	0 – 20 mA
Resistance measurement tolerance	1 % ± 2 Ω out of measured value
Voltage measurement tolerance	1,5 % ± 1mV out of measured value
Current measurement tolerance	2,5 % ± 0,5mA out of measured value

IGL-RA15

Power supply

Voltage supply	8-36V DC
Consumption	0,35-0,1A (+1A max horn output)

Depend on supply voltage

Operating conditions

Operating temperature	-20..+70°C
Storage temperature	-40..+80°C
Protection front panel	IP65

Dimensions and weight

Dimensions	180x120x55mm
Weight	950g

Horn output

Maximum current	1 A
Maximum switching voltage	36 VDC

IG-IB

Voltage supply	8-36V DC
Consumption	0,1A depend on supply voltage
Mechanical dimensions:	95 x 96 x 43 mm , DIN rail (35 mm) mounted
Interface to controller	RS232
Interface to modem	RS232
Interface to Ethernet	RJ45 (10baseT)
Operating temperature	-30..+70°C
Storage temperature	-30..+70°C