

SST-2000 Series

Universal Speed Switch & Speed Transmitter

An Operator's Guide

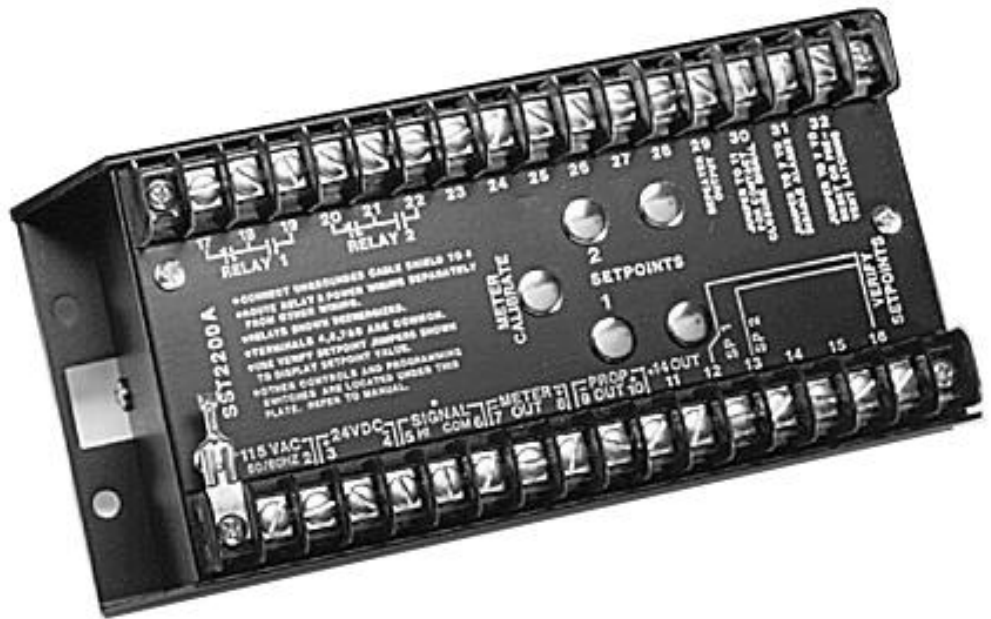

Copyright

Specifications and information herein are subject to change without notice. Dynalco Controls reserves the right to make changes to the equipment described herein to improve function or design. Although the information contained in this manual has been carefully reviewed and is believed to be reliable, Dynalco Controls does not assume any liability for special, indirect, incidental, or consequential damages arising out of the application or use of the equipment described herein. Warranty is limited and cannot exceed the price paid for the product upon which the warranty is based.

Copyright ©2001. All rights reserved.

Trademarks

SST-2000A/H, SST-2200A, SST-2400H are trademarks of Dynalco Controls.

Dynalco Controls
3690 N.W. 53rd Street,
Fort Lauderdale, FL 33309 U.S.A.
☎ (954) 739-4300
Fax (954) 484-3376
www.dynalco.com • mailbox@dynalco.com

Printed in U.S.A.

Contents

Chapter 1	Getting Started	1
	About your speed switch	2
	Models	4
	Features	4
	Specifications	5
Chapter 2	Installing the SST-2000A/H	9
	Mounting the unit	10
	About Electrical Connections	10
	Connecting Signal Inputs	11
Chapter 3	Powering External Devices	13
	Powering an SPD-100, SPD-700, or other frequency instruments	14
	Using DPM-105 meters as external speed indicators	14
	Powering Zero Velocity Pickups and Other Loads	16
	Driving an SPV-200 Solenoid Pneumatic Valve	17
Chapter 4	Calibrating the Speed Switch	19
	Locating the programming switch instructions	20
	Changing the full-scale input frequency range	21
	Input frequency range <i>less than</i> 80 Hz full-scale	21
	Input frequency range <i>greater than</i> 20,000 Hz full-scale	21
	Calibrating the SST-2000A/H	22
	Calibrating the 4-20 mA Proportional Output	24
	Programming Set Points and Relays	25
	Adjusting Signal Sensitivity	27
	Response Time	28
	Adjusting Individual Set Points	28
	Verifying Set Point Values	31
	Adjusting Set Point Values	32

Chapter

1

Getting Started

About your speed switch

WARNING

When the SST-2000A/H Series Speed Switch/Transmitter is used as the primary overspeed shutdown device, it *must* be tested regularly.

The SST-2000A/H series is a speed switch and signal transmitter that provides alarm set points for over- and underspeed control for sequential, startup, and shutdown switching for:

- ◆ engines
- ◆ machines
- ◆ I/P drivers
- ◆ instrumentation
- ◆ process control
- ◆ recording
- ◆ measurement

How it works

The SST-2000A/H accepts a full-scale frequency input value from 0–0.1 Hz (6 pulses per minute) to 0–50,000 Hz. Standard: 0–80 Hz to 0–20,000 Hz.

Examples of input devices include:

- ◆ passive or active magnetic pickups
- ◆ shaft encoders
- ◆ contact closures
- ◆ flow meters
- ◆ photocells

The speed switch converts frequency input (speed, rate) into linear proportional dc outputs:

- ◆ 0–1 mA (standard - meter out)
- ◆ 4–20 mA (standard - proportional out)
- ◆ 0–5 Vdc (switch selectable)
- ◆ 0–10 Vdc (switch selectable)

It provides 0, 2, or 4 relay trip set points (depending on the model)

Physical Dimensions

Fig. 1-1 Top and side view of the SST-2000A/H. Dimensions in inches and (centimeters).

Special explosion proof housings kits (complete with mounting hardware) are also available. See XP rated housings on page 6.

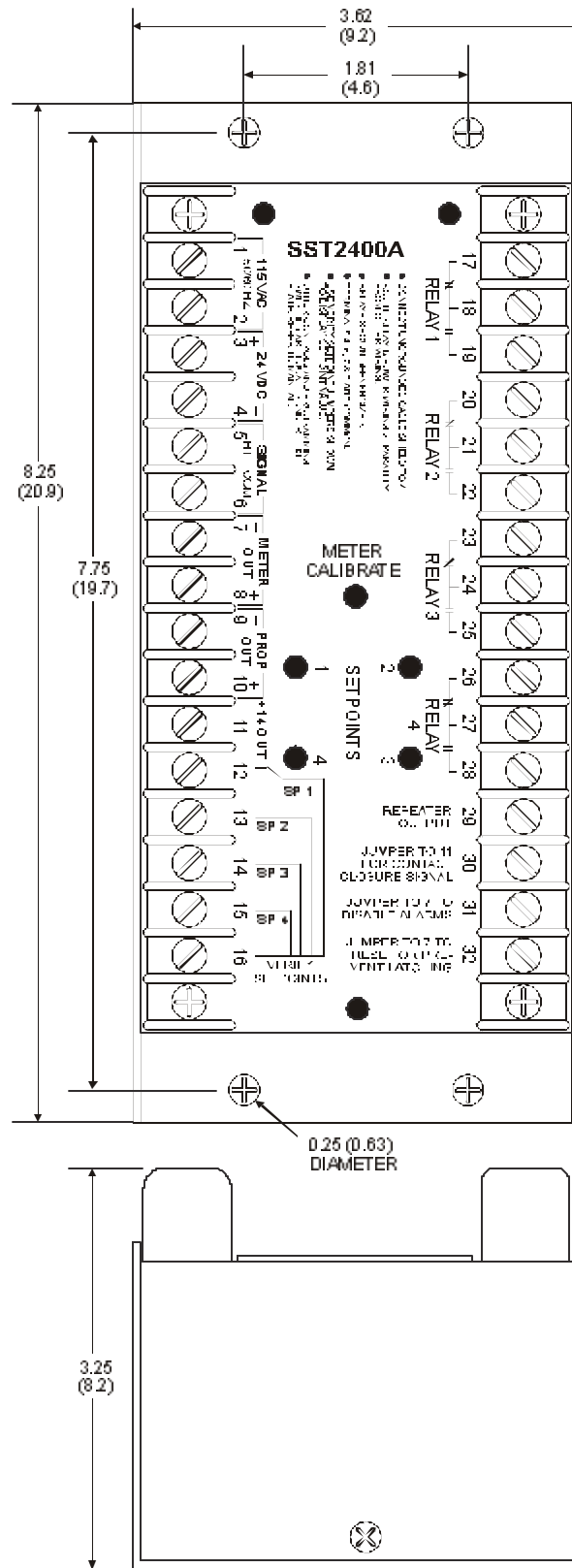

Dimensions in inches (centimeters)

Models

Model	No. Of Set Points	3rd Party Certification(s)
<i>A series - standard relays</i>		
SST-2000A	0	CSA: general certification LR 92270
SST-2200A	2	ABS: type approval
SST-2400A	4	CE: 89/336/EEC, Light Industrial CE: 72/23/EEC, Low Voltage Directive
<i>H series - hermetically sealed relays</i>		
SST-2000H	0	CSA: Class I, Div. 2, Grp. D, LR 45322*
SST-2200H	2	CE: 89/336/EEC, Light Industrial
SST-2400H	4	CE: 72/23/EEC, Low Voltage Directive
* Approval contingent upon housing an SST-2000H series device in a CSA-certified enclosure.		

Features

Signal Sources	Field-programmable for: sensors, including contact closure input, magnetic pickups, ac generators, contact closures, photocells.
Input Frequency	<ul style="list-style-type: none"> ◆ Full-scale values from 0-0.1 Hz (6 pulses/minute) to 0-20 kHz. ◆ Field-adjustable range and sensitivity control.
Alarm Set Points	0 SST-2000A/H (when only proportional output is required) 2 SST-2200A/H 4 SST-2400A/H
Alarm Settings	Alarms are field-configurable for overspeed, underspeed, energize, de-energize, latch, auto-reset.
Alarm Disable	Disable all alarms (for startup conditions and special functions)
Alarm Reset	<ul style="list-style-type: none"> ◆ Momentarily reset all latched alarms ◆ Permanently converts all latching alarms to auto-reset
Set Point Verification	Integral VERIFY permits viewing and setting of set point value without actuating the relays. Requires an external meter.
Proportional Outputs	0-1 mA and 4-20 mA (standard) 0-5 Vdc or 0-10 Vdc (field-selectable)
Output Power	Repeater output drives counters and self-powered tachometers. Regulated 14 Vdc output powers active pickups, accessories, and meters (e.g. DPM-105; MTH-103D; SPD-100L; LST-100L).
Output Range	Current source up to 50 mAdc output always included.

Specifications

Electrical

Input Signal Frequency Range	<ul style="list-style-type: none"> ◆ 0-20 kHz (standard) (field-adjustable) ◆ 0-0.1 Hz (special order) ◆ 0-80 Hz (special order) ◆ 0-50K Hz (special order)
Waveforms	◆ Accepts pulsed, sinusoidal, square, TTL, or CMOS
Input Signal Sensitivity	<ul style="list-style-type: none"> ◆ 25 mVrms (typical factory setting) ◆ 5 mVrms to 100 mVrms (field-adjustable) ◆ 50 Vrms (maximum for standard units) ◆ 1.0 volt threshold (requires input signal desensitizing)
Input Impedance	<ul style="list-style-type: none"> ◆ Nearly infinite at low signal levels ◆ 10 kΩ (min.) at signals exceeding +15.0 V peak, -1.0 V peak
Power Input	<ul style="list-style-type: none"> ◆ 115 Vac \pm10%, 47-420 Hz ◆ 22-30 Vdc, maximum 5 W or 150 mAdc ◆ 220 Vac, 50/60 Hz (optional)
Proportional Output	<ul style="list-style-type: none"> ◆ 0-1 mAdc (standard) ◆ 4-20 mAdc (standard) ◆ 0-5 Vdc or 0-10Vdc (field-selectable; for external load resistance of 20 kΩ or higher) ◆ Custom ranges available <p>MAXIMUM LOAD</p> <ul style="list-style-type: none"> ◆ 1 kΩ with 115/ 220 Vac or 30 Vdc power ◆ 750 ohms with 22 Vdc power ◆ linear between 22 and 30 Vdc
Output Current	Independent of load resistance up to the rated load resistance
Span/zero adj.	\pm 5% (minimum) of full-scale
Auxiliary Meter Output	Proportional 0-1 mAdc, filtered, for meter or recorder loads up to 750 Ω .
Supply Output	Regulated +14 Vdc \pm 5%; 40 mAdc (maximum load)
Repeater Output	Square wave 14 V peak-to-peak, zero based, positive going
Output Ripple and Noise	0.1% of full-scale maximum over 10% to 100% of full-scale.
Response Time	150 milliseconds, 10% to 90% rise (standard). Full-scale frequency ranges below 80 Hz are proportionally slower.
Linearity	0.1% of full-scale (0.05%, typical), all outputs.
Stability	Less than 0.05% of full-scale change with a 10% change in supply voltage. Temp. coeff. \pm 0.01% per $^{\circ}$ F (\pm 0.018% per $^{\circ}$ C)

Relays

Logic	Field-programmable by switches for: <ul style="list-style-type: none"> ◆ overspeed/underspeed ◆ energize/de-energize ◆ latch/auto-reset ◆ SPST/DPDT (2 DPDT set points maximum)
A Series Contact Rating	<ul style="list-style-type: none"> ◆ 6.0 A @ 28 Vdc or 115 Vac (resistive) ◆ 2.0 A @ 220 Vac ◆ 1.0 A into 500 mH for up to 100,000 cycles ◆ SPDT* <p>*For DPDT, Relays 1 & 3 and 2 & 4 work together as separate DPDT trips.</p>
H Series Contact Rating	<ul style="list-style-type: none"> ◆ 5 A (resistive) @ 24 Vdc ◆ 1.0 A @ 120 Vac ◆ 0.5 A @ 220 Vac ◆ SPDT* <p>*For DPDT, Relays 1 & 3 and 2 & 4 work together as separate DPDT trips.</p>
Alarm Set Points	◆ Adjustable, 25-turn cermet potentiometers
Hysteresis	◆ 1% of full-scale frequency
Isolation Transformer	◆ Optional. Isolates the transmitter input from the probe or sensor.

XP Rated Housings (optional)

ENC-6210	XP Cast Housing: 8"H x 10"W x 5" D; 100's window + P-button UL/CSA Class I, Groups C,D Class II, Groups E,F,G NEMA 3,4
ENC-6311	XP Cast Housing: 8"H x 10"W x 5" D; 100's window UL/CSA Class I, Groups B,C, D Class II, Groups E,F,G NEMA 3,4
ENC-3000 ENC-4000	Sheet Meta:l 6"H x 9"W x 4" D; NEMA 1; No Window Sheet Meta:l 8"H x 10"W x 4" D; NEMA 12; No Window
ENC-5000	XP Cast Housing: 7"H x 9"W x 5"D; No Window UL/CSA Class I, Groups C,D; Class II, Groups E,F,G

Options

Enclosures	XP and NEMA rated enclosures are available.
Open Pickup	Relay 1 switches in the event of an open or disconnected magnetic pickup. Relay 1 will still react when its set point is traversed (field-configurable). NOTE: Not available with signal isolation transformer option.
Pneumatic Trip	Pulses relay 1 for 100 milliseconds Trips Dynalco SPV-200 Solenoid Pneumatic Valve on overspeed (optional)
Underspeed Class "C" Logic	Arms relay 2 as set point 2 is traversed on increasing speed. Pulses relay 2 as set point 2 is traversed on decreasing speed. Use for tripping the pneumatic SPV-200 on underspeed or for general underspeed electrical shutdown.
Expanded Scale Input	Provides full meter output, full proportional output, and full set point range over a limited input range e.g. 0-1 mA and 4-20 mA over 800-1000 Hz input frequency.

Environmental

Temperature Range	-40°F to +160°F (-40°C to +71°C) operating -40°F to + 180°F (-40°C to +82°C) storage
Weight	2.6 lbs (1.17 kg)

Chapter

2

Installing the SST-2000A/H

Mounting the unit

The SST-2000A/H is installed using standard hand tools. It is generally mounted in a panel or enclosure using standard practices.

About Electrical Connections

Internal Commons, Isolation

WARNING: AVOID DAMAGE WHEN DC-POWERED

Install a current loop isolator between the 4-20mA output and the load if the load does not reference the same common as the SST-2000A/H.

Signal input (low side, terminal 6) is common to the auxiliary output (low side, terminal 7), to the dc supply (terminal 4), and to the main proportional output low side (terminal 9). Relay contacts are always isolated

When powered with ac: all circuitry is isolated from the power line by the built-in supply transformer

When powered with dc: the transmitter output is *not* isolated from the dc power source. Any load driven by the transmitter (i.e. recorder, controller, etc.) must have the same common as the negative side of the dc supply. Install a current loop isolator between the 4–20mA output and the load if the load does not reference the same common as the SST-2000.

Fig. 2-1 Electrical Connection Drawing.

Use shielded cable: connect ungrounded shield to terminal 4. Route power line and relay connections separate from signal meter and reset lines to prevent electrical noise interference. Terminals 4, 6, 7, and 9 are internally tied together to circuit common unless unit has signal isolation transformer. In that case, terminal 6 is isolated.

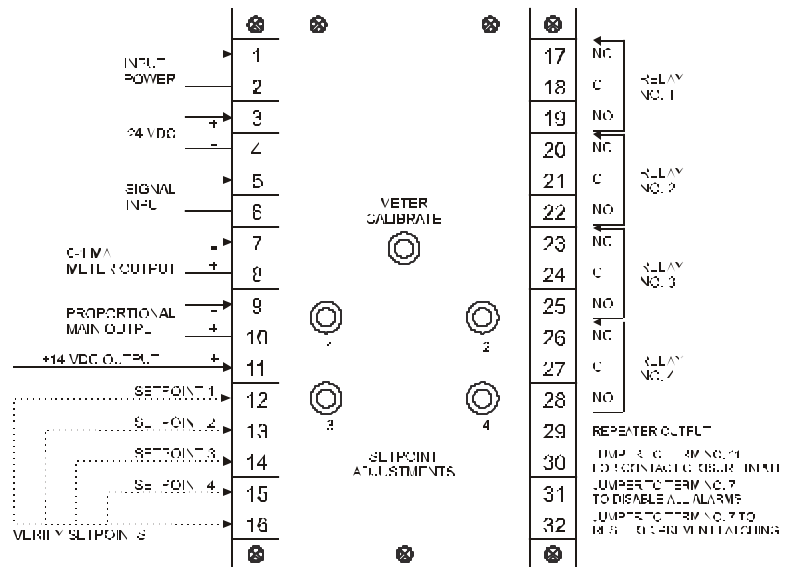

Connecting Signal Inputs

Connecting a PG-278 Pulser

Connect signal source Common to terminal 6 on the SST-2000A/H. Connect signal HI to terminals on the SST-2000A/H.

Fig. 2-2 Connecting a PG-278 Pulser to the SST-2000A/H.

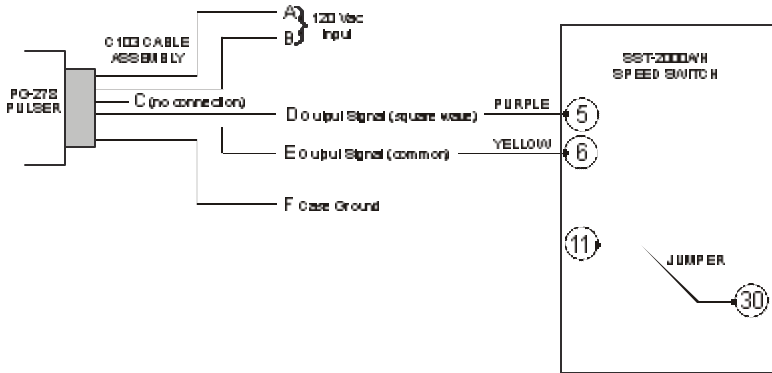

Terminals 11 and 30 on the SST-2000A/H are jumpered to create a one volt threshold.

Chapter

3

Powering External Devices

Powering an SPD-100, SPD-700, or other frequency instruments

The SST-2000A/H has a repeater output that can be used to power external frequency instruments.

A square wave (14-volt peak-to-peak, zero-based, positive-going) is brought out at terminals 29 and 4 (common) to drive self-powered digital tachometers such as the SPD-100, SPD-700, and MTH-103D, or to use as a conditioned high level signal source into counters or other instruments. The frequency of the signal is equal to that being applied at the signal input: terminals 5 (+) & 6 (-).

This output has an internal resistance of 1 k Ω .

Using DPM-105 meters as external speed indicators

You can use the DPM-105 as an external indicator. You can connect one or more DPM-105 meters to your SST-2000A/H.

The 0-1 mA meter output of the SST-2000A/H [terminals 7 (-) and 8 (+)] is factory-calibrated into an external load of 40 Ω . The load resistance of the DPM-105 is 95 Ω .

Connecting one DPM-105

- 1 On the DPM-105, retain the jumper across terminals 1 and 2.
- 2 Connect the meter as shown in Fig. 3-3.
- 3 Calibrate the SST-2000A/H.

Fig. 3-3 Connecting one DPM-105 to the SST-2000A/H.

- ◆ Keep the jumper between terminal 1 & 2 on the DPM-105

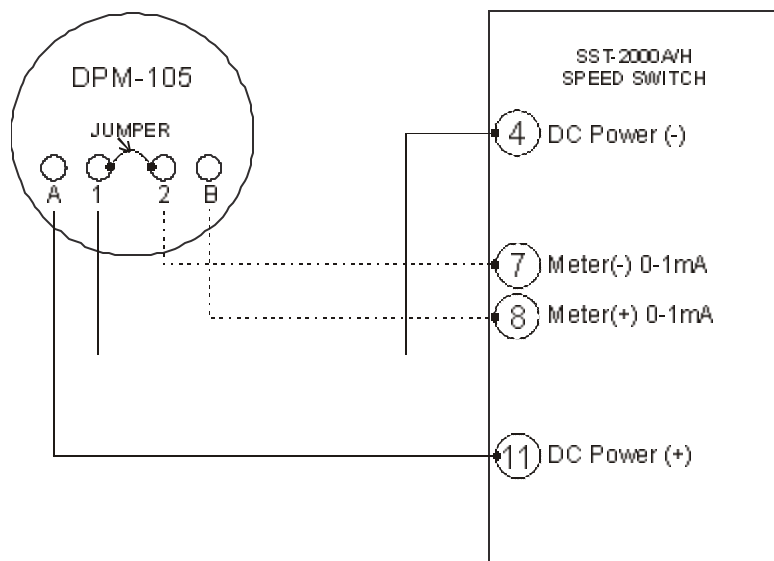

- ◆ Confirm the meter is properly connected to the SST-2000A/H.
- ◆ Use a frequency generator (e.g. F-16) to apply full-scale frequency to terminal 5 (HI) & 6 (COM) on the SST-2000A/H. Maximum signal input is 50 Vrms for a standard unit.
- ◆ Adjust the METER CALIBRATE potentiometer on the SST-2000A/H for the appropriate full-scale reading on each DPM-105.
- ◆ Use a DPM-105 data sheet, if necessary, to calibrate the DPM-105 meters.

Connecting more than one DPM-105

- 1 Remove the jumper across terminals 1 and 2 on each DPM-105.
- 2 Connect the meters as shown in Fig. 3-4.
- 3 Calibrate the SST-2000A/H.

Fig. 3-4 Connecting more than one DPM-105 to the SST-2000A/H.

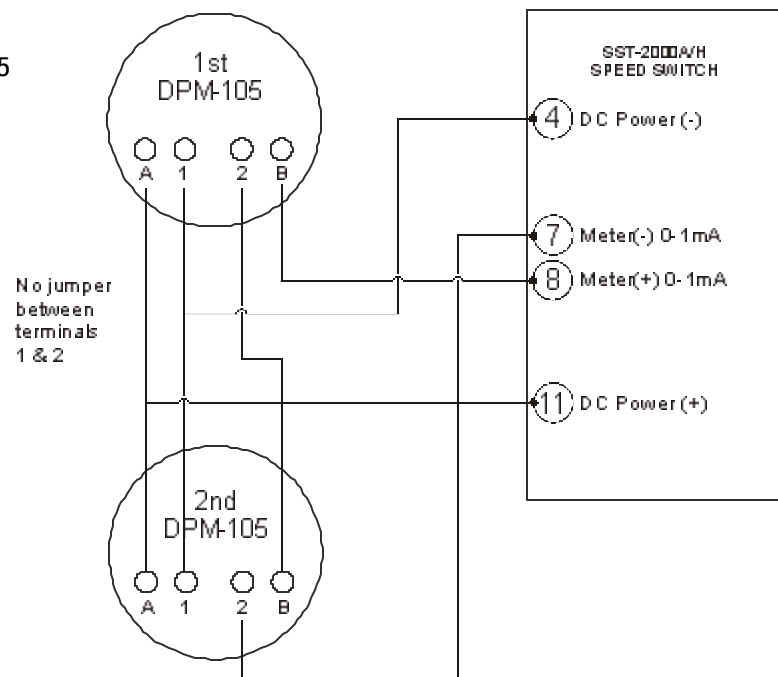

- ◆ Confirm the meter is properly connected to the SST-2000A/H.
- ◆ Apply full-scale frequency to terminal 5 (HI) & 6 (COM) on the SST-2000A/H. Maximum signal input is 50 Vrms for a standard unit.
- ◆ Adjust the METER CALIBRATE potentiometer on the SST-2000A/H for the appropriate full-scale reading on each DPM-105.
- ◆ Use a DPM-105 data sheet, if necessary, to calibrate the DPM-105 meters.

Powering Zero Velocity Pickups and Other Loads

The regulated 14 Vdc supply brought out at terminals 11 (+) & 4 (-) has a capacity of 40 mA. This output can power zero velocity pickups (e.g. M928) and digital indicators like a DPM-105.

- 1 Connect the M928 pickup as indicated in Fig. 3-5.
- 2 Jumper terminals 11 and 30 to desensitize the input signal to a 1.0 V threshold.
- 3 Adjust signal sensitivity if necessary. See page 27 for instructions on how to adjust input sensitivity.

Fig. 3-5 Jumper terminals 11 and 30 to desensitize the input signal circuit to a one-volt threshold.

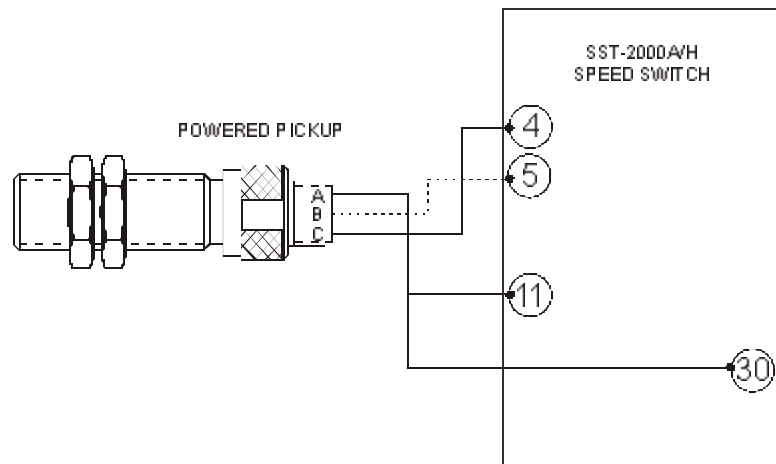

Driving an SPV-200 Solenoid Pneumatic Valve

WARNING: TO AVOID SPV-200 COIL DAMAGE

Use a current limiting resistor in series with the dc power source and the transferring relay contacts.

The SPV -200 coil has a resistance of 50 Ω and requires 6 Vdc to trip.

Switching the Regulated 14 Vdc Supply

The regulated 14 Vdc supply at terminals 11 (+) & 4 (-) does not have the capacity to drive the SPV-200 continually.

When the SST-2000A/H speed transmitter is supplied with the Pneumatic Trip Option for Overspeed, Relay 1 transfers for only 100 milliseconds on overspeed; the 14 volt supply can then be used with a series limiting resistor to power the pneumatic trip.

Use a ¼ watt, 47–50 Ω resistor in series with the 14 volt supply.

Fig. 3-6 Switching the regulated 14 Vdc supply.

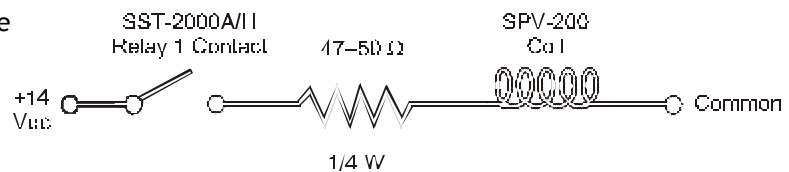

Switching 28 Vdc

When switching 28 Vdc into the coil, use a 5–10 watt, 180 Ω resistor in series with the SPV-200 coil.

Fig. 3-7 Switching the 28 Vdc supply.

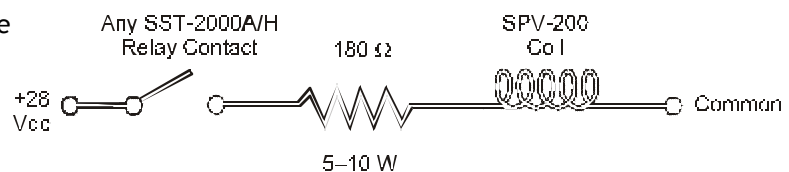

Chapter

4

Calibrating the Speed Switch

Locating the programming switch instructions

Fig. 4-8 A full description of the programming switches and controls is located under the top plate of the SST-2000A/H.

1 Use a no. 1 or no. 2 Phillips screwdriver to remove the top plate of the switch.

2 The underside of the plate contains instructions for how to:

- ◆ latch set point relays on alarm
- ◆ actuate relays on overspeed
- ◆ actuate 2 relays simultaneously (as DPDT relay)
- ◆ de-energize relays on alarm
- ◆ change proportional output to 0-5 Vdc or 0-10 Vdc
- ◆ recalibrate the full-scale input frequency range (switch A settings)

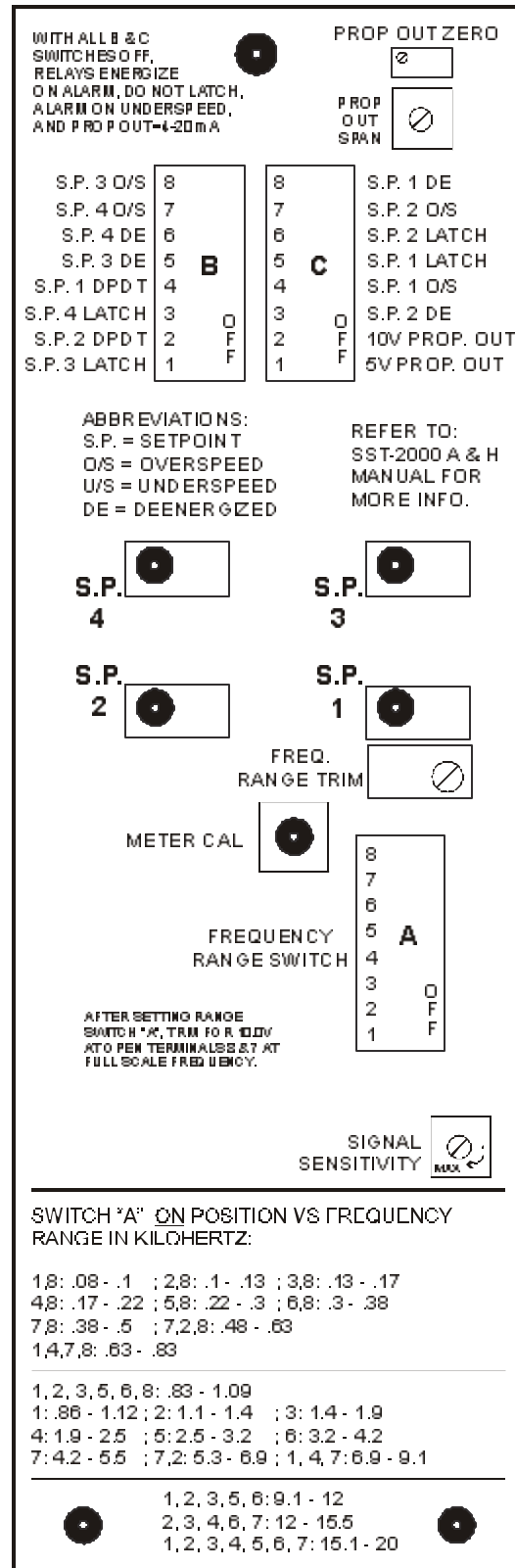

Changing the full-scale input frequency range

You can set the standard full-scale frequency range from as low as 0–80 Hz to as high as 0–20 kHz.

- 1 Remove the top plate from the SST-2000A/H to reveal the “A” DIP switches.
- 2 Use Table 4-1, page 23, or the underside of the top plate (bottom of Fig. 4-9, page 22) to determine the correct DIP switch settings.
- 3 Calibrate the SST-2000A/H using the procedure on page 22.

Input frequency range *less than 80 Hz full-scale*

The full-scale frequency input range is usually set up at the factory when an SST-2000A/H is ordered.

The SST-2000A/H can easily be field-modified for any standard full scale input frequency range from 0–80 Hz to 0–20,000 Hz using the procedure Recalibration of Full-Scale Input Frequency Range.

Field-changing the SST-2000A/H to accept input frequencies *less than 0-80 Hz full-scale is not recommended*. Damage might result that could void the product warranty.

Please contact the Dynalco *Customer Service Department* at (954) 739-4300 for guidance in arranging for a low input frequency range.

Input frequency range *greater than 20,000 Hz full-scale*

The full-scale frequency input range is usually set up at the factory when an SST-2000A/H is ordered.

The SST-2000A/H can easily be field-modified for any standard full scale input frequency range from 0–80 Hz to 0–20,000 Hz using the procedure Recalibration of Full-Scale Input Frequency Range.

Field-changing the SST-2000A/H to accept input frequencies *greater than 0-20,000 Hz full-scale is not recommended*. Damage might result that could void the product warranty.

Please contact the Dynalco *Customer Service Department* at (954) 739-4300 for guidance in arranging for a high input frequency range.

Calibrating the SST-2000A/H

WARNING

Calibrate the speed switch:

- immediately after any contact change in Switch A
- before adjusting set points or proportional output

You must calibrate the SST-2000A/H if you have made a change in the full-scale frequency range (changed contacts to DIP switch A).

- 1 Disconnect any meter connected to terminals 7 & 8. Mark or position the wires so they can be correctly reattached later.
- 2 Connect a digital voltmeter across terminals 7(-) & 8 (+).
- 3 Connect a frequency generator (e.g. F-16) at terminals 5 (HI) & 6 (COM). Use the frequency generator to input the new full-scale frequency.
- 4 Adjust the FREQ RANGE TRIM potentiometer for 10.00 Vdc on the voltmeter. (See Fig. 4-9.)
- 5 Reattach the meter that is normally connected to terminals 7(-) & 8 (+). *Observe polarity.*

Fig. 4-9 The contact arrangements for the full-scale frequency range switch (A) are on underside of the top plate.

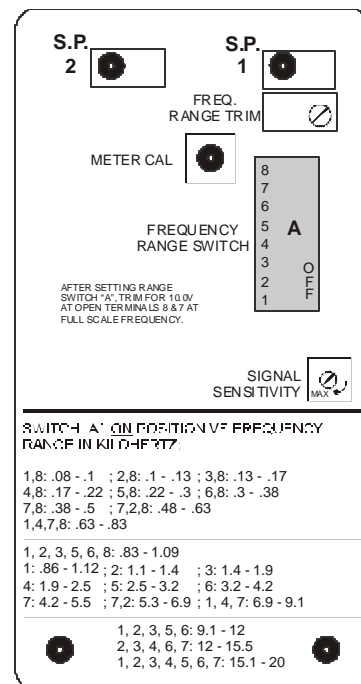

Table 4-1 Table of full-scale frequency and the corresponding switch "A" ON settings.

Freq. Range (in kHz)	Switch A ON Positions	Freq. Range (in Hz)
0.08 - 0.10	1, 8	80 - 100
0.10 - 0.13	2, 8	100 - 130
0.13 - 0.17	3, 8	130 - 170
0.17 - 0.22	4, 8	170 - 220
0.22 - 0.30	5, 8	220 - 300
0.30 - 0.38	6, 8	300 - 380
0.38 - 0.50	7, 8	380 - 500
0.48 - 0.63	7, 2, 8	480 - 630
0.63 - 0.83	1, 4, 7, 8	630 - 830
0.83 - 1.09	1, 2, 3, 5, 6, 8	830 - 1,090
0.86 - 1.12	1	860 - 1,120
1.10 - 1.40	2	1,100 - 1,400
1.40 - 1.90	3	1,400 - 1,900
1.90 - 2.50	4	1,900 - 2,500
2.50 - 3.20	5	2,500 - 3,200
3.20 - 4.20	6	3,200 - 4,200
4.20 - 5.50	7	4,200 - 5,500
5.30 - 6.90	7, 2	5,300 - 6,900
6.90 - 9.10	1, 4, 7	6,900 - 9,100
9.10 - 12.0	1, 2, 3, 5, 6	9,100 - 12,000
12.0 - 15.5	2, 3, 4, 6, 7	12,000 - 15,500
15.1 - 20.0	1, 2, 3, 4, 5, 6, 7	15,100 - 20,000

Calibrating the 4-20 mA Proportional Output

You must calibrate the speed switch if the standard proportional output of 4 to 20 mA is changed to :

- ◆ 0–5 Vdc using switch C1, or
- ◆ 0–10 Vdc using switch C2

To calibrate the new proportional output

- 1 Attach a digital voltmeter to terminals 9 (-) & 10 (+).
- 2 Apply 10% of the full-scale frequency to input terminals 5 (+), 6 (-).
- 3 Adjust the PROP OUT ZERO adjust potentiometer (See Fig. 4-10, below) to yield 10% of full-scale proportional output on the voltmeter.

Fig. 4-10 The PROP OUT ZERO and PROP OUT SPAN adjustments are located in the upper right corner under the top plate of the SST-2000A/H.

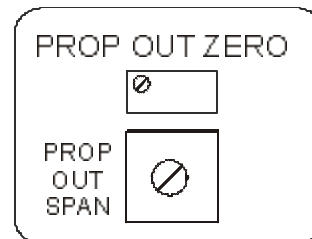

- 4 Apply 100% of full-scale frequency to terminals 5 (+) & 6 (-).
- 5 Turn PROP OUT SPAN adjust potentiometer (See example below) to yield 100% of full-scale proportional output on the voltmeter .
- 6 Repeat steps 2, 3, 4, and 5 three or four times to assure accuracy.

EXAMPLE: A unit calibrated for 0-500 Hz input is being recalibrated to 0-10 Vdc proportional output (from 4-20 mAdc proportional output).

- ◆ Apply 10% of full-scale (50 Hz) to terminals 5 (+) & 6 (-).
- ◆ Adjust PROP OUT SPAN adjust potentiometer to yield 1.000 Vdc on the voltmeter.
- ◆ Apply full-scale frequency (500 Hz) to terminals 5 (+) & 6 (-).
- ◆ Turn PROP OUT ZERO adjust potentiometer to yield 10.00 Vdc.
- ◆ Repeat 3 or 4 times for accuracy.

Programming Set Points and Relays

Remove the top plate from the SST-2000A/H to reveal DIP switches B and C.

Use DIP switches B and C to program relay set points to:

- ◆ energize (OFF) / de-energize (ON) on alarm
- ◆ non-latch (OFF) / latch (ON) on alarm
- ◆ actuate SPST (OFF) / DPDT (ON) trip on alarm
- ◆ change proportional voltage output

Fig. 4-11 The DIP switch settings available to you depend on the model of speed switch you purchased:

- ◆ SST-2400A/H series switches have four set point relay adjustments (DIP switches B and C).
- ◆ SST-2200A/H series switches only have relays 1 and 2 (adjustable using DIP switch C).
- ◆ SST-2000A/H switches have no set point relays.

S.P. 3 O/S	8	8	S.P. 1 DE
S.P. 4 O/S	7	7	S.P. 2 O/S
S.P. 4 DE	6	6	S.P. 2 LATCH
S.P. 3 DE	5	5	S.P. 1 LATCH
S.P. 1 DPDT	4	4	S.P. 1 O/S
S.P. 4 LATCH	3	3	S.P. 2 DE
S.P. 2 DPDT	2	2	10V PROP. OUT
S.P. 3 LATCH	1	1	5V PROP. OUT

The underside of the top plate contains labels for each DIP switch setting.

Resetting a latched relay

To momentarily reset a latched relay, jumper terminals 32 and 7.

Set points 3 & 4 and selecting DPDT trip

WHEN ALL B SWITCHES ARE OFF

- ◆ relays 3 and 4 are energized, underspeed
- ◆ non-latching
- ◆ all relays are SPST

EXAMPLE: To set relays 3 and 4 to actuate, de-energize, and latch on overspeed, turn on B1, B3, B5, B6, B7, and B8.

THE EFFECT OF TURNING B SWITCHES ON

Turn on B to...

B1	LATCH set point 3 on alarm
B2	ACTUATE relay 4 simultaneously with relay 2, creating two Form C contacts for set point 2 (DPDT relay).
B3	LATCH set point 4 on alarm
B4	ACTUATE relay 3 simultaneously with relay 1, creating two Form C contacts for set point 1 (DPDT relay).
B5	DE-ENERGIZE relay 3 on alarm
B6	DE-ENERGIZE relay 4 on alarm
B7	ACTUATE set point 4 on overspeed.
B8	ACTUATE set point 3 on overspeed.

Set points 1 & 2: 0-5 & 0-10 Vdc proportional output

WHEN ALL C SWITCHES ARE OFF

- ◆ the proportional output is 4-20 mA
- ◆ relays 1 and 2 are energized, underspeed
- ◆ non-latched

EXAMPLE: To change the proportional output to 0-10 Vdc, and set relay 2 to actuate, energize, and latch on overspeed, turn on C2, C6, and C7.

THE EFFECT OF TURNING C SWITCHES ON

Turn on C to...

C1	Change proportional output to 0-5 Vdc*. Confirm C2 is OFF.
C2	Changes proportional output to 0-10 Vdc*. Confirm C1 is OFF.
C3	DE-ENERGIZE relay 2 on alarm.
C4	ACTUATE relay 1 on overspeed, non-latch.
C5	LATCH relay 1 on alarm.
C6	LATCH relay 2 on alarm.
C7	ACTUATE relay 2 on overspeed, non-latch.
C8	DE-ENERGIZE relay 1 on alarm.

* Requires recalibration.

Adjusting Signal Sensitivity

Desensitizing Standard Inputs

Signal sensitivity is factory set to 25 mVrms (about 35 mV peak or 70 mV peak-to-peak) and satisfies most applications.

Fig. 4-12 The signal sensitivity control is located under the A DIP switch.

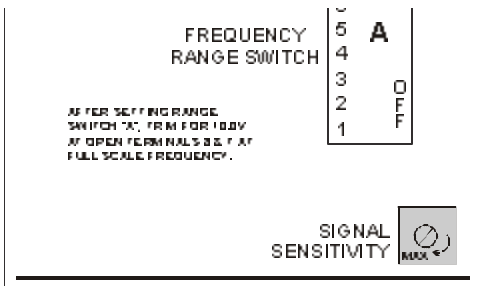

Higher sensitivities can be more vulnerable to noise.

To raise sensitivity Turn the SIGNAL SENSITIVITY potentiometer (Fig. 4-12) clockwise. At full clockwise rotation, sensitivity is approximately 5 mVrms.

To lower sensitivity Turn the SIGNAL SENSITIVITY potentiometer counterclockwise. At full counterclockwise rotation, the sensitivity is approximately 100 mVrms.

Desensitizing Contact Closure

Jumper terminals 30 and 11 to desensitize the unit to about 1 Vrms. Signal Sensitivity pot setting does not affect this procedure.

Fig. 4-13 Jumper terminals 11 to 30 to desensitize the SST-2000A/H for contact closure input.

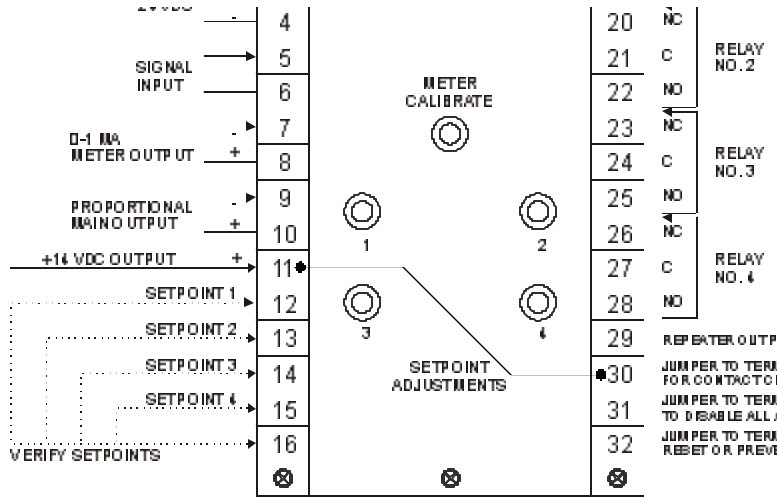

Response Time

Response time is the time required for the proportional outputs to change from 10% to 90% of the maximum calibrated value for an instantaneous step change of the input frequency. Response time affects the transfer speed of the relays.

RELAY RESPONSE

Contact Dynalco if you need a different relay response time.

Standard response time is 150 milliseconds over all standard input frequency ranges: 0-80 Hz full-scale to 0-20,000 Hz full-scale. Response times below 80 Hz full-scale are proportionally slower.

While other response times can be provided, field modification is not recommended since damage might result that could void the product warranty.

Contact Dynalco if you need a different relay response time.

Adjusting Individual Set Points

- 1 Verify that the SST-2000A/H is calibrated to the correct full-scale frequency range (see page 22).
- 2 Tools required: Either a very thin-bladed screwdriver or a transformer alignment tool; signal generator (Dynalco's F-16 or equivalent).
- 3 Provide a signal source. Use an F-16 signal generator or similar zero-crossing signal source, or use the frequency signal generated by the magnetic pickup on the engine.
- 4 Apply a frequency signal to terminals 5 & 6. This frequency input should equal the target RPM value of the set point being adjusted.

$$\text{Setpoint Frequency (Hz)} = \frac{\text{RPM} \times \text{No. of teeth or holes on flywheel}}{60}$$

For example: Calculate the set point frequency for a gear with 72 teeth rotating at 800 RPM.

$$\text{Frequency (Hz)} = \frac{(800) \times (72 \text{ teeth})}{60} = 960 \text{ Hz (to terminals 5 \& 6)}$$

Alternate Method 1: Adjusting set points while the engine is not running

Use a signal generator to adjust individual set points when the engine is not operating and if you do not have an analog RPM meter.

- 1 Disconnect the wires to terminals 5 & 6. Mark or position the wires to assure correct replacement.

- 2 Apply the calculated set point frequency to terminals 5 (HI) & 6 (COM).
- 3 Apply operating power to the SST-2000A/H. See lid of your SST-2000A/H or spec sheet for power choices.
- 4 Select the appropriate set point trim pot.
- 5 Turn the pot:
 - ◆ Counterclockwise to lower the set point value (reduce the speed at which the set point relay will trip).
 - ◆ Clockwise to raise the set point value (increase the speed at which the set point relay will trip).
- 6 Turn the pot slowly so as not to pass the target set point by a large amount. The pot has fine resolution, so a large change in set point value may take several turns.
- 7 While adjusting the pot, listen for the relay to trip at the set point. You can hear a distinct click when the contacts transfer. If high ambient noise makes it impossible to hear the relay click: use an ohmmeter as described in Alternate Method 2, below.
- 8 Fine tune the adjustment:
 - ◆ After the relay trips, slowly REVERSE the adjustment of the set point pot until the relay again trips.
 - ◆ Again, slowly turn the pot FORWARD until the relay trips.
- 9 Reattach the wires to terminals 5 (HI) & 6 (COM). Observe polarity.
- 10 Repeat the above procedure for other set points to be changed.

Alternate Method 2: Adjusting Individual Set Points While The Engine Is Operating

A *non-critical* overspeed value is one that will not stress the engine. Use Alternate Method 3 to adjust set points while the engine is operating at a non-critical speed. NOTE: when the set point value is reached the relay will cause an engine shutdown or activate whatever is connected to that relay.

A *critical* overspeed is typically the actual engine shutdown overspeed; running

WARNING: DO NOT RUN AT OVERSPEED

Use Alternate Method 3 to adjust set points while the engine is operating at NON-CRITICAL speed only.

the engine at this speed is generally not desired. Use Alternate Method 1 if you cannot guarantee engine overspeed.

- 1 Run the engine at the desired speed using:

- ◆ an RPM indicator/tachometer operating from one of the proportional outputs of the SST-2000A/H:
 - ◆ an independent meter mounted elsewhere on or near the engine.
- 2 Wait for the RPM to stabilize.
 - 3 When RPM is stable, select the appropriate set point trim pot .
 - 4 Follow the procedure in Alternate Method 1: steps 1-10.

Alternate Method 3: Adjusting individual set points in high noise areas

If high ambient noise makes it impossible to hear the relay click:

- 1 Disconnect the wire from:
 - ◆ the center post of the SST-2000A/H set point relay being adjusted.
 - ◆ either one of the other two contacts on the same relay.[Mark the wires or position them so they can be correctly reattached.]
- 2 Connect an ohmmeter to the center terminal of this relay and to either one of the other terminals of this relay. [If adjusting Relay 1, connect the ohmmeter to terminals 18 & 17 or 18 & 19.] The ohmmeter will indicate either a short or an open condition depending on which terminals are chosen.
- 3 Adjust the relay as outlined in Method 1: 1-10. When the relay trips, the ohmmeter will show a short or an open, opposite to the indication it had before the relay tripped.
- 4 Reattach the wires to the relays.
- 5 Repeat the above procedure for other set points to be changed.

Verifying Set Point Values

You can view and adjust the set point values without having to run the engine.
 NOTE: The SST-2000A/H (no set points) does not have set points.

The temporary jumper does not interfere with the normal operation of any relays.

The 4-20 mA proportional output (terminals 9 & 10) is NOT affected by this procedure.

The 14 Vdc pulsed output is not affected by this procedure.

- 1 Jumper terminal 16 with the terminal that corresponds with the set point you want to view (for SST02200A/H and SST-2400A/H):
 - ◆ Set point 1: jumper 16 to 12
 - ◆ Set point 2: jumper 16 to 13
 - ◆ Set point 3: jumper 16 to 14
 - ◆ Set point 4: jumper 16 to 15
- 2 When you jumper the two terminals, the 0–1 mA output meter connected to terminals 7 and 8 disconnects and displays the RPM (frequency, rate, etc.) value at that set point.
- 3 When the jumpers are removed, the meter switches back to its normal operation.

Fig. 4-14 Verify the set point values and view the RPM (frequency, rate, etc.) on the 0-1 mA output meter connected to terminals 7 & 8.

(Shown is the procedure for verifying Set point 1.)

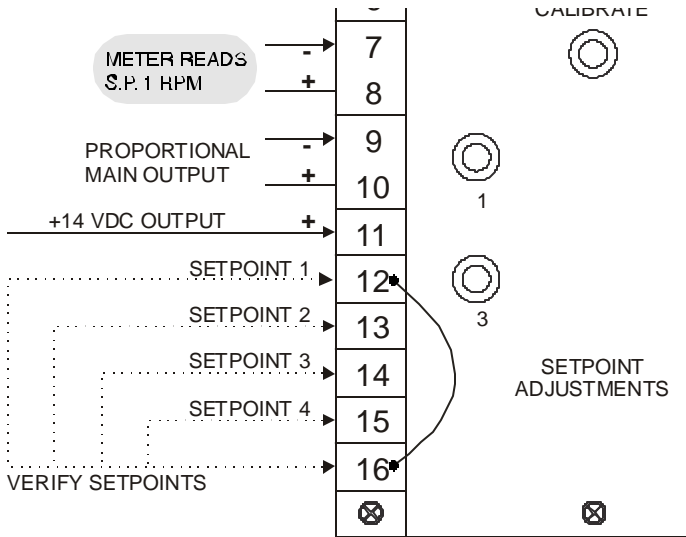

Adjusting Set Point Values

WARNING

You can adjust set points while the engine or other device is operating. However, if you adjust a set point relay to a value lower than the current operating speed, the relay will trip.

You will need a 0–1 mA meter for this procedure. If a meter was supplied with the speed switch, you can use it. Otherwise, you can use a DPM-105 meter, or any 0-1mA ammeter.

The external meter should be calibrated : “0–1 mA = 0 to full-scale input frequency” of the SST-2000A/H.

See the specification sheet or serial number label that accompanied the unit for the full-scale frequency value.

- 1 Observe polarity. Connect an external 0-1 mA meter to terminals 7 (–) & 8 (+).
- 2 Depending on the set point to be adjusted, connect a temporary jumper from :
 - ◆ Terminal 16 to 12 (for Set point 1) or
 - ◆ Terminal 16 to 13 (for Set point 2) or
 - ◆ Terminal 16 to 14 (for Set point 3) or
 - ◆ Terminal 16 to 15 (for Set point 4)
- 3 The 0–1 mA meter will now indicate the current value for the chosen set point (see Fig. 4-14, page 31).
- 4 If necessary, first adjust the selected set point using procedures outlined in Adjusting Individual set points, page 28.
- 5 Remove the temporary jumper.
- 6 The output from terminals 7 & 8 will again provided the standard 0–1 mA proportional output.
- 7 Repeat steps 1–5 for additional set points.

Index

C

- calibrating, 19, 21 - 23, 25, 27, 29, 31
- commons, 10
- contact closure, 27
- CSA
 - Class I, Div.2, Grp. D (H series), 4
 - general certification (A series), 4
- current loop isolator, 10

D

- dc power, 10
- dimensions, 3
- DPM-105, 14

E

- electrical
 - commons, 10
 - connections, 10
 - specifications, 5
- environmental specifications, 7
- explosion-proof housings, 6
- external devices, 13, 15, 17
 - DPM-105, 14
 - MTH-103D, 14
 - SPD-100, 14
 - SPD-700, 14
 - SPV-200, 17

F

- features, 4
- frequency
 - equation for setpoints, 28
 - table, 23
- full-scale input frequency range, 21

H

- housings, 6

I

- input signal, 11
 - desensitizing, 27
 - full scale range, 21
 - sensitivity, 27
- installing, 9, 11
- isolator, 10

L

- latched relay, 25
 - resetting, 25

M

- model numbers, 4

O

- output, 24
 - 4-20 mA , 24

P

- PG-278 pulser, 11
- pickups
 - powering, 16
- power
 - ac, 10
 - dc, 10
 - external devices, 13, 15, 17
 - M928, 16
 - SPV-200, 17
 - zero velocity pickups, 16
- proportional output, 24

R

- relay, 25
 - resetting, 25
 - response, 28
 - setpoints, 6, 20

S

- setpoints, 25
 - 1 & 2, 26
 - 3 & 4, 26
 - 5-10 V prop. output, 26
 - adjusting, 28, 32
 - DPDT trip, 26
 - verifying, 31
- size, 3
- SPD-100, 14
- SPD-700, 14
- specifications, 5

X

- XP housings, 6