

# ECU<sup>®</sup> PROGRAMMABLE TIMER MANUAL

## ECU<sup>®</sup>-PMTN2

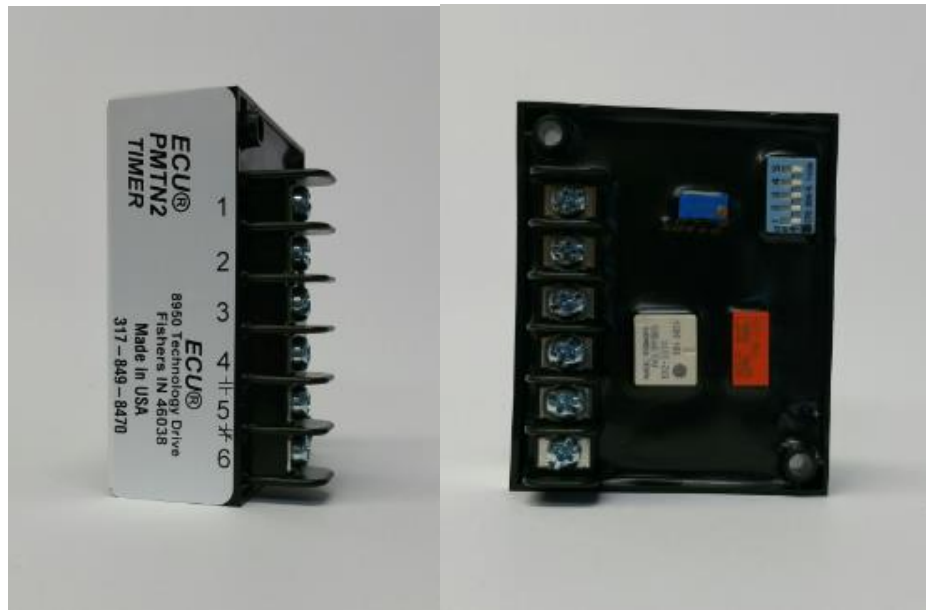

ENGINEERING CONCEPTS UNLIMITED, INC.

8950 Technology Drive

Fishers, Indiana 46038

Telephone: 317-849-8470

Fax: 317-849-6475

# TABLE OF CONTENTS

	PAGE
1. Introduction.....	3
2. Specifications.....	4
3. Operating Block Diagram.....	5
4. Hookup For Delay On Make.....	6
5. Hookup For Delay On Release.....	7
6. Hookup For One Shot Timer.....	8
7. General Hookup For Flasher.....	9
8. Cool Down Timer For Engine Systems.....	10
9. Engine Warm Up Full throttle Timer .....	11
10. Energize To Shutdown Solenoid (Rack) Timer.....	12
11. Delay On Start Timer For Engine Systems .....	13
12. Adjustments.....	14
13. Quick Adjustment For Long Delay Times .....	15
14. Dimensional and Mounting.....	16
15. Terminal Identification.....	16
16. Drill Template.....	17

## INTRODUCTION

The ECU-PMTN2 is an advanced electronic delay timer with the capability to handle severe electrical system noise.

Features:

- SPDT contact output rated at 5 amps DC Current
- 9 to 30 VDC Input Operation
- Wide temperature range -40C to +85C
- Quartz Based – High Repeatability
- 4 Time Ranges
- Seconds to 30 Minutes
- Quick Adjust for Long Times
- No Stand-by Power for Delay on Release Modes

This timer is specifically designed for engine system use and can replace up to 12 types of engine timers:

- Cool Down Timer
- Warm up Timer
- Rack Timer
- Full Throttle Timer
- Delay on make Timer
- Delay On Start Timer
- Crank Cycle Timer
- Flasher Timer
- Shut Down Solenoid Timer
- One Shot Timer
- Cranking Limiter Timer

## **SPECIFICATIONS**

Input voltage Range:	9 to 30 VDC
Operating Temperature:	-40C to +85C
Shock and Vibration Tolerance:	10 G's
Life Expectance:	50,000 cycles
Output Rating:	10 Amps @ 28 VDC resistive
Current Consumption (worst case):	100 mA @ 30 VDC
Power Consumption in standby state:	None
Reset Time:	1 second maximum
Time Ranges:	0 to 9 sec. 0 to 36 sec. 0 – 4.8 min. 0 – 30.0 min.
Size:	3.0 X 2.5 X 1.85 (inches)
Weight:	10.4 oz
Mounting:	Direct mount, no socket required

## OPERATING BLOCK DIAGRAM

Please refer to the block diagram below for timer operation information.

In every mode, except the Delay On Release (DOR) and the Rack mode, once the power is applied to the unit the system clock begins operating. The speed of the clock is adjusted via the pot. The timing block utilizes the system clock and the *divide* by switches (SW4 and SW5) to calculate the delay time. These two *divide* by switches determine the number of delay elements involved in the timing process. Basically, the more delay elements involved, the longer the delay time at the same system clock speed. It is because of these delay elements that the *ECU-PMTN2* can be quickly set for long delay times.

Once the desired time has elapsed, a signal is sent to the mode select block. This block uses this signal in conjunction with the mode settings of the mode switch to feed the appropriate control signal to the relay(s).

The initiate/hold signal is only used in the Delay On Release and Rack modes. When the initiate/hold signal is applied, the output relays(s) energize and the system clock is stopped. Upon the removal of the signal, the system clock starts and the delay period begins. After the appropriate delay has expired, the relay(s) de-energize. If at any time during the delay process the initiate/hold signal is re-applied, the timing stages are reset and the system clock stopped. The entire time delay will begin again when the signal is removed.

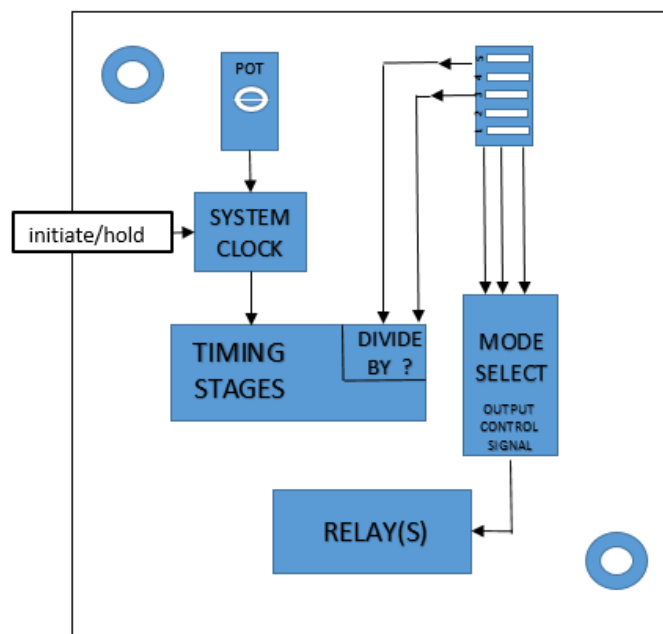

# HOOKUP FOR DELAY ON MAKE

In automation systems a frequent delay task is delay on make. The course of events are the following:

1. Apply power to PMTN2
2. Delay
3. Transfer the relay contacts

To reset the timer, power must be removed from the input terminals.

Below is an example showing a simple usage of the PMTN2. Upon application of power to terminal 1 via the activation switch, the timer goes through a delay cycle. After the appropriate delay has passed, the "FORM C" contacts will transfer and voltage applied to terminal 4 will pass to terminal 5 therefore, operating the load. The system will reset upon the removal of voltage from terminal 1.

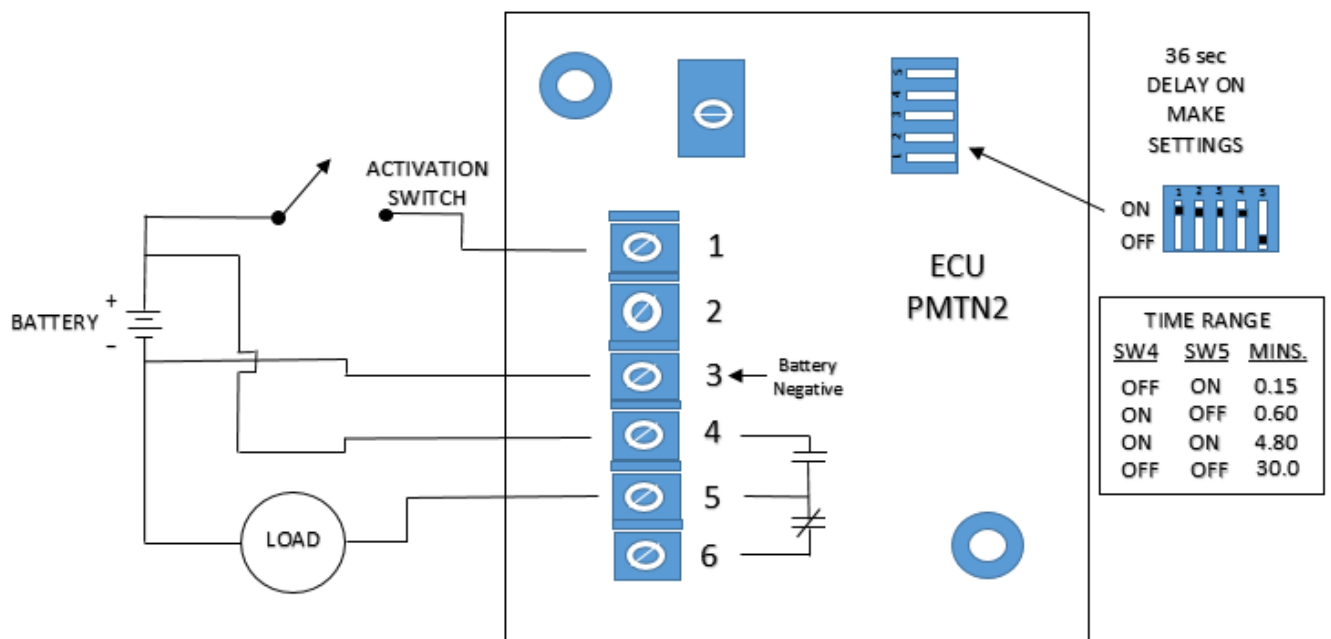

## HOOKUP FOR DELAY ON RELEASE

The delay on release function is used in many applications. Its primary goal is to be initiated thus turning on the load. A delay will go into effect after the activation switch is opened.

After the delay has expired, the relay(s) will de-energize. One advantage of the ECU-PMTN2 over other timers is that it does not draw power in the off mode. This adds to its reliability and assures no battery drainage on standby systems such as irrigation pumps and compressors.

As illustrated in the circuit below, when the activation switch closes, the run relay will operate. This is a result of the PMTN2 locking in and supplying power via its contacts. Even if the activation switch should open, the delay time of the timer must expire before the engine would shut off.

This circuit shows how the timer “buffers” the engine system against false starts. If the activation switch opens, the timer will run and when it expires, it will shut the system down.

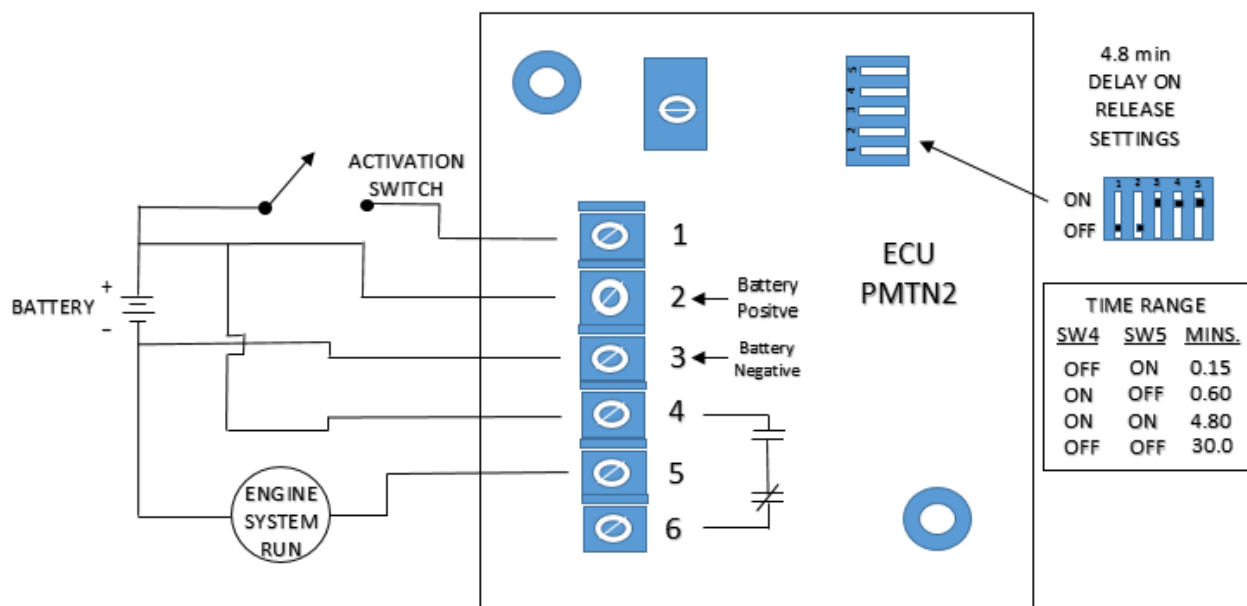

## HOOKUP FOR ONE SHOT TIMER

The interval, or one shot timer, allows for an event to be initiated, operated and de-energized. This could be used for many functions such as timed engine cranking, pre-lube oil pumps, shut down solenoids and many more.

The example below shows a one shot timer's main function. The load is to be energized for an adjustable time period after initiation by the activation switch.

The moment power is applied to Terminal 1, the relay will operate thus causing power to be connected from Terminal 4 to Terminal 5. This will cause the load to turn on. After an adjustable time period has elapsed, the load will be de-energized. The system will reset upon the removal of voltage from Terminal 1.

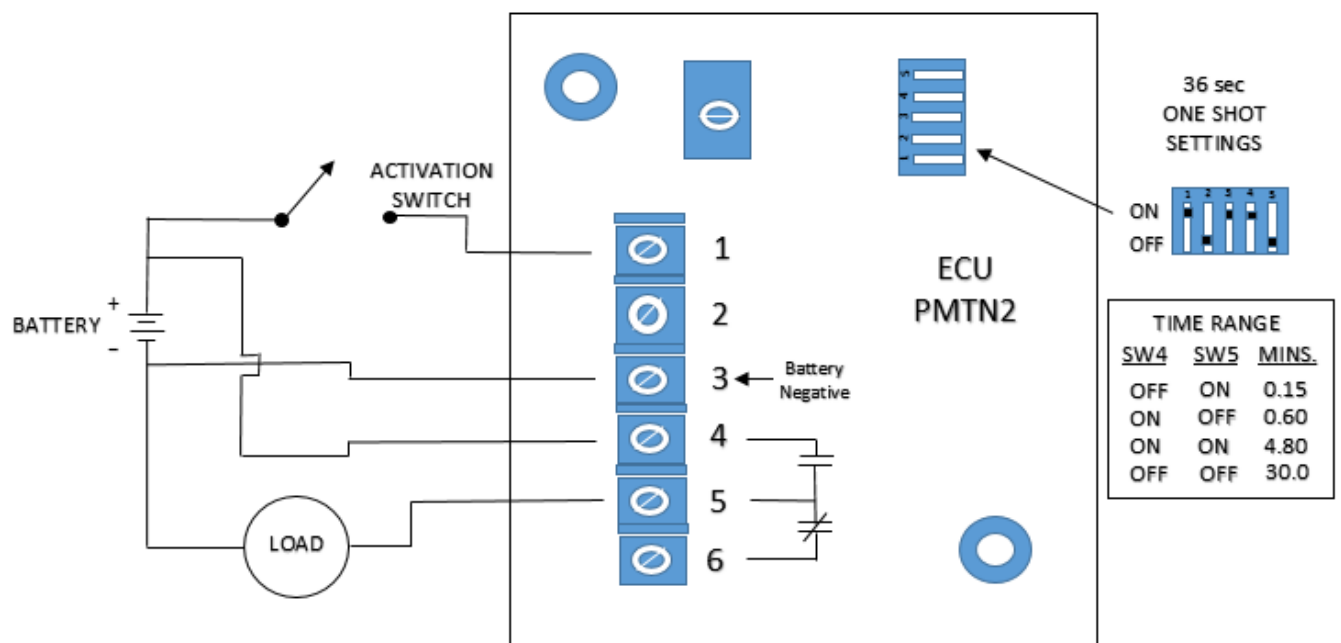

## GENERAL HOOKUP FOR FLASHER

The ECU-PMTN2 incorporates an adjustable circuit with a 50% duty cycle coupled to a “FORM C” relay(s). The timer can be adjusted to either operate in an on-off-on sequence or an off-on-off sequence as long as power is applied to the input.

The diagram below shows the basic use for the flasher circuit. When voltage is applied to Terminal 1, the contacts will connect voltage from Terminal 4 to Terminal 5 thus lighting the lamp. After the designated amount of time, the relay(s) will turn off. This action will repeat until the voltage is removed from Terminal 1.

Notice that the configuration below will give the on-off-on sequence. To obtain the off-on-off sequence, set switch 2 on the Mode Switch to the ON position.

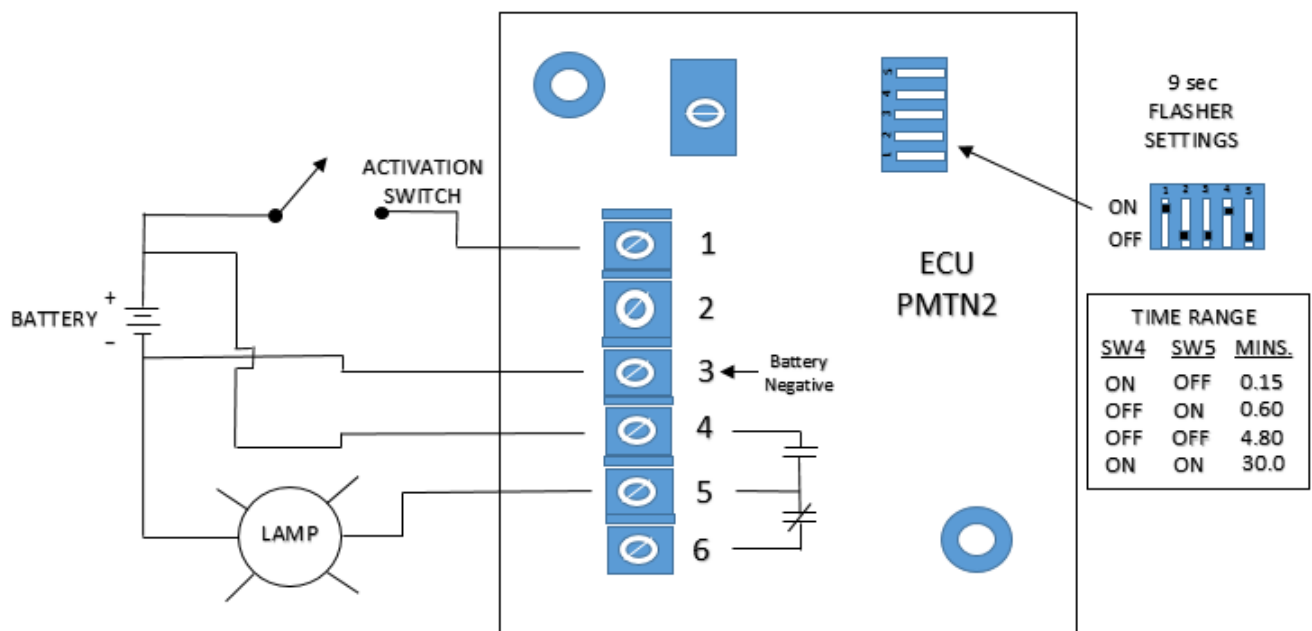

## COOLDOWN TIMER FOR ENGINE SYSTEMS

Engines often run for hours (and sometimes days) under full load conditions. In automatic engine systems when the power requirement is relaxed, the engine is sometimes shutdown from full load. This causes the engine to heat soak and can cause premature wear due to oil breakdown and warpage of engine parts.

By adding an ECU-PMTN2 timer, an adjustable delay period will occur under no load conditions. This will allow coolant to circulate through the engine block. This function is done in conjunction with the automatic transfer switch in generator sets and cool down only occurs on non-fault related shutdowns.

The opposite page shows an ECU-PMTN2 connected between the remote start contacts and the ECU-9957/9988N engine control. While in the auto mode, if the remote start contacts close, voltage will be applied to Terminal 1 of the timer. This will cause the relay to operate thus causing the engine control to start the engine via Terminal 4 and Terminal 5. As long as the remote start contacts remain closed, the engine will continue to run. When the remote start contacts open (signifying the load has been removed), the ECU-PMTN2 will continue to run the engine until the adjustable time period is over. At this time, the PMTN2 will disconnect itself from the battery.

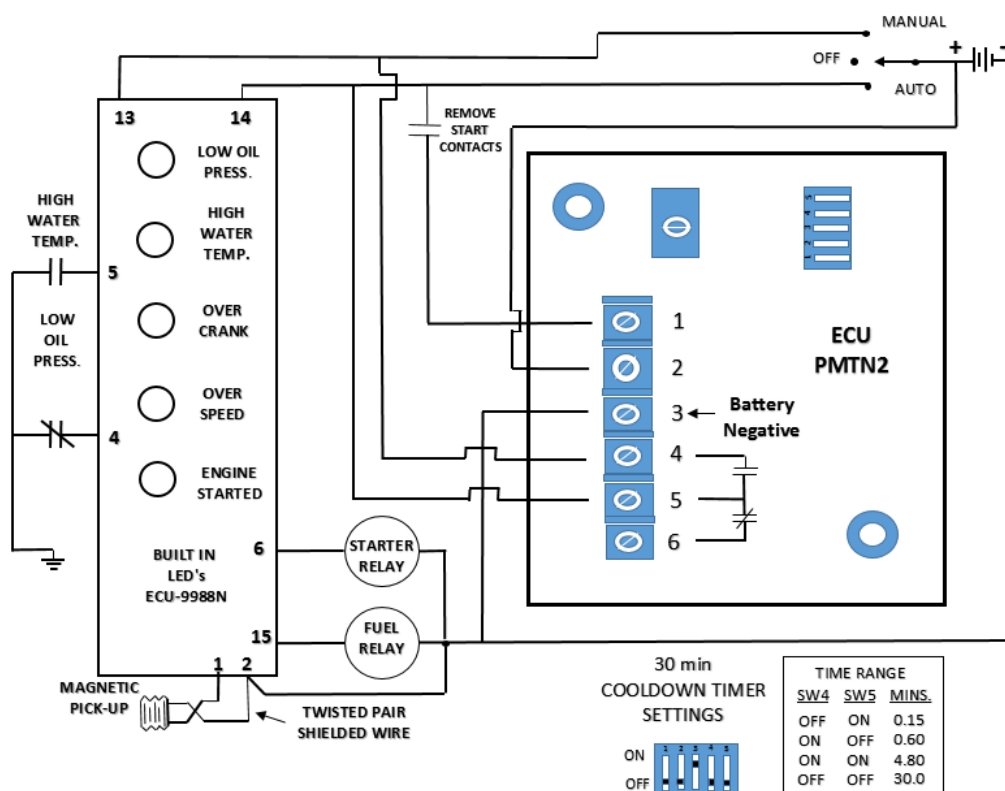

# ENGINE WARM UP FULL THROTTLE TIMER

Not all engines like to come up screaming on line. Some equipment attached to the engine needs a “priming” period as well. For this reason the ECU-PMTN2 will accept a signal that the engine has started and wait the desired time before going to full RPM (via a full throttle solenoid or governor signal.)

This example shows the hook up for using a PMTN2 with an ECU-9957 or ECU-9988NC to achieve a warm up period. After the engine control sends an engine started signal, it is also applied to Terminal 1 of the PMTN2 which starts the delay cycle. After the adjustable warm up period has expired, the timer activates its relay(s), in doing so it applies voltage to the full throttle solenoid. The system will remain at full throttle until the system is shutdown, thus resetting the ECU-PMTN2.

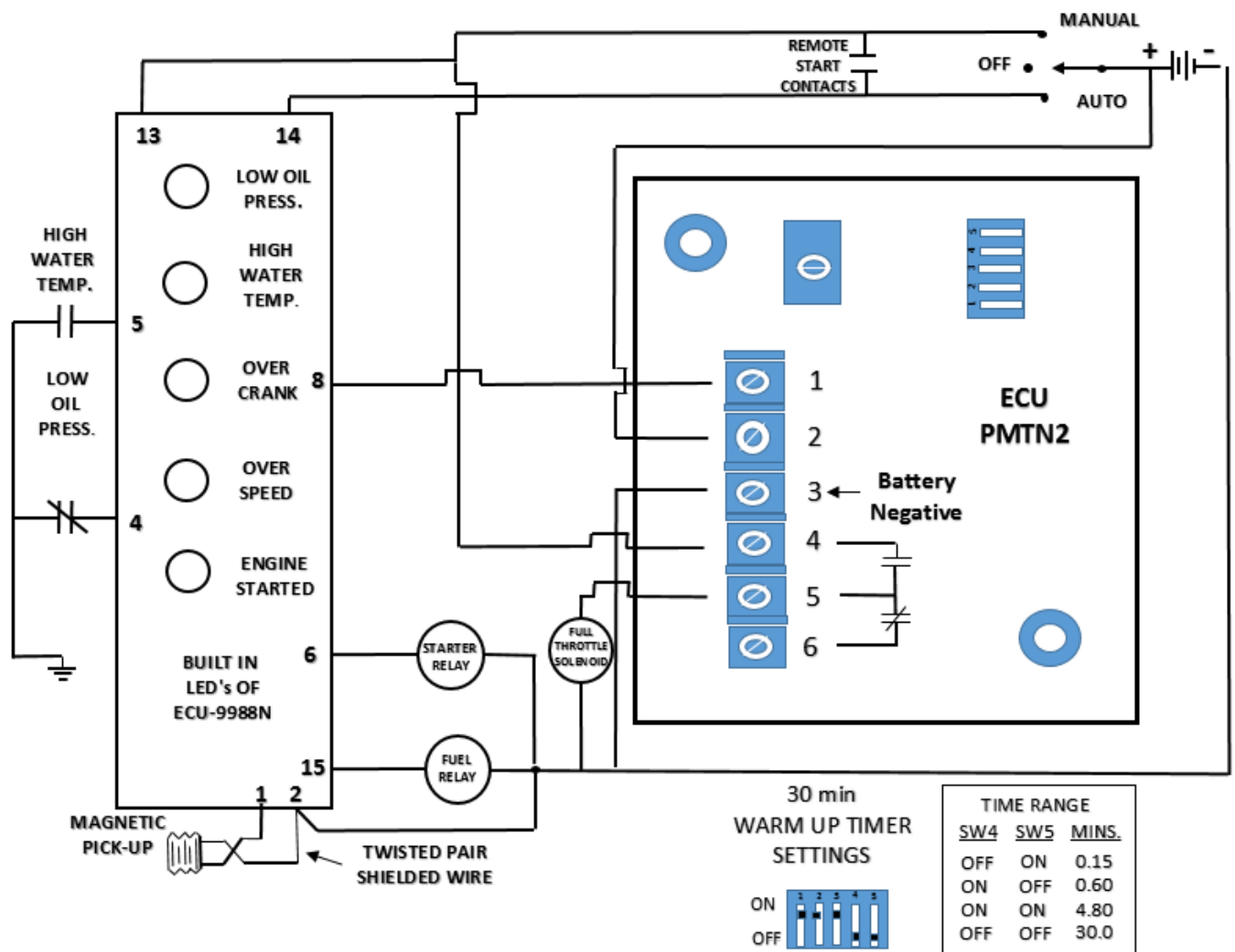

## ENERGIZE TO SHUTDOWN SOLENOID (RACK) TIMER

On many systems the fuel control is set up such that a solenoid must be turned on to hold the fuel off until the engine comes to a stop. These systems are known as an energized to shutdown system.

By using the ECU-PMTN2 in conjunction with an ECU-9957, 9988NC and a "FORM C" relay, a system is formed that shuts the engine down and uses no power until the next engine use cycle. The advantages of this system is the increased reliability as well as no battery drain in the standby state.

The diagram on the opposite page shows the PMTN2 connected such that when the ECU-9957 or ECU-9988NC is energized, a voltage appears at Terminal 15 which energizes the auxiliary relay. This in turn causes the auxiliary relay contacts to transfer and apply a voltage to Terminal 1 of the timer. This effectively "arms" the timer and closes its contacts across Terminals 4 and 5. As long as the engine is running, the inhibit timer signal is held at Terminal 1. When required for shutdown, the ECU-9957 or ECU-9988NC removes the voltage from Terminal 15; thereby, de-energizing the auxiliary relay. This causes the auxiliary contacts to transfer both removing voltage from Terminal 1 and applying voltage to Terminal 4. This energizes the shutdown solenoid. After an adjustable time delay, the timer expires and disconnects the shutdown solenoid and itself from the battery.

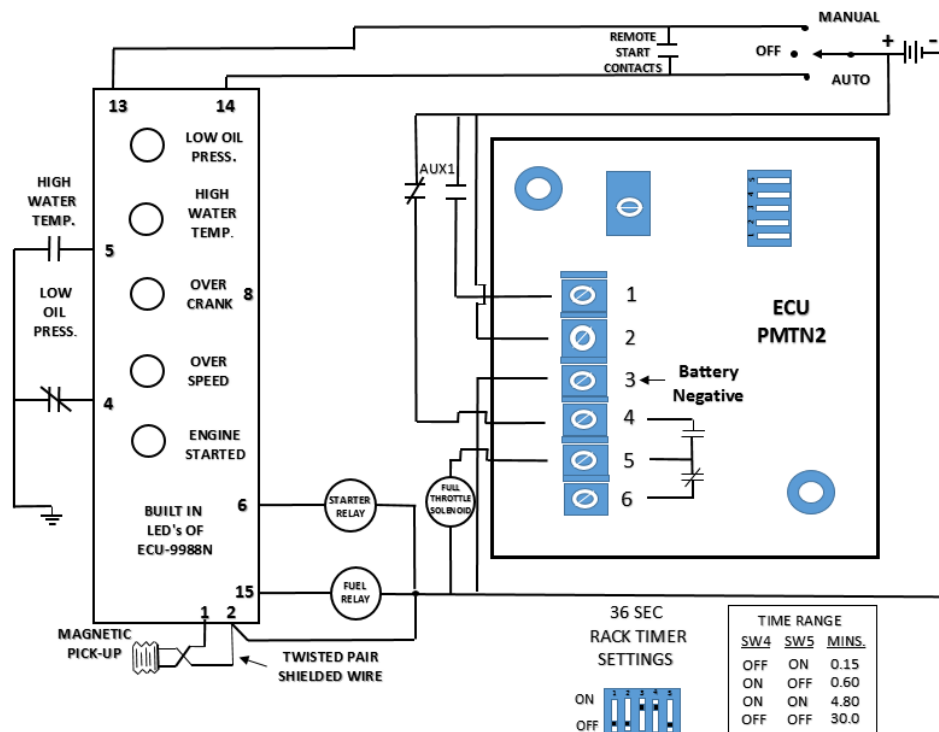

## DELAY ON START TIMER FOR ENGINE SYSTEMS

The ECU-PMTN2 can be set to hold the engine for pre-start conditioning. This delay of an engine start can allow many advantages to the engine package. Sometimes the engine run signal may flutter on and off causing jerky and false starts. Other instances are power outages that are very short in duration and do not merit a standby generator start up. All of these problems can be solved with the ECU-PMTN2 module. It simply allows a delay period to occur before a signal is sent to the automatic engine control.

The example of the opposite page is shown with an ECU-9957 or 9988NC automatic engine control. The engine demand contacts are wired from the auto position to Terminal 1 of the ECU-PMTN2. When the engine demand contacts close, voltage is placed on Terminal 1 causing the timer to run. If the voltage remains for the duration of the adjusted delay, the contacts of the module will close thus supplying power to the engine control via Terminal 4 and 5, and the engine will start. Removing voltage from Terminal 1 will cause the engine to shut down and reset the timer.

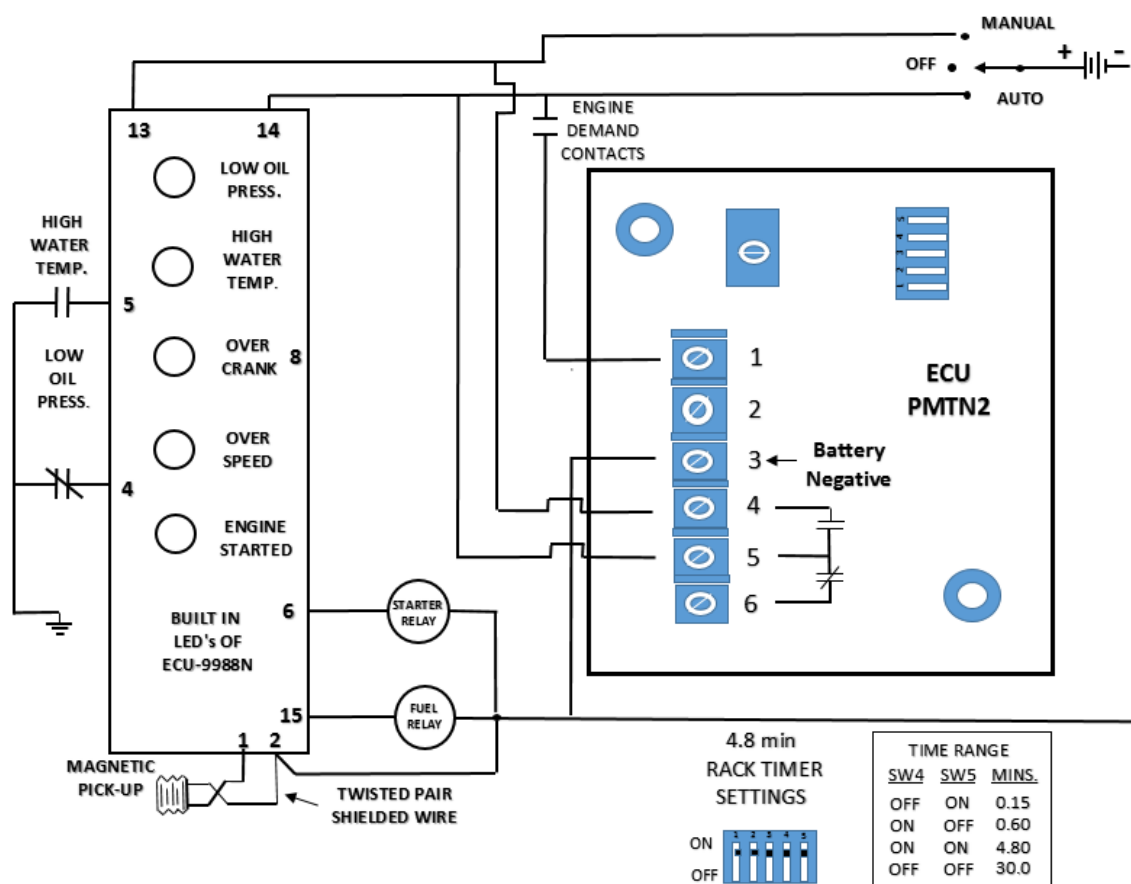

## ADJUSTMENTS

The first of three switches (SW1, SW2, and SW3) of the mode switch determine what mode the PMT2 will operate in. Below is a table showing the various switch positions and the resulting operation modes:

OPERATING MODE	SW1	SW2	SW3
COOL DOWN TIMER	OFF	OFF	ON
WARM UP TIMER	ON	ON	ON
RACK TIMER	OFF	OFF	ON
FULL THROTTLE TIMER	ON	ON	ON
DELAY ON MAKE TIMER	ON	ON	ON
DELAY ON RELEASE TIMER	OFF	OFF	ON
DELAY ON START TIMER	ON	ON	ON
CRANK CYCLE TIMER	ON	OFF	OFF
FLASHER TIMER (ON-OFF-ON)	ON	OFF	OFF
FLASHER TIMER (OFF-ON-OFF)	ON	ON	OFF
SHUT DOWN SOLENOID TIMER	OFF	OFF	ON
ONE SHOT TIMER	ON	OFF	ON
CRANKING LIMITER TIMER	ON	ON	ON

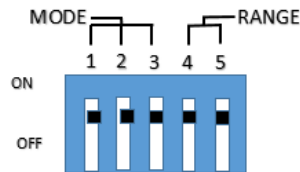

The delay time can be adjusted by using switches 4 and 5 on the mode switch and the adjustment pot,. Switches 4 and 5 will choose one of the four time ranges in the table below:

TIME RANGE	SW4	SW5
0 - 9 sec.	OFF	ON
0 - 36 sec.	ON	OFF
0 - 4.8 min.	ON	ON
0 - 30.0 min.	OFF	OFF

The adjustment pot is used to adjust the timer to the desired delay time within a range. To increase the delay time turn the adjustment pot clockwise.



## QUICK ADJUSTMENT FOR LONG DELAY TIMES

For long delay times there is a way to quickly adjust the PMTN2 to give the proper delay. First it is important to understand how the PMTN2 calculates its delay. The timer derives the delay time by using a multiple of the base time. The table below shows the four different settings and the associated multiples:

SETTING	RANGE	SW4	SW5	BASE MULTIPLE
A	0 - 9 sec.	OFF	ON	1
B	0 - 36 sec.	ON	OFF	4 TIMES SETTING A
C	0 - 288 sec.	ON	ON	32 TIMES SETTING A 8 TIMES SETTING B
D	0 - 1800 sec.	OFF	OFF	256 TIMES SETTING A 64 TIMES SETTING B 8 TIMES SETTING C

Setting a 30 minute delay:

- Step 1:       $30 \text{ mins} \times 60 \text{ sec/min} = 1800 \text{ sec}$   
                This requires setting D to achieve the final time range
- Step 2:      Choose a time range setting lower than desired time (note: avoid using very small ranges.). For setting long times, pick one or two ranges below but not three.
- Step 3:      Example: Setting B, the timer expires 64 times faster than setting D noted in Step 1. Now calculate the time needed at Setting B to get 1800 seconds divided by 64 which is 28.1 secs. With timer set at Setting B adjust to this value. Now set timer settings to D and time will be 64 times B or 1800 secs.

## DIMENSIONAL AND MOUNTING

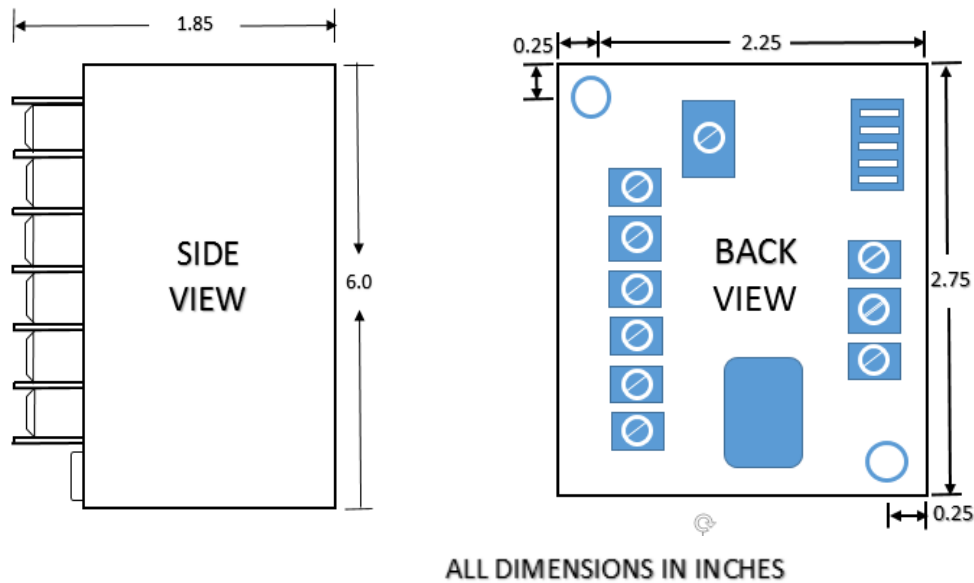

## TERMINAL IDENTIFICATION FOR ECU-PMTN2

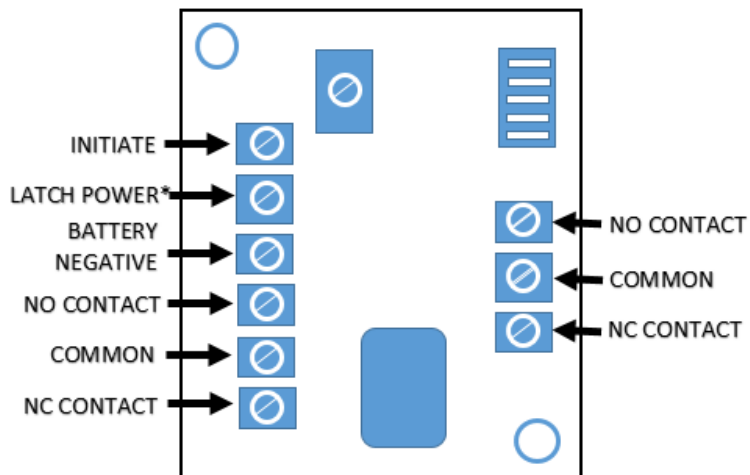

\*The Latch Power terminal is connected to battery positive only in the Delay on Release, Rack, and Cool Down modes.

# DRILLING TEMPLATE

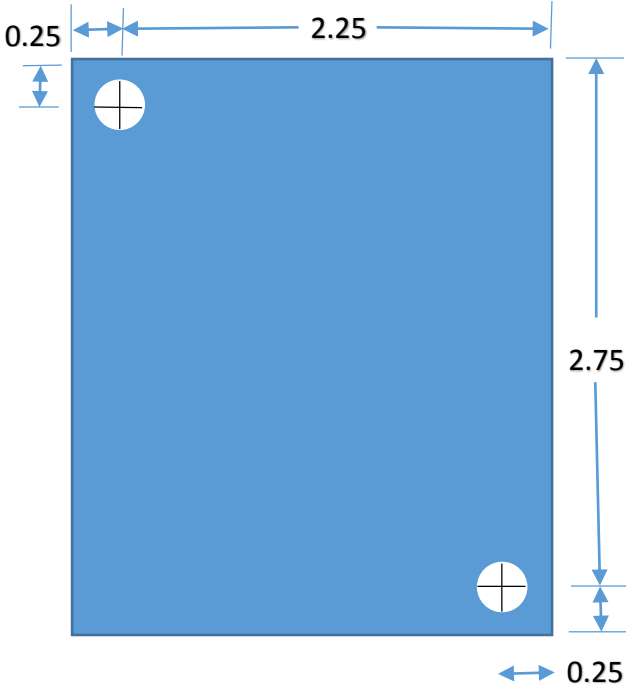

Use this template for accurate hole locations.  
All holes are 0.25 inch in diameter.  
All dimensions are in inches.  
Drawing is to scale.

## **MANUFACTURER'S WARRANTY**

Engineering Concepts Unlimited, Inc. warrants and guarantees that its electronic control modules are free from any defects in workmanship and/or materials for (1) year from date of shipment from its factory. If it is determined the unit is defective by the factory, they will be replaced, F.O.B. Fishers, IN. This warranty does not cover incidental and consequential damages, nor does this warranty cover defects caused by misuse, faulty installation, alteration, accident, or any labor charges, service charges, or anything else except the replacement of the product. THIS IS IN LIEU OF ANY OTHER WARRANTIES, EXPRESSED OR IMPLIED.

**ENGINEERING CONCEPTS UNLIMITED, INC.**

**8950 Technology Drive**

**Fishers, Indiana 46038**

**Telephone: 317-849-8470**

**Fax: 317-849-6475**

**ECU® IS A REGISTERED TRADE MARK OF**

**ENGINEERING CONCEPTS UNLIMITED INC.**

All rights Reserved. © 2015, Engineering Concepts Unlimited, Inc.