



# SEL-700G Family of Generator and Intertie Protection Relays

Basic to Comprehensive Protection



**SEL-700GO, SEL-700G1**

Small, Medium, and Large Generators

Intertie Protection



**SEL-700GT**

Intertie and Generator

Basic Dual-Feeder Overcurrent Protection



**SEL-700GW**

Wind Generator

## New Features

- A new front-panel layout option with a 5-inch, color, 800 x 480-pixel touchscreen interface to navigate the screens, folders, and applications. The new touchscreen display layout allows bay control. You can also view metered quantities and perform HMI functions including viewing and editing settings, event summaries, target status, SER, etc.
- Increased the number of pushbuttons to eight for all of the relay models
- Increased the maximum number of GOOSE subscriptions to 64
- I/O board option with fourteen optoisolated inputs
- Inverse-time over- and undervoltage elements
- Vector shift elements for islanding detection
- IEC 61850 Edition 2
- IEC 60870-5-103 protocol
- Parallel redundancy protocol (PRP) for dual Ethernet models
- Spanish language support

## Major Features and Benefits

---

The SEL-700G family of protection relays provides unsurpassed protection, integration, and control features in a flexible, compact, and cost-effective package.

- **Basic Generator Protection Features (SEL-700G0):** Ground differential; sensitive restricted earth fault; thermal overload; phase, negative-sequence, residual-ground, and neutral-ground overcurrent elements for backup; residual-ground and neutral-ground time-overcurrent elements; directional residual-ground and neutral-ground overcurrent elements; current unbalance element; voltage-controlled, voltage-restrained time-overcurrent element for backup protection; breaker failure protection for three-pole breaker; under- and overvoltage elements; inverse-time over- and undervoltage elements; loss-of-potential element; volts/hertz or overexcitation protection; directional power elements; loss-of-field; over- and underfrequency protection elements; off-frequency time accumulators; rate-of-change-of- frequency elements; vector shift elements for islanding detection; inadvertent energization protection; RTD protection (requires internal or external SEL-2600 RTD option); field ground using an SEL-2664 Field Ground Module.
- **Optional Generator Protection Features (SEL-700G0+, SEL-700G1, SEL-700G1+):** Generator synchronism-check elements; synchronism-check under- and overvoltage elements; inverse-time over- and undervoltage elements; autosynchronism; backup compensator distance elements; out-of-step elements; vector shift elements for islanding detection; 100% stator ground protection elements; and dual-slope current differential protection with harmonic blocking and restraint elements to provide sensitive and secure protection. The high-security mode provides additional security against CT saturation during external events including external transformer energization, external faults, etc.
- **Intertie Protection Features (SEL-700GT):** Phase, negative-sequence, and residual-ground overcurrent elements for overcurrent, time-overcurrent, and directional overcurrent protection; breaker failure protection for three-pole breaker; under- and overvoltage elements; inverse-time over- and undervoltage elements; loss-of-potential element; directional power elements; over- and underfrequency protection elements; rate-of-change-of-frequency elements; vector shift elements for islanding detection; tie synchronism-check elements; synchronism-check under and overvoltage elements; autosynchronism; and RTD protection (requires internal or external SEL-2600 RTD option).
- **Optional Intertie Protection Features (SEL-700GT+).** Addition of basic generator protection features, as shown above for the SEL-700G0, to create intertie and generator protection. The relay also includes generator synchronism-check and autosynchronism functions.
- **Wind Generator Protection Features (SEL-700GW).** The SEL-700GW is configured with two sets of phase, negative-sequence, and residual-ground overcurrent elements, and phase, negative-sequence, and residual-ground time-overcurrent elements to provide dual-feeder protection in a multiple wind generator network application. The relay also includes three-pole breaker failure protection for two breakers.
- **Generator Monitoring.** Monitor ambient and generator winding temperature using optional analog inputs or RTDs and protect the generator from thermal damage. Use off-frequency time accumulators and protect steam turbine blades from fatigue failures because of off-frequency vibration.
- **Operator Controls.** Eight programmable front-panel pushbuttons each with two programmable tricolor LEDs allow for a wide variety of uses, including easy trip and close control and status indications for a breaker. Implement local and remote operator control schemes using 32 local and 32 remote control bits.
- **Relay and Logic Settings Software.** ACSELERATOR QuickSet<sup>®</sup> SEL-5030 Software reduces engineering costs for relay settings and logic programming. The tools in ACSELERATOR QuickSet make it easy to develop SELOGIC<sup>®</sup> control equations. Use the built-in phasor display to verify proper CT polarity and phasing. Use the synchroscope to watch the autosynchronism controls.
- **Metering and Reporting.** Built-in metering functions eliminate separately mounted metering devices. Analyze Sequential Events Recorder (SER) reports and oscillographic event reports for rapid commissioning, testing, and post-fault diagnostics. Unsolicited SER protocol allows station-wide collection of binary SER messages.
- **Front-Panel HMI.** Navigate the relay HMI using a 2 x 16-character LCD or optional 5-inch, color, 800 x 480-pixel touchscreen display.
- **Additional Standard Features.** Includes Modbus<sup>®</sup> RTU, Event Messenger support, MIRRORED BITS<sup>®</sup> communications, load profile report, 128 remote analogs, support for 12 external RTDs (SEL-2600 module), IRIG-B input, advanced SELOGIC, configurable labels, IEEE C37.118-compliant synchrophasor protocol, and fiber-optic serial port.

- **Optional Features.** Select from a wide offering of optional features, including SNTP (Simple Network Time Protocol), IEC 61850 Edition 2, Modbus<sup>®</sup> TCP/IP, DNP3 LAN/WAN, DNP3 serial, IEC 60870-5-103, PRP with dual Ethernet ports, 10 internal RTDs, voltage/current inputs, additional EIA-232 or EIA-485 communications ports, and single or dual, copper wire or fiber-optic Ethernet ports. Several analog and digital I/O options are available. These include 4 AI/4 AO, 4 DI/4 DO, 8 DI, 8 DO, 3 DI/4 DO/1 AO, 4 DI/3 DO, and 14 DI. Conformal coating for chemically harsh and/or high-moisture environments is available as an option.
- **Language Support.** Choose English or Spanish for your serial ports, including the front-panel serial port. The standard relay front-panel overlay is in English; a Spanish overlay is available as an ordering option.

### **Intertie Standards and Compliance**

The SEL-700GT Intertie Protection Relay provides comprehensive multifunction protection, control, and monitoring for intertie applications as well as intertie generator applications. The SEL-700GT Relay capabilities meet or exceed the protection and control requirements specified in the ANSI/IEEE Std 1547-2014, *Standard for Interconnecting Distributed Resources with Electric Power Systems*.

# Functional Overview

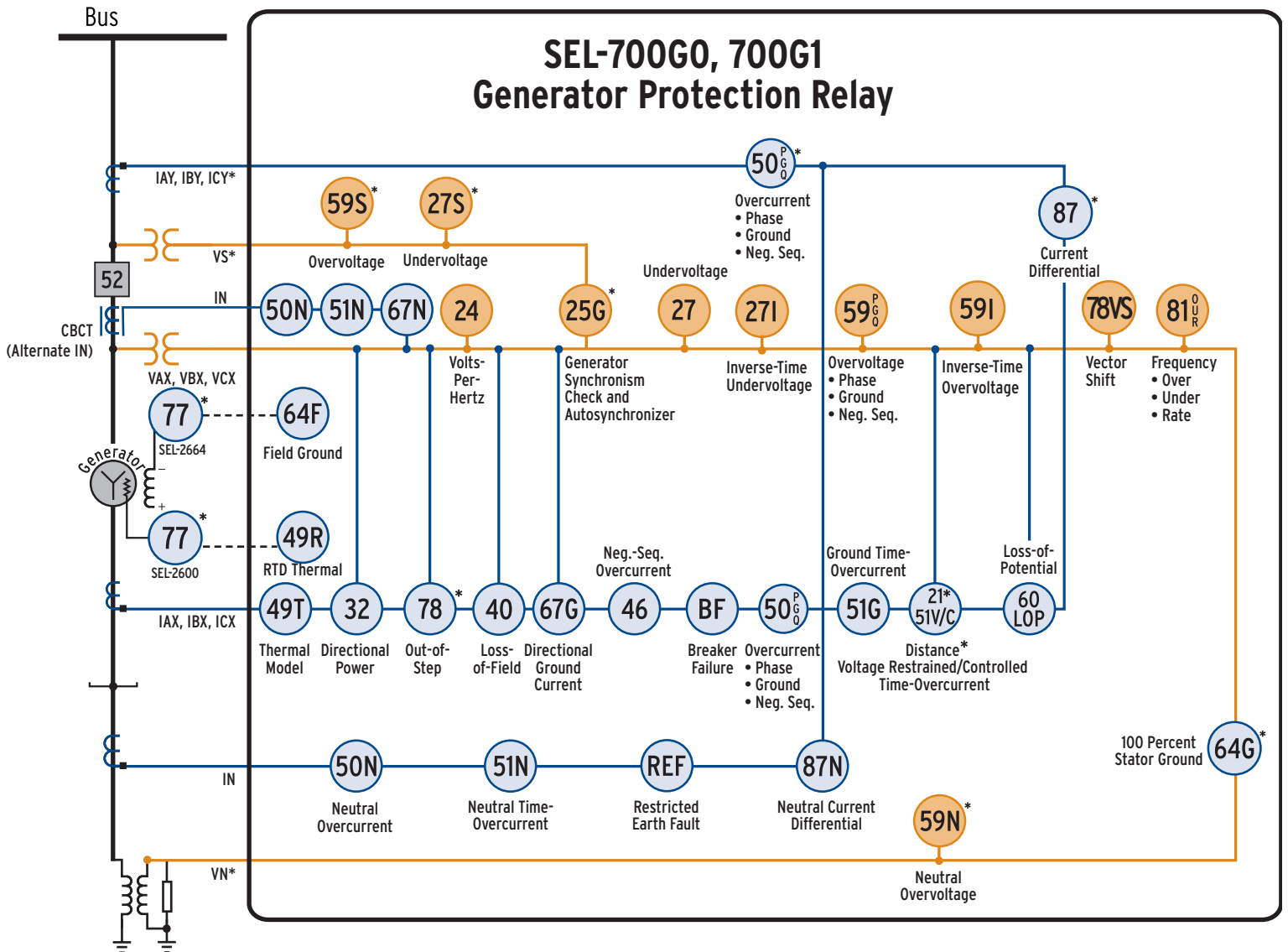

- Sequential Events Recorder
- Event Reports
- SEL ASCII, Ethernet\*, Modbus TCP\*, SNTP\*, IEC 61850\*, IEC 60870-5-103\*, PRP\*, DNP3 LAN/WAN\*, DNP3 Serial\*, Modbus RTU, Telnet, FTP, and DeviceNet™ Communications\*
- Eight Front-Panel Target LEDs, Six of Which Are Programmable
- Two Inputs and Three Outputs Standard
- I/O Expansion\*—Additional Contact Inputs, Contact Outputs, Analog Inputs, Analog Outputs, and RTD Inputs
- Single or Dual Ethernet Copper or Fiber-Optic Communications Port\*
- Battery-Backed Clock, IRIG-B Time Synchronization
- Instantaneous Metering, Demand Metering
- Eight Programmable Pushbuttons Each With Two Tricolor LEDs
- Off-Frequency Operation Time Accumulators
- Advanced SELoGIC Control Equations
- 32 Programmable Display Messages
- MIRRORING BITS Communications
- Synchrophasor (IEEE C37.118)
- Breaker Wear Monitor
- Event Messenger Compatible
- Front-Panel HMI With 2 x 16-Character LCD or Optional 5-Inch, Color, 800 x 480-Pixel Touchscreen Display

\*Optional

Figure 1 SEL-700GO, SEL-700G1 Generator Protection Relay

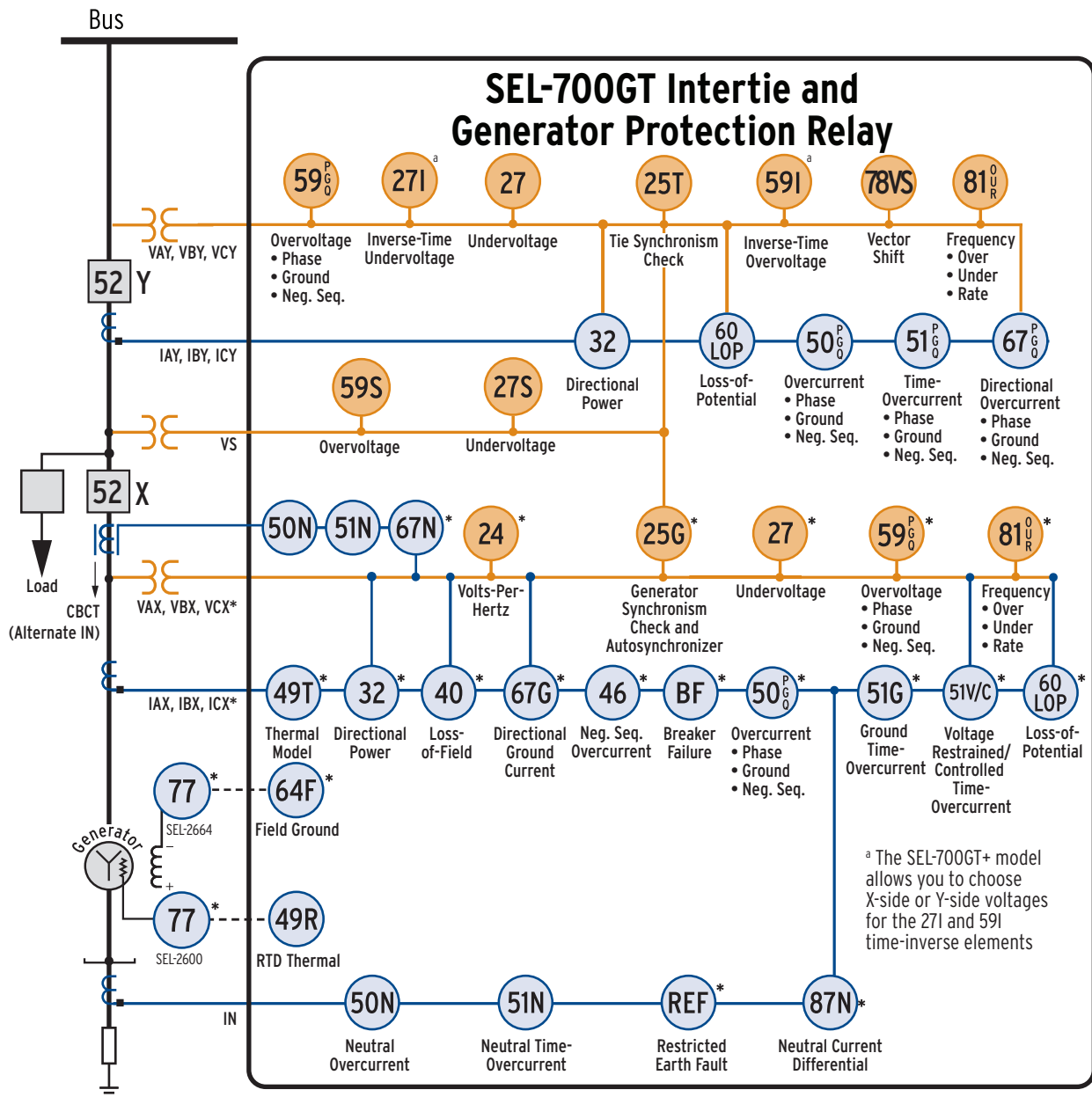

- Sequential Events Recorder
- Event Reports
- SEL ASCII, Ethernet\*, Modbus TCP\*, SNMP\*, IEC 61850\*, IEC 60870-5-103\*, PRP\*, DNP3 LAN/WAN\*, DNP3 Serial\*, Modbus RTU, Telnet, FTP, and DeviceNet Communications\*
- Eight Front-Panel Target LEDs, Six of Which Are Programmable
- Two Inputs and Three Outputs Standard
- I/O Expansion\*—Additional Contact Inputs, Contact Outputs, Analog Inputs, Analog Outputs, and RTD Inputs
- Single or Dual Ethernet Copper or Fiber-Optic Communications Port\*
- Battery-Backed Clock, IRIG-B Time Synchronization
- Instantaneous Metering, Demand Metering
- Eight Programmable Pushbuttons Each With Two Tricolor LEDs
- Off-Frequency Operation Time Accumulators
- Advanced SELogic Control Equations
- 32 Programmable Display Messages
- MIRRORING BITS Communications
- Synchrophasor (IEEE C37.118)
- Breaker Wear Monitor
- Event Messenger Compatible
- Front-Panel HMI With 2 x 16-Character LCD or Optional 5-Inch, Color, 800 x 480-Pixel Touchscreen Display

\*Optional

Figure 2 SEL-700GT Intertie and Generator Protection Relay



## Protection Features

### AC Analog Inputs

The SEL-700G has between 6 and 14 analog inputs, depending on the model and options selected. All analog inputs are recorded for event reporting and oscillography.

Table 1 shows the current and voltage inputs for the different models available. Current inputs are 1 A or 5 A nominal rating and voltage inputs are 300 V continuous rating.

**Table 1 Current (ACI) and Voltage (AVI) Card Selection for SEL-700G Models**

| Model  | Description  | Slot Z Card (MOT Digits)     | Slot Z Inputs                    | Slot E Card (MOT Digits) | Slot E Inputs                    |
|--------|--|------------------------------|----------------------------------|--------------------------|----------------------------------|
| 700G0  | Basic generator protection   | 4 ACI/3 AVI (81, 82, 85, 86) | IAX, IBX, ICX, IN, VAX, VBX, VCX | (OX)                     |                                  |
| 700G0+ | Basic generator protection plus (see Table 2 for additional protection elements) | 4 ACI/3 AVI (81, 82, 85, 86) | IAX, IBX, ICX, IN, VAX, VBX, VCX | 2 AVI (74)               | VS, VN                           |
| 700G1  | Full generator protection  | 4 ACI/3 AVI (81, 82, 85, 86) | IAX, IBX, ICX, IN, VAX, VBX, VCX | 3 ACIE (73, 77)          | IAY, IBY, ICY                    |
| 700G1+ | Full generator protection plus (see Table 2 for additional protection elements)  | 4 ACI/3 AVI (81, 82, 85, 86) | IAX, IBX, ICX, IN, VAX, VBX, VCX | 3 ACI/2 AVI (72, 76)     | IAY, IBY, ICY, VS, VN            |
| 700GT  | Intertie protection  | 1 ACI (84, 88)               | IN                               | 3 ACI/4 AVI (71, 75)     | IAY, IBY, ICY, VS, VAY, VBY, VCY |
| 700GT+ | Intertie and generator protection  | 4 ACI/3 AVI (81, 82, 85, 86) | IAX, IBX, ICX, IN, VAX, VBX, VCX | 3 ACI/4 AV (71, 75)      | IAY, IBY, ICY, VS, VAY, VBY, VCY |
| 700GW  | Basic wind generator protection  | 3 ACIZ (83, 87)              | IAX, IBX, ICX                    | 3 ACIE (73, 77)          | IAY, IBY, ICY                    |

The SEL-700G offers an extensive variety of protection features, depending on the model and options selected. Table 2 shows the protection features available in the different models.

**Table 2 SEL-700G Protection Elements (Sheet 1 of 3)**

| Protection Elements | Basic Generator Protection | Basic With       |             |                      |        | Intertie Protection | Intertie and Generator Protection | Wind Generator Protection |
|---------------------|----------------------------|------------------|-------------|----------------------|--------|---------------------|-----------------------------------|---------------------------|
|                     |                            | 21C, 25, 64G, 78 | 21C, 78, 87 | 21C, 25, 64G, 78, 87 |        |                     |                                   |                           |
|                     |                            | 700G0            | 700G0+      | 700G1                | 700G1+ |                     |                                   |                           |
| 87                  | Phase Differential         |                  |             | X                    | X      |                     |                                   |                           |
| 87N                 | Ground Differential        | X                | X           | X                    | X      |                     | X                                 |                           |
| REF                 | Restricted Earth Fault     | X                | X           | X                    | X      |                     | X                                 |                           |
| 64G                 | 100% Stator Ground         |                  | X           |                      | X      |                     |                                   |                           |
| 64F                 | Field Ground               | X                | X           | X                    | X      |                     | X                                 | X                         |
| 40                  | Loss of Field              | X                | X           | X                    | X      |                     | X                                 |                           |
| 49T                 | Thermal Overload           | X                | X           | X                    | X      |                     | X                                 |                           |
| 49RTD               | RTDs                       | X                | X           | X                    | X      | X                   | X                                 | X                         |
| 46                  | Current Unbalance          | X                | X           | X                    | X      |                     | X                                 |                           |
| 24                  | Volts/Hz                   | X                | X           | X                    | X      |                     | X                                 |                           |
| 78                  | Out of Step                |                  | X           | X                    | X      |                     |                                   |                           |
| 78VS                | Vector Shift               | X                | X           | X                    | X      | X                   | X                                 |                           |
| INAD                | Inadvertent Energization   | X                | X           | X                    | X      |                     | X                                 |                           |
| 21C                 | Compensator Distance       |                  | X           | X                    | X      |                     |                                   |                           |
| 51C                 | Voltage-Controlled TOC     | X                | X           | X                    | X      |                     | X                                 |                           |
| 51V                 | Voltage-Restrained TOC     | X                | X           | X                    | X      |                     | X                                 |                           |
| 51PX                | Phase Time-Overcurrent     |                  |             |                      |        |                     |                                   | X                         |

Table 2 SEL-700G Protection Elements (Sheet 2 of 3)

| Protection Elements |  | Basic Generator Protection | Basic With       |                |                      | Intertie Protection | Intertie and Generator Protection | Wind Generator Protection |
|---------------------|--|----------------------------|------------------|----------------|----------------------|---------------------|-----------------------------------|---------------------------|
|                     |  |                            | 21C, 25, 64G, 78 | 21C, 78, 87    | 21C, 25, 64G, 78, 87 |                     |                                   |                           |
|                     |  | 700G0                      | 700G0+           | 700G1          | 700G1+               | 700GT               | 700GT+                            | 700GW                     |
| 51PY                | Phase Time-Overcurrent                 |                            |                  |                |                      | X <sup>a</sup>      | X <sup>a</sup>                    | X                         |
| 51QX                | Neg.-Seq. Time-Overcurrent             |                            |                  |                |                      |                     |                                   | X                         |
| 51QY                | Neg.-Seq. Time-Overcurrent             |                            |                  |                |                      | X <sup>a</sup>      | X <sup>a</sup>                    | X                         |
| 51GX                | Ground Time-Overcurrent                | X <sup>a</sup>             | X <sup>a</sup>   | X <sup>a</sup> | X <sup>a</sup>       |                     | X <sup>a</sup>                    | X                         |
| 51GY                | Ground Time-Overcurrent                |                            |                  |                |                      | X <sup>a</sup>      | X <sup>a</sup>                    | X                         |
| 51N                 | Neutral Time-Overcurrent               | X <sup>a</sup>             | X <sup>a</sup>   | X <sup>a</sup> | X <sup>a</sup>       | X                   | X <sup>a</sup>                    |                           |
| 50PX                | Phase Overcurrent                      | X                          | X                | X              | X                    |                     | X                                 | X                         |
| 50PY                | Phase Overcurrent                      |                            |                  | X              | X                    | X                   | X                                 | X                         |
| 67PY                | Directional Phase Overcurrent          |                            |                  |                |                      | X                   | X                                 |                           |
| 50QX                | Neg.-Seq. Overcurrent                  | X                          | X                | X              | X                    |                     | X                                 | X                         |
| 50QY                | Neg.-Seq. Overcurrent                  |                            |                  | X              | X                    | X                   | X                                 | X                         |
| 67QY                | Directional Neg.-Seq. Overcurrent      |                            |                  |                |                      | X                   | X                                 |                           |
| 50GX                | Ground Overcurrent                     | X                          | X                | X              | X                    |                     | X                                 | X                         |
| 67GX                | Directional Ground Overcurrent         | X                          | X                | X              | X                    |                     | X                                 |                           |
| 50GY                | Ground Overcurrent                     |                            |                  | X              | X                    | X                   | X                                 | X                         |
| 67GY                | Directional Ground Overcurrent         |                            |                  |                |                      | X                   | X                                 |                           |
| 50N                 | Neutral Overcurrent                    | X <sup>b</sup>             | X <sup>b</sup>   | X <sup>b</sup> | X <sup>b</sup>       | X                   | X <sup>b</sup>                    |                           |
| 67N                 | Directional Neutral Overcurrent        | X                          | X                | X              | X                    |                     | X                                 |                           |
| 27X                 | Undervoltage                           | X                          | X                | X              | X                    |                     | X                                 |                           |
| 27Y                 | Undervoltage                           |                            |                  |                |                      | X                   | X                                 |                           |
| 27S                 | Synchronism Undervoltage               |                            | X                |                | X                    | X                   | X                                 |                           |
| 27I                 | Inverse-Time Undervoltage <sup>c</sup> | X                          | X                | X              | X                    | X                   | X                                 |                           |
| 59X                 | Overvoltage (P, Q, G)                  | X                          | X                | X              | X                    |                     | X                                 |                           |
| 59Y                 | Overvoltage (P, Q, G)                  |                            |                  |                |                      | X                   | X                                 |                           |
| 59S                 | Synchronism Overvoltage                |                            | X                |                | X                    | X                   | X                                 |                           |
| 59I                 | Inverse-Time Overvoltage <sup>d</sup>  | X                          | X                | X              | X                    | X                   | X                                 |                           |
| 32X                 | Directional Power                      | X                          | X                | X              | X                    |                     | X                                 |                           |
| 32Y                 | Directional Power                      |                            |                  |                |                      | X                   | X                                 |                           |
| 81X                 | Over/Underfrequency                    | X                          | X                | X              | X                    |                     | X                                 |                           |
| 81Y                 | Over/Underfrequency                    |                            |                  |                |                      | X                   | X                                 |                           |
| 81RX                | Rate-of-Change of Frequency            | X                          | X                | X              | X                    |                     | X                                 |                           |
| 81RY                | Rate-of-Change of Frequency            |                            |                  |                |                      | X                   | X                                 |                           |
| BFX                 | Breaker Failure                        | X                          | X                | X              | X                    |                     | X                                 | X                         |
| BFY                 | Breaker Failure                        |                            |                  |                |                      | X                   | X                                 | X                         |
| 60LOPX              | Loss of Potential                      | X                          | X                | X              | X                    |                     | X                                 |                           |
| 60LOPY              | Loss of Potential                      |                            |                  |                |                      | X                   | X                                 |                           |
| 25 GEN              | Synchronism Check                      |                            | X                |                | X                    |                     | X                                 |                           |
| 25 TIE              | Synchronism Check                      |                            |                  |                |                      | X                   | X                                 |                           |

**Table 2 SEL-700G Protection Elements (Sheet 3 of 3)**

| Protection Elements |                            | Basic Generator Protection | Basic With       |             |                      | Intertie Protection | Intertie and Generator Protection | Wind Generator Protection |
|---------------------|----------------------------|----------------------------|------------------|-------------|----------------------|---------------------|-----------------------------------|---------------------------|
|                     |                            |                            | 21C, 25, 64G, 78 | 21C, 78, 87 | 21C, 25, 64G, 78, 87 |                     |                                   |                           |
|                     |                            | 700G0                      | 700G0+           | 700G1       | 700G1+               | 700GT               | 700GT+                            | 700GW                     |
|                     | Autosynchronizer           |                            | X                |             | X                    |                     | X                                 |                           |
|                     | Off-Frequency Accumulators | X                          | X                | X           | X                    |                     | X                                 |                           |

<sup>a</sup> These inverse time-overcurrent elements have directional control.

<sup>b</sup> The 50N element uses the 67NnP and 67NnT Relay Word bits for the SEL-700G0, SEL-700G0+, SEL-700G1, SEL-700G1+, and SEL-700GT+ models.

<sup>c</sup> Two elements are available (select X- and/or Y-side phase, phase-to-phase, positive sequence, or synchronism voltage VS, depending on the part number).

<sup>d</sup> Two elements are available (select X- and/or Y-side phase, phase-to-phase, residual, positive sequence, negative sequence, neutral voltage VN, or synchronism voltage VS, depending on the part number).

## Overcurrent Protection

The SEL-700G provides complete overcurrent protection with as many as two sets of three-phase CTs and one neutral CT input. Phase overcurrent protection is provided for both three-phase inputs. The following overcurrent elements are provided.

### Instantaneous Overcurrent Elements

The following instantaneous overcurrent elements are provided in the SEL-700G Relay as shown in *Table 2*. All instantaneous overcurrent elements provide torque control and definite-time delay settings.

- As many as six instantaneous phase overcurrent elements (50P) with peak detection algorithms to enhance element sensitivity during high-fault current conditions where severe CT saturation may occur.
- As many as four instantaneous negative-sequence overcurrent (50Q) elements.
- As many as four residual-ground instantaneous overcurrent (50G) elements. These elements use calculated residual (3I0) current levels.
- As many as two neutral instantaneous overcurrent elements (50N).

### Directional Instantaneous Overcurrent Elements

The following directional overcurrent elements are available in the SEL-700G with directional control (see *Table 2*).

- As many as three directional phase overcurrent elements (67P).
- As many as two directional negative-sequence overcurrent elements (67Q).
- As many as four directional residual-ground overcurrent elements (67G).
- As many as two directional neutral-ground overcurrent elements (67N).

### Time-Overcurrent Elements

The SEL-700G provides the time-overcurrent elements listed in *Table 2*. These time-overcurrent elements

support the IEC and US (IEEE) time-overcurrent characteristics. Electromechanical disc reset capabilities are provided for all time-overcurrent elements.

- As many as two phase time-overcurrent (51P) elements are provided. These phase elements operate on the maximum of phase currents. One 51P element has directional control.
- As many as two negative-sequence time-overcurrent (51Q) elements are provided. These elements operate on the calculated negative-sequence current for each set of three-phase inputs. One 51Q element has directional control.
- As many as two residual time-overcurrent (51G) elements are provided. These elements use calculated residual (3I0) current levels. Both 51G elements have directional control.
- One neutral time-overcurrent (51N) element is provided with directional control.

## Differential Protection (87)

When specified, the SEL-700G detects stator faults using a secure, sensitive current differential function. This function has a sensitive percentage-restrained differential element and an unrestrained element. The differential function provides the unique capability of power transformer and CT connection compensation. This allows you to conveniently include the unit step-up transformer in the generator differential zone using wye-connected CTs for both input sets. The relay allows you to choose harmonic blocking, harmonic restraint, or both, providing a reliable differential protection during transformer inrush conditions. Even-numbered harmonics (second and fourth) provide security during energization, while fifth harmonic blocking provides security for over-excitation conditions. Set second-, fourth-, and fifth-harmonic thresholds independently. The dual-slope percentage restraint characteristic improves element security for through-fault conditions. The high-security mode provides additional security against CT saturation

during external events including external transformer energization, external faults, etc.

### Restricted Earth Fault (REF) Protection

Apply the REF protection feature for sensitive detection of internal ground faults on grounded wye-connected windings. The neutral current CT provides the operating current. Polarizing current is derived from the residual current calculated for the protected winding. A sensitive directional element determines whether the fault is internal or external. Zero-sequence current thresholds and selectable CT saturation logic supervise tripping.

### Ground Differential Protection (87N)

SEL-700G Relays with generator protection are equipped with a ground differential function that provides selective ground fault detection for solidly grounded and low-impedance grounded generators. This function helps protect generators on multimachine buses, because the element does not respond to ground faults on the parallel generators.

### Generator Synchronism Check (25G)

You can specify the SEL-700G Relay with a built-in generator synchronism-check function (25G). The synchronism-check function is extremely accurate and provides supervision for acceptable voltage window and maximum percentage difference, maximum and minimum allowable slip frequency, target closing angle, and breaker closing delay. The synchronism-check report gives complete information on the three latest paralleling operations, including the generator and system voltages and frequencies, slip frequency, and phase angle when the close was initiated. The relay also keeps a running average of the breaker close time.

### Intertie Synchronism Check (25T)

The intertie model of the SEL-700G has the tie synchronism-check function (25T), which provides the closing window for the bus-tie breaker when connecting to the utility system.

### Autosynchronizer

Selected SEL-700G models have the built-in autosynchronizer function, which provides output contact interfaces for the generator field voltage regulator and the prime mover speed control governor. Frequency, voltage, and phase are automatically synchronized and the generator is connected to the power system with this function. The relay also provides generator autosynchronism reports to record the automatic synchronizing event. The generator synchronization process can be viewed on a

PC-based synchroscope (see example in *Figure 4*) with ACCELERATOR QuickSet.

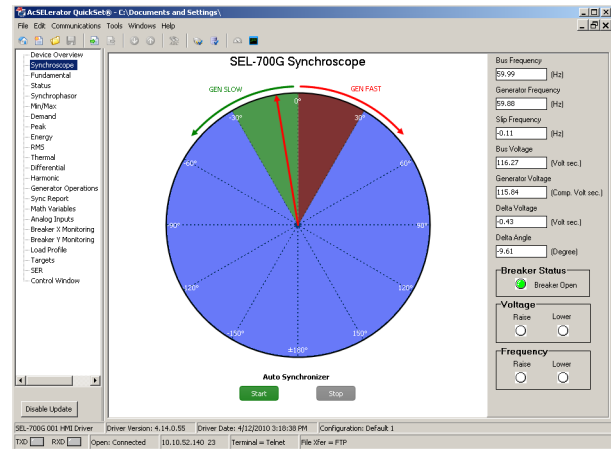

**Figure 4 QuickSet Synchroscope**

### 100 Percent Stator Ground Detection (64G)

The SEL-700G detects stator ground faults on high-impedance grounded generators using a conventional neutral-overvoltage element and a third-harmonic voltage differential detection scheme for 100 percent stator winding coverage. The neutral overvoltage element detects winding ground faults in approximately 85 percent of the winding. Faults closer to the generator neutral do not result in high neutral voltage but are detected using third harmonic neutral and terminal voltages. The combination of the two measuring methods provides ground fault protection for the full winding.

Use the SEL-2664S Stator Ground Protection Relay for 100 percent stator ground protection using a multisine signal injection method for a superior solution that is independent of third-harmonic voltage magnitude. This relay works with the generator in or out of service and during generator ramp up without any blind spots.

### Field Ground Protection (64F)

The SEL-700G, with the SEL-2664 Field Ground Module, detects field ground faults by measuring field insulation-to-ground resistance using the switched dc voltage injection method. Two-level protection for alarm and trip functions is provided.

### Directional Power Detection (32)

Sensitive directional power elements in the SEL-700G provide antimotoring and/or low forward power tripping. As many as eight elements (four each for the X side and Y side) for detecting real (Watts) or reactive (VARs) directional power flows, having independent time-delays and sensitivities are provided. Directly trip the generator under loss-of-prime mover conditions to prevent prime movers from motoring, or use low forward power indica-

tion as a tripping interlock when an orderly shutdown is required.

### Over-Excitation Protection (24)

The SEL-700G provides one definite-time for alarm and one composite inverse-time volts/hertz element. The composite inverse-time characteristic may be enabled with a two-step definite-time characteristic, a definite/inverse-time characteristic, or a simple inverse-time characteristic. A custom curve option is also available.

### Loss-of-Field Protection (40)

Two offset positive-sequence mho elements detect loss-of-field conditions. Settable time-delays help reject power swings that pass through the machine impedance characteristic. By using the included directional supervision, one of the mho elements can be set to coordinate with the generator minimum excitation limiter and its steady-state stability limit.

### Out-of-Step Protection (78)

SEL-700G Relays use a single or a double-blinder scheme, depending on user selection, to detect an out-of-step condition. In addition to the blinders, the scheme uses a mho circle that restricts the coverage of the out-of-step function to the desired extent. Furthermore, both schemes contain current supervision and torque control to supervise the operation of the out-of-step element.

### Negative-Sequence Overcurrent Protection (46)

Negative-sequence current heats the rotor at a higher rate than positive-sequence or ground current. The negative-sequence definite-time element provides alarm for early stages of an unbalanced condition. The inverse time-overcurrent element provides tripping for sustained unbalance conditions to prevent machine damage. The inverse-time negative-sequence element provides industry standard  $(I_2)^2 \cdot t$  protection curves.

### System Backup Protection (21C, 51V, 51C)

The SEL-700G offers you the choice of three methods for performing system backup protection. Compensator distance elements (21C), a voltage-restrained phase time-overcurrent element (51V), and a voltage-controlled phase time-overcurrent (51C) element are all available; you simply enable the element you wish to use.

### Over- and Undervoltage Protection (27, 59)

Phase, phase-to-phase, and positive-sequence undervoltage (27), overvoltage (59), residual overvoltage (59G) and negative-sequence overvoltage (59Q) elements help you create protection and control schemes,

such as undervoltage load shedding, or standby generation start/stop commands.

- Phase and phase-to-phase undervoltage elements operate with the minimum of the measured voltage magnitudes; these elements operate when any single measurement falls below the set thresholds.
- Phase and phase-to-phase overvoltage elements operate with the maximum of the measured voltage magnitudes.
- The positive-sequence undervoltage elements operate when the calculated positive-sequence voltage  $V1$  drops below the set thresholds.
- The positive-sequence overvoltage elements operate when the calculated positive-sequence voltage  $V1$  exceeds the set thresholds.
- The negative-sequence overvoltage elements operate when the calculated negative-sequence voltage  $V2$  exceeds set thresholds.
- The residual-ground voltage element operates when the zero-sequence voltage  $3V0$  exceeds the set point.
- Inverse-time overvoltage (59I) and inverse-time undervoltage (27I) elements that operate on the measure phase-to-neutral voltages, phase-to-phase voltages, or VS channel voltage, depending on the relay part number.

All voltage elements provide definite-time delay settings.

### Loss-of-Potential Logic (60LOP)

Relay functions that use phase voltages or symmetrical component voltages rely on valid inputs to make the correct decisions. The LOP logic detects open voltage transformer fuses or other conditions that cause a loss of relay secondary voltage input. The SEL-700G with voltage inputs, includes loss-of-potential logic that detects one, two, or three potentially blown fuses. This patented logic is unique and is universally applicable. It also offers a SELOGIC setting to block the LOP logic under user-defined conditions. The LOP feature allows for the blocking of protection elements to add security during fuse failure.

### Breaker Failure Protection (BF)

The SEL-700G offers breaker failure protection for up to two three-pole breakers. Use the breaker failure detection to issue re-trip commands to the failed breaker, or to trip adjacent breakers using the relay's contact output logic or communications-based tripping schemes.

### Inadvertent Energization Detection

Occasionally, the unit breaker for an out-of-service generator is closed inadvertently. The SEL-700G detects this condition using voltage, current, and other supervi-

sory conditions you select through an SELOGIC control equation.

### Frequency Protection (81)

Six levels of over- or underfrequency elements detect abnormal frequency operating conditions. Use the independently time-delayed output of these elements to trip or alarm. Phase undervoltage supervision prevents undesired frequency element operation during start-up, shut-down, and faults, and while the field is de-energized. SEL-700G frequency elements have high accuracy (less than 0.01 Hz).

### Rate-of-Change-of-Frequency Protection (81R)

Four independent rate-of-change-of-frequency elements are provided with individual time delays for use when frequency changes occur, for example, when there is a sudden imbalance between generation and load. They call for control action or switching action such as network decoupling or load shedding. Each element includes logic to detect either increasing or decreasing frequency and above or below nominal frequency.

### Vector Shift Protection (78VS)

When distributed generators (DG) are connected in the utility network, the vector shift element (78VS) is used to detect islanding conditions and trip the DG. Failure to trip islanded generators can lead to problems such as personnel safety, out-of-synchronization reclosing, and degradation of power quality. Based on the change in the angle of the voltage waveform, the islanding condition can be detected by the vector shift function. Use the vector shift element with the 81RF element as a backup for fast and secure islanding detection. The vector shift element operates within three cycles, which is fast

enough to prevent reclosing out-of-synchronism with the network feeders to avoid generator damage.

### Off-Frequency Accumulators

The SEL-700G tracks the total time-of-operation in up to six off-nominal frequency bands. If the off-nominal time of operation exceeds one of the independent time set points, the relay can trip or alarm.

### Thermal Overload Protection (49T)

The SEL-700G thermal element provides generator overload protection based on the thermal model described in IEC standard 60255-8. The model can be biased by ambient temperature if the RTD option is used.

The relay operates a thermal model with a trip value defined by the relay settings and a present heat estimate that varies with time and changing generator current.

### RTD Thermal Protection

When the SEL-700G is equipped with either an optional 10 RTD input expansion card or an external SEL-2600 RTD Module with up to 12 RTD inputs, as many as 12 thermal elements in the relay can be programmed for two levels of thermal protection per element. Each RTD input provides an alarm and trip thermal pickup setting in degrees C, provides open and shorted RTD detection, and is compatible with the following three-wire RTD types:

- PT100 (100  $\Omega$  platinum)
- NI100 (100  $\Omega$  nickel)
- NI120 (120  $\Omega$  nickel)
- CU10 (10  $\Omega$  copper)

Additionally, the winding RTDs and the ambient temperature RTD can be configured and used to bias the generator thermal model and thermal protection.

## Operator Controls

Operator controls eliminate traditional panel control switches. Eight conveniently sized operator controls are located on the relay front panel (see *Figure 5*). The SER can be set to track operator controls. Change operator control functions using SELOGIC control equations.

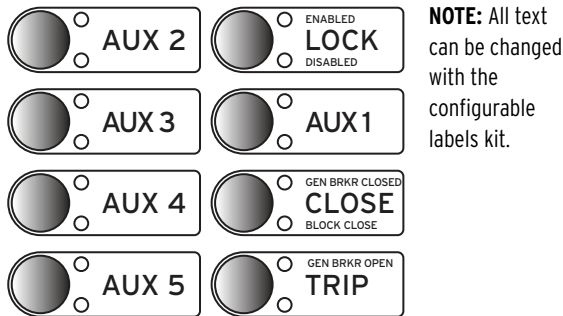

**Figure 5 Operator Controls (Shown for the SEL-700G0, SEL-700G1 Models)**

The following operator control descriptions are for factory-set logic for the model shown.

**LOCK:** The **LOCK** operator control blocks selected functions. Press it for at least three seconds to engage or

disengage the lock function. While locked in position, the following operator controls cannot change state if pressed: **TRIP** and **CLOSE**.

**AUX:** The **AUX** operator control and LEDs are user programmable.

**CLOSE and TRIP:** Use the **CLOSE** and **TRIP** operator controls to close and open the connected circuit breaker. They can be programmed with intentional time delays to support operational requirements for breaker-mounted relays. This allows the operator to press the **CLOSE** or **TRIP** pushbutton, then move to an alternate location before the breaker command is executed.

In the SEL-700G with the touchscreen display, you can also use the front-panel operator control pushbuttons to jump to a specific screen while also using them for **LOCK/CLOSE/TRIP** operations, etc. You can program the selectable operator pushbutton screen settings under the Touchscreen settings category in QuickSet and map the button to a specific screen.

## Relay and Logic Settings Software

QuickSet Software simplifies settings and provides analysis support for the SEL-700G. With QuickSet you have several ways to create and manage relay settings:

- Develop settings off-line with an intelligent settings editor that only allows valid settings.
- Create SELOGIC control equations with a drag-and-drop text editor.
- Configure proper settings using online help.
- Organize settings with the relay database manager
- Load and retrieve settings using a simple PC communications link.

With QuickSet you can verify settings and analyze events; and analyze power system events with the integrated waveform and harmonic analysis tools.

The following features of QuickSet can monitor, commission, and test the SEL-700G:

- The PC interface remotely retrieves power system data.
- The HMI monitors meter data, Relay Word bits, and output contacts status during testing. The control window allows resetting of metering quantities, and other control functions.

- The synchroscope screen provides a visual display of the autosynchronizer function.
- Bay control allows you to design new bay screens and edit existing bay screens by launching ACSELERATOR Bay Screen Builder SEL-5036 Software for the SEL-700G Relays with the touchscreen display.

### ACSELERATOR Bay Screen Builder SEL-5036 Software

The SEL-700G Relay with the touchscreen display layout option provides you with the ability to design bay configuration screens to meet your system needs. You can display the bay configuration as a single-line diagram (SLD) on the touchscreen. You can use ANSI and IEC symbols, along with analog and digital labels, for the SLD to indicate the status of the breaker and disconnects, bus voltages, and power flow through the breaker. In addition to SLDs, you can design the screens to show the status of various relay elements via Relay Word bits or to show analog quantities for commissioning or day-to-day operations. You can design these screens with the help of Bay Screen Builder in conjunction with QuickSet. Bay Screen Builder provides an intuitive and powerful interface to design bay screens to meet your application needs.

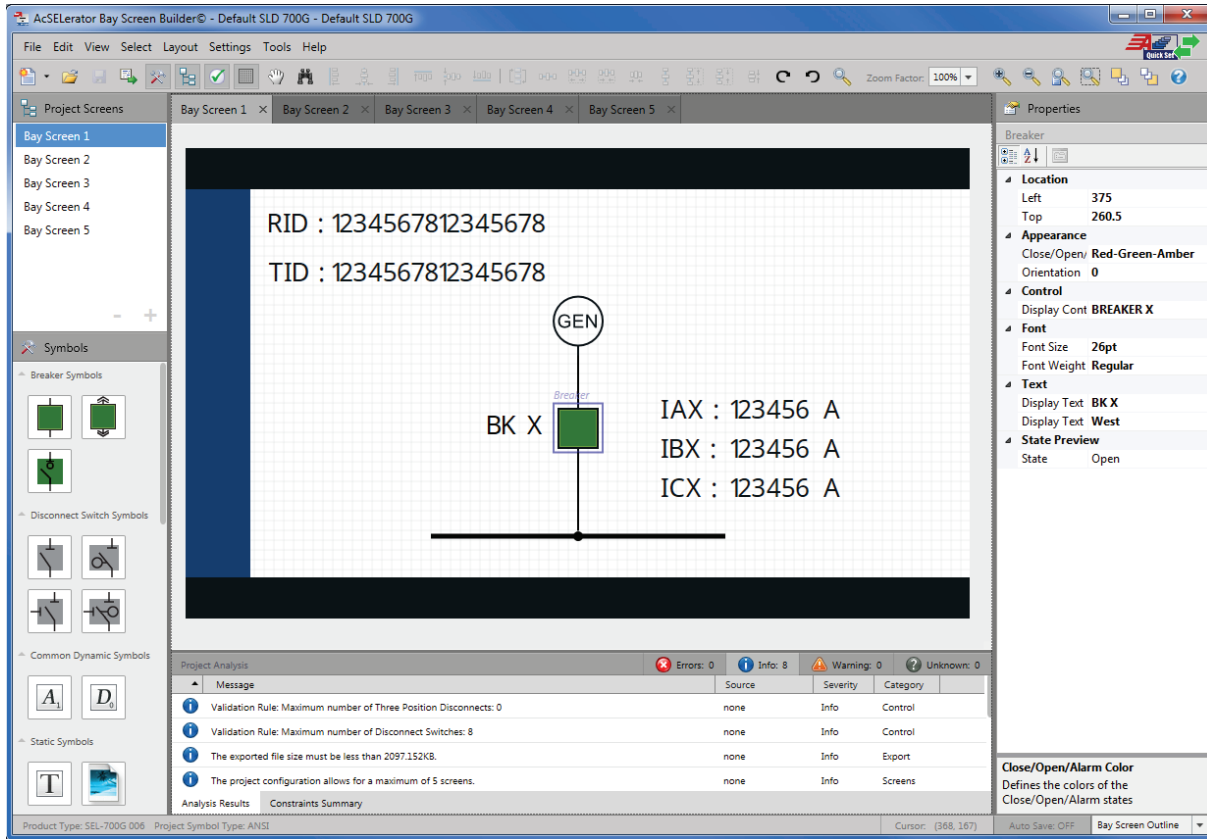

Figure 6 Bay Screen Builder

## Metering and Monitoring

The SEL-700G, depending on the model selected, provides extensive metering capabilities. See *Specifications on page 35* for metering and power measurement accuracies. As shown in *Table 3*, metered quantities include voltages and currents; sequence voltages and

currents; power, frequency, and energy; and maximum/minimum logging of selected quantities. The relay reports all metered quantities in primary quantities (current in A primary and voltage in V primary).

Table 3 SEL-700G Metered Values (Sheet 1 of 2)

| Types of Metering   |  |                |               |
|---|--|----------------|---------------|
| Instantaneous   | Differential   | Max/Min        | Analog Inputs |
| Remote Analogs  | Math Variables   | Synchrophasors | Thermal       |
| Demand and Peak Demand  | Energy   | RMS            | Harmonics     |
| Quantities  | Description  |                |               |
| Currents: $I_{An}$ , $I_{Bn}$ , $I_{Cn}$ , $I_{Gn}$ , $I_N$   | Phase currents, calculated residual currents ( $I_G = 3I_0 = I_A + I_B + I_C$ ) and neutral current, for $n = X$ and $Y$ |                |               |
| Voltages: $V_{An}$ , $V_{Bn}$ , $V_{Cn}$ , $V_N$  | Wye-connected voltage inputs for $n = X$ and $Y$   |                |               |
| Voltages: $V_{ABn}$ , $V_{BCn}$ , $V_{CAn}$   | Delta-connected voltage inputs for $n = X$ and $Y$   |                |               |
| Voltage $V_S$   | Synchronism-check voltage input  |                |               |
| Power $kW_{An}$ , $Bn$ , $Cn$ , $3P_n$<br>$kVAR_{An}$ , $Bn$ , $Cn$ , $3P_n$<br>$kVA_{An}$ , $Bn$ , $Cn$ , $3P_n$ | Single and three-phase kilowatts, kilovars, and kilovolt-amps for $n = X$ and $Y$  |                |               |

**Table 3 SEL-700G Metered Values (Sheet 2 of 2)**

| Types of Metering  |   |                |               |
|--|---|----------------|---------------|
| Instantaneous  | Differential  | Max/Min        | Analog Inputs |
| Remote Analogs   | Math Variables  | Synchrophasors | Thermal       |
| Demand and Peak Demand   | Energy  | RMS            | Harmonics     |
| Quantities   | Description   |                |               |
| Energy MWh <sub>An, Bn, Cn, 3Pn</sub><br>MVARh <sub>An, Bn, Cn, 3Pn</sub><br>MVAh <sub>An, Bn, Cn, 3Pn</sub> | Single and three-phase real, reactive and apparent energy for $n = X$ and $Y$                       |                |               |
| Power Factor PF <sub>An, Bn, Cn, 3Pn</sub>   | Single and three-phase power factor for $n = X$ and $Y$   |                |               |
| Sequence I <sub>1n, 3I2n, 3I0n, V1n, 3V2n, 3V0n</sub>  | Positive, negative and zero-sequence currents and voltages for $n = X$ and $Y$                      |                |               |
| Frequency FREQ <sub>n, FREQS</sub> (Hz)  | Instantaneous power system frequency for $n = X$ and $Y$ and for synchronism-check voltage input VS |                |               |
| V/Hz   | Calculated volts/hertz in percent, using highest measured voltage and measured frequency            |                |               |
| VPX3, VN3  | Phase and neutral third harmonic voltage for stator ground protection                               |                |               |
| Gen TCU %  | Generator thermal capacity used (%)   |                |               |
| Rf kOhm  | Field winding insulation resistance to ground (kOhm)  |                |               |
| AXx01–AXx04  | Analog inputs   |                |               |
| MV01–MV32  | Math variables  |                |               |
| RA001–RA128  | Remote analogs  |                |               |
| RTD <sub>n</sub> ( $n = 1$ to $12$ )   | RTD temperature measurement (degrees C)   |                |               |

**Synchronized Phasor Measurement**

Combine the SEL-700G with an SEL IRIG-B time source to measure the system angle in real time with a timing accuracy of  $\pm 10 \mu s$ . Measure instantaneous voltage and current phase angles in real time to improve system operation with synchrophasor information. Replace state measurement, study validation, or track system stability. Use SEL-5077 SYNCHROWAVE<sup>®</sup> Server Software or SEL-5078 SYNCHROWAVE<sup>®</sup> Console Software to view system angle at multiple locations for precise system analysis and system-state measurement (see Figure 7).

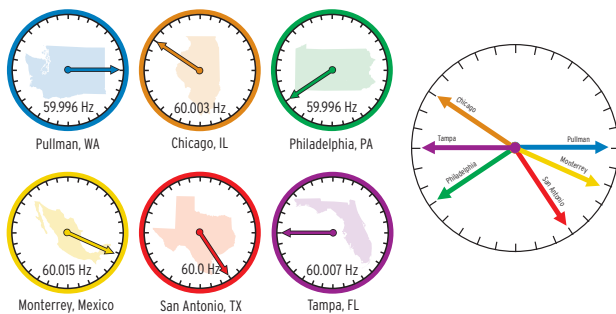

**Figure 7 View of System Angle at Multiple Locations**

**Load Profile**

The SEL-700G features a programmable Load Profile (LDP) recorder that records as many as 17 metering quantities into nonvolatile memory at fixed time intervals. The LDP saves several days to several weeks of the most recent data depending on the LDP settings (9800 entries total).

**Generator Operating Statistics Monitoring**

The SEL-700G Relay, having generator elements, tracks the performance and utilization of the protected generator by tracking the following generator operating statistics.

- Total generator running hours
- Total generator stopped hours
- Generator full load hours
- Percent of time running
- Accumulated generator  $I_2^2 \cdot t$
- Average real and reactive power outputs
- Average power factor

## Improve Situational Awareness

Provide improved information to system operators. Advanced synchrophasor-based tools produce a real-time view of system conditions. Use system trends, alarm points, and preprogrammed responses to help operators prevent a cascading system collapse and maximize system stability. Awareness of system trends provides operators with an understanding of future values based on measured data.

- Increase system loading while maintaining adequate stability margins.
- Improve operator response to system contingencies such as overload conditions, transmission outages, or generator shutdown.
- Advance system knowledge with correlated event reporting and real-time system visualization.
- Validate planning studies to improve system load balance and station optimization.

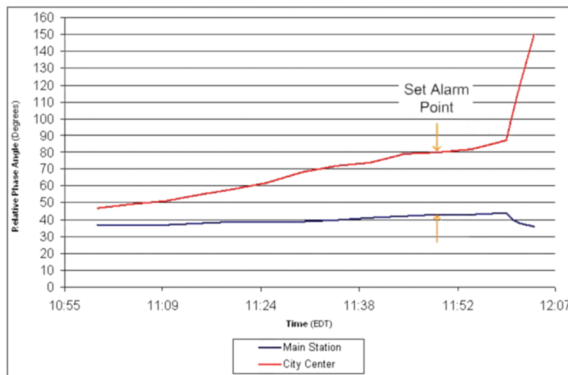

**Figure 8 Visualization of Phase Angle Measurements Across a Power System**

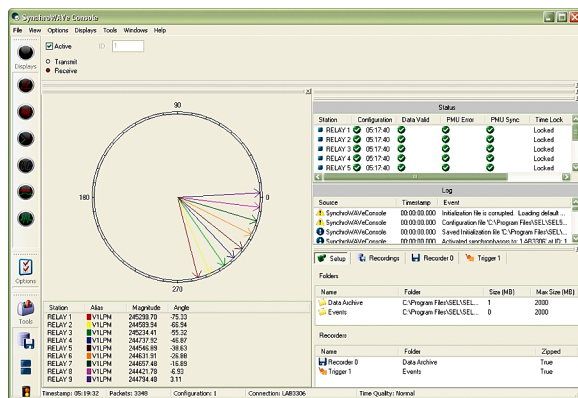

**Figure 9 SEL-5078 SYNCHROWAVE Console Real-Time, Wide-Area Visualization Tool**

## Event Reporting and SER

Event reports and the SER simplify post-fault analysis and improve understanding of simple and complex protective scheme operations. In response to a user-selected trigger, the voltage, current, frequency, and element status information contained in each event report confirms the relay scheme and system performance for every fault. Decide how much detail is necessary when you request an event report (e.g., 1/4-cycle or 1/32-cycle resolution, filtered or raw analog data, respectively).

The relay stores as many as 6 of the most recent 180-cycle event reports, 18 of the most recent 64-cycle event reports, or 74 of the most recent 15-cycle event reports in nonvolatile memory. The relay always appends relay settings to the bottom of each event report.

The following analog data formats are available:

- 1/4-cycle or 1/32-cycle resolution, filtered or unfiltered analog, ASCII or Compressed ASCII reports
- 1/32-cycle resolution COMTRADE reports

The relay SER feature stores the latest 1024 entries. Use this feature to gain a broad perspective at a glance. An SER entry helps to monitor input/output change-of-state occurrences and element pickup/dropout.

The IRIG-B time-code input synchronizes the SEL-700G time to within  $\pm 5$  ms of the time-source input. A convenient source for this time code is an SEL-2401 Satellite-Synchronized Clock, the SEL-3530 Real Time Automation Controller (RTAC), or the SEL-2032, SEL-2030, or SEL-2020 Communications Processor (via Serial Port 3 on the SEL-700G).

Available reports, which also show the status of digital inputs and outputs, include the following:

- **Analog event reports** that use filtered data and show all analog channels at four samples per cycle.
- **Digital event reports** that show pickup of protection elements including overcurrent, demand, voltage overexcitation, frequency, and over- and undervoltage elements at four samples per cycle.
- **Differential event reports** that show differential quantities, element pickup, SELOGIC control equation set variables, and inputs and outputs at four samples per cycle.
- **Raw analog event reports** that use unfiltered data at 32 samples per cycle.

## Generator Autosynchronism Report

The SEL-700G with the autosynchronism function generates a generator autosynchronism report with all the relevant analog and digital signals for a quick analysis of the event. The sample rate can be selected between 0.25, 1, and 5 cycles. The report captures 4800 time-stamped data points.

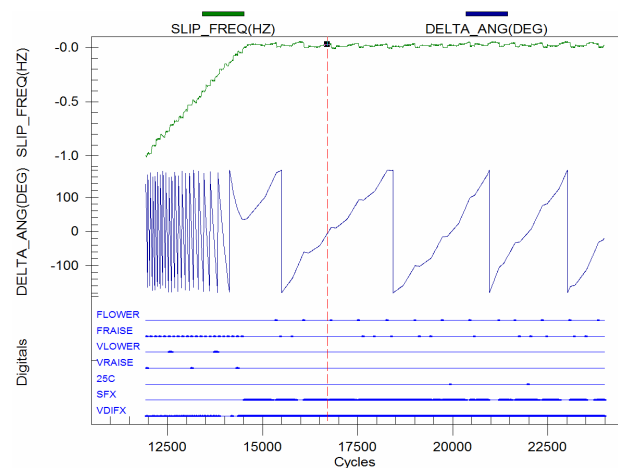

**Figure 10** Graphical Display of Generator Synchronizer Report

## Touchscreen Display

You can order the SEL-700G Feeder Protection Relay with an optional touchscreen display (5-inch, color, 800 x 480 pixels). The touchscreen display makes relay data metering, monitoring, and control quick and efficient. The touchscreen display option in the SEL-700G features a straightforward application-driven control structure and includes intuitive and graphical screen designs.

The touchscreen display allows you to:

- View and control bay screens
- Access metering and monitoring data
- Inspect targets
- View event history, summary data, and SER information
- View relay status and configuration
- Control relay operations
- View and edit settings
- Enable the rotating display
- Program control pushbuttons to jump to a specific screen

You can navigate the touchscreen by tapping the folders and applications. The folders and applications of the Home screen are shown in *Figure 11*. Folders and applications are labeled according to functionality. Additional folder and application screens for the SEL-700G touchscreen display option can be seen in *Figure 12* through *Figure 20*.

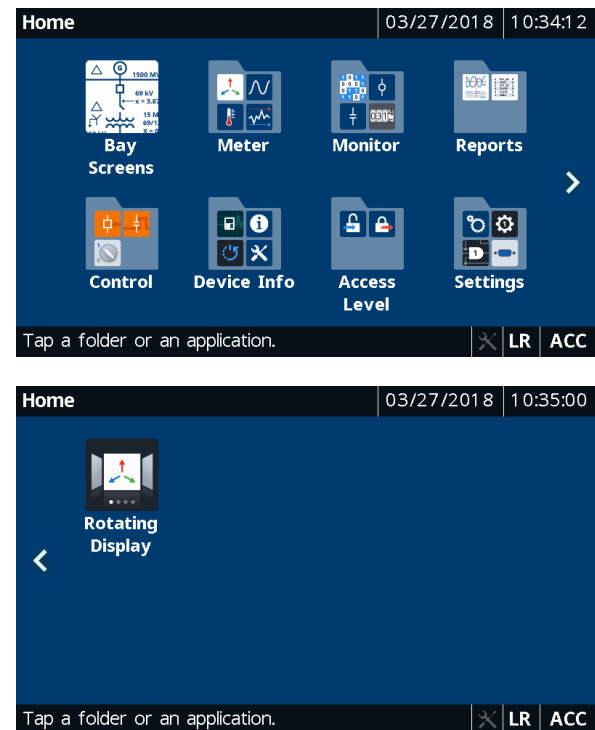
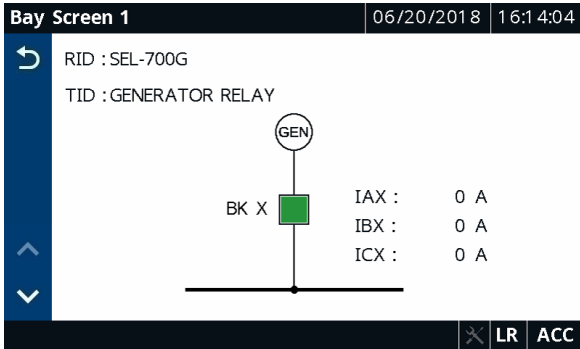

**Figure 11** Home (Default FPHOME Screen)

## Bay Screens Application

The SEL-700G Relay with the touchscreen display option provides you with the ability to design bay configuration screens to meet your system needs. The bay configuration can be displayed as an SLD on the touchscreen. You can create as many as five bay screens with one controllable breaker and as many as five monitor-only disconnects. ANSI and IEC symbols, along with analog and digital labels, are available for you to create detailed SLDs of the bay to indicate the status of the

breaker and disconnects, bus voltages, and power flow through the breaker. *Figure 12* shows the default SLD for the touchscreen display option.



**Figure 12 Default Bay Screen**

### Meter Folder Applications

The applications in the Meter folder are part-number dependent. Only those metering applications specific to your part number appear in the Meter folder. Tapping an application in the **Meter** folder shows you the report for that particular application. Tap the **Phasor** application to view the current and voltage phasors (see *Figure 13*).

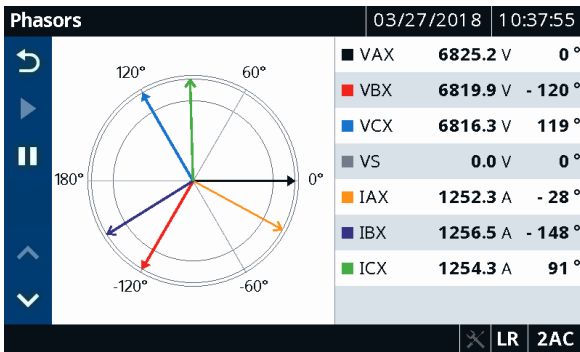

**Figure 13 Meter Phasors**

Tap the **Energy** application to view the energy metering quantities (see *Figure 14*). A reset feature is provided for the Energy, Max/Min, Thermal, Demand, and Peak Demand applications. Tap the **Reset** button  (see *Figure 14*) to navigate to the reset confirmation screen. Once you confirm the reset, the data are reset to zero.

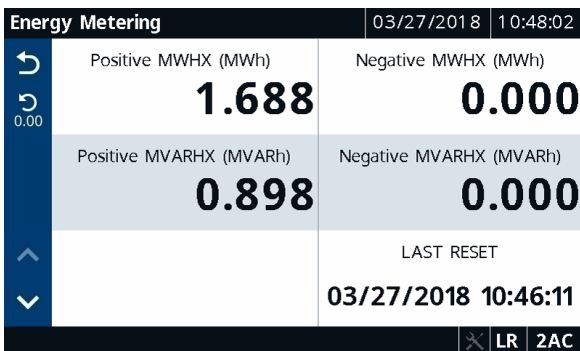

**Figure 14 Meter Energy**

### Reports Folder Applications

Tapping the **Reports** folder navigates you to the screen where you can access the Events and SER applications. Use these applications to view events and SERs. To view the event summary (see *Figure 15*) of a particular event record, you can tap the event record on the Event History screen.

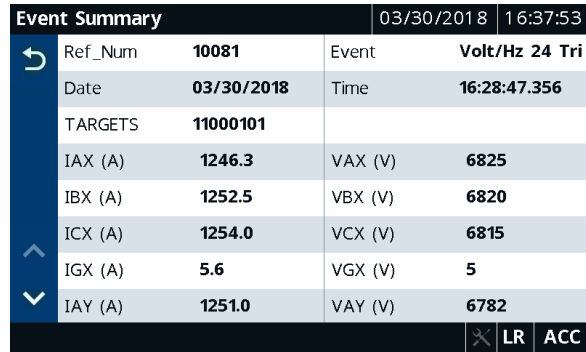

**Figure 15 Event Summary**

Tap the **Sequential Events Recorder** application to view a history of the SER reports (see *Figure 16*).



**Figure 16 Sequential Events Recorder**

Tapping the **Trash** button, shown in *Figure 15*, on the Event History and Sequential Events Recorder screens and confirming the delete action removes the records from the relay.

### Control Folder Applications

Tapping the **Control** folder navigates you to the screen where you can access the Breaker Control, Output Pulsing, Local Bits, and Reset TCU applications. Use the applications to perform breaker control operations, pulse output contacts (*Figure 17*), control the local bits (*Figure 18*), and reset TCU for the thermal overload element.

| Digital Output Pulsing - Slot A |        |        |  | 02/08/2017 | 10:16:10 |
|---------------------------------|--------|--------|--|------------|----------|
| OUT101                          | OUT102 | OUT103 |  |            |          |
| 1                               | 0      | 0      |  |            |          |

Tap an output button. LR 2AC

Figure 17 Digital Output Pulsing-Slot A

| Local Bits |                |       |  | 02/08/2017 | 10:25:26 |
|------------|----------------|-------|--|------------|----------|
| #          | LOCAL BIT NAME | STATE |  |            |          |
| LB01       | SPERV SW       | OPEN  |  |            |          |
| LB02       | FAN START      | OFF   |  |            |          |

Tap a row. LR 2AC

Figure 18 Local Bits

### Device Info Folder Applications

Tapping the **Device Info** folder navigates you to the screen where you can access specific device information applications (Status, Configuration, and Trip & Diag. Messages) and the Reboot application.

Tap the **Status** application to view the relay status, firmware version, part number, etc. (see *Figure 19*).

## Automation

### Flexible Control Logic and Integration

The SEL-700G can be ordered with as many as four independently operated serial ports:

- EIA-232 port on the front panel
- EIA-232 or EIA-485 port on the Slot B in the rear
- EIA-232 fiber-optic port on Slot B card in the rear
- EIA-232 or EIA-485 port on the optional communications card in Slot C in the rear

Optionally, the relay supports single or dual, copper or fiber-optic Ethernet ports.

| Device Status    |                                   | 03/30/2018 | 16:51:15 |
|------------------|-----------------------------------|------------|----------|
| Status           | Relay Enabled                     |            |          |
| Serial No        | 3162580026                        |            |          |
| FID String       | SEL-700G-X346-V0-Z006003-D2018031 |            |          |
| Part Number      | 0700GT1B1X0X7585A33X              |            |          |
| SEL Display      | 1.0.40700.3450                    |            |          |
| Customer Display | 1.540384993                       |            |          |
| IEC-61850 CID    |                                   |            |          |

LR 2AC

Figure 19 Status

To view the trip and diagnostic messages, tap the **Trip & Diag. Messages** application (see *Figure 20*). When a diagnostic failure, trip, or warning occurs, the relay displays the diagnostic message on the screen until it is either overridden by the restart of the rotating display, or the inactivity timer expires.

| Trip, Warning, & Diagnostic Messages |            |              |                 | 03/30/2018 | 16:52:46 |
|--------------------------------------|------------|--------------|-----------------|------------|----------|
| TYPE                                 | DATE       | TIME         | EVENT           |            |          |
| TRIP                                 | 03/30/2018 | 16:27:33.912 | Volt/Hz 24 Trip |            |          |

View Events or Status reports for details. LR 2AC

Figure 20 Trip and Diagnostics

The relay does not require special communications software. You can use any system that emulates a standard terminal system. Establish communication by connecting: computers, modems, protocol converters, printers, an SEL Real-Time Automation Controller (RTAC), SEL communications processor, SEL computing platform, SCADA serial port, and RTUs for local or remote communication. Refer to *Table 4* for a list of communications protocols available in the SEL-700G.

**Table 4 Communications Protocols**

| Type                                 | Description   |
|--------------------------------------|---|
| Simple ASCII                         | Plain language commands for human and simple machine communications. Use for metering, setting, self-test status, event reporting, and other functions.   |
| Compressed ASCII                     | Comma-delimited ASCII data reports. Allows external devices to obtain relay data in an appropriate format for direct import into spreadsheets and database programs. Data are checksum protected.   |
| Extended Fast Meter and Fast Operate | Binary protocol for machine-to-machine communications. Quickly updates SEL communications processors, RTUs, and other substation devices with metering information, relay element, I/O status, time-tags, open and close commands, and summary event reports. Data are checksum protected. Binary and ASCII protocols operate simultaneously over the same communications lines so control operator metering information is not lost while a technician is transferring an event report. Direct communications with the SEL-2600 RTD Module are possible using the unsolicited Fast Meter protocol to read incoming temperature data from the SEL-2600. |
| Fast SER Protocol                    | Provides SER events to an automated data collection system.   |
| Fast Message Protocol                | Use this protocol to write remote analog data from other SEL relays or communications processors via unsolicited writes.  |
| DNP3                                 | Serial or Ethernet-based DNP3 protocols. Provides default and mappable DNP3 objects that include access to metering data, protection elements, Relay Word bits, contact I/O, targets, SER, relay summary event reports, and setting group selection.  |
| Modbus                               | Serial- or Ethernet-based Modbus with point remapping. Includes access to metering data, protection elements, contact I/O, targets, SER, relay summary event reports, and setting groups.   |
| IEC 61850 Edition 2                  | Ethernet-based international standard for interoperability between intelligent devices in a substation. Operates remote bits and I/O. Monitors Relay Word bits and analog quantities.   |
| Synchrophasors                       | IEEE C37.118-compliant synchrophasors for system state, response, and control capabilities.   |
| Event Messenger                      | The use of SEL-3010 Event Messenger allows you to receive alerts directly on your cell phone. Alerts can be triggered through relay events and can include quantities measured by the relay.  |
| DeviceNet                            | Allows for connection to a DeviceNet network for access to metering data, protection elements, contact I/O, targets, and setting groups.  |
| SNTP                                 | Ethernet-based protocol that provides time synchronization of the relay.  |
| PRP                                  | Provides seamless recovery from any single Ethernet network failure in a dual redundant Ethernet network, in accordance with IEC 62439-3  |
| IEC 60870-5-103                      | Serial communications protocol—international standard for interoperability between intelligent devices in a substation.   |

Apply an SEL communications processor as the hub of a star network, with point-to-point fiber or copper connection between the hub and the SEL-700G (Figure 21).

The communications processor supports external communications links including the public switched telephone network for engineering access to dial-out alerts and private line connections of the SCADA system.

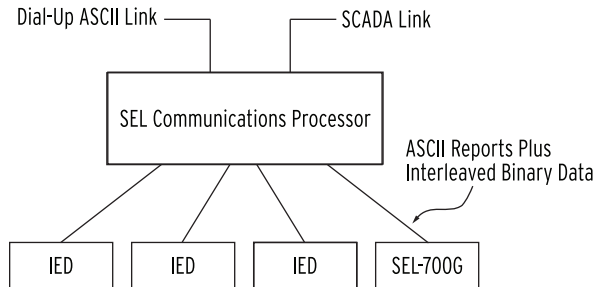

**Figure 21 Example Communications System**

SEL manufactures a variety of standard cables for connecting this and other relays to a variety of external devices. Consult your SEL representative for more information on cable availability. SEL-700G control logic improves integration in the following ways:

- ▶ **Replaces traditional panel control switches.** Eliminate traditional panel control switches with 32 local bits. Set, clear, or pulse local bits with the front-panel pushbuttons and display. Program the local bits into your control scheme with SELOGIC control equations. Use the local bits to perform functions such as a trip test or a breaker trip/close.
- ▶ **Eliminates RTU-to-relay wiring.** Eliminate RTU-to-relay wiring with 32 remote bits. Set, clear, or pulse remote bits using serial port commands. Program the remote bits into your control scheme with SELOGIC control equations. Use remote bits for SCADA-type control operations such as trip, close, and settings group selection.
- ▶ **Replaces traditional latching relays.** Replace up to 32 traditional latching relays for such functions as “remote control enable” with latch bits. Program latch set and latch reset conditions with SELOGIC control equations. Set or reset the nonvolatile latch bits using optoisolated inputs, remote bits, local bits, or any programmable logic condition. The latch bits retain their state when the relay loses power.
- ▶ **Replaces traditional indicating panel lights.** Replace traditional indicating panel lights with 32 programmable displays. Define custom messages (e.g., Breaker Open, Breaker Closed) to report power system or relay conditions on the front-panel display. Use Advanced SELOGIC control equations to control which messages the relay displays.
- ▶ **Eliminates external timers.** Eliminate external timers for custom protection or control schemes with 32 general purpose SELOGIC control equation timers. Each timer has independent time-delay pickup and dropout settings. Program each timer input with any desired element (e.g., time qualify a current element). Assign the timer output to trip logic, transfer trip communications, or other control scheme logic.
- ▶ **Eliminates settings changes.** Selectable setting groups make the SEL-700G ideal for applications requiring frequent setting changes and for adapting the protection to changing system conditions.

The relay stores three setting groups. Select the active setting group by optoisolated input, command, or other programmable conditions. Use these setting groups to cover a wide range of protection and control contingencies.

Switching setting groups switches logic and relay element settings. Program groups for different operating conditions, such as station maintenance, seasonal operations, emergency contingencies, loading, source changes, and downstream relay setting changes.

### Fast SER Protocol

SEL Fast SER Protocol provides SER events to an automated data collection system. SEL Fast SER Protocol is available on any rear serial port. Devices with embedded processing capability can use these messages to enable and accept unsolicited binary SER messages from SEL-700G Relays.

SEL relays and communications processors have two separate data streams that share the same serial port. The normal serial interface consists of ASCII character commands and reports that are intelligible to people using a terminal or terminal emulation package. The binary data streams can interrupt the ASCII data stream to obtain information, and then allow the ASCII data stream to continue. This mechanism allows a single communications channel to be used for ASCII communications (e.g., transmission of a long event report) interleaved with short bursts of binary data to support fast acquisition of metering or SER data.

### Fast Message Protocol

SEL Fast Message Protocol is a method to input or modify remote analogs in the SEL-700G. These remote analogs can then be used in SEL Math or SELOGIC control equations. Remote analogs can also be modified via Modbus, DNP3, and IEC 61850.

# Ethernet Network Architectures

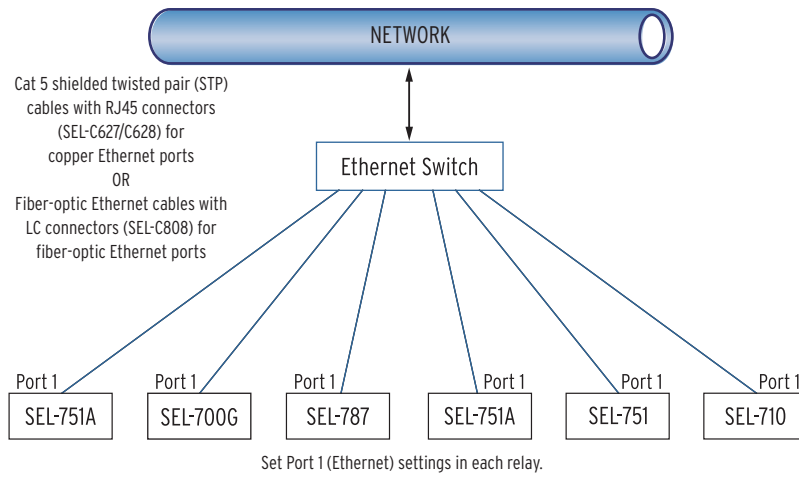

**Figure 22 Simple Ethernet Network Configuration**

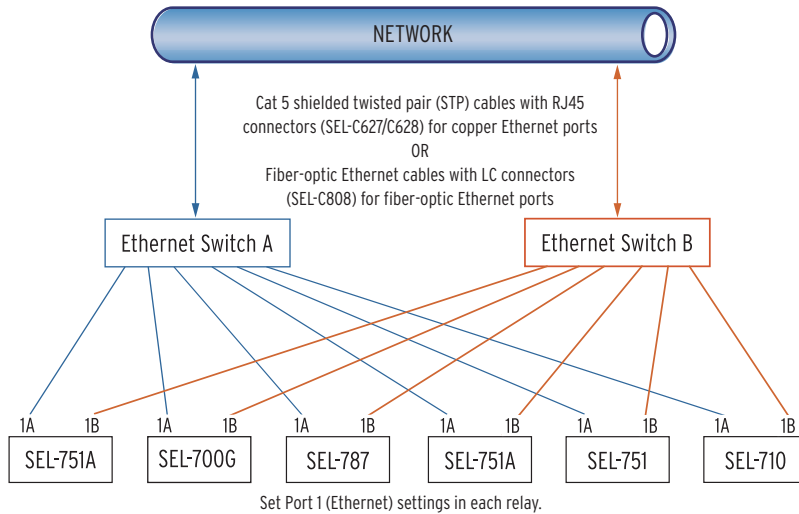

**Figure 23 Ethernet Network Configuration With Dual Redundant Connections (Failover Mode)**

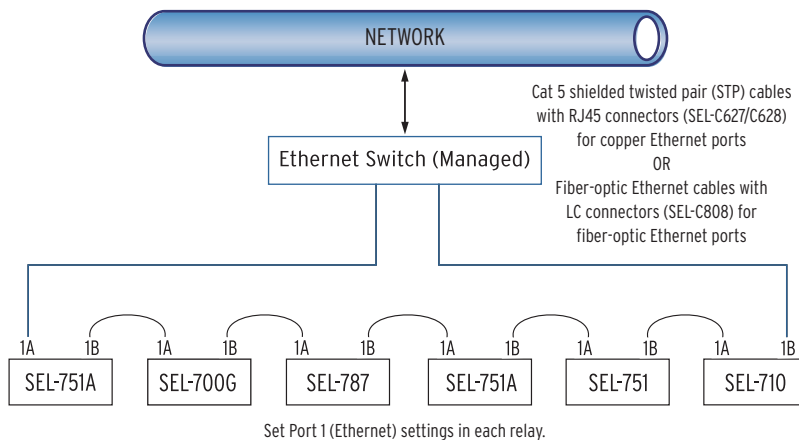

**Figure 24 Ethernet Network Configuration With Ring Structure (Switched Mode)**

## Additional Features

### MIRRORED BITS Relay-to-Relay Communications

The SEL-patented MIRRORED BITS communications technology provides bidirectional relay-to-relay digital communications. MIRRORED BITS can operate independently on as many as two EIA-232 rear serial ports and one fiber-optic rear serial port on a single SEL-700G.

This bidirectional digital communication creates eight additional virtual outputs (transmitted MIRRORED BITS) and eight additional virtual inputs (received MIRRORED BITS) for each serial port operating in the MIRRORED BITS mode (see *Figure 25*). Use these MIRRORED BITS to transmit/receive information between upstream relays and a downstream relay to enhance coordination and achieve faster tripping for downstream faults. MIRRORED BITS technology also helps reduce total scheme operating time by eliminating the need to assert output contacts to transmit information.

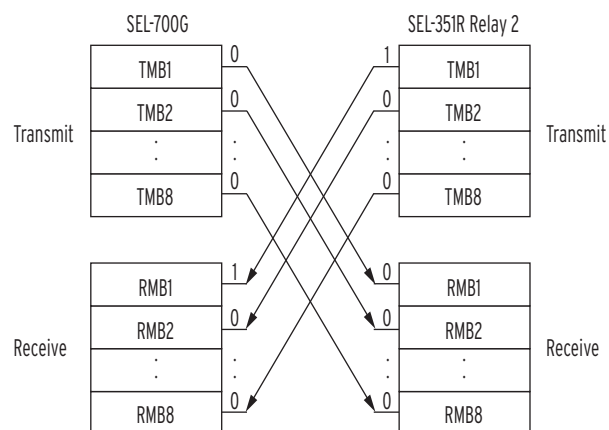

**Figure 25** MIRRORED BITS Transmit and Receive Bits

### Status and Trip Target LEDs

The SEL-700G includes 24 tricolor status and trip target LEDs on the front panel. When shipped from the factory, all LEDs are predefined and fixed in settings. You can

reprogram these LEDs for specific applications. This combination of targets is explained and shown in *Figure 28*. Some front-panel relabeling of LEDs may be needed if you reprogram them for unique or specific applications—see *Configurable Labels*.

### Event Messenger Points

The SEL-700G, when used with the SEL-3010 Event Messenger, can allow for ASCII-to-voice translation of as many as 32 user-defined messages, along with analog data that have been measured or calculated by the relay. With this combination, you can receive voice messages on any phone for alerts to transition of any Relay Word bits in the relay.

Verbal notification of breaker openings, fuse failures, RTD alarms, etc. can now be sent directly to your cell phone through the use of your SEL-700G and SEL-3010 (must be connected to an analog telephone line). In addition, messages can include an analog value such as current, voltage, or power measurements made by the SEL-700G.

### Configurable Labels

Use the configurable labels to relabel the operator controls and LEDs (shown in *Figure 28*) to suit the installation requirements. This feature includes preprinted labels (with factory-default text), blank label media, and a Microsoft® Word template on CD-ROM. This allows quick, professional-looking labels for the SEL-700G. Labels may also be customized without the use of a PC by writing the new label on the blank stock provided. The ability to customize the control and indication features allows specific utility or industry procedures to be implemented without the need for adhesive labels. All of the figures in this data sheet show the factory-default labels of the SEL-700G, including the standard model shown in *Figure 28*.

# Relay Dimensions

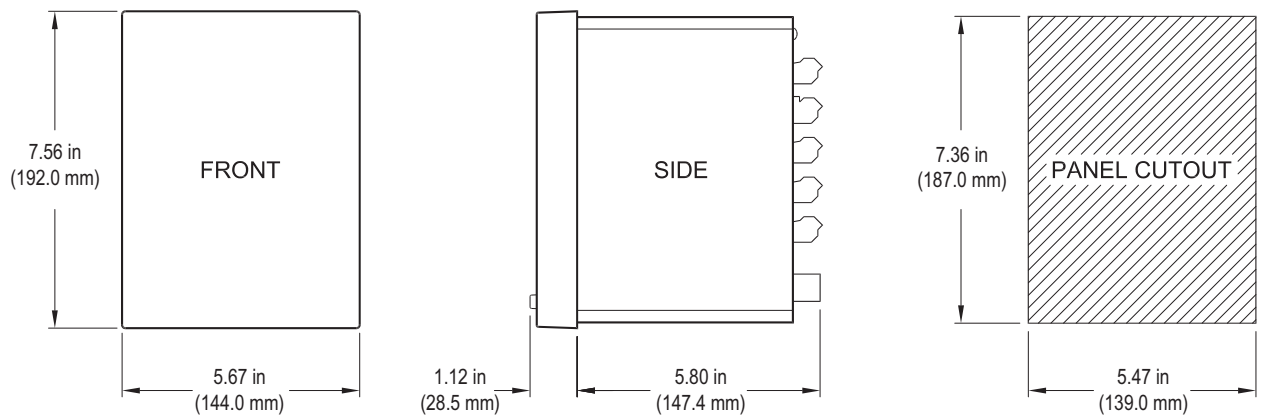

**Figure 26 SEL-700G Dimensions for Rack- and Panel-Mount Models**

# Hardware Overview

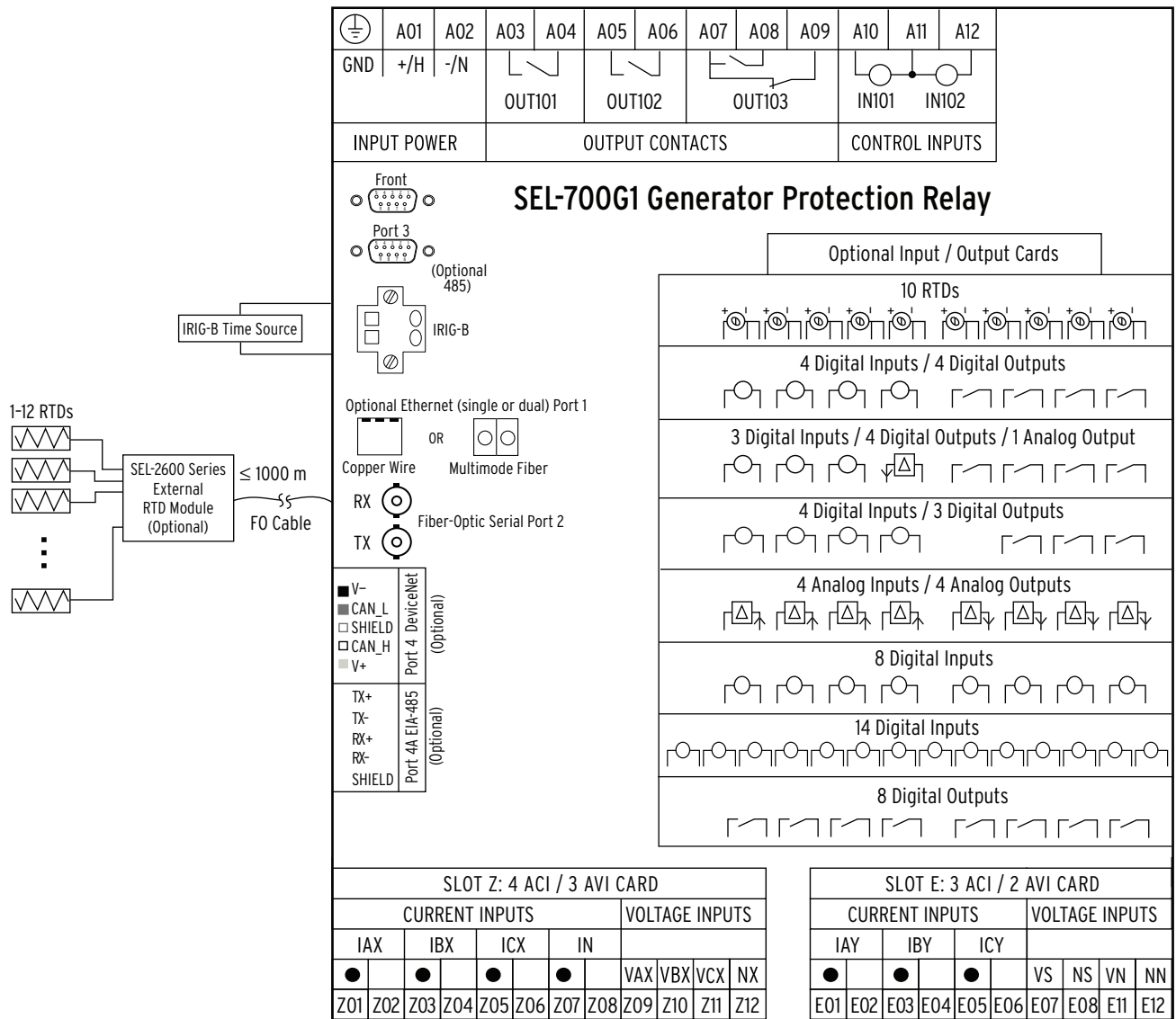
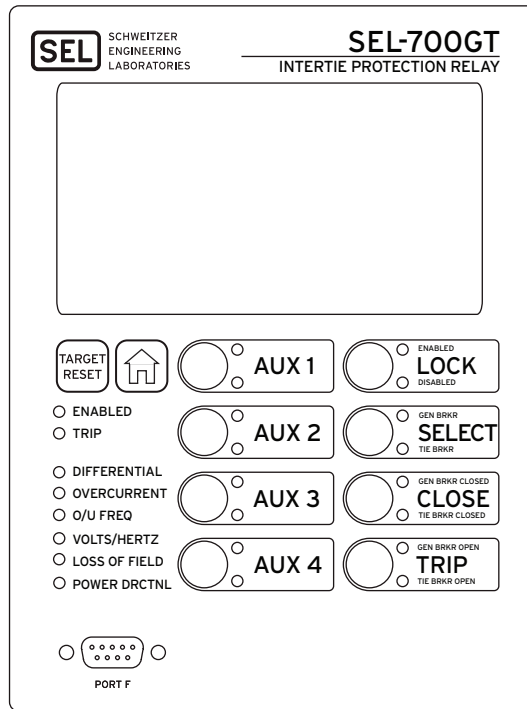

Figure 27 Typical Connection Diagram



# SEL-700GT Intertie

(A) Front Panel With Default Configuration Labels



(B) Rear-Panel View

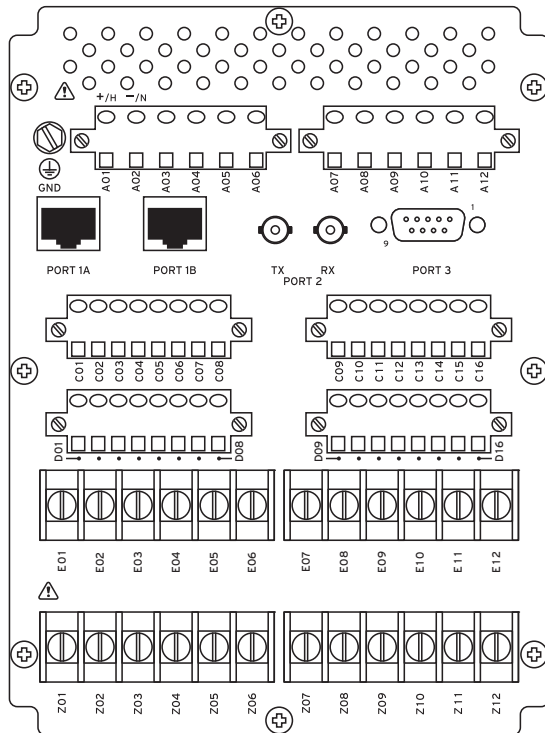

i4492a

(C) Side-Panel View

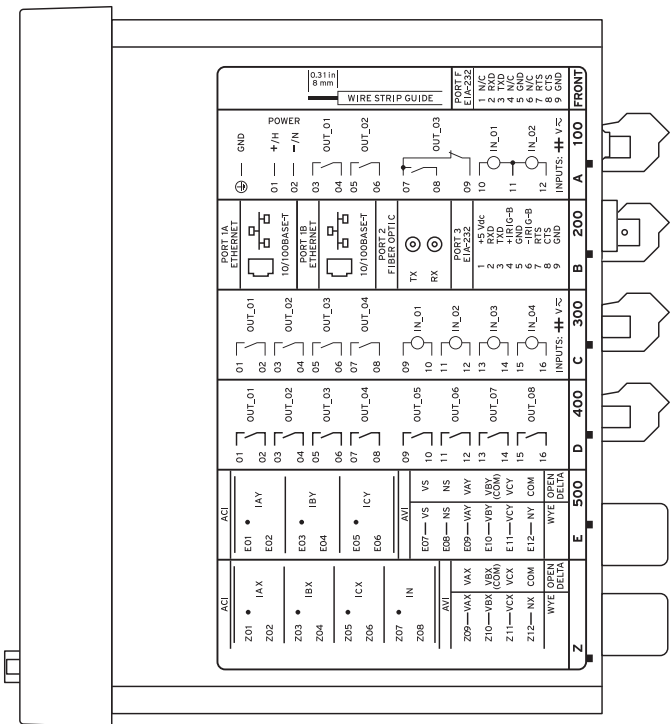

i4489a

† SEE DOCUMENTATION FOR INPUT VOLTAGE RATING

**Figure 29 Dual Copper Ethernet, 4 DI/4 DO, 8 DO, 3 ACI/4 AVI, 4 ACI/3 AVI (Relay MOT 0700GT1A2X7585A630)**

**SEL-700GW Wind Generator**

(A) Front Panel With Default Configuration Labels

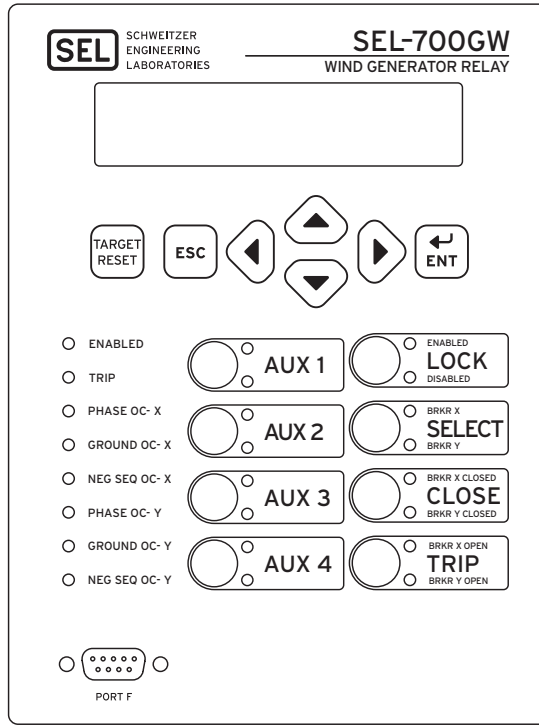

i4487a

(B) Rear-Panel View

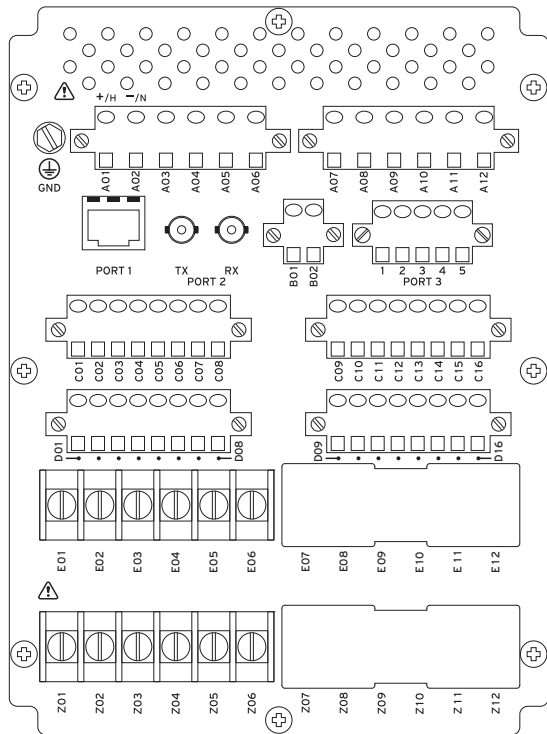

i4493b

(C) Side-Panel View

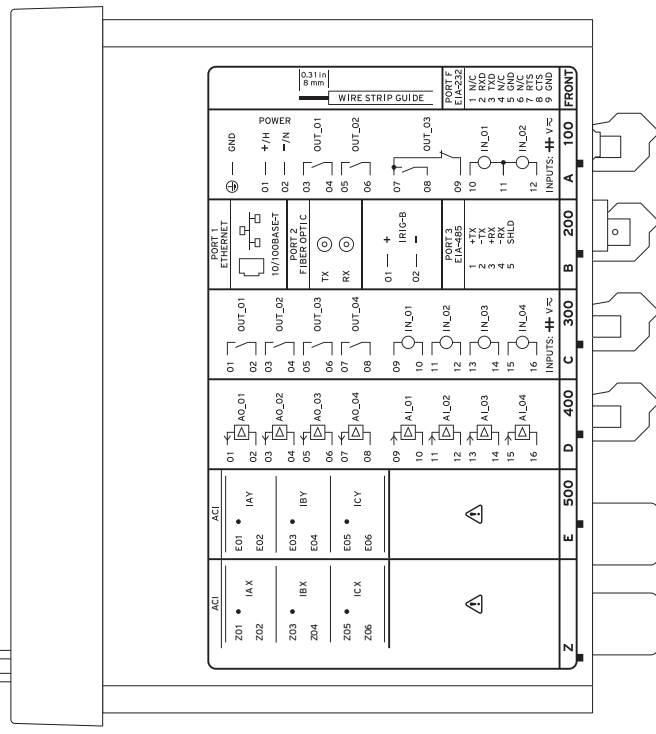

i4490b

**Figure 30 Copper Ethernet, 4 DI/4 DO, 4 AI/4 AO, 3 ACIE, 3 ACIZ (Relay MOT 0700GW1A1A6X77870310)**



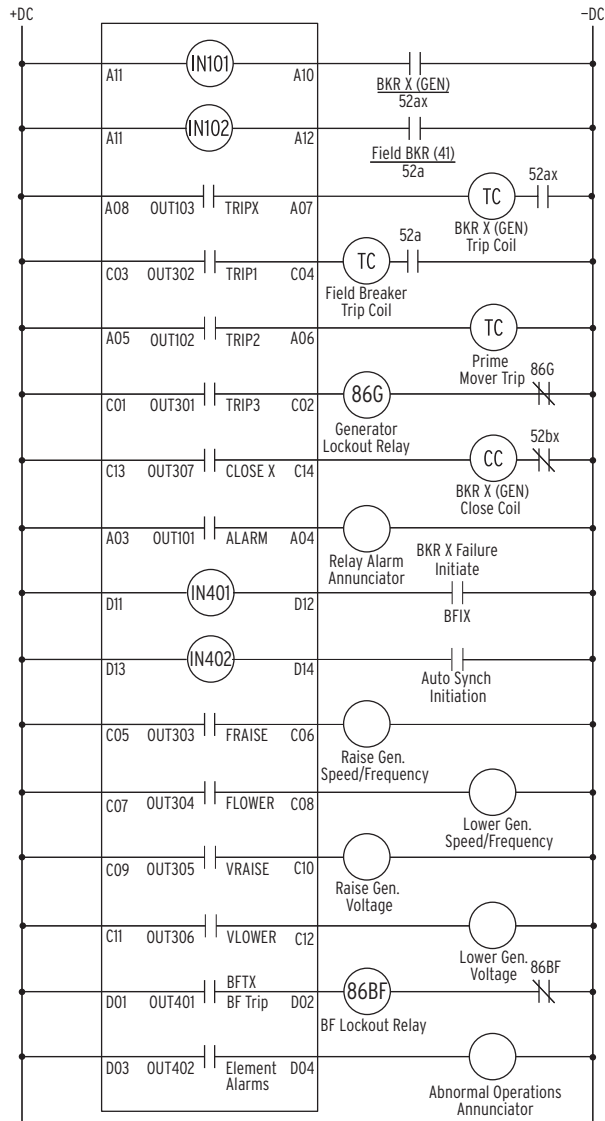

- NOTES:
- IN101-102 and OUT 101-103 are in the "base" relay-Slot A Power Supply card.
  - Slot C-Select 8D0 card, OUT301-OUT308.
  - Slot D-Select 3D1/4D0/1A0, IN401-IN403, OUT401-OUT404, or A0401.
  - Spares IN403, OUT403-404, A0401, OUT308.
  - Use Ethernet Port 1 for Synchrophasors, Modbus, DNP or IEC 61850.
  - Use Port 2 for SEL-2600 RTD Module.
  - Use Port 3 for SEL-2664 Field Ground Module (with a SEL-2812MR or 2812MT and a C805 fiber-optic cable).
  - Settings changes required are not shown.
  - Additional I/O and relay logic may be necessary for a specific application.

Figure 32 SEL-700G1 Typical DC External Connections

### SEL-700G1 Generator Relay—Example 2

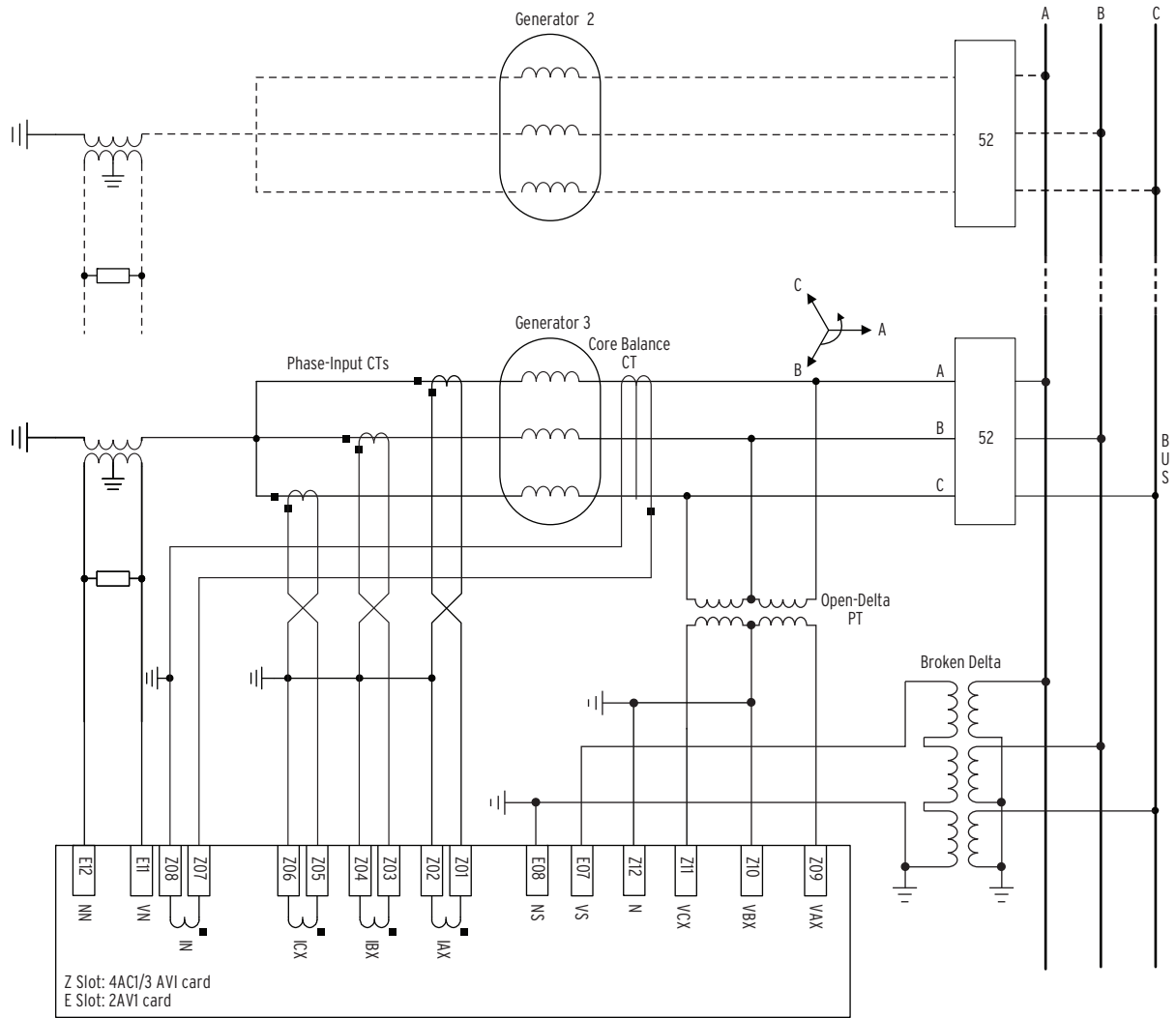

**Figure 33 SEL-700G1+ Relay AC Connection Example, Multiple High-Impedance Grounded Generators Connected to a Common Bus, With 67N and Other Protection**

# SEL-700GT Intertie Relay

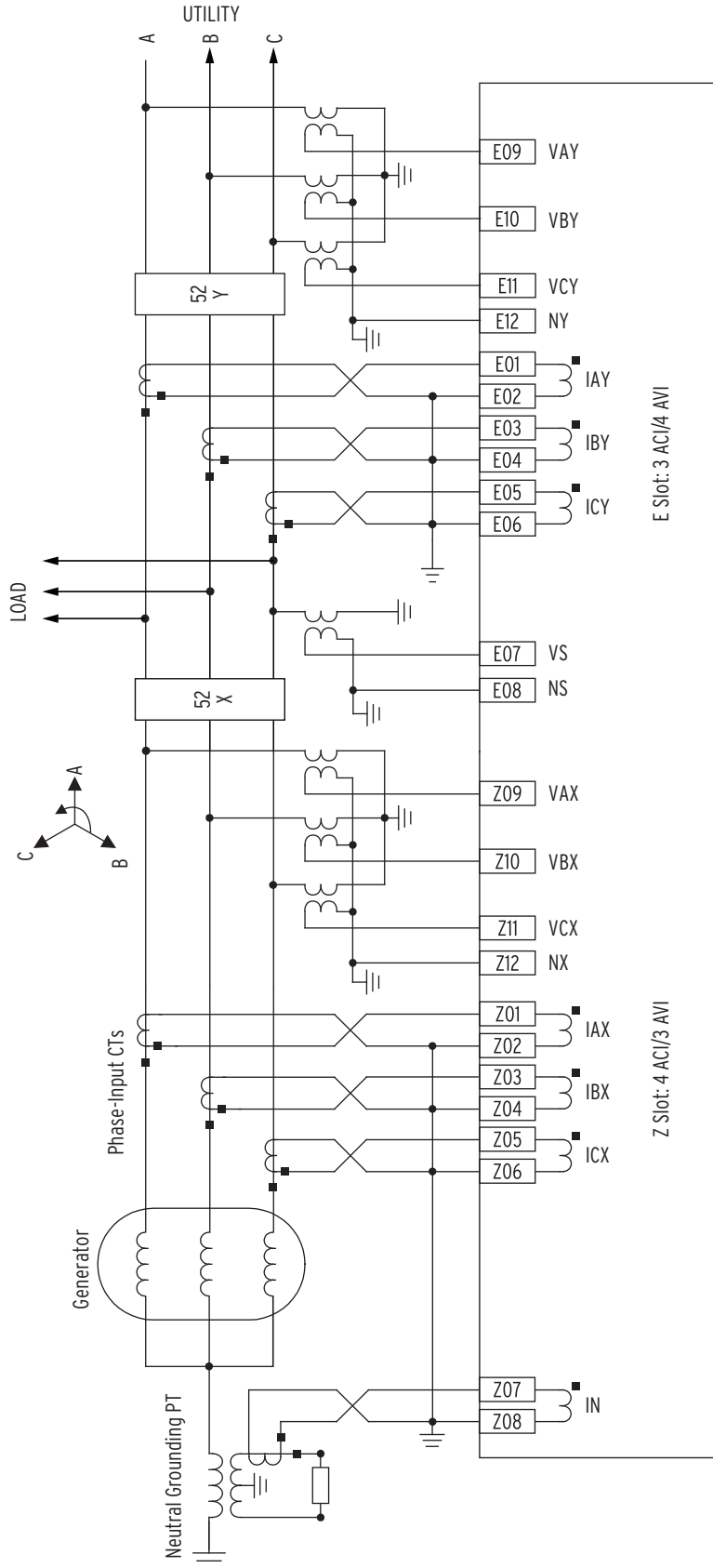
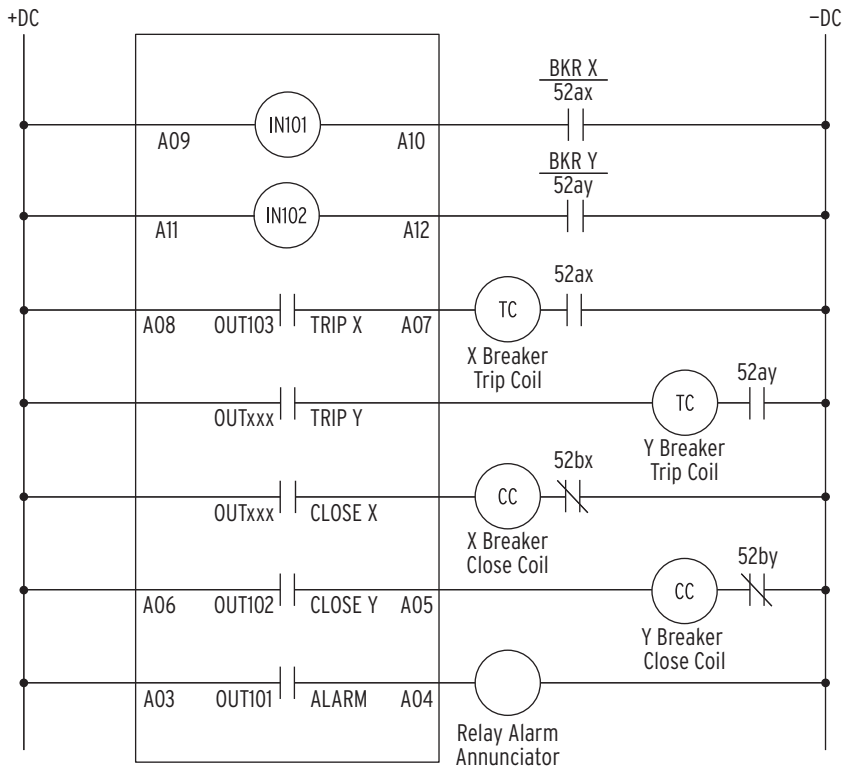

Figure 34 SEL-700GT Relay Typical AC Current and Four-Wire Wye Voltage Connection



NOTES:

- OUTxxx requires an additional I/O card in Slot C or D.
- IN101-102 and OUT 101-103 are in the "base" relay.
- Additional I/O and relay logic may be necessary for a specific application.
- Settings changes are not shown.
- RTD Inputs—requires SEL-2600 RTD Module or RTD input card in Slot D.

Figure 35 SEL-700GT Typical DC External Connections

### SEL-700GW Wind Generator Relay

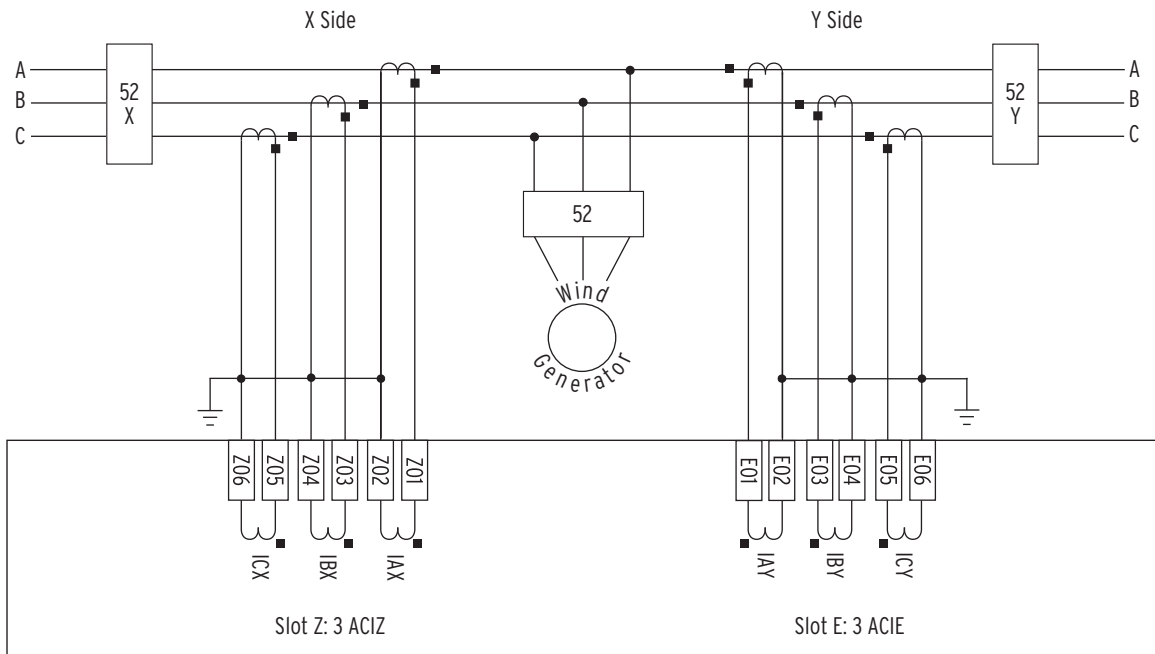

Figure 36 SEL-700GW Dual Feeder AC Current Connections

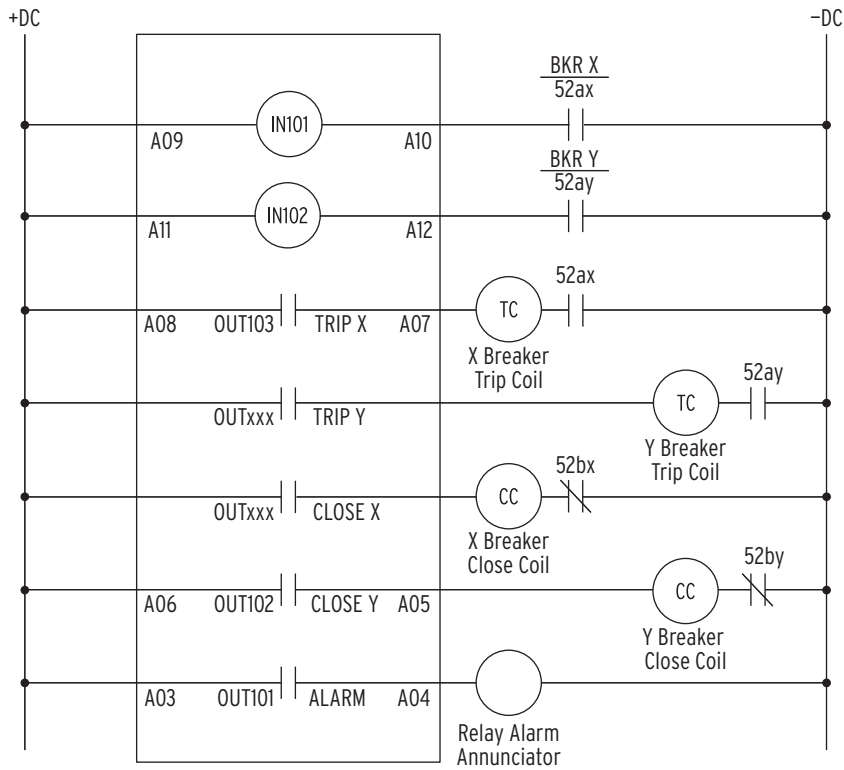

Figure 37 SEL-700GW Typical DC External Connections

NOTES:

- OUTxxx requires an additional I/O card in Slot C or D.
- IN101-102 and OUT 101-103 are in the "base" relay.
- Additional I/O and relay logic may be necessary for a specific application.
- Settings changes are not shown.
- Field ground element (64F) requires SEL-2664 Field Ground Module.
- RTD Inputs—requires SEL-2600 RTD Module or RTD input card in Slot D.

# Specifications

## Compliance

Designed and manufactured under an ISO 9001 certified quality management system

47 CFR 15B, Class A

**NOTE:** This equipment has been tested and found to comply with the limits for a Class A digital device, pursuant to part 15 of the FCC Rules. These limits are designed to provide reasonable protection against harmful interference when the equipment is operated in a commercial environment. This equipment generates, uses, and can radiate radio frequency energy and, if not installed and used in accordance with the instruction manual, may cause harmful interference to radio communications. Operation of this equipment in a residential area is likely to cause harmful interference in which case the user will be required to correct the interference at his own expense.

UL Listed to U.S. and Canadian safety standards (File E212775, NRGU, NRGU7)

CE Mark

RCM Mark

## Hazardous Locations

UL Certified Hazardous Locations to U.S. and Canadian standards (File E470448)

EU



EN 60079-0:2012 + A11:2013, EN 60079-7:2015,  
EN 60079-15:2010, EN 60079-11:2012

**NOTE:** Where so marked, ATEX and UL Hazardous Locations Certification tests are applicable to rated supply specifications only and do not apply to the absolute operating ranges, continuous thermal, or short circuit duration specifications.

## General

### AC Current Input

Phase and Neutral Currents

$I_{NOM} = 1 \text{ A}$  or 5 A secondary depending on model

**$I_{NOM} = 5 \text{ A}$**

Continuous Rating: 3 •  $I_{NOM}$  @ 85°C, linear to 100 A symmetrical  
4 •  $I_{NOM}$  @ 55°C, linear to 100 A symmetrical

1-Second Thermal: 500 A

Burden (per Phase): <0.1 VA @ 5 A

**$I_{NOM} = 1 \text{ A}$**

Continuous Rating: 3 •  $I_{NOM}$  @ 85°C, linear to 20 A symmetrical  
4 •  $I_{NOM}$  @ 55°C, linear to 20 A symmetrical

1-Second Thermal: 100 A

Burden (per Phase): <0.01 VA @ 1 A

Measurement Category: II

### AC Voltage Inputs

VNOM (L-L secondary) Range: 20–250 V (if DELTA\_Y := DELTA)  
20–440 V (if DELTA\_Y := WYE)

Rated Continuous Voltage: 300 Vac

10-Second Thermal: 600 Vac

Burden: <0.1 VA

Input Impedance: 4 M $\Omega$  differential (phase-to-phase)  
7 M $\Omega$  common mode (phase-to-chassis)

## Power Supply

Relay Start-Up Time: Approximately 5–10 seconds (after power is applied until the **ENABLED** LED turns on)

### High-Voltage Supply

Rated Supply Voltage: 110–240 Vac, 50/60 Hz  
110–250 Vdc

Input Voltage Range (Design Range): 85–264 Vac  
85–275 Vdc

Power Consumption: <50 VA (ac)  
<25 W (dc)

Interruptions: 50 ms @ 125 Vac/Vdc  
100 ms @ 250 Vac/Vdc

### Low-Voltage Supply

Rated Supply Voltage: 24–48 Vdc

Input Voltage Range (Design Range): 19.2–60 Vdc

Power Consumption: <25 W (dc)

Interruptions: 10 ms @ 24 Vdc  
50 ms @ 48 Vdc

## Fuse Ratings

### LV Power Supply Fuse

Rating: 3.15 A  
Maximum Rated Voltage: 300 Vdc, 250 Vac  
Breaking Capacity: 1500 A at 250 Vac  
Type: Time-lag T

### HV Power Supply Fuse

Rating: 3.15 A  
Maximum Rated Voltage: 300 Vdc, 250 Vac  
Breaking Capacity: 1500 A at 250 Vac  
Type: Time-lag T

## Output Contacts

The relay supports Form A, B, and C outputs.

Dielectric Test Voltage: 2500 Vac

Impulse Withstand Voltage ( $U_{IMP}$ ): 5000 V

Mechanical Durability: 100,000 no-load operations

## Standard Contacts

Pickup/Dropout Time:  $\leq 8$  ms (coil energization to contact closure)

## DC Output Ratings

Rated Operational Voltage: 250 Vdc

Rated Voltage Range: 19.2–275 Vdc

Rated Insulation Voltage: 300 Vdc

Make: 30 A @ 250 Vdc per IEEE C37.90

Continuous Carry: 6 A @ 70°C  
4 A @ 85°C

1-Second Thermal: 50 A

Contact Protection: 360 Vdc, 115 J MOV protection across open contacts

Breaking Capacity (10,000 Operations) per IEC 60255-0-20:1974:

|         |        |             |
|---------|--------|-------------|
| 24 Vdc  | 0.75 A | L/R = 40 ms |
| 48 Vdc  | 0.50 A | L/R = 40 ms |
| 125 Vdc | 0.30 A | L/R = 40 ms |
| 250 Vdc | 0.20 A | L/R = 40 ms |

Cyclic (2.5 Cycles/Second) per IEC 60255-0-20:1974:

|         |        |             |
|---------|--------|-------------|
| 24 Vdc  | 0.75 A | L/R = 40 ms |
| 48 Vdc  | 0.50 A | L/R = 40 ms |
| 125 Vdc | 0.30 A | L/R = 40 ms |
| 250 Vdc | 0.20 A | L/R = 40 ms |

#### AC Output Ratings

|   |         |
|---|---------|
| Maximum Operational Voltage ( $U_o$ ) Rating:               | 240 Vac |
| Insulation Voltage ( $U_i$ ) Rating (excluding EN 61010-1): | 300 Vac |
| 1-Second Thermal:   | 50 A    |
| Contact Rating Designation:                                 | B300    |

| B300 (5 A Thermal Current, 300 Vac Max) |                 |         |        |
|---|-----------------|---------|--------|
|   | Maximum Current |         | Max VA |
| Voltage                                 | 120 Vac         | 240 Vac | —      |
| Make                                    | 30 A            | 15 A    | 3600   |
| Break                                   | 3 A             | 1.5 A   | 360    |
| PF < 0.35, 50–60 Hz                     |                 |         |        |

Utilization Category: AC-15

| AC-15   |         |         |
|---|---------|---------|
| Operational Voltage ( $U_e$ )                     | 120 Vac | 240 Vac |
| Operational Current ( $I_e$ )                     | 3 A     | 1.5 A   |
| Make Current                                      | 30 A    | 15 A    |
| Break Current                                     | 3 A     | 1.5 A   |
| Electromagnetic loads > 72 VA, PF < 0.3, 50–60 Hz |         |         |

Voltage Protection Across Open Contacts: 270 Vac, 115 J

#### Fast Hybrid (High-Speed, High-Current Interrupting)

##### DC Output Ratings

|                             |                                |
|-----------------------------|--------------------------------|
| Rated Operational Voltage:  | 250 Vdc                        |
| Rated Voltage Range:        | 19.2–275 Vdc                   |
| Rated Insulation Voltage:   | 300 Vdc                        |
| Make:                       | 30 A @ 250 Vdc per IEEE C37.90 |
| Continuous Carry:           | 6 A @ 70°C<br>4 A @ 85°C       |
| 1-Second Thermal:           | 50 A                           |
| Open State Leakage Current: | <500 $\mu$ A                   |

MOV Protection (Maximum Voltage): 250 Vac/330 Vdc

Pickup Time: <50  $\mu$ s, resistive load

Dropout Time:  $\leq$ 8 ms, resistive load

Break Capacity (10,000 Operations) per IEC 60255-0-20:1974:

|         |        |             |
|---------|--------|-------------|
| 48 Vdc  | 10.0 A | L/R = 40 ms |
| 125 Vdc | 10.0 A | L/R = 40 ms |
| 250 Vdc | 10.0 A | L/R = 20 ms |

Cyclic Capacity (4 Cycles in 1 Second, Followed by 2 Minutes Idle for Thermal Dissipation) per IEC 60255-0-20:1974:

|         |        |             |
|---------|--------|-------------|
| 48 Vdc  | 10.0 A | L/R = 40 ms |
| 125 Vdc | 10.0 A | L/R = 40 ms |
| 250 Vdc | 10.0 A | L/R = 20 ms |

##### AC Output Ratings

See AC Output Ratings for Standard Contacts.

#### Optoisolated Control Inputs

When Used With DC Control Signals

|                      |   |
|----------------------|---|
| Pickup/Dropout Time: | Depends on the input debounce settings    |
| 250 V:               | ON for 200–312.5 Vdc<br>OFF below 150 Vdc |
| 220 V:               | ON for 176–275 Vdc<br>OFF below 132 Vdc   |
| 125 V:               | ON for 100–156.2 Vdc<br>OFF below 75 Vdc  |
| 110 V:               | ON for 88–137.5 Vdc<br>OFF below 66 Vdc   |
| 48 V:                | ON for 38.4–60 Vdc<br>OFF below 28.8 Vdc  |
| 24 V:                | ON for 15–30 Vdc<br>OFF for <5 Vdc        |

When Used With AC Control Signals

|               |   |
|---------------|---|
| Pickup Time:  | 2 ms  |
| Dropout Time: | 16 ms                                       |
| 250 V:        | ON for 170.6–312.5 Vac<br>OFF below 106 Vac |
| 220 V:        | ON for 150.2–275 Vac<br>OFF below 93.3 Vac  |
| 125 V:        | ON for 85–156.2 Vac<br>OFF below 53 Vac     |
| 110 V:        | ON for 75.1–137.5 Vac<br>OFF below 46.6 Vac |
| 48 V:         | ON for 32.8–60 Vac<br>OFF below 20.3 Vac    |
| 24 V:         | ON for 14–30 Vac<br>OFF below 5 Vac         |

Current Draw at Nominal DC Voltage: 2 mA (at 220–250 V)  
4 mA (at 48–125 V)  
10 mA (at 24 V)

Rated Impulse Withstand Voltage ( $U_{imp}$ ): 4000 V

#### Analog Output (Optional)

|                               | 1A0                                      | 4A0             |
|-------------------------------|--|-----------------|
| Current:                      | 4–20 mA                                  | $\pm$ 20 mA     |
| Voltage:                      | —  | $\pm$ 10 V      |
| Load at 1 mA:                 | —  | 0–15 k $\Omega$ |
| Load at 20 mA:                | 0–300 $\Omega$                           | 0–750 $\Omega$  |
| Load at 10 V:                 | —  | >2000 $\Omega$  |
| Refresh Rate:                 | 100 ms                                   | 100 ms          |
| % Error, Full Scale, at 25°C: | < $\pm$ 1%                               | < $\pm$ 0.55%   |
| Select From:                  | Analog quantities available in the relay |                 |

#### Analog Input (Optional)

|                                      |  |
|--------------------------------------|--|
| Maximum Input Range:                 | $\pm$ 20 mA<br>$\pm$ 10 V<br>Operational range set by user                 |
| Input Impedance:                     | 200 $\Omega$ (current mode)<br>>10 k $\Omega$ (voltage mode)               |
| Accuracy at 25°C                     |  |
| With user calibration:               | 0.050% of full scale (current mode)<br>0.025% of full scale (voltage mode) |
| Without user calibration:            | Better than 0.5% of full scale at 25°C                                     |
| Accuracy Variation With Temperature: | $\pm$ 0.015% per °C of full scale<br>( $\pm$ 20 mA or $\pm$ 10 V)          |

#### Frequency and Phase Rotation

|                     |           |
|---------------------|-----------|
| System Frequency:   | 50, 60 Hz |
| Phase Rotation:     | ABC, ACB  |
| Frequency Tracking: | 15–70 Hz  |

## Time-Code Input

|  |                               |
|--|-------------------------------|
| Format:  | Demodulated IRIG-B            |
| On (1) State:                                    | $V_{ih} \geq 2.2 \text{ V}$   |
| Off (0) State:                                   | $V_{il} \leq 0.8 \text{ V}$   |
| Input Impedance:                                 | 2 k $\Omega$                  |
| Synchronization Accuracy                         |                               |
| Internal Clock:                                  | $\pm 1 \mu\text{s}$           |
| Synchrophasor Reports<br>(e.g., MET PM):         | $\pm 10 \mu\text{s}$          |
| All Other Reports:                               | $\pm 5 \text{ ms}$            |
| Simple Network Time<br>Protocol (SNTP) Accuracy: | $\pm 5 \text{ ms}$            |
| Unsynchronized Clock Drift<br>Relay Powered:     | 2 minutes per year, typically |

## Communications Ports

### Standard EIA-232 (2 Ports)

|             |                           |
|-------------|---------------------------|
| Location:   | Front Panel<br>Rear Panel |
| Data Speed: | 300–38400 bps             |

### EIA-485 Port (Optional)

|             |               |
|-------------|---------------|
| Location:   | Rear Panel    |
| Data Speed: | 300–19200 bps |

### Ethernet Port (Optional)

|  |  |
|--|--|
| Single/Dual 10/100BASE-T copper (RJ45 connector) |  |
| Single/Dual 100BASE-FX (LC connector)            |  |

### Standard Multimode Fiber-Optic Port

|             |               |
|-------------|---------------|
| Location:   | Rear Panel    |
| Data Speed: | 300–38400 bps |

## Fiber-Optic Ports Characteristics

### Port 1 (or 1A, 1B) Ethernet

|                            |                        |
|----------------------------|------------------------|
| Wavelength:                | 1300 nm                |
| Optical Connector Type:    | LC                     |
| Fiber Type:                | Multimode              |
| Link Budget:               | 16.1 dB                |
| Typical TX Power:          | –15.7 dBm              |
| RX Min. Sensitivity:       | –31.8 dBm              |
| Fiber Size:                | 62.5/125 $\mu\text{m}$ |
| Approximate Range:         | ~6.4 km                |
| Data Rate:                 | 100 Mbps               |
| Typical Fiber Attenuation: | –2 dB/km               |

### Port 2 Serial

|                            |                        |
|----------------------------|------------------------|
| Wavelength:                | 820 nm                 |
| Optical Connector Type:    | ST                     |
| Fiber Type:                | Multimode              |
| Link Budget:               | 8 dB                   |
| Typical TX Power:          | –16 dBm                |
| RX Min. Sensitivity:       | –24 dBm                |
| Fiber Size:                | 62.5/125 $\mu\text{m}$ |
| Approximate Range:         | ~1 km                  |
| Data Rate:                 | 5 Mbps                 |
| Typical Fiber Attenuation: | –4 dB/km               |

## Optional Communications Cards

|           |  |
|-----------|--|
| Option 1: | EIA-232 or EIA-485 communications card |
| Option 2: | DeviceNet communications card          |

## Communications Protocols

SEL, Modbus, DNP, FTP, TCP/IP, Telnet, SNTP, IEC 61850 Edition 2, IEC 60870-5-103, PRP, MIRRORED BITS, EVMSG, C37.118 (synchrophasors), and DeviceNet

## Operating Temperature

IEC Performance Rating: –40° to +85°C (–40° to +185°F)  
(per IEC/EN 60068-2-1 and 60068-2-2)

**NOTE:** Not applicable to UL applications

**NOTE:** The front-panel display is impaired for temperatures below –20°C and above +70°C

### DeviceNet Communications

|                              |   |
|------------------------------|---|
| Card Rating:                 | +60°C (140°F) maximum   |
| Optoisolated Control Inputs: | As many as 26 inputs are allowed in ambient temperatures of 85°C or less.<br>As many as 34 inputs are allowed in ambient temperatures of 75°C or less.<br>As many as 44 inputs are allowed in ambient temperatures of 65°C or less. |

## Operating Environment

|   |                       |
|---|-----------------------|
| Insulation Class:   | I                     |
| Pollution Degree:   | 2                     |
| Overvoltage Category:   | II                    |
| Atmospheric Pressure:   | 80–110 kPa            |
| Relative Humidity:  | 5%–95%, noncondensing |
| Maximum Altitude Without Derating (Consult the Factory for Higher Altitude Derating): | 2000 m                |

## Dimensions

144.0 mm (5.67 in) x 192.0 mm (7.56 in) x 147.4 mm (5.80 in)

## Weight

2.0 kg (4.4 lb)

## Relay Mounting Screw (#8-32) Tightening Torque

|          |                   |
|----------|-------------------|
| Minimum: | 1.4 Nm (12 in-lb) |
| Maximum: | 1.7 Nm (15 in-lb) |

## Terminal Connections

### Terminal Block

|                      |                    |
|----------------------|--------------------|
| Screw Size:          | #6                 |
| Ring Terminal Width: | 0.310 inch maximum |

### Terminal Block Tightening Torque

|          |                   |
|----------|-------------------|
| Minimum: | 0.9 Nm (8 in-lb)  |
| Maximum: | 1.4 Nm (12 in-lb) |

### Compression Plug Tightening Torque

|          |                    |
|----------|--------------------|
| Minimum: | 0.5 Nm (4.4 in-lb) |
| Maximum: | 1.0 Nm (8.8 in-lb) |

### Compression Plug Mounting Ear Screw Tightening Torque

|          |                     |
|----------|---------------------|
| Minimum: | 0.18 Nm (1.6 in-lb) |
| Maximum: | 0.25 Nm (2.2 in-lb) |

## Product Standards

|                                |   |
|--------------------------------|---|
| Electromagnetic Compatibility: | IEC 60255-26:2013<br>IEC 60255-27:2013<br>UL 508<br>CSA C22.2 No. 14-05 |
|--------------------------------|---|

## Type Tests

### Environmental Tests

|                           |   |
|---------------------------|---|
| Enclosure Protection:     | IEC 60529:2001 + CRDG:2003<br>IP65 enclosed in panel (2-line display models)<br>IP54 enclosed in panel (touchscreen display models)<br>IP50 for terminals enclosed in the dust protection assembly (protection against solid foreign objects only) (SEL Part #915900170). The 10°C temperature derating applies to the temperature specifications of the relay. |
| Vibration Resistance:     | IEC 60255-21-1:1998<br>IEC 60255-27:2013, Section 10.6.2.1<br>Endurance: Class 2<br>Response: Class 2   |
| Shock Resistance:         | IEC 60255-21-2:1998<br>IEC 60255-27:2013, Section 10.6.2.2<br>IEC 60255-27:2013, Section 10.6.2.3<br>Withstand: Class 1<br>Response: Class 2<br>Bump: Class 1   |
| Seismic (Quake Response): | IEC 60255-21-3:1993<br>IEC 60255-27:2013, Section 10.6.2.4<br>Response: Class 2   |
| Cold:                     | IEC 60068-2-1:2007<br>IEC 60255-27:2013, Section 10.6.1.2<br>IEC 60255-27:2013, Section 10.6.1.4<br>-40°C, 16 hours   |
| Dry Heat:                 | IEC 60068-2-2:2007<br>IEC 60255-27:2013, Section 10.6.1.1<br>IEC 60255-27:2013, Section 10.6.1.3<br>85°C, 16 hours  |
| Damp Heat, Steady State:  | IEC 60068-2-78:2001<br>IEC 60255-27:2013, Section 10.6.1.5<br>40°C, 93% relative humidity, 10 days  |
| Damp Heat, Cyclic:        | IEC 60068-2-30:2001<br>IEC 60255-27:2013, Section 10.6.1.6<br>25°-55°C, 6 cycles, 95% relative humidity   |
| Change of Temperature:    | IEC 60068-2-14:2009<br>IEC 60255-1:2010, Section 6.12.3.5<br>-40° to 85°C, ramp rate 1°C/min, 5 cycles  |

### Dielectric Strength and Impulse Tests

|                     |  |
|---------------------|--|
| Dielectric (HiPot): | IEC 60255-27:2013, Section 10.6.4.3<br>IEEE C37.90-2005<br>1.0 kVac on analog outputs, Ethernet ports<br>2.0 kVac on analog inputs, IRIG<br>2.5 kVac on contact I/O<br>3.6 kVdc on power supply, IN and VN terminals   |
| Impulse:            | IEC 60255-27:2013, Section 10.6.4.2<br>0.5 J, 5 kV on power supply, contact I/O, ac current, and voltage inputs<br>0.5 J, 530 V on analog outputs<br>IEEE C37.90:2005<br>0.5 J, 5 kV<br>0.5 J, 530 V on analog outputs |

## RFI and Interference Tests

### EMC Immunity

|  |  |
|--|--|
| Electrostatic Discharge Immunity:                  | IEC 61000-4-2:2008<br>IEC 60255-26:2013, Section 7.2.3<br>IEEE C37.90.3:2001<br>Severity Level 4<br>8 kV contact discharge<br>15 kV air discharge  |
| Radiated RF Immunity:                              | IEC 61000-4-3:2010<br>IEC 60255-26:2013, Section 7.2.4<br>10 V/m<br>IEEE C37.90.2-2004<br>20 V/m   |
| Fast Transient, Burst Immunity <sup>a</sup> :      | IEC 61000-4-4:2012<br>IEC 60255-26:2013, Section 7.2.5<br>4 kV @ 5.0 kHz<br>2 kV @ 5.0 kHz for comm. ports   |
| Surge Immunity <sup>a</sup> :                      | IEC 61000-4-5:2005<br>IEC 60255-26:2013, Section 7.2.7<br>2 kV line-to-line<br>4 kV line-to-earth  |
| Surge Withstand Capability Immunity <sup>a</sup> : | IEC 61000-4-18:2010<br>IEC 60255-26:2013, Section 7.2.6<br>2.5 kV common mode<br>1.0 kV differential mode<br>1.0 kV common mode on comm. ports<br>IEEE C37.90.1-2012<br>2.5 kV oscillatory<br>4.0 kV fast transient  |
| Conducted RF Immunity:                             | IEC 61000-4-6:2008<br>IEC 60255-26:2013, Section 7.2.8<br>10 Vrms  |
| Magnetic Field Immunity:                           | IEC 61000-4-8:2009<br>IEC 60255-26:2013, Section 7.2.10<br>Severity Level:<br>1000 A/m for 3 seconds<br>100 A/m for 1 minute; 50/60 Hz<br>IEC 61000-4-9:2001<br>Severity Level:<br>1000 A/m<br>IEC 61000-4-10:2001<br>Severity Level:<br>100 A/m (100 kHz and 1 MHz) |
| Power Supply Immunity:                             | IEC 61000-4-11:2004<br>IEC 61000-4-17:1999<br>IEC 61000-4-29:2000<br>IEC 60255-26:2013, Section 7.2.11<br>IEC 60255-26:2013, Section 7.2.12<br>IEC 60255-26:2013, Section 7.2.13   |

### EMC Emissions

|                      |   |
|----------------------|---|
| Conducted Emissions: | IEC 60255-26:2013 Class A<br>FCC 47 CFR Part 15.107 Class A<br>ICES-003 Issue 6<br>EN 55011:2009 + A1:2010 Class A<br>EN 55022:2010 + AC:2011 Class A<br>EN 55032:2012 + AC:2013 Class A<br>CISPR 11:2009 + A1:2010 Class A<br>CISPR 22:2008 Class A<br>CISPR 32:2015 Class A |
| Radiated Emissions:  | IEC 60255-26:2013 Class A<br>FCC 47 CFR Part 15.109 Class A<br>ICES-003 Issue 6<br>EN 55011:2009 + A1:2010 Class A<br>EN 55022:2010 + AC:2011 Class A<br>EN 55032:2012 + AC:2013 Class A<br>CISPR 11:2009 + A1:2010 Class A<br>CISPR 22:2008 Class A<br>CISPR 32:2015 Class A |

## Processing Specifications and Oscillography

|                                    |   |
|------------------------------------|---|
| AC Voltage and Current Inputs:     | 32 samples per power system cycle   |
| Analog Inputs:                     | 4 samples per power system cycle  |
| Frequency Tracking Range:          | 15–70 Hz  |
| Digital Filtering:                 | One-cycle cosine after low-pass analog filtering. Net filtering (analog plus digital) rejects dc and all harmonics greater than the fundamental.  |
| Protection and Control Processing: | Processing interval is 4 times per power system cycle (except for math variables and analog quantities, which are processed every 100 ms). The protection elements 40, 51, and 78 are processed twice per cycle. Analog quantities for rms data are determined through use of data averaged over the previous 8 cycles. |

### Oscillography

|                        |   |
|------------------------|---|
| Length:                | 15, 64, 180 cycles  |
| Sampling Rate:         | 32 samples per cycle unfiltered<br>4 samples per cycle filtered                 |
| Trigger:               | Programmable with Boolean expression  |
| Format:                | ASCII and Compressed ASCII<br>Binary COMTRADE (32 samples per cycle unfiltered) |
| Time-Stamp Resolution: | 1 ms  |
| Time-Stamp Accuracy:   | ±5 ms   |

### Sequential Events Recorder

|  |       |
|--|-------|
| Time-Stamp Resolution:                             | 1 ms  |
| Time-Stamp Accuracy (With Respect to Time Source): | ±5 ms |

## Relay Elements

### Instantaneous/Definite Time-Overcurrent (50P, 50G, 50N, 50Q)

|                                   |  |
|-----------------------------------|--|
| Pickup Setting Range, A secondary |  |
| 5 A models:                       | 0.50–96.00 A, 0.01 A steps   |
| 1 A models:                       | 0.10–19.20 A, 0.01 A steps   |
| Accuracy:                         | ±5% of setting plus ±0.02 • I <sub>NOM</sub> A secondary (steady-state pickup)   |
| Time Delay:                       | 0.00–400.00 seconds, 0.01 seconds steps, ±0.5% plus ±0.25 cycle<br>0.10–400.00 seconds, 0.01 seconds steps, ±0.5% plus ±0.25 cycle for 50Q |
| Pickup/Dropout Time:              | <1.5 cycle   |

### Inverse-Time Overcurrent (51P, 51G, 51N, 51Q)

|                                   |   |
|-----------------------------------|---|
| Pickup Setting Range, A secondary |   |
| 5 A models:                       | 0.50–16.00 A, 0.01 A steps  |
| 1 A models:                       | 0.10–3.20 A, 0.01 A steps   |
| Accuracy:                         | ±5% of setting plus ±0.02 • I <sub>NOM</sub> A secondary (steady-state pickup)            |
| Time Dial                         |   |
| US:                               | 0.50–15.00, 0.01 steps  |
| IEC:                              | 0.05–1.00, 0.01 steps   |
| Accuracy:                         | ±1.5 cycles plus ±4% between 2 and 30 multiples of pickup (within rated range of current) |

### Differential (87)

|  |                                   |
|--|-----------------------------------|
| Unrestrained Pickup Range:                   | 1.0–20.0 in per unit of TAP       |
| Restrained Pickup Range:                     | 0.10–1.00 in per unit of TAP      |
| Pickup Accuracy (A secondary)                |                                   |
| 5 A Model:                                   | ±5% plus ±0.10 A                  |
| 1 A Model:                                   | ±5% plus ±0.02 A                  |
| TAP Range (A secondary)                      |                                   |
| 5 A Model:                                   | 0.5–31.0 A                        |
| 1 A Model:                                   | 0.1–6.2 A                         |
| Unrestrained Element                         |                                   |
| Pickup Time:                                 | 0.8/1.0/1.9 cycles (Min/Typ/Max)  |
| Restrained Element (With Harmonic Blocking)  |                                   |
| Pickup Time:                                 | 1.5/1.6/2.2 cycles (Min/Typ/Max)  |
| Restrained Element (With Harmonic Restraint) |                                   |
| Pickup Time:                                 | 2.6/2.7/2.86 cycles (Min/Typ/Max) |

### Harmonics

|                                  |                                      |
|----------------------------------|--------------------------------------|
| Pickup Range (% of fundamental): | 5%–100%                              |
| Pickup Accuracy (A secondary)    |                                      |
| 5 A Model:                       | ±5% plus ±0.10 A of harmonic current |
| 1 A Model:                       | ±5% plus ±0.02 A of harmonic current |
| Time Delay Accuracy:             | ±0.5% plus ±0.25 cycle               |

### Restricted Earth Fault (REF)

|   |   |
|---|---|
| Pickup Range (per unit of INOM of neutral current input, IN): | 0.05–3.00 per unit, 0.01 per-unit steps   |
| Pickup Accuracy (A secondary)                                 |   |
| 5 A Model:  | ±5% plus ±0.10 A  |
| 1 A Model:  | ±5% plus ±0.02 A  |
| Timing Accuracy   |   |
| Directional Output  |   |
| Maximum Pickup/Dropout Time:                                  | 1.75 cycles   |
| ANSI Extremely Inverse TOC Curve (U4 With 0.5 Time Dial):     | ±5 cycles plus ±5% between 2 and 30 multiples of pickup (within rated range of current) |

### Undervoltage (27P, 27PP, 27V1, 27S)

|                      |   |
|----------------------|---|
| Pickup Range:        | Off, 2.0–300.0 V (2.0–520.0 V for phase-to-phase wye connected; 2.0–170.0 V positive-sequence, delta connected) |
| Accuracy:            | ±5% of setting plus ±2 V  |
| Pickup/Dropout Time: | <1.5 cycle  |
| Time Delay:          | 0.00–120.00 seconds, 0.01 second steps  |
| Accuracy:            | ±0.5% plus ±0.25 cycle  |

### Overvoltage (59P, 59PP, 59V1, 59S, 59Q, 59G)

|                          |   |
|--------------------------|---|
| Pickup Range:            | Off, 2.0–300.0 V (2.0–520.0 V for phase-to-phase wye connected; 2.0–170.0 V positive sequence, delta connected) |
| Pickup Range (59G, 59Q): | Off, 2.0–200.0 V  |
| Accuracy:                | ±5% of setting plus ±2 V  |
| Pickup/Dropout Time:     | <1.5 cycle  |
| Time Delay:              | 0.00–120.00 seconds, 0.01 second steps  |
| Accuracy:                | ±0.5% plus ±0.25 cycle  |

**Inverse-Time Undervoltage (27I)**

|                |   |
|----------------|---|
| Setting Range: | OFF, 2.00–300.00 V (Phase elements, positive-sequence elements, phase-to-phase elements with delta inputs or synchronism voltage input)<br>OFF, 2.00–520.00 V (Phase-to-phase elements with wye inputs) |
| Accuracy:      | ±1% of setting plus ±0.5 V  |
| Time Dial:     | 0.00–16.00 s  |
| Accuracy:      | ±1.5 cyc plus ±4% between 0.95 and 0.1 multiples of pickup  |

**Inverse-Time Overvoltage (59I)**

|                |   |
|----------------|---|
| Setting Range: | OFF, 2.00–300.00 V (Phase elements, sequence elements, or phase-to-phase elements with delta inputs, neutral voltage input, or synchronism voltage input)<br>OFF, 2.00–520.00 V (Phase-to-phase elements with wye inputs) |
| Accuracy:      | ±1% of setting plus ±0.5 V  |
| Time Dial:     | 0.00–16.00 s  |
| Accuracy:      | ±1.5 cyc plus ±4% between 1.05 and 5.5 multiples of pickup  |

**Volts/Hertz (24)**

|                               |  |
|-------------------------------|--|
| <b>Definite-Time Element</b>  |  |
| Pickup Range:                 | 100%–200%  |
| Steady-State Pickup Accuracy: | ±1% of set point   |
| Pickup Time:                  | 25 ms @ 60 Hz (Max)  |
| Time-Delay Range:             | 0.04–400.00 s  |
| Time-Delay Accuracy:          | ±0.1% plus ±4.2 ms @ 60 Hz   |
| Reset Time Range:             | 0.00–400.00 s  |
| <b>Inverse-Time Element</b>   |  |
| Pickup Range:                 | 100%–200%  |
| Steady-State Pickup Accuracy: | ±1% of set point   |
| Pickup Time:                  | 25 ms @ 60 Hz (Max)  |
| Curve:                        | 0.5, 1.0, or 2.0   |
| Factor:                       | 0.1–10.0 s   |
| Timing Accuracy:              | ±4% plus ±25 ms @ 60 Hz, for V/Hz above 1.2 multiple of pickup setting, and for operating times >4 s |
| Reset Time Range:             | 0.00–400.00 s  |

**Composite-Time Element**

Combination of Definite-Time and Inverse-Time specifications

**User-Definable Curve Element**

|                               |                     |
|-------------------------------|---------------------|
| Pickup Range:                 | 100%–200%           |
| Steady-State Pickup Accuracy: | ±1% of set point    |
| Pickup Time:                  | 25 ms @ 60 Hz (Max) |
| Reset Time Range:             | 0.00–400.00 s       |

**Vector Shift (78VS)**

|                                |                                       |
|--------------------------------|---------------------------------------|
| Pickup Setting Range:          | 2.0°–30.0°, 0.1° increment            |
| Accuracy:                      | ±10% of the pickup setting, ±1 degree |
| Voltage Supervision Threshold: | 20.0%–100.0% • VNOM                   |
| Pickup Time:                   | <3 cycles                             |

**Directional Power (32)**

Instantaneous/Definite Time, 3 Phase Elements

|                                     |  |
|-------------------------------------|--|
| Type:                               | +W, –W, +VAR, –VAR   |
| Pickup Settings Range, VA secondary |  |
| 5 A Model:                          | 1.0–6500.0 VA, 0.1 VA steps  |
| 1 A Model:                          | 0.2–1300.0 VA, 0.1 VA steps  |
| Accuracy:                           | ±0.10 A • (L-L voltage secondary) and ±5% of setting at unity power factor for power elements and zero power factor for reactive power element (5 A nominal)<br>±0.02 A • (L-L voltage secondary) and ±5% of setting at unity power factor for power elements and zero power factor for reactive power element (1 A nominal) |
| Pickup/Dropout Time:                | <10 cycles   |
| Time Delay:                         | 0.00–240.00 seconds, 0.01 second steps   |
| Accuracy:                           | ±0.5% plus ±0.25 cycle   |

**Frequency (81)**

|                      |  |
|----------------------|--|
| Setting Range:       | Off, 15.0–70.0 Hz                      |
| Accuracy:            | ±0.01 Hz (V1 > 60 V)                   |
| Pickup/Dropout Time: | <4 cycles                              |
| Time Delay:          | 0.00–240.00 seconds, 0.01 second steps |
| Accuracy:            | ±0.5% plus ±0.25 cycle                 |

**RTD Protection**

|                               |   |
|-------------------------------|---|
| Setting Range:                | Off, 1°–250°C                                   |
| Accuracy:                     | ±2°C  |
| RTD Open-Circuit Detection:   | >250°C  |
| RTD Short-Circuit Detection:  | <–50°C  |
| RTD Types:                    | PT100, NI100, NI120, CU10                       |
| RTD Lead Resistance:          | 25 ohm max. per lead                            |
| Update Rate:                  | <3 s  |
| Noise Immunity on RTD Inputs: | To 1.4 Vac (peak) at 50 Hz or greater frequency |
| RTD Trip/Alarm Time Delay:    | Approx. 6 s                                     |

**Distance Element (21)**

|   |  |
|---|--|
| Two zones of compensator distance elements with load encroachment block |  |
| Reach Pickup Range:   | 5 A model: 0.1–100.0 ohms<br>1 A model: 0.5–500.0 ohms       |
| Offset Range:   | 5 A model: 0.0–10.0 ohms<br>1 A model: 0.0–50.0 ohms         |
| Steady-State Impedance Accuracy:  | 5 A model: ±5% plus ±0.1 ohm<br>1 A model: ±5% plus ±0.5 ohm |
| Pickup Time:  | 33 ms at 60 Hz (Max)   |
| Definite-Time Delay:  | 0.00–400.00 s  |
| Accuracy:   | ±0.1% plus ±0.25 cycle                                       |
| Minimum Phase Current:  | 5 A model: 0.5 A<br>1 A model: 0.1 A                         |
| Maximum Torque Angle Range:   | 90°–45°, 1° step   |

**Loss-of-Field Element (40)**

Two Mho Zones

|                |  |
|----------------|--|
| Zone 1 Offset: | 5 A model: –50.0 to 0.0 ohms<br>1 A model: –250.0 to 0.0 ohms    |
| Zone 2 Offset: | 5 A model: –50.0 to 50.0 ohms<br>1 A model: –250.0 to 250.0 ohms |

|   |  |
|---|--|
| Zone 1 and Zone 2 Diameter:             | 5 A model: 0.1–100.0 ohms<br>1 A model: 0.5–500.0 ohms   |
| Steady-State Impedance Accuracy:        | 5 A model: $\pm 0.1$ ohm plus $\pm 5\%$ of (offset + diameter)<br>1 A model: $\pm 0.5$ ohm plus $\pm 5\%$ of (offset + diameter) |
| Minimum Pos.-Seq. Signals:              | 5 A model: 0.25 V (V1), 0.25 A (I1)<br>1 A model: 0.25 V (V1), 0.05 A (I1)   |
| Directional Element Angle:              | $-20.0^\circ$ to $0.0^\circ$   |
| Pickup Time:                            | 3 cycles (Max)   |
| Zone 1 and Zone 2 Definite-Time Delays: | 0.00–400.00 s  |
| Accuracy:                               | $\pm 0.1\%$ plus $\pm 1/2$ cycle   |

#### Voltage-Restrained Phase Time-Overcurrent Element (51V)

|                                 |  |
|---------------------------------|--|
| Phase Pickup (A secondary):     | 5 A Model: 2.0–16.0 A<br>1 A Model: 0.4–3.2 A  |
| Steady-State Pickup Accuracy:   | 5 A Model: $\pm 5\%$ plus $\pm 0.10$ A<br>1 A Model: $\pm 5\%$ plus $\pm 0.02$ A                                 |
| Time Dials:                     | US: 0.50–15.00, 0.01 steps<br>IEC: 0.05–1.00, 0.01 steps   |
| Accuracy:                       | $\pm 4\%$ plus $\pm 1.5$ cycles for current between 2 and 20 multiples of pickup (within rated range of current) |
| Linear Voltage Restraint Range: | 0.125–1.000 per unit of VNOM   |

#### Voltage-Controlled Phase Time-Overcurrent Element (51C)

|                               |  |
|-------------------------------|--|
| Phase Pickup (A secondary):   | 5 A Model: 0.5–16.0 A<br>1 A Model: 0.1–3.2 A  |
| Steady State Pickup Accuracy: | 5 A Model: $\pm 5\%$ plus $\pm 0.10$ A<br>1 A Model: $\pm 5\%$ plus $\pm 0.02$ A                                 |
| Time Dials:                   | US: 0.50–15.00, 0.01 steps<br>IEC: 0.05–1.00, 0.01 steps   |
| Accuracy:                     | $\pm 4\%$ plus $\pm 1.5$ cycles for current between 2 and 20 multiples of pickup (within rated range of current) |

#### 100 Percent Stator Ground Protection (64G)

|   |                                   |
|---|-----------------------------------|
| Neutral Fundamental Overvoltage (64G1):   | OFF, 0.1–150.0 V                  |
| Steady-State Pickup Accuracy:   | $\pm 5\%$ plus $\pm 0.1$ V        |
| Pickup Time:  | 1.5 cycles (Max)                  |
| Definite-Time Delay:  | 0.00–400.00 s                     |
| Accuracy:   | $\pm 0.1\%$ plus $\pm 0.25$ cycle |
| Third-Harmonic Voltage Differential or Third-Harmonic Neutral Undervoltage Pickup 64G2: | 0.1–20.0 V                        |
| Steady-State Pickup Accuracy:   | $\pm 5\%$ plus $\pm 0.1$ V        |
| Third-Harmonic Voltage Differential Ratio Setting Range:                                | 0.0 to 5.0                        |
| Pickup Time:  | 3 cycles (Max)                    |
| Definite-Time Delay:  | 0.00–400.00 s                     |
| Accuracy:   | $\pm 0.1\%$ plus $\pm 0.25$ cycle |

#### Field Ground Protection (64F) (Requires SEL-2664 Field Ground Module)

|                                  |   |
|----------------------------------|---|
| Field Ground Protection Element: | 0.5–200.0 kilohms, 0.1 kilohm step  |
| Pickup Accuracy:                 | $\pm 5\%$ plus $\pm 500$ ohms for $48 \pm VF \pm 825$ Vdc<br>$\pm 5\%$ plus $\pm 20$ kilohms for $825 < VF \pm 1500$ Vdc<br>(VF is the generator field winding excitation dc voltage) |

|                                       |   |
|---------------------------------------|---|
| Pickup Time:                          | 2 s if the injection frequency in the SEL-2664 is selected at 1 Hz<br>8 s if the injection frequency in the SEL-2664 is selected at 0.25 Hz |
| Definite-Time Delay:                  | 0.0–99.0 s  |
| Maximum Definite-Time Delay Accuracy: | $\pm 0.5\%$ plus $\pm 5$ ms   |

#### Out-of-Step Element (78)

|                                  |  |
|----------------------------------|--|
| Forward Reach:                   | 5 A model: 0.1–100.0 ohms<br>1 A model: 0.5–500.0 ohms   |
| Reverse Reach:                   | 5 A model: 0.1–100.0 ohms<br>1 A model: 0.5–500.0 ohms   |
| Single Blinder                   |  |
| Right Blinder:                   | 5 A model: 0.1–50.0 ohms<br>1 A model: 0.5–250.0 ohms  |
| Left Blinder:                    | 5 A model: 0.1–50.0 ohms<br>1 A model: 0.5–250.0 ohms  |
| Double Blinder                   |  |
| Outer Resistance Blinder:        | 5 A model: 0.2–100.0 ohms<br>1 A model: 1.0–500.0 ohms   |
| Inner Resistance Blinder:        | 5 A model: 0.1–50.0 ohms<br>1 A model: 0.5–250.0 ohms  |
| Steady-State Impedance Accuracy: | 5 A model: $\pm 0.1$ ohm plus $\pm 5\%$ of diameter<br>1 A model: $\pm 0.5$ ohm plus $\pm 5\%$ of diameter |
| Pos.-Seq. Current Supervision:   | 5 A model: 0.25–30.00 A<br>1 A model: 0.05–6.00 A  |
| Pickup Time:                     | 3 cycles (Max)   |
| Definite Time Delay:             | 0.00–1.00 s, 0.01 s step   |
| Trip Delay Range:                | 0.00–1.00 s, 0.01 s step   |
| Trip Duration Range:             | 0.00–5.00 s, 0.01 s step   |
| Definite-Time Timers:            | $\pm 0.1\%$ plus $\pm 1/2$ cycle   |

#### Ground Differential Elements (87N)

|                               |   |
|-------------------------------|---|
| Ground Differential Pickup:   | 5 A Model: $0.10 * CTR / CTRN - 15.00$ A<br>1 A Model: $0.02 * CTR / CTRN - 3.00$ A<br>(Ratio CTR/CTR <sub>N</sub> must be within 1.0–40.0) |
| Steady-State Pickup Accuracy: | 5 A Model: $\pm 5\%$ plus $\pm 0.10$ A<br>1 A Model: $\pm 5\%$ plus $\pm 0.02$ A  |
| Pickup Time:                  | 1.5 cycles (Max)  |
| Time Delay Range:             | 0.00–5.00 s   |
| Time Delay Accuracy:          | $\pm 0.5\%$ plus $\pm 1/4$ cycle  |

#### Negative-Sequence Overcurrent Elements (46)

|   |  |
|---|--|
| Definite-Time and Inverse-Time Neg.-Seq. I <sup>2</sup> Pickup: | 2%–100% of generator rated secondary current                                       |
| Generator Rated Secondary Current:                              | 5 A Model: 1.0–10.0 A secondary<br>1 A Model: 0.2–2.0 A secondary                  |
| Steady-State Pickup Accuracy:                                   | 5 A Model: $\pm 0.025$ A plus $\pm 3\%$<br>1 A Model: $\pm 0.005$ A plus $\pm 3\%$ |
| Pickup Time:  | 50 ms at 60 Hz (Max)   |
| Definite-Time Delay Setting Range:                              | 0.02–999.90 s  |
| Maximum Definite-Time Delay Accuracy:                           | $\pm 0.1\%$ plus $\pm 4.2$ ms at 60 Hz   |
| Inverse-Time Element Time Dial:                                 | K = 1 to 100 s   |
| Linear Reset Time:  | 240 s fixed  |
| Inverse-Time Timing Accuracy:                                   | $\pm 4\%$ plus $\pm 50$ ms at 60 Hz for $ I_2 $ above 1.05 multiples of pickup     |

**Rate-of-Change of Frequency (81R)**

|   |   |
|---|---|
| Pickup Setting Range:                                 | Off, 0.10–15.00 Hz/s                      |
| Accuracy:   | ±100 mHz/s plus ±3.33% of pickup          |
| Trend Setting:  | INC, DEC, ABS                             |
| Pickup/Dropout Time:                                  | 3–30 cycles, depending on pickup setting  |
| Pickup/ Dropout Delay Range:                          | 0.10–60.00/0.00–60.00 s, 0.1 s increments |
| Voltage Supervision (Positive Sequence) Pickup Range: | Off, 12.5–300.0 V, 0.1 V increments       |

**Synchronism Check (25Y) for Tie Breaker**

|  |   |
|--|---|
| Synchronism-Check Voltage Source:      | VAY, VBY, VCY, VABY, VBCY, VCAY or angle from VAY or VABY |
| Voltage Window High Setting Range:     | 0.00–300.00 V   |
| Voltage Window Low Setting Range:      | 0.00–300.00 V   |
| Steady-State Voltage Accuracy:         | ±5% plus ±2.0 V (over the range of 12.5–300 V)            |
| Maximum Percentage Voltage Difference: | 1.0–15.0%   |
| Maximum Slip Frequency:                | –0.05 Hz to 0.50 Hz                                       |
| Steady-State Slip Accuracy:            | ±0.02 Hz  |
| Close Acceptance Angle 1, 2:           | 0°–80°  |
| Breaker Close Delay:                   | 0.001–1.000 s   |
| Steady-State Angle Accuracy:           | ±2°   |

**Synchronism Check (25X) for Generator Breaker**

|  |   |
|--|---|
| Synchronism-Check Voltage Source:      | VAX, VBX, VCX, VABX, VBCX, VCAX or angle from VAX or VABX |
| Voltage Window High Setting Range:     | 0.00–300.00 V   |
| Voltage Window Low Setting Range:      | 0.00–300.00 V   |
| Steady-State Voltage Accuracy:         | ±5% plus ±2.0 V (over the range of 12.5–300 V)            |
| Maximum Percentage Voltage Difference: | 1.0–15.0%   |
| Minimum Slip Frequency:                | –1.00 Hz to 0.99 Hz                                       |
| Maximum Slip Frequency:                | –0.99 Hz to 1.00 Hz                                       |
| Steady-State Slip Accuracy:            | ±0.02 Hz  |
| Close Acceptance Angle 1, 2:           | 0°–80°  |
| Target Close Angle:                    | –15° to 15°   |
| Breaker Close Delay:                   | 0.001–1.000 s   |
| Close Failure Angle:                   | 3°–120°   |
| Steady-State Angle Accuracy:           | ±2°   |

**Generator Thermal Model (49T)**

|                                     |  |
|-------------------------------------|--|
| Thermal Overload Trip Pickup Level: | 30–250% of full load current (full load current $I_{NOM}$ range: $0.2-2.0 \cdot I_{NOM}$ , where $I_{NOM} = 1$ A or 5 A) |
| TCU Alarm Pickup Level:             | 50–99% Thermal Capacity Used   |
| Time-Constant Range (2):            | 1–1000 minutes   |
| Time Accuracy Pickup/ Dropout Time: | ±(5% + 25 ms) at multiple-of-pickup $\geq 2$ , 50/60 Hz (pre-load = 0)   |

**Autosynchronizing****Frequency Matching****Speed (Frequency) Control Outputs:**

|        |  |
|--------|--|
| Raise: | Digital output, adjustable pulse duration and interval |
| Lower: | Digital output, adjustable pulse duration and interval |

**Frequency Synchronism**

|                            |                                      |
|----------------------------|--------------------------------------|
| Timer:                     | 5–3600 s, 1 s increments             |
| Frequency Adjustment Rate: | 0.01–10.00 Hz/s, 0.01 Hz/s increment |
| Frequency Pulse Interval:  | 1–120 s, 1 s increment               |
| Frequency Pulse Minimum:   | 0.10–60.00 s, 0.01 s increment       |
| Frequency Pulse Maximum:   | 0.10–60.00 s, 0.01 s increment       |
| Kick Pulse Interval:       | 1–120 s, 1 s increments              |
| Kick Pulse Minimum:        | 0.02–2.00 s, 0.01 s increments       |
| Kick Pulse Maximum:        | 0.02–2.00 s, 0.01 s increments       |

**Voltage Matching****Voltage Control Outputs:**

|        |  |
|--------|--|
| Raise: | Digital Output, adjustable pulse duration and interval |
| Lower: | Digital Output, adjustable pulse duration and interval |

**Voltage Synchronized Timer:** 5–3600 s, 1 s increments

|   |                                    |
|---|------------------------------------|
| Voltage Adjustment Rate (Control System): | 0.01–30.00 V/s, 0.01 V/s increment |
| Voltage Pulse Interval:                   | 1–120 s, 1 s increment             |
| Voltage Control Pulse Minimum:            | 0.10–60.00 s, 0.01 s increment     |
| Voltage Control Pulse Maximum:            | 0.10–60.00 s, 0.01 s increment     |
| Timing Accuracy:                          | ±0.5% plus ±1/4 cycle              |

**Metering Accuracy**

|   |  |
|---|--|
| Accuracies are specified at 20°C, nominal frequency, ac currents within $(0.2-20.0) \cdot I_{NOM}$ A secondary, and ac voltages within 50–250 V secondary unless otherwise noted. |  |
| Phase Currents:   | ±1% of reading, ±1° (±2.5° at 0.2–0.5 A for relays with $I_{NOM} = 1$ A) |
| 3-Phase Average Current:  | ±1% of reading   |
| Differential Quantities:  | ±5% of reading plus ±0.1 A (5 A nominal), ±0.02 A (1 A nominal)          |
| Current Harmonics:  | ±5% of reading plus ±0.1 A (5 A nominal), ±0.02 A (1 A nominal)          |
| IG (Residual Current):  | ±2% of reading, ±2° (±5.0° at 0.2–0.5 A for relays with $I_{NOM} = 1$ A) |
| IN (Neutral Current):   | ±1% of reading, ±1° (±2.5° at 0.2–0.5 A for relays with $I_{NOM} = 1$ A) |
| 3I2 Negative-Sequence Current:  | ±2% of reading   |
| System Frequency:   | ±0.01 Hz of reading for frequencies within 20–70 Hz ( $V_1 > 60$ V)      |
| Line-to-Line Voltages:  | ±1% of reading, ±1° for voltages within 24–264 V                         |
| 3-Phase Average Line-to-Line Voltage:   | ±1% of reading for voltages within 24–264 V                              |
| Line-to-Ground Voltages:  | ±1% of reading, ±1° for voltages within 24–264 V                         |
| 3-Phase Average Line-to-Ground Voltages:  | ±1% of reading for voltages within 24–264 V                              |
| Voltage Harmonics:  | ±5% of reading plus ±0.5 V   |
| 3V2 Negative-Sequence Voltage:  | ±2% of reading for voltages within 24–264 V                              |
| Real 3-Phase Power (kW):  | ±3% of reading for $0.10 < pf < 1.00$                                    |

|                                |  |
|--------------------------------|--|
| Reactive 3-Phase Power (kVAR): | $\pm 3\%$ of reading for $0.00 < \text{pf} < 0.90$ |
| Apparent 3-Phase Power (kVA):  | $\pm 3\%$ of reading                               |
| Power Factor:                  | $\pm 2\%$ of reading                               |
| RTD Temperatures:              | $\pm 2^\circ\text{C}$                              |

## Synchrophasor Accuracy

### Maximum Message Rate

|                       |                        |
|-----------------------|------------------------|
| Nominal 60 Hz System: | 60 messages per second |
| Nominal 50 Hz System: | 50 messages per second |

### Accuracy for Voltages

Level 1 compliant as specified in IEEE C37.118 under the following conditions for the specified range.

#### Conditions

- At maximum message rate
- When phasor has the same frequency as the positive-sequence tracking quantity (see *Table J.10*)
- Frequency-based phasor compensation is enabled (PHCOMP := Y)
- The narrow bandwidth filter is selected (PMAPP := N)

#### Range

|   |   |
|---|---|
| Frequency:                              | $\pm 5.0$ Hz of nominal (50 or 60 Hz)               |
| Magnitude:                              | 30 V–250 V  |
| Phase Angle:                            | $-179.99^\circ$ to $180^\circ$                      |
| Out-of-Band Interfering Frequency (Fs): | $10 \text{ Hz} \leq F_s \leq (2 \cdot \text{FNOM})$ |

### Accuracy for Currents

Level 1 compliant as specified in IEEE C37.118 under the following conditions for the specified range.

#### Conditions

- At maximum message rate
- When phasor has the same frequency as the positive-sequence tracking quantity (see *Table J.10*)
- Frequency-based phasor compensation is enabled (PHCOMP := Y)
- The narrow bandwidth filter is selected (PMAPP := N)

#### Range

|   |   |
|---|---|
| Frequency:                              | $\pm 5.0$ Hz of nominal (50 or 60 Hz)   |
| Magnitude:                              | $(0.4\text{--}2) \cdot I_{\text{NOM}}$ ( $I_{\text{NOM}} = 1 \text{ A or } 5 \text{ A}$ ) |
| Phase Angle:                            | $-179.99^\circ$ to $180^\circ$  |
| Out-of-Band Interfering Frequency (Fs): | $10 \text{ Hz} \leq F_s \leq (2 \cdot \text{FNOM})$                                       |

<sup>a</sup> Front port serial cable (non-fiber) lengths assumed to be <3 m.

© 2010-2018 by Schweitzer Engineering Laboratories, Inc. All rights reserved.

All brand or product names appearing in this document are the trademark or registered trademark of their respective holders. No SEL trademarks may be used without written permission. SEL products appearing in this document may be covered by U.S. and Foreign patents.

Schweitzer Engineering Laboratories, Inc. reserves all rights and benefits afforded under federal and international copyright and patent laws in its products, including without limitation software, firmware, and documentation.

The information in this document is provided for informational use only and is subject to change without notice. Schweitzer Engineering Laboratories, Inc. has approved only the English language document.

This product is covered by the standard SEL 10-year warranty. For warranty details, visit selinc.com or contact your customer service representative.

**SCHWEITZER ENGINEERING LABORATORIES, INC.**

2350 NE Hopkins Court • Pullman, WA 99163-5603 U.S.A.

Tel: +1.509.332.1890 • Fax: +1.509.332.7990

selinc.com • info@selinc.com

