

For Additional Technical Assistance Call +1.509.332.1890

Express Installation Guide

SEL-787 Transformer Protection Relay



Package Contents

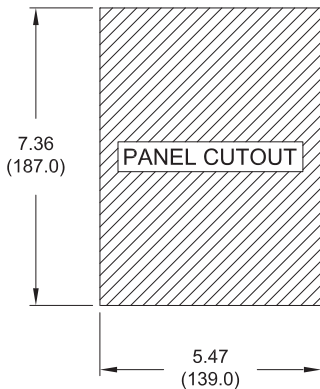

Panel Cutout Template

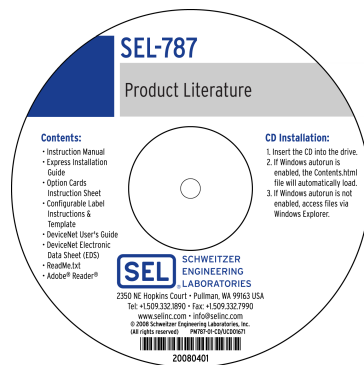

Product Literature CD



No. 8-32 Mounting Screws, Gasket, & Serial Port Cover

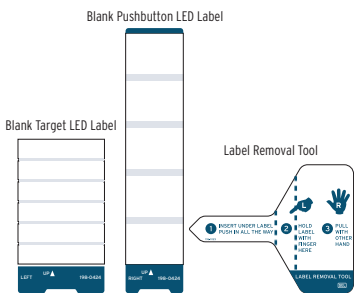

Configurable Label Kit

Typical Connections

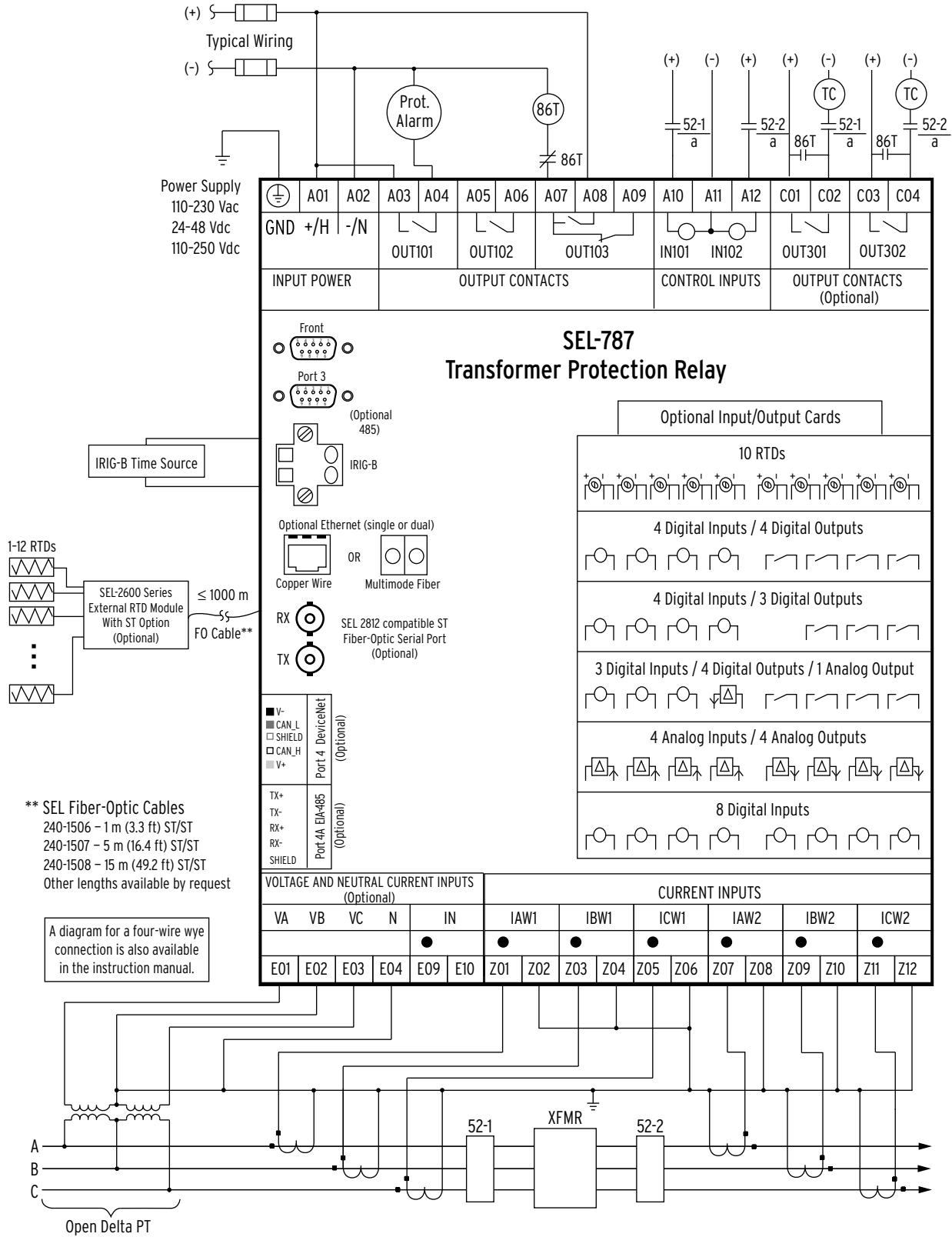

Rack Mounting

You can mount the SEL-787 in a sheltered indoor environment (a building or an enclosed cabinet) that does not exceed the temperature rating of -40°C to $+85^{\circ}\text{C}$. For mounting consideration the relay dimensions are shown below.

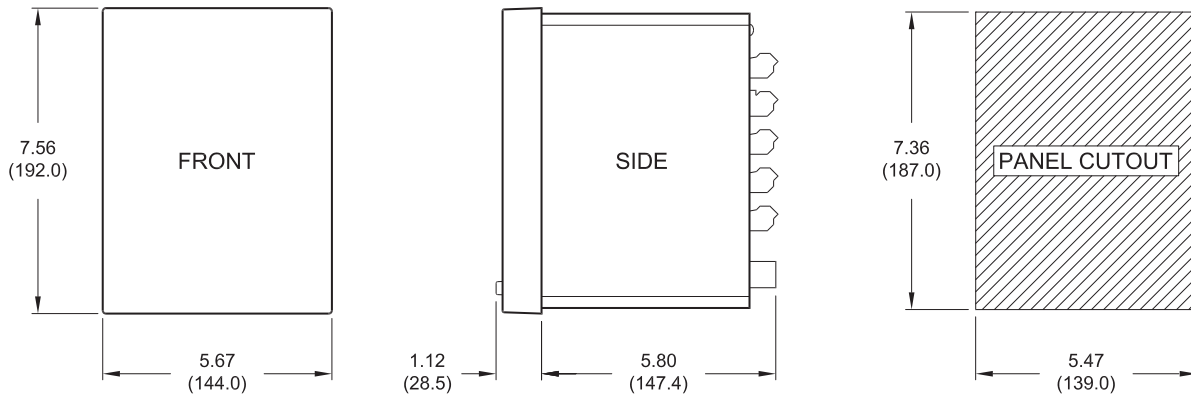

New Control Center

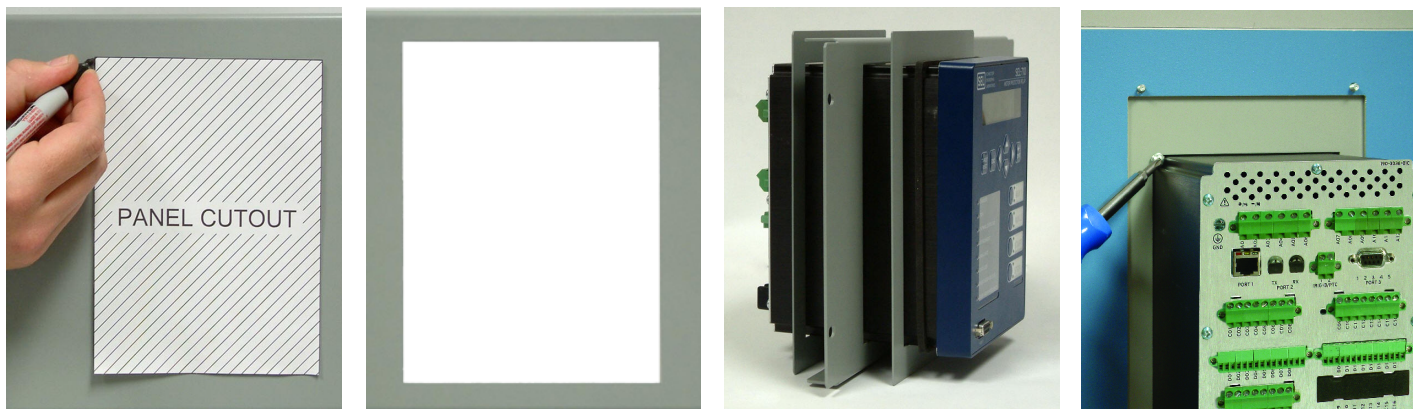

1. Place the enclosed Panel Cutout over desired mounting location and trace.
2. Make smooth cut around cutout.
3. Place mounting gasket around relay and insert unit into hole. (The photo displays optional appearance bezel.)
4. Fasten relay to mounting plate with included screws.

Retrofitting

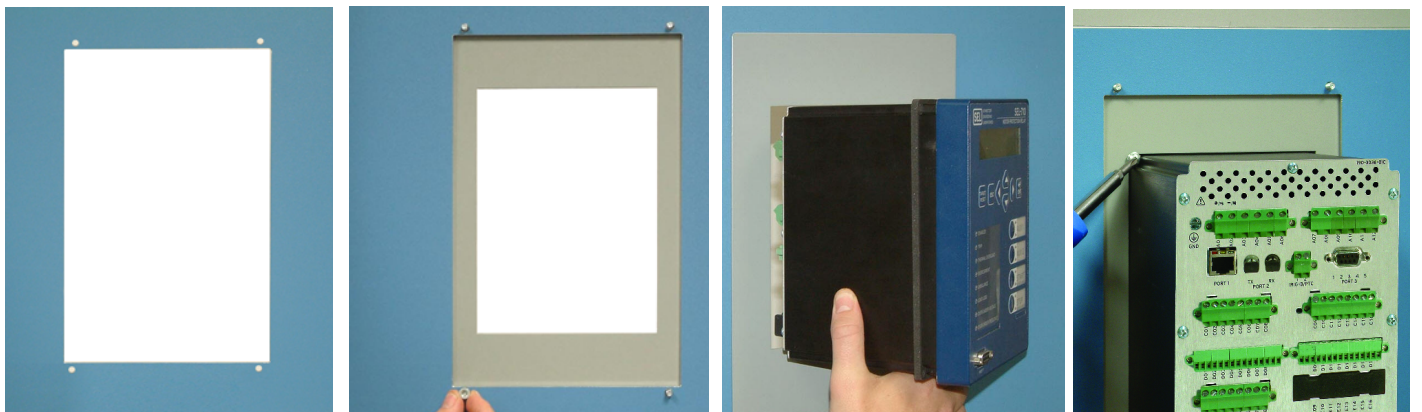

1. Remove old relay.
2. Insert retrofitting plate and fasten (see www.selinc.com/sel-787.htm for retrofits).
3. Place mounting gasket around relay and insert unit into retrofitting plate.
4. Fasten relay to mounting plate with included screws.

Connections

Connections are shown for the SEL-787 with Ethernet, Fiber Optic EIA-232, IRIG-B, EIA-485, 3 DI/4 DO/1 AO Option, 8 DI Option, and Voltage/Current (3 AVI/1 ACI) Option. Refer to the SEL-787 manual for additional details and other options.

Wire sizes for connections are dictated by the terminal blocks and expected load currents. You may use the following table as a guide in selecting wire sizes:

Connection Type	Minimum Wire Size	Maximum Wire Size
Grounding (Earthing) Connection	18 AWG (0.8 mm ²)	14 AWG (2.1 mm ²)
Current Connection	16 AWG (1.3 mm ²)	12 AWG (3.3 mm ²)
Potential (Voltage) Connection	18 AWG (0.8 mm ²)	14 AWG (2.1 mm ²)
Contact I/O	18 AWG (0.8 mm ²)	14 AWG (2.1 mm ²)
Other Connection	18 AWG (0.8 mm ²)	14 AWG (2.1 mm ²)

Card Slot A: Power Supply Card With 2 DI/3 DO

- Step 1. Connect ground terminal **GND** to a rack frame or switchgear ground for proper safety and performance.
- Step 2. Connect appropriate power supply to terminal 01 (+/H) and terminal 02 (-/N). Note that power terminals are isolated from chassis ground.
- Step 3. Connect as many as 2 digital inputs, per application requirements, to optoisolated inputs **IN101** (terminals 10 and 11) and **IN102** (terminals 11 and 12).
- Step 4. Connect the 3 output contacts, per application requirements, to **OUT101** (terminals 03 and 04), **OUT102** (terminals 05 and 06), and **OUT103** (terminals 07, 08, and 09).

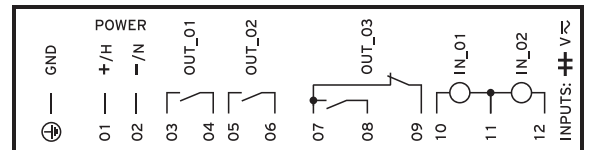
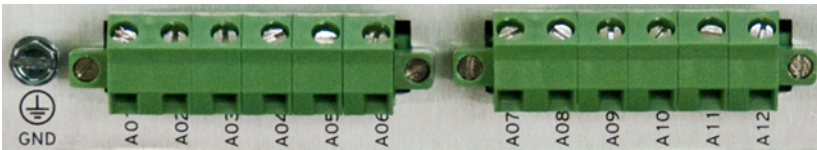

Card Slot B: Main Board With Ethernet, Fiber Optic, IRIG-B, and EIA-232

- Step 1. Connect communications devices as required to front DB-9 serial Port F (EIA-232), rear Port 3 (EIA-485), 10/100BASE-T Ethernet (RJ-45 connector) Port 1 and fiber-optic (ST[®] connector) serial Port 2.
- Step 2. Connect IRIG-B time-code input to terminals 01 (+) and 02 (-).

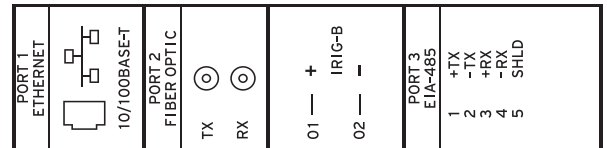
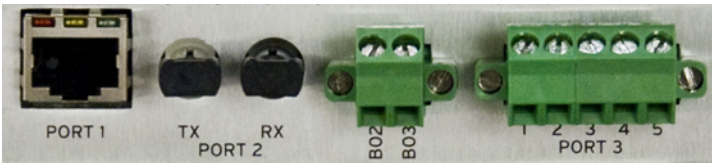

Card Slot C: 3 Digital Inputs, 4 Digital Outputs, 1 Analog Output Card (3 DI/4 DO/1 AO)

- Step 1. Connect additional digital inputs (**IN_01**, **IN_02**, **IN_03**) and outputs (**OUT_01**, **OUT_02**, **OUT_03**, **OUT_04**), if required by application, using the connection diagram.
- Step 2. Connect the analog (transducer) output **AO_01** using terminals 09 and 10.

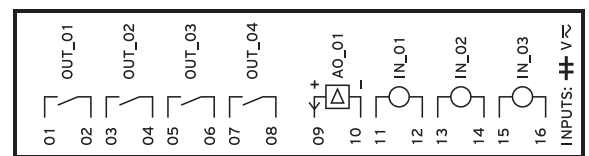

Connections

Card Slot D: 8 Digital Inputs Card (8 DI)

Connect as many as 8 digital inputs per application requirements to inputs IN_01 (terminals 01 and 02), IN_02 (terminals 03 and 04), . . . , IN_08 (terminals 15 and 16).

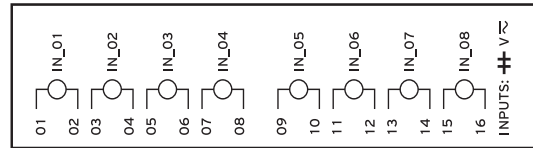
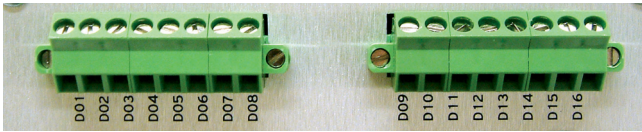

Card Slot E: Voltage/Current Inputs Card

Connect 4-wire wye-connected PTs or open-delta connected PTs as shown in the typical connections diagram. For other PT connection options refer to Section 2 in the SEL-787 manual. Connect neutral current input to terminals 09 and 10.

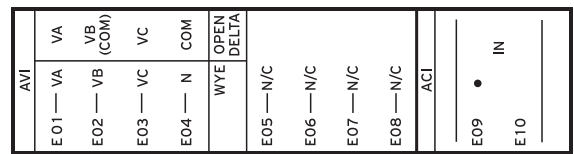
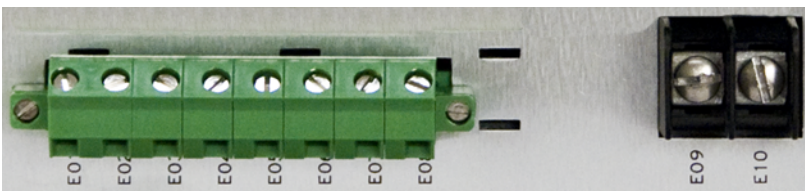

Card Slot Z: Current Inputs Card

Connect Winding 1 and Winding 2 phase current inputs as shown in the typical connections diagram.

- Step 1. Connect Winding 1 Phase A, Phase B, and Phase C current inputs to terminals 01 and 02, terminals 03 and 04, and terminals 05 and 06, respectively, following the convention shown in the typical connections diagram.
- Step 2. Connect Winding 2 current inputs similarly to terminals 07–12.

Refer to Section 2 in the SEL-787 manual for additional details.

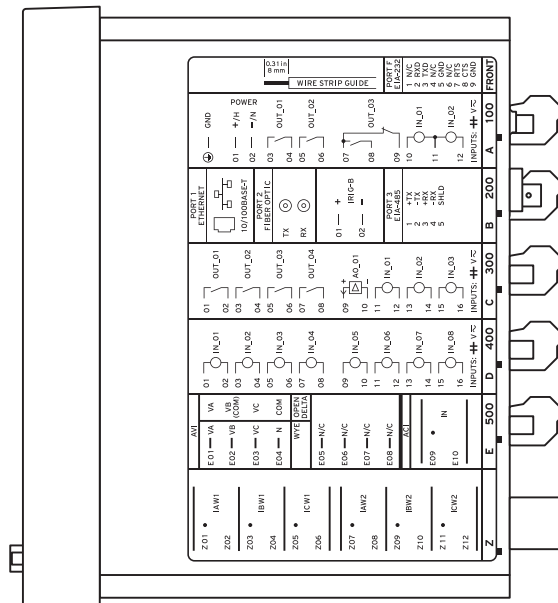
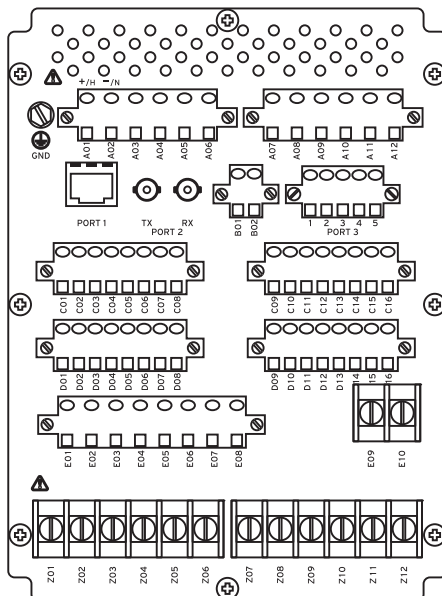
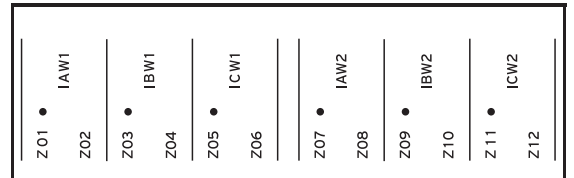

Communication With Relay

There are two ways of communicating with the SEL-787 Motor Relay. You can communicate with the relay using the Human Machine Interface (HMI) on the front panel or through serial port communications with a computer. For communications, the computer must have a serial port and the operating system should be Windows® 2000 or newer. A standard EIA-232 crossover cable or an SEL-234A cable will also be necessary.

HMI Pushbuttons

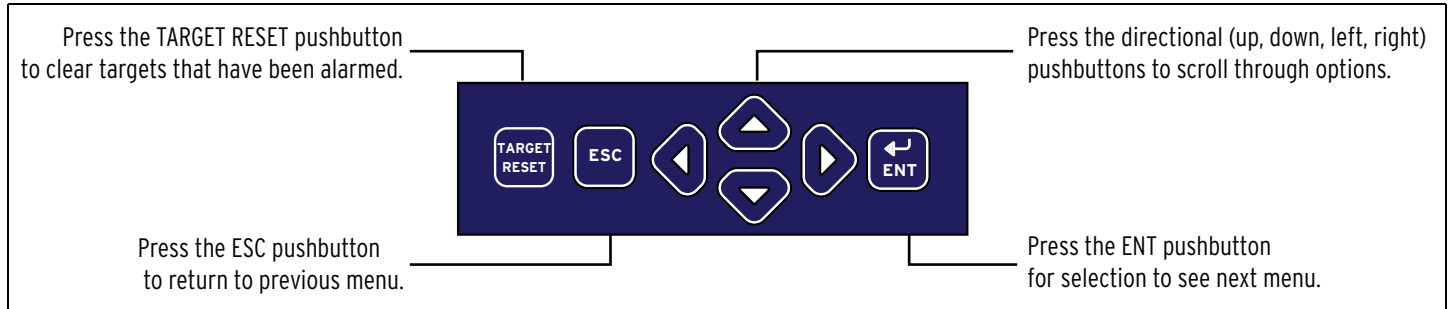

Computer Connection Steps

- Step 1. Connect the PC and the relay using a serial communications cable.
- Step 2. Apply power to both the PC and the relay.
- Step 3. Open a terminal emulation program.



Option 1: ACSELERATOR QuickSet SEL-5030 Software

Open ACSELERATOR QuickSet and proceed to *Step 4*. If you do not have ACSELERATOR QuickSet, you can download the program from www.selinc.com/sel-5030.htm. Refer to Section 3 of the SEL-787 manual for more information about ACSELERATOR QuickSet.

Option 2: HyperTerminal

To open HyperTerminal go to Start > Programs > Accessories > Communications > HyperTerminal. Once there you will be prompted to enter a name of your choice for the connection. Then you will choose the port through which you will connect. Make sure you select the same port to which you connected the cable and then click OK.

- Step 4. Set the PC terminal emulation program to the same communications port settings as shown in the figure to the right and click **OK**.
- Step 5. Press the **<Enter>** key on the PC keyboard to check the communications link. You should see the = prompt. If you do not see the = prompt, check the cable connections, confirm that the settings in the terminal emulation program are the default values, and that the emulation mode is set to VT100.
- Step 6. Once connected, you can set all other relay settings and obtain values as necessary. Refer to Section 6 in the SEL-787 manual for more information.

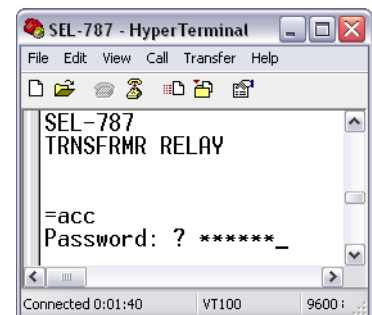

SEL-787 Relays are shipped with default passwords. To prevent unauthorized access, change default passwords to private passwords at installation. SEL shall not be responsible for damage resulting from unauthorized access.

Relay Settings

This section of the Express Installation Guide provides step-by-step instructions for a typical application of the SEL-787 Transformer Protection Relay. For more information on the setting procedures, please refer to the SEL-787 manual, or contact your local SEL representative. For more information on relay setting using ACSELERATOR QuickSet SEL-5030 Software as shown in this example, refer to Section 3 in the SEL-787 manual.

Transformer applications of the SEL-787 will require the configuration of the relay to match the transformer winding construction, as well as current and voltage transformer ratios and configurations. The relay is equipped with a wide selection of protection and logic elements. Section 4 in the SEL-787 manual, describes all the protection and logic functions of the relay, together with all the necessary settings.

Design the specific protection, logic, and communications system for your transformer application. Use the Settings Sheets provided in Section 6 of the manual to record the relay settings, or connect the relay to a personal computer (PC) and use ACSELERATOR QuickSet to enter the settings. Follow the steps below to set the relay.

Step 1. Connect to the SEL-787 via ACSELERATOR QuickSet.

- Connect the relay to a PC by using a SEL-C234A serial or SEL-C662 USB cable.
- Apply power to the relay.
- Start the ACSELERATOR QuickSet software program and establish communication with the relay.
- Click on the **Read Settings From Device** icon  to download the current settings from the relay.
- Save the downloaded setting file into your ACSELERATOR QuickSet database.

Step 2. Gather transformer nameplate information. Typical information should include the following:

- ▶ Transformer MVA ratings
- ▶ Transformer winding voltages
- ▶ Transformer winding configurations
- ▶ Transformer impedances

Additionally, verify the connection method used for the current transformers that will be monitoring the transformer windings. Current transformers will be connected in a wye or delta configuration. Record the current transformer ratios.

Record the information you gathered in this step for use in the following steps.

Step 3. Edit the ACSELERATOR QuickSet relay settings file.

Group 1 Settings

- Open and edit the Group Configuration settings. Typically, the transformer configuration information will be the same for all protection settings groups used in the SEL-787.
- Set the transformer CT connections, W1CT and W2CT, to DELTA or WYE as dictated by the recorded CT connection information from *Step 1*.
- Set the CT ratio settings CTR1 and CTR2.
- Set the transformer winding rated voltages VWDG1 and VWDG2.
- Set the transformer capacity setting MVA. Setting MVA should be set to the maximum MVA rating of the transformer.

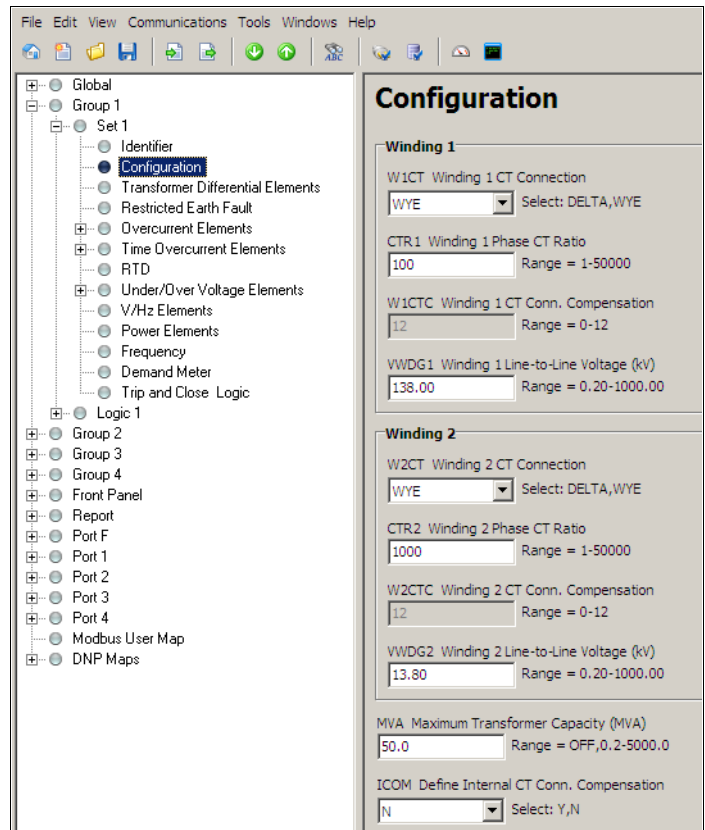

Relay Settings

- f. Set the current compensation setting ICOM. When set to Y, this setting enables the individual CT compensation settings W1CTC and W2CTC.
- g. Set the neutral CT ratio CTRN1.
- h. Enable and set the differential element settings. Set the differential element pickup, slope, and harmonic blocking and/or restraint characteristics for the transformer application.
- i. Enable and set the optional restricted earth fault (REF) protection elements if the application calls for it.
- j. Enable backup overcurrent elements. Select instantaneous and time-overcurrent elements as necessary to provide backup protection and coordination.
- k. Enable and enter RTD settings if RTDs are used for temperature measurements in the transformer tank and ambient air temperature.
- l. If voltage measurements are supported in the relay:
 - Enable and set over- and undervoltage protection elements.
 - Enable and set volts/Hz protection elements (overexcitation protection).
 - Enable and set power elements as the application requires.
 - Enable and set over- and underfrequency elements necessary for the application.
 - Enable and set demand and peak demand metering as necessary.
 - Set the trip/close logic settings using the Relay Word bits of the enabled protection and logic elements to drive the transformer trip logic and the winding breakers trip logic.

Group 1 Logic Settings

- a. Enable and enter SELOGIC equations settings according to the needs of the application.
- b. Repeat previous steps for Group 2, 3, and 4 settings if necessary for the application.

Global Settings

Review, enable, and enter the Global settings the application requires. Global settings include synchrophasors, through-fault event monitoring, breaker failure, etc.

Front-Panel Settings

- a. Configure relay display points. Use the front-panel display to indicate fault conditions, alarms, and operational parameters.
- b. Configure relay front-panel target indications.

Report Settings

- a. Configure relay event reporting (ER) to capture relay trip conditions.
- b. Configure and set the SER (sequence-of-events report) settings.
- c. Configure and set the LDP (load profile report settings) report, if necessary.

Communications Ports and Protocol Settings

Enable and enter the communications ports and protocol settings as necessary for the application.

- Step 4. Save the revised setting file into the database, and then with the settings still open, click the **Send Active Settings** icon  and then click **OK** when prompted to upload the revised settings into relay.
- Step 5. Perform relay verification and commissioning tests per your requirements. Refer to Section 10 in the SEL-787 manual for details on relay testing.

NOTE: Be sure to evaluate and confirm all relay settings before implementing this application on an actual transformer.

