

L
HEAD
ENGINES

Operation and Maintenance *Instructions*

Continental

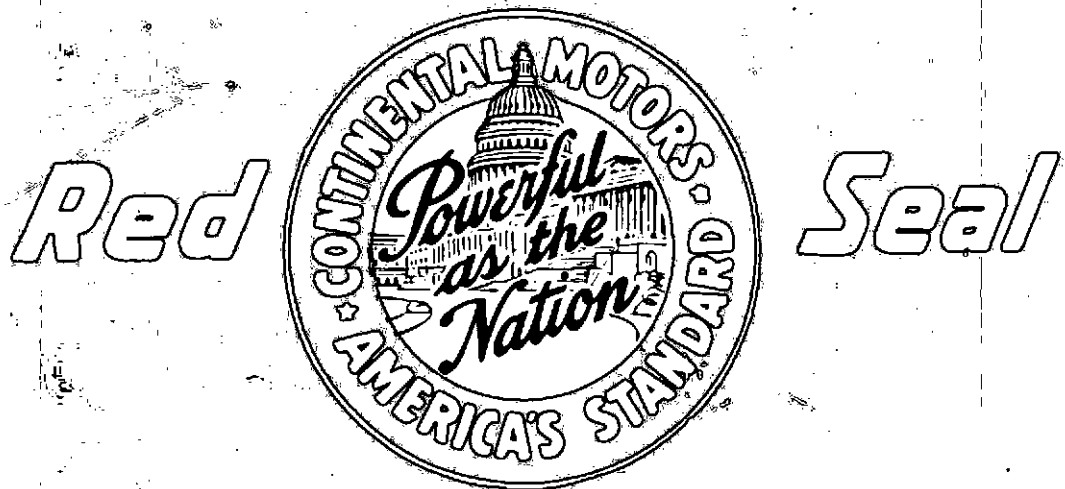

L-HEAD ENGINES

FOUR CYLINDER

N56 — N62

Y69 — Y91 — Y112

F124 — F140 — F162

SIX CYLINDER

F180 — F209 — F226 — F244

M271 — M290 — M330 — M363

B37L — B427

Operation and Maintenance Instructions

L-HEAD ENGINES

FOUR CYLINDER

N56 — N62

Y69 — Y91 — Y112

F124 — F140 — F162

SIX CYLINDER

F186 — F209 — F226 — F244

M271 — M290 — M330 — M363

B371 — B427











**Continental Motors Corporation
Muskegon, Michigan**

Copyright 1962
CONTINENTAL MOTORS CORPORATION
Printed in U.S.A.

QUICK REFERENCE SECTION INDEX

Index

First page of each group has black tab in same position as below.

SECTION I — General Information.....	Page 5	
SECTION II — Lubrication	Page 11	
SECTION III — Operation	Page 17	
SECTION IV — Preventive Maintenance.....	Page 23	
SECTION V — Cooling System.....	Page 28	
SECTION VI — Fuel System.....	Page 35	
SECTION VII — Ignition	Page 43	
SECTION VIII — Engine Repair & Overhaul.....	Page 52	
SECTION IX — Trouble Shooting	Page 73	
SECTION X — Torque Specifications	Page 76	
SECTION XI — Limits & Clearance Data.....	Page 77	

(See following pages for details of each section)

INDEX

SECTION I — GENERAL INFORMATION

Four Cylinder L-Head Engine Specifications.....	5
Six Cylinder L-Head Engine Specifications.....	6
How to Order Parts	7
Continental L-Head Engine Features	8

SECTION II — LUBRICATION

Engine Lubricating System	11
Oil Pump	12
Air Cleaner	13
Lubrication Recommendations	14
Transmission and Converter Lubrication Recommendations.....	16

SECTION III — OPERATION

Preparation of New Engine for Operation.....	17
Starting the Engine	18
Stopping the Engine	20
10 Operating Precautions	21
Cold Weather Operation	21
Seasonal Storage of Engine	22

SECTION IV — PREVENTIVE MAINTENANCE

Daily Preventive Maintenance Schedule.....	23
50-Hour Preventive Maintenance Schedule.....	25
250-Hour Preventive Maintenance Schedule.....	26
500-Hour Preventive Maintenance Schedule.....	27

SECTION V — COOLING SYSTEM

Continental L-Head Cooling System.....	28
Effect of Altitude on Cooling.....	29
Anti-Freezes	29
Cleaning Cooling System	30
Testing Thermostat	31
Radiator Pressure Cap	32
Fan Belt Tension	33
Water Pump	33

SECTION VI — FUEL SYSTEM

Gravity Fuel System	35
Mechanical Fuel Pump	35
Electrical Fuel Pump	36
Zenith Carburetor	36
Marvel-Schebler Carburetor	37
Carburetor Chokes	38
Novi Governor	39
Pierce Governor	40
Cam Gear Governor.....	41
Tail-Shaft Governors	42

INDEX**SECTION VII — IGNITION**

Battery — Ignition System	43
Ignition Coil — Distributor & Condenser	44
Distributor Maintenance	45
Spark Plugs	45
Distributor — Ignition Timing, with Timing Light	47
Ignition Timing, without Timing Light	48
Magneto — Ignition	49
Magneto Impulse Coupling	50
Timing Magneto to Engine	51

SECTION VIII — ENGINE REPAIR AND OVERHAUL

Cylinder Head	52
Cylinder Block	53
Valve Seat Inserts	54
Valves	55
Valve Springs	56
Preparing Cylinder Bores	57
Pistons	58
Connecting Rods	59
Piston Rings	60
Bearings	61
Crankshaft	63
Camshaft	64
Valve Tappets	64
Timing Gears	65
Crankshaft End Play	66
Rear Oil Seals	67
Oil Pumps	69
Flywheels and Housings	71
Reassembling Engine	72

SECTION IX — TROUBLE-SHOOTING

Starting Motor Will Not Crank Engine	73
Engine Will Not Start	73
Engine Runs Unevenly	74
Poor Compression	74
High Oil Pressure	75
Engine Knocks	75
Engine Vibration	75

SECTION X — TORQUE SPECIFICATIONS 76**SECTION XI — LIMITS & CLEARANCE DATA** 77

FOREWORD

Gasoline engines have, over the years, maintained a position of importance in the field of power development. Because of their inherent characteristics of dependable and economical service, they have been the answer to a long standing demand for power. CONTINENTAL MOTORS CORPORATION, with their extensive research, maintain a reputation earned in over 60 years of leadership in the internal combustion engine industry.

Continental gasoline engines are designed for rugged service and are simple to service and maintain; they are capable of producing smooth dependable power, with excellent fuel economy.

Good operation and a planned maintenance program as outlined in this manual are of vital importance in obtaining maximum engine performance, and long engine life. The instructions on the following pages have been written with this in mind, to give the operator a better understanding of the various problems which may arise, and the manner in which these problems can best be solved or avoided.

Procedure in the Preventive Maintenance Section must be set up and followed by the owner and operator to obtain dependable service and long life from the engine. Owners and operators are expected to perform these maintenance procedures as outlined under the daily schedule as well as 50-hr., 250-hr., and 500-hr. periods WHILE IN THE WARRANTY PERIOD AS WELL AS DURING THE LIFE OF THE ENGINE.

Warranty service does not include tune-up of the engine such as replacing spark plugs, distributor points, tappet settings, ignition timing, ignition wiring, air cleaner service and lubrication and filter maintenance.

The operator is cautioned against the use of any parts, other than **Genuine Continental Parts** for replacement or repair. Genuine Continental parts have been engineered and tested for their particular job, and the use of any other parts may result in unsatisfactory performance and short engine life. Likewise, Continental distributors and dealers, because of their close factory relations, can render the best and most efficient service.

**THE LIFE OF YOUR ENGINE DEPENDS ON
THE CARE IT RECEIVES.**

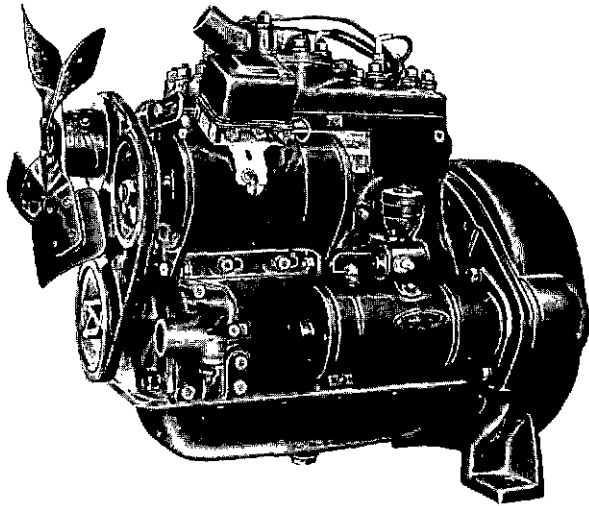

Figure 1 — N Series

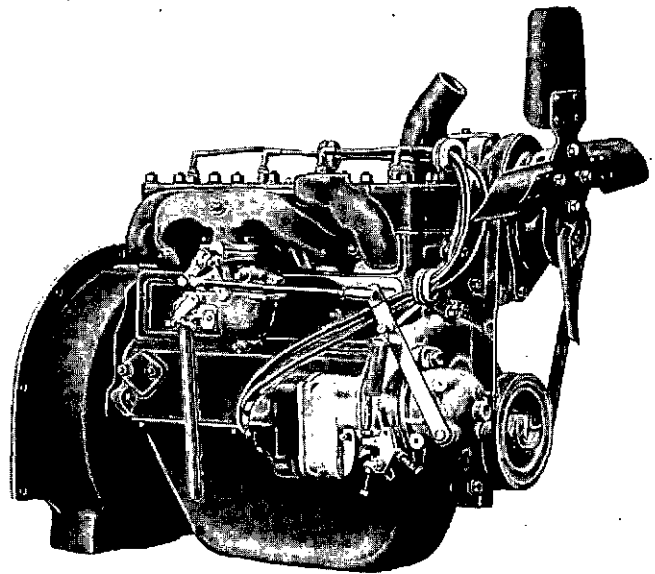

Figure 2 — Y400 Series

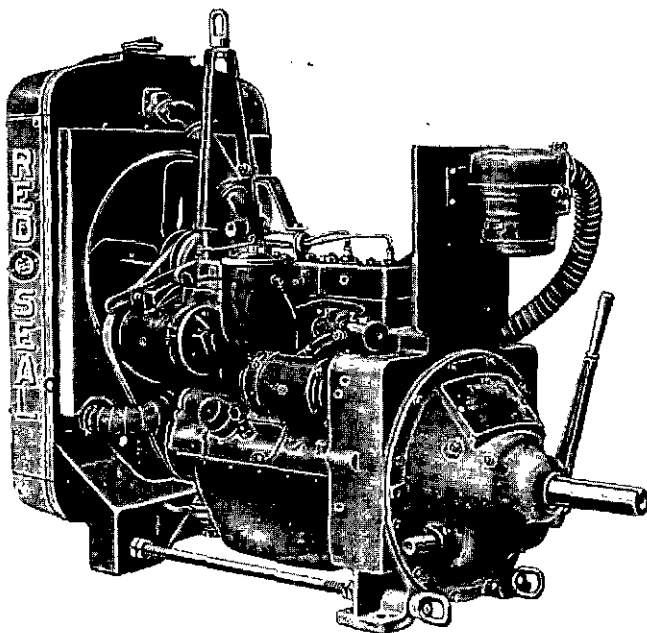

Figure 3 — F400 Series — Open Power Unit

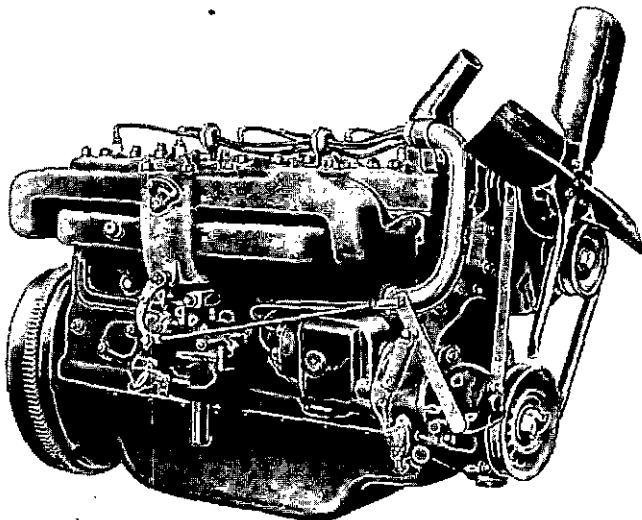

Figure 4 — F600 Series

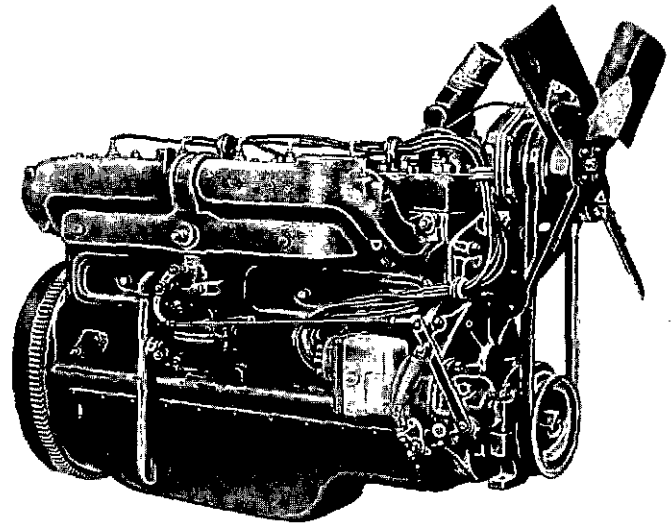

Figure 5 — M600 Series

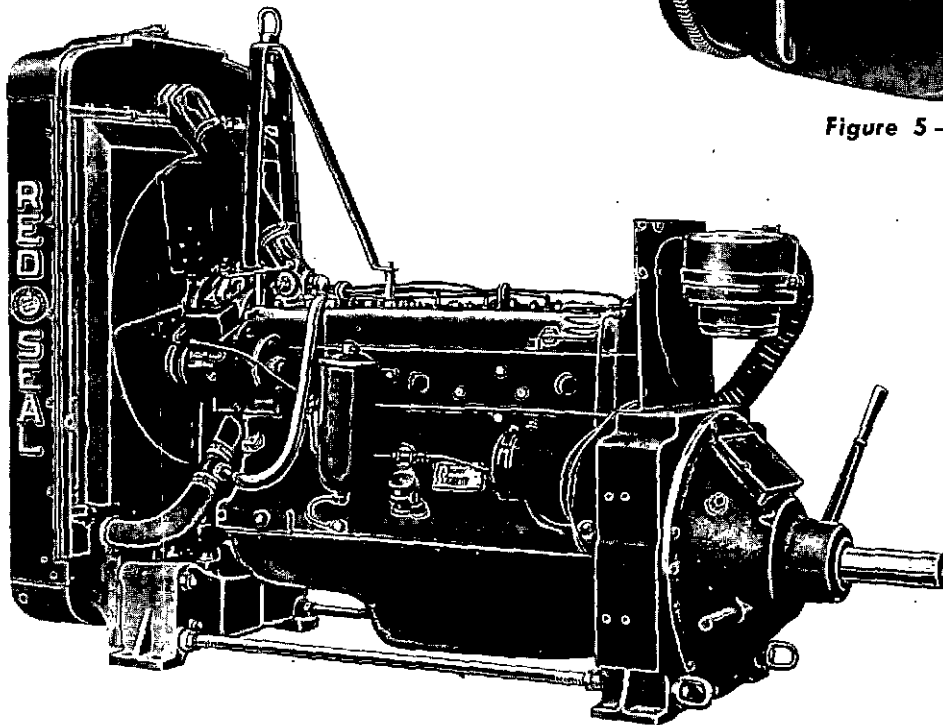

Figure 6 — B600 Series — Open Power Unit

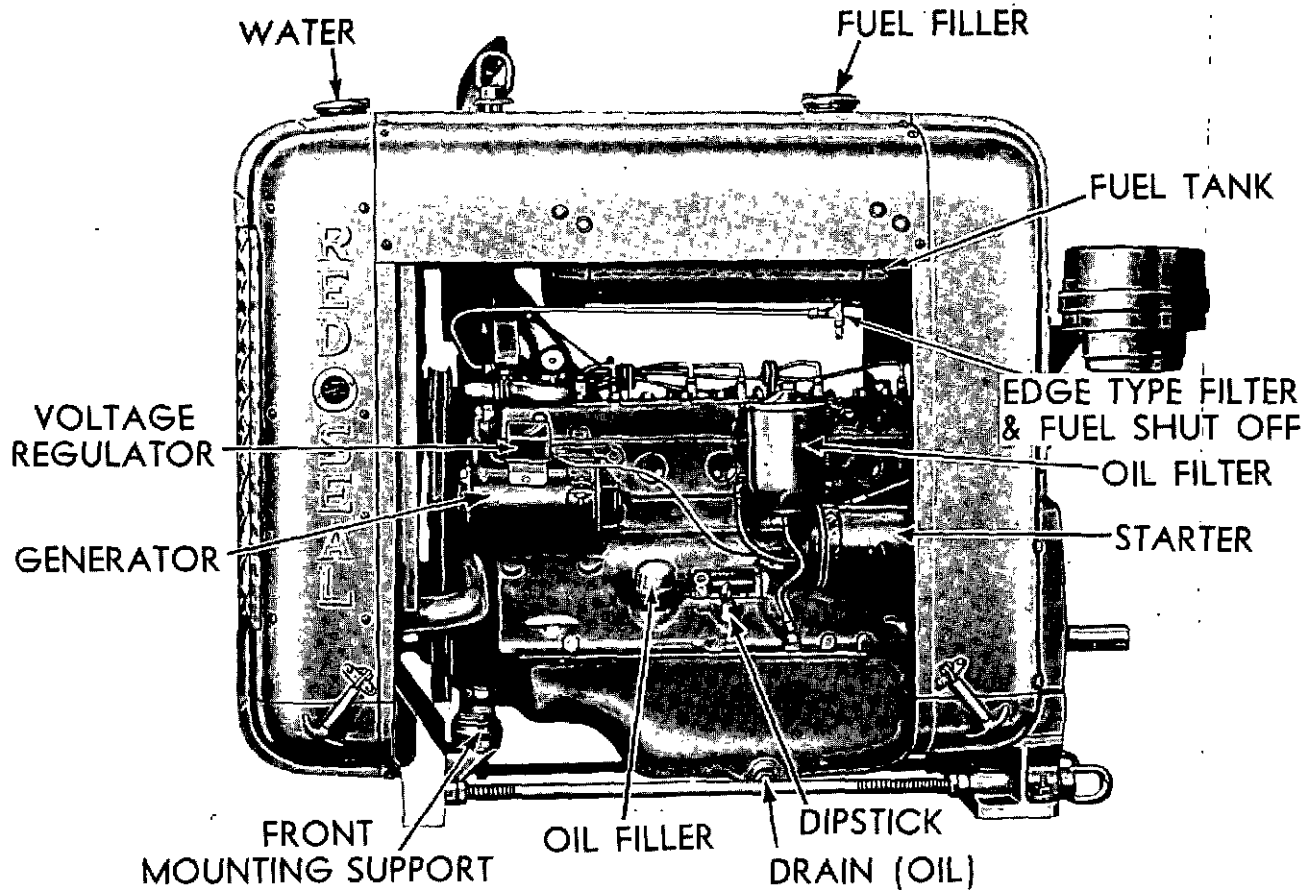

Figure 7 — F600 Power Unit (left side)

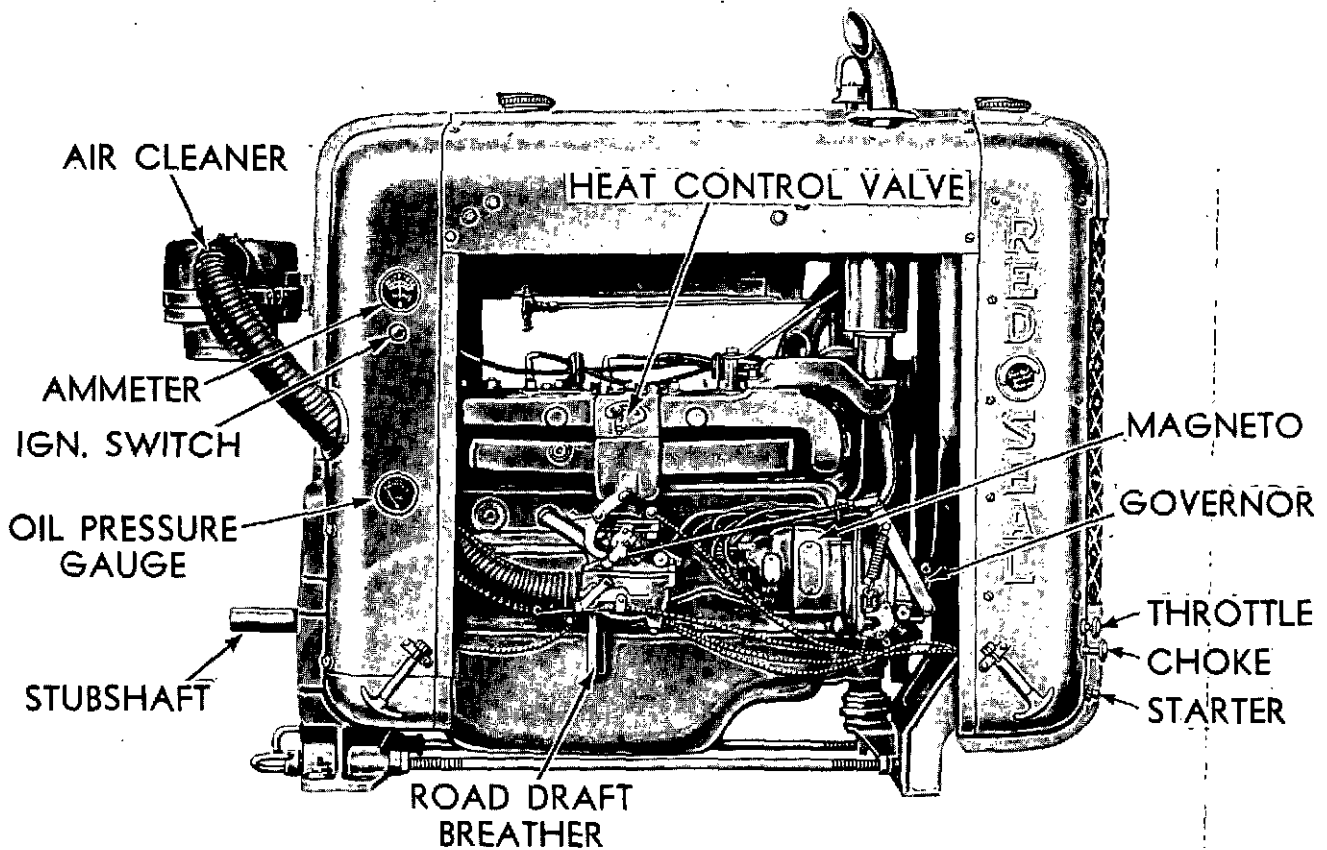

Figure 8 — F600 Power Unit (right side)

FOUR CYLINDER INDUSTRIAL L-HEAD ENGINES*

MODEL	N-56	N-62	Y-69	Y-91	Y-112	F-124	F-140	F-162
No. of cylinders	4	4	4	4	4	4	4	4
Bore and Stroke	$2\frac{1}{4} \times 3\frac{1}{2}$	$2\frac{3}{8} \times 3\frac{1}{2}$	$2\frac{1}{2} \times 3\frac{1}{2}$	$2\frac{7}{8} \times 3\frac{1}{2}$	$3\frac{3}{16} \times 3\frac{1}{2}$	$3 \times 4\frac{3}{8}$	$3\frac{3}{16} \times 4\frac{3}{8}$	$3\frac{7}{16} \times 4\frac{3}{8}$
Displacement Cu. In.	56	62	69	91	112	124	140	162
Compression Ratio	6.12	6.46	6.66	6.46	6.07	6.28	6.00	6.01
Max. Oil Pressure**	20-30	20-30	30-40	30-40	30-40	20-30	20-30	20-30
Min. Oil Pressure (Idling)	7	7	7	7	7	7	7	7
Firing Order	1-3-4-2	1-3-4-2	1-3-4-2	1-3-4-2	1-3-4-2	1-3-4-2	1-3-4-2	1-3-4-2
Main Brg. Frt.	$2 \times 1\frac{13}{32}$	$2 \times 1\frac{13}{32}$	$1\frac{3}{4} \times 1\frac{1}{2}$	$1\frac{3}{4} \times 1\frac{1}{2}$	$1\frac{3}{4} \times 1\frac{13}{32}$	$2\frac{1}{4} \times 1\frac{5}{16}$	$2\frac{1}{4} \times 1\frac{5}{16}$	$2\frac{1}{4} \times 1\frac{5}{16}$
Main Brg. Center			$1\frac{3}{4} \times 1\frac{23}{32}$	$1\frac{3}{4} \times 1\frac{23}{32}$	$1\frac{3}{4} \times 1\frac{5}{8}$	$2\frac{1}{4} \times 1\frac{3}{4}$	$2\frac{1}{4} \times 1\frac{3}{4}$	$2\frac{1}{4} \times 1\frac{3}{4}$
Main Brg. Rear	$2 \times 1\frac{13}{32}$	$2 \times 1\frac{13}{32}$	$1\frac{3}{4} \times 1\frac{25}{32}$	$1\frac{3}{4} \times 1\frac{25}{32}$	$1\frac{3}{4} \times 1\frac{21}{32}$	$2\frac{1}{4} \times 1\frac{5}{16}$	$2\frac{1}{4} \times 1\frac{5}{16}$	$2\frac{1}{4} \times 1\frac{5}{16}$
Conn. Rod Brg. Dia. and Length	$1\frac{1}{2} \times 1$	$1\frac{1}{2} \times 1$	$1\frac{1}{2} \times 1\frac{1}{16}$	$1\frac{1}{2} \times 1\frac{1}{16}$	$1\frac{1}{2} \times 1\frac{1}{16}$	$1\frac{1}{16} \times 1\frac{1}{16}$	$1\frac{1}{16} \times 1\frac{1}{16}$	$1\frac{1}{16} \times 1\frac{1}{16}$
Oil Capacity								
Crankcase	$3\frac{1}{2}$	$3\frac{1}{2}$	$3\frac{1}{2}$	$3\frac{1}{2}$	$3\frac{1}{2}$	4	4	4
Filter	$\frac{1}{2}$	$\frac{1}{2}$	$\frac{1}{2}$	$\frac{1}{2}$	$\frac{1}{2}$	$\frac{1}{2}$	$\frac{1}{2}$	$\frac{1}{2}$
Total	4	4	4	4	4	$4\frac{1}{2}$	$4\frac{1}{2}$	$4\frac{1}{2}$
Valve Clearance								
Intake	.015	.012	.012	.012	.012	.014	.014	.014
Exhaust	.015	.012	.012	.012	.012	.014	.014	.014
Water Capacity	(Given in quarts — add approximately 1 quart for hoses)							
Engine	2	2	$3\frac{3}{4}$	$3\frac{3}{4}$	$3\frac{3}{4}$	5	5	5
Engine and Radiator	11	11	14	15	15	14	14	15
Weight (Bare Engine)	180	210	290	290	290	415	415	415

*Dimensions and data shown are for Standard Industrial Engines.

**Note: Other oil pressures are available, based on customer specifications.

SIX CYLINDER L-HEAD ENGINES*

MODEL	F-186	F-209	F-226	F-244	M-271	M-290	M-330	M-363	B-371	B-427
No. of Cylinders	6	6	6	6	6	6	6	6	6	6
Bore & Stroke	3 x 4 $\frac{3}{8}$	3 $\frac{3}{16}$ x 4 $\frac{3}{8}$	3 $\frac{5}{16}$ x 4 $\frac{3}{8}$	3 $\frac{3}{16}$ x 4 $\frac{3}{8}$	3 $\frac{5}{8}$ x 4 $\frac{3}{8}$	3 $\frac{3}{4}$ x 4 $\frac{3}{8}$	4 x 4 $\frac{3}{8}$	4 x 4 $\frac{1}{2}$	4 $\frac{1}{8}$ x 4 $\frac{5}{8}$	4 $\frac{1}{2}$ x 4 $\frac{7}{8}$
Displacement Cu. In.	186	209	228	244	271	290	330	363	371	427
Compression Ratio	6.43	6.09	6.02	6.9	6.12	5.96	6.75	6.70	5.96	5.76
Max. Oil Pressure**	20-30	20-30	20-30	20-30	40-50	40-50	40-50	40-50	40-50	40-50
Min. Oil Pressure	7	7	7	7	7	7	7	7	7	7
Firing Order	1-5-3-6-2-4	1-5-3-6-2-4	1-5-3-6-2-4	1-5-3-6-2-4	1-5-3-6-2-4	1-5-3-6-2-4	1-5-3-6-2-4	1-5-3-6-2-4	1-5-3-6-2-4	1-5-3-6-2-4
Main Brg. — Front	2 $\frac{1}{4}$ x 1 $\frac{3}{8}$	2 $\frac{1}{4}$ x 1 $\frac{3}{8}$	2 $\frac{3}{8}$ x 1 $\frac{1}{2}$	2 $\frac{3}{8}$ x 1 $\frac{1}{2}$	2 $\frac{5}{8}$ x 1 $\frac{1}{2}$	2 $\frac{3}{8}$ x 1 $\frac{1}{2}$	2 $\frac{5}{8}$ x 1 $\frac{1}{2}$	2 $\frac{5}{8}$ x 1 $\frac{1}{2}$	2 $\frac{5}{8}$ x 1 $\frac{1}{2}$	2 $\frac{5}{8}$ x 1 $\frac{1}{2}$
Main Brg. — Int.	(2) 2 $\frac{1}{4}$ x 1 $\frac{1}{2}$	(2) 2 $\frac{1}{4}$ x 1 $\frac{1}{2}$	(2) 2 $\frac{3}{8}$ x 1 $\frac{1}{2}$	(2) 2 $\frac{3}{8}$ x 1 $\frac{1}{2}$	(4) 2 $\frac{5}{8}$ x 1 $\frac{1}{2}$	(4) 2 $\frac{5}{8}$ x 1 $\frac{1}{2}$	(4) 2 $\frac{5}{8}$ x 1 $\frac{1}{2}$	(4) 2 $\frac{5}{8}$ x 1 $\frac{1}{2}$	(4) 2 $\frac{5}{8}$ x 1 $\frac{1}{2}$	(4) 2 $\frac{5}{8}$ x 1 $\frac{1}{2}$
Main Brg. — Center					2 $\frac{5}{8}$ x 2 $\frac{3}{8}$	2 $\frac{5}{8}$ x 2 $\frac{3}{8}$	2 $\frac{5}{8}$ x 2 $\frac{3}{8}$	2 $\frac{5}{8}$ x 2 $\frac{3}{8}$	2 $\frac{5}{8}$ x 2 $\frac{3}{8}$	2 $\frac{5}{8}$ x 2 $\frac{3}{8}$
Main Brg. — Rear	2 $\frac{1}{4}$ x 1 $\frac{3}{8}$	2 $\frac{1}{4}$ x 1 $\frac{3}{8}$	2 $\frac{3}{8}$ x 1 $\frac{1}{2}$	2 $\frac{3}{8}$ x 1 $\frac{1}{2}$	2 $\frac{5}{8}$ x 2 $\frac{3}{8}$	2 $\frac{5}{8}$ x 2 $\frac{3}{8}$	2 $\frac{5}{8}$ x 2 $\frac{3}{8}$	2 $\frac{5}{8}$ x 2 $\frac{3}{8}$	2 $\frac{5}{8}$ x 2 $\frac{3}{8}$	2 $\frac{5}{8}$ x 2 $\frac{3}{8}$
Conn. Rod Brg. Dia. & Length	1 $\frac{1}{2}$ x 1 $\frac{3}{8}$	1 $\frac{1}{2}$ x 1 $\frac{3}{8}$	2 $\frac{1}{8}$ x 1 $\frac{3}{8}$	2 $\frac{1}{8}$ x 1 $\frac{3}{8}$	2 $\frac{1}{4}$ x 1 $\frac{3}{8}$	2 $\frac{1}{4}$ x 1 $\frac{3}{8}$	2 $\frac{1}{4}$ x 1 $\frac{3}{8}$	2 $\frac{1}{4}$ x 1 $\frac{3}{8}$	2 $\frac{1}{2}$ x 1 $\frac{1}{8}$	2 $\frac{1}{2}$ x 1 $\frac{1}{8}$
Oil Capacity										
Crankcase	5	5	5	5	7	7	7	7	8	8
Filter	$\frac{1}{2}$	$\frac{1}{2}$	$\frac{1}{2}$	$\frac{1}{2}$	1	1	1	1	1	1
Total	5 $\frac{1}{2}$	5 $\frac{1}{2}$	5 $\frac{1}{2}$	5 $\frac{1}{2}$	8	8	8	8	9	9
Valve Clearance										
Intake	.014	.014	.014	.014	.017	.017	.017	.017	.017	.017
Exhaust	.014	.014	.014	.014	.020	.020	.020	.020	.022	.022
Water Capacity	(Given in quarts — add approximately 1 quart for hoses)									
Engine	8 $\frac{1}{2}$	8 $\frac{1}{2}$	8 $\frac{1}{2}$	8 $\frac{1}{2}$	13 $\frac{1}{2}$	13 $\frac{1}{2}$	13 $\frac{1}{2}$	13 $\frac{1}{2}$	16	16
Radiator	10 $\frac{1}{2}$	10 $\frac{1}{2}$	10 $\frac{1}{2}$	10 $\frac{1}{2}$	17 $\frac{1}{2}$	17 $\frac{1}{2}$	19 $\frac{1}{2}$	19 $\frac{1}{2}$	20	20
Total	17	17	17	17	31	31	33	33	36	36
Weight — Bare Engine	550	550	555	565	800	800	800	800	945	950

*Dimensions and data shown are for Standard Industrial Engines.

**Note: Other oil pressures are available, based on customer specifications.

INFORMATION FOR ORDERING PARTS

When ordering parts, refer to the **engine name plate** attached to side of the cylinder block, which lists the **model** and **serial number**. In most cases a **specification number** is listed. This data is of vital importance in obtaining the correct parts: **always include this information on your parts order.**

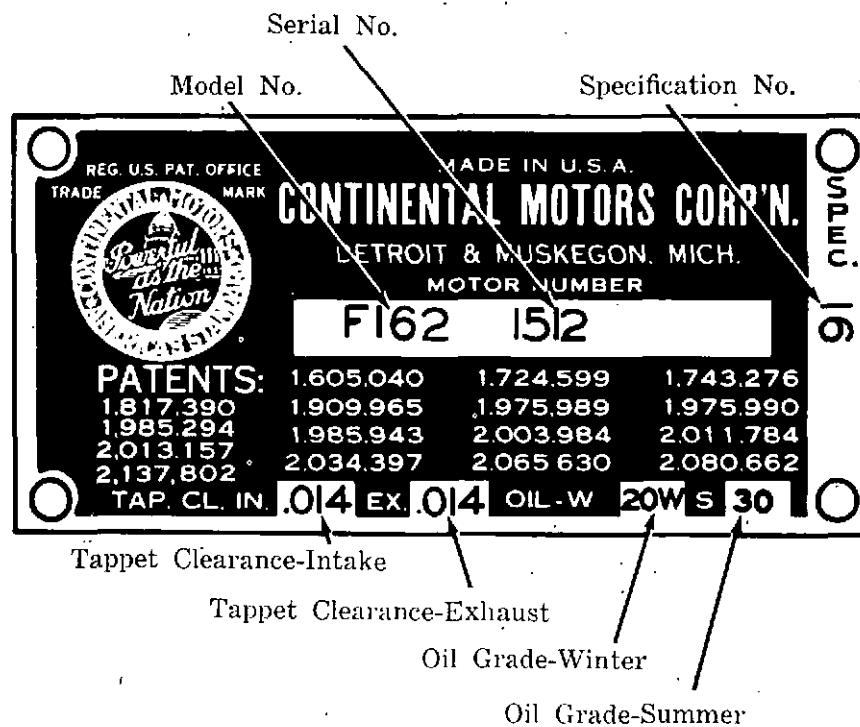

Figure 9 — Nameplate

SECTION 1 GENERAL INFORMATION

L-Head engines have inherent design advantages which result in a more simple engine of lower height, weight and cost. All valves, cams, valve lifters and all other moving parts are a part of the cylinder block assembly.

The cross-section of an L-Head engine resembles the letter "L" written upside down and engines with this type of combustion chamber are also called side-valve engines.

Intake and exhaust valves are located in the side pocket and both are directly operated through tappets from a single camshaft. This provides a simple and heavy duty valve gear, since there is no deflection.

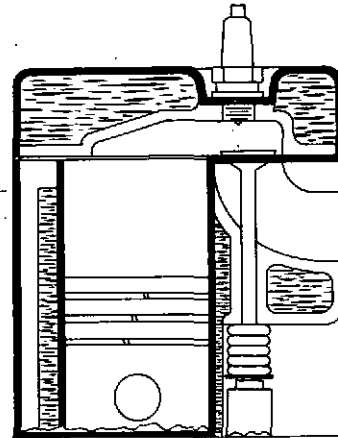

Figure 10 — L-head design

CONTINENTAL L-HEAD ENGINES

Continental has eight basic four-cylinder and ten six-cylinder L-Head type engines, ranging in size from 56 to 427 cubic inch displacement.

The combustion chamber design has been tailored for the required turbulence, charge flow and burning characteristics to provide dependable and economical heavy duty service.

Some of the principal design features are:

1. **Individual Porting** — of the intake manifold whereby each cylinder is fed with the fuel-air mixture individually and not influenced by other cylinders of the engine.

This is accomplished by casting the cylinder block with individual intake valve passages for each cylinder and connecting these passages to an intake manifold which also has individualized passages for each cylinder.

This equal distribution results in maximum power, smooth operation, easy starting and longer engine life.

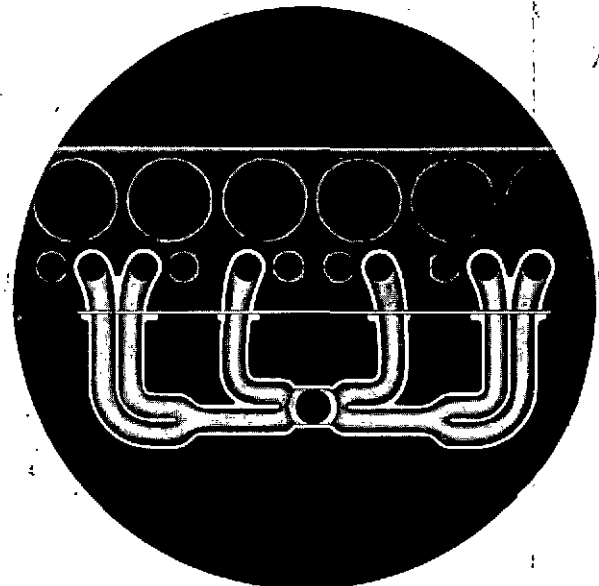

Figure 11 — Individual Porting

2. **Directional Cooling** — is accomplished by regulating the course of the cool water from the water pump so it first comes in contact with exhaust valve seats and then to other points as indicated by their relative temperatures.

This feature promotes uniform cooling throughout the system, prevents hot-spots and prolongs valve life.

This coupled with the by-pass and thermostat included in the engine assembly, insures rapid warm-up and even temperature distribution.

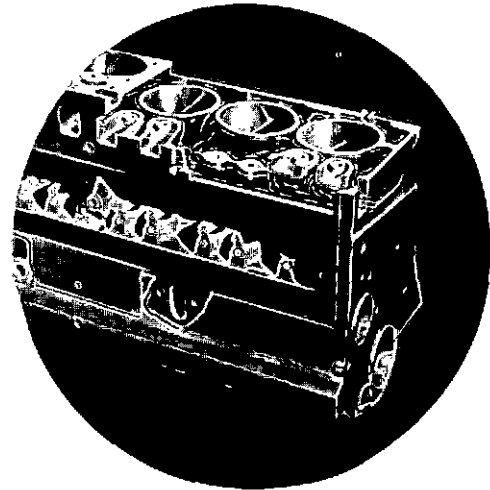

Figure 12 — Directional Cooling in Block

3. **Full Length Water Jackets** — completely surround all cylinder bores the full length of the piston travel.

This insures uniform cooling with minimum bore distortion — which results in lower oil consumption; less blow-by and minimum tendency to sludge.

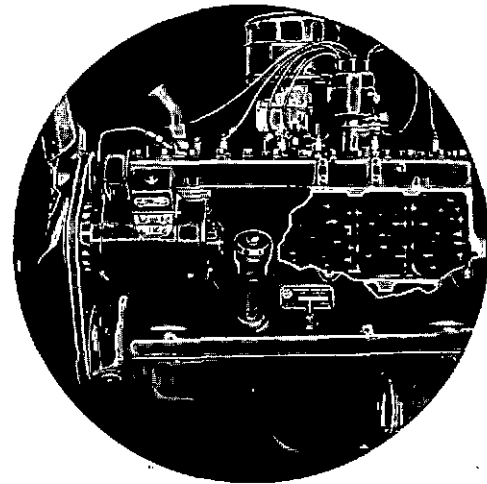

Figure 13 — Full Length Water Jackets

4. **Removable Tappets** — The large, barrel shaped, pressure lubricated tappets are so designed that by removing the adjusting screw — the main body can be lifted out and replaced from above through the valve chamber. This eliminates the costly service operation of dropping the oil pan and pulling the camshaft. Locking of the adjustment is both simple and effective.

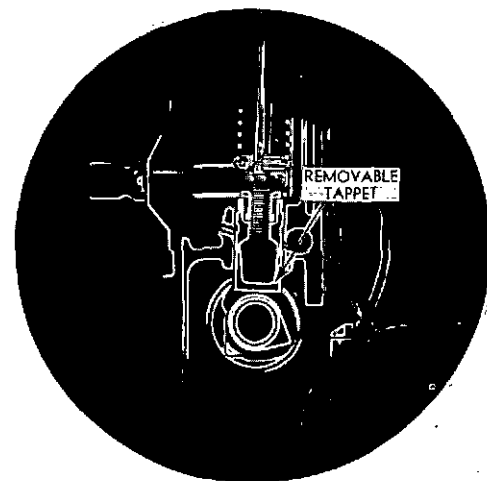

Figure 14 — Removable Tappets

5. **Choice of Fuels** — Gasoline - LPG - Natural Gas - Fuel Oil — Continental L-Head engines have been tailored for heavy-duty operation using gasoline - LPG - natural gas - fuel oil fuels.

More than conventional number of studs to prevent gasket failures, distortion of cylinder bores and valve seats

Cylinder head gasket

Chrome top rings

Full length water jackets

Piston

Heavily ribbed alloy cast iron block

Full pressure lubrication to all main, connecting rod and cam bearings, as well as tappets and timing gears

Spurt hole for lubrication of thrust side of cylinder walls, piston pins, and cooling of piston head

Oil filler

Drop forged, counterweighted crankshaft

Alloy steel heat treated connecting rod and main bearing bolts and nuts

Dipstick

Float-o Screen

Lubrication to piston pins

Valve seat inserts

Exhaust valves

Valve guides

Valve springs

Positive Roto exhaust valves

Tappets removable without pulling camshaft

Camshaft

Main and connecting rod bearings

Crankcase ventilation

Submerged gear type oil pump driven off camshaft

Figure 15 — Cross Section of a Typical Continental "L" Head Engine

SECTION II LUBRICATION

ENGINE LUBRICATION SYSTEM

Continental L-Head engines have full pressure lubrication to all main, connecting rod and camshaft bearings as well as tappets and timing gears.

To insure piston pin lubrication and prevent piston scuffing during the warm-up period in cold

weather — the large end of the connecting rods have drilled spurt holes pointing toward the thrust side of the pistons. These line up with the oil hole in the crank pin so that once each revolution, oil is sprayed on the cylinder wall for lubrication.

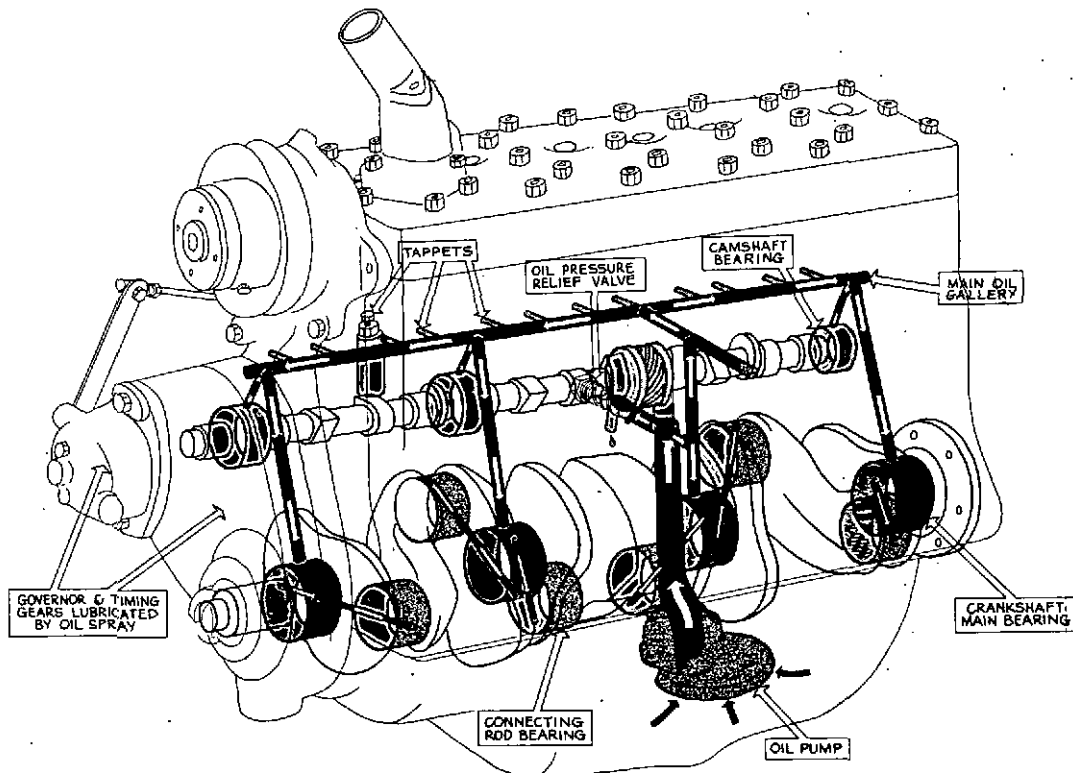

Figure 16 — Oiling Diagram

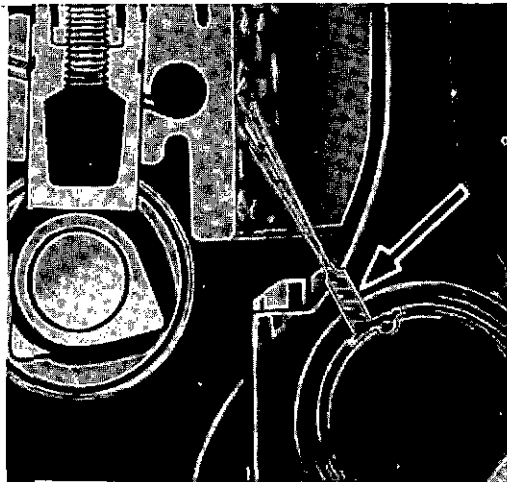

Figure 17 — Connecting Rod Spurt Hole

OIL PUMP

On all engines except the N-series, a large capacity, submerged, gear type oil pump is driven off the camshaft and protected by a large screen inlet; on the N-series the oil pump is mounted on the rear end plate.

An adjustable by-pass valve maintains suitable oil pressure from idle to maximum speed automatically. The normal oil pressure at full throttle is 20-30 pounds for the N- Y- F type engines and 40-50 pounds for the B and M type engines and should not fall below 7 pounds pressure at 400-600 R.P.M. idling speed.*

CAUTION: If the oil pressure is erratic or falls below these limits, stop the engine **IMMEDIATELY** and find the cause of the trouble. Refer to trouble shooting section for this information.

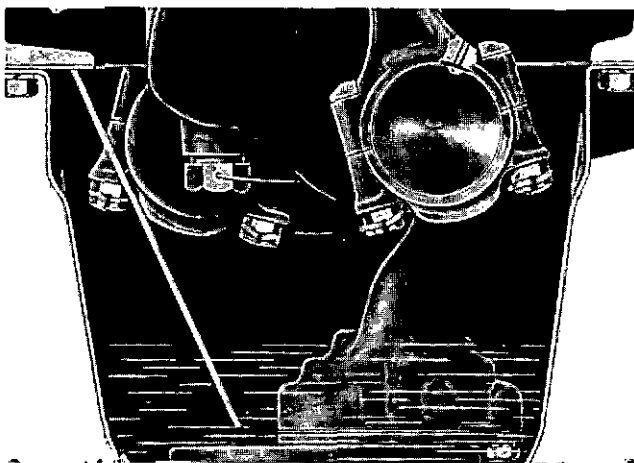

Figure 18 — Oil Pump

*Other pressures are available, based on customer specifications.

A by-pass type oil filter is normally provided to remove dirt and foreign elements from the oil, a percentage of which is passed through the filter during the operating period. The removal of grit, sludge and foreign particles causes filter elements to clog and become ineffective unless they are normally replaced every 150 hours.

OIL CHANGE FREQUENCY

Engine oil does not "wear out". However, the lubricating oil in internal-combustion engines becomes contaminated from the by-products of combustion: dirt, water, unburned fuel entering the crankcase, and the detergents holding the carbon particles in suspension in the crankcase.



Figure 19 — Oil Filter

The frequency with which engine oil should be changed depends upon (1) The quality of the oil, (2) Type of operation, (3) Mechanical condition of the engine and (4) The type of contaminants from the engine operation and the surrounding atmosphere.

In normal Industrial operation, the Continental L-Head engines should have the oil changed after every 50 hours of operation. The oil filter should be changed every 150 hours. The oil should be drained when the engine is at normal operating temperature.

BREAKING-IN NEW OR RECONDITIONED ENGINES

New or reconditioned engines have very small clearances. To assure adequate oil distribution to these closely fitted surfaces during the first week or 50 hours of engine operation, the use of a lighter bodied oil is desirable.

When the engine break-in is performed during the warmer months of the year, an SAE 10-W-30 oil should be used. Be sure to allow a several-minutes warm-up period before applying the load.

DO NOT FLUSH CRANKCASE WITH KEROSENE

Some operators unwisely put kerosene in the crankcase after draining the engine oil, then turn the engine over with the starter — in the belief they are doing a better job of crankcase cleaning.

In doing this, kerosene is circulated through the oil pump, the main oil header and the branches leading into the engine bearings — thereby washing away the protective oil film. In addition, some of the kerosene will be trapped and remain to thin out the new oil, reducing its lubricating qualities.

Do not put kerosene into the crankcase. The best method is to drain the oil when the engine is thoroughly heated — which will carry off most of the sediment.

AIR CLEANER

All engines, when operating, consume several thousand cubic feet of air per hour. Since dusty air is full of abrasive matter, the engine will soon wear excessively if the air cleaner does not remove the dust before entering the cylinders.

Two basic types of air cleaners are normally used — the oil bath type and the dry replaceable element type.

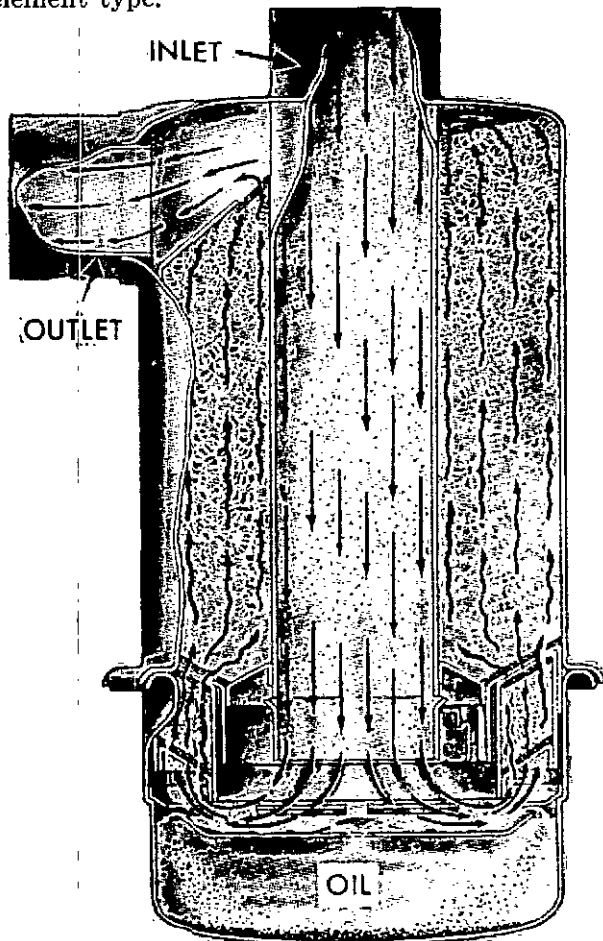

Figure 20 — Sectional View of Oil Bath Air Cleaner

Operating conditions determine the air cleaner service periods. In extremely dusty operations, this may be once or twice daily. In dust protected

areas, the air cleaner should be serviced when changing oil.

As the dirt is strained from the air flowing through the cleaner, it thickens the oil in the cup and raises the level. If the level is too high, agitation of the oil on the screen is affected and gritty oil is carried over into the air stream, through the carburetor and into the engine cylinders. This would actually introduce a grinding compound with resulting very rapid wear.

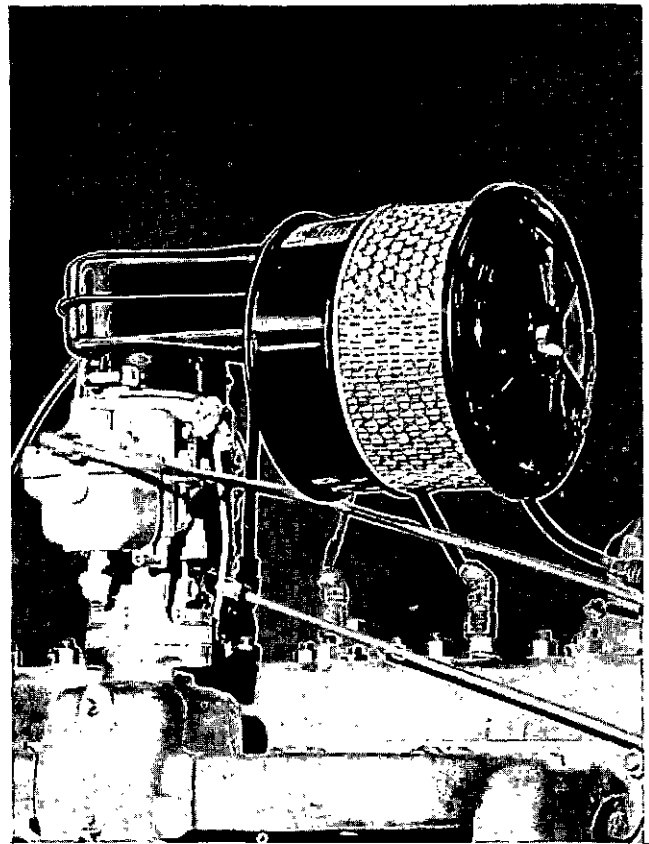

Figure 21 — Dry Replaceable Element Type Air Cleaner

By actual measurement, the amount of dust shown below, when admitted in the volume shown every hour, will completely ruin an engine in an eight hour day.



Figure 22

Proper servicing means **Cleaning Thoroughly and Refilling with New Engine Oil, and Maintaining Air-Tight Connections** between the air cleaner and intake manifold so that **All Air Entering The Engine Is Filtered.**

LUBRICATION RECOMMENDATIONS

Motor oils used for internal-combustion engine lubrication perform many useful functions including: dissipating heat; sealing piston rings; preventing metal to metal contact wear and reducing power loss through friction.

The lubricating oil recommendation is based upon engine design; type of service and the atmospheric temperature prevailing. High quality oils are required to assure maximum performance, long engine life and minimum cost of operation.

L-Head gasoline engines operate in a wide range of service conditions and seasonal temperatures, so our recommendations are given for various types of service and ambient temperatures.

The American Petroleum Institute (API) has established new service classifications so that the engine operator can properly select the best type of oil.

They have the following three classifications of engine oils relating to the different operating conditions for gasoline or other spark-ignition engines:

SERVICE ML — (Former API Designation: Regular)

Light or Easy Service Conditions — Such as moderate operating speed at normal engine temperatures — especially where the engine is relatively insensitive to promote deposit formation and bearing corrosion.

SERVICE MM — (Former API Designation: Premium)

Moderate Severe Service Conditions — Involving higher speeds and operating temperatures; particularly when the higher temperatures tend to promote deposit formation and bearing corrosion.

SERVICE MS — (Former API Designation: Heavy-Duty Type)

Severest Service Conditions — include:

Start-Stop Operation — which leads to emulsion sludge and corrosive wear; involves essentially a low-temperature condition, and one which gets worse in colder weather.

Severe High Temperature Operation — Resulting from high loads or overloads or high operating speed which tends to result in carbon, lacquer and sludge deposits.

S.A.E. OIL BODY GRADES

The oil body grades available from the lightest (SAE 5W) to the heaviest (SAE 40) are:

5W	10W	20W	20	30	40
← 5W - 20 →					
	← 10W - 30 →				

MULTI-GRADE OILS — Such as SAE 5W-20 and SAE 10W-30 have the starting grade characteristics of the lighter oil and after it warms up it has the running characteristic of the heavier grade.

The following SAE grades are general recommendations for Continental L-Head engines during changing seasonal atmospheric temperatures:

ENGINE SERIES	* SEVERE WINTER BELOW 0°F.	NORMAL WINTER 0° - 32°F.	SPRING-FALL 32° - 75°F.	SUMMER ABOVE 75°F.
N	10W	10W	SAE 20W	SAE 30
Y	10W	10W	SAE 20W	SAE 30
F	10W	10W	SAE 20W	SAE 30
M	10W	20W	SAE 30	SAE 40
B	10W	20W	SAE 30	SAE 40

*Below -10° F. use SAE 5W-20 Grade

The Multi-Grade oil used should cover the single grade recommendation for the atmospheric temperature involved, e.g. SAE 10W-30 covers SAE-10W, SAE 20W, SAE 20 and SAE 30.

Use High Grade MS Oils such as Socony Mobile Oil Company Mobiloil or Delvac 900-series. Favorable conditions may warrant oils listed under ML and MM service; however our above general recommendations are listed under SERVICE MS Oils such as:

Mobiloil AF (SAE 40)	Delvac 940 (SAE 40)
Mobiloil A (SAE 30)	Delvac 930 (SAE 30)
Mobiloil Arctic (SAE 20-20W)	Delvac 920 (SAE 20W)
Mobiloil 10W (SAE 10W)	Delvac 910 (SAE 10W)
Mobiloil 5W (SAE 5W-20)	Delvac Special (SAE 10W-30)
Mobiloil Special (SAE 10W-30)	

Generators - Starters - Distributors — Add 3-5 Drops of engine oil to the generator and starter oil cups every 50 hours and to the distributor every 250 hours.

AIR COMPRESSORS (ENGINE MOUNTED) normally are engine lubricated. — however, if lubricated separately from the engine, use the same type and grade as used in the engine.

Clutches — Use a high temperature bearing grease such as Mobilgrease No. 5 or Mobilgrease MP. Do not over-lubricate.

Conventional Transmissions — For the greatest efficiency over the life of the transmission, use a high quality straight mineral oil such as the "Mobilube C" line. The oil should be changed seasonally.

Use the following proper grades:

	SUMMER	WINTER
Clark	SAE 90	SAE 90
Fuller	SAE 140	SAE 90
Twin Disc	SAE 40	SAE 40
Warner	SAE 140	SAE 90

Torque Converters and Hydraulic or Automatic Transmissions — These units employ a fluid medium to transmit power which must be very stable

to resist formation of harmful deposits or change in body in use. The correct fluid must be selected to obtain maximum efficiency of the transmission. All fluids should be changed seasonally.

Type "A" Automatic Transmission fluid is most widely used. There are many widely distributed brands of this type, such as Socony Mobil Oil Company's Mobilfluid 200.

For some models of Twin Disc Clutch Company's torque converters, a Special Fluid having a viscosity of 35 Saybolt seconds @ 100° F. is required — other models use SAE 10W engine oil. The Special low viscosity fluid may be obtained from Twin Disc Clutch Company Dealers. To satisfy the SAE 10W requirement, we recommend the use of MS type oils, such as, Socony Mobil Oil Company's Delvac 910 or Mobiloil 10W.

Allison Division torque converters and Torqmatic transmissions require a type C fluid, which is on their approved list, such as, Delvac 910.

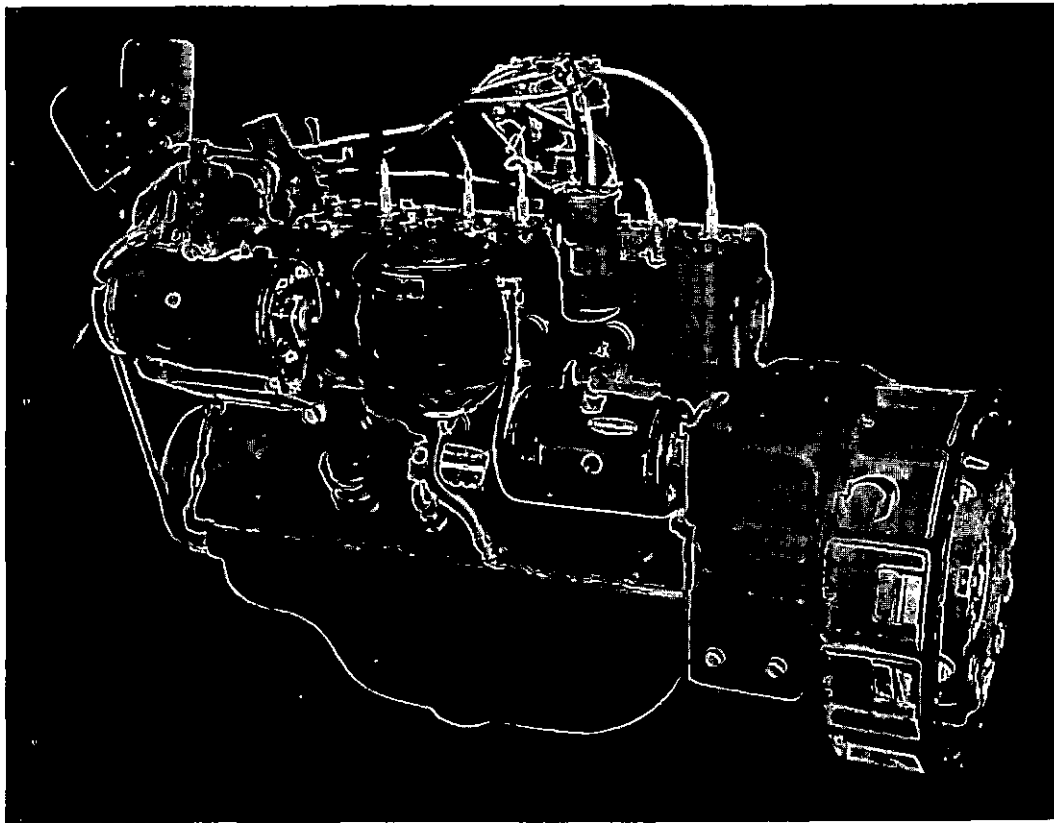

Figure 22A
F600 Engine with a Hydraulic Coupling

TRANSMISSION AND CONVERTER LUBRICATION RECOMMENDATIONS

The following grades are generally recommended for hydraulic torque converters and transmissions for Summer and Winter operation:

MANUFACTURER	SUMMER	WINTER
Continental Motors Corp. Co-Matic Drive Fluid Coupling HC15	Type A Type A	Type A Type A
Clark Equipment Co. Torcon (converter only) Torcon Converter and Transmission	SAE 10W Type A	Type A (below 10° F.) Type A
Fuller Mfg. Co. Torque Converter	SAE 10W	Type A (below 0° F.)
Borg-Warner Borg & Beck & Long Mfg. Co. All converters and hydraulic transmissions	Type A	Type A
Allison Division Torque Converters and Torqmatic Transmissions	Type C	Type C
Twin Disc Clutch Co. Hydraulic Reverse Gears Coupling or Power Take-off	SAE 10W	SAE 10W
Hydraulic Converter Transmissions Input shaft & impeller bearings (C, FC)	Same as Engine	
Fluid Medium except Two speed transmission and converter transmission combinations (Models T-DRR-FT-IT)	Special Twin-Disc Fluid	
	Type A	Type A
Reverse Transmissions Models RR-CRR-ICRR	SAE 40	SAE 20
NOTE: For all Grease applications on the above units a good high temperature grease, such as, Socony Mobil Oil Company's Mobilgrease No. 5 or MP should be used.		

SECTION III OPERATION

OPERATING INSTRUCTIONS

The person operating the engine naturally assumes responsibility for its care while it is being operated. This is a very important responsibility since the care and attention given the engine goes a long way in determining how long a period it will operate satisfactorily before having to be shut down for repairs.

The operating and preventive maintenance instructions for the L-Head type engines are simple and should be followed without deviation.

The entire aim in setting forth these instructions is to give you the benefit of the knowledge and experience gained over a long period of collaboration between Engineering Research and Field Service.

PREPARATION OF NEW ENGINE FOR OPERATION

Before placing a new engine in operation, it must be thoroughly inspected for external damage and particular attention paid to the following items:

1. **Inspect Engine Hold Down Bolts** — To make certain that they are firmly set.

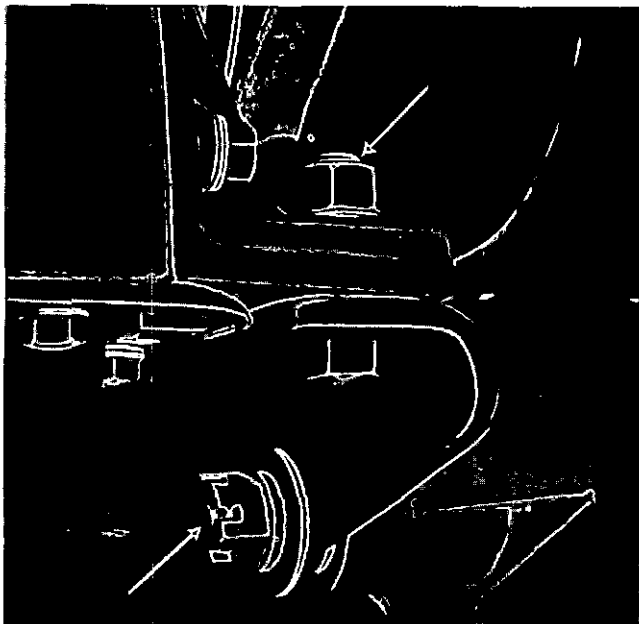

Figure 23 — Engine Mounting Bolts

2. **Open Fuel Tank Shut Off Valve** — By turning handle counter-clockwise as far as it will go.

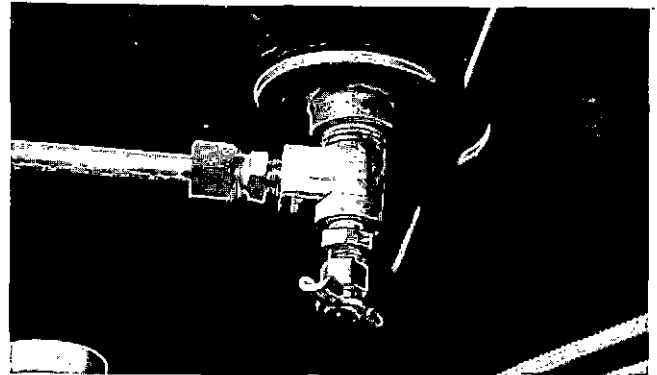

Figure 24 — Fuel Shut-off Valve

3. **Close water drain cock** — in lower radiator connection, also on the side of the block. (In some cases, this may be a pipe plug.)

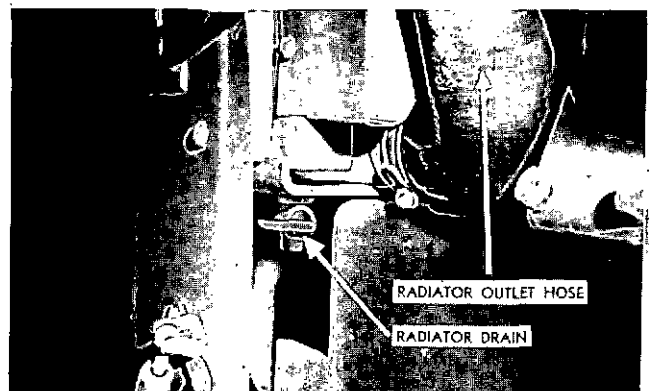

Figure 25 — Water Drain Cock

4. **Examine Oil Drain Plug** — to make certain that it is tightly closed.

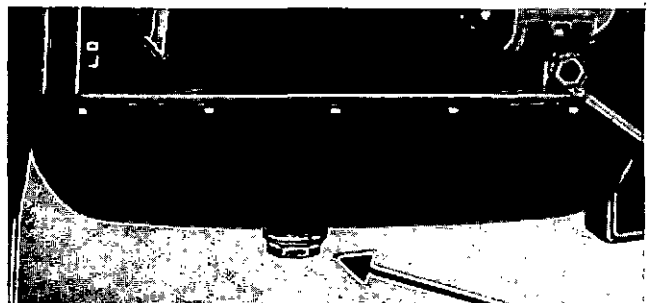

Figure 26 — Oil Drain Plug

5. **Fill Crankcase with SAE 10W-30 Oil** — for the first week or 50 hours operation — then follow lubrication recommendations in Section II.

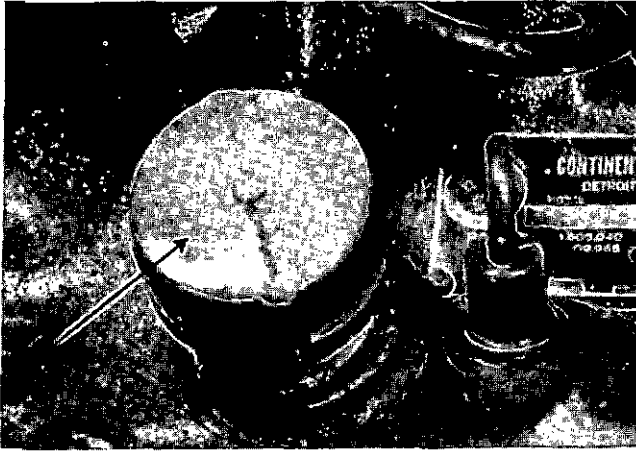

Figure 27

6. **Fill Radiator with Clean Water** — during freezing weather, use a sufficient amount of anti-freeze to protect the system for the lowest anticipated temperature — refer to Section V.

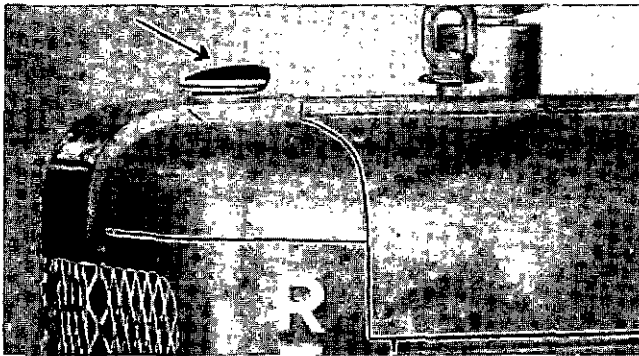

Figure 28

7. **FILL GASOLINE TANK FULL** — All new engines are shipped with a treated tank which should be completely diluted with a full tank of gasoline to eliminate any tendency to clog.

Be sure that the container used for filling is clean and free from dirt. Replace cap securely.

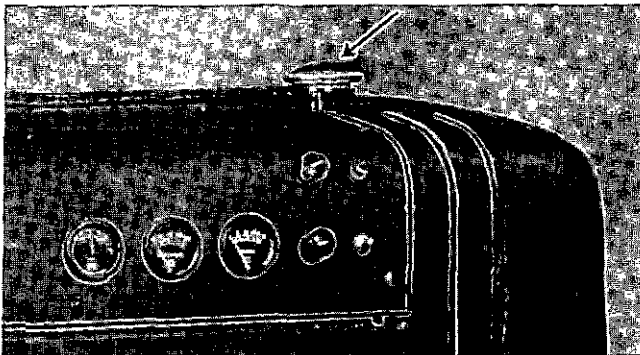

Figure 29

8. **Engine Accessories** — see that all points requiring lubrication are properly supplied.

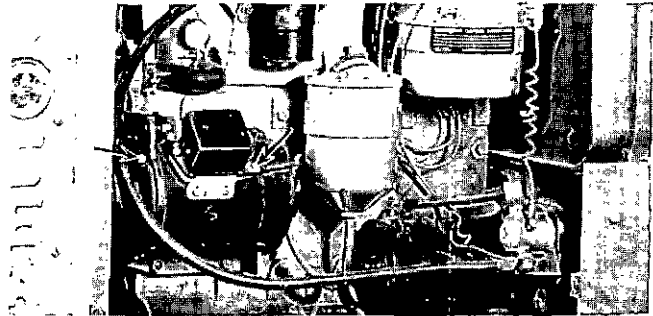

Figure 30

9. **Electrical Connections** — check storage battery terminals and all electrical connections. Check each spark plug wire for tightness.

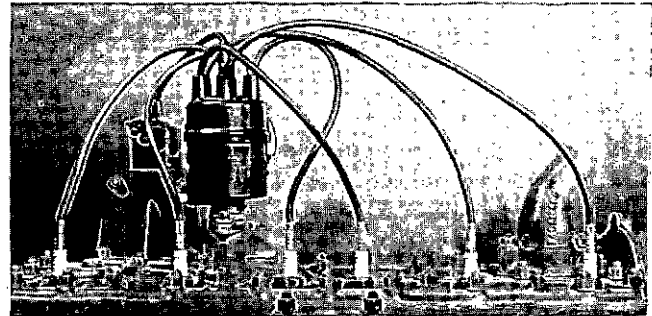

Figure 31

10. **RADIATOR COOLANT CAPSULE** — The radiator coolant capsule, which comes with the engine, should not be removed: this is a water conditioner and anti rust inhibitor to protect the cooling system.

STARTING THE ENGINE

Normally check daily preventive maintenance schedule before starting. — (See Section IV).

1. **Safety Control Switch** — (If supplied) Turn Manual control knob with arrow pointing toward "on" position. When oil pressure builds up to normal, control knob will automatically release and arrow will point to "run" position.

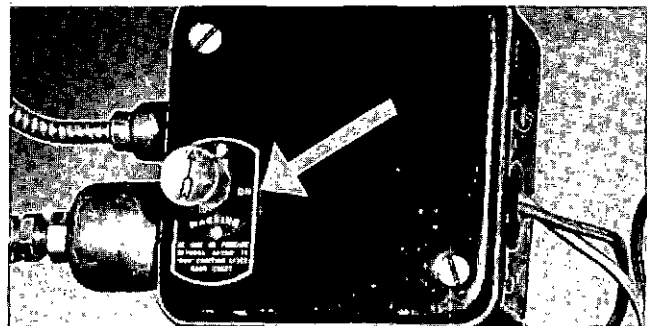

Figure 32 — Safety Switch

2. Disengage Power Take-Off — (if equipped)
Starting engine under load throws overload on starter and battery.

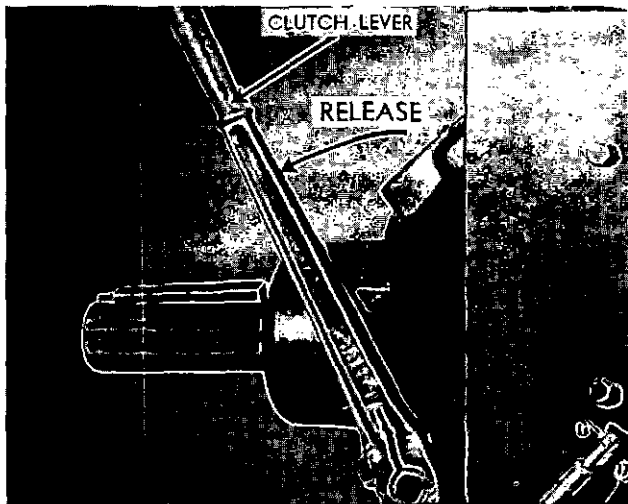

Figure 33 — Power Take-off

3. Open throttle Control about 1/3 open
4. Turn on Ignition Switch
5. Pull Out Choke (if manually operated)
But avoid flooding the engine. Operate the engine without choking as soon after starting as possible.
6. Push Starter Button In
Keep on until engine starts; but not longer than 15 seconds at a time.

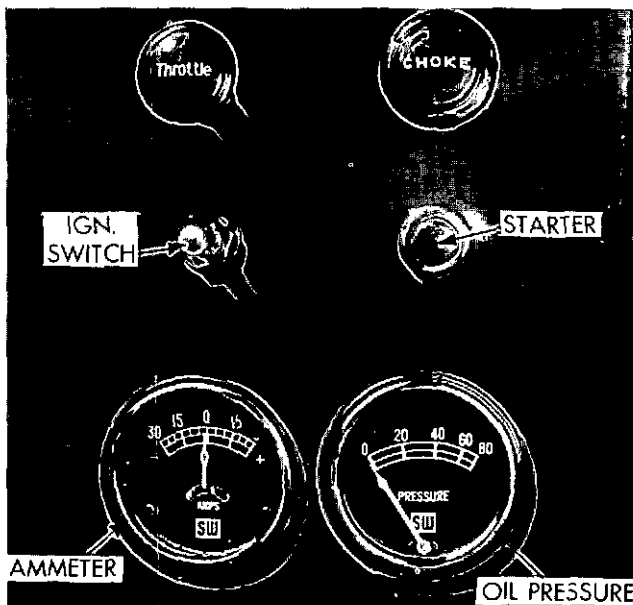

Figure 34 — Instrument Panel

7. Warm-up Before Applying Load
Idle the engine about 700 R.P.M. for a few minutes to circulate and warm oil — then increase the speed to approximately half throttle until the engine water reaches 100° F. This procedure will prolong the engine life.

8. Check Oil Pressure

N-Y-F SERIES M-B SERIES

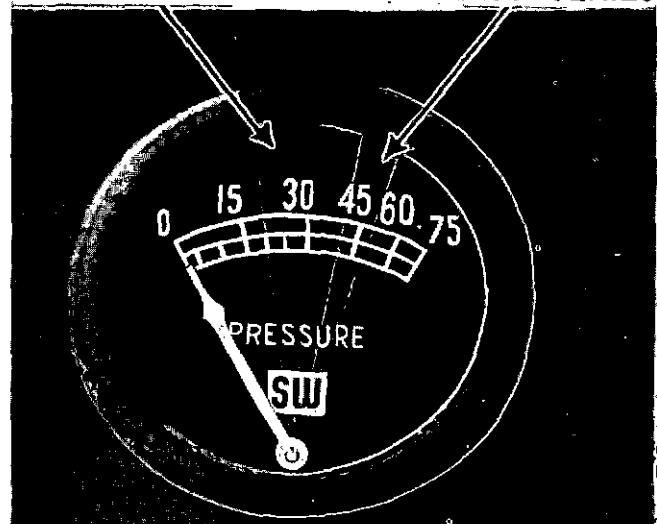

Figure 35 — Oil Pressure Gauge

(Other pressures available for special Applications)

9. Check Water Temperature

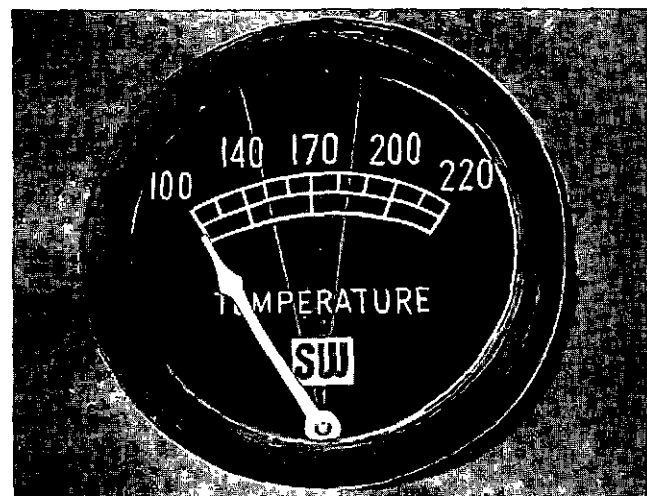

Figure 36 — Water Temperature Gauge

CAUTION:

After starting new engine — run it at idle for 5 minutes, then stop engine and recheck oil level in crankcase — then bring oil level to high mark on dipstick.

IMPORTANT!

Breaking in a new or rebuilt engine — for peak performance and economical operation, the following adjustments should be made at end of first 50 hrs. operation.

- 1) Torque down cylinder head studs to specifications.
- 2) Adjust valve tappets to specified clearances.
- 3) Adjust idle mixture and idle speed to 400-600 R.P.M.

SPEED CONTROL

The throttle control is used to close the carburetor butterfly valve to limit engine speed below governed speed.

Engines are provided with a mechanical or velocity governor set to maintain the load and speed specified when the engine is ordered. If individual requirements necessitate a change of governed speed — reset governor as outlined under

“Governor adjustment”, but do not exceed manufacturers recommended maximum speed, since this has been worked out with the end product requirements in mind.

When extended periods occur between the applications of load, it is recommended that the engine be throttled down to minimum idling speed or, if the intervals are unusually long, that it be shut down.

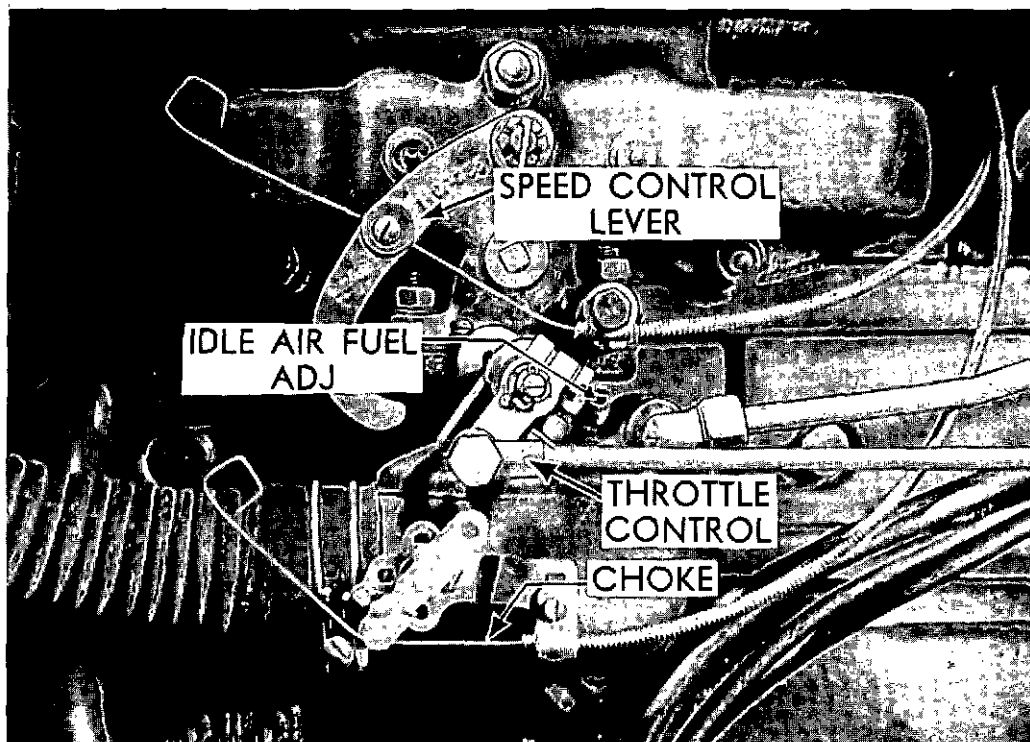

Figure 37 — Throttle Lever
(This may vary with the application.)

STOPPING THE ENGINE

1. Disengage Power Take-Off
2. Reduce engine Speed to Idle — If hot, run engine at idle (400-600) for several minutes to cool.

3. Turn Off Ignition Switch — if engine continues to run due to high combustion chamber temperatures, either continue idling to further cool or shut off fuel supply.

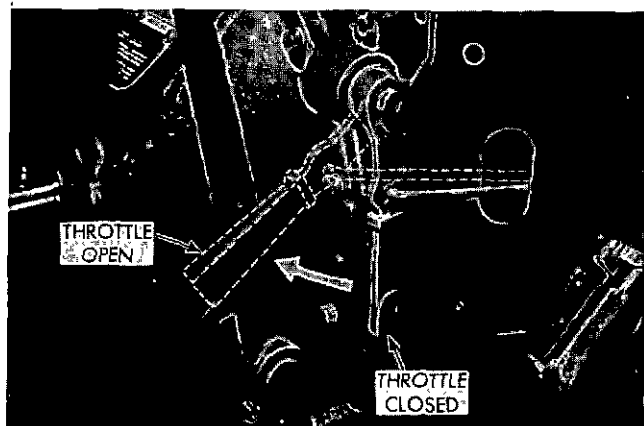

Figure 37A — Hand Throttle Control

CAUTION:

NEVER PULL OUT CHOKE WHEN STOPPING ENGINE — BECAUSE RAW GASOLINE WILL WASH LUBRICANT FROM CYLINDER WALLS.

9 OPERATING PRECAUTIONS

1. **Oil Pressure** — should be up to recommended pressure at operating speed and over 7 pounds at idle (400-600 R.P.M.)

2. **Ammeter** — should register "Charging" at all times engine is running. (A voltage regulator, if used, may limit it to a very low reading).

3. **Water temperature** — should be maintained 150-185° F. — continued overheating may cause internal damage. "**Frequent Readings of Gauge should become a Habit**".

4. **Muffler Restriction** — should not exceed 20" water or 1½" Mercury. Inspect mufflers periodically for restrictions to prevent burned valves.

5. **Clean and Service Air Cleaner** — as recommended to maintain its efficiency. The rapidity that dirt collects in the oil cup indicates how often the air cleaner should be serviced.

6. **When engine is Over-Heated** — do not add water — allow engine to cool so as to prevent cracking the cylinder head.

7. **Engine Load Indication** — a manifold vacuum of 6 inches of Mercury indicates the recommended maximum continuous full load operation and a vacuum of 18-20 inches of Mercury indicates normal idling vacuum. Between full load and idling, vacuum gauge readings may be used to approximate the percent. Any reading below 6" HG indicates engine is overloaded for continuous duty.

8. **Avoid Cold-Sludge Condensation** — by protecting unit to maintain crank case temperature over 135° F.

9. **Follow Preventive Maintenance Schedules Recommended** — This will avoid troubles which might cause expensive breakdowns and maintain your engine for dependable and economical operation.

COLD WEATHER OPERATION

The oil used during cold weather should have a cold test below the lowest anticipated temperatures that will be encountered during its use. The new multigrade lubricating oils 5W-20 and 10W-30 are ideal for cold starting with its reduced initial drag until warmed up, when it assumes the characteristics of the heavier oil.

Sludge formation at low temperatures is a close second to dirt in causing engine damage and wear. This is formed by the piston combustion gases mixing with the fine oil mist in the crankcase and condensing on a cold surface. This condensation forms both a sulphuric and sulphurous acid which combines with the oil to become a highly injurious sludge. This dew point is about 135° F. — when crankcase temperatures are higher, the contaminated gases remain in gaseous form and the engine operates clean as long as breather system is kept clean — however temperatures below this will result in injurious sludge formation. It is vitally important therefore to maintain oil and crankcase temperatures above 135° F., as shown on the following chart;

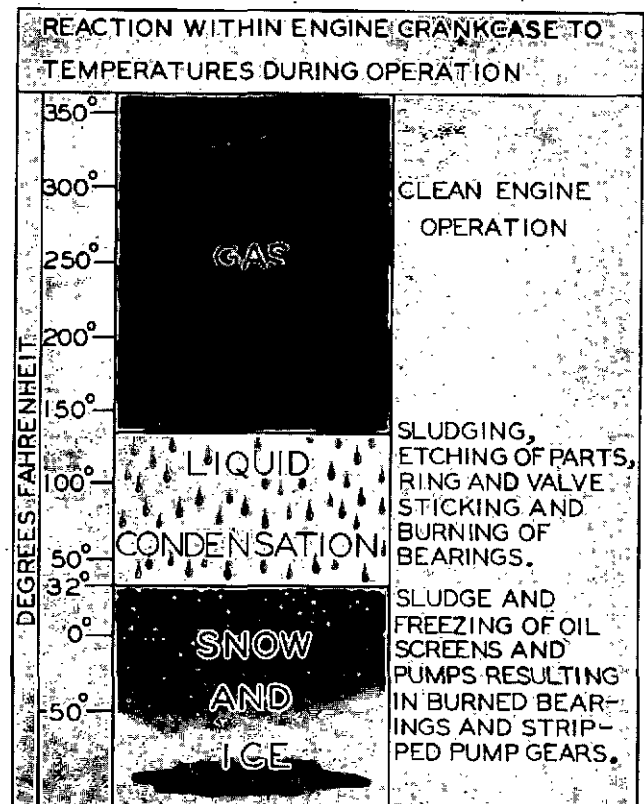

Figure 38

When sludging conditions prevail, the oil should be examined daily and changed as it may freeze, or clog the inlet strainer and cause bearing failures.

High Altitude Operation — High Altitude operation reduces the power output approximately 3½% for every 1000 feet of altitude above sea level.

High Temperature Operation—for every 10° above 60° F. carburetor air temperature — a power loss of 1% results.

PREPARATION OF ENGINE FOR SEASONAL STORAGE

CAUTION

Before starting the processing, engine must be cooled down to the surrounding temperature, since oil will adhere much better to cold metal surfaces.

1. **Drain Oil from Oil Pan** — and replace drain plug.
2. **Refill Oil Pan** — with high grade SAE 50 engine oil to ½ its normal capacity.
3. **Start up Engine** — and run at above 600 R.P.M. for 2 minutes to complete oil distribution on all surfaces — **Do Not Run Longer Than 2 Minutes.**
4. **Stop Engine**—Remove all Spark Plugs.
5. **Pour 3 Ounces of SAE 50 Engine Oil** — into each Spark Plug Hole.
6. **With Ignition Cut Off** — Crank engine with Starter — for at least a dozen revolutions to distribute this oil over the cylinder walls and valve mechanism.
7. **Drain Oil from Pan and Reassemble Plug.**
8. **Drain Cooling System and Close Drain Cocks.**
9. **Drain All Gasoline** — from tank, lines and carburetor bowl.
10. **Replace All Spark Plugs.**
11. **Seal Air Cleaner Inlet** — exhaust outlet — Crankcase Breather Tube — with weather proof masking tape.
12. **Check Oil Filler Cap** — Gas Tank Cap and Radiator Cap to make certain they are securely in place.

SECTION IV PREVENTIVE MAINTENANCE

In order to obtain maximum efficiency from your gasoline engine, a definite maintenance program should be set-up and followed. Haphazard maintenance will only lead to faulty engine performance and shorten engine life.

All moving parts in the engine are subject to wear; however, wear can be retarded by careful operation and a planned maintenance program.

In general, gasoline engine operation demands careful attention to the cleanliness of air, fuel and oil and maintaining operating temperatures of 150°-185° F.

The following pages, covering DAILY, 50-250 and 500 hour maintenance, have been worked out with our field service division as "Minimum Requirements" to keep your engine in dependable operating condition.

DAILY

PREVENTIVE MAINTENANCE SCHEDULE

1. OVERALL VISUAL INSPECTION OF ENGINE

Look for evidence of fluid leaks on floor, cylinder head and block, indicating loose fuel, oil or water connections — **tighten if found.**

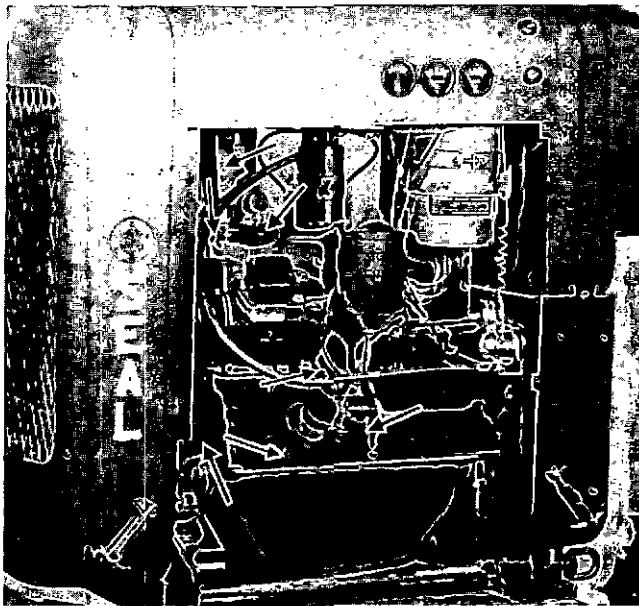

Figure 39 — Check for Possible Leakage

2. CHECK OIL LEVEL OF ENGINE

The dipstick indicates the high and low oil level in the crankcase—make allowance for additional oil drainage back into oil pan if engine has not been stopped 15 minutes. The most efficient oil level is between the two dipstick levels.

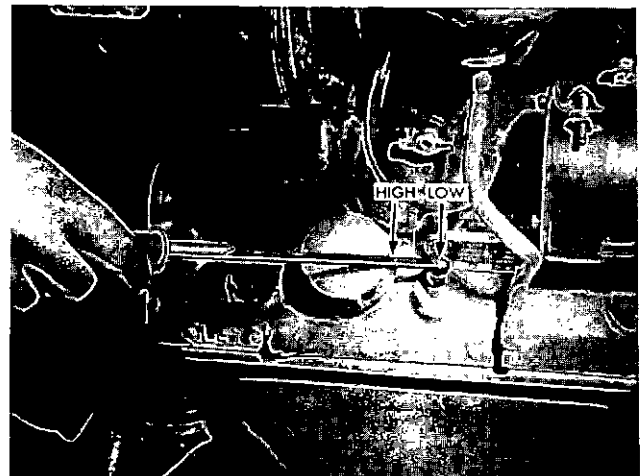

Figure 40 — Check Oil Level of Engine

Do not add oil until oil level approaches the low mark — then add only enough to bring it to high level — NEVER above.

Do not operate the engine with oil below low level mark.

3. CHECK RADIATOR

Fill radiator with clean water or anti-freeze to normal level maintained due to expansion when heated. Visually inspect fan and belt for condition and adjustment.

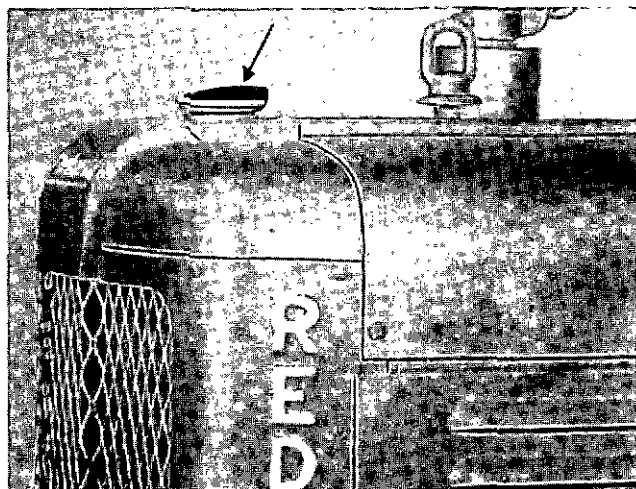

Figure 41

4. FILL FUEL TANK

Should be done at end of day's operation to prevent condensation forming in tank. Clean filler cap and area around spout before filling to prevent entrance of dust into fuel system.



Figure 42

5. CHECK AIR CLEANER

Remove air cleaner oil cup and note amount of sediment—if required, clean and refill with engine oil to level. Visually inspect air cleaner connections to manifold.

Extremely dusty conditions may require servicing the air cleaner daily or even twice daily.

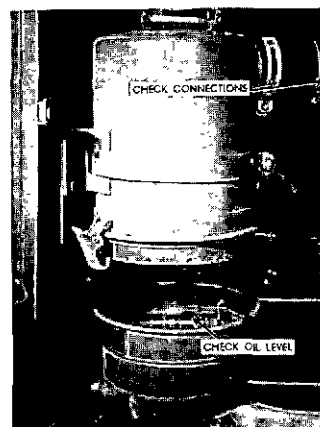

Figure 43 — Air Cleaner

Several types of air cleaners are supplied depending upon the application and specification. Some models are supplied with a removable screen above the oil cup which can be removed and cleaned in a solvent, other types have built in screens which can not be removed. In this case it is necessary to remove entire cleaner after the oil cup is removed and wash the air cleaner in a good cleaning solvent. Frequency of cleaning depending upon operating conditions.

6. CHECK OIL PRESSURE*

Note oil pressure gauge which should indicate the following pressure range at full throttle and a minimum of 7 pounds pressure at idling speed (400-600 R.P.M.):

- 20-30# Pressure — Model N-Y-F Engines
- 40-50# Pressure — Model B-M Engines

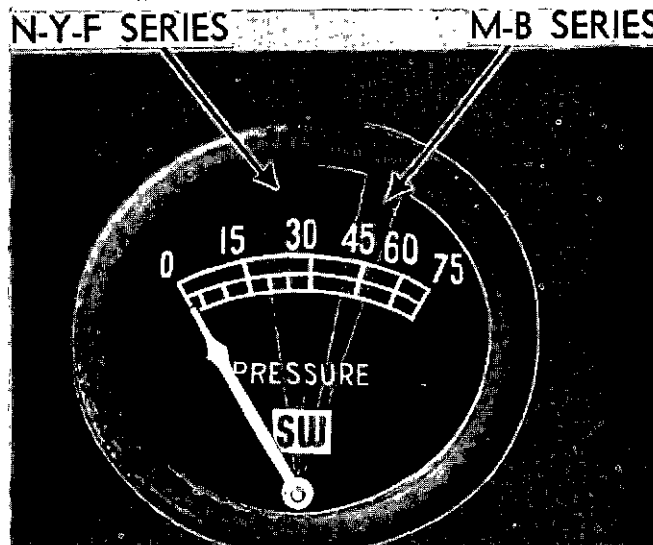

Figure 44 — Operating Oil Pressures

*Standard Engines: on some special customer specifications, this may change.

7. NOTE ANY UNUSUAL NOISE

Operators familiar with daily engine operation soon become alert to any noise not normally present. This is very valuable in correcting defects in the early stages and preventing expensive repairs or delays.

**1. REPEAT DAILY OPERATIONS OUTLINED**

Follow previous instructions.

2. CHANGE CRANKCASE OIL

Engine life is dependent upon clean oil being circulated to all moving parts; therefore, the frequency of oil changes and oil filter replacement is very important and should be made at regular, scheduled periods.

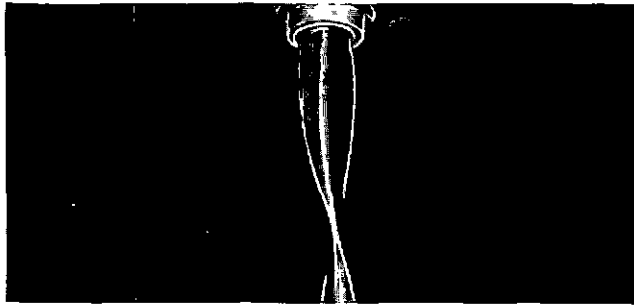

Figure 45

The crankcase oil should be changed after 50 hours service and when the oil is at operating temperatures so that complete drainage will result.

Replace the oil filter element every 150 hours unless extremely unfavorable operating conditions indicate that filter replacements should be made at every oil change period.

Thoroughly clean the filter, cover and sealing surfaces before replacing new element and gasket.

3. SERVICE AIR CLEANER

If oil-bath air cleaner is used, remove bottom half of air cleaner — clean thoroughly and fill with engine oil to oil level mark on cup, avoid overfilling. Replace cup and check all connections to manifold. Be sure that no unfiltered air can enter the engine intake manifold.

If a dry type air cleaner is used, clean element with compressed air.

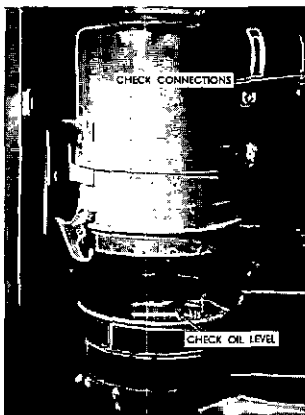

Figure 46 — Air Cleaner

4. CHECK FAN BELT TENSION

Figure 47 — Fan Belt Tension

Inspect wear condition of fan belt; note alignment and check belt tension which should allow $\frac{3}{4}$ " to 1" deflection on long span.

5. CHECK BATTERY

Check specific gravity of each cell — which should be at least 1.250. Add distilled water, if required, to raise level $\frac{3}{8}$ " above the separators.

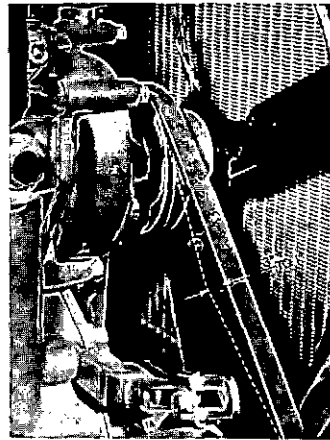
Particular attention should be given battery during cold weather. The cranking power of a fully charged battery @ 80° F. is reduced 60% @ 0° F. — yet the power required to crank the engine is $2\frac{1}{2}$ times greater @ 0° F. than @ 80° F.

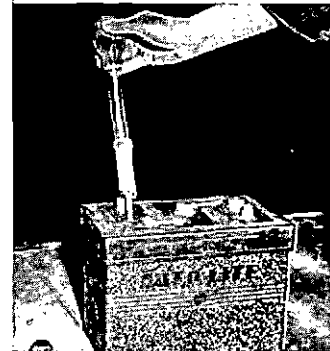

Figure 48 — Checking Battery

6. LUBRICATE GENERATOR AND STARTER

Apply 3-5 drops of engine oil to each cup on the generator and if required on the starter (Many starters have sealed bearings).



Figure 49 — Generator Lubrication

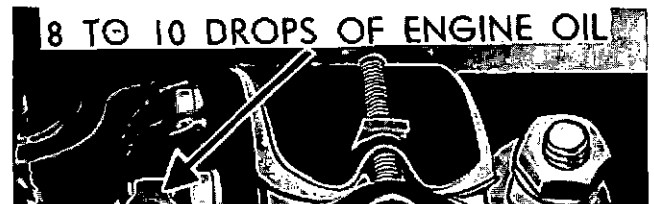

Figure 50 — Starter Lubrication Point

7. LUBRICATE POWER TAKE OFF

Using grease gun, lubricate the clutch throw-out bearing and output shaft bearing with approved ball bearing grease.

Operations requiring frequent de-clutching should be lubricated daily.



Figure 51

EVERY 250 HOURS

1. REPEAT DAILY AND 50-HOUR SCHEDULES

Follow previous instructions.

2. CLEAN EXTERIOR OF ENGINE

Use steam if available, otherwise any good commercial engine cleaner to wash down the engine.

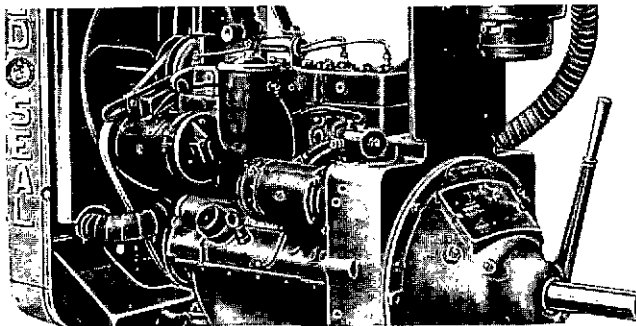

Figure 52

3. CHECK GOVERNOR CONTROL

Clean and lubricate all governor linkage to insure free operation of governor. Free-up any joints that may be binding or rods or levers that may be twisted. Check for full throttle opening.

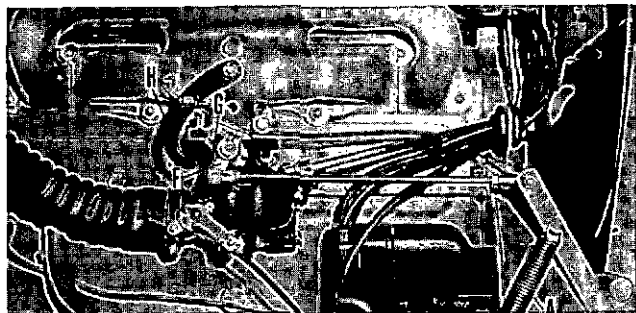

Figure 53

4. CLEAN SPARK PLUGS

Clean depressions around plugs before removing them — then clean and re-set point gap to .025 on standard plugs and .035 on resistor plugs.

Install spark plugs (18 mm) and tighten to 35 ft. lbs. torque.



Figure 54

5. CHECK DISTRIBUTOR

Clean distributor cap inside and outside with solvent without removing wires and blow off with compressed air — inspect cap and rotor for cracks.

Examine contact surfaces of points — replace if burned or pitted and adjust to .020 gap.

Lubricate distributor cam sparingly with a lubricant such as Mobilgrease Special (with Moly).

Check distributor clamp bolts and if found loose — retiming the engine is necessary.

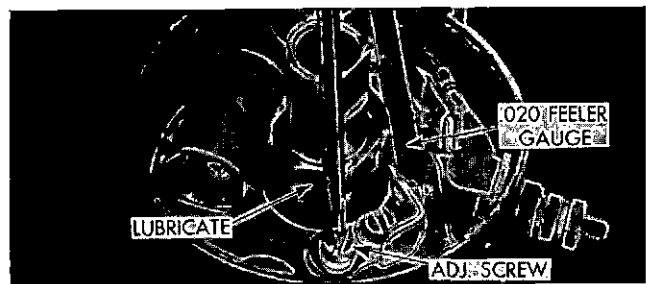

Figure 55

6. INSPECT IGNITION WIRES AND CONNECTIONS

Examine ignition wires for breaks in insulation, chafing and loose connections. Replace if defective.

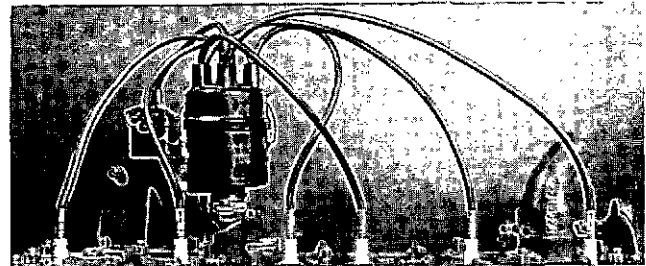

Figure 56

7 IF DRY REPLACEABLE ELEMENT AIR CLEANER IS USED, REPLACE ELEMENT.

EVERY 500 HOURS

1. REPEAT DAILY — 50 HOUR AND 250 HOUR SCHEDULES

2. COOLING SYSTEM

Clean radiator core by blowing out with compressed air.
 Inspect radiator mounting.
 Inspect water pump and connections for leaks.
 Check fan and accessory drive belts.

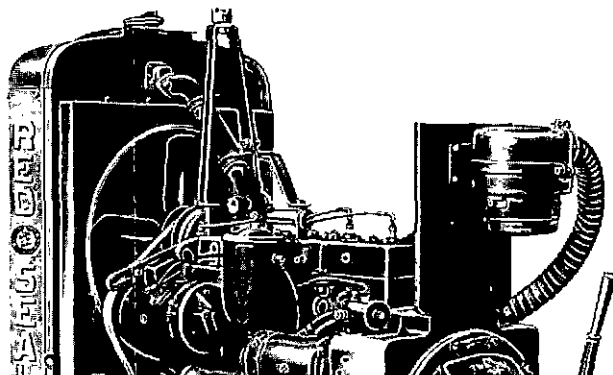

Figure 57

3. ADJUST VALVE TAPPET CLEARANCE

Check and adjust intake and exhaust valve tappets to following clearances at idling speed and running temperature:

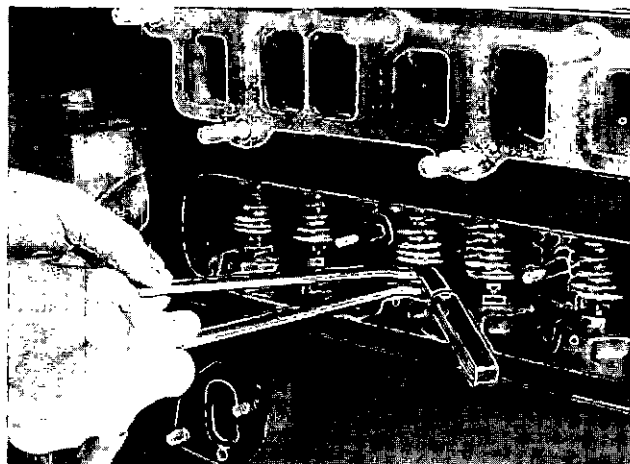

Figure 58 — Adjusting Valve Tappet Clearance

	INTAKE	EXHAUST
N-56	.015	.015
N-62	.012	.012
Y Series	.012	.012
F Series	.014	.014
M Series	.017	.020
B Series	.017	.022

4. CARBURETOR

Clean exterior and check mounting to manifold.
 Adjust carburetor air adjustment for even running and adjust idle speed to 400-600 R.P.M. minimum.
 Inspect throttle and choke linkage for free operation.

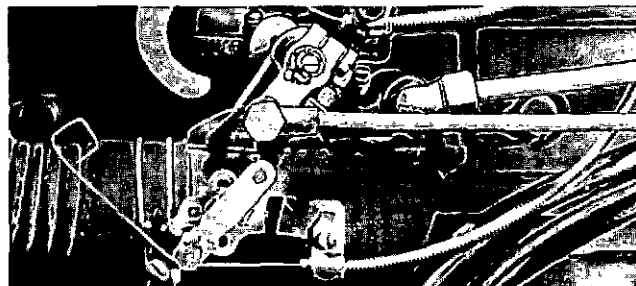

Figure 59 — Carburetor

5. FUEL PUMP

Clean Filter bowl and screen.
 Inspect mounting and gasket.
 Check all connections for leaks.

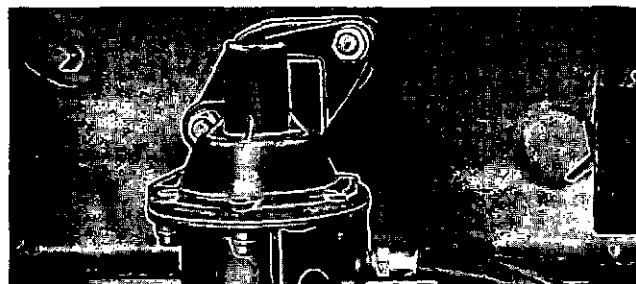

Figure 60 — Fuel Pump Mounting

6. MAGNETO (when equipped)

Spark test with engine operating by checking firing with each high tension cable held about 1/16" away from spark plug terminal.

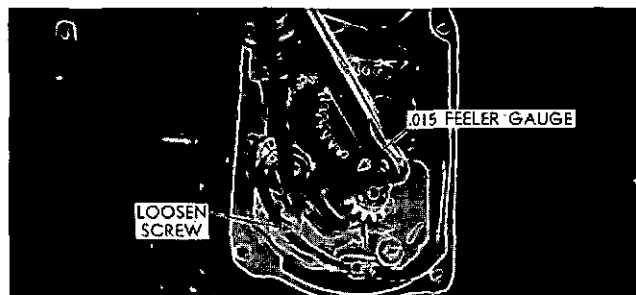

Figure 61

Remove end cap and examine carbon brushes for free-movement and inspect breaker points for wear and gap. Gap should be .015.

7. SAFETY AND THERMAL CONTROLS

Inspect control wires and connections.
 Examine armored capillary tubing on water temperature element for visual damage that may cause faulty operation.

SECTION V COOLING SYSTEM

The function of the cooling system is to prevent the temperatures in the combustion chamber, which may reach as high as 4000° F., from damaging the engine and at the same time keep the operating temperatures within safe limits.

Maintaining the cooling system efficiency is important, as engine temperatures must be brought up to and maintained within satisfactory range for efficient operation; however, must be kept from overheating, in order to prevent damage to valves, pistons and bearings.

CONTINENTAL L-HEAD COOLING SYSTEM

With the exception of some "N" and a few "Y" engine specifications, all Continental L-Head engines have the cooling water force-circulated by a water pump and use a thermostat and by-pass system to control the temperature range.

Some of the "N" and a few of the "Y" specifications circulate the cooling water using the Thermo-Syphon system — which requires no water pump or thermostat — but circulates the water from the resulting liquid expansion when heated and contraction during cooling.

The coolant from the water pump is first directed in the block against the exhaust valve seats and into passages connecting the cylinder head. This method provides the coldest water reaching the parts subjected to the highest temperatures.

The cylinder walls, in turn, are cooled their full length by convection currents only, which keeps

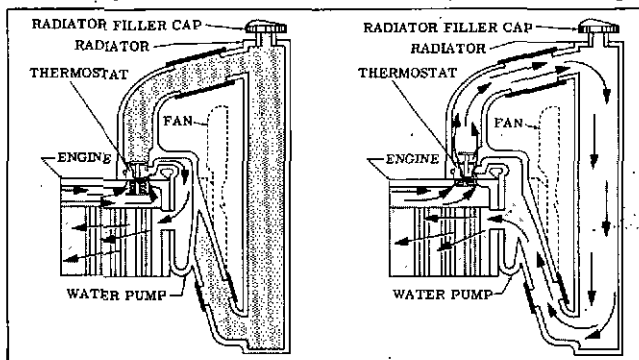

**Figure 62 — Thermostat
Flow Control**
Thermostat Closed, Water Re-Circulating through Engine ONLY

Thermostat Open, Water Circulating through BOTH Engine and Radiator

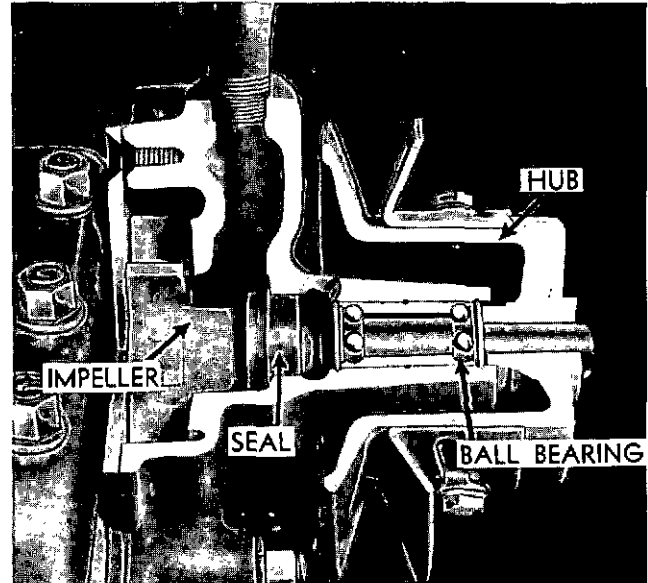

Figure 63 — Water Pump

the cylinder barrels at a more uniform temperature and thereby reduces crankcase oil dilution and sludge formation.

Upon leaving the cylinder head, the water enters the thermostat housing, in which is mounted the by-pass type thermostat, which controls the opening to the radiator or heat exchanger. Upon being discharged from the thermostat housing, the water enters the radiator or heat exchanger, depending upon the application, where it is cooled before re-entry into the engine.

Continental L-Head gasoline engines operate most efficiently with water temperatures of 150°-185° F. and a thermostat and by-pass system is generally used to control these temperatures.

The thermostat valve remains closed and only allows the water to recirculate within the engine itself until normal operating temperatures are reached. This provides for both rapid and even temperature increase of all engine parts during the warm-up period. When desired temperature is reached, the thermostat valve opens and allows the water to circulate through both the engine and radiator.

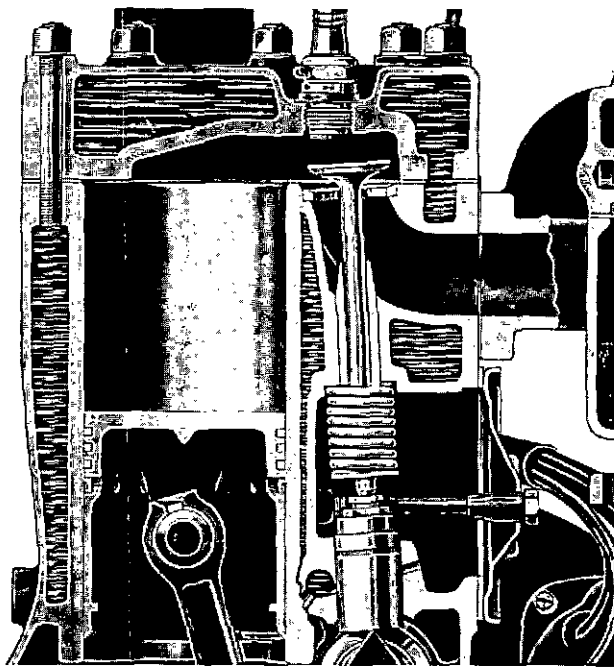

Figure 64 — Sectional View Showing Water Passages in head and block

EXPANSION OF WATER

Water has always been the most commonly used coolant for internal combustion engines because it has excellent heat transfer ability and is readily obtained everywhere. Like all liquids it expands when heated, the rate of expansion being $\frac{1}{4}$ pint per gallon when the temperature is raised from 40° to 180° F.

For example: If a 4 gallon cooling system is filled completely full of water at 40° F, 1 pint will be lost through the radiator overflow pipe by the time the water temperature reaches 180° F.

WATER FILTERS

In some areas, the chemical content of the water is such, that even the best of rust inhibitors will not protect the cooling system from the formation of rust and scale.

There are instances where this corrosive element has eaten holes through cast iron parts such as water pump impellers and bodies. This condition is caused by electrolysis taking place in the parts involved.

Where these conditions exist, water filters, such as those made by the Perry Co. and the Fram Corp., should be incorporated in the assembly to remove these troublesome elements and offset the electrolytic action.

EFFECT OF ALTITUDE ON COOLING

Water boils at 212° F under atmospheric pressure at sea level. This pressure becomes less

at higher altitudes and the reduced pressure causes water and other liquids to boil at a lower temperature. The following chart shows the effect on boiling point of water and anti-freeze solution:

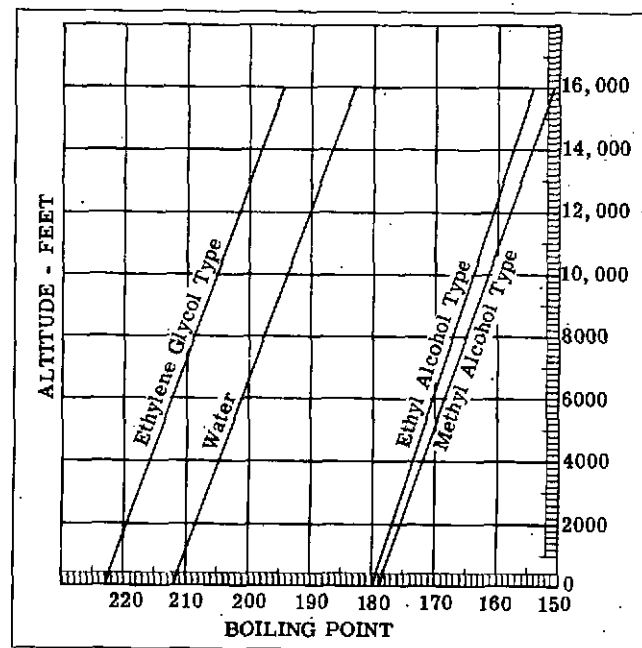

Figure 65 — Effect of Altitude on Boiling Point of Coolant

ANTI-FREEZES

Water freezes at 32° F., forms solid ice and expands about 9% in volume — which causes tremendous pressure and serious damage when allowed to freeze inside the cooling system.

When operating temperatures are below 32° F. an anti-freeze liquid must be added which will lower the freezing point a safe margin below the anticipated temperature of outside air.

Anti-freeze solutions come in 3 general types and may be used in the following proportions by volume to withstand the temperatures indicated: for example, 1 quart of alcohol to 3 quarts of water for 10° F.

TYPES OF ANTI-FREEZE	OPERATING TEMPERATURE RANGE		
	32° to 10° F	+10° to -10° F	-10° to -30° F
PLAIN ALCOHOL — (evaporates easily) — Check with Hydrometer and replenish often. — If spilled on paint wash thoroughly immediately.....	1 to 3*	4 to 9	5 to 8
METHYL ALCOHOL COMPOUNDS — such as Mobil Freezone, etc., (evaporates less easily) — Check and replenish occasionally.	1 to 4	2 to 5	1 to 1
ETHYLENE GLYCOL — such as Mobil Permazone, (permanent type) — When there are no leaks add water only to make up for evaporation.....	1 to 4	2 to 5	1 to 1

*Example: 1 qt. of alcohol to 3 qts. of water.

NOTE: While the above list includes information on three types of generally used Anti-Freeze, the Ethylene Glycol or Permanent Type will be found to be the most desirable and likewise the most economical because of the temperatures desirable to maintain for efficient operation.

CORROSION INHIBITORS

Water forms rust due to its natural tendency to combine chemically with iron and air in the system. Rust inhibitors for water are inexpensive, simple to use and make cleaning and flushing necessary only after long periods of operation.

The most commonly used are either a 3% addition of soluble oil or commercial corrosion inhibitors such as Mobil Hydrotone that are readily available at low cost. The addition of corrosion inhibitors are not necessary if an anti-freeze containing a rust inhibitor is used.

RADIATOR

The radiator or heat exchanger consists of a series of copper tubes through which the cooling water is circulated. In standard radiator design fins are connected to the copper tubes to give an extended surface through which heat can be dissipated. It is important that these tubes be kept clean on the inside and the fins free of dirt on the outside so that maximum heat transfer can take place in the radiator.

Blowing out between the fins of the radiator, using compressed air, in a direction opposite to

that of the fan circulated air, will serve to keep the cooling surfaces of the core free of dirt and other particles.

Every 500 hours of operation the radiator and cooling system should be well cleaned and flushed with clean water. (See Radiator Drain.)

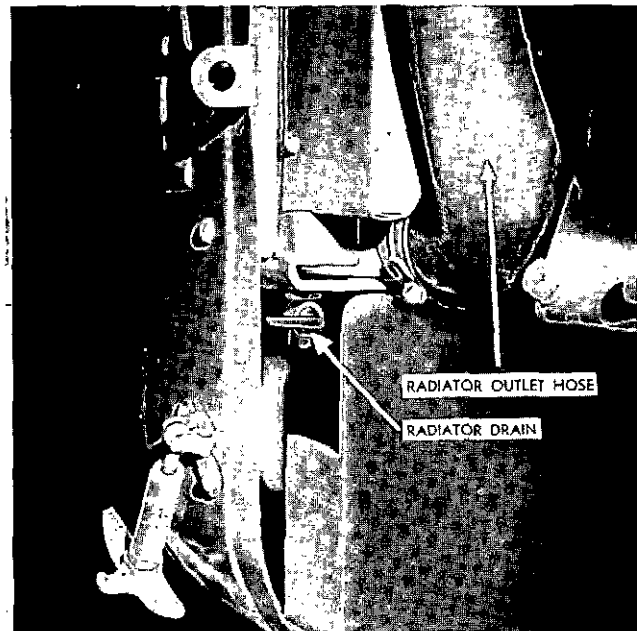

Figure 66 — Radiator Drain

Wherever possible, only soft clean water should be used in the cooling system. Hard water will cause scale to form in the radiator and the engine water jackets and cause poor heat transfer. Where the use of hard water cannot be avoided an approved water softener can be used.

CLEANING COOLING SYSTEM

Deposits of sludge, scale and rust on the cooling surfaces prevent normal heat transfer from the metal surfaces to the water and in time render the

COOLING SYSTEM

cooling system ineffective to properly maintain normal operating temperatures. The appearance of rust in the radiator or coolant is a warning that the corrosion inhibitor has lost its effectiveness and should be cleaned before adding fresh coolant.

Dependable cleaning compounds should be used. Follow the procedure recommended by the supplier. This is of prime importance because different cleaners vary in concentration and chemical compositions. After cleaning and flushing, the system should be filled with an approved anti-freeze compound containing a rust and corrosion inhibitor or water with a corrosion inhibitor.

REVERSE FLOW FLUSHING

Whenever a cooling system is badly rust-clogged as indicated by overflow loss or abnormally high operating temperatures, corrective cleaning by reverse flow flushing will most effectively remove the heavy deposits of sludge, rust and scale. The reverse flow flushing should be performed immediately after draining the cleaning solution and it is advisable to flush the radiator first, allowing the engine to cool as much as possible.

Reverse flush the radiator, as follows:

1. Disconnect the hoses at the engine.
2. Put radiator cap on tight.
3. Clamp the flushing gun in the lower hose with a hose clamp.

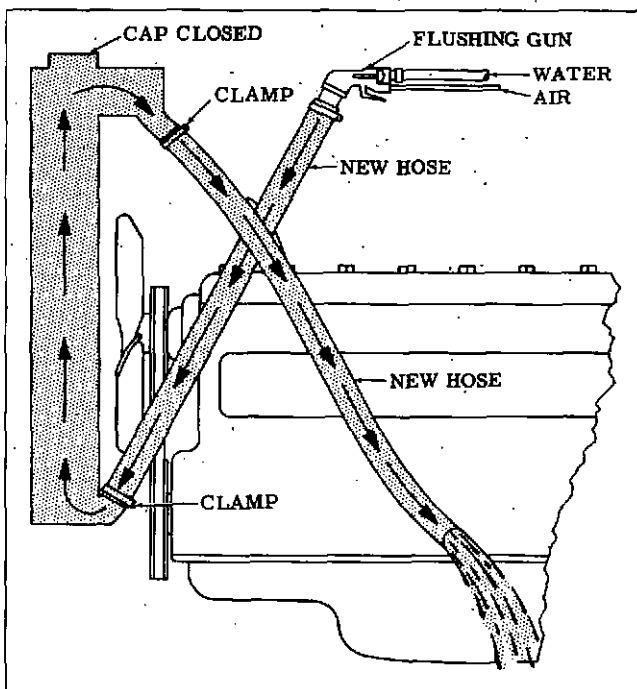

Figure 67 — Reverse Flushing Radiator

4. Turn on the water and let it fill the radiator.
5. Apply air pressure gradually, to avoid radiator damage.
6. Shut off the air, again fill the radiator with water and apply air pressure — repeat until the flushing stream runs out clear.
7. Clean and inspect radiator cap.

To Reverse flush the engine water Jacket

1. Remove the thermostat.
2. Clamp the flushing gun in the upper hose.
3. Partly close the water pump opening to fill the engine jacket with water before applying the air.
4. Follow the same procedure outlined above for the radiator by alternately filling the water jacket with water and blowing it out with air (80# pressure) until the flushing stream is clear.

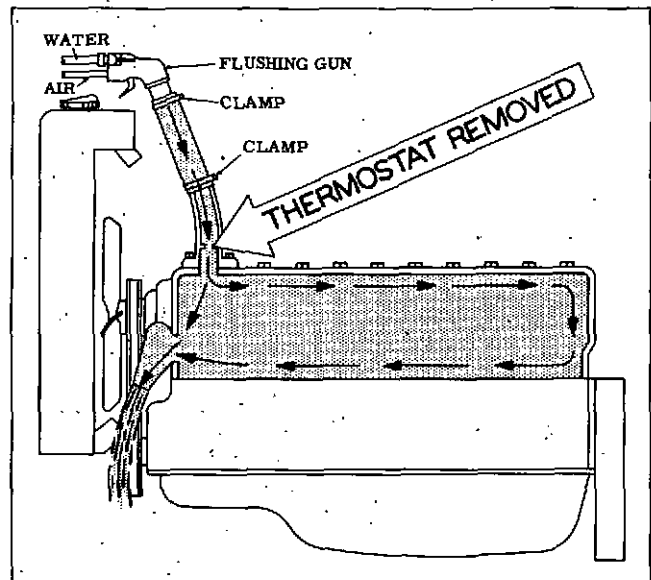

Figure 68 — Reverse Flushing Engine

TESTING THERMOSTAT

Remove Water Pump Header as shown in illustration. Before testing, clean and examine the bellows for rupture or distortion. If the valve can be pulled or pushed off its seat with only a slight effort when cold or it does not seat properly, the unit is defective and should be replaced.

The thermostatic operation can be checked in the following method:

1. Hang thermostat by its frame in a container of water so that it does not touch the bottom.
2. Heat the water and check temperature with a thermometer.

3. If the valve does not start to open at temperatures of 150-185° F or if it opens well before the 150° point is reached the thermostat should be replaced.

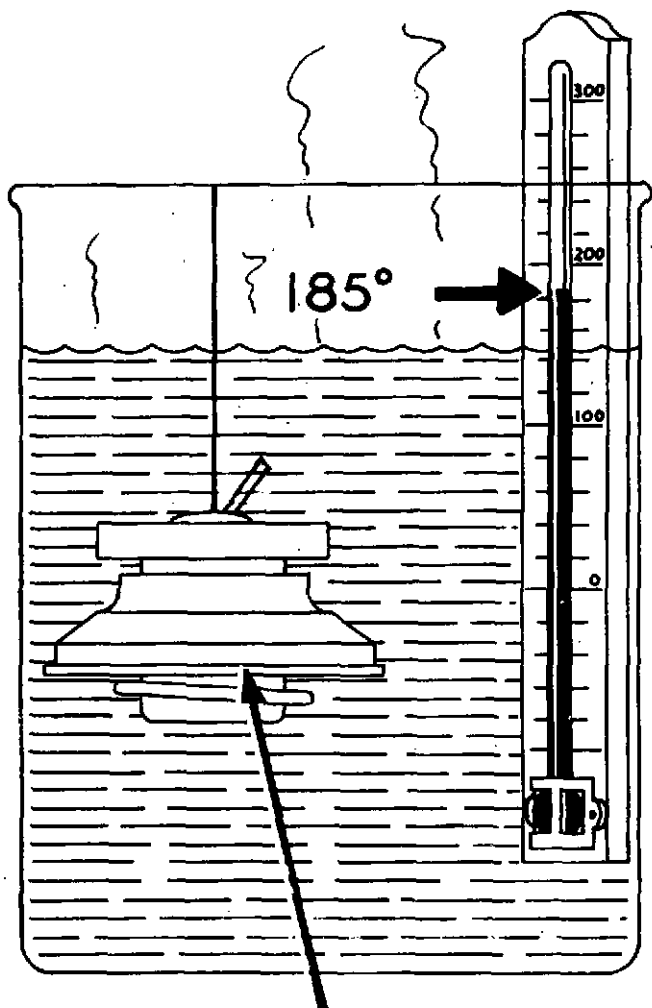

THERMOSTAT

Figure 69 — Checking Thermostat

When replacing the thermostat in the water outlet elbow, be sure seal is in place, and seal seat as well as the counterbore is clean.

Assemble new gasket to pump body or spacer. Thermostat flange must seat in counterbore with gasket sealing contact between it and the pump body.

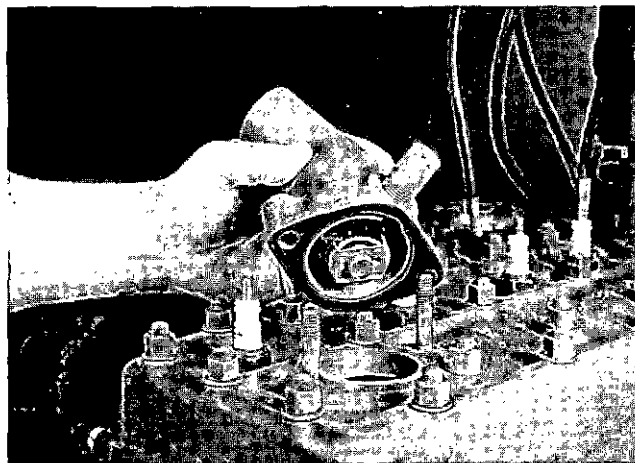

Figure 70 — Replacing Thermostat

RADIATOR PRESSURE CAP

Many operations use a pressure cap on the radiator to prevent overflow loss of water during normal operation. This spring loaded valve in the cap closes the outlet to the overflow pipe of the radiator and thus seals the system, so that pressure developing within the system raises the boiling point of the coolant and allows higher temperatures without overflow loss from boiling. Most pressure valves open at 4½ or 7 pounds, allowing steam and water to pass out the overflow pipe, however, the boiling point of the coolant at this pressure is 224° F or 230° F at sea level. When a pressure cap is used an air tight cooling system is necessary with particular attention to tight connections and a radiator designed to withstand the extra pressure.

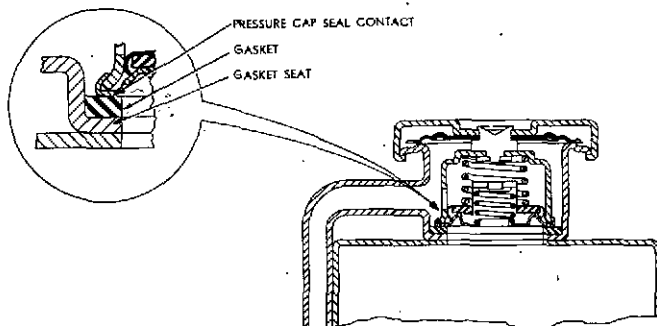

Figure 71 —

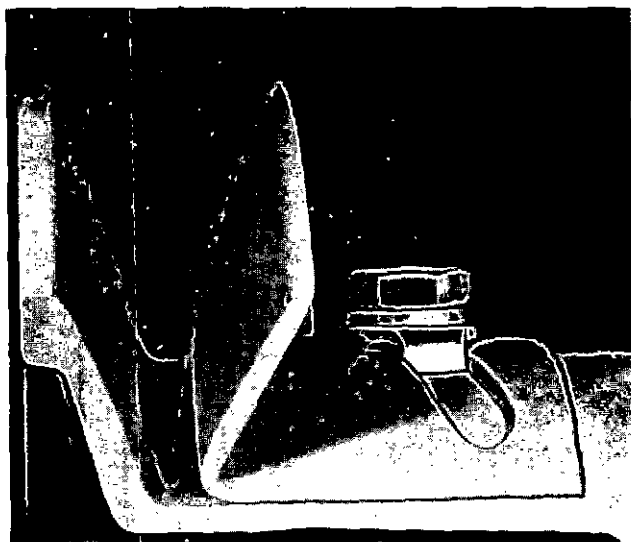

Figure 72 — Fan Belt Adjusting Flange

FAN BELT TENSION

When tightening fan belts, loosen the generator adjusting bolts and pull out on the generator by hand until the belt is just snug. Under no circumstances should a pry bar be used on the generator to obtain fan belt tension or damage to the bearings will result. Some engines have an adjustable fan pulley flange for belt adjustment.

When adjusted correctly the fan belt should have between $\frac{3}{4}$ " to 1" deflection on the long side.

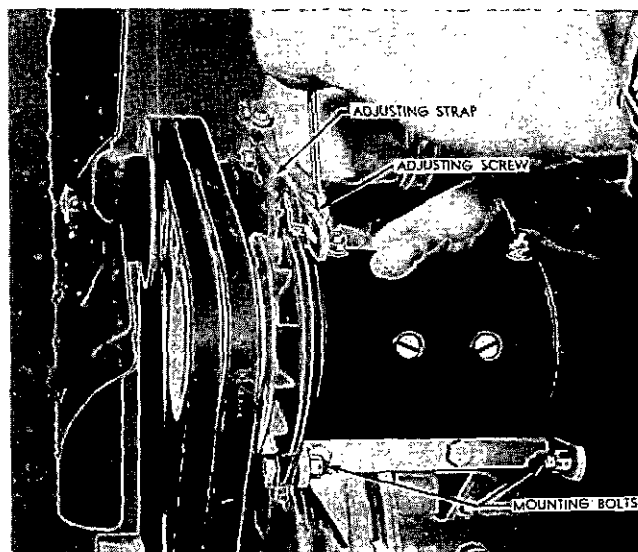

Figure 73 — Adjusting Fan Belt Tension

CYLINDER BLOCK WATER DRAINS

When the cooling system is to be completely drained, there are one or two drain plugs on the right hand side of the cylinder block depending upon engine models, which drain all cooling water which might be trapped in the base of the block.

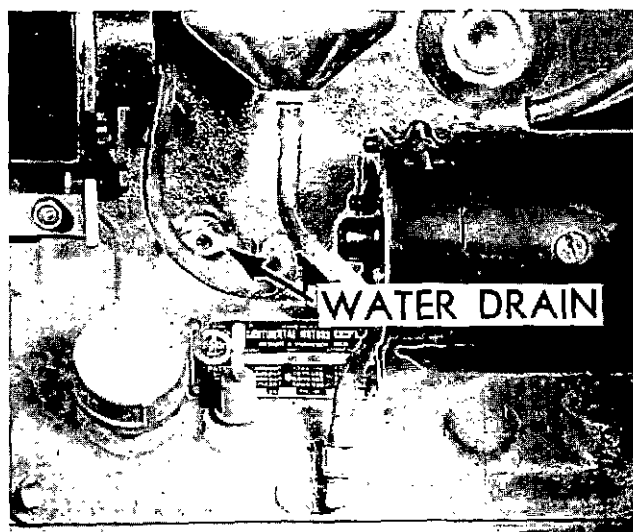

Figure 74 — Water Drain

CAUTION: OVERHEATED ENGINE

Never pour cold water or cold anti-freeze into the radiator of an overheated engine. Allow the engine to cool and avoid the danger of cracking the cylinder head or block. Keep engine running while adding water.

OVERCOOLING

Continuously low operating temperature wastes fuel, increases engine wear and causes oil sludge and corrosion of engine parts.

Overcooling may be caused by operating conditions such as excessive idling, low speeds and light loads during cold weather. Partly covering the radiator or use of a thermostatic or manually controlled shutter will improve this condition. Improper thermostat or shutter operation can also regulated to maintain 150° - 185° operating temperature.

WATER PUMP

The water pump is located in the front of the cylinder block and is driven by the fan belt from the crankshaft pulley. The inlet of the water pump is connected to the lower radiator connection and the outlet flow from the pump is through integral passages cast in the block.

No lubrication of the pump is required except on the M and B series as the bearings are of the permanently sealed type and are packed with special lubricant for the life of the bearing.

The water pump requires no attention other than bearing replacement when they show excessive looseness or if a water leak develops which shows a damaged or badly worn seal that needs replacement.

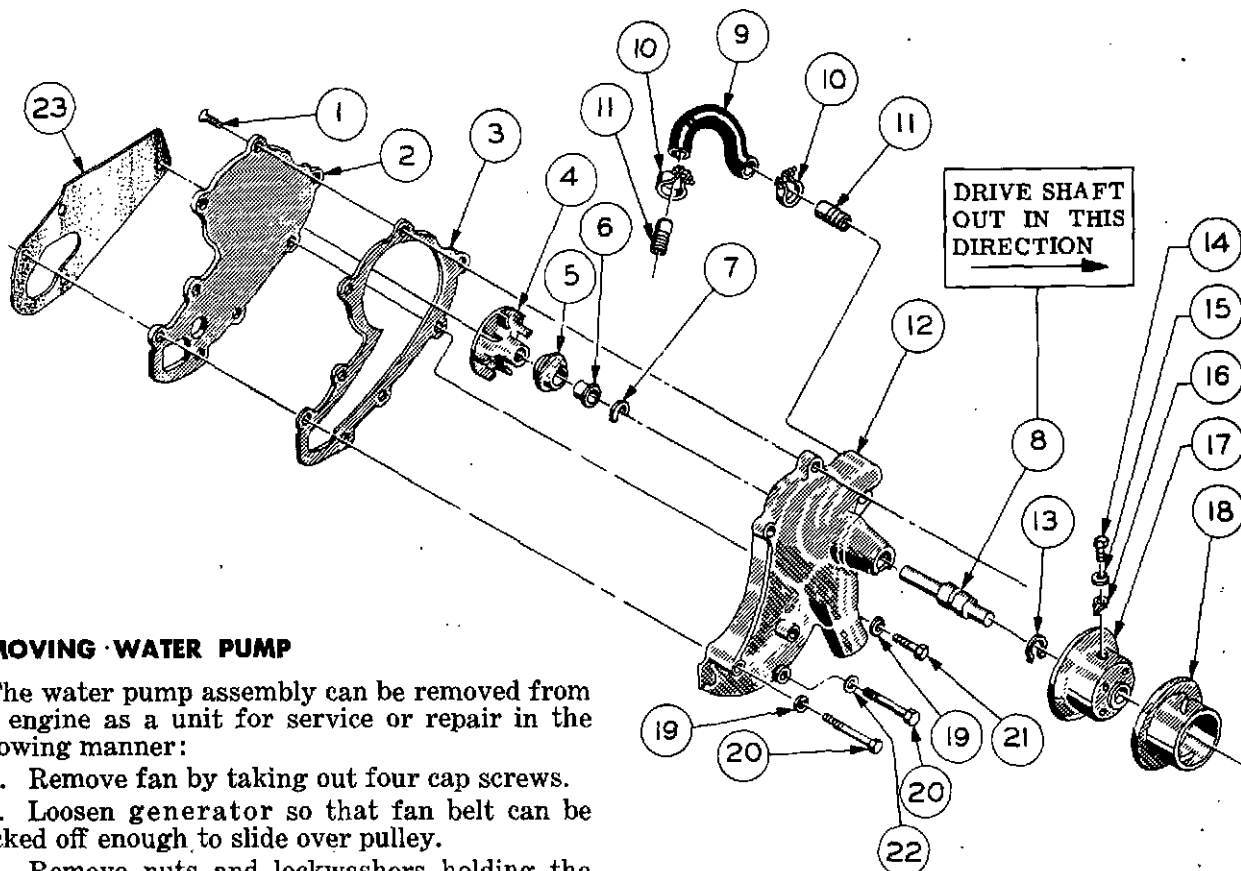

REMOVING WATER PUMP

The water pump assembly can be removed from the engine as a unit for service or repair in the following manner:

1. Remove fan by taking out four cap screws.
2. Loosen generator so that fan belt can be slacked off enough to slide over pulley.
3. Remove nuts and lockwashers holding the pump body to the front of the block and remove the pump assembly.

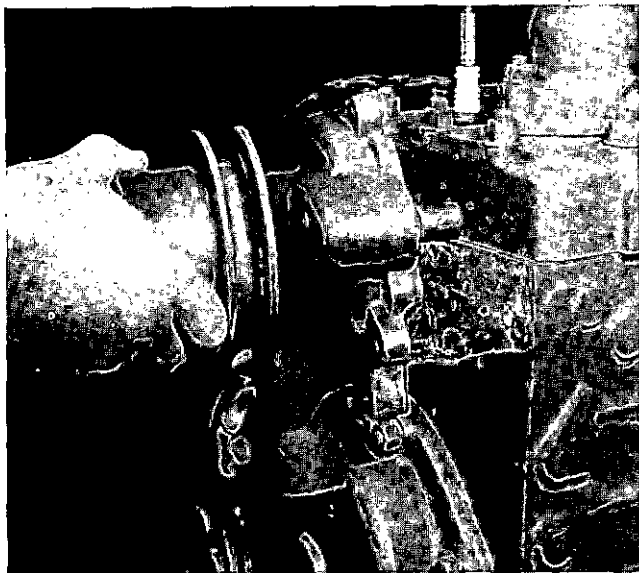

Figure 75 — Removing Water Pump

DISASSEMBLY OF WATER PUMP

When replacement of any internal parts becomes necessary, disassembly must be in the following sequence in order to prevent damage to the pump.

1. Before removing pump use puller to remove fan hub (17) from shaft.
2. Remove cap screws attaching pump to engine (20) (21).

Figure 76 — Disassembling Water Pump

3. Remove countersunk screws (1) holding cover (2) removing cover and gasket.
4. Use puller to remove impeller (4) taking precautions to prevent damage to the casting.
5. Remove seal (5) and water shedder (6).
6. Remove lock ring (13) holding bearing and shaft assembly in body after which shaft (8) can be forced out through the front with an arbor press or lead hammer. **DO NOT ATTEMPT TO DRIVE WATER PUMP SHAFT (8) OUT THROUGH REAR OF HOUSING.** To do so will damage the housing beyond repair.

REASSEMBLY AND INSTALLATION

1. Reassemble pump, replacing worn or failed parts and reverse above instructions.

Seal contact surface must be smooth and flat. The bushing should be replaced, if scored or cut, but may be refaced and polished for further use, if not excessively worn or grooved.

A light film of lubricant applied to the face of the seal will facilitate seating and sealing.

2. Use thick soapsuds on both the seal and shaft when assembling in order to prevent damage to the seal.

3. Mount pump assembly on block using a new housing gasket.

4. Install fan belt and adjust belt tension to have $\frac{3}{4}$ " to 1" deflection on long side. Pull out the generator by hand, as bearing damage will result with a pry bar; in some cases this may be adjusted by the adjustable fan pulley.

SECTION VI FUEL SYSTEM

The basic purpose of the fuel system is to store, convey, mix fuel with air, then vaporize and introduce the mixture into the engine.

Fuel is stored in the gasoline tank; it is filtered and flows through the fuel supply line to the carburetor — either by gravity or under pressure of a fuel pump. The carburetor mixes the fuel with proper proportions of air and at the same time breaks it into very fine spray particles. This atomized spray changes to vapor, by absorbing heat as it travels through the intake manifold to the combustion chamber. Fuel must be vaporized since it will not burn well as a liquid.

GRAVITY FUEL SYSTEM

This is the most simple fuel system and is generally used on power units as it eliminates the need of a fuel pump — it only requires the fuel tank located higher than the carburetor.

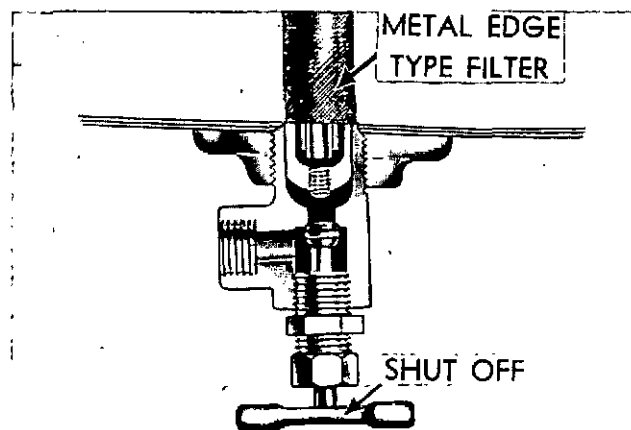

Figure 77 — Edge Type Filter

All power units with fuel tank have a combination shut-off valve and an efficient metal edge type filter. This filter prevents all foreign particles and water from entering the carburetor.

With reasonable care in filling the tank with clean fuel, this filter will require only seasonal cleaning of both the filter and tank.

MECHANICAL FUEL PUMP

The Mechanical Fuel Pump is generally used when the fuel supply is below the level of the carburetor. They are of several models dependent upon the diaphragm diameter and assembly arrangement with fuel strainer bowl, air dome and manual primer.

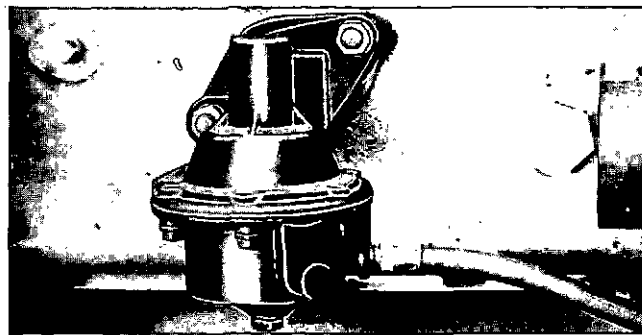

Figure 78 — Fuel Pump

This mechanical fuel pump mounts on the cylinder block pad and is driven by an eccentric on the engine camshaft contacting the fuel pump rocker arm.

Constant fuel pressure is maintained by an air dome and a pulsating diaphragm operated and controlled by linkage which adjusts itself to pressure demands.

Fuel Pump Tests — The fuel pressure may be measured by installing the pressure gauge between the fuel pump and carburetor.

The AC fuel pump size and static pressures @ 1800 R.P.M for the L-Head engines are.

ENGINE MODEL	DIAPHRAGM DIAMETER	FUEL PRESSURE	MAX. LIFT
N	3 1/4	1 1/2 - 2 3/4 #	10'
Y	3 1/4	2 - 2 3/4 #	10'
F	3 1/4	1 1/2 - 2 1/4 #	10'
M	3 7/8	3 - 4 1/2 #	10'
B	3 7/8	3 - 4 1/2 #	10'

When pressures are below the range, pump should be disassembled and reconditioned with the special overhaul kits available.

Maintenance — Fuel pump trouble is of only two kinds — either the pump is supplying too little gas or, in rare cases, too much.

If the pump is supplying too little gas, the engine either will not run or it will cough and falter. If too much gas — it will not idle smoothly or you will see gasoline dripping from the carburetor.

If the engine is getting too little gas — the trouble may be in the pump, fuel line or the gas tank. First, be sure there is gas in the tank, then disconnect the pump to carburetor line at the pump or carburetor, and turn the engine over a few times with the ignition off. If gas spurts from the pump or open end of the line — the pump, gasoline and tank are OK.

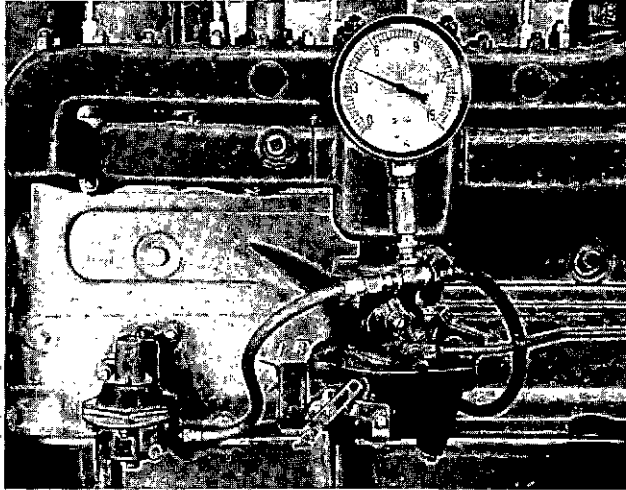

Figure 79 — Checking Fuel Pressure

If there is little or no Flow—check the following:

1. Look for leaky bowl gasket or line connections — tighten them.
2. Remove and clean with solvent the gas strainer or screen inside the pump bowl.
3. Look for clogged fuel line — Blow out with compressed air.
4. Make sure that all pump cover screws and external plugs are tight.
5. Inspect flexible fuel line for deterioration, leaks, chafing, kinks or cracks. If none of these items restore proper flow — remove the pump for replacement or overhaul.

If getting too much gas — an oversupply of gasoline is generally caused by trouble other than the fuel pump — so first check the following:

1. Defective Automatic Choke.
2. Excessive use of hand choke.
3. Loosely connected fuel line, or loose carburetor assembly screws.
4. Punctured carburetor float.
5. Defective carburetor needle valve.
6. Improper carburetor adjustment.

If none of these items corrects flooding, remove the fuel pump for replacement or overhaul.

ELECTRIC FUEL PUMP

Many L-Head engines use electric fuel pumps operated from the storage battery supply. The pump should be mounted close to the fuel tank so as to provide fuel pressure at all points along the fuel line and so eliminate vapor lock.

The electric fuel pump is energized in the ignition circuit — which assures quick filling of the carburetor and fuel lines to effect easy starting.

When fuel pump trouble is suspected, disconnect the fuel line at the carburetor and turn on the ignition switch. Pump fuel into a small container, then place your finger on the outlet side of the fuel line. If the pump stops or ticks very infrequently, the pump and fuel line connections are satisfactory. Remove your finger from the outlet side of the fuel

line and if ample fuel flows — the pump is satisfactory.

If fuel does not flow and all connections are tight, the pump should be replaced or repaired. Always be sure of a good ground and check for faulty flexible fuel lines and poor electrical connections.

CARBURETOR

Continental L-Head gasoline engines normally use various models of Zenith and Marvel-Schebler carburetors — of both the updraft and downdraft types.

The carburetor mixes fuel with air and meters the mixture into the engine as the power is demanded. Most carburetors incorporate the following systems to provide the flexibility and sensitive requirements of varying loads and conditions:

- 1 — **Float System** — Controls the level and supply of fuel.
- 2 — **Idle or Low Speed** — Furnishes the proper mixture for the engine idle, light load and slow speeds, until the main metering system functions.
- 3 — **Main Metering System** — Controls the fuel mixture from part throttle operation to wide open throttle.
- 4 — **Power or Economizer System** — Provides a richer mixture for maximum power and high speed operation. This system ceases to function when the manifold vacuum is above 6" Hg.
- 5 — **Compensating System** — Provides a mixture which decreases in richness as the air speed increases.
- 6 — **Choke System** — Delivers additional fuel to the manifold for cold engine starting.

ZENITH CARBURETOR

The Zenith 62 Series carburetor shown below has the following three adjustments:

- 1 — **Main Adjustment Screw** — Determines the amount of fuel which may be obtained for high speed operations.

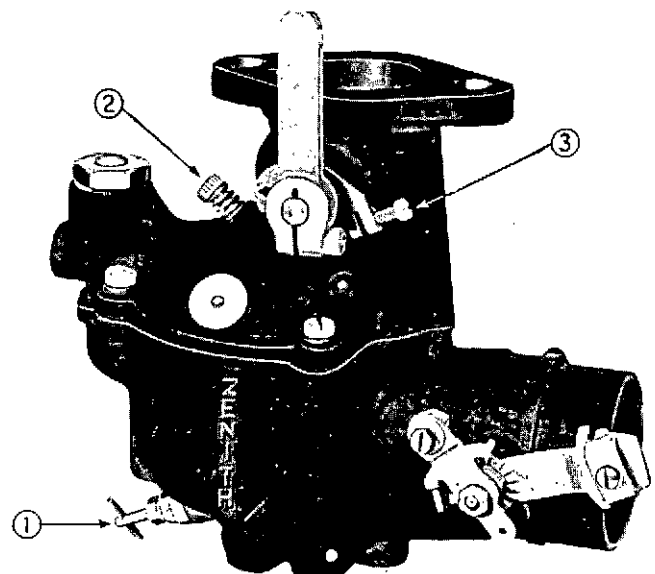

Figure 80 — Zenith 62 Series Carburetor

To set this adjustment, open the throttle to about $\frac{1}{4}$ open. Turn the adjustment clockwise, shutting off the fuel until the engine speed decreases or begins to miss due to lean mixture. Now open the adjustment until the engine reaches its maximum speed and runs smoothly without missing.

2 — **Idle Mixture Adjustment Needle**—Controls the amount of air admitted to the idling system, which functions only at low speeds.

Turning the screw clockwise cuts off the air, making the mixture richer — while unscrewing it admits more air making the mixture leaner. The idling adjustment needle should be set for the smoothest running of the engine; or, if a vacuum gauge can be attached to the manifold, set the adjustment for highest manifold vacuum.

3 — **Idle Speed Adjustment Screw** — controls the idling speed — which should be 400-600 R.P.M. for most industrial applications.

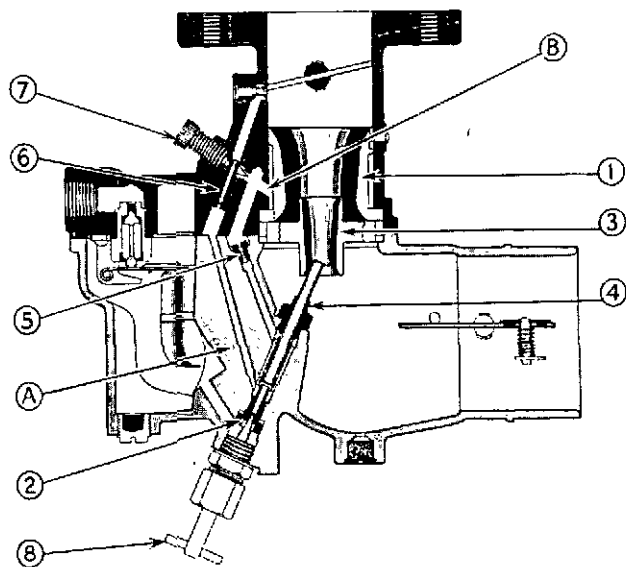

Figure 81 — Sectional View of a Zenith Carburetor

- No. 1. Venturi
- No. 2. Main Jet (High Speed)
- No. 3. Secondary Venturi
- No. 4. Main Discharge Jet
- No. 5. Well Vent
- No. 6. Idling Jet
- No. 7. Idle Adjusting Needle
- No. 8. Main Jet Adjustment
- A — Main Jet Channel
- B — Idle Channel

MARVEL-SCHEBLER CARBURETOR
(Model TSX)

The Model TSX carburetor without power adjustment has the following two adjustments.

Preliminary Adjustments

- 1 — Set throttle stop screw "A" so that throttle disc is open slightly.
- 2 — Make certain that gasoline supply to carburetor is open.
- 3 — Set throttle control lever to $\frac{1}{3}$ open position.

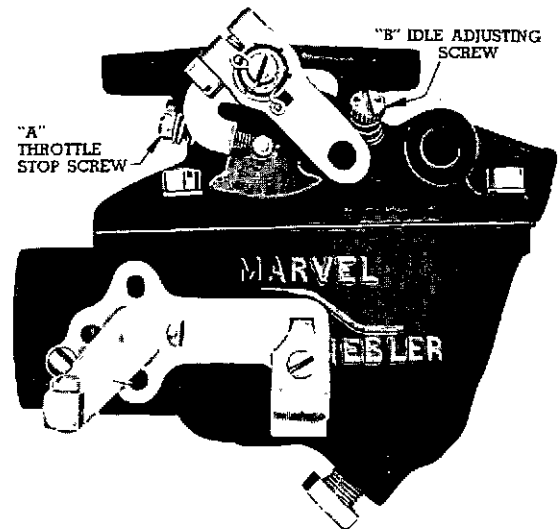

Figure 82 — Marvel-Schebler TSX Carburetor

- 4 — Close choke valve by means of choke control button.
- 5 — Start engine and partially release choke.
- 6 — After engine is up to operating temperature throughout, see that choke is returned to wide open position.

Low Speed or Idle Adjustment

- 1 — Set throttle or governor control lever in slow idle position.

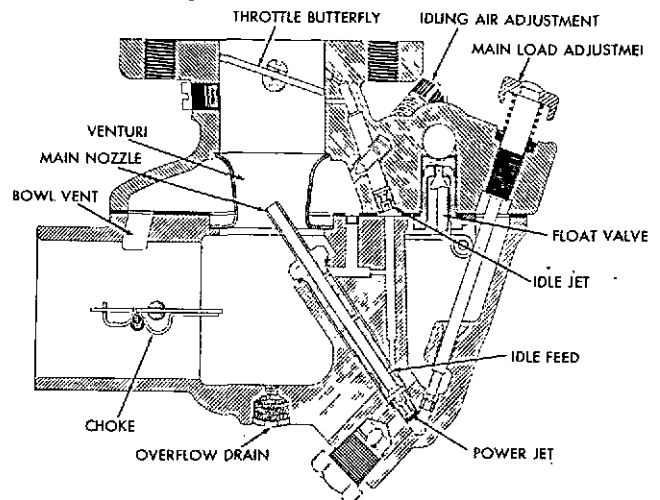

Figure 83 — Sectional View of the Marvel-Schebler Carburetor

- 2 — Adjust throttle stop screw "A" for correct engine idle speed (normally 400-600 RPM).
- 3 — Turn idle adjusting screw "B" in, or clockwise, until engine begins to falter or roll from richness, then turn screw "B" out, or counter-clockwise, until the engine runs smoothly.

NOTE: IT IS BETTER TO HAVE THIS ADJUSTMENT SLIGHTLY TOO RICH THAN TOO LEAN.

CARBURETOR CHOKES

Manually Operated Choke — is operated by a flexible cable control from the instrument panel or rear house panel. While this is the most simple

type, it is most important that the operator have the choke valve in wide open position when engine operating temperature is reached.

ZENITH ELECTRIC CHOKE CONTROL

Is made as part of the carburetor assembly. It is directly connected to the choke shaft and automatically controls the opening during the entire engine operation.

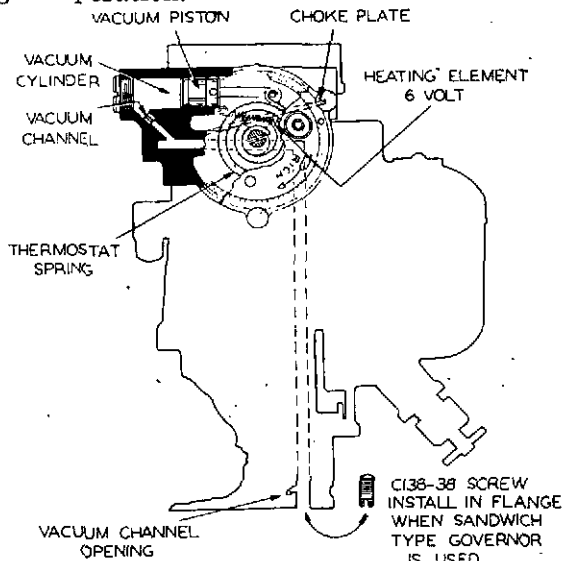

Figure 84 — Zenith Electric Choke

Manifold vacuum is used to open the choke shaft partially after the initial firing of the engine, and heat is used on the thermostat spring to control the amount of opening during the warming up period. This heat is provided by an electric element in the thermostat chamber. Fast idling during the warm-up period is also provided by a throttle advance mechanism which is actuated from the choke shaft.

The heating element which is energized when the ignition is "on" gradually warms the thermostat, decreasing its resistance to the pull of the vacuum piston, which gradually causes the choke to open and moves the throttle advance to the warm idle position.

All units are initially set with the thermostat 15 notches rich for 70° F. ambient temperature. Temperature corrections can be made by allowing one notch on the cover for each 5 degrees variation — making certain that the choke valve is fully open when operating temperatures are reached.

SISSON AUTOMATIC CHOKE

Uses an electro-magnet and a thermostat to automatically close the carburetor choke valve for cold starting and regulates its degree of opening as the engine warms.

The unit is mounted on the exhaust manifold and a small rod connects it to the carburetor choke lever. The electro-magnet is energized by the starter circuit which pulls an armature lever down, closing the choke valve.

As soon as the engine starts, the electro-magnet circuit is broken and then the thermostat provides automatic adjusting of the choke valve during the warming-up period.

The carburetor choke lever should be adjusted so that when the carburetor choke valve is closed

tight, there will be .015" to .020" clearance between the automatic choke lever and the field pole that serves as a stop. This measurement is taken at "A" and must be made with thermostatic control "B" pushed down as far as it will go.

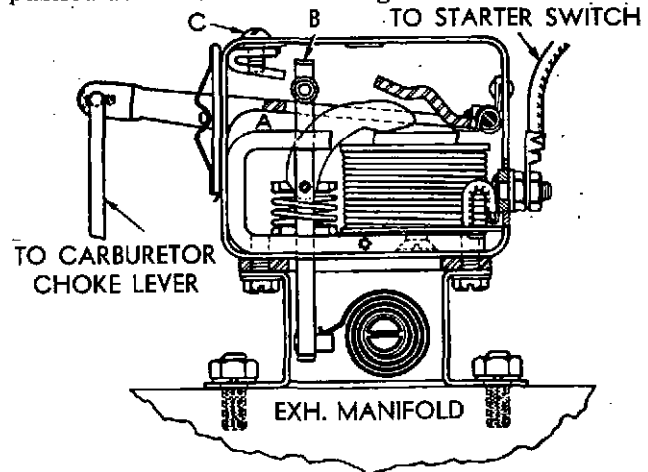

Figure 85 — Sisson Automatic Choke

CAUTION: Do not oil the Sisson automatic choke under any circumstance.

Carburetor Service — In general any change in carburetor action will usually come gradually, therefore, if the carburetor operated satisfactorily when last used, it can reasonably be assumed that some other part of the engine is at fault — which should be corrected before disturbing the carburetor.

Dirt is the main enemy of good carburetion as it fills up the minute air and gasoline passages and accelerates the wear of delicate parts.

Never use a wire to clean out restrictions in jets as this will destroy the accurate calibrations of these parts — **always use compressed air**. The jets are made of brass to prevent rust and corrosion and a wire would cut or ream the hole in the jet and ruin it.

Maintaining correct fuel level in the carburetor bowl is important — as the fuel flow through the jets is naturally affected by the amount of fuel in the bowl.

After a carburetor has been in service for some time, the holes in the jets and the float valve and seat become worn from the constant flow of fuel through them and should be overhauled by a competent carburetor service station.

Do not experiment with other size jets or any so-called fuel-saving gadgets as your arrangement has been thoroughly tested on a dynamometer program.

GOVERNORS

The governor is a device which controls engine speed — either keeping it operating at a constant speed or preventing it from exceeding a predetermined speed. It promotes engine operation economy and eliminates needless engine failures.

Continental L-Head engines use many types of velocity and centrifugal governors — however the majority use centrifugal (Mechanical) governors.

VELOCITY GOVERNORS

Velocity Governors — are generally used to prevent engine speed from exceeding a predetermined maximum. The governor is mounted between the carburetor and manifold flanges. In its most simple form, it consists of a main body, which contains a throttle shaft, a throttle valve and a main governor spring. The main governor spring is attached by linkage to the governor shaft and the spring force holds the throttle valve open.

When the engine is started, air flows through the carburetor throat and the governor throat. The velocity of the air creates a pressure above the throttle valve. When this pressure exceeds the force exerted by the spring, the throttle will move toward a closed position. The adjusting screw varies the spring tension.

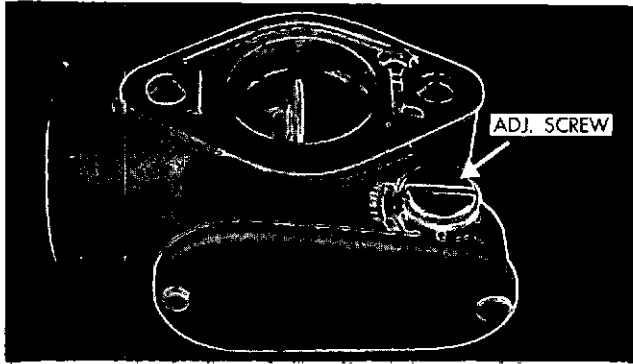

Figure 86 — Hoof Velocity Governor

When this closing action of the valve exactly balances the spring, governing action takes place and maximum speed is fixed at this point.

When load is applied — the engine speed tends to drop — the velocity of the gas through the manifold and the pressure against the governing valve is reduced and the spring opens the valve to feed more gasoline to the engine to handle the increased load demand. Thus an almost constant speed is maintained whether the engine is running with or without load.

CHECKING AND ADJUSTING GOVERNOR LINKAGE

The following is a step by step procedure to follow in checking and adjusting the governor linkage:

- 1 — With the engine stopped and spring tension about normal, the governor should hold the throttle in the open position. The governor to carburetor control rod should be adjusted in length so the throttle stop lever is $\frac{1}{64}$ to $\frac{1}{32}$ off the stop pin.
- 2 — Make certain that all linkage is free with spring at operating tension disconnect the governor spring and check movement of levers and rods.
- 3 — The carburetor lever "F" is attached to the throttle shaft by a coil spring, which must be under sufficient tension to move the throttle as a unit with the lever, without any fluctuation due to the velocity of air striking the throttle butterfly. This tension is adjustable by winding up or unwinding spring.

- 4 — Lever "G", which is firmly attached to throttle shaft, serves to slow the engine down, overriding the governor, through the spring loaded lever "F". A throttle control cable attached to lever "H" provides this idle control, since as this lever "H" is pulled toward the front of the engine, it moves lever "G" to close the carburetor throttle.

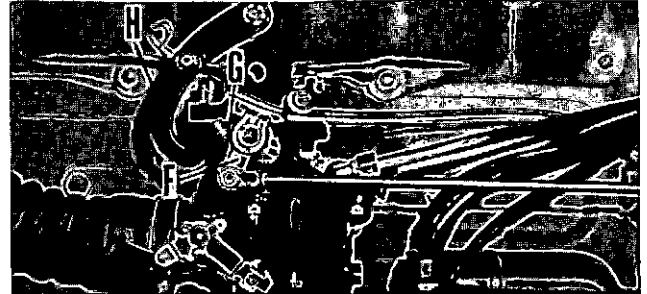

Figure 87 — Governor Linkage

(NOTE: Lever "G" must be located so as to clear lever "F". This may be checked by moving lever "G" forward with the finger and noting if it returns to position freely and quickly.)

NOVI GOVERNOR

The **Novi Governor** — is used on most industrial units requiring normal industrial speed regulation. Novi governors differ from conventional centrifugal governors mainly in that round steel balls are used as the motivating force producer instead of masses of weight.

When the governor is driven at increasing speeds by the engine through the governor gear, the hardened steel balls, move outward, forcing the conical upper race, fork base, fork and lever assembly toward a closed throttle position.

An externally mounted spring imposes tension on the lever assembly toward the open throttle position. As the engine speed increases, the centrifugal force created by the balls will increase until a balanced condition between the governor force and the spring force exists and the governing lever remains stationary — holding a constant engine R.P.M.

Adjustment — The desired engine speed is obtained by increasing or decreasing the governor spring tension.

NOVI CONSTANT SPEED GOVERNOR

- 1 — Start the engine. While it is warming up, back out surge adjusting screw "C" (Figure 88) so it will have no effect.
- 2 — With engine warmed up, adjust idle speed approximately 150 R.P.M. higher than the required speed under load, by turning screw "B" in or out, thus either increasing or decreasing pull on the spring. Lock screw "A" should be backed out so as not to interfere with the adjustment.
- 3 — Apply the desired load, and readjust screw "B" in order to obtain the required speed under load. Release load and note R.P.M. at which engine settles out. Again apply load, and observe the drop in R.P.M. before governor opens throttle to compensate.

- 4 — The range of a governor's action is indicated by the differential between R.P.M. under load and that under no load. This can be varied and the sensitivity of governor changed by changing the length of screw "E".
- 5 — To broaden the range of the governor and produce a more stable action, lengthen screw "E" and compensate for this change by turning screw "B" in to restore speed. Lengthening screw "E" changes pull on spring to more nearly the arc of the lever action, thus having the effect of increasing the spring rate.

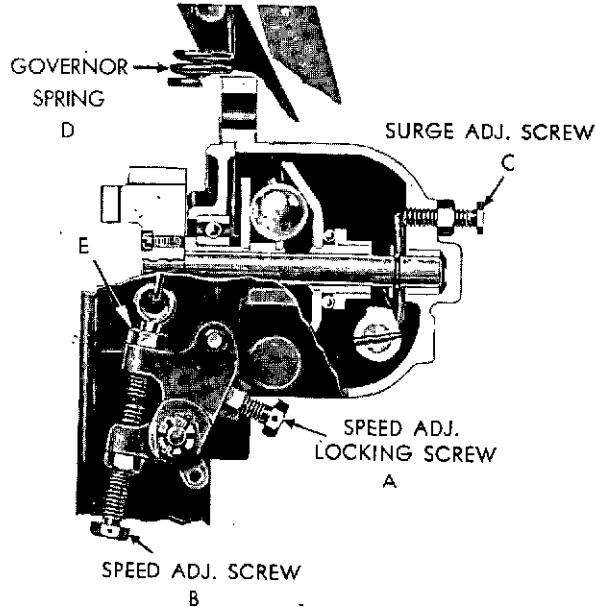
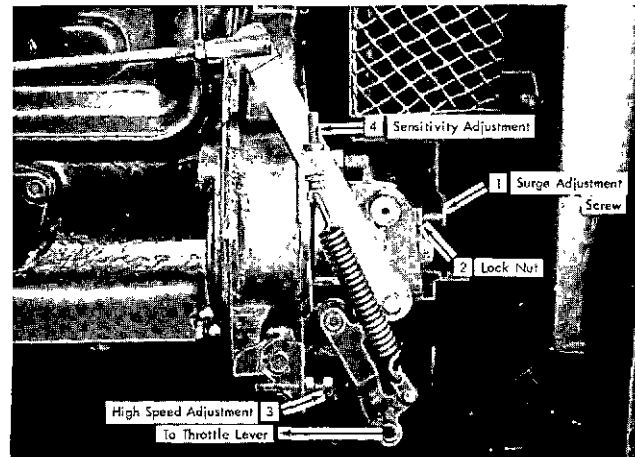

Figure 88 — Novi Governor

- 6 — To narrow the range and increase the sensitivity of the governor, reverse procedure outlined in 5. (Changing the length of screw "E" has the same effect as using a stronger or weaker spring.)
- 7 — With the governor adjusted for desired performance, release the load and allow engine speed to settle. If it idles without surging, turn the screw "C" in, raising the speed 10 to 20 R.P.M. If engine surges at idle, first be sure that the carburetor idle is correctly adjusted before adjusting screw "C".
- 8 — When governor adjustment is completed, tighten locking screw "A", which locks the cam in position. Then make sure that all lock nuts are tight, in order to maintain the adjustment.

NOVI VARIABLE SPEED GOVERNOR

- 1 — Back Out Surge Screw "1" — until only 3-4 threads hold — then lock with lock nut "2".
- 2 — Start Engine and Idle — until warmed to operating temperature.
- 3 — Set Specified High Idle No-Load Speed — by moving throttle to required position and adjusting high speed screw "3".



Novi Variable-Speed Governor

- 4 — Check Regulation — by applying and removing engine load.
- (1) If regulation is too broad — increase spring tension with sensitivity screw "4" and readjust high speed screw "3" throttle stop to obtain high idle speed.
 - (2) If regulation is too narrow — decrease spring tension with sensitivity screw "4" and readjust high speed screw "3" throttle stop to obtain desired high idle speed.
 - (3) If governor surges under load — decrease spring tension with sensitivity screw "4" and readjust throttle lever position to desired high idle speed.
 - (4) Repeat above steps as required — until desired performance is obtained. When adjustment is complete, lock all lock nuts to maintain settings.

Surge Screw "1" — is used to remove a no-load surge only

If governor surges at no-load, turn surge screw in a turn at a time until the surge is removed. Do not turn-in far enough to increase the no-load speed more than a few RPM, if at all. On variable speed governors, the surge screw may be used only at the low speed setting.

Maintenance — The slotted driver, in which the balls move, is pinned to the governor shaft; the two races are free floating on the shaft. When the engine is running at a fixed speed all parts go around with the governor shaft and the thrust is taken on the thrust bearing between conical shaped race and fork base. When a change in speed, due to change in load, takes place, the relative speed between the balls and races is changed. Consequently, wear is distributed over the entire operating surface of the races and balls. Since the surfaces are hardened, little or no wear other than a polish should ever take place on these parts.

The driver must always be tight to the shaft. The races must be free on the shaft.

In assembly of the governor a space of .004 to .006 is provided between the driver and the flat race. This is to assure freedom for movement of the flat race. When servicing the governor, make sure that both races revolve freely on the shaft.

When the balls are "in", that is in the bottom of the driver slots, the space between the top of the conical shaped race bushing and hairpin clip should be .230-.240. Use .010 spacer washers to obtain required space.

The governor shaft is pressed into gear and secured with screw that is partially in the shaft and partially in gear.

Lubrication is supplied the governor by splash from the front end gear train through holes provided in the governor base. Like all mechanical governors, the Novi must have ample lubrication for its functioning. Make sure the governor parts are being well supplied with oil.

PIERCE GOVERNORS

Pierce Centrifugal Governors — are used for many close generator applications and also as tail-shaft governors on torque converter installations.

Governors for engines driving generators are of the constant speed type — which provide close regulation at a fixed speed to prevent excessive frequency variation. Close regulation with a single spring and weights is possible only in a short range of engine speeds — not exceeding 400 R.P.M. The reason for this is that the forces of the governor spring and weights do not increase and decrease at the same rate.

Operation (See Fig. 90) — Pierce governors operate as follows:

The governor shaft (10) is driven by gears (1). The shaft is mounted on a heavy-duty radial ball bearing (3) to minimize friction and wear. On the main shaft is a spider (4) which supports two governor weights (6). The weight noses (2) rest against a hardened thrust sleeve (14) with thrust bearing (8).

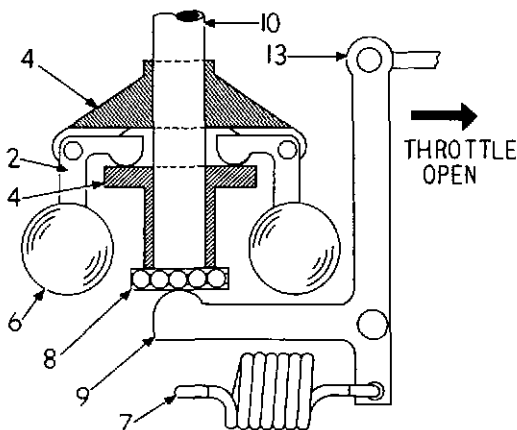

Figure 89 — Schematic Drawing of a Pierce Centrifugal Governor

In operation, the governor shaft turns with the engine. As the shaft rotates, the centrifugal energy developed in the weights (6) causes them to swing outward on their pivots — this energy is opposed by the governor spring (7). The tension of this

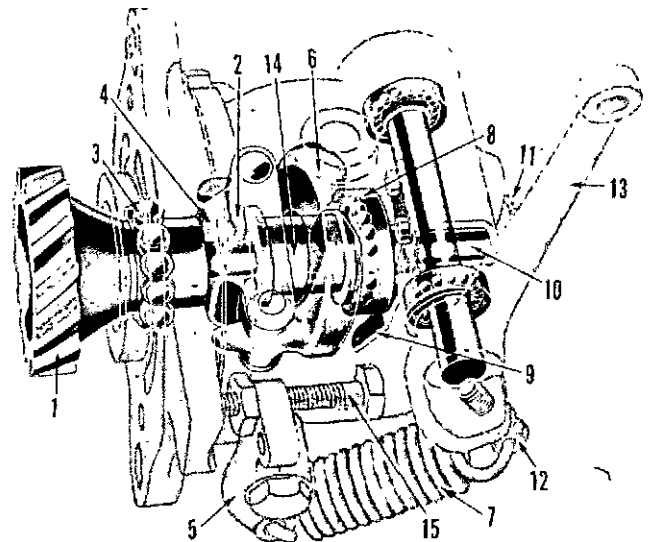

Figure 90 — Sectional Drawing of a Pierce Centrifugal Governor

spring is the means of setting the governor to act at a predetermined speed.

When the engine is not running, the governor spring holds the throttle valve wide open.

When the engine is started, the weights swing out, moving the thrust sleeve (14) along the drive-shaft. This movement is transmitted through the thrust bearing (8) to the rocker yoke (9) on the throttle lever shaft. This movement, in turn, moves the governor control lever (13) toward the closed throttle position. The weights continue to move out until the weight force and spring force are in balance — when the throttle will be in position to maintain the governed R.P.M.

Adjustment

- 1 — The Speed of the Governor is regulated by adjusting screw (15).
- 2 — Sensitivity of the governor can be regulated, by auxiliary adjusting screw (12). Surging or hunting under load conditions can usually be eliminated by broadening the regulation with this adjusting screw.
- 3 — No Load Surge — is eliminated by means of the bumper screw (11).

CAM GEAR GOVERNOR

Some L-head engines use the Continental designed "built-in" cam gear driven governor. Sealed, dust proof and engine lubricated, it is compact and

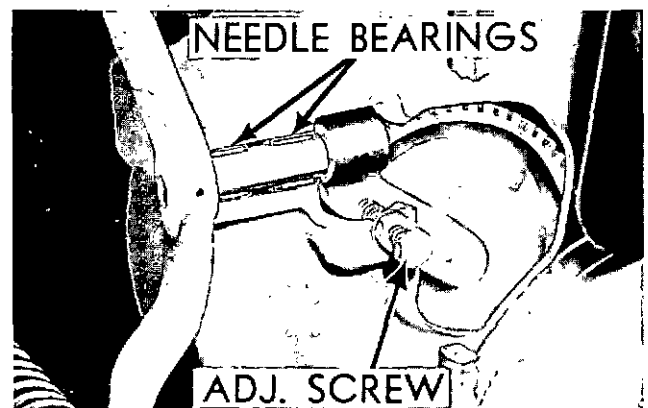

Figure 91 — Cam Gear Governor

easily adjusted. The control shaft floats on two needle bearings to remove friction for closer, more accurate control through the whole power range.

This governor is a variable speed type and has no speed adjustment other than amount of travel the control rod is moved. Control rod movement is determined by accelerator pedal or hand control linkages. Idle surge adjusting screw should be adjusted in just enough to eliminate any tendency of engine to surge.

TAILSHAFT GOVERNORS

Many industrial applications with torque converter drives want to maintain a constant output shaft speed under varying load conditions. This requires the governor to be driven by the output shaft where it can sense output shaft speed variations rather than engine speed.

Tailshaft governors are of the long range type which provide regulation over a wide range of speeds and can be set up to maintain any desired speed in that range.

The tailshaft governor is mounted on the torque converter and is gear-driven. This type governor has two operating levers — one of which is the throttle lever to set the desired output shaft speed and the other lever is connected directly to and operates the carburetor throttle control lever by a mechanical linkage. This linkage, preferably should be a short, straight rod with ball joints at each end or if the linkage is long — walled tubing should be used — so that weight and friction of the linkage is reduced to an absolute minimum.

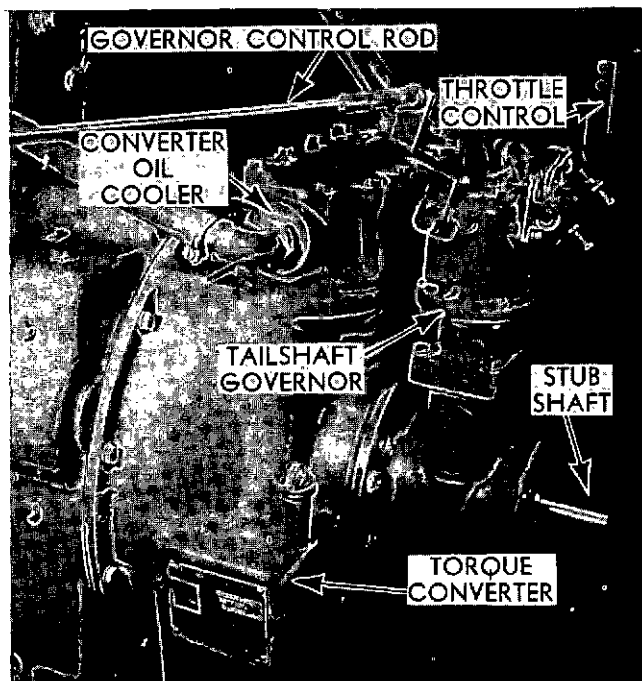

Figure 92 — Tailshaft Governor

The torque converter governor, being driven by the output shaft, senses only output shaft speed and controls the engine throttle accordingly. It is therefore very important that the engine be protected, with an overspeed device which will sense engine speed and limit that speed to a safe maximum. This protection may be obtained with a mechanical, electrical or a velocity type governor whichever may be the most simple arrangement.

Adjustments — include the following:

(A) **High Idle Speed**—Limits maximum engine speed, follow manufacturers recommendations.

(B) **Low Idle Speed** — Limits engine idling speed — 400-600 R.P.M.

(C) **Sensitivity Adjustment** — will eliminate surging or hunting by broadening regulation.

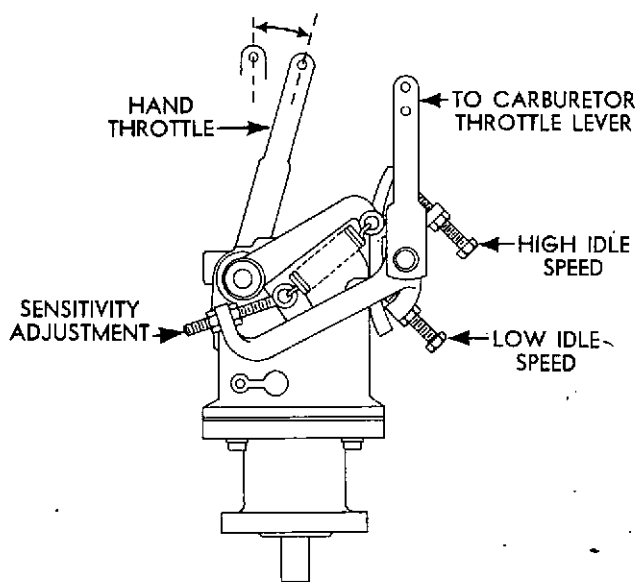

Figure 92A — Tailshaft Governor Adjustments

The hook-up of governor lever to carburetor lever should be done in the following manner:

1. Make sure carburetor shaft does not stick nor bind.
2. With governor lever in its normal position under spring tension, with engine shut off, with carburetor lever in wide open throttle position, a rod of exact length to connect the two levers is inserted.
3. Make sure that there is no bind or sticking in the assembly of rods and levers. **THIS IS IMPORTANT.**

IMPORTANT:

Pressure lubricated line must be connected to the torque converter or supply with an orifice.

Governor control linkage must be absolutely free to obtain correct governor operation.

SECTION VII IGNITION

Continental L-Head engines are equipped with either battery ignition or magneto ignition. Both systems consist of an induction coil; breaker points, with a condenser connected across the points to absorb any arcing, and a distributor which connects to each spark plug. The main difference is that the battery-ignition system requires a storage battery and the magneto system uses the engine to supply energy to rotate a permanent magnet armature.

The ignition system has the job of producing and delivering high voltage surges of about 20,000 volts to the correct spark plug, at the correct intervals and with the correct timing to the engine. Each high voltage surge produces a spark at the spark plug gap to which it is delivered, so that the mixture of air and fuel in the cylinder is ignited.

BATTERY-IGNITION SYSTEM

This battery-ignition circuit consists of the battery, ammeter, ignition-switch, ignition coil, distributor, spark plugs and low and high tension wiring.

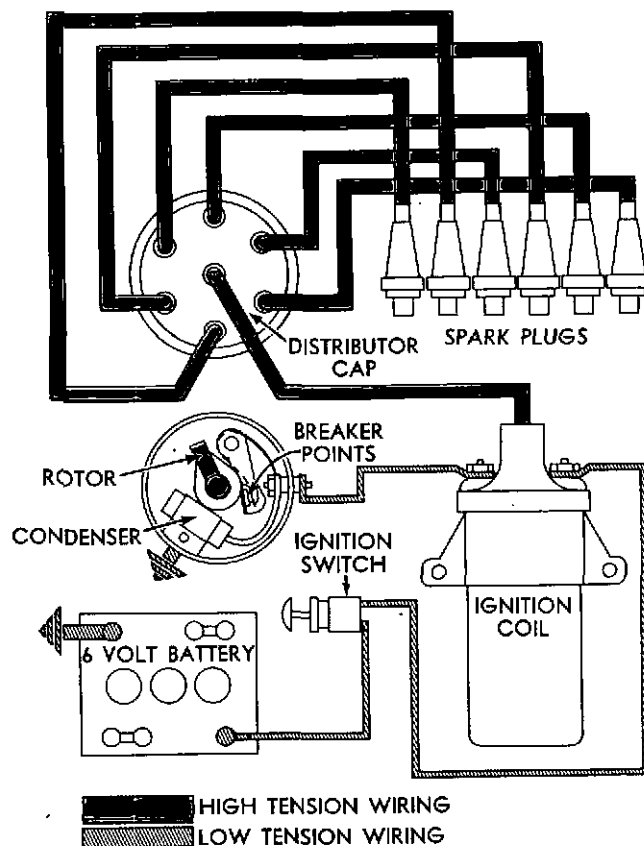

Figure 93 — Schematic drawing of battery ignition system

These parts can be divided into separate circuits consisting of a low tension circuit carrying battery voltage and a high tension spark circuit of about 20,000 volts.

The low tension primary circuit consists of the battery, ammeter, ignition switch, primary winding of the ignition coil, distributor contacts and condenser, and the primary wiring.

The secondary high tension circuit includes the coil secondary winding, distributor cap and rotor, spark plugs, and high tension wiring.

IGNITION SYSTEM COMPONENTS

The Battery supplies the voltage for producing a current flow through the ignition circuit.

The Ammeter indicates the amount and direction of current flow.

The Ignition Switch is an "Off" and "On" switch and the Breaker Contacts function as an intermittent switch. Current flows only when both switches are closed and returns by the ground through the engine or frame. The resistance of the primary winding of the ignition coil restricts the primary current flow.

The Ignition Coil consists of two windings, a primary winding and a secondary winding and is a transformer to increase the voltage high enough to jump a spark gap at a spark plug.

The Condenser momentarily provides a place for the current to flow until the distributor contacts are safely separated in order to reduce arcing.

The Distributor interrupts the primary winding current in the ignition coil and distributes the high tension current to the correct spark plug at the correct time.

The Spark Plugs provide a spark gap in the combustion chamber. The compressed air and fuel mixture is ignited when the high voltage jumps across this gap.

The Low Tension Primary Wiring conducts battery current through the ignition coil and contacts.

The High Tension Secondary Wiring conducts the high voltage, produced by the ignition coil, to the distributor and from the distributor to the spark plugs.

Operation — A primary current flows from the battery, through the ammeter and ignition switch to the coil primary winding, then to ground through the distributor contacts.

When the contacts open, the current tends to continue flowing across the contact gap. The condenser, which is connected across the contacts, momentarily absorbs this current and in doing so hastens the collapse of the magnetic field produced by the current in the coil primary winding.

This collapsing field induces a very high voltage in the secondary winding which is carried by the high tension wire to the center terminal of the distributor cap. The rotor connects this center terminal to one of the cap terminals which in turn is connected to the proper spark plug.

The spark produced by this high tension current ignites the fuel in that cylinder. This process is repeated for every power stroke of the engine and at high speeds, an impulse may be required as often as 300 times per second.

Ignition Coil — The function of the ignition coil is to transform the low voltage supplied by the battery into the high voltage to jump the spark plug gap.

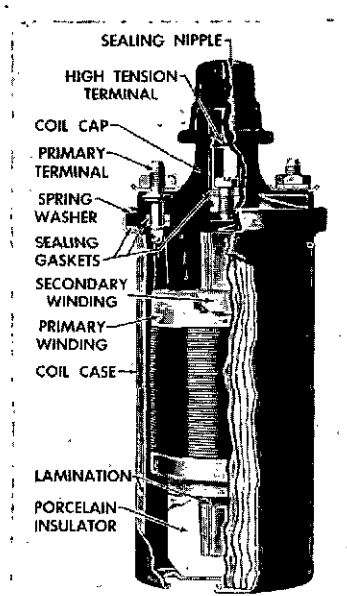

Figure 94 — Cutaway View of an Ignition coil

An ignition coil has two windings wound on a soft iron core; the primary winding which consists of a comparatively few turns of heavy wire, and the secondary winding of many thousand turns of very fine wire. The primary winding is wound around the outside of the secondary winding. A soft iron shell encloses the outside of both windings and serves to complete the magnetic circuit.

Ignition coils do not normally require any service except keeping all terminals and connections clean and tight. The coil should be kept reasonably clean; however, it must not be subjected to steam cleaning or similar cleaning methods that may cause moisture to enter the coil.

Ignition coils can be tested for grounded windings by placing one test point on a clean part of the metal container and touching the other point to the primary and high voltage terminals. If tiny sparks appear at the points of contact, the windings are grounded.

If the coil is further suspected of being faulty, remove and check its operation on a coil tester and replace it if inoperative. Most coil testers compare the operation of the coil being tested with one known to be in good condition. This test should be made with the coils at room temperature and then

warming the coils five minutes by connecting the primary to a battery of the same voltage rating as the coils. Recheck the comparison test to see if the expansion due to heating has caused some defect to appear.

Distributor — The distributor conducts and interrupts the current through the primary winding of the ignition coil at the correct time and distributes the high tension voltage to the correct spark plug.

There are two separate electrical circuits in a distributor. The breaker contacts and condenser are in the primary circuit and carry low voltage current — while the cap and rotor are in the secondary circuit and carry the high voltage spark current.

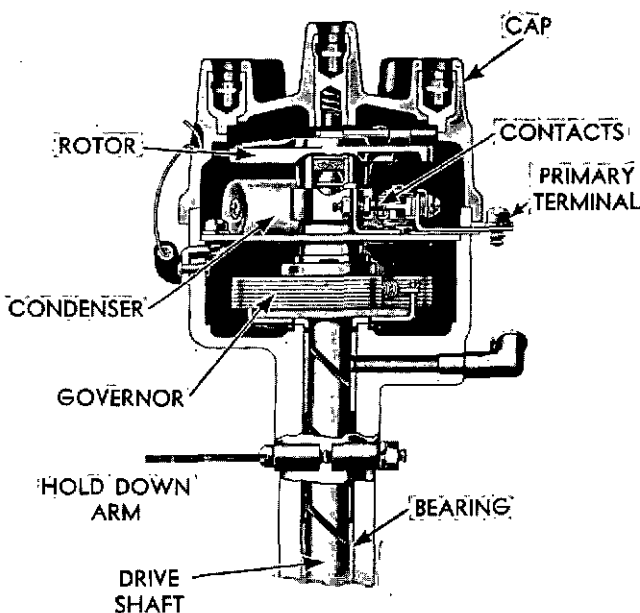

Figure 95 — Cutaway View of a distributor

The breaker contacts are mounted on a plate in the top part of the distributor housing. The grounded contact is stationary and the insulated contact is mounted on a breaker arm which is actuated by a cam near the top of the distributor shaft.

The rotor is mounted above the cam and turns with it to make a connection between the cap center contact and the various side contacts.

Continental L-Head engines have distributors equipped with a centrifugal governor which varies the timing by advancing the breaker cam as the engine speed increases. This mechanism consists of weighted levers which revolve with the distributor rotor and act against a set of springs. As the speed of rotation increases, the weights are moved out and the timing is advanced. With this arrangement it is possible to have a retarded spark for idling and obtain a gradual advance in spark timing as the engine speed is increased.

The **condenser** in the distributor prevents excessive arcing at the contacts. When the contacts first open, the current tends to continue flowing across the gap. The condenser absorbs this current until it becomes fully charged; but by this time, the contacts have opened far enough to prevent the current flow. If there were no condenser in the circuit, the current would continue to flow and cause an arc that would soon burn the contacts. The capacity of the condenser is designed to be large enough to prevent arcing and burning of the contacts and small enough to reduce the transfer of material from one contact to the other.

The **cam** is designed so that the breaker points remain closed for a certain number of degrees so as to give the coil a given length of time to build up or become energized. This is called the cam angle, as shown below:

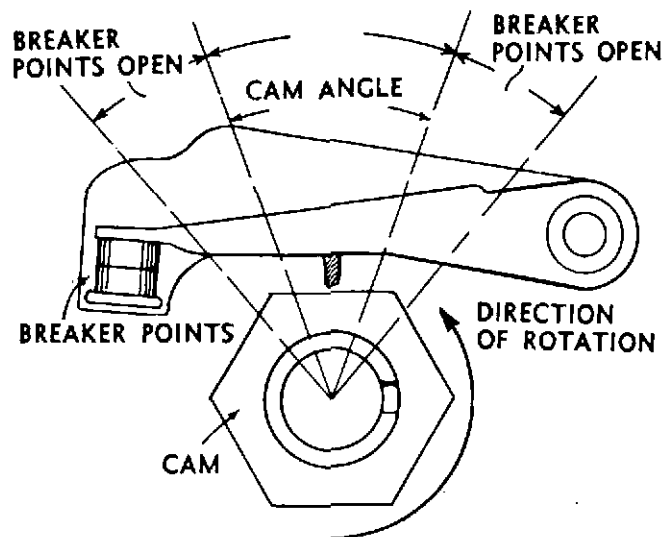

Figure 96 — Diagram illustrating cam angle

The cam is further designed to open the breaker points at a given speed in relation to cam travel to obtain proper point and condenser action. It is therefore important that the breaker points be adjusted to .020 gap so that proper cam angle is obtained.

DISTRIBUTOR MAINTENANCE — The distributor operation is vital to the operation of the engine and the following items should be carefully inspected every 250 hours of normal operation; however, dirt, dust, water and high speed operation may cause more rapid wear and necessitate more frequent inspections:

1 — **Remove Distributor Cap** — (without removing wires) — Clean cap and examine for cracks, carbon runners, corroded terminals or if the vertical faces of the inserts are burned — install a new cap.

If the horizontal faces of the inserts are burned — replace the cap and rotor as this is due to the rotor being too short.

2 — **Check Centrifugal Advance Mechanism** — for “freeness” by turning the breaker cam in the direction of rotation and then releasing it. The advance springs should return the cam to its original position.

3 — **Inspect Breaker Points and Gap** — if points are pitted, burned or worn to an unserviceable condition, install a new set of points. Badly pitted points may be caused by a defective or improper condenser capacity.

If the condenser capacity is too high, the crater (depression) will form in the positive contact; and, if condenser is too low, the crater will form in the negative contact as shown on the following sketch.

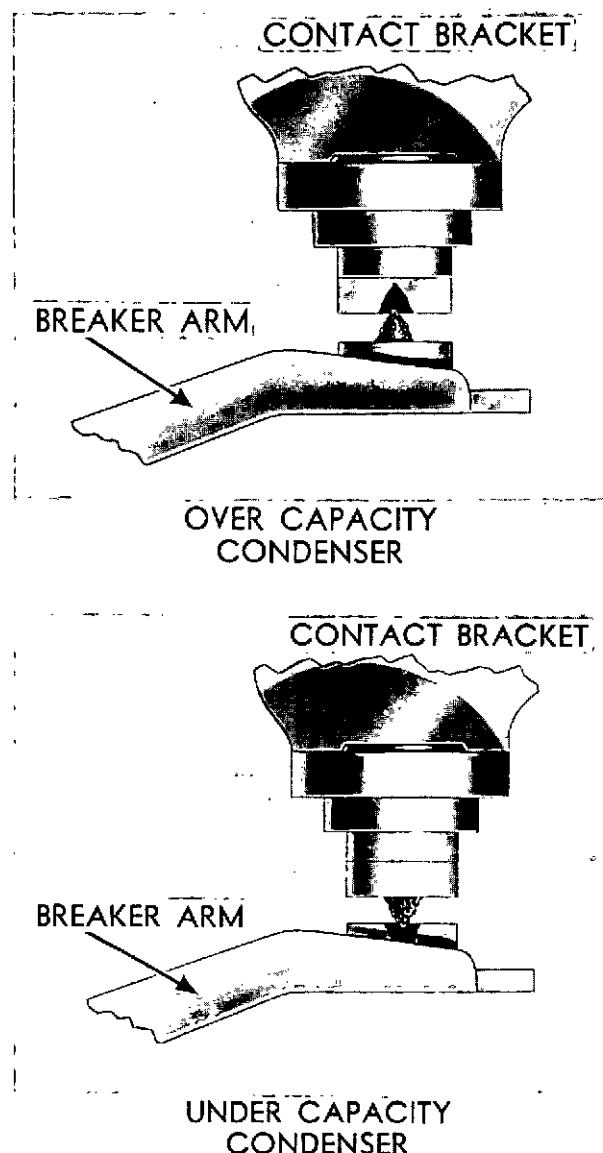

Figure 97 — Badly pitted breaker points caused by arcing due to incorrect condenser capacity

If the points are servicable, they should be dressed down with a fine-cut stone or point file. The file must be clean and sharp — never use emery cloth to clean contact points.

After filing, check the point gap and reset to .020 — the breaker arm must be resting on the high point of the cam during this operation.

When replacing points, make sure they are aligned and that they make full contact. Bend the stationary arm to obtain proper alignment — do not bend the breaker arm.

4 — Lubrication — is required at the shaft, advance mechanism, breaker cam and pivot. The shaft may be either oil or grease cup lubricated and should be given attention every oil change. Make sure the breaker arm moves freely on its hinge and apply a drop of light oil. A trace of ball bearing lubricant such as Mobilgrease Special (with Moly) should be used sparingly on the breaker cam unless lubricated by a felt wick with a few drops of oil.

CAUTION:

AVOID EXCESSIVE LUBRICATION — AS THE EXCESS MAY GET ON THE CONTACT POINTS AND CAUSE BURNING.

SPARK PLUGS — A spark plug consists of two electrodes; one grounded to the outer shell of the plug and the other well insulated with a core of porcelain or other heat resistant material. The space between these two electrodes is called the gap which should be set at .025 on standard plugs, and .035 on resistor type plugs for Continental L-Head Engines. Correct and uniformity of the gaps of all spark plugs in the engine is important for smooth running.

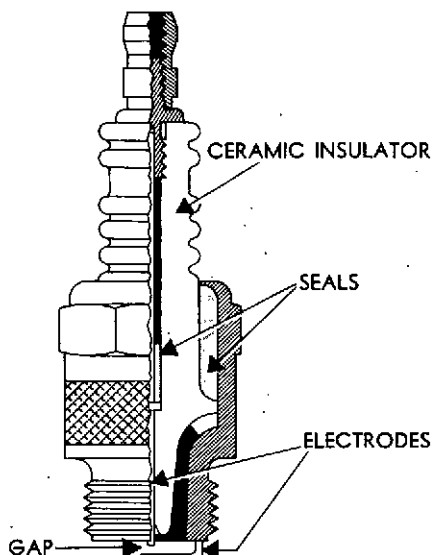

Figure 98 — Sectional view of spark plug

Spark plug gaps are best checked with a wire gauge unless the points are dressed to obtain a correct reading with a flat gauge. The adjustment should always be made on the side electrode and

never on the center electrode which may cause a broken porcelain.

“Gapping” the electrode tip is more easily done with proper tools.

GAPPING THE SPARK PLUG. This illustration shows the use of the gapping tool which both measures and adjusts the electrode gap.

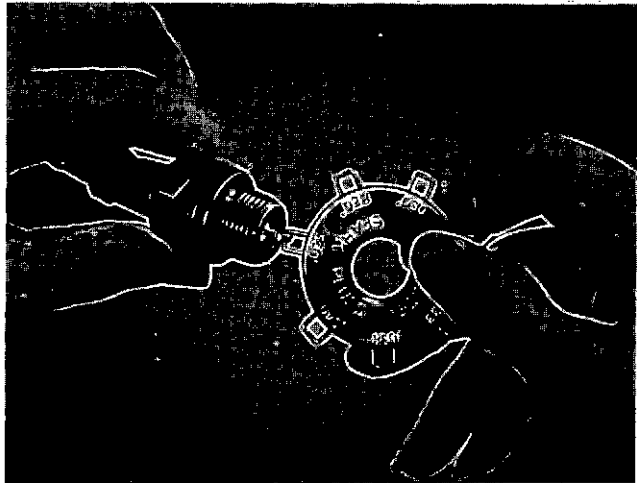

Figure 99 — Checking spark gap

Spark Plugs must operate within a certain temperature range to give good performance — not too hot and not too cold. The ability of a spark plug to conduct heat away from the center electrode and porcelain is controlled by the design of the shell and insulator — so varying the length of the insulator below the gasket shoulder controls the temperature.

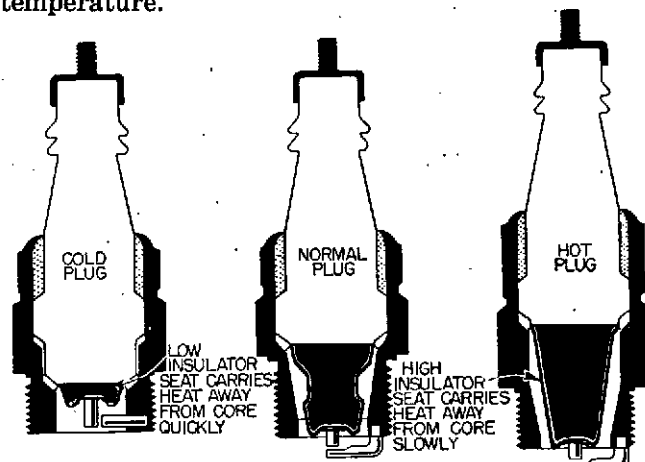

Figure 100 — Cold — Normal — Hot Spark Plugs

Cold-Normal-Hot Spark Plugs

Examination of a used spark plug will show if it is in the correct heat range for the operating conditions. If the plug runs too hot, the insulator will blister or crack and the electrodes burn away rapidly. If the plug remains too cool — soot and carbon will deposit on the insulator causing fouling and missing.

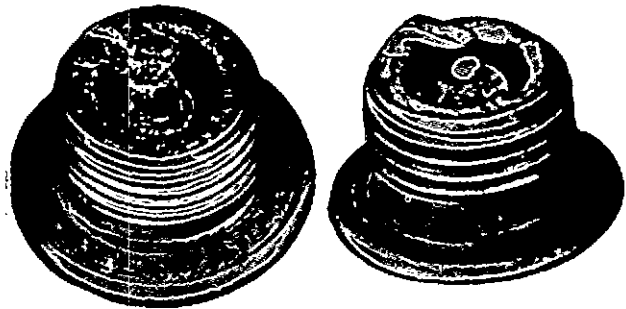

Figure 101 — Faulty spark plugs. Left: cold plug used in an engine that should have a hot plug. Right: hot plug used in an engine that should have a cold plug.

Spark plug electrodes will wear in the course of time and present day fuels have a tendency to form rusty-brown oxide deposits on the insulator tip. Therefore it is necessary to periodically clean the plugs with a plug cleaner and to reset the gaps to specifications.

Spark plugs must be correctly installed in order to obtain good performance from them. It is a simple but important matter to follow the following procedure when installing plugs:

1. Clean the spark plug seat in the cylinder head.
2. Use new seat gasket and screw plug in by hand.
3. Tighten all 18mm plugs to 35# torque with socket wrench of correct size.

DISTRIBUTOR — IGNITION TIMING With Timing Light

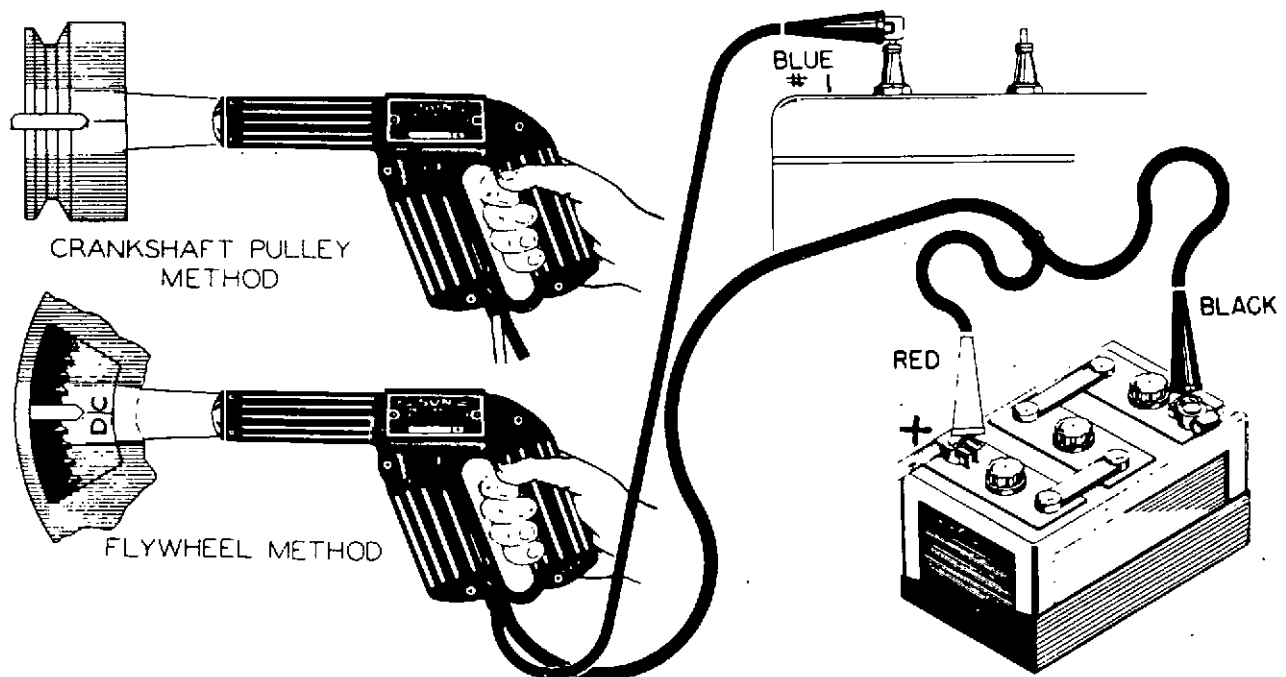

Figure 102 — Schematic diagram showing timing light hookup

Normally Continental L-Head engines with distributor-ignition are timed to have the distributor points start to open when #1 cylinder is on compression stroke and the flywheel mark "DC" (top-dead-center) lines up with the pointer in the bell housing.

There are two methods of checking ignition timing — *with or without a timing light.*

The *preferred method* is to use a timing light in following sequence:

Paint a line on the flywheel (or in some cases, on the front pulley) so the timing mark will be more legible under the timing light.

1. Clip blue secondary lead of light to the #1 spark plug — leave spark plug wire on plug.
2. Connect primary positive lead (red) to positive terminal of battery.
3. Connect primary negative lead (black) to negative battery terminal.

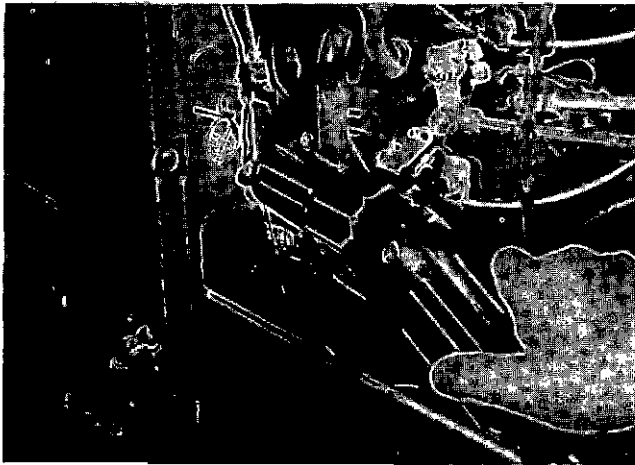

Figure 103 — Checking flywheel timing with timing light

4. Start engine and run at idle speed, 400 RPM or lower, so the automatic advance of the distributor is completely retarded. **THIS IS VERY IMPORTANT TO OBTAIN CORRECT TIMING.**

5. Direct timing light on the flywheel through opening in bell housing and note timing marks as light flashes.

6. Timing is normally at "D.C." unless specified otherwise on your engine specification sheet.

7. To advance timing, turn distributor body clockwise. To retard timing, turn distributor body counter-clockwise.

8. When timing is correct, tighten distributor clamp screw securely. Then recheck timing again with light.

9. This operation is best performed in shaded area, so timing light is visible.

DISTRIBUTOR IGNITION TIMING Without Timing Light (Emergency Method)

An alternative method without timing light, is as follows:

1. Remove #1 Spark Plug — put your thumb over the spark plug hole and crank engine by hand until air is exhausting.

2. Set piston on top-dead-center by slowly cranking until "DC" mark on flywheel will line up with the pointer in bell housing.

Note: Some special applicator may have timed several degrees before top dead center (BTDC).

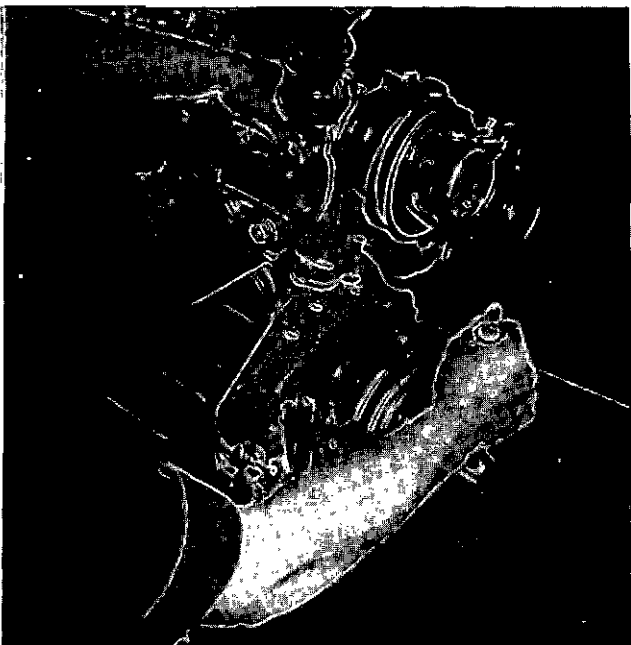

Figure 104 — Checking No. 1 Cylinder on Compression Stroke



Figure 104A — Flywheel timing marks

3. Loosen the distributor clamp bolt and rotate the distributor body until the contact points just *Start to Open*.

This may be more accurately checked by means of a test lamp connected between the distributor primary lead and the negative terminal of the battery — when the points are closed the light will be ON and as soon as the points break the light will go OFF.

4. Tighten distributor mounting bolts.

In high altitudes there is less tendency for sparking as well as low altitudes with premium gasolines. In such cases, improved performance may be obtained by advancing the spark not to exceed 4 degrees ahead of specified setting.

CAUTION: WHEN ENGINE SPECIFICATIONS HAVE SPECIAL TIMING OTHER THAN TOP-DEAD-CENTER — THEY MUST BE FOLLOWED IN ORDER TO OBTAIN SATISFACTORY SERVICE IN SPECIAL APPLICATIONS OR HIGHER ALTITUDES.

MAGNETO - IGNITION

Magneto-Ignition is furnished on Continental L-Head engines on special applications to provide a complete ignition system without requiring a battery. The smaller engines are easily hand-cranked so that the starters and generators are not furnished in many of these applications.

The magneto comprises all the parts of the battery-ignition system with the exception of the

battery, and in addition, means for generating current impulses directly in the primary winding — which is in effect a spark coil.

The advantage of the magneto is this self-contained character. All the elements of the ignition system are in one compact unit, from which it only requires a low-tension cable to the ignition switch and high-tension cables to the spark plugs.

Operation

Magnetos are of the rotating magnet type with jump-spark distributor and are flange mounted to an accessory timing gear drive.

The rotation of the magnetic rotor sets up an alternating magnetic flux which cuts the primary winding each time it rises and falls. This induces electric currents, alternating in direction, to flow in the primary circuit during the intervals the breaker points are closed.

The current in the primary winding of the coil establishes a magnetic field which interlocks the turns of the coil secondary winding, this field reaching its maximum simultaneously with the primary current. Breaker point action at the instant of maximum primary current and field, opens the primary circuit so the primary current can't flow — causing the immediate and complete collapse of the magnetic field existing in the coil.

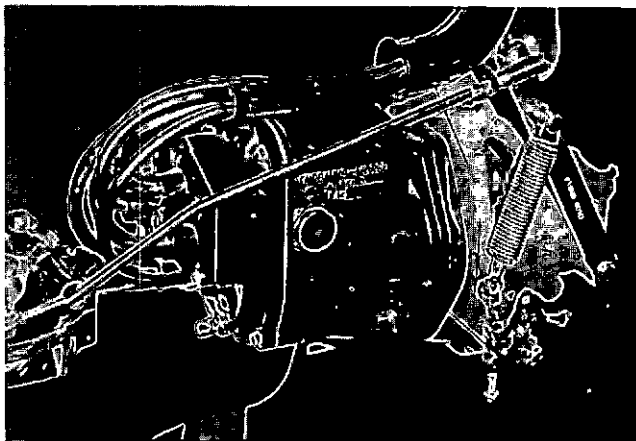

Figure 104B — Magneto installation

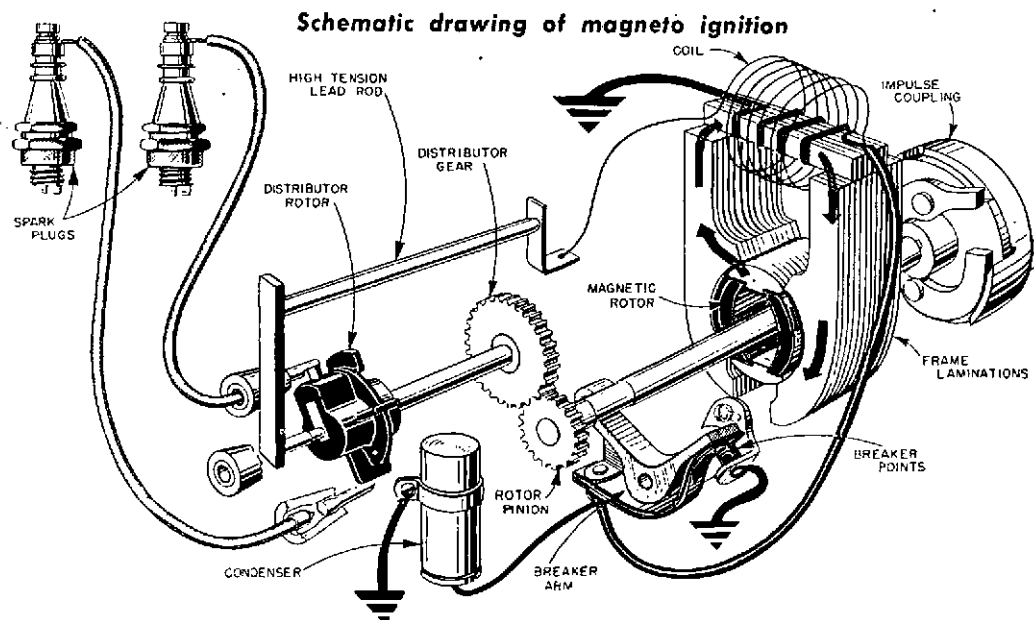

Figure 105

The ratio of turns in the coil secondary winding to those of the primary is very high so the induced voltage in the secondary winding is also very high.

The self-induced voltage occurring in the primary winding, as a result of the quick break of the

primary circuit, is absorbed by the condenser which is shunted across the breaker points. This action promotes a more rapid collapse of the primary field and at the same time reduces contact point burning caused by arcing.

IMPULSE COUPLING

All magnetos have an impulse coupling which assists starting by automatically retarding the ignition spark during the starting operation and at the same time producing an intense, hot spark — which would otherwise be impossible at very low engine speeds.

This device prevents the rotor of the magneto from turning during the starting operation until the engine piston is about at top-dead-center, at which instant the rotor is snapped forward at very high speed, producing an intense spark which is

automatically retarded to prevent back-firing. Since the point at which the release occurs can be controlled in the coupling construction — it is possible to provide an automatic retard of the ignition spark during the starting period.

Basically the impulse coupling consists of a shell and a hub, connected together by a strong spring. One half of the coupling (shell) is fitted to a drive member on the engine drive shaft — while the other half (hub) is keyed to the magneto rotor shaft.

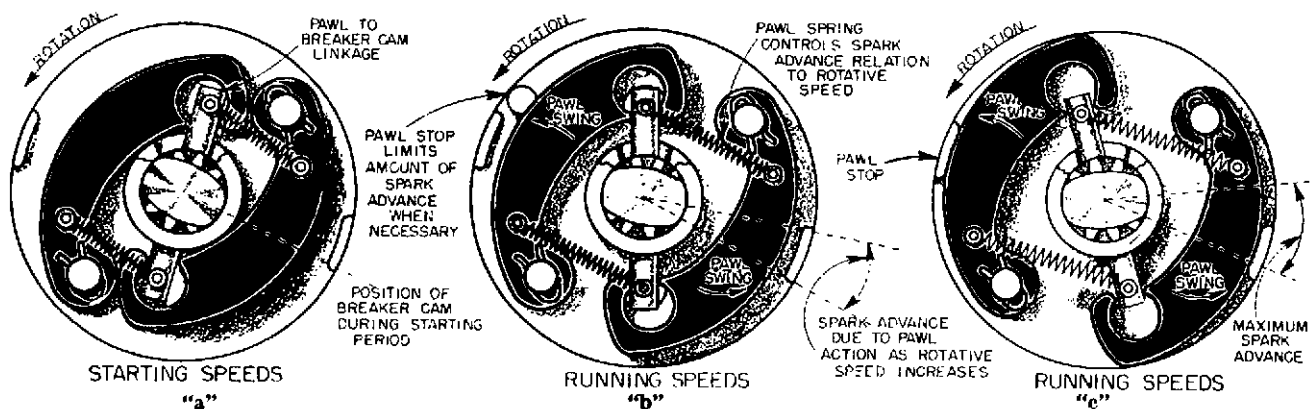

Figure 106 — Operation of Automatic Spark Advance Rotor

AUTOMATIC SPARK ADVANCE

In slow speed operation, a pawl on the magneto half of the coupling engages a stop pin mounted on the magneto frame — which prevents further movement of the rotor. The engine half of the coupling continues to rotate and the relative change in position winds up the connecting spring.

When the desired point of ignition spark is

reached, the pawl is released and the drive spring snaps the magneto rotor forward at high speed through its firing position.

As the engine speed increases, the centrifugal force acting on the pawls — withdraws them to a position not engaging the coupling stop pin — the impulse coupling then acts as a solid drive member.

TIMING MAGNETO TO ENGINE

1. Remove rear spark plug (#4 on four cylinder and #6 on six cylinder engines.) Put your thumb over the spark plug hole and crank engine by hand until air is exhausting.

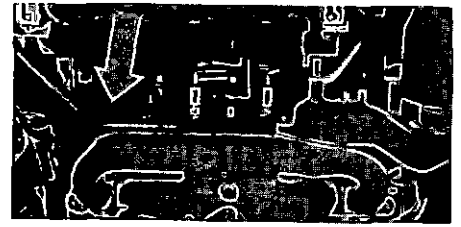

2. Set piston on top-dead-center by slowly cranking until "DC" mark on flywheel will line up with the pointer in the flywheel housing.

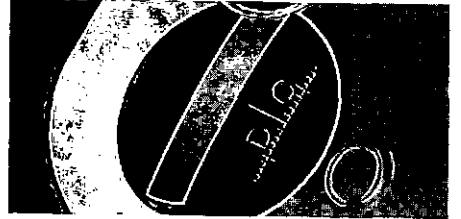

3. With magneto removed from the engine — put it firmly in a vise lined with soft cloths and turn drive lugs of impulse coupling until lead to rear plug (#4 or #6) fires.

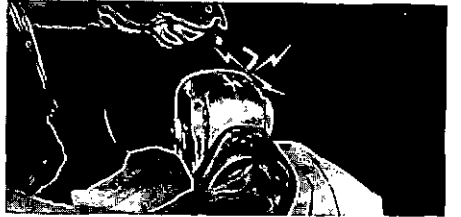

Bosch and Wico magneto indicate #1 lead so rear plug is directly opposite — F. M. magnetos are not marked, but rear plug lead is at 5 o'clock position when facing distributor end.

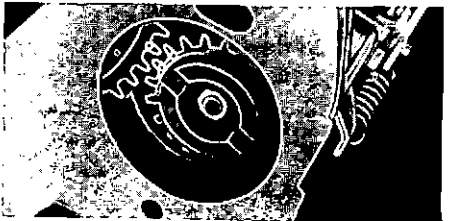

4. Check front end governor drive and make certain that punch-marked tooth of timing gear is meshing between the two punch-marked teeth of the governor drive gear.

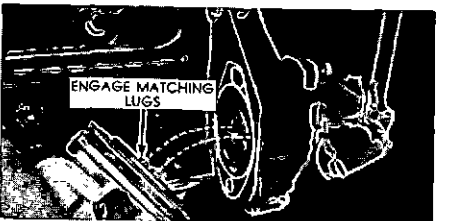

5. Turn back magneto drive lugs of impulse coupling counter-clockwise about $\frac{1}{4}$ turn so as to mesh with the driving slots of the engine drive member.

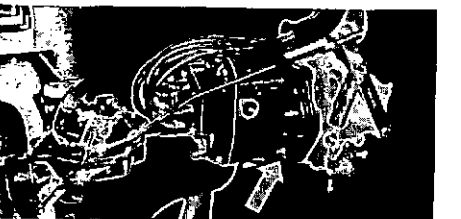

6. Position magneto on engine and tighten mounting bolts moderately and connect wires to spark plugs.

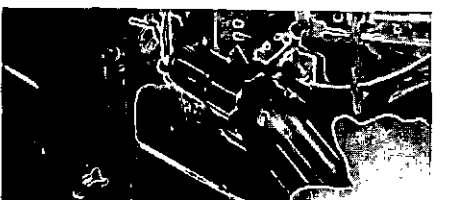

7. Start and idle engine 600 R.P.M. and using a timing light connected to rear plug and battery source — check to see if timing is directly at "IGN-M" indicated by pointer.

If not, rotate magneto assembly until timing is correct, then tighten magneto mounting bolts.

IMPORTANT: Engine specifications require magnetos with the correct amount of "Built-in Lag" — which permits timing the magneto to the engine correctly as outlined.

Do not substitute other magnetos.

SECTION VIII ENGINE REPAIR AND OVERHAUL

This section includes instructions for repairs and overhaul of the component units of Continental Red Seal L-Head engines.

Provide a clean place to work and clean the engine exterior before you start disassembling — dirt causes engine failures. Many shop tools have been developed to save time and assure good workmanship; these should be included in your equipment.

Use only genuine Red Seal parts in Continental engines since years of development and testing have gone into these specifications to assure maximum life and performance.

CYLINDER HEAD

The cylinder head is an important part of the engine assembly since it contains the complete combustion chamber and cored passage for water flow. Remove the cylinder head in the following sequence:

1. Drain water from engine and disconnect radiator or heat exchanger outlet hose.
2. Loosen and remove the nuts holding the cylinder head to the block.
3. Lift the cylinder head off the engine and carry to a clean bench for further disassembly.
4. Remove all carbon from combustion areas using a scraper and wire brush.

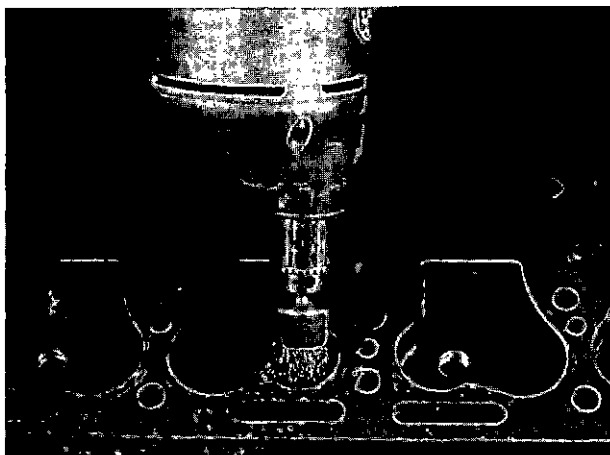

Figure 110 — Cleaning carbon from combustion chamber

5. Clean the cylinder head thoroughly with a solvent or degreasing solution and blow it off with air pressure.

6. Make sure that gasket contact surfaces on the head and block are clean, smooth and flat.

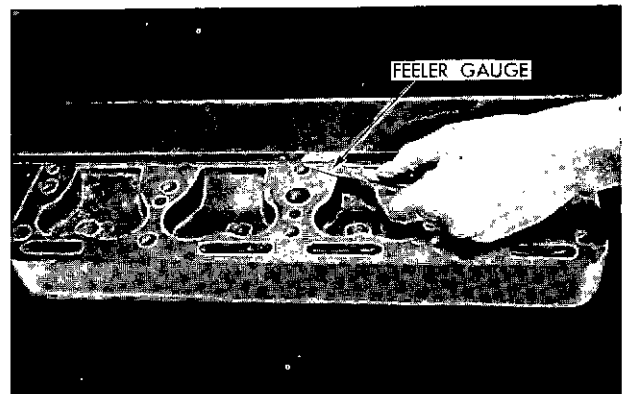

Figure 111 — Checking cylinder head flatness lengthwise. (.004 max.)

7. Check flatness with straight edge and feeler gauge in three positions lengthwise and five crosswise. The maximum permissible is .004 low in the center lengthwise, gradually decreasing towards the ends, or .003 crosswise or in localized low spots.

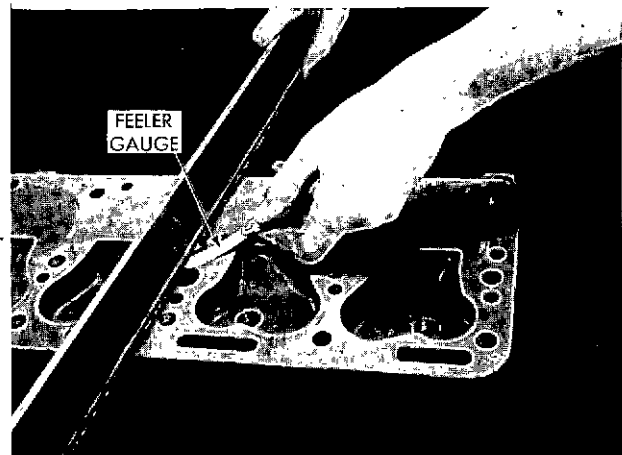
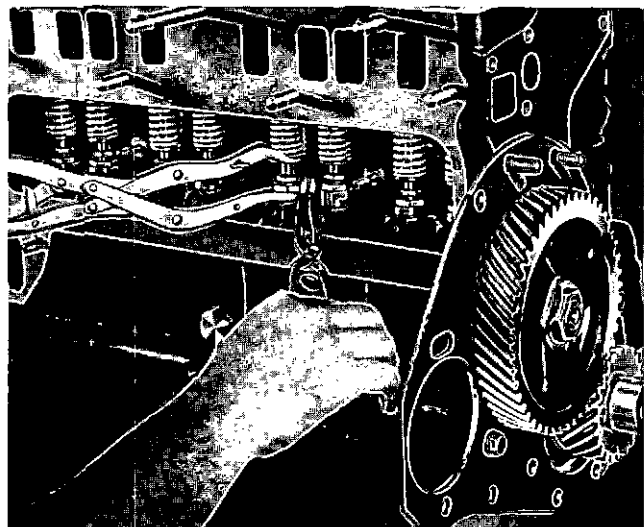
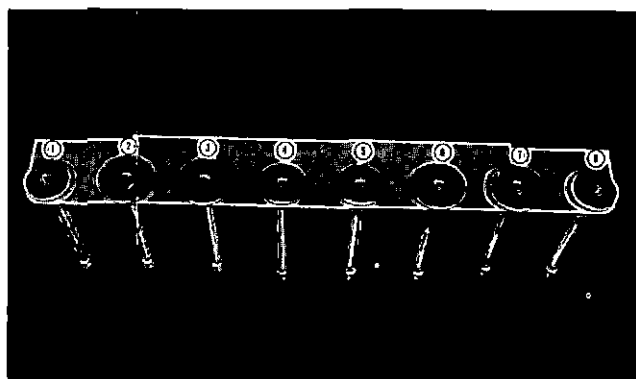

Figure 112 — Checking cylinder head flatness crosswise. (.003 max.)

CYLINDER BLOCK*Figure 113 — Valve Removal*

1. With a valve spring lifter, compress the springs and remove the locks or pins from the valve stems which are in a closed position. Close the other valves by rotating the crankshaft and remove the locks (or pins) from these valves in the same manner. Remove all valves and place in order in a rack, with holes numbered for both intake and exhaust valves so they will not be mixed in handling.

*Figure 114 — Valves in rack***VALVE GUIDES**

1. Clean the valve stem guides, removing lacquer or other deposits by running a valve guide cleaner or wire brush through the guides.

2. Check guides for wear by using "Go and No-Go" plug gage or a telescope gage and 1" micrometer. Replace all guides that are worn bell-mouthed and have increased .0015 in diameter. See Limits and Clearance Section for maximum diameter permissible to determine actual amount the diameter has increased. Remove all valve guides when necessary by driving them out from the combustion chamber side with a driver slightly smaller than the O.D. of the valve guide.

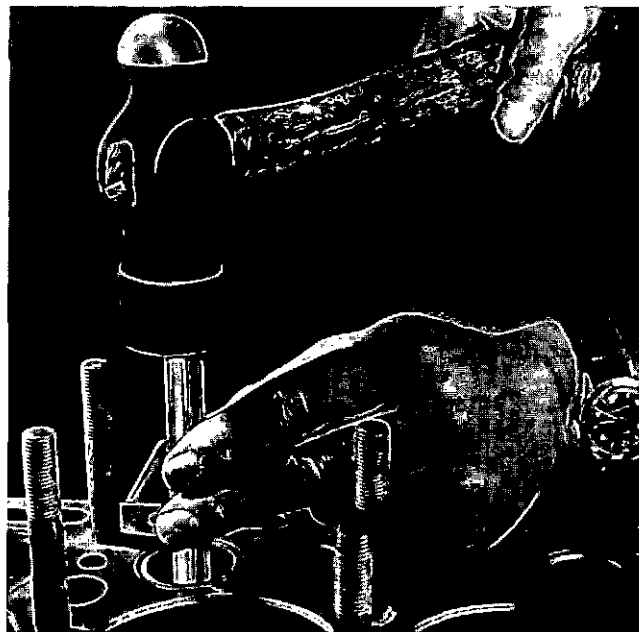
*Figure 115 — Removing valve guides with a driver*

3. Replace worn guides as required by using a suitable driver from the combustion side to the correct depth below the valve seat as given in the Limits and Clearance Chart.

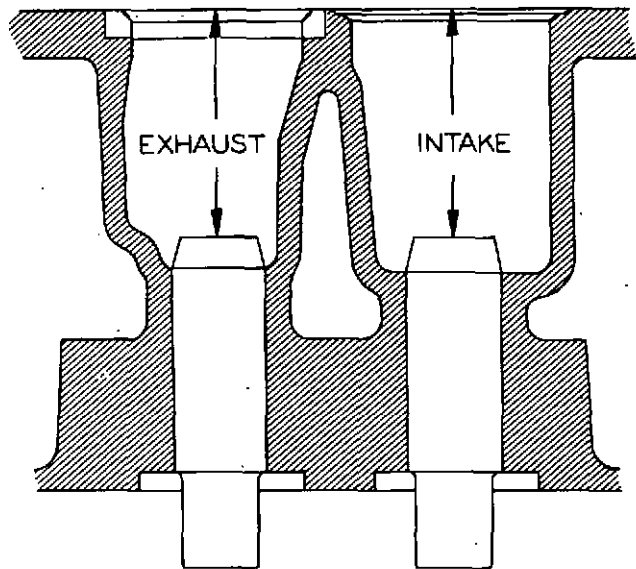

Engine	Distance from Block Face to Top of Guide	
	Intake	Exhaust
N56, N62	$\frac{25}{32}$	$\frac{25}{32}$
Y69, Y91, Y112	$\frac{7}{8}$	$\frac{7}{8}$
F124, F140, F162, F186, F209, F226, F244	$1\frac{15}{32}$	$1\frac{15}{32}$
M271, M290 M330, M303	$1\frac{1}{4}$	$1\frac{9}{16}$
B371, B427	$1\frac{7}{8}$	$1\frac{5}{16}$

Figure 116 — Diagram and chart showing valve guide location

4. Ream new valve stem guides to size given in Limits and Clearance Chart, using a straight reamer ground to correct size and having a pilot which will properly locate it and keep it from wandering from the original reamed hole.

CAUTION: When replacing guides that are ferrox coated do not ream since these are all pre-reamed before being ferrox coated — any further reaming will remove the coating.

VALVE SEAT INSERTS

1. The exhaust valve seat insert is held in place by a shrink fit.

Inspect all exhaust valve inserts in the block and replace any that are loose, cracked or otherwise damaged. Use puller for removing faulty insert as shown in illustration.

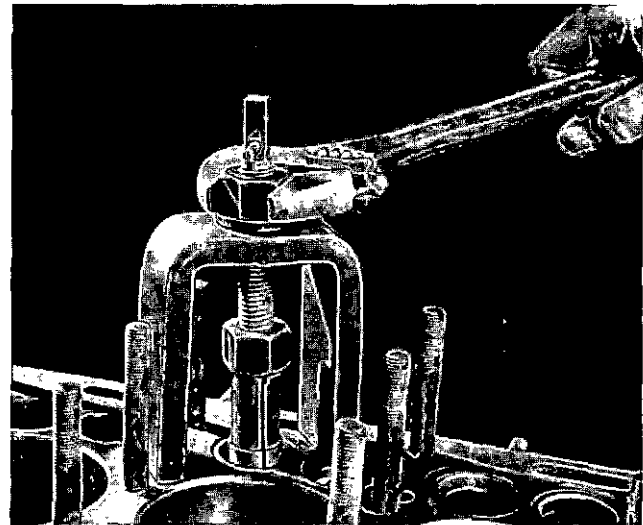

Figure 117 — Removing exhaust valve seat insert

2. When required to replace with new insert, clean and counterbore for .010 larger insert using counterbore tool with correct fitting pilot.

When machining the counterbore, be sure to go deep enough with the tool to clean up the bottom so that the insert will have full contact to carry away the heat.

Continental does not recommend installing new inserts having the same outside diameter as the one removed. The following chart shows the dimensions of Standard Inserts and counterbores:

DIMENSIONS OF STANDARD INSERTS AND COUNTERBORES

Engine Model	Outside Dia. of Insert (A)	Inside Dia. of Counterbore (B)	Press Fit
N-56 N-62	1.068-1.067	1.063-1.062	.004-.006
Y-69 Y-91 Y-112	1.1295-1.1285	1.1255-1.1245	.003-.005
F-124 F-140 F-162	1.3485-1.3475	1.3445-1.3435	.003-.005
F-186 F-209 F-226 F-244	1.442-1.441	1.438-1.437	.003-.005
M-271 M-290 M-330 M-363	1.692-1.691	1.688-1.687	.003-.005
B-371 B-427	1.8785-1.8775	1.8755-1.8745	.003-.005

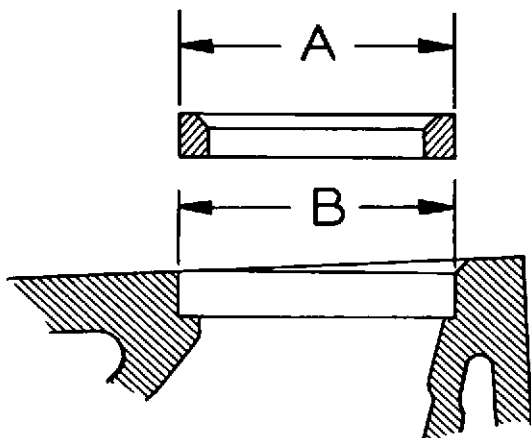

Figure 117-A — Insert and counterbore

When OVERSIZE inserts are used, dimensions of the insert and counterbore increase proportionately (.010, .020, .030—depending on the oversize).

New insert installation should have a press fit. Chill insert in container with dry ice for 20 minutes before assembling.

Insert may then be installed in the counterbore using a piloted driver, tapping in place with very light hammer blows, without the possibility of shearing the side walls. This assures it being seated firmly on the bottom of the counterbore.



Figure 118 — Installing valve seat insert with driver

3. Grind the intake and exhaust valve seats in the block in accordance with instructions in the limits and clearance chart and before removing the arbor, indicate the seat. Total indicator reading of the run-out must not be more than .002". Use a pilot having a solid stem with a long taper, as all valve seats must be ground concentric and square with either new or worn valve stem guide holes.

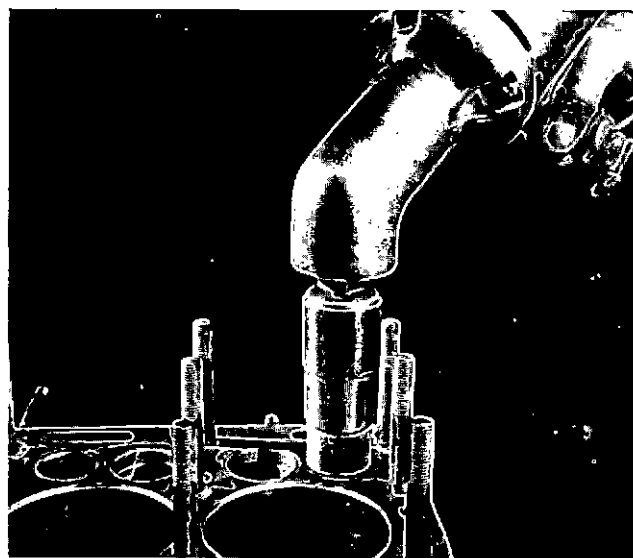

Figure 119 — Grinding Valve Seat

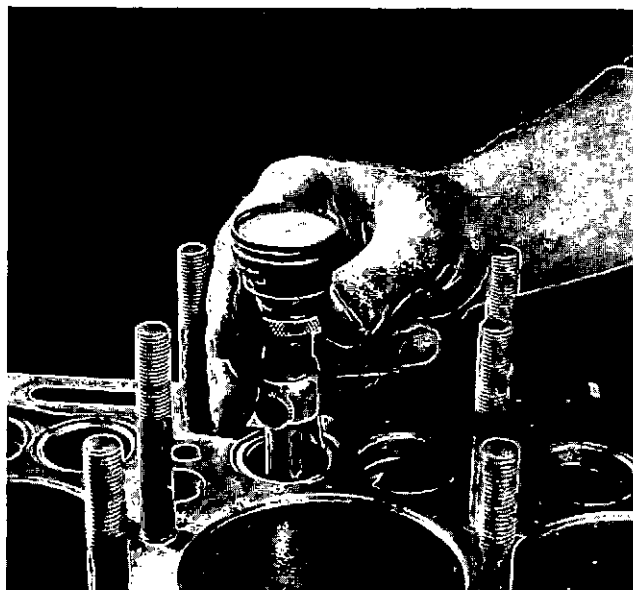

Figure 120 — Indicating Valve Seat

VALVES

1. Inspect valves for condition and replace any that are "necked", cracked or burned, also any on which valve stems are bent or worn more than .002 over the maximum allowable limits. Reface or replace all valves.

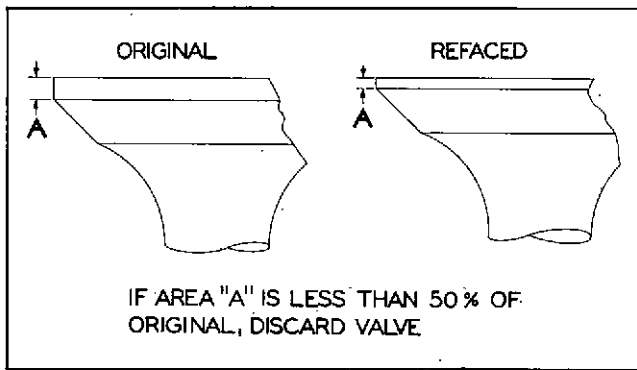

Figure 121 — Allowable head thickness of refaced valves

2. All valves having less than 50% margin thickness (outer edge of valve head) after refacing has been completed must be replaced. To check this dimension, compare the refaced valve with a new valve.

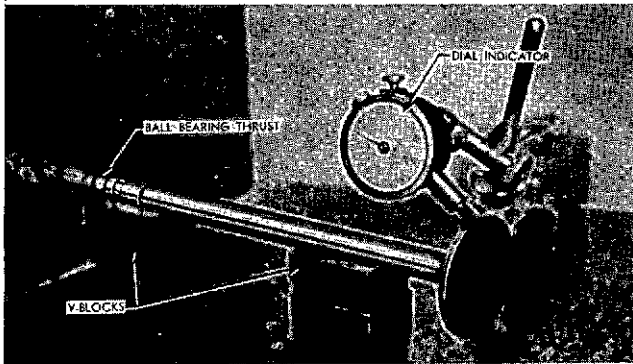

Figure 122 — Checking valve face in "V" blocks

3. Check all refaced or new valves in V-blocks with indicator to determine if the contact face is true with the stem within .002. If not, repeat the refacing operation.

4. After the valves and seats have been refaced and reground, coat the seat lightly with Prussian blue and drop the valve into position, oscillating it slightly to transfer the blue pattern to the valve face. This should show a contact width of $\frac{1}{16}$ " to $\frac{3}{32}$ " and should fall well within the width of the valve face, leaving at least $\frac{1}{64}$ " on either side where

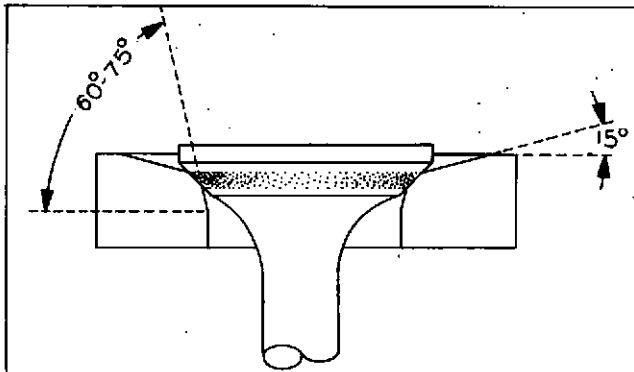

Figure 123 — Method of narrowing valve seats

the blue does not show. If the contact is over $\frac{3}{32}$ " wide, the seat in the head may be narrowed by using a 15° stone to reduce the outside diameter or using a 60° or 75° stone to increase the inside diameter.

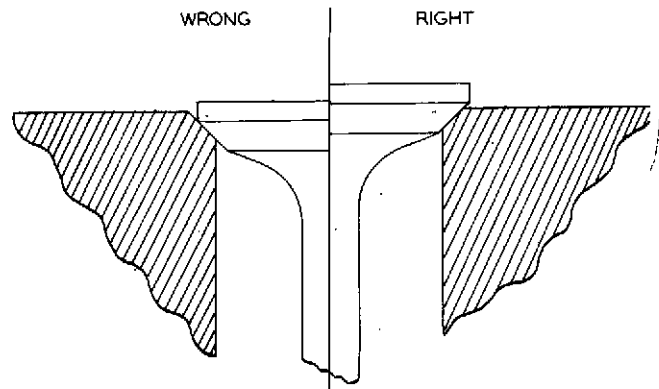

Figure 124 — Valve position in block

Never allow valves to set down inside the seat.

After the narrowed-down seat is brought within specifications, the seat should be retouched lightly with the original stone to remove burrs or feathered edge.

"A poor valve grinding job cannot be corrected by valve lapping."

5. Coat the valve stem with a light film of engine oil.

VALVE SPRINGS

1. Check all valve springs on a spring tester to make sure they meet specifications regarding weight and length. Springs, when compressed to the "valve open" or "valve closed" length, must fall within the specifications shown on the chart when new, and must not show more than 10% loss to re-use.

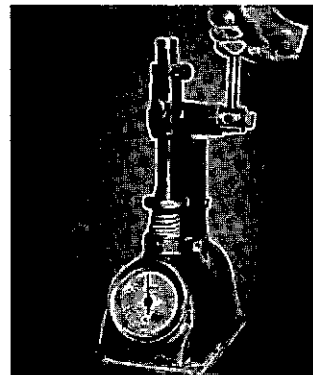

Figure 125 — Valve spring tester

2. Reassemble the valves and springs in the block with the retainer and retainer lock.

CYLINDER BLOCK

All "L" head engines, except the N56, have cylinder barrels cast in the block.

CHECKING BORE WEAR

1. Clean the ring of carbon from around the top of the cylinder bore formed above the travel of the top ring.
2. Determine the original diameter of the cylinder barrel by checking this unworn area with a pair of inside micrometers at intervals of approximately 45°.

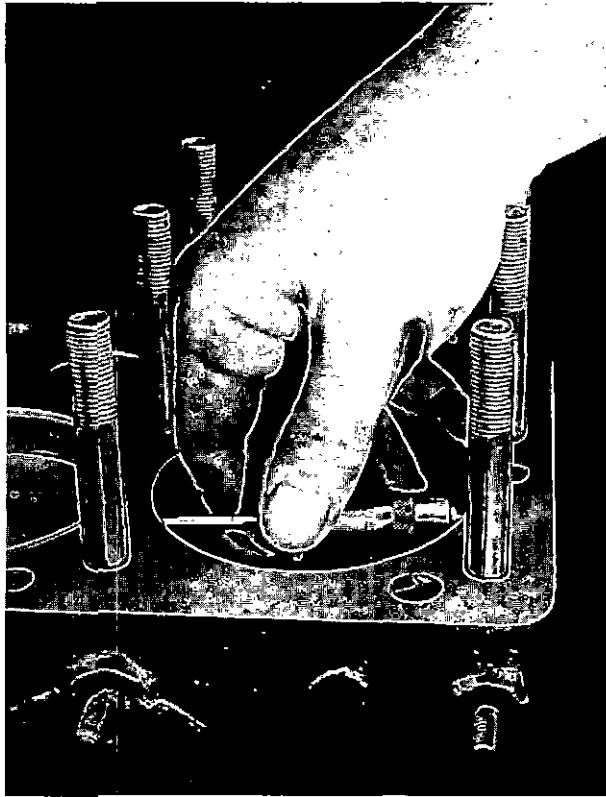

Figure 126 — Measuring original bore diameter above ring travel

3. Check in same manner the top of the ring travel area approximately $\frac{1}{4}$ " below the shoulder.
4. The maximum difference in the above checks, indicates the amount of cylinder bore wear. If less than .008, re-ringing will be suitable and if over .008 re-boring is recommended.

PREPARING CYLINDER WALLS FOR RE-RINGING OR REBORING

1. Ridge ream the cylinders to remove the unworn area at the top so that the new rings when assembled will not bump and distort both themselves and the piston lands.



Figure 127 — Ridge reaming top of cylinder bore

Several good makes of ridge reamers are available which will ream the top of the bore in direct relation to the worn area so that should the worn area be off center slightly there will be no partial ridge remaining.

2. Drain the crankcase and remove the oil pan.
3. Remove the cap screws holding the connecting rod caps to the rod. *Keep the cap and bolts in numerical order so that when the pistons and rods are removed from the engine, the cap can be reassembled and kept with its mating part.*
4. Push the pistons and connecting rods up through the top of the cylinder, carrying with them all the carbon and metal chips left from the cleaning and ridge reaming operation. *When doing this, every precaution must be taken to prevent damage to cylinder bores by the sharp corners and rough edges of the connecting rods and bolts.*

5. It is important to remove the glaze on the cylinder bores by using a glaze breaker in order to assure quick seating of the new piston rings. If the cylinder glaze is not removed, you will have no assurance as to when the rings will begin to function properly and control the oil; this is especially true when chrome rings are used.

The following step by step procedure is recommended:

a. Cover the entire crankshaft with a clean, slightly oily cloth to prevent abrasives and dirt from getting on the crankshaft.

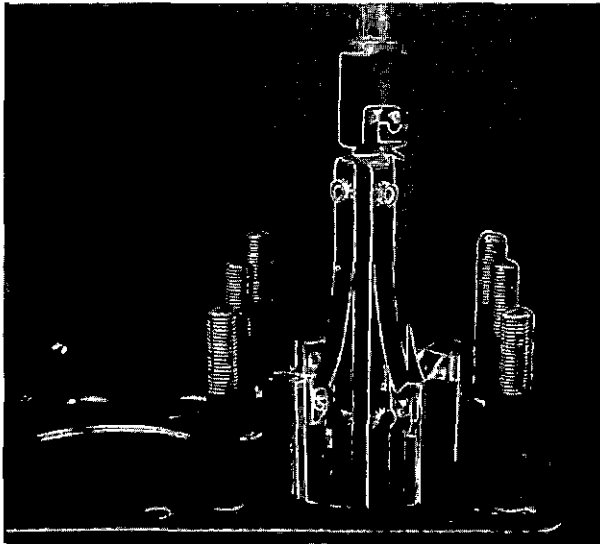

Figure 128 — Removing cylinder wall glaze

b. Remove the excess carbon deposits from the top of the cylinder wall before beginning the glaze breaking operation. (This is to prevent loading the stones.)

c. Surface hone each cylinder several times; move the glaze breaker up and down in the cylinder rapidly to produce a 45 degree cross hatch pattern similar to that illustrated.

d. Clean the loose abrasives from the stones by using kerosene and a wire brush. (Do not use thinner to clean the stones because of the ex-



Figure 129 — Desirable cross hatch pattern obtained with a glaze breaker

plosion hazard.) Dry the glaze breaker before moving to the next cylinder.

e. The most desirable cylinder finish is 30 — 40 micro inches; with this finish the depressions in the surface tend to keep the supply of lubrication between the mating parts. This finish can be obtained by using 220 grit stones on the glaze breaker.

f. Clean all bores thoroughly with a clean oiled rag to pick up all the small particles of dust that may be embedded in the walls. Follow this with a clean cloth to make certain the walls are CLEAN.

PISTONS

Check the pistons for excessive ring groove wear, and replace any that exceed the allowable limits in our limits and clearance data.

The cylinder walls and pistons must be perfectly clean and dry when fitting pistons in the cylinder bores. Pistons should be fitted with the block and piston at room temperature (68° - 70° F).

PISTON FIT ON STANDARD PISTONS* (with 5 to 10# Pull)

N-Y Series	.002
F4, F6 Series	.003
M271	.004
M330	.005
M363	.003
B Series	.005

*This fit may vary on some special applications.

Check the piston fit in the bore using a half-inch wide strip of feeler stock, of the thickness specified in the Limits and Clearance Chart, the feeler being attached to a small scale of approximately 15 lbs. capacity.

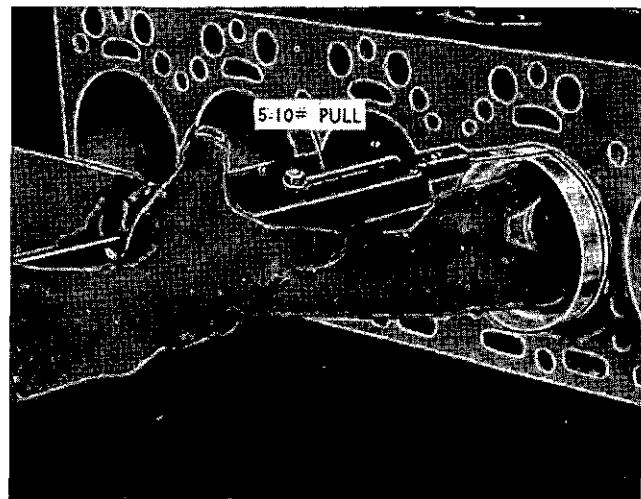

Figure 130 — Checking Piston fit in bore

When the correct fit is obtained you must be able to withdraw the feeler with a pull of 5-10 pounds on the scale, with the feeler inserted between the piston and the cylinder midway between the piston pin bosses where the diameter of the piston is the greatest. Check the fit of the piston when it is approximately 2" down in the cylinder bore in an inverted position.

PISTON PINS

Check the bushing in the upper end of the connecting rod for wear. If worn and you are using the original pistons with a service set of rings, an oversize piston pin may be obtained in .003 or .005" oversize.

The piston pin hole in the piston and the bushing in the connecting rod may be honed to increase

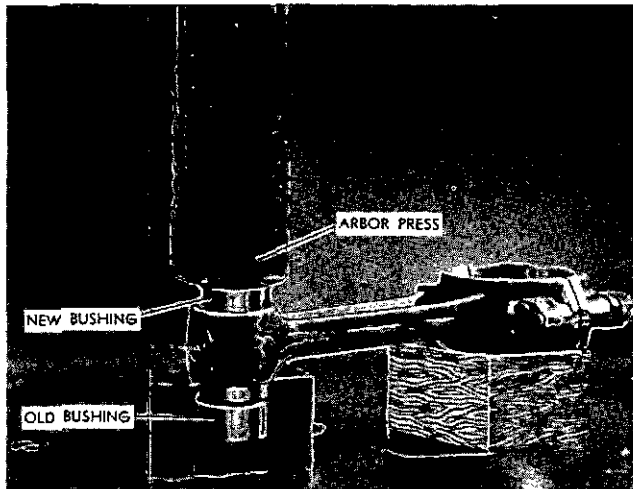

Figure 131 — Pressing in Piston Pin Bushing

their diameter to obtain the desired fit as shown in your Limits and Clearance Chart.

Note that while the chart specifies a light push fit of the pin in the piston, there is a definite clearance of the piston pin in the connecting rod.

CONNECTING ROD

Replace the bushing in the connecting rod if new pistons and sleeves are used. Using an arbor press, press out the old bushing and press in the new one — after which the bushing must be honed to obtain the correct fit of the pin in the bushing as shown on Limits and Clearance Chart.

If there is an excess of stock in the piston pin bushing, it may be reamed first, then honed. In any event, the final operation should be done with a hone to obtain the desired fit with better than 75% bearing area on the pin.

PISTON AND CONNECTING ROD ASSEMBLY

1. Assemble the pistons on the connecting rod by first heating them in some form of oven or in hot water to a minimum temperature of 160°F. When heated, the piston pin will enter the piston very easily and can be tapped through the connecting rod and into place without distorting the piston.

The snap rings must be assembled in the grooves, making sure they are fully seated in place.

2. The piston pin hole in the connecting rod must be parallel to and in plane with, the large bore in the bearing end of the connecting rod.

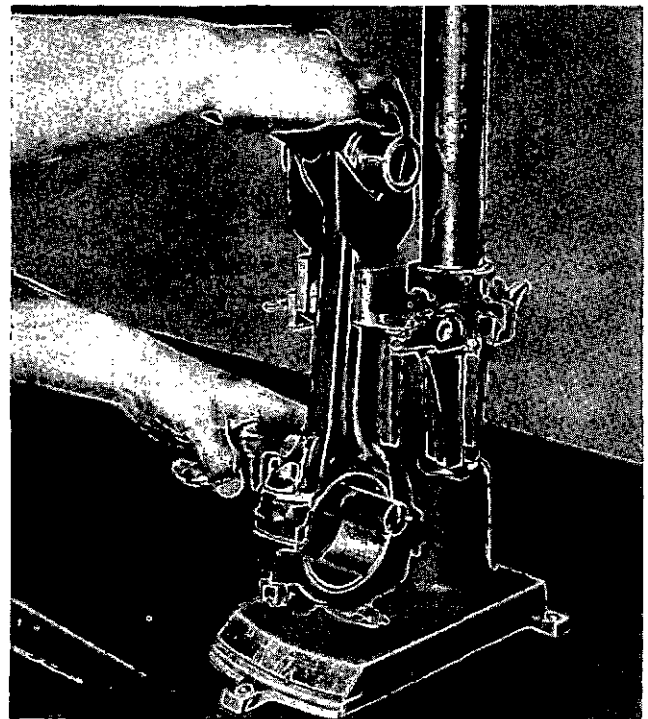

Figure 132 — Checking connecting rod for twist

This may be checked on a fixture with the piston pin assembled in the rod before assembling the piston; but regardless of this preliminary check, the completed piston and rod assembly must be rechecked and there must not be more than .002" twist or out of squareness checked over a spread of approximately 4 inches. The connecting rod can be bent or twisted to meet this specification.

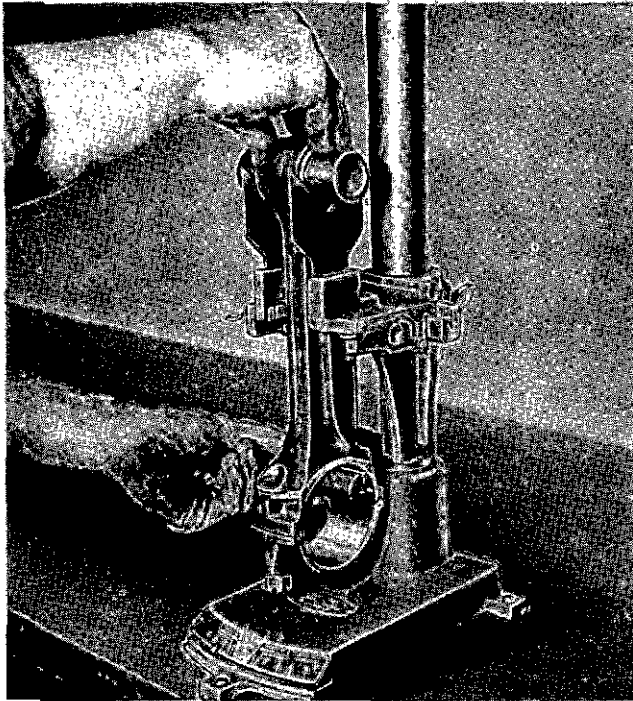

Figure 133 — Checking connecting rod for alignment

Pistons are cam and taper ground, and this must be taken into consideration when checking alignment of the assembly, since the diameter in line with the piston pin would be less at the top of the skirt than at the bottom.

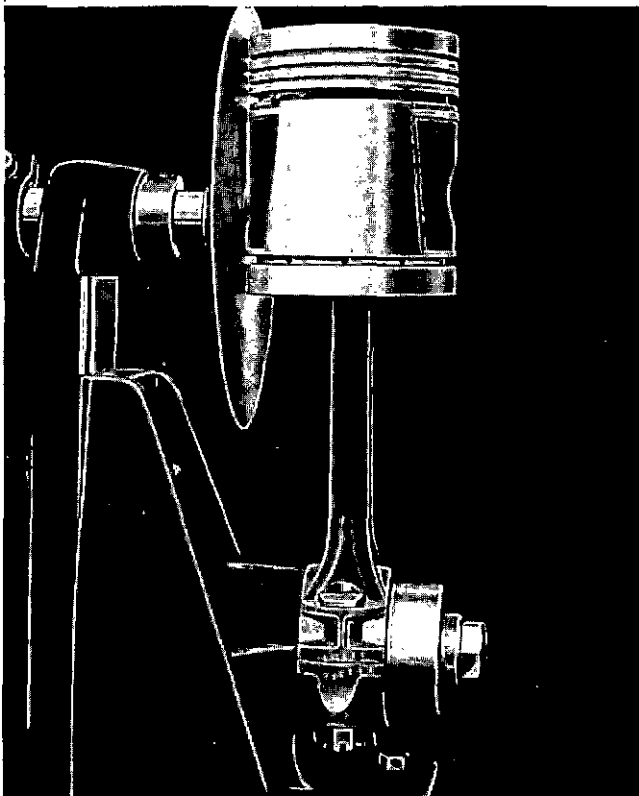

Figure 134 — Checking connecting rod assembly for alignment

PISTON RINGS

Check the piston rings in the cylinders for gap.

To do this, insert a piston in the cylinder bore in an inverted position and then insert each ring one at a time about 2" down in the bore and bring the bottom edge of the piston up against the ring to square it up in the cylinder bore.

Check the gap between the ends of the ring with a feeler gauge in accordance with specifications shown in the Limits and Clearance chart. If any of the rings do not have enough gap, they may be filed either in a ring filing fixture or by clamping the file in a vise and holding the two ends against opposite sides of the file.

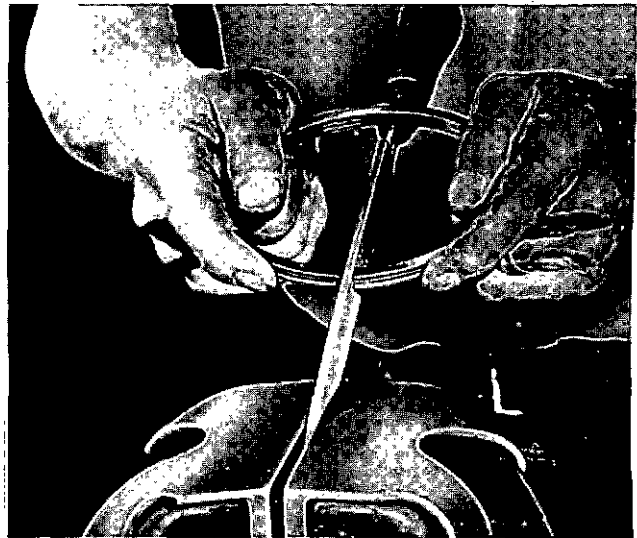

Figure 135 — Filing piston ring to increase gap

RECOMMENDED METHOD OF INSTALLING PISTON RINGS

1. Grip the connecting rod in a vise with lead lined jaws to hold the piston firmly and roll each of the straight side rings in its groove to be sure there are no burrs or other interference with the free action of the ring in the groove.

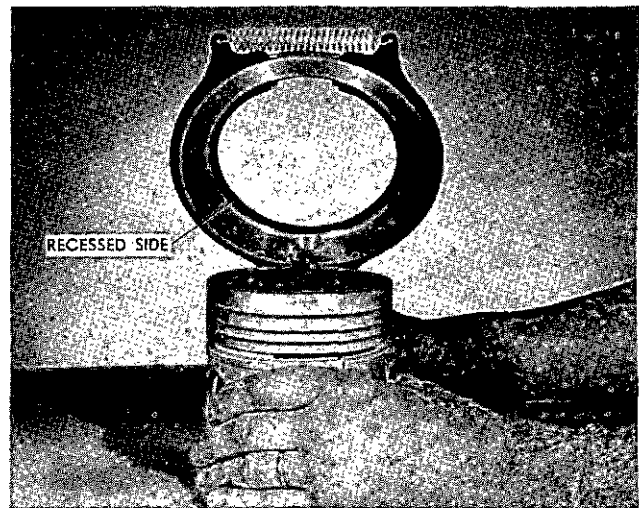

Figure 136 — Installing Rings with Ring Expander Tool

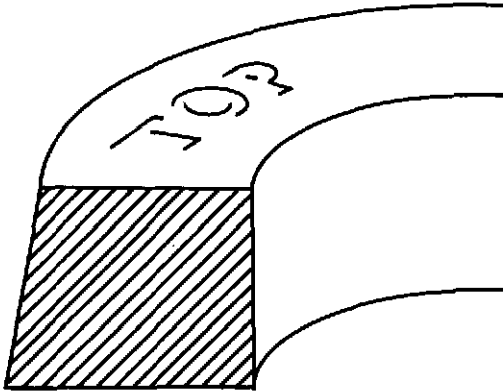

Figure 137 — Install Tapered Rings with "Top" Side Up

2. Hold the ring tool with recess side up and place the ring in with the bottom side up. Start with the lowest ring first.

Some piston rings are taper faced. These are clearly marked "TOP" on the side to be up when assembled on piston.

3. Position ring in the tool so the expanding fingers will fully engage both ends.

4. Apply pressure on handles so ring is completely expanded. Pass the expanded ring and tool recessed side down over the piston to the proper groove.

5. Check the ring side clearance at various positions with a feeler in accordance with the tolerances shown on the Limits and Clearance Chart.



Figure 138 — Checking Ring Clearance in Groove

CRANKSHAFT AND MAIN BEARINGS

1. Using a puller, remove pulley from crankshaft.
2. Take out screws and remove gear cover.
3. Drop the oil pump, by removing nut or cap screws holding pump to center main bearing cap.

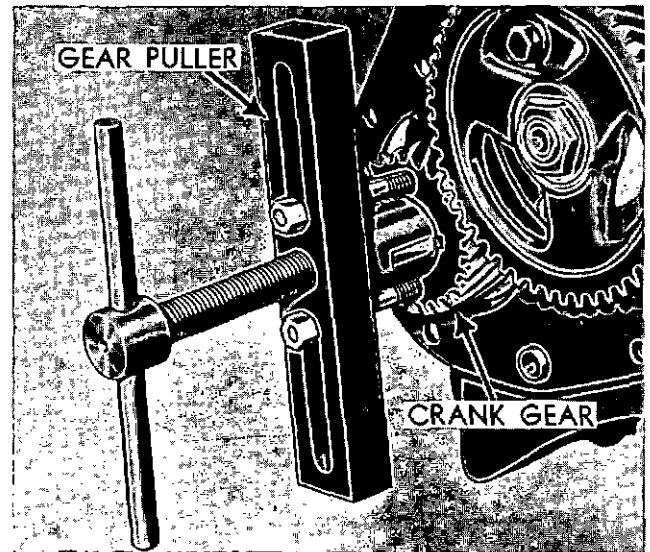

Figure 138A — Removing Crank Gear

4. Remove each main bearing cap, one at a time, and inspect the bearing and crankshaft journals.

If there is any indication of flaking out, scoring or actual wear, — they must be replaced.

BEARINGS

Some models use tri-metal bearings which when new are smooth and highly polished. However, a *very few hours of operation will change their appearance completely.* The bearing surface becomes a leaden gray in color and develops minute craters, almost cellular in appearance as indicated in the photograph, which follow the pattern of the matrix. *This appearance is a natural characteristic of this type bearing and in no way indicates failure.*

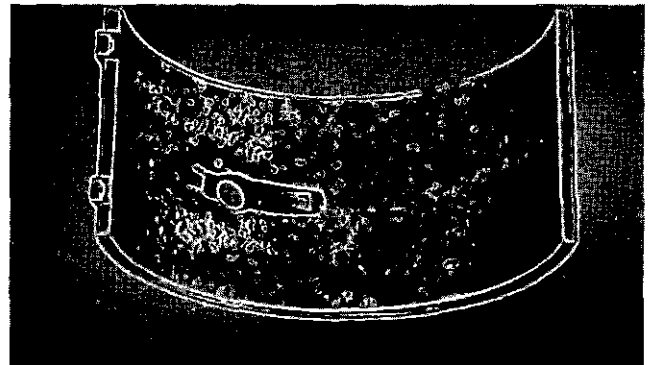

Figure 139 — Appearance of a Good Bearing

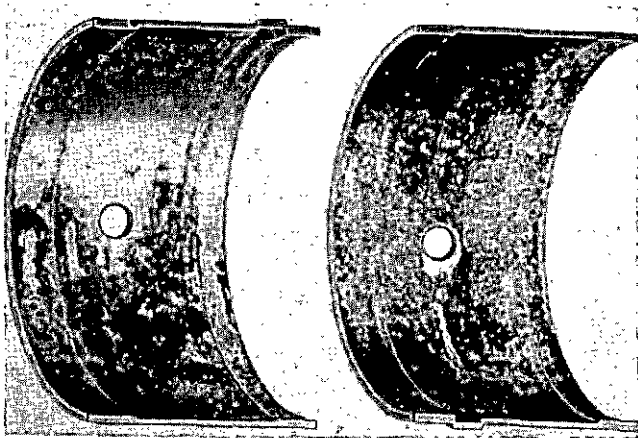

Figure 140 — Bearing Damage Due to Corrosion

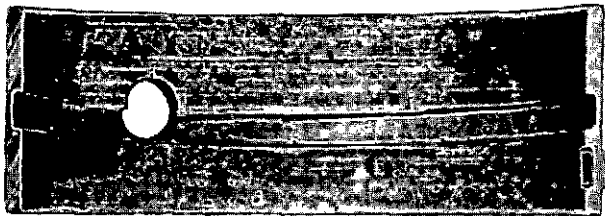
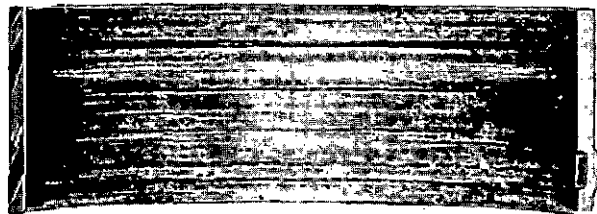

Figure 141 — Scored Bearing Due to Dirt or Lack of Oil



5. If the visual inspection appears satisfactory, they should be removed and checked for thickness using a ball micrometer.

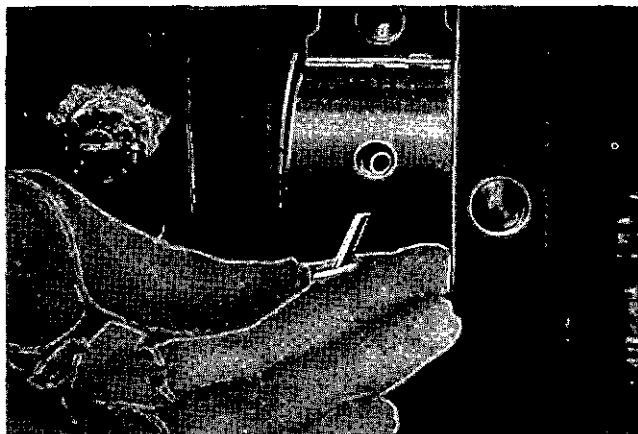

Figure 142 — Removing Main Bearing

To remove the upper half of the bearing shell use a special tool obtainable at most parts houses, which is a pin with an angular head. It may be inserted in the oil hole of the crankshaft and as the crankshaft is turned in a clockwise direction, the head of this pin picks up the bearing shell and forces it out of the bore in the block.

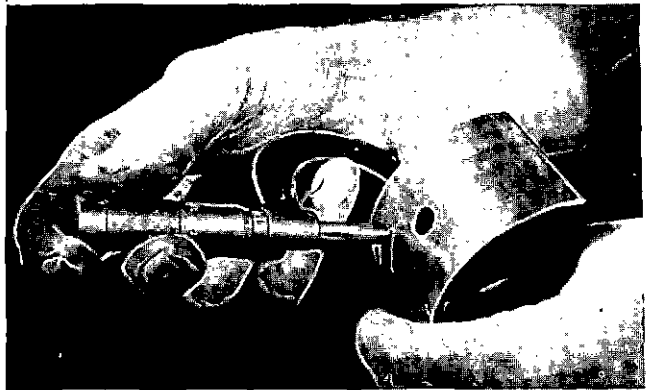

Figure 143 — Measuring Bearing Thickness

The thickness of the bearing shells is given in the Limits and Clearance Chart, and if this thickness has been reduced more than .0005 beyond the maximum allowable tolerance the bearing shell must be replaced.

6. If visual inspection of the crankshaft shows no indication of excessive wear or scoring, the clearance of the feeler should be checked.

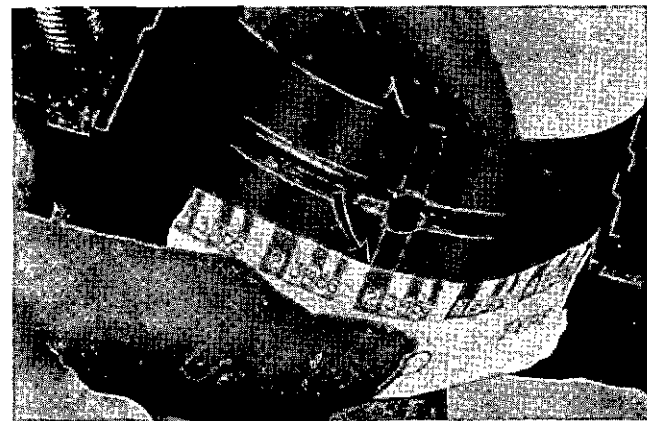

Figure 144 — Checking Bearing Clearance with Plastigauge

7. Check each bearing, one at a time, by using a piece of Plastigage of a diameter specified to check certain clearances.

By placing this Plastigage in the bearing and tightening it in place, the width of the Plastigage after crushing it determines the bearing clearance as shown above.

CAUTION

When using this method DO NOT TURN the crankshaft as that would destroy the Plastigage.

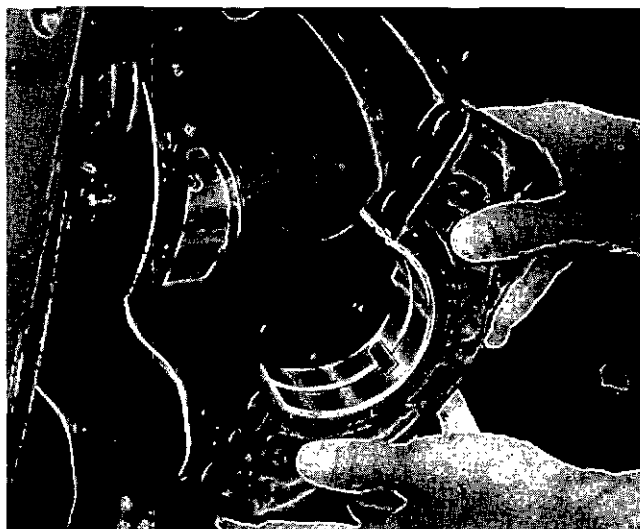

Figure 145 — Checking Bearing Clearance with Feeler Stock

An alternative method is to use a piece of $\frac{1}{2}$ " feeler stock (the thickness of which should be equivalent to the maximum clearance permissible in the bearing) lengthwise, in the bearing shell, on a film of oil. Assemble the bearing cap and tighten the screws, torquing them to the specifications, — then try to turn the crankshaft by hand to determine whether or not you can feel a drag.

If a definite drag is felt and the piece of feeler stock is equivalent to, but no more in thickness than the maximum clearance specified, you may be sure that neither the crankshaft nor bearing are worn excessively as far as clearance is concerned.

When using new bearings and the crankshaft is not worn, checking with a piece of feeler stock as outlined above should lock up the crankshaft, making it possible to turn only by use of a bar or wrench.

If crankshaft is scored, or worn enough so that new bearings will not fit with the required clearance, it should be removed and reground.

Standard crankshafts may be reground to decrease the diameter a maximum of .040.

Before shaft is reground, it must be checked for straightness and straightened if necessary to be within .002 indicator reading. When reground, the fillet radii must be within dimensional limits and must be perfectly blended into thrust and bearing surfaces.

8. Connecting rod bearings and crank pins may be checked in the same manner with one exception; instead of trying to turn the crankshaft when the connecting rod bearing is tightened on it with a piece of feeler gauge assembled, try to move the connecting rod from side to side.

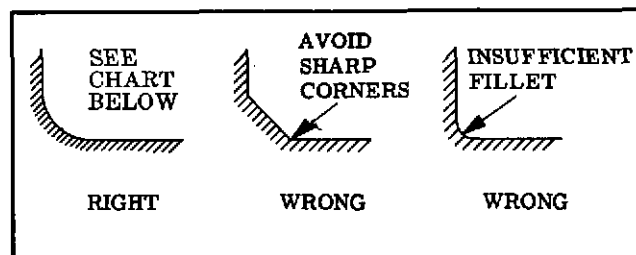

Figure 146 — Crankshaft Fillet Radii

N	$\frac{3}{32}$ " R on all crankpins and mains
Y	$\frac{5}{64}$ " R on all crankpins and front & center mains $\frac{3}{32}$ " R on rear main
F M	$\frac{3}{32}$ " \pm $\frac{1}{64}$ " R on all crankpins and mains except rear $\frac{1}{8}$ " \pm $\frac{1}{64}$ " R on rear main
B	$\frac{3}{32}$ " \pm $\frac{1}{64}$ " R on all crankpins and mains

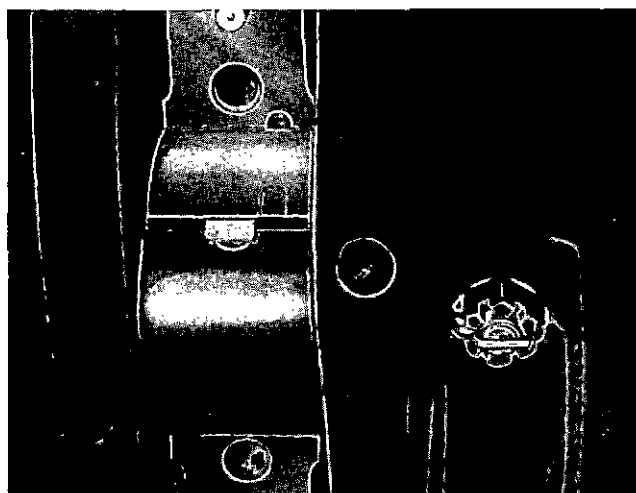

Figure 147 — Replacing Bearing

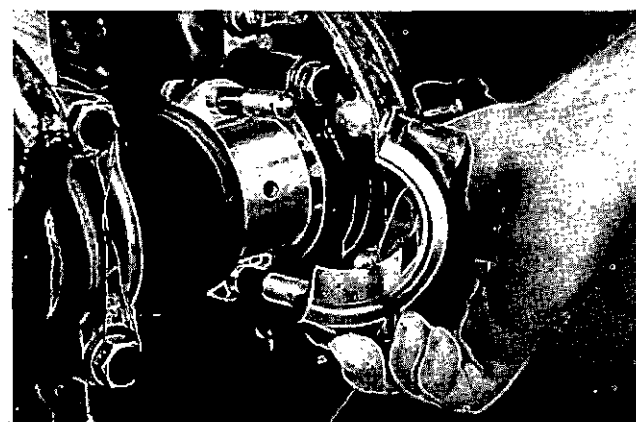

Figure 148 — Checking Rod Bearing with Feeler Stock

With new bearing shells and feeler stock equivalent to the specified clearance in thickness, if the crank pin is not worn you will quite probably have to use a hammer tap to move the rod from side to side, indicating that the clearance is well within the specification range.

CAMSHAFT

1. Using a puller, remove the cam and crank gears.

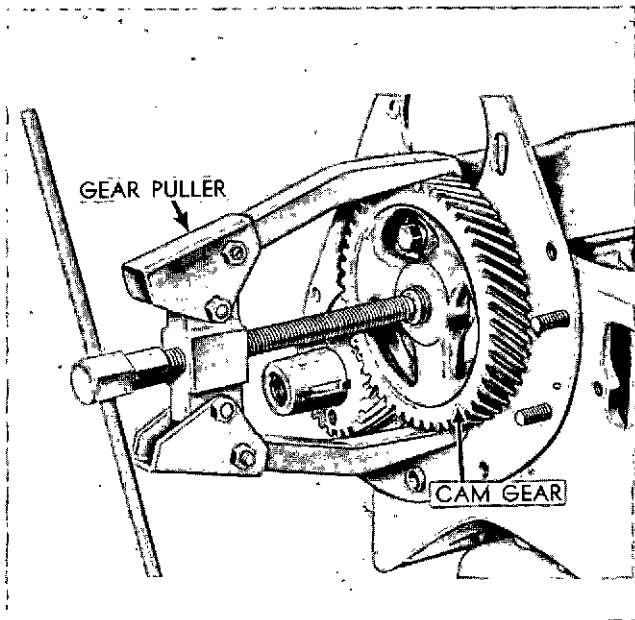

Figure 149 — Removing Cam Gear with Puller

2. Remove the screws holding the camshaft thrust plate to the front of the cylinder block, which makes it possible to pull the camshaft forward out of the bearings.

3. Unless engine is lying on its side, tappets must be removed or lifted before camshaft can be pulled.

4. Remove tappet chamber covers.

5. Tappets can then be lifted out and lined up in sequence, for installation in the same location unless inspection shows that they require replacement.

6. Before pulling the camshaft completely, check the clearance of the bearing journals in the bushing (or block in some models). To do this use strips of feeler stock 1/4" wide with edges dressed with a stone to eliminate any burrs or feathered edges.

7. If clearance is equal to or greater than the amount indicated under wear limits, check the diameter of the camshaft journals to determine the next step. Excess wear at these positions require replacement of the shaft.

If wear is found to be in the bushings instead, these must be replaced using precision service bushings, available for that purpose, which require no reaming, only care in assembly, to line up oil holes, and not to damage the bushings as they are being pressed in.

TAPPETS

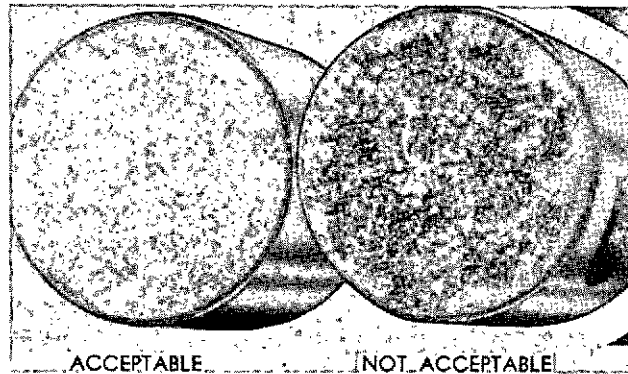

Figure 150 — Valve Tappet Wear Comparison

1. Inspect each tappet carefully. Two or more small pits on the contact face is acceptable; more than that calls for replacement of the tappet on the N, Y, F4, F6 Series.

Oversize tappets are available as required.

2. Check the outside diameter with micrometers to determine if replacement is necessary because of wear.

3. On the M and B series, tappet guides or guide bushings may be checked for wear with a plug gauge or preferably with a telescopic gauge and micrometer.

If guide bushings are used, they may be replaced and std. tappets used. If bushings are not used, the tappet bore may be reamed oversize, and oversize tappets installed.

TAPPETS				
ENGINE	O. D. TAPPET	BORE IN BLOCK	TOTAL MAX. WEAR LIMITS	
N, Y, F4, F6 Series	.9995 .9990	1.0008 1.0000	.005	Oversize tappets available.

ENGINE	O.D. TAPPET	SLEEVE DIA.	TOTAL MAX. WEAR LIMITS	
M-B Series	1.1242 1.1237	1.1260 1.1250	.005	Std. sleeves and Std. Tappets available

Note: On the N, Y, F4, F6 engines, the tappets ride in a tappet bore in the block. On the M and B, guide bushings are used: the dimension shown is the I.D. after bushing is installed in block.

CAUTION — WHEN INSTALLING CAMSHAFT USE SPECIAL CARE TO PREVENT CAMSHAFT BUMPING AND LOOSENING EXPANSION PLUG TO CAUSE AN OIL LEAK

TIMING GEARS

1. Timing gears and timing gear fits must be checked carefully while the engine is being overhauled. To check the fit, use a screw driver to force the mating teeth as far apart as possible and check this clearance with a feeler gauge. If this clearance is .002" or greater, or if the gear teeth are badly scuffed and worn, the gear must be replaced. Timing gears must be replaced in pairs.

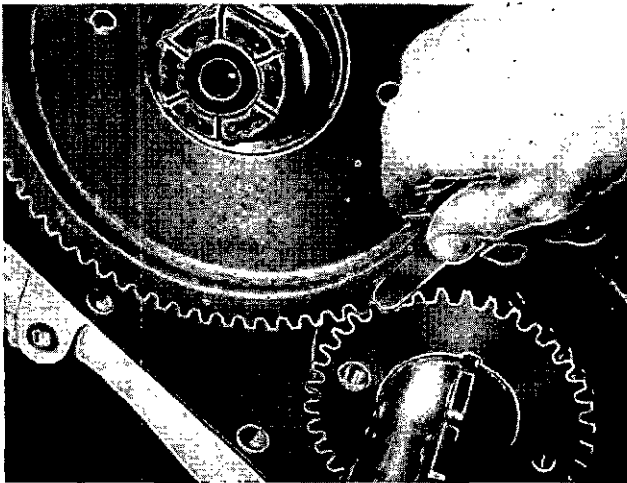

Figure 152 — Checking Timing Gear Backlash

Gears marked same as the original as far as sizes are concerned should be used as replacements.

2. Examine the camshaft thrust plate carefully for scoring and wear and if any indication of either shows, a new thrust plate should be assembled without question.

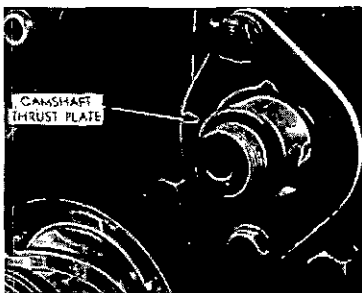

Figure 153 — Camshaft Thrust Plate

3. Assemble the cam gear to the camshaft by driving or pressing it on, at the same time holding the camshaft forward with a suitable bar through the fuel pump opening in the block so there is no possibility of the camshaft bumping the expansion plug at the rear end and forcing it out of position, thus causing an oil leak.

Check camshaft end play as shown in illustration. Refer to limits and clearance section for the correct dimension.

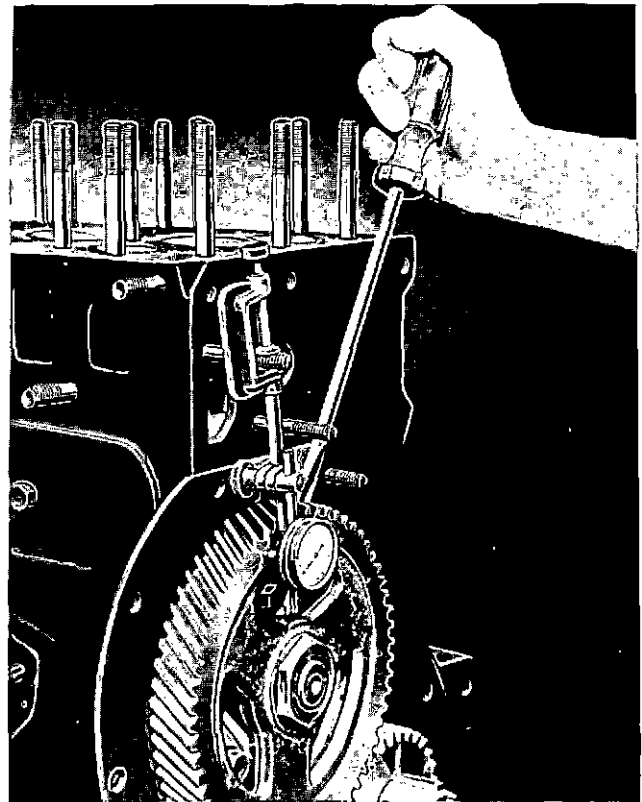

Figure 154 — Checking Camshaft End Play

4. Inspect crankshaft thrust washers for wear and scoring. Replace if necessary before reassembling gear.

5. Drive the crank gear on the shaft making sure that the marked teeth on the cam gear straddle the marked tooth on the crank gear, which assures you of the crankshaft and camshaft being in time.

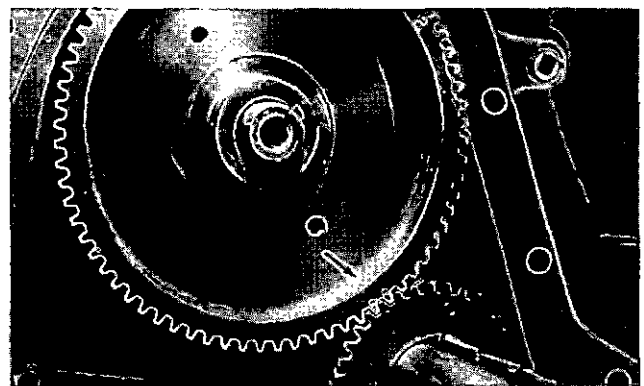

Figure 155 — Timing Gears Assembled According to Timing Marks

6. Check for clearance with the above gears assembled in place, since it may be possible that it is not within specifications. Repeat the operation previously outlined. Using a screwdriver pry the teeth as far apart as possible and check the clearance with a feeler gauge. If a .0015" feeler will not enter the gap the clearance is not excessive.

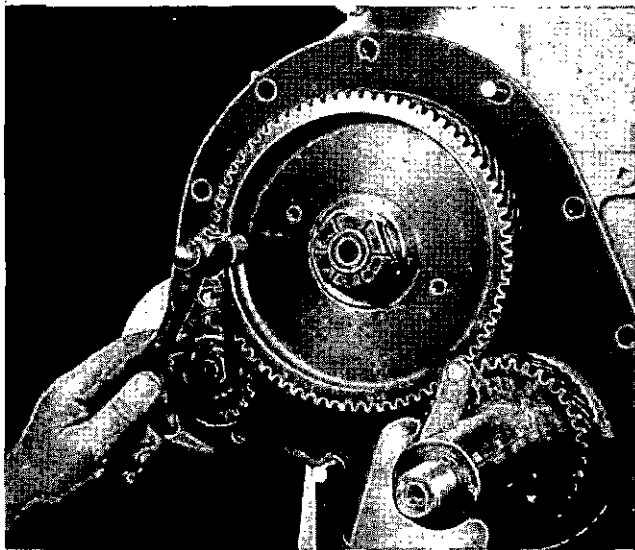

Figure 156 — Checking Gear Fit

To be certain that there is enough clearance, hold your finger at the junction of the two gears and with a light hammer tap the rim of the cam gear and note if there is vibration felt at this point.

If there is vibration and a .0015" feeler gauge will not enter the gap between the two gear teeth, the gear fit is within specifications.

7. Crankshaft gears and camshaft gears are furnished in standard and under and over sizes. Gears marked "S" are standard; if they are marked with figures "1" or "2" in a letter "U" this signifies undersize. If they are marked with figures in the letter "O" this signifies oversize.

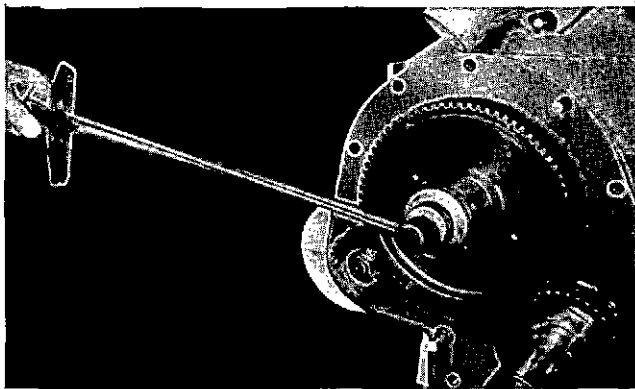

Figure 157 — Torquing Cam Gear Nut

CRANKSHAFT END PLAY

1. Check the crankshaft end play before replacing the gear cover. A shim pack containing shims of .002" and .008" thickness is incorporated in the assembly between the front end of the main bearing journal and the crank gear and by removing or adding shims, this end play can be corrected to fall within the specifications.

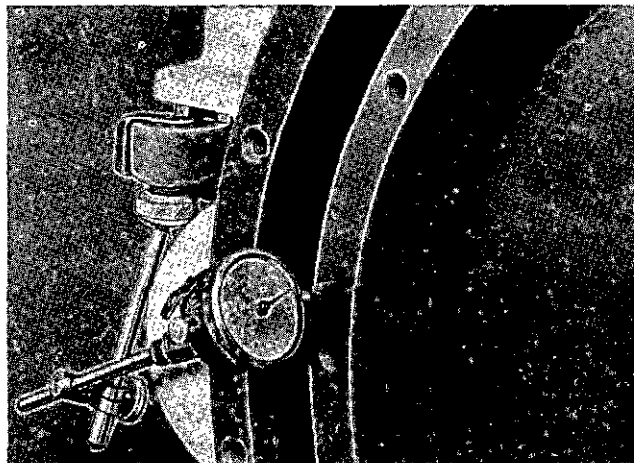

Figure 158 — Checking End Play with Indicator

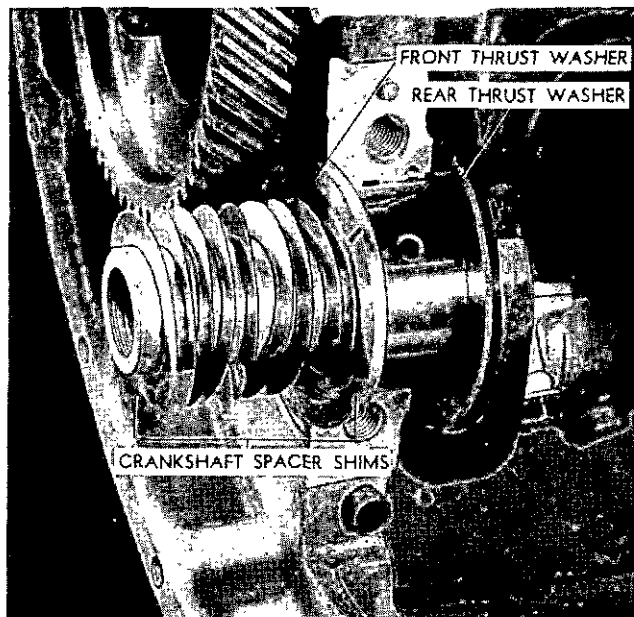

Figure 159 — Thrust Washers and Shims Controlling Crankshaft End Play

At all times when checking end play, the crank gear must be tightened firmly against the shim pack, which can be done by using a sleeve or the regular pulley, slipping it over the crankshaft and using the standard assembly parts to tighten the pulley and gear in place.

On some models, end play is controlled by center thrust bearings, which require no shims.

ASSEMBLING OIL SEALS IN FILLER BLOCK AND OIL GUARD

Continental L-head engines have 3 types of crankshaft and oil pan seals.

The first type is jute packing which is used in sealing the filler block and oil guard in block to crankshaft.

The second type is a neoprene seal which is used in sealing the oil pan to the filler block.

The third type is a neoprene circular spring type which is currently used on the N-series engines.

JUTE TYPE OIL SEALS

First, remove the filler block and oil guard, the latter being the semi-circular die casting which fits in the cylinder block just to the rear of the rear bearing bore. Clean out the grooves thoroughly and clean the outer surface of this oil guard so as to remove all dried cement and grease.

Jute packing for crankshaft seal as it is received is approximately one-third larger in diameter than the width of the groove. To fit the grooves in the filler block, this must be crushed in a vise or flattened with a hammer on a flat surface so the jute packing is narrow enough to fit into the grooves.

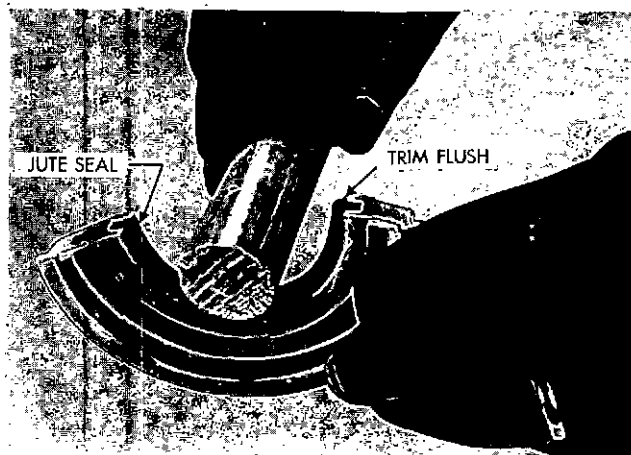

Figure 160 — Top Half of Rear Seal

Next, press it into the grooves of both the filler block and the oil guard. Then, using a piston pin, a smooth hammer handle or some other instrument with a rounded surface, iron this packing into the groove so that it is seated firmly and expanded so that it seizes the sides.

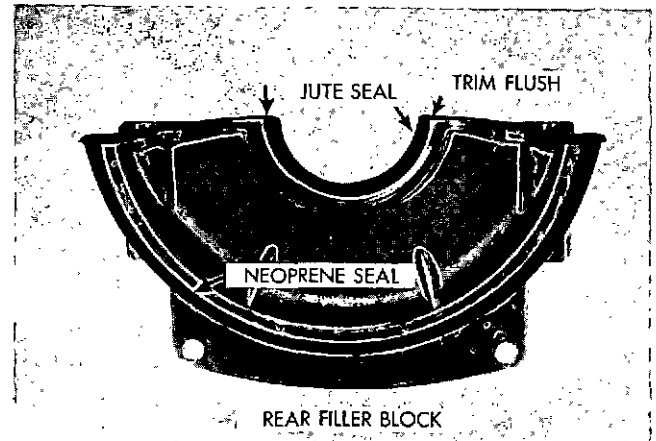

Figure 161 — Lower Half of Rear Seal

In its present condition the packing will protrude from the grooves at either end in varying amounts. With a sharp knife, or razor blade, cut this off flush, making the cut parallel to the surface of the casting. Then slip it into place, either around the crankshaft, if the engine is still assembled, or directly into the groove if the crankshaft is out.

NEOPRENE OIL SEAL

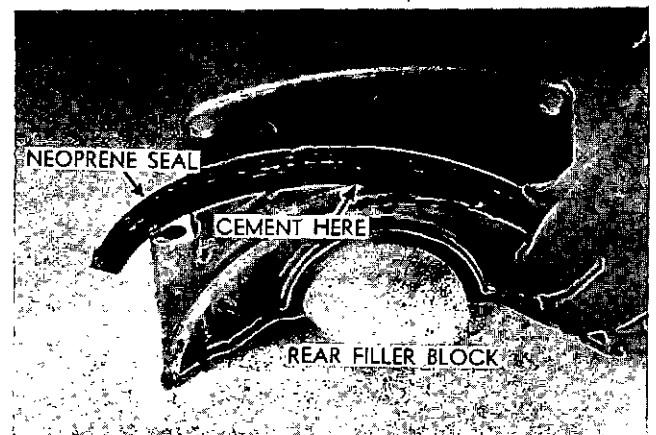

Figure 162 — Installing Neoprene Seal in Rear Filler Block

1. To replace neoprene seal, thoroughly clean all cement, dirt, and oil from the contacting surface of the filler block. To hold seal in place for assembly, use only a small spot of non-hardening cement in the center of the contacting surface, before inserting seal in groove. No other cement is required.

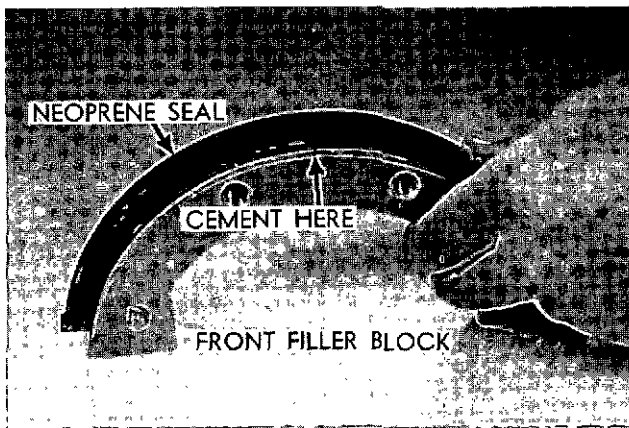

Figure 163 — Installing Neoprene Seal in Front Filler Block

2. Neoprene seal on front filler block is installed in the same manner.

When replacing gear cover, cement gasket to gear cover with a quick drying gasket cement and reassemble to engine block.

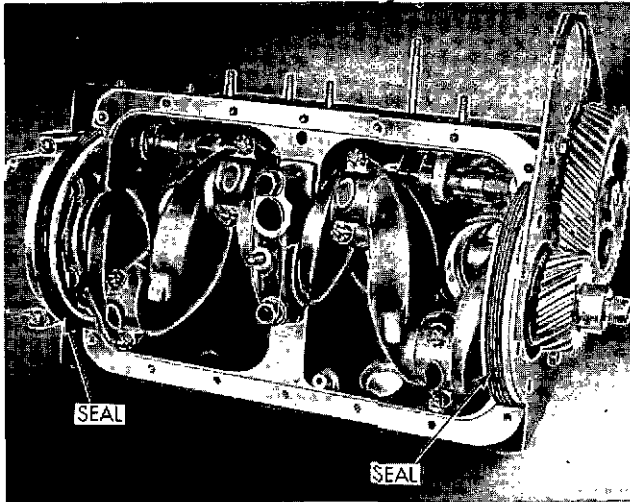

Figure 164 — Neoprene Seals in Place

In order to prevent possible oil leaks, it is imperative to use **only** genuine Continental replacement gaskets and seals — since these have been engineered and designed to do a superlative job.

NEOPRENE CIRCULAR SPRING TYPE SEAL

The "N" series of engines uses a circular spring type seal which is replaced as follows:

1. Remove flywheel assembly.
2. Remove cap screws from oil seal retainer assembly.
3. Remove retainer from 2 dowel pins and slide off seal surface of crankshaft.
4. Press oil seal from retainer with a driver slightly smaller than seal diameter. Thoroughly clean back of cylinder block and retainer in a solvent.
5. On an arbor press, press in new seal with driver which fits oil seal to prevent damage to seal. If a driver of the correct diameter is not avail-

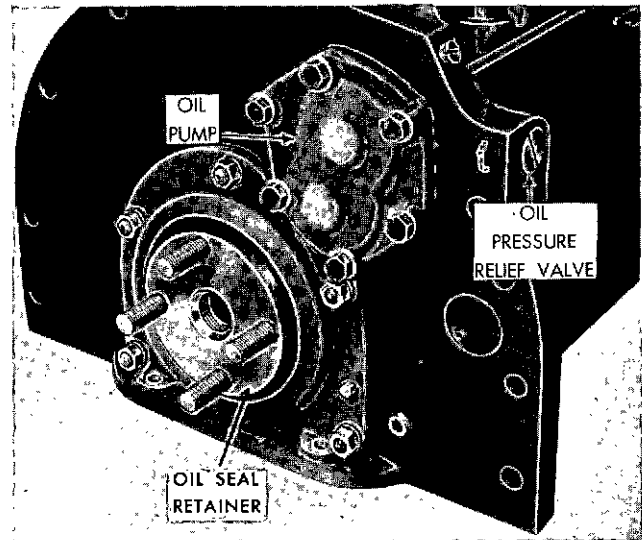

Figure 165 — "N" Series Circular Spring Type Seal

able, use a piece of $\frac{1}{4}$ " sheet steel, 8" x 8" or larger, and press seal into retainer on an arbor press. Be sure the seal wiping edge and spring face is toward engine.

6. Examine crank flange seal surface carefully. Any roughness or scratches should be polished off, otherwise they will damage new seal.
7. Apply coat of fibre lubricant to seal as well as seal surface of crankshaft (A good wheel bearing type of lubricant should be used).
8. Install a new gasket between retainer and cylinder block.
9. Carefully slide seal assembly over crankshaft seal surface using a piece of shim stock to guide it in place. Align dowel holes of retainer with dowel pins in block and tap retainer gently in place.
10. Replace retainer cap screws and torque evenly to 15 - 20 ft. pounds so as not to distort the retainer.
11. Replace flywheel.

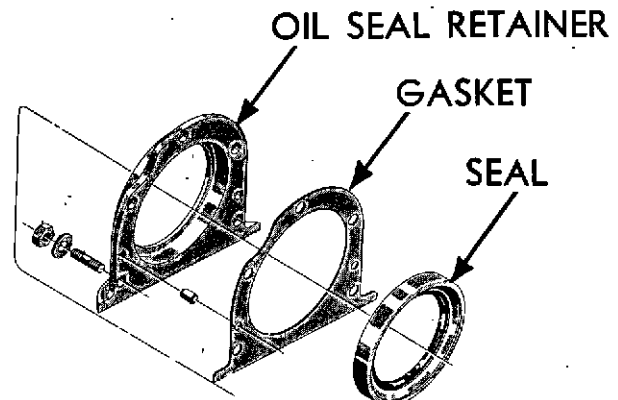

Figure 166 — Exploded View of Oil Seal Retainer and Seal

OIL PUMPS

The oil pump is assembled to the center main bearing, held in position vertically against a machined pad by studs, (except the "N" series engines, which have the oil pump on the rear end plate, and driven off end of camshaft.)

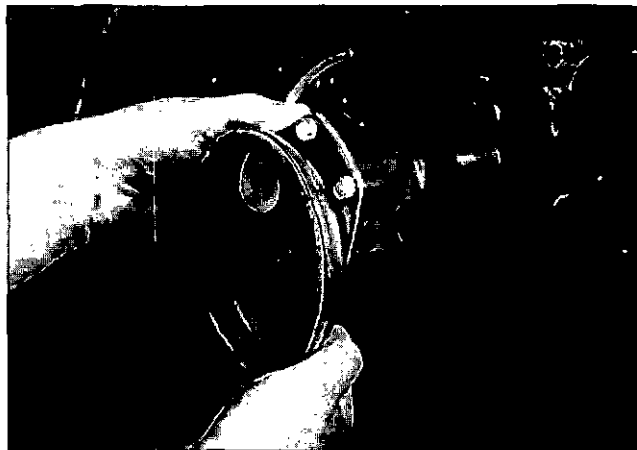

Figure 167 — Oil Pump Removal

The extended portion of the body acts as a pilot, fitting closely in a reamed hole in the main bearing web, maintaining definite relationship between the camshaft and the oil pump drive shaft.

A gear assembled to the upper end of this shaft is driven by a mating gear cut on the camshaft and drives the oil pump gear which is assembled to the lower end of the pump shaft.

The pump shaft is carried in two bronze bushings assembled in the cast iron housing, which is also a part of the oil distributing system, transmitting oil to the drilled passages.

The gear type pump has a capacity well in excess of that required by the engine.

When the pump is removed, examine the drive gear carefully for wear, inspecting the gear on the camshaft at the same time. If scored or worn badly, both the camshaft and the gear on the pump must be replaced.

Examine the pick-up screen (which may be either the Floato type or the stationary screen type) for clogging or damage.

Remove the cover, being careful not to damage the lead gasket which acts as a spacer as well as a gasket to seal the joint.

Examine the gears and pump body for any sign of wear indicating lack of clearance. The gears should have from .001 to .003 clearance in the chamber and should make no contact with the walls.

Inspect the cover and face of the gears for excessive wear or scoring. With the gasket assembled to the body there should be .0015 - .006 clearance between the gears and the cover.

Worn or scored gears can be replaced, as can a worn cover. If the body shows wear in the chamber, it can be replaced, but in a case like this a new pump would be the most economical.

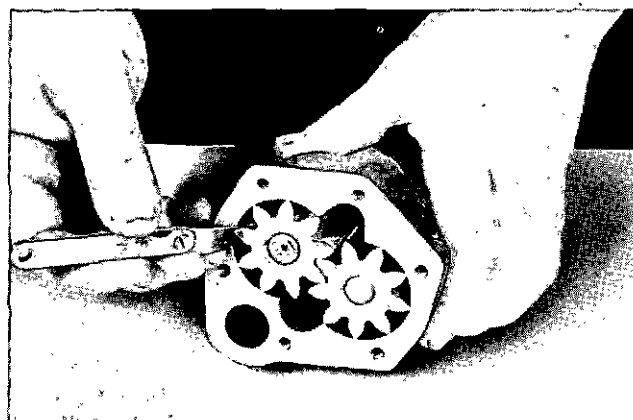

Figure 168 — Checking Oil Pump Gear Clearance in Body

Engine oil pressure must be maintained to specification for satisfactory engine life.



Figure 169 — Checking Oil Pump End Clearance

Pressure relief is located externally on the right-hand side, near the oil pan flange at the center. (on the N series, it is located in the rear end plate). Pressure is controlled by a plunger and spring. The latter specifically for a certain range. The only adjustment variation is either to change springs or assemble or remove washers from behind the present spring. Up to four washers are permissible.

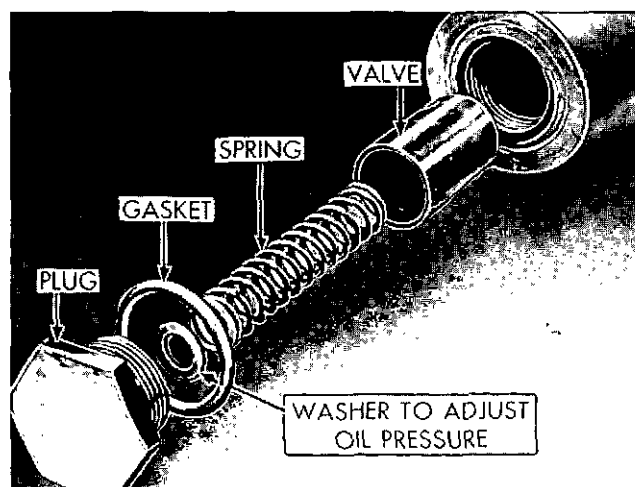

Figure 170 — Oil Pressure Relief Valve

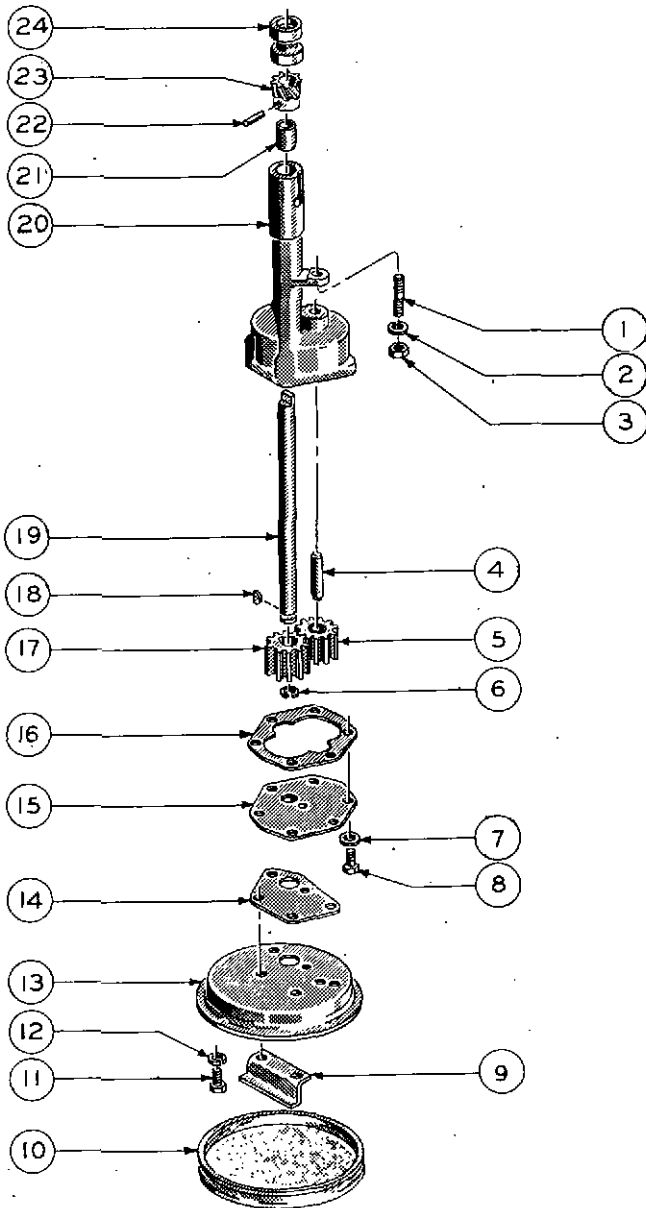

Figure 171 — Typical Oil Pump

- | | |
|-----------------|-----------------------------|
| 1. Stud | 13. Frame — oil pump screen |
| 2. Washer | 14. Gasket |
| 3. Nut | 15. Cover — oil pump |
| 4. Stud | 16. Gasket |
| 5. Gear — idler | 17. Gear — driver |
| 6. Snap ring | 18. Key |
| 7. Washer | 19. Drive shaft |
| 8. Screw | 20. Body assembly |
| 9. Spacer | 21. Bushing |
| 10. Screen | 22. Pin |
| 11. Screw | 23. Gear |
| 12. Washer | 24. Bushing |

CAUTION

On several models of our L-Head engines, a 1/8" flat spacer washer is used between the oil pump mounting lug and the center main bearing cap. When reassembling, be **SURE** that this washer is placed on the oil pump mounting stud before the oil pump is installed in place. Failure to do this will cause interference between oil pump and camshaft and will not allow the distributor drive to mesh correctly.

NOTE

When replacing oil pump drive gear (Item 23, Fig. 171) it is necessary to line up the hole in the gear with the hole in shaft and drill through the other half of the gear before pinning in place.

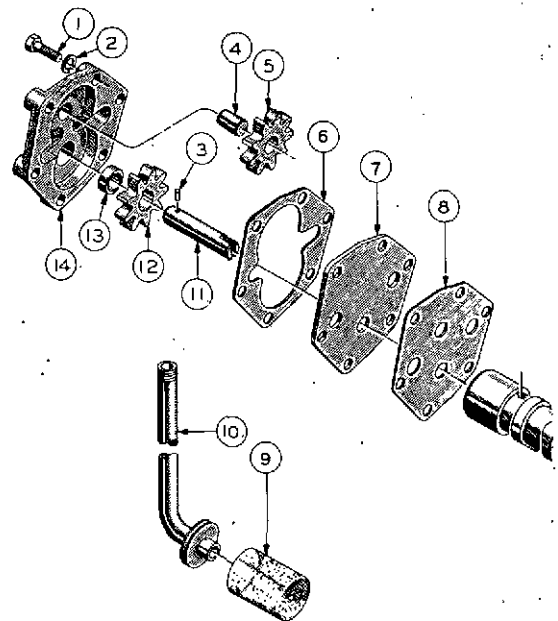

Figure 172 — "N" Series Oil Pump

- | | |
|---------------|-------------------|
| 1. Screw | 8. Gasket |
| 2. Lockwasher | 9. Screen |
| 3. Pin | 10. Tube assembly |
| 4. Stud | 11. Shaft |
| 5. Idler gear | 12. Gear |
| 6. Gasket | 13. Bushing |
| 7. Cover | 14. Body |

FLYWHEEL AND FLYWHEEL HOUSING

The flywheel is machined and balanced so that the clutch face and locating counterbore will run true with its axis.

To be sure that the crankshaft flange has not been sprung or otherwise damaged or that the counterbore in the flywheel, which locates it on the crankshaft, is not damaged, mount an indicator on the flywheel housing and check the flywheel for runout. Caution: When checking runout remove spark plugs to allow engine to be turned over freely.

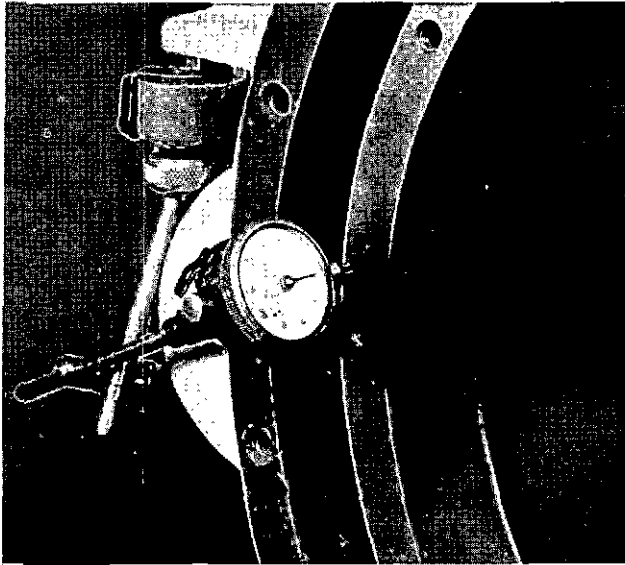

Figure 173 — Checking Flywheel Run-Out

The indicator should be set up so that it contacts the clutch face or the vertical surface of the clutch counterbore, then turn the flywheel at least one full revolution at the same time holding against the crankshaft to offset the possibility of end play.

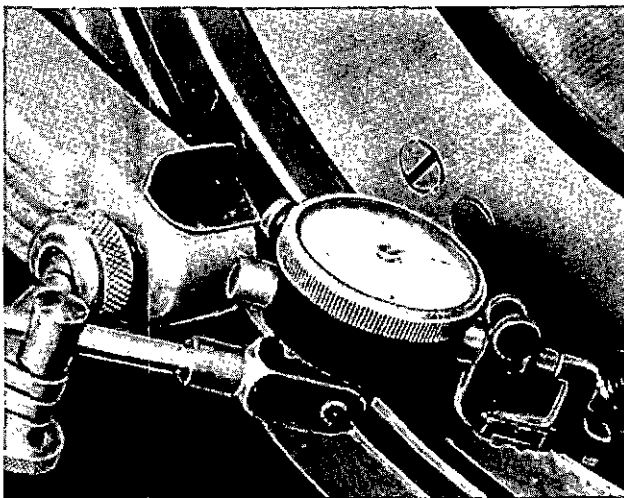

Figure 174 — Checking Flywheel Counterbore

Excessive runout of the flywheel, in either position, is probably caused by dirt in or damage to counterbore locating the flywheel on the crankshaft flange.

Re-locate the indicator to check the inside diameter of the counterbore. In both cases the maximum indicator reading must not be more than .008.

When assembled, mount the indicator on the flywheel so that it contacts the housing face and turn the crankshaft, at the same time holding against it to counteract end play. The maximum indicator reading must not exceed .008.

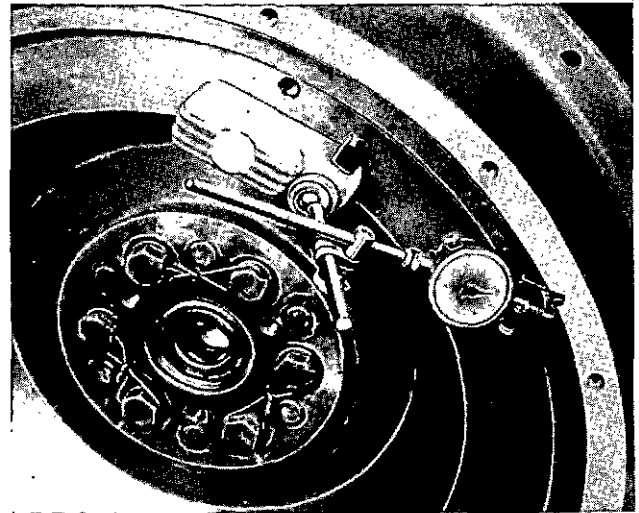

Figure 175 — Checking Flywheel Housing Face

Re-locate the indicator to contact the housing bore and check this in the same manner. The same runout limits prevail.

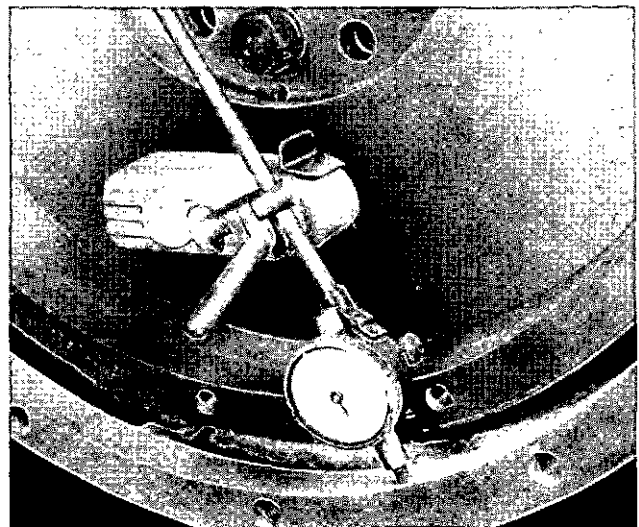

Figure 176 — Checking Housing Bore

If more than one engine is being rebuilt at a time, the housing should be identified with its original cylinder block and should be reassembled to that block in the rebuilding process.

REASSEMBLING ENGINE

In the foregoing, we have outlined procedures for checking, repairing or replacing the many wearing parts in the engine.

In most cases, the instructions have covered the reassembly of parts or subassemblies made up of several parts.

When reassembling pistons and connecting rods, use a good ring compressor and oil the bores thoroughly. A hammer handle may be used to bump the pistons out of the ring compressor into the cylinder bore.

Once more, we call attention to care demanded to prevent connecting rods damaging the cylinder bore finish and at the same time as they are assembled over the crank pin, locate them carefully in order to protect the bearing surfaces.

Always lubricate the bearings with clean engine oil when assembling, and tighten them to the torque specified. Use lockwires, cotter pins or lockwashers as required to prevent nuts and screws from loosening.

Clean cylinder head and block surfaces thoroughly before installing gasket. Tighten all cylinder heads or cap screws evenly and torque in following sequence to the recommended torque.

Before assembling the oil pan with new gaskets make certain that gasket surfaces are flat and clean. Tighten screws in accordance with limits prescribed in torque chart — to avoid looseness or overstressing.

Torque Specifications for Cylinder Head Tightening Sequence in Foot Pounds

Size - Diameter	3/8"	7/16"	1/2"	9/16"	5/8"
Cylinder Heads	35-40	70-75	100-110	130-140	145-155

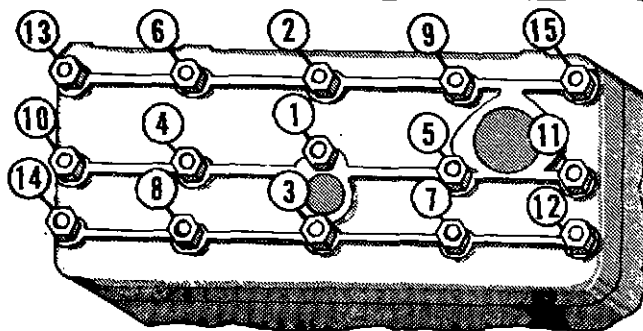

Figure 177 — Cylinder Head Tightening Sequence — Four Cylinder

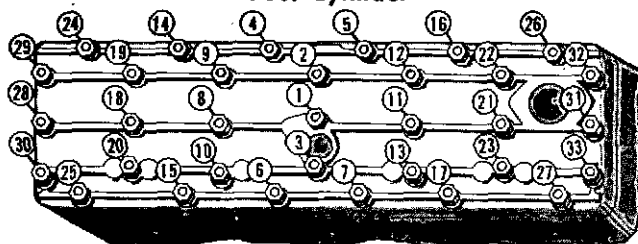

Figure 178 — Cylinder Head Tightening Sequence — Six Cylinder

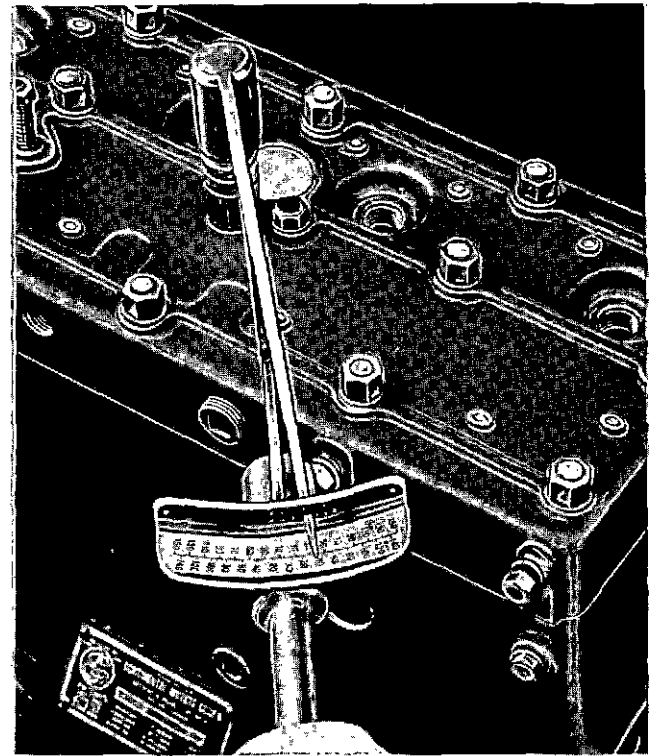

Figure 179

When engine is completely assembled and filled with proper oil, (See Lubrication Sec.) set tappets according to the following chart:

	INTAKE	EXHAUST
N-56	.015	.015
N-62	.012	.012
Y Series	.012	.012
F Series	.014	.014
M Series	.017	.020
B Series	.017	.022

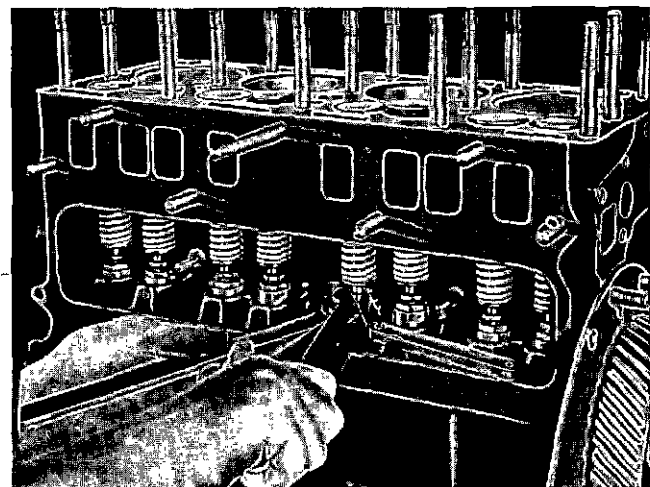

Figure 180 — Setting Tappets

SECTION IX TROUBLE SHOOTING

A preventive maintenance system including inspection, lubrication and adjustment as recommended in our Maintenance Section will prevent the greater portion of gasoline engine troubles.

Failure of a gasoline engine to start is mainly due to two things: ignition trouble or failure in the fuel system.

Operators handling the same engine every day, soon develop a sense of impending trouble when abnormal operation occurs. Immediate attention to these danger signals can prevent major failures, insure dependable operation and increase the life of the engine.

Operators should depend on their well-developed senses of feeling, hearing, seeing and smelling and replace their sense of taste in this type of work — with a generous amount of "Common-Sense".

A good rule to follow in locating trouble is to never make more than one adjustment at a time — then locate the trouble by a process of elimination. Remember the cause is usually Simple — rather than mysterious and complicated.

Following are listed some of the normal complaints encountered in routine operation of all gasoline engines and the probable causes.

A — STARTING MOTOR — WILL NOT CRANK ENGINE:

- 1 — Weak or dead battery.
- 2 — Poor ground connection.
- 3 — Faulty starting switch or relay.
- 4 — Defective starting motor.
- 5 — Internal engine seizure — turn engine manually to determine cause.

B — ENGINE CRANKS — BUT DOES NOT START:

Disconnect one spark plug wire, turn ignition on with starter cranking engine and free end of wire $\frac{1}{8}$ " from cylinder head — note spark.

1 — NO SPARK:

(A) — If Ammeter Shows No Discharge — it indicates an open primary circuit due to:

- 1 — Points not closing.
- 2 — Open primary wires.
- 3 — Defective ignition switch.
- 4 — Faulty coil.

(B) — Normal Ammeter Reading (2-5 Amps) — this indicates that primary circuit is OK — trouble may be in secondary circuit due to:

- 1 — Broken or grounded high tension wire from coil to distributor.
- 2 — Wet high tension wires.
- 3 — Faulty distributor cap or rotor.
- 4 — Broken secondary winding of coil.

(C) — Excessive Ammeter Reading (over 5 Amps) — indicates a "short" in the primary winding which may be due to:

- 1 — Shorted or grounded primary winding.
- 2 — Distributor or magneto points not opening.
- 3 — Grounded breaker point arm.
- 4 — Defective condenser.

2 — **WEAK SPARK** — may be caused by:

- (A) Loose ignition wiring connections.
- (B) Burned or pitted distributor points.
- (C) Wet spark plug wires.
- (D) Defective condenser.
- (E) Cracked distributor cap.
- (F) Weak ignition coil.

3 — **GOOD SPARK AT EACH PLUG** — indicates that ignition system is OK and trouble is in fuel system — which may be due to:

(A) No Gas in Carburetor — which may be due to:

- 1 — No gas in tank.
- 2 — Clogged filter or lines.
- 3 — Faulty fuel pump.
- 4 — Leaky fuel line from tank.
- 5 — Plugged vent in fuel tank cap.

(B) Gas in Carburetor — which may be flooded due to:

- 1 — Too much choking — plugs are wet.
- 2 — Wrong float level.
- 3 — Choke not operating correctly.
- 4 — Water in Gas.

C — ENGINE RUNS WITH CONTINUOUS MIS-FIRING: Due to:

- 1 — Uneven compression.
- 2 — Wet or deteriorated high tension wires.
- 3 — Cracked distributor cap.
- 4 — Faulty spark plugs—if spark plug porcelain is white when removed, use **Colder** plug — if light brown OK — if Black or oily use **Hotter** plug.

D — ENGINE RUNS UNEVENLY

- 1 — **At Idling Speed**—which may be due to:
 - (A) Too wide spark plug gaps.
 - (B) Poor Carburetor idle adjustment.
 - (C) Wrong float level.
 - (D) Carburetor or intake manifold air leaks.
 - (E) Leaky cylinder head gasket.
- 2 — **At High Speed** — which may be due to:
 - (A) Wide breaker points.
 - (B) Weak distributor breaker arm spring
 - (C) Weak valve springs.
 - (D) Spark plug of wrong type or incorrect gap.

E — ENGINE RUNS IMPROPERLY

- 1 — **Back-Firing into Manifold** — indicates **Too Rich** a fuel mixture; into carburetor indicates **Too Lean** a mixture—may be due to:
 - (A) Late Ignition Timing.
 - (B) Clogged Air Cleaner.
 - (C) Fuel line restrictions.
 - (D) Clogged carburetor jets.
 - (E) Sticking Valves.
 - (F) Weak or broken valve springs.
- 2 — **Excessive Ping (Detonation)**—Results in damaged pistons and bearings and is caused by pre-ignition or using inferior grade of gas.
- 3 — **Engine Idles Too Fast** — indicates improper throttle adjustment or weak throttle return springs.
- 4 — **Engine Dies When Idling** — which indicates incorrect speed or mixture adjustment; clogged idling circuit in carburetor or wrong choke adjustment, or air leaks in intake manifold.
- 5 — **Engine "Stumbles" on Acceleration** — which may be due to defective accelerator pump or air in fuel lines.

6 — Defective Spark Plugs.

F — LACK OF POWER — which may be due to:

- 1 — Poor Compression.
- 2 — Wrong Timing.
- 3 — Throttle control not opening fully.
- 4 — Air leak in fuel system.
- 5 — Restriction in air cleaner — should have vacuum less than 10" water.
- 6 — Exhaust line obstructed — should have back pressure of not more than 20" water.
- 7 — Poor fuel.
- 8 — Piston rings sticking or worn.

G — POOR COMPRESSION—check with compression gauge — if irregular, seal the piston with a teaspoonful of engine oil poured through the spark plug hole, and take a second reading; if pressure does not increase this will indicate that poor seating of valves are at fault. Poor compression may be due to:

- 1 — Valves holding open — no tappet clearance.
- 2 — Leaky cylinder head gasket.
- 3 — Broken or weak valve springs.
- 4 — Burned or sticking valves.
- 5 — Badly worn, broken or stuck piston rings.
- 6 — Wrong valve timing.

H — OVERHEATING

- 1 — Lack of water in radiator.
- 2 — Fan belts slipping.
- 3 — Thermostat sticking or inoperative.
- 4 — Radiator clogged or leaky.
- 5 — Late ignition timing.
- 6 — Back pressure in exhaust line.
- 7 — Defective water pump.
- 8 — Overloading of engine.

I — LOW OIL PRESSURE

- 1 — Low Oil level.
- 2 — Oil pressure gauge or line faulty.
- 3 — Oil too light — diluted.
- 4 — Suction screen plugged.
- 5 — Dirt in relief valve or broken spring.
- 6 — Worn bearings.
- 7 — Worn or damaged oil pump gears.
- 8 — Worn Cam Bushings.

J — HIGH OIL PRESSURE—should not exceed recommended pressures except when engine is starting up cold. Abnormally high oil pressure is not desirable because it increases oil consumption — possible causes of high oil pressures are:

- 1 — Engine oil too heavy.
- 2 — Stuck relief valve.
- 3 — Obstruction in distributing line.
- 4 — Faulty oil pressure gauge.

K — HIGH OIL CONSUMPTION

- 1 — Oil leaks.
- 2 — Too high oil level.
- 3 — Incorrect grade of oil used.
- 4 — Clogged crankcase breather.
- 5 — Oil pressure too high — stuck relief valve.
- 6 — Piston rings not run-in, due to too smooth cylinder bore finish or glazed condition.
- 7 — Worn, broken or stuck piston rings and clogged oil control rings.
- 8 — Worn pistons and sleeves.
- 9 — Worn bearings.
- 10 — Worn valve guides.

(Manifold may be removed for visual inspection.)

L — ENGINE KNOCKS AND OTHER NOISES

1 — Operating Knocks — which may be due to:

(A) **Pre-Ignition** — Most common cause is due to wrong type plugs which are too hot.

(B) **Carbon** — noticeable when engine is accelerated while hot — clean head and pistons.

(C) **Timing**—early timing causes knocks similar to carbon — but may tend to kick back when starting.

(D) **Fuel** — detonation knock caused by poor gas.

(E) **Overloads** — particularly at lower operating speeds.

2 — **Mechanical Knocks**—result from wear, abuse or improper adjustments — which may be due to:

(A) **Crankshaft and Main Bearings:**

(1) **Worn or burned-out Main Bearings** — A heavy, dull knock when accelerating under load. Locate by shorting out plugs on both sides of the bad bearing.

(2) **Crankshaft End-Play** — excessive end-play is indicated by an intermittent

knock which will come and go when the load is released and engaged.

(B) **Connecting Rod Bearings**

(1) **Worn or Burned-out Bearings** — The worst condition, a light pound or metallic knock, is noted at idling and to about $\frac{2}{3}$ maximum speed. Bad bearings can be determined by shorting out plugs.

(C) **Pistons and Wrist-Pins**

(1) **Loose Wrist Pins** — noise doubles when the correct plug is shorted out — most noticeable at idling speed.

(2) **Piston Loose in Cylinder** — “Piston-Slap” is noted by metallic knocking at low speed under load; but disappears at high speed — also most noticeable when starting cold — test by shorting out plugs.

(D) **Broken Piston Ring or Pin**

sharp clicking noise that won't short out.

(E) **Valves**

(1) **Burned Valves and Seats** — engine misses, especially at low speeds, or acceleration under load.

(2) **Weak or Broken Valve Springs** — missing at low or high speeds when under load.

(3) **Sticking Valves** — loss of power and popping sound when bad.

(4) **Tappet noise** — excessive clearances cause noise when cold — which diminishes at normal operating temperature.

(F) **Camshaft** — Noise due to loose bearings or end play — usually occurs at half engine speed.

(G) **Timing Gear Noise** — Loose or worn gears rattle or knock — tight gears hum.

3 — **Vibration Originating at Engine** — The most common sources of vibration originating in or on the engine, as distinguished from causes created outside the engine are as follows:

(A) Misfiring

(B) Misalignment of engine

(C) Bent or off-center coupling

(D) Engine loose on bed and type of mountings.

(E) Out of balance condition of flywheel and clutch assembly.

SECTION X TORQUE SPECIFICATIONS

Continental L-Head engines have many studs, bolts, and cap screws of special material and sizes and it is very important that special care be exercised to replace all studs and bolts in their respective locations during assembly of engine.

The torque specifications, foot pounds, listed below, **MUST** be followed in order to have the assembled engine conform to the original specifications:

Size-Diameter	5/16"	3/8"	7/16"	1/2"	9/16"	5/8"
Cylinder Heads	35-40	70-75	100-110	130-140	145-155
Main Bearing Caps	35-40	70-75	85-95	110-120	140-150
Connecting Rods	20-25	40-45	55-60	90-100	110-120
Flywheels	20-25	35-40	70-75	85-95	100-110	145-155
Manifolds	15-20	25-30	40-50	50-60	50-60	60-70
Gear Covers, Water Pumps, Front and Rear End Plates	15-20	25-30	50-55	80-90
Oil Pans	12-16	12-16
Flywheel Housings	15-20	25-30	50-55	80-90	115-125

Camshaft Nut

Thread Size	3/4"	7/8"	1"	1 1/8"	1 1/4"	
C.I. Shafts	65-70#	70-80#	95-100#	125-130#	145-150#	
Forged Steel Shafts		120-125#	175-180#			
Elastic Stop Nut w/C.I. or Forged Steel Shaft		65-70#				

SECTION XI

LIMITS AND CLEARANCE DATA

**NOTE: DIMENSIONS SHOWN ARE FOR
STANDARD ENGINES**

Engine Model	N-56 N-62	Y-69 Y-91 Y-112	F-124 F-140 F-162	F-186 F-209 F-226 F-244	M-271 M-290 M-330 M-363	B-371 B-427
VALVE GUIDE	INTAKE AND EXHAUST	INTAKE AND EXHAUST	INTAKE AND EXHAUST	INTAKE AND EXHAUST	INT. EXH.	INT. EXH.
Length	1 $\frac{1}{2}$ / ₃₂	2 $\frac{1}{32}$	2 $\frac{1}{16}$	2 $\frac{1}{16}$	3 $\frac{1}{16}$ 3.0	2 $\frac{1}{8}$ 3 $\frac{1}{16}$
Outside Dia.	.5645/.5635	.5645/.5635	.6575/.6565	.6575/.6565	.752/.751	.814/.813
Stem Hole Dia.	.3169/.3159	.3167/.3157	.3432/.3422	.3432/.3422	.4067/.4057	.4370/.4360
*Wear Limits—Max. Dia.	.3184	.3182	.3447	.3447	.4082	.4385
Distance, Cyl. Block Contact Face to Guide	2 $\frac{1}{32}$	$\frac{7}{8}$	1 $\frac{1}{2}$ / ₃₂	1 $\frac{1}{2}$ / ₃₂	1 $\frac{1}{4}$ 1 $\frac{1}{16}$	1 $\frac{1}{8}$ 1 $\frac{1}{16}$
VALVES, INTAKE						
Stem Dia.	.3149/.3141	.3149/.3141	.3414/.3406	.3414/.3406	.4037/.4026	.4340/.4329
*Wear Limits, Min. Dia.	.3121	.3121	.3386	.3386	.4006	.4309
Seat Angle	30°	30°	30°	30°	30°	30°
Stem Clearance Limits	.001/.0006	.001/.0006	.0026/.0008	.0026/.0008	.0036/.002	.0036/.002
*Wear Limits—Max. Cl.	.003	.003	.0046	.0046	.0056	.0056
Desired Stem Clear.	.0008	.0008	.0015	.0015	.002	.002
VALVES, EXHAUST						
Stem Dia.	.3132/.3124	.3132/.3124	.3385/.3377	.3385/.3357	.4014/.4007	.4315/.4305
*Wear Limits—Min. Dia.	.3104	.3104	.3357	.3357	.3987	.4285
Seat Angle	45°	45°	45°	45°	45°	45°
Stem Clearance—Limits	.0047/.0043	.0047/.0043	.0055/.0037	.0055/.0037	.0055/.0043	.006/.0045
*Wear Limits, Max. Cl.	.0063	.0063	.0075	.0075	.0075	.008
Desired Stem Cl.	.0035	.0035	.0045	.0045	.0045	.0045
VALVE SPRINGS						
Outside Dia.	$\frac{7}{8}$	3 $\frac{1}{32}$	3 $\frac{1}{32}$	1.150/1.130	1.302/1.282	1 $\frac{1}{16}$
Length—Valve closed	1 $\frac{3}{8}$	1 $\frac{45}{64}$	1 $\frac{45}{64}$	1 $\frac{21}{32}$	1 $\frac{7}{8}$	1.617
Load—Valve closed	18-22 #	47-53 #	47-53 #	47-53 #	58-64 #	65 $\frac{1}{2}$ -72 $\frac{1}{2}$
*Wear Limits—Min. Wgt.	16 #	42 #	42 #	42 #	52 #	59 #
Length—Valve open	1 $\frac{1}{8}$	1 $\frac{27}{64}$	1 $\frac{27}{64}$	1 $\frac{3}{8}$	1.521	1.316
Load—Valve open	32-38 #	96-104 #	96-104 #	103-110 #	115-123 #	137-151 =
*Wear Limits—Min. Wgt.	29 #	86 #	86 #	93 #	103 #	123 =

LIMITS AND CLEARANCE DATA

Engine Model	N-56 N-62	Y-69 Y-91 Y-112	F-124 F-140 F-162	F-186 F-209	F-226 F-244	M-271 M-290 M-330 M-363	B-371 B-427
CAMSHAFT							
Brg. Journal Dia. #1	1.7465/1.7455	1.8095/1.8085	1.8725/1.8715	1.8725/1.8715	1.8725/1.8715	2.1850/2.1840	2.2430/2.2420
#2	1.7465/1.7455	1.7465/1.7457	1.7465/1.7457	1.8095/1.8085	1.8095/1.8085	2.1225/2.1215	2.2430/2.2420
#3	1.2465/1.2455	1.2475/1.2465	1.2475/1.2465	1.7465/1.7457	1.7465/1.7457	2.0600/2.0590	2.2430/2.2420
#4	None	None	None	1.2475/1.2465	1.2475/1.2465	1.7475/1.7465	2.2430/2.2420
*Wear Limits—Min. Dia.	(001 UNDER MINIMUM NEW SHAFT DIAMETER)						
Bushing—Inside Dia. #1	1.750/1.749	1.8125/1.8115	1.8755/1.8745	1.8755/1.8745	1.8755/1.8745	2.1870/2.1865	2.2450/2.2445
#2	1.750/1.749	1.7502/1.7495	1.7502/1.7495	1.8125/1.8115	1.8125/1.8115	2.1245/2.1240	2.2450/2.2445
#3	1.250/1.249	1.2505/1.2495	1.2505/1.2495	1.7502/1.7495	1.7502/1.7495	2.0620/2.0615	2.2450/2.2445
#4	(No Bushings)	None	None	1.2505/1.2495	1.2505/1.2495	1.7495/1.7490	2.2450/2.2445
Bushing—Clearance Limits	.0045/.0025	.004/.002	.004/.002	.004/.002	.004/.002	.003/.0015	.003/.0015
End Play	.007/.003	.007/.003	.009/.005	.009/.005	.009/.005	.008/.005	.009/.005

CONNECTING RODS

Bush. Hole Dia.	.6067/.6057	.7632/.7622	.914/.913	.914/.913	.914/.913	1.313/1.312	1.500/1.499
Brg. Hole Dia.	1.6240/1.6245	1.6245/1.6240	2.0620/2.0615	2.0620/2.0615	2.1870/2.1865	2.3745/2.3740	2.6870/2.6865
Brg. Thickness	.06175/.06150	.06190/.06165	.06190/.06165	.0619/.06165	.06130/.06155	.06180/.06205	.09300/.09325
*Wear Limits—Min. Thk.	.0610	.06115	.06115	.06115	.0608	.0613	.0925
Dia.—Crank Pin	1.499-1.500	1.499/1.500	1.9375/1.9365	2.0623/2.0619	2.0619/2.0627	2.248/2.249	2.498/2.499
*Wear Limits—Min. Dia.	1.498	1.498	1.9355	2.0609	2.0609	2.247	2.497
Clearance Limits	.0005/.0025	.0002/.0022	.0002/.0022	.0002/.0022	.0007/.0025	.0009/.0029	.001/.003
Desired Clearance	.0015	.001	.001	.001	.0015	.0015	.002
*Wear Limits—Max. Cl.	.0035	.0032	.0032	.0032	.0035	.0039	.004
Side Play	.010/.006	.0105/.006	.010/.006	.010/.006	.010/.006	.010/.006	.010/.006
Desired Side Play	.006	.0065	.006	.006	.006	.006	.006

MAIN BEARINGS

Dia. of Brg. Bore in Block	2.1710/2.1703	1.8747/1.8740	2.4372/2.4365	2.4372/2.4365	2.5615/2.5622	2.8122/2.8115	3.0622/3.0615
Brg. Shell Thickness	.08475/.08450	.06265/.06240	.09315/.09290	.09315/.09290	.09250/.09275	.0930/.09275	.09300/.09275
*Wear Limits—Min. Thk.	.0840	.0619	.0924	.0924	.0920	.09225	.09225
Dia. of Main Brg. Jr.	2.000/1.999	1.7485/1.7475	2.250/2.2490	2.3744/2.3752	2.3744/2.3752	2.624/2.623	2.874/2.873
*Wear Limits—Min. Dia.	1.998	1.7465	2.248	2.3734	2.3734	2.622	2.872
Clearance Limits	.003/.0008	.0024/.0002	.0024/.0002	.0024/.0002	.0028/.0008	.0037/.0015	.0037/.0015
Desired Clearance	.0015	.001	.001	.001	.0015	.0025	.0025
C/S End Play.	.003/.008	.003/.008	.003/.008	.003/.008	.003/.008	.003/.008	.003/.008

PISTON PIN

	See Note 1	See Note 2	See Note 3	See Note 4	See Note 5	See Note 6	
Length	1.925/1.920	2.066/2.056	2.504/2.489	2.504/2.489	2.815/2.805	3.190/3.175	3.365/3.355
Diameter	.5435/.5433	.7085/.7083	.8593/.8591	.8593/.8591	.8593/.8591	1.1093/1.1091	1.2500/1.2498
*Wear Limits—Min. Dia.	.5430	.7080	.8588	.8588	.8588	.8588	1.2495
Desired Fit	Light Push	Light Push	Light Push	Light Push	Light Push	Light Push	Light Push
Bush. Hole Dia.—Fin.	.5438/.5436	.7089/.7087	.8597/.8595	.8597/.8595	.8597/.8595	1.1097/1.1095	1.2504/1.2502
*Wear Limits—Max. Dia.	.5448	.7099	.8607	.8607	.8607	1.1107	1.2514
Pin Cl. in Bushing	.0005/.0001	.0006/.0002	.0006/.0002	.0006/.0002	.0006/.0002	.0006/.0002	.0006/.0002
Desired Pin Fit	.0003	.0004	.0004	.0004	.0004	.0004	.0004

NOTE 1 — Y-91 PISTON PIN LENGTH 2.441 /2.431
Y-112 PISTON PIN LENGTH 2.7553/2.7543

NOTE 2 — F-140 PISTON PIN LENGTH 2.691 /2.676
F-162 PISTON PIN LENGTH 2.878 /2.868

NOTE 3 — F-209 PISTON PIN LENGTH 2.691 /2.676

NOTE 4 — F-244 PISTON PIN LENGTH 2.878 /2.868

NOTE 5 — M-271 PISTON PIN LENGTH 3.065/3.050

M-330 PISTON PIN LENGTH 3.440/3.425

M-363 PISTON PIN LENGTH 3.440/3.425

NOTE 6 — B-427 PISTON PIN LENGTH 3.630/3.620

LIMITS AND CLEARANCE DATA

Engine Model	N-56	N-62	Y-69	Y-91	Y-112	F-124	F-140	F-162
PISTONS								
Cylinder Dia.	2.252 / 2.250	2.377 / 2.375	2.502 / 2.500	2.877 / 2.875	3.3145 / 3.3125	3.002 / 3.000	3.1895 / 3.1875	3.4395 / 3.4375
*Wear Limits—Cyl. Bore	.008	.008	.008	.008	.008	.008	.008	.008
Piston Pin Hole Dia.	.5436 / .5434	.5436 / .5434	.7086 / .7084	.7086 / .7084	.7086 / .7084	.8594 / .8592	.8594 / .8592	.8594 / .8592
Ring Groove Width—# 1	.096 / .095	.096 / .095	.0955 / .0945	.0955 / .0945	.0955 / .0945	.127 / .126	.1265 / .1255	.1285 / .1275
*Max. Wear Limits	.098	.098	.0975	.0975	.0975	.129	.1285	.1305
Ring Groove Width # 2—	.096 / .095	.096 / .095	.0955 / .094	.0955 / .094	.0955 / .094	.127 / .126	.126 / .125	.1285 / .1275
# 3—	.1885 / .1875	.1885 / .1875	.251 / .250	.251 / .250	.251 / .250	.127 / .126	.126 / .125	.1285 / .1275
*Max. Wear Limit # 2—	.098	.098	.0975	.0975	.0975	.1290	.1280	.1305
# 3—	.1905	.1905	.253	.253	.253	.1290	.1280	.1305
Ring Groove Width # 4	None	None	None	None	None	.251 / .250	.251 / .250	.253 / .252
*Max. Wear Limit	—	—	—	—	—	.253	.253	.255
Ring Groove Width # 5	None	None	None	None	None	None	None	None
Max. Wear Limit	—	—	—	—	—	—	—	—
Piston Fit-Feeler Gauge	.002	.002	.002	.002	.002	.003	.003	.003
Lbs. Pull	5-10 #	5-10 #	5-10 #	5-10 #	5-10 #	5-10 #	5-10 #	5-10 #

PISTON RINGS

Ring Width—# 1	.0935 / .0925	.0935 / .0925	.0935 / .0925	.0935 / .0925	.0935 / .0925	.124 / .123	.124 / .123	.124 / .123
*Wear Limits—Min. Width	.0905	.0905	.0905	.0905	.0905	.121	.121	.121
Ring Width—# 2	.0935 / .0925	.0935 / .0925	.0935 / .0925	.0935 / .0925	.0935 / .0925	.124 / .123	.124 / .123	.124 / .123
# 3	.1865 / .1860	.1865 / .1860	.249 / .2485	.249 / .2485	.249 / .2485	.124 / .123	.124 / .123	.124 / .123
*Wear Limits—								
Min. Width # 2	.0905	.0905	.0905	.0905	.0905	.121	.121	.121
# 3	.1840	.1840	.2465	.2465	.2465	.121	.121	.121
Ring Width—# 4	None	None	None	None	None	.249 / .2485	.249 / .2485	.249 / .2485
Wear Limits—Min. Width	—	—	—	—	—	.2465	.2465	.2465
Ring Width—# 5	None	None	None	None	None	None	None	None
Wear Limits—Min. Width	—	—	—	—	—	—	—	—
Ring Gap Clear.—# 1	.013 / .005	.017 / .007	.015 / .007	.015 / .007	.013 / .008	.013 / .008	.017 / .007	.017 / .007
Ring Gap Clear.—# 2 & 3	.013 / .005	.017 / .007	# 2—.015 / .007 # 3—.013 / .005	# 2—.015 / .007 # 3—.013 / .005	# 2—.013 / .008 # 3—.016 / .008	.013 / .008	.017 / .007	.017 / .007
Ring Gap Clear.—# 4	None	None	None	None	None	.017 / .007	.016 / .008	.017 / .007
Ring Gap Clear.—# 5	None	None	None	None	None	None	None	None
Ring Side Clear.—# 1	.0035 / .0015	.0035 / .0015	.003 / .001	.0025 / .001	.003 / .001	.004 / .002	.0035 / .0015	.0055 / .0035
Ring Side Clear.—# 2	.0035 / .0015	.0035 / .0015	.003 / .001	.0025 / .001	.003 / .001	.004 / .002	.0035 / .0015	.0055 / .0035
# 3	.0025 / .001	.0025 / .001	.0025 / .001	.0025 / .001	.0025 / .001	.004 / .002	.0035 / .0015	.0055 / .0035
Ring Side Clear.—# 4	None	None	None	None	None	.0025 / .001	.0025 / .001	.0045 / .003

LIMITS AND CLEARANCE DATA

Engine Model	F-186	F-209	F-226	F-244	M-271
PISTONS					
Cylinder Dia.	3.002 /3.000	3.1895/3.1875	3.3145/3.3125	3.4395/3.4375	3.627/3.625
*Wear Limits—Cyl. Bore	.008	.008	.008	.008	.008
Piston Pin Hole Dia.	.8594/.8592	.8594/.8592	.8594/.8592	.8594/.8592	1.1094/.1.1092
Ring Groove Width—#1	.127 / .126	.1285/.1275	.1265/.1255	.1285/.1275	.1275/ .1265
*Max. Wear Limits	.129	.1305	.1285	.1305	.1295
Ring Groove Width—#2-3	.127 / .126	.1285/.1275	.126 / .125	.1285/.1275	.1265/ .1255
*Max. Wear Limit	.1290	.1305	.1280	.1305	.1285
Ring Groove Width—#4	.251 / .250	.253 / .252	.251 / .250	.253 / .252	.1895/ .1880
*Max. Wear Limit	.2530	.2550	.2530	.2550	.1915
Ring Groove Width—#5	None	None	None	None	.1895/ .1880
*Max. Wear Limit	—	—	—	—	.1915
Piston Fit-Feeler Gauge	.003	.003	.003	.003	.004
Lbs. Pull	5-10 #	5-10 #	5-10 #	5-10 #	5-10 #

PISTON RINGS

Ring Width—#1	.124 / .123	.124 / .123	.124 / .123	.124 / .123	.124 / .123
*Wear Limits—Min. Width	.121	.121	.121	.121	.121
Ring Width—#2 & 3	.124 / .123	.124 / .123	.124 / .123	.124 / .123	.124 / .123
*Wear Limits—Min. Width	.121	.121	.121	.121	.121
Ring Width—#4	.249 / .2485	.249 / .2485	.249 / .2485	.249 / .2485	.1865 / .1860
*Wear Limits—Min. Width	.2465	.2465	.2465	.2465	.184
Ring Width—#5	None	None	None	None	.1865 / .1855
*Wear Limits—Min. Width	—	—	—	—	.1835
Ring Gap Clearance—#1	.013 / .008	.017 / .007	.020 / .010	.017 / .007	.015 / .008
Ring Gap Clearance—#2 & 3	.013 / .008	.017 / .007	.020 / .010	.017 / .007	.015 / .008
Ring Gap Clearance—#4	.017 / .007	.017 / .007	.016 / .008	.017 / .007	.015 / .008
Ring Gap Clearance—#5	None	None	None	None	.018 / .008
Ring Side Clearance—#1	.004 / .002	.0055 / .0035	.0035 / .0015	.005 / .0035	.0045 / .002
Ring Side Clearance—#2 & 3	.004 / .002	.0055 / .0035	.003 / .001	.0055 / .0035	.0035 / .0015
Ring Side Clearance—#4	.0025 / .001	.0045 / .003	.0025 / .001	.0045 / .003	.0035 / .0015
Ring Side Clearance—#5	None	None	None	None	.004 / .0015

LIMITS AND CLEARANCE DATA

Engine Model	M-290	M-330	M-363	B-371	B-427
PISTONS					
Cylinder Dia.	3.752 /3.750	4.002 /4.000	4.000 /3.9995	4.127 /4.125	4.3145/4.3125
*Wear Limits—Cyl. Bore	.008	.008	.008	.008	.008
Piston Pin Hole Dia.	1.1094/1.1092	1.1094/1.1092	1.1097/1.1095	1.2501/1.2499	1.2501/1.2499
Ring Groove Width—#1	.1275/ .1265	.1275/ .1265	.0975/ .0965	.1275/ .1265	.0975/ .0965
*Max. Wear Limits	.1295	.1295	.0995	.1295	.0995
Ring Groove Width—#2-3	.1265/ .1255	.1265/ .1255	.0975/ .0965	.1265/ .1255	.0975/ .0965
*Max. Wear Limit	.1285	.1285	.0995	.1285	.0995
Ring Groove Width—#4	.1895/ .1880	.1895/ .1880	.1885/ .1875	.251 / .250	.251 / .250
*Max. Wear Limit	.1915	.1915	.1915	.2530	.2530
Ring Groove Width—#5	.1895/ .1880	.1895/ .1880	.1895/ .1880	.1885/ .1875	.1885/ .1875
*Max. Wear Limit	.1915	.1915	.1915	.1905	.1905
Piston Fit-Feeler Gauge Lbs. Pull	.005 5-10 #	.005 5-10 #	.003 5-10 #	.005 5-10 #	.005 5-10 #
PISTON RINGS					
Ring Width—#1	.124 / .123	.124 / .123	.0935/.0930	.124 / .123	.0935/.0930
*Wear Limits—Min. Width	.121	.121	.0910	.121	.0910
Ring Width—#2 & 3	.124 / .123	.124 / .123	.0935/.0930	.124 / .123	.0935/.0930
*Wear Limits—Min. Width	.121	.121	.0910	.121	.0910
Ring Width—#4	.1865/.1860	.1865/.1860	.1865/.1860	.249 / .2485	.249 / .2485
*Wear Limits—Min. Width	.184	.184	.1840	.2465	.2465
Ring Width—#5	.1865/.1855	.1865/.1855	.1865/.1860	.1865/.1855	.1865/.1855
*Wear Limits—Min. Width	.1835	.1835	.1840	.1835	.1835
Ring Gap Clearance—#1	.013 / .008	.013 / .008	.025 / .013	.016 / .011	.023 / .013
Ring Gap Clearance—#2 & 3	.018 / .008	.016 / .011	.023 / .013	.016 / .011	.023 / .013
Ring Gap Clearance—#4	.018 / .008	.020 / .010	.023 / .013	.017 / .007	.023 / .013
Ring Gap Clearance—#5	.018 / .008	.016 / .011	.023 / .013	.017 / .007	.023 / .013
Ring Side Clearance—#1	.0045/.0025	.0045/.0025	.0045/.003	.0045/.0025	.0045/.003
Ring Side Clearance—#2 & 3	.0035/.0015	.0035/.0015	.0045/.003	#2—.0045/.0025 #3—.0035/.0015	.0045/.003
Ring Side Clearance—#4	.0035/.0015	.0035/.0015	.0025/.001	.0025/.001	.0025/.001
Ring Side Clearance—#5	.004 / .0015	.004 / .0015	.0035/.0015	.003 / .001	.0025/.001