

Maintenance Manual

GENERATOR DIESEL ENGINE















DB33, P034 Ti

TO THE CUSTOMERS

This operation and maintenance manual is designed to serve as a reference for DAEWOO Heavy Industries Ltd's (here after DAEWOO's) customers and distributors who wish to gain basic product knowledge on DAEWOO's DB33 and P034TI Generator Diesel engine.

To maintain the engine in optimum condition and retain maximum performance for a long time, **CORRECT OPERATION** and **PROPER MAINTENANCE** are essential.

In this manual, the following symbols are used to indicate the type of service operations to be performed.

	Removal		Adjustment
	Installation		Cleaning
	Disassembly		Pay close attention-Important
	Reassembly		Tighten to specified torque
	Align the marks		Use special tools of manufacturer's
	Directional Indication		Lubricate with oil
	Inspection		Lubricate with grease
	Measurement		

During engine maintenance, please observe following instructions to prevent environmental damage ;

- Take old oil to an old oil disposal point only.
- Ensure without fail that oil and diesel fuel will not get into the sea or rivers and canals or the ground.
- Treat undiluted anti-corrosion agents, antifreeze agents, filter element and cartridges as special waste.
- The regulations of the relevant local authorities are to be observed for the disposal of spent coolant and special waste.

If you have any question or recommendation in connection with this manual, please do not hesitate to contact our head office, dealers or authorized service shops.

For the last, the content of this maintenance instruction may be changed without notice for some quality improvement. Thank you.

DAEWOO Heavy Industries LTD.

April. 1999

CONTENTS

1. General Informations.....	1
1.1. General Repair Instructions	
1.2. Engine Specifications	
1.3. Torque Specifications	
1.4. Major Parts Fixing Bolts	
1.5. Engine Repair Kit	
1.6. Repair	
1.7. Engine Oil Viscosity Chart	
2. Engine Assembly.....	20
2.1. Section Figures	
2.2. Disassembly	
2.3. Inspection and Repair	
2.4. Engine Reassemble	
3. Lubricating System.....	70
3.1. General Description	
3.2. Oil Pump	
3.3. Oil Filter	
3.4. Oil Cooler	
4. Cooling System.....	75
4.1. General Description	
4.2. Water Pump	
4.3. Thermostat	
5. Fuel System.....	81
5.1. General Description	
5.2. Fuel Filter	
5.3. Injection Nozzle	
5.4. Injection Pump Calibration	
6. Engine Electricals.....	88
6.1. Starting Motor	
6.2. Alternator	
7. Troubleshooting.....	90
8. Special Tool List.....	96

• **Worldwide Network**

1. General Information

1.1. General Repair Instructions

1. Before performing service operation, disconnect the grounding cable from the battery for reducing the chance of cable damage and burning due to short-circuiting.
2. Use covers for preventing the components from damage or pollution.
3. Engine oil and anti-freeze solution must be handled with reasonable care as they cause paint damage.
4. The use of proper tools and special tools where specified is important to efficient and reliable service operation.
5. Use genuine DAEWOO parts necessarily.
6. Used cotter pins, gaskets, O-rings, oil seals, lock washer and self-lock nuts should be discarded and new ones should be prepared for installation as normal function of the parts can not be maintained if these parts are reused.
7. To facilitate proper and smooth reassemble operation, keep disassembled parts neatly in groups. Keeping flexing bolts and nut separate is very important as they vary in hardness and design depending on position of installation.
8. Clean the parts before inspection or reassembly. Also clean oil ports, etc. using compressed air to make certain they are free from restrictions.
9. Lubricate rotating and sliding faces of parts with oil or grease before installation.
10. When necessary, use a sealer on gaskets to prevent leakage.
11. Carefully observe all specifications for bolts and nuts torques.
12. When service operation is completed, make a final check to be sure service has been done property.

1.2. Engine Specifications



Items		Engine Model			
		DB33		P034TI	
Engine type		Water-cooled, 4 cycle in-line		← Turbo charged & intercooled	
Combustion chamber type		Direct injection type			
Cylinder liner type		Dry type, chromated or casting liner			
Timing gear system		Gear driven type			
No. of piston ring		Compression ring 2, oil ring 1			
No. of cylinder-bore x stroke (mm)		4 - 102 x 100			
Total piston displacement (cc)		3,268			
Compression ratio		17.5 : 1		17.2 : 1	
Engine dimension (length x width x height) (mm)		870 x 705 x 723		847.5 x 728 x 832	
Engine weight (kg)		310		335	
Rotating direction(from fly wheel)		Counter clockwise			
Fuel injection order		1 - 3 - 4 - 2			
Fuel injection timing (B.T.D.C static)		18°		13°	
Injection pump type		Zexel in-line A type			
Governor type		Mechanical governor RSV type			
Injection nozzle type		Multi-hole type (5 hole)			
Fuel injection pressure (kg/cm ²)		220			
Compression pressure (kg/cm ²)		28 (at 200 rpm)			
Power (ISO 3046)	Condition	60Hz (1,800rpm)	50Hz (1,500rpm)	60Hz (1,800rpm)	50Hz (1,500rpm)
	Continuous	-	-	69PS (51kW)	48PS (35kW)
	Prime	43PS (32kW)	35PS (26kW)	75PS (55kW)	57PS (42kW)
	Stand by	47PS (35kW)	39PS (29kW)	82PS (60kW)	65PS (48kW)
Intake and exhaust valve clearance (at cold) (mm)		0.4			
Intake valve	Open at	28° (B.T.D.C)			
	Close at	62° (A.B.D.C)			
Exhaust valve	Open at	70° (B.B.D.C)			
	Close at	28° (A.T.D.C)			
Lubrication method		Pressurized circulation			
Oil pump type		Gear type			
Oil filter type		Full-flow, cartridge type			
Lubricating oil capacity (max./min.) (lit)		7.5/ 6.5		6.5/ 5.5	
Oil cooler type		Water cooled			
Water pump		Belt driven impeller type			
Cooling Method		Pressurized circulation			
Cooling water capacity (engine only) (lit)		8.5			
Thermostat type		Wax pallet type (82 - 95 °C)			
Alternator voltage - capacity (V - A)		24 - 45			
Starting Motor voltage - output (V - kW)		24 - 4.5			

1.3. Torque Specifications

- Standards bolts

The torque values given in the following table should be applied where a particular torque is not specified.

(Unit : kg.m)

Bolt identification Bolt diameter x pitch			
	4T Low carbon steel	7T High carbon steel	9T Alloy steel
6 X 1.0	0.4 ~ 0.8	0.5 ~ 1.0	-
8 X 1.25	0.8 ~ 1.8	1.2 ~ 2.3	1.7 ~ 3.1
10 X 1.25	2.1 ~ 3.5	2.8 ~ 4.7	3.8 ~ 6.4
★ 10 X 1.5	2.0 ~ 3.4	2.8 ~ 4.6	3.7 ~ 6.1
12 X 1.25	5.0 ~ 7.5	6.2 ~ 9.3	7.7 ~ 11.6
★ 12 X 1.75	4.6 ~ 7.0	5.8 ~ 8.6	7.3 ~ 10.9
14 X 1.5	7.8 ~ 11.7	9.5 ~ 14.2	11.6 ~ 17.4
★ 14 X 2.0	7.3 ~ 10.9	9.0 ~ 13.4	10.9 ~ 16.3
16 X 1.5	10.6 ~ 16.0	13.8 ~ 20.8	16.3 ~ 24.5
★ 16 X 2.0	10.2 ~ 15.2	13.2 ~ 19.8	15.6 ~ 23.4
18 X 1.5	15.4 ~ 23.0	19.9 ~ 29.9	23.4 ~ 35.2
★ 20 X 1.5	21.0 ~ 31.6	27.5 ~ 41.3	32.3 ~ 48.5
22 X 1.5	25.6 ~ 42.2	37.0 ~ 55.5	43.3 ~ 64.5
24 X 2.0	36.6 ~ 55.0	43.9 ~ 72.5	50.5 ~ 54.7

The ★ mark indicates that the bolts are used for female-threaded parts that are made of soft materials such as casting, etc.

1.4. Major Parts Fixing Bolts

- Cylinder head and cover, rocker arm

(unit : kg.m)

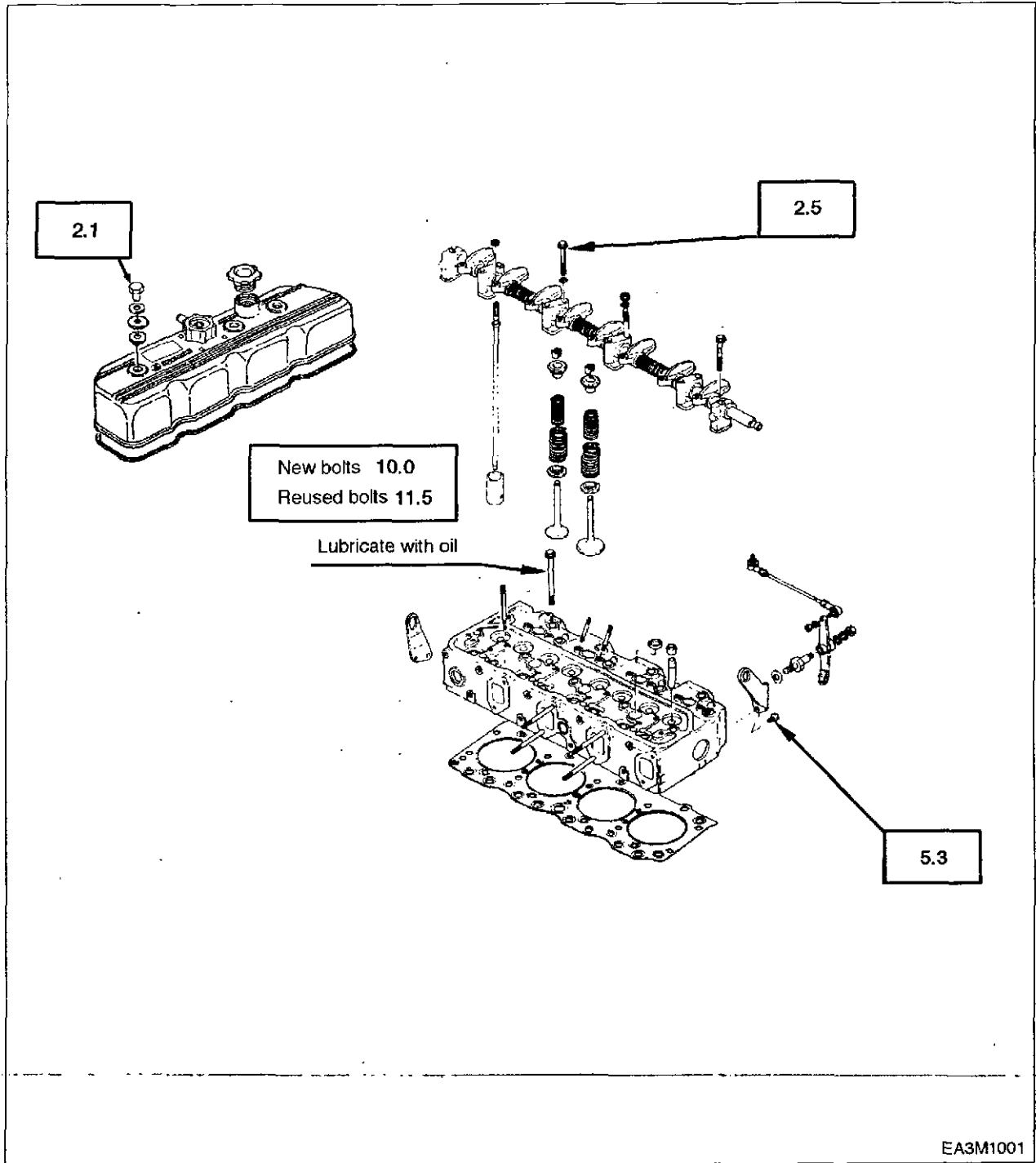

● Intake and exhaust manifold

(unit : kg.m)

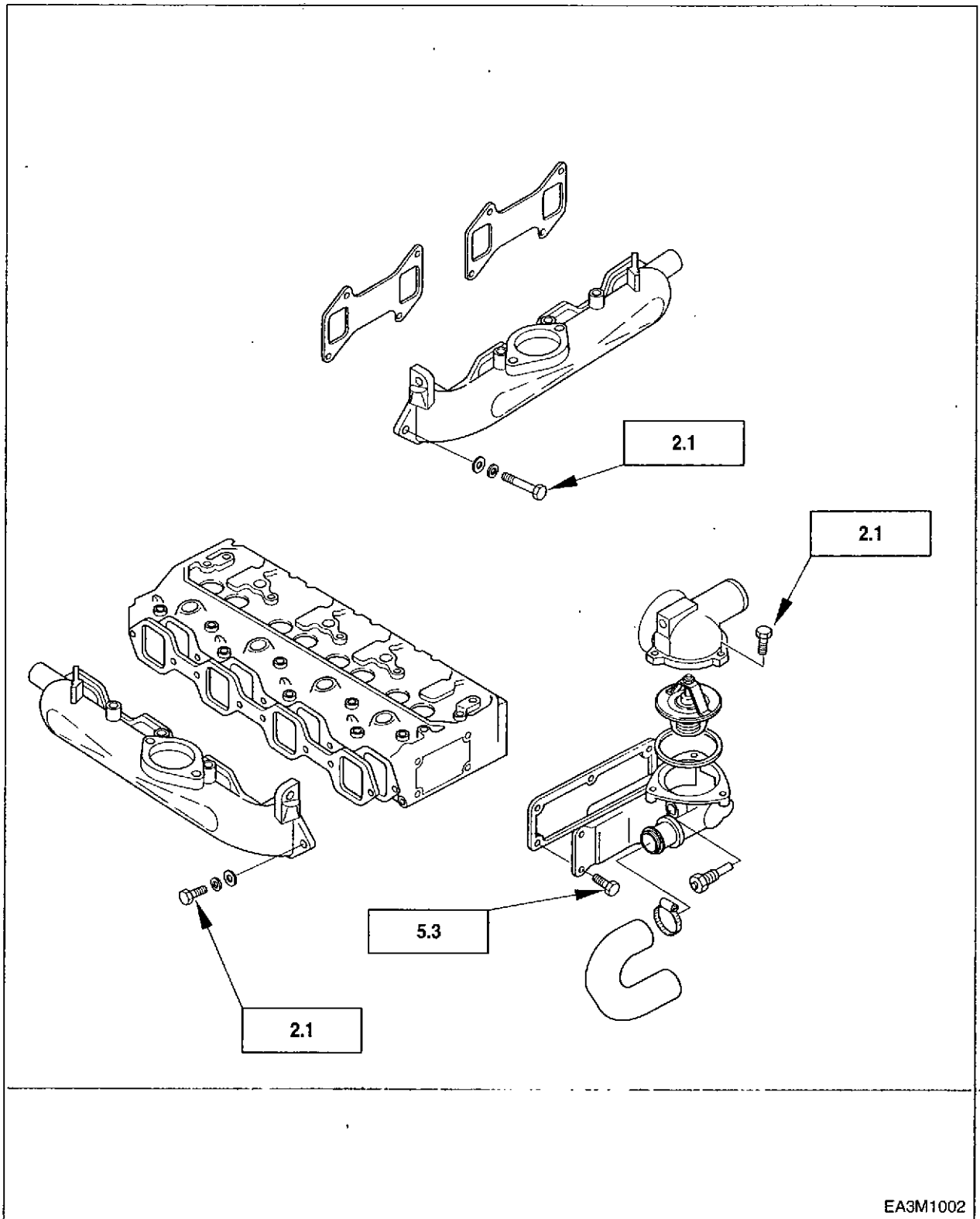

EA3M1002

● Cylinder block and others

(unit : kg.m)

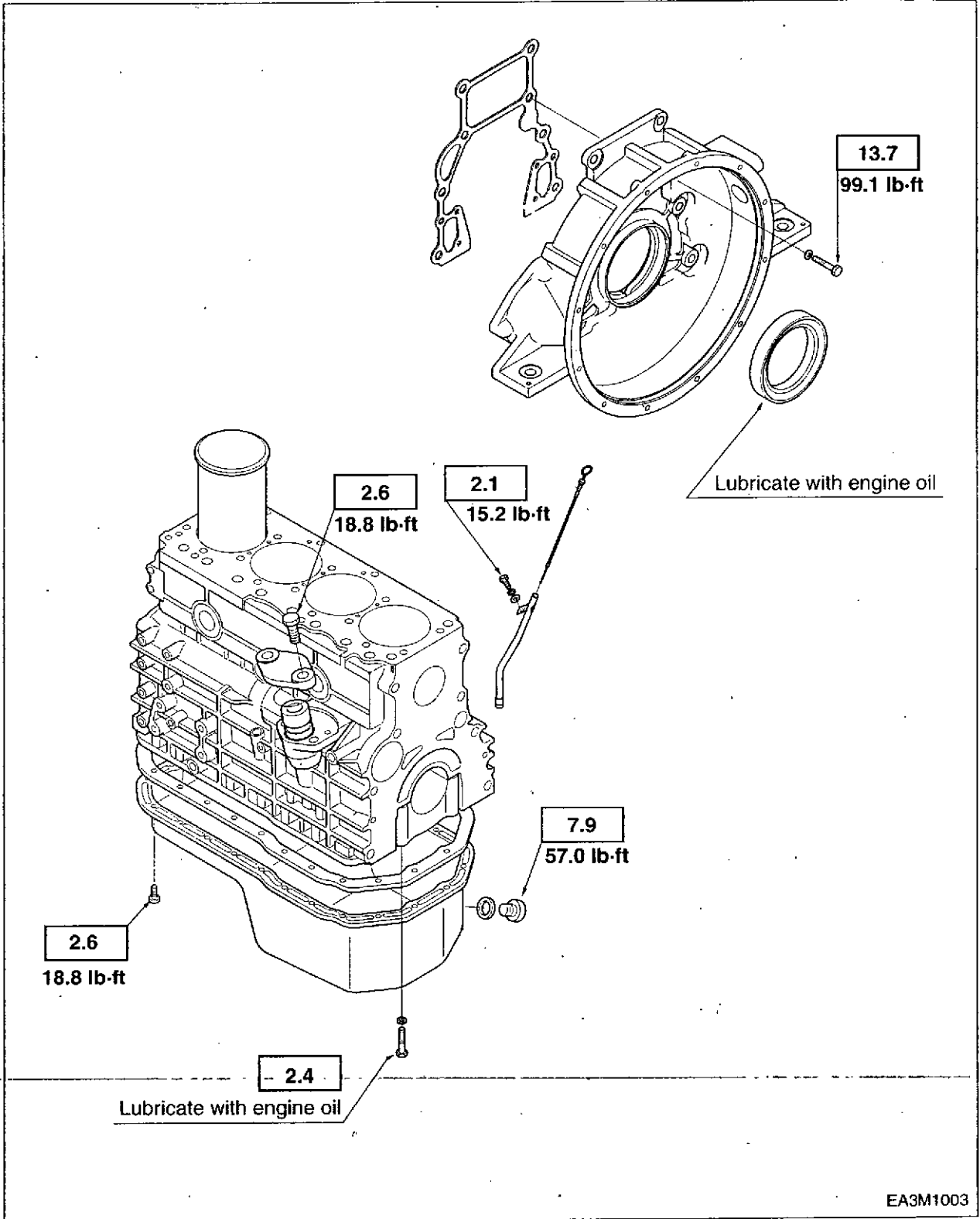

● Cylinder block and others

(unit : kg.m)

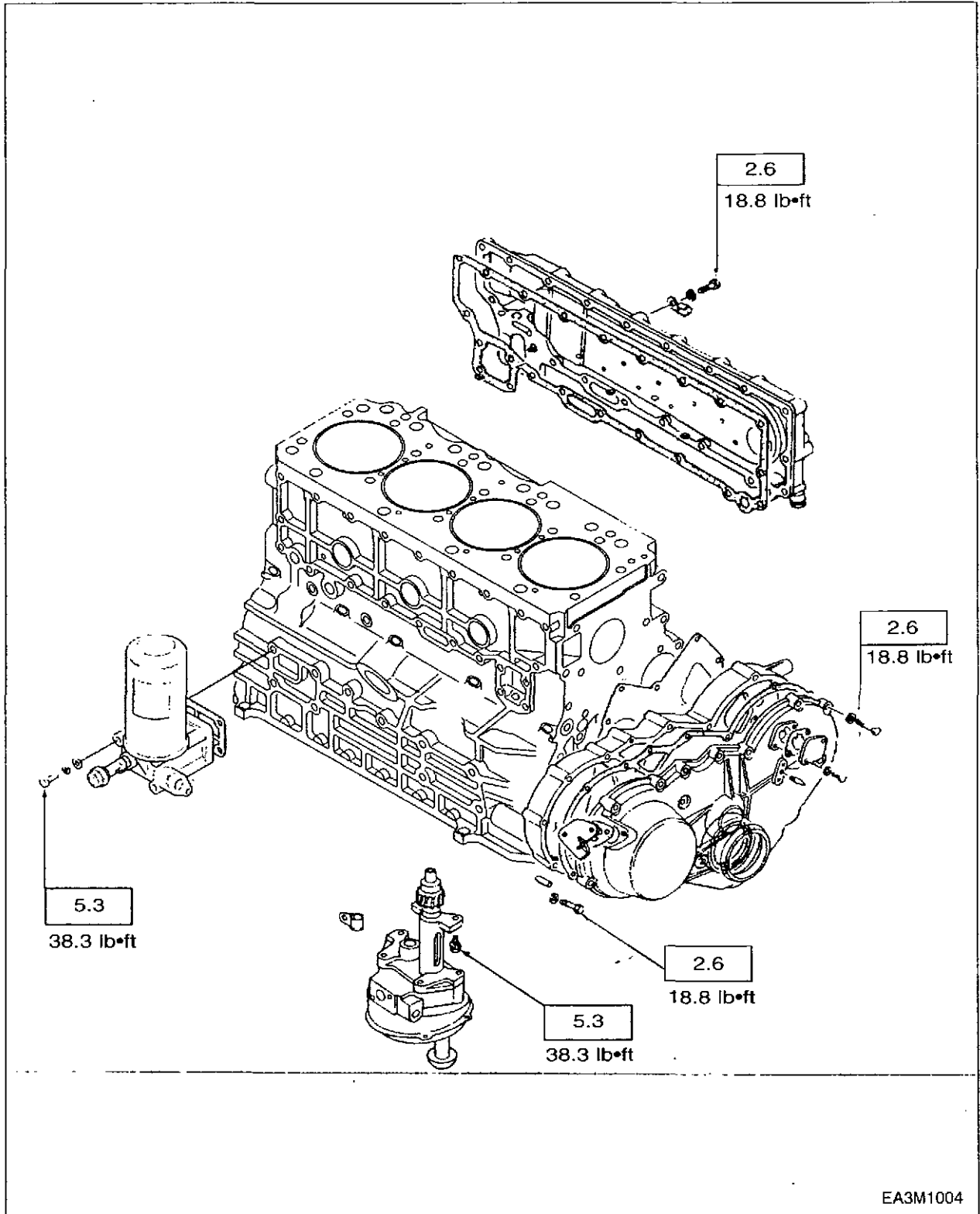

● Crankshaft and camshaft

(unit : kg.m)

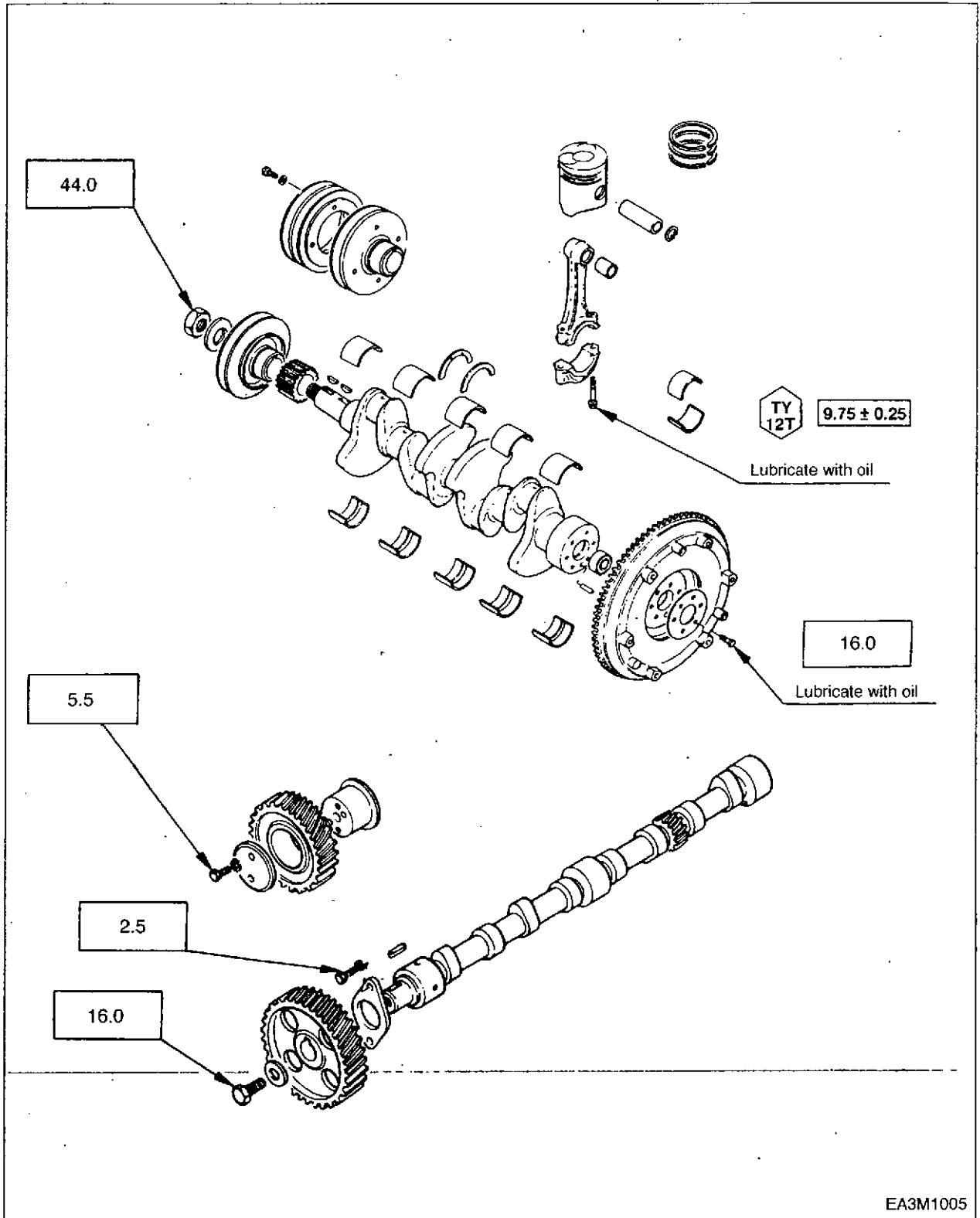

1.5. Engine Repair kit



Part No. 1 ~ 26 : Engine disassembly components

Part No. 1, 3, 21, 25 : Engine top disassembly components

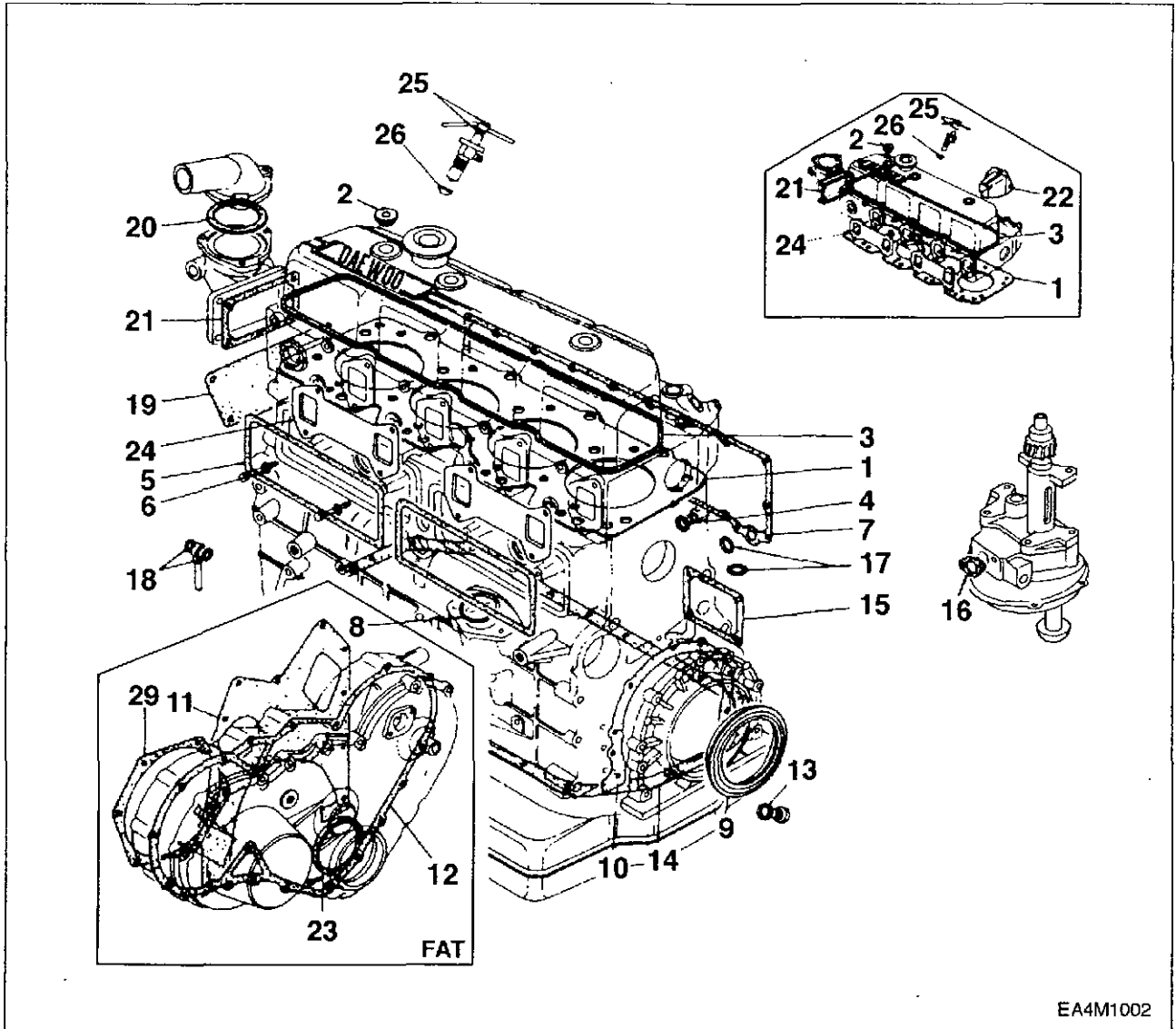

- | | |
|---|-------------------------------------|
| 1. Gasket : Cylinder head | 14. Gasket : Oil pan and body |
| 2. Packing : Cylinder head cover and bolt | 15. Gasket : Oil filter |
| 3. Gasket : Head cover | 16. Gasket : Oil pump and pipe |
| 4. Gasket : Relief valve | 17. Gasket : Oil filter pipe |
| 5. Gasket : Gasket : Injection pump | 18. Gasket : Oil jet pipe |
| 6. Gasket : Tappet chamber and bolt | 19. Gasket : Water pump |
| 7. Gasket : Oil cooler | 20. Gasket : Outlet pipe |
| 8. Gasket : Oil pump cover | 21. Gasket : Thermostat housing |
| 9. Oil seal : Crankshaft(RR) | 23. Oil seal : Crank gear case (FR) |
| 10. Gasket : Retainer | 24. Gasket : Exhaust manifold |
| 11. Gasket : Case and cylinder block | 25. Seal Ring : Injection nozzle |
| 12. Gasket : Cover and case | 26. Seal Ring : Nozzle gasket |
| 13. Seal Ring : Oil pan drain plug | |

1.6. Repair

1.6.1. Cylinder Head Bolt



Tighten the cylinder head bolts in sequence as shown in the figure.

Torque	11.5 kg.m
--------	-----------

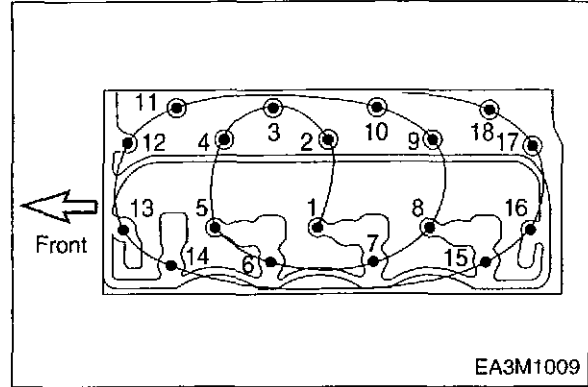

1.6.2. Valve Clearance



Adjust the valve clearance in the following manner using a feeler gauge.



Standard(in cold)

Intake and exhaust	0.4 mm
--------------------	--------

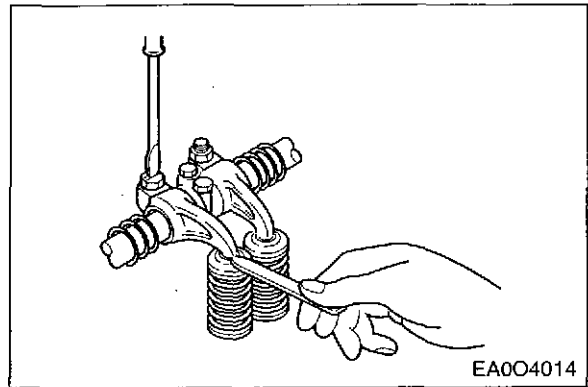

1. Bring the piston in either the No. 1 cylinder or the No. 4 cylinder to top dead center on the compression stroke by turning the crankshaft until the TDC notched line on the crankshaft pulley is aligned the timing pointer.

2. Check to see if there is play in the No. 1 intake and exhaust valve rocker arms. If the No. 1 cylinder intake and exhaust valve rocker arms are depressed, the No.4 piston is at TDC on the compression stroke.

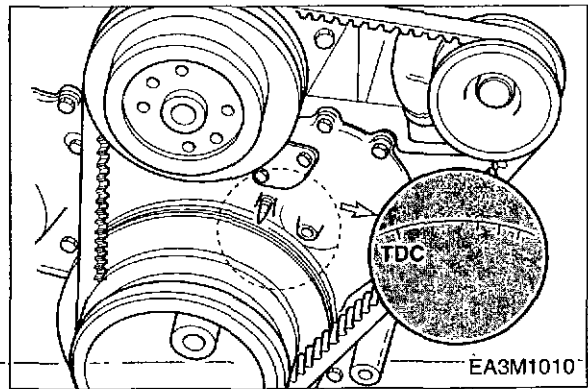



Adjust the clearances of valves marked with an arrow.



Rocker arm screw
lock nut torque

2.5 kg.m

After adjusting the valve clearances referring to the drawing, turn the crankshaft one full turn in the rotative direction and align the TDC mark with the pointer, then adjust the remaining valve clearances.

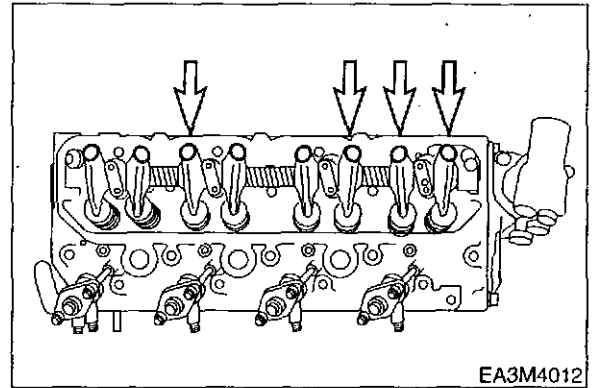

EA3M4012

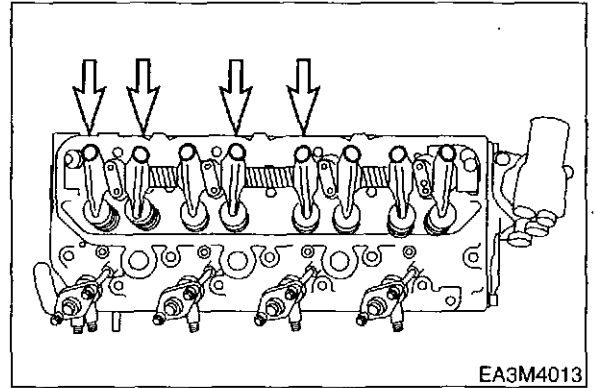

EA3M4013

1.6.3. Injection Timing



Inspection

Check the notched line on the crankshaft pulley and timing pointer are aligned.

	DB33	P034TI
Timing (BTDC)	18°	13°

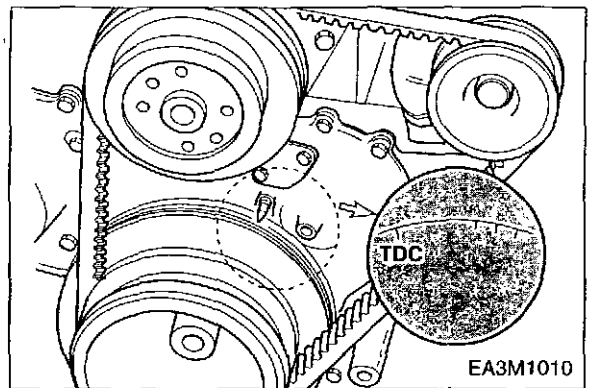

EA3M1010



Remove the inspection hole cover at the front of gear case cover. Check the alignment between the notched line on the camshaft gear and the arrow mark of gear case cover.

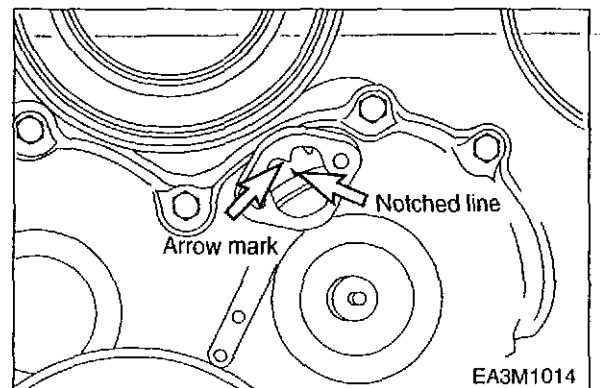

EA3M1014



Check the notched line on the injection pump is in alignment with the notched line on the timing gear cover.

Check the alignment of the notched lines injection pump and bracket.

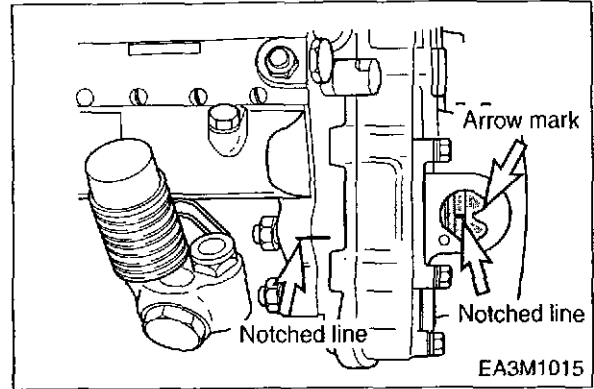

Injection timing adjustment

1. Adjust fuel injection timing with crank pulley notched line and timing pointer.

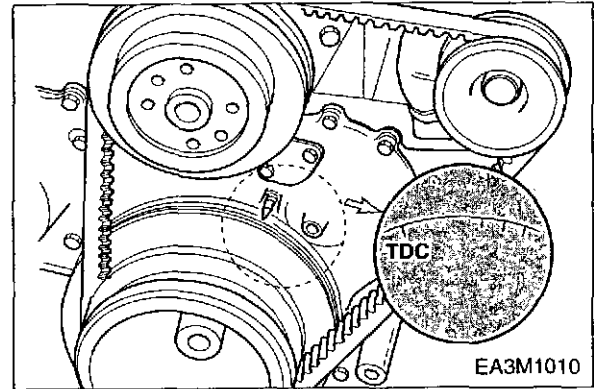

2. Remove 4 fixing bolts of injection pump.

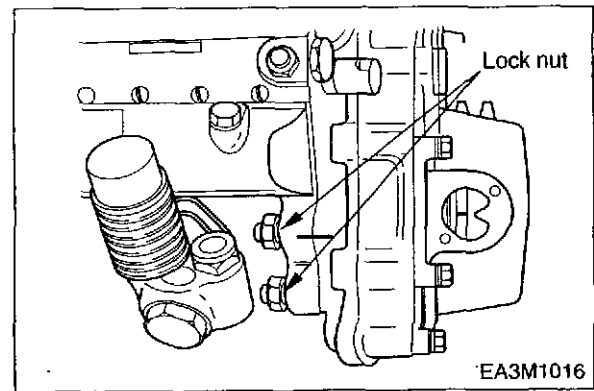

3. Disconnect the injection pipe from the No 1 plunger.

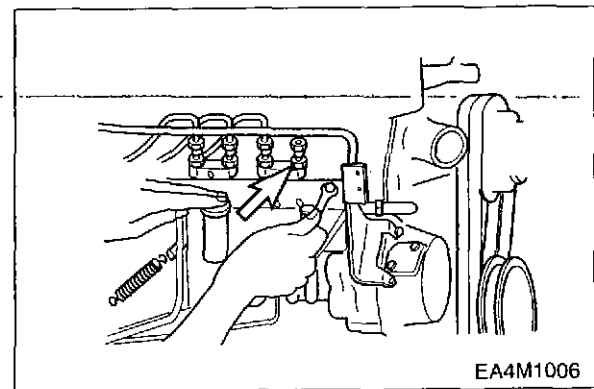



- Remove the delivery valve holder valve spring, valve seat and delivery valve from the No. 1 plunger.

This will allow you to visually check the fuel injection starting flow at No. 1 plunger.

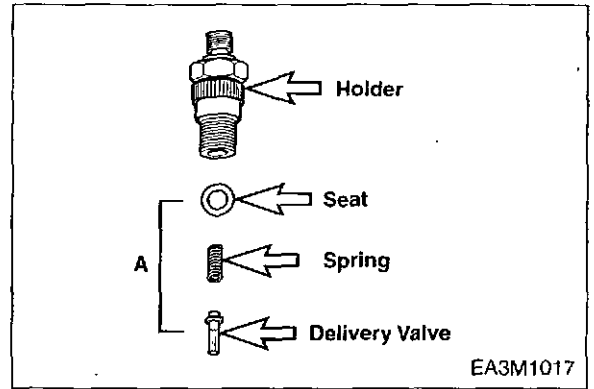

- Reinstall the delivery valve holder and tighten it. (except "A")



Torque	4 ~ 4.5 kg•m
--------	--------------

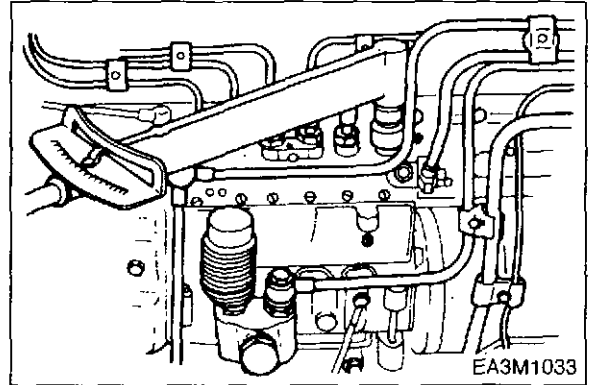

- Turn the injection pump body clockwise.

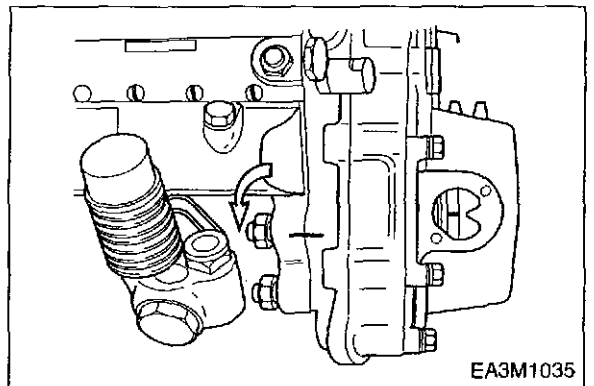

- While operating the priming pump, turn the injection pump body in reverse direction paragraph 6, until fuel stops flowing from the delivery valve holder. This crank angle position is the fuel injection starting point of the engine. And slowly turn the crankshaft pulley clockwise, at the same time, continue to feed the fuel with pumping the priming pump. When the fuel stop to flow out from the No. 1 delivery valve holder, stop the pump instantaneously.

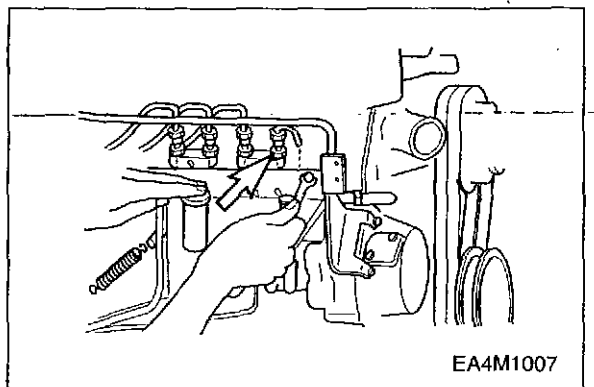



8. Blow out the remaining fuel from the delivery valve holder.

Make sure that there is no fuel being delivered from the priming pump and then retighten the coupling bolts.

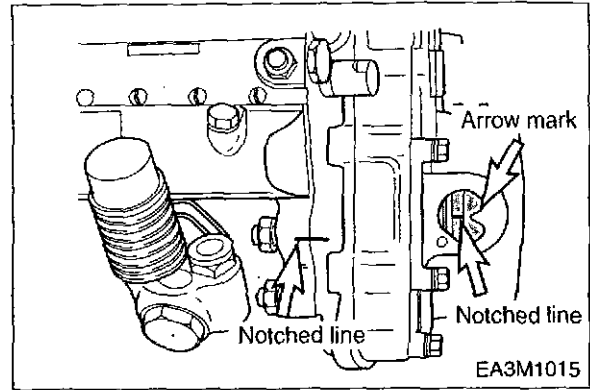

9. Remove the delivery valve holder and then reinstall the internal parts (seat, spring, valve) including valve holder.



Tighten it to the specified torque.



Torque	4 - 4.5 kg•m
--------	--------------

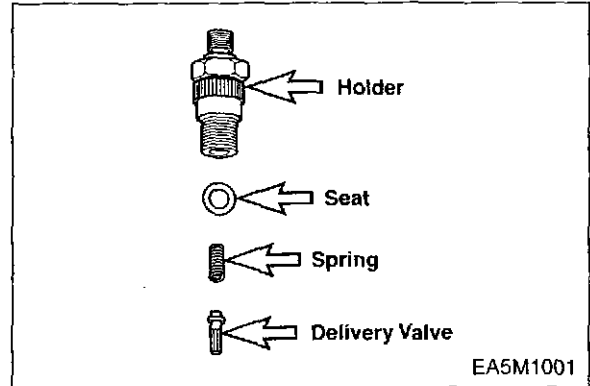

10. Install the No. 1 injection pipe and tighten it specified torque.

Injection pipe nut torque	3 ~ 3.5 kg•m
---------------------------	--------------



Do not overtighten the delivery valve holder. It will distort the injection pump body shape and adversely affect control rack operation.

1.6.4. Compression Pressure



Remove the glow plugs from all cylinders, then check the compression pressure in each cylinder with a compression gauge by engaging starter.



Before this step, disconnect the fuel line.

(at 200 rpm)

Standard	28 kg/cm ² over
Limit	23 kg/cm ² or less
Difference between each cylinder	±10% or less

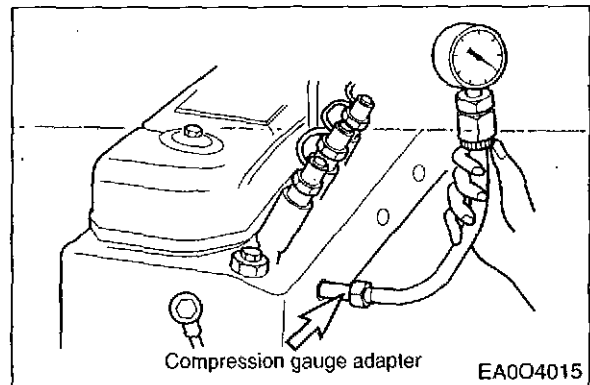

Compression gauge adapter.

1.6.5. Air Cleaner



Dry type air cleaner

- Observe the air cleaner service indicator
- Clean the air cleaner element and dust pan when the RED band in the service indicator looks in the visible position.

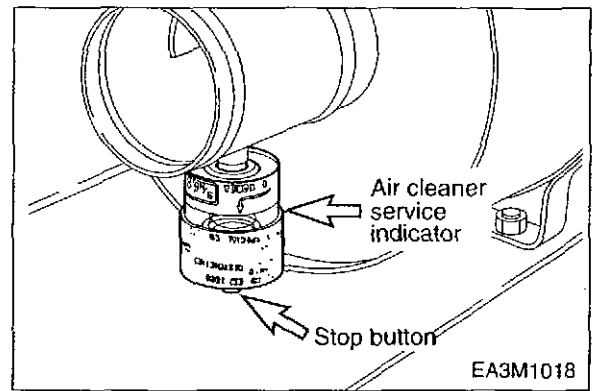

Cleaning element

- Direct air inside of the element and blow out dusts from the pleat completely.
(Maximum air pressure does not exceed 7 kg /cm²)

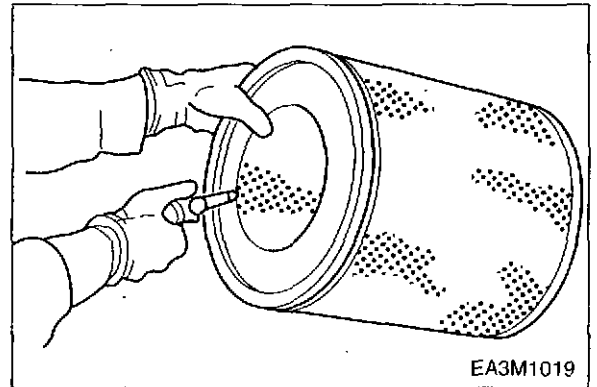

Detergent

- Wash the element in warm water and nonsudsing household detergent.
- Rinse the element with clean water
- Dry it thoroughly with natural air or electric fan.
Don't use a flame or compressed air for dry. It makes damages to the element.

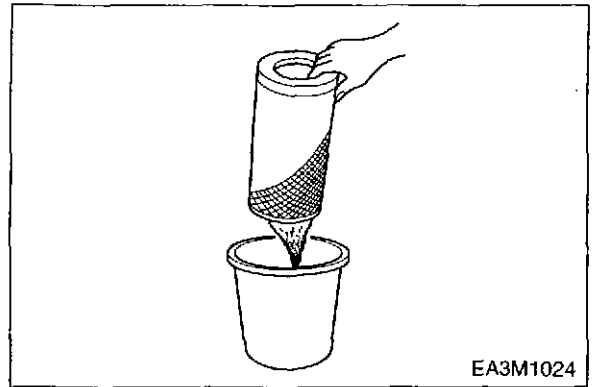

Checking element

- Confirm inside the clean and dry element.
- Replace the new element if tears, rips or damages are found.

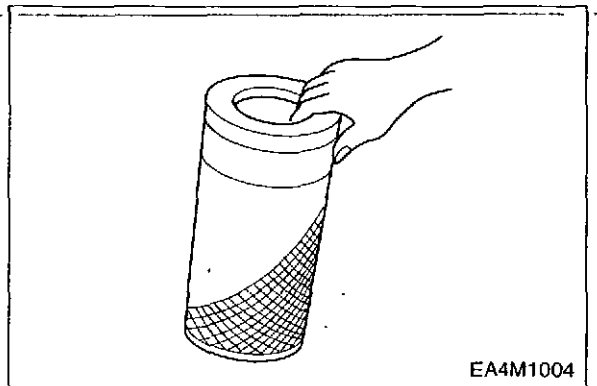



Oil bath type air cleaner

- Wash the element cleanly with oil detergent.

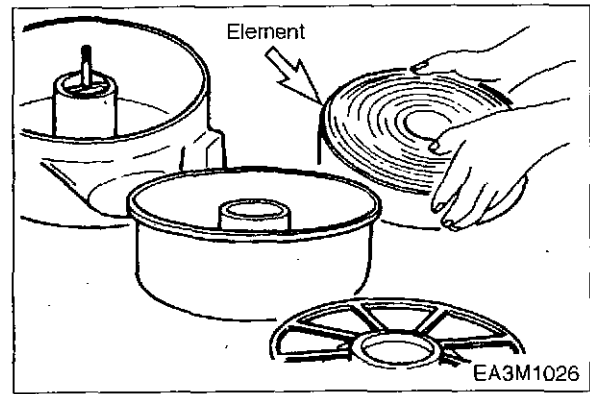

- Fill the engine oil in the oil pan to the indicated volume.

Oil	about 0.7 liter
-----	-----------------

- Refer to operation manual for oil volume specification.

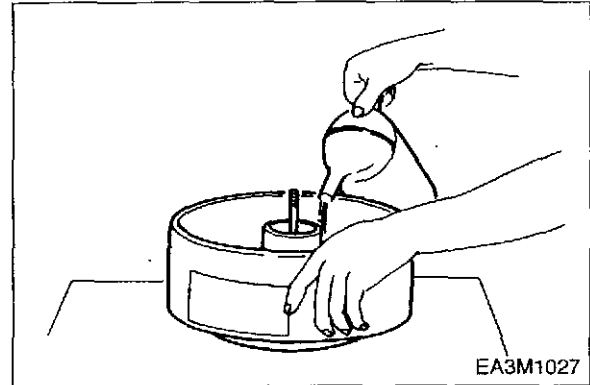

1.6.6. Radiator



- Install the radiator cap tester and compressing the measuring pressure.
- Inspect the cooling system if there any leak.

Measuring pressure	1.0 kg/cm ²
--------------------	------------------------

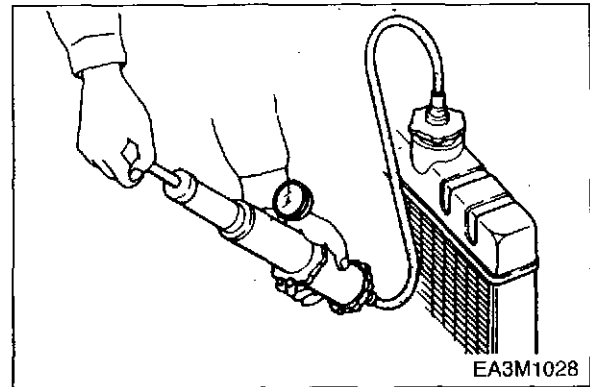

Radiator cap

Measuring pressure	1.0 kg/cm ²
--------------------	------------------------

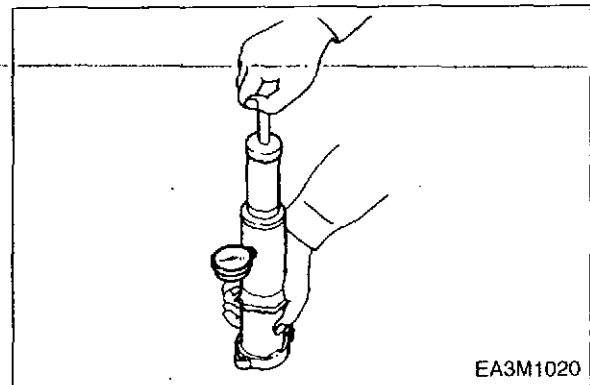

1.6.7. Lubricating System



Oil filter replacement

- Before installing a new filter cartridge apply a light coat of clean engine oil to the element O-ring and filter housing.
- Install the new cartridge. When the O-ring contacts the base, tighten it 3/4 of a turn more. Do not overtighten.

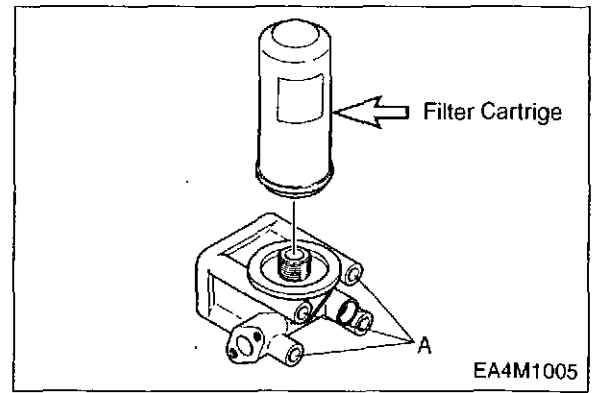

1.6.8. Fuel System



Injection nozzle

Check the spraying condition and injection starting pressure.



Injection starting pressure

220 kg/cm²

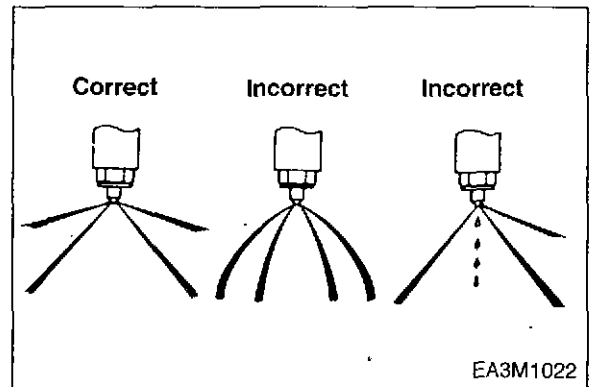

Adjustment

Adjust the injection starting pressure with adjusting screw using a nozzle tester.

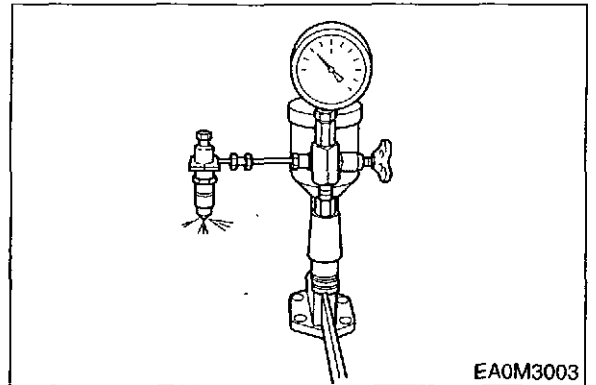

Air bleeding

Bleed the system by manually operating the priming pump with the fuel filter outlet joint bolt and injection pump bleeder screw loosened.

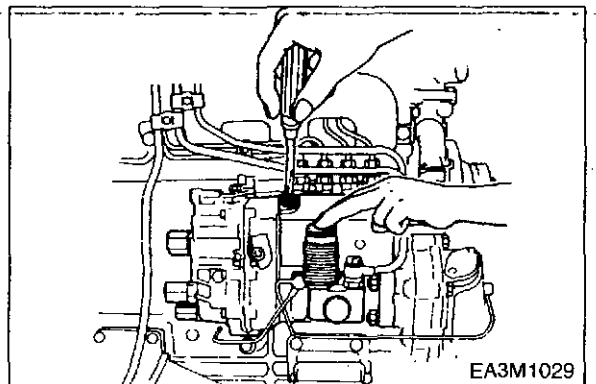

Fuel filter

- Loosen the fuel filter by turning it counterclockwise with the filter wrench.
- Discard the used filter
- Wipe the filter fitting face clean
- Apply a light coat of engine oil to the O-ring and supply fuel to the new filter
- Turn in the next filter until the filter O-ring is fitted against the sealing face.
- Use the filter wrench.

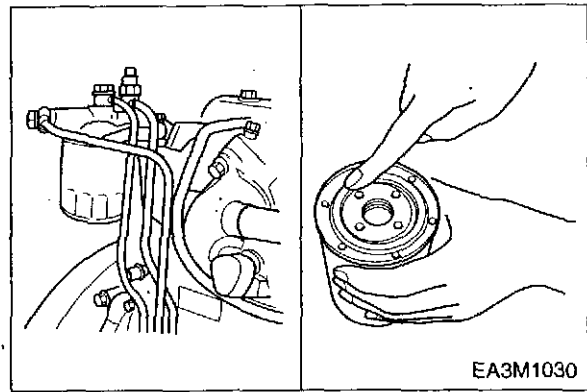

Remover and installer

Filter wrench

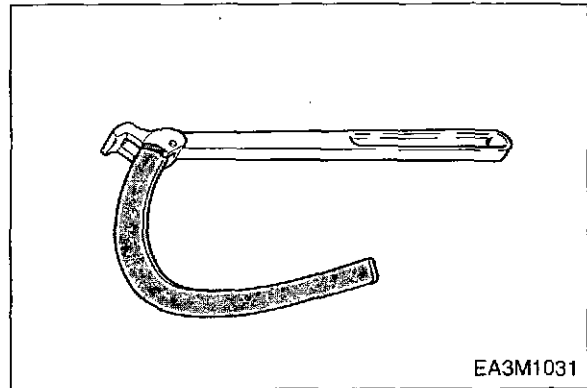

1.6.9. Fan Belt



Specified belt deflection

10 mm

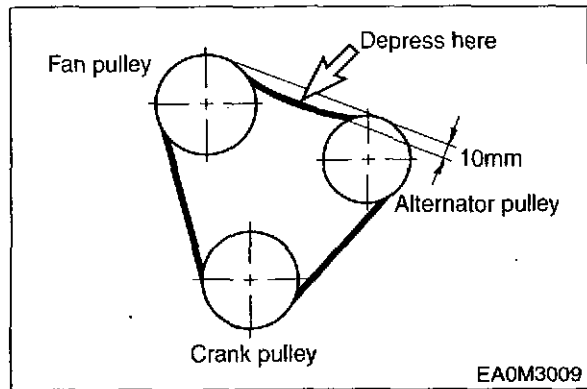

1.6.10. Glow Plug



Inspection (Resistance)

Silver color	1.8 Ω
Black color	4.8 Ω

Check the continuity across the plug terminals and body.

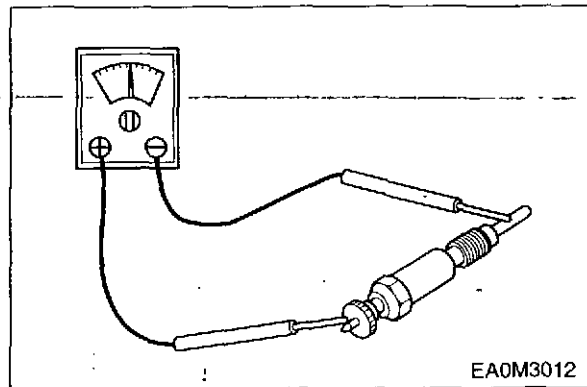

1.7. Engine Oil Viscosity Chart

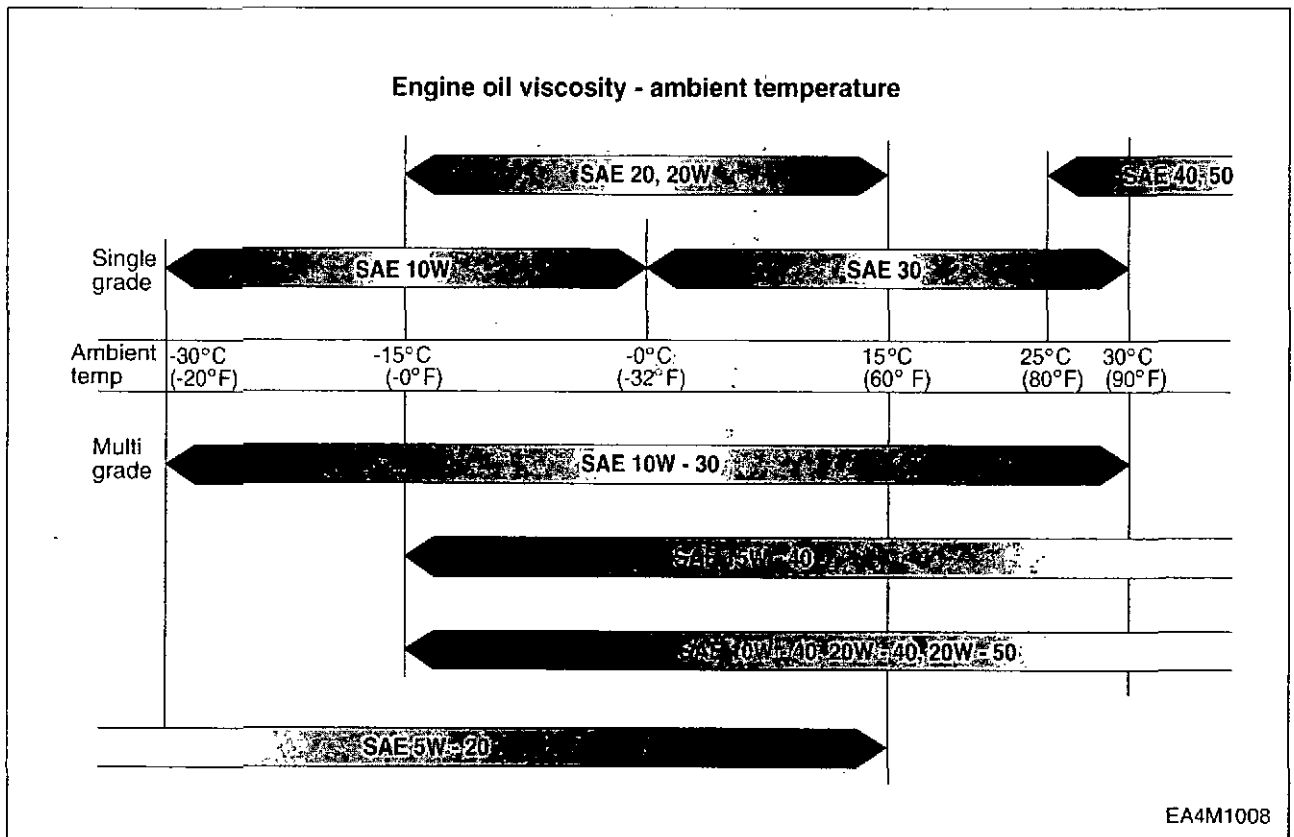

* Recommended lubricants

-Diesel engine oil "CD" or "CE" grade (API)

2. Engine Assembly

2.1. Sectional Figures(DB33)

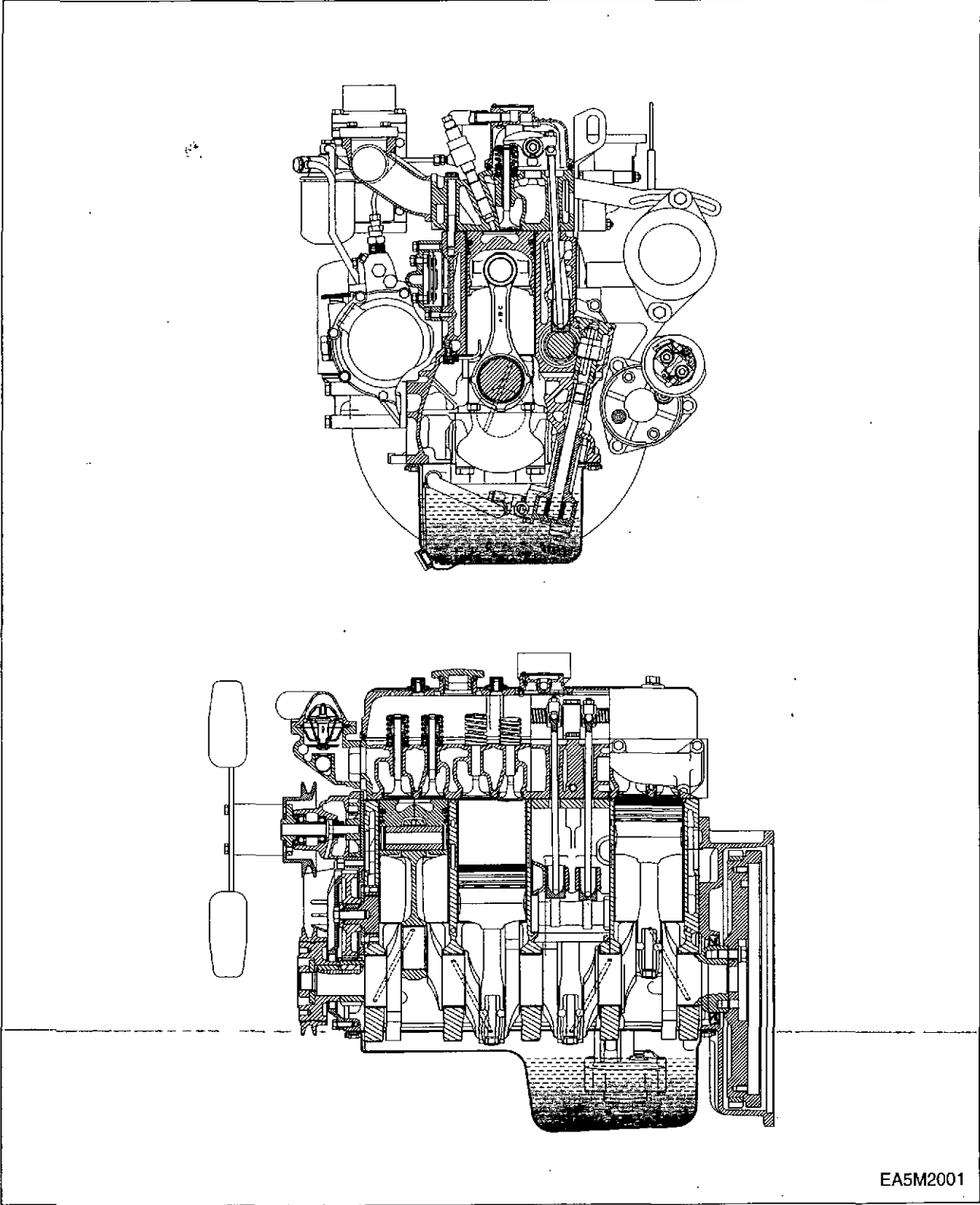

EA5M2001

2.2. Disassembly

2.2.1. External Parts(DB33)

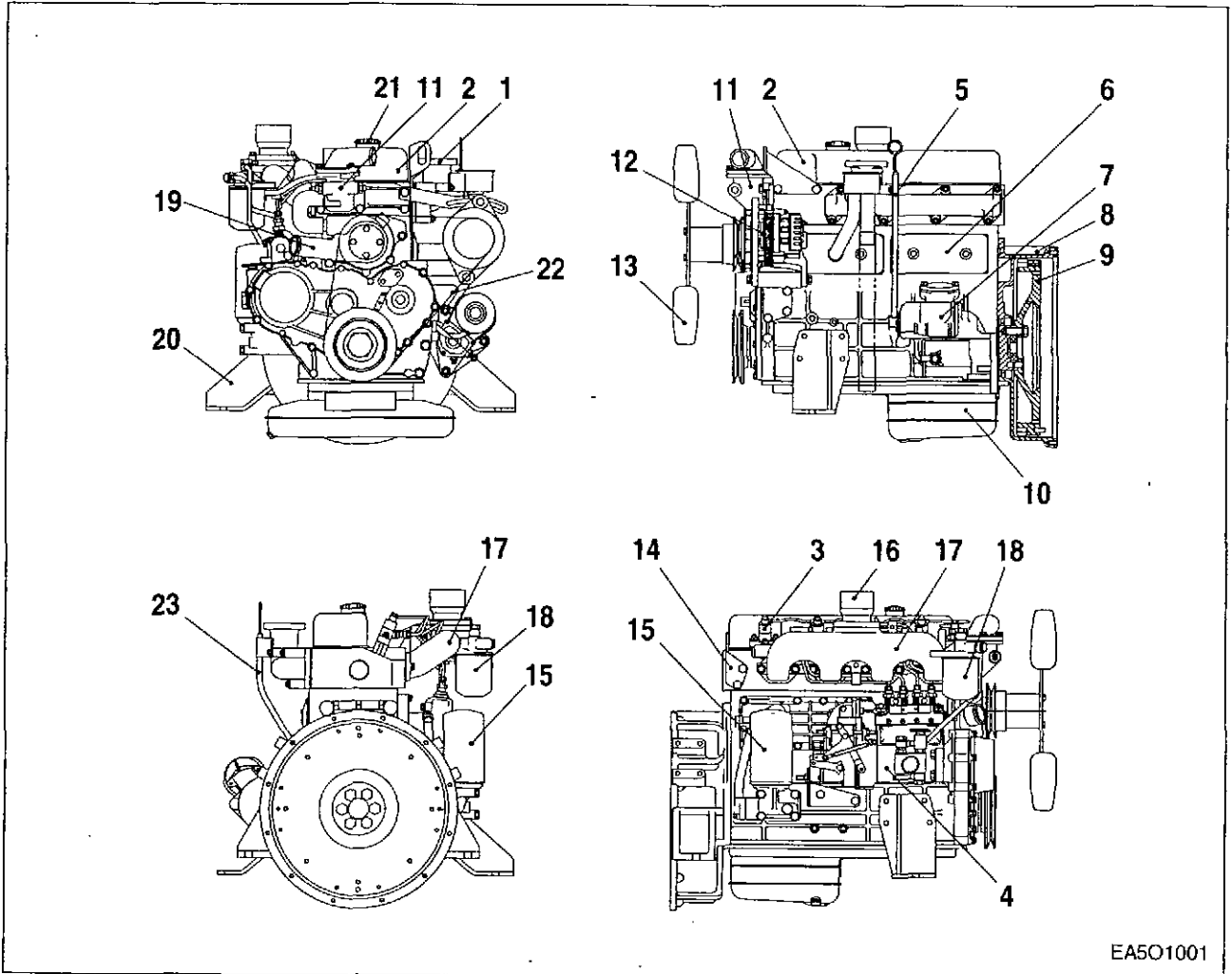

<Disassembly steps>

- ▲ 1. Exhaust manifold assembly
- ▲ 2. Cylinder head cover
- ▲ 3. Injection nozzle
- ▲ 4. Injection pump assembly
- 5. Oil level gauge
- 6. Push rod chamber cover
- 7. Starting Motor assembly
- 8. Flywheel housing
- 9. Flywheel
- 10. Oil pump assembly
- 11. Thermostat housing assembly
- 12. Alternator assembly
- 13. Cooling fan
- 14. Lifting hook
- 15. Oil filter assembly
- 16. Intake stake
- 17. Intake manifold assembly
- 18. Fuel filter assembly
- 19. Water pump assembly
- 20. Mounting bracket assembly
- 21. Oil filler cap
- 22. V-belt
- 23. Oil level gauge

2.2.2. External Parts(P034TI)

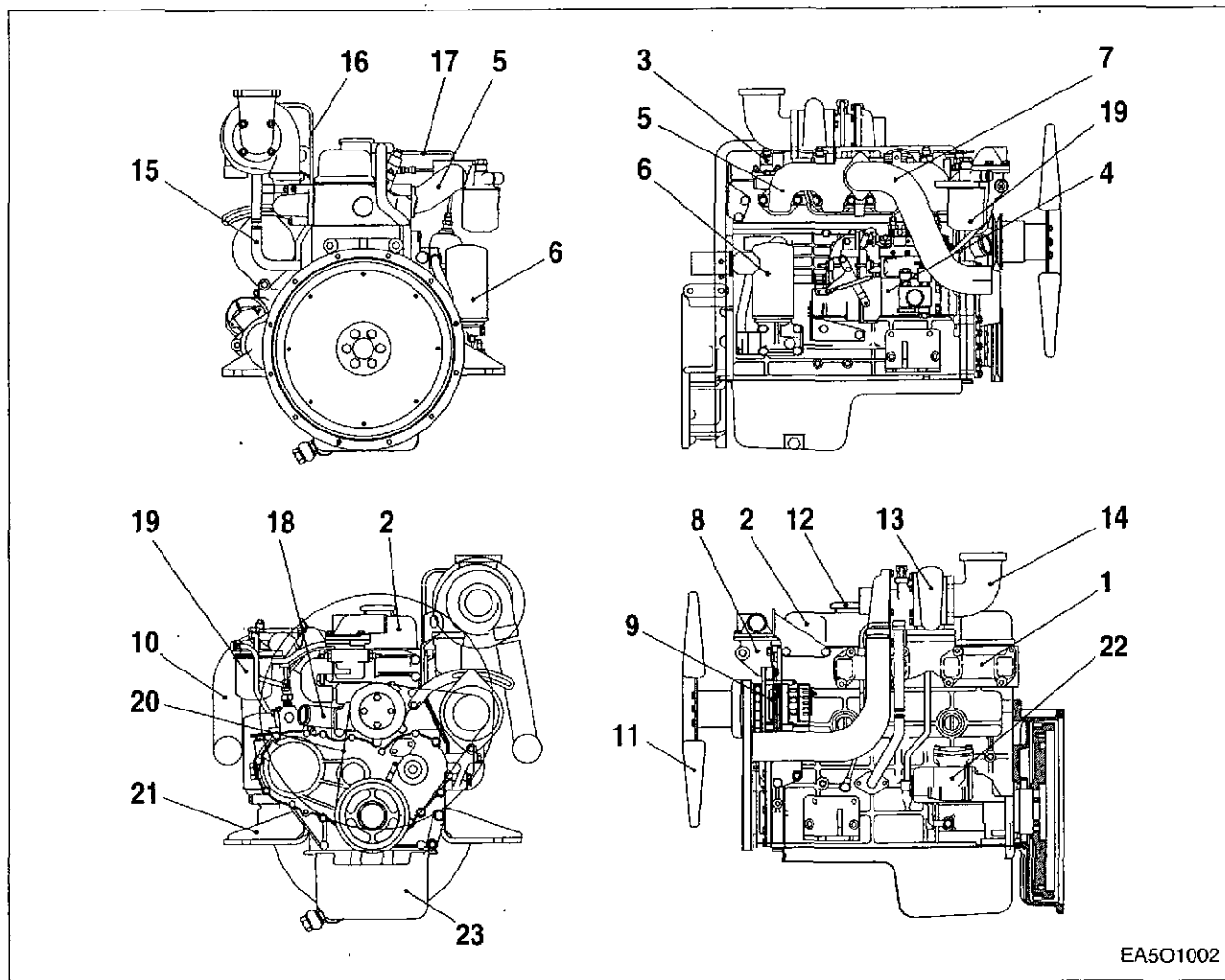

EA501002

<Disassembly steps>

- | | |
|--|-----------------------------|
| ▲ 1. Exhaust manifold assembly | 13. Turbocharger assembly |
| ▲ 2. Cylinder head cover | 14. Exhaust elbow |
| ▲ 3. Injection nozzle | 15. Oil return pipe |
| ▲ 4. Injection pump assembly | 16. Oil delivery pipe |
| 5. Intake manifold assembly | 17. Fuel return pipe |
| 6. Oil filter assembly | 18. Water pump assembly |
| 7. Air pipe assembly(from intercooler ass'y) | 19. Fuel filter assembly |
| 8. Thermostat housing assembly | 20. V belt |
| 9. Alternator assembly | 21. Mounting bracket |
| 10. Air pipe assembly(to intercooler ass'y) | 22. Starting Motor assembly |
| 11. Cooling fan | 23. Oil pan assembly |
| 12. Oil filler cap | |



Important operation

1. Exhaust manifold assembly

Loosen the manifold fixing bolts in sequence of figure's shown

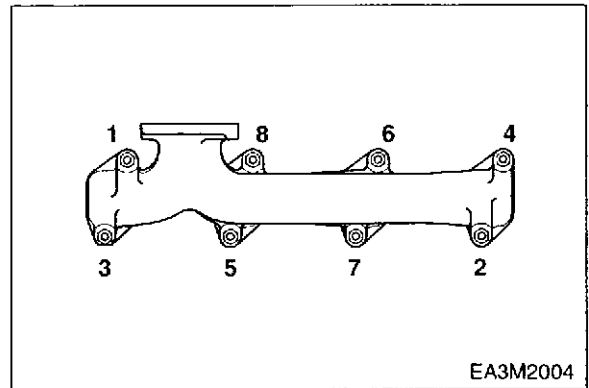

2. Cylinder head cover

Loosen the head cover bolts in sequence of figure's shown.

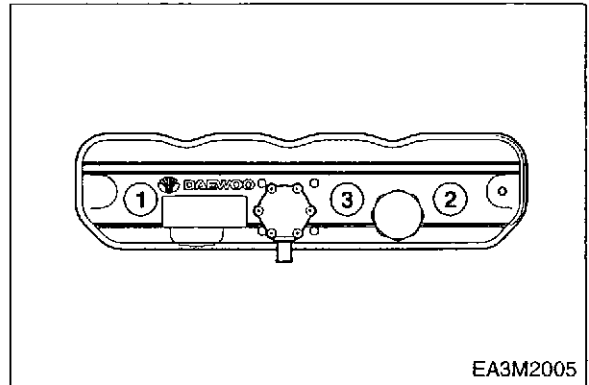

Engine control rod

Disassemble the engine control rod.

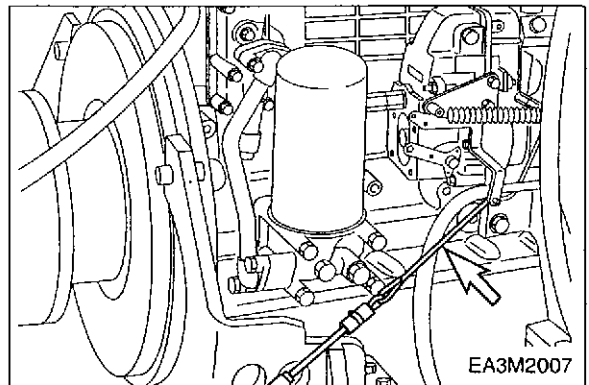

3. Injection nozzle

Be careful of nozzle tip or other parts from damage when disassemble.

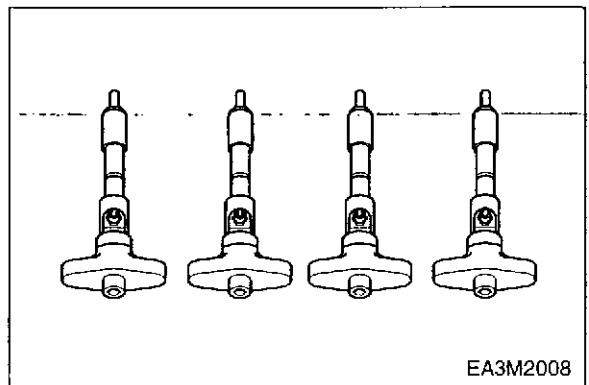

4. Injection pump assembly

When injection pump disassemble, put on rubber cap or taping the delivery valve holder for preventing from dusts.

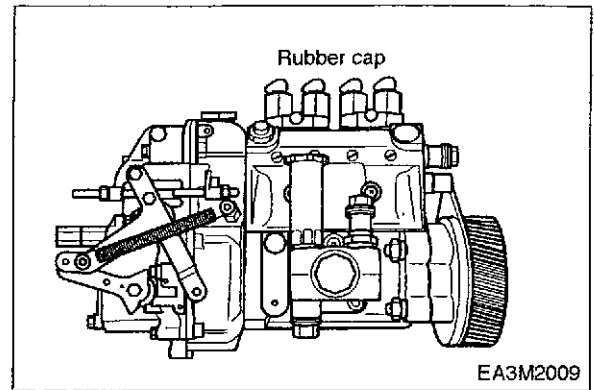

2.2.3. Internal Parts

● Major Components

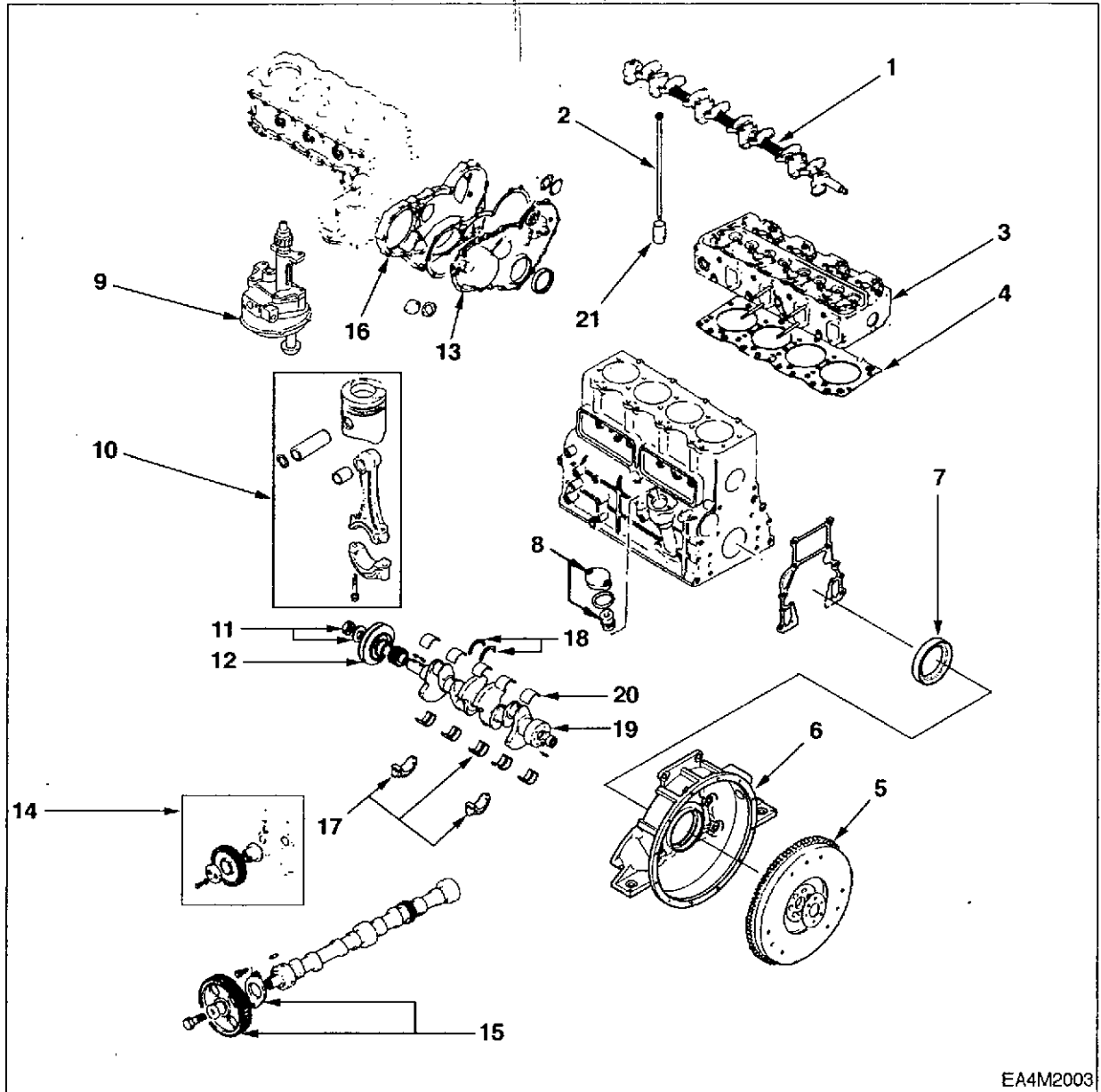

EA4M2003

<Disassembly steps>

- ▲ 1. Rocker arm shaft assembly
- ▲ 2. Push rod
- ▲ 3. Cylinder head assembly
- ▲ 4. Cylinder head gasket
- ▲ 5. Fly wheel
- ▲ 6. Fly wheel housing
- ▲ 7. Rear oil seal assembly
- ▲ 8. Oil pump cover
- ▲ 9. Oil pump assembly
- ▲ 10. Piston and connecting rod assembly
- ▲ 11. Crankshaft front nut and washer
- ▲ 12. Crankshaft pulley
- ▲ 13. Gear case cover
- ▲ 14. Idle gear
- ▲ 15. Camshaft assembly
- ▲ 16. Timing gear case
- ▲ 17. Crankshaft bearing cap and bearing
- ▲ 18. Thrust bearing
- ▲ 19. Crankshaft assembly
- ▲ 20. Crankshaft bearing
- ▲ 21. Tappet



Important operations

1. Rocker arm shaft assembly

Loosen the rocker arm shaft assembly fixing bolts a little at a time in numerical sequence as shown in the figure.

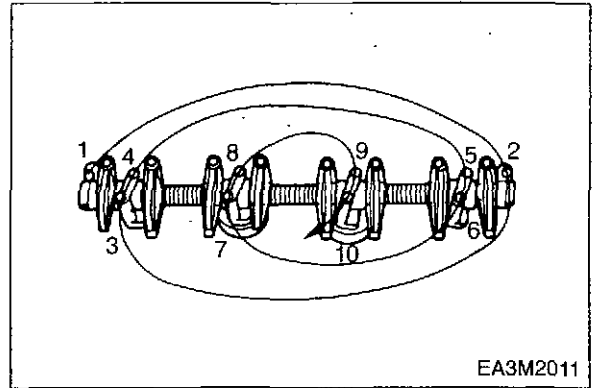

3. Cylinder head assembly

Loosen the cylinder head bolts a little at a time in the numerical sequence as shown in the figure.

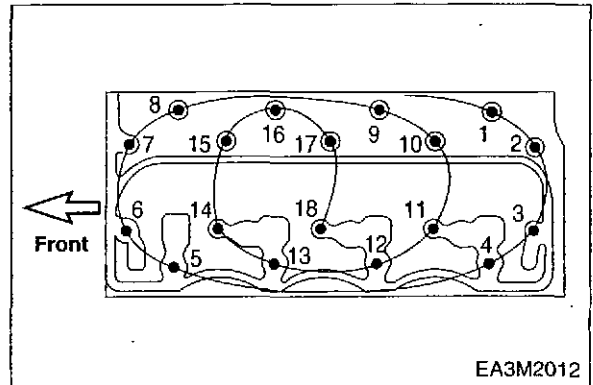

5. Fly wheel

Loosen the flywheel fixing bolts a little at a time in numerical sequence as shown in the figure.

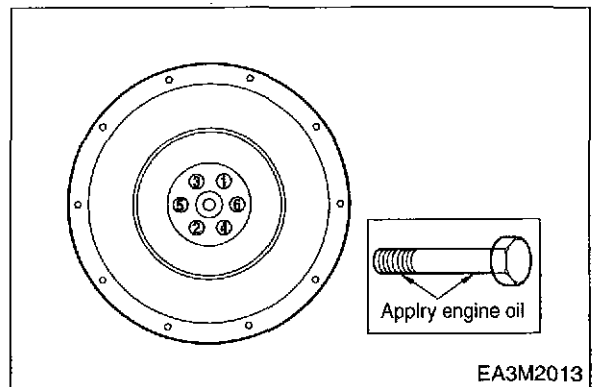

10. Piston assembly

Remove any carbon deposits from the upper part of the cylinder bore using a scraper.

This will prevent damage to the piston and the piston rings when they are removed from the cylinder bore.

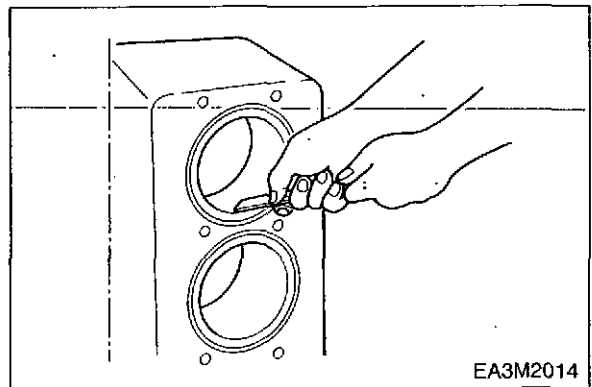

Bring the piston to top dead center by turning the crankshaft, then push out the piston and connecting rod assembly from the cylinder using the handle of a hammer or wooden bar.

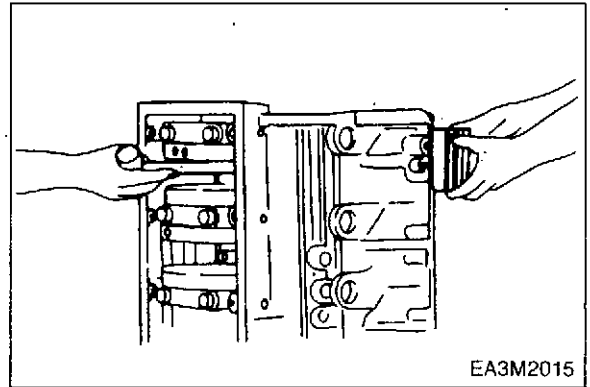

EA3M2015



11. Crankshaft front nut and washer

Wrench : 41 mm

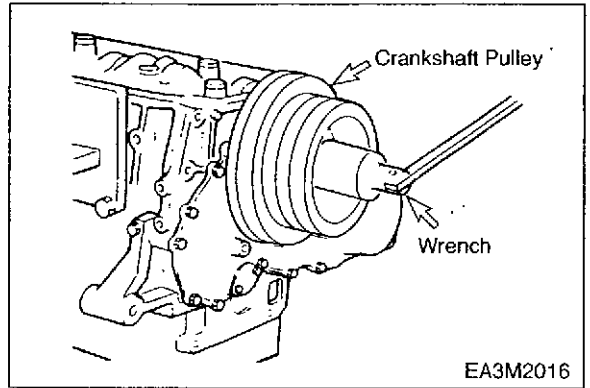

EA3M2016



14. Idle gear

Measure the following points before disassembly.

Idle gear end play

Standard	Limit
0.058 ~ 0.115	0.2 mm

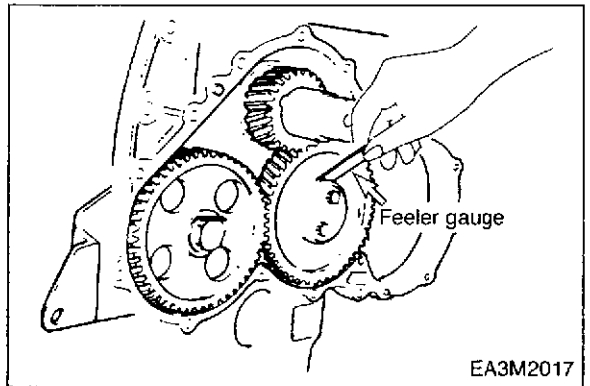

EA3M2017



Backlash.

Standard	Limit
0.10 ~ 0.17	0.3 mm

Includes the crankshaft gear, camshaft gear and idle gear.

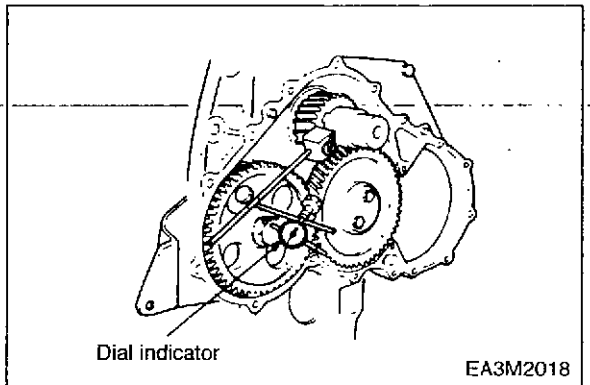

EA3M2018



17. Crankshaft bearing cap & bearing

Measure the crankshaft end play before disassembly.

Crankshaft end play

Standard	Limit
0.10 ~ 0.17	0.3 mm

Includes the crankshaft gear, camshaft gear and idle gear.

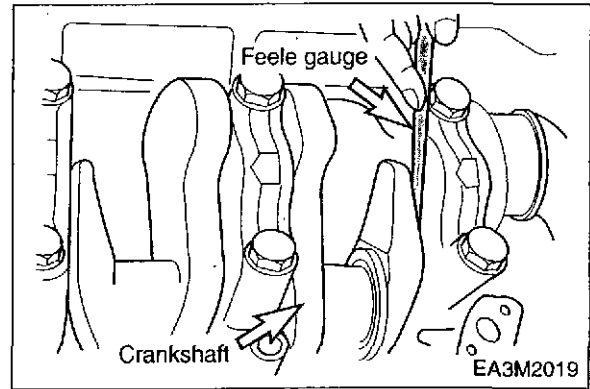

Loosen the crankshaft bearing cap bolts in numerical sequence as shown in the figure.

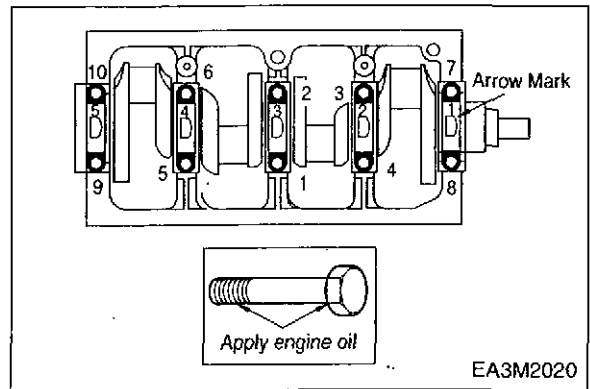

18. Thrust bearing

Remove the thrust bearing with steel wire.

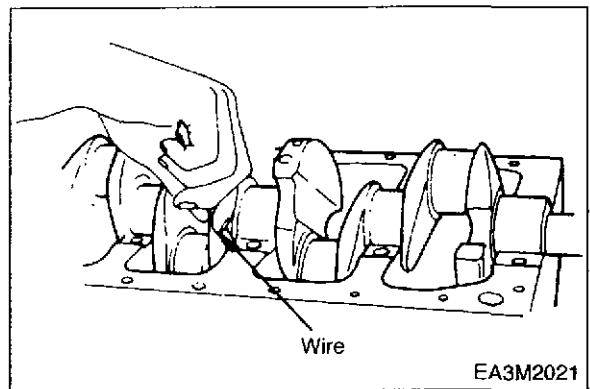

21. Tappet

Remove the tappets and mark the cylinder number each tappet. (Be careful against the damages)

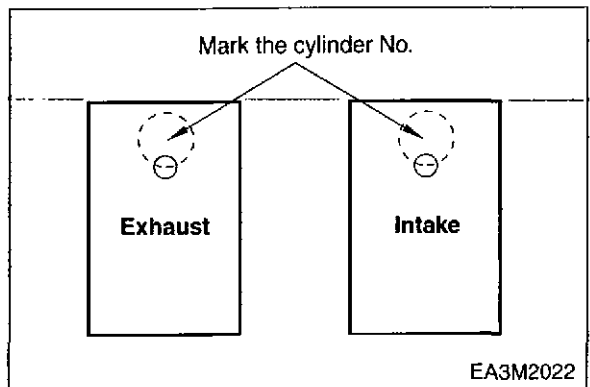

2.2.4. General Components

• Rocker arm, Bracket and shafts assembly

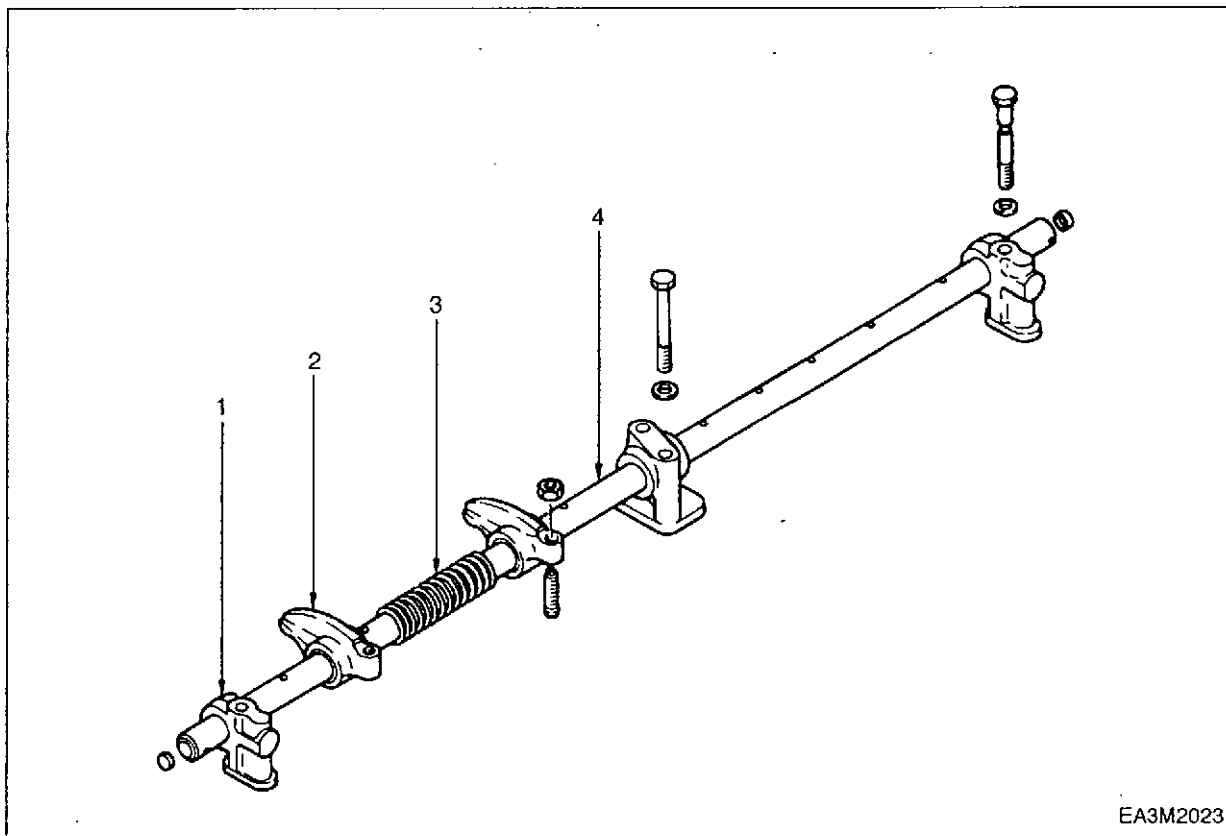

<Disassembly steps>

1. Bracket

2. Rocker arm

3. Spring

4. Rocker arm shaft

• Cylinder head assembly

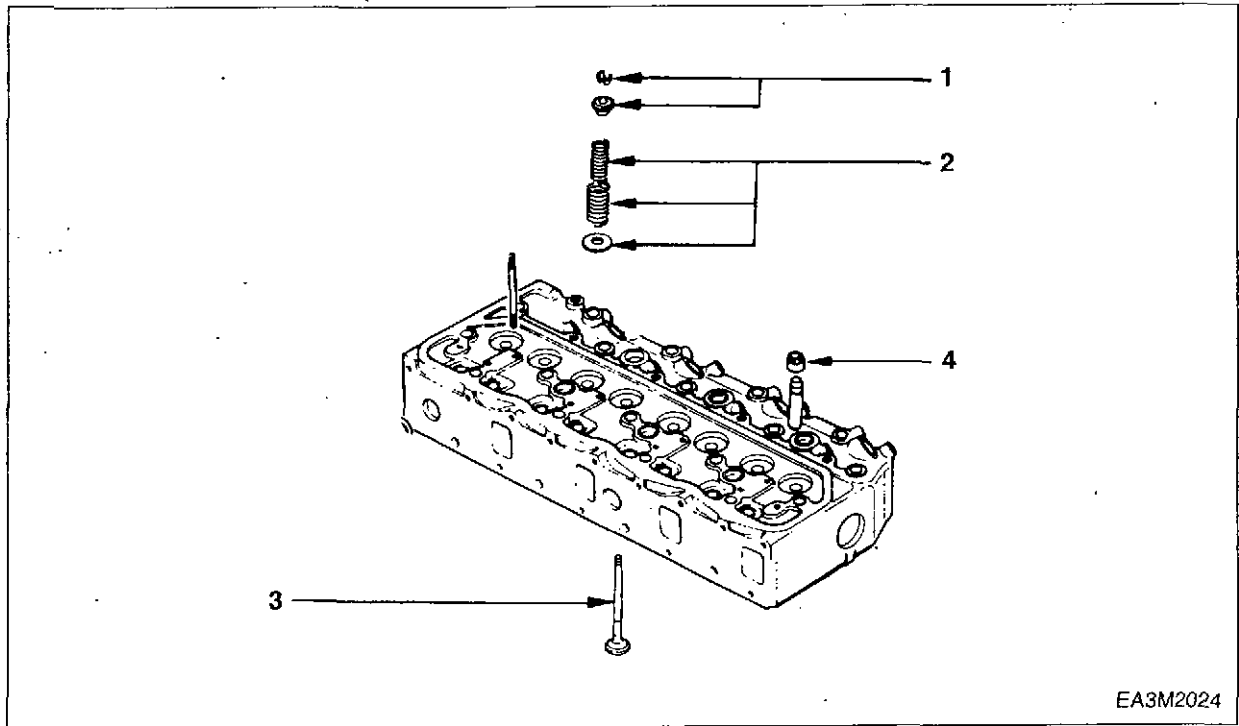

EA3M2024

<Disassembly steps>

- ▲ 1. Spring retainer and valve cotter
- ▲ 2. Spring and spring seat

- ▲ 3. Valve
- ▲ 4. Valve stem and oil seal



Important operations

Mark the cylinder No. each component when it disassembles.

- Valve spring
- Valve
- Valve seat

EA3M2025



1. Retainer and valve cotter

Spring compressor

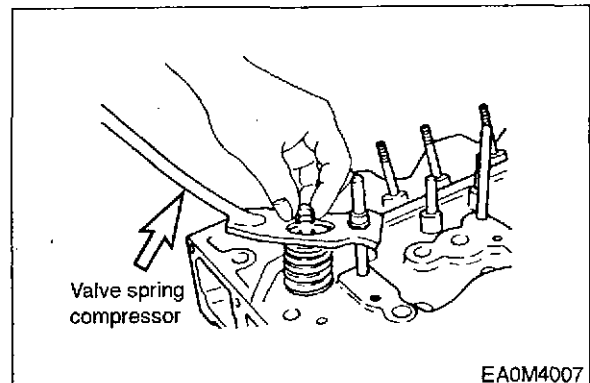

EA0M4007

● Piston and connecting-rod assembly

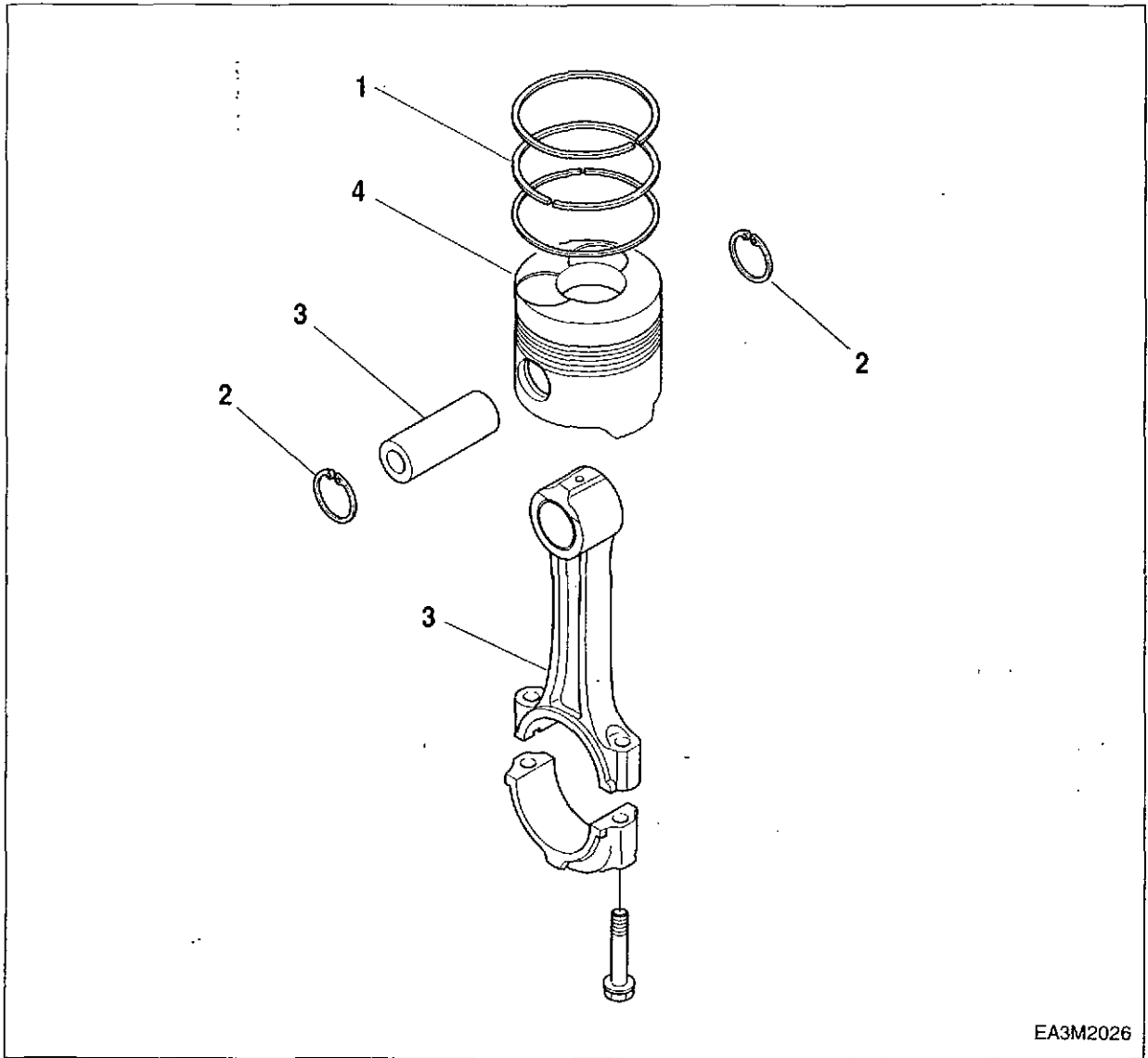

EA3M2026

<Disassembly steps>

- ▲ 1. Piston ring
- ▲ 2. Snap ring

- ▲ 3. Piston pin and connecting-rod
- ▲ 4. Piston



Important operations

Mark the cylinder No. each component when it disassembles.

- Piston ring
- Piston
- Piston pin
- Connecting-rod

EA3M2027



1. Piston ring

Remove the piston rings.

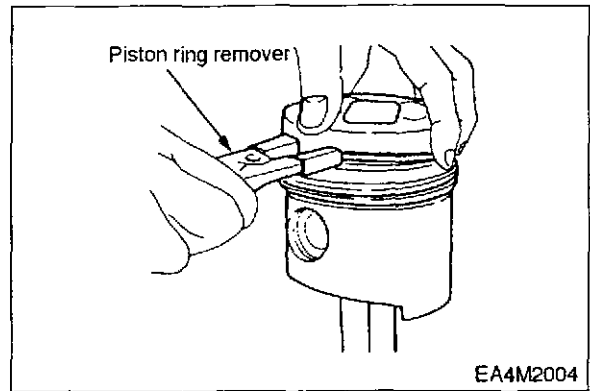

2. Snap ring

Remove the piston pin snap ring.

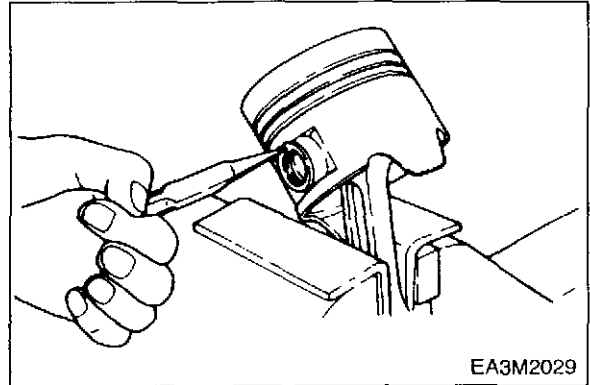

3. Piston pin and connecting-rod

Pull out the piston pin with brass bar.

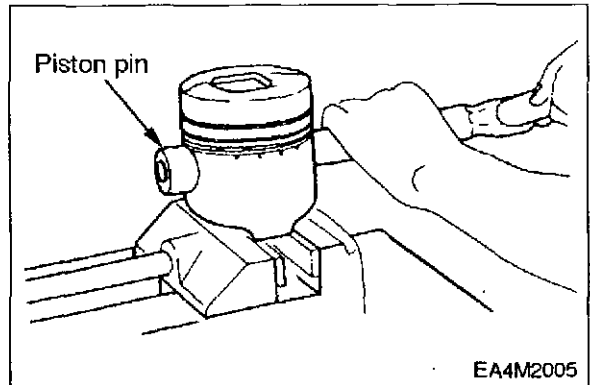

2.3. Inspection and Repair

Make the necessary adjustments, repairs and replacements if excessive wear or damage is discovered during inspection.

2.3.1. Cylinder Head



Distortion at lower face

- Check in six different (A ~ F) using a straight edge and a feeler gauge.

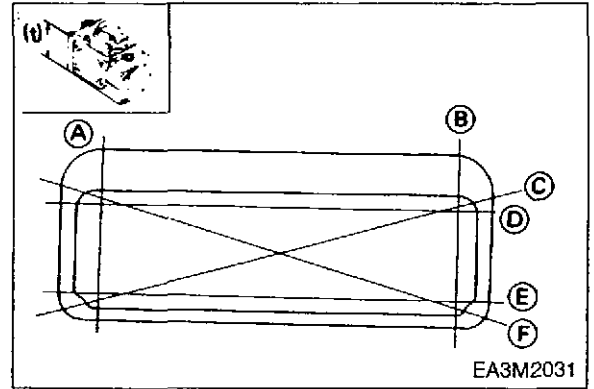

Lower face warpage and height

	Standard	Limit
Warpage	0.05mm or less	0.2 mm
Thickness : t (reference)	89.95~90.05 mm	89.75 mm

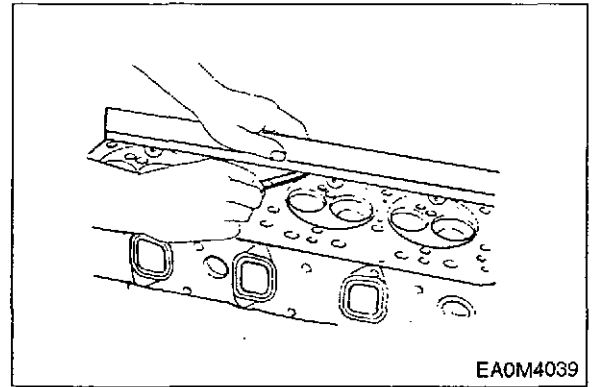

2.3.2. Valve, Valve Guide and Valve Seat Insert



Valve contact width

Standard	Limit
1.5 mm	2.0 mm

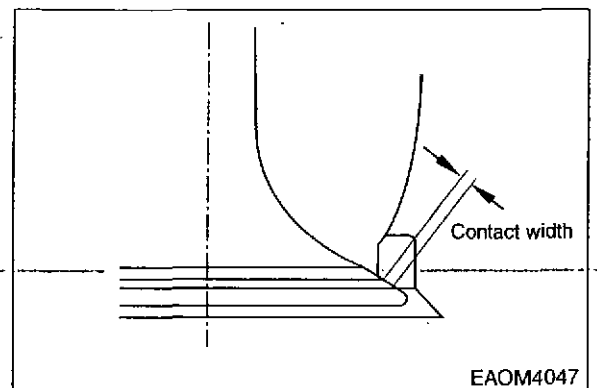



Valve depression

Standard	Limit
1.0 mm	2.5 mm

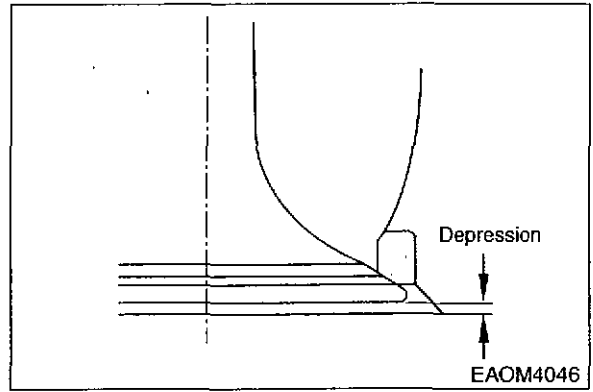

Valve seat angle

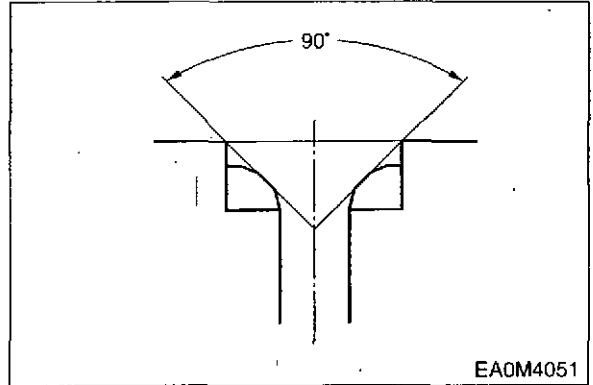

Valve seat insert replacement

Removal : Arc weld the entire inside circumference of the valve seat insert.

- Cooling the valve insert for a few minutes and pull out with a screw driver.

Installation : Use a bench press to smoothly press the valve seat insert.

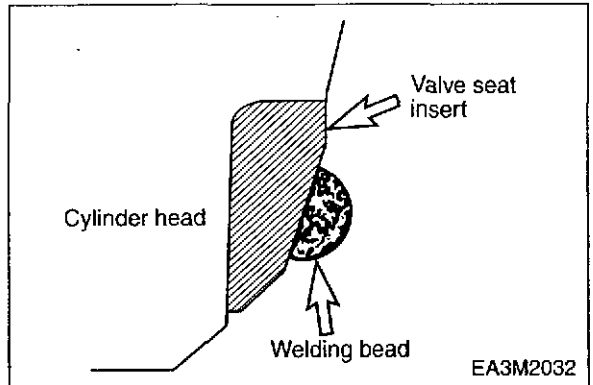

Valve angle

Intake	45°
Exhaust	45°

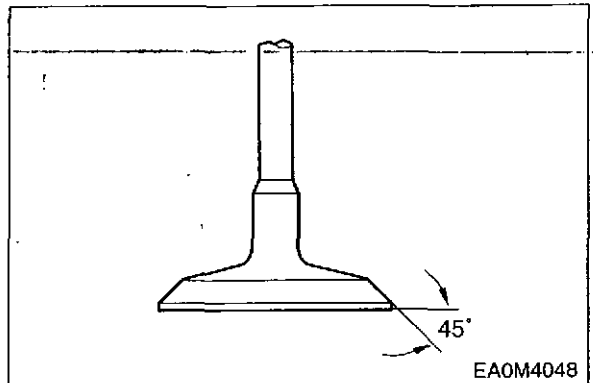



Valve seat thickness

Standard	Limit
1.5 mm	2.0 mm

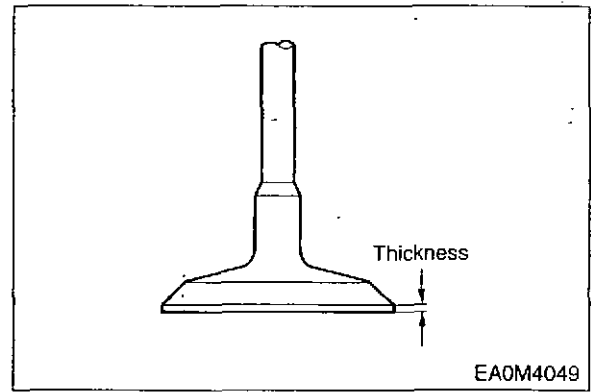

Valve stem outer diameter

	Standard	Limit
Intake valve	$\phi 8.946 \sim \phi 8.961$ mm	$\phi 8.88$ mm
Exhaust valve	$\phi 8.921 \sim \phi 8.936$ mm	$\phi 8.88$ mm

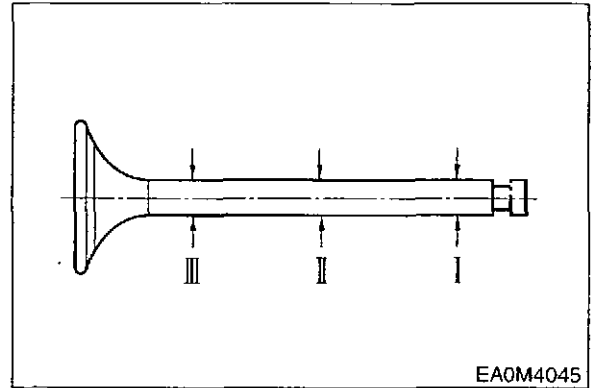

Valve stem end play

	Standard	Limit
Intake valve	0.04 ~ 0.07 mm	0.2 mm
Exhaust valve	0.06 ~ 0.09 mm	0.25 mm

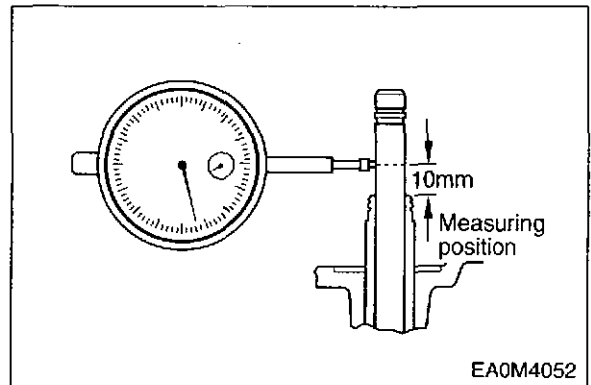

Valve guide replacement

Remover, installer

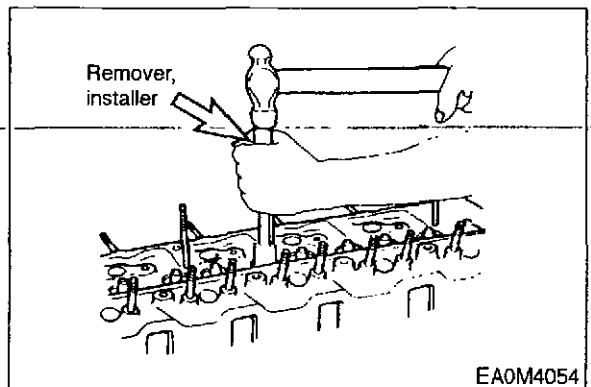

2.3.3. Valve Spring



Valve spring free length

Use a vernier caliper to measure the valve spring free length.

If the measured value is less than the specified limit, the valve spring must be replaced.

(unit : mm)		Standard	Limit	Remark
Exhaust and Intake valve Spring free Length		49.0	47.0	Generator and Industrial
Free length	Inner	52.4	50.0	Marine and Automotive
	Outer	53.6	50.6	

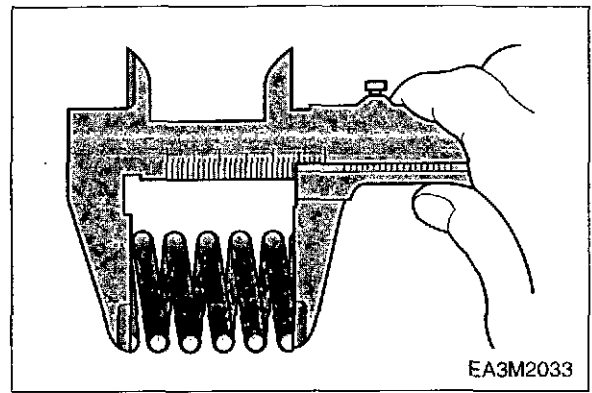

Valve spring inclination

Use a surface plate and a square to measure the valve spring inclination.

If the measured value exceeds the specified limit, the valve spring must be replaced.

(unit : mm)		Standard	Limit	Remark
Valve Spring Inclination		less than 1.3	2.7	Generator and Industrial
Free length	Inner	-	1.0	Marine and Automotive
	Outer	-	1.6	

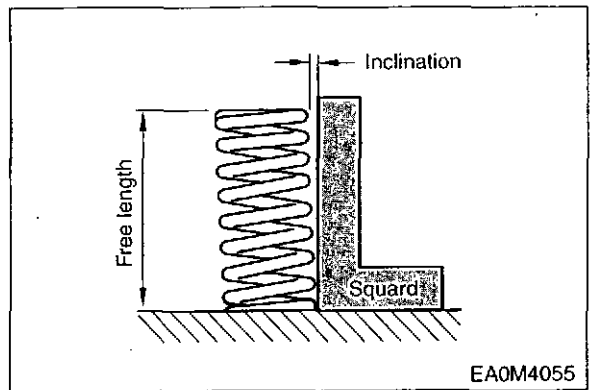

Valve spring tension

Use a spring tester to measure the valve spring tension if the measured value is less than the specified limit, the valve spring must be replaced.

(Set Length)		Standard	Limit	Remark
Valve Spring Tension at 40mm Set Length		14.5 kg	11.5 kg	Generator and Industrial
Inner Outer	42 mm	10.9 kg	9.9 kg	Marine and Automotive
	44 mm	23.0 kg	20.0 kg	

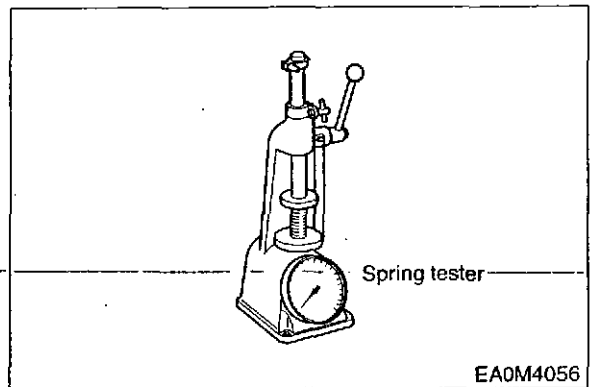

2.3.4. Tappet



Inspect the tappets for excessive wear, damage and any abnormal conditions.

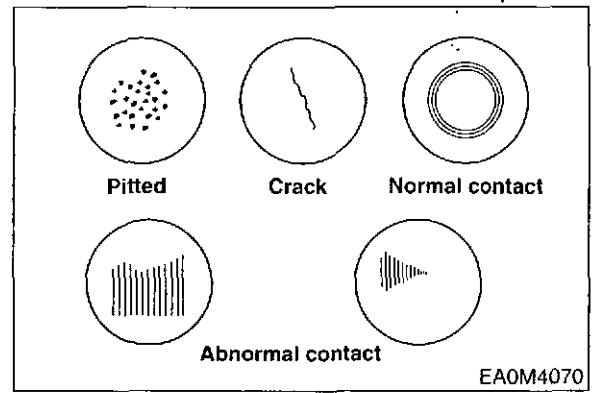

Diameter

Standard	Limit
27.97 ~ 27.98 mm	27.92 mm

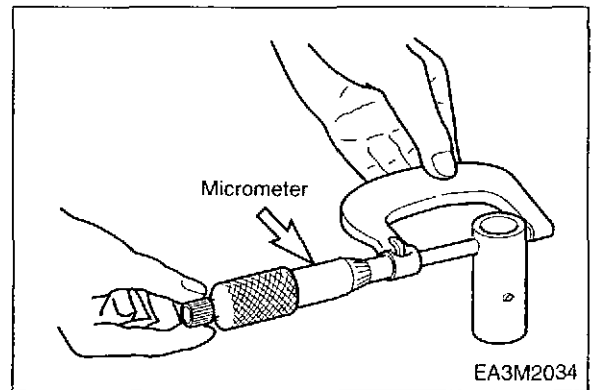

Clearance

between the tappet and cylinder body

Standard	Limit
0.02 ~ 0.054 mm	0.1 mm

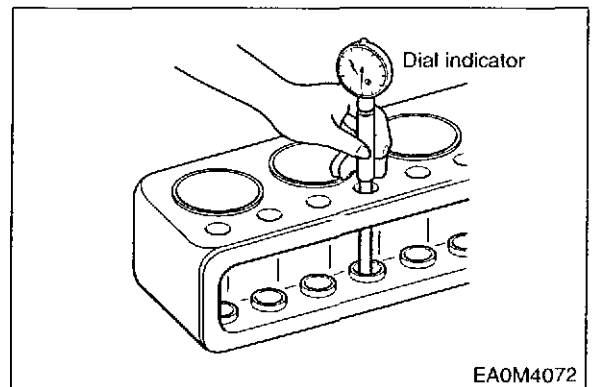

2.3.5. Push Rod



Run-out

Limit	0.3 mm or less
-------	----------------

- Use a feeler gauge to measure the push rod run-out.
- Roll the push rod along a smooth flat surface as shown in the figure.

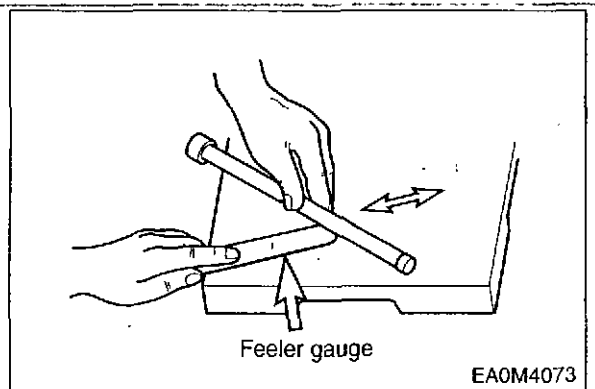

2.3.6. Rocker Arm Shaft Assembly



Inspect all disassembled parts for wear, damage and any abnormalities.

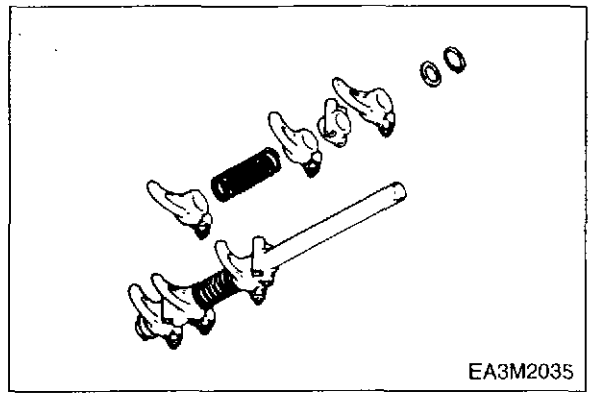

EA3M2035



Rocker arm shaft

Standard	Limit
$\phi 18.98 \sim \phi 19.00$	$\phi 18.85 \text{ mm}$

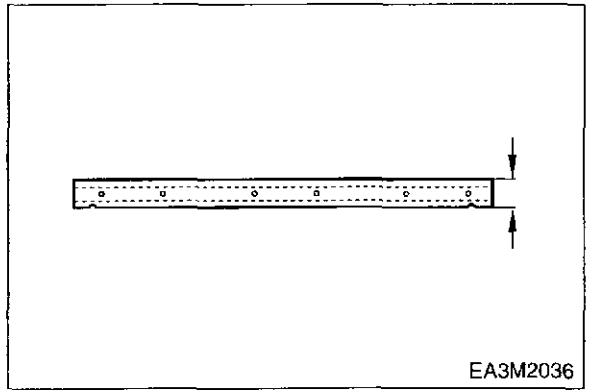

EA3M2036



Rocker arm bushing

Standard	Limit
$\phi 19.01 \sim 19.03$	$\phi 19.05 \text{ mm}$

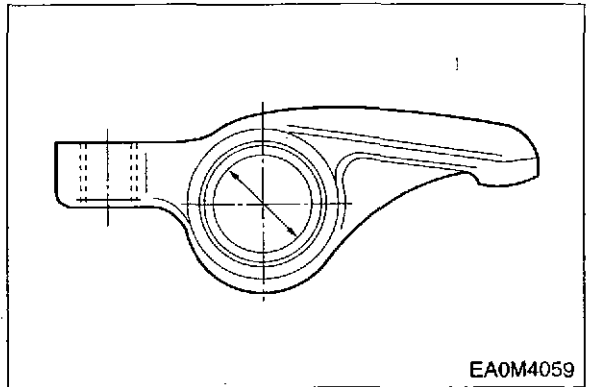

EA0M4059



Clearance

Between the rocker arm shaft and bushing

Standard	Limit
0.01 ~ 0.05 mm	0.2 mm

2.3.7. Camshaft Assembly



Inspection all disassembled parts for wear, damaged and other abnormal conditions.

- Camshaft
- Cam gear
- Thrust plate

EA3M2037



Cam gear end play

Standard	Limit
0.050 ~ 0.114 mm	0.2 mm

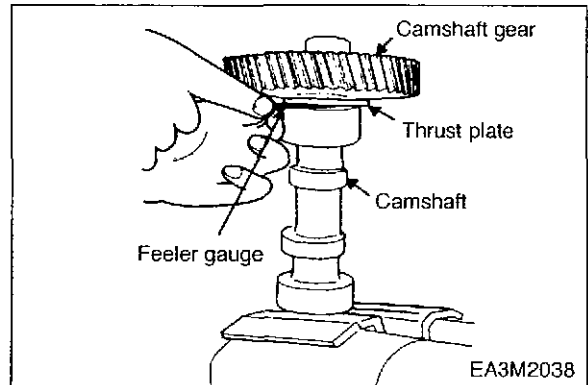

Camshaft journal diameter

Standard	Limit
$\phi 55.94 \sim \phi 55.97 \text{ mm}$	$\phi 55.60 \text{ mm}$

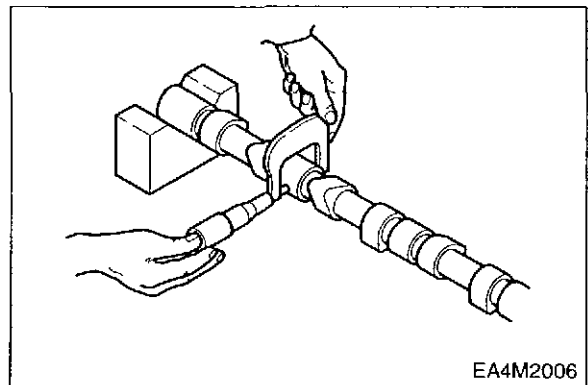

Cam bearing diameter

Standard	$\phi 56.00 \sim \phi 56.03 \text{ mm}$
----------	---



Clearance between camshaft journal and body

Standard	Limit
0.03 ~ 0.09 mm	0.15 mm

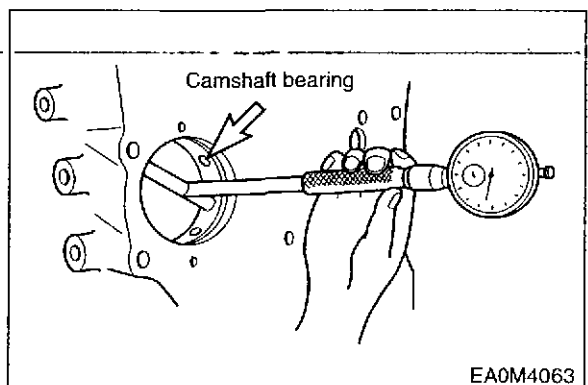



Camshaft bearing replacement

Remover, installer

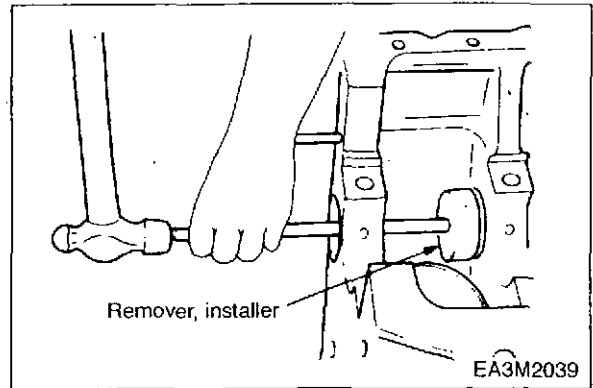

Align the camshaft bearing oil holes with the ports in the cylinder body.

No. 1 camshaft bearing (front side) has two oil ports while others have only one oil port.

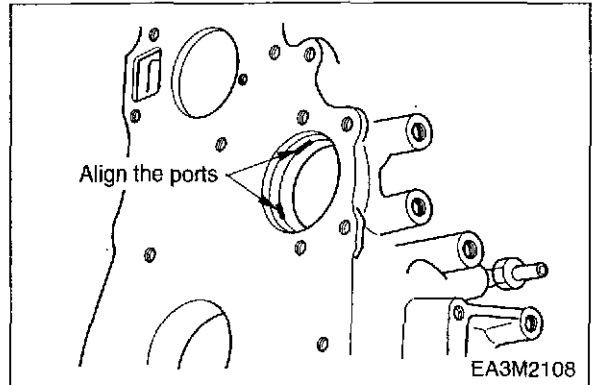

Camshaft run-out (T.I.R.)

Standard	0.1 mm
----------	--------

- Place the camshaft on a measuring stand.
- Use a dial indicator to measure the camshaft run-out.
- Note the total indicator values. (T.I.R.)

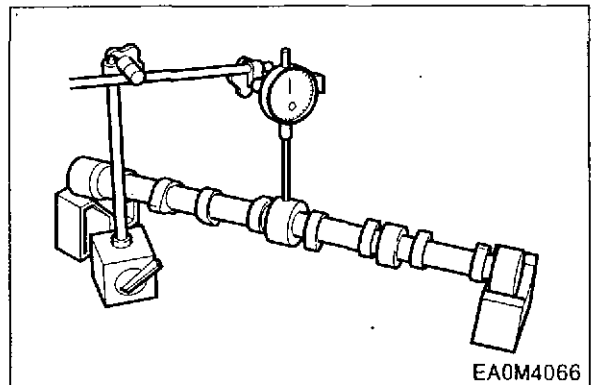

Camshaft gear

Replace the camshaft gear if any damages or excessive backlash are found.



Gear bolt torque	14.0 kg.m
------------------	-----------

- Refer to "Major components disassembly" for the backlash measurement (2.2.3 - 14)

EA4M2020



Cam gear and thrust plate replacement

Disassembly : Gear puller

Install : Use a bench press and a hammer



Torque	14.0 kg.m
--------	-----------

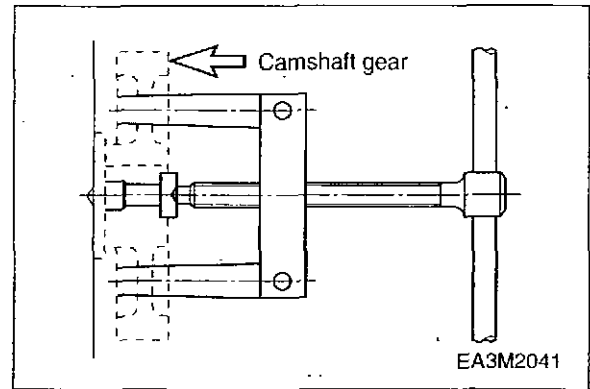

Cam lobe height

	Standard	Limit
Cam lobe height (C)	47.7 mm	46.5 mm
Cam journal diameter(A,B)	φ56.0 mm	φ55.6 mm

Use a micrometer to measure the cam lobe height and journal diameter.

If the measured number is less than the specified limit, the camshaft must be replaced.

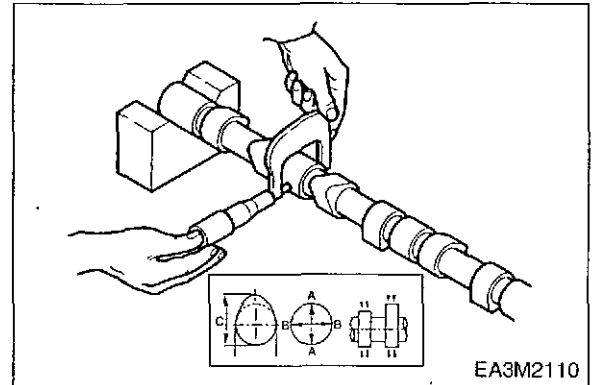

2.3.8. Idle Gear and Idle Gear Shaft



Shaft outside diameter

Replace the idle gear shaft if the measured value escaped from the specified limit.

Use a micrometer.

Standard	Limit
φ44.94 ~ φ44.97 mm	φ44.84 mm

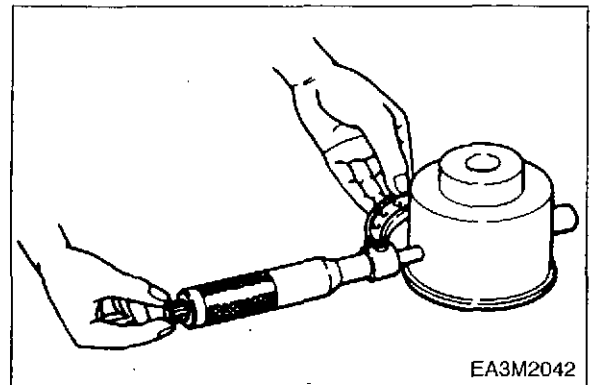

Clearance between shaft and gear

Measure the inside diameter of idle gear with the dial indicator.

Standard	Limit
0.009 ~ 0.060 mm	0.2 mm

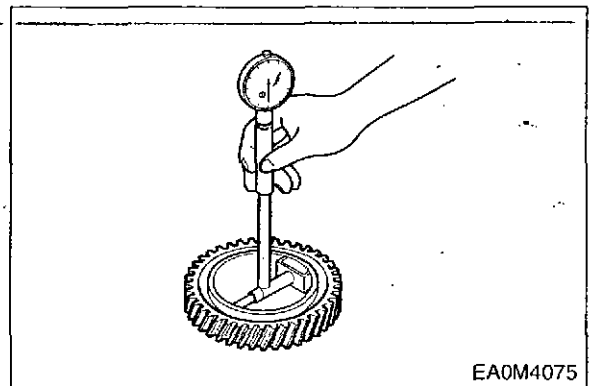

2.3.9. Cylinder Block and Liner



Cylinder body bore measurement

Measuring point : Approx. 20mm below from upper face (Maximum wear portion)

	Standard	Limit
For cast liner	$\phi 105.99 \sim \phi 106.01$ mm	$\phi 106.10$ mm
For steel liner	$\phi 105.00 \sim \phi 105.04$ mm	$\phi 105.10$ mm

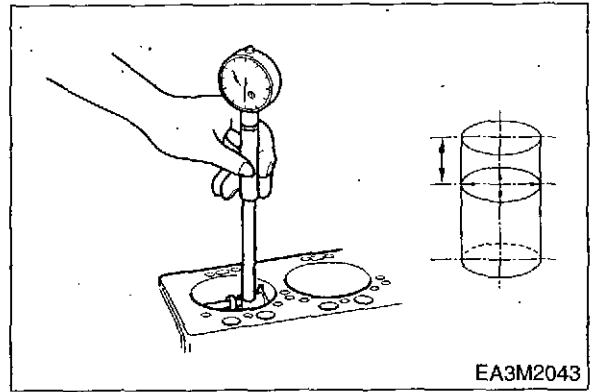

EA3M2043



Cylinder liner replacement

Disassembly : Remover

(Turn for steel liner only)

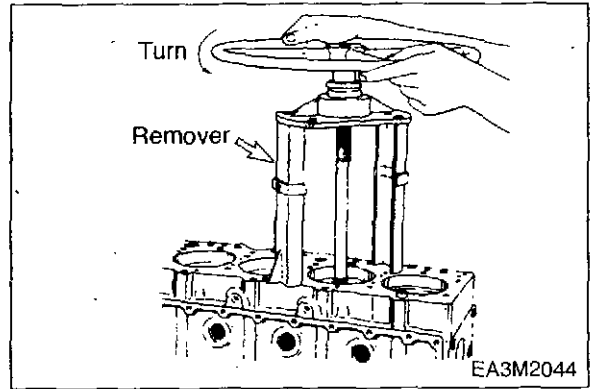

EA3M2044



Liner Installation

Installer



- First, apply a load of 500kg using a bench press. Do not use a hammer.
- And then apply a final seating force of 2,500kg to seat the cylinder liner fully.

Cast liner	Loose fit	0.005 - 0.026 mm
Steel liner	Tight fit	0.001 - 0.019 mm

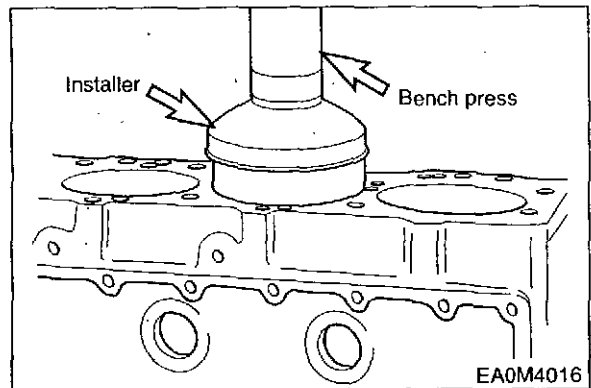

EA0M4016

After installing the liner, measure the cylinder liner projection and inner diameter.



Liner projection

Standard	0.03~0.10 mm
----------	--------------



- For the cast liner, removal or installation is worked smoothly.

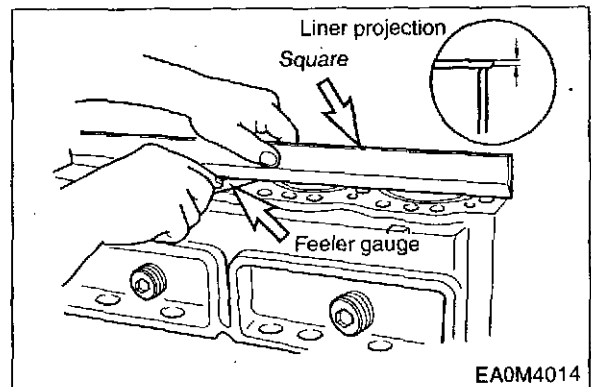

EA0M4014



Cylinder liner inner diameter

	Liner Grade	Standard
For cast liner	A	φ102.021~φ102.030 mm
	B	φ102.031~φ102.042 mm
For steel liner	A	φ102.021~φ102.040 mm
	B	φ102.041~φ102.060 mm

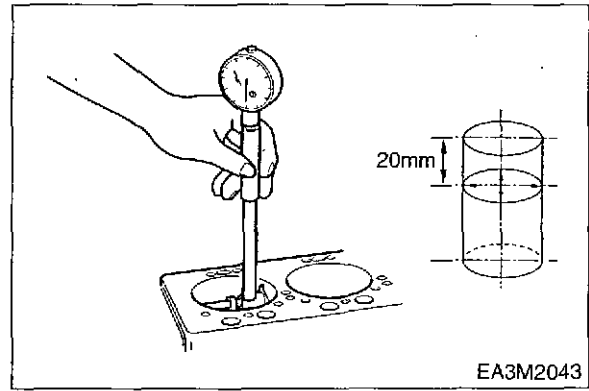

2.3.10. Piston, Piston Pin and Piston Ring



Piston outer diameter

	Piston Grade	Standard
For cast liner	A	φ101.953~φ101.967 mm
	B	φ101.963~φ101.977 mm
For steel liner	A	φ101.955~φ101.974 mm
	B	φ101.975~φ101.994 mm

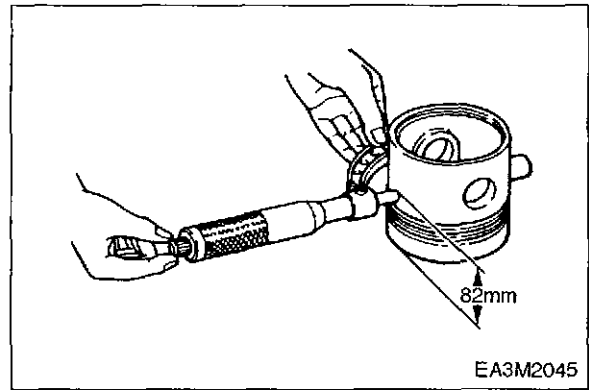

Piston and liner bore clearance

Standard	0.055 ~ 0.075 mm
----------	------------------



Piston ring

Piston ring and ring groove clearance

	Standard	Limit
1st compression ring	0.085 ~ 0.11 mm	0.2 mm
2nd compression ring	0.035 ~ 0.055 mm	0.15 mm
Oil ring	0.03 ~ 0.07 mm	0.15 mm

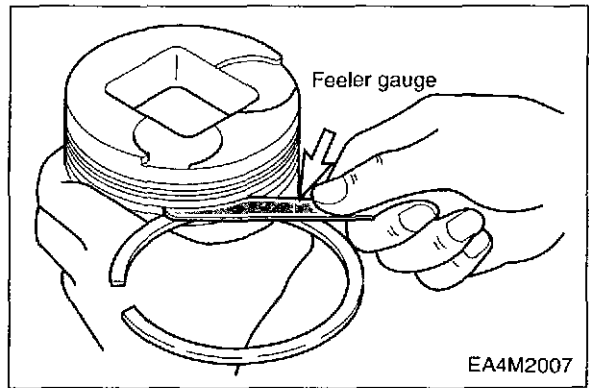

Piston ring gap

	Standard	Limit
1st compression ring	0.25 ~ 0.45 mm	1.5 mm
2nd compression ring	0.2 ~ 0.4 mm	1.5 mm
Oil ring	0.2 ~ 0.4 mm	1.5 mm

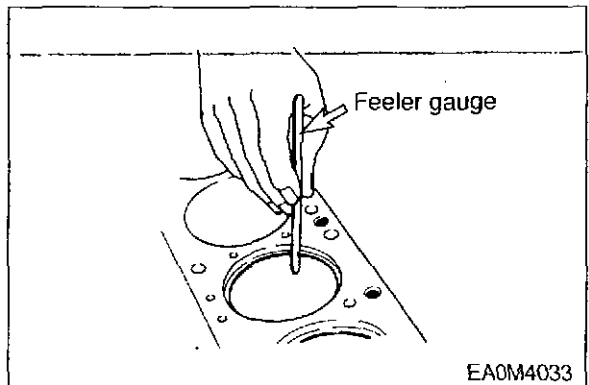



Piston pin outer diameter

Measure the various placed pin outside with a micrometer. Replace the pin if the measured value escaped from the specified limit.

Standard	Limit
$\phi 35.000 - \phi 35.005$ mm	$\phi 34.95$ mm

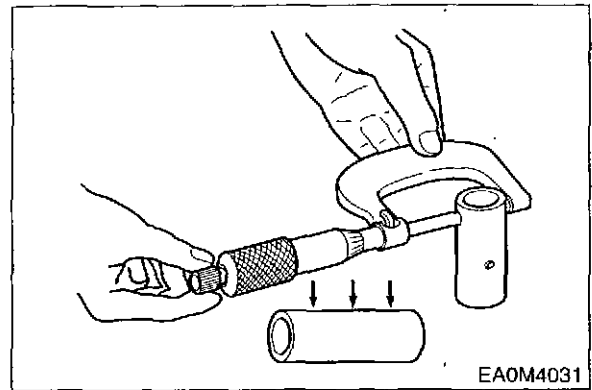

Piston pin and piston clearance

Measure diameter of the piston pin hole with an inside dial gauge.

Limit	0.05 mm
-------	---------

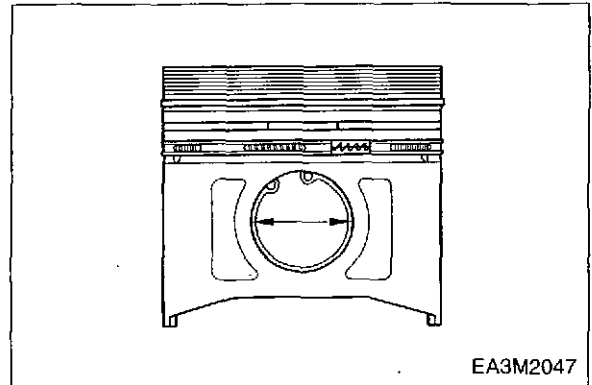

2.3.11. Connecting Rod and Bearing



Connecting rod alignment (parallelism)

Standard	Limit
0.05 mm	0.2 mm

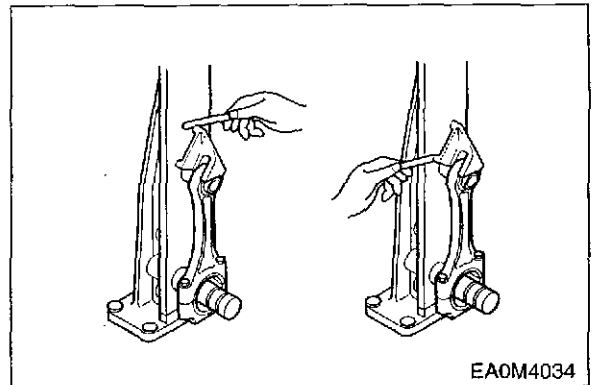

Bushing inside diameter

Standard	$\phi 35.017 - \phi 35.025$ mm
----------	--------------------------------

Use a caliper calibrator and micrometer to measure the piston pin and connecting rod small end bushing clearance.

Clearance between piston pin and connecting rod small end bushing

Standard	Limit
0.01 ~ 0.03 mm	0.05 mm

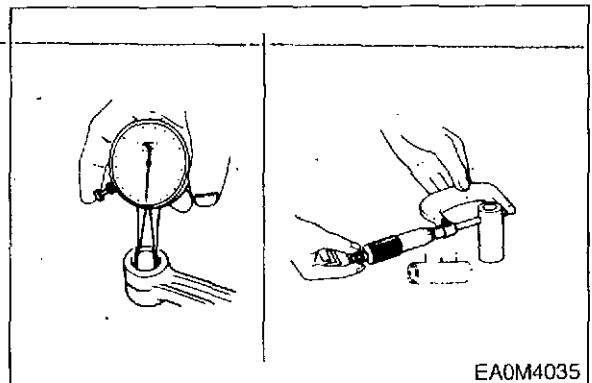



Bushing replacement

Removal : Use a brass bar and a bench press or hammer.



Installation : Use a brass bar and a bench press. The connecting rod busing oil port must be aligned with the connecting rod oil port.

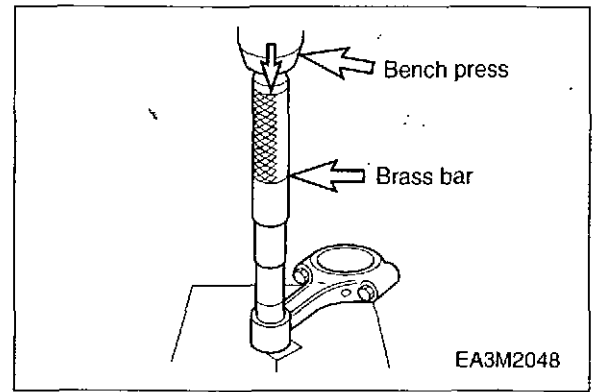

After new bushing installation, finish the bushing inside diameter with a pin hole grinder or a reamer to fit the piston pin.

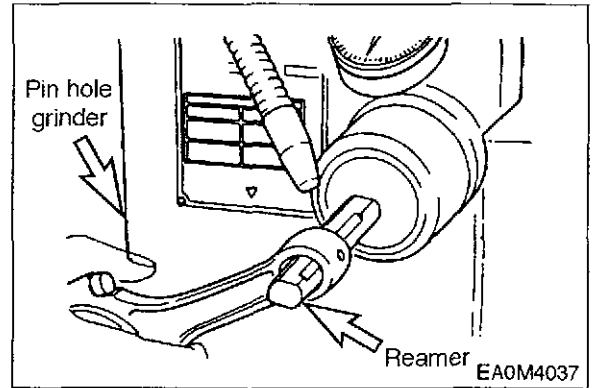

Connecting rod bearing

Bearing spread

Standard	68.00 ~ 68.01 mm
----------	------------------

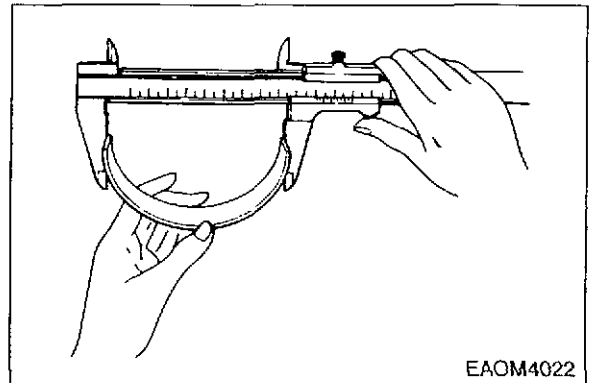

Bearing tension

1. Check to see if the bearing has enough tension, so that a good finger pressure is needed to fit the bearing into position.
2. Reassemble the connecting rod and bearing cap.

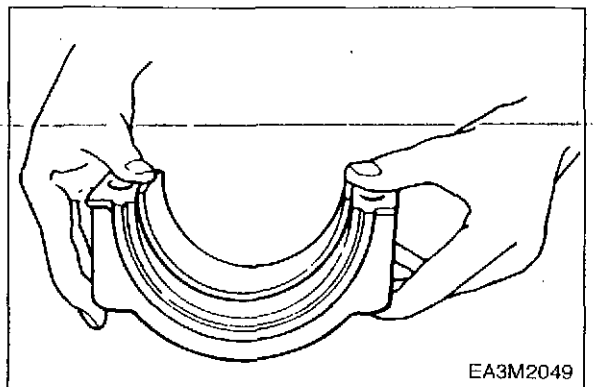

2.3.12. Crankshaft and Bearing

● Crankshaft and bearing inspection

1. Inspect the crankshaft journal and pin surfaces for excessive wear and damage.
2. Inspect the oil seal fitting surfaces of the crankshaft front and rear ends for excessive wear and damage..
3. Replace or repair the crankshaft if any excessive wear or damage is found.
4. Inspect the crankshaft oil ports for obstructions.
5. Use high pressure air to clean the oil ports if necessary.



Crankshaft pin outside diameter

Standard	$\phi 63.932\text{--}\phi 63.944\text{ mm}$
----------	---

Use a micrometer to measure the crankshaft pin outside diameter across points ① and ② at the two each points ③ and ④.

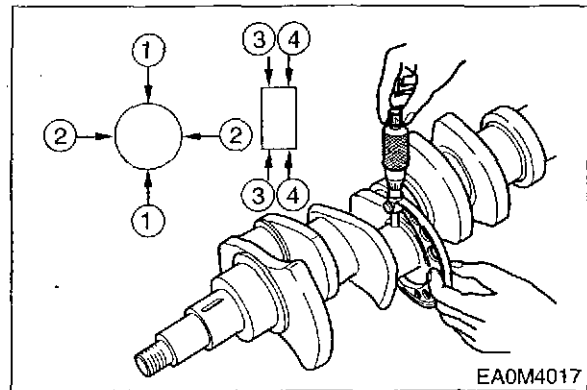

Connecting rod bearing cap reassembly

Connecting rod bolt torque	$9.75\pm 0.25\text{kg.m}$
----------------------------	---------------------------

Bolt Head : 

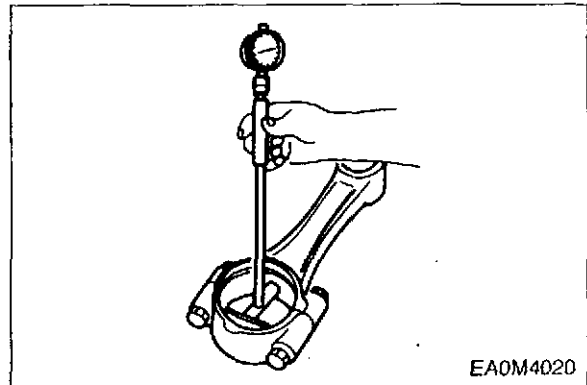

Inside diameter

- Measure the connecting rod inside diameter with an inside dial indicator.

Connecting rod bearing nominal diameter	$\phi 64\text{ mm}$
---	---------------------



- Apply engine oil to bearing surface.



Crankshaft pin and bearing clearance

Standard	Limit
0.03 ~ 0.07 mm	0.10 mm

Under size bearing specification	0.25~0.50 mm
----------------------------------	--------------

Crankshaft journal bearing



Tension

Fit the journal bearing into the journal bearing cap and check the tension with the same method of connecting rod cap bearing.

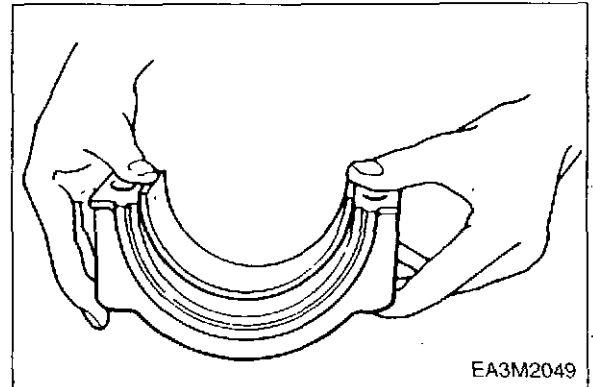

EA3M2049



Crankshaft journal outside diameter

Standard	$\phi 75.913 \sim \phi 75.925$ mm
----------	-----------------------------------

Use a micrometer to measure the crankshaft journal outside diameter across points (A) and (B) at the two each points (I) and (II).

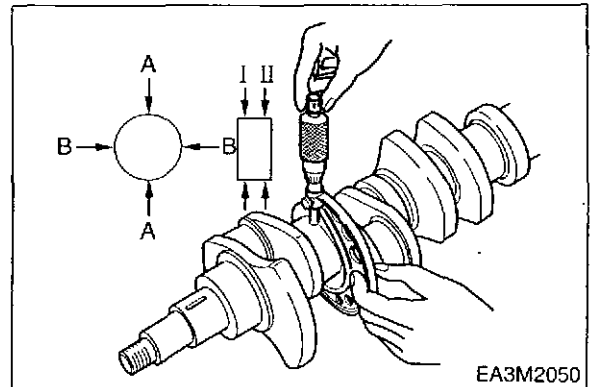

EA3M2050

Journal bearing cap reassembly

Torque	24 kg.m
--------	---------



Inside diameter

- Apply engine oil to bearing surface.
- Measure the journal bearing cap inside diameter with an inside dial indicator.



Journal bearing nominal diameter	$\phi 76$ mm
----------------------------------	--------------

- Refer to "Major components reassembly" for the crankshaft bearing cap (2.4.2-5)

EA4M3004



Crankshaft journal and bearing clearance

	Standard	Limit
Center bearing	0.065-0.116 mm	0.15 mm
Other bearing	0.025-0.076 mm	0.11 mm

Under size bearing specification	0.25-0.50 mm
----------------------------------	--------------

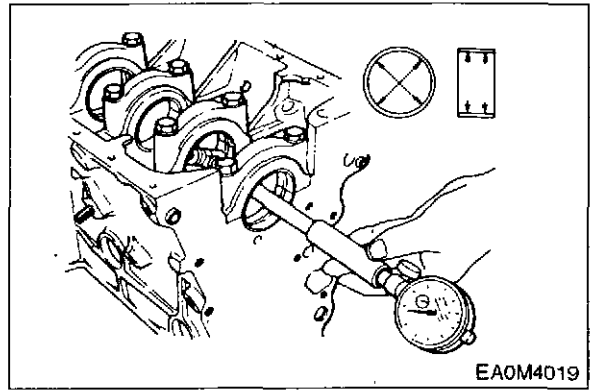

Crankshaft run-out

Standard	Limit
0.05 mm	0.40 mm

1. Place the crankshaft on a set of v-blocks.
2. Set a dial indicator to the center of the crankshaft journal.
3. Gently turn the crankshaft in the normal direction of engine rotation.
4. Read the dial indicator (TIR) as you from the crankshaft.

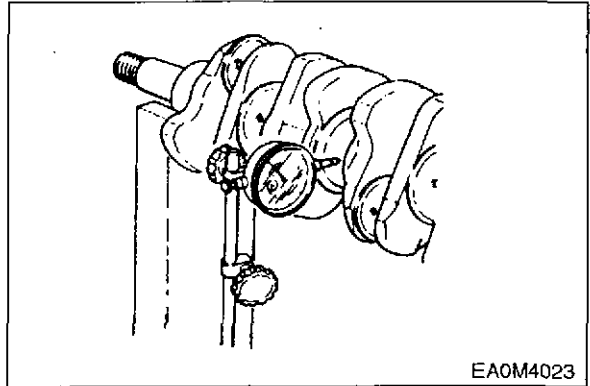

Crankshaft gear

Inspect the crankshaft gear

If any abnormal conditions are found, or if the amount of backlash measured at disassembly is excessive, replace the crankshaft gear.

- Refer to "Major components disassembly" for the backlash measurement (2.2.3 - 14)

EA4M2020



Crank gear replacement

Removal : Use a remover.

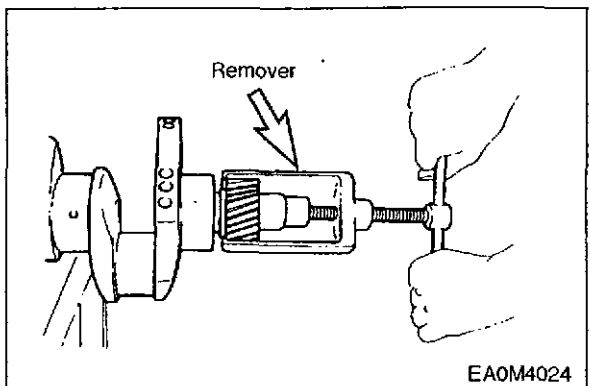



Installer

Use an installer.

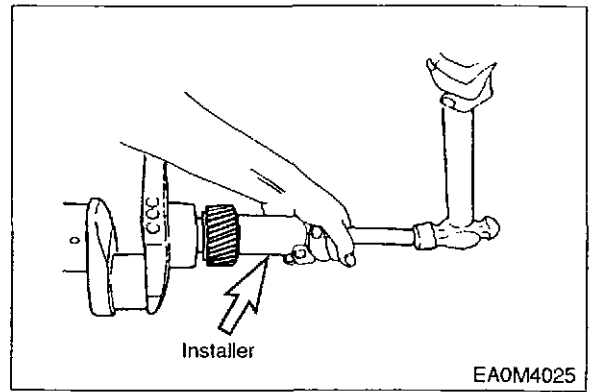

EA0M4025

2.3.13. Flywheel and housing (Rear oil seal)



• Flywheel thickness (Friction face)

Standard	Limit
33.4 – 33.6 mm	32.5 mm

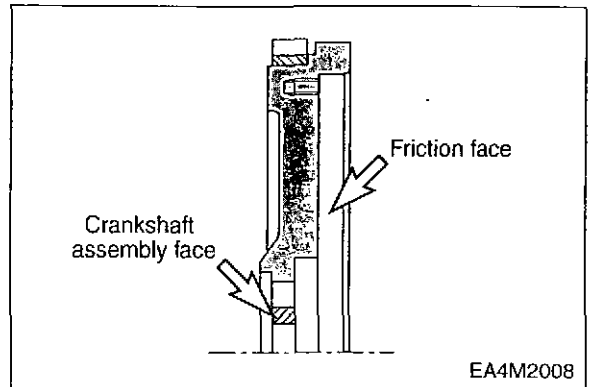

EA4M2008

Ring gear replacement

Removal : Use a brass bar and hammer

- Strike around the edges of the ring gear with a hammer and brass bar to remove it.

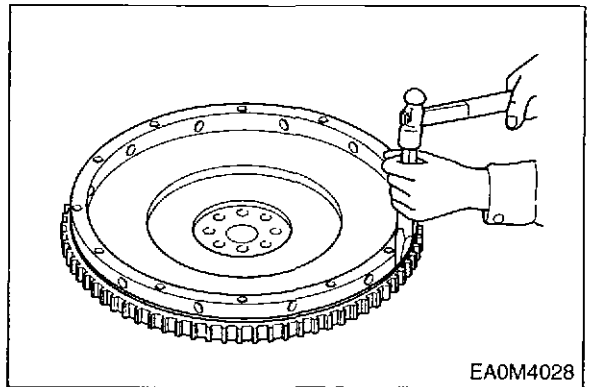

EA0M4028

Installation

- With a gas burner, heat the ring gear evenly until heat expansion takes place, then install it using a hammer.
- Do not allow the temperature of the ring gear to exceed 200 °C (390 °F).

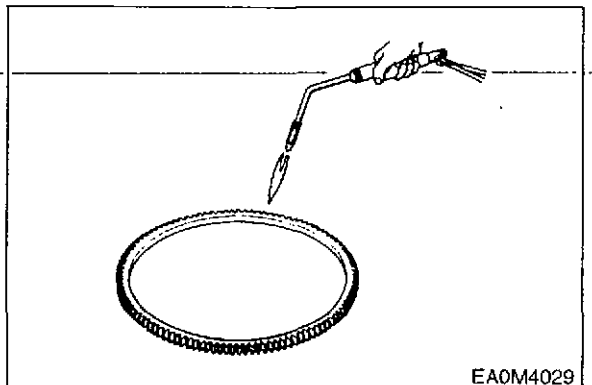

EA0M4029



Flywheel housing oil seal replacement

Removal : Pull out with a pry bar or brass hammer.

Installation : Use an oil seal installer.

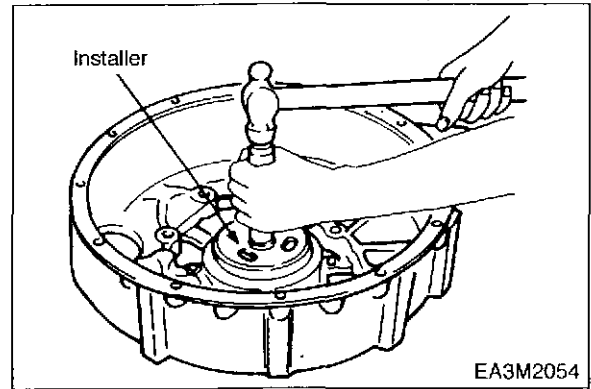

When the oil seal face in contact with the crankshaft is worn, the contact portion on the crankshaft can be changed by taking out the spacer.

Discard the used one, and install a new one.

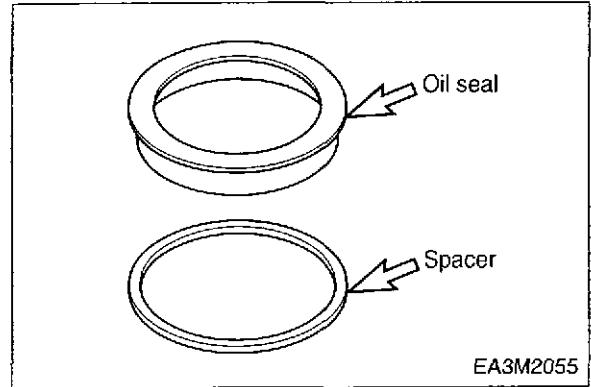

2.3.14. Timing gear case cover



Oil seal replacement

Removal : Pry off or pull out.

Installation : Use an installer.

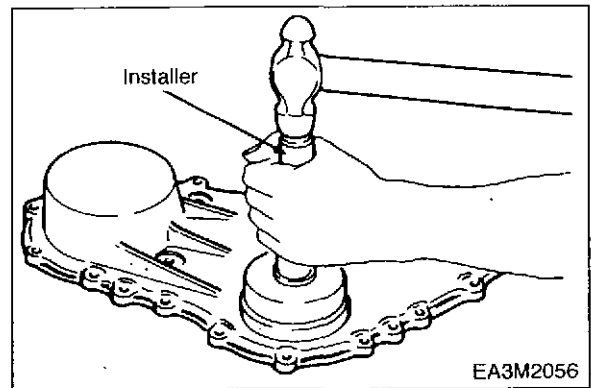

2.4. Engine Reassemble

2.4.1. General Component

● Piston and connecting-rod assembly

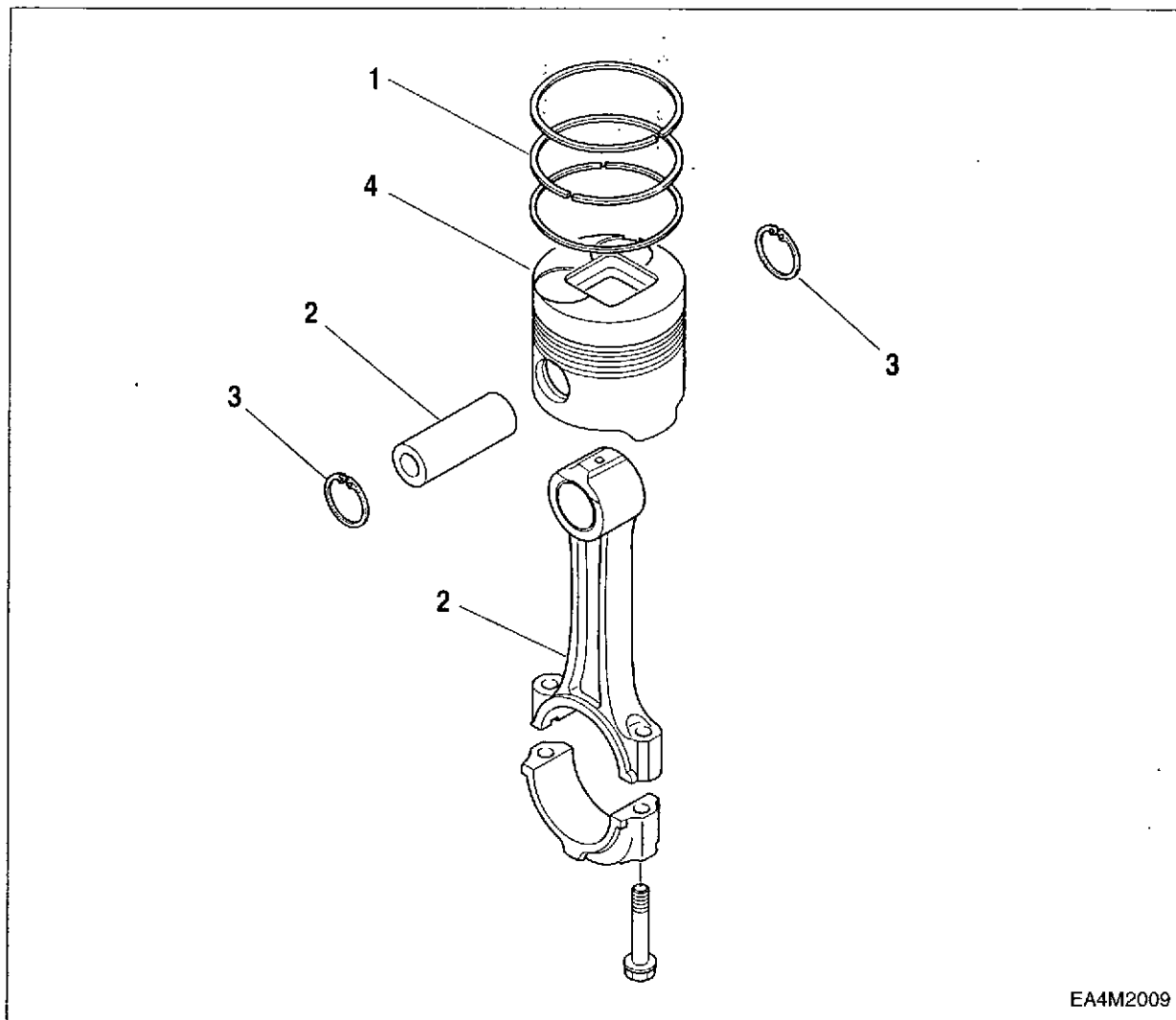

<Reassembly steps>

- ▲ 1. Piston
- ▲ 2. Piston pin and connecting-rod
- ▲ 3. Snap ring
- ▲ 4. Piston ring



Important operation



1. Piston

Use a piston heater to heat the piston approximately 60 °C (140 °F).

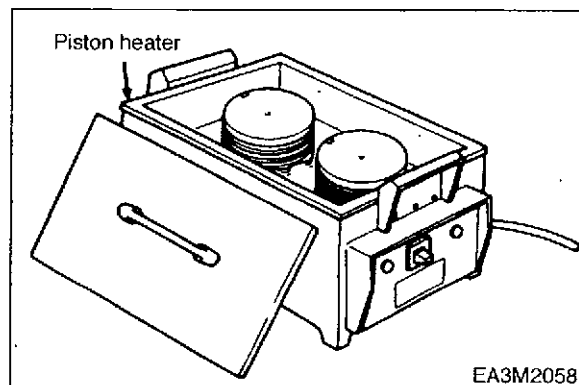



2. Piston pin and connecting-rod

- 1) Install the connecting-rod to the piston with setting the marks as illustrated.
- 2) Install the piston pin into the piston and the connecting-rod bushing.

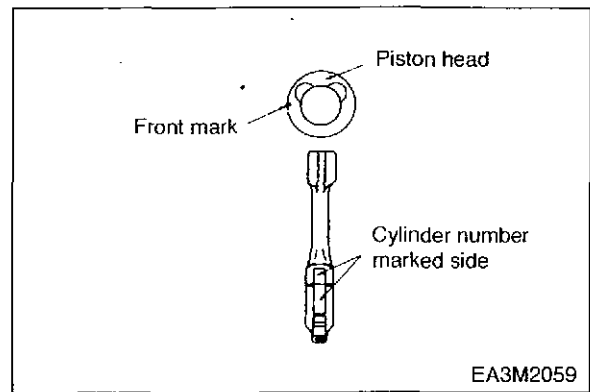

3. Snap ring

- 1) Use a pair of snap ring pliers to install the piston pin snap ring.
- 2) Check that the piston moves smoothly on the piston pin.

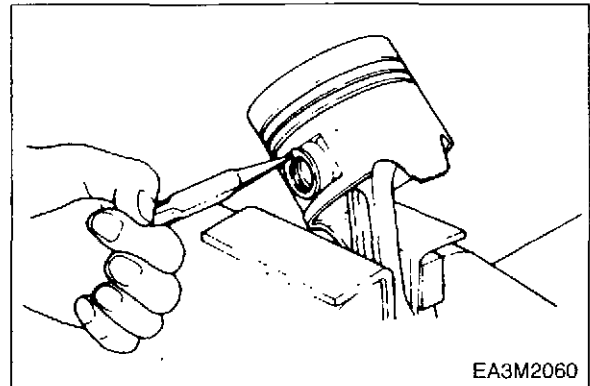

4. Piston ring

- 1) Use a piston ring installer to install the three piston rings.
 - Install the piston rings in the following order oil ring.
 - 2nd compression ring
 - 1st compression ring



The marked side of the two compression ring must be facing up. The undercut side of the 2nd compression ring will be facing up (for cast liner). As the oil ring has no any facing mark, it may face in either direction.

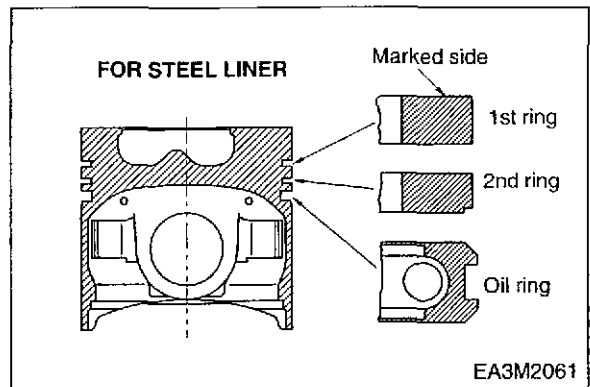

- 2) Lubricate the piston ring surfaces with engine oil.
- 3) Check the piston ring rotate smoothly in the piston.
- 4) Use Cr-coating piston ring for cast liner and normal piston ring for steel liner

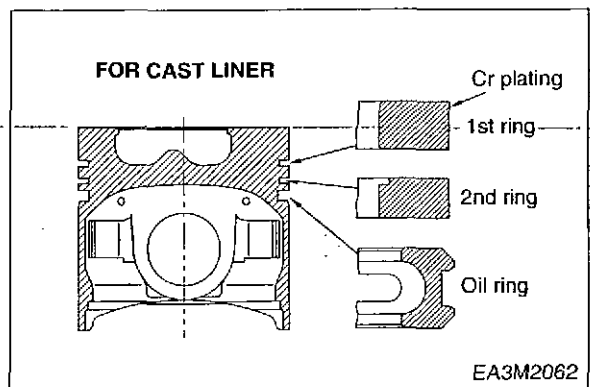



Maintenance of cylinder block, cylinder liner and piston

To maintain the engine in optimum condition and retain maximum performance for a long time, the cylinder block, cylinder liner and piston which have the same grade marking number (the same size tolerance) should be assembled. The marking number (the part's grade) and marking position is as follows.

• Cylinder block

- a) Marking number ; 1 or 2
(Size grade for of cylinder bore diameter)
- b) Marking position ; Center of the cylinder block upper surface

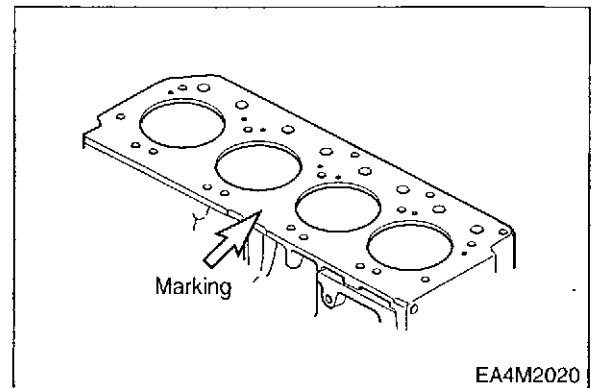

• Cylinder liner

- a) Marking number ; 1A, 1B, 2A, 2B
(Size grade for cylinder liner inner diameter)
- b) Marking position ; Cylinder liner lower surface

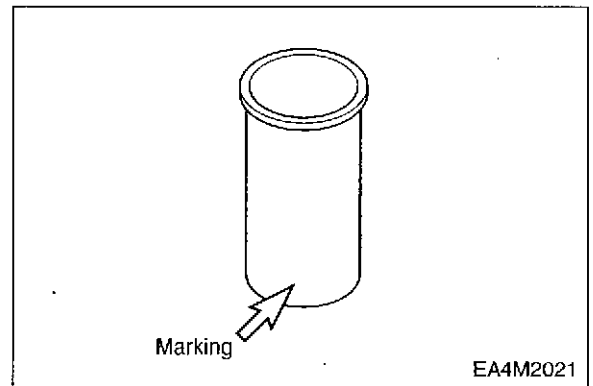

• Piston

- a) Marking number ; A or B
(Size grade for piston outer diameter)
- b) Marking position ; Center of the piston upper surface

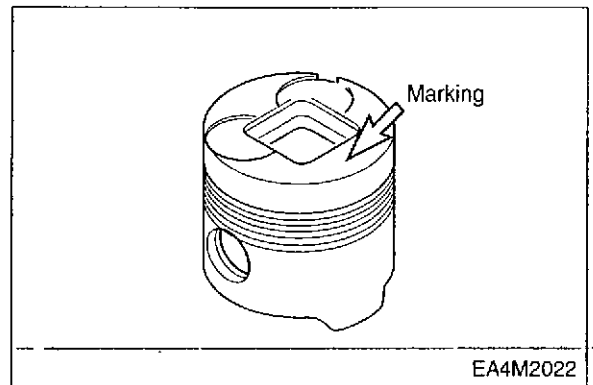

Assembly process of cylinder block, cylinder liner and piston

1. Check the marking number (1 or 2) of cylinder block. (center of upper surface)
2. Then assemble the liner whose first digit of the marking(1A, 1B, 2A, 2B) is just the same with it on the cylinder block.
3. Assemble the piston whose marking is just same with the second digit(A or B) of the assembled cylinder liner's marking.

● Cylinder head assembly

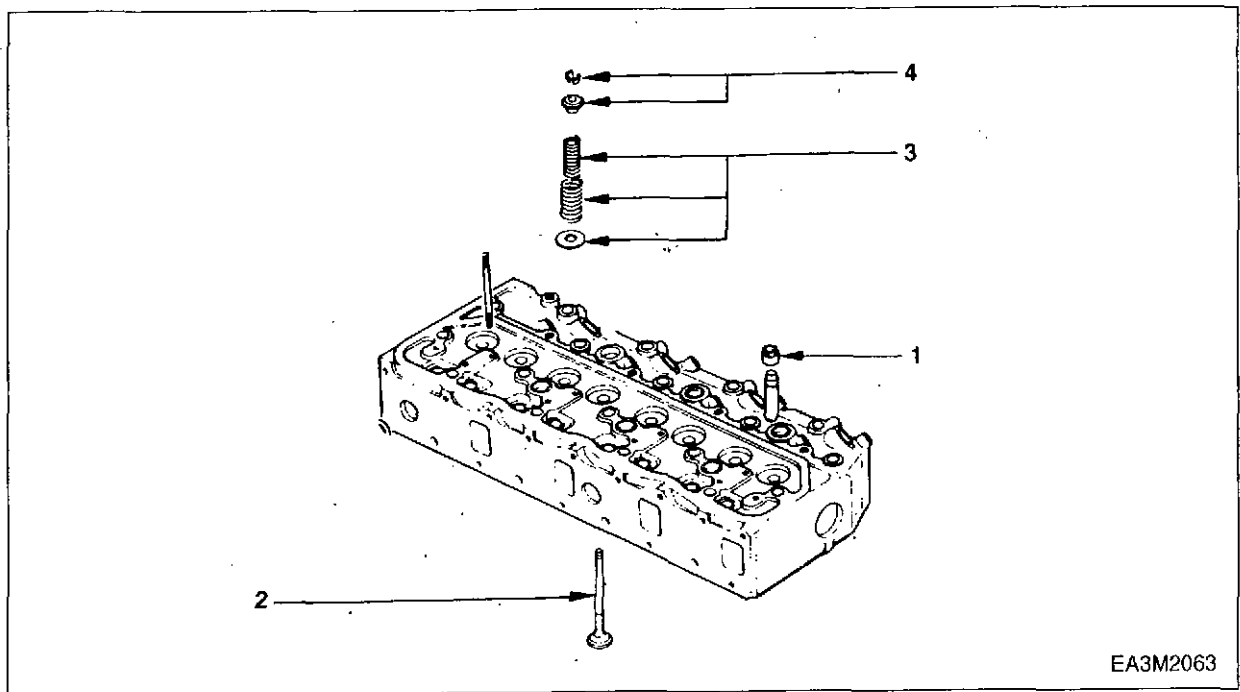

<Reassembly steps>

- ▲ 1. Valve stem oil seal
- ▲ 2. Valve
- ▲ 3. Spring seat and spring
- ▲ 4. Spring retainer and cotter key



! Important operation



1. Valve stem oil seal

Installer

Install valve stem oil seals after lubricating them with clean engine oil.

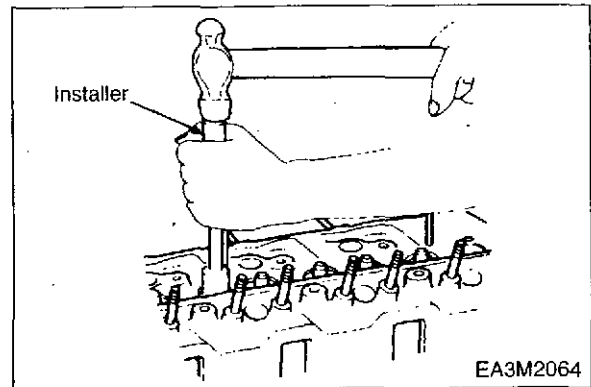

2. Intake and exhaust valves

- 1) Lubricate valve stem with clean engine oil.
- 2) Install the each valves in the intake and exhaust valve seats.

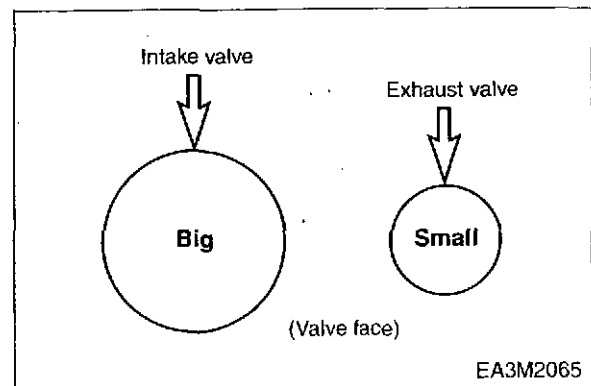



3. Spring seat and spring

Install the valve spring to contact their painted end face downward.

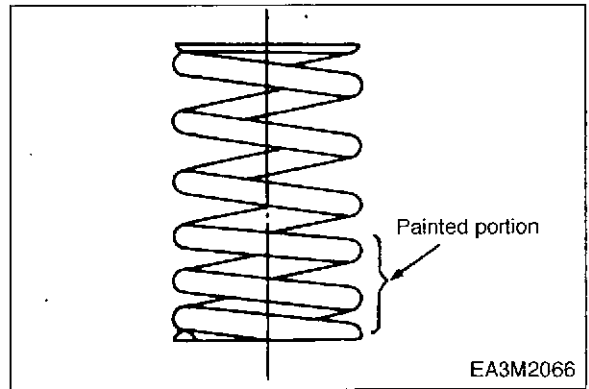

4. Spring retainer and cotter

Installer : Spring compressor

- Using the spring compressor, press the valve spring to each position downward.
- And then install cotter key.
- Set the cotter key by tapping lightly around the head of the cotter with a rubber hammer.

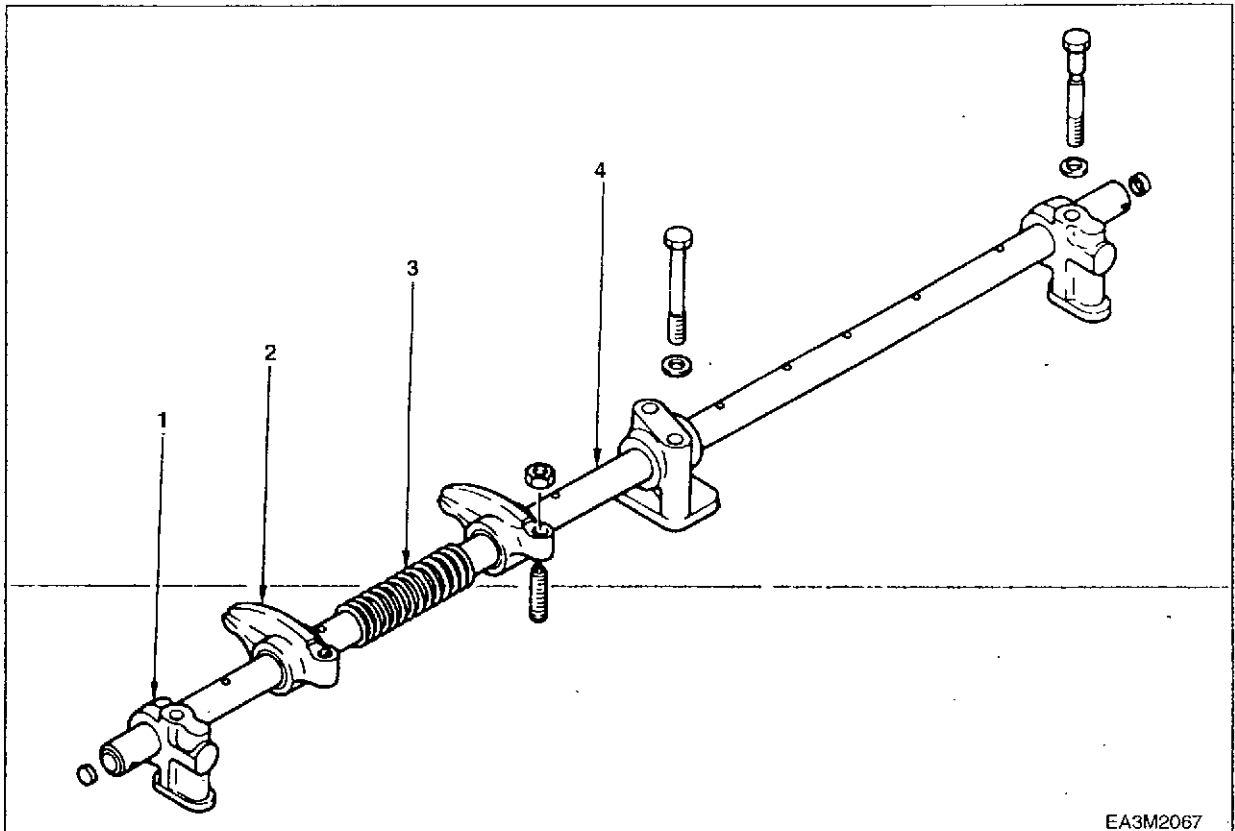
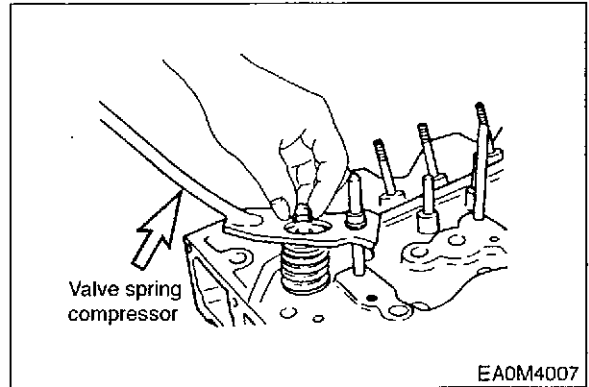

<Reassembly steps>

▲ 1. Bracket

▲ 2. Rocker arm

▲ 3. Spring

▲ 4. Rocker arm shaft

2.4.2. Internal Parts

• Major components

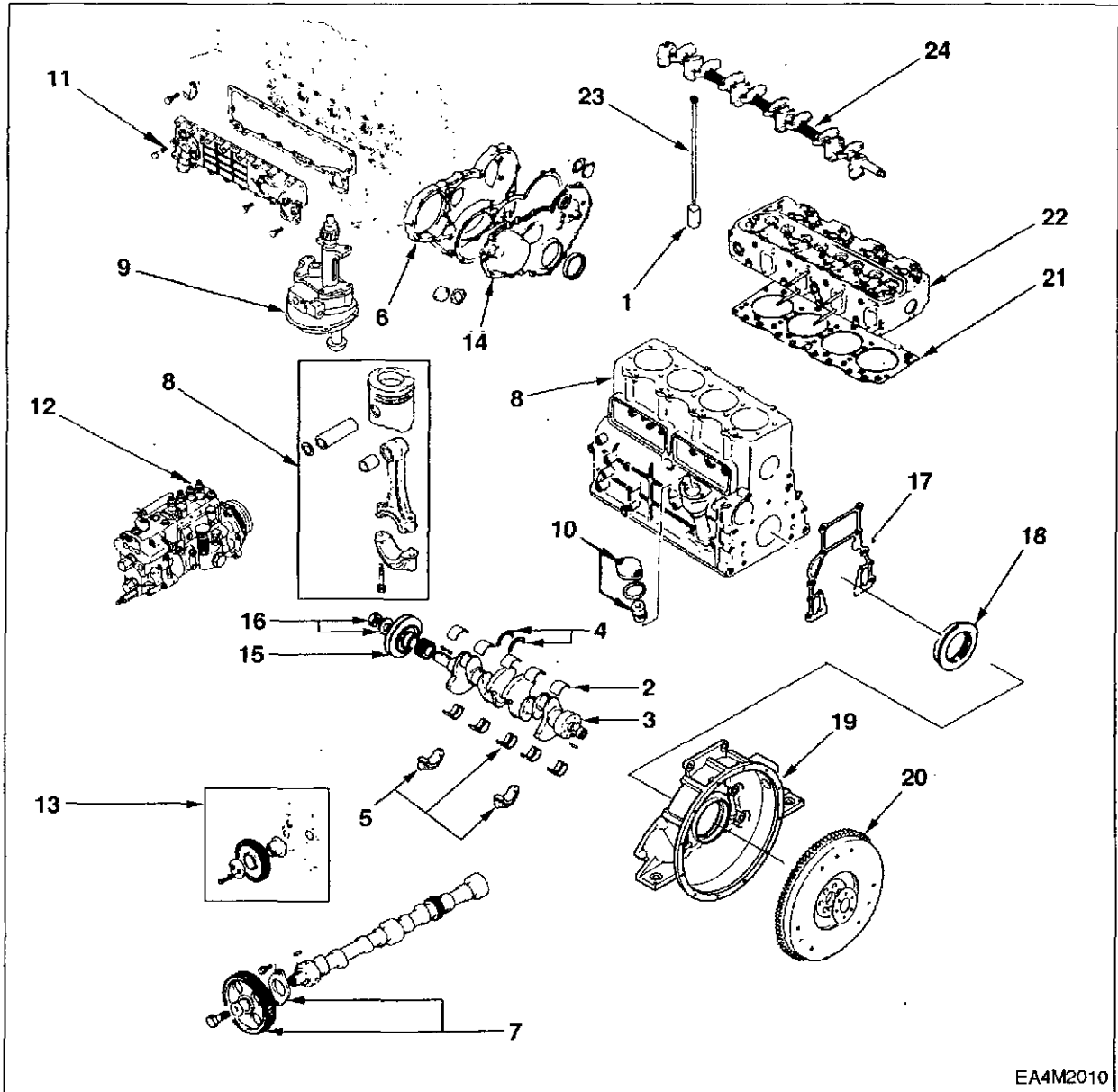

<Reassembly steps>

- | | |
|---|---------------------------------------|
| 1. Tappet | ▲ 13. Idle gear |
| ▲ 2. Crankshaft bearing (upper) | 14. Timing gear case cover |
| ▲ 3. Crankshaft | 15. Crankshaft pulley |
| ▲ 4. Thrust bearing | ▲ 16. Crankshaft front nut and washer |
| ▲ 5. Crankshaft bearing cap and bearing (lower) | 17. Gasket |
| ▲ 6. Timing gear case | ▲ 18. Rear oil seal |
| ▲ 7. Camshaft assembly | ▲ 19. Flywheel housing |
| ▲ 8. Piston and connecting rod assembly | ▲ 20. Flywheel |
| ▲ 9. Oil pump assembly | ▲ 21. Cylinder head gasket |
| 10. Oil pump cover | ▲ 22. Cylinder head assembly |
| ▲ 11. Oil cooler | 23. Push rod |
| ▲ 12. Injection pump assembly | ▲ 24. Rocker arm shaft assembly |



Important operation



2. Crankshaft bearing (upper)

5. Crankshaft bearing (lower)



The center lower half bearing has no oil groove and oil hole, but the others have oil groove and oil hole.

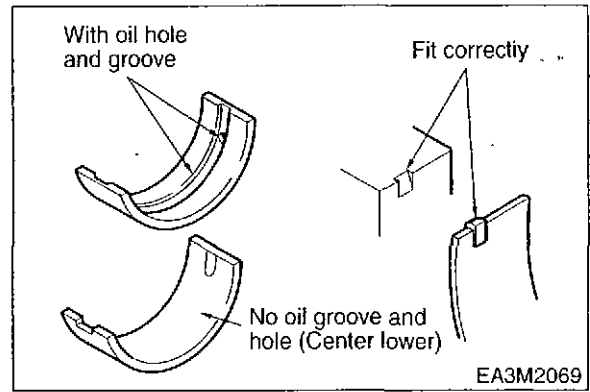

3. Crankshaft

Install the crankshaft so that crank gear assembled part must be placed towards the front of the engine.

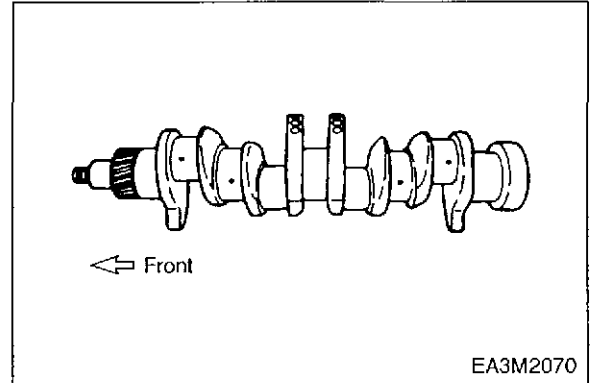

4. Thrust bearing

Thrust bearing should be installed so that their oil grooves are faced to the sliding face of crankshaft.

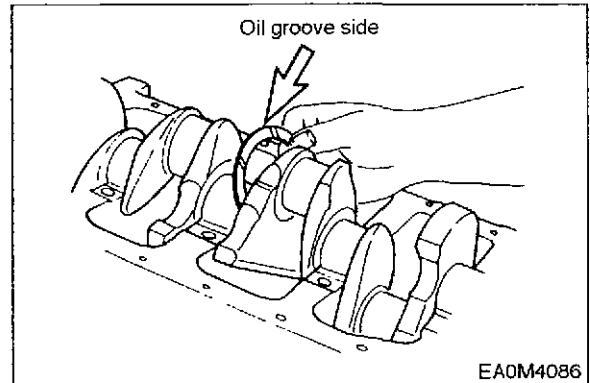

5. Crankshaft bearing cap and bearing (lower)

- Lubricate the bearing cap bolts with engine oil.
- Each bearing cap has a position number that is punched onto the arrow mark.
- The arrow mark should be pointed to the front of engine.

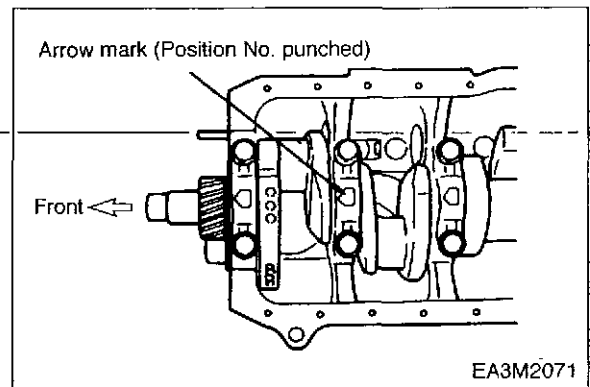



Tighten the bearing cap bolts to the specified torque a little at a time in the numerical order shown in the figure.

Torque	24 kg•m
--------	---------

Check whether the crankshaft turns smoothly by rotating it manually.

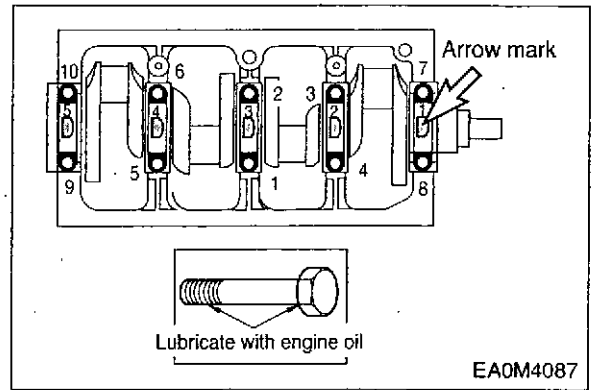

6. Timing gear case

Torque	2.6 kg•m
--------	----------

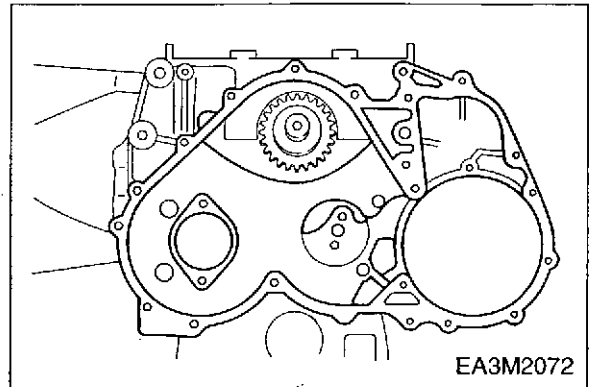

7. Camshaft

Tighten the thrust plate bolts through the camshaft gear hole.

- Torque

Thrust plate bolt	2.1 kg•m
Camshaft gear bolt	16 kg•m

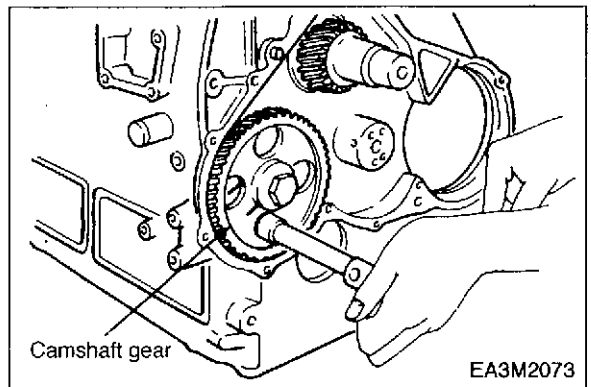

8. Piston and connecting rod assembly

Set the piston ring gaps as shown in the figure.

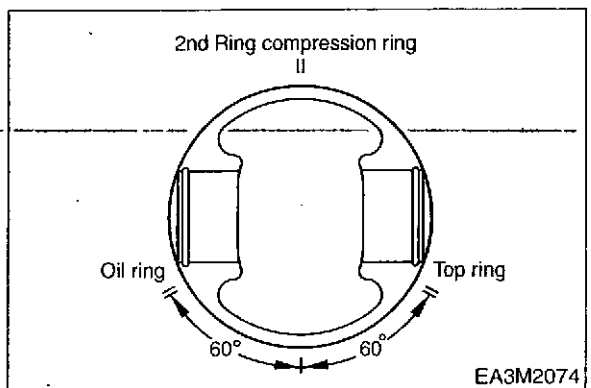



Set the piston front mark towards the front of the engine. After rotating the crankshaft until the crank pin reaches its highest point, and then push the piston using a grip until it contacts with the crank pin.

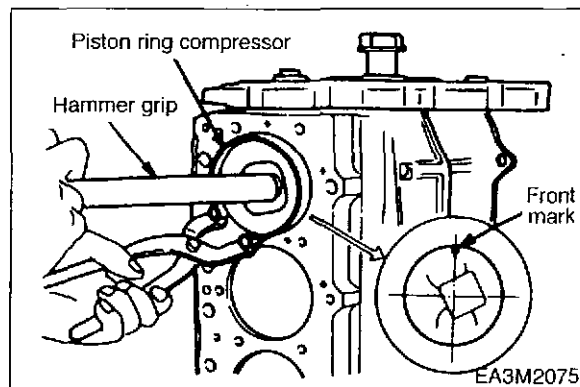

Set the cylinder number marked on the cap and the connecting-rod.

The marks must be faced on the exhaust manifold.

● **Connecting rod cap bolt**

Bolt head	
Torque	9.75±0.25 kg.m

- Lubricate the connecting-rod cap bolt threads surface.

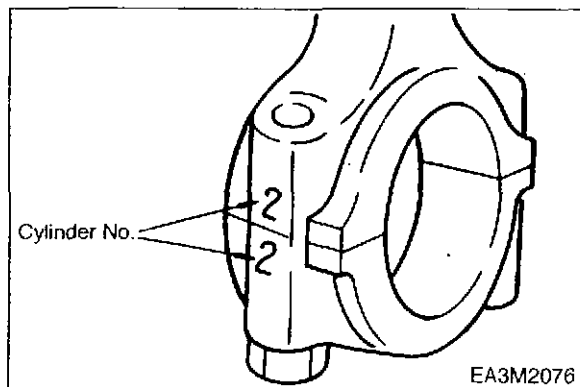

9. Oil pump assembly

Install the oil pump after filling it with engine oil.

Grade	CD or CE
-------	----------

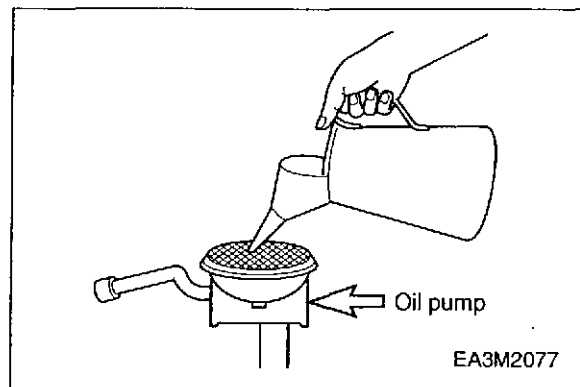

10. Oil pump fixing bolts

Torque	3.8 kg.m
--------	----------

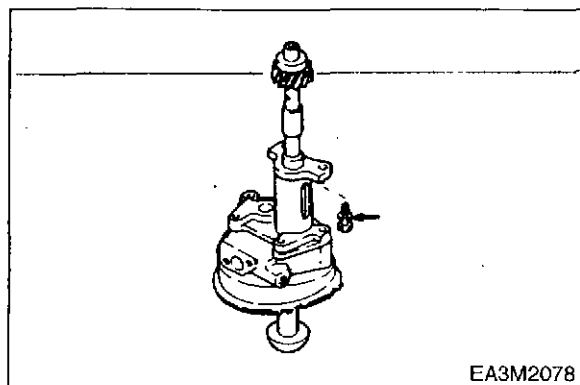



11. Oil cooler

Tighten the cooler bolts to the specified torque. Start from the middle and work out to the out side.

Torque	1.8 kg.m
--------	----------

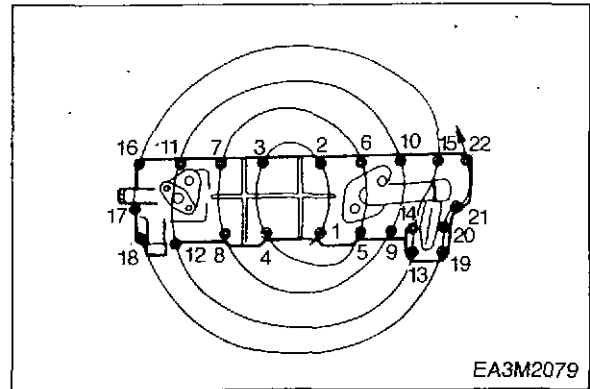

12. Injection pump assembly

Torque	2.6 kg.m
--------	----------

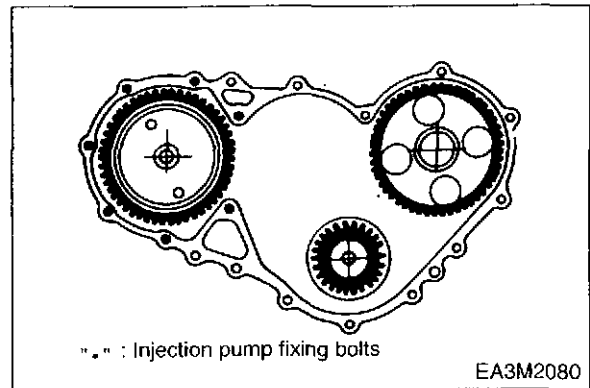

Check whether the punched line of the injection pump body is aligned to the pump bracket line.

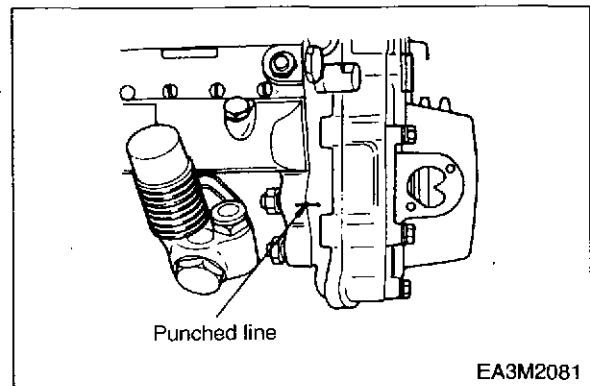

13. Idle gear

Use the thrust collar fixed bolt as a guide to install the idle gear shaft. The oil port should be faced on the camshaft.

Torque	2.6 kg.m
--------	----------

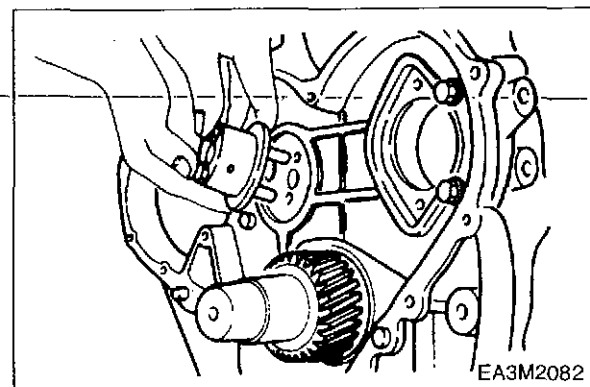



Set the timing marks ("A", "B", "C") on the gear as shown in the figure.



Torque	5.3 kg.m
--------	----------

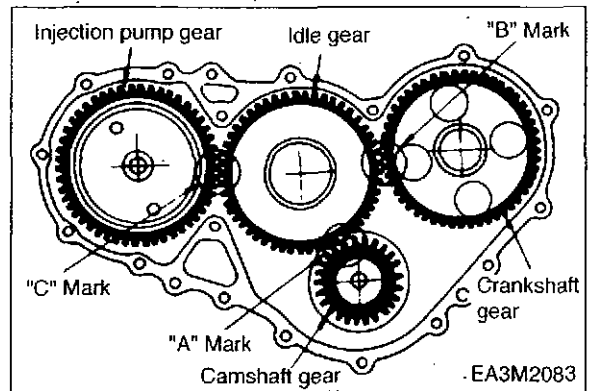

16. Crankshaft front nut

Wrench : 41 mm



Torque	44.0 kg.m
--------	-----------

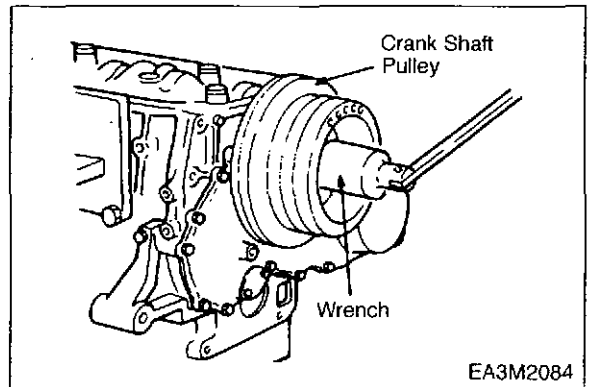

18. Rear oil seal

19. Flywheel housing

Apply a gasket.

Fixing bolts torque	14.0 kg.m
---------------------	-----------

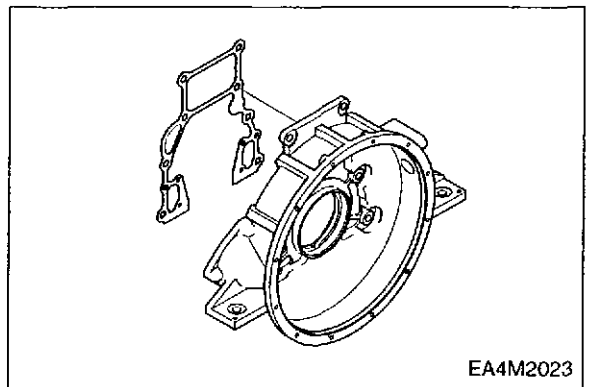

20. Flywheel

Torque	16.0 kg.m
--------	-----------

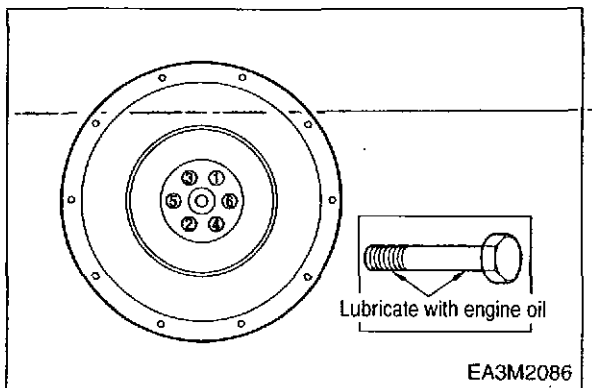



21. Cylinder head gasket

The gasket "TOP" mark should be faced up and "FRONT" mark is towards the front of the engine:

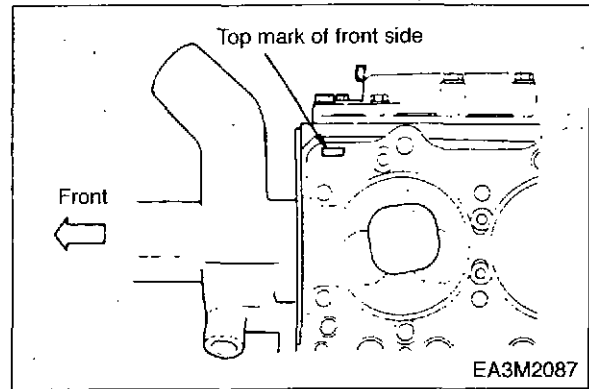

EA3M2087



22. Cylinder head assembly

Lubricate the head bolts with engine oil and tighten them in the following two steps. there are two kinds of head bolt in length. The shorter ones are used on injection pump side. Tighten the head bolts in the numerical order as shown in the figure.

DB33	1st step	2nd step
	7.0 kg.m	11.5 kg.m

P034TI	1st step	2nd step	3rd step
	4.0 kg.m	+ 90°	+ 60°(+ 30°)

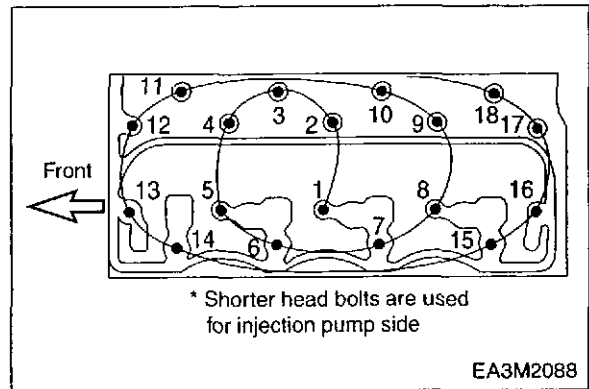

EA3M2088



24. Rocker arm shaft assembly

Tighten the rocker arm bracket bolts a little at a time as specified torque according to the numerical order shown in the figure.

Torque	3.1 kg.m
--------	----------

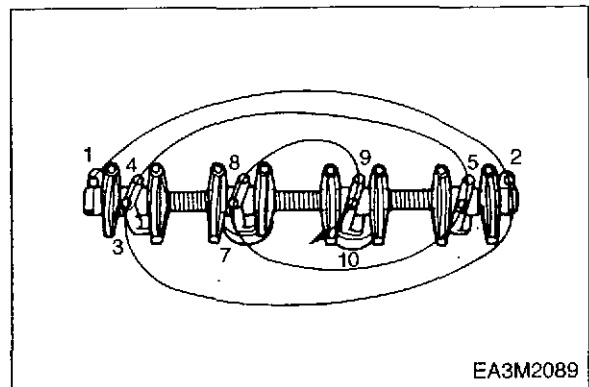

EA3M2089



Adjust the valve clearance.

Intake	0.4 mm
Exhaust	0.4 mm

- Refer to MAINTENANCE for the valve clearance adjustment procedure. (1.6.2)

EA3M2090

2.4.3. External Parts(P034Ti)

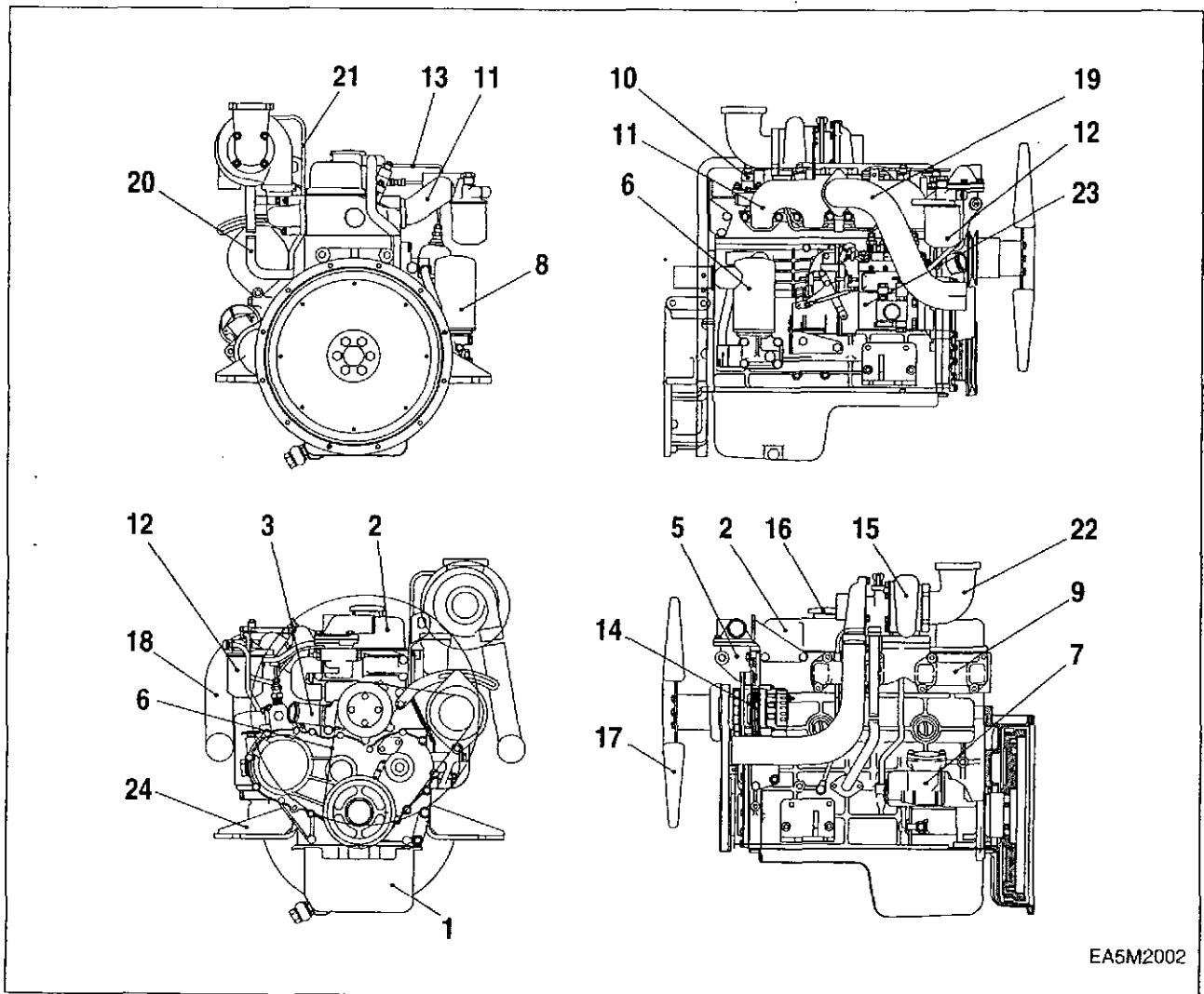

EA5M2002

<Reassembly steps>

- ▲ 1. Oil pan assembly
- ▲ 2. Cylinder head cover
- ▲ 3. Water pump assembly
- ▲ 4. Fuel return pipe
- ▲ 5. Thermostat housing assembly
- ▲ Push rod chamber cover
- ▲ 6. Cooling fan belt
- ▲ 7. Starter motor assembly
- ▲ 8. Oil filter assembly
- ▲ Exhaust manifold gasket
- ▲ 9. Exhaust manifold assembly
- ▲ Glow plug
- ▲ 10. Injection nozzle
- ▲ Intake manifold gasket
- ▲ 11. Intake manifold assembly
- ▲ Fuel injection pipe
- ▲ 12. Fuel filter assembly
- ▲ 13. Fuel pipe
- ▲ 14. Alternator assembly
- ▲ Gasket, turbo-charger
- ▲ 15. Turbo-charger assembly
- ▲ 16. Oil filler cap
- ▲ 17. Cooling fan
- ▲ 18. Air pipe assembly(to intercooler)
- ▲ 19. Air pipe assembly(from intercooler)
- ▲ 20. Oil return pipe
- ▲ 21. Oil delivery pipe
- ▲ 22. Exhaust elbow
- ▲ 23. Injection pump assembly
- ▲ 24. Mounting bracket



Important operation



1. Oil pan assembly

Apply the gasket to the cylinder block and oil pan.

Install oil pan gasket and oil pan.

Bolt torque	1.6 kg.m
-------------	----------

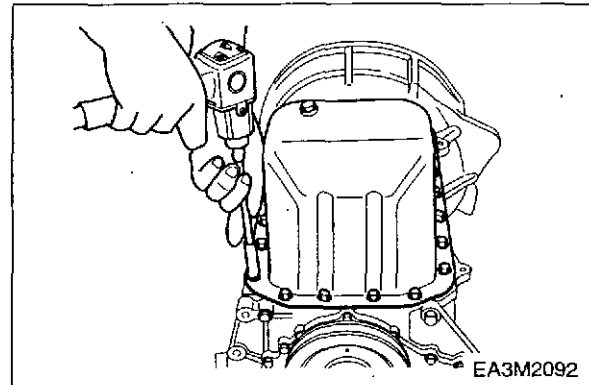

2. Cylinder head cover

Bolt torque	2.1 kg.m
-------------	----------

Tighten the bolts as shown in the figure.

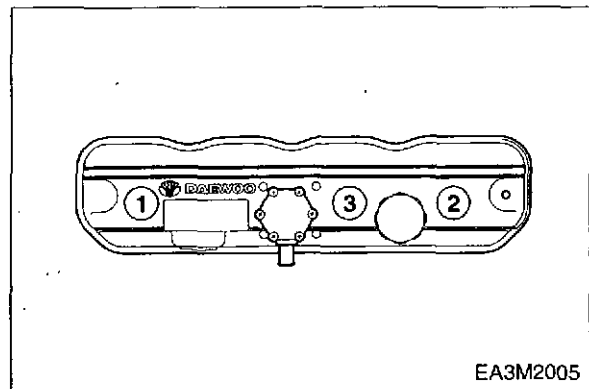

3. Water pump assembly

Apply the water pump gasket before installing the water pump.

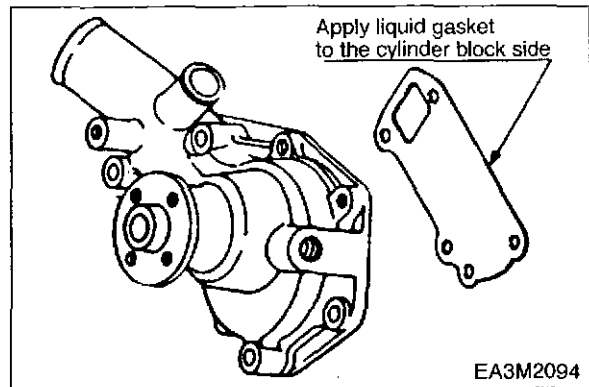

5. Thermostat housing assembly

Bolt torque	5.3 kg.m
-------------	----------

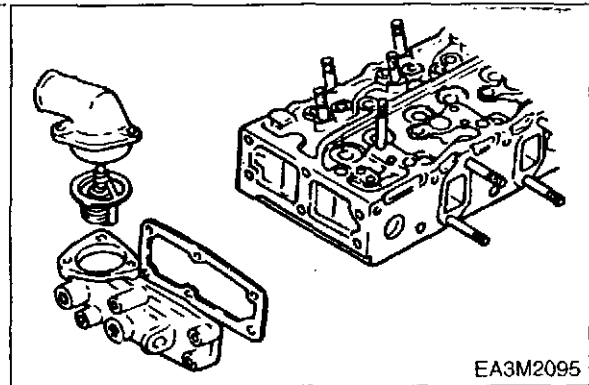



• Push rod chamber cover

	Aluminium	Steel
Torque	2.1 kg.m	2.6 kg.m

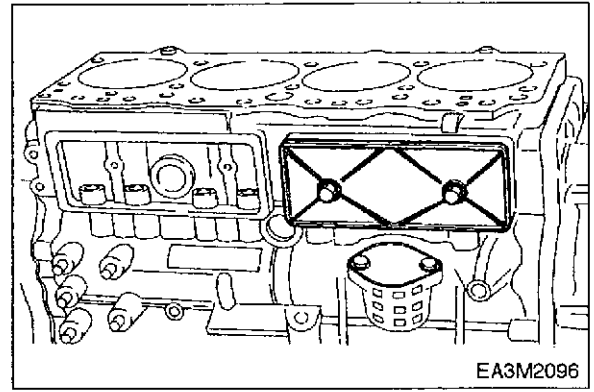

EA3M2096



6. Cooling fan belt

Adjust the cooling fan belt tension

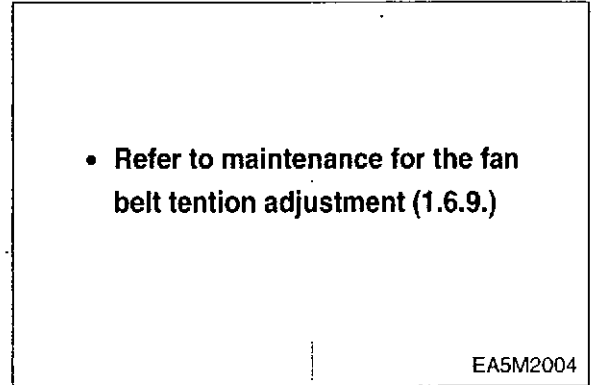

- Refer to maintenance for the fan belt tension adjustment (1.6.9.)

EA5M2004



7. Starting motor assembly

Torque	8.6 kg.m
--------	----------

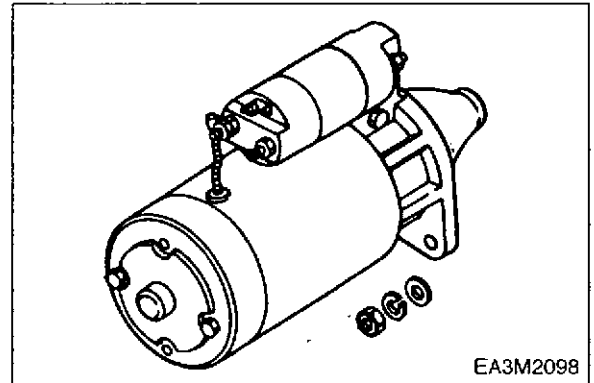

EA3M2098



8. Oil filter assembly

'A' bolt torque	5.3 kg.m
-----------------	----------

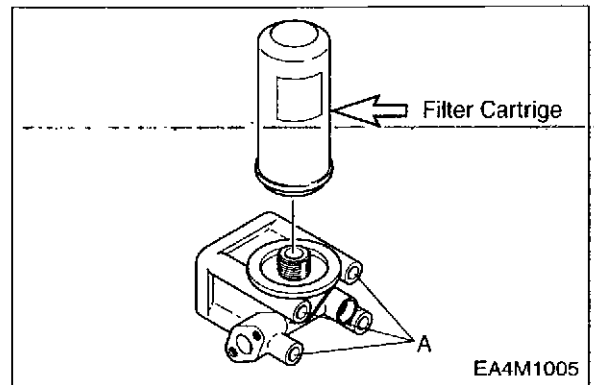

EA4M1005



• **Exhaust manifold gasket**

Carefully install the gasket so that the "TOP" mark side is faced on outside and upwards as figure.

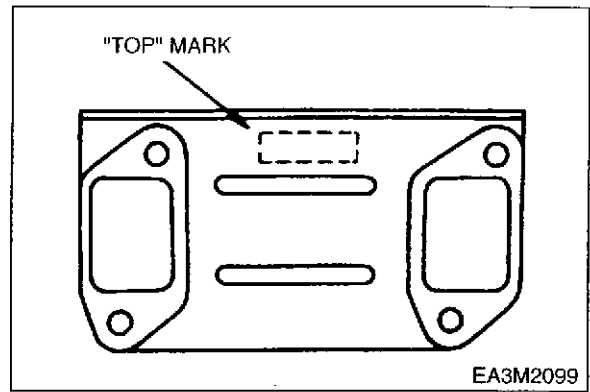

9. Exhaust manifold assembly

Tighten the exhaust manifold and gasket fixing bolts in numerical order as shown in the figure.

Torque	2.6 kg.m
--------	----------

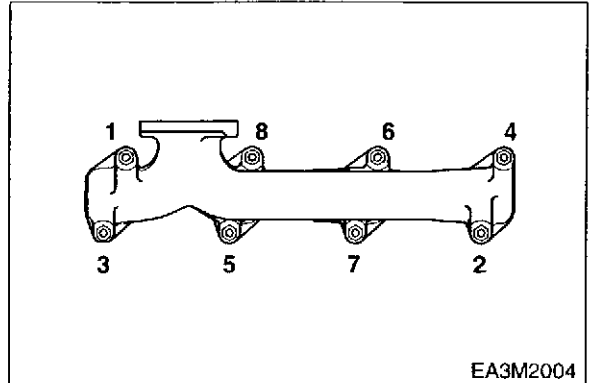

• **Glow plug**

Torque	5.3 kg.m
--------	----------



10. Injection nozzle

Adjust the injection nozzle opening pressure with the adjusting screw using a nozzle tester.

Opening pressure	220 kg/cm ²
------------------	------------------------

• Refer to "5. the fuel system" of maintenance for the injection nozzle opening pressure adjustment.

EA4M2012



Replace the nozzle seal ring and o-ring to new one.

Tighten the injection pipe sleeve nut and flange nut.

Torque	2.6 kg.m
--------	----------

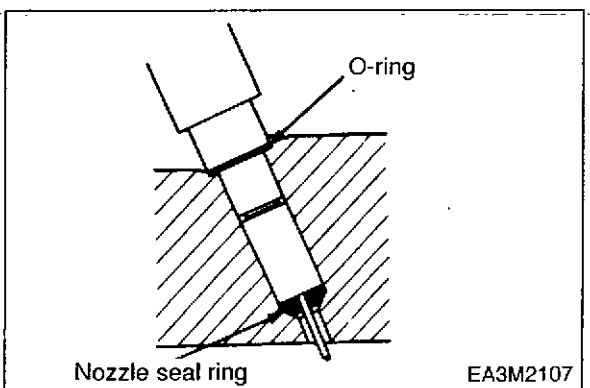



● Intake manifold gasket

Install gasket so that the side with the projection is faced on rearward and upward.

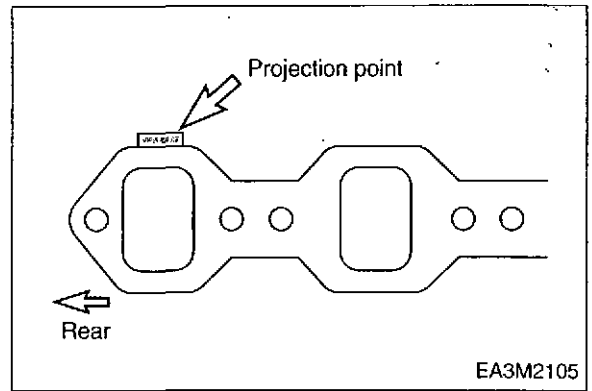

● Fuel injection pipe

Torque	3.0 kg.m
--------	----------



Delivery valve holder must be tightened as specified torque.

It may cause the malfunction of control rack, holder clip and pipe, if the torque is excessive.

Delivery valve holder torque	4.0~4.5 kg.m
------------------------------	--------------

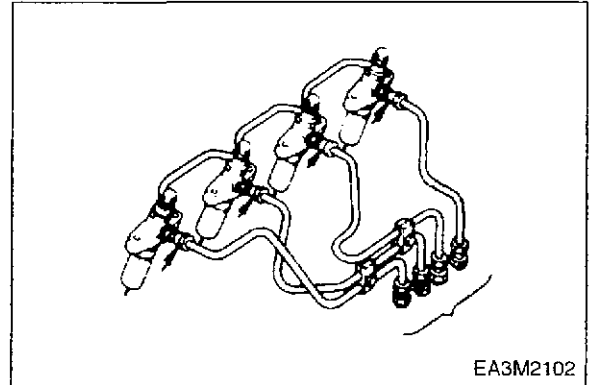

13. Fuel pipe

When installing fuel pipes, avoid interchanging check valve and joint bolts.

Torque	1.7~1.8 kg.m
--------	--------------

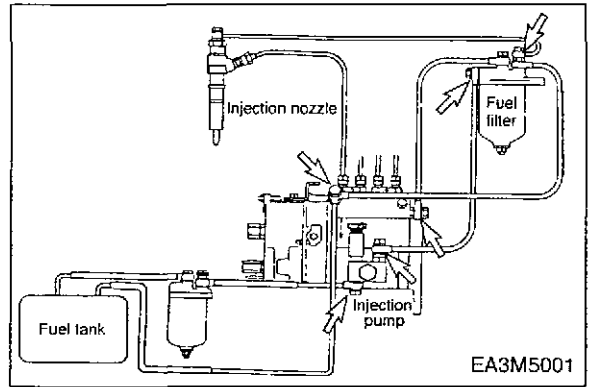



• Turbocharger mounting flange gasket



Carefully posit the gasket with the edged side facing up.

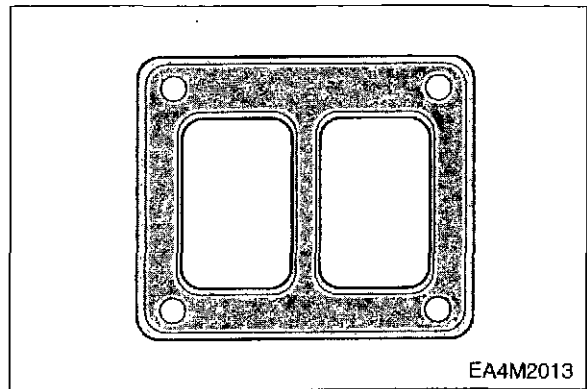

15. Turbocharger assembly

Tighten in the turbocharger mounting nut. Completely tighten the nut after it is assemble oil pipe.

Torque	$5.3 \pm 1 \text{ kg.m}$
--------	--------------------------

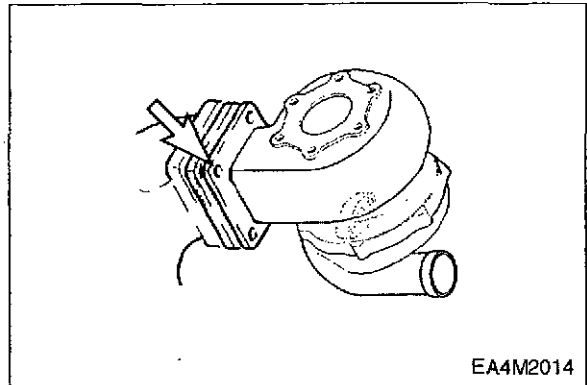

20. Oil return pipe



- Disassemble the exhaust manifold spacer which it is just bottom of the turbocharger part so as to be easily set up oil drain pipe.



- Tighten the flange nut as it is the specified torque after it is assemble oil return pipe.

Oil return pipe torque	$2.6 \pm 0.7 \text{ kg.m}$
------------------------	----------------------------

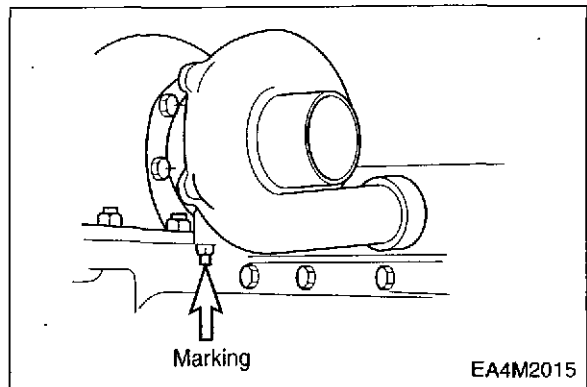

21. Oil delivery pipe



- Pre-lubricate turbocharger with CD grade oil through the oil port shown by the arrow in the figure.



- Tighten flange bolt as it is a specified torque after oil delivery pipe is installed on the flange.

Oil delivery pipe torque	$2.6 \pm 0.5 \text{ kg.m}$
--------------------------	----------------------------

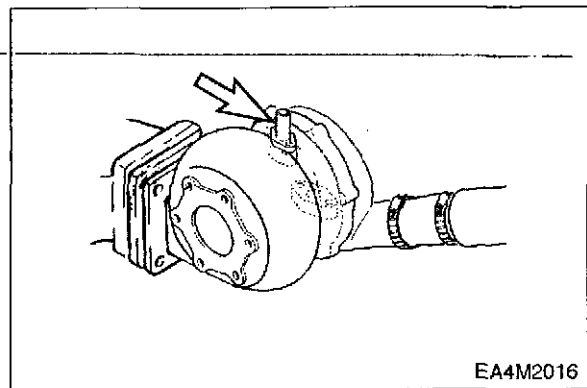

2.4.4. Inspection of Rotor Shaft



• Rotor Shaft Axial Play Measurement

- Assemble dial indicator at the turbine housing as the shown in figure.
- Use dial indicator to measure the rotor shaft axial play with the moving shaft push and pull. Read the total indicator reading (TIR).

Item	Limit
Rotor shaft axial play (TIR)	0.11 mm

- Replace the shaft if the measured value is in excessive of specified limit.

• Rotor Shaft Radial Play Measurement

- Turn over the turbo charger with the turbine exhaust inlet flange facing up.
- Install a dial indicator to measure the rotor shaft radial play. Use the dial indicator to measure the play.

Read the TIR.

RHB6A	Limit
Rotor shaft radial play (TIR)	0.19 mm

RHC7, RHB7	Limit
Rotor shaft radial play (TIR)	0.215 mm

- Replace the shaft if the measured value is in excessive of specified limit.

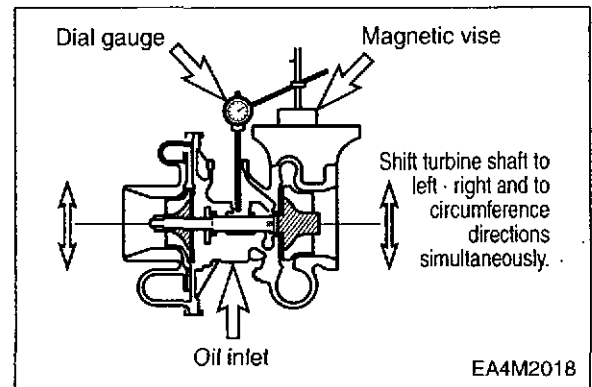
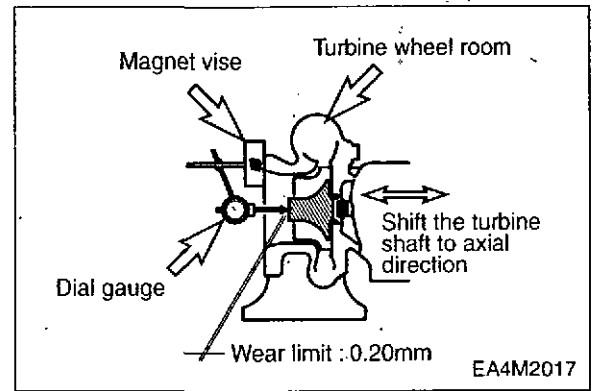

3. Lubricating System

3.1. General Description

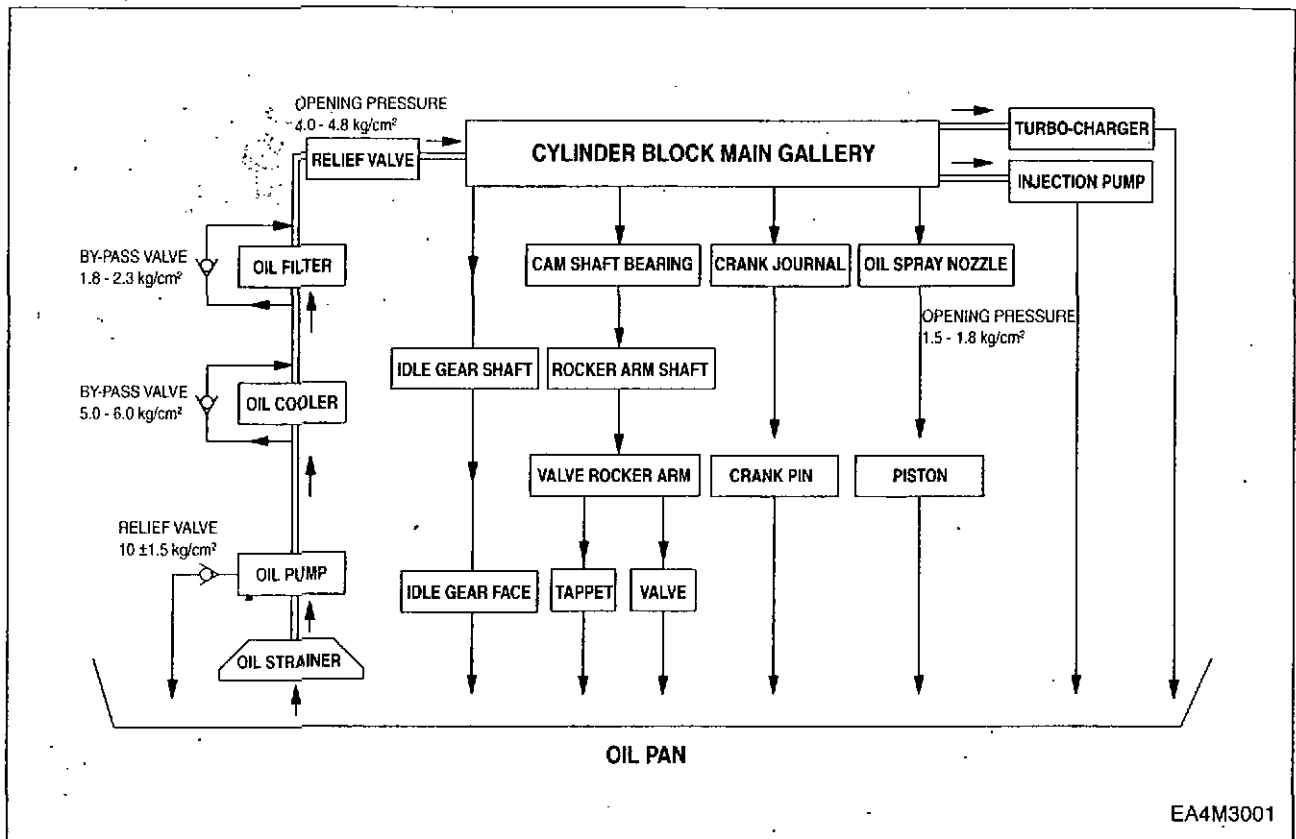

Notes : DB33 model does not have a turbo-charger. (Turbo-charger is only for P034TI.)

3.2. Oil Pump



Disassemble

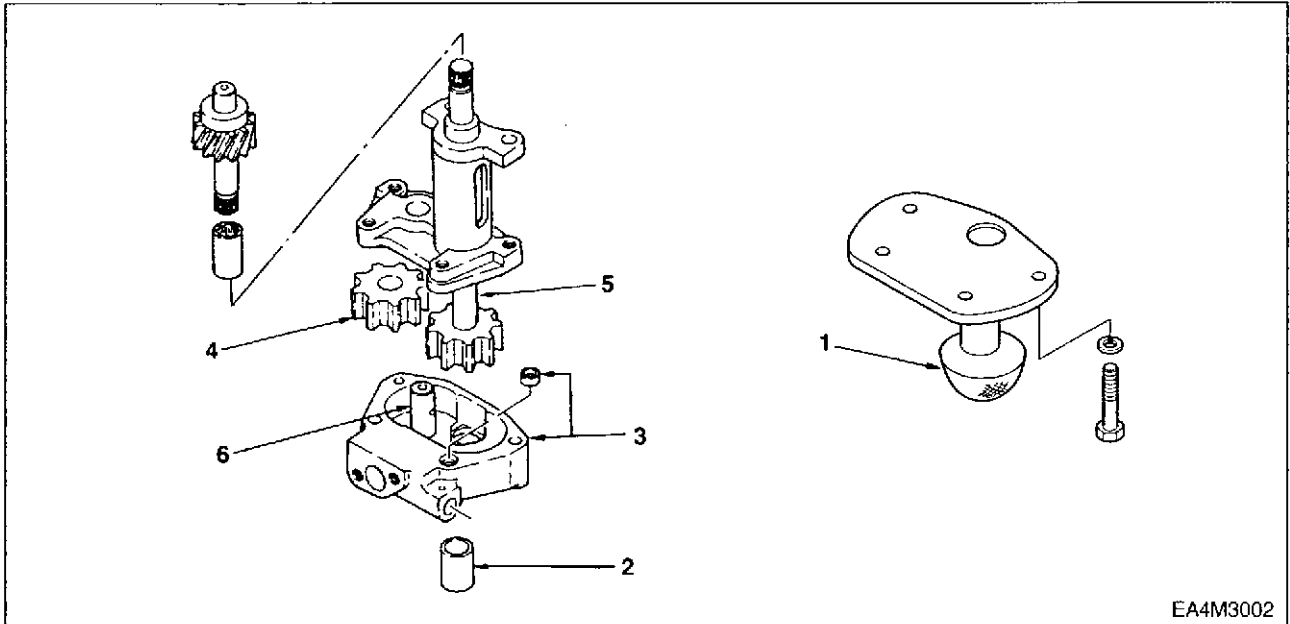

EA4M3002

<Disassembly steps>

- ▲ 1. Strainer
- 2. Suction pipe
- 3. Cover and dowel
- 4. Drive gear
- 5. Drive shaft and gear
- 6. Drive gear shaft



Inspection and repair

Make the necessary adjustments, repairs and part replacements if excessive wear or damage is found through inspection.

Visually inspect the disassembled parts for excessive wear and damage.

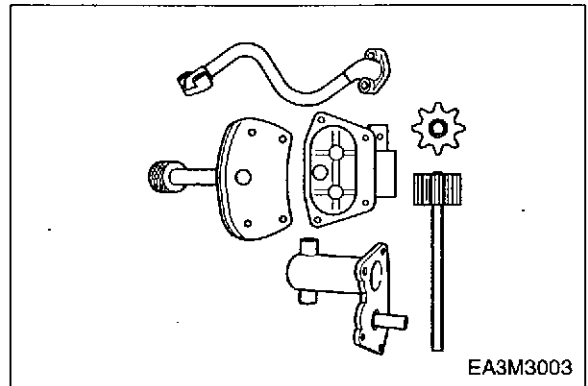

EA3M3003



Oil pump cover and oil pump drive gear clearance

Limit	0.18.mm
-------	---------

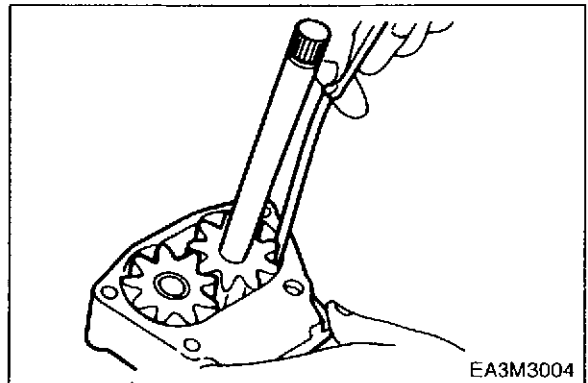

EA3M3004



Cover and drive gear clearance

Limit	0.12.mm
-------	---------

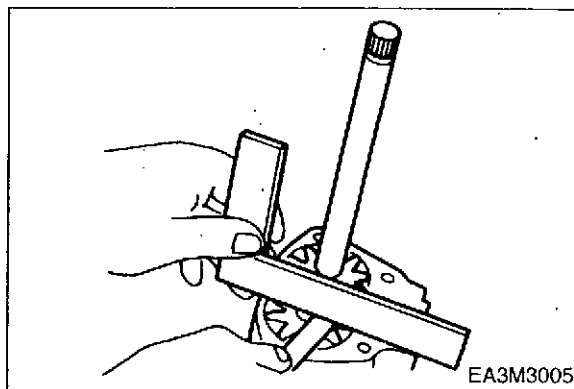

Drive gear shaft diameter

Standard	Limit
16.0 mm	15.9.mm

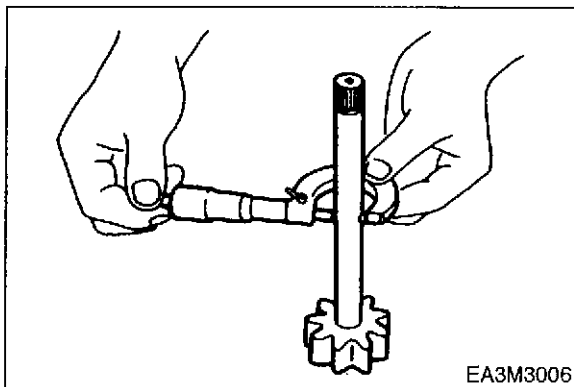

Reassembly

To assemble, follow the disassembly procedures in reverse order.



Important operation



1. Strainer

Torque	1.0~1.8 kg.m
--------	--------------

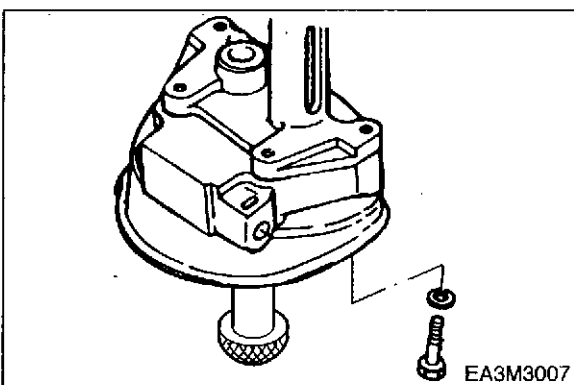

3.3. Oil Filter



Disassemble

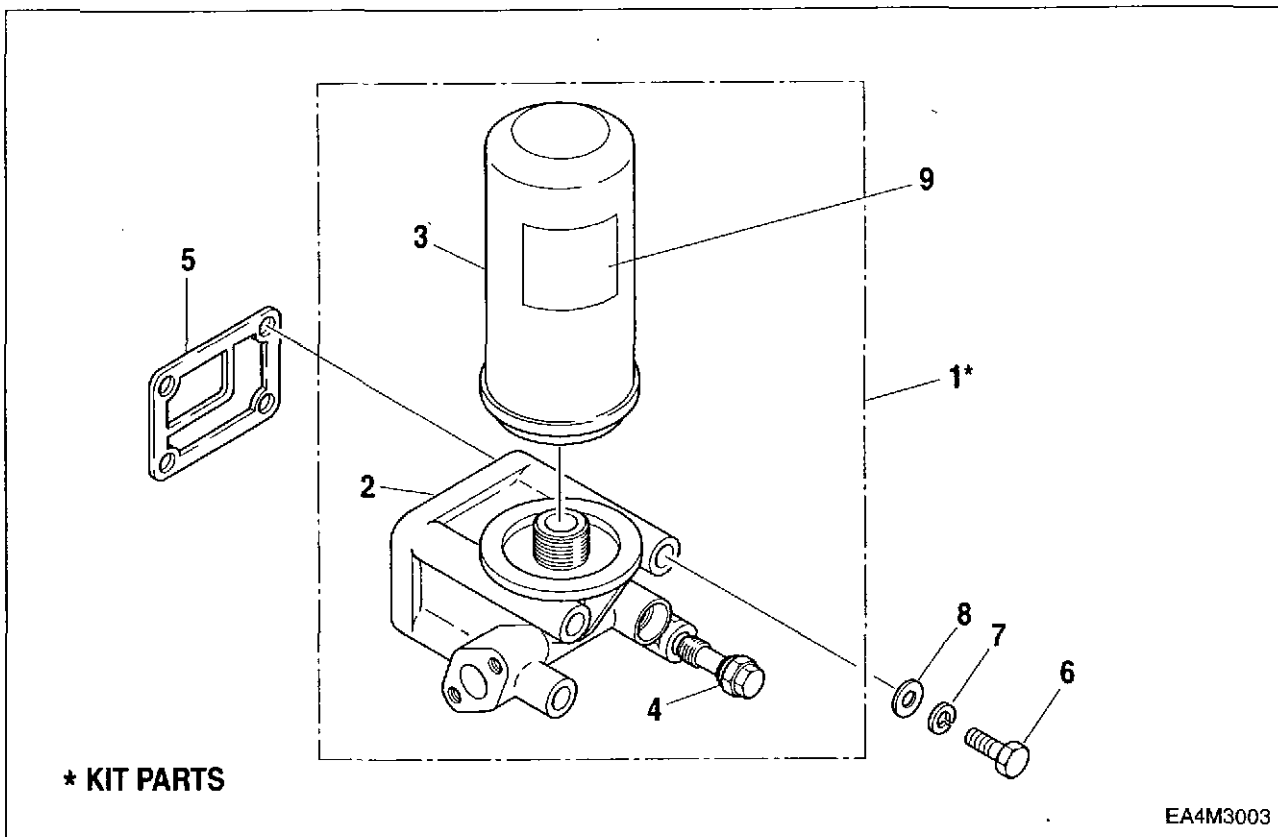

<Disassembly steps>

- ★ 1. Oil filter assembly
- ▲ 4. Relief valve assembly
- 7. Spring washer
- 2. Head-oil filter
- 5. Gasket
- 8. Plain washer
- 3. Element-oil filter
- 6. Bolt
- 9. Plate-caution



Inspection and repair

Make the necessary adjustments, repairs and part replacements if excessive wear or damage is found through inspection.



Reassembly

To assemble, follow the disassembly procedures in reverse order.



Important operation



4. Relief valve assembly

Torque	2.5 kg.m
--------	----------

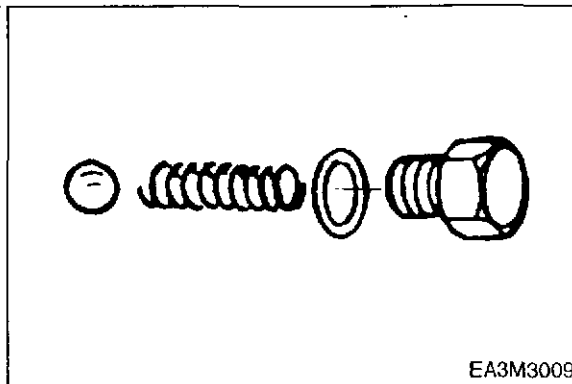

3.4. Oil Cooler



Disassemble

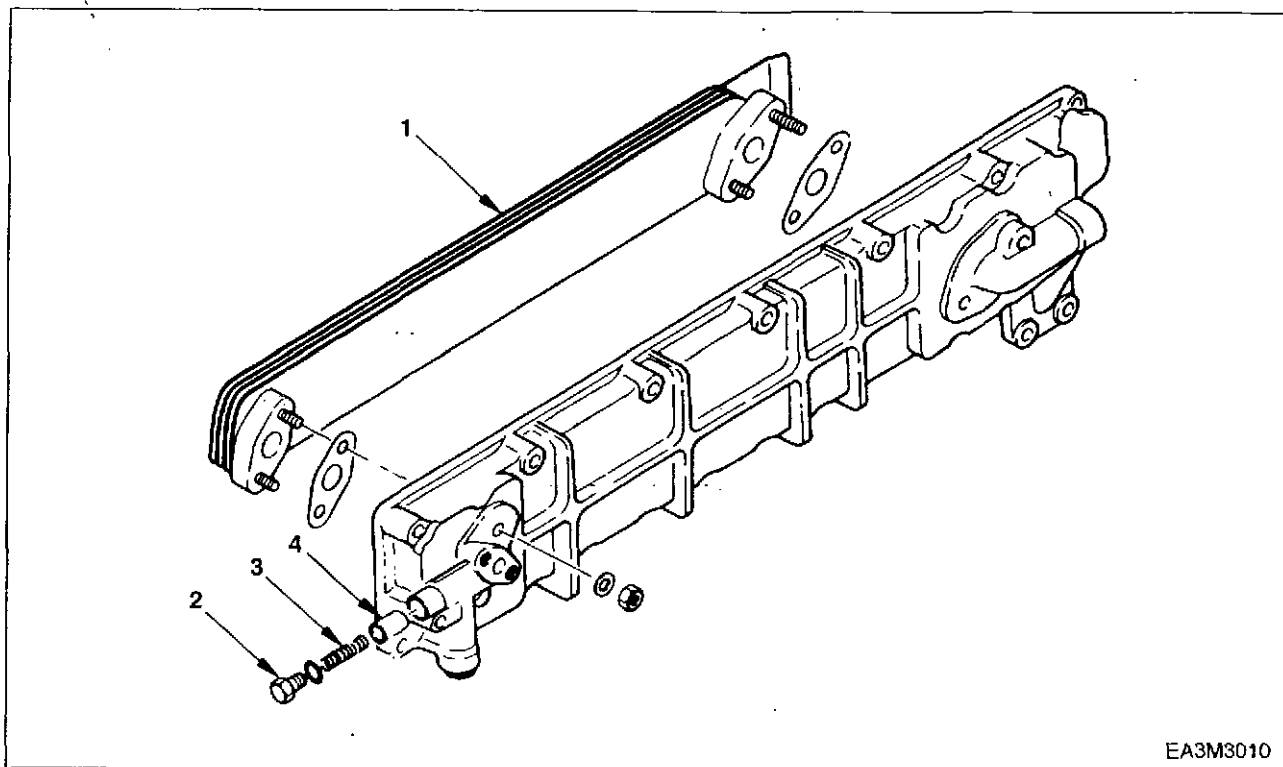

<Disassembly steps>

- | | |
|------------|------------------|
| 1. Element | 3. Spring |
| 2. Bolt | 4. By-pass valve |



Inspection and repair

Make the necessary adjustments, repairs and part replacements if excessive wear or damage is found through inspection.



Reassembly

To assemble, follow the disassembly procedures in reverse order.



Important operation



1. Element

Torque	2.6 kg.m
--------	----------

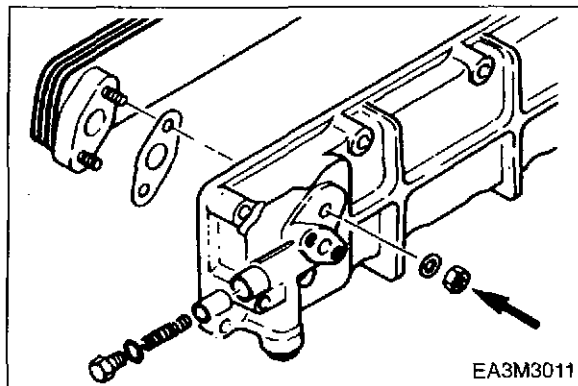

4. Cooling System

4.1. General Description

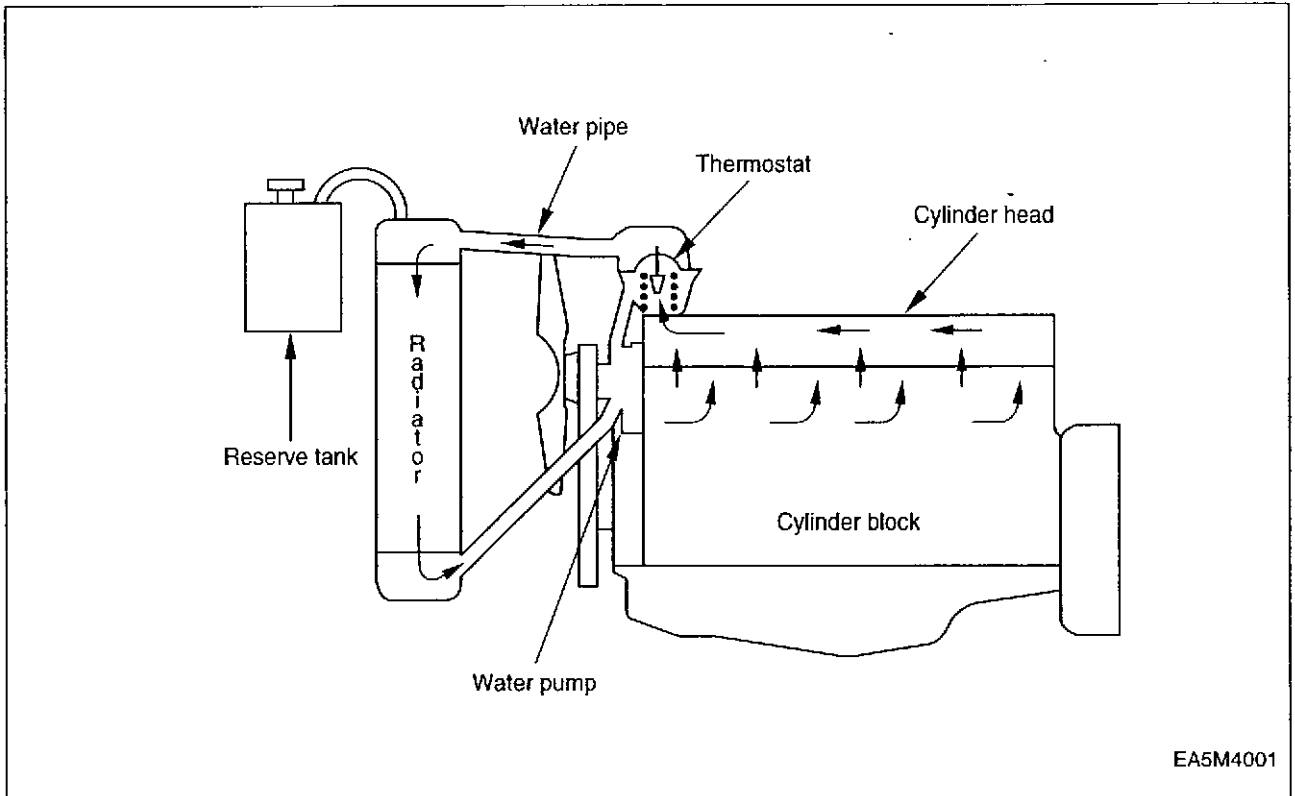

4.2. Water Pump



Disassemble

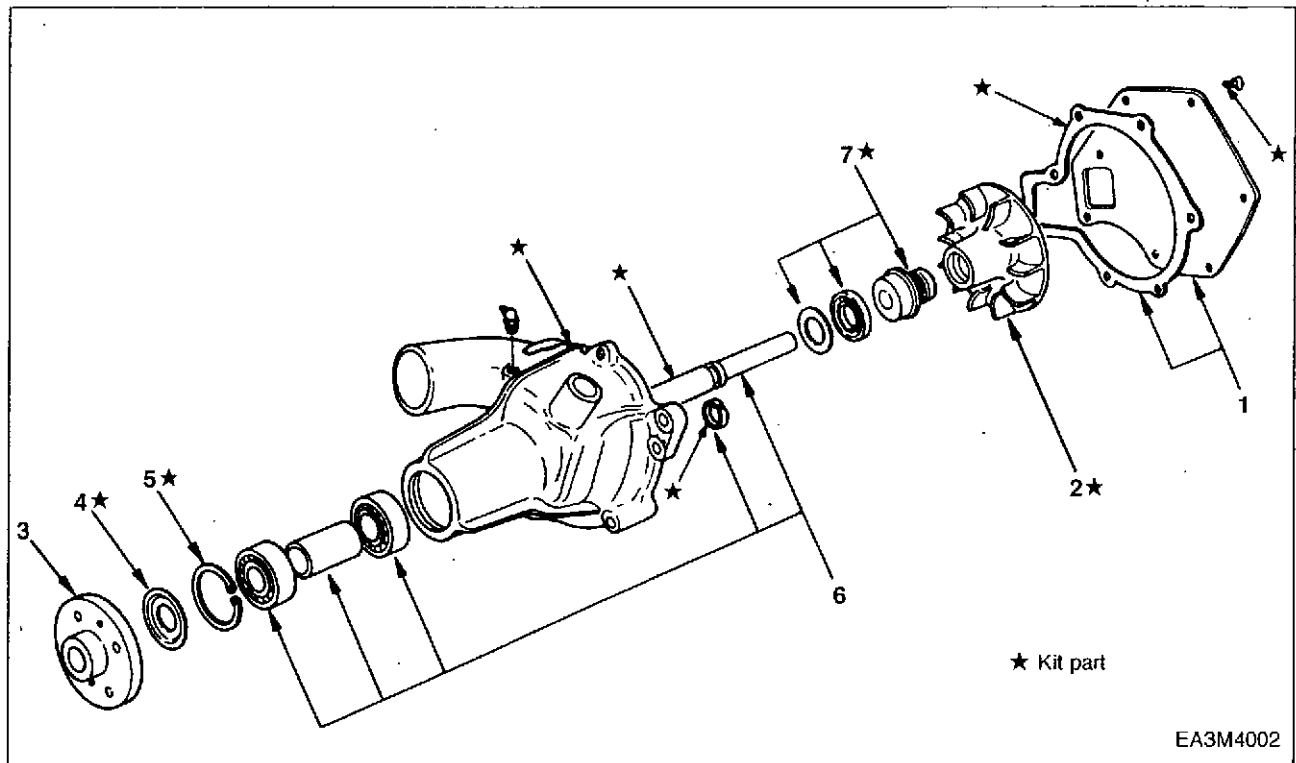

<Disassembly steps>

- | | |
|--------------------|---------------------------------|
| 1. Cover | ▲ 5. Snap ring |
| ▲ 2. Impeller | ▲ 6. Shaft bearing and spacer |
| ▲ 3. Pulley center | ▲ 7. Seal unit, washer and seal |
| 4. Dust thrower | |



Important operation



2. Impeller

Removal : Remover

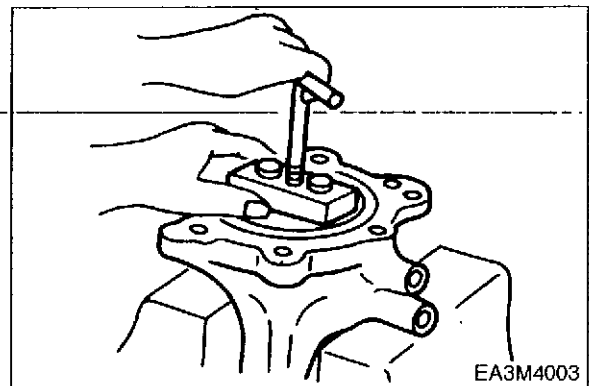



3. Pulley center

Remove the pulley center using a bench press and a bar.

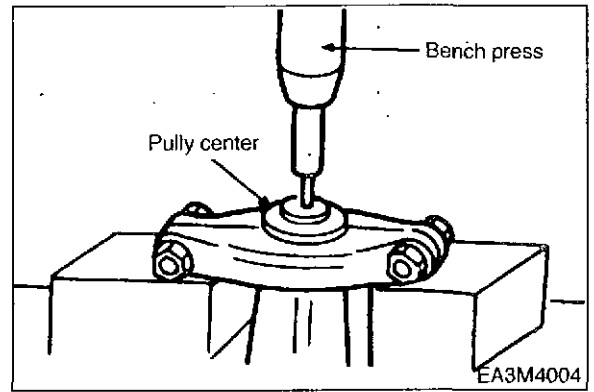

5. Snap ring

Remove the snap ring using a pair of snap ring pliers.

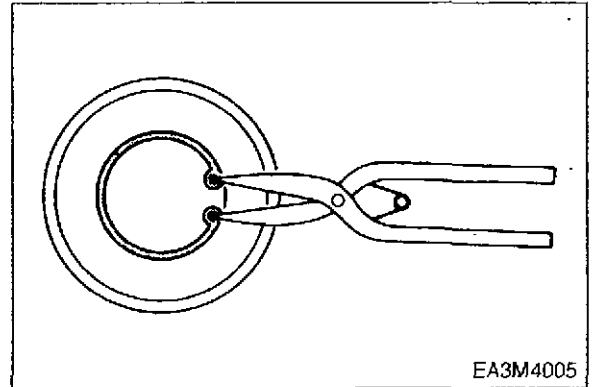

6. Shaft, bearing and spacer

Remove the shaft and bearings using a bench press and suitable remover.

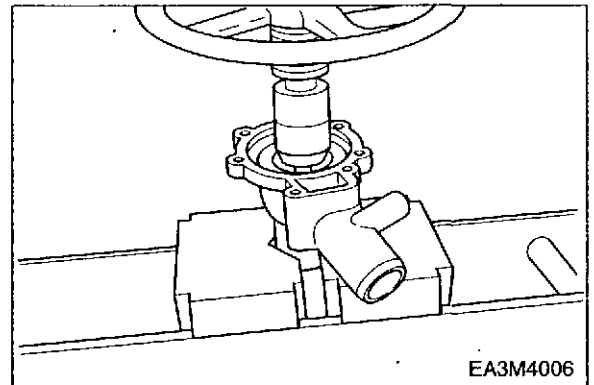

7. Seal unit, washer and seal

Remove the seal unit using a bench press and suitable remover.

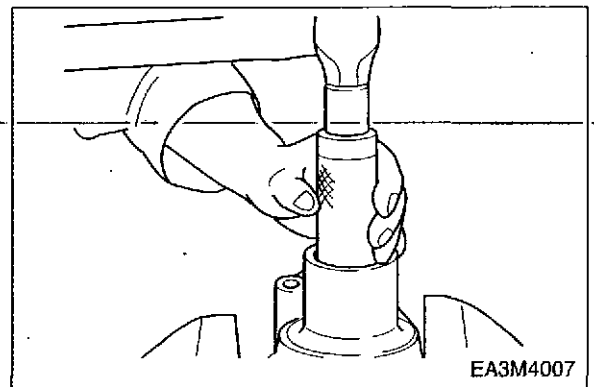



Inspection and repair

Make the necessary adjustments, repairs and part replacements if excessive wear or damage is found through inspection.

• Bearing replacement Procedure



Removal

Use a bench press

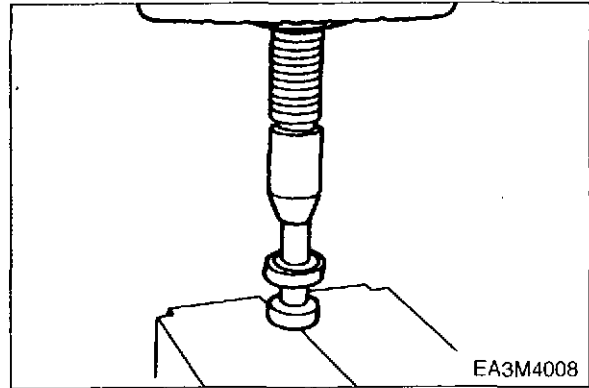

Assembly

Use a bench press to install the front and rear bearing.



The bearings should be installed so that their sealed sides are faced on outwards.

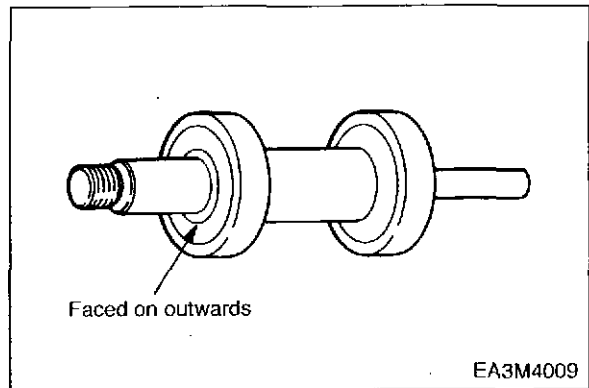

Reassembly

To assemble, follow the disassembly procedures in reverse order.



Important operation

6. Shaft, bearing and spacer

Lubricate the bearing with multi-purpose grease before installing into the pump body.

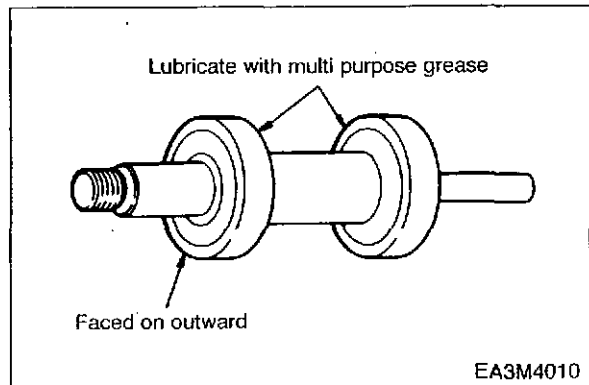

7. Washer, seal and seal unit

Before installation, apply a thin coat of liquid seal (Belco bond No. 4) on the surface in contact with the pump body as figure.

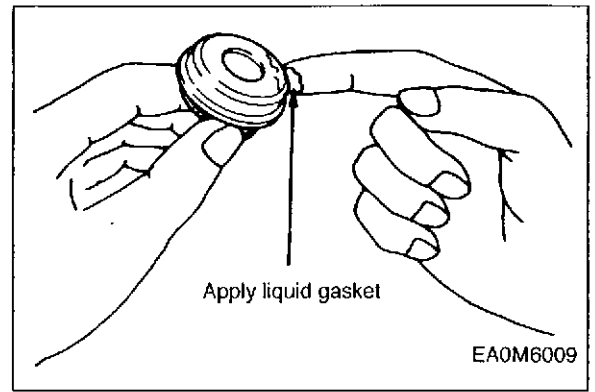

4. Snap ring

Install the snap ring using a pair of snap ring pliers.

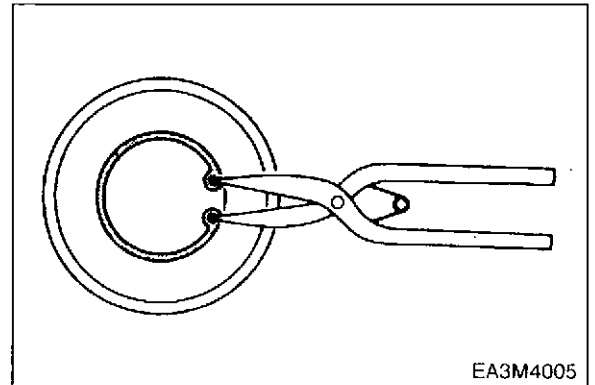

3. Pulley center

Press in until it stops using a bench press.

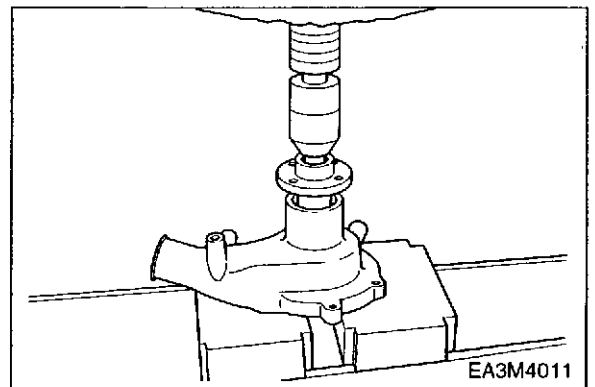

2. Impeller

Install the impeller using a bench press so that the clearance between the impeller and body is reached within the specified value.

Standard	0.3 ~ 0.8 mm
----------	--------------

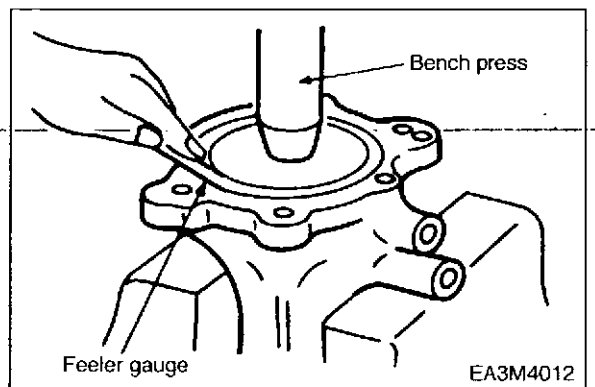

4.3. Thermostat



Inspection and repair

Make the necessary adjustments, repairs and part replacements if excessive wear or damage is found through inspection.



Valve opening temperature

Opening temperature	82 °C
Full opening temperature	95 °C

Valve lift (at testing temperature)

Standard	approx. 10 mm (at 95 °C)
----------	--------------------------

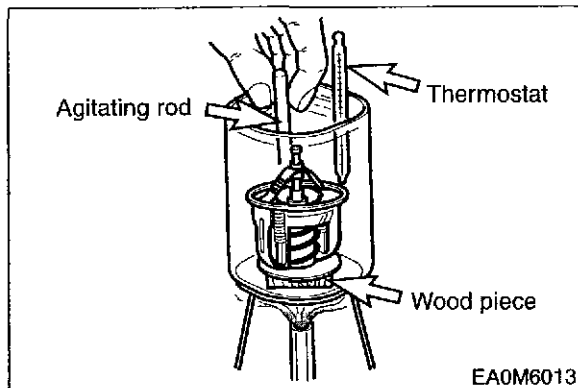

5. Fuel System

5.1. General Description

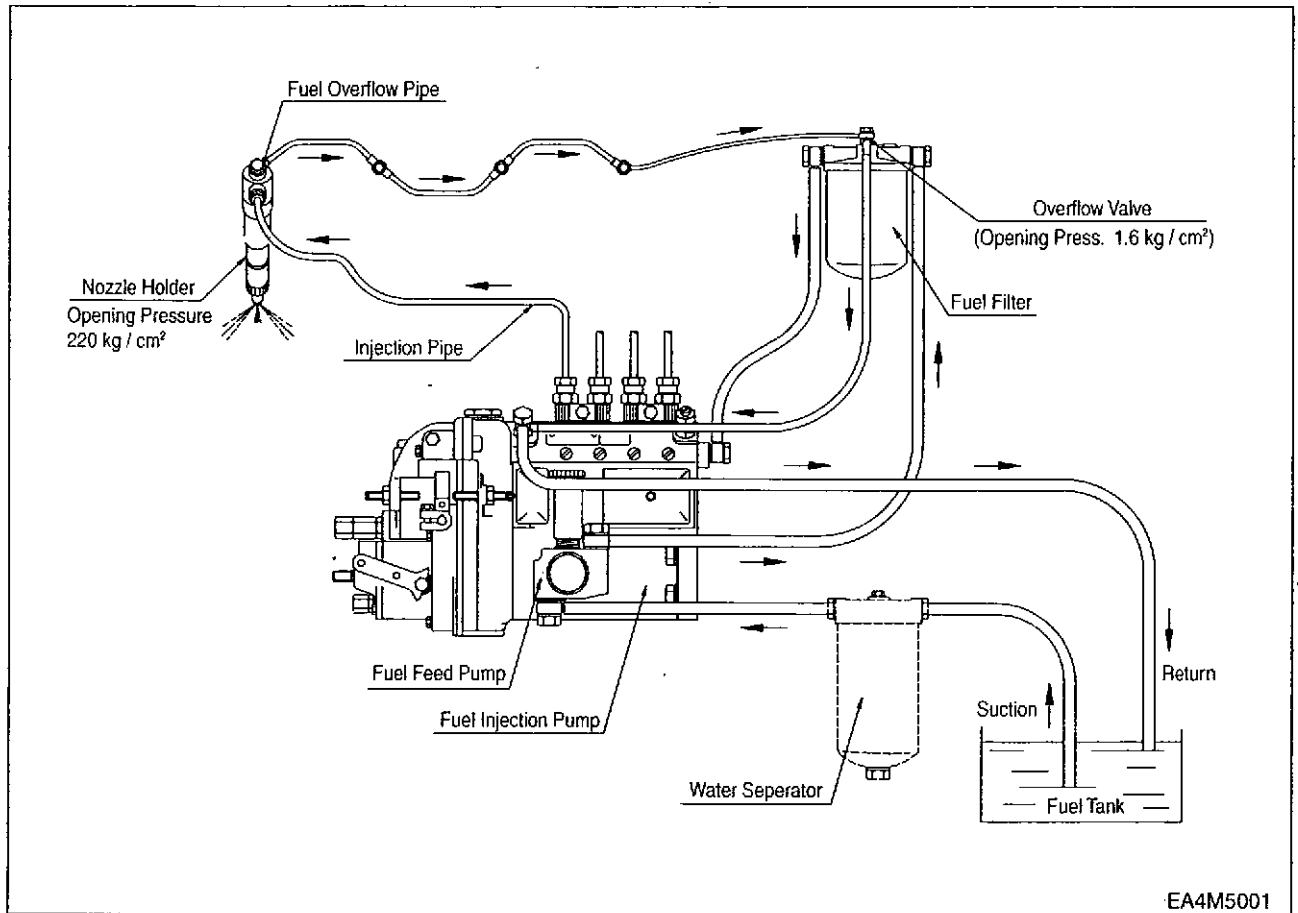

5.2. Fuel Filter



Disassemble

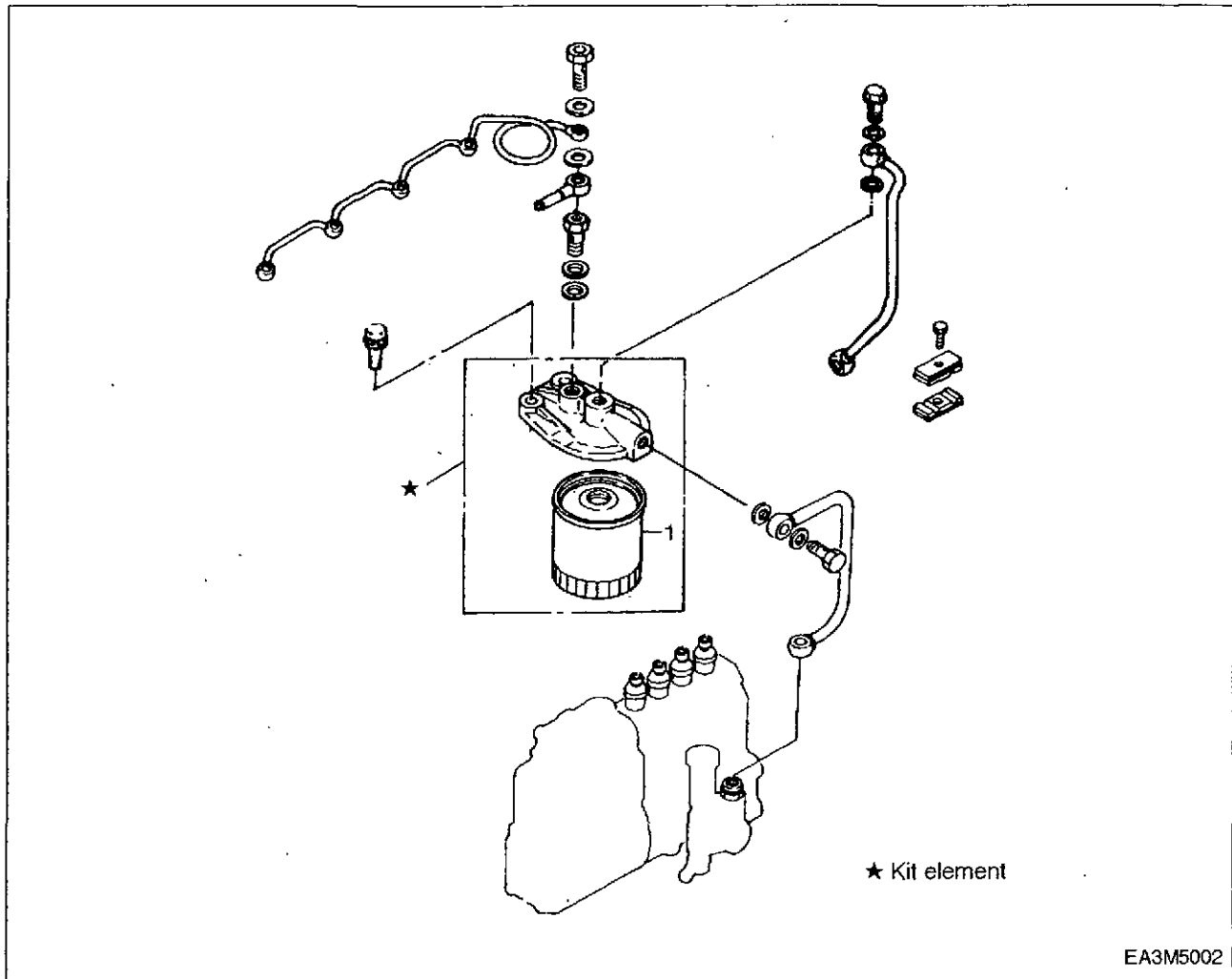

<Disassembly steps>

1. Cartridge



Inspection and repair

Make the necessary adjustments, repairs and part replacements if excessive wear or damage is found through inspection.



Reassembly

To assemble, follow the disassembly procedures in reverse order.

5.3. Injection Nozzle



Disassemble

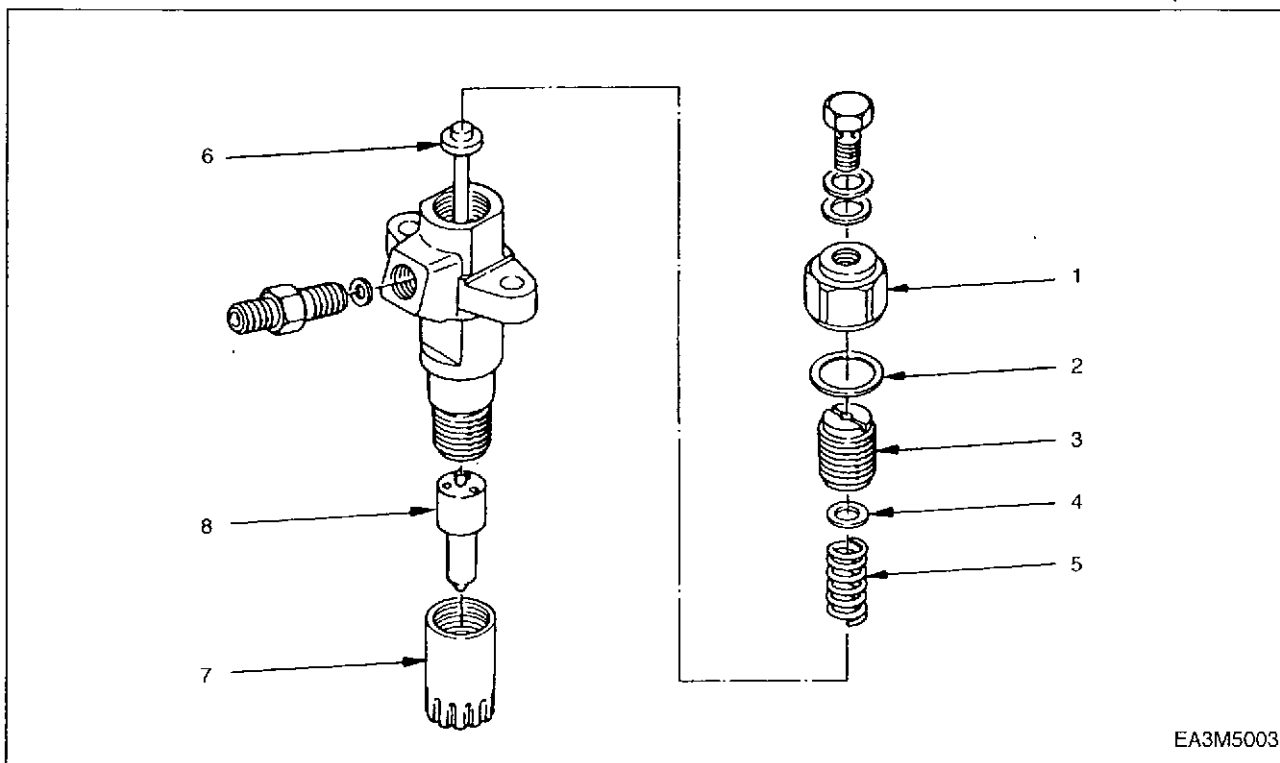

EA3M5003

<Disassembly steps>

1. Cap nut
2. Seal ring
3. Adjust screw
4. Washer
5. Snap ring
6. Push rod
7. Retaining nut
- ▲ 8. Injection nozzle



Important operation

8. Injection nozzle

Remove the nozzle assembly from the nozzle body. Keep the parts separately to maintain the proper needle valve and body combination.

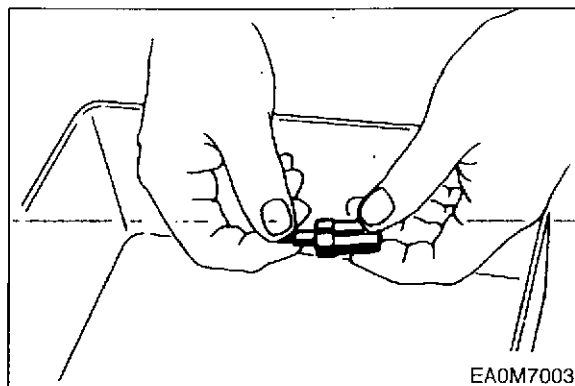

EA0M7003



Inspection and repair

Make the necessary adjustments, repairs and part replacements if excessive wear or damage is found through inspection.



Reassembly

To assemble, follow the disassembly procedures in reverse order.



Important operation



8. Injection nozzle

Align the nozzle dowel pin with the dowel hole in the nozzle holder body.

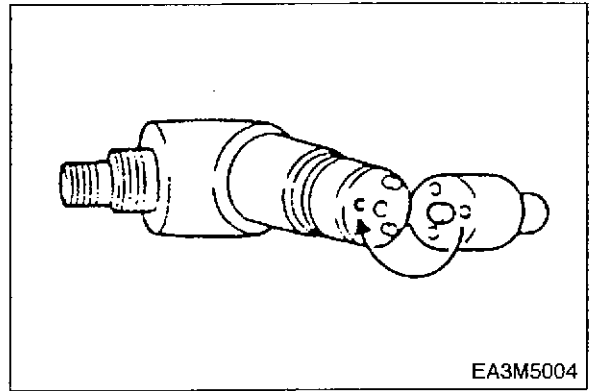

7. Retaining nut

Torque	6 ~ 8 kg.m
--------	------------

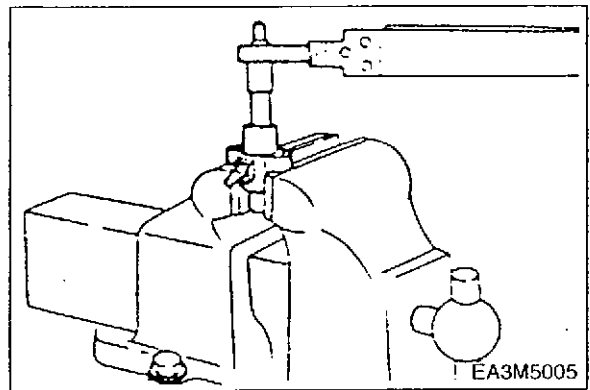

3. Adjust screw

The injection nozzle injection opening pressure must be confirmed after the adjusting screw is installed.

Injection opening pressure	220 kg/cm ²
----------------------------	------------------------

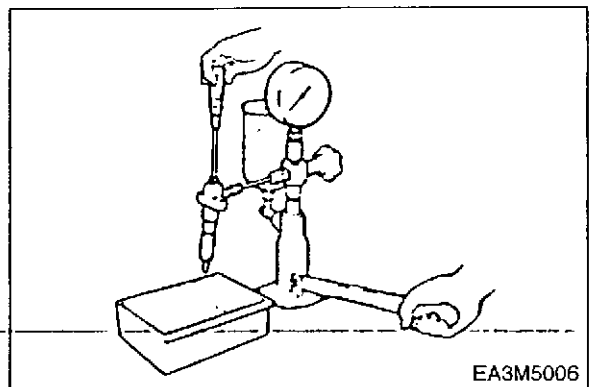



1. Cap nut

Torque	4 ~ 5 kg.m
--------	------------

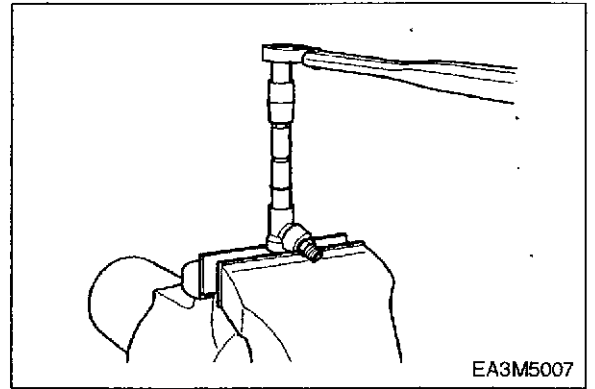

5.4. Injection Pump Calibration

5.4.1. P034Ti engine

- (1) Injection pump : 65.11101-7312(101402-9900 ZEXEL)
- (2) Nozzle holder assembly : 65.10101-7073
- (3) Injection pipe : 65.10301-6032
- (4) Injection order : 1-3-4-2
- (5) Injection timing : BTDC 13 ± 1°

(A) Test condition for injection pump	Nozzle & holder ass'y	105780-8140	Opening pressure:175 kg/cm ²
	Injection pipe(ID,OD,L)	-	ø6.0 X ø2.0 - 600mm
	Test oil	ISO4113	Temperature:40 ± 5°C
(B) Engine standard parts	Nozzle & Holder Ass'y	9135-236(LUCAS)	Nozzle(5 X ø0.26)
		9135-237(LUCAS)	NHA(220 bar)
	Injection pipe(ID,L)		ø1.8 X 400MM

Rack diagram and setting valve at each point(Refer to next figure)

Check point	Rack position (mm)	Pump speed (rpm)	Injection Q'ty on RIG(mm ³ /1,000st)		Press. (mmHg)
			(A) Test condition for inj.pump	(B) Engine standard parts	
A	9.1	900	76.7	-	-
B	10.0	890	90	-	-
C	7.8	350	13.9	-	-
E	-	100	106.5	-	-
F	5.94	940	4.0	-	-

Notch- Approx. 12

Boost pressure dependent full-load stop(boost compensator spring operation point)

No boost compensator	Check point	Rack position (mm)	Pump speed (rpm)	Injection Q'ty RIG (mm ³ /1,000st)		Press. (mmHg)
				(A) Test condition for inj. pump	(B) Engine standard parts	

Weight	Weight=740 kg	Lever ratio(min/max)	1 : 1.2
Governor	k=6.08 kg/mm	Plunger	ø9.5, 30 lead
Idle spring	k=2.2 kg/mm	Delivery valve retraction volume	43 mm ³ /st
Start spring	k=0.014 kg/mm	Delivery valve opening pressure	12.4 kg/cm ²
Boost compensator spring	-	Delivery valve spring	k=0.64 kg/mm
Feed pump		Timer	-

• Rack Diagram

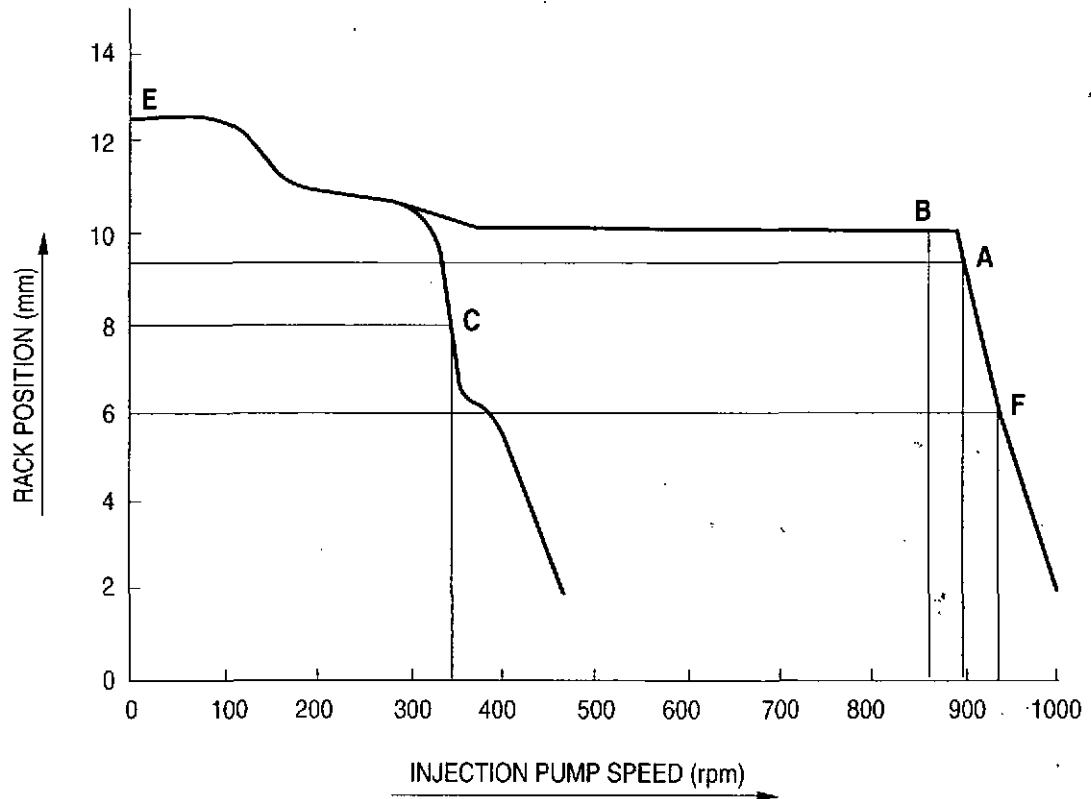

EA5M5001

6. Engine Electricals

6.1. Starting Motor

• Main data and specification

Rated voltage	24 V
Rated output	4.5 kW
Rating	30 sec
Direction of rotation(viewed from the pinion side)	clockwise
Operation speed	More than 3,500 rpm (No load) More than 1,080 rpm (Load)

• Construction

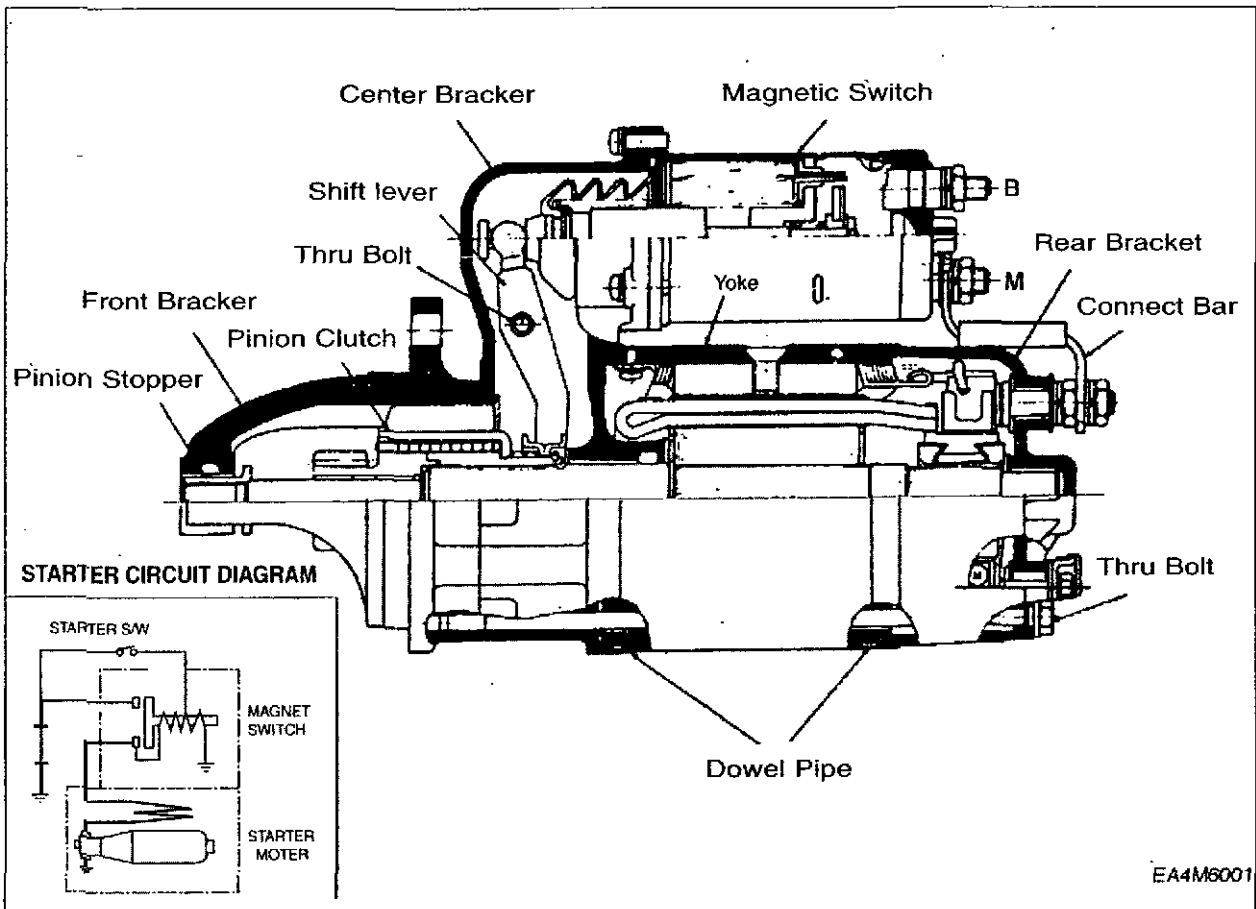

EA4M6001

6.2: Alternator

• Specification

Type	3 phase AC alternator (Built in IC regulator)
Rated voltage	24 V
Rated output	45 A
Max. allowable speed	5,000 rpm
Polarity grounded	Negative (-)
Direction of rotation	clockwise (viewed from pulley side)
Weight	6 kg



• Construction

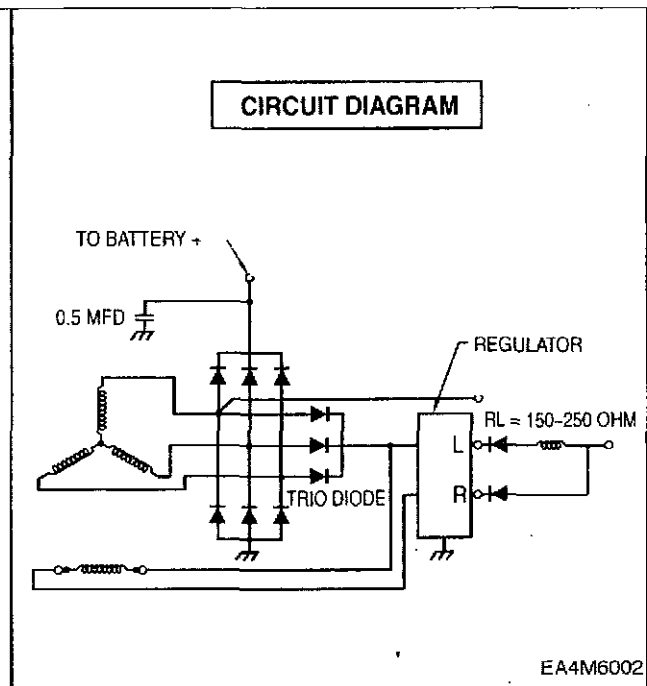
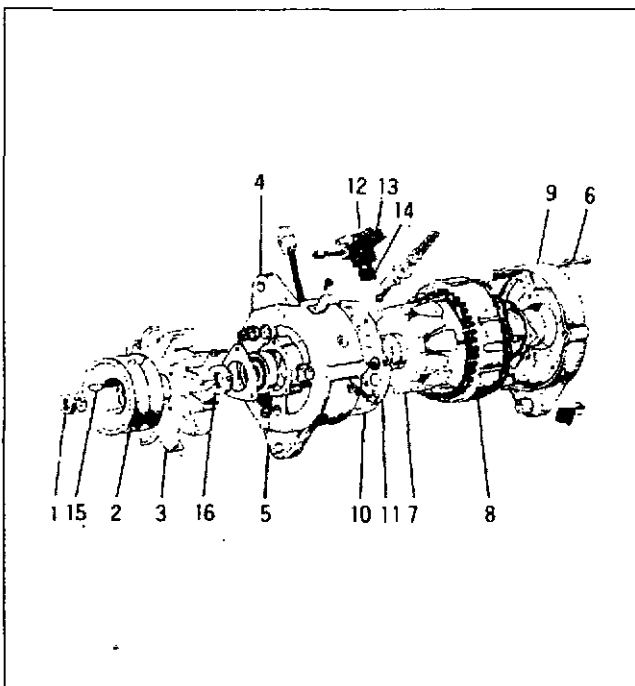

<Disassembly steps>

- | | |
|--|--|
| <ol style="list-style-type: none"> 1. Lock nut 2. Pulley 3. Fan 4. Front cover 5. Ball bearing 6. Thread bolt 7. Rotor assembly 8. Stator assembly | <ol style="list-style-type: none"> 9. Rear side cover assembly 10. Diode assembly (+) 11. Diode assembly (-) 12. Brush holder assembly 13. Brush spring 14. Brush 15. Key 16. Bearing lock nut |
|--|--|

7. Troubleshooting

The following description summarizes the probable cause of and remedy for general failure by item. Immediate countermeasures should be taken before a failure is inflamed if any symptom is detected.

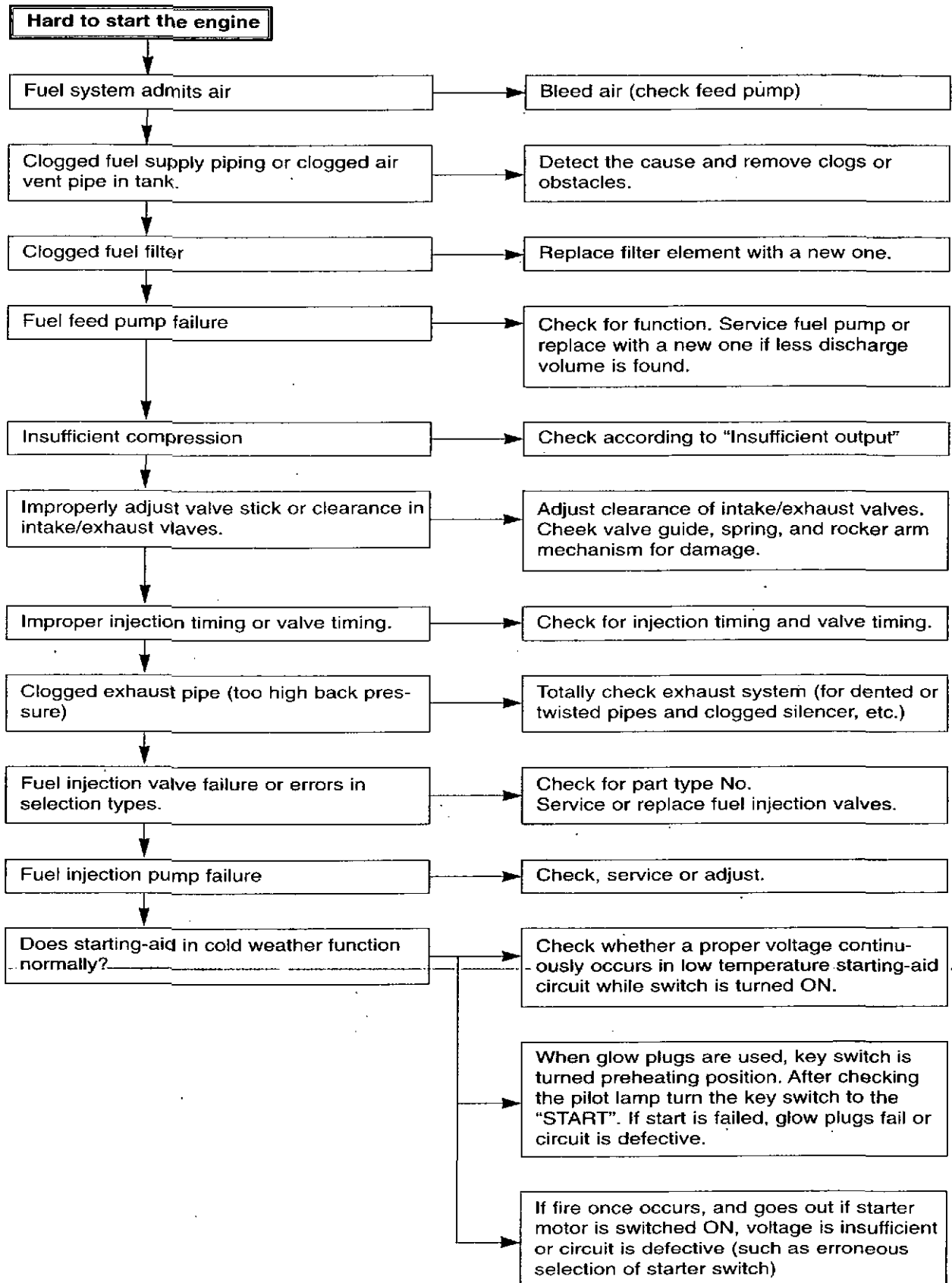

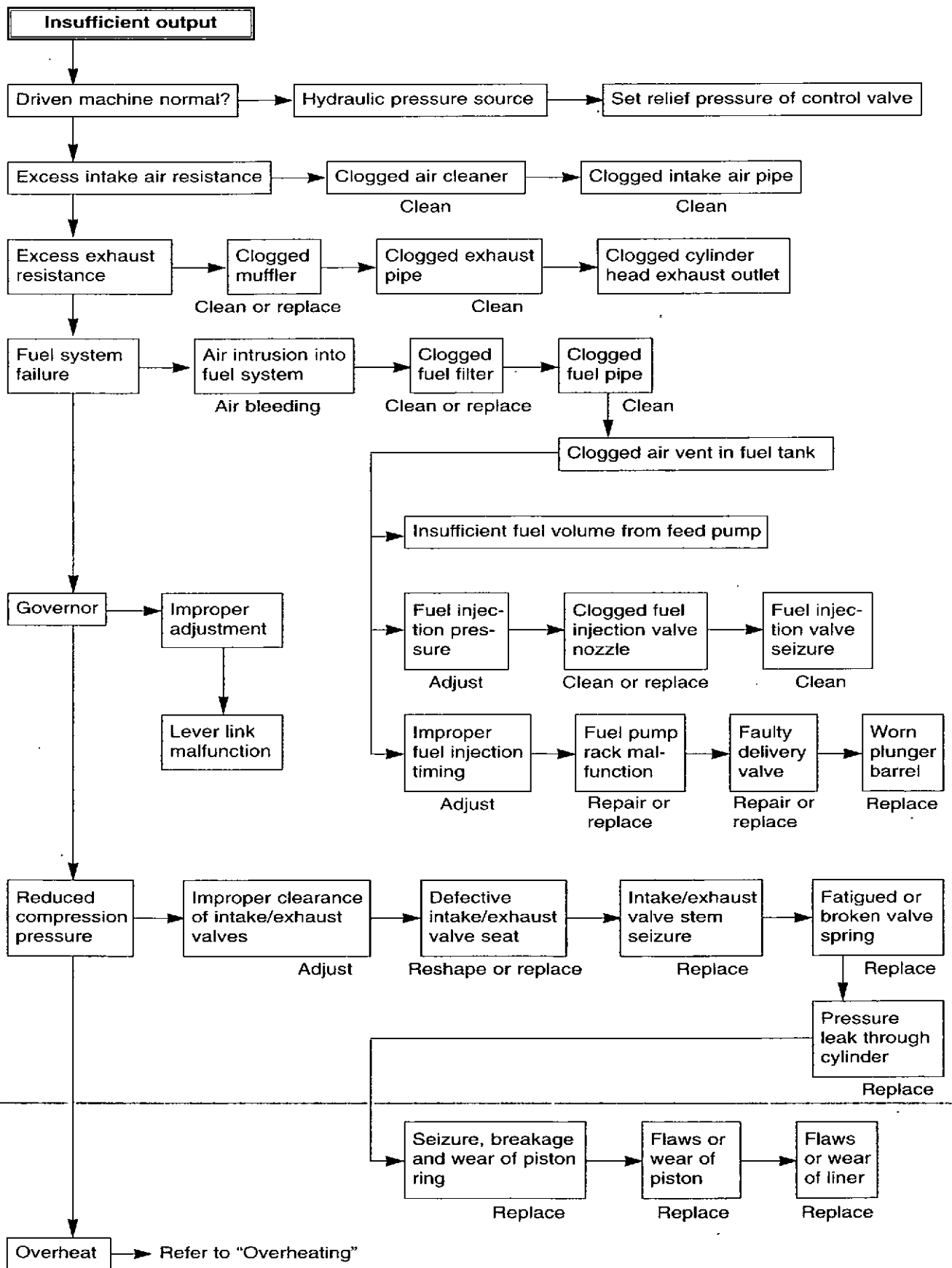

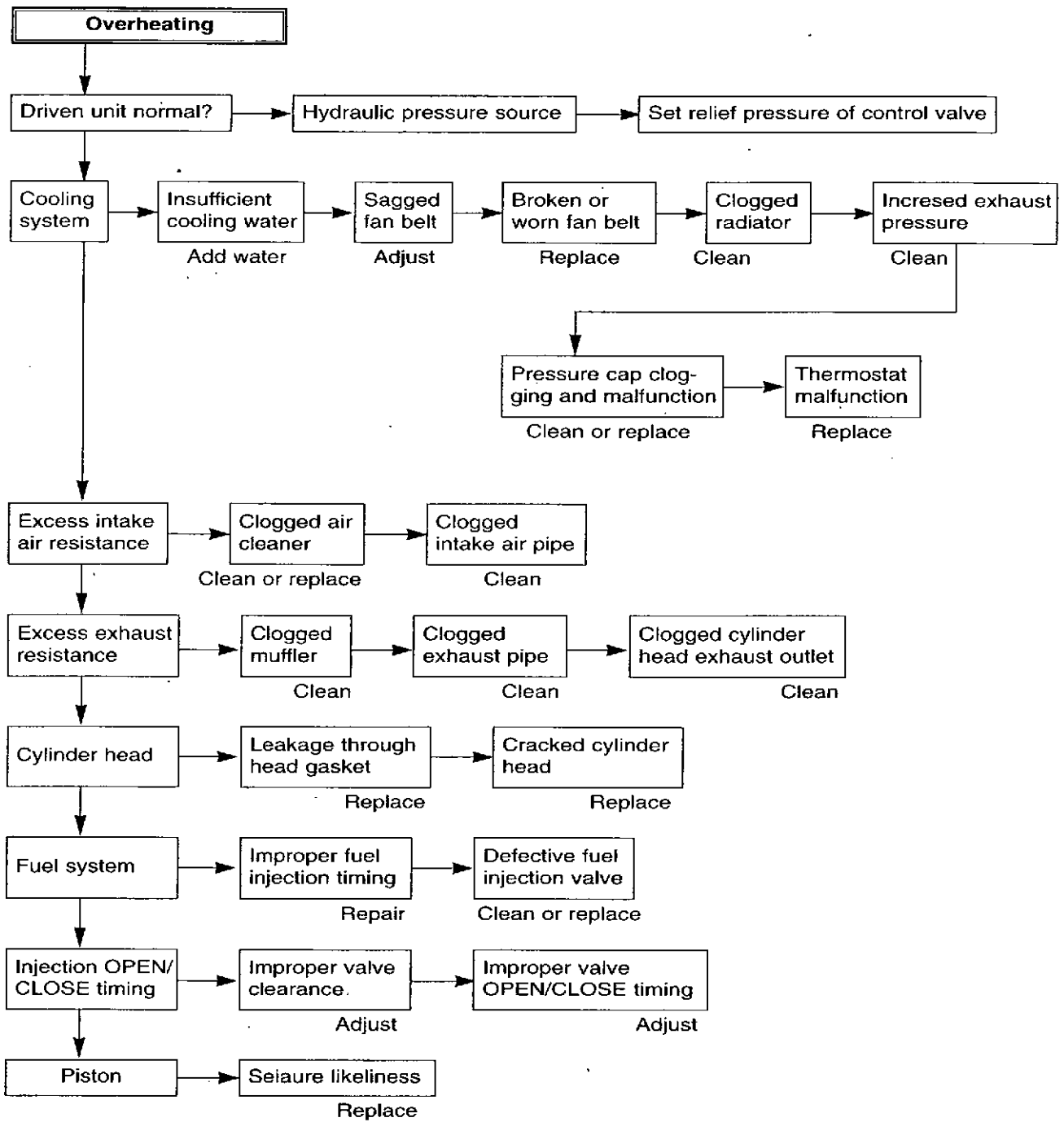

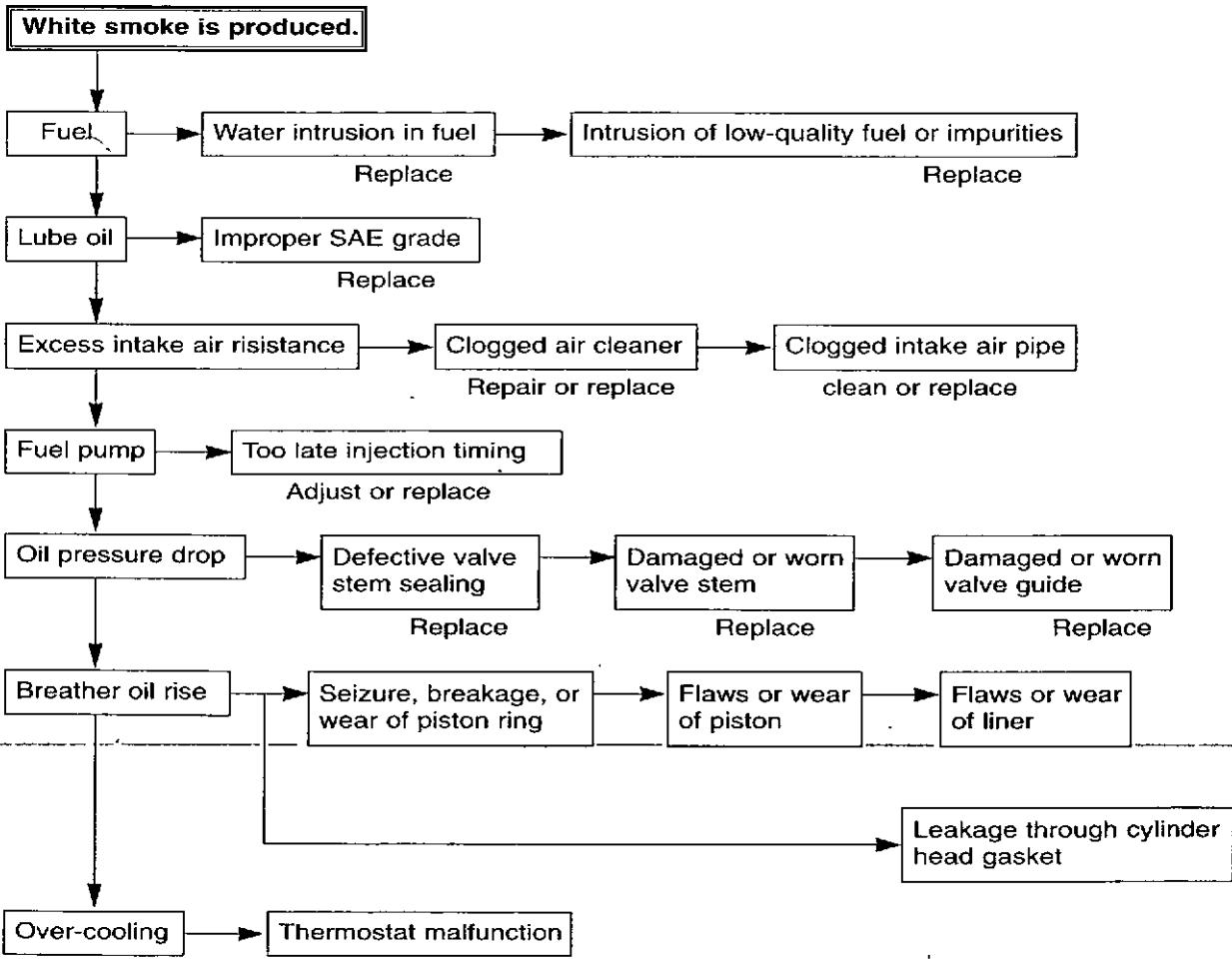
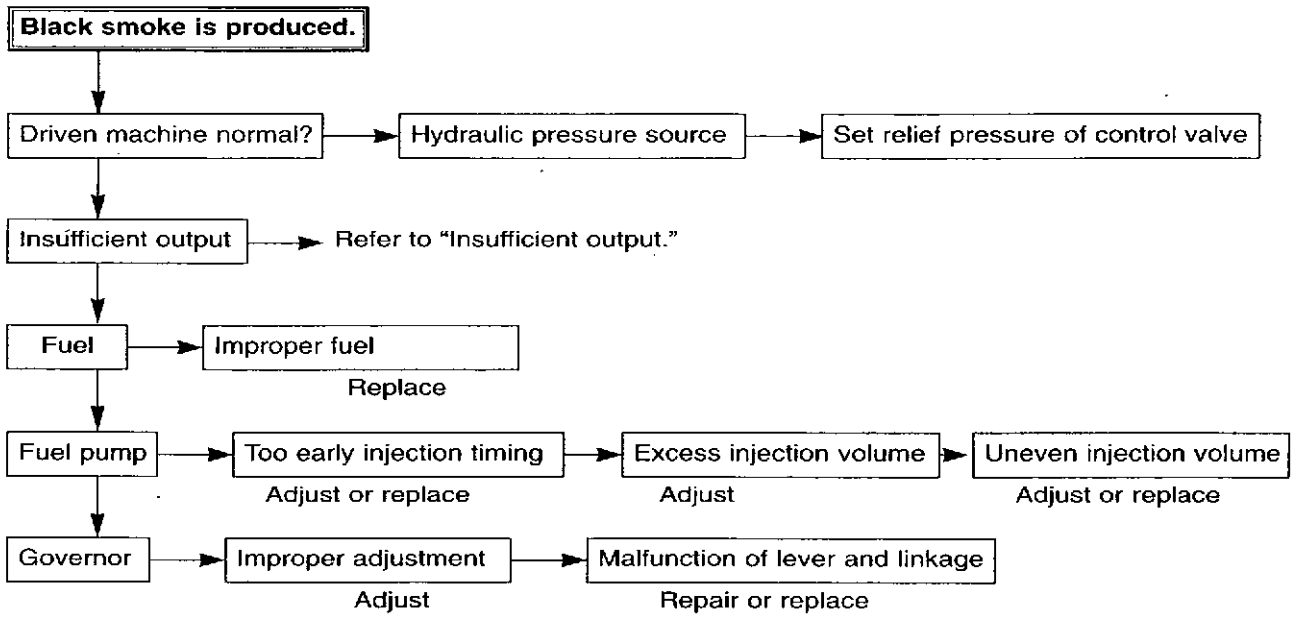

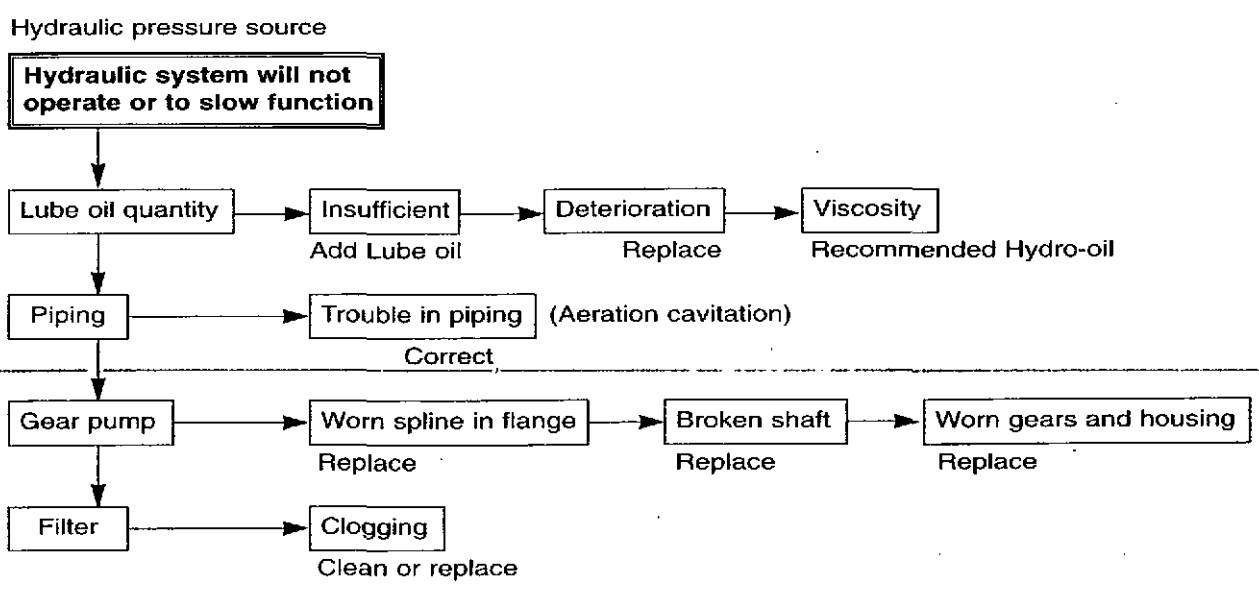
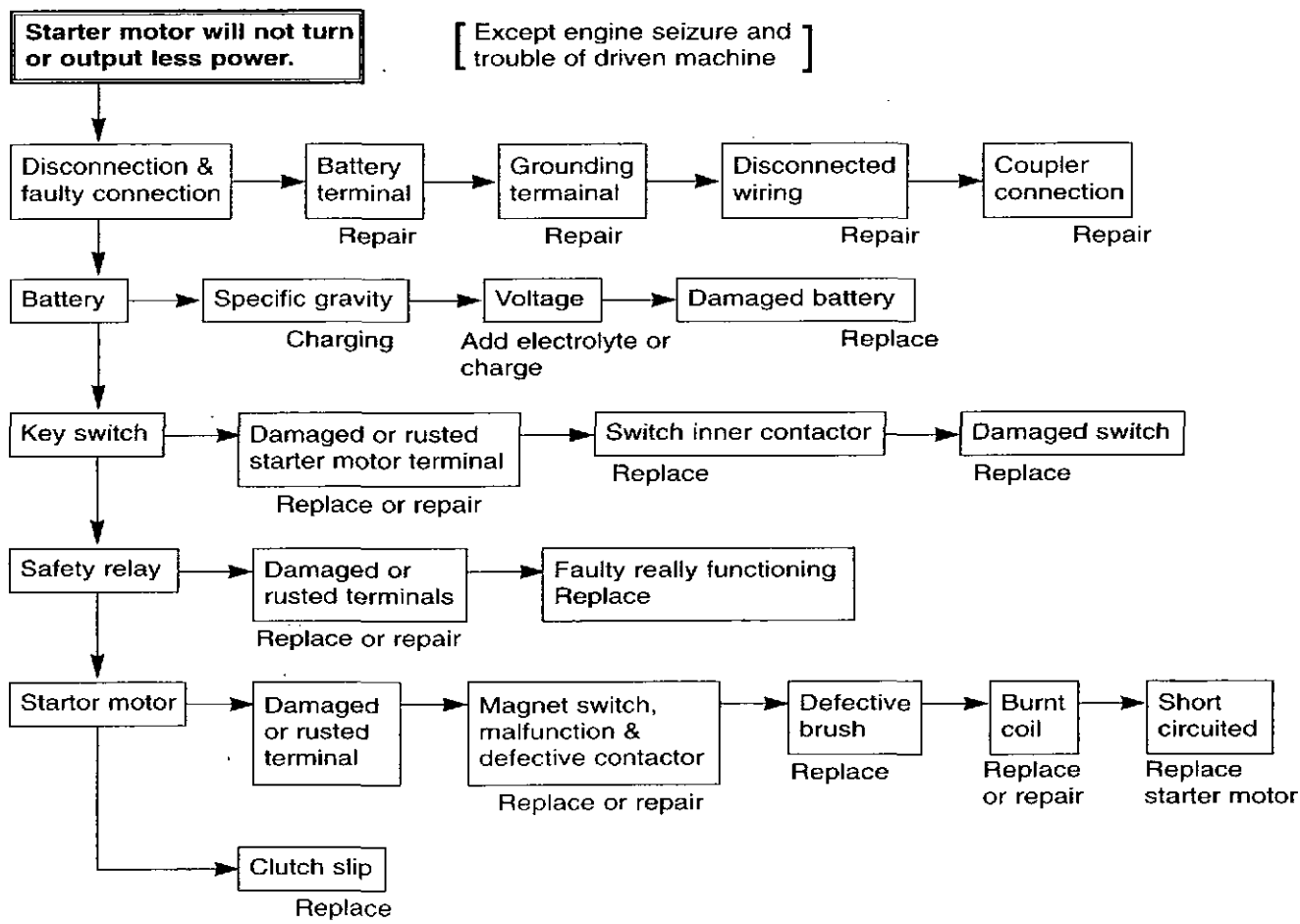

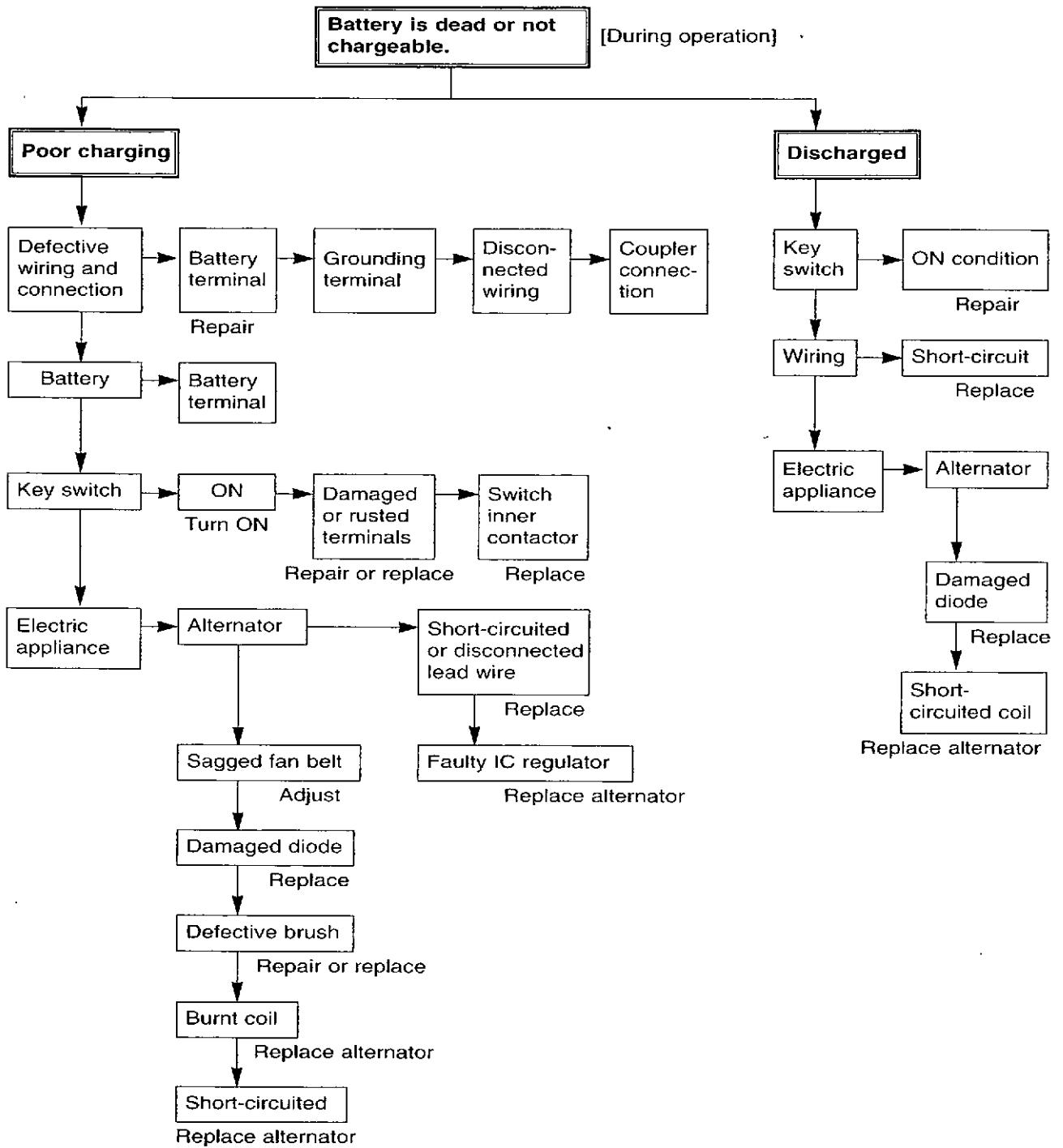







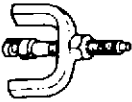





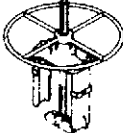

8. Special Tool List

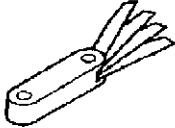
No.	Part No.	Figure	Tool Name
1	EU.2-0528		Compression gauge adapter
2	EF.122-249		Valve spring compressor
3	EF.122-265		Crankshaft gear punch
4	EF.122-253		Crankshaft pilot bearing remover
5	EF.122-257		Crankshaft rear oil seal punch
6	EF.122-255		Crankshaft front oil seal punch
7	EF.122-289		Valve stem oil seal installer
8	T7621010E		Piston ring compressor
9	E1.03901-0124	 EA5M8001	Piston sleeve

No.	Part No.	Figure	Tool Name
10	EF.122-259		Cylinder liner remover
11	EF.122-261		Cylinder liner installer
12	T7621010E		Piston ring plier
13	60.99901-0027		Feeler gauge
14	T761-0001E	 <p data-bbox="865 1066 971 1094">EA5M8001</p>	Snap ring plier

Daewoo Heavy Industries Around the World

NORTH AMERICA

New Jersey
Daewoo Int'l(America) Corp.
85 Challenger Road, Ridgely Park,
NJ 07660-2114, U.S.A.
Tel : 1-201) 229-4500
Fax : 1-201) 440-2244

Atlanta(H.Q.)
Daewoo Heavy Industries America
Corporation
2905 Shawnee Industrial Way,
Suite 100, Suwanee, GA 30024, U.S.A.
Tel : 1-770) 831-2201
Fax : 1-770) 831-0480

Chicago
Daewoo Int'l(America) Corp.
3206 North Kennicott Ave.
Arlington Heights, IL 60004, U.S.A.
Tel : 1-847) 590-8800
Fax : 1-847) 590-8814

Detroit
Daewoo Int'l(America) Corp.
2855 Coolidge Hwy, Suite 224 Troy,
MI 48064, U.S.A.
Tel : 1-248) 649-0003
Fax : 1-248) 649-0130

Los Angeles
Daewoo Int'l(America) Corp.
14848 East Northam St.
La Mirada, CA 90638, U.S.A.
Tel : 1-310) 884-5800
Fax : 1-310) 869-2020

Miami
Daewoo Int'l(America) Corp.
5200 Blue Lagoon Dr. Suite 770
Miami, FL 33126, U.S.A.
Tel : 1-305) 267-0091
Fax : 1-305) 267-0016

San Francisco
Daewoo Int'l(America) Corp.
1900 South Norfolk Street,
Suite 220, San Mateo,
CA 94403, U.S.A.
Tel : 1-650) 341-0888
Fax : 1-650) 341-4377

Seattle
Daewoo Int'l(America) Corp.
Plaza Center, Suite 1105
10900 N.E. 8th St Bellevue,
WA 98004 U.S.A.
Tel : 1-425) 454-1425
Fax : 1-425) 453-7004

Toronto
Daewoo Corp.
Toronto Branch, Suite #403,
1500 Don Mills Road,
North York, Ontario,
Canada, M3B 3K4
Tel : 1-416) 510-2886
Fax : 1-416) 510-0908

Vancouver
Daewoo Corp. Vancouver Branch
3820 Jacobs Road, Suite 103
Richmond, B.C. V6V 1Y6,
Canada
Tel : 1-604) 270-4772
Fax : 1-604) 270-3022

Mexico City
Daewoo Corp. Mexico
Bosques De Chuscos No. 130-5 Piso
Col. Bosques De Las Lomas
C.P. 11700 Mexico D.F., Mexico
Tel : 52-5) 596-5757
Fax : 52-5) 596-1585

CENTRAL & SOUTH AMERICA

Bogota
Daewoo Corp.
Oficina Santafe de Bogota
Av. 13, No. 109-20/48, Piso 5,
Edificio Holding Empresarial
Santafe de Bogota, Colombia
Tel : 57-1) 629-0211
Fax : 57-1) 520-6670

Buenos Aires
Daewoo Corp. Sucursal Buenos Aires
Carrilo 1294, Piso 17, Cap. Fed.
Buenos Aires, Argentina
Tel : 54-1) 816-3201
Fax : 54-1) 815-1158

Caracas
Daewoo Corp. Caracas Office
Av. Principal de Bello Monte
con Calle Leonardo Da Vinci,
Centro Comercial Bello
Monte, Piso 4, Ofic. 4E y 4F,
Caracas, Venezuela
Tel : 58-2) 751-8580
Fax : 58-2) 753-3643

Lima
Daewoo Corp. Sucursal Peruana
Av. Canaval Y Moreya
N 452, Edif. Extebandes,
Piso 15, San Isidro, Lima, Peru
Tel : 51-1) 221-4244
Fax : 51-1) 421-1333

Panama City
Daewoo Int'l(Panama) S.A.
P.O.Box 6-2240 El Dorado, PMA
Calle Aquilino De La Guardia
Calle 54 Marbella Torre Banco
General Piso 22 Panama City
Rep. of Panama
Tel : 507) 269-4533
Fax : 507) 269-4811

Santiago
Daewoo Corp. Santiago Office
El Bosque Norte 0440 Oficina 407
Edificio Atlantis, Las Condes,
Santiago, Chile
Tel : 56-2) 246-6480
Fax : 56-2) 246-6483

Sao Paulo
Daewoo do Brazil Imp e Exp Ltda.
(Daewoo Corp. Sao Paulo Branch)
Av. Paulista 777 13 and Conj.
1311/32 Conj. Cesar Sao Paulo-SP
Cep 01311-100, Brazil
Tel : 55-11) 285-5699
Fax : 55-11) 283-1535

Daewoo Maquinas E Equipamentos Ltda.
Alameda Araguacema,
138-Tambore Cep-06460,
070. Munkpio E Comarca De Barueri, Estado De
Sao Paulo, Brazil
Tel : 55-11) 7291-7200
Fax : 55-11) 7291-7211

EUROPE

Almaty
Daewoo Corp. Almaty Office
Kaz Zhd B/D 7th Fl.,
Gegol Str., 86, Almaty, 480091
Rep. of Kazakhstan
Tel : 7-3272) 324679
Fax : 7-3272) 508829

Amsterdam
Daewoo Corp. Amsterdam Branch
L'Arche Bleue Bldg. 1st Fl.
Overschiepstraat 180, 1092 XG,
Amsterdam, Netherlands
Tel : 31-20) 617-8105
Fax : 31-20) 617-8125

Athens
Daewoo Heavy Industries Ltd.
Greece Office
21, Aki Miaouli Street,
Piraeus 185-35, Greece
Tel : 30-1) 422-6786
Fax : 30-1) 422-6788

Bucharest
Daewoo Corp. Bucharest Branch
Int'l Business Center
(Modem B/D) 14th FL,
44-46 Carol 1, Sector 2
Bucharest, Romania
Tel : 40-1) 250-0055
Fax : 40-1) 250-0396

Budapest
Daewoo Corp.
Budapest Rep. Office
H-1054, Budapest
Bajcsy-Zsilinszky Ut. 42-46,
Daewoo Bank Bldg. 2nd Floor, Hungary
(Eco City Center Bldg. Room No. 304)
Tel : 36-1) 266-3737
Fax : 36-1) 266-3636

Cardiff
Euro Daewoo U.K. Ltd.
Daewoo House, Unit 6.3,
Nantgarw Park, Cardiff CF4
7QU, U.K.
Tel : 44-1443) 84-2273
Fax : 44-1443) 84-1933

Frankfurt
Euro Daewoo S.A.
1A, Rue Achille Degraze 7080
Frankfurt, Belgium
Tel : 32-65) 61-3230
Fax : 32-65) 67-7338

Frankfurt
Daewoo Handels GmbH
Postfach 710254 80492
Frankfurt/M., Germany
Tel : 49-69) 684040
Fax : 49-69) 68404-112

Istanbul
Daewoo Corp. Istanbul Branch
Gumussuyu Mah. Inonu Cad.
Boefer Han. No. 41/3 Taksim,
Istanbul, Turkey
Tel : 90-212) 285-4132
Fax : 90-212) 285-4137

Kiev
Daewoo Corp. Kiev Branch
252005, Saksagansky St. 115,
7th Fl., Room No. 704
Kiev, Ukraine
Tel : 38-044) 248-6366
Fax : 38-044) 246-6419

Langenfeld-Fuhrhamp
Daewoo Maschinen Vertriebs GmbH.
Hans-Boeker Strasse 29, D-40764,
Langenfeld-Fuhrhamp, Germany
Tel : 49-2173) 8509-20
Fax : 49-2173) 8509-60

London
Daewoo U.K. Ltd.
Templar House, 82 Northolt Road,
South Harrow Middlesex, HA2 0YL
United Kingdom
Tel : 44-181) 423-7200
Fax : 44-181) 864-6070

Daewoo Heavy Industries Ltd.
London Office
Templar House, 82 Northolt Road,
South Harrow, Middlesex HA2 0YL,
London, U.K.
Tel : 44-181) 423-7243
Fax : 44-181) 423-7274

Madrid
Daewoo Corp. (Oficina en Madrid)
Pasco De La Castellana,
135 2-B 28046 Madrid, Spain
C.P.O.Box 36192, Madrid
Tel : 34-91) 571-0583
Fax : 34-91) 571-6827

Mangalia
Daewoo Mangalia Heavy Industries S.A.
1 Portului Street, 8727 Mangalia Romania
Tel : 40-41) 75-3639
Fax : 40-41) 312-2234

Milano
Daewoo Italia S.R.L.
Centro Direzionale Colleoni Palazzo
Locomo (A2) Via Paracelso 6
20041 Agrate Brianza (MI), Italy
Tel : 39-039) 6091-861
Fax : 39-039) 6091-887

Moscow
Daewoo Corp. Moscow Office
Room 1903; 1904; 1706 Office B/D,
Sovincenter
12, Krasnopresnenskaya Nad. 123610, Moscow,
Russia
Tel : 7-095) 258-1981
Fax : 7-095) 258-1994

**Daewoo Institute of Science
& Technology**
Ferganskaya 25, Moscow 109507,
Russian Federation
Tel : 7-095) 372-4408
Fax : 7-095) 377-0311

Oslo
Daewoo Heavy Industries Ltd.
Oslo Office
Vollsvelen 13, P.O.Box 67, 1324,
Lysaker, Norway
Tel : 47-67) 53-5379
Fax : 47-67) 53-5901

Sofia
Daewoo Corp. Sofia Branch
Intar Prod Bldg. 36
Dragon Tzankov Blvd.
Room 403, 1040 Sofia,
Bulgaria
Tel : 359-2) 971-1170
Fax : 359-2) 971-1169

Tashkent
Daewoo Corp. Tashkent Office
Furkat St. 1st Block,
Building No. 1, 6th Fl.,
Tashkent 700027, Uzbekistan
Tel : 7-3712) 391507
Fax : 7-3712) 453856

Vladivostok
Daewoo Corp. Vladivostok Branch
5th Fl. Sukhanova St. 3A
Vladivostok, 680029, Russia
Tel : 7-4232) 26-7635
Fax : 7-4232) 26-0709

Warsaw
Daewoo Handels GmbH. Warsaw Office
Ul. Wyszpina 62, Room No. 354 00-584, Warsaw,
Poland
Tel : 48-22) 627-1627
Fax : 48-22) 627-1625

MID. EAST & AFRICA

Amman
Daewoo Corp. Amman Branch
3rd Fl. Strand Building No. 2 Shmelsari
P.O.Box 940667, (Post Code : 11194)
Amman, Jordan
Tel : 962-6) 5683058
Fax : 962-6) 5683059

Cairo
Daewoo Corp. Cairo Liaison Office
11th Fl. 48 El Sawra St. Dokki,
Cairo, Egypt
Tel : 20-2) 337-0015
Fax : 20-2) 348-6381

Dubai
Daewoo(GULF)
P.O.Box 8090 Flat No. 1701
Al Moosa Tower Dubai-Abudhabi Road, Dubai,
U.A.E.
Tel : 971-4) 313384
Fax : 971-4) 313609

Harare
Daewoo Corp. Harare Branch
2nd Fl., East Wing Adven
House, Corner Robert Mugabe Rd.
Insz Terrace, Harare, Zimbabwe
Tel : 263-4) 753278
Fax : 263-4) 758178

Johannesburg
Daewoo Corp. Johannesburg Branch
1st Fl., Norwich Life Towers
13 Fredman Drive Sandown,
Sandton 2196, Rep. of South Africa
P.O.Box 786734 Sandton 2146
Tel : 27-11) 784-1328
Fax : 27-11) 784-1301

Karachi
Daewoo Corp. Karachi Liaison Office
11th Fl., Shaheen Complex Bldg.
M.R. Kayani Road, Karachi, Pakistan
Tel : 92-21) 263-3863
Fax : 92-21) 263-2674

Lagos
Daewoo Nigeria Ltd.
Plot 1608, Adoola Hopewell
St., Victoria Island,
Lagos, Nigeria G.P.O. Box 8686
Tel : 234-1) 281-7108
Fax : 234-1) 282-2110

Nairobi
Daewoo Corp. Nairobi Branch
Posta Sacco Bldg., 11th Fl.,
University Way P.O.Box 43739
Nairobi, Kenya
Tel : 254-2) 22-8688
Fax : 254-2) 33-5174

Rabat
Daewoo Corp. Rabat Branch
Hotel Hilton Mazzarine Etage
Aviation Soussal,
Rabat, Morocco
Tel : 212-7) 674509
Fax : 212-7) 674510

Riyadh
Al-Bab Care of Daewoo
King Fahad Foundation Bldg.
South Tower, 8th Fl.
P.O.Box 89644, Riyadh 11692,
Saudi Arabia
Tel : 966-1) 464-6814
Fax : 966-1) 464-6814

Tehran
Daewoo Corp. Tehran Branch
No. 27 Reza Navebi St., Vessaf
Shirazi Ave., P.O.Box 14155-3531,
Tehran, Iran
Tel : 98-21) 646-3571
Fax : 98-21) 646-9805

Tripoli
Daewoo Corp. Tripoli Office
P.O.Box 14110 Tripoli
Mahara Road, Benghazi Tripoli,
Libya
Tel : 218-22) 30895
Fax : 218-22) 30877

ASIA & OCEANIA

Bangkok
Daewoo Corp.
Unit 1901-1902, M. Thai Tower
All Seasons Place, 87 Wireless Road,
Lumphini, Pathumwan,
Bangkok 10330, Thailand
Tel : 66-2) 654-0124
Fax : 66-2) 654-0129

Beijing
Daewoo Corp. Beijing Rep. Office
Office C-701, Beijing Lufthansa Center
50 Liangmaqiao Road, Chaoyang
District, Beijing 100016, China
Tel : 86-10) 6485-2226
Fax : 86-10) 6485-1531

Colombo
Daewoo Corp. Liaison Office
Colombo #23-01(23rd Fl.) East Tower,
World Trade Center,
Echelon Square, Colombo 1,
Sri Lanka
Tel : 94-1) 34-6822
Fax : 94-1) 34-6821

Dalian
Daewoo Corp. Dalian Rep. Office
Dalian Int'l Hotel, #911-914,
No. 9, Renmin Road,
Dalian, China
Tel : 86-411) 263-8238
Fax : 86-411) 280-7272

Dhaka
Daewoo (Bangladesh) Co., Ltd.
BRAC Center (7th Fl.) 356, Mohakhali
CIA, Dhaka-1212 Dhaka, Bangladesh
Tel : 880-2) 988-1316
Fax : 880-2) 889484

Fukuoka
Daewoo Int'l(Japan) Corp.
Fukuoka Branch
6th Fl., AIT Bldg., 2-2-22 Momochi-Hama
Sawara-Ku, Fukuoka-City, 814 Japan
Tel : 81-92) 852-5800
Fax : 81-92) 852-5801

Guangzhou
Daewoo Corp. Guangzhou Branch
Room 1301, Glic Plaza Main Bldg.,
339 Huanshi Dong Road,
Guangzhou, China
Tel : 86-20) 8331-1371
Fax : 86-20) 8331-2789

Hanoi
Daewoo Corp. Vietnam Rep. Office
8th Fl., Office Tower
Daeha Business Center,
360 Kim Ma Street, Ba Dinh District,
Hanoi, S.R. Vietnam
Tel : 84-4) 8315220
Fax : 84-4) 8317889

Hochiminh
Daewoo Corp. Hochiminh Branch
7th Fl., Saigon Tower, 29 Le
Duan St., 1st District,
Hochiminh City, Vietnam
Tel : 84-8) 822-4313
Fax : 84-8) 822-4323

Hong Kong
Daewoo Hong Kong Ltd.
Suites 2301-2308, 23/F,
Natwest Tower, Times Square,
1 Madison Street,
Causeway Bay, Hong Kong
G.P.O. Box 5726, Hong Kong
Tel : 852) 25965-700
Fax : 852) 25060-688

Jakarta
Daewoo Corp. Jakarta Branch
Lippo Plaza 7th Fl.,
Jl. Jend. Sudirman Kav 25
Jakarta 12920, Indonesia
P.O.Box 2810
Tel : 62-21) 5204520
Fax : 62-21) 5203478

Kuala Lumpur
Daewoo (M) Sdn Bhd
Suite 308, 3rd Fl., Pomas Int'l,
Jalan Sultan Ismail, 50250
Kuala Lumpur, Malaysia
Tel : 60-3) 2618033
Fax : 60-3) 2615790

Manila
Daewoo Corp. Manila Rep. Office
5th Fl., Pacific Star Bldg.
San. Gil J. Puyat Avenue,
Cor Makati Ave., Makati City,
Philippines
Tel : 63-2) 818-1031
Fax : 63-2) 817-5297

Mumbai
Daewoo Corp. Mumbai Branch
107, Maker Chamber VI,
Nariman Point, Mumbai-400 021,
India
Tel : 91-22) 283-5947
Fax : 91-22) 204-4470

Nagoya
Daewoo Int'l(Japan) Corp.
Nagoya Branch
10th Fl., Nagoya Hirokoji Bldg.
3-1, Sakae 2 Chome, Naka-ku,
Nagoya, 460 Japan
Tel : 81-52) 222-3717
Fax : 81-52) 222-3719

New Delhi
Daewoo Corp. New Delhi Branch
4/6, Sinfoni Institutional Area,
1st Fl., New Delhi-110048, India
Tel : 91-11) 649-8201
Fax : 91-11) 649-5387

Osaka
Daewoo Int'l(Japan) Corp. Osaka Branch
Midosuji Mitsui Bldg. 10th Fl., 1-3,
4-Chome, Binomachi, Chuoh-Ku,
Osaka, 541 Japan
Tel : 81-6) 222-0848
Fax : 81-6) 222-0855

Phnom Penh
Daewoo Corp. Phnom Penh Rep. Office
No. 2 Moha Vitheol Norodom
Phnom Penh, Cambodia
Tel : 855-23) 217988
Fax : 855-23) 217989

Qingdao
Daewoo Corp. Qingdao Office
(Ba-Da-Guan Hotel)
16, Shaoguan Road,
Qingdao, China
Postal Code No. : 266071
Tel : 86-532) 573-1688
Fax : 86-532) 572-7588

Saitama
Daewoo Construction Machinery Co., Ltd.
No. 1483-1 Kamikomi,
Miyoshi-Cho Inuma-Gun,
Saitama Pref., 354 Japan
Tel : 81-482) 59-8255
Fax : 81-482) 59-8259

Shanghai
Daewoo Shanghai Office
Room 1309-1307, 1318, 1907 Ruijin B/D
206, Mao-Ming Road (South)
Shanghai, China
Tel : 86-21) 6472-4280
Fax : 86-21) 6472-0437

Shantou
Daewoo Corp. Shantou Rep.
B1113th Fl., Evergreen Building,
East Insha Road, Shantou, China
Tel : 86-754) 816-3442
Fax : 86-754) 816-3445

Shenyang
Daewoo Corp. Shenyang Branch
Room No. 2107, Shenyang Sankel
High Technology Tower,
No. 262-A Shifu Avenue,
Shenhe District, Shenyang, China
Tel : 86-24) 2278-0086
Fax : 86-24) 2279-0099

Daewoo(Liaoning) Machinery Co., Ltd.
No.32 Dongling Road, Dongling District
Shenyang, Liaoning, China
Tel : 86-24) 8841-1407
Fax : 86-24) 8841-1404

Singapore
Daewoo Singapore Pte Ltd.
7 Temasek Boulevard
#26-03 Suntec Tower One
Singapore 038987
Tel : 65) 332-3700
Fax : 65) 336-6960

Sydney
Daewoo Australia Pty Ltd.
Suite 405, Victoria Cross Bldg.
60 Miller St., North Sydney NSW
2060, Australia
Tel : 61-2) 9957-5599
Fax : 61-2) 9925-0458

Taipei
Daewoo Corp. Taiwan Branch
No. 134, Cosmos Bldg. 3Fl.,
Min Sheng E. Rd., 3,
P.O.Box 34-58, Taipei, Taiwan
Tel : 886-2) 716-0002
Fax : 886-2) 514-8174

Taoyuan Hsien
Daewoo Machinery Co., Ltd.
83 Wen-hua 1st Road,
Lin-kou, Kuai-Shan Hsien,
Taoyuan Hsien, Taiwan
Tel : 886-3) 327-5578
Fax : 886-3) 327-3013

Tianjin
**Daewoo(Tianjin) Mechanical
Construction Co., Ltd.**
No.87, Gong Xing Road, Tanggu,
Tianjin, China
Tel : 86-222) 521-0714
Fax : 86-222) 521-0714

Tokyo
Daewoo Int'l(Japan) Corp.
RM 906 Toranomon Mitsui Bldg.
3-8-1 Kasumigaseki,
Chiyoda-ku, Tokyo 100, Japan
Tel : 81-3) 3597-7801
Fax : 81-3) 3597-9021

Wuhan
Daewoo Corp. Wuhan Branch
#707 Wuhan Int'l Trade Commerce Center,
No. 297 Xinhua Road, Wuhan, China
Tel : 86-27) 8577-0963
Fax : 86-27) 8577-0992

Xinjiang
Xinjiang Daewoo Machinery Co., Ltd.
Tajik Building 13-A No.2
South Beijing Road,
Urumqi, Xinjiang, China
Tel : 86-991) 483-2217
Fax : 86-991) 483-8541

Yangon
Myanmar Daewoo Ltd.
No. 22, Yaw Min Gyi Road,
Dagon Township,
Yangon, Myanmar
Tel : 95-1) 289939-9
Fax : 95-1) 284246, 284202

Yantai
**Daewoo Heavy Industries
Yantai Co., Ltd.**
E-10 Wuzhishan Road, Eco. & Tech.
Development Zone,
Yantai Shandong, China
Tel : 86-535) 638-2000
Fax : 86-535) 638-2004

DAEWOO



DAEWOO HEAVY INDUSTRIES LTD.

HEAD OFFICE : 6, Manseok-dong, dong-gu, Incheon, Korea
Tel : (032) 760-1114 Telex : DHILTD K28473

[http : //www. dhiltltd. co. kr](http://www.dhiltltd.co.kr)

EBMGA32-2904