

Operation & Maintenance Manual

GENERATOR NATURAL GAS ENGINE

GV158TIC

GV180TIC

GV222TIC















FOREWORD

This manual is designed to serve as a reference for DOOSAN Infracore (hereafter DOOSAN) customers and distributors who wish to gain basic product knowledge on DOOSAN **GV158TIC, GV180TIC, GV222TIC** natural gas generator engines.

These economical and high-performance natural gas engines (GV158TIC 8 cylinders) (GV180TIC 10 cylinders), (GV222TIC 12 cylinders) are 4 strokes and V-type have been so designed and manufactured to be used for the generator & power unit application. They meet all the requirements such as low noise, fuel economy, high engine speed and durability.

To maintain the engine in optimum condition and retain maximum performance for a long time, **CORRECT OPERATION** and **PROPER MAINTENANCE** are essential.

In this manual, the following symbols are used to indicate the type of service operations to be performed.

	Removal		Adjustment
	Installation		Cleaning
	Disassembly		Pay close attention-Important
	Reassembly		Tighten to specified torque
	Align the marks		Use special tools of manufacturer's
	Directional Indication		Lubricate with oil
	Inspection		Lubricate with grease
	Measurement		

During engine maintenance, please observe following instructions to prevent environmental damage;

- Take old oil to an old oil disposal point only.
- Ensure without fail that oil and diesel fuel will not get into the sea or rivers and canals or the ground.
- Treat undiluted anti-corrosion agents, antifreeze agents, filter element and cartridges as special waste.
- The regulations of the relevant local authorities are to be observed for the disposal of spent coolants and special waste.

If you have any question or recommendation in connection with this manual, please do not hesitate to contact our head office, dealers or authorized service shops.

For the last, the content of this maintenance instruction may be changed without notice for some quality improvement and please feel free to contact to our agents near by your location for any services. Thank you

CONTENTS

1. Safety Regulations & Engine Specifications	1
1.1. General notes	
1.2. Handle compressed natural gas safety	
1.3. Engine characteristics	
1.4. Engine assembly	
2. Technical Information	15
2.1. Engine model and serial number	
2.2. Diagnostic display module(CPU-95)	
2.3. Engine characteristic	
2.4. Diagnosis and Remedy	
2.5. Engine inspection	
3. Disassembly and Reassembly of Major Components	45
3.1. Engine disassembly	
3.2. Engine inspection	
3.3. Engine reassembly	
3.4. Starting and Trial Operation	
3.5. Speed controller setting	
3.6. Display module	
3.7. Diagnosis and remedies of trouble causes	
4. Electrical Equipment	108
4.1. Gas fuel circuit	
4.2. Electrical wiring diagram	
4.3. Speed controller	
4.4. Ignition controller	
4.5. Ignition control module	
5. Maintenance of major parts	119
5.1. Turbo charger	
5.2. Lubricating System	
5.3. Cooling system	
5.4. Thermostat	
5.5. V - Belts	
5.6. Air Intake System	
6. Engine Installation	136
6.1. Installing	
6.2. Inspection prior to installation	
7. Special Tool List	139
● Appendix	141
● Parts & After service center	
● Applications for DOOSAN Engine	
● Worldwide Network	

1. Safety Regulations & Engine Specifications

1.1. General notes

Day-to-day use of power engines and the service products necessary for running them presents no problems if the persons occupied with their operation, maintenance and care are given suitable training and think as they work.

This summary is a compilation of the most important regulations, These are broken down into main sections which contain the information necessary for preventing injury to persons, damage to property and pollution. In addition to these regulations those dictated by the type of engine and its site are to be observed also.



IMPORTANT:

If despite all precautions, an accident occurs, in particular through contact with caustic acids, fuel penetrating the skin, scalding from oil, antifreeze being splashed in the eyes etc, consult a doctor immediately.

1.2. Handle compressed natural gas safety

Natural gas is highly flammable and explosive and may be extremely cold. The following cautions must be taken to avoid personal injury or engine damage

- Do not smoke when installing or servicing the engine or fuel system.
- Installation or servicing of natural gas equipment must only be conducted in well ventilated, natural gas compatible areas. Do not install or service equipment in an enclosed area where ignition sources are present without ensuring that an undetected gas leak may be safely vented without being ignited.
- Do not vent natural gas or permit leaks inside an enclosed area.

Bleed natural gas lines before installing or servicing any component connected to the fuel lines.



1.2.1. Avoid heating near pressurized fluid lines

- Wear welding goggles and gloves when welding or using an acetylene torch.
- Insure a that metal shield separated the acetylene and oxygen which must be chained to a cart.
- Do not weld or heat areas near fuel tanks or fuel lines.



1.2.2. Venting an operable engine to relieve natural gas pressure

- To avoid personal injury an operable natural gas engine must be kept in a well ventilated area away from open flames and sparks.
- If the engine can run, use the following venting procedure to relieve the natural gas pressure downstream of the shutoff valve.
 - 1) Shut off manual valves on natural gas supply tanks and main shutoff valve on natural gas fuel supply line.
 - 2) Start engine and run until it stalls due to fuel starvation.
 - 3) Check to make sure gauge pressure at point on the natural gas fuel line to be vented has been reduced to zero. If not, repeat step 1) Then repeat step 2).
 - 4) Disconnect vehicle batteries using switch in battery compartment or by disconnecting battery ground cable.
 - 5) Slightly loosen the NG fuel line fitting to be serviced in a well ventilated area to allow any remaining gas to vent.
 - 6) Completely open the fitting that was slightly opened and allow to vent in a well ventilated area.

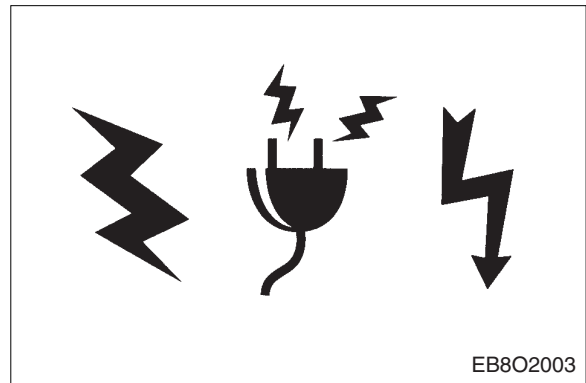

1.2.3. During commissioning, starting and operation



- This is the safety alert symbol. When you see this symbol in this manual, be alert to the potential for personal injury.



- Carefully read all safety message in this manual and on your safety signs. Be sure new equipment components and repair parts include the current safety signs.



- Avoid possible injury or death from runaway. Do not start engine by shorting across starter terminals.



- Prevent fires by keeping machine clean of accumulated trash, grease, fuel and debris.
- When the engine is running, do not get too close to the rotating parts.



- Do not touch the engine with bare hands when it is warm from operation risk of burns.



- Exhaust gases are toxic. If it is necessary to run an engine in an enclosed area, remove the exhaust gases from the area with an exhaust pipe extension. If you do not have an exhaust pipe extension, open the doors and get outside air into the area.



- Keep vicinity of engine free of oil and grease. Accidents caused by slipping can have serious consequences.

1.2.4. During maintenance and care



- Always carry out maintenance work when the engine is switched off. If the engine has to be maintained while it is running, e.g. changing the elements of change-over filters, remember that there is a risk of scalding. Do not get too close to rotating parts.
- Change the oil when the engine is warm from operation.



CAUTION:

There is a rise of burns and scalding. Do not touch oil drain plug or oil filters with bare hands.

- Take into account the amount of oil in the sump. Use a vessel of sufficient size to ensure that the oil will not overflow.
- Open the coolant circuit only when the engine has cooled down. If opening while the engine is still warm is unavoidable, comply with the instructions in the chapter "Maintenance and Care".
- Neither tighten up nor open pipes and hoses (lube oil circuit, coolant circuit and any additional hydraulic oil circuit) during the operation. The fluids which flow out can cause injury.



- Fuel is inflammable. Do not smoke or use naked lights in its vicinity. The tank must be filled only when the engine is switched off.



- When using compressed air, e.g. for cleaning the radiator, wear goggles.
- Keep service products (anti-freeze) only in containers which can not be confused with drinks containers.
- Comply with the manufacturer's instructions when handling batteries.



CAUTION:

Accumulator acid is toxic and caustic. Battery gases are explosive.

1.2.5. When carrying out checking, setting and repair work

- Checking, setting and repair work must be carried out by authorized personnel only.
- Use only tools which are in satisfactory condition. Worn open-end wrench slip. which could lead to Injury.
- When the engine is hanging on a crane, no-one must be allowed to stand or pass under it. Keep lifting gear in good condition.
- When working on parts which contain asbestos, comply with the notes.
- When checking spark plug do not put your hands under the electric.
- When working on the electrical system disconnect the battery earth cable first. Connect it up again last in prevent short circuits.



1.2.6. To prevent damage to engine and premature wear

- (1) If faults occur, find the cause immediately and have it eliminated in order to prevent more serious of damage.
- (2) Use only genuine DHIM spare parts. DHIM will accept no responsibility for damage resulting from the installation of other parts which are supposedly "just as good".
- (3) In addition to the above, note the following points.
 - Never let the engine run when dry, i.e. without lube oil or coolant.
 - Use only DHIM-approved service products (engine oil, anti-freeze and anticorrosion agent).
 - Have the engine maintained at the specified intervals.
 - Do not switch off the engine immediately when it is hot, but let it run without load for about 5 minutes so that temperature equalization can take place.
 - Never put cold coolant into an overheated engine. See "Maintenance and care".
 - Do not add so much engine oil that the oil level rises above the max. marking on the dipstick. Do not exceed the maximum permissible tilt of the engine. Serious damage to the engine may result if these instructions are not adhered to.
 - Always ensure that the testing and monitoring equipment (for battery charge, oil pressure, coolant temperature) function satisfactorily.
 - Do not let the raw water pump run dry, If there is a risk of frost, drain the pump when the engine is switched off.

1.2.7. To prevent pollution

(1) Engine oil, filter elements, fuel filters

- Take old oil only to an oil collection point.
- Take strict precautions to ensure that oil does not get into the drains or into the ground. The drinking water supply could be contaminated.
- Filter elements are classed as dangerous waste and must be treated as such.

(2) Coolant

- Treat undiluted anti-corrosion agent and / or antifreeze as dangerous waste.
- When disposing of spent coolant comply with the regulations of the relevant local authorities.

1.2.8. Notes on safety in handling used engine oil

Prolonged or repeated contact between the skin and any kind of engine oil decreases the skin. Drying, irritation or inflammation of the skin may therefore occur. Used engine oil also contains dangerous substances which have caused skin cancer in animal experiments. If the basic rules of hygiene and health and safety at work are observed, health risks are not to the expected as a result of handling used engine oil



Health precautions:

- Avoid prolonged or repeated skin contact with used engine oil.
- Protect your skin by means of suitable agents (creams etc.) or wear protective gloves.
- Clean skin which has been in contact with engine oil.
 - Wash thoroughly with soap and water, A nailbrush is an effective aid.
 - Certain products make it easier to clean your hands.
 - Do not use petrol, Diesel fuel, gas oil, thinners or solvents as washing agents.
- After washing apply a fatty skin cream to the skin.
- Change oil-soaked clothing and shoes.
- Do not put oily rags into your pockets.



Ensure that used engine oil is disposed of properly:

- Engine oil can endanger the water supply -

For this reason do not let engine oil get into the ground, waterways, the drains or the sewers. Violations are punishable.

Collect and dispose of used engine oil carefully. For information on collection points please contact the seller, the supplier or the local authorities.

1.2.9. General repair instructions



1. Before performing service operation, disconnect the grounding cable from the battery for reducing the chance of cable damage and burning due to short-circuiting.
2. Use covers for preventing the components from damage or pollution.
3. Engine oil and anti-freeze solution must be handled with reasonable care as they cause paint damage.
4. The use of proper tools and special tools where specified is important to efficient and reliable service operation.
5. Use genuine DAEWOO parts necessarily.
6. Used cotter pins, gaskets, O-rings, oil seals, lock washer and self-lock nuts should be discarded and new ones should be prepared for installation as normal function of the parts can not be maintained if these parts are reused.
7. To facilitate proper and smooth reassemble operation, keep disassembled parts neatly in groups. Keeping fixing bolts and nut separate is very important as they vary in hardness and design depending on position of installation.
8. Clean the parts before inspection or reassembly. Also clean oil ports, etc. using compressed air to make certain they are free from restrictions.
9. Lubricate rotating and sliding faces of parts with oil or grease before installation.
10. When necessary, use a sealer on gaskets to prevent leakage.
11. Carefully observe all specifications for bolts and nuts torques.
12. When service operation is completed, make a final check to be sure service has been done properly.

1.3. Engine Specifications

1.3.1. Specification

Items		Engine Model		
		GV158TIC	GV180TIC	GV222TIC
Engine type		Water-cooled, 4 cycle Vee type Turbo charged & intercooled		
Ignition system		Spark plug ignition		
Combustion chamber type		Open dish type		
Used fuel		NG(natural gas)		
Fuel supply system		Venturi mixer throttle valve type		
Cylinder liner type		Wet type, chromated or casting liner		
Timing gear system		Gear driven type		
No. of piston ring		2 Compression ring, 1 oil ring		
No. of cylinder-bore X stroke	(mm)	8 - 128 x 142	10 - 128 x 142	12 - 128 x 142
Total piston displacement	(cc)	14,618	18,273	21,927
Compression ratio		10.5 : 1		
Engine dimension (length X width X height)	(mm)	1,388 x 1,222 x 1,238	1,546 x 1,222 x 1,334	1,704 x 1,222 x 1,369
Engine weight	(kg)	950	1,175	1,509
Fuel injection order		1-5-7-2-6-3-4-8	1-6-5-10-2-7-3-8-4-9	1-12-5-8-3-10-6-7-2-11-4-9
Fuel ignition timing	Adjust angle	40° (B.T.D.C)		40° (B.T.D.C)
	Operate angle	14° (B.T.D.C)		12° (B.T.D.C)
Engine control system		ECM(engine control module) type		
Compression pressure (kg/cm ²)		16 (at 200 rpm)		
Intake and exhaust valve clearance (at cold) (mm)		0.30/0.40		
Intake valve	Open at	24° (B.T.D.C)		
	Close at	36° (A.B.D.C)		
Exhaust valve	Open at	63° (B.B.D.C)		
	Close at	27° (A.T.D.C)		
Lubrication method		Pressurized circulation		
Oil pump type		Gear type driven by crank shaft		
Engine oil pressure	Low idle	0.8 ~ 1.4		
	High idle	3.0 ~ 4.8		
Oil filter type		Full-flow, cartridge type		
Lubricating oil capacity (max./min.)	(lit)	28/26	35/28	40/33
Oil cooler type		Water cooled		
Water pump type		Belt driven centrifugal type		
Cooling Method		Pressurized circulation		
Cooling water capacity (engine only)	(lit)	20	21	23
Thermostat type		Wax pallet type (71 ~ 85°C)		
Alternator voltage - capacity (V - A)		24 - 45		
Starting Motor voltage - output (V - kW)		24 - 6.6		
Fuel system	System	Air-Fuel mixer		
	Control	Throttle valve control		

Items		Engine Model		
		GV158TIC	GV180TIC	GV222TIC
Ignition system	Ignition type	One coil per cylinder (no waste spark)		
	Spark plug	Iridium plug		
	Spark plug gap	0.39 ~ 0.4		
	Ignition coil	Inductive coil pack		
	Ignition timing adjustment	Controlled by ESC and ICM		
Control system	Control system	On-highway heavy-duty		
	Voltage (V)	24		
	Component	ESC, ICM, sensor, harness		
Turbo charger	Model	Holset HX35	Holset HX40	Holset HX50
	Type	Water cooled, Exhaust gas driving		
	Exhaust gas temperature (°C)	Max. 560		
Battery capacity	(V - AH)	24 - 200		

1.3.2. Engine Power

Production tolerance : $\pm 5\%$

Engine model		Condition		
		Stand-by	Prime	Continuous
GV158TIR	50 Hz (1,500 rpm)	253 kW (344 PS)	230 kW (313 PS)	207 kW (281 PS)
	60 Hz (1,800 rpm)	300 kW (408 PS)	270 kW (367 PS)	243 kW (330 PS)
GV158TIC	50 Hz (1,500 rpm)	-	230 kW (313 PS)	207 kW (281 PS)
	60 Hz (1,800 rpm)	-	270 kW (367 PS)	243 kW (330 PS)
GV180TIR	50 Hz (1,500 rpm)	319 kW (434 PS)	290 kW (394 PS)	261 kW (355 PS)
	60 Hz (1,800 rpm)	375 kW (510 PS)	340 kW (462 PS)	306 kW (416 PS)
GV180TIC	50 Hz (1,500 rpm)	-	290 kW (394 PS)	261 kW (355 PS)
	60 Hz (1,800 rpm)	-	340 kW (462 PS)	306 kW (416 PS)
GV222TIR	50 Hz (1,500 rpm)	385 kW (523 PS)	350 kW (476 PS)	315 kW (428 PS)
	60 Hz (1,800 rpm)	451 kW (613 PS)	410 kW (557 PS)	369 kW (502 PS)
GV222TIC	50 Hz (1,500 rpm)	-	350 kW (476 PS)	315 kW (428 PS)
	60 Hz (1,800 rpm)	-	410 kW (557 PS)	369 kW (502 PS)

Note : All data are based on operation without cooling fan at ISO 3046.

1.4. Engine Assembly

1.4.1. Engine Sectional View (longitudinal)

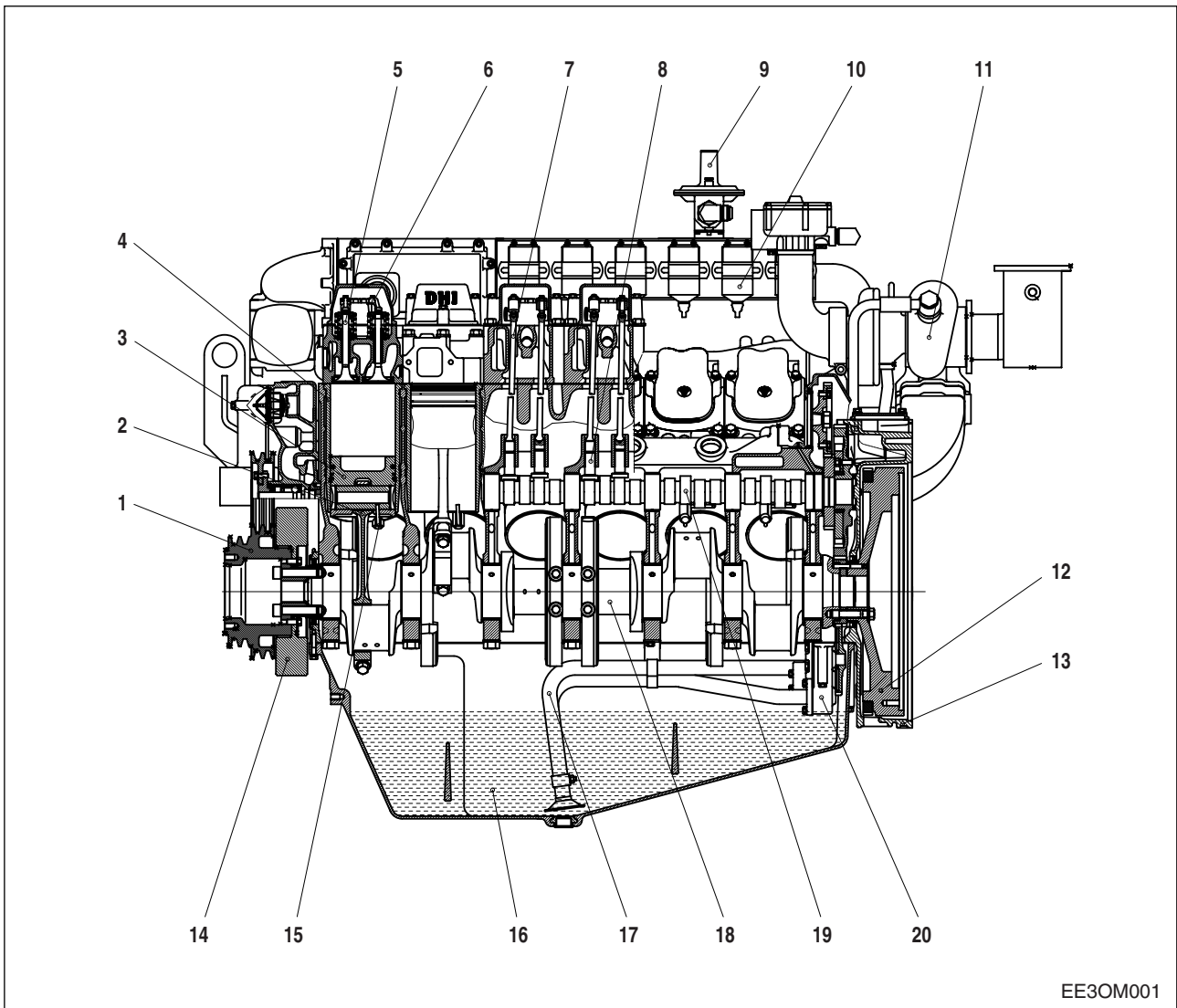

EE3OM001

- | | |
|-----------------------|-----------------------|
| 1. Crank shaft pulley | 11. Turbo charger |
| 2. Connecting rod | 12. Flywheel |
| 3. Piston | 13. Fly wheel housing |
| 4. Cylinder liner | 14. Vibration damper |
| 5. Valve | 15. Oil spray nozzle |
| 6. Rocker arm | 16. Oil pan |
| 7. Push rod | 17. Oil suction pipe |
| 8. Tappet | 18. Crank shaft |
| 9. Gas regulator | 19. Cam shaft |
| 10. Ignition coil | 20. Oil pump |

1.4.2. Engine Sectional View (cross)

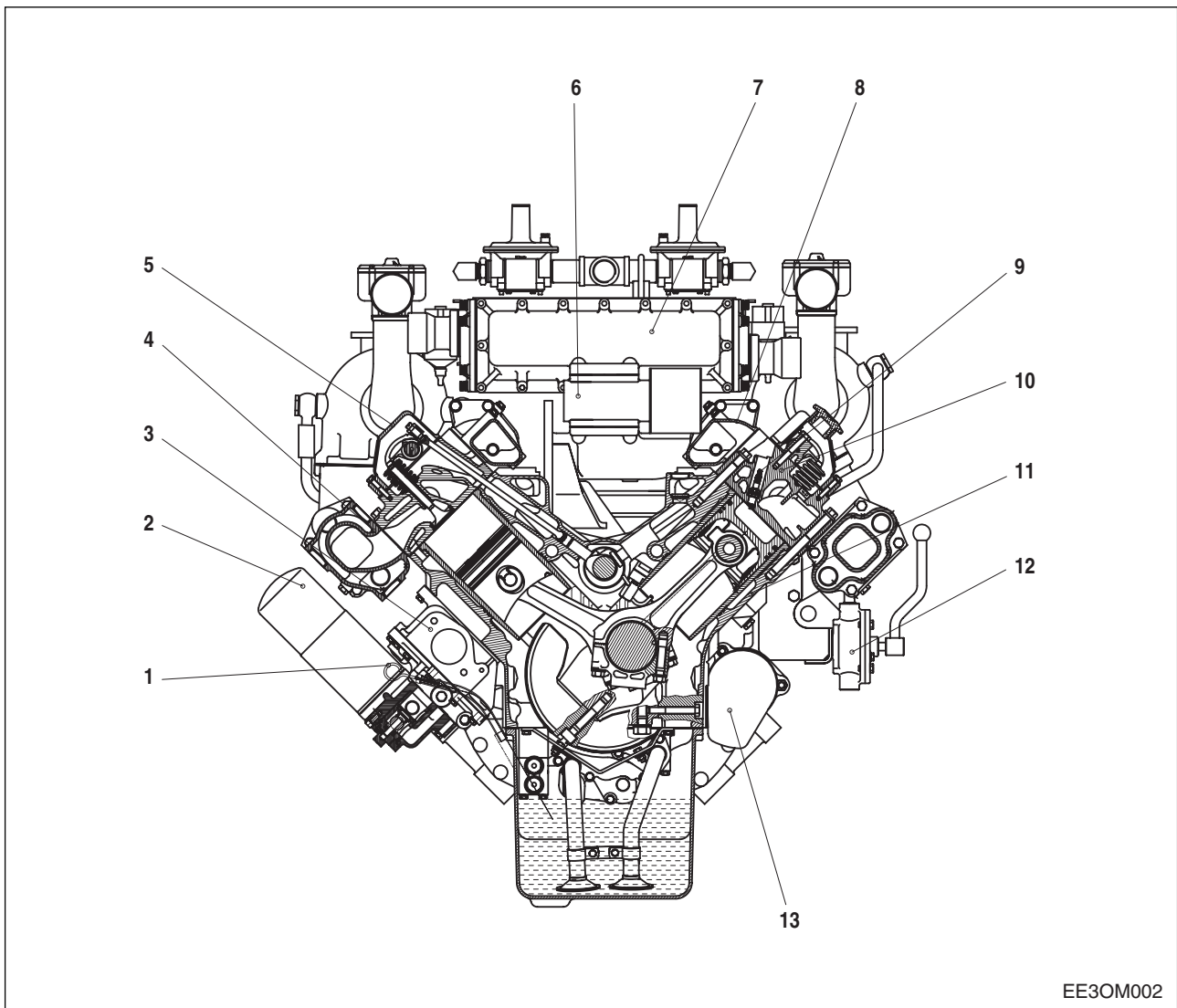

EE3OM002

- | | |
|------------------------|--------------------|
| 1. Oil level gauge | 8. Intake manifold |
| 2. Oil filter | 9. Spark plug |
| 3. Oil cooler | 10. Cylinder head |
| 4. Exhaust manifold | 11. Cylinder block |
| 5. Cylinder head cover | 12. Oil drain pump |
| 6. Throttle valve | 13. Starting motor |
| 7. Inter cooler | |

1.4.3. Engine Assembly Views

(1) GV158TIC

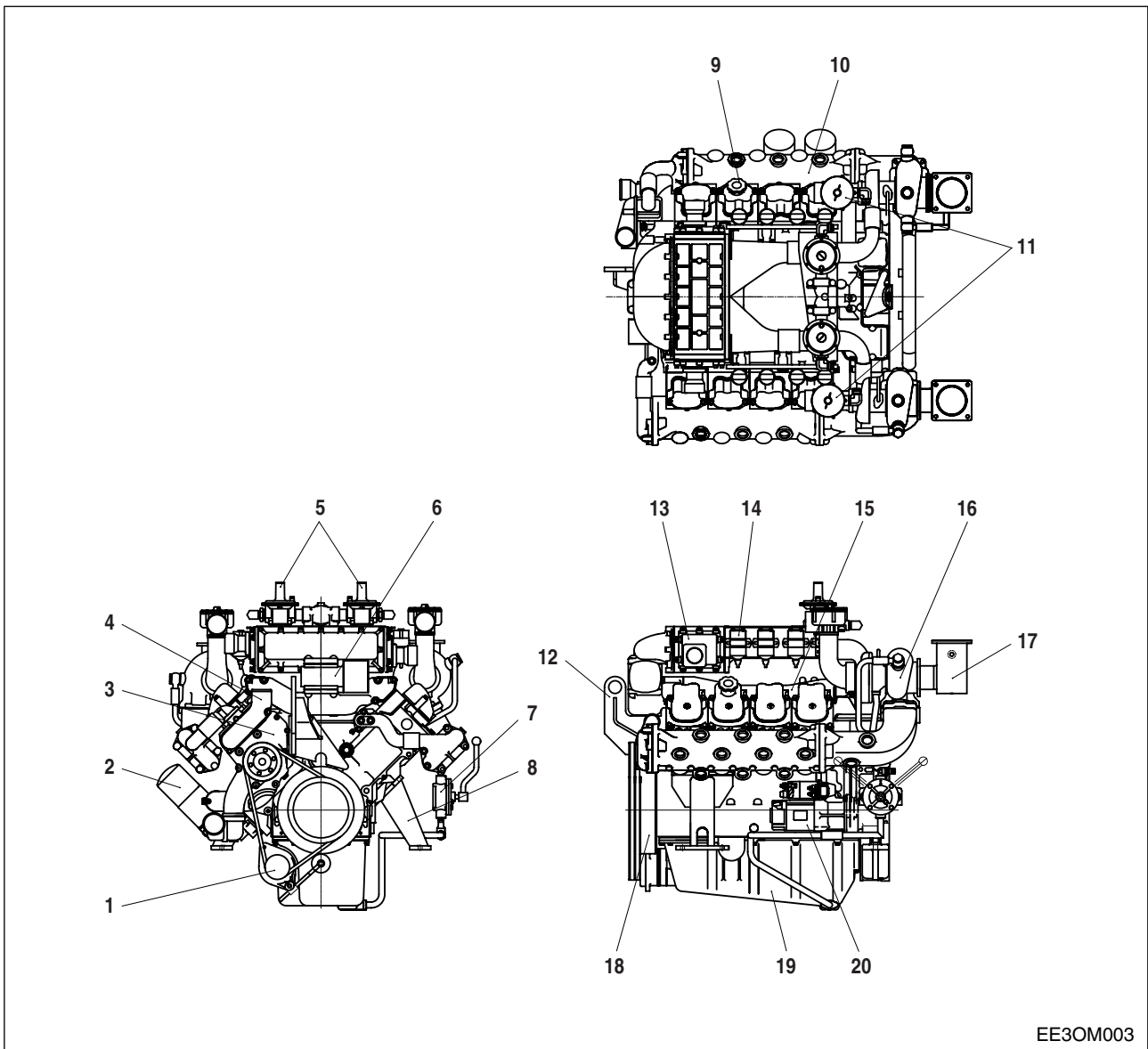

- | | |
|----------------------------|----------------------|
| 1. Alternator | 11. Gas fuel mixer |
| 2. Oil cooler & oil cooler | 12. Lifting hook |
| 3. Cooling water pump | 13. Inter cooler |
| 4. Water outlet | 14. Ignition coil |
| 5. Gas pressure regulator | 15. Intake manifold |
| 6. Throttle valve | 16. Turbo charger |
| 7. Oil drain pump | 17. Exhaust elbow |
| 8. Mounting bracket | 18. Vibration damper |
| 9. Oil filler cap | 19. Oil pan |
| 10. Exhaust manifold | 20. Starting motor |

(2) GV180TIC

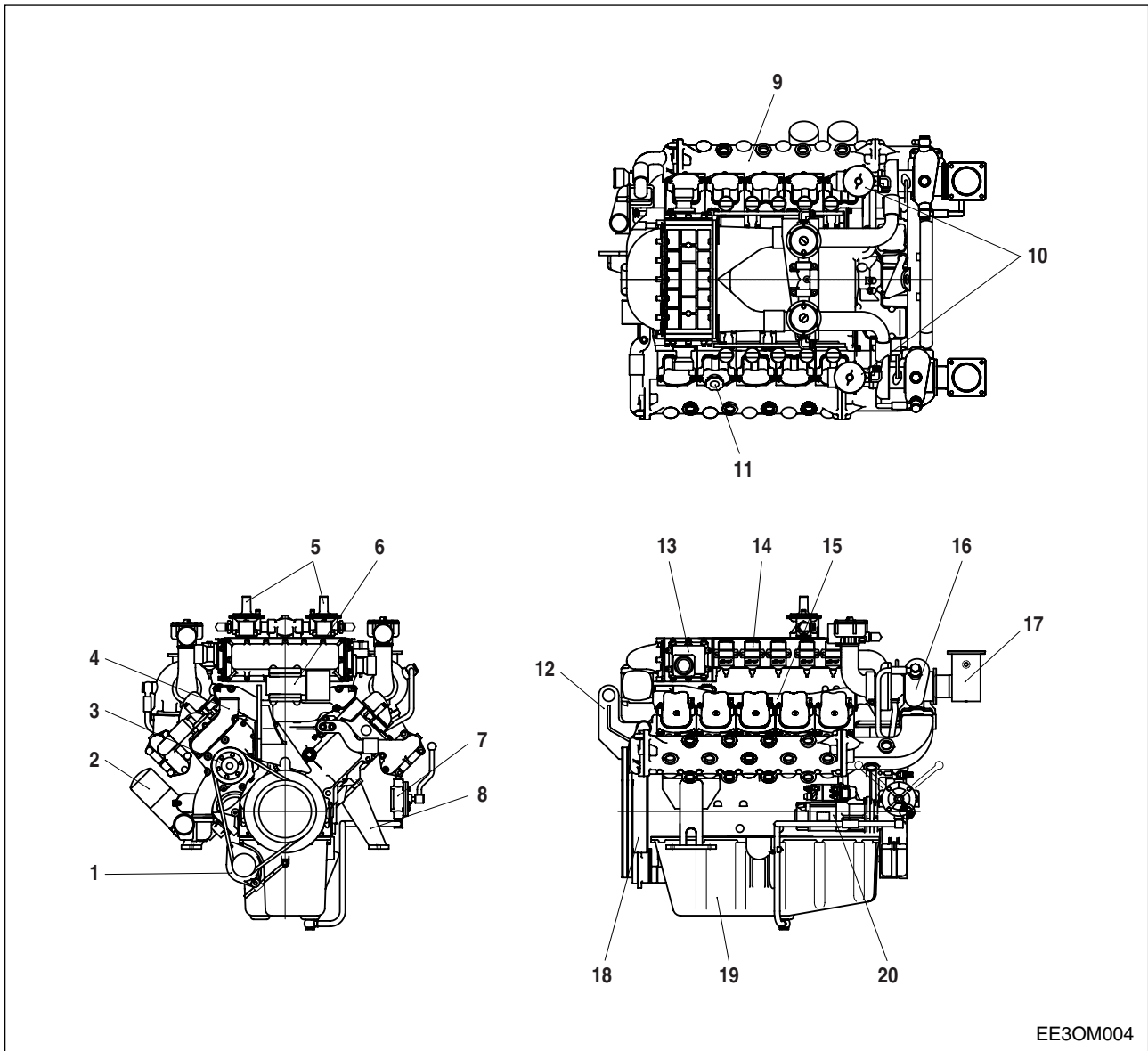

EE3OM004

- | | |
|----------------------------|----------------------|
| 1. Alternator | 11. Gas fuel mixer |
| 2. Oil cooler & oil cooler | 12. Lifting hook |
| 3. Cooling water pump | 13. Inter cooler |
| 4. Water outlet | 14. Ignition coil |
| 5. Gas pressure regulator | 15. Intake manifold |
| 6. Throttle valve | 16. Turbo charger |
| 7. Oil drain pump | 17. Exhaust elbow |
| 8. Mounting bracket | 18. Vibration damper |
| 9. Oil filler cap | 19. Oil pan |
| 10. Exhaust manifold | 20. Starting motor |

(3) GV222TIC

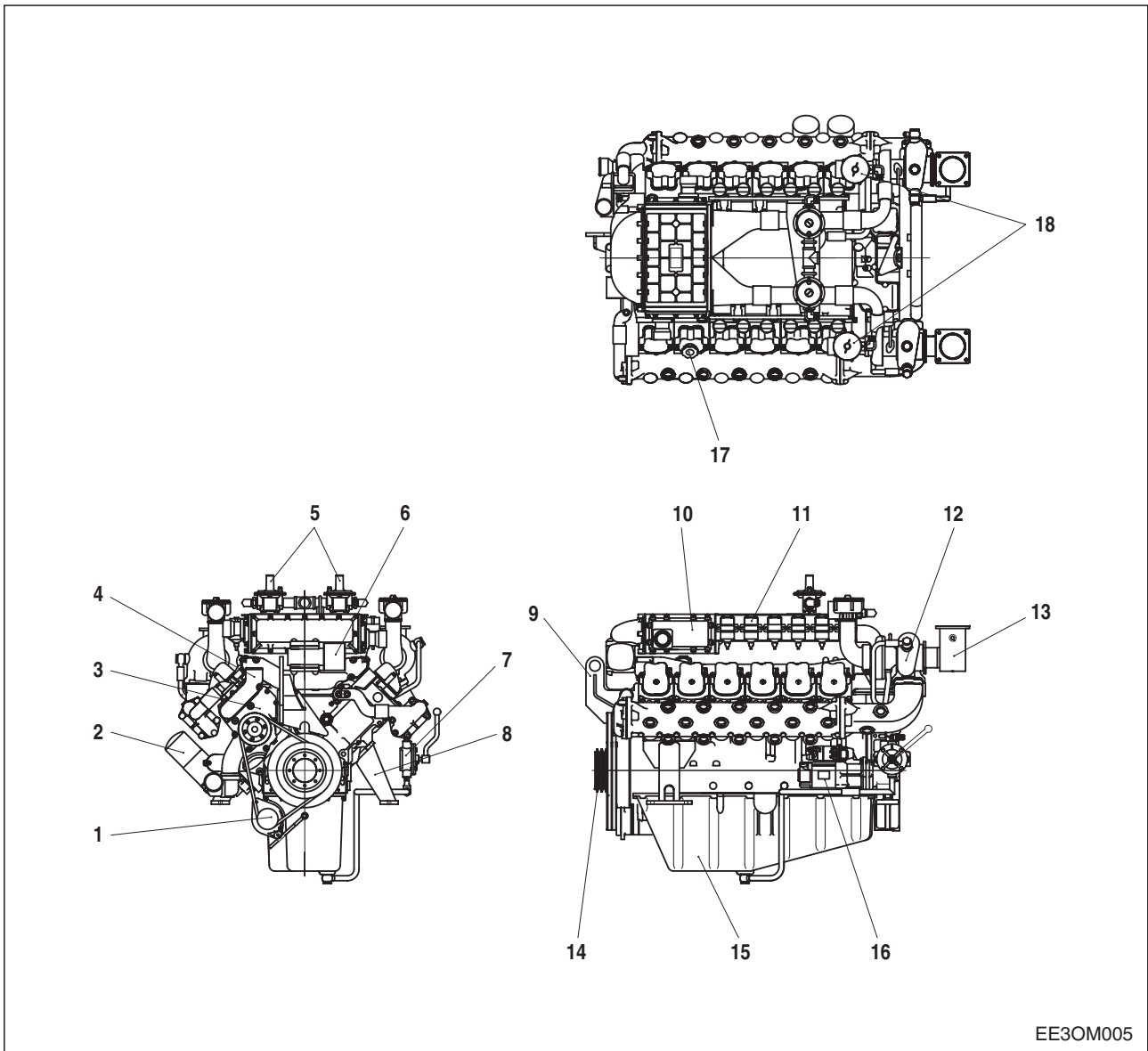

- | | |
|---------------------------|------------------------|
| 1. Alternator | 10. Inter cooler |
| 2. Oil filter & cooler | 11. Ignition coil |
| 3. Cooling water pump | 12. Turbo charger |
| 4. Water outlet | 13. Exhaust elbow |
| 5. Gas pressure regulator | 14. Crank shaft pulley |
| 6. Throttle valve | 15. Oil pan |
| 7. Oil drain pump | 16. Starting motor |
| 8. Mounting bracket | 17. Oil filler cap |
| 9. Lifting hook | 18. Gas fuel mixer |

2. Technical Information

2.1. Engine model and serial number

- The engine model and serial number is located on the engine as illustrated.
- These numbers are required when requesting warranty and ordering parts. They are also referred to as engine model and serial number because of their location.

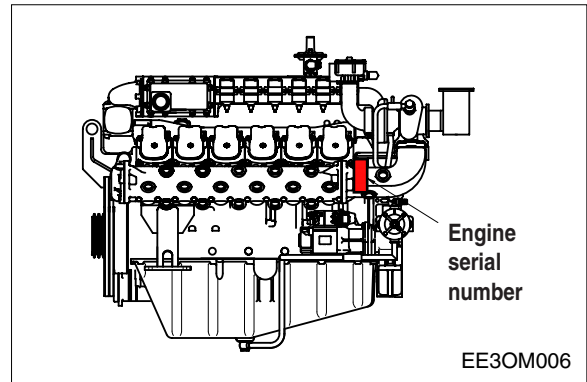

• Engine serial No. (example1 : GV158TIC)

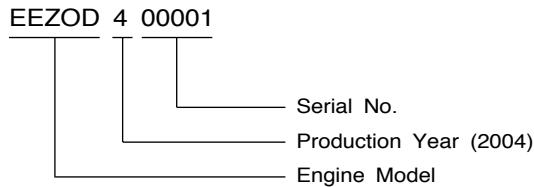

• Engine serial No. (example1 : GV180TIC)

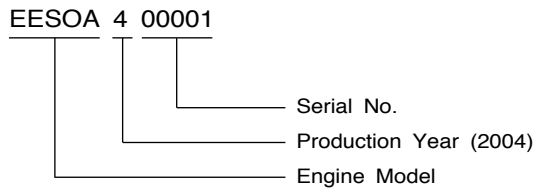

• Engine serial No. (example1 : GV222TIC)

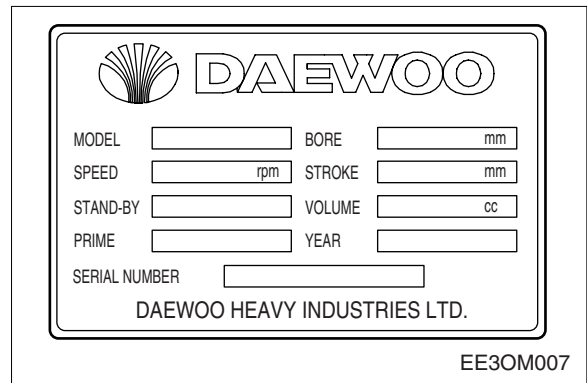
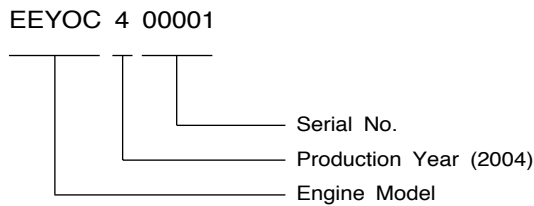

2.2. Diagnostic display module(CPU-95)

- The diagnostic display module is designed to operate in conjunction with a variety of display/control options.
- This facilitates the application of diagnostic display module systems to gas engines operating at varying stages of automation and sophistication.



CAUTION:

1. Do not connect or disconnect the diagnostic display module to/from the wiring harness without first removing the negative (-) battery cable from the battery.
2. Do not perform remove the inner parts of the Diagnostic display module.

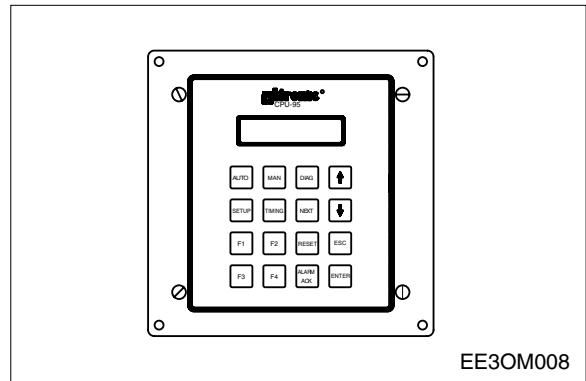

2.3. Engine characteristic

The DAEWOO **GV158TIC**, **GV180TIC**, **GV22TIC** natural gas engine is an overhead valve, turbo charged, water-to-air charge cooled, electronically controlled engine

2.3.1. Design characteristic

- Spark-ignited by the spark plug
- Electric engine control through the ECM(engine control module) system
- Turbocharger with a water cooled bearing-housing

2.3.2. Natural gas

- Natural gas is a clean burning fuel, and offers a low particulate emission. Natural gas is also a very economical fuel.
- From the gas producing areas in the country, the distribution companies and local utilities from a complex nation-wide-delivery-network that supplies natural gas for home and industry use. The network is highly developed and extended to all major population center in the country.

2.3.3. Engine ignition system

- This system changes the general combustion concept of the diesel engine. Specifically, it changes a compression-ignition diesel to a spark-ignited engine. However, this engine is unlike the typical generator engine that has spark plugs.
- The primary difference is this system uses a combustion concept. That is, excess air is mixed in with the combustion system. When combined with a gaseous fuel like natural gas, it allows greatly reduced emissions compared to diesel, plus high efficiencies and excellent high-performance.
- The GV158TIC, GV180TIC, GV222TIC engine is an integrated package featuring computer-controlled electronic engine system by the engine speed controller. This system controls fuel, ignition and speed, and has engine protection features.

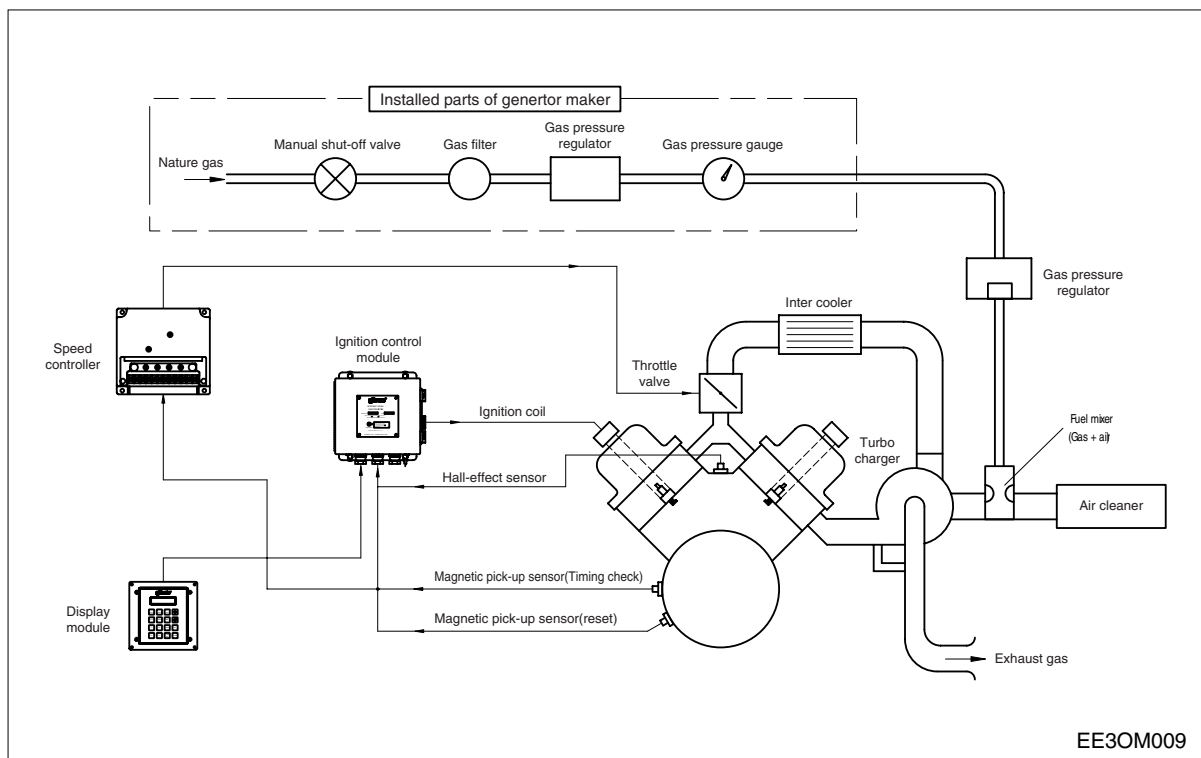

2.3.4. Engine speed controller : ESC

- The Engine Speed Control is designed to provide basic isochronous speed control for gas engines using the Flo-Tech Throttle.
- Engines with mechanical loads and generator loads are handled equally well.



2.3.5. Ignition control module : ICM

- This digital ignition system has been designed for application on nature gas fueled engines.
- This system is offers a variety of advanced control, emissions reduction, primary and spark diagnostics, self diagnostic serial communications and engine protection features.

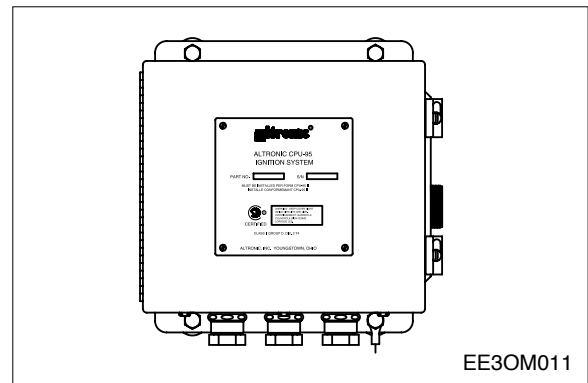

2.3.6. Cylinder block

- The cylinder block is a single piece of alloy cast iron. To increase its stiffness, it is extended to a level below the crankshaft center line. The engine has replaceable wet cylinder liners and individual cylinder heads.

2.3.7. Piston, con-rod and crankshaft

- The forged crankshaft has screwed-on the balance weights. Radial seals with replaceable wearing rings on crankshaft and flywheel are provided to seal the crankcase penetrations.
- The connecting rods are die-forged, diagonally split and can be removed through the top of the cylinders together with the pistons. Crankshaft and connecting rods run in steel-backed lead bronze ready-to fit type bearings.

2.3.8. Engine timing

- Camshaft, oil pump and hall-effect sensor are driven by a gear train arranged at the flywheel end.

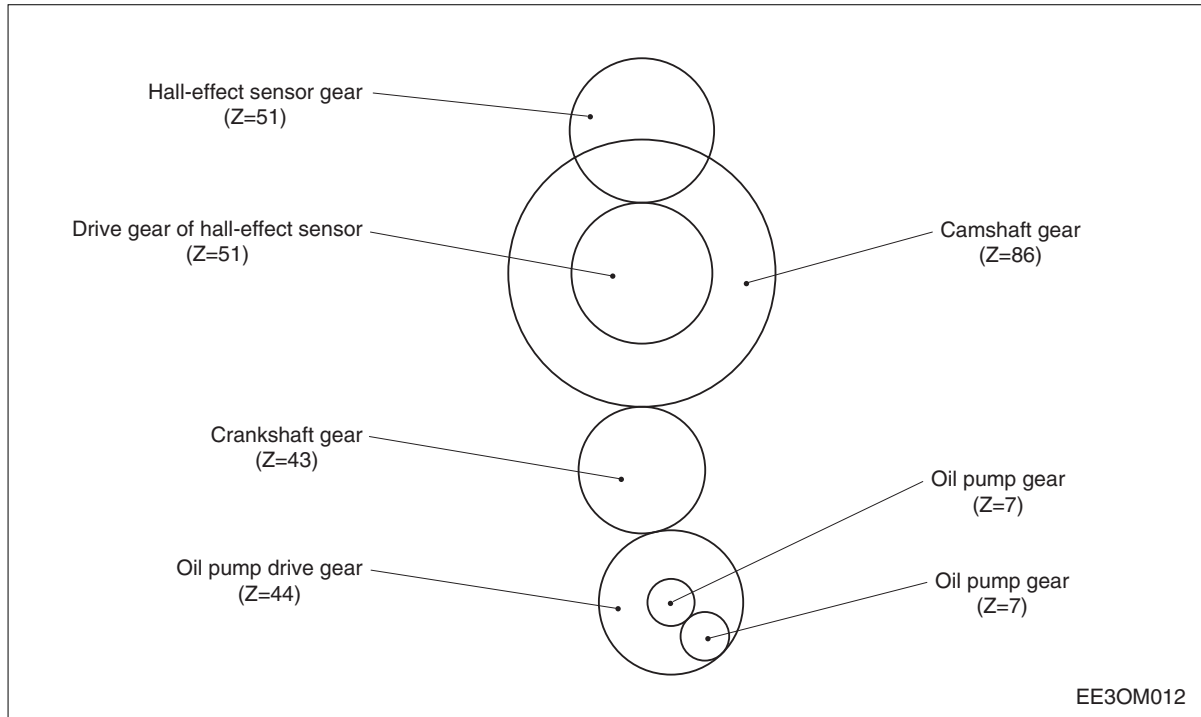

2.3.9. Valves

- The overhead valves are actuated via chilled cast iron tappets, push rods and rocker arms from the camshaft

2.3.10. Engine lubrication system

- The engine is equipped with force-feed lubrication. The pressure is produced by a gear pump whose drive gear is in direct mesh with the crankshaft gear at the flywheel end.
- The oil pump draws the oil from the oil sump and delivers it through the oil filter and oil cooler to the main distributor gallery and from there to the main bearings, big-end bearings and camshaft bearings as well as to the small-end bearings and the rocker arms.
- The turbocharger is also connected to the engine lubricating system. The cylinder walls and timing gears are splash-lubricated.
- Each cylinder has an oil jet provided for cooling the underside of the pistons. The lube oil is cleaned in a full-flow oil filter.

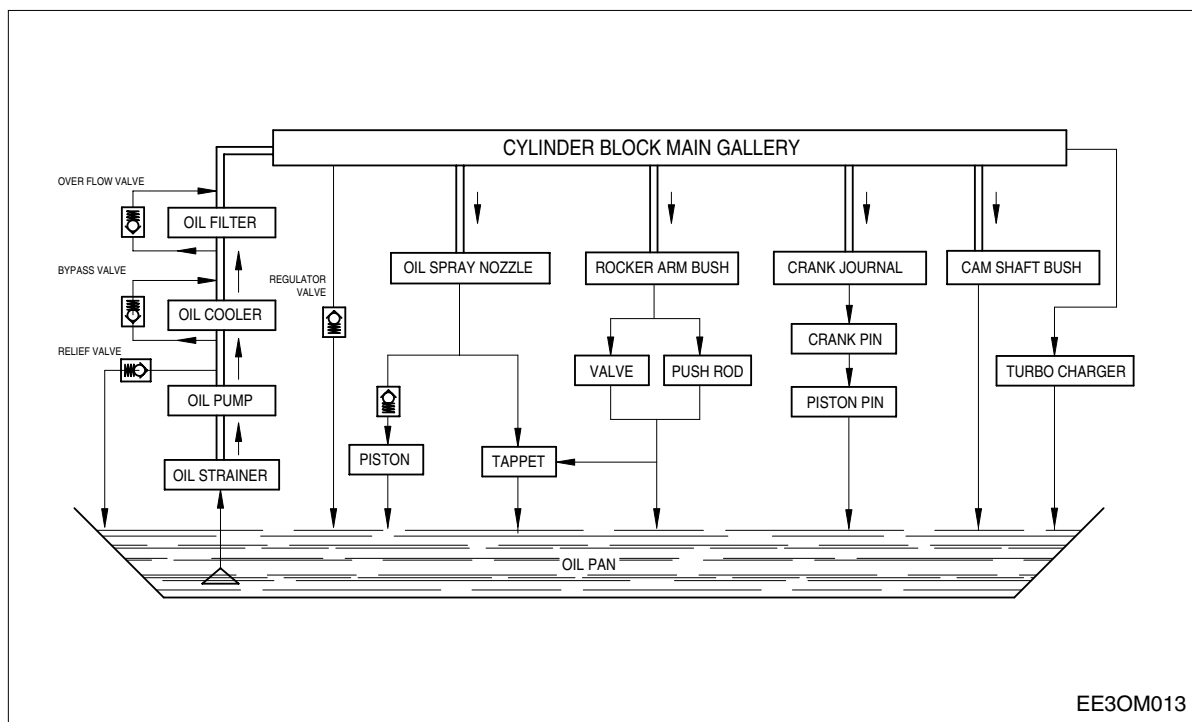

- Depending on the agreed extent of delivery and the design of the engine, the lube oil circuit can be equipped with oil pressure monitors (advance warning and cut-off function) which shut the engine down in the event of a sudden loss of pressure

2.3.11. Oil cooler

- An oil cooler is provided between the oil filter and the crankcase. This cooler is of the flat tube type with turbulence inserts and operated by the coolant

2.3.12. Engine oil



- Check oil level with the oil level gauge and replenish if necessary.
- Check the oil level with the engine cooled. If the engine is warm, allow time for 5 ~ 10 minutes for oil drain into the crankcase before checking oil level. The oil level must be between **Max.** and **Min.** lines on the gauge.
- Engine oil should be changed at the specified intervals. Oil in the oil filter cartridge should be changed simultaneously.

First oil change		After 50hr operation
Engine model	GV158TIC	every 200hr
	GV180TIC	
	GV222TIC	

• The following oils are also recommended

SAE No.	API No.	Sulfated ash content
15W40	above CD or CE	Bellow 0.5 %

Recommend oil : TOTAL LMG-405

Mobil Delvac super GEO 15W40

• Engine oil capacity

Engine oil capacity			
Engine model	in Oil pan		Total (lit)
	Max. (lit)	Min. (lit)	
GV158TIC	28	26	31
GV180TIC	35	28	38
GV222TIC	40	33	43

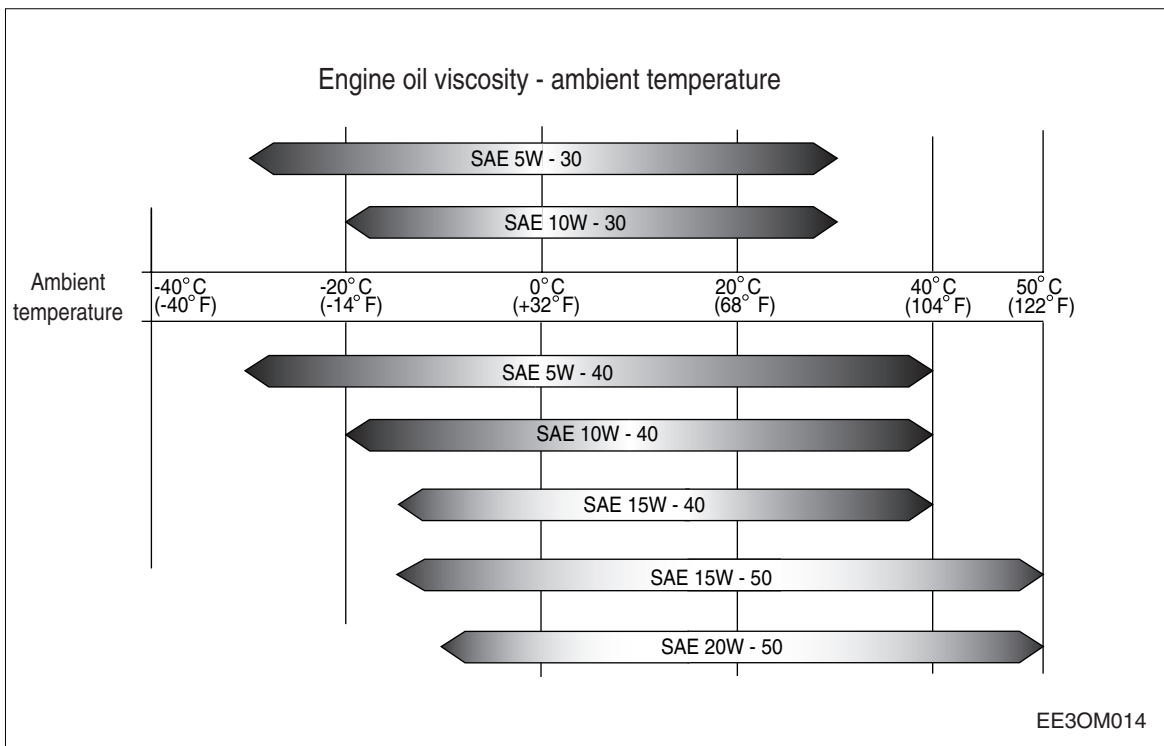

2.3.13. Exchanging of lubrication oil

- Engine oil and the oil filter are important factors affecting engine life. They affect ease of starting, fuel economy, combustion chamber deposits and engine wear.
- While the oil is still hot, discharge the sump oil by motion oil drain pump lever manually as figure.
- Refill new engine oil to the filler neck on the head cover in accordance with the oil capacity of the engine. Be careful about the mixing of dust or contaminator during the supplement of oil. Then confirm whether the oil level gauge indicates the vicinity of its maximum level.
- For a few minutes, operate the engine at idling in order to circulate oil through lubrication system. Thereafter shut down the engine. After waiting for about 10 minutes measure the quantity of oil and refill the additional oil if necessary.

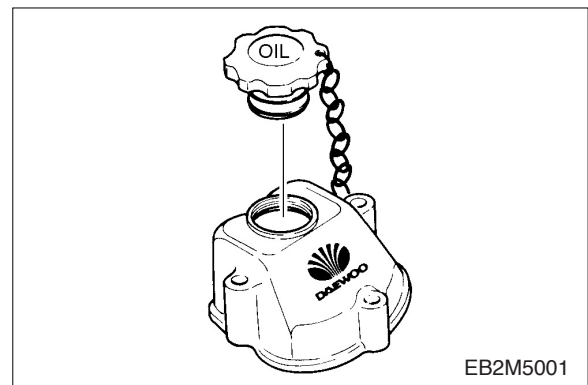
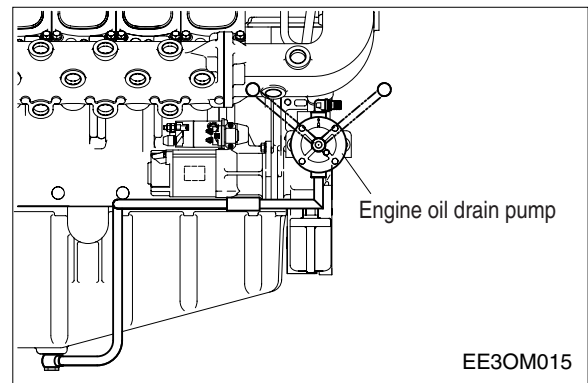

2.3.14. Replacement of oil filter cartridge

- Every time oil exchanges, replace the oil filter cartridge.
- Drain engine oil by loosening the drain plug on the filter head.



CAUTION:

Don't forget tightening the drain plug after having drained engine oil.

- Remove the oil filter by turning it counter-clockwise with a filter wrench.
- Wipe, clean the fitting face of the filter body and the oil filter body with a rag so that the new oil filter cartridge can be seated properly.
- Lightly oil the O-ring and turn the oil filter until O-ring is fitted against the seal face. And then turn it in addition by 3/4 ~1 turns further with hand or the filter wrench.

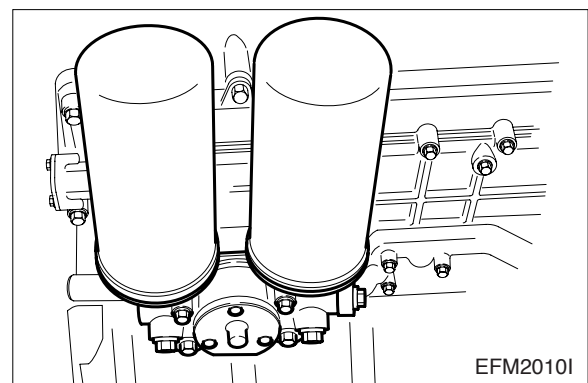



NOTE:

It is strongly advisable to use DAEWOO genuine oil filter cartridge for replacement.

2.3.15. Cooling System

- The engine has a liquid-cooling system. The water pump is a maintenance-free impeller pump driven by V-belts from the crankshaft pulley.
- Depending on the agreed extent of delivery and the design of the engine, the coolant circuit can be equipped with temperature monitors which, in the event of loss of coolant, shut the engine down.

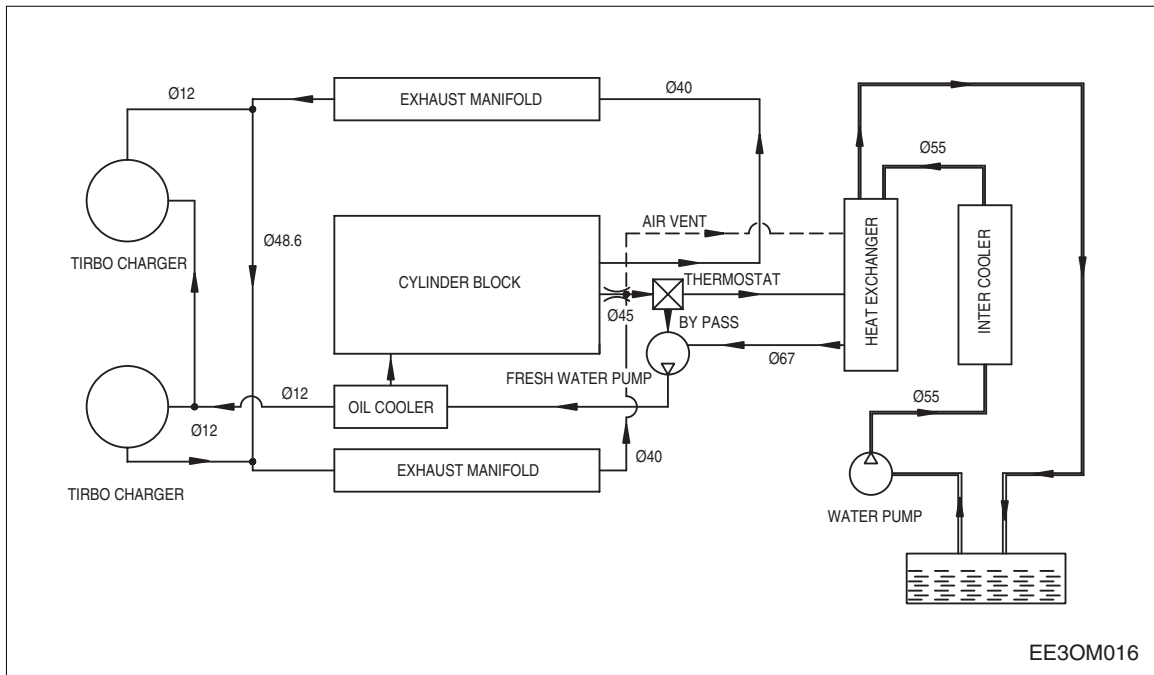

2.3.16. Cooling water

- Regarding the cooling water that is to be used for engine, the soft water not the hard water must be used.
- The engine cooling water can be used diluting it with antifreezing solution 40% and the additive for rust prevention (DCA4) 3 ~ 5 %.
- The density of above solution and additive must be inspected every 500 hours to maintain it properly.



NOTE:

The proper density control of antifreezing solution and rust preventing additive will be able to prevent the rusting effectively and maintain the stable quality of engine.

For the improper control might give the fatal damage to the cooling water pump and cylinder liners, detail care is needed.

- Since **GV158TIC**, **GV180TIC**, **GV222TIC**(Engine of **D28** base engine) cylinder liner is wet type, particularly the cooling water control should be applied thoroughly.
- The density of antifreezing solution and additive for rust prevention is able to be confirmed by the cooling water test kit. (Fleetguard no. : **CC2602M** or DAEWOO no. : **60.99901-0038**)
- How to use the cooling water test kit
 - (1) When the cooling water temp. of engine is in the range of 10 ~ 55°C, loosen the plug for cooling water discharge and fill the plastic cup about a half.



NOTE:

In taking the cooling water sample, if the water in auxiliary tank were taken, it is hard to measure the accurate density. Take the cooling water sample necessarily loosening the cooling water discharge plug.

- (2) At the state of a test paper soaked in the sampled water, after taking the paper out through water agitation, shake off the water.
- (3) Wait for about 45 sec. till the color change of test paper.



NOTE:

However, it should not elapse longer than 75 sec, and if it did, the hue would change.

- (4) Make the numerical value by comparing the test paper which hue has changed with the color list of label on storage bottle.
- (5) By comparing the hue changed into yellowish green or so with the green color indication of test paper storage bottle, confirm the density. (Then, the density indication must be in the hue range of 33% to 50%).
- (6) The brown at the middle of test paper and the lower pink color indication represent the additive state for rust prevention, and the proper range is that the meeting numerical value of brown (vertical) and pink color (horizontal) locates in the range of 0.3 to 0.8 at the color list of label on the test paper storage bottle.
- (7) In case of less than 0.3, replenish the additive for rust prevention (DCA4), and in case of more than 0.8, pour out the cooling water about 50% and then readjust the density after refilling with clean fresh water.

- Amount of Anti-freeze in winter

Ambient Temperature (°C)	Cooling water (%)	Anti-freeze (%)
Over -10	85	15
-10	80	20
-15	73	27
-20	67	33
-25	60	40
-30	56	44
-40	50	50

2.3.17. V-belt

- Use a V - belt of specified dimensions, and replace if damaged, frayed, or deteriorated.
- Check the V - belt for belt tension. If belt tension is lower than the specified limit, adjust the tension by relocating the alternator. (specified deflection: 10 ~ 15 mm when pressed down with thumb)

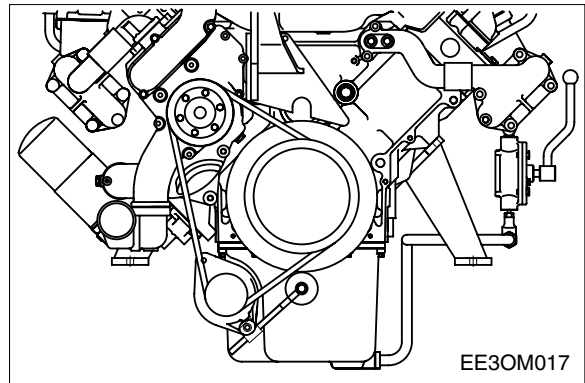

2.3.18. Air Cleaner

- Air cleaner is mounted on the engine to purify the air for combustion. The intervals at which the air cleaner requires servicing depend on the specific operating conditions encountered. Clogged air filters may cause black smoke and reduce power.
- A check should be made from time to time to see that the fastening elements securing the air cleaner to the intake manifold seal the connection tightly. Any ingress of unfiltered air is liable to cause a high rate of cylinder and piston wear.

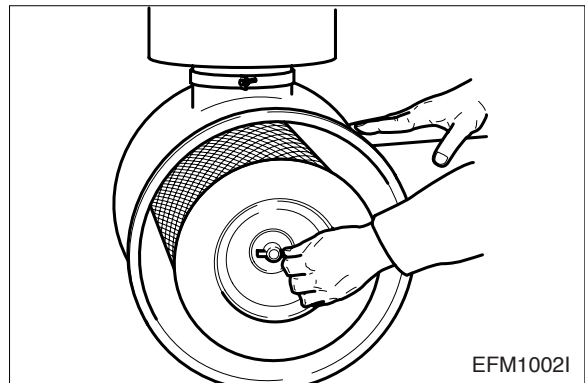

2.3.19. Intercooler

- The intercooler is water to air type. The intercooler life and performance depends on the intake air condition greatly. Fouled air pollutes and clogs the air fins of intercooler. As a result of this, the engine output is decreased and engine malfunction is occurred.
- So you always check whether the intake air systems like air filter element are worn or polluted.

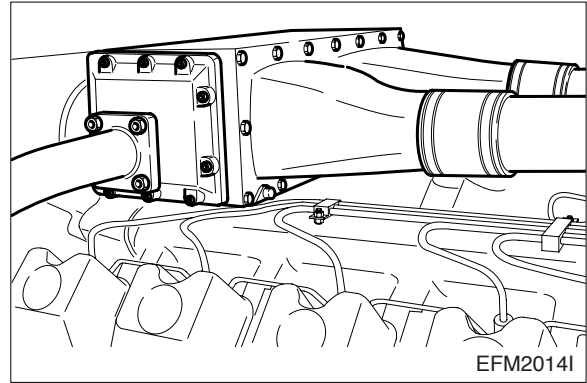

2.3.20. Valve Clearance Adjust Procedure



- After letting the #1 cylinder's piston come at the compression top dead center by turning the crankshaft, adjust the valve clearances.



- Loosen the lock nuts of rocker arm adjusting screws and push the feeler gauge of specified value between a rocker arm and a valve stem and adjust the clearance with adjusting screw respectively and then tighten with the lock nut.
- As for the valve clearance, adjust it when in cold, as follows.

Model	Intake Valve	Exhaust Valve
GV158TIC	0.30 mm	0.40 mm
GV180TIC		
GV222TIC		

• Adjusting Sequence of Valve Clearance (1 Type)

- By cranking the engine, let #1 cylinder's valves overlap.
- In time, adjust the valve clearance corresponding to " ⇨ " of lower lists.
- In time, turning crankshaft one full turn, let the valves of #7 (10 cylinder engine) or #6 (8 cylinder engine and 12 cylinder engine) cylinder's valves overlap.
- Adjust the valve clearance corresponding to " ➡ " of lower lists.
- After reinsuring the valve clearances, retighten if necessary.

- No. 1 Cylinder is located at the side where cooling water pump was installed.

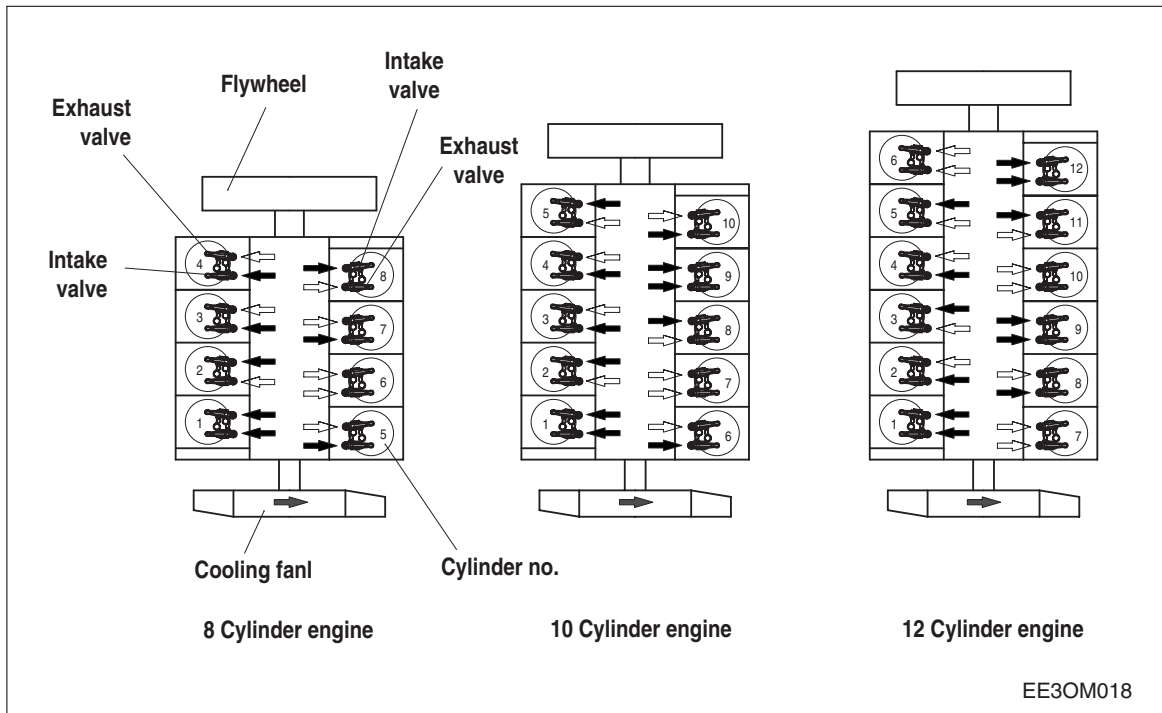

- **Adjusting Sequence of Valve Clearance (2 Type)**

Type 1 is the conventional and simple method, but if you have some problem to adjust your engine, please try type 2 sequence. This is a precision method, but it takes more time.

- * **8 Cylinder Engine (GV158TIC)**

Valve overlapping on cylinder (Intake & Exhaust valve)	1	5	7	2	6	3	4	8
Adjusting valves on cylinder (Intake & Exhaust valve)	6	3	4	8	1	5	7	2

- * **10 Cylinder Engine (GV180TIC)**

Valve overlapping on cylinder (Intake & Exhaust valve)	1	6	5	10	2	7	3	8	4	9
Adjusting valves on cylinder (Intake & Exhaust valve)	7	3	8	4	9	1	6	5	10	2

- * **12 Cylinder Engine (GV222TIC)**

Valve overlapping on cylinder (Intake & Exhaust valve)	1	12	5	8	3	10	6	7	2	11	4	9
Adjusting valves on cylinder (Intake & Exhaust valve)	6	7	2	11	4	9	1	12	5	8	3	10

2.3.21. Cylinder Compression Pressure



- Stop the engine after warming up, and take out the spark plug.

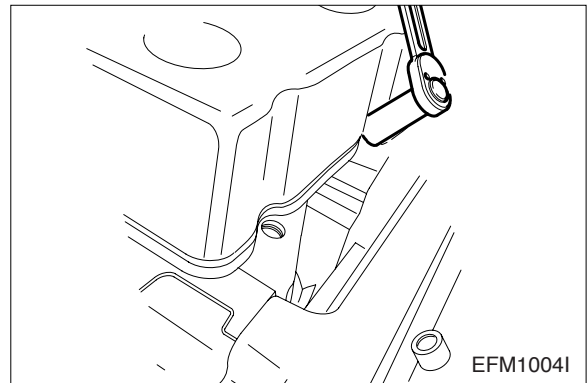

- Install the special tool (compression gauge adapter) at the spark plug hole, and connect the compression pressure gauge there.



Standard value	16kg/cm ² over
Limit value	13kg/cm ²
Difference between each cylinder	Within $\pm 10 \%$

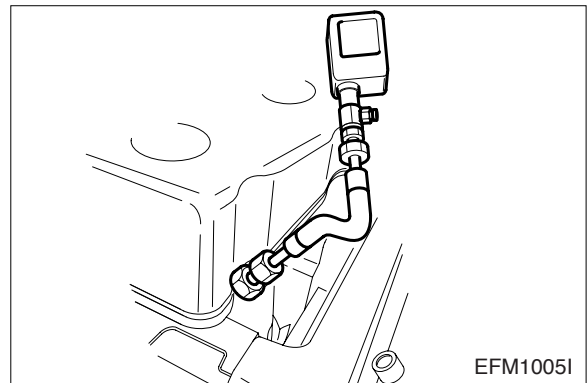

- Condition : Water temperature 20°C,
Engine rotation 200rpm

2.3.22. Spark plug



- Remove spark plug. Clean threads by hand with brush and solvent.
- Clean any deposits from electrode and Inspect insulator area
- Measure the spark plug distance at electrode position.(A)
- Replace spark plug if necessary.

	Standard
Distance(A)	0.39 ~ 0.40 mm

- Install spark plug.

Torque	2.5 ~ 3.0 kg.m
--------	----------------

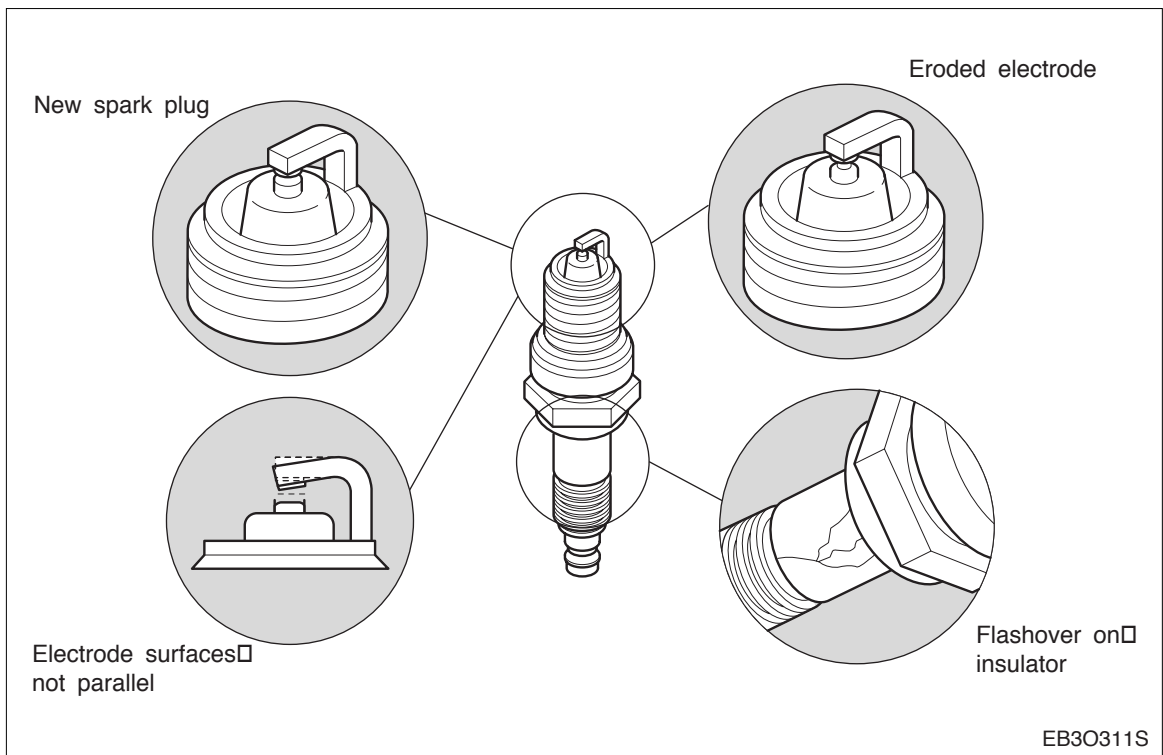
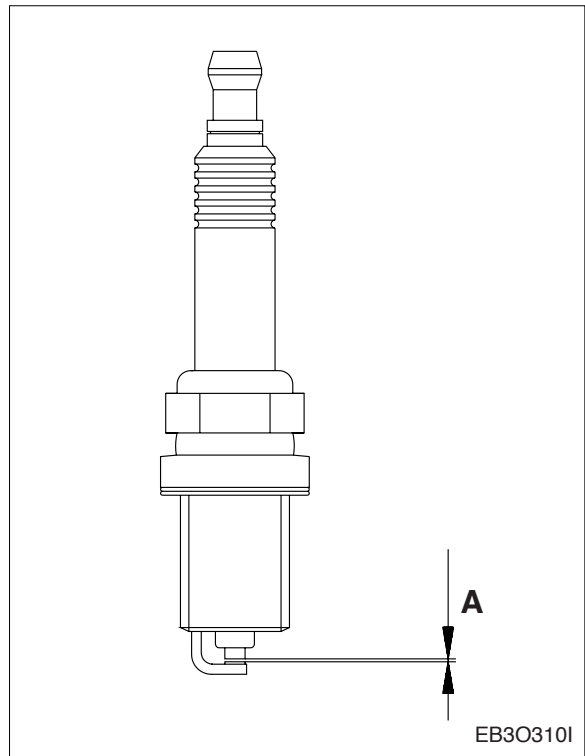

2.3.23. Battery



- Inspect for any leakage of electrolytic solution owing to battery crack, and replace the battery in case of poor condition.
- Inspect for amount of electrolytic solution, and replenish if insufficient.
- Measure the gravity of electrolytic solution, if less than specified value (1.12 ~ 1.28), replenish.

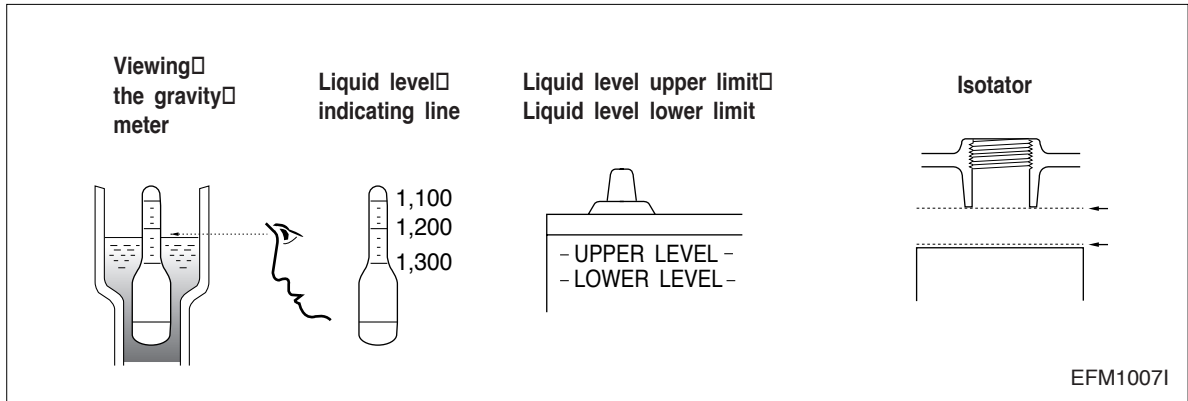

2.3.24. Turbocharger



- The turbocharger needs not any special equipment.
- Every time of engine replacement, a leakage or clogging of oil pipes should be inspected. Air cleaner should be maintained carefully for nut or foreign material not to get in. Periodic inspection should be applied on the compressed air and exhaust gas pipes, For leaking air will bring the overheat engine, an immediate repair must be done.
- During the operation that is surrounded by the dust and oil mixed air, frequent cleaning must be done on the impellers. Tear down the impeller casing (attention: be careful not to bend) and must clean with non-acid solvent solution. If necessary, use plastic scraper. If impeller is severely polluted, dip the impeller into solution and may be better to clean it with stiff brush. Then one thing to beware is to dip only impeller part and so do not support by impeller but bearing housing.

2.3.25. Alternator

- The alternator is fitted with integral silicon rectifiers. A transistorized regulator mounted on the alternator body interior limits the alternator voltage. The alternator should not be operated except with the regulator and battery connected in circuit to avoid damage to the rectifier and regulator.

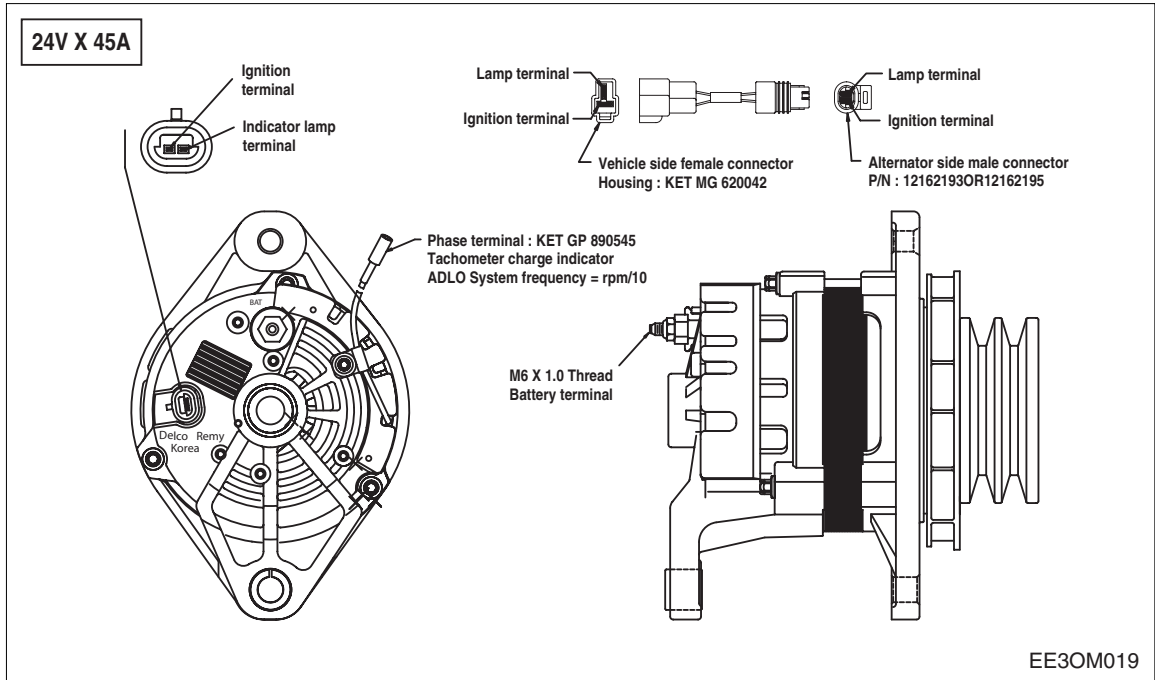

- The alternator is maintenance-free, nevertheless, it must be protected against dust and, above all, against moisture and water.

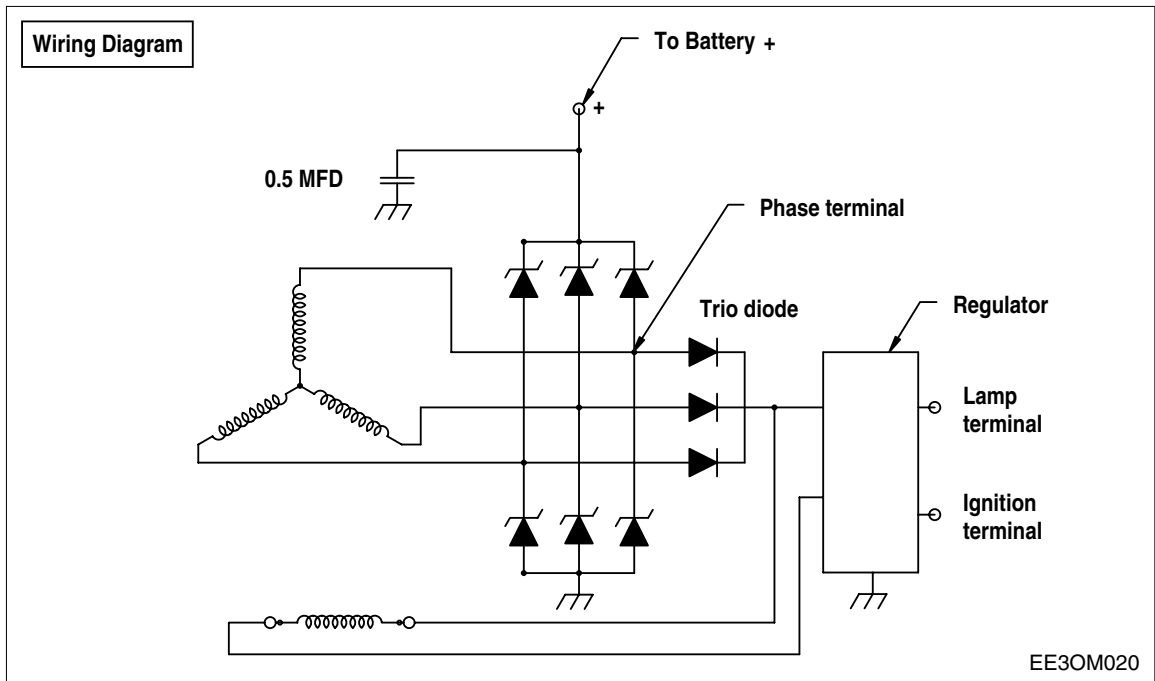

Operate the alternator according to the instructions given in the chapter.

2.3.26. Starting motor

- The sliding-gear starter motor is flanged to the rear of the flywheel housing on the left-hand side. As parts of every engine overhaul, the starter pinion and ring gear should be cleaned with a brush dipped in fuel and then a coat of grease should be applied again.

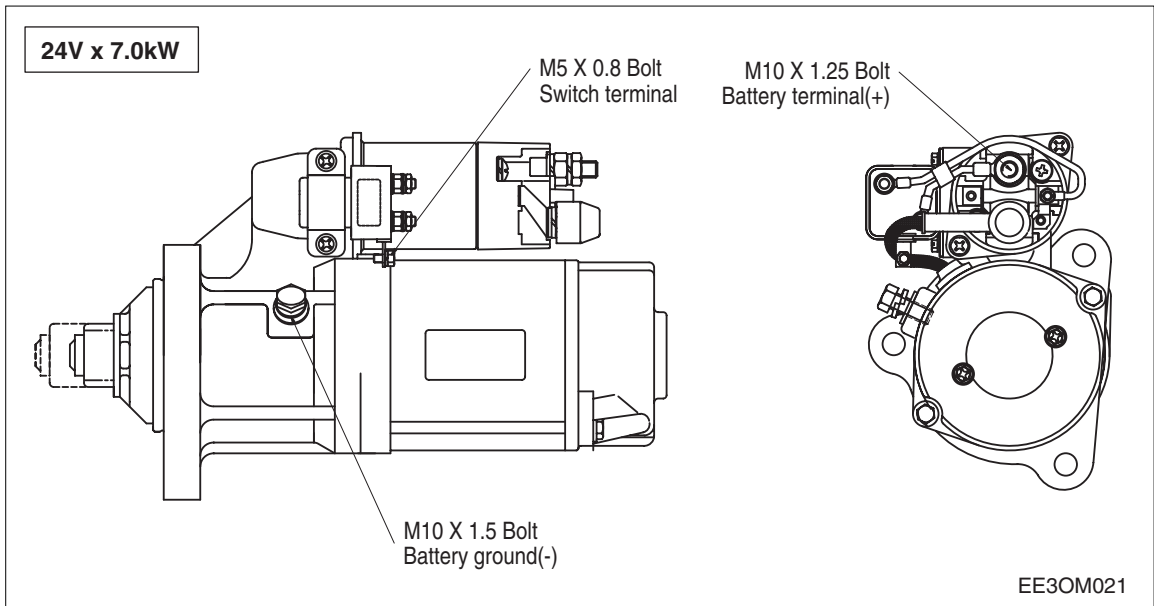

- Always protect starter motor against moisture

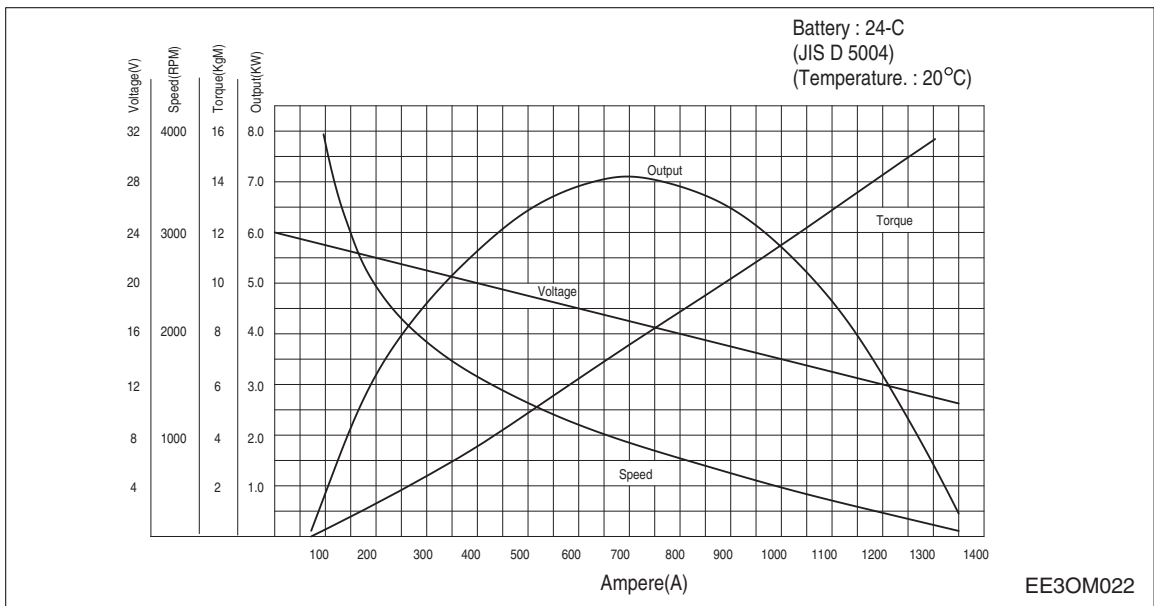

IMPORTANT:

Always disconnect the battery earth cable before starting work on the electrical system. Connect up the earth cable last, as there is otherwise a risk of short-circuits.

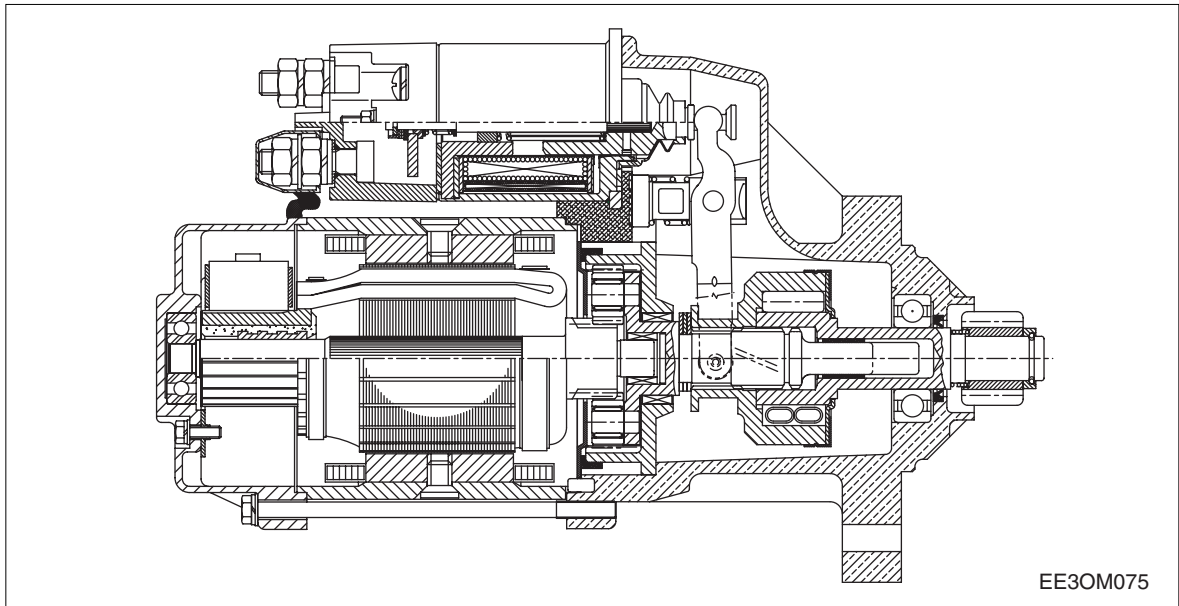

2.3.27. Precautions in use



- Pay attention to dropping the battery voltage capacity when they are left for long time even without use.
- As starting may not be done well sometime in cold winter season, do not try it to be continuous immediately but try to start again after waiting about 30 seconds.
- Prior to operating the gauge panel, make sure the polarity of battery once again (In majority of polarities, red side is "+" and black one is "-")
- On disassembling the gauge panel may be accompanied a risk of electrical shock, always work after pulling off the connector at rear side of it without fail.
- If the silver paper etc is used for connecting the cut-off fuse, because the excessive current might flow into the parts to damage, when fuse is cut off, after resolving the problem locating the cause, replace it with new fuse.
- Since battery has a danger of explosion by a heat, it must not be placed at the spot where generates a lot of heat.
- When engine is in stop, pull out the key always. Thus, a hazard of fire or wound due to wrong operation may not happen.
- In case of scrapping the batteries, observe the followings.



NOTE:

Do not throw it in the fire to scrap. It should not be thrown away into the places where are liable to cause the environmental pollution such as stream, river and mountain. Pack them as far as possible and dispose it as rubbish that is unable to use again.

- DAEWOO will not be responsible to the problems that might be raised by the disassembling and structural change of this product without consultation.

2.4. Diagnosis and Remedy

- The following description summarizes the probable cause of and remedy for general failure by item.
- Immediate countermeasures should be taken before a failure is inflamed if any symptom is detected.
- Inspect the electrical parts problem by the Display module.

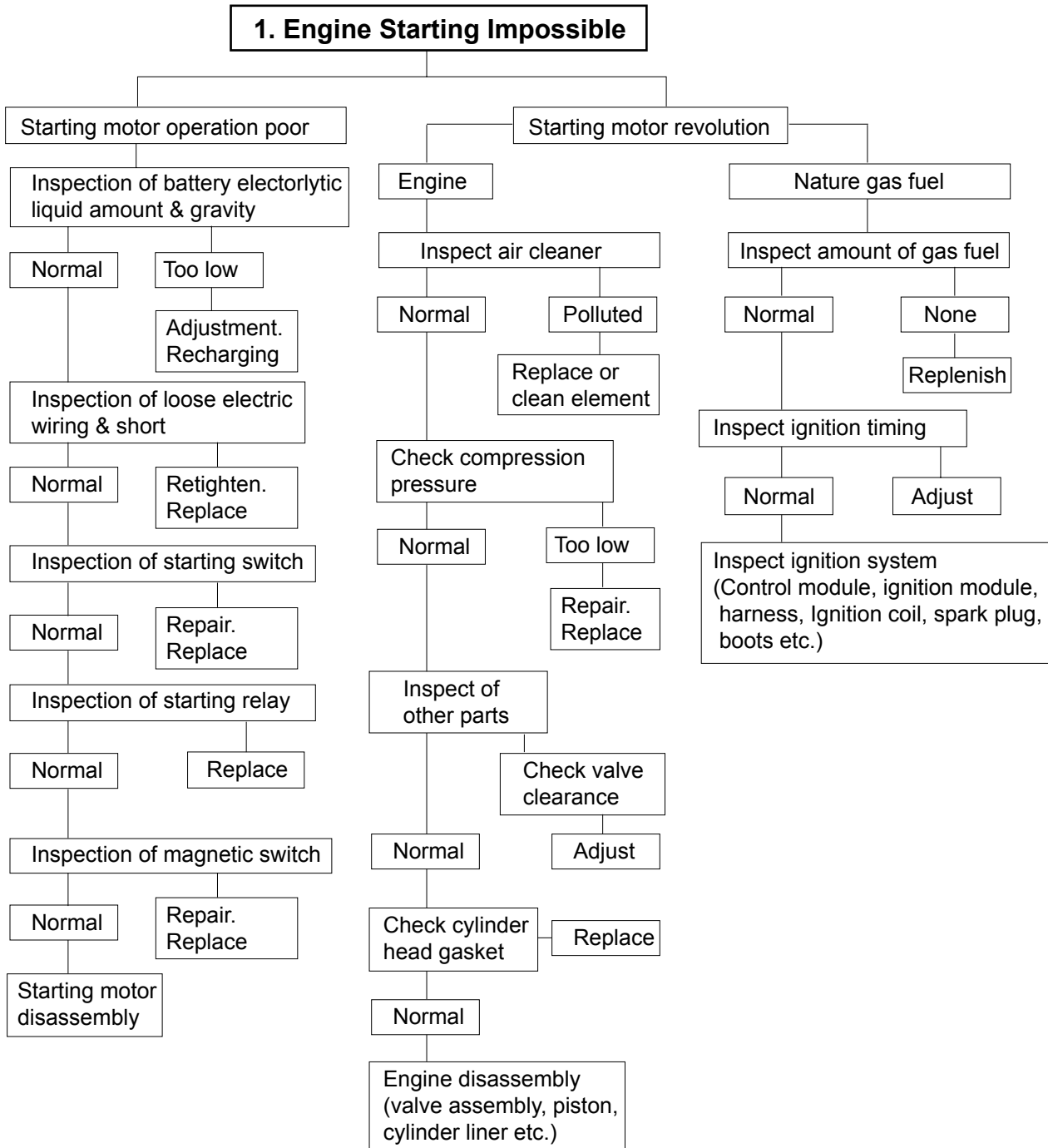

2. Engine Overheated

Operating state
1. Overload
2. Radiator core clogged

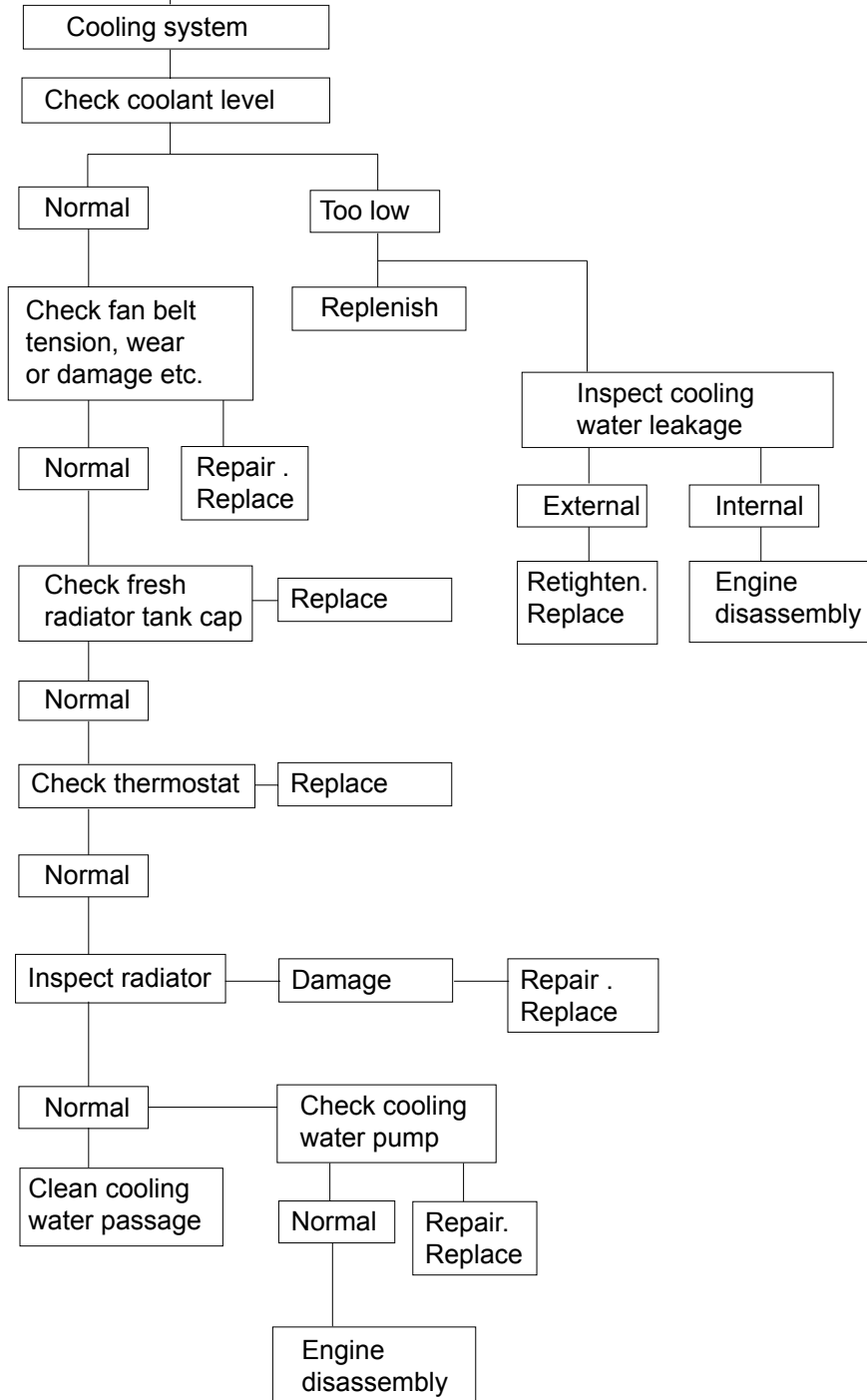

3. Output insufficient

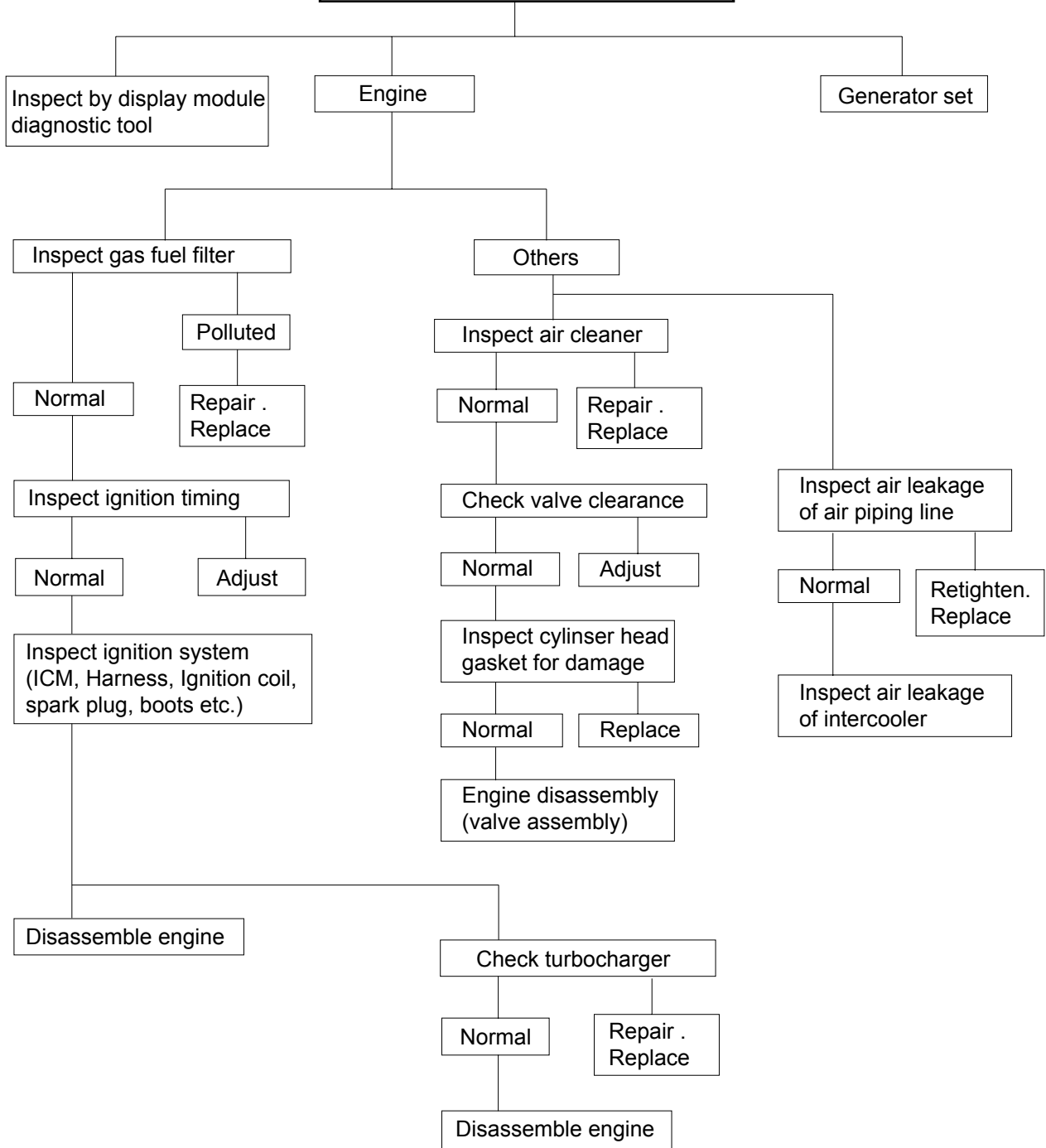

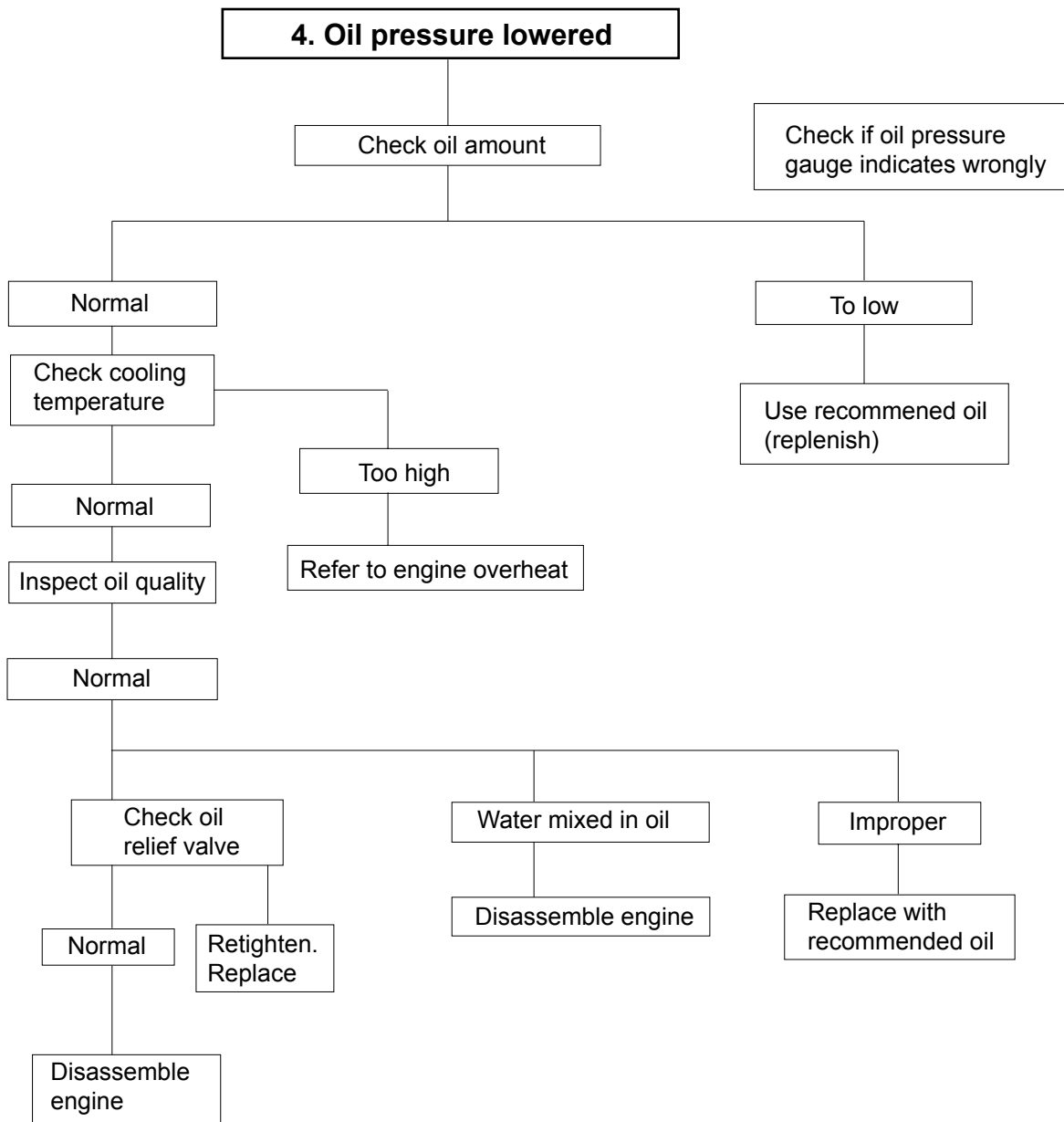

5. Fuel Consumption Excessive

Cause according to use conditions

1. Overload
2. Generator set

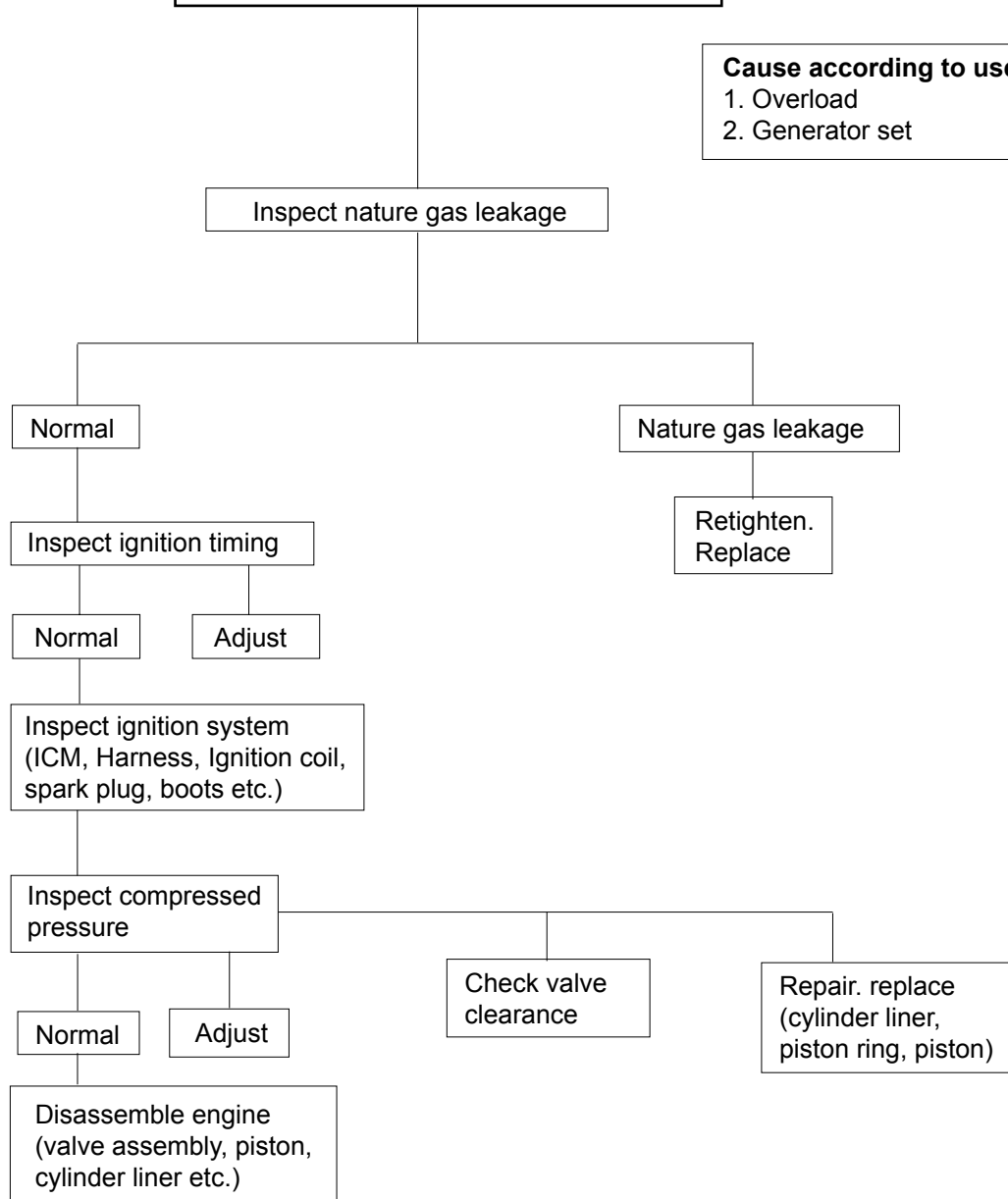

6. Oil Consumption Excessive

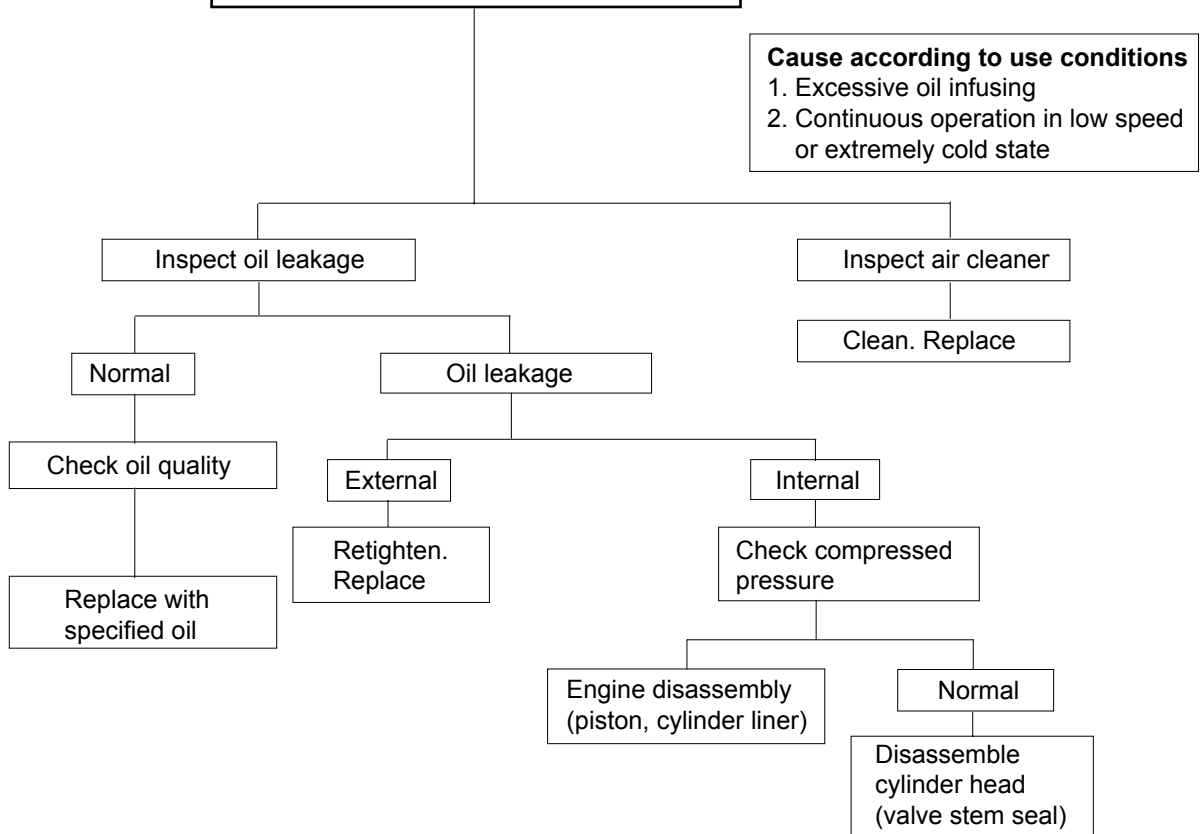

7. Engine Knocking

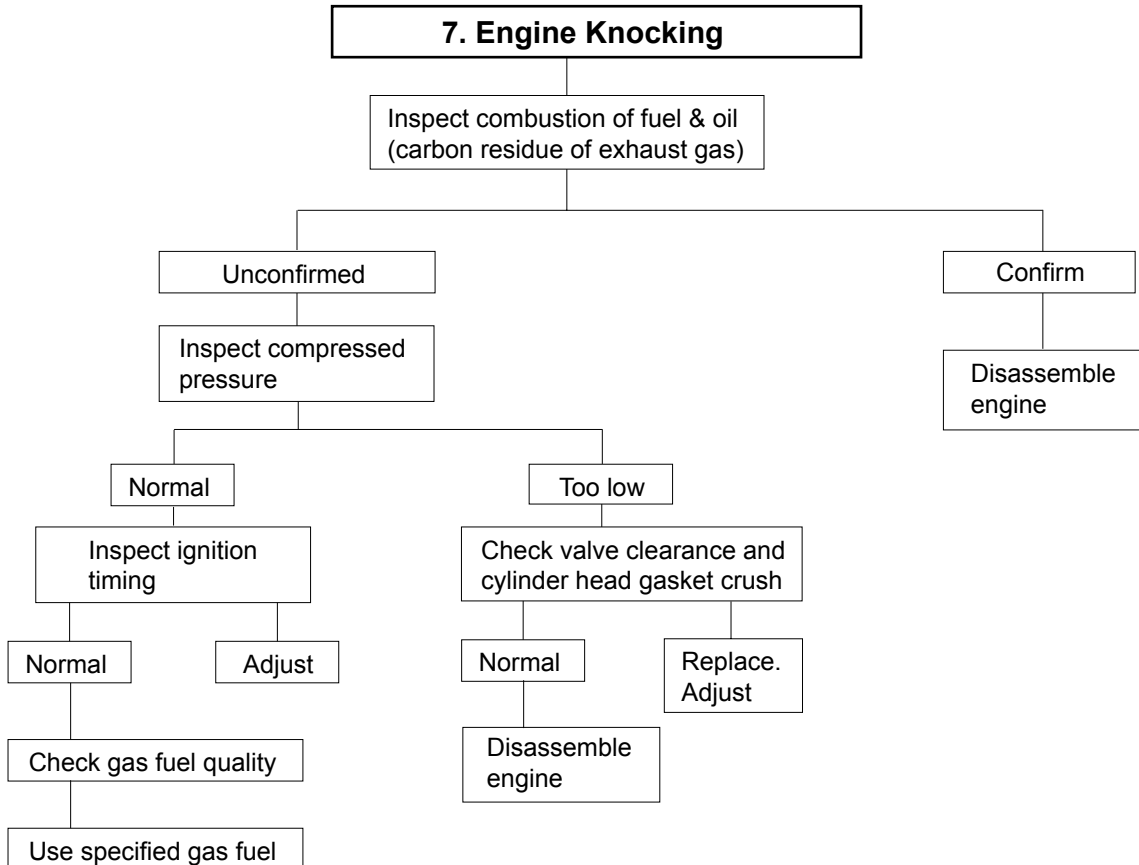

Condition	Causes	Remedies
1) Starting difficult (1) Compression pressure	<ul style="list-style-type: none"> ● Valve's poor shut, stem distortion ● Valve spring damage ● Cylinder head gasket's leak ● Wear of piston, piston ring or liner 	Repair or replace Replace valve spring Replace gasket Adjust
2) Idle operation abnormal	<ul style="list-style-type: none"> ● Ignition timing incorrect 	Adjust
3) Engine output insufficient (1) Continuous output Insufficient	<ul style="list-style-type: none"> ● Valve clearance incorrect ● Valve tightness poor ● Cylinder head gasket's leak ● Wear, stick, damage of piston ring ● Ignition timing incorrect ● Damage of spark plug & ignition coil ● Air suction amount insufficient ● Turbocharger poor 	Adjust Repair Replace gasket Replace piston ring Adjust Adjust or replace Clean or replace air cleaner Repair or replace
(2) Output insufficient when in acceleration	<ul style="list-style-type: none"> ● Compression pressure insufficient ● Ignition timing incorrect ● Damage of spark plug & ignition coil ● Air intake amount insufficient 	Disassemble engine Adjust Repair or replace Clean or replace air cleaner
4) Overheating	<ul style="list-style-type: none"> ● Engine oil insufficient or poor ● Cooling water insufficient ● Fan belt loosened, worn, damaged ● Cooling water pump's function lowered ● Thermostat operation poor ● Valve clearance incorrect ● Exhaust system's resistance increased 	Replenish or replace Replenish or replace Adjust or replace Repair or replace Replace Adjust Clean or replace
5) Engine noisy	For noises arise compositely such as rotating parts, lapping parts etc., there is necessity to search the cause of noises accurately.	
(1) Crankshaft	<ul style="list-style-type: none"> ● As the wear of bearing or crankshaft progress, the oil clearances increase. ● Lopsided wear of crankshaft ● Oil supply insufficient due to oil passage clogging ● Stuck bearing 	Replace bearing & grind crankshaft Grind or replace Clean oil passage Replace bearing & grind
(2) Connecting rod and Connecting rod bearing	<ul style="list-style-type: none"> ● Lopsided wear of con rod bearing ● Lopsided wear of crank pin ● Connecting rod distortion ● Stuck bearing ● Oil supply insufficiency as clogging at oil passage progresses 	Replace bearing Grind crankshaft Repair or replace Replace & grind crankshaft Clean oil passage

Condition	Causes	Remedies
(3) Piston, piston pin & piston ring	<ul style="list-style-type: none"> ● Piston clearance increase as the wear of piston and piston ring progresses ● Wear of piston or piston pin ● Stuck piston ● Piston insertion poor ● Piston ring damaged 	Replace piston & piston ring Replace Replace piston Replace piston Replace piston
(4) Others	<ul style="list-style-type: none"> ● Wear of crankshaft, thrust bearing ● Camshaft end play increased ● Idle gear end play increased ● Timing gear backlash excessive ● Valve clearance excessive ● Abnormal wear of tappet, cam ● Turbocharger inner part damaged 	Replace thrust bearing Replace thrust plate Replace thrust washer Repair or replace Adjust valve clearance Replace tappet, cam Repair or replace
6) Oil Consumption Excessive (1) Oil level elevated	<ul style="list-style-type: none"> ● Clearance between cylinder liner & piston ● Wear of piston ring, ring groove ● Piston ring's damage, stick, wear ● Piston ring opening's disposition improper ● Piston skirt part damaged or abnormal wear ● Oil ring's oil return hole clogged ● Oil ring's contact poor 	Replace Replace piston, piston ring Replace piston ring Correct position Replace piston Replace piston ring Replace piston ring
(2) Oil level lowered	<ul style="list-style-type: none"> ● Looseness of valve stem & guide ● Wear of valve stem seal ● Cylinder head gasket's leak 	Replace in set Replace seal Replace gasket
(3) Oil leak	<ul style="list-style-type: none"> ● Looseness of connection parts ● Various parts' packing poor ● Oil seal poor 	Replace gasket, repair Replace packing Replace oil seal

2.5. Engine inspection

2.5.1. Stopping engine

- Cut off the main circuit breaker of the generator control panel. After checking the engine for any unusual condition at the idling speed, then press the stop button to stop the engine.

2.5.2. General engine inspection cycle

- In order to insure maximum, trouble-free engine performance at all times, regular inspection, adjustment and maintenance are vital.
 - Daily inspections in below figure should be checked every day.
 - The following maintenance details should be executed thoroughly at regular intervals.

○ : Check & adjust ● : Replace

Inspection Item		Daily	Every 50hrs	Every 200hrs	Every 500hrs	Every 1500hrs	Every 3000hrs	Remark
Cooling System	Check for leakage(hoses, clamp)	○						
	Check the water level	○						
	Adjust the V-belt tension	○						
	Change the coolant water							● 1 year
Lubrication System	Check for leakage	○						
	Check the oil level gauge	○						
	Change the lubricating oil		● 1st	●				Every 200hr
	Replace the oil filter cartridge		● 1st	●				Every 200hr
Intake & Exhaust System	Check the leakage for intercooler (hoses, clamp)	○				●		
	Check the air cleaner indicator	○						
	Check the air cleaner element and/or repair			○ clean	●			
	Clean the exhaust system						○	
Fuel System	Check the leakage fuel line	○						
	Check the fuel mixer							○ 1 year
	Check the throttle body							○ 1 year
	Check the speed controller							○ 1 year
	Check the gas pressure regulator							○ 1 year
Ignition System	Check the state of ignition timing							When necessary
	Check the spark plug					●	●	
	Check the ignition cable							● 1 year
	Check the ignition coil							○ 1 year
	Check the sensors (ignition or timing)	○						
Engine Adjust	Check the state of exhaust gas	○						
	Check the exhaust gas pressure							When necessary
	Check the battery charging	○						
	Check the compression pressure							When necessary
	Adjust Intake/Exhaust valve clearance				○			When necessary

2.5.3. Use of original parts for repair and replacement

- For engine is being mechanically harmonized with many parts, only when the original parts that the manufacture recommends to use is used, the engine trouble would be preventively maintained and capable to keep up the maximum performances.
- For the analogous parts not the original parts are poor in qualities and gives ill performances, it may rather bring early engine failure

3. DISASSEMBLY AND REASSEMBLY OF MAJOR COMPONENTS

3.1. Engine Disassembly



- Engine parts' disassembly procedures are as follows;

3.1.1. General precautions



- For the various tool storage before disassembly and parts storage after disassembly, the shelf for parts is prepared
- At the time of disassembly and reassembly, do the work with the naked and clean hand, and also the working place must be maintained clean
- The torn parts after disassembly must be kept not to collide each other.
- In disassembling, torn parts should be laid in disassembled order.
- Always close all the fuel valves before serving the system.

3.1.2. Oil level gauge

- Take out the oil level gauge.

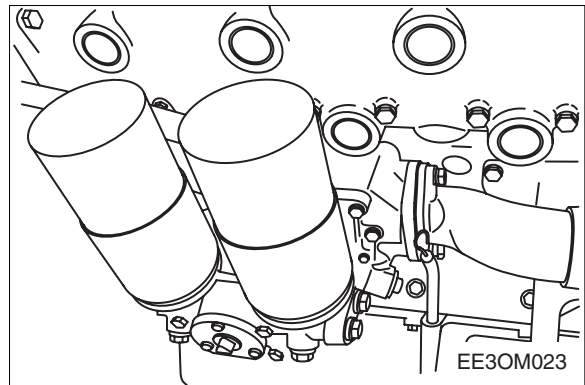

3.1.3. Engine oil

- Turn the valve opening and then move the oil drain pump lever as figure by hand, and let engine oil discharge into the prepared vessel

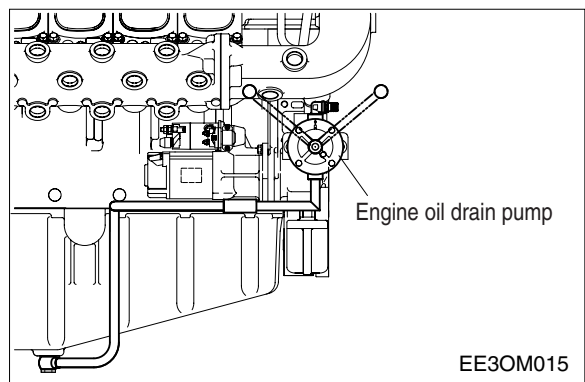

3.1.4. Cooling water

- Remove the cooling water drain plug from the cylinder block and oil cooler, various pipes, etc. and let the cooling water discharge into the prepared vessel.

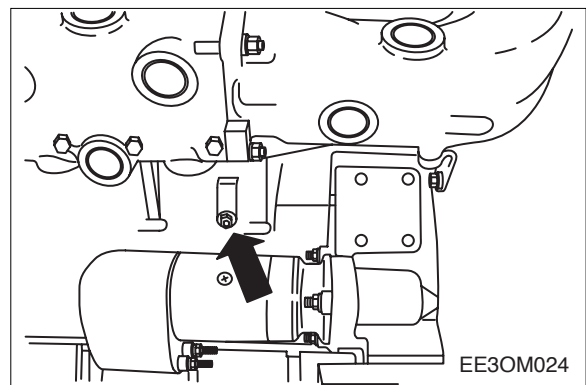
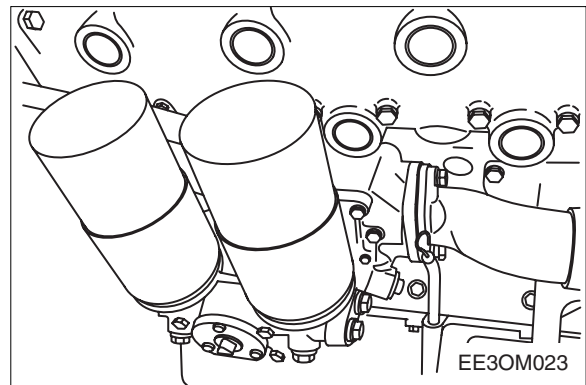

3.1.5. V-belt.

- Loosen the V-belt tension adjusting bolts, and remove the V-belt.

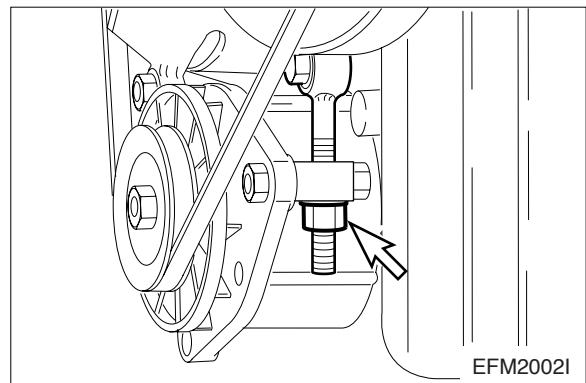

3.1.6. Ignition coil & gas pressure regulator

- Remove the high voltage cable by hand from each cylinder.
- Remove the gas pressure regulator fixing bolts and then tear down the gas pressure regulator and others parts.

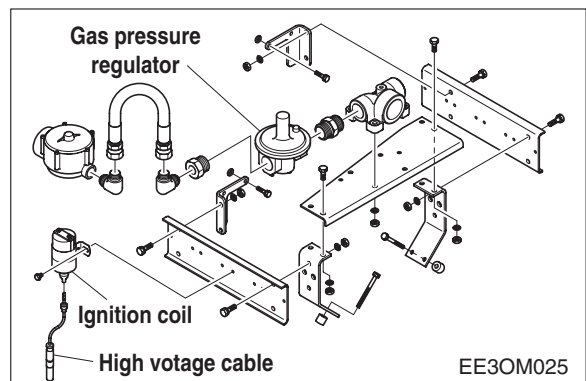

3.1.7. Intercooler

- Tear down the various hoses and air pipes from the inter cooler.
- Remove the intercooler fixing bolts and tear it down.

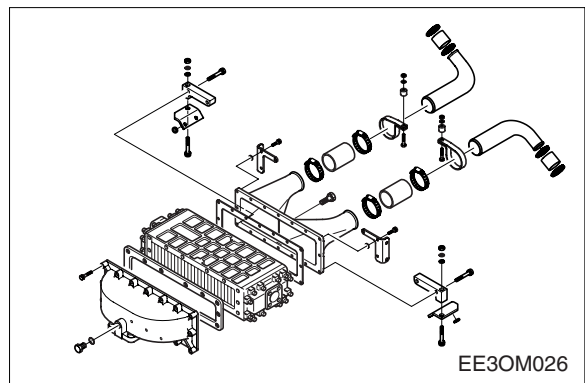
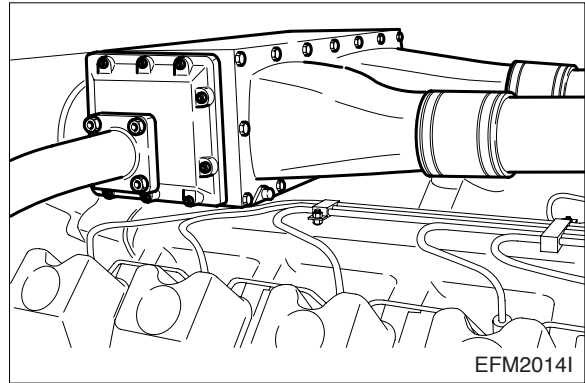

3.1.8. Turbocharger and gas fuel mixer

- Loosen the gas hose and air cleaner hose for connecting the gas fuel mixer.
- Loosen the clamp and fixing bolt for connecting the turbocharger and then tear down the air intake stake and gas fuel mixer.
- Remove the hollow screws of pipes for turbocharger and its discharge, and tear the pipes down.
- Remove the turbocharger fixing nuts and separate the turbocharger from the exhaust manifold.

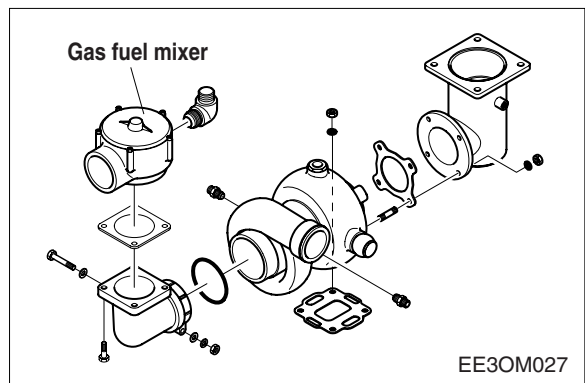

3.1.9. Exhaust manifold

- Remove the exhaust manifold fixing bolts and tear the manifold from the cylinder head.



CAUTION:

Be careful not to drop the manifold because it is very heavy.

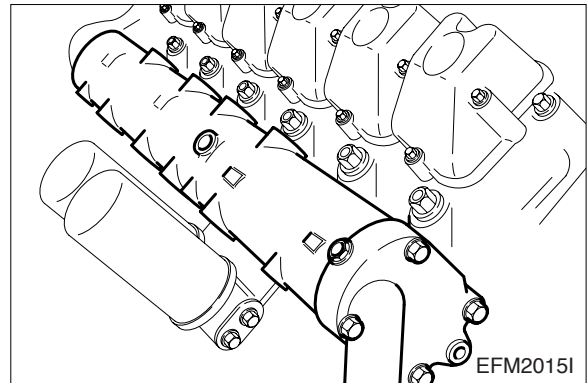

3.1.10. Intake manifold & throttle valve

- Remove the throttle valve fixing bolts and tear the throttle valve down from the intake stake.
- Remove the manifold fixing bolts and tear the manifold down from the cylinder head.

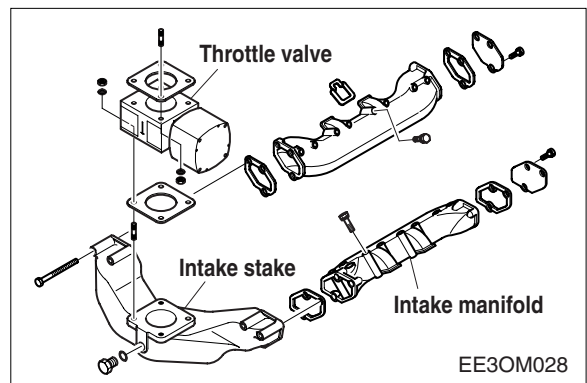

3.1.11. Alternator

- Remove the supporting guide piece for installing the alternator and the bracket bolts.
- Disassemble the alternator.

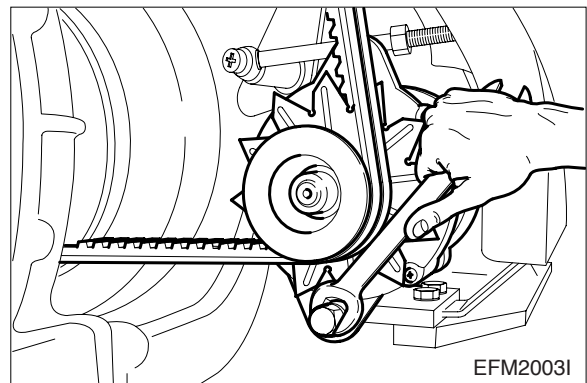

3.1.12. Oil filter



- Disassemble the oil filter cartridge with filter wrench by means of a filter wrench.



- Do not use again the cartridge removed after use.

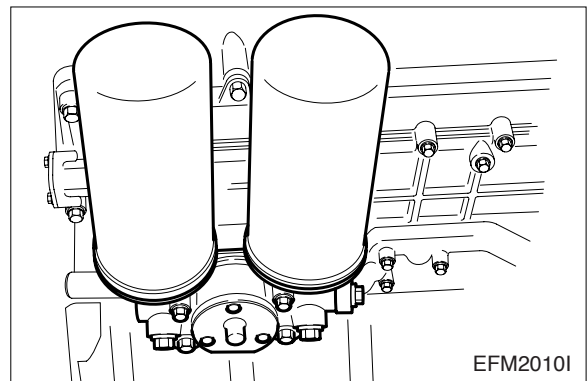

- Remove the oil filter head fixing bolts and disassemble the filter head

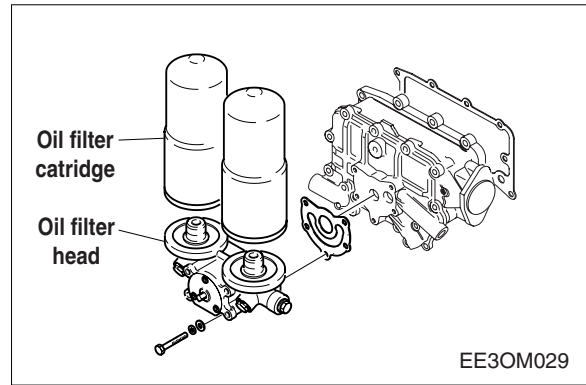

3.1.13. Cooling water pump

- Loosen the various hose clamps for the connections.
- Remove the cooling water discharging pipe and disassemble the thermostat.
- Remove the cooling water pump fixing bolts and disassemble the cooling water pump.

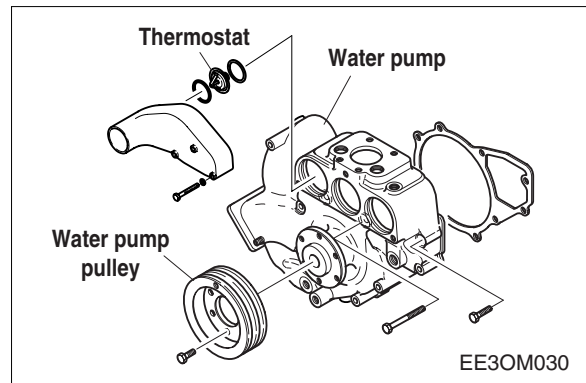

3.1.14. Oil cooler

- By removing the plug screw of cooling water discharge port, the cooling water is discharged.
- Remove the oil cooler cover fixing bolts and disassemble the oil cooler.

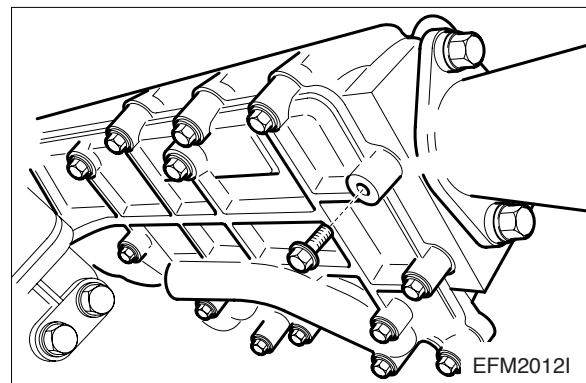

- By removing the cooler housing fixing bolts and disassemble the oil cooler housing from the cylinder block.

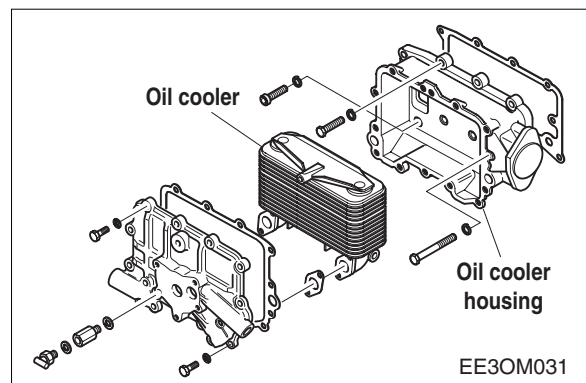

- Remove the oil cooler insert fixing bolts, and then disassemble the cooler insert.

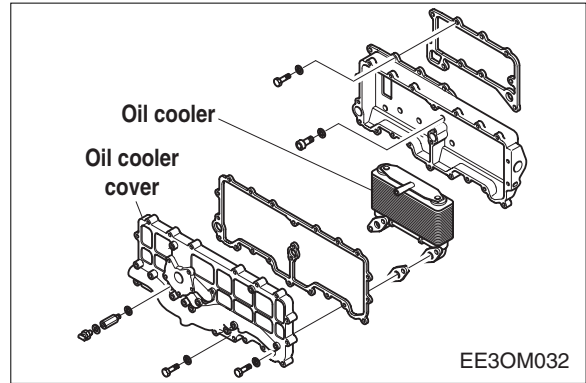

3.1.15. Starting motor

- Remove the starting motor fixing nuts and disassemble the starting motor.

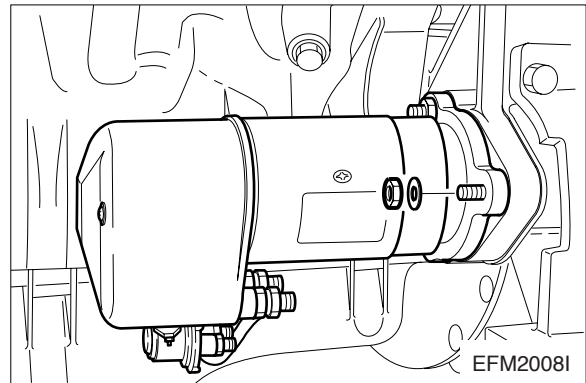

3.1.16. Timing drive & sensor

- Remove the timing drive fixing bolts and disassemble the timing drive and timing sensor.

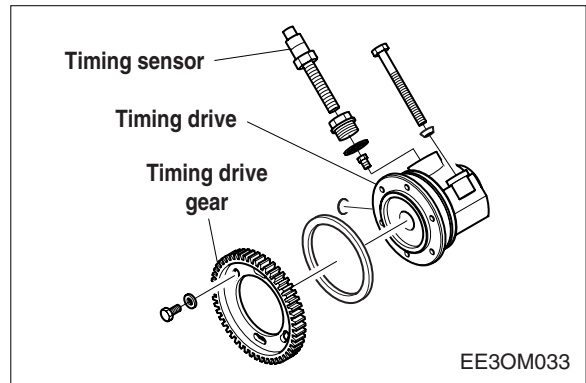

3.1.17. Flywheel housing cover

- Separate the side cover.
- Disassemble the flywheel housing cover.

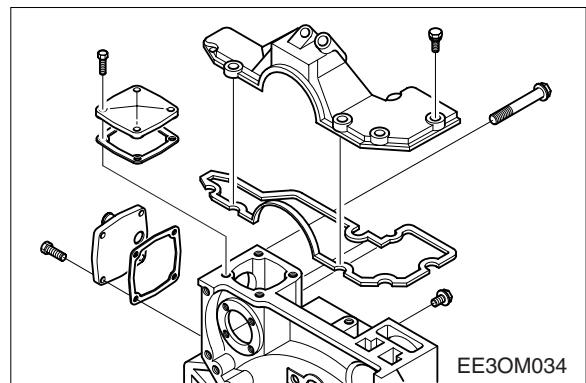

3.1.18. Cylinder head cover

- Remove the fixing bolts and tear the cylinder head cover down

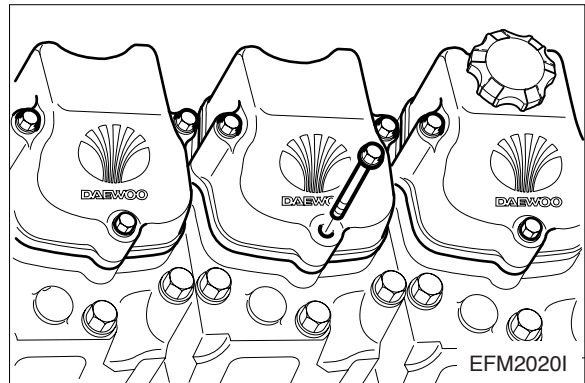

3.1.19. Spark plug



- By means of a long impact tool, loosen the spark plug and take it out.

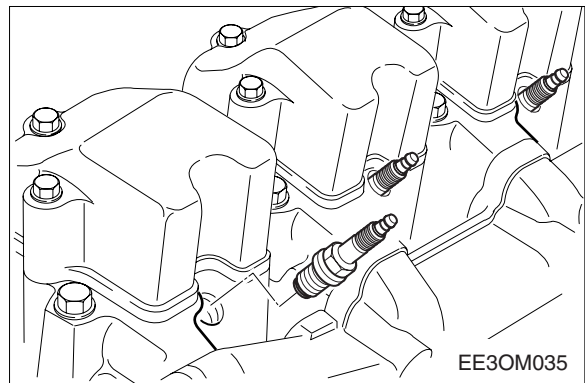

3.1.20. Rocker arm

- Remove the rocker arm bracket fixing bolts and take the rocker arm assembly out.
- Pull out the push rod.

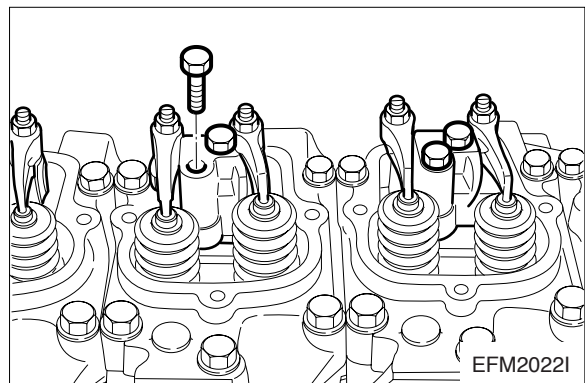

3.1.21. Cylinder head

- Loosen the cylinder head fixing bolts in the reverse order of assembling, and remove them all and then take the cylinder head out.
- Remove the cylinder head gasket and scrap it.
- Eliminate the residue from the cylinder head face and cylinder block face.

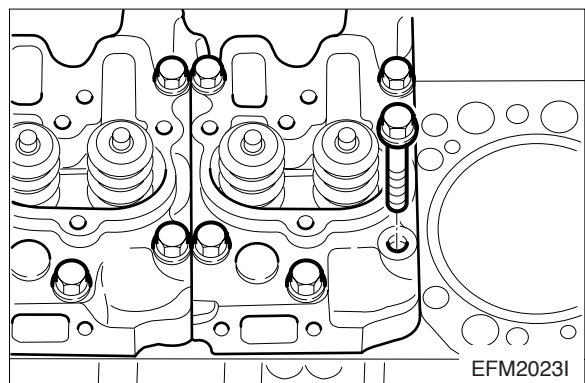



Notes:

Be careful not to damage the cylinder head face where its gasket contacts.

3.1.22. Vibration damper

- Remove the fixing bolts for crankshaft pulley in reverse order of assembling and disassemble the crankshaft pulley and vibration damper.

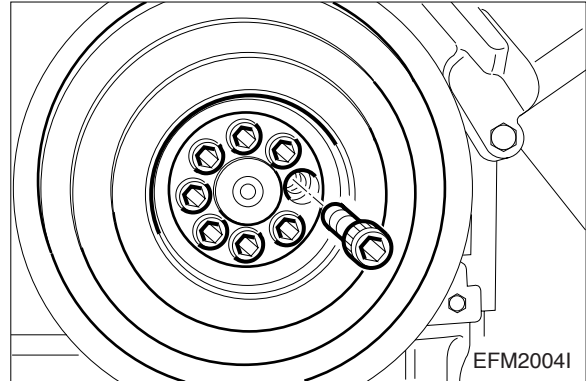

3.1.23. Oil pan

- Remove the oil pan fixing bolts and separate the pan.
- Remove the oil pan gasket and scrap it.

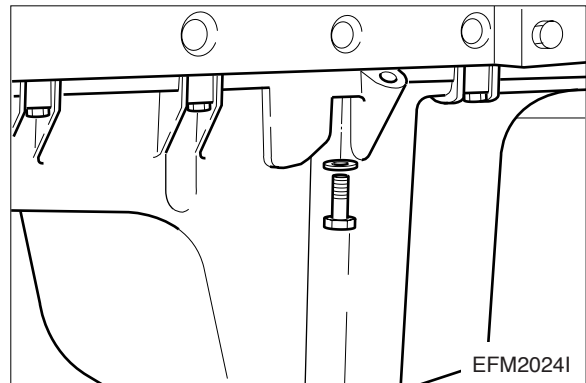

3.1.24. Oil pump

- Remove the oil suction pipe fixing bolts and tear them down.
- Remove the oil relief valve fixing bolts and take them out.
- Remove the oil pump fixing bolts and separate it.

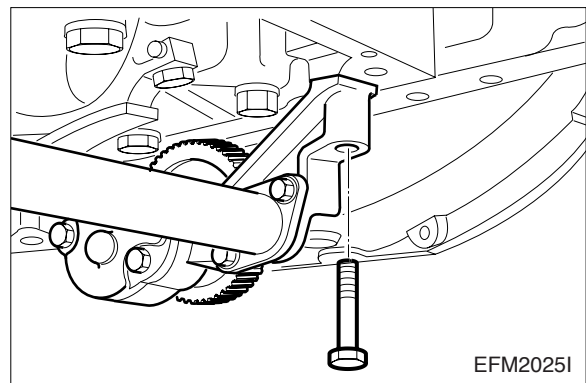

3.1.25. Piston

- Remove the connecting rod cap bolts in the reverse order of assembling and follow the similar method as in the cylinder head bolt removal.
- Tapping the upper and lower connecting rod caps lightly with an urethane hammer, separate them and take the bearings out.
- By pushing the piston assembly with a wooden bar toward the cylinder head's direction remove the piston.

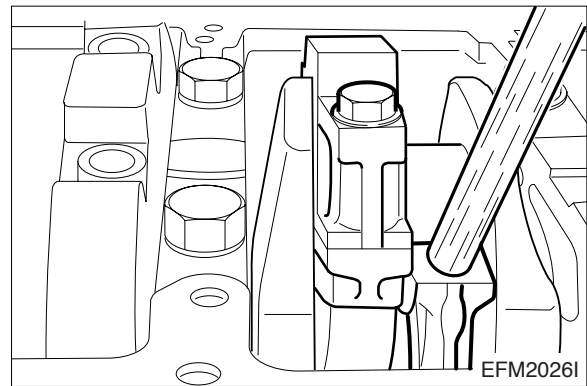

Notes:

- Be careful for the removed pistons not to collide each other or with the other parts.
- At the storage of pistons, maintain them in the order of cylinders. (In order for connecting rod caps not to mix one another, temporarily assemble them to the corresponding connecting rods.)

3.1.26. Front oil seal holder

- Remove the oil seal holder fixing bolts and tear down.
- Remove the oil seal and gasket from the oil seal holder and scrap them.

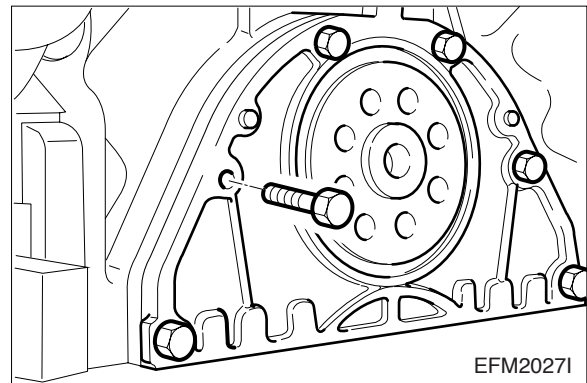

3.1.27. Fly wheel

- Remove the flywheel fixing bolts in the order of disassembling and remove the flywheel.

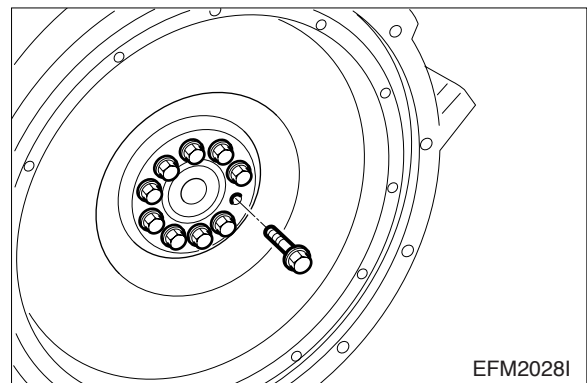

- Remove the flywheel ring gear.
 - Heat the ring gear evenly with a gas burner (up to 200°C) to invite volumetric expansion.
 - Tapping around the edges of the ring gear with a hammer and brass bar to remove it.

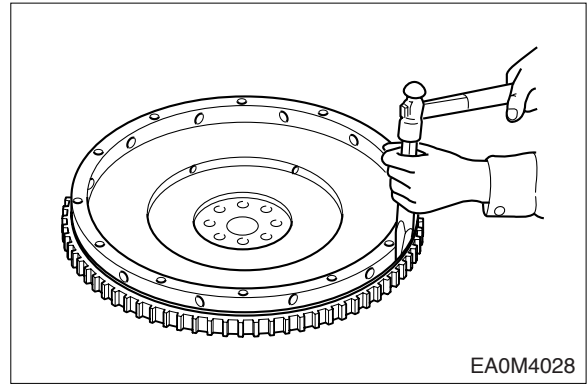

CAUTION:
Do not damage the flywheel.

3.1.28. Flywheel housing

- Remove the flywheel housing fixing bolts and take them out.
- Remove the oil seal from the flywheel housing.

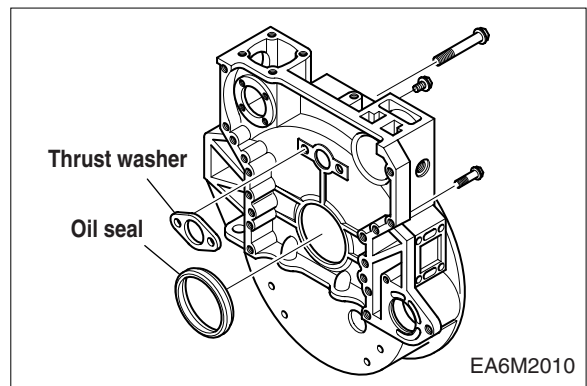

3.1.29. Crank shaft

- Remove the bolts from bearing caps.
- Remove the main bearing cap fixing bolts in the reverse order of assembling.
- Maintain the removed bearing caps in the order of cylinders.
- Temporarily install the bolts at the both side of crankshaft, and lift the shaft with a rope.

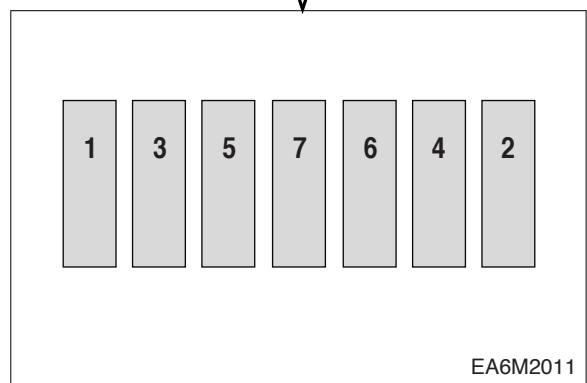
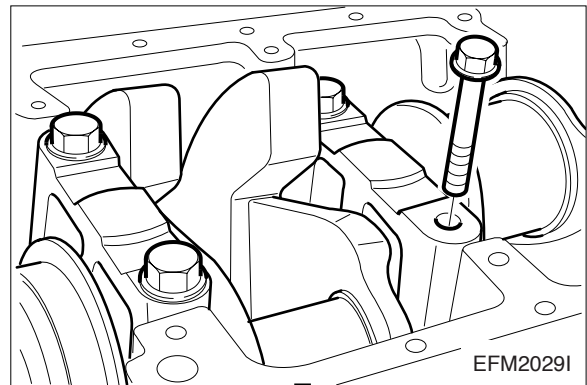



Notes:

Do not mingle with the metal bearings and bearing caps randomly. To prevent mixing, temporarily assemble the metal bearings to the corresponding bearing caps in turn.

3.1.30. Camshaft and tappet

- Pull out the tappets from the cylinder block.
- Remove the camshaft being careful not to damage the camshaft and its bearings.

3.1.31. Oil spray nozzle

- Remove the oil injection nozzle fixing bolts and tear down the oil injection nozzles.

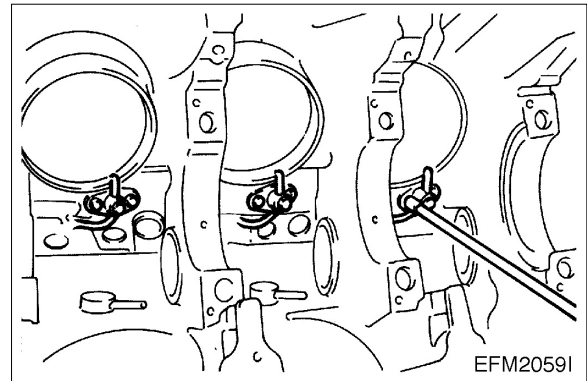

3.1.32. Cylinder liner



- By means of a special tool(Extractor), pull out the liner from the cylinder block.

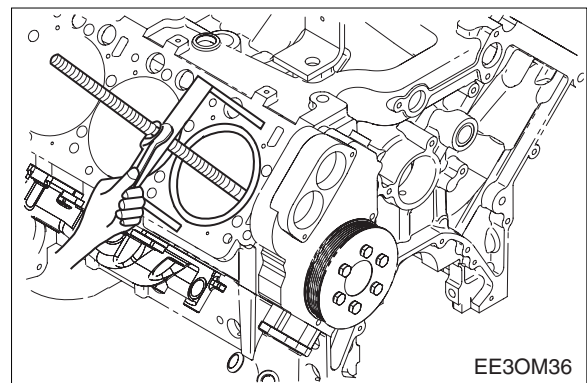

3.2. Measurement and Inspection of Major Parts

3.2.1. Cleaning and inspection of cylinder block



- Clean the cylinder block and inspect it for any crack or damaged.



- Inspect the oil passage and water passage for any clog and erosion.
- By performing the hydraulic test, inspect for any leaks. With plugging the water and oil passages of cylinder block, put in the air of 5 kg/cm² pressure in the Inlet port of cylinder block and then soak the cylinder block in the water for about 1 minute to check for any leaks. (water temperature: 70°C)
- Inspect the cylinder block's camshaft bush to any damage and the alignment of oil supply holes and if abnormal, replace it.

3.2.2. Cylinder liner measurementv



- Assemble the cylinder liner at the cylinder block and measure inner diameters at upper, middle, lower 3 levels by 45° interval and calculate the average values after eliminating the max. and min. values.



- If the measured values are very close to the limit value or beyond, replace it.

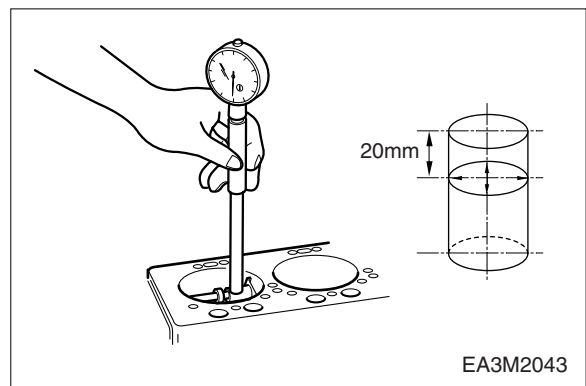

Liner inner dia.	Standard	Limit
	φ127.990~φ128.010 mm	0.15 mm

3.2.3. Cylinder head

1) Cylinder head disassembly



- Be careful for the cylinder head gasket contacting surface of cylinder head not to be damaged.



- Remove the cotter pin pressing the valve spring by means of a special tool.
- Take out the valve stem seal.
- Pull out the intake and exhaust valves.

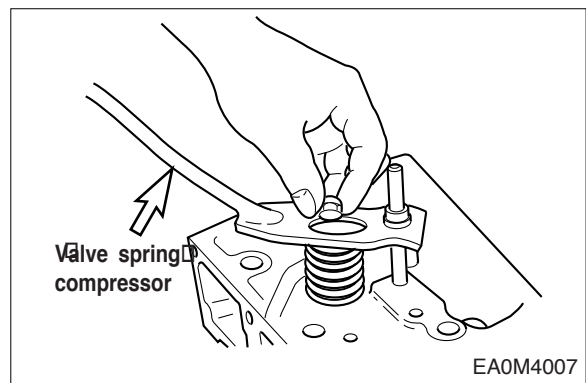

3.2.4. Spark plug



- Remove spark plug. Clean threads by hand with brush and solvent.
- Clean any deposits from electrode and inspect insulator area



- Measure the spark plug distance at electrode position.(A)
- Correct or replace the spark plug if necessary.

Standard(A)	0.39 ~ 0.40 mm
--------------------	----------------

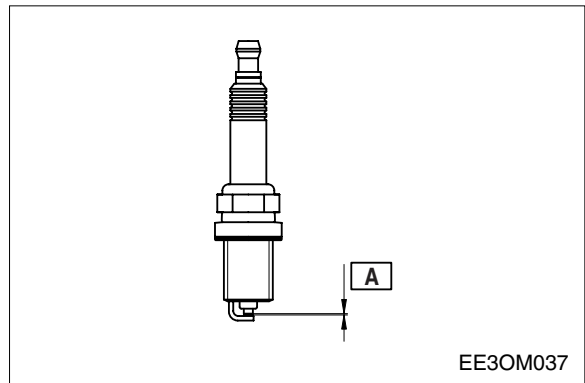

EE3OM037



- Insert the spark plug into cylinder head and measure distance(B)

Torque	3.6 ~ 4.1 kg.m
---------------	----------------

Standard(B)	3.38 ~ 3.76 mm
--------------------	----------------

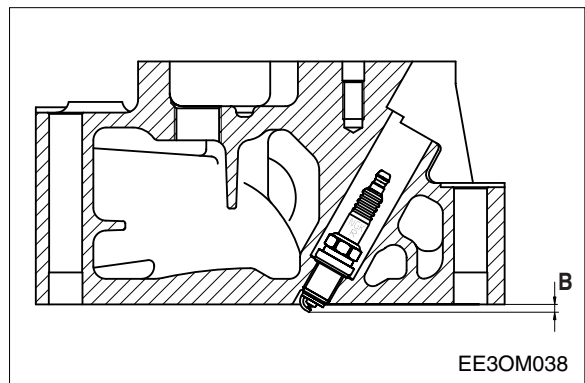

EE3OM038

3.2.5. Inspection and measurement of cylinder head

1) Damage check



- Inspect the cylinder head for any crack or damage.
- Eliminate the carbon residue and gasket piece from the cylinder head lower face thoroughly. Then be careful for the valve seat not to be damaged.
- The cracks or damages that are difficult to search may be inspected by a hydraulic test or a magnetic powder test. (Hydraulic test is same as for cylinder block.)



2) Distortion



- Measure the flatness degree (any distortion) of cylinder head. Even beyond the limit value of maintenance, it may be corrected by grinding. (if more than limit value of use, replace it.)

Warpage	Standard	Limit
	0.05 mm or less	0.2 mm

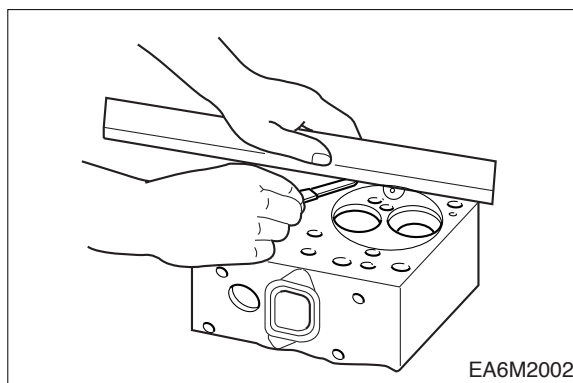
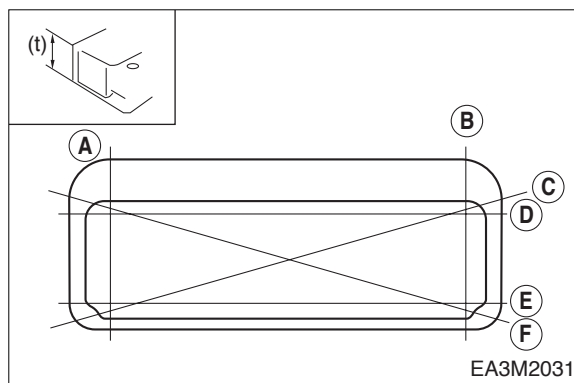

3.2.6. Inspection and measurement of valve and valve guide

1) Valve



- After cleaning the valves with clean diesel oil, measure the valve stem's outside diameter at upper, middle, and lower to determine the wears and when the wear limit is more than allowable limit, replace the valves.

Valve	Standard	Limit
Intake	$\phi 11.969 \sim \phi 11.980$ mm	$\phi 11.830$ mm
Exhaust	$\phi 11.969 \sim \phi 11.980$ mm	$\phi 11.830$ mm

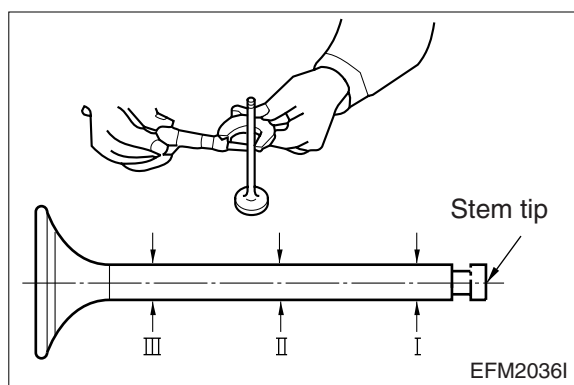



- Inspect the scratch and wear of valve stem seal contacting face, and if necessary correct with the grinding paper but if severe replace it.



- If valve head thickness (A) becomes less than 1.6mm for intake and 1.3mm for exhaust, replace the valve.

Valve	Standard	Limit
Intake(A)	2.6 ~ 3.0 mm	1.6 mm
Exhaust(B)	1.9 ~ 2.3 mm	1.3 mm

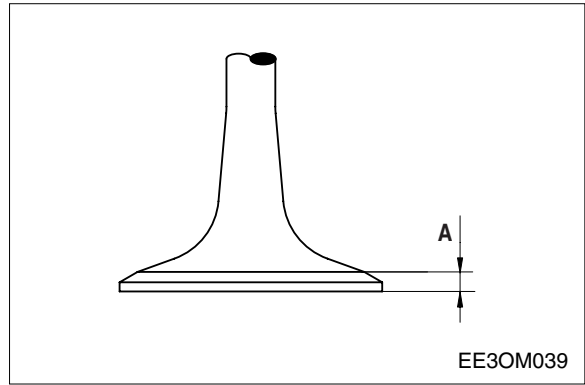

2) Valve guide



- Insert the valve into valve guide and measure the clearance between valve and valve guide by the shaking degree of valve. If the clearance is bigger, measure the valve and then replace the more worn cylinder head.

Valve	Standard	Limit
Intake	0.020 ~ 0.049 mm	0.20 mm
Exhaust	0.045 ~ 0.074 mm	0.25 mm

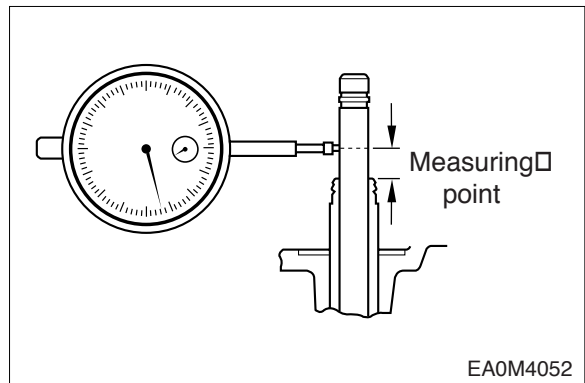

3) Valve seat



- Assemble the valves at the cylinder head and using the measuring instrument from the lower face, measure the projection amount of valve. If the measured value is more than the use limit, replace the valve or cylinder head.

< Valve seat thickness >

Standard	Limit
0.65 ~ 0.95 mm	2.5 mm

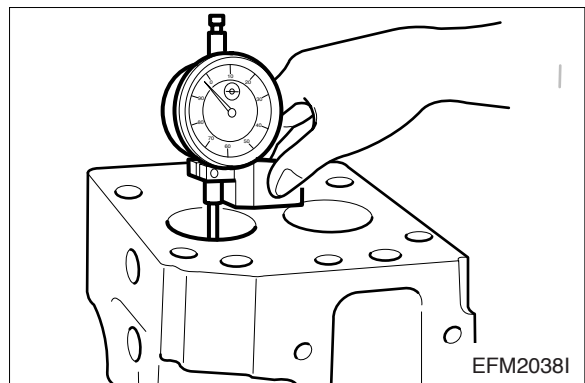

3.2.7. Valve spring



- Inspect the outlook of valve spring and if necessary replace it.



- By means of spring tester, measure the tension and free length.
- Measure the perpendicularity of valve spring.
- In case that the measured value exceeds the limit value, replace it.

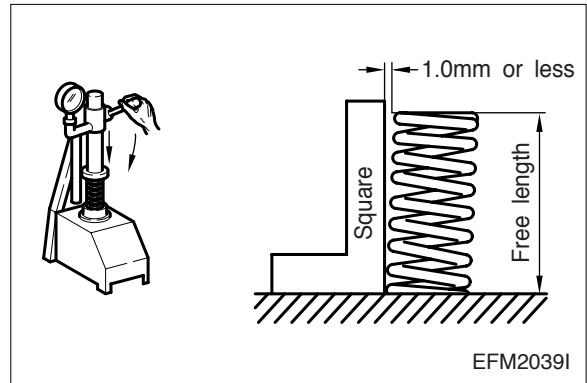

< Perpendicularity regular >

Inside Spring	Free length	65.5 mm
	When given a regular load (15 ~ 17 kg)	46.3 mm
Outside Spring	Free length	64 mm
	When given a regular load (37 ~ 41 kg)	46.3 mm

3.2.8. Assembling cylinder head



- Clean the cylinder head thoroughly.
- Coat the valve stems and valve guides with engine oil and assemble the valves.



- Replace the valve stem seals with new ones and insert the stem seals to the valve guides of cylinder head with a special tool. (Be careful for the valve stem seals not to be damaged.)

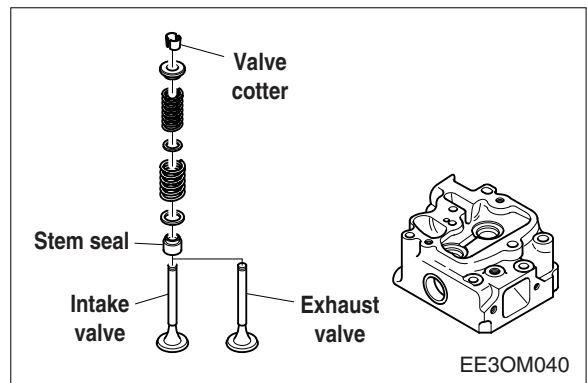

- Install the valve spring washer to valve guide.
- After putting on the inside, outside spring, install the valve spring seat on them.



NOTE:

Install the valve spring seat with "TOP" (painted in yellow) side up.

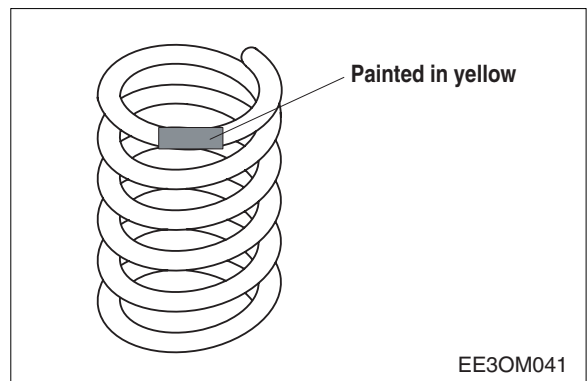



- Pressing the spring down with a special tool, assemble by inserting the valve cotter.



- After the valve is assembled, inspect the valve tapping it lightly with an urethane hammer if accurate assembling was done.

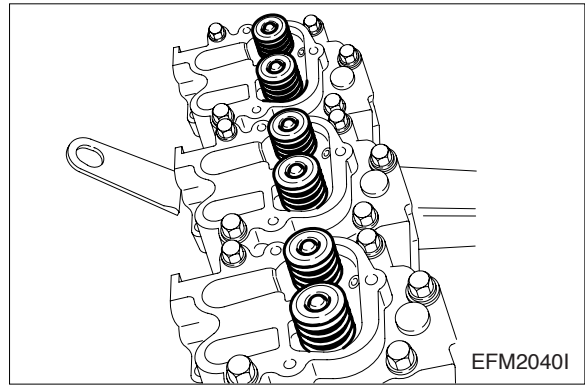

3.2.9. Rocker arm

1) Rocker arm disassembling



- Remove the snap rings in both ends of rocker arm with a pair of pliers.
- Tear down washer, rocker arm.
- Disassemble the rocker arm bush by means of a press.

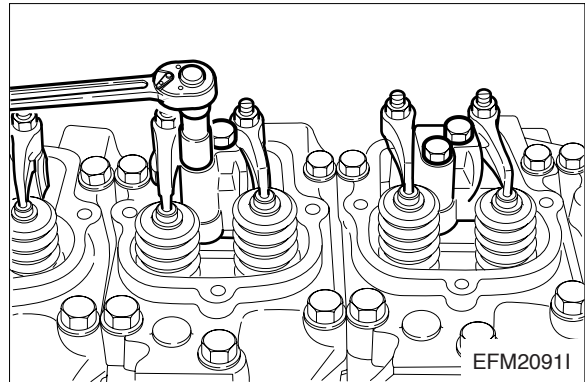

2) Inspection rocker arm bracket



- Measure the outer diameter of rocker arm bracket with outside micrometer at the position that the rocker arm is installed, and in case that it exceeds the limit value, replace.

	Standard	Limit
Bush inner dia.	$\phi 25.005 \sim \phi 25.035$ mm	$\phi 25.055$ mm
Shaft outer dia.	$\phi 24.967 \sim \phi 24.990$ mm	$\phi 24.837$ mm
Clearance	0.015 ~ 0.068 mm	0.25 mm

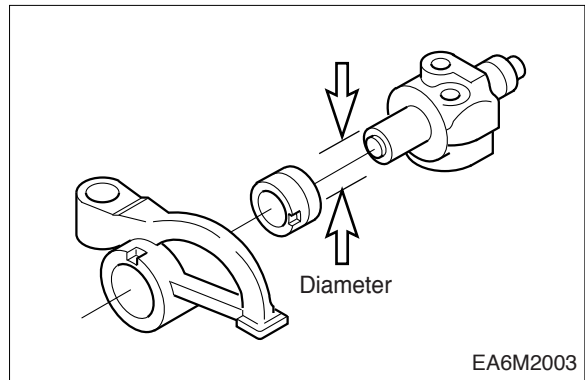

- Inspect the rocker arm surface that contacts with the valve stem for any scratch, step wear and correct the minor degree of wear with an oil stone or the fine grinding paper and replace if they are severe.

3.2.10. Tappet and push rod



- By means of outside micrometer, measure the outer diameter of tappet and replace the severe ones.

Tappet clearance	Standard	Limit
	0.035 ~ 0.077 mm	0.25 mm



- By inspecting the tappet surface that contacts with the camshaft's cam for any crack and scratch etc., and if the degree is small, correct them with an oil stone or the grinding paper but if severe replace them.



- Place the push rod on the surface plate and rolling it, inspect the curving degree with a clearance gauge and if abnormal, replace it.

< Run-out >

Limit	0.3 mm or less



- Inspect the oil passages of rocker arm and rocker arm bracket for any clogs and reassemble them in the reverse order of disassembling after thorough cleaning.

3.2.11. Cam shaft

1) Axial end play

- Push the camshaft toward the pulley side.
- Place a dial gauge onto the camshaft gear.

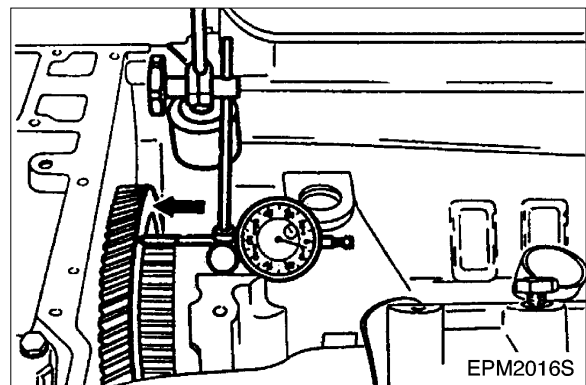
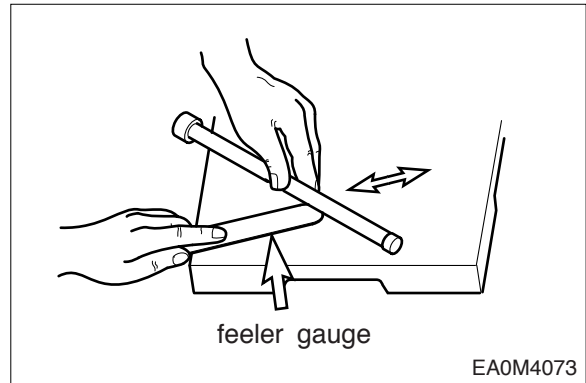
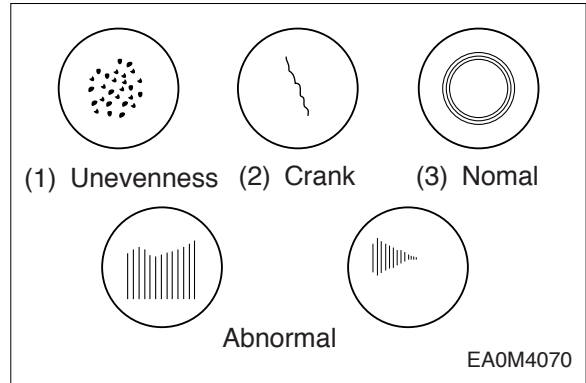



- Measure the camshaft's axial end play, moving the camshaft gear by means of a driver.

Limit	0.2 ~ 0.9 mm
--------------	--------------

- If excessive end play, assemble it by means of other thrust washer.

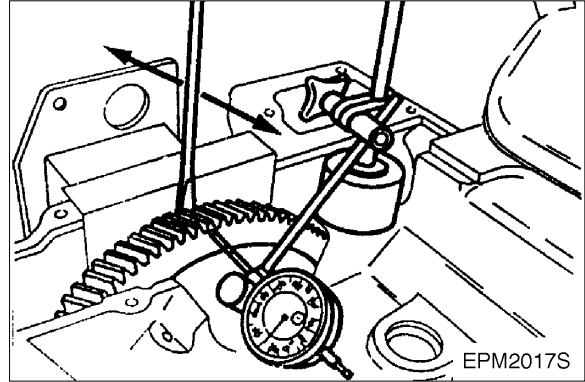

2) Inspection and measurement



- With inspecting the cam surface for any damage with naked eyes and correct any minor scratch by means of an oil stone grinding and if severe, replace it.

3) Cam lobe height



- Use a micrometer to measure the cam lobe height and journal diameter.
- If the measured number is less than the specified limit, the camshaft must be replaced.

	Standard	Limit
Cam lobe height(C)	47.7 mm	46.5 mm
Cam journal diameter(A,B)	∅56.0 mm	∅55.6 mm

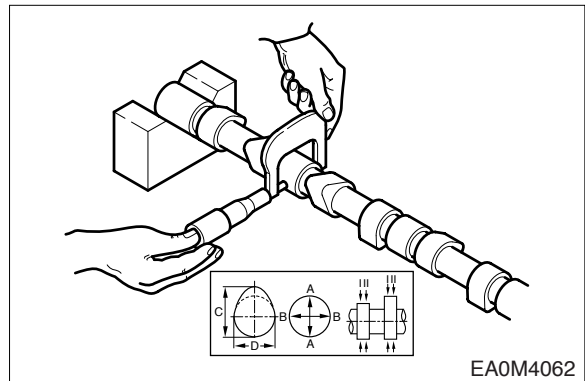

4) Cam journal diameter



- By means of outside micrometer, measure the camshaft journal.

Standard	∅ 69.91 ~ ∅ 69.94 mm
-----------------	----------------------

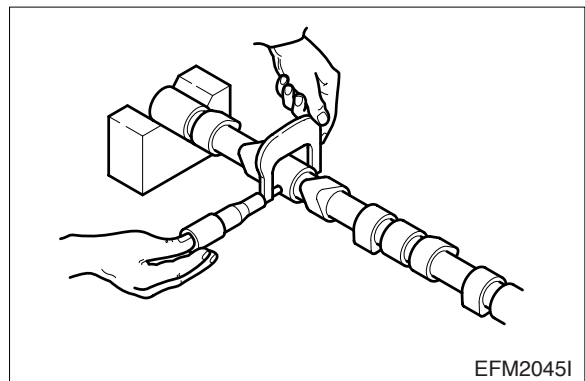

5) Cam bearing diameter



- Measure the camshaft bush inside diameter with a cylinder gauge and by comparing the inside and outside diameters, replace if abnormal.

Standard	$\phi 70.077 \sim \phi 70.061$ mm
-----------------	-----------------------------------

- Clearance between camshaft outside diameter and bush inner diameter of cylinder block.

Standard	Limit
0.060 ~ 0.120 mm	0.18 mm

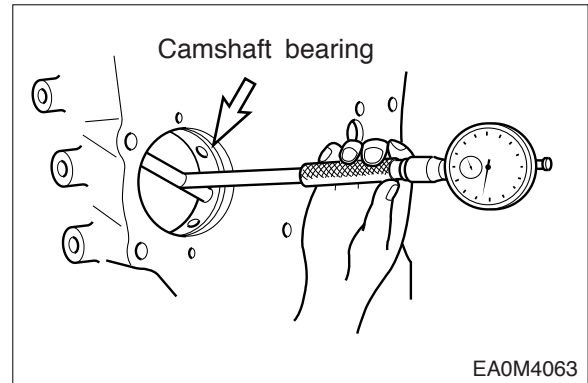

6) Camshaft bearing replacement



- Remover, installer

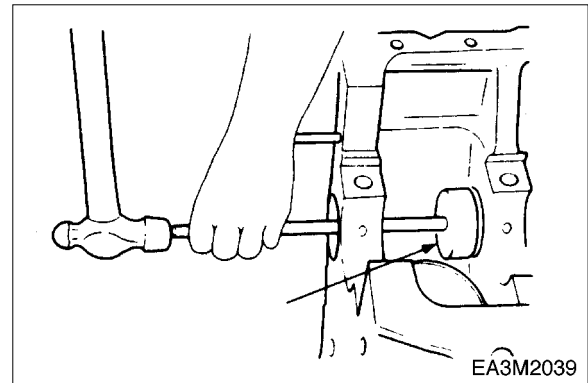

7) Camshaft run-out



- With placing the camshaft on the 2ea of V-blocks, and inspect the run-out of the camshaft, adjust or replace the severe one.

Standard	0.1 mm
-----------------	--------

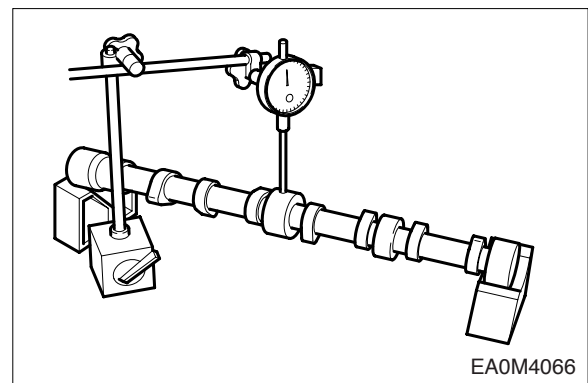

3.2.12. Crank shaft

1) Inspection and measurement



- Inspect for any scratch or damage with naked eyes, and grind to the undersize according to the damaged degree and use the undersized bearing.
- Inspect for any crack by means of magnetic powder and color check, and replace the cracked ones.

2) Journal and pin diameter



- With outside micrometer, measure the outside diameter of crank journal and crank pin at the direction and position of the figure shown and take the wear.

< Crankshaft journal outside diameter >

Standard	$\phi 103.98 \sim \phi 104.00 \text{ mm}$
-----------------	---

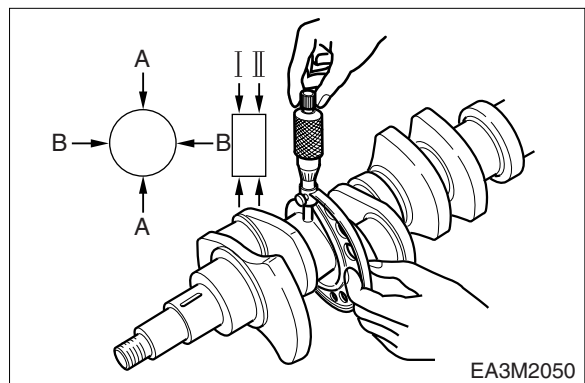

< Crankshaft pin outside diameter >

Standard	$\phi 89.98 \sim \phi 90.00 \text{ mm}$
-----------------	---

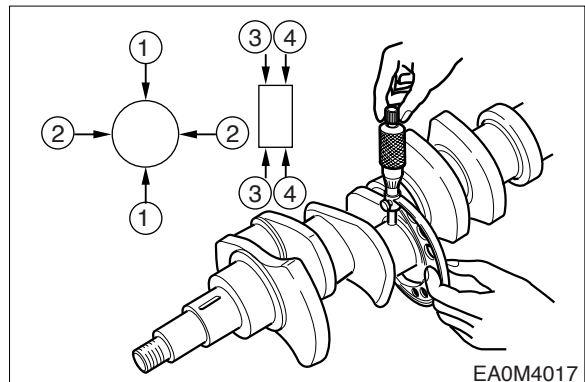

- In case that the lopsided wear is more than the limit value, grind to the undersize, and use the undersized bearing.

< Kinds of bearings for undersize >

- Standard
- 0.25 (Inside diameter 0.25mm less than standard)
- 0.50 (Inside diameter 0.50mm less than standard)
- 0.75 (Inside diameter 0.75mm less than standard)
- 1.00 (Inside diameter 1.00mm less than standard)



- There are 4 kinds as above, and the crankshaft also can be used by regrinding as above.

< "R part" standard value >

- (a) Crank pin "R part" : $4.0 \begin{smallmatrix} 0 \\ -0.5 \end{smallmatrix}$
- (b) Crank journal "R part" : $4.0 \begin{smallmatrix} 0 \\ -0.5 \end{smallmatrix}$

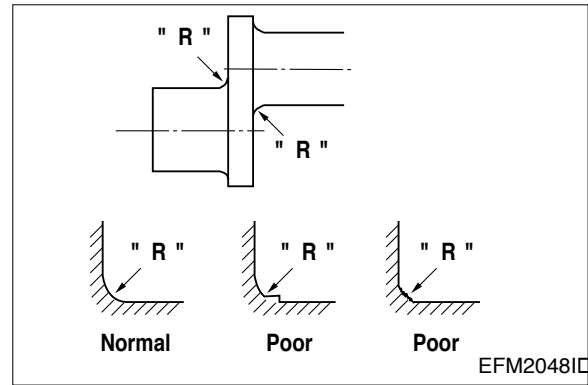

NOTE:

In case of crankshaft regrinding, the "R part" at the end of bearing must accurately be ground without fail and should avoid any processed jaw or coarse surface.

3) Run out of crankshaft



- Place the crankshaft on the V-block.
- Place the dial gauge on the surface plate and measure the run out of crankshaft rotating the crankshaft.

Standard	Limit
0.06 mm	0.4 mm

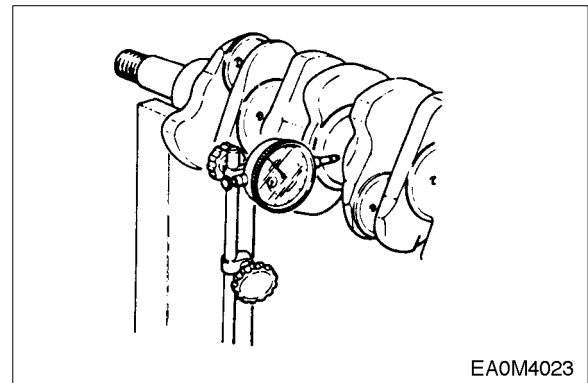

4) Inspection on crankshaft bearing and connecting rod bearing



- Inspect the crankshaft bearing and connecting rod bearing for any damages such as lopsided wear, scratch etc. and if abnormal, replace it.



- Inspect the oil clearance between the crankshaft and bearing.

a) How to utilize the cylinder gauge

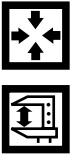

- Assemble the main bearing at the cylinder block and after tightening the bearing cap at the specified torque, measure the inside diameter.

Journal bearing nominal diameter	∅ 104 mm
----------------------------------	----------

Bearing cap bolt torque	Initial 30 kg.m + angle 90°
-------------------------	-----------------------------

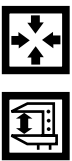
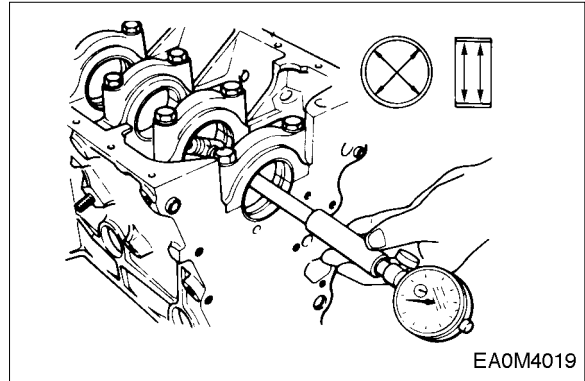

- Assemble the bearing at the bigger end of connecting rod, and after tightening the bearing cap at the specified torque, measure the inside diameter.

Connecting rod bearing journal diameter	∅ 90 mm
---	---------

Connecting rod bolt torque	Initial 10 kg.m + angle 90°
----------------------------	-----------------------------

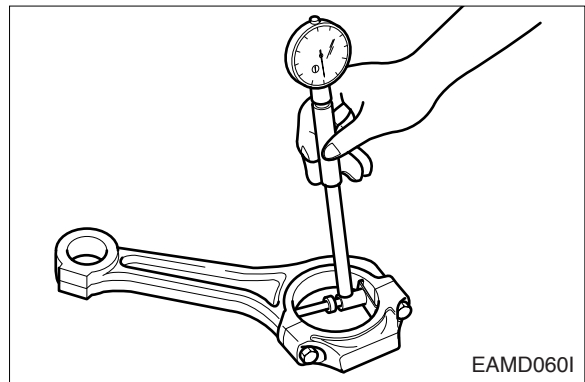

- Crankshaft pin and bearing clearance value exceeds the limit value, grind the crankshaft journal and pin and then use the undersized bearing.

Standard	Limit
0.066 ~ 0.132 mm	0.166 mm

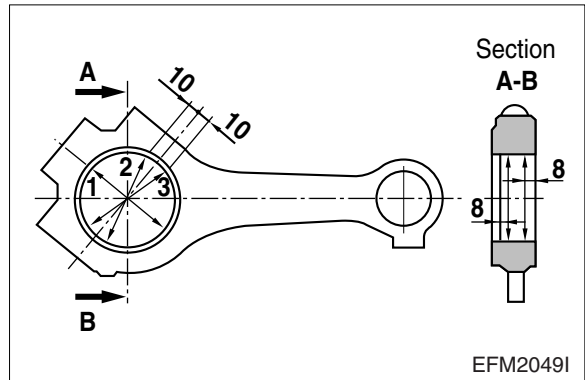

b) How to utilize plastic gauge



- Install the crankshaft in the cylinder block and place the plastic gauge on the crankshaft journal and pin at axial direction and then after tightening the bearing cap at the specified torque and again after tearing apart the bearing cap, measure the flatten plastic gauge thickness by pick it up. This is the oil clearance.
- With the same points, the oil clearance of connecting rod also can be measured.

5) End play



- Assemble the crankshaft in the cylinder block.



- Install the dial gauge, and measure the end play of crankshaft by pushing the crankshaft to axial direction.

Standard	Limit
0.190 ~ 0.322 mm	0.452 mm

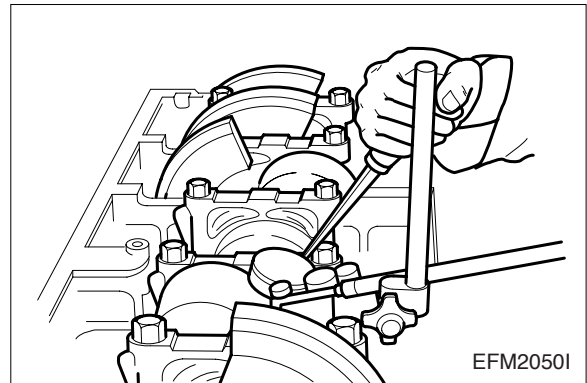

3.2.13. Piston

1) Piston disassembling



- Pull out the snap ring for piston pin and with a pair of snap ring pliers.

- With a round bar, remove the piston pin.

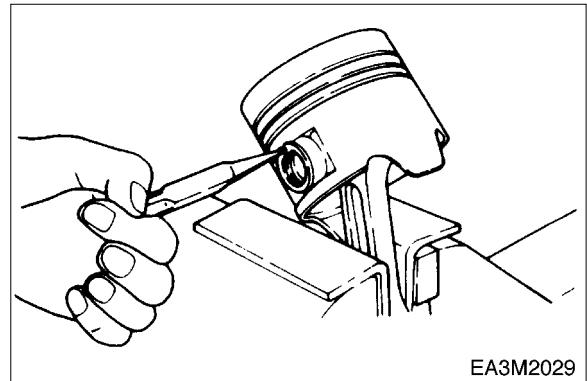

- With a pair of pliers, remove the piston rings.



- Clean the piston thoroughly.



2) Piston inspection



- With naked eyes, inspect the piston for any wear, crack and scratch and particularly inspect carefully at the ring grooves for any wear.



- With the outside micrometer, measure the piston's outside diameter the measuring position is 71.5mm from the piston lower end, and the direction of measurement must be perpendicular to the piston pin direction.

Standard	$\phi 127.739 \sim \phi 127.757 \text{ mm}$
-----------------	---

- By comparing the measured value of the piston outside diameter with the cylinder liner inside diameter, the bigger clearance is replaced.

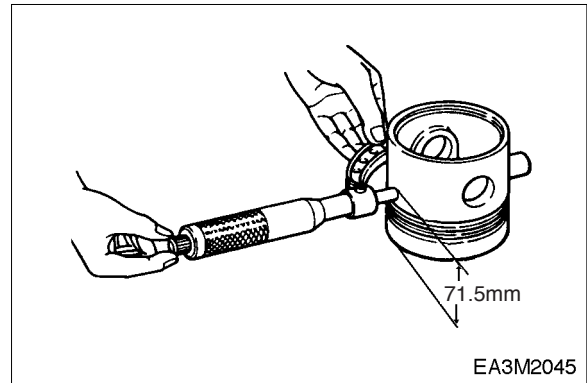

3) Piston ring and ring groove



- In case of piston ring's wear, damage or engine overhaul, replace piston rings.



- Insert the piston ring at the cylinder liner's upper part perpendicularly.
- With a feeler gauge, measure the gap clearance of piston ring.
- If the measured value exceeds the limit value, replace it.

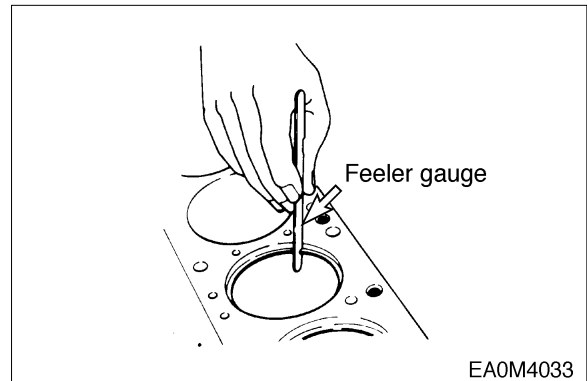

< Piston ring gap >

Division	Standard	Limit
Top ring	0.35 ~ 0.55 mm	1.5 mm
2nd ring	0.40 ~ 0.60 mm	1.5 mm
Oil ring	0.35 ~ 0.55 mm	1.5 mm

4) Piston side clearance

- Assemble the piston ring at the piston.
- Measure the each ring's side clearance and if the measured value exceeds the limit value, replace rings or piston.

< Piston side clearance >

Division	Specified value	Limit value
Top ring	0.35 ~ 0.55 mm	1.5 mm
2nd ring	0.050 ~ 0.082 mm	1.5 mm
Oil ring	0.030 ~ 0.062 mm	1.5 mm

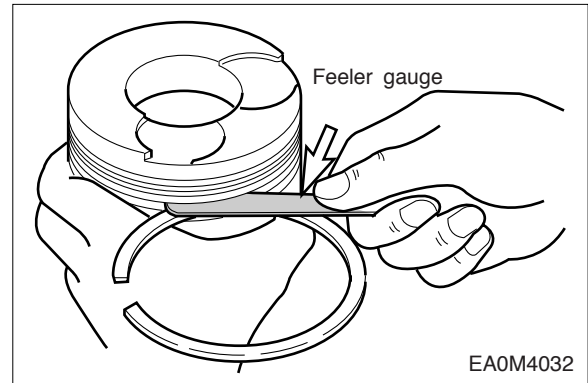

5) Piston pin



- With the outside micrometer, measure the piston pin's outside diameter and if the value is same as the use limit value or less, replace it.

Standard	Limit
$\phi 45.994 \sim \phi 46.000$ mm	$\phi 45.983$ mm or less

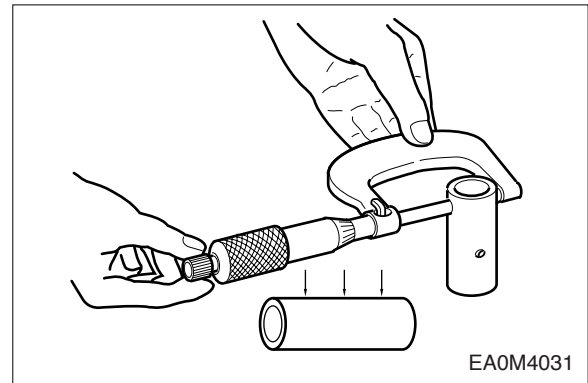

6) Piston pin and connecting rod bush clearance



- Inspect the clearance between the piston pin and the connecting rod bush, if it is more than the use limit value, replace either one that is more severe.

Limit	0.003 ~ 0.015 mm
-------	------------------

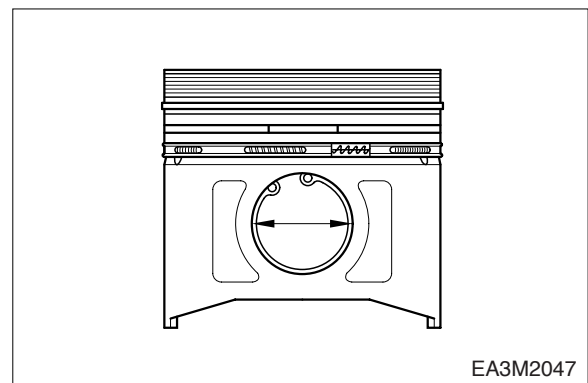

7) Connecting rod



- Inspect and measure the bigger end bearing hole and the smaller end bearing hole with respect to the parallelness and if abnormal, replace the rod.

Standard	Limit
0.02 mm	0.2 mm

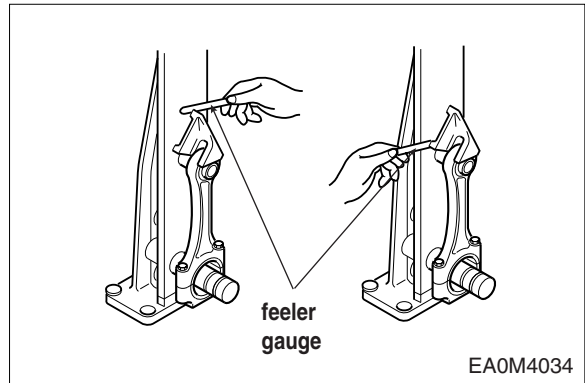

8) Piston reassembling



- After heating the piston at the piston heater for about 5 min (120 ~ 150°C), by aligning the piston pin hole with the pin hole of connecting rod's smaller end, insert the oil coated piston pin.



NOTE:
Confirm the direction of connecting rod and assemble.

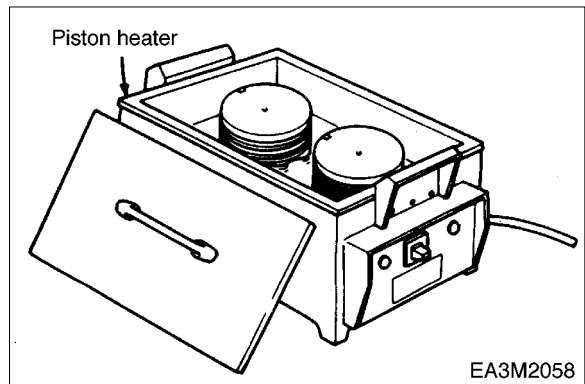

- With the snap ring plier, insert the piston pin snap ring.
- With confirming the upper side indication of piston ring, after assembling the ring in the piston ring groove, inspect if the movement of ring is smooth.
- Keep in order of the assembled piston as the cylinder No. turn.

3.2.14. Thermostat



- Inspect the wax case and spring for any damage.
- With putting the water temperature gauge into water and heating the water at the indirect method, when the water temp reaches to 71°C, the valve begin to open and fully open when it reaches to 85°C.



- Measure the valve opening temperature and the valve full opening temperature and inspect if the valve lift is more than 8mm and if abnormal, replace it.

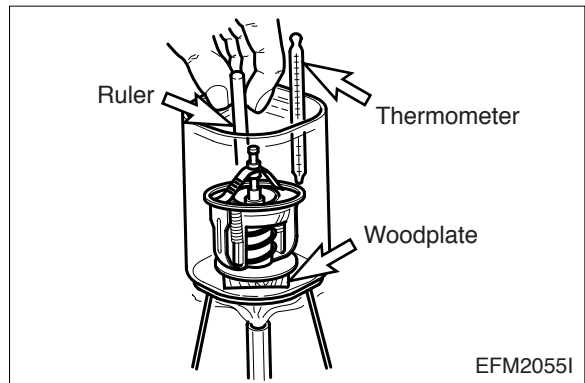

3.3. Engine Reassembly

3.3.1. Preparation and precaution before and after engine reassembly



- Clean all the parts thoroughly and also clean thoroughly by blowing into each passage of oil and cooling water.



- Disposition the various special and general tools for assembling in order.
- In order to coat the lapping parts with engine oil, prepare the clean engine oil.
- Prepare the sub-material such as an adhesive etc.
- Use three bond as an adhesive in the engine oil system and use silicone in the cooling system.
- Scrap the used gasket and seal ring, consumable parts etc. and replace with new ones.
- Tighten the various bolts in the specified tightening torque, and also according to the tightening order but the excessive torque must be avoided.
- Inspect if the movement of engine is smooth after assembling.
- After completion of assembling, whether various bolts are loose or not should necessarily be insured.
- Make sure that there is any missing parts or insufficient parts after full completion of assembling. Work only with clean hands.
- Before serving any fuel system component make certain that the fuel lines are fully closed and the fuel line pressure properly relieved.

3.3.2. Cylinder liner



- Replace O-ring with new one without fail and at the upper side, insert to the cylinder liner, but at the lower side, to the cylinder block.



- Coat the joint parts where O-ring contacts with oil.

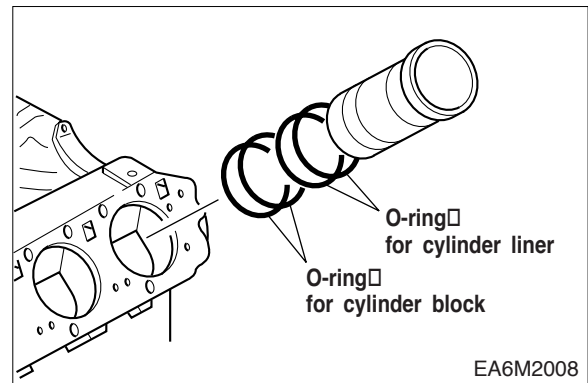

- After slipping the cylinder liner smoothly into the cylinder block, press it in being careful for O-ring not to damage.



- After completion of assembling the cylinder liner, confirm no leaks with 4 kg/cm² hydraulic test.

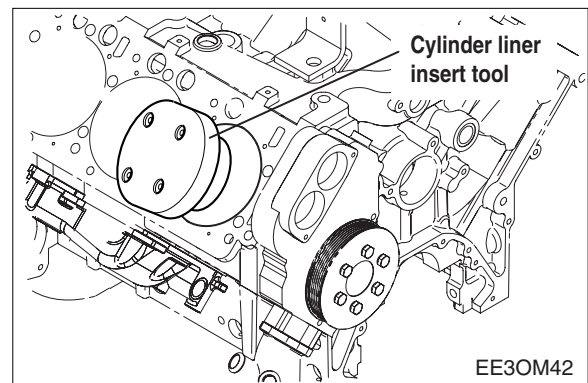

3.3.3. Oil spray nozzle

- Tighten the oil injection nozzle flange with hollow screws.
- Assemble the oil injection nozzle with the fixing bolts.



Torque	Hollow screw	7 kg.m
	Fixing bolt	1.2 kg.m

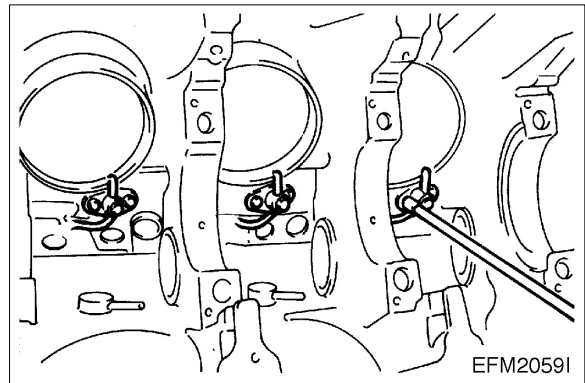

3.3.4. Tappet

- Coat the tappet wholly clean oil and push in the tappet hole of the cylinder block.

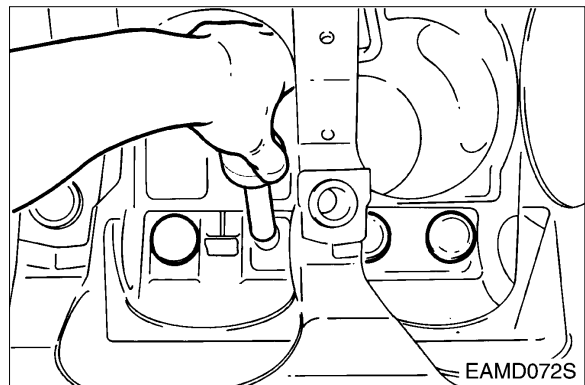

3.3.5. Crank shaft

- Put the wear ring into the heater to heat it up to 150 ~ 200°C level, push it over the crankshaft by means of a jig.

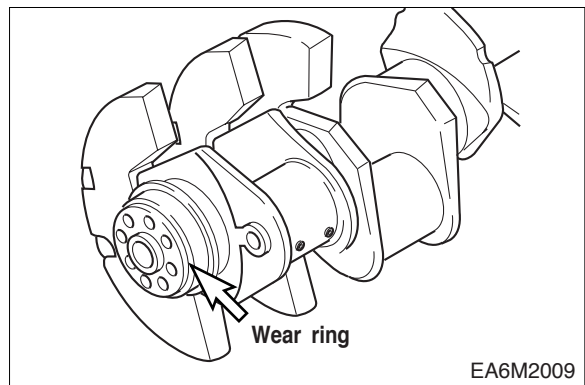

- Assemble the main bearing to the cylinder block and coat it with engine oil. Then assemble the bearing that has a hole to the cylinder block side and one that has no hole to the bearing cap and be careful not to change.

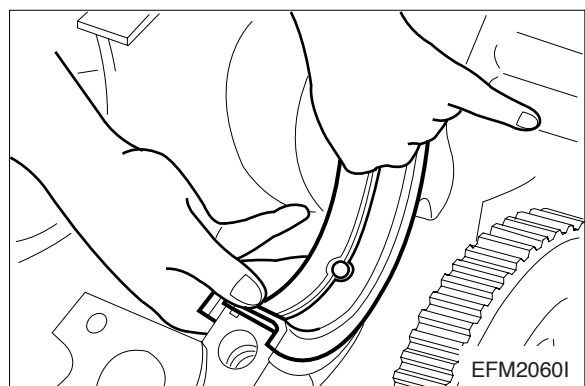

- Assemble temporarily one bolt each at both bolt holes and by connecting the wire to the bolts, lift it with crane or chain block and put down on the cylinder block carefully.



- Coat the crankshaft journal and pin parts with engine oil, and after fitting the main bearing into the bearing cap and assemble it to the cylinder block making sure of the number in order not to change the bearing cap.

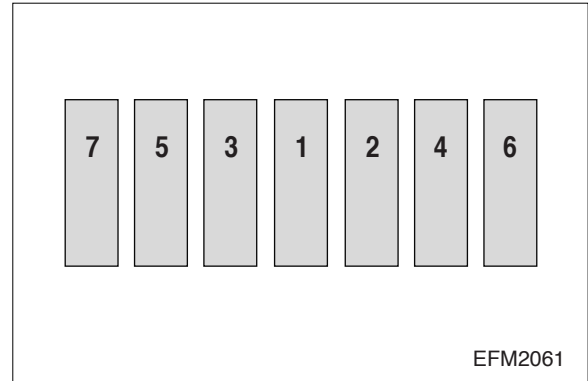

- Coat the bearing cap bolt and its bolt seat part with engine oil necessarily and according to the tightening order, tighten them with 30kg.m and with rotating angle method ($90^{\circ} +10^{\circ}$) and tightening order are as follows.

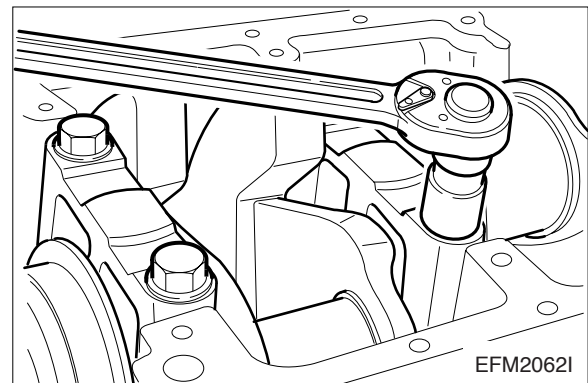

< Bearing cap bolt's tightening order >

- (1) **First step** : Coat the bolts with engine oil.
- (2) **Second step** : Screw down 1 ~ 2 threads.
- (3) **Third step** : Tighten with about 15kg.m by wrench.
- (4) **Fourth step** : Tighten with about 25kg.m by torque wrench.
- (5) **Fifth step** : Tighten with 30kg.m by torque wrench.
- (6) **Sixth step** : Tighten with final rotating angle method $90^{\circ} +10^{\circ}$.

However, according to above tightening order, tighten step by step.



- Inspect if the crank shaft's rotation is smooth.
- Assemble the crankshaft gear on the crankshaft and coat a white paint mark on "1" part in order to find easily.

3.3.6. Cam shaft



- Coat the cam bush of cylinder block and camshaft with engine oil.

- Assemble the cam bush and camshaft for them not to be damaged.



- Assemble the crankshaft gear and the camshaft gear making sure that the gear marks on both gears are aligned together.

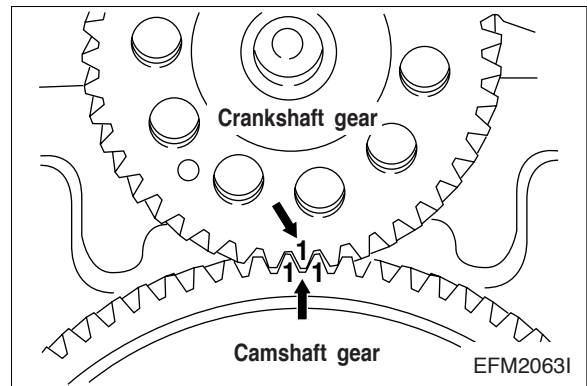

3.3.7. Flywheel housing



- Coat the thrust washer fixing bolt with an adhesive and tighten it with specified torque.

Torque	4 kg.m
---------------	--------

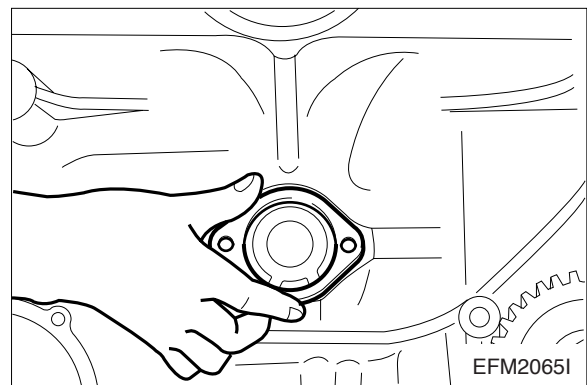

- Coat the oil seal (P.T.F.E.) with lubricating oil and assemble the oil seal carefully for it not to deviate or be damaged by means of special tool. (Mandrel for assembling).

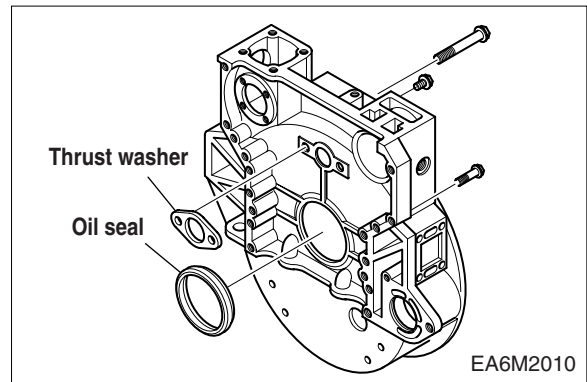

- Attach the gasket on the surface of cylinder block where the flywheel housing is to be installed. (In order to prevent the gasket slip down, coat a grease on the cylinder block surface.)
- Temporarily assemble 2ea of guide bolts for installing the flywheel housing to the cylinder block.

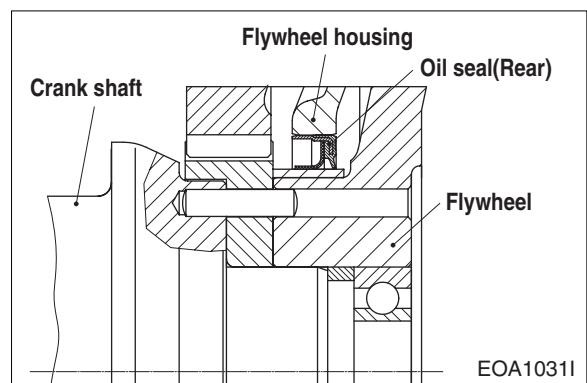



- After fitting the flywheel housing holes to the guide pins and engage temporarily 2 ~ 3 threads of fixing bolts, and according to the tightening order (zigzag method) tighten them in the specified torque.

Torque	M12 x 1.5	10 kg.m
	M10	7.5 kg.m

3.3.8. Flywheel

- Installation of flywheel ring gear with a gas burner, heat the ring gear evenly until heat expansion takes place, then install it using a hammer.



- Do not allow the temperature of the ring gear to exceed 200°C (390°F).
- By means of mandrel, assemble pilot bearing to the flywheel.

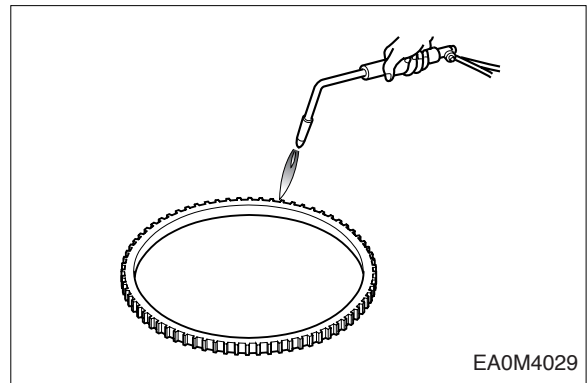

- By means of mandrel, press in the wear ring at the backward face.
- Install two guide bolts for installing the flywheel to the crankshaft.

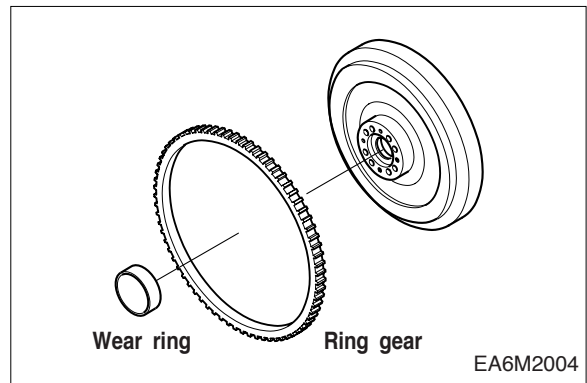

- After letting the guide pin insert through the flywheel holes and engaging the fixing bolts by 2 ~ 3 threads temporarily, tighten them to the specified torque according to lightening order. (Zigzag order)

Torque	26 kg.m
---------------	---------

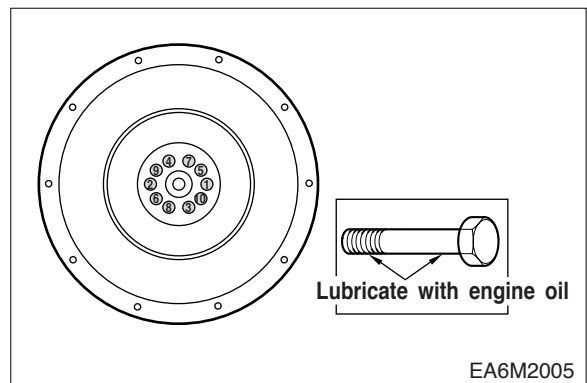

3.3.9. Front oil seal holder



- After placing the oil seal in the oil holder hole properly, press it in with a mandrel. (Be careful for oil seal must not be damaged.)
- Attach a gasket at the oil seal holder.

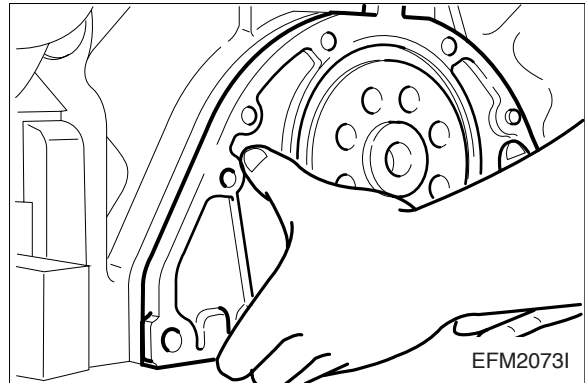

- Align the dowel pin with the oil seal holder dowel hole and assemble them by tapping lightly the dowel pin part with an urethane hammer when in assembling, take care not to hurt the oil seal by the crankshaft.

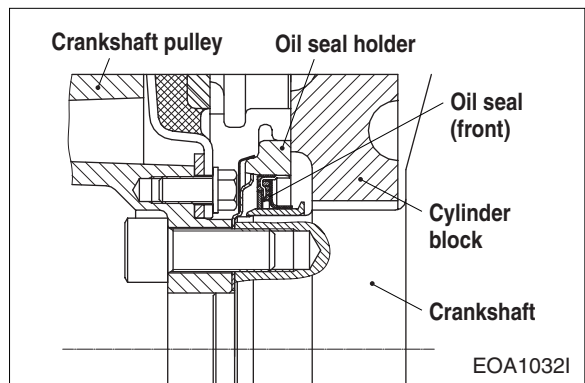

NOTE:

Without coating the oil seal with oil or lubricant, assemble it in the dry state.

- Tighten the fixing bolts in the zigzag method.

3.3.10. Piston



- Line up the piston assembly in the order of cylinders and fit the bearings to the connecting rods and bearing caps. However, take care not to swap between the connecting rods and bearing caps.



- Coat the pistons and connecting rod bearings sufficiently with clean engine oil.

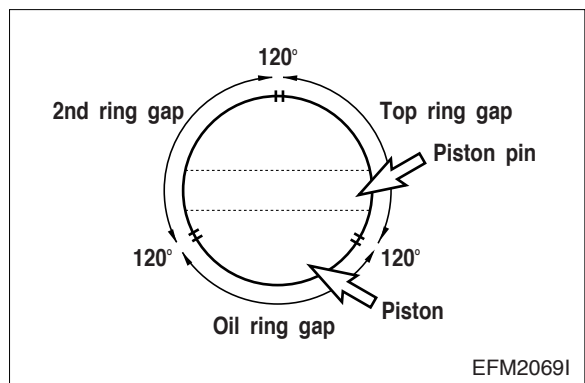



- By means of a special tool, insert the piston rings and adjust the angles between the ring gaps at 120°.



- Push in the piston with hands or wooden bar into cylinder. (Be careful for piston and rings not be damaged.)

- Pushing the piston down, rotate the crankshaft about 180° and fit the bearing cap to the connecting rod.



- Coat the tap parts of connecting rod bolts and their seats with engine oil,



- and after engaging 2 ~ 3 threads of bolts primarily rind then tighten them to the specified torque. (10 kg.m + 90° +10°)

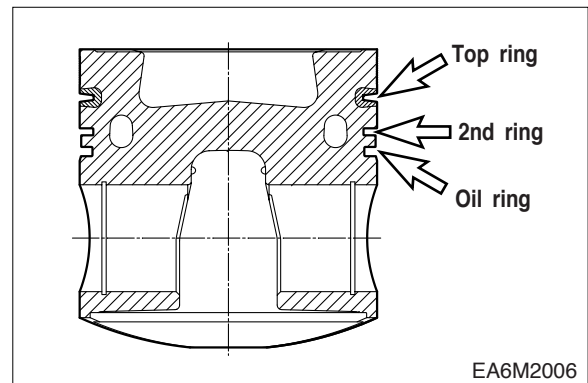

EA6M2006

< Connecting rod bolt tightening order >

- (1) **First step** : Coat the bolts with engine oil.
- (2) **Second step** : Engage 2 ~ 3 threads by hands.
- (3) **Third step** : Tighten to about 7kg.m with wrench.
- (4) **Fourth step** : By means of torque wrench tighten to 10 kg.m.
- (5) **Fifth step** : Finally assemble by means of rotation angle method 90° +10°.

However, according to above tightening order, tighten step by step.

* **Standard length of bolt and use limit:**

- From head seat to bolt tip

Standard length	Use Limit
67.5 ^{±0.3} mm	69 mm



- By moving the connecting rod bearing cap by hands, make sure if there is any play in left and right.
- With the same method as above, assemble in each cylinder rotating the crankshaft.

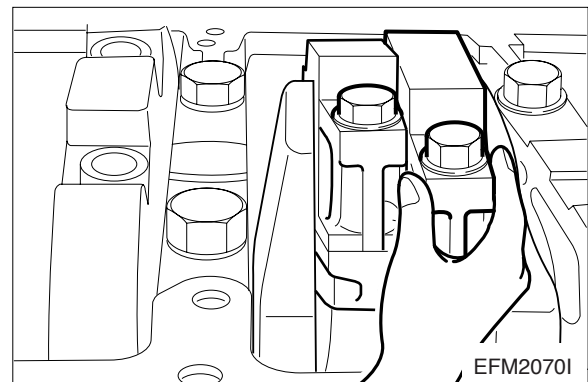

EFM2070I

3.3.11. Oil pump

- Put the oil pump at the place to be installed on the cylinder block.
- Attach a gasket at the surface of oil pump where the pressure regulating valve is to be installed and place the regulating valve on a gasket.
- Assemble the oil pump by tightening the fixing bolts.



Torque	2.2 kg.m
---------------	----------

- Attach a gasket at the surface of the oil pump where the oil suction pipe is to be installed, and install the oil suction pipe by tightening the fixing bolts.
- Assemble the pipe bracket on the cylinder block side with bolts.



Torque	2.2 kg.m
---------------	----------

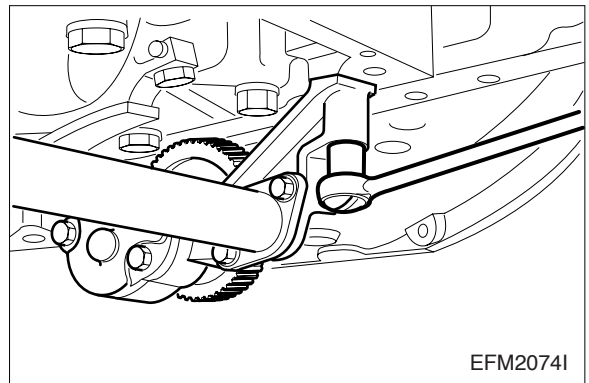

EFM2074I

3.3.12. Vibration damper

- Assemble the vibration damper tightening firstly by the crankshaft pulley and the fixing bolts.
- Insert the crankshaft pulley assembly to the crankshaft and tighten the fixing bolts in the method of zigzag to the specified torque.



Torque	Vibration damper & pulley	6 kg.m
	Crank shaft pulley	21 kg.m

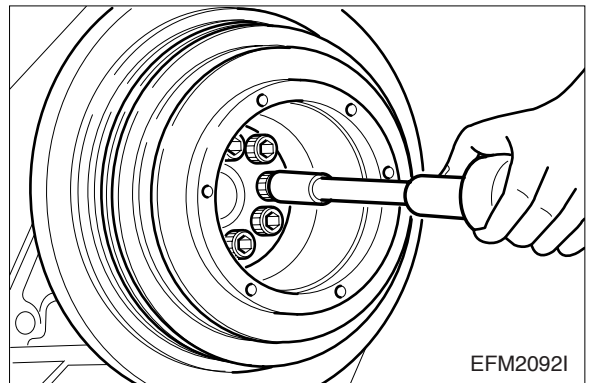

EFM2092I

3.3.13. Oil pan



- Clean thoroughly the gasket that is projecting at the junction parts of front oil seal holder and flywheel housing of cylinder block's lower face with a scraper.



- In the process of gasket removal, be careful for the gasket pieces not to get into the engine inside.

- Attach a gasket to the cylinder block.
- Install the oil pan and tighten the fixing bolts. Then takes care not to squeeze out the gasket.



- Install the guide tube and insert the oil level gauge.

Torque	2.2 kg.m
---------------	----------

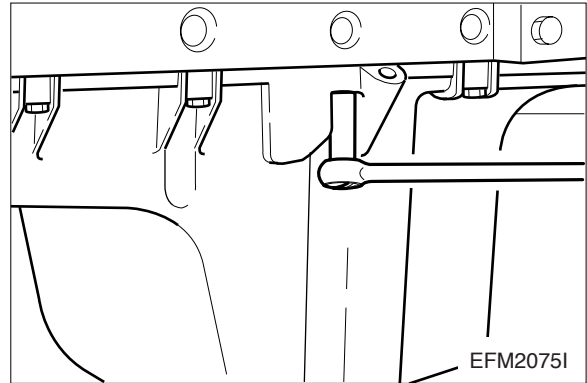

3.3.14. Intake and exhaust valve



- Identify the marks of "GI" and "GE" impressed on the valve head before assembling the valve with the valve head.



- With a valve stem seal fitting jig, assemble the valve stem seal with the valve guide.

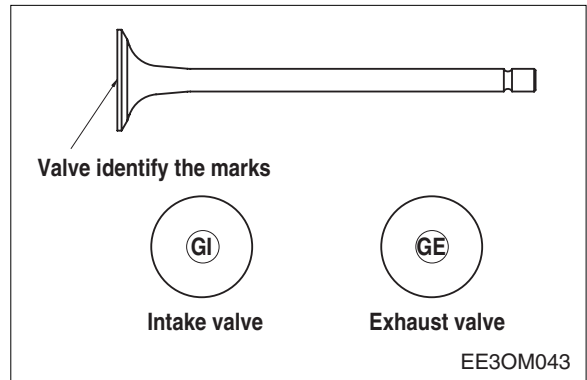

3.3.15. Cylinder head



- Blow the cylinder head bolt holes with compressed air to remove the foreign material cleanly.

- Wipe off cleanly the junction part of cylinder block's head gasket.



- After confirming whether there is foreign material or not necessarily, if there is, remove it.

- Assemble a gasket fitting with the fixing pin of cylinder block.

- Position the cylinder head assembly on the cylinder block aligning with its dowel pin. (Take care not to damage the head gasket.)

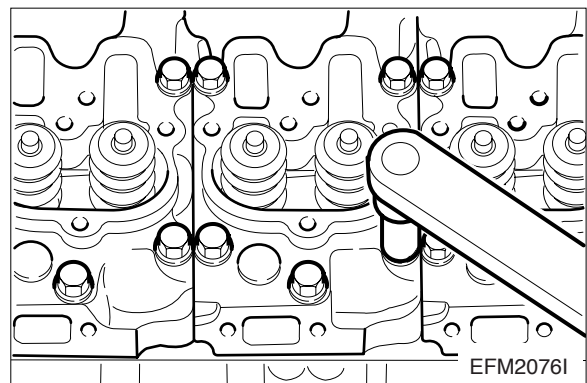



- Coat the cylinder head bolts with engine oil and tighten them to the specified torque according to step by step.



- However, prior to tightening the bolts, with a long steel rule, the parallelness between the cylinder heads must be adjusted.

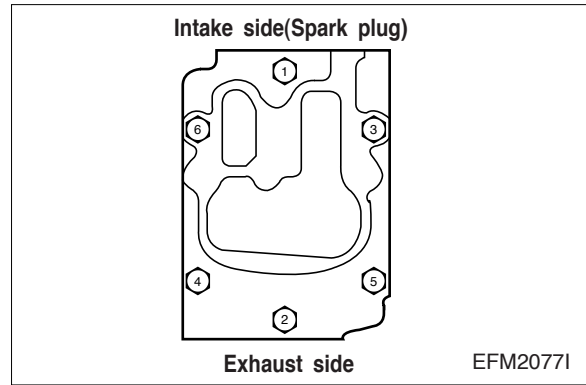

< Cylinder head bolts tightening order >

- (1) **First step** : Coat bolts with engine oil.
- (2) **Second step** : Tighten temporarily 1 ~ 2 threads by hands.
- (3) **Third step** : Tighten to about 8kg.m with a wrench.
- (4) **Forth step** : Tighten to 15kg.m with a torque wrench.
- (5) **Fifth step** : Rotate 90° by rotation angle method.
- (6) **Sixth step** : Finally tighten additionally rotating 90°.

*** Standard length of bolt and use limit:**

- From the head seat face to tip

Bolt no.	Standard length	Use limit
3, 6	168 mm	171 mm
2, 4, 5	144 mm	147 mm
1	109 mm	112 mm

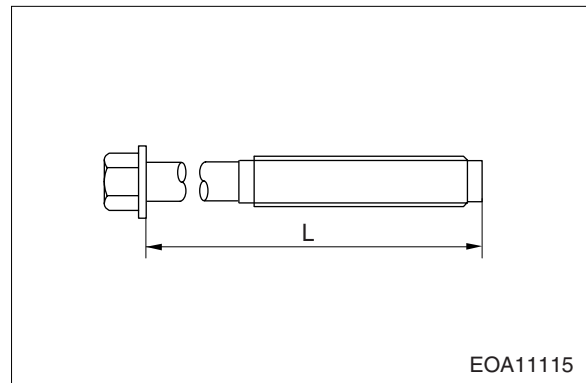

CAUTION:

Take care for the foreign material not to get into the cylinder head suction passages.

3.3.16. Spark plug



- Put the spark plug hole of cylinder head and after inserting the spark plug assembly into it, tighten to assemble.

Torque	2.5 ~ 3.0 kg.m
---------------	----------------

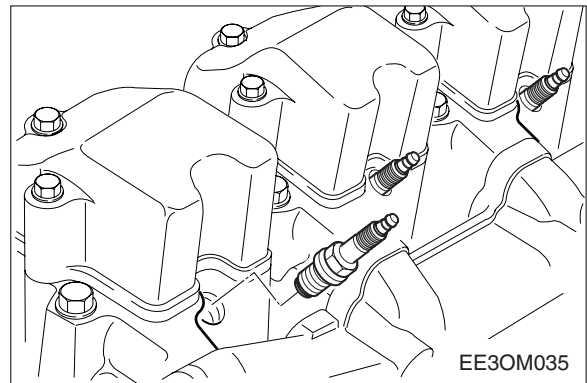

3.3.17. Rocker arm



- Coat the push rod with engine oil and put it into the push rod hole.



- Position the rocker arm assembly on the cylinder head and tighten the fixing bolts to the specified tightening torque.

Torque	6.5 kg.m
---------------	----------

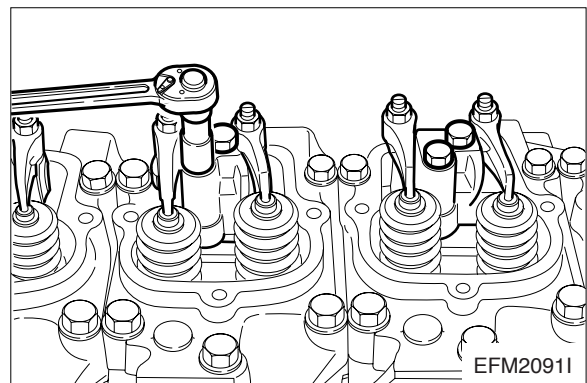

- Adjust the valve clearance. Regarding the adjustment, refer to the regular maintenance part.

3.3.18. Timing drive & sensor



- Attach an O-ring to the cylinder block and install the timing drive on the cylinder block and then tighten the fixing bolts.

Torque	6.5 kg.m
---------------	----------



- Install the timing sensor on the timing drive and rotate (CW) the timing sensor. (Be careful for sensor magnet not to be broken)

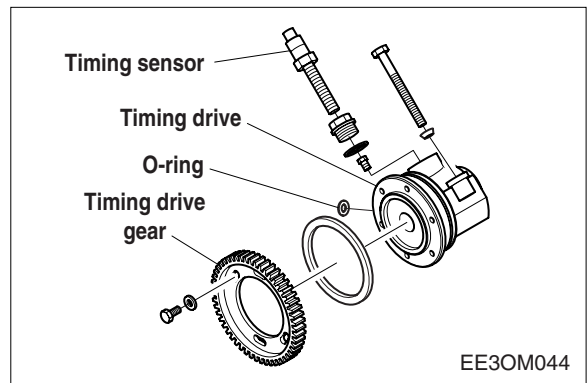



- Until the end of it reach on trigger magnet and reverse rotate (CCW) the timing sensor for 255°(gap 1.0 mm) and then fix lock nut.

Timing sensor gap	0.7 ~ 1.0 mm (178° ~ 255°)
--------------------------	-------------------------------

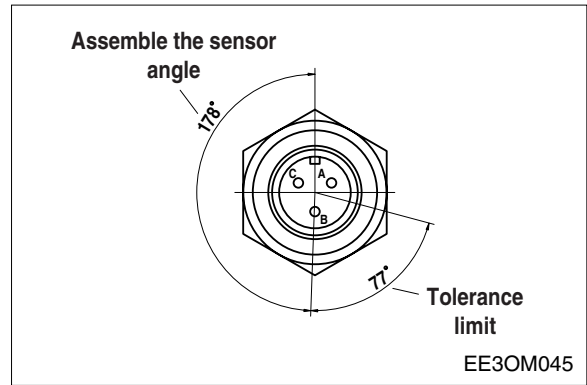

3.3.19. Ignition timing angle check & adjustment

1) Check ignition timing angle



- Turning crankshaft, let the valves of #7 (10 cylinder engine) or #6 (8 cylinder engine and 12 cylinder engine) cylinder's valves overlap.
- Rotate the flywheel to the opposite direction about 30°(in order to remove a back lash) and then rotate in normal direction to set the flywheel timing angle and effect-hole sensor magnet position.

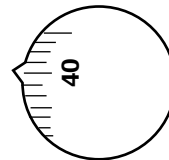
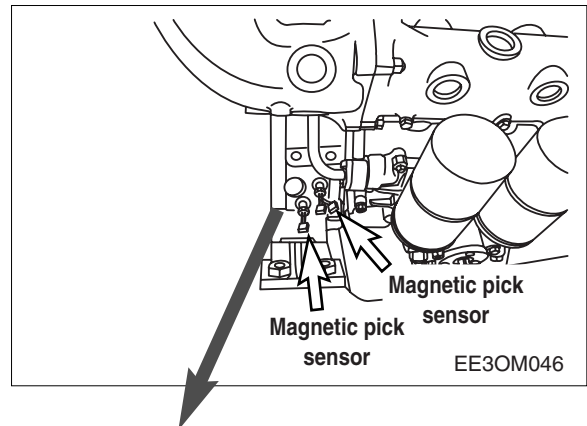

- If not aligned, the start of effect-hole sensor setting has to be corrected.

Engine model	GV158TIC	GV180TIC	GV222TIC
Adjusting angle of ignition timing(BTDC)	40°	40°	40°
Operating angle of ignition timing(BTDC)	14°	14°	12°

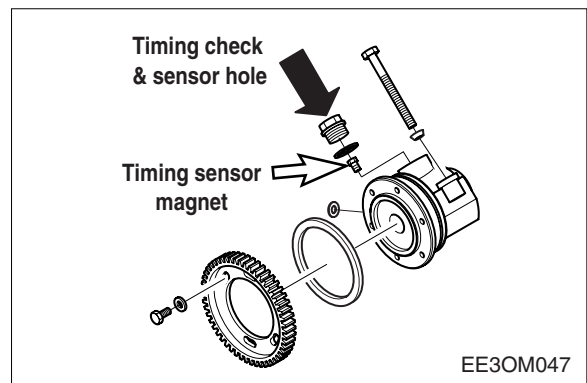

2) Adjust ignition timing angle

- Remove the effect-hole sensor drive gear cover.
- Correct start of effect-hole sensor setting by turning the drive gear flange in the oblong holes of the drive gear.
- Mark sure after every adjustment that fastening bolts are carefully tightened.
- Check start of effect-hole sensor setting once more.

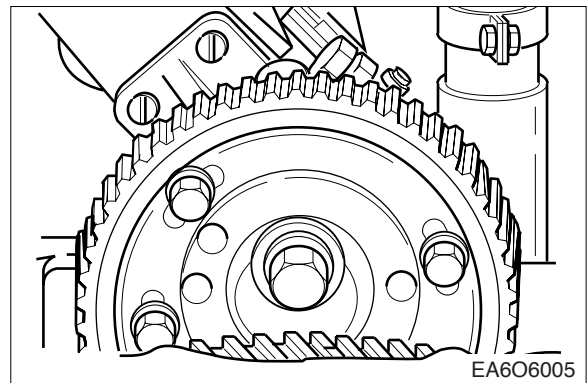

3.3.20. Flywheel housing cover

- Attach a gasket to the flywheel housing cover.
- Install the flywheel housing cover and tighten the fixing bolts by the zigzag method.



Torque	2.2 kg.m
---------------	----------

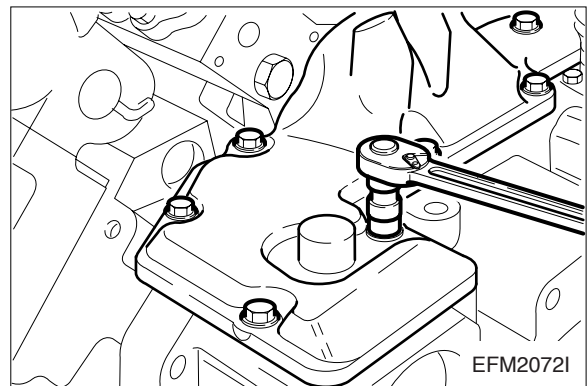

3.3.21. Intake manifold & gas regulator

- Attach a new gasket to the cylinder head side.
- Assemble the intake manifold by tightening the fixing bolts.
- Attach a gasket to the inlet flange and assemble by tightening the fixing bolts.
- Attach a gasket to the equalizing pipe and gas regulator that connects the intake manifolds of both sides and assemble both manifolds by tightening the fixing bolts.

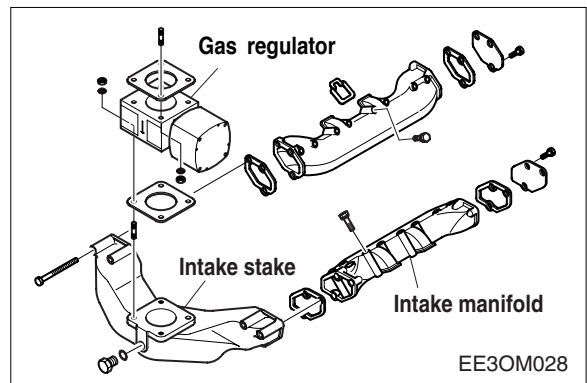

CAUTION:

Check assembled after the all engine parts install and tighten fuel line. Open fuel line valve and check for leaks using soapy water or commercial leak detector.

3.3.22. Cylinder head cover

- Attach a new gasket on the surface of cylinder head where the cover is to be installed.
- Assemble the cylinder head cover by tightening the fixing bolts.
- Insert the oil filler cap.



Torque	2.2 kg.m
---------------	----------

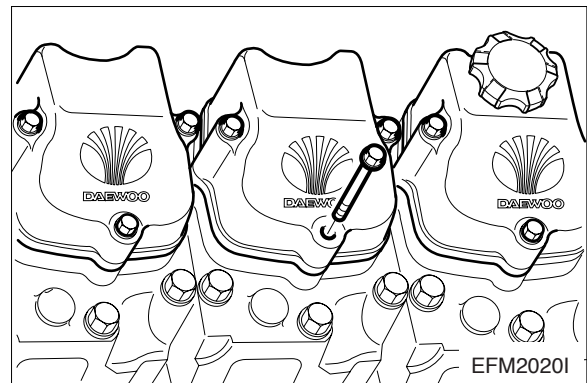

3.3.23. Exhaust manifold

- Prior to assembling the exhaust manifold, attach a gasket firstly to the cover and exhaust elbow pipe and assemble them tightening the bolts evenly as the right figure.

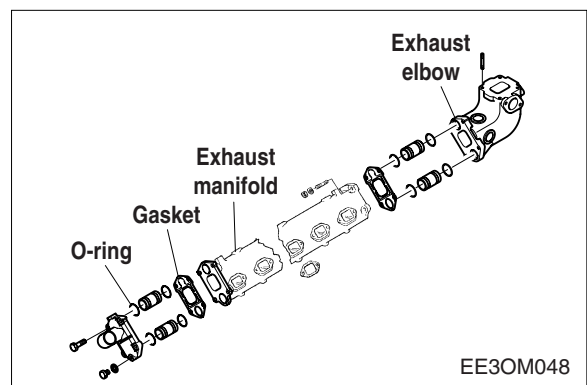

- Attach new gaskets to the exhaust manifold and then assemble the exhaust manifold with the fixing bolts.

Torque	5.0 kg.m
---------------	----------

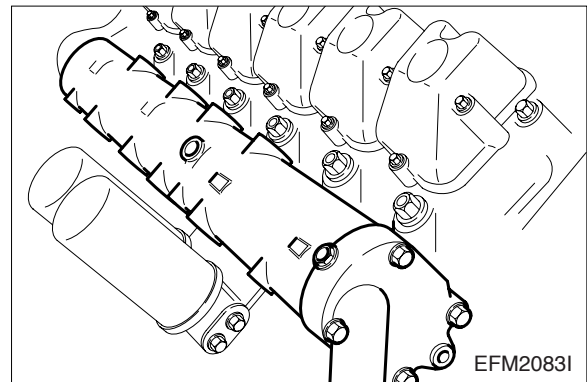

CAUTION:
Be careful not to drop the manifold because it is very heavy.

3.3.24. Reset & magnetic pick-up sensor

- Move the lock nut to hexagonal side of sensor completely.
- Rotate (CW) the Magnetic pick-up sensor on fly wheel housing, until the end of it reach on flywheel ring gear and/or reset pin.

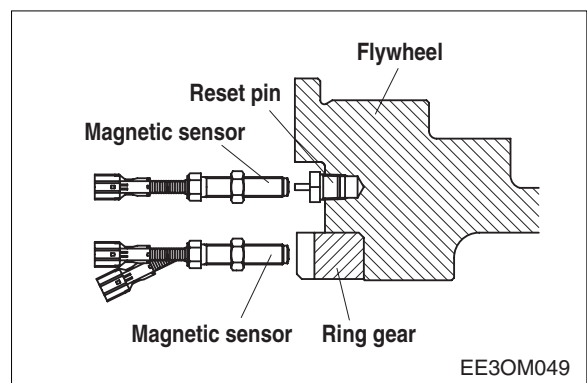



- Rotate (CCW) the Magnetic pick-up sensor for 270°(gap 1.0 mm) and fix lock nut.
- Tolerance limit is 27°.(gap ± 0.1 mm)

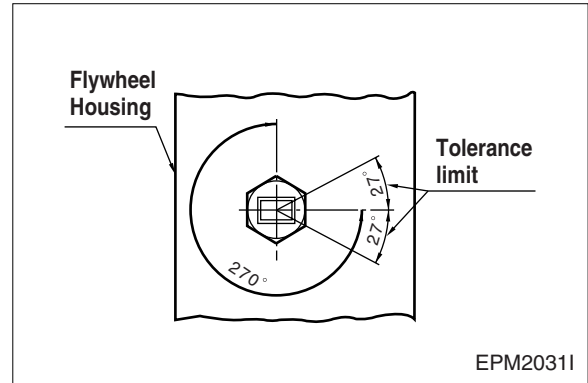

3.3.25. Oil cooler

- Attach a gasket on the surface in the oil cooler housing where the oil cooler is installed.
- Tighten the oil cooler with fixing bolts.
- Install the oil cooler assembly by tightening the fixing bolts in the zigzag order.



Torque	2.2 kg.m
---------------	----------

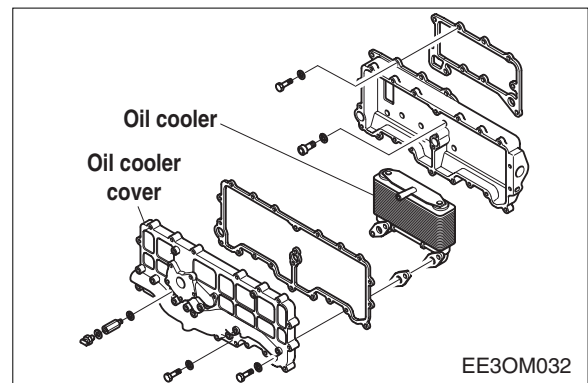
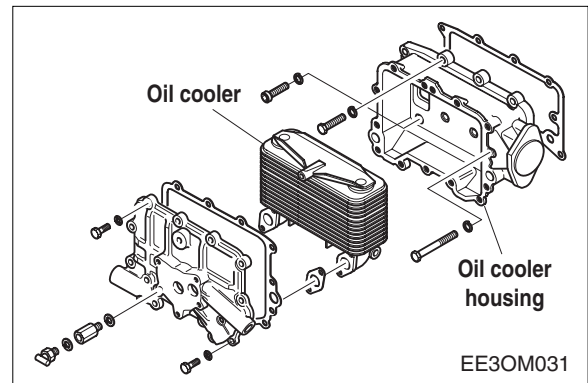
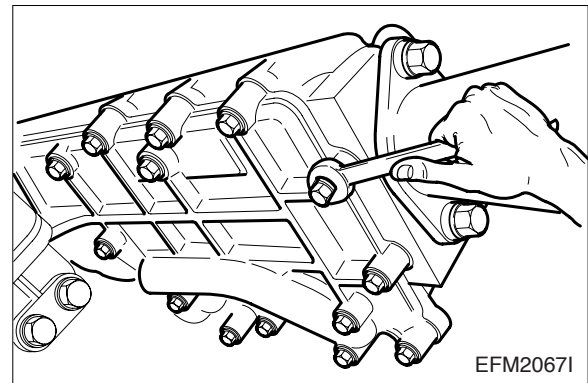

3.3.26. Oil filter

- Attach the oil filter gasket on the oil cooler.
- Install the filter head on the oil cooler and then tighten bolts in a diagonal sequence.



Torque	2.2 kg.m
---------------	----------

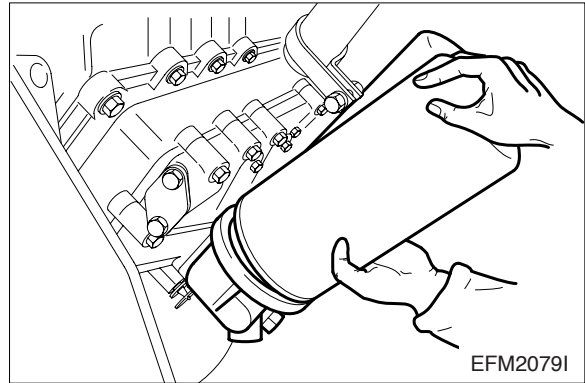

- Lubricate the cartridge gasket and spin filter until gasket contacts oil filter head, then tighten additional 3/4 to 1 turn.



- Start engine and check for leaks.

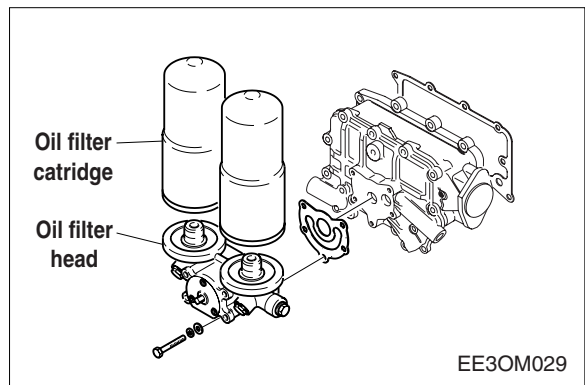

3.3.27. Cooling water pump

- Attach a gasket at the cooling water pump. (at cylinder block side)
- Assemble the cooling water pump by tightening the fixing bolts. (zigzag method)



Torque	Water pump	4.4 kg.m
	Water pump pulley	4.4 kg.m

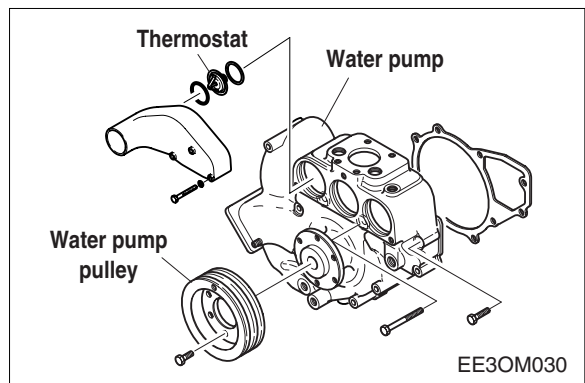

- Insert the thermostat of cooling water pump.
- Insert the O-ring to the thermostat and assemble the cooling water pipes by tightening the fixing bolts.

Thermostat torque	2.2 kg.m
--------------------------	----------

3.3.28. Starting motor

- Install stud bolts at the bolt holes on the flywheel housing for installing the starter.



- Insert the starter into the flywheel housing and tighten the fixing bolts.

Torque	8 kg.m
---------------	--------

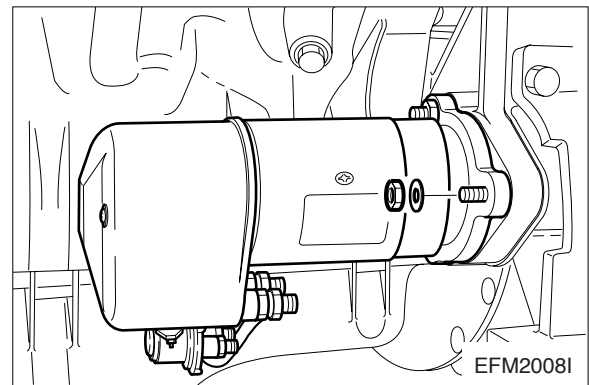

3.3.29. Turbo charger



- Attach a gasket to the exhaust elbow and assemble the turbocharger with fixing bolts.

Torque	4.4 kg.m
---------------	----------

- Attach a gasket on the oil supply pipe and assemble the pipe with the fixing bolts.
- Attach a gasket on the oil discharge pipe and assemble the pipe by tightening the bolts.
- At the same method as above, both sides are assembled.

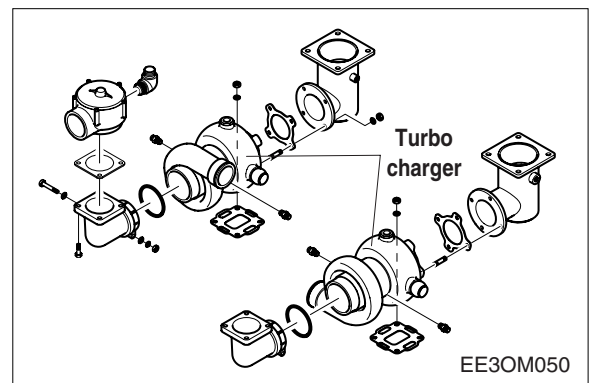

CAUTION:

Check assembled after the all engine parts install and tighten fuel line.

Open fuel line valve and check for leaks using soapy water or commercial leak detector.

3.3.30. Gas fuel mixer

- Attach a gasket to the intake elbow and assemble the gas fuel mixer with fixing bolts.
- At the same method as above, both sides are assembled.



CAUTION:

Check assembled after the all engine parts install and tighten fuel line.

Open fuel line valve and check for leaks using soapy water or commercial leak detector.

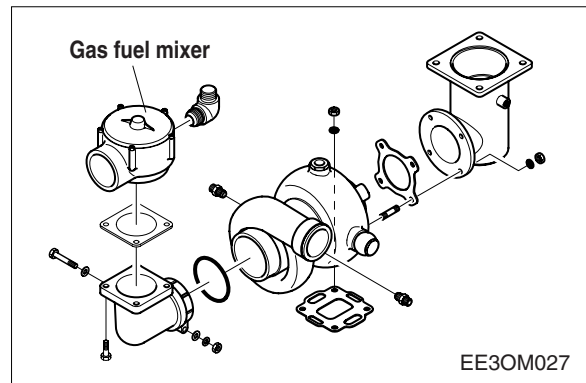

3.3.31. Inter cooler

- After assembling the intercooler fixing bracket on the intake manifold and then assemble the intercooler with the fixing bolts.
- Assemble the various hoses and pipes.



CAUTION:

Check assembled after the all engine parts install and tighten fuel line.

Open fuel line valve and check for leaks using soapy water or commercial leak detector.

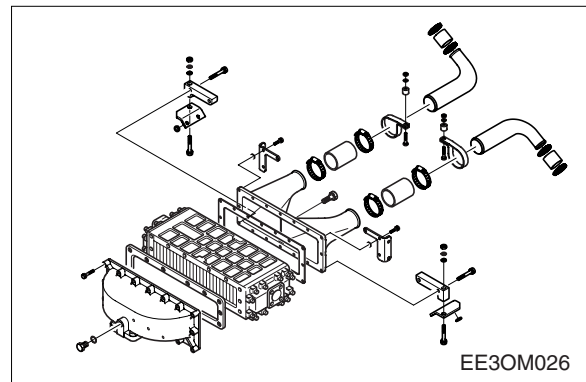

3.3.32. Ignition coil & gas pressure regulator

- Attach a bracket to the intake manifold and assemble the gas pressure regulator with fixing bolts.
- Assemble the ignition coil and high voltage cable.



CAUTION:

Check assembled after the all engine parts install and tighten fuel line.

Open fuel line valve and check for leaks using soapy water or commercial leak detector.

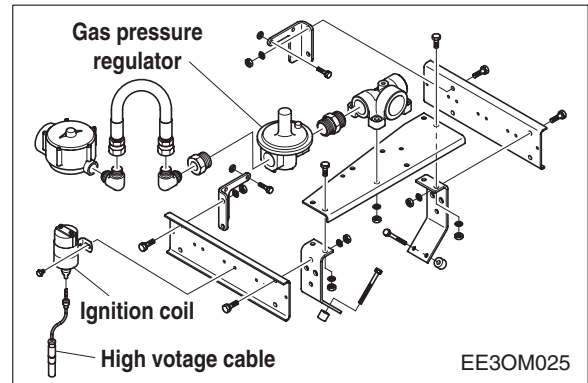

3.3.33. Alternator

- Assemble the alternator bracket to the lower part of cylinder block by tightening the fixing bolts.
- Install the alternator supporting plate (belt tension plate) to the oil pan by means of bolts.
- Assemble the alternator to the bracket and supporting plate tightening the bolts.
- Connect the crankshaft pulley and the alternator pulley and water pump pulley with V-belts by inserting them into the respective pulleys.
- Adjust the driving belt tension by regulating the alternator supporting plane. (Belt tension adjusting bolts: 10mm ~ 15mm by pushing with thumb)

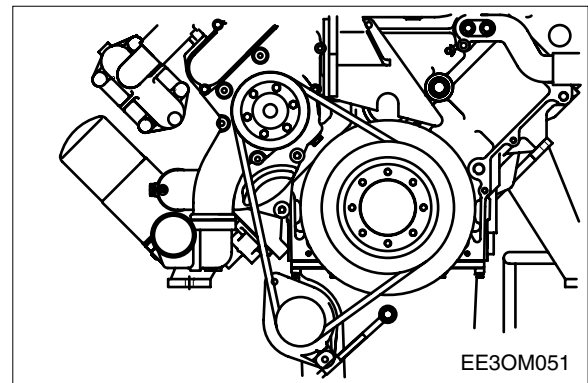
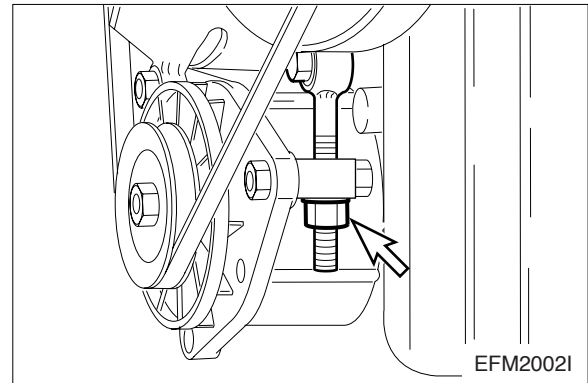

3.4. Starting and Trial Operation

3.4.1. Preparations for breaking-in



- Fill of new engine oil through the oil filler cap.
- When measuring the oil level with the oil level gauge with the engine mounted, the oil level must indicate about 10mm above the max. line.
- Connect water hoses and fill up cooling water.
- Connect the fuel hoses to the fuel tank and to top(radiator or surge tank).
- Check the air bleeding of the fuel system.
- Connect the electrical systems such as starter, air heater, etc. with power source.

3.4.2. Operation of a new engine (Break-In)

Because the sliding surfaces of a new engine are not lapped enough, the oil film can be destroyed easily by overload or overspeed and the engine life-time may be shortened.

Therefore the following things must be obeyed by all means.

Up to the first 50 hours

- Engine should be run at fast idling until the temperature of the engine becomes normal operating condition.
- Overload or continuous high speed operation should be avoided.
- High speed operation with no load should be prevented.
- Abrupt start and stop of the engine should be avoided.
- Engine speed must be under 70% of its maximum speed.
- Maintenance and inspection must be accomplished thoroughly.

3.4.3. Check points for break-in

During the break-in (the initial running of the engine) period, be particularly observant as follows:

- a) Check engine oil level frequently. Maintain oil level in the safe range, between the "min." and "max." marks on dipstick.



NOTE:

If you have a problem getting a good oil level reading on dipstick, rotate dipstick 180° and re-insert for check.

- b) Watch the oil pressure warning lamp. If the lamp blinks, it may be the oil pick-up screen is not covered with oil. Check oil dipstick. Add oil to the oil pan, if required. Do not overfill. If level is correct and the status still exists, see your DEALER for possible switch or oil pump and line malfunction.



NOTE:

Oil pressure will rise as RPM increases, and fall as RPM decreases. In addition, cold oil will generally show higher oil pressure for any specific RPM than hot oil. Both of these conditions reflect normal engine operation.

- c) Watch the engine water temperature gauge and be sure there is proper water circulation. The water temperature gauge needle will fluctuate if water level in expansion tank is too low. At the end of the break-in period, remove break-in oil and replace the oil filter. Fill oil pan with recommended engine oil. Refer to following table.

Engine model	Engine oil capacity			Recommend oil	
	in Oil pan		Total (lit)	API No.	Sulfated ash content
	Max. (lit)	Min. (lit)			
GV158TIC	28	26	31	SAE 15W40 above CD or CE	Bellow 0.5%
GV180TIC	35	28	38		
GV222TIC	40	33	43		

Recommend oil : TOTAL LMG-405

Mobil Delvac super GEO 15W40

3.5. Speed controller setting

3.5.1. Installation checks



Do the checks in the order indicated. Terminal numbers in this chapter refer to the speed controller. (4.3. Speed controller)

- 1) Check that all electrical connections are correctly made and terminal screws tightened, the magnetic pickup is properly installed and the jam nut tightened, and the fuel valve and drain line are securely fastened and correctly installed.
- 2) Do not start the engine now. Turn on governor power. Check the battery voltage at terminals 1(+) and 2(-). It must be from 18 to 32Vdc.
- 3) If a signal generator is available : Attach the output to terminals 5 and 6, leaving the magnet pick-up connections off. Set the signal-generator output between 2 and 10 Vrms. If a signal generator is not available, proceed to step 8.
- 4) Set the signal-generator frequency to about half of idle speed. Close the **IDLE/RATED** switch. Turn the signal generator and governor power on. The voltage across terminals 3 and 4 should measure about 5Vdc (**START FUEL LIMIT** must be fully clockwise).
- 5) Set the signal generator for magnet pick-up frequency at rated speed. Close the **IDLE/RATED** switch. Set the external speed trim pot (if used) at mid position. Observe the output from terminals 3 and 4.
 - a) If the output is at max-fuel position (about 5Vdc), slowly turn the rated-speed potentiometer counterclockwise until the signal just begins to move to minimum.
 - b) If the output is at minimum, slowly turn the rated-speed potentiometer clockwise until the signal just begins to move to maximum.
 - c) Continue to adjust the rated-speed pot very slowly, trying to stop the signal between minimum and maximum. Stop adjusting when the signal moves slowly. It will not be possible to stop the motion. The rated-speed reference is now set very close to desired speed.
- 6) Open the **IDLE/RATED** switch. Set the signal generator for magnet pick-up frequency at idle speed. (Preset the idle speed only after presetting rated speed.)
 - a) If the signal is at maximum-fuel position, slowly turn the idle-speed potentiometer counterclockwise until the signal begins to move to minimum.
 - b) If the signal is at minimum, slowly turn the idle-speed potentiometer clockwise until the signal just begins to move to maximum.
- 7) Continue to adjust the idle-speed pot very slowly, trying to stop the signal between minimum and maximum. Stop adjusting when the signal moves slowly. It will not be possible to stop the signal. The idle-speed reference is now set very close to desired idle speed.
- 8) **If a signal generator is not available** : turn the rated speed pot fully counterclockwise. Turn the idle-speed pot fully clockwise. Remove the magnet pick-up wires from the speed control and measure resistance across the magnet pick-up wires. If the resistance is correct replace the connection.

3.5.2. Initial pre-start settings

In case the newly installed the speed controller does not control engine speed, be prepared to bellows sequence.

1) Rated Speed

If **RATED SPEED** was not set with a signal generator, set the **RATED SPEED** potentiometer to minimum (fully counterclockwise). Set the external speed trim, if used, to mid-position.

2) Stability

Set the **RATED** and **IDLE STABILITY** potentiometers to mid position.

3) Gain

Set the **RATED** and **IDLE GAIN** potentiometers to mid position.

4) Idle Speed

If **IDLE SPEED** was not set with a signal generator, set the **IDLE SPEED** potentiometer at maximum (fully clockwise).

5) Start Fuel Limit

Set the **START FUEL LIMIT** pot at mid point (maximum is fully clockwise).

6) Close the circuit between terminals 9 and 10 (Close for rated).

3.5.3. Start-up and stable adjustments

Prepare to start the engine. Read this entire chapter before attempting to start the engine. Interrelated problems can occur, and an understanding of all possibilities is needed before using a control for the first time.



CAUTION:

To protect against possible injury, loss of life, and/or property damage when starting the engine, turbine, or other type of prime mover, be prepared to make an emergency shutdown to protect against runaway or overspeed should the fuel control(s), the driving mechanism(s), or the control device(s) fail.

1) Adjust for stable operation

Read the following paragraphs before attempting initial engine start up. Dynamics must be quickly adjusted after initial start up.

2) Immediately after the initial start up, it will be necessary to adjust the governor for stable operation. Idle and Rated dynamics are completely separate. In most cases the idle speed has been preset at maximum (fully clockwise) and Rated Speed is selected. In many cases the selection of rated speed will not indicate a desire for rated dynamics, which will be used when the engine is loaded. Idle dynamics may be selected and adjusted while rated speed is selected.

- 3) If the engine is hunting at a rapid rate, slowly decrease the **GAIN** (turn the potentiometer counterclockwise) until performance is stable.
- 4) If the engine is hunting at a slow rate, increase the **STABILITY** (turn the potentiometer clockwise) until the engine stabilizes. If increasing the **STABILITY** potentiometer does not stabilize the engine, it also may be necessary to slowly decrease the **GAIN** (turn the potentiometer counterclockwise).
 - a) Start cranking the engine. If the signal from terminals 3 and 4 does not show a positive voltage (2 to 6 Vdc) check the magnetic pick-up sensor.
 - b) Minimum voltage required from the magnetic pick-up sensor to operate the electronic control is 1.0 Vrms, measured at cranking speed or the lowest controlling speed. Measure the voltage while cranking with the speed sensor connected to the control. Be sure to prevent the engine from starting.
- 5) If the engine stops, it indicates a magnetic pick-up problem. The magnetic pick-up must produce a minimum of 1 Vac rms to activate the control. Failure to produce the minimum signal can be caused by improper magnetic pick-up installation, selection of an incorrect gear, improper wiring between the magnetic pick-up and the control, or a defective magnetic pick-up.
- 6) With the engine running and stable, slowly increase the rated-speed setting with the **RATED SPEED** pot until the desired rated speed is reached.
- 7) Dynamic adjustment
The object of the **GAIN** and **STABILITY** potentiometer adjustments is to obtain the optimum, or desired, stable engine-speed response.
- 8) Increasing the setting of the **GAIN** potentiometer provides faster transient response (decreases the amount of speed change from a sudden change in load).
To achieve the best response, slowly increase the **GAIN** (turn the potentiometer clockwise) until the engine becomes slightly unstable, then slowly turn the **GAIN** back counterclockwise as necessary to stabilize engine speed.
- 9) Step load the engine to make sure the engine returns to the proper speed with little overshoot or undershoot of the speed setting. (To reduce overshoot, increase the **STABILITY** setting by turning the potentiometer clockwise).
- 10) Increasing the **STABILITY** clockwise will require decreasing the **GAIN** (turning the **GAIN** potentiometer counterclockwise) to maintain stable operation.
- 11) If the engine is slow in returning to the proper speed, decrease the **STABILITY** by turning the potentiometer counterclockwise.
- 12) **Low idle speed adjustment** : The engine should be at rated speed with the **IDLE SPEED** potentiometer set at maximum (fully clockwise). Open the external **CLOSE FOR RATED** contact.

13) Decrease the **IDLE SPEED** (turn the potentiometer counterclockwise) until the desired idle speed is reached. It may be necessary to adjust the idle dynamics to maintain stability as speed is lowered.

14) Dynamic Adjustment

a) Gain is too high and stability too low. There are secondary overshoots on transients and large overshoots on starts (under damped)

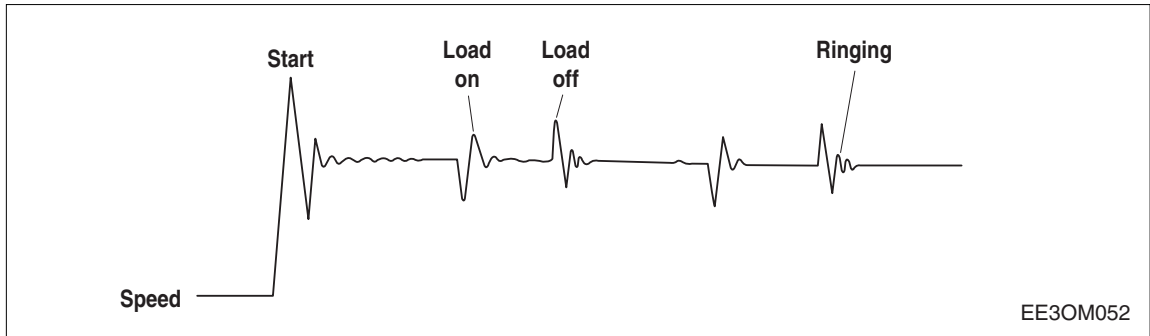

b) Optimum performance on load transients with slight overshoot on starts (optimum damping)

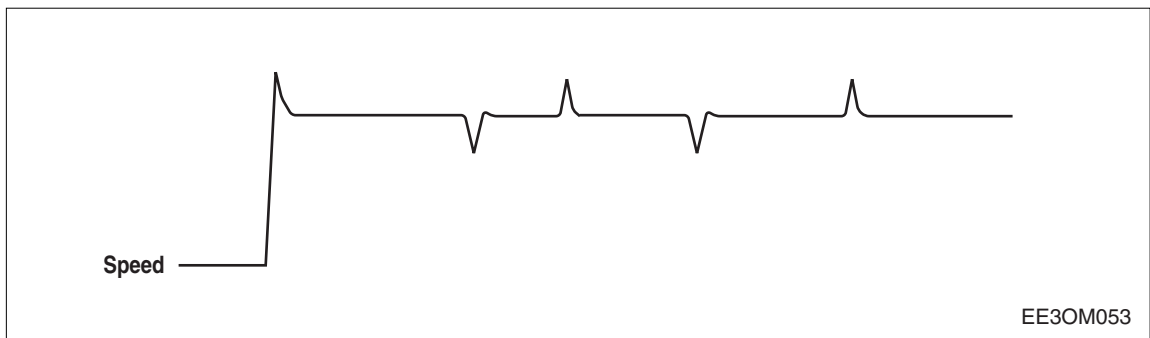

c) Optimum performance on start with slight time extension of load transients (optimum damping)

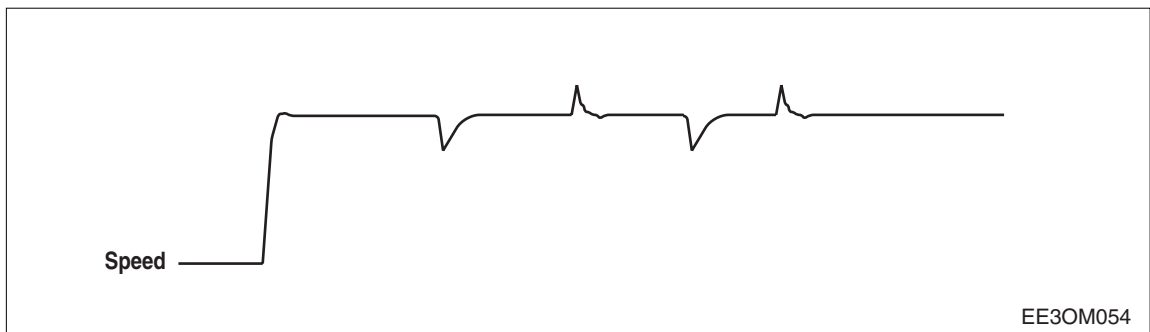

d) Stability too high, long time to settle to rated speed (over damped)

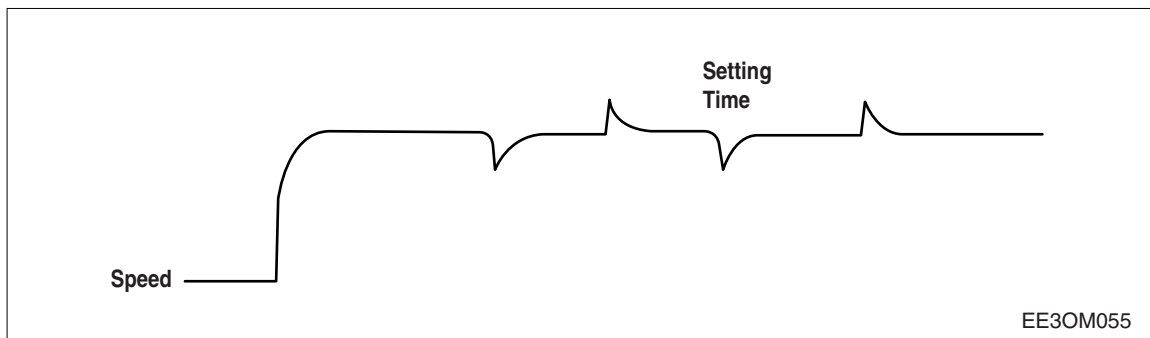

- 15) If idle dynamics were selected on initial start-up, it will now be necessary to set rated dynamics. Load the engine, then select rated dynamics.
- 16) Engine response will change as the engine warms up. It may be necessary to tune dynamics after warm-up. It may be necessary to compromise optimum control dynamics with a cold engine in order to have optimum dynamics when the engine is at operating temperature.
- 17) The **START FUEL LIMIT** was set at a point that allowed the cold engine to start during initial start up procedures. If **START FUEL LIMIT** is to be used, it should now be adjusted after engine stability and response rates are correctly adjusted.
 - a) Adjusting the **START FUEL LIMIT** counterclockwise will prevent the fuel valve from delivering a maximum amount of fuel to the injectors until the selected speed (Idle or Rated) is reached. Adjust for desired engine performance during start up. The Start Fuel Limit must be set high enough to allow the engine to reach the selected speed.
 - b) The **START FUEL LIMIT** should be adjusted from counterclockwise to obtain the desired characteristics while starting the engine. There may be differences in startup characteristics of cold and hot engines.

3.6. Display module

3.6.1. Display module system



The Display module, typically mounted in an engine control panel or other enclosure off the engine, offers users comprehensive display and control functionality. It features a two-line, backlit, alphanumeric display, in conjunction with a front accessible, sealed membrane keypad and gives users access to critical operating, setup, and diagnostic information.

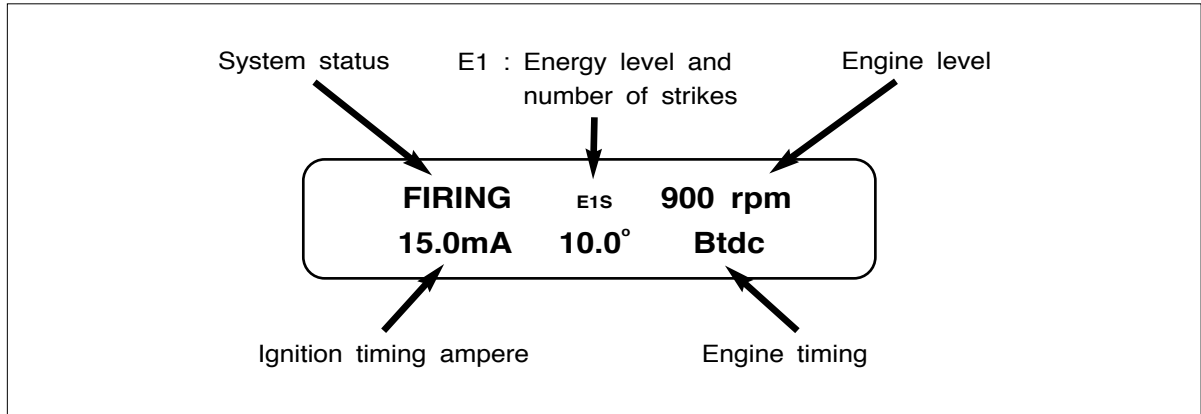

3.6.2. Typical system diagnostics

- 1) Engine overspeed has been reached with the maximum observed speed displayed.
- 2) Indicative of a condition where an incorrect number of gear tooth pulses have been received between reset events. Often the result of an improperly gapped magnetic pickup or a damaged ring gear.
- 3) This diagnostic is flagged when zero gear tooth pulses are between two reset pulses. An open, shorted, or damaged magnetic pickup cable is typically the source of this fault.
- 4) Diagnostic faulted when too many gear tooth pulses are received without detection of reset pulse. An open, shorted, or damaged magnetic pickup cable is also typically the source of this fault.

ENGINE OVERSPEED
1800 rpm

RING-GEAR FAULT
160 TEETH READ

GT PICK-UP FAULT
MISSING PULSES

RS PICK-UP FAULT
MISSING PULSES

5) No Hall-effect pickup (4-cycle indicator) signal has been detected or it is improperly synchronized with the reset pickup.

**HE PICK-UP FAULT
MISSING / / NO - SYNC**

6) The expected 4 ~ 20mA control signal used for timing control is either below 2mA or above 22mA. Annunciated when timing control loop is either not present or out of range.

**CURRENT LOOP
OUT OF RANGE**

Timing control sensor ampere	4 ~ 20 mA
---------------------------------	-----------

3.6.3. Patented primary and secondary diagnostic

1) Indicates the ignition system has detected an open circuit on output "A" ; usually the result of faulty wiring or a failed coil.

**PRIMARY OPEN
A**

2) A short circuit condition detected on output "B" ; may be the result of an improperly wired coil or a short to ground inside the conduit.

**PRIMARY SHORT
B**

3) A low voltage demand condition on output "C" ; typically indicates a shorted spark plug or secondary wire.

**LO SPARK VOLT.
C**

4) A high voltage demand condition detected on output "D" ; generally encountered when spark plugs become worn and require replacement.

**HI SPARK VOLT.
D**

5) No secondary spark on output "E" ; indicates disconnected secondary lead or voltage demand exceeding the coil's output.

**NO SEC. SPARK
E**

6) Output "F" is indicating that its monitored spark voltage demand is dramatically lower than the average of the cylinders. This indicates potentially an overly rich air/fuel mixture, a short in the secondary wiring, or perhaps an improperly gapped spark plug.

LO FROM ENGINE
F

7) A high spark voltage demand than that seen the other engine power cylinders has been detected on output "K". This may also be related to air/fuel ratio or the condition of the secondary wiring and/or spark plugs.

HI FROM ENGINE
K

3.6.4. Understanding the home screen

1) The **READY** message is displayed when the ignition is ready for the engine to crank for starting.

READY **0rpm**
15.0mA **10.0°** **Btdc**

2) Once the engine begins turning, the **SYNCING** message is displayed while the ignition system verifies signals from the engine pickups.

SYNCING **155rpm**
15.0mA **10.0°** **Btdc**

3) The **FIRING** message is displayed when the ignition begins firing. Additional data is provided on this screen to describe the selected mode of operation for the ignition. The energy mode (E1, E2, E3) and the single-strike / multi-strike type (S or M) are described in the middle of the upper line in small characters.

FIRING E1S **1000rpm**
15.0mA **10.0°** **Btdc**

4) The **STALLED** message is displayed when a loss of rotation is detected after the ignition is firing and neither a Shutdown or Fault has occurred. This signifies that the engine has stopped without any detected cause from the ignition system.

STALLED **0rpm**
15.0mA **10.0°** **Btdc**

5) The **WARNING** message will supersede all of the above home screens if a diagnostic warning condition is present. When a diagnostic warning exists, a View Diagnostics message will flash on the bottom line of the display.

a) The Ignition Module will continue to operate under a warning condition while alerting the operator of a potential problem in several ways: by turning on the Alarm LED in the Ignition Module and by changing the state of the Alarm Out switch (switch opens).

b) The Display Module will display the Warning message. The various types of diagnostic warnings are described in section.

WARNING	1000rpm
15.0mA	10.0° Btdc

WARNING	1000rpm
VIEW	DIAGNOSTICS

6) The **FAULT** message will supersede all of the above home screens if a diagnostic fault condition is present.

a) When a diagnostic fault exists, a View Diagnostics message will flash on the bottom line of the display.

b) The ignition system will stop operating under a fault condition and will alert the operator to the problem in several ways: by changing the state of the Fire Confirm Out switch (switch opens), by turning on the alarm LED inside the Ignition Module, by changing the state of the Alarm Out switch (switch opens), by changing the state of the Fault Out switch (switch opens), and by displaying the Fault message.

c) The various types of diagnostic faults are described in section.

FAULT	0rpm
15.0mA	10.0° Btdc

FAULT	0rpm
VIEW	DIAGNOSTICS

7) The **SHUTDOWN** screen will supersede all other home displays if the logic level shutdown input of the Ignition Module or the G-Lead of the output primary connector is grounded or was previously grounded and the engine has not stopped rotating.

a) This screen indicates that the ignition is not firing because a shutdown input was triggered to shutdown the engine. If a diagnostic fault or warning exists while the ignition is in shutdown, a View Diagnostics message will flash on the bottom line of the display.

b) The Fire Confirm Out switch will change state (switch opens) and the other outputs will function as described above based on the existence of faults or warnings.

SHUTDOWN	0rpm
15.0mA	10.0° Btdc

SHUTDOWN	0rpm
VIEW	DIAGNOSTICS

8) The following types of screens can be viewed by pressing enter to start and next to advance.

- GV158TIC

H4A160 . FS100#001
UNIT 791950-16

- GV180TIC

J4H160 . FS100#001
UNIT 791950-16

- GV222TIC

L4B160 . FS100#001
UNIT 791950-16

- H : Represents the engine model
(H:GV158TIC, J:GV180TIC, L:GV222TIC)
- 4 : 4-cycle engine
- A : Represents the Altronic pattern code
(A:GV158TIC, H:GV180TIC, B:GV222TIC)
- 160 : Represents the number of gear teeth or holes to be sensed
- FS100#001 : Special pattern code
- UNIT 791950 -16 : Ignition module no.

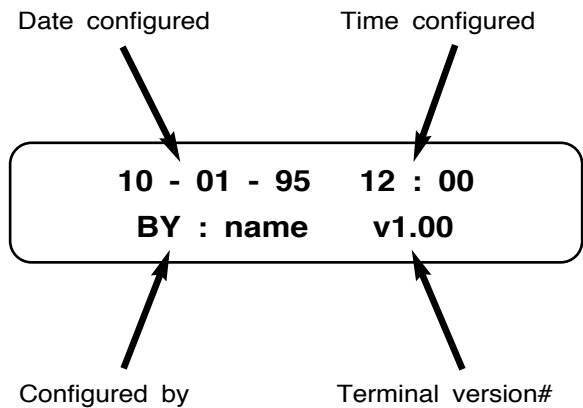

3.6.5. Ignition state checks

1) The last setup screen permits the operator to enter an ignition test mode. This test mode can fire all outputs in rotation, or individual outputs at a slow rate. This feature can be used to troubleshoot primary wiring and operation. Test mode will terminate if rotation of the engine is sensed. Diagnostic features do not function while in test mode.

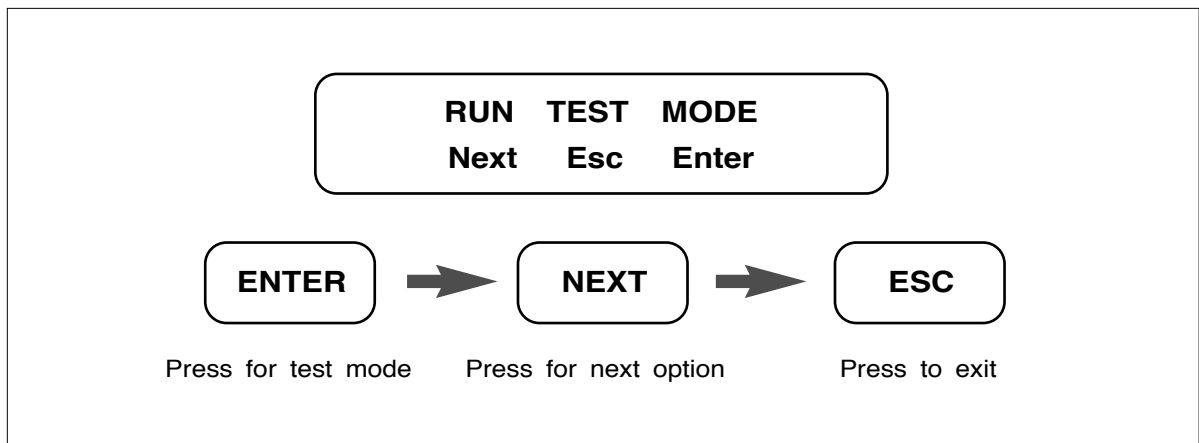



CAUTION:

The operator must fully purge the engine of combustible mixtures prior to selecting the test mode operation. Pressing the enter key again is a confirmation of this action.

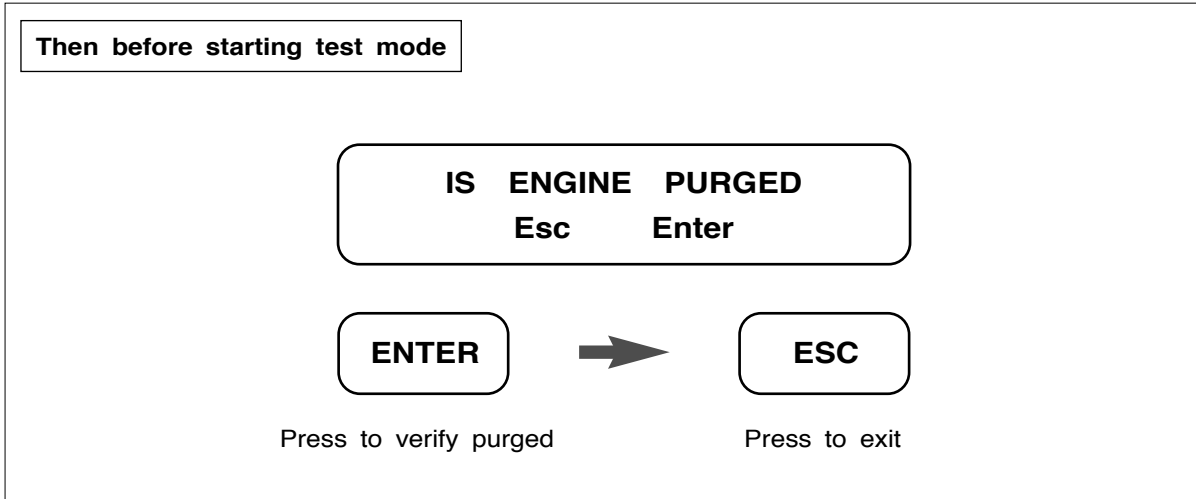

- 2) Then the test mode screen indicates that the ignition is firing and permits the operator to select the output to be fired.

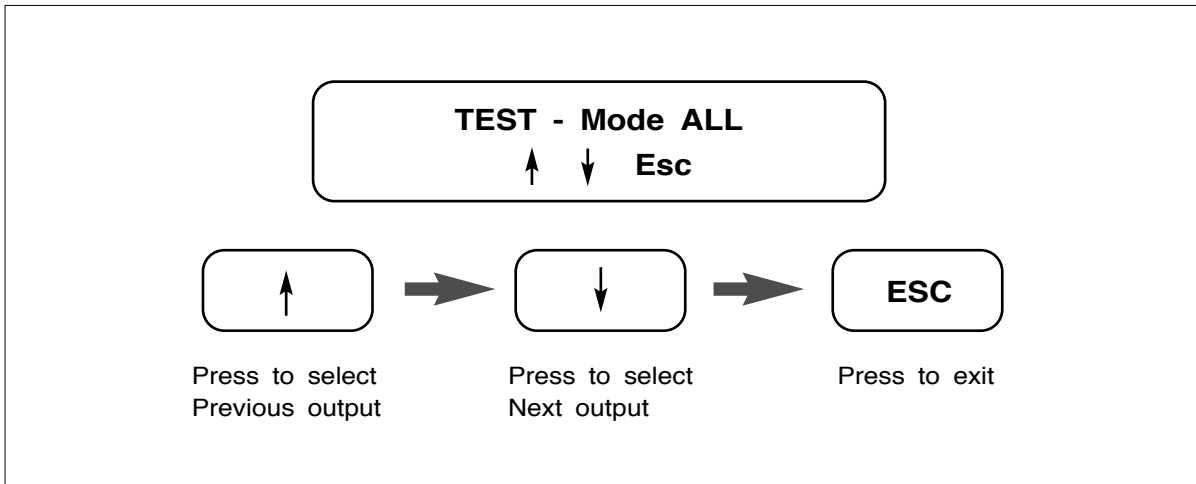

3.6.6. Ignition control module diagnostics

- 1) A diagnostic fault represents the most severe classification of problems. The presence of a diagnostic fault will inhibit the ignition from firing. When a fault is detected several things will occur:
 - a) The ignition will stop firing.
 - b) The Fire Confirm Out switch will open.
 - c) The Fault Out switch will open.
 - d) The Alarm Out switch will open.
 - e) The Alarm LED in the ignition unit will turn on.
 - f) The home status will read Fault, and the bottom line will flash View Diagnostics.



NOTE:

Diagnostic FAULTS will supersede diagnostic WARNINGS.

**FAULT 0rpm
VIEW DIAGNOSTICS**

- 2) A diagnostic warning represents the least severe classification of problems. The ignition will continue to fire in the presence of a diagnostic warning. When a warning is detected, several things will occur:
 - a) The Alarm Out switch will open.
 - b) The Alarm LED in the ignition unit will turn on.
 - e) The home status will read **WARNING**, and the bottom line will flash View Diagnostics.

**WARNING 3000rpm
VIEW DIAGNOSTICS**

- 3) If the Alarm Out switch is being used to turn on an audible alarm or flasher, the user can acknowledge the alarm as described below.

**ALARM
ACK**

- 4) Acknowledgment of the alarm results in the following until a reset is commanded or until another fault or warning may occur.
 - a) The Alarm Out switch will return to its closed position.
 - b) The Alarm LED will flash to indicate that an alarm is present but acknowledged.

- 5) When a fault or warning is present, the operator can display the actual cause of the diagnostic as depicted below.

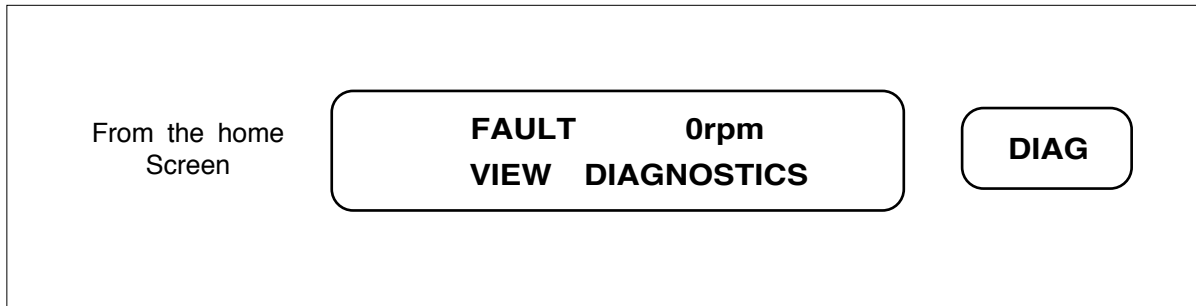

- 6) Then from the diagnostic description screens use the following keys.

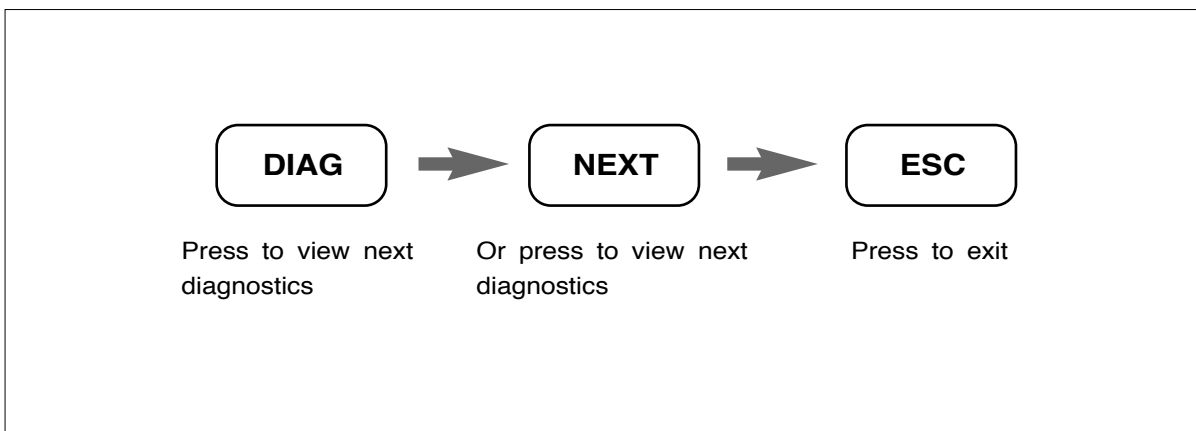

- 7) Diagnostic Fault screens, in order of display priority, are described below.

- a) When zero gear-tooth pluses are seen between two reset pluses.

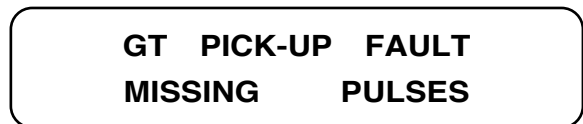

- b) When too many gear-tooth pluses are seen without a reset pluses.

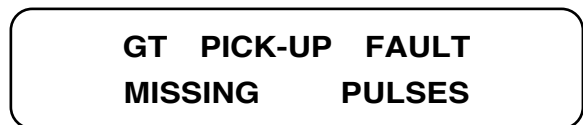

- c) When there are no hall-effect pickup pluses or when the pick-ups are not synchronized.



- d) When too many or too few gear-tooth pluses are seen between reset pluses. The received number or pluses is displayed.



e) When the engine speed exceeds the overspeed setpoint. Maximum observed speed is also displayed.

**ENGINE OVERSPEED
1023 RPM**

f) When the check-sum of microprocessor firmware cannot be verified. Unit requires service.

**BOTTOM BOARD uP
CHECKSUM FAILED**

3.7. Diagnosis and remedies of trouble causes

- Prior to asking for repair, please check the following items

Generated Problem	Inspection Items	Inspecting Position
Starting failure, starting motor not rotate	<ul style="list-style-type: none"> ◆ Confirm connector that connects electric wiring to gauge panel if it is correctly connected ◆ Confirm connection of electric wiring and batteries if it is connected correctly. ◆ Confirm connection of electric wiring and starting motor if it is connected correctly. 	backward of gauge panel Battery terminal Starting motor terminal
Starting motor rotates but starting fail	<ul style="list-style-type: none"> ◆ Make sure that fuel quantity is sufficient. 	Fuel tank
Engine revolution meter not operates	<ul style="list-style-type: none"> ◆ Confirm connector that connects wiring and gauge panel if it is correctly connected. ◆ Check if terminal resistance of tacho sensor is pulled out 	Backward of gauge panel Tacho sensor terminal
Cooling water temp. gauge fails	<ul style="list-style-type: none"> ◆ Confirm connector that connects wiring and gauge panel if it is correctly connected. ◆ Confirm connector of cooling temp sensor if it is correctly connected. 	backward of gauge panel Cooling water pipe
Engine oil pressure gauge not operate	<ul style="list-style-type: none"> ◆ Confirm connector that is connected to engine oil pressure sensing sensor if it is pulled out. 	Side of oil filter
Charging abnormality warning lamp lights continuously	<ul style="list-style-type: none"> ◆ Confirm that the electric wiring terminal that is connected to generator's L terminal if it is pulled out and touched to engine body. 	Alternator terminal
Though engine stopped, engine revolution meter works continuously	<ul style="list-style-type: none"> ◆ Characteristics of engine revolution meter is so designed that it may slowly drop down, and so it's not trouble. 	Starting key
Cooling water temp. gauge and engine revolution meter not operate simultaneously.	<ul style="list-style-type: none"> ◆ Confirm if the present position of start switch is at ACC. ◆ For power source of gauge panel goes from starting key, if the start key is at OFF, though engine is running, gauge panel does not move. ◆ Confirm connector that connects wiring and gauge panel if it is correctly connected. ◆ Confirm if connector that connected to solenoid and wiring is pulled out. 	backward of gauge panel
Though engine switch is pushed, it does not stall.	<ul style="list-style-type: none"> ◆ Confirm if the cable that connects electric governor and injection pump is cut. 	Electric governor

4. ELECTRICAL EQUIPMENT

4.1. Gas fuel circuit

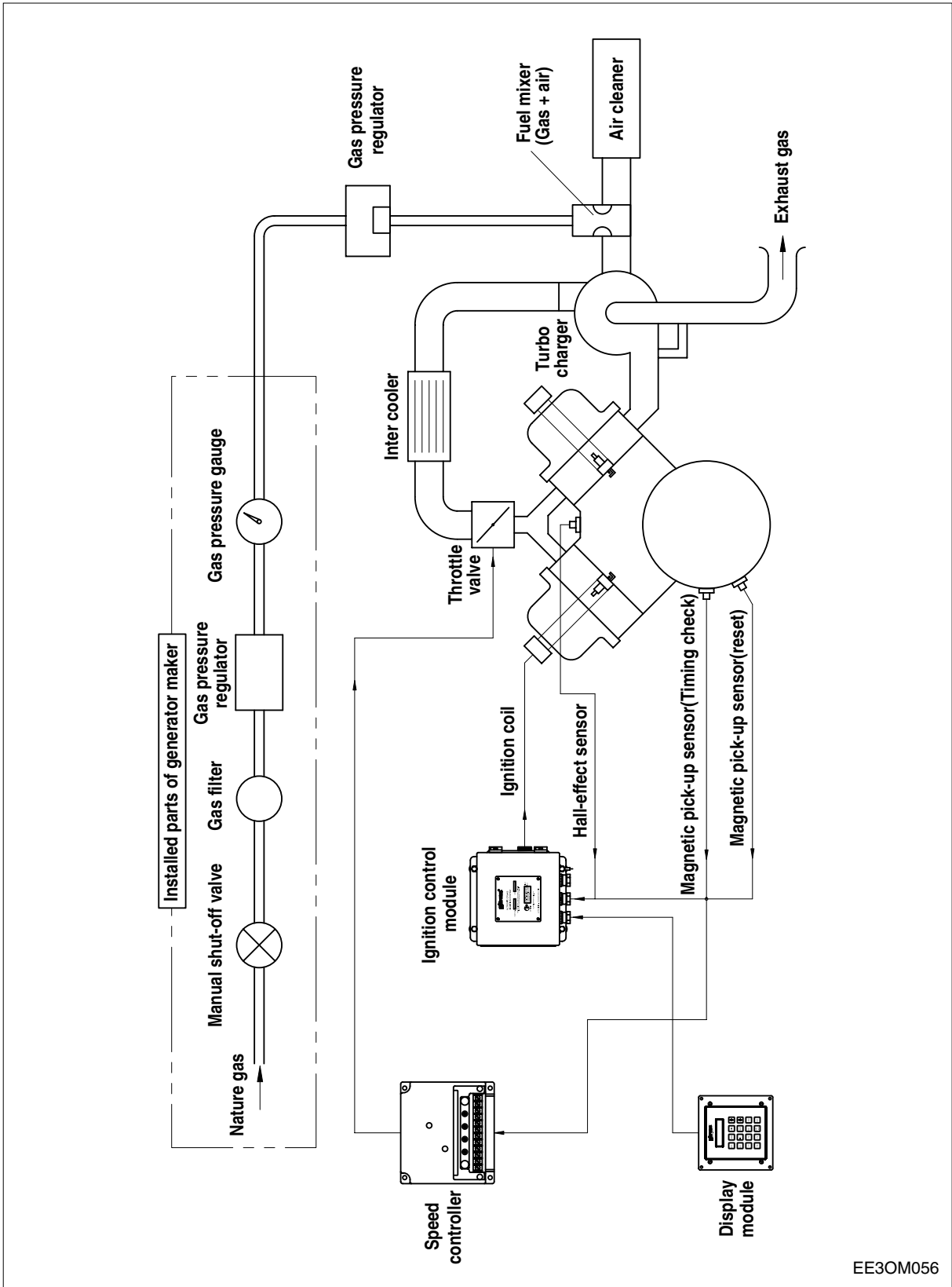

EE3OM056

4.2. Electrical wiring diagram

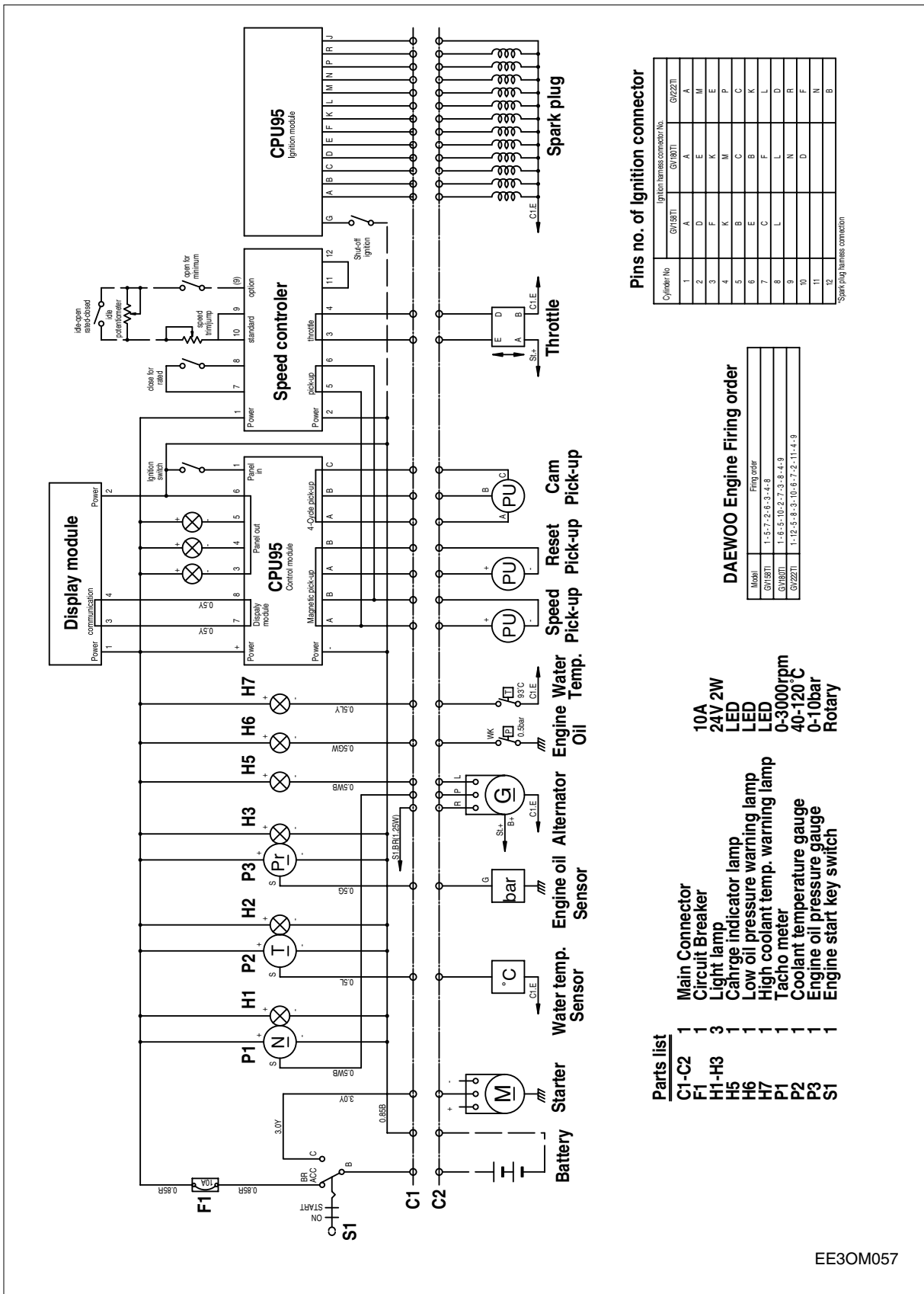

4.3. Speed controller

4.3.1. Speed controller description

- The Speed Controller is designed to provide basic isochronous speed control for gas engines.
- Engines with mechanical loads and generator loads are handled equally well.

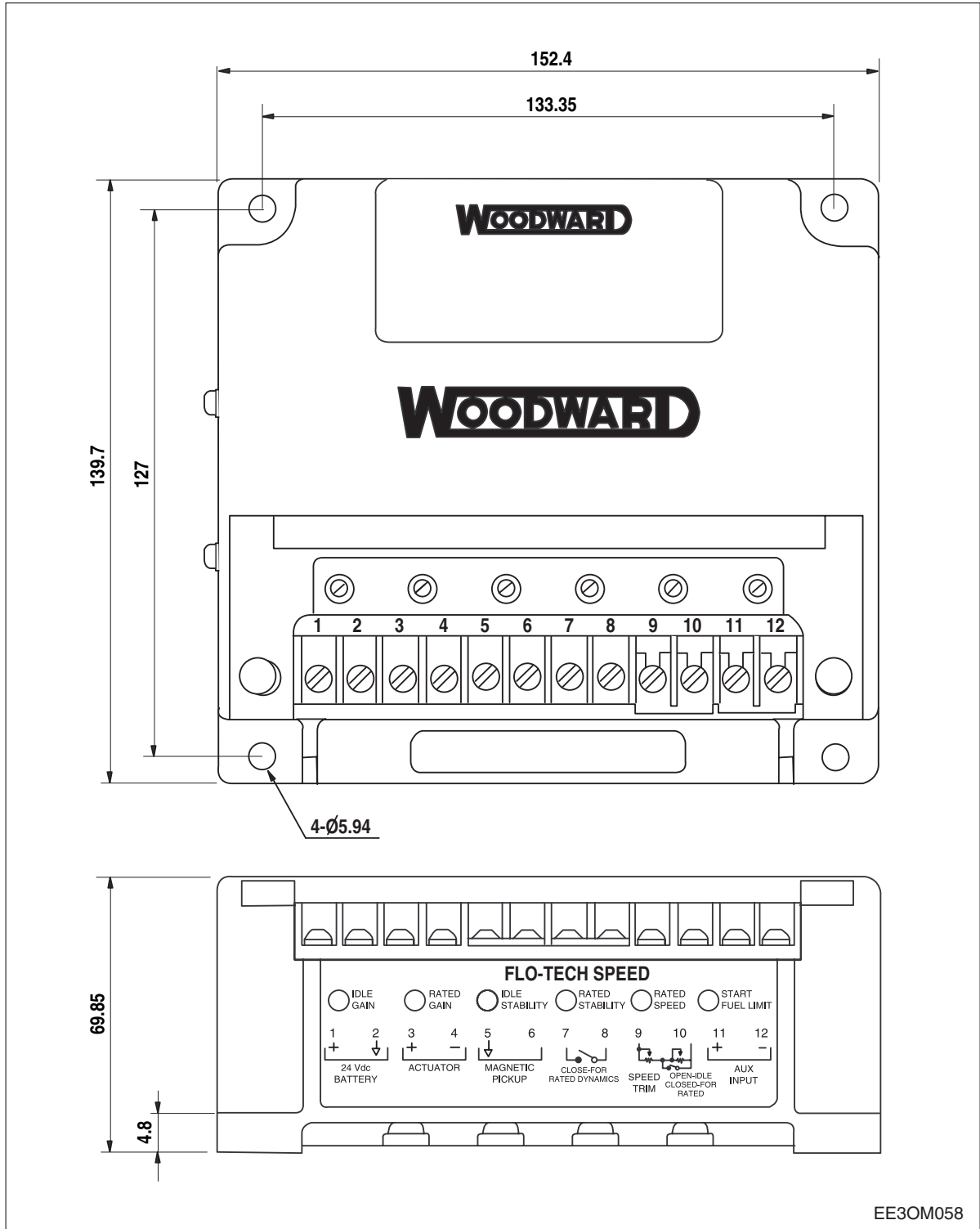

4.3.2. Speed controller circuit

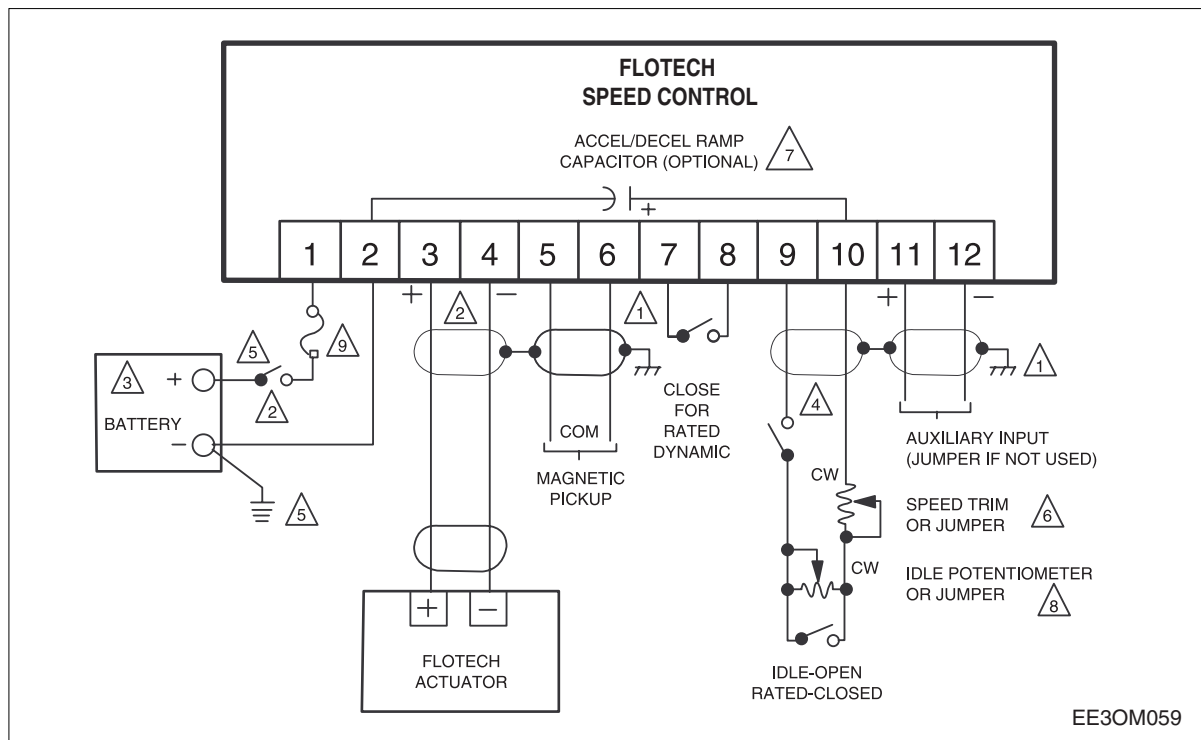

- **1** : Shield wires to be twisted pairs with shield grounded at one end only.
- **2** : No. 18AWG or 20AWG standard wire. Must be as short as possible. 50ft. maximum wire length for 20AWG wire. 80ft. maximum wire length for 18AWG wire.
- **3** : Use 24 volt system.
- **4** : Open for minimum fuel.
- **5** : For positive ground systems, switch and fuse to be located in series with battery (-) and terminal 2. Positive terminal becomes chassis ground. Leads from battery to terminals 1 & 2 must be direct and not pass through distribution points.
- **6** : Approximate speed change with trim potentiometer
 - ◆ $\pm 2.5\%$ using a $1K\Omega$ potentiometer
 - ◆ $\pm 5\%$ using a $2K\Omega$ potentiometer
- **7** : About one second ramp time per $50\mu F$. Capacitor specifications : $200\mu F$ maximum, 15WVdc minimum. 15WVdc maximum. Less than $30\mu A$ DC leakage current over temperature range.
- **8** : Idle range about 25% to 100% rated using 50K potentiometer.
- **9** : Use a 1 amp fuse(3 AWG)

4.4. Ignition controller

4.4.1. Ignition controller circuit

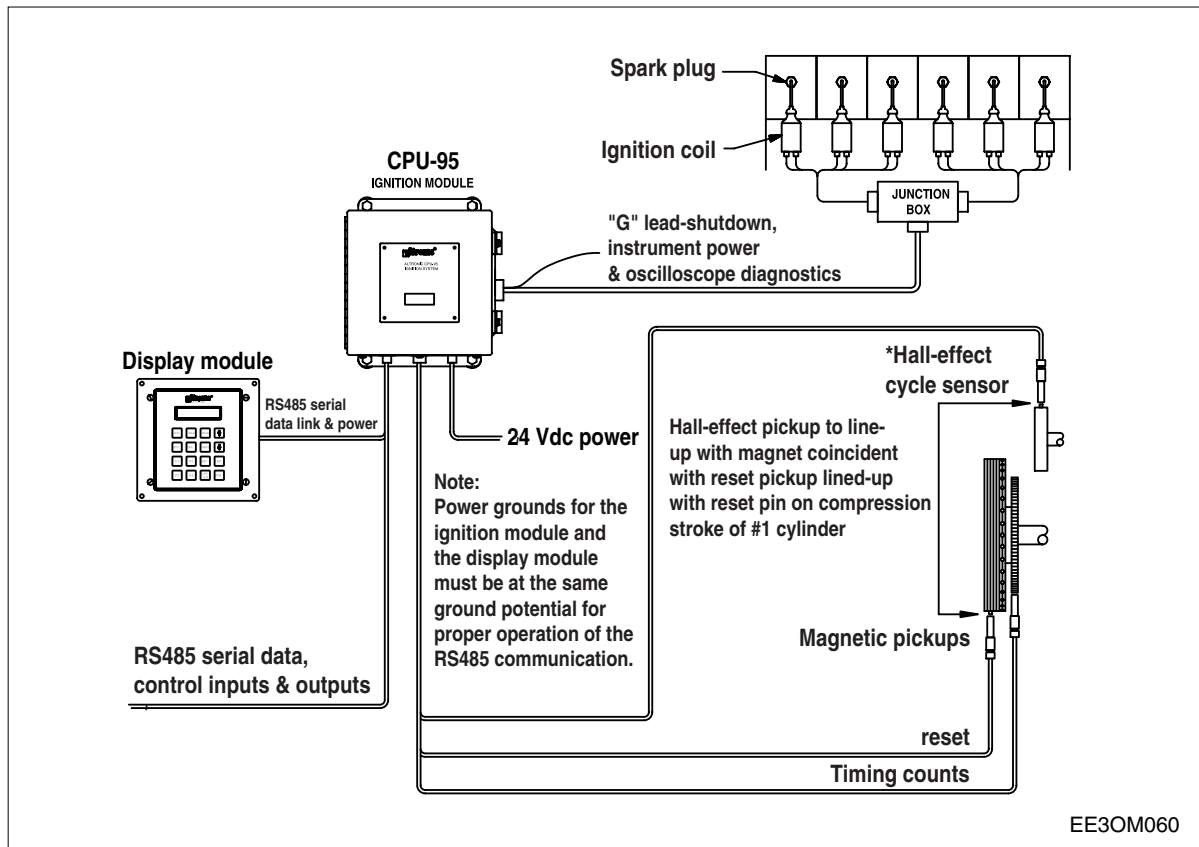

a) Display module

- Displays operating mode, rpm, timing, status
- Displays diagnostic fault messages
- 24Vdc nominal input power
- Digital input(MISC)
- 4-20mA input for timing control
- Digital output, alarm or overspeed via RS485

b) RS485 serial data, control inputs and outputs

- RS485 serial communications from P.C.
- Low voltage shutdown input
- Miscellaneous input
- Alarm output switch
- Fault output switch
- Fire confirm output switch



NOTE:

RS485 serial communications & MISC. input to either display module or P.C., not both at same time.

4.4.2. DC power hookup of ignition system

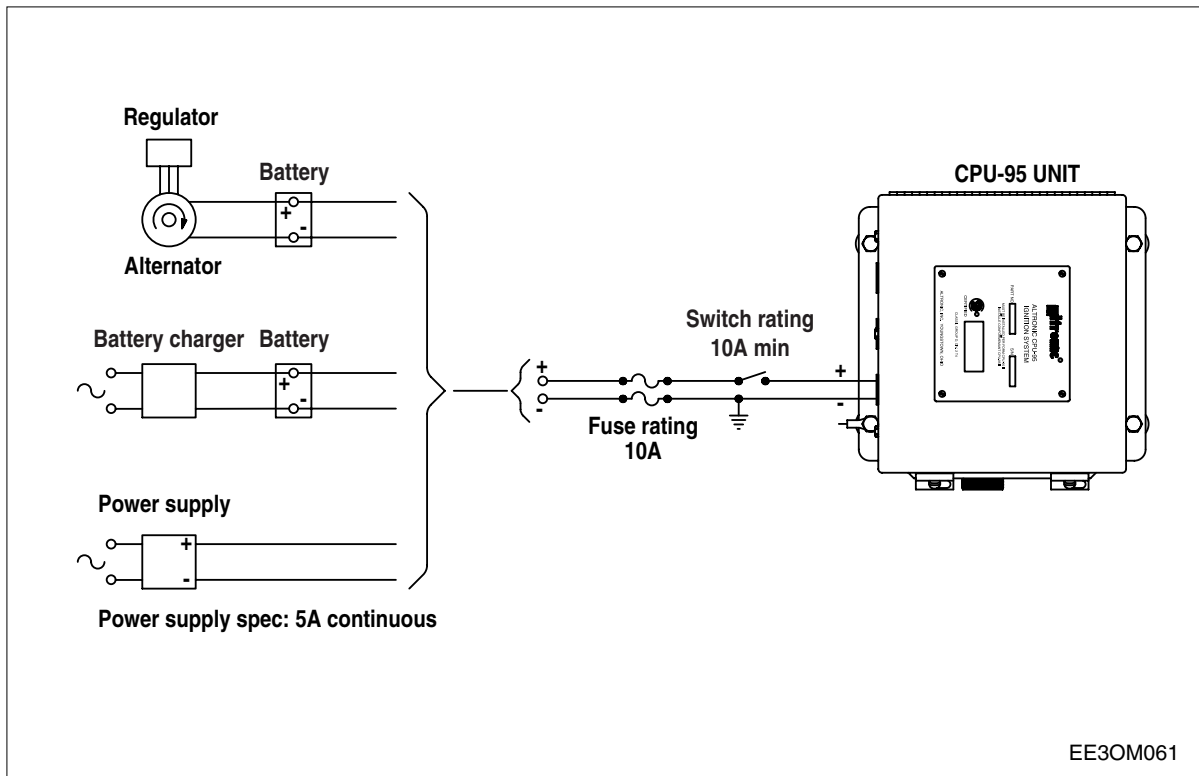

- **Operating voltage requirements**

Starting	20 VDC min.
Running	24 ~ 28 VDC

- **Dimensions of cable**

* It is recommended that each system be connected separately back to the power source. Determine the wire size required.

Distance in Cm	Minimum wire size	Distance in Cm	Minimum wire size
up to 762	16 AWG	2,012 - 3,048	10 AWG
793 - 1,219	14 AWG	3,079 - 4,877	8 AWG
1,250 - 1,981	12 AWG		

- **Dimensions of cable**

* If multiple units are powered from a source located in a separate building, Determine the wire size required between the power source and the engine room. Create a common power hookup point in the engine room, Then use determine the wire size required from this common point to each ignition module.

Distance in Cm	Minimum wire size	Distance in Cm	Minimum wire size
790 - 1,220	14 AWG	3,080 - 4,880	8 AWG
1,250 - 1,980	12 AWG	4,910 - 7,620	6 AWG
2,010 - 3,050	10 AWG	7,650 - 12,190	4 AWG



NOTE:

above 12,190Cm use multiple pairs of wires from the power source to the engine room

4.4.3. Display module

1) Feature of display module

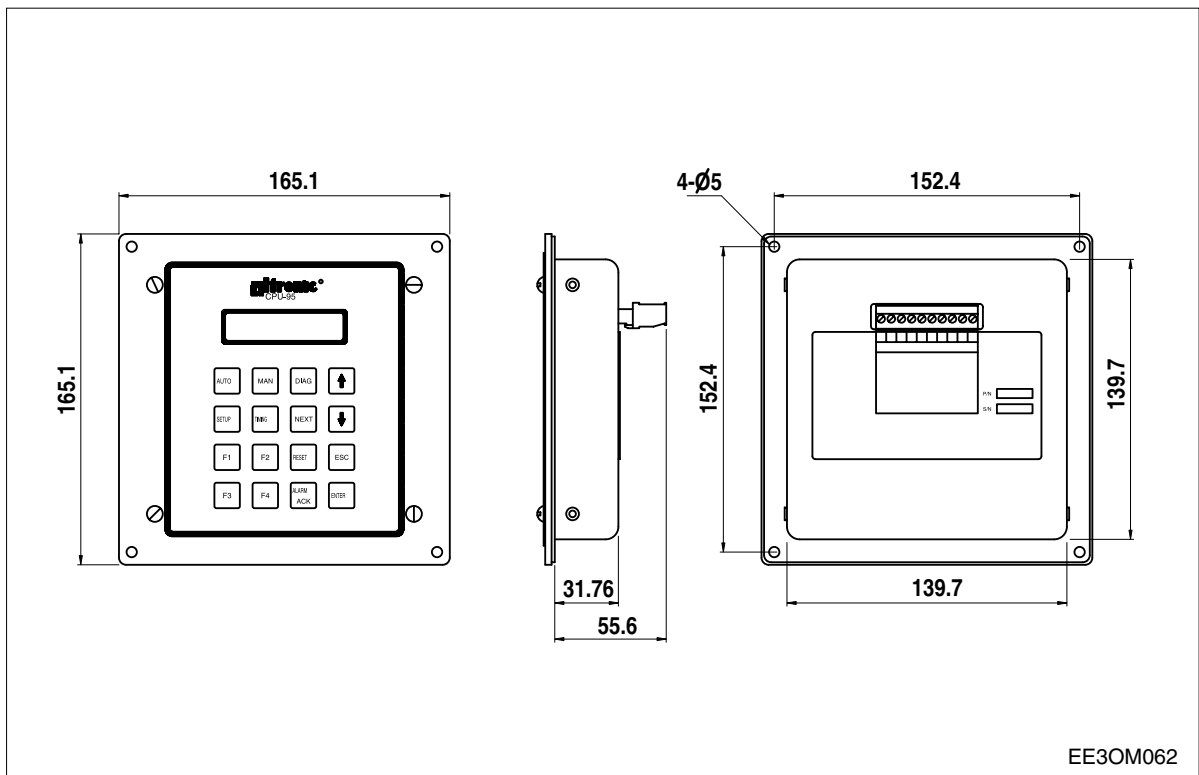

2) Display module circuit

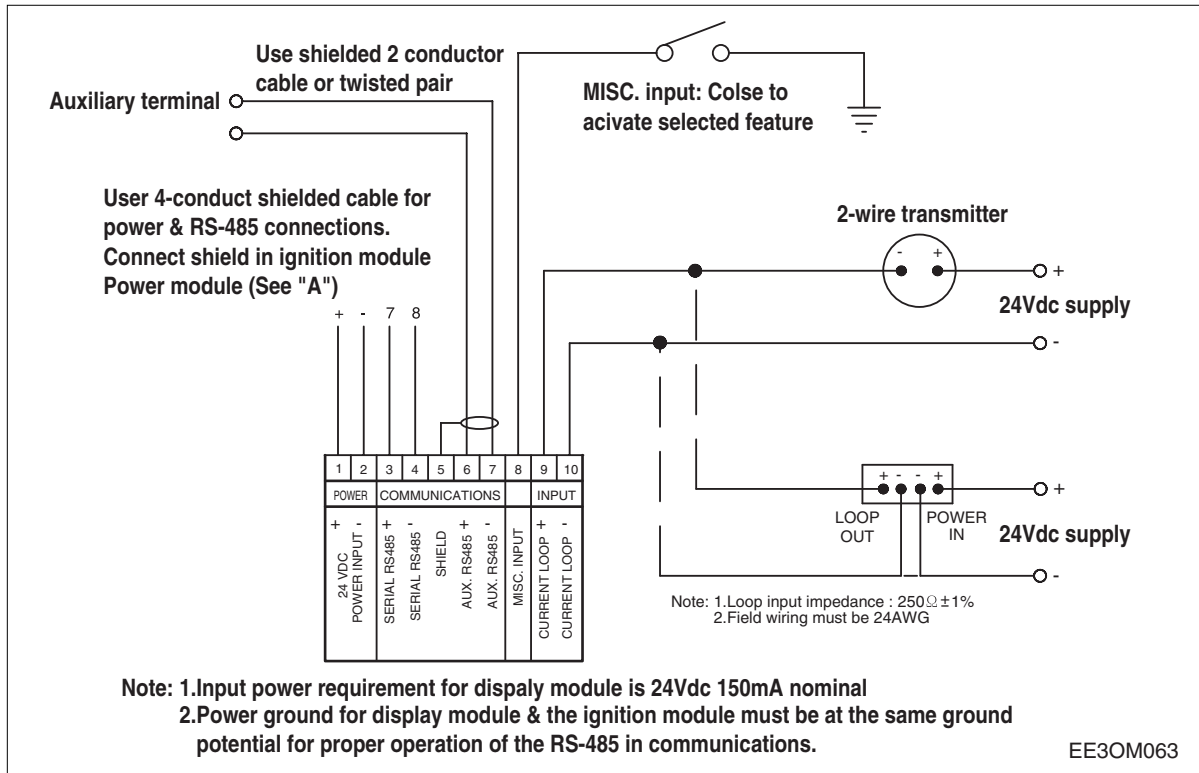

3) Voltage supply of display module

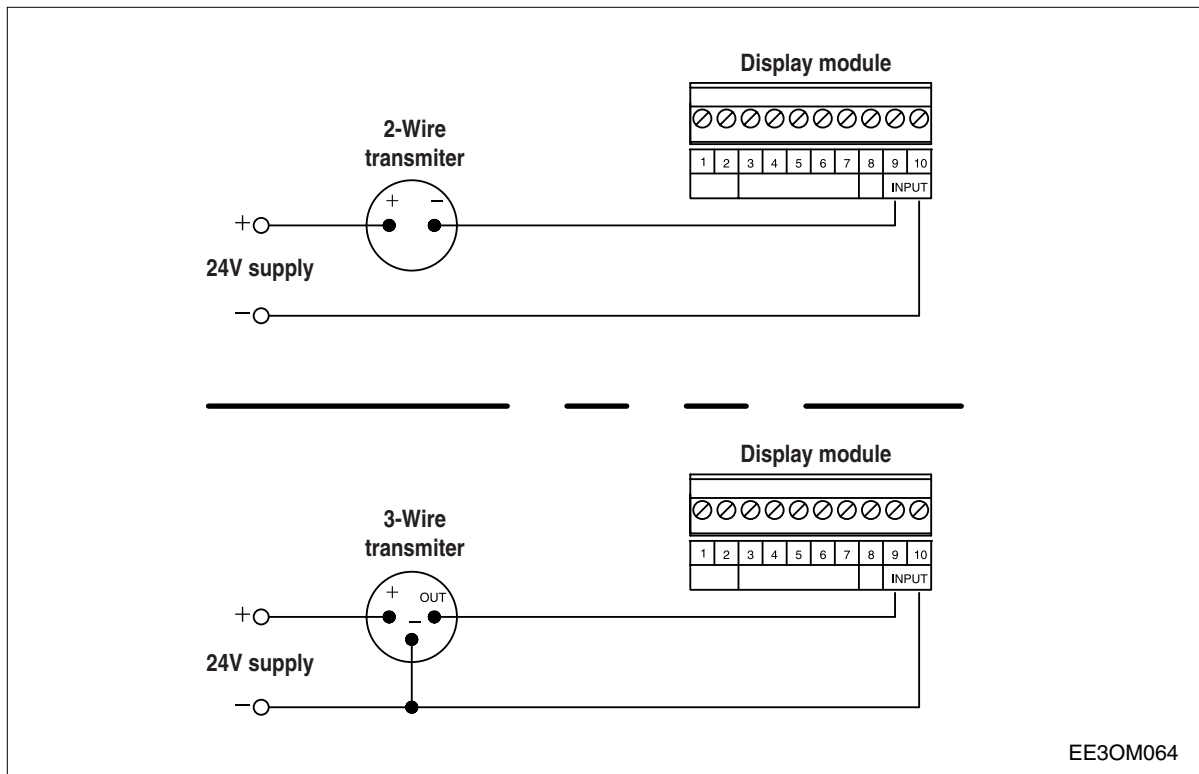

Note : 1. Loop input impedance : $250\Omega \pm 1\%$
2. Field wiring must be 24AWG

4.5. Ignition control module

4.5.1. Ignition control module views

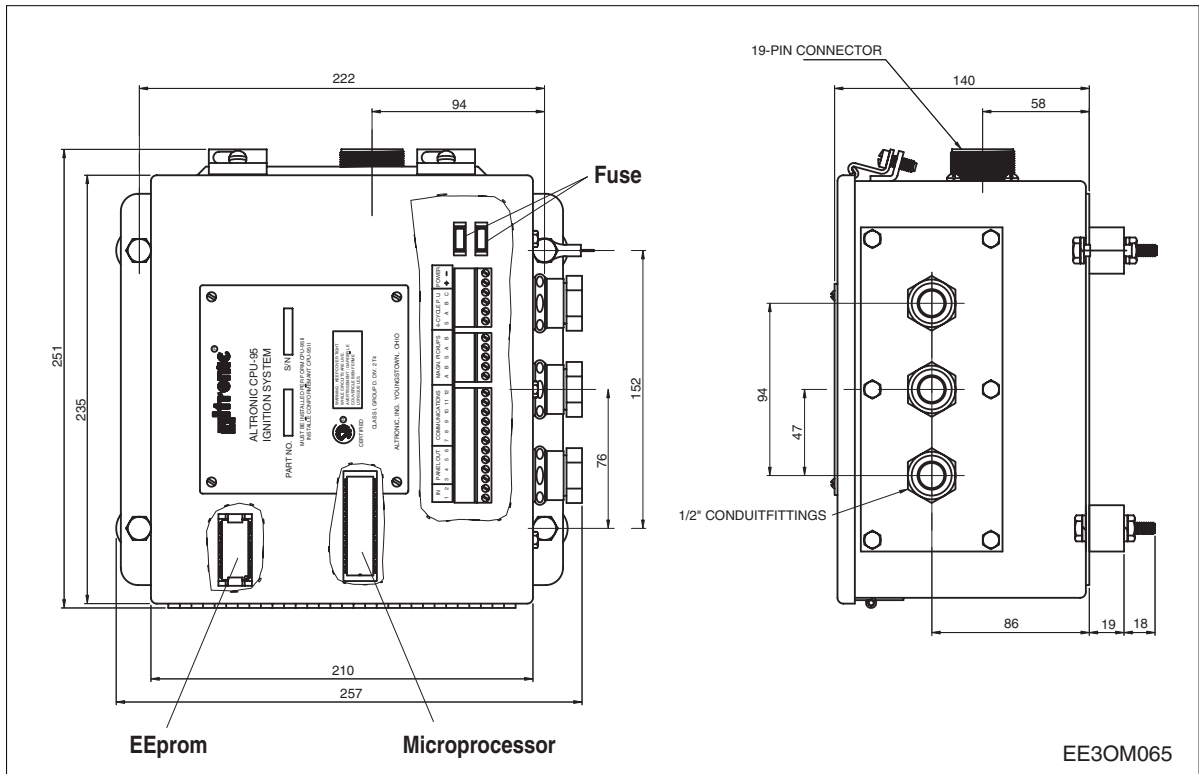

4.5.2. Ignition control circuit

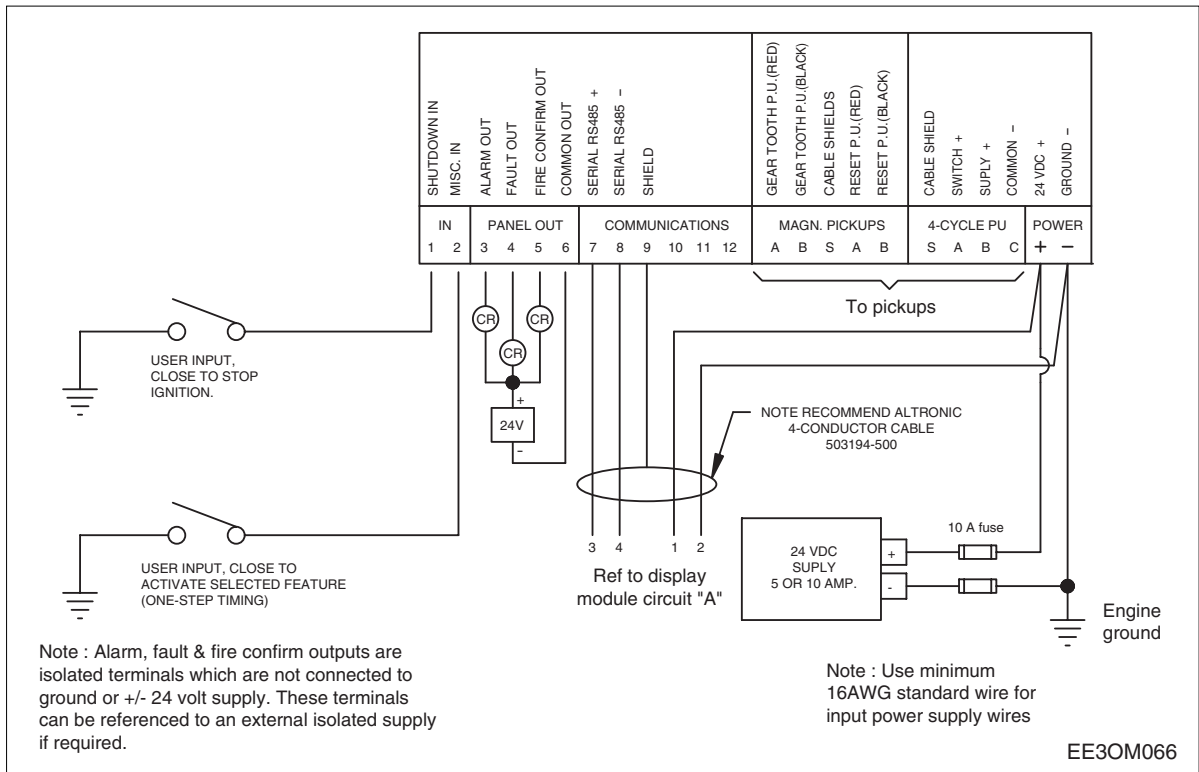

4.5.3. Ignition harness connector

Cylinder no.	Connector pin no. of ignition harness		
	GV158TIC	GV180TIC	GV222TIC
1	A	A	A
2	D	E	M
3	F	K	E
4	K	M	P
5	B	C	C
6	E	B	K
7	C	F	L
8	L	L	D
9	-	N	R
10	-	D	F
11	-	-	N
12	-	-	B
GND	G	G	G
Off to GND	J	J	J

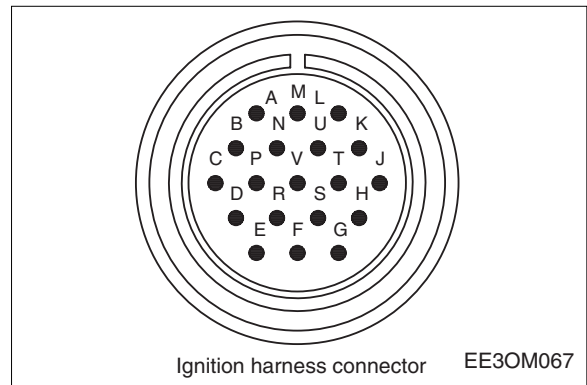

4.5.4. Ignition harness connector

Engine model	Firing order
GV158TIC	1-5-7-2-6-3-4-8
GV180TIC	1-6-5-10-2-7-3-8-4-9
GV222TIC	1-12-5-8-3-10-6-7-2-11-4-9

4.5.5. Engine cylinder no.

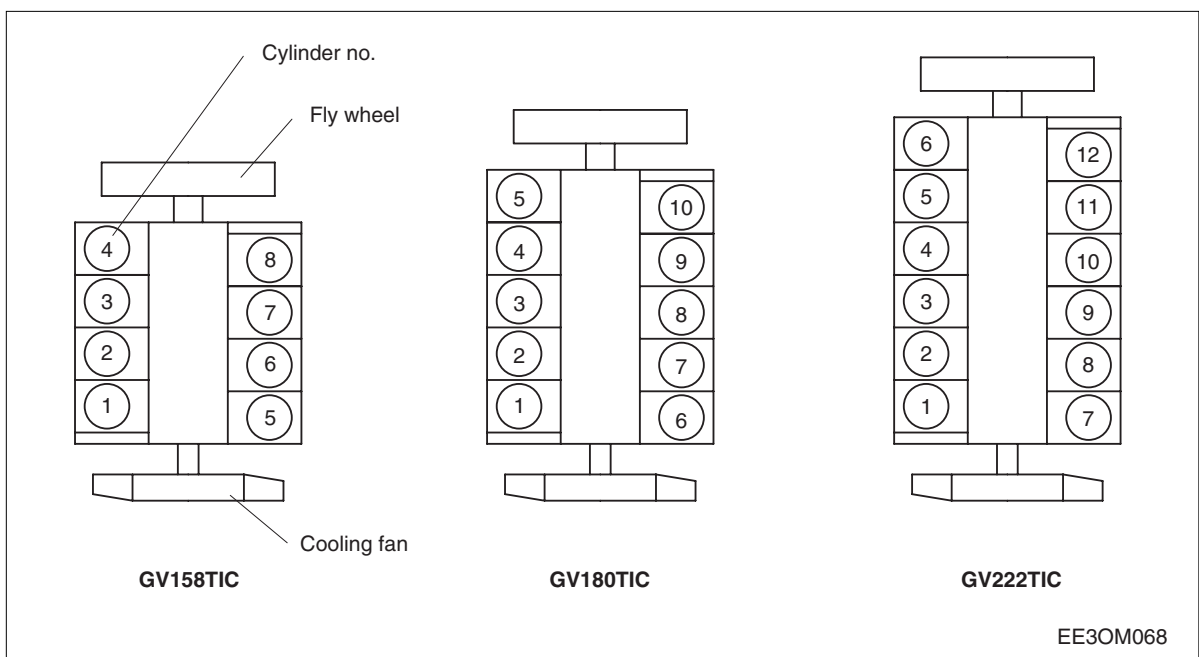

4.5.6. Ignition system

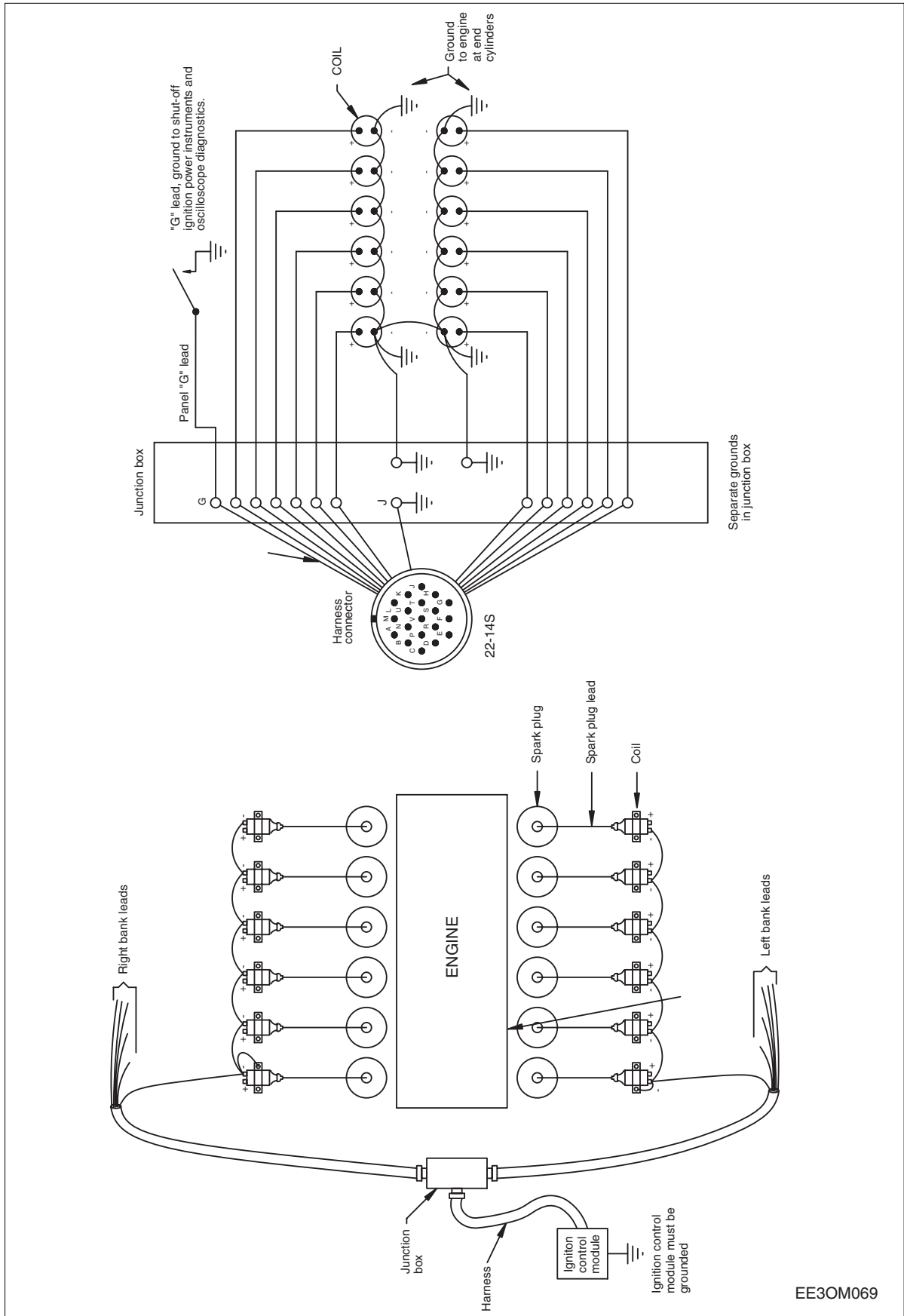

EE3OM069

5. MAINTENANCE OF MAJOR PARTS

5.1. Turbo charger

5.1.1. Main data and specification

Generator engine	GV158TI	GV180TI	GV222TI
Turbocharger model	HOLSET HX35	HOLSET HX40	HOLSET HX50
Rated revolution(rpm)	80,000	80,000	60,000
Intake air quality(m ³ /sec)	0.28	0.35	0.43
Compression efficiency(%)	77	75.0	76
Compression ratio	1.8	2.0	1.66
Weight	14 kg	14 kg	14 kg

5.1.2. Operating principle

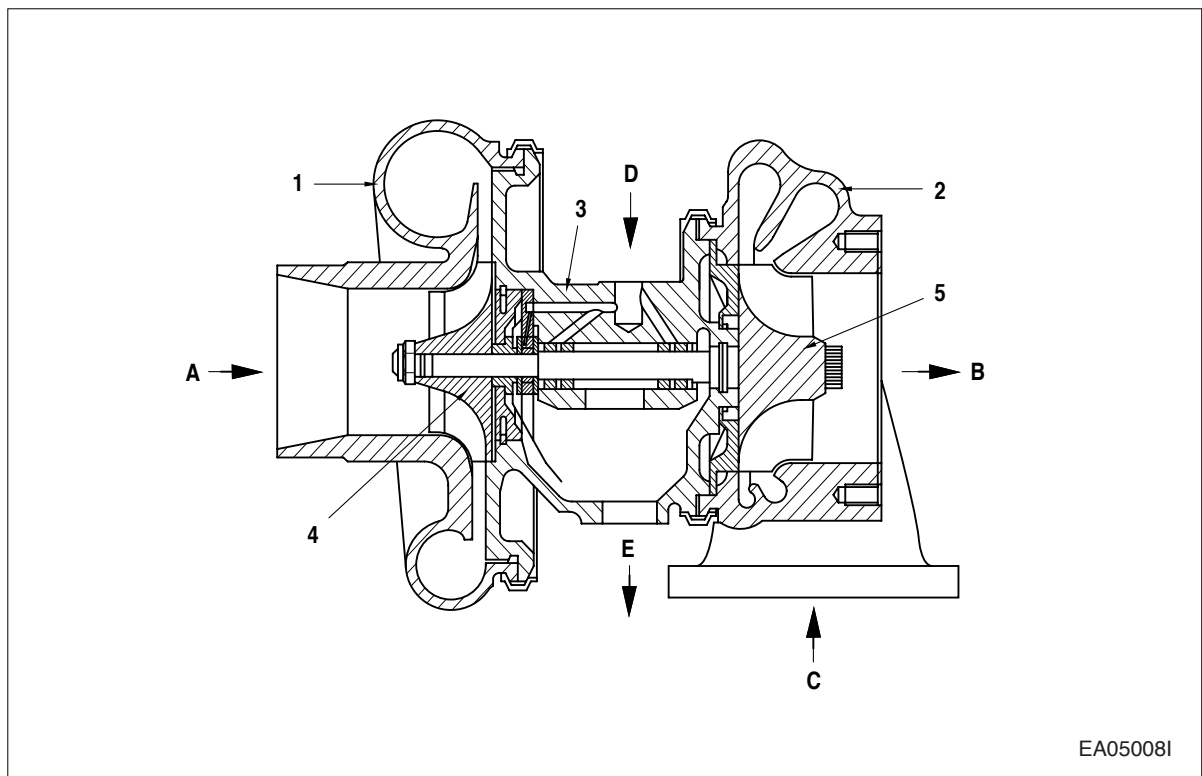

1. Impeller casing
2. Turbine housing
3. Bearing casing
4. Impeller
5. Turbine

- A. Air inlet
- B. Gas outlet
- C. Gas inlet
- D. Oil supply
- E. Oil return

5.1.3. Construction



Make sure that servicing should be performed at the professional maintenance shop as authorized by HOLSET or DAEWOO Company.

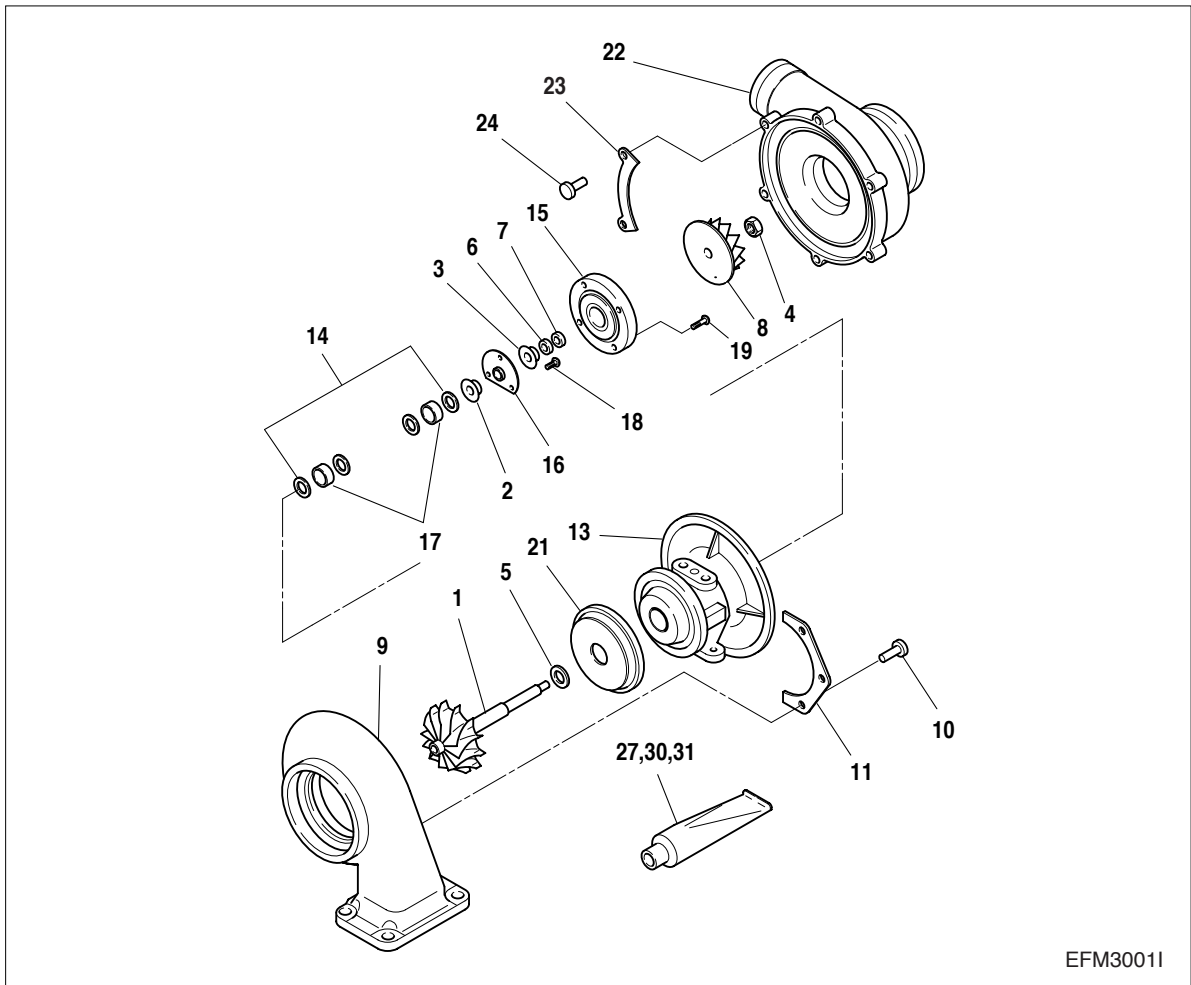

- | | |
|--------------------------|-----------------------------|
| 1. Turbine shaft | 15. Seal plate |
| 2. Thrust bush | 16. Thrust bearing |
| 3. Oil shut off | 17. Journal bearing |
| 4. Fixing nut | 18. Screw |
| 5. Seal ring | 19. Screw |
| 6. Seal ring | 21. Heat dissipater |
| 7. Seal ring | 22. Compressor housing |
| 8. Compressor wing wheel | 23. Clamp |
| 9. Turbine housing | 24. Bolt |
| 10. Bolt | 27. Liquid gasket |
| 11. Clamp | 30. Loctite |
| 13. Bearing housing | 31. Liquid anti-burn agents |
| 14. Retainer ring | |

5.1.4. General information

- The engine output depends upon the supplied fuel quantity and the engine efficiency. In order to transform into the effective work of engine by burning the supplied fuel fully, the sufficient air to burn the fuel should be supplied to the cylinder.
- Therefore, the engine output is essentially determined by the size of the cylinder, and for if the air is supplied to the given volume of cylinder with the air being compressed, the air quantity in the cylinder will increase as much to result in that it may burn more fuel. the output will also be able to increase.
- Supplying the air by compressing like this into the engine cylinder is called as supercharging, and super charging by means of exhaust gas energy that discharges to the atmosphere is called as the turbocharging.

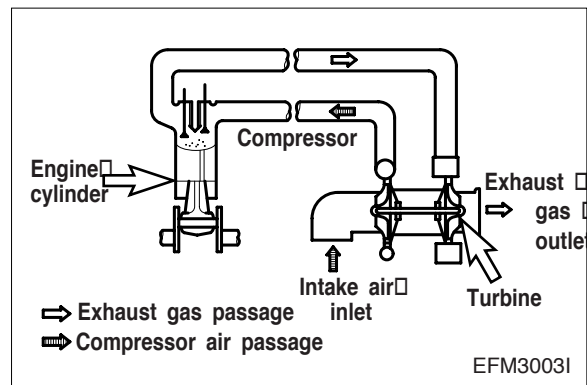
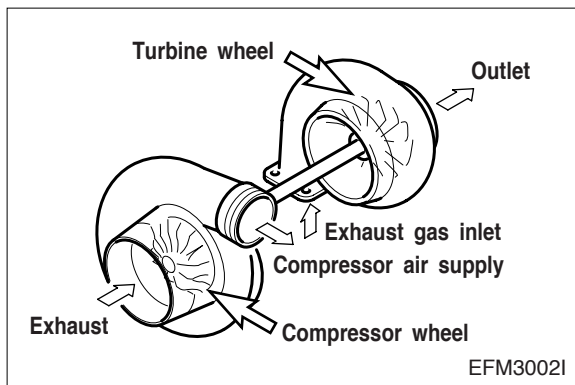

5.1.5. Function

1) Turbine

- The exhaust gas that is discharged from combustion chamber passes through turbine housing conveying an energy to turbine wings to give the rotating power, This is called as the turbine and in order not to influence a bad effect at bearing part, there are the seal ring and heat dissipater.

2) Compressor

- It is connected to the same shaft with the turbine to make a revolving assembly, and receive the revolving force of turbine, and sends air to the suction manifold by suctioning and compressing it. This is called as the compressor.

3) Bearing

- Thrust bearing force is applied to the turbine wheel and an arrangement is made for the shaft not to shift.
- Journal bearing (floating bearing) is adopted and it forms the double oil films at the inner and outer surfaces in comparison to the general stationary type so that the bearing may be able to rotate independently and consequently the double layers of films act as the damper to make the slipping speed on the bearing surface less than the rotating speed of shaft so that the dynamic stability may be obtained.

4) Sealing at compressor shaft

- In order for the compressed intake air and lubricating oil not to leak, a seal plate and a seal ring are made to the double structures.

5.1.6. How to handle the engine

1) Precautions for operation of the engine

Operation following items must be observed at the starting, operation and stop of engine.

Operation	Caution	Reason
At starting	<p>1) Inspect oil quantity</p> <p>2) After confirming that oil pressure rises by starting engine with starter (until the pointer of oil pressure gauge moves or pressure indicating lamp operates), the starting must be done.</p> <p>3) In case that oil, oil filter and lubricating system's part are replaced or engine was stalled for long time (more than a week), and in case of operation under cold weather, loosen the oil pipe connecting parts of turbocharger inlet, and operate the starting motor until oil comes out the connecting parts. Care must be paid that after the confirming above, retighten the pipe connecting parts without fail, and proceed with the normal starting.</p>	<p>2) If engine is started quickly, of course beginning with every parts of engine, for it revolves without oil that is to reach to the turbocharger, the bearing's abnormal wear or stuck may be caused.</p> <p>3) In case that engine stalled for long time and of cold weather, the fluidity of oil may be get worse.</p>
Immediately After starting	<p>1) Perform idling operation for about 5 min. immediately after engine starting.</p> <p>2) Various inspections must insure that there are no leakage of oil, gas and air.</p>	<p>1) Sudden load at time soon after engine starting and at the state when turbocharger did not yet reach to smooth revolution, if abrupt load is applied to engine, some parts where oil did still not reach may cause a burn to be stuck.</p> <p>2) If there are the leakage of oil, gas, air, particularly oil, for the oil pressure lowers, it causes a burn of bearing to be stuck.</p>
During operation	<p>Following items must be confirmed.</p> <p>1) Oil pressure at idling : 0.9 ~ 3.0 bar at full load : 3.0 ~ 6.5 bar</p>	<p>1) If the pressure is too low, abnormal wear or stuck may be caused. Or if too high, the oil leak may be generated.</p>

Operation	Caution	Reason
During operation	2) When abnormal noises and vibration are generated, slow down the revolution and must stop it to investigate the causes.	2) If the engine operation were continued with abnormal noises and vibration, it causes the engine trouble that can not be repaired or some other troubles.
At stop	1) At stopping the engine, perform the idling operation for 5min. and then stop it.	1) After heavy load operation, if the engine were stopped suddenly, the heat would be conducted to bearing parts from red hot turbine wings that would result in burning the oil to cause the stuck bearing metal and revolving shaft.

5.1.7. Routine inspection and maintenance

- Since the state of turbocharger depends largely on the state of engine maintenance, to perform the specified keep up thoroughly is needed.

1) Air intake system

- System in the intake air system, care must be taken to the air cleaner. In case of oil passing type air cleaner, if the oil level is lower than the specified value, the cleaning efficiency get worse, if higher, the sucked oil pollutes a case.
- Particularly, for if the rotor were polluted, the balance adjusted precisely would be deviated to cause a vibration that may cause the stuck or abnormal wear by loading large force to the bearing, the perfect air cleaner must always be used.
- In case of dry type filter, according to the indication of a dust indicator, cleaning must be done to make the intake air resistance as small as possible.

2) Exhaust system

- In exhaust system, a care must be taken to the gas leak and the stuck prevention. If exhaust gas leaks from the exhaust pipe and turbocharger etc., for the super charging effect will be lowered, the installed states of various parts must be paid with careful attention.
- Since the parts that reach to high temperature during operation such as the turbine room use the anti-heat nuts, a care must be paid not to mix with the general nuts and at the same time, bolt stuck preventing paint should be coated on the nut for the designated places.

3) Lubricating system

- In the lubricating system, a care must be paid to the oil quality and oil element replacement cycle.
- For the oil deterioration of turbocharger equipped engine, needless to speak of engine assembly itself, influences badly to the turbocharger too, the specified engine oil should used.

5.1.8. Periodical servicing

The turbocharger assembly must be inspected periodically.

1) Rotating condition of the rotor and checking tips

- Inspection on the revolving state of rotor is performed according to abnormal noises.
- In case of using an acoustic bar, touch the turbocharger housing with a tip of bar and raise the engine revolution slowly. Then, in case that high sound is heard by every 2 ~ 3 sec. continuously, for there should be the possibility to be abnormal metal and rotor, replace or repair the turbocharger.

2) Measuring rotor clearance

- Disassemble the turbocharger from the engine and should inspect the end plays in axial and circumference direction.
- In case of disassembling the turbocharger, the oil inlet and outlet should necessarily be sealed with a tape.

a) Rotor axial direction end play

- Wear limit : 0.20mm

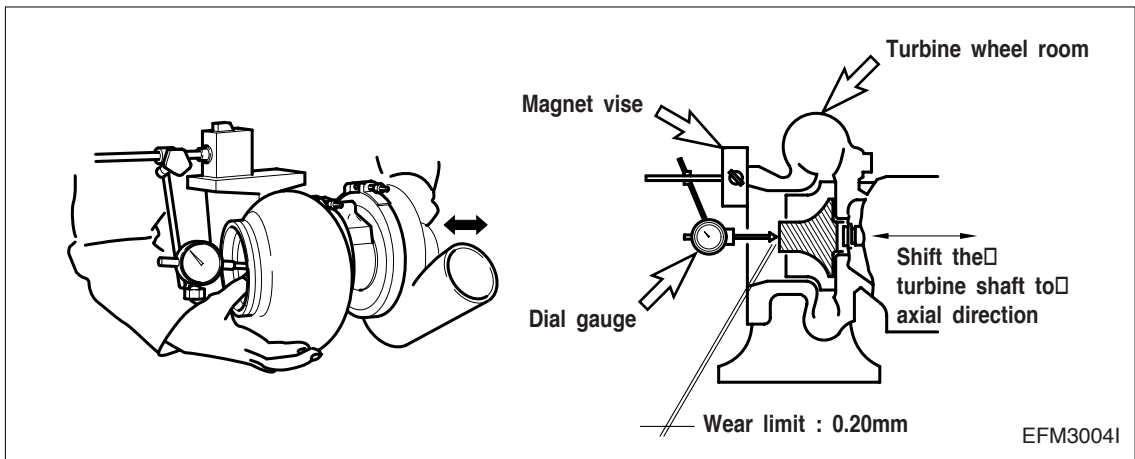

b) Rotor's circumference direction end play.

- Wear limit : 0.65mm

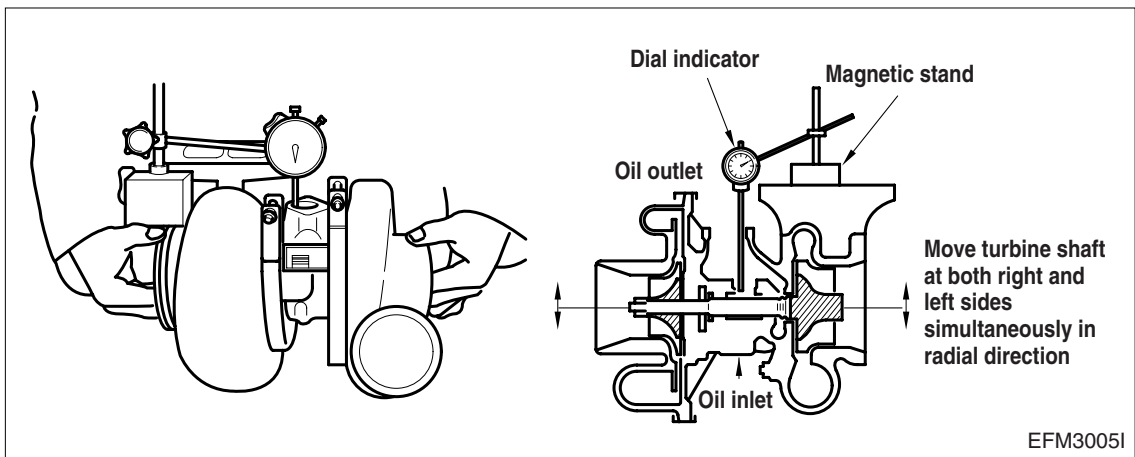

c) In case that the end plays to axial and circumference directions, replace or repair the turbocharger.

3) Overhaul and cleaning points

- Be sure to dismantle the turbocharger from the engine before cleaning.
- Also, make sure to seal the oil inlet and outlet with tape or similar.

4) Precautions for turbocharger reassembly

- When in assembling the turbocharger or the handling after assembling should work observing the following precautions necessarily.
- Particularly, precise care should be taken for foreign material not to get into the turbocharger.

a) Lubricating system



- Prior to assembling it into the engine, fill new oil into oil Inlet and turning turbine shaft with hand, lubricate journal and thrust bearing.
- Clean the pipe and oil outlet pipe between engine and oil inlet, and confirm if there is
- In order for oil not to leak from various connections, assemble securely.

b) Air intake system



- Confirm if there is any foreign material inside the air intake system.
- Assemble securely the air intake duct and air cleaner so that the connections from them may not leak an air.

c) Exhaust system

- Confirm if there is any foreign material in the exhaust system.
- Bolts and nuts must be made of anti-heat steel and in assembling, care should be taken not use the general nuts and coat the bolts and nuts with the anti-stuck agents at the same time.
- Assemble securely for gas not to leak from various connecting parts of exhaust pipes.

5.1.9. Trouble cause diagnosis and remedy

Condition	Causes	Remedies
1. Exhaust gas excessive	<ol style="list-style-type: none"> 1) Air cleaner elements clogged 2) Air Inlet port clogged 3) Air leaks from air intake system 4) Turbocharger impossible to rotate due to stuck 5) Turbine wing's contact 6) Piping deformation or clogging of exhaust system 	<p>Replace or clean</p> <p>Inspect or repair</p> <p>Inspect or repair</p> <p>Overhaul and repair or replace</p> <p>Overhaul and repair or replace</p> <p>Inspect and repair</p>
2. White smoke excessive	<ol style="list-style-type: none"> 1) Oil leaks into turbine and compressor. 2) Seal ring's abnormal wear or damage 	<p>Overhaul and repair or replace</p> <p>Overhaul and repair or replace</p>
3. Output lowered	<ol style="list-style-type: none"> 1) Gas leak from various parts of exhaust system 2) Air cleaner's elements clogged 3) Turbocharger's pollution or damage 4) Air leaks from discharge part of compressor side 	<p>Inspect and repair</p> <p>Replace or clean</p> <p>Overhaul and repair or replace</p> <p>Inspect and repair</p>
4. Abnormal noises or vibrations	<ol style="list-style-type: none"> 1) Revolving parts' contact 2) Revolving imbalance of rotor 3) Stuck 4) Various connections loose 	<p>Overhaul and repair or replace</p> <p>Overhaul and repair or replace</p> <p>Overhaul and repair or replace</p> <p>Inspect and repair</p>

5.2. Lubricating System

- Lubricating oil pumped by the gear oil pump in the oil pan is filtrated in the oil filter. This filtrated oil passed on the oil cooler and next the main oil gallery of the cylinder block where is distributed to lubricate the various sliding parts and turbocharger etc also in order to ensure normal engine performance.

5.2.1. Specifications

Item	Specifications	Item	Specifications
Lubricating system	Forced pressure circulation	Oil filter type	Full flow
Oil pump type	Gear type	Filter element type	Cartridge type
Relief valve opening pressure	10 \pm 0.1 kg/cm ²	Bypass valve opening pressure	2.5 \pm 0.5 kg/cm ²
Bypass for oil cooler opening pressure	5 \pm 0.5 kg/cm ²	Bypass for entire oil filter valve opening pressure	4.0~4.8 kg/cm ²
Adjusting valve for spray nozzle opening pressure	1.5~1.8 kg/cm ²		

5.2.2. Oil pump

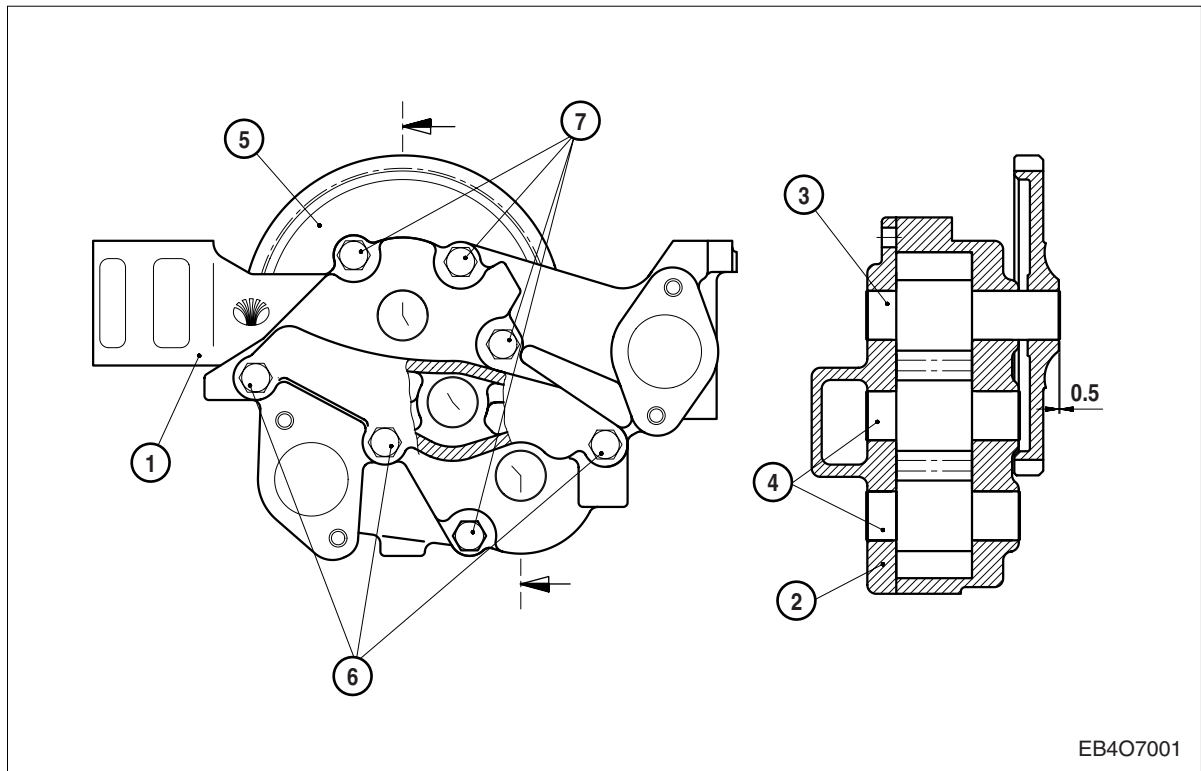

- | | |
|---------------------|------------------------|
| 1. Oil pump housing | 4. Oil pump gear |
| 2. Cover | 5. Oil pump drive gear |
| 3. Oil pump gear | 6,7. Hex bolt |

5.3. Cooling system

- The engine has a liquid-cooling system. The water pump is a maintenance-free impeller pump driven by v-belts from the crankshaft pulley.

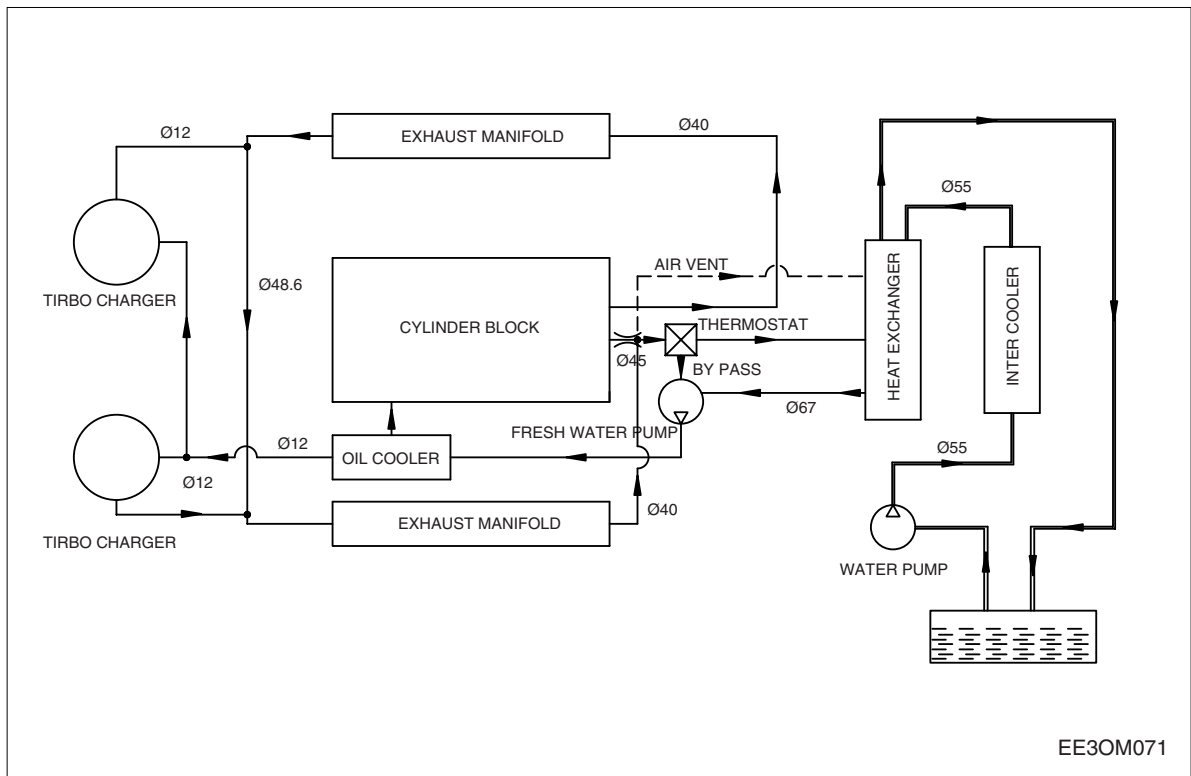

5.3.1. Cooling water pump

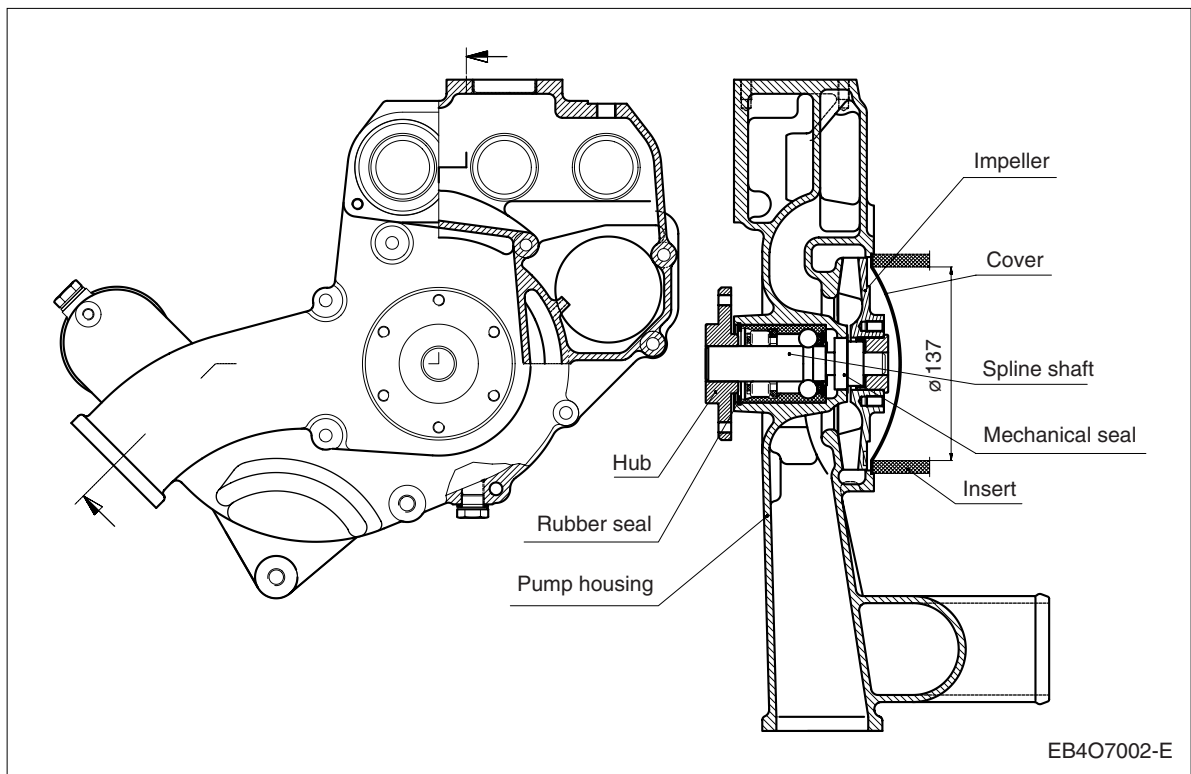

5.4. Thermostat

5.4.1. General descriptions and main data

- The thermostat maintains a constant temperature of coolant (90 ~ 95°C) and improves thermal efficiency of the engine by preventing heat loss.
- Namely, when the temperature of coolant is low, the thermostat valve is closed to make the coolant bypass to directly enter the water pump; when the coolant temperature rises to open wide the thermostat valve, the bypass circuit is closed and the water passage to the radiator is opened so that the coolant is forced to flow into the radiator.

Item	Specifications
Type	Wax-pallet type
Open at	71°C
Open wide at	85°C
Valve lift	8 mm or more

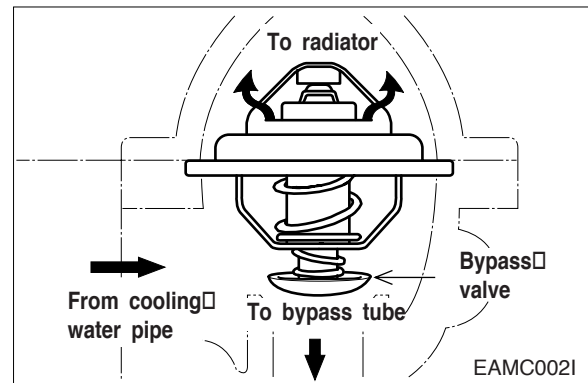

5.4.2. Inspecting

- Check the wax pallet and spring for damage.
- Put the thermostat in a container of water, then heat the water slowly and check temperature with a thermometer. If the valve lift is 0.1 mm (starting to open) at temperature of 71°C and 8 mm or more (opening wide) at temperature of 85°C, the thermostat is normal.

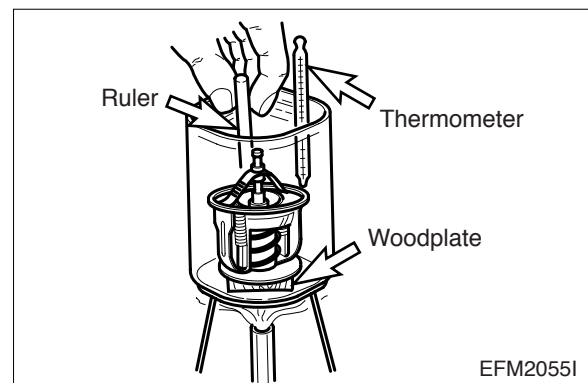

5.4.3. Replacing thermostat and precautions for handling

- Precautions for handling

The wax pellet type thermostat does not react as quickly as bellows type one to a variation of temperature of coolant. Such relatively slow reaction is mainly due to the large heat capacity of the wax pellet type thermostat. Therefore, to avoid a sharp rise of coolant temperature, it is essential to idle the engine sufficiently before running it. In cold weather, do not run the engine at overload or overspeed it immediately after starting off.

- When draining out or replenishing coolant, doing it slowly so that air is bleed sufficiently from the entire cooling system.

- Replacing thermostat

If the thermostat is detected defective, replace with a new one.

5.4.4. Diagnostics and troubleshooting

Complaints	Possible causes	Corrections
1. Engine over-heating	<ul style="list-style-type: none"> ● Lack of coolant ● Radiator cap pressure valve spring weakened ● Fan belt loosened or broken ● Fan belt fouled with oil ● Thermostat inoperative ● Water pump defective ● Restrictions in water passages due to deposit of scales ● Ignition timing incorrect ● Restriction in radiator core ● Gases leaking into water jacket due to broken cylinder head gasket 	<ul style="list-style-type: none"> ● Replenish coolant ● Replace cap ● Adjust or replace fan belt ● Replace fan belt ● Replace thermostat ● Repair or replace ● Clean radiator and water passages ● Adjust ignition timing correctly ● Clean exterior of radiator ● Replace cylinder head gasket
2. Engine over-cooling	<ul style="list-style-type: none"> ● Thermostat inoperative ● Ambient temperature too low 	<ul style="list-style-type: none"> ● Replace thermostat ● Install radiator curtain
3. Lack of coolant	<ul style="list-style-type: none"> ● Radiator leaky ● Radiator hoses loosely connected or damaged ● Radiator cap valve spring weakened ● Water pump leaky ● Cylinder head gasket leaky ● Cylinder head or cylinder block cracked 	<ul style="list-style-type: none"> ● Correct or replace ● Retighten clamps or replace hoses ● Replace cap ● Repair or replace ● Replace cylinder head gasket ● Replace cylinder head or block
4. Cooling system noisy	<ul style="list-style-type: none"> ● Water pump bearing defective ● Fan out of balance ● Fan belt defective 	<ul style="list-style-type: none"> ● Replace bearing ● Replace fan ● Replace fan belt

5.5. V - Belts

- The tension of the belts should be checked after every 2,000 hours of operation.

5.5.1. Change the belts if necessary

- If in the case of a multiple belt drive, wear or differing tensions are found, always replace the complete set of belts.

5.5.2. Checking condition

- Check belts for cracks, oil, overheating and wear.

5.5.3. Testing by hand

- By the finger-pressure the belt is pressed by 10-15mm between the pulleys in normal condition. (Pressed midway between the belt pulleys)
- A more precise check of the V-belt tension is possible only by using a V-belt tension tester.

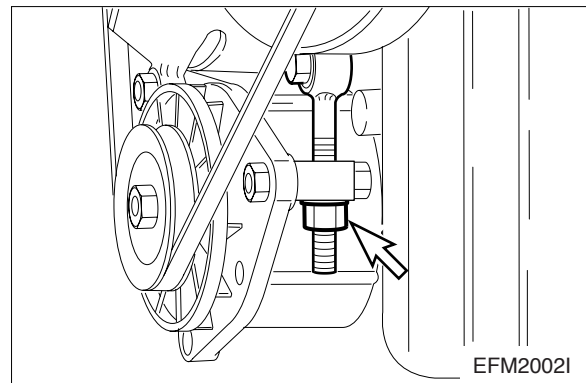

5.5.4. Measuring tension

a) Lower indicator arm (1) into the scale.

- Apply tester to belt at a point midway between two pulleys so that edge of contact surface (2) is flush with the V-belt.
- Slowly depress pad (3) until the spring can be heard to disengage. This will cause the indicator to move upwards.
- If pressure is maintained after the spring has disengaged a false reading will be obtained!

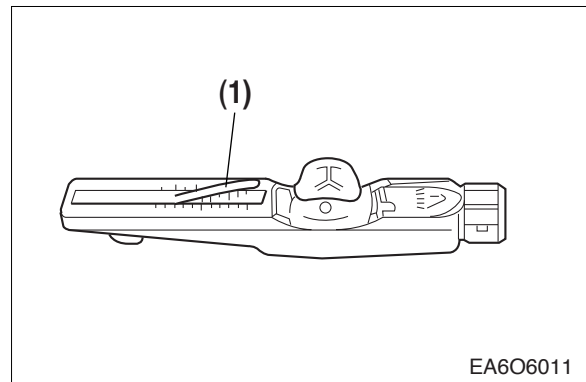

b) Reading of tension

- Read of the tensioning force of the belt at the point where the top surface of the indicator arm (1) intersects with the scale.
- Before taking readings make ensure that the indicator arm remains in its position.

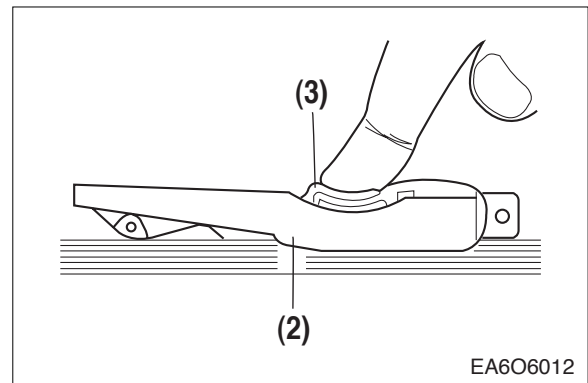

- V-belt tension

Type	Drive belt width	Tensioning forces on the tester		
		new installation		When servicing after long running time
		instration	After 10 min. running time	
M	9.5 mm	50 kg	45 kg	40 kg
A *	11.8 mm	55 kg	50 kg	45 kg
B	15.5 mm	75 kg	70 kg	60 kg
C	20.2 mm	75 kg	70 kg	60 kg

* : Adopted in GV158TIC, GV180TIC, GV222TIC engine

5.5.5. Tensioning and changing belts

- Loosen fixing bolts and nuts.
- Adjust the alternator until belts have correct tensions.
- Retighten fixing bolts and nuts.
- To change the belts loosen fixing bolts and nuts. Then push the alternator toward water pump pulley by hand.

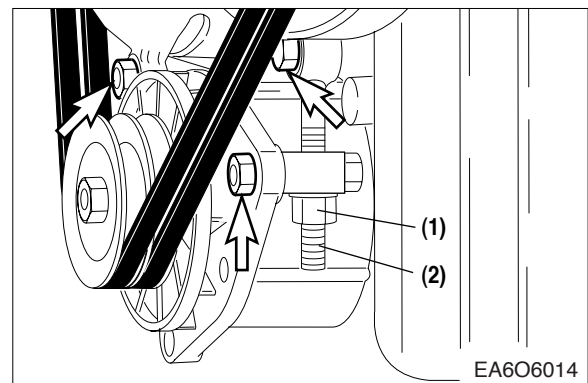

5.6. Air Intake System

5.6.1. Maintenance

(Only when engine is switched off)

Empty the dust bowl (7) regularly. The bowl should never be filled more than halfway with dust. On slipping off the two clamps (3), the dust bowl can be removed. Take off the cover (6) of the dust bowl and empty.

Be careful to assemble cover and bowl correctly.

There is a recess in the cover rim and a lug on the collector which should register. Where the filter is installed horizontally, watch for "top" mark on cleaner bowl.

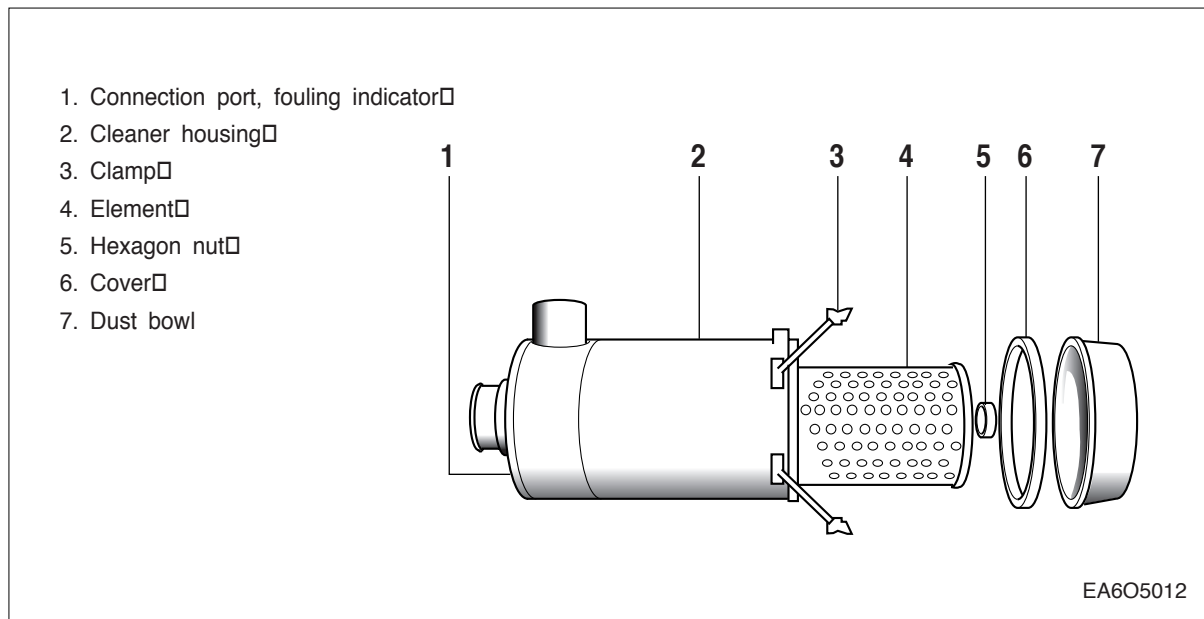

5.6.2. Changing filter element

- On removing the hexagon nut, take out the dirty cartridge and renew or clean.
- Wipe the cleaner housing with a damp cloth, in particular the sealing surface for the element.



NOTE:

Do not allow dirt to get into the clean air end.

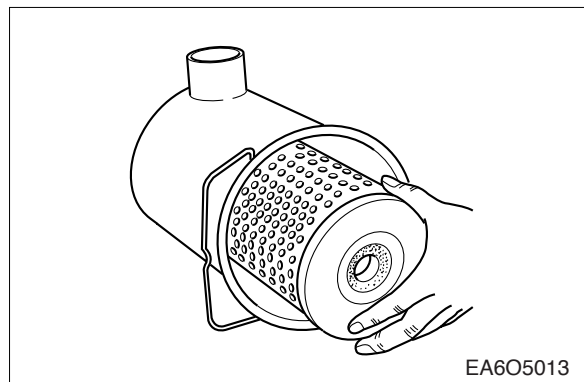

5.6.3. Cleaning filter elements

- **By compressed air (wear goggles)**

- For the purpose, the air gun should be fitted with a nozzle extension which is bent 90° at the discharge end and which is long enough to reach down inside to the bottom of the element.
- Moving the air gun up and down, blow out the element from the inside (maximum 500kPa - 5 bar) until no more dust comes out of the filter pleats.

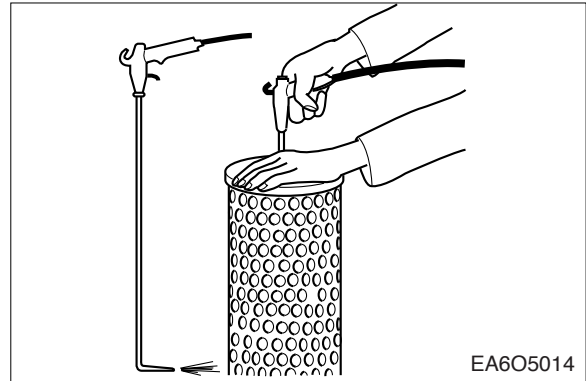

- **By washing**

- Before washing, the element should be precleaned by means of compressed air, as described above.
- Then allow the element to soak in lukewarm washing solvent for 10 minutes, and then move it to and for in the solvent for about 5 minutes.
- Rinse thoroughly in clean water, shake out and allow drying at room temperature. The cartridge must be dry before it is reinstalled.
- Never use steam sprayers, petrol (gasoline), alkalis or hot liquids etc. to clean the filter elements.

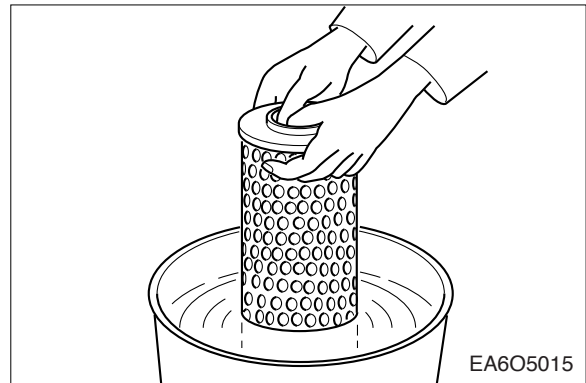

- **Knocking out dirt by hand**

- In emergencies, when no compressed air or cleaning agent is available, it is possible to clean the filter cartridge provisionally by hitting the end disk of the cartridge with the ball of one's thumb.
- Under no circumstances should the element be hit with a hard object or knocked against a hard surface to loosen dirt deposits.

• **Checking the filter cartridge**

- Before reinstalling the cartridge, it must be checked for damage e.g. to the paper pleats and rubber gaskets, or for bulges and dents etc. in the metal jacket.
- Cracks and holes in the paper pleating can be established by inspecting the cartridge with a flashlight.
- Damaged cartridges should not be reused under any circumstances. In cases of doubt, discard the cartridge and install a new one.

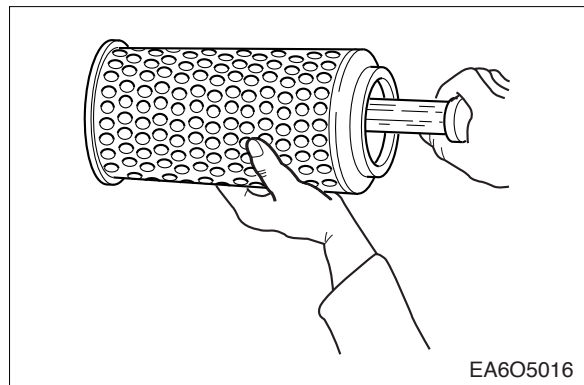

6. ENGINE INSTALLATION

6.1. Installing

- The center alignment of engine and Generator set is the most important factor for the extension of performance and life. Although aligning the center perfectly and accurately requires only few minutes, it is able to prevent unnecessary mechanical trouble at the future.

6.1.1. Bed rail

- At the installation of Generator set's bed rail, use steel.
- If the bed rail is strong enough, the center alignment of engine with Generator gets worse so that the excessive vibration may occur.

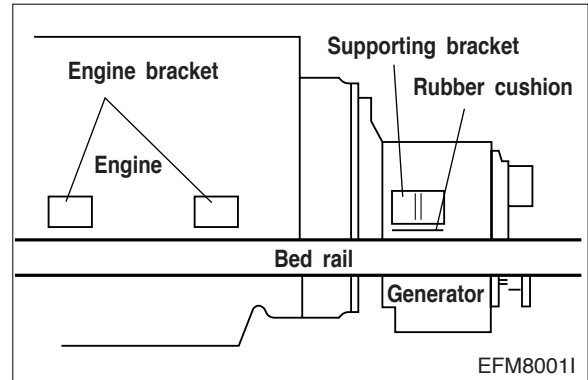

6.1.2. Supporting

- As in the engine installation, the supporting brackets are used even at the installation of Generator.
- The bracket must be solidly fixed at the Generator installing platform and the bed rail.

6.1.3. Aligning center

- The center alignment of engine and Generator is the most important factor for the extension of life cycle.
- Output shaft flange and opponent side flange of Generator should be aligned in their centers horizontal and parallel direction
- The adjustment between flange surfaces at the lower part should maintain less than 0.15 mm when the upper part's surfaces just meet and the deviation around the circumference should be maintained within 0.1 mm as following figure.

Surface (TIR)	Less than 0.15 mm
Center (TIR)	Less than 0.1 mm

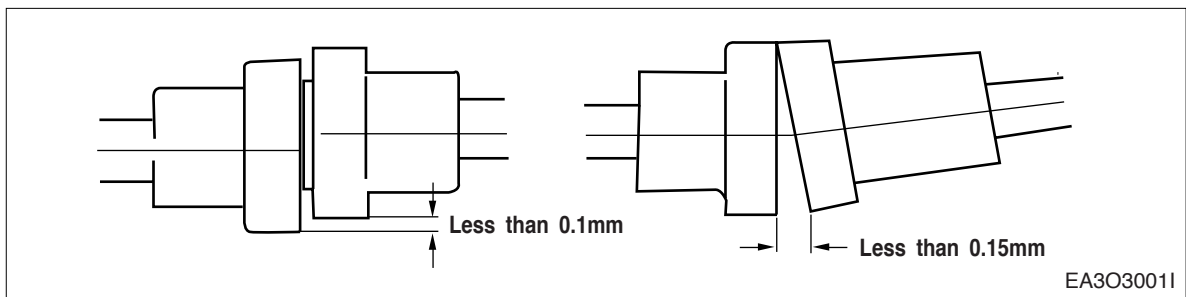

- For bed rail is apt to deform for 6 months after initial performance, adjusting the center should be checked after 1 ~ 2 months.

6.2. Inspection prior to installation

6.2.1. Inspection Prior to Installation



- Measure the correctness of flywheel and flywheel housing. Prior to inspection, clean the flywheel and flywheel housing.

1) Measuring flywheel housing

- Measure the flywheel housing surface and install the dial gauge (1/1,000) at the flywheel so as to be vertical to the flywheel housing, and let the gauge stem to contact to the flange.
- Rotate the flywheel, and measure the surface error of flywheel housing flange. The surface error should not exceed 0.2mm.

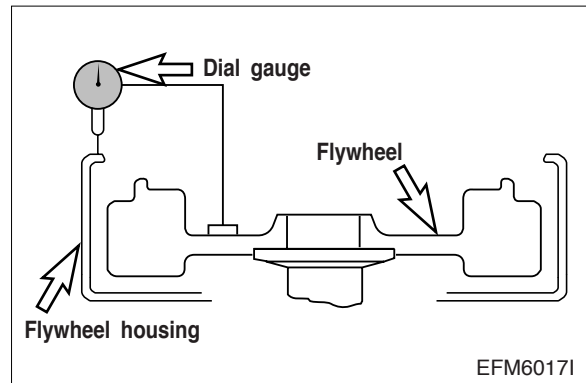

2) Measuring bore of flywheel housing

- Attach the gauge as above so that the gauge stem may contact the flywheel housing bore as the right figure.
- Measure the eccentrics of flywheel housing bore by rotating the flywheel. The eccentrics should not exceed 0.2 mm.

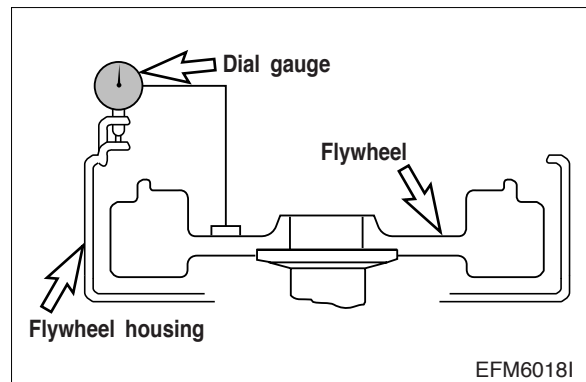

3) Measuring deformation of flywheel installing surface

- Fix the dial gauge to the flywheel housing so as for the gauge stem to be vertical to the surface to be installed.
- The deviation quantity should not exceed 0.127 mm/inch.

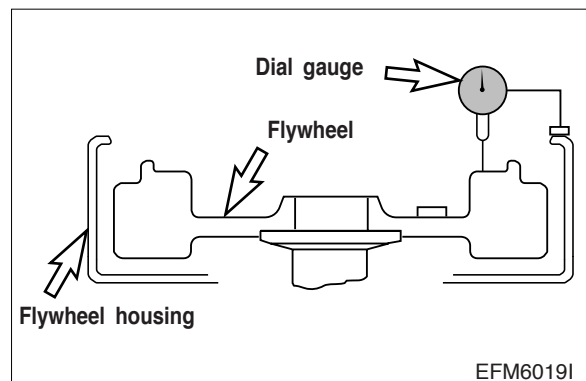

4) Measuring pilot bore of flywheel

- Install the gauge as below so as for the gauge stem to contact to the pilot bore of the surface to be installed.
- The eccentrics of the pilot bore of flywheel should not exceed 0.127mm at maximum.

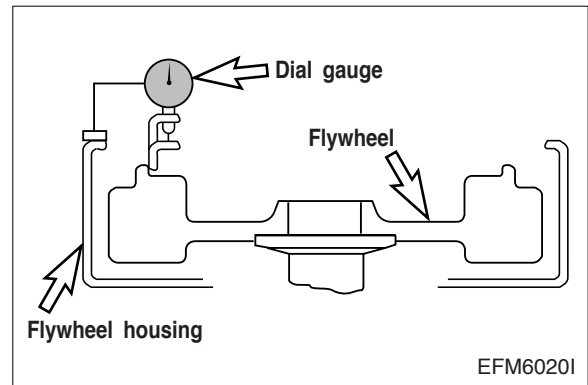

7. SPECIAL TOOL LIST

No.	Part No.	Figure	Tool Name	Remark
1	EF.120-029	A cylindrical metal component with a threaded end and a flange.	Oil seal insert Assembly (RR)	
2	EF.120-183	A cylindrical metal tool with a textured, knurled section.	Valve stern oil seal installer	
3	EF-123-193	A long, thin cylindrical metal tool with a threaded end.	Cylinder pressure tester adapter	
4	EF.120-031	A simple cylindrical metal sleeve.	Piston sleeve	GV only
	EF.120-208	A piston sleeve with a clamping mechanism on one end.		All engine
5	EF.120-028	A circular metal component with four small holes around its perimeter.	Cylinder liner insert	
6	T7621010E	A pair of pliers with long, curved handles and a pointed tip.	Piston ring plier	
7	60.99901-0027	A metal tool with several thin, flat blades of varying lengths.	Feeler gauge	
8	T7610001E	A pair of pliers with long handles and a pointed tip.	Snap ring plier	

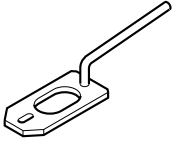
No.	Part No.	Figure	Tool Name	Remark
9	EF.123.-065		Valve spring presser	

APPENDIX

• Standard table of tightening torque

Specification	Screw	Strength	Tightening Torque kg-m
Cylinder block bearing cap			
- main bolt	M18 x 2	12.9	Initial 30 kg-m + rotating angle 90° 8
- side bolt	M12 x 1.5	10.9	
Flywheel housing			
- tightening bolt	M12 x 1.5	10.9	10
- cover bolt	M10	12.9	7.5
	M8	8.8	2.2
Counter weight	M16 x 1.5	10.9	Initial 10 kg-m + rotating angle 90° 21
Crank pulley	M16 x 1.5	10.9	
Vibration damper	M10	10.9	6
Flywheel	M16 x 1.5	12.9	26
Cooling fan	M8	8.8	2.2
Connecting rod cap	M16 x 1.5	10.9	Initial 10 kg-m + rotating angle 90°
Cylinder head	M15 x 2	12.9	8 kg.m + 15 kg.m +angle 90° + angle 90° 2.2 3.6 ~ 4.1
Cylinder head cover	M8	8.8	
Ignition plug	M14 x 1.25	-	
Cam shaft timer	M10	10.9	9
Rocker arm bracket	M10	10.9	6.5
Lock nut(adjusting screw)	M12 x 1	8.8	5
Oil pump cover	M8	8.8	2.2
Oil pump	M8	8.8	2.2
Oil cooler	M12	10.9	5
Oil pan	M8	8.8	2.2
Oil pan plug	M26 x 1.5	-	8
Exhaust manifold	M10	10.9	5.0
Intake manifold	M8	8.8	2.2
Starting motor	M12 x 1.5	8	8
Alternator bracket	M14	8.8	12
Oil pressure switch	PT1/8	-	2
Water temperature switch	M14	8.8	2

• Tightening torque for plug screw

Diameter x pitch	M10x1.0	M12x1.5	M14x1.5	M16x1.5	M18x1.5	M22x1.5	M26x1.5	M30x1.5
Torque (kg.m)	5.0	5.0	8.0	8.0	10.0	12.0	12.0	15.0

• **Tightening torque for hollow screw(4-hole)**

Material	M8	M10	M12	M14	M16	M18	M22	M26	M30	M38
SM25C	-	1.6	2.5	3.5	4.5	5.5	9.0	13.0	18.0	30.0
SUM22L*	0.8	1.8	3.0	4.0	5.5	6.5	11.0	16.0	20.0	35.0
STS304	0.8	1.8	3.0	4.0	5.5	6.5	11.0	16.0	20.0	35.0

* : Adopted in DAEWOO engine

• **Standard bolt tightening torque table**

Refer to the following table for bolts other then described above

Diameter x pitch (mm)	Degree of strength										
	3.6	4.6	4.8	5.6	5.8	6.6	6.8	6.9	8.8	10.9	12.9
	(4A)	(4D)	(4S)	(5D)	(5S)	(6D)	(6S)	(6G)	(8G)	(10K)	(12K)
	Limit value for elasticity (kg/mm ²)										
	20	24	32	30	40	36	48	54	64	90	108
Tightening torque (kg.m)											
M5	0.15	0.16	0.25	0.22	0.31	0.28	0.43	0.48	0.5	0.75	0.9
M6	0.28	0.30	0.45	0.4	0.55	0.47	0.77	0.85	0.9	1.25	0.5
M7	0.43	0.46	0.7	0.63	0.83	0.78	1.2	1.3	1.4	1.95	2.35
M8	0.7	0.75	1.1	1	1.4	1.25	1.9	2.1	2.2	3.1	3.8
M8x1	0.73	0.8	1.2	1.1	1.5	1.34	2.1	2.3	2.4	3.35	4.1
M10	1.35	1.4	2.2	1.9	2.7	2.35	3.7	4.2	4.4	6.2	7.4
M10x1	1.5	1.6	2.5	2.1	3.1	2.8	4.3	4.9	5	7	8.4
M12	2.4	2.5	3.7	3.3	4.7	4.2	6.3	7.2	7.5	10.5	12.5
M12x1.5	2.55	2.7	4	3.5	5	4.6	6.8	7.7	8	11.2	13.4
M14	3.7	3.9	6	5.2	7.5	7	10	11.5	12	17	20
M14x1.5	4.1	4.3	6.6	5.7	8.3	7.5	11.1	12.5	13	18.5	22
M16	5.6	6	9	8	11.5	10.5	17.9	18.5	18	26	31
M16x1.5	6.2	6.5	9.7	8.6	12.5	11.3	17	19.5	20	28	33
M18	7.8	8.3	12.5	11	16	14.5	21	24.2	25	36	43
M18x1.5	9.1	9.5	14.5	12.5	18.5	16.7	24.5	27.5	28	41	49
M20	11.5	12	18	16	22	19	31.5	35	36	51	60
M20x1.5	12.8	13.5	20.5	18	25	22.5	35	39.5	41	58	68
M22	15.5	16	24.5	21	30	26	42	46	49	67	75
M22x1.5	17	18.5	28	24	34	29	47	52	56	75	85
M24	20.5	21.5	33	27	40	34	55	58	63	82	92
M24x1.5	23	25	37	31	45	38	61	67	74	93	103

Others :

1. The above torque rating have been determined to 70% or so of the limit value for bolt elasticity.
2. Tension is calculated by multiplying tensile strength by cross section of thread.
3. Special screws should be tightened to 85% or so of the standard value.

For example, a screw coated with MoS2 should be tightened to 60% or so of the standard value.

• Engine assembly tolerance

(unit : mm)

	Items	Specifications	Remarks
Cylinder block	Inside dia. of liner forced in joint part (upper part)	$\Phi 145.800 \sim \Phi 145.840$	$\Phi 145.8$ H7
	Inside dia. of liner forced in joint part (lower part)	$\Phi 144.500 \sim \Phi 144.540$	$\Phi 144.5$ H7
	Inside dia. of liner color forced in part	$\Phi 153.900 \sim \Phi 154.150$	$\Phi 153.9$ H11
	Liner colored surface depth	9.97 ~ 9.99	
Cylinder liner	Outside dia.of liner forced in joint part(upper)	$\Phi 145.741 \sim \Phi 145.786$	$\Phi 145.8$ g6
	Outside dia. of liner forced in joint part(lower)	$\Phi 144.432 \sim \Phi 144.457$	$\Phi 144.5$ f6
	Outside dia. of liner color part	$\Phi 153.65 \sim \Phi 153.75$	$\Phi 153.8$
	Liner collar height	10.03 ~ 10.05	
	Liner forced in joint part (upper)	0.014 ~ 0.099	
	Liner forced in joint part (lower)	0.043 ~ 0.108	
	Liner collar part clearance	0.150 ~ 0.500	
	Inside dia. of liner	$\Phi 127.990 \sim \Phi 128.010$	$\Phi 128 \pm 0.01$
	Liner's roundness & columness (upper)	0.01	from top up to 168mm
	Liner's roundness & columness (lower)	0.015	from bottom up to 85mm
Liner's projection	0.04 ~ 0.08	measure at 4 place	
Piston	Outside diameter of piston	$\Phi 127.739 \sim \Phi 127.757$	measure 71.5mm part from bottom(long length)
	Inside diameter of piston pin	$\Phi 46.003 \sim \Phi 46.009$	
	Max. allowable weight per engine	50g	
	1st ring groove width	3.5	
	2nd ring groove width	3.040 ~ 3.060	
	Oil ring home width	4.020 ~ 4.040	
Piston ring	1st ring height (thickness)	3.5	
	2nd ring height (thickness)	2.978 ~ 2.990	
	Oil ring height (thickness)	3.97 ~ 3.99	
	1st ring axial direction clearance	-	
	2nd ring axial direction clearance	0.050 ~ 0.082	
	Oil ring axial direction clearance	0.030 ~ 0.070	
	1st ring end part clearance	0.35 ~ 0.55	
	2nd ring end part clearance	0.40 ~ 0.60	
	Oil ring end part clearance	0.40 ~ 0.70	
Piston pin	Piston pin's outside diameter	$\Phi 45.994 \sim \Phi 46.000$	
	Clearance between piston pin & pin hole	0.003 ~ 0.015	
Connecting rod	Con rod small end part width	38.070 ~ 39.000	
	Con rod large end part width	35.341 ~ 35.380	35.5 C8
	Con rod cap	32.800 ~ 33.100	32.8+0.3
	Con rod axial direction clearance	0.240 ~ 0.392	
	Con rod small end part axial direction clearance	0.064 ~ 0.126	
	Con rod bush oil clearance	0.055 ~ 0.071	
	Con rod small end inside diameter (w/h bush)	$\Phi 46.055 \sim \Phi 46.065$	

(unit : mm)

	Items	Specifications	Remarks
Connecting rod	Con rod small end inside diameter (w/o bush)	$\Phi 50.600 \sim \Phi 50.630$	$\Phi 50.6$ H7
	Con rod bush's diameter	$\Phi 50.670 \sim \Phi 50.700$	
	Tightness	0.04 ~ 0.10	
	Con rod large end part's inside diameter	$\Phi 95.000 \sim \Phi 95.022$	$\Phi 95$ H6
	Con rod bearing spread (MIBA)	0.5 ~ 1.4	
	Con rod max. weight tolerance per engine	50g	
	Perpendicularity of large end inside diameter	0.035	reference to con -rod side face
	Large end part's inside roundness & columnness	0.01	
	Large end part's inside straightness	0.005	
	Parallelness of small end inside with large end	0.02	
Crank shaft	Bearing housing diameter	$\Phi 111.000 \sim \Phi 111.022$	$\Phi 111$ H7
	Maximum shaking	$\Phi 0.05$	
	Main bearing journal diameter		
	Standard	$\Phi 103.98 \sim \Phi 104.00$	
	Undersize 0.10	$\Phi 103.88 \sim \Phi 103.90$	
	Undersize 0.25	$\Phi 103.73 \sim \Phi 103.75$	
	Undersize 0.50	$\Phi 103.48 \sim \Phi 103.50$	
	Undersize 0.75	$\Phi 103.23 \sim \Phi 103.25$	
	Undersize 1.00	$\Phi 102.98 \sim \Phi 103.00$	
	Thrust bearing journal width		
	Standard	38.000 ~38.062	38H9
	Undersize 1, 2	38.500 ~38.562	
	Undersize 3, 4	39.000 ~39.062	
	Con rod bearing journal diameter		
	Standard	$\Phi 89.98 \sim \Phi 90.00$	
	Undersize 0.10	$\Phi 89.88 \sim \Phi 89.90$	
	Undersize 0.25	$\Phi 89.73 \sim \Phi 89.75$	
	Undersize 0.50	$\Phi 89.48 \sim \Phi 89.50$	
	Undersize 0.75	$\Phi 89.23 \sim \Phi 89.25$	
	Undersize 1.00	$\Phi 89.98 \sim \Phi 89.90$	
	Main bearing journal's roundness	0.01	
	Main bearing journal's parallelness	0.005	
	Medium main bearing journal's shake	0.06	no 1, no 5 support
Wear ring press in part's journal diameter	$\Phi 99.985 \sim \Phi 100.020$	$\Phi 100$ j7	
Wear ring's inside diameter	$\Phi 99.9907 \sim \Phi 99.942$	$\Phi 100$ S7	
Overlap	0.043 ~ 0.113		
Thrust bearing width			
Standard	37.74 ~ 37.81		
Oversize	38.24 ~ 38.31		
Oversize	38.74 ~ 38.81		

(unit : mm)

	Items	Specifications	Remarks
Crank shaft	Crankshaft's axial direction's clearance	0.190 ~ 0.322	
	Main bearing thickness		
	Standard	3.460 ~ 3.472	
	Oversize 0.10	3.510 ~ 3.522	
	Oversize 0.25	3.585 ~ 3.597	
	Oversize 0.50	3.710 ~ 3.722	
	Oversize 0.75	3.835 ~ 3.847	
	Oversize 1.00	3.960 ~ 3.972	
	Main bearing oil gap	0.066 ~ 0.132	
Main bearing spread	0.3 ~ 1.2		
Thrust bearing's spread	0.3 ~ 1.2		
Flywheel	Ring Gear assembly part's Outside diameter	$\Phi 432.490 \sim \Phi 432.645$	
	Ring gear inside diameter	$\Phi 432.000 \sim \Phi 432.155$	
	Overlap	0.335 ~ 0.645	
	Heat fitting temp. (°C)	200 ~ 230	
	Allowable shaking amount after assembly	0.5	
	Outside diameter after reassembly used ring	$\Phi 114.980 \sim \Phi 115.015$	
Cylinder head & valve	Head gasket thickness (after tightening bolts)	1.205 ~ 1.295	
	Cylinder head height	113.9 ~ 114.0	
	Cylinder head seal surface roughness	max. 16 μ	
	Valve projecting amount	- 0.65 ~ - 0.95	
	Exhaust valve		
	Stem diameter	$\Phi 11.945 \sim \Phi 11.955$	
	Radius direction clearance	0.045 ~ 0.073	
	Seat angle	45°	
	Head diameter	$\Phi 50.9 \sim \Phi 51.1$	
	"H" thickness of valve head	1.9 ~ 2.3	
	Valve seat part diameter of head	$\Phi 53.00 \sim \Phi 53.03$	
	Outside diameter of valve seat	$\Phi 53.10 \sim \Phi 53.11$	
	Intake valve		
	Stem diameter	$\Phi 11.969 \sim \Phi 11.980$	
	Radius direction clearance	0.020 ~ 0.049	
	Seat angle	30°	
	Head diameter	$\Phi 57.85 \sim \Phi 58.15$	
	"H" thickness of valve head	2.6 ~ 3.0	
	Valve seat part diameter of head	$\Phi 61.00 \sim \Phi 61.03$	$\Phi 61$ H7
	Outside dia. of valve seat	$\Phi 61.10 \sim \Phi 61.11$	
	Depth of head's valve seat assembly part	12.5 ~ 12.6	
	Valve guide inside diameter	$\Phi 12.000 \sim \Phi 12.018$	$\Phi 12$ H7
	Valve guide's inside diameter of head	$\Phi 18.000 \sim \Phi 18.018$	$\Phi 18$ H7
Valve guide's outside diameter	$\Phi 18.028 \sim \Phi 18.046$	$\Phi 18.25$ S7	
Valve guide assembly locking piece	0.010 ~ 0.046		
Valve seat's shaking	0.04	reference to valve guide	

(unit : mm)

	Items	Specifications	Remarks
Valve spring	Valve lift	14.1	
	Projecting amount of valve guide	17.1 ~ 17.5	Above valve spring
	Free length of inside spring	72.43	
	Spring load of inside spring	15 ~ 17 kg	at 46.3 mm
	Spring load of inside spring	27 ~ 32 kg	at 32.3 mm
	Free length of outside spring	68.17	
	Spring load of outside spring	37 ~ 41 kg	at 46.3 mm
	Spring load of outside spring	66.5 ~ 76.5 kg	at 32.8 mm
Timing	Rocker arm bush's inside diameter	$\phi 25.005 \sim \phi 25.035$	when assembled
	Rocker arm bearing journal's diameter	$\phi 24.967 \sim \phi 24.990$	
	Bearing's clearance	0.015 ~ 0.068	
	Push rod's shaking	0.3	
	Valve tappet ass'y part's inside dia. of block	$\phi 20.000 \sim \phi 20.021$	
	Push rod's outside diameter	$\phi 19.944 \sim \phi 19.965$	$\phi 20$ H7
	Tappet clearance	0.035 ~ 0.077	
	Bush assembly's inside diameter of block	$\phi 70.077 \sim \phi 70.061$	
	Camshaft diameter	$\phi 69.910 \sim \phi 69.940$	$\phi 70$ e7
	Camshaft bearing oil gap	0.060 ~ 0.120	
	Camshaft axial direction play	0.20 ~ 0.90	
	Backlash (crank gear-camshaft gear)	0.118 ~ 0.242	
	Backlash (driving gear - injection pump gear)	0.102 ~ 0.338	
	Intake valve clearance	0.30	
Exhaust valve clearance	0.40		
Engine lubricating system	Oil pressure at idling	0.9 ~ 3.0 bar	
	Oil pressure at rated speed operation	3.0 ~ 6.5 bar	
	Oil temperature	less than 110°C	
	Instantaneous allowable temperature	max. 100°C	
	Bypass valve opening pressure	1.8 ~ 2.4 bar	
	Pressure regulating valve of oil pump	8.5 ~ 10 bar	
	Spray nozzle		
	Operating pressure	1.6 ~ 1.9 bar	
	Crossing pressure	1.3 ~ 1.6 bar	
	Tip diameter	$\phi 2$	
	Backlash (crankshaft gear-oil pump drive gear)	0.10 ~ 0.45	
	Oil pump housing's depth/gear width	43.000 ~ 43.039	43 H8
	42.910 ~ 42.950	43 e8	
Oil pump housing axial play	0.050 ~ 0.128		
Engine cooling system	Cooling water pump shaft diameter	$\phi 21.930 \sim \phi 21.950$	
	Bearing gap	0.050 ~ 0.091	
	Impeller clearance (impeller - body)	1.0 ~ 1.5	
	Thermostat Operating temperature (°C)	71°C	

(unit : mm)

	Items	Specifications	Remarks
Inspection on compressed pressure	Good Need up keep Allowable max pressure difference between cylinders	above 16 bar bellow 13 bar 4 bar	
Fuel igni- tion sys- tem	Ignition plug clearance project ignition plug from cylinder head low sur- face	0.38 ~ 0.40 3.38 ~ 3.76	

• GV180TIC Engine assembly

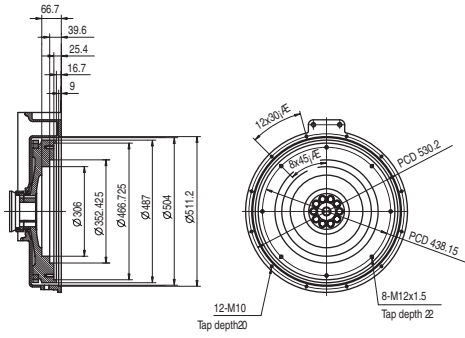

Power train

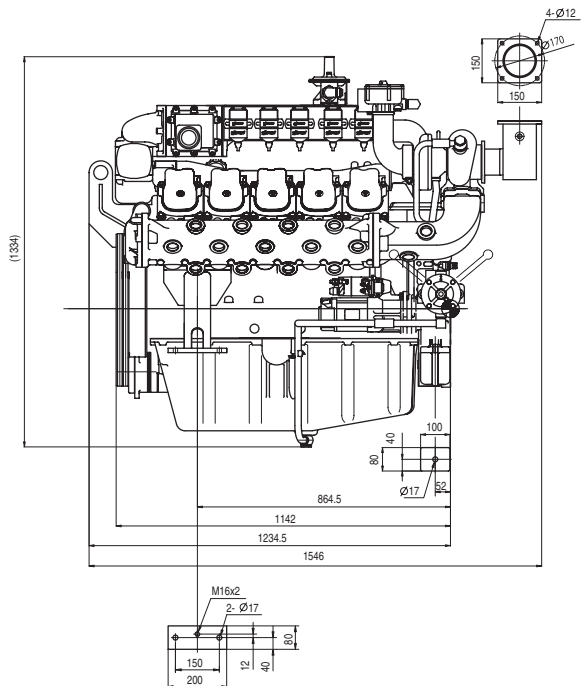
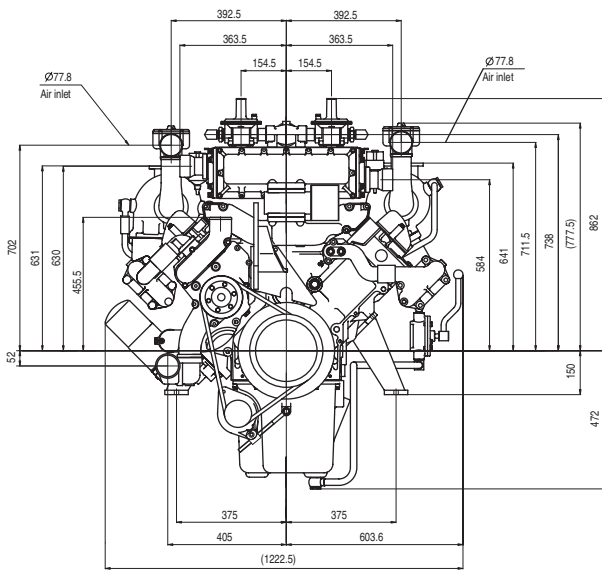
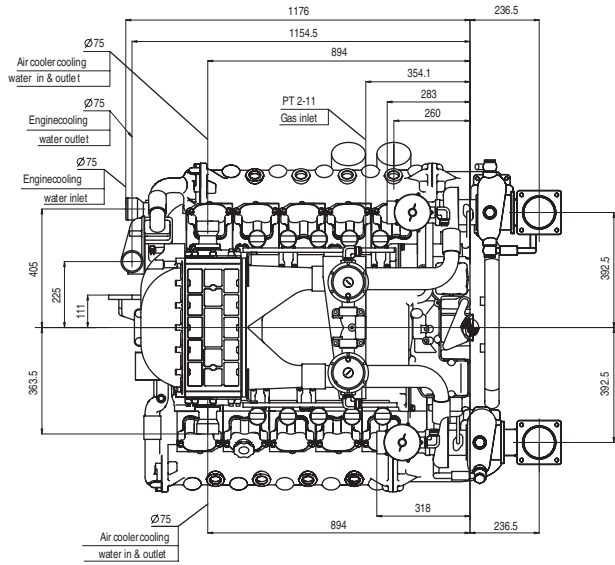

EE3OM073

