



ALTERNATORS and CHARGING SYSTEMS

INDEX

	Page
INTRODUCTION	1
General Description	1
Basic Operation	1
Complaints	1
Diagnosis Chart	2
DESCRIPTION AND OPERATION	3
Alternator	3
Drive	3
Stator Core and Coil Assy.	4
Rotor Coil and Coil Assy.	4
Brushes and Holders	4
Diode Rectifiers	5
Operation	6
Battery	6
Regulator	7
Electro-Mechanical	7
Transistorized	8
Wiring	9
DIAGNOSIS AND TESTING	12
Battery	12
Visual Inspection	12
Specific Gravity Test	13
Capacity Test	13
Safety Precautions	14
Visual Inspection	14
Adjusting Belt Tension	14
Voltage Drop Test	14
Motorola Charging Systems	15
Test #1	15
Test #2	15
Field Draw Test	15
Voltage Regulation	15
Alternator Output Test	16
Ford Charging System	16
Three Point Voltmeter Test	16
Over Charging Test	17
Regulator Bypass Test	17
Wiring Harness Test	18
Alternator Bench Tests	19
Rotor and Stator Tests	20
Diode Tests	21

foreword . . .

This handbook has been prepared to provide you with a valuable reference source for information regarding Ford Motor Company Industrial Engine Alternators and Charging Systems.

FORD MOTOR COMPANY
INDUSTRIAL ENGINE OPERATIONS
FORD PARTS AND SERVICE DIVISION
300 RENAISSANCE CENTER
P.O. BOX 43338
DETROIT, MICHIGAN 48243

The information and specifications contained in this manual were in effect at the time the publication was approved for printing. The Ford Parts and Service Division of Ford Motor Company reserves the right, however, to alter its product line at any time, or change specifications or design without notice and without incurring obligation.

NOTE: The recommendations and suggestions contained in this publication are made to assist the distributor in improving his distributorship parts and/or service department operations. These recommendations and suggestions do not supersede or override the provisions of the Warranty and Policy Manual and in any cases where there may be a conflict, the provisions of the Warranty and Policy Manual shall govern.

**INTRODUCTION
GENERAL DESCRIPTION**

The alternator-type charging system consists of an alternator, an alternator regulator, a battery, a charge indicator light or gauge, and the necessary wiring to connect the components. (Figure 1)

Industrial Engine Operation installs two types of alternators; a Ford Alternator and a Motorola Alternator. Diagnosis and testing remains basically the same for both.

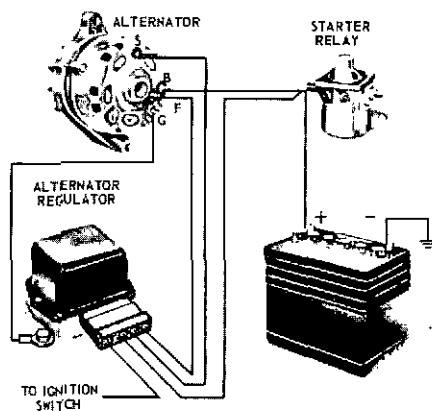

FIGURE 1. CHARGING SYSTEM COMPONENT PARTS

BASIC OPERATION

Lets take a look at the basic operation of an alternator charging system . . . The alternator is belt driven from the engine. The mechanical construction of the alternator differs from a generator in that the field rotates and the generating windings are stationary. Energy is supplied to the rotating field through two brushes and slip rings. The slip rings are mounted on the rotor shaft and are connected to the field coil. (Figure 2)

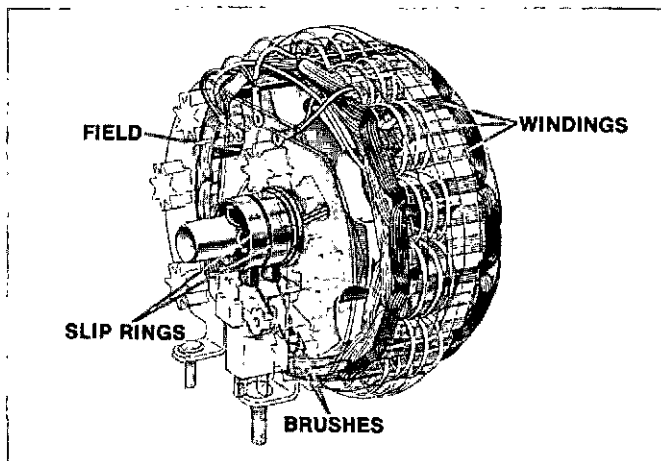

FIGURE 2. FIELD WINDINGS, SLIP RINGS AND BRUSHES

The alternator produces power in the form of alternating current, rectified to direct current by six diodes. The direct current is then used for charging the battery and supplying power to the electrical system.

The output of the alternator is controlled by a simplified regulator. The regulator is composed of two control units, a field relay and a voltage limiter, mounted as an assembly. A cutout relay is not needed as the alternator diodes block reverse current when the engine is not running. In addition, the alternator is self current limiting, thus a current limiter is not needed.

COMPLAINTS

When the charging system fails in some aspect of its operation, you will be faced with one of these complaints: Your charge indicator light does not light when the ignition switch is turned on; your charge indicator light stays on after engine starts; your charge indicator light flickers while your engine is being run; your charge indicator gauge does not give a normal reading; your battery does not stay charged but your engine starts okay; your battery uses an excessive amount of water and your lights and/or fuses burn out frequently, or your alternator is noisy. (Figure 3)

COMPLAINTS

- INDICATOR LIGHT DOES NOT LIGHT WHEN IGNITION SWITCH IS ON
- BATTERY DOESN'T STAY CHARGED
- CHARGE INDICATOR LIGHT STAYS ON AFTER ENGINE STARTS
- BATTERY USES EXCESSIVE WATER
- CHARGE LIGHT FLICKERS
- LIGHTS AND FUSES BURN OUT
- CHARGE INDICATOR GAUGE ABNORMAL
- ALTERNATOR NOISY

FIGURE 3. CHARGING SYSTEM COMPLAINTS

INTRODUCTION

DIAGNOSIS CHART

Once you have verified your complaint, you will be able to use this Diagnosis Chart to locate your problem. (Figure 4) The test sequence included on this chart is based on the principle that if there is adequate charging voltage at the battery terminals in both the "no load" and "loaded" conditions, the charging system is doing its job. As you can see from the chart you will be asked to perform preliminary checks, to perform a three-Point Test, an Overcharging Test, a Regulator Bypass Test, a Wiring Harness Test and Alternator Tests.

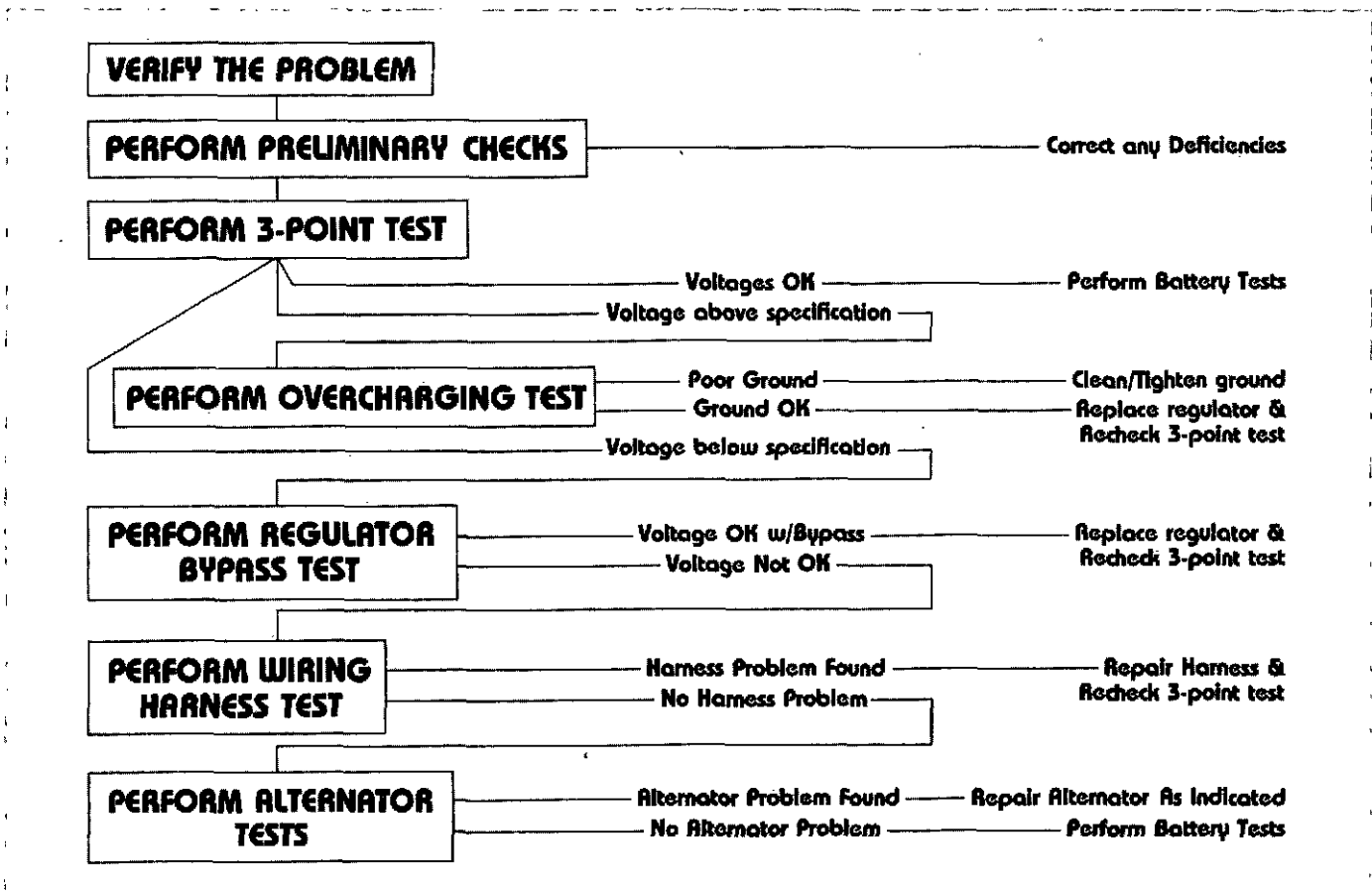

FIGURE 4. CHARGING SYSTEM DIAGNOSTIC CHART

SYSTEM COMPONENTS — DESCRIPTION AND OPERATION

ALTERNATOR

Now, lets take a look at the description and operation of the component parts of an alternator charging system.

The alternator consists of the drive, (which includes the front housing, fan and pulley), the stator core and coil assembly, the rotor core and coil assembly, the brushes and holders, and the diode rectifiers. (Figure 5)

Drive

A die-cast aluminum front housing is used to meet design requirements for a light-weight, non-magnetic material. This casting incorporates the bosses used to attach the assembly to its mounting bracket and provides the supporting surface for the rotor shaft front bearing. It also provides a place for identifying the unit. (Figure 6)

The fan and pulley is attached to the rotor shaft with a nut and lock-washer. The shaft is threaded at its forward end to accept the nut. (Figure 6)

The alternator rear housing which is also an aluminum die casting, supports the rotor shaft rear bearing and provides mounting bosses for the rectifier assembly. The illustration shown in Figure 7 depicts typical rear housing designs and identifies the terminals for each. The housing contains the openings needed for cooling and making electrical connections.

DESCRIPTION AND OPERATION

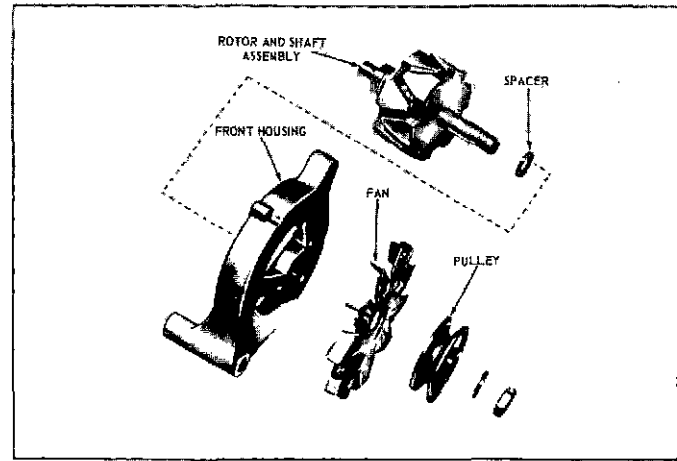
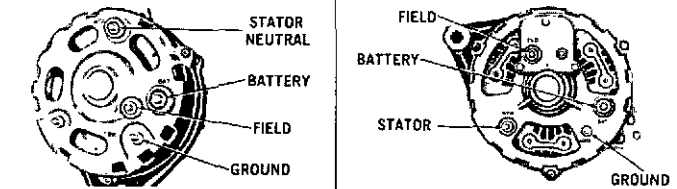

FIGURE 6. ALTERNATOR FRONT HOUSING, FAN, PULLEY, ROTOR & SHAFT ASSY. & SPACER

ALTERNATOR TERMINAL LOCATIONS



70/90 AMPERE

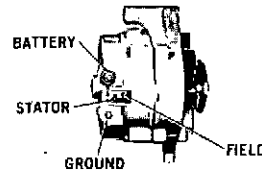

FIGURE 7. TYPICAL REAR HOUSING DESIGNS AND TERMINALS.

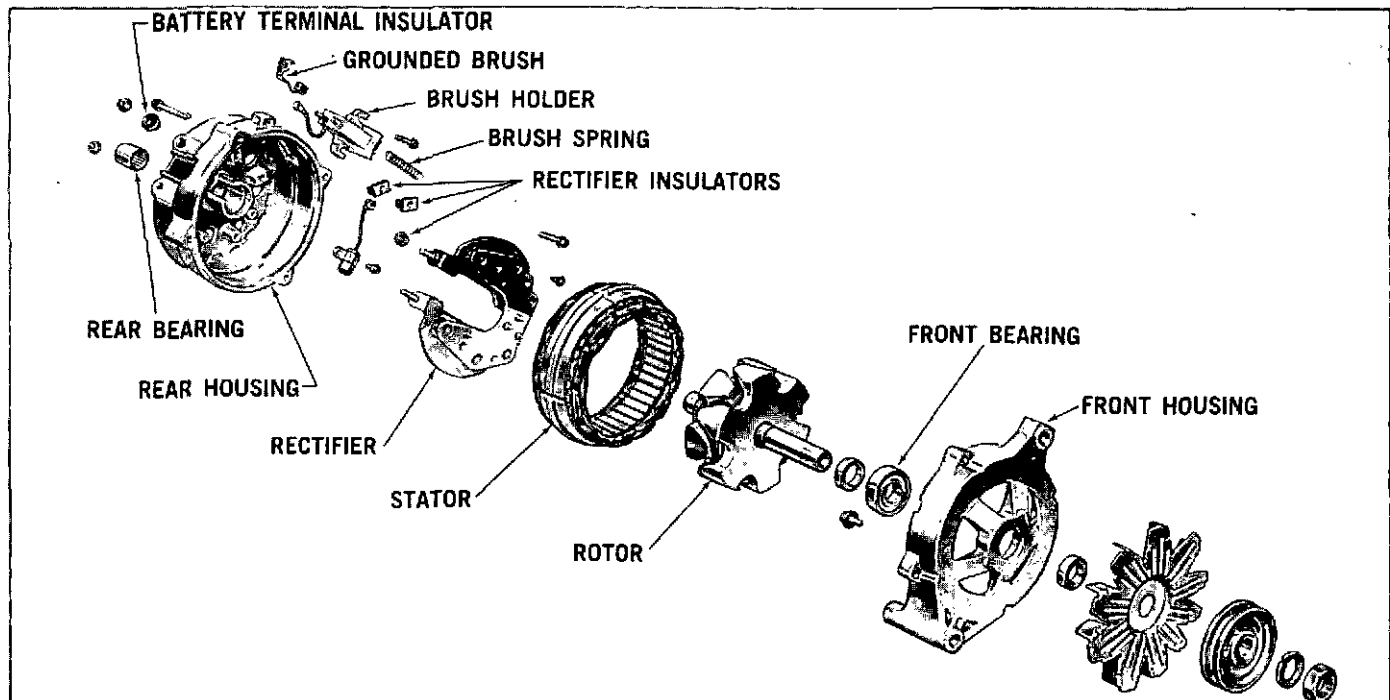

FIGURE 5. ALTERNATOR EXPLODED VIEW

DESCRIPTION AND OPERATION

Stator Core and Coil Assembly

A number of steel stampings are riveted together to form the stator core. The inner surface of this core contains thirty-six equally spaced vertical slots which accommodates the stator coil windings. (Figure 8)

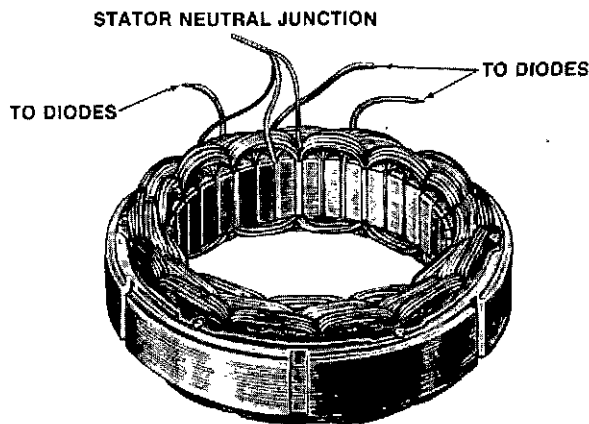

FIGURE 8. STATOR COIL

There are two types of stator windings used in the Motorcraft alternator. They are the Delta and the Wye.

The Delta winding receives its name from its schematic symbol which resembles the Greek letter Delta. (Figure 9) Each coil winding end is connected to another to form a closed series circuit.

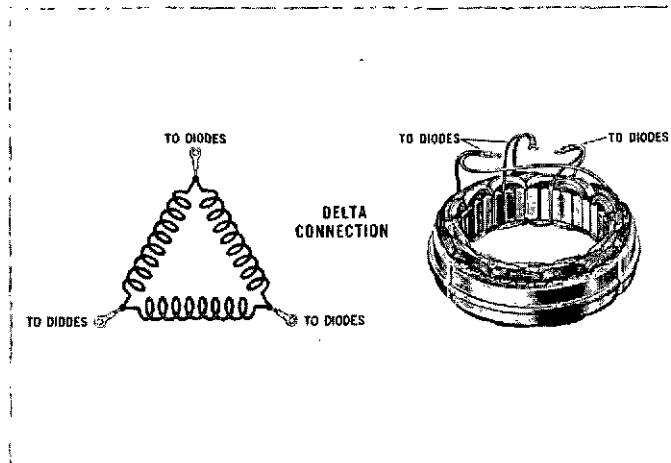

FIGURE 9. DELTA WINDINGS

The Wye winding also receives its name from its schematic symbol which resembles the letter "Y". Two of the coil windings form a series circuit and the third coil winding is neutral. (Figure 10)

Rotor Coil and Coil Assembly

The rotor core and coil assembly includes a rotor shaft, two slip rings, two rotor halves and a coil assembly. (Figure 11)

The rotor shaft is supported at each end by bearings. The front bearing, a ball-type, is a slip fit on the rotor shaft and

is retained in the front housing with a retainer. The rear bearing, a needle-type, is pressed into the rear housing.

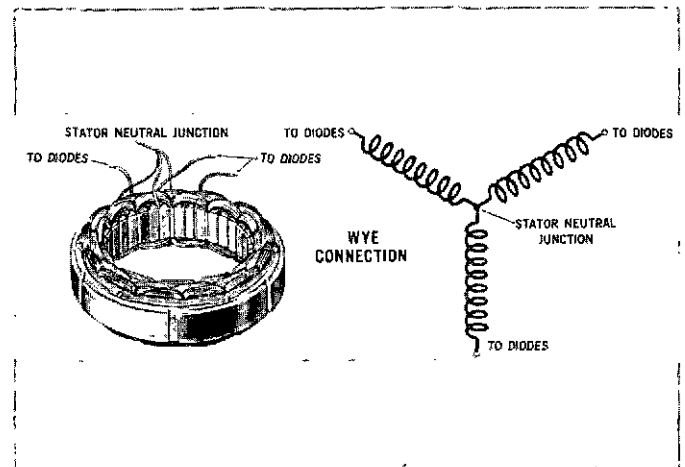

FIGURE 10. WYE WINDINGS

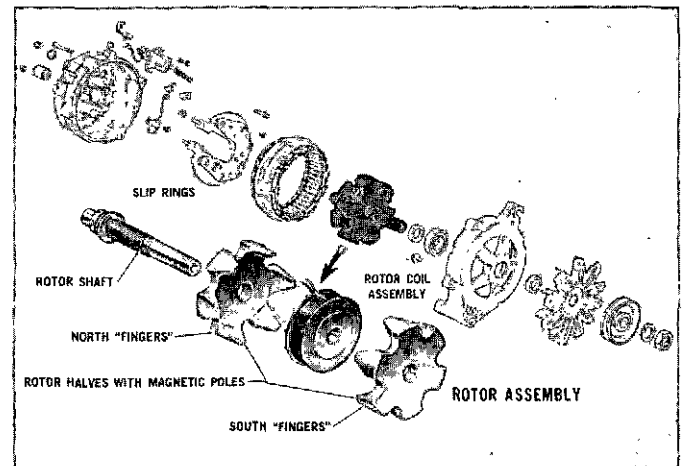

FIGURE 11. ROTOR CORE AND COIL ASSEMBLY

The slip rings and the core and coil assembly are press-fitted to the shaft with a rotor half enveloping each end of the coil.

The rotor core and coil assembly turns inside the stator core and coil assembly and a very narrow air gap exists between the two assemblies. This narrow clearance permits maximum magnetic power.

Brushes and Holders

The brushes in an alternator ride the surfaces of the slip rings on the rotor shaft under spring pressure and transmit field current through their circuit to ground. One brush or field terminal is, therefore, insulated from the housing.

In the standard alternators, the brush and holder assembly is installed in a cavity inside the rear housing, as shown in Figure 12.

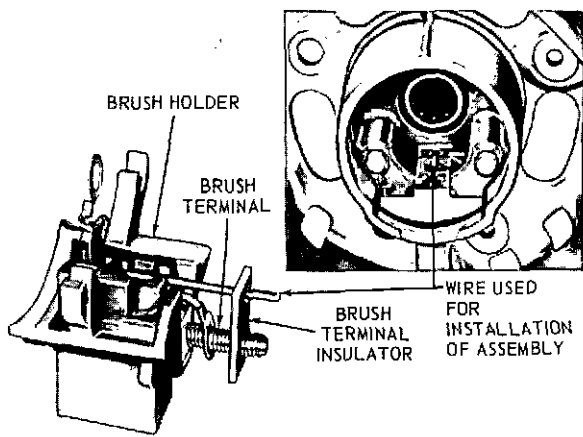

FIGURE 12. BRUSH AND HOLDER INSTALLATION — STANDARD ALTERNATORS

The brush and holder assembly in the 70 and 90 ampere alternators is retained in a cavity on the back of the rear housing (Figure 13). This type of installation makes it possible to change brushes without disassembling the alternator. As with standard design alternators, a hole is provided in the holder for retracting the brushes upon installation.

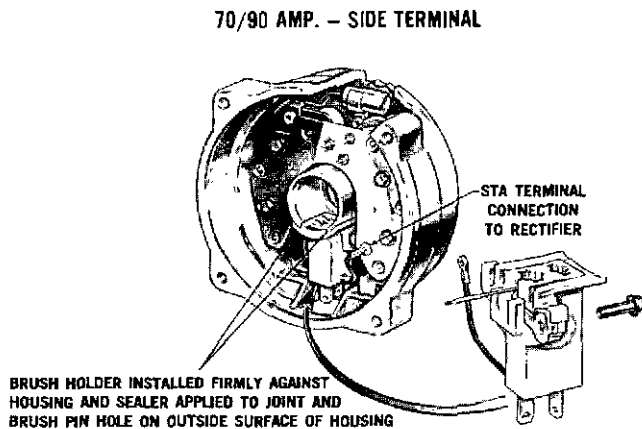

FIGURE 13. BRUSH AND HOLDER INSTALLATION — 70 AND 90 AMPERE ALTERNATORS

Diode Rectifiers

The rectifier assembly is located between the stator and the inside surface of the rear housing. Attachment to the housing is made by means of mounting studs that protrude from the positive and negative diode plates. The positive plate is insulated from the housing and the negative plate is grounded to the housing through the studs.

Two types of rectifier assemblies are used in the Motorcraft alternator. One type has the printed circuit board spaced away from the heat sinks. The other type is of single layer construction that incorporates the circuit board and heat sinks in a single layer. For purposes of clarification we will identify the rectifiers as "stacked type" and "flat" type. (Figure 14)

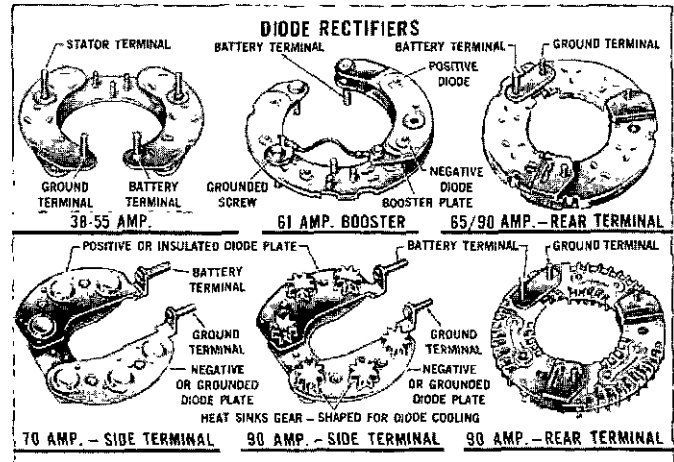

FIGURE 14. DIODE RECTIFIERS

In both designs of rectifier assemblies, the stator windings leads are soldered to integral terminals on the back of the circuit board. The stator neutral lead is attached to the insulated stator terminal.

The active device that controls current flow in "rectification" is the diode. (Figure 15)

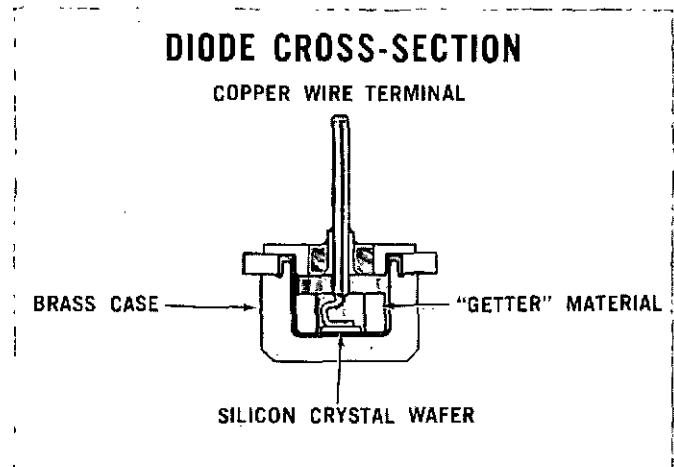

FIGURE 15. DIODE

The actual "rectifying" component of the diode is a very small metallic disc, or square wafer, of pure silicon, treated with a controlled impurity. The manner in which the metallic disc is installed in the diode assembly determines whether the diode is negative or positive. The disc is only .008 to .010 of an inch thick and approximately 1/8 of an inch square, depending on current rating. Some rectifier assemblies contain diodes that are exposed while others have them built in. Those with built-in diodes contain only the wafer portion of the diode, while those with exposed diodes, like the one in Figure 15, contain the entire assembly.

It is important to remember that the chemical composition of the silicon wafer or disc is such that it passes current in one direction only. If the battery polarity is reversed, full battery voltage will impress excessive current on the diodes causing their destruction.

DESCRIPTION AND OPERATION

Operation

Now, let's take a look at the operating principles of the alternator.

The purpose of the alternator is to produce electrical energy which is used to maintain the proper state of charge in the battery and to supply current to all electrically powered equipment on the engine when the engine is running. It performs this function by converting the mechanical energy derived from its moving parts into electricity.

Under normal operating conditions, a belt driven pulley is turning the alternator rotor assembly inside the motionless stator core and coil assembly. The slip rings, which are pressed onto the rear portion of the rotor shaft, are connected with the rotor coil winding. A brush holder assembly retains two brushes which are spring loaded in the holder so that they will maintain a desirable contact with the slip rings throughout the service life of the brushes. The illustration in Figure 16 simulates the relationship between the rotor and stator assemblies.

Three separate series of coils are wound on the stator core (Figure 16). These windings are arranged in three layers in each stator core slot with their installed positions occupying a staggered relationship to each other.

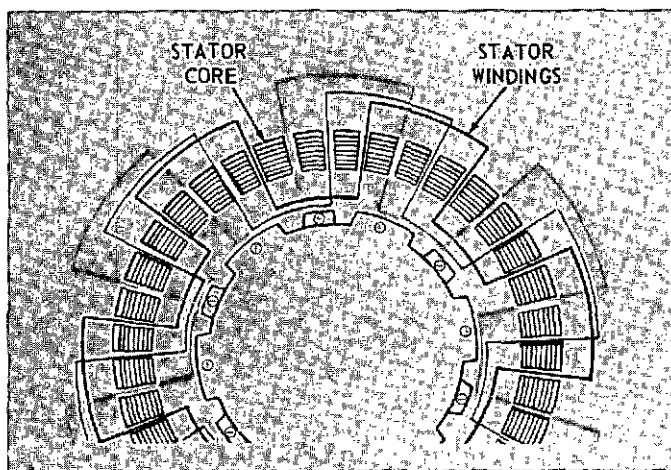

FIGURE 16. STATOR CORE AND WINDINGS

When the winding process is completed, a loose end for each coil remains. These ends are directed through a printed circuit board to a pair of diodes — one is positive and one is negative.

The diodes (Figure 17) are installed in arc-shaped metal plates, or heat sinks, which serve as conductors by transmitting current from the diode to a terminal. The positive diode plate assembly includes the battery and stator terminals . . . the negative plate assembly includes the ground terminal. All of these terminals protrude through the rear housing with the "BAT" and "STA" terminals being insulated from the housing. The stator terminal is also insulated from the positive plate.

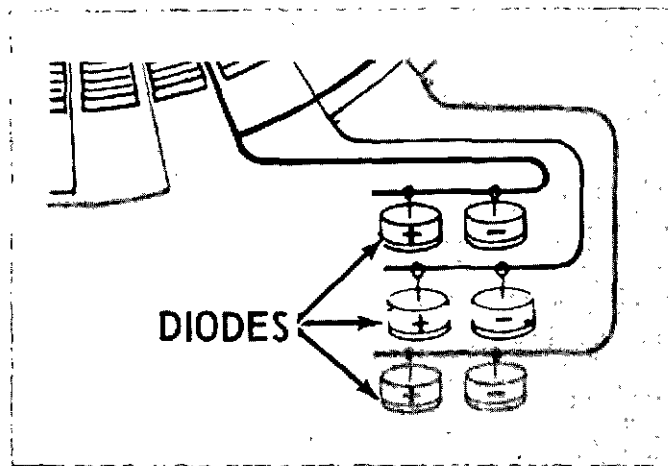

FIGURE 17. DIODES

BATTERY

Now, let's take a closer look at the battery (Figure 18). While the alternator supplies the electrical power when the engine is running, your battery is the source of electrical current for starting the engine and is the source of power when the ignition is in the "ACCESSORY" or "ON" position.

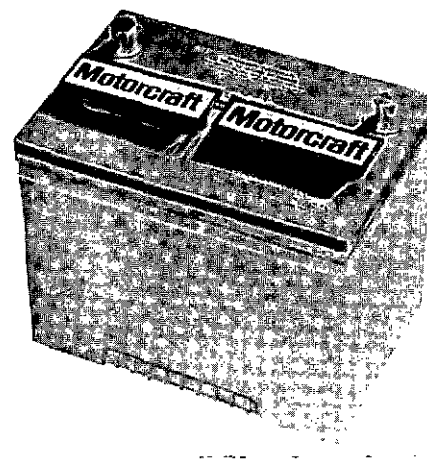

FIGURE 18. BATTERY

The battery is an electro-chemical device which is designed to convert an electrical input from the charging circuit into chemical energy and store it until there is a demand from an external circuit.

However, it doesn't store electricity in the sense that a capacitor will accumulate and hold an electrical charge. It converts electrical energy into chemical energy, then back into electricity, by means of a fully reversible chemical reaction. (Figure 19)

The amount of current that the battery can supply is limited to the CAPACITY of the battery, which, in turn, is dependent upon the amount of chemicals and plate size that are used in making the battery.

DESCRIPTION AND OPERATION

Remember that cold weather stiffens the engine and drastically reduces the battery output by slowing down the chemical reaction. The Cold Cranking Performance rating system will aid you in the selection of a battery with the correct electrical capacity.

This rating specifies, in number of amperes, the load that a battery will maintain at zero degrees Farenheit for a period of thirty seconds, without the terminal voltage falling below 7.2 volts for a twelve-volt battery, or 3.6 volts for a six-volt battery.

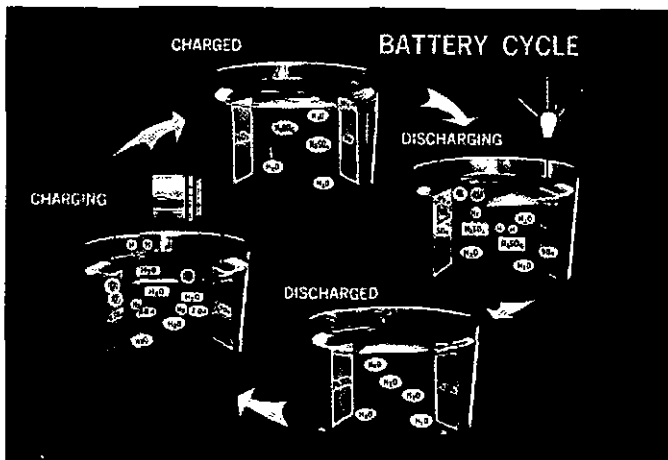

FIGURE 19. BATTERY CYCLES

There are two things you must know in order to select a battery to fit the needs of a particular engine. The first thing that you must know is what total current demands will be made on the battery, and the second thing is what actually determines the current capacity of the battery. (Figure 20)

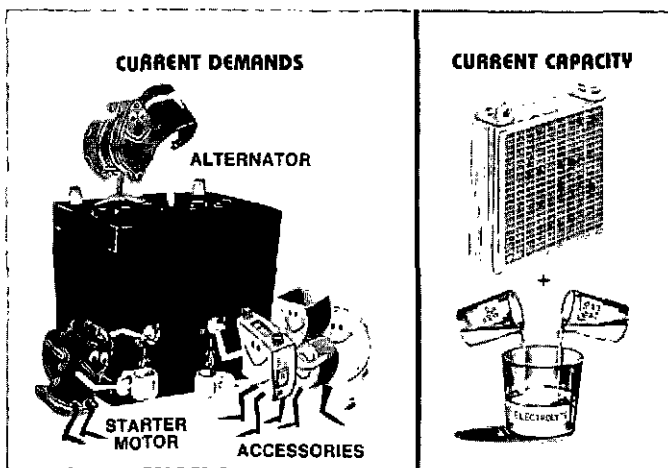

FIGURE 20. CURRENT DEMANDS & CAPACITY

The current capacity of the battery is dependent upon the number of plates, their size and thickness and the acid content of the electrolyte. The open circuit voltage, regardless of the size of the cell, remains the same — slightly over two volts.

For example, if we compare a nine plate per cell battery to a fifteen plate battery, they both have the same open circuit voltage; however, the fifteen plate battery has the greater capacity and higher voltage on discharge.

You, then, must determine what other electrical accessories the battery will be called upon to provide energy for. By familiarizing yourself with the engine you are working with, you will be able to decide what size battery you will need for maximum output.

REGULATOR

A regulator (Figure 21) is included in the charging circuit to protect it from any excessive amount of voltage that may be delivered by an alternator. This is accomplished with a vibrating type electro-mechanical regulator, or with a transistorized regulator.

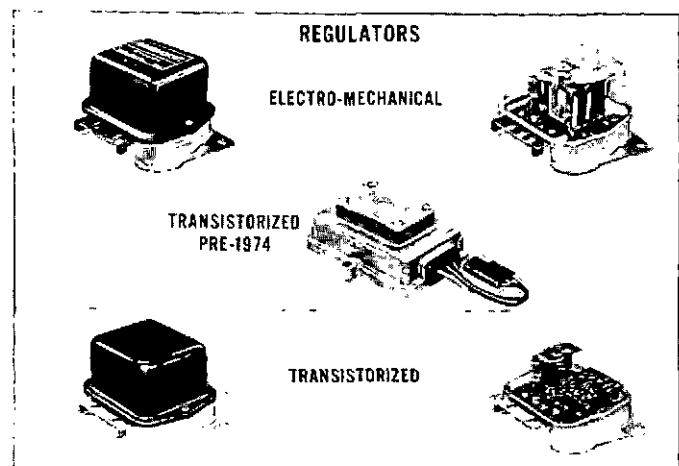

FIGURE 21. REGULATORS

Electro-Mechanical Regulator

The electro-mechanical regulator, when used with an alternator, need only provide one basic function; that is to maintain the charging system voltage at a constant level. To accomplish this, we use a field relay and a two-stage voltage limiter. A current limiter is not used since an alternator is "self-limiting" in its production of current. The field relay acts as a means for connecting the voltage limiter to the charging system.

When the ignition switch is turned on, (Figure 22) battery current flows through the ignition switch, through the alternator indicator lamp and 15 ohm resistor to the voltage regulator "I" terminal. From there you can trace the current to the voltage limiter upper contacts, via integral connections, and out through the voltage regulator "F" terminal to the alternator "FLD" terminal which is the rotor coil. Enough current flows through the circuit to prime the alternator so that when the engine is started, the magnetism in the field will cause the alternator to start generating voltage.

DESCRIPTION AND OPERATION

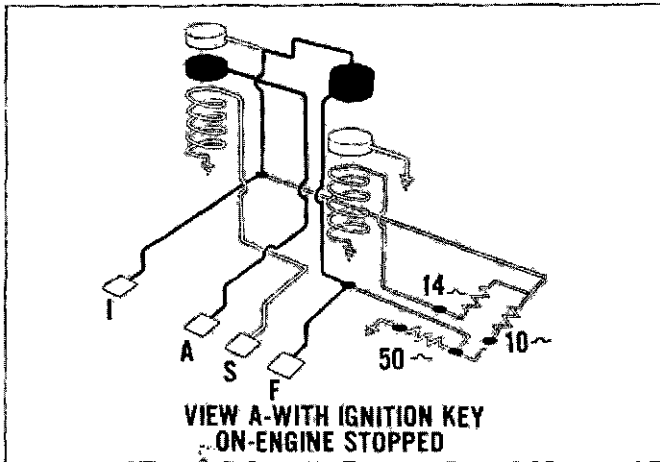

FIGURE 22. CURRENT FLOW — VIEW A

While engine rpm is increasing from cranking speed to idle speed the alternator develops sufficient voltage at its "STA" terminal to close the field relay contacts (Figure 23). This action turns out the alternator indicator lamp and applies battery voltage to the alternator field via the voltage regulator "A" terminal, the field relay contacts and the voltage limiter upper contacts.

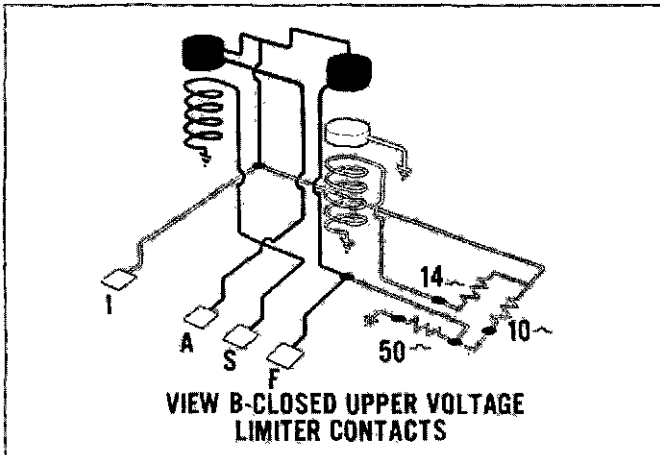

FIGURE 23. CURRENT FLOW — VIEW B

The voltage limiter is a two-stage device. It is used to control high field current and to extend the range of alternator rpm that can be controlled before the voltage limiter loses control.

When the alternator is operating at comparatively low speeds, or when the system load is heavy, the voltage limiter armature will vibrate on the upper contacts and limit voltage by intermittently inserting resistance (ten ohms) in the alternator field circuit. Regulation will continue on the upper contacts until the voltage rises to a value at which the resistor will no longer provide control.

At high alternator speeds, or when the battery is fully charged and the electrical load is light, the voltage attempts to rise, and in so doing, the armature is pulled down as shown in view "C" and starts vibrating on the lower

contacts shown in view "D" (Figure 24). This provides additional control by intermittently inserting the resistance, ten ohms, or bypassing the field to ground. When the contacts are closed, as shown in view "D", the current in the field circuit decays as the magnetic field in the rotor collapses. The result is a drop in alternator output voltage. When the voltage drops below the lower stage calibration point, the lower contacts open as shown in view "C". This vibrating action between view "C" and "D" takes place many times per second. Changes in the system load or changes in speed may cause the sequence of operations to vary.

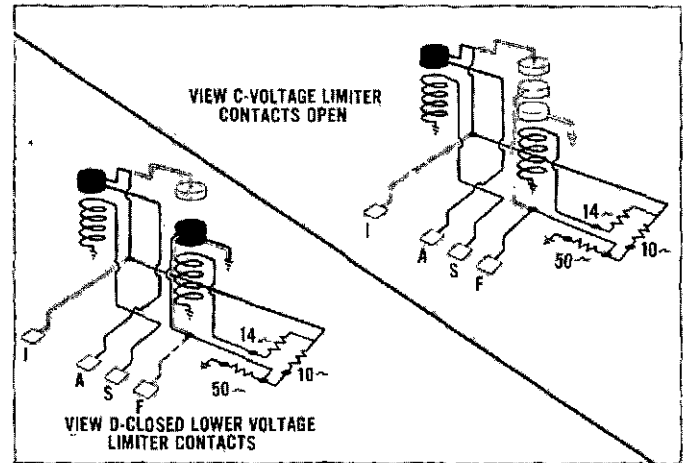

FIGURE 24. CURRENT FLOW — VIEWS C & D

To summarize, the voltage limiter may be found to be operating on either set of contacts (upper or lower) depending on load and speed conditions at the time . . . but never on both.

The 50 ohm resistor is connected across the rotor field coil to act as a dampening device for electrical surges in the field circuit. This resistor is called an absorbing resistor.

The 14-ohm resistor is in series with the voltage limiter coil. The resistor, a magnetic shunt, and bimetal hinge in the voltage limiter assembly constitutes the voltage temperature compensation system for the voltage limiter. The 14-ohm resistor is called a ballast resistor.

Transistorized Regulator

The transistorized regulator (Figure 25) maintains the charging system voltage at a constant level through transistors and printed circuitry rather than through vibrating contacts. The cover is removable and an integral voltage adjustment is provided as shown here. Turning the adjustment screw clockwise will increase the voltage setting. This regulator can be used as a replacement for the electro-mechanical regulator without altering the system. Adapting this regulator to pre-1974 transistor systems will require the installation of a jumper harness.

DESCRIPTION AND OPERATION

WIRING

Now, lets turn to the wiring in your charging system . . .

If a charging circuit is equipped with an ammeter, the hook-up is shown in Figure 26. The field relay is connected to the battery through the ignition switch and through the regulator "S" terminal. Thus, when the ignition switch is turned on, battery current flows through the ignition switch and the "S" terminal of the regulator to the field relay, causing the relay points to close. This completes a path for battery current to pass through the closed upper set of voltage limiter contacts and out through the regulator "F" terminal to the rotor field coil.

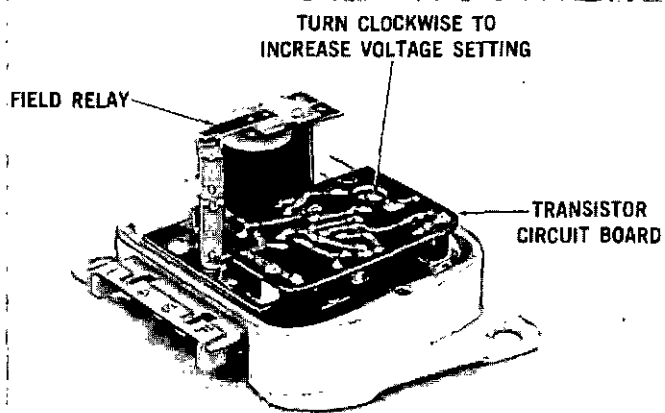

FIGURE 25. TRANSISTORIZED REGULATOR

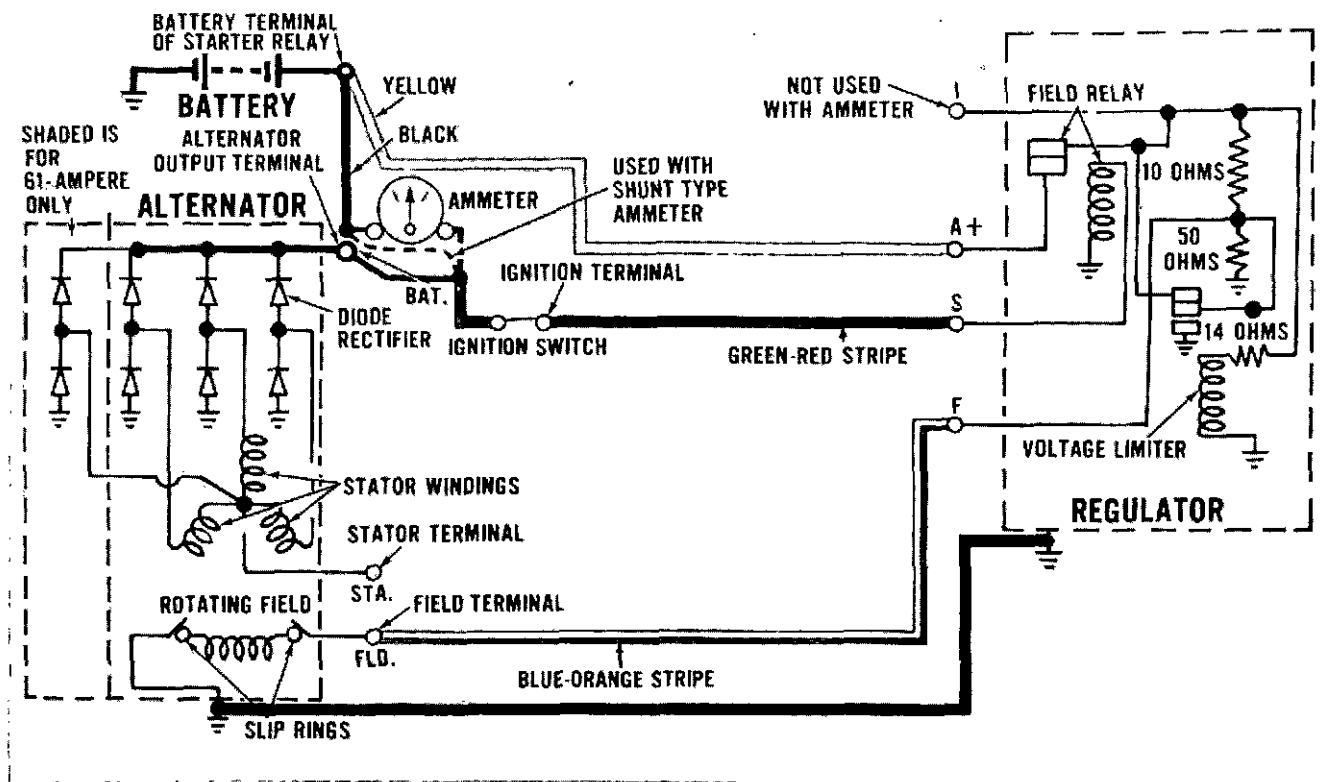

FIGURE 26. AMMETER-WIRING

DESCRIPTION AND OPERATION

The two basic paths current will follow in a charging system equipped with a charge indicator light is shown in Figure 27. The current flows in sequence from the battery, to the starter relay, ignition switch, indicator light, regulator, and alternator rotor assembly; then back through the ground side of the circuit to the battery.

In "View A" Figure 28, notice that the open starter relay plunger position indicates that the ignition switch is in the "ACC" or "IGN" position and the current not only passes through the indicator light but through the parallel 15 ohm resistor as well.

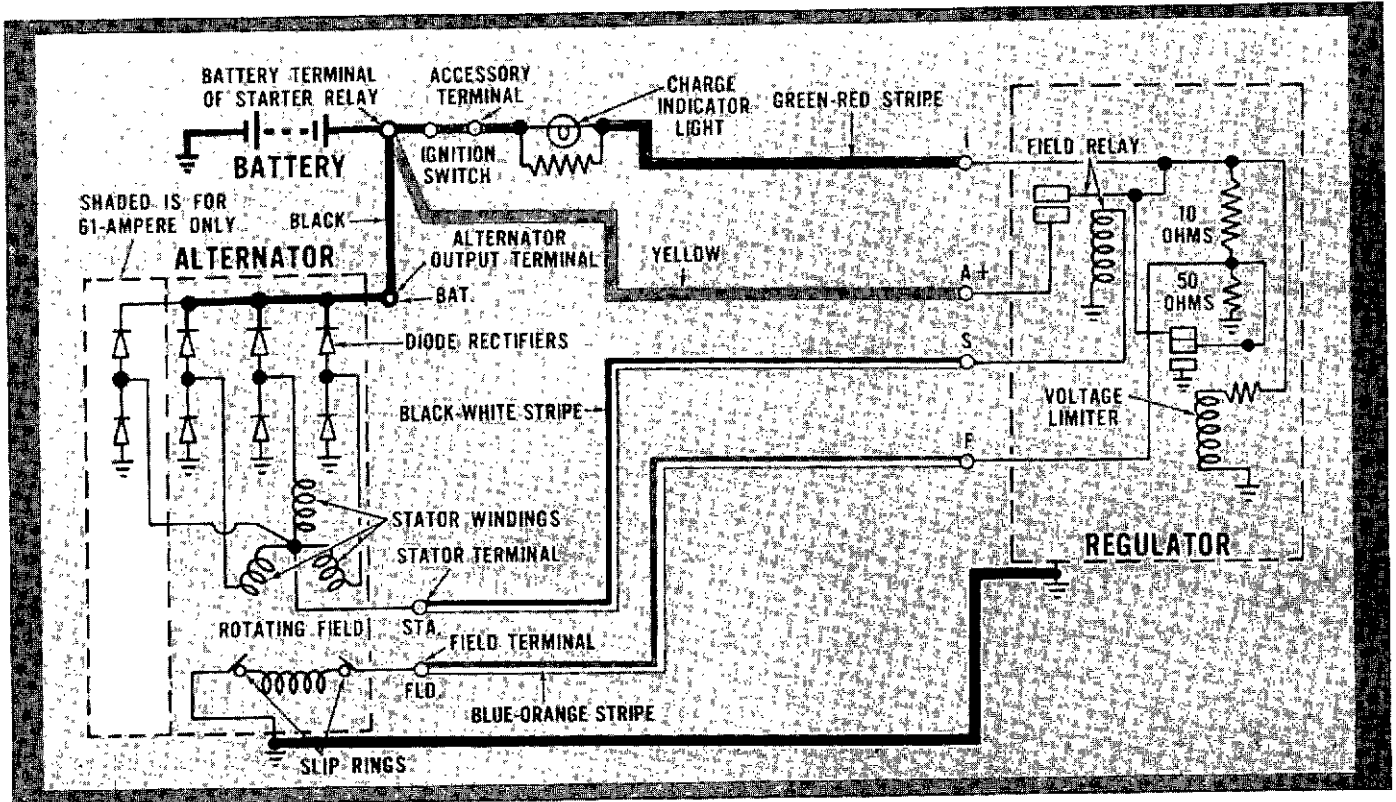

FIGURE 27. INDICATOR LIGHT — WIRING

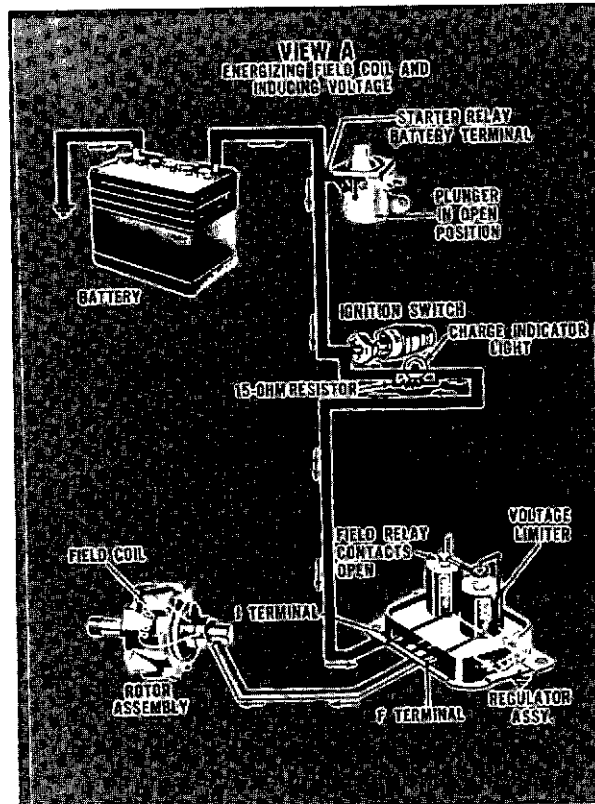

FIGURE 28. ENERGIZING FIELD COIL AND INDUCING VOLTAGE

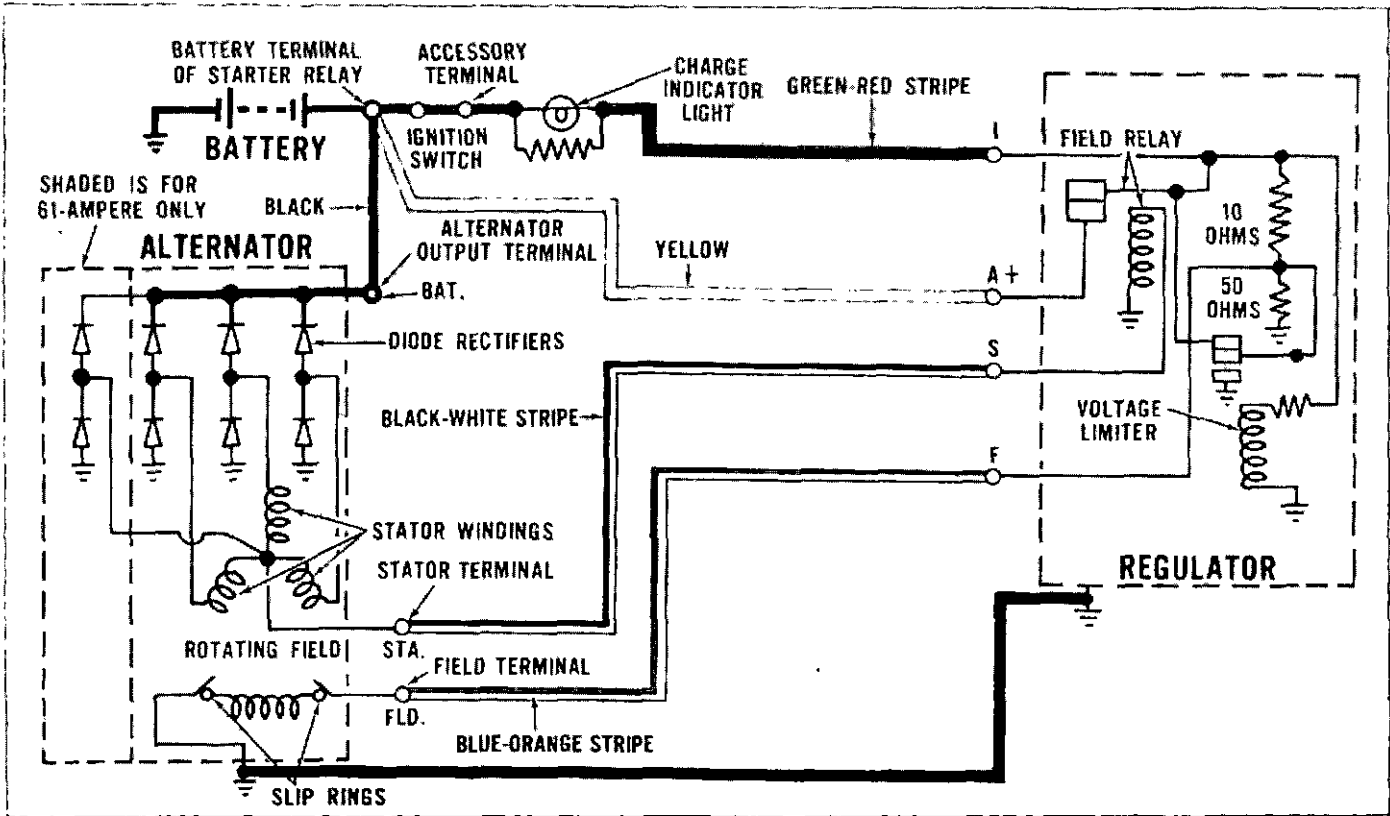
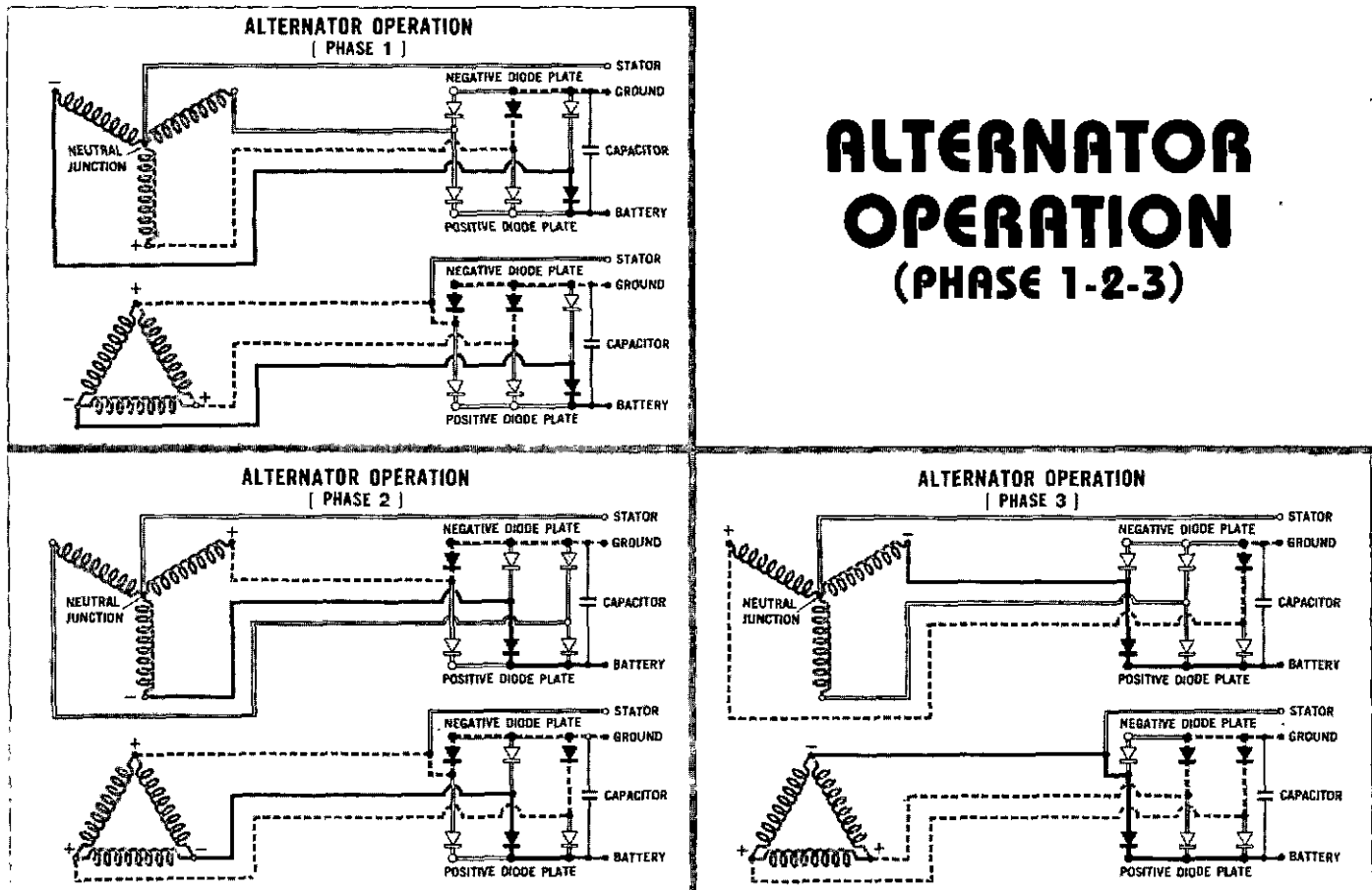

FIGURE 29. INDICATOR LIGHT CURRENT FLOW



ALTERNATOR OPERATION (PHASE 1-2-3)

FIGURE 30. ALTERNATOR OPERATION — PHASES 1, 2, 3

DESCRIPTION AND OPERATION

The current passes through the "I" terminal of the regulator and "bypasses" the open field relay via an internal connection. It then passes through the closed upper contacts of the voltage limiter and out through the regulator "F" terminal to the rotor field coil.

This circuit involves a relatively small amount of current but it is enough to energize the rotor and develop sufficient voltage at the stator neutral junction, when the engine is started, to close the field relay as shown in Figure 29. When the field relay closes, current flows through the regulator "A" terminal and closed field relay contacts. This causes system voltage to appear across both ends of the indicator light and the light will go out.

Now, let's look at the paths current will flow in the alternator as the rotor fingers turn past the triple-wound, three-phase windings in the stator. (Figure 30)

Three coils are joined together to form a "wye" winding. Each of these coils represents one of the three windings which is wound through the stator slots. These have been named and numbered Phase 1, Phase 2 and Phase 3 and these windings and their related parts in the alternator have been color coded.

Each winding leads to a separate terminal and then branches off to two diodes — one that is positive and the other is negative.

DIAGNOSIS AND TESTING

Diagnosing and testing the charging system may involve any one or more of the components in the system — the alternator, the alternator regulator, the battery, the charge indicator light or ammeter and the wiring which connects these components into a circuit.

But, remember, there is one thing you must observe before diagnosing ANY problem — that is to verify your complaint as you read earlier on the diagnosis chart.

BATTERY

Visual Inspection

A visual inspection of your battery (Figure 31) may aid you in diagnosing a battery problem or to evaluate its condition. The battery cables must be clean and tight and should make full contact. If they are corroded, clean them with a solution of ammonia or baking soda. If the contact surface is dark and dull, clean it with a wire battery brush until it is shiny. If there is poor contact with the post, adjust it to full length contact. If the clamp bolt is loose, tighten enough to assure full contact with the post but do not overtighten — and, if you have broken or separated wires, replace the cable.

You should also check the condition of the battery case and cover, look for evidence of acid on top, check electrolyte level, discoloration and odor, proper "cold cranking performance" rating, group size, and installation date. (Figure 32)

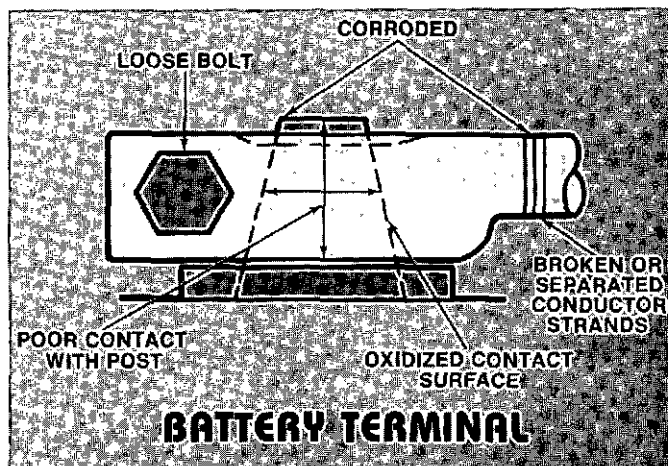

FIGURE 31. VISUAL INSPECTION OF BATTERY

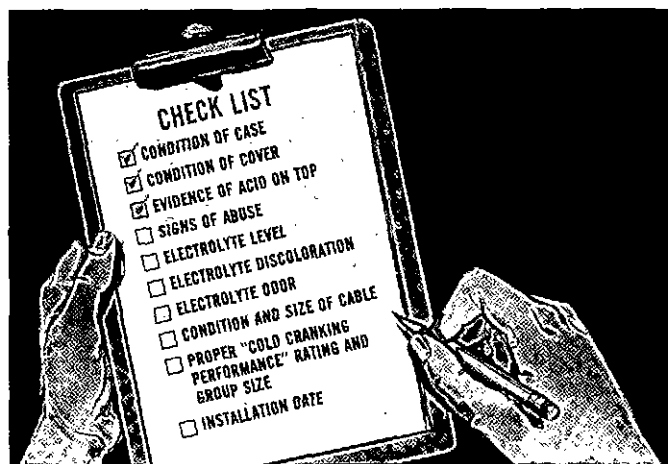

FIGURE 32. BATTERY CHECK LIST

Specific Gravity Test

You can perform a specific gravity test on your battery (Figure 33), to determine if the battery is defective or if the battery can be charged. The basic equipment you will need to do this test is a syringe-type hydrometer and a dairy-type, mercury in-glass thermometer which has a scale reading up to 125° Farenheit, and a pick-up tube immersion requirement of not more than one inch. The float in the basic design of hydrometers covers an approximate specific gravity range from 1.100 to 1.300 gravity points, which is based on the relative weight of equal volumes of water and electrolyte.

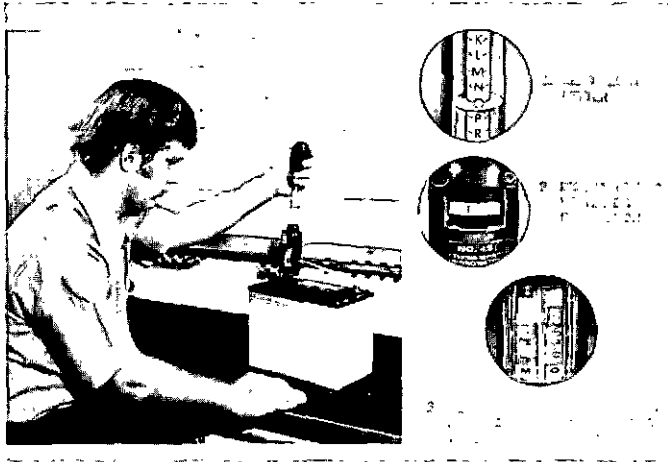

FIGURE 33. SPECIFIC GRAVITY TEST

The following procedure is followed for the Specific Gravity Test:

- Remove the battery caps.
- Draw the electrolyte into the hydrometer until the float is suspended freely in the barrel.
- Read the scale for results.
- Check each cell, then observe the temperature reading of the electrolyte and correct the specific gravity reading as necessary.

If the reading is above 1.230 for each cell, the battery is OK.

If the reading is below 1.230 for each cell, the battery needs a charge. This reading is often referred to as twelve hundred and thirty points.

If the variation is greater than 50 points between any two cells, the battery must be replaced.

Capacity Test

Another test you can perform to check for a chargeable or a defective battery is the Capacity Test.

The hookup for the ammeter and voltmeter are shown in Figure 34.

HOOKUP FOR AMMETER AND VOLTMETER

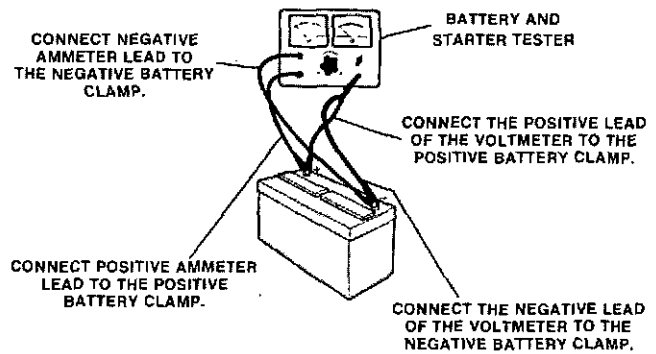

FIGURE 34. CAPACITY TEST — AMMETER AND VOLTMETER HOOKUP

- Connect the negative ammeter lead to the negative battery clamp.
- Connect the positive ammeter lead to the positive battery clamp.
- Connect the positive lead of the voltmeter to the positive battery clamp.
- Connect the negative lead of the voltmeter to the negative battery clamp.

Next, turn the ammeter control knob until the reading is three times the Ampere Hour Rating (Figure 35), which is printed on top of the battery. For example, if the rating is 70 ampere hour, turn the ammeter to 210 amperes, because 3 times 70 equals 210, for the test.

Wait fifteen seconds and then read the voltmeter.

If the battery reads 9.6 volts or greater, the battery is OK.

If the battery reads less than 9.6 volts, the battery needs a charge.

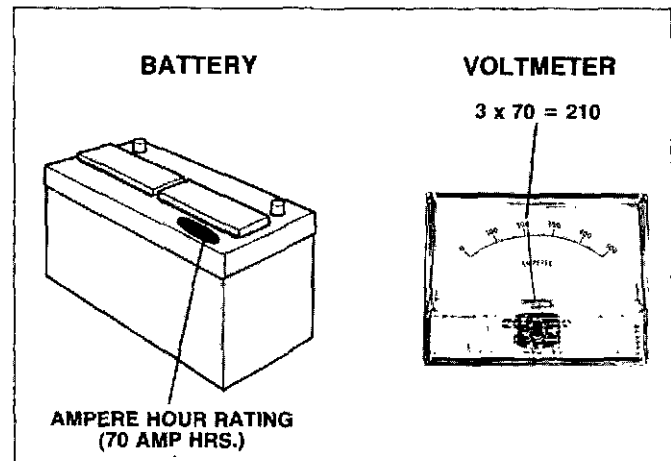

FIGURE 35. AMPERE HOUR RATING

DIAGNOSIS AND TESTING

SAFETY PRECAUTIONS

Before we get into the test procedures for the alternator, regulator and the charging system wiring, let's review some basic safety precautions.

- Always disconnect the battery ground cable before "breaking" any connections.
- Avoid contact with the alternator output terminal, BAT, since it is "hot" at all times when the battery cables are connected.
- Never connect the battery ground cable until all wiring harness connections have been made.
- When adjusting belt tension, always pry against the front housing to prevent damage to the stator and rectifier.
- Never attempt to polarize the alternator as damage to the regulator could result.
- Observe polarity when installing a battery. Reverse polarity will destroy the diodes.
- Always connect a booster battery in parallel; negative to negative and positive to positive.
- Disconnect the battery ground cable before connecting a charger to the battery.

VISUAL INSPECTION

A visual inspection should be performed prior to testing. What may at first appear to be a "real" charging system problem can often be traced to loose connections or to something as simple as a loose alternator drive belt. Check for the following before performing any tests:

- Proper belt tension (Figure 36). If the alternator fan can be turned by hand, the belt is too loose.

PROPER BELT TENSION

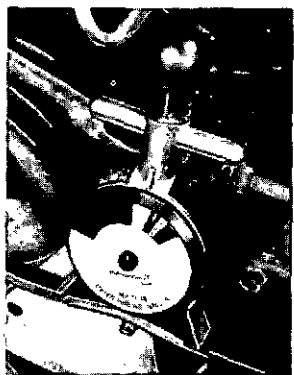

FIGURE 36. PROPER BELT TENSION

Adjusting Belt Tension

Adjust belt tension (Figure 37) by loosening the pivot bolt and adjusting arm bolt slightly. Install the belt tension gauge. Adjust belt tension by using a one and one-eighth open end wrench or pry bar on the housing and pulling the

alternator to the belt tension required. Tighten the adjusting arm bolt first, then the pivot bolt. Remember, a belt that has been in use ten minutes or more is considered to be a used belt.

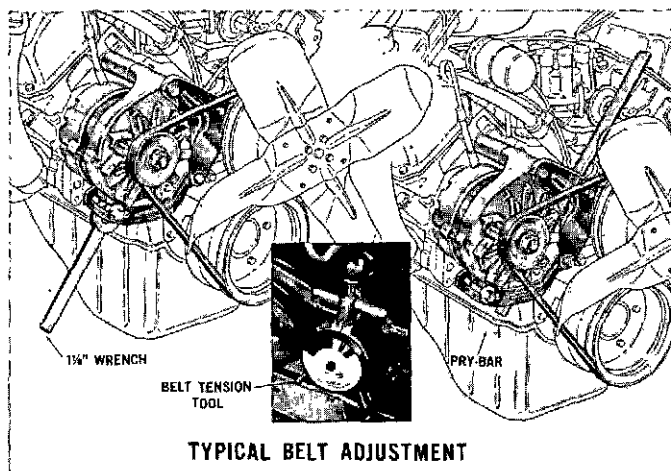

FIGURE 37. TYPICAL BELT ADJUSTMENT

- Examine the wiring in the charging system carefully and check their connections at the battery, alternator and regulator. Pay special attention to the battery connectors. Where wires are routed across sharp edges without proper protection, the result is often cut, pinched or otherwise damaged wires. Check for this.

VOLTAGE DROP TEST

If all of your visual inspections are satisfactory, you should determine the voltage at your battery. There is a quick test that will ensure you that there is no abnormal resistance at this point. To perform the test, connect the voltmeter leads to the relay stud and the positive battery post (Figure 38). Turn on your ignition and your engine accessories. Then repeat the test at the negative battery post. If the voltmeter reading is less than half a volt, it is okay. If it is over half a volt, clean and tighten the terminals.

VOLTAGE DROP TEST

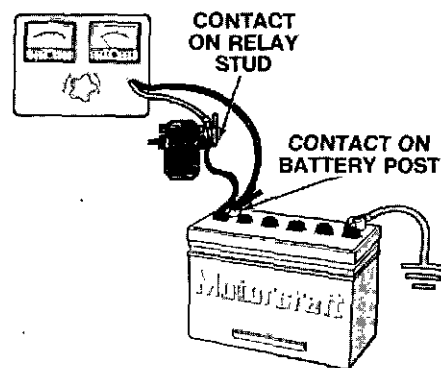

FIGURE 38. VOLTAGE DROP TEST

MOTOROLA CHARGING SYSTEMS

If your charging system is equipped with a Motorola alternator, you should return it to them for service. There are just a few basic tests you can perform on it so let's take a look at them. The following tests are made with the alternator on the engine with output and regulator connections maintained to the alternator except where instructed. The field lead and voltage regulator are disconnected for these tests.

Test #1 Ignition On—Engine Not Running

The first test you can perform evaluates the excitation circuit. This test is done with the ignition on but the engine not running (Figure 39). Correct voltage at the regulator terminal is approximately 1½ to 2½ volts.

If the voltage at the regulator terminal is five to seven volts, you have an open rotor or field circuit. If it is ¾ of one volt to 1.10 volt, you have a grounded rotor circuit. 8½ to 10 volts indicates an open in the regulator's load circuit. Zero volts indicate an open ignition switch or excitation resistor.

If test results are uncertain, proceed to the following test.

IGNITION ON—ENGINE NOT RUNNING

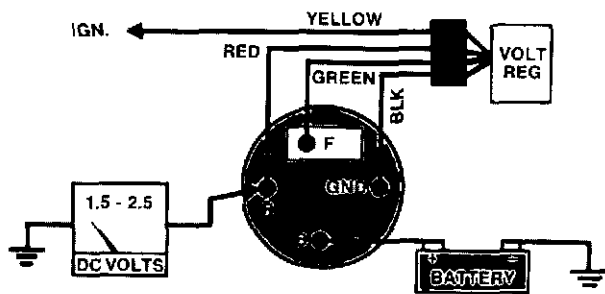

FIGURE 39. MOTOROLA TEST #1—IGNITION ON—ENGINE NOT RUNNING

IGNITION ON—ENGINE NOT RUNNING

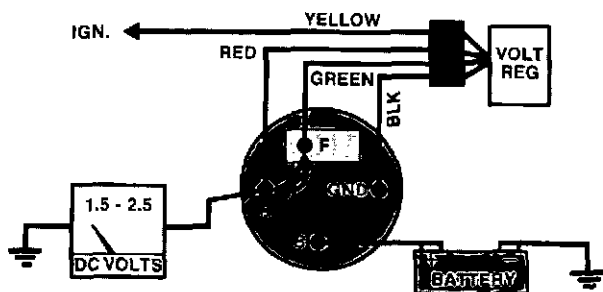

FIGURE 40. MOTOROLA TEST #2—IGNITION ON—ENGINE NOT RUNNING.

Test #2 Ignition On—Engine Not Running

Test #2 (Figure 40) is also performed with the ignition on but the engine not running. The voltage regulator may be bypassed with a short jumper between the regulator and field terminals. If the jumper provides approximate correct voltage, the fault is in the regulator. No change from high voltage indicates that the defect is in the brush or rotor circuit.

Field Draw Test

The next test you can perform is the Field Draw Test with the ignition off (Figure 41). This test evaluates complete field circuit, independent of the voltage regulator. The circuit is through brushes, slip rings, and field coil to ground. Current should be 2 to 2½ amps. If less than this, check your brushes and slip rings. It is desirable to use a field rheostat in series with the meter for protection of the meter. If the field is shorted, excessive current will flow through the meter and possible damage will result.

FIELD DRAW TEST—IGNITION OFF

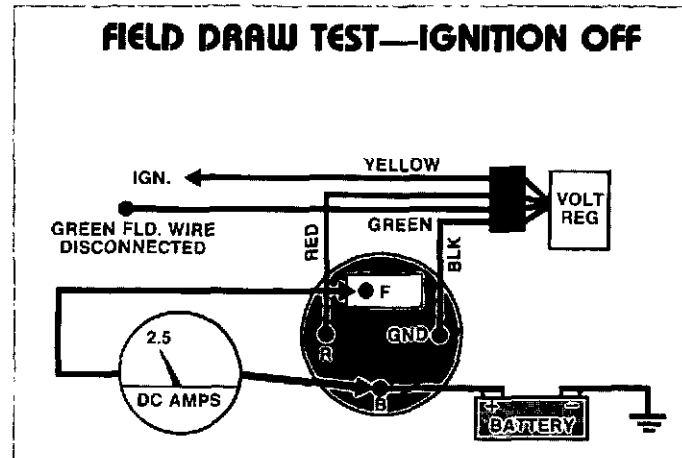

FIGURE 41. MOTOROLA — FIELD DRAW TEST — IGNITION OFF

Voltage Regulation

The voltage regulation test is done with the ignition on and the engine running at fast idle (Figure 42). The voltage indicated is usually 13.9 to 14.7 volts depending on regulator ambient temperature. High voltage may be due to a poor ground connection. If the ground connection is not faulty, the regulator will require replacement.

IGNITION ON—ENGINE RUNNING AT FAST IDLE

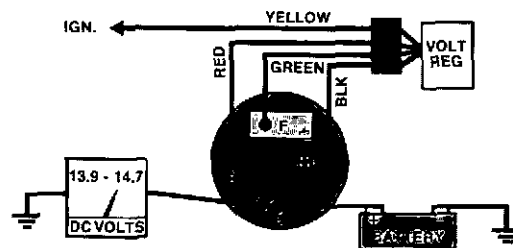

FIGURE 42. MOTOROLA — VOLTAGE REGULATION

DIAGNOSIS AND TESTING

Alternator Output Test

The final test you can perform on your Motorola charging system is the alternator output test (Figure 43). It is done with the Field Terminal and Voltage Regulator disconnected, the battery terminal shorted to the field terminal, and the ignition on with the engine running at idle. This test isolates the defect to either the alternator or regulator. If the voltage at the battery terminal rises to 15 or 16 volts now, when it did not in the previous test with the regulator connected, then the defect is in the regulator and it should be replaced. If the voltage does not rise at the auxiliary terminal, the defect is in the alternator stator or rectifier diodes, if the field circuit checked out properly. For defects in the stator or the diodes, remove the alternator.

**FIELD TERM DISCONNECTED VOLT REG.
PLUG DISCONNECTED
BAT. TERM. SHORTED TO FLD. TERM.
IGNITION ON—ENGINE
RUNNING AT IDLE**

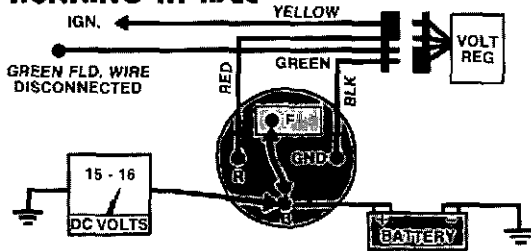

FIGURE 43. ALTERNATOR OUTPUT TEST

FORD CHARGING SYSTEM Three Point Voltmeter Test

We will now focus our attention on tests you can perform on your Ford charging system. The key test that you can perform is the Three Point Voltmeter Test. It will tell you whether or not there is a problem in the alternator regulator or wiring harness. It pays to perform this test even if you have found and corrected some abnormal conditions during the preliminary checks. To make this test, connect a voltmeter with a zero to twenty volt scale across the terminals of the battery.

BASE VOLTAGE TEST

The first step in the Three Point Voltmeter Test is the Base Voltage Test (Figure 44). This is done with the engine off and all electrical accessories off. The reading will vary depending on battery condition and state of charge and will normally be between 12 and 12.6 volts. You should record the voltage and perform the No-Load Voltage Test.

BASE VOLTAGE TEST

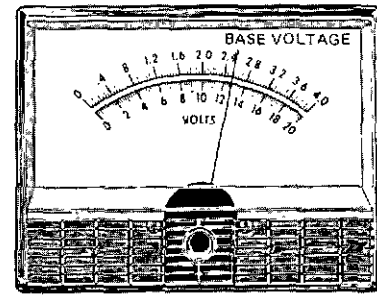
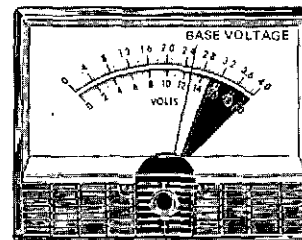

FIGURE 44. BASE VOLTAGE TEST

NO-LOAD VOLTAGE TEST

To perform the No-Load Voltage Test, (Figure 45) run the engine at 2,000 rpm. All electrical accessories should be off. The only current draw should be the ignition and alternator field. Record the reading when the voltmeter stabilizes. If the reading is less than 2 volts increase over the base voltage, perform the load test. If it is more than 2 volts increase over the base voltage, perform the overcharge test. No-load voltage should be higher than base voltage but not more than 2 volts higher.

NO LOAD VOLTAGE TEST



< 2.0 VOLTS = PERFORM
LOAD TEST

> 2.0 VOLTS = PERFORM
OVERCHARGING TEST

FIGURE 45. NO-LOAD VOLTAGE TEST

LOAD VOLTAGE TEST

The Load Voltage Test (Figure 46) is done by running the engine at 2,000 rpm and turning on two electrical accessories at full speed. Record the reading when the voltmeter stabilizes. If your reading is $\frac{1}{2}$ to 2 volts increase over the base voltage, the system is okay and your battery should be tested. If it is less than $\frac{1}{2}$ volt increase over the base voltage, you should perform a regulator bypass test. If the reading is more than 2 volts increase over the base voltage perform the Overcharging Test.

LOAD VOLTAGE TEST

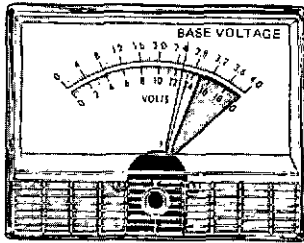

0.5 TO 2.0 VOLTS =
SYSTEM OKAY

< 0.5 VOLTS = PERFORM
REGULATOR BYPASS TEST

> 2.0 VOLTS = PERFORM
OVERCHARGING TEST

FIGURE 46. LOAD VOLTAGE TEST

Overcharging Test

An Overcharging Test (Figure 47) is performed when the no-load or load voltage in the three point test is more than 2 volts higher than base voltage. The voltmeter connections remain the same as for the three point test. Connect a jumper wire between the regulator base and a good ground. An improperly grounded regulator cannot feed reliable signals to the alternator.

OVERCHARGING TEST

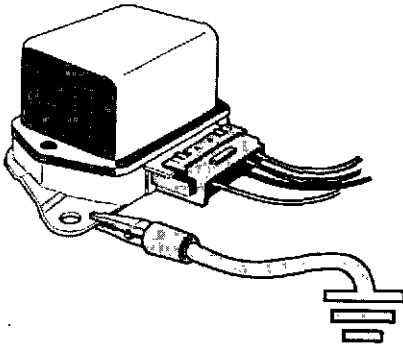

FIGURE 47. OVERCHARGING TEST

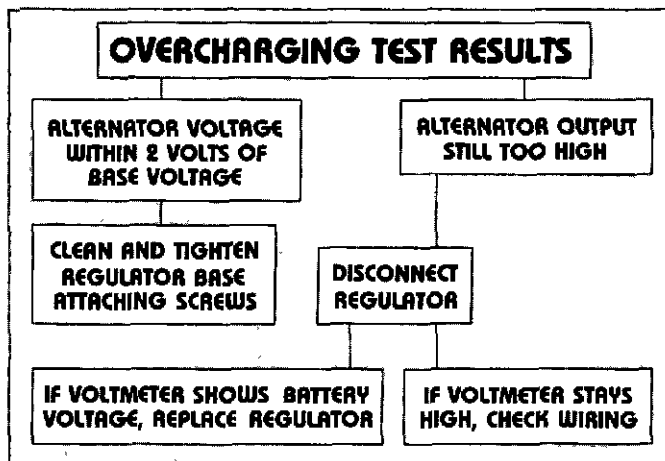

FIGURE 48. OVERCHARGING TEST RESULTS

If the alternator voltage comes within 2 volts of the base voltage, clean and tighten the regulator base attaching screws. If the alternator output is still too high disconnect the regulator. The alternator output should drop to zero. The voltmeter should show only the battery voltage. If the voltmeter shows battery voltage, replace the regulator. If the voltmeter stays high, check the wiring. The field wire and alternator or battery wire may be touching the inside harness (Figure 48).

Regulator Bypass Test

A Regulator Bypass Test (Figure 49) is done when the load voltage in the three-point test increases less than ½ volt from the base voltage. The voltmeter connections remain the same as the ones for the Three Point Test. Turn on the electrical accessories as for the load voltage test. In step one of this test, you should disconnect the plug connector to the regulator, if so equipped, or the individual wires. The regulator now has no control over the alternator and no field current flow to the alternator. Run the engine at 2000 RPM. The voltmeter should show base voltage. If the voltage increases, the harness is shorted.

REGULATOR BY-PASS TEST

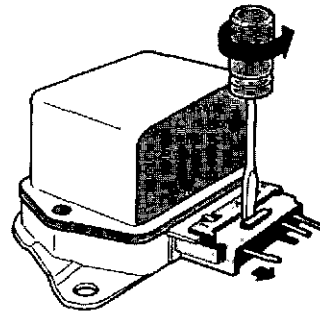

FIGURE 49. REGULATOR BY-PASS TEST

To proceed with step two of the Regulator Bypass Test, (Figure 50) connect a jumper wire between "A" and "F" as shown. This will bypass the regulator and give maximum field current to the alternator if the wiring is okay. Run the engine at 2000 RPM. Turn on your electrical

BY-PASS TEST—STEP TWO

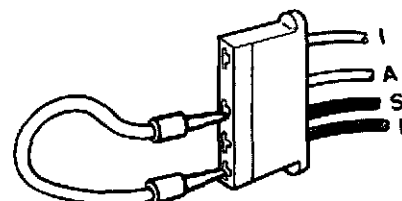

FIGURE 50. REGULATOR BY-PASS TEST — STEP TWO

DIAGNOSIS AND TESTING

accessories as you did for the Load Voltage Test. If the voltage at the battery is now over $\frac{1}{2}$ volt above the base voltage, replace the regulator. If there is no increase, the alternator or wiring are at fault. Check the wiring harness.

For step three of the Bypass Test, (Figure 51) connect a jumper wire between the positive battery post and field (F) terminal on the connector plug. This will bypass the A circuit wiring as well as the regulator. Run the engine at 2000 RPM. Turn on your electrical accessories as you did for the Load Voltage Test. If the voltage at the battery is now more than $\frac{1}{2}$ volt above the base voltage, repair the open in the "A" circuit and recheck with the three point tests. If the voltmeter still reads base voltage you should perform the wiring harness test.

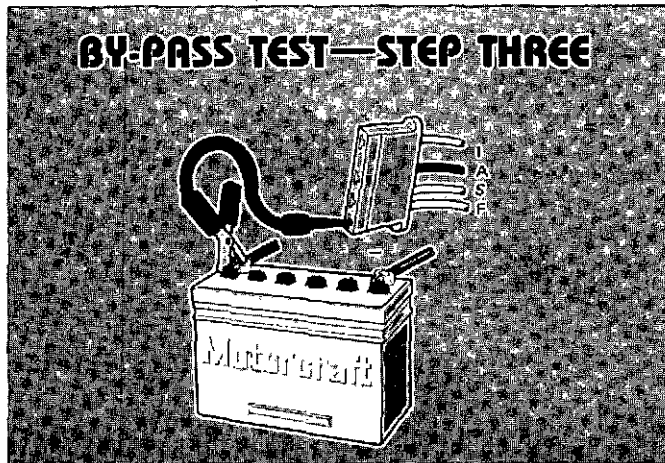

FIGURE 51 REGULATOR BY-PASS TEST — STEP THREE

Wiring Harness Test

To perform your wiring harness tests, connect the voltmeter as you did for the Three Point Test. Turn on your electrical accessories as you did for the Load Voltage Test. For Step One of this test, connect a jumper wire between the positive post of the battery and the F terminal of the alternator (Figure 52). Run the engine at 2000 RPM. If the voltage at the battery is more than $\frac{1}{2}$ volt above base voltage, repair the open in the "F" circuit and recheck the Three Point Tests.

WIRE HARNESS TEST—STEP ONE

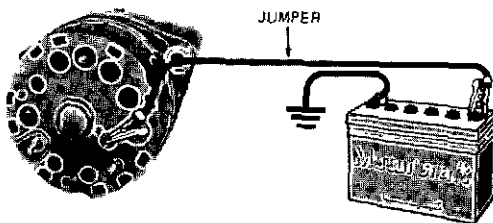

FIGURE 52. WIRE HARNESS TEST — STEP ONE

For Step Two in the Wire Harness Test (Figure 53), connect a jumper wire between the alternator case and a good ground. Run the engine at 2000 RPM. If the voltage at the battery is now more than $\frac{1}{2}$ a volt above base voltage, clean and tighten the alternator mounting bolts. Recheck with the Three Point Test. If the voltmeter reads base voltage, perform the next step.

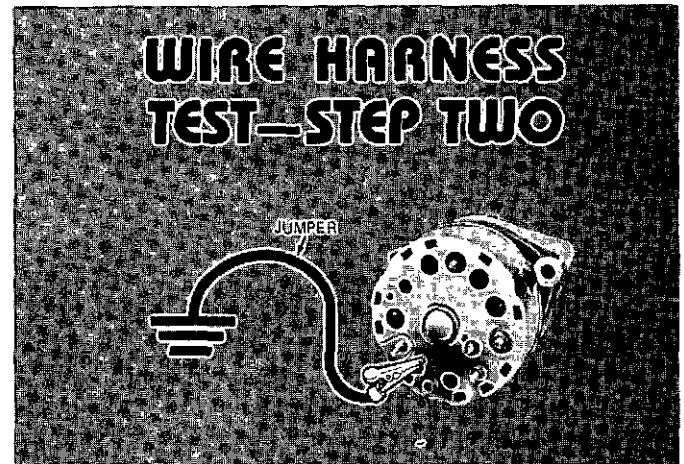

FIGURE 53. WIRE HARNESS TEST — STEP TWO

In Step Three of the Harness Test (Figure 54), connect a heavy jumper wire between the battery positive post and the "B" terminal of the alternator. Run the engine at 2000 RPM. If the voltage at the battery is now more than $\frac{1}{2}$ a volt above base voltage, repair the open in the circuit to the battery. Recheck with the Three Point Test. If the voltmeter reads base voltage, perform Step Four.

WIRE HARNESS TEST—STEP THREE

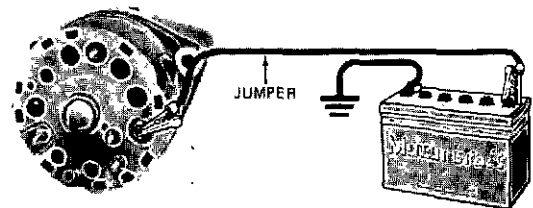

FIGURE 54. WIRE HARNESS TEST — STEP THREE

In Step Four of the Harness Test (Figure 55), plug in the connector at the regulator and remove all jumper wires. For systems equipped with an indicator light, connect the voltmeter between the "S" terminal of the regulator and a good ground. If the reading is approximately one-half of the "Load Voltage," the circuit is okay. If there is no reading, connect a voltmeter between the "S" terminal of the alternator and a good ground. If your reading is approximately one-half of the "Load Voltage," repair the open in the circuit. If there is no reading, repair the short in the circuit.

WIRE HARNESS TEST—STEP FOUR

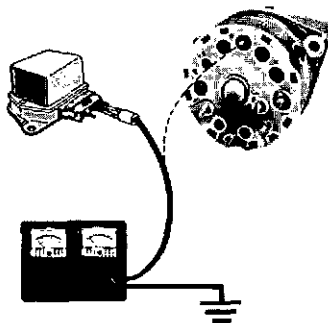

FIGURE 55. WIRE HARNESS TEST — STEP FOUR

If your charging system is equipped with an ammeter, connect the voltmeter between the "S" terminal of the alternator and a good ground. If the reading is approximately one-half of the "Load Voltage," the circuit is okay. If there is no reading, repair the short in the circuit.

After you have completed the Wire Harness Tests, see if your charging system can pass the Three Point Tests. If it does, perform the battery tests. If the wiring harness checks out OK but the system will not pass the Three Point Test, you should perform the following Alternator Bench Tests.

Alternator Bench Tests

An ohmmeter is the only equipment required for performing the Alternator Bench Tests. Make sure the meter is zeroed after setting the selector switch to the positions specified. "Zeroing" is accomplished by touching the meter probes together and adjusting the meter to read zero (Figure 56).

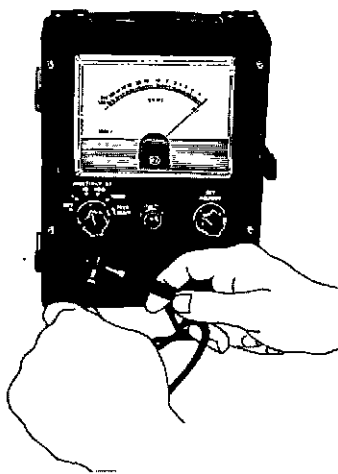

FIGURE 56. "ZEROING"

FIELD CIRCUIT OPEN OR GROUND TEST

The first alternator bench test you can perform is the Field Circuit Open or Ground Test (Figure 57). Set the ohmmeter selector switch at one and zero the meter. Touch one probe to the "FLD" terminal and the other probe to the

"GRD" terminal. Spin the pulley and note the ohmmeter reading. It should read between 2.4 and 200 ohms and fluctuate while the rotor is turning. A reading lower than 2.4 ohms indicates a grounded positive brush, a grounded field terminal or a damaged rotor. A reading higher than 200 ohms indicates worn out or hung brushes, an open brush lead or a damaged rotor.

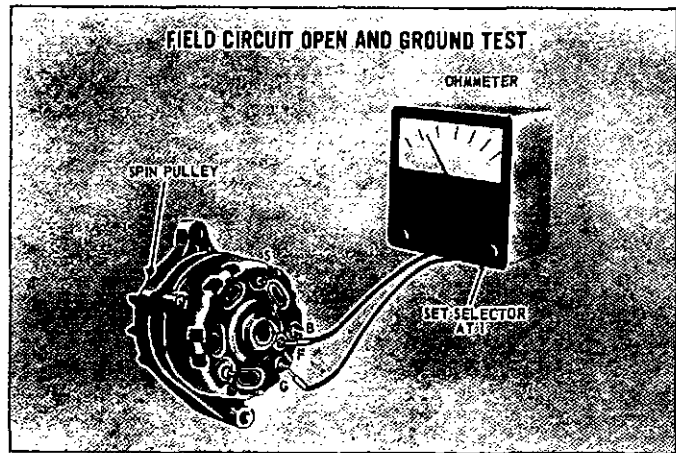

FIGURE 57. FIELD CIRCUIT TEST

STATOR GROUND AND NEGATIVE DIODE TEST

A Stator Ground and Negative Diode Test (Figure 58) is another alternator bench test you can perform. Set the ohmmeter selector switch at 10 and zero the meter. Touch one probe to the "STA" terminal and the other probe to the "GRD" terminal. Check continuity in the other direction by reversing the probes. A reading of approximately 60 ohms should be obtained in one direction and an infinite reading, one with no needle movement, in the other direction.

A reading of 60 ohms or less in both directions indicates either a damaged negative diode, a grounded positive diode plate, a grounded alternator "BAT" terminal, a grounded "STA" terminal, or grounded stator winding with the laminations grounded to the front or rear housing. Infinite readings in both directions indicates an open "STA" terminal connection.

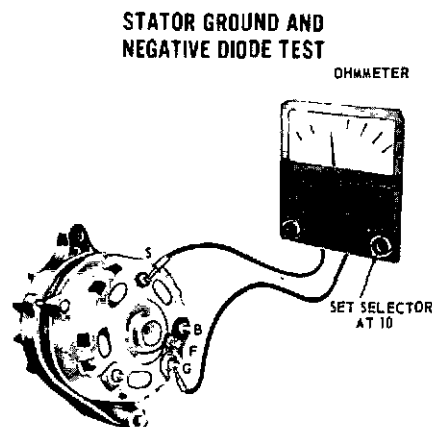

FIGURE 58. STATOR GROUND OR NEGATIVE DIODE TEST

DIAGNOSIS AND TESTING

RECTIFIER GROUND AND POSITIVE DIODE TEST

Another Alternator Bench Test you can perform is the Rectifier Ground and Positive Diode Test (Figure 59). Set the ohmmeter selector switch at ten and zero the meter. Touch one probe to the alternator "BAT" terminal and the other probe to the "STA" terminal. Check continuity in the other direction by reversing the probes. A reading of approximately 60 ohms should be obtained in one direction and an infinite reading in the other direction. A reading of 60 ohms or less in both directions indicates a damaged positive diode, a grounded positive diode plate or a grounded alternator "BAT" terminal. Infinite readings in both directions indicates an open "STA" terminal connection.

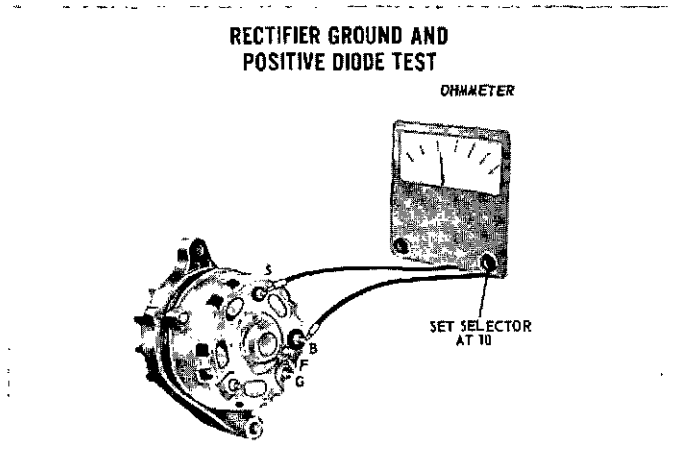

FIGURE 59. RECTIFIER GROUND AND POSITIVE GROUND TEST

Rotor and Stator Tests

ROTOR CONTINUITY TEST

The following Rotor and Stator Tests can also be performed on the bench. The first test we will cover is the Rotor Continuity Test (Figure 60). Separate the front housing and rotor assembly from the rear housing and stator assembly. Set the ohmmeter selector switch at one and zero the meter. Touch the probes to the slip rings. The meter should register 2.4 to 4.9 ohms. Readings higher than 4.9 ohms indicate a damaged solder connection at the slip rings or a broken wire. Readings lower than 2.4 ohms indicate a shorted wire or slip ring. Replace the rotor if repairs cannot be made.

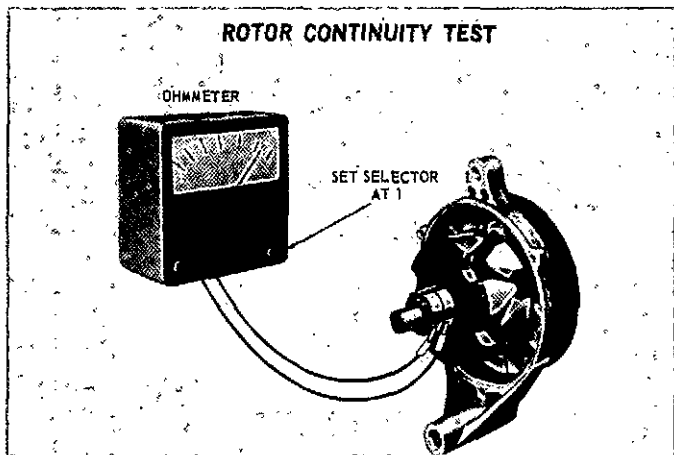

FIGURE 60. ROTOR CONTINUITY TEST

ROTOR GROUND TEST

To perform a Rotor Ground Test (Figure 61), separate the front housing and rotor assembly from the rear housing and stator assembly. Set the ohmmeter selector switch at 1000 and zero the meter. Touch one probe to the rotor shaft and the other probe to first one slip ring and then the other. The ohmmeter should register infinity in both cases. If the meter shows a reading, a short to ground exists. Check the soldered connections at the slip rings to make sure they are secure and not grounding out against the rotor shaft, or that excess solder is not grounding the rotor coil. Replace the rotor if repairs cannot be made. If both the Rotor Continuity Test and the Rotor Ground Test proved satisfactory, and the Field Circuit Open or Ground Test showed trouble, the brushes are the cause.

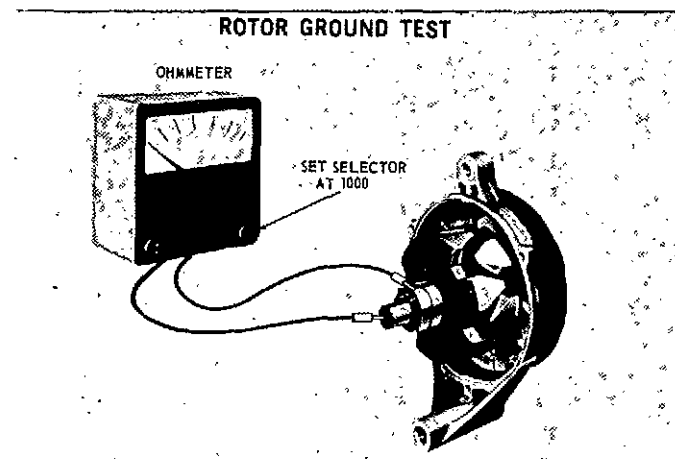

FIGURE 61. ROTOR GROUND TEST

STATOR CONTINUITY TEST

A Stator Continuity Test (Figure 62), is done by removing the stator and rectifier assembly from the rear housing and disconnecting the stator leads from the rectifier. Set the ohmmeter selector switch at one and zero the meter. Touch the probes to two of the bare stator lead wires. Move one of the probes to the third wire. Equal readings should be obtained between each pair of leads. If unequal readings are obtained, the stator is open. Check the neutral junction splices, if a break is found, make the necessary repairs and retest. If unequal readings still exist, replace the stator.

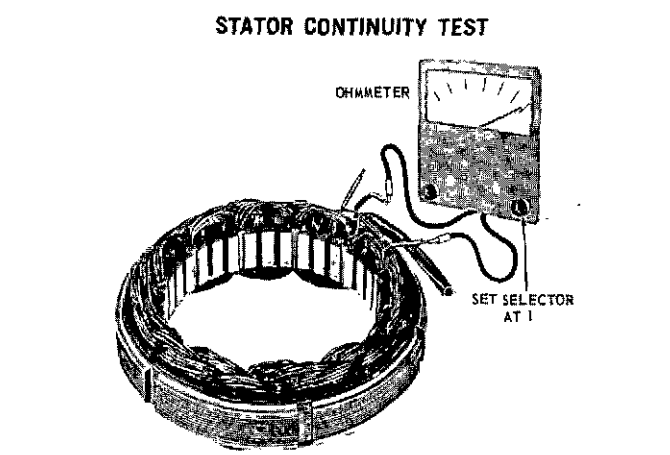

FIGURE 62. STATOR CONTINUITY TEST

STATOR GROUND TEST

The Stator Ground Test (Figure 63) is the final bench test you can perform on your rotor and stator. Remove the stator and rectifier assembly from the rear housing and disconnect the stator leads from the rectifier. Set the ohmmeter selector switch at 1000 and zero the meter. Touch one probe to the bare metal surface of the stator core and the other probe to a bare stator lead wire. The ohmmeter should register infinity. Be sure the probe makes good contact with the bare metal of the core. If the meter shows a reading, the stator is grounded and it must be replaced.

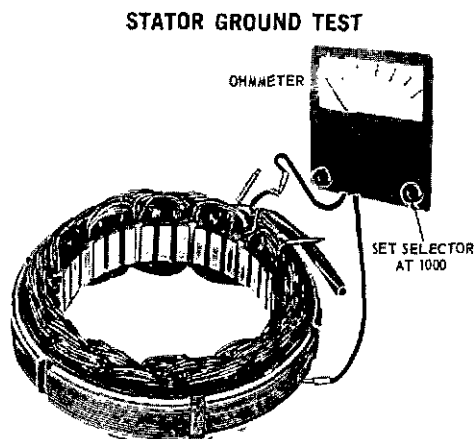

FIGURE 63. STATOR GROUND TEST

Diode Tests

The other bench tests you can perform are the Diode Tests (Figure 64). Before attempting to test individual diodes, the rectifier must be disconnected from the stator. To test the Standard and Integral System, set the tester selector switch at ten and zero the meter. Test the negative diodes by touching one probe to the ground terminal and the other probe to each of the stator lead terminals as shown. Reverse the probes to check the diodes in the other direction. Test the positive diodes by touching one probe to the battery terminal and the other probe to each of the stator lead terminals as shown. Reverse the probes to check the diodes in the other direction.

If continuity is observed in both directions, the diode is shorted. If no continuity is observed in both directions, the diode is open. Replace the rectifier assembly if open or shorted diodes are found. If continuity is observed in only one direction, the diode is okay.

BOOSTER DIODE TEST

61 Ampere

A Booster Diode Test (Figure 65) is performed on the sixty-one ampere alternator. Test the negative booster diode by touching one probe to the grounded screw and the other probe to the booster plate as shown. Reverse the probes to check the diodes in the other direction. Test the positive booster diode by touching one probe to the threaded portion of the battery terminal stud and the other probe to the booster plate. Reverse the probes to check

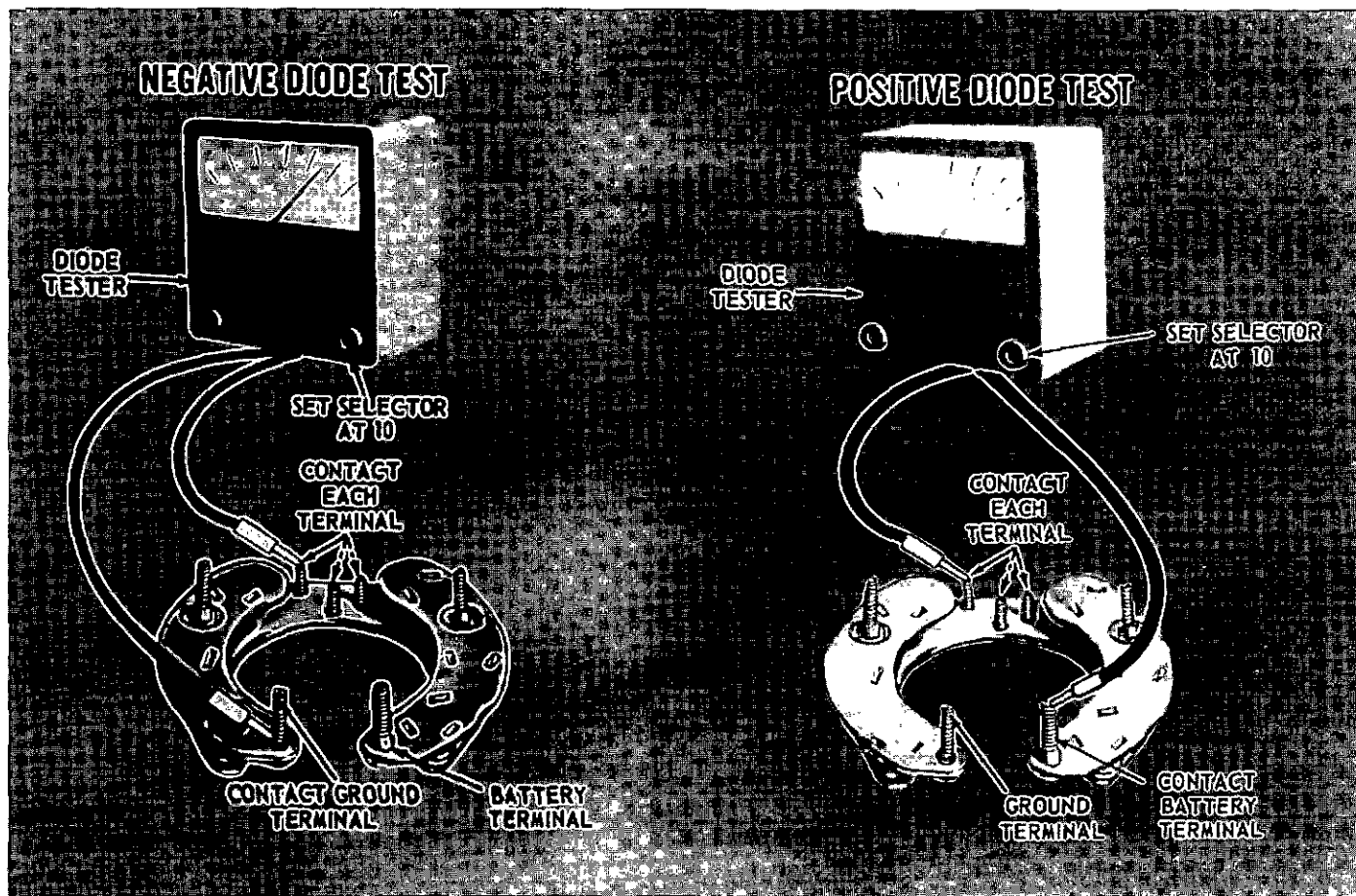

FIGURE 64. POSITIVE AND NEGATIVE DIODE TEST

DIAGNOSIS AND TESTING

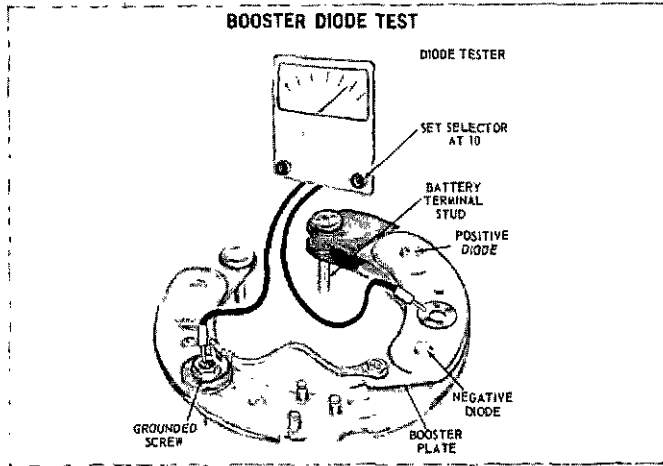

FIGURE 65. BOOSTER DIODE TEST — 61 AMPERE ALTERNATOR

the diodes in the other direction. All of the diodes should show continuity, approximately sixty ohms, in one direction and no continuity in the other direction.

If continuity is observed in both directions, the diode is shorted. If no continuity is observed in both directions, the diode is open. Replace the rectifier assembly if open or shorted diodes are found. If continuity is observed in only one direction, the diode is okay.

65-70 and 85-90 Ampere Alternators

You can also perform a Booster Diode Test on the 65-70 and 85-90 ampere alternators (Figure 66). Set the tester selector switch at ten and zero the meter. Test the negative diodes by touching one probe to the ground terminal and the other probe to each of the diode heat sinks. Reverse the probes to check the diodes in the other direction. Test the positive diodes by touching one probe to the battery terminal and the other probe to each of the diode heat sinks. Reverse the probes to check the diodes in the other direction. All of the diodes should show continuity in one direction only and no continuity in the other direction. The conclusions set forth in the Standard and Integral Systems Test apply here also.

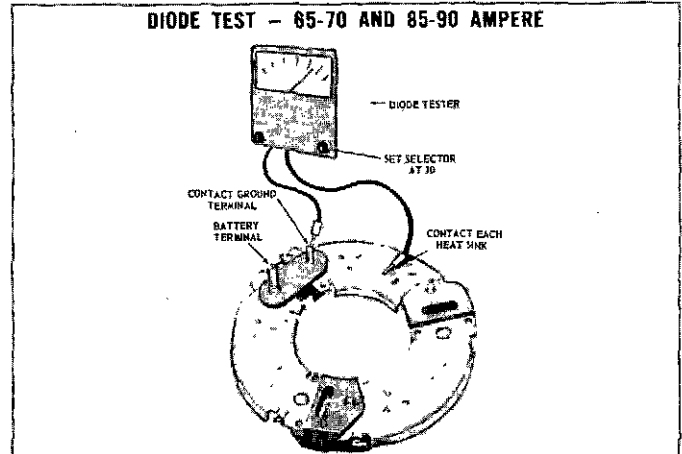

FIGURE 66. BOOSTER DIODE TESTING — 65-70 AND 85-90 ALTERNATORS