



I - 6 GASOLINE ENGINES CSG - 649

The Source for Power...
Worldwide™

MAINTENANCE AND OPERATOR'S MANUAL



TABLE OF CONTENTS

INTRODUCTION	2
---------------------------	---

OPERATING INSTRUCTIONS

Controls	5
Instruments	7
Starting the Engine	8
Stopping the Engine	9
Special Situations	10
Emergency Starting	13

MAINTENANCE INSTRUCTIONS

Preventive Maintenance Schedule	15
Initial Start Up	16
Routine Service	16
Scheduled Preventive Maintenance	16
Storage	35

SPECIFICATIONS	37
-----------------------------	----

INDEX	38
--------------------	----

INTRODUCTION

INTRODUCTION

We are highly pleased that you have selected a Ford unit for your engine requirements. The Ford Motor Company takes great pride in the long tradition of quality products and great values that the Ford name represents.

Ford Industrial Engines are tested and inspected before leaving the factory. However, certain checks should be made before putting them into regular operation. Read the Initial Start Up requirements in the Maintenance Instructions.

HOW TO USE THIS MANUAL

We wrote the manual especially for you. We hope you use it to get to know your engine and how to get the most out of it. That is why we urge you to read this manual from cover to cover. First, you'll become familiar with the various controls and instruments. As you read further, we tell you how to maintain your engine and what services need to be performed to keep it in excellent running condition.

The Subject Index on the title page permits you to quickly open the manual to any section. The Alphabetical Index at the back of the manual provides a page reference to a particular item or procedure.

Ford Industrial Engines are built with a variety of standard and/or optional components to suit a wide range of customer requirements. This manual does not identify equipment as standard or optional. All the equipment described in this manual may not be found on your engine or power unit.

The descriptions and specifications contained in this manual were in effect at the time it was approved for printing. The Ford Companies reserve the right to discontinue models at any time, or to change specifications or design without notice and without incurring obligation.



The Source for Power...
Worldwide™

Power Products Division
Geometric Results Incorporated
28333 Telegraph Road
Southfield, MI 48034

INTRODUCTION

ENGINE IDENTIFICATION

An Identification Decal is affixed to the left side of the rocker cover of each engine. The decal contains the engine serial number which identifies this unit from all others. Next is the model number and S.O. or options which determine the parts or components required on this unit. Use all numbers when seeking information or ordering replacement parts for this engine. For a handy reference, record the information on the decal below.

	SERIAL NUMBER

	MODEL NUMBER

S.O./OPTIONS	MODEL CODE
_____	_____

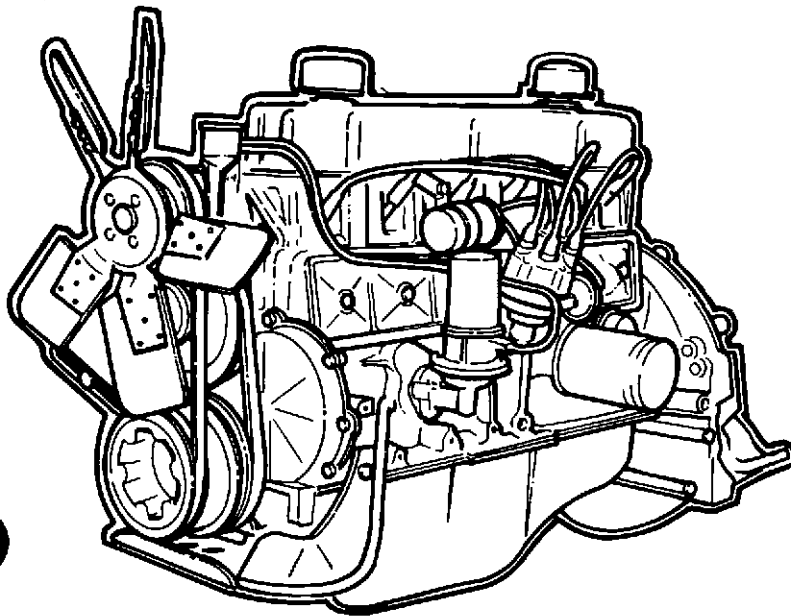

INTRODUCTION

PARTS AND SERVICE

Replacement parts can be obtained through your local Ford Power Products Distributors and Dealers. The Distributors are listed in the accompanying directory or can be found in the yellow pages under "Engines".

Ford Power Products Distributors and Dealers are equipped to perform major and minor repairs. They are anxious to see that all of your maintenance and service needs are quickly and courteously completed.

SERVICE LITERATURE

A service manual and parts list can be obtained from your distributor or dealer. These publications will provide the necessary servicing, overhaul and replacement parts information for your Ford Industrial Engine.

PARTS LIST	IEO 194-203A
SERVICE MANUAL	IEO 194-210

OPERATING INSTRUCTIONS

CONTROLS

Ignition Switch

This two-position switch is located on the control panel. In the OFF position, the switch disconnects the auxiliary electrical equipment and the starting circuit from the battery. The key can be removed from the switch when it is in this position. In the ON position, the switch connects the auxiliary electrical equipment and the starting circuit to the battery.

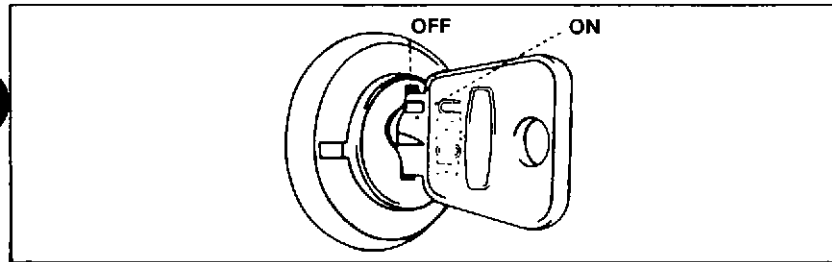

Starter Button

Engage the starter by turning the ignition switch to the ON position and depress the starter button. Release the button when the engine starts.

Choke Control

The choke control is connected to the carburetor and operates the choke butterfly to enrich the fuel mixture on cold starts. Pulling the control out closes the choke and pushing it in opens the choke.

Throttle Control

The throttle control is connected to the carburetor throttle shaft. Initial engine speed adjustment is obtained by pressing the throttle control release button while pulling the throttle knob out to increase the engine speed or pushing it in to decrease the engine speed.

A final fine speed adjustment is obtained by turning the throttle control counterclockwise to increase engine speed or clockwise to decrease engine speed.

Power Take-Off

The power take-off control handle allows engagement and disengagement of the power take-off clutch.

OPERATING INSTRUCTIONS

On Rockford Units, moving the lever towards the engine engages the clutch, and pulling the lever away from the engine disengages the clutch.

On Funk Units, moving the lever away from the engine engages the clutch.

When moving the handle to engage the clutch and pick up the load, do so in a smooth manner. Moving the clutch handle too slowly will cause slippage and wear, while moving it too fast will cause quick engagement and possible damage to the power take-off, engine or driven equipment. The normal force required to engage the Rockford Unit clutch is 65-80 pounds. On Funk Units the force required is considerably less.

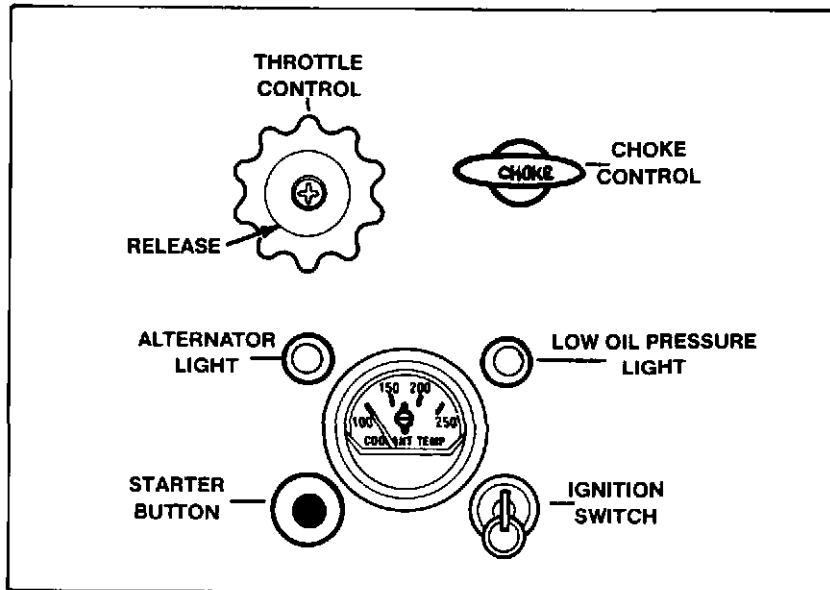

OPERATING INSTRUCTIONS

INSTRUMENTS

Temperature Gauge

The temperature gauge registers the coolant temperature and will indicate overheating which may arise from low coolant level, clogged radiator, loose fan belt or faulty thermostat.

By operating the engine at the correct temperature maximum power, longer life and better fuel economy will be ensured.

Engine Warning Lights

Units equipped with an engine warning light system have indicator lights mounted on the control panel. These lights come on to indicate dangerously low oil pressure or alternator not charging. *If any light comes on with engine running, stop and correct cause of oil pressure or alternator not charging.*

Safety Switch (Optional)

The optional low oil pressure — high water temperature safety switch automatically shuts off the ignition when the oil pressure drops below a preset value, or when the water temperature rises above a preset value. The switch operates in conjunction with contacts integral with the oil pressure warning mechanism and the water temperature gauge. The contacts are adjusted by an Allen head screw on the face of the gauge. A button on the instrument panel is used to override the safety switch when starting the engine.

Tachometer (Optional)

The tachometer indicates the engine speed in hundreds of revolutions per minute. It serves as a guide to maintain engine speed in the most desirable operating ranges.

Hourmeter (Optional)

This instrument records the hour of operation and is used to determine when periodic maintenance is required.

OPERATING INSTRUCTIONS

STARTING THE ENGINE

Release the load on the power take-off, or if the engine is equipped with a transmission, disengage the clutch. If the engine is started with the load engaged, it imposes an unnecessary strain on the starter and battery.

If your unit is equipped with the engine warning light system, always turn the ignition switch to the ON position to make sure that each warning light is operating before starting engine.

WARNING — All internal combustion engines give off various fumes and gases while running. Do not start or run the engine in a closed or poorly ventilated building where the exhaust gases can accumulate. Avoid breathing these gases as they may contain poisonous carbon monoxide which can endanger your health or life if inhaled steadily for even a few minutes.

Normal Starts

Pull the throttle out about 1/2-inch and the choke out about halfway. Turn the ignition switch to the ON position. Push the starter button. Release the starter button when the engine starts, decrease the throttle setting and adjust the choke for fast idle warm-up. When the engine is at operating temperature, push the choke in all the way.

CAUTION — If the engine stalls or falters in starting, wait three or four seconds before re-engaging starter. This will prevent possible damage to the starter or engine.

The starter should not be operated for periods longer than 30 seconds at a time. An interval of at least two minutes should be observed between such cranking periods to protect the starter from overheating.

Engine Cold

Pull the throttle out about 1/2-inch and the choke all the way out. Turn the ignition switch to the ON position. Press the starter button. When the engine starts, adjust the choke setting to keep the engine running smoothly. When the engine is at normal operating temperature, push the choke in all the way.

OPERATING INSTRUCTIONS

To assure satisfactory operation in cold weather, allow approximately five minutes for engine warm-up before engaging load.

CAUTION — If the engine stalls or falters in starting, wait three or four seconds before re-engaging starter. This will prevent possible damage to the starter or engine.

The starter should not be operating for periods longer than 30 seconds at a time. An interval of at least two minutes should be observed between such cranking periods to protect the starter from overheating.

Engine Flooded

To start a "flooded" engine, press the throttle control release button and pull the throttle out all the way and push the choke in all the way. Turn the ignition switch to the ON position. Press the starter button until the engine starts. Release the starter button. Push the throttle in gradually as engine speed increases.

CAUTION — If the engine stalls or falters in starting, wait three or four seconds before re-engaging the starter. This will prevent possible damage to the starter or engine.

The starter should not be operated for periods longer than 30 seconds at a time. An interval of at least two minutes should be observed between such cranking periods to protect the starter from overheating.

STOPPING THE ENGINE

Normal Conditions

Following normal operating conditions, lower the engine speed to idle, disengage the clutch, and then turn the ignition switch to the OFF position. If the engine has been running under high power, let it run at fast idle speed a few minutes to cool the engine down.

OPERATING INSTRUCTIONS

Never turn off the ignition, then suddenly pull the choke out, with the thought in mind that this will “prime” the system for the next start. This is poor practice, because the large quantity of raw gasoline entering the combustion chambers will wash all the oil off the cylinder walls. When started again, the engine will operate for a few moments without any lubrication on the cylinder walls, which may result in scuffing the pistons, rings, and cylinder walls. At best, engine life will be shortened considerably.

Abnormal Conditions

Under abnormally overheated conditions, the engine may continue to run after the ignition switch is turned off. If this case is ever encountered, turn on the ignition switch immediately and allow the engine to idle until it has cooled enough to stop. If the engine is overheated due to a loss of coolant, it is best to stop the engine immediately, if necessary by applying the load. Allow the engine to cool, then check the coolant and oil levels. Add engine oil if necessary, then, after the engine has returned to a normal temperature, add coolant slowly until the radiator is full.

WARNING — Avoid injury when checking a hot engine. Cover the radiator cap in a thick cloth and turn it slowly counterclockwise to the first stop. After the pressure has been completely released, press the cap downward and finish removing the cap.

The above instructions also apply to engines that stop due to operation of the low oil pressure-high water temperature safety switch. However, if engine stops due to low oil pressure, do not restart until the cause has been determined and corrected.

SPECIAL SITUATIONS

Problem Diagnosis

Most operating troubles that might be encountered with a new or well maintained unit will be of a minor nature. Therefore, if you have troubles starting or operating your engine, look for some simple cause rather than failure of a major component. For instance: Loose or corroded battery connections are much more likely than battery failure.

A loose ignition wire is much more likely than distributor, coil or ignition system failure.

OPERATING INSTRUCTIONS

In many cases, engine operating troubles are coupled with outside factors, such as climatic conditions, operating conditions, change of servicing or fueling source, or change of operator.

Engine troubles that occur as a result of normal use and wear usually give plenty of advance warning. These troubles usually result from overlooking the Preventive Maintenance Schedule services (Page 15).

Whenever engine performance seems less than normal in any category, it is best to consult with your dealer at the first symptom rather than wait until a serious problem develops. One of the aims of regular maintenance is to help you in just these circumstances.

Engine Won't Crank

1. Turn the key to the ON position and press the starter button. If nothing happens, an electrical lead(s) may be loose or disconnected, the battery cables may be loose, disconnected or corroded or the battery discharged.
2. Another indication of loose battery connections or low battery condition is a stuttering noise from the engine compartment when the ignition switch is turned to ON and the starter button depressed. Check the connections to the starter motor and the solenoid switch in addition to the battery and ground connections.
3. Try operating the starter button several times. Should the switch be corroded, this operation may clean the contacts enough to make the switch temporarily operable until you can reach your dealer.
4. If all the electrical connections are tight and you need assistance to start, read the instructions under Emergency Starting (Page 13).

Engine Cranks But Won't Start

1. Check the fuel tank. You may be out of fuel. If there is fuel in the tank, the trouble may be in either the ignition system or the fuel system.
2. Check the ignition system. Remove the wire from one of the spark plugs by grasping the moulded cap of the wire only, and insert a short piece of bare wire or other metal in the terminal of the wire.

OPERATING INSTRUCTIONS

NOTE — Spark plug wires carry high tension electrical current, capable of giving a shock. Be sure to grasp the moulded boot well back from the open end.

Hold the cap so that the inserted bare wire is about 1/4-inch from the engine block and crank the engine (with the ignition switch ON) for at least three seconds. If there is no spark between the wire and the metal, the trouble may be in the distributor or coil. If you see a spark, then check the fuel system for trouble.

3. The fuel system may have a restricted fuel line, plugged fuel filter, air leaks in the fuel line or a faulty fuel pump.
4. Check the manual choke. The choke linkage may be binding or damaged so that the choke plate in the carburetor is not opening and closing properly.

Engine Runs Hot

Listed below are items which could cause an engine to overheat.

1. Low coolant level.
2. Loose or broken fan belt.
3. Inoperative thermostat.
4. Dirty cooling system.
5. Radiator fins restricted with leaves, dirt, etc.
6. Prolonged idling.
7. Running engine with frozen coolant.
8. Leaky head gasket.
9. Overloading, especially during hot weather.

OPERATING INSTRUCTIONS

EMERGENCY STARTING

Use of booster battery and jumper cables — particular care should be used when connecting to a booster battery in order to prevent sparks. To jump start (negative grounded battery):

- Shield eyes.
- Connect end of one cable to positive (+) terminals of each battery.
- Connect one end of other cable to negative (-) terminal of "good" battery.
- Connect other end of cable to engine block of unit being started (NOT TO NEGATIVE (-) TERMINAL OF BATTERY).

To prevent damage to other electrical components on unit being started, make certain that engine is at idle speed before disconnecting jumper cables.

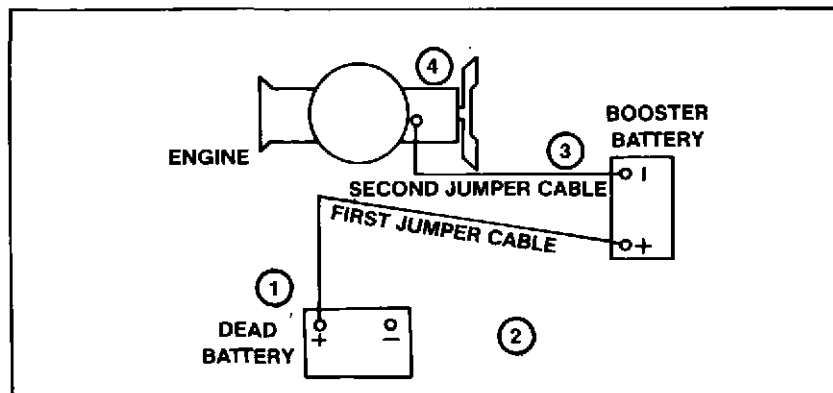

WARNING — Batteries contain SULFURIC ACID. In case of acid contact with skin, eyes, or clothing, FLUSH IMMEDIATELY WITH WATER FOR A MINIMUM OF FIVE MINUTES. Get "on-the-spot" medical attention immediately.

OPERATING INSTRUCTIONS

Hydrogen and oxygen gases are produced during normal battery operation. This gas mixture can explode if flames or sparks are brought near the battery. When charging or using battery in an enclosed space always provide ventilation.

Keep fire away from the top of open battery cells. Combustion gas is always present.

CAUTION — Avoid the use of a 24-volt battery and jumper cable hookup to start an engine with a dead battery, as this will damage the unit's electrical system.

FUEL RECOMMENDATIONS

The engine is designed to operate on "regular" gasoline. When the engine is adjusted to factory recommended specifications, you may use a fuel with a minimum octane rating as designated by the following:

(R+M)/2 87

CAUTION — Dry fuel (LPG and Natural Gas) usage requires valve seat inserts. Contact your Ford Power Products Distributor with your engine identification information (Page 3) to determine suitability of your engine for this usage.

MAINTENANCE INSTRUCTIONS

PREVENTIVE MAINTENANCE SCHEDULE

Initial Start-Up Sequence	Operation	100 Hrs.	200 Hrs.	300 Hrs.	400 Hrs.	500 Hrs.	600 Hrs.	700 Hrs.	800 Hrs.	900 Hrs.	1000 Hrs.
1	Oil, Engine, Check Level	Daily									
2	Coolant, Check Level in Radiator	Daily									
3	Fuel, Oil and Coolant Leaks, Check	Daily									
	PTO Release Bearing, Lubricate	Daily									
4	Governor, Check Oil Level ②	X	X	X	X	X	X	X	X	X	X
	Oil, Engine Change ①	X	X	X	X	X	X	X	X	X	X
	Oil Filter, Change ①	X	X	X	X	X	X	X	X	X	X
5	Air Cleaner, Clean or Replace Element ①	X	X	X	X	X	X	X	X	X	X
6	Battery, Check Charge and Level	X	X	X	X	X	X	X	X	X	X
7	PTO Bearings, Lubricate	X	X	X	X	X	X	X	X	X	X
	Radiator, Inspect and Clean Exterior		X		X		X		X		X
	Battery Cables, Clean		X		X		X		X		X
9	Fan, Alternator & Governor Belts, Check and Adjust		X		X		X		X		X
	Throttle, Governor and Choke Linkage, Lubricate		X		X		X		X		X
	Fuel Filter, Replace ①				X				X		
	Cooling System, Check or Refill				X				X		
12	Idle Speed, Check and Adjust				X				X		
13	Idle Mixture, Check and Adjust				X				X		
	Spark Plugs, Clean, Adjust and Test or Replace				X				X		
	Distributor, Clean and Check Points (If So Equipped)				X				X		
	Distributor, Lubricate				X				X		
10	Ignition Timing, Check and Adjust (Check Advance)				X				X		
	PCV Valve, Replace (If So Equipped)								X		
14	Throttle and Governor, Adjust								X		
	Spark Plugs, Replace								X		
	Points, Replace (If So Equipped)								X		
	Coolant, Replace								X		
11	All Bolts and Nuts, Check for Tightness ③										
8	PTO Clutch Release and Shaft Bearings, Adjust ③										

① More frequent intervals may be required in dusty areas.

② Mechanical governor (belt driven).

③ Seasonal or as required.

NOTE: Scheduled Maintenance beyond 1000 hours should be continued at the same intervals as before.

MAINTENANCE INSTRUCTIONS

Initial Start Up

Your Ford Industrial Engine was inspected before leaving the factory. However, the initial start-up checks must be made before putting the unit into operation. The Preventive Maintenance Schedule (Page 15) provides a handy check-off list. Perform the operations in the sequence listed in the left hand column.

Routine Service

Make sure your unit is ready to go whenever you need it. There are some things that you can do, or have done, to be sure it is well cared for:

- Keep the fuel tank filled. A full tank reduces the possibility of condensation forming in the tank moisture entering the fuel lines.
- Make frequent checks of the engine oil and coolant levels.
- Check the battery fluid level often, especially if your engine is being operated in a warm, dry climate.
- Keep engine air filter clean.
- Watch the engine temperature.
- Lube power take-off regularly.

Scheduled Preventive Maintenance

The operations listed in the Preventive Maintenance Schedule are covered in detail on the following pages. Whenever your vehicle requires maintenance of any kind, your Ford Power Products distributor or dealer has skilled technicians who will do an expert job of keeping your engine in its prime condition.

MAINTENANCE INSTRUCTIONS

ENGINE OIL

Checking Oil Level

The oil level should be checked frequently, at least daily, and maintained between the FULL and ADD marks on the dipstick. Allow a few minutes after shutting the engine off for the oil to drain down before checking.

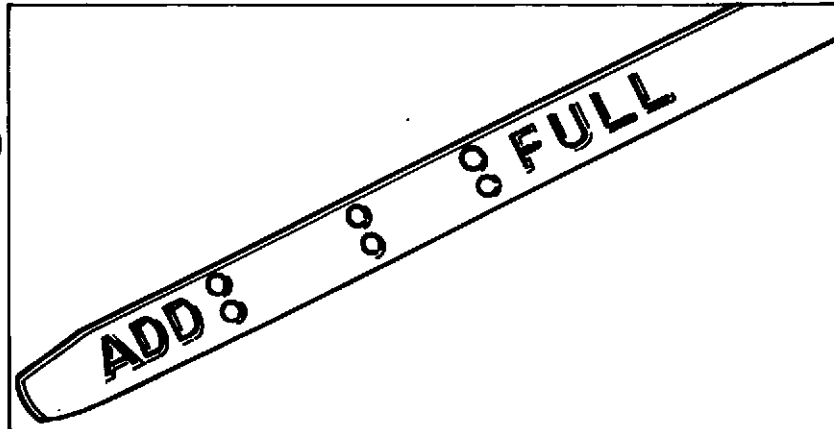

CAUTION — Do not operate the engine with the oil level below the ADD mark on the dipstick.

Adding Oil

It is normal to add some oil between oil changes. The amount will vary with the severity of operations. When adding or replacing engine oil be sure oils meet the specifications listed.

Changing Oil and Filter

For most operations, the engine oil and filter must be changed every 100 hours or seasonally. Under normal operating conditions, you do not need to change more often if you use oil and filters of the recommended quality.

The oil and filter should be changed more often if the engine is operated in dusty areas, for extended idling or low speed operation, or frequent stops during cold weather. No break-in oil change is required.

MAINTENANCE INSTRUCTIONS

Oil Quality

To help achieve proper engine performance and durability, it is important that you use only engine lubricating oils of the proper quality in your engine. Proper quality oils also provide maximum efficiency for the crankcase ventilation system which reduces pollution.

Use Ford or Motorcraft oil or equivalent that meets Ford Specification ESE-M2C153-E and API categories SG or SH.

It is best not to mix different brands of lubricants and oils, because sometimes they are not compatible and deteriorate when mixed. Stay with one brand to assure compatibility.

Oil Identification Logo

A logo has been developed to help you select the proper quality oil. It will be included on the oil can you purchase. The top section of the logo shows the oil quality by the API designation. The center section will show S.A.E. viscosity grade. The lower section will "state energy conserving" if the oil has proven fuel-saving capabilities.

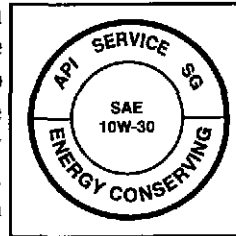

Oil Viscosity

When you change or add oil, you should select oil with the proper specifications and with the viscosity, (selected from the following table), which most closely matches the temperature range you expect to encounter for the next 100 hours of operation.

The use of engine oil that does not meet current API Specification is unacceptable and can result in premature engine failure.

Gasoline engines that are converted for LPG or Natural Gas applications must use oils labeled SG and/or SH. Do not use oils formulated for Natural gas Engines.

MAINTENANCE INSTRUCTIONS

Single-Viscosity Oils

When Outside Temperature Is Consistently	Use SAE Viscosity Number
-10°F to +60°F	*10W
+10°F to +90°F	20W-20
Above +32°F	30
Above +50°F	40

Multi-Viscosity Oils

When Outside Temperature Is Consistently	Use SAE Viscosity Number
Below +10°F	* 5W-20
Below +60°F	5W-30
-10°F to 90°F	10W-30
Above -10°F	10W-40 or 10W-50
Above +20°F	20W-40 or 20W-50

*Not recommended for severe service — including high RPM operation.

Oil Filter

Use a Motorcraft FL-1A Long-Life Oil Filter or equivalent which meets Ford Specification ES-E1ZE-6714-AA.

These filters protect your engine by filtering harmful, abrasive, or sludgy particles without blocking the flow of oil to vital engine parts.

To replace, use a filter wrench to remove filter.

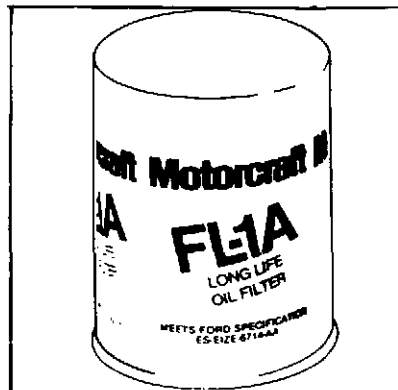

WARNING — Do not handle a hot oil filter with bare hands.

Clean the filter mounting base on the engine block, lightly coat the gasket surface of the new filter with engine oil and hand-tighten until the gasket contacts the base, then tighten another half turn. Fill the crankcase and run the engine to check for leaks.

MAINTENANCE INSTRUCTIONS

Air Cleaner

Your air cleaner filters air entering the engine induction system and acts as a silencer. Air that contains dirt and grit produces an abrasive fuel mixture and can cause severe damage to the cylinder walls and piston rings. Damage to the cylinder walls and piston rings will cause high oil consumption and short engine life. A restricted or dirty air cleaner will also cause a rich fuel mixture. Thus, it is extremely important that the air cleaner be serviced at recommended intervals.

CAUTION — Service the air cleaner more frequently under severe dust conditions.

Clean or replace the air cleaner paper filter element.

Remove the paper filter element from the air cleaner. Inspect the element for mud caking or signs of excessive wear or damage. Replace as necessary.

Remove all dust and foreign matter from the air cleaner housing.

Make sure that the air cleaner is seated properly on the carburetor with the seal installed.

COOLING SYSTEM

Coolant Level

Check the coolant level in the radiator daily, only when the engine is cool.

Maintain the coolant level at approximately 3/4 to 1-1/2 inches (19-38 mm) below the filler neck seat on the radiator when the coolant is cold.

Whenever coolant level checks are made check condition of radiator cap rubber seal. Make sure it is clean and free of any dirt particles. Rinse off with clean water if necessary. When replacing cap on radiator, also make sure radiator filler neck is clean.

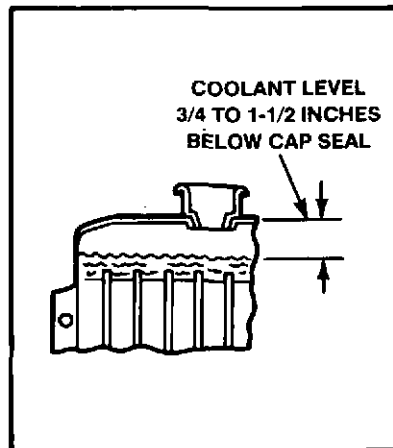

MAINTENANCE INSTRUCTIONS

WARNING — Never remove the radiator cap under any conditions while the engine is operating. Failure to follow these instructions could result in damage to the cooling system or engine and/or personal injury. To avoid having scalding hot coolant or steam blow out of the radiator, use extreme care when removing the cap from a hot radiator. If possible, wait until the engine has cooled, then wrap a thick cloth around the radiator cap and turn it slowly to the first stop. Step back while the pressure is released from the cooling system. When you are sure all the pressure has been released, press down on the cap (still with a cloth), turn and remove it.

Do not add coolant to an engine that has become overheated until the engine cools. Adding coolant to an extremely hot engine can result in cracked block or cylinder head.

Use only a permanent-type coolant that meets Ford Specification ESE-M97B44-A such as Ford Cooling System Fluid. Refer to the coolant mixture chart on the container for additional antifreeze protection information. Do not use alcohol or methanol antifreeze, or mix them with the specified coolant.

Plain water may be used in an emergency, but replace it with the specified coolant as quickly as possible to avoid damage to the system.

Radiator

Inspect the exterior of the radiator for obstructions. Remove all bugs, dirt or foreign material with a soft brush or cloth. Use care to avoid damaging the fins. If available, use compressed air or a stream of water in the opposite direction to normal airflow.

Check all hoses and connections for leaks. If any of the hoses are cracked, frayed, or feel spongy, they should be replaced.

Drive Belts

The water pump is belt driven. This same belt may also drive the fan and/or alternator. The drive belt(s) should be properly adjusted at all times. A loose drive belt causes improper alternator, fan and water pump operation, in addition to overheating.

MAINTENANCE INSTRUCTIONS

Overtightening the belt may result in excessive wear on the alternator and water pump bearings, as well as premature wear on the belt itself. Therefore, it is recommended that a belt tension gauge be used to check and adjust the belt tension. **Any belt that has operated for a minimum of 10 minutes is considered a used belt, and when adjusted, it must be adjusted to the reset tension shown in the specifications.**

Belt Tension

Install the belt tension tool on the drive belt and check the tension following the instructions of the tool manufacturer.

If the tension is not to specification, loosen the alternator mounting and adjusting arm bolts. Move the alternator away from the engine until the correct tension is obtained. Remove the gauge. Tighten the alternator adjusting arm and mounting bolts. Install the tension gauge and recheck the belt tension.

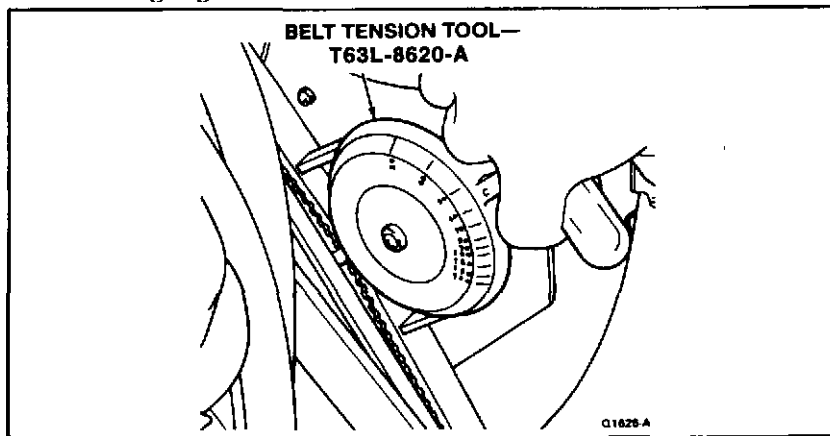

BATTERY

If there is any corrosion on the cables and terminals, remove it with a wire brush and neutralize the acid with a solution of baking soda or ammonia with water. After cleaning, flush the top of the battery with clean water, install the terminal clamps on the battery posts, and coat the parts with grease to retard further corrosion.

MAINTENANCE INSTRUCTIONS

Fluid Level

(Non-Maintenance Free Battery)

Because the battery is the "heart" of your unit's electrical system, periodic checks are necessary to keep it functioning properly. Keep the battery level in each cell up to the level indicator.

Ordinary tap water may be used except in areas where the water is known to be exceptionally hard or to have a high mineral or alkali content. In such areas, use distilled water. If water is added during freezing weather, run the engine 20 to 30 minutes before shutting it off. This mixes the added water with the electrolyte and will prevent it from freezing and damaging the battery. Have the battery charge checked regularly during extreme cold weather. When the specific gravity falls below 1.230 (corrected to 80°F), recharge the battery. Make sure the cables are clean and tightly clamped to the battery terminals. Keep the top of the battery clean and dry.

WARNING — Batteries normally produce explosive gases which can cause personal injury. Therefore, do not allow flames, sparks or any ignited object to come near the battery. When charging or working near a battery, always shield your eyes. Always provide ventilation.

When lifting a plastic-cased battery, excessive pressure on the end walls could cause acid to spew through the vent caps, resulting in personal injury. Lift with a battery carrier or with your hands on opposite corners.

CRANKCASE VENTILATION SYSTEM

Open System

The engines equipped with the open crankcase ventilation have two breather caps, located on the rocker cover. The caps should be cleaned in a petroleum solvent at every oil change.

Closed System (P.C.V.)

The closed system is known as the positive crankcase ventilation system. Clean air is supplied from the air cleaner by a hose to the closed cap on the front opening of the rocker cover. The fumes are vented out the rear opening of the rocker cover through a regulator valve and into the intake manifold. The P.C.V. valve (regulator valve) must be replaced at 400 hours.

MAINTENANCE INSTRUCTIONS

FUEL FILTERS

Disposable Filter

The disposable filter is located on the fuel pump body. Unscrew the filter housing from the body and remove the filter element and gasket. Discard the element and gasket. Clean the filter housing in a petroleum cleaning solvent.

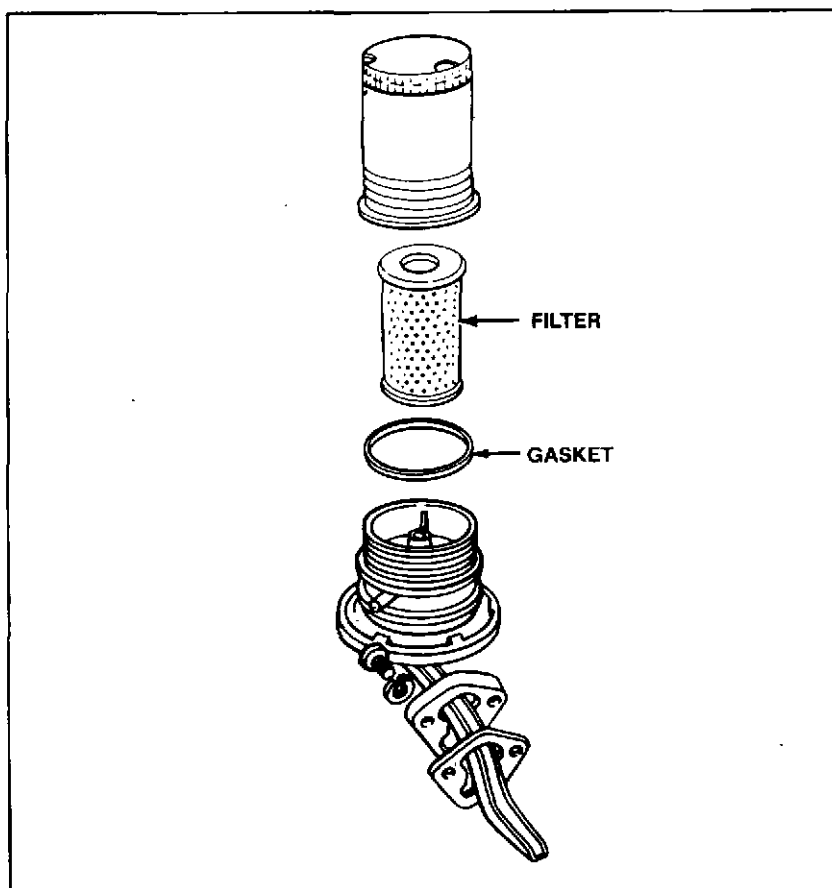

Place a new filter element over the spout in the body. Be sure to use the proper type element for the installation. Coat the new gasket with light engine oil and position the gasket on the filter housing or body. Screw the filter housing onto the filter body. Hand tighten the filter housing until gasket contacts the body, and then tighten an additional 1/8-turn. Start the engine and check for leaks.

MAINTENANCE INSTRUCTIONS

CARBURETOR ADJUSTMENTS

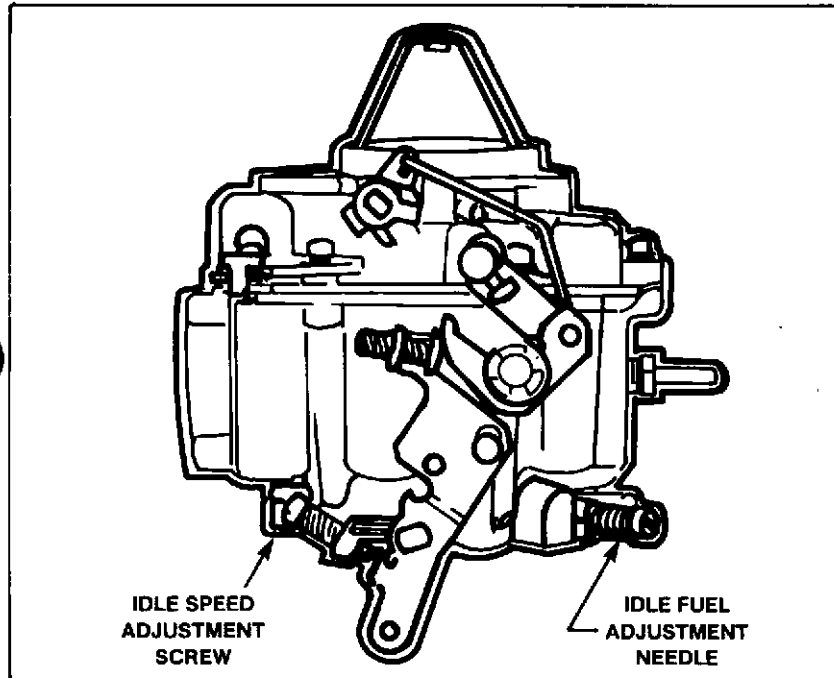

Operate the engine until a normal operating temperature is obtained. Make sure the choke plate is fully open. Turn the idle speed adjustment screw until the desired rpm is obtained. Turn the idle fuel adjustment screw inward until the engine rpm begins to drop from the lean mixture. Turn the needle outward (counterclockwise) until the engine rpm increases and just begins to drop from the rich mixture; then turn the screw inward for maximum engine rpm and smoothness. Always favor a rich mixture rather than a lean mixture for final adjustment. A lean mixture will put an unnecessary heat load on the valves, and may cause premature valve failure.

Check the engine idle speed and adjust it to specifications if necessary. Final engine idle speed may be varied within the specified rpm range to suit the conditions under which the unit is to be operated.

MAINTENANCE INSTRUCTIONS

IGNITION SYSTEM

Two types of ignition systems are used on this series of engines. The conventional type with breaker points and the breakerless solid state type. Use the appropriate maintenance procedures for the system on your engine.

A dual advance distributor with a centrifugal and vacuum spark advance system, is used with both systems.

The direction of distributor rotation is clockwise as viewed from the top of the distributor.

The spark plug wires are inserted in the distributor cap in the firing order of the engine 1-5-3-6-2-4. Number one socket is identified by the number one on the cap. The cylinders are numbered from front to rear — 1-2-3-4-5-6.

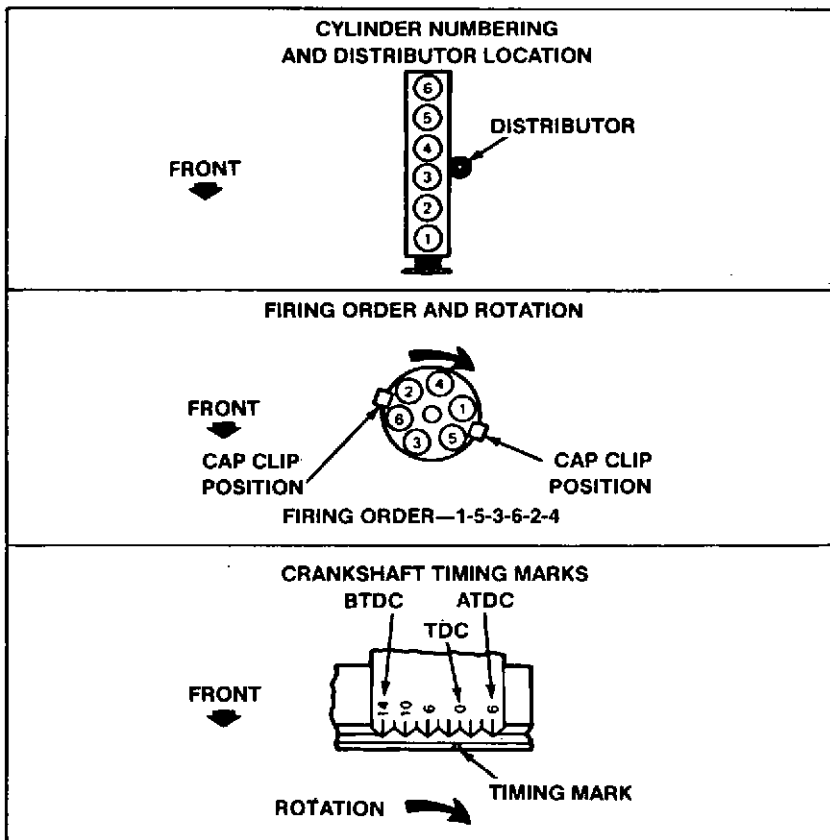

MAINTENANCE INSTRUCTIONS

Solid-State Ignition

The Solid-State Ignition system has a larger rotor, distributor cap and adapter, ignition secondary wires and wide gap spark plugs to take advantage of the higher energy produced.

No adjustments are made to the ignition system except initial timing and spark plug gap.

When installing a new distributor cap or rotor, coat the brass rotor electrode surfaces on all sides outboard of the plastic, including the outer edge, with D7AZ-19A331-A silicone dielectric compound, or equivalent to approximately 1/32-inch thickness. Do not reapply or attempt to remove any silicone coating from the distributor cap electrodes. As this compound ages, it has the appearance of being a contaminant of the cap and rotor electrode. This condition is normal and causes no performance loss.

Coat the inside of each spark plug boot with silicone dielectric compound D7AZ-19A331-A or equivalent, using a small screwdriver blade. Connect each spark plug wire to the plug from which it was removed. Be sure each wire is fully depressed on each plug and molded boot is firmly in place.

Breaker Point Ignition

Disconnect the coil high tension lead and the spark plug wires at the distributor cap. Remove the distributor cap and rotor. Clean the inside of the cap and the rotor with a mild cleaning solvent. Remove dirt or corrosion from the terminals on the distributor cap. Inspect the rotor for cracks or a burned tip. Replace cap or rotor as required.

Open the points and inspect them for a badly pitted or burned condition. Replace the points whenever inspection indicates or at the recommended interval. Replacement can be made without removing the distributor.

To replace the breaker points, remove the leads to the breaker assembly. Remove the screw that secures the assembly to the breaker plate, then remove the assembly. Remove the condenser retaining screw and remove the condenser.

Clean the breaker plate and cam. Apply a light film of distributor cam lubricant to cam. **Do not use engine oil.**

MAINTENANCE INSTRUCTIONS

To install, place the assembly in position and install the retaining screw. Position the condenser and install the retaining screw. Attach condenser lead and primary lead to breaker assembly.

The breaker points must be accurately aligned and strike squarely in order to realize the full advantage provided by this design and to insure normal breaker point life. Turn the distributor cam (energize starter if distributor is in engine) so that breaker points are closed. Check the alignment of the points with a magnifying glass. Align the points to make full face contact by bending the stationary point bracket. **Do not bend the movable arm.** It is recommended that a special tool be used for this operation.

After the breaker points have been aligned, they should be adjusted to the correct gap with a feeler gauge or dwell meter. To adjust the points with a feeler gauge, turn the distributor shaft until the rubbing block rests on the peak of a cam lobe. Insert the correct blade of a clean feeler gauge between the points. The gap should be set to the larger opening because the rubbing block will wear down slightly while seating to the cam. When setting the points with a dwell meter, adjust the dwell angle to the low setting. This will also compensate for rubbing block wear. Lubricate the felt under the rotor using two drops of engine oil.

Ignition Timing

The ignition timing should be checked and adjusted at the recommended intervals. Proper adjustment of ignition timing *must be maintained to provide maximum engine power output and best possible fuel economy.*

The timing marks are located on the engine front cover and can be seen from the left side. These marks and a notch on the crankshaft pulley or damper are used to time the engine. Adjust the ignition timing as follows:

The recommended timing setting is:

6 degrees BTDC	Gasoline
16 degrees BTDC	LPG
16 degrees BTDC	N.G.

MAINTENANCE INSTRUCTIONS

Disconnect the distributor vacuum line. Connect the timing light high tension lead to the No. 1 spark plug (front cylinder), and the other two leads to the proper battery terminals. Clean and chalk the timing marks to improve legibility.

Operate the engine at a maximum of 550 rpm, and direct the timing light at the pointer, keeping the timing marks in line with the center of the pulley and the light. The light should flash just as the 6° mark lines up with the notch on the damper.

If the 6° mark and the notch do not line up, loosen the distributor body clamp, and rotate the distributor until the mark and notch are in line.

NOTE — Ignition timing is advanced by counterclockwise rotation of the distributor body — retarded by clockwise rotation.

When the proper timing is obtained, tighten the distributor body clamp and connect the distributor vacuum line, then accelerate the engine while watching the timing mark with the timing light to determine if the advanced mechanism is functioning. The notch on the crankshaft pulley should advance as engine rpm increases. This check will confirm whether or not the advance mechanism is functioning.

Spark Plugs

The spark plugs should be cleaned, tested and gapped at the recommended intervals.

Remove the wires from each spark plug by grasping, twisting and then pulling the moulded cap of the wire only. Do not pull directly on the wire because the wire connection inside the cap may become separated.

After loosening each spark plug one or two turns, clean the area around each spark plug port with compressed air, then remove the spark plugs.

After cleaning, examine the plug carefully for cracked or broken insulators, badly pitted electrodes, and other signs of malfunction. Replace as required.

MAINTENANCE INSTRUCTIONS

After cleaning, dress the electrodes with a small file to obtain flat parallel surfaces on both the center and side electrodes. Set the spark plug gap to specifications by bending the ground electrode. All spark plugs new or used should have the gap checked as required.

Install the spark plugs and torque each plug to specifications.

Connect the spark plug wires.

NOTE — Do not overtighten spark plugs. The gap may change considerably due to distortion of the plug outer shell.

LUBRICATION

At the specified intervals, apply a few drops of engine oil to the distributor oil felt and apply an appropriate lubricant, such as Lubriplate (COAZ-19584-A) at the pivot points of the throttle, governor and choke linkage.

MAINTENANCE INSTRUCTIONS

MECHANICAL GOVERNOR

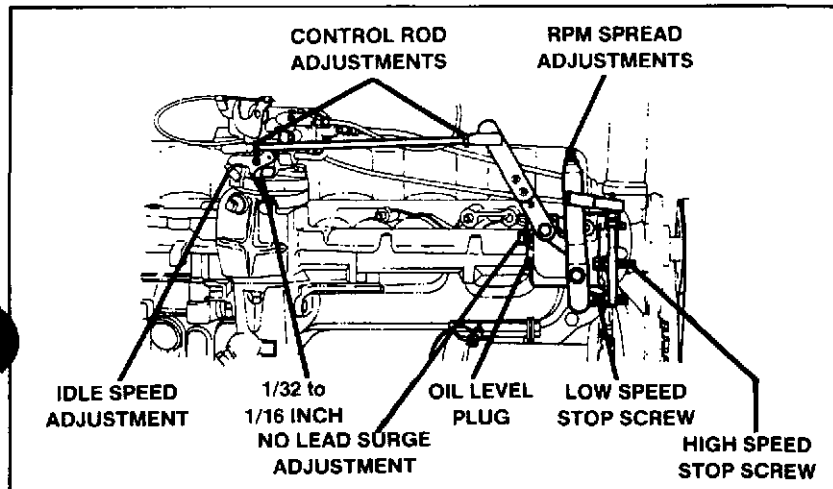

Oil Level

Clean the body of the governor in the area of the fill plug.

Check the oil level by slowly removing the oil level plug. If oil drips out the oil level is full. If oil doesn't drip out, slowly add engine oil into the oil fill hole. As soon as it begins dripping out the oil level hole, insert the plug.

Adjustment

Before making any governor adjustments, check the governor drive belt tension with a belt tension gauge. Set the belt to the tension listed in the Specifications section.

MAINTENANCE INSTRUCTIONS

The first adjustment is the governor-to-carburetor control rod adjustment. With the control rod connected, manually move the governor throttle lever to the maximum open throttle position. Check that the carburetor throttle shaft lever is set from 1/32 to 1/16 of an inch from its maximum open position stop. If necessary adjust length of the control rod to obtain the setting.

To perform a high-speed adjustment, attach a tachometer to the engine, then run the engine until it reaches normal operating temperature.

- loosen the locknut on the high speed stop screw
- disengage engine load
- slowly pull the throttle to desired maximum engine speed
- adjust the high speed stop screw on the governor to attain the desired maximum engine speed
- tighten the locknut

The next adjustment is for spread. Proper governor operation requires a difference between full-load and no-load governor speed. Too small an rpm spread between the two speeds will cause governor hunting and surging. Too large a spread will cause low response. For this governor, normal rpm spread is 5 to 10 percent.

To decrease the rpm spread with the engine running under no-load at maximum governed speed, loosen the rpm spread adjusting screw lock nut and turn the adjusting screw clockwise until engine speed increase 150 rpm; then tighten the lock nut. Recheck governor operation. You might also have to readjust the governor high-speed stop screw to maintain the correct high-speed under load.

To increase rpm speed, run the engine under no-load at maximum governed speed and loosen adjusting screw lock nut. Turn the adjusting screw counterclockwise until engine speed decreases one hundred fifty rpm tighten the lock nut. Recheck governor operation under load and no-load conditions.

MAINTENANCE INSTRUCTIONS

To perform a low-speed adjustment, move the hand throttle, or variable speed lever, to the closed position and loosen locknut on governor low-speed screw. Turn stop screw in or out until you can maintain the desired speed.

The no-load surge adjustment is set at the factory and rarely requires adjustment. If necessary, this adjustment can be used to prevent **hunting and surging at no-load speeds only, provided the rpm spread adjustment is set properly.** Make the adjustment with the tachometer installed. Increase the engine speed with the hand throttle control at 75 rpm lower than the maximum no-load desired control rpm. (NOTE: At this point if the engine continues to surge, light pressure applied to governor throttle lever will dampen surges.) Then loosen the no-load surge adjustment screw locknut and turn the screw inward until rpm increases to the desired control rpm. Reset high speed adjustment screw and tighten lock-nuts.

CAUTION — Do not turn the screw in all the way. It will interfere with proper governor operation and prevent the governor from returning the engine to idle speed.

POWER TAKE-OFF

Rockford Over Center Clutch

A new clutch generally requires several adjustments until the friction surfaces are worn in. Do not let a clutch slip as this will glaze the friction plates and may ruin them.

To adjust the clutch, place the shifter lever in the released position, then remove the patent plate on the top of the housing. Rotate the clutch until the adjusting lock and lock screw can be reached. Remove or disengage the adjustment ring lock. Then turn the adjusting ring. Counterclockwise rotation tightens the adjustment. Turn the adjusting ring until a pressure of 65-80 lbs. is required to engage the clutch. Reinstall the adjustment lock. Lubricate the friction points on the levers and linkage inside the housing with SAE 30 engine oil.

Funk Spring Loaded Clutch

The clutch does not require adjustment. However, the free travel of the shift lever will decrease as the clutch lining wears.

MAINTENANCE INSTRUCTIONS

Bearings of power take-off unit should be lubricated at the specified intervals. Use a high grade, Lithium Base #2, short fiber grease, such as Ford CIAZ-19590-B. Clean the fittings before and after greasing.

On the Rockford PTO, lubricate the release bearing, thrust bearing, shifting lever bearings, and the pilot bearing.

NOTE: The release bearing fitting may be located inside the housing beneath the cover.

On the Funk PTO, lubricate the thrust bearing and shifting lever bearings only. The pilot bearing and release bearing are pre-lubricated.

CAUTION — Do not use excessive force when greasing, and do not over grease. Use grease sparingly. Excessive grease can coat the clutch plates and cause slippage.

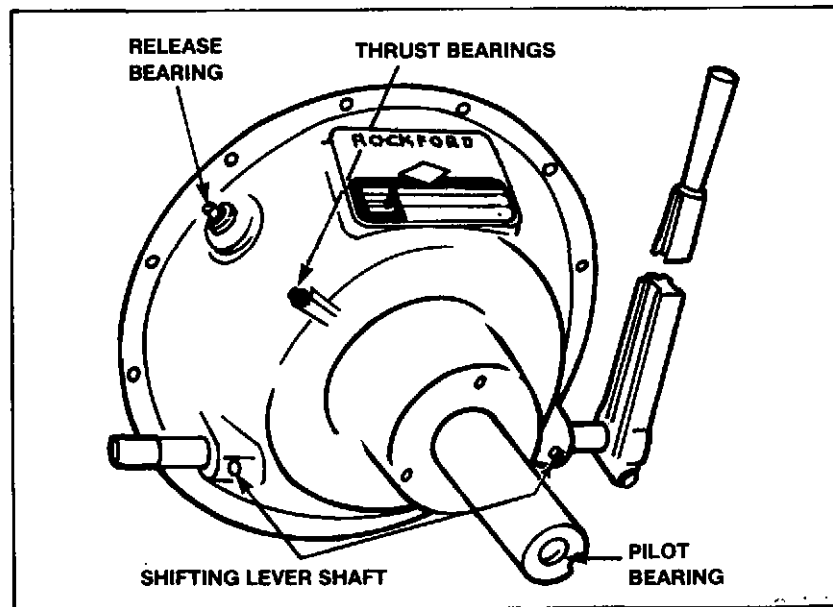

MAINTENANCE INSTRUCTIONS

STORAGE

One-Month

While the engine is running, treat upper cylinders by spraying recommended engine oil (SAE-10), or equivalent into the air intake for about two minutes. Open throttle for short burst of speed, shut off engine and allow it to come to a stop while continuing to spray recommended engine oil into air intake.

Leave spark plugs in holes or seal spark plug holes with suitable threaded metal plugs and cover all openings into engine with dustproof caps or shields.

If engine is less transmission, spray flywheel and ring gear with mixture of one part recommended engine oil, and one part Stoddard Solvent or equivalents.

Check coolant protection.

For Indefinite Period

Drain crankcase completely and refill with recommended engine oil, (SAE 10), or equivalent.

Run engine until completely out of gasoline, then restart and run on unleaded, undyed gasoline for at least 10 minutes.

While engine is still running and at completion of above run, treat upper cylinders by spraying recommended engine oil into the air intake for about two minutes. Open throttle for short burst of speed, shut off engine and allow it to come to a stop while continuing to spray recommended engine oil into air intake.

Check coolant protection.

Disconnect and remove battery.

Clean exterior surface of engine.

Leave spark plugs in holes or seal spark plug holes with suitable threaded metal plugs.

Seal all openings in engine and accessories with Nonhydroscopic Adhesive Tape. Mask off all areas to be used for electrical contact.

Make sure all surfaces are dry, then spray all taped openings, all engine accessories including ignition wiring, and all exterior surfaces of engine with Insulation Compound.

MAINTENANCE INSTRUCTIONS

If engines are equipped with automotive type clutch, block clutch in slightly disengaged position so that lining and pressure plates are not in contact.

INDEX

Air Cleaner	20
Antifreeze	20
Battery	22
Belt Adjustment	22
Carburetor Adjustment	25
Choke Control	5
Controls	5
Coolant Level	20
Cooling System	20
Crankcase Ventilation System	23
Distributor Points Adjustments	27
Distributor Points Replacement	27
Engine Warning Lights	7
Emergency Starting	13
Fuel Filter	24
Fuel System	24
Governor Adjustments	31
Hourmeter	7
Identification Decal	3
Ignition Switch	5
Ignition Timing	28
Initial Start Up	16
Instruments	7
Lubrication	30
Oil Filter	19
Oil Level	17
Oil Recommendations	18
Parts and Service	4
Power Take-Off Adjustments	33
Power Take-Off Control	5
Power Take-Off Lubrication	34
Preventive Maintenance Schedule	15
Problem Diagnosis	10
Radiator	21
Spark Plugs	29
Specifications	37
Starting the Engine	8
Stopping the Engine	9
Storage	35
Tachometer	7
Temperature Gauge	7
Throttle Control	5

⚠ WARNING: ⚠

The Engine Exhaust from this product contains chemicals known to the State of California to cause cancer, birth defects or other reproductive harm.

REV. 7-97

PPD 194-127

LITHO IN USA