



LSG-875 7.5 LITER (460 CID)

The Source for Power...
Worldwide™

MAINTENANCE AND OPERATOR'S MANUAL



TABLE OF CONTENTS

INTRODUCTION	2
How To Use This Manual	2
Engine Identification	3
Parts And Service	3
Service Literature	3
OPERATING INSTRUCTIONS	4
Controls	4
Instruments	6
Starting The Engine	8
Stopping The Engine	9
Problem Diagnosis	10
Emergency Starting	12
Fuel Recommendation	14
MAINTENANCE INSTRUCTIONS	16
Maintenance Schedule	16
Initial Start-up Maintenance	17
Routine Service	17
Scheduled Preventive Maintenance	17
SPECIFICATIONS	33
INDEX	36

INTRODUCTION

INTRODUCTION

We are highly pleased that you have selected a Ford unit for your engine requirements. The Ford Motor Company takes great pride in the long tradition of quality products and great values that the Ford name represents.

Ford Industrial Engines are tested and inspected before leaving the factory. However, certain checks should be made before putting them into regular operation. Read the Initial Start Up requirements in the Maintenance Instructions.

HOW TO USE THIS MANUAL

We wrote this manual especially for you. We hope you use it to get to know your engine and how to get the most out of it. That is why we urge you to read this manual from cover to cover. First, you'll become familiar with the *various controls and instruments*. As you read further, we tell you how to maintain your engine and what services need to be performed to keep it in excellent running condition.

The Subject Index on the title page permits you to quickly open the manual to any section. The Alphabetical Index at the back of the manual provides a page reference to a particular item or procedure.

Ford Industrial Engines are built with a variety of standard and/or optional components to suit a wide range of customer requirements. This manual does not identify equipment as standard or optional. All the equipment described in this manual may not be found on your engine or power unit.

As you read through, you will come across **NOTES**, **CAUTIONS**, and **WARNINGS**. **WARNINGS** remind you to be careful in areas where carelessness can cause you personal injury. **CAUTIONS** are given to prevent you from error that could damage the equipment. **NOTES** give you added information designed to help you.

The descriptions and specifications contained in this manual were in effect at the time it was approved for printing. The Ford Companies reserve the right to discontinue models at any time, or to change specifications or design without notice and without incurring obligation.



The Source for Power...
Worldwide™

Ford Power Products
Industrial Power Products, LLC
28333 Telegraph Rd.
Southfield, MI 48034

INTRODUCTION

ENGINE IDENTIFICATION

An identification Decal is affixed to the left side of the engine. The decal contains the engine serial number which identifies this unit from all others. The model number and special options (S.O.) determine the parts or components required on this unit. Use all numbers when seeking information or ordering replacement parts for this engine. For a handy reference, this information is recorded on your Ford Power Products Operations Engine Registration copy (Form #194-103-D).

	SERIAL NUMBER
	MODEL NUMBER
	S.O./OPTIONS MODEL CODE

PARTS AND SERVICE

Replacement parts can be obtained through your local Ford Power Products Distributors and Service Dealers. They may be found in the yellow pages under "Engines" or contact Ford Power Products: 1-800-833-4773.

Ford Power Products Distributors and Dealers are equipped to perform major and minor repairs. They are anxious to see that all of your maintenance and service needs are quickly and courteously completed.

SERVICE LITERATURE

A service manual can be purchased from your distributor or dealer. This publication will provide the necessary servicing and overhaul information for your Ford Industrial Engine.

SERVICE MANUAL PPO 194 208-86
PARTS LIST PPD 194-177A (Marine)
PARTS LIST PPD 194-284A (Industrial, Power Unit & Irrigation)

OPERATING INSTRUCTIONS

CONTROLS

IGNITION SWITCH

This four position switch is located on the control panel. In the ACC position, electrical accessories can be operated without electricity flowing through the ignition circuit. In the OFF position, the switch disconnects the electrical system from the battery. The key can be removed from the switch when it is in this position. In the ON position, the electrical system is activated. Engage the starter by turning the key to the START position. Release the key when the engine starts and it will return to the ON position.

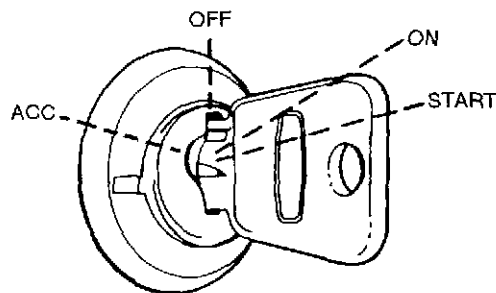

CHOKE CONTROL (MANUAL)

The choke control is connected to the carburetor and operates the choke butterfly to enrich the fuel mixture on cold starts. Pulling the control out closes the choke and pushing it in opens the choke.

THROTTLE CONTROL

The throttle control adjusts engine speed. Initial engine speed adjustment is obtained by pressing the throttle control release button while pulling the throttle knob out to increase the engine speed or pushing it in to decrease the engine speed.

A final fine speed adjustment is obtained by turning the throttle control counterclockwise to increase engine speed or clockwise to decrease engine speed.

OPERATING INSTRUCTIONS

POWER TAKE-OFF

The power take-off control handle allows engagement and disengagement of the power take-off clutch. Moving the lever towards the engine engages the clutch, and pulling the lever away from the engine disengages the clutch.

When moving the handle to engage the clutch and pick up the load, do so in a smooth manner. Moving the clutch handle too slowly will cause slippage and wear, while moving it too fast will cause quick engagement and possible damage to the power take-off, engine or driven equipment.

The normal force required to engage the clutch is 65 – 80 pounds.

OPERATING INSTRUCTIONS

INSTRUMENTS

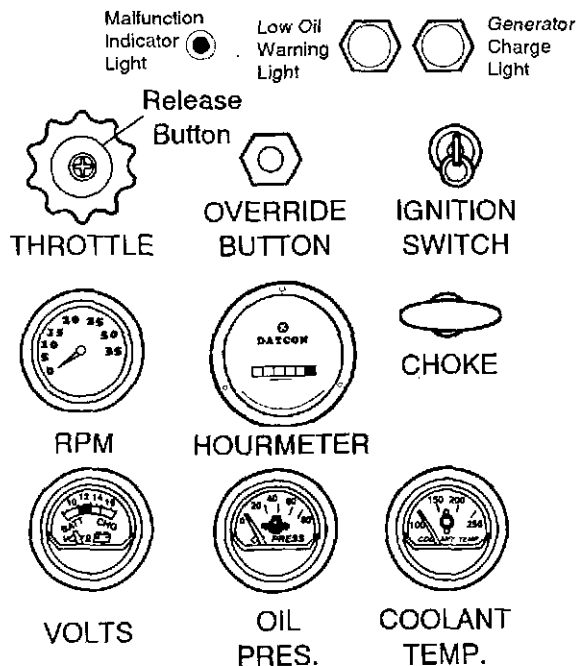

ENGINE WARNING LIGHTS (if equipped)

Units equipped with an engine warning light system have indicator lights mounted on the control panel. These lights come on to indicate dangerously low oil pressure or generator not charging. If any light comes on with engine running, stop and correct cause of low oil pressure or generator not charging before restarting the engine.

MALFUNCTION INDICATOR LIGHT (EFI only)

The malfunction indicator light is used on engines equipped with electronic fuel injection systems. This light will illuminate whenever there is an engine malfunction such as low oil pressure, high engine temperature, fuel injection system fault. The engine can be programmed to shut down in the event of a malfunction.

OPERATING INSTRUCTIONS

OIL PRESSURE GAUGE

The oil pressure gauge registers the lubricating system pressure in pounds-per-square-inch (psi) and should be frequently checked to ensure that the system is functioning correctly. Normally the pressure registered by the gauge should remain constant for a given engine speed (see Specifications). Should the pressure fluctuate or drop, stop the engine and find the cause. Do not operate the engine at lower than normal oil pressures.



CAUTION: Do not continue to operate your engine below normal operating pressure range. Otherwise your engine may be severely damaged.

VOLTMETER

The voltmeter measures the battery charging voltage. If the meter consistently indicates less than 13 volts or more than 15.5 volts under normal operation, have your engine's electrical system checked.

TEMPERATURE GAUGE

The temperature gauge registers the coolant temperature and will indicate overheating which may arise from low coolant level, clogged radiator, loose fan belt or faulty thermostat. By operating the engine at the correct temperature, maximum power, longer life and battery fuel economy will be ensured.



CAUTION: If the engine continues to overheat, have the cooling system checked and serviced.

SAFETY SWITCH (if equipped)

The optional low oil pressure / high water temperature safety switch automatically shuts off the ignition when the oil pressure drops below a preset value, or when the water temperature rises above a preset value. The switch operates in conjunction with contacts integral with the oil pressure warning mechanism and the water temperature gauge. The contacts are adjusted by an Allen head screw on the face of the gauge. A button on the instrument panel is used to override the safety switch when starting the engine. **The safety switch override button must be depressed to start the engine.**

TACHOMETER

The tachometer (optional) indicates the engine speed in hundreds of revolutions per minute (rpm). It serves as a guide to maintain engine speed in the most desirable operating ranges.

HOURLY METER

This instrument (optional) records the hours of operation and is used to determine when periodic maintenance is required.

OPERATING INSTRUCTIONS

STARTING THE ENGINE



WARNING: ALL INTERNAL COMBUSTION ENGINES GIVE OFF VARIOUS FUMES AND GASES WHILE RUNNING. DO NOT START OR RUN THE ENGINE IN A CLOSED OR POORLY VENTILATED BUILDING WHERE THE EXHAUST GASES CAN ACCUMULATE. AVOID BREATHING THESE GASES AS THEY MAY CONTAIN POISONOUS CARBON MONOXIDE WHICH CAN ENDANGER YOUR HEALTH OR LIFE IF INHALED STEADILY FOR EVEN A FEW MINUTES.

Release the load on the power take-off, or if the engine is equipped with a transmission, disengage the clutch and/or select a neutral position. If the engine is started with the load engaged, it imposes an unnecessary strain on the starter and battery.

If your unit is equipped with the engine warning light system, always turn the ignition switch to the ON position to make sure that each warning light is operating before starting engine.



CAUTION: If the engine stalls or falters in starting, wait 3-4 seconds before re-engaging starter. This will prevent possible damage to the starter or engine. The starter should not operate for periods longer than 30 seconds at a time. An interval of at least two minutes should be observed between such cranking periods to protect the starter from overheating.

NOTE: In the following procedures, reference is made to manual choke operation. Disregard if equipped with an automatic choke, no operator intervention is required.

NORMAL STARTS

Pull the throttle out about 1/2 inch and the choke out about halfway (manual choke only). Turn the ignition switch to the START position. After the engine starts, release the key, decrease the throttle setting and adjust the choke for fast idle warm-up. When the engine is at normal operating temperature, push the choke in all the way.

ENGINE COLD

Pull the throttle out about 1/2 inch and the choke all the way out (manual choke only). Turn the ignition switch to the START position. When the engine starts, release the key, adjust the choke setting to keep the engine running smoothly. When the engine is at normal operating temperature, push the choke in all the way.

To assure satisfactory operation in cold weather, allow approximately five minutes for engine warm-up before engaging load.

OPERATING INSTRUCTIONS

ENGINE FLOODED

To start a "flooded" engine, press the throttle control release button and pull the throttle out all the way and push the choke in all the way (manual choke only). Turn the ignition switch to the START position until the engine starts. Release the key. Push the throttle in gradually as engine speed increases.

STOPPING THE ENGINE

NORMAL CONDITIONS

Following normal operating conditions, **lower the engine speed to idle**, disengage the clutch, and then turn the ignition switch to the OFF position. If the engine has been running under high power, let it run at fast idle speed a few minutes to cool the engine down.

Never turn off the ignition, then suddenly pull the choke out, with the thought in mind that this will "prime" the system for the next start. This is poor practice, because the large quantity of raw gasoline entering the combustion chambers will wash all the oil off the cylinder walls. When started again, the engine will operate for a few moments without any lubrication on the cylinder walls, which may result in scuffing of the pistons, rings and cylinder walls. At best, engine life will be shortened considerably.

ABNORMAL CONDITIONS

Under abnormally overheated conditions, the engine may continue to run after the ignition switch is turned off. If this case is ever encountered, turn on the ignition switch immediately and allow the engine to idle until it has cooled enough to stop. If the engine is overheated due to loss of coolant, it is best to stop the engine immediately, if necessary by applying the load. Add engine oil if necessary, then after the engine has returned to a normal temperature, add coolant slowly until the radiator is full.



WARNING: AVOID INJURY WHEN CHECKING A HOT ENGINE. COVER THE RADIATOR CAP IN A THICK CLOTH AND TURN IT SLOWLY COUNTERCLOCKWISE TO THE FIRST STOP. AFTER THE PRESSURE HAS BEEN COMPLETELY RELEASED, PRESS THE CAP DOWNWARD AND FINISH REMOVING THE CAP.

The above instructions also apply to engines that stop due to operation of the low oil pressure / high water temperature safety switch. However, if the engine stops due to low oil pressure, do not restart until the cause has been determined.

OPERATING INSTRUCTIONS

PROBLEM DIAGNOSIS

Most operating troubles that might be encountered with a new or well maintained unit, will be of a minor nature. Therefore, if you have troubles starting or operating your engine, look for some simple cause rather than failure of a major component. For instance: Loose or corroded battery connections are much more likely than battery failure.

- A loose ignition wire is much more likely than a coil or ignition system failure.
- In many cases, engine operating troubles are coupled with outside factors, such as climatic conditions, operating conditions, change of servicing or fueling source, or change of operator.
- Engine troubles that occur as a result of normal use and wear usually give plenty of advance warning. These troubles usually result from overlooking the Scheduled Preventive Maintenance Services.
- Whenever engine performance seems less than normal in any category, it is best to consult with your distributor at the first symptom rather than wait until a serious problem develops. One of the aims of regular maintenance is to help you in just these circumstances.

ENGINE WON'T CRANK

1. Turn the key to the START position. If nothing happens, an electrical lead(s) may be loose or disconnected, the battery cables may be loose, disconnected or corroded or the battery discharged.
2. Another indication of loose battery connections or low battery condition is a stuttering noise from the starter relay when the ignition switch is turned to the START position. Check the connections to the starter motor and the solenoid switch in addition to the battery and ground connections.
3. Try operating the start switch several times. Should the switch be corroded, this operation may clean the contacts enough to make the switch temporarily operable until you can reach your distributor.
4. If all the electrical connections are tight and you need assistance to start, read the instructions under Emergency Starting.

OPERATING INSTRUCTIONS

ENGINE CRANKS BUT WON'T START

1. Check the fuel tank. You may be out of fuel. If there is fuel in the tank, the trouble may be in either the ignition system or in the fuel system.
2. Check the ignition system. Remove the wire from one of the spark plugs by grasping the moulded cap of the wire only, and insert a short piece of bare wire or other metal in the terminal of the wire.



WARNING: SPARK PLUG WIRES CARRY HIGH TENSION ELECTRICAL CURRENT CAPABLE OF GIVING A SHOCK. BE SURE TO GRAB THE MOULDED BOOT USING AN INSULATED TOOL.

Hold the cap, using an insulated tool, so that the inserted bare wire is about 1/4 inch from the engine block and crank the engine (with the ignition switch on) for at least three seconds. If there is no spark between the wire and the metal, check the ignition system for trouble. If you see a spark, then check the fuel system for trouble.

3. The fuel system may have a restricted fuel line, plugged fuel filter, air leaks in the fuel line or a faulty fuel pump.
4. Check the electric or manual choke. The choke linkage may be binding or damaged so that the choke plate in the carburetor is not opening and closing properly. Check the wire continuity from the electric choke (if equipped) to the generator and replace if open.

ENGINE RUNS HOT

Listed below are items which could cause an engine to overheat:

1. Low coolant level
2. Loose or broken fan belt(s)
3. Inoperative thermostat
4. Dirty cooling system
5. Radiator fins restricted with leaves, dirt, etc.
6. Prolonged idling
7. Running engine with frozen coolant
8. Leaky head gasket
9. Overloading, especially during hot weather
10. Ambient temperatures 125° F or higher

OPERATING INSTRUCTIONS

EMERGENCY STARTING

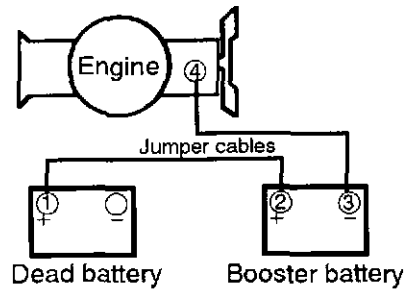

When using booster battery and jumper cables, particular care should be used when connecting to a booster battery in order to prevent sparks. Use the following to jump start (negative grounded battery):

1. Remove vent caps (if equipped) and cover the battery fill openings with a cloth
2. Shield eyes
3. Connect end of one cable to positive (+) terminals of each battery
4. Connect one end of other cable to negative (-) terminal of "good" battery
5. Connect other end of cable to engine block on unit being started.



WARNING: DO NOT ATTACH JUMPER TO NEGATIVE TERMINAL - ATTACH TO ENGINE BLOCK OF UNIT BEING STARTED.



CAUTION: To prevent damage to other electrical components on unit being started, make certain that engine is at idle speed before disconnecting jumper cables.

OPERATING INSTRUCTIONS

Do NOT attach jumper to negative terminal - Attach to engine block of unit being started

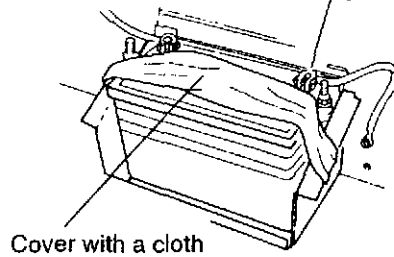

REMOVE CELL CAPS AND COVER THE BATTERY FILL OPENINGS WITH A CLOTH WHEN CHARGING OR USING JUMPER CABLES.



WARNING: BATTERIES CONTAIN SULFURIC ACID. IN CASE OF ACID CONTACT WITH SKIN, EYES, OR CLOTHING, FLUSH IMMEDIATELY WITH WATER FOR A MINIMUM OF FIVE MINUTES. GET "ON-THE-SPOT" MEDICAL ATTENTION IMMEDIATELY.



WARNING: HYDROGEN AND OXYGEN GASES ARE PRODUCED DURING NORMAL BATTERY OPERATION. THIS GAS MIXTURE CAN EXPLODE IF FLAMES OR SPARKS ARE BROUGHT NEAR THE BATTERY. WHEN CHARGING OR USING BATTERY IN AN ENCLOSED SPACE, ALWAYS PROVIDE VENTILATION.



WARNING: KEEP FIRE AWAY FROM THE TOP OF OPEN BATTERY CELLS. COMBUSTIBLE GAS IS ALWAYS PRESENT.



CAUTION: Avoid the use of a 24 volt battery and jumper cable hookup to start an engine with a dead battery, as this will damage the unit's electrical system.

OPERATING INSTRUCTIONS

FUEL RECOMMENDATION

This engine is designed to operate on unleaded 87 or 89 octane gasoline. The engine, with the proper fuel equipment, can also operate on dry fuel such as LPG and natural gas.

Use of unleaded gasoline with lower than 87 octane can cause persistent, heavy spark knock, which can lead to engine damage. If your engine knocks heavily when using unleaded gasoline with 87 octane or higher, or if you hear continuous spark knock while maintaining constant operating speeds, consult your distributor or another qualified technician.

FUEL QUALITY

Using a high quality gasoline will help maintain the power, fuel economy and emissions performance of your engine. A properly formulated gasoline will be comprised of well refined hydrocarbons and chemical additives and will perform the following functions:

- Minimize varnish, lacquer, and other induction system deposits.
- Prevent gum formation or other deterioration during storage.
- Protect fuel tank and other fuel system components from corrosion or degradation.
- Provide the correct seasonally and geographically adjusted volatility. This will provide easy starting in the winter and avoid vapor lock in the summer.
- Avoid fuel system icing.

In addition, the fuel will be free of water, debris, and other impurities.

We also recommend that the fuel supply be kept fresh; when the equipment is in storage (especially in hot weather), the fuel tank should be kept at least 3/4 full.

If you anticipate storage of your engine in excess of two months, consult your distributor or other qualified technician. Also refer to the information on storage in the "*Maintenance Instructions*" section of this manual.

OPERATING INSTRUCTIONS

ALCOHOL GASOLINE BLENDS (GASOHOL)

Gasohol, a mixture of gasoline and ethanol (grain alcohol), is available in some areas. Ford engines should operate satisfactory on gasohol blends containing no more than 10% ethanol by volume and having an octane (anti-knock) index of 87 or 89, reference engine specifications.



CAUTION: In some cases, methanol (wood alcohol) or other alcohols may be added to gasoline. Ford engines should operate satisfactory on blends containing up to 5% methanol by volume when cosolvents and other necessary additives are used. If not properly formulated with appropriate cosolvents and corrosion inhibitors, such blends may cause performance problems or damage emissions and fuel system materials. Insufficient data is available to insure the suitability of all methanol/gasoline blends at this time. To avoid jeopardizing your engine warranty or incurring unnecessary repairs costs, **DO NOT USE** blends containing more than 5% methanol by volume, or blends that do not contain cosolvents and corrosion inhibitors.

If you are uncertain as to the presence of alcohols in the gasoline you are purchasing, check the label on the pump or ask the station attendant.



CAUTION: Discontinue use of any gasohol or alcohol/gasoline blend if performance problems occur. Do not use such fuels unless they are UNLEADED.

MAINTENANCE INSTRUCTIONS

Initial Start-up Sequence checks	MAINTENANCE SCHEDULE					
	Operation	Daily	Every 100 Hours	Every 200 Hours	Every 400 Hours	Every 800 Hours
1	Check engine oil level	x				
2	Check coolant level [4]	x				
3	Check for fluid leaks	x				
	Lubricate PTO release bearing	x				
4	Governor, Check oil level [2]		x			
	Change engine oil & filter [1]		x			
5	Air cleaner, clean or replace element [1]				x	
6	Battery, check charge & fluid level [3]		x			
7	Lubricate PTO bearings		x			
	Inspect & clean radiator exterior [3]			x		
	Clean battery cables [3]			x		
9	Fan, Alternator, and Governor Belts, check and adjust tension			x		
	Lubricate Throttle, Governor and Choke Linkage			x		
12	Check and adjust idle speed				x	
13	Check and adjust idle mixture				x	
	Check or refill cooling system [3] [4]				x	
	Replace fuel filter [5]				x	
	Spark plugs: clean, adjust and test or replace [3]				x	
10	Ignition timing, check & adjust (check advance)				x	
	Replace PCV valve					x
	Clean PCV hoses, tubes and fittings					x
	Replace spark plugs [3]					x
14	Adjust throttle and governor [3]					x
11	Check all bolts & nuts for tightness [3]					
8	Adjust PTO clutch release and shaft bearings [3]					
	[1] More frequent intervals may be required in dusty areas. [2] Mechanical governor (belt driven). [3] Seasonal or as required. [4] Check engine coolant condition and protection, hoses and clamps annually (prior to cold weather). [5] More frequent intervals may be required with dirt in fuel or system.					

MAINTENANCE INSTRUCTIONS

INITIAL START UP MAINTENANCE

Your Ford Industrial Engine was inspected before leaving the factory. However, the initial start-up checks must be made before putting the unit into operation. The Preventive Maintenance Schedule (at the beginning of this section) provides a handy check-off list. **Perform the initial start up operations in the sequence listed in the left hand column.**

ROUTINE SERVICE

Make sure your unit is ready to go whenever you need it. There are some things that you can do or have done, to be sure it is well cared for:

- Keep the fuel tank filled. A full tank reduces the possibility of condensation forming in the tank and moisture entering the fuel lines.
- Make frequent check of the engine oil and coolant levels.
- Check the battery fluid level often, especially if your engine is being operated in a warm, dry climate (if applicable).
- Keep engine air filter clean.
- Watch the engine temperature.
- Watch the engine oil pressure.
- Watch the voltmeter.
- Lube power take-off regularly (if applicable).

NOTE: It is highly recommended that a Fuel Stabilizer, Ford Part Number E8AZ-19C544-A or an equivalent additive be used for any length of storage. It is imperative in any application where the fuel will not be consumed within thirty days. Refer to "STORAGE" in this section for further information.

SCHEDULED PREVENTIVE MAINTENANCE

The operations listed in the maintenance schedule are covered in detail on the following pages. Whenever your engine requires maintenance of any kind, your Ford Power Products distributor has skilled technicians who will do an expert job of keeping your engine in its prime condition.

MAINTENANCE INSTRUCTIONS

ENGINE OIL LEVEL CHECK

The oil level should be checked frequently, at least daily, and maintained between the SAFE marks on the dipstick. Allow a few minutes after shutting the engine off for the oil to drain down before checking.

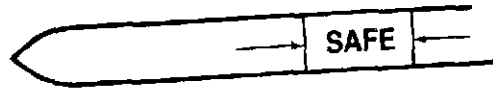

CAUTION: Do not operate the engine with the oil level:
– below the bottom mark on the dipstick – engine damage will occur. – above the top mark on the dipstick – oil consumption will increase.

ADDING ENGINE OIL

It is normal to add some oil between oil changes. The amount will vary with the severity of operations. When adding or replacing engine oil be sure oils meet the specifications listed.

CHANGING ENGINE OIL AND FILTER

For most operations, the engine oil and filter must be changed every 100 hours or seasonally. Under normal operating conditions, you do not need to change more often if you use oil and filters of the recommended quality.

The oil and filter should be changed more often if the engine is operating in dusty areas, for extended idling or low speed operation, or frequent stops during cold weather. No oil additives or break-in oil change is required.



WARNING: THE AMERICAN PETROLEUM INSTITUTE (API) HAS ANNOUNCED THAT CONTINUOUS CONTACT WITH USED MOTOR OIL HAS CAUSED SKIN CANCER IN LABORATORY MICE. THE EFFECTS OF USED MOTOR OIL ON HUMANS HAS NOT BEEN ESTABLISHED. IT IS RECOMMENDED, HOWEVER, THAT AS A PRECAUTIONARY MEASURE, HUMANS PROTECT THEIR SKIN BY WASHING WITH SOAP AND WATER AFTER COMING IN CONTACT WITH USED MOTOR OIL.

MAINTENANCE INSTRUCTIONS

ENGINE OIL QUALITY

To help achieve proper engine performance and durability, it is important that you use only engine lubricating oils of the proper quality in your engine. Proper quality oils also provide maximum efficiency for crankcase ventilation system which reduces pollution.

Use Ford or Motorcraft oil or equivalent that meets Ford Specification

ESE-M2C153-E (API Classification-SH). If SH oils are not available, SG oils are acceptable. Use only engine oil displaying the American Petroleum Institute Certification Mark on the front of the container, or API specification SH or SG

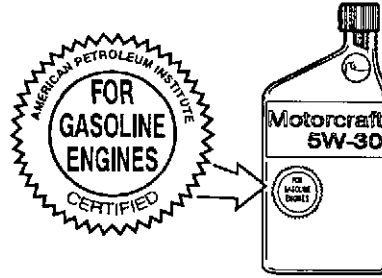

Gasoline engines that are converted for LPG or Natural Gas applications must use oils labeled SG and/or SH. Do not use oils that are specifically formulated for Diesel Engines only. CC or CD classification, even when labeled Heavy Duty or for Natural Gas Engines, are not acceptable.

ENGINE OIL VISCOSITY

When you change or add oil, you should select oil with the proper specifications and with the viscosity (selected from the following tables) which most closely matches the temperature range you expect to encounter for the next 100 hours of operation.

The use of SAE 5W-30 is preferred for all temperatures:

COLD BELOW 0°F (-18°C)	MODERATE TEMPERATURE	HOT ABOVE 100°F (38°C)

NOTE: Single viscosity oils are **never required**, but can be used if desired:

MAINTENANCE INSTRUCTIONS

SINGLE VISCOSITY OILS	
When outside temperature is consistently:	Use SAE viscosity #:
Above +32°F (0° C)	30
Above +50°F (10° C)	40

ENGINE OIL FILTER

Your engine is equipped with a Motorcraft oil filter. A filter of this quality should be used throughout the life of the engine. It is designed to protect your engine by filtering harmful abrasive and sludgy particles without clogging up or blocking the flow of the oil to vital engine parts. This filter is especially designed for use in engines built by Ford to give successful operation with the recommended oil filter change intervals.

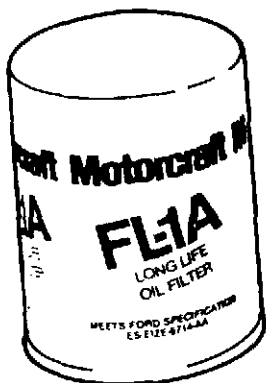

Part number FL-1A

Spin-on Type Filter Replacement – Place a drain pan under the filter and unscrew the filter using a filter wrench. Discard the filter. Clean the filter mounting base, and coat the gasket surface of the new filter with clean engine oil. Hand-tighten the filter until the gasket contacts the face of the mounting base, then tighten another one-half turn. Fill the crankcase and run the engine to check for leaks. Tighten the filter more if necessary.



WARNING: DO NOT HANDLE A HOT OIL FILTER WITH BARE HANDS. CONTINUOUS CONTACT WITH USED MOTOR OIL HAS CAUSED SKIN CANCER IN LABORATORY MICE. PROTECT YOUR SKIN BY WASHING WITH SOAP AND WATER.

MAINTENANCE INSTRUCTIONS

AIR CLEANER

Air that contains dirt and grit produces an abrasive fuel mixture, and can cause severe damage to the cylinder walls and piston rings. Your air cleaner filters air entering the engine induction system and acts as a silencer and a flame arrester. Damage to the cylinder walls and piston rings will cause high oil consumption and short engine life. A restricted or dirty air cleaner will also cause a rich fuel mixture. Thus, it is extremely important that the air cleaner be serviced at recommended intervals.



CAUTION: Service the air cleaner more frequently under severe dust conditions.

Dry type filter replacement – Remove the paper filter element from the air cleaner. Inspect the element for mud caking, foreign material restrictions or signs of excessive wear or damage. Replace as necessary. Remove all dust and foreign matter from the air cleaner housing. The inlet will be dirty if air cleaner servicing has been neglected or if dust laden air has been leaking past the air cleaner. Make sure that the air cleaner is seated properly on the inlet housing with all necessary seals installed.

MAINTENANCE INSTRUCTIONS

COOLING SYSTEM LEVEL CHECK

Whenever coolant level checks are made check condition of radiator cap rubber seal. Make sure it is clean and free of any dirt particles. Rinse off with clean water if necessary. When replacing cap on radiator, also make sure radiator filler neck is clean.

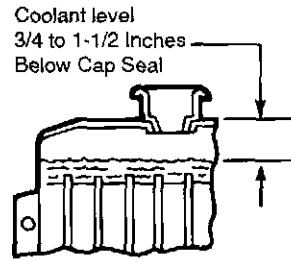

To refill the cooling system, fill radiator to the proper level with the recommended coolant mixture. Operate engine until thermostat opens and the radiator upper hose becomes hot. Stop the engine and add coolant to 3/4" – 1 1/2" below the filler neck. For marine expansion tank systems, reference the manufacturers recommendations for filling levels.



WARNING: AVOID INJURY WHEN CHECKING A HOT ENGINE. COVER THE RADIATOR CAP IN A THICK CLOTH AND TURN IT SLOWLY COUNTERCLOCKWISE TO THE FIRST STOP. AFTER THE PRESSURE HAS BEEN COMPLETELY RELEASED, PRESS DOWNWARD AND FINISH REMOVING CAP. DO NOT ADD COOLANT TO AN ENGINE THAT HAS BECOME OVERHEATED UNTIL THE ENGINE COOLS. ADDING COOLANT TO AN EXTREMELY HOT ENGINE CAN RESULT IN A CRACKED BLOCK OR CYLINDER HEAD. FAILURE TO FOLLOW THESE INSTRUCTIONS COULD RESULT IN DAMAGE TO THE COOLING SYSTEM OR ENGINE AND/OR PERSONAL INJURY.

Use only a permanent-type coolant that meets Ford Specification ESE-M97B44-A, such as Ford Cooling System Fluid. Refer to the coolant mixture chart on the container for additional antifreeze protection information. Do not use alcohol or methanol antifreeze, or mix them with the specified coolant.

NOTE: In an emergency, plain water may be used. Replace it with the specified coolant as quickly as possible to avoid damage to the system. With only water in the system, do not let engine run hot.

RADIATOR

Inspect the exterior of the radiator for obstructions. Remove all bugs, dirt or foreign material with a soft brush or cloth. Use care to avoid damaging the fins. If available, use low pressure compressed air or a stream of water in the opposite direction to normal air flow. Check all hoses and connections for leaks. If any of the hoses are cracked, frayed, or feel spongy, they should be replaced.

MAINTENANCE INSTRUCTIONS

DRIVE BELTS

The drive belts should be properly adjusted at all times. A loose drive belt can cause improper operation, in addition to overheating. Overtightening the belt may result in excessive bearing wear, as well as premature wear on the belt itself.

DRIVE BELT TENSION

A belt tension gauge should be used to check V-belt tension. **Any belt that has operated for a minimum of 10 minutes is considered a used belt.** It must be adjusted to the reset tension shown in the specifications.

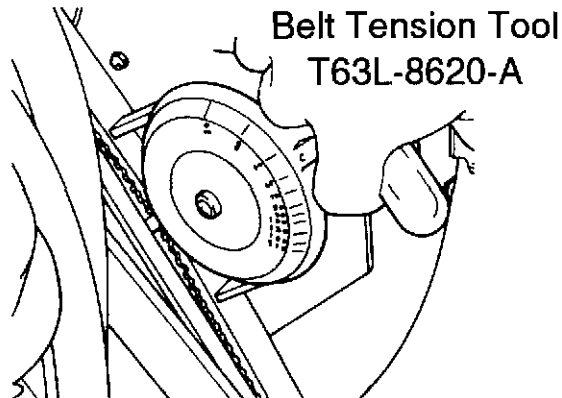

To adjust V-drive belt tension:

1. Loosen the mounting bolts.
2. Move the driven component until the correct tension is obtained (see "Belt Tension" in the Specifications Section).
3. Remove the gauge.
4. Tighten the mounting bolts.
5. Recheck belt tension with tension gauge.

MAINTENANCE INSTRUCTIONS

BATTERY FLUID LEVEL CHECK

Because the battery is the "heart" of your unit's electrical system, periodic checks are necessary to keep functioning properly. Keep the battery fluid level up to the ring under the filler cap (if applicable).

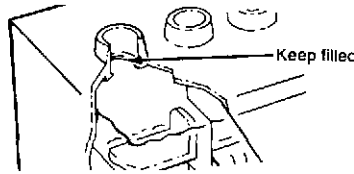

ADDING BATTERY WATER

Ordinary tap water may be used except in areas where the water is known to be exceptionally hard or to have a high mineral or alkali content. In such areas, use distilled water. If water is added during freezing weather, run the engine 20 to 30 minutes before shutting it off. This mixes the added water with the electrolyte and will prevent it from freezing and damaging the battery.

Have the battery charge checked regularly during extreme cold weather. When the specific gravity falls below 1.230 (corrected to 80°F), recharge the battery. Make sure the cables are clean and tightly clamped to the battery terminals. Keep the top of the battery clean and dry.



WARNING: BATTERIES NORMALLY PRODUCE EXPLOSIVE GASES WHICH CAN CAUSE PERSONAL INJURY. THEREFORE, DO NOT ALLOW FLAMES, SPARKS OR ANY IGNITED OBJECT TO COME NEAR THE BATTERY. WHEN CHARGING OR WORKING NEAR A BATTERY, ALWAYS SHIELD YOUR EYES. ALWAYS PROVIDE VENTILATION.

If there is any corrosion on the cables and terminals remove it with a wire brush and neutralize the acid with a solution of baking soda or ammonia with water. After cleaning, flush the top of the battery with clean water, install the terminal clamps on the battery posts, and coat the parts with grease to retard further corrosion.



WARNING: WHEN LIFTING A BATTERY, ALWAYS LIFT WITH A BATTERY CARRIER OR WITH YOUR HANDS ON OPPOSITE CORNERS. EXCESSIVE PRESSURE ON THE END WALLS COULD CAUSE ACID TO SPEW THROUGH THE VENT CAPS, RESULTING IN PERSONAL INJURY.

MAINTENANCE INSTRUCTIONS

CRANKCASE VENTILATION SYSTEM

All engines are equipped with a positive crankcase ventilation system. Clean air is supplied from the air cleaner by a tube to the closed cap on the rocker cover. The fumes are vented through a regulator valve on the rocker cover and then into the intake manifold. The P.C.V. valve (regulator valve) must be replaced and the hoses, tubes and fittings of this system must be cleaned at the recommended intervals.

FUEL FILTER

The disposable filter is part of the fuel pump. Replace the filter by unscrewing the canister. Remove the filter element and gasket. Place a new filter element in the canister. Coat a new gasket with light engine oil and position the gasket on the canister. Screw the canister onto the filter body. Hand tighten the filter until the gasket contacts the body and then advance it 1/8 turn. Start the engine and check for leaks.

CARBURETOR ADJUSTMENTS – Holley

The idle speed adjustment screw, and the idle fuel mixture adjustment needle are accessible on the exterior of the carburetor.

There are three factors that control conversion of the fuel and air mixture into engine power. These factors are engine compression, ignition and correct carburetor adjustment. Correct carburetor adjustment cannot be obtained, however, unless engine compression and ignition meet specifications.

To make the adjustments, start the engine and operate it until it has reached normal operating temperature. Be sure the choke and throttle controls are pushed all the way in.

Start the adjustments by setting the idle speed screw to obtain an engine speed of 650 – 750 rpm. Then turn the idle fuel mixture adjustment needle in (clockwise) until the engine begins to roll. Then, back it out slowly until the engine is running smoothly. Reset the idle speed to 650 – 750 rpm.

MAINTENANCE INSTRUCTIONS

IGNITION SYSTEM

A dual advance distributor, with a centrifugal and vacuum spark advance system, is used with this engine. The direction of distributor rotation is counterclockwise as viewed from the top of the distributor. The spark plug wires are inserted in the distributor cap in the firing order of the engine 1-5-4-2-6-3-7-8. The number one socket is identified by the number one on the cap. The cylinders are numbered from front to rear - 1-2-3-4 right side, and 5-6-7-8 left side, as viewed from the rear of the engine.

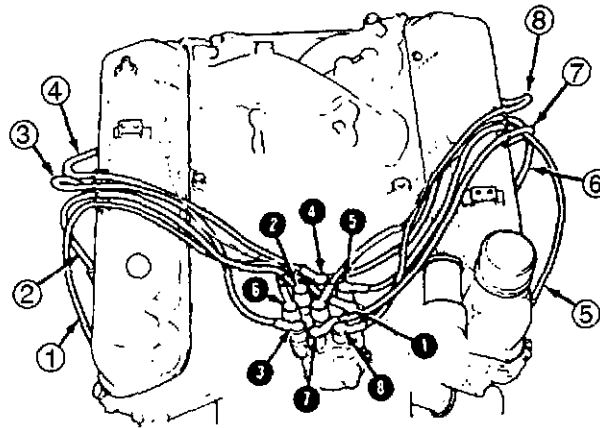

FPP00300

The Solid-State Ignition system has a larger rotor, distributor cap and adapter ignition secondary wires and wide gap spark plugs to take advantage of the higher energy produced. No adjustments are made to the ignition system except initial timing and spark plug gap.

When installing a new distributor cap or rotor, coat the brass rotor electrode surfaces on all sides outboard of the plastic, including the outer edge, with D7AZ-19A331-A silicone dielectric compound, or equivalent to approximately 1/32 inch thickness. Do not reapply or attempt to remove any silicone coating from the distributor cap electrodes. As this compound ages, it has the appearance of being a contaminant of the cap and rotor electrode. This condition is normal and causes no performance loss.

Coat the inside of each spark plug boot with silicone dielectric compound D7AZ-19A331-A or equivalent, using a small screwdriver blade. Connect each spark plug wire to the plug from which it was removed. Be sure each wire is fully depressed on each plug and molded boot is firmly in place.

MAINTENANCE INSTRUCTIONS

IGNITION TIMING CHECK

Proper adjustment of ignition timing must be maintained to provide maximum engine power output and best possible fuel economy. The timing marks are located on the crankshaft damper and can be seen from the right side. These marks and a pointer on the engine front cover are used to time the engine. The recommended timing setting is 10° BTDC. Adjust the ignition timing as follows:

Disconnect and plug the distributor vacuum line. Connect the timing light high tension lead to the No. 1 spark plug (right front cylinder), and the other two leads to the proper battery terminals. Clean and chalk the timing marks to improve legibility.

Operate the engine at a maximum of 600 rpm, and direct the timing light at the pointer. The light should flash just as the 10° mark on the damper lines up with the pointer. If the 10° mark and the pointer do not line up, loosen the distributor retaining bolt, and rotate the distributor until the mark and notch are in line.

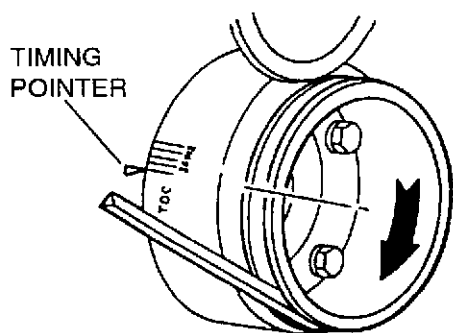

FPPO0301

NOTE: Ignition timing is advanced by clockwise rotation of the distributor body – retarded by counterclockwise rotation.

When the proper timing is obtained, tighten the distributor retaining bolt and unplug and connect the distributor vacuum line, then accelerate the engine while watching the timing mark with the timing light to determine if the advance mechanism is functioning. The marks on the crankshaft damper should advance as engine rpm increases. This check will confirm whether or not the advance mechanism is functioning.

MAINTENANCE INSTRUCTIONS

SPARK PLUGS

The spark plugs should be replaced at the recommended intervals. Remove the wires from each spark plug by grasping, twisting and then pulling the moulded cap of the wire only.



Caution: Do not pull directly on the wire because the wire connection inside the cap may become separated.

After loosening each spark plug one or two turns, clean the area around each spark plug port with compressed air, then remove the spark plugs. Set the spark plug gap to specifications by bending the ground electrode. All spark plugs new or used should have the gap checked. Install the spark plugs and torque each plug to specifications.

NOTE: Do not overtighten spark plugs. Refer to torque specification chart. The gap may change considerably due to distortion of the plug outer shell.

Coat the inside of each spark plug boot with silicone dielectric compound D7AZ-19A331-A or equivalent, using a small screwdriver blade. Connect each spark plug wire to the plug from which it was removed. Be sure each wire is fully depressed on each plug and molded boot is firmly in place.

MAINTENANCE INSTRUCTIONS

MECHANICAL GOVERNOR LUBRICATION

Clean the body of the governor in the area of the fill plug. Check the oil level by slowly removing the oil level plug. If oil drips out, the oil level is full. If oil doesn't drip out, slowly add engine oil into the oil fill hole. As soon as it begins dripping out the oil level hole, insert the plug.

At the specified intervals, apply an appropriate lubricant, such as Lubriplate (COAZ-19584-A) at the pivot points of the throttle, governor and choke linkage.

MECHANICAL GOVERNOR ADJUSTMENT

NOTE: Before making any governor adjustments, check the governor drive belt tension with a belt tension gauge. Set the belt to the tension listed in the Specification Section (replace belt if cracked or damaged).

The first adjustment is the governor-to-carburetor control rod adjustment. With the control rod connected, manually move the governor throttle lever to the maximum open throttle position. Check that the carburetor throttle shaft lever is set from 1/32 to 1/16 of an inch from its maximum open position stop. If necessary adjust length of the control rod to obtain the setting.

To perform a high-speed adjustment, attach a tachometer to the engine, then run the engine until it reaches normal operating temperature.

1. Loosen the locknut on the high speed stop screw
2. Disengage engine load
3. Slowly increase the throttle to desired maximum no load engine speed.
4. Adjust the high speed stop screw on the governor to attain the desired maximum engine speed – do not exceed the recommended maximum rpm.
5. Tighten the locknut.

MAINTENANCE INSTRUCTIONS

The next adjustment is for spread. Proper governor operation requires a difference between full-load and no-load governor speed. Too small an rpm spread between the two speeds will cause governor hunting and surging. Too large a spread will cause the low response. For this governor, normal rpm spread is approximately 250 rpm within the full load speed range of 2000–2800 rpm.

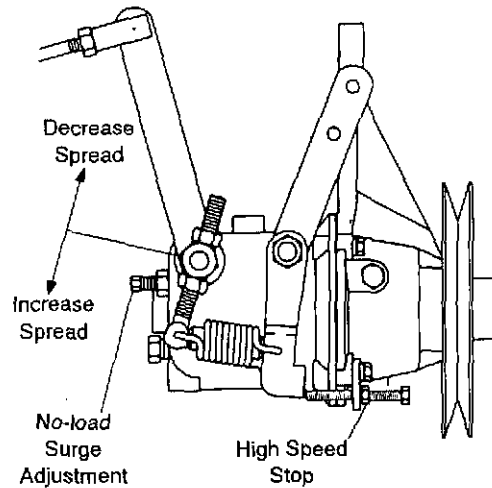

To increase the rpm spread, adjust the screw to move the spring away from the lever hub. To decrease the rpm spread, adjust the screw to move the spring closer to the lever hub.

The no-load surge adjustment is set at the factory and rarely requires adjustment. If necessary, this adjustment can be used to prevent **hunting and surging at no-load speeds only, provided the rpm spread adjustment is set properly**. Make the adjustment with the tachometer installed. Increase the engine speed with the hand throttle to 75 rpm lower than the maximum no-load desired control rpm. (NOTE: At this point if the engine continues to surge, light pressure applied to governor throttle lever will dampen surges). Then loosen the no-load surge adjustment screw locknut and turn the screw inward until the rpm increases to the desired control rpm. Reset high speed adjustment screw and tighten lock-nuts.



CAUTION: Do not turn the screw in all the way. It will interfere with proper governor operation and prevent the governor from returning the engine to idle speed.

MAINTENANCE INSTRUCTIONS

STORAGE

NOTE: It is highly recommended that a Fuel Stabilizer, Ford Part Number E8AZ-19C544-A or an equivalent additive be used for any length of storage. It is imperative in any application where the fuel will not be consumed within thirty days. Ford Fuel stabilizer comes in an 8 fl. oz. bottle for consumer use and should be available through all Power Products Distributors. The correct ratio is 2 oz. Stabilizer to 5 gallons of gasoline. Without the use of an additive, the unused fuel in your fuel tank can and will go sour in a very short period of time, causing varnish and contaminants to form. This causes problems in fuel delivery by clogging the Inlet Needle & Seat and Jets.

STORAGE – ONE MONTH

- Add fuel stabilizer (see note above).
- While the engine is running, treat upper cylinders by spraying engine fogging agent (from your local aftermarket supplier), recommended engine oil (SAE 10) or equivalent into the air intake for about two minutes. Open throttle for short burst of speed, shut off engine and allow it to come to a stop while continuing to spray into air intake.
- Leave spark plugs in holes or seal spark plug holes with suitable threaded metal plugs and cover all openings into engine with dust-proof caps or shields (suitable non-hygroscopic material).
- If engine is less transmission, spray flywheel and ring gear with mixture of one part recommended engine oil, and one part Standard Solvent or equivalent.
- Check coolant protection. Store indoors in dry area.

MAINTENANCE INSTRUCTIONS

STORAGE – INDEFINITE PERIOD

- Add fuel stabilizer (see note above).
- Drain crankcase completely and refill with recommended engine oil, (SAE 10) or equivalent.
- Run engine until completely out of gasoline, then restart and run on unleaded gasoline, mixed with stabilizer, for at least 10 minutes. While engine is still running and at completion of above run, treat upper cylinders by spraying fogging agent or recommended engine oil into the air intake for about two minutes. Open throttle for short burst of speed, shut off engine and allow it to come to a stop while continuing to spray into air intake.
- Check coolant protection.
- Disconnect and remove battery.
- Clean exterior surface of engine.
- Leave spark plugs in holes or seal spark plug holes with suitable threaded metal plugs.
- Seal all openings in engine and accessories with Non-hydroscopic material. Mask off all areas to be used for electrical contact.
- Make sure all surfaces are dry, then spray all taped openings, all engine accessories including ignition wiring, and all exterior surfaces of engine with Insulation Compound.
- If engines are equipped with automotive type clutch, block clutch in slightly disengaged position so that lining and pressure plates are not in contact.

SPECIFICATIONS

GENERAL

Number of cylinders	V8
Displacement	460 CID (7.5 L)
Valve system	pushrod/rockerarm
Firing order	1-5-4-2-6-3-7-8
Low idle speed	650-750 rpm
Max. operating speed (no load-high idle)	3050 rpm
Cylinder placement – right bank	1-2-3-4
– left bank	5-6-7-8

* Engine speeds for "standard" power unit configuration with mechanical governor. Engine speeds for other applications may vary. In those cases, refer to the applicable equipment operator's manual.



WARNING: UNLESS YOU HAVE DOCUMENTED APPROVAL FROM YOUR EQUIPMENT MANUFACTURER, DO NOT OPERATE THE ENGINE ABOVE 3050 RPM!

APPROXIMATE CAPACITIES

Oil capacity (including filter)	9 quarts (8.5 liters)
---------------------------------	-----------------------

IGNITION SYSTEM

Spark plug	AWSF-42
.. Gap	.032-.036" (.812-.914mm)

BELT TENSION

New	120-150 lb.ft. (163-203Nm)
Used	90-120 lb.ft. (122-163Nm)
Minimum	75 lbs.ft. (102 Nm)

(A used belt is one that has been in operation for 10 minutes or more.)

SPECIFICATIONS

TORQUE SPECIFICATIONS – Special Applications		
ITEM	Nm	lb.ft.
Front cover	21–28	15–21
Head bolts – step 1	95–108	70–80
– step 2	136–149	100–110
– step 3	177–189	130–140
Damper to crankshaft	95–122	70–90
Fuel pump	26–36	19–27
Flywheel	102–115	75–85
Intake manifold	30–43	22–32
Exhaust manifold	38–44	28–33
Oil filter insert	62–74	45–55
Oil filter (oiled gasket)	1/2 turn past gasket contact.	
Oil filter center bolt	55–67	40–50
Oil pan drain plug	21–33	15–25
Oil pan	13–14	9–11
Oil pump to block	30–43	22–32
Pulley to damper bolt	48–67	35–50
Spark plug	7–13	5–10
Rocker arm cover	7–8	5–6
Water outlet housing	14–20	10–15
Water pump	21–28	15–21
Generator bracket to block	41–61	30–45
Generator pivot bolt	62–77	45–57
Generator adjusting arm to block	48–67	35–50
Generator adjusting arm to generator ..	33–54	24–40
Carburetor nuts	17–20	12–15

SPECIFICATIONS

NOTE: Oil threads with a lightweight engine oil unless the threads require oil or water resistant sealer.

TORQUE SPECIFICATIONS – General Applications		
U.S. TREAD SIZES	Nm	lb. ft.
1/4-20	8-12	6-9
5/16-18	16-24	12-18
5/16-24	19-27	14-20
3/8-16	30-43	22-32
3/8-24	37-51	27-38
7/16-14	54-75	40-55
7/16-20	54-81	40-60
1/2-13	75-108	55-80
METRIC THREAD SIZES		TORQUE
M-6	8-12	6-9
M-8	19-28	14-21
M-10	38-54	28-40
M-12	68-96	50-71
M-14	108-155	80-114
PIPE THREAD SIZES		TORQUE
1/8-27	7-11	5-8
1/4-18	11-16	8-12
3/8-18	16-24	12-18
1/2-14	16-24	12-18

INDEX

Air cleaner	21
Battery fluid level check	24
Battery—adding water	24
Carburetor adjustments	25
Choke control (manual)	4
Cooling system level check	22
Crankcase ventilation system	25
Drive belts	23
Emergency starting	12
Engine identification	3
Engine oil — adding oil	18
Engine oil and filter change	18
Engine oil filter	20
Engine oil level check	18
Engine oil quality	19
Engine oil viscosity	19
Engine warning lights	6
Fuel filter	25
Fuel recommendation	14
Governor, mechanical — adjustment	29
Governor, mechanical — lubrication	29
Hourmeter	7
Ignition switch	4
Ignition system	26
Ignition timing	27
Maintenance schedule	16
Malfunction indicator light	6
Oil pressure gauge	7
Power take—off control	5
Problem diagnosis	10
Radiator	22
Safety switch	7
Service literature	3
Spark plugs	28
Specifications	33
Starting the engine	8
Stopping the engine	9
Storage	31
Tachometer	7
Temperature gauge	7
Throttle control	4
Voltmeter	7

! WARNING: !

*The Engine Exhaust from this product
contains chemicals known to the State
of California to cause cancer, birth
defects or other reproductive harm.*

REV. 11-97

PPD 194-231

LITHO IN USA