



**Power
Products**

**MAINTENANCE and
OPERATOR'S MANUAL**

**V-8 GASOLINE ENGINES
330, 361 and 391 CID**

Table of Contents

INTRODUCTION	2
OPERATING INSTRUCTIONS	
Controls	5
Instruments	6
Starting the Engine	8
Stopping the Engine	9
Special Situations	10
Emergency Starting	12
MAINTENANCE INSTRUCTIONS	
Preventive Maintenance Schedule Chart	14
Initial Start Up	15
Routine Service	15
Scheduled Preventive Maintenance	15
Storage	37
SPECIFICATIONS	39
INDEX	48

Introduction

INTRODUCTION

We are highly pleased that you have selected a Ford unit for your engine requirements. The Ford Motor Company takes great pride in the long tradition of quality products and great values that the Ford name represents.

Ford Industrial Engines are tested and inspected before leaving the factory. However, certain checks should be made before putting them into regular operation. Read the Initial Start Up requirements in the Maintenance Instructions.

HOW TO USE THIS MANUAL

We wrote the manual especially for you. We hope you use it to get to know your engine and how to get the most out of it. That is why we urge you to read this manual from cover to cover. First, you'll become familiar with the various controls and instruments. As you read further, we tell you how to maintain your engine and what services need to be performed to keep it in excellent running condition.

The *Subject Index on the title page* permits you to quickly open the manual to any Section. The *Alphabetical Index* at the back of the manual provides a page reference to a particular item or procedure.

Ford Industrial Engines are built with a variety of standard and/or optional components to suit a wide range of customer requirements. This manual does not identify equipment as standard or optional. All the equipment described in this manual may not be found on your engine or power unit.

The descriptions and specifications contained in this manual were in effect at the time it was approved for printing. The Ford Companies reserve the right to discontinue models at any time, or to change specifications or design without notice and without incurring obligation.



FORD MOTOR COMPANY
INDUSTRIAL ENGINE OPERATIONS
FORD PARTS AND SERVICE DIVISION
P.O. BOX 3080
LIVONIA, MICHIGAN 48151

INTRODUCTION

ENGINE IDENTIFICATION

An Identification Decal is affixed to the right side rocker cover of each engine. The decal contains the engine serial number which identifies this unit from all others. Next is the engine displacement which determines the engine specifications; then the model number and S.O. or special options which determine the parts or components required on this unit. Use all numbers when seeking information or ordering replacement parts for this engine. For a handy reference, record the information on the decal below:

 Power Products	Serial	<input type="text"/>
	Eng. Displ.	<input type="text"/>
	Model	<input type="text"/>

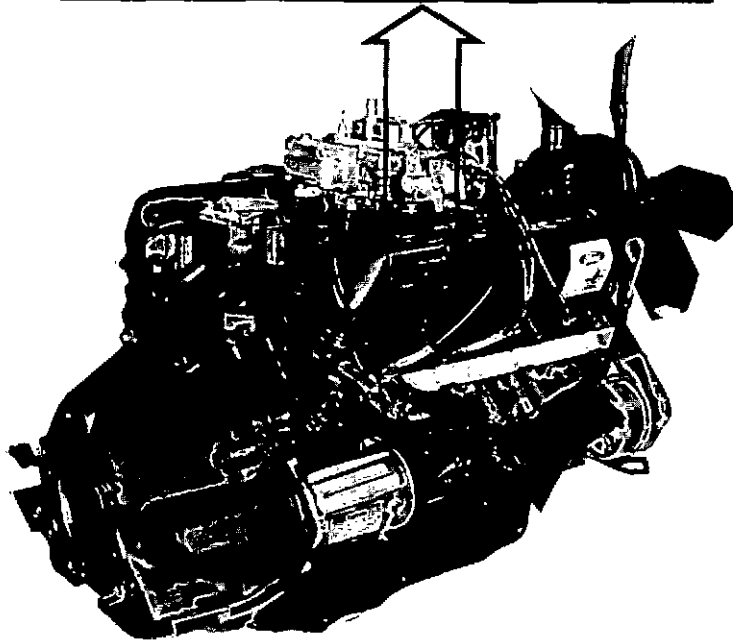

INTRODUCTION

PARTS AND SERVICE

Replacement parts can be obtained through your local Ford Power Products Distributors and Dealers. They are listed in the accompanying directory or can be found in the yellow pages under "Engines".

Ford Power Products Distributors and Dealers are equipped to perform major and minor repairs. They are anxious to see that all of your maintenance and service needs are quickly and courteously completed.

Operating Instructions

CONTROLS

Ignition Switch

This two-position switch is located on the control panel. In the OFF position, the switch disconnects the auxiliary electrical equipment and the starting circuit from the battery. The key can be removed from the switch when it is in this position. In the ON position, the switch connects the auxiliary electrical equipment and the starting circuit to the battery.

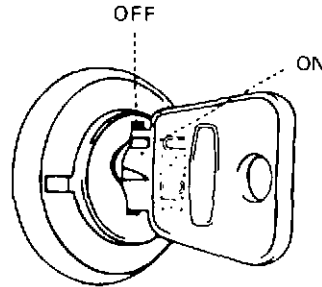

Starter Button

Engage the starter by turning the ignition switch to the ON position and depress the starter button. Release the button when the engine starts.

Choke Control

The choke control is connected to the carburetor and operates the choke butterfly to enrich the fuel mixture on cold starts. Pulling the control out closes the choke and pushing it in opens the choke.

Throttle Control

The throttle control is connected to the carburetor throttle shaft. Initial engine speed adjustment is obtained by pressing the throttle control release button while pulling the throttle knob out to increase the engine speed or pushing it in to decrease the engine speed.

A final fine speed adjustment is obtained by turning the throttle control counterclockwise to increase engine speed or clockwise to decrease engine speed.

Power Take-Off

The power take-off control handle allows engagement and disengagement of the power take-off clutch.

OPERATING INSTRUCTIONS

On Rockford Units, moving the lever towards the engine engages the clutch, and pulling the lever away from the engine disengages the clutch.

On Funk units, moving the lever away from the engine engages the clutch.

When moving the handle to engage the clutch and pick up the load, do so in a smooth manner. Moving the clutch handle too slowly will cause slippage and wear, while moving it too fast will cause quick engagement and possible damage to the power take-off, engine or driven equipment. The normal force required to engage the Rockford unit clutch is 65-80 pounds. On Funk units the force required is considerably less.

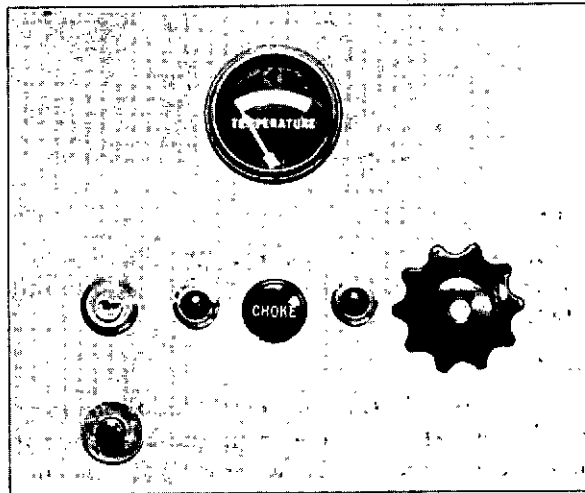

Typical Instrument Panel

INSTRUMENTS

Oil Pressure Gauge

The oil pressure gauge registers the lubricating system pressure in pounds-per-square-inch and should be frequently checked to ensure that the system is functioning correctly. Normally the pressure registered by the gauge should remain constant for a given engine speed (see Specifications).

Should the pressure fluctuate or drop, stop the engine and find the cause. Do not operate the engine at lower than normal oil pressures.

OPERATING INSTRUCTIONS

Ammeter

This instrument registers the charging current which is being passed to the battery by the alternator. It also registers a discharge equivalent to the amount of current being used by the electrical equipment when the alternator is not charging.

Temperature Gauge

The temperature gauge registers the coolant temperature and will indicate overheating which may arise from low coolant level, clogged radiator, loose fan belt or faulty thermostat.

By operating the engine at the correct temperature maximum power, longer life and better fuel economy will be ensured.

Engine Warning Lights

Units equipped with an engine warning light system have indicator lights mounted on the control panel. These lights come on to indicate dangerously low oil pressure or alternator not charging. If any light comes on with engine running, stop and correct cause of low oil pressure or alternator not charging.

Safety Switch

The optional low oil pressure – high water temperature safety switch automatically shuts off the ignition when the oil pressure drops below a preset value, or when the water temperature rises above a preset value. The switch operates in conjunction with contacts integral with the oil pressure warning mechanism and the water temperature gauge. The contacts are adjusted by an Allen head screw on the face of the gauge. A button on the instrument panel is used to override the safety switch when starting the engine.

Tachometer

The tachometer (optional) indicates the engine speed in hundreds of revolutions per minute. It serves as a guide to maintain engine speed in the most desirable operating ranges.

Hourmeter

This instrument (optional) records the hours of operation and is used to determine when periodic maintenance is required.

OPERATING INSTRUCTIONS

STARTING THE ENGINE

Release the load on the power take-off, or if the engine is equipped with a transmission, disengage the clutch. If the engine is started with the load engaged, it imposes an unnecessary strain on the starter and battery.

If your unit is equipped with the engine warning light system, always turn the ignition switch to the ON position to make sure that each warning light is operating before starting engine.

CAUTION — All internal combustion engines give off various fumes and gases while running. Do not start or run the engine in a closed or poorly ventilated building where the exhaust gases can accumulate. Avoid breathing these gases as they may contain poisonous carbon monoxide which can endanger your health or life if inhaled steadily for even a few minutes.

Normal Starts

Pull the throttle out about 1/2 inch and the choke out about halfway. Turn the ignition switch to the ON position. Push the starter button. After the engine starts, decrease the throttle setting and adjust the choke for fast idle warm-up. When the engine is at normal operating temperature, push the choke in all the way.

CAUTION — If the engine stalls or falters in starting, wait three or four seconds before re-engaging starter. This will prevent possible damage to the starter or engine.

The starter should not be operated for periods longer than 30 seconds at a time. An interval of at least two minutes should be observed between such cranking periods to protect the starter from overheating.

Engine Cold

Pull the throttle out about 1/2 inch and the choke all the way out. Turn the ignition switch to the ON position. Press the starter button. When the engine starts, adjust the choke setting to keep the engine running smoothly. When the engine is at normal operating temperature, push the choke in all the way.

To assure satisfactory operation in cold weather, allow approximately five minutes for engine warm-up before engaging load.

OPERATING INSTRUCTIONS

CAUTION — If the engine stalls or falters in starting, wait three or four seconds before re-engaging starter. This will prevent possible damage to the starter or engine.

The starter should not be operated for periods longer than 30 seconds at a time. An interval of at least two minutes should be observed between such cranking periods to protect the starter from overheating.

Engine Flooded

To start a "flooded" engine, press the throttle control release button and pull the throttle out all the way and push the choke in all the way. Turn the ignition switch to the ON position. Press the starter button until the engine starts. Release the starter button. Push the throttle in gradually as engine speed increases.

CAUTION — If the engine stalls or falters in starting, wait three or four seconds before re-engaging the starter. This will prevent possible damage to the starter or engine.

The starter should not be operated for periods longer than 30 seconds at a time. An interval of at least two minutes should be observed between such cranking periods to protect the starter from overheating.

STOPPING THE ENGINE

Normal Conditions

Following normal operating conditions, lower the engine speed to idle, disengage the clutch, and then turn the ignition switch to the OFF position. If the engine has been running under high power, let it run at fast idle speed a few minutes to cool the engine down.

Never turn off the ignition, then suddenly pull the choke out, with the thought in mind that this will "prime" the system for the next start. This is poor practice, because the large quantity of raw gasoline entering the combustion chambers will wash all the oil off the cylinder walls. When started again, the engine will operate for a few moments without any lubrication on the cylinder walls, which may result in scuffing of the pistons, rings, and cylinder walls. At best, engine life will be shortened considerably.

OPERATING INSTRUCTIONS

Abnormal Conditions

Under abnormally overheated conditions, the engine may continue to run after the ignition switch is turned off. If this case is ever encountered, turn on the ignition switch immediately and allow the engine to idle until it has cooled enough to stop. If the engine is overheated due to a loss of coolant, it is best to stop the engine immediately, if necessary by applying the load. Allow the engine to cool, then check the coolant and oil levels. Add engine oil if necessary, then, after the engine has returned to a normal temperature, add coolant slowly until the radiator is full.

CAUTION – Avoid injury when checking a hot engine. Cover the radiator cap in a thick cloth and turn it slowly counterclockwise to the first stop. After the pressure has been completely released, press the cap downward and finish removing the cap.

The above instructions also apply to engines that stop due to operation of the low oil pressure-high water temperature safety switch. However, if engine stops due to low oil pressure, do not restart until the cause has been determined and corrected.

SPECIAL SITUATIONS

Problem Diagnosis

Most operating troubles that might be encountered with a new or well maintained unit will be of a minor nature. Therefore, if you have troubles starting or operating your engine, look for some simple cause rather than failure of a major component. For instance: Loose or corroded battery connections are much more likely than battery failure.

A loose ignition wire is much more likely than distributor, coil or ignition system failure.

In many cases, engine operating troubles are coupled with outside factors, such as climatic conditions, operating conditions, change of servicing or fueling source, or change of operator.

Engine troubles that occur as a result of normal use and wear usually give plenty of advance warning. These troubles usually result from overlooking the Scheduled Preventive Maintenance Services.

OPERATING INSTRUCTIONS

Whenever engine performance seems less than normal in any category, it is best to consult with your dealer at the first symptom rather than wait until a serious problem develops. One of the aims of regular maintenance is to help you in just these circumstances.

Engine Won't Crank

1. Turn the key to the ON position and press the starter button. If nothing happens, an electrical lead(s) may be loose or disconnected, the battery cables may be loose, disconnected or corroded or the battery discharged.
2. Another indication of loose battery connections or low battery condition is a stuttering noise from the engine compartment when the ignition switch is turned to ON and the starter button depressed. Check the connections to the starter motor and the solenoid switch in addition to the battery and ground connections.
3. Try operating the starter button several times. Should the switch be corroded, this operation may clean the contacts enough to make the switch temporarily operable until you can reach your dealer.
4. If all the electrical connections are tight and you need assistance to start, read the instructions under Emergency Starting.

Engine Cranks But Won't Start

1. Check the fuel tank. You may be out of fuel. If there is fuel in the tank, the trouble may be in either the ignition system or the fuel system.
2. Check the ignition system. Remove the wire from one of the spark plugs by grasping the moulded cap of the wire only, and insert a short piece of bare wire or other metal in the terminal of the wire.

NOTE – Spark plug wires carry high tension electrical current, capable of giving a shock. Be sure to grasp the moulded boot well back from the open end.

Hold the cap so that the inserted bare wire is about 1/4 inch from the engine block and crank the engine (with the ignition

OPERATING INSTRUCTIONS

switch on) for at least three seconds. If there is no spark between the wire and the metal, the trouble may be in the distributor or coil. If you see a spark, then check the fuel system for trouble.

3. The fuel system may have a restricted fuel line, plugged fuel filter, air leaks in the fuel line or a faulty fuel pump.
4. Check the manual choke. The choke linkage may be binding or damaged so that the choke plate in the carburetor is not opening and closing properly.

Engine Runs Hot

Listed below are items which could cause an engine to overheat.

1. Low coolant level.
2. *Loose or broken fan belt.*
3. Inoperative thermostat.
4. Dirty cooling system
5. Radiator fins restricted with leaves, dirt, etc.
6. Prolonged idling.
7. Running engine with frozen coolant.
8. Leaky head gasket.
9. Overloading, especially during hot weather.

Emergency Starting

Use of Booster Battery and Jumper Cables — Particular care should be used when connecting a booster battery in order to prevent sparks. To jump start (negative grounded battery):

- (1) remove vent caps and cover the battery fill openings with a cloth
- (2) shield eyes

OPERATING INSTRUCTIONS

- (3) connect ends of one cable to positive (+) terminals of each battery
- (4) connect one end of other cable to negative (-) terminal of "good" battery
- (5) connect other end of cable to engine block on unit being started (NOT TO NEGATIVE (-) TERMINAL OF BATTERY).

To prevent damage to other electrical components on unit being started, make certain that engine is at idle speed before disconnecting jumper cables.

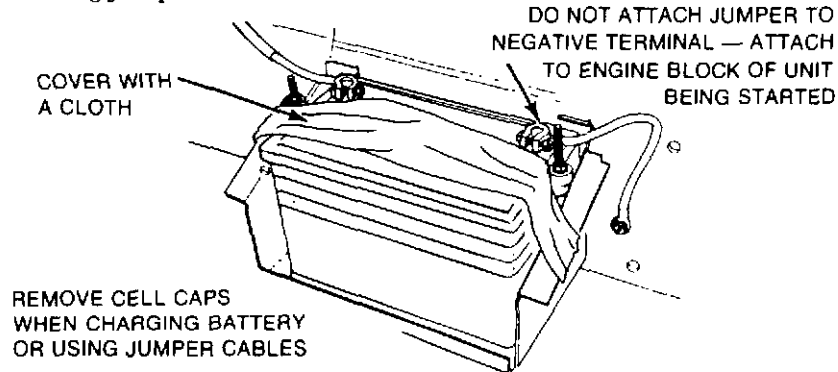

REMOVE CELL CAPS AND COVER THE BATTERY FILL OPENINGS WITH A CLOTH WHEN CHARGING OR USING JUMPER CABLES.

WARNING — Batteries contain **SULFURIC ACID**. In case of acid contact with skin, eyes, or clothing, **FLUSH IMMEDIATELY WITH WATER FOR A MINIMUM OF FIVE MINUTES**. Get "on-the-spot" medical attention immediately.

Hydrogen and oxygen gases are produced during normal battery operation. This gas mixture can explode if flames or sparks are brought near the battery. When charging or using battery in an enclosed space always provide ventilation.

Keep fire away from the top of open battery cells. Combustible gas is always present.

CAUTION — Avoid the use of a 24-volt battery booster and jumper cable hook-up to start an engine with a dead battery, as this will damage the unit's electrical system.

MAINTENANCE INSTRUCTIONS

MAINTENANCE SCHEDULE AND RECORD

Initial Start-up Sequence	Operation	Daily	Every 100 Hours	Every 200 Hours	Every 400 Hours	Every 800 Hours	Seasonal or As Required	More Frequent ^①
1	Oil, Engine, Check Level							
2	Coolant, Check Level in Radiator							
3	Fuel, Oil and Coolant Leaks, Check							
4	Governor, Check Oil Level	②						
	PTO Release Bearing, Lubricate							
	Oil, Engine Change							
	Oil Filter, Change							
5	Air Cleaner (Oil Bath), Clean and Refill							
5	Air Cleaner (Dry Type), Clean or Replace Element							
6	Battery, Check Charge and Level							
	Crankcase Vent System (If so equipped)							
	Distributor, Lubricate							
7	PTO Bearings, Lubricate							
	Radiator, Inspect and Clean Exterior							
	Battery Cables, Clean							
9	Fan, Alternator & Governor Belts, Check and Adjust							
	Throttle, Governor and Choke Linkage, Lubricate							
	Fuel Filter, Replace							
	Cooling System, Check or Refill							
14	Idle Speed, Check and Adjust							
15	Idle Mixture, Check and Adjust							
	Spark Plugs, Clean, Adjust and Test							
	Distributor, Clean and Check Points							
10	Ignition Timing, Check and Adjust (Check Advance)							
	PCV Valve, Replace (If So Equipped)							
	PCV Hoses, Tubes, and Fittings, Clean (If So Equipped)							
11	Intake Manifold Bolts, Torque							
16	Throttle and Governor, Adjust							
	Spark Plugs, Replace							
	Points, Replace							
12	Cylinder Head Bolts, Torque							
13	All Bolts and Nuts, Check for Tightness							
8	PTO Clutch Release and Shaft Bearings, Adjust							

 Not applicable.

① More frequent intervals may be required in dusty areas.

② Check Governor oil level weekly (belt driven).

Maintenance Instructions

MAINTENANCE INSTRUCTIONS

Initial Start Up

Your Ford Industrial Engine was inspected before leaving the factory. However, the initial start-up checks must be made before putting the unit into operation. The Preventive Maintenance Schedule (Page 14) provides a handy check-off list as well as a sign-off and record as to when the operations were performed. Perform the operations in the sequence listed in the left hand column.

Routine Service

Make sure your unit is ready to go whenever you need it. There are some things that you can do, or have done, to be sure it is well cared for:

- Keep the fuel tank filled. A full tank reduces the possibility of condensation forming in the tank and moisture entering the fuel lines.
- Make frequent checks of the engine oil and coolant levels.
- Check the battery fluid level often, especially if your engine is being operated in a warm, dry climate.
- Keep engine air filter clean.
- Watch the engine temperature.
- Watch engine oil pressure.
- Watch the ammeter.
- Lube power take-off regularly.

Scheduled Preventive Maintenance

The operations listed in the maintenance schedule are covered in detail on the following pages. Whenever your vehicle requires maintenance of any kind, your Ford Power Products distributor or dealer has skilled technicians who will do an expert job of keeping your engine in its prime condition.

MAINTENANCE INSTRUCTIONS

Engine Oil

Checking Oil Level

The oil level should be checked frequently, at least daily, and maintained between the ADD and FULL marks on the dipstick. Allow a few minutes after shutting the engine off for the oil to drain down before checking.

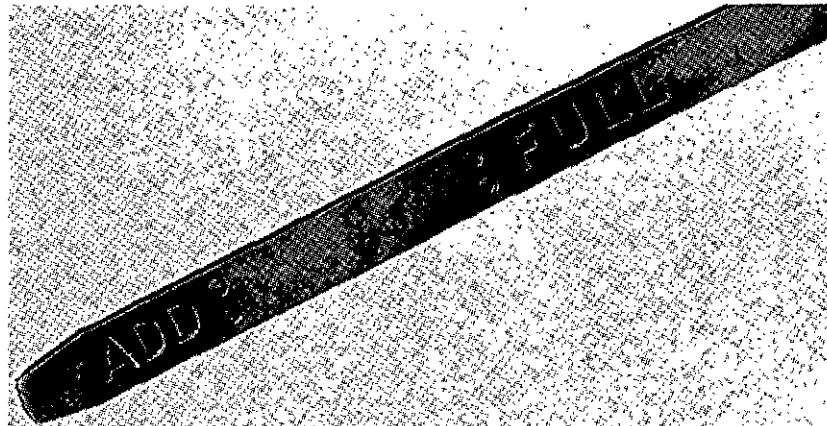

CAUTION – Do not operate the engine with the oil level below the ADD mark on the dipstick.

Adding Oil

It is normal to add some oil between oil changes. The amount will vary with the severity of operations. When adding or replacing engine oil be sure oils meet the specifications listed.

Changing Oil and Filter

For most operations, the engine oil and filter must be changed every 100 hours or seasonally. Under normal operating conditions, you do not need to change more often if you use oil and filters of the recommended quality.

The oil and filter should be changed more often if the engine is operated in dusty areas, for extended idling or low speed operation, or frequent stops during cold weather. No break-in oil change is required.

MAINTENANCE INSTRUCTIONS

Oil Quality

To help achieve proper engine performance and durability, it is important that you use only engine lubricating oils of the proper quality in your engine. Proper quality oils also provide maximum efficiency for the crankcase ventilating system which reduces air pollution.

Use only those oils that meet Ford Specification ESE-M2C144-A or API Classification SE or SE/CC.

NOTE: Oil of the above classifications which also meet API Classification CD *are not recommended* unless:

- The oil supplier indicates they contain a minimum of 0.1 weight percent phosphorus as zinc dialkyldithiophosphate (alkyl zinc)

OR

- A high quality fully formulated zinc dialkyldithiophosphate oil conditioner such as Ford Part Number D2AZ-19579-A is added at each oil change in a quantity sufficient to provide a minimum of 0.1 weight percent phosphorus as zinc dialkyldithiophosphate. 16 oz. Conditioner to 5 qts. oil.

It is best not to mix different brands of lubricants and oils, because sometimes they are not compatible and deteriorate when mixed. Stay with one brand to assure compatibility.

Oil Viscosity

When you change or add oil, you should select oil with the proper specifications and with the viscosity, selected from the following table, which most closely matches temperature range you expect to encounter for the next 100 hours of operation.

SINGLE VISCOSITY OILS

When Outside Temperature is Consistently	Use SAE Viscosity Number
-10°F. to +32°F.	(*) 10W
+10°F. to +60°F.	20W-20
+32°F. to +90°F.	30
Above 60°F.	40

MULTI-VISCOSITY OILS

When Outside Temperature is Consistently	Use SAE Viscosity Number
Below +32°F.	(*) 5W-30
-10°F. to +90°F.	10W-30
-10°F. to +90°F. (or above)	10W-40
Above +10°F.	20W-40

(*) Where sustained high RPM operation is anticipated, use 20W20.

MAINTENANCE INSTRUCTIONS

Oil Filter

Your engine is equipped with a Motorcraft oil filter. A filter of this quality should be used throughout the life of the engine. It is designed to protect your engine by filtering harmful abrasive and sludgy particles without clogging up or blocking the flow of oil to vital engine parts. This filter is especially designed for use in engines built by Ford to give successful operation with the recommended oil and filter change intervals.

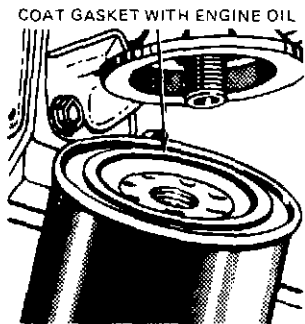

Spin-On Type Filter Replacement — To replace the spin-on filter, place a drain pan under the filter and unscrew the filter unit. Discard the entire unit. Coat the gasket surface of the new filter with engine oil and hand-tighten it onto the adaptor until the gasket contacts the adaptor face; then advance another one-half turn. Fill the crankcase and run the engine to check for leaks.

CAUTION — Do not handle a hot oil filter with bare hands.

Refer to the maintenance schedules for the proper intervals for changing the oil filter.

Air Cleaner

Oil Bath

The air cleaner should be inspected constantly for leaks. A damaged air cleaner can seriously affect the performance and life of the engine. The following service steps should be made each time the engine is serviced.

- Watch all connections for mechanical tightness.
- If cleaner has been dented or damaged, check all connections immediately.
- In case of leakage and if adjustment does not correct the trouble, replace necessary parts or gaskets.

MAINTENANCE INSTRUCTIONS

Cleaning

Industrial Engines. Remove the filter from the engine, drain the oil reservoir, wash the components in solvent, then saturate the maze screen with oil. Fill the reservoir with engine oil to the level indicated in the reservoir. Use SAE 30 for temperatures above 32°F., and SAE 10 for temperatures below 32°F.

Power Units. Remove the air cleaner lower section which consists of the oil cup. Remove the body of the air cleaner from its mounting. Soak the body assembly or element in fuel oil to loosen the dirt, then flush the element with clean fuel oil and allow it to drain thoroughly. Push a lint-free cloth through the center tube to remove any dirt or oil. Pour out the oil in the cup, remove all sludge and wipe the baffle and cup clean. Clean and check all gaskets and sealing surfaces to ensure the air-tight seals.

CAUTION – Do not over or under fill the cup. Over-filling means loss of filtering capacity. Under-filling means lack of efficiency.

Check the air inlet housing before installing the air cleaner assembly on the engine. The inlet will be dirty if the air cleaner servicing has been neglected, if dust-laden air has been leaking past the air cleaner to air inlet housing seal or if the flex tubing is ruptured.

Install the body of the air cleaner in its mounting bracket and then install the lower portion to the body. Make sure that the flex tubing is mounted securely to the air inlet housing and the filter outlet.

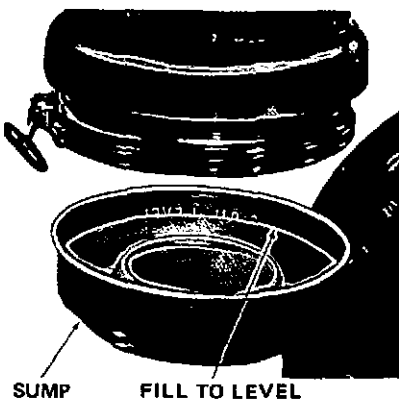

Air Cleaner – Oil Bath Type

MAINTENANCE INSTRUCTIONS

COOLING SYSTEM

Coolant Level

Maintain the coolant level at one inch below the top of the radiator upper tank.

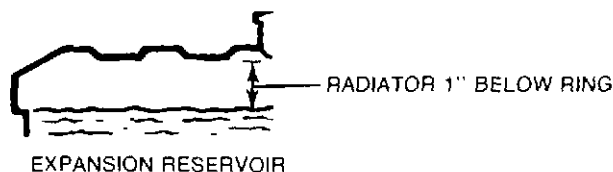

CAUTION – Avoid injury when checking a hot engine. Cover the radiator cap in a thick cloth and turn it slowly counterclockwise to the first stop. After the pressure has been completely released, press downward and finish removing cap. Do not add coolant to an engine that has become overheated until the engine cools. Adding coolant to an extremely hot engine can result in a cracked block or cylinder head.

In freezing weather, test the coolant for proper antifreeze protection to anticipated lowest temperature. Add antifreeze solution to maintain proper protection.

Radiator

Inspect the exterior of the radiator for obstructions. Remove all bugs, dirt or foreign material with a soft brush or cloth. Use care to avoid damaging the fins. If available, use compressed air or a stream of water to dislodge particles between the fins. Use compressed air or water in the opposite direction to normal air flow.

Check all hoses and connections for leaks. If any of the hoses are cracked, frayed, or feel spongy, they should be replaced.

When refilling the cooling system with plain water add one can of Ford Rotunda Rust Inhibitor 8A-19546-C. If temperatures below +32°F. are anticipated, replenish coolant with equal parts water and Ford Rotunda Long Life Coolant Concentrate 8A-19549-A. This will provide protection to -35°F., and at the

MAINTENANCE INSTRUCTIONS

same time will permit engine operation up to temperatures of +240°F. If coolant other than this is used it must meet Ford Specification M-97B18-C.

DRIVE BELTS

The water pump is belt driven. This same belt may also drive the fan and/or alternator. The drive belt(s) should be properly adjusted at all times. A loose drive belt causes improper alternator, fan and water pump operation, in addition to overheating. Overtightening the belt may result in excessive wear on the alternator and water pump bearings, as well as premature wear on the belt itself. Therefore, it is recommended that a belt tension gauge be used to check and adjust the belt tension. Any belt that has operated for a minimum of 10 minutes is considered a used belt, and, when adjusted, it must be adjusted to the reset tension shown in the specifications.

Belt Tension

Install the belt tension tool on the drive belt and check the tension following the instructions of the tool manufacturer.

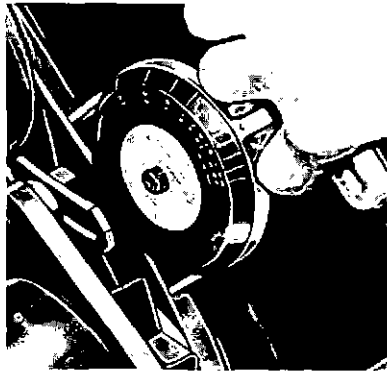

Checking Belt Tension

If the tension is not to specification, loosen the alternator mounting and adjusting arm bolts. Move the alternator away from the engine until the correct tension is obtained. Remove the gauge. Tighten the alternator adjusting arm and mounting bolts. Install the tension gauge and recheck the belt tension.

MAINTENANCE INSTRUCTIONS

BATTERY

Checking Water Level

Because the battery is the "heart" of your unit's electrical system, periodic checks are necessary to keep it functioning properly. Keep the battery fluid level up to the ring under the filler cap.

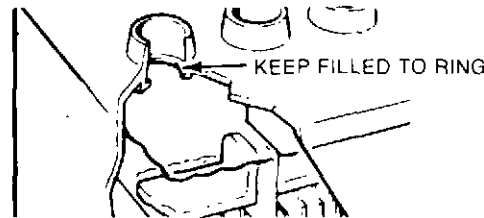

Adding Water

Ordinary tap water may be used except in areas where the water is known to be exceptionally hard or to have a high mineral or alkali content. In such areas, use distilled water. If water is added during freezing weather, run the engine 20 to 30 minutes before shutting it off. This mixes the added water with the electrolyte and will prevent it from freezing and damaging the battery. Have the battery charge checked regularly during extremely cold weather. When the specific gravity falls below 1.230 (corrected to 80°F), recharge the battery. Make sure the cables are clean and tightly clamped to the battery terminals. Keep the top of the battery clean and dry.

Keep fire away from the top of open battery cells. Combustible gas is always present.

If there is any corrosion on the cables and terminals remove it with a wire brush and neutralize the acid with a solution of baking soda or ammonia and water. After cleaning, flush the top of the battery with clean water, install the terminal clamps on the battery posts, and coat the parts with grease to retard further corrosion.

MAINTENANCE INSTRUCTIONS

CRANKCASE VENTILATION SYSTEM

Open System

The engines equipped with the open crankcase ventilation have a breather cap, located on each rocker cover. The caps should be cleaned in a petroleum solvent at every oil change.

Closed System (P.C.V.)

The closed system is known as the positive crankcase ventilation system. Clean air is supplied through the oil filler cap on one rocker cover. The fumes are vented out through a regulator valve on the opposite rocker cover and into the intake manifold. The P.C.V. valve (regulator valve) must be replaced at 400 hours. The hoses, tubes and fittings of this system must be cleaned at 800 hours.

FUEL FILTERS

Disposable Filter

The disposable filter is located on the fuel pump body. Unscrew the filter housing from the body and remove the filter element and gasket. Discard the element and gasket. Clean the filter housing in a petroleum cleaning solvent.

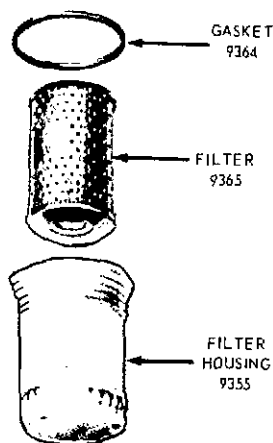

Disposable Filter

MAINTENANCE INSTRUCTIONS

Place a new filter element over the spout in the body. Be sure to use the proper type element for the installation. Coat the new gasket with light engine oil and position the gasket on the filter housing or body. Screw the filter housing onto the filter body. Hand tighten the filter housing until the gasket contacts the body, and then tighten an additional 1/8 turn. Start the engine and check for leaks.

CARBURETOR ADJUSTMENTS

Idle Speed and Idle Mixture Adjustment

The idle speed adjustment screw, and the idle fuel mixture adjustment needle(s) are accessible on the exterior of the carburetor. Actually, there are three factors that control the conversion of the fuel and mixture into engine power. These factors are engine compression, ignition and correct carburetor adjustment. Correct carburetor adjustment cannot be obtained, however, unless engine compression and ignition meet specifications.

To make the adjustments, start the engine and operate it until it has reached normal operating temperature. Be sure the choke and throttle controls are pushed all the way in.

Start the adjustments by setting the idle speed screw to obtain an engine speed of 600 rpm. Then turn idle fuel mixture adjustment needle(s) in (clockwise) until the engine begins to roll. Then, back it out slowly until the engine is running smoothly. Reset the idle speed to 600 rpm.

MAINTENANCE INSTRUCTIONS

IGNITION SYSTEM

A dual advance distributor with a centrifugal and vacuum spark advance system, is generally used with this engine.

The direction of distributor rotation is counter clockwise as viewed from the top of the distributor.

The spark plug wires are inserted in the distributor cap in the firing order of the engine 1-5-4-2-6-3-7-8. Number one socket is identified by the number one on the cap. The cylinders are numbered from front to rear — 1-2-3-4 right side, and — 5-6-7-8 left side as viewed from the rear of the engine.

FIRING ORDER 1-5-4-2-6-3-7-8

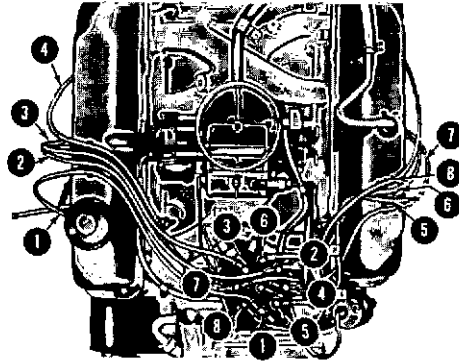

Engine Ignition Wiring

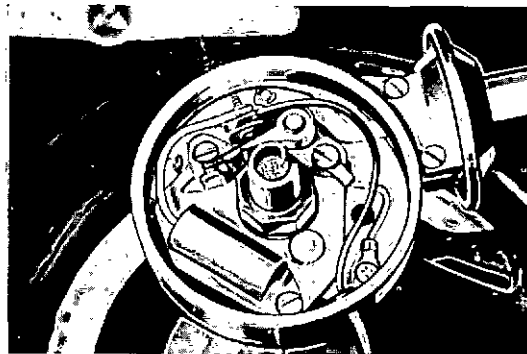

Dual Advance Distributor

MAINTENANCE INSTRUCTIONS

Performance, fuel economy, and life expectancy of the engine depend largely on the correct distributor maintenance.

Breaker Point Check and Adjustment

At the specified intervals, the breaker points should be checked and adjusted as necessary. Inspect the points for excessive metal transfer, or a pitted or badly burned condition. Inspect the rubbing block for a loose, chipped or broken condition. Replace the defective points.

NOTE: Do not use a file, sandpaper, or emery cloth to clean or remove pits from distributor points. Any abrasion of the point surfaces only causes them to burn faster. Files should be used only on spark plug electrodes.

Replace Distributor Points

At the recommended intervals, or whenever inspection indicates a need, the distributor breaker points should be replaced. Replacement can be made without removing the distributor.

Disconnect the condenser and primary leads from the breaker point assembly. Remove the screws that secure the assembly to the breaker plate, then remove the assembly.

To install, place the assembly in position and install retaining screws. Be sure that the ground wire is under the breaker point screw near the pivot. Attach primary and condenser wires to assembly. Apply a light film of distributor cam lubricant to the cam. *Do not use engine oil.*

The vented-type breaker points must be accurately aligned and strike squarely in order to realize the full advantage provided by this design and to insure normal breaker point life. Turn the distributor cam (energize starter if distributor is in engine) so that breaker points are closed. Check the alignment of the points with a magnifying glass. Align the points to make full face contact by *bending the stationary point bracket. Do not bend the movable arm.* It is recommended that a special alignment tool be used for this operation.

MAINTENANCE INSTRUCTIONS

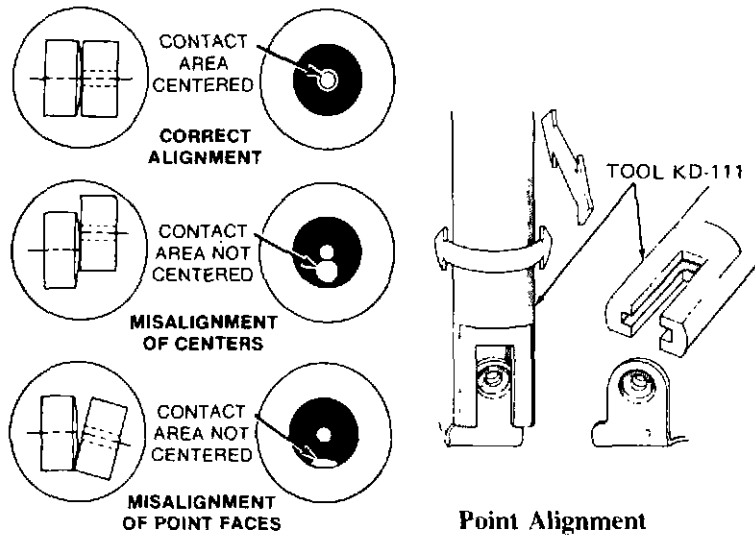

Point Alignment

Breaker Point Alignment

After the breaker points have been aligned, they should be adjusted to the correct gap with a feeler gauge or dwell meter. To adjust the points with a feeler gauge, turn the distributor shaft until the rubbing block rests on the peak of a cam lobe. Insert the correct blade of a clean feeler gauge between the points. The gap should be set to the larger opening (0.020 inch) because the rubbing block will wear down slightly while seating to the cam. When setting the points with a dwell meter, adjust the dwell angle to the low setting (26°). This will also compensate for rubbing block wear.

IGNITION TIMING

Each time the distributor points are replaced or adjusted, the ignition timing should be checked and adjusted as necessary. Proper adjustment of ignition timing must be maintained to provide maximum engine power output and best possible fuel economy.

The timing marks are located on the crankshaft pulley or damper and can be seen from the right side. These marks and a pointer on the engine front cover are used to time the engine. The recommended timing setting is 6° B.T.D.C. Adjust the ignition timing as follows:

MAINTENANCE INSTRUCTIONS

Disconnect the distributor vacuum line. Connect the timing light high tension lead to the No. 1 spark plug (right front cylinder), and the other two leads to the proper battery terminals. Clean and chalk the timing marks to improve legibility.

Operate the engine at a maximum of 600 rpm, and direct the timing light at the pointer. The light should flash just as the 6° mark on the damper lines up with the pointer.

If the 6° mark and the pointer do not line up, loosen the distributor retaining bolt, and rotate the distributor until the mark and notch are in line.

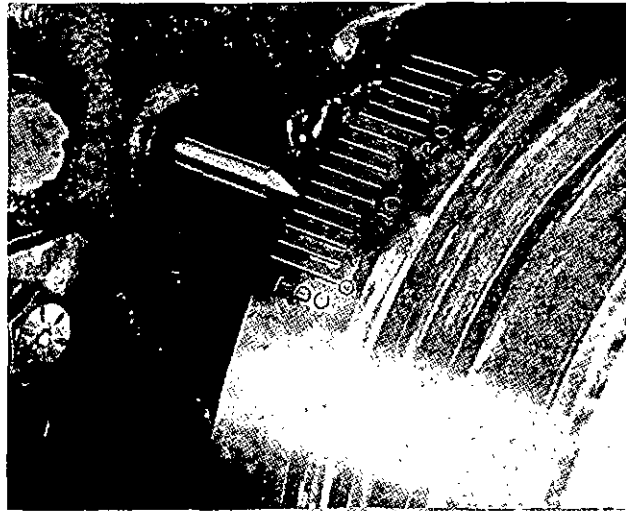

Ignition Timing Marks

NOTE: Ignition timing is advanced clockwise rotation of the distributor body – retarded by counterclockwise rotation.

When the proper timing is obtained, tighten the distributor retaining bolt and connect the distributor vacuum line, then accelerate the engine while watching the timing mark with the timing light to determine if the advance mechanism is functioning. The marks on the crankshaft pulley should advance as engine rpm increases. This check will confirm whether or not the advance mechanism is functioning, but it does not indicate proper distributor calibration.

MAINTENANCE INSTRUCTIONS

In order to properly adjust the distributor advance, the distributor must be removed from the engine and checked on a distributor testing machine. If you do not have the proper equipment, your local Ford Industrial Products Dealer will be pleased to perform this operation for you. The distributor advance specifications are given in the Specifications Section.

Spark Plugs

The spark plugs should be cleaned, tested and gapped at the recommended intervals.

Remove the wires from each spark plug by grasping, twisting and then pulling the moulded cap of the wire only. Do not pull directly on the wire because the wire connection inside the cap may become separated.



**Dressing Spark Plug
Electrodes**



Spark Plug Gapping

MAINTENANCE INSTRUCTIONS

After loosening each spark plug one or two turns, clean the area around each spark plug port with compressed air, then remove the spark plugs.

After cleaning, examine the plug carefully for cracked or broken insulators, badly pitted electrodes, and other signs of malfunction. Replace as required.

After cleaning, dress the electrodes with a small file to obtain flat parallel surfaces on both the center and side electrodes. Set the spark plug gap to specifications by bending the ground electrode. All spark plugs new or used should have the gap checked as required.

Install the spark plugs and torque each plug to specifications.

Connect the spark plug wires.

NOTE — Do not overtighten spark plugs. The gap may change considerably due to distortion of the plug outer shell.

GOVERNOR

Three types of governors are used on these engines. A centrifugal type (Centri-Vac) has components in the distributor and on the carburetor, and the velocity type mounted between the carburetor and intake manifold provide top speed control only. Where variable speed control is required, the engine is fitted with a mechanical-type governor. This unit is attached to the front of the engine and driven by a belt from the crankshaft pulley.

DISTRIBUTOR BODY

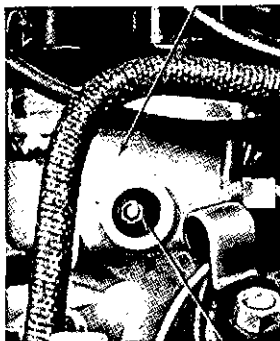

ADJUSTING NUT

Centri-Vac Governor Adjustment

MAINTENANCE INSTRUCTIONS

These governors are checked and set at the factory and normally do not require adjustment. However, if a different setting is desired, or replacement parts are installed, the no-load cut-off speed can be adjusted as follows:

Connect a tachometer to the engine. Operate the engine until normal operating temperature is reached. With the load disengaged, operate the engine at wide open throttle to determine the maximum governed speed.

NOTE: The no-load governed speed is approximately 10% greater than the fully loaded governed speed.

Stop the engine and remove the adjusting hole plug from the distributor housing. With the ignition switch off, turn the engine over until the governor adjusting nut appears in the hole. A 1-1/8 inch socket on the crankshaft damper bolt can be used to turn the engine over. Turn the adjusting nut clockwise to increase speed and counterclockwise to decrease speed. One full turn of the adjusting nut will change the governed speed about 150 rpm. If necessary, repeat the above procedure until the correct top governed speed is attained. After adjustment is correct, install the adjusting hole plug and tighten it securely. Attach a new locking wire and lead seal to the adjusting hole plug and the adjacent fin.

Velocity Governor – Adjustment

The velocity governor is a single unit mounted between the carburetor and the intake manifold. There is no provision for repair of this unit. It should be replaced when defective.

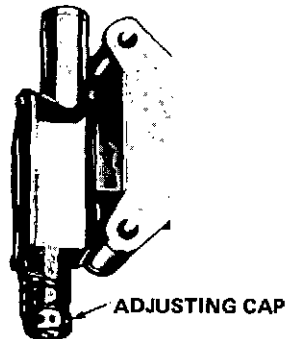

Velocity Governor

MAINTENANCE INSTRUCTIONS

With the engine at normal operating temperature, operate the engine at wide open throttle and compare the rpm with the operating range which is stamped on the governor plate. In no case is the engine rpm to exceed 2800 rpm.

If adjustment is required, remove the seal attached to the governor adjusting cap. Turn the cap counterclockwise to increase rpm, clockwise to decrease rpm. When the adjustment is completed, stop the engine and reattach the seal.

Mechanical Governor

Oil Level

Check the oil level by slowly removing the oil level plug. If oil drips out the oil level is full. If oil doesn't drip out, slowly add 10W-30, 10W-40 engine oil into the oil fill hole. As soon as it begins dripping out the oil level hole, insert the plug.

Adjustment

Before making any governor adjustments, check the governor drive belt tension with a belt tension gauge. Set the belt to the tension listed in the Specification Section.

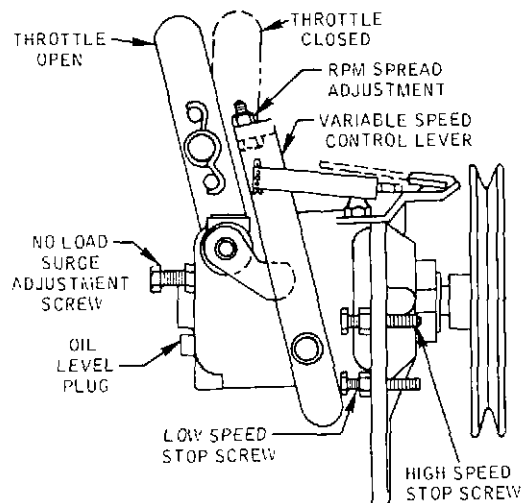

Mechanical Governor - Adjustment

MAINTENANCE INSTRUCTIONS

The first adjustment is the governor-to-carburetor control rod adjustment. With the control rod connected, manually move the governor throttle lever to the maximum open throttle position. Check that the carburetor throttle shaft lever is set from 1/32 to 1/16 of an inch from its maximum open position stop. If necessary adjust length of the control rod to obtain the setting.

To perform a high-speed adjustment, attach a tachometer to the engine, then run the engine until it reaches normal operating temperature.

- loosen the locknut on the high speed stop screw
- disengage engine load
- slowly pull the throttle to desired maximum engine speed
- adjust the high speed stop screw on the governor to attain the desired maximum engine speed
- tighten the locknut

The next adjustment is for spread. Proper governor operation requires a difference between full-load and no-load governor speed. Too small an rpm spread between the two speeds will cause governor hunting and surging. Too large a spread will cause low response. For this governor, normal rpm spread is 5 to 10 percent.

To decrease the rpm spread with the engine running under no-load at maximum governed speed, loosen the rpm spread adjusting screw lock nut and turn the adjusting screw clockwise until engine speed increases 150 rpm; then tighten the lock nut. Recheck governor operation is stabilized and sensitivity is satisfactory. You might also have to readjust the governor high-speed stop screw to maintain the correct high-speed under load.

To increase rpm spread, run the engine under no-load at maximum governed speed and loosen adjusting screw lock nut. Turn the adjusting screw counterclockwise until engine speed decreases one hundred fifty rpm tighten the lock nut. Recheck governor operation under load and no-load conditions.

MAINTENANCE INSTRUCTIONS

To perform a low-speed adjustment, move the hand throttle, or variable speed lever, to the closed position and loosen locknut on governor low-speed screw. Turn stop screw in or out until you can maintain the desired speed.

The no-load surge adjustment is set at the factory and rarely requires adjustment. If necessary, this adjustment can be used to prevent **hunting and surging at no-load speeds only, provided the spread adjustment is set properly**. Make the adjustment with the tachometer installed. Increase the engine speed with the hand throttle to 75 rpm lower than the maximum no-load desired control rpm. Then loosen the no-load surge adjustment screw locknut and turn the screw inward until the rpm increases to the desired control rpm.

CAUTION – DO NOT TURN THE SCREW IN ALL THE WAY. IT WILL INTERFERE WITH PROPER GOVERNOR OPERATION AND PREVENT THE GOVERNOR FROM RETURNING THE ENGINE TO IDLE SPEED.

POWER TAKE-OFF

Rockford Over-Center Clutch Adjustment

Power take-off is the over-center clutch type, which is the heavy-duty, gear-tooth drive, single-plate type with clutch facing member in three sections. To adjust the clutch, place it in released position, then remove the cover. Rotate the clutch until the adjusting lock and lock screw can be reached. Remove or disengage the adjustment ring lock.

Turn the adjusting ring counterclockwise until pressure required on shifting handle to engage clutch is approximately 60-70 pounds, measured at small finger position on shifter with a fish scale. If fish scale is not available, tighten adjusting nut until clutch engagement is no longer possible by exerting pressure on shifting handle then back up the equivalent of two notches. Install the adjusting lock and lock screw.

A new clutch generally requires several adjustments until the friction surfaces are worn in. Do not let a clutch slip as this will glaze the friction plates and may ruin them.

MAINTENANCE INSTRUCTIONS

Lubrication

Bearings of power take-off unit should be lubricated at the specified intervals with a Lithium Base, short fiber grease (ESA-MIC75-B). The release bearing must be lubricated daily. Complete lubrication instruction for the power take-off are given on the patent plate attached to the power take-off clutch adjustment handhole cover. These instructions should be carefully followed when lubricating this unit. If your engine is equipped with truck type clutch, lubricate linkage at the same interval.

WARNING — Never over lubricate clutch pilot bearing as slippage or grabbing of the clutch may result.

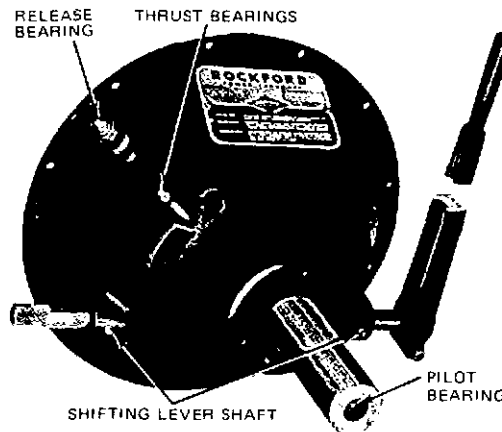

Lubrication Fittings

CYLINDER HEAD BOLT TORQUE

The cylinder head bolts are tightened in three progressive steps, starting with the center bolts and working outward. Torque the bolts to 60-70 ft-lbs then to 70-80 ft-lbs and finally to 80-90 ft-lbs.

Torque the cylinder head bolts before starting your engine and also after the engine has been warmed up to normal operating temperature.

MAINTENANCE INSTRUCTIONS

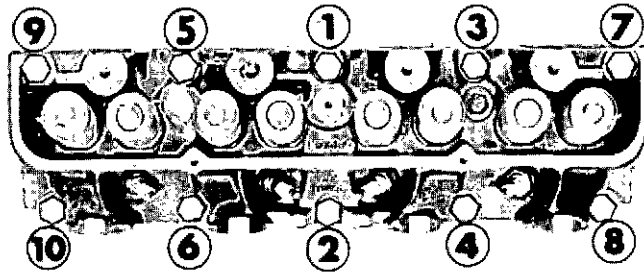

Cylinder Head Tightening Sequence

INTAKE MANIFOLD BOLT TORQUE

Check the torque on all intake manifold bolts. Retorque all bolts as necessary to 32-35 ft-lbs. Torque the bolts in sequence as shown in the illustration.

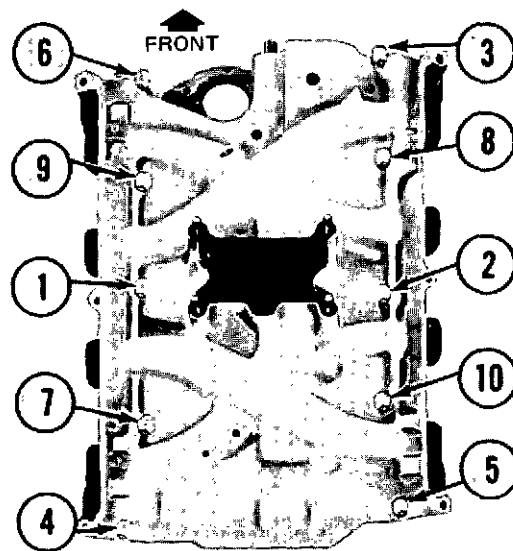

Intake Manifold Tightening Sequence

MAINTENANCE INSTRUCTIONS

Lubrication

At the specified intervals, apply a few drops of engine oil to the distributor oil felt and apply an appropriate lubricant, such as Lubriplate (COAZ-19584-A) at the pivot points of the throttle, governor and choke linkage.

If equipped with a tachometer, disconnect the distributor head connections and remove cable from housing. Coat lightly with an appropriate lubricant such as Lubriplate (Ford part number COAZ-19584-A) or speedometer cable lubricant (B5A-19581-A). Replace cable in housing and attach housing to distributor and tachometer head. Be sure that the ends of the cable are firmly seated in their respective receptacles before starting the engine.

Perform this operation at specified intervals, and oftener if needle shows a tendency to fluctuate during operation.

STORAGE

One Month

While engine is running, treat upper cylinders by spraying M-4834-A, Engine Preservative Oil (S.A.E. 10), or equivalent into carburetor air intake for about two minutes. Open throttle for short burst of speed, shut off ignition and allow engine to come to a stop while continuing to spray M-4834-A into air intake.

Leave spark plugs in holes or seal spark plug holes with suitable threaded metal plugs and cover all openings into engine with dustproof caps or shields.

Drain oil, water, and gasoline.

If engine is less transmission, spray flywheel and ring gear with mixture of one part M-4850, Anti-Rust Bodied Oil, and one part M-4970, Stoddard Solvent, or equivalents.

For Indefinite Period

Drain crankcase completely and refill with M-4834-A, Engine Preservative Oil (S.A.E. 10), or equivalent.

MAINTENANCE INSTRUCTIONS

Run engine until completely out of gasoline, then restart and run on M-534-H or equivalent unleaded, undyed gasoline for at least 10 minutes.

While engine is still running and at completion of above run, treat upper cylinders by spraying M-4834-A into carburetor air intake for about two minutes. Open throttle for short burst of speed, shut off ignition and allow engine to come to a stop while continuing to spray M-4834-A into air intake.

Drain oil and gasoline. Drain water at the bottom of radiator and also both sides of the cylinder block.

Disconnect and remove battery.

Remove grease and oil from exterior surface of engine.

Leave spark plugs in holes or seal spark plug holes with suitable threaded metal plugs.

Seal all openings in engine and accessories with M-6471, Non-hydroscopic Adhesive Tape, or equivalent. Mask off all areas to be used for electrical contact.

Make sure all surfaces are dry, then spray all taped openings, all engine accessories including ignition wiring, and all exterior surfaces of engine with M-4858-B, Insulation Compound, or equivalent.

If engines are equipped with automotive type clutch, block clutch in slightly disengaged position so that lining and pressure plate are not in contact.

Specifications

All specifications are given in inches unless otherwise noted.

GENERAL

Displacement (Cubic Inches)	330,361,391
Bore and Stroke	
330	3.87 x 3.50
361	4.05 x 3.50
391	4.05 x 3.78
Oil Pressure — Hot @ 2000 rpm (PSI)	35-75
Firing Order	1-5-4-2-6-3-7-8
Oil Capacity (Qts)	8
—with Filter Change	9

CYLINDER HEAD

Valve Guide Bore Diameter (Standard)	
Intake	0.3728-0.3738
Exhaust	0.4368-0.4378
Valve Seat Width	
Intake	0.070-0.090
Exhaust	0.090-0.110
Valve Seat Angle — Intake and Exhaust	45°
Valve Seat Runout — Maximum	0.0015
Intake Valve Seat Insert Bore Diameter — Standard (Not used in 330 engine)	1.812-1.813
Intake Valve Seat Insert to Bore Interference Fit — Standard (Not used in 330 engine)	0.002-0.0035
Exhaust Valve Seat Insert Bore Diameter — Standard	1.626-1.627
Exhaust Valve Seat Insert to Bore Interference Fit — Standard	0.0015-0.0035
Gasket Surface Flatness	0.003 inch in any 6 inches or 0.006 overall
Gasket Surface Finish RMS	60-150

VALVE ROCKER ARMS, ROCKER ARM SHAFT, PUSH RODS AND LIFTERS

Rocker Arm Lift Ratio	1.73:1
Valve Push Rod Runout (Maximum)	0.020
Rocker Arm Shaft O.D.	0.839-0.840
Rocker Arm to Rocker Shaft Clearance	0.0020-0.0050
	Wear Limit — 0.0065

SPECIFICATIONS

Rocker Arm Bore Diameter	0.8425-0.8440
Hydraulic Lifter Leakdown Rate	5-50 seconds maximum— measured at 1/16-inch plunger travel
Hydraulic Lifter Standard Diameter	0.8740-0.8745
Hydraulic Lifter Clearance to Bore	0.0007-0.0027 Wear Limit — 0.005
Hydraulic Lifter Collapsed Gap	
Allowable	0.080-0.180
Desired	0.105-0.155

VALVES

Valve Stem Diameter	
Intake	
Standard	0.3711-0.3718
0.003 Oversize	0.3741-0.3748
0.015 Oversize	0.3861-0.3868
0.030 Oversize	0.4011-0.4018
Exhaust	
Standard	0.4338-0.4348
0.003 Oversize	0.4368-0.4378
0.015 Oversize	0.4488-0.4498
0.030 Oversize	0.4638-0.4648
Valve Face Angle — Intake and Exhaust	44°
Intake Valve Stem to Valve Guide Clearance	0.0010-0.0027 Wear Limit — 0.0055
Exhaust Valve Stem to Valve Guide Clearance	0.0020-0.0040 Wear Limit — 0.0055
Intake Valve Head Diameter	1.745-1.760
Exhaust Valve Head Diameter	1.500-1.510
Valve Face Runout	0.002
Valve Spring Free Length — Approximate	2.00
Valve Spring Out of Square — Maximum078
Valve Spring Pressure — Lbs at Specified Length	76-84 at 1.670 Wear Limit — 69 at 1.670 175-194 at 1.240 Wear Limit — 157 at 1.240
Valve Spring Assembled Height — Pad to Retainer	1-21/32-1-11/16

CAMSHAFT AND BEARINGS

Camshaft Journal Diameter Standard	2.1238-2.1248
Camshaft Journal Runout	0.005

SPECIFICATIONS

Camshaft Journal to Bearing Clearance	0.001-0.003
	Wear Limit — 0.006
Camshaft Journal Out-of-Round.	0.0005
Camshaft End Play	0.001-0.007
	Wear Limit — 0.009
Camshaft Lobe Lift	
Intake	
330.	0.2446
361, 391	0.2448
Exhaust	
330.	0.2328
361, 391	0.2448
Maximum Allowable Lobe Lift Loss	0.005
Bearing Inside Diameter	2.1258-1.1268
Camshaft Bearing Location — No. 1 Bearing	0.005-0.020*
Timing Chain Deflection — Maximum	0.680

* Distance in inches that the front edge of the bearing is installed past the front face of the cylinder block.

CRANKSHAFT AND FLYWHEEL

Main Bearing Journal Diameter	
330.	2.7484-2.7492
361, 391	2.7479-2.7492
Main Bearing Journal Runout	0.002
	Wear Limit — 0.005
Main Bearing Journal Out-of-Round — Maximum	0.0006
Main Bearing Journal Taper — . . 0.0005/inch(330)-0.0003/inch(361,391)	
Maximum	
Connecting Rod Journal Diameter	
330	2.4380-2.4388
361, 391	2.4377-2.4385
Connecting Rod Journal Out-of-Round — Maximum	0.0006
Connecting Rod Journal Taper — Maximum	0.0006
Thrust Bearing Journal Length	1.124-1.126
Crankshaft to Rear Face of Block Runout TIR — Maximum	0.005
Crankshaft Free End Play	0.004-0.010
	Wear Limit — 0.014
Flywheel Clutch Face Runout — Maximum	0.010
Assembled Flywheel O.D. Runout	
Standard Transmission	0.040
Automatic Transmission	0.075

SPECIFICATIONS

MAIN BEARINGS

Journal Clearance	Desired 0.0005-0.0015
	Allowable 0.0018-0.0038
Wall Thickness	0.0955-0.0960

CONNECTING ROD

Piston Pin Bushing I.D. Standard	0.9752-0.9755
Piston Pin Bushing Out-of-Round - Maximum	0.0003
Piston Pin Bushing Taper - Maximum	0.0004
Bearing Bore Diameter	2.5907-2.5915
Bearing Bore Out-of-Round and Taper	0.0004
Connecting Rod Length - Center to Center	
330	6.5380-6.5400
361, 391	6.4860-6.4900
Twist Total Difference - Maximum	0.024*
Bend Total Difference - Maximum	0.012*
Side Clearance	0.010-0.020
	Wear Limit - 0.030

CONNECTING ROD BEARINGS

Bearing to Crankshaft Clearance	Desired 0.0008-0.0015
	Allowable 0.001-0.0029
Wall Thickness	
Standard	0.0755-0.0760
0.002 Undersize	0.0765-0.0770

PISTONS

Piston Diameter	
Coded Red	
330	3.8724-3.8734
361, 391	4.0474-4.0480
Coded Blue	
330	3.8736-3.8742
361, 391	4.0486-4.0492
.003 Oversize	
330	3.8748-3.8754
361, 391	4.0498-4.0504

*Pin bushing and crankshaft bearing bore must be parallel and in the same vertical plane within the specified total difference at ends of an 8-inch long bar measured 4 inches on each side of rod.

SPECIFICATIONS

Piston to Cylinder Bore Clearance	0.0025-0.0033
Piston Pin Bore Diameter	0.9754-0.9757
Ring Groove Width	
Compression Top	
330	0.080-0.081
361, 391	0.097-0.098
Bottom	
330	0.097-0.098
361, 391	0.081-0.082
Oil Ring	0.188-0.189

PISTON PIN

Piston Pin Diameter	
Standard	0.9749-0.9754
0.001 Oversize	0.9760-0.9763
0.002 Oversize	0.9770-0.9773
Piston Pin Length	3.150-3.170
Piston Pin to Piston Clearance	0.0003-0.0005
Piston Pin to Connecting Rod Bushing Clearance	0.0002-0.0005

PISTON RINGS

Top Compression Ring Width	
330	0.077-0.078
361, 391	0.0930-0.0935
Bottom Compression Ring Width	
330	0.0930-0.0940
361, 391	0.077-0.078
Oil Ring Width (361, 391)	0.1859-0.1866
Top Compression Ring Side Clearance	
330	0.0024-0.0040
361, 391	0.0035-0.0050
	Wear Limit – 0.002 Max. increase in total clearance
Bottom Compression Ring Side Clearance	
330	0.003-0.005
361, 391	0.0035-0.0050
	Wear Limit – 0.002 Max. increase in total clearance
Oil Ring Side Clearance	
330	Snug
361, 391	0.0029-0.0046

SPECIFICATIONS

Top Compression Ring Gap	
330	0.010-0.015
361, 391	0.015-0.023
Bottom Compression Ring Gap	
330	0.010-0.015
361, 391	0.010-0.020
Oil Ring Gap	
330	0.015-0.055
361, 391	0.015-0.025

CYLINDER BLOCK

Cylinder Bore Diameter	
330	3.8750-3.8786
361, 391	4.0500-4.0536
Maximum Out-of-Round	0.0015
	Wear Limit – 0.005
Maximum Taper	0.001
	Wear Limit – 0.010
Crankshaft to Rear Face of Block Runout TIR Maximum	0.005
Lifter Bore Diameter	0.8752-0.8767
Main Bearing Bore Diameter	2.9417-2.9425
Distributor Shaft Bearing Bore Diameter	0.5155-0.5165
Head Gasket Surface Flatness	0.003 inche in any 6 inches or 0.006 inch overall
Head Gasket Surface Finish RMS	60-150

OIL PUMP

Relief Valve Spring Tension (Lbs at Specified Length) .	11.1-11.8 at 1.560
Drive Shaft to Housing Bearing Clearance	0.0015-0.0029
Relief Valve Clearance	0.0015-0.0029
Rotor Assembly End Clearance	0.001-0.004
Outer Race to Housing Clearance (Radial)	0.001-0.013

TORQUE LIMITS – FT-LBS

Cylinder Head Bolts	
Step 1	70
Step 2	80
Step 3	90
Main Bearing Cap Bolts	95-105
Exhaust Manifold to Cylinder Head	18-24
Oil Pump to Cylinder Block	17-27

SPECIFICATIONS

Oil Pump Cover Plate	9-14
Damper or Pulley to Crankshaft(330) 130-150 — (361, 391) 150-175	
Valve Rocker Shaft Support to Cylinder Head	40-45
Water Pump to Cylinder Block or Front Cover	17-27
Oil Pick-Up Tube to Oil Pump	10-15
Cylinder Front Cover	19-27
Water Outlet Housing	10-15
Oil Pan to Cylinder Block	4-7
Oil Pan Drain Plug	15-25
Intake Manifold to Cylinder Head	40-45
Flywheel to Crankshaft	75-85
Exhaust Manifold to Muffler Inlet Pipe	25-30
Oil Filter Adapter to Cylinder Block	17-25
Valve Rocker Arm Cover	4-7
Fuel Pump to Cylinder Block or Cylinder Front Cover	19-27
Connecting Rod Nuts	40-45
Camshaft Sprocket or Gear to Camshaft	45-57
Oil Filter Insert to Adapter	50-60
Camshaft Thrust Plate to Block	12-15
Alternator Pivot Bolt	65-75

TORQUE LIMITS FOR VARIOUS SIZE BOLTS — FT-LBS

CAUTION: If any of the torque limits listed in this table disagree with any of those listed in the preceding tables, the limits listed in the preceding tables prevail.

Size (Inches)	1/4-20	5/16-18	3/8-16	7/16-14	1/2-13	9/16-18
Torque (Foot-Pounds)	6-9	12-18	33-32	40-55	55-80	85-120

IGNITION SYSTEM

Initial Spark Advance — BTDC	6°
Contact Spacing	0.014-0.020
Dwell Angle at Idle Speed	26°-30°
Gear Location Dimensions — Distributor (Distance from Bottom of Mounting Flange to Bottom of Gear) . . .	3.071-3.080
Shaft End Play — Distributor	0.025-0.035
Condenser	
Capacity — Microfarads	0.21-0.25
Minimum Leakage — Megohms	10
Maximum Series Resistors — Ohms	1

SPECIFICATIONS

Coil	
Primary Resistance — Ohms	1.40-1.54 (75°F)
Secondary Resistance — Ohms	7600-8800 (75°F)
Amperage Draw	
Engine Stopped	4.5
Engine Idling	2.5
Primary Circuit Resistor — Ohms	1.30-1.40 (75°F)
Spark Plugs	
Plugs	BRF31
Size	18 mm
Gap	.035

Centrifugal Advance. Set the test stand to 0° at 250 rpm and 0 inches of Hg.

Distributor (rpm)	Advance (Degrees)	Vacuum (Inches of Mercury)
500	1-1/2-3	0
750	4-1/2-6	0
1000	6-1/2-8	0
1500	9-1/2-11	0
2000	11-1/2-13	0

Vacuum Advance. Set the test stand to 0° at 1000 rpm and 0 inches of Hg.

Distributor (rpm)	Advance (Degrees)	Vacuum (Inches of Mercury)
1000	0-1-1/2	5
1000	6-9	10
1000	6-9	15
1000	6-9	20

FUEL SYSTEM

Fuel Pump Static Pressure @ 500 rpm	5.0-7.0
Minimum Fuel Pump Volume Flow @ 500 rpm	1 pint/20 seconds
Eccentric Total Lift	0.690-0.710

SPECIFICATIONS

COOLING SYSTEM

Thermostat

Low Temperature

Opens 157°-164°F
Fully Open 184°F

High Temperature

Opens 188°-195°F
Fully Open 212°F

Drive Belt Tension — All Except Governor

New 140 Lbs
Used (Any belt operated over 10 minutes) 110 Lbs

Governor Belt Tension

New 70 Lbs
Used (Any Belt Operated over 10 Minutes) 50 Lbs

LUBE OIL SPECIFICATIONS

There are numerous commercial crankcase oils marketed today. Lubricants marketed for gasoline and/or diesel service consist of refined crude oil to which has been added additives compounded to meet desired engine performance levels. Oil additive selection is based on evaluations conducted by the oil supplier. (The term oil supplier refers to refiners, blenders and rebranders of petroleum products and does not include distributors of such products.) Experience has shown that oil performance in commercial gasoline and diesel service applications varies from brand to brand.

Ford industrial engines have given optimum performance and experienced the longest service with oils which meet Ford Specification ESE-M2C-144-A or API Rating SE or SE/CC.

The oil filter elements must be replaced each time the oil is changed. It is recommended that only oil filters that meet Ford Specification ESE-C8AF-6714-A, or "C" be used. Oil filters that state on the filter or container that they are acceptable for engine manufacturers' warranty coverage replacement are acceptable to Ford Industrial Engine Operations.

The importance of adhering to the foregoing recommendation—particularly in service applications—cannot be over-emphasized. Operators should be cautioned that failure to adhere to Ford lubrication system recommendations can void their warranty coverage.

Index

Air Cleaner	18
Ammeter	7
Antifreeze	20
Battery	22
Belt Adjustment	21
Carburetor Adjustment	24
Choke Control	5
Controls	5
Coolant Level	20
Cooling System	20
Crankcase Ventilation System	23
Cylinder Head Torque	35
Distributor Points Adjustments	27
Distributor Points Replacement	26
Engine Warning Lights	7
Emergency Starting	12
Fuel Filter	23
Fuel System	23
Governor Adjustments	30
Hour Meter	7
Identification Decal	3
Ignition Switch	5
Ignition Timing	27
Initial Start Up	15
Instruments	6
Intake Manifold Torque	36
Lubrication	37
Lube Oil Specifications	47
Maintenance Schedule	14
Oil Filter	18
Oil Level	16
Oil Pressure Gauge	6
Oil Recommendations	17
Parts and Service	4
Power Take-Off Adjustments	34
Power Take-Off Control	5
Power Take-Off Lubrication	35
Problem Diagnosis	10
Radiator	20
Spark Plugs	29
Specifications	39
Starting the Engine	8
Stopping the Engine	9
Storage	37
Tachometer	7
Temperature Gauge	7
Throttle Control	5

NOV. 76

IEO-194-133

LITHO IN U.S.A.