

**GENERAC**<sup>®</sup>  
POWER SYSTEMS, INC.

**2.5** LITER

***FORD  
GAS  
ENGINE***

---

***SERVICE  
MANUAL***

# FOREWORD

This manual has been published by GENERAC<sup>®</sup> POWER SYSTEMS, INC. to aid our dealers' mechanics, company service personnel and general consumers when servicing the products described herein.

It is assumed that these personnel are familiar with the servicing procedures for these products, or like or similar products, manufactured and marketed by GENERAC<sup>®</sup> POWER SYSTEMS, INC. It is also assumed that they have been trained in the recommended servicing procedures for these products, which includes the use of mechanics hand tools and any special tools that might be required.

Proper service and repair is important to the safe, economical and reliable operation of the products described herein. The troubleshooting, testing, service and repair procedures recommended by GENERAC<sup>®</sup> POWER SYSTEMS, INC. and described in this manual are effective methods of performing such operations. Some of these operations or procedures may require the use of specialized equipment. Such equipment should be used when and as recommended.

We could not possibly know of and advise the service trade of all conceivable procedures or methods by which a service might be performed, nor of any possible hazards and/or results of each procedure or method. We have not undertaken any such wide evaluation. Therefore, anyone who uses a procedure or method not recommended by the manufacturer must first satisfy himself that neither his safety, nor the product's safety, will be endangered by the service or operating procedure selected.

All information, illustrations and specifications contained in this manual are based on the latest product information available at the time of publication. However, GENERAC<sup>®</sup> POWER SYSTEMS, INC. reserves the right to change, alter or otherwise improve the product at any time without prior notice.

Some components or assemblies of the product described in this manual may not be considered repairable. Disassembly, repair and reassembly of such components may not be included in this manual.

The engines described herein may be used to power a wide variety of products. Service and repair instructions relating to any such products are not covered in this manual. For information pertaining to use of these engines with other products, refer to any owner's or service manuals pertaining to said products.

SERVICE RECOMMENDATIONS ..... A\_2  
FORD CONTENTS .....

This engine has been engineered for use in Generac Power Systems products. The contents of this manual have been reprinted from the original manufacturer's service and repair manual.

## 2.5 Liter Gas Engine Service Recommendations

### ◆ ENGINE OIL RECOMMENDATIONS

The unit has been filled with “break in” engine oil at the factory. Use a high-quality detergent oil classified “For Service CC, SD, SE or SF.” Detergent oils keep the engine cleaner and reduce carbon deposits. Use oil having the following SAE viscosity rating, based on the ambient temperature range anticipated before the next oil change:

#### Engine Lubrication System:

Type of Oil Pump .....Gear  
 Oil Filter .....Full Flow, Cartridge  
 Crankcase Oil Capacity .....xx liters (xx U.S. quarts.)

Temperature	Oil Grade (Recommended)
Above 80° F (27° C)	SAE 5W-20
32° to 86° F (0° to 30° C)	SAE 5W-20
Below 32° F (0° C)	SAE 5W-20

### ◆ COOLANT

Use a mixture of half low silicate, ethylene glycol base antifreeze and half soft water. Use only soft water and only low silicate antifreeze. If desired, you may add a high quality rust inhibitor to the recommended coolant mixture. When adding coolant, always add the recommended 50-50 mixture.

#### Cooling System:

Type.....Pressurized, Closed Recovery  
 Coolant Capacity  
 System .....xx liters (xx U.S. gallons.)

### —▲ DANGER ▲—

- ▲ Do not remove the radiator pressure cap while the engine is hot or serious burns from boiling liquid or steam could result.
- ▲ Ethylene glycol base antifreeze is poisonous. Do not use your mouth to siphon coolant from the radiator, recovery bottle or any container. Wash your hands thoroughly after handling. Never store used antifreeze in an open container because animals are attracted to the smell and taste of antifreeze even though it is poisonous to them.

### —▲ CAUTION ▲—

- ▲ Do not use any chromate base rust inhibitor with ethylene glycol base antifreeze, or chromium hydroxide (“green slime”) will form and cause overheating. Engines that have been operated with a chromate base rust inhibitor must be chemically cleaned before adding ethylene glycol base antifreeze. Using any high silicate antifreeze boosters or additives also will cause overheating. We also recommend that you DO NOT use any soluble oil inhibitor for this equipment.

### PERIODIC MAINTENANCE SCHEDULE:

#### SCHEDULED MAINTENANCE

Following is a recommended maintenance schedule for Generac small standby and residential generator sets. The established intervals in the schedule are the *maximum* recommended when the unit is used in an average service application. They will need to be decreased (performed more frequently) if the unit is used in a severe application. Use the unit hour meter or calendar time, whichever occurs first, from the previous maintenance interval to determine the next required maintenance interval.

#### Service Maintenance Interval Information:

The various service maintenance intervals are designated by interval numbers as follows:

- 1 An early inspection of the generator set to ensure it is ready to operate when required and to identify any potential problem areas.

*Performed monthly or following each 10 hours of operation of the unit and requires approximately **.5 man-hours** per unit to complete.*

*This inspection may be performed by the end user providing the following safety steps are taken to prevent the engine from starting automatically without warning:*

**To prevent injury, perform the following steps in the order indicated before starting any maintenance:**

- **Disable the generator set from starting and/or connecting to the load by setting the control panel AUTO-OFF-MANUAL switch to the "OFF" position.**
- **Remove the control panel fuse.**
- **Turn off the battery charger.**
- **Remove the negative battery cable.**

**The battery charger must be turned off BEFORE removing the battery cable to prevent an over current condition from burning out sensitive control panel components and circuits.**

**Following all maintenance, reverse these steps to insure the unit is returned to standby setup for normal operation when required.**

- 2 A break-in service inspection of the generator set to ensure it is ready to operate and carry the load when required, and to identify any potential problem areas.

*Performed **ONLY ONCE** following the first three months or the first 30 hours of operation after purchase of the unit and requires approximately **2.5 man-hours** per unit to complete.*

*This inspection contains some maintenance tasks which require special tools, equipment, and/or knowledge to accomplish and should be performed only by an authorized Generac Service Dealer.*

- 3 An operational inspection of the generator set to ensure it is ready to operate and carry the load when required, and to identify any potential problem areas.

*Performed semi-annually or following each 50 hours of operation of the unit and requires approximately **1.5 man-hours** per unit to complete.*

*This inspection contains some maintenance tasks which require special tools, equipment, and/or knowledge to accomplish and should be performed only by an authorized Generac Service Dealer.*

- 4 A mid-level inspection of the generator set to ensure it is ready to operate and carry the load when required, and to identify any potential problem areas.

*Performed annually or following each 100 hours of operation of the unit and requires approximately **4.0 man-hours** per unit to complete.*

*This inspection contains some maintenance tasks which require special tools, equipment, and/or knowledge to accomplish and should be performed only by an authorized Generac Service Dealer.*

## 2.5 Liter Gas Engine Service Recommendations

Maintenance Tasks	Level 1		Level 2		Level 3		Level 4	
	Recommended to be done monthly/ 10 hrs.	Task Comp. (Date-Initials)	Required to be done 3 months/ Break-in 30 hrs.	Task Comp. (Date-Initials)	Required to be done Semi-annually/ 50 hrs.	Task Comp. (Date-Initials)	Required to be done Annually/ 100 hrs.	Task Comp. (Date-Initials)
1. Disable the unit from operating per the first page warning.	○		○		○		○	
2. Check the engine oil level. Adjust as necessary.	○		○		○		○	
3. Check the engine coolant level. Adjust as necessary.	○		○		○		○	
4. Check the engine coolant thermal protection level. Correct as necessary.							○	
5. Check the natural gas delivery system on gas engine driven units. Tighten connections as necessary.			○		○		○	
6. Check the air inlets and outlets for debris. Clean as necessary.	○		○		○		○	
7. Check the battery electrolyte level if accessible. Adjust as necessary.	○		○		○		○	
8. Check the battery posts, cables, and charger for loose connections, corrosion, and proper operation. Correct as necessary.	○		○		○		○	
9. Check the unit wiring for loose connections, corrosion, and damage. Correct as necessary.							○	
10. Check the engine accessory drive belts for wear, weather cracking, and damage. Replace as necessary.							○	
11. Visually inspect the unit looking for leaks, wear or damage, loose connections or components, and corrosion. Correct as necessary.	○		○		○		○	
12. Test the engine and transfer switch safety devices. Correct and/or adjust as necessary.							○	

## 2.5 Liter Gas Engine Service Recommendations

Maintenance Tasks	Level 1	Task Comp. (Date-Initials)	Level 2	Task Comp. (Date-Initials)	Level 3	Task Comp. (Date-Initials)	Level 4	Task Comp. (Date-Initials)
	Recommended to be done monthly/ 10 hrs.		Required to be done 3 months/ Break-in 30 hrs.		Required to be done Semi-annually/ 50 hrs.		Required to be done Annually/ 100 hrs.	
13. Initiate an automatic start and transfer of the unit to site load and exercise it for at least 1 hour looking for leaks, loose connections or components, and abnormal operating conditions. Correct as necessary.			○		○			
14. Start and exercise the unit at full rated load (use a load bank if the site load is not enough) for at least 2 hours looking for leaks, loose connections or components, and abnormal operating conditions. Correct as necessary.							○	
15. Change the engine oil.			○				○	
16. Replace the engine oil filter(s).			○				○	
17. Replace the engine air filter(s).							○	
18. Replace the engine fuel filter(s) on diesel engine driven units and re-prime the fuel system.			○				○	
19. Check the engine spark plugs on gas engine driven units. Clean and re-gap or replace as necessary.			○				○	
20. Perform a 5 minute no-load operational run of the unit looking for any post service problems.			○				○	
21. Return the unit to standby setup for operation when required.	○		○		○		○	





The Source for Power...  
Worldwide™

# LRG-425 2.5 LITER (153 CID)

## INDUSTRIAL ENGINE SERVICE MANUAL

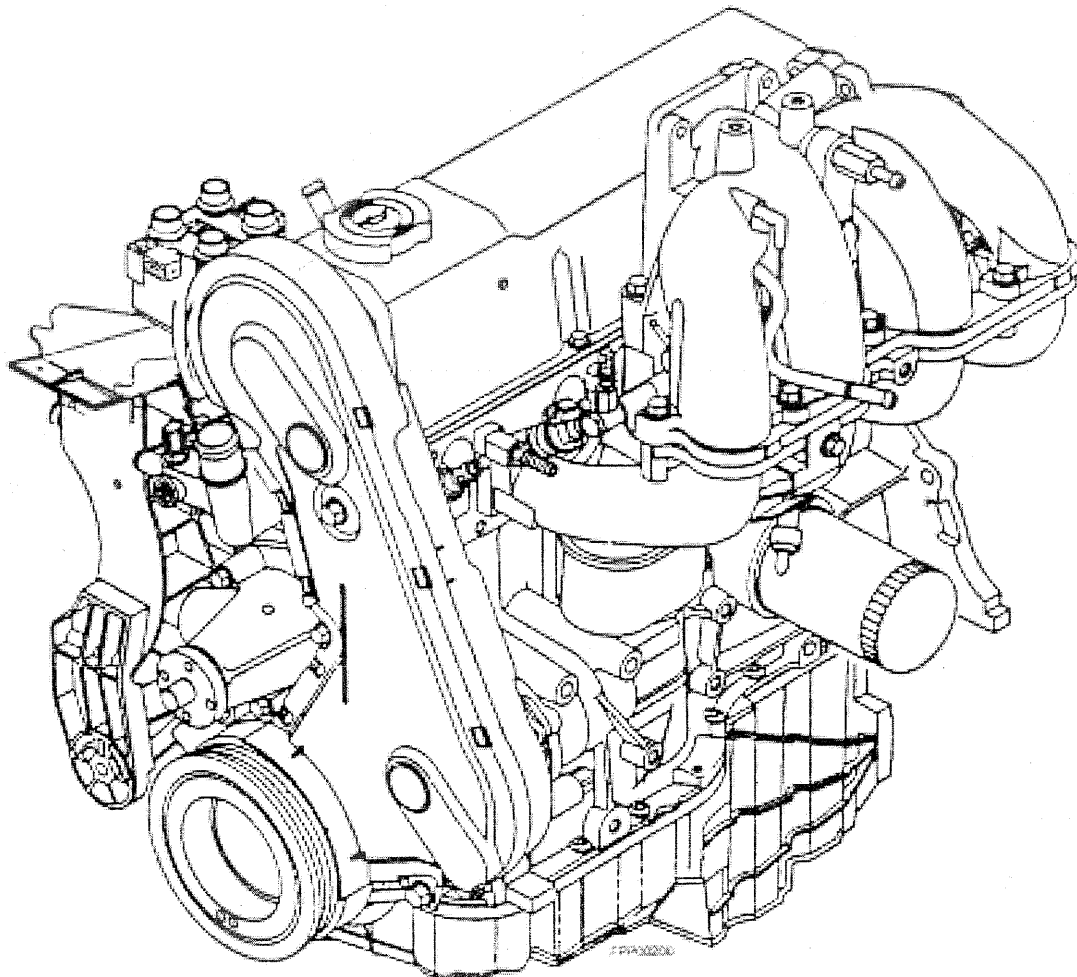

## IMPORTANT SAFETY NOTICE

Appropriate service methods and proper repair procedures are essential for the safe, reliable operation of all industrial engines as well as the personal safety of the individual doing the work. This Service Manual provides general directions for accomplishing service and repair work with tested, effective techniques. Following them will help assure reliability.

There are numerous variations in procedures, techniques, tools and parts for servicing equipment, as well as in the skill of the individual doing the work. This Manual cannot possibly anticipate all such variations and provide advice or cautions as to each. Accordingly, anyone who departs from the instructions provided in this Manual must first establish that he compromises neither his personal safety nor the equipment integrity by his choice of methods, tools or parts.

## NOTES, CAUTIONS, AND WARNINGS

As you read through the procedures, you will come across NOTES, CAUTIONS, and WARNINGS. Each one is there for a specific purpose. NOTES give you added information that will help you to complete a particular procedure. CAUTIONS are given to prevent you from making an error that could damage the equipment. WARNINGS remind you to be especially careful in those areas where carelessness can cause personal injury. The following list contains some general WARNINGS that you should follow when you work on the equipment.

- Always wear safety glasses for eye protection.
- Use safety stands whenever a procedure requires you to be under the equipment.
- Be sure that the ignition switch is always in the OFF position, unless otherwise required by the procedure.
- Set the parking brake (if equipped) when working on the equipment. If you have an automatic transmission, set it in PARK REVERSE (engine off) or NEUTRAL (engine on) unless instructed otherwise for a specific operation. Place wood blocks (4" x 4" or larger) to the front and rear surfaces of the tires to provide further restraint from inadvertent equipment movement.
- Operate the engine only in a well ventilated area to avoid the danger of carbon monoxide.
- Keep yourself and your clothing away from moving parts when the engine is running, especially the fan and belts.
- To prevent serious burns, avoid contact with hot metal parts such as the radiator, exhaust manifold, tail pipe, catalytic converter and muffler.
- Do not smoke while working on the equipment.
- To avoid injury, always remove rings, watches, loose hanging jewelry, and loose clothing before beginning to work on the equipment. Tie long hair securely behind the head.
- Keep hands and other objects clear of the radiator fan blades. Electric cooling fans can start to operate at any time by an increase in underhood temperatures, even through the ignition is in the OFF position. Therefore, care should be taken to ensure that the electric cooling fan is completely disconnected when working under the hood.

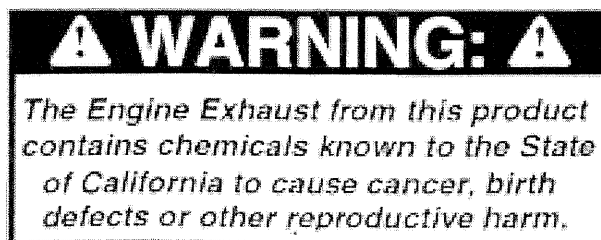

# Introduction

In general, this manual covers the servicing of the engine and associated standard equipment. In many cases, engines are supplied with accessories and equipment that are unique to the application. If service information is ever required on such unique accessories or equipment it is suggested that Ford Power Products be contacted. The proper information will either be forwarded or the Service Technician will be advised where it can be obtained.

The information in this manual is grouped in sections according to the type of work being performed. The various sections are indicated in the index. In addition, each section is subdivided to include topics such as diagnosis and testing, cleaning and inspection, overhaul, removal and installation procedures, disassembly and assembly procedures, and service specifications.

Special service tools called for by the procedures can be obtained by calling:

**1-800-ROTUNDA (1-800-768-8632).**

*The descriptions and specifications contained in this manual were in effect at the time the book was released for printing. Ford Power Products reserves the right to discontinue models at any time, or change specifications or design, without notice and without incurring obligation.*

**NOTE:** *The recommendations and suggestions contained in this publication are made to assist the distributor in improving his distributorship parts and/or service department operations. These recommendations and suggestions do not supersede or override the provisions of the Warranty and Policy Manual and in any cases where there may be a conflict, the provisions of the Warranty and Policy Manual shall govern.*

*Reproduction in any manner, in whole or in part, is prohibited without  
The express permission in writing from:*

*Ford Power Products, Marketing Department.*

---

# TABLE OF CONTENTS

---

SECTION TITLE	PAGE
ENGINE SERVICE - GENERAL .....	01
ENGINE SERVICE – 2.5L .....	02
IGNITION SYSTEM .....	03
FUEL PUMP .....	04
CARBURETOR.....	05
STARTER MOTOR.....	06
GOVERNOR.....	07
COOLING SYSTEM.....	08
GENERATOR .....	09

<b>SECTION TITLE</b>	<b>PAGE</b>
ENGINE SERVICE - General .....	01-01
ENGINE SERVICE - 2.5L .....	02-01
IGNITION SYSTEM .....	03-01
FUEL PUMP .....	04-01
CARBURETOR.....	05-01
STARTER MOTOR.....	06-01
GOVERNOR.....	07-01
COOLING SYSTEM .....	08-01
GENERATOR.....	09-01

---

## SECTION 01 - Engine Service - General

---

<b>SUBJECT</b>	<b>PAGE</b>
DESCRIPTION .....	2
Introduction.....	2
Engine Identification Nameplate.....	2
DIAGNOSIS.....	3
Inspection.....	3
Symptom Chart.....	3
PCV System Malfunction.....	5
Engine Oil Leak Check .....	5
Compression Test.....	7
Cylinder Leakage Test.....	8
Oil Leak and Valve Guide Seal Test.....	8
Intake Manifold Vacuum Test.....	8
Oil Consumption Test .....	10
Oil Pressure Test.....	11
SERVICE PROCEDURES.....	12
Camshaft Service.....	12
Connecting Rod Service .....	14
Crankshaft Bearing Service.....	15
Crankshaft Service.....	18
Cylinder Block Service.....	20
Cylinder Head Service .....	23
Engine Block Plug Service.....	31
Exhaust Manifold Service .....	32
Hydraulic Valve Tappet/Adjuster Service.....	32
Intake Manifold Service.....	34
Oil Pan Service .....	34
Piston Service.....	34
SPECIAL TOOLS .....	38

## DESCRIPTION

### Introduction

This section covers various engine tests, adjustments, service procedures and cleaning/inspection procedures. Engine assembly and service specifications appear at the end of Section 02.

For engine disassembly, assembly, installation, adjustment procedures and specifications, refer to Section 02.

Most Ford Power Product engines incorporate a closed-type crankcase ventilation system. Other than the crankcase ventilation system there are no exhaust emission controls or engine/emission control systems used with industrial versions of these engines.

To maintain the required performance level, the fuel system, ignition system and engine must be kept in good operating condition and meet recommended adjustment specifications.

Before replacing damaged or worn engine components such as the crankshaft, cylinder head, valve guide, valves, camshaft or cylinder block, make sure part(s) is not serviceable.



**WARNING: TO AVOID THE POSSIBILITY OF PERSONAL INJURY OR DAMAGE, DO NOT OPERATE THE ENGINE UNTIL THE FAN BLADE HAS FIRST BEEN EXAMINED FOR POSSIBLE CRACKS OR SEPARATION.**



**CAUTION:** Use of abrasive grinding discs to remove gasket material from the engine sealing surfaces during repair procedures can contribute to engine damage and wear. Airborne debris and abrasive grit from the grinding disc may enter the engine through exposed cavities causing premature wear and eventual engine damage.

Ford Power Products does not recommend using abrasive grinding discs to remove engine gasket material. Use manual gasket scrapers for removing gasket material from the engine sealing surfaces.

Take added care to prevent scratching or gouging

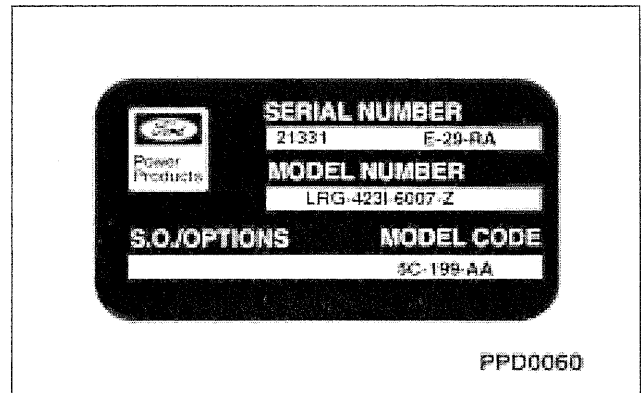

aluminum sealing surfaces.

### Engine Identification Nameplate

For quick engine identification, refer to the Engine Identification Nameplate. The nameplate lists engine information required for proper servicing of the engine. The Engine Identification Nameplate and identification label provide information pertaining to engine displacement, serial number, model number, S.O./Options, and model code.

An engine code decal is attached to the engine front cover. The symbol code on the decal identifies each engine for determining parts usage.

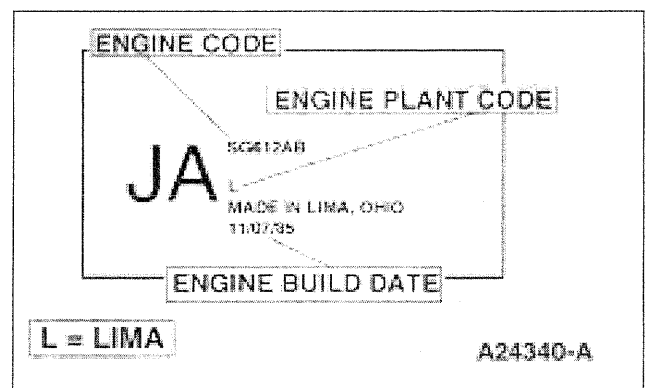

## DIAGNOSIS

### Inspection

Inspect to determine if any of the following mechanical concerns apply:

- Engine oil leaks.
- Damaged and/or severely worn parts.
- Loose mounting bolts, studs and nuts.

CONDITION	POSSIBLE SOURCE	ACTION
DIFFICULT STARTING	<ul style="list-style-type: none"> <li>• Burnt valve.</li> <li>• Worn piston.</li> <li>• Worn piston ring(s).</li> <li>• Worn cylinder.</li> <li>• Damaged cylinder head gasket.</li> <li>• Malfunctioning or damaged fuel system.</li> <li>• Malfunctioning or damaged ignition system.</li> </ul>	<ul style="list-style-type: none"> <li>• Replace valve.</li> <li>• Replace piston.</li> <li>• Replace piston ring(s).</li> <li>• Service or replace cylinder block.</li> <li>• Replace cylinder head gasket.</li> <li>• Refer to section on fuel system.</li> <li>• Refer to section on ignition system.</li> </ul>
POOR IDLING	<ul style="list-style-type: none"> <li>• Damaged hydraulic valve tappet.</li> <li>• Damaged hydraulic valve tappet guide.</li> <li>• Improper valve to valve seat contact.</li> <li>• Damaged cylinder head gasket.</li> <li>• Malfunctioning or damaged fuel system.</li> <li>• Malfunctioning or damaged ignition system.</li> </ul>	<ul style="list-style-type: none"> <li>• Replace hydraulic valve tappet.</li> <li>• Replace hydraulic valve tappet guide.</li> <li>• Replace valve and/or valve seat.</li> <li>• Replace cylinder head gasket.</li> <li>• Refer to section on Fuel system.</li> <li>• Refer to section on ignition system.</li> </ul>
ABNORMAL COMBUSTION	<ul style="list-style-type: none"> <li>• Damaged hydraulic valve tappet.</li> <li>• Damaged hydraulic valve tappet bore.</li> <li>• Burnt or sticking valve.</li> <li>• Weak or broken valve spring.</li> <li>• Carbon accumulation in combustion chamber.</li> <li>• Malfunctioning or damaged fuel system.</li> <li>• Malfunctioning or damaged ignition system.</li> </ul>	<ul style="list-style-type: none"> <li>• Replace hydraulic valve tappet.</li> <li>• Replace cylinder block.</li> <li>• Service or replace valve.</li> <li>• Replace valve spring.</li> <li>• Eliminate carbon buildup.</li> <li>• Refer to section on fuel system.</li> <li>• Refer to section on ignition system.</li> </ul>
EXCESSIVE OIL CONSUMPTION	<ul style="list-style-type: none"> <li>• Worn piston ring groove.</li> <li>• Sticking piston ring(s).</li> <li>• Worn piston or cylinder.</li> <li>• Worn valve stem seal.</li> <li>• Worn valve stem or valve guides.</li> <li>• Leaking oil.</li> <li>• Worn piston rings.</li> <li>• Plugged pcv system.</li> </ul>	<ul style="list-style-type: none"> <li>• Replace piston.</li> <li>• Service or replace piston ring (s).</li> <li>• Service or replace piston or cylinder block.</li> <li>• Replace valve stem seal.</li> <li>• Replace valve stem and guide.</li> <li>• Service oil leak.</li> <li>• Replace piston rings.</li> <li>• Service PCV system.</li> </ul>

CONDITION	POSSIBLE SOURCE	ACTION
ENGINE NOISE	<ul style="list-style-type: none"> <li>• Excessive main bearing oil clearance.</li> <li>• Seized or heat damaged crankshaft main bearing.</li> <li>• Excessive crankshaft end play.</li> <li>• Excessive connecting rod bearing oil clearance.</li> <li>• Heat damaged connecting rod bearing.</li> <li>• Damaged connecting rod bushing.</li> <li>• Worn cylinder.</li> <li>• Worn piston or piston pin.</li> <li>• Damaged piston ring(s).</li> <li>• Bent connecting rod.</li> <li>• Malfunctioning hydraulic valve tappet.</li> <li>• Excessive hydraulic valve tappet clearance.</li> <li>• Broken valve spring.</li> <li>• Excessive valve guide clearance.</li> <li>• Malfunctioning or damaged cooling system.</li> <li>• Malfunctioning or damaged fuel system.</li> <li>• Leaking exhaust system.</li> <li>• Improper drive belt tension.</li> <li>• Malfunctioning generator bearing.</li> <li>• Loose riming belt.</li> <li>• Damaged timing belt tensioner.</li> <li>• Malfunctioning water pump bearing.</li> </ul>	<ul style="list-style-type: none"> <li>• Adjust clearance or replace crankshaft main bearing.</li> <li>• Replace crankshaft main bearing.</li> <li>• Adjust end play or replace crankshaft.</li> <li>• Adjust clearance or replace connecting rod.</li> <li>• Replace connecting rod bearing.</li> <li>• Replace connecting rod bushing.</li> <li>• Service or replace cylinder block.</li> <li>• Replace piston or piston pin.</li> <li>• Replace piston ring(s).</li> <li>• Replace connecting rod.</li> <li>• Replace hydraulic valve tappet.</li> <li>• Adjust clearance or replace hydraulic valve tappet.</li> <li>• Replace valve spring.</li> <li>• Service clearance or replace valve guide/stem.</li> <li>• Refer to section on cooling system.</li> <li>• Refer to section on fuel system.</li> <li>• Service exhaust leakage.</li> <li>• Refer to section on accessory drivebelts.</li> <li>• Refer to section on charging system.</li> <li>• Adjust or replace timing belt.</li> <li>• Replace timing belt tensioner.</li> <li>• Refer to section on cooling system.</li> </ul>
INSUFFICIENT POWER	<ul style="list-style-type: none"> <li>• Malfunctioning hydraulic valve tappet.</li> <li>• Damaged hydraulic valve tappet bore.</li> <li>• Seized valve stem.</li> <li>• Weak or broken valve spring.</li> <li>• Damaged cylinder head gasket.</li> <li>• Cracked or distorted cylinder head.</li> <li>• Damaged, worn or sticking piston ring(s).</li> <li>• Worn or damaged piston.</li> <li>• Malfunctioning or damaged fuel system.</li> <li>• Malfunctioning or damaged ignition system.</li> </ul>	<ul style="list-style-type: none"> <li>• Replace hydraulic valve tappet.</li> <li>• Replace cylinder block.</li> <li>• Service or replace valve, valve seat and/or cylinder head.</li> <li>• Replace valve spring.</li> <li>• Replace cylinder head gasket.</li> <li>• Replace cylinder head.</li> <li>• Service or replace piston ring(s).</li> <li>• Replace piston.</li> <li>• Refer to section on fuel system.</li> <li>• Refer to section on ignition system.</li> </ul>

## PCV System Malfunction

A malfunctioning Positive Crankcase Ventilation System (closed type) may be indicated by loping or rough engine idle. Do not attempt to compensate for this idle condition by disconnecting the crankcase ventilation system and making an air bypass or idle speed adjustment. **The removal of the crankcase ventilation system from the engine will adversely affect fuel economy and engine crankcase ventilation with resultant shortening of engine life.**

## Engine Oil Leak Check

When diagnosing engine oil leaks, it is important that the source and location of the leak be positively identified prior to service.

**NOTE:** Due to their remote location, rear engine oil leaks may be very difficult to pinpoint. This area is also very difficult to clean. Make sure to eliminate all other possibilities before removing the engine to repair a suspected leak in this area.

There are two methods of diagnosing engine oil leaks. The following procedure has been found to be very effective and requires only a minimum of equipment. Prior to using this procedure, it is important to clean the cylinder block, cylinder heads, valve covers, oil pan and flywheel housing areas with a suitable solvent to remove all traces of oil.

## Fluorescent Oil Additive Method

To perform oil leak diagnosis using Rotunda Oil Leak Detector Kit 112-R0030, or equivalent, perform the following procedure.

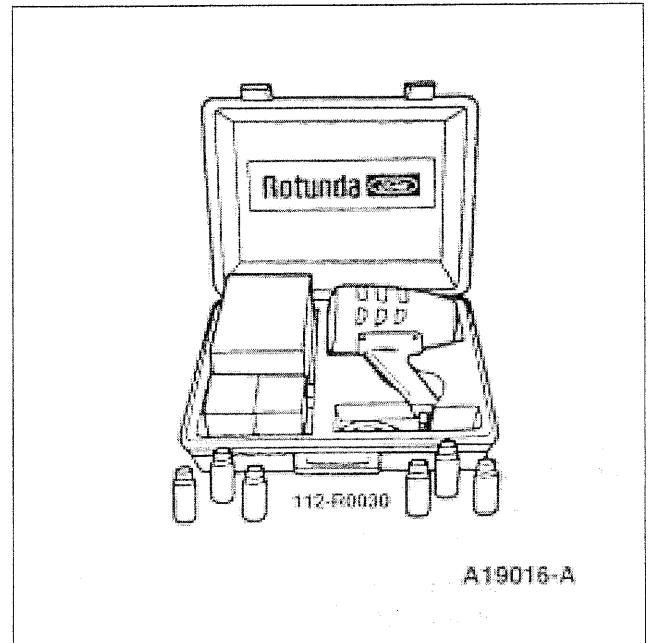

1. Clean engine with a suitable solvent to remove all traces of oil.
2. Drain engine oil from crankcase and refill with recommended oil, premixed with Rotunda Fluorescent Oil Additive 112-R0015, or equivalent. Use 29.6ml (1 fluid ounce) of fluorescent additive. If oil is not premixed, fluorescent additive must be added to crankcase first.
3. Run engine for 15 minutes. Stop engine and inspect all seal and gasket areas for leaks using Rotunda Oil Leak Detector Y112-R0021 (part of 112-R0030 kit) Lamp or equivalent. A clear bright yellow or orange area will identify leak. For extremely small leaks, several hours may be required for the leak to appear.
4. If necessary, pressurize main oil gallery system to locate leaks due to improperly sealed, loose or cocked plugs. If flywheel bolts leak oil, look for sealer on threads.
5. Service all leaks as required.

## Pressure Method

As an alternative testing procedure, the crankcase can be pressurized, not to exceed 27 kPa (4 psi), to locate oil leaks. The following materials are required to fabricate the tool to be used:

- Air supply and air hose.
- Air pressure gauge that registers pressure in increments of one psi.
- Air line shutoff valve.
- Appropriate fittings to attach the above parts to oil fill, PCV grommet holes and PCV fresh air hose tube.
- Appropriate plugs to seal any openings leading to crankcase.
- A solution of liquid detergent and water to be applied with a suitable type applicator such as a squirt bottle or brush.

Fabricate the air supply hose to include the air line shutoff valve and the appropriate adapter to permit the air to enter the engine through the rocker arm cover tube. Fabricate the air pressure gauge to a suitable adapter for installation on the engine at the oil fill opening.



**CAUTION:** Use extreme caution when pressurizing crankcase. Applying air pressure above specified pressure risks damage to seals, gaskets and core plugs. Under no circumstances should pressure be allowed to exceed 27 kPa (4 psi).

1. Open air supply valve until pressure gauge maintains 20 kPa (3 psi).
2. Inspect sealed and/or gasketed areas for leaks by applying a solution of liquid detergent and water over areas for formation of bubbles, which indicates leakage.
3. Examine the following areas for oil leakage:
  - Rocker cover sealant or gaskets
  - Intake manifold gaskets/end seals
  - Cylinder head gaskets
  - Oil bypass filter
  - Oil level indicator (dipstick) tube connection

- Oil pressure sensor
- Cup plugs and/or pipe plugs at end of oil passages
- Oil pan gasket
- Oil pan front and rear end seals
- Oil pan front and rear end seals
- Crankshaft front seal
- Crankshaft rear oil seal
- Oil pump
- Crankshaft rear oil seal

Air leakage in area around a crankshaft rear oil seal does not necessarily indicate a rear seal leak. However, if no other cause can be found for oil leakage, it can be assumed that rear seal is the cause of the oil leakage:

- Rear main bearing cap parting line.
- Rear main bearing cap and seals.
- Flywheel mounting bolt holes.
- Rear cup plugs and/or pipe plugs at the end of oil passages.

Oil leaks at crimped seams in sheet metal parts and cracks in cast or stamped parts can be detected when pressurizing the crankcase.

Light foaming equally around rocker arm cover bolts and crankshaft seals is not detrimental and no corrections are required in such cases.

## Compression Test

1. Make sure oil in crankcase is of the correct viscosity and at proper level, and battery is properly charged. Operate the engine until it is at normal operating temperature. Turn off ignition switch, then remove all spark plugs .
2. Set throttle plates in wide-open position.
3. Install a compression gauge such as Rotunda Compression Tester 059-R0009, or equivalent, in No. 1 cylinder.
4. Install an auxiliary starter switch in starting circuit. With ignition switching the OFF position, and using auxiliary starter switch, crank engine at least five compression strokes and record highest reading. Note the approximate number of compression strokes required to obtain the highest reading.
5. Repeat test on each cylinder, cranking the engine approximately the same number of compression strokes.

The indicated compression pressures are considered within specification if the lowest reading cylinder is within 75 percent of the highest (refer to chart ).

If one or more cylinders reads low, squirt approximately one tablespoon of SAE 50 weight, or equivalent, engine oil on top of the pistons in the low reading cylinders. Repeat compression pressure check on these cylinders.

1. If compression improves considerably, piston rings are at fault.
2. If compression does not improve, valves are sticking or seating poorly.
3. If two adjacent cylinders indicate low compression pressures and squirting oil on pistons does not increase compression, cause may be a cylinder head gasket leak between cylinders. Engine oil and/or coolant in cylinders could result from this problem.

## Example Readings

If, after checking the compression pressures in all cylinders, it was found that the highest reading obtained was 1351 kPa (196 psi) and the lowest pressure reading was 1069 kPa (155 psi), the engine is within specification and the compression is considered satisfactory.

134 - 101	136 - 102	138 - 104	140 - 105
142 - 107	144 - 108	146 - 110	148 - 111
150 - 113	152 - 114	154 - 115	156 - 117
158 - 118	160 - 120	162 - 121	164 - 123
166 - 124	168 - 126	170 - 127	172 - 129
174 - 131	176 - 132	178 - 133	180 - 135
182 - 136	184 - 138	186 - 140	188 - 141
190 - 142	192 - 144	194 - 145	196 - 147
198 - 148	200 - 150	202 - 151	204 - 153
206 - 154	208 - 156	210 - 157	212 - 158
214 - 160	216 - 162	218 - 163	220 - 165
222 - 166	224 - 168	226 - 169	228 - 171
230 - 172	232 - 174	234 - 175	236 - 177
238 - 178	240 - 180	242 - 181	244 - 183
246 - 184	248 - 186	250 - 187	

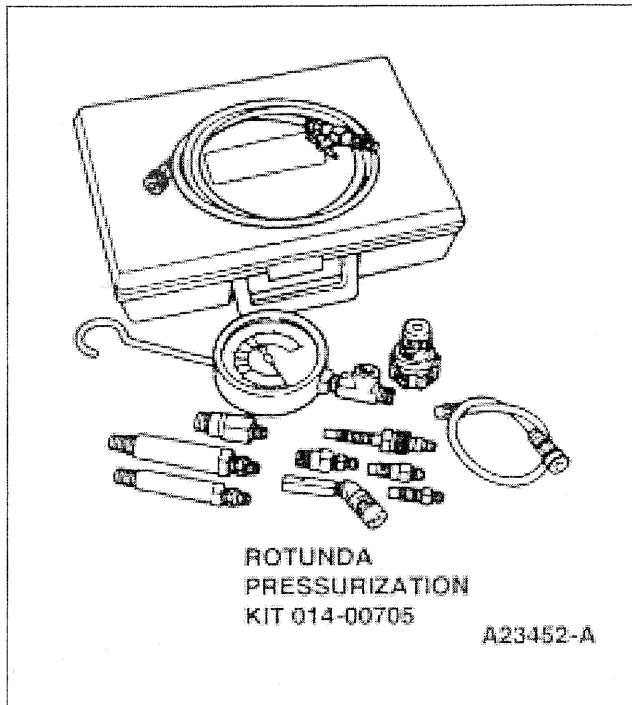

### Cylinder Leakage Test

When a cylinder produces a low reading, the use of Rotunda Pressurization Kit 014-00705, or equivalent, will be helpful in pinpointing the exact cause.

The leakage detector is inserted in the spark plug hole, the piston is brought up to top dead center on the compression stroke, and compressed air is admitted.

Once the combustion chamber is pressurized, a special gauge will read the percentage of leakage. Leakage exceeding 20 percent is considered excessive.

While the air pressure is retained in the cylinder, listen for the hiss of escaping air. A leak by the intake valve will be audible in the carburetor. A leak by the exhaust valve can be heard at the exhaust pipe. Leakage past the rings will be audible at the positive crankcase ventilation (PCV) connection. If air is passing through a blown gasket to an adjacent cylinder, the noise will be evident at the spark plug hole of the cylinder block, or gasket leakage into the cooling system may be detected by a stream of bubbles in the radiator.

### Oil Leak and Valve Guide Seal Test

The cylinder leakage detector can be used to test for engine oil leaks and to check the valve seals for leakage.

1. Plug all crankcase openings except the one used for connecting the leakage detector.
2. Connect the detector to a crankcase opening. The oil level indicator tube is convenient. Adjust the air pressure to approximately 34 kPa (5 psi).
3. Using a solution of liquid soap and water, brush the solution along the gasket sealing surfaces and bearing seals. Look for bubbles or foam.
4. Remove the spark plugs and rotate the engine slowly with a wrench. Check for large amounts of air escaping into the cylinders as each intake and exhaust valve opens.

The spark plugs on the leaking cylinders will probably show deposits of burned oil.

### Intake Manifold Vacuum Test

Bring the engine to normal operating temperature. Connect Rotunda Vacuum/Pressure Tester 059-00008, or equivalent, to the intake manifold. Run the engine at the specified idle speed.

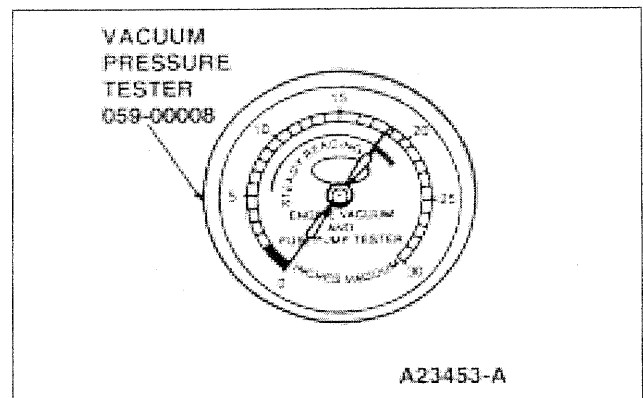

The vacuum gauge should read between -51 and -74 kPa (15 and 22 in-Hg) depending upon the engine condition and the altitude at which the test is performed.

Subtract 5.5 kpa from the specified reading for every 500 meters (1 in-hg for every 1,000 feet) of elevation above sea level.

The reading should be quite steady. It may be necessary to adjust the gauge damper control (where used) if the needle is fluttering rapidly. Adjust damper until needle moves easily without excessive flutter.

A careful study of the vacuum gauge reading while the engine is idling will help pinpoint trouble areas. Always conduct other appropriate tests before arriving at a final diagnostic decision. Remember that vacuum gauge readings, although helpful, must be interpreted with care.

Most vacuum gauges have a "normal" band indicated on the gauge face. The following are potential gauge readings, compare with the corresponding text.

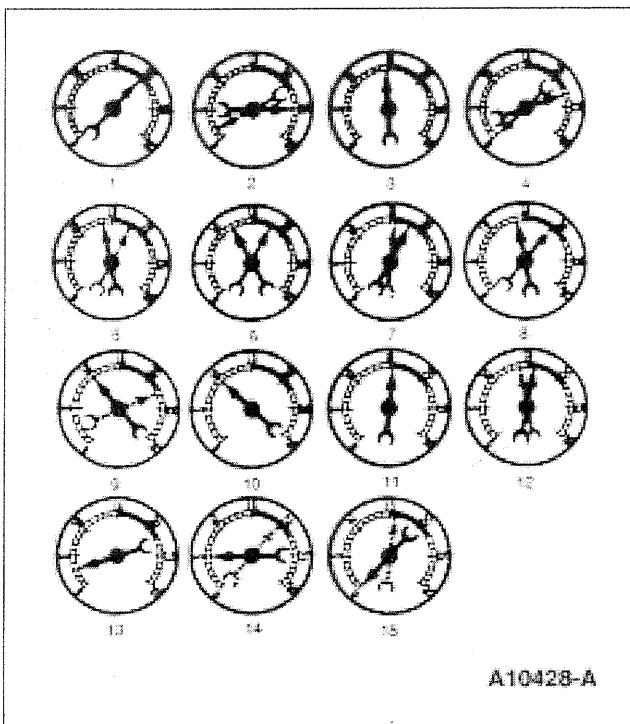

1. NORMAL READING: Needle between -51 and -75 kPa (15 and 20 in-Hg) and holding steady.
2. NORMAL READING DURING RAPID ACCELERATION AND DECELERATION: When engine is rapidly accelerated (dotted needle), needle will drop to a low (not to 0) reading. When throttle is suddenly released, the needle will snap back up to a higher than normal figure.

3. NORMAL FOR HIGH LIFT CAM WITH LARGE OVERLAP: Needle will register as low as -50 kPa (15 in-Hg) but will be relatively steady. Some oscillation is normal.
4. WORN RINGS OR DILUTED OIL: When engine is accelerated (dotted needle), needle drops to 0 kPa (0 in-Hg). Upon deceleration, needle runs slightly above 74 kPa (22 in-Hg).
5. STICKING VALVE(S): When the needle (dotted) remains steady at a normal vacuum but occasionally flicks (sharp, fast movement) down and back about 13 kPa (4 in-Hg), one or more valves may be sticking.
6. BURNED OR WARPED VALVES: A regular, evenly spaced, downscale flicking of the needle indicates one or more burned or warped valves. Insufficient hydraulic lash adjuster clearance will also cause this action.
7. POOR VALVE SEATING: A small but regular downscale flicking can mean one or more valves are not seating.
8. WORN VALVE SPRINGS: When the needle oscillates (swings back and forth) over a 13 kPa (4 in-Hg) range at idle speed, the valve guides could be worn. As engine speed is increased, the needle will become steady if the guides are responsible.
9. WEAK VALVE SPRINGS: When the needle oscillation becomes more violent as engine rpm is increased, weak valve springs are indicated. The reading at idle could be relatively steady.
10. LATE VALVE TIMING: A steady but low reading could be caused by late valve timing.
11. IGNITION TIMING RETARDING: Retarded ignition timing will produce a steady but low reading.
12. INSUFFICIENT SPARK PLUG GAP: When plugs are gapped too close, a regular, small pulsation of the needle can occur.
13. INTAKE LEAK: A low, steady reading can be caused by an intake manifold or carburetor mounting flange gasket leak.
14. BLOWN HEAD GASKET: A regular drop of approximately 33-50 kPa (10-15 in-Hg) can be caused by a blown head gasket or warped head-to-block mounting surface.

15. **RESTRICTED EXHAUST SYSTEM:** When the engine is first started and idled, the reading may be normal. But as the engine rpm is increased, back pressure caused by a clogged exhaust pipe, etc., will cause the needle to slowly drop to 0. The needle then may slowly rise. Excessive exhaust clogging will cause the needle to drop to a low point even if the engine is only idled.

When vacuum leaks are indicated, search out and correct the condition. Excess air leaking into the system will upset the fuel mixture and cause conditions such as rough idle, missing, or burned valves. **ALWAYS SERVICE VACUUM LEAKS.**

### Oil Consumption Test

The following diagnostic procedure is intended to be used to determine the source of excessive internal oil consumption.

Determine what is considered to be excessive oil consumption. Note hours of engine service and the following observations:

- How many hours of engine use per 0.95 liter (1 U.S. quart) of oil used?
- How is the engine being used (e.g., sustained high-speed operation, heavy loads, high ambient temperature, etc.)?
- What is the expected normal oil consumption?

Verify that the engine has no external oil leak as described under Engine Oil Leaks in this section.

Verify that the oil level dipstick and oil level indicator tube are unmodified and in good condition. Verify that the oil level indicator tube is properly seated in the block, and the dipstick seats properly in the oil level indicator tube .

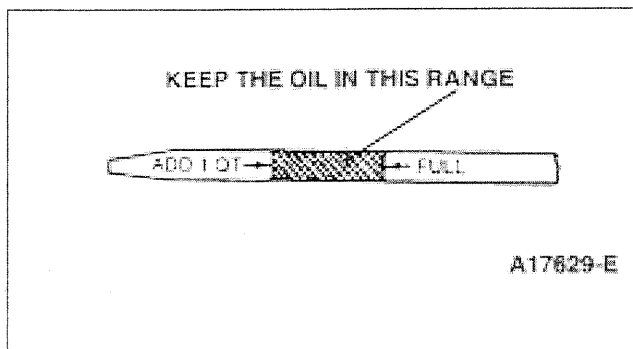

Verify that the engine is not being run in an overfilled condition. Check the oil level at least five minutes after a hot shutdown (engine must be level). Under no circumstances should the oil level be above the FULL line. If a significant overfill is indicated, perform Steps 1 through 4 to verify the dipstick calibration. If the dipstick calibration checks OK, instruct the operator to avoid overfilling the engine and return the engine to service. To verify the engine's actual oil consumption, perform Steps 5 and 6 only after the dipstick has been calibrated.

Perform engine oil consumption test as follows:

1. Drain engine oil. Remove and replace oil filter. Using 0.95 liter (1 U.S. quart) less than recommended, refill crankcase with recommended quality of oil.
2. Run the engine for three minutes (10 minutes if cold), then turn engine off. Allow oil to drain into the oil pan for an additional five minutes (engine should be level).
3. Remove oil level dipstick and wipe clean. Do not wipe using anything contaminated with silicone compounds. Reinstall oil level dipstick being sure to seat the oil level dipstick firmly in the oil level indicator tube. Remove the oil level dipstick and scribe a mark on the back (unmarked) surface at the indicated oil level. This should be about the same level as the ADD mark on the face of the oil level dipstick .
4. Add 0.95 liter (1 U.S. quart) of oil. Restart the engine and allow it to idle for at least two minutes. Shut down and allow oil to drain back for at least five minutes. Mark the dipstick using the procedure above. This level may range from slightly below the top of the cross-hatched area to slightly below the letter F in FULL.
5. Instruct the operator to run the engine as usual and :
  - Check the oil level regularly at intervals of three to five hours.
  - Call for service when the oil level drops below the lower (ADD) mark previously scribed on the dipstick.
  - In an emergency, add only 0.95 liter (1 U.S. quart) of the same oil and note the engine hours at which the oil was added.

6. Check the oil level under the same conditions as in Steps 3 and 4, reading the back of the dipstick where the scribe marks are located.
  - Measure the distance from the oil level to the upper scribe mark on the dipstick and record the measurement.
  - Measure the distance between the two scribe marks and record the measurement.
  - Divide the first measurement by the second. Add one to this total for every 0.95 liters (1 U.S. quart) added by the customer as instructed in Step 5.
  - Divide the engine hours operated during the oil test by the result. This quantity is the approximate oil consumption rate in hours per quart.
7. If the calculated oil consumption rate is unacceptable, proceed as follows.
  - Check PCV system. Make sure system is not plugged.
  - Check for plugged oil drain-back holes in cylinder heads and cylinder block.
  - If condition still exists, perform a cylinder compression test as described in this section, and/or perform a cylinder leak detection test with Rotunda Pressurization Kit 014-00705, or equivalent. This can be helpful in determining the source of oil consumption, as an example, valves, piston rings, etc.
  - Check valve guides for excessive clearance. Replace all valve stem seals after correct valve guide clearance has been verified.

**NOTE: After checking for worn parts, if it is determined parts should be replaced, make sure correct replacement parts are used. Worn or damaged internal engine components can cause excessive oil consumption. Small deposits of oil on tip of spark plugs can be a clue to internal oil consumption.**

If internal oil consumption still persists, proceed as follows:

1. Remove intake manifold(s), cylinder heads, oil pan and oil pump.
2. Check piston ring clearance, ring gap and ring orientation as outlined in this section. Service as required.
3. Check for excessive bearing clearance as outlined in this section. Service as required.
4. Perform Oil Consumption Test again to verify that the oil consumption concern has been resolved.

### Oil Pressure Test

Special Tool Required	
Engine Oil Pressure Gauge	T73L-6600-A

1. Disconnect and remove the oil pressure sensor from the engine.
2. Connect an Engine Oil Pressure Gauge T73L-6600-A, or equivalent, to the oil pressure sensor screw port.
3. Run the engine until normal operating temperature is reached.
4. Run the engine at 3,000 rpm and record the gauge reading.
  - The oil pressure should be 250-490 kPa (36-71 psi) at 3,000 rpm.
5. If the pressure is not within specification, check the following possible sources:
  - Insufficient oil
  - Oil leakage
  - Worn or damaged oil pump
  - Clogged oil pump screen cover and tube
  - Excessive main bearing clearance
  - Excessive connecting rod bearing clearance

## SERVICE PROCEDURES

### Camshaft Service

#### Camshaft End Play



**CAUTION:** Prying against the camshaft sprocket with valve train load on the camshaft, can break or damage the camshaft sprocket. Remove load on camshaft prior to checking end play.

#### Cleaning

1. Remove camshaft from engine
2. Remove sprocket.
3. Clean the camshaft in an appropriate solvent.
4. Wipe it dry with a clean lint free cloth.
5. Remove light scuffs, scores, or nicks from the camshaft machined surfaces with an oil stone.

#### Inspection

- Inspect the camshaft journals and lobes for scoring and signs of abnormal wear.
- Lobe pitting, except in the general area of the lobe toe, is not detrimental to the operation of the camshaft. The camshaft should not be replaced unless lobe lift loss has exceeded the specifications or pitting has occurred in the lobe lift area. Refer to Cam Lobes in this section.
- Inspect camshaft sprocket for worn or broken teeth. If necessary, remove and replace.

#### Camshaft Bearings

1. Wipe bearing bore clean with a clean rag and solvent.
2. Dry with a clean rag.
3. Inspect for scoring and visible wear.
4. Inspect bearings for excessive wear. If visibly worn or damaged, replace bearings. If one of the center bearings is worn significantly more than the end bearings, check camshaft for excessive runout.

5. Using suitable bore gauge or inside micrometer, measure each bearing, 90 degrees apart, to determine bearing size and out-of-round. Double-check by measuring twice.
6. Check results against specifications in the specification section. If bearings are out of specifications, they will have to be replaced. Check camshaft journals before replacing bearings to determine if undersize bearings are required.
7. If necessary, replace the bearings.

#### Camshaft Bearing Journals

1. Measure each journal twice, 90 degrees apart, to determine journal wear, size, and out-of-round.
2. Check measurements against specifications in the specification section.
3. If journals are excessively out-of-round or worn, regrind to a standard undersize. Refer to Master Parts Catalogue.
4. If journals are too worn to be refinished to an available undersize, replace camshaft.

#### Camshaft Journals Oil Clearance

1. Measure camshaft bearings and camshaft bearing journals as outlined in this section.
2. Subtract size of journal from the size of its bearing.
3. Check clearance against specifications in specification section.
4. If clearance is excessive, but camshaft journals are within specifications, simply install new bearings.
5. If both bearings and journals are worn, turn camshaft journals to a standard undersize and install new undersize bearings.

## Camshaft Runout

**NOTE:** Check camshaft journals for out-of-round before checking for runout. An out-of-round condition on the center journal could be confused for an excess runout condition. Set suitable V-blocks on surface plate. Support outer camshaft journals on V-blocks.

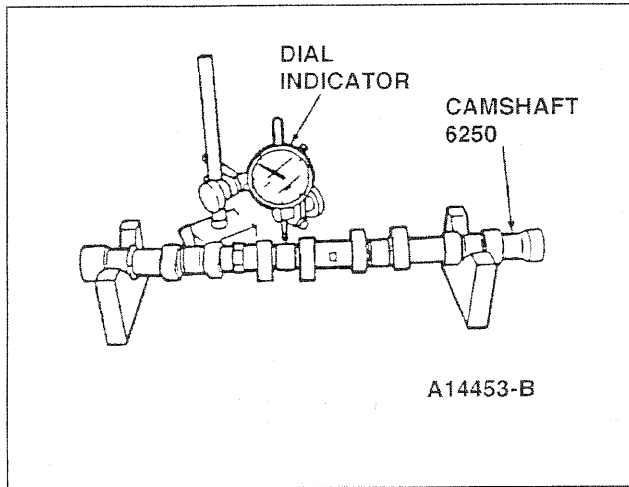

1. Set up TOOL-4201-C, or equivalent, Dial Indicator with bracketry to check center bearing journal.
2. Zero dial indicator.
3. Slowly rotate camshaft to determine overall runout. If runout exceeds 0.03mm (0.0012 in.), replace camshaft.

## Cam Lobe Lift Measurement

There are two ways of measuring cam lobe lift:

- micrometer
- dial indicator (more accurate)

### Cam Lobe Lift (with micrometer)

1. Inspect camshaft bearing as outlined in this section.
2. Measure the distance of each cam lobe at the major diameter.
3. Measure the distance of each cam lobe at the minor diameter.
4. For each cam lobe, subtract the minor diameter from the major diameter. The result for each lobe is the lobe lift.

5. Check the lobe lift for each cam lobe against the Specifications .
6. If any cam lobe is worn excessively, replace the camshaft and tappets.

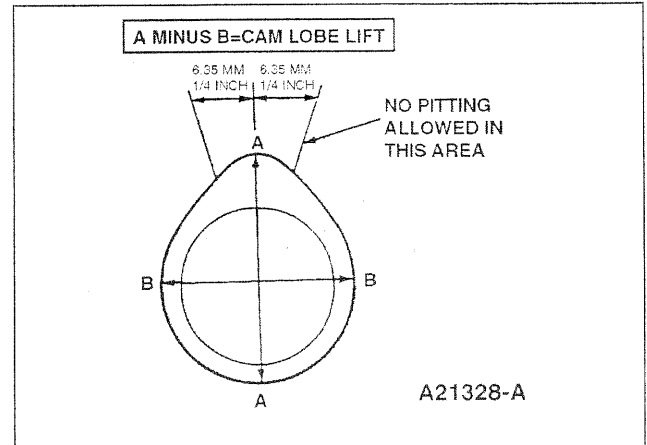

### Cam Lobe Lift (with dial indicator)

1. Clean and inspect the camshaft as outlined in this section.
2. Install the camshaft on a lathe or camshaft grinder centers.
3. Position the machine's dial indicator at the heel of the cam lobe you are going to check.
4. Zero the dial indicator.
5. Slowly turn the camshaft until the point of the dial indicator is on the tip of the cam lobe.
6. Read the dial indicator. This is your cam lobe lift.
7. Check the lobe lift against the specifications in the specifications section. If any cam is excessively worn, replace the camshaft and tappets.

## Connecting Rod Service

### Connecting Rod Side Clearance

1. Install Rotunda Dial Indicator with Bracketry TOOL-4201-C, or equivalent so that the contact point rests against the connecting rod cap.
2. Pull cap toward front of engine and zero the dial indicator.
3. Push cap toward rear of engine and observe amount of side clearance on dial indicator.
4. If side clearance exceeds specification, replace connecting rod and cap. Refer to the specification section.

If side clearance is less than specification, remove rod and cap and inspect for scratches, burrs, nicks or dirt between crankshaft and connecting rod.

### Cleaning

Remove the bearings from the rod and cap. Identify each bearing location if they are to be used again. Clean the connecting rod in solvent, including the rod bore and the back of the inserts. Do not use a caustic cleaning solution. Blow out all passages with compressed air.

### Inspection

The connecting rods and related parts should be carefully inspected and checked for conformance to specifications. Refer to the specifications section. Various forms of engine wear caused by these parts can be readily identified.

A shiny surface on either pin boss inside of the piston usually indicates that a connecting rod is bent.

Abnormal connecting rod bearing wear can be caused by either a bent connecting rod, worn or damaged piston pin, or a tapered connecting rod crankshaft pin.

Twisted connecting rods can create an identifiable piston skirt wear pattern, but badly twisted rods will disturb the action of the entire piston, rings, and connecting rod assembly and may be the cause of excessive oil consumption.

Check the connecting rods for bend or twist on a suitable alignment fixture. Follow the instructions of the fixture manufacturer. If the bend and/or twist exceeds specification, the connecting rod must be replaced.

Inspect the connecting rods for signs of fractures and the rod bearing bores for out-of-round and taper. If the bore exceeds the recommended limits and/or if the connecting rod is fractured, it should be replaced.

## Crankshaft Bearing Service

### Main Bearing Bore Alignment

Main bearing bore misalignment may be suspected in cases of premature bearing wear if one bearing wears considerably more than the others or bearings wear cone-shaped.

**NOTE: Bearings are not available with oversize outside diameters to allow line boring.**

If bearing misalignment is suspected:

1. Acquire a gauge bar the same diameter as the crankshaft journals and straight within 0.076mm (0.003 in.).
2. Put a thin coating of Prussian Blue or similar die on gauge bar.
3. Insert good bearings in block.
4. Insert gauge bar in bearings and rotate one turn.
5. Remove gauge bar.
6. Inspect bearings. Blue die should be deposited evenly on all bearings. If die appears on only one side or bottom of bearing or not at all, block is distorted and should be replaced.

### Cleaning

**NOTE: Do not scrape gum or varnish deposits from the bearing shells.**

Bearings that are to be reused should be identified so they can be installed in their original locations.

Clean the bearing inserts and caps thoroughly in solvent, and dry them with compressed air.

### Inspection

Inspect each bearing carefully. Bearings that have a scored, chipped or worn surface should be replaced. Typical examples of unsatisfactory bearings and their causes are shown in the illustration. The copper lead bearing base may be visible through the bearing overlay. If the base showing is less than 20 percent of the total area, the bearing is not excessively worn. It is not necessary to replace the bearing if the bearing clearance is within recommended limits. Check the clearance of bearings that appear to be satisfactory with Plastigage as described in this section.

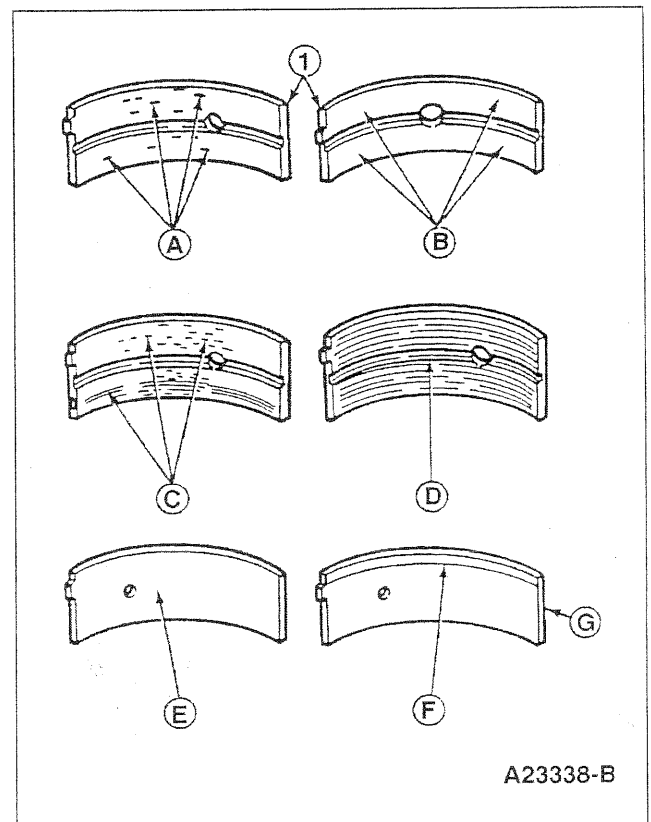

A23338-B

ITEM	DESCRIPTION
1	Connecting Rod Bearing
A	Fatigue Failure - Craters or Pockets
B	Improper Seating - Bright (polished) Sections
C	Dirt Scratching, Imbedding
D	Overlay Wiped Out - Lack of Oil or Improper Clearance
E	Hourglass - Overlay Gone from Edges
F	Radius Ride
G	Overlay Gone from Mating Edge, One Side Only. Rod Cap Shift.

## Crankshaft Bearing Clearance

### (Plastigage Method)

1. Clean crankshaft journals.
2. Inspect journals and thrust faces for nicks, burrs or roughness that would cause premature bearing wear.

When replacing standard bearings with new bearings, it is good practice to fit bearing to minimum specified clearance. If desired clearance cannot be obtained with a standard bearing, try a 0.050 mm (0.002-inch) undersize bearing set to obtain proper clearance.



**CAUTION: Do not position jack under crankshaft pulley. Crankshaft post damage will result.**

3. If fitting main bearing in-equipment, position a jack under counterweight adjoining bearing which is being checked. Support crankshaft with jack so its weight will not compress Plastigage and cause an incorrect reading.
4. Place a piece of Plastigage D81L-6002-B, or equivalent, on bearing surface across full width of bearing cup and about 6.35mm (1/4 inch) off center.
5. Install cap and tighten bolts to specification. Do not turn crankshaft while Plastigage is in place.
6. Remove cap. Using Plastigage scale, check width of Plastigage at widest point to get minimum clearance. Check at narrowest point to get maximum clearance. Difference between reading is taper of journals.

7. If bearing clearance exceeds the specified limits,

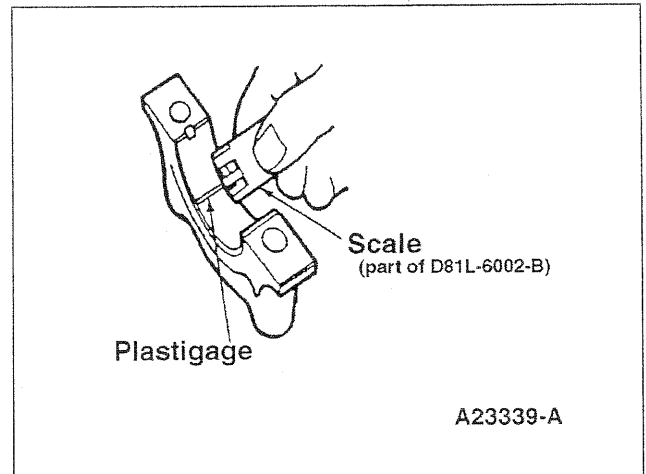

try using one of the various combinations of undersize bearings as directed by the accompanying table. Use of any other bearing combination is not recommended. Bearing clearance must be within specified limits. Refer to specifications in specification section for main and connecting rod bearing clearance limits. If use of these bearing combinations does not bring clearance to the desired limits, refinish the crank journal to a standard undersize, and use the appropriate undersize bearing.

8. After bearing has been fitted and cleaned, apply a light coat of engine oil to journal and bearings.
9. Install bearing cap. Tighten cap bolts to specifications found in the specifications section.
10. Repeat procedure for remaining bearings that require replacement.

For This Amount of		Use This Bearing Size			
Bearing Clearance Excess		Upper Bearing		Lower Bearing	
mm	inch	mm	inch	mm	inch
0-.013	0-.0005	.025	.001	Standard	Standard
.013-.026	.0005-.0010	.025	.001	.025	.001
.026-.039	.0010-.0015	.050	.002	.025	.001
.039-.052	.0015-.0020	.050	.002	.050	.002

## Crankshaft Bearing Clearance

### (Bore Gauge Method)

1. Install bearings in the cylinder block
2. Install bearing caps.
3. Install crankshaft and tighten main bearing cap bolts to the specified torque .
4. Remove bearing caps and crankshaft.
5. Reinstall bearing caps with bearings still installed in cylinder block and caps.
6. Tighten bearing cap bolts to torque specified.
7. Using micrometer, measure main bearing journals as outlined in this section.
8. Using bore gauge, measure the inside diameter of each bearing assembly. It may be necessary to measure the outer bearings first, then remove those caps and measure the inner bearings.
9. Subtract the maximum measurement for each journal from the minimum measurement of each bearing to determine the minimum oil clearance. Compare with specifications.

## Crankshaft Service

### Crankshaft End Play

Crankshaft must be installed in block with the bearings that will be used, but without connecting rods, pistons, or flywheel installed to check end play.

1. Install Dial Indicator with Bracketry TOOL-4201-C, or equivalent, so contact point rests against the end of the crankshaft post and indicator axis is parallel to crankshaft axis.
2. Force crankshaft toward rear of engine.

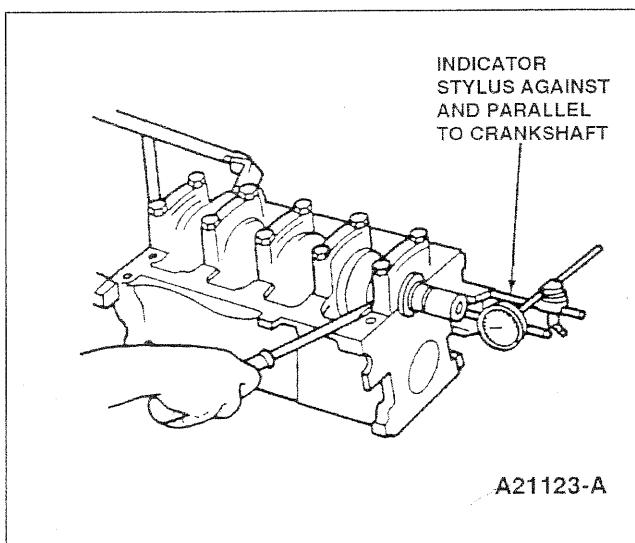

3. Zero dial indicator. Push crankshaft forward and note reading on dial.
4. If the end play exceeds the wear limit listed in the specification section, replace the thrust bearing. Inspect the crankshaft for damage to the thrust face before installing the new bearing. If the end play is less than the minimum limit, inspect the thrust bearing faces for scratches, burrs, nicks, or dirt. If the thrust faces are not damaged or dirty, the main thrust bearing may not be aligned properly. Lubricate and install the thrust bearing and align the faces, following Main Bearing Replacement procedure in the appropriate engine section. Re-check crankshaft end play.

### Cleaning



**CAUTION:** Handle the crankshaft with care to avoid possible damage to the finished surfaces.

Clean the crankshaft with solvent, then blow out all oil passages with compressed air.

### Inspection

Measure the diameter of each journal in at least four places to determine an out-of-round, taper or undersize condition. For specifications, refer to the specification section.

Inspect crankshaft sprocket for chipped, broken, or excessively worn teeth. Remove and replace as outlined in Section 02 if necessary.

### Crankshaft Runout

**NOTE:** Check crankshaft journals for out-of-round before checking runout. An out-of-round condition on the center journal could be confused as excess runout.

1. Set V-blocks on surface plate and set crankshaft on V-blocks supported on the outer two main bearing journals.
2. Set up TOOL-4201-C, or equivalent, Dial Indicator with Bracketry to measure runout on

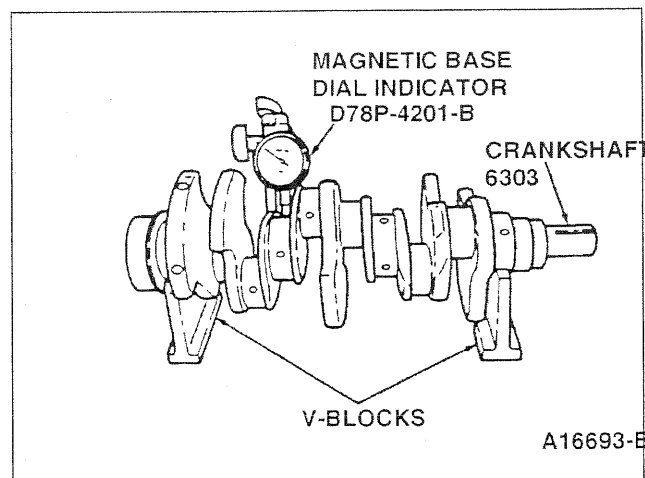

center main bearing journal.

3. Zero dial indicator.
4. Slowly rotate crankshaft one revolution and record highest and lowest readings.
5. Crankshaft runout should not exceed 0.050 mm (0.002 in.). If crankshaft runout is excessive, replace crankshaft.

## Crankshaft Journals

Inspect the main journal and crankpin journal diameters. Measure the diameter of each journal at two different points in the directions as shown.

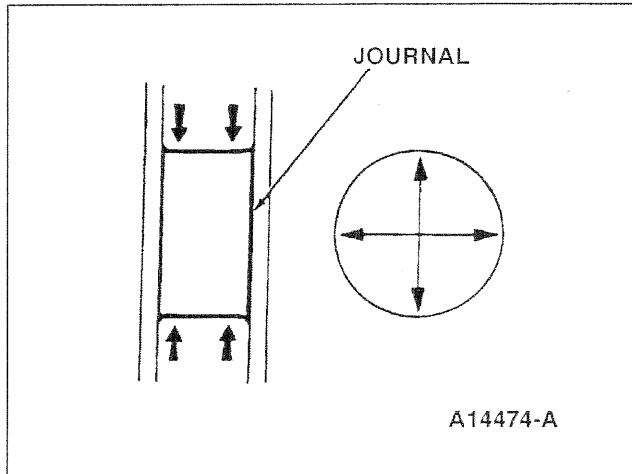

Refer to Section 02 for crankshaft journal specifications.

## Journal Refinishing

**NOTE: Polish direction is clockwise as viewed from the front of the crankshaft.**

Dress minor imperfections such as scores, nicks or burrs with an oil stone.

If journals are severely marred or exceed service limits for wear, taper, or out-of-round, they should be refinished to size for the next undersize crankshaft main bearing.

Follow crankshaft lathe manufacturer's instructions for refinishing crankshaft.

If the journals will not clean up to less than the maximum undersize bearing available, replace the crankshaft.

Always reproduce the same journal shoulder radius that existed originally. Too small a radius will result in fatigue failure of the crankshaft. Too large a radius will result in bearing failure due to radius ride of the crankshaft bearing.

After refinishing the journals, chamfer the oil holes. Polish the journals with a No. 500 grit polishing cloth and engine oil (crocus cloth may also be used as a polishing agent) to obtain a smooth finish.

## Cylinder Block Service

### Cleaning and Inspection

If the engine has been removed and disassembled, remove all core plugs and pipe plugs. Clean the cylinder block using solvent, preferably in a hot tank. Follow all safety and environmental precautions with regard to the solvent. Make sure all oil and dirt is cleaned from the cylinder block.

Make sure all oil passageways are clean. A rifle-cleaning brush is useful for this purpose.

Use a long, thin screwdriver to scrape the bottom of the water jackets through the openings in the top deck to make sure all scale and deposits are removed. Most engines have a "dead spot" at the back of the block where the coolant makes a U-turn and drops any deposits. If the water jackets are not thoroughly cleaned, overheating will result.

### Cylinder Block Distortion

Cylinder block distortion is rare because cylinder blocks are normalized after casting, and before machining, to relieve internal stresses from the casting process.

The most probable cause of cylinder block distortion would be extreme overheating which would probably be accompanied by other damage such as scored bearings or cylinder walls, warped cylinder heads, and possible cylinder block cracks.

### Cylinder Head Deck Flatness

Place a straightedge across the cylinder head deck in three positions and check for any gaps between the straightedge and the deck with a feeler gauge.

The deck should be flat within 0.76 mm (0.003 in.) over 152 mm (6 inches) and 0.152mm (0.006 in.) overall. If necessary, resurface or replace cylinder block.

### Cylinder Walls, Refinishing

If the entire engine has NOT been disassembled, clean the individual cylinder bore(s) with a cloth soaked in solvent. Dry with a clean, lint-free cloth.

If the entire engine HAS been disassembled, refer to Cleaning and Inspection in this section.

After any cylinder bore service operation, such as honing or deglazing, clean the bore(s) with soap or detergent and water. Then thoroughly rinse the bore(s) with clean water to remove the soap or detergent, and wipe the bore(s) dry with a clean lint-free cloth.

Finally wipe the bore(s) with a clean cloth dipped in XO-10W30-QSP or -DSP, or equivalent, motor oil meeting Ford specification ESE-M2C153-E.

Before removing the piston:

1. Check the amount of ridge at the top of the bore. A thick ridge is a sign of considerable wear.
2. Look for signs of coolant in the bore, especially rust on the bore surface indicating possible leaking head gasket or a crack in the cylinder bore.
3. Check the top of the piston for possible oversize. If oversize pistons have been installed, the oversize will be stamped in the top of the piston.

After the piston is removed and the bore cleaned:

4. Look for scoring. These are parallel gouges usually on the piston thrust side, that is, at right angles to the piston pin. If scored, the cylinder will have to be refinished.
5. Look for cracks. If unsure about a crack, tiny cracks may be detected by coating the bore with a mixture of 25 percent kerosene and 75 percent light engine oil. Wipe the bore dry and immediately apply a coating of zinc oxide dissolved in wood alcohol. Do not use rubbing alcohol as a substitute. If cracks are present, the coating will become discolored at the damaged area. Replace the cylinder block if it is cracked. Magnafluxing may also be used.

6. Check for cylinder wall glazing. When refinished, the cylinder bore is given a slightly rough finish with a cylinder hone to help seat the new piston rings. This finish is worn away as the rings and cylinder bore "mate" and the bore becomes glassy smooth. If the engine has been run enough for this to have happened, the cylinder will at least have to be honed to seat the new rings on the piston.
7. New rings should be installed when the piston is removed and reinstalled because piston rings are given a special finish by the factory to help them wear-in and seat. In seating, the special finish is worn off. Reusing piston rings will result in high oil consumption.

### Cylinder Bore Diameter

Make sure cylinder bore is clean and dry before measuring.

Using a suitable cylinder bore micrometer or gauge, measure the cylinder bore(s) in the X and Y directions (90 degrees apart) at points A, B, and C. The X direction is parallel to the piston pin. The Y direction is perpendicular to the piston pin and is the direction of piston thrust.

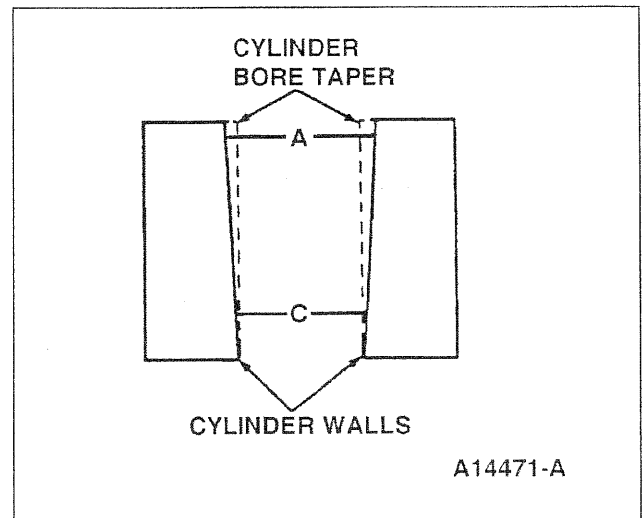
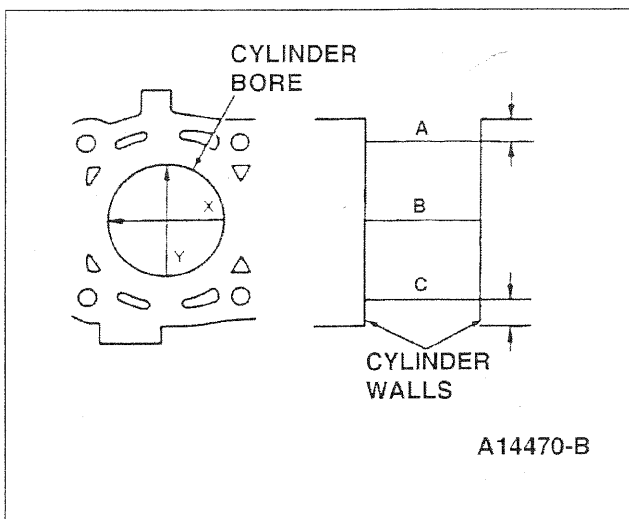

### Cylinder Bore Taper

Subtract the micrometer or gauge reading from point C direction Y from point A direction Y. Also from point C direction X from point A direction X. Each difference should be less than 0.127mm (0.005 inch). If taper exceeds this specification, cylinder will have to be refinished.

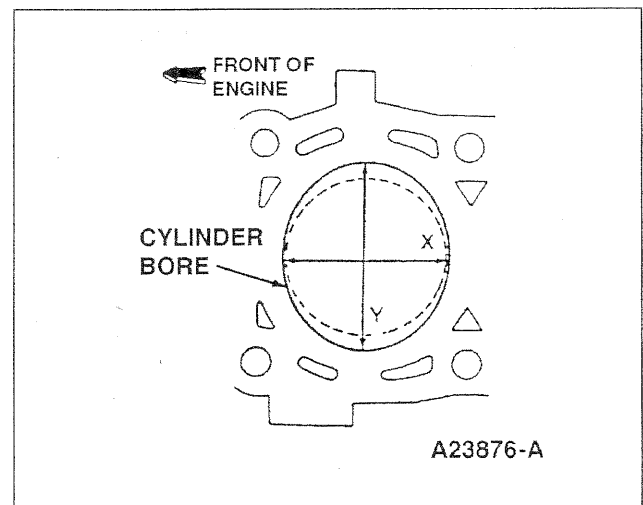

### Cylinder Out-of-Round

Subtract the reading in direction X (non-thrust) from direction Y (thrust side) at all points A, B, and C. All readings should be less than 0.127mm (0.005 inch). If out-of-round exceeds this specification, cylinder will have to be refinished.

## Cylinder Bore Clearance

1. Measure the diameter of the piston on the thrust side at right angles to the piston pin--25.4mm (1.00 inch) below the oil ring groove.

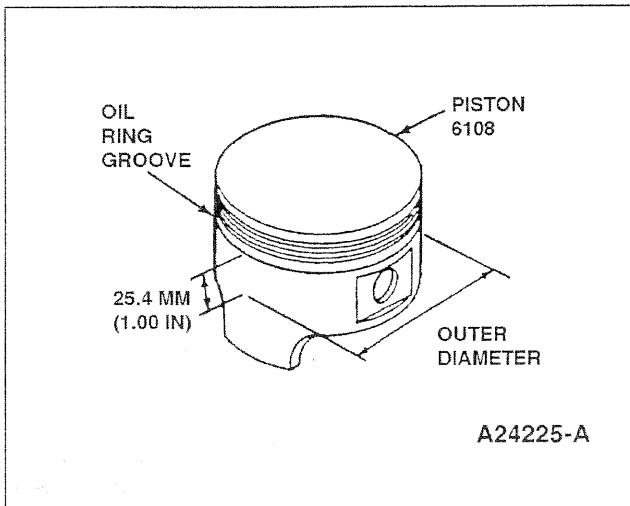

2. Measure the cylinder bore diameter at right angles to the piston pin at points A, B, and C as described under cylinder taper.
3. Subtract the piston diameter from the cylinder bore diameter. The difference should not exceed the maximum piston-to-bore clearance found in Specifications in Section 02.

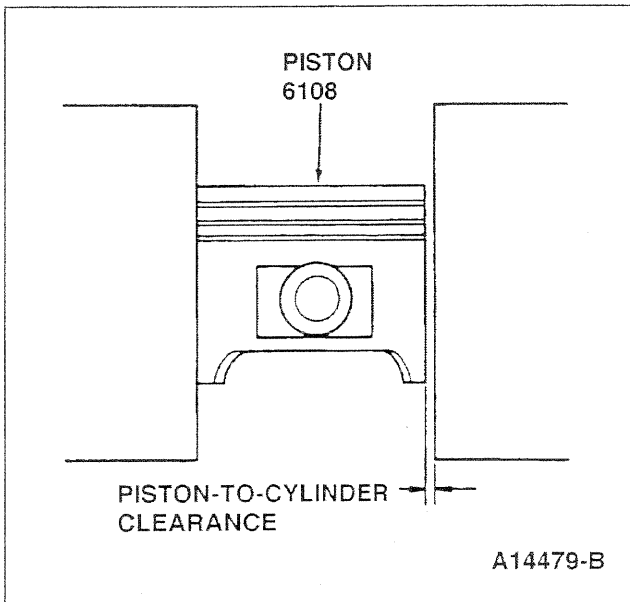

## Cylinder Wall Honing

Hone the cylinder bore:

- When reinstalling a piston with new rings.
  - To resize a cylinder to accept a service parts piston going into it.
1. Measure the diameter of the piston on the thrust side at right angles to the piston pin -- 25.4mm (1.00 inch) below the oil ring groove.
  2. Measure the cylinder bore diameter at right angles to the piston pin at points A, B, and C as described under cylinder taper.
  3. Subtract the piston diameter from the maximum cylinder bore diameter to determine the maximum amount of material that can be removed.
  4. Hone the cylinder according to the hone manufacturer's instructions to obtain the proper bore surface finish of 18-38 RMS.
  5. Keep the hone moving up and down to achieve the proper crosshatch pattern.
  6. Measure frequently to make sure that you do not remove too much of the cylinder wall, creating excess clearance.

## Cylinder Head Service

### On Engine Inspection

- Check for loose mounting bolts, studs and nuts.
- Check for a plugged oil feed in the rocker arm, or cylinder head.
- Check for broken or damaged valve springs.
- Check for proper seating of valve spring retainer keys on valve stem and in valve spring retainer.
- Check for signs of improper head gasket installation, such as the shape of the head and block and shape of the gasket not matching .
- Check for signs of cylinder head gasket leakage such as coolant or oil leaking between the cylinder block and cylinder head.
- Check for plugged oil drain-back holes.
- Check for worn or damaged valve tips.
- Check for missing or damaged intake and exhaust valve stem seals.
- Check valve clearance.
- Check installed spring height.
- Check for missing or worn valve spring seats, if equipped.



**CAUTION:** The overuse of cleaning fluids may cause engine damage not covered under warranty.



**CAUTION:** Only walnut shell blasting using Rotunda 014-00975 Carbon Blaster and Automotive Borescope, or equivalent is recommended for removing carbon from engine valves with the engine assembled. Other abrasives may cause engine damage on start-up if not completely removed.

1. Perform engine inspection of vacuum lines and wiring.
2. Perform normal engine diagnostics. Check fuel and ignition systems.
3. If normal diagnostics have not resolved the engine performance concerns, proceed with the following IVD inspection steps.
4. Remove any two spark plugs.



**CAUTION:** Do not bump the engine with the remote starter switch or ignition switch with the borescope in the spark plug hole or attempt to view the valve while rotating the engine. Damage to the borescope or engine may result.

5. Use a remote starter switch to bump the engine over until the intake valve is fully open in the cylinder to be inspected.



**CAUTION:** Do not power the borescope light source from a vehicle battery while it is being charged. For example, if the engine is running or the battery is connected to a charger, the lamp may fail.

### On Engine Valve Cleaning

The intake valve cleaning procedure is to be used if there is a concern with engine hesitation, rough idle, long crank times, and stall at idle and engine engagement after cold starts.

Many fluids are available to clean carburetors. Some cleaning fluids also claim to remove intake valve deposits (IVD). Engineering evaluation of these fluids indicates no ability to remove the intake valve deposits. If engine performance concerns have been affected by cleaning fluids, it is most likely due to cleanup of carburetor deposits. IVD is more difficult to remove than carburetor deposits. IVD must be COMPLETELY removed to restore cold start and normal engine performance.

6. Using the Rotunda Carbon Blaster and Automotive Borescope 014-00975, or equivalent automotive borescope, inspect the backside of the intake valves through the spark plug holes for the presence of carbon deposits. Compare the deposits with the deposit rating system chart. If any of the intake valves appear to have a carbon deposit level of 7 or less (lower number rating), intake valve cleaning is required. If no carbon deposits are seen or the deposit level is 8 or cleaner, the drive concern may be the result of low volatility fuel.
  7. Remove the intake manifold assembly as outlined in Section 02.
  8. Remove flex hose and manifold adapter from the hand-held vacuum included with the Rotunda 014-00975 Carbon Blaster and Automotive Borescope. Insert tapered end of vacuum hose into intake port of cylinder head using a twisting motion to ensure a tight fit.
- NOTE: Detailed written instructions and a procedural video tape are included with the Rotunda 014-00975 Carbon Blaster and Automotive Borescope. Perform the intake valve carbon cleaning procedure, using the Rotunda 014-00975 Carbon Blaster or equivalent. The intake valves should be in the closed position. Cleaning takes approximately 1 to 1 ½ minutes per valve.
9. Confirm the intake valve is clean using Rotunda 014-00975, or equivalent automotive borescope.
  10. Using a remote starter switch, bump the engine over until the remaining intake valves to be cleaned, are in the closed position, and clean them as outlined above.
  11. Install the intake manifold as outlined in Section 02.

### Cleaning

With the valves installed to protect the valve seats, remove deposits from the combustion chambers and valve heads with a scraper and a wire brush. Be careful not to damage the cylinder head gasket surface. After the valves are removed, clean the valve guide bores. Use cleaning solvent to remove dirt, grease and other deposits from the valves with a fine wire brush or buffing wheel.



**CAUTION: Do not plane or grind more than 0.25mm (0.010") from original cylinder head gasket surface.**

### Inspection

- Inspect the cylinder head for cracks or excessively burned areas in the exhaust outlet ports. Replace the cylinder head if it is cracked.
- Check the cylinder head gasket surface for burrs and nicks. Small imperfections of this type can be dressed down using an oil stone.

## Spark Plug Thread Service

**NOTE:** The use of power or air driven tools is not approved for the installation of tapersets.

Damaged spark plug threads in the cylinder head can be serviced using Rotunda Taperset Installation Kit 107-R0901, or equivalent.

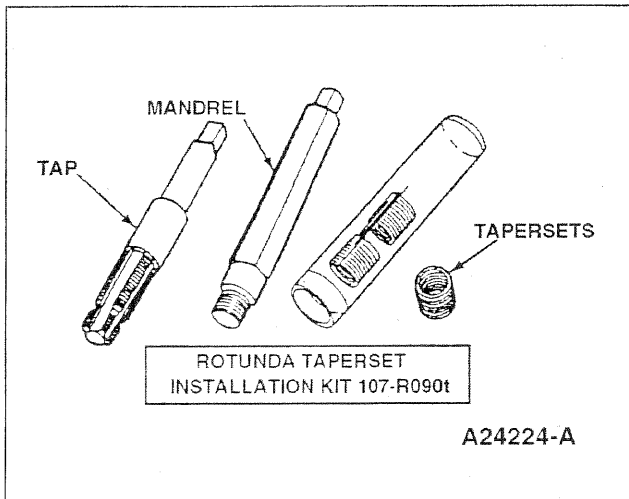

The procedure involves cutting new threads in the spark plug hole. After rethreading operation, a tapered sleeve will be installed in the cylinder head. The sleeve is threaded on the inside and outside. The outside threads into the cylinder head while the inside provides new threads for the spark plug.

The service is permanent and will have no effect on cylinder head or spark plug life.



**CAUTION:** The cylinder head must be removed from the engine before installing a taperset. The service procedure includes a thread cutting process which produces metal chips. Performing this procedure while the cylinder head is on the engine will cause metal chips to fall into the cylinder. Once in the cylinder, these chips can damage the cylinder wall when the engine is started.

1. Thoroughly clean spark plug counter bore, seat and threads of all dirt or other foreign material.
2. Start tap into spark plug hole being careful to keep it properly aligned. As tap begins cutting new threads, apply oil to tap. Continue cutting threads and applying oil until stop ring bottoms against spark plug seat.

3. Remove tap. Remove all metal chips using compressed air.
4. Coat threads of mandrel with cutting oil. Thread taperset onto mandrel until one thread of mandrel

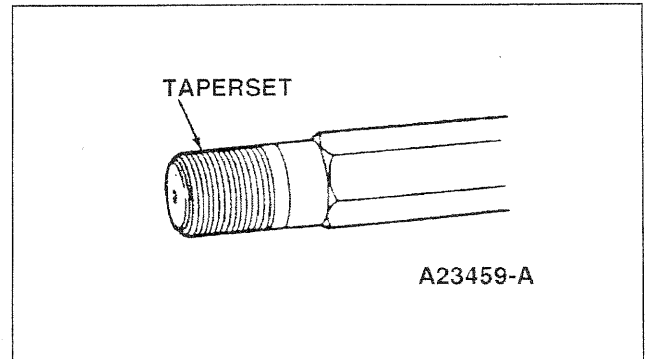

extends beyond taperset.

**NOTE:** A properly installed taperset will be flush to one millimeter below spark plug gasket seat.

5. Thread taperset into tapped spark plug hole using a torque wrench. Continue tightening mandrel until torque wrench indicates 61 N-m (45 lb-ft).
6. To loosen mandrel for removal, hold mandrel stationary and turn mandrel body approximately on-half turn. Remove mandrel.

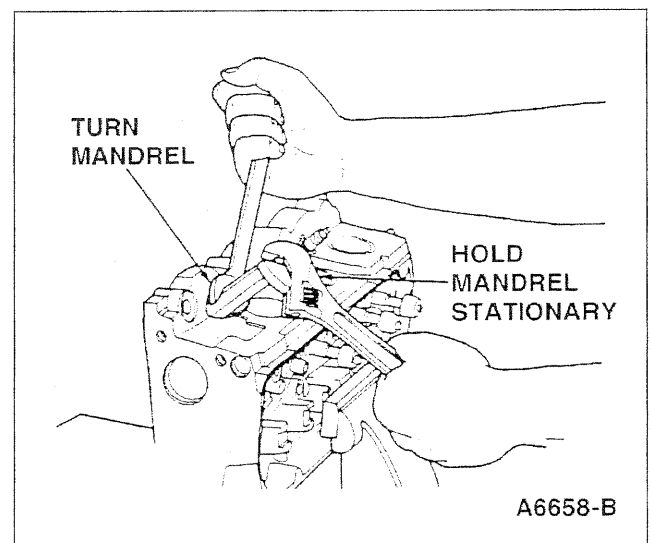

### Cylinder Head Flatness

**NOTE: Do not plane or grind off more than 0.254mm (0.010 inch).**

When a cylinder head is removed because of gasket leaks, check the flatness of the cylinder head gasket surface for conformance to specification. If necessary, refinish the cylinder head gasket surface.

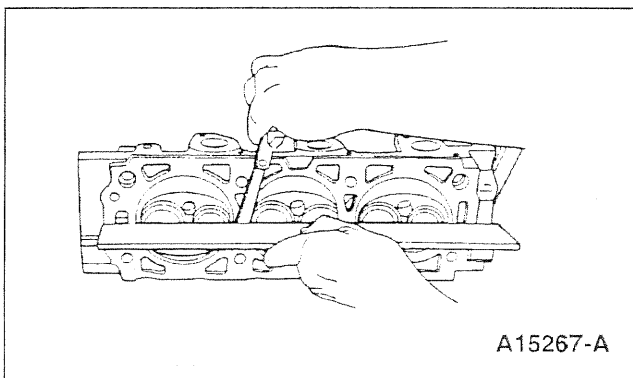

A15267-A

### Valve Seat Runout

Check the valve seat runout with Valve Seat Runout Gauge D81P-6002-E, or equivalent, as illustrated below.

Follow the instructions of the gauge manufacturer. If the runout exceeds the wear limit, reface the valve and valve seat. For specifications, refer to Section 02.

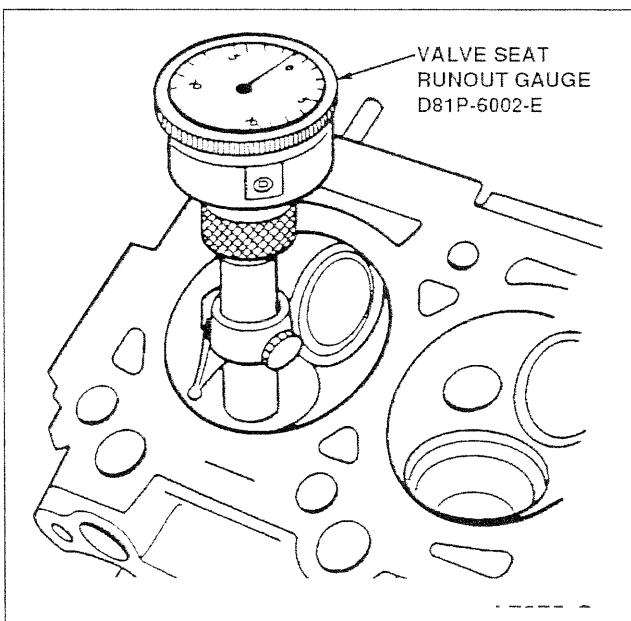

### Valve Stem-to-Guide Clearance

1. Check the valve stem-to-guide clearance of each valve in its respective valve guide with Valve Stem Clearance Tool TOOL-6505-E, or equivalent. Use a flat-end indicator point.
2. Install TOOL-6505-E to cylinder head. Permit the valve to drop away from its seat 9.55mm (0.375 inch). Contact tip of valve stem with dial indicator and tighten clamping knob.

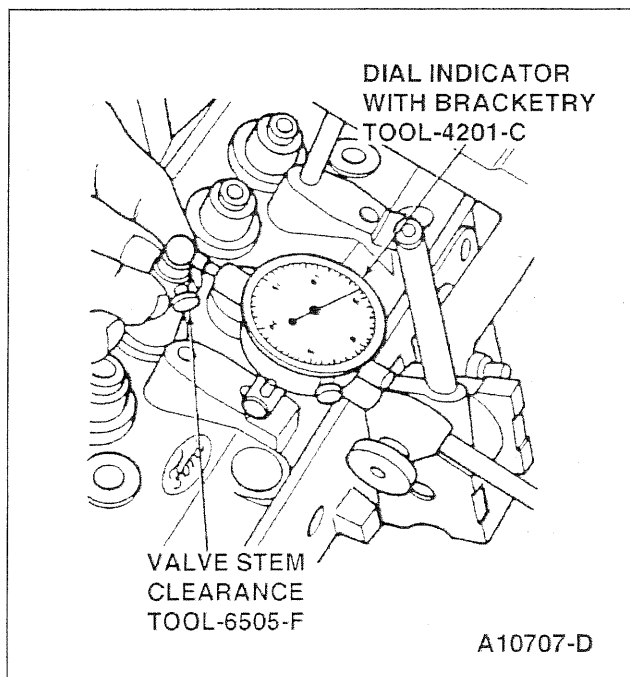

A10707-D

3. Position the dial indicator with its flat tip against the center portion of the tool's spherical section at approximately 90 degrees to the valve stem axis.
4. Move the valve stem back and forth in line with the indicator stem.
5. Take a reading on the dial indicator without removing the tool from the valve guide upper surface.
6. Divide the reading by two, the division factor for the tool.
7. If valve stem-to-guide clearance exceeds the wear limit, ream the valve guide for the next oversize valve stem as described in this section.

## Valves, Select Fitting

If the valve stem-to-guide clearance exceeds the service clearance, ream the valve guide for the next oversize valve stem. Valves with oversize stem diameters are available for service. Refer to Master Parts Catalogue for available sizes. **Always reface the valve seat after the valve guide has been reamed. Refer to Valve Guide Reaming.**

In the case of valve stem-to-guide clearance, the service clearance is intended as an aid to diagnosing engine noise only, and does not constitute a failure or indicate need for service. However, when overhauling or reconditioning a cylinder head, the service clearance should be regarded as a practical working value, and used as a determinant for installing the next oversize valve to make sure service life is extended.

## Valve Guide Reaming

If it becomes necessary to ream a valve guide to install a valve with an oversize stem, a hand reaming kit is available which contains the following reamer and pilot combinations:

- 0.38mm (0.015-inch) OS reamer with a 0.076mm (0.003-inch) OS pilot.
- 0.76mm (0.030-inch) reamer with a 0.38mm (0.015-inch) OS pilot.

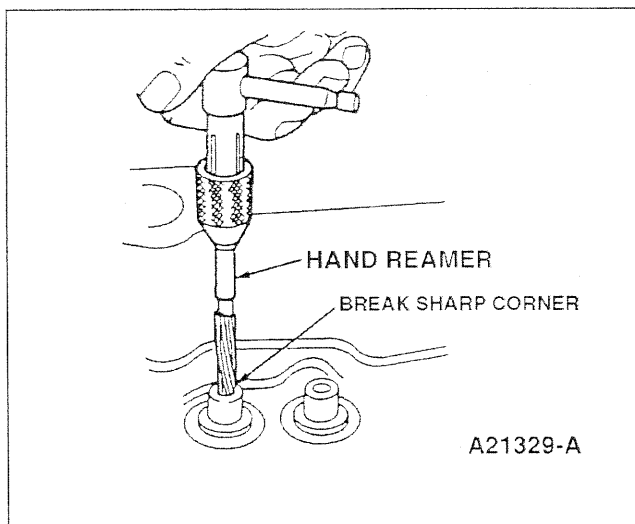

**NOTE: If oversize valve stems and oversize stem seals are not available, bore out original valve guide and install service bushing (if available). Ream inside diameter for specified clearance for standard size valve. Reface valve seat, as required. Install standard size valve stem oil seal.**

When replacing a standard size valve with an oversize valve, always use the reamer in sequence (smallest oversize first, and then the next smallest, etc.) so as not to overload the reamers. **Always reface the valve seat after the valve guide has been reamed, and use a suitable scraper to break the sharp corner (inside diameter) at the top of the valve guide.**

**NOTE: The interference angle of the valve and seat should not be lapped out. Remove all grooves or score marks from the end of the valve stem and chamfer it as necessary. Do not remove more than 0.254mm (0.010 inch) from the end of the valve stem.**

If the valve face runout is excessive and/or to remove pits and grooves, reface the valves to a true 45 degree angle. Remove only enough stock to correct the runout or to clean up the pits and grooves. If the edge of the valve head is less than 0.0794mm (1/32 inch) thick after grinding, replace the valve as the valve will run too hot in the engine.

If the valve and/or valve seat has been refaced, it will be necessary to check the clearance between the rocker arm pad and the valve stem with the valve train assembly installed in the engine.

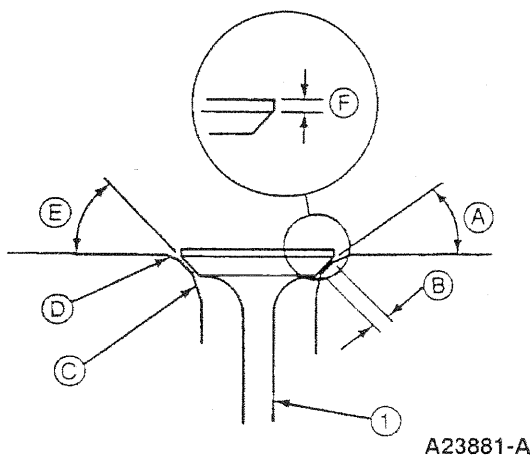

Item	Description
1	Valve
A	Valve Seat Angle
B	Seat Width and Proper Location on Valve
C	Bottom Narrowing Angle 75 degrees
D	Top Narrowing Angle 30 degrees
E	Valve Face Angle
F	Valve Margin

### Valve Seats, Refacing

Measure the valve seat width. Reface the valve seat(s) if the width is not within specifications. Refer to the specifications section.

Refer to Engine Service in the Rotunda Tool catalog for a description of the various types of valve seat grinders and cutters available.

Refacing the valve seat should be closely coordinated with the refacing of the valve face so that the finished seat and valve face will be concentric and the specified interference angle will be maintained. This is important so that the valve and seat will have a compression-tight fit. Make sure refacer grinding wheels are properly dressed.

Grind the valve seats of all engines to a true 45-degree angle. Remove only enough stock to clean up pits and grooves or to correct the valve seat runout. After the seat has been refaced, use a seat width scale or a machinist scale to measure the seat width. Narrow the seat, if necessary, to bring it within specification.

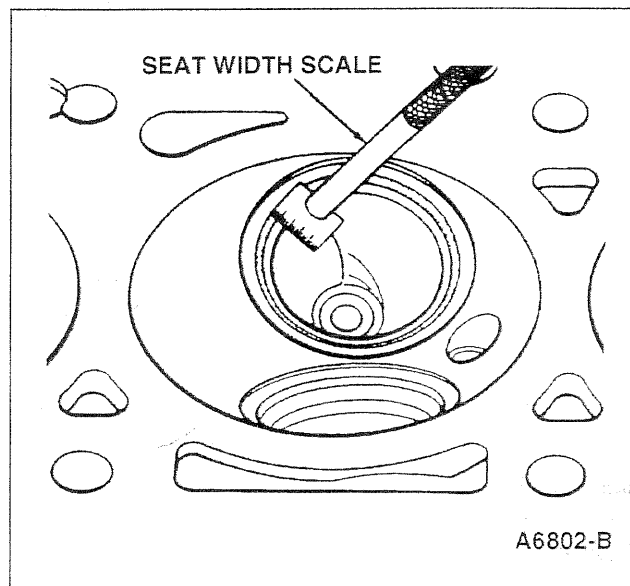

If the valve seat width exceeds the maximum limit, remove enough stock from the top edge and/or bottom edge of the seat to reduce the width to specification.

On the intake and exhaust seats, use a 60-degree angle grinding wheel to remove stock from the bottom of the seat (raise the seats). A 30-degree angle wheel is used to remove stock from the top of the seats (lower the seats).

The finished valve seat should contact the approximate center of the valve face. It is good practice to determine where the valve seat contacts the face.

To do this, coat the seat with Prussian Blue and set the valve in place. Rotate the valve with light pressure. If the blue is transferred to the center of the valve face, the contact is satisfactory. If the blue is transferred to the top edge of the valve face, lower the valve seat. If the blue is transferred to the bottom edge of the valve face, raise the valve seat.

## Valve Inspection

- Inspect the valve stem for bends, and the end of the stem for grooves or scoring.
- Inspect the valve face and the edge of the valve head for pits, grooves or scores.
- Inspect the stem for a bend condition and the end of the stem for grooves or scores.
- Check the valve head for signs of burning or erosion, warpage and cracking. Minor pits, grooves, etc., may be removed. Discard severely damaged valves.
- Inspect the valve spring, valve spring retainer, valve spring retainer keys and discard any visually damaged parts.

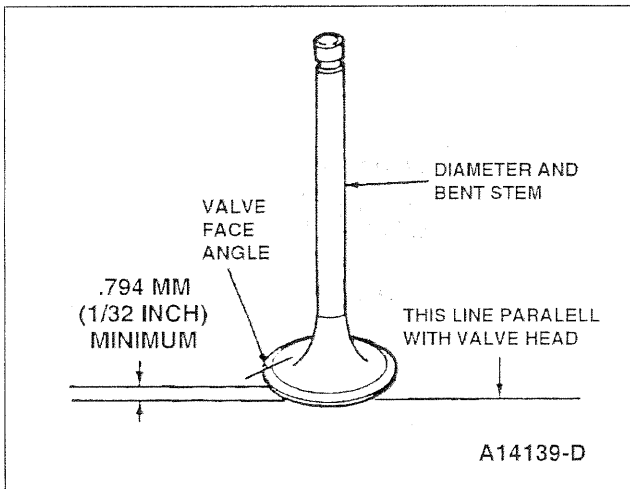

## Valves, Refacing

**NOTE: Discard any excessively worn or damaged valve train parts.**

- Minor pits or grooves may be removed.
- Discard valves that are severely damaged if the face runout cannot be corrected by refinishing or if stem clearance exceeds specification. Refer to specifications section for valve specifications.
- Refer to Engine Service in the Rotunda Tool catalog for a description of the various types of valve resurfacing equipment.
- The valve refacing operation should be closely coordinated with the valve seat refacing operations so that the finished angles of the valve face and valve seat will be to specifications and provide a compression-tight fit.
- Make sure refacer grinding wheels are properly dressed.

## Valve Spring Tension

Inspect the valve spring, valve spring retainers, and keys for wear or damage. Discard any damaged parts.

Check the valve springs for proper pressure at the specified spring lengths using Valve/Clutch Spring Tester TOOL-6513-DD, or equivalent.

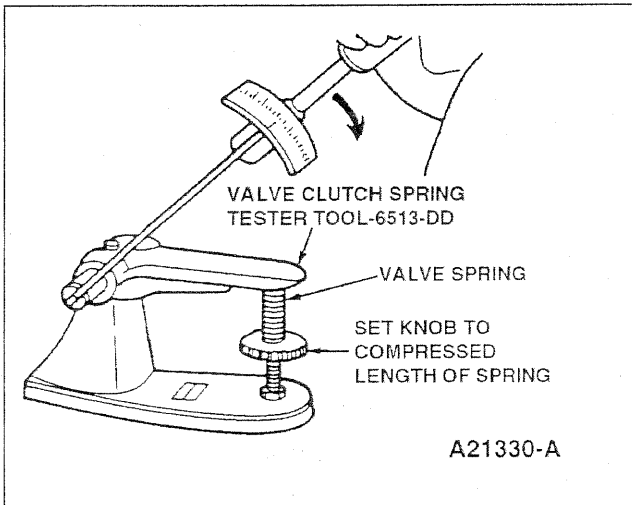

Apply torque until click is heard, read torque wrench and multiply reading by two. Weak valve springs cause poor engine performance. Replace any valve spring not within specification. Refer to the specification section. Manually rotating the valve spring assemblies while installed in the engine will not determine condition of valve springs.



**CAUTION:** Make sure the valve springs are reassembled to their own original dampers by pushing damper on the spring. Do not open damper with any kind of tool in order to reassemble.

## Valve Spring Squareness

Check each valve spring for squareness using a steel square and a flat surface. Stand the valve spring and square on end of the flat surface. Slide the valve spring up to the square. Revolve the valve spring slowly and observe the space between the top coil of the valve spring and the square.

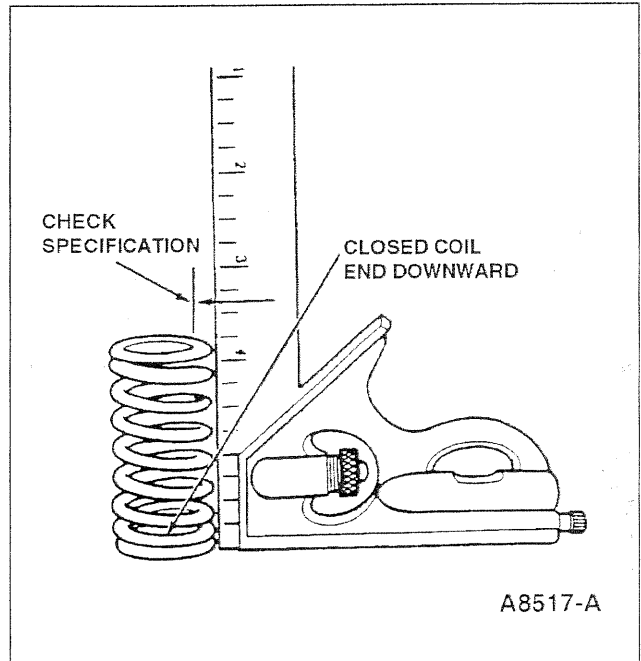

Refer to specifications for out-of-square limits. Follow this same procedure for new valve springs before installation. Make sure the proper valve spring (color-coded) is installed.



**CAUTION:** Make sure the valve springs are reassembled to their own original dampers by pushing damper on the valve spring. Do not open damper with any kind of tool in order to reassemble.

## Engine Block Plug Service

Special Tools	
Impact Slide Hammer	T59L-100-B
Impact Slide Hammer	T50T-100-A

### Removal and Installation

To remove a large core plug, drill a 12.70mm (1/2 inch) hole in the center of the plug and remove with an Impact Slide Hammer T59L-100-B or T50T-100-A or pry it out with a large drift punch. On a small core plug, drill a 6.35mm (1/4 inch) hole in the center of the plug and pry it out with a small pin punch. Clean and inspect the plug bore.

Prior to installing a core plug, the plug bore should be inspected for any damage that would interfere with the proper sealing of the plug. If the bore is damaged, it will be necessary to true the surface by boring for the next specified oversize plug.

Oversize plugs are identified by the OS stamped in the flat located on the cup side of the plug.

Coat the plug and/or bore lightly with an oil-resistant (oil galley) Stud and Bearing Mount E0AZ-19554-BA, or equivalent, meeting Ford specification WSK-M2G349-A1 or Threadlock 262 E2FZ-19554-B, or equivalent, meeting Ford specification WSK-M2G351-A6, and install it following the procedure for cup-type or expansion-type below:

#### Expansion-Type

Expansion-type core plugs are installed with the flange edge inward. The maximum diameter of this plug is located at the base of the flange with the flange flaring inward.



**CAUTION:** It is imperative to push or drive the plug into the machined bore using a properly designed tool. Under no circumstances is the plug to be driven using a tool that contacts the crowned portion of the plug. This method will expand the plug prior to installation and may damage the plug and/or plug bore.

When installed, the trailing (maximum) diameter must be below the chamfered edge of the bore to effectively seal the plugged bore.

If the core plug replacing tool has a depth seating surface, do not seat the tool against a non-machined (casting) surface.

#### Cup-Type

Cup-type core plugs are installed with the flanged edge outward. The maximum diameter of this plug is located at the outer edge of the flange. The flange on cup-type plugs flare outward with the largest diameter of the outer (sealing) edge.



**CAUTION:** It is imperative to pull the plug into the machined bore by using a properly designed tool. Under no circumstances is the plug to be driven into the bore using a tool that contacts the flange. This method will damage the sealing edge and will result in leakage and/or plug blowout.

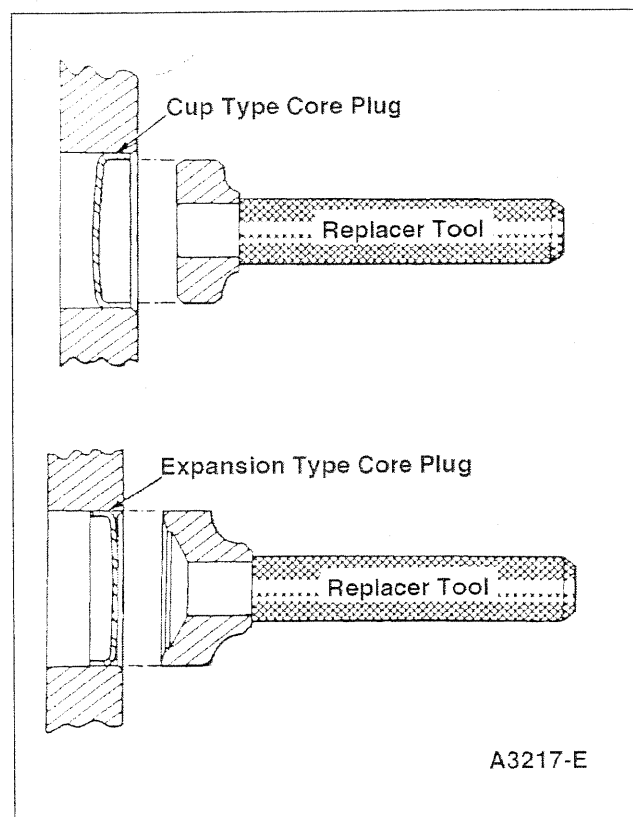

The flanged (trailing) edge must be below the chamfered edge of the bore to effectively seal the plugged bore.

## Exhaust Manifold Service

### Cleaning

Remove all gasket or foreign material from all inlet and outlet sealing surfaces of the exhaust manifold.

### Inspection

- Inspect the cylinder head joining flanges of the exhaust manifold for evidence of exhaust gas leaks.
- Inspect the exhaust manifold for cracks, damaged gasket surfaces, or other damage that would make it unfit for further service.
- A warped or cracked exhaust manifold must be replaced.

## Hydraulic Valve Tappet/Adjuster Service

The hydraulic lash adjusters used in overhead cam engines are zero-lash hydraulic devices similar in construction and operation to the hydraulic valve tappets used on push rod engines. They are cleaned, inspected and checked in the same manner as hydraulic valve tappets. The instructions below apply equally to the lash adjuster and the valve tappet.

Hydraulic tappet noise may be caused by any of the following:

1. Excessive collapsed tappet gap
2. Sticking tappet plunger
3. Tappet check valve not functioning properly
4. Air in lubrication system
5. Leak-down rate too rapid
6. Excessive valve guide wear

Excessive collapsed tappet gap may be caused by loose valve train parts such as wear of tappet face, worn roller finger follower, or worn valve tip. With valve tappet collapsed, check gap between valve tip and roller finger follower to determine if any other valve train parts are damaged, or worn. Replace any worn or damaged parts.

A sticking tappet plunger may be caused by dirt, chips, or varnish inside the tappet. The sticking can be corrected by disassembling the valve tappet and removing the dirt, chips or varnish that are causing the condition.

A tappet check valve that is not functional may be caused by an obstruction such as dirt or chips preventing it from closing when operated, or it may be caused by broken check valve spring within the tappet.

Air bubbles in the lubrication system will prevent the valve tappet from supporting the valve spring load and may be caused by an oil level that is too high or too low, or by air being drawn into the system through a hole, crack or leaking gasket on the oil pump screen cover and tube.

If the leakdown time is below the specified time for used valve tappets, noisy operation may result. If no other cause for noisy valve tappets can be found, the leakdown rate should be checked, and any outside the specification should be replaced.

Valve tappet assemblies should be kept in proper sequence so that they can be installed in their original position. Inspect and test each valve tappet separately. Do not intermix tappet positions. **If any part of the tappet assembly is worn or otherwise damaged, replace the entire assembly.**

### Cleaning

Thoroughly clean all parts in clean solvent and wipe them with a clean, lint-free cloth.

### Inspection

- Inspect the parts and discard the entire tappet/lash adjuster assembly if any part shows pitting, scoring or excessive wear.
- Replace the entire assembly if the plunger is not free in the body. The plunger should drop to the bottom of the body by its own weight when assembled dry and check ball assembly removed.
- Assemble the hydraulic tappet/lash adjuster assembly and check for freeness of operation by pressing down on the plunger.
- The lash adjusters can also be checked with a hydraulic tester to test the leakdown rate. Follow the instructions of the test unit manufacturer or Leakdown Testing in this section.

## Leakdown Testing

Assembled valve tappets can be tested with Hydraulic Tappet Leakdown Tester TOOL-6500-E, or equivalent, to check the leakdown rate. The leakdown rate specification is the time in seconds for the plunger to move a specified distance of its travel while under a 22.7 kg (50 lb.) load. Test the valve tappets as follows:

**NOTE: Do not mix parts from different valve tappets. Parts are select-fitted and are not interchangeable.**

**NOTE: Tappets cannot be checked with engine oil in them. Only testing fluid can be used. Disassemble and clean valve tappet to remove all traces of engine oil.**

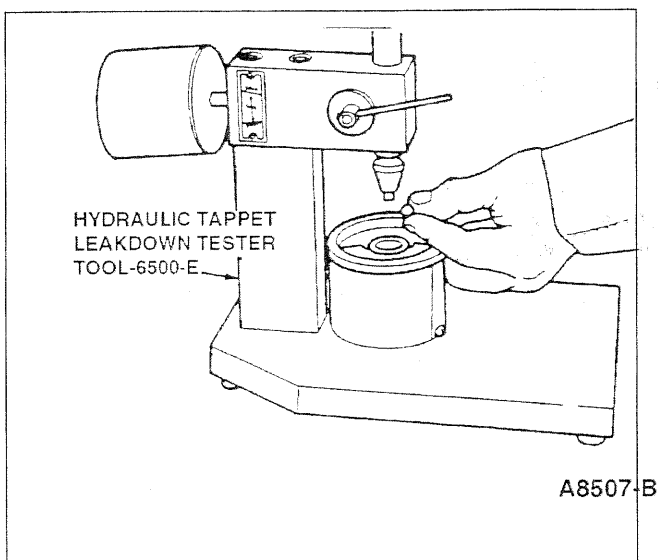

- Place valve tappet in tester, with plunger facing upward. Pour hydraulic tester fluid into cup to a level that will cover tappet assembly. The fluid can be purchased from tester manufacturer. Using kerosene or any other fluid will not provide an accurate test.
- Place a 7.94mm (5/16-inch) steel ball provided with a tester in plunger cap.
- Work tappet plunger up and down until tappet fills with fluid and all traces of air bubbles have disappeared.
- Adjust length of ram so that pointer is 1.59mm (1/16 inch) below starting mark when ram contacts tappet plunger, to facilitate timing as pointer passes Start Timing mark.
- Use mark on pointer scale as Stop Timing point instead of original Stop Timing mark at top of scale.
- Allow ram and weight to force tappet plunger downward. Measure exact time it takes for pointer to travel from Start Timing to Stop Timing marks of tester.

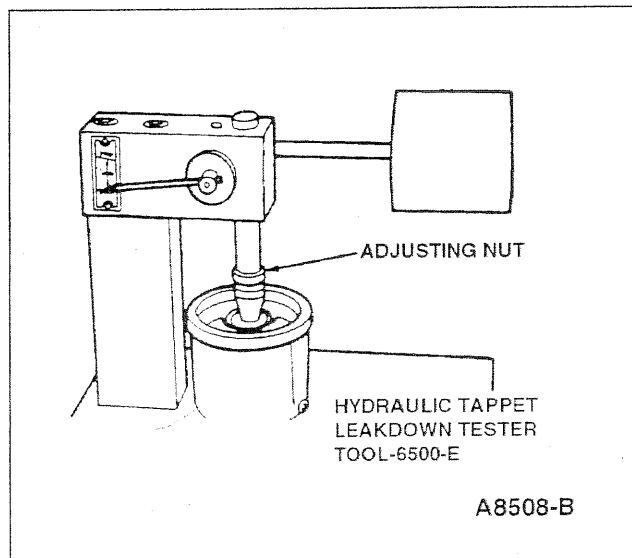

- A valve tappet that is satisfactory must have a leakdown rate (time in seconds) within minimum and maximum limits specified in Section 02.
- Remove fluid from cup and bleed fluid from tappet by working plunger up and down. This step will aid in depressing tappet plungers when checking valve clearance.
- If a valve tappet is not within specifications replace defective valve tappets with new ones. It is not necessary to disassemble and clean new valve tappets to test them since they are shipped with testing fluid.

## Camshaft Follower (if equipped)

- Clean all parts thoroughly.
- Make sure all oil passages are open.
- Inspect the roller finger follower for indications of scuffing or abnormal wear.
- If the pad is grooved, replace the roller finger follower.
- **Do not attempt to true this surface by grinding.**

## Intake Manifold Service

### Cleaning

Remove all gasket material from the machined surfaces of the intake manifold. Clean the manifold in a suitable solvent and dry it with compressed air.

### Inspection

**NOTE: Remove all filings and foreign matter that may have entered the manifold as a result of service.**

- Inspect the manifold for cracks, damaged gasket surfaces, or other problems that would make it unfit for further service.
- Replace all studs that are stripped or otherwise damaged.

## Oil Pan Service

### Cleaning

Scrape any dirt or metal particles from the inside of the oil pan. Scrape all old gasket material from the gasket surface. Wash the pan in a solvent and dry it thoroughly. Make sure all foreign particles are removed.

### Inspection

- Check the oil pan for cracks, holes or damaged drain plug threads.
- Check the gasket surface for damage caused by overtightened bolts.
- Replace with a new oil pan if repairs cannot be made.

## Piston Service

### Cleaning

- Clean piston using suitable solvent.
- Using a putty knife or scraper, clean carbon off of the top of the piston.
- Do not use a power wire brush to clean the piston skirt, crown, or piston ring grooves as it will remove metal.
- If using a ring groove scraper, be careful not to remove metal from the piston ring lands.

### Inspection

- Check for a hole or crack in top of piston caused by pre-ignition or foreign object damage.
- Inspect for excess wear in ring lands indicated by visible steps worn in ring lands.
- Check for scoring or gouges on piston skirt or crown.
- Check for looseness between piston and piston pin.

### Fitting Pistons

Special Tool	
Engine Cylinder Hone Set	T73L-6011-A

**NOTE: There may be a piston that can be used when the original standard-size bore shows little wear and can be cleaned up. This piston must be select-fitted to the cylinder bore. It will likely be necessary to hone the cylinder bore in order to produce the specified piston-to-bore clearance.**

To determine if a Service Parts piston can be installed, and if so, to fit the Service Parts piston, proceed as follows:

1. Measure the cylinder bore as outlined in this section under Cylinder Bore Measuring. If the cylinder bore is not damaged, and wear, taper and out-of-round are within specifications listed in Section 02, the cylinder bore may be cleaned up and a new Service Parts piston select-fitted to the refurbished bore.
2. Hone the cylinder, if necessary, to restore a proper crosshatch pattern so new rings can seat. Remove as little of the cylinder wall as possible.

3. After any necessary honing of the cylinder bore, check that the piston-to-bore clearance is to specification. If the clearance is too great, measure the cylinder bore diameter to determine if it falls within the Service Limits found in the Specifications in Section 02. If the bore diameter falls within the Service Limits, it will be possible to select-fit a new Service piston. If the bore diameter exceeds the Service Limits, it will be necessary to replace the cylinder block assembly. Oversize pistons are not available for this engine.

### Fitting Piston Rings

Do not reinstall used piston rings. A special break-in finish, and sometimes an anti-scuff coating, is given to new piston rings by the factory. The purpose of this special finish is to help the new piston rings and cylinder bore mate properly. The special finish, like the crosshatching on the cylinder bore, wears off during break-in. The special finish will be already worn off used rings so they probably will not seat properly. For this reason, attempting to reuse piston rings could lead to excess oil consumption and possible cylinder scoring.

1. Insert each piston ring backwards in the piston ring groove into which it will be installed.
2. Measure the clearance between the ring and groove (side clearance) with a feeler gauge and check against the side clearance specifications in Section 02.

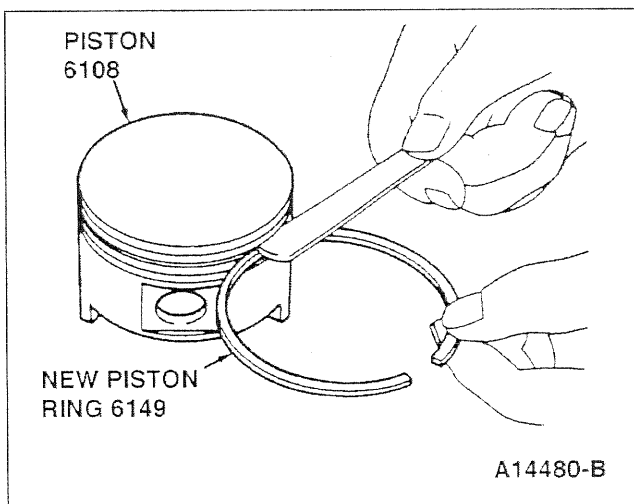

3. Insert the ring in the cylinder bore.
4. Using the piston, without rings, turned upside down, press the ring down to the center of the bore.

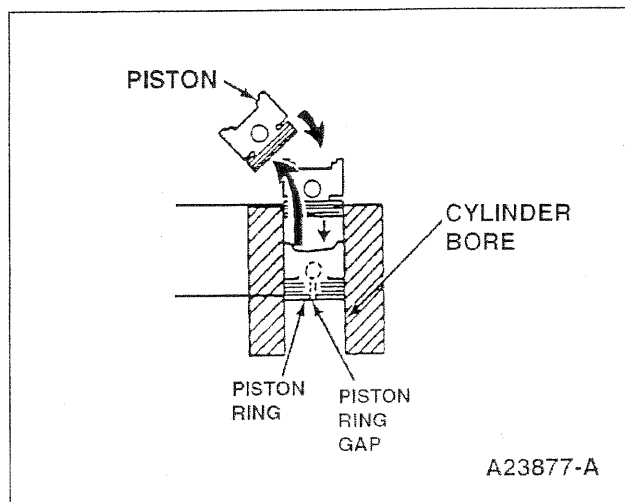

5. Make sure that the ring is "square" in the bore.
6. Using a feeler gauge, check the piston ring end gap and compare to specification found in Section 02.

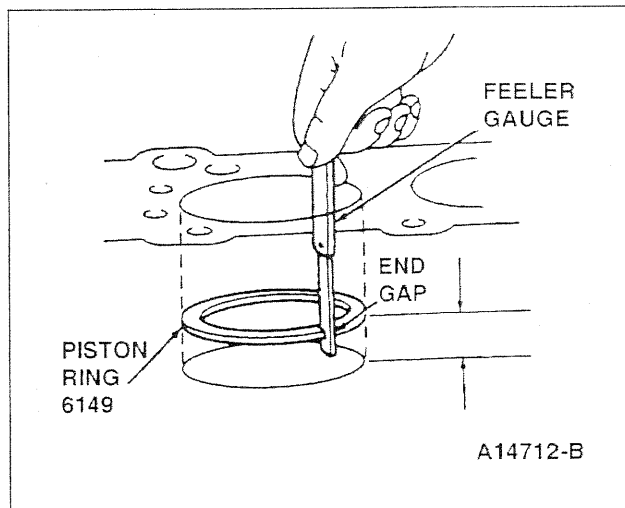

7. If the ring is too small, the ring will have to be filled until the end gap is within specifications. The use of a ring filing block helps ensure that the ring ends are filed square.

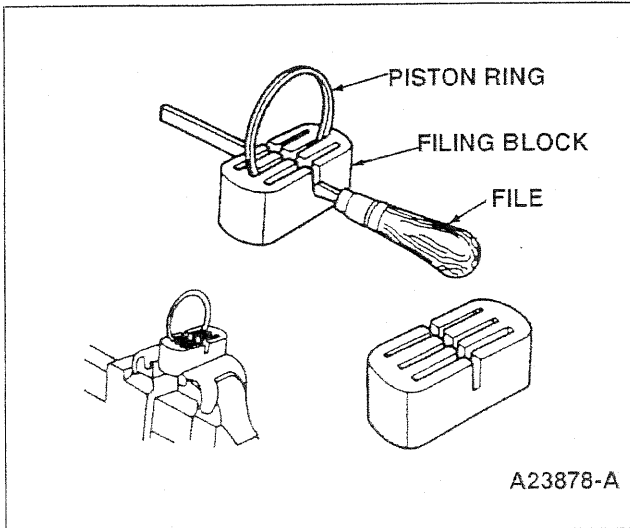

**CAUTION:** Install the piston rings after the piston has been installed on the connecting rod. Since the piston may be supported by the crown during this operation, the rings could be damaged.



**CAUTION:** Use a piston ring expander to install the piston rings. Attempting to wind them on by hand may put a deep scratch in the piston or break the ring.

8. Using a piston ring expander, install the piston rings starting with the oil control rings. Make sure rings are installed right side up. Refer to instructions with the ring set.
9. Rotate the rings so the end gaps are NOT lined up but are spaced properly as shown.

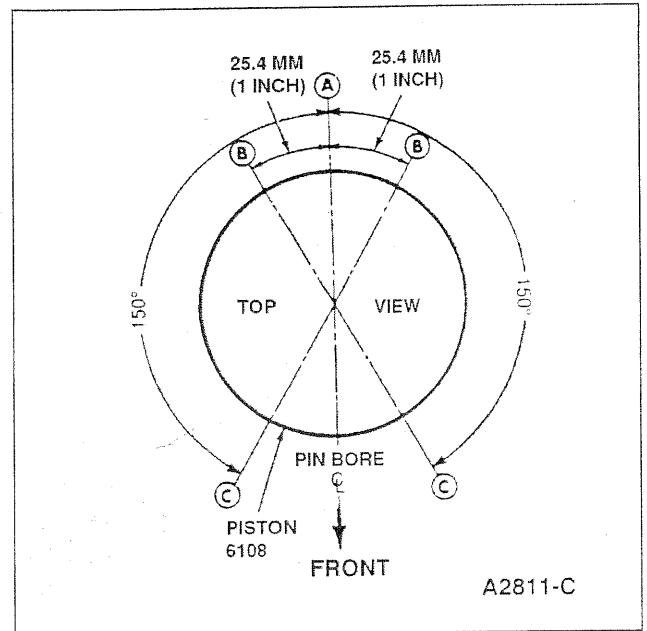

10. Using a feeler gauge, recheck piston ring side clearance.
11. Continue with engine assembly as outlined in Section 02.

### Piston and Piston Pin Fit

**NOTE: New pistons come with fitted piston pins and should not require refitting unless the connecting rod bore is oversize.**

Some Power Product engines use piston pins which press into the connecting rods. The piston pivots on the pin. There is no connecting rod bushing but rather an interference fit between the piston and the connecting rod.



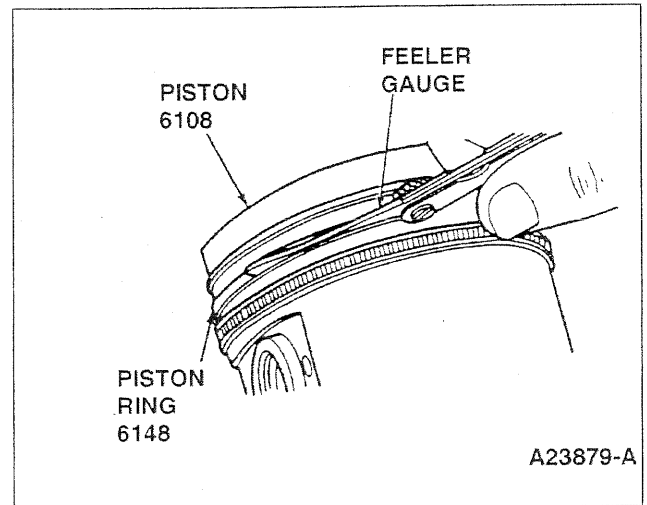

Refer to Section 02 for specifications and assembly instructions.

1. Clean and inspect the connecting rod as outlined in this section.
2. Clean and inspect the piston and piston pin as outlined in this section.
3. Using a suitable micrometer, measure the piston pin where the piston pivots and in the center where it is pressed into the connecting rod.



4. Using a suitable set of plug gauges or bore gauge, measure the upper bore of the connecting rod. An interference fit is required. If the bore is oversize it will be necessary to install an oversize piston pin. It is not necessary to reborn or ream the connecting rod.
5. If the pin-to-rod fit is OK, measure the piston pin bores in the piston.
6. Subtract the piston pin size from the piston pin bore sizes. Pin-to-piston clearance is listed in the specifications section. If clearance is excessive it will be necessary to fit an oversize piston pin.
7. To fit an oversize piston pin because either the pin-to-connecting rod or pin-to-piston clearance was excessive:
  - Obtain an appropriate oversize piston pin.
  - Hone or ream the piston pin bores in the piston to obtain the correct clearance.
  - It is not necessary to hone or ream the connecting rod piston pin bore oversize.
8. Once pin, connecting rod, and piston are correctly sized, assemble as outlined in Section 02.

## SPECIAL TOOLS

REQUIRED TOOLS	
Tool Number/Description	Illustration
T50T-100-A Impact Slide Hammer	 FPP00145
T59L-100-B Impact Slide Hammer	 FPP00031
T73L-6011-A Engine Cylinder Hone Set	 FPP00046
T73L-6600-A Engine Oil Pressure Gauge	 FPP00145

DESIRED TOOLS (cont.)	
Tool Number	Description
TOOL-6513-DD	Valve/Clutch Spring Tester
TOOL-6565-AB	Cup Shaped Adapter
TOOL-4201-C	Dial Indicator with Bracketry

ROTUNDA EQUIPMENT	
Model	Description
112-R0030	Oil Leak Detector Kit
059-R0009	Compression Tester
014-00705	Pressurization Kit
059-00008	Vacuum/Pressure Tester
107-R0901	Taperset Installation Kit
054-00038	Boring Machine
112-r0015	Fluorescent Oil Additive
014-00975	Carbon Blaster and Automotive Borescope

DESIRED TOOLS	
Tool Number	Description
D81L-6002-D	Piston Ring Groove Cleaner
D81P-6002-E	Valve Seat Runout Gauge
D81L-6002-B	Plastigage®
D87C-77000-A	Transmission Test Adapter
TOOL-6500-E	Hydraulic Tappet Leakdown Tester
TOOL-6505-E	Valve Stem Clearance Tool

SECTION TITLE	PAGE
ENGINE SERVICE - General .....	01-01
ENGINE SERVICE - 2.5L .....	02-01
IGNITION SYSTEM .....	03-01
FUEL PUMP .....	04-01
CARBURETOR.....	05-01
STARTER MOTOR.....	06-01
GOVERNOR.....	07-01
COOLING SYSTEM .....	08-01
GENERATOR .....	09-01

## SECTION 02 - Engine Service - 2.5L

SUBJECT .....	PAGE	SUBJECT .....	PAGE
DESCRIPTION .....	2	Cylinder Head .....	27
Engine Identification.....	2	Water Pump .....	32
Engine Code Information .....	3	Water Thermostat/Outlet Connection .....	33
Crankshaft.....	3	Intake Manifold (carb. only) .....	33
Camshaft.....	3	Intake Manifold (EFI only).....	35
Valve Train.....	4	Carburetor .....	38
Positive Crankcase Ventilation System.....	4	Exhaust Manifold .....	39
Oil Pan .....	4	Oil Pump .....	40
Oil Pump .....	4	Crankshaft Rear Oil Seal .....	42
Engine Cooling System.....	4	Oil Filter and Adapter .....	42
Lubrication System.....	5	Oil Pressure Sender .....	43
Drive Belt System.....	6	Engine Front Cover .....	44
Ignition System.....	6	Oil Pan .....	46
Fuel System .....	6	Oil Pump Screen, Cover, and Tube .....	47
Engine Governing System .....	7	Crankshaft .....	47
Wiring Diagrams.....	8	Crankshaft Main Bearings .....	51
Engine Components.....	10	Pistons and Connecting Rods .....	53
REMOVAL AND INSTALLATION .....	14	Connecting Rod Bearings .....	55
Valve Cover and Gasket .....	14	Camshaft Position Sensor .....	56
Camshaft Follower/Hydraulic Lash Adjuster .....	14	Engine Coolant Temperature Sensor .....	56
Valve Spring/Retainer/Stem Seal .....	15	Intake Air Temperature Sensor .....	57
Crankshaft Pulley and Damper .....	17	Heated Oxygen Sensor .....	57
Camshaft Timing Belt Outer Cover .....	17	Flywheel Ring Gear.....	58
Camshaft Timing Belt Inner Cover .....	18	DISASSEMBLY AND ASSEMBLY .....	59
Camshaft Timing Belt .....	19	Cylinder Head.....	59
Camshaft and Oil Pump Sprocket .....	21	Piston and Piston Pins.....	64
Crankshaft Sprocket .....	22	Cylinder Block.....	64
Timing Belt Tensioner .....	22	Hydraulic Lash Adjuster.....	65
Camshaft .....	23	Bare Cylinder Block.....	65
Camshaft and Oil Pump Oil Seal .....	25	ADJUSTMENTS .....	66
Cylinder Block Front Cover Seal .....	26	SPECIFICATIONS.....	67

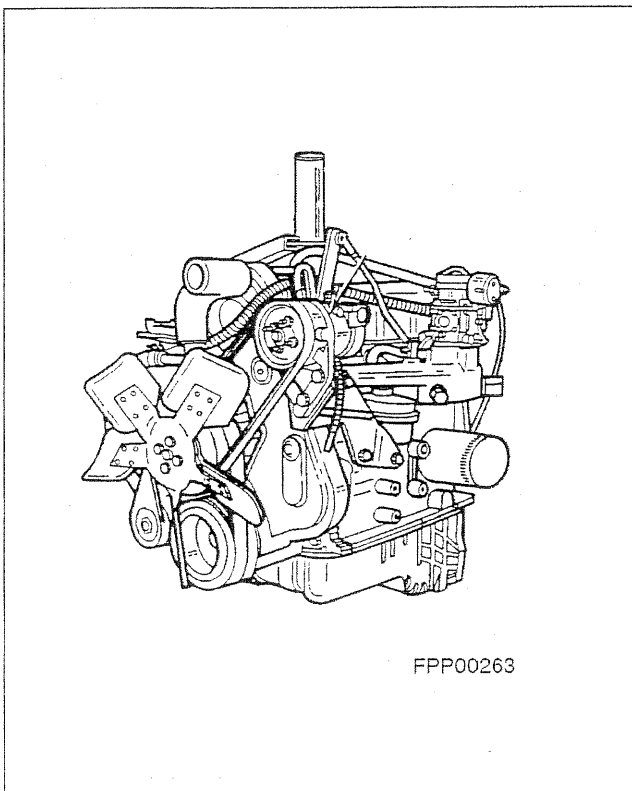

## DESCRIPTION

### Engine

The crankshaft is supported by five main bearings and the camshaft by four. Main, connecting rod, and camshaft shaft bearings are replaceable.

The camshaft is driven by the crankshaft with a cogged timing belt. The timing belt also operates the oil pump. Tension on the timing belt is maintained by a timing belt tensioner which bears on the outside of the belt.

The water pump and the fan are driven from the crankshaft by a six-ribbed poly-V belt which also drives the generator.

Hydraulic lash adjusters are used in the valve train. These units are placed at the fulcrum point of the cam followers. Their action is similar to the hydraulic tappets used in a push rod engine. The cylinder head has drilled oil passages to provide engine oil pressure to the lash adjusters.

NOTE: A set of metric wrenches is required to service the 2.5L engine.



**WARNING: TO AVOID THE POSSIBILITY OF PERSONAL INJURY OR DAMAGE, DO NOT OPERATE THE ENGINE UNTIL THE FAN BLADE HAS BEEN FIRST EXAMINED FOR POSSIBLE CRACKS OR SEPARATION.**

### Engine Identification

For quick engine identification, refer to the identification nameplate.

- The nameplate is mounted on the applicable equipment panels.
- A build code and information label is also attached to the engine.
- The symbol code on the build code and information label identifies each engine for determining parts usage; for instance, engine cubic inch displacement (CID) and model year.

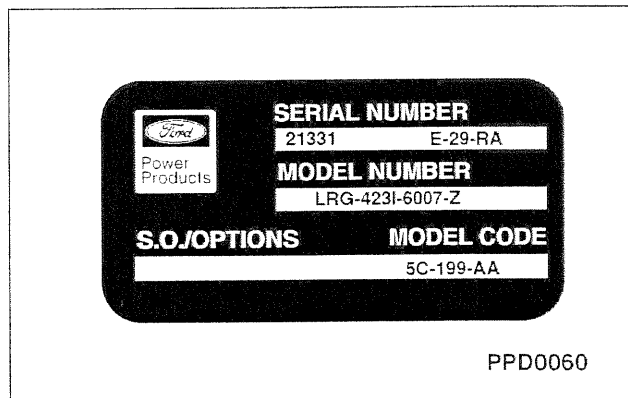

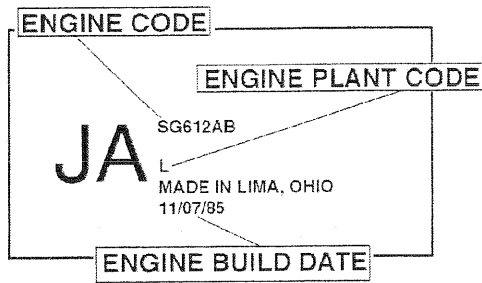

L = LIMA

A24340-A

## Engine Code Information

The engine code information label, located on the timing belt cover, provides the engine build date, engine plant code and engine code as well as other data.

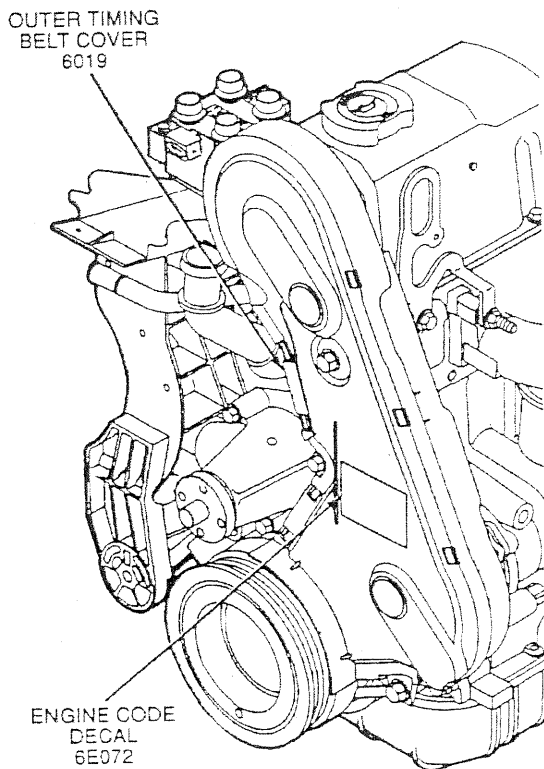

FPP00002

## Crankshaft

The crankshaft:

- Is made from precision cast nodular iron.
- Has five main bearings so each connecting rod is between two main bearings.
- Thrust is taken on the center main bearing to control end play.
- Has a crankshaft damper consisting of a cast iron hub, pulley and internal ring with rubber compressed between them to help control torsional vibration.
- The crankshaft damper also has an integral pulse wheel which provides timing information to the crankshaft position sensor mounted in the engine front cover.

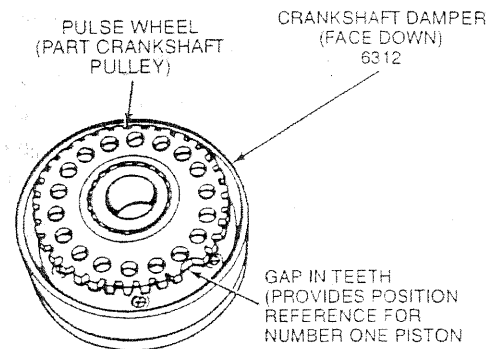

FPP00003

## Camshaft

The camshaft operates the engine valves and:

- Is located in the cylinder head.
- Is supported by four bearings which are pressed into the cylinder head.
- Has end play controlled by a combination thrust and retainer plate which bolts to the rear camshaft bearing support.
- Is driven by a cogged timing belt which runs off the crankshaft and also drives the engine oil pump.

## Valve Train

The valve train consists of:

- Roller finger follower arms.
- Hydraulic lash adjusters.

Camshaft motion is transmitted through the rollers in the finger follower arms to the engine valves.

The lash adjusters provide the finger follower fulcrum point and automatically adjust valve lash for silent operation.

## Positive Crankcase Ventilation System

This engine is equipped with a positive, closed-type crankcase ventilation system, which recycles crankcase vapors to the intake manifold.

## Oil Pan

The oil pump is a rotor type with an inner rotor which turns inside of an off-center outer ring.

The oil pump is located in the front of the cylinder block and is driven by the timing belt through a sprocket identical to the camshaft sprocket.

## Oil Pump

The oil pump contains a pressure relief valve. To deliver sufficient pressure and volume at low rpm, the pump is designed to provide high pressure and volume at high rpm. To prevent damage or excess oil consumption, the pressure relieve valve exhausts excess pressure and volume at high rpm.

The oil pump is not serviced except to replace the front seal and the two O-rings that seal it to the cylinder block.

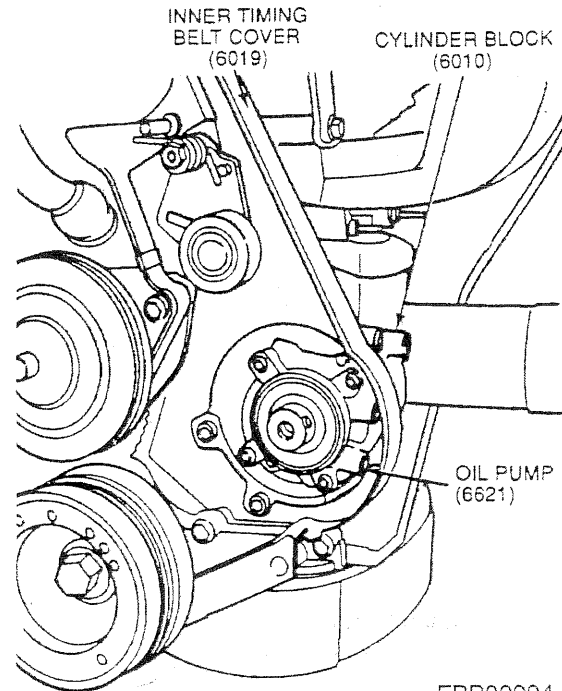

## Engine Cooling System

The 2.5L Engine is liquid cooled using an engine mounted water pump and external radiator. This is a full flow system regulated by a water thermostat located behind the water outlet connection. The thermostat controls and maintains engine temperature.

Typical coolant flow produced by the centrifugal water pump is through the engine block and then into the cylinder head. From the cylinder head it flows through the thermostat and water outlet connection into the upper radiator hose and down through the radiator for cooling. A passage from the water outlet connection through a heater/by-pass hose allows coolant to flow to the intake manifold which provides heat for fuel atomization. It then flows through another heater/by-pass hose assembly to the inlet side of the water pump.

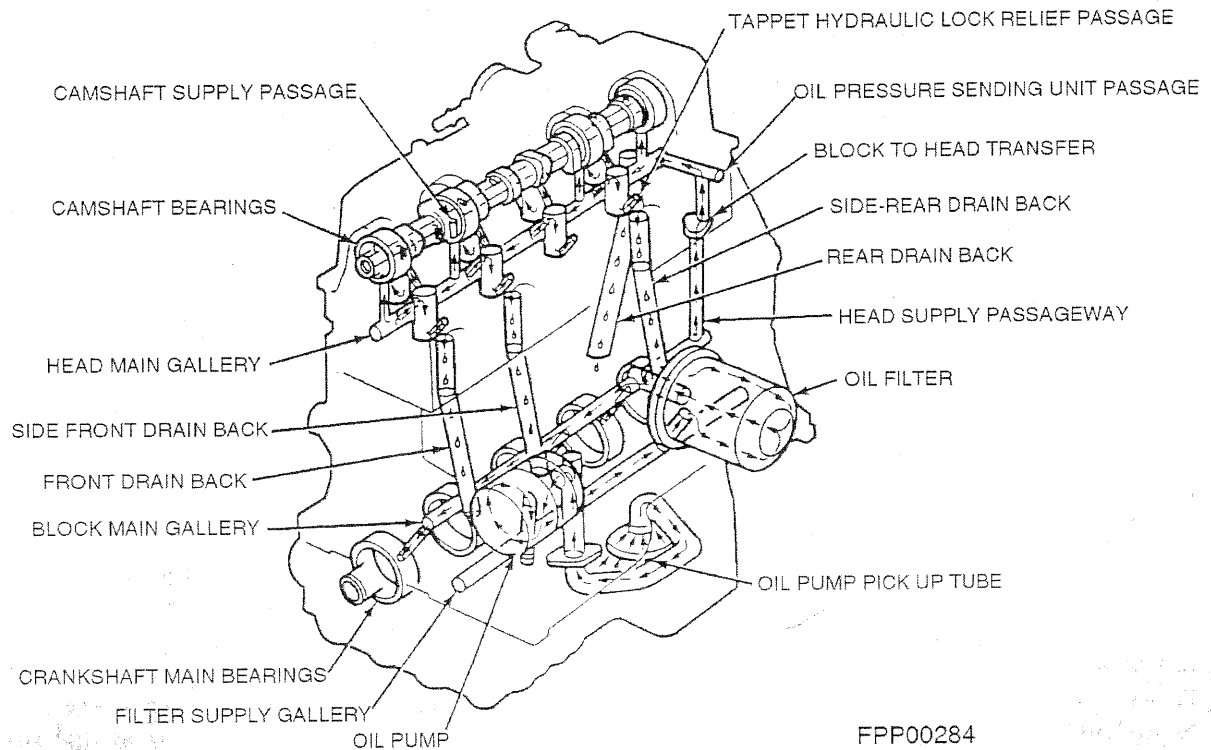

FPP00284

## Lubrication System

The engine lubrication system consists of:

- Oil pan
- Oil pump screen cover and tube
- Oil pump
- Oil filter
- Passageways in the cylinder block , crankshaft , camshaft and cylinder head.

The oil pan is pressure-cast aluminum and serves as both an oil reservoir and engine bottom cover. The oil pan has reinforcing ribs which strengthen the pan, reduce engine noise transmission, and aid in oil cooling.

## Drive Belt System

Engine accessories, such as the generator and water pump, are driven by a single poly-V belt. A direct drive fan is attached to the water pump pulley which is driven by the poly-V belt when the engine is running.

## Ignition System

The ignition used on the 2.5L engine is an Electronic Distributorless Ignition System (EDIS). A crankshaft position (CKP) sensor and vacuum port on the intake manifold provide the necessary information to an ignition module. The module determines when to fire the ignition coil mounted on the generator bracket, based on the two sensors. Standard distributorless ignition coil, wires and spark plugs are used to ignite the fuel in the cylinders.

## Fuel System

The fuel system includes a REMOTE-MOUNTED electric fuel pump. The pump regulates and maintains fuel flow, through an in-line fuel filter to the carburetor mounted on the intake manifold. Depending on engine application, either a Holley or Zenith model carburetor can be used to provide the necessary fuel for combustion.

## Engine Governing System

### Mechanical Governor (Carb)

Mechanical, belt driven, flyweight type governors are used on the 2.5L engine. Constant speed and variable speed governors can be used depending on application. The governor is attached to the carburetor by a linkage system. The governor, through the linkage, limits carburetor throttle plate opening. This provides regulation and control of engine rpm during operating engine loads.

The governor is attached to a bracket bolted to the lower left front of the engine block and is slotted for belt adjustment. A single V-type belt and pulley are used to operate the governor.

### Electronic Governor (Carb)

The electronic governor consists of three main components:

- Controller
- Actuator
- Carburetor with special throttle shaft and mounting pad for the actuator

The controller is connected to the actuator by a wire harness. The controller receives two input signals:

- Engine speed is sensed from the EDIS (Electronic Distributorless Ignition System)
- Using a remote-mounted speed select switch, up to four engine operating speeds can be selected.

There is one output from the controller:

- The controller sends a modulated signal to the actuator at the carburetor. The actuator in turn controls the throttle shaft, which determines throttle plate position. Signal strength is varied, by the controller, depending on the input values.

The electronic governor has an internal FAIL-SAFE circuit that instantly reacts to:

- Interruption of power to the controller which removes power to the actuator. A return spring in the actuator moves the throttle shaft to minimum fuel position.
- Loss of speed signal input which causes the controller to remove power to the actuator. A return spring in the actuator moves the throttle shaft to minimum fuel position.

### Velocity Governor

The velocity governor is an engine speed limiting type, and operates by metering the air/fuel mixture flow from the carburetor. The governor is installed between the carburetor and the intake manifold. It contains a disc valve mounted on a shaft which is similar in appearance to a carburetor butterfly valve. However, unlike a butterfly valve, the governor shaft is mounted off center in the governor bore.

As engine speed increases, the velocity of the air/fuel mixture passing across the disc valve increases. Since the governor shaft is mounted off center, the force of the flowing air/fuel mixture attempts to close the disc valve, therefore restricting the flow and slowing the engine. The force of the flowing air/fuel mixture attempting to close the valve is opposed by a spring. The force of the spring therefore establishes maximum engine speed.

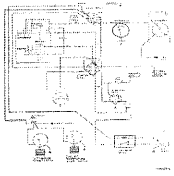

### Wiring Diagrams - Carbureted

Faint, illegible text, possibly bleed-through from the reverse side of the page.

### Wiring Diagrams - Carbureted

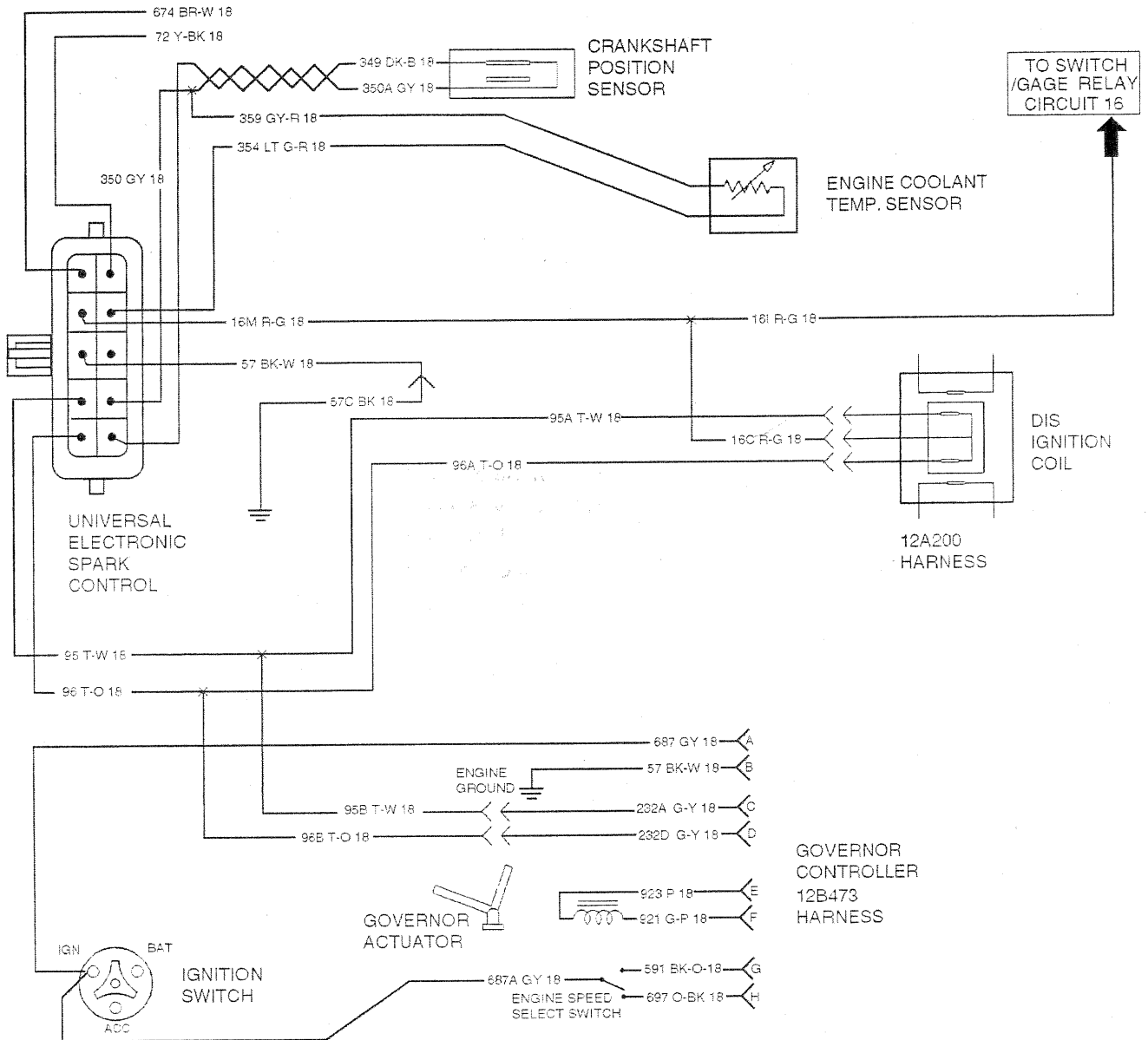

FPP00279

### Wiring Diagrams - EFI

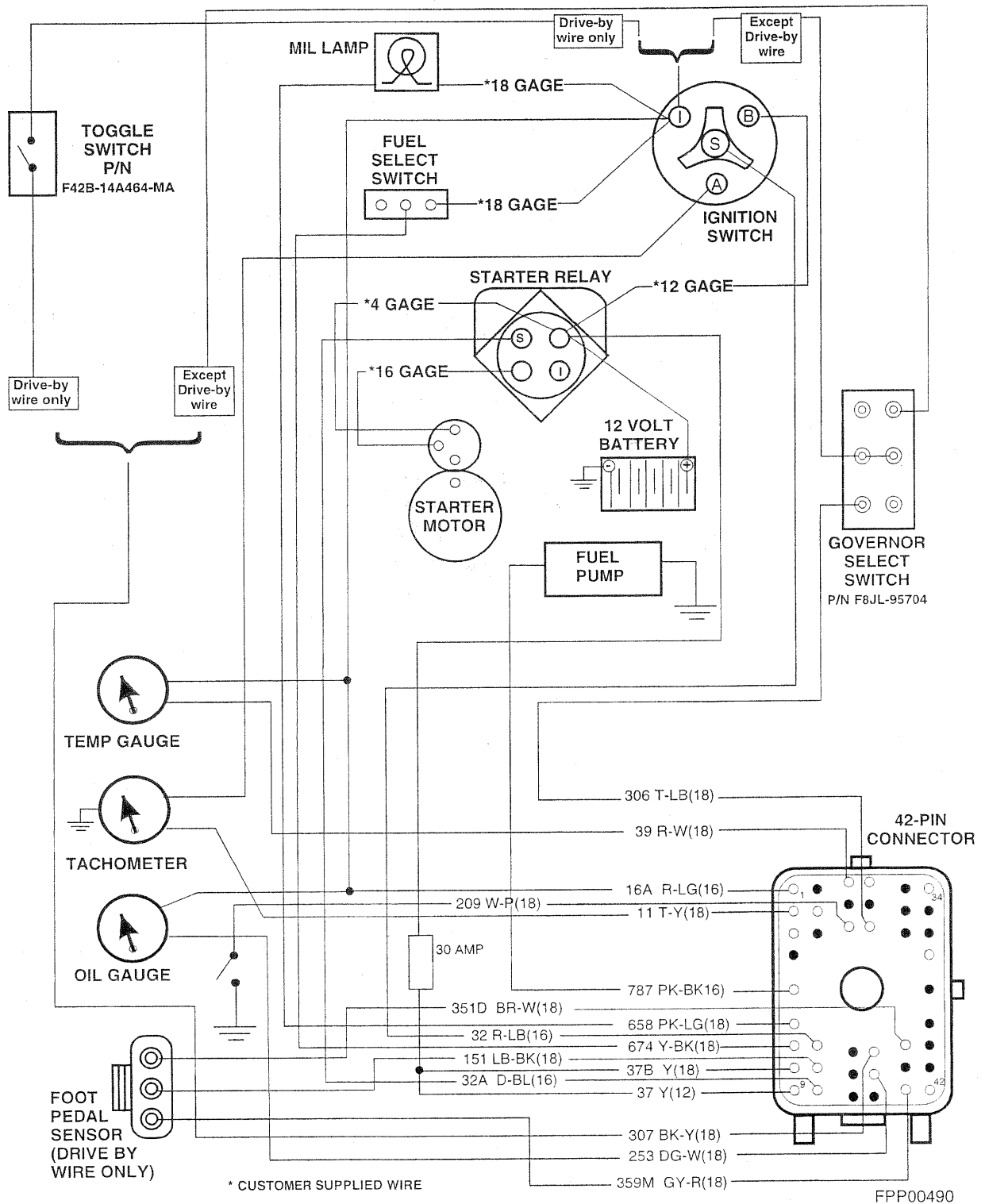

DESCRIPTION

Wiring Diagrams – EFI

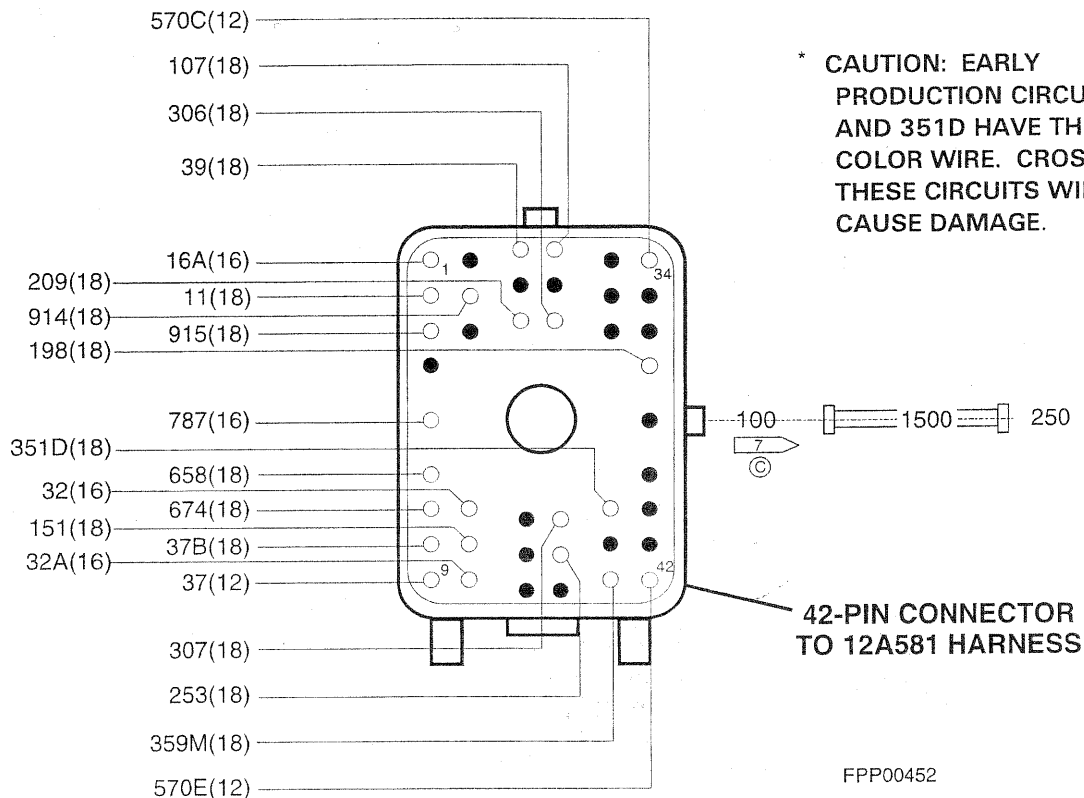

FPP00452

CIRCUIT #	CIRCUIT DESCRIPTION	COLOR	GAUGE	42 PIN
915	DATA LINK CONNECTOR – RS485 (NEGATIVE)	PK-LB	18	3
914	DATA LINK CONNECTOR – RS485 (POSITIVE)	T-O	18	11
787	TO FUEL PUMP	PK-BK	16	5
* 674	FUEL SELECT (OPEN CIRCUIT = PRIMARY FUEL; 12V = SECONDARY)	Y-BK	18	7
658	MALFUNCTION INDICATOR LAMP (OPEN COLLECTOR OUTPUT – 500 mA)	PK-LG	18	6
570E	POWER GROUND – BATTERY (NEGATIVE)	BK-W	12	42
570C	POWER GROUND – BATTERY (NEGATIVE)	BK-W	12	34
359M	DRIVE BY WIRE – SIGNAL RETURN (SIGNAL RETURN FOR DRIVE BY	GY-R	18	33
* 351D	DRIVE BY WIRE – VREF (5V REF VOLT FOR DRIVE BY WIRE POT)	BR-W	18	31
307	GOVERNOR SPEED SELECT #2 (GVS2) – SEE BELOW DESCRIPTION FOR	BK-Y	18	25
306	GOVERNOR SPEED SELECT #1 (GVS1)	T-LB	18	24
253	OIL PRESSURE – FOR INDICATOR LIGHT (OPEN = LOW PRESSURE;	DG-W	18	26
209	SELF TEST INPUT (SHORT TO GROUND TO ACCESS TROUBLE CODES)	W-P	18	18
198	AUXILLIARY INPUT	DG-O	18	37
151	DRIVE BY WIRE – SIGNAL INPUT (0-5V SIGNAL)	LB-BK	18	14
107	DATA LINK CONNECTOR – RS485 (GROUND)	P	18	22
39	WATER TEMPERATURE INDICATOR SENDER TO GAUGE	R-W	18	16
37B	KEEP ALIVE POWER – BATTERY	Y	18	8
37	VPWR – POWER RELAY "SWITCHED SIDE" – 12V (BATT+)	Y	12	9
32A	TO STARTER SOLENOID "S" TERMINAL	DB	16	15
32	FROM IGNITION SWITCH "START MODE" TERMINAL	R-LB	16	13
16A	SWITCHED IGNITION – 12V	R-LG	16	1
11	TO TACHOMETER	T-Y	18	2

DESCRIPTION

Item	Description
1	Bolt, M10-1.5 x 55 (7 places)
2	Exhaust Manifold
3	Engine Lifting Eye (rear)
4	Nut, M10-1.5
5	Stud, M10-1.5 x M10-1.5 x 84
6	Exhaust Manifold Gasket
7	Valve Cover Gasket
8	Valve Cover
9	Crankcase Ventilation Hose
10	Oil Filter Cap
11	Screw, M6-1 x 15
12	Bolt, M8-1.25 x 25 (7 places)
13	Engine Lifting Eye (front)
14	Nut, M8-1.25
15	Bolt, M8-1.25 x 33
16	Stud, M8-1.25 x 1.25 x 63.7
17	Intake Manifold
18	Intake Manifold Gasket
19	Head Gasket
20	Cylinder Block
21	Inner Timing Belt Cover
22	Screw, M6-1 x 22.5
23	Nut, M6-1
24	Stud, M8-1.25 x 51
25	Plug, Rubber 1-1/4 x 7/16 "
26	Bolt, M6-1 x 17
27	Outer Timing Belt Cover
28	Bolt, M8-1.25 x 20
29	Timing Belt Spring Bolt
30	Timing Belt Tension Spring
31	Belt Tensioner Assembly
32	Timing Belt
33	Bolt, M12-1.75 x 45
34	Camshaft Sprocket Washer

Item	Description
35	Camshaft Sprocket
36	Crankshaft Front Seal
37	Camshaft
38	Water Outlet Connection
39	Bolt, M8-1.25 x 18
40	Water Thermostat
41	Thermostat Gasket
42	Intake Valve
43	Exhaust Valve
44	Cylinder Head
45	Engine Oil Pressure Sender
46	Camshaft Retaining Plate
47	Screw, M6-1 x 16
48	Spark Plug
49	Spark Plug Wire and Bracket Assembly
50	Bolt, M12-1.75 x 100.7 (10 places)
51	Valve Stem Seal
52	Valve Spring
53	Valve Spring Retainer
54	Valve Spring Retainer Key
55	Roller Finger Follower
56	Hydraulic Lash Adjuster
57	Camshaft Oil Flow Control Rod
58	Expansion Plug

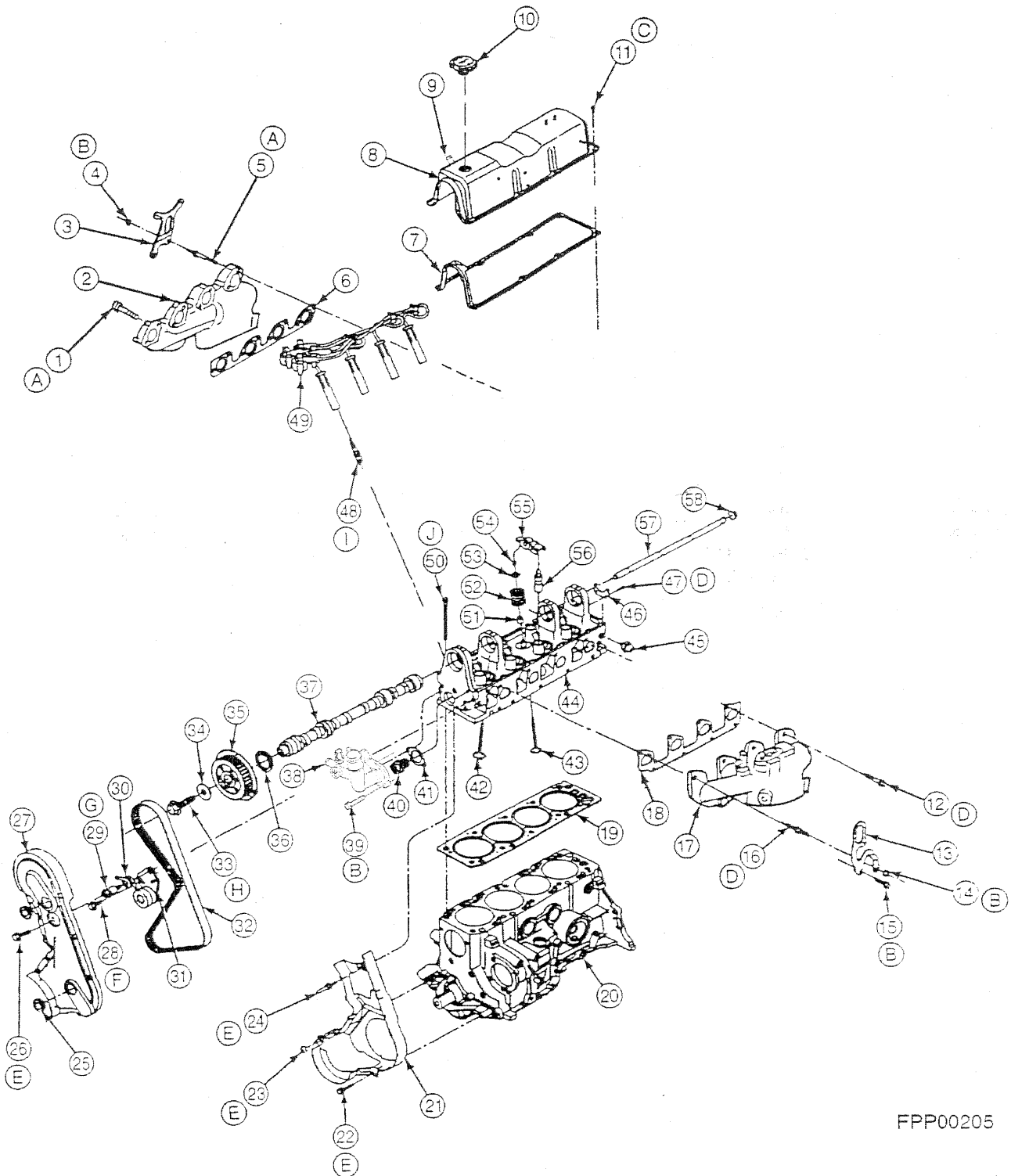

FPP00205

DESCRIPTION

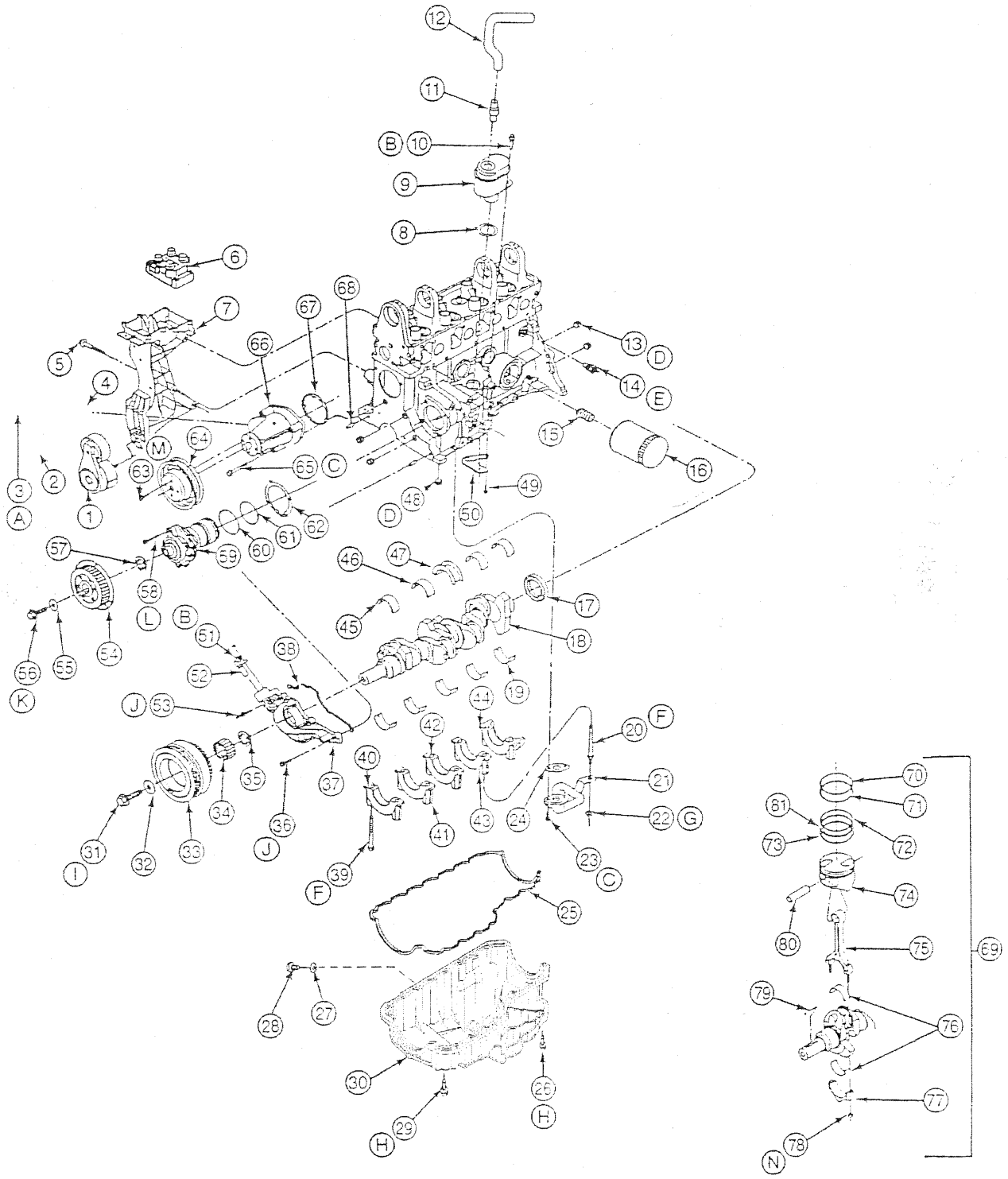

FPP00206

DESCRIPTION

Item	Description
1	Drive Belt Tensioner
2	Water Pump Inlet Tube
3	Screw, M6-1 x 22.5
4	O-ring
5	Bolt, M10-1.5 x 60
6	Ignition Coil
7	Generator Mounting Bracket
8	O-ring
9	Crankcase Vent Oil Separator
10	Screw, M6-1 x 15
11	PCV Valve and Hose Assembly
12	Closed Crankcase Vent Hose
13	Pipe Plug, 3/8-18 x 3/8
14	Water Temperature Indicator Sender
15	Oil Filter Mounting Insert
16	Oil filter
17	Crankshaft Rear Oil Seal
18	Crankshaft
19	Crankshaft Main Bearing (lower)
20	Stud, M10-1.5 x M12-1.75 x 108.5
21	Oil Pump Cover Screen and Tube
22	Nut, M10-1.5
23	Bolt, M8-1.25 x 20
24	Oil Pump Inlet Tube Gasket
25	Oil Pan Gasket
26	Bolt, M6-1 x 57.5
27	Oil Pan Drain Plug Gasket
28	Oil Pan Drain Plug
29	Screw, M6-1 x 27.5
30	Oil Pan
31	Bolt, M14-1.5 x 55
32	Crankshaft Pulley Retaining Washer
33	Crankshaft Pulley
34	Crankshaft Sprocket
35	Crankshaft Front Seal
36	Bolt, M6-1 x 37.5
37	Engine Front Cover
38	Engine Front Cover Gasket
39	Bolt, M12-1.75 x 80
40	Front Main Bearing Cap
41	Front Intermediate Main Bearing Cap
42	Center Main Bearing Cap
43	Rear Intermediate Main Bearing Cap

Item	Description
44	Rear Main Bearing Cap
45	Crankshaft Main Bearing – Upper (blue)
46	Crankshaft Main Bearing – Upper (3 places)
47	Crankshaft Thrust Main Bearing
48	Pipe Plug, 3/8-18
49	Bolt, M6-1 x 14
50	Cylinder Block Ventilation Baffle
51	Bolt, M6-1 x 20
52	Crankshaft Position Sensor
53	Stud, M6-1 x 1 x 61.9
54	Oil Pump Sprocket
55	Oil Pump Sprocket Washer
56	Bolt, M10-1.5-40
57	Oil Pump Front Seal
58	Bolt, M6-1 x 47.5
59	Oil Pump Assembly
60	O-ring, Oil Pump Outlet/Vent
61	O-ring, Oil Pump Inlet/Outlet
62	Oil Pump to Cylinder Block Gasket
63	Screw, M8-1.25 x 25
64	Water Pump Pulley
65	Bolt, M8-1.25 x 53
66	Water Pump
67	Water Pump Housing Gasket
68	Dowel
69	Piston and Connecting Rod
70	Upper Compression Ring
71	Second Compression Ring
72/73	Oil Control Ring
74	Piston and Rod Assembly
75	Connecting Rod
76	Connecting Rod Bearings
77	Connecting Rod Cap
78	Nut, M9-1
79	Woodruff Key
80	Piston Pin
81	Oil Control Ring Segment

DESCRIPTION

## REMOVAL AND INSTALLATION

### Valve Cover and Gasket Removal

1. Remove ignition harness.
2. Snap ignition cables out of ignition coil and place to the side.
3. Remove bolts and valve cover.
4. Remove valve cover gasket from valve cover. If necessary, remove oil filler cap.

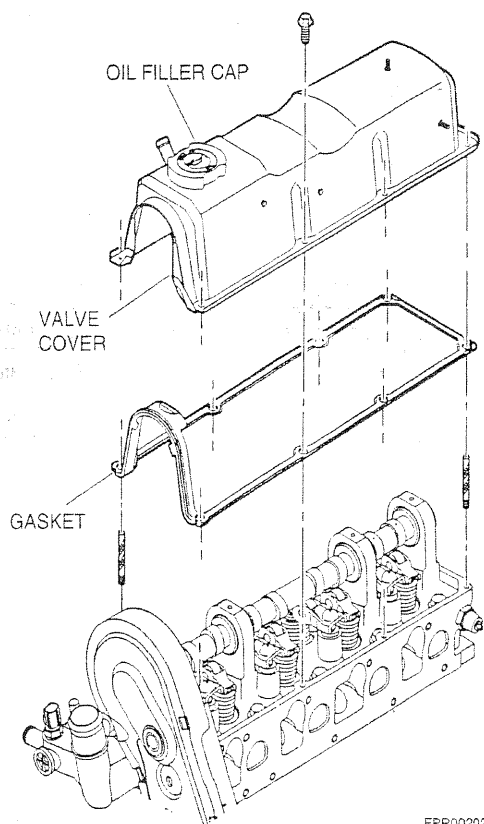

FPP00202

4. Snap ignition wiring harness and ignition cables back into place in brackets attached to valve cover.
5. If removed, install oil filler cap.
6. Start engine and check for leaks.

### Camshaft Follower and Hydraulic Lash Adjuster Removal

Special Tools Required	
Valve Spring Compressor	T95T-6565-A

1. Remove the valve cover as outlined in this section.
2. Rotate the camshaft so the rocker arm to be removed is on the heel of its cam.
3. Using Valve Spring Compressor T95T-6565-A, compress and hold down the valve and valve spring. Slide out the roller finger follower over the lash adjuster.
4. Lift out the hydraulic lash adjuster.

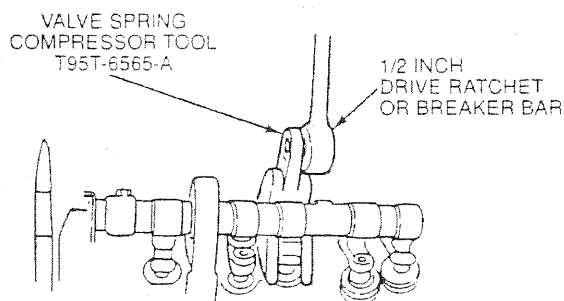

FPP00009

### Valve Cover and Gasket Installation

1. Clean valve cover. Clean valve cover gasket surface on cylinder head.
2. Put valve cover gasket in place on cylinder head.
3. Install valve cover. Alternately tighten bolts to 9-13 N·m (84-120 lb-in).

## Camshaft Follower and Hydraulic Lash Adjuster Installation

1. Rotate camshaft so roller finger follower can be slid under heel of cam.
2. Lubricate contact points of roller finger follower with Ford Multi-Purpose Grease D0ZA-19584-AA, or equivalent, meeting Ford specification ESR-M1C159-AA.
3. If removed, place the lash adjuster in position in the bore.
4. Compress the valve spring using Valve Spring Compressor T95T-6565-A. Position the roller finger follower over the hydraulic lash adjuster and the valve stem. Release valve spring.



**CAUTION:** Make sure the hydraulic lash adjuster has been collapsed and released before rotating camshaft.

5. Using Valve Spring Compressor T88T-6565-BH, compress and release hydraulic lash adjuster.
6. Install valve cover as outlined in this section.

## Valve Spring, Retainer and Valve Stem Seal Removal

Special Tools Required	
Valve Spring Compressor	T95T-6565-A
Valve Guide Replacer	T95T-6510-A
Valve Stem Seal Replacer	T95T-6510-B

If the valve or valve seat has not been damaged, the valve spring, valve stem seal, valve spring retainer or valve spring retainer keys may be replaced by holding the affected valve against its seat using compressed air.

Use an appropriate air line tool installed in the spark plug hole. A minimum of 965 kPa (140 psi) line pressure is required. If air pressure does not hold the valve shut, the valve is damaged or burned and the cylinder head must be removed and serviced. Refer to the engine service section.

1. Remove the valve cover as outlined in this section.
2. Rotate the camshaft so the roller finger follower for the valve to be serviced is on the heel of the cam.
3. Using Valve Spring Compressor T95T-6565-A, compress and hold down the valve spring. Slide out the roller finger follower over the lash adjuster.
- 4.
5. Replace spark plug for cylinder being serviced with an air line adapter. Mark location so spark plug is returned to the same cylinder.



**CAUTION:** The crankshaft may rotate when air pressure is applied. Remove all objects from fan area (lights, extension cords, etc.).

6. Turn on air supply and pressurize cylinder. Air pressure may rotate the crankshaft until the piston reaches the bottom of the stroke.
7. Using Valve Spring Compressor T95T-6565-A, compress the valve spring and remove the valve spring retainer keys and valve spring retainer. Remove and discard the stem seal.
8. If air pressure has forced the piston to the bottom of the cylinder, any removal of air pressure will allow the valve(s) to drop into the cylinder. Wrap a rubber band, tape or string around the end of the valve stem in such a way to prevent the valve from falling in and to allow enough travel to check the valve for binds.
9. Inspect the valve stem for damage. Rotate the valve and check the stem tip for eccentric movement. Move the valve up and down through normal travel in the valve guide and check the stem for any binding. If the valve has been damaged, it will be necessary to remove the cylinder head as outlined in this section.

## Valve Spring, Retainer and Valve Stem Seal Installation



**CAUTION:** Install valve seal protector (plastic installation cap), included with valve seal kit, over end of valve before installing valve stem seal or valve stem seal will be cut by valve retainer key grooves in valve. If valve stem seal is cut it will leak causing oil burning and valve fouling.

1. Put valve seal protector (plastic installation cap) over end of valve as illustrated.

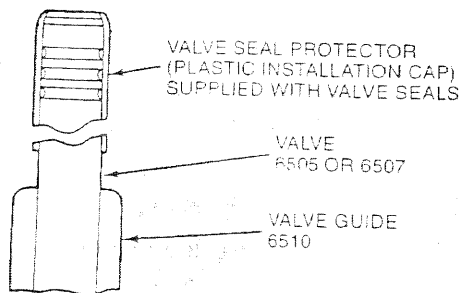

FPP00010

2. Start valve stem seal carefully over cap. Push valve stem seal down until jacket touches top of valve guide.
3. Remove seal protector (plastic cap). Use Valve Stem Seal Replacer T95T-6510-B to install valve stem seal on valve guide.

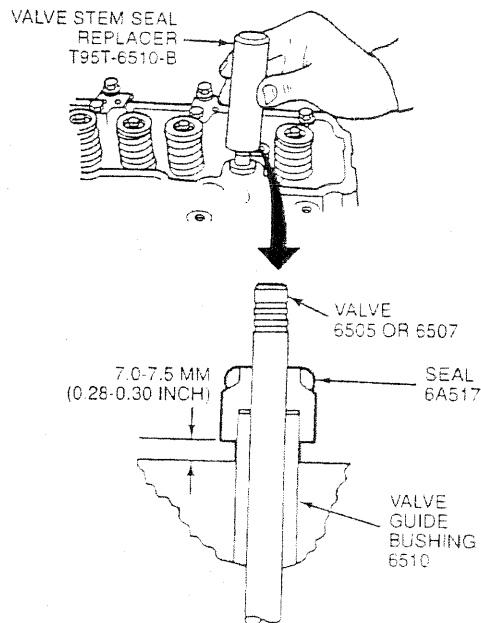

4. Apply a small amount of Ford Multi-Purpose Grease D0A2-19584-AA, or equivalent, meeting Ford specification ESR-M1C159-A to valve spring retainer key to hold in place during installation.
5. With cylinder pressurized, place valve spring and valve spring retainer into position.
6. Compress valve spring with Valve Spring Compressor T95T-6565-A and install valve spring retainer keys. Release spring to seat valve spring retainer keys in proper cylinder.
7. Release air pressure and remove air adapter. Install spark plug in proper cylinder.
8. Grease contact surfaces of roller finger follower with Ford Multi-Purpose Grease D0AZ-19584-AA, or equivalent, meeting Ford specification ESR-M1C159-A.
9. Using Valve Spring Compressor T95T-6565-A, compress and hold down the valve and spring. Slide the roller finger follower into place over valve and lash adjuster. Release spring.
10. Using Valve Spring Compressor T95T-6565-A, compress and release lash adjuster.
11. Install valve cover as outlined in this section.

## Crankshaft Pulley and Damper Removal

1. Loosen crankshaft damper bolt.
2. Using flex handle, rotate drive belt tensioner and remove drive belt.
3. Remove crankshaft damper from crankshaft.

## Crankshaft Pulley and Damper Installation

1. Align keyway with key, install crankshaft damper on crankshaft, and snug crankshaft damper bolt.
2. Position drive belt and rotate drive belt tensioner away from drive belt.
3. Position drive belt under drive belt tensioner and release drive belt tensioner, tensioning drive belt.
4. Tighten crankshaft damper retaining bolt to 127-165 N·m (93-121 lb-ft).

## Camshaft Timing Belt Outer Cover Removal

1. Loosen four fan and water pump pulley -to-water pump bolts.
2. Rotate drive belt tensioner and remove drive belt.

4. Remove timing belt outer cover retaining screw.
5. Release seven cover interlocking tabs and remove outer timing belt cover.

## Camshaft Timing Belt Outer Cover Installation

1. Position outer timing belt cover and secure by snapping the seven interlocking tabs into place.
2. Install timing belt cover retaining screw and tighten to 8-12 N·m (70-106 lb-in).
3. Install water pump pulley and fan; snug bolts, but do not tighten.
4. Install drive belt.
5. Using flex handle, rotate drive belt tensioner, position drive belt, and rest tensioner pulley on belt.
6. Tighten four clutch and pulley-to-water pump bolts to 18-22 N·m (13-16 lb-ft).

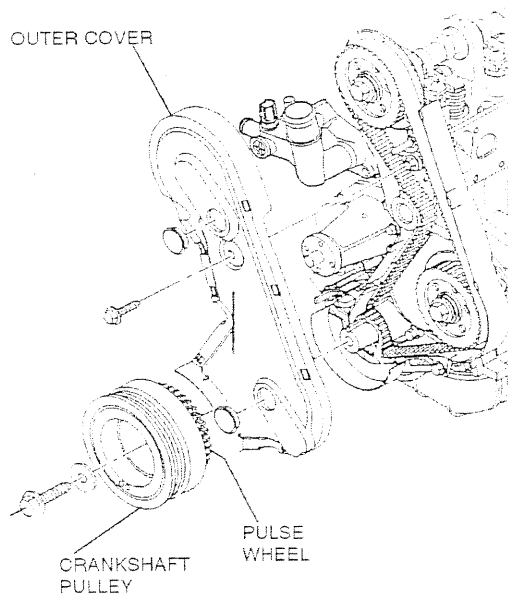

FPP00207

3. Remove four bolts, fan, and water pump pulley.

## Camshaft Timing Belt Inner Cover Installation

1. Position inner timing belt cover on front of engine and stud.
2. Install nut and bolt and tighten to 8-12 N·m (72-108 lb-in).
3. Tighten stud to 20-30 N·m (15-22 lb-ft).
4. Install oil pump sprocket as outlined in this section.
5. Install timing belt tensioner as outlined in this section. Tighten M8 bolt to 22-27 N·m (16-20 lb-ft) and M10 bolts (3) to 40-55 N·m (29-40 lb-ft).
6. Install timing belt as outlined in this section.

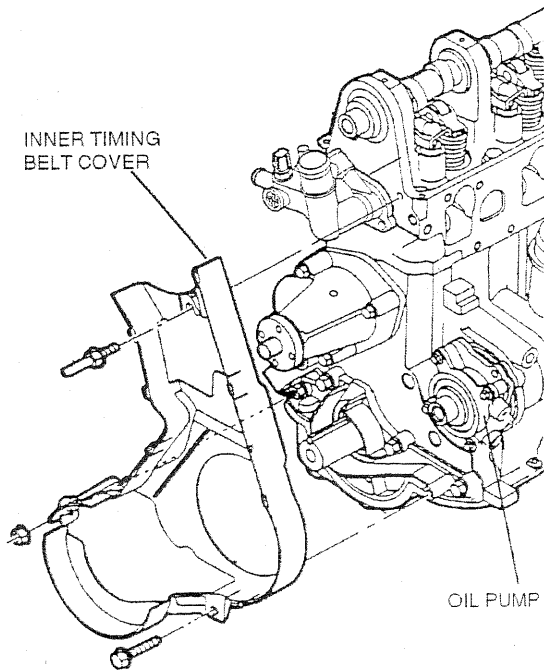

FPP00208

## Camshaft Timing Belt Inner Cover Removal

1. Remove timing belt as outlined in this section.
2. Remove timing belt tensioner as outlined in this section.
3. Remove oil pump sprocket as outlined in this section.
4. Remove screw and nut securing inner timing belt cover to cylinder block.
5. Loosen stud two or three turns.
6. Remove inner timing belt cover.

## Camshaft Timing Belt Removal

Special Tools Required	
Camshaft Belt Tension Adjusting Tool	T74P-6254-A

1. Remove spark plugs.
2. Align crankshaft so number one piston is at TDC (top dead center) as indicated by timing marks. Refer to illustration.
3. Remove outer timing belt cover as outlined in this section.



**CAUTION:** If you attempt to remove timing belt or adjust tension without loosening both timing belt tensioner adjusting bolt and spring pivot bolt, you will break Camshaft Belt Tension Adjusting Tool T74P-6254-A when you attempt to relieve tension on belt.

4. Loosen timing belt spring pivot bolt. Do not remove.
5. Hold tensioner with Camshaft Belt Tension Adjusting Tool T74P-6254-A.
6. While holding tensioner, loosen adjusting bolt and gradually release spring tension.
7. Using adjusting tool, rotate tensioner against spring pressure, as far clockwise as possible. While holding, tighten adjusting bolt to hold tensioner away from belt.
8. Remove timing belt.

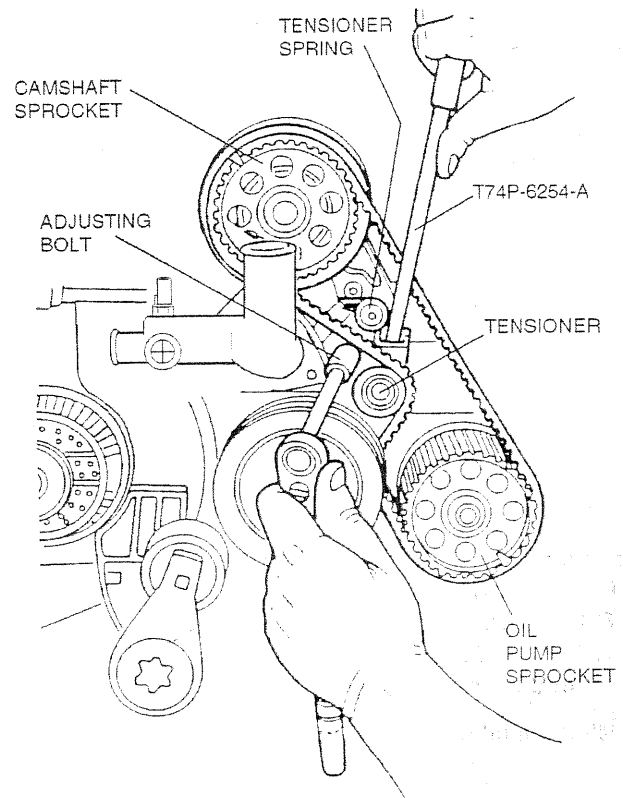

FPP00209

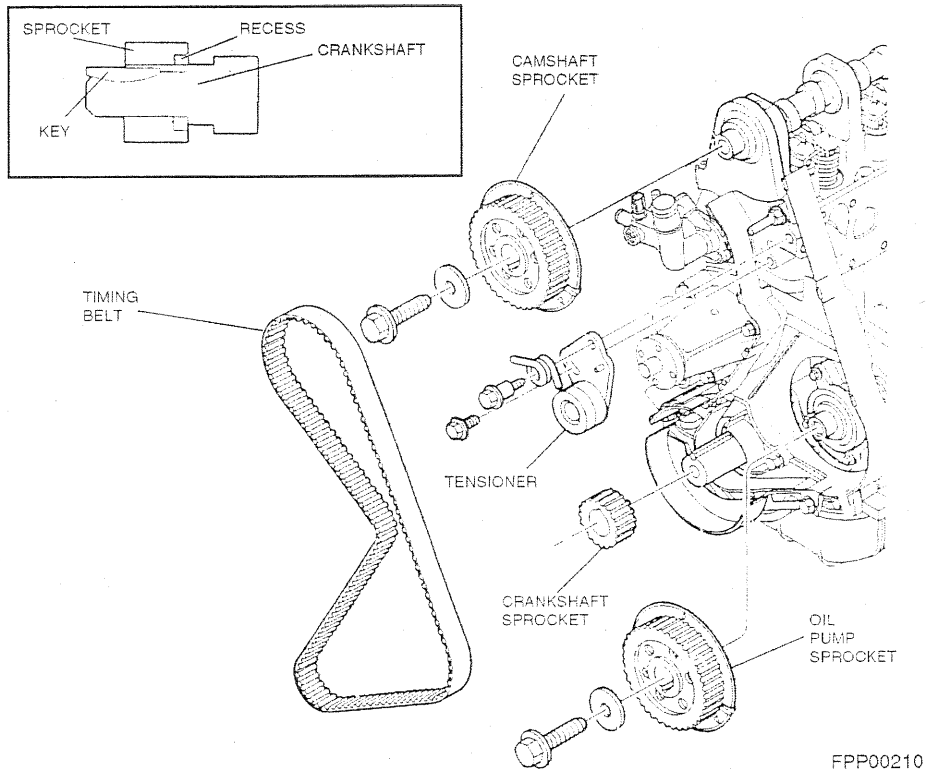

REMOVAL AND INSTALLATION



NOTE: Camshaft and oil pump gears are identical and are interchangeable. Align the triangle mark on the camshaft gear and the diamond mark on the oil pump gear as shown in the above illustration.

## Camshaft Timing Belt Installation

NOTE: Care must be taken during timing belt installation to prevent damage to the inner timing cover.

1. If not done:
  - a. Loosen tensioner adjusting bolt.
  - b. Using Camshaft Belt Tension Adjusting Tool T74P-6254-A, pry tensioner clockwise against spring tension as far as possible.
  - c. Tighten adjusting bolt to hold tensioner in released position.
2. Align crankshaft so number one piston is at TDC (top dead center) with crankshaft key pointing straight up and circle on crankshaft sprocket aligned with notch in engine front cover.
3. Align triangle on camshaft sprocket with triangle on inner timing belt cover.
4. Install timing belt over crankshaft sprocket. Then, proceeding counterclockwise, install timing belt over oil pump sprocket and camshaft sprocket.
5. Loosen tensioner adjusting bolt allowing tensioner pulley to press against timing belt.
 

NOTE: When performing the following step, do not rotate crankshaft counterclockwise as timing belt may jump a cog, putting camshaft out of time.
6. Rotate crankshaft two revolutions clockwise.
7. Bring crankshaft slowly, without stopping, to number one cylinder firing position (keyway directly up).
8. Recheck timing mark alignment. Repeat the above Steps if timing marks are not properly aligned.
9. Rotate tensioner assembly against belt with torque wrench up to 40-45 N·m (29-33 lb-ft) and tighten adjusting bolt.
10. Tighten adjusting bolt to 35-45 N·m (26-33 lb-ft).
11. Tighten spring pivot bolt to 40-55 N·m (29-40 lb-ft).

12. Install outer timing belt covers as outlined in this section.

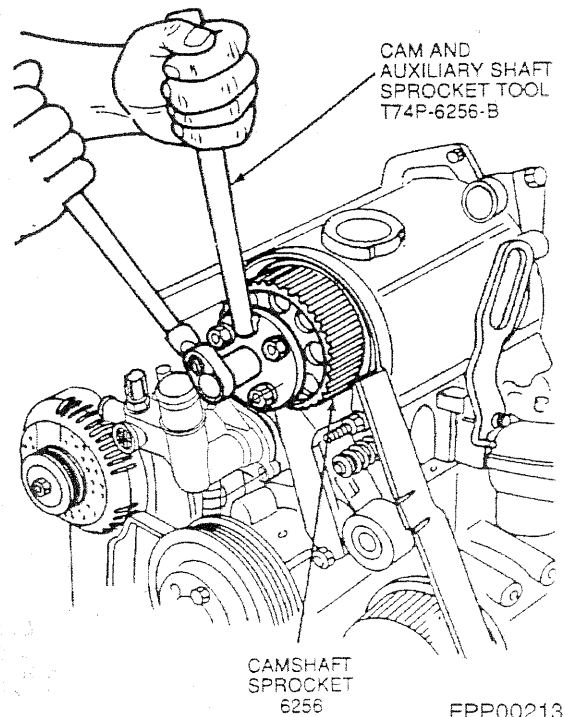

## Camshaft and Oil Pump Sprocket Removal

NOTE: Removal and installation steps are the same for both camshaft and oil pump (6600) sprockets.

### Special Tools Required

Cam Sprocket Holding Tool	T74P-6256-B
---------------------------	-------------

1. Remove outer timing belt cover as outlined in this section.
2. Remove timing belt as outlined in this section.
3. Install Cam Sprocket Holding/Removing Tool T74P-6256-B on sprocket. Use tool to hold sprocket and remove bolt and washer.
4. Install threaded puller insert in Cam Sprocket Holding/Removing Tool T74P-6256-B and remove sprocket.
5. Remove tool from sprocket.

## Camshaft and Oil Pump Sprocket Installation

1. Position key and sprocket on shaft.
2. Install Cam Sprocket Holding/Removing Tool T74P-6256-B, without threaded puller insert, on sprocket.
3. Install sprocket bolt and washer and tighten to 71-95 N·m (52-70 lb-ft).
4. Remove tool.
5. Install timing belt as outlined in this section.
6. Install outer timing belt cover as outlined in this section.

## Crankshaft Sprocket Removal

1. Remove outer timing belt cover as outlined in this section.
2. Remove crankshaft damper and crankshaft pulley retaining washer.
3. Remove crankshaft damper.
4. Remove timing belt as outlined in this section.
5. Remove crankshaft sprocket.

## Crankshaft Sprocket Installation

1. Install crankshaft sprocket.
2. Install timing belt as outlined in this section.
3. Install outer timing belt cover as outlined in this section.
4. Install crankshaft pulley, washer, and bolt. Tighten bolt to 125-165 N·m (92-121 lb-ft).

## Timing Belt Tensioner Removal

Special Tools Required	
Belt Tension Adjusting Tool	T74P-6254-A
Camshaft Belt Tensioner Tool	T74P-6256-B

1. Remove outer timing belt cover as outlined in this section.
2. Remove timing belt as outlined in this section.  
NOTE: Belt tensioner assembly is under spring tension.
3. Hold tensioner by prying against spring pressure with Belt Tensioner Adjusting Tool T74P-6254-A. Remove adjustment bolt (which goes through slot in base of tensioner).
4. Release pressure.
5. Remove spring pivot bolt, spring, and tensioner assembly.

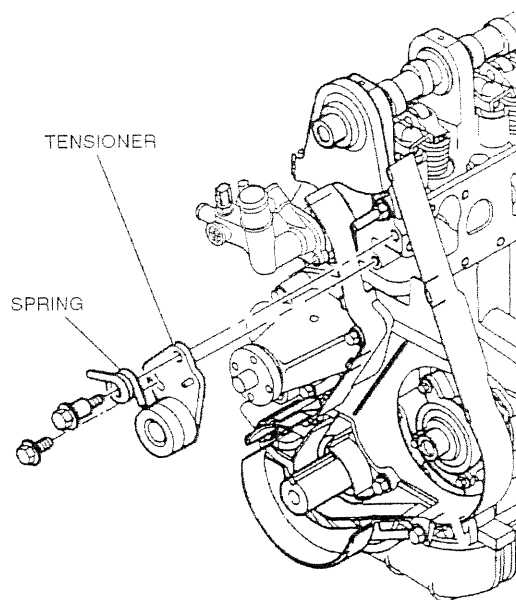

FPP00212

## Timing Belt Tensioner Installation

1. Install belt tensioner and timing belt tensioner spring on cylinder head placing one leg of spring under stud on cylinder head and other leg against pin on tensioner and install spring pivot bolt loosely.
2. Using Camshaft Belt Tensioner Tool T74P-6256-B, rotate tensioner clockwise against spring tension as far as possible and install adjustment bolt and tighten to restrain tensioner.

NOTE: Spring pivot bolt is to be tightened after timing belt is installed. Adjusting bolt is tightened as part of timing belt installation.

3. Install timing belt as outlined in this section.
4. After installing timing belt, tighten spring pivot bolt to 40-55 N·m (29-40 lb-ft).
5. Install outer timing belt cover as outlined in this section.

## Camshaft Removal

Special Tools Required	
Valve Spring Compressor	T95T-6565-A
Cam Sprocket Holding Tool	T74P-6256-B
Front Seals Replacer	T74P-6150-A
Front Cover Seal Remover	T74P-6700-B

1. Remove outer timing belt cover as outlined in this section.
2. Remove valve cover as outlined in this section.
3. Rotate the camshaft so the rocker arm is on the heel of its cam.
4. Using Valve Spring Compressor T95T-6565-A, compress valve springs and remove all roller finger followers.

5. Remove camshaft sprocket using Cam Sprocket Holding/Removing Tool T74P-6256-B.
6. Remove camshaft seal using Front Cover Seal Remover T74P-6700-B.
7. Remove camshaft retainer plate (two screws).



**CAUTION: Be careful to avoid damaging journal and lobes.**

8. Remove camshaft.

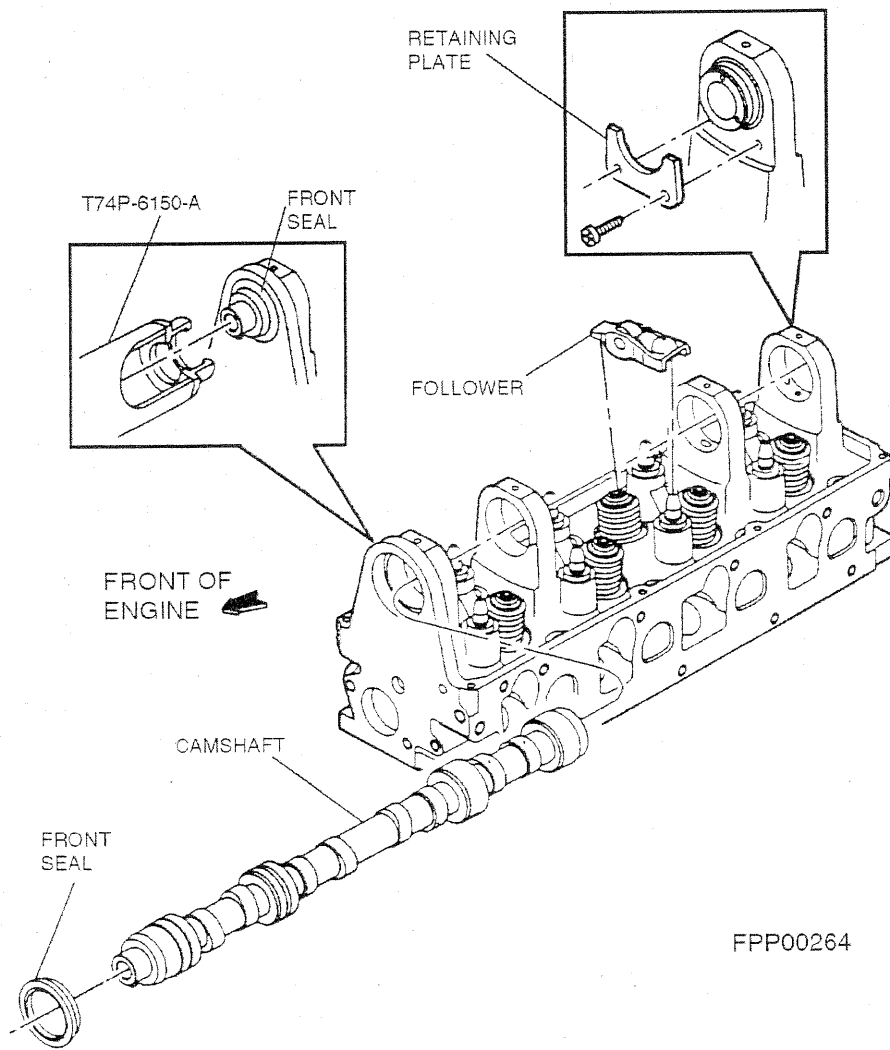

FPP00264

## Camshaft Installation

1. Coat the camshaft lobes with Ford Multi-Purpose Grease D0AZ-19584-AA, or equivalent, meeting Ford specification ESR-M1C159-A and lubricate the journals with heavy oil before installation. Carefully slide the camshaft through the camshaft bearings.
2. Install camshaft retaining plate. Tighten screws to 8-12 N·m (6-9 lb-ft).
3. Install camshaft front seal using Front Seals Replacer T74P-6150-A.
4. Install camshaft sprocket to camshaft.
5. Install retaining bolt using Cam Sprocket Holding/Removing Tool T74P-6256-B to hold sprocket. Tighten to 71-95 N·m (52-70 lb-ft).
6. Install timing belt as outlined in this section.
7. Install outer timing belt cover as outlined in this section.
8. Using Valve Spring Compressor T95T-6565-A, compress valve spring and install followers.
9. Using Valve Spring Compressor T95T-6565-A, compress and release valve tappet.
10. Install valve cover as outlined in this section.
11. Start engine and check for leaks.

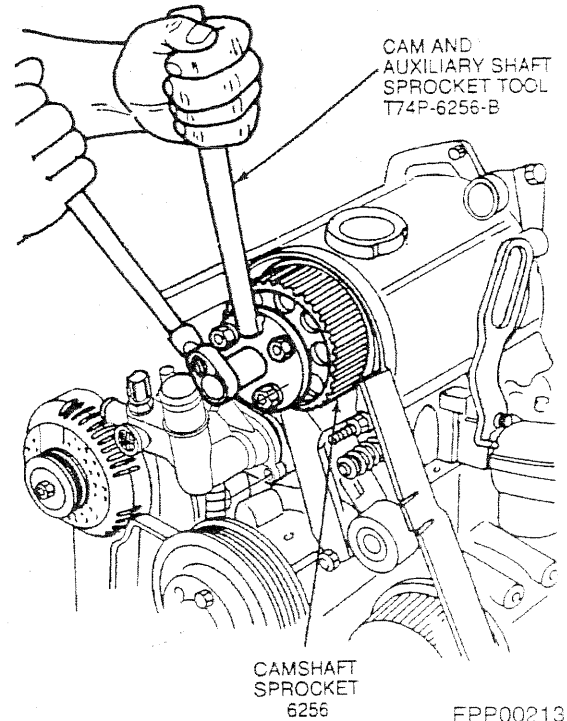

## Camshaft and Oil Pump Oil Seal Removal

NOTE: The camshaft and oil pump shaft seals are each replaced in the same manner with the same tools after the respective sprocket has been removed.

NOTE: Always use a new attaching bolt when replacing the camshaft sprocket or use Teflon®, or equivalent, sealing tape on the threads of the old bolt.

Special Tools Required	
Cam Sprocket Holding Tool	T74P-6256-B
Front Cover Seal Remover	T74P-6700-B
Front Seals Replacer	T74P-6150-A

1. Remove outer timing belt cover as outlined in this section.
2. Remove timing belt as outlined in this section.
3. Install Cam Sprocket Holding/Removing Tool T74P-6256-B on sprocket and use tool to hold sprocket and remove bolt and washer.
4. Install threaded puller insert in Cam Sprocket Holding/Removing Tool T74P-6256-B and pull sprocket.

NOTE: When positioning Front Cover Seal Remover T74P-6700-B, make sure the jaws are gripping the thin edge of the seal very tightly before operating the jack screw portion of the tool.

5. Install Front Cover Seal Remover T74P-6700-B, making sure jaws are tightly gripping the thin edge of the seal. Clean journal of debris.
6. Remove seal.

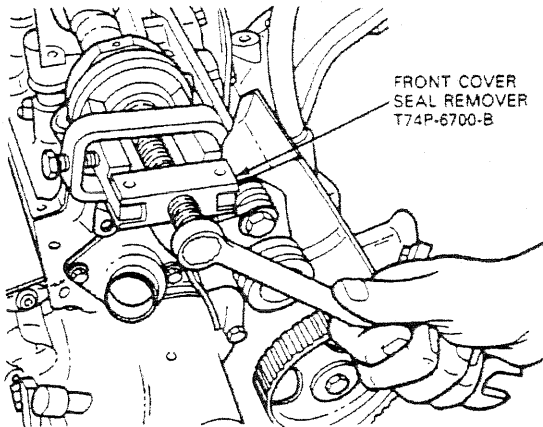

FPP00021

### Camshaft and Oil Pump Oil Seal Installation

1. Position camshaft or oil pump shaft seal on Front Seals Replacer T74P-6850-A and press into place.

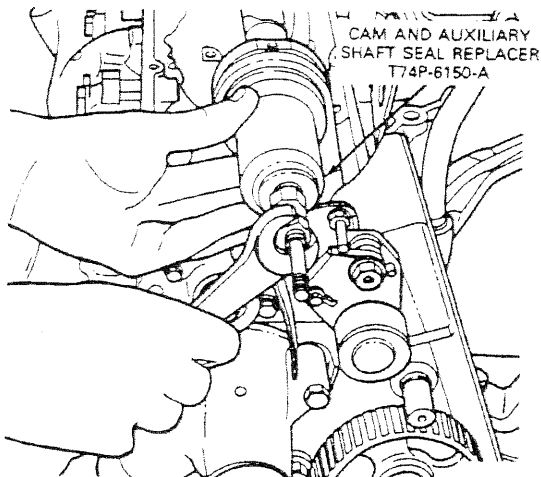

FPP00022

2. Remove tool.
3. Position sprocket on shaft.
4. Install Cam Sprocket Holding/Removing Tool T74P-6256-B, without threaded puller insert, on sprocket.
5. Install sprocket bolt and washer and tighten to 71-95 N·m (52-70 lb-ft).
6. Remove tool.
7. Install timing belt as outlined in this section.

8. Install outer timing belt cover as outlined in this section.

### Cylinder Block Front Cover Seal Removal

Special Tools Required	
Front Cover Seal Remover	T74P-6700-B
Cam Bearing Adapter Tube	T72C-6250

1. Remove outer timing belt cover as outlined in this section.
2. Remove timing belt as outlined in this section.
3. Remove crankshaft pulley hub bolt.
4. Slide crankshaft pulley (63120 off crankshaft (63030).
5. Slide crankshaft sprocket off of crankshaft.
6. Remove key from crankshaft.

NOTE: When positioning Front Cover Seal Remover T74P-6700-B, make sure jaws are gripping the thin edge of the seal tightly before operating the jack screw portion of the tool.

7. Install Front Cover Seal Remover T74P-6700-B, making sure jaws are gripping the thin edge of the seal.
8. Remove seal.
9. Clean journal of debris.

### Cylinder Block Front Cover Seal Installation

1. Using Cam Bearing Adapter Tube T72C-6250 and crankshaft pulley hub bolt, press engine front cover seal into engine front cover.
2. Remove tool.
3. Install key.
4. Install crankshaft sprocket, crankshaft pulley, washer, and bolt. Tighten bolt to 125-165 N·m (92-121 lb-ft).
5. Install timing belt as outlined in this section.
6. Install outer timing belt cover as outlined in this section.

## Cylinder Head Removal

Special Tools Required	
Camshaft Belt Tensioner Tool	T74P-6254-A

1. Disconnect battery ground cable.
2. Drain cooling system.
3. Remove intake manifold as outlined in this section.
4. Remove ignition harness.
5. Remove spark plug wire set from spark plugs and valve cover attachments.
6. Disconnect vacuum hose from ignition module.
7. Remove valve cover and retaining bolts and remove cover.
8. Using flex handle, rotate drive belt tensioner counterclockwise and remove drive belt.
9. Disconnect generator electrical connections.
10. Remove lower radiator hose and heater water hose from water pump inlet tube and thermostat housing.
11. Remove bolts securing water pump inlet tube to generator mounting bracket and remove water pump inlet tube.
12. Remove three bolts from generator. Remove generator. Remove 3 bolts from generator mounting bracket. Remove bracket with ignition coil and ignition wire and brackets attached.
13. Disconnect upper radiator hose at both ends and remove.
14. Remove fan and water pump pulley.
15. Remove timing belt outer cover as outlined in this section.
16. Remove timing belt as outlined in this section.
17. Remove timing belt tensioner adjuster bolt, spring pivot bolt, timing belt tensioner spring, and tensioner.
18. Remove front engine lifting eye.
19. Remove retaining bolts and intake manifold.
20. Remove rear engine lifting eye.

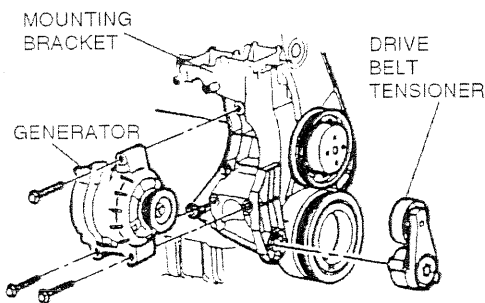

FPP00265

12. Remove three bolts from generator. Remove generator. Remove 3 bolts from generator mounting bracket. Remove bracket with ignition coil and ignition wire and brackets attached.
13. Disconnect upper radiator hose at both ends and remove.

21. Remove the eight exhaust manifold retaining bolts and studs (6 bolts, 2 studs).
22. Remove cylinder head retaining bolts (10).
23. Remove the cylinder head.
24. Clean cylinder head gasket surface at the block.
25. Clean intake manifold gasket surfaces.
26. Clean exhaust manifold gasket surface.
27. Clean exhaust manifold gasket surface at the cylinder head.
28. Clean cylinder head gasket surface at the cylinder head.
29. Clean intake manifold gasket surface at the cylinder head.
30. Blow oil out of the cylinder block bolt holes.
31. Clean valve cover gasket surface on the cylinder head.
32. Check cylinder head for flatness as outlined in the engine service section. Cylinder head and cylinder block head gasket surface should be flat to 0.08mm (0.003 inch) over any 152mm (6 inches) and flat within 0.15mm (0.006 inch) overall.

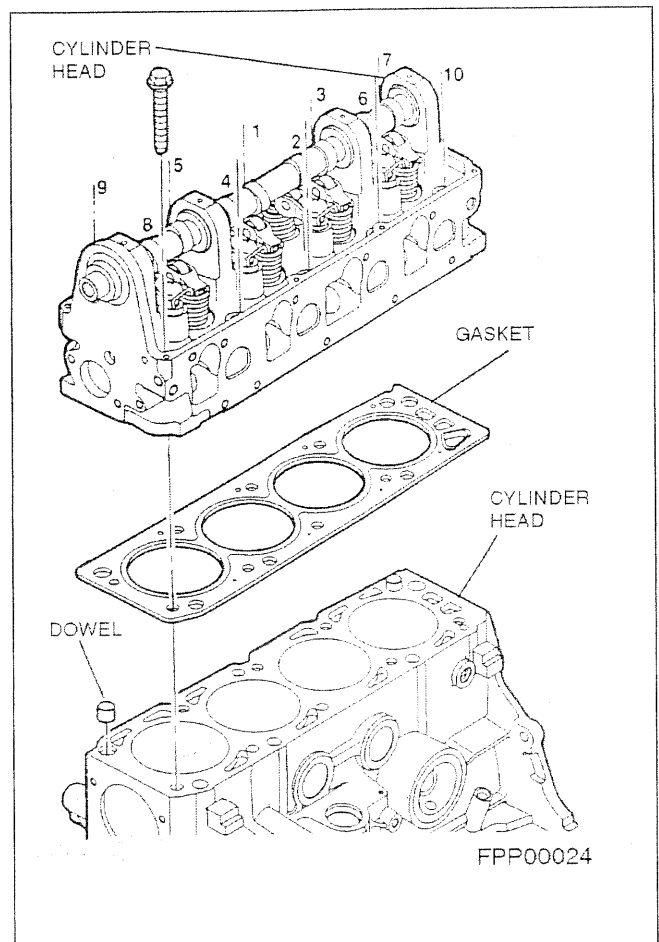

### Cylinder Head Installation

1. Position head gasket on the block.
2. Position cylinder head to cylinder block.
3. Install 10 cylinder head bolts in numerical sequence. Tighten to 70 N·m (52 lb-ft) in illustrated sequence. Retighten to 70 N·m (52 lb-ft) in sequence. Then turn all head bolts an additional 90-100 degrees in sequence.

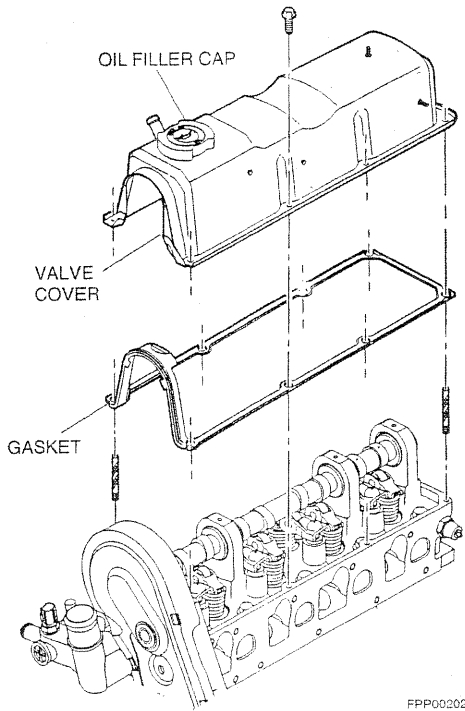

FPP000202

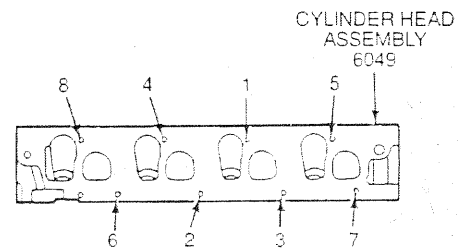

← FRONT OF ENGINE

FPP00026

4. Install valve cover and valve cover gasket . Tighten retaining bolts to 9-13 N·m (80-115 lb-in).
5. Install intake manifold and gasket. Tighten retaining bolts in sequence (refer to illustration) to 6-38 N·m (19-28 lb-ft).
6. Install front lifting eye and tighten nut and bolt to 20-30 N·m (15-22 lb-ft).
7. Install exhaust manifold, gasket, and eight exhaust manifold retaining bolts and/or stud bolts. Tighten the bolts in sequence in two steps: 20-30 N·m (15-22 lb-ft), then 48-68 N·m (35-50 lb-ft).

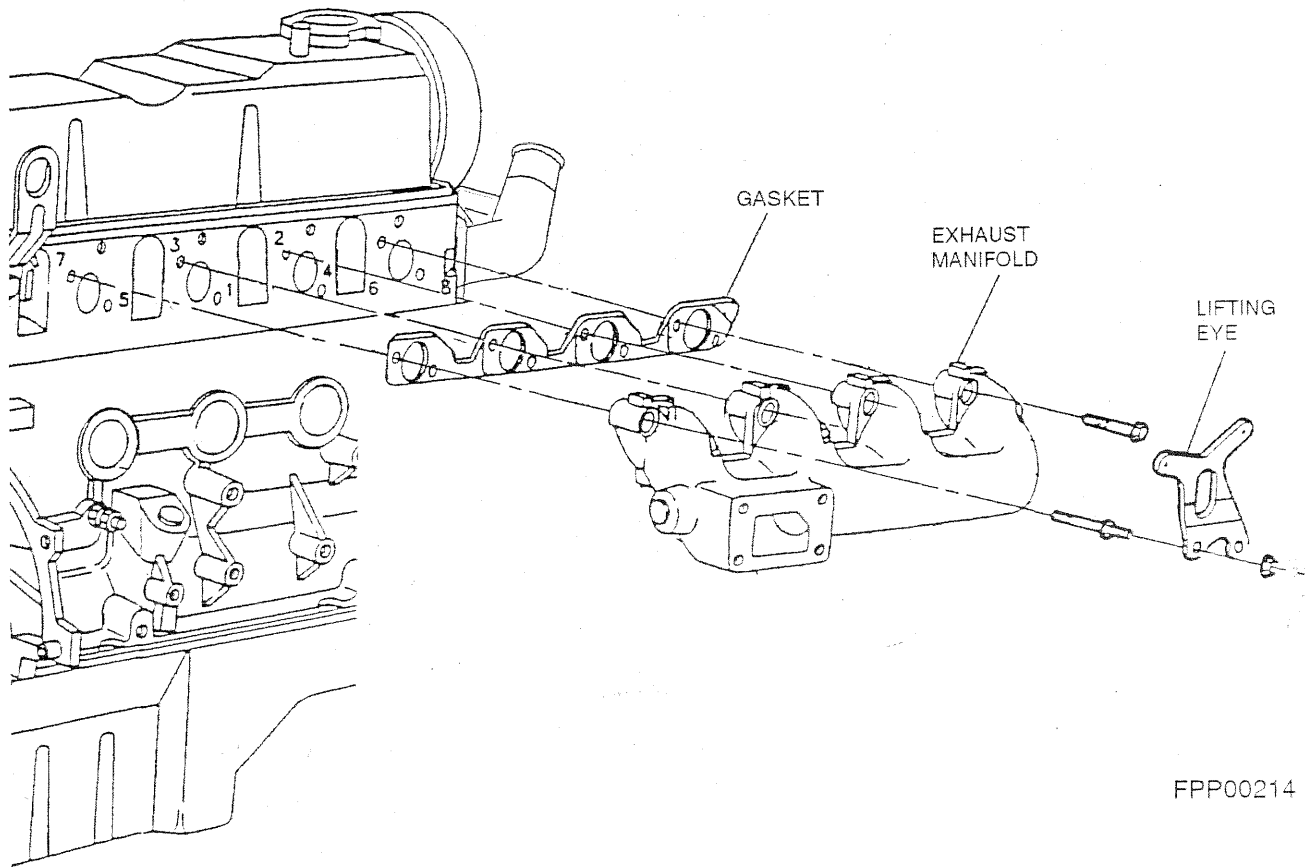

FPP00214

8. Install timing belt tensioner and timing belt tensioner spring on cylinder head placing one leg of timing belt tensioner spring under stud on cylinder head and other leg against pin on timing belt tensioner and install spring pivot bolt.
9. Install timing belt as outlined in this section.
10. Install outer timing belt cover as outlined in this section.
11. Install generator mounting bracket with assembled ignition coil and ignition wire and brackets. Refer to the following installation drawing for correct torque sequence. Tighten in order illustrated.

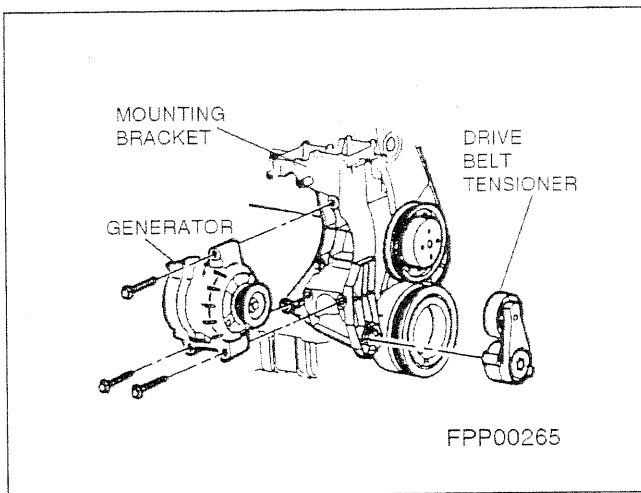

12. Replace O-ring lubricated with silicone grease on water pump inlet tube.
13. Install water pump inlet tube into water pump. Tighten inlet tube-to-generator bracket bolts to 9-12 N·m (84-108 lb-in).
14. Install lower radiator hose.
15. Install generator. Tighten generator-to-bracket bolts to 40-55 N·m (29-40 lb-ft).
16. Connect upper radiator hose and heater water hose and tighten hose clamps.
17. Install water pump pulley and fan. Tighten bolts snug.
18. Position drive belt.
19. Using flex handle, rotate drive belt tensioner, position drive belt, and rest tensioner pulley on drive belt.
20. Tighten four fan and pulley-to-water pump bolts to 17-23 N·m (13-17 lb-ft).  
NOTE: Spark plug gap is 1.07-1.17mm (0.042-0.046 inch).
21. Install spark plugs in proper locations.
22. Position and connect ignition harness. Install ignition wires.
23. Fill cooling system.
24. Connect battery ground cable.
25. Start engine and check for leaks.

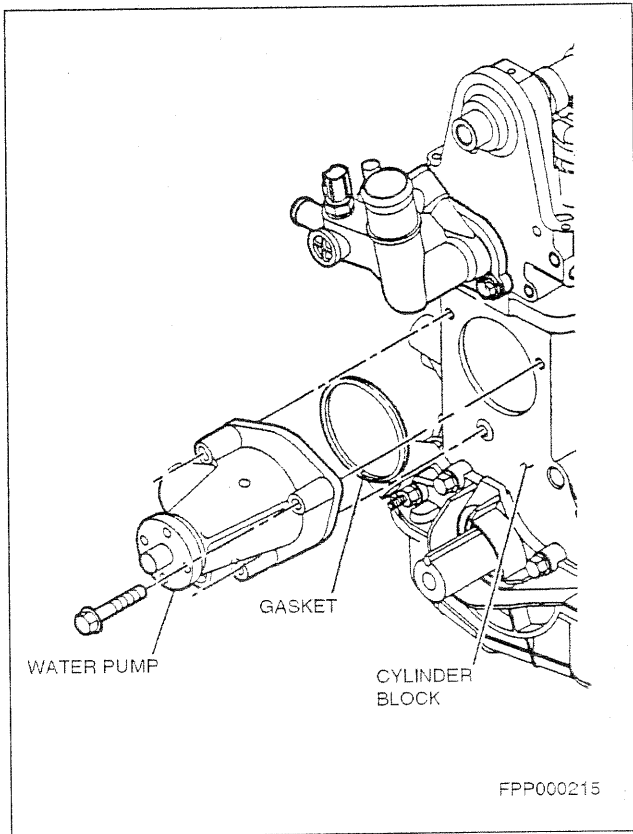

## Water Pump Installation

1. Apply Pipe Sealant with Teflon® D8AZ-19554A, or equivalent, meeting Ford specification ESG-M4G194-A to water pump bolts prior to installation.
2. Position gasket and water pump on cylinder block (6010) and install screws. Alternately tighten to 20-30 N·m (15-22 lb-ft).
3. Replace water inlet tube O-ring (lubricated with silicone grease).
4. Install water pump inlet tube in water pump. Tighten water inlet tube-to-generator bracket bolts to 9-12 N·m (84-108 lb-in).
5. Install lower radiator hose to water pump.
6. Install heater water hose to the water pump inlet tube.
7. Install water pump pulley and fan and tighten bolts finger-tight.
8. Using half-inch drive handle, rotate drive belt tensioner and install drive belt.
9. Tighten fan and water pump pulley bolts to 20-25 N·m (15-19 lb-ft).
10. Fill cooling system.
11. Start engine and check for leaks.

## Water Pump Removal

1. Drain cooling system.
2. Using 1/2-inch drive handle, rotate drive belt tensioner and remove drive belt.
3. Remove fan.
4. Remove water pump pulley.
5. Remove heater water hose to water pump inlet tube.
6. Remove lower radiator hose from the water pump inlet tube.
7. Remove water inlet tube-to-generator bracket bolts and water pump inlet tube.
8. Remove water pump retaining bolts and remove water pump.
9. Clean water pump gasket surface of cylinder block.

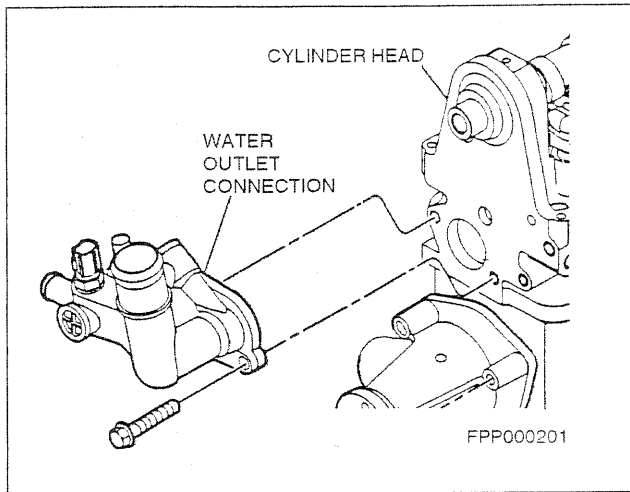

### Water Thermostat and Outlet Connection Removal

1. Drain the cooling system through the radiator until the coolant level is below the water thermostat and water outlet connection.
2. Loosen the hose clamp securing the heater hose to the water outlet and remove the heater hose.
3. Loosen the clamp securing the upper radiator hose to the water outlet connection and remove the hose.
4. Remove water outlet connection retaining bolts (2) and remove water outlet connection, thermostat and gasket.

### Water Thermostat and Outlet Connection Installation

1. Clean the water outlet connection and cylinder head water outlet connection gasket surfaces.
2. Apply Pipe Sealant with Teflon® D8AZ-19554-A, or equivalent, meeting Ford specification ESG-M4G194-A to water outlet connection bolts prior to installation.

NOTE: To prevent incorrect thermostat installation, the water outlet connection contains a locking recess into which the thermostat is turned and locked.

3. Install the thermostat with its bridge section in the water outlet connection. Twist and lock thermostat into place.

4. Position the water outlet connection retaining bolts through the water outlet connection holes and hang gasket on retaining bolts.
5. Install water outlet connection, thermostat, and gasket to cylinder head and hand-tighten retaining bolts.
6. Tighten retaining bolts to 20-30 N·m (15-22 lb-ft).
7. Position hose clamp on upper radiator hose and install clamp and upper radiator hose to water outlet connection. Tighten and secure hose clamp.
8. Position hose clamp on heater hose and install heater hose and clamp on water outlet connection. Tighten and secure hose clamp.
9. Fill cooling system.
10. Start engine and check for leaks.

### Intake Manifold Removal (carb. only)

NOTE: If removing the intake manifold for access to other components only, the carburetor may remain attached.

1. Disconnect the battery ground cable.
2. Remove the air cleaner assembly.
3. Drain the coolant from the radiator to a level lower than the intake manifold.
4. Loosen the heater hose clamp and remove the heater hose from the coolant fitting on the intake manifold.
5. Disconnect the electrical connections to:
  - the choke thermostat (if used).
  - Electronic governor actuator (if used).
6. Disconnect the manual choke cable from the choke lever on the carburetor.
7. Remove the support bracket securing the choke cable and set aside.
8. Disconnect the governor throttle control rod (if used) from the throttle lever on the carburetor.
9. Remove the vacuum line from the vacuum tee on the intake manifold leading to the ignition control module.
10. Disconnect the PCV valve from the oil separator beneath the intake manifold.

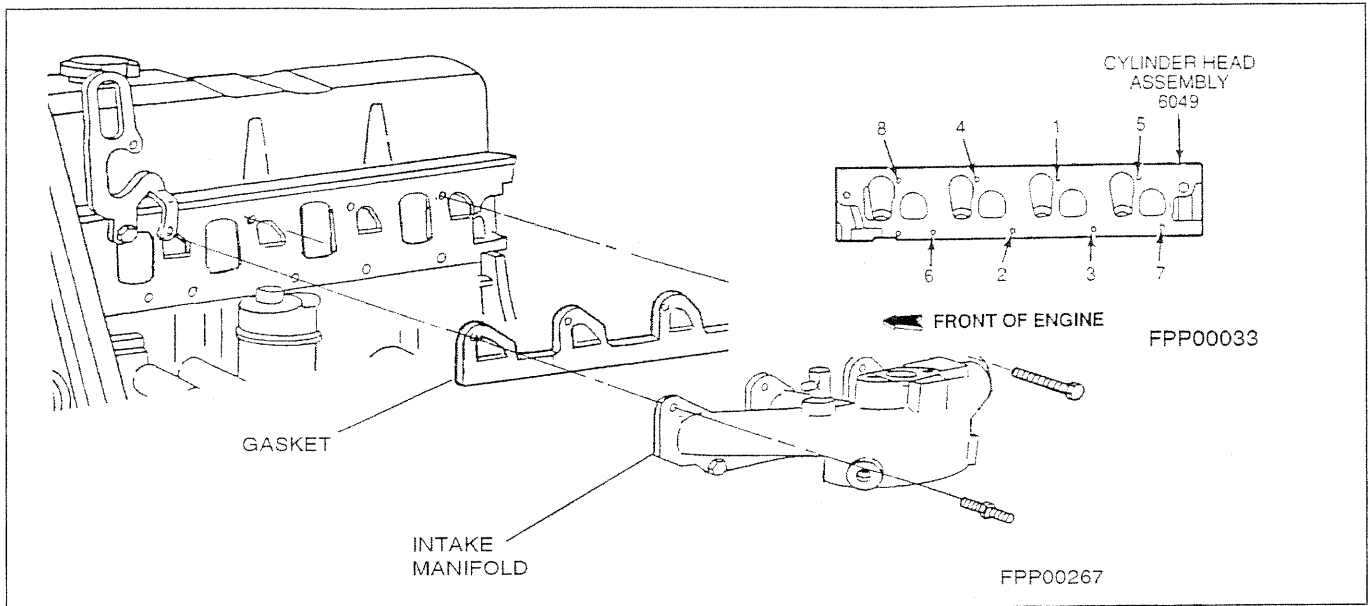

- 11.
12. Disconnect the fuel inlet line from the carburetor (9510) or fuel filter on the carburetor, depending on the application.
 

**Caution: Avoid spilling fuel on hot surfaces. Use an absorbent rag placed under the fuel line or fuel filter being removed to collect any spilled fuel.**
13. Remove the engine lifting eye.
14. Remove four bottom bolts from intake manifold.
15. Remove the four upper bolts/studs from the intake manifold.
16. Remove the intake manifold and gasket.
6. Install the PCV valve into the oil separator. Install the vacuum line from the ignition control module.
7. Connect the governor throttle control rod (if used) to the carburetor throttle lever.
8. Install the choke cable bracket and the choke cable to the choke lever on the carburetor.
9. Connect the electrical connections at the choke thermostat (if used) and electronic governor actuator (if used).
10. Install the hose clamp on the heater hose and connect the heater hose to the fitting on the intake manifold.
11. Install the air cleaner assembly.
12. Fill the cooling system.
13. Install the negative battery cable.
14. Start the engine and check for leaks.

### Intake Manifold Installation

1. Clean and inspect the mounting surfaces of the intake manifold and the cylinder head. Both surfaces must be clean and flat.
2. Clean and lightly oil the manifold bolt/stud threads.
  3. Install a new intake manifold gasket.
  4. Position the intake manifold to the cylinder head. Install four manifold upper retaining bolts/studs finger tight.
5. Install four remaining manifold bolts/studs. Tighten all bolts/studs to 26-38 N·m (919-28 lb-ft) following the tightening sequence. Install the engine lifting eye.



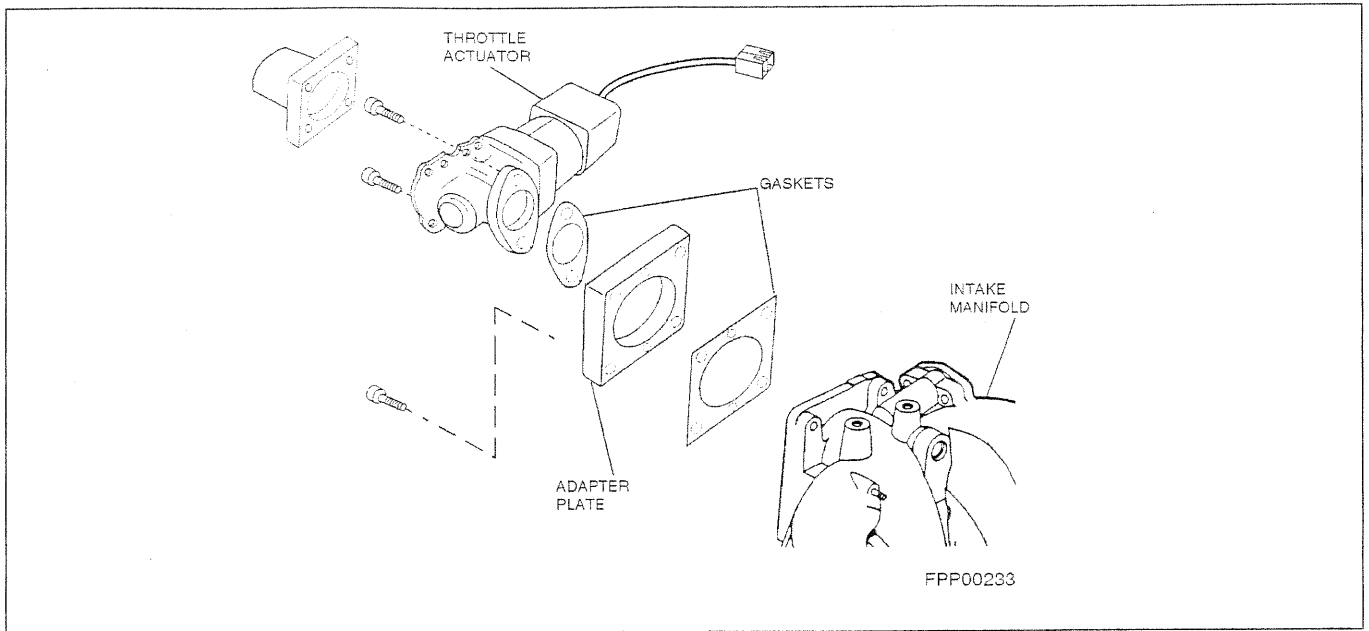

### Intake Manifold (EFI only)

1. Disconnect the battery ground cable.
2. Remove the air cleaner assembly.
3. Drain the coolant from the radiator to a level lower than the intake manifold.
4. Loosen the hose clamp and remove the coolant hose from the coolant fitting on the intake manifold.
5. Mark and disconnect necessary electrical connections.
6. Mark and remove vacuum lines from the vacuum tee on the intake manifold.
7. Disconnect the PCV tube.
8. Remove the throttle actuator (if necessary).
9. Relieve fuel system pressure.
- 10.
11. Disconnect the fuel lines to the fuel rail.



**Caution:** Avoid spilling fuel on hot surfaces. Use an absorbent rag placed under the fuel line being removed to collect any spilled fuel.

11. Remove the engine lifting eye.

12. Remove bolts attaching upper intake manifold.
13. Remove upper intake manifold and gasket.

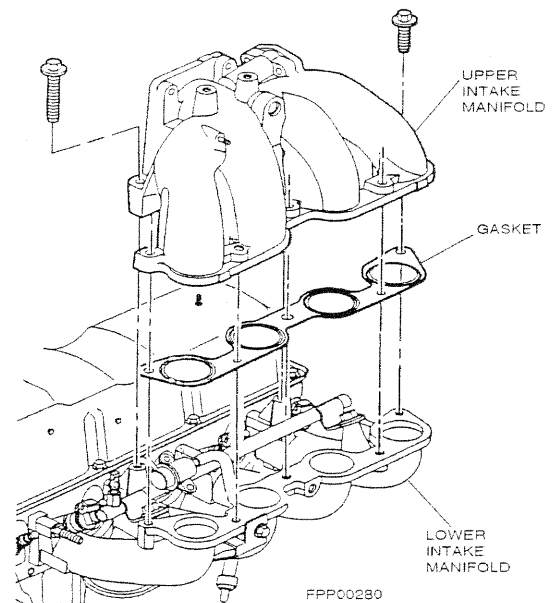

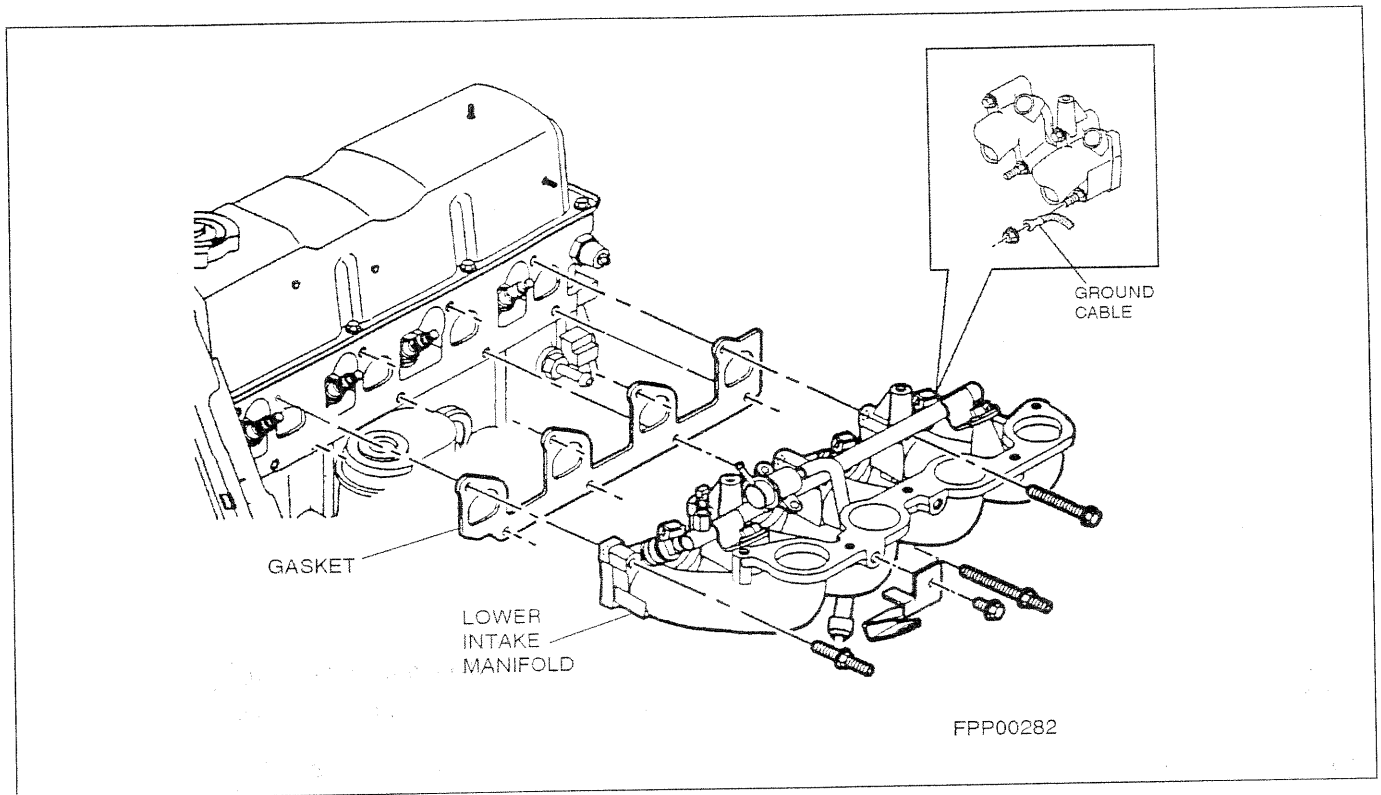

14. Remove engine ground cable at lower intake manifold.
15. Remove bolts attaching lower intake manifold.
16. Remove lower intake manifold and gasket.

## Intake Manifold Installation

1. Clean and inspect the mounting surfaces of the intake manifold and the cylinder head. Both surfaces must be clean and flat.
2. Clean and lightly oil the manifold bolt/stud threads.
3. Install a new lower intake manifold gasket.
4. Position the lower intake manifold to the cylinder head.
5. Install retaining bolts/studs finger tight.
6. Tighten all bolts/studs to specifications in the tightening sequence shown:

- First pass = 7-10 N•m (5-7 lb-ft).

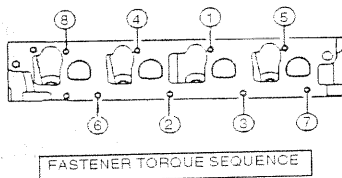

FPP00283

- Final pass = 26-38 N•m (19-28 lb-ft).

7. Install engine ground cable and nut at lower intake manifold. Tighten to:
  - 9-12 N•m (7-9 lb-ft).
8. Install a new upper intake manifold gasket.
9. Position the upper intake manifold to the cylinder head. Install retaining bolts finger tight.

10. Tighten all bolts to specifications in the tightening sequence shown:

- First pass = 7-10 N•m (5-7 lb-ft).
- Final pass = 26-38 N•m (19-28 lb-ft).

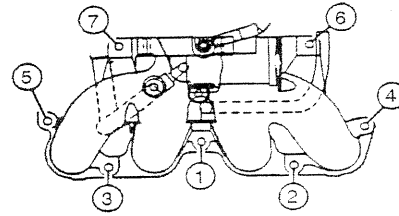

FPP00281

11. Install the engine lifting eye.
12. Connect the PCV tube.
- 13.
14. Connect the fuel lines to the fuel rail.



**Caution: Avoid spilling fuel on hot surfaces. Use an absorbent rag placed under the fuel line being removed to collect any spilled fuel.**

15. Install the throttle actuator (if removed).
16. Connect the electrical connections and vacuum lines as necessary.
17. Install the hose clamp on the coolant hose and connect to the fitting on the intake manifold.
18. Install the air cleaner assembly.
19. Fill the cooling system.
20. Install the negative battery cable.
21. Start the engine and check for leaks.

## Carburetor Removal

1. Disconnect the negative battery cable.
2. Remove the air cleaner assembly.
3. Disconnect the electrical connections to:
  - the choke thermostat (if used).
  - electronic governor actuator (if used).

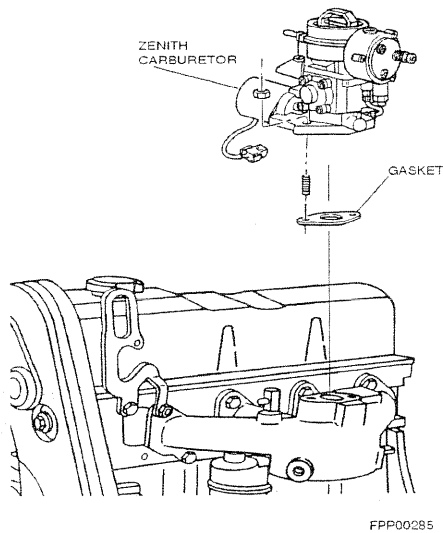

4. Disconnect the manual choke cable from the choke lever on the carburetor.
5. Disconnect the governor throttle control rod (if used) from the throttle lever on the carburetor.
- 6.
7. Disconnect the fuel inlet line from the carburetor or fuel filter on the carburetor, depending on the application.



**Caution: Avoid spilling fuel on hot surfaces. Use an absorbent rag placed under the fuel line or fuel filter being removed, to collect any spilled**

**fuel.**

8. Remove the retaining nuts from the studs securing the base of the carburetor.
9. Remove the carburetor and carburetor base gasket from the intake manifold.

NOTE: If the carburetor is not being serviced and is going to be placed back on the intake manifold, do not turn the carburetor upside down. This may cause any float bowl sediment to restrict or clog carburetor passages or prevent the inlet needle and seat assembly from closing. The carburetor's operation may be affected.

## Carburetor Installation

1. Clean and inspect the mounting surfaces of the intake manifold and the base of the carburetor. Both surfaces must be clean and free of any gasket material.
2. Install the carburetor base gasket and carburetor on the intake manifold.
3. Install the retaining nuts on the studs securing the base of the carburetor.
4. Reconnect the fuel inlet line to the carburetor or fuel filter on the carburetor, depending on the application.
5. Reconnect the governor throttle control rod (if used) to the throttle lever on the carburetor.
6. Perform governor adjustment after carburetor installation is complete. Refer to Governor Section.
7. Reconnect the manual choke cable to the choke lever on the carburetor. Adjust cable so that full opening and closing of the choke plate is possible.
8. Reconnect the electrical connections to:
  - the choke thermostat (if used).
  - electronic governor actuator (if used).
9. Install air cleaner assembly.

Start the engine, let it warm to operating temperature, and perform idle mixture and speed adjustments.

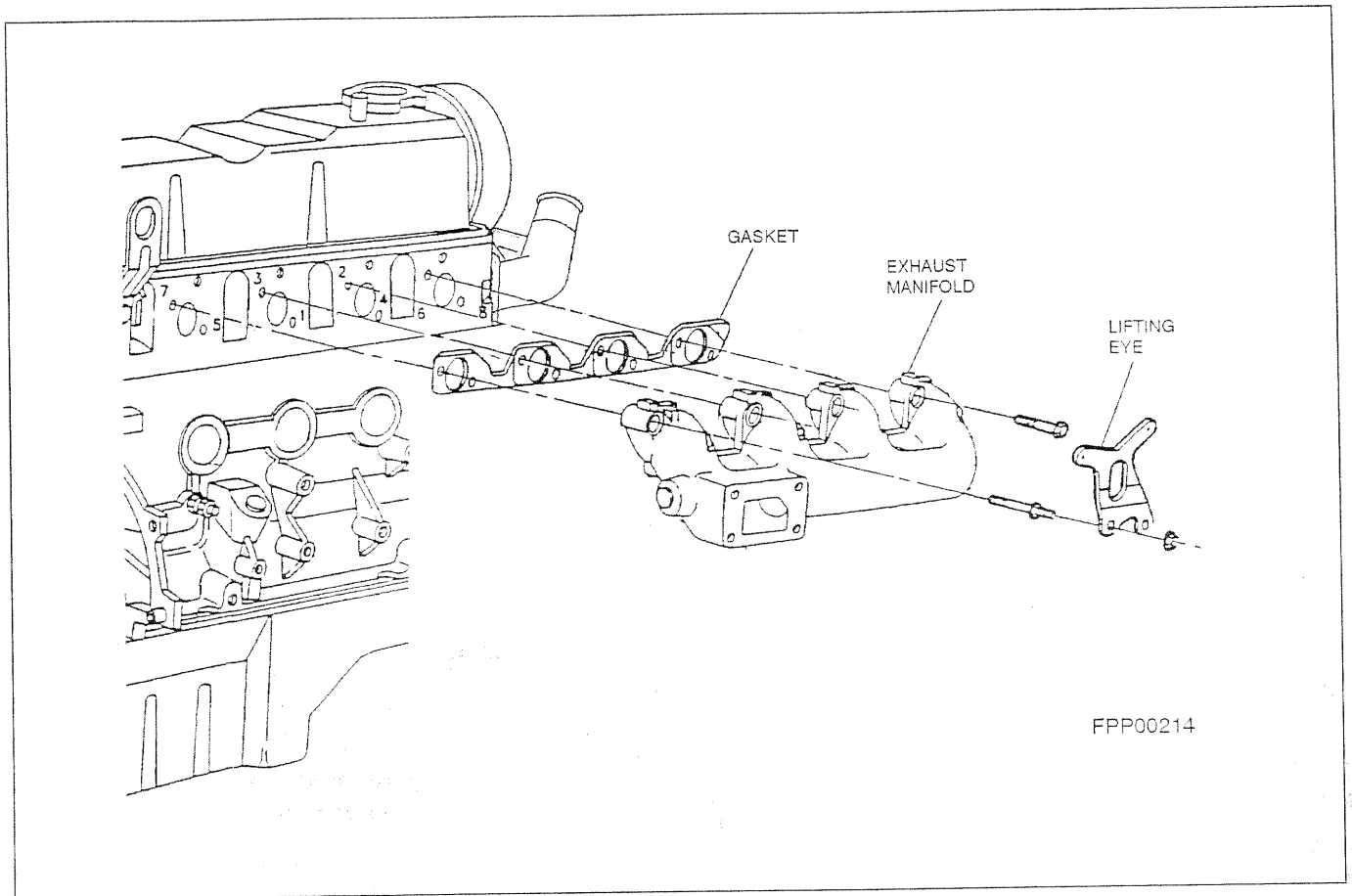

### Exhaust Manifold Removal

1. Remove exhaust pipe and bracket.
2. Remove two nuts and rear engine lifting eye from exhaust manifold studs.
3. Remove two studs and six bolts
4. Remove exhaust manifold and gasket from cylinder head.

### Exhaust Manifold Installation

1. If necessary, clean gasket surfaces on exhaust manifold and cylinder head.
2. Install exhaust manifold and exhaust manifold gasket.
3. Install fasteners.  
NOTE: Exhaust manifold fasteners must be tightened in two stages.
4. Tighten fasteners to 20-30 N•m (15-22 lb-ft) during the first stage.
5. Retighten fasteners to 60-80 N•m (44-59 lb-ft) during the second stage.
6. Position rear engine lifting eye on studs and install retaining nuts and tighten to 20-30 N•m (15-22 lb-ft).
7. Install exhaust pipe and bracket.

### Oil Pump Removal

1. Rotate crankshaft so number one piston is at TDC (Top Dead Center) of its compression stroke. Refer to the camshaft timing procedure in this section.

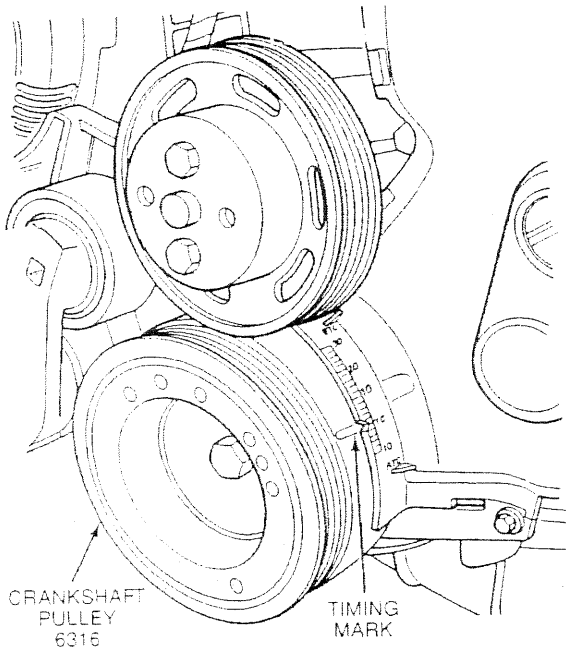

FPP00036



**CAUTION: Do not pry on sealing surfaces.**

6. Pry between cylinder block and ear on oil pump as show to loosen oil pump.

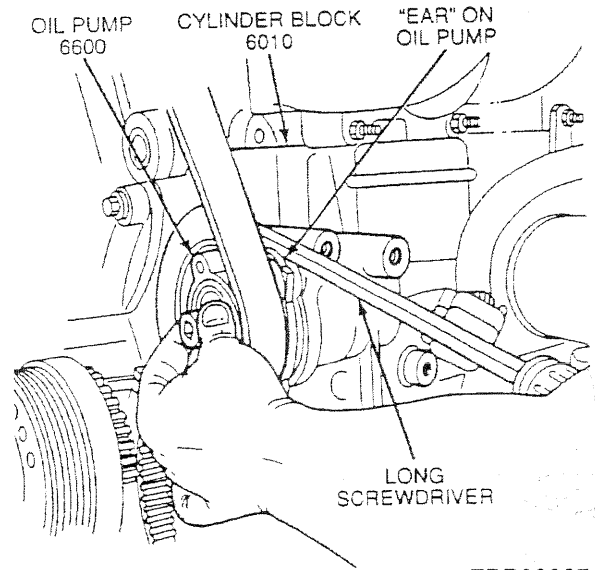

FPP00037

2. Remove outer timing belt cover as outlined in this section.
3. Remove timing belt as outlined in this section.
4. Remove oil pump timing belt sprocket as outlined in this section.
5. Remove four oil pump screws.

7. Remove oil pump and oil pump-to-cylinder block gasket.

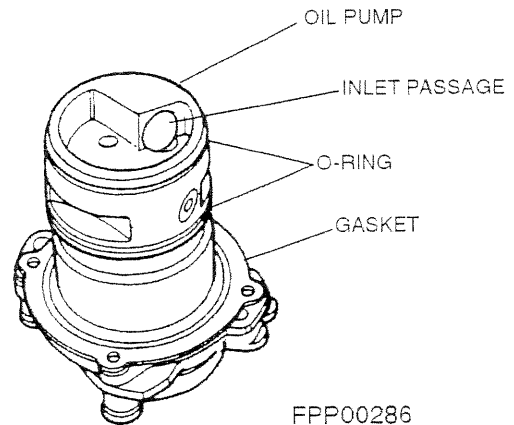

FPP00286

## Oil Pump Installation

NOTE: Inspect and clean oil pump hole in the cylinder block before installing the oil pump.

1. If original oil pump is to be reused, install new oil pump O-rings seals on oil pump.
2. Prime back of oil pump and O-rings with 236 ml (eight ounces) of fresh motor oil.
3. Add oil to cylinder block hole.

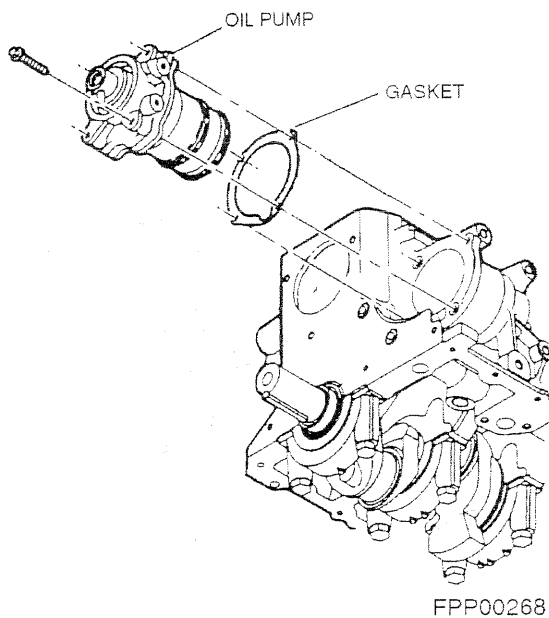

4. Install oil pump and oil pump-to-cylinder block gasket being careful to retain the priming oil in the back of the pump.
5. Install four oil pump screws and tighten to 10-14 N·m (89-124 lb-in).
6. Install oil pump sprocket as outlined in this section.
7. Check to make sure crankcase is filled to proper level with motor oil.
8. Prime oil pump with a drill motor, by rotating oil pump sprocket approximately 10 revolutions or until resistance is felt.
9. Align timing marks and install timing belt as outlined in this section.
10. Install outer timing belt cover as outlined in this section.
11. Install oil filler cap and tighten until it ratchets.

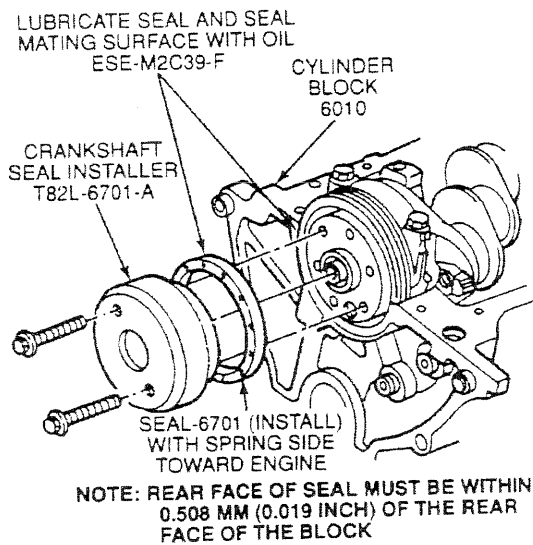

FPP00040

### Crankshaft Rear Oil Seal Removal

Special Tools Required	
Jet Plug Remover	T77L-9533-B
Rear Main Seal Replacer	T82L-6701-A

NOTE: Clean exterior surface of crankshaft rear oil seal and cylinder block before removing crankshaft rear oil seal.

1. Using a sharp awl, punch one hole into the seal metal surface between the seal lip and the cylinder block.
2. Screw in the end of Jet Plug Remover T77L-9533-B.
3. Remove crankshaft rear oil seal.



**CAUTION:** Use caution to avoid scratching or damaging block or crankshaft oil seal surface.

### Crankshaft Rear Oil Seal Installation

1. Apply clean Motorcraft Super Premium Motor Oil XO-5W30-QSP, or equivalent, meeting Ford specification ESE-M2G153-E to seal lips and inner seal edge.
2. Place crankshaft rear oil seal on Rear Main Seal Replacer T82L-6701-A.

3. Position tool and crankshaft rear oil seal to rear of engine. Alternate bolt tightening to seat the crankshaft rear oil seal properly.

### Oil Filter and Adapter Removal

1. Position oil drain pan under oil filter.
2. Using suitable oil filter wrench, loosen oil filter.
3. Unscrew oil filter by hand and remove. Properly recycle or dispose of oil in filter.

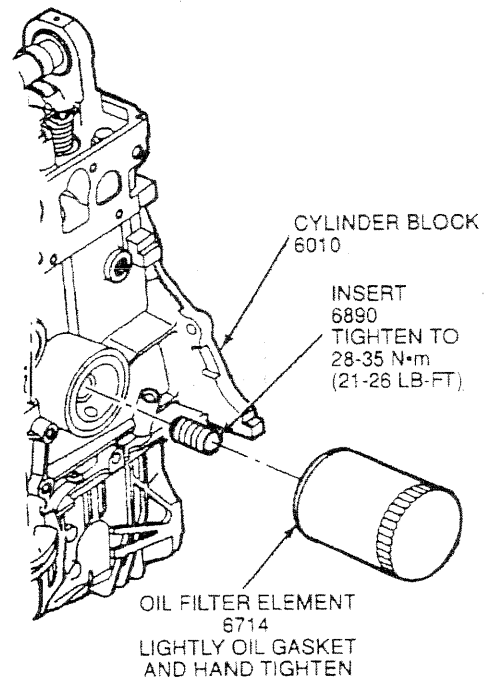

FPP00041

### Oil Filter and Adapter Installation

1. Apply clean motor oil, of the same type as is being used in the engine, to the oil filter gasket.  
NOTE: Do not tighten filter with oil filter wrench.
2. Install oil filter and tighten by hand.

## Oil Pressure Sender

NOTE: The pressure switch-type sender used with the indicator lamp system is not interchangeable with the variable resistance-type unit which is used with the gauge system. Refer to the Master Parts Catalog for proper parts usage. Installation of the wrong part will result in an inoperative oil pressure indicating system and a damaged sender unit or gauge.

1. Make sure the ignition switch is turned off.
2. Disconnect the wire at the sender terminal.
3. Remove the oil pressure sender from the cylinder head.
4. Apply Pipe Sealant with Teflon® D8AZ-19554-A, or equivalent, meeting Ford specification WSK-M2G350-A2 to new sender threads.
5. For installation, follow removal procedures in reverse order. Tighten switch to 11-24 N·m (8-18 lb-ft).

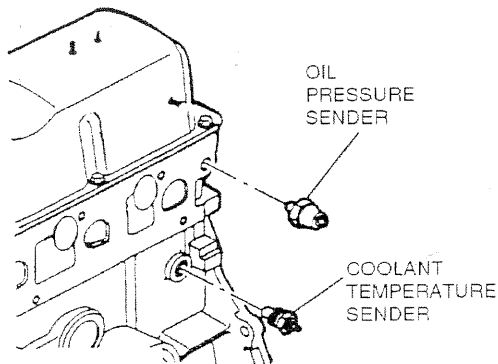

FPP00269

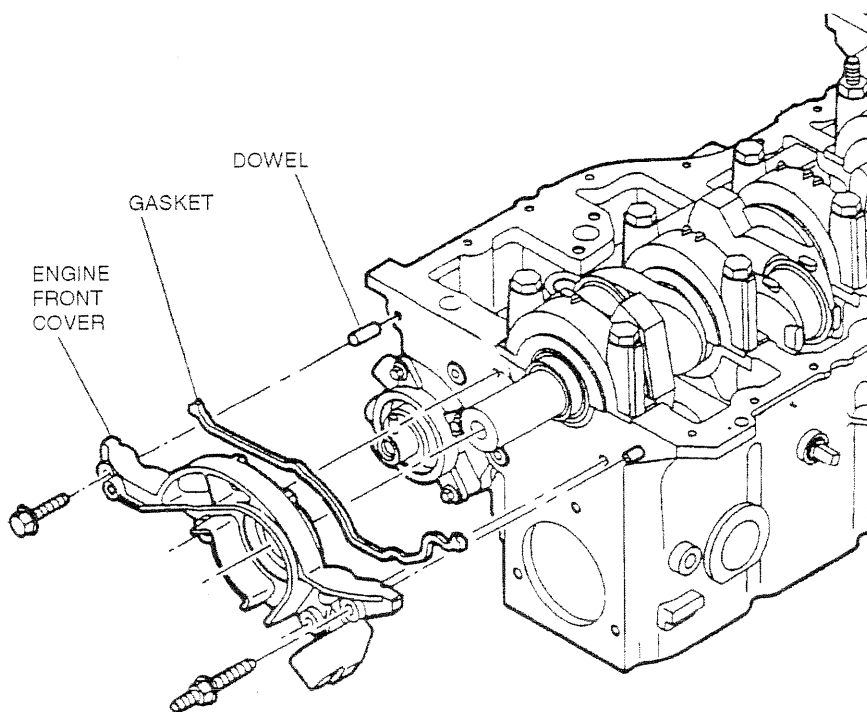

FPP00270

## Engine Front Cover Removal

### Special Tools Required

Cam Sprocket Holding Tool	T74P-6256-B
Front Cover Seal Remover	T74P-6700-B
Front Cover Alignment Tool	T74P-6019-B
Front Seals Replacer	T74P-6150-A

NOTE: This procedure will require the following replacement parts: oil pan gasket, crankshaft front seal, engine front cover gasket and a water pump inlet tube O-ring.

- Remove outer timing belt cover and timing belt as outlined in this section.
- Remove engine oil pan as outlined in this section.
- Remove crankshaft damper bolt.
- Remove crankshaft damper.
- Remove crankshaft sprocket.
- Remove oil pump sprocket bolt. Using Cam Sprocket Holding/Removing Tool T74P-6256-B; remove oil pump sprocket.
- Remove stud, screw, nut and timing belt tensioner.
- Remove two screws and water pump inlet tube.
- Remove one screw and crankshaft position sensor.
- Remove one bolt and one nut from inner timing belt cover.
- Remove inner timing belt cover.  
NOTE: Remove the crankshaft front seal while the front cover is still mounted on the engine.
- Using Front Cover Seal Remover T74P-6700-B, remove crankshaft front seal.
- Remove four bolts, engine front cover and gasket.

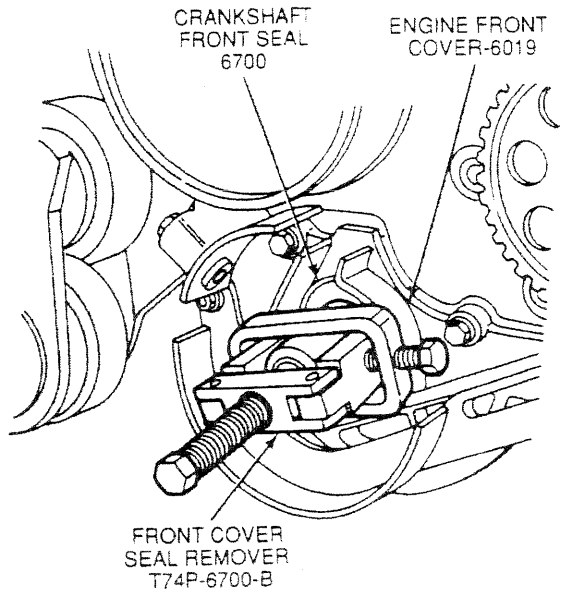

FPP00043

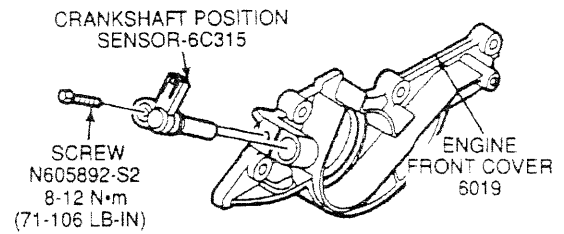

FPP00045

## Engine Front Cover Installation

1. Install a new engine front cover gasket in engine front cover.
2. Install front cover assembly onto cylinder block .
3. Tighten three bolts and one stud to 13-15 N·m (10-12 lb-ft).
4. Position a new crankshaft front seal on Front Seals Replacer T74P-6150-A and press into place using vibration damper bolt. Remove bolt and tool.
5. Install a new oil pan gasket and the oil pan as outlined in this section.
6. Install inner timing belt cover.
7. Tighten inner timing belt cover bolts to 8-12 N·m (72-108 lb-in).
8. Install crankshaft position sensor and tighten bolt to 8-12 N·m (72-108 lb-in).
9. Lubricate and install new O-ring on water pump inlet tube.
10. Install water pump inlet tube into water pump.
11. Install water inlet tube-to-generator bracket bolts and tighten to 9-12 N·m (84-108 lb-in).
12. Install crankshaft sprocket, crankshaft damper, washer, and bolt. Tighten bolt to 125-165 N·m (92-121 lb-ft).
13. Install oil pump sprocket and tighten bolt to 40-55 N·m (29-40 lb-ft).
14. Align sprockets and install timing belt as outlined in this section.
15. Install outer timing belt cover as outlined in this section.

## Oil Pan Removal

1. Remove the oil pan retaining bolts
2. Remove the oil pan.
3. Remove the oil pan gasket.
4. Thoroughly clean the engine and oil pan gasket surfaces.

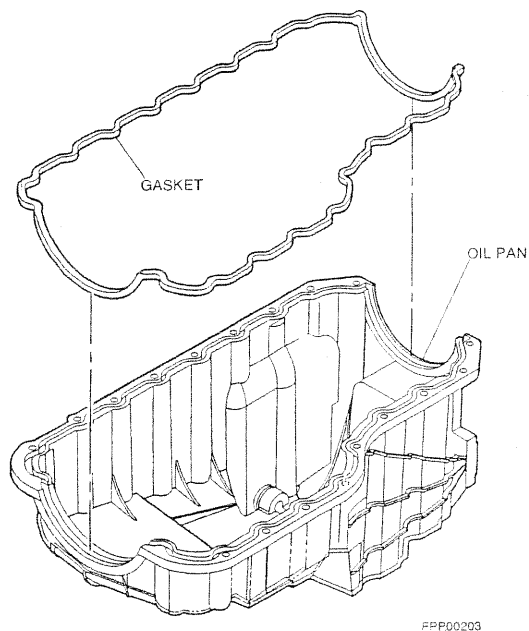

## Oil Pan Installation

1. Apply Silicone Gasket and Sealant F1AZ-19562-A, or equivalent, meeting Ford specification WSE-M4G320-A2, in six places at joints between engine front cover and the cylinder block and rear main bearing cap and engine block as shown.
2. Install a new oil pan gasket to the oil pan
3. Position the oil pan to the engine.
4. Install and tighten oil pan retaining bolts to 14-16 N·m (132-144 lb-in).

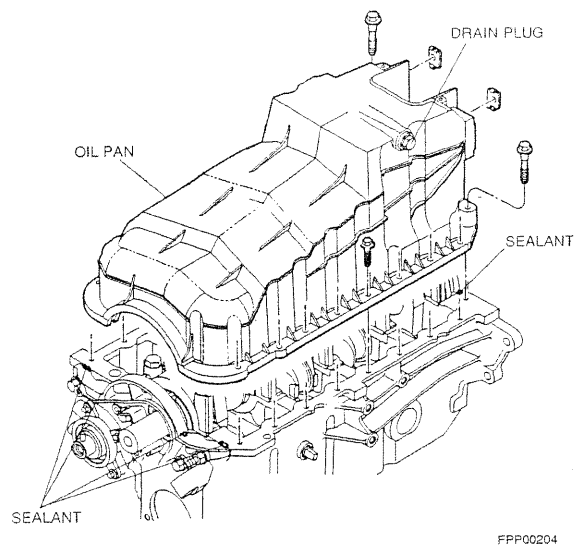

## Oil Pump Screen, Cover, and Tube Removal

1. Remove oil pan as outlined in this section.
2. Remove nut, two screws, oil pump screen cover and tube.
3. Remove oil pump inlet tube gasket.

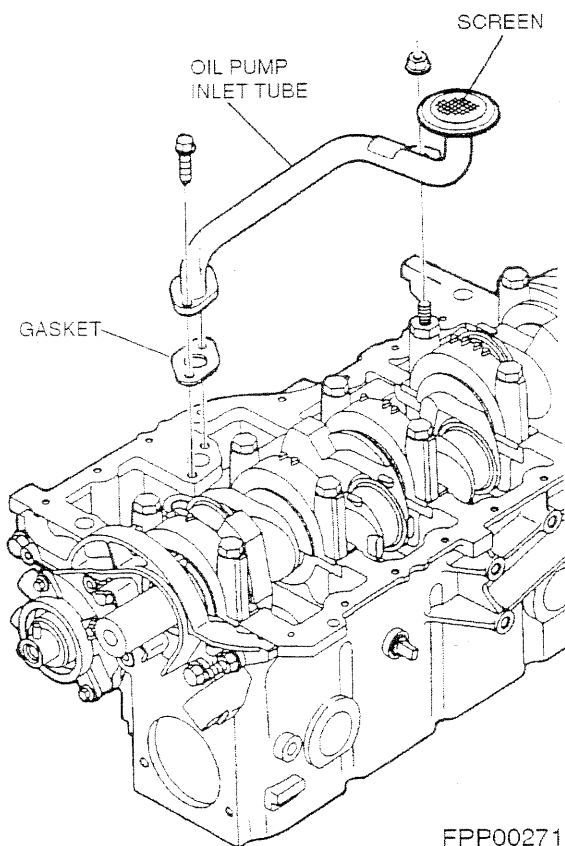

## Crankshaft Removal

Special Tools Required	
Cam Sprocket Holding Tool	T74P-6256-B
Front Cover Seal Remover	T74P-6700-B
Cam Bearing Adapter Tube	T72C-6250
Clutch Aligner	T71P-7137-H

1. Remove engine and install on suitable engine stand.
2. Drain oil from engine.
3. Remove engine oil level dipstick.
4. Remove crankshaft bolt and washer.
5. Remove crankshaft damper.
6. Remove outer timing belt cover screw, depress tabs, and remove outer timing belt cover.
7. Remove screw retaining crankshaft position sensor. Remove crankshaft position sensor from engine front cover.
8. Loosen timing belt pivot bolt one-half turn.
9. Hold timing belt tensioner with T74P-6254-A Camshaft Belt Tensioner Tool and remove adjusting bolt. Relax tensioner spring.
10. Remove timing belt.
11. Install T74P-6256-B Cam Sprocket Holding/Removing Tool on oil pump sprocket.
12. Remove oil pump sprocket bolt and washer.

## Oil Pump Screen, Cover, and Tube Installation

1. Thoroughly clean oil pump screen cover and tube.
2. Clean all mounting surfaces.
3. Install oil pump screen cover and tube and oil pump inlet tube gasket.
4. Install two screws and one nut.
5. Tighten screws to 20-30 N·m (15-22 lb-ft).
6. Tighten nut to 40-55 N·m (29-40 lb-ft).
7. Install oil pan as outlined in this section.

13. Install puller part of T74P-6256-B Cam Sprocket Holding/Removing Tool. Remove oil pump sprocket.
14. Slide crankshaft sprocket off crankshaft.
15. Remove inner timing belt cover.
16. Remove oil pan screws and oil pan.
17. Remove oil pan gasket.
- 18.
19. Rotate engine on stand so crankshaft is up.
20. Remove two bolts and nut and remove oil pump screen cover and tube.
21. Using T74P-6700-B Front Cover Seal Remover, remove front cover oil seal as outlined in this section.
22. Remove bolts and front engine cover.
23. Make sure connecting rod caps are marked so each cap can be kept with each rod.
24. Remove connecting rod nuts and four caps.

NOTE: Each main bearing cap, except rear cap, is marked with arrows pointing to the front of the engine. The number of arrows corresponds to the number of the main bearing cap. For example, one arrow for the front cap, two arrows for the number two cap.

25. Remove bolts and main bearing caps.
26. Lift out crankshaft. Crankshaft rear oil seal (6701) will come out with crankshaft. Remove seal from crankshaft.
27. Inspect bearings and replace as necessary. Inspect crankshaft as outlined in Section 01 and recondition or replace as necessary.

## Crankshaft Installation

**CAUTION:** Lubricate parts with Motorcraft Super Premium Motor Oil XO-5W30-QSP, or equivalent, meeting Ford specification ESE-M2C153-E during assembly to prevent a dry start and engine damage.



1. If removed, install upper crankshaft bearings. If reusing bearings, reinstall each bearing in the same place from which it was removed.
2. Install crankshaft.
3. If removed, install bearings in main bearing caps. If reusing bearings, install bearing in same place from which it was removed.
4. Apply Plastigage® to crankshaft bearing journals.
5. Install main bearing caps and bolts. Alternately tighten bolts to 68-81 N·m (50-60 lb-ft). Retighten to 108-122 N·m (79-90 lb-ft).

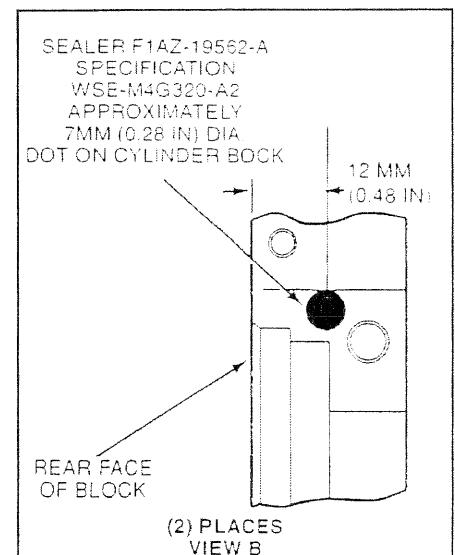
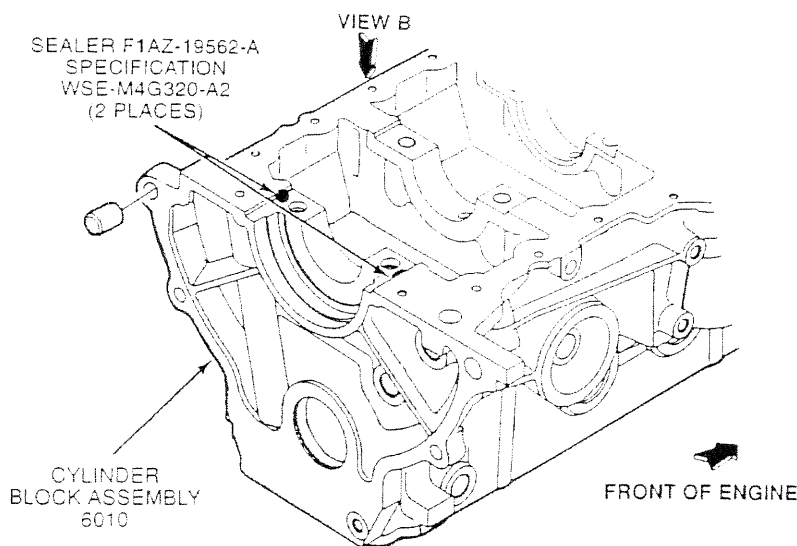

18. Remove caps. Check Plastigage® for bearing clearance using chart on package. If OK, go on to next step. If not, correct clearance.
19. Apply 7mm (0.28-inch) dot of Silicone Gasket and Sealant F1AZ-19562-A, or equivalent, meeting Ford specification WSE-M4G320-A2 on each side of cylinder block as shown in illustration. No sealer allowed on inside diameter of seal lip.
20. Lubricate bearings and reinstall main bearing caps and bolts.
21. Alternately tighten main bearing bolts to 68-81 N·m (50-60 lb-ft). Retighten 102-115 N·m (75-85 lb-ft).
22. Check crankshaft end play as outlined in Section 01.

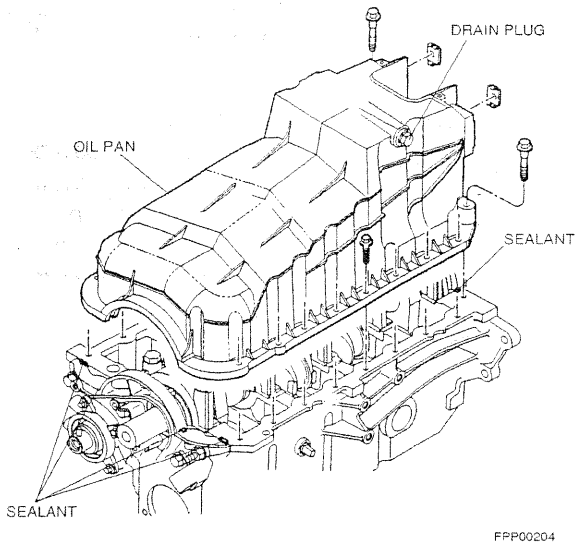

FFP00204

23. Attach piston and rod assemblies to crankshaft. For each assembly:
  - a. Put a piece of hose or other protector over connecting rod bolts to protect the crankshaft journal.
  - b. Place the crankshaft journal for the piston being installed, at the bottom of its stroke by rotating the crankshaft.
  - c. Push piston and rod assembly into place guiding the rod bolts around crankshaft journal.
  - d. Insert connecting rod bearings in connecting rod end cap.

- e. Finish pushing piston and rod assembly in place.
  - f. Apply Plastigage® to bearing journal.
  - g. Install connecting rod cap and alternately tighten connecting rod nuts to an initial torque of 34-41 N·m (25-30 lb-ft). Then continue tightening to a final torque of 41-49 N·m (30-36 lb-ft).
  - h. Remove cap and check bearing clearance with chart on Plastigage® package.
  - i. If within specification, lubricate connecting rod bearings and reinstall cap.
  - j. Alternately tighten connecting rod nuts to an initial torque of 34-41 N·m (25-30 lb-ft). Then continue tightening to a final torque of 41-49 N·m (30-36 lb-ft).
  - k. Repeat for remaining piston and connecting rod assemblies.
24. Using Cam Bearing Adapter Tube T72C-6250 and crankshaft damper bolt, press crankshaft front seal into place in engine front cover.
  25. Install oil pump screen cover and tube. Tighten bolts to 20-30 N·m (15-22 lb-ft). Tighten pickup tube-to-main bearing cap nuts to 40-55 N·m (29-40 lb-ft).
  26. Apply a small amount of Silicone Gasket and Sealant F1AZ-19562-A, or equivalent meeting Ford specification WSE-M4G320-A2 at joints between front engine cover and cylinder block and rear main cap and cylinder block as shown.
  27. Press new oil pan gasket into groove in oil pan and install oil pan. Tighten screws to 13-16 N·m (10-12 lb-ft).

28. Install inner timing belt cover.
29. Install inner timing belt cover screw and nut and tighten to 8-11 N·m (72-97 lb-in). Install stud nut to inner timing belt cover and cylinder head and tighten to 20-30 N·m (15-22 lb-ft).

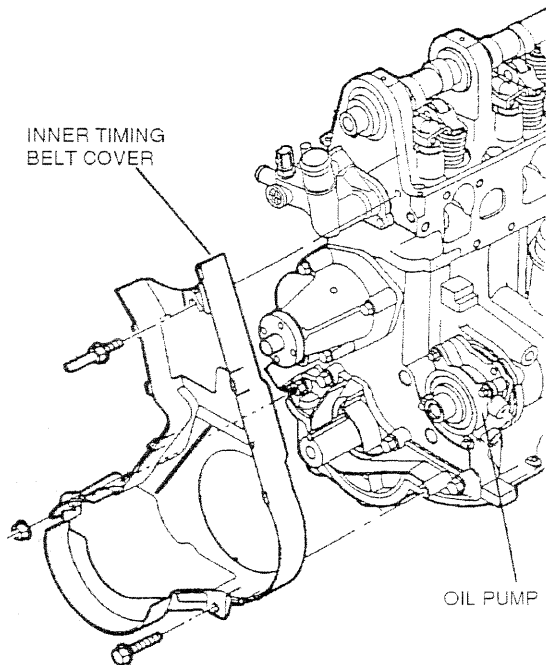

FPP00208

37. Install and adjust timing belt as outlined in this section.
38. Install crankshaft position sensor and tighten bolt to 8-12 N·m (72-108 lb-in).
39. Install outer timing belt cover. Snap tabs into slot. Install screw and tighten to 8-12 N·m (72-108 lb-in).
40. Install crankshaft pulley, and washer. Tighten bolt to 125-165 N·m (72-108 lb-in).
41. Connect retaining clip for crankshaft position sensor lead.
42. Remove engine from engine stand.
43. Install crankshaft rear oil seal using T82L-6701-A Crankshaft Seal Installer.
44. Install engine.

30. Slide crankshaft sprocket onto crankshaft. Recess goes toward cylinder block.
31. Apply Threadlock 262 E2FZ-19554-B, or equivalent, meeting Ford specification WSK-M2G351-A6 to camshaft bolt threads. Install bolt and washer finger-tight.
32. Install Cam Sprocket Holding/Removing Tool T79P-6256-B on sprocket. Tighten camshaft bolt to 70-95 N·m (52-70 lb-ft). Remove tool.
33. Install oil pump sprocket.
34. Install oil pump sprocket bolt and washer finger-tight.
35. Prime oil pump.
36. Install Cam Sprocket Holding/Removing Tool T74P-6256-B on sprocket. Tighten bolt to 40-55 N·m (29-40 lb-ft). Remove tool.

## Crankshaft Main Bearings Removal

NOTE: The main bearing inserts are a precision selective fit. To check bearing clearances or to select-fit a new bearing, refer to the engine service section.

1. Remove oil pan as outlined in this section.
2. Remove oil pump screen cover and tube as outlined in this section.

NOTE: Replace one bearing at a time, leaving the other bearings securely fastened.

3. Remove main bearing cap to which new bearings are to be installed.
4. Remove bearing from cap.
5. Press on end of upper bearing without tang to start it out.
6. Rotate bearing out from between crankshaft and cylinder block.

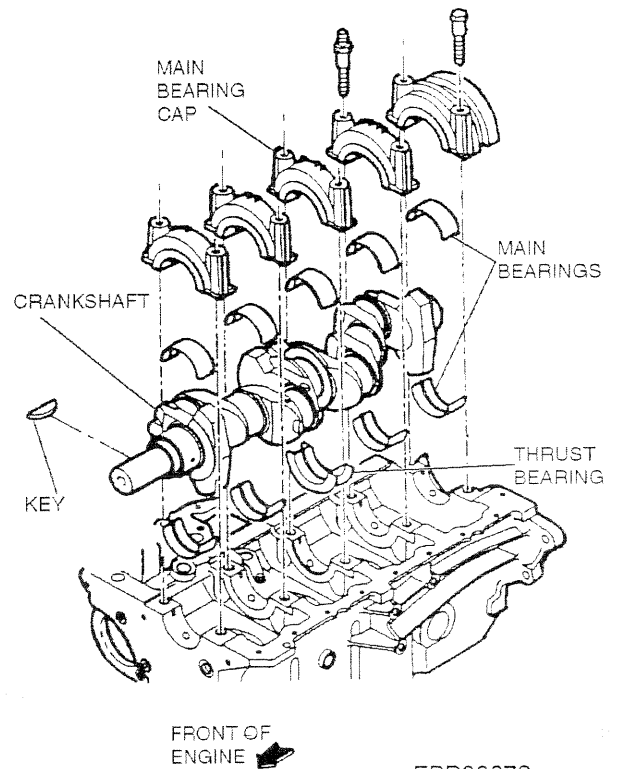

FPP00272

## Crankshaft Main Bearings Installation

1. Place lubricated, upper bearing on crankshaft and rotate into place.
2. Place lower bearing into cap.
3. Apply Plastigage® across lower bearing.
4. Support crankshaft on either side of bearing being installed.

NOTE: Failure to support crankshaft will cause incorrect reading of Plastigage® while checking bearing clearance when installing bearing cap.

5. Install bearing cap.
6. Lightly oil main bearing bolt or stud. Alternately tighten to an initial torque of 68-81 N·m (50-60 lb-ft). Then tighten bolt or stud to a final torque of 108-122 N·m (79-90 lb-ft).
7. Remove main bearing cap.

8. Check Plastigage® for bearing clearance using chart on package. Clearance should be 0.010-0.056mm (0.0004-0.0022 inch) for front main bearing or 0.020-0.066mm (0.0008-0.0026 inch) for bearings 2-5.
9. If clearance is OK, lubricate bearings with Super Premium Motor Oil X0-5W30-QSP, or equivalent, meeting Ford specification ESE-M2C153-E and reinstall cap.
10. Apply a 7mm (0.27-inch) dot of Silicone Gasket and Sealant F1AZ-19562-A, or equivalent, meeting Ford specification WSE-M4G320-A2 on each side of cylinder block as shown in illustration before installing the No. 5 cap.
11. Alternately tighten bolts or stud to an initial torque of 68-81 N·m (50-60 lb-ft). Then tighten the bolts or stud to a final torque of 102-115 N·m (75-85 lb-ft).
12. Check crankshaft end play as outlined in the Section 01.
13. Install oil pump screen cover and tube as outlined in this section.
14. Install oil pan as outlined in this section.

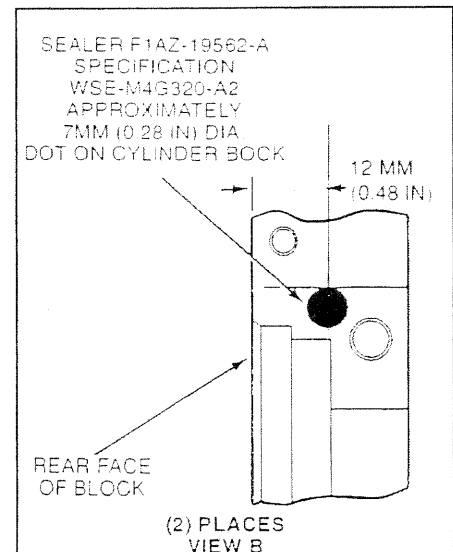
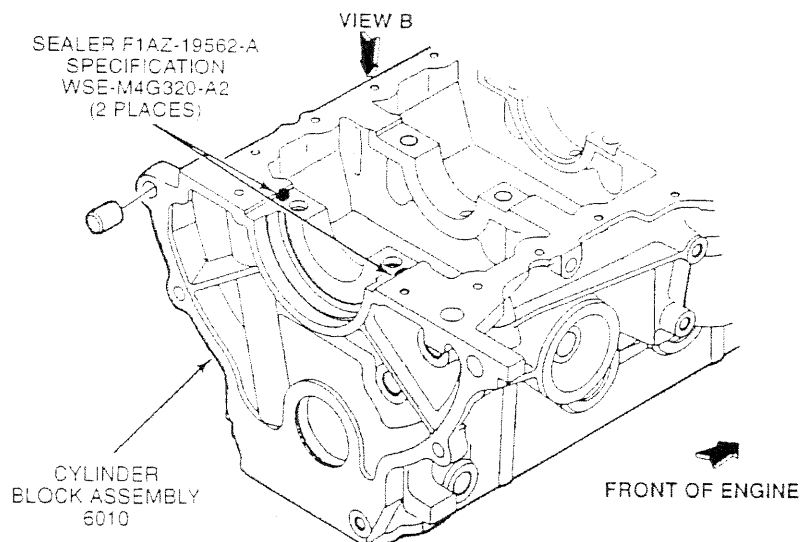

FPP00050

## Pistons and Connecting Rods Removal

- 1.
2. Remove oil pan as outlined in this section.
3. Remove oil pump screen cover and tube as outlined in this section.
4. Remove cylinder head as outlined in this section.

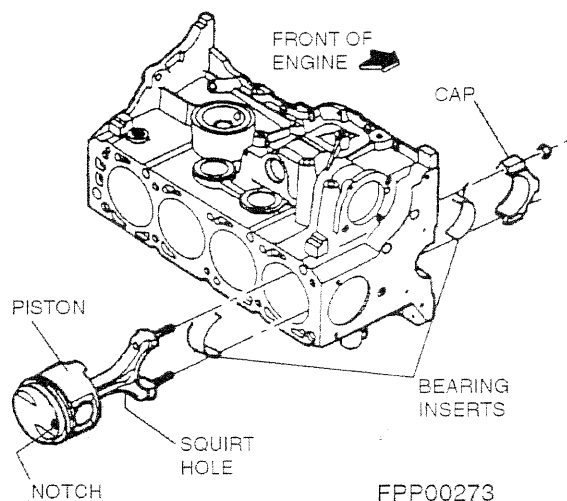

**CAUTION:** Never cut into the ring travel area in excess of 0.8mm (1/32 inch) when removing ridges.



4. Remove any ridges and/or deposits from the upper end of the cylinder bores as follows.

Turn the crankshaft until the piston to be removed is at the bottom of its travel and place a cloth on the piston head to collect the cuttings. Remove any ridge and/or deposits from the upper end of the cylinder bores. Remove the cylinder ridge with a ridge cutter. Follow the instructions furnished by the tool manufacturer.

5. Make sure all connecting rod caps are marked so that they can be installed in their original positions.
6. Turn the crankshaft until the connecting rod being removed is down.
7. Remove the connecting rod nuts and caps.



**CAUTION:** Avoid damage to the crankshaft journal or the cylinder wall when removing the piston and rod.

8. Push the connecting rod and piston assembly out the top of the cylinder with the handle end of a hammer.
9. Remove the bearing inserts from the connecting rod and cap.
10. Select the proper bore gauge and micrometer. Measure the cylinder bore for out-of-round and taper as outlined in the engine service section. Deglaze cylinder bore as outlined in the engine service section.
11. Remove rings and clean ring grooves. Clean carbon from piston, pin and ring.
12. Check ring gaps using the procedure given in the engine service section.

**NOTE:** Never install compression rings on pistons by hand. Always use a ring expander tool.

13. Install rings using a ring expander tool. Check ring side clearance.
14. Clean crankshaft journals.
15. If necessary, disassemble piston and rod assemblies as outlined in this section.
16. Clean gasket surfaces and fasteners.

## Pistons and Connecting Rods Installation

1. If disassembled, assemble piston and connecting rod assembly as outlined in this section.
2. Refer to Pistons, Piston Pins, and Piston Rings in the engine service section for Cleaning, Inspection, Pistons - Fitting, and Piston Rings - Fitting.
3. If necessary, install piston and pin on connecting rod as outlined in this section.
4. Using a piston ring expander, install the piston rings, starting with the oil control rings. Make sure rings are installed right side up. Refer to instructions with piston ring set.
5. Rotate the rings so the end gaps are NOT lined up but are spaced properly as shown.

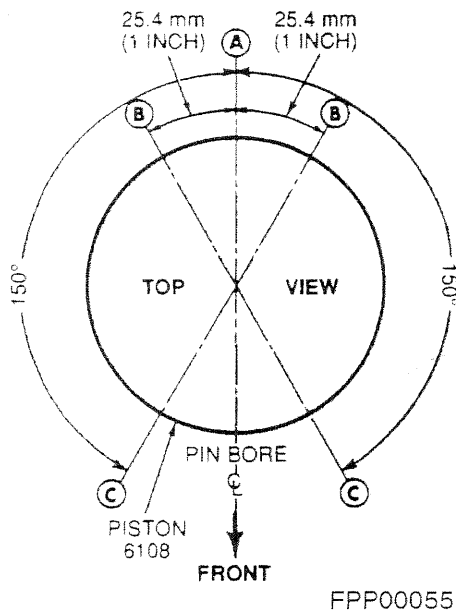

6. Check the ring side clearance as outlined in the engine service section. Side clearance for both compression rings should be 0.041-0.084mm (0.016-0.0033 inch) and snug fit for the oil control ring.
7. Put a piece of hose or other protector over connecting rod bolt to protect crankshaft journal.
8. Rotate crankshaft so journal for piston to be installed is at the bottom of its stroke.

piston head toward the front of the engine.

9. Apply motor oil to piston and cylinder bore and start piston and rod assembly into cylinder, guiding bolts around crankshaft journal.
10. Compress piston rings using suitable piston ring compressor.
11. Tap piston assembly into place using bottom of hammer handle.

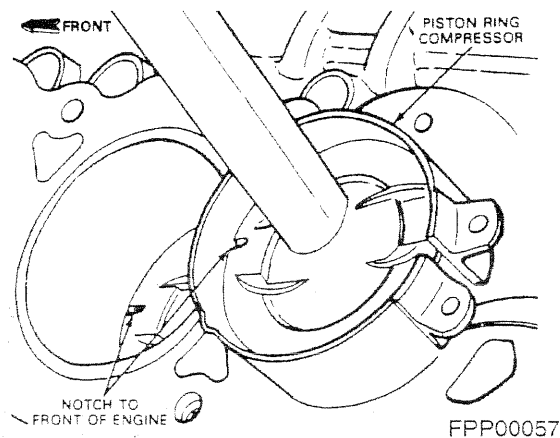

12. Insert bearings in connecting rod and cap.
13. Apply Plastigage® to bearing journal. Refer to the engine service section.
14. Install connecting rod cap. Hand-start each connecting rod nut until flush with end of rod bolt. Alternately tighten connecting rod nuts to 34-41 N·m (25-30 lb-ft). Then continue tightening to achieve a final torque of 41-49 N·m (30-36 lb-ft).
15. Remove cap and check bearing clearance with chart on Plastigage® package.
16. Lubricate connecting rod bearings with Super Premium Motor Oil XO-5W30-05P, or equivalent, meeting Ford specification ESE-M2C153-E.
17. Reinstall connecting rod cap.
18. Alternately tighten connecting rod nuts to 34-41 N·m (25-30 lb-ft). Then continue tightening to achieve a final torque of 41-49 N·m (30-36 lb-ft).



**CAUTION:** Install the piston, pin and ring with the indentation notch in the

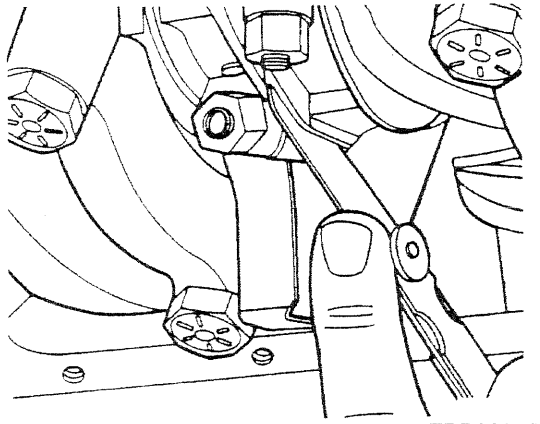

FPP00058

19. Check side clearance. Side clearance should be 0.09-0.29mm (0.0035-0.0114 inch).
20. Repeat for other piston and rod assemblies as needed.
21. Install cylinder head as outlined in this section.
22. Install oil pump screen cover and tube as outlined in this section.
23. Install oil pan as outlined in this section.

### Connecting Rod Bearings Removal

1. Remove spark plug of cylinder where bearing is to be replaced.
2. Remove oil pan as outlined in this section.
3. Rotate engine so it is upside down and remove oil pump screen cover and tube as outlined in this section.
4. Rotate crankshaft until connecting rod and bearing being serviced is placed at the bottom of its stroke.
5. Remove two connecting rod nuts.
6. Remove connecting rod cap.
7. Push piston and connecting rod assembly up into bore.
8. Remove bearing insert from connecting rod.
9. Remove bearing insert from connecting rod cap.
10. Inspect connecting rod bearings as outlined in the engine service section.
11. Inspect journal and measure for taper and out-of-round as outlined in the engine service section.

12. Out-of-round should be less than 0.01524mm (0.0006 inch). Taper should be less than 0.06mm per centimeter of length (0.006 inch per inch of length).
13. Inspect connecting rod bearing bore, measure for out-of-round and taper. Maximum out-of-round is 0.0120mm (0.0004 inch). Maximum taper is 0.0102mm (0.004 inch).
14. Thoroughly clean bearing bore of connecting rod and cap.

### Connecting Rod Bearings Installation

1. Make sure bearing bore of connecting rod and cap and bearing journal are clean.
  2. Insert upper bearing insert into connecting rod.
  3. Insert lower bearing insert into connecting rod cap.
  4. Apply Plastigage® to bearing journal. Refer to the engine service section.
- NOTE: Do not scratch journal with connecting rod bolts.
5. Carefully pull piston and connecting rod assembly into place on crankshaft.
  6. Install connecting rod cap. Hand-start each connecting rod nut until flush with end of rod bolt. Alternately tighten connecting rod nuts to 34-41 N·m (25-30 lb-ft). Then continue tightening to a final torque of 41-49 N·m (30-36 lb-ft).
  7. Remove cap and check bearing clearance.
  8. Lubricate connecting rod bearings with Motorcraft Super Premium Motor Oil XO-5W30-QSP, or equivalent, 5W30 motor oil meeting Ford specification ESG-M2C153-E.
  9. Install connecting rod cap.
  10. Hand start connecting rod nuts until nuts are flush with ends of connecting rod bolts.
  11. Alternately tighten connecting rod nuts to 34-41 N·m (25-30 lb-ft). Then alternately tighten again to a final torque of 41-49 N·m (30-36 lb-ft).
  12. Install oil pump screen cover and tube as outlined in this section.
  13. Install oil pan as outlined in this section.
  14. Install spark plugs.

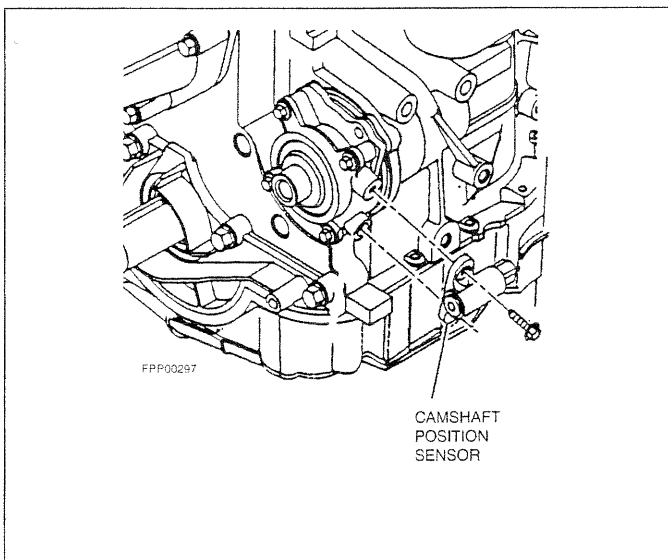

### Camshaft Position Sensor Removal

1. Disconnect the negative battery cable.
2. Disconnect electrical connector.
3. Remove screws.
4. Remove the sensor.

### Camshaft Position Sensor Installation

1. Install the sensor.
2. Install screws. Tighten to:
  - 5-7 N•m (45-61 lb-in).
3. Connect electrical connector.
4. Connect the negative battery cable.

### Engine Coolant Temperature Sensor Removal

1. Disconnect the negative battery cable.
2. Partially drain the cooling system.
3. Disconnect the electrical connector.
4. Remove the sensor.

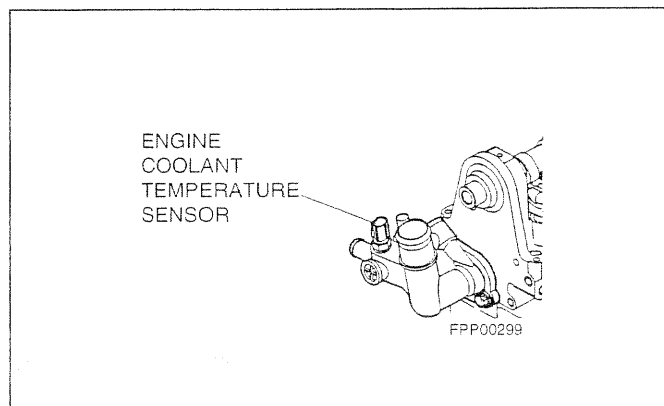

### Engine Coolant Temperature Sensor Installation

1. Install the sensor. Tighten to:
  - 16-24 N•m (12-17 lb-ft).
2. Connect the electrical connector.
3. Connect the negative battery cable.
4. Fill the cooling system with the proper coolant.

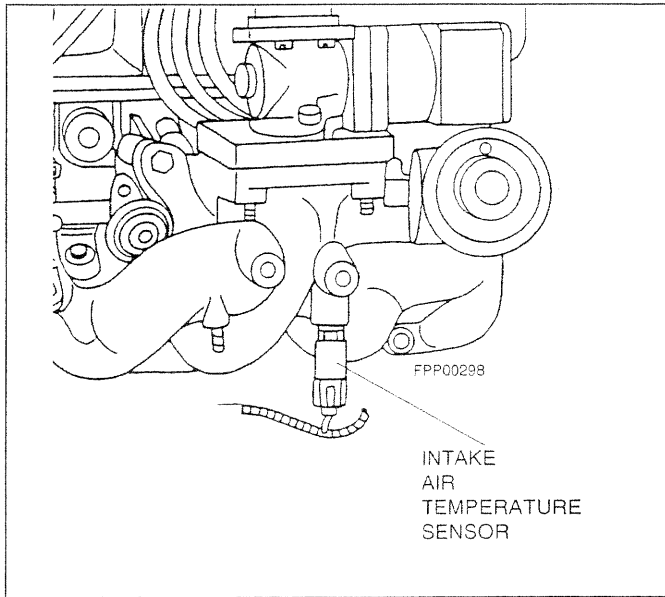

### Intake Air Temperature Sensor Removal

1. Disconnect the negative battery cable.
2. Disconnect electrical connector.
3. Remove the sensor.

### Intake Air Temperature Sensor Installation

1. Install the sensor. Tighten to:
  - ♦ 13-16 N•m (7-12 lb-ft).
2. Connect electrical connector.
3. Connect the negative battery cable.

### Heated Oxygen Sensor Removal

1. Disconnect the negative battery cable.
2. Disconnect electrical connector.
3. Remove the sensor using an oxygen sensor wrench.
  - If necessary, lubricate sensor using penetrating lubricant such as E8AZ-19A501-B or equivalent.

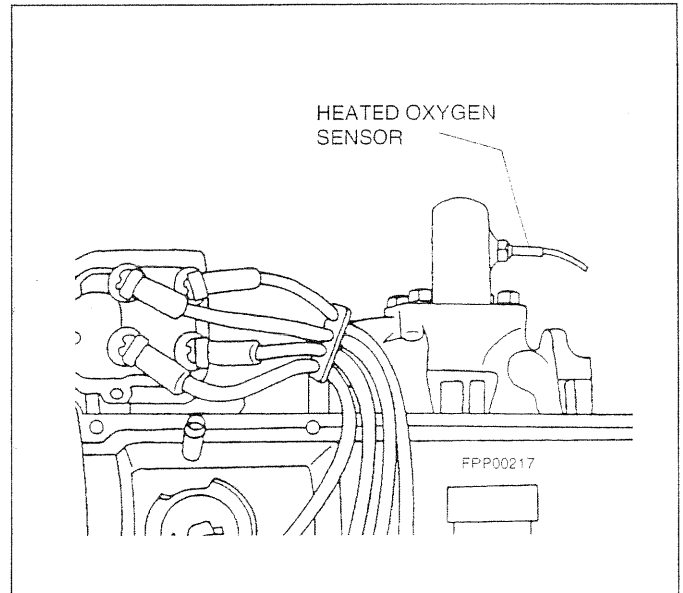

### Heated Oxygen Sensor Installation

1. Apply a light coat of Anti-seize compound such as F6AZ-9L494-AA or equivalent meeting Ford specification ESE-M12A4-A to the threads of the sensor.
2. Install the sensor using an oxygen sensor wrench. Tighten to:
  - 36-46 N•m (27-33 lb-ft).
3. Connect electrical connector.
4. Connect the negative battery cable.

## Flywheel Ring Gear Removal

1. Center punch ring gear and drill two holes approximately 5/16" (7 to 8mm) diameter offset as illustrated. Drill must only pass through ring gear and not flywheel.

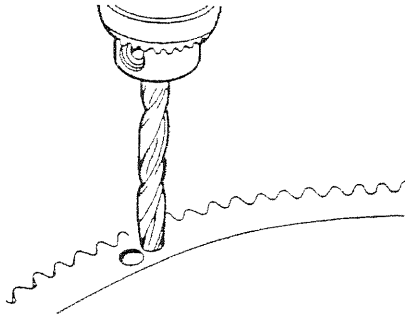

2. Remove ring gear by means of a light blow with a hammer noting position of chamfer on ring gear teeth.

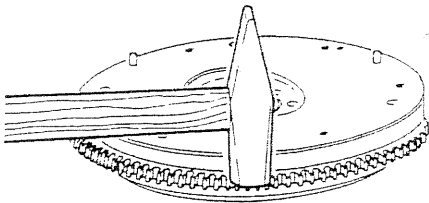

## Flywheel Ring Gear Installation

1. Place a new ring gear on a plate approximately 1/8" (2 - 3mm) thick and heat up to 260° - 280° Centigrade from below in area of ring gear itself using a welding torch to give uniform heating.

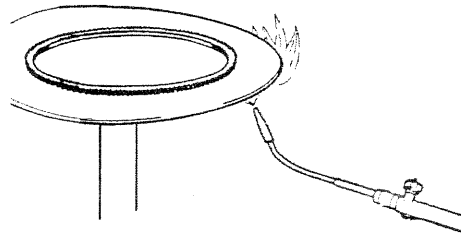

2. Note position of gear tooth chamfer. Slip ring gear over flywheel with tongs so that ring gear comes to rest on abutment rim. Allow to cool in this position.
3. Starter ring gear is induction-hardened and loses this hardness as soon as it is heated to over 290°. To monitor temperature, mark ring gear with a thermochromatic colored pencil (Faber Castell 2815) before starting heating operation. On reaching temperature required, color marked on gear changes to color of pencil cover.

*Example: If colored pencil is green and cover black, indicated temperature of 260 - 280° C is reached when green colored mark on ring gear changes to black.*

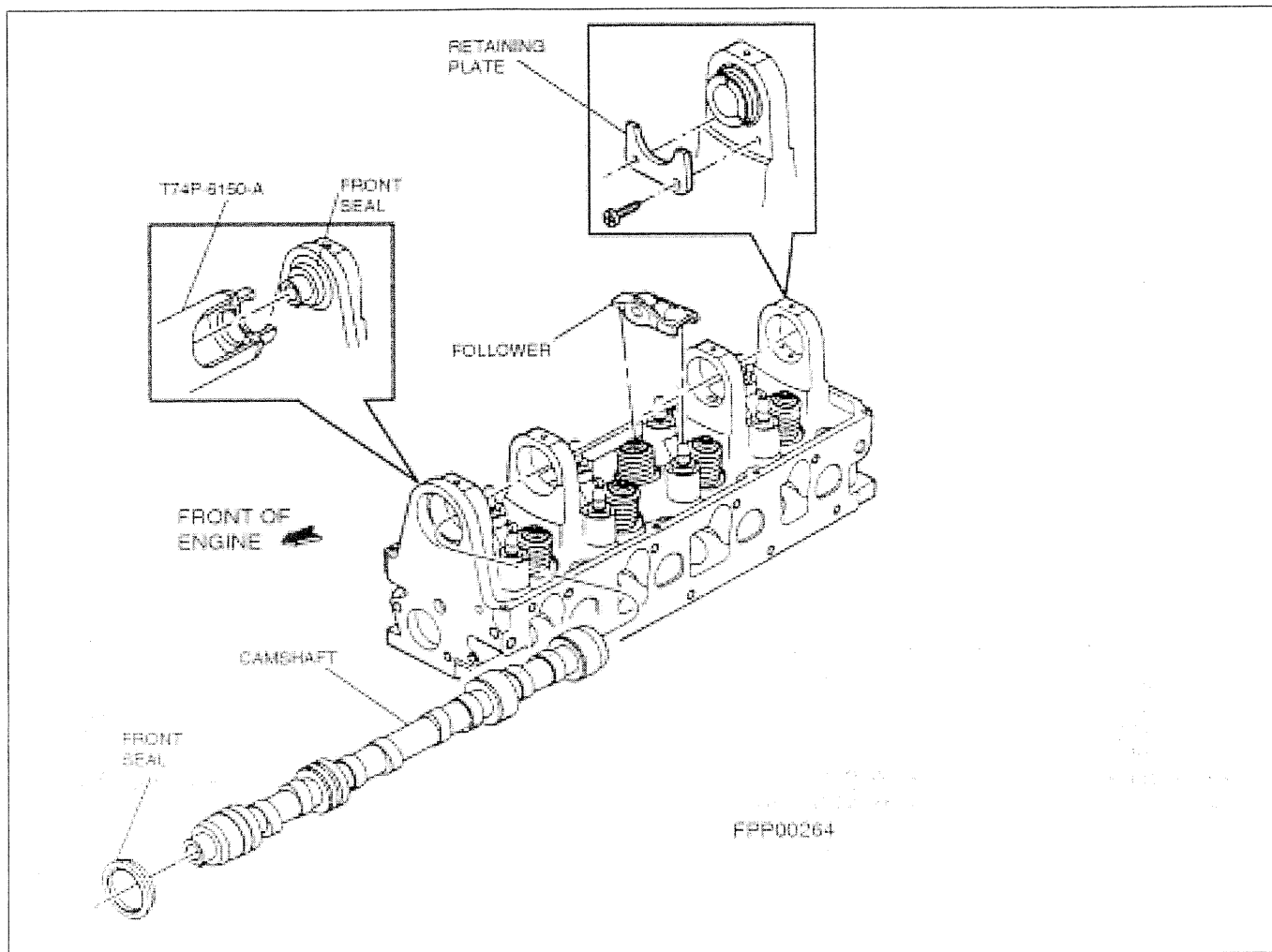

## DISASSEMBLY AND ASSEMBLY

### Cylinder Head Disassembly

Special Tools Required	
Valve Spring compressor	T95T-6565-A
Cam Sprocket Holding Tool	T74P-6256-B
Front Cover Seal Remover	T74P-6700-B
Cam Bearing Replacer	T71P-6250-A
Camshaft Bearing Set	T65L-6250-A
Front Seals Replacer	T74P-6150-A
Valve Stem Seal Replacer	T95L-6510-A
Valve Guide Replacer	T95T-6510-B

NOTE: When disassembling cylinder head, mark the cam followers, lash adjusters, and valves so that they can be installed in their original positions.

1. Remove cylinder head as outlined in this section.
2. Remove the deposits from the combustion chambers with scraper and wire brush.
3. Mount cylinder head on bench fixture.
4. Rotate the camshaft so the cam follower to be removed is on the heel of its cam.

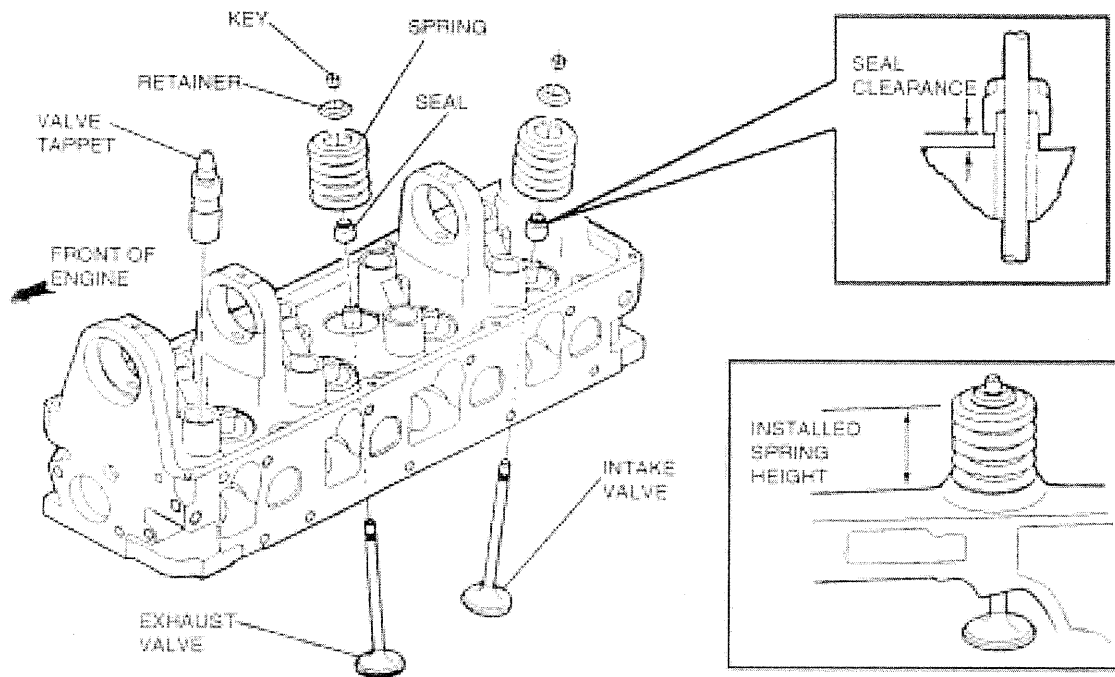

FFP00274

5. Using Valve Spring Compressor T95T-6565-A, compress and hold down the valve spring. Slide out the cam follower over the lash adjuster.
6. Repeat steps 4 and 5 until all the cam followers are removed.
7. Store lash adjusters in order.
8. Using Valve Spring Compressor T95T-6565-A, compress valve spring and remove valve spring retainer key, valve spring retainer, and valve spring.
9. Remove valve and store in order.
10. Remove valve stem seal.
11. Repeat above steps until all the valves are removed.

NOTE: It is not necessary to remove sprocket from camshaft unless camshaft or sprocket is to be serviced.

12. Install Cam Sprocket Holding/Removing Tool T74P-6256-B on sprocket. Using tool to hold sprocket remove bolt and washer.
13. Install threaded puller insert in Cam Sprocket Holding/Removing Tool T74P-6256-B and remove sprocket.

14. Remove tool from sprocket.

NOTE: When positioning Front Cover Seal Remover T74P-6700-B, make sure the jaws are gripping the thin edge of the seal tightly before operating the jack screw portion of the tool.

15. Install Front Cover Seal Remover T74P-6700-B. Pull camshaft front seal.
16. Remove two screws and camshaft retaining plate.
17. Remove camshaft.

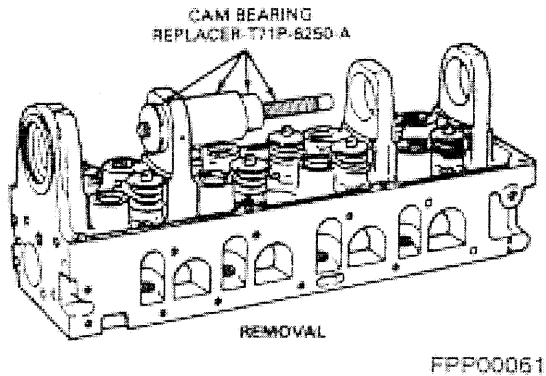

### 18. To remove camshaft bearing:

- Use tool sets Cam Bearing Replacer T71P-6250-A and Camshaft Bearing Set T65L-6250-A.
- Select proper size expanding collet and backup nut, and assemble on expanding mandrel.
- With expanding collet collapsed, install coiled assembly in the camshaft bearing, and tighten backup nut on the expanding mandrel until the collet fits the camshaft bearing.
- Assemble puller screw, cup, and nut on expanding mandrel.
- Tighten the puller nut against the thrust bearing to remove the camshaft bearing. Be sure to hold the end of the puller screw to prevent it from turning.
- Repeat steps to remove the other three bearings.

## Cylinder Head Assembly

- Clean and inspect cylinder head, cam followers, valve springs, and valves as outlined in the Section 01.



**CAUTION:** Failure to use the correct expanding collet can cause severe bearing damage.

NOTE: The camshaft bearings are available prefinished to size and require no reaming for

standard and 0.08mm (0.003-inch) undersize journal diameters.

NOTE: Make sure to align oil hold in camshaft bearing with the oil hole in the cylinder head before pressing camshaft bearing into place.

- Position new camshaft bearing at the bearing bore and press into place using Camshaft Bearing Set T65L-6250-A and Cam Bearing Replacer T71P-6250-A.

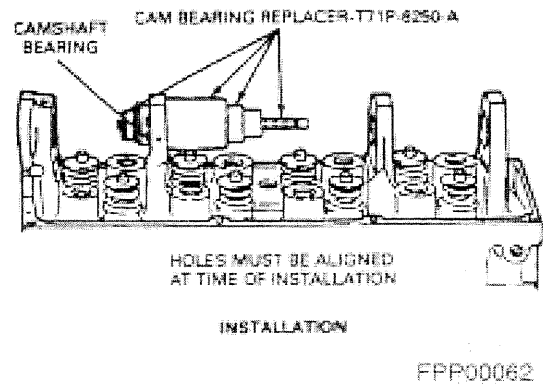

- Make sure the cup plug is in the rear of the camshaft.
- Lubricate the camshaft lobes and journals with Motorcraft Super Premium Motor Oil XO-5W30-ASP, or equivalent, meeting Ford specification ESE-M2C153-E.
- Carefully slide the camshaft into place through the camshaft bearings. Be careful not to scratch camshaft bearings.
- Install the camshaft rear retainer. Tighten the two screws to 8-12 N·m (72-108 lb-in).
- Position camshaft front seal on Front Seals Replacer T74P-6150-A and press into place.
- Remove tool.
- Check camshaft end play as outlined in the engine service section.
- Position camshaft sprocket on camshaft.
- Install Cam Sprocket Holding/Removing Tool T74P-6256-B, without threaded puller insert, on sprocket.
- Install sprocket bolt and washer. Tighten to 70-95 N·m (52-70 lb-ft).
- Remove tool.

14. Install valve lash adjusters.
15. Install one valve and check valve runout, looseness in guide, and seating as outlined in the engine service section.



**CAUTION:** Install valve seal protector (plastic installation cap) included with valve seal kit over end of valve before installing valve stem seal or valve stem seal will be cut by valve-keeper grooves in valve. If valve stem seal is cut, it will leak, causing oil burning and valve fouling.

16. Put valve seal protector (plastic installation cap) over end of valve as illustrated.

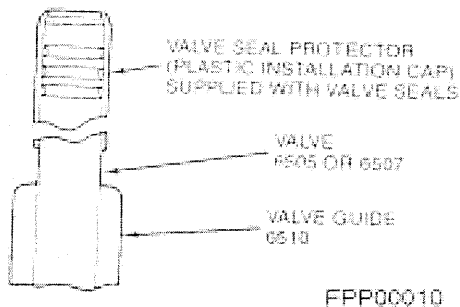

17. Start valve stem seal carefully over cap. Push valve stem seal down until jacket touches top of guide.

18. Remove seal protector (plastic cap). Use Valve Stem Seal Replacer T95T-6510-B to seat valve stem seal on valve guide.

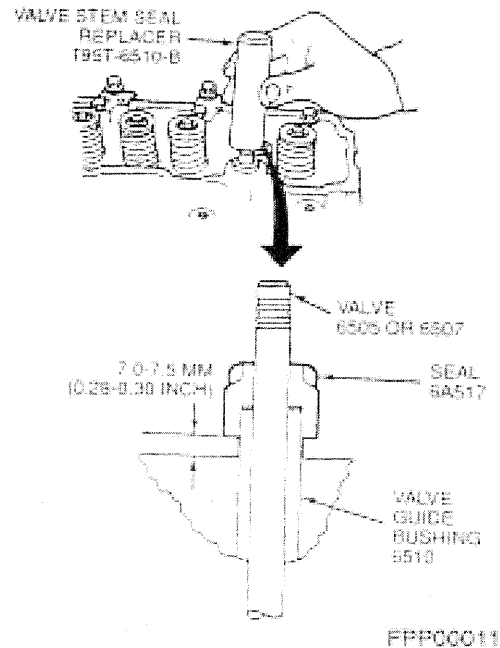

19. Apply a small amount of Ford Multi-Purpose Grease D0AZ-19584-AA, or equivalent, to valve spring retainer keys to hold them in place during installation.

20. Put valve spring and valve spring retainer into place.

**NOTE:** Spring must not be compressed beyond a height of 27.5mm (1.08 inch) during assembly.

21. Compress valve spring with Valve Spring Compressor T95T-6565-A and install valve spring retainer keys. Release spring to seat valve spring retainer keys.

22. Check installed height of valve spring assembly:
- Measure from cylinder head-machined spring pad to top of valve spring. Dimension should be 38.278-40.157mm (1.507-1.581 inch).

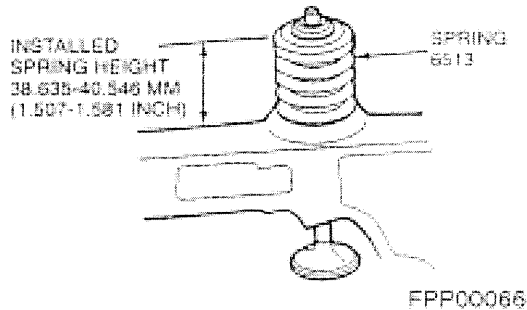

23. Repeat steps 15 through 22 until all valves are installed.
24. Oil contact surfaces of cam followers with clean engine oil.
25. With heel of cam facing down, use Valve Spring Compressor T95T-6565-A to compress and hold down the valve spring. Slide the cam follower into place.



**CAUTION:** Make sure the affected lash adjuster has been collapsed and released before rotating camshaft.

26. Using Valve Spring Compressor T95T-6565-A, compress and release lash adjuster.
27. Repeat the above steps until all cam followers are installed.
28. Install cylinder head as outlined in this section.

## Piston and Piston Pins Disassembly

Special Tools Required	
Piston Pin Removing and Installing Set	T68P-6135-A

1. Remove the connecting rod bearing from the connecting rod and cap.
2. Install the cap on the connecting rod from which it was removed.
3. Remove the piston rings using a suitable piston ring expander.
4. Store the piston, pin and connecting rod to ensure assembly with the same rod and installation in the same cylinders from which they were removed.
5. Using an arbor press and Piston Pin Removing and Installing Set T68P-6135-A, press the piston pin from the piston and connecting rod .

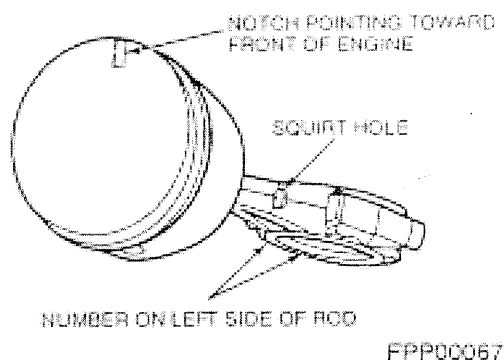

## Piston and Piston Pins Assembly

1. Apply a light coat of Motorcraft Super Premium Motor Oil XO-5W30-QSP, or equivalent, to all parts. Assemble the piston to the connecting rod with the oil squirt hole on the side of the connecting rod and the notch in the piston positioned as shown. Use arbor press and Piston Pin Removing and Installing Set T68P-6135-A.

2. Install the piston rings using a suitable piston ring expander. Check the end gap of all piston rings. They must be within specifications of 0.203-0.406mm (0.008-0.016 inch) for top ring, 0.33-0.50mm (0.013-0.019 inch) for second ring, and 0.254-0.762mm (0.010-0.030 inch) for oil control ring.
3. Check the ring side clearance. Refer to Section 01. Side clearance for both compression rings should be 0.041-0.084mm (0.0016-.0033 inch) and a snug fit for the oil control ring.
4. Make sure the connecting rod bearings and the bearing bore in the connecting rod and cap are clean. Foreign material under the inserts will distort the bearing and cause a failure. Install the connecting rod bearings in the connecting rod and cap with the tangs fitting in the slots provided.
5. Make certain lock slots in cap are on the same side of bore as the lock slot in rod. Avoid nicking crank pin journals during rod installation.
6. Install piston and connecting rod assembly as outlined in this section.

## Cylinder Block Disassembly

1. Mount the engine on a work stand
2. Remove all parts not furnished with the new cylinder block following engine disassembly and assembly in this section.
3. Remove the old cylinder block from the work stand.

## Cylinder Block Assembly

1. Clean the gasket and seal surfaces of all serviceable parts and assemblies.
2. Position the new cylinder block on a work stand
3. Transfer all serviceable parts removed from the old cylinder block, following engine disassembly and assembly as outlined in this section.
4. Check all assembly clearances and correct as necessary.

## Hydraulic Lash Adjuster Disassembly

NOTE: Do not mix parts between different lash adjusters. Parts are select-fit and not interchangeable.

1. Remove snap ring.
2. Remove fulcrum, plunger, and spring.
3. Clean to remove all traces of motor oil and varnish. Make sure check ball is free.
4. To assemble, lubricate parts with clean Super Premium Motor Oil XO-5W30-QSP or equivalent, meeting Ford specification ESE-M2C153-E and reverse disassembly steps. If it is necessary to store lash adjusters for some time before installation, protect them from dust and dirt. If not kept clean, they may stick during operation.
5. Perform leak-down test as outlined in the engine service section.

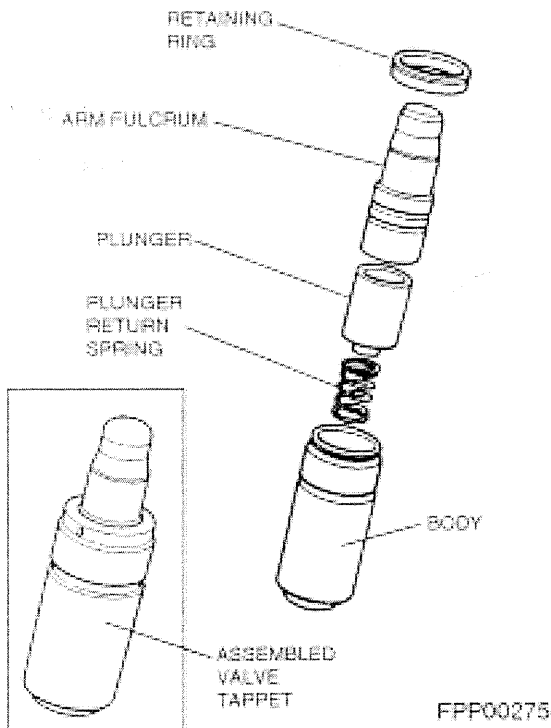

## Bare Cylinder Block Disassembly

1. Before replacing a cylinder block, determine if it is repairable. If so, make the necessary repairs following the procedures given in the engine service section.
2. Completely disassemble the old engine, following the engine disassembly procedure in this section.
3. Remove core plugs as outlined in the engine service section.
4. Remove oil gallery pipe plugs.

NOTE: A rifle-cleaning brush is helpful for cleaning engine oil galleries.

5. Clean cylinder block and inspect as outlined in the engine service section.

## Bare Cylinder Block Assembly

1. If using new or reconditioned cylinder block, uncrate and clean preservative materials according to the supplier's instructions.
2. Position the new cylinder block in a work stand and install all serviceable parts removed from the old cylinder block, following engine assembly procedure in this section.
3. Check all assembly clearances and correct as necessary.

## ADJUSTMENTS

### Valve Clearance, Hydraulic Valve Lash Adjuster

Special Tools Required	
Valve Spring compressor	T95T-6565-A

1. Position the camshaft so that the base circle of the lobe is facing the roller finger follower of the valve to be checked.
2. Using Valve Spring Compressor T95T-6565-A, slowly apply pressure to the roller finger follower until the lash adjuster is completely collapsed. Hold the follower in this position and insert the proper size feeler gauge between the base circle of the cam and the follower.

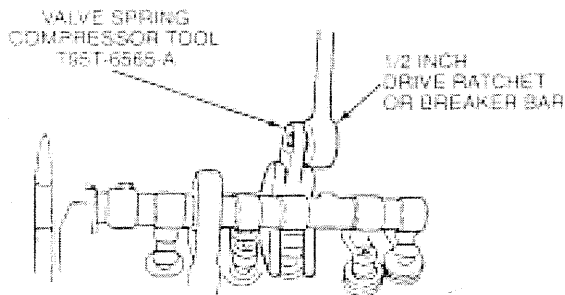

FPP00009

3. Remove the roller finger follower and inspect for damage if the clearance is excessive.
4. If the cam follower appears to be intact and not excessively worn, measure the valve spring assembled height to make sure the valve is not sticking.
5. If the valve spring assembled height is correct, check the dimensions of the camshaft. Refer to Camshaft Lobe Lift in the engine service section.
6. If the camshaft dimensions meet specifications, remove, clean and test the lash adjuster. Refer to Hydraulic Tappets in the engine service section.
7. Install the lash adjuster and check the clearance. Replace damaged or worn parts as necessary.

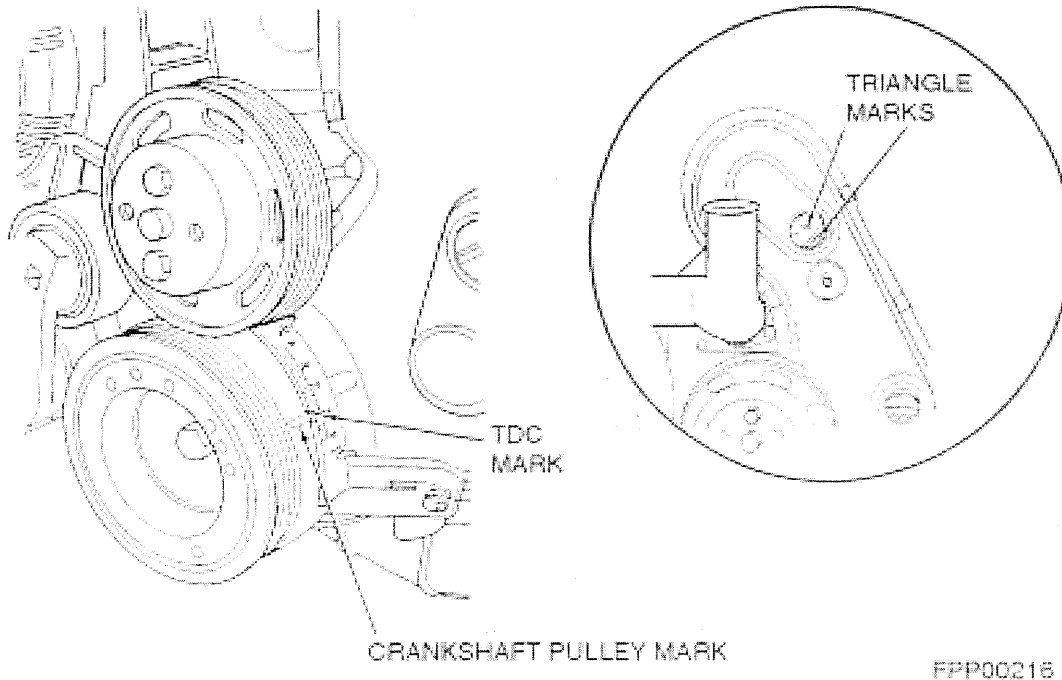

## Camshaft Timing Check

An access plug is provided in the cam drive belt cover so that camshaft timing can be checked without removal of the cover or any other parts.

NOTE: Camshaft and timing belt sprockets turn one revolution for every two revolutions of the crankshaft.

NOTE: If the timing belt has greater than 3,000 hours or five years of use, replace it. Refer to the service procedures in this section.

1. Remove the rubber access cap in front of the camshaft sprocket from the outer timing cover.
2. Rotate crankshaft so that number one cylinder is at the compression stroke of Top Dead Center (TDC). TDC will be indicated when the timing marks are aligned:
  - The timing mark on the crankshaft damper assembly will align with "TC" on outer timing cover.
  - The triangular timing mark on the camshaft sprocket will align with the timing mark on the inner timing cover.
3. If the triangle timing mark cannot be seen through the access hole of the outer timing cover, rotate crankshaft one revolution. TDC will be indicated when the timing marks are aligned.
4. If the triangle timing mark cannot be properly aligned, timing must be adjusted. Refer to Adjusting Timing Belt in this section.

## Adjusting Timing Belt

Special Tools Required	
Crankshaft Belt Tension Adjuster	T74P-6254-A

1. Remove the outer timing belt cover as outlined in this section.

NOTE: Timing belt should be replaced at 3,000 hours or five-year intervals. If the timing belt has more than 3,000 hours or five years of use, replace it. Refer to the procedure in this section.

2. Inspect belt for cracked or damaged teeth, fraying, cracking, or oil. If the belt is worn or damaged, replace it. If there is oil on the belt, determine the source of the oil leak and repair or replace as necessary.

**CAUTION: Attempting to adjust timing belt tension without loosening spring pivot bolt will break Crankshaft Belt Tension Adjusting Tool T74P-6254-A when relieving tension on the belt.**

3. If belt timing or tension is incorrect, loosen timing belt spring pivot bolt.
4. Hold tensioner with Camshaft Belt Tension Adjusting Tool T74P-6254-A.
5. While holding tensioner, loosen adjusting bolt and gradually release spring tension.
6. Using adjusting tool, pry tensioner away from belt. While holding tensioner, tighten adjusting bolt. There should be no tension on belt.
7. Remove bolt, washer, and crankshaft damper.
8. Remove the drive belt and inspect it for wear or damage. If the belt is damaged, replace it.
9. Remove the spark plugs. Mark locations on a piece of tape for reinstallation.
10. If not done:
  - Loosen tensioner adjusting bolt.
  - Using Camshaft Belt Tension Adjusting Tool T74P-6254-A, pry tensioner clockwise against spring tension as far as possible.
  - Tighten adjusting bolt to hold tensioner in released position.
11. Align crankshaft (6303) so number one piston (6108) is at TDC (top dead center) as indicated by timing mark.
12. Align pointer circle on crankshaft sprocket with line on engine front cover.

13. Align triangle on camshaft sprocket with triangle on inner timing belt cover.
14. Install timing belt over crankshaft sprocket (6306). Then, proceeding counterclockwise, over oil pump sprocket and camshaft sprocket, verify timing marks are aligned.

15. Loosen tensioner adjusting bolt allowing tensioner pulley to press against timing belt.

NOTE: When performing the following step, do not rotate crankshaft counterclockwise as timing belt may jump a cog, putting camshaft out of time.

16. Rotate crankshaft two revolutions clockwise.
17. Bring crankshaft slowly, without stopping, to number one cylinder firing position (keyway directly up).
18. Recheck timing mark alignment. Repeat the above steps if timing marks are no longer properly aligned.
19. Rotate tensioner assembly against bolt with torque wrench up to 40-45 N·m (29-33 lb-ft) and tighten adjusting bolt.
20. Tighten adjusting bolt to 35-45 N·m (26-33 lb-ft).
21. Tighten spring pivot bolt to 40-55 N·m (29-40 lb-ft).
22. Install outer timing belt cover as outlined in this section.
23. Install spark plugs in proper locations.

## SPECIFICATIONS

### GENERAL

Displacement .....	2.5L (153 CID)
Bore .....	96.01 mm (3.78")
Stroke.....	86.36 mm (3.40")
Firing order.....	1-3-4-2
Idle speed.....	750 rpm
Rated engine speed .....	3600 rpm
Oil pressure (hot @ 2000 rpm).....	275.79-413.69 kPa (40-60 psi)

### CYLINDER HEAD

Combustion chamber volume .	1409.70-1485.90 mm (55.5-58.5")
Compression pressure:	
.....The lowest cylinder must be at least 75% of the highest cylinder	
Valve guide bore diameter...	7.0155-7.0434 mm (0.2762-0.2773")
Valve seat width (intake) .....	1.7200-2.2352 mm (0.068-0.088")
Valve seat width (exhaust) .....	1.7780-2.2860 mm (0.070-0.090")
Valve seat angle.....	45°
Valve seat runout (max.) .....	0.0508 mm (0.0020")
Valve arrangement (front to rear).....	E-I-E-I-E-I-E-I
Valve tappet bore .....	20.5359-20.6375 mm (0.8085-0.8125")
Gasket surface flatness:	
.....in any 152.4 mm (6") .....	0.0762 mm (0.003")
.....overall .....	0.1524 mm (0.006")
Head gasket surface finish RMS .....	78-157

### CAMSHAFT

Lobe lift .....	5.4940 mm (0.2163)
.....max. allowable loss.....	0.1270 mm (0.005")
Theoretical valve lift @ zero lash.....	10.2108 mm (0.402")
End play .....	0.0254-0.1778 mm (0.001-0.007")
.....wear limit .....	0.2286 mm (0.009")
Journal to bearing clearance ..	0.0254-0.0762 mm (0.001-0.003")
.....wear limit .....	0.1524 mm (0.006")
Journal diameter.....	44.9910-45.0088 mm (1.7713-1.7720")
.....max. runout.....	0.1270 mm (0.005")
.....max. out-of-round.....	0.1270 mm (0.005")
Bearing location:	
(distance that the rear edge of the bearing is installed towards the front from the rear face of the bearing tower).....	0.0-0.2540 mm (0.0-0.010")

### CYLINDER BLOCK

Cylinder bore.....	95.9993-96.0145 mm (3.7795-3.7801")
Bore out-of-round (max.) .....	0.0381 mm (0.0015")
..... wear limit .....	0.1270 mm (0.005")
Bore taper - wear limit .....	0.2540 mm (0.010")
Bore surface finish RMS .....	18-38
Main bearing bore	
..... diameter.....	60.8863-60.9067 mm (2.3971-2.3979")
Gasket surface flatness: .....	
.....in any 152.4 mm (6") .....	0.0762 mm (0.003")
.....overall .....	0.1524 mm (0.006")
Head gasket surface finish RMS .....	60-150
Crankshaft to rear face of block runout	
.....max. TIR .....	0.1270 mm (0.005")

### CRANKSHAFT AND FLYWHEEL

Main bearing journal	
..... diameter.....	56.0095-56.0299 mm (2.2051-2.2059")
..... maximum out-of-round .....	0.0152 mm (0.0006")
..... maximum runout .....	0.0508 mm (0.0020")
..... wear limit .....	0.1270 mm (0.005")
..... thrust face runout .....	0.0254 mm (0.001")
..... maximum taper.....	0.0127 mm (0.0005")
Thrust bearing journal length .....	30.5054-30.4546 mm (1.201-1.199")
Main and rod bearing journal finish RMS (max) .....	10
Main bearing thrust face finish RMS .....	35 front/25 rear max.
Connecting rod bearing journal:	
..... diameter.....	51.9786-51.9989 mm (2.0464-2.0472")
..... max. out-of-round.....	0.0152 mm (0.0006")
..... max. taper.....	0.0152 mm (0.0006") per inch
Crankshaft free end play .....	0.1016-0.2032 mm (0.004-0.008")
..... wear limit .....	0.3048 mm (0.012")
Flywheel clutch face runout .....	0.1270 mm (0.005")
Flywheel ring gear lateral runout	
..... standard trans.....	0.6350 mm (0.025")
..... automatic trans.....	1.5240 mm (0.060")

### CRANKSHAFT BEARINGS

Connecting rod bearings to crankshaft clearance:	
..... desired .....	0.0203-0.0381 mm (0.0008-0.0015")
..... allowable.....	0.0203-0.0660 mm (0.0008-0.0026")
Wall thickness	
..... standard.....	1.5723-1.5850 mm (0.0619-0.0624")
..... 0.0508 mm (0.002") thickness.....	add 0.0254 mm (.001") to standard thickness
Main bearing to crankshaft clearance	
..... desired .....	0.0203-0.0381 mm (0.0008-0.0015")
..... allowable.....	0.0203-0.0660 mm (0.0008-0.0026")
Wall thickness (standard) .....	2.4155-2.4282 mm (0.0951-0.0956")

**CONNECTING ROD**

Piston pin bore or bushing inside diameter	23.1242-23.1445 mm (0.9104-0.9112")
Connecting rod bearing bore	
.....diameter	55.1688-55.1891 mm (2.1720-2.1728")
.....out-of-round (max.)	0.0102 mm (0.0004")
.....taper (max.)	0.0102 mm (0.0004")
Connecting rod alignment - maximum total diff. pin bushing and crankshaft bearing bore must be parallel and in the same vertical plane within the specified total difference at ends of 203.2 mm (8") long bar measured 101.6 mm (4") on each side of rod.	
.....twist	0.0762 mm (0.003")
.....bend	0.0381 mm (0.0015")
Connecting rod assembled to crankshaft	
.....side clearance	0.0889-0.2921 mm (0.0035-0.0115")
.....wear limit	0.3810 mm (0.0150")

**CAPACITIES (approximate)**

Crankcase capacity	4.26 L (4.5 quarts)
	(includes oil filter)

**FUEL PUMP - CARBURETED**

Static pressure	24.13-34.47 kPa (3.5-5.0 psi)
Volume flow	1.9 Liters (2 quarts) per minute

**FUEL PUMP - EFI**

Static pressure	399.90 kPa (64 psi)
NOTE: When pump return line is plugged, pressure can go to 100 psi.	
Volume flow	2.18 liters (2.3 quarts) per minute

**IGNITION SYSTEM**

Spark plug (EFI & carburetor)	AWSF-52-C
.....gap	1.1176 mm (0.044")

**MECHANICAL GOVERNOR BELT TENSION**

New	70 lbs (311.38 N)
Used	50 lbs (222.41 N)
(a used belt is one that has been in operation for 10 minutes or more.)	

**OIL PUMP**

Relief valve spring tension	37.37-47.15 N @ 33.5280 mm
	(8.4-10.6 lbs @ 1.32")
Drive shaft to housing bearing clearance	0.0356-0.0838 mm
	(0.0014-0.0033")
Relief valve clearance	0.0381-0.0762 mm (0.0015-0.0030")
Rotor assembly end clearance	
.....pump assembled	0.0254-0.1016 mm (0.0010-0.0040")
Outer race to housing radial clearance	0.1397-0.3175 mm
	(0.0055-0.0125")

**PISTON**

Diameter	95.961-95.974 mm (3.7779-3.7784")
	(measured 90° to pin centerline and at 0.887" from bottom of skirt)
Piston to cylinder bore clearance	0.0254-0.0508 mm
	(0.0010-0.0020")
Piston pin bore diameter	23.184-23.1800 mm (0.9127-0.9125")
Ring groove width	
.....top compression ring	1.536-1.525 mm (0.0604-0.0600")
.....bottom compression ring	1.536-1.525 mm (0.0604-0.0600")
.....oil ring	3.0302-3.0556 mm (0.1193-0.1203")

**PISTON PIN**

Length	69.2912-70.1040 mm (2.728-2.760")
Diameter - standard	23.1673-23.1699 mm (0.9121-0.9122")
To piston clearance	0.0051-0.0117 mm (0.0002-0.00046")
To connecting rod clearance	interference fit

**PISTON RINGS**

Compression ring width	
.....top	1.4605-1.4910 mm (0.0575-0.0587")
.....bottom	1.4605-1.4910 mm (0.0575-0.0587")
Side clearance	
.....compression rings	0.0406-0.0838 mm (0.0016-0.0033")
.....oil ring	snug fit
.....wear limit	0.1524 mm (0.006") max.
Ring gap	
.....compression (top)	0.0-0.4064 mm (0.000-0.016")
.....compression (bottom)	0.3302-0.4826 mm (0.013-0.019")
.....oil ring	0.2540-0.7620 mm (0.010-0.030")

## VALVE TRAIN

Rocker arm lift ratio .....	1.86:1
Valve lifter	
.....diameter.....	21.3919-21.4046 mm (0.8422-0.8427")
.....clearance to bore .....	0.0178-0.0686 mm (0.0007-0.0027")
.....hydraulic leakdown rate .....	2-8 seconds
Collapsed lifter gap (at cam/roller)	
.....allowable.....	0.8890-1.3970 mm (0.035-0.055")
.....desired.....	1.0160-1.2700 mm (0.040-0.050")
Valve spring pressure - intake	
.....	253.55-280.24 N @ 39.6240 mm (57-63 lbs. @ 1.56")
Valve spring pressure - exhaust	
.....	524.89-587.17 N @ 29.4640 mm (118-132 lbs. @ 1.16")
Valve spring:	
.....wear limit .....	10% loss of pressure
.....free length.....	approx. 51.3080 mm (2.02")
.....assembled height (pad to retainer).....	39.1160-40.1320 mm
.....	(1.54-1.58")
.....out of square (max.).....	1.27 mm (0.050")
Valve stem to guide clearance	
.....intake .....	0.0254-0.0686 mm (0.0010-0.0027")
.....exhaust .....	0.0381-0.0813 mm (0.0015-0.0032")
.....wear limit .....	0.1397 mm (0.0055")
Valve head diameter	
.....intake .....	43.9420-44.1960 mm (1.73-1.74")
.....exhaust .....	37.8460-38.3540 mm (1.49-1.51")
Valve face angle.....	45°
Valve face runout (max.) .....	0.0508 mm (0.002")
Valve stem diameter - standard	
.....intake .....	6.9748-6.9952 mm (0.2746-0.2754")
.....exhaust .....	6.9494-6.9698 mm (0.2736-0.2744")
Valve stem diameter - 0.015 oversize	
.....intake .....	7.3558-7.3761 mm (0.2896-0.2904")
.....exhaust .....	7.3304-7.3507 mm (0.2886-0.2894")
Valve stem diameter - 0.030 oversize	
.....intake .....	7.7368-7.7571 mm (0.3046-0.3054")
.....exhaust .....	7.7114-7.7317 mm (0.3036-0.3044")

## STARTER

Motor diameter .....	78 mm (3")
Current draw under normal load .....	140-200 amps
Normal engine cranking speed .....	200-250 rpm
Minimum stall torque @ 5 volts .....	14.7 N•m (11 lb.ft.)
Maximum load .....	800 amps
No load .....	70±10 amps
Brush mfg. length .....	16.8 mm (0.66")
Spring tension .....	18 N (64 oz.)
Maximum commutator runout .....	0.12 mm (0.005")
Maximum starting circuit voltage drop .....	0.5 volt
(battery pos. terminal to starter terminal at normal engine temperature)	

NOTE: Oil threads with a lightweight engine oil unless the threads require oil or water resistant sealer.











TORQUE SPECIFICATIONS - General Applications		
U.S. THREAD SIZES .....	Nm.....	LB. FT.
1/4 - 20 .....	8 - 12 .....	6 - 9
5/16 - 18 .....	16 - 24 .....	12 - 18
5/16 - 24 .....	19 - 27 .....	14 - 20
3/8 - 16 .....	30 - 43 .....	22 - 32
3/8 - 24 .....	37 - 51 .....	27 - 38
7/16 - 14 .....	54 - 75 .....	40 - 55
7/16 - 20 .....	54 - 81 .....	40 - 60
1/2 - 13 .....	75 - 108 .....	55 - 80
METRIC THREAD SIZES.....	Nm.....	LB. FT.
M-6 .....	8 - 12 .....	6 - 9
M-8 .....	19 - 28 .....	14 - 21
M-10 .....	38 - 54 .....	28 - 40
M-12 .....	68 - 96 .....	50 - 71
M-14 .....	108 - 155 .....	80 - 114
PIPE THREAD SIZES .....	Nm.....	LB. FT.
1/8.....	7 - 11 .....	5 - 8
1/4.....	16 - 24 .....	12 - 18
3/8.....	30 - 45 .....	22 - 33
1/2.....	34 - 47 .....	25 - 35

**TORQUE SPECIFICATIONS - Special Applications**

ITEM	Nm	LB. FT.
Air Charge Temperature Sensor .....	13-16 .....	7-12
Belt tensioner (timing) pivot bolt .....	40-55 .....	30-41
Belt tensioner (timing) adjusting bolt .....	35-45 .....	26-33
Camshaft gear bolt .....	70-95 .....	52-70
Camshaft thrust plate bolt .....	8-12 .....	6-9
Connecting rod nut * .....	41-49 .....	30-36
Crankcase vent baffle to block .....	8-12 .....	6-9
Crankshaft damper bolt .....	125-165 .....	92-122
Crank position sensor to front cover .....	8-12 .....	6-9
Cylinder head bolt * .....	step 1 = 70 .....	52
.....	step 2 = turn 90°	
ECT sensor to water outlet connector .....	16-24 .....	12-18
Exhaust man. to cyl head bolts/stud/nut * .....	60-80 .....	44-59
Flywheel to crankshaft bolt .....	73-87 .....	54-64
Front lifting eye bolt/nut .....	20-30 .....	15-22
Generator bracket to head & block * .....	40-55 .....	30-41
Ignition coil to bracket .....	5-7 .....	4-5
Intake manifold, upper-vacuum fitting .....	16-24 .....	12-18
Intake manifold, elbows & pipe plugs * .....	step 1 = 7-10 .....	5-7
.....	step 2 = additional 1/2 turn	
Intake manifold, upper to lower, * .....	step 1 = 7-10 .....	5-7
and also manifold to cyl. head bolt or nut * .....	step 2 = 26-38 .....	19-28
Main bearing cap bolt * .....	step 1 = 68-81 .....	50-60
.....	step 2 = 102-115 .....	75-85
Oil pressure sending unit to block .....	11-24 .....	8-18
Oil pump pickup tube to block .....	20-30 .....	15-22
Oil pump to block .....	10-14 .....	7-10
Oil pan drain plug to pan .....	20-34 .....	15-25
Oil pan to block .....	14-16 .....	10-12
Oil filter insert to block .....	28-35 .....	21-26
Oil separator bolt .....	8-12 .....	6-9
Rear lifting eye nut .....	20-30 .....	15-22
Rocker arm cover to cylinder head .....	9-13 .....	7-10
Starter solenoid bolt .....	5-9 .....	4-7
Starter M & B terminal nuts .....	9-13 .....	7-10
Starter through bolt .....	5-9 .....	4-7
Starter mounting bolt .....	21-27 .....	15-20
Starter brush plate screw .....	3 .....	2
Spark plug to cylinder head .....	9-20 .....	7-15
Temperature sending unit to block .....	11-24 .....	8-18
Water jacket drain plug to block .....	16-24 .....	12-18
Water outlet connection bolt .....	20-30 .....	15-22
Water pump to block bolt .....	20-30 .....	15-22
Cylinder front cover bolt .....	13-16 .....	10-12
Inner timing belt cover stud/bolt/nut .....	20-30 .....	15-22
Outer timing belt cover bolt .....	8-12 .....	6-9
42 pin connector to lower intake .....	20-30 .....	15-22

\* Apply Teflon tape or liquid sealer to threads.

\* Refer to service manual for proper sequence.

REQUIRED TOOLS	
Tool Number/Description	Illustration
T59L-100-B Impact Slide Hammer	 FPP00031
T58L-101-B Puller Attachment	 FPP00035
T73L-6011-A Engine Cylinder Hone Set	 FPP00045
T74P-6015-A Engine Plug Replacer	 FPP00051
T68P-6135-A Piston Pin Remover/Replacer	 FPP00052
T74P-6150-A Front Seals Replacer	 FPP00053
T71P-6250-A Cam Bearing Replacer	 FPP00060
T74P-6254-A Camshaft Belt Tensioner Tool	 FPP00063
T74P-6256-B Cam Sprocket Holding/Removing Tool	 FPP00064
T74P-6306-A Crankshaft Sprocket Remover	 FPP00065

T74P-6312-A Crankshaft Damper Remover	 FPP00059
T95T-6565-A Valve Spring Compressor	 FPP00071
T95T-6510-A Valve Stem Seal Installer	 FPP00072
T74P-6700-B Front Cover Seal Remover	 FPP00073
T82L-6701-A Rear Main Seal Replacer	 FPP00074
T95T-6510-B Valve Stem Seal Replacer	 FPP00075
DESIRED TOOLS	
Tool Number	Description
D81L-6500-A	Blind Hole Puller
D79L-6731-B	Oil Filter Wrench
D78P-4201-G	Dial Indicator
Tool-4201-C	Dial Indicator with Bracketry

ROTUNDA EQUIPMENT	
Model	Description
021-00045	Belt Tension Gauge

SECTION TITLE	PAGE
ENGINE SERVICE - General .....	01-01
ENGINE SERVICE - 2.5L .....	02-01
IGNITION SYSTEM .....	03-01
FUEL PUMP .....	04-01
CARBURETOR.....	05-01
STARTER MOTOR.....	06-01
GOVERNOR.....	07-01
COOLING SYSTEM .....	08-01
GENERATOR .....	09-01

## SECTION 03 - IGNITION SYSTEM

NOTE: This system is used on both carbureted and EFI engines.

SUBJECT	PAGE
DESCRIPTION.....	2
Operation .....	3
Inputs Affecting Ignition.....	3
UESC Module Outputs.....	4
Wiring Diagram.....	4
DIAGNOSIS.....	5
Diagnosis Equipment.....	5
Service Checks.....	5
DIS Harness Checks.....	6
Secondary Resistance Checks.....	7
Spark Plug Inspection.....	8
REMOVAL AND INSTALLATION.....	9
Ignition Coil .....	9
Crankshaft Position Sensor .....	10
Engine Coolant Temperature Sensor .....	11
Ignition Wires .....	12
Spark Plug .....	12
ADJUSTMENT.....	13
Ignition Timing.....	13
SPECIFICATIONS .....	14
General Ignition .....	14
Torques.....	14
Special Tools.....	14

**REFER TO SEPARATE PUBLICATION ON ELECTRONIC FUEL INJECTION (EFI) SYSTEMS  
FOR INFORMATION ON THAT SYSTEM.**

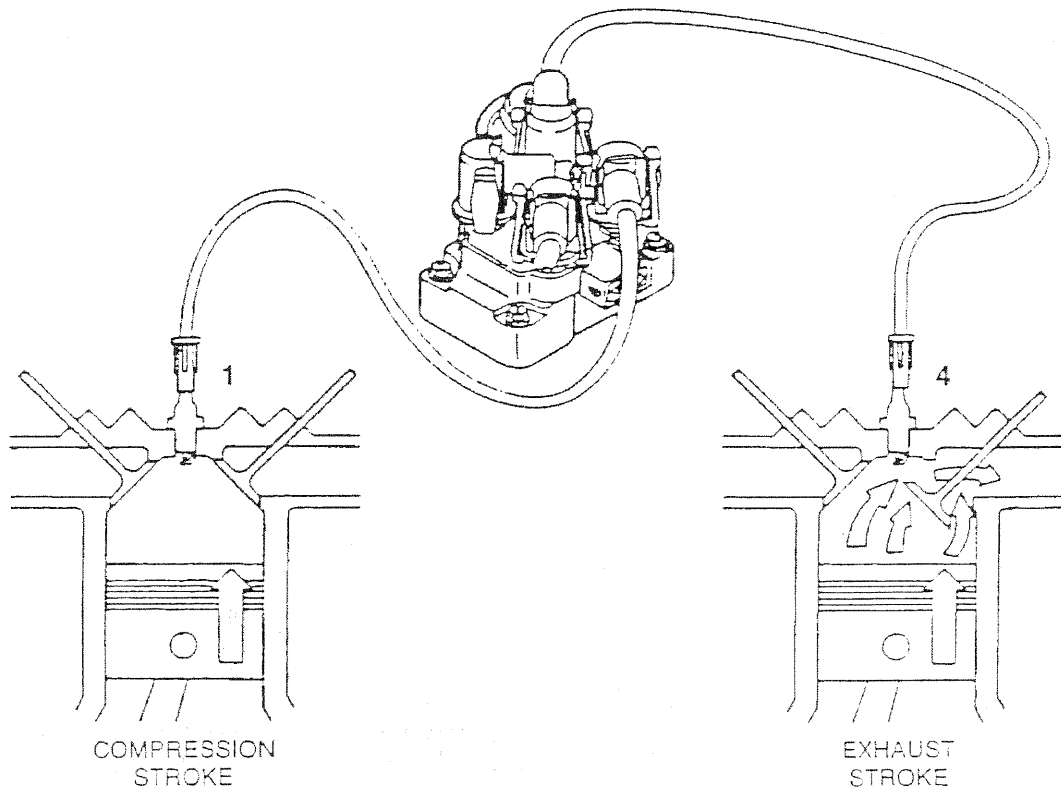

FPP00075

## DESCRIPTION



**WARNING: HIGH TENSION VOLTAGE PRODUCED BY A DISTRIBUTORLESS IGNITION SYSTEM IS HIGHER THAN FOR A CONVENTIONAL IGNITION SYSTEM. WHEN CARRYING OUT SERVICE OPERATIONS ON AN ENGINE EQUIPPED WITH DISTRIBUTORLESS IGNITION, IT IS IMPORTANT TO BE AWARE OF THE ABOVE POINT AS WELL AS ALL THE USUAL SAFETY MEASURES TO PREVENT THE POSSIBILITY OF ELECTRIC SHOCKS.**

The Purpose of an engine's ignition system is to ignite the fuel/air mixture at the correct time and sequence based upon the input it receives.

The Distributorless Ignition System (DIS) is a state of the art system. The brain of this system is the Universal Electronic Spark control (UESC) module. This module receives four inputs:

- Crankshaft position
- Crankshaft speed
- Engine temperature
- Engine vacuum (load)

From these inputs, the UESC computes spark strategy (spark advance) to obtain optimum engine performance for correct input conditions.

## Operation

With this system, the electronic control module monitors the engine load, speed and operating temperature and decides what degree of spark advance is correct for all of the operating conditions. Because timing is set for life inherently in the design of the engine, and there are no moving parts in the ignition system itself, no maintenance is required except for periodic spark-plug checks. The system provides for fixed spark advance at start-up, for cold weather starting, and for "average value" default settings in case of component failure. Particular attention has been given to spark optimization for excellent fuel economy in the warm-up mode.

The spark plugs are paired so that one plug fires during the compression stroke and its companion plug fires during the exhaust stroke. The next time that coil is fired, the plug that was on exhaust will be on compression, and the one that was on compression will be on exhaust. The spark in the exhaust cylinder is wasted but little of the coil energy is lost.

## Inputs Affecting Ignition

The spark strategy is based on sensors and manifold vacuum input to the UESC module, which include the following inputs:

### Engine Speed and Crankshaft Position

The crankshaft position and speed information comes to the UESC from the Crankshaft Position Sensor (CKP Sensor), mounted in the engine front cover. The CKP Sensor is triggered by teeth in the pulse wheel. The pulse wheel is an integral part of the crankshaft front pulley and damper assembly. The 36 teeth minus 1, spaced 10 degrees apart, indicate to the UESC the crankshaft speed. The missing tooth indicates crankshaft position.

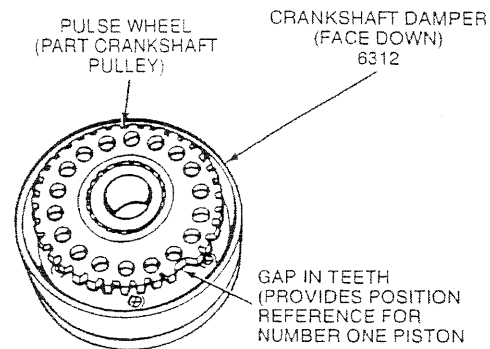

FPP00003

### Engine Load

The engine load information is processed into the UESC's electronics by a pressure transducer located within the UESC. A vacuum line connects the transducer to the engine intake manifold. The engine vacuum is proportional to its load.

### Engine Temperature

The Engine Coolant Temperature Sensor (ECTS) sends engine temperature information to the UESC. The ECTS is located above the thermostat at the front of the engine.

### Fuel Octane Level Adjustment

In the event that the engine is operated on dry fuels such as natural gas, compressed natural gas (CNG), or liquefied petroleum gas (LPG), timing can be modified. See the Adjustments section for details.

### UESC Module Outputs (Carb.)

#### Ignition Coil Driver

The UESC switches two ignition coils on and off at the correct times to give the desired spark advance.

Ignition timing is adjusted constantly by the UESC module. Many factors, including all the sensor inputs, affect the final ignition setting.

#### Run Mode

The UESC interprets engine speed above 200 RPM as Run Mode.

The Base Spark advance (BSA) is calculated by the UESC module processing the engine speed and load (Manifold Absolute Pressure) inputs.

#### Transient Mode

This function is to provide detonation protection when the engine load is increased rapidly by fast opening of the throttle plate. Rapid increases in engine load are determined by large changes in consecutive Manifold Absolute Pressure (MAP) values to the UESC module.

#### Overspeed Mode

If the engine speed exceeds 4000 RPM the dwell will be reduced until the speed drops below 4000 RPM.

### Wiring Diagram

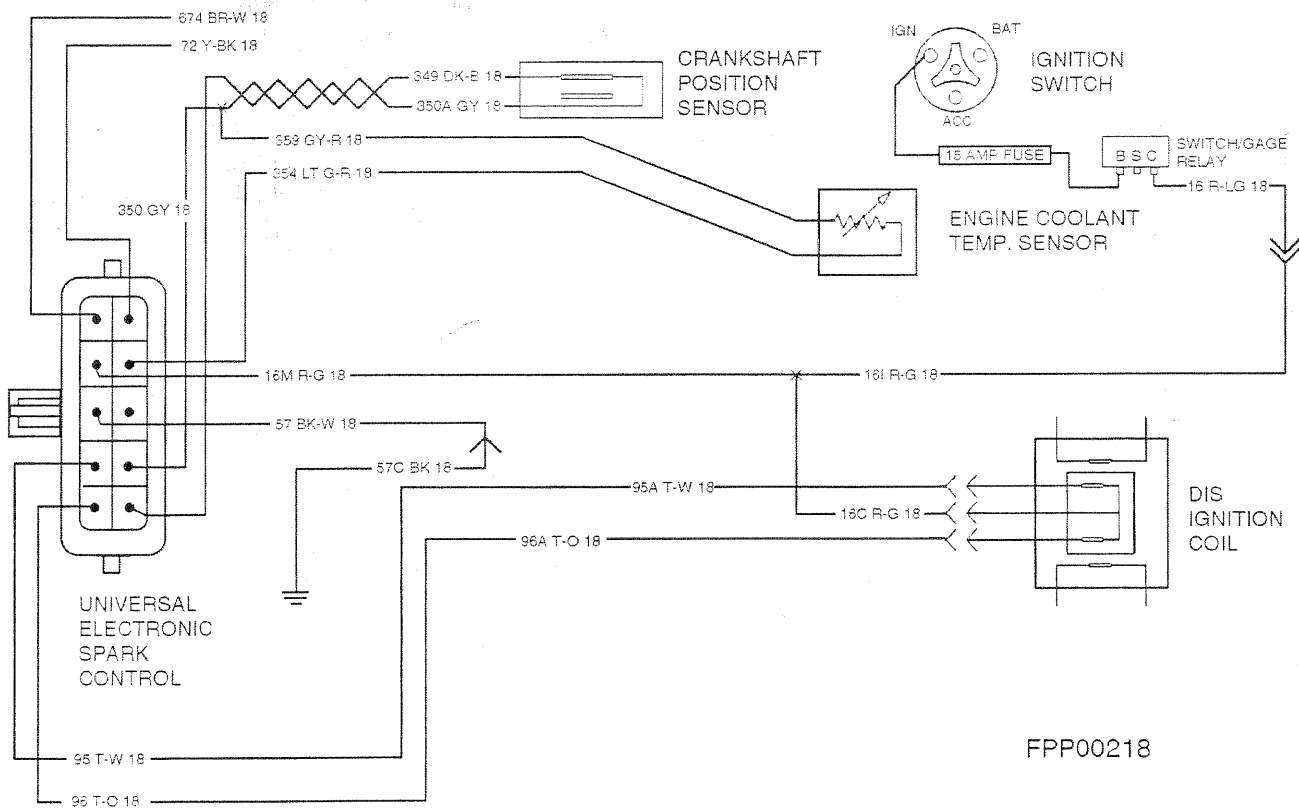

## DIAGNOSIS

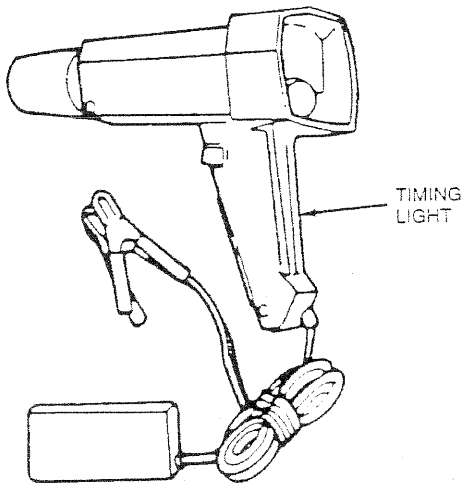

FPP00077

### Diagnosis Equipment

To accurately diagnose DIS, certain diagnostic equipment and tools are required. In addition, the suggested diagnostic equipment may make the job easier and more convenient.

- Spark tester, neon bulb type (Champion CT-436)

There is no need to disconnect a plug wire; just place this spark tester on a spark plug wire to determine if spark is being provided to the plug. This is especially useful for those hard-to-reach plug wires.

- Spark tester, gap type (D81P-666-A)

Connect this gap type spark tester between any spark plug wire and engine ground to instantly determine if spark is being provided to the plug. A spark plug with a broken side electrode is not sufficient to check for spark and may lead to incorrect results.

- Volt-ohmmeter (Rotunda 014-00575)

A volt-ohmmeter is essential for gathering system operating data during diagnosis, testing, and engine servicing procedures. This digital volt-ohmmeter (DVOM) can also be used for general purpose electrical troubleshooting on conventional starting and charging systems.

- 12 volt timing light (Rotunda 059-00006)

This timing light uses an inductive pickup for convenience and safety on 12 volt systems. This timing light includes a tachometer which reads from zero to 3000 RPM.

### Service Checks.

- Each 400 hours of engine operation remove the spark plugs and clean and adjust the electrode.
- Clean and visually check spark plug high tension leads, check for secure fit, and replace if necessary.
- Clean spark plugs as necessary using a wire brush or professional spark plug cleaner (follow manufacturer's instructions). Inspect the firing tip. Refer to Spark Plug Inspection Chart. Replace spark plugs if they are worn or damaged.
- Wipe the coil towers with a clean cloth dampened with soap and water. Remove any soap film and dry with compressed air. Inspect for cracks, carbon tracking and dirt.
- Wipe the spark plug wire set with a clean, damp cloth before inspecting it. Without removing the spark plug wire set from the spark plugs or ignition coil, inspect the wire set for visible damage such as cuts, pinches, or cracked or torn boots. Refer to Ignition Wires Removal and Installation in this section and replace as necessary.

## DIS Harness Checks

Check the following circuits with the volt-ohmmeter. Compare readings with the following chart. All sensors connected to harness. Checks are made with the UESC disconnected.

Test No.	Harness Connector Pin No.	DVOM Set Selection	Reading Ohms/VDC	Description of Circuit
1	A-B	Ohm	315-385	Crankshaft Position Sensor (CKP)
2	B-D	Ohm (1)	95,851±5%	Engine Coolant Temp. (ECT) Sensor
3	E-F	Ohm	Continuity (0 resistance)	Engine Spark Advance Circuit Base Advance (Level 0)
4	F-H	Ohm	Continuity	Engine Spark Advance Circuit
	E-H	Ohm	Infinity (open)	Level 1 Advance
5	E-H	Ohm	Continuity	Engine Spark Advance Circuit
	F-H	Ohm	Infinity (open)	Level 2 Advance
6	E-H	Ohm	Continuity	Engine Spark Advance Circuit
	F-H	Ohm	Continuity	Level 3 Advance
7	G-H	20 VDC (2)	12 VDC	UESC Power Supply Circuit
8	J-K	Ohm	0.5-1.3	Coil Primary Circuit

(1) ECTS brass only portion in 32°F ice water. for the complete range of ECTS values, see the chart on the following page.

(2) Test must be conducted with KEY ON, ENGINE OFF (KOEO).

If readings are not to specifications, complete the following:

- Remove the wire harness connector to the UESC.
- Remove each sensor or component from the harness.
- Using a high impedance digital volt-ohmmeter (DVOM) check each wire for continuity or resistance for wire numbers and colors for the harness being used.
- If the wire harness has open circuits or resistance higher than specifications, repair or replace the harness.
- If the wire harness checks are to specifications, reconnect each sensor and component and complete another DIS Harness Check.
- If the same sensor or component circuit does not test to specifications, replace that sensor or coil.
- If the engine will not start and/or run, install a new module and make a normal start.

### Secondary Resistance Checks

Test No.	Test Connections	DVOM Set Selection	Reading Ohms/VDC	Description of Circuit
1	Coil Secondary Towers 1-4	Ohm	14,000	Coil Secondary Circuit
2	Coil Secondary Towers 2-3	Ohm	14,000	Coil Secondary Circuit
3	Ends of Each Spark Plug Wire	Ohm	9,000 to 16,000 Max. -30,000	Spark Plug Wire Resistance

### Engine Coolant Temperature sensor Characteristics

°C	°F	Ohms (± 5%)
-30	-22	496,051
-20	4	209,816
-10	14	160,313
0	32	95,851
10	50	58,987
20	68	37,340
30	86	24,253
40	104	16,113
50	122	10,926
60	140	7,548
70	158	5,335
80	176	3,837
90	194	2,804
100	212	2,080
110	230	1,564
120	248	1,191
130	266	918
140	284	715
150	302	563

### Spark Plug Inspection

#### Carbon Fouled

- Caused by:
- \* too cold a plug
  - \* dirty air cleaner
  - \* defective fuel pump
  - \* too rich a fuel mixture
  - \* faulty heat riser
  - \* excessive idling

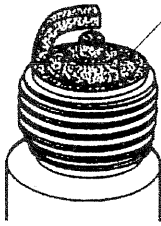

Black, dry fluffy carbon deposits all over.

Spark plug can be cleaned.

#### Oil Fouled

Caused by excessive oil entering combustion chamber.

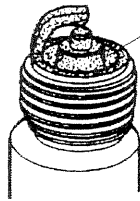

Wet black deposits all over.

Correct oil problem and replace the plug.

#### Normal

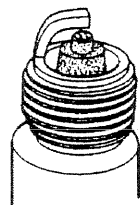

Identified by light tan or gray deposits on the firing tip.

#### Gap Bridged

Caused by oil or carbon fouling.

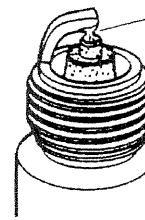

Deposit build-up closing gap.

If deposits are not excessive the plug can be cleaned.

#### Overheating

- Caused by:
- \* engine overheating
  - \* wrong type of fuel
  - \* loose spark plugs
  - \* too hot a plug
  - \* low fuel pump pressure
  - \* incorrect ignition timing

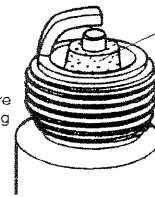

White or light gray insulator with small black or gray brown spots and with bluish-burnt appearance of electrodes.

Replace the spark plug.

#### Pre-Ignition

- Caused by:
- \* wrong type of fuel
  - \* incorrect ignition timing
  - \* too hot a plug
  - \* burnt valves
  - \* engine overheating

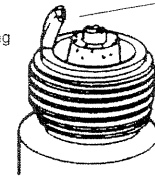

Melted electrodes and possibly blistered insulator.

Replace the plug. Metallic deposits on insulator indicate engine damage.

#### Fused Spot Deposit

Caused by sudden acceleration.

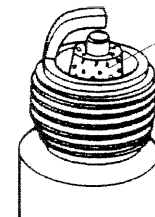

Melted or spotty deposits resembling bubbles or blisters.

If not excessive, plug can be cleaned. Otherwise replace plug.

## REMOVAL AND INSTALLATION

### Ignition Coil Removal

1. Disconnect battery ground cable.
2. Disconnect ignition coil multiplug.

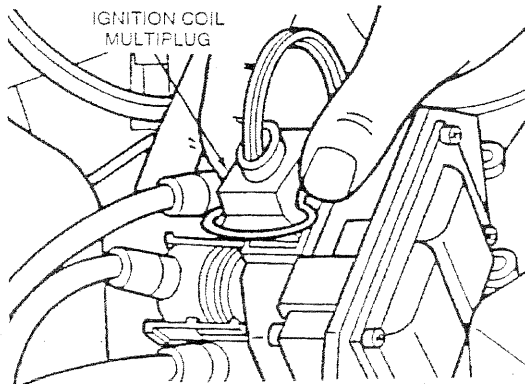

FPP00078

3. Squeeze the locking tabs on the coil retainer and pull upward on the boot with a slight side-to-side twist.



**CAUTION:** Do not pull on the spark plug wire set.

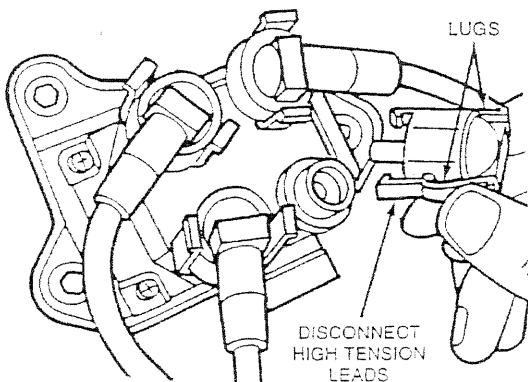

FPP00079

4. Remove four screws
5. Remove the ignition coil assembly.

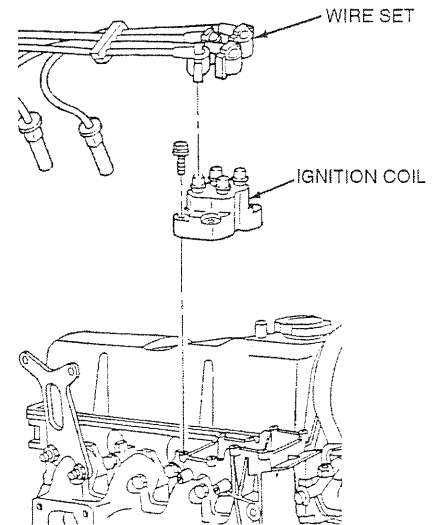

FPP00225

### Ignition Coil Installation

1. Position coil assembly, secure with four screws.
2. Tighten screws to 4.5-7 N•m (36-63 lb-in).
3. Connect HT leads at coil, ensuring that locking tabs snap into position.

NOTE: HT connections at coil are marked 1 to 4. It is important that each HT lead is connected in correct sequence.

4. Connect ignition coil multiplug.
5. Connect battery ground cable.
6. Start engine and check coil operation.

## Crankshaft Position Sensor Removal

1. Disconnect battery ground cable.
2. Drain cooling system.
3. Using flex handle, rotate drive belt tensioner and remove drive belt.
4. Disconnect generator connectors.
5. Remove three bolts and generator.
6. Remove lower radiator hose and heater water hose from water pump inlet tube.

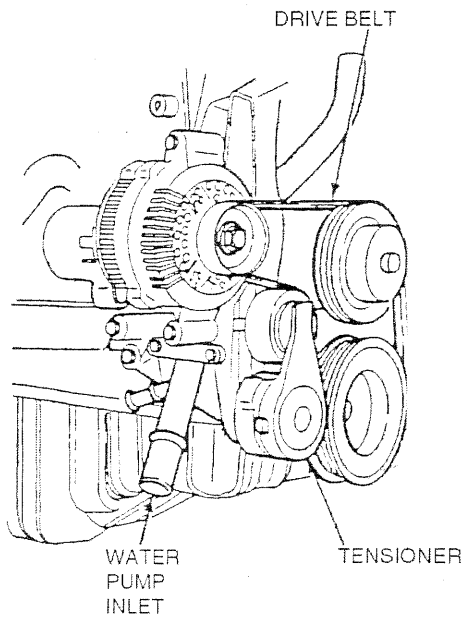

FPP00221

7. Remove two bolts and water pump inlet tube.
8. Remove o-ring from water pump inlet tube.

9. Disconnect multiplug from sensor.

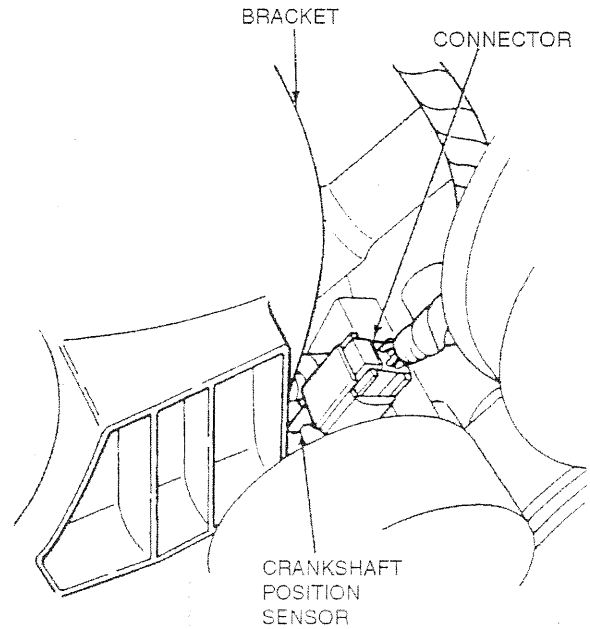

FPP00222

10. Remove one screw.

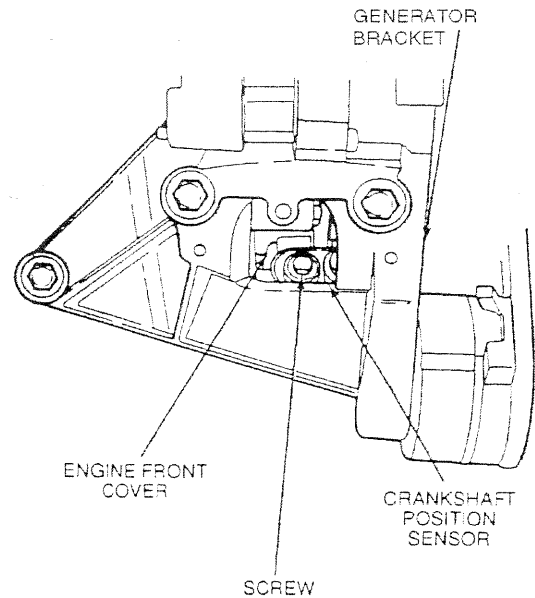

FPP00223

11. Carefully pry crankshaft position sensor from engine front cover.

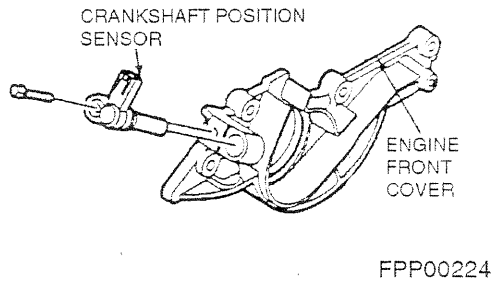

### Crankshaft Position Sensor Installation

NOTE: Engine front cover design precisely locates crankshaft position sensor so no adjustment is required.

1. Fit engine speed sensor.
2. Install screw and tighten to 8-12 N•m (72-108 lb-in).
3. Connect crankshaft position sensor.
4. Install new o-ring on water pump inlet tube.
5. Install water pump inlet tube into water pump.
6. Install water pump inlet tube to generator bracket bolts and tighten to 9-12 N•m (84-108 lb-in).
7. Install lower radiator hose and heater water hose on water pump inlet tube.
8. Install generator to generator mounting bracket and hand start generator to bracket bolts. Alternately tighten bolts to 41-54 N•m (30-40 lb-ft).
9. Connect generator electrical connectors.
10. Position drive belt. Rotate drive belt tensioner, position drive belt and rest tensioner pulley on belt.
11. Connect battery ground cable.
12. Fill cooling system.

### Engine Coolant Temperature Sensor Removal

- 1.
2. Disconnect battery and release cooling system pressure.



**WARNING: WHEN RELEASING SYSTEM PRESSURE, COVER CAP WITH A THICK CLOTH TO PREVENT COOLANT**

### SCALDING.

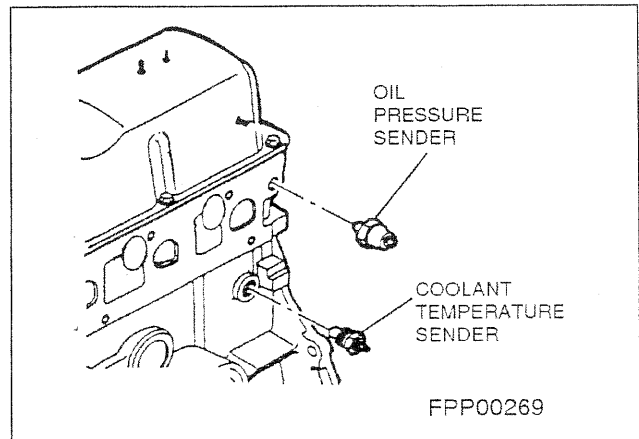

3. Place a clean drain tray below engine under radiator drain plug and remove drain plug. To assist draining remove radiator cap. Drain sufficient coolant to lower the level below the temperature sensor.
4. Remove temperature sensor multiplug. To remove multiplug, pull on multiplug, do not pull on wiring.
5. Unscrew the sensor.

### Engine Coolant Temperature Sensor Installation

1. Install the sensor. Do not overtighten. Connect multiplug, ensuring that locking tabs snap into position.
2. Replace radiator drain plug and refill system with correct solution. Remove rubber blanking cap on water outlet. When coolant is evident, refit blanking cap. Fill container to "maximum" mark allowing time for air in system to bubble through. Install radiator cap.
3. Connect battery and start engine. Allow engine to warm to normal operating temperature. Check and, if necessary, add coolant.

## Ignition Wires Removal

Special Tools Required	
Spark Plug Wire Remover	T74P-6666-A

1. Remove spark plug wires from spark plugs with Spark Plug Wire Remover T74P-6666-A, pulling outward on the boot with a slight side-to-side twist.



**CAUTION:** Do not pull on the spark plug wire set.

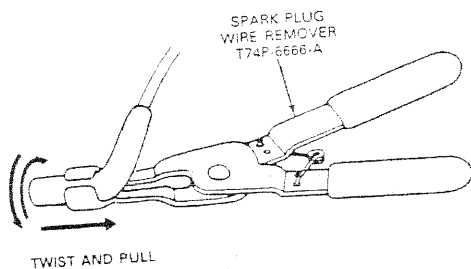

FPP00089

2. Squeeze the locking tabs on the coil retainer and pull upward on the boot with a slight side-to-side twist to disconnect the spark plug wire set from the ignition coil.



**CAUTION:** Do not pull on the spark plug wire set.

## Ignition Wires Installation

1. Apply an even coating of Silicone Dielectric Compound WA-10, D7AZ-19A331-A, or equivalent, meeting Ford specification ESE-M1C171-A to the entire interior surface of the spark plug boot.
2. Squeeze locking tabs on coil retainer and push down on boot with a slight side-to-side twist to connect spark plug wire set on the ignition coil. Each of the terminals is identified on the ignition coil. The firing order of the coil is 1-3-4-2. Check that each of the spark plug wires is fully seated and both locking tabs are engaged.

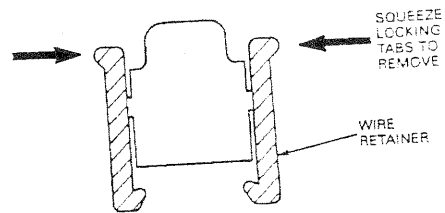

FPP00090

3. Remove the ignition wire separator from the spark plug wire set and reinstall it in the same relative position on the new set.
4. Route the spark plug wire set toward the spark plugs.
5. Connect each spark plug wire set on the proper spark plug.

## Spark Plug Removal

**NOTE:** Refer to the Spark Plug Inspection Chart to determine spark plug condition.

1. Remove ignition wires as outlined.
2. Loosen spark plugs and remove any dirt or foreign material from spark plug areas of cylinder head with compressed air.
3. Remove spark plugs and mark location using a piece of masking tape.
4. To install, reverse removal procedure. Check and adjust spark plugs. Tighten spark plugs to 9-20 N•m (7-15 lb-ft).

# ADJUSTMENT

## Ignition Timing

In the event that the engine is operated on dry fuels, the timing can be modified by grounding, leaving open, or applying 12 volts to circuits 674 and 72 of the module connector. The fuel type determines which circuit is altered as shown in the chart below.

	NORMAL OPERATION			IF DETONATION OCCURS		
	Circuit 674 (BR-W)	Circuit 72 (Y-BK)	Timing effect	Circuit 674 (BR-W)	Circuit 72 (Y-BK)	Timing effect
Gasoline	open	open	base = 15°	open	ground	base = 12°
LPG	ground	open	base = 30°	ground	ground	base = 27°
Natural gas	ground	+12 volts	base = 35°	ground	open	base = 30°

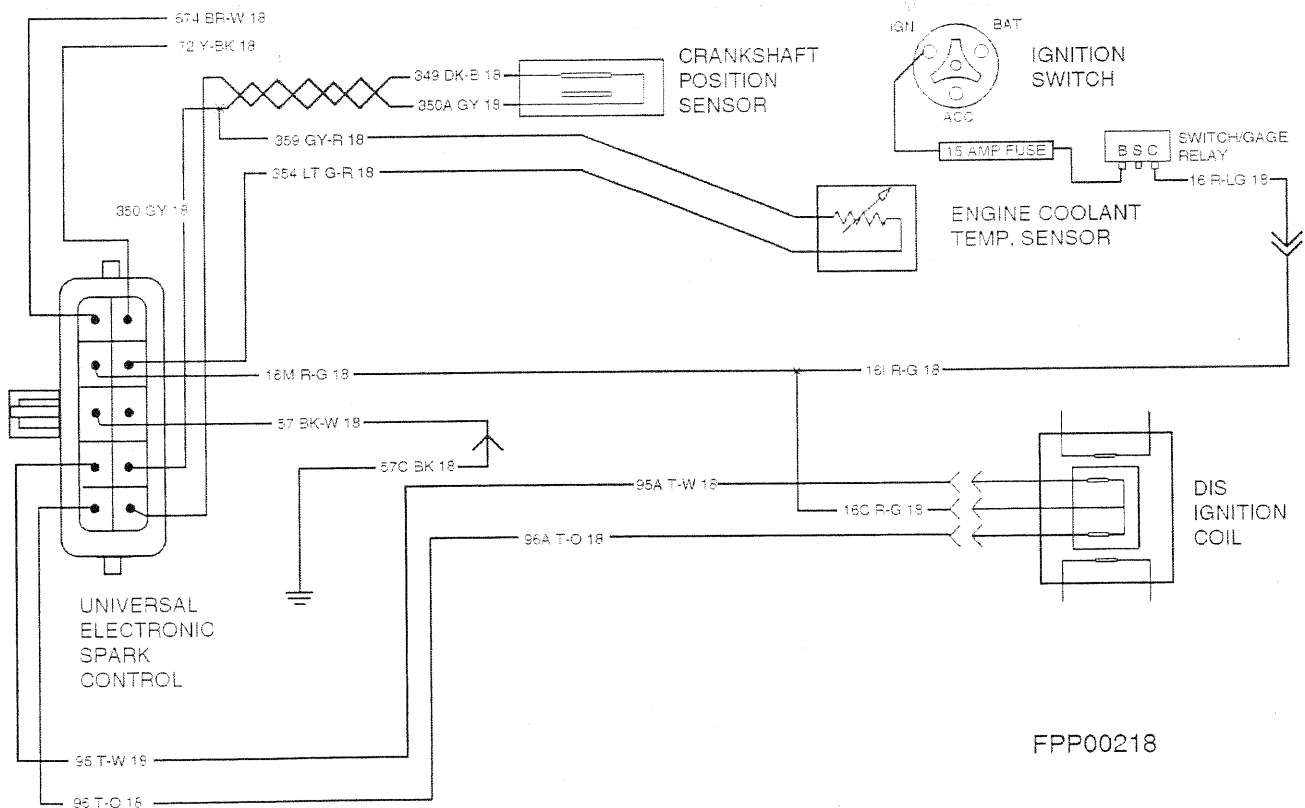

## SPECIFICATIONS

### General Ignition

Firing Order	Ignition Timing	Plug Type	Plug Gap
1-3-4-2	10° ±1	AWSF-52C	1.07-1.17mm (.042-.046 in.)

### Torques

Description	N•m	lb-ft	lb-in
Spark Plugs	9-20	7-15	
Coil Mounting Screws	5-7		44-62
Crankshaft Hub Bolt	125-165	93-121	
Crankshaft Position Sensor	8-12		71-106

### Special Tools

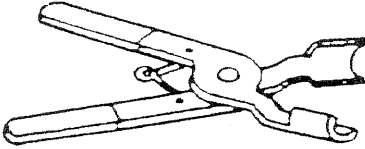
Special Tools Required	
Spark Plug Wire Remover	T74P-6666-A
	
FPP00091	

<b>SECTION TITLE</b>	<b>PAGE</b>
ENGINE SERVICE - General .....	01-01
ENGINE SERVICE - 2.5L .....	02-01
IGNITION SYSTEM .....	03-01
FUEL PUMP .....	04-01
CARBURETOR.....	05-01
STARTER MOTOR.....	06-01
GOVERNOR.....	07-01
COOLING SYSTEM .....	08-01
GENERATOR .....	09-01

---

## SECTION 04 - FUEL PUMP

---

<b>SUBJECT</b>	<b>PAGE</b>
DESCRIPTION - EFI.....	2
DESCRIPTION - CARB.....	3
DIAGNOSIS .....	4
Electrical.....	4
Fuel Supply and Pressure.....	4
SPECIFICATIONS .....	5

**REFER TO SEPARATE PUBLICATION ON ELECTRONIC FUEL INJECTION (EFI) SYSTEMS  
FOR INFORMATION ON THAT SYSTEM.**



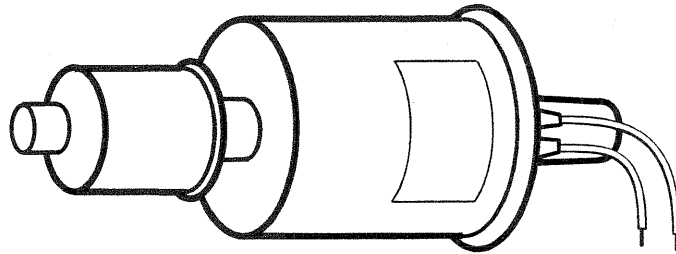

FPP00489

## DESCRIPTION - CARB.

The carbureted fuel system includes a remote mounted electric fuel pump.



**CAUTION:** The electric fuel pump **MUST NOT** be mounted directly on the engine assembly, as engine vibration will shorten the life of the pump.

The fuel pump regulates and maintains fuel flow which will be used to provide necessary fuel for combustion.

This Section deals with the carbureted system only. Refer to the separate publication on electronic fuel injection for information on this system.

## DIAGNOSIS

NOTE: For the following tests, TEMPORARILY place a jumper wire across the terminals of the oil pressure switch.

### Electrical

1. Connect the positive lead of a voltmeter to the pump power wire, and the negative lead to the pump housing.
2. Turn on the ignition switch.
3. The voltmeter should read 12 volts. If not, check the power supply to the pump, and the ground wire between pump housing and engine cylinder block.
4. ONCE YOU HAVE ESTABLISHED THE INTEGRITY OF THE POWER SUPPLY AND GROUND to the pump, if it still will not operate replace the pump assembly.

### Fuel Supply and Pressure

If a problem with fuel supply or delivery is suspected, first ensure that there is fuel in the tank. Then, proceed as follows:

1. Tee a pressure gauge into the fuel line at the carburetor inlet.
2. Turn on the ignition switch, but do not start the engine.
3. The pump should "click" rapidly for a short time, and pressure should build to, and level off at, 3.5 to 5 psi.

4. If pressure fails to come up, check for an obstruction in the supply line from the tank to the pump, and between the pump and carburetor.
5. Ensure that the fuel cap vent is operating properly. The vent should allow air to enter the tank as fuel is removed. Correct any obstruction or restriction found.

NOTE: IF NO OBSTRUCTION IS FOUND, AND THE ELECTRICAL SUPPLY, GROUND, AND FUEL SUPPLY TO THE PUMP AS DESCRIBED ABOVE ARE VERIFIED ALL RIGHT, REPLACE THE PUMP ASSEMBLY.

1. Start the engine and allow it to come up to operating temperature.
2. Set the throttle control to high idle. Place as full a load onto the engine as possible.
3. Fuel pressure should be maintained at a minimum of 3.5 psi.
4. If fuel pressure cannot be maintained, verify that all of the above checks have been carried out.

IF ALL OF THE ABOVE CHECKS HAVE BEEN CARRIED OUT, AND FUEL PRESSURE CANNOT BE MAINTAINED, REPLACE THE FUEL PUMP ASSEMBLY.

**WARNING: ONCE ALL OF THE ABOVE TESTS**



**ARE COMPLETED, REMOVE THE JUMPER WIRE FROM THE OIL PRESSURE SWITCH.**

For additional diagnostic information, see the Service Check Chart below.

CONDITION	POSSIBLE SOURCE	ACTION
Insufficient fuel delivery	<ul style="list-style-type: none"> <li>• Clogged pump filter, screen, or fuel filter.</li> <li>• A break or restriction in fuel lines</li> <li>• An incorrect float level, malfunctioning inlet needle valve, or clogged inlet screen in the carburetor.</li> </ul>	<ul style="list-style-type: none"> <li>• Clean or replace filter.</li> <li>• Repair fuel line or remove restriction.</li> <li>• Repair or replace as needed.</li> </ul>
Pump not operating	<ul style="list-style-type: none"> <li>• Damaged, loose ground, or improper wiring.</li> </ul>	<ul style="list-style-type: none"> <li>• Inspect all mounting or wiring.</li> </ul>
Carburetor flooding	<ul style="list-style-type: none"> <li>• Worn needle and seat assembly in carburetor.</li> <li>• Wrong pump application; that is, standard pressure pump for low pressure application.</li> <li>• Air leak on inlet side of pump due to holes in fuel line or loose fittings.</li> </ul>	<ul style="list-style-type: none"> <li>• Replace worn needle and seat assembly in carburetor.</li> <li>• Change to a low pressure pump.</li> <li>• Replace fuel line, and tighten fittings (apply a sealer, if necessary).</li> </ul>
Fuel pump leaks	<ul style="list-style-type: none"> <li>• Fuel line fitting connections at pump are loose or dirty.</li> </ul>	<ul style="list-style-type: none"> <li>• Tighten and clean all connections at pump.</li> </ul>

**SPECIFICATIONS**

ITEM	SPECIFICATION
Shutoff pressure	3.5 - 5 psi
Maximum current draw	1.5 amp.
Minimum flow @ 3 psi, 12 volt input	3 GPH

<b>SECTION TITLE</b>	<b>PAGE</b>
ENGINE SERVICE - General .....	01-01
ENGINE SERVICE - 2.5L .....	02-01
IGNITION SYSTEM .....	03-01
FUEL PUMP .....	04-01
CARBURETOR.....	05-01
STARTER MOTOR.....	06-01
GOVERNOR.....	07-01
COOLING SYSTEM .....	08-01
GENERATOR .....	09-01

---

## SECTION 05 - CARBURETOR

---

<b>SUBJECT</b>	<b>PAGE</b>
DESCRIPTION.....	2
Fuel Supply System.....	2
Idle System.....	2
High Speed System.....	3
Accelerating Pump System.....	3
DIAGNOSIS.....	4
Percolation.....	4
Flooding.....	4
Hard Starting .....	4
Stalling .....	4
Rough Idle.....	5
Surging Above Idle.....	5
Poor Acceleration.....	5
Leaking Carburetor.....	5
Inconsistent Idle Speed .....	5
Reduced Power Output.....	5
DISASSEMBLY AND ASSEMBLY .....	6
Cleaning and Inspection.....	6
Air Intake Assembly .....	7
Fuel Bowl Assembly.....	8

**REFER TO SEPARATE PUBLICATION ON ELECTRONIC FUEL INJECTION (EFI) SYSTEMS FOR  
INFORMATION ON THAT SYSTEM.**

## DESCRIPTION

On each carburetor an identification tag is found on the carburetor body. Do not remove this tag for any reason. The numbers stamped on this tag identify the carburetor for the particular engine usage. These numbers are used when finding specifications for carburetor adjustments or in ordering replacement parts.

The Zenith model #33 carburetor is a single downdraft unit of two-piece construction, consisting of a cast aluminum air intake and throttle body with a fuel bowl. The single venturi is removable for easy adaptability to meet different size engine requirements.

The mounting flange holes are elongated to allow it to fit either the SAE 1" or 1 1/4" flange. A vacuum-operated accelerator pump is used.

### Fuel Supply System

The fuel supply system consists of the threaded fuel inlet connection and fuel valve seat, fuel valve, float and fuel chamber. The fuel supply line is connected to the threaded inlet. Gasoline passes through the connection, through the fuel valve seat and past the fuel valve and into the fuel chamber. The level of the fuel in the fuel chamber is regulated by the float through its control of the fuel valve. The fuel valve does not open and close alternately. It assumes a more or less fixed-opening position as regulated by the float, sufficient to maintain a proper level in the fuel chamber equal to the fuel demand of the engine according to its speed and load.

### Idle System

The idle system supplies fuel to run the engine at curb idle and also slow speeds until sufficient velocity is built up in the main venturi to operate the main system.

This system consists of the idle discharge holes, the idle adjusting needle, the passage or channel between the idle jet and the discharge holes, the idle air bleed, and the idle jet and pickup tubes.

At idling speeds, manifold vacuum is transmitted through the primary idle discharge hole to the idle jet through a passage running through the throttle and air intake bodies. Fuel from the fuel bowl flows through the main jet into the fuel well where it is picked up by the pickup tube to be metered by the idle jet.

As the fuel leaves the idle jet it is mixed with air from the idle air bleed, which is located just above the jet in the air intake, therefore a fuel and air mixture is provided just before the passage to the idle discharge holes. This air bleed calibration is to provide better control of the fuel delivery and to prevent the fuel in the bowl from being siphoned into the intake manifold through the idle system when the engine is shut off.

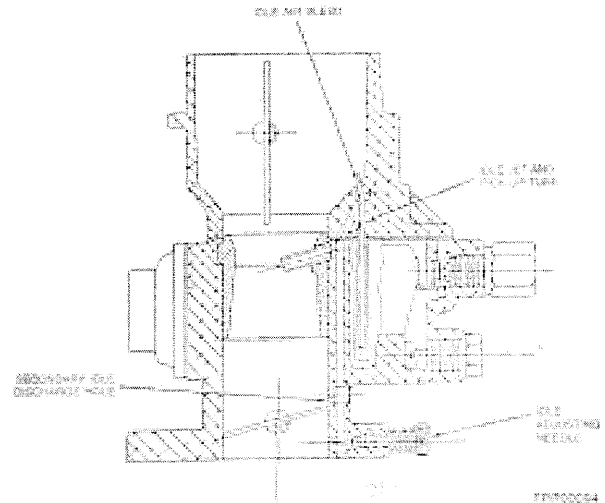

The discharge of the idle fuel into the air stream at curb idle is controlled by the idle adjusting needle in the primary idle discharge hole. Turning the needle out (counterclockwise) allows a richer mixture.

As the throttle plate opens, extra fuel is discharged from the secondary idle discharge holes as the throttle plate passes them. This hole is precisely located from the closed throttle plate with the size and location depending on fuel requirements. As the throttle plate is opened wider, the idle system gradually ceases to function. The delivery of fuel through the high speed system increases as the throttle plate is advanced. Although the delivery of fuel through the idle system diminishes as the throttle plate approaches the wide open position, it continues to deliver a small volume of fuel contributing to the fuel delivered by the high speed system. It cannot be said that the idle system ceases to deliver fuel entirely at wide open throttle, but it must be made clear that the amount of fuel delivered from the idle system at wide open throttle is minute and relatively unimportant.

## High Speed System

The high speed system consists of a venturi, a main jet, a well vent, and a well tube. This system also controls the mixture at part throttle speed.

the main jet controls fuel delivery from about one quarter to three quarters throttle opening. To maintain a proper mixture ratio, a small amount of air is admitted through the well vent. There are also air bleed holes located in the well tube at a point below the level of fuel in the well. Introducing air into the well tube below the level of fuel, reduces the surface tension of the fuel and helps fuel flow at low suction. This bleed also restricts fuel flow through the main jet under high suction.

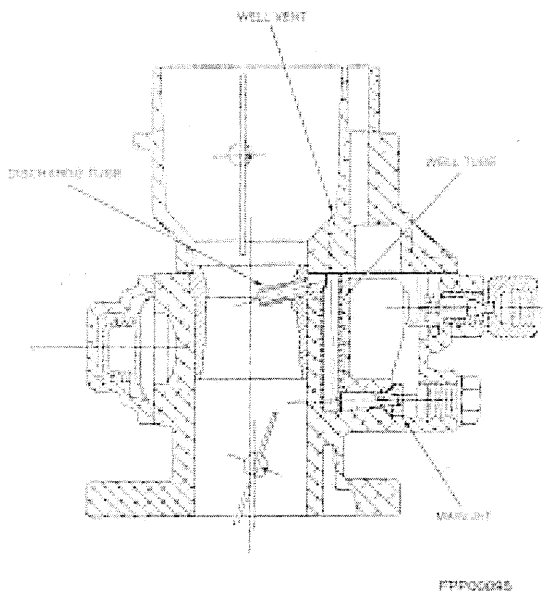

When the throttle plate is opened to a point just above the idle position, enough air passes through the carburetor to lower the pressure at the discharge tube. The float chamber is open to atmospheric pressure; consequently, the greater pressure in the float chamber will cause the fuel to flow from the fuel bowl through the main jet into the main well and well tube.

Air admitted through bleed holes in the well tube, an amount measured by the well vent, is mixed with the fuel. This mixture of fuel from the main well tube passes through the discharge tube in the venturi and is added to the air stream in the venturi. This mixture then passes into the intake manifold.

## Accelerating Pump System

The accelerating pump controls the amount of fuel that is discharged into the air stream on sudden throttle openings. When the throttle is opened suddenly, air rushes through the carburetor into the intake manifold and to the engine. This air is lighter than the liquid fuel and gets into motion more quickly. That means that the air reaches the cylinders of the engine before the first charge of fuel supplied by the high speed system. A lean mixture would result momentarily in this case, and to counteract the condition, additional fuel must be supplied instantly. The supply of that extra fuel is the job of the accelerating pump system.

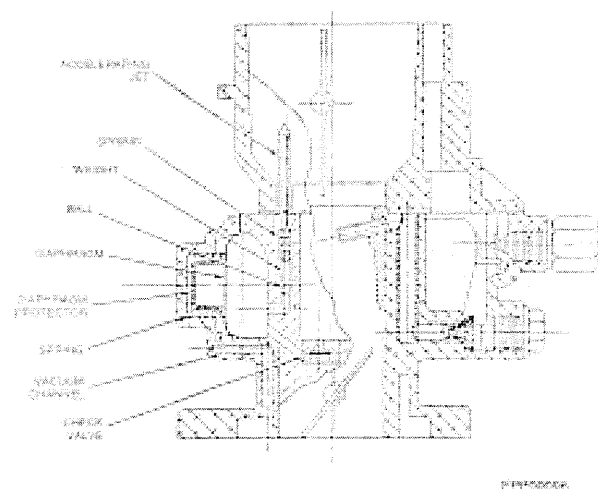

The accelerating system consists of the pump diaphragm assembly, accelerating jet, intake check valve, and three parts making up the refill check. The pump is vacuum operated. In this system the pump diaphragm is pulled against the pump spring by the engine manifold vacuum. When the throttle is opened, the pull on the diaphragm drops allowing the spring to push the diaphragm against the fuel causing it to discharge through the accelerator jet. This amount may be varied by adjusting the travel of the pump spring. Such adjustment is made possible by changing the length of the diaphragm protector and the end of the pump spring.

## DIAGNOSIS

Water and dirt that accumulate in the fuel tank can cause a restricted fuel line or filter and malfunction of the fuel pump or carburetor. Condensation, which is the greatest source of water entering the fuel tank, is formed by moisture in the air when it strikes the cold interior walls of the fuel tank.

If the accumulation of dirt and water in the filter is excessive, the fuel tank should be removed and flushed, and the line from the fuel pump to the tank should be blown out. Air leakage in the fuel inlet line can cause low fuel pump pressure and volume.

A restricted fuel tank vent can cause low fuel pump pressure and volume and can result in collapsed inlet hoses or a collapsed fuel tank. High or low pressure and the two most likely fuel pump troubles that will affect engine performance. Low pressure will cause a lean mixture and fuel starvation at high speeds and excessive pressure will cause high fuel consumption and carburetor flooding.

Dirt accumulation in the fuel and air passages, improper idle adjustments, and improper fuel level are the major sources of carburetor troubles.

Many problems attributed to the carburetor are caused by other systems. Proper and careful diagnosis is a must.

If the problem seems to occur in one engine cylinder, the ignition system may be at fault. If the problem seems to occur in all engine cylinders, then the problem most likely is carburetion. When the carburetor is thought to be at fault, check the fuel system first. Dirt or water in the gas tank, leaks in the fuel lines, or a defective fuel pump often show the same symptoms as carburetion problems.

Observation, pressure and volume tests on the fuel system show whether the fuel system is the cause of the problem.

When the carburetor is shown to be at fault, a simple cleaning may often solve the problem. Spraying a carburetor cleaning solvent into the carburetor's air intake assembly with the engine running may solve the problem.

## Percolation

Percolation symptoms are a strong smell of fuel vapors and hard starting of a hot engine that has been sitting for 20 minutes. Fuel drips from the end of the throttle shaft or from the main discharge nozzle causing a rich mixture in the air intake. Opening the choke completely and cranking the engine clears the vapors and eliminates percolation.

## Flooding

Flooding occurs from a float level set too high, a sticking choke plate, float, or float valve, or a fuel inlet needle held off its seat either by improper seating or dirt particles. A punctured or leaking float admitting fuel becomes gas-logged causing a heavy float, high fuel level and flooding.

Flooding has decreased due to the use of fuel filters and Vitron fuel inlet needles. If flooding does occur, disassemble the carburetor, observe the operation and condition of components, and repair or replace as necessary.

## Hard Starting

Hard starting when attributed to the carburetor is caused by a flooded engine due to improper starting procedures. An improper idle fuel mixture, sometimes due to improper fuel mixture, or idle fuel mixture adjusting needles not turned equally in relation to the other adjusting needle causes hard starting. A too high or too low float level, due to misadjustment or wear also causes hard starting. Repair, adjust or replace components as necessary.

## Stalling

Improper idle air/fuel mixture or an idle speed set too low causes an engine to stall. Adjust these systems as necessary. The stalling problem may be due to a loose throttle shaft in the bore of the throttle body. Repair as necessary. Clogged idle air bleeds, idle air passages, or an idle discharge port cause stalling. Cleaning eliminates this problem. Carburetor icing is also a cause of stalling.

## Rough Idle

An improper idle air/fuel mixture can cause rough idle. This may be due to improper adjustment or damaged, worn or grooved idle mixture adjusting screws. Rough idle is caused by too high or too low a fuel level due to floats misadjusted or damaged. A leak between the carburetor and intake manifold, due to a carburetor not tightened down, a damaged gasket or a crack in either the carburetor or intake manifold causes rough idle. Adjust, repair, or replace as necessary. Clogged idle air bleeds, restricted idle air passages or idle discharge ports also cause rough idle. Clean or repair as necessary.

## Surging Above Idle

Surging above idle is caused by a fuel level too low, due to an improperly adjusted float, clogged main jets, restricted main jet passages, or main jet having a size not suited for the application. Adjust, clean, or replace as necessary.

## Poor Acceleration

Poor acceleration is caused by a mixture being too rich or too lean. If a rich mixture is the cause of poor acceleration, the fault may be an improperly adjusted accelerator pump, a fuel level too high due to damaged or misadjusted floats, fuel inlet needle not seating due to damage or restriction, restricted air bleeds, or a worn or damaged main jet. Adjust, repair or replace as necessary.

If a lean mixture is the cause of poor acceleration, the fault may be an improperly adjusted accelerator pump, a damaged accelerator pump piston cap, an accelerating pump check valve that is missing, damaged, or not seating, a fuel float level set too low, a clogged main metering jet, or a restricted main fuel passage. Air leaks are also responsible for a lean mixture causing poor acceleration. Leaks may occur at the carburetor base to the intake manifold, or the intake manifold to the cylinder head. Cracks in the assemblies or worn gaskets cause these air leaks. Clean, adjust, repair or replace as necessary.

## Leaking Carburetor

The causes of a carburetor leaking fuel are loose fuel connections or a cracked carburetor body. Repair or replace as needed.

## Inconsistent Idle Speed

Inconsistent idle speed is mostly a throttle related problem. An incorrect throttle linkage adjustment, a binding throttle linkage, a sticking throttle shaft, or a loose throttle shaft in the throttle body or bore can cause inconsistent idle speed. A sticking fuel inlet needle can also cause this problem. Repair, replace or adjust as necessary.

## Reduced Power Output

Reduced power output is caused by a choke not fully opened, an improperly adjusted throttle linkage, a throttle not opening fully, a main jet not suited for this application, or clogged main jets, main fuel passage, or air bleeds. Clean, adjust, repair, or replace as necessary.

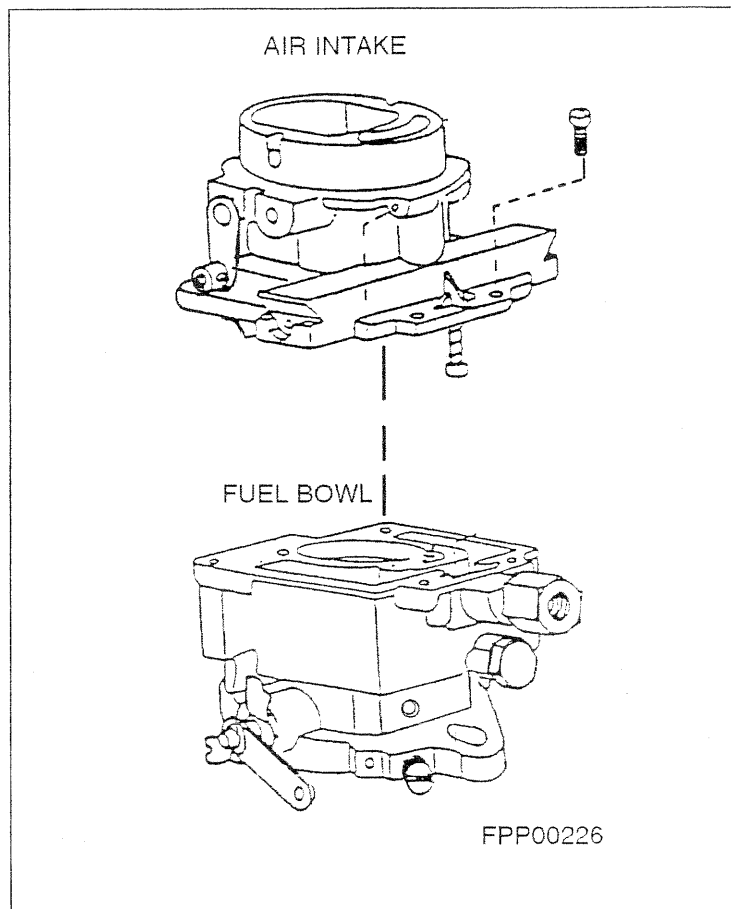

## DISASSEMBLY AND ASSEMBLY

Disassembly consists of separating the carburetor into two basic groups:

- air intake
- fuel bowl/throttle body

### Cleaning and Inspection

Thoroughly clean all metal parts in solvent or deepclene. Blow out all parts and channels with air pressure. Inspect for damage, excessive wear, burrs or warpage. DO NOT CLEAN NON-METALLIC PARTS in solvent or Deepclene.

NOTE: The following assembly instructions and the exploded illustration are generalized and include all parts possibly found in the carburetor at this time. Therefore, all of the parts shown and mentioned may not be included in the particular assembly being worked on.

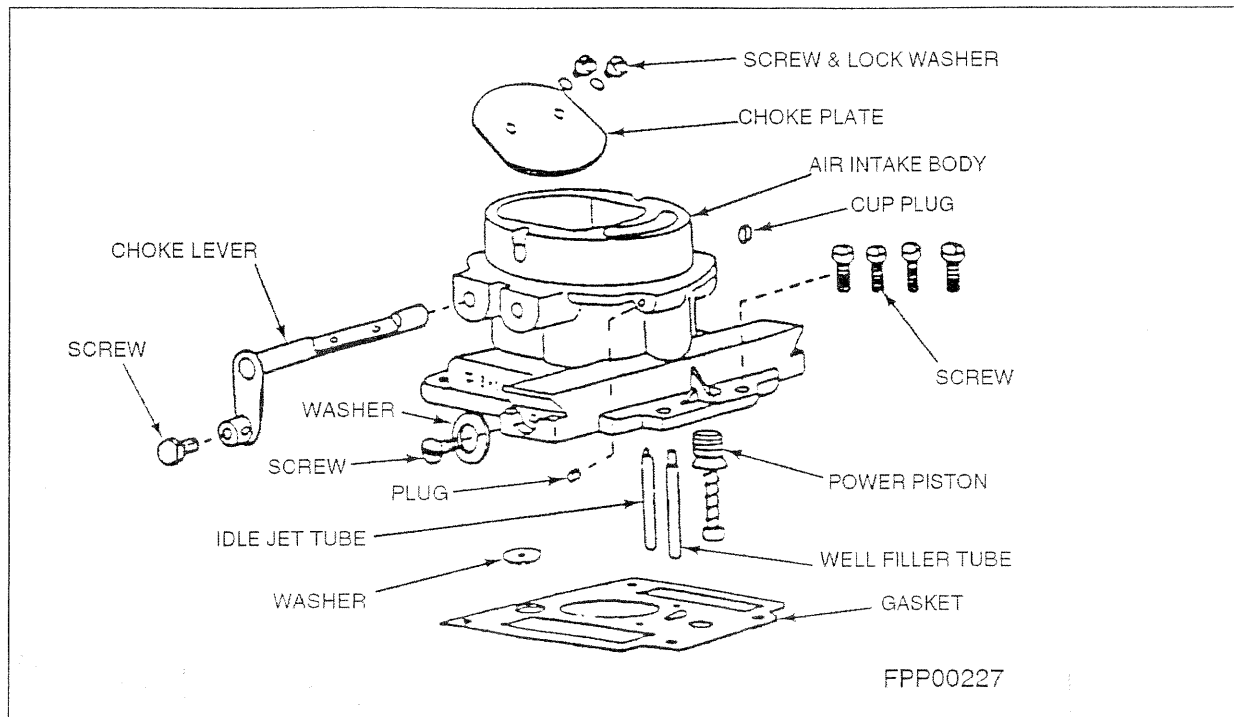

### Air Intake Assembly

1. Drive channel plug into vacuum channel flush with surface.
2. Drive cup plug into end of choke shaft hole opposite choke lever.
3. Insert choke shaft with milled flat toward top.
4. Install choke plate in air intake and start screws.

NOTE: Edges are beveled to fit against wall when closed. On plates including poppet valve, the spring should face the top. Hold choke plate closed with finger and tighten screws.

1. Turn air intake upside down and insert vacuum power piston into cylinder, making sure it will move freely. Hold in place and stake casting with punch at three points to retain piston assembly.
2. Press well filler tube into casting with rolled down orifice into casting until the bottom end is 1.25 inches from the cast surface. Do not bend or distort.
3. Press idle tube into casting with rolled down orifice into casting until the bottom end is 1.25 inches from the cast surface. Do not bend or distort.

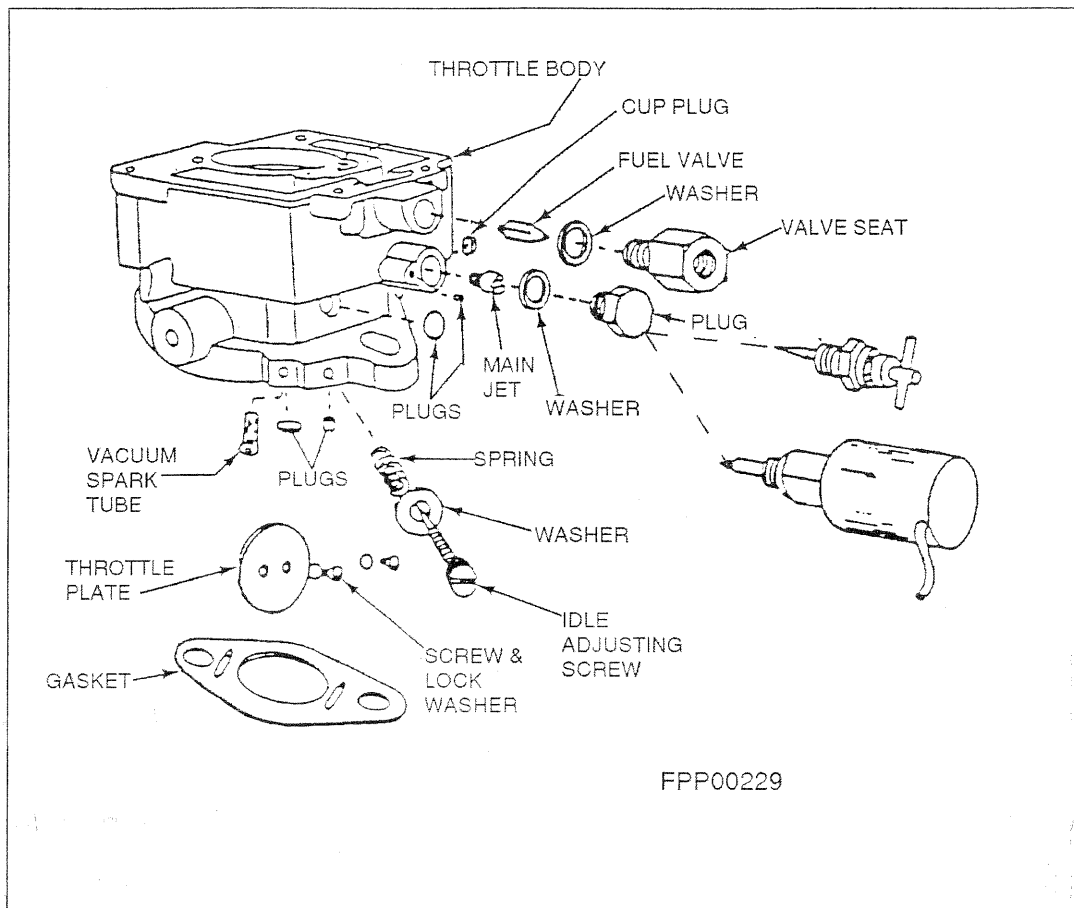

### Fuel Bowl Assembly

1. Install the following parts as needed (not normally removed for service):
  - a) Cup plug in shaft hole flush.
  - b) Fuel channel plug flush.
  - c) Welch plug over idle port.
  - d) Idle channel plug flush.
  - e) Welch plug over spark vacuum port.
  - f) Spark vacuum tube to approximately 9/16 from casting.
  - g) Throttle body plug flush.
  - h) Pump Check Valve flush using tool C151-53.
  - i) Well tube making sure that end openings align with notch in casting at top and fuel channel at bottom.
2. Slide seal over throttle shaft with lip toward lever and install shaft in body.
3. Back out throttle stop screw and place body on bench with mounting flange up.
4. With milled flat up, install throttle plate with short side toward idle port and start screws. Make sure beveled sides of plate are next to throttle body bore. Tap the plate lightly (plate held closed) to center it and tighten screws.
5. While holding throttle closed, screw idle stop screw in until it touches the casting, then screw in an additional 3/4 turn.
6. Install idle needle washer and spring and screw in to gently touch the seat. Back screw out approximately one turn.

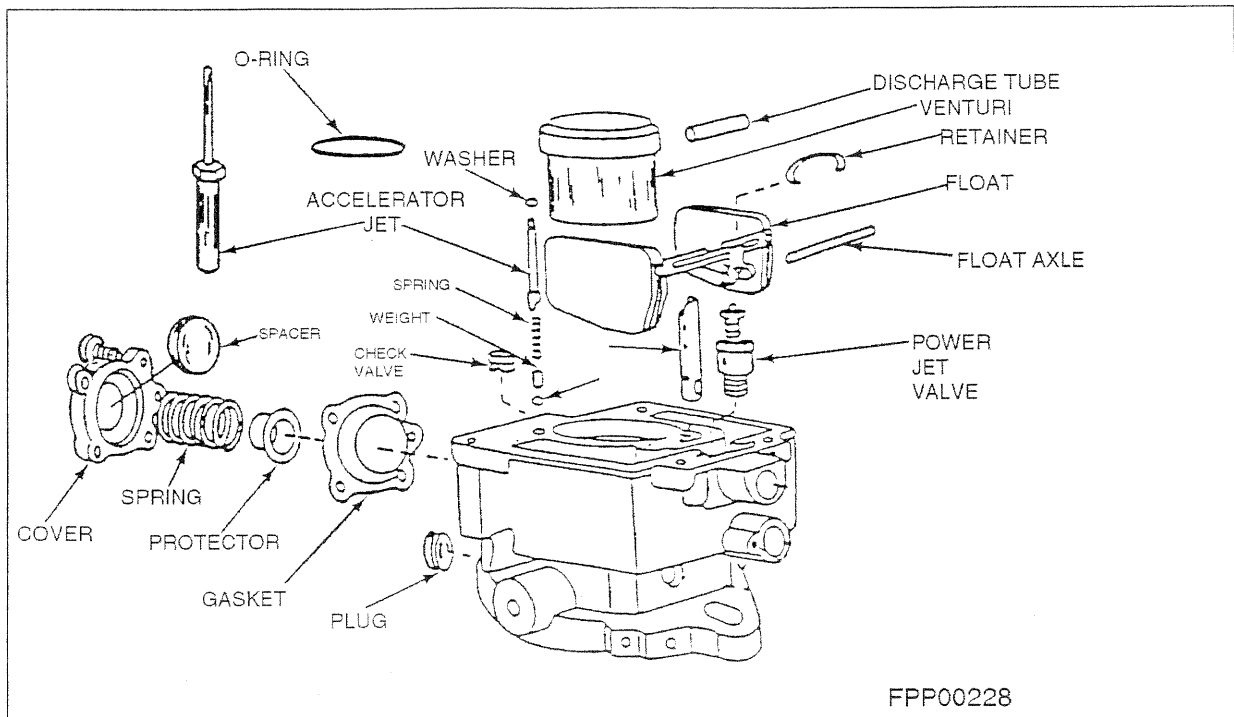

7. Install power jet valve using C161-9 wrench. No gasket required.
8. Install main jet and seat firmly with screwdriver. No gasket required.
9. Install main jet plug and washer and tighten securely. If main jet adjustment or solenoid shutoff are used, install in place of plug.
10. Turn body right side up. Insert float axle into holes in float.
11. Lower float axle and float into slot provided in body with the float needle sticking into the threaded opening.
12. Install the fuel valve seat and washer making sure that the fuel valve enters the seat properly (the valve will enter the seat more easily if the float is held in the up position) and tighten securely.
13. Insert float axle clip in slot to bear against axle ends. Holding axle in place, raise float by applying light finger pressure to the float bracket. Float pontoons should be approximately level when the valve is seated. If not, bend tab carefully to adjust.
14. Install o-ring on venturi skirt and place venturi into recess provided in body making sure that the nozzle lines up with the notch in the fuel well.
15. Place intake gasket in position on body.

NOTE: If you have an older model unit with removable accelerator jet; after intake gasket is in place, an additional washer will be assembled over the accelerator jet tube and set inside the large hole in the intake gasket and on top of the smaller washer. Lower air intake carefully onto bowl and fasten securely and evenly using attaching screws.

16. Place accelerator pump diaphragm in place on body with bagged section into cavity. Insert diaphragm protector into end of spring and install spring with protector against diaphragm.
17. Place cover over spring and compress. Insert screws and tighten evenly and securely.

NOTE: Pump spacer will install into cover before assembly if required.

<b>SECTION TITLE</b>	<b>PAGE</b>
ENGINE SERVICE - General .....	01-01
ENGINE SERVICE - 2.5L .....	02-01
IGNITION SYSTEM .....	03-01
FUEL PUMP .....	04-01
CARBURETOR.....	05-01
STARTER MOTOR.....	06-01
GOVERNOR.....	07-01
COOLING SYSTEM .....	08-01
GENERATOR .....	09-01

---

## SECTION 06 - STARTER MOTOR

---

<b>SUBJECT</b>	<b>PAGE</b>
DESCRIPTION.....	2
Starter Operation.....	2
DIAGNOSIS .....	3
Preliminary Inspection.....	3
Symptom Chart .....	4
TEST A - Starter Voltage Test.....	5
TEST B - Starter Relay Test.....	5
Starter Load Test.....	6
Starter No-Load Test.....	7
Armature Open Circuit Test.....	7
Grounded Armature Test .....	7
Starter Solenoid Test.....	7
Jump Starting.....	8
REMOVAL AND INSTALLATION.....	9
Starter Motor .....	9
DISASSEMBLY AND ASSEMBLY .....	10
Disassembly .....	10
Cleaning and Inspection.....	10
Assembly.....	12
Starter Drive Replacement .....	12
Armature Replacement.....	12
SPECIFICATIONS .....	14
Torque Specifications.....	14
General Specifications.....	14
Special Tools.....	14

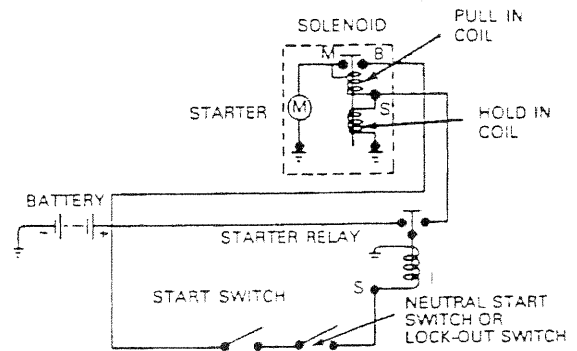
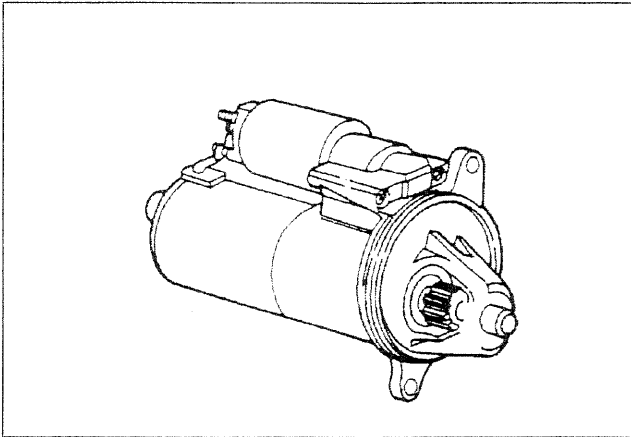

FPP00118

## Description

The function of the starting system is to crank the engine at a speed fast enough to permit the engine to start. Heavy cables, connectors and switches are used in the starting system because of the large current required by the starter while it is cranking the engine.

The amount of resistance in the starting circuit must be kept to an absolute minimum to provide maximum current for starter operation. A discharged or damaged battery, loose or corroded connections, or partially broken cables will result in slower than normal cranking speeds, and may even prevent the starter from cranking the engine.

The starting system includes the permanent magnet gear-reduction starter motor with a solenoid-actuated drive, the battery, a remote-control starter switch (part of the ignition switch), the starter relay, the heavy circuit wiring, and may include starter lock-out devices.

An overrunning clutch in the drive assembly protects the starter from excessive speeds during the brief period as the engine starts.

## Starter Operation

1. The ignition switch is turned to the START position.
2. A remote starter relay is energized, which provides voltage to the starter solenoid. The starter solenoid is energized, creating a magnetic field in the solenoid coil.
3. The iron plunger core is drawn into the solenoid coil.
4. A lever connected to the drive assembly engages the drive pinion gear to the flywheel ring gear.
5. When the iron plunger core is all the way into the coil, its contact disc closes the circuit between the battery and the motor terminals.
6. The current flows to the motor, and the drive pinion gear drives the flywheel and the engine crankshaft.
7. As current flows to the motor, the solenoid pull-in coil is bypassed.
8. The hold-in coil keeps the drive pinion gear engaged with the flywheel.
9. The gear remains engaged until the ignition switch is released from the START position.

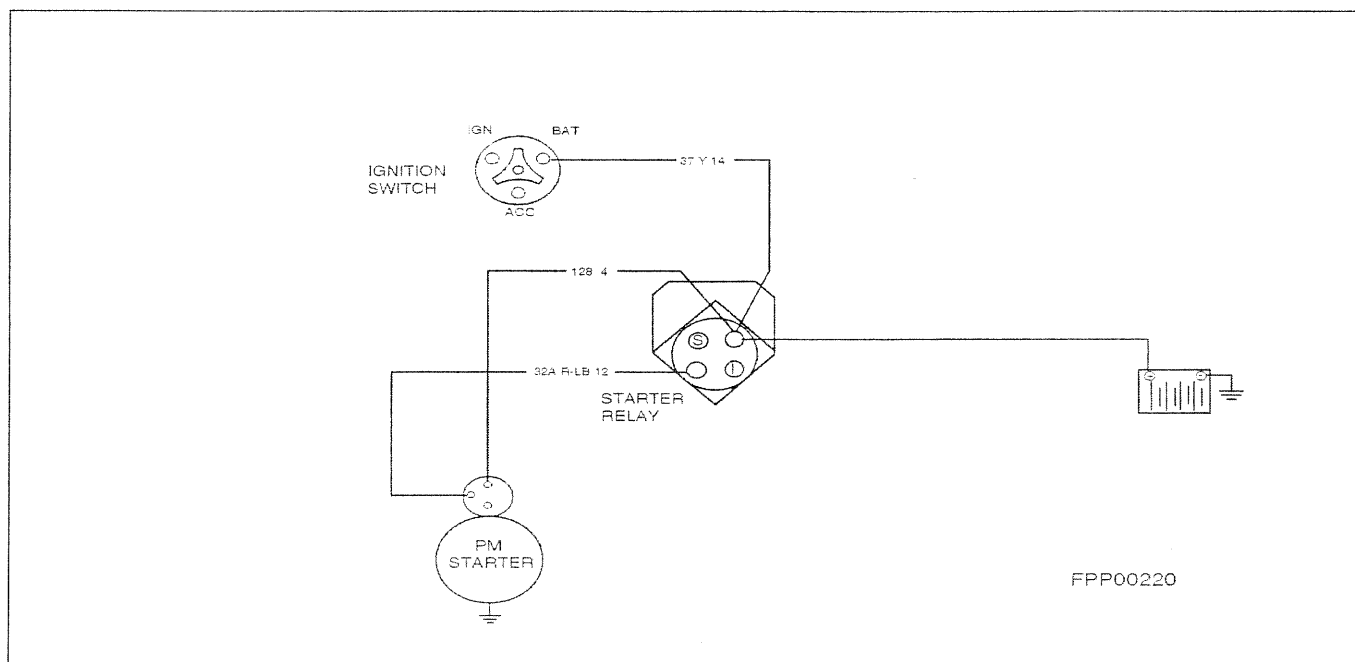

## DIAGNOSIS

A great many problems with the starting system are caused by the malfunctioning of other components in the electrical system. Therefore, it is best to start with a battery check first when dealing with a starting problem.



**CAUTION:** Be sure to disconnect battery negative cable before servicing starter.



**CAUTION:** When disconnecting the plastic hardshell connector at the solenoid "S" terminal, grasp the plastic connector and pull lead off. **DO NOT** pull separately on lead wire.



**WARNING:** WHEN SERVICING STARTER OR PERFORMING OTHER WORK IN THE VICINITY OF THE STARTER, BE AWARE THAT THE HEAVY GAUGE BATTERY INPUT LEAD AT THE STARTER SOLENOID IS "ELECTRICALLY HOT" AT ALL TIMES.



**WARNING:** WHEN WORKING IN AREA OF THE STARTER, BE CAREFUL TO AVOID TOUCHING HOT EXHAUST COMPONENTS.

Make all digital volt/ohmmeter connections at the component terminal rather than the cable or wiring terminal. Making a connection at the wiring terminal could result in false readings because the meter will not pick up a high resistance between the wiring connector and the component.

### Preliminary Inspection

Inspect the following items before performing any starter system diagnosis:

- Inspect the condition of the battery using a battery tester. A slow or no crank condition is often caused by an undercharged battery.
- Inspect for frayed or damaged battery and starter cables and wires.
- Make sure all the terminal connections at the battery, starter relay, solenoid and starter are clean and tight.

## Symptom Chart

If system does not operate properly, note condition, inspect starting system for loose connections, and continue diagnosis using the following symptom chart:

CONDITION	POSSIBLE SOURCE	ACTION
Starter solenoid does not pull in and starter does not crank (audible click may or may not be heard).	<ul style="list-style-type: none"> <li>• Open fuse.</li> <li>• Low battery.</li> <li>• Defective remote relay.</li> <li>• Open circuit or high resistance in external feed circuit to starter solenoid.</li> <li>• Defective starter.</li> </ul>	<ul style="list-style-type: none"> <li>• Check fuse continuity.</li> <li>• Test battery.</li> <li>• Perform starter relay test.</li> <li>• Perform starter voltage test.</li> <li>• Replace starter.</li> </ul>
Unusual starter noise during starter overrun.	<ul style="list-style-type: none"> <li>• Starter not mounted flush (cocked).</li> <li>• Noise from other components.</li> <li>• Ring gear tooth damage or excessive ring gear runout.</li> <li>• Defective starter.</li> </ul>	<ul style="list-style-type: none"> <li>• Realign starter on transmission bell housing.</li> <li>• Investigate other accessory noise contributors.</li> <li>• Replace flywheel ring gear.</li> <li>• Replace starter.</li> </ul>
Starter cranks but engine does not start.	<ul style="list-style-type: none"> <li>• Problem in fuel system.</li> <li>• Problem in ignition system.</li> <li>• Engine related problem.</li> </ul>	<ul style="list-style-type: none"> <li>• Refer to fuel system sections.</li> <li>• Refer to Ignition system section.</li> <li>• Refer to section 01, Diagnosis.</li> </ul>
Starter cranks slowly.	<ul style="list-style-type: none"> <li>• Low battery.</li> <li>• High resistance or loose connections in starter solenoid battery feed or ground circuit.</li> <li>• Ring gear runout excessive.</li> <li>• Defective starter.</li> </ul>	<ul style="list-style-type: none"> <li>• Charge or replace battery.</li> <li>• Check that all connections are secure.</li> <li>• Replace ring gear.</li> <li>• Replace starter.</li> </ul>
Starter remains engaged and runs with engine.	<ul style="list-style-type: none"> <li>• Shorted ignition switch.</li> <li>• Battery cable touching solenoid "S" terminal.</li> <li>• Defective starter.</li> </ul>	<ul style="list-style-type: none"> <li>• Replace ignition switch.</li> <li>• Replace or relocate cable.</li> <li>• Replace starter.</li> </ul>

**TEST A - Starter Voltage Test**

TEST STEP		RESULT	ACTION TO TAKE
<b>A1</b>	<b>CHECK FOR VOLTAGE TO STARTER</b>	<b>Yes</b>	Go to A2.
	<ul style="list-style-type: none"> <li>• Key OFF. Transmission in Neutral.</li> <li>• Check for voltage between starter B+ terminal and starter drive housing.</li> <li>• Is voltage 12-12.45 volts?</li> </ul>	<b>No</b>	Check wire connections between battery and starter solenoid and the ground circuit for open or short.
<b>A2</b>	<b>CHECK STARTER MOTOR</b>	<b>Yes</b>	Check connections from output of starter relay to "S" terminal for open or short.
	<ul style="list-style-type: none"> <li>• Key OFF. Transmission in Neutral.</li> <li>• Connect one end of a jumper wire to the starter B+ terminal and momentarily touch the other end to solenoid "S" terminal.</li> <li>• Does starter crank?</li> </ul>	<b>No</b>	Defective starter. Replace starter.

**TEST B - Starter Relay Test**

TEST STEP		RESULT	ACTION TO TAKE
<b>B1</b>	<b>CHECK STARTER RELAY</b>	<b>Yes</b>	Go to B2.
	<ul style="list-style-type: none"> <li>• Key in START. Transmission in NEUTRAL.</li> <li>• Is case ground OK?</li> </ul>	<b>No</b>	Repair ground. Go to B2.
<b>B2</b>	<b>CHECK VOLTAGE AT STARTER RELAY START TERMINAL</b>	<b>Yes</b>	Go to B3.
	<ul style="list-style-type: none"> <li>• Key in START. Transmission in NEUTRAL.</li> <li>• Check for voltage between relay start terminal and case ground.</li> <li>• Is voltage 12-12.45 volts?</li> </ul>	<b>No</b>	Open circuit or high resistance exists in external circuit wiring or components. Check the following: <ul style="list-style-type: none"> <li>• All circuit connections including plastic hard shell connector at solenoid "S" terminal to make sure it is not broken or distorted.</li> <li>• Ignition switch.</li> <li>• Neutral switch or manual lever position sensor.</li> </ul>
<b>B3</b>	<b>CHECK STARTER RELAY OUTPUT TERMINAL VOLTAGE</b>	<b>Yes</b>	Refer to starter system diagnosis in this section.
	<ul style="list-style-type: none"> <li>• Key in START. Transmission in NEUTRAL.</li> <li>• Check for voltage at output terminal of remote relay.</li> <li>• Is voltage 12-12.45 volts?</li> </ul>	<b>No</b>	<ul style="list-style-type: none"> <li>• Defective starter relay. Replace relay.</li> </ul>

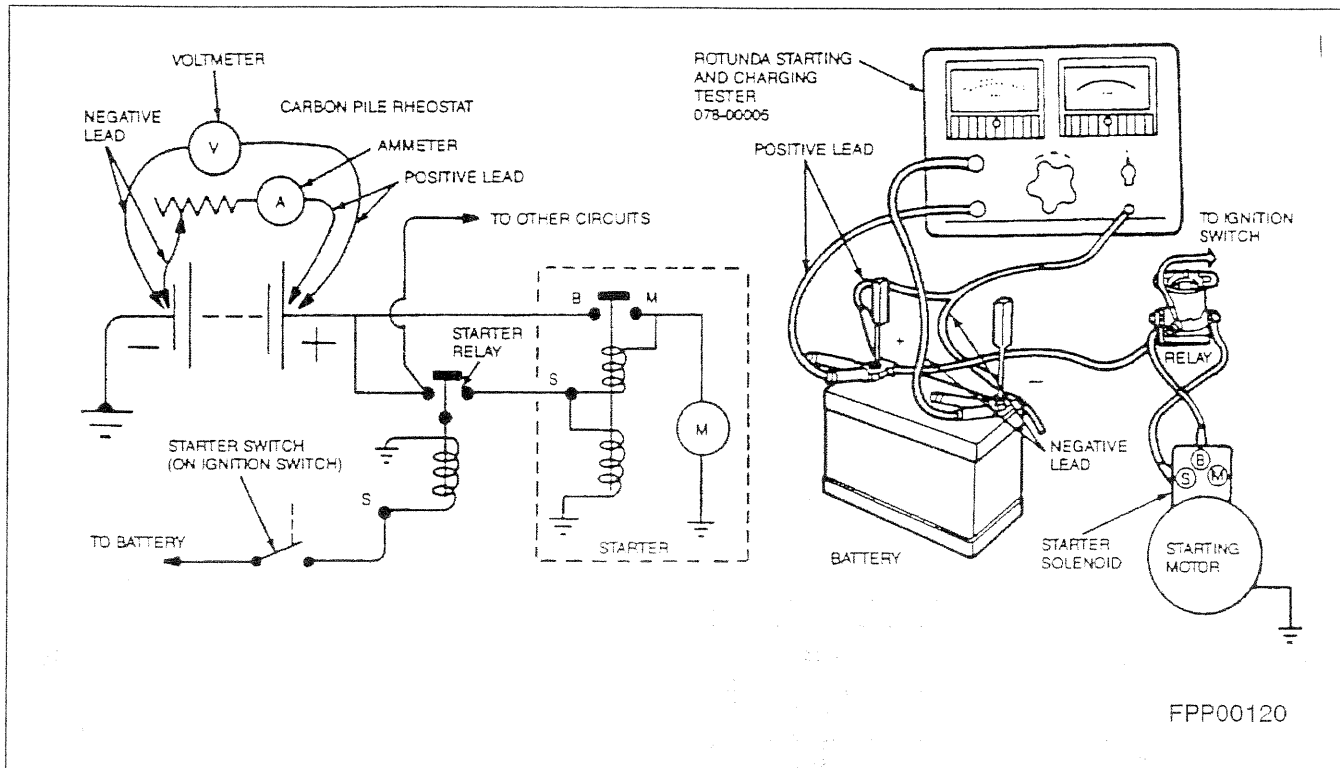

## Starter Load Test

Conduct this test if the starter cranks slowly and it is desired to compare current to specifications.

1. Connect Rotunda Starting and Charging Tester 078-00005, or equivalent. Make sure that current is not flowing through ammeter and heavy-duty carbon pile rheostat portion of circuit (rheostat at maximum counterclockwise position).
2. Place transmission or transaxle in NEUTRAL. Crank engine with ignition off, and determine exact reading on voltmeter. This test is accomplished by disconnecting push-on connector "S" at starter relay and by connecting a remote control starter switch from positive battery terminal to "S" terminal starter relay.
3. Stop cranking engine and reduce resistance of carbon pile until voltmeter indicates same reading as that obtained while starter cranked the engine. The ammeter will indicate starter current draw under load. Check this with value listed in specifications.

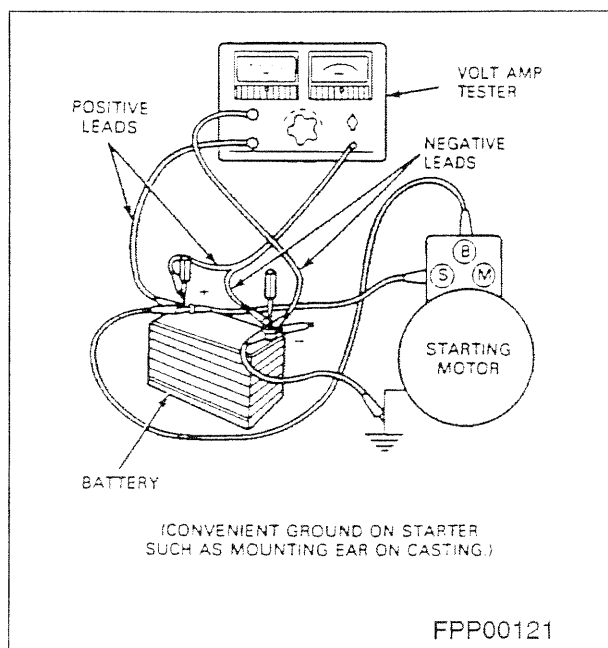

### Armature Open Circuit Test

An open circuit armature may sometimes be detected by examining the commutator for evidence of burning. A burn spot on the commutator is caused by an arc formed every time the commutator segment, connected to the open circuit winding, passes under a brush.

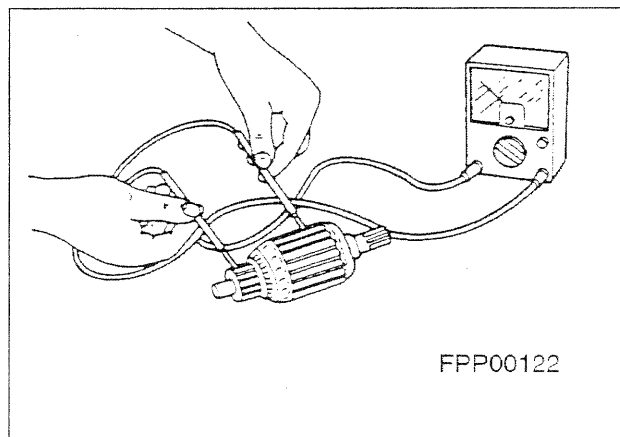

### Starter No-Load Test

The starter no-load test will uncover such conditions as open or shorted windings, or rubbing armature. The starter can be tested, at no-load, on the test bench only.

1. Make test connections with Rotunda Starting and Charging Tester 078-00005, or equivalent, cables connected to starter, large enough to carry high current (the same as in the vehicle). The starter will run at no-load. Be sure that no current is flowing through ammeter (rheostat at maximum counterclockwise position). determine exact reading on voltmeter.



**CAUTION:** Make sure that the starter is securely mounted in bench vise while energizing, as starter will move

or jump

2. Disconnect starter from battery. Then, reduce resistance of rheostat until voltmeter indicates same reading as that obtained while starter was running. The ammeter will indicate starter no-load current draw. Refer to Specifications for a comparative value.
3. If current exceeds specification, check for rubbing armature, bent shaft, binding bearings, or shorts in armature, or brush assembly.

### Grounded Armature Test

This test will determine if the winding insulation has been damaged, permitting a conductor to touch the frame or armature core. To determine if the armature windings are grounded, check with a VOM as shown. Infinite resistance indicates a normal condition.

### Starter Solenoid Test

Make sure that the solenoid is isolated electrically from the motor. Using a VOM, check for continuity between "S" terminal and "M" terminal, and between "S" terminal and ground (frame). If there is no continuity, the wire is broken and the solenoid should be replaced.

## Jump Starting

For cases of a starter that cranks the engine very slowly, connect a 12 volt booster battery to the system.

To avoid damage to the equipment and battery or the possibility of personal harm, follow these instructions and precautions:



**WARNING: HYDROGEN AND OXYGEN GASES ARE PRODUCED DURING NORMAL BATTERY OPERATION. THIS GAS MIXTURE CAN EXPLODE IF FLAMES, SPARKS OR LIGHTED TOBACCO ARE BROUGHT NEAR THE BATTERY. WHEN CHARGING OR USING A BATTERY IN AN ENCLOSED SPACE, ALWAYS PROVIDE VENTILATION AND SHIELD YOUR EYES.**

**KEEP OUT OF REACH OF CHILDREN. BATTERIES CONTAIN SULFURIC ACID. AVOID CONTACT WITH SKIN, EYES OR CLOTHING. ALSO, SHIELD YOUR EYES WHEN WORKING NEAR THE BATTERY TO PROTECT AGAINST POSSIBLE SPLASHING OF THE ACID SOLUTION. IN CASE OF ACID CONTACT WITH SKIN, EYES OR CLOTHING, FLUSH IMMEDIATELY WITH WATER FOR A MINIMUM OF 15 MINUTES. IF ACID IS SWALLOWED, DRINK LARGE QUANTITIES OF MILK OR WATER, FOLLOWED BY MILK OF MAGNESIA, A BEATEN EGG, OR VEGETABLE OIL. CALL A PHYSICIAN IMMEDIATELY.**

**DO NOT DISCONNECT THE BATTERY OF THE EQUIPMENT TO BE STARTED. DISCONNECTING THE BATTERY COULD DAMAGE THE EQUIPMENT'S ELECTRONIC SYSTEM.**

**TO AVOID POSSIBILITY OF INJURY, USE PARTICULAR CARE WHEN CONNECTING A BOOSTER BATTERY TO A DISCHARGED BATTERY.**

1. Connect one end of first jumper cable to positive (+) terminal of discharged battery and other end to positive (+) terminal of booster battery.

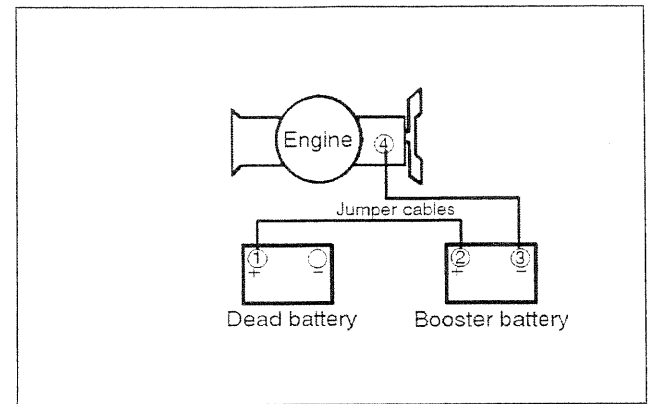

2. Connect one end of second jumper cable to negative (-) terminal of booster battery and other end to an engine bolthead or good metallic contact spot on engine of equipment to be started, NOT TO NEGATIVE (-) BATTERY TERMINAL.



**WARNING: MAKING THE FINAL CABLE CONNECTION COULD CAUSE AN ELECTRICAL SPARK NEAR THE BATTERY AND COULD CAUSE AN EXPLOSION. REFER TO WARNING AT THE BEGINNING OF THE JUMP STARTING PROCEDURE.**



**CAUTION: When servicing starter or performing other underhood work in the vicinity of the starter, be aware that the heavy gauge battery input lead at the starter solenoid is "electrically hot" at all times.**

**Be sure to disconnect battery negative cable before servicing starter.**

3. Make sure jumper cables are not in way of moving engine parts.
4. Start engine of equipment with good battery. Run engine at a moderate speed.
5. Start engine of equipment with discharged battery. Follow starting instructions in the Operator's Manual.
6. Completely discharged batteries may require an electrical load to initialize charging.
7. Remove cables in exact REVERSE sequence. Begin by removing cable from engine of equipment that had discharged battery.

If the starter does not turn the engine over, even with the booster battery attached, refer to Diagnosis.

## REMOVAL AND INSTALLATION



**WARNING: WHEN SERVICING STARTER OR PERFORMING ANY MAINTENANCE IN THE AREA OF THE STARTER, NOTE THAT THE HEAVY GAUGE INPUT LEAD CONNECTED TO THE STARTER SOLENOID IS HOT AT ALL TIMES. MAKE SURE THE PROTECTIVE CAP IS INSTALLED OVER THE TERMINAL AND IS REPLACED AFTER SERVICE.**

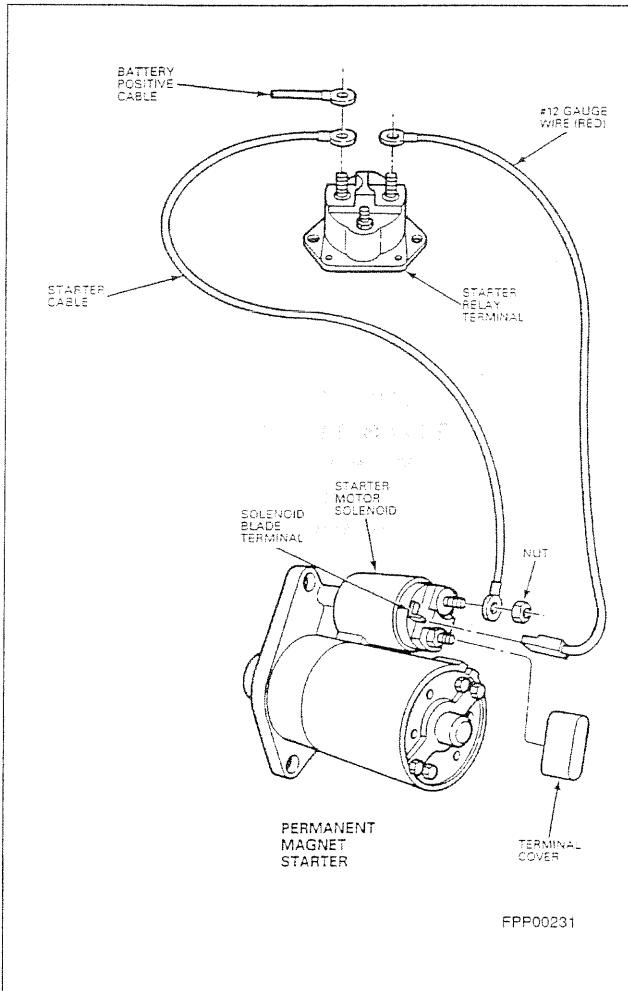

**CAUTION: A jumper wire must not be installed between the large round electrical terminal and the solenoid blade terminal at the starter, to avoid use of the #12 wire. If done, voltage is generated to the solenoid by the spinning starter after release of the start key or button, causing the starter to remain engaged, resulting in failure.**

## Starter Motor Removal

1. Disconnect the negative battery ground cable.
2. Disconnect starter cable and push-on connector from starter solenoid.



**CAUTION: When disconnecting hardshell connector at "S" terminal, grasp the plastic shell and pull off.**

**Do not pull on wire. Be careful to pull straight off to prevent damage to the connector and "S" terminal. If any part of the connection is damaged, replace the damaged components.**

3. Remove upper bolt with a 3/8 inch drive ratchet, swivel socket and a 22 inch long extension. Access is in front of, and along side, the right hand front engine mount.
4. Remove lower bolt.

## Starter Motor Installation

1. Position starter motor to engine and install upper and lower bolt finger tight.
2. Tighten the upper bolt to 21-27 N•m (15-20 lb-ft). Access to upper bolt is with a 3/8 inch drive ratchet, swivel socket and a 22 inch long extension. Access is in front of, and along side, the right hand front engine mount.
3. Tighten the lower bolt to 21-27 N•m (15-20 lb-ft).
4. Connect starter solenoid connector. Be careful to push straight on and make sure connector locks in position with a notable click or detent.
5. Install starter cable nut to starter terminal. Tighten to 9-13 N•m (80-120 lb-in).
6. Replace red solenoid safety cap.
7. Connect negative battery ground cable.

It is recommended that wiring service kit F2PZ-11K162-A be used, which includes a 70 inch long #12 gauge wire, a terminal nut, a terminal cover, four tie wraps and insulation instructions.

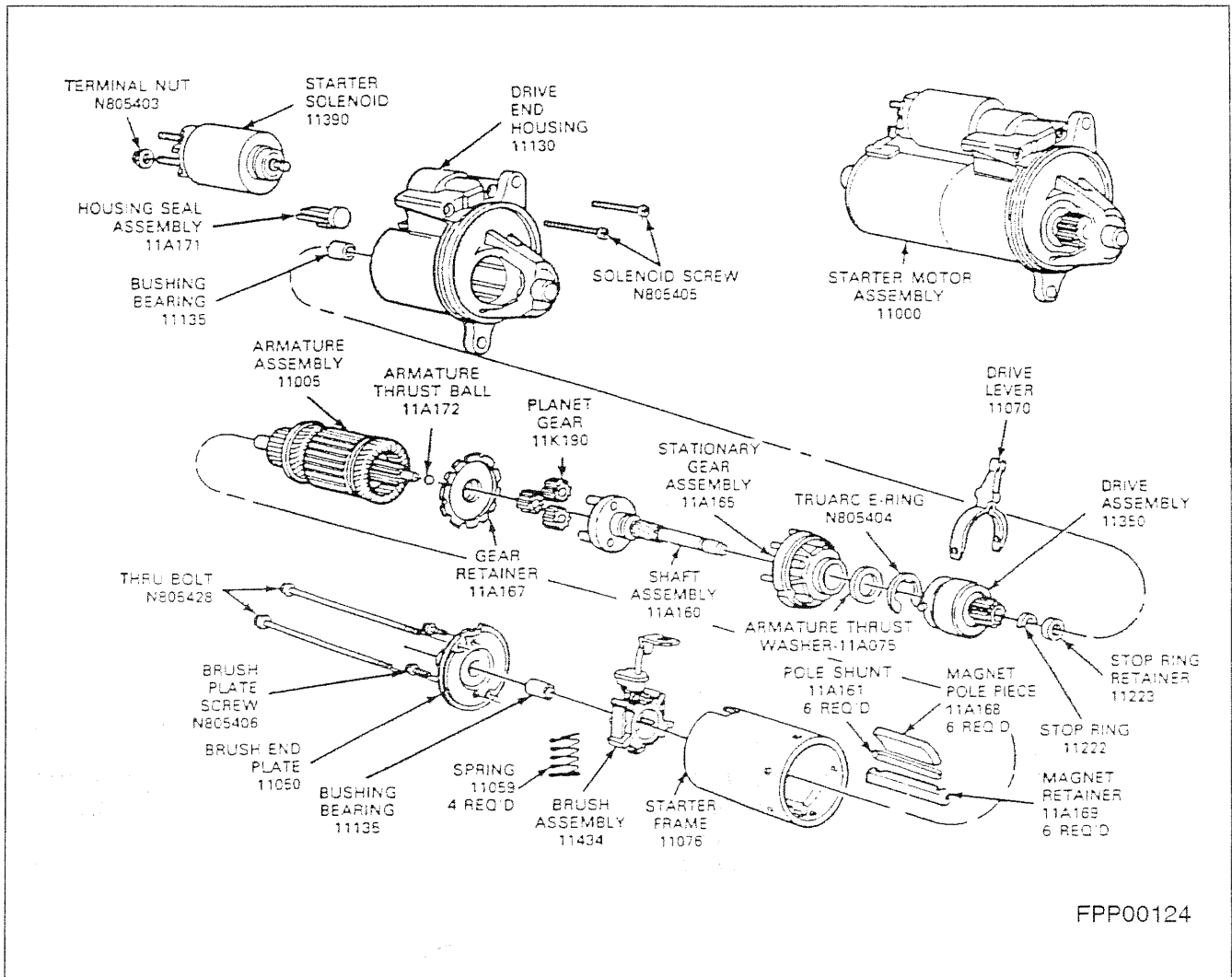

## Disassembly

1. Remove positive brush connector from solenoid motor "M" terminal.
2. Remove solenoid retaining screws and solenoid.
3. Remove through bolts and separate drive end housing from motor frame. Remove housing seal assembly from drive. Remove drive and gear assembly from drive end housing.
4. Remove drive lever from drive assembly. Remove stop ring and retainer from driveshaft, then remove drive assembly from shaft. Push C-ring off driveshaft, and separate gear assembly from driveshaft.
5. Remove brush plate screws and brush end plate from motor frame. Remove brush assembly and push armature out of frame.

## Cleaning and Inspection



**CAUTION:** Do not wash the drive because the solvent will wash out the lubricant causing drive to slip. Use a brush or compressed air to clean the drive, armature, brush, and gear assemblies, drive end housing, pole pieces and planet gears. Wash all other parts in solvent and dry.

1. Inspect armature windings for broken or burned insulation and unwelded or open connections.
2. Check armature for open circuits, shorts and grounds. Check for pole rub or rub on magnetic shunts.

3. Check commutator for runout. Inspect armature shaft and two bearings for scoring and excessive wear with Dial Indicator TOOL-4201-C or equivalent. If commutator is rough, or more than 0.12mm (.005 inch) out of round, it must be replaced.

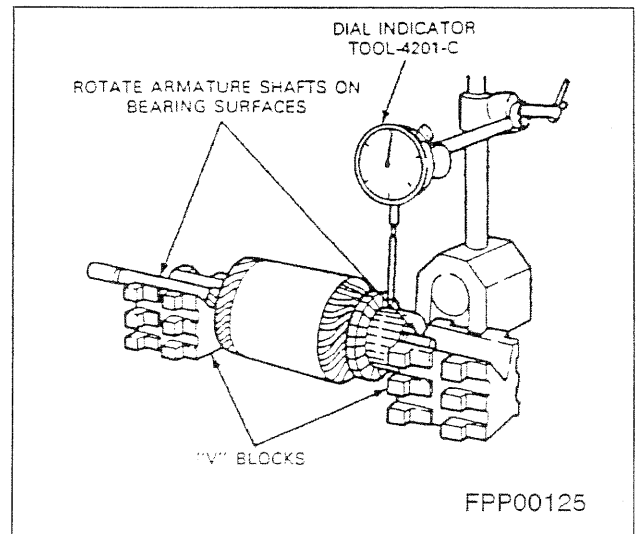

4. Examine gears, spline on driveshaft, and drive pinion for chipped, broken or worn conditions. Replace if required.

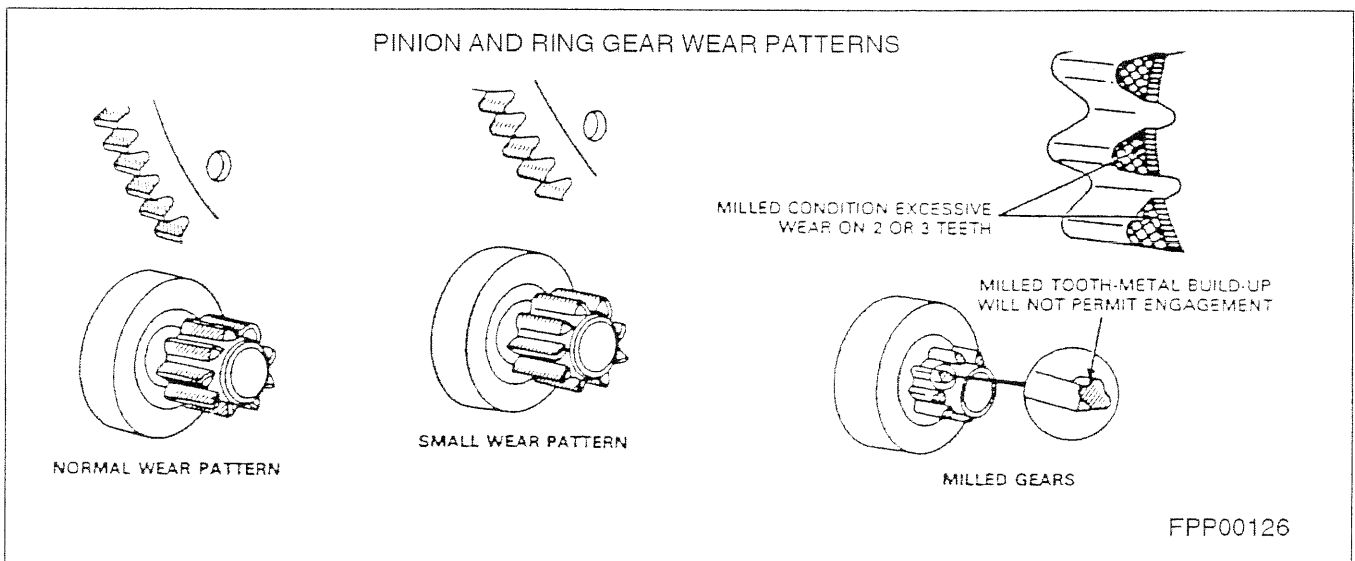

## Assembly

1. Install armature assembly in starter frame. Apply a thin coating of ESF-M1C218-A grease, or equivalent low temperature grease, on both ends of armature shaft and spline. Install brush assembly ensuring brushes fit over commutator. Apply grease to bearing bore in brush end plate. Push back grommet onto frame and attach brush end with brush plate screws. Tighten to 2.3-3.4 N•m (20-30 lb-in).
2. Apply grease to driveshaft spline and place stationary gear assembly over driveshaft. Install armature thrust washer and push C-ring onto driveshaft. Place drive assembly onto shaft and install stop ring and retainer. Attach drive lever to drive assembly.
3. Grease and install planet gears.
4. Apply grease into drive end housing bearing bore (approximately one-quarter full). Install drive gear assembly into housing, making sure to line up bolt holes in gear assembly and housing. Place gear retainer over gear assembly. Install housing seal assembly into drive end housing.
5. Position starter frame to housing and install through bolts. Tighten to 5.0-9.5 N•m (45-84 lb-in).
6. Correctly position solenoid to housing ensuring that solenoid plunger is attached through drive lever (bottom solenoid terminal "M" should have a metal strip attached to it). Tighten solenoid bolts to 5.1-9.6 N•m (45-85 lb-in).
7. Attach positive brush connector to solenoid (bottom terminal). Tighten nut to 9-13 N•m (80-120 lb-in).
8. Check that starter no-load current draw is within specification. Refer to Bench Tests.
4. Apply a thin coating of ESF-M1C218-A grease, or equivalent low temperature grease, on driveshaft spline. Install new drive gear assembly on driveshaft. Install new stop ring and retainer. Attach drive lever.
5. Partially fill drive end housing bearing bore with grease (approximately one-quarter full). Install drive gear assembly in housing, making sure to line up bolt holes in gear assembly and housing.
6. Install lever support and housing seal in drive end housing.
7. Position starter frame to housing and install through-bolts. Tighten to 5.0-9.5 N•m (45-84 lb-in).
8. Install solenoid. Refer to Assembly.

## Armature Replacement

1. Remove positive brush connector from solenoid motor "M" terminal.
2. Remove through-bolts and separate motor from gear assembly and drive end housing.
3. Remove brush end plate screws, brush end plate and brush assembly from starter frame. Remove armature from frame.
4. Install new armature in frame. Apply a thin coating of ESF-M1C218-A grease, or equivalent low temperature grease, on both ends of armature shaft and pinion.

## Starter Drive Replacement

1. Remove positive brush connector from solenoid motor "M" terminal. Remove solenoid retaining screws and remove solenoid.
2. Remove through-bolts and separate motor assembly drive end housing. Remove housing seal from drive end housing. Remove drive gear assembly from housing and detach drive lever.
3. Remove stop ring and retainer from driveshaft and then remove drive assembly.

5. Install brush assembly. Using tool, make sure that brushes fit over commutator. Push black grommet onto frame. Apply grease to bearing bore in brush end plate and attach to starter frame.

TOOL TO ASSEMBLE BRUSH HOLDER TO ARMATURE

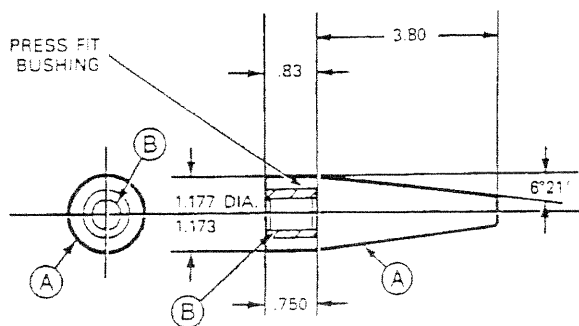

BRUSH HOLDER ASSEMBLY

- (A) MANDREL  
MAT'L: MICAATA LL221  
TAN:TYPE FBL  
STK: 13.8 DIA. + ▲-LG  
(1) REQ'D
- (B) BUSHING  
UNIVERSAL HEADLESS TYPE  
PRESS FIT BUSHING  
CAT. NO: GS-93  
.471/.472 I.D. .7518 O.D. .750 LG.  
(1) REQ'D

FPP00127

6. Position starter frame to gear assembly and drive end housing and install through-bolts. Tighten to 5.0-9.5 N•m (45-84 lb-in).
7. Attach positive brush connector to solenoid (bottom terminal). Tighten nut to 9-13 N•m (80-120 lb-in).
8. Check that starter no-load current draw is within specification. Refer to "Starter No-Load Test".

## SPECIFICATIONS

### Torque Specifications

Description	N•m	Lb-In
Solenoid Bolt	5.1-9.6	45-85
"M" Terminal Nut	9.0-13.5	80-120
"B" Terminal Nut	9.0-13.5	80-120
Through-bolt	5.0-9.5	45-84
Mounting Bolt	20.3-27	15-20 (lb-ft)
Brush Plate Screw	2.3-3.4	20-30

### General Specifications

Motor Diameter	78mm (3")
Current draw under normal load	140-200 amps
Normal cranking speed	200-250 rpm
Minimum stall torque @ 5 volts	14.7 N•m (11.0 lb-ft)
Maximum load	800 amps
No load	70 ± 10
Brush length	16.8 mm (0.66")
Brush spring tension	18 N (64 oz.)
Maximum commutator runout	0.12 mm (0.005")
Maximum voltage drop (battery positive to starter)	0.5 volts @ normal operating temperature

### Special Tools

Tool Number	Description
TOOL-4201-C	Dial Indicator
078-00005	Starting/Charging Tester

<b>SECTION TITLE</b>	<b>PAGE</b>
ENGINE SERVICE - General .....	01-01
ENGINE SERVICE - 2.5L .....	02-01
IGNITION SYSTEM .....	03-01
FUEL PUMP .....	04-01
CARBURETOR.....	05-01
STARTER MOTOR.....	06-01
GOVERNOR.....	07-01
COOLING SYSTEM .....	08-01
GENERATOR.....	09-01

---

## SECTION 07 - GOVERNOR

---

<b>SUBJECT</b>	<b>PAGE</b>
MECHANICAL GOVERNOR .....	2
Description .....	2
Diagnosis.....	3
Adjustment.....	5
Removal and Installation.....	8
ELECTRONIC GOVERNOR (CARB.).....	9
Description .....	9
Diagnosis.....	10
Adjustments.....	12

**REFER TO SEPARATE PUBLICATION ON ELECTRONIC FUEL INJECTION (EFI) SYSTEMS  
FOR INFORMATION ON THAT SYSTEM.**

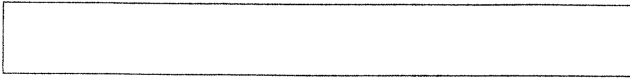

### DESCRIPTION

The mechanical flyweight type governors can be used on these engines. They are belt driven from the front of the engine.

A direct mechanical linkage from the governor throttle control lever to the carburetor throttle lever limits carburetor action to the governor setting.

### No Load on Engine

As the shaft rotates, centrifugal force developed by the flyweights causes them to swing outward.

The force of the flyweight increases in proportion to engine speed and is always used to close the engine throttle. A spring is used to oppose this force and balance it at a predetermined speed. The speed at which the flyweight force and the spring force are in

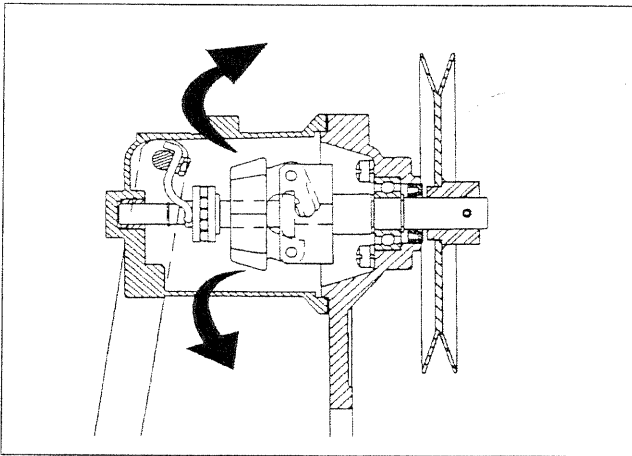
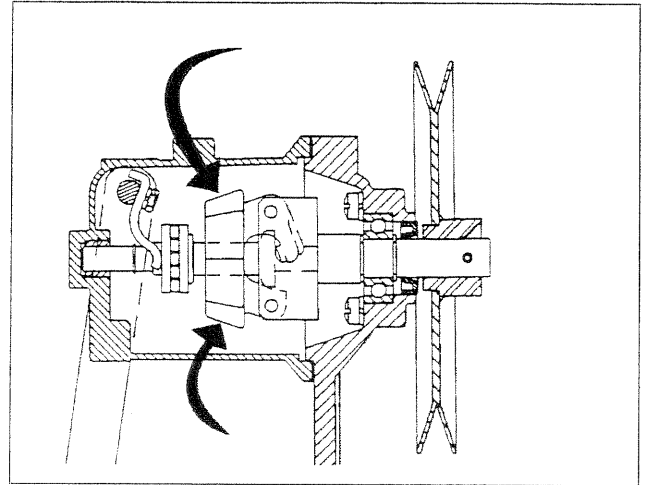

balance is the *governed speed*.

### Engine Load Applied

When a load is applied to the engine, it tends to slow down, and the flyweight force decreases.

The spring force being now greater than the flyweight force causes the governor throttle lever to move in a direction to open the carburetor throttle to a point at which the flyweight and spring forces are again in balance.

## DIAGNOSIS

### Full-Load Surge

1. Shorten throttle rod two or three turns at the rod-end ball joint.
2. Check for extra rich or extra lean air/fuel mixture at the carburetor.
3. Look for air leaks caused by a loose intake manifold.
4. Look for loose or worn linkage between the governor and the carburetor.
5. Look for engine parts or wires rubbing against the governor linkage.

### No-Load Surge

The no-load surge adjustment is set at the factory and rarely requires adjustment. If necessary, this adjustment can be used to prevent hunting and surging at no-load speeds, provided the rpm spread adjustment is set properly.

Make the adjustment with the tachometer installed. Increase the engine speed with the hand throttle or variable speed lever to 75 rpm lower than the maximum no-load desired control rpm.

NOTE: At this point, if the engine continues to surge, light pressure applied to the governor throttle lever will dampen surge.

- Adjust the surge screw located on back of the governor housing.
1. Loosen the no-load surge adjusting screw locknut.
  2. Turn this screw clockwise into the governor until the engine speed stabilizes.



**CAUTION:** Do not turn the surge screw into the housing any further, or attempt to adjust this screw when the engine is under a load; the engine speed may run away when the load is removed.

1. Tighten the lock-nut securely.
2. Readjust the governor high-speed stop screw to maintain the correct high-speed under load.

### Part-Load Surge

1. Shorten the throttle rod two or three turns at the rod-end ball joint.
2. Look for worn flyweights in the governor.

### Unresponsive To Changing Loads

1. Incorrectly adjusted throttle linkage.
2. Engine parts (wires) rubbing on throttle linkage.
3. Surge screw turned too far into governor body.
4. Worn or broken governor flyweights.
5. Damaged flyweight carrier.

### Engine Dies Down Under Load

1. Incorrectly adjusted throttle linkage.
2. Lengthen throttle rod two, three, or more turns at the rod-end ball joint.
3. Check engine timing, and distributor advance.
4. Look for excessive friction in the throttle link, at governor and at carburetor.
5. The load may be more than the engine can handle at wide-open throttle.

### Overspeeds When Load Is Removed

1. The governor drive belt may be slipping. Tighten belt 40 to 45 pounds tension.
2. Back off surge screw one or two turns.
3. Shorten the throttle rod two or three turns at the rod-end ball joints.

### **Governor Does Not Re-Set At Load Or No-Load Point**

1. Carburetor throttle shaft may be sticking due to carbon or fuel deposits.
2. Worn ball joints on the throttle linkage.
3. Worn governor flyweights.

### **Noisy Governor Operation**

1. Governor main bearing worn.
2. Governor flyweights worn or broken.
3. Governor thrust sleeve and bearing worn.
4. Governor main shaft bent.

### **Excessive Governor Vibration**

1. Governor pulley or main shaft bent or damaged.
2. Governor flyweights worn or broken.

## ADJUSTMENT

Three preliminary checks must be made on the mechanical governor before attempting any adjustments:

1. governor oil level
2. drive belt tension
3. throttle control rod length

### Oil Level Check

Clean the body of the governor in the area of the fill plug. Remove the oil level plug. If oil drips out, the level is full. If oil doesn't drip out, remove the oil fill plug and add 10W-30 or 10W-40 engine oil into the fill hole until it starts dripping out of the oil level hole. Reinstall plugs.

### Belt Tension Adjustment

Belt tension should be checked on a cold belt only.

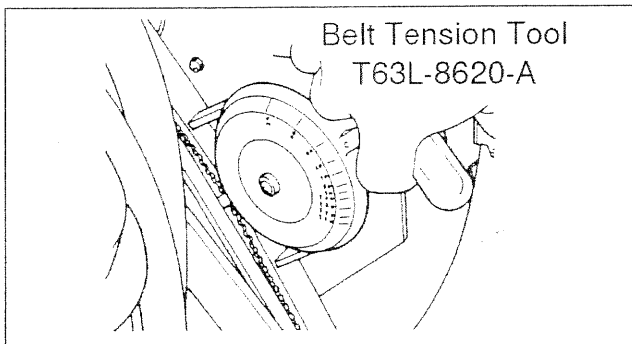

1. Install the belt tension tool on the drive belt and check the tension.

BELT TENSION	
New belt.....	70 lb.ft. (95 Nm)
Used belt.....	50 lb.ft. (68 Nm)
(used belt = in operation 10 minutes or more)	

2. If adjustments required, loosen the governor adjusting bolts and move the governor until the correct tension is obtained.
3. Remove the gauge.
4. Tighten the governor adjusting bolts.
5. Install the tension gauge and recheck the belt tension.

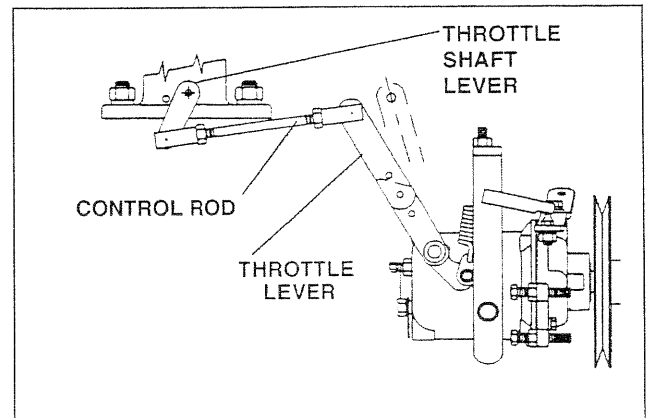

### Throttle Control Rod Length

1. Manually move the governor throttle lever to the maximum open throttle with spring tension on the governor.
2. Check the gap between the carburetor throttle shaft lever and its maximum open position stop. It should be 1/32 to 1/16 inch wide.
3. If adjustment is necessary, loosen the control rod ball joint locknuts, remove the rod from the carburetor throttle lever and adjust the length of



5. the rod with the ball joints.

3. Install the throttle control rod on the carburetor throttle lever.
4. Recheck the gap.
- 5.
6. Tighten the locknuts.

**CAUTION:** Be sure the throttle control rod is properly installed with the long end at the governor to prevent binding on the ignition wires.



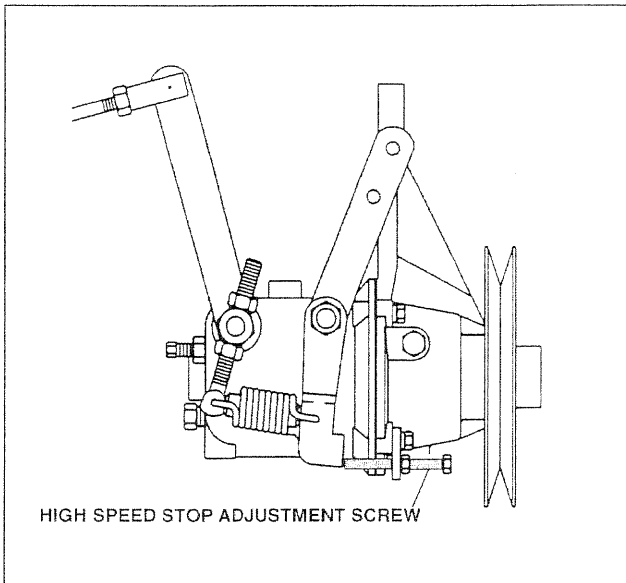

### High Speed Adjustment

First attach a tachometer to the engine, then run the engine until it reaches normal operating temperature.

1. Loosen the locknut on the high-speed stop screw.
2. Disengage engine load.
3. Slowly pull the throttle to desired maximum engine speed.
4. Adjust the high speed stop screw on the governor to attain the desired maximum engine speed. Do not exceed the recommended maximum rpm.
5. Tighten the locknut.

### Sensitivity or Droop Adjustment

Proper governor operation requires a difference between full-load and no-load governed speed. Too small an rpm spread between the two speeds will cause governor hunting and surging. Too large a spread will cause low response. For this governor, normal rpm spread, or droop is approximately 250 rpm with the full-load speed range of 2000 - 2800

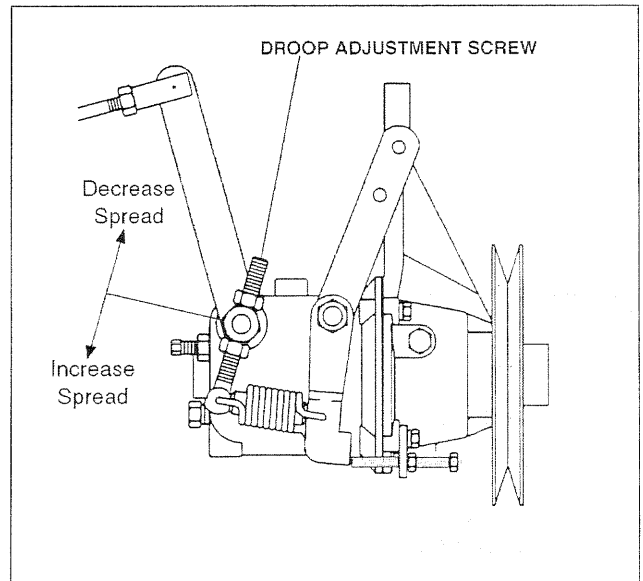

rpm.

1. With the engine running under no-load at maximum governed speed, loosen the locknuts.

- **Increase Droop** = adjust the screw to move the spring **away** from the lever hub.
- **Decrease Droop** = adjust the screw to move the spring **closer** to the lever hub.

2. Tighten the locknuts.
3. Recheck governor operation under full-load and no-load conditions to determine if operation is stabilized and sensitivity is satisfactory.
4. Readjust the governor high-speed stop screw to maintain the correct high-speed under load.

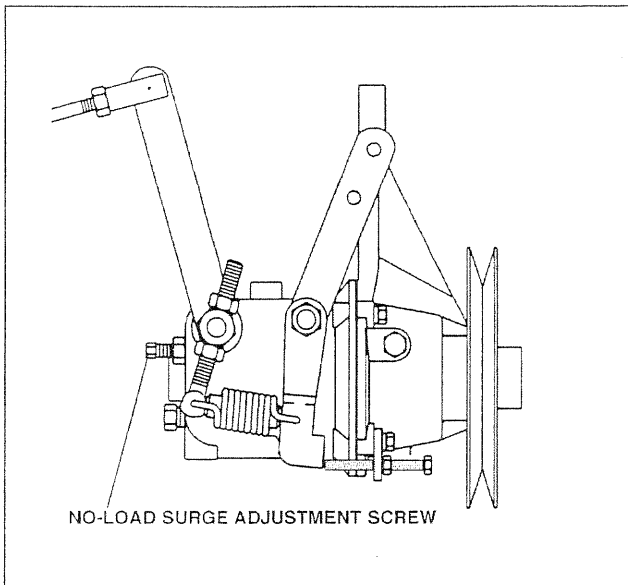

### No-Load Surge Adjustment

The no-load surge adjustment is set at the factory and rarely requires adjustment. If necessary, this adjustment can be used to prevent hunting and surging at no-load speeds, provided the rpm spread adjustment is set properly.

1. Make the adjustment with the tachometer installed. Increase the engine speed with the hand throttle or variable speed lever to 75 rpm lower than the maximum no-load desired control rpm.

**NOTE:** At this point, if the engine continues to surge, light pressure applied to the governor throttle lever will dampen surge.

- 2.
3. Then loosen the no-load surge adjusting screw locknut and turn the screw inward until the rpm increases to the desired control rpm.

∟

2.

**CAUTION:** Do not turn the screw in all the way. It will interfere with proper governor operation and prevent the governor from returning the engine to idle speed.

3. Readjust the governor high-speed stop screw to maintain the correct high-speed under load.

## REMOVAL AND INSTALLATION

### Mechanical Governor Removal

1. Disconnect hand throttle connection at governor variable speed lever.
2. Disconnect governor to carburetor throttle control rod at governor.
3. Loosen governor mounting nuts and bolts and move governor toward engine to loosen drive belt.
4. Remove drive belt from governor pulley.
5. Remove governor to bracket attaching bolts and remove governor.

### Mechanical Governor Installation

1. Position the governor to the mounting bracket and install the attaching bolts snugly.
2. Position drive belt to governor pulley and move the governor away from the engine to tighten the belt. Tighten the attaching bolts.
3. Adjust the belt tension.
4. Connect the governor to carburetor throttle control rod. Adjust the rod as described previously.
5. Connect hand throttle cable to governor variable speed lever. Adjust cable as necessary to permit operation from idle to maximum speed.

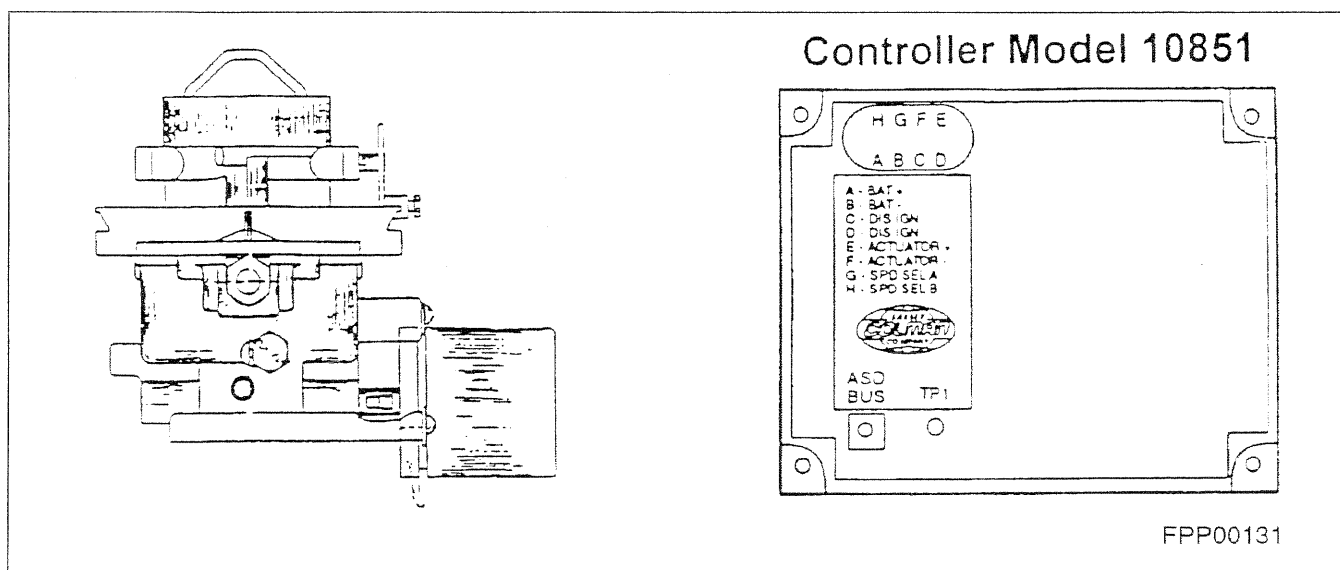

## DESCRIPTION

The Barber Colman electronic governor consists of three main components:

- controller
- actuator
- carburetor

The controller is a Barber Colman model 10851 digital unit. This controller allows up to four engine speeds to be used on one application. The operator changes the engine speeds via a run speed select switch, mounted on the control panel of the machine.

These governors are isochronous in operation; there is no governor droop. The governor maintains the same engine speed from no-load to full-load operation. Each controller can be programmed with up to four separate engine speeds. The carburetor and actuator are integrated into one unit.

The carburetor is a Zenith model 33, offered with either a manual or automatic choke. It is spring loaded to keep the carburetor at its minimum fuel position when no power is applied. This feature causes the carburetor to go fully closed in the event of governor power failure.

The rotary actuator is mounted directly to the end of the throttle shaft. This feature eliminates any need for throttle linkage. The actuator is electrically connected to the controller through a two-wire Packard connector. If the governor is used with any other fuel system, such as LPG, then a linear actuator is available.

## DIAGNOSIS

This governor system is comprised of three major components; the carburetor, actuator and controller. The objective of this document is to help a technician identify which component is creating a problem so it can be fixed or replaced.

CONDITION	POSSIBLE SOURCE	ACTION
Governor appears dead.	Battery power is not supplied to controller.	<ul style="list-style-type: none"> <li>Remove the connector from the controller and with a voltmeter check for battery power across pins A&amp;B of the wiring harness connector.</li> <li>If battery power is not present, check wiring to the controller.</li> </ul>
	Controller is not receiving the speed signal. NOTE: This controller receives its speed signal from the ignition.	<ul style="list-style-type: none"> <li>If the controller is connected to an engine with a distributor, pins C&amp;D should both be connected to the negative side of the coil, or the tachometer output.</li> <li>If the controller is connected to an engine with a DIS ignition, pin C should be connected to one of the two tachometer outputs, and pin D should be connected to the other tachometer output. The DIS ignition utilizes two coils.</li> <li>NOTE: Do not short the tach leads; doing so could damage the spark controller.</li> <li>Using an ohmmeter, check continuity from pins C&amp;D to the termination points. If continuity is not present, repair the wiring.</li> </ul>
	Actuator fails to operate.	<ul style="list-style-type: none"> <li>Remove the wires connected to the actuator. With a DC voltmeter, check between the actuator wires to battery (-). The voltmeter should read 12 volts <math>\pm</math> 2 volts.</li> <li>If the voltage is low, disconnect the connector from the controller and check continuity between the wiring harness pins E&amp;F, to their respective actuator terminals. If there is no continuity, check for openings in the wires.</li> <li>Using a voltmeter, check for battery voltage from controller terminals E&amp;F to battery (-). If battery power is not found, replace the controller and check the actuator and actuator wiring for grounds and shorts.</li> </ul> <p>NOTE: Check wiring before replacing controller. Bad wiring might destroy the new controller.</p> <ul style="list-style-type: none"> <li>Check continuity across actuator wires. 2 ohms <math>\pm</math> .5 ohm should be measured. Check the continuity of actuator wires to the case. The ohms measured should be 1M or greater. If these values are out of tolerance, replace actuator.</li> </ul>
Engine doesn't change speeds.	Incorrect engine speed.	<ul style="list-style-type: none"> <li>With the engine running, connect battery power to pin H. This will select Run 2. If Run 2 is set at a higher speed than Run 1 and the speed does not change, replace the controller. Contact OEM for speed settings.</li> <li>With the engine running, connect battery power to pin G. This will select Run 3. If Run 3 is set higher than the previous speed and the speed does not change, replace the controller. Contact OEM for speed settings.</li> <li>With the engine running, connect battery power to pins G&amp;H. This will select Run 4. If Run 4 is set higher than the previous speed and the speed does not change, replace the controller. Contact OEM for speed settings.</li> </ul>
Engine is hunting.	Engine is misfiring due to idle mixture mis-adjustment. This causes engine hunt at no-load condition.	<ul style="list-style-type: none"> <li>Disconnect the connector from the controller. The governor is now disabled and a warm engine should be running at a mechanical idle of approximately 600 rpm.</li> <li>If the engine is not running at the mechanical idle and is governed by an integrated carburetor, loosen the three actuator fasteners and rotate the actuator to achieve an idle of 600 rpm. If the engine is governed by a linear actuator, adjust the idle speed screw to achieve 600 rpm.</li> <li>Slowly rotate the idle mixture screw clockwise (CW) until the engine speed begins to decrease. Slowly turn the idle mixture screw counterclockwise (CCW) until the engine speed begins to decrease. Now, turn the idle mixture screw clockwise (CW) until maximum idle speed is achieved. The idle mixture is now adjusted.</li> </ul>
	Engine is misfiring.	<ul style="list-style-type: none"> <li>disconnect the connector from the controller and consult the engine repair manual.</li> </ul>

## DIAGNOSIS

### Basic Wiring Diagram — DYN1-10851 Controller

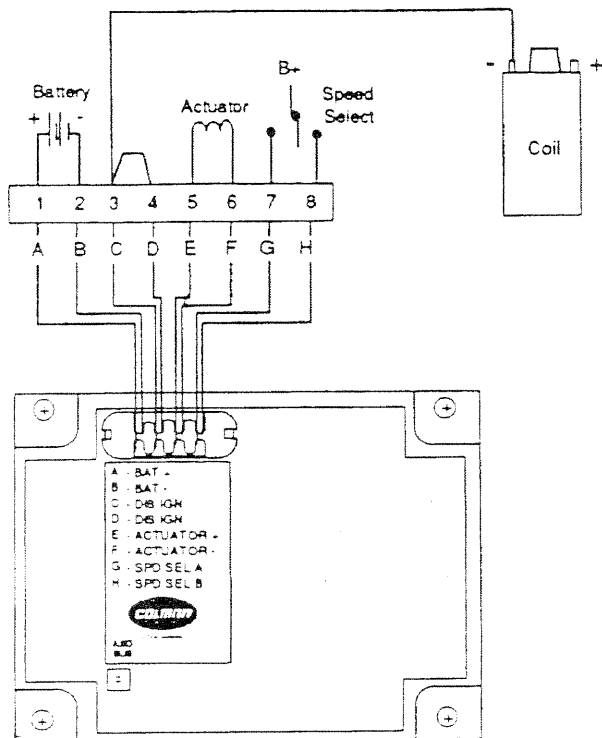

FPP00133

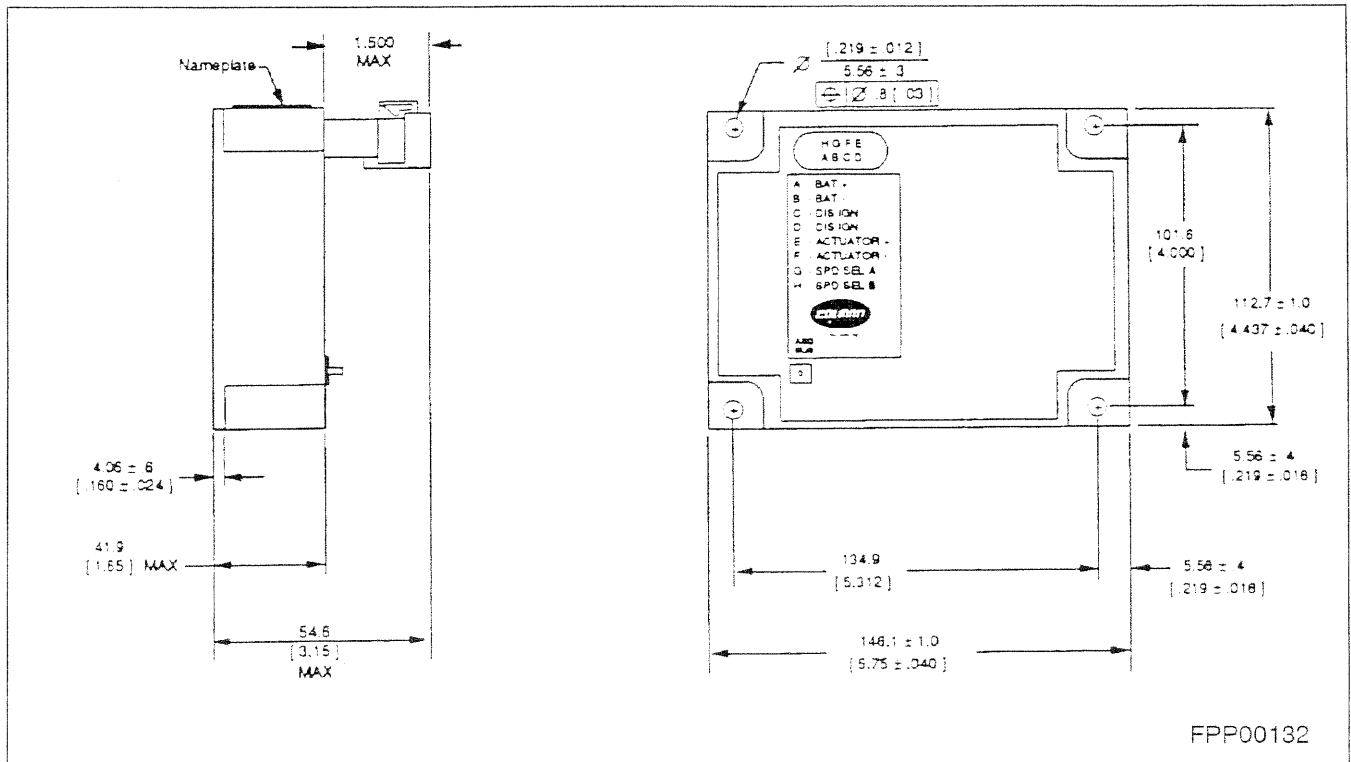

## ADJUSTMENTS

### Calibration

Initial speed settings, as well as other parameters, can be set using a special interface connector, and an IBM compatible PC 286 minimum with 640K RAM, of which 512K of conventional RAM must be available. Also required is a 1.44 Meg High Density floppy drive and a VGA graphic display. Programming of the controller is covered in a separate publication.

<b>SECTION TITLE</b>	<b>PAGE</b>
ENGINE SERVICE - General .....	01-01
ENGINE SERVICE - 2.5L .....	02-01
IGNITION SYSTEM .....	03-01
FUEL PUMP .....	04-01
CARBURETOR.....	05-01
STARTER MOTOR.....	06-01
GOVERNOR.....	07-01
COOLING SYSTEM .....	08-01
GENERATOR .....	09-01

---

## SECTION 08 - COOLING SYSTEM

---

<b>SUBJECT</b>	<b>PAGE</b>
Description .....	2
Cleaning Cooling System.....	2
Diagnosis .....	3
Visual Inspection.....	3
Cooling System Pressure Test .....	4
Radiator Cap Pressure Test .....	5
Thermostat Operation Check.....	5
Removal and Installation.....	6
Cooling Fan.....	6
Drive Belt .....	6
Radiator Hose .....	7
Drain & Refill Cooling System.....	7
Thermostat Replacement.....	8

**REFER TO SEPARATE PUBLICATION ON ELECTRONIC FUEL INJECTION (EFI)  
SYSTEMS FOR INFORMATION ON THAT SYSTEM.**

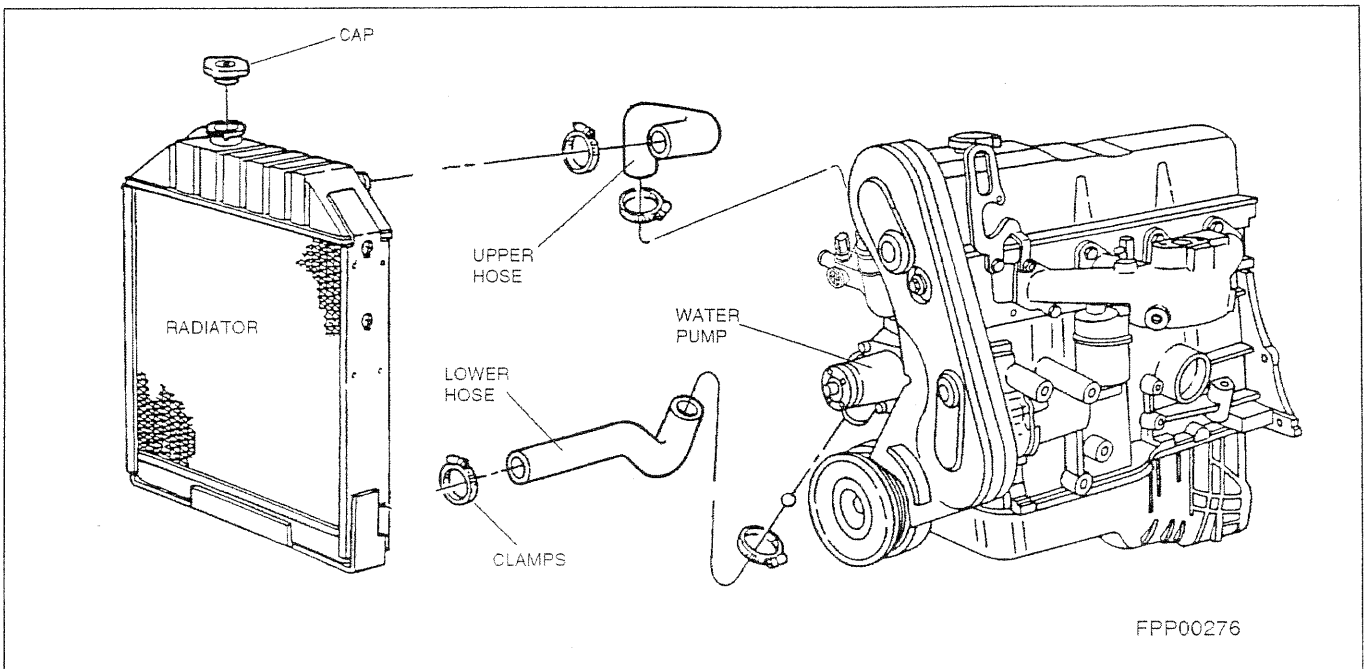

## Description

The cooling system is of the full flow type with a centrifugal pump. The thermostat, located in the cylinder head, controls the flow through the system, maintaining the proper temperature.

The coolant flows from the bottom of the radiator to the water pump which delivers it to the cylinder block. It then flows through the cored passages to cool each cylinder wall. Upon reaching the rear of the cylinder block, the coolant is directed upward in to the cylinder head where it cools the combustion chambers, valves and valve seats.

The coolant from the cylinder head flows past the thermostat, if it is open, through the coolant outlet housing and into the top of the radiator.

Another passage in the head routes the warm coolant through the intake manifold to help atomize the fuel mixture, and then exits the intake manifold through a hose to the inlet of the water pump.

## Cleaning Cooling System

To remove rust, sludge and other foreign material from the cooling system, use Rotunda Cooling System Cleanser. Removal of such material restores cooling efficiency and avoids overheating. Always remove the thermostat prior to pressure flushing. A pulsating or reversed direction of

flushing water flow will loosen sediment more quickly than a steady flow in the normal direction of coolant flow. In severe cases where cleaning solvents will not properly clean the cooling system for efficient operation, it will be necessary to use the pressure flushing method. Various types of flushing equipment are available.

MIXTURE % (by volume)		
PROTECTION	Anti-freeze Solution	Water
Above $-X^{\circ} F$ ( $-4^{\circ} C$ )	20%	80%
Above $-X^{\circ} F$ ( $-16^{\circ} C$ )	35%	65%
Above $-X^{\circ} F$ ( $-26^{\circ} C$ )	45%	55%
Above $-X^{\circ} F$ ( $-40^{\circ} C$ )	55%	45%

## Diagnosis

The most frequent cooling system complaints are leakage and overheating. Either of these problems will soon render the engine inoperable.

Most engines use an ethylene glycol base antifreeze solution to which the manufacturers have added a dye color. The dye color makes the antifreeze solution an excellent leak detector.

If this type of solution is not being used in the cooling system, a vegetable dye may be added to aid in locating external leakage.

## Visual Inspection

Check for leakage at:

- all hoses and hose connections.
- radiator seams, radiator core, and radiator drain petcock.
- all block core plugs and drain plugs.
- edges of all cooling system gaskets.
- transmission oil cooler.
- water pump shaft and bushing.

Examine oil dipstick for evidence of coolant contaminated engine oil (white milky appearance). check radiator for evidences of oil in coolant (leakage at transmission oil cooler).

Refer to the following Diagnosis Chart for cooling system problems, their possible cause and recommended correction. Refer to the pertinent part for testing and repair.

CONDITION	POSSIBLE SOURCE	ACTION
Loss of coolant	<ul style="list-style-type: none"> <li>• Pressure cap and gasket</li> <li>• Leakage</li> <li>• External leakage</li> <li>• Internal leakage</li> </ul>	<ul style="list-style-type: none"> <li>• Inspect, wash gasket and test. Replace only if cap will not hold pressure to specification.</li> <li>• Pressure test system.</li> <li>• Inspect hose, hose connection, radiator, edges of cooling system gaskets, core plugs and drain plugs, transmission oil cooler lines, water pump, heater system components. Repair or replace as required.</li> <li>• Disassembly engine as necessary - check for:cracked intake manifold, blown head gaskets, warped head or block gasket surfaces, cracked cylinder head or engine block.</li> </ul>
Engine Overheats	<ul style="list-style-type: none"> <li>• Low coolant level</li> <li>• Loose fan belt</li> <li>• Pressure cap</li> <li>• Radiator obstruction</li> <li>• Closed thermostat</li> <li>• Fan drive clutch</li> <li>• Ignition</li> <li>• Temp gauge or cold light</li> <li>• Engine</li> <li>• Coolant mixture</li> </ul>	<ul style="list-style-type: none"> <li>• Fill as required. Check for coolant loss.</li> <li>• Adjust.</li> <li>• Test. Replace if necessary.</li> <li>• Remove bugs, leaves, etc.</li> <li>• Test, Replace if necessary.</li> <li>• Test, replace if necessary.</li> <li>• Check timing and advance. Adjust as required.</li> <li>• Check electrical circuits and repair as required.</li> <li>• Check water pump, block for blockage.</li> <li>• 1/2 water and 1/2 permanent anti-freeze mixture.</li> </ul>
Engine fails to reach normal operating temperature	<ul style="list-style-type: none"> <li>• Open thermostat</li> <li>• Temperature gauge or cold light</li> </ul>	<ul style="list-style-type: none"> <li>• Test, replace if necessary.</li> <li>• Check electrical circuits and repair as required.</li> </ul>

## Cooling System Pressure Test

- 1.
2. Shut the engine off.



1.

**CAUTION: To prevent loss of coolant and to avoid the danger of being burned, let the engine cool before removing the radiator cap.**

1. When removing the radiator cap, place a cloth over the cap and rotate the cap SLOWLY counter-clockwise to the safety stop and allow the pressure to escape completely. Then, turn the cap again SLOWLY counter-clockwise past the safety stop to remove.
2. Adjust the radiator coolant (fill or drain) to one inch below the filler neck opening before testing. Wet the rubber sealing surface of the cap before installing the cap tightly on the radiator.
3. Disconnect the electrical connector from the engine temperature sending unit and remove the temperature sending unit from the manifold.

**NOTE:** With the radiator cap installed and the cooling system pressure relieved, only a small amount of coolant will be lost when the sending unit is removed.

1. Install the adapter fitting from the Rotunda Pressure Tester 21-0012 (or equivalent) male thread on one end, and a hose connector on the other end to accommodate the tester hose, tightly

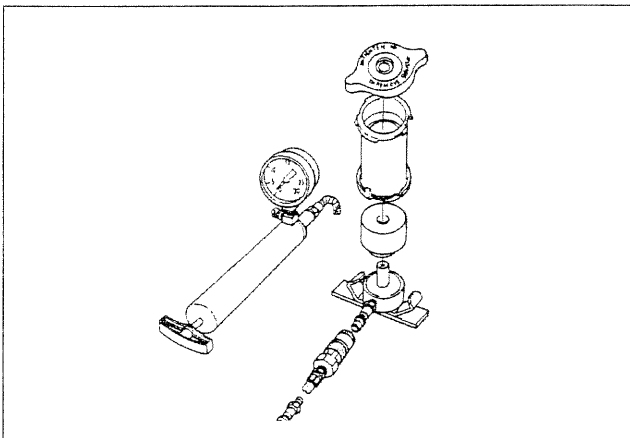

into the cylinder block in place of the sending unit.

2. Remove the radiator overflow hose from the retainer clips. Make sure the hose is firmly installed on the radiator overflow nipple and is in good condition. Insert the free end of the overflow hose into a container of water.
3. Attach the pressure pump and gauge to the adapter fitting and pressurize the cooling system to the cap LOWER LIMIT.
4. No bubbles should appear in the water container when the system is pressurized to the cap's LOWER LIMIT. If the system is satisfactory at the lower limit, gradually increase the system pressure until a slight stream of bubbles appears in the water container. This is the upper limit of the pressure cap.
5. Replace any radiator cap that exceeds the specified UPPER LIMIT pressure without discharging bubbles.
6. If the radiator cap does not hold pressure, remove and wash the cap in clean water to dislodge all foreign particles from the gaskets. Check the sealing surface in the radiator filler neck. Inspect the cam lock flanges on both sides of the filler neck for maximum cap engagement.
7. Pressurize the cooling system (using a radiator cap that operates within the original cap upper and lower pressure limits) and observe the gauge reading for approximately two minutes. Pressure should not drop during this time.

### **RESULTS:**

***If the pressure drops, check for leaks at engine-to radiator hoses, bypass hose, water valve hose (if applicable), thermostat housing gasket and radiator. Also refer to engine system checks if a leak cannot be located in the cooling system. Any leaks which are found must be corrected and the system rechecked.***

***If the system holds pressure, proceed to the next step.***

12. Release the system pressure by loosening the radiator cap and remove the adapter. Reinstall the temperature sending unit, check coolant level and replenish (if necessary) with the correct coolant solution: 1/2 water and 1/2 permanent anti-freeze mixture.

## Radiator Cap Pressure Test

1. Remove the radiator cap from the radiator filler neck.
2. Immerse the radiator cap in water and install on the shallow filler neck of the Rotunda 21-0012 Radiator Cap Pressure Test Adapter (or equivalent).

**NOTE: The adapter is designed to accept both deep and shallow neck radiator caps.**

1. Immerse the filler neck seal in water and install in the filler neck adapter.

**NOTE: the filler neck seal is reversible so that it may be used on either a deep or shallow radiator filler neck. It will also fit either end of the radiator cap pressure test adapter.**

1. Install the filler neck adapter with filler neck seal on the deep filler neck end to the radiator cap pressure test adapter.
2. Connect the female quick disconnect fitting of the pressure test pump to the male quick disconnect fitting of the filler neck adapter.
3. SLOWLY depress the plunger of the pressure test pump until the pressure gauge reading stops increasing and note the highest pressure reading obtained.

**NOTE: If the plunger of the pump is depressed too fast, an erroneous pressure reading will result.**

1. Release the pressure by turning the pressure relief screw counter-clockwise. Then tighten the pressure relief screw and pressure test again (at least twice) to be sure the pressure test reading is repeatable within the acceptable gauge reading limits of the radiator cap and is not erratic.
2. If the pressure test gauge readings are not within the acceptable gauge reading limits, replace the radiator cap. If the pressure test gauge readings are within the acceptable gauge reading limits, perform the Cooling System Pressure Test.

## Thermostat Visual Inspection

1. Hold thermostat up to the light.
2. Leakage of light all around the valve (room temperature) indicates a bad thermostat.
3. A slight leakage of light at one or two locations on the perimeter of the valve is normal.

## Thermostat Operation Check

1. Visually check the valve to be sure it is air tight.
2. Place the thermostat and a thermometer in water.
3. Gradually increase the water temperature

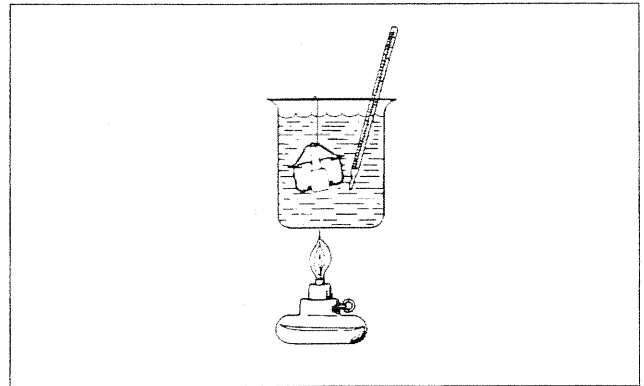

- Replace thermostat if it does not open at least 0.23" after one minute at 212° F.

<b>INITIAL OPENING TEMPERATURE</b>	<i>180° F (82° C)</i>
<b>FULL-OPEN TEMPERATURE</b>	<i>199° F - 204° F (93 - 96° C)</i>
<b>FULL-OPEN LIFT</b>	<i>0.33" (0.013 mm)</i>

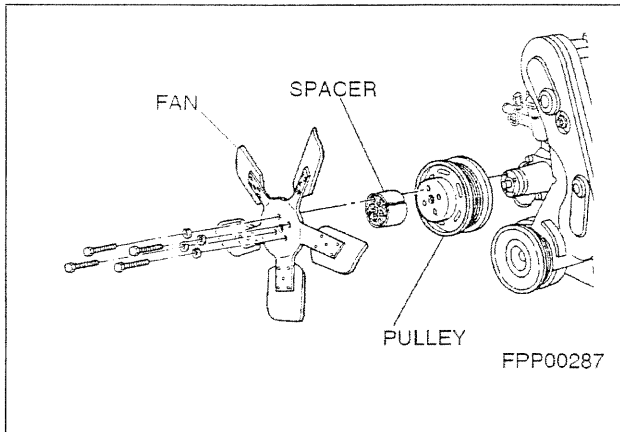

## REMOVAL AND INSTALLATION

### Cooling Fan Removal

1. Remove the screws and washer assemblies attaching the fan and pulley to the water pump hub.
2. Remove the fan and pulley.

### Cooling Fan Installation

1. Position the fan and pulley on the water pump hub.
2. Loosen fan belt, if necessary.
3. Install the lock washer and screws and torque the capscrews to specifications.
4. Adjust the fan belt tension to specifications.

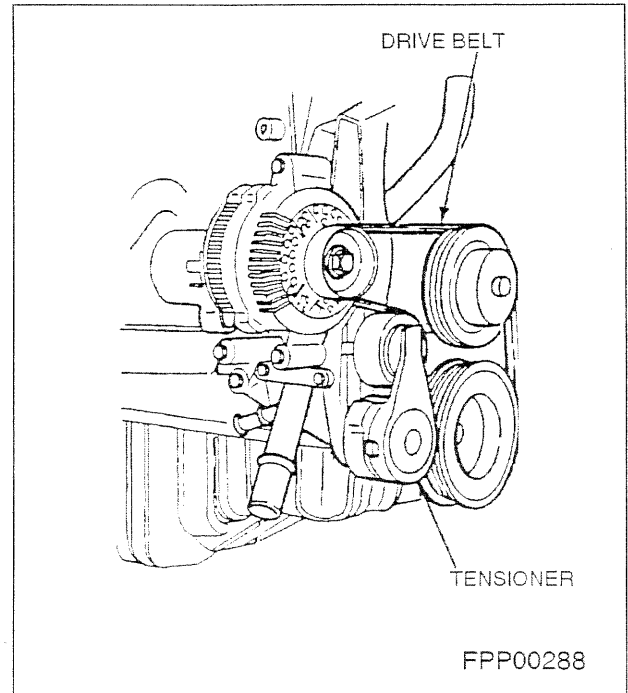

### Drive Belt Removal

1. Using a 3/8" breaker bar, pry against the tension of the tensioner.
2. Remove the belt.

### Drive Belt Installation

1. Using a 3/8" breaker bar, pry against the tension of the tensioner.
2. Install the belt.

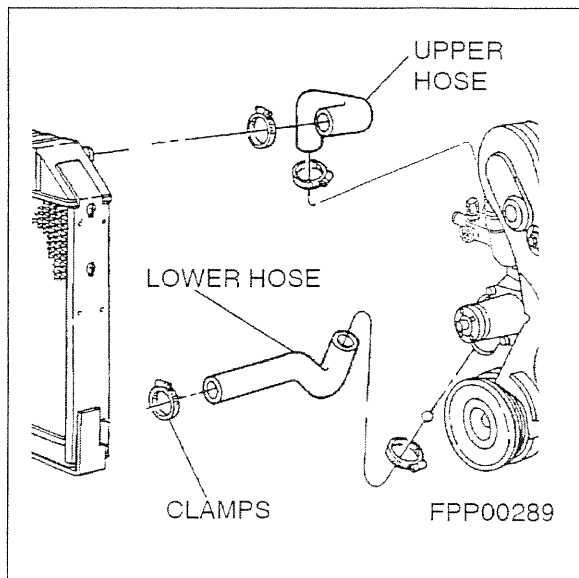

### Radiator Hose Removal

Radiator hoses should be replaced as directed in the maintenance schedule or whenever they become cracked, rotted or have a tendency to collapse.

1. Drain the radiator.
2. Loosen the clamps at each end of the hose to be removed.
3. Slide the hose off the radiator connection and the engine water outlet connection (upper hose) or the water pump connection (lower hose).

### Radiator Hose Installation

1. Position the clamps at least 1/8" from each end of the hose.
2. Coat the connection areas with an approved water-resistant sealer and slide the hose on the connection.
3. Make sure the clamps are beyond the bead and placed in the center of the clamping surface of the connections.
4. Tighten the clamps.
5. Fill the radiator with the recommended permanent antifreeze and water mixture.

**Operate the engine for several minutes, then check the hoses and connections for leaks.**



**WARNING: AVOID INJURY WHEN CHECKING A HOT ENGINE. COVER THE RADIATOR CAP IN A THICK CLOTH AND TURN IT SLOWLY COUNTERCLOCKWISE TO THE FIRST STOP. AFTER THE PRESSURE HAS BEEN COMPLETELY RELEASED, PRESS DOWNWARD AND FINISH REMOVING THE CAP. DO NOT ADD COOLANT TO AN ENGINE THAT HAS BECOME OVERHEATED UNTIL THE ENGINE COOLS. ADDING COOLANT TO AN EXTREMELY HOT ENGINE CAN RESULT IN A CRACKED BLOCK OR CYLINDER HEAD. FAILURE TO FOLLOW THESE INSTRUCTIONS COULD RESULT IN DAMAGE TO THE COOLING SYSTEM OR ENGINE AND/OR PERSONAL INJURY.**

### Drain & Refill Cooling System

1. Remove radiator cap.
2. Open drain cock at radiator and drain old coolant from engine.
3. If rust, sludge or other foreign material are present in the old coolant, see "Cleaning Cooling System" at the beginning of this section.
4. Fill radiator with a permanent type coolant that meets ford specification ESE-M97B44-A, such as Ford Cooling System Fluid.
5. Operate engine until thermostat opens and the radiator upper hose becomes hot.
6. Stop the engine and add coolant to approximately one inch below the filler neck.
7. Install radiator cap.
8. Operate engine and check all hoses and connections for leaks.



**CAUTION: Do not use alcohol or methanol antifreeze, or mix them with the specified coolant.**

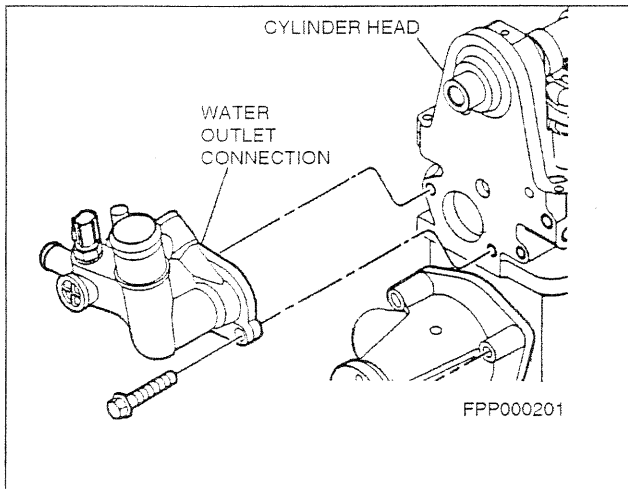

### Thermostat Removal

1. Drain the radiator so that the coolant level is below the thermostat.
2. Disconnect the heater return hose at the thermostat housing located on the left front lower side of engine.
3. Remove the coolant outlet housing retainer bolts.
4. Pull the elbow away from the cylinder head or manifold sufficiently to provide access to the thermostat.
5. Remove the thermostat and gasket.

### Thermostat Installation

1. Check the thermostat before installing it, following the procedures in this section.
2. Clean the coolant outlet housing and cylinder head or manifold gasket surfaces.
3. Coat a new gasket with water resistant sealer.
4. Position the gasket on the cylinder head opening.
5. The gasket must be positioned on the cylinder head before the thermostat is installed.



**Caution:** To prevent incorrect installation of the thermostat, the water outlet casting contains a locking recess into which the thermostat is turned and locked.

1. Install the thermostat with the bridge section in the outlet casting.
2. Turn the thermostat clockwise to lock it in position on the flats cast into the outlet elbow.
3. Position the coolant outlet elbow against the cylinder head.
4. Install and torque the retaining bolts to specifications.
5. Connect heater return hose to thermostat housing.
6. Fill the cooling system with the recommended permanent antifreeze and water mixture.
7. Check for leaks and proper coolant level after the engine has reached normal operating temperatures.

<b>SECTION TITLE</b>	<b>PAGE</b>
ENGINE SERVICE - General .....	01-01
ENGINE SERVICE - 2.5L .....	02-01
IGNITION SYSTEM .....	03-01
FUEL PUMP .....	04-01
CARBURETOR.....	05-01
STARTER MOTOR.....	06-01
GOVERNOR.....	07-01
COOLING SYSTEM .....	08-01
GENERATOR.....	09-01

---

## SECTION 09 - GENERATOR

---

<b>SUBJECT</b>	<b>PAGE</b>
DESCRIPTION.....	2
Operation .....	2
DIAGNOSIS .....	3
Visual Inspection .....	3
Generator Output Test .....	4
Generator Voltage Test.....	4
Symptom Chart .....	5
Pinpoint Tests.....	6
TEST A - Dead Battery - No Generator Output .....	6
TEST B - Indicator Lamp On, Engine Running .....	7
TEST C - Indicator Lamp Flickers/Intermittent .....	8
TEST D - Charging Voltage High.....	9
TEST E - Indicator Lamp Off, Key On, Engine Not Running.....	9
TEST F - Generator Noisy .....	10
TEST G - Radio Interference.....	11
TEST H - Indicator Lamp On, Key Off.....	11
REMOVAL AND INSTALLATION.....	12
Generator .....	12
Regulator .....	13

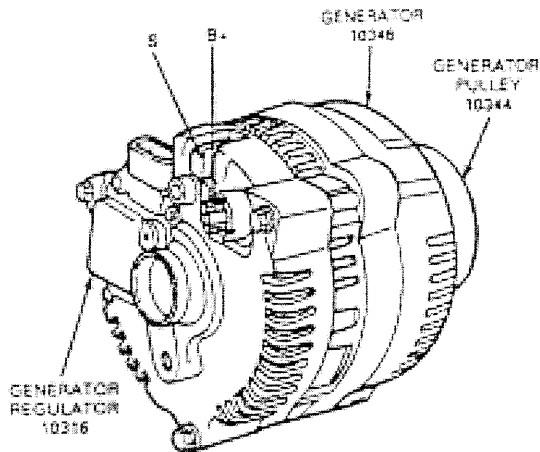

FPP00138

## DESCRIPTION

The generator output circuit 38 (BK/O) is supplied through the battery positive voltage (B+) output connection to the battery and electrical system. The B+ circuit is hot at all times. This circuit is protected by a fuse link.

The "I" circuit or ignition switch, circuit 904 (LG/R) is used to turn on the voltage regulator. This circuit is closed with the ignition switch in the RUN position. This circuit is also used to turn the charge indicator lamp on if there is a fault in the charging system operation or associated wiring circuits.

The "A" circuit, or battery sense circuit, circuit 36 (Y/W) is used to sense the battery voltage. This voltage is used by the voltage regulator to determine the output. This circuit is also used to supply power to the field coil. The "A" circuit is hot at all times. This circuit is protected by a fuse in the power distribution box or a fuse link.

The "S" circuit, or stator circuit, circuit 4 (W/BK) is used to feed back a voltage signal from the generator to the voltage regulator. This voltage, typically 1/2 battery voltage when the generator is operating, is used by the voltage regulator to turn off the charge indicator lamp.

## Operation

With the key in the RUN position, voltage is applied through the charge indicator lamp "I" circuit to the voltage regulator. This turns the voltage regulator on allowing current to flow from the battery sense "A" circuit to the generator field coil. When the engine is started, the generator begins to generate alternating (AC) current which is converted to direct (DC) current by the rectifier internal to the generator. This current is then supplied to the electrical system through the Battery Positive Voltage (B+) terminal located on the rear of the generator.

Once the generator begins generating current, a voltage signal is taken from the stator and fed back to the voltage regulator "S" circuit, turning off the charge indicator lamp.

with the system functioning normally, the generator output current is determined by the voltage at the "A" circuit. This voltage is compared to a set voltage internal to the voltage regulator, and the voltage regulator controls the generator field current to maintain proper generator output. The set voltage will vary with temperature and is typically higher in the winter than in the summer, allowing for better battery recharge.

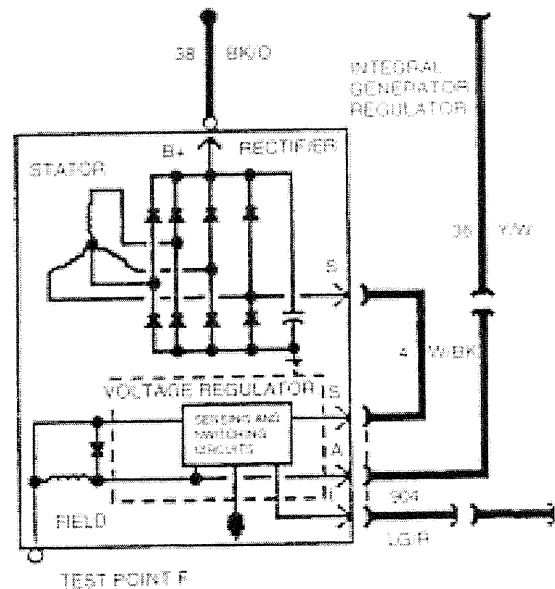

FPP00139

## DIAGNOSIS

Before performing generator tests on the unit, note conditions such as:

- slow cranking
- dead battery
- charge indicator lamp stays on with engine running

This information will aid in isolating the problem.

### Visual Inspection

Preliminary checks to the charging system should be made regardless of the fault condition:

1. Check battery posts and cable terminals for clean and tight connections. Clean the posts and the cables to ensure good electrical contact.
2. Check for secure connections at the generator output, regulator and engine ground. Also check the connection at the load distribution point (starter relay).
3. Check the fuses/fuse links and wiring to the generator to ensure that they are not burned or damaged. This condition, resulting in an open circuit or high resistance, can cause erratic or intermittent charging system concerns.
4. Check the battery voltage. If less than 12.3 volts with the engine and all accessories off, charge battery before proceeding.
5. Check belt condition and tension.

In order to check the generator, the use of Rotunda Starting and Charging System Tester 078-00005 (VAT-40) or equivalent, is recommended.

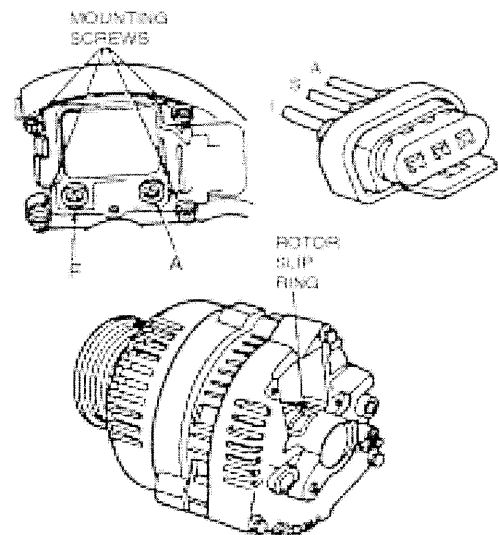

FPF00230

## Generator Output Test

1. Connect Rotunda Starting and Charging System Tester 078-00005 (VAT-40) or equivalent as shown.

NOTE: Refer to the test equipment user's manual for complete directions on examining the charging system.

1. Switch the tester to ammeter function.
2. Connect the positive and negative leads of the tester to the battery.
3. Connect current probe to generator B+ output lead circuit 38 (BK/O) to measure generator output.

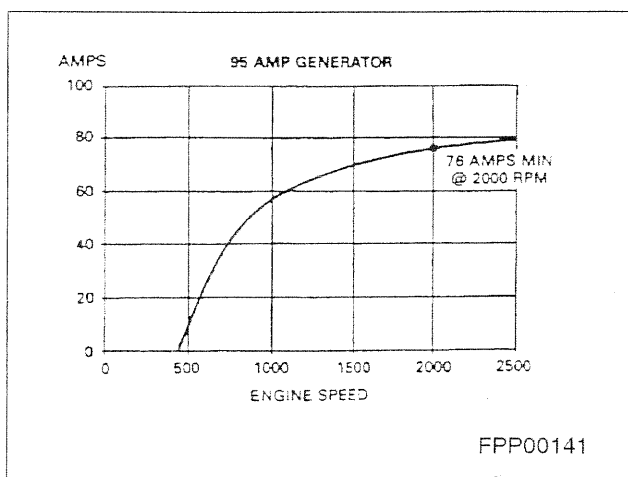

4. With the engine running at 2000 rpm, adjust the VAT-40 or equivalent load bank to determine the maximum output of the generator. Generator output should be greater than the values shown in the graph.

If amperage is **NOT** within specifications, refer to symptom chart.

## Generator Voltage Test

1. Switch the tester to the voltmeter function.
2. Connect the positive lead to the generator "A" terminal connector and the negative lead to ground.
3. Turn off all electrical accessories.
4. With the engine running at 2000 rpm, check the generator voltage.
5. Voltage should be between 13.0-15.5 volts.

If voltage is **NOT** within specifications, refer to symptom chart.

## Symptom Chart

CONDITION	POSSIBLE SOURCE	ACTION
Dead battery. Battery will not stay charged. Slow crank. Low battery voltage. No generator output.	<ul style="list-style-type: none"> <li>• Key-off battery drain.</li> <li>• Open/voltage drop in B+ circuit.</li> <li>• Open voltage drop in A circuit.</li> <li>• Open/high resistance in I circuit.</li> <li>• Voltage regulator.</li> <li>• Generator.</li> </ul>	Go to Pinpoint Test A.
Indicator lamp on with engine running.	<ul style="list-style-type: none"> <li>• Open "A" circuit.</li> <li>• Shorted "I" circuit.</li> <li>• Open/high resistance in "S" circuit.</li> <li>• Voltage regulator.</li> <li>• Generator.</li> </ul>	Go to Pinpoint Test B.
Indicator lamp flickers or intermittent.	<ul style="list-style-type: none"> <li>• Loose connection to generator, voltage regulator or battery.</li> <li>• Loose fuse or poor connection in "A" circuit.</li> <li>• Loose brush holder screw.</li> <li>• Voltage regulator.</li> <li>• Generator.</li> </ul>	Go to Pinpoint Test C.
Battery over charging (battery voltage greater than 15.5 volts).	<ul style="list-style-type: none"> <li>• Voltage drop in "A" circuit.</li> <li>• Voltage drop in "I" circuit.</li> <li>• Poor ground.</li> <li>• Voltage regulator.</li> <li>• Generator.</li> </ul>	Go to Pinpoint Test D.
Indicator lamp off, key on, engine not running.	<ul style="list-style-type: none"> <li>• Open/high resistance in "I" circuit.</li> <li>• Burned out bulb.</li> <li>• Poor ground.</li> <li>• "S" circuit shorted to B+.</li> <li>• Voltage regulator.</li> <li>• Generator.</li> </ul>	Go to Pinpoint Test E.
Generator noisy.	<ul style="list-style-type: none"> <li>• Accessory drive belt.</li> <li>• Accessory brackets.</li> <li>• Bent generator pulley.</li> <li>• Generator.</li> <li>• Other components.</li> </ul>	Go to Pinpoint Test F.
Indicator lamp on, key off.	<ul style="list-style-type: none"> <li>• Lamp circuit shorted to B+.</li> <li>• Improper lamp circuit wiring.</li> </ul>	Go to Pinpoint Test H.

## Pinpoint Tests

All voltage measurements are referenced to the negative (-) battery post unless otherwise specified. Do not make jumper connections except as directed. Improper connections may damage the voltage regulator or fuses/fuse links. All "key ON" measurements are made with the engine not running unless directed to "start engine".

### TEST A - Dead Battery - No Generator Output

TEST STEP		RESULT	ACTION TO TAKE
A1	CHECK FOR KEY-OFF DRAIN	Yes	Go to A2.
	<ul style="list-style-type: none"> <li>Turn key to OFF position.</li> <li>Turn off all accessories.</li> <li>Connect an ammeter or test lamp between the negative (-) battery cable and the negative battery post.</li> <li>Is current drain less than 100 mA (or test lamp off)?</li> </ul>	No	Check to ensure that the key switch is functioning properly, and that all lights and accessories are "off" with the key switch in the "off" position.
A2	CHECK FOR OPEN B+ CIRCUIT	Yes	Go to A3.
	<ul style="list-style-type: none"> <li>Measure voltage at B+ terminal on the back of the generator.</li> <li>Is voltage equal to battery voltage?</li> </ul>	No	Check fuse link in circuit 38, 290 and 37 and replace if required. If OK, repair open in circuits 38, 290 and 37.
A3	CHECK FOR OPEN A CIRCUIT	Yes	Go to A4.
	<ul style="list-style-type: none"> <li>Measure voltage at test point "A" on the voltage regulator.</li> <li>Is voltage equal to battery voltage?</li> </ul>	No	Check fuse or fuse link in circuit 36 and replace if required. If OK repair open in circuit 36.
A4	CHECK FOR OPEN FIELD CIRCUIT	Yes	Go to A5.
	<ul style="list-style-type: none"> <li>Measure voltage at test point "F" on the voltage regulator.</li> <li>Is voltage equal to battery voltage?</li> </ul>	No	Go to A11.
A5	CHECK FOR OPEN "I" CIRCUIT	Yes	Go to A6.
	<ul style="list-style-type: none"> <li>Turn key to ON position.</li> <li>Measure voltage at wiring harness "I" terminal.</li> </ul> NOTE: Voltage regulator must be connected to wiring harness for this test. <ul style="list-style-type: none"> <li>Is voltage greater than 1 volt?</li> </ul>	No	Repair open or high resistance in circuit 904.
A6	CHECK VOLTAGE DROP IN "A" CIRCUIT	Yes	Go to A7.
	<ul style="list-style-type: none"> <li>Measure voltage drop between test point "A" on the voltage regulator and the positive (+) battery post.</li> <li>Is voltage drop less than 0.25 volts?</li> </ul>	No	Repair excess voltage drop in circuit 36. Check fuses or fuse link and connectors in circuit 36 and service as required.
A7	CHECK FIELD TURN-ON	Yes	Go to A8.
	<ul style="list-style-type: none"> <li>Measure voltage at test point "F" on the voltage regulator.</li> <li>Is voltage less than 2 volts?</li> </ul>	No	Go to A11.
A8	CHECK FOR SHORTED RECTIFIER	Yes	Replace generator.
	<ul style="list-style-type: none"> <li>Remove one pin "S" connector from generator.</li> <li>Measure voltage between the "S" terminal on the back of the generator and ground.</li> <li>Measure voltage between the positive (+) battery terminal and the "S" terminal on the back of the generator.</li> <li>Is either voltage reading greater than 1 volt?</li> </ul>	No	Go to A9.

<b>A9</b>	<b>CHECK VOLTAGE DROP IN B+ CIRCUIT</b>	<b>Yes</b>	Go to A10.
	<ul style="list-style-type: none"> <li>Install "S" connector.</li> <li>Start engine.</li> <li>Turn on headlights or any accessory.</li> <li>With engine running at 2000 rpm, measure voltage drop between the B+ terminal on the back of the generator and the positive (+) battery post.</li> <li>Is voltage drop less than 0.5 volt?</li> </ul>	<b>No</b>	Repair excess voltage drop in circuits 38, 290, and 37. Check fuse link in circuits 38, 290, and 37 and the connections between the battery and under hood fuse box.
<b>A10</b>	<b>CHECK FOR OPEN STATOR PHASE</b>	<b>Yes</b>	Replace voltage regulator.
	<ul style="list-style-type: none"> <li>Connect test point "F" on the voltage regulator to the negative (-) battery post using a jumper wire.</li> <li>Repeat generator output test.</li> <li>Is generator output greater than the minimum output specified?</li> </ul>	<b>No</b>	Replace generator.
<b>A11</b>	<b>CHECK FOR OPEN/SHORTED FIELD</b>	<b>Yes</b>	Replace generator.
	<ul style="list-style-type: none"> <li>Remove generator.</li> <li>Remove voltage regulator.</li> <li>Measure resistance between the generator slip rings.</li> <li>Is resistance greater than 10 ohms or less than 1 ohm?</li> </ul>	<b>No</b>	Check for worn brushes (less than 8mm long) or open brush leads and replace if required. If OK, replace voltage regulator.

## TEST B - Indicator Lamp On, Engine Running

TEST STEP		RESULT	ACTION TO TAKE
<b>B1</b>	<b>CHECK FOR OPEN "A" CIRCUIT</b>	<b>Yes</b>	Go to B2.
	<ul style="list-style-type: none"> <li>Measure voltage at test point "A" on the voltage regulator.</li> <li>Is voltage equal to battery voltage?</li> </ul>	<b>No</b>	Check fuse or fuse link in circuit 36 and replace if required. If OK, repair open in circuit 36.
<b>B2</b>	<b>CHECK FOR SHORTED "I" CIRCUIT</b>	<b>Yes</b>	Repair short to ground in circuit 904.
	<ul style="list-style-type: none"> <li>Remove three pin voltage regulator connector.</li> <li>Turn key to ON position.</li> <li>Is indicator lamp on?</li> </ul>	<b>No</b>	Go to B3.
<b>B3</b>	<b>CHECK "S" CIRCUIT FUNCTION</b>	<b>Yes</b>	Remove jumper wire. Go to B4.
	<ul style="list-style-type: none"> <li>Install voltage regulator connector.</li> <li>Remove one pin "S" connector.</li> <li>Connect wiring harness "S" terminal, circuit 4 to the positive battery post using a jumper wire.</li> <li>Is indicator lamp on?</li> </ul>	<b>No</b>	Remove jumper wire. Go to B5.
<b>B4</b>	<b>CHECK FOR OPEN "s" CIRCUIT</b>	<b>Yes</b>	Repair open or excess resistance in circuit 4.
	<ul style="list-style-type: none"> <li>Remove three pin voltage regulator connector.</li> <li>Measure wiring resistance between the one in "S: connector and the "S" (center) pin of the voltage regulator connector.</li> <li>Is resistance greater than 1 ohm?</li> </ul>	<b>No</b>	Check for loose or bent pin in voltage regulator or connector. If OK, replace voltage regulator.
<b>B5</b>	<b>CHECK STATOR OUTPUT VOLTAGE</b>	<b>Yes</b>	Go to B6.
	<ul style="list-style-type: none"> <li>Start engine.</li> <li>Measure voltage at the "S" terminal on the back of the generator.</li> <li>Is voltage at least 1/2 of battery voltage?</li> </ul>	<b>No</b>	Go to Pinpoint Test A to find the cause of low generator output

<b>B6</b>	<b>CHECK GENERATOR OUTPUT VOLTAGE</b>	<b>Yes</b>	Go to Pinpoint Test D to find the cause of high output voltage.
<ul style="list-style-type: none"> <li>Measure voltage at the B+ terminal on the back of the generator with the engine running at 2000 rpm and all accessories turned off.</li> <li>Is voltage greater than 15.5 volts?</li> </ul>		<b>No</b>	Replace voltage regulator.

### TEST C - Indicator Lamp Flickers/Intermittent

TEST STEP		RESULT	ACTION TO TAKE
<b>C1</b>	<b>CHECK FOR LOOSE CONNECTIONS</b>	<b>Yes</b>	Go to C2.
<ul style="list-style-type: none"> <li>Check these connections for corrosion, loose or bent pins, or loose eyelets: Three-pin voltage regulator connector. One-pin "S" connector. Generator B+ eyelet. Battery cables.</li> <li>Are all connections clean and tight?</li> </ul>		<b>No</b>	Clean or repair connections as required.
<b>C2</b>	<b>CHECK FOR FIELD CIRCUIT DRAIN</b>	<b>Yes</b>	Go to C3.
<ul style="list-style-type: none"> <li>Turn key to off position.</li> <li>Measure voltage at test point "F" on the voltage regulator.</li> <li>Is voltage equal to battery voltage?</li> </ul>		<b>No</b>	Go to C5.
<b>C3</b>	<b>CHECK FOR LOOSE "A" CIRCUIT FUSE</b>	<b>Yes</b>	Repair loose fuse connection.
<ul style="list-style-type: none"> <li>Start engine.</li> <li>Check the generator fuse loose connection by wiggling the fuse with the engine running.</li> <li>Does indicator lamp flicker?</li> </ul>		<b>No</b>	Go to C4.
<b>C4</b>	<b>CHECK "A" CIRCUIT CONNECTIONS</b>	<b>Yes</b>	Replace voltage regulator. If problem still exists, replace generator.
<ul style="list-style-type: none"> <li>With engine running, connect test point "A" on the voltage regulator to the positive (+) battery post using a jumper wire.</li> <li>Does indicator lamp flicker?</li> </ul>		<b>No</b>	Repair poor connection in circuit 36.
<b>C5</b>	<b>CHECK BRUSH HOLDER SCREWS</b>	<b>Yes</b>	Go to C6.
<ul style="list-style-type: none"> <li>Remove generator from unit.</li> <li>Check the brush holder screws, located on the voltage regulator (test points "F" and "A").</li> <li>Are the brush holder screws tight?</li> </ul>		<b>No</b>	Tighten screws to specification. 2.8-4.0 N•m (25-35 lb-in).
<b>C6</b>	<b>CHECK FOR GROUNDED SLIP RING</b>	<b>Yes</b>	If grease or dirt has accumulated near the slip rings, clean the slip rings and recheck resistance. If still less than 200 ohms, replace generator.
<ul style="list-style-type: none"> <li>Remove voltage regulator.</li> <li>Measure resistance from each generator slip ring to the generator housing.</li> <li>Is resistance from either slip ring to housing less than 200 ohms?</li> </ul>		<b>No</b>	Replace voltage regulator.

## TEST D - Charging Voltage High

TEST STEP		RESULT	ACTION TO TAKE
D1	CHECK VOLTAGE DROP IN "A" CIRCUIT	Yes	Go to D2.
	<ul style="list-style-type: none"> <li>Turn key to ON position.</li> <li>Measure voltage between test point A on the voltage regulator and the positive (+) battery post.</li> <li>Is voltage drop less than 0.25 volt?</li> </ul>	No	Repair excess voltage drop in circuit 36. Check fuse or fuse link and connectors in circuit 36 and service as required.
D2	CHECK VOLTAGE DROP IN "I" CIRCUIT	Yes	Go to D3.
	<ul style="list-style-type: none"> <li>Measure voltage at wiring harness "I" terminal, circuit 904.</li> </ul> NOTE: Voltage regulator must be connected to wiring harness for this test. <ul style="list-style-type: none"> <li>Is voltage greater than 1 volt?</li> </ul>	No	Repair high resistance in circuit 904.
D3	CHECK FOR POOR GROUNDS	Yes	Go to D4.
	<ul style="list-style-type: none"> <li>Check for poor ground connections between voltage regulator and generator, generator and engine, or engine and battery.</li> <li>Are all ground connections clean and tight?</li> </ul>	No	Clean or repair grounds as required.
D4	CHECK FOR FIELD CIRCUIT DRAIN	Yes	Generator is OK. Replace voltage regulator.
	<ul style="list-style-type: none"> <li>Turn key to OFF position.</li> <li>Measure voltage at test point "F" on the voltage regulator.</li> <li>Is voltage equal to battery voltage?</li> </ul>	No	Go to D5.
D5	CHECK FOR GROUNDED SLIP RING	Yes	If grease or dirt has accumulated near the slip rings, Clean the slip rings and recheck resistance. If still less than 200 ohms, replace generator.
	<ul style="list-style-type: none"> <li>Remove generator from vehicle.</li> <li>Remove voltage regulator.</li> <li>Measure resistance from each generator slip ring to the generator housing.</li> <li>Is resistance from either slip ring to housing less than 200 ohms?</li> </ul>	No	Replace voltage regulator.

## TEST E - Indicator Lamp Off, Key On, Engine Not Running

TEST STEP		RESULT	ACTION TO TAKE
E1	CHECK FOR OPEN "I" CIRCUIT	Yes	Go to E2.
	<ul style="list-style-type: none"> <li>Remove three-pin voltage regulator connector.</li> <li>Turn key to ON position.</li> <li>Measure voltage at wiring harness "I" terminal.</li> <li>Is voltage greater than 0 volts?</li> </ul>	No	Repair open in circuit 904.
E2	CHECK FOR BURNED OUT BULB	Yes	Remove jumper wire. Go to E3.
	<ul style="list-style-type: none"> <li>Connect wiring harness "I" terminal to ground with a jumper wire.</li> <li>Is indicator lamp on?</li> </ul>	No	Replace bulb or repair high resistance in bulb socket or circuit 904.

<b>E3</b>	<b>CHECK FOR POOR GROUNDS</b>	<b>Yes</b>	Go to E4.
	<ul style="list-style-type: none"> <li>Check for poor ground connections between voltage regulator and generator, generator and engine, or engine and battery.</li> <li>Are all ground connections clean and tight?</li> </ul>	<b>No</b>	Clean or repair grounds as required.
<b>E4</b>	<b>CHECK "S" CIRCUIT WIRING</b>	<b>Yes</b>	Service circuit 4. Circuit should be hot only when engine is running. Check for swapped wires in voltage regulator connector.
	<ul style="list-style-type: none"> <li>Remove one-pin "S" connector from generator.</li> <li>Measure voltage at wiring harness "S" terminal.</li> <li>Is voltage greater than 0 volts?</li> </ul>	<b>No</b>	Go to E5.
<b>E5</b>	<b>CHECK FOR SHORTED RECTIFIER</b>	<b>Yes</b>	If lamp is on with one-pin "S" connector removed, replace generator.
	<ul style="list-style-type: none"> <li>Measure voltage at the "S" terminal on the back of the generator.</li> <li>Is voltage greater than 1 volt?</li> </ul>	<b>No</b>	Replace voltage regulator.

### TEST F - Generator Noisy

TEST STEP		RESULT	ACTION TO TAKE
<b>F1</b>	<b>CHECK FOR ACCESSORY-DRIVE NOISE</b>	<b>Yes</b>	Go to F2.
	<ul style="list-style-type: none"> <li>Check the drive belt to make sure that it is installed properly and is not damaged.</li> <li>Check the accessory mounting brackets for loose bolts or out of alignment condition.</li> <li>Check for a bent pulley.</li> <li>Is accessory drive OK?</li> </ul>	<b>No</b>	Service accessory drive as required.
<b>F2</b>	<b>SUBSTITUTE KNOWN GOOD GENERATOR</b>	<b>Yes</b>	Generator is OK. Install original part. Check other accessories to find the cause of the noise.
	<ul style="list-style-type: none"> <li>Remove generator and replace with a known good generator.</li> <li>Is noise present with known good part?</li> </ul>	<b>No</b>	Replace generator.

**TEST G - Radio Interference**

TEST STEP		RESULT	ACTION TO TAKE
G1	VERIFY RADIO INTERFERENCE	Yes	Generator is OK. Interference is occurring elsewhere in the electrical system.
	<ul style="list-style-type: none"> <li>Start engine.</li> <li>Tune radio to a station where interference is present.</li> <li>Remove three-pin voltage regulator connector.</li> <li>Is interference present with connector removed?</li> </ul>	No	Go to G2.
G2	SUBSTITUTE KNOWN GOOD GENERATOR	Yes	Generator is OK. Interference is occurring elsewhere in the electrical system.
	<ul style="list-style-type: none"> <li>Remove generator and replace with a known good generator.</li> <li>Is interference present with known good part?</li> </ul>	No	Replace generator.

**TEST H - Indicator Lamp On, Key Off**

TEST STEP		RESULT	ACTION TO TAKE
H1	CHECK LAMP CIRCUIT WIRING	Yes	Service circuit 904. Circuit should be hot in run position only.
	<ul style="list-style-type: none"> <li>Turn key to OFF position.</li> <li>Remove three-pin voltage regulator connector.</li> <li>Measure voltage at wiring harness "I" terminal, circuit 904.</li> <li>Is voltage greater than 0 volts?</li> </ul>	No	Service instrumentation system. Indicator lamp circuit is finding a path to ground at a point other than the generator.



**WARNING: BATTERIES NORMALLY PRODUCE EXPLOSIVE GASES WHICH CAN CAUSE PERSONAL INJURY. THEREFORE, DO NOT ALLOW FLAMES, SPARKS OR LIGHTED SUBSTANCES TO COME NEAR THE BATTERY. WHEN CHARGING OR WORKING NEAR A BATTERY, ALWAYS SHIELD YOUR FACE AND PROTECT YOUR EYES. ALWAYS PROVIDE VENTILATION.**

**WHEN LIFTING A PLASTIC-CASED BATTERY, EXCESSIVE PRESSURE ON THE END WALLS COULD CAUSE ACID TO SPEW THROUGH THE VENT CAPS, RESULTING IN PERSONAL INJURY. LIFT WITH A BATTERY CARRIER OR WITH YOUR HANDS ON OPPOSITE CORNERS.**

**WARNING: KEEP BATTERIES OUT OF REACH OF CHILDREN. BATTERIES CONTAIN SULFURIC ACID. AVOID CONTACT WITH SKIN, EYES OR CLOTHING. ALSO, SHIELD YOUR EYES WHEN WORKING NEAR THE BATTERY TO PROTECT AGAINST POSSIBLE SPLASHING OF THE ACID SOLUTION. IN CASE OF ACID CONTACT WITH THE SKIN, EYES OR CLOTHING, FLUSH IMMEDIATELY WITH WATER FOR A MINIMUM OF FIFTEEN MINUTES. IF ACID IS SWALLOWED, DRINK LARGE QUANTITIES OF MILK OR WATER, FOLLOWED BY MILK OF MAGNESIA, A BEATEN EGG, OR VEGETABLE OIL. CALL A PHYSICIAN IMMEDIATELY.**

## REMOVAL AND INSTALLATION

**NOTE:** Only the regulator, brush holder and generator pulley are serviceable. If the generator needs further service, it must be replaced as an assembly.

### Generator Removal

1. Disconnect battery ground cable.
2. Remove snow/ice shield.
3. Remove engine air cleaner intake tube.
4. Disconnect the generator voltage regulator wiring to the voltage regulator.
5. Remove wiring connector bracket.
6. Loosen the drive belt tensioner and remove the drive belt.

1. Remove the bolts holding the generator to the generator bracket.
2. Remove the generator from the generator bracket.

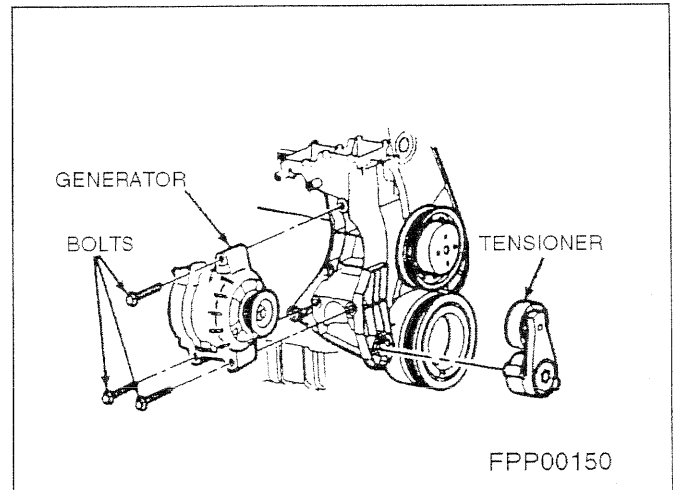

### Generator Installation

1. Position the generator on the generator bracket.
2. Install generator.
3. Tighten generator-to-bracket bolts to 40-55 N·m (29-40 lb-ft).
4. Position drive belt.
5. Using flex handle, rotate drive belt tensioner, position drive belt, and rest tensioner pulley on drive belt.
6. Connect generator voltage regulator wiring to the voltage regulator. Tighten generator battery positive voltage (B+) wire attaching nut to 9-12 N·m (6.5-9 lb-ft).
7. Install wiring connector bracket.
8. Install engine air cleaner intake tube.
9. Install snow/ice shield.
10. Connect battery ground cable.

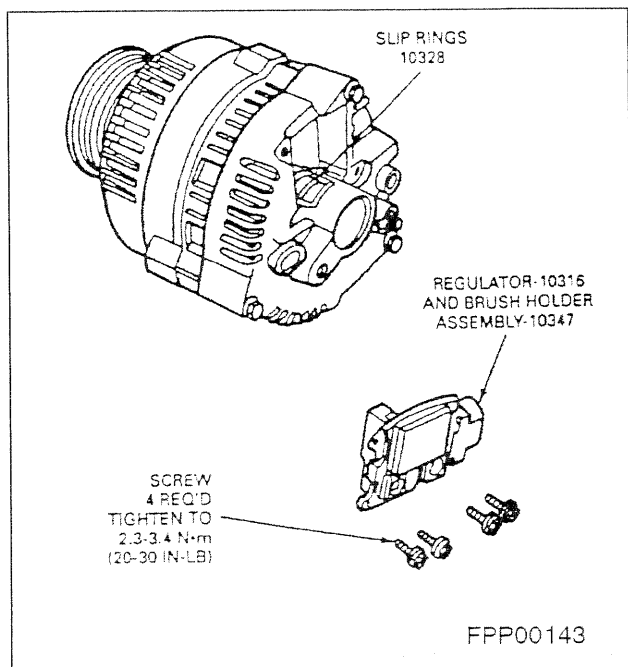

## Regulator Installation

1. Replace generator brush holder to voltage regulator and install attaching screws.
2. Replace cap on the head of the "A" terminal screw.
3. Depress the generator brushes into the generator brush holder.
4. Hold the generator brushes in position by inserting a standard size paper clip (or equivalent) through both the location hole in the voltage regulator and through the holes in the generator brush holders.
5. Install the voltage regulator and generator brush holder to the generator with attaching screws.
6. Remove paper clip (or equivalent) from the regulator.

## Regulator Removal

1. Remove the four screws (T20 Torx® type head) attaching the voltage regulator to the generator housing. Remove the voltage regulator with generator brush holder attached, from the generator.
2. Hold the voltage regulator generator regulator in one hand and pry off the cap covering the "A" screw head with a screwdriver.
3. Remove two screws (T20 Torx® type head) attaching the regulator to the generator brush holder. Separate the regulator from generator brush holder.

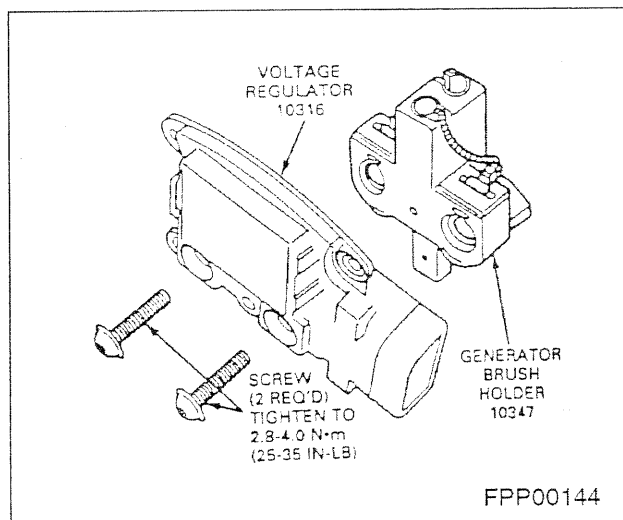



**GENERAC<sup>®</sup>**  
**POWER SYSTEMS, INC.**

*P.O. BOX 310 EAGLE, WI 53119*

**Part No. OE9693**

**Revision \* (01/05/03)**

**Printed in U.S.A.**