

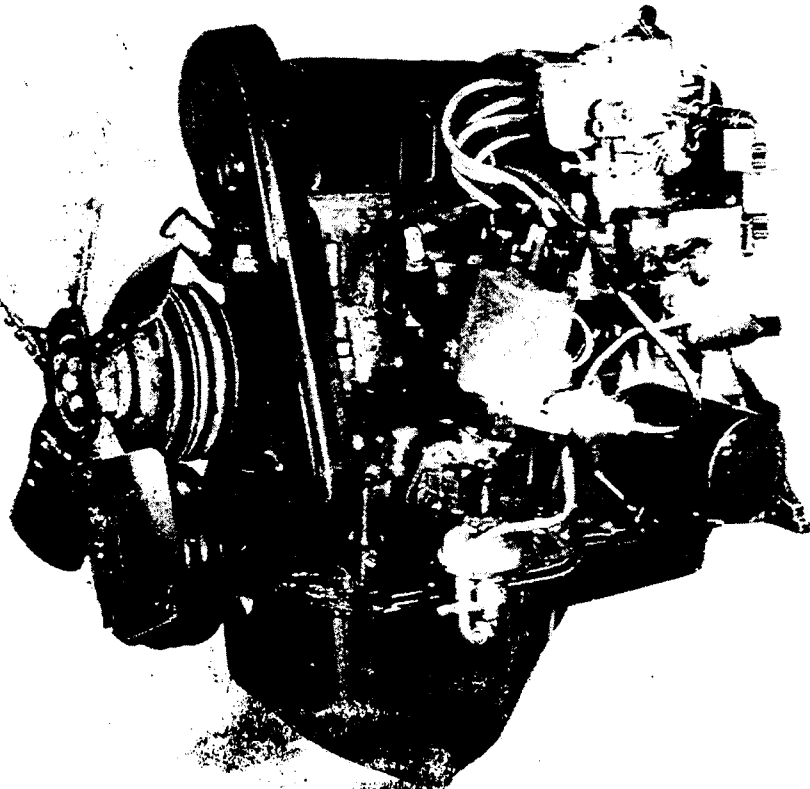

**LSG-423
2.3 LITRE**

**The Source for Power...
Worldwide™**



**INDUSTRIAL ENGINE
SERVICE MANUAL**

Introduction

In general, this manual covers the servicing of the engine and associated standard equipment. In many cases, engines are supplied with accessories and equipment that are unique to the application. If service information is ever required on such unique accessories or equipment it is suggested that the Power Products Operations of Ford Motor Company be contacted. The proper information will either be forwarded or the Service Technician will be advised where it can be obtained.

The information in this manual is grouped in sections according to the type of work being performed. The various sections are indicated in the index. In addition, each section is subdivided to include topics such as diagnosis and testing, cleaning and inspection, overhaul, removal and installation procedures, disassembly and assembly procedures, and service specifications.



The Source for Power...
Worldwide™

Power Products Division
Geometric Results Incorporated
28333 Telegraph Road
Southfield, MI 48034

The descriptions and specifications contained in this manual were in effect at the time the book was released for printing. Ford Motor Company reserves the right to discontinue models at any time, or change specifications or design, without notice and without incurring obligation.

NOTE: *The recommendations and suggestions contained in this publication are made to assist the distributor in improving his distributorship parts and/or service department operations. These recommendations and suggestions do not supersede or override the provisions of the Warranty and Policy Manual and in any cases where there may be a conflict, the provisions of the Warranty and Policy Manual shall govern.*

IMPORTANT SAFETY NOTICE

Appropriate service methods and proper repair procedures are essential for the safe, reliable operation of all motor vehicles as well as the personal safety of the individual doing the work. This Shop Manual provides general directions for accomplishing service and repair work with tested, effective techniques. Following them will help assure reliability.

There are numerous variations in procedures, techniques, tools, and parts for servicing vehicles, as well as in the skill of the individual doing the work. This Manual cannot possibly anticipate all such variations and provide advice or cautions as to each. Accordingly, anyone who departs from the instructions provided in this Manual must first establish that he compromises neither his personal safety nor the vehicle integrity by his choice of methods, tools or parts.

NOTES, CAUTIONS, AND WARNINGS

As you read through the procedures, you will come across NOTES, CAUTIONS, and WARNINGS. Each one is there for a specific purpose. NOTES give you added information that will help you to complete a particular procedure. CAUTIONS are given to prevent you from making an error that could damage the vehicle. WARNINGS remind you to be especially careful in those areas where carelessness can cause personal injury. The following list contains some general WARNINGS that you should follow when you work on a vehicle.

- Always wear safety glasses for eye protection.
- Use safety stands whenever a procedure requires you to be under the vehicle.
- Be sure that the ignition switch is always in the OFF position, unless otherwise required by the procedure.
- Set the parking brake when working on the vehicle. If you have an automatic transmission, set it in PARK unless instructed otherwise for a specific operation. If you have a manual transmission, it should be in REVERSE (engine OFF) or NEUTRAL (engine ON) unless instructed otherwise for a specific operation. Place wood blocks (4" x 4" or larger) to the front and rear surfaces of the tires to provide further restraint from inadvertent vehicle movement.
- Operate the engine only in a well-ventilated area to avoid the danger of carbon monoxide.
- Keep yourself and your clothing away from moving parts, when the engine is running, especially the fan and belts.
- To prevent serious burns, avoid contact with hot metal parts such as the radiator, exhaust manifold, tail pipe, catalytic converter and muffler.
- Do not smoke while working on the vehicle.
- To avoid injury, always remove rings, watches, loose hanging jewelry, and loose clothing before beginning to work on a vehicle. Tie long hair securely behind the head.
- Keep hands and other objects clear of the radiator fan blades. Electric cooling fans can start to operate at any time by an increase in underhood temperatures, even though the ignition is in the OFF position. Therefore, care should be taken to ensure that the electric cooling fan is completely disconnected when working under the hood.

2.3 LITRE (140 CID) GASOLINE ENGINES

	PAGE		
PART 1 Basic Engine	1-01	PART 5 Starting System	5-01
PART 2 Ignition System	2-01	PART 6 Governors	6-01
PART 3 Fuel System	3-01	PART 7 Cooling System	7-01
PART 4 Charging System	4-01	PART 8 Specifications	8-01

PART 1 Basic Engine

COMPONENT INDEX	Page	COMPONENT INDEX	Page
IDENTIFICATION	1-02	Oil Pan	1-15
DESCRIPTION	1-03	Oil Pump	1-16
DIAGNOSIS AND TESTING		Positive Closed Type Crankcase Ventilation System	1-16
Positive Closed-Type Ventilation System	1-04	REMOVAL AND INSTALLATION	
Compression Test	1-04	Valve Rocker Arm Cover and Rocker Arm	1-16
Camshaft Lobe Lift	1-05	Valve Spring, Retainer and Stem Seal	1-17
Value Clearance	1-05	Camshaft and Bearings	1-18
Hydraulic Lash Adjuster	1-06	Intake Manifold	1-18
Camshaft Timing	1-06	Exhaust Manifold	1-18
Camshaft End Play	1-07	Auxiliary Shaft	1-18
Crankshaft End Play	1-07	Crankshaft Sprocket	1-19
Flywheel Face Runout	1-07	Belt Tensioner	1-19
OVERHAUL		Thermostat and Water Pump	1-19
Cylinder Head	1-08	Cylinder Head	1-20
Valves	1-08	Oil Pan	1-21
Camshaft	1-09	Crankshaft Rear Oil Seal	1-21
Crankshaft	1-09	Crankshaft Main Bearings	1-22
Pistons, Pins and Rings	1-10	Oil Pump	1-22
Valve Rocker Arm and/or Shaft Assembly	1-10	Oil Filter	1-22
Cylinder Block	1-10	Connecting Rods and Pistons	1-22
CLEANING AND INSPECTION		Flywheel	1-23
Intake Manifold	1-11	Flywheel Ring Gear	1-23
Exhaust Manifold	1-11	Crankshaft	1-23
Valve Rocker Arm and/or Shaft Assembly	1-11	DISASSEMBLY AND ASSEMBLY	
Cylinder Heads	1-12	Cylinder Head	1-25
Timing Belt and Sprockets	1-13	Oil Pump	1-25
Camshaft	1-13	Hydraulic Lash Adjuster	1-26
Crankshaft	1-13		
Flywheel	1-13		
Connecting Rods	1-14		
Pistons, Pins and Rings	1-14		
Bearings, Main and Connecting Rod	1-14		
Cylinder Block	1-15		

IDENTIFICATION

An Identification Decal (Fig. 1) is affixed to the left side of the rocker cover of the engine. The decal contains the engine serial number which identifies this unit from all others. Next is the engine displacement which determines the engine specifications, then the model number and S.O. or special options which determines the parts or components required on this unit. Use all the numbers when seeking information or ordering replacement parts for this engine.

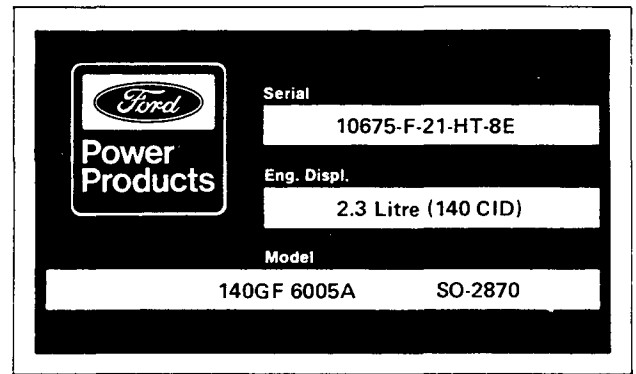

FIG. 1 Identification Decal

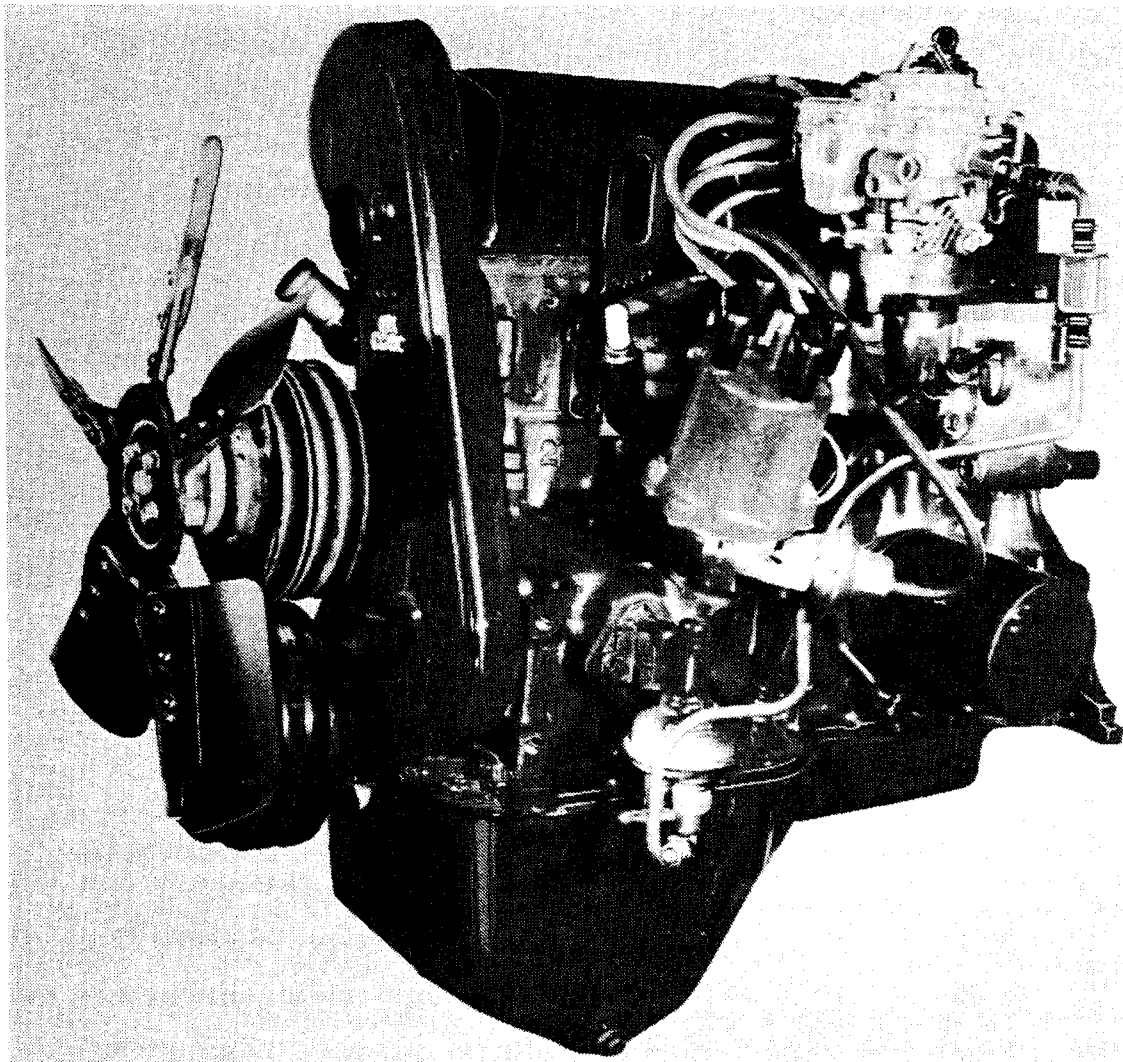

FIG. 2 2300 cc Engine

DESCRIPTION

The 4-cylinder 2300 cc (2.3 L) (Fig 2) overhead cam engine is of lightweight iron construction. The crankshaft is supported on five main bearings and the camshaft by four. Main, connecting rod, camshaft and auxiliary shaft bearings are all replaceable.

The camshaft is driven from the crankshaft by a cogged belt, which also operates the auxiliary shaft, and through this shaft, the oil pump, fuel pump and the distributor. Tension on the cam drive belt is maintained by a preloaded and locked idler pulley bearing on the outside of the belt.

Water pump and fan are separately driven from the crankshaft by a conventional V-belt, which also drives the alternator.

Hydraulic valve lash adjusters are used in the valve train. These units are placed at the fulcrum point of the cam followers (or rocker arms). Their action is similar to the hydraulic valve lifters used in push-rod engines and they are constructed and serviced in the same manner. The cylinder head has drilled oil passages to provide engine oil pressure to the lash adjusters (Fig. 3).

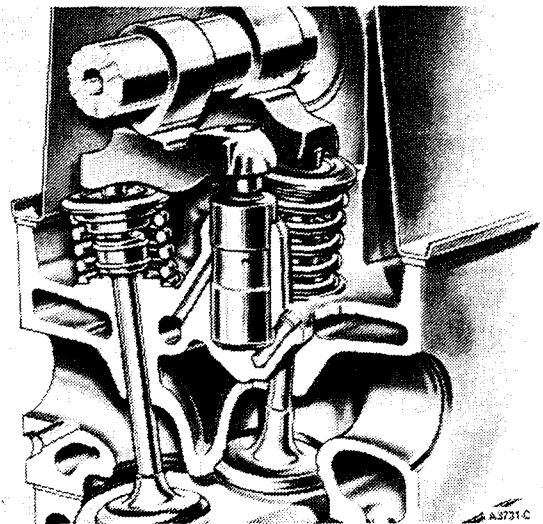

FIG. 3 Valve Train Lubrication System

DIAGNOSIS AND TESTING

POSITIVE CLOSED-TYPE CRANKCASE VENTILATION SYSTEM

A malfunctioning closed crankcase ventilation system may be indicated by loping or rough engine idle. Do not attempt to compensate for this idle condition by disconnecting the crankcase ventilation system and making carburetor adjustments. The removal of the crankcase ventilation system from the engine will adversely affect the fuel economy and engine ventilation with resultant shortening of engine life. To determine whether the loping or rough idle condition is caused by a malfunctioning crankcase ventilation system, perform the following test.

CRANKCASE VENTILATION REGULATOR VALVE TEST

If the ventilation system passes Tests "A" and "B", it can be considered functionally OK, and no further service is required. If it fails either of the tests, replace the PCV valve and repeat test "A".

If the system still does not pass Test "A", clean the ventilation system hoses and all passages to the induction system in accordance with established procedures.

With the Engine Idling — (Test "A"):

1. Remove the PCV valve from its mounting (such as the rocker arm cover) but leave the vacuum inlet side connected to the hose. If the valve is functioning properly and not plugged, a hissing noise will be heard as air passes through the valve. A strong vacuum will be felt when a finger is placed over the valve inlet, check for vacuum leaks in the hose line and at all connections.
2. Re-install the PCV valve, then remove the crankcase air inlet hose at the air cleaner connection. Loosely hold a small piece of stiff paper (such as a 3 x 5 memo card or parts tag card) over the opening at the end of the inlet hose. After a minute or so, (to allow crankcase pressure to lower) the paper should be sucked against the hose opening with a noticeable force.

With the Engine Stopped — (Test "B"):

Remove the PCV valve from its mounting and shake it. A metallic clicking noise should be heard, indicating that the valve parts are free, and not sticking.

AIR INTAKE TEST

As an alternate test, on those installations where the system fresh air inlet is located in the oil filler cap, a Crankcase Ventilation Tester, C8AZ-6B27-A (Fig. 4) may be used. This tool indicates whether or not a sufficient amount of fresh air is being drawn into the system. When using this tool, be sure it fits the oil filler cap opening tightly, because it registers vacuum and air leaks will cause an erroneous reading. To use this tool:

1. With the engine idling at normal operating temperature, remove the oil filler cap and hold the tool tightly against the oil filler cap opening.
2. If the ball (Fig. 4) settles in the Good (green) area, the system is functioning properly. If the ball settles in the Repair (red) area, perform Tests "A" and "B" to isolate the problem. Clean, repair or replace system components as necessary.

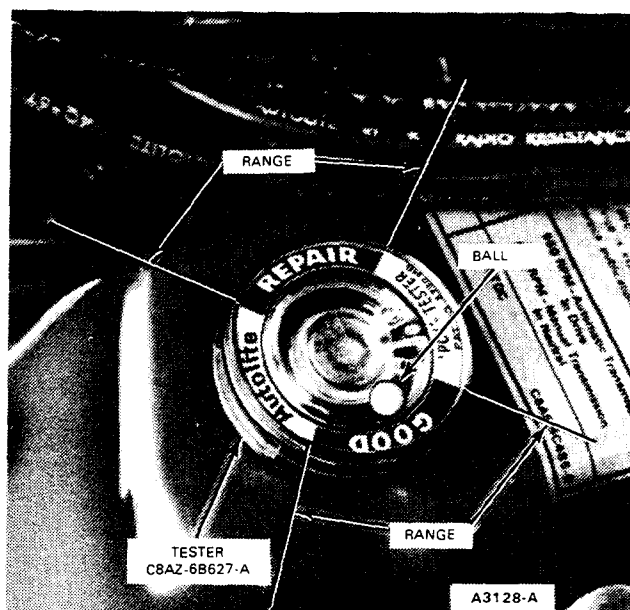

FIG. 4 Crankcase Ventilation System Tester

3. Re-test when repairs are complete, to be sure that the crankcase ventilation system is operating satisfactorily.

COMPRESSION TEST

Compression Gauge Check

1. Be sure the crankcase oil is at the proper level and the battery is properly charged. Operate the engine for a minimum of 30 minutes at 1200 rpm or until the engine is at normal operating temperature. Turn the ignition switch off; then remove all the spark plugs.
2. Set the carburetor throttle plate and choke plate in the wide open position.
3. Install a compression gauge in No. 1 cylinder.
4. Install an auxiliary starter switch in the starting circuit. Using the auxiliary starter switch, crank the engine (with the ignition switch off) at least five compression strokes and record the highest reading. Note the approximate number of compression strokes required to obtain the highest reading.
5. Repeat the test on each cylinder as was required to obtain the highest reading on the No. 1 cylinder.

Test Conclusion

The indicated compression pressures are considered normal if the lowest reading cylinder is not less than 75 percent of the highest. (See the percentage chart given in Fig. 5.)

If one, or more cylinders read low, squirt approximately (1) tablespoon of engine oil on top of the pistons in the low reading cylinders. Repeat compression pressure check on these cylinders.

1. If compression improves considerably, the piston rings are at fault.
2. If compression does not improve, valves are sticking or seating poorly.
3. If two adjacent cylinders indicate low compression pressures and squirting oil on the pistons does not increase the compression, the cause may be a cylinder head gasket leak between the cylinders. Engine oil and/or coolant in the cylinders could result from this problem.

Maximum PSI	Minimum PSI	Maximum PSI	Minimum PSI	Maximum PSI	Minimum PSI
134	101	174	131	214	160
136	102	176	132	216	162
138	104	178	133	218	163
140	105	180	135	220	165
142	107	182	136	222	166
144	108	184	138	224	168
146	110	186	140	226	169
148	111	188	141	228	171
150	113	190	142	230	172
152	114	192	144	232	174
154	115	194	145	234	175
156	117	196	147	236	177
158	118	198	148	238	178
160	120	200	150	240	180
162	121	202	151	242	181
164	123	204	153	244	183
166	124	206	154	246	184
168	126	208	156	248	186
170	127	210	157	250	187
172	129	212	158		

CA1005-A

FIG. 5 Quick Reference Compression Pressure Limit Chart

It is recommended the above quick reference chart (Fig. 5) be used when checking cylinder compression pressures. The chart has been calculated so that the lowest reading number is 75 percent of the highest reading.

Example

If, after checking the compression pressures in all cylinders, it was found that the highest reading obtained was 196 psi and the lowest pressure reading was 155 psi, the engine is within specifications and the compression is considered satisfactory.

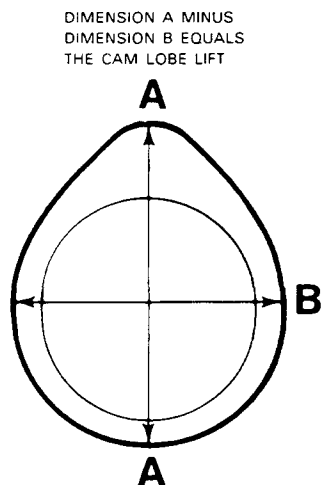

A3454-B

FIG. 6 Measuring Camshaft Lobe Lift

Camshaft Lobe Lift

Check the lift of each lobe in consecutive order and make a note of the readings.

1. Remove the air cleaner and the valve rocker arm cover.
2. Measure the distance between the major and minor diameters (Fig. 6) of each cam lobe with a Vernier caliper and record the readings. The difference in the readings on each cam is the lobe lift.
3. If the readings do not meet specifications, replace the camshaft.
4. Install the valve rocker arm cover and the air cleaner.

CHECKING VALVE CLEARANCE — HYDRAULIC VALVE LASH ADJUSTERS

1. Position the camshaft so that the base circle of the lobe is facing the cam follower of the valve to be checked (Fig. 7).
2. Using the tool shown in Fig. 7, slowly apply pressure to the cam follower until the lash adjuster is completely collapsed. Hold the follower in this position and insert the proper size feeler gauge between the base circle of the cam and the follower.
3. If the clearance is excessive, remove the cam follower and inspect for damage.
4. If the cam follower appears to be intact, and not excessively worn, measure the valve spring assembled height to be sure the valve is not sticking.
5. If the valve spring assembled height is correct, check the dimensions of the camshaft following the procedure under Basic Engine Diagnosis and Testing.
6. If the camshaft dimensions are to specifications, remove, clean and test the lash adjuster, following the procedures given in this section.
7. Re-install the lash adjuster and check the clearance. Replace damaged or worn parts as necessary.

NOTE: For any repair that requires the removal of the camshaft follower (rocker arm), each affected hydraulic lash adjuster must be collapsed after re-installation of the camshaft follower, and then released. This step must be taken prior to any rotation of the camshaft.

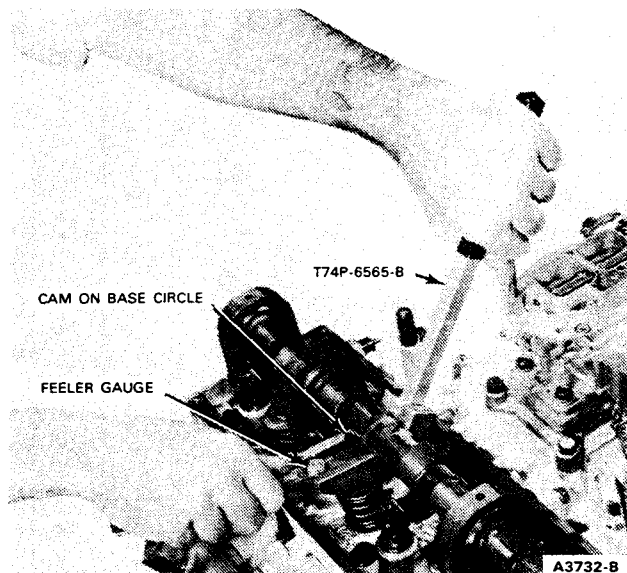

FIG. 7 Checking Hydraulic Valve Lash Adjuster

HYDRAULIC LASH ADJUSTER

The hydraulic lash-adjusters used in the overhead cam 2300 cc engine are a zero-lash hydraulic device, similar in construction and operation to the hydraulic valve lifters used on push-rod engines. They are cleaned, inspected and checked in the same manner. The instructions below apply equally to the lash adjuster. Leak down rates for the lash adjuster are covered in the Specifications Section.

Hydraulic valve lifter noise may be caused by improper operating clearance as a result of loose adjusting nuts or improper initial adjustment. Always check rocker arm to valve stem clearance before replacing a valve lifter.

Dirt, deposits of gum and varnish and air bubbles in the lubricating oil can cause hydraulic valve lifter failure or malfunction.

Dirt, gum and varnish can keep a check valve from seating and cause a loss of hydraulic pressure. An open valve disc will cause the plunger to force oil back into the valve lifter reservoir during the time the push rod is being lifted and force the valve from its seat. Air bubbles in the lubricating system can be caused by too much oil in the system or too low an oil level. Air may also be drawn into the lubricating system through an opening in a damaged oil pick-up tube. **Air in the system will cause a loss of hydraulic pressure.** Assembled valve lifters can be tested with Tool 6500-E to check the leak down rate. The leak down rate specification is the time in seconds for the plunger to move a specified distance of its travel while under a 50 lb. load. Test the valve lifters as follows:

1. Disassemble and clean the lifter to remove all traces of engine oil.

Lifters can not be checked with engine oil in them. Only the testing fluid can be used.

2. Place the valve lifter in the tester, with the plunger facing upward. Pour hydraulic tester fluid into the cup to a level that will cover the valve lifter assembly. The fluid can be purchased from the manufacturer of the tester. Using kerosene or any other fluid will not provide an accurate test.
3. Adjust the length of the ram (Fig. 8) so that the pointer is 1/16 inch below the starting mark when the ram contacts the valve lifter plunger, to facilitate timing as the pointer passes the Start Timing mark.

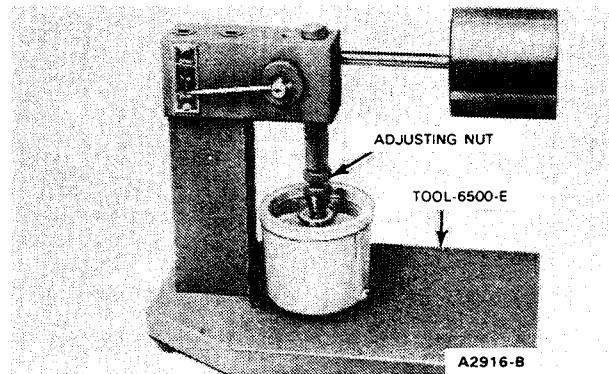
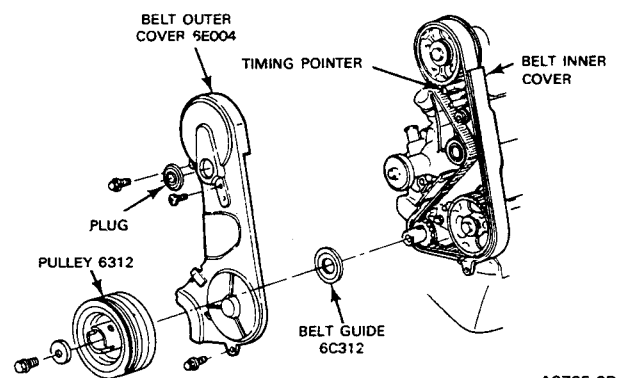

FIG. 8 Adjusting the Ram Length

Use the center mark on the pointer scale as the Stop Timing point instead of the original Stop Timing mark at the top of the scale.

4. Work the valve lifter plunger up and down until the lifter fills with fluid and all traces of air bubbles have disappeared.
5. Allow the ram and weight to force the valve lifter plunger downward. Measure the exact time it takes for the pointer to travel from the Start Timing to the Stop Timing marks of the tester.
6. A valve lifter that is satisfactory must have a leak-down rate (time in seconds) within the minimum and maximum limits specified.
7. If the valve lifter is not within specifications, replace it with a new lifter. It is not necessary to disassemble and clean the new valve lifters before testing, because the oil contained in new lifters is test fluid.
8. Remove the fluid from the cup and bleed the fluid from the lifter by working the plunger up and down. **This step will aid in depressing the lifter plungers when checking the valve clearance.**

CAMSHAFT TIMING



A3735-2D

FIG. 9 Camshaft Timing Assembly

CAMSHAFT TIMING

Checking Timing

An access plug is provided in the cam drive belt cover so that camshaft timing can be checked without removal of the cover or any other parts.

1. Remove the access plug (Figure 9) from the cam drive belt cover.
2. Set the crankshaft to TDC by aligning the timing pointer on the belt cover with the O mark on the crankshaft damper. **Always turn the engine in the direction of normal rotation. Backward rotation may cause the timing belt to jump time, due to the arrangement of the belt tensioner.**
3. Look through the access hole in the belt cover to be sure that the timing mark on the cam drive sprocket (Figure 9) is lined up with the pointer on the inner belt cover.
4. Remove the distributor cap and check that the distributor rotor is facing the No. 1 position on the distributor cap.
5. Install the distributor cap.
6. Install the belt cover access plug.

Adjusting Timing

1. Refer to Figure 9 and remove the timing belt outer cover.
2. If the belt timing is incorrect, loosen the belt tensioner adjustment screw (Figure 9), position the tool shown on the tension spring rollpin and release the belt tensioner. Tighten the adjustment screw to hold the tensioner in released position.
3. Remove the crankshaft damper and belt guide (Figure 9).
4. Remove the drive belt and inspect it for wear or damage. If the belt is damaged, replace it.
5. Position the crankshaft sprocket and the camshaft sprocket as shown in Figure 9B. Remove the distributor cap and set the distributor rotor to No. 1 firing position by turning the auxiliary shaft.
6. Install the timing belt over the crankshaft sprocket and then counterclockwise over the auxiliary and camshaft sprockets. Align the belt fore and aft on the sprockets.

7. Loosen the tensioner adjustment bolt to allow the tensioner to move against the belt. To be sure that the belt does not jump time during rotation in Step 8, remove the spark plugs.
8. Rotate the crankshaft two complete turns in normal rotation to remove the slack from the belt. Torque tensioner adjustment and pivot bolts to specifications. Re-check the alignment of the timing marks (Figure 9B).
9. Install the crankshaft damper and belt guide (Figure 9).
10. Install the timing belt outer cover and the spark plugs.
11. Start the engine and check the ignition timing. Adjust the ignition timing to specification as required.

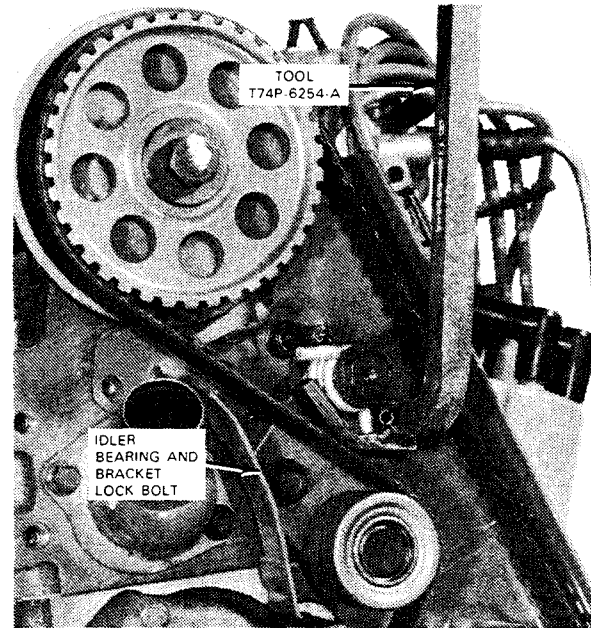

FIG. 9A Removing Timing Belt

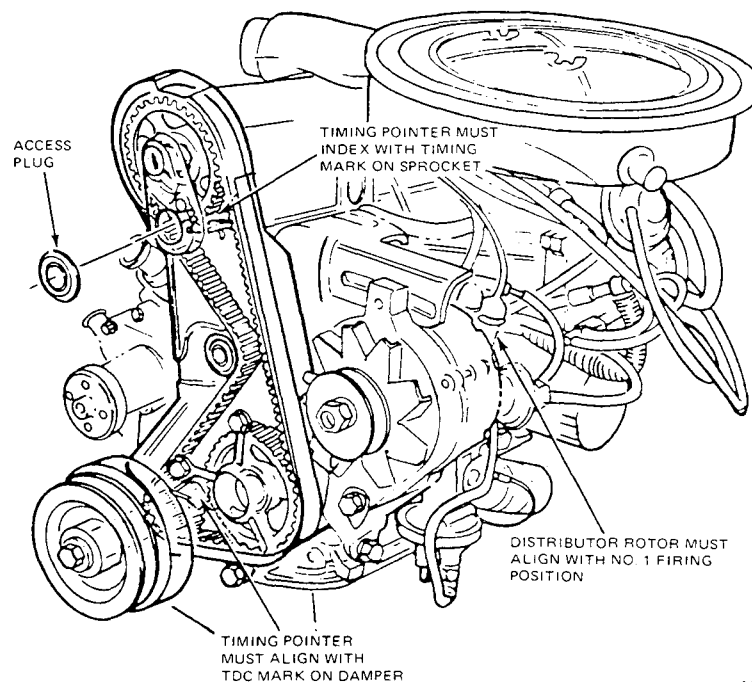

FIG. 9B Camshaft Drive Train Installation

A3373-B

4. Remove the distributor cap and check that the distributor rotor is facing the No. 1 position on the distributor cap.
5. Install the distributor cap.
6. Install the belt cover access plug.

CAMSHAFT END PLAY

Remove the camshaft drive belt cover. Push the camshaft toward the rear of the engine. Install a dial indicator so that the indicator point is on the camshaft sprocket attaching screw or gear hub. Zero the dial indicator. Position a large screwdriver between the camshaft sprocket or gear and the cylinder head. Pull the camshaft forward and release it. Compare the dial indicator reading with specifications. If the end play is excessive, replace the thrust plate at the rear of the cylinder head (Fig. 10). Remove the dial indicator and install the camshaft drive belt cover.

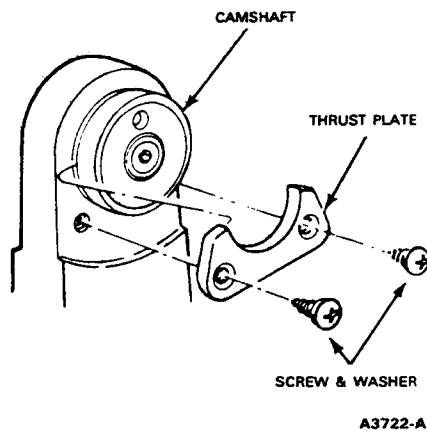

FIG. 10 Camshaft Thrust Plate Installation

CRANKSHAFT END PLAY

1. Force the crankshaft toward the rear of the engine.
2. Install a dial indicator so that the contact point rests against the crankshaft flange and the indicator axis parallel to the crankshaft axis (Fig. 11).

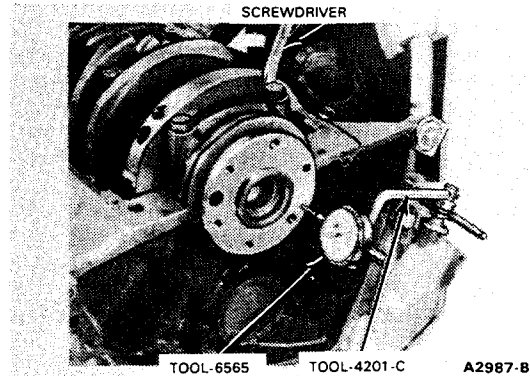

FIG. 11 Checking Crankshaft End Play

3. Zero the dial indicator. Push the crankshaft forward and note the reading on the dial.
4. If the end play exceeds the wear limit, replace the thrust bearing. If the end play is less than the minimum limit inspect the thrust bearing faces for scratches, burrs, nicks, or dirt. If the thrust faces are not damaged or dirty, they probably were not aligned properly. Install the thrust bearing and align the faces following the procedure recommended under Main Bearing Replacement in the pertinent engine section. Check the end play.

FLYWHEEL FACE RUNOUT

Install a dial indicator so that the indicator point bears against the flywheel face (Fig. 12). Turn the flywheel making sure to hold it in the full forward or rearward position so that crankshaft end play will not be indicated as flywheel runout.

If the clutch face runout exceeds specifications, remove the flywheel and check for burrs between the flywheel and the face of the crankshaft mounting flange. If no burrs exist, check the runout of the crankshaft mounting flange. Replace the flywheel or machine the crankshaft-flywheel mounting face sufficiently to true up the surface if the mounting flange runout exceeds specifications.

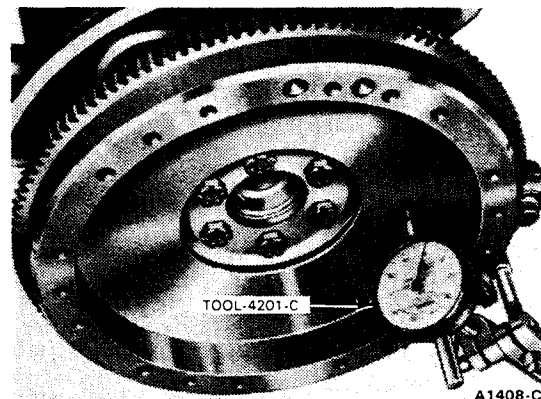

FIG. 12 Checking Flywheel Face Runout

OVERHAUL

CYLINDER HEAD

Replace the head if it is cracked. **Do not plane or grind more than 0.010 inch from the cylinder head gasket surface.** Remove all burrs or scratches with an oil stone.

REAMING VALVE GUIDES

If it becomes necessary to ream a valve guide (figure 13) to install a valve with an oversize stem, a reaming kit is available which contains the following reamer and pilot combinations: a 0.003-inch OS reamer with a standard diameter pilot, a 0.015-inch OS reamer with a 0.003-inch OS pilot, and a 0.030-inch reamer with a 0.015-inch OS pilot.

When going from a standard size valve to an oversize valve always use the reamer in sequence. **Always reface the valve seat after the valve guide has been reamed, and use a suitable scraper to break the sharp corner (ID) at the top of the valve guide.**

REFACING VALVE SEATS

Refacing of the valve seat should be closely coordinated with the refacing of the valve face so that the finished seat and valve face will be concentric and the specified interference fit will be maintained. This is important so that the valve and seat will have a compression-tight fit. Be sure that the refacer grinding wheels are properly dressed.

Grind the valve seats of all engines to a true 45 degree angle (Figure 14). Remove only enough stock to clean up pits and grooves or to correct the valve seat runoff. After the seat has been refaced, use a seat width scale or a machinist scale to measure the seat width (Figure 15). Narrow the seat, if necessary, to bring it within specifications.

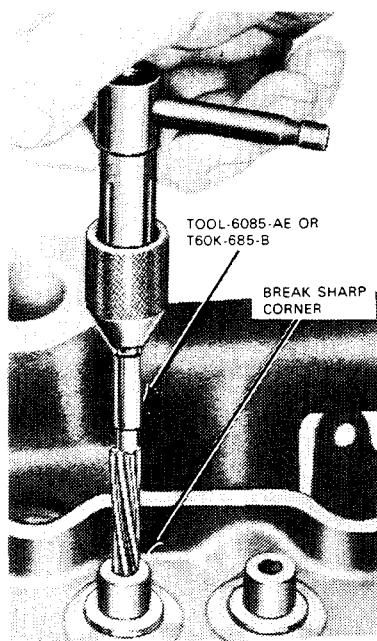

A2910-B

FIG. 13 Reaming Valve Guides

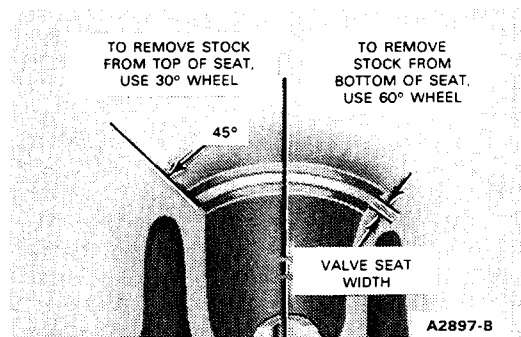

FIG. 14 Refacing Valve Seat

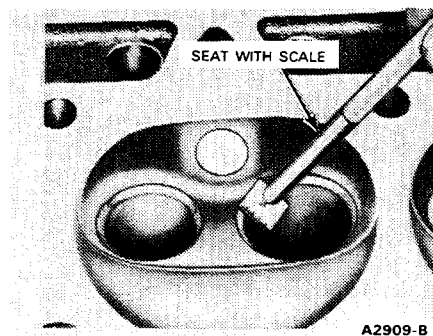

FIG. 15 Checking Valve Seat Width

If the valve seat width exceeds the maximum limit, remove enough stock from the top edge and/or bottom edge of the seat to reduce the width to specifications.

On the valve seats of all engines, use a 60 degree angle grinding wheel to remove stock from the bottom of the seats (raise the seats) and use a 30 degree angle wheel to remove stock from the top of the seats (lower the seats).

The finished valve seat should contact the approximate center of the valve face. It is good practice to determine where the valve seat contacts the face. To do this, coat the seat with Prussian blue and set the valve in place. Rotate the valve with light pressure. If the blue is transferred to the center of the valve face, the contact is satisfactory. If the blue is transferred to the top edge of the valve face, lower the valve seat. If the blue is transferred to the bottom edge of the valve face, raise the valve seat.

VALVES

Minor pits, grooves, etc., may be removed. Discard valves that are severely damaged, if the face runoff cannot be corrected by refinishing or stem clearance exceeds specifications. Discard **any excessively worn or damaged valve train parts.**

REFACING VALVES

The valve refacing operation should be closely coordinated with the valve seat refacing operations so that the finished angles of the valve face and of the valve seat will be to specifications and provide a compression-tight fit. Be sure that the refacer grinding wheels are properly dressed.

Under no circumstances should the faces of aluminized intake valves be ground or the valves lapped in as this will remove the diffused aluminum coating and reduce the valves wear and heat resistant properties. If the

valve faces are worn or pitted it will be necessary to install new valves and to resurface the valve seats or, alternatively, lap the seats using dummy valves. The exhaust valves may be lapped in or the faces ground if required.

If the valve face runout is excessive and/or to remove pits and grooves, reface the valves to a true 44 degree angle. Remove only enough stock to correct the runout or to clean up the pits and grooves. If the edge of the valve head is less than 1/32 inch thick after grinding (Figure 16), replace the valve as the valve will run too hot in the engine. **The interference fit of the valve and seat should not be lapped out. Remove all grooves or score marks from the end of the valve stem, and chamfer it as necessary. Do not remove more than 0.010 inch from the end of the valve stem.**

If the valve and/or valve seat has been refaced, it will be necessary to check the clearance between the rocker arm pad and the valve stem with the valve train assembly installed in the engine.

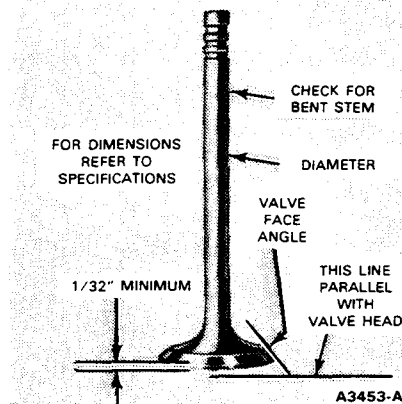

FIG. 16 Critical Valve Dimensions

SELECT FITTING VALVES

If the valve stem to valve guide clearance exceeds the wear limit, ream the valve guide for the **next** oversize valve stem. Valves with oversize stem diameters of 0.003 and 0.015 inch are available for service. **Always reface the valve seat after the valve guide has been reamed. Refer to Reaming Valve Guides.**

CAMSHAFT REPAIR

Remove light scuffs, scores or nicks from the camshaft machined surfaces with a smooth oil stone.

CRANKSHAFT REPAIR

Dress minor scores with an oil stone. If the journals are severely marred or exceed the wear limit, they should be refinished to size for the next undersize bearing.

REFINISHING JOURNALS

Refinish the journals to give the proper clearance with the next undersize bearing. If the journal will not clean up to maximum undersize bearing available, replace the crankshaft.

Always reproduce the same journal shoulder radius that existed originally. Too small a radius will result in fatigue failure of the crankshaft. Too large a radius will result in bearing failure due to radius ride of the bearing.

After refinishing the journals, chamfer the oil holes; then polish the journal with a No. 320 grit polishing cloth and engine oil. Crocus cloth may also be used as a polishing agent.

FITTING MAIN OR CONNECTING ROD BEARINGS WITH PLASTIGAGE

1. Clean crankshaft journals. Inspect journals and thrust faces (thrust bearing) for nicks, burrs or bearing pickup that would cause premature bearing wear. **When replacing standard bearings with new bearings, it is good practice to fit the bearing to minimum specified clearance.** If the desired clearance cannot be obtained with a standard bearing, try a 0.002 inch undersize in combination with a standard bearing to obtain the proper clearance.
2. If fitting a main bearing in the chassis, **position a jack under counterweight adjoining bearing which is being checked.** Support crankshaft with jack so its weight will not compress Plastigage and provide an erroneous reading.
3. Place a piece of Plastigage on bearing surface across full width of bearing cap and about 1/4 inch off center (Figure 17).

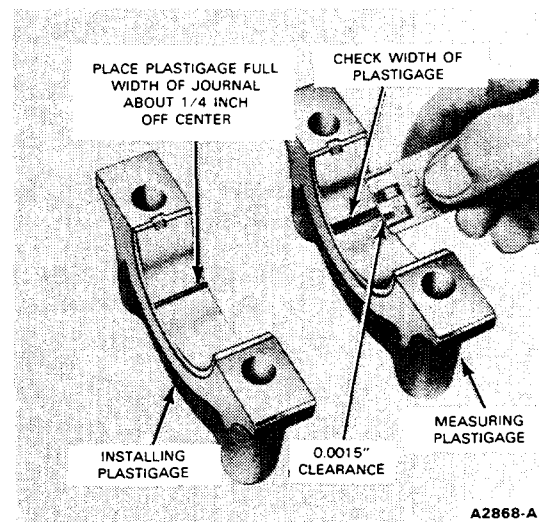

FIG. 17 Installing and Measuring Plastigage

4. Install cap and torque bolts to specifications. Do not turn crankshaft while Plastigage is in place.
5. Remove cap. Using Plastigage scale, check width of Plastigage at widest point to get minimum clearance. Difference between readings is taper of journals.
6. If clearance exceeds specified limits, on the connecting rod bearings, try a 0.002 inch undersize bearing in combination with the standard bearings. Bearing clearance must be within specified limits. If 0.002 undersize main bearings are used on more than one journal, be sure they are all installed in cylinder block side of bearing. If standard and 0.002 inch undersize bearings do not bring clearance within desired limits, refinish crankshaft journal, then install undersize bearings.
7. After bearing has been fitted, remove Plastigage, apply light coat of engine oil to journal and bearings. Install bearing cap. Torque cap bolts to specifications.
8. Repeat procedure for remaining bearings that require replacement.

PISTONS, PINS AND RINGS

Fitting Pistons

Pistons are available for service in standard sizes and the oversizes shown in the specifications.

The standard size pistons are color coded red or blue, or have 0.003 O.S. stamped on the dome. Refer to the Specifications for standard size piston dimensions.

Measure the cylinder bore and select the piston to assure the proper clearance. When the bore diameter is in the lower one third of the specified range, a red piston should be used. When the bore diameter is in the middle one third a blue piston should be used. When the bore diameter is in the upper one third, a 0.003 O.S. piston possibly can be used.

Measure the piston diameter to ensure that the specified clearance is obtained. It may be necessary to use another piston (red or blue) that is either slightly larger or smaller to achieve the specified clearance. **If none can be fitted, refinish the cylinder to provide the proper clearance for the piston. When a piston has been fitted, mark it for assembly in the cylinder to which it was fitted. If the taper, out-of-round and piston to cylinder bore clearance conditions of the cylinder bore are within specified limits, new piston rings will give satisfactory service. If new rings are to be installed in a used cylinder that has not been refinished, remove the cylinder wall glaze (Refer to Cylinder Block, Refinishing Cylinder Walls). Be sure to clean the cylinder bore thoroughly.**

1. Calculate the size piston to be used by taking a cylinder bore check. Follow the procedures outlined under Cleaning and Inspection.
2. Select the proper size piston to provide the desired clearance (refer to the specifications). The piston should be measured 1/2 inches below and at 90° to the piston pin bore.
3. Make sure the piston and cylinder block are at room temperature (70 degrees F.). **After any refinishing operation allow the cylinder bore to cool, and make sure the piston and bore are clean and dry before the piston fit is checked.**

FITTING PISTON RINGS

Three piston rings are fitted, two compression and one oil control ring. The lower compression ring is stepped externally to the bottom face and the upper ring is of square section. The top ring has a dot on the top. The oil control rings have narrow ring lands and may be fitted either way.

1. Select the proper ring set for the size cylinder bore.
2. Position the ring in the cylinder bore in which it is going to be used.
3. Push the ring down into the bore area where normal ring wear is not encountered.
4. Use the head of a piston to position the ring in the bore so that the ring is square with the cylinder wall. **Use caution to avoid damage to the ring or cylinder bore.**
5. Measure the gap between the ends of the ring with a feeler gauge (Figure 18). If the ring gap is less or greater than the specified limits, try another ring set.
6. Check the ring side clearance of the compression rings with a feeler gauge inserted between the ring

and its lower land (Figure 19). The gauge should slide freely around the entire ring circumference without binding. Any wear that occurs will form a step at the inner portion of the lower land. **If the lower lands have high steps, the piston should be replaced.**

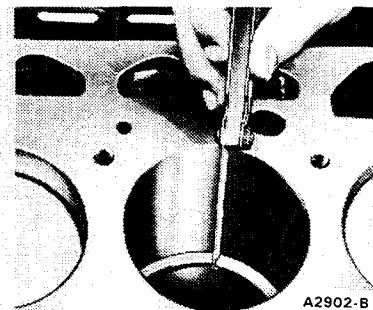

FIG. 18 Checking Piston Ring Gap

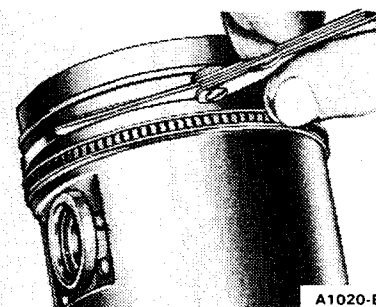

FIG. 19 Checking Piston Ring Side Clearance

FITTING PISTON PINS

The piston pins are selected to give the correct fit in the piston pin bore and bushing in the connecting rod. Pistons are only supplied in service complete with the piston pin, to ensure the correct fit. The piston pins should not be interchanged.

VALVE ROCKER ARM

Dress up minor surface defects on the rocker arm with a fine stone.

If the pad at the valve end of the rocker arm has a grooved radius, replace the rocker arm. **Do not attempt to true this surface by grinding.**

CYLINDER BLOCK Refinishing Cylinder Walls

Honing is recommended for refinishing cylinder walls **only** when the walls have minor scuffs or scratches, or for fitting pistons to the specified clearance. The grade of hone to be used is determined by the amount of metal to be removed. Follow the instructions of the hone manufacturer. If coarse stones are used to start the honing operation, leave enough material so that all hone marks can be removed with the finishing hone which is used to obtain the proper piston clearance. Cylinder walls that are severely marred and/or worn beyond the specified limits should be refinished. **Before any cylinder is refinished, all main bearing caps must be in place and tightened to the proper torque so that the crankshaft bearing bores will not**

become distorted from the refinishing operation. Refinish only the cylinder or cylinders that require it. All pistons are the same weight, both standard and oversize; therefore, various sizes of pistons can be used without upsetting engine balance. Refinish the cylinder with the most wear first to determine the maximum oversize. If the cylinder will not clean up when refinished for the maximum oversize piston recommended, replace the block. Refinish the cylinder to within approximately 0.0015 inch of the required oversize diameter. This will allow enough stock for the final step of honing so that the correct surface finish and pattern are obtained. For the proper use of the refinishing equipment follow the instructions of the manufacturer. Only experienced personnel should be allowed to perform this work. Use a motor-driven, spring pressure-type hone at a speed of 300-500 rpm. Hones of grit sizes 180-220 will normally provide the desired bore surface finish of 15/32 RMS. When honing the cylinder bores use a lubricant mixture of equal parts of kerosene and SAE No. 20 motor oil. Operate the hone in such a way to produce a cross-hatch finish on the cylinder bore. The cross-hatch pattern should be at an angle of approximately 30 degrees to the cylinder bore. After the final operation in either of the two refinishing methods described and prior to checking the piston fit, thoroughly clean and oil the cylinder walls. Mark the pistons to correspond to the cylinders in which they are to be installed. When the refinishing of all cylinders that require it has been completed and all pistons are fitted, thoroughly clean the bores with soap and water and oil the cylinder walls.

REPAIRING SAND HOLES OR POROUS ENGINE CASTINGS

Porosity or sand hole(s) which will cause oil seepage or leakage can occur with modern casting processes. A complete inspection of engine and transmission should be made. If the leak is attributed to the porous condition of the cylinder block or sand hole(s), repairs can be made

with metallic plastic (part No. C6AZ-19554-A). **Do not repair cracks with this material.** Repairs with this metallic plastic must be confined to those cast iron engine component surfaces where the inner wall surface is not exposed to engine coolant pressure or oil pressure, for example:

1. Cylinder block surfaces extending along the length of the block, upward from the oil pan rail to the cylinder water jacket but not including machined areas.
2. Lower rear face of the cylinder block.
3. Intake manifold casting.
4. Cylinder head, along the rocker arm cover gasket surface.

The following procedure should be used to repair porous areas or sand holes in cast iron.

- a. Clean the surface to be repaired by grinding or rotary filing to a clean bright metal surface. Chamfer or undercut the hole or porosity to a greater depth than the rest of the cleaned surface. Solid metal must surround the hole. Openings larger than 1/4 inch should not be repaired using metallic plastic. Openings in excess of 1/4 inch can be drilled, tapped and plugged using common tools. Clean the repair area thoroughly. Metallic plastic will not stick to a dirty or oily surface.
- b. Mix the metallic plastic base and hardener as directed on the container. Stir thoroughly until uniform.
- c. Apply the repair mixture with a suitable clean tool, (putty knife, wood spoon, etc.) forcing the epoxy into the hole or porosity.
- d. Allow the repair mixture to harden. This can be accomplished by two methods, heat cure with a 250 degree watt lamp placed 10 inches from the repaired surface, or air dry for 10-12 hours at temperatures above 50 degrees F.
- e. Sand or grind the repaired area to blend with the general contour of the surrounding surface.
- f. Paint the surface to match the rest of the block.

CLEANING AND INSPECTION

The cleaning and inspection procedures are for complete engine overhaul; therefore, for partial engine overhaul or parts replacement, follow the pertinent cleaning or inspection procedure.

INTAKE MANIFOLD

Cleaning

Remove all gasket material from the machined surfaces of the manifold. Clean the manifold in a suitable solvent and dry it with compressed air.

Inspection

Inspect the manifold for cracks, damaged gasket surfaces, or other defects that would make it unfit for further service. Replace all studs that are stripped or otherwise damaged. **Remove all filings and foreign matter that may have entered the manifold as a result of repairs.**

EXHAUST MANIFOLDS

Cleaning

Remove all gasket material from the manifolds.

Inspection

Inspect the cylinder head joining flanges of the exhaust manifold for evidence of exhaust gas leaks.

Inspect the manifolds for cracks, damaged gasket surfaces, or other defects that would make them unfit for further service.

VALVE ROCKER ARM

Cleaning

Clean all the parts thoroughly.

Inspection

Inspect the rocker arms for nicks, scratches, scores or scuffs.

Inspect the pad at the valve end of the rocker arm for indications of scuffing or abnormal wear. If the pad is grooved, replace the rocker arm. **Do not attempt to true this surface by grinding.**

CYLINDER HEADS

Cleaning

With the valves installed to protect the valve seats, remove deposits from the combustion chambers and valve heads with a scraper and a wire brush. Be careful not to damage the cylinder head gasket surface. After the valves are removed, clean the valve guide bores with a valve guide cleaning tool. Use cleaning solvent to remove dirt, grease and other deposits. Clean all bolt holes. Remove all deposits from the valves with a fine wire brush or buffing wheel.

Inspection

Check the cylinder head for cracks and inspect the gasket surface for burrs and nicks. Replace the head if it is cracked.

The following inspection procedures are for a cylinder head that is to be completely overhauled. For individual repair operations, use only the pertinent inspection procedure.

When a cylinder head is removed because of gasket leaks, check the flatness of the cylinder head gasket surface (Figure 20) for conformance to specifications. If necessary to refinish the cylinder head gasket surface, do not plane or grind off more than 0.010 inch.

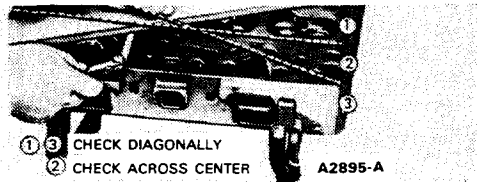

FIG. 20 Typical Cylinder Head Flatness Check

Check the valve seat runout with an accurate gauge (Figure 21). Follow the instructions of the gauge manufacturer. If the runout exceeds the wear limit, reface the valve and valve seat. Measure the valve seat width (Figure 15). Reface any valve seat whose width is not within specifications.

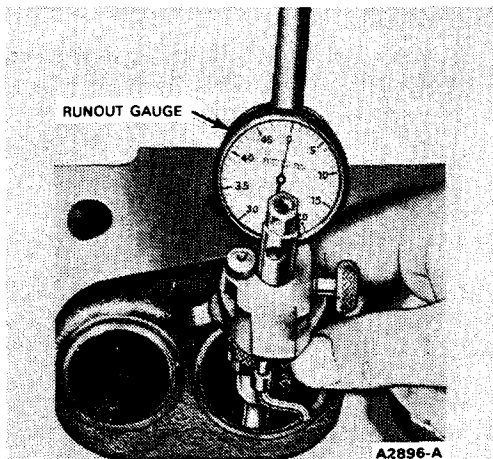

FIG. 21 Checking Valve Seat Runout

Inspect the valve face and the edge of the valve for pits, grooves, scores or other damage. Inspect the stem for a bent condition and the end of the valve head for pits, grooves, scores or other wear. Inspect the stem for a bent

condition and the end of the stem for grooves or scores. Check the valve head for signs of burning, erosion, warpage and cracking. Minor pits, grooves, etc., may be removed. Discard valves that are severely damaged.

Inspect the valve spring, valve spring retainers, locks and sleeves for wear or damage. Discard any visually damaged parts.

Check the valve stem to valve guide clearance of each valve in its respective valve guide with the tool shown in Figure 22 or its equivalent. Use a flat end indicator point.

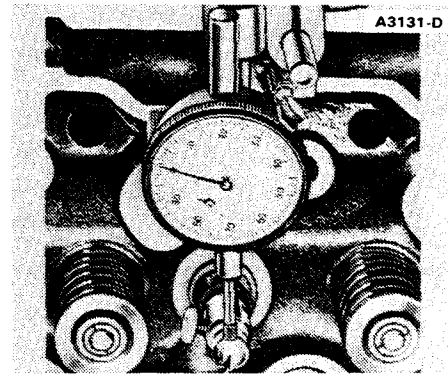

FIG. 22 Checking Valve Stem Clearance

Install the tool on the valve stem until it is fully seated, and tighten the knurled set screw firmly. Permit the valve to drop away from its seat until the tool contacts the upper surface of the valve guide.

Position the dial indicator with its flat tip against the center portion of the tool's spherical section at approximately 90 degrees to the valve stem axis. Move the tool back and forth in line with the indicator stem. Take a reading on the dial indicator without removing the tool from the valve guide upper surface. Divide the reading by two, the division factor for the tool.

Check the springs for proper pressure (Figure 23) at the specified spring lengths. (Tool 6513-DD) **Manually rotating the valve spring assemblies while installed in the engine, must not be used to determine good and/or bad valve springs.** Weak valve springs cause poor engine performance. Replace any spring not within specifications.

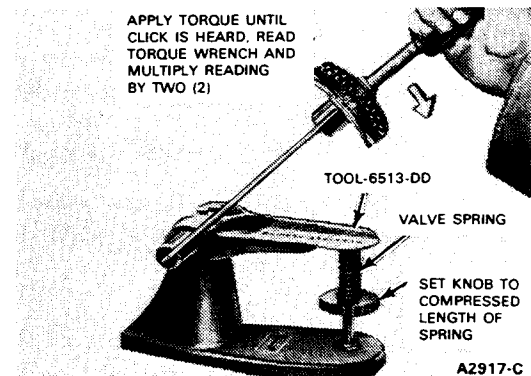

FIG. 23 Checking Valve Spring Pressure

Check each spring for squareness, using a steel square and a flat surface (Figure 24). Stand the spring and square on the end on the flat surface. Slide the spring up to the square. Revolve the spring slowly and observe the space between the top coil of the spring and the square. The out-of-square limits are $5/64$ inch.

Follow the same procedure to check new valve springs before installation. **Make certain the proper spring (color coded) is installed.**

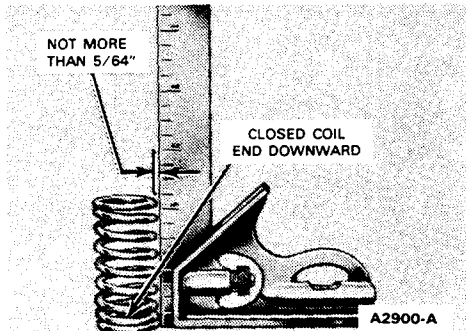

FIG. 24 Checking Valve Spring Squareness

HYDRAULIC LASH ADJUSTERS

Cleaning

Thoroughly clean the tappets in cleaning solvent and wipe them with a clean lint-free cloth. Cleaning, inspection and testing is covered under Diagnosis and Testing.

TIMING SPROCKETS AND BELT

Cleaning

Clean the sprockets in solvent and the belt in detergent and water. Dry them with compressed air.

Inspection

Inspect the sprockets for cracks and worn or damaged teeth. Inspect the idler bearing for wear or looseness. Replace all necessary parts.

CAMSHAFT

Cleaning and Inspection

Clean the camshaft in solvent and wipe it dry. Inspect the camshaft lobes for scoring and signs of abnormal wear. Lobe wear characteristics may result in pitting in the general area of the lobe toe. This pitting is not detrimental to the operation of the camshaft; therefore, the camshaft should not be replaced unless the lobe lift loss has exceeded 0.005 inch. Remove the rear camshaft plug and clean the interior of the camshaft.

The lift of the camshaft lobes can be checked with the camshaft installed in the engine or on centers. Refer to Camshaft Lobe Lift.

AUXILIARY SHAFT

Check the distributor drive gear for broken or chipped teeth and the journals for wear or scoring. Replace the shaft if this condition exists.

CRANKSHAFT

Cleaning

Handle the crankshaft with care to avoid possible fractures or damage to the finished surfaces. Clean the crankshaft with solvent, then blow out all oil passages with compressed air.

Inspection

Inspect the main and connecting rod journals for cracks, scratches, grooves or scores. Inspect the crankshaft oil seal surface for nicks, sharp edges or burrs that might damage the oil seal during installation or cause premature seal wear.

Measure the diameter of each journal in at least four places to determine an out-of-round, taper or undersize condition. (Figure 25)

A VS B = VERTICAL TAPER
C VS D = HORIZONTAL TAPER
A VS C AND B VS D = OUT-OF-ROUND
CHECK FOR OUT OF ROUND AT EACH END OF JOURNAL

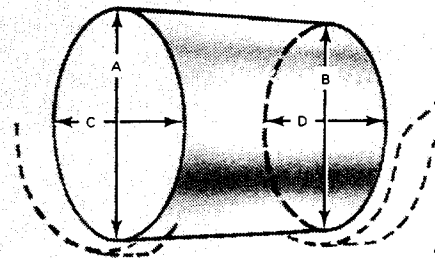

FIG. 25 Crankshaft Journal Measurement

On engines used with a manual shift transmission, check the fit of the clutch pilot bushing in the bore of the crankshaft. The bushing is pressed into the crankshaft and should not be loose. Inspect the inner surface of the bushing for wear or a bell-mouth condition. Check the ID of the bushing for wear (Figure 26). Replace the bushing if it is worn or damaged or the ID is not within specifications.

Inspect the pilot bearing (ball bearing) when so equipped, for roughness, evidence of overheating or loss of lubricant. Replace it if any of these conditions are found.

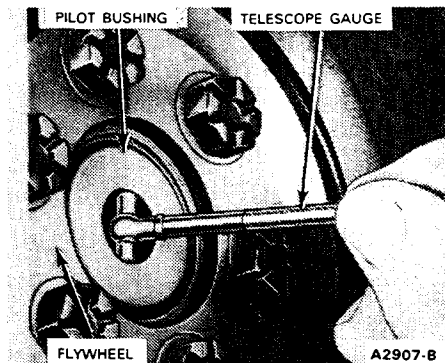

FIG. 26 Checking Clutch Pilot Bushing Wear

FLYWHEEL

Inspection

Inspect the flywheel for cracks, heat check, or other damage that would make it unfit for further service. Machine the friction surface of the flywheel if it is scored

or worn. If it is necessary to remove more than 0.045 inch of stock from the original thickness, replace the flywheel.

Inspect the ring gear for worn, chipped, or cracked teeth. If the teeth are damaged, replace the ring gear.

With the flywheel installed on the crankshaft, check the flywheel face runout, following the procedure under Diagnosis and Testing.

CONNECTING RODS

Cleaning

Remove the bearings from the rod and cap. Identify the bearings if they are to be used again. Clean the connecting rod in solvent, including the rod bore and the back of the inserts. **Do not use a caustic cleaning solution.** Blow out all passages with compressed air.

Inspection

The connecting rods and related parts should be carefully inspected and checked for conformance to specifications. Various forms of engine wear caused by these parts can be readily identified.

A shiny surface on either pin boss side of the piston usually indicates that a connecting rod is bent.

Abnormal connecting rod bearing wear can be caused by either a bent connecting rod, worn or damaged crankpin, or a tapered connecting rod bore.

Twisted connecting rods will not create an identifiable wear pattern, but badly twisted rods will disturb the action of the entire piston, rings and connecting rod assembly and may be the cause of excessive oil consumption.

Inspect the connecting rods for signs of fractures and the bearing bores for out-of-round and taper. If the bore exceeds the recommended limits and/or if the connecting rod is fractured, it should be replaced. Check the ID of the connecting rod piston pin bore. If the pin bore in the connecting rod is larger than specifications, install a .001 or 0.002 inch oversize piston pin. First, prefit the oversize piston pin to the piston pin bore by reaming or honing the piston. Then, assemble the piston, piston pin and connecting rod following the procedures for assembly. **It is not necessary to ream or hone the pin bore in the connecting rod. Replace damaged connecting rod nuts and bolts. Check the connecting rods for bend or twist on a suitable alignment fixture. Follow the instructions of the fixture manufacturer. If the bend and/or twist exceeds specifications, the connecting rod must be straightened or replaced.**

PISTONS, PINS AND RINGS

Cleaning

Remove deposits from the piston surfaces. Clean gum or varnish from the piston skirt, piston pins and rings with solvent. **Do not use a caustic cleaning solution or a wire brush to clean pistons.**

Clean the ring grooves with a ring groove cleaner (Figure 27). Make sure the oil ring slots (or holes) are clean.

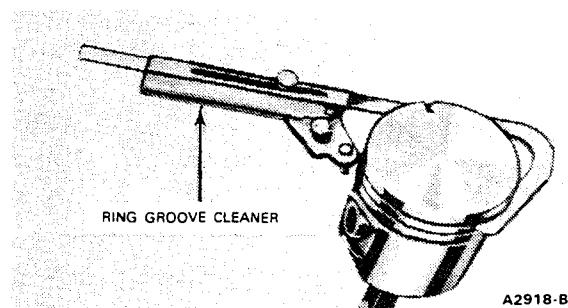

FIG. 27 Cleaning Piston Ring Grooves

Inspection

Carefully inspect the pistons for fractures at the ring lands, skirts and pin bosses, and for scuffed, rough or scored skirts. If the lower inner portion of the ring grooves has a high step, replace the piston. The step will interfere with ring operation and cause excessive ring slide clearance.

Spongy, eroded areas near the edge of the top of the piston are usually caused by detonation or pre-ignition. A shiny surface on the thrust surface of the piston, offset from the centerline between the piston pin holes, can be caused by a bent connecting rod. Replace pistons that show signs of excessive wear, wavy ringlands or fractures or damage from detonation or pre-ignition.

Check the piston to cylinder bore clearance by measuring the piston and bore diameters. Refer to the specifications for the proper clearance. Refer to Cylinder Block Inspection for the bore measurement procedure. **Measure the OD of the piston with micrometers approximately 1/2 inch below the piston pin and at 90 degrees to the piston pin bore.** Check the ring side clearance following the procedure under Fitting Piston Rings in this section.

Replace piston pins showing signs of fracture, etching or wear. Check the piston pin fit in the piston and rod. Refer to Piston and Connecting Rod Assembly.

Check the OD of the piston pin and the ID of the pin bore in the piston. Replace any piston pin or piston that is not within specifications.

Replace all rings that are scored, broken, chipped or cracked. Check the end gap and side clearance. **Rings should not be transferred from one piston to another regardless of mileage or hours.**

MAIN AND CONNECTING ROD BEARINGS

Cleaning

Clean the bearing inserts and caps thoroughly in solvent, and dry them with compressed air. **Do not scrape gum or varnish deposits from the bearing shells.**

Inspection

Inspect each bearing carefully. Bearings that have a scored, chipped, or worn surface should be replaced. Typical examples of unsatisfactory bearings and their causes are shown in Figure 28. The copper lead bearing base may be visible through the bearing overlay. This does not mean that the bearing is worn. It is not necessary to replace the bearing if the bearing clearance is within recommended limits. Check the clearance of bearings that appear to be satisfactory with Plastigage as detailed under Main and Connecting Rod Bearings.

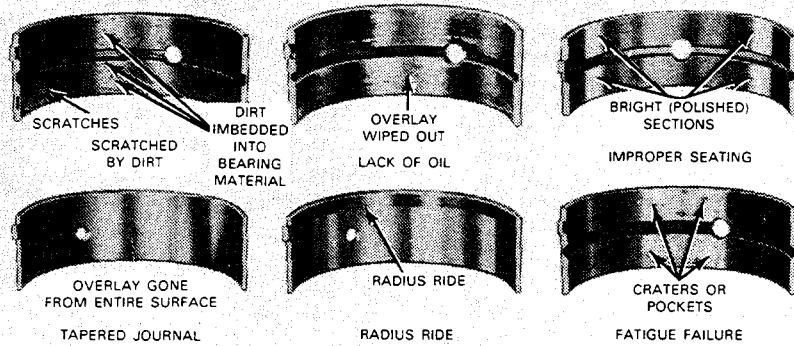

A2903-A

FIG. 28 Typical Bearing Failures

CYLINDER BLOCK Cleaning

After any cylinder bore repair operation, such as honing or deglazing, clean the bore(s) with soap or detergent and water. Then, thoroughly rinse the bore(s) with soap or detergent and water. Then, thoroughly rinse the bore(s) with clean water to remove the soap or detergent, and wipe the bore(s) dry with a clean, lint-free cloth. Finally wipe the bore(s) with a clean cloth dipped in engine oil. If these procedures are not followed, rusting of the cylinder bore(s) may occur.

If the engine is disassembled, thoroughly clean the block with solvent. Remove old gasket material from all machined surfaces. Remove all pipe plugs that seal oil passages; then clean out all the passages. Blow out all passages, bolt holes, etc., with compressed air. Make sure the threads in the cylinder head bolt holes are clean. Dirt in the threads may cause binding and result in a false torque reading. Use a tap to true up threads and to remove any deposits. Thoroughly clean the grooves in the crankshaft bearings and bearing retainers.

Inspection

After the block has been thoroughly cleaned, check it for cracks. Minute cracks not visible to the naked eye may be detected by coating the suspected area with a mixture of 25% kerosene and 75% light engine oil. Wipe the part dry and immediately apply a coating of zinc oxide dissolved in wood alcohol. If cracks are present, the coating will become discolored at the defective area. Replace the block if it is cracked.

Check all machined gasket surfaces for burrs, nicks, scratches and scores. Remove minor imperfections with an oil stone.

Replace all expansion-type plugs that show evidence of leakage.

Inspect the cylinder walls for scoring, roughness, or other signs of wear. Check the cylinder bore for out-of-round and taper. Measure the bore with an accurate bore gauge following the instructions of the manufacturer. Measure the diameter of each cylinder bore at the top, middle and bottom with the gauge placed at right angles and parallel to the centerline of the engine (Figure 29). **Use only the measurements obtained at 90 degrees to the engine centerline when calculating the piston to cylinder bore clearance.**

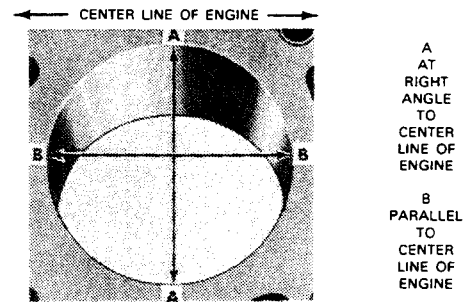

1. OUT-OF-ROUND = DIFFERENCE BETWEEN A AND B
2. TAPER = DIFFERENCE BETWEEN THE A MEASUREMENT AT TOP OF CYLINDER BORE AND THE A MEASUREMENT AT BOTTOM OF CYLINDER BORE

A2905-A

FIG. 29 Cylinder Bore Out-of-Round and Taper

Refinish cylinders that are deeply scored and/or when out-of-round and/or taper exceed the wear limits. If the cylinder walls have minor surface imperfections, but the out-of-round and taper are within limits, it may be possible to remove the imperfections by honing the cylinder walls and installing new service piston rings providing the piston clearance is within specified limits.

OIL PAN Cleaning

Scrape any dirt or metal particles from the inside of the pan. Scrape all old gasket material from the gasket surface. Wash the pan in a solvent and dry it thoroughly. Be sure all foreign particles are removed from below the baffle plate.

Inspection

Check the pan for cracks, holes, damaged drain plug threads, and a loose baffle or a damaged gasket surface.

Inspect for damage (uneven surface) at the bolt holes caused by over-torquing the bolts. Straighten surfaces as required. Repair any damage, or replace the pan if repairs cannot be made satisfactorily.

OIL PUMP

Cleaning

Wash all parts in a solvent and dry them thoroughly with compressed air. Use a brush to clean the inside of the pump housing and the pressure relief valve chamber. Be sure all dirt and metal particles are removed.

Inspection

Refer to the specifications for clearances and wear limits.

Check the inside of the pump housing and the outer race and rotor for damage or excessive wear.

Check the mating surface of the pump cover for wear. If the cover mating surface is worn, scored or grooved, replace the cover.

Measure the outer race to housing clearance (Figure 30). Then check the clearance between the outer race and the rotor lobes.

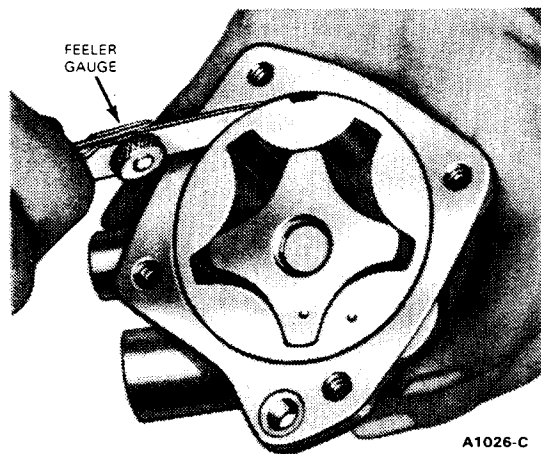

FIG. 30 Checking Outer Race to Housing Clearance

With the rotor assembly installed in the housing, place a straight edge over the rotor assembly and the housing. Measure the clearance (rotor end play) between the straight edge and the rotor and outer race (Figure 31). **The outer race, shaft and rotor are replaceable only as an assembly.** Check the drive shaft to housing bearing

clearance by measuring the OD of the shaft and the ID of the housing bearing. Inspect the relief valve spring for a collapsed or worn condition. Check the relief valve spring tension. If the spring tension is not within specifications and/or the spring is worn or damaged, replace the spring. Check the relief valve piston for scores and free operation in the bore. **If any of the above defects are found, replace the oil pump assembly.**

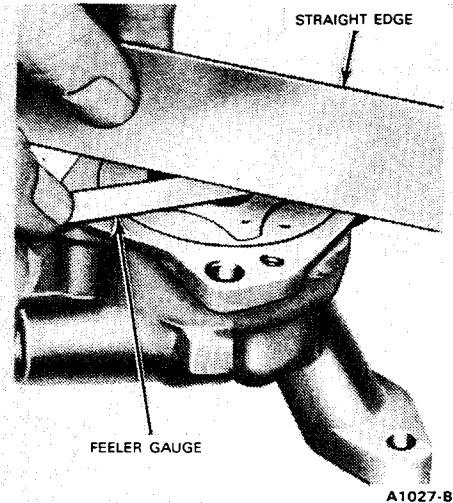

FIG. 31 Checking Rotor End Play

POSITIVE CLOSED-TYPE CRANKCASE VENTILATION SYSTEM

Cleaning

Do not attempt to clean the crankcase ventilation regulator valve; it should be replaced at the specified maintenance interval. The oil filler cap and oil separator should be cleaned at the proper mileage interval. Remove the cap and the oil separator and wash them in a low volatility, petroleum base solvent. Shake the cap dry and install them. Clean the crankcase ventilation system connection(s) on the intake manifold by probing with a flexible wire or bottle brush. Clean the hoses, fittings, tubes and associated hardware with a low volatility, petroleum base solvent and dry with compressed air.

REMOVAL AND INSTALLATION

ROCKER ARM (Camshaft) COVER

1. Remove the air cleaner if necessary.
2. Remove 10 screws from the cover (Fig. 32).
3. Remove the cover.
4. Clean the old gasket from the head and cover.
5. With oil resistant sealer, install the gasket on the cover and retain with as many cover bolts as required.
6. Install the cover and gasket on the head with 10 screws loosely.
7. Torque the 6 rear screws, then the two front screws.

ROCKER ARMS AND HYDRAULIC ADJUSTERS

1. Remove the rocker arm cover.
2. Turn the engine and camshaft until the tip of a camshaft lobe is facing up.
3. With tool T74P-6565-B depress valve spring and remove rocker arm over hydraulic adjuster. (Fig 33).
4. The hydraulic adjusters may now be lifted out.
5. Repeat steps 2 and 3 for necessary rocker arms.
6. Reinstall the hydraulic adjusters and then the rocker arms with camshaft lobes in the proper position and with the tool used above.

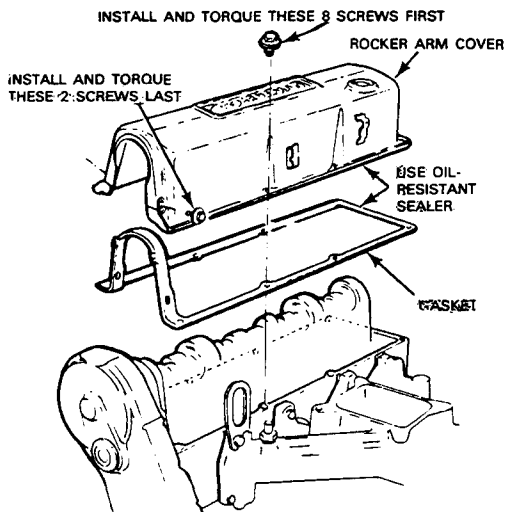

A3737-A

FIG. 32 Valve Rocker Arm Cover Installation

VALVE SPRING, RETAINER AND STEM SEAL

If the valve or valve seat has not been damaged; valve springs, seals and retainers may be replaced by holding the affected valve against its seat using compressed air. Use the tool shown in Fig. 33 installed in the spark plug hole. A minimum of 140 psi line pressure is required. If air pressure does not hold the valve shut, the valve is damaged or burnt and the cylinder head must be removed and repaired. See Disassembly and Assembly.

1. Remove the valve rocker arm cover and associated parts as required.
2. Remove the cam follower.
3. Using the tool shown in Fig. 33, compress the valve spring and remove the retainer locks, spring retainer, and valve spring. Remove and discard the stem seal.

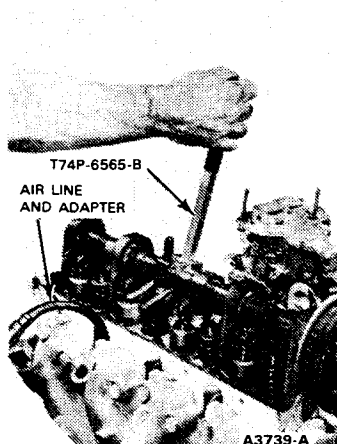

FIG. 33 Removing Valve Spring Retainer

4. If air pressure has forced the piston to the bottom of the cylinder, any removal of air pressure will allow the valve(s) to fall in the cylinder. A rubber band, tape or

string wrapped around the end of the valve stem will prevent this condition and will still allow enough travel to check the valve for binds.

5. Inspect the valve stem for damage. Rotate the valve and check the stem tip for eccentric movement. Move the valve up and down through normal travel in the valve guide and check the stem for binds. If the valve has been damaged, it will be necessary to remove the cylinder head and repair as outlined in the Overhaul Section.

INSTALLATION

1. Install a new valve stem seal using a plastic installation cap. Use the tool shown in Fig. 34 and the procedure given in Fig. 35. Install the valve spring, retainer and locks, Turn off the air and remove the air line and adapter.
2. Apply Lubriplate to all contact surfaces of the cam follower and install in position. Install the spark plug. **Be sure that the affected lash adjuster has been collapsed and released before rotating the camshaft.**
3. Install the rocker arm cover.

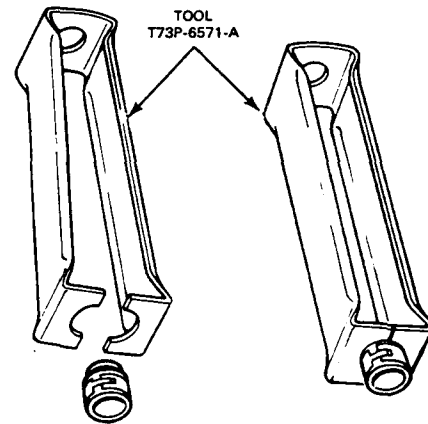

A3299-B

FIG. 34 Valve Stem Seal Installation Tool

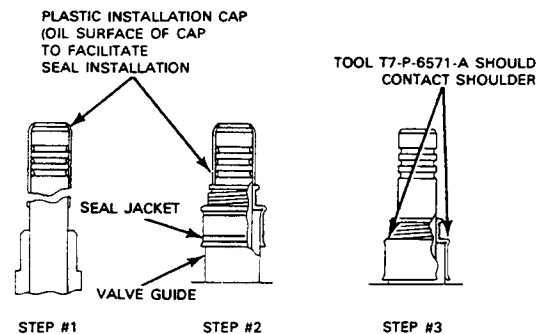

- STEP #1 — WITH VALVES IN HEAD, PLACE PLASTIC INSTALLATION CAP OVER END OF VALVE STEM.
- STEP #2 — START VALVE STEM SEAL CAREFULLY OVER CAP. PUSH SEAL DOWN UNTIL JACKET TOUCHES TOP OF GUIDE.
- STEP #3 — REMOVE PLASTIC INSTALLATION CAP. USE INSTALLATION TOOL - T73P-6571-A OR SCREWDRIVERS TO BOTTOM SEAL ON VALVE GUIDE

A3451-D

FIG. 35 Installing Valve Stem Seal

CAMSHAFT AND BEARINGS

1. Remove the rocker arm cover and the rocker arm.
2. Remove the timing belt front cover and the belt guide (Fig. 36)
3. After loosening the belt tension bracket bolt, and with the use of tool T74P6524-A (Fig. 37) relieving the belt tension, remove the belt.
4. With tool T74P-6256-A, hold the camshaft sprocket and remove the sprocket bolt and sprocket.
5. Using tool T74P-6700-B, remove the camshaft front seal. Be sure to get a good grip on the seal edge with the tool clamp and tightening bolt.
6. Remove the camshaft rear thrust plate (Fig. 38) (2 screws), and remove the camshaft.
7. If cleaning or changing the camshaft, remove and replace the rear camshaft plug (Fig. 39) into the new camshaft, or low oil pressure will result. Also use sealer or teflon tape on the front sprocket bolt.
8. Remove or replace the camshaft bearings with tool T65L-6250-A (Fig. 40) and adapter T72C-6250 or tool T71P-6250-A.
9. When installing camshaft bearings be sure to align the bearing oil holes with head oil holes and to center the bearings in the head supports.
10. Use tool T74P-6150-A to install the camshaft front seal. (Fig. 41)

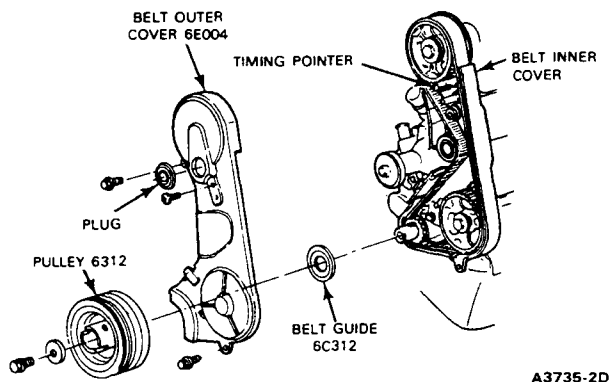

FIG. 36 Camshaft Timing Assembly

INTAKE MANIFOLD

1. Remove 8 bolts and remove the manifold (Fig. 42).
2. Clean the gasket from the head and manifold.
3. Install a new gasket onto the manifold and start the bolts through manifold and gasket into the head. The manifold is aluminum so be careful when torquing the bolts to specification.

EXHAUST MANIFOLD

Remove 8 bolts and remove the manifold. Apply a light coating of graphite grease to the head surface of the manifold and install the manifold. Torque the bolts to specification, Fig. 43.

AUXILIARY SHAFT

1. Remove the front cover and timing belt.
2. Remove the auxiliary sprocket with the same tool as used on the camshaft sprocket.
3. Remove the auxiliary shaft seal, if replacing it, with the same tool as used on the camshaft seal.
4. Remove the auxiliary shaft cover.
5. Remove the thrust plate, 2 screws.
6. Remove the distributor and fuel pump.
7. Remove the auxiliary shaft.
8. The auxiliary shaft bearings may be removed with tool T58L-101-A and replaced with tool T-57T-7003-A. Be sure to align the oil holes with those in the cylinder block.

FIG. 37 Removing Timing Belt

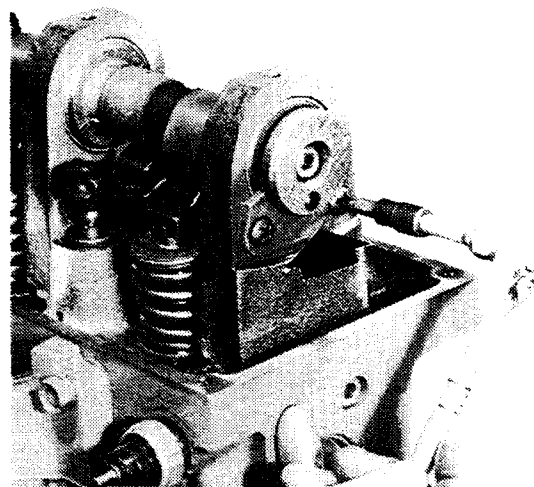

FIG. 38 Removing Camshaft Rear Thrust Plate

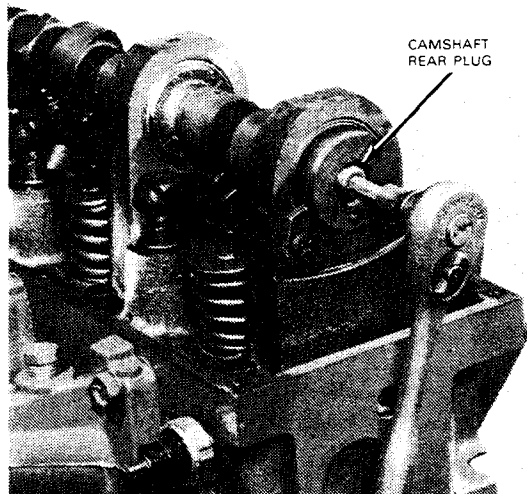

FIG. 39 Removing Rear Camshaft Plug

CRANKSHAFT SPROCKET

1. Remove the front timing belt cover and the belt.
2. Remove the crankshaft damper (pulley) bolt, damper, and belt guide.
3. Remove the crankshaft sprocket with tool T74P6306-A, (Fig. 44).
4. No special tool is required to install the sprocket or crankshaft damper.
5. The front cover seal (crankshaft seal) may be removed at this time with the tool used on the camshaft and auxiliary shaft seals.
6. Remove the cylinder front cover if necessary.

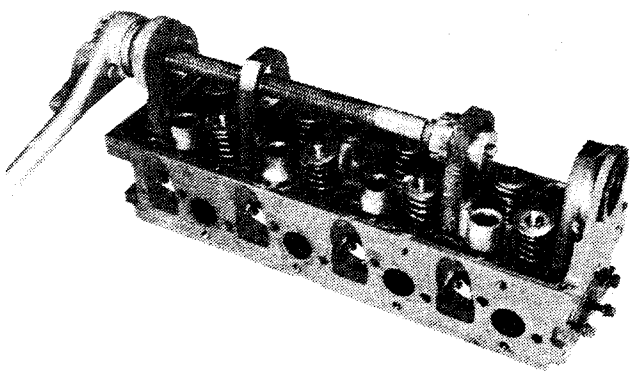

FIG. 40 Removing Camshaft Bearings

BELT TENSIONER

The belt tensioner and spring stud may be removed by unscrewing the adjusting bolt, the spring retaining bolt, and the spring stop stud. (Fig. 41)

The belt tensioner tool may be required to reinstall the tensioner bracket and spring.

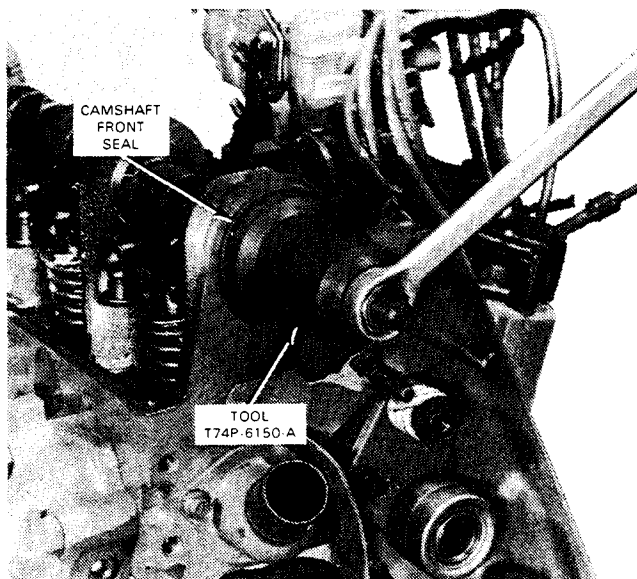

FIG. 41 Installing Camshaft Front Seal

THERMOSTAT AND WATER PUMP

After removing the timing belt front cover the retaining bolts for the water pump and thermostat housing or water outlet connection are accessible. On late 1977 and later engines the thermostat housing may be removed without removing the front belt cover. (Fig. 45)

The thermostat has a twist lock design that holds it in the housing during installation. The thermostat will only install in one direction.

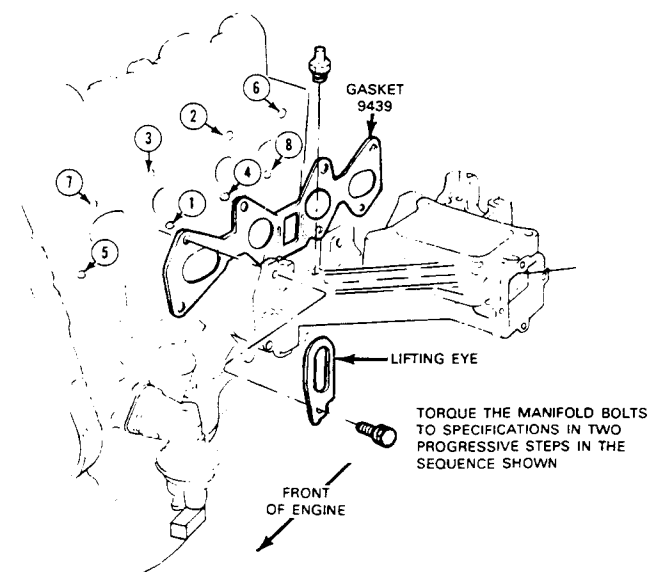

FIG. 42 Intake Manifold Installation

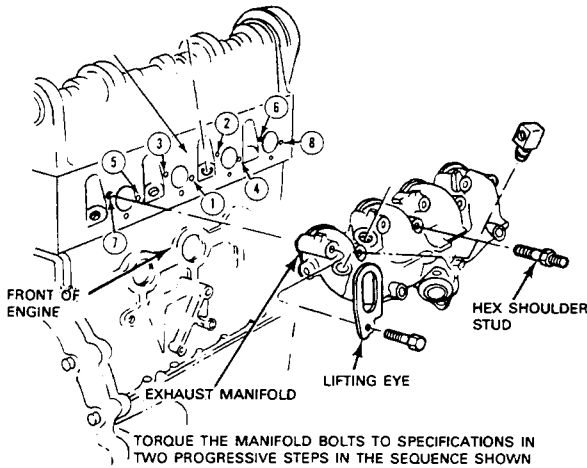
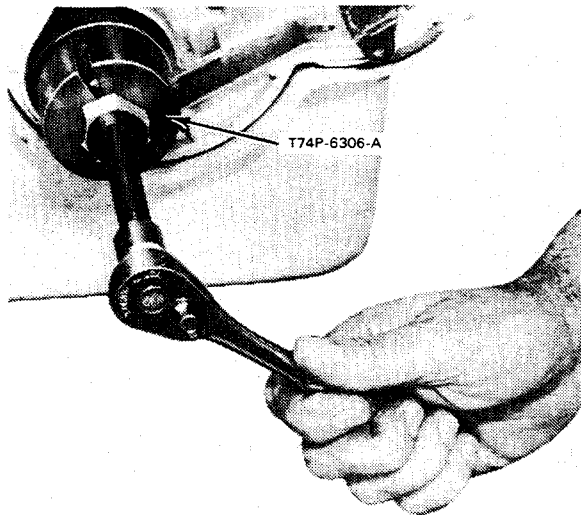

FIG. 43 Exhaust Manifold Installation



A374-A

FIG. 44 Removing Crankshaft Sprocket

CYLINDER HEAD

1. Remove the oil dipstick tube, the fan and alternator belt and the alternator bracket to cylinder head bolts.
2. Remove the intake and exhaust manifold to cylinder head bolts.
3. Disconnect the oil pressure sending unit wire at the unit.
4. Remove the outer timing belt cover and the timing belt tensioner and bearing assembly.
5. Remove the tensioner spring stop stud from the cylinder head.
6. Remove 10 cylinder head bolts and the head.
7. Clean all mating surfaces and use new gaskets during assembly.
8. **Before installing the cylinder head position the camshaft with the sprocket positioning pin facing down as shown in Fig 46.**

9. After installing the cylinder head, torque the bolts to specification in the sequence shown in Fig. 46.
10. Install the removed components in the reverse order of disassembly above.

OIL PAN

1. Remove 22 screws and remove the oil pan.
2. Clean the old gaskets and seals from the pan, front cover and rear main cap.
3. With the use of adhesive or sealer install the front and rear seals first to the rear main cap and front cover. (Fig. 47)
4. Fasten the pan side gaskets to the pan with adhesive and install the pan.
5. Torque the screws to specification.

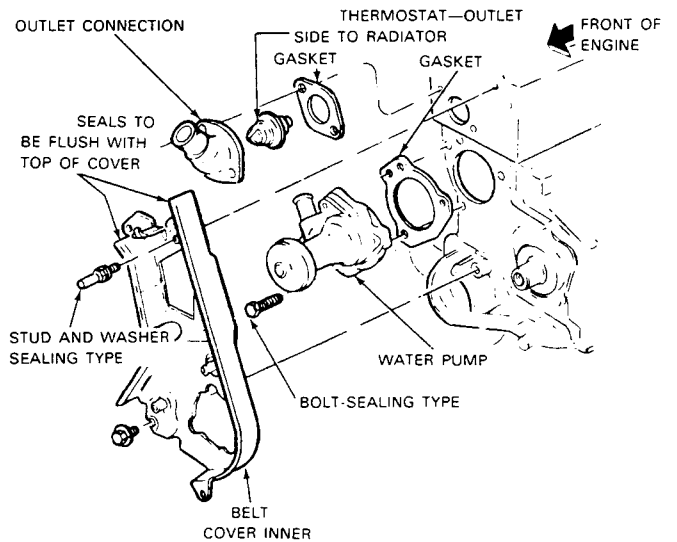

FIG. 45 Water Pump, Thermostat and Inner Timing Belt Cover

TORQUE THE CYLINDER HEAD BOLTS TO SPECIFICATIONS IN TWO PROGRESSIVE STEPS IN THE SEQUENCE SHOWN.

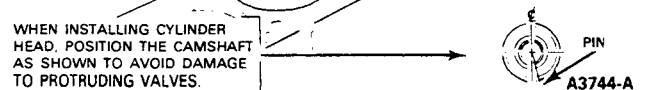
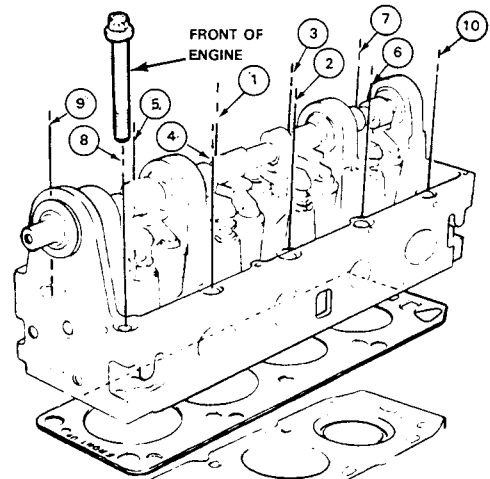
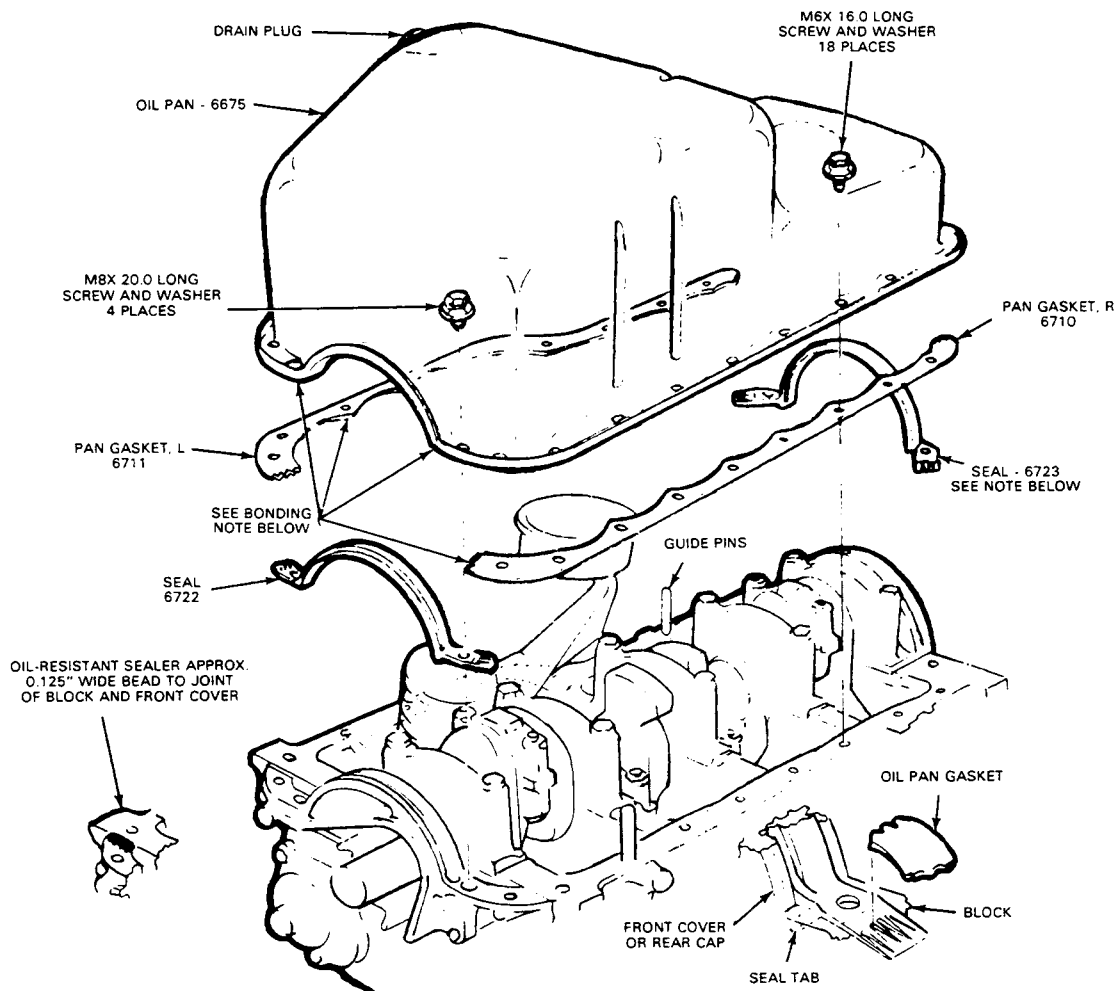

FIG. 46 Cylinder Head Installation



- 1 APPLY GASKET ADHESIVE EVENLY TO OIL PAN FLANGE AND TO PAN SIDE GASKETS. ALLOW ADHESIVE TO DRY PAST WET STAGE, THEN INSTALL GASKETS TO OIL PAN.
- 2 APPLY SEALER TO JOINT OF BLOCK AND FRONT COVER. INSTALL SEALS TO FRONT COVER AND REAR BEARING CAP AND PRESS SEAL TABS FIRMLY INTO BLOCK. BE SURE TO INSTALL THE REAR SEAL BEFORE THE REAR MAIN BEARING CAP SEALER HAS CURED.
- 3 POSITION 2 GUIDE PINS AND INSTALL THE OIL PAN. SECURE THE PAN WITH THE FOUR M8 BOLTS SHOWN ABOVE.
- 4 REMOVE THE GUIDE PINS AND INSTALL AND TORQUE THE EIGHTEEN M6 BOLTS, BEGINNING AT HOLE A AND WORKING CLOCKWISE AROUND THE PAN.

FIG. 47 Oil Pan Installation

A3759-A

CRANKSHAFT REAR OIL SEAL TWO PIECE

1. Remove the oil pan.
2. Remove the rear main bearing cap and lower oil seal half.
3. Remove the lower seal half from the cap.
4. Loosen the remaining main bearing bolts to allow the crankshaft to lower approximately 1/16 inch at the rear.
5. With a pin punch, start the removal and complete it with long nose pliers or a piece of heavy wire.
6. Clean the upper seal groove with a small bottle brush and solvent or push a piece of lint free cloth, such as nylon through it.
7. Lubricate a new seal half and slide it in the upper groove around the crankshaft until it is centered. Be sure the tab faces the rear.
8. Tighten the main bearing bolts except the rear.
9. Clean and install the lower seal half in the cap, tab to rear.
10. Place sealer on the cylinder block as shown in Fig. 48.
11. Install the rear main cap and bearing and torque all main caps to specifications.
12. Install new seals, gaskets and the oil pan.

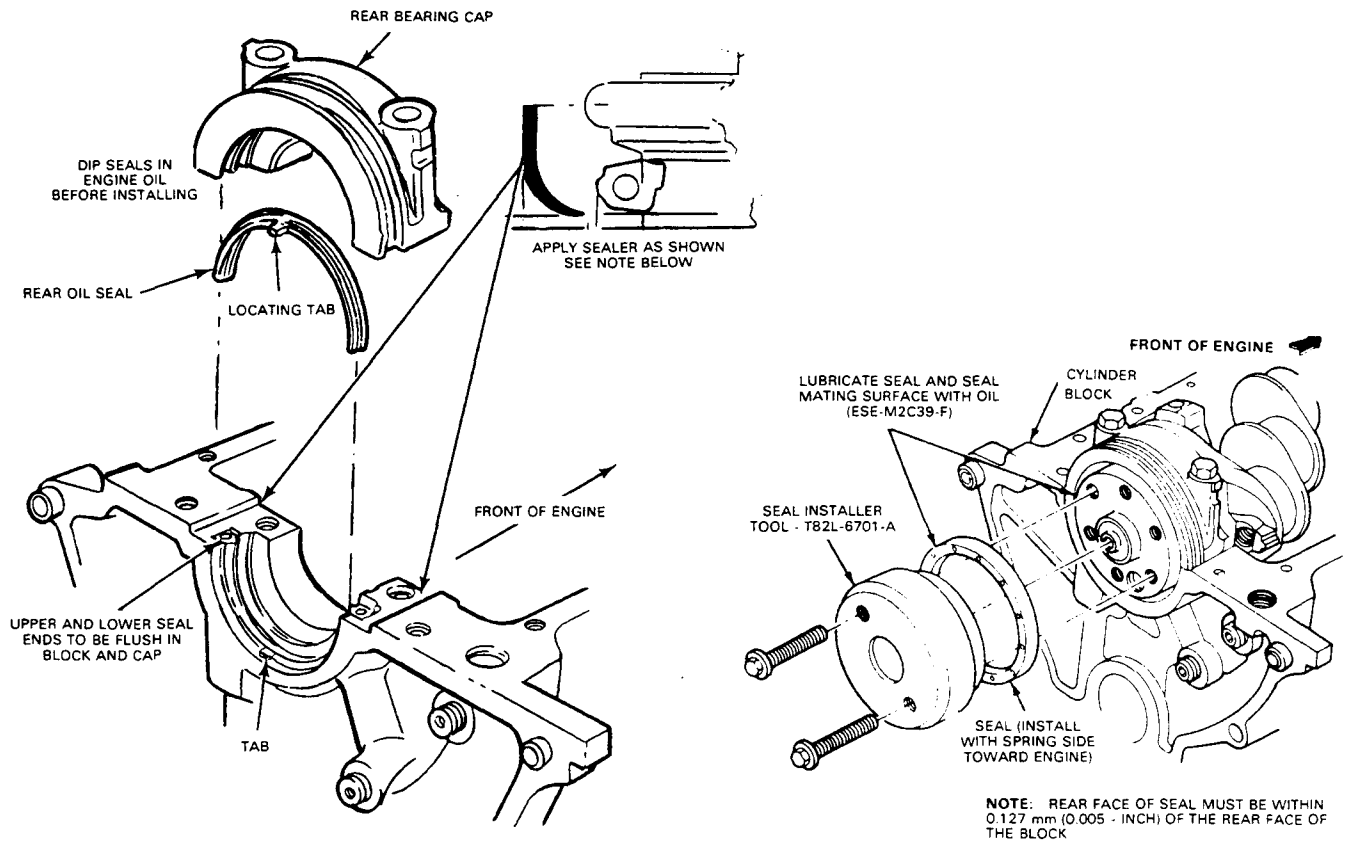

SEALER NOTE: CLEAN THE AREA WHERE SEALER IS TO BE APPLIED BEFORE INSTALLING THE SEALS. USE FORD SPOT REMOVER B7A-19521-A OR EQUIVALENT. AFTER THE SEALS ARE IN PLACE, APPLY A 1/16 INCH BEAD OF C3AZ-19562-A RO-B SEALER AS SHOWN. SEALER MUST NOT CONTACT SEALS.

FIG. 48 Rear Oil Seal Installation

ONE PIECE Removal

1. Using a sharp awl, punch one hole into the seal metal surface between the seal lip and the engine block.
2. Screw in the threaded end of Slide Hammer Tool T82L-9533-B or equivalent. Use the slide hammer to remove the seal. Use caution to avoid scratching or damaging the oil seal surface.

Installation

1. Lubricate seal with engine oil.
2. Position oil seal on Installer Tool T82L-6701-A or equivalent. Position tool and seal on the rear of the engine. Alternate bolt tightening to properly seat the seal. (Two bolts are supplied with Tool T82L-6701-A. Engine flywheel bolts may also be used.)

CRANKSHAFT MAIN BEARINGS

1. Remove the oil pan.
2. Remove one main bearing cap at a time and spin the upper bearing half out with the aid of a bearing removal tool inserted into the crankshaft oil hole.
3. Install the main bearing by reversing the above procedure.

See the Overhaul Section to properly fit new bearings.

OIL PUMP

1. Remove the oil pan.
2. Remove 2 screws.
3. Remove the pump and shaft, Fig. 49.
4. Before installing the oil pump, inspect it. See Cleaning and Inspection.
5. Fill the pump with oil before installing it.

OIL FILTER

1. With the use of an oil filter wrench, remove and discard the oil filter.
2. Coat the new filter gasket with clean engine oil and screw the filter on the cylinder block and threaded adapter.
3. Tighten the filter 1/2 turn after the gasket contacts the cylinder block. Fig. 50.

CONNECTING RODS AND PISTONS

1. Remove the cylinder head.
2. Remove the oil pan and oil pump.
3. Remove any cylinder ridge with the proper tool.
4. With the crankshaft positioned to gain access to the rod bolts, remove one set of rod bolts at a time. Remove the rod cap and bearing.
5. Using a hammer handle or piece of hardwood, drive the rod and piston assembly out through the top of the cylinder bore.

6. Repeat the above operation as required.
7. Repair or replace the affected parts as described in the Overhaul Section.
8. When installing the piston and rod assemblies, be sure to use a piston ring compressor and do not damage the crankshaft with the rod bolts.
9. Install the rod bearings with the locating tangs in their grooves or slots and on the same side of the rod.
10. Torque the rod nuts to specification.

2. Inspect pilot bearing and starter gear teeth for wear. Fig. 51.
3. Install the flywheel and torque the bolts to specification.

FLYWHEEL RING GEAR

1. To remove the ring gear, use a hacksaw and split.
2. To install a new ring gear, heat the new gear to no more than 600°F or until it reaches a dark blue color on a polished surface.
3. Install the gear with the chamfer facing the starter or pinion gear.
4. Tap the gear to seat it on the flywheel shoulder.
5. Allow the gear to air cool only.

CRANKSHAFT

1. The engine should be mounted on an engine overhaul stand before removing the crankshaft.

NOTE: The following parts removal procedures, except crankshaft may be found under the Components Removal and Installation Section.

2. Remove the cylinder head.
3. Remove the cylinder front cover.
4. Remove the oil pan and oil pump.
5. Remove the piston and rod assemblies.
6. Remove five main bearing caps and bearing valves.
7. Lift the crankshaft out of the cylinder block.
8. Clean the cylinder block, oil holes and the crankshaft.
9. Check the journals and bearings for proper clearance. See the Overhaul Section.
10. Install the seals, bearings and crankshaft in the block. Use sealers as shown in Fig. 48.
11. Install the caps and torque them to specification.
12. Install the remaining engine components as required.

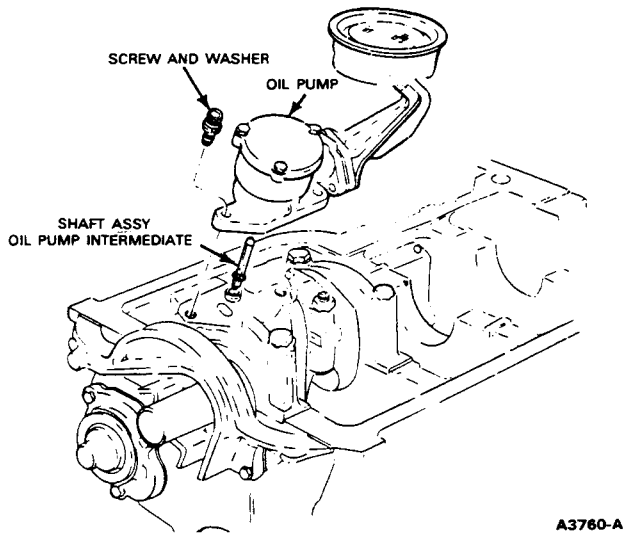

FIG. 49 Oil Pump Installation

FLYWHEEL

1. Remove 6 bolts and remove flywheel.

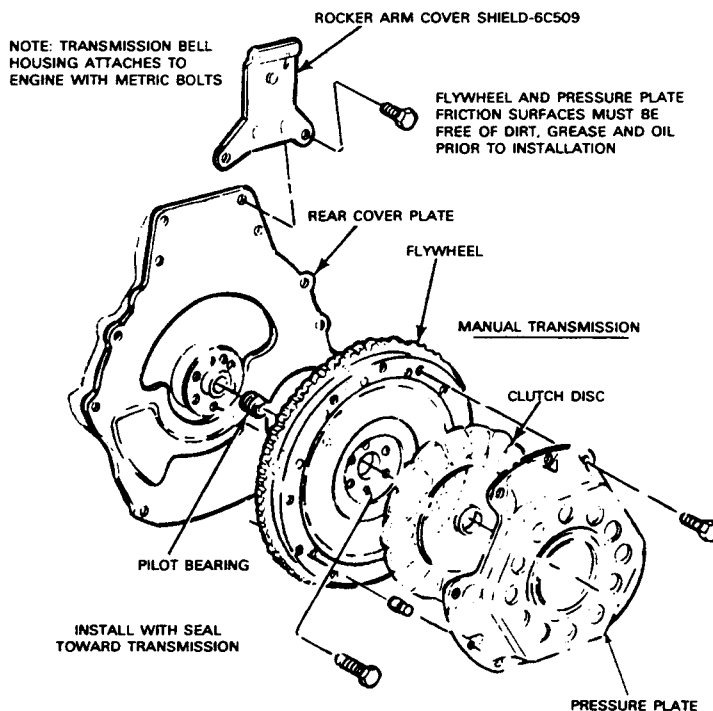

FIG. 50 Flywheel Installation

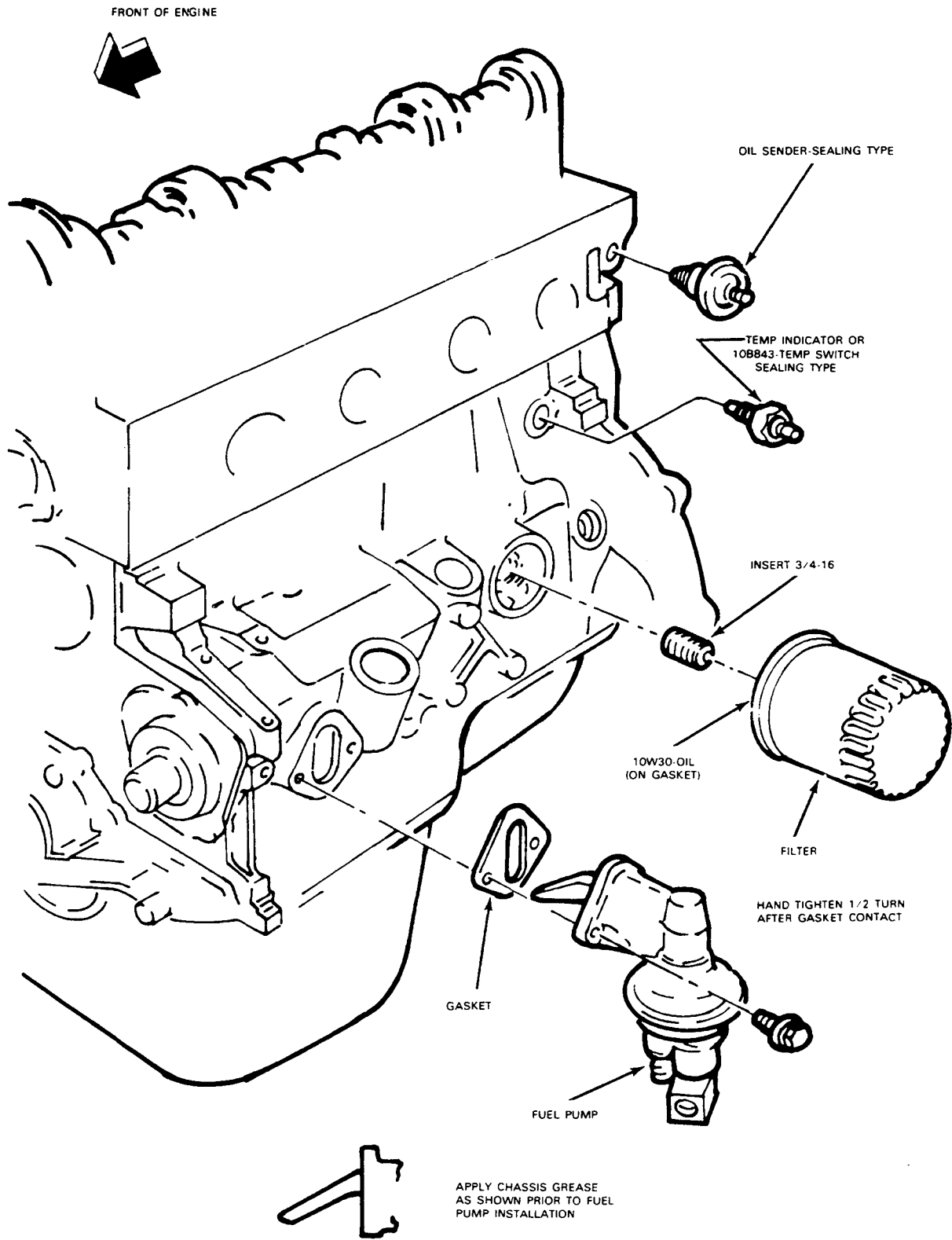

FIG. 51 Oil Filter, Fuel Pump and Sending Units

DISASSEMBLY AND ASSEMBLY

CYLINDER HEAD

1. Using a valve spring compressor, horseshoe type, compress the spring and remove the 2 keepers on each valve, the spring retainer and spring.
2. Remove the valves.
3. Remove the seals.
4. Inspect and/or recondition as described in the Inspection and Diagnosis or Overhaul Sections.
5. Install new valve seals with the caps and tool shown in Fig. 34 and 35.

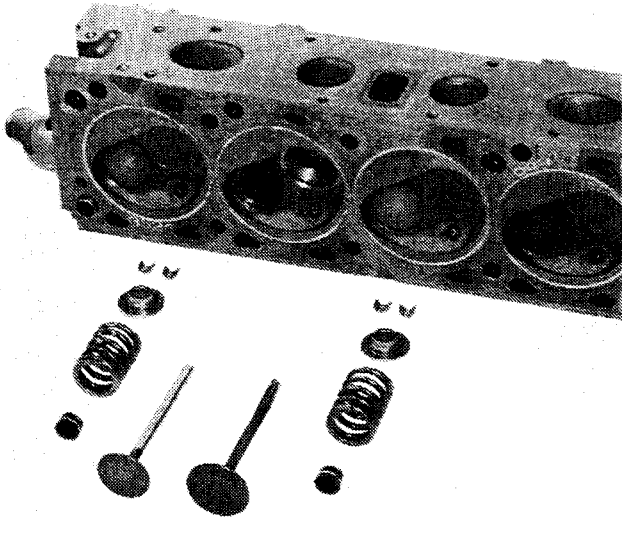

FIG. 52 Valve Spring Assembly

The assembled height of the valve spring can be checked as shown in Fig. 53.

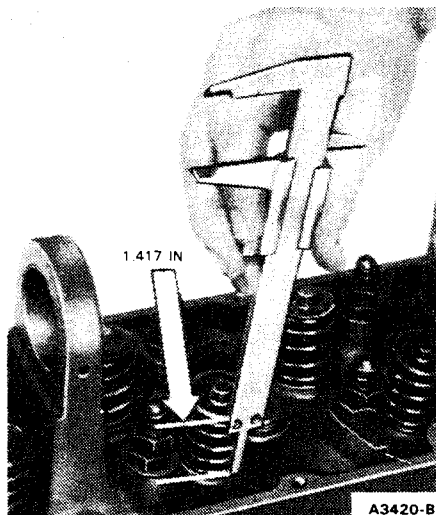

FIG. 53 Checking Valve Spring Assembled Height

If the assembled height is greater than specified, install the necessary 0.030 inch thick spacer(s) between the cylinder head spring pad and the valve spring to bring the assembled height to the recommended dimension. **Do not install spacers unless necessary. Use of spacers in excess of recommendations will result in overstressing the valve spring and overloading the camshaft lobes. This could lead to spring breakage and worn cam lobes.**

When assembling the cylinder head apply heavy SE oil to the valve stems cam bearings and like parts. Apply Lubriplate or equivalent to the wiping surfaces of the cam and cam followers.

OIL PUMP

1. Remove the inlet tube and screw, 2 screws Fig. 54.
2. Remove the cover, 4 screws.
3. Remove the inner and outer rotors. They are sintered iron. Do not drop on a hard surface as they may crack.

The relief valve and spring are not serviceable. The pump is serviced as an assembly. Inspect as described in Inspection and Diagnosis. Reverse the above steps for reassembly. Keep the pump oiled as the sintered iron will rust if not coated with oil.

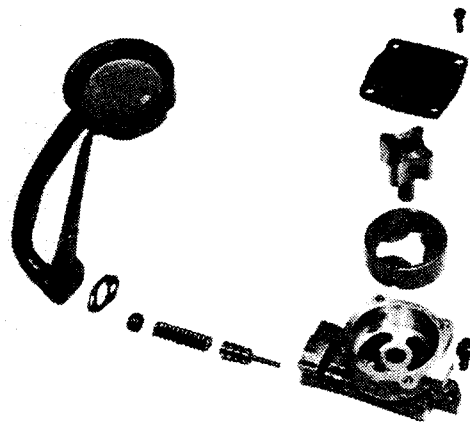

FIG. 54 Oil Pump Assembly

PISTON AND CONNECTING ROD Disassembly

1. Remove the bearing inserts from the connecting rod and cap.
2. Mark the piston and pins to assure assembly with the same rod and installation in the same cylinders from which they were removed.
3. Press the piston pin from the piston and connecting rod. Remove the piston rings.

Assembly

Check the fit of a new piston in the cylinder bore before assembling the piston and pin to the connecting rod.

The piston pin bore of a connecting rod and the diameter of the piston pin must be within specifications.

1. Apply a light coat of engine oil, SE, to all pins. Assemble the piston to the connecting rod with the boss on the side of the connecting rod and the arrow in the piston positioned as shown in Fig. 55.
2. Start the piston pin in the piston and connecting rod (this may require a very light tap with a mallet). Press the piston pin through the piston and connecting rod until the pin is centered in the piston.
3. Check the end gap and spacing (Fig. 18) of all piston rings. They must be within specifications.
4. Check the ring side clearance as outlined in Part 1.
5. Be sure the bearing inserts and the bearing bore in the connecting rod and cap are clean. Foreign material under the inserts will distort the bearing and cause a failure. Install the bearing inserts in the connecting rod and cap with the tangs fitting the slots provided. Make certain lock slots in cap are on the same side of bore as the lock slot in rod. Avoid nicking crank pin journals during rod installation.

HYDRAULIC LASH ADJUSTER

Two types of hydraulic lash adjusters are used. Type I is shown in Fig. 56. Type II in Fig. 57.

Both lash adjusters are assembled with a simple crimped collar which snaps into a groove on the outside body. This collar can be removed and re-installed as necessary without damaging it.

Use the hydraulic valve lifter leakdown tester to fill the lash adjusters with test fluid.

SPECIAL TOOLS

A special tool kit is available for the 2.3 litre engine as shown in Fig. 58. In addition, the following tools should be used during a complete engine overhaul.

Description	Tool Number
Dial Indicator Set	Tool 4201-C
Piston Pin Remover and Replacer Kit	T68P-6135-A
Valve Guide Reamer Kit	T52L-6085-AEE
Hydraulic Tappet Leakdown Tester	Tool 6500-E

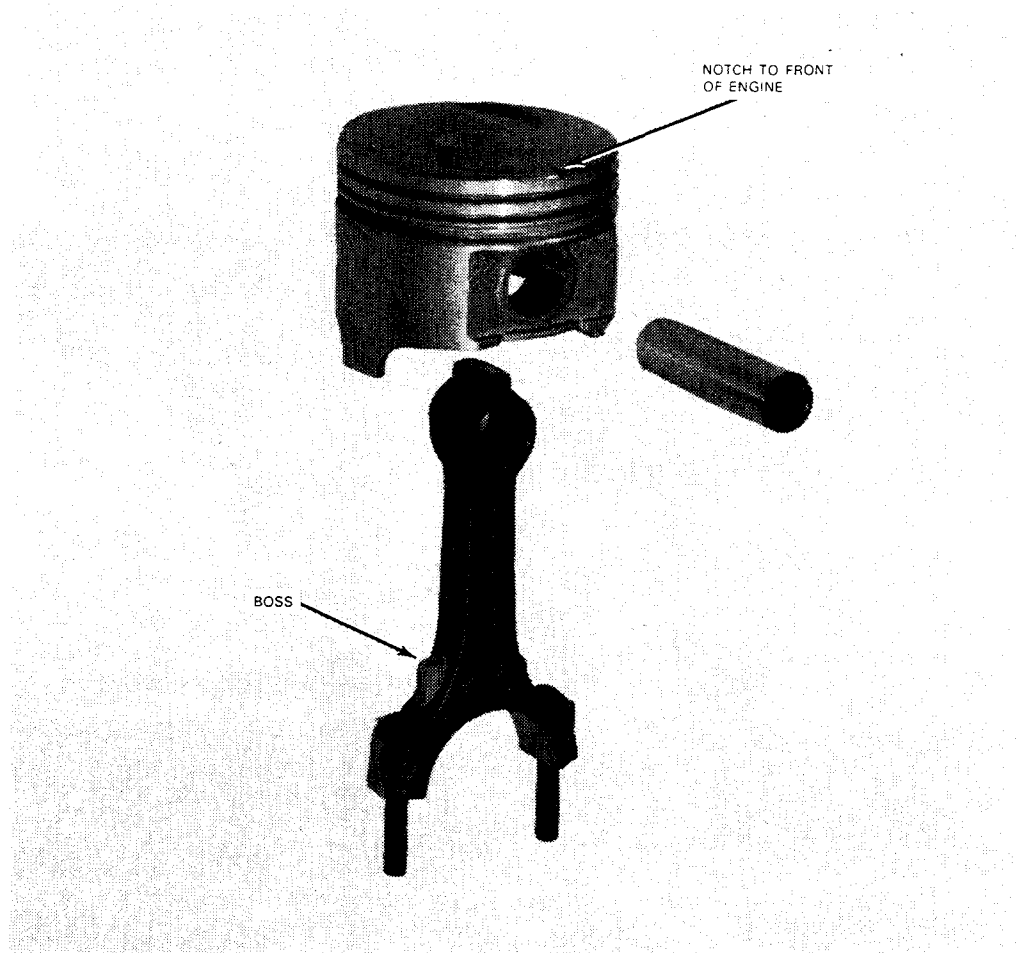
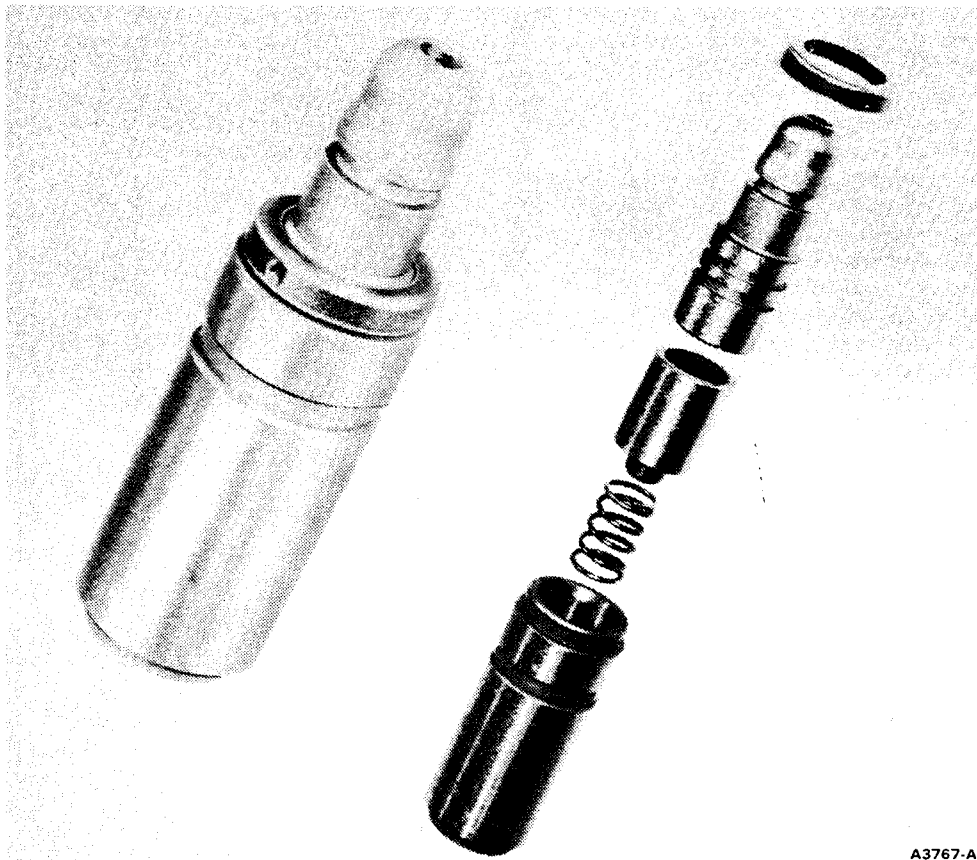
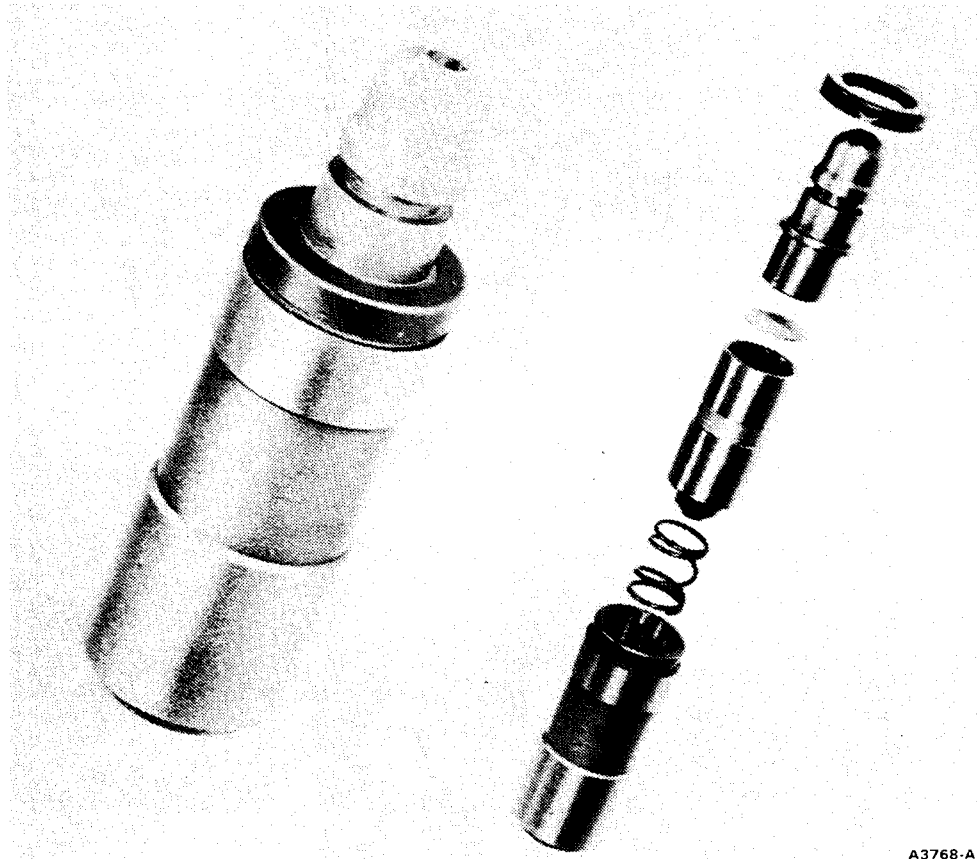

FIG. 55 Correct Piston and Rod Piston



A3767-A

FIG. 56 Type I Lash Adjuster



A3768-A

FIG. 57 Type II Lash Adjuster

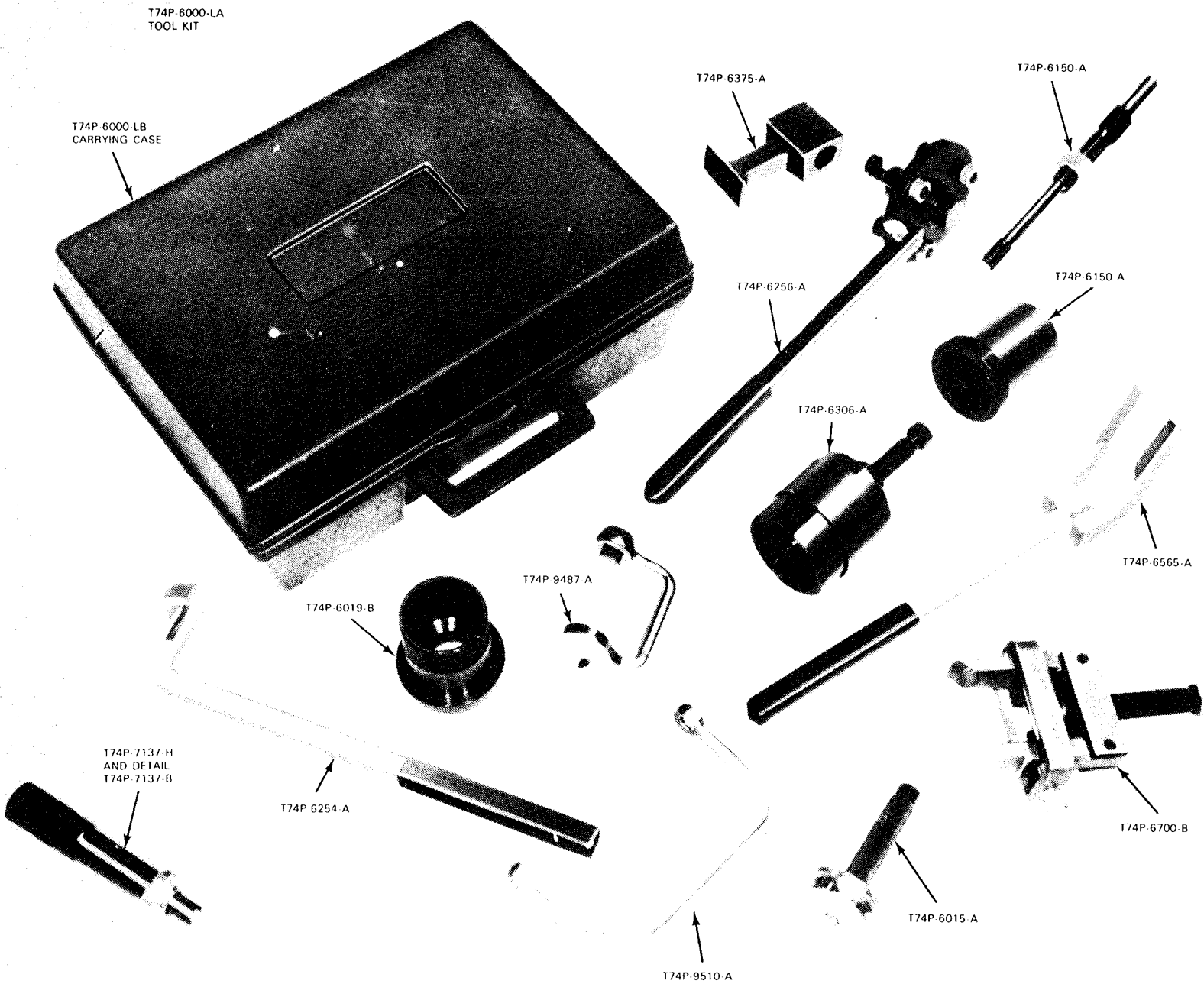

FIG. 58 Special Tools - 2300cc Engine

PART 2 Ignition System

COMPONENT INDEX	Page	COMPONENT INDEX	Page
IDENTIFICATION	2-01	Breaker Points and/or Condenser	2-12
DESCRIPTION	2-01	REMOVAL AND INSTALLATION	
Conventional System	2-01	Breaker Points and/or Condenser	2-13
Solid State System	2-02	Vacuum Advance Unit	2-13
DIAGNOSIS AND TESTING	2-03	Distributor (Breaker Point System)	2-14
Spark Intensity Tests	2-03	Breaker Plate & Sub-Plate	2-14
Ignition System Tests	2-04	Distributor (Solid State)	2-14
Distributor Tests — On Engine ...	2-05	Magnetic Pickup Coil Assembly ..	2-14
Distributor Tests — Off Engine ...	2-06	Spark Plug Wires	2-16
ADJUSTMENTS		Spark Plugs	2-16
Ignition Timing	2-11		

IDENTIFICATION

The distributor identification number is stamped on the distributor housing or a metal tag. The basic part number for distributors is 12127. To procure replacement parts, it is necessary to know the part number prefix and suffix (Figure 1).

Always refer to the Parts Catalog for parts usage and interchangeability before replacing a distributor or a component part for a distributor.

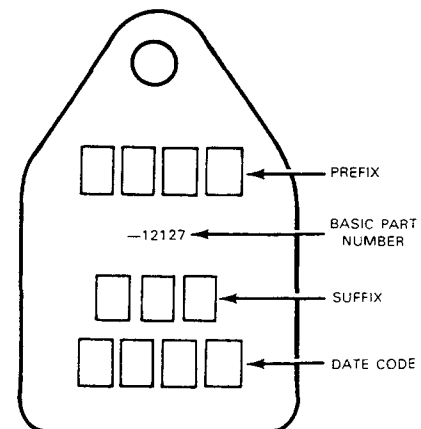

FIG. 1 Distributor Identification

DESCRIPTION AND OPERATION

The 2.3 Litre engines use either a breaker point ignition system or a solid state ignition system.

The direction of distributor rotation is clockwise as viewed from the top of the distributor.

The spark plug wires are inserted in the distributor cap in the firing order of the engine, 1-3-4-2. Number one socket is identified by the number one on the cap. The cylinders are numbered from front to rear — 1-2-3-4.

Breaker Point System

The distributor used in the breaker point system is the

dual advance type (Figure 2) with two independently operated spark advance systems.

A vacuum operated spark advance control diaphragm is located on the side of the distributor base. A centrifugal advance mechanism is located beneath the stationary subplate assembly.

The diaphragm is connected to the movable breaker plate by a link. An increase in vacuum will move the diaphragm against the advance diaphragm spring tension, causing the movable breaker plate to pivot opposite the distributor rotation. Thus, ignition timing is advanced, and this is calculated to occur during normal operation, but not during deceleration or idle.

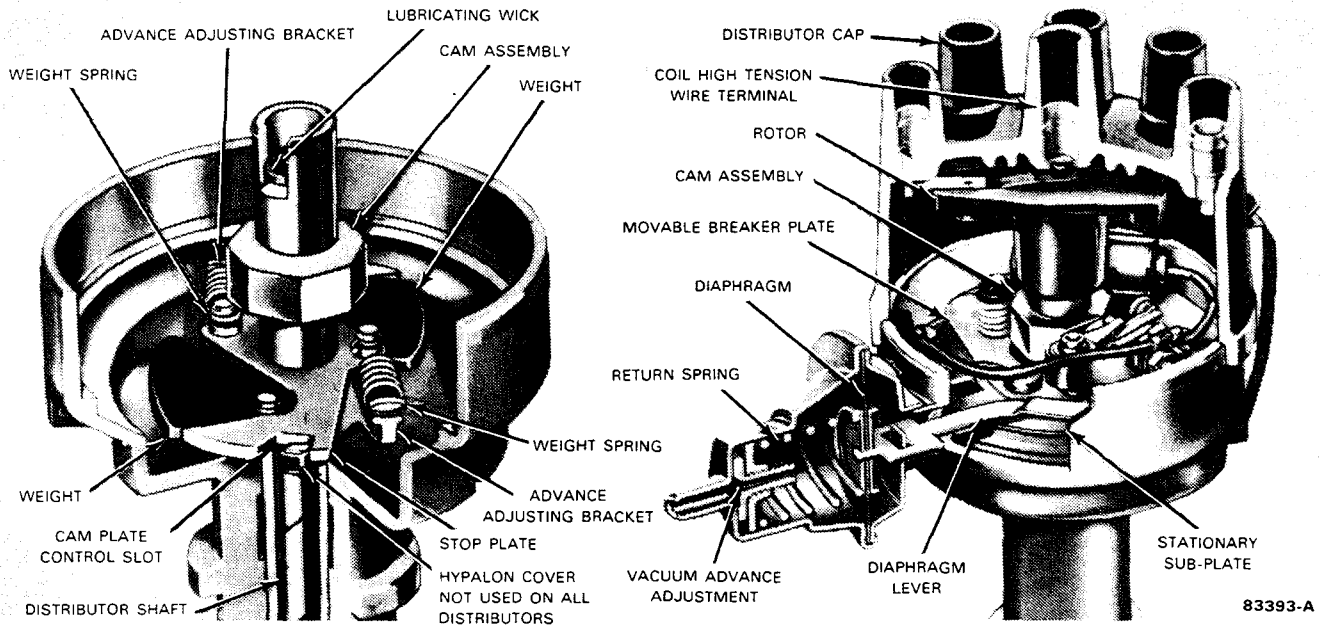

FIG. 2 Dual Advance Distributor

Solid State System

The solid state ignition system is found on some of these engines. It employs a unique armature and magnetic pickup coil assembly in the distributor and a solid state amplifier module. (Figures 3, 4 and 5).

The armature turns with the distributor shaft, causing fluctuations in the magnetic field generated by the pickup coil assembly. These fluctuations cause the amplifier to turn the ignition coil current off and on, causing the high tension spark needed to fire the spark plugs.

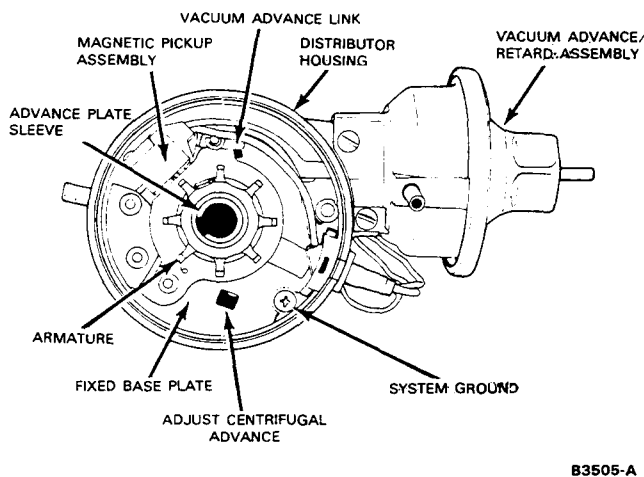

FIG. 3 Solid State Ignition System Distributor — Typical

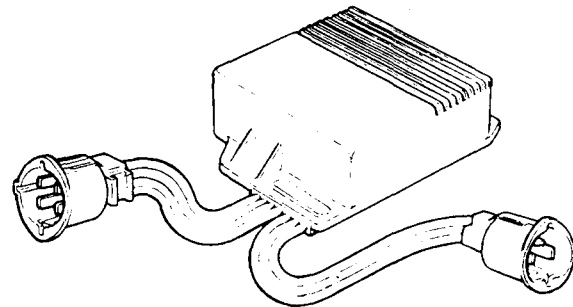

FIG. 4 Solid State Ignition System Amplifier Module

Circuit Operation

The ignition system consists of a primary (low voltage) and a secondary (high voltage) circuit (Figure 5).

The primary consists of the:

Breaker Point System

1. Battery.
2. Ignition switch.
3. Primary circuit resistor.
4. Primary windings of the ignition coil.
5. Breaker points.
6. Condenser.

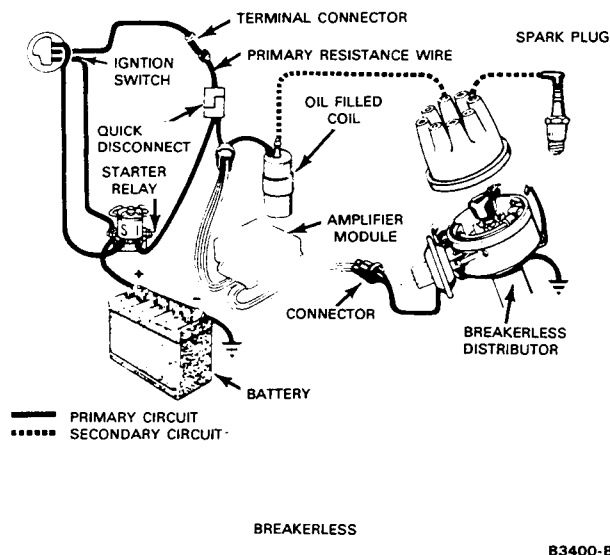

FIG. 5 Typical Ignition System Circuits

Solid State System

1. Battery.
2. Ignition switch.
3. Primary circuit resistance wire.
4. Primary windings of the ignition coil.
5. Magnetic pick-up assembly.
6. Amplifier module.

The secondary circuit for both systems consists of the:

1. Secondary windings of the ignition coil.
2. Distributor rotor.
3. Distributor cap.

4. High tension (spark plug) wires.
5. Spark plugs.

Breaker Point Ignition System

When the breaker points are closed, current flows from the battery through the ignition switch to the primary windings in the coil, then to ground through the closed breaker points. When the breaker points open, the magnetic field built up in the primary windings of the coil moves through the secondary windings of the coil, producing high voltage. **High voltage is produced each time the breaker points open.** The high voltage flows through the coil high tension lead to the distributor cap where the rotor distributes it to one of the spark plug terminals in the distributor cap. This process is repeated for every power stroke of the engine.

Solid State Ignition System

With the ignition switch "on", the primary circuit is on and the ignition coil is energized. When the armature "spokes" approach the magnetic pickup coil assembly, they induce a voltage which tells the amplifier to turn the coil primary current off. A timing circuit in the amplifier module will turn the current on again after the coil field has collapsed. When the current is "on", it flows from the battery through the ignition switch, the primary windings of the ignition coil; and through the amplifier module circuits to ground.

When the current is off, the magnetic field build up in the ignition coil is allowed to collapse, inducing a high voltage into secondary windings of the coil. High voltage is produced each time the field is built up and collapsed.

The high voltage flows through the coil high tension lead to the distributor cap where the rotor distributes it to one of the spark plug terminals in the distributor cap. This process is repeated for every power stroke of the engine.

DIAGNOSIS AND TESTING

Ignition systems troubles are caused by a failure in the primary and/or the secondary circuit; incorrect ignition timing; or incorrect distributor advance. Circuit failures may be caused by shorts, corroded or dirty terminals, loose connection, defective wire insulation, cracked distributor cap or rotor, defective distributor points, fouled spark plugs, or by improper dwell angle.

If engine starting or operating trouble is attributed to the ignition system, start the engine and verify the complaint. On engines that will not start, be sure there is gasoline in the fuel tank and that fuel is reaching the carburetor. Then locate the ignition system problem by an oscilloscope test or by a spark intensity test.

SPARK INTENSITY TESTS

Trouble Isolation

1. Connect an auxiliary starter switch in the starting circuit.
2. Remove the coil high tension lead from the distributor cap.
3. Turn on the ignition switch.
4. While holding the high tension lead approximately 3/16 inch from the cylinder head or any other good

ground, crank the engine with an auxiliary starter switch.

If the spark is good, then the trouble is in the primary circuit, coil to distributor high tension lead, or the coil.

If there is no spark or a weak spark, the trouble is in the primary circuit, coil to distributor high tension lead, or the coil.

Primary Circuit

A breakdown or energy loss in the primary circuit can be caused by: defective primary wiring, or loose or corroded terminals; burned, shorted, sticking or improperly adjusted breaker points; an open or shorted coil; defective pickup coil assembly or amplifier module (breakerless systems); or condenser.

A complete test of the primary circuit consists of checking the circuit from the coil to ground, and the starting ignition circuit.

Excessive voltage drop in the primary circuit will reduce the secondary output of the ignition coil, resulting in hard starting and poor performance.

To isolate a trouble in the primary circuit, use a voltmeter and perform the Ignition System Tests.

Secondary Circuit

A breakdown or energy loss in the secondary circuit can be caused by: fouled or improperly adjusted spark plugs; defective high tension wiring or high tension leakage across the coil, distributor cap or rotor resulting from an accumulation of dirt.

To check the spark intensity at the spark plugs, thereby isolating an ignition problem to a particular cylinder, proceed as follows:

1. Disconnect a spark plug wire. **Check the spark intensity of one wire at a time.**
2. Install a terminal adapter in the terminal of the wire to be checked. Hold the adapter approximately 3/16 inch from the exhaust manifold and crank the engine, using an auxiliary starter switch. The spark should jump the gap regularly.
3. If the spark intensity of all the wires is satisfactory, the coil, condenser, rotor, distributor cap and the secondary wires are probably satisfactory.

If the spark is good at only some wires, check the resistance of those particular leads.

If the spark is equal at all wires, but weak or intermittent, check the coil, distributor cap and the coil to distributor high tension wire. The wire should be clean and bright on the conducting ends, and on the coil tower and distributor sockets. The wire should fit snugly and be bottomed in the sockets.

IGNITION SYSTEM TESTS

Breaker Point System

Battery to Coil Voltmeter Test

1. Connect the voltmeter leads as shown in Figure 6.
2. Connect a jumper wire to the distributor terminal of the coil to a good ground on the distributor housing.
3. Turn the accessories off.

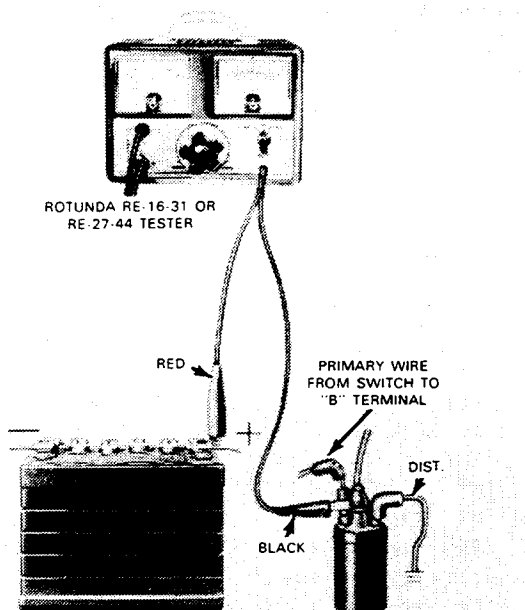

FIG. 6 Battery-to-Coil and Starting Ignition Circuit Test

4. Turn the ignition switch on.
5. If the voltmeter reading is between 4.5 and 6.9 volts, the primary circuit from the battery to the coil is satisfactory.
6. If the voltmeter reading is greater than 6.9 volts, check the following:
 - The battery and cables for loose connections or corrosion
 - The resistance wire for damage
 - The primary insulation, broken strands, and loose or corroded terminals
 - The starter-relay-to-ignition switch for damage

If the voltmeter reading is less than 4.5 volts, the ignition resistor should be replaced.

Starting Ignition Circuit Voltmeter Test

1. Connect the voltmeter leads as shown in Figure 6.
2. Disconnect and ground the coil to distributor high tension lead at the distributor.
3. With the ignition switch off, crank the engine with an auxiliary starter switch while observing the voltage drop.
4. If the voltage drop is 0.4 volt or less, the starting ignition circuit is satisfactory.
5. If the voltage drop is greater than 0.4 volt, clean and tighten the terminals in the circuit or replace the wiring as necessary.

Coil to Ground Voltmeter Test

1. Connect the voltmeter leads as shown in Figure 7.
2. Close the breaker points.
3. Turn all lights and accessories off.
4. Turn the ignition switch on.
5. If the voltmeter reading is 0.25 volt or less, the primary circuit from coil to ground is satisfactory.

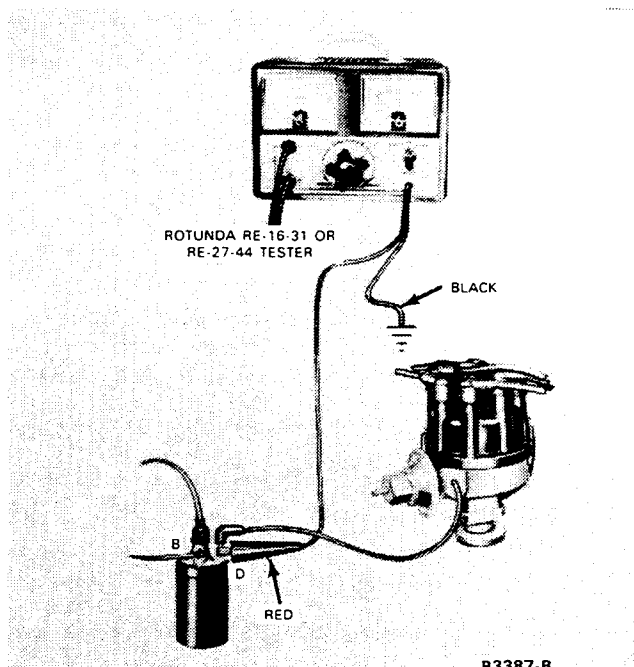

B3387-B

FIG. 7 Coil to Ground Test

6. If the voltmeter reading is greater than 0.25 volt, test the voltage drop between each of the following:
 - The coil and the breaker point connections of the coil to distributor primary wire
 - The movable breaker point and the breaker plate
 - The breaker plate and the distributor housing
 - The distributor housing and engine ground.
7. Turn the ignition switch off. Disconnect the voltmeter leads.

Breaker Points Check — (Breaker Point System)

Clean and inspect the breaker points by following the procedure under Cleaning and Inspection.

The breaker point dwell can be checked with a distributor tester or a dwell meter by following the procedure under Distributor Tests.

The breaker point resistance can be checked with a Rotunda RE-1416 distributor tester by following the procedure under Distributor Tests.

Coil Test

Check the coil on a coil tester following the manufacturer's instructions. Check for ohms resistance both primary and secondary. Also check the amperage draw both with the engine idling and stopped. These checks should all fall within specifications.

Secondary (High Tension Wires) Resistance Test

The secondary wires include the wires connecting the distributor cap to the spark plugs and the wire connecting the center terminal of the distributor cap to the center terminal of the ignition coil.

These wires are the radio resistance-type which filter out the high frequency electrical impulses that are the source of ignition noise interference. The resistance of each wire should not exceed 5000 ohms per inch. **When checking the resistance of the wires or setting ignition timing, do not puncture the wires with a probe. The probe may cause a separation in the conductor.**

When removing the wires from the spark plugs, grasp and twist the moulded cap, then pull the cap off the spark plug by hand only. Do not pull on the wire because the wire connection inside the cap may become separated or the insulator may be damaged.

To check the spark intensity at the spark plugs, proceed as follows:

1. Disconnect a spark plug wire. **Check the spark intensity of one wire at a time.**
2. Install a terminal adapter in the terminal of the wire to be checked. Hold the adapter approximately 3/16 inch from the exhaust manifold and crank the engine, using an auxiliary starter switch. The spark should jump the gap regularly.
3. If the spark intensity of all the wires is satisfactory, the coil, condenser, rotor, distributor cap and the secondary wires are probably satisfactory.

If the spark is good at only some wires, check the resistance of those particular leads.

If the spark is equal at all wires, but weak or intermittent, check the coil, distributor cap and the coil to distributor secondary (high tension) wires.

Spark Plug Test

Inspect, clean, file the electrodes and gap the plugs. After the proper gap is obtained, check the plugs on a testing machine. Compare the sparking efficiency of the cleaned and gapped plug with a new plug. Replace the plug if it fails to meet 70 percent of the new plug performance.

DISTRIBUTOR TESTS — ON ENGINE

Breaker Point System Test Connections

1. Disconnect the distributor primary wire at the coil. Connect a short jumper wire to the DIST terminal of the coil and the distributor primary wire. Connect the red lead of the tester to the jumper wire.
2. Connect the black lead to a good ground on the engine.

Dwell Angle Check

1. Disconnect and plug the distributor vacuum line. Connect the tester.
2. Turn the test control knob to the set position.
3. Adjust the set control knob until the needle on the dwell meter lines up with the set line.
4. Start the engine and let it idle.
5. Turn the test control knob to the 8 CYL position.
6. Read the dwell angle on the dwell meter and compare the reading to specifications.
7. Turn off the engine.
8. If the dwell angle was below the specified amount, the breaker point gap is too wide. If the dwell angle was above the specified amount, the breaker point gap is too close.

If the dwell is to specifications, turn the test selector knob to the OFF position and disconnect the tester leads and jumper wire; then connect the distributor vacuum line.

Dwell Angle Adjustment

If the dwell angle is not within specifications, proceed as follows:

1. Remove the coil high tension lead from the distributor and ground it.
2. Remove the distributor cap and place it out of the way. Remove the rotor.
3. Connect an auxiliary starter switch in the circuit.
4. Loosen the breaker point assembly retaining screw near the breaker point contacts.
5. With the ignition on, crank the engine with an auxiliary starter switch and adjust the gap to specifications.
6. Release the auxiliary starter switch and tighten the breaker point attaching screw.
7. Since the adjustment may have changed when the attaching screw was tightened, crank the engine again with the auxiliary starter switch and check the dwell. When the dwell is properly adjusted, remove the jumper wire, auxiliary starter switch and tester leads and install the rotor, distributor cap, coil high tension lead and starter relay wires. Connect the distributor vacuum line.

DISTRIBUTOR TESTS — OFF ENGINE

Distributor Shaft End Play

If the shaft end play is not to specifications, check the location of the collar on the distributor shaft.

1. Remove the distributor from the engine.
2. Place the distributor in the holding tool and clamp it in a vise.
3. Push the distributor shaft downward as far as it will go, and check the end play with a feeler gauge placed between the collar and the distributor base. The end play should be within the specified limits. If the shaft end play is not to specifications, check the location of the distributor shaft collar.

BREAKER POINT IGNITION

General Principles for Testing

The following instructions indicate the general principles to be followed for testing the distributor on a tester. The method of testing, however, may vary for machines of different manufacture. For specific instructions refer to the equipment manufacturer's handbook.

1. Mount the distributor on the tester. Check that the distributor is free to rotate.
2. Make the necessary electrical connections and zero the instrument if required.
3. Tighten the drive chuck to the distributor drive shaft securely.
4. Rotate the drive chuck by hand to make sure the distributor shaft turns freely and then tighten the locking screw on the distributor support arm.
5. Connect the Synchograph test lead to the primary lead wire of the distributor.

Breaker Point Resistance

1. Turn the test selector to the position for checking resistance.
2. Rotate the chuck by hand until the distributor breaker contacts are closed.
3. The pointer on the cam angle meter should read in the OK zone of the meter scale. If the meter pointer does not fall in the OK zone, there is excessive resistance caused by a faulty contact across the distributor points, a damaged primary lead, or a poorly grounded base plate. A faulty contact across the distributor points indicates improper spring or burned or pitted points.

Insulation and Leakage

1. Turn the test selector to the cam angle position and rotate the chuck by hand until the distributor breaker contacts are open.
2. The cam angle meter should show a zero reading. If a zero reading is not obtained, a short circuit to ground exists.

A short could be caused by poor primary wire insulation, a shorted condenser or a short between the breaker arm and breaker plate.

Mechanical Operation

1. Manually check the advance mechanism by turning the rotor in the direction of distributor rotation and then releasing it. The rotor will return to its original position if the mechanism has freedom of movement and the springs are in good condition.

2. Make the necessary connections for the stroboscopic timing light or sparking protractor. (Refer to equipment manufacturer's handbook).
3. Adjust the speed control to vary the distributor speed between 400 and 4000 engine rpm, or at the maximum speed of the engine on which the distributor is used. Erratic or then faint flashes of light preceding the regular flashes as the speed of rotation is increased can be due to weak breaker arm spring tension or binding of the breaker arm on the pivot pin.
4. Operate the distributor at approximately 2500 engine rpm and move the protractor scale so that the zero degree mark on the scale is opposite one of the neon flashes. The balance of all the flashes should come within 1 degree, plus or minus, evenly around the protractor scale. A variation larger than 1 degree or erratic or wandering flashes may be caused by a worn cam or distributor shaft or a bent distributor shaft.

Breaker Plate Wear

A worn breaker plate on the distributor will usually cause the breaker point gap and contact dwell to be erratic as engine speed and load conditions are varied.

Adjust the test set to 0 degree advance, 0 inches vacuum, and 100 rpm. Adjust the dwell angle to 39 degrees. Apply vacuum to the distributor diaphragm and increase it very slowly while observing the indicated dwell angle. The maximum dwell angle variation should not exceed 4 degrees when going from zero to maximum vacuum at constant rpm. If the dwell angle variation exceeds this limit, there is excessive wear.

Distributor Spark Advance Test

The spark advance is checked to determine if the ignition timing advances in proper relation to engine speed and load.

1. Check the contact dwell. If the contact dwell is not within specifications, adjust the breaker points.
2. Check the breaker arm spring tension and adjust it or replace the points as necessary.

The dual advance distributor has two independently operated spark advance systems. Each system is adjusted separately. **Adjust the centrifugal advance before adjusting the vacuum advance.**

SOLID STATE SYSTEM TESTS

The procedure, on the following pages, is a systematic approach to diagnose the primary portion of the ignition system and provides a logical sequence of testing. The following pieces of test equipment are required in connection with the test procedure.

- VOM (Volt-Ohmmeter)
- 15" jumper wire (with one small and one large alligator clip)
- Modified spark plug (with side electrode removed)
- Known good distributor
- Known good coil
- Known good ignition module
- Paper clip
- Straight pin

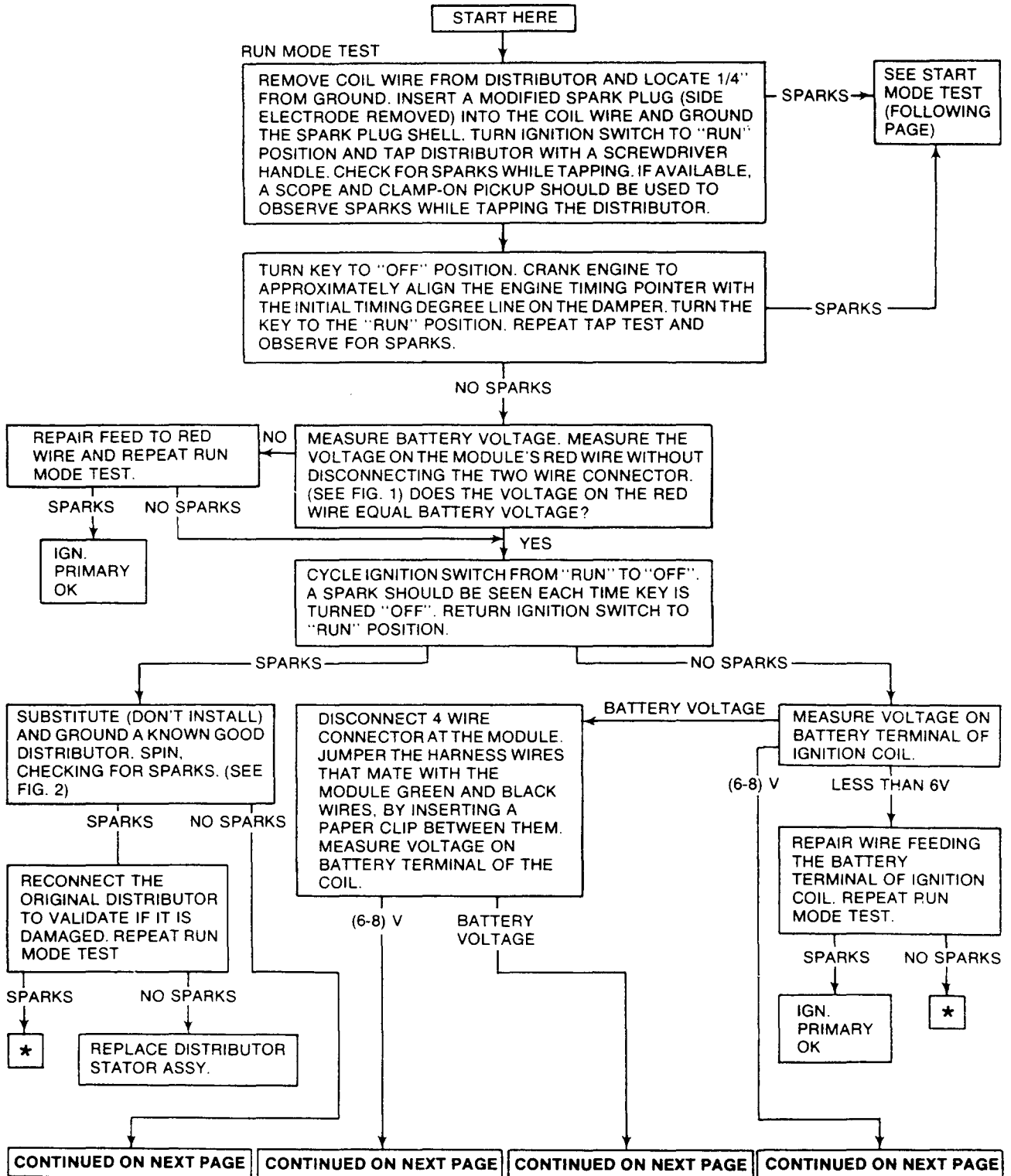

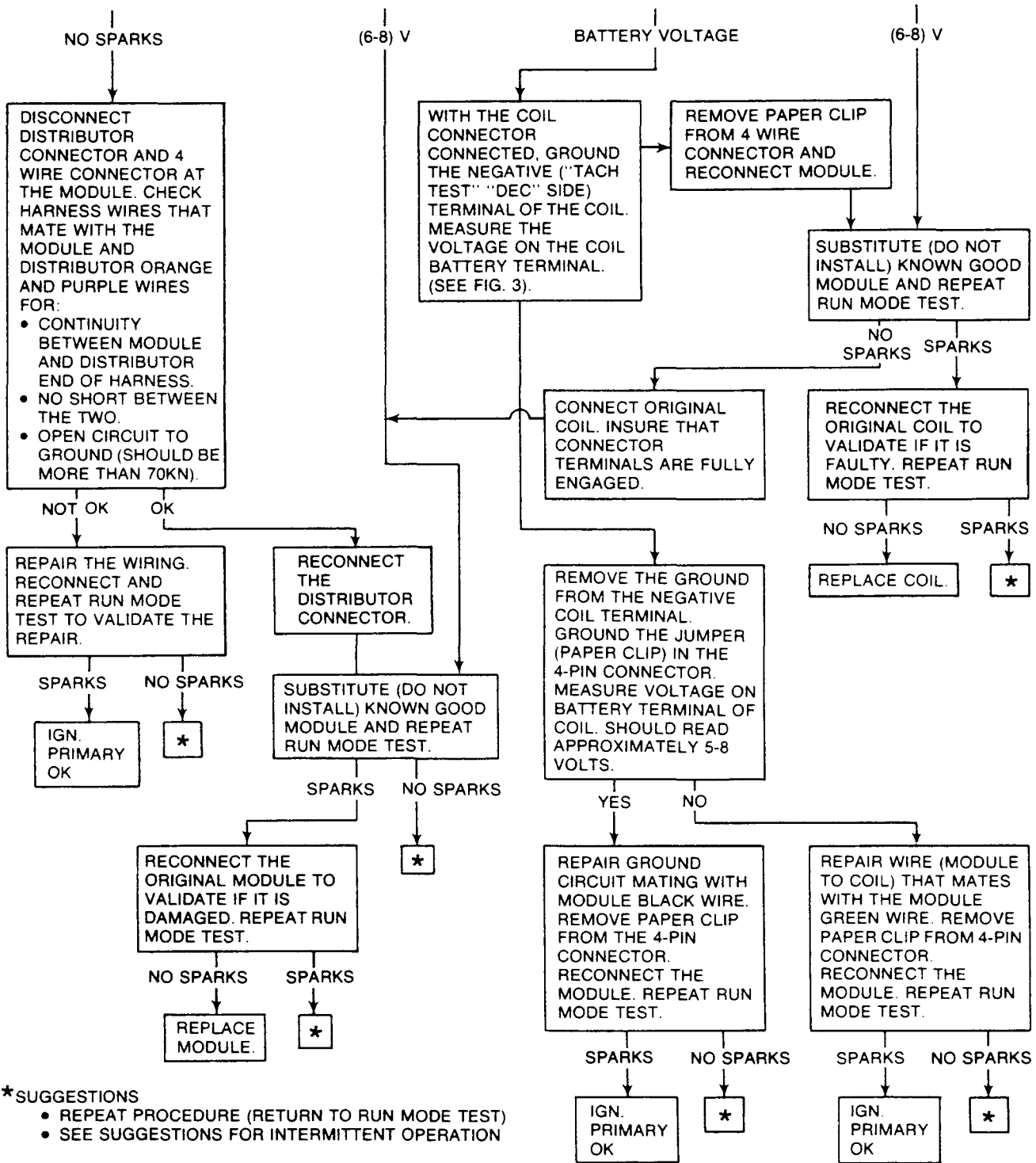

***SUGGESTIONS**

- REPEAT PROCEDURE (RETURN TO RUN MODE TEST)
- SEE SUGGESTIONS FOR INTERMITTENT OPERATION

IMPORTANT

- WHEN REINSTALLING COIL WIRE, COAT THE INSIDE OF THE BOOT WITH SILICONE GREASE (D7AZ-19A331-A or EQUIVALENT) USING A SMALL, CLEAN SCREWDRIVER BLADE.

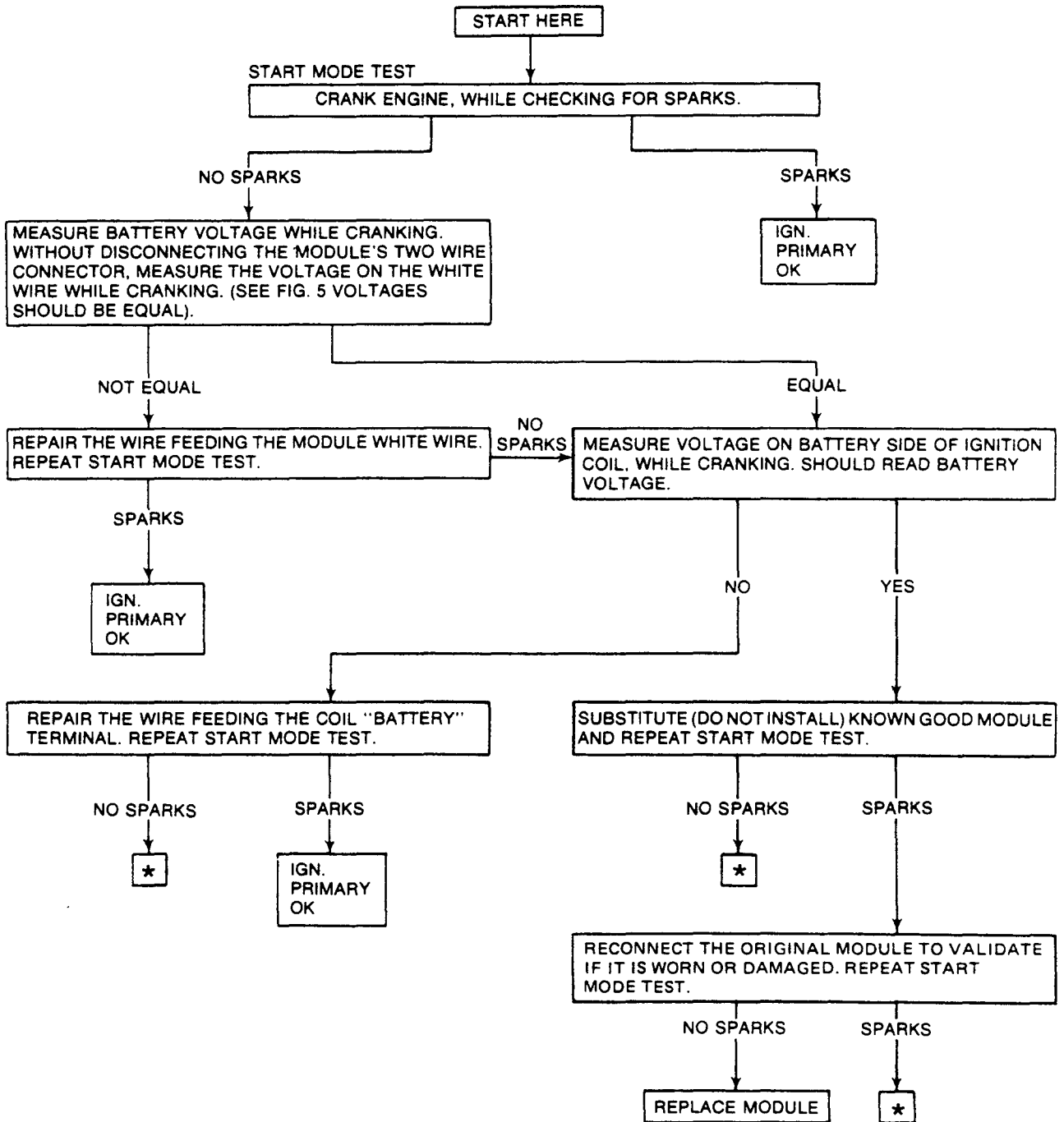

★ SUGGESTIONS

- REPEAT PROCEDURE (RETURN TO RUN MODE TEST)
- SEE SUGGESTIONS FOR INTERMITTENT OPERATION

IMPORTANT

- WHEN REINSTALLING COIL WIRE, COAT THE INSIDE OF THE BOOT WITH SILICONE GREASE (D7AZ-19A331-A OR EQUIVALENT) USING A SMALL, CLEAN SCREWDRIVER BLADE.

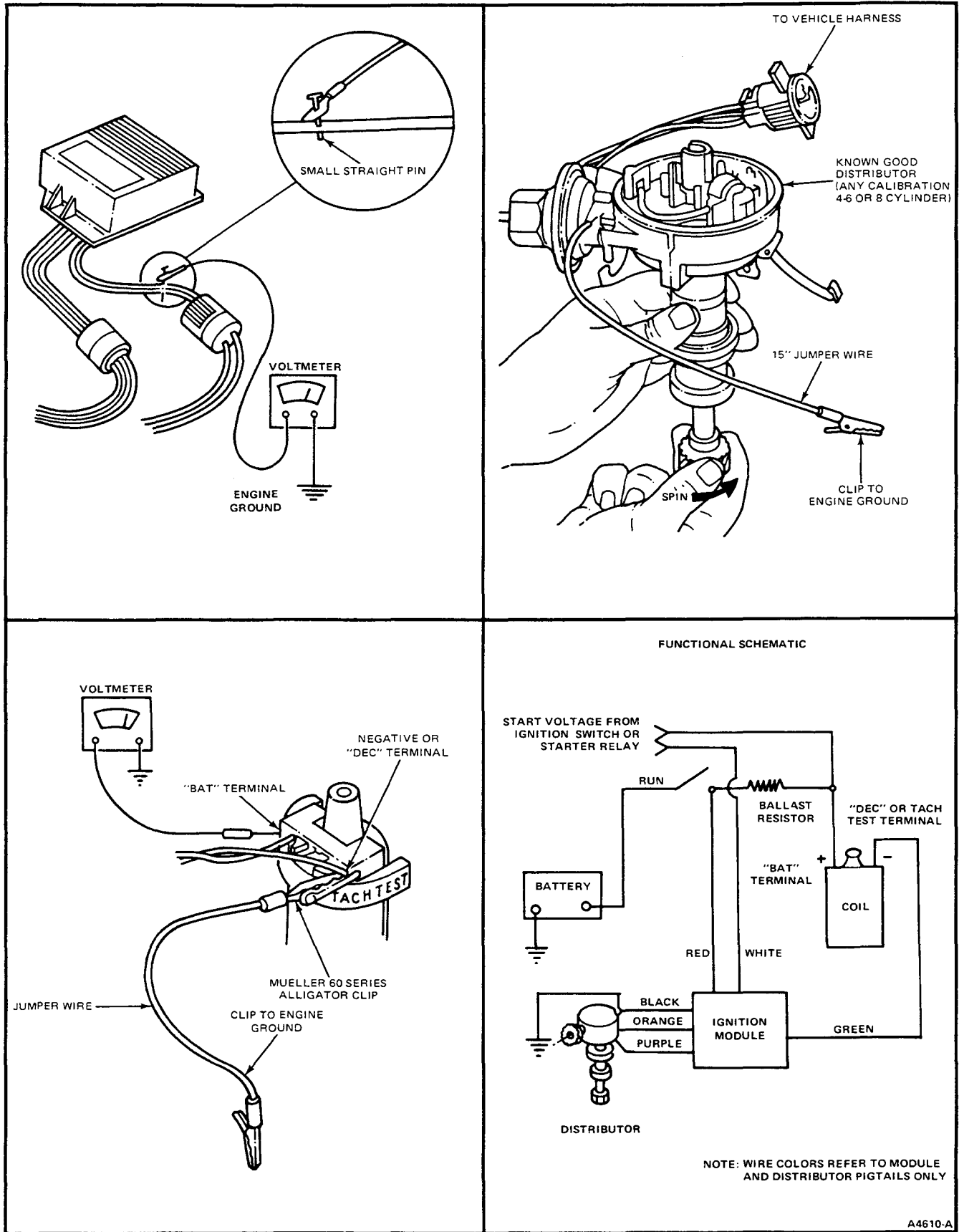

FIG. 8 Solid State System Tests

*SUGGESTIONS FOR INTERMITTENT OPERATION

If ignition system becomes operative in the course of performing these procedures and you have not made a repair, it is likely an intermittent connection or an intermittent ignition component has become functional. The following suggestions are offered:

Perform First: With the engine running, attempt to recreate the problem by wiggling the wires at the coil, module, distributor and other harness connectors. Start first with the connections you might have already disturbed. Also check the ground connection in the distributor. Disconnection and reconnecting connectors may also be helpful.

CAUTION: DO NOT CLEAN GREASE FROM CONNECTORS as it is required to prevent terminal corrosion.

Perform Second: Intermittent Component Testing

Pick-Up Coil: With the engine off, heat the stator pick-up coil by placing a 250 watt heat lamp approximately 1" to 2" from its top surface. Apply heat for 5 to 10 minutes while monitoring pick-up coil continuity between the

parallel blades of the disconnected distributor connector. The resistance should be 400-1000 ohms. Tapping with a screwdriver handle may also be helpful.

Ignition Module: With the engine running, heat module by placing a 250 watt heat lamp approximately 1" to 2" from the top surfaces of the module. Tapping may also be helpful.

CAUTION: THE MODULE TEMPERATURE SHOULD NOT EXCEED 212 DEGREES F (BOILING). AFTER THE FIRST 10 MINUTES OF HEATING, CHECK THE TEMPERATURE BY APPLYING A FEW DROPS OF WATER TO THE MODULE HOUSING. REPEAT THE CHECK EVERY TWO MINUTES UNTIL THE WATER DROPLETS BOIL. AVOID TAPPING THE MODULE TO THE EXTENT THAT THE HOUSING IS DISTORTED.

If this procedure results in ignition malfunction, substitute (do not install) a known good module. If the malfunction is corrected by the substitution, VALIDATE THAT THE ORIGINAL MODULE IS DAMAGED BY RECONNECTING IT TO THE VEHICLE. A functional check of the original and known good module can quickly be accomplished by using the "RUN MODE TEST."

ADJUSTMENTS

Accurate ignition system adjustments are of great importance in the proper operation and performance of the engine.

No adjustments are to be made to the solid state ignition system except ignition timing and spark plug gap.

After any adjustment of ignition timing, check the distributor automatic advance for proper operation.

IGNITION TIMING Timing Mark Location

Each time the distributor points are replaced or adjusted, the ignition timing should be checked and adjusted as necessary. Proper adjustment of the ignition timing must be maintained to provide maximum engine power output and best possible fuel economy.

The timing marks and their locations are illustrated in Figure 9.

For checking and adjusting the ignition timing with a scope refer to the scope manufacturer's instructions. To check and adjust the timing with a timing light, proceed as follows:

Initial Ignition Timing

1. Clean and mark the specified timing mark with chalk or white paint.
2. Disconnect the vacuum line and plug the disconnected vacuum line.
3. Connect a timing light to the No. 1 cylinder spark plug wire. Connect a tachometer to the engine.
4. Start the engine and reduce the idle speed to 600 rpm to be sure that the centrifugal advance is not operating. Adjust the initial ignition timing to specifications by rotating the distributor in the proper direction.

5. Check the centrifugal advance for proper operation by starting the engine and accelerating it to approximately 2000 rpm. If the ignition timing advances, the centrifugal advance mechanism is functioning properly. Note the engine speed when the advance begins and the amount of total advance. Stop the engine.
6. Unplug the vacuum line and connect it to the distributor vacuum advance unit. Start the engine and accelerate it to approximately 2000 rpm. Note the engine speed when the advance begins and the total amount of advance.

Advance of the ignition timing should begin sooner and advance farther than when checking the centrifugal advance alone. Stop the engine.

7. If the vacuum advance is not functioning properly, remove the distributor and check it on a distributor tester. Replace the diaphragm unit if the vacuum portion is out of calibration.

DUAL-ADVANCE DISTRIBUTOR

Adjust the centrifugal advance before adjusting the vacuum advance.

Centrifugal Advance — (Breaker Point System)

1. Operate the distributor in the direction of rotation and adjust the speed to the initial rpm setting listed in the specifications. Move the protractor scale so that one of the flashes lines up with the zero degree mark.
2. Slowly increase the rpm to the setting specified for the first advance reading listed in the specifications.

If the correct advance is not indicated at this rpm, stop the distributor and bend one spring adjustment bracket to change its tension (Figure 10). Bend the adjustment bracket away from the distributor shaft to decrease advance (increase spring tension) and toward the shaft to increase advance (decrease spring tension). After the adjustment is made, identify the

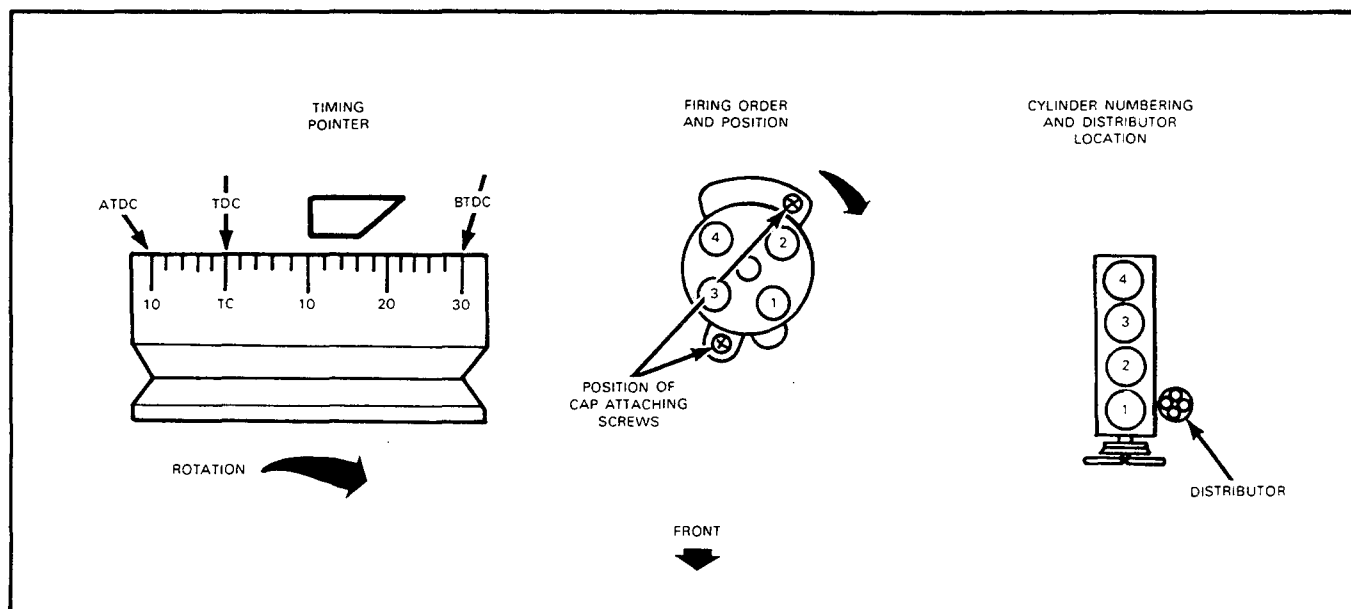

FIG. 9 Engine Timing and Cylinder Firing Order — Typical

bracket so as not to repeat the adjustment on the same spring.

3. After an adjustment has been made to one spring, check the minimum advance point again.
4. Operate the distributor at the specified rpm to give an advance just below the maximum. If this advance is not to specifications, stop the distributor and bend the other spring bracket to obtain the correct advance.
5. Check the advance at all rpm settings listed in the specifications. Operate the distributor both up and down the rpm range.

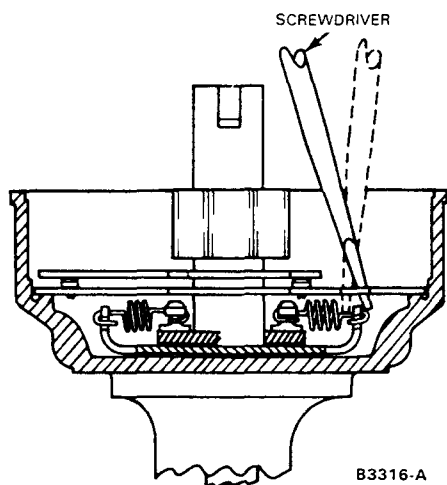

FIG. 10 Centrifugal Advance Adjustment

Vacuum Advance — (Breaker Point System)

1. Connect the test set vacuum line to the fitting on the diaphragm.
2. Set the test set to 0 degree advance, 0 vacuum, and at 1000 rpm.
3. Check the advance at the first vacuum setting given in the specifications.
4. If the advance is incorrect, turn the allen head screw clockwise to increase the vacuum advance and counterclockwise to decrease it (Fig. 11).

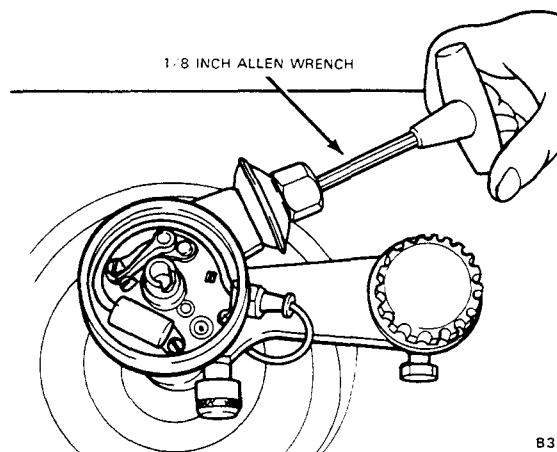

FIG. 11 Adjusting Vacuum Advance

5. After one vacuum setting has been adjusted, the others should be checked. Do not change the original rpm setting when going to a different vacuum setting. If the other settings are not within limits, there is incorrect spring tension, leakage in the vacuum chamber and/or line.

To check the diaphragm for leakage:

Remove the vacuum line from the distributor. Adjust the vacuum pressure of a distributor tester to its maximum position. Hold your hand over the end of the tester's vacuum hose and note the maximum reading obtained. **Do not exceed 25 inches Hg.**

If the maximum reading is 25 inches Hg or less, connect the tester's vacuum line to the vacuum fitting on the diaphragm to be tested without changing any of the adjustments. The maximum gauge reading should not be less than it was above. If it is less, the diaphragm is leaking and should be replaced.

BREAKER POINTS AND/OR CONDENSER Breaker Point Alignment

The breaker points must be accurately aligned and stroke squarely to assure normal breaker point life.

Misalignment of these breaker point surfaces can cause premature wear, overheating and pitting.

1. Turn the cam so that the breaker points are closed, then check the alignment of the points (Figure 12).

If the distributor is on the engine, close the points by proceeding as follows:

1. With the ignition switch off, crank the engine by using an auxiliary starter switch.
2. Using the tool shown (Figure 13) and exerting **very light pressure**, align the breaker point bracket. **Do not bend the breaker arm.**
3. After the breaker points have been properly aligned, adjust the breaker point gap.

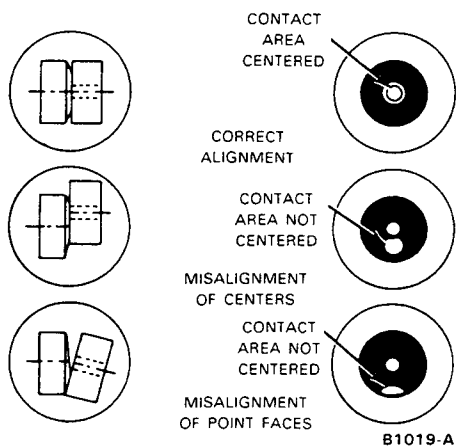

FIG. 12 Checking Breaker Point Alignment

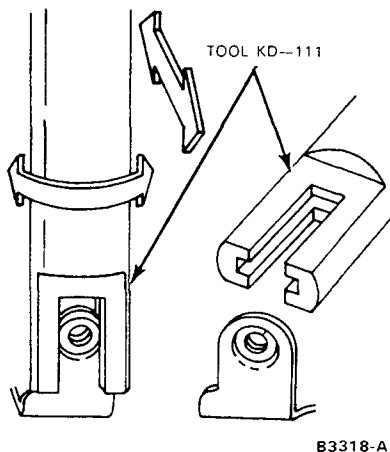

FIG. 13 Using Alignment Tool

Breaker Point Gap Adjustment

A scope, a dwell meter, or a feeler gauge can be used to check the gap of new breaker points.

A scope or a dwell meter should be used to check the gap of used breaker points. Due to the roughness of used points, it is not advisable to use a feeler gauge to check the gap.

To check and adjust the breaker points with a feeler gauge:

1. Check and adjust the breaker point alignment.
2. Rotate the distributor until the rubbing block rests on the peak of a cam lobe.

If the distributor is on the engine, place the rubbing block on the peak of the cam by proceeding as follows:

Crank the engine with an auxiliary starter switch.

Insert the correct thickness blade of a clean feeler gauge between the breaker points. Adjust the points to the correct gap and tighten the screws.

Clean the cam, then apply a light film of distributor cam lubricant (C4AZ-19D530-A) to the cam when new points are installed. **Do not use engine oil to lubricate the distributor cam.**

Lubricate the felt under the rotor using two drops of engine oil.

Set the ignition timing.

To check and adjust the breaker points with a scope or a dwell meter, refer to the manufacturer's instructions.

Also, set the contact dwell to the low setting.

REMOVAL AND INSTALLATION Breaker Points and/or Condenser

Removal

1. Remove the distributor cap and rotor.
2. Disconnect the primary and the condenser wires from the breaker point terminal.
3. Remove the breaker point assembly and condenser attaching screws. Lift the breaker point assembly and condenser out of the distributor.

Installation

1. Clean the distributor cam thoroughly.
2. Apply a light film of distributor cam lubricant C4AZ19D530-A on the cam. **Do not use any type of oil.**
3. Place the breaker point assembly and the condenser in position and install the attaching screws.
4. Align and adjust the breaker points.
5. Connect the primary and condenser wires to the breaker point terminal.
6. Install the rotor and the distributor cap.

VACUUM ADVANCE UNIT

Removal

1. Remove the distributor cap and rotor.
2. Disconnect the vacuum line.
3. Remove the spring clip that secures the diaphragm link to the movable breaker plate.
4. Remove the diaphragm unit attaching screws, and carefully remove the unit.

Installation

1. Position the diaphragm unit on the distributor and hook the diaphragm link in position.
2. Install the spring clip that secures the diaphragm link to the movable breaker plate. Install the diaphragm unit attaching screws.
3. Connect the vacuum line.
4. Install the rotor and the distributor cap.

DISTRIBUTOR — (BREAKER POINT SYSTEM)

Removal

1. Disconnect the primary wire from the coil.
Disconnect the vacuum advance line(s) at the distributor. Remove the distributor cap.
2. Scribe a mark on the distributor body and the cylinder block indicating the position of the body in the block, and scribe another mark on the distributor body indicating the position of the rotor. These marks can be used as guides when installing the distributor in a correctly timed engine.
3. Remove the distributor hold down bolt and clamp. Lift the distributor out of the block.

Do not rotate the crankshaft while the distributor is removed, or it will be necessary to time the engine.

Installation

1. If the crankshaft was rotated while the distributor was removed from the engine, it will be necessary to time the engine. Rotate the crankshaft until No. 1 piston is on TDC after the compression stroke. Align the timing pointer with the TDC mark on the crankshaft damper. Position the distributor in the block with the rotor at the No. 1 firing position.

Make sure the oil pump intermediate shaft properly engages the distributor shaft. It may be necessary to crank the engine with the starter, after the distributor drive gear is partially engaged to engage the oil pump intermediate shaft.

Install, but do not tighten, the retaining clamp and bolt, rotate the distributor to advance the timing to a point where the breaker points are just starting to open. Tighten the clamp.

2. If the crankshaft has not been moved, position the distributor in the block with the rotor aligned with the mark previously scribed on the distributor body and the marks on the distributor body and cylinder block in alignment.
3. Install the distributor cap.
4. Connect the primary wire to the coil.
5. Check the ignition timing with a timing light and adjust to specifications. Connect the vacuum line, and check the advance with the timing light when the engine is accelerated.

BREAKER PLATE AND SUB-PLATE

Refer to Figure 14 for the correct location of parts.

Removal

1. Remove the distributor cap and rotor.
2. Remove the breaker point assembly and the condenser. Remove the vacuum diaphragm.
3. Working from the inside of the distributor, pull the primary wire through the opening out of the distributor.
4. Remove the sub-plate attaching screws and lift the assembly from the distributor.

Installation

1. Place the breaker plate assembly in position in the distributor.
2. Install the sub-plate hold down screws (the ground wire should be under the sub-plate hold down screw from which it was removed) (Figure 14).
3. Insert the primary wire in the distributor. Install the breaker points and the condenser. Connect the primary wire and the condenser wire to the breaker point terminal. Install the vacuum diaphragm.
4. Install the rotor and the distributor cap.

DISTRIBUTOR — SOLID STATE

Removal

1. Using a remote starter switch or rotating the engine by hand, position the proper timing mark on the engine crankshaft damper with the timing pointer.
2. Remove the distributor cap and check to see that the rotor and armature are lined up with the index mark on the top of the magnetic pickup (Fig. 15), and the marks on the side of the distributor body.
3. Disconnect the vacuum hose from the distributor. Disconnect the distributor wiring connector from the wiring harness.
4. Remove the distributor hold-down bolt and remove the distributor from the block. The hex shaft that drives the oil pump may stick in the distributor shaft and be withdrawn from the pump.

Installation

1. Make sure the engine is still aligned with the proper timing marks. Align the distributor rotor with the marks on the distributor and the armature with the marks on the top of the magnetic pickup (Fig. 15). If the oil pump drive shaft was withdrawn with the distributor, coat one end with heavy grease, insert that end into the hex hole in the distributor shaft and position the distributor into the cylinder block. Make sure the oil pump drive shaft is fully seated in the pump, and that the distributor rotor and body are in the proper position.
2. Install the distributor hold-down bolt and bracket.
3. Install the vacuum hose and connect the distributor wire to the wiring harness.
4. Install the rotor and distributor cap.
5. Check engine timing.

MAGNETIC PICKUP COIL ASSEMBLY

Refer to Figure 16 for the correct location of parts.

Removal

1. Remove the distributor cap and rotor and disconnect the distributor harness plug.
2. Using a small gear puller or two screwdrivers, lift or pry the armature from the advance plate sleeve. Remove the roll pin.
3. Remove the snap ring, washer and wave washer that secure the pickup coil assembly to the lower plate.
4. Remove the magnetic pickup assembly ground screw and lift the assembly from the distributor.

Installation

1. Place the pickup assembly in position over the fixed base plate and insert the pickup assembly post into the vacuum advance arm.

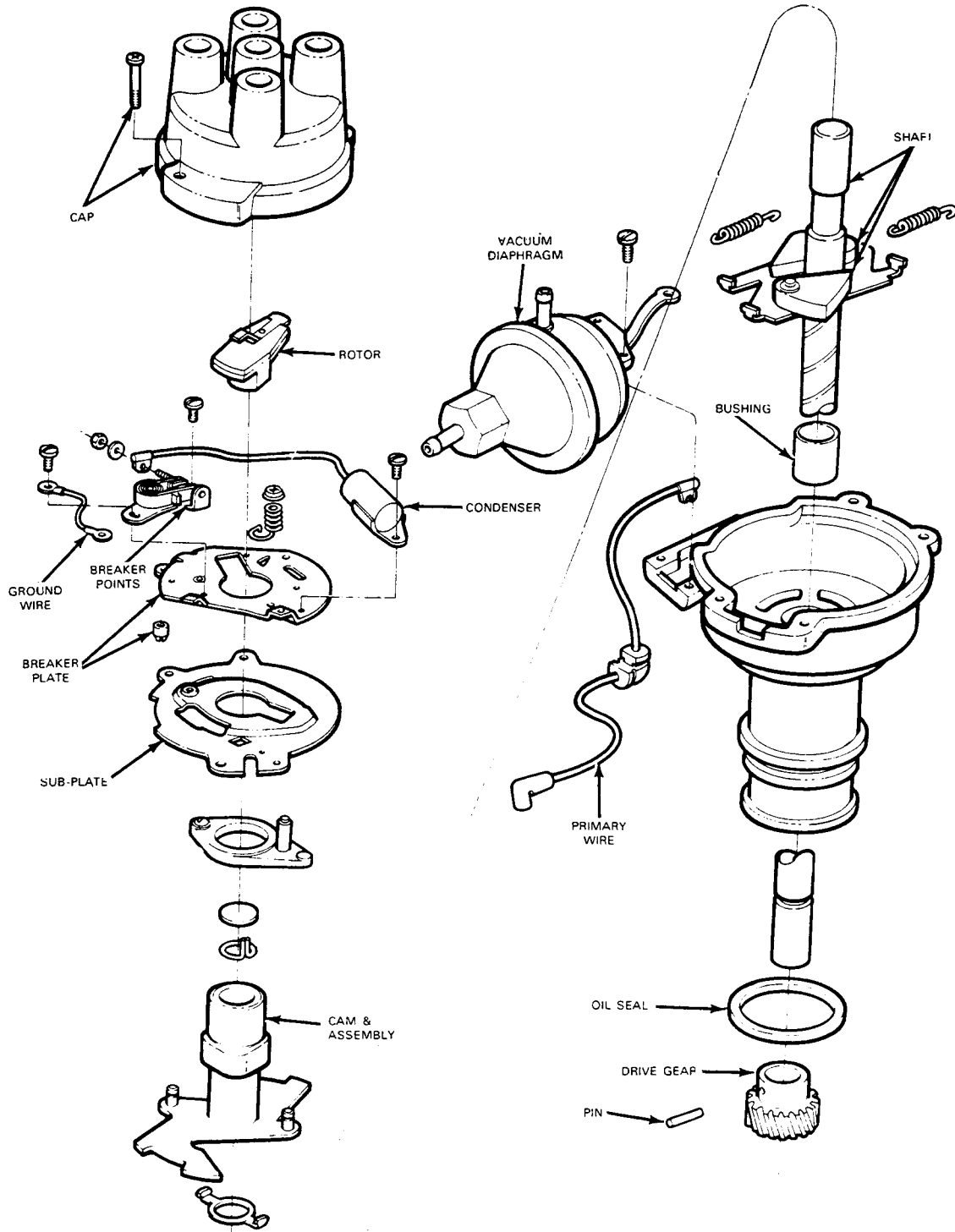
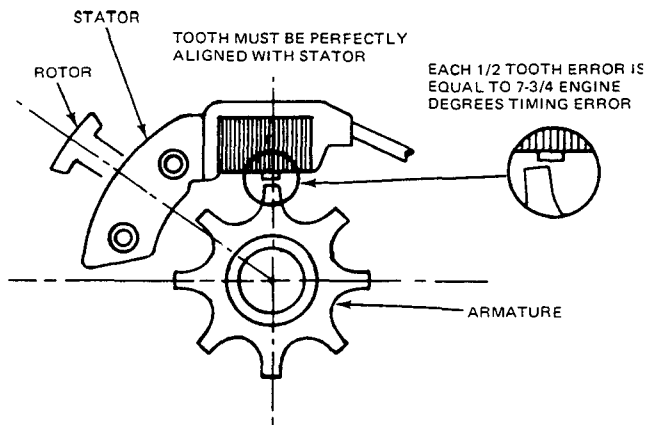

FIG. 14 Distributor (Breaker Point Type) — Typical



B3509-1A

**FIG. 15 Static Timing Position—6-Cylinder —
Shown—4-Cylinder Similar**

- Slide the wiring grommet into the slot at the edge of the lower plate and install the ground screw. Install the washers and snap ring to secure the pickup coil assembly to the lower plate.
- Install the armature on the advance plate sleeve, making sure the roll pin is engaged in the matching slots.
- Install the distributor rotor and cap and connect the distributor wiring plug to the vehicle harness.

VACUUM ADVANCE

Removal

- Remove the distributor cap and rotor.
- Disconnect the vacuum line.
- Remove the diaphragm unit attaching screws and carefully remove the unit by tilting downward to disengage the link from the advance plate.

Installation

- Hook the diaphragm link in position and position the diaphragm unit on the distributor.
- Install the vacuum line.
- Connect the vacuum line.
- Install the rotor and distributor cap.

SPARK PLUG WIRES

Secondary (High Tension) Wires

The secondary wires include the wires connecting the distributor cap to the spark plugs and the wire connecting the center terminal of the distributor cap to the center terminal of the ignition coil.

These wires are the radio resistance-type which filter out the high frequency electrical impulses that are the source of ignition noise interference.

Check ignition wire resistance through the distributor cap. To check the secondary wire resistance, turn the ignition switch "off" and then remove the distributor cap. It is important that the ignition system be "off" to prevent inadvertent engine rotation due to firing of the ignition system.

Do not, under any circumstance, puncture an ignition cable when checking resistance. Do not use a commercial probing device, but measure resistance only from the ends of the wire or the wire terminals inside the distributor cap.

If the resistance of a wire exceeds 5,000 ohms per inch, it should be completely removed from the distributor cap and the resistance measured directly from the wire ends. If the resistance still exceeds 5,000 ohms per inch, the wire should be replaced.

When removing wire from spark plugs, use Tool T74P6666-A or equivalent. (Fig. 17.) Grasp and twist the molded cap back and forth on the plug insulator to free cap. Use the special tool to pull the cap from the plug. Do not pull on the wire directly, or it may become separated from the connector inside the cap.

Whenever a high tension wire is removed for any reason from a spark plug, coil or distributor terminal housing, silicone grease must be applied to the boot before it is reconnected. Using a small clean tool, coat the entire interior surface of the boot with Ford silicone grease D7AZ-19A331-A or equivalent.

Installation

- Insert each wire on the proper terminal of the distributor cap. Be sure the wires are forced all the way down over their terminals. The No. 1 terminal is identified on the cap. Install the wires starting with No. 1. Each spark plug wire is numbered. Cylinders are numbered front to rear, 1-2-3-4.
- Remove the wire retaining brackets from the old spark plug wire set and install them on the new set in the same relative position.
- Connect the wires to the proper spark plugs. Install the coil high tension lead.

DISTRIBUTOR ROTOR AND CAP — (SOLID STATE)

When installing a new distributor cap or rotor, coat the brass rotor electrode surfaces, including the outer edge, with D7AZ-19A331-A silicone grease (or equivalent Dow Corning No. 111 or General Electric G-627 compounds) to approximately 1/16" thickness. Do not reapply or attempt to remove any silicone coating from the distributor cap electrodes. As this compound ages, it has the appearance of being a contaminant of the cap and rotor electrodes. This condition is normal and causes no performance loss.

REPLACING SPARK PLUGS

Removal

- Remove the wire from each spark plug by grasping the molded boot with Tool T74P-6666-A (Fig. 17). Twist the

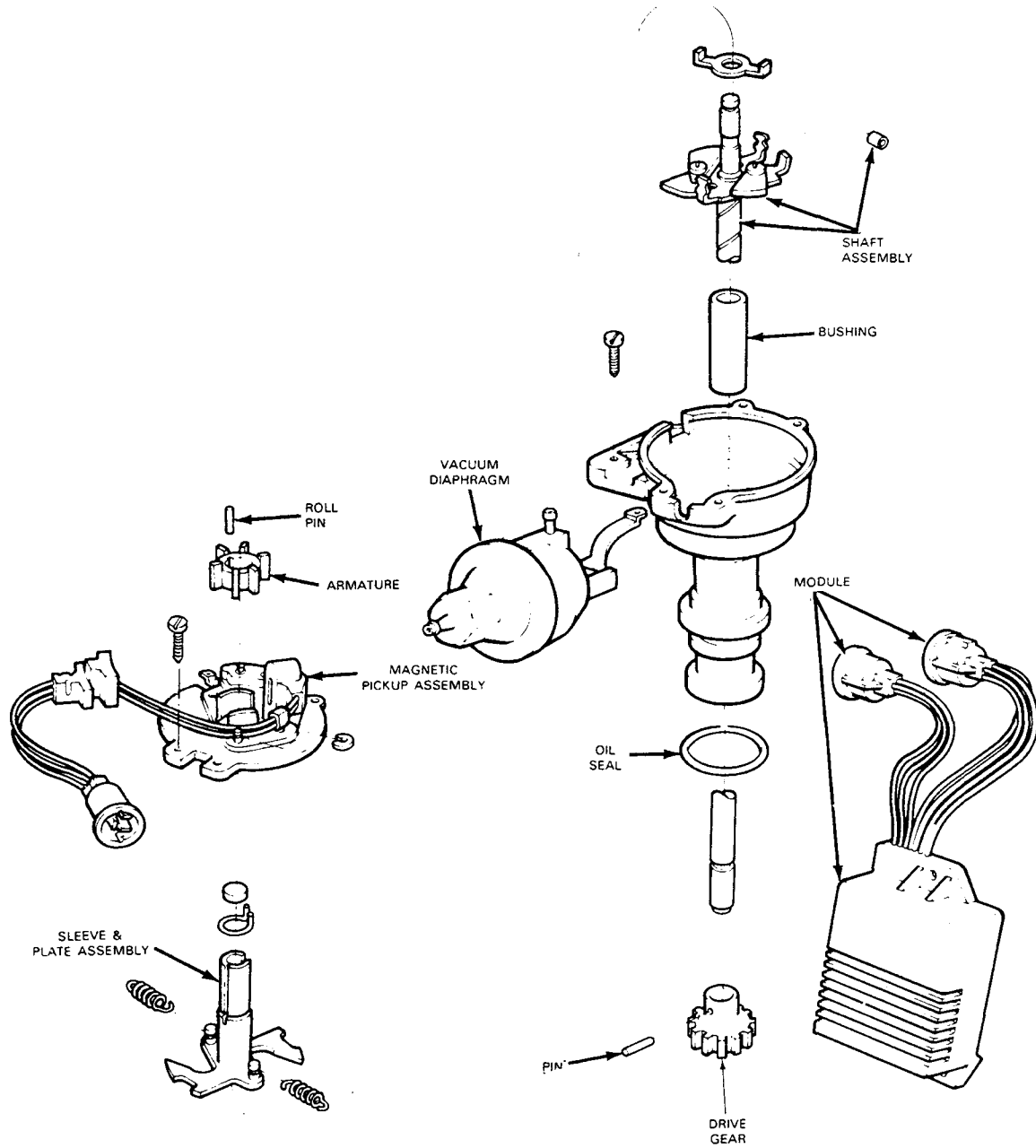

FIG. 16 Distributor (Solid State) — Typical

boot until it loosens and then pull it off the spark plug. Do not pull on the wire, as the connection may become damaged.

- Any wire damaged must be replaced. Each original spark plug wire is numbered for the cylinder to which it is designed. If wires are not numbered, each wire should be numbered as to the plug from which it was removed.
- Clean the area around each spark plug port with compressed air.
- Using the proper size spark plug socket remove the spark plugs.

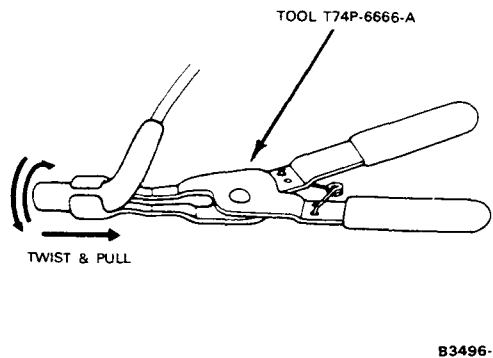

FIG. 17 Removing Wires from Spark Plugs

Installation

- Check the gap on each new spark plug and set to specification, if necessary.
- Install each spark plug and torque to specification.
- Coat the inside of each spark plug boot with silicone grease D7AZ-19A331-A or equivalent, using a small screwdriver blade. Connect each spark plug wire to the plug from which it was removed. Be sure each wire is fully depressed on each plug and molded boot is firmly in place.

CONNECTING TO COIL CONNECTOR FOR TACHOMETER TEST—ALL VEHICLES

The ignition coil connector allows a tachometer test lead with an alligator-type clip to be connected to the DEC (Distributor Electronic Control) terminal without removing the connector (Fig. 18).

When engine rpm must be checked, install the tachometer alligator clip into the "TACH TEST" cavity as shown. If the coil connector must be removed, grasp the wires and pull in the direction of the wires until it disconnects from the terminals.

SPARK PLUG BOOT REPLACEMENT — ALL ENGINES

When it is necessary to replace only the boot on a particular spark plug wire, proceed as follows:

- Cut off the old boot. Apply silicone lubricant D7AZ19A331-A or equivalent to that area of the old wire that will contact the new boot.
- Position the new boot onto Tool T75L-6666-A as shown in Fig. 19.

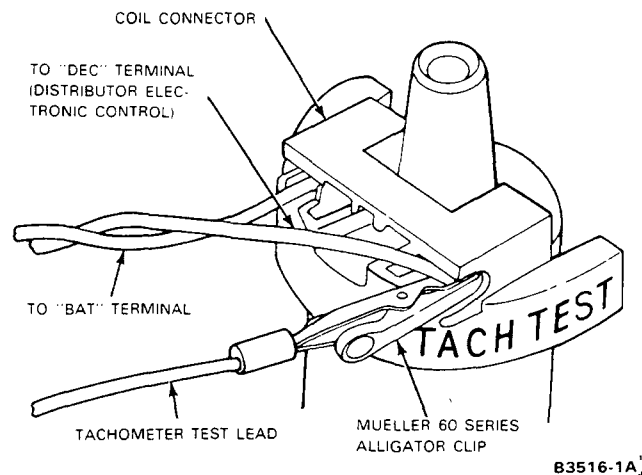

FIG. 18 Attaching Tachometer Lead to Coil Connector

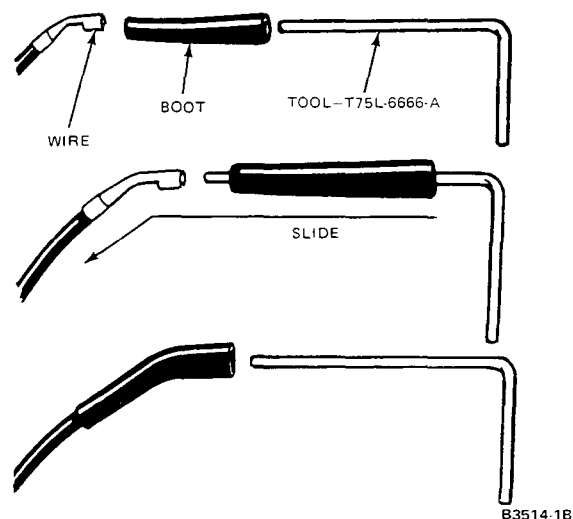

FIG. 19 Installing Spark Plug Wire Boot on Wire

- Position the tool onto the wire terminal and slide the boot onto the wire. Remove the tool from the end of the wire terminal.

CLEANING AND INSPECTION Spark Plugs

Examine the firing ends of the spark plugs, noting the type of deposits and the degree of electrode erosion.

Clean the plugs on a sand blast cleaner, following the manufacturer's instruction. **Do not prolong the use of the abrasive blast as it will erode the insulator and electrodes.**

Examine the plug carefully for cracked or broken insulators, badly pitted electrodes, and other signs of failure. Replace as required.

DISTRIBUTOR

Inspect distributor components to see that all snap rings are in place, and that the magnetic pickup assembly moves freely on the fixed base plate. Blow assembly clean with compressed air. Make sure no filings or metal chips adhere to pickup magnet face.

Distributor Cap

Wipe the distributor cap with a clean, damp cloth. Dry the cap with compressed air. Inspect the cap for cracks, burned contacts, broken carbon button, carbon tracks or dirt or corrosion in the sockets. Replace the cap if it is damaged.

Rotor

Wipe the rotor with a clean, damp cloth. Dry the rotor with compressed air. Inspect the rotor for breaks, cracks, carbon tracks or burns. Replace the rotor if it is corroded or damaged.

On a Solid State Ignition System, when it is necessary to clean a distributor cap or rotor for inspection, or when a new cap or rotor is being installed, silicone grease must be applied as outlined under distributor Rotor and Cap Installation.

Secondary Wiring

Without removing from the engine, inspect the secondary wires for visible damage such as cuts, pinches, cracks or torn boots. Do not remove wires from distributor cap. Replace wires that are damaged. If spark plug boot is damaged, replace it (refer to Spark Plug Boot Replacement—All Engines, in this Part).

Coil

Wipe the coil with a damp cloth and check for any cracks or other defects.

Ignition Resistor Wire

The special ignition resistance wire must be of a specified length and diameter to reduce the operating voltage of the ignition system. Due to its special resistance, under no circumstances should it be replaced by any other wire other than the correct service resistor wire. When a new resistor wire is installed, the old one should be isolated from the system.

PART 3 Fuel System

COMPONENT INDEX	Page	COMPONENT INDEX	Page
IDENTIFICATION	3-01	Idle Speed	3-05
DESCRIPTION	3-01	Idle Mixture	3-06
DIAGNOSIS AND TESTING		Fast Idle	3-06
Pressure Test	3-04	REMOVAL AND INSTALLATION	
Capacity (Volume Test)	3-05	Carburetor	3-06
ADJUSTMENTS	3-05	Fuel Pump	3-06
Float	3-05	DISASSEMBLY AND ASSEMBLY	
Pump Stroke	3-05	Carburetor	3-06

IDENTIFICATION

The carburetor identification tag (Fig. 1) is attached to the upper body of the carburetor. The basic part number for all carburetors is 9510. To procure replacement parts, it is necessary to know the part number prefix and suffix.

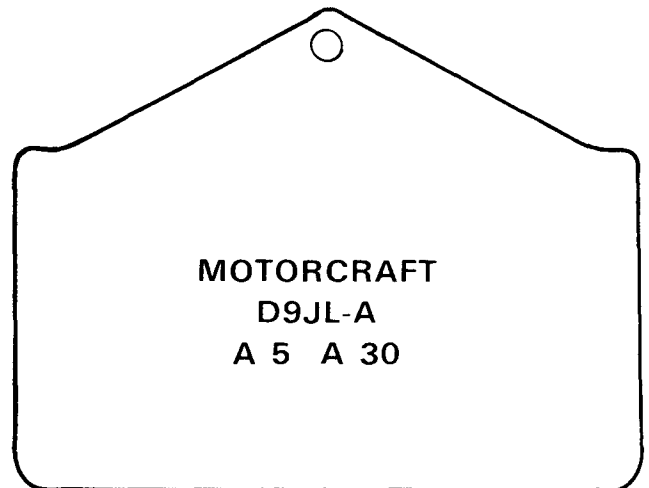

FIG. 1 Carburetor Identification

FUEL SYSTEM DESCRIPTION

The fuel system (Fig. 2) includes a single action fuel pump operated by a lobe on the camshaft. It is a permanently sealed unit and is not repairable.

The fuel filter is the disposable in-line type located in the line between the fuel pump and carburetor.

The carburetor is a Holley, Model 1940, single venturi, downdraft design.

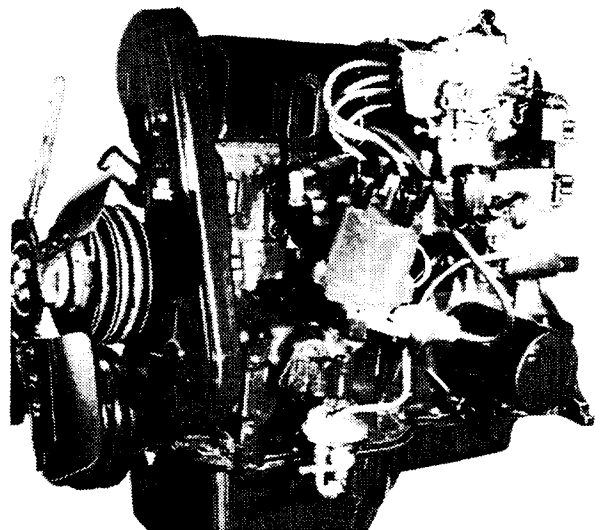

FIG. 2 Fuel Pump and Filter

HOLLEY ONE-BARREL CARBURETOR MODEL 1940

CARBURETOR DESCRIPTION

Three main assemblies make up the Holley Model 1940 one-barrel carburetor: the fuel bowl cover, the main body and the throttle body (Fig. 3).

HOLLEY IV CARBURETOR



FIG. 3 Holley One-Barrel Carburetor—Model 1940

On each carburetor an identification tag is found on the carburetor body. Do not remove this tag for any reason. The numbers stamped on this tag identify the carburetor for the particular engine usage. These numbers are used when finding specifications for carburetor adjustments or in ordering replacement parts.

The fuel bowl cover assembly contains the choke plate and serves as a cover for the fuel bowl. It also houses the accelerator pump piston assembly and the power system vacuum piston (Fig. 4).

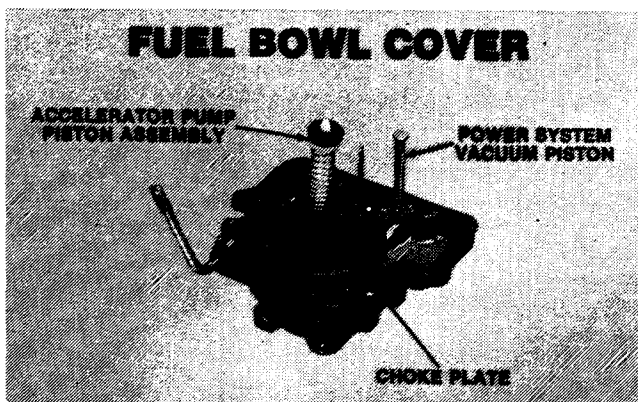

FIG. 4 Model 1940 Fuel Bowl Cover

Found in the main body assembly (Fig. 5) are the main and booster venturis, fuel bowl and dual float assembly, main metering jet, accelerator pump cylinder, power valve, all the jets and most of the fuel passages.

The throttle body assembly (Fig. 6) consists of the throttle plate, idle port, idle transfer slot, idle speed adjustment screw and idle mixture adjustment needle screw.

CARBURETOR SYSTEMS

The Holley 1940 carburetor uses four systems to provide carburetion. Together these four systems vaporize and meter fuel into the proper air/fuel mixture for every

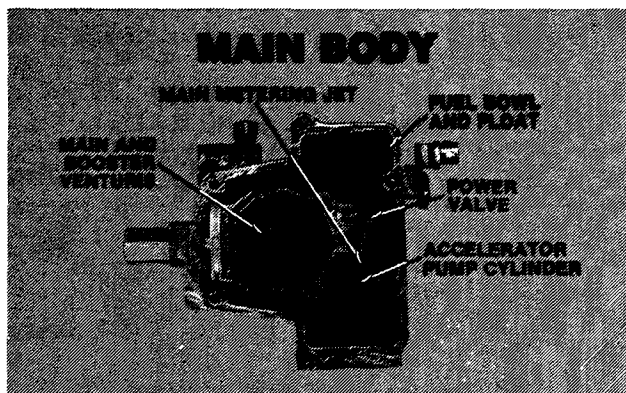

FIG. 5 Model 1940 Main Body

THROTTLE BODY

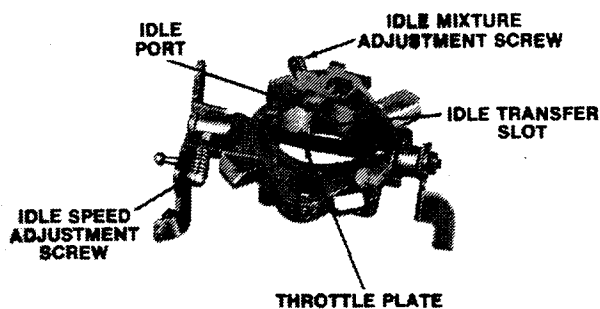

FIG. 6 Model 1940 Throttle Body

mode of engine operation. The four systems are: idle, main metering, accelerator pump, and power enrichment. Two other systems, fuel inlet and choke, supplement these systems.

The idle system provides a reasonably rich mixture for smooth engine idling speed and a transfer system that is in operation during low speeds. The main metering system provides the most economical mixture for normal cruising conditions. The accelerator pump system mechanically supplies additional fuel during acceleration. The power enrichment system provides a richer mixture when high power output is desired. Each of these systems is constantly supplied with fuel by the fuel inlet system.

A choke system provides a rich mixture to start the engine when cold and a slightly richer-than-normal mixture for cold engine operation. The 1940 carburetor is equipped with a manually-operated choke.

FUEL INLET SYSTEM

All fuel enters the fuel bowl through the fuel inlet in the carburetor main body (Fig. 7). The fuel inlet needle has a Viton tip which seats directly into the fuel inlet fitting. The needle is retained by a cap which permits fuel to flow out of holes in the side of the cap. The design of the fuel bowl eliminates the need for a fuel baffle. The fuel inlet needle is controlled by a dual-float assembly with stainless steel levers hinged on a stainless steel float shaft. The floats are made of nitrophenyl, a cellular buoyant material that cannot leak, collapse or become gas-logged.

The fuel inlet system maintains a constant, specified fuel level because the basic fuel metering systems are

calibrated to deliver the proper fuel/air mixture only when the fuel is at this level. When the fuel level in the bowl drops, the float also drops permitting additional fuel to flow past the fuel inlet needle into the bowl.

The float chamber is vented internally into the air horn.

FUEL INLET SYSTEM

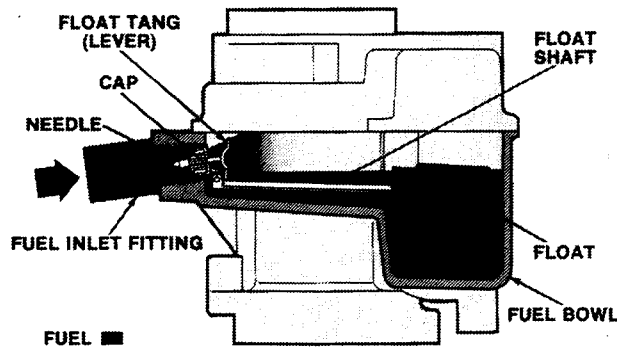

FIG. 7 Model 1940 Fuel Inlet System

IDLE FUEL SYSTEM

Fuel used during idle and low engine speed operation flows through the main metering jet and into the main fuel well (Fig. 8).

An angular connecting idle well intersects the main fuel well. An idle tube is installed in the idle well. Fuel travels into the idle well and through the restriction into the idle tube. The metered fuel is mixed with air entering through the idle air bleed in the fuel bowl cover.

At idle the air/fuel mixture flows down the idle channel. It is mixed or broken up by air entering the idle channel through the transfer slot which is above the throttle plate at idle.

During low speed operation the throttle plate moves, exposing the transfer slot to manifold vacuum, and fuel begins to flow through the transfer slot as well as the idle port. As the throttle plate opens further and engine speed increases, the air flow through the carburetor also increases. The increased air flow creates a vacuum or depression in the venturi and booster nozzle. At this point the main metering system begins to discharge fuel.

IDLE SYSTEM

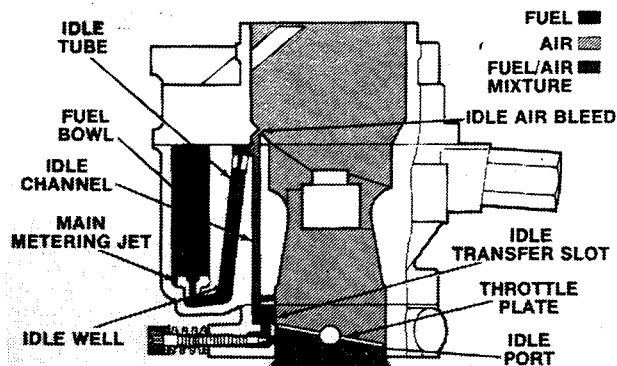

FIG. 8 Model 1940 Idle System

MAIN METERING SYSTEM

In the main metering system, the engine approaches cruising speed (Fig. 9). The air flowing through the venturi increases, thus creating a low pressure area in the carburetor venturi. Fuel in the fuel bowl is at nearly

atmospheric pressure. The low pressure, created by the venturi and magnified by the dual booster venturi, forces the fuel in the fuel bowl to flow through the discharge nozzle.

Fuel flows through the main jet into the main well; air enters through the main well air bleed and into the main well through holes in the main well tube. Because the air/fuel mixture is lighter than raw fuel, it responds faster to venturi vacuum changes and is vaporized more readily when discharged into the venturi.

The main discharge nozzle passage is part of the dual booster venturi, which is an integral part of the main body casting. Some carburetors may have distribution tabs in the main venturi that provide the proper channeling of the air/fuel mixture to the engine cylinders for specific engine applications.

The main metering system is calibrated to deliver the proper mixture for best overall economy. When additional power is required, a vacuum-operated power system enriches the air/fuel mixture.

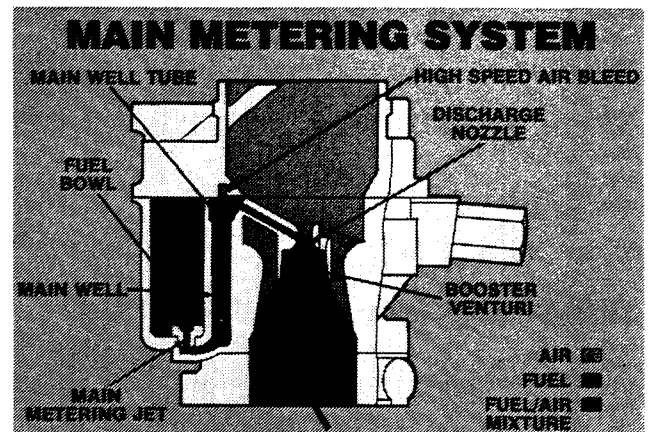

FIG. 9 Model 1940 Main Metering System

POWER FUEL SYSTEM

The power fuel system consists of a power valve installed near the center of the carburetor main body and a vacuum piston installed in the fuel bowl cover (Fig. 10). A vacuum passage leads from the top of the piston down to the manifold flange.

When manifold vacuum is high, the vacuum piston is raised to the top of its cylinder and the spring in the piston is compressed.

POWER ENRICHMENT SYSTEM

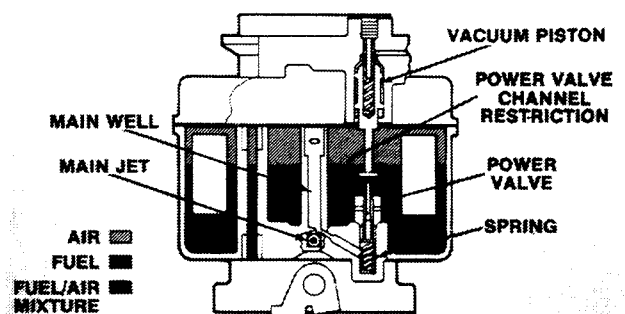

FIG. 10 Model 1940 Power Enrichment System

When manifold vacuum drops to a predetermined level, the spring overcomes the vacuum and pushes the piston stem down. The piston stem, in turn, pushes the power valve down, opening the power valve and permitting fuel to flow through the power valve, through the channel restriction and into the main well located near the power valve.

ACCELERATOR PUMP SYSTEM

Upon sudden opening of the throttle plates, air flow through the carburetor increases almost immediately; however, there is a brief time interval or lag before the fuel can overcome its inertia and attain required flow to maintain the desired air/fuel ratio.

The piston-type accelerating pump system mechanically supplies the fuel necessary to overcome this deficiency for a short period of time.

Fuel enters the pump cylinder from the fuel bowl through the pump cup stem clearance hole when the pump is lifted to a refill position (Fig 11). The fuel level is above the normal position of the pump piston. This is known as a wet pump system.

As the throttle lever is moved, the pump link, operating through a series of levers and a drive spring,

pushes the pump cylinder down, seating the pump cup against the stem face. Fuel is forced through a passage around the pump discharge jet which is drilled in the main body.

When the pump is not in operation, vapors or bubbles forming in the pump cylinder can escape through the stem clearance hole of the floating piston cup and flow past the pump stem.

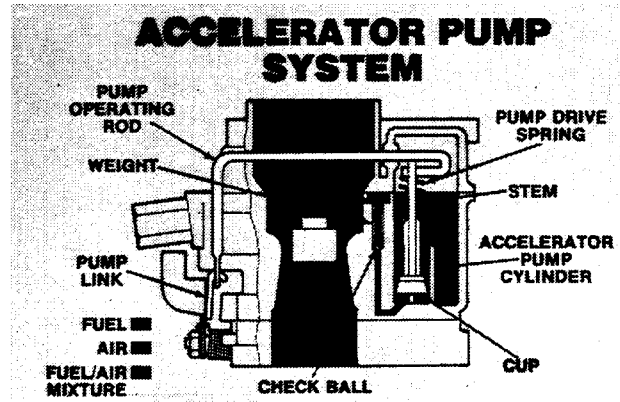

FIG. 11 Model 1940 Accelerator Pump System

DIAGNOSIS AND TESTING

To determine that the fuel pump is in satisfactory operating condition, tests for both fuel pump pressure and fuel pump capacity (volume) should be performed.

The tests are performed with the fuel pump installed on the engine and the engine at normal operating temperature at idle speed.

Before the tests, make sure the replaceable fuel filter has been changed within the recommended maintenance mileage interval. When in doubt, install a new filter.

PRESSURE TEST

Refer to the fuel pump specification in this Part, and note the fuel pump pressure and capacity (volume) design tolerances.

1. Remove the air cleaner assembly. Disconnect the fuel inlet line or the fuel filter at the carburetor. **Use care to prevent combustion due to fuel spillage.**
2. Connect a pressure gauge, a restrictor and a flexible hose (Figure 12) between the fuel filter and the carburetor.

NOTE: Inside diameter of smallest passage in test flow circuit must not be smaller than .220.

3. Position the flexible fuel outlet hose and the restrictor so the fuel can be discharged into a suitable, graduated container (Figure 12).

4. Before taking a pressure reading operate the engine at the specified idle rpm and vent the system into the container by opening the hose restrictor momentarily.
5. Close the hose restrictor and the pump to tank return line, allow the pressure to stabilize, and note the reading. Refer to the Specifications Section.

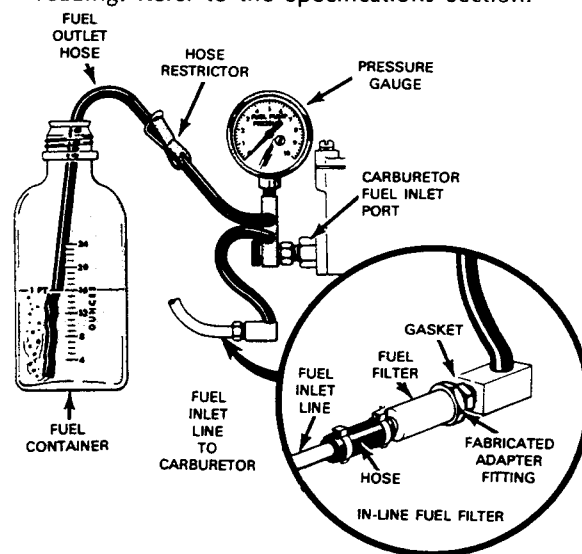

82630-B

FIG. 12 Typical Fuel Pump Pressure and Capacity Test Equipment

If the pump pressure is not within specifications, and the fuel lines and filter are in satisfactory condition, the pump is defective and should be replaced.

If the pump pressure is within specifications, perform the tests for fuel capacity (volume).

CAPACITY (VOLUME) TEST

With the fuel pump pressure within specifications, test the capacity (volume) as follows:

1. Operate the engine at the specified idle rpm.

2. Open the hose restrictor and expel the fuel into the container (Figure 12), while observing the time required to expel one pint. Close the restrictor. One pint or more of fuel should be expelled with the specified time limit.

If the pump volume is below specifications, repeat the test using an auxiliary fuel supply and a new fuel filter. If the pump volume meets specifications while using the auxiliary fuel supply, check for a restriction in the fuel supply from the tank and for the tank not venting properly.

ADJUSTMENTS

There are four adjustable items on the Holley Model 1940. They are idle speed, idle mixture, pump piston stroke and float adjustment. The entire carburetor assembly is to be removed from the intake manifold to perform a float level adjustment. The pump piston stroke adjustment is made by expanding or contracting a 'U' adjustment bend in the accelerator pump linkage. Idle speed adjustment is performed by turning the idle speed screw with the engine at normal operating temperature. Idle mixture adjustment is performed by turning the idle mixture screw with the engine at normal operating temperature.

FLOAT ADJUSTMENT

To perform the float adjustment, the entire carburetor assembly must be removed from the intake manifold and all connections to the carburetor disconnected. Remove the fuel bowl cover from the carburetor main body assembly and drain the fuel from the fuel bowl. Invert the carburetor assembly. Place a straight-edge across the surface of the fuel bowl (Fig. 13). The toes of the floats (the portion of the float that hangs farthest from the fuel inlet) should just lightly touch the straight-edge. To adjust, bend the float tang (lever). Both floats must be parallel to the straight-edge and not cocked or offset. Bend the float shafts to even out the floats. Recheck float level. **CAUTION: When bending the tang, do not force the Viton-tipped fuel inlet needle against the seat or the Viton tip on the needle will be damaged.**

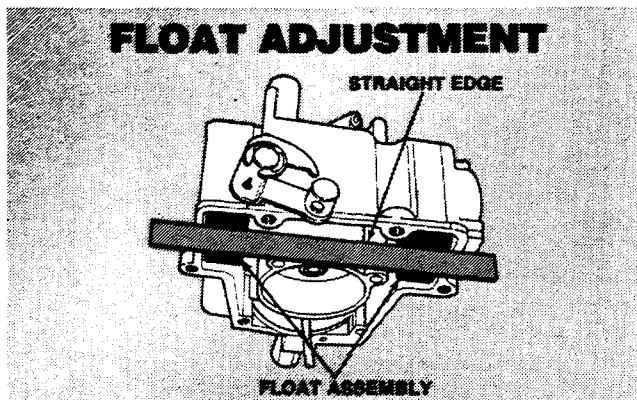

FIG. 13 Model 1940 Float Adjustment

PUMP PISTON STROKE ADJUSTMENT

The accelerating pump stroke is controlled by the position of the accelerating pump link in one of the three slots of the rocker arm. Use the specified slot for the carburetor application.

Proper positioning of the linkage is controlled by the link. Back off the idle speed adjusting screw and close the throttle late. Measure the distance from the vacuum passage casting in the carburetor main body to the center of the hole in the upper pump linkage which connects with the links (Fig. 14). If not to specification, increase the distance by expanding the "U" in the link or contract the "U" to decrease the distance. Place the idle speed screw in the proper position.

PUMP PISTON STROKE ADJUSTMENT

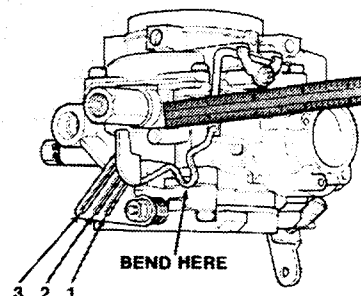

FIG. 14 Model 1940 Pump Piston Stroke Adjustment

IDLE SPEED ADJUSTMENT

Idle speed adjustment is performed with the engine air cleaner in place. The engine must be run at fast idle for 5-10 minutes or until normal operating temperature is reached. The idle speed screw is found in the throttle body (Fig. 6). The tip of the screw rests on a tang on the outer throttle shaft assembly to control engine idle speed. Make sure the screw is in contact with this tang when setting engine idle speed. Connect a tachometer to the engine and turn the idle speed screw until engine speed is at specifications. Turn the screw "in" to increase idle speed. Turning the screw "out" decreases idle speed. After each adjustment, pull back on the throttle lever and release. Engine idle speed should increase and then return to normal on release. Reset if necessary.

IDLE MIXTURE ADJUSTMENT

Idle mixture adjustment is performed with the air cleaner in place. The engine must be run 5-10 minutes at a fast idle speed or until normal operating temperature is reached. Make sure engine idle speed is at specifications.

The idle mixture adjusting screw is found in the throttle body (Fig. 6). The needle tip of this screw is not exposed to view as it is seated in the throttle body. With the engine off, turn the idle mixture adjustment screw "in" until it is lightly seated. Back out screw two turns. Start the engine. Turn the screw "in" until the engine begins to run rough or stumble due to a lean mixture. Slowly turn the

needle out until the engine begins to "roll" due to a rich mixture. Slowly turn the needle "in" to a point between the two extremes until the engine runs smoothly. Always favor a slightly rich setting rather than a lean setting.

Recheck idle speed. Adjust if necessary.

FAST IDLE ADJUSTMENT

Run the engine until normal operating temperature is reached. Attach tachometer to engine. Pull manual choke control to fastest engine speed setting. Adjust fast idle speed screw until specified engine speed is reached. Disconnect tachometer.

REMOVAL AND INSTALLATION

CARBURETOR

REMOVAL

1. Remove the air cleaner.
2. Disconnect the fuel inlet line and distributor vacuum hose.
3. Disconnect the carburetor throttle linkage. Disconnect choke cable.
4. Remove carburetor retaining nuts and lift off carburetor.
5. Remove and discard carburetor gasket.

Installation

1. Install new carburetor gasket and mount carburetor. Secure with retaining nuts.
2. Connect throttle linkage and the choke cable. Check operation of throttle and choke for full travel.

3. Connect fuel line and distributor vacuum line.
4. Start engine and adjust idle speed and idle fuel mixture.
5. Install the air cleaner.

FUEL PUMP

Removal

1. Disconnect the fuel inlet, outlet and fuel tank return lines at the fuel pump.
2. Remove fuel pump retaining screws. Lift off pump and gasket.

Installation

1. Place new gasket on pump and position pump on cylinder block. Install retaining screws.
2. Connect fuel inlet, outlet, and fuel tank return lines.

DISASSEMBLY

The Model 1940 carburetor is assembled of three major sub-assemblies. These assemblies are the air horn or bowl cover, carburetor body assembly and throttle body assembly. Servicing of the carburetor can be simplified if these sub-assemblies are disassembled and kept together in their respective groups.

1. Remove nut and lockwasher retaining the pump rocker arm and pump link.
2. Remove the bowl cover screws.
NOTE: The position of the link in the rocker arm slots and the position of the throttle return spring or the positive throttle return spring on some model applications for proper reassembly (Fig. 15).
3. Separate the bowl cover from the carburetor body. **Do not pry.** Tap gently from side to side with a plastic hammer or screwdriver handle.
4. Remove the accelerating pump operating rod retainer screw and retainer.
5. Rotate the pump operating rod and disconnect the pump drive spring and accelerating pump assembly (Fig. 16). Set the pump assembly aside. Do not immerse in cleaner. A new pump cup is in the kit.

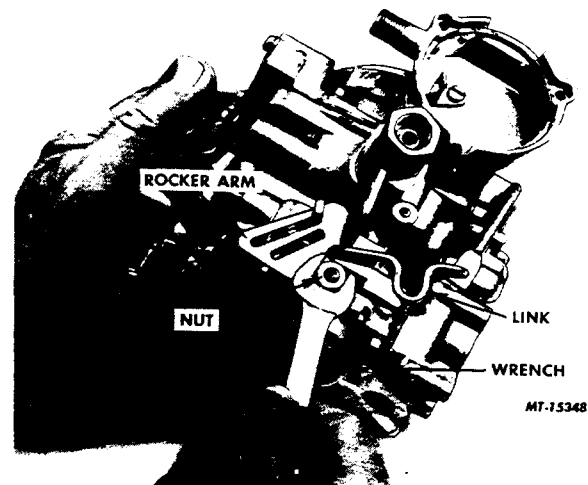

FIG. 15 Remove or Install Accelerator Pump Rocker Arm

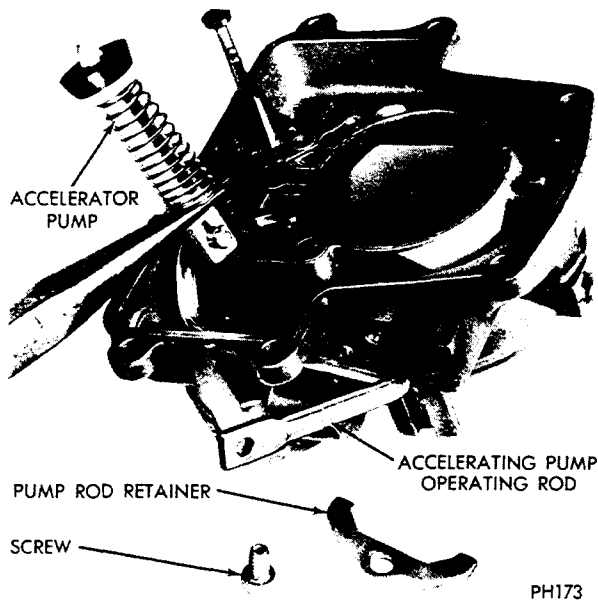

FIG. 16 Remove or Install Accelerator Pump Assembly

6. Rotate the pump operating rod and remove the rod and grommet from the bowl cover (Fig. 17).

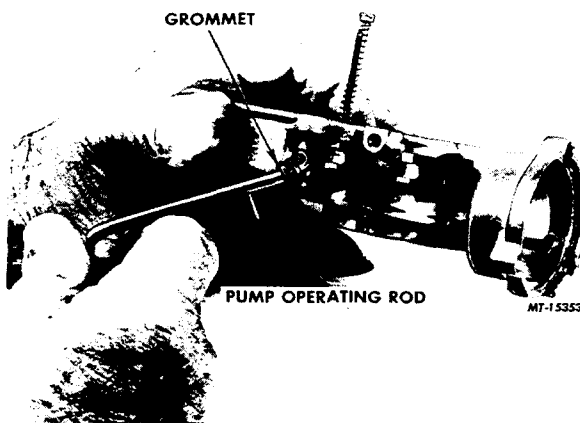

FIG. 17 Remove or Install Accelerator Pump Operating Rod and Grommet

7. With a bearing scraper or a scraper ground from an old triangle file remove all the staking from the vacuum piston retainer (Fig. 18).
With a suitable puller or long-nosed pliers and support, remove the vacuum piston assembly (Fig. 19).
9. Remove bowl vent valve from rod if so equipped. The rod cannot be removed.
10. Remove hot idle compensator valve cover, valve and gasket from cover, if so equipped.

This normally completes disassembly of the bowl cover. If the carburetor is equipped with a mechanical power valve modulator rod, it cannot be removed.

CAUTION: Unless the choke valve is bent or damaged **DO NOT REMOVE** the choke valve screws, valve or shaft for normal service.



FIG. 18 Remove Staking from Vacuum Piston Retainer

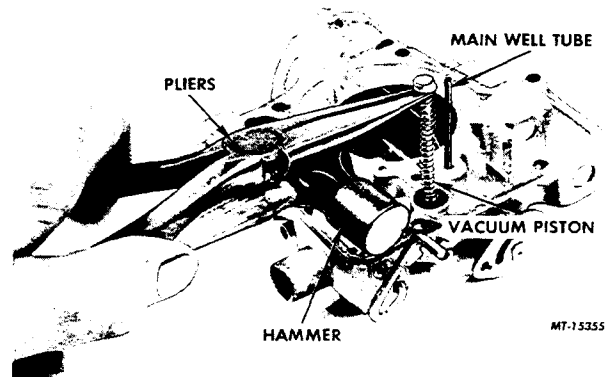

FIG. 19 Removing the Vacuum Piston Assembly

CARBURETOR BODY DISASSEMBLY

1. Turn the carburetor body upside down and remove the pump discharge ball and weight (Fig. 20). Save the old ball in case the seat needs staking (Fig. 25).

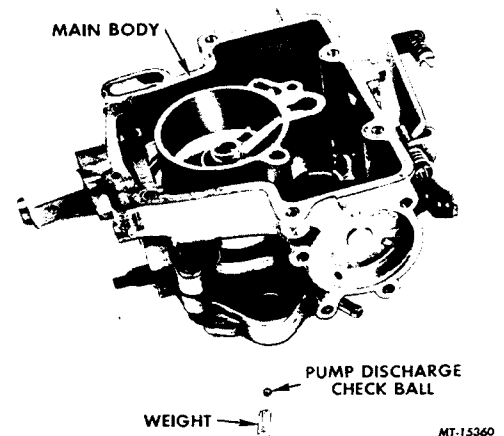

FIG. 20 Remove or Install the Pump Discharge Ball and Weight

- Remove the fuel inlet valve and fitting assembly; remove gasket. Remove spring float shaft retainer, float shaft and float (Fig. 21).

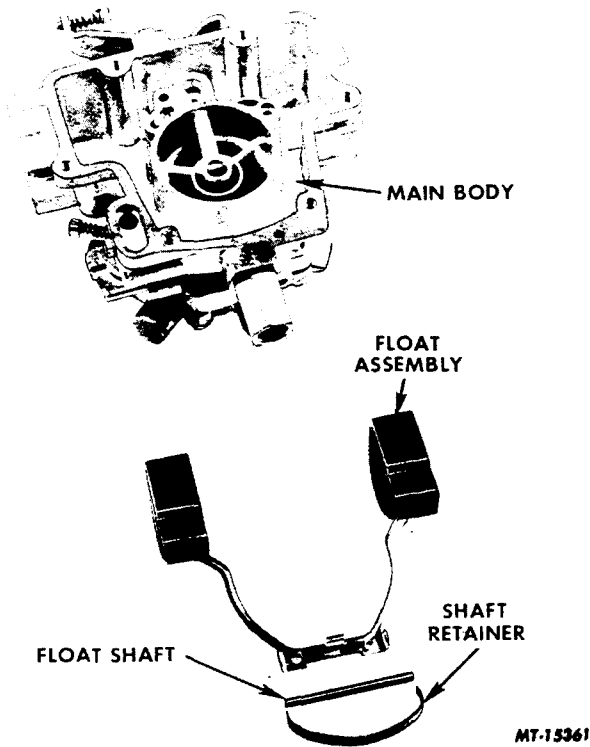

FIG. 21 Remove or Install the Float Assembly

- Remove the main jet with a jet wrench. A 3/8" wide square point screwdriver may be used (Fig. 22).
- Remove the power valve assembly with a proper socket or a 3/8" wide screwdriver blade with a 1/16" x 3/8" deep slot sawed in the center of the blade. The slot will clear the power valve stem and prevent damage (Fig. 23).

This completes the disassembly of the carburetor body. Remove the three carburetor body to throttle body screws. Tap gently and separate the throttle body from the main body.

CLEANING

Clean all parts in a carburetor cleaning solvent or denatured alcohol. Do not place rubber or plastic parts in the cleaning solution. During cleaning the bowl cover should be placed on top of the other parts in the basket with the main well tube projecting upward and protected. It is a part of the bowl cover and cannot be replaced. Blow out passages with low pressure air.

ASSEMBLY

Except for the following vacuum piston staking operation (Fig. 24), and testing the pump discharge valve (Fig. 25), reassembly is the reverse of disassembly.

NOTE: Before installing the vacuum piston assembly, be sure to remove all previous staking from the retainer recess. Install the piston in the vacuum cylinder and stake lightly with a suitable tool.

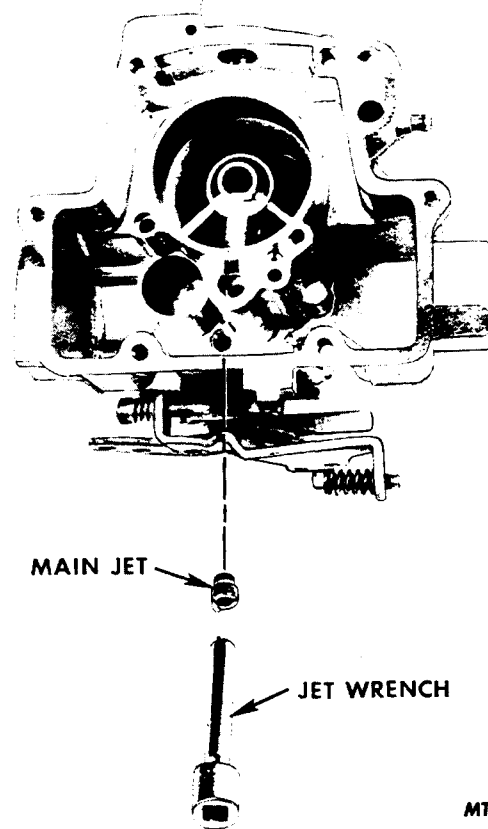

FIG. 22 Remove or Install Main Jet

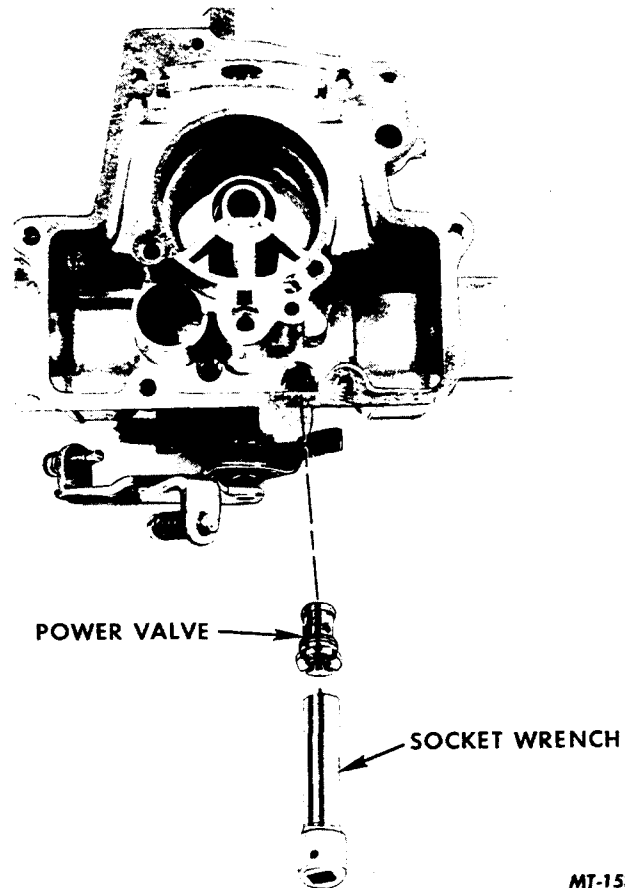
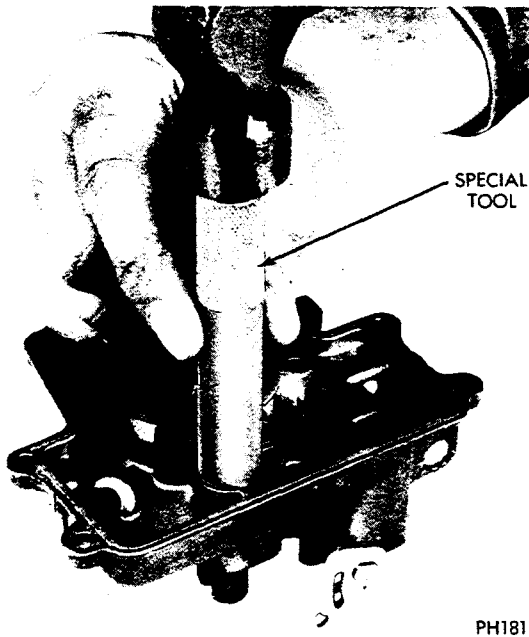

FIG. 23 Remove or Install Power Valve



PH181

FIG. 24 Staking the Vacuum Piston

Test the pump discharge valve prior to assembly by filling the pump cylinder with clean fuel. Hold the pump discharge ball and weight down with a small punch or drift and operate the pump plunger by hand. If the valve and seat are leaking, fuel will rise around the valve weight and spill over (Fig. 25).

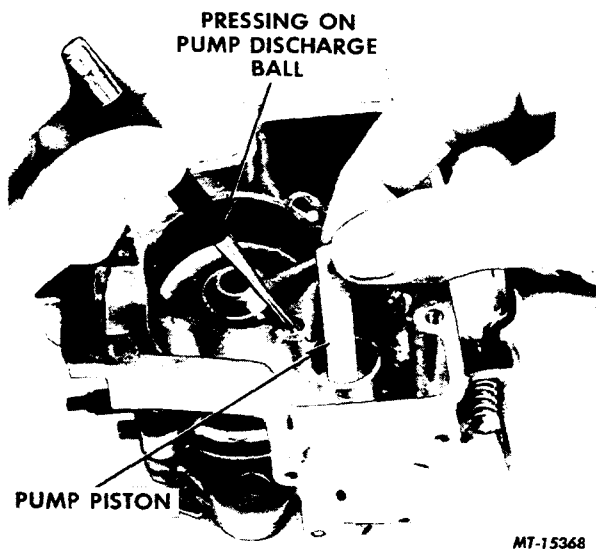

MT-15368

FIG. 25 Testing the Accelerator Pump System

ADJUSTMENTS DURING ASSEMBLY

Assemble the throttle body, and assemble the throttle body to the main body. Use a new gasket and torque the screws to 30 in-lbs. in three even steps. Install the main jet and power valve with the proper tools.

If the valve is leaking remove the hexagon weight and lightly stake the seat with the old ball using a suitable punch or drift. Throw the old ball valve away and install the new ball from the kit, at the proper time during reassembly.

Install the float shaft in the float lever and insert assembly in the float shaft cradle. Insert the retaining spring.

Install a new gasket on the new fuel inlet valve (needle and seat).

Hold the retaining spring with the fingers and invert the bowl. A straight-edge placed across the surface of the bowl should just touch the toes of the float (the portion of the float that hangs farthest from the fuel inlet). If necessary, bend the float tang to obtain this adjustment (Fig. 26). Complete the reassembly.

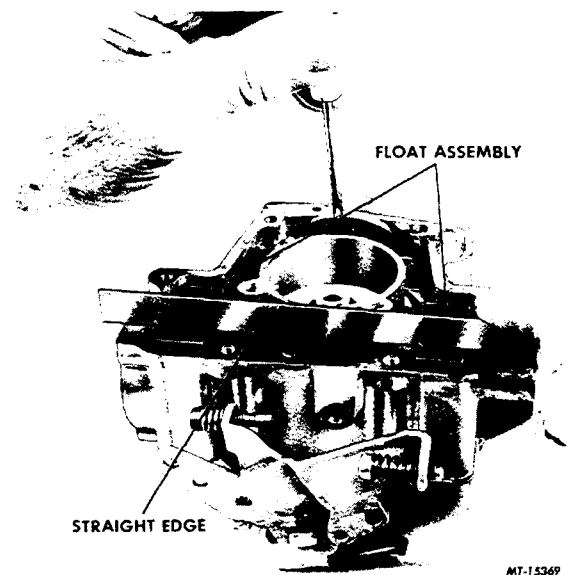

MT-15369

FIG. 26 Testing Dry Float Adjustment

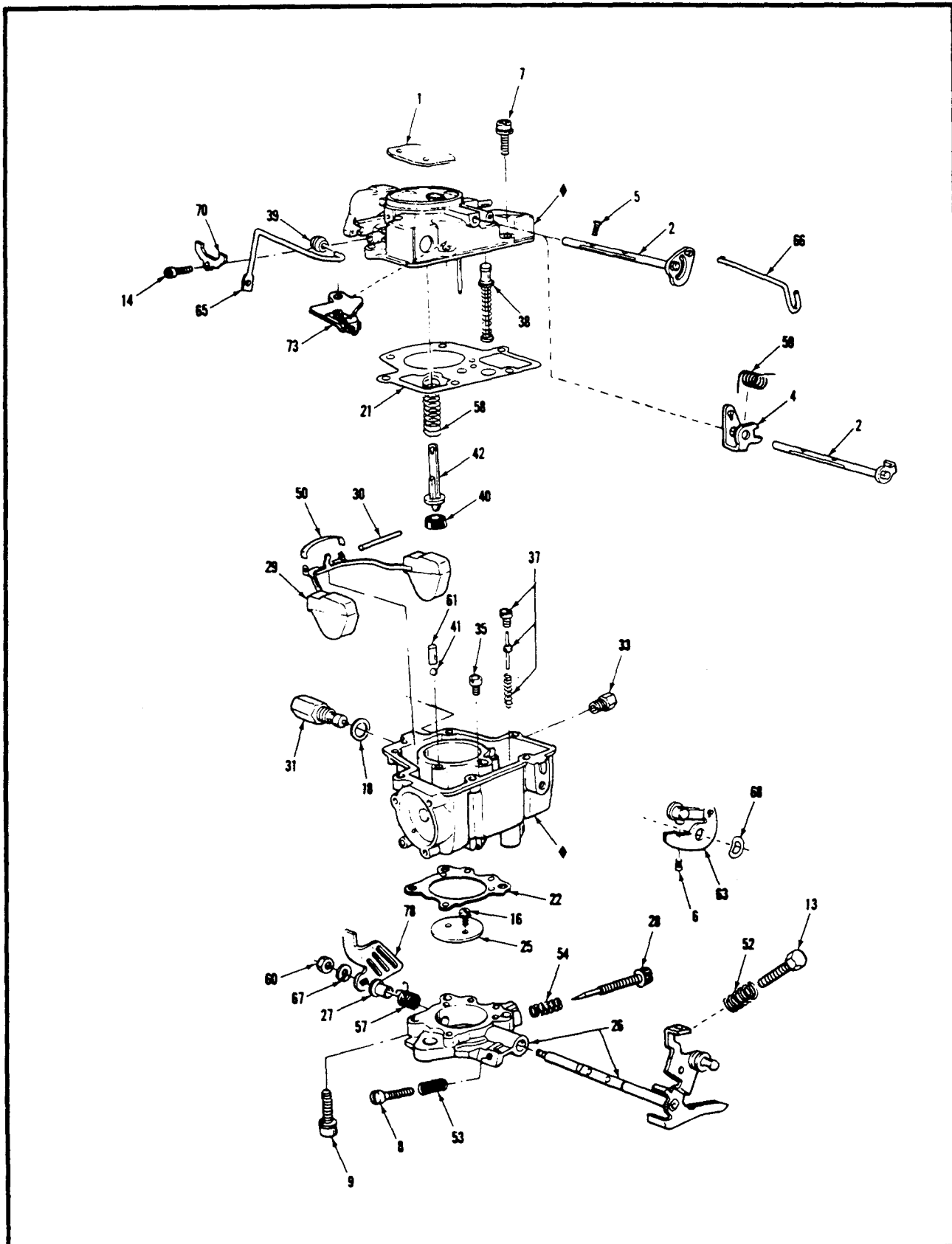

See Service Parts List for items not illustrated here.

Parts having ♦ designation are not available for service.

FIG. 27 Holley One-Barrel Carburetor — Model 1940 (Exploded View)

INDEX NUMBER	PART NAME	INDEX NUMBER	PART NAME
	Air Horn & Plugs Assembly	37	Power Valve Assembly
1	Choke Plate	38	Power Valve Piston Assembly
2	Choke Shaft & Lever Assembly	39	Pump Rod Seal
4	Choke Control Lever	40	Pump Piston Cup
5	Choke Plate Screw	41	Pump Discharge Valve
6	Fast Idle Cam Swivel Screw	42	Pump Piston Stem
7	Air Horn to Main Body Screw & L.W.	50	Float Shaft Retainer
8	Throttle Adjusting Screw	52	Fast Idle Adjusting Screw Spring
9	Throttle Body to Main Body Screw & L.W.	53	Throttle Adjusting Screw Spring
13	Fast Idle Adjusting Screw	54	Idle Adjusting Needle Spring
14	Pump Rod Clamp Screw	57	Throttle Return Spring
16	Throttle Plate Screw	58	Pump Drive Spring
	Main Body & Plugs Assembly	59	Choke Lever Spring
18	Fuel Inlet Seat Gasket	60	Pump Operating Lever Nut
21	Main Body Gasket	61	Pump Discharge Valve Weight
22	Throttle Body Gasket	63	Fast Idle Cam & Swivel Assembly
25	Throttle Plate	65	Pump Rod
26	Throttle Body Shaft Assembly	66	Fast Idle Rod
27	Throttle Return Spring Bushing	67	Pump Operating Lever Nut L.W.
28	Idle Adjusting Needle	68	Spring Washer
29	Float & Hinge Assembly	70	Pump Rod Clamp
30	Float Hinge Shaft	78	Pump Operating Lever
31	Fuel Inlet & Needle Seat Assembly	**	Fuel Inlet Fitting
33	Spark Fitting	79	Fast Idle Cam Retainer
35	Main Jet		

PART 4 Charging System

COMPONENT INDEX	Page	COMPONENT INDEX	Page
DESCRIPTION AND OPERATION		Bench Test	4-06
Alternator	4-01	ADJUSTMENTS	
DIAGNOSIS AND TESTING		Belt Adjustments.....	4-08
MOTOROLA	4-02	REMOVAL AND INSTALLATION.....	4-08
DIAGNOSIS AND TESTING		OVERHAUL.....	4-08
FORD ALTERNATOR		MOTOROLA	4-08
On Engine Test	4-03		

DESCRIPTION AND OPERATION

ALTERNATOR

The Alternator charging system is a negative ground system, and consists of an alternator, a regulator, a charge indicator, a storage battery, and associated wiring.

The alternator is belt driven from the engine. Current is supplied from the alternator-regulator system to the rotating field of the alternator through two brushes to two slip rings.

The alternator produces power in the form of alternating current. The alternating current is rectified to direct current by six diodes. The alternator regulator automatically adjusts the alternator field current to maintain the alternator output voltage with prescribed limits to correctly charge the battery.

If a charge indicator lamp is used in the charging system (Fig. 1), the system operation is as follows: When the ignition switch is turned ON, a small electrical current flows through the lamp filament (turning the lamp ON)

and through the alternator regulator to the alternator field. When the engine is started, the alternator field rotates and produces a voltage in the stator winding. When the voltage at the alternator stator terminal reaches about 3 volts, the regulator field relay closes. This puts the same voltage potential on both sides of the charge indicator lamp causing it to go out. When the field relay has closed, current passes through the regulator A terminal and is metered to the alternator field.

If an ammeter is used in the charging system (Fig. 2), the regulator I terminal and the alternator stator terminal are not used. When the ignition switch is turned ON, the field relay closes and electrical current passes through the regulator A terminal and is metered to the alternator field. When the engine is started, the alternator field rotates causing the alternator to operate. The ammeter indicates current flow into (charge) or out of (discharge) the vehicle battery.

The 2.3 engine uses either a Ford alternator or a Motorola alternator. Most of this section applies to the Ford alternator, because the Motorola unit is serviced by them.

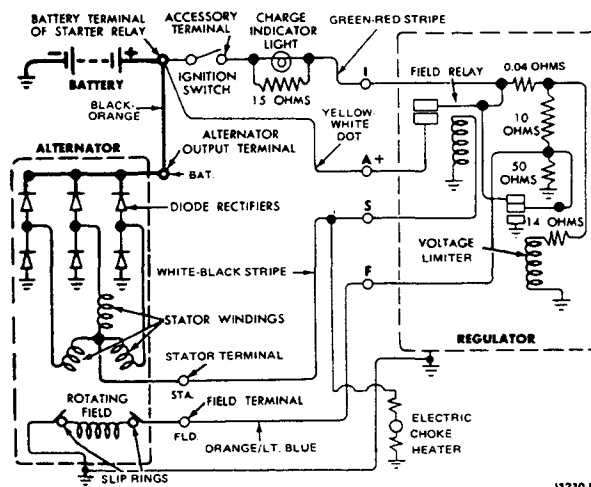

FIG. 1 Alternator Charging System — Indicator Light

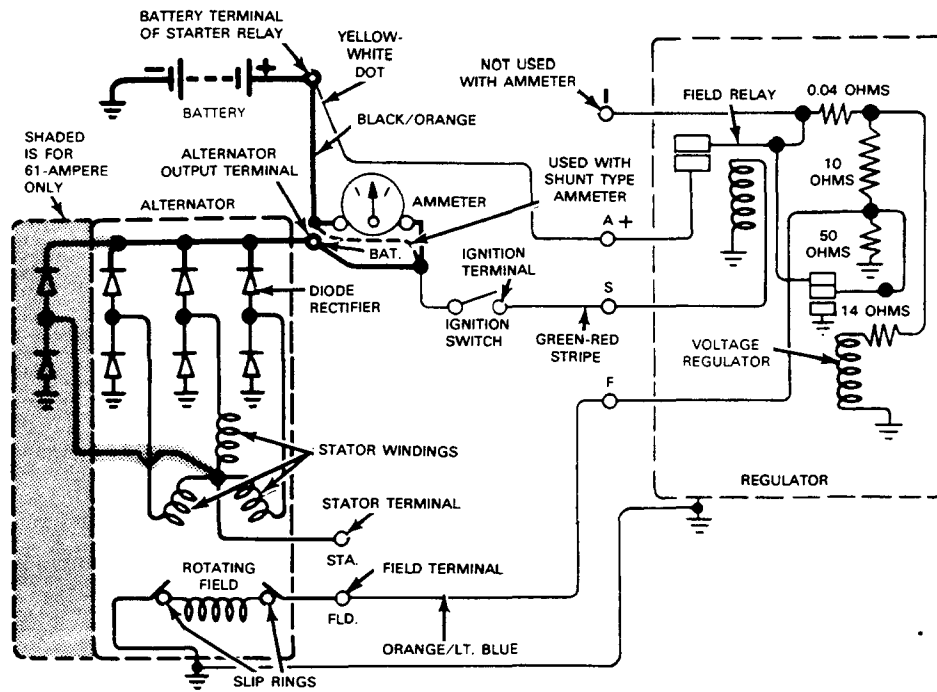

FIG. 2 Alternator Charging System — Ammeter

J1205-J

DIAGNOSIS AND TESTING —

MOTOROLA

Before performing charging system tests on the engine, note the complaint such as: slow cranking, battery dead or using an excessive amount of water, top of battery wet, ammeter shows charge at all times and/or never goes out. This information will aid in isolating the part of the system causing the problem. The battery must be in proper state of charge (at least 1.200 specific gravity).

The following tests are made with the alternator in the engine with output and regulator connections maintained to the alternator except as noted in Steps 3 and 5. The field lead and voltage regulator are disconnected for these tests.

Test precautions:

- DO NOT disconnect alternator output lead while alternator is operating.
 - DO NOT disconnect voltage regulator while alternator is operating.
 - DO NOT ground field terminal.
 - Check battery condition. Use a fully charged battery when testing alternator.
 - Disconnect ground cable of battery when removing and installing the alternator.
- All readings indicated are for correct operation.

TEST 1 — IGNITION ON — ENGINE NOT RUNNING (Refer to Fig. 3)

Correct voltage at regulator terminal is approximately 1.5 to 2.5 volts. This test evaluates excitation circuit.

- If voltage at regulator terminal is:
 - 5.0 to 7.0 volts = open rotor (field circuit)
 - .75 to 1.1 volts = grounded rotor circuit
 - 8.5 to 10.0 volts = open in regulator's load circuit
 - 0 volts = open ignition switch or excitation resistor
- If test results are uncertain, make Test 2.

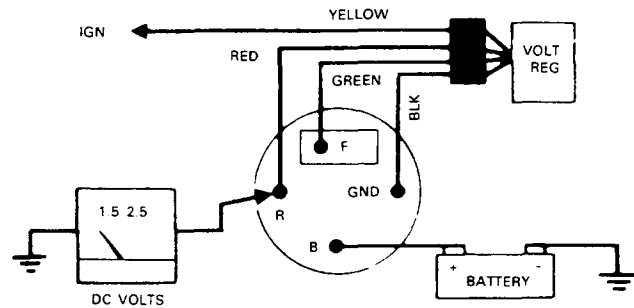

FIG. 3 Ignition On — Engine Not Running

TEST 2 — IGNITION ON — ENGINE NOT RUNNING (Refer to Fig. 4)

The voltage regulator may be bypassed with a short jumper between the regulator and field terminals. If jumper provides approximate correct voltage, fault is in the regulator. No change from high voltage indicates that the defect is in the brush or rotor circuit.

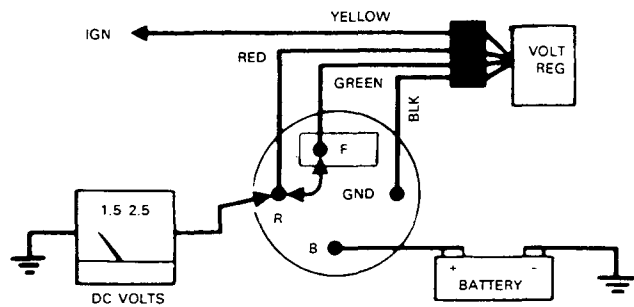

FIG. 4 Ignition On — Engine Not Running

TEST 3 — FIELD DRAW TEST — IGNITION OFF (Refer to Fig. 5)

This test evaluates complete field circuit, independent of voltage regulator. Circuit is through brushes, slip rings, field coil to ground. Current should be 2 to 2.5 amps. If less than this, check brushes and slip rings. It is desirable to use a field rheostat in series with meter for protection of the meter. If field is shorted, excessive current would flow through meter and possible damage would result.

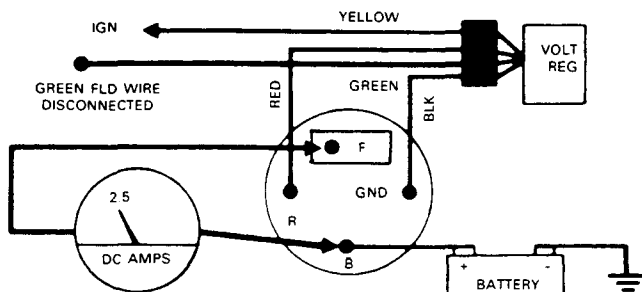

FIG. 5 Field Draw Test — Ignition Off

TEST 4 — IGNITION ON — ENGINE RUNNING AT FAST IDLE (Refer to Fig. 6)

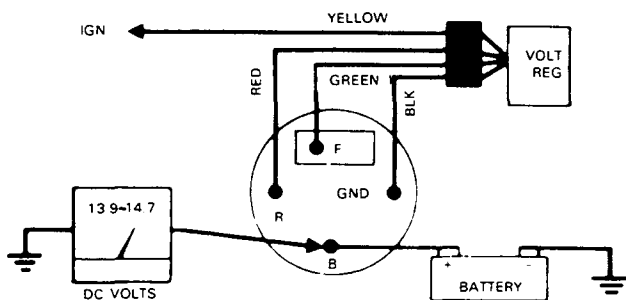

FIG. 6 Ignition On-Engine Running at Fast Idle

Voltage indicated is usually 13.9 to 14.7 volts depending on regulator ambient temperature. High voltage may be due to a poor ground connection. If ground connection is not faulty, regulator will require replacement.

TEST 5 — FIELD TERM DISCONNECTED VOLTAGE REGULATOR PLUG DISCONNECTED BATTERY TERMINAL SHORTED TO FIELD TERMINAL IGNITION ON — ENGINE RUNNING AT IDLE

This test isolates defect to either the alternator or regulator. If voltage at auxiliary terminal rises to 15-16 volts now, when it did not in Test 4 with regulator connected, then defect is in regulator and it should be replaced. If voltage does not rise at auxiliary terminal, defect is in alternator stator or rectifier diodes, if field circuit checked out properly. For defects in stator or diodes, remove alternator.

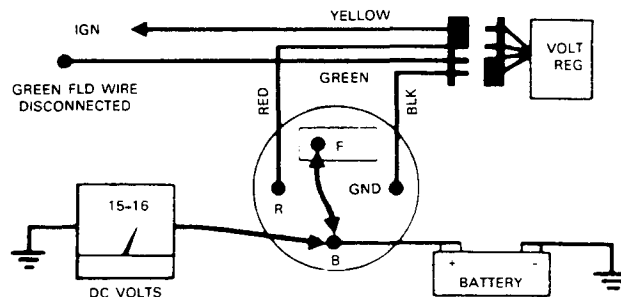

FIG. 7 Field Term Disconnected Volt Reg. Plug Disconnected Bat. Term. Shorted to Fld. Term. Ignition On — Engine Running at Idle

DIAGNOSIS AND TESTING

FORD ALTERNATOR

Certain tests outlined are illustrated in the schematic and in pictorial form. The schematic illustrates the internal connections of the Rotunda equipment so these connections can be duplicated when this equipment is not available. The various circuits involved in the tests can be selected by means of switches without the necessity of changing connections when the illustrated equipment is used. This reduces the time required to test units and circuits on the vehicle.

Where applicable, the tests are divided into On The Engine and On the Test Bench procedures. Either procedure can be followed depending on the equipment available for the tests.

Troubleshooting or diagnosis is required before actual repairs can be made in the electrical system. Even where an obvious fault makes the replacement of a unit necessary, you must still find out why the unit failed. When a trouble is diagnosed correctly, unnecessary repairs are prevented, the time the engine is out of service will be

decreased, and the repairs that are made will be permanent.

ON ENGINE TESTS

Before performing charging system tests on the engine, note the complaint such as: slow cranking, battery dead or using an excessive amount of water, top of battery wet, ammeter shows charge at all times and/or no charge, alternator warning lamp does not come on and/or never goes out. This information will aid in isolating the part of the system causing the problem. The battery must be in proper state of charge (at least 1.200 specific gravity).

Visual Inspection

1. Check the battery posts and battery cable terminals for clean and tight connections. Remove the battery cables (if corroded), clean and install them securely.
2. Check for clean and tight wiring connections at the alternator, regulator and engine.
3. Check the alternator belt tension and tighten to specification (if necessary).

INDICATOR LIGHT — ALTERNATOR CHARGING SYSTEM

Normal Charge Indicator

With Ignition switch off . . . alternator lamp is off.

With ignition switch on (engine not running . . . alternator lamp is on.

With ignition switch on (engine running) . . . alternator lamp is off.

1. If the charge indicator lamp does not come on with the ignition key in the ON position and the engine not running, check the I wiring circuit for an open circuit or burned out charge indicator lamp (ignition switch to regulator I terminal).
2. If the charge indicator light does not come on, disconnect the wiring plug connector at the regulator and connect a jumper wire from the I terminal of the regulator wiring plug to the negative battery post cable clamp.
3. The charge indicator lamp should go on with the ignition key turned to the ON position.
4. If the charge indicator bulb does not go on, check the bulb for continuity and replace (if burned out).
5. If the bulb is not burned out, an open circuit exists between the ignition switch and the regulator.

A good indication of a problem in the I wiring circuit (ignition switch to regulator I terminal) will show when the charge indicator light goes out with high engine rpm. This is caused by an open circuit in the 15 ohm resistor wire (connected in parallel with the indicator light) generally at the terminal point (either end of the resistor wire).

AMMETER-ALTERNATOR CHARGING SYSTEM

Normal Charge Indicator

With ignition switch off and no electrical load . . . ammeter should show 0 or center scale.

With ignition switch on and engine running . . . needle deflects towards charge and returns toward center scale in two steps (fully charged battery).

With ignition switch off and lights on . . . ammeter should shown between 0 and discharge scale.

Tests Using a Voltmeter

When performing charging system tests with a voltmeter, turn OFF all lights and electrical components. Place the engine in neutral. The battery must be charged to at least 1.200 specific gravity before starting the test.

Voltmeter Test Procedure

1. Connect the negative lead of the voltmeter to the negative battery cable clamp (not bolt or nut), and the positive lead of the voltmeter to the positive battery cable clamp (not bolt or nut) (Fig. 9).
2. Record the battery voltage reading shown on the voltmeter scale.
3. Connect the red lead of a tachometer to the distributor terminal of the coil and the black tachometer lead to a good ground.
4. The, start the engine and operate the engine at approximately 1500 rpm. With no other electrical load the voltmeter reading should increase 1 volt and not exceed 2 volts above the first recorded battery voltage reading. The reading should be taken when the voltmeter needle stops moving.

5. With the engine running, turn on all the electrical equipment.
6. Increase the engine speed to 2000 rpm. The voltmeter should indicate a minimum of 0.5 volt above the first recorded battery voltage (Fig. 8).

If the above test indicate proper voltage readings, the charging system is operating normally. Proceed to Test Results if a problem still exists.

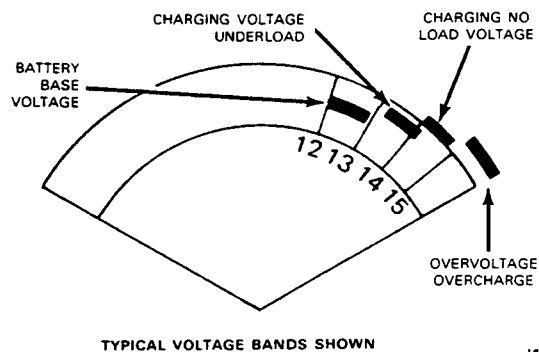

J1631-B

FIG. 8 Voltmeter Test Scale

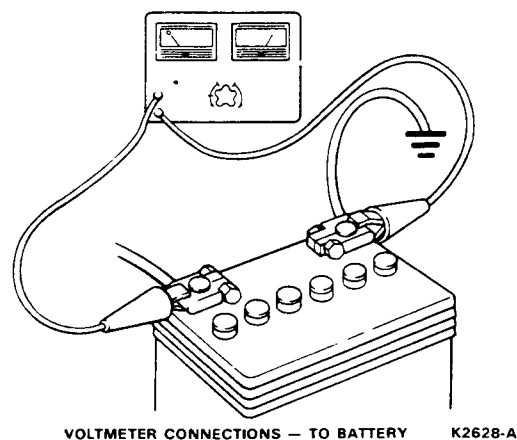

K2628-A

FIG. 9 Voltmeter-to-Battery Connections

TEST RESULTS

1. If the voltmeter reading indicates over voltage (more than 2.0 volts above battery voltage), stop the engine and check the ground connections between the regulator and alternator and/or regulator to engine. Clean and tighten connections securely and repeat the Voltmeter Test Procedure.
2. If over voltage condition still exists, disconnect the regulator wiring plug from the regulator and repeat the Voltmeter Test Procedure.
3. If over voltage condition disappears (voltmeter reads battery voltage), replace voltage regulator and repeat the voltmeter test procedure.
4. If over voltage still exists with the regulator wiring plug disconnected, repair the short in the wiring harness between the alternator and regulator. Then, replace the regulator and connect the regulator wiring plug to the regulator and repeat the Voltmeter Test Procedure.
5. If the voltmeter reading does not increase (one volt), check for the presence of battery voltage at the alternator BAT terminal and the regulator A terminal. Repair the wiring if no voltage is present at these terminals, and repeat the Voltmeter Test Procedure.

- If the voltmeter reading does not increase one volt above battery voltage, proceed to the next step before performing other tests, the field circuit (regulator plug to alternator) must be checked for a grounding condition. If the field circuit is grounded and the jumper wire is used as a check at the regulator wiring plug from the A to F terminals (Figure 10), excessive current will cause heat damage to the regulator wiring plug terminals and may burn the jumper wire (Fig. 10). Also, if the field circuit was grounded, the connector wire inside the regulator will be burned open and an under voltage condition will result.

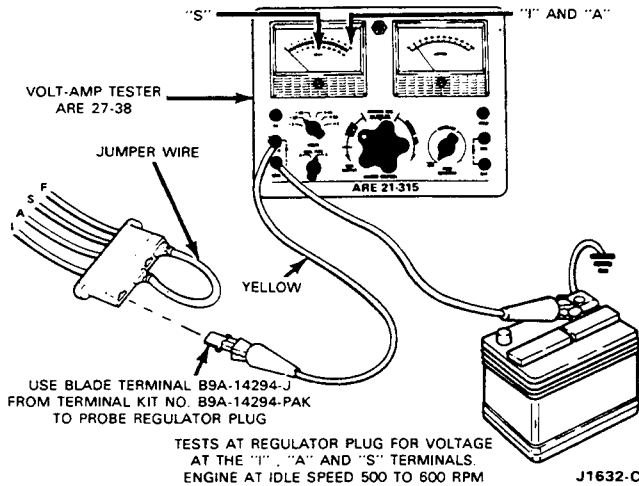

FIG. 10 Regulator Plug Voltage Tests

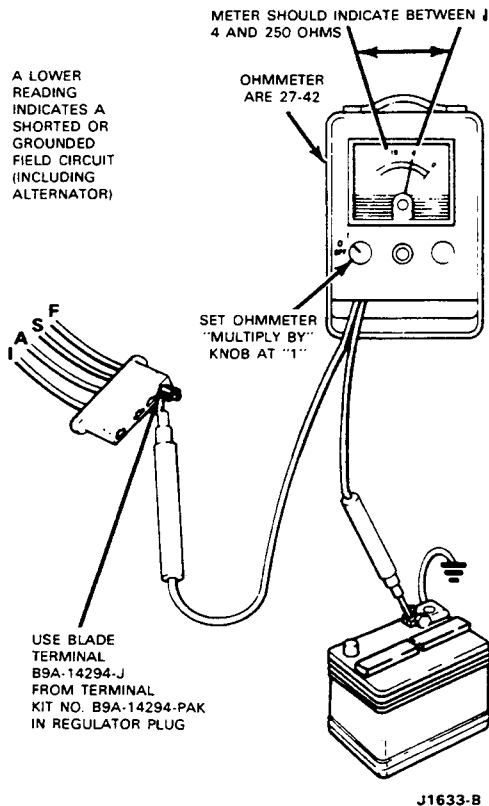

FIG. 11 Field Circuit Test

- The field circuit should be checked with the regulator wiring plug disconnected and an ohmmeter connected from the F terminal of the regulator wiring plug to the battery ground. The ohmmeter should indicate between 4 and 250 ohms (Fig. 11).
- A check for the regulator burned-open wire is made by connecting an ohmmeter from the I to F terminals of the regulator (Figure 12). The reading should indicate 0 (no resistance). If the reading indicates approximately 10 ohms, the connector wire inside the regulator is open. **The field circuit grounded condition must be found and repaired before installing a new regulator.**

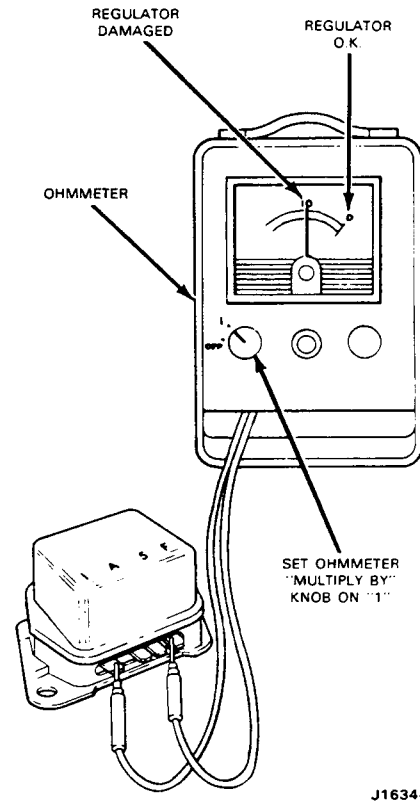

FIG. 12 Regulator Burned — Open Connector Wire Test

Field Circuit and Alternator Tests

- If the field circuit is satisfactory, disconnect the regulator wiring plug at the regulator and connect the jumper wire from the A to the F terminals on the regulator wiring plug (Fig. 10).
- Repeat the Voltmeter Test Procedure.
- If the Voltmeter Test Procedure still indicates a problem (under voltage), remove the jumper wire from the regulator plug and leave the plug disconnected from the regulator. Then, connect a jumper wire to the FLD and BAT terminals on the alternator (Fig. 13).
- Repeat the Voltmeter Test Procedure.
- If the voltmeter Test results are now satisfactory, repair the wiring harness to the regulator. Then, **remove the jumper wire at the alternator** and connect the regulator wiring plug to the regulator.
- Repeat the Voltmeter Test Procedure to be sure the charging system is operating normally.

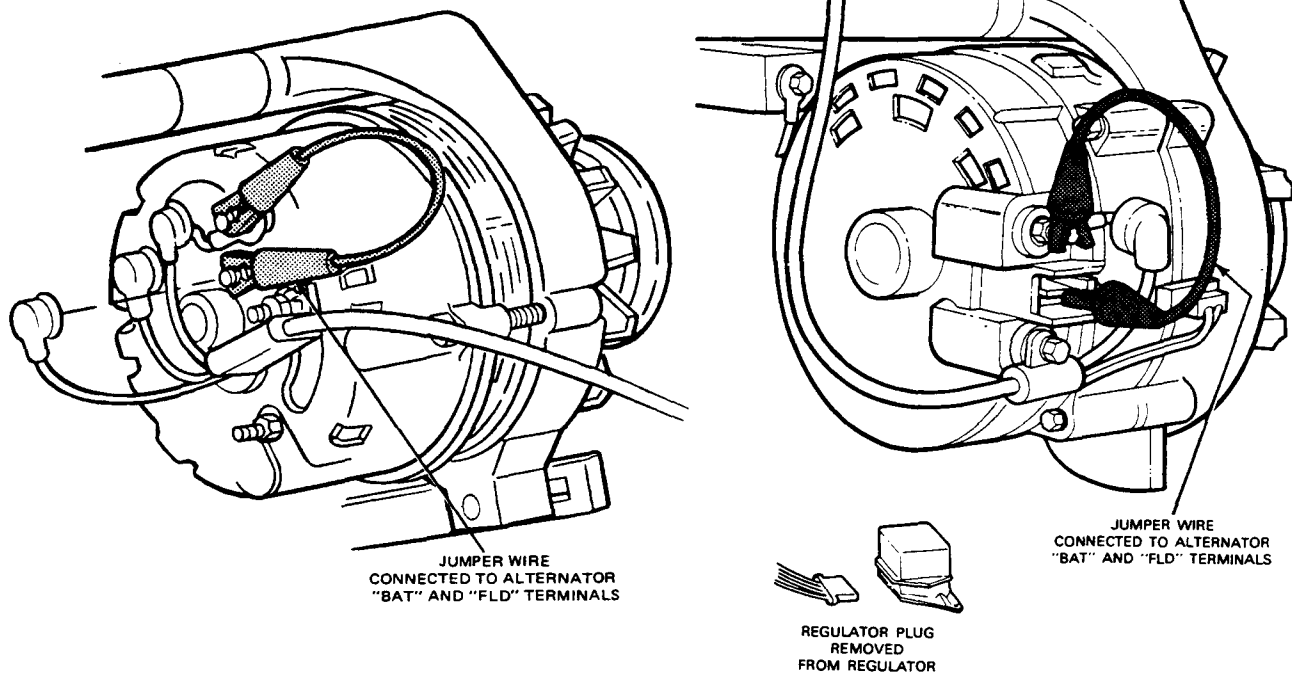

FIG. 13 Jumper Wire Connections

7. If the Voltmeter Test results still indicate (under voltage), repair or replace the alternator. With the jumper wire removed, connect the wiring to the alternator and regulator.
8. Repeat the Voltmeter Test Procedure.

Regulator I and S Circuit Tests S Circuit — With Ammeter

1. Connect the positive lead of the voltmeter to the S terminal of the regulator lead of the wiring plug (Fig. 10). Then, turn the ignition switch to the ON position. Do not start the engine.
2. The voltmeter reading should indicate battery voltage.
3. If there is no voltage reading, disconnect the positive voltmeter lead from the positive battery clamp and repair the S wire lead from the ignition switch to the regulator wiring plug.
4. Connect the positive voltmeter lead to the positive battery cable terminal, connect regulator wiring plug to regulator and repeat the Voltmeter Test Procedure.

S and I Circuit — With Indicator Light

1. Disconnect the regulator wiring plug and install a jumper wire between the A and F terminal.
2. With the engine idling, connect the positive lead of the voltmeter to the S terminal and then to the I terminal of the regulator wiring plug (Fig. 10). The voltage of the S circuit should read approximately 1/2 of the I circuit.
3. If no voltage is present, repair the alternator or the wiring circuit at fault. Reconnect the positive voltmeter lead to the positive battery cable terminal.
4. If the above circuit tests are satisfactory, install a new regulator.

5. Then, remove the jumper wire from the regulator wiring plug and connect the wiring plug to the regulator. Repeat the Voltmeter Test Procedure.

Diode Test — On Vehicle

1. Disconnect voltage regulator wiring plug.
2. Connect a jumper between "A" and "F" terminal of voltage regulator wiring plug.
3. Connect voltmeter to battery cable clamps.
4. Start engine — let engine run at idle.
5. Read and record voltmeter reading.
6. Move positive voltmeter lead to "S" terminal in voltage regulator wiring plug.
7. Note voltmeter reading.

Test Results

1. If voltmeter reads 1/2 of battery voltage, diodes are okay.
2. If voltmeter reads approximately 1.5 volts, alternator has shorted **negative** diode, or a grounded stator winding.
3. If voltmeter reads approximately 1.5 volts less than battery voltage, alternator has shorted **positive** diode.
4. If voltmeter reads about 1.0 to 1.5 volts less than 1/2 battery voltage, alternator has an **open positive** diode.
5. If voltmeter reads about 1.0 to 1.5 volts more than 1/2 battery voltage, alternator has an **open negative** diode.

BENCH TESTS

Rectifier Short or Grounded and Stator Grounded Test — On Bench

These tests are performed with an ARE 27-42 ohmmeter. Set the Multiply By knob at 10, and calibrate

the ohmmeter as directed inside the instrument cover.

Contact one ohmmeter probe to the alternator BAT terminal and the other probe to the STA terminal, Then, reverse the ohmmeter probes and repeat the test. A reading of about 60 ohms should be obtained in one direction and no needle movement with the probes reversed. A reading in both directions indicates a bad positive diode, a grounded positive diode plate, or a grounded BAT terminal.

Infinite readings (no needle movement) in all four probe positions in the preceding tests indicates an open STA terminal lead connection inside the alternator.

Field Open or Short Circuit Test — On Bench

This test is performed with an ohmmeter (Tool ARE 27-42). Set the ohmmeter Multiply By knob at 1 and calibrate the ohmmeter as directed inside the instrument cover.

Contact the alternator field terminal with one probe and the ground terminal with the other probe. Then, spin the alternator pulley. The ohmmeter reading should be between 4 and 250 ohms, and should fluctuate while the pulley is turning. An infinite reading (no meter movement) indicates an open brush lead, worn or stuck brushes, or a bad rotor assembly. An ohmmeter reading less than 4 ohms indicates a grounded brush assembly, a grounded field terminal or a bad rotor.

Diode Test — On Bench

Remove the rectifier assembly from the alternator as outlined under Disassembly. Set the ohmmeter Multiply By knob at 10 and calibrate the meter as directed inside the cover.

To test one set of diodes, contact one probe to the terminal bolt as shown in Figure 14 and contact each of the three stator lead terminals with the other probe. Reverse the probes and repeat the test. All diodes should show a low reading of about 60 ohms in one direction, and an infinite reading (no needle movement) with the probes reversed. Repeat the preceding tests for the other set of diodes except that the other terminal screw is used.

If the meter readings are not as specified, replace the rectifier assembly.

Stator Coil Open or Grounded Test — On Bench

These tests are made to determine if the stator coil is operating properly. Disassemble the stator from the alternator as outlined under Disassembly.

Set the ARE 27-42 ohmmeter Multiply By knob at 1, and calibrate the meter as directed inside the cover. Connect the ohmmeter probes between such pair of stator leads (3 different ways). The ohmmeter must show equal readings for each pair of stator leads. Replace the stator if the readings are not the same.

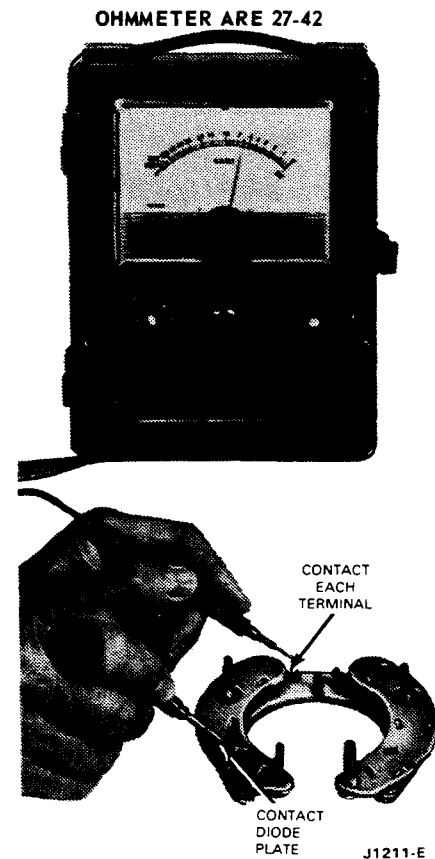

FIG. 14 Diode Test — Rear Terminal Alternator

Set the ARE 27-42 ohmmeter Multiply By knob at 1000. Connect the ohmmeter probes to one of the stator leads and to the stator laminated core. Be sure that the probe makes a good electrical connection with the stator core. The meter should show an infinite reading (no meter movement). If the meter does not indicate an infinite reading (no meter movement), the stator winding is shorted to the core and must be replaced. Repeat this test for each of the stator leads.

Rotor Open or Short Circuit Test — On Bench

Disassemble the front housing and rotor from the rear housing and stator as outlined under Disassembly. Set the ohmmeter (ARE 27-42) Multiply By knob at 1 and calibrate the meter as directed inside the ohmmeter cover.

Contact each ohmmeter probe to a rotor slip ring. The meter reading should be 4 or 5 ohms. A higher reading indicates a damaged slip ring solder connection or a broken wire. A lower reading indicates a shorted wire or slip ring. Replace the rotor if it is damaged and cannot be repaired.

Contact one ohmmeter probe to a slip ring and the other probe to the rotor shaft. The meter reading should be infinite (no deflection). A reading other than infinite indicates the rotor is shorted to the shaft. Inspect the slip ring soldered terminals to be sure they are not bent and touching the rotor shaft, or that excess solder is grounding the rotor coil connections to the shaft. Replace the rotor if it is shorted and cannot be repaired.

ADJUSTMENTS

BELT ADJUSTMENTS

1. Check the belt tension with Tool T63L-8620-A. The belt should be within specifications (Specifications Section).
2. If the belt is not within specifications, loosen the alternator mounting bolt to a snug position and
3. **Apply pressure on the alternator front housing only** and tighten the adjusting arm to alternator bolt.
4. Check the belt tension using Tool T63L-8620-A. Adjust the belt for specified tension.
5. Tighten all mounting bolts.

REMOVAL AND INSTALLATION

REMOVAL

1. Disconnect the battery ground cable.
2. Loosen the alternator mounting bolts and remove the adjustment arm-to-alternator attaching bolt.
3. Remove the electrical connectors from the alternator.
4. Disengage the alternator belt. Remove the alternator mounting bolt, and remove the alternator.

INSTALLATION

1. Install the alternator wiring harness. Position the alternator to the engine, and install the spacer (if used)

2. Install the adjustment arm-to-alternator attaching bolt.
3. Position the belt on the pulley and adjust the belt tension using Tool T63L-8620-A. Apply pressure on the alternator front housing only, when tightening the belt. Tighten the adjusting arm bolt and the mounting bolt.
4. Connect the battery ground cable.

OVERHAUL

FORD ALTERNATOR

Disassembly

- Figure 15 shows a disassembled view of the alternator.
1. Mark both end housings and the stator with a scribe mark for assembly.
 2. Remove the three housing through bolts.
 3. Separate the front housing and rotor from the stator
 4. Remove all the nuts and insulators from the rear housing and remove the rear housing from the stator and rectifier assembly.
 5. Remove the brush holder mounting screws and

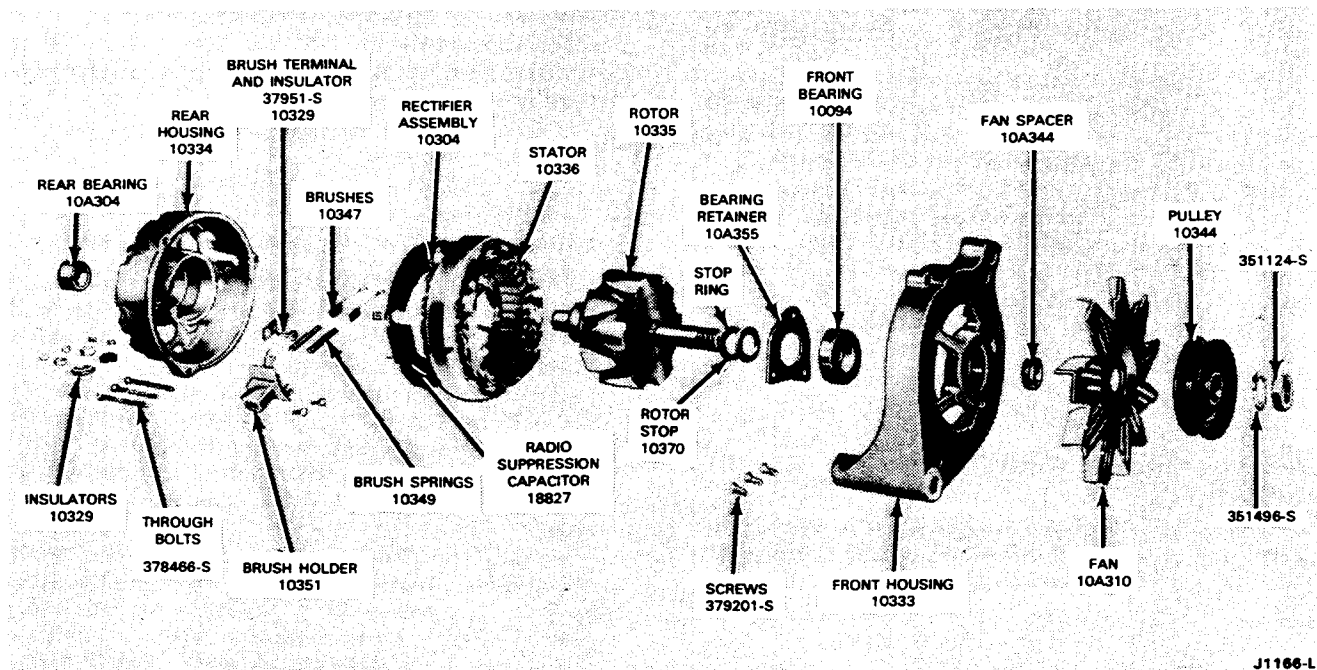

J1166-L

FIG. 15 Disassembled Alternator

- remove the holder, brushes, brush springs, insulator and terminal.
6. If replacement is necessary, press the bearing from the rear housing supporting the housing on the inner boss.
 7. If the rectifier assembly is being replaced, unsolder the stator leads from rectifier terminals, and separate the stator leads from rectifier terminals, and separate the stator from the rectifier assembly. Use a 100-watt soldering iron.
 8. Original production alternators will have one of three types of rectifier assembly circuit boards (Fig. 16); one has the circuit board spaced away from the diode plates with the diodes exposed. Another type is a single circuit board with built-in diodes. The third type circuit board has built-in diodes with an additional booster diode plate containing two diodes. This circuit board is used only in the 61-ampere alternator.
- If the alternator rectifier has an exposed board, remove the screws from the rectifier by rotating the bolt heads 1/4 turn clockwise to unlock them and then remove the screws (Fig. 16). Push the stator terminal straight out on a rectifier with the diodes built into the circuit board (Fig. 16). Avoid turning the screw while removing, to make certain that the straight knurl will engage the insulators when installing. Do not remove the grounded screw (Fig. 17).
9. Remove the drive pulley nut with the tool shown in Fig. 18; then, pull the lock washer, pulley, fan, fan spacer, rotor and rotor stop from the rotor shaft.
 10. Remove the three screws that hold the front end bearing retainer, and remove the retainer. If the bearing is damaged or has lost its lubricant, support the housing close to the bearing boss, and press out the old bearing from the housing.
 11. Perform a diode test and a field open or short circuit test (Refer to Testing in this Part).

Assembly

1. The rotor, stator and bearings must not be cleaned with solvent. Wipe these parts off with a clean cloth.
2. Press the front bearing in the front housing bearing boss (put pressure on the bearing outer race only), and install the bearing retainer (Fig. 15).

3. If the stop-ring on the rotor drive shaft was damaged, install a new stop-ring. Push the new ring on the shaft and in the groove. **Do not open the ring with snap ring pliers as permanent damage will result.**
4. Position the rotor stop on the drive shaft with the recessed side against the stop-ring.
5. Position the front housing, fan, spacer, fan, pulley and lock washer on the drive shaft and install the retaining nut. Tighten the retaining nut with the tool shown in Fig. 18 to the specified torque.
6. If the rear housing bearing was removed, support the housing on the inner boss and press in a new bearing flush with the outer end surface.
7. Place the brush springs, brushes, brush terminal and terminal insulator in the brush holder and hold the brushes in position by inserting a piece of stiff wire in the brush holder as shown in Fig. 19.
8. Position the brush holder assembly in the rear housing and install the mounting screws. Position the brush leads in the brush holder as shown in Fig. 20.
9. Wrap the three stator winding leads around the rectifier terminals and solder them. Use a 100-watt soldering iron and rosin-core solder. Position the stator neutral lead element on the stator terminal screw and install the screw in the rectifier assembly (Fig. 21).
10. For a rectifier with the diodes exposed, insert the special screws through the wire lug, dished washers and circuit board (Fig. 16). Turn them 1/4 turn counterclockwise to lock them. For single circuit boards with built-in diodes, insert the screws straight through the wire lug, insulating washer and rectifier into the insulator. (Fig. 16).

The dished washers are to be used only on the circuit board with exposed diodes (Fig. 16). If they are used on the single circuit board, a short circuit will occur. A flat insulating washer is to be used between the stator terminal and the board, when a single circuit board is used (Fig. 17).

11. Position the radio noise suppression capacitor on the rectifier terminals. On the circuit board with exposed diodes, install the STA and BAT terminal insulators (Fig. 21). On the single circuit board, position the square hole in the rectifier assembly (Fig. 22) on the BAT terminal.

Position the stator and rectifier assembly in the rear housing. Make certain that all terminal insulators are seated properly in their recesses. Position the STA (black),

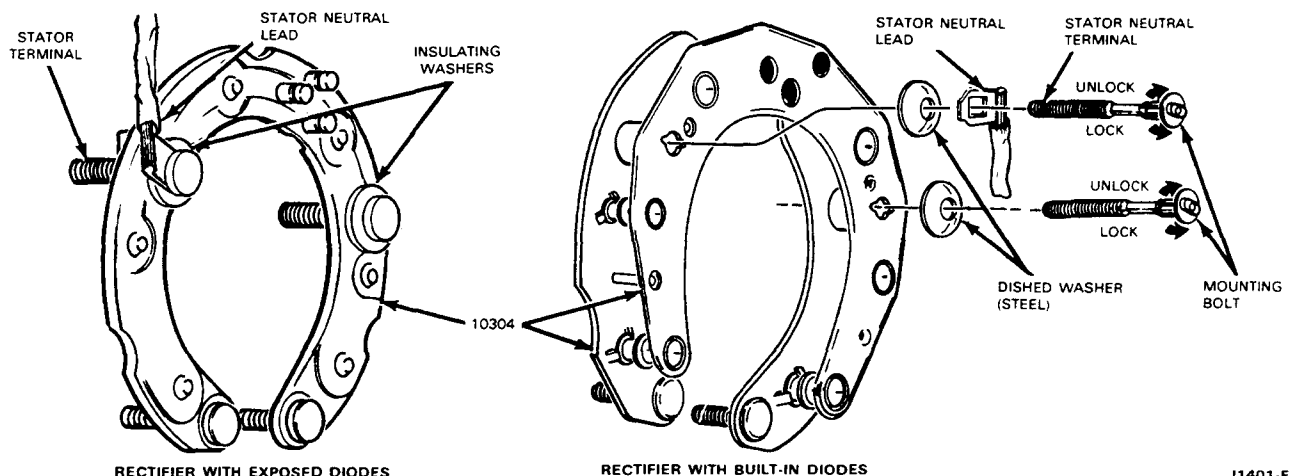

FIG. 16 Rectifier Assembly

BAT (red), and FLD (orange) insulators on the terminal bolts, and install the retaining nuts (Fig. 23).

12. Wipe the rear end bearing surface of the rotor shaft with a clean lint-free rag.

13. Position the rear housing and stator assembly over the rotor and align the scribe marks made during disassembly. Seat the machined portion of the stator core into the step in both end housings. Install the housing through bolts. Remove the brush retracting wire, and put a daub of waterproof cement over the hole to seal it.

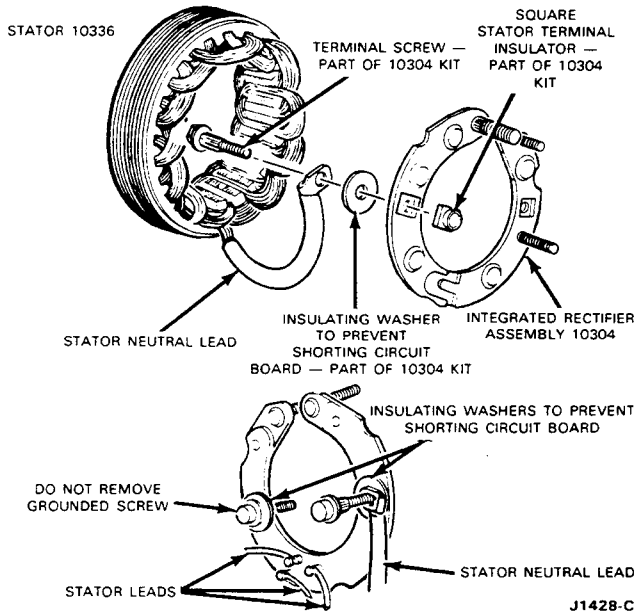

FIG. 17 Stator Terminal Installation — Integral Rectifier Circuit Board

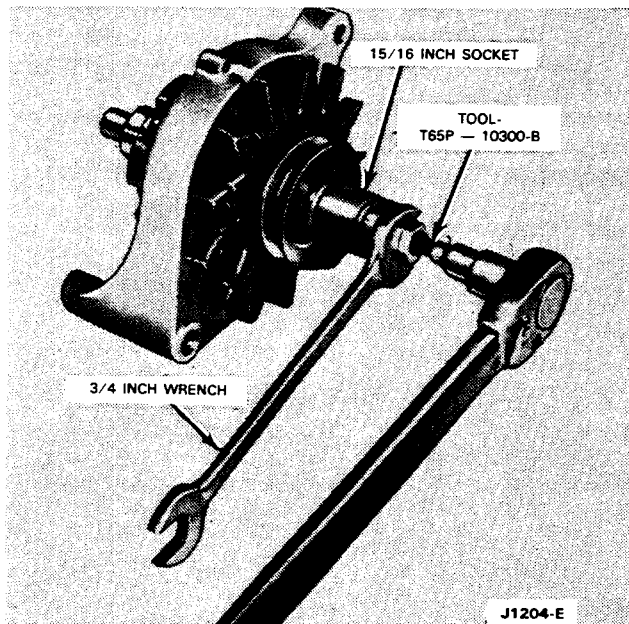

FIG. 18 Pulley Removal

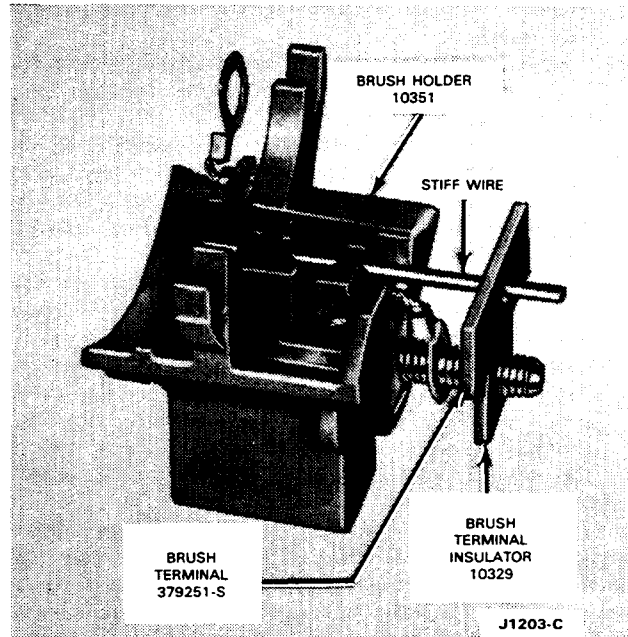

FIG. 19 Brush Holder Assembly

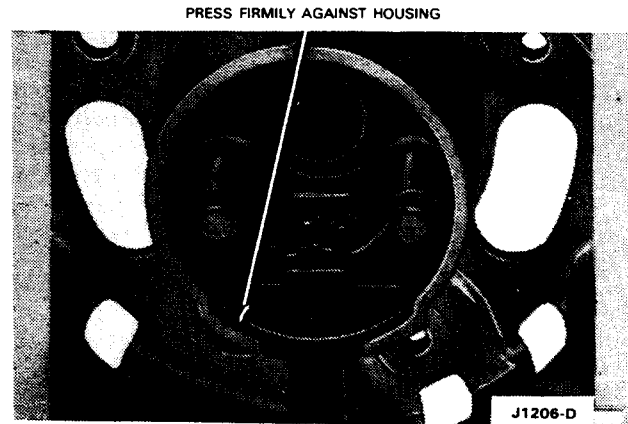

FIG. 20 Brush Lead Positions

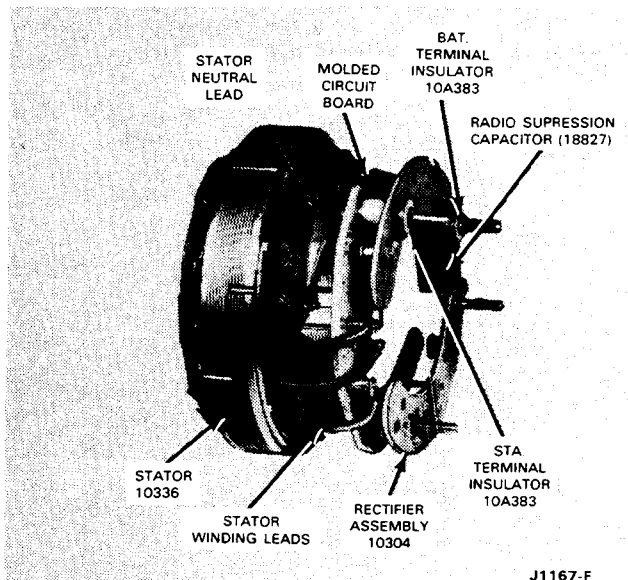
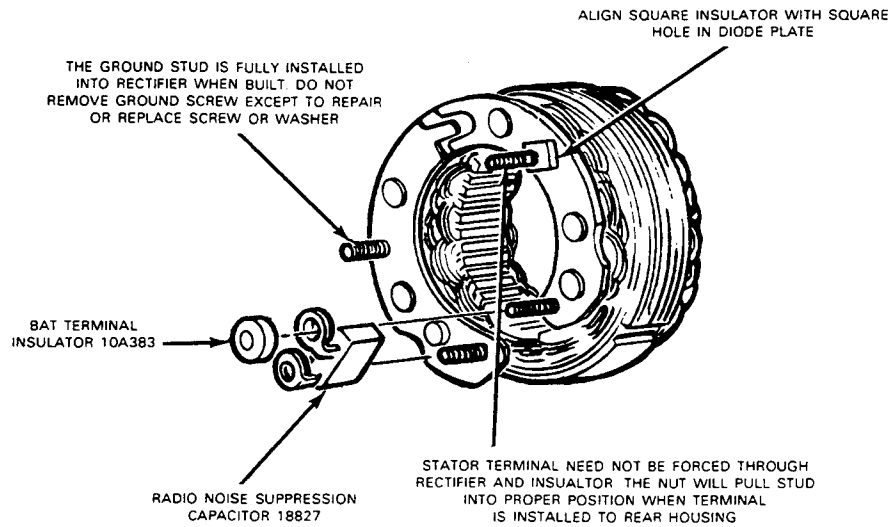
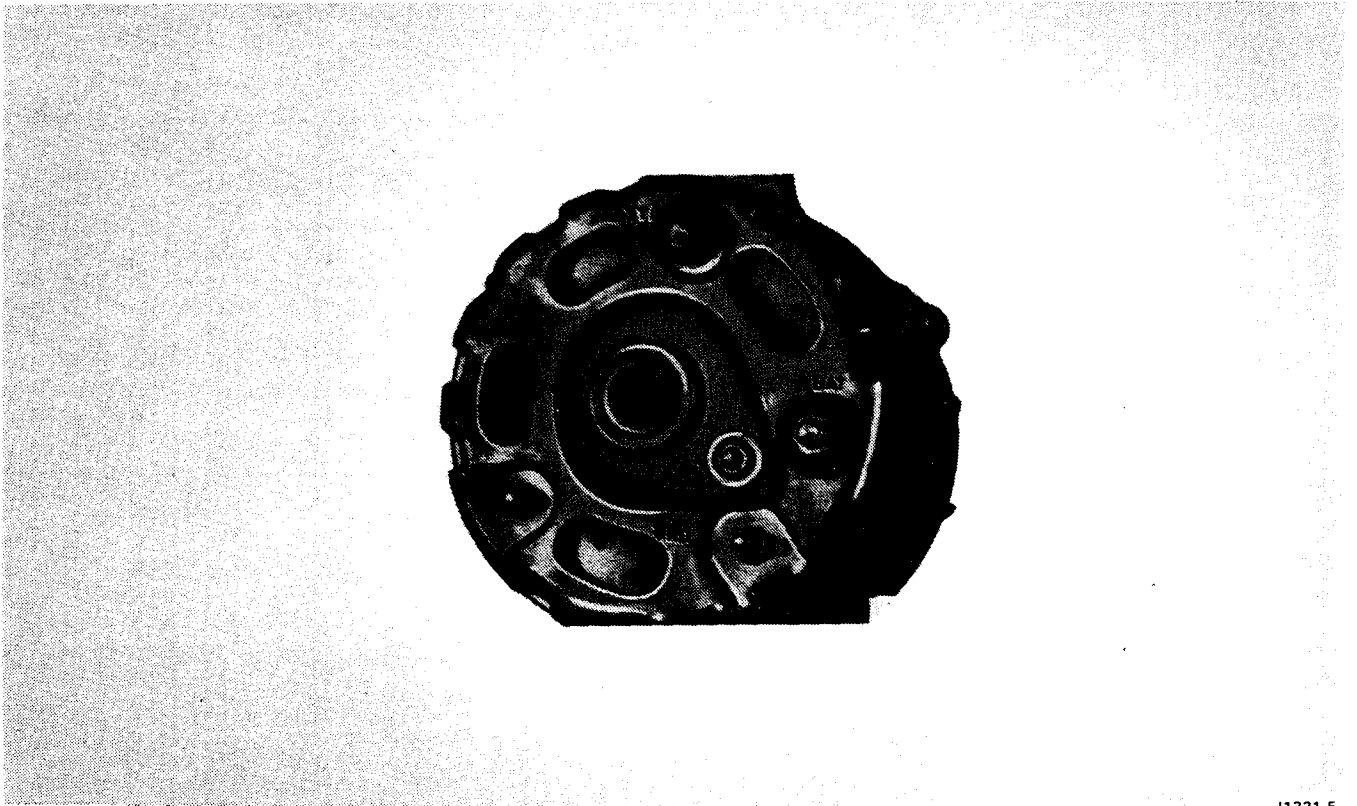

FIG. 21 Stator Lead Connections



J1429-D

FIG. 22 Terminal Insulators — Fiber Glass Circuit Board



J1221-F

FIG. 23 Alternator Terminal Locations



PART 5 Starting System

COMPONENT INDEX	Page		COMPONENT INDEX	Page
DESCRIPTION AND OPERATION	5-01		Bench Tests	
TESTING			No-Load Test	5-02
On Engine Tests			Armature Open Circuit Test	5-03
Road Service	5-02		Armature and Field Grounded Test	5-03
Drive and Starter Test	5-02		REMOVAL AND INSTALLATION	5-04
Cranking Circuit Test	5-02		OVERHAUL	5-04
Load Test	5-02			

GENERAL INFORMATION

The function of the starting system is to crank the engine at a speed fast enough to permit the engine to start. Heavy cables, connectors, and switches are used in the starting system because of the large current required by the starter while it is cranking the engine. The amount of resistance in the starting circuit must be kept at an absolute minimum to provide maximum current for starter operation. Loose or corroded connections, relay contacts,

or partially broken cables will result in slower than normal cranking speeds, and may even prevent the starter from cranking the engine.

In cases of starting system trouble, the owner may have discharged the battery before calling for assistance. A road service procedure is presented to aid the service technician in such cases of starting trouble. Once the engine is started, be sure to locate the cause of the starting difficulty.

DESCRIPTION AND OPERATION

POSITIVE ENGAGEMENT STARTER

The starting system includes the starter motor with an integral positive-engagement drive, the battery, a remote control starter switch (part of the ignition switch), the neutral-start switch (automatic transmission with floor shift only), the starter relay, and heavy circuit wiring.

Turning of the ignition key to the START position actuates the starter relay, through the starter control circuit. The starter relay then connects the battery to the starter.

When the starter is not in use, one of the field coils is connected directly to ground through a set of contacts (Fig. 1). When the starter is first connected to the battery, a large current flows through the grounded field coil, actuating a movable pole shoe. The pole shoe is attached to the starter drive plunger lever and thus the drive is forced into engagement with the flywheel ring gear.

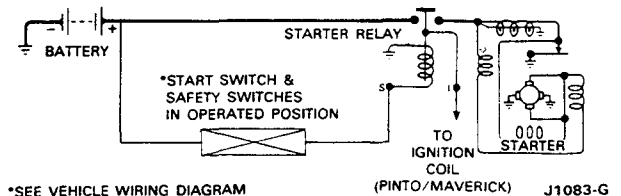

FIG. 1 Starting Circuit

When the movable pole shoe is fully seated, it opens the field coil grounding contacts and the starter is then in normal operation. A holding coil is used to maintain the movable pole shoe in the fully seated position during the time that the starter is turning the engine.

TESTING

ROAD SERVICE

On road service calls, connect a booster battery to the system for cases of a starter that will not crank the engine or starter that cranks the engine very slowly. If the starter does not turn the engine over, even with the booster battery attached, refer to the following tests. **Be certain that correct battery polarity is observed when using a booster battery; positive to positive, and negative to negative connection of the auxiliary cables. The starter should not be operated continuously for periods longer than one minute at a time. An interval of at least two minutes should be observed between such cranking periods to protect the starter from overheating.**

ON ENGINE TESTING

Starter Drive and Starter Test

Flood the warm engine by pumping the accelerator eight to ten times. Turn the ignition key to start and hold it in the start position. The engine should fire immediately, but should not start and run. The starter should continue to crank the engine. This indicates a normal acceptable starter drive. If the engine stops turning and the starter spins at high speed, the drive is not operating properly and should be replaced. Whenever possible, remove the plunger cover to observe if the plunger pole is operating on the vehicle. **Do not damage the exposed switch during starter installation or removal.**

Alternate Starter Drive Test

1. Pull the push-on connector from the ignition coil primary terminal. Place the connector loosely on the coil terminal.
2. Connect a remote control starter switch to the starter relay.
3. Turn the ignition switch key to the ON position and depress the remote control starter switch. As soon as the engine begins to run, pull the push-on connector from the coil terminal while holding the remote control switch in the START position. **Pulling the wire off the coil kills the ignition, and the dead engine should now be cranked by the starter.**
4. Observe to see if the starter begins to crank the dead engine and if it continues to crank the engine until the remote control switch is released. If the starter does not crank the **dead engine, the drive assembly is slipping.**
5. Repeat the test at least three times in succession to detect intermittent operation.

Starter Cranking Circuit Test

Excessive resistance in the starter circuit can be determined from the results of this test. Make the test connections as shown in Fig. 2. Crank the engine with the ignition OFF. This is accomplished by disconnecting and grounding the high tension lead from the ignition coil and by connecting a jumper from the battery terminal of starter relay to the S terminal of the relay.

The voltage drop in the circuit will be indicated by the voltmeter (0 to 2 volt range). Maximum allowable voltage drop should be:

1. 0.5 volt with the voltmeter negative lead connected to the starter terminal and the positive lead connected to the battery positive terminal (Fig. 2, connection 1).
2. 0.1 volt with the voltmeter negative lead connected to the battery terminal of the starter relay and the positive lead connected to the positive terminal of the battery (Fig. 2, connection 2).
3. 0.3 volt with the voltmeter negative lead connected to the starter terminal of the starter relay and the positive lead connected to the positive terminal of the battery (Fig. 2, connection 3).
4. 0.1 volt with the voltmeter negative lead connected to the negative terminal of the battery and the positive lead connected to the engine ground (Fig. 2, connection 4).

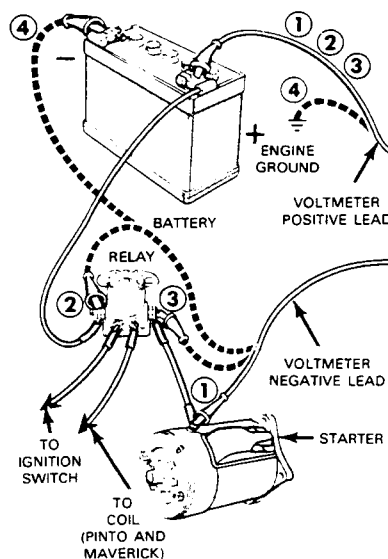

FIG. 2 Starter Cranking Circuit Test

Starter Load Test

Connect the test equipment as shown in Fig. 3. Be sure that no current is flowing through the ammeter and heavy-duty carbon pile rheostat portion of the circuit (rheostat at maximum counterclockwise position).

Crank the engine with the ignition OFF, and determine the exact reading on the voltmeter. This test is accomplished by disconnecting and grounding the high tension lead from the ignition coil, and by connecting a jumper from the positive battery terminal to the S-terminal of the starter relay.

Stop cranking the engine, and reduce the resistance of the carbon pile until the voltmeter indicates the same reading as that obtained while the starter cranked the engine. The ammeter will indicate the starter current draw under load.

BENCH TESTS

Starter No-Load Test

The starter no-load test will uncover such faults as open or shorted windings, rubbing armature, and bent armature shaft. The starter can be tested, at no-load, on the test bench only.

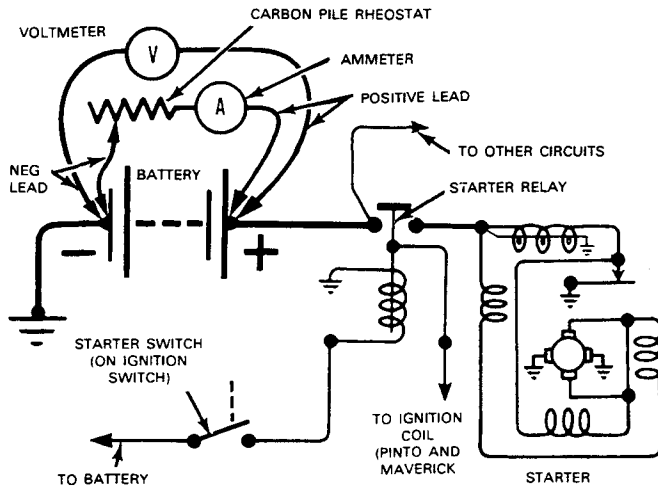

FIG. 3 Starter Load Test

Make the test connections as shown in Fig. 4. The starter will run at no-load. Be sure that no current is flowing through the ammeter (rheostat at maximum counterclockwise position). Determine the exact reading on the voltmeter.

Disconnect the starter from the battery, and reduce the resistance of the rheostat until the voltmeter indicates the same reading as that obtained while the starter was running. The ammeter will indicate the starter no-load current draw.

Armature Open Circuit Test

An open circuit armature may sometimes be detected by examining the commutator for evidence of burning. A spot burned on the commutator is caused by an arc formed every time the commutator segment, connected to the open circuit winding, passes under a brush.

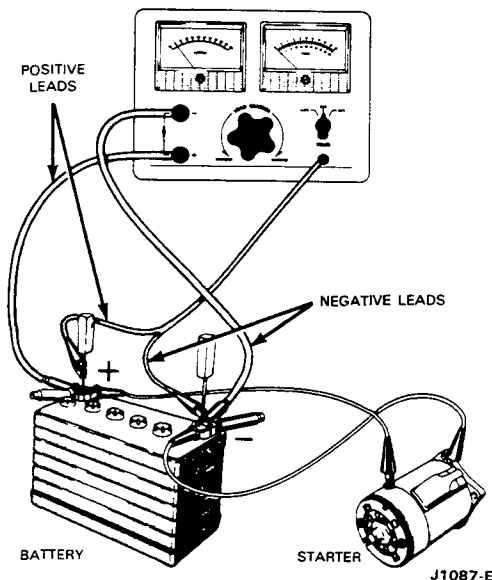
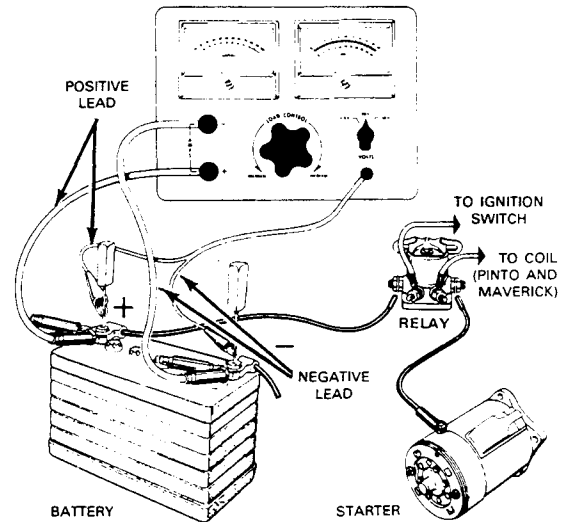

FIG. 4 Starter No-Load Test on Test Bench



Armature and Field Grounded Circuit Test

This test will determine if the winding insulation has failed, permitting a conductor to touch the frame or armature core.

To determine if the armature windings are grounded, make the connections as shown in Fig. 5. If the voltmeter indicates any voltage, the windings are grounded.

Grounded field windings can be detected by making the connections as shown in Fig. 6. If the voltmeter indicates any voltage, the field windings are grounded.

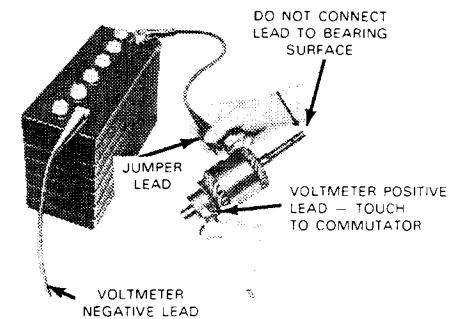

FIG. 5 Armature Grounded Circuit Test

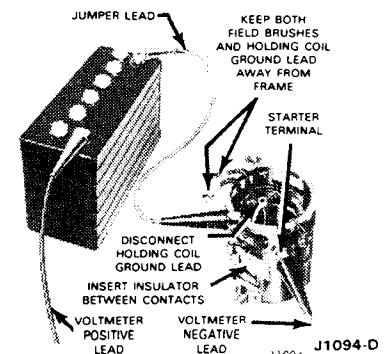

FIG. 6 Field Grounded Circuit Test

REMOVAL AND INSTALLATION

POSITIVE ENGAGEMENT STARTER

1. Disconnect negative battery cable.
2. Disconnect the starter cable at the starter terminal.
3. Remove the starter mounting bolts.
4. Remove the starter assembly (Fig. 7).
5. Position the starter assembly to the flywheel housing, and start the mounting bolts.
6. Snug all bolts, while holding the starter squarely against its mounting surface and fully inserted into the pilot hole. Torque the bolts to specification.
7. Connect the starter cable. Connect battery cable.

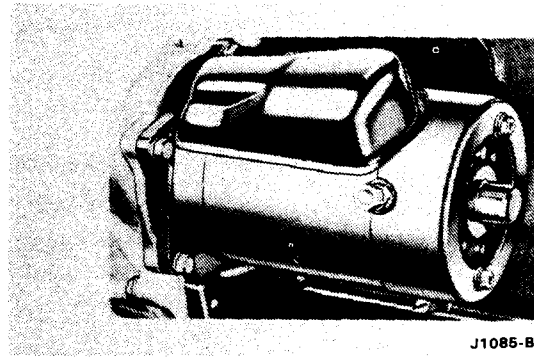

FIG. 7 Starter Mounting

OVERHAUL

POSITIVE ENGAGEMENT STARTER

Use the following procedure when it becomes necessary to completely overhaul the starter. Fig. 8 illustrates a disassembled starter.

Disassembly

1. Loosen the brush cover band retaining screw and remove the brush cover band and the starter drive plunger lever cover. Observe the lead positions for assembly and then remove the commutator brushes from the brush holders.
2. Remove the through bolts, starter drive end housing, and the starter drive plunger lever return spring.
3. Remove the pivot pin retaining the starter gear plunger lever and remove the lever and the armature.
4. Remove the stop ring retainer. Remove and discard the stop ring retaining the starter drive gear to the end of the armature shaft, and remove the starter drive gear assembly.

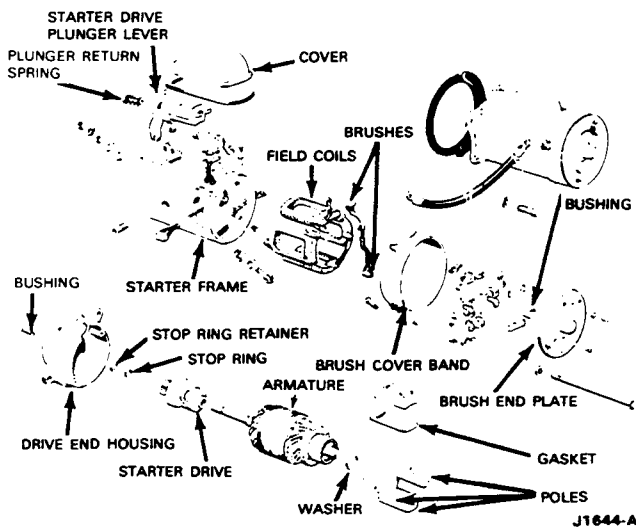
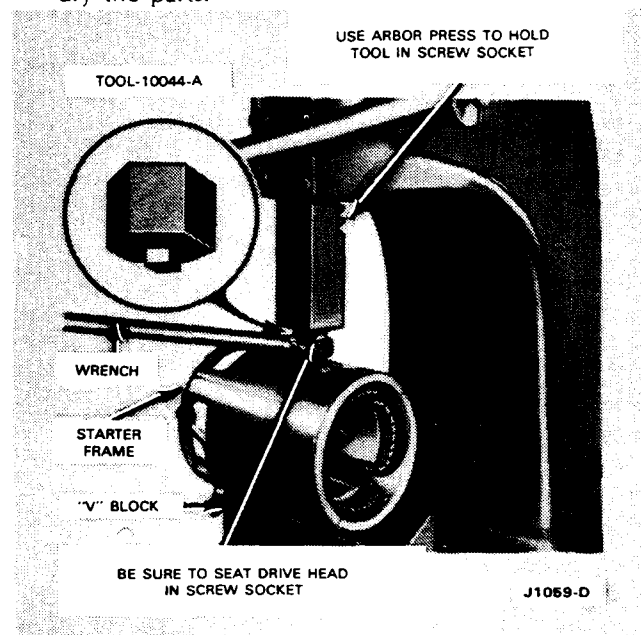

FIG. 8 Positive Engagement Starter Disassembled

5. Remove the brush end plate.
6. Remove the two screws retaining the ground brushes to the frame.
7. On the field coil that operates the starter drive gear actuating lever, bend the tab up on the field coil retaining sleeve and remove the sleeve.
8. Remove the three coil retaining screws, using Tool 10044-A and an arbor press (Fig. 9). The arbor press prevents the wrench from slipping out of the screw. Unsolder the field coil leads from the terminal screw, and remove the pole shoes and coils from the frame. Use a 300-watt iron.
9. Cut (or unsolder) the insulated brush leads from the field coils, as close to the field connection point as possible.
10. Remove the starter terminal nut, washer, insulator and terminal from the starter frame. Remove any excess solder from the terminal slot.

Cleaning and Inspection

1. Use a brush or air to clean the field coils, armature, commutator, armature shaft, brush end plate, and drive end housing. Wash all other parts in solvent and dry the parts.



2. Inspect the armature windings for broken or burned insulation and unsoldered connections.
3. Check the armature for open circuits and grounds.
4. Check the commutator for run out (Fig. 10). Inspect the armature shaft and the two bearings for scoring and excessive wear. If the commutator is rough, or more than 0.005 inch out-of-round, turn it.

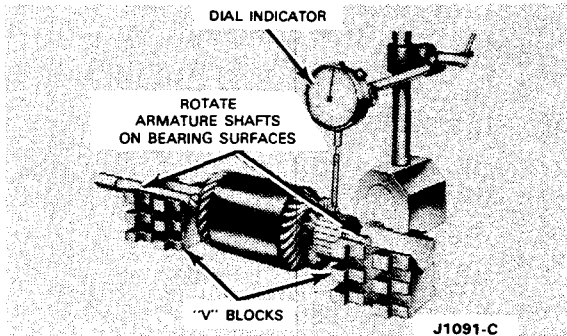

FIG. 10 Commutator Runout Check

5. Check the brush holders for broken springs and the insulated brush holders for shorts to ground. Tighten any rivets that may be loose. Replace the brushes if worn to 1/4 inch in length.
6. Check the brush spring tension. Replace the springs if the tension is not within specified limits.
7. Inspect the field coils for burned or broken insulation and continuity. Check the field brush connections and lead insulation. A brush kit and a contact kit are available. All other assemblies are to be replaced rather than repaired.
8. Examine the wear pattern on the starter drive teeth. The pinion teeth must penetrate to a depth greater than 1/2 the ring gear tooth depth (Fig. 11), to eliminate premature ring gear and starter drive failure.
9. Replace starter drives and ring gears with milled, pitted or broken teeth or evidence of inadequate engagement (Fig. 11).

Assembly

1. Install the starter terminal, insulator, washers, and retaining nut in the frame (Fig. 12). Be sure to position the slot in the screw perpendicular to the frame end surface.
2. Position the coils and pole pieces, with the coil leads in the terminal screw slot, and then install the retaining screws (Fig. 9). As the pole shoe screws are tightened, strike the frame several sharp blows with a soft-faced hammer to seat and align the pole shoes, then stake the screws.
3. Install the solenoid coil and retainer and bend the tabs to retain the coils to the frame.
4. Solder the field coils and solenoid wire to the starter terminal using rosin core solder. Use a 300-watt iron.
5. Check for continuity and grounds in the assembled coils.
6. Position the new insulated field brushes lead on the field coil terminal. Install the clip provided with the brushes to hold the brush lead to the terminal. Solder the lead, clip, and terminal together, using rosin core solder (Fig. 12). Use a 300-watt iron.
7. Position the solenoid coil ground terminal over the nearest ground screw hole.

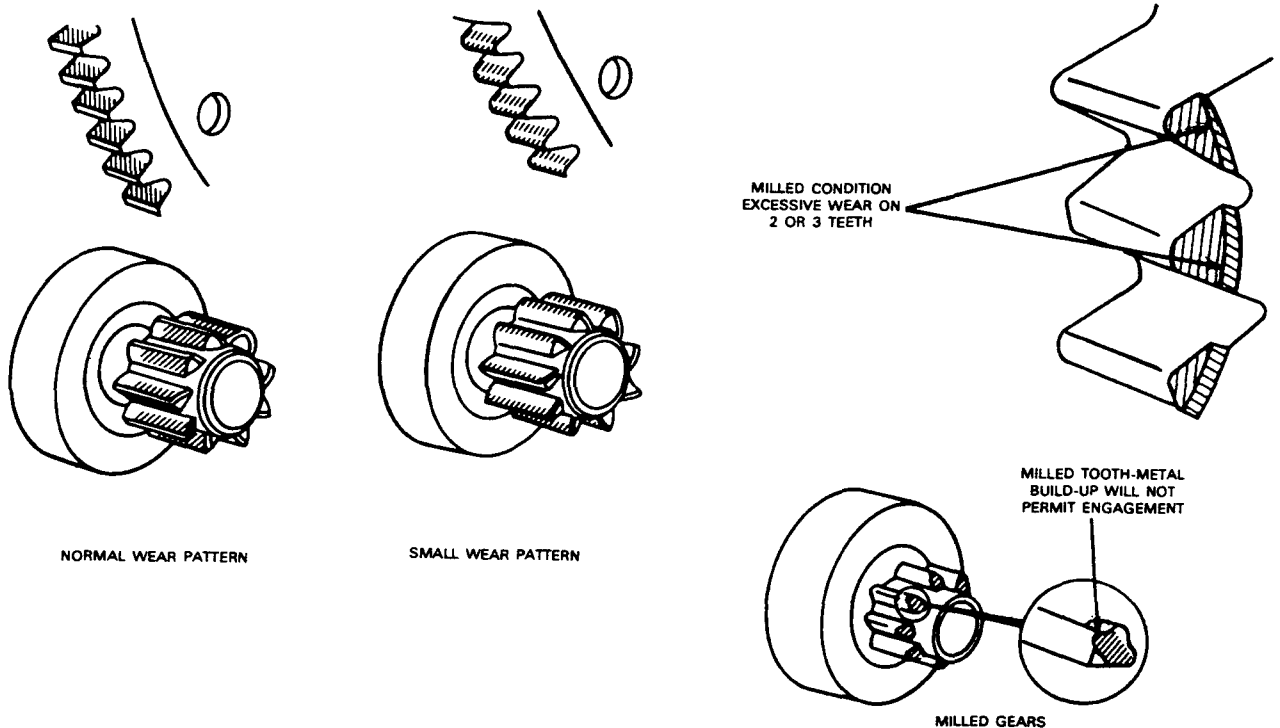
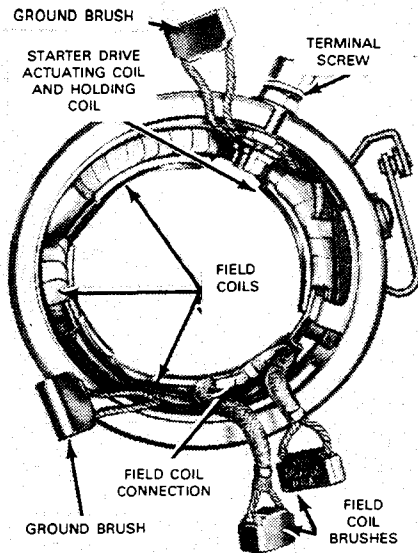

FIG. 11 Pinion and Ring Gear Wear Patterns



J1092-E

FIG. 12 Field Coil Assembly

8. Position the ground brushes to the starter frame and install the retaining screws (Fig. 12).
 9. Position the starter brush end plate to the frame with the end plate boss in the frame slot.
 10. Apply a thin coating of Lubriplate 777 on the armature shaft splines.
- Install the starter motor drive gear assembly to the armature shaft and install a new stop ring. Install a new stop-ring retainer.
11. Position the fiber thrust washer (except molded commutator armatures) on the commutator end of the armature shaft and position the armature in the starter frame.
 12. Position the starter drive gear plunger lever to the frame and starter drive assembly, and install the pivot pin.
 13. Partially fill the drive end housing bearing bore with grease (approximately 1/4 full). Position the starter drive plunger lever return spring and the drive end housing to the frame and install and tighten the through bolts to specification (55 to 75 in-lbs.). **Do not pinch the brush leads between the brush plate and the frame.** Be sure that the stop ring retainer is seated properly in the drive housing.
 14. Install the brushes in the brush holders. **Be sure to center the brush springs on the brushes.**
 15. Position the drive gear plunger lever cover on the starter and install the brush cover band with a gasket. Tighten the band retaining screw.
 16. Check the starter no-load current draw.

Starter Drive Replacement

1. Loosen and remove the brush cover band and the starter drive plunger lever cover (Fig. 8).
2. Loosen the through bolts enough to allow removal of the drive end housing and the starter drive plunger lever return spring.
3. Remove the pivot pin retaining the starter drive plunger lever and remove the lever.

4. Remove the drive gear stop ring retainer and stop ring from the end of the armature shaft and remove the drive gear assembly.
5. Apply a thin coating of Lubriplate 777 on the armature shaft splines. Install the drive gear assembly on the armature shaft and install a new stop ring.
6. Position the starter gear plunger lever on the starter frame and install the pivot pin. **Be sure that the plunger lever properly engages the starter drive assembly.**
7. Install a new stop-ring retainer. Partially fill the drive end housing bearing bore with grease (approximately 1/4 full). Position the starter drive plunger lever return spring and drive end housing to the starter frame, and then tighten the through bolts to specifications (55 to 75 in-lbs.).
8. Position the starter drive plunger lever cover and the brush cover band, with its gasket, on the starter. Tighten the brush cover band retaining screw.

Brush Replacement

Replace the starter brushes when they are worn to 1/4 inch. Always install a complete set of new brushes.

1. Loosen and remove the brush cover band, gasket, and starter drive plunger lever cover. Remove the brushes from their holders.
2. Remove the two through bolts from the starter frame.
3. Remove the drive end housing, and the plunger lever return spring.
4. Remove the starter drive plunger lever pivot pin and lever, and remove the armature.
5. Remove the brush end plate.
6. Remove the ground brush retaining screws from the frame and remove the brushes.
7. Cut the insulated brush leads from the field coils, as close to the field connection point as possible.
8. Clean and inspect the starter motor.
9. Replace the brush end plate if the insulator between the field brush holder and the end plate is cracked or broken.
10. Position the new insulated field brushes lead on the field coil connection. Position and crimp the clip provided with the brushes to hold the brush lead to the connection. Solder the lead, clip, and connection together, using rosin core solder (Fig. 12). Use a 300-watt iron.
11. Install the ground brush leads to the frame with the retaining screws.
12. Clean the commutator with 00 or 000 sandpaper.
13. Position the brush end plate to the starter frame, with the end plate boss in the frame slot.
14. Install the armature in the starter frame.
15. Install the starter drive gear plunger lever to the frame and starter drive assembly, and install the pivot pin.
16. Partially fill the drive end housing bearing bore with grease (approximately 1/4 full). Position the return spring on the plunger lever, and the drive end housing to the starter frame. Install the through bolts and tighten to specified torque (55 to 75 in-lbs.). Be sure that the stop ring retainer is seated properly in the drive end housing.
17. Install the commutator brushes in the brush holders. Center the brush springs on the brushes.
18. Position the plunger lever cover and the brush cover band, with its gasket, on the starter. Tighten the band retaining screw.
19. Connect the starter to a battery to check its operation.

Armature Replacement

1. Loosen the brush cover band retaining screw and remove the brush cover band, gasket, and the starter drive plunger lever cover. Remove the brushes from their holders.
2. Remove the through bolts, the drive end housing, and the drive plunger lever return spring.
3. Remove the pivot pin retaining the starter gear plunger lever, and remove the lever.
4. Remove the armature. If the starter drive gear assembly is being reused, remove the stop ring retainer and the stop ring from the end of the armature shaft, and remove the drive.
5. Place the drive gear assembly on the new armature with a new stop ring.
6. Install the armature in the starter frame.
7. Position the drive gear plunger lever to the frame and drive gear assembly and install the pivot pin.
8. Partially fill the drive end housing bearing bore with grease (approximately 1/4 full). Position the drive plunger lever return spring, the drive end housing and the front end plate to the starter frame, and then install and tighten the through bolts to specification. Be sure that the stop ring retainer is seated properly in the drive housing.
9. Place the brushes in their holders, and center the brush springs on the brushes.
10. Position the plunger lever cover and the brush cover band, with its gasket, and then tighten the retaining screw.
11. Connect the starter to a battery to check its operation.

STARTER TERMINAL

Removal

1. Loosen the brush cover band retaining screw and remove the brush cover band and the starter drive plunger lever cover. Observe the lead positions for assembly and then remove the commutator brushes from the brush holders.

2. Remove the through bolts, starter drive end housing, starter drive plunger lever return spring, and the brush end plate.
3. Remove the pivot pin retaining the starter gear plunger lever and remove the lever and the armature assembly.
4. Unsolder the field coil and solenoid wire leads from the terminal screw. Use a 300-watt soldering iron.
5. Remove the starter terminal nut, washer, insulator and terminal from the starter frame.

Installation

1. Install the new starter terminal, insulator, washers, and retaining nut in the frame (Fig. 8). Be sure to position the slot in the screw perpendicular to the frame end surface.
2. Solder the field coils and solenoid wire to the starter terminal using rosin core solder. Use a 300-watt iron.
3. Check for continuity and grounds in the assembled coils.
4. Position the starter brush end plate to the frame with the end plate boss in the frame slot.
5. Position the armature in the starter frame.
6. Position the starter drive gear plunger lever to the frame and starter drive assembly, and install the pivot pin.
7. Partially fill the drive end housing bearing bore with grease (approximately 1/4 full). Position the starter drive plunger lever return spring and the drive end housing to the frame and install and tighten the through bolts to specification (55 to 75 in.-lbs.). **Do not pinch the brush leads between the brush plate and the frame. Be sure that the stop ring retainer is seated properly in the drive housing.**
8. Install the brushes in the brush holders. **Be sure to center the brush springs on the brushes.**
9. Position the drive gear plunger lever cover on the starter and install the brush cover band with a gasket. Tighten the band retaining screw.
10. Check the starter no-load current draw.

PART 6 Governors

COMPONENT INDEX	Page		COMPONENT INDEX	Page
DESCRIPTION AND OPERATION	6-01		RPM Adjustments	6-01
ADJUSTMENTS			Removal and Installation	6-03
Preliminary Checks	6-01			

GOVERNORS

DESCRIPTION AND OPERATION

The mechanical flyweight type governors are used on these engines. They are mounted on the front of the engine and are belt driven from the engine accessory pulley.

A direct mechanical linkage from the governor throttle control lever to the carburetor throttle lever limits carburetor action to the governor setting. As the engine speed increases, the rotation of the governor shaft increases. Centrifugal force causes the weights to move outward as the rotation of the governor shaft increases. However, a spring retards or limits the movement of the weights until centrifugal force overcomes the spring tension. At this time the weights are forced outward closing the throttle plates through the linkage to the throttle shaft.

ADJUSTMENTS

Preliminary Checks

Three preliminary checks must be made on the mechanical governor before attempting any repair adjustments. These are the governor oil level, drive belt tension and the throttle control rod length.

Oil Level

Clean the body of the governor in the area of the fill plug.

Remove the oil level plug. If oil drips out the level is full. If oil doesn't drip out, remove the oil fill plug and add 10W-30 or 10W-40 engine oil into the fill hole until it starts dripping out oil level hole. Install the oil level and oil fill plugs.

Belt Tension

Belt tension should be checked on a cold belt only.

1. Install the belt tension tool on the drive belt (Figure 1) and check the tension.
2. If adjustment is required, loosen the governor adjusting bolts and move the governor until the correct tension is obtained.
3. Remove the gauge. Tighten the governor adjusting bolts. Install the tension gauge and recheck the belt tension.

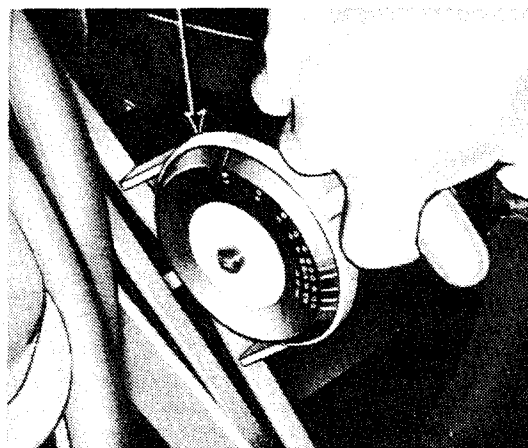

FIG. 1 Belt Tension

Throttle Control Rod

1. Manually move the governor throttle lever to the maximum open throttle with spring tension on the governor.
 2. Check the gap between the carburetor throttle shaft lever and its maximum open position stop (Figure 2). It should be 1/32 to 1/16 inch wide.
 3. If adjustment is necessary, loosen the control rod ball joint lock nuts, remove the rod from the carburetor throttle lever and adjust the length of the rod with the ball joints.
 4. Install the throttle control rod on the carburetor throttle lever and recheck the gap. Tighten the lock nuts.
- CAUTION** — Be sure the throttle control rod is properly installed with the long end at the governor to prevent binding on the ignition wires.

RPM ADJUSTMENTS

High Speed

First attach a tachometer to the engine, then run the engine until it reaches normal operating temperature.

1. Loosen the locknut on the high-speed stop screw.
2. Disengage engine load.
3. Slowly pull the throttle to desired maximum engine speed.

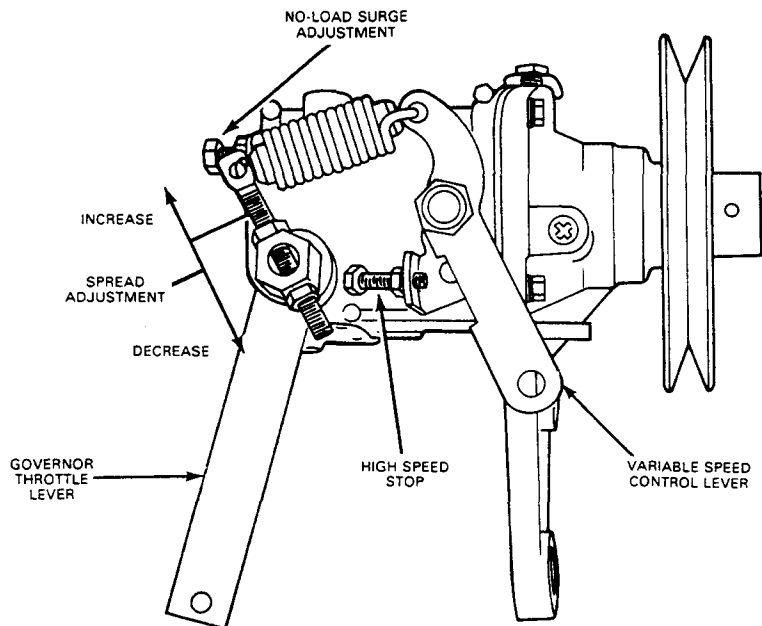

FIG. 2 Throttle Control Rod

4. Adjust the high-speed stop screw on the governor to attain the desired maximum engine speed. (Figure 3). Do not exceed the recommended maximum rpm.
5. Tighten the locknut.

Spread or Sensitivity

Proper governor operation requires a difference between full-load and no-load governed speed. Too small an rpm spread between the two speeds will cause governor hunting and surging. Too large a spread will cause low response. For this governor, normal rpm spread is

approximately 250 rpm with the full load speed range of 2000-2800 rpm.

Increase Spread

1. With the engine running under no-load at maximum governed speed, loosen the lock nuts and adjust the screw to move the spring away from the lever hub. Tighten the lock nuts.
2. Recheck governor operation under full-load and no-load conditions to determine if operation is stabilized and sensitivity is satisfactory.
3. Readjust the governor high-speed stop screw to maintain the correct high-speed under load.

Decrease Spread

1. With the engine under no-load at maximum governed speed, loosen the lock nuts and adjust the screw to move the spring closer to the lever hub. Tighten the lock nuts.
2. Recheck governor operation under load and no-load conditions.
3. Readjust the governor high-speed stop screw to maintain the correct high-speed under load.

Low Speed

1. Attach a tachometer and move the hand throttle, or variable speed lever, to the closed position.
2. Adjust the carburetor idle speed screw to obtain the desired idle speed.

No-Load Surge

The no-load surge adjustment is set at the factory and rarely requires adjustment. If necessary, this adjustment can be used to prevent hunting and surging at no-load speeds, provided the rpm spread adjustment is set properly.

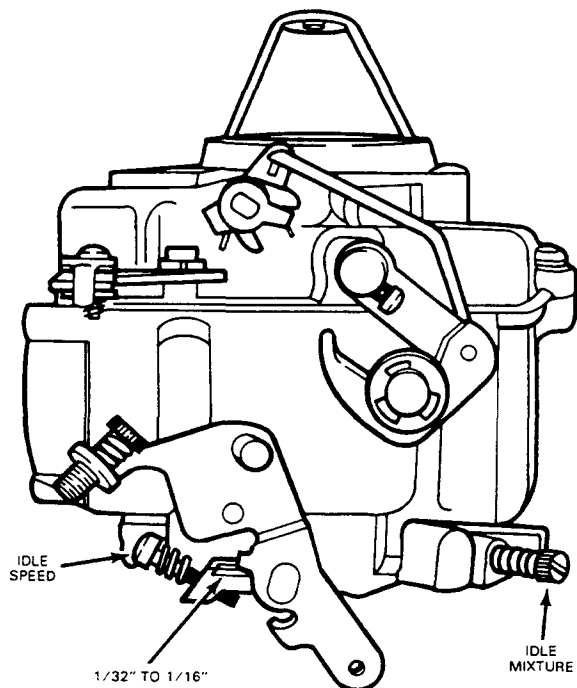

FIG. 3 Governor Adjustments

1. Make the adjustment with the tachometer installed. Increase the engine speed with the hand throttle or variable speed lever to 75 rpm lower than the maximum no-load desired control rpm.

NOTE: At this point if the engine continues to surge, light pressure applied to the governor throttle lever will dampen surge.

2. Then loosen the no-load surge adjustment screw locknut and turn the screw inward until the rpm increases to the desired control rpm.

CAUTION: Do not turn the screw in all the way. It will interfere with proper governor operation and prevent the governor from returning the engine to idle speed.

3. Readjust the governor high-speed stop screw to maintain the correct high-speed under load.

REMOVAL AND INSTALLATION

Removal

1. Disconnect hand throttle connection at governor variable speed lever.

2. Disconnect governor to carburetor throttle control rod at governor.
3. Loosen governor mounting nuts and bolts and move governor towards engine to loosen drive belt.
4. Remove drive belt from governor pulley.
5. Remove governor to bracket attaching bolts and remove governor.

Installation

1. Position the governor to the mounting bracket and install the attaching bolts snugly.
 2. Position drive belt to governor pulley and move the governor away from the engine to tighten the belt. Tighten the attaching bolts.
 3. Adjust the belt tension.
 4. Connect the governor to carburetor throttle control rod. Adjust the rod as described previously.
 5. Connect hand throttle cable to governor variable speed lever. Adjust cable as necessary to permit operation from idle to maximum speed.
-

PART 7 Cooling System

COMPONENT INDEX	Page	COMPONENT INDEX	Page
DESCRIPTION AND OPERATION	7-01	ADJUSTMENTS	
GENERAL INFORMATION	7-01	Drive Belts	7-04
DIAGNOSIS	7-01	Belt Tension	7-04
TESTING	7-02	REMOVAL AND INSTALLATION	
General Test Procedures	7-02	Cooling Fan	7-04
Cooling System Pressure Test ...	7-02	Fan Drive Belt	7-04
Radiator Cap Pressure Test	7-03	Radiator Hose	7-04
Thermostat Test-		Thermostat	7-04
Thermostat Removed	7-03	CLEANING AND ISPECTION	7-05

DESCRIPTION AND OPERATION

The system is of the full flow type with a centrifugal pump (Figure 1). The thermostat, located in the cylinder, controls the flow through the system maintaining the proper temperature.

The coolant flow is from the bottom of the radiator to the pump which delivers it to the cylinder block. It then flows through the cored passages to cool the entire length of each cylinder wall. Upon reaching the rear of the cylinder block, the coolant is directed upward into the cylinder head where it cools the combustion chambers, valves and valve seats.

The coolant from the cylinder head flows past the thermostat, if it is open, through the coolant outlet housing and into the top of the radiator.

Another passage in the head routes the warm coolant through the intake manifold to help atomize the fuel mixture, and then through a hose to the inlet of the water pump.

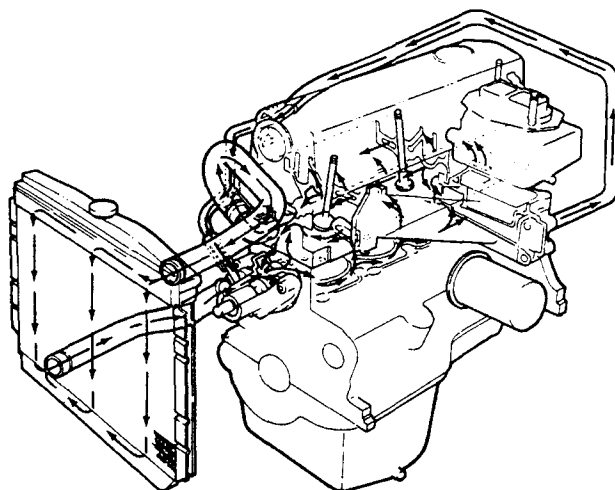

FIG. 1 Cooling System

GENERAL INFORMATION

This part covers general cooling system diagnosis service. For cooling system component removal,

disassembly, assembly, installation and repair procedures and specifications, refer to the pertinent Part of this Group.

DIAGNOSIS

Refer to the following Diagnosis Chart for cooling system problems, their possible cause and recommended correction. Refer to the pertinent Part for testing and repair.

The most frequent cooling system complaints are leakage and overheating. Either of these problems will soon render the vehicle inoperable.

Most vehicles use an Ethylene glycol base anti-freeze solution to which the manufacturers have added a dye color. The dye color makes the anti-freeze solution an excellent leak detector. If this type of solution is not being used in the cooling system, a vegetable dye may be added to aid in locating external leakage.

Complaint	Possible Cause	Resolution
<ul style="list-style-type: none"> Loss of coolant. 	<ul style="list-style-type: none"> Pressure cap and gasket. <ul style="list-style-type: none"> Leakage. <ul style="list-style-type: none"> External Leakage. Internal Leakage. 	<ul style="list-style-type: none"> Inspect, wash gasket and test. Replace only if cap will not hold pressure test specification. Pressure test system. <ul style="list-style-type: none"> Inspect hose, hose connection, radiator, edges of cooling system gaskets, core plugs and drain plugs, transmission oil cooler lines, water pump, heater system components. Repair or replace as required. Disassemble engine as necessary – check for: cracked intake manifold, blown head gaskets, warped head or block gaskets surfaces, cracked cylinder head or engine block.
<ul style="list-style-type: none"> Engine overheats. 	<ul style="list-style-type: none"> Low coolant level. Loose fan belt. Pressure cap. Radiator or A/C condenser obstruction. Closed thermostat. Fan drive clutch. Ignition. Temp gauge or cold light. Engine 	<ul style="list-style-type: none"> Fill as required. Check for coolant loss. Adjust. Test. Replace if necessary. Remove bugs, leaves, etc. Test, replace if necessary. Test, replace if necessary. Check timing and advance. Adjust as required. Check electrical circuits and repair as required. Refer to Volume 3. Check water pump, block for blockage.
<ul style="list-style-type: none"> Engine fails to reach normal operating temperature. 	<ul style="list-style-type: none"> Open thermostat. Temperature gauge or cold light. 	<ul style="list-style-type: none"> Test, replace if necessary. Check electrical circuits and repair as required. Refer to electrical section.

TESTING

GENERAL TEST PROCEDURES

Visual Inspection

- A. Check for leakage at:
 1. All hoses and hose connections.
 2. Radiator seams, radiator core, and radiator drain petcock.
 3. All block core plugs and drain plugs.
 4. Edges of all cooling system gaskets.
 5. Transmission oil cooler.
 6. Vehicle heating system components.
 7. Water pump shaft and bushing.
- B. Examine oil dipstick for evidence of coolant contaminated engine oil.
Check radiator for evidences of oil in coolant (leakage at transmission oil cooler).

COOLING SYSTEM PRESSURE TEST

1. Shut the engine off. To prevent loss of coolant and to avoid the danger of being burned, let the engine cool before removing the radiator cap. When removing the radiator cap, place a cloth over the cap and rotate the cap **SLOWLY** counterclockwise to the safety stop and allow the pressure to escape completely. Then, turn the cap again **SLOWLY** counterclockwise past the safety stop to remove.
2. Adjust the radiator coolant (Fill or drain) to one inch below the filler neck opening before testing. Wet the rubber sealing surface of the cap before installing the cap tightly on the radiator.
3. Disconnect the electrical connector from the engine temperature sending unit and remove the temperature sending unit from the manifold.

With the radiator cap installed and the cooling system pressure relieved, only a small amount of coolant will be lost when the sending unit is removed.

4. Install the adapter fitting from the Rotunda Pressure Tester 21-0012 (or equivalent) (male thread on one end, and a hose connector on the other end to accommodate the tester hose) tightly into the intake manifold or cylinder head in place of the sending unit. (See Fig. 2).
5. Remove the radiator overflow hose from the retainer clips. Make sure the hose is firmly installed on the radiator overflow nipple and is in good condition. Insert the free end of the overflow hose into a container of water.
6. Attach the pressure pump and gauge (Fig. 2) to the adapter fitting and pressurize the cooling system to the cap **LOWER LIMIT** as shown in the test chart.

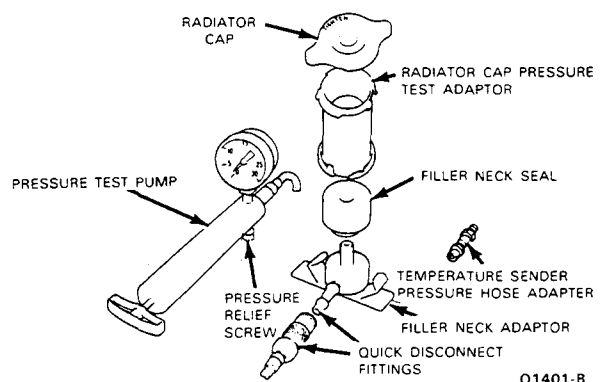

FIG. 2 Pressure Test Pump and Attachments

No bubbles should appear in the water container when the system is pressurized to the **LOWER LIMIT**. If the system is satisfactory at the lower limit, gradually increase the system pressure until a slight stream of bubbles appears in the water container. This is the upper limit of the pressure cap.

- Replace any radiator cap that exceeds the specified **UPPER LIMIT** pressure without discharging bubbles.
- If the radiator cap does not hold pressure, remove and wash the cap in clean water to dislodge all foreign particles from the gaskets. Check the sealing surface in the radiator filler neck.

Inspect the cam lock flanges on both sides of the filler neck for maximum cap engagement.

- Pressurize the cooling system as outlined in Step 6 (using a radiator cap that operates within the specified upper and lower pressure limits) and observe the gauge reading for approximately two minutes. See Specifications. Pressure should not drop during this time.

RESULTS: If the pressure drops, check for leaks at the engine to heater core hoses, engine to radiator hoses, bypass hose, water valve hose (if applicable), thermostat housing gasket, radiator and heater core, etc. Also refer to engine system checks if a leak cannot be located in the cooling system. Any leaks which are found must be corrected and the system rechecked.

If the system holds pressure proceed to Step 9.

- Release the system pressure by loosening the radiator cap and remove the adapter. Reinstall the temperature sending unit, check coolant level and replenish (if necessary) with the correct coolant solution.

RADIATOR CAP PRESSURE TEST

Refer to Fig. 2.

- Remove the radiator cap from the radiator filler neck.
- Immerse the radiator cap in water and install on the shallow filler neck of the Rotunda 21-0012 Radiator Cap Pressure Test Adapter or equivalent adapter.

NOTE: The adapter is designed to accept both deep and shallow neck radiator caps.

- Immerse the filler neck seal in water and install in the filler neck adapter.

NOTE: The filler neck seal is reversible so that it may be used on either a deep or shallow radiator filler neck. It will also fit either end of the radiator cap pressure test adapter.

- Install the filler neck adapter with filler neck seal on the deep filler neck end to the radiator cap pressure test adapter.
- Connect the female quick disconnect fitting of the pressure test pump to the male quick disconnect fitting of the filler neck adapter.
- SLOWLY** depress the plunger of the pressure test pump until the pressure gauge reading stops increasing and note the highest pressure reading obtained.

NOTE: If the plunger of the pump is depressed too fast, an erroneous pressure reading will result.

- Release the pressure by turning the pressure relief screw counterclockwise. Then tighten the pressure relief screw and repeat Step 6 (at least twice) to be sure the pressure test reading is repeatable within the acceptable gauge reading limits of the radiator cap and is not erratic. Refer to Specifications.
- If the pressure test gauge readings are not within the acceptable gauge reading limits, replace the radiator cap. If the pressure test gauge readings are within the acceptable gauge reading limits, perform the Cooling System Pressure Test.

THERMOSTAT TEST THERMOSTAT REMOVED

Remove the thermostat and immerse it in boiling water. Replace the thermostat if it does not open at least 0.230" after one minute at 212°F.

If the problem being investigated is insufficient heat, the thermostat should be checked for leakage. This may be done by holding the thermostat up to the lighted background. Leakage of light all around the thermostat valve (thermostat at room temperature) indicates that the thermostat is unacceptable and should be replaced. It is possible, on some thermostats, that a **slight** leakage of light at one or two locations on the perimeter of the valve may be detected. This should be considered normal.

ADJUSTMENTS

DRIVE BELTS

The fan drive belt(s) should be properly adjusted at all times. Loose drive belt(s) cause improper alternator, fan and water pump operation. A belt that is too tight places a severe strain on the water pump and the alternator bearings.

Properly tensioned drive belts minimize the noise and also prolong service life of the belt. Therefore, it is recommended that a belt tension gauge be used to check and adjust the belt tension. **Any belt that has operated for a minimum of 10 minutes is considered a used belt, and, when adjusted, it must be adjusted to the reset tension shown in the specification.**

Belt Tension

1. Install the belt tension tool on the drive belt (Fig. 3) and check the tension following the instructions of the tool manufacturer.
2. If adjustment is necessary, loosen the alternator mounting and adjusting arm bolts. Move the alternator toward or away from the engine until the correct tension is obtained. Remove the gauge. Tighten the alternator adjusting arm and mounting bolts. Install the tension gauge and check the belt tension.

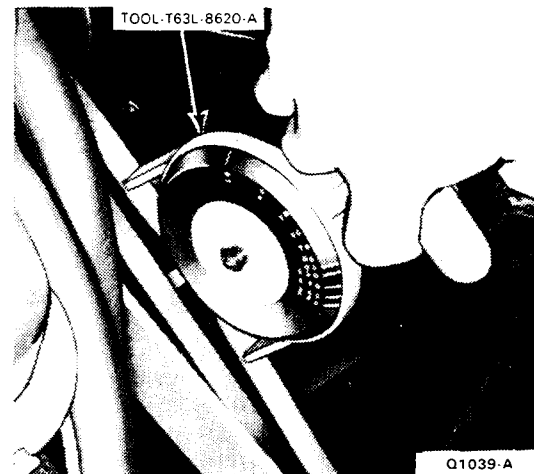

FIG. 3 Checking Drive Belt Tension

REMOVAL AND INSTALLATION

COOLING FAN

Removal

Remove the screws and washers assemblies attaching the fan to the water pump hub. Remove the fan.

Installation

Position the fan and spacer on the water pump hub. Loosen fan belt, if necessary. Install the lock washer and screws and torque the capscrews to specifications. Adjust the fan belt tension to specifications.

FAN DRIVE BELT

Removal

Loosen the alternator mounting and adjusting arm bolts. Move the alternator toward the engine. Remove the belt(s) from the alternator and crankshaft pulleys, and lift them over the fan.

Installation

Place the belt(s) over the fan. Insert the belt(s) in the water pump pulley, crankshaft pulley and alternator pulley grooves. Adjust the belt tension to specifications.

RADIATOR HOSE

Removal

Radiator hoses should be replaced as directed in the pertinent car Maintenance Schedule or whenever they become cracked, rotted or have a tendency to collapse.

Drain the radiator; then loosen the clamps at each end of the hose to be removed. Slide the hose off the radiator

connection and the engine water outlet connection (upper hose) or the water pump connection (lower hose).

Installation

Position the clamps at least 1/8 inch from each end of the hose. Coat the connection areas with an approved water-resistant sealer and slide the hose on the connection. **Make sure the clamps are beyond the bead and placed in the center of the clamping surface of the connections. Tighten the clamps. Fill the radiator with the recommended permanent antifreeze and water mixture. Operate the engine for several minutes, then check the hoses and connections for leaks.**

THERMOSTAT

Removal

1. Drain the radiator so that the coolant level is below the thermostat.
2. Disconnect the heater return hose at the thermostat housing located on the left front lower side of engine.
3. Remove the coolant outlet housing retaining bolts. Pull the elbow away from the cylinder head or manifold sufficiently to provide access to the thermostat. Remove the thermostat and gasket.

Installation

Check the thermostat before installing it, following the procedure under **Thermostat Test**, Part 27-01, Section 1.

1. Clean the coolant outlet housing and cylinder head or manifold gasket surfaces. Coat a new gasket with water resistant sealer. Position the gasket on the cylinder head opening. **The gasket must be positioned**

on the cylinder head before the thermostat is installed.

To prevent incorrect installation of the thermostat, the water outlet casting contains a locking recess into which the thermostat is turned and locked. Install the thermostat with the bridge section (Fig. 4) in the outlet casting. Turn the thermostat clockwise to lock it in position on the flats cast into the outlet elbow.

2. Position the coolant outlet elbow against the cylinder head. Install and torque the retaining bolts to specifications.
3. Connect heater return hose to thermostat housing.
4. Fill the cooling system with the recommended Permanent Antifreeze and water mixture. Check for leaks and proper coolant level after the engine has reached normal operating temperatures.

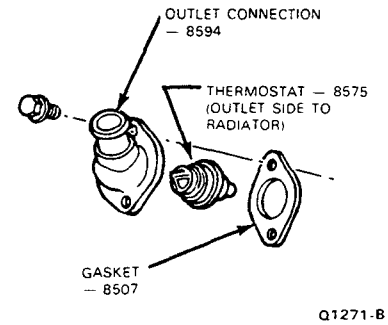

FIG. 4 4-Cylinder Thermostat and Housing — Disassembled View

CLEANING AND INSPECTION

CLEANING COOLING SYSTEM

To remove rust, sludge and other foreign material from the cooling system, use Rotunda Cooling System Cleanser. Removal of such material restores cooling efficiency and avoids overheating. **Always remove the thermostat prior to pressure flushing.** A pulsating or reversed direction of flushing water flow will loosen

sediment more quickly than a steady flow in the normal direction of coolant flow. In severe cases where cleaning solvents will not properly clean the cooling system for efficient operation, it will be necessary to use the pressure flushing method. Various types of flushing equipment are available.



SPECIFICATIONS

GENERAL SPECIFICATIONS

Bore	3.78
Stroke	3.126
Firing Order	1-3-4-2
Idle Speed	600 RPM
Rated Engine Speed	2800 rpm
Oil Pressure — Hot @ 2000 rpm	40-60 psi

CYLINDER HEAD

Combustion Chamber Volume	59.8 - 62.8
Compression Pressure	PSI of the lowest cylinder must be at least 75% of the highest cylinder
Valve Guide Bore Diameter—Standard	
Intake and Exhaust	0.3433 - 0.3443
Valve Seat Width —	
Intake	0.060 - 0.080
Exhaust	0.070 - 0.090
Valve Seat Angle (Int. & Exh.)	45°
Valve Seat Runout (Max.)	0.0016
Valve Arrangement (Front to Rear)	E-I-E-I-E-I-E-I
Valve Tappet Bore Diameter	0.8430 - 0.8449
Gasket Surface Flatness. 0.003 inches in any 6 inches 0.007 overall	
Head Gasket Surface Finish RMS	60-150

VALVE ROCKER ARMS, ROCKER ARM SHAFT, PUSHRODS AND TAPPETS

Rocker Arm Lift Ratio	1.64:1
Valve Tappet or Lifter —	
Standard Diameter	0.8422 - 0.8427
Clearance to Bore	0.0007 - 0.0027
Wear Limit	0.005
Hydraulic Leakdown Rate (Seconds)	2 - 8
Collapsed Tappet Gap —	
Allowable @ Cam	0.035 - 0.055
Desired @ Cam	0.040 - 0.050

VALVE SPRINGS

Valve Spring Pressure — Lbs. @ Specified Length	
Intake	71-79 @ 1.56
Exhaust	159-175 @ 1.16
Wear Limit	10% Loss of Pressure
Valve Spring Free Length (Approx.)	1.89
Valve Spring Assembled Height	
(Pad to Retainer)	1-17/32 - 1-19/32
Valve Spring Out of Square (Max.)	5/64 (0.078)

VALVES

Valve Stem to Valve Guide Clearance	
Intake	0.0010 - 0.0027
Exhaust	0.0015 - 0.0032
Wear Limit	0.0055
Valve Head Diameter	
Intake	1.73 - 1.74
Exhaust	1.49 - 1.51
Valve Face Angle	44°
Valve Face Runout (Max.)	0.002
Valve Stem Diameter	

Standard	
Intake	0.3416 - 0.3423
Exhaust	0.3411 - 0.3418
0.003 Oversize	
Intake	0.3446 - 0.3453
Exhaust	0.3441 - 0.3448
0.015 Oversize	
Intake	0.3566 - 0.3573
Exhaust	0.3561 - 0.3568
0.030 Oversize	
Intake	0.3716 - 0.3723
Exhaust	0.3711 - 0.3718

CAMSHAFT

Lobe Lift	
Intake & Exhaust	0.2381
Allowable Lobe Lift Loss (Max.)	0.005
Theoretical Valve Lift @ Zero Lash	
Intake & Exhaust	0.390
Camshaft	
End Play	0.001 - 0.007
Wear Limit	0.009
Camshaft Journal to Bearing Clearance ...	0.001-0.003
Wear Limit	0.006
Camshaft Journal Diameter	1.7713-1.7720
Camshaft Journal Maximum Runout	0.005
Camshaft Journal	
Maximum Out-of-Round	0.005

Camshaft Bearings Location

Distance in inches that the front edge of the bearing is installed towards the rear from the front face of the bearing tower. 0.000 - 0.010

CYLINDER BLOCK

Cylinder Bore Diameter	3.7795 - 3.7831
Maximum Out-of-Round	0.0015
Wear Limit — Out-of-Round	0.005
Wear Limit — Taper	0.010
Cylinder Bore Surface Finish RMS	18 - 38
Main Bearing Bore Dia.	2.5902 - 2.5910
Distributor Shaft Bearing Bore Dia. ..	0.5155 - 0.5170
Head Gasket Surface Flatness	0.003 inch in any 6 inches 0.006 inch overall
Head Gasket Surface Finish RMS	60 - 150
Crankshaft to Rear Face of Block Runout	
TIR Maximum	0.005

CRANKSHAFT AND FLYWHEEL

Main Bearing Journal Diameter	2.3990 - 2.3982
Main Bearing Journal Max. Out-of-Round ...	0.0006
Main Bearing Journal Runout — Max.	0.0020
Wear Limit	0.005
Main Bearing Journal Thrust Face Runout	0.001
Main Bearing Journal Taper — Max. 0.0006 per inch	
Thrust Bearing Journal Length	1.201-1.199
Main and Rod Bearing Journal	
Finish RMS — Max.	12
Main Bearing Thrust Face	
Finish RMS	35 Front/25Rear (Max.)

Connecting Rod Journal Diameter ...	2.0464 - 2.0472
Rod Bearing Journal	
Maximum Out-of-Round	0.0006
Connecting Rod Bearing Journal	
Maximum Taper	0.0006 per inch
Crankshaft Free End Play	0.004 - 0.008
Wear Limit	0.012
Flywheel Clutch Face Runout	0.005
Flywheel Ring Gear Lateral Runout	
Standard Transmission	0.025
Automatic Transmission	0.060

CRANKSHAFT BEARINGS

Connecting Rod Bearings	
To Crankshaft Clearance	
—Desired	0.0008 - 0.0015
—Allowable	0.0008 - 0.0026
Wall Thickness — Standard	0.0619 - 0.0624
0.002 U.S. Thickness — Add 0.001 to	
Standard Thickness	
Main Bearings	
To Crankshaft Clearance	
—Desired	0.0008 - 0.0015
—Allowable	0.0008 - 0.0026
Wall Thickness — Standard	0.0951 - 0.0956

CONNECTING ROD

Piston Pin Bore or Bushing ID	0.9104 - 0.9112
Connecting Rod Bearing Bore Dia. ..	2.1720 - 2.1728
Out-of-Round (Max.)	0.0004
Taper (Max.)	0.0004

Connecting Rod Alignment — Maximum total diff. Pin Bushing and crankshaft bearing bore must be parallel and in the same vertical plane within the specified total difference at ends of 8-inch long bar measured 4 inches on each side of rod.

Twist	0.024
Bend	0.012
Connecting Rod Assembly (assembled to Crankshaft)	
Side Clearance	0.0035 - 0.0105
Wear Limit	0.0150

PISTON

Diameter	
(Measured 90° to pin centerline and at	
pin centering height.)	
Coded Red	3.7780 - 3.7786
Coded Blue	3.7792 - 3.7798
0.003 Oversize	3.7804 - 3.7810
Piston to Cylinder Bore Clearance ...	0.0014 - 0.0022
Piston Pin Bore Diameter	0.9123 - 0.9126
Ring Groove Width	
Top Compression Ring	0.080 - 0.081
Bottom Compression Ring	0.080 - 0.081
Oil Ring	0.1880 - 0.1890

PISTON PIN

Length	3.010 - 3.040
Diameter	
Standard	0.9119 - 0.9124
To Piston Clearance	0.0002 - 0.0004
To Connecting Rod Clearance	Interference Fit

PISTON RINGS

Ring Width	
Compression Ring (Top & Bottom) ..	0.077 - 0.078
Side Clearance	
Compression Ring (Top & Bottom) ..	0.002 - 0.004
Oil Ring	Sung Fit
Wear Limit	0.006 Maximum
Ring Gap	
Compression Ring (Top & Bottom) ..	0.010 - 0.020
Oil Ring	0.015 - 0.055

OIL PUMP

Relief Valve Spring Tension —	
Lbs. @ Specified Length	15.2 - 17.2 @ 1.20
Drive Shaft to Housing Bearing	
Clearance	0.0015 - 0.0030
Relief Valve Clearance	0.0015 - 0.0030
Rotor Assembly End Clearance —	
Pump Assembled	0.0010 - 0.0040
Outer Race to Housing —	
Radial Clearance	0.001 - 0.0013

APPROXIMATE CAPACITIES

Crankcase Capacity (Quarts)	4
Add one quart extra when changing oil filter.	
Coolant Capacity (Quarts) (Power Units)	11.5

TORQUE LIMITS

NOTE — All values are in ft-lbs unless otherwise stated. Oil threads with lightweight engine oil unless the threads require oil resistant or water resistant sealer.

TORQUE SPECIFICATIONS — Special Application

ITEM	SIZE	TORQUE (FT. LB)
Auxiliary Shaft Gear Bolt	M-10	28-40
Auxiliary Shaft Thrust Plate Bolt	M-6	6-9
Belt Tensioner (Timing) Pivot Bolt	M-10	28-40
Belt Tensioner (Timing) Adjusting Bolt	M-8	14-21
Camshaft Gear Bolt	M-12	80-90
Camshaft Thrust Plate Bolt	M-6	6-9
Carburetor to Spacer Stud	M-8	7.5-15
Carburetor Spacer to Manifold Bolt	M-8	10-14
Connecting Rod Nut	M-9	30-36
Crankshaft Damper Bolt	M-14	100-120
Cylinder Head Bolt	M-12	50-60 Step 1 80-90 Step 2
Distributor Clamp Bolt	M-10	14-21
Distributor Vacuum Tube to Manifold Adapter		5-8
Exhaust Man to Cyl Head Bolt Stud or Nut	M-10	16-23
Flywheel to Crankshaft Bolt	M-10	54-64
Fuel Pump to Cylinder Block	M-8	14-21
Intake Manifold to Cyl Head Bolt or Nut	M-8	5-7 Step 1 14-21 Step 2
Main Bearing Cap Bolt	M-12	80-90
Oil Pressure Sending Unit to Block		8-18
Oil Pump Pickup Tube to Pump	M-8	14-21
Oil Pump to Block	M-8	14-21
Oil Pan Drain Plug to Pan	M-14	15-25
Oil Pan to Block	M-6	6-8
	M-8	8-10
Oil Filter Insert to Block		20-25
Rocker Arm Cover to Cylinder Head	M-6	4-7
Spark Plug to Cylinder Head	M-14	5-10
Temperature Sending Unit to Block		8-18
Water Jacket Drain Plug to Block		23-28
Water Pump to Block Bolt	M-8	14-21
Auxiliary Shaft Cover Bolt	M-6	6-9
Water Outlet Connection Bolt	M-8	14-21
Cylinder Front Cover Bolt	M-6	6-9
Inner Timing Belt Cover Stud	M-8	14-21
Outer Timing Belt Cover Bolt	M-6	6-9

TORQUE SPECIFICATIONS — General Applications

U.S. THREAD SIZES	TORQUE
1/4-20	6-9
5/16-18	12-18
5/16-24	14-20
3/8-16	22-32
3/8-24	27-38
7/16-14	40-55
7/16-20	40-60
1/2-13	55-80

METRIC THREAD SIZES

TORQUE

M-6	6-9
M-8	14-21
M-10	28-40
M-12	50-71
M-14	80-114

PIPE THREAD SIZES

TORQUE

1/8	5-8
1/4	12-18
3/8	22-33
1/2	25-35

FUEL PUMP

Static Pressure (P.S.I.)	5.0 - 7.0
Minimum Volume Flow	1 Pint in 25 Seconds
Eccentric Total Lift (Inches)	0.304 - 0.326

STARTER

Positive Engagement Starter Motor					
Diameter	Current Draw Under Normal Load (Amps)	Normal Engine Cranking Speed (rpm)	Min. Stall Torque @ 5 Volts	Max. Load (Amps)	No Load (Amps)
4 in.	150	110	9.0 ft.-lbs.	460	70

Starter Brushes				
Mfg. Length	Wear Limit	Spring Tension (Ounces)	Through Bolt Torque	Mounting Bolt Torque
0.50 in.	0.25 in.	40	55-75 in.-lbs.	15-20 ft.-lbs.

Maximum Commutator runout is 0.005 inch. Maximum starting circuit voltage drop (battery positive terminal to starter terminal) at normal engine temperature is 0.5 volt.

IGNITION SYSTEM

DISTRIBUTOR

Gear Location Dimension — Distributor (Distance from bottom of mounting flange to bottom of gear)	2.220 - 2.230
Shaft End Play Clearance — Distributor	0.022 - 0.033

BREAKER POINT TYPE

Initial Spark Advance — BTDC	10°
Breaker Arm Spring Tension.....	17-21 oz.
Contact Spacing	0.025
Dwell Angle at Idle Speed	37°-41°
Condenser	
Capacity — Microfarads	0.21 - 0.25
Minimum Leakage — Megohms	10
Maximum Series Resistance Ohms	1
Coil	
Primary Resistance — Ohms.....	1.40 - 1.54 (75°F.)
Secondary Resistance — Ohms .	7600 - 8800 (75°F.)
Amperage Draw	
Engine Stopped.....	4.5
Engine Idling	2.5
Primary Circuit Resistance — Ohms	1.30 - 1.40 (75°F.)
Spark Plugs	
Plugs (Motorcraft)	AWSF-42
Gap (inches).....	0.032-0.036

SOLID STATE TYPE

Initial Spark Advance — BTDC	10°
Coil	
Primary Resistance Wire — Ohms	1.13 - 1.23(75°F.)
Secondary Resistance — Ohms .	7700 - 9300 (75°F.)
Amperage Draw	
Engine Cranking	4.0
Engine Idling	5.0
Emitter (Ohms)	0.31 - 0.35 (75°F.)
Collector (Ohms)	0.41 - 0.45 (75°F.)
Base (Ohms).....	7.1 - 7.9 (75°F.)
Rotor Air Gap Voltage Drop (KV Max.)	8.0
Spark Plugs..... AWSF-42	
Gap (Inches) (Service)	0.050

**DISTRIBUTOR
ADVANCE CHARACTERISTICS**

Centrifugal Advance. Set the test stand to 00° at 250 rpm and 0 inches at vacuum.

Distributor (rpm)	Advance (Degrees)	Vacuum (Inches of Mercury)
500	0 - ½	0
750	3 - 5	0
1000	5 - 7	0
1500	9½ - 11½	0
2000	10½ - 13	0

Vacuum Advance. Set the test stand to 0° at 1000 rpm and 0 inches of Hg.

Distributor (rpm)	Advance (Degrees)	Vacuum (Inches of Mercury)
1000	0 - 2½	5
1000	4 - 7	10
1000	6¾ - 9¼	15
1000	6¾ - 9¼	20

BELT TENSION

Belt Tension — All Except Governor

New	140 ft.-lbs.
Used	100 ft.-lbs.

Governor

New	140 ft.-lbs.
Used	100 ft.-lbs.

A used belt is one that has been in operation for 10 minutes or more.