

LC50 INITIAL ADJUSTMENTS:

THE MAIN ADJUSTMENT SCREW (MAS) SETTINGS ARE MEASURED FROM THE MAS VALVE BODY (NOT THE JAM NUT) TO THE EXTERIOR END OF THE MAS SCREW. THE ZERO-PRESSURE REGULATOR SETTINGS ARE MEASURED FROM THE TOP OF THE SPRING ADJUSTMENT SCREW TO THE TOP OF THE SPRING TOWER.

THESE INITIAL SETTINGS SHOULD GET THE GENSETS UP AND RUNNING FOR THE FINAL ADJUSTMENTS WITH AN OXYGEN SENSOR OR EXHAUST ANALYZER. THE MAS SHOULD BE ADJUSTED FIRST WITH SIGNIFICANT (75-95) LOAD ON THE ENGINE. THE ZPR SHOULD THEN BE ADJUSTED AT NO-LOAD. ONE OR TWO MORE ITERATIONS AT FULL LOAD FOR THE MAS AND NO LOAD FOR THE ZPR SHOULD PROVIDE THE CORRECT AIR/FUEL RATIO OVER THE ENTIRE OPERATING RANGE.

FOR DUAL-FUEL CONFIGURATIONS, THE STANDARD NG FUEL SET UP SHOULD HAVE A TEE ADDED BETWEEN THE ZPR AND MAS. THE SIDE-LEG OF THE TEE SHOULD THEN HAVE THE MAS AND ZPR FOR THE LP FUEL. THE FINAL SETTINGS FOR THE DUAL-FUEL NG AND LP ARE THE SAME AS THE SINGLE-FUEL SETTINGS BELOW. THE FINAL AIR/FUEL RATIO ADJUSTMENTS SHOULD BE DONE ON NG FIRST, THEN LP, USING THE PROCEDURE ABOVE FOR EACH FUEL.

- 50MM LC50 (5.7 GM)
NG: MAS (3/4") 19MM, ZPR (MAXITROL R5002) (5/8) 18MM
LP (VAP): MAS (5/8") 18MM, ZPR (MAXITROL R5002) (9/16) 14MM
 - 43MM LC50 (4.5 GM)
NG: MAS (11/16") 17MM, ZPR (MAXITROL R6002) (5/8) 18MM
LP (VAP): MAS (19/32") 15MM, ZPR (MAXITROL R5002) (9/16) 14MM
 - 36MM LC50 (3.0 GM)
NG: MAS (7/16") 11MM, ZPR (MAXITROL R5002) (5/8) 18MM
LP (VAP): MAS (3/8") 9.5MM, ZPR (MAXITROL R5002) (9/16) 14MM
 - 36MM LC50 (2.5L NISSAN)
NG: MAS (3/8") 10MM, ZPR (MAXITROL R6002) (9/16) 14MM
LP (VAP): MAS (5/16") 8MM, ZPR (MAXITROL R6002) (9/16) 14MM
- (NISSAN TIMING: NG=17 LP=12)

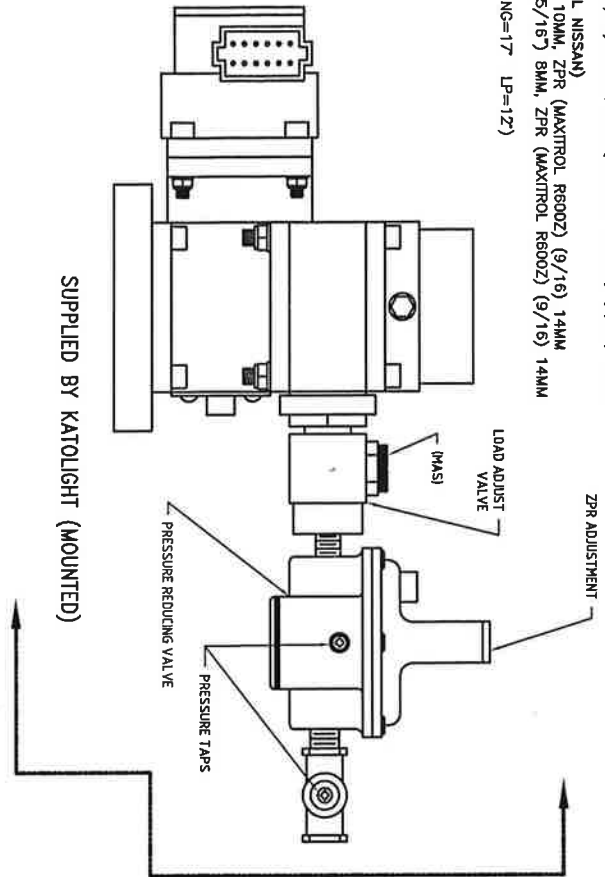

SUPPLIED BY KATOLIGHT (MOUNTED)

CONTROL PANEL	+ TERMINAL #	-TERMINAL
40 & 50 SERIES	TERMINAL #2	9
KDGC-2000/2001	* TERMINAL #2	* 9
KGM-250	TERMINAL #2	9
KDGC-500	TERMINAL #2	9

ENERGIZE TO RUN GROUND

* SEE ELECTRICAL SCHEMATIC FOR PROPER TERMINAL NUMBERS USED FOR FUEL SOLENOID WIRING

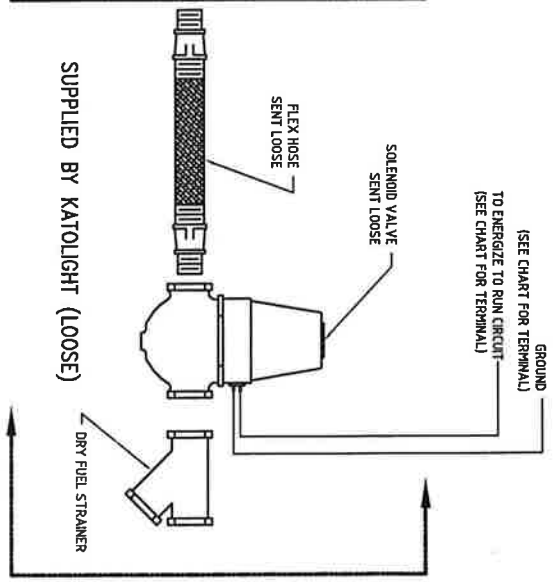

SUPPLIED BY KATOLIGHT (LOOSE)

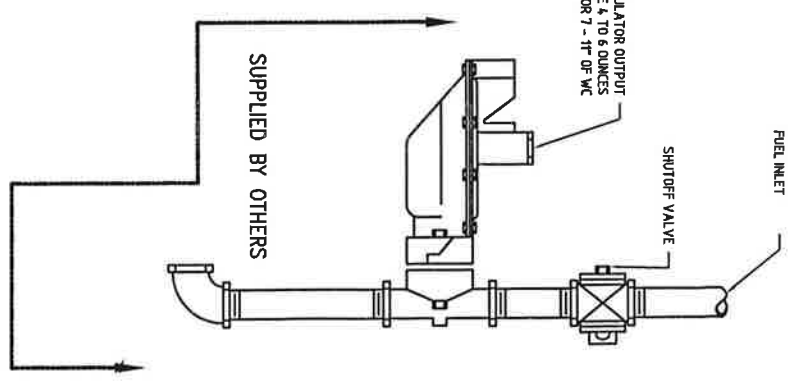

SUPPLIED BY OTHERS

- NOTES:**
1. TYPICAL SPRING LAYOUT WHEN LINE REGULATOR IS MOUNTED AND MORE THAN TEN FEET FROM COMPENSATOR
 2. FOR LP VAPOR FUEL DO NOT REMOVE REGULATOR SPRING THE REGULATOR DOES NOT NEED TO BE TURNED DOWN

- REVISIONS:**
1. ADDED MM CONVERSIONS TO INCHES, 6-14, 01 GAG
 2. ADDED NISSAN ENGINE SETTINGS TO DRAWING, 1-19, 04, HRL

FOR PGL GM ENGINES & NISSAN ENGINES ONLY

KATOLIGHT
MANKATO, MINNESOTA

GM & NISSAN ENGINES NG AND LP FUEL SYSTEM

SIZE	DATE	DWG NO
B	4-18-01	204-206-26-1

SCALE NONE PART NO DWG BY SAAI SHEET 1 OF 1

THIS DRAWING IS PROPERTY OF KATOLIGHT CORPORATION AND IS INTENDED FOR USE WITH OUR VEHICLES AND CUSTOMERS. ANY CHANGES/MODIFICATIONS BY OTHERS MAY VOID DRAWING. DRAWING CHANGES MUST BE DONE BY KATOLIGHT AND MAY BE DONE SO AT ANYTIME.

GM 2.5

NG: MAS (3/8) 9.5mm, ZPR (9/16) 14mm 24°
LP: MAS (5/16) 8mm, ZPR (9/16) 14mm 18°
Dual Fuel 21°

GM 3.0

NG: MAS (7/16) 11mm ZPR (5/8) 16mm 36°
LP: MAS (3/8) 9.5mm ZPR (9/19) 14mm 26°
Dual Fuel 30°

GM 4.3

NG: MAS (11/16) 17mm ZPR (5/8) 16mm 36°
LP: MAS (19/32) 15mm ZPR (9/16) 14mm 26°
Dual Fuel 30°

GM 5.0°

NG: MAS (3/4) 19mm ZPR (5/8) 16mm 36°
LP: MAS (5/8) 16mm ZPR (9/16) 14mm 26°
Dual Fuel 30°

GM 5.7

- NG: MAS (3/4) 19mm ZPR (5/8) 16mm 36°
- LP: MAS (5/8) 16mm ZPR (9/16) 14mm 26°
Dual Fuel 30°

Nissan H25

NG: MAS (3/8) 9.5mm, ZPR (9/16) 14.5mm 17°
LP: MAS (5/16) 8mm, ZPR (9/16) 14.5mm 12°
Dual Fuel 15°

MAS - LOAD ADJUST
ZPR - START ADJUST

CRV 2.8
Timing - NG 26°
LP 24°

MAS - 12mm NG
10mm LP

ZPR - 14mm LP
12mm NG