

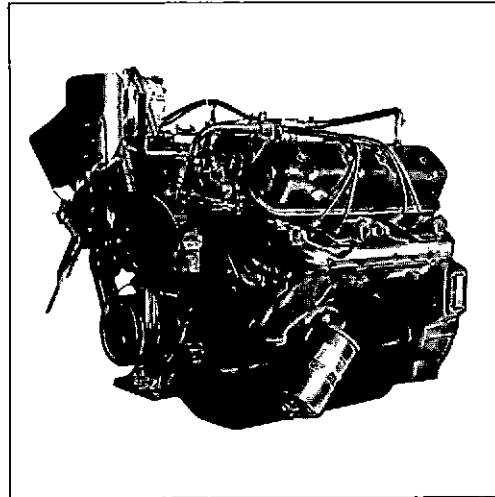

International Engine Model

# C-549



**Gasoline/Natural gas 178 hp @ 2600 rpm  
(natural gas)**

### Standard Engine Includes:

Intake manifold.  
Exhaust manifold, down outlet.  
Distributor ignition (12 volt), spark plugs and cables.  
Electric 12 volt cranking motor, 37 amp.  
alternator.  
Lubricating oil filter.  
Flywheel for 11½ in. driving ring clutch.  
Flywheel housing, industrial, SAE No. 2.  
Positive crankcase ventilation.  
Full pressure lubrication pump, oil cooler and oil pan.  
Water pump.  
Front mounting bracket. (optional)  
Tachometer drive, 2:1 ratio.  
Gear-driven mechanical governor. (optional)

### General Specifications

Max. hp @ rpm (natural gas)	178 @ 2600
Peak Torque @ rpm (natural gas)	395 @ 1200
Number of cylinders	8
Bore and stroke, in.	4.500 x 4.312
Displacement, cu. in.	548.7
Compression ratio: gasoline	7.57:1
natural gas	9.5:1
Engine rotation, flywheel end	counterclockwise
Weight, lbs. (approximate)	1240

### Features

Machined combustion chambers for efficient combustion.

Heavy-duty replaceable, tri-metal main bearings.

Controlled flow cooling system assures fast warmup and uniform engine temperature.

Gear type oil pump with full-flow filter.

### Engineering Data

Water flow @ 2400 rpm	83 gpm
Fan to crank ratio	1:1
Heat rejection @ 2400 rpm (full load)	35.0 btu/hp-min
Air flow @ 2400 rpm (Int.)	320 cfm
Exhaust gas flow @ 2400 rpm (Int.)	972 cfm
Max. permissible restrictions:	
Intake system	8" H <sub>2</sub> O initial 20" H <sub>2</sub> O final
Exhaust system	20" H <sub>2</sub> O
Cooling system capacity:	
Engine	22 U.S. quarts
Lubricating system capacity	15 U.S. quarts

# C-549

## Dimensions in inches

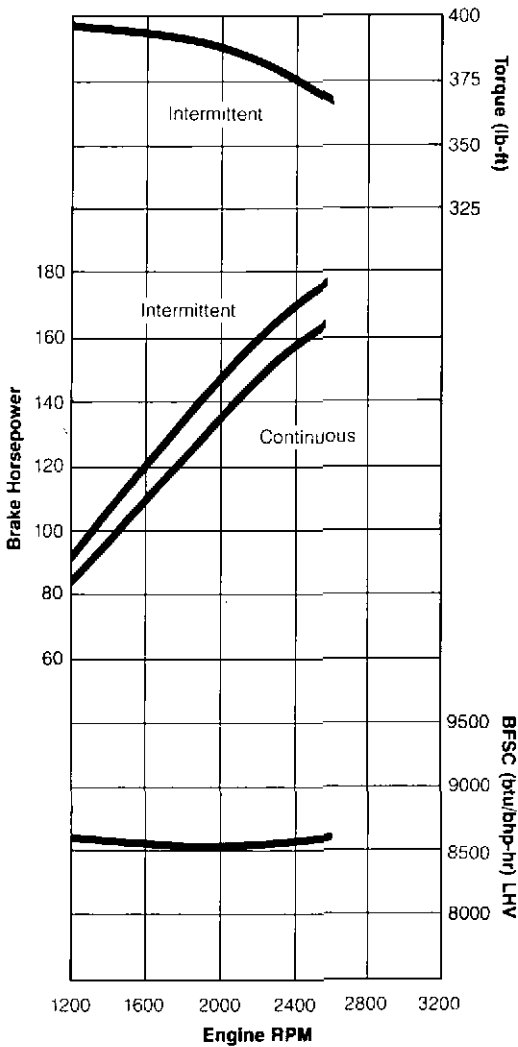
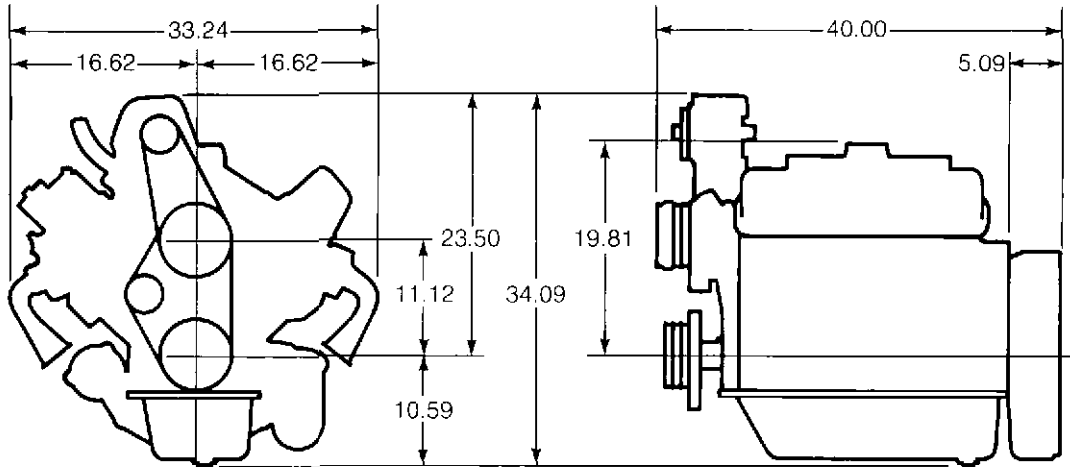

Engine Performance Curve

## Engine Performance Curve

4.500 in. (114.3 mm) x 4.312 in. (109.5 mm) x 8 cyl. engine

Displacement—548.7 cu. in. (8991cc)

Performance curves are for a complete engine less fan and air cleaner, alternator not charging.

This chart represents performance at approx. 500 ft. altitude and 85°F air temperature (SAE J-816a). Thereafter derate 3½% per 1000 ft. altitude and 1% each of 10°F temperature increase.

Fuel: Natural Gas LHV 936 btu/cu. ft.



**INTERNATIONAL HARVESTER**