

INTERNATIONAL[®] ENGINES

OPERATOR'S MANUAL

**UV-401 AND UV-549
ENGINES AND
ATTACHMENTS
FORM 1 085 521 R 3
AUGUST, 1974**

(Supersedes FORM 1 085 521 R 2)

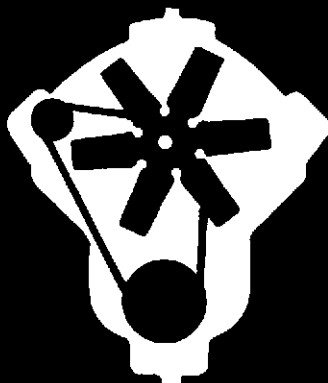
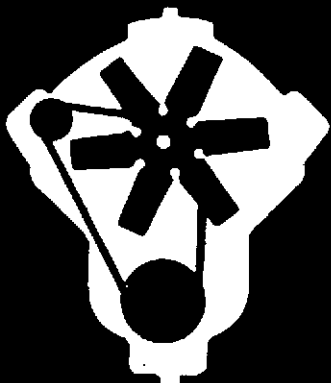
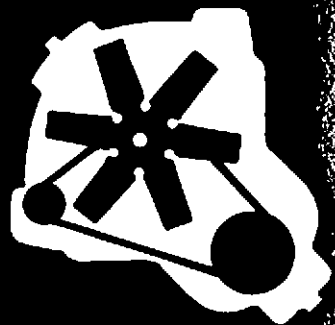
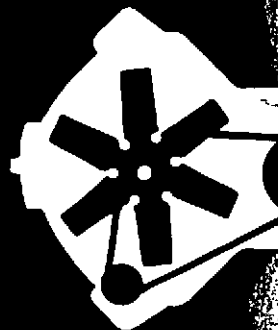
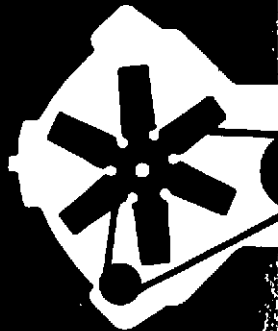

TECHNICAL PUBLICATIONS

An Operator's Manual and a Parts Catalog are packed and shipped with this machine for customer use. Additional technical publications are available for this machine, at a nominal cost, through your authorized International Engine distributor or dealer. This material includes Service Manuals and Technical Training Courses.

These additional publications are strongly recommended for the customer who performs his own maintenance and service on this equipment.

It is the policy of International Harvester Company to improve its products whenever it is possible and practical to do so. We reserve the right to make changes or add improvements at any time without incurring any obligation to make such changes on products sold previously.

UV-401 AND UV-549

ENGINES AND ATTACHMENTS

FORM 1 085 521 R 3

AUGUST, 1974

(Supersedes FORM 1 085 521 R 2)

SERVICE MANUAL INFORMATION

Your Authorized International Engine Distributor and his factory trained servicemen are best qualified to service your equipment. Up-to-date instructions and adequate special tools are also a part of your Distributor's service facilities.

This Operator's Manual was prepared to instruct you in proper operation and maintenance of your engine. If you desire additional information you may purchase Service Manuals.

Cut out this order blank and forward, together with your check or money order in the appropriate amount (U.S. Funds) to:

International Harvester Company

IHC Printing and Distribution Services

807 Blackhawk Drive

Westmont, Illinois 60559

Attention: Cashier

----- Cut along this line -----

Please send me (check items in box)

ISS-1034-1 Engine Service Manual \$7.00

TOTAL _____

Please print

Name

Street Address

City

State

Zip Code

Prices subject to change without notice.

	Page
INTRODUCTION	1B to 3
Serial Numbers.....	2
Ventilation of engines installed inside buildings.....	2
Suggested engine and fuel tank arrangement	2
DESCRIPTION	4 to 8
Specifications and capacities	4
Instruments and controls.....	5 to 8
OPERATION	9 to 13
Before starting a new engine	9
Lubrication when shipped	9
Precautions	10
Liquified petroleum gas or natural gas engines.....	10, 11
Preparing the engine for each day's work.....	11
Operating the engine	11
Starting the engine.....	11 to 13
Instrument panel (regular gauges).....	11, 12
Instrument panel (safety gauges)	12
Instrument check.....	12, 13
Stopping the engine.....	13
SCHEDULED MAINTENANCE	15 to 21
Scheduled	15, 16
Periodic	16
Lubrication	16, 17
Lubrication specifications and capacities chart	18
Lubrication guide (engine).....	19, 20
Lubrication guide (power take-off)	21
MAINTENANCE	23 to 63
Preparing for cold weather.....	23
Preparing for hot weather.....	23, 24
Cooling system.....	24 to 30
Radiator type.....	24
Flo-matic type	24
Care of the system.....	24
Anti-freeze solution	24
Cooling conditioners	25
Water	25
Preventive maintenance	25, 26
Radiator cap	26
Cleaning the radiator core	27
Thermostats.....	28
Water pump	28
Flo-matic valve.....	28, 29
Belts.....	30 to 32
Air cleaner (wet type)	32, 33
Cleaning the oil cup.....	32
Washing the air cleaner.....	32, 33
Air cleaner (dry type)	33 to 36
Automatic dust unloader	33
Filter element service.....	33
Air intake cap.....	33
Air cleaner pre-cleaner (collector type).....	33
Lubricating oil filter.....	36

C O N T E N T S

PAGE 1A

	Page
MAINTENANCE - Continued	23 to 63
Crankcase ventilation	36, 37
Oil cooler	37
Hydraulic valve lifters	37
Oil level sight gauge	37
Electrical system	38 to 51
Regulator	38
Alternator	38
Cranking motor	38
Ignition coil	39
Spark plugs	39
Spark plug cables	40
Storage battery	40
Distributor	40
Wiring Diagram	44 to 51
Side mounted instrument panel	44 to 47
Rear mounted instrument panel	48 to 51
Fuel system (gasoline)	51 to 53
Carburetor	51, 52
Fuel pump and filter	53
Cleaning the filter screen	53
Fuel system (liquefied petroleum gas)	53 to 55
Carburetor and regulator	53, 54
Fuel filter	55
Fuel system (natural gas)	55, 56
Carburetor and regulator	55, 56
Governor	57, 58
Power take-off	59, 60
Storing the engine	60, 61
Starting engines that have been in storage	61

Instructions on operation, lubrication and maintenance for the basic engine and attachments are covered in this manual. Disregard any instructions on attachments that are not applicable to your engine.

when following instructions (Illust. 1 and 2). Some illustrations and text in this manual are of general application on machines of this model and may not show your equipment accurately in all details.

Throughout this manual, the use of the terms "left," "front" and "rear" must be understood to avoid confusion

Continued on next page.

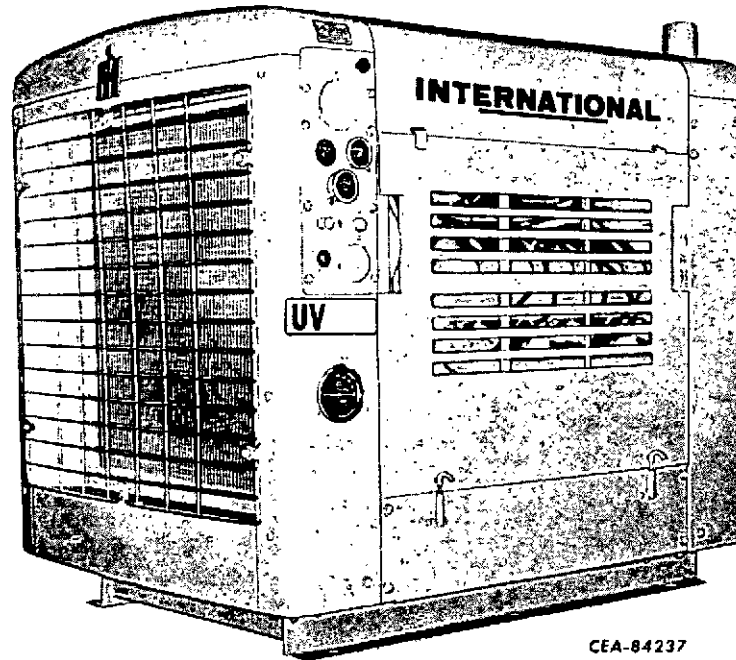

CEA-84237

Illust. 1

Left side view of engine with hood, dash radiator and radiator grille, side mounted instrument panel, mufflers, and base attachments.

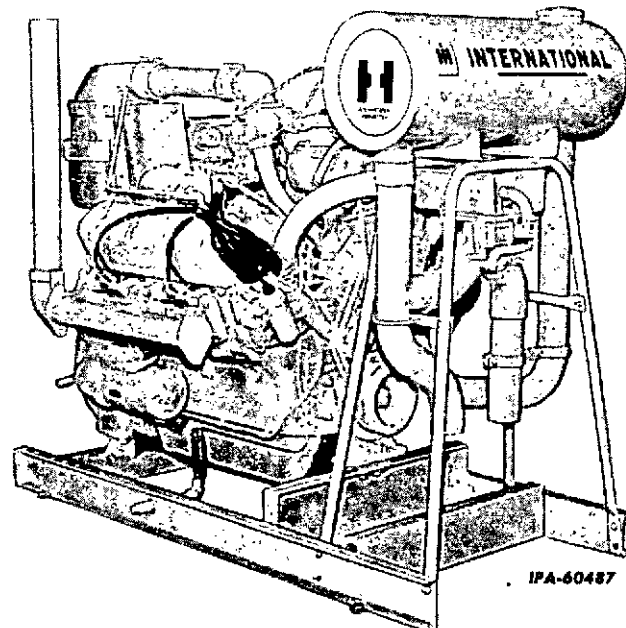

IPA-60487

Illust. 2

Right side view of UV-549 irrigation engine with air cleaner, rear mounted instrument panel, exhaust pipe, expansion tank, fomatic valve, oil level sight gauge, and base attachments.

SERIAL NUMBERS

When in need of parts, always specify the chassis and engine serial numbers. The engine serial number is stamped on the front left side of the engine, in line with the manifold. (Illust. 3.) The chassis serial numbers are stamped on a name plate attached to the left side of the flywheel housing. (Illust. 4.)

For ready reference, we suggest that you write these serial numbers in the spaces provided.

Chassis Serial No: UV-401 _____
 UV-549 _____

Engine Serial No: V-401 _____
 V-549 _____

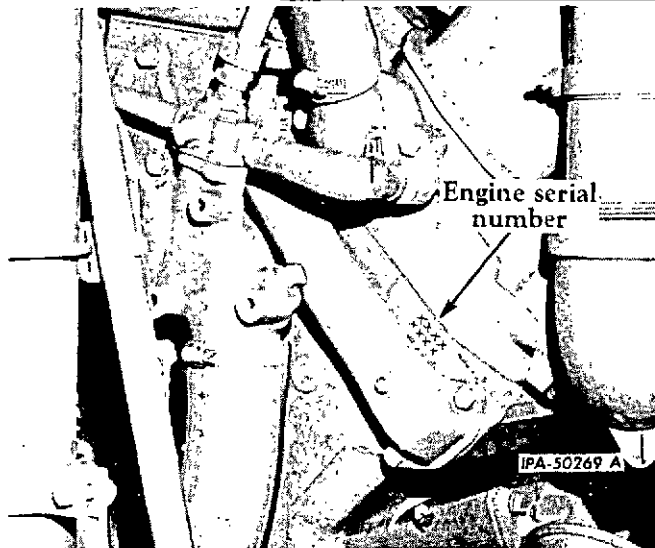

Illust. 3
 Engine serial number.

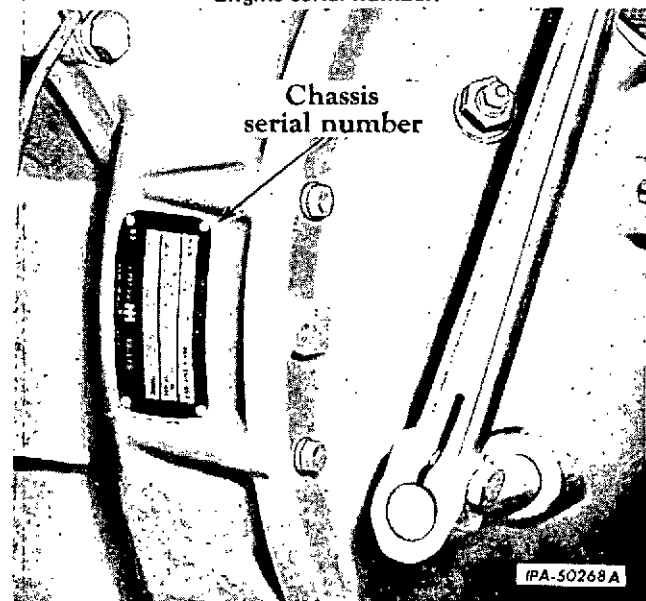

Illust. 4
 Chassis serial number.

VENTILATION FOR ENGINES INSTALLED INSIDE OF BUILDINGS

Engines installed inside buildings, sheds or cabs should be the open type; that is, with the engine hood and back panel removed to permit free circulation of fresh air around the engine, radiator, etc. Steps must be taken to carry the waste heat to the outside, or to change the air in the engine room rapidly.

The exhaust pipe should be arranged to provide the shortest possible length within the engine room. The part of the exhaust pipe inside the building should be surrounded with a light steel tube, sufficiently large to permit a two inch to four inch air space all around. This space should be ventilated to the outside. Another method of insulation is to cover the exhaust pipe completely with at least two inches of air-cell asbestos.

Ventilate the engine room thoroughly and install the engine so that air can flow freely through the radiator. An opening to the outside, in front of the radiator, is extremely desirable. Ducts should be provided between the radiator and the wall openings. On some installations, it may be necessary to provide a reverse-flow fan to blow the heated air out of the buildings.

Where the door or window area is restricted, galvanized ducts extending from the ceiling above the engine to the top of the building are recommended to carry off the hot air. Not less than two ducts, 24 x 24 inches in cross section, should be installed. At the same time, as many openings in the sides of the engine room as possible should be provided to let in cool outside air. Openings to the north or to a shaded side of the building are preferred.

SUGGESTED ENGINE AND FUEL TANK ARRANGEMENT

1. Anchor the engine securely to a level solid foundation, preferably concrete.
2. Mount the engine or driven equipment so that the belts may be removed or tightened.
3. Do not support a long exhaust pipe on the exhaust manifold; instead, use a flexible pipe at the engine and support the rigid pipe from the ceiling or floor.
4. Use long-sweep elbows in exhaust pipes.
5. For every 12 feet of exhaust pipe, enlarge the diameter of the pipe one standard pipe size.
6. Install the flexible exhaust piping so the belting may be adjusted without disconnecting any pipes or lines.
7. NATURAL GAS ENGINES ONLY: Gas flow is 1700 C.F.H. maximum on UV-549 engines. Gas line pressure to regulator inlet (1, Illust. 4A) is 15-27 "H₂O." Gas source, piping and line regulator must meet these requirements.

CAUTION: GAS INLET PIPE MUST BE FLEXIBLE PIPE CONNECTION TO PREVENT INLET PIPING FROM TRANSFERRING WEIGHT TO THE REGULATOR AND CARBURETOR.

8. Install flexible fuel lines between the pipes to the fuel tank and the engine and fuel shut-off valve at the tank.

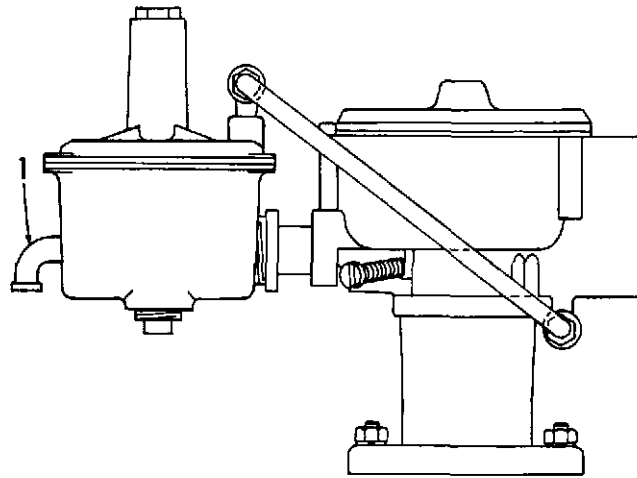

CF-107766

Illust. 4A
Natural Gas Fuel Supply Connection.

1. ELBOW, 1" NPT. street, inlet.

DESCRIPTION

PAGE 4

SPECIFICATIONS AND CAPACITIES

Capacities (U.S. Measure)

Air Cleaner oil cup (wet cup)
 Standard 4-1/4 pts
 Heavy duty 6 pts

Crankcase:
 Less oil filter and oil cooler 11 qts
 With oil filter 12 qts
 With oil filter and oil cooler 13 qts

Cooling system:
 Radiator type:
 UV-401 30 qts
 UV-549 31 qts
 Flow-matic type — less heat exchanger * 74 qts

* — Add approximately four additional quarts for engines equipped with water cooled exhaust manifolds.

The capacities which appear throughout this manual are specifically for these engines and their attachments.

Transmission

Five speed (T-51) (UV-401) 19 pts
 Five speed (T-72) (UV-549) 26 pts

Specifications

Engine

Type Overhead valve
 Cylinders 8
 Bore:
 UV-401 4-1/8 in.
 UV-549 4-1/2 in.

Stroke:
 UV-401 3-3/4 in.
 UV-549 4-5/16 in.

Compression Ratio:
 UV-401 Gasoline and LPG 7.69:1
 UV-401 Natural Gas 8.78:1
 UV-549 Gasoline and LPG 7.57:1
 UV-549 Natural Gas 9.5:1

Timing:
 Gasoline (Holley distributor) 7° BTDC
 Gasoline (Delco distributor) TDC
 LPG TDC
 Natural Gas
 Standard - 2600 RPM 2° BTDC
 Generator Set - 1800 RPM 5° BTDC

Firing order 1, 8, 7, 3, 6, 5, 4, 2

Fan, water pump and alternator belt tensions (Refer to "Belts" in "MAINTENANCE").

Distributor:

Holley (Model 1510)
 Dwell angle 25 to 29 deg.
 Point gap017 in.

Delco-Remy

Dwell angle 26 to 33 deg.
 Point gap016 to .020 in.

Spark plug gap:

Gasoline028 - .033 in.
 LPG or Natural Gas015 - .020 in.

Carburetor:

Gasoline:

UV-401 Holley (2 Barrel)
 UV-549 Holley (4 Barrel)
 UV-401 and UV-549 Zenith (2 Barrel)

LPG Impco

Natural gas:

UV-401 and UV-549 Impco

Torques

Torques (threads lubricated with Grade-30 engine oil):

Cranking motor bolts 33 to 37 ft-lbs.
 Fuel pump bowl retainer screw
 (dry torque) 12 to 25 in-lbs.
 Lubricating oil filter bolt
 Radiator and air cleaner hose clamps 20 to 25 in-lbs.
 Spark plugs 28 to 30 ft-lbs.
 Thermostat housing bolts 33 to 37 ft-lbs.

Engine Speeds

Optional engine speeds are available. The high idle and full load governed speeds for which this engine is equipped and adjusted is stamped on the chassis serial number plate on the flywheel housing.

Dimensions (Approximate)

Length (overall):
 UV-401 67-7/8 in.
 UV-549 68-1/4 in.
 Width (overall) 41-7/8 in.
 Height (overall) 48-5/8 in.

Fuel (Gasoline)

These engines are shipped with the ignition timing set for maximum power on the average regular grade of gasoline of 93 Research octane number as domestically available in the U.S.A. For fuels of lower Research octane number, the timing may require retarding (approximately one degree retard from factory setting for each decrease of one octane number). Overseas fuels may, in many areas, be considerably lower in Research octane number than regular grade fuels obtainable in the U.S.A. Advancing the timing beyond the initial factory setting is not recommended and may only result in adverse effects. There is no particular advantage in using a fuel having a higher antiknock value than the engine requires.

Fuel (LPG)

NOTE: It is recommended that LP Gas fuel meeting the Natural Gas Processor's Association (NGPA) specification for Propane HD5 be used if available.

Specifications subject to change without notice.

INSTRUMENT AND CONTROLS

The operator must thoroughly familiarize himself with the instruments and controls provided for operation of this engine. There are important differences between various engines; therefore, regardless of previous experience with other machines, the operator must fully understand what each control is for and how to use it before starting to operate the engine.

Safety shut-off gauges have been pre-set at the factory. If any of these gauges fail to operate properly, consult your authorized International Engine Distributor or Dealer.

Instruments (Illust. 5, 6, 7 or 8)

This section describes the purpose or function of each instrument. For detailed information on correct operating indications or ranges, refer to "Instrument Check" on page 12.

Ammeter

The ammeter indicates the rate at which the battery is being charged or discharged.

Continued on next page.

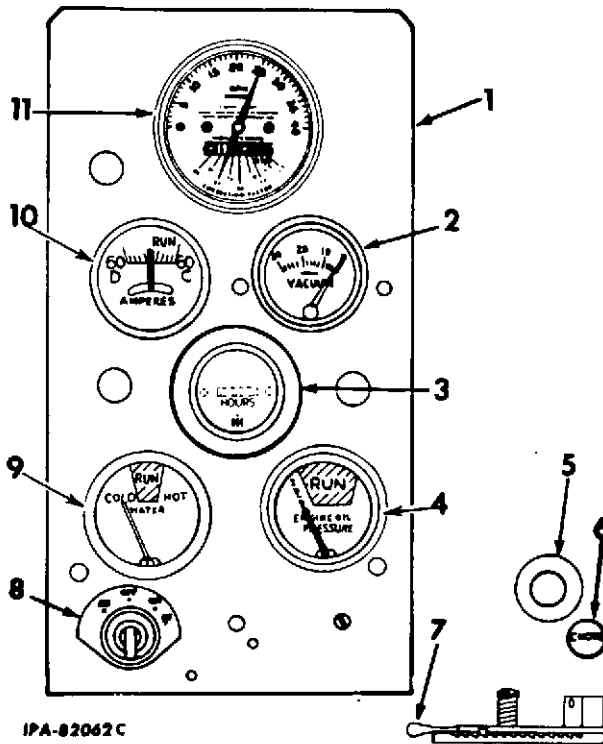

Illust. 5
Rear mounted instrument panel
(regular gauges).

1. PANEL, instrument.
2. GAUGE, vacuum.
3. HOURMETER.
4. GAUGE, engine oil pressure.
5. KNOB, engine throttle control.
6. BUTTON, choke control.
7. LEVER, governor control.
8. SWITCH, ignition and starter.
9. GAUGE, engine coolant temperature.
10. AMMETER.
11. TACHOURMETER.

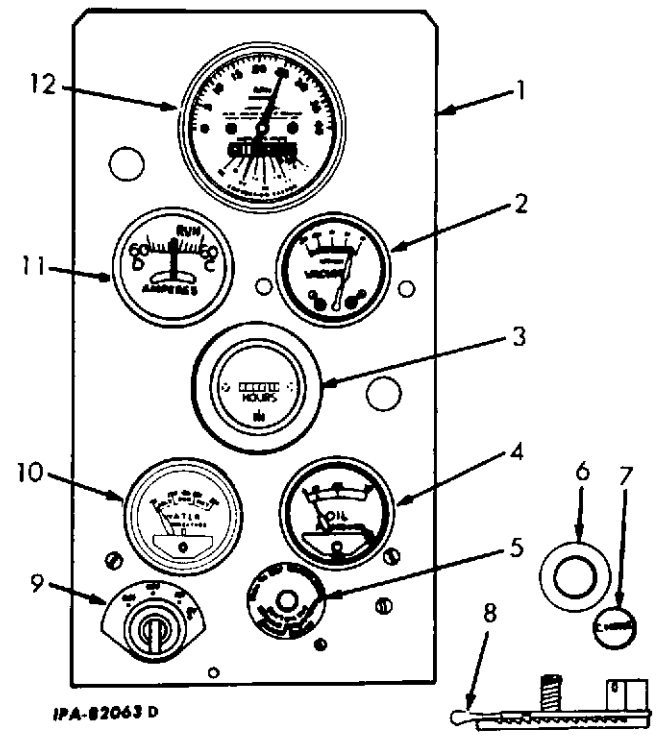

Illust. 6
Rear mounted instrument panel
(safety gauges).

1. PANEL, instrument.
2. GAUGE, safety vacuum.
3. HOURMETER.
4. GAUGE, engine oil pressure safety.
5. SWITCH, ignition relay.
6. KNOB, engine throttle control.
7. BUTTON, choke control.
8. LEVER, governor control.
9. SWITCH, ignition and starter.
10. GAUGE, engine coolant temperature safety.
11. AMMETER.
12. TACHOURMETER.

Engine Oil Pressure Gauge

This gauge registers the pressure of the lubricating oil circulating through the engine.

Safety Engine Oil Pressure Gauge

This gauge is part of the instrument panel (safety gauges) attachment. The gauge shows the pressure of the lubricating oil circulating through the engine. If the oil pressure drops to 40 PSI (rear mounted) and 20 PSI (side mounted) the engine will automatically stop.

Heat Indicator

The heat indicator shows the temperature of the coolant circulating in the engine.

Engine Coolant Temperature Gauge

This gauge is part of the instrument panel (safety gauge) attachment. The safety heat indicator registers the temperature of the coolant circulating in the engine. If the temperature of the coolant reaches 195°F, the engine will automatically stop.

Vacuum Gauge

This gauge indicates the amount of vacuum that is present in the intake manifold. (Refer to "Instrument Check" on page 12 for additional information.)

Safety Vacuum Gauge

This gauge is part of the vacuum safety shut-off attachment.

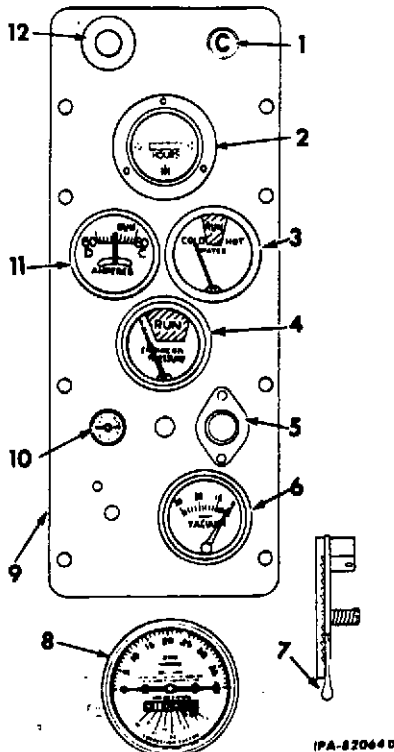

Illustr. 7
Side mounted instrument panel
(regular gauges).

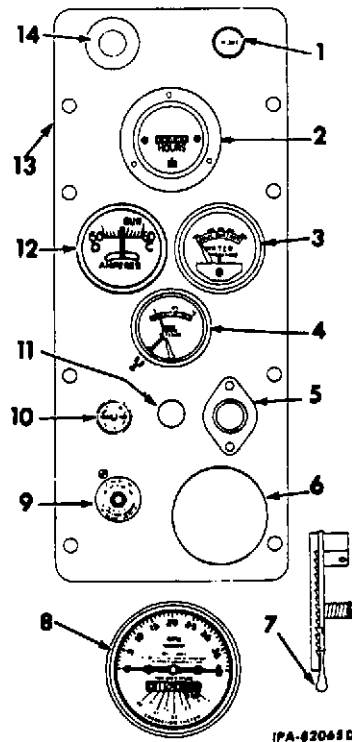

Illustr. 8
Side mounted instrument panel
(safety gauges).

1. BUTTON, choke control.
2. HOURMETER.
3. GAUGE, engine coolant temperature.
4. INDICATOR, engine oil pressure.
5. BUTTON, starting switch.
6. GAUGE, vacuum.
7. LEVER, governor control.
8. TACHOURMETER.
9. PANEL, instrument
10. SWITCH, ignition.
11. AMMETER.
12. KNOB, engine throttle control.

1. BUTTON, choke control.
2. HOURMETER.
3. GAUGE, engine coolant temperature safety.
4. GAUGE, safety engine oil pressure.
5. BUTTON, starting switch.
6. PLUG, button.
7. LEVER, governor control.
8. TACHOURMETER.
9. SWITCH, ignition relay.
10. SWITCH, stop.
11. PLUG, button.
12. AMMETER.
13. PANEL, instrument.
14. KNOB, engine throttle control.

The safety vacuum gauge indicates the amount of vacuum that is present in the intake manifold.

If the engine should over-speed due to a drop off in load, engine vacuum increases. The engine will shut off automatically when the vacuum reaches 16 inches.

If the engine lugs down due to an overload, engine vacuum decreases. When the vacuum falls to 4 inches, the engine will shut off automatically.

Hourmeter

This meter records the actual hours of engine operation. It eliminates guess work when determining proper lubrication and maintenance periods. It also assists in computing specific job per hour costs.

Tachourmeter (Illust. 9)

The upper half of this indicator shows the engine rpm; the lower half of the indicator shows the indicated hours of engine operation.

This indicator has a correction factor to determine the actual hours of engine operation from the indicated hours. Refer to example following.

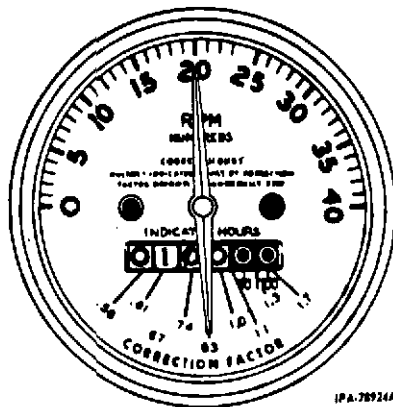

Illust. 9
Tachourmeter.

EXAMPLE:

Engine rpm - 2000

Indicated hours - 100

To determine the actual hours of operation, multiply the indicated hours (100) by the correction factor (.83). The actual hours: 83 hours.

Controls

Ignition and Starter Switch (Illust. 5 or 6)

This switch has four positions: 1. Switch to the left ("ON" position) for accessories; 2. "OFF" position; 3. "ON" position to the right to energize the electrical system; 4. switch all the way to the right ("ST" position) for cranking the engine.

Choke Control Button (Illust. 5, 6, 7 or 8)

The choke control button aids in starting the engine when it is cold. On gasoline engines, the choke control button can be used to put the choke valve in intermediate positions.

On liquified petroleum gas engines, the choke control button puts the choke valve in two positions (all the way opened or all the way closed).

Stop Switch Button (Illust. 8)

Pressing this button grounds the electrical circuit and stops the engine.

Starting Switch Button (Illust. 7 or 8)

Pressing the button completes the electrical circuit between the batteries and cranking motor to crank the engine.

Engine Throttle Control Knob (Illust. 5, 6, 7 or 8)

This knob connects to the carburetor thereby controlling the speed of the engine.

To obtain a specified engine rpm, depress the button in the center of the control knob and pull on the knob. When the approximate engine rpm is reached, release the button and the knob will automatically lock in place. If a finer adjustment is necessary, the knob can be rotated in a counterclockwise (to increase rpm) or clockwise (to decrease engine rpm) direction.

Governor Control Lever (Illust. 5, 6, 7 or 8)

This lever connects to the governor which connects to the carburetor thereby controlling the speed of the engine.

Move the lever clockwise to increase engine speed and counterclockwise to decrease engine speed.

Ignition Switch (Illust. 7)

This is a "push-pull" type switch having two positions, "OFF" and "ON".

Continued on next page.

Ignition Relay Switch (Illust. 6 or 8)

This switch is part of the instrument panel (safety gauges) attachment. It is a push-button type switch.

Power Take-Off Clutch Shaft Outer Bearing Housing Temperature Switch

This switch is part of the power take-off attachment. The switch is located at the bottom of the clutch shaft outer bearing housing. If the temperature of the lubricant in the housing reaches 250°F, the engine will automatically stop.

Power Take-Off Clutch Lever (Illust. 10)

This lever is used to engage or disengage the engine from the load.

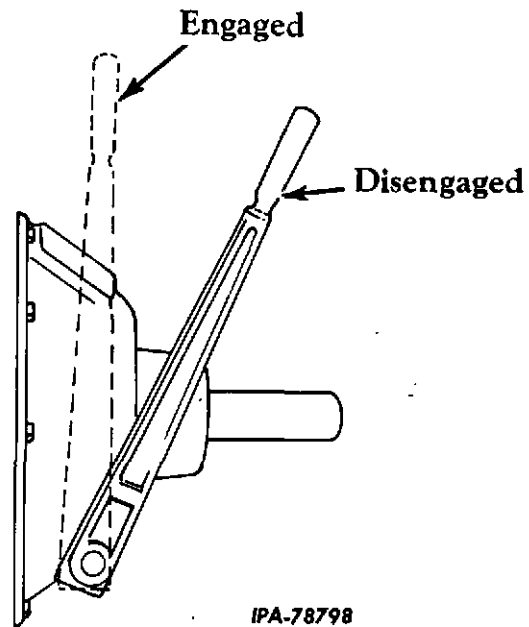

IPA-78798
Illust. 10
Power take-off clutch lever positions
(left hand lever installation).

BEFORE STARTING A NEW ENGINE

This engine has been given predelivery and delivery service by your distributor or dealer.

As an added precaution, the following steps must be observed.

1. Check the cooling system level and fill if necessary. (Refer to "Filling the Cooling System" on page 27.)
2. Check the oil in the engine crankcase, the air cleaner oil cup (wet type - if equipped), and power take-off (if equipped) to be sure they are filled to the correct levels with the proper grades of oil for the prevailing temperature. Refer to "LUBRICATION WHEN SHIPPED" on this page.
3. Check the clutch lever for ease of movement. If the clutch lever doesn't move freely, lubrication of the cross shaft, release bearing and over-center clutch linkage may be necessary.

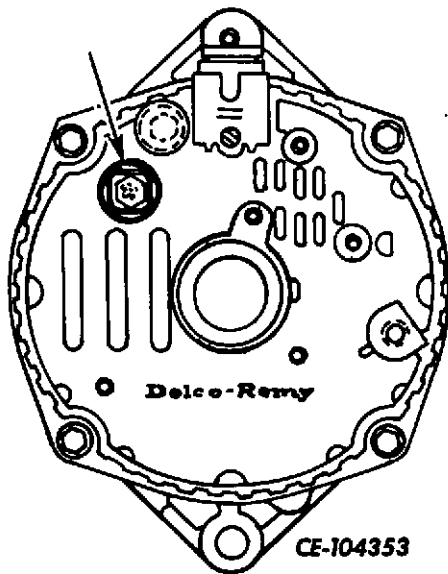

Illust. 11
Alternator Connections.

4. Be sure the "BAT" terminal on the alternator is clean and the brown cable (units with side mounted instrument panel) or red cable (units with rear mounted instrument panel), from the negative (-) terminal of the ammeter is securely fastened to it.

NOTE: BE SURE BATTERY IS CONNECTED PROPERLY.

5. Connect the battery cable to the "BAT" terminal on the cranking motor solenoid and to the positive (+) terminal on the battery. Connect the ground strap to the negative (-) ter-

minal on the battery. (Refer to the "Wiring Diagrams" on pages 44 to 51 for proper connections.)

6. Service the battery as instructed on the tag attached to the battery.
7. Remove the spark plugs and put about one teaspoonful of engine oil into each cylinder. Install and tighten the spark plugs (refer to "Torques" on page 4) and crank the engine to distribute the oil over the cylinder walls.

NOTE: The lubrication procedure above is necessary only in starting a new engine or one that has been idle for a long time. For the procedure in starting an engine that has been removed from storage, refer to "STARTING ENGINES THAT HAVE BEEN IN STORAGE" on page 63.

LUBRICATION WHEN SHIPPED

Engine

The crankcase was filled at the factory with engine oil for operation in an air temperature range of -10°F to +90°F. For operation above or below this range, change to the correct lubricant shown on "LUBRICANT SPECIFICATIONS AND CAPACITIES CHART" on page 18.

Air Cleaner

Wet Type (If Equipped)

The oil in the air cleaner (wet type only) may be used in 0°F to +90°F temperature range until the normal change period occurs. If the prevailing air temperature is above +90°F or below 0°F, change to the proper viscosity of oil specified in the "LUBRICANT SPECIFICATIONS AND CAPACITIES CHART" on page 18.

Dry Type (If Equipped)

DO NOT OIL THE AIR CLEANER ELEMENT.

Power Take-Off

Some engine power take-offs have a compartment of engine oil for lubrication of the clutch shaft outer bearing. If your power take-off has this compartment, use this lubricant until the normal change period occurs.

Export

The preceding information applies, except: the air cleaner (wet type) is drained before shipment, and must be filled before operation. Refer to the "LUBRICANT SPECIFICATIONS AND CAPACITIES CHART" on page 18.

PRECAUTIONS

General

Your engine is designed to operate on one of the following fuels: *gasoline, liquefied petroleum or natural gas*. Do not attempt to operate this unit on a fuel other than that for which it is equipped.

The power take-off clutch must be adjusted several times within the first 10 hours of operation. Refer to "Adjustment" on page 61 for the correct adjusting procedure.

Do not operate the engine under load until it is thoroughly warmed up. Never operate the engine at more than the regular governed speed. Excessive speeds are harmful.

Never pour cold coolant into the radiator or expansion tank if the engine is very hot unless conditions make it absolutely necessary. Under such conditions, start the engine and let it idle while slowly pouring the coolant into the radiator or expansion tank. Tighten the radiator cap securely.

Do not attempt to adjust the velocity type governor. The velocity type governor is set at the factory. If the governor does not function properly, consult your authorized International Engine Distributor or Dealer for repair or replacement.

CAUTION: FOR PERSONAL PROTECTION, OBSERVE THE FOLLOWING SAFETY PRECAUTIONS.

Never operate the engine at more than the regular governed speed shown on the serial number plate. Excessive speeds are harmful and dangerous. Do not rework or modify engine flywheel.

Never operate an engine in an enclosed building unless the exhaust is properly ventilated. Refer to "VENTILATION FOR ENGINES INSTALLED INSIDE OF BUILDINGS" on page 2.

Because of fire hazards and insurance regulations, do not use gasoline for cleaning parts, especially when service is performed inside buildings. A less flammable fluid, such as a commercial solvent or kerosine, should be used.

Never attempt to clean or oil the engine while the engine is operating.

Liquefied Petroleum Gas or Natural Gas Engines

CAUTION: SAFETY PRECAUTIONS IN THE HANDLING OF BUTANE-PROPANE CANNOT BE OVER-EMPHASIZED. THERE ARE STATE, COUNTY OR CITY LAWS, ORDINANCES, AND FIRE REGULATIONS COVERING THE UTILIZATION OF LIQUEFIED PETROLEUM GAS OR NATURAL GAS. SUCH LAWS, ORDINANCES AND FIRE REGULATIONS ON THIS SUBJECT MUST BE ADHERED TO IN ADDITION TO THE SAFETY RULES GIVEN BELOW.

Where local rules are more stringent than these given, the local rules are to be given priority.

These rules apply to servicing any engine using liquefied petroleum gas (butane-propane) or natural gas for engine fuel regardless of the nature of the work to be performed.

Select a location for servicing these engines where there will be good air circulation. This is to avoid accumulation of gas-air mixtures in and about the engine caused by undetected leaks.

Such location must be as far as possible from steam cleaners, hot water cleaners, hot dip tanks, etc., and other device operating with an open flame.

Shut off the main valves at the fuel tanks and allow the engine to run until all fuel in the system, from the tank to the engine, is exhausted. In the event the engine is inoperative, shut the valve at the tank. Vent the fuel system of liquefied petroleum or natural gas outside the building before moving the engine into the shop.

"DANGER" signs must be placed on both sides of the engine. There is to be no smoking in the vicinity. No work is to be performed on this engine or on others in a nearby zone involving open flames, such as cutting, welding, grinding, chiseling or any similar operation which may produce sparks.

A fire extinguisher (dry powder or carbon dioxide, CO₂) must be placed adjacent to the mechanic's working area, handy for immediate use. When liquefied petroleum gas ignites, it should be allowed to burn, if possible, until the source of fuel is shut off. Extinguishing the fire before this is accomplished can result in dangerous accumulations of gas which might cause a more serious flash or explosion.

After completing service work and before starting the engine, allow air to circulate around the engine to remove any possible gas accumulation.

Never use liquefied petroleum gas from the fuel tanks for cleaning parts. This is mentioned because inspections have revealed that operators have used it as a substitute for solvents and compressed air, not realizing the extreme danger of this practice.

Whenever the nature of service work requires any operation on the fuel system, the following must be observed:

(a) All threaded connections should be treated with an insoluble lubricant (Permatex or aviation gasket maker). Replace worn or defective fittings.

(b) After connecting the fuel system, check it for leaks. Leaks are not permissible. Odorants, which are strong smelling compounds (an odor similar to spoiled cabbage), are added to liquefied petroleum gas as warning agents to indicate the leakage of even small quantities of gas.

(c) A lather of soap, brushed on with a soft brush, will indicate the presence of leaks, which are dangerous and wasteful. Never use an open flame to check for leakage.

Pay particular attention to short lengths of rubber hose used anywhere in the piping system to relieve stress and vibration.

Any necessary work on liquefied petroleum gas or natural gas fuel tanks must be performed by qualified concerns who normally service such containers and who are familiar with local regulations, inspections and tests after any repairs are made.

It is important to remember that all liquefied petroleum gas systems are pressurized. Be certain that the tank valves are tightly closed and all fuel has been exhausted from the lines before starting any repair work on the fuel system.

PREPARING THE ENGINE FOR EACH DAY'S WORK

Fuel System (Gasoline)

Fill the main fuel tank. Use a gasoline conforming to the specifications as shown on page 4. **DO NOT USE DIRTY FUEL.**

CAUTION: NEVER FILL THE FUEL TANK WHEN NEAR AN OPEN FLAME OR WHEN THE ENGINE IS OPERATING. KEEP THE FUNNEL OR HOSE NOZZLE, USED FOR POURING IN THE FUEL, IN CONTACT WITH THE METAL OF THE TANK TO AVOID THE POSSIBILITY OF AN ELECTRIC SPARK IGNITING THE GAS. DO NOT LIGHT MATCHES NEAR GASOLINE, AS THE AIR WITHIN A RADIUS OF SEVERAL FEET IS PERMEATED WITH A HIGHLY EXPLOSIVE VAPOR.

Cooling System

NOTE: Do not start the engine until the cooling system is filled with coolant.

Remove the radiator cap or the expansion tank filler cap and check to be sure the coolant comes to a level approximately one inch below the filler neck. Add coolant if necessary. Install the filler cap or the radiator cap and tighten it securely.

Lubrication

Check the air cleaner to be sure the oil is up to the "OIL LEVEL" bead marking on the inside of the oil cup.

Be sure that the oil level in the crankcase is up to the "FULL" mark on the crankcase oil level gauge. Refer to the "LUBRICATION GUIDE" on pages 19, 20 and 21 for complete requirements.

OPERATING THE ENGINE

Starting the Engine

Read and observe the "PRECAUTIONS" on pages 10 and 11.

Two separate procedures for starting the engine are provided: The first, covers engines equipped with instrument panel (regular gauges); the second, covers engines equipped with instrument panel (safety gauges).

Instrument Panel (regular gauges)

1. Open the shut-off valve on the fuel supply line.
2. **POWER TAKE-OFF (IF EQUIPPED):** Place the clutch lever in the "Disengaged" position (Illust. 10).
3. **THROTTLE CONTROL KNOB OR GOVERNOR CONTROL LEVER (IF EQUIPPED):** Move the knob or lever until it is about one-quarter advanced.

NOTE: LIQUEFIED PETROLEUM AND NATURAL GAS ENGINES ONLY: Set the knob or lever a one-half advanced.

4. **GASOLINE ENGINES ONLY:** Pull the choke control button out part way. (In cold weather pull it out all the way.)
5. **SIDE MOUNTED INSTRUMENT PANEL ONLY (IF EQUIPPED):** Pull the ignition switch out to the "ON" position and press the starting switch button.

REAR MOUNTED INSTRUMENT PANEL ONLY (IF EQUIPPED): Turn the ignition and starter switch all the way to the right to the "ST" position.

NOTE: Never operate the cranking motor for more than 30 seconds at one time. If the engine does not start, allow the cranking motor to cool two or three minutes before cranking again.

6. If the engine will not start in cold or damp weather, remove and dry the spark plugs. Check the spark plug gap. Refer to "SPECIFICATIONS" on page 4. Reinstall and tighten the plugs. Refer to "Torques" on page 4 for the specified torque.

7. **GASOLINE ENGINES ONLY:** After the engine starts push the choke control button into a point where the engine runs without missing and, as the engine warms up, gradually push the choke all the way in.

OPERATION

PAGE 12

8. **THROTTLE CONTROL KNOB OR GOVERNOR CONTROL LEVER (IF EQUIPPED):** Adjust the knob or lever to meet the load requirements.

9. **POWER TAKE-OFF (IF EQUIPPED):** Place the power take-off clutch lever in the "engaged" position (Illustr. 10).

10. Check all instruments for the proper readings. Refer to "Instrument Check" on this page.

Instrument Panel (Safety Gauges)

1. Open the shut-off valve on the fuel supply line.

2. **POWER TAKE-OFF (IF EQUIPPED):** Place the clutch lever in the "Disengaged" position (Illustr. 10).

3. **THROTTLE CONTROL KNOB OR GOVERNOR CONTROL LEVER (IF EQUIPPED):** Move the knob or lever until it is about one-quarter advanced.

NOTE: LIQUEFIED PETROLEUM AND NATURAL GAS ENGINE ONLY: Set the knob or lever at one-half advanced.

4. **GASOLINE ENGINES ONLY:** Pull the choke control button out part way. In cold weather, pull it out all the way.

5. **SIDE MOUNTED INSTRUMENT PANEL ONLY (IF EQUIPPED):** Simultaneously push in the ignition relay and starting switch buttons and hold until the engine starts. Release the starting switch button.

Continue to hold the ignition relay switch button until the pointer has separated from the contact in the safety engine oil pressure gauge. Release this button.

REAR MOUNTED INSTRUMENT PANEL ONLY (IF EQUIPPED): Simultaneously push in the ignition relay switch button and turn the ignition and starter switch all the way to the right to the "ST" position and hold until the engine has started. Release the ignition and starter switch.

Continue to hold the ignition relay switch button in until the pointer has separated from the contact in the safety engine oil pressure gauge. Release this button.

NOTE: Never operate the cranking motor for more than 30 seconds at one time. If the engine does not start, allow the cranking motor to cool two or three minutes before cranking again.

6. If the engine will not start in cold or damp weather, remove and dry the spark plugs. Check the spark plug gap. Refer to "SPECIFICATIONS" on page 4. Reinstall and tighten the plugs. Refer to "Torques" on page 4 for the specified torque.

7. **GASOLINE ENGINES ONLY:** After the engine starts, push the choke control button into a point where the engine runs without missing and, as the engine warms up, gradually push the choke all the way in.

8. **THROTTLE CONTROL KNOB OR GOVERNOR CONTROL LEVER (IF EQUIPPED):** Adjust the knob or lever to meet the load requirements.

9. **POWER TAKE-OFF (IF EQUIPPED):** Place the power take-off clutch lever in the "engaged" position (Illustr. 10).

10. Check all instruments for the proper readings. Refer to "Instrument Check" on this page.

Instrument Check

Check all gauges (Illustr. 5, 6, 7 or 8) immediately after starting, again upon reaching operating temperature and at frequent intervals during operation to assure proper care through prompt detection of irregularities. If any of the gauges do not register properly; stop the engine, and locate and correct the cause immediately. If unable to find the cause consult your authorized International Engine Distributor or Dealer.

Ammeter

The ammeter should indicate "charge" whenever the engine is operating at a speed faster than low idle speed. If it indicates "discharge" or a high rate of "charge" continuously while the engine is operating at this speed, investigate the cause immediately.

Engine Coolant Temperature Gauge

The gauge pointer must be in the "RUN" range, after the engine is warmed up, for the most efficient operation.

Engine Oil Pressure Gauge

If the gauge pointer does not move into the "IDLE" range while idling or into the "RUN" range when the speed of the engine is increased, stop the engine and inspect the oil system to find the cause. If unable to find the cause, consult your authorized International Engine Distributor or Dealer.

Vacuum Gauge

Refer to the chart below to be sure your gauge is registering the correct inches of vacuum.

Vacuum Chart	
Approximate percentage of load.	Approximate inches of intake manifold vacuum.
0	21
10	19
20	17
30	15
40	13
50	11-12
60	9-10
70	7-8
80	5-6
90	3-4
100	1-2

Stopping the Engine

1. **POWER TAKE-OFF (IF EQUIPPED):** Place the clutch lever in the "disengaged" position (Illust. 10).
2. **THROTTLE CONTROL KNOB OR GOVERNOR CONTROL LEVER (IF EQUIPPED):** Move the knob or lever to the "low idle" position.

Operate the engine at low idle for a minimum of three minutes to avoid excessive loss of coolant due to "afterboil" or heat surge.

NOTE: Serious damage can result to the engine if the above step is neglected.

3. **SIDE MOUNTED INSTRUMENT PANEL (SAFETY GAUGES) (IF EQUIPPED):** Push the ignition switch in to the "OFF" position.

REAR MOUNTED INSTRUMENT PANEL (SAFETY GAUGES) (IF EQUIPPED): Turn the ignition and starter switch to the "OFF" position.

MEMORANDA

PAGE 14

Scheduled and periodic maintenance and inspections are very important functions which every owner and/or operator must follow to assure the maximum performance of the engine.

To assure mechanical efficiency, it is necessary that this engine be systematically inspected and maintained at the intervals outlined below.

SCHEDULED

<u>Point of Inspection</u>	<u>Remarks</u>
<u>After Every 10 Hours of Operation</u>	
*Air cleaner oil cup	Check to be sure the oil is up to the "OIL LEVEL" mark on the oil cup. Clean and refill the oil cup when 1/2 inch of dirt has accumulated in the cup. Refer to "Cleaning the Oil Cup" on page 32.
*Air pre-cleaner	Clean. Refer to page 33.
*Air intake cap	Remove dirt and chaff. Refer to page 33.
Cooling system	Check level of coolant in radiator or expansion tank. Refer to "Filling the Cooling System" on page 27.
Lubrication points	Refer to "LUBRICATION GUIDE" on pages 19, 20 and 21.

After Every 50 Hours of Operation

*Air cleaner element (dry type)	Clean. Refer to "Filter Element Service" on pages 33 and 34.
Fan and water pump belt	Check tension: replace when necessary. Refer to page 30.
Flexible rubber connections between air cleaner and carburetor	Inspect for loose fit or damage. Refer to page 32 or 34 and 35.
Flo-matic control linkage	Apply two or three drops of oil to the Flo-matic control linkage.
Alternator belt	Check tension. Replace when necessary. Refer to page 31.
**Power take-off clutch	Check and adjust if necessary. Refer to "Adjustment" on page 59.
Radiator core	Clean spaces. Refer to page 27.
Lubrication points	Refer to "LUBRICATION GUIDE" on pages 19, 20 and 21.

After Every 100 Hours of Operation

Automatic dust unloader (dry type air cleaner only)	Empty. Refer to "Automatic Dust Unloader" on page 33.
***Battery liquid level	Check. Refer to "Liquid Level" on page 40.
Lubrication points	Refer to the "LUBRICATION GUIDE" on pages 19, 20 and 21.

After Every 150 Hours of Operation

****Spark plugs	Gasoline Engines: Remove and clean. Check gap. Refer to "Spark Plugs" on page 39.
-----------------------	---

*When unusual dust or dirt conditions are encountered during operation, it may be necessary to service these points more frequently.

**This interval specified for clutch adjustment must be used only as a guide or reminder for checking the engagement. Experience will indicate if this adjustment can be checked less frequently.

***When the ambient temperature is continuously +90°F or higher, the liquid level must be checked every 50 hours.

****The spark plug maintenance hourly interval can be extended on engines using straight natural gas or LPG as fuel.

SCHEDULED MAINTENANCE

PAGE 16

After Every 200 Hours of Operation

Crankcase ventilator metering valve	Clean. Refer to page 36.
Distributor contact points	Check gap. Refer to "Checking the Breaker Chamber and Breaker Points" on page 40.
Fuel pump filter	Check bowl for sediment. Refer to "Cleaning the Fuel Filter" on page 53.
Lubrication points	Refer to the "LUBRICATION GUIDE" on pages 19, 20 and 21.

After Every 500 Hours of Operation

Carburetor fuel screen (gasoline)	Remove and clean. Refer to page 52.
Distributor cap	Remove and clean. Refer to page 40.
Lubrication points	Refer to the "LUBRICATION GUIDE" on pages 19, 20 and 21.

After Every 1000 Hours of Operation

*Air cleaner, complete	Remove and clean. Refer to pages 32 to 35.
Lubrication points	Refer to the "LUBRICATION GUIDE" on pages 19, 20 and 21.

PERIODIC

Battery terminals	Clean terminals with steel wool or brush.
Cooling system	Clean. Refer to "Cleaning the Cooling System" on page 27.
Oil pump screen	Clean this screen whenever the oil pan is removed.
Wiring	Check for worn, cracked or frayed insulation, broken wires, loose or corroded connections.

*When unusual dust or dirt conditions are encountered during operation; it may be necessary to service more frequently.

LUBRICATION

For information about the lubrication of a new engine, refer to "LUBRICATION WHEN SHIPPED" on page 9.

The life and performance of an engine depends on the care that it is given and proper lubrication is probably the most important maintenance service for your engine.

Thorough lubrication service performed at the scheduled intervals and according to an established routine will aid greatly in prolonging the life of the engine and in reducing operating expense.

The type of work being done, load and weather conditions are all factors to consider in the frequency of lubrication. The scheduled intervals of lubrication shown on the "LUBRICATION GUIDE" are approximate, being based on average operating conditions.

It may be necessary to lubricate after shorter working periods under severe operating conditions such as extremely dusty conditions, low engine temperatures, intermittent operation, excessively heavy loads with high oil temperatures. However, the time intervals between lubrication periods must never exceed those indicated in this manual.

Selection of Lubricants

The selection of the proper type (specification) and grade (weight or viscosity) of lubricant is not guess work. Many tests have been made to determine the correct lubricants for this engine and its equipment. For detailed information regarding lubricants, refer to "LUBRICANT SPECIFICATIONS AND CAPACITIES" on page 17.



Lubricant Viscosities

During cold weather, base the selection of a crankcase lubricating oil viscosity on the lowest anticipated temperature for the day to make starting easier. For hot weather operation, base the selection on the highest anticipated temperature. Refer to "LUBRICANT SPECIFICATIONS AND CAPACITIES CHART" on page 18.

When the temperature changes, even though the regular interval of lubrication has not been reached, the lubricants must be altered to agree with the temperature.

NOTE: It is not necessary to change the lubrication in the different compartments when the temperature falls into a different range during a working day. For example: Grade-30 oil may be used instead of Grade-10 oil in temper-

atures below +32°F if not starting difficulty is experienced; Grade-10 oil, that is specified for use in temperatures of +32°F to -10°F, may be used in temperatures as high as +40°F, except when operating under continuously heavy loads.

Thinning the Crankcase Oil

In LPG or natural gas engines there may be a tendency for the oil in the crankcase, to gradually become thicker. In such cases, it may be desirable to use a lighter grade oil or in cold weather to add one quart of kerosine to the crankcase between specified oil changes in order to maintain easy cranking.

Precautions

After changing engine oil, operate the engine at low idle, without load, for at least five to ten minutes. This will allow the oil to work into the bearings and onto the cylinder walls.

LUBRICANT SPECIFICATIONS AND CAPACITIES

It is not the policy of the International Harvester Company to approve lubricants or to guarantee oil performance in service. The responsibility for the quality of the lubricant must remain with the supplier of the lubricant. When in doubt, consult your authorized International Engine Distributor or Dealer for information given in the latest service bulletin on crankcase lubricating oils or gear lubricants. The specified type and viscosity of lubricants recommended for use with this engine are shown in the "LUBRICANT SPECIFICATIONS AND CAPACITIES CHART" on page 18.

SCHEDULED MAINTENANCE

LUBRICANT SPECIFICATIONS AND CAPACITIES CHART (U.S. MEASURE)					
LUBRICANT KEY: EO - Engine Oil					
MPG - Multi-purpose Grease					
Lubrication Point	Capacity	ANTICIPATED AIR TEMPERATURE			
		Above +32°F	+32°F to +10°F	+10°F to -10°F	Below -10°F
Crankcase: Less oil filter and oil cooler With oil filter With oil filter and oil cooler	11 qts. 12 qts. 13 qts.	EO - Gasoline engines - Use I.H. No. 1 or API CC/SD or CC/SC or MIL-L-2104B/SD Natural gas and LPG engines USE: IH Low ash, low ash or ashless API CC/SC or CB/SC (See Note 1)			
		SAE 30 or SAE 20W-40	SAE 20W or SAE 10W-30	SAE 10W or SAE 10W-30	SAE 5W-20
Air Cleaner Oil Cup (Wet Type): Standard Heavy duty	4-1/4 pts. 6 pts.	Use the same type and grade lubricant as in the crankcase.			
Water Pump Housing	1-1/2 oz.	MPG - IH 25 IH EP or equivalent #2 multi-purpose Lithium grease.			
Power Take-Off	Fill as instructed	EQ - MIL-L-2104B, Sup. 1, DEF-2101D, or Service "MS" (*)			
		SAE-30	SAE-20	SAE-10	
All Lubrication Fittings	Fill as instructed	MPG - IH 251H EP or equivalent #2 multi-purpose Lithium grease.			

(*) - If an oil for service "MS" is used, it should have been performance tested in accordance with the "Engine Operating Test Sequences for MS Service" as published in the current hand book of the SAE (Society of Automotive Engineers, Inc.). These sequences are sometimes referred to as the "ASTM G-IV Test Sequences". Oil so tested should have their containers marked with a closely related qualifying phrase.

NOTE 1 - Ashless oils refers to oils containing complete ashless additive formulations; low-ash oils refer to those oils containing ashless detergent/dispersants additives and metal-organic oxidation inhibitors.

LUBRICATION GUIDE

Always use clean containers. Keep lubricants clean. Wipe dirt from fittings before fresh lubricant is added. Occasionally apply a few drops of engine oil to the engine speed control linkage and flo-matic control linkage.

ITEM NO.

ITEM NO.

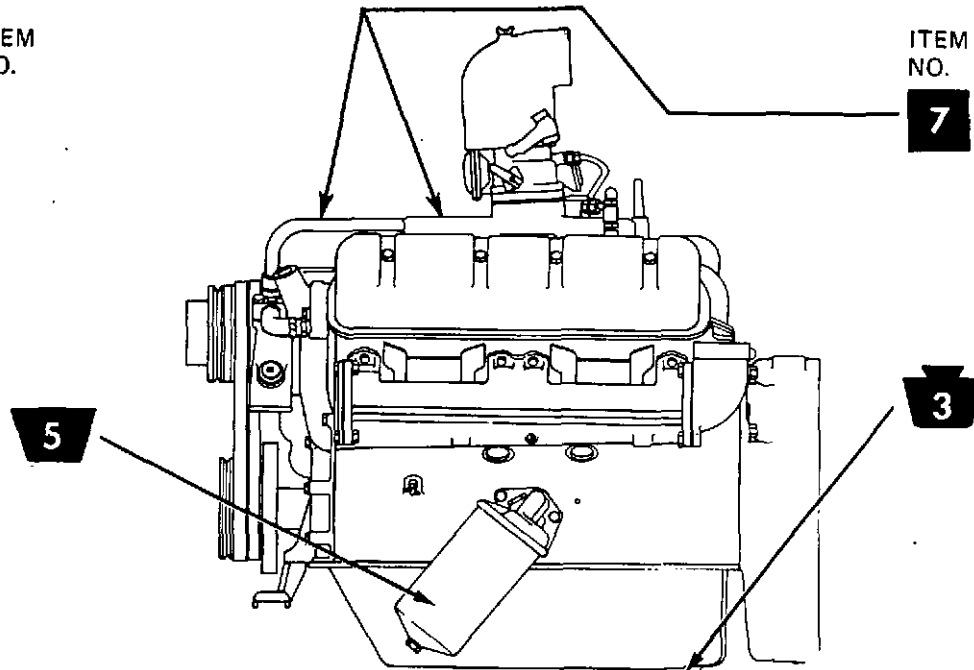

LUBRICATION POINTS ON LEFT SIDE

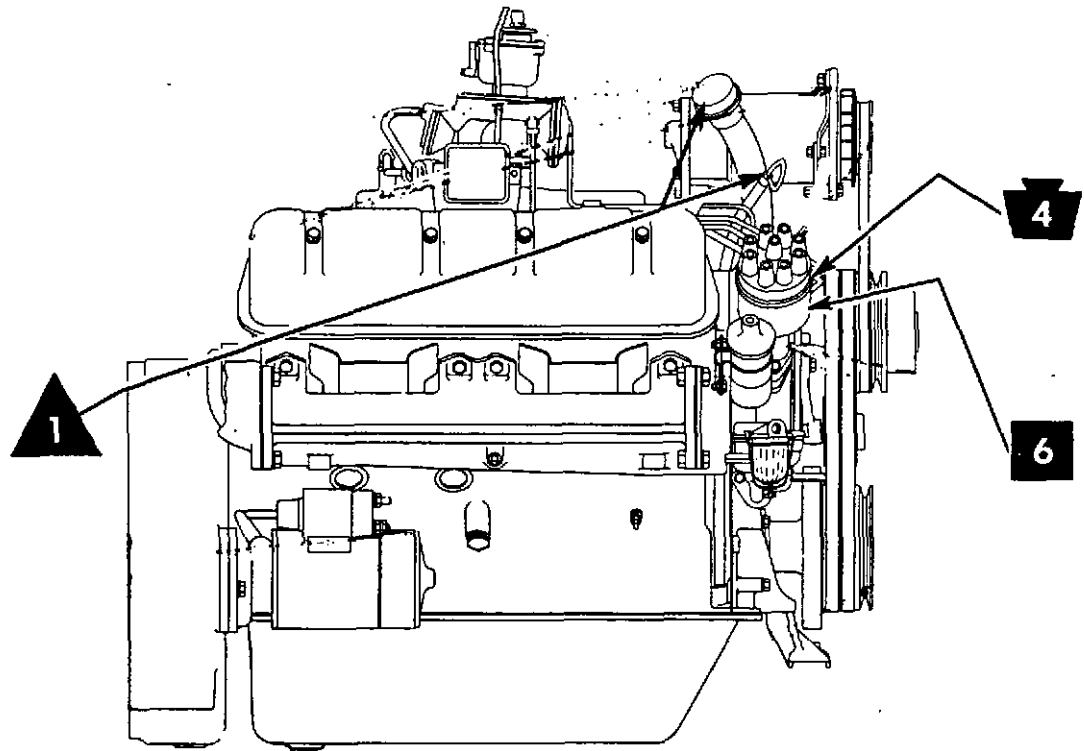

LUBRICATION POINTS ON RIGHT SIDE

The symbols around the item numbers indicate the intervals between service.

- ▲ - 10 hours
- - 50 hours

- ☒ - 100 hours
- ☒ - 200 hours

- - 250 hours
- - 500 hours

SCHEDULED MAINTENANCE

PAGE 20

Key to Lubrication Guide

The symbols shown around the reference numbers shown in the illustration on page 19 indicate the intervals of lubrication. Paragraph numbers correspond to reference numbers shown on these illustrations.



- Daily or After Every 10 Hours of Operation

1. Engine Oil Filler and Oil Level Gauge

{ Check the oil with the engine stopped and add sufficient new oil to bring it to the "FULL" mark on the gauge. Do not check the oil level while the engine is operating or operate the engine if the oil level is below the add mark on the gauge. Unscrew the cap and refill to the "FULL" mark on the oil level gauge.



- After Every 100 Hours of Operation

3. Crankcase drain.

{ Remove the crankcase oil pan drain plug (the oil in the engine oil cooler is drained when the crankcase is drained) and drain completely while the oil is warm, refill to the "FULL" mark on the gauge. (On engines equipped with an oil level sight gauge, remove the crankcase drain (pipe plug) from the tee or nipple). (On LPG or natural gas engines, drain after 500 hours operation.)

4. Distributor

{ Arm pivot and felt wick under rotor. Apply two or three drops of Grade-10 engine oil.



- After Every 200 Hours of Operation

5. Lubricating Oil Filter

{ Drain the filter and replace the element. For the correct procedure, refer to "LUBRICATING OIL FILTER" in the "MAINTENANCE" section. (On LPG or natural gas engines, replace the filter element after 500 hours of operation.)



- After Every 500 Hours of Operation

6. Distributor Rubbing Block

{ Pack a small quantity of high temperature grease in the back of the block.

Distributor Housing

{ Apply 8 to 10 drops of light engine oil until the oil cup remains full.

Distributor drive shaft

{ Apply two or three strokes of hand lubricator. Do not overlubricate.

7. Governor Control Wire

{ Apply one or two strokes of hand lubricator to each fitting.



- After Every 1000 Hours of Operation

- Oil Level Sight Gauge

{ (If equipped.) This gauge allows the oil level to be checked with the engine running. Always check the oil level with the engine running at its normal operating speed. To set the gauge after changing the crankcase oil, refer to "OIL LEVEL SIGHT GAUGE" in the "MAINTENANCE" section.

POWER TAKE-OFF LUBRICATION POINTS

Points of lubrication are individually explained under "LUBRICATION INSTRUCTIONS" below.

ROCKFORD AND TWIN DISC

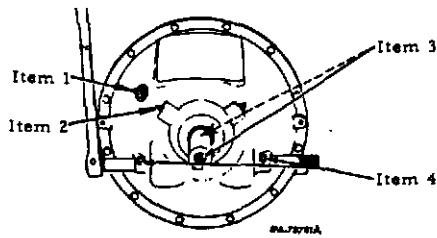

EXTENDED SHAFT AND OUTBOARD BEARING

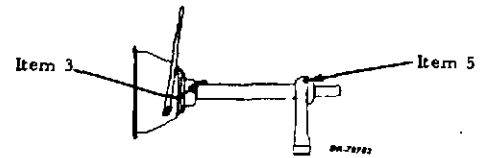

TWIN DISC WITH OIL LUBRICATED OUTER BEARING

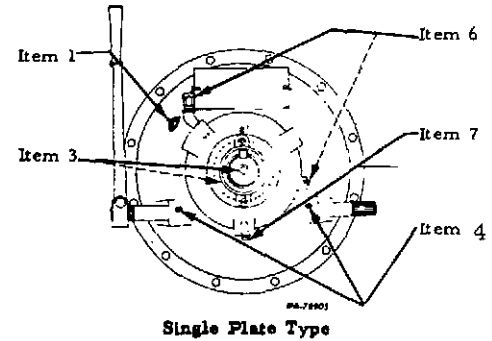
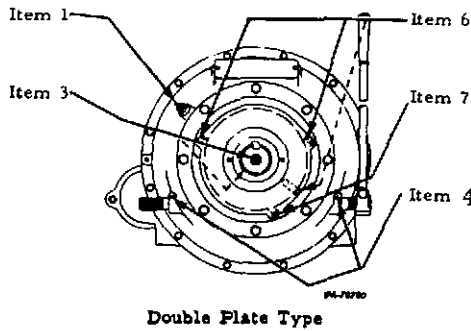

LUBRICATION INSTRUCTIONS

Item No.	Description	Lubricant	Hours	Item No.	Description	Lubricant	Hours
1	Clutch Throwout Bearing* Day-in and day-out full speed operation Less than 10 engagements per day-normal daily usage Over 10 engagements per day-normal daily usage Apply one or two strokes from a hand operated grease gun	MPG	10 50 10	4	Clutch Hand Lever Shaft (or Cross Shaft) depending on the type of lubrication <u>Greased Type</u> Apply two or three strokes of the lubricator <u>Oiled Type</u> Apply five or six drops of oil in each cup	MPG EO	100 100
2	Clutch Shaft Outer Bearing* Day-in and day-out full speed operating-In-line and side load drives In-line drives-normal daily usage Heavy side load drives-daily usage Apply four or five strokes from a hand operated grease gun (on some clutches, the fitting is located on the opposite side)	MPG	50 100* 50	5	Outboard Bearing, Extended Shaft Apply four or five strokes from a hand operated grease gun	MPG	50
3	Clutch Pilot Bearing* <u>Grease Type</u> Day-in and day-out full speed operation Less than 10 engagements per day-normal daily usage Over 10 engagements per day-normal daily usage Apply one or two strokes from a hand operated grease gun. Refer to NOTES 1 and 2.	MPG	200† 100* 50	6	Clutch Shaft Outer Bearing Filler and Level Plugs Remove either filler plug (indicated by solid arrows) and the level plug (indicated by dotted arrows) and fill until oil runs out of level hole. Reinstall the plugs. When P.T.O. is equipped with oil level gauge, check oil level. If low, add oil to bring to proper level.	EO	100
	<u>Sealed-for-Life type</u> Requires no greasing	Replace every 4000 hrs. or two years.		7	Clutch Shaft Outer Bearing Drain Plug Remove drain plug while lubricant is still warm. After allowing time for complete draining, reinstall plug and refill at filler.	EO	500
				8	Miscellaneous (Not illustrated) Remove P.T.O. name plate and lubricate Overcenter Clutch Release Linkage Joints and Pins Apply slight amount of grease or one or two drops of oil Clutch Throwout Collar (or bearing) Bosses and Yoke Forks Apply slight amount of grease to each boss.	MPG or EO MPG	500 500

* - If excessive amount of grease accumulates inside the clutch housing and/or engine flywheel housing resulting from over greasing or too frequent greasing of clutch outer bearing, throwout bearing and pilot bearing, reduce the amount of grease utilized or extend the period of lubrication interval.

* - Certain light duty application may permit greasing intervals up to 200 hours.

† - Certain light duty application may permit greasing intervals up to 500 hours.

NOTE 1 - If the P.T.O. output shaft does not have end or cross (side) drilled grease fitting hole provision, P.T.O. attachment is, or may be equipped with sealed-for-life type pilot bearing. For applications where pilot bearing is subjected to severe rotational service check pilot bearing status.

NOTE 2 - On applications where the end of the output shaft is covered with a universal joint or flexible coupling, transfer the lubrication fitting from the end of the shaft to the cross drilled location (indicated by dotted arrow). Use the pipe plug removed from the cross drilled hole to close the opening in the end of the output shaft. This fitting is the only means of lubricating the clutch pilot bearing.

PREPARING FOR COLD WEATHER

In order to operate the engine in temperatures of +32°F or lower, observe the following instructions:

Fuel System

Use only a fuel conforming to the proper specifications as shown under fuel specifications on page 4.

GASOLINE ENGINES ONLY: Fill the fuel tank at the end of each day's work to prevent condensation of moisture in the tank.

Lubrication

Lubricate the engine completely with lubricants specified for operation below +32°F as outlined in the "LUBRICATION GUIDE" on pages 19, 20 and 21.

Cooling System

When the air temperature is consistently at the freezing point (+32°F) or lower, install anti-freeze in the cooling system.

Before installing anti-freeze in the system, make the following check:

1. Check the system for leaks.
2. Inspect all hoses and tighten all hose clamps. Install new hoses if necessary.
3. Drain and clean the system. Refer to "Draining the Cooling System" and "Cleaning the Cooling System" on pages 26 and 27.
4. Check the operating condition of the thermostat. Refer to "Thermostat" on page 28.
5. Check the condition and tension of the fan and water pump belts and generator belt. Replace the belts if necessary. Refer to "BELTS" on page 30.
6. Be sure radiator drain valve (Illust. 13) and the crankcase drain valve (Illust. 14) are closed, and all connections are securely tightened.
7. Install the required amount of anti-freeze (refer to "Anti-Freeze Solution" on page 24) into the engine and fill the system with coolant as outlined under "Filling the Cooling System" on page 27.
8. Start the engine. After normal operating temperature has been reached, check the system to be sure there are no leaks.

Battery

When the air temperature drops to +32°F or lower, the efficiency of the battery decreases rapidly. At temperatures of -20°F or lower, it may be necessary to raise battery temperature by applying heat from a suitable source.

It is especially important to keep the battery at full charge for cold weather operation. Check the specific gravity of the battery electrolyte at frequent intervals, and keep the battery as fully charged as possible. Add distilled water to the battery in freezing temperatures only when the engine is to operate for several hours to thoroughly mix the water and the electrolyte, or damage to the battery will result from the water freezing.

 **CAUTION: BATTERIES GIVE OFF HIGHLY INFLAMMABLE GAS. NEVER ALLOW SPARKS OR OPEN FLAME NEAR THE BATTERIES. AVOID SPILLING ANY ELECTROLYTE ON HANDS OR CLOTHING.**

PREPARING FOR HOT WEATHER

Lubrication

Lubricate the engine completely with the lubricants specified for operation above +32°F as outlined in the "LUBRICATION GUIDE" on pages 19, 20 and 21.

Fuel System

GASOLINE ENGINES ONLY: Fill the fuel tank at the end of each day's work to prevent condensation of moisture in the tank.

Battery

Inspect the battery frequently to be sure the electrolyte is at the correct level. (Refer to "Liquid Level" on page 40.)

Cooling System

To prevent overheating, these steps must be followed:

1. Clean and flush the internal parts of the cooling system. (Refer to "Cleaning the Cooling System" on page 27.) When filling the cooling system, follow the method described under "Filling the Cooling System" on page 27.
2. Insects and dirt must be cleaned from the external part of the radiator. (Refer to "Cleaning the Radiator Core" on page 27.)

Continued on next page.

3. Check the condition and tension of the fan and water pump belts and generator belt. Replace the belt if necessary. Refer to "BELTS" on page 30.

4. Check the operating condition of the thermostat. Refer to "Thermostat" on page 28.

COOLING SYSTEM

The following maintenance procedures cover two types of cooling systems; the radiator type and the Flo-matic type. These procedures are the same for both types except as indicated.

Radiator Type

The radiator type is a pressure-cooled system and will not operate properly unless the cooling system is tight. The filler cap must be properly tightened to the stop. The gasket surface of the cap must be in good condition. The system must not have loose connections or leaks. Unless these instructions are followed, pressure will not be maintained and loss of coolant and consequent overheating will result.

Flo-matic Type

The Flo-matic type cooling system automatically maintains the proper engine temperature under normal conditions of operation. A positive centrifugal pump circulates the coolant through the engine block, engine heads and expansion tank.

NOTE: This system is not a pressurized system and is equipped with a vented filler cap.

When the coolant in the cooling system begins to get warm, the double acting flo-matic valves direct coolant from the engine through the expansion tank and back to the engine. (Solid line, illust. 12.)

As the coolant temperature rises, the valves function in unison. One valve starts to open and the other valve starts to close to permit the flow of greater amounts of coolant through the heat exchanger. (Dotted line, illust. 12.)

After the engine warm-up, the flo-matic control maintains coolant temperature automatically by modulating flow to the heat exchanger circuit while sustaining a full flow through the engine cooling system.

Care of the Cooling System

To keep the cooling system free of rust and sludge during warm weather add a cooling system conditioner; or to keep it from freezing during cold weather add anti-freeze in accordance with the following information.

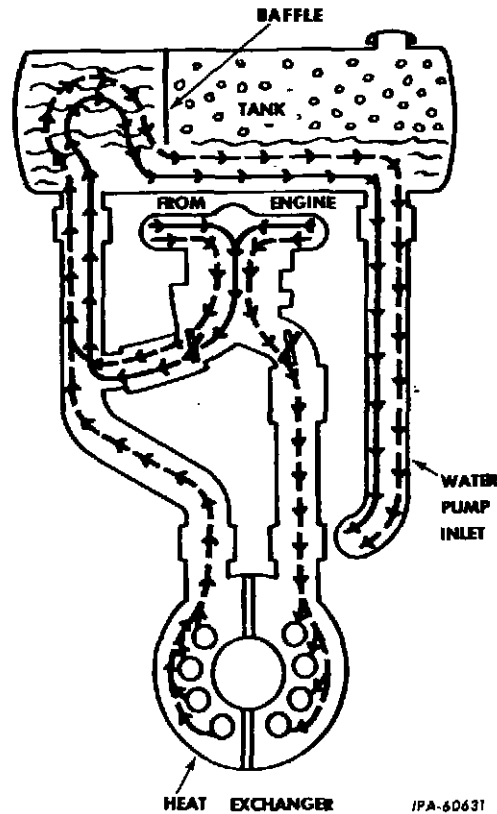

Illust. 12
Cooling System Circulation

Anti-Freeze Solutions

1. I.H. Anti-freeze permanent type (ethylene glycol) is recommended. This product, specifically formulated for I.H. equipment, contains all necessary and proper inhibitors and has been thoroughly evaluated for optimum effectiveness. DO NOT use methanol or alcohol as an anti-freeze.
2. I.H. Anti-freeze is now compatible with both chromate and non-chromate corrosion resistors.
3. Do not use anti-freeze year-round where ambient temperatures exceed 100°F, except on units equipped with an automotive type, combination air conditioner-heater coil in the cab. Seasonal changes are recommended to replace inhibitors which may become exhausted and to flush out the system. When inhibitors become depleted, the anti-freeze becomes a corroding agent which attacks and coats the metallic surfaces of the cooling system, thus reducing heat transfer.

The boiling point of ethylene glycol solutions is higher than plain water, but their ability to transfer heat is less. In hot weather, this difference will result in coolant temperatures running hotter than with water and, where oil-to-water coolers are used, the transmission oil temperatures will run hotter.

4. Do not use anti-freeze with sealer or anti-leak additives. These additives may cause plugging problems throughout various areas of the cooling system and will restrict coolant flow.

5. A minimum volume of 30% anti-freeze is required to provide suitable corrosion protection. A concentration greater than 68% will adversely affect freeze protection and heat transfer rates.

The following table shows the percentage of anti-freeze solution required for the various temperatures.

Freezing Point (Fahrenheit)	USE IN COOLING SYSTEM
	IH Premium (Ethylene Glycol-Permanent Type)
+20°	16%
+10°	25%
0°	33-1/3%
-10°	40%
-20°	45%
-30°	50%
-40°	54%
-50°	58%
-60°	62%
-70°	65%

NOTE: Do not mix brands of anti-freeze solutions. Mixed solutions make it impossible to determine if the cooling system has adequate protection against freezing. When testing the solution, be sure the system is at normal operating temperature. This is necessary to obtain an accurate reading.

Check the solution frequently and at normal operating temperatures, to be sure the cooling system has sufficient protection against freezing.

Cooling Conditioners

All cooling system inhibitors become depleted through normal operation and additional cooling conditioner must be added to the coolant every 500 - 1000 hours of engine operation at the rate of one pint for each eight gallons of cooling capacity to maintain original strength levels.

The use of new I.H. Cooling System Conditioner is recommended. This product is a complete inhibitor system, of a non-chromate type, which provides corrosion protection, pH control for maintaining an acid-free coolant, and water softening to prevent the formation of mineral deposits. It is suitable for use in all systems being compatible with both water and ethylene glycol anti-freeze solutions.

Do not use soluble oil as a corrosion inhibitor. It requires

careful control of concentration level to prevent adverse effects on heat transfer.

Do not use additives or solutions that claim to improve heat transfer and prevent engine overheating. Tests indicate that none perform as claimed; in fact, some may do severe damage. There are no miracle additives that will increase heat transfer; conditioned water is still the best coolant.

Water

1. Use clean water inhibited with I.H. Cooling System Conditioner to minimize corrosion and scale deposits. Never use water alone.

2. Clean water should comply with the following requirements before addition of conditioner:

a. Total hardness - Not to exceed 170 parts per million (10 grains/gal. max.) to prevent scale deposits; if greater, the water should be softened.

b. Chlorides - Not to exceed 40 parts per million (2.5 grains/gal. max.) and sulfates not to exceed 100 parts per million (5.8 grains/gal. max.) to prevent corrosion. If greater, the water should be distilled, de-ionized, or de-mineralized.

c. Dissolved solids - Not to exceed 340 parts per million (20 grains/gal. max.) to minimize sludge deposits, scale deposits, corrosion, or a combination of these; if greater, treat as noted above.

Preventive Maintenance

The best way to avoid overheating problems is through preventive maintenance; keeping the components in top operating condition. This includes keeping the inside as well as the outside of the engine and radiator clean and:

1. Thoroughly flush the system with water before installing anti-freeze or cooling conditioner. If the system has been permitted to become rusty or dirty, use I.H. Cooling System Cleaner and Neutralizer carefully following cleaning recommendations on container.

2. For rust prevention during winter, a fresh filling of I.H. permanent-type Anti-freeze is recommended. In the spring, drain and discard the old anti-freeze solution, as the rust inhibitor may be exhausted from contamination and continued use.

3. During warm weather, it is necessary that I.H. Conditioner be added to the coolant (water) to protect the cooling system after draining the anti-freeze. This inhibitor solution should be drained and discarded in the fall before installing anti-freeze.

4. Draining the Cooling System in Freezing Temperature -

Continued on next page.

The cooling system of all engines, when drained, will retain some coolant in pockets. This is especially true in engines equipped with oil coolers or heat exchangers having a tube bundle. If only water is used, and these engines are drained and then exposed to freezing temperatures, the water retained in the cooler tubes will freeze, possibly rupturing one or more of the tubes. The resulting leak will be difficult to locate and could eventually damage the engine by mixing water in the crankcase oil.

Important

To avoid possible damage in engines equipped with oil coolers or heat exchangers, take one of the following precautions when draining for shipment or storage in freezing temperatures:

- a. Fill the cooling system with anti-freeze solution, operate until the thermostat opens or until circulation is observed in the radiator or heat exchanger circuit, then drain.
- b. If only water is used, drain the engine, then blow out the residual water in the cooler tubes with compressed air through one of the drain cocks or plugs, preferably the one on the cooler. Do not rely upon only draining the water.

Radiator Cap

A regulating pressure valve, built into the radiator cap, is designed to open at a pressure of approximately seven pounds per square inch.

Removal

CAUTION: THE PRESSURE TYPE CAP IS PROVIDED WITH A SAFETY STOP TO ALLOW THE PRESSURE OR ANY STEAM TO ESCAPE WHILE THE CAP IS BEING REMOVED, SHOULD THE ENGINE RUN VERY HOT.

Turn the cap to the left (counterclockwise) to the safety stop until pressure is released; then press down on the cap and continue to turn until the cap is free to be removed.

NOTE: Do not attempt to repair or replace any of the regulating valve parts. If the valve is faulty, replace it with a new radiator cap of the same type.

Draining the Cooling System

Drain the cooling system immediately after stopping the engine while most of the sediment is in suspension.

Radiator Type

- 1. Remove the radiator cap.
- 2. Open the radiator drain valve (Illust. 13) and the crankcase drain valve (Illust. 14).

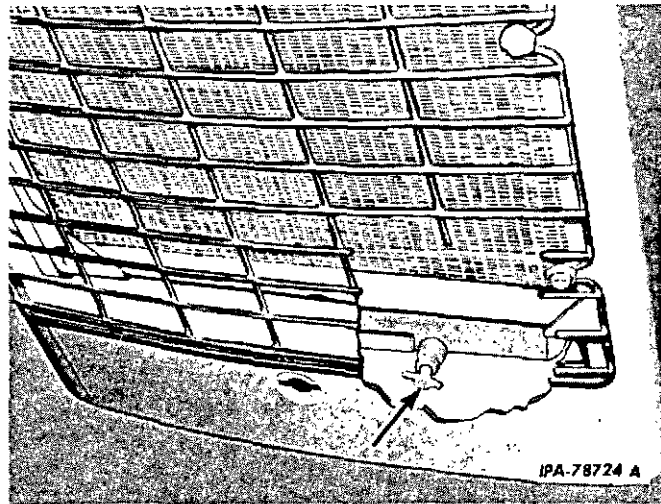

Illust. 13
Radiator Drain Valve.

- 3. ENGINES EQUIPPED WITH WATER COOLED EXHAUST MANIFOLDS: Remove the drain plugs located on the sides of the exhaust manifolds.
- 4. LIQUEFIED PETROLEUM GAS ENGINES ONLY: Open the water drain valve (Refer to Illust. 39).
- 5. Allow the system to drain completely. Be sure that the drain valves do not plug up during the draining.
- 6. Close all of the drain outlets.



Illust. 14
Crankcase Drain Valve.

Flo-matic Type

Drain the cooling system immediately after stopping the engine while most of the sediment is in suspension.

1. Remove the expansion tank cap.
2. Open the flo-matic vent valve (refer to Illust. 16) and the crankcase drain valve (Illust. 14). Open the drain valve on the underside of the water outlet tube and the drain valves on the heat exchanger.
3. ENGINES EQUIPPED WITH WATER COOLED EXHAUST MANIFOLDS: Remove the drain plugs located on the sides of the exhaust manifolds.
4. LIQUEFIED PETROLEUM GAS ENGINES ONLY: Open the water drain valve (refer to Illust. 39).
5. Allow the system to drain completely. Be sure the drain valves do not plug up during the draining.
6. Close all of the drain outlets.

Cleaning the Cooling System

Drain and thoroughly flush the cooling system once a year or more often if necessary. The appearance of rust in the radiator, expansion tank or in the coolant is an indication that the inhibitor has become weakened and it is possible that some sludge has accumulated in the system. When this condition exists, proceed as follows:

1. Run the engine until it reaches normal operating temperature; then stop the engine and drain the cooling system (refer to "Draining the Cooling System" on page 26).
2. Fill the cooling system with clean coolant (refer to "Filling the Cooling System" on this page.)
3. Add a flushing compound, that is compatible with aluminum, to the cooling system in accordance with the instructions furnished with the compound.
4. Start the engine and flush the system as directed by the instructions furnished with the compound.
5. After the system has been flushed and thoroughly cleaned of the compound, refill with clean coolant (refer to "Filling the Cooling System" on this page).

Cleaning the Radiator Core

Blow out insects and dirt from the radiator core air passages, using air or water under pressure. Engine overheating is often caused by bent or clogged radiator fins. When straightening bent fins, be careful not to injure the tubes or to break the bond between the fins and tubes.

Filling the Cooling System

Radiator Type

1. Be sure the drain valves are tightly closed.
2. Pour or run coolant into the radiator slowly until partly full.
3. Add a cooling system corrosion inhibitor (for warm weather operation) or 1H anti-freeze (when the air temperature is consistently at the freezing point (+32°F and lower) according to instructions printed on each container.

NOTE: Use only a corrosion inhibitor that is compatible with aluminum. Do not use inhibitors labeled as "acid neutralizers."

4. Continue to fill until the coolant reaches a level approximately one inch below the filler neck. Wait a few minutes to allow any air to escape, then add coolant if needed.
5. Install the radiator cap. Start and run the engine until the operating temperature is reached. Stop the engine, remove the radiator cap and recheck the level. Add coolant, if needed, to fill to the required one inch level below the filler neck. Install the radiator cap.

Flo-matic Type

1. Be sure the drain valves are tightly closed.
2. Add a cooling system corrosion inhibitor (for warm weather operation) or 1H anti-freeze (when the air temperature is consistently at the freezing point (+32°F and lower) according to instructions printed on each container.

NOTE: Use only a corrosion inhibitor that is compatible with aluminum. Do not use inhibitors labeled as "acid neutralizers".

3. Pour or run coolant into the expansion tank slowly until partly full, then add the rust inhibitor or anti-freeze. Continue to fill until the coolant reaches a level approximately one inch below the bottom of the filler neck.
4. Open the vent valve (Illust. 16) to permit the escape of air. Close the vent valve, then add coolant if needed.
5. Install the expansion tank cap. Start and run the engine until operating temperature is reached. Stop the engine, remove the expansion tank cap and recheck the level. Add coolant if needed, to fill to the required one inch level below the filler neck. Install the expansion tank cap.

Continued on next page.

Adding Coolant to an Overheated Cooling System

Use caution when removing the radiator or expansion tank cap when adding coolant. Do not pour cold coolant into the radiator or the expansion tank if the engine is very hot, unless conditions make it absolutely necessary. In this case, start the engine and let idle; then slowly pour the coolant into the radiator or the expansion tank.

Thermostats (Radiator Type Only)

The thermostats are the nonadjustable type and are incorporated in the cooling system for the purpose of retarding or restricting circulation of coolant to achieve rapid engine warm-up. The thermostat operating range is +158°F to +183°F.

NOTE: Permanent type anti-freeze must be used with this thermostat.

Engine overheating and loss of coolant is sometimes due to an inoperative thermostat. When this condition exists, remove and check the thermostats. Refer to "Removing and Checking the Thermostats" on this page.

Removing and Checking the Thermostats (Illust. 15)

1. Drain the cooling system.
2. Disconnect both radiator upper hoses at the thermostat housings.
3. Remove the two cap screws securing each thermostat housing to the cylinder block and remove each housing. Remove the thermostats. Discard the housing gaskets.
4. Remove the seals from the thermostats.
5. If the thermostats are scaly or rusty, replace them. Check each thermostat for correct operation. This can be done by submerging the thermostat and a thermometer in water and heating the water. (Refer to "NOTE" below.) Check the temperature of the water when the thermostat starts to open (approximately +158°F) and the temperature of the water when it is fully open (approximately +183°F).

NOTE: When placing the thermostat and the thermometer in the water, be sure they do not touch the side or bottom of the container at any time.

6. If a thermostat does not function as stated above, it must be replaced with a new one. Refer to "Installing the Thermostats" on this page.

Installing the Thermostats (Illust. 15)

1. Position the thermostat seal over the thermostat as shown.

2. Insert the thermostat into the housing with the word "TOP" facing up.
3. Using a new gasket, install the housing to the cylinder head and secure with two cap screws and lock washers.

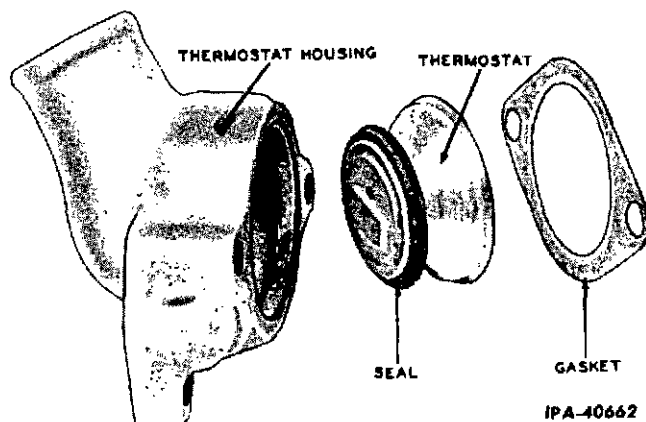

Illust. 15
Thermostat, Housing and Gasket.

4. Reconnect the radiator upper hose to the thermostat housing. Repeat the procedure on the opposite cylinder head.
5. Close the drains and fill the cooling system.
6. Operate the engine and check for correct thermostat performance and observe all cooling system hoses and connections for leaks. Correct all leaks, no matter how minor.

Water Pump

The water pump housing is packed with grease at the factory and requires no attention other than replacing the bearings when they show excessive looseness or if a water leak develops which indicates that a damaged or badly worn seal needs replacement.

When overhauling the water pump, prepack the bearings with grease before assembling them into the housing. Pack the housing with grease. Refer to the "LUBRICATION GUIDE" on page 18 for the type and quantity of grease required.

Flo-matic Valve

There is no adjustment that can be made to the Vernatherm unit to increase or decrease operating temperatures. The following adjustments establish only the proper relationship of Vernatherm control unit and the butterfly valves to provide full opening and complete closing of the by-pass and heat exchanger circuit.

Flo-matic Valve Adjustment (Illust. 16)

1. Drain the cooling system. (Refer to "Flo-matic Type" under "Draining the Cooling System" on page 27.)
2. Remove the by-pass and heat exchanger hoses.

3. Remove Vernatherm return spring.

4. The purpose of the two set screws (A and B) on lever (C) is to prevent butterfly valves from binding and must just

Continued on next page.

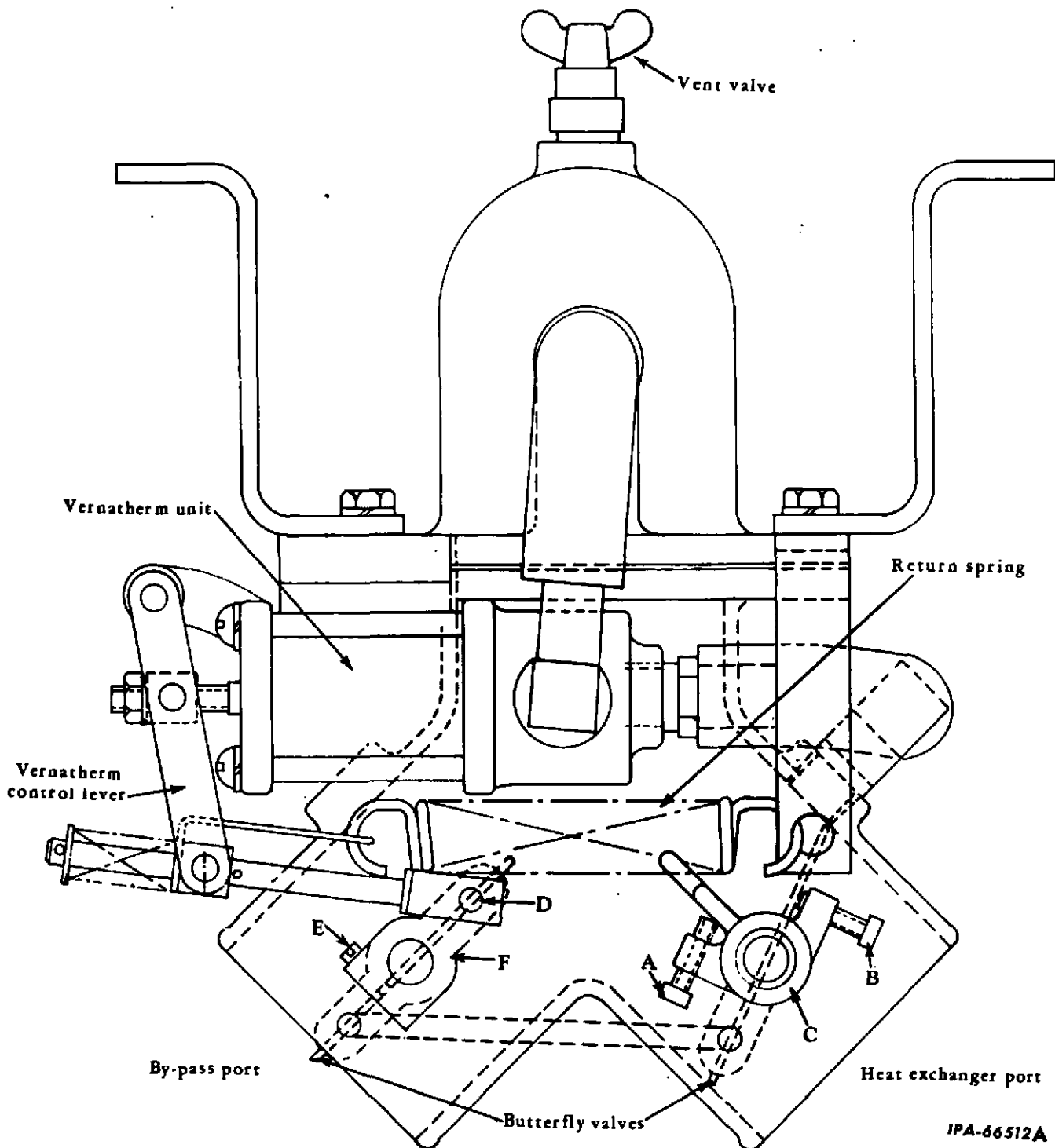

IPA-66512A

Illust. 16
Flo-matic By-pass Control Valve.
 PRINTED IN UNITED STATES OF AMERICA

make contact with the stop as the valves reach full open and full close positions. Adjust if required.

5. Remove the pin (D) holding the Vernatherm control lever in (toward Vernatherm control unit). The pin (D) must fall in place without binding. The by-pass port valve must be in full open position and the heat exchanger port valve must be fully closed. If correction is required, proceed as follows:

- a. Loosen the screws (E) on the lever (F).
- b. Position the lever (F) as outlined in Step 5.
- c. Tighten the screw (E) (40-45 inch pounds).
- d. Operate the valve assembly by hand, being sure all linkage operates freely.
- e. Install the Vernatherm control return spring.

6. Install the by-pass and heat exchanger hoses.

7. Fill the cooling system. (Refer to "Flo-matic Type" under "Filling the Cooling System" on page 27.)

NOTE: If the above adjustments have been made and the satisfactory temperatures are not maintained, consult your authorized International Engine Distributor or Dealer.

BELT

A new belt loses its tension as it seats into the pulleys. Check and adjust a new belt at 1, 10 and 50 hours to stabilize its tension. After the tension has been stabilized it may be checked at intervals of 200 hours. The belt tension must be watched during the break-in period.

Tension (Illust. 17)

The tension applied to a new belt (initial installation only) is different than the retention applied to a used belt.

The required belt tension is checked by "Deflection Method." The use of "Fishhook Scale and Straight Edge" is preferred over the unreliable "Thumb Method." The required belt deflection under 25 lbs. deflecting force at Points "A" or "B" (Illust. 17) to the deflection values shown in the following chart.

BELT TENSION CHART		
Condition	Alternator Belt	Fan and Water Pump Belt
	Point A	Point B
New Belt Installation	17/32	1/2
Used Belt (one that has been run 5 minutes or longer)	9/16	17/32

NOTE: Do not allow belt deflection to exceed 19/32 inch for "A" or "B." Check tensions more often if necessary. Do not retension the used belts to deflections less than 17/32 inch for "B" or 19/32 inch for "A."

NOTE: When operating in abrasive environment, check the belt tension before reaching 200 hours, preferably at 100 hours during the oil change period.

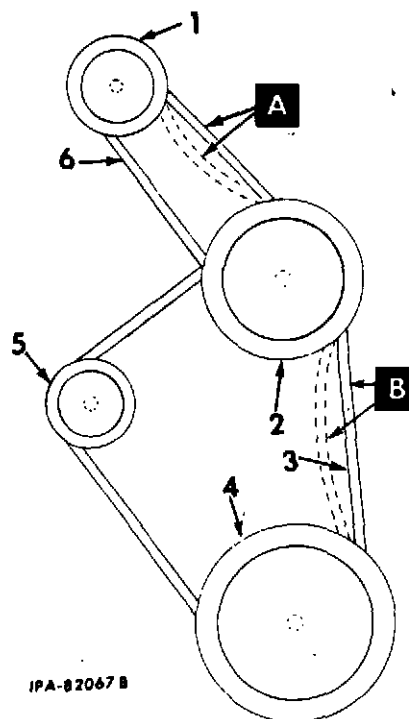

IPA-82067 B

**Illust. 17
Belt Tension.**

1. PULLEY, alternator.
2. PULLEY, fan and water pump.
3. BELTS, fan and water pump.
4. PULLEY, crankshaft.
5. PULLEY, idler.
6. BELT, alternator.

ADJUSTMENT

Fan and Water Pump Belt (Illust. 18)

Adjust the belts as follows:

1. Loosen the cap screws (1).
2. Using a short lever, move the idler pulley (2) against or away from the belts until the specified tension is obtained.
3. After making the adjustment, hold the idler pulley (2) in place and tighten the cap screws (1).



Illust. 18
Adjusting the Fan and Water Pump Belts.

1. SCREW, idler pulley cap.
2. PULLEY, idler.

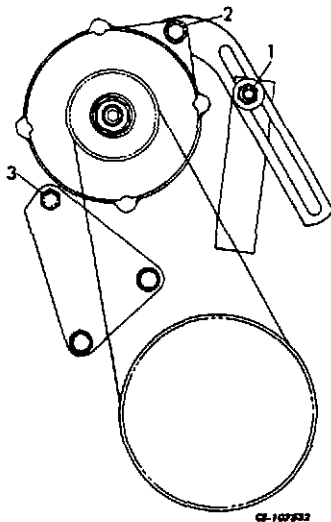

Illust. 19
Adjusting the Alternator Belt.

Alternator Belt (Illust. 19)

Adjust the belt as follows:

1. Loosen the alternator brace bolts (1 and 2) and the alternator mounting bolt (3).
2. Move the alternator toward the engine or away from the engine to get the correct tension.
3. After making the adjustment, hold the alternator in place. Tighten the alternator brace bolts (1 and 2) and the alternator mounting bolt (3).

NOTE: Excess belt tension will damage the alternator bearings. If a pry bar is used, **DO NOT OVER TENSION.**

REMOVAL

Fan and Water Pump Belts (Illust. 18)

Replace both belts as a set if one of the belts become soaked with grease or is so badly worn that the correct belt tension cannot be maintained.

1. Remove the alternator belt. (Refer to "Removing the Alternator Belt" on this page).
2. Loosen the cap screws (1) and move the idler pulley (2) in towards the engine to loosen the belts.
3. Remove the belts.

Alternator Belt (Illust. 19)

Replace the alternator belt if it becomes soaked with grease or is so badly worn that the correct belt tension cannot be maintained.

1. Loosen the alternator mounting bolt (3).
2. Loosen the alternator brace bolt (1 and 2).
3. Remove the fan mounting bolts. Move the fan forward far enough to remove the belt.

NOTE: When moving the fan forward, be sure none of the blades damage the radiator core.

INSTALLATION

Prior to installing the new belts inspect all pulley grooves for wear and the presence of grease, oil, dirt, etc. If foreign material is present, it should be removed. If a pulley is damaged or grooves worn, it should be replaced. When replacing belts and pulleys, pulley alignment must be checked. A misalignment that can be detected by the naked eye is detrimental.

Fan and Water Pump Belts

1. Install the fan and water pump belts.
2. Adjust the fan and water pump belts. (Refer to "Fan and Water Pump Belt Adjustment" on page 31.)
3. Install the alternator belt.
4. Adjust the alternator belt. (Refer to "Alternator Belt Adjustment" on page 31.)

Alternator Belt

1. Install the alternator belt.
2. Install and secure the fan.
3. Adjust the alternator belt. (Refer to "Alternator Belt Adjustment" on page 31.)

AIR CLEANER (WET TYPE)

Precautions

Frequently inspect the flexible rubber hoses between the carburetor and the air cleaner. If they show any sign of deterioration, replace them.

All joints between the air cleaner and the carburetor must be tight.

Cleaning the Oil Cup (Illust. 20 and 21)

1. Before removing the oil cup clean or wipe the outer surface of the body.
2. Loosen the screw of the clamp. Grasp the cup at the sides and, with a downward movement, separate the cup from the body.
3. Pour out the old oil and thoroughly clean the inside of the cup with kerosine.
4. Fill the cup to the "OIL LEVEL" mark with the proper grade of oil. (Refer to "LUBRICANT SPECIFICATIONS AND CAPACITIES CHART" on page 18.)
5. Lift the cup into place on the body. Place the clamp around the cup and the body and tighten the thumb screw.

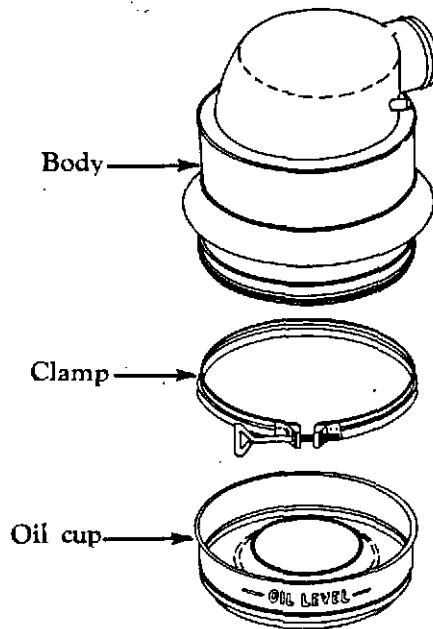

IPA-50253A

Illust. 20
Air Cleaner Disassembled (Standard Type).

Washing the Air Cleaner (Illust. 20 and 21)

1. Disconnect the hose between the air cleaner pipe and the air cleaner.
2. Loosen the screw of the clamp. Remove the clamp, grasp the oil cup at the sides and with a downward movement, separate the oil cup from the air cleaner body.

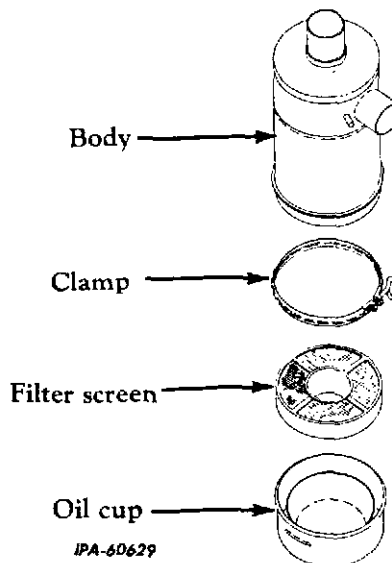

IPA-6D629

Illust. 21
Air Cleaner Disassembled (Heavy Duty Type).

3. Empty the oil from the cup.
4. Loosen the nut on each mounting bracket. Remove the body.
5. Clean the cup in kerosine.
6. Wash the body in warm water (+70°F to +100°F). A small amount of non-sudsing detergent added to the water will facilitate the removal of soot. Rinse the body in clear water and dry thoroughly.
7. Clean the air intake cap. Refer to "Air Intake Cap" on this page.
8. Install the body of the power unit. Tighten the nut on each mounting bracket.
9. Fill the cup to the "OIL LEVEL" mark with the proper grade of oil. Refer to "LUBRICANT SPECIFICATIONS AND CAPACITIES CHART" on page 18.
10. Lift the cup into place on the body. Place the clamp around the cup and body and tighten the thumb screw.
11. Install the air intake cap and reconnect the hose to the air cleaner.

AIR INTAKE CAP

The dome of the air intake cap serves as a rain shield, and the screen prevents chaff and coarse dirt from getting into the air cleaner. Keep this screen clean from all chaff, oil or dust. Clogged holes in the screen will reduce the power of the engine by restricting the flow of air.

A twist and an upward pull will remove the cap. Use compressed air to clean the screen. If compressed air is not available, wash in clean hot water or preferably water containing a small amount of non-sudsing detergent. Clean at the interval specified under "Scheduled Maintenance" on page 15 or more often under extremely heavy dust conditions.

AIR CLEANER PRE-CLEANER
(COLLECTOR TYPE)

The pre-cleaner takes the place of the air intake cap. It must be frequently removed and the body cleaned out, at least before it becomes 3/4 filled with dirt. Remove and inspect the fins regularly. When fins become oily or dirty, wash the entire pre-cleaner in kerosine.

AIR CLEANER
(DRY TYPE)

The air cleaner is the "dry-type" with replaceable filter element and automatic dust unloader features. The element may be cleaned several times before requiring replacement (additional information can be found in the following text).

Precautions

As an added precaution against dirt getting into the engine, frequently inspect the flexible pipe connection between the carburetor and the air cleaner. If it shows any sign of leakage, correct it.

To eliminate strain on the pipe connection, be sure the pipe lines up.

All the joints between the air cleaner and the carburetor and between the manifold and cylinder head must be tight. All the gaskets must be in good condition and the bolts must be drawn up tight.

Never operate the engine unless the filter element is in place in the air cleaner body and/or the dust unloader is in place.

Never remove the element from the air cleaner body while the engine is running.

Automatic Dust Unloader

The dust unloader (8, Illust. 22) automatically allows the accumulated dirt in the air cleaner body to drop out when the weight of the dirt overcomes the vacuum that keeps the unloader lips closed. At the interval specified under "SCHEDULED MAINTENANCE" on page 15, stop the engine and squeeze the dust unloader lips to be sure they are not blocked.

NOTE: When installing the unloader, be sure the flat side is in line and not broadside to the fan blast, or proper function will be affected.

Filter Element Service

The element can be cleaned by either of two methods; washing or compressed air.

Washing is the preferred method as it removes more dust and soot and restores the element to an almost new condition. The result being better performance and longer intervals between required element service. It is suggested that a spare element be available for use while the serviced element is drying. This will reduce engine down-time to only a few minutes and will allow sufficient time to service the restricted element properly. (Refer to "Washing" on page 34.)

NOTE: A filter element must be replaced after six washings.

Cleaning the element with compressed air is not considered an entirely satisfactory method. Some dust will remain in the element causing more frequent servicing of the element. Use this method only as a temporary measure until sufficient time is available to clean the element by "washing". (Refer to "Compressed Air" on page 35.)

Continued on next page.

NOTE: After cleaning, if an element is to be stored for later use, place it in a plastic bag and store in an element shipping container to protect against dirt and damage.

Removal (Illust. 22)

1. Stop the engine. Wipe off any accumulation of dust from the element removal end of the air cleaner body (4). Be careful not to dislodge dust from the dirty element into the clean air side or outlet of the air cleaner. (Any dust accidentally dislodged into the outlet or clean air side must be cleaned up before installing an element.)
2. Loosen the element lock nut and remove the element retainer (1). Remove the gasket (2) and the element (3).
3. Inspect the "clean air side" of the element (3) and air cleaner body (4) for unusual accumulation of dust. Dust accumulation on the "clean air side" of the element usually means a rupture in the paper and element must be discarded.
4. Inspect all gaskets and gasket sealing surfaces in the air cleaner body and the element. If any gaskets are damaged, missing, or show signs of leakage, these must be corrected before operating the unit.

Washing

NOTE: Never wash elements in fuel oil, gas or solvent. **DO NOT OIL ELEMENTS.** Do not attempt to take elements apart.

1. Before washing, tap the side or end of the element against the palm of your hand to remove loose dust.

NOTE: Do not tap the element against a hard surface; this will damage the element.

2. Wash the element in clean, warm water (+70°F to +100°F). A small amount of non-sudsing detergent added to water will facilitate the removal of soot.
3. Rinse the element in clear water (if a-hose is used, do not exceed 40 psi). Shake the element carefully to remove excess water.

NOTE: Do not use compressed air to speed the drying of the element; the air pressure will rupture the wet element.

4. Lay the element on its side and allow it to air dry before reinstalling. Overnight drying is usually sufficient. When drying the element protect it from dirt and/or freezing.

NOTE: If no spare element is available, the wet element, after excess water has been shaken out, may be installed in the air cleaner and the engine operated at low idle for 10 minutes before operating.

5. Inspect for damage. Refer to "Inspection" on page 35.

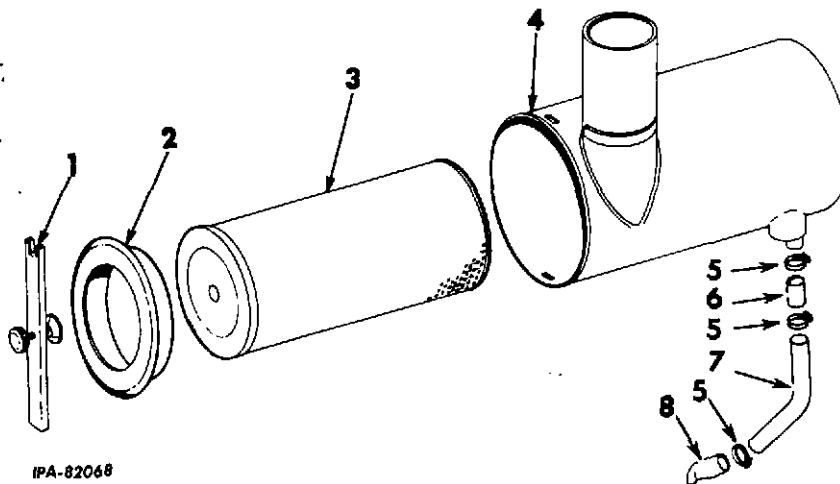

Illust. 22
Air Cleaner Components (Dry Type).

- | | |
|-----------------------|-------------------------|
| 1. RETAINER, element. | 5. CLAMP, hose. |
| 2. GASKET, end seal. | 6. HOSE, unloader tube. |
| 3. ELEMENT, filter. | 7. TUBE, dust unloader. |
| 4. BODY, air cleaner. | 8. UNLOADER, dust. |

Compressed Air

An element cleaning tool (IH Part No. 407 073 R1, Illust. 23) for use with compressed air, is available from your authorized International Engine distributor or dealer, and will do a faster and more efficient job of removing dust than a regular air gun or nozzle.

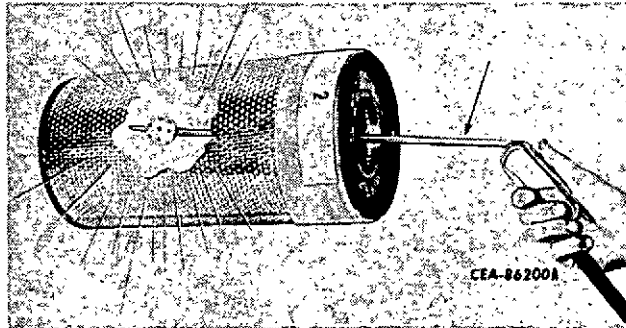

Illust. 23
Using Element Cleaning Tool.

1. Carefully tap side or end of the element against the palm of your hand to remove loose dust.

NOTE: Do not tap the element against a hard surface; this will damage the element.

2. Direct clean, dry compressed air up and down the pleats on the "CLEAN SIDE" of the element. Always direct the compressed air opposite the normal operating air flow through the element.

NOTE: Air pressure at the nozzle must not exceed 100 psi. Keep a reasonable distance between the air nozzle and the element.

3. Inspect the element for damage. Refer to "Inspection" as outlined in the following text.
4. Squeeze or remove and clean the dust unloader to be sure it is open and contains no obstructions.

Inspection

1. Inspect the filter element for leaks or damage by placing a bright light inside the element. Inspection of the element on the outside will disclose any holes where concentrated light shines through. The slightest rupture requires replacement of the filter element.
2. Inspect the contact surfaces of the element and the air cleaner body. If faulty or damaged gaskets or surfaces are noted, correct these conditions immediately.

3. Remove all dirt from the inside of the air cleaner body with a damp cloth. A small amount of non-sudsing detergent added to the water will remove the soot.

Installation (Illust. 22)

1. Install the open end of the element (3) into the air cleaner body (4). Install the gasket (2) on the element (3). Install the element retainer (1) and tighten the thumb screw in the retainer so that the element is air-tight.

NOTE: Under no circumstances, should the engine be without the element in the air cleaner and the dust unloader in place.

2. Clean the air intake cap screen. Refer to "AIR INTAKE CAP" on page 33.
3. After the element has been installed, but before resuming operation, inspect and tighten all air cleaner and air induction system connections.

Air Cleaner Complete (Illust. 22)

At the interval shown under "SCHEDULED MAINTENANCE" on page 16, the air cleaner must be serviced as outlined below.

1. Stop the engine. Wipe off any accumulation of dust from the element removal end of the air cleaner body (4). Loosen the element lock nut and remove the element retainer (1). Remove gasket (2) and the element (3).
2. Remove the air intake cap from the air intake pipe.
3. Loosen the clamp securing the air outlet hose to the air cleaner. Disconnect the hose from the air cleaner.
4. Disconnect the breather tube from the air cleaner.
5. Loosen the clamp (5) and remove the hose (6) from the air cleaner body (4).
6. Remove the cap screws, lock washers and nuts securing the air cleaner body (4) to the air cleaner mounting clamps, and remove the air cleaner body from the engine.
7. Clean the disassembled air cleaner as follows:
 - a. Wash the air cleaner body (4) and gasket (2) in warm water (+70°F to +100°F). A small amount of non-sudsing detergent added to the water will facilitate removal of soot. Rinse these parts in clear water and dry thoroughly.
 - b. Clean the element (3). Refer to "Washing" on page 34.

Continued on next page.

c. Clean the air intake cap. Refer to "AIR INTAKE CAP" on page 33.

8. Check the condition of the unloader (8). If found faulty or damaged, replace.

9. Install the air cleaner onto the engine as follows:

a. Position the air cleaner body (4) onto the mounting clamps and secure in place with the cap screws, lock washers and nuts previously removed.

b. Secure the hose (6) to the body (4) with the clamp (5).

c. Connect the air outlet hose to the air cleaner body (4) and secure with the clamp.

d. Connect the breather tube to the air cleaner.

e. Insert the open end of the element (3) into the air cleaner body (4). Install the gasket (2) on the element (3). Install the element retainer (1) and tighten the thumb screw in the retainer so that the element is airtight.

f. Install the air intake cap.

9. Before resuming operation, inspect and tighten all air cleaner and air induction system connections.

LUBRICATING OIL FILTER

Changing the Filter Element (Illust. (24))

1. Drain the oil immediately after stopping the engine, when complete circulation has been established and while most of the sediment is in suspension.

2. Remove both the crankcase oil pan drain plug and oil filter body drain plug and allow to drain completely. Install the crankcase oil pan drain plug.

3. Clean the filter base to prevent dirt from dropping into the body.

4. Unscrew the retaining bolt.

5. Remove the retaining bolt and the body together with the spring.

6. Remove the old element.

7. Wipe out the base with a cloth dampened with kerosine. Wash the filter body in kerosine being sure that all of the sediment is removed from the inside of the body.

8. Be sure that the body gasket is in good condition. We recommend replacing the gasket.

9. Inspect the retaining bolt and be sure it is clean. Do not allow dirt to go into the threaded center of the base, as this passage returns the oil to the engine.

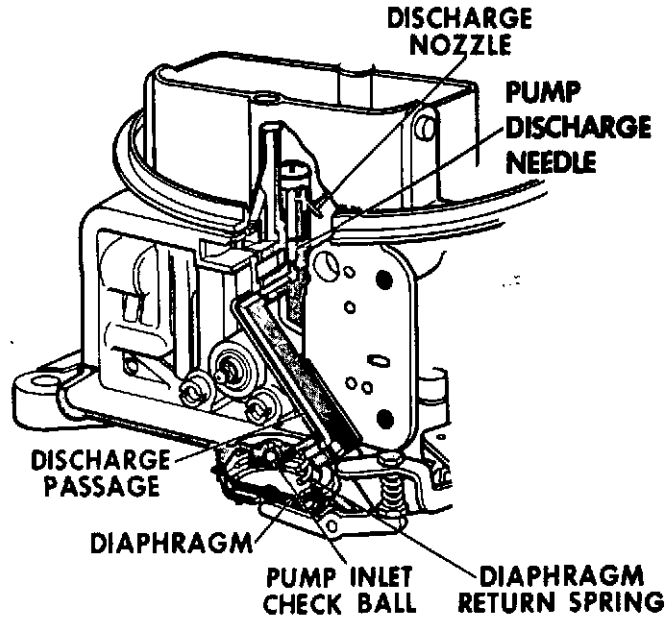

Illust. 24
Lubricating Oil Filter.

10. Position the new filter element to the oil filter base with the seal end of the element away from the base.

NOTE: The element must be seated on the pilot of the base to avoid damage to the element when the filter body is installed.

11. Install the filter body and bolt with spring assembly to the filter, being sure that the filter body seats on the gasket in the filter base. Tighten the retaining bolt (refer to "Torques" on page 4.)

12. Replace and tighten the oil filter drain plug.

13. Fill the crankcase oil pan with new oil as instructed in the "LUBRICATION GUIDE" on pages 19 and 20.

14. Start the engine and check the oil pressure indicator to see whether lubricating oil is circulating through the engine; then inspect the filter for leaks.

CRANKCASE VENTILATION

Crankcase Ventilator Metering Valve (5, Illust. (25))

To retard the accumulation of harmful substances in the engine crankcase, positive ventilation of the crankcase has been provided. This valve maintains positive air flow through the engine crankcase at all engine speeds.

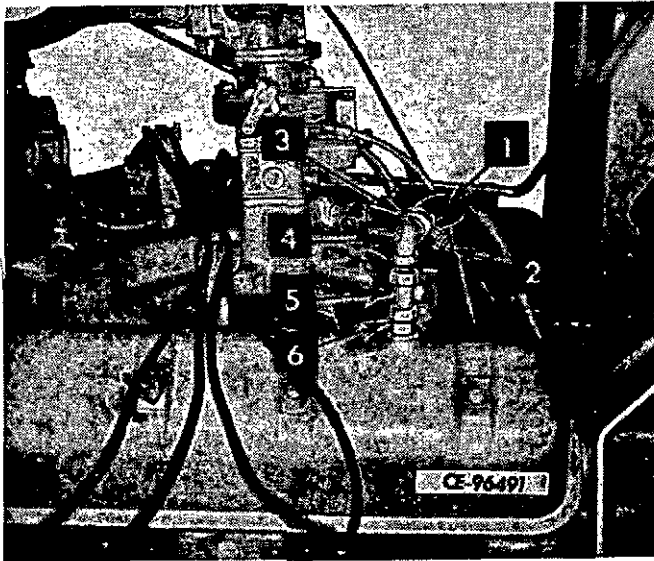

Illust. 25
Crankcase Ventilator Metering Valve.

- | | |
|------------------|---------------------|
| 1. HOSE. | 4. ELBOW, 90°. |
| 2. CLAMP, hose. | 5. VALVE, metering. |
| 3. NIPPLE, hose. | 6. NIPPLE, pipe. |

Cleaning the Crankcase Ventilator Metering Valve (Illust. 25)

Remove and clean the valve. Proceed as follows:

1. Loosen the hose clamp (2). Disconnect the hose (1).
2. Remove the metering valve (5) and the elbow (4) with the hose nipple (3) as an assembly from the engine.
3. Disassemble the elbow, nipple and valve. Wash these parts in kerosine or diesel fuel. Dry all parts thoroughly.
4. Reassemble the valve, the elbow and the hose nipple. Install the valve assembly in the valve cover.
5. Connect the hose w/nipple to the elbow. Secure with the clamp.
6. Check all connections for alignment and/or leaks. Correct, if necessary.

OIL COOLER

The oil cooler is a safety feature which assures safe lubricating oil temperatures and oil economy. It is a self-contained unit mounted in the "V" of the engine.

HYDRAULIC VALVE LIFTERS

The hydraulic valve lifters contribute to engine quietness and maintain zero valve lash or tappet clearance. This eliminates the need for periodic valve adjustment.

OIL LEVEL SIGHT GAUGE (Illust. 26)

To set the oil level sight gauge after changing the crankcase oil, proceed as follows:

1. Operate the engine until it is thoroughly warmed up.
2. Pull the throttle control handle out until the desired engine rpm is reached.
3. Slide the marker on the sight level gauge up or down so that it is even with the level of the oil in the gauge.

NOTE: To insure an accurate sight level oil gauge reading, the balance line connections and gauge fittings must be kept tight. An air leak, particularly at the upper side of the level gauge column or the balance line fittings, will result in a false sight level reading. Tighten all fittings periodically.

To check for possible air leaks, remove the oil filler cap and note the reaction of the oil column. If an air leak exists, the level of the oil column in the gauge will change considerably. If the oil column falls more than 1/8 to 1/4 inch maximum, air leak exists. Oil trapped in the balance line will also result in incorrect readings.

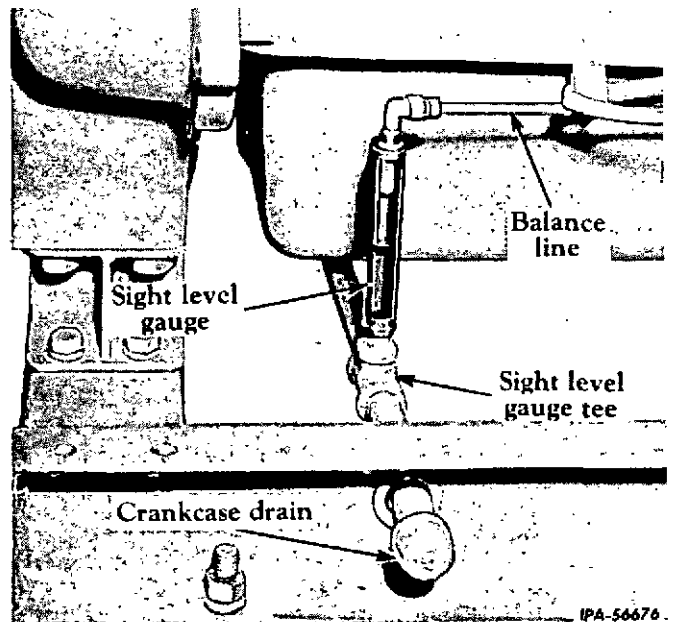

Illust. 26
Oil Sight Level Gauge.

Continued on next page.

When there is no trapped oil in the balance line and no leak exists above the oil column, there is only a slight change, if any, in the oil column with the filler cap on or off.

ELECTRICAL SYSTEM

Precautions

The electrical generating system now incorporates a direct diode rectified generator (alternator w/integral regulator) which requires special handling and procedures different from those associated with the old style DC generator.

CAUTION: BEFORE WORKING ON ANY PART OF THE ELECTRICAL SYSTEM, DISCONNECT THE BATTERY GROUND CABLE UNTIL ALL ELECTRICAL WORK HAS BEEN COMPLETED.

Repair or replace all broken wires immediately. All terminals must be clean and securely fastened; never paint connections.

Alternator w/Integral Regulator

The alternator incorporates a built in transistorized voltage regulator. The alternator requires no lubrication since it's bearings are factory lubricated for life and require attention only at time of major overhaul. The integral regulator is sealed by the manufacturer.

NOTE: The unit electrical system is negative ground. Be CERTAIN the ground polarity is correct when:

- a. Installing a new battery.
- b. Connecting a battery charger.
- c. Using a booster.

Failure to observe proper polarity will result in damage to the alternator.

NEVER use a fast charger as a booster to start the engine.

NEVER unhook a battery terminal while the engine is running.

NEVER disconnect the alternator cable while the engine is running.

DO NOT POLARIZE THE ALTERNATOR.

DO NOT SHORT ACROSS OR GROUND ANY TERMINALS OF THE ALTERNATOR OR REGULATOR.

Voltage Regulator (Illust. 27)

This engine is equipped with a transistor type voltage regulator. This regulator incorporates a voltage adjustment that

can be used to maintain the battery in a satisfactory charge condition, thereby obtaining maximum battery life.

When to Adjust the Regulator

1. If battery uses too much water at normal setting (position "2" on the cap aligned with the arrow) reduce the voltage setting by aligning position "LO" on the cap (2) with the arrow.
2. If the battery is consistently under charged at the normal setting (position "2" on the cap aligned with the arrow), increase the voltage setting by aligning the "3" position on the cap with the arrow. If further increase is desired, align the "HI" position on cap with arrow.

NOTE: If either of the conditions in Steps 1 or 2 persists after making the adjustment, consult your authorized International Engine Distributor or Dealer.

Adjustment

1. To adjust the regulator setting, remove voltage adjustment cap (2) from alternator.
2. Position the cap until the desired setting is aligned with the arrow on the alternator. Refer to Steps 1 and 2 under the "Voltage Regulator" for the desired setting.
3. Reinstall the cap in the alternator.

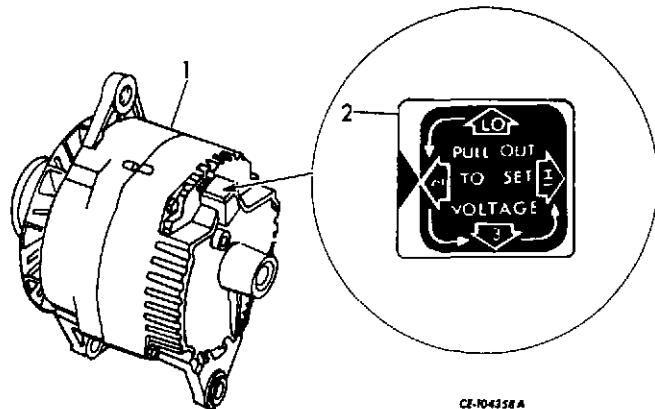

CZ-104358 A

Illust. 27
Voltage Adjustment Cap.

1. ALTERNATOR.
2. CAP, voltage adjustment.

Cranking Motor

The cranking motor does not require lubrication, except during overhaul.

If the cranking motor is removed, it can be lubricated as follows:

1. At time of removal, motor should be cleaned, disassembled and inspected for further maintenance requirements. Consult your International Engine Distributor or Dealer for procedure to follow.
2. All oil wicks (if equipped) and oil reservoirs must be saturated with SAE Grade-20 engine oil.
3. Bushings should be coated with a small amount of Delco-Remy lubricant No. 1960954 or a "Molybdenum Disulfide" No. 1 Multi-Purpose grease.
4. The armature shaft and splines must be coated lightly with the same grease as used in step 3.
5. The drive assembly must be wiped clean.

NOTE: DO NOT CLEAN THE DRIVE ASSEMBLY IN ANY DEGREASING TANK OR WITH GREASE DISSOLVING SOLVENTS; THIS WILL DISSOLVE THE LUBRICANT IN THE CLUTCH MECHANISM.

6. The overrunning clutch requires no lubrication.

Ignition Coil

The ignition coil does not require special service other than to keep all terminals and connections clean and tight.

Spark Plugs

For the recommended spark plugs, consult your authorized International Engine Distributor or Dealer.

USE ONLY A COMPLETE SET OF THE SAME TYPE OF SPARK PLUGS.

NOTE: Before removing a spark plug from the cylinder head, remove all dirt around the base of the plug.

Use a spark plug wrench to remove the plugs. After the plugs have been removed, remove each spark plug gasket. Do not re-use these gaskets.

If the plugs are greasy or oily when removed, wash them with a petroleum solvent and dry them thoroughly. After drying the plugs, hard deposits can best be removed with an abrasive or by use of a sand-blasting machine. **DO NOT USE A WIRE BRUSH;** wire brushing the spark plug electrodes will simply load the firing bore with electrically conductive metal particles from the brush and can cause misfiring when the plugs are reinstalled.

When cleaning spark plugs with a conventional sand-blasting machine, **THE PLUG SHOULD NOT BE EXPOSED TO THE SAND BLAST FOR MORE THAN THREE OR FOUR SECONDS.** If longer exposure is needed to clean the plug, the insulator will be damaged, rendering the plug either inoperative or very undependable. Use compressed air to remove any sand from inside the plug shell. Before setting the gap on a used plug, file the center electrode until it is flat.

If the center electrode is shorter than the shell skirt before or after filing or if the porcelain is chipped, scratched or broken, replace the plug.

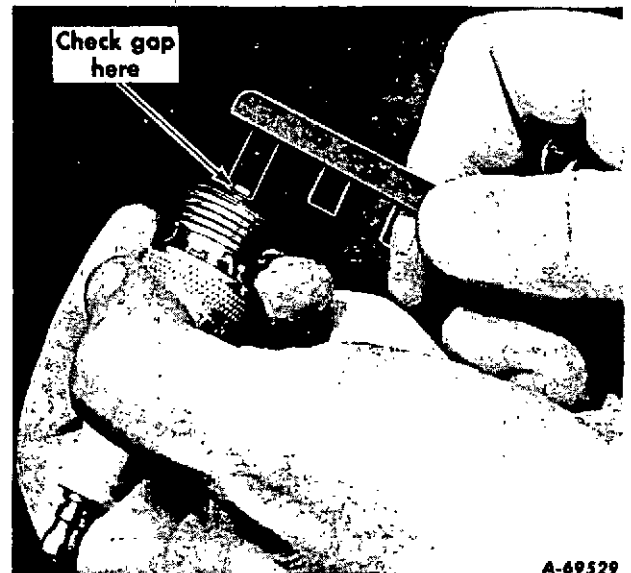

A-69529

Illust. 28
Checking Spark Plug Gap.

When adjusting the spark plug gap, bend the outer electrode only. Never bend the center electrode as this will damage the insulator. If the gap between the electrodes is too great (refer to "Specifications" on page 4) due to improper setting or burning off the ends, the engine will misfire and will be hard to start.

Ignition Requirements When Using Natural Gas

Ignition requirements are greatly increased on engines using straight natural gas as fuel. Because of the dry nature of the fuel, spark plugs run hotter and have a tendency to burn more rapidly. If missing or pre-ignition occurs when the engine is operating at low speeds and with heavy loads, reset the spark plug gap, as shown in "Specifications" on page 4. Inspect spark plugs regularly and maintain this gas setting.

Continued on next page.

Spark Plug Cables

If the spark plug cables are removed for any reason, note the position of each cable on the distributor.

A minimum clearance of 1/4 inch between the spark plug cables and the cylinder head is recommended. By maintaining this clearance, shorting out the spark plugs will be prevented and the cable will be away from the heat of the cylinder head, the heat will soon cause the rubber to become soft and will ruin the cable.

Storage Battery

Complete instructions for dry-charged batteries are included with the battery.

CAUTION: BATTERIES GIVE OFF HIGHLY INFLAMMABLE GAS. NEVER ALLOW SPARKS OR OPEN FLAME NEAR THE BATTERIES. AVOID SPILLING ANY ELECTROLYTE ON HANDS OR CLOTHING.

Battery Installation

Never allow the battery to stand on the concrete, ground or a metal support unless proper insulation is provided. A wooden platform or board is sufficient insulation. Be sure the battery is fastened securely to avoid damage from vibration.

NOTE: If tightened excessively, the battery case could warp or break.

Cleaning and Servicing the Battery

If the top of the battery is dirty, it may be cleaned with a brush dipped in ammonia or soda solution. The vent plugs must be tightened to prevent any solution from getting into the battery cells. After the foaming stops, flush off the battery with clean water. Brighten the terminal contact surfaces with steel wool or a stiff brush.

Check that the vent holes in the filler caps are not clogged. Replace unserviceable cables.

Liquid Level

The electrolyte in each cell should be above the plates at all times to prevent battery failure. Check the level of the electrolyte. When the electrolyte is below this level, pure distilled water should be added. Never use hydrant water or any water which has been a metal container. Acid or electrolyte should never be added except by a skilled batteryman. Under no circumstances add any special battery "dopes", solutions or powders.

It is especially important to keep the battery at full charge for cold weather operation. Add distilled water to the battery in freezing temperatures only when the engine is to operate for several hours to thoroughly mix the water and the electrolyte, or damage to the battery will result from the water freezing.

Distributor

Your unit is equipped with either a vacuum advance controlled ignition distributor (Illust. 30) or a mechanical advance ignition distributor (Illust. 29). All maintenance of either distributor is similar. The following text applies to each unless otherwise indicated.

Distributor Cap

Remove the distributor cap and examine the inside. If any dust, moisture, or oil deposits are present, thoroughly clean and wipe dry. To assure long life of the distributor, care must be taken to keep the ventilator flats, at the inside edge of the distributor cap, open at all times. Keep the distributor rotor clean.

If the terminal nipples are removed, be sure the distributor cap terminals and coil terminal are clean and dry. The distributor is equipped with these nipples to prevent any external electrical leakage when the engine is operating under adverse conditions.

Checking the Breaker Chamber and Breaker Points

It is important that the breaker chamber be kept clean because oil on the breaker points will cause rapid burning.

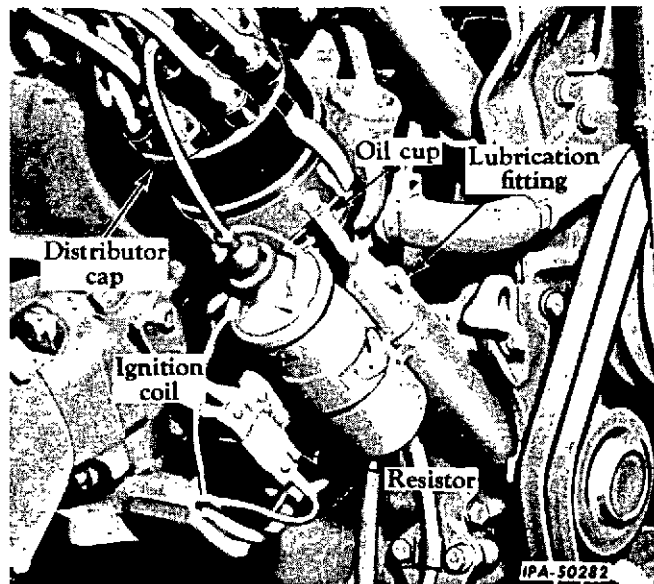

Illust. 29
Distributor Assembly (Mechanical Advance).

Remove the distributor cap, distributor rotor, and the breaker cover for breaker chamber inspection. Care must be taken, when removing the breaker cover, to prevent dirt from entering the breaker chamber. Be sure the chamber is clean and the breaker points are in good condition and have the proper opening.

Check the condition of the breaker points for build-up of lip formation. If present, the points must be dressed before the point opening can be checked or set. NEVER USE EMERY CLOTH OR SANDPAPER TO CLEAN THE POINTS. IF THE POINTS ARE WORN EXCESSIVELY, REPLACE BOTH POINTS. Check the opening between the breaker points with a feeler gauge when the rubbing block is on the high part of the cam. (Refer to "Specifications" on page 4.) If the gap is not correct, adjust it by loosening the breaker arm locking screw with a screwdriver and turning the eccentric screw until the gap between the contact points, is correct (Illust. 31). After the adjustment has been made, tighten the locking screw.

NOTE: When replacing breaker points grease the recess in the pivot post with a small amount of Anco grease 4X or Andok-260 grease.

Install the distributor cap to the housing with the tang in the cap in line with the slot in the distributor housing.

NOTE: If the cap is incorrectly positioned on the housing, it will usually result in a broken rotor when attempting to start the engine.

Continued on next page.

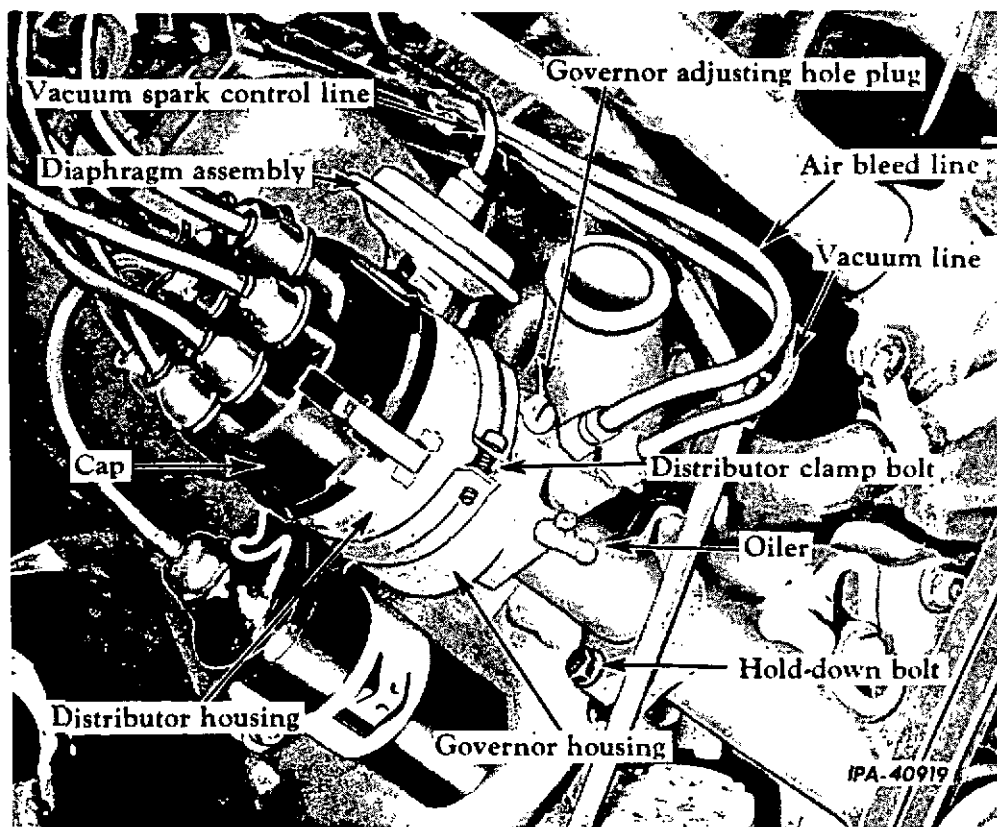

Illust. 30
Distributor and Governor Assembly
(Vacuum Advance).

Ignition Timing

1. Be sure that the distributor cap is properly located on the distributor housing and that both bail clips are in place.

NOTE: If the distributor cap is incorrectly positioned on the distributor housing, it will usually result in a broken rotor when attempting to start the engine.

The firing order is 1, 8, 7, 3, 6, 5, 4, 2 and spark plug cables must be assembled in the distributor cap in this order in a counterclockwise rotation.

2. **VACUUM ADVANCE DISTRIBUTOR ONLY:** Disconnect the distributor vacuum advance line (Illust. 29) at the carburetor and close the fitting with a piece of tape.

3. Connect a timing light to the No. 1 spark plug.

NOTE: Follow the manufacturer's instructions on the use of the timing light.

4. Set the initial timing to the point indicated on the timing chart on page 43. White chalk or paint will highlight the timing mark for easier recognition.

5. Start the engine, and check the timing light operation.

6. Rotate the throttle stop screw on the carburetor to reduce the idle speed of the engine to approximately 300 rpm for timing purposes.

7. Direct the light to the timing location on the fan drive pulley. Each light flash should be fast and accurate, and the timing marks should be readily seen.

8. Loosen the adjusting clamp screw on the distributor sufficiently to permit rotation of the distributor housing until the timing mark is in alignment with the pointer or quadrant.

9. Tighten the adjusting clamp screw and recheck to be certain that tightening the screw did not disturb the timing setting.

10. Readjust engine idle speed as follows:

Gasoline	475 - 525 RPM
LPG or Natural Gas	575 - 625 RPM

11. Stop the engine. Disconnect the timing light.

12. **VACUUM ADVANCE DISTRIBUTOR ONLY:** Connect the distributor vacuum advance line to the carburetor.

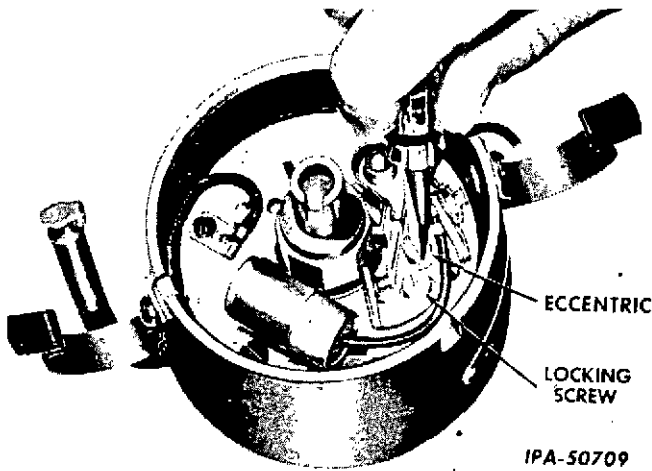

Illust. 31
Adjusting Breaker Points
(Mechanical Advance Distributor Shown;
Vacuum Advance Distributor Similar).

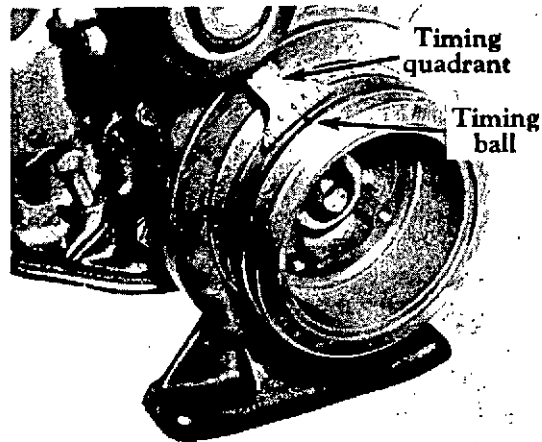

Illust. 32
Ignition Timing Quadrant And Ball.

TIMING CHART

APPLICATION	TIMING SETTINGS (Refer to Illust. 32)
Gasoline - Holley distributor	Set with ball on crankshaft pulley in line with seven degrees advance mark on timing quadrant.
Gasoline and LPG Delco - Remy distributor	Set with ball on crankshaft pulley in line with zero degree mark on the timing quadrant, which is top-dead-center.
Natural gas Standard - 2600 RPM	Set with ball on crankshaft pulley in line with two degree advance mark on timing quadrant.
Natural gas Generator Set - 1800 RPM	Set with ball on crankshaft pulley in line with five degree advance mark on timing quadrant.

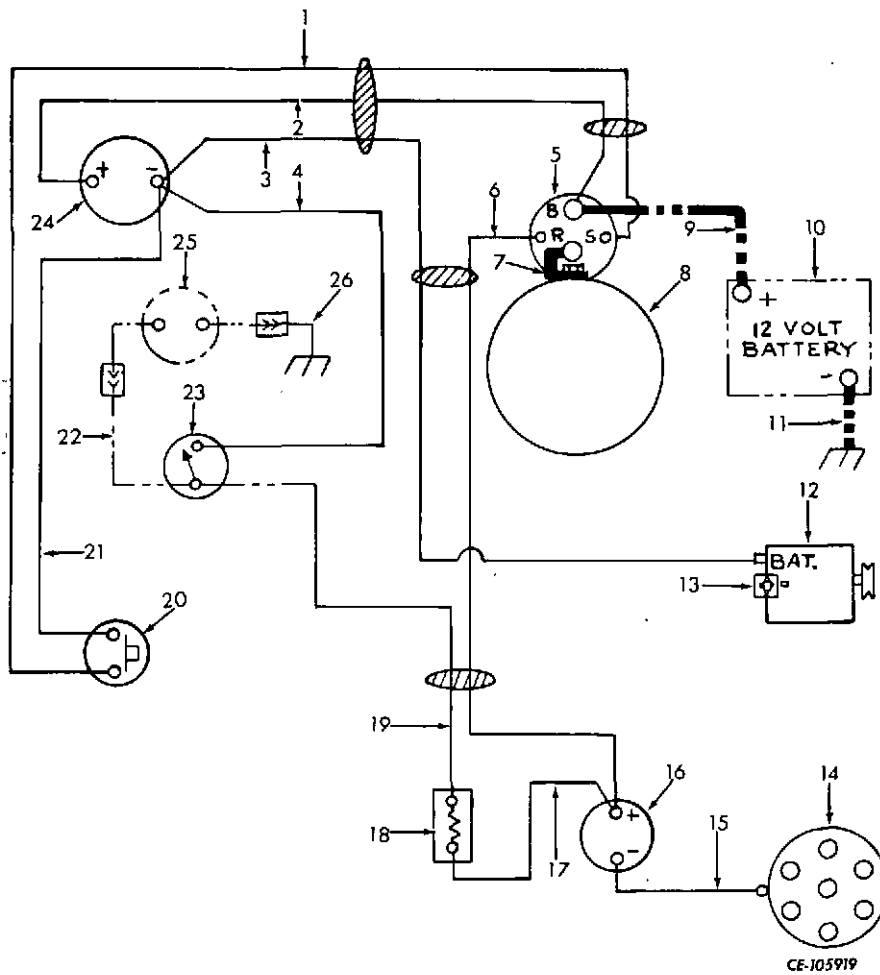

Illust. 33
Wiring Diagram for Engines Equipped with Regular Gauges.
(Side Mounted Instrument Panel)

CABLE COLOR CODE - All cables are black unless otherwise specified.

CABLE GAUGE - All cables are 16 gauge except battery cables and those noted below:

Cable Ref. 2, 3	10 gauge
Cable Ref. 1, 4, 21	12 gauge
Cable Ref. 6, 19	14 gauge

Index to reference numbers in Wiring Diagram, Illust. 33.

Ref. No.	Description	Ref. No.	Description
1.	CABLE, starting switch to "S" terminal on solenoid (Green).	11.	CABLE, battery to ground.
2.	CABLE, plus (+) terminal on ammeter to "B" terminal on solenoid (Red).	12.	ALTERNATOR w/REGULATOR.
3.	CABLE, minus (-) terminal on ammeter to "BAT" terminal on alternator (Brown).	13.	ADJUSTER, voltage.
4.	CABLE, minus (-) terminal on ammeter to ignition switch.	14.	DISTRIBUTOR.
5.	SOLENOID.	15.	CABLE, distributor to coil.
6.	CABLE, "R" terminal on solenoid to plus (+) terminal on ignition coil (Pink).	16.	COIL, ignition.
7.	CABLE, cranking motor to solenoid.	17.	CABLE, plus (+) terminal on coil to resistor.
8.	MOTOR, cranking.	18.	RESISTOR.
9.	CABLE, plus (+) terminal on battery to "B" terminal on solenoid.	19.	CABLE, resistor to ignition switch (Orange).
10.	BATTERY (12 Volt).	20.	SWITCH, starting.
		21.	CABLE, starting switch to minus (-) terminal on ammeter.
		22.	CABLE, hourmeter to ignition switch.
		23.	SWITCH, ignition.
		24.	AMMETER.
		25.	HOURMETER, electric.
		26.	CABLE, hourmeter to ground.
			HARNESS, main cable (Consists of Ref. Nos. 1, 2, 3, 6 and 19).

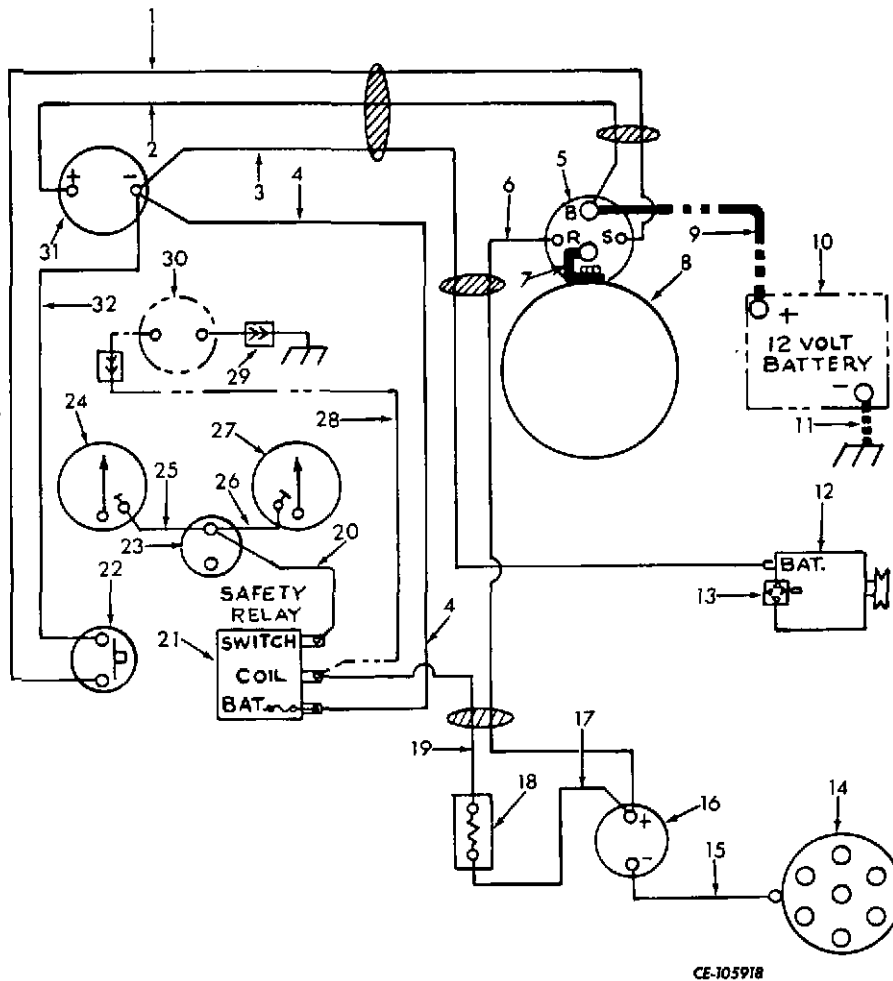

Illust. 34
Wiring Diagram for Engines Equipped with Safety Gauges.
(Side Mounted Instrument Panel).

CABLE COLOR CODE - All cables are black unless otherwise specified.

CABLE GAUGE - All cables are 16 gauge except battery cables and those noted below:

Cable Ref. 2, 3	10 gauge
Cable Ref. 1, 4	12 gauge
Cable Ref. 6	14 gauge

Legend for Illust. 34

Ref. No.	Description	Ref. No.	Description
1.	CABLE, starting switch to "S" terminal on solenoid (Green).	19.	CABLE, resistor to coil terminal on safety relay (Orange).
2.	CABLE, plus (+) terminal on ammeter to "B" terminal on solenoid (Red).	20.	CABLE, switch terminal on safety relay to stop switch.
3.	CABLE, minus (-) terminal on ammeter to "BAT" terminal on alternator (Brown).	21.	SWITCH, relay.
4.	CABLE, minus (-) terminal on ammeter to "BAT" terminal on relay switch.	22.	SWITCH, starting.
5.	SOLENOID.	23.	SWITCH, stop.
6.	CABLE, "R" terminal on solenoid to plus (+) terminal on coil (Pink).	24.	GAUGE, engine coolant temperature safety.
7.	CABLE, cranking motor to solenoid.	25.	CABLE, engine coolant temperature safety gauge to stop switch.
8.	MOTOR, cranking.	26.	CABLE, stop switch to engine oil pressure safety gauge.
9.	CABLE, plus (+) terminal on battery to "B" terminal on solenoid.	27.	GAUGE, safety oil pressure.
10.	BATTERY (12 Volt).	28.	CABLE, electric hourmeter to coil terminal on safety relay.
11.	CABLE, battery to ground.	29.	CABLE, hourmeter to ground.
12.	ALTERNATOR w/REGULATOR.	30.	HOURLMETER, electric.
13.	ADJUSTER, voltage.	31.	AMMETER.
14.	DISTRIBUTOR.	32.	CABLE, minus (-) terminal on ammeter to starting switch.
15.	CABLE, minus (-) on coil to distributor.		
16.	COIL, ignition.		
17.	CABLE, plus (+) on ignition coil to resistor.		
18.	RESISTOR, ignition.		HARNESS, main cable (Consists of Ref. Nos. 1, 2, 3, 6 and 19).

Legend for Illust. 35

Ref. No.	Description	Ref. No.	Description
1.	CABLE, "S" terminal on solenoid to "SOL" terminal on ignition and starter switch (Green).	15.	CABLE, "R" terminal on solenoid to plus (+) terminal on coil (Pink).
2.	CABLE, plus (+) terminal on ammeter to "B" terminal on solenoid (Red).	16.	CABLE, cranking motor to solenoid.
3.	AMMETER.	17.	SOLENOID.
4.	CABLE, minus (-) terminal on ammeter to "BAT" terminal on alternator (Red).	18.	CABLE, plus (+) terminal on coil to resistor.
5.	HARNESS, cranking motor (Consists of Ref. Nos. 1 and 2).	19.	RESISTOR, ignition coil.
6.	CABLE, plus (+) terminal on battery to "B" terminal on solenoid.	20.	CABLE, resistor to "IGN" terminal on ignition and starter switch (Orange).
7.	MOTOR, cranking.	21.	HARNESS, ignition cable (Consists of Ref. Nos. 15 and 20).
8.	BATTERY (12 Volt).	22.	SWITCH, ignition and starter.
9.	CABLE, battery to ground.	23.	CABLE, "BAT" terminal on ignition and starter switch to minus (-) terminal on ammeter.
10.	ALTERNATOR w/REGULATOR.	24.	CABLE, "ACC" terminal on ignition and starter switch to hourmeter.
11.	ADJUSTER, voltage.	25.	HOURMETER, electric.
12.	DISTRIBUTOR.	26.	CABLE, hourmeter to ground.
13.	CABLE, minus (-) on coil to distributor.	27.	PANEL, instrument.
14.	COIL, ignition.		

Legend for Illust. 36

Ref. No.	Description	Ref. No.	Description
1.	AMMETER.	21.	CABLE, coil terminal on relay switch to hourmeter.
2.	CABLE, plus (+) terminal on ammeter to "B" terminal on solenoid (Red).	22.	CABLE, switch terminal on relay switch to safety oil pressure gauge.
3.	CABLE, "S" terminal on solenoid to "SOL" terminal on ignition and starter switch (Green).	23.	CABLE, switch terminal on relay switch to engine coolant temperature safety gauge.
4.	HARNESS, cranking motor (Consists of Ref. Nos. 2 and 3).	24.	GAUGE, safety oil pressure.
5.	SOLENOID.	25.	CABLE, hourmeter to ground.
6.	CABLE, "R" terminal on solenoid to plus (+) terminal on coil (Pink).	26.	CABLE, minus (-) terminal on ammeter to "BAT" terminal on alternator (Red).
7.	CABLE, cranking motor to solenoid.	27.	HOURMETER.
8.	MOTOR, cranking.	28.	CABLE, minus (-) terminal on ammeter to "BAT" terminal on ignition and starter switch.
9.	CABLE, plus (+) terminal on battery to "B" terminal on solenoid.	29.	GAUGE, engine coolant temperature safety.
10.	BATTERY (12 Volt).	30.	SWITCH, ignition and starter.
11.	CABLE, battery to ground.	31.	CABLE, "IGN" terminal on ignition and starter switch to "BAT" terminal on relay switch.
12.	ALTERNATOR w/REGULATOR.	32.	CABLE, instrument panel to ground.
13.	ADJUSTER, voltage.	33.	PANEL, instrument.
14.	DISTRIBUTOR.	34.	FUSE, SFE - 14 AMP.
15.	CABLE, minus (-) on coil to distributor.	35.	HARNESS, ignition cable (Consists of Ref. Nos. 6 and 19).
16.	COIL, ignition.		
17.	CABLE, plus (+) terminal on coil to resistor.		
18.	RESISTOR.		
19.	CABLE, resistor to coil terminal on relay switch (Orange).		
20.	SWITCH, relay.		

Condenser

A condenser must be proved defective before being replaced. It is seldom that burned or oxidized contact points are due to a defective condenser. A high voltage, overcharged battery, an excessive oil vapor or oil on the contact surface has the effect of increasing the normal rate of wear on the contacts. A short-circuited condenser will cause complete failure of the ignition system.

Governor (Vacuum Advance Distributor)

The governor was adjusted and sealed at the factory. If the governor becomes inoperative or does not function properly, consult your authorized International Engine Distributor or Dealer.

FUEL SYSTEM (GASOLINE)

General

When excessive fuel consumption or inefficient engine performance is encountered, be careful in determining the exact cause before assuming the carburetor to be at fault. Consider engine compression, ignition timing, defective wiring, improperly gapped or fouled plugs, distributor or magneto contact points, condenser, coil and fuel pump. These are all factors

in obtaining maximum fuel economy and must be within the limits specified by the manufacturer.

Due to the technical knowledge and skill required and the special equipment needed to make the necessary tests and corrections, we recommend the work be done by your authorized International Engine Distributor or Dealer.

Use clean fuel. The presence of dirt and water will disturb the functioning of the carburetor.

Carburetor

At the interval shown under "SCHEDULED MAINTENANCE" on page 15, remove and clean the filter screen as follows:

ENGINES EQUIPPED WITH A ZENITH CARBURETOR:
Unscrew and remove the filter and screen plug (Illust. 35).

ENGINES EQUIPPED WITH A HOLLEY CARBURETOR:
Unscrew the fuel line fitting and remove the screen.

Wash the screen in a commercial carburetor cleaning solvent. Dry thoroughly and reinstall the screen.

Continued on next page.

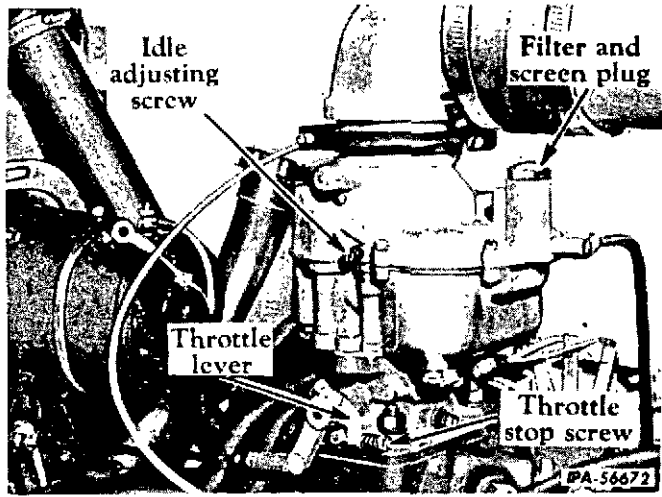

Illust. 37
Zenith Carburetor (UV-401 and UV-549).

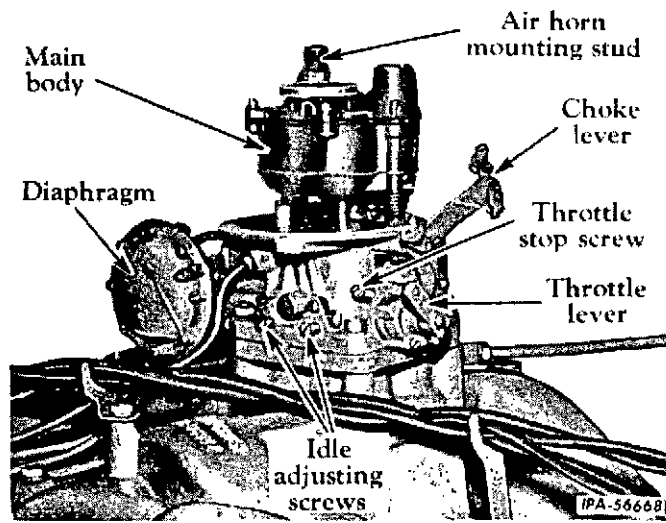

Illust. 39
Holley Carburetor (UV-549).

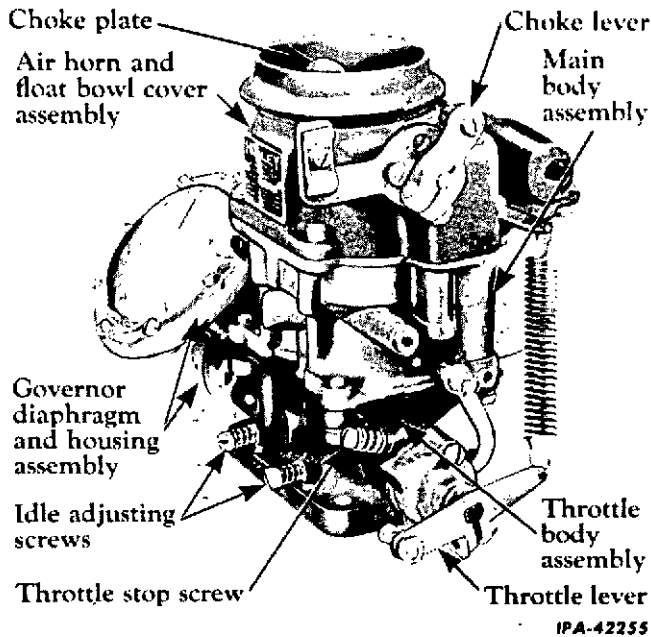

Illust. 38
Holley Carburetor (UV-401).

The flange nuts which hold the carburetor to the intake manifold must be checked periodically for tightness.

Occasionally check the cover screws which fasten the fuel bowl to the fuel bowl cover. They should be kept tight to avoid any air leakage past the fuel bowl cover gasket.

Carburetor Adjustment

The engine and carburetor are correctly set when shipped from the factory. If this setting has been disturbed for any reason, proceed as follows:

Adjusting the Idle Adjusting Screw(s)

1. Be sure the engine is on level ground.
2. Seat the idle adjusting screw(s) lightly; then back the screw(s) off one full turn.

NOTE: Do not seat the idle adjusting screw(s) too tightly as this will groove the tip(s) of the needle(s) and prevent a smooth idle. If the needle(s) become grooved, they must be replaced.

3. Start the engine and operate it at high idle until the normal operating temperature is reached.
4. Replace the engine throttle control knob or governor control lever in the "low idle" position and adjust the throttle stop screw until the engine is idling at the desired idle speed.

5. **HOLLEY CARBURETOR ONLY:** With the use of a vacuum gauge, set one idle adjusting screw to obtain the highest steady manifold vacuum reading. If a vacuum gauge is not available, set the idle adjusting screw to obtain the smoothest running and maximum idle speed. This is done by turning the adjusting screw in until the engine slows down. Then turn "out" over the "high spot" until the engine again

slows down. Setting the screw mid-way between these two points or setting it slightly on the rich side will give a satisfactory idle mixture. Repeat this procedure with the other adjusting screw. Final adjustment may vary slightly from these settings but the adjustment must not exceed 1/2 turn difference between the two screws.

ZENITH CARBURETOR ONLY: If the engine misses or rolls while adjusting the throttle lever stop screw, the idle adjusting screw may be adjusted either in or out until the engine operates smoothly.

6. If the adjustment results in an increased idle rpm, reset the throttle stop screw to the desired idle rpm and again check the idle adjusting screw(s).

Fuel Pump and Filter

The fuel pump and filter are an integral unit. The sediment bowl and filter element are provided to prevent the entry of foreign materials into the carburetor and, thus, cause engine failure.

Do not attempt to disassemble the fuel pump diaphragm. If a sufficient amount of fuel is not being delivered to the carburetor, make a careful check for the cause. Usually the cause will be from such sources as bent, leaky or clogged fuel lines, loose fuel bowl or a dirty element or fuel bowl. If servicing these parts does not correct the problem consult your authorized International Engine Distributor or Dealer.

Cleaning the Fuel Filter (Illust. 40)

Disassemble and clean the filter as follows:

1. Loosen the screw (6) at the bottom of the bowl (2) to relieve the tension on the retainer (3).
2. Remove the bowl (2) from the cover (1). Remove the filter (4) and the spring (5) from the bowl. Separate the spring from the filter. Dump out the gasoline in the bowl.
3. Remove the bowl gasket from the cover (1). This gasket should not be re-used.
4. Wash the bowl (2), filter (4) and the spring (5) in a commercial carburetor cleaning solvent.

NOTE: A restricted filter is usually slippery to the touch. If this condition exists after cleaning the filter, replace it with a new one.

5. Thoroughly dry these parts using compressed air.
6. Install the spring (5) in the bowl (2). Install the filter (4) so the spring fits in the recess in the bottom of the filter.
7. Place a new bowl gasket in the cover (1). Position the bowl (2) to the cover (1). Be sure the bowl and the gasket make an air-tight seal at the cover (1). Tighten the screw (6) (refer to "Torques" on page 4).

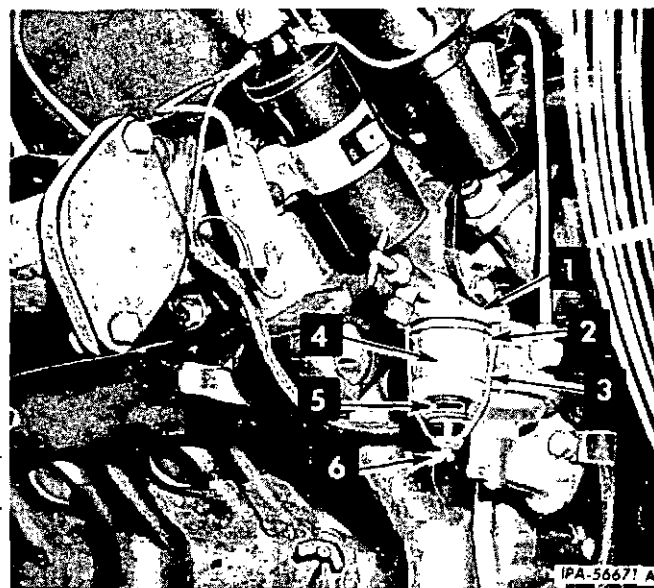

Illust. 40
Fuel Pump and Filter.

- | | |
|---------------------------------|------------------------------|
| 1. COVER. | 4. FILTER. |
| 2. BOWL. | 5. SPRING FILTER. |
| 3. RETAINER, bowl (with screw). | 6. SCREW (part of retainer). |

FUEL SYSTEM (LIQUEFIED PETROLEUM GAS)

General

When excessive fuel consumption or inefficient engine performance is encountered, be careful in determining the exact cause before assuming the carburetor to be at fault. Consider engine compression, ignition timing, defective wiring, improperly gapped or fouled plugs, distributor or magneto contact points, condenser, coil and fuel filter. These are all factors in obtaining maximum fuel economy and must be within the limits specified by the manufacturer.

Due to the technical knowledge and skill required and the special equipment needed to make the necessary tests and corrections, we recommend that the work be done by your authorized International Engine Distributor or Dealer.

Carburetor and Regulator

The regulator controls the flow of fuel to the carburetor.

The carburetor is used to mix accurately the correct proportion of fuel with air to satisfy the speed and load demand of the engine.

Continued on next page.

There are three fuel adjustments. These adjustments were correctly set at the factory and should require no alteration. If these adjustments have been disturbed in some manner, however, they can be correctly reset by following the instructions outlined below.

Adjusting the Carburetor (Illust. 41)

1. The carburetor mixture adjuster (12) is normally set at 1 notch "R" (rich) when engine is equipped with a dry-type air

cleaner and 1/2 notch toward "L" (lean) for engines equipped with oil bath air cleaners.

2. Should low idle adjustment be necessary, start and operate the engine at a fast idle of 1000 - 1500 rpm, without load, until thoroughly warm before making adjustments.

3. Position throttle control at low idle and adjust screw (13) to obtain a low idle of 600 plus or minus 25 rpm. Turn idle adjusting screw (11) in or out to give the best idle, then readjust the throttle lever screw (13) for proper low idle speed, if required.

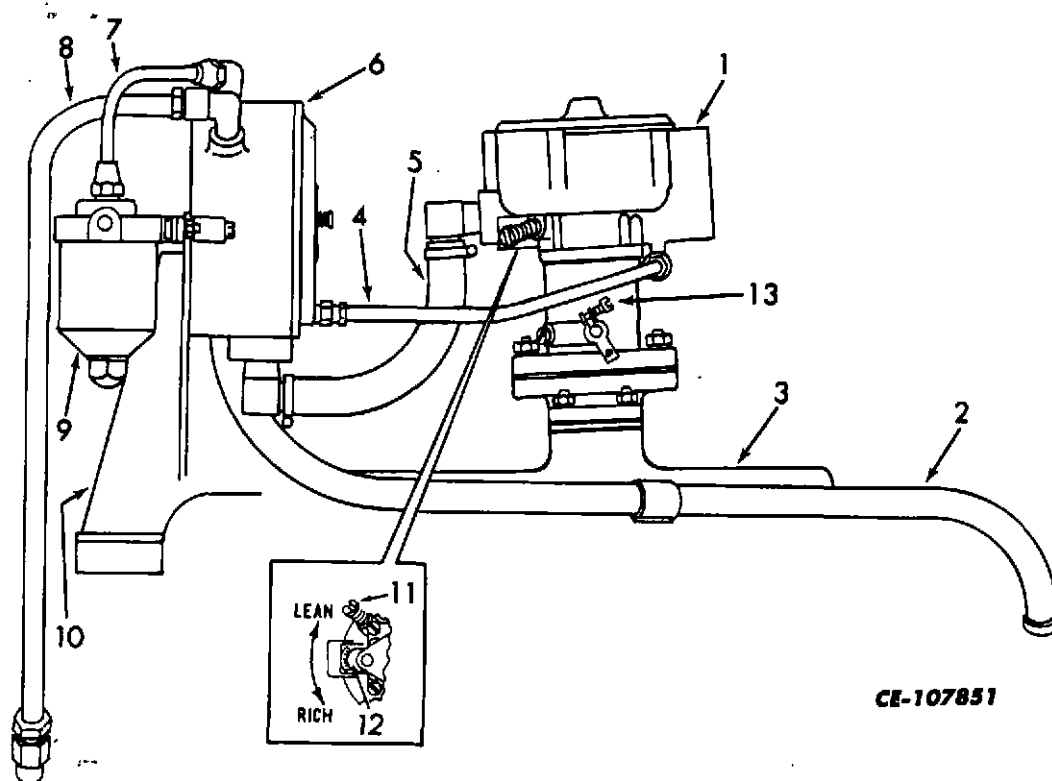

CE-107851

**Illust. 41
Carburetor Adjustments (LPG).**

- | | | |
|---------------------------------|----------------------------------|---------------------------------------|
| 1. CARBURETOR. | 6. REGULATOR, fuel vaporizer. | 10. BRACKET, fuel regulator mounting. |
| 2. HOSE, regulator water inlet. | 7. TUBE, LPG fuel. | 11. SCREW, idle adjusting. |
| 3. MANIFOLD, intake. | 8. TUBE, regulator-water outlet. | 12. ADJUSTER, carburetor mixture. |
| 4. TUBE, balance. | 9. FILTER, fuel. | 13. SCREW, throttle lever. |

Fuel Filter

CAUTION: THE PRECAUTIONS OUTLINED ON PAGES 9 TO 11 MUST BE CLOSELY FOLLOWED TO AVOID INJURY AND DAMAGE WHEN CHANGING THE FUEL FILTER.

The fuel filter element must be changed when it becomes clogged sufficiently to restrict the flow of fuel. A clogged filter element causes a pressure drop within the filter with consequent vaporization of the fuel which may cause freezing at the filter and engine starvation for fuel. Remove the filter as follows:

1. Close the valve on the supply line.
2. Remove the filter stud nut and filter bottom.
3. Remove the filter cartridge and replace the cartridge with a new one.

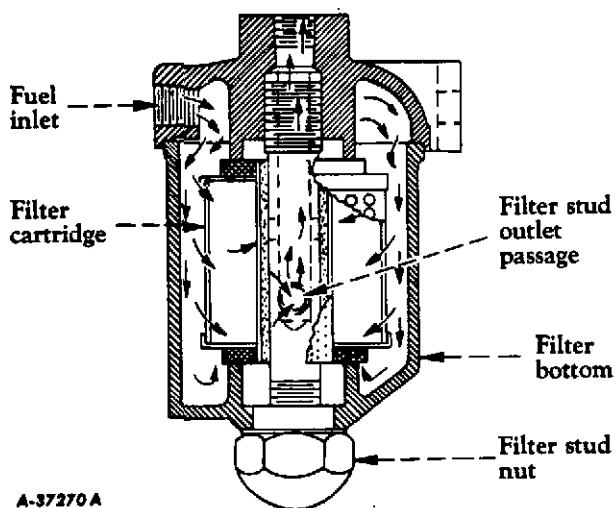

A-37270 A

Illust. 42
Cutaway view of fuel filter (liquefied petroleum gas).

4. When reassembling the filter, be sure the contact surfaces of the bowl gasket and the fiber washer on the filter stud nut are clean.
5. Install the filter bottom and the filter stud nut.
6. Open the valve on the supply line.

FUEL SYSTEM (NATURAL GAS)

General

When excessive fuel consumption or inefficient engine performance is encountered, be careful in determining the exact cause before assuming the carburetor to be at fault. Consider engine compression, ignition timing, defective wiring, improperly gapped or fouled plugs, distributor or magneto contact points, condenser, coil and fuel pump. These are all factors in obtaining maximum fuel economy and must be within the limits specified by the manufacturer.

Due to the technical knowledge and skill required and the special equipment needed to make the necessary tests and corrections, we recommend that the work be done by your authorized International Engine Distributor or Dealer.

Carburetor and Regulator

The regulator controls the flow of fuel to the carburetor.

The carburetor is used to mix accurately the correct proportion of fuel with air to satisfy the speed and load demand of the engine.

There are three fuel adjustments. These adjustments were correctly set at the factory and should require no alteration. However, if these adjustments have been disturbed in some manner, they can be correctly reset by the following instructions.

Adjusting the Carburetor (Illust. 43)

1. The carburetor adjustments are factory set for LHV (Low-Heat-Value) 936 BTU/cu.ft. of natural gas at the top rated speed stamped on the serial number plate. The carburetor adjuster (3) is normally set at 1 notch "R" (rich), when the engine is equipped with a dry type air cleaner and 1/2 notch toward "L" (lean) for engines equipped with oil bath air cleaners.

2. Should low idle adjustment be necessary, start and operate the engine at a fast idle of 1000 - 1500 rpm, without load, until thoroughly warm before making adjustments.

3. Position throttle control at low idle and adjust screw (2) to obtain a low idle of 600 plus or minus 25 rpm. Turn screw (4) in or out to give the best idle, then readjust screw (2) for proper low idle speed, if required.

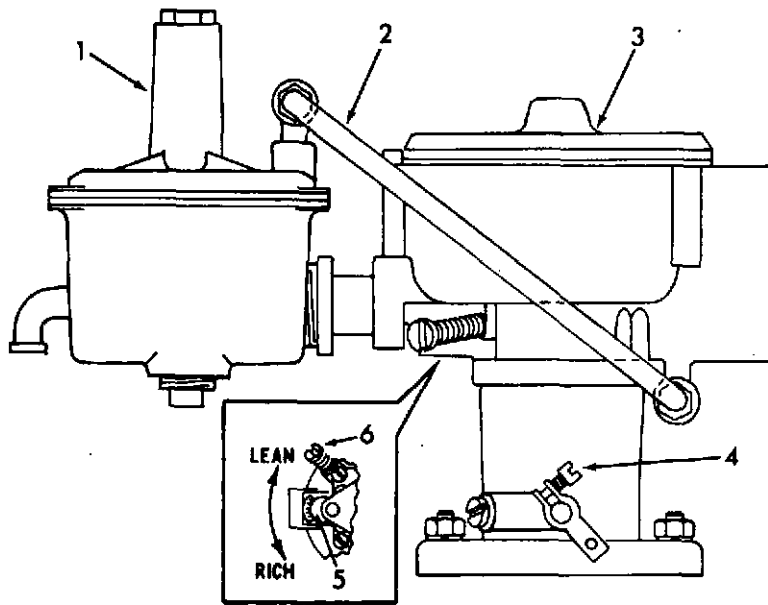

CE-107846

Illust. 43
Carburetor Adjustments (Natural Gas).

- | | |
|---|---|
| <p>1. VALVE, pressure reducer.</p> <p>2. TUBE, balance.</p> <p>3. CARBURETOR.</p> | <p>4. SCREW, throttle lever.</p> <p>5. ADJUSTER, carburetor mixture.</p> <p>6. VALVE, pressure reducer.</p> |
|---|---|

GOVERNOR

Variable Speed Adjustment (Illust. 44):

Stop the engine and adjust the governor control rod and governor as follows:

1. Back off the high speed stop screw "A".
2. Back off the bumper screw and tighten locknut.
3. Adjust the spring tension "B" to approximately 1.0". This is a basic dimension.
4. Adjust the throttle rod (3) so that with governor throttle control lever (4) in the wide open position, there is a gap of approximately 1/32" between the throttle shaft stop screw and stop on the carburetor as required.
5. Set "HIGH IDLE" (No Load) by setting and locking the governor high speed stop screw "A" to produce the required governor fast idle speed.

6. If surging occurs at high idle (No Load), turn in the bumper screw (6) just enough to dampen out the surge.

7. Run the engine at rated load speed.

a. If surging occurs (governor regulation too sharp), decrease dimension "B" until the surge is eliminated.

b. If the governor regulation is too broad, dimension "B" must be increased.

NOTE: If dimension "B" is changed, it may be necessary to re-set the rated speed by readjusting the high speed stop screw "A".

8. Set "LOW IDLE" at carburetor low speed stop screw to produce an engine low idle speed of 500 RPM ± 25. If Low Idle cannot be obtained, recheck bumper screw (6) as the bumper screw may be turned in too far.

NOTE: Do not use the bumper screw (6) for final speed adjustment.

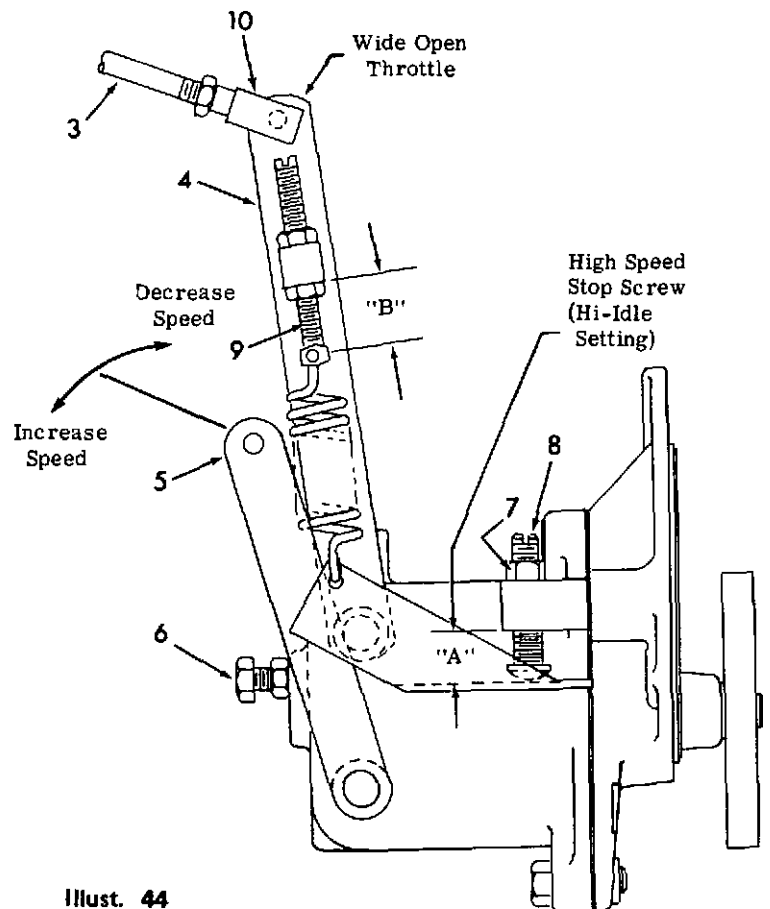
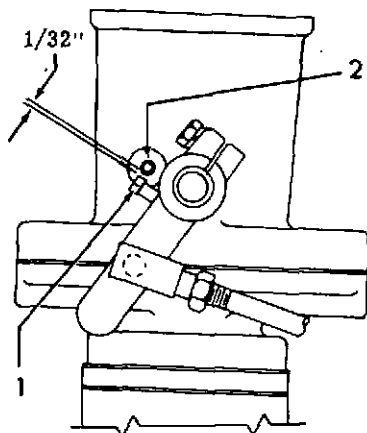

Illust. 44
Governor Control Adjustment (Variable Speed).

CE-104961A

- | | |
|---|---|
| <ol style="list-style-type: none"> 1. SCREW, throttle shaft stop. 2. PIN, stop. 3. ROD, throttle. 4. LEVER, governor throttle control. 5. LEVER, governor speed control. | <ol style="list-style-type: none"> 6. SCREW, bumper. 7. NUT, high speed stop screw lock. 8. SCREW, high speed stop. 9. SCREW, governor regulation adjusting. 10. BALL JOINT. |
|---|---|

Constant Speed Adjustment (Illust. 45)

1. Adjust speed control screw (9) to dimension "A" (approximately 7/8") by turning speed control nut (8). Hold screw from turning with screwdriver. Do not allow governor spring to twist otherwise damage to spring may result.

2. Adjust the throttle rod (1). With the governor lever (4) in the weights closed position (held in place by spring tension) the rod should just hold the throttle lever (3) in the wide open position against the internal stop. Then, shorten rod by 1-1/2 to two turns.

3. Tighten rod locknuts. Check for binding in both ball joints.

4. Set speed regulation adjustment screw (6) to dimension "B" (approx. 1/2").

5. Speed Setting - - No load.

a. Set "high idle" by turning the speed control nut (see Step 1) to produce the required high idle speed.

b. If surging occurs at "high idle," turn in the bumper screw (5) just enough to dampen the surge.

NOTE: DO NOT use the bumper screw (5) for speed adjustment.

6. Speed Setting - - Engine loaded.

a. Set engine load to maximum rated power. Adjust speed control nut (8) to attain rated power speed.

b. Remove load and note high idle speed. If this speed is too high (broad regulation), back out speed regulation screw (6). If high idle speed is too low (sharp regulation), turn screw in.

c. Again load engine to maximum rating and reset speed nut (8) if required.

d. Run engine thru varying step load values.

NOTE: If surging occurs when changing load, regulation setting is too sharp on dimension "B" must be increased.

e. If surging occurs at "high idle," see Step 5b.

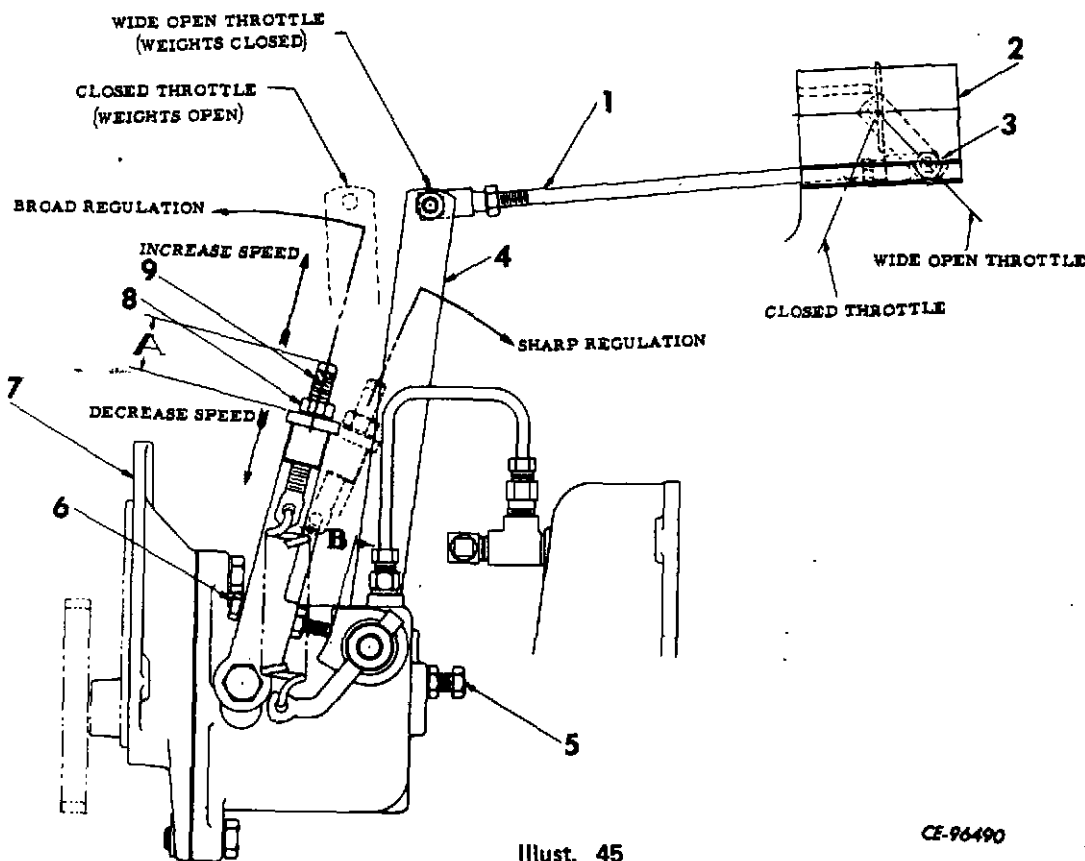

CE-96490

**Illust. 45
Governor Control Adjustment (Constant Speed).**

- 1. ROD, throttle.
- 2. BODY, throttle.
- 3. LEVER, throttle.

- 4. LEVER, governor.
- 5. SCREW, bumper.
- 6. SCREW, regulation.

- 7. GOVERNOR.
- 8. NUT, speed control.
- 9. SCREW, speed control.

POWER TAKE-OFF

This over-center type clutch is designed to require a minimum of attention. Overlubrication is as detrimental to the clutch as underlubrication. It is important to follow the lubrication instructions as given in "LUBRICATION GUIDE" on page 21.

Adjustment

Adjustment is required when a diminished effort is required to "engage" the clutch.

Rapid wear of the clutch facings will result if slippage takes place while the engine is under heavy load.

NOTE: New clutch facings have a series of high spots or feather edges which must be worn away before the lining is capable of transmitting its full torque capacity. Hence, clutch adjustment will be required several times within the first 10 hours of operation. These adjustments will avoid rapid clutch facing wear due to slippage and will allow the clutch to handle full engine power.

Adjust the clutch as follows:

1. Remove the clutch instruction plate.
2. Disengage the clutch and crank the engine until the adjusting points appear in the center of the opening.
3. **TWIN DISC CLUTCH ONLY:** Depress the lock pin (A) and hold the power take-off shaft to keep the clutch from turning. Insert a pry bar in the notch in the adjusting yoke (B) and turn the yoke clockwise one notch at a time (Illust. 46).
4. **ROCKFORD CLUTCH ONLY:** Loosen the adjusting ring lock screw (A) with an offset screwdriver to free the lock (B). Hold the power take-off shaft to keep the clutch from turning and insert a pry bar into a notch in the adjusting ring (C) for leverage. Turn the ring a notch at a time in a counterclockwise direction (Illust. 47).
5. Be sure the clutch lever is in the "disengaged" position (Illust. 10).
6. To determine the correct amount of hand-pull effort, specified for your engine, proceed as follows:
 - a. Refer to the instruction plate located on the clutch housing for the IH power take-off number.
 - b. Using this part number, refer to the charts shown below for the specified hand-pull effort.

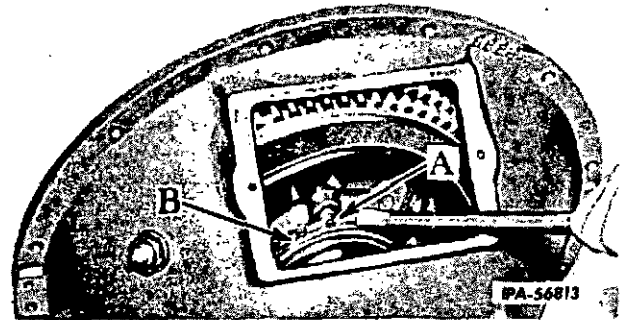

Illust. 46
Adjusting the Twin Disc over-center clutch.

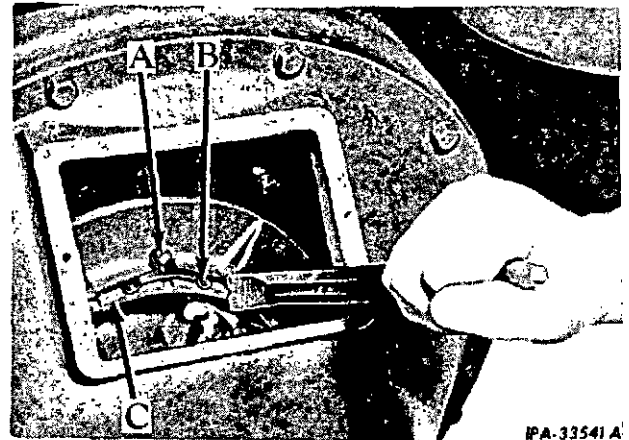

Illust. 47
Adjusting the Rockford over-center clutch.

ROCKFORD	
IH POWER TAKE-OFF PART NUMBER	POUNDS OF HAND-PULL EFFORT
319 521 R91	75
319 529 R91	95

TWIN DISC	
IH POWER TAKE-OFF PART NUMBER	POUNDS OF HAND-PULL EFFORT
321 043 R91	70 - 80
619 744 C91	82 - 100
338 804 R91	90 - 100
346 881 R91	90 - 100

Continued on next page.

NOTE: The figures shown in the above charts are based on the clutch lever originally furnished with the power take-off.

7. Using a spring scale hooked at the handle notch, adjust the pull required to engage the clutch (Illust. 48).
8. ROCKFORD CLUTCH ONLY: Tighten the adjusting ring lock screw.
9. TWIN DISC CLUTCH ONLY: Secure the adjusting lock pin.
10. Install the clutch instruction plate.

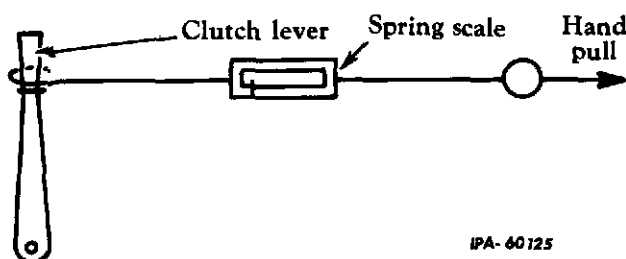

IPA-60125

Illust. 48
Method of checking clutch adjustment.

STORING THE ENGINE

Gasoline Engines

When the engine is not to be used for a period of time, it must be stored in a dry and protected place. Leaving equipment outdoors, exposed to the elements, will result in materially shortening its life.

The following procedure must be followed when the engine is placed in storage for 30 days or more and the lubrication procedures repeated every six months.

We recommend that caution be taken in starting an engine that has been in storage. Refer to the procedure shown under "STARTING ENGINES THAT HAVE BEEN IN STORAGE" on page 61.

1. Thoroughly wash or clean the engine.
2. Run the engine long enough to warm the oil in the crankcase. Drain the crankcase, change the lubricating oil filter element (as described on page 36) and fill the crankcase. (Refer to the "LUBRICANT SPECIFICATIONS AND CAPACITIES CHART" on page 18, for the correct viscosity of oil used for the prevailing temperature.)
3. Completely lubricate the rest of the engine as outlined in the "LUBRICATION GUIDE" on pages 19, 20 and 21.

4. Drain the fuel from the fuel tank and carburetor and clean out the fuel pump filter. (Refer to "Cleaning the Fuel Filter" on page 53).

NOTE: Present-day grades of gasoline have a tendency to form gum; therefore, it is necessary that the gasoline tank and carburetor be completely drained of fuel when the engine is to be out of service for more than two weeks. These gum deposits can be dissolved with a mixture of one part alcohol and one part benzol, or with acetone.

5. Remove the spark plugs and pour one tablespoonful of Grade-30 lubricating oil into each cylinder. Crank the engine two or three times to distribute the oil over the cylinder walls; then reinstall the spark plugs.

6. Remove the valve housing cover and flush the valves, rocker arms and push rods with Grade-30 lubricating oil. (If any evidence of rust is found, remove it before lubricating.) Use a paint brush to coat the inside of the valve cover with Grade-30 lubricating oil. Install the valve housing cover.

7. If engine is equipped with oil cooler or heat exchanger, take one of the following precautions when draining for storage in freezing temperatures:

- a. Fill the cooling system with anti-freeze solution, then drain.
- b. If only water is used, drain the engine, then blow out the residual water in the cooler tubes with compressed air. DO NOT RELY ONLY UPON DRAINING WATER.
- c. Install a "RADIATOR DRAINED" tag.

8. Remove and clean the crankcase ventilator metering valve as described on page 36.

9. Completely service the air cleaner as outlined under "AIR CLEANER" on pages 32 and 33.

10. Remove the air cleaner intake cap and store it in a clean dry place. Cover or plug the exhaust pipe and the air cleaner pipe.

11. Remove the battery and store it in a cool, dry place above freezing (+32°F). The battery must be fully charged at the time of storage. Check the battery liquid level at least once a month for water level and specific gravity. (Refer to "Liquid Level" on page 40.) Never allow the battery to run down below 3/4 full charge while in storage.

Liquefied Petroleum and Natural Gas Engines

Follow the same procedure used for preparing the gasoline engines for storage, except as follows:

1. If the fuel lines are going to be disconnected from the engine; close the supply valve on the fuel line. Run the engine until it stops from lack of fuel, and proceed as follows:

LIQUEFIED PETROLEUM GAS ENGINES: Disconnect the fuel line at the fuel inlet (Illust. 41). Plug the fuel inlet. Cover the end of the fuel inlet line.

NATURAL GAS ENGINES: Disconnect the fuel line at the fuel inlet (Illust. 43). Plug the fuel inlet. Cover the end of the fuel inlet line.

2. Remove the drain plug (headless, slotted) from the bottom of the regulator and drain off any accumulation of water. Install the plug.

3. Replace the fuel filter element on liquefied petroleum gas engines. (Refer to pages 53 to 55.)

STARTING ENGINES THAT HAVE BEEN IN STORAGE

1. Install a fully charged battery and be sure the proper connections are made. (Refer to the wiring diagrams on pages 44 or 46.)

2. Remove the spark plugs and pour a mixture on one-half gasoline and one-half light lubricating oil into each cylinder; one ounce (two tablespoonfuls) per cylinder is enough.

3. Remove the valve housing cover and flush the valve and valve operating mechanism with the same mixture.

4. Crank the engine rapidly until the excess oil has been blown out of the spark plug holes. This operation will loosen any tight piston rings and wash old, gummy oil from the valves and pistons.

5. Drain and flush out the crankcase with kerosine or flushing oil and fill with the specified lubricating oil. (Refer to the "LUBRICANT SPECIFICATIONS AND CAPACITIES CHART" on page 18.) Be sure a new element has been installed in the lubricating oil filter.

6. Remove the exhaust pipe and the air cleaner opening plugs and/or covers.

7. Install the exhaust pipe.

8. **AIR CLEANER (WET TYPE ONLY):** Remove and clean the oil cup. Refer to "Cleaning the Oil Cup" on page 32.

9. Install the air intake cap.

10. Install the spark plugs after cleaning and setting the taps (refer to "Spark Plugs" on page 39).

11. Be sure the cooling system drains are closed and fill the cooling system. Check for leaks and loose connections. Remove the "RADIATOR DRAINED" tag.

12. If the fuel lines have been disconnected from the engine, remove the plugs from the fuel inlet. Remove the covers from the fuel inlet lines. Reconnect the fuel inlet lines being sure the connections are tight.

13. Fill the fuel tank or tanks.

14. Start the engine and let it run slowly; observe if any valves are sticking. If so, pour a small quantity of kerosine on the valve stems until loose.

CAUTION: DO NOT RUN THE ENGINE RAPIDLY OR OPERATE IT AT HIGH SPEED IMMEDIATELY AFTER STARTING. KEEP THE DOORS WIDE OPEN OR MOVE THE ENGINE OUTSIDE THE STORAGE ROOM IMMEDIATELY TO AVOID DANGER FROM EXHAUST GAS.

15. Install the valve housing cover. Tighten the valve cover bolts (refer to "Torques" on page 4).

16. After the engine has been run long enough to clean the excess oil out of the cylinders, the spark plugs should be removed and checked for oil fouling. If fouled, clean and re-install them in the engine.

NOTE: When installing the spark plugs, refer to "Torques" on page 4 for the specified torque.



WORLD WIDE PRODUCT SUPPORT

Quality Product Support (Parts and Service) is of prime importance to the user of construction equipment. International Harvester Company has Product Support throughout the world. The dots on the world map show the location of distributors with service and parts availability for INTERNATIONAL CONSTRUCTION EQUIPMENT.

Distributors parts stock is supported by a network of company-operated Parts Depots. This combination of INTERNATIONAL CONSTRUCTION EQUIPMENT Distributor Product Support backed by the International Harvester Company assures you of a minimum of down time and lower operating cost.