

ISUZU DIESEL ENGINE

3LA1, 3LB1, 3LD1

INSTRUCTION MANUAL

INDUSTRIAL VERSION

ISUZU MOTORS LIMITED

CALIFORNIA

Proposition 65 Warning

Diesel engine exhaust and some of its constituents are known to the State of California to cause cancer, birth defects, and other reproductive harm.

FOREWORD

The ISUZU industrial diesel engines are a product of ISUZU's long years of experience, advanced technology. ISUZU takes great pride in the superior durability and operating economy of these engines.

In order to get the fullest use and benefit from your industrial engine, it is important that you operate and maintain it correctly. This Manual is designed to help you do this.

Please read this Manual carefully and follow its operating and maintenance recommendations. This will ensure many years of trouble-free and economical engine operation.

Should your engine require servicing, please contact your nearest ISUZU engine outlet. He knows your engine best and is ready to meet your satisfaction.

All information, illustrations, and specifications contained in this Manual are based on the latest product information available at the time of publication.

ISUZU reserves the right to make changes in this Manual at any time without prior notice.

CAUTION AND NOTICE

SAFETY WARNINGS

CAUTION: These mean there is something that could hurt you or other people.

In the caution area, we tell you what the hazard is. Then we tell you what to do to help avoid or reduce the hazard. Please read these cautions. If you don't, you or others could be hurt.

ENGINE OR EQUIPMENT DAMAGE WARNINGS

NOTICE: These mean there is something that could damage your engine or equipment.

In the notice area, we tell you about something that can damage your engine or equipment. Many times, this damage would not be covered by your warranty, and it could be costly. But the notice will tell you what to do to help avoid the damage.

TABLE OF CONTENTS

1. ENGINE EXTERNAL VIEWS	1
2. GENERAL INFORMATION	3
1. STANDARD ENGINE DATA AND SPECIFICATIONS.....	3
2. CARB CERTIFIED ENGINE MAIN DATA AND SPECIFICATIONS	7
3. ENGINE IDENTIFICATION	13
4. ISUZU ENGINE AFTER SERVICE.....	14
3. FUEL, LUBRICANT, AND COOLANT	15
1. FUEL.....	15
2. LUBRICANT	21
3. COOLANT	22
4. ENGINE OPERATION	23
1. CHECK BEFORE OPERATION	25
2. ENGINE STARTING	31
3. CHECK AND OPERATION AFTER THE ENGINE START-UP ...	35
4. CARE IN THE ENGINE OPERATION.....	38
5. ENGINE STOPPING	44
6. OPERATION AND CARE FOR NEW ENGINE.....	45
7. ENGINE CARE FOR OVER-COOLING.....	45

8. STARTING THE ENGINE AFTER BEING LEFT UNUSED FOR A LONG PERIOD OF TIME	46
5. PERIODICAL INSPECTION AND MAINTENANCE	47
1. LUBRICATING SYSTEM	47
2. COOLING SYSTEM	51
3. FUEL SYSTEM	55
4. AIR INTAKE SYSTEM	59
5. ENGINE ELECTRICAL	61
6. ENGINE ASSEMBLY AND OTHERS	64
6. ENGINE CARE IN COLD SEASON	68
7. ENGINE ELECTRICAL WIRING DIAGRAMS	73
8. ENGINE MAINTENANCE SCHEDULE	74
9. SIMPLE ENGINE TROUBLESHOOTING	81

1. ENGINE EXTERNAL VIEWS

1. EXTERNAL VIEW (LH)

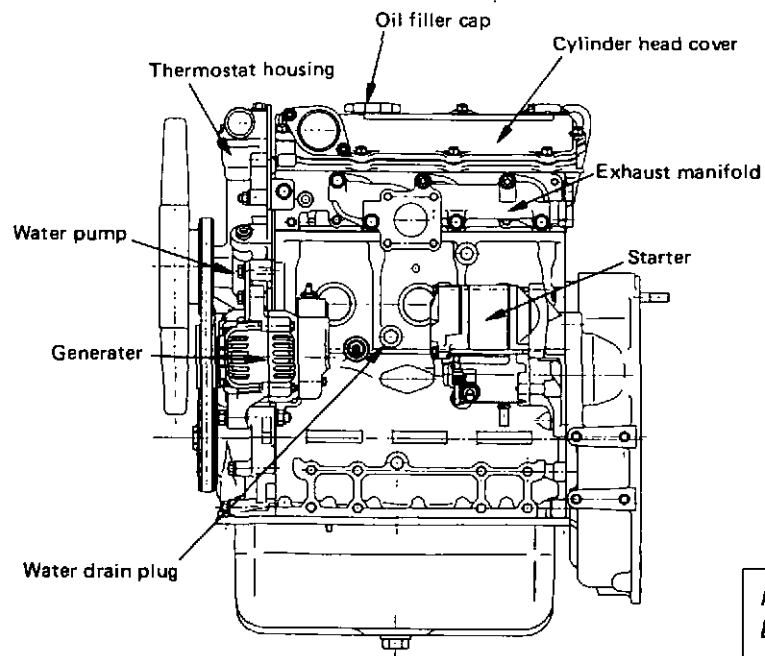
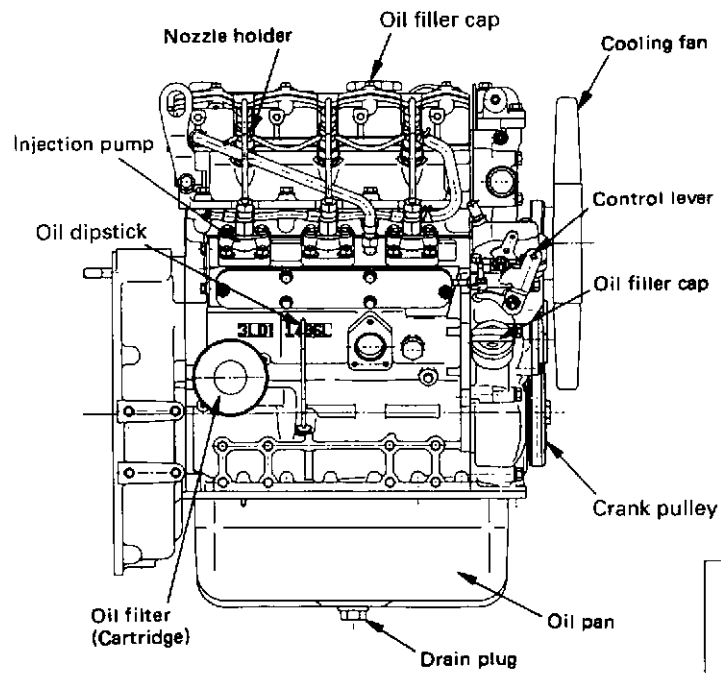

Fig. 1

*Note:
Engine details may
vary depending on the
specifications.*

2. EXTERNAL VIEW (RH)



Note:
Engine details may vary depending on the specifications.

Fig. 2

2. GENERAL INFORMATION

1. STANDARD ENGINE DATA AND SPECIFICATIONS

(1) Model 3LA1, 3LB1

	3LA1	3LB1
Engine type	Water-Cooled, four cycle, in-line overhead valve type	
Combustion type	Swirl chamber type	
No. of cylinders - bore × stroke (mm)	3 - 70 × 79.7	3 - 77.4 × 79.7
Piston displacement lit (cid)	0.920 (56)	1.124 (69)
Compression ratio	22 to 1	
Firing order	1 - 3 - 2	
*Rated output kW(hp)/rpm	13.1 (17.6) / 2400	22 (29.5) / 3600
*Max. torque Nm (lbft)/rpm	57 (42) / 1800	69.5 (51.3) / 1800
Injection pump	Bosch, PFR type	
Governor	Mechanical type	
Injection nozzles	Throttle type	
Specified fuel	Diesel fuel (ASTM D975 No.2-D)	

		3LA1	3LB1
*Starter	(V-kW)	12 - 1.0	
*Generator	(V-A)	12 - 35	
Specified engine oil (API grade)		CC or CD	
*Lubrication oil volume	lit (qts)	About 5.1 (5.4)	
Coolant volume (Engine only)lit (qts)		About. 2.4 (2.5)	About 2.2 (2.3)
*Engine dry weight	kg (lb)	116 (256)	
*Engine dimensions	Overall length mm (in)	495.5 (19.5)	
	Overall width mm (in)	436 (17.2)	
	Overall height mm (in)	528 (20.8)	
Valve clearance (cold) mm (in)		0.20 (0.0078) for exhaust and intake	
Nozzle injection pressure MPa (psi)		13.2 (1920)	
*Injection timing B.T.D.C.		16°	19°

NOTE: 1. These specifications are based on the standard engine.

2. Specifications for items marked with an asterisk (*) will vary according to the type of equipment in which the engine is installed.

If you are unable to locate these data applicable to your engine, please contact your equipment supplier.

(2) **Model 3LD1**

	3LD1
Engine type	Water-Cooled, four cycle, in-line overhead valve type
Combustion type	Swirl chamber type
No. of cylinders - bore × stroke (mm)	3 - 83.1 × 92
Piston displacement lit (cid)	1.496 (91)
Compression ratio	22 to 1
Firing order	1 - 3 - 2
*Rated output kW (hp)/rpm	28.0 (37.5) / 3600
*Max. torque Nm (lbft)/rpm	95 (70) / 1800
Injection pump	Bosch, PFR type
Governor	Mechanical type
Injection nozzles	Throttle type
Specified fuel	Diesel fuel (ASTM D975 No.2-D)

		3LD1
*Starter	(V-kW)	12 - 1.2
*Generator	(V-A)	12 - 35
Specified engine oil (API grade)		CC or CD
*Lubrication oil volume	lit (qts)	About 6.8 (7.2)
Coolant volume (Engine only)lit (qts)		About 2.5 (2.6)
*Engine dry weight	kg (lb)	123 (271)
*Engine dimensions	Overall length mm (in)	516.5 (20.3)
	Overall width mm (in)	436 (17.2)
	Overall height mm (in)	589 (23.2)
Valve clearance (cold)	mm (in)	0.20 (0.0078) for exhaust and intake
Nozzle injection pressure	MPa (psi)	13.2 (1920)
*Injection timing B.T.D.C.		19°

NOTE: 1. These specifications are based on the standard engine.
2. Specifications for items marked with an asterisk (*) will vary according to the type of equipment in which the engine is installed.
If you are unable to locate these data applicable to your engine, please contact your equipment supplier.

2. CARB CERTIFIED ENGINE DATA AND SPECIFICATIONS

(1) Model 3LB1, 3LD1

ISUZU engine model name	3LB1	3LD1
Engine family	SSZ1. 1U6D2RA	SSZ1. 5U6D2RA
Engine type	Water-Cooled, four cycle, in-line overhead valve type	
Combustion type	Swirl chamber type	
No. of cylinders - bore x stroke (mm)	3 - 77.4 x 79.7	3 - 83.1 x 92
Engine displacement lit (cid)	1.124 (69)	1.496 (91)
Compression ratio	22 to 1	
Firing order	1 - 3 - 2	
Rated power: SAE NET kW(hp)/rpm	22.2 (29.8) / 3600	25.8 (34.6) / 3000
Fuel flow at rated power (mm ³ /stroke)	21.5	32.0
Max. torque: SAE NET Nm (lbft)/rpm	70 (51.6)/1800-2000	95 (70)/1800-2000
Fuel flow at max. torque (mm ³ /stroke)	24.7	33.7
Exhaust emission control system	Indirect Fuel Injection	
Injection pump	Bosch, PFR type	
Governor	Mechanical, variable speed type	
Injection nozzles	Throttle type	
Specified fuel	Diesel fuel (ASTM D975 No.2-D)	

		3LB1	3LD1
Starter	(V-kW)	12 - 1.0	12 - 1.2
Alternator	(V-A)	12 - 20	
Specified engine oil (API grade)		CC or CD	
Lubrication oil volume	lit (qts)	3.1 ~ 4.5 (3.3 ~ 4.8)	3.5 ~ 6.3 (3.7 ~ 6.7)
Coolant volume (Engine only)lit (qts)		About. 2.2 (2.3)	About 2.5 (2.6)
Engine dry weight		116 (256)	123 (271)
Engine dimensions	Overall length	mm (in)	495.5 (19.5)
	Overall width	mm (in)	436.0 (17.2)
	Overall height	mm (in)	528.0 (20.8)
Valve clearance (cold)		mm (in)	
		0.20 (0.0078) for exhaust and intake	
Nozzle injection pressure		MPa (psi)	
		13.2 (1920)	
Injection timing B.T.D.C.		16° for 4 pole Gene-set, 19° for other specifications	

EMISSION CONTROL LABEL: ENGINE LABEL

Emission control label is attached at the center of injection pump cover located at the center of cylinder body (right side).

Label and Location for Engine Family SSZ1. 1U6D2RA

The following is the detail of a label required for engine emission control information, along with location.

ISUZU IMPORTANT ENGINE INFORMATION
ISUZU MOTORS LTD. MADE IN JAPAN

ENGINE FAMILY : SSZ1. 1U6D2RA

MODEL : **3LB1**

ENGINE DISPLACEMENT : 1124 cm³

DATE OF ENGINE MANUFACTURE :

REFER TO OWNER'S MANUAL FOR MAINTENANCE
SPECIFICATION AND ADJUSTMENT.

THIS ENGINE MEETS 1995-1998 CALIFORNIA
EMISSION REGULATIONS FOR UTILITY AND
LAWN AND GARDEN EQUIPMENT ENGINES.

Letter Size: height 2.108mm

Color; Background : Silver

Letter : Black

→ Month/Year, ex. 01/95

We will affix a label
on the pump chamber

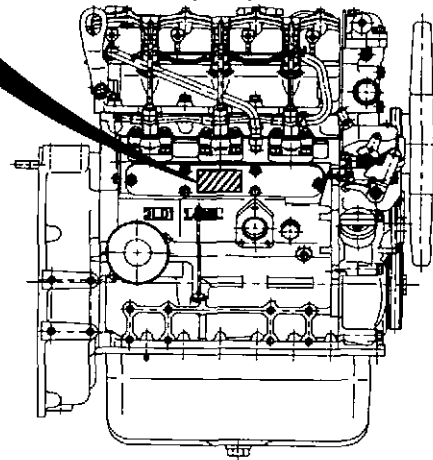

Label and Location for Engine Family SSZ1. 5U6D2RA

The following is the detail of a label required for engine emission control information, along with location.

ISUZU IMPORTANT ENGINE INFORMATION
ISUZU MOTORS LTD. MADE IN JAPAN

ENGINE FAMILY : SSZ1. 5U6D2RA

MODEL : **3LD1**

ENGINE DISPLACEMENT : 1496 cm³

DATE OF ENGINE MANUFACTURE :

REFER TO OWNER'S MANUAL FOR MAINTENANCE
SPECIFICATION AND ADJUSTMENT.

THIS ENGINE MEETS 1995-1998 CALIFORNIA
EMISSION REGULATIONS FOR UTILITY AND
LAWN AND GARDEN EQUIPMENT ENGINES.

Letter Size: height 2.108mm

Color; Background : Silver

Letter : Black

→ Month/Year, ex. 01/95

We will affix a label
on the pump chamber

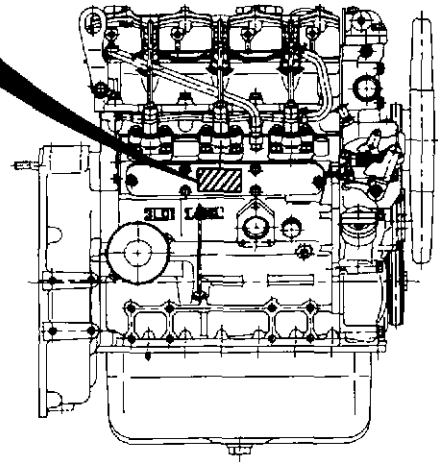

SUPPLEMENTAL: ENGINE LABEL

Emission control label is attached at a visible point on the equipment when the label that is attached to the engine is not visible due to the structure of the equipment.

Engine Family SSZ1. 1U6D2RA

ISUZU IMPORTANT ENGINE INFORMATION	
ISUZU MOTORS LTD. MADE IN JAPAN	
ENGINE FAMILY : SSZ1. 1U6D2RA	ENGINE SPECIFICATION
MODEL : 3LB1	ADVERTISED MAX. POWER
ENGINE DISPLACEMENT : 1124 cm ³	SAE NET
EXHAUST EMISSION CONTROL SYSTEM : IFI	22.2 kW/3600 min ⁻¹
DATE OF ENGINE MANUFACTURE : /	FUEL RATE
THIS ENGINE IS CERTIFIED TO OPERATE ON DIESEL FUEL.	21.5 mm ³ /st.
THIS ENGINE MEETS 1995-1998 CALIFORNIA EMISSION REGULATIONS FOR UTILITY AND LAWN AND GARDEN EQUIPEMENT ENGINES.	VALVE LASH (COLD)
	IN : 0.2 mm
	EXH : 0.2 mm
	INITIAL INJECTION
	TIMING : 19° BTDC
	CURB IDLE : 850 min ⁻¹

Engine Family SSZ1. 5U6D2RA

ISUZU IMPORTANT ENGINE INFORMATION ISUZU MOTORS LTD. MADE IN JAPAN

ENGINE FAMILY : SSZ1. 5U6D2RA	ENGINE SPECIFICATION
MODEL : 3LD1	ADVERTISED MAX. POWER
ENGINE DISPLACEMENT : 1496 cm ³	SAE NET
EXHAUST EMISSION	25.8 kW/3000 min ⁻¹
CONTROL SYSTEM : IFI	FUEL RATE
DATE OF ENGINE	32 mm ³ /st.
MANUFACTURE : /	VALVE LASH (COLD)
THIS ENGINE IS CERTIFIED TO	IN : 0.2 mm
OPERATE ON DIESEL FUEL.	EXH : 0.2 mm
THIS ENGINE MEETS 1995-1998 CALIFORNIA	INITIAL INJECTION
EMISSION REGULATIONS FOR UTILITY	TIMING : 19° BTDC
AND LAWN AND GARDEN EQUIPEMENT	CURB IDLE : 850 min ⁻¹
ENGINES.	

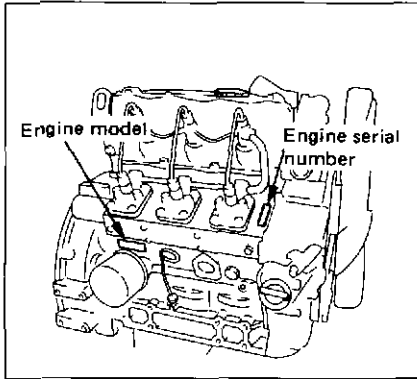

Fig. 3

3. ENGINE IDENTIFICATION

(1) Position of Display

The engine serial number is stamped on the front upper right side of the cylinder body, and the engine model is cast on the rear lower right side of cylinder body just above the oil filter. Further, engine model is described also on an ID label on the top of the cylinder head cover.

(2) Confirmation of Engine Serial Number

It is advisable to check the engine serial number, engine model name and type of machine together with the equipment manufacturer's name, as it is required when you contact the distributor for repair service or parts ordering.

CAUTION: *Conduct confirmation of engine serial number with the engine stopped.
To avoid being injury, don't check it, while the engine is still hot.*

4. ISUZU ENGINE AFTER SERVICE

(1) Isuzu Engine After Service

Please feel free to contact your ISUZU dealer for periodical inspection and maintenance.

(2) Isuzu Genuine Parts

The ISUZU genuine parts are identical with those of used in the engine production, and accordingly, they are warranted by ISUZU MOTORS LIMITED.

The ISUZU genuine parts are supplied by the ISUZU distributors or the authorized parts suppliers. Please designate "ISUZU Genuine Parts" when you need engine parts.

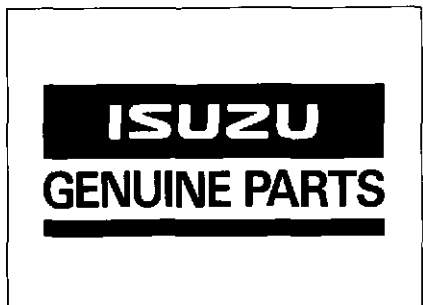

Fig. 4

3. FUEL, LUBRICANT, AND COOLANT

1. FUEL

(1) Fuel Selection

The following specific advantages are required for the diesel fuel.

- 1) Must be free from minute dust particles.
- 2) Must have adequate viscosity.
- 3) Must have high cetane value.
- 4) Must have high fluidity at low temperature.
- 5) Must have low sulfur content.
- 6) Must have little residual carbon.

(2) Fuel Requirements

NOTICE: *The fuel injection pump, injector or other parts of the fuel system and engine can be damaged if you use any fuel or fuel additive other than those specifically recommended by Isuzu.*

Such damage is not Isuzu's responsibility, and is not covered by the Warranty. To help avoid fuel system or engine damage, please heed the following:

- *Some service stations mix used engine oil with diesel fuel. Some manufacturers of large diesel engines allow this; however, for your diesel engine, do not use diesel fuel which has been contaminated with engine oil. Besides causing engine damage, such fuel can also affect emission control. Before using any diesel fuel, check with the service station operator to see if the fuel has been mixed with engine oil.*
- *Do not use any fuel additive (other than as recommended under "Biocide" in this section). At the time this manual was printed, no other fuel additive was recommended. (See your authorized dealer to find out if this has changed.)*

Your engine is designed to use either Number 1-D or Number 2-D diesel fuel. However, for better fuel economy, use Number 2-D diesel fuel whenever possible. At temperatures less than -7°C , (20°F), Number 2-D fuel may pose operating problems (see "Cold Weather Operation" which follows). At colder temperatures, use Number 1-D fuel (if available) or use a "winterized" Number 2-D (a blend of Number 1-D and Number 2-D). This blended fuel is usually called Number 2-D also, but can be used in colder temperatures than Number 2-D fuel which has not been "winterized." Check with the service station operator to be sure you get the properly blended fuel. Note that diesel fuel may foam during a fill-up. This can cause the automatic pump nozzle to shut off even though your tank is not full.

NOTICE: Do not use home heating oil or gasoline in your diesel engine; either may cause engine damage.

(3) Handling of the Fuel

The fuel containing dust particles or water will cause engine failure.

Therefore, the following notice must be observed.

- 1) Take care to prevent the fuel from entry of dust particles or water when filling the fuel tank.

When fueling is done from an oil drum directly, keep the drum stationary over a long time so that clean fuel can be used after the dust particles or water is completely sedimented.

- 2) Always fully fill the fuel tank. Drain the sedimented particles in the fuel tank frequently by opening the tank draining hole.

(4) Water in Fuel

During refueling, it is possible for water (and other contaminants) to be pumped into your fuel tank along with the diesel fuel. This can happen if a service station does not regularly inspect and clean its fuel tanks, or if a service station receives contaminated fuel from its supplier(s).

To protect your engine from contaminated fuel, there is a fuel filter system on the engine which allows you to drain excess water.

CAUTION: *The water/diesel fuel mixture is flammable, and could be hot. To help avoid personal injury and/or property damage, do not touch the fuel coming from the drain valve, and do not expose the fuel to open flames or sparks. Be sure you do not overfill the container. Heat (such as from the engine) can cause the fuel to expand. If the container is too full, fuel could be forced out of the container. This could lead to a fire and the risk of personal injury and/or vehicle or equipment damage.*

(5) Biocides

In warm or humid weather, fungus and/or bacteria may form in diesel fuel if there is water in the fuel.

NOTICE: *Fungus or bacteria can cause fuel system damage by plugging the fuel lines, fuel filters or injector. They can also cause fuel system corrosion.*

If fungus or bacteria has caused fuel system problems, you should have your authorized dealer correct these problems. Then, use a diesel fuel biocide to sterilize the fuel system (follow the biocide manufacturer's instructions). Biocides are available from your dealer, service stations, parts stores and other automotive places. See your authorized dealer for advice on using biocides in your area and for recommendations on which biocides you should use.

(6) Smoke Suppressants

Because of extensive testing of treated fuel versus untreated fuel, the use of a smoke suppressant additive is not recommended because of the greater possibility of stuck rings and valve failure, resulting from excessive ash deposits.

2. LUBRICANT

The quality of engine oil may largely affect engine performance, startability and engine life.

Use of unsuitable engine oil will result in piston ring, piston and cylinder seizure and accelerate the sliding surface wear causing increased oil consumption, lowered output and, finally engine failure. To avoid this, use the specified engine oil.

(1) Engine Oil Selection

API, CC or CD grade

(2) Oil Viscosity

Engine oil viscosity largely affect engine startability, performance, oil consumption, speed of wearing and occurrence of seizure, etc. Using lubricants whose viscosity selected according to the atmospheric temperature is important.

NOTICE: 1) *Using a mixture of different brand or quality oils will adversely affect the original oil quality; therefore, never mix up different brand or different type oils.*
2) *Don't use API, CA, CB grade and refined engine oil.*
3) *Engine damage due to improper maintenance, or using oil of the improper quality and/or viscosity, is not covered by the warranty.*

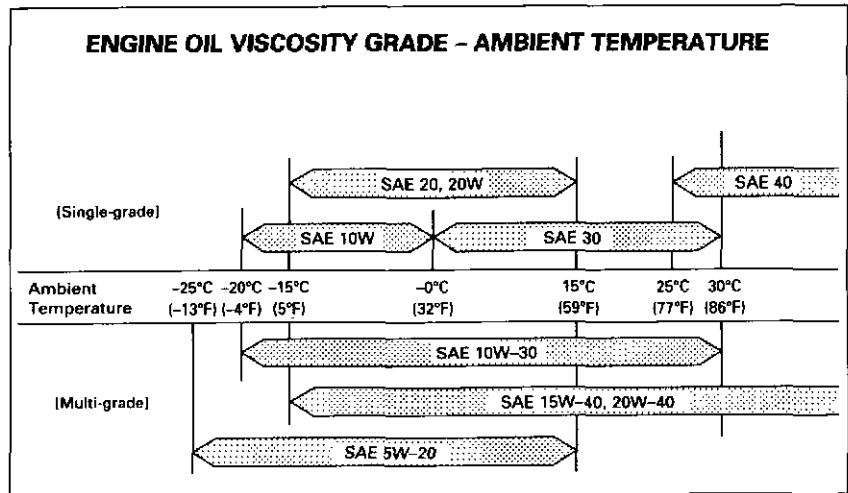

Fig. 5

3. COOLANT

Use drinking water for coolant and replace it periodically.

4. ENGINE OPERATION

Engine Exhaust Gas Caution (Carbon Monoxide)

CAUTION: Do not breathe exhaust gas because it contains carbon monoxide, which by itself has no color or odor. Carbon monoxide is a dangerous gas. It can cause unconsciousness and can be lethal.

If at any time you think exhaust fumes are entering the cab, have the cause determined and corrected as soon as possible. If you must drive under these conditions, drive only with all windows fully open.

Protect against carbon monoxide entry into the cab. The best way is to keep the engine exhaust system, cab and cab ventilation system properly maintained. We recommend that the exhaust system and cab be inspected by competent technician:

- Each time the vehicle has an oil change.
- Whenever a change is noticed in the sound of the exhaust system.
- Whenever the exhaust system, underbody or cab is damaged or becomes corroded.

See "Maintenance Schedule" in Section 8 of this manual for parts requiring inspection.

To allow proper operation of your vehicle's ventilation system, keep the air inlet grille clear of snow, leaves or other obstructions at all times.

CAUTION (Continued):

Do not run the engine in confined areas (such as garages or next to a building) any more than needed to move the vehicle or the equipment.

Keep the exhaust tailpipe area clear of snow and other material to help reduce the buildup of exhaust gases under the vehicle or the equipment. This is particularly important when parked in blizzard conditions.

1. CHECK BEFORE OPERATION

CAUTION: For Safety's sake, conduct the inspection before start-up with the engine stopped.

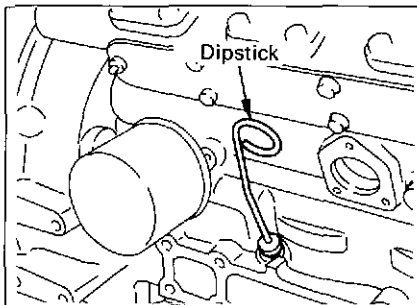

Fig. 6

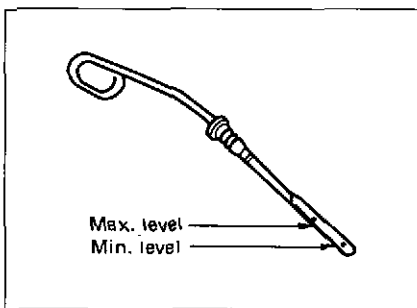

Fig. 7

(1) Engine Oil Level

- 1) Place the engine on a level surface.
- 2) Remove the dipstick from the crankcase, wipe it with clothing. Insert it fully and take out it gently again.

Check the oil level by the level marks on the dipstick. The oil level must be between the "Max." level mark and the "Min." level mark as illustrated.

Take care not to add too much engine oil.

- Drain oil to the max. oil level if oil level is above the max. level mark.
- Add oil to the max. oil level if oil level is below the min. level mark.

- 3) Also check the sample oil on the dipstick for fouling and degrees of viscosity.

NOTICE: Oil level check must be made ten or twenty minutes later after the engine has been stopped. When the oil level check is necessary while the engine is running, stop the engine and keep it stationary ten or twenty minutes until the oil thoroughly flows down to the crankcase.

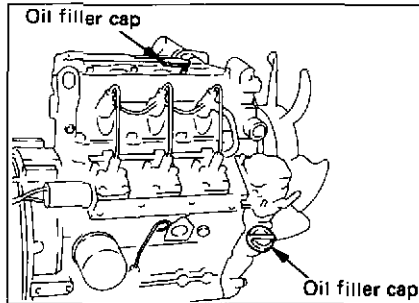

Fig. 8

- 4) Oil is poured either through the oil filler at the front of the cylinder head cover or through the oil filler on the right side of the timing gear case.

A certain period of time is required before the engine oil completely flows down from the oil filler to the crankcase. Check the oil level ten or twenty minutes after oil replenishment.

NOTICE: If the engine oil is splashed on the fan drive belt, it causes belt slippage or slackness; therefore, take care to avoid it.

CAUTION: In adding oil, take care not to spill it. If you spill oil on engine or equipment, wipe it properly, or this could lead to a fire and the risk of personal injury and/or equipment damage.

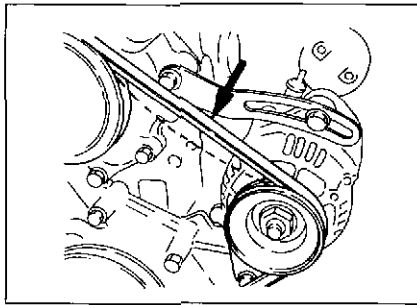

Fig. 9

(2) Fan Belt Check

Check the fan belt for tension and abnormalities.

- 1) When the belt is depressed **about 10 mm (0.39 in)** with the thumb (about 10 kg (22 lb) pressure) at midway between the fan pulley and generator pulley, the belt tension is correct.

When the belt tension is too high, it will result in generator failure.

Contrarily, loose belt will cause belt slippage which may result in damaged belt and abnormal noise.

- 2) Check the belts. Replace them if any damage is found.

NOTICE: *Replace all belts as a set even when one is not usable. Single belt of similar size must not be used as a substitute for a matched belt set. Otherwise, premature belt wear would result because of uneven belt length.*

(3) Coolant Level Check

- 1) The coolant level must be between "FULL" and "LOW" marks on the reserve tank.
Check and see that the level is correct.
When the coolant level is lower than the "LOW" mark, replenish the reserve tank by the filler port, but when the reserve tank is empty, replenish by the radiator filler port.

CAUTION: *When removing the radiator filler cap while the engine is still hot, cover the cap with clothing, then turn it slowly to gradually release the internal steam pressure. This will prevent you from getting burnt with hot steam spouted out from the filler port.*

- 2) Use clean drinking water as coolant. When an anti-freeze solution is required, keep to the specified mixing ratio.

(4) Radiator Cap Condition

After the replenishment of the coolant, install the radiator cap. Make sure the cap is securely installed.

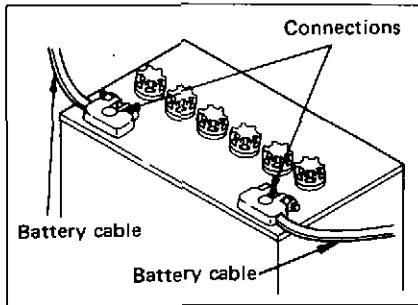

Fig. 10

(5) Battery Cable Connection

Check the battery cable connections for looseness or corrosion. The loosened cable connection will result in hard engine starting or insufficient battery charge.

The battery cables must be tightened securely.

Never reverse "+" and "-" terminals when reconnecting cables after disconnection.

Even a short period of reverse connection will damage the electrical parts.

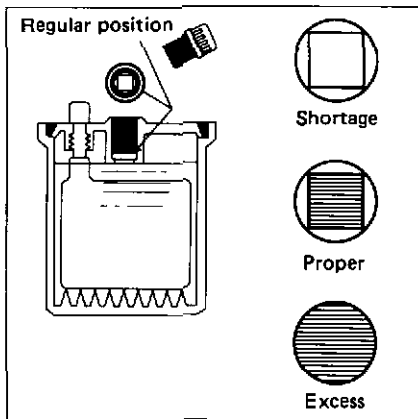

Fig. 11

(6) Battery Electrolyte Level

The amount of electrolyte in the batteries will be reduced after repeated discharge and recharge.

Check the electrolyte for the level in the batteries, replenish with a commercially available electrolyte such as distilled water, if necessary.

The battery electrolyte level checking procedure will vary with battery type. Follow the equipment manufacturer's instructions.

NOTICE: Do not replenish with dilute sulfuric acid in the daily service.

- CAUTION:**
1. When inspecting the batteries, be sure to stop the engine.
 2. As diluted sulfuric acid is used as electrolyte, be careful not to stain your eyes, hands, clothes, and metals with the electrolyte. If it gets in your eye, wash with a large amount of water at once. Then go and see a doctor.
 3. As highly flammable hydrogen gas is rising from the batteries, do not make a spark or use fire in any other way near the batteries.
 4. When handling such metallic articles as a tool near the batteries, be sure not to contact \oplus terminal. As the vehicle body is \ominus , it may cause a big danger.
 5. When disconnecting the terminals, start with \ominus terminal. When connecting them, connect the \ominus terminal last.

2. ENGINE STARTING

In case of the type with QOS system

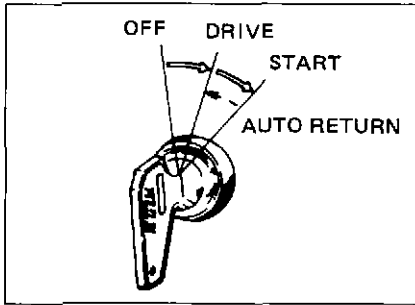

Fig. 12

In case of the type with control resistance

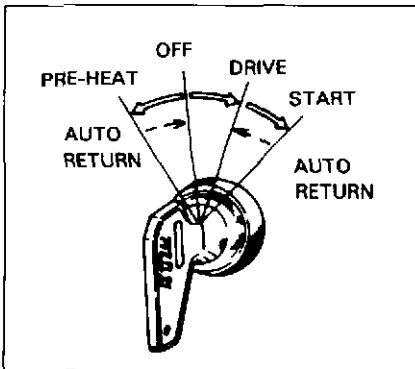

Fig. 13

(1) Pre-starting Preparation

- 1) Make sure that all hydraulic control levers etc. on the equipment are in the NEUTRAL position.
- 2) Set the engine stop knob in the START position.
- 3) Switch ON the battery switch (if so equipped).
- 4) Insert the starter switch key into the switch key hole. Turn the key clockwise to DRIVE position and, make sure that the meters and warning lamps are actuated.

(2) Pre-heating Procedures

As an engine starting aid, pre-heating is required in a cold engine starting.

The type with QOS system:

This pre-heating uses "QOS," a quick pre-heating system which automatically controls pre-heating time utilizing coolant temperature to conduct the irreducible minimum of pre-heating.

- 1) Turn the key to the DRIVE position, and the glow plug built in the engine will grow red-hot to pre-heat the engine. At this time the pre-heating indicator lamp on the meterboard is actuated.
- 2) When the pre-heating indicator lamp goes out, try starting the engine at once.

Relationship between water temperature and pre-heating time
(For ref.)

50°C (122°F).....	About 1 sec.
20°C (68°F)	About 2 sec.
0°C (32°F).....	About 3.5 sec.
-15°C (5°F)	About 5 sec.

The type with a control resistance

- 1) Turn the starter switch key counter-clockwise to PRE-HEAT position in order to heat the glow plugs on the engine.
The Pre-heating time of 5 seconds is required until the control resistance coil become red.
- 2) Turn the starter switch key clockwise to START position as soon as the control resistance coil red heat.

CAUTION: Don't touch the red (hot) control resistance coil or allow combustible materials such as paper, cloth or leaves on it. This could lead to a fire and the risk of personal injury and/or equipment damage.

(3) Engine Starting

- 1) Depress the engine throttle lever or throttle pedal and turn the starter switch key clockwise to START position.
The cranking period must not exceed ten seconds.
Continuous starter operation of more than ten seconds will lead to overdischarge of the batteries as well as starter seizure.
If the engine cannot be started in one time attempt, keep the batteries and the starter stationary at least 30 seconds for their functional recovery, then repeat the pre-heating and the starting operations.

NOTICE: *Continuous re-engagement of the starter to the flywheel ring gear without giving them a break will result in the damaged starter pinion gear and flywheel ring gear.*

- 2) If, despite repeated operations, the engine does not start, wait for a minute or more until the functions of the batteries and starter are recovered and then repeat pre-heating and starting operations.
- 3) When repeating starting operation, return the key to the OFF position and then pre-heat and start the engine once again.
If the engine still remains unstarted, something may be wrong with the engine. Check the repeated parts to locate the cause.

NOTICE: *Do not use starting "aids" in the air intake system. Such aids can cause immediate engine damage.*

3. CHECK AND OPERATION AFTER THE ENGINE START-UP

(1) Warming-up Operation

Do the warming-up operation at 1000 rpm about ten minutes after the engine has started.

As the lubrication for the entire engine systems will be done in this warming-up, do not speed up and load it abruptly. Particularly, observe this in cold season operation.

(2) Check after the Engine Start-up

Check the following items in the engine warming-up operation.

Engine oil pressure

Although the engine oil pressure gauge readings vary depending on ambient temperature or a type of oil, the gauge registers around 4 to 5kg/cm² (57 to 71 psi) in the warming-up.

In the oil pressure warning lamp type, make sure that the lamp is off.

Charge condition

The charge condition is normal when once the ammeter registers plus side greatly in the engine starting, then gradually the meter registering will be minimized.

In the warning lamp type, make sure that the lamp is completely off during the warming-up.

Engine noise and exhaust smoke colour

Pay attention to engine noise and, if any abnormal noise is heard, check the engine to detect the cause.

Check the fuel combustion condition by exhaust smoke colour. The exhaust smoke colour after engine warming-up and at no-load operation:

{ Colourless or light blue.....	Normal (Perfect combustion)
{ Black colour	Abnormal (Imperfect combustion)
{ White colour.....	Abnormal (Imperfect combustion)

NOTICE: *Engine noise after start-up might be noisy than that of warmed-up engine and, the exhaust smoke colour also being more blackish than the normal condition. However, it will be normalized after warming-up engine.*

Leakage in the systems

Check the following items:

- Lube oil leakage
Check both sides and bottom of the engine assembly for lube oil leaks, paying particular attention to the lube oil pressure gauge pipe joint, lube oil filter and lube oil pipe joints.
- Fuel leakage
Check the fuel injection pump, fuel lines and fuel filter for leakage.

-
- Coolant leakage

Check the radiator and water pump hose connections also the water drain cocks on the radiator and cylinder body for leakage.

- Exhaust smoke or gas leakage

Checking coolant level

The coolant level could drop depending on the equipment because the mixed air is expelled in about 5 minutes after the engine started.

Stop the engine, remove radiator cap, and add coolant.

CAUTION: Hot steam will rush out and you could get burnt, if the radiator cap is removed when the engine is hot. Cover the radiator cap with a thick cloth and loosen the cap slowly to reduce the pressure, then remove the cap.

4. CARE IN THE ENGINE OPERATION

In the engine operation, always pay attention to the following items if the engine indicates any sign of abnormalities.

(1) Engine Oil Pressure

Engine oil pressure is normal when the oil pressure gauge shows 3 to 4 kg/cm² (43 to 57 psi) in the engine warmed-up condition.

In the continuous engine operation, engine oil pressure is slightly lower than the pressure at start-up time.

If, in continuous engine operation, the engine oil pressure warning lamp is off, engine oil pressure is normal.

When the engine oil pressure gauge shows the following abnormal conditions, stop the engine immediately and check the engine oil amount in the oil sump and oil leakage:

- The engine oil pressure gauge shows below 2 kg/cm² (28 psi) though the engine speed is raised.
- The oil pressure gauge indicator oscillates greatly in the engine low speed range.
- When the engine oil pressure warning lamp goes on and off repeatedly.

When no lack of engine oil or no oil leakage is found, contact your equipment supplier to determine the cause of the abnormal reading.

(2) **Coolant Temperature**

The engine performance will be adversely affected if engine coolant temperature is too hot or too cold.

The normal coolant temperature is 75 to 85°C (167 to 185 °F).

Overheating

CAUTION: *If the Engine Coolant Temperature Gage shows an overheat condition or you have other reason to suspect the engine may be overheating, continued operation of the engine (other than as spelled out here) even for a short period of time may result in a fire and the risk of personal injury and severe vehicle or equipment damage. Take immediate action as outlined following.*

If you see or hear escaping steam or have other reason to suspect there is a serious overheat condition, stop and park the vehicle or equipment as soon as it is safe to do so and then turn off the engine immediately and get out of the vehicle or equipment.

The engine cooling system may overheat if the engine coolant level is too low, if there is a sudden loss of engine coolant (such as hose splitting), or if other problems occur. It may also temporarily overheat during severe operating condition such as:

- Climbing a long hill on a hot day.
- Stopping after high rpm.

If the Engine Coolant Temperature gage shows an overheat condition, or you have reason to suspect the engine may be overheating, take the following step:

- If your air conditioner (if equipped) is on, turn it off. And turn on the heater.
- Don't turn off your engine.
- With the transmission in Neutral, increase the engine speed to about one-half full operating speed or 1200 RPM, maximum. Bring the idle speed back to normal after two or three minutes.

If the engine coolant temperature does not start to drop within a minute or two:

- Let the engine run at normal idle speed for two or three *minutes*.

If the engine coolant temperature does not start to drop, turn off the engine and get out of the vehicle or equipment then proceed as follows:

CAUTION: To help avoid being burned-

- Do not open the engine access cover if you see or hear steam or engine coolant escaping from the engine compartment. Wait until no steam or engine coolant can be seen or heard before opening the engine cover.
- Do not remove the radiator cap or engine coolant reserve tank cap if the engine coolant in the tank is boiling. Also do not remove the radiator cap while the engine and radiator are still hot. Scalding fluid and steam can be blown out under pressure if either cap is taken off too soon.

If no steam or engine coolant can be seen or heard, tilt the cab or open the engine access cover. If the engine coolant is boiling, wait until it stops before proceeding. Look at the see-through reserve tank. The engine coolant level should be between the "MAX" and "MIN" marks on the reserve tank. If necessary, pour engine coolant into the reserve tank only, never directly into the radiator. Also, do not check engine coolant level at the radiator.

Make sure the fan belts are not broken, or off the pulleys, and that the fan turns when the engine is started.

If the engine coolant level in the reserve tank is low, look for leaks at the radiator hoses and connections, heater hoses and connections, radiator, and water pump. If you find major leaks, or spot other problems that may have caused the engine to overheat, do not run the engine until these problems have been

corrected. If you do not find a leak or other problem, carefully add engine coolant to the reserve tank. (Engine coolant is a mixture of ethylene glycol antifreeze and water. See "Engine Care in cold season" in Section 6 for the proper antifreeze and mixture.)

CAUTION: *To help avoid being burned, do not spill antifreeze or engine coolant on the exhaust system or hot engine parts. Under some conditions the ethylene glycol in engine coolant is combustible.*

If the engine coolant level in the reserve tank is at the correct level but there is still an indication on the instrument panel of an overheat condition:

- **YOU MUST LET ENGINE COOL FIRST.** You may then add engine coolant directly to the radiator.

Once the Engine Coolant Temperature Gage no longer signals an overheat condition, you can resume operating at a reduced speed. Return to normal operating after about ten minutes if the gage pointer does not again show an overheat condition.

If no cause for the overheat condition was found, see a qualified service technician.

Overcooling

The engine operation at low coolant temperature will not only increase the oil and fuel consumption but also will lead to premature parts wear which may result in engine failure.

(3) **Engine Hourmeter (Engine Operation Hour Indicating)**
(If so equipped)

This meter indicates the engine operation hours. Make sure that the meter is always working during engine operation. Periodical engine maintenance is scheduled on the operation hours indicated on the hourmeter.

(4) **Liquid and Exhaust Smoke Leakage**

Be careful with lubricant, fuel, coolant and exhaust smoke leakage.

(5) **Abnormal Engine Noise**

Pay attention to the noise from the engine or other related parts, checking if the noise is normal.

(6) **State of the Exhaust Smoke**

Be careful with exhaust smoke colour, check if it is whitish or blackish.

(7) **Electrical System**

Don't turn the key to OFF position during engine running. This may cause electrical parts damage.

5. ENGINE STOPPING

- (1) Make sure that all of the control levers on the equipment are in *NEUTRAL position*.
- (2) Before stopping the engine, cool down the engine by operating it at low idle speed about three minutes.
In this operation, check the engine noise and the engine oil pressure for abnormalities.
- (3) To stop the engine, turn the starter switch key to OFF position. Switch off the battery (if so equipped).

NOTICE: *Leaving the starter switch key in the DRIVE position for a long while after the engine has been stopped, will discharge the batteries wastefully.*

6. OPERATION AND CARE FOR NEW ENGINE

Your ISUZU engine is carefully tested and adjusted in the factory, however, further, thorough run-in (i.e. break-in) operation is necessary.

If the new engine is harshly operated, lubricating oil film will be reduced leading to abnormal wear or seizure. Particularly, avoid a harsh engine operation within the initial 100 operation hours observing the following notice.

- (1) Do the warming-up operation continuously until the engine is warmed-up. In this operation, do not race the engine.
- (2) Also do not operate the engine with rapid acceleration, rapid machine starting and continuous high speed operation.

7. ENGINE CARE FOR OVER-COOLING

Engine over-cooling cause premature wear and increased fuel consumption. When the coolant temperature is not raised to 75 to 85°C (167 to 185°F) indefinitely, take an action to recover this with means of radiator curtain or such like.

8. STARTING THE ENGINE AFTER BEING LEFT UNUSED FOR A LONG PERIOD OF TIME

When the vehicle or equipment is left unused for "more than three months" without running the engine (warming up), conduct a thorough inspection of the vehicle before starting the engine. After starting the engine, be sure to warm it up for more than ten minutes at 1000 rpm.

5. PERIODICAL INSPECTION AND MAINTENANCE

1. LUBRICATING SYSTEM

Servicing of the engine oil or the oil filter element will affect on the engine performance as well as the engine life.

Change the engine oil and the oil filter element periodically with the specified ones. (Refer to LUBRICANT at page 21 ~ 22.)

(1) Engine Oil and Oil Filter Element Change

Engine oil change and oil filter element change must be made simultaneously according to the following change schedule.

Change interval

Engine Oil..... Initial 50 and thereafter
every 250 operating hours

Oil Filter Element Initial 50 and therefore
every 500 operating hours

Engine oil draining

CAUTION: To help avoid the damage of being burned, do not drain oil while the engine is still hot.

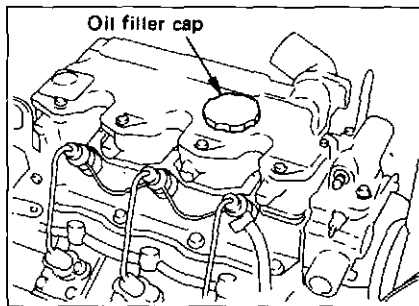

Fig. 14

- 1) Wipe clean around the oil filler cap taking care so that no foreign particles entry. Remove the filler cap.

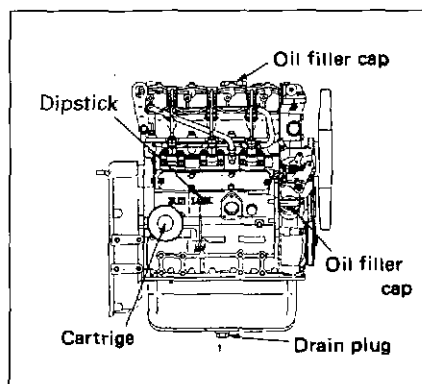

Fig. 15

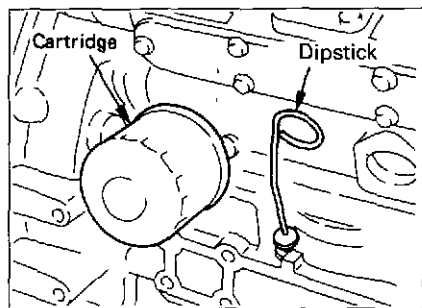

Fig. 16

- 2) Remove the oil pan drain plug and drain the engine oil completely.
It is advisable that draining be done while the engine is warm, to minimize the draining time.

NOTICE: Use a receptacle to receive the drained oil so that the engine and equipment may not be stained with the drained oil.

Oil filter element removal

Use a filter wrench to remove the cartridge type oil filter element.

Oil filter element installation

- 1) Apply lightly engine oil to the O-ring.
- 2) Turn in new cartridge until its sealed face comes in contact with the O-ring.
- 3) Use a filter wrench to further turn in the cartridge by 3/4 turn.

Engine oil refilling

- 1) Reinstall the drain plugs.
- 2) Fill with new engine oil by the oil filler port.
Wait about fifteen minutes until the oil gets down to the oil pan.
Then check the oil level with a dipstick.

(2) Check after Oil and Filter Changes

Oil leakage check

Idle the engine to raise the oil pressure, then check for oil leakage.

Oil level recheck

Stop the engine and keep it stationary about twenty minutes.

Use the dipstick to recheck the oil level.

Replenish with engine oil, if necessary, to the specified level.

NOTICE: *When the engine is started, the oil level will slightly drop from the initial level as the oil fully comes into the entire oil circuit.*

(3) Engine Oil Additives

Engine oils contain a variety of additives. Your engine should not need any extra additives if you use the recommended oil quality and change intervals.

(4) Used Oil Disposal

Do not dispose of used engine oil (or any other oil) in a careless manner such as pouring it on the ground, into sewers, or into streams or bodies of water. Instead, recycle it by taking it to a used oil collection facility which may be found in your community. If you have a problem disposing of your used oil, it is suggested that you contact your dealer or service station. (This also applies to diesel fuel which is contaminated with water. See "Diesel Fuel" in Section 3.)

(5) Used Engine Oil

CAUTION: *Used engine oil contains harmful contaminants that have caused skin cancer in laboratory animals. Avoid prolonged skin contact. Clean skin and nails thoroughly using soap and water - not mineral oil, fuels, or solvents. Launder or discard clothing, shoes, or rags containing used engine oil.*

Discard used engine oil and other oils properly.

2. COOLING SYSTEM

(1) Fan Belt Tension Adjustment

Adjust fan belt tension when belt slackness is greater than the specified amount and when the belts are replaced.

CAUTION: To help avoid being injured, check and adjust fan belt tension with engine stopped.

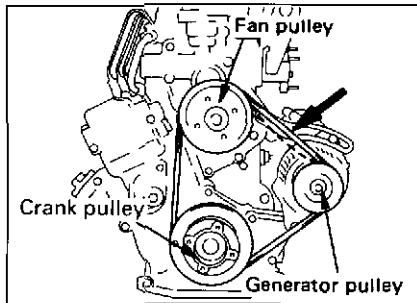

Fig. 17

Belt tension

Belt tension is normal when it is depressed 10 mm (0.39 in) with the thumb at the midway between the fan pulley and generator pulley. (about 10 kg (22 lb) depressing force.)

Fan belt slackness : **About 10 mm (0.39 in)**

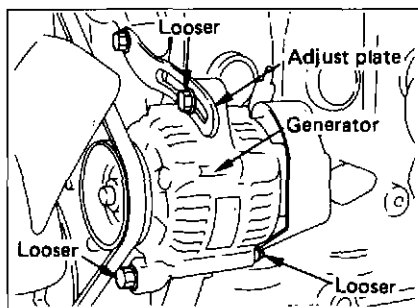

Fig. 18

Adjusting procedure

Belt tension adjustment is made by pivoting the generator at the generator mounting bolt.

- 1) Loosen the generator adjusting plate bolt and the generator mounting bolt.
- 2) Pivot the generator at the mounting bolt toward the engine left or right hand side as required.
- 3) Tighten the mounting bolt and the adjusting bolt.

NOTICE: *Belt tension may vary slightly after the generator is fixed. Therefore, recheck the belt tension after tightening the bolts.*

- 4) After the adjustment, operate the engine about five minutes at a low idle speed and recheck the belt tension. Particularly, pay attention to this matter when installing new belts. Belt tension may vary due to the initial belt conforming.

(2) Fan Belt Change

Use of fan belt with poor quality will result in premature belt wear or belt elongation leading to engine damage such as overheat. Therefore use of the ISUZU genuine fan belts are highly recommended.

(3) **Coolant Change**

The coolant must be changed at intervals of **six months**.

If the coolant is being fouled greatly, it will lead to engine overheat or coolant blow-off from the radiator.

Coolant draining

- 1) Remove the radiator cap.

Open the drain cock at the radiator lower part to drain the coolant in the radiator.

CAUTION: When removing the radiator filler cap while the engine is still hot, cover the cap with a rag, then turn it slowly to release the internal steam pressure. This will prevent a person from scalding with hot steam spouted out from the filler port.

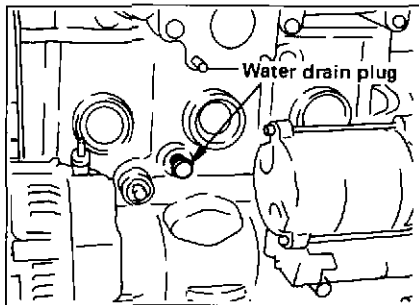

Fig. 19

- 2) Drain away the coolant from the engine by loosening the water drain plug at the rear of generator on the left side of cylinder body.

Filling with coolant

- 1) Close or tighten the coolant drain plug.
- 2) Use clean drinking water as a coolant. Fill up the radiator with the coolant until the level comes up to the filler port neck. Fill gradually to prevent air entry.

Coolant volume (Engine only) :

Refer to "Main Data Specifications"

- 3) With the coolant poured, operate the engine about five minutes at a low idle speed, then the air contained in the coolant circuit is bled. The coolant level will drop. Stop the engine to replenish with the coolant.

(4) Cleaning outside of Radiator

Mud or dried grass caught between radiator fins will block the air flow, resulting in lower cooling efficiency.

Clean the radiator fins with steam or compressed water.

For the cleaning interval, refer to the instruction manual prepared by the equipment manufacturer.

If the fins are stuffed, however, clean them at any time. Further, if the fins are deformed, repair or replace them.

(5) Cooling System Circuit Cleaning

When the cooling system circuit is fouled with water scales or sludge particles, cooling efficiency will be lowered.

Periodically clean the circuit interior with a cleaner.

Cooling system cleaning interval : **Every 1000** operation hours.

3. FUEL SYSTEM

The fuel injection pump and fuel injection nozzles are precisely manufactured, and therefore, using the fuel which contains water or dust particles will result in either injection pump plunger seizure or injection nozzle seizure, and the fouled fuel filter element with sludge or dust particles lead to decreased engine output.

In addition, clogged filter element can cause low output or automatic air bleeding failure.

Perform inspection and maintenance periodically as follows:

(1) Removal of Water from the Fuel

If water reaches the fuel filter element bottom, follow the procedure below to drain the water.

Procedure:

- 1) Turn the fuel filter lever just above (close) until it stops to cut off the fuel. (See Fig. 20)
- 2) Loosen the ring nut, remove the cup together with the element, and drain the fuel.
- 3) Clean the cup, install the element and tighten to the filter body with the ring nut.
- 4) Turn the fuel filter lever just below (open) until it stops to conduct air bleeding for the fuel.

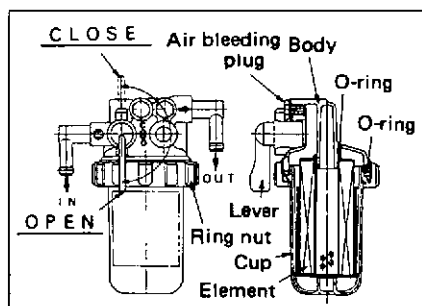

Fig. 20

NOTICE: 1. If the cup is removed without turning the fuel filter lever just above, the fuel may flow out.
2. The cartridge and cup contain fuel. Take care not to spill it during disassembly.
3. Perform the "fuel system air bleeding" after the water in the fuel is drained.

(2) **Fuel System Air Bleeding**

The entry of air into the fuel system will cause hard engine starting or engine malfunction.

When once the servicing such as emptying the fuel tank, draining for the water sedimentor, and the fuel filter element change is done, be sure to conduct air bleeding.

Because of the "automatic air-bleeding system" being employed, turn the starter switch to the "Drive" position and activate the "electromagnetic pump" to bleed the air.

Air bleeding procedure:

- 1) When the "starter switch" is set to the "Drive" (ON) position to activate the electromagnetic pump, fuel is forcibly sent to the fuel valve of each injection pump and further to the leak-off pipe of each nozzle holder, where air in the fuel leaks off automatically to the fuel tank.
- 2) Start the engine and check the fuel system for fuel leak.

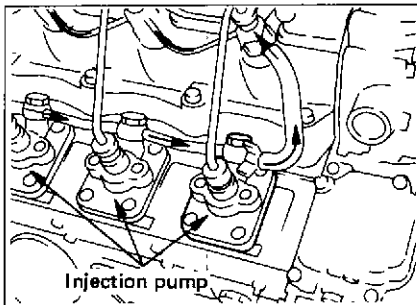

Fig. 21

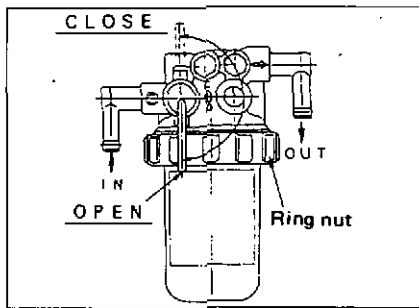

Fig. 22

(3) Fuel Filter Element Change

Change interval

Fuel filter element change interval : **Every 500** operating hours

Change procedure

- 1) Turn the fuel filter lever to the closed position.

NOTICE: If the cup is removed without turning the lever as instructed, the fuel may flow out.

- 2) Loosen the ring nut, remove the cup, and take out the element.
- 3) Clean the cup, install a new element, and install new packing on the ring nut.
- 4) Tighten the cut to the body securely with the ring nut.
- 5) After installation, turn the fuel filter lever to the open position.

NOTICE:

1. With the lever positioned just above the fuel remains off, and therefore, the engine cannot be started.
2. During removal, be careful not to stain the parts around with the fuel in the cup.
3. After changing the fuel filter element, conduct fuel air bleeding.

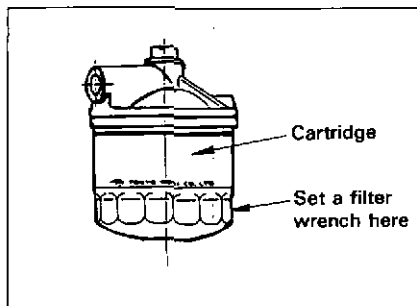

Fig. 23

Change procedure with spin-on type filter

- 1) Loosen the fuel filter turning it counterclockwise with a filter wrench.
- 2) With a rag wipe clean the fitting face on the upper cover, so that new fuel filter can be seated properly.
- 3) Lightly oil the O-ring. To reinstall, turn the filter assembly clockwise carefully to prevent the fuel from spilling until the O-ring is fitted against the sealing face of the filter cover. Turn 2/3 turn further with the filter wrench.

(4) Governor Control Seals

As the governor (timing gear case) is precisely adjusted, most of the controls are sealed, please do not break them. When the adjustment is necessary, contact with your machine supply source.

NOTICE: *The manufacturer does not warrant the claim on the engine with the broken governor seals.*

4. AIR INTAKE SYSTEM

(1) Air Cleaner

Engine performance and life vary with the air intake conditions. A dirty air cleaner element reduces the amount of intake air, causing reduced engine output or disordered engine.

Also, a damaged element leads to abrasion of cylinders and valves, resulting in increased oil consumption, reduced output and shortened engine life.

Handling of air cleaner varies with the equipment model.

Perform periodic inspection and maintenance following the equipment manufacturer's instructions.

- | |
|---|
| <p>NOTICE: 1. Shorten the cleaning or change interval when the equipment is used in dusty areas.
2. Change the element, if element damage is found during air cleaner cleaning.
3. Take care not to cause air leakage (sucking) when reassembling the air cleaner.</p> |
|---|

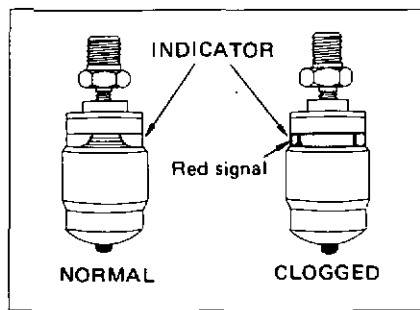

Fig. 24

(2) Air Cleaner with Dust Indicator

This indicator is attached to the air cleaner. When the air cleaner element is clogged, air intake resistance becomes greater and the dust indicator signal turns into red indicating the element change timing.

When the signal turns into red, clean the air cleaner or replace the element. Then press the dust indicator button to reset the indication.

5. ENGINE ELECTRICAL

The ISUZU engines uses a 12 volt system and a negative grounding type for the electrical system.

(1) Battery Servicing

Battery maintenance schedules will vary with equipment and battery types.

Follow the equipment manufacturer's instructions.

Gravity of the batteries

The battery charge condition is judged by the electrolyte gravity measurement.

Periodically measure the electrolyte gravity of the batteries.

For the internal check follow the equipment manufacturer's standard.

The relationship between the electrolyte specific gravity and the battery conditions are as follows:

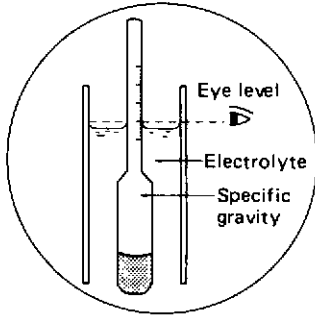

Fig. 25

Electrolyte Specific Gravity	Battery Conditions
Over 1.300	Over 100% (Over charged)
1.290 ~ 1.270	100%
1.260 ~ 1.240	75%
Below 1.230	Below 50% (Insufficiently charged)

Fig. 26

NOTICE: *The battery electrolyte is dilute sulfuric acid. So, be careful not to stain your body and clothes with it. If stained, rinse portion in clean water.*

Gravity conversion

The specified electrolyte temperature for the gravity measurement is 20°C (68°F).

Measure the electrolyte temperature and do the conversion in accordance with the following formula when the temperature does not fall to the specified temperature.

$$S_{20} = S_t + 0.0007 (t - 20)$$

S_{20} ; gravity at 20°C

S_t ; gravity measured

t ; electrolyte temperature when measured

Battery terminal connections

Periodically, check the battery terminals for loose connection and corrosion.

For the check interval, follow the machine manufacturer's standard. Loose connection will cause hard engine starting or deficient battery charging.

If the terminals are excessively corroded, disconnect the battery cables and polish them with a wire brush or sandpaper.

Never reverse the "+" and "-" terminals when reconnecting the cables. Even a short period of reverse connection could damage the electrical parts.

Cleaning of Battery

When the battery is fouled clean it with clean water or tepid water and wipe them with a dry cloth to remove the water. Apply a light coat of vaseline or a grease to the battery post.

(2) Generator Servicing

- 1) The polarity of the generator is negative grounding type. When an inverted circuit connection take place, the circuit will be in short circuit instantaneously resulting the generator failure.
- 2) Do not put water directly on the generator. Entry of water into the generator leads an electrolyte corrosion causing a generator failure.
Pay attention particularly when cleaning the engine.
- 3) When the battery is charged with a external electric source, be sure to disconnect the battery cables.

(3) Wiring Connections

Check all of the electric wiring connections for looseness and damage.

6. ENGINE ASSEMBLY AND OTHERS

To continue trouble free engine operation over a long period of time, the servicing items need a skilled maintenance technician, therefore, consult your machine supply source on the following items when necessary.

(1) Fuel Injection Nozzle

Use an injection nozzle tester to check the static injection starting pressure and the fuel spray conditions.

Injection nozzle pressure test interval : **Every 500** operation hours

When the injection starting pressure is too high or too low or the fuel spray pattern is improper, an abnormal fuel combustion take place in the engine leading a lowered output and blackish exhaust smoke. Further, it causes a piston seizure or piston damage etc. In such cases, the injection nozzle test or the nozzle replacement is required.

Injection starting pressure 12.7 ~ 13.7 MPa
(1850 ~ 1990 psi)

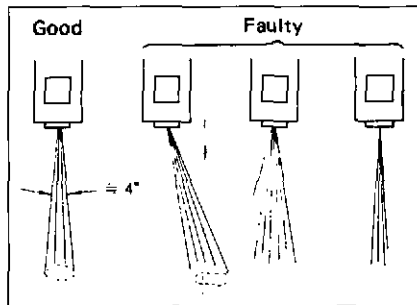

Fig. 27

CAUTION: While using a nozzle tester, it may happen that high pressure blow off the fuel oil and injure the worker. Keep off the nozzle end.

(2) Valve Clearance Adjustment

The valve clearance must be adjusted **every 1000** operating hours, or whenever the valve rocker is abnormally noisy, or in an engine malfunction though the fuel system is properly working.

Valve clearance : 0.20 mm (0.0078 in) (When the engine is cold.)

Adjustment Procedure

- 1) Turn the crankshaft clockwise so that the mark groove on the crank pulley is aligned with the TDC mark (cast out) on the timing gear case cover.
- 2) Remove the cylinder head cover and check to see if cylinder No. 1 is at TDC in the compression stroke or at TDC in the exhaust stroke. When the intake and exhaust valves are closed, the cylinder is at TDC in the compression stroke, and when only the exhaust valve is open, it is at TDC in the exhaust stroke.

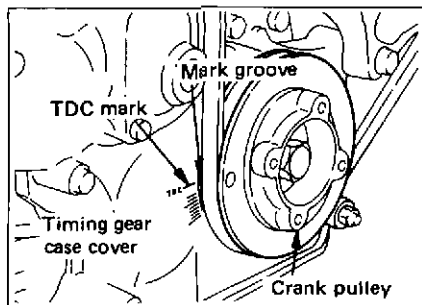

Fig. 28

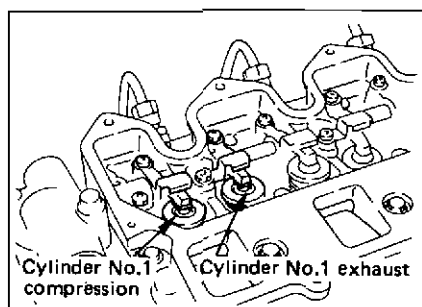

Fig. 29

- 3) In accordance with the conditions of cylinder No. 1, measure and adjust, if required the clearance of the valves marked with either ○ or ⊙ in the table below.

Cylinder No.	1		2		3	
Valve arrangement	I	E	I	E	I	E
When No. 1 cylinder is at TDC in the compression stroke	○	○	○			○
When No. 3 cylinder is at TDC in the compression stroke				⊙	⊙	

I: Inlet E: Exhaust

Fig. 30

- 4) On completion of the valve clearance adjustment in 3) above, make mark alignment as in 1) above by giving a turn to the crankshaft in normal direction.
Then measure and adjust the clearance of the other valves.

NOTICE: The rocker arm is made of die-cast aluminum. Therefore, be careful not to tighten the adjusting screw to excess.

(3) Adjustment of Injection Timing

The injection timing may not be readjusted.

Take care not to forget to insert a shim on the mounting surface when reassembling the injection pump after it was removed.

(4) Cylinder Compression Pressure Measurement

The cylinder compression pressure measurement must be done **every 1000** operation hours, or whenever the engine output is reduced.

Compression pressure 3.04 MPa (441 psi)

Test condition: Cranking speed 250 rpm

 Coolant temperature 75°C (167°F)

Repair the engine and/or replace some parts of engine if compression pressure is lower than 2.55 MPa (370 psi)

(5) Starter and Generator Servicing

Do the starter and the generator servicing **every 1000** operating hours on the following items.

- Starter commutator cleaning.
- Generator slip ring cleaning.
- Carbon brushes and the brush contact check.

(6) Radiator Pressurization Valve Check

A pressurization valve is incorporated in the radiator cap assembly. Check the valve actuating pressure with a radiator compression tester. For the pressurization valve actuating pressure and the check interval, follow the equipment manufacturer's standards.

6. ENGINE CARE IN COLD SEASON

1. FUEL

(1) Fuel Selection

In the cold zone, the fuel might be frozen resulting in hard engine starting; therefore, select a suitable fuel for such engine operation.

Use ASTM 975 No. 2-D fuel if you expect temperature above -7°C (20°F).

Use Number 1-D if you expect temperatures below -7°C (20°F). If Number 1-D is not available, a "winterized" blend of 1-D and 2-D is available in some areas during the winter months.

Check with the service station operator to be sure you get the properly blended fuel.

2. COOLANT

Where the atmospheric temperature falls below freezing point, the cooling system should be drained after engine operation, but to eliminate the need for repeated draining and refilling, the use of anti-freeze solution is highly recommended.

A 50/50 Ethylene glycol base antifreeze/water mix.

(which provides protection to -37°C (-34°F) is recommended for use in these ISUZU diesel engines).

Concentrations over 65% adversely affect freeze protection, heat transfer rates, and silicate stability which may cause water pump leakage.

Never exceed a 60/40 antifreeze/water mix.

(which provides protection to about -50°C (-58°F).

CAUTION: Under some conditions the ethylene glycol in the engine coolant is combustible. To help avoid being burned when adding engine coolant, do not spill it on the exhaust system or engine parts that may be hot. If there is any question, have this service performed by a qualified technician.

NOTICE: 1. Methyl alcohol base antifreeze is not recommended because of its effect on the non-metallic components of the cooling system and because of its low boiling point.
2. High silicate antifreeze is not recommended because of causing serious silica gelation problems.
3. Usage and mixing ratio etc. should be followed to the antifreeze manufacture's recommendations.

3. ENGINE OIL

Engine oil viscosity largely affects engine startability, so the use of lubricant with selected viscosity according to the atmospheric temperature is important. (Refer to page 21 ~ 22)

At low atmospheric temperature, engine oil viscosity will increase to cause hard engine starting.

4. BATTERY

- (1) Always pay attention to charging the batteries completely in cold season.

As the discharge current from the battery is large in cold engine starting, it takes a comparatively long while to recharge the batteries than the recharge after the normal engine starting.

Particularly, as the gravity of the insufficiently charged battery's electrolyte is low, it will easily be frozen.

Pay attention to keep the batteries warm in the cold season.

- (2) To replenish the battery with distilled water, do it immediately before the engine operation.

If the work is done after the engine has already been in an operation, the distilled water replenished will not be mixed with the original electrolyte, allowing the danger of freezing the not mixed distilled water staying in the battery cell upper part.

5. ENGINE STARTING

In cold engine starting at atmospheric temperature of below 0°C (32°F), pay attention to the following items:

- (1) Do the preheating operation before cranking the engine with the starter.
- (2) Set the engine throttle lever or pedal to the 1/3 position of the full lever or pedal stroke.
- (3) If the engine does not start with the initial cranking, keep the batteries stationary a while to recover their power and, reattempt the preheating and the cranking operation.
- (4) In order to protect the starter, one time cranking must be limited to within 10 seconds.
- (5) In cranking operation, when a phenomenon, that the starter pinion and the flywheel ring gear engagement to repeated disengage and engage take place, as this is a sign of weakened battery power, charge the batteries with an external electrical source.
- (6) In an extreme cold temperature engine starting, do the engine cranking a while with setting the throttle lever at no fuel position to allow the engine rotating or travelling parts come to an unrestricted condition from the adhesive cold lubricant, after then do preheating and cranking to start the engine.

NOTICE: Do not use starting "aids" in the air intake system. Such aids can cause immediate engine damage.

7. ENGINE ELECTRICAL WIRING DIAGRAMS

As the electrical wiring differs depending on the respective equipment, merely standard wirings are shown in the diagrams.

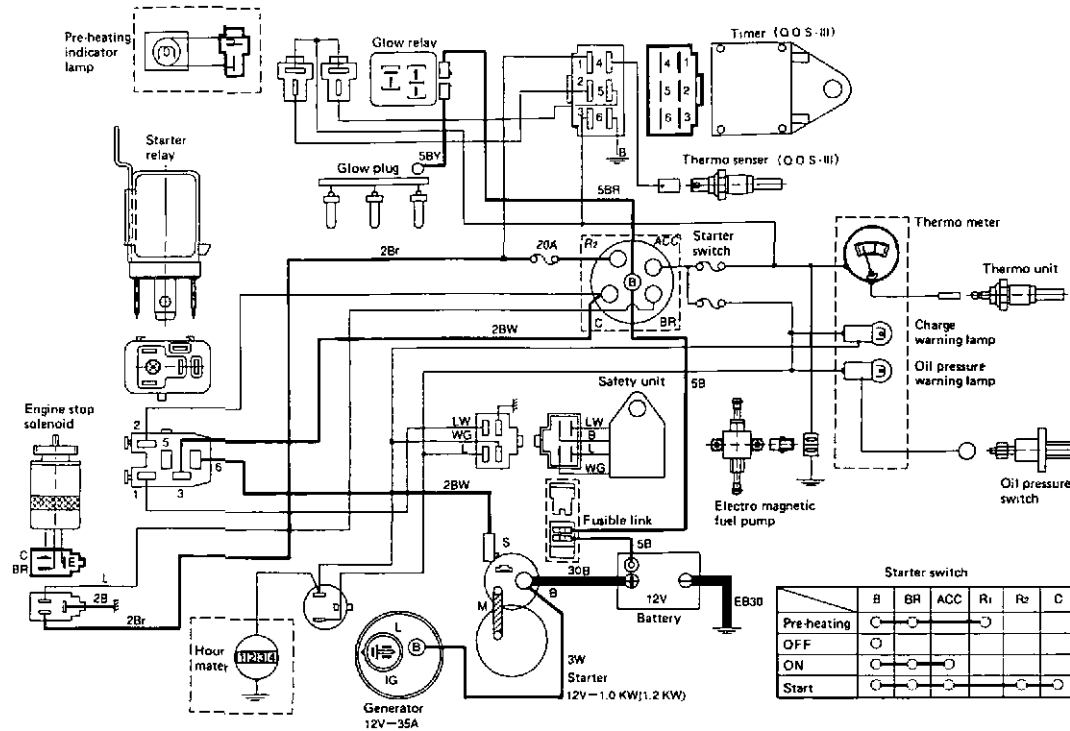

Fig. 31

8. ENGINE MAINTENANCE SCHEDULE

When performing the following items, the daily inspection items should also be carried out.

NO.	Description of check and maintenance	Daily	(operation hours)					Remark
			50	250	500	750	1000	
1.	Oil level and oil fouling	○						See "EXPLANATION OF MAINTENANCE SCHEDULE"
2.	Oil leakage check	○						
3.	Oil pressure gauge registration	○						
4.	Oil pressure warning lamp	○						
5.	Engine oil replacement		(○)	○	○	○	○	
6.	Oil filter element replacement		(○)		○		○	
7.	Fuel leakage check	○						
8.	Draining water in fuel filter	○						
9.	Fuel filter element replacement				○		○	
10.	Injection nozzle check (*)				○ ★		○	

★ This is a recommended maintenance. The failure to perform this maintenance item will not nullify the emission warranty or limit recall liability prior to the completion engine useful life. Isuzu, however, urges that recommended maintenance service is performed at the indicated intervals.

NO.	Description of check and maintenance	Daily	(operation hours)					Remark
			50	250	500	750	1000	
11.	Coolant level and fouling check	<input type="radio"/>						See "EXPLANATION OF MAINTENANCE SCHEDULE"
12.	Coolant leakage check	<input type="radio"/>						
13.	Radiator filler cap fitting condition	<input type="radio"/>						
14.	Fan belt tension check (Replace if necessary.)	<input type="radio"/>						
15.	Coolant temperature registration	<input type="radio"/>						
16.	Coolant replacement							
17.	Radiator external face cleaning							
18.	Cooling system circuit cleaning						<input type="radio"/>	
19.	Radiator filler cap function check (*)							

NO.	Description of check and maintenance		Daily	(operation hours)					Remark
				50	250	500	750	1000	
20.	Electrolyte level check		<input type="radio"/>						See "EXPLANATION OF MAINTENANCE SCHEDULE"
21.	Battery cleaning		<input type="radio"/>						
22.	Battery charge condition	Ammeter registration	<input type="radio"/>						
		Charge warning lamp	<input type="radio"/>						
23.	Electrolyte gravity check								
24.	Starter and generator check and cleaning (*)						<input type="radio"/>		
25.	Wiring and connection check								
26.	Preheating condition check		<input type="radio"/>						
27.	Air cleaner element replacement								

NO.	Description of check and maintenance	Daily	(operation hours)					Remark
			50	250	500	750	1000	
28.	Engine starting conditions and noise conditions	<input type="radio"/>						See "EXPLANATION OF MAINTENANCE SCHEDULE"
29.	Exhaust smoke condition	<input type="radio"/>						
30.	Cylinder compression pressure (*)						<input type="radio"/>	
31.	Valve clearance check (*)						<input type="radio"/>	

Note:

1. The service intervals after 1000 operation hours should also be made every 250 operation hours in accordance with this check and maintenance schedule.
2. When the servicing on the asterisked (*) items are necessary, consult the equipment supplier.

EXPLANATION OF MAINTENANCE SCHEDULE

The following is a brief explanation of the services listed in the preceding Engine Maintenance schedule.

1. **Oil level and oil fouling** Check that the oil level is between the max. level mark and the min. level mark. Drain oil to the max. level mark if oil level is above the max. level mark. Add oil to the max. level mark if oil is below the min. level mark.
2. **Oil leakage check** Replace any damaged or malfunctioning parts which could cause leakage.
3. **Oil pressure gauge registration** Engine oil pressure is normal at about 3 to 5 kg/cm² in warmed-up condition. Check and repair the lubrication oil system, if it is abnormal.
4. **Oil pressure warning lamp** Warning lamp is off while engine running. If it stays on, check and repair the lubrication system.
5. **Engine oil replacement** Change oil every 250 hours.
6. **Oil filter element replacement** Change element every 500 hours.
7. **Fuel leakage check** Inspect the fuel lines for damage which could cause leakage. Replace any damaged or malfunctioning parts.
8. **Draining water in fuel filter** Drain water in fuel filter if water reaches the fuel element.
9. **Fuel filter element replacement** Change element every 500 hours.
10. **Injection nozzle check** Check and adjust injection opening pressure and spray condition. (This is a recommended maintenance)

-
- | | |
|--|--|
| 11. Coolant level and fouling check | Check coolant level and add coolant if necessary. |
| 12. Coolant leakage check | Repair part for coolant leakage. |
| 13. Radiator filler cap fitting condition | The radiator cap must be installed tightly. |
| 14. Fan belt tension check | Check and adjust fan belt deflection. Look for cracks, fraying and wear. |
| 15. Coolant temperature registration | Coolant temperature is normal at about 75 to 85°C (167 to 185°F). Check and repair the cooling system if coolant temperature is abnormal. |
| 16. Coolant replacement | Change coolant at intervals of 6 months or 12 months respectively if coolant is plain water, or long life coolant (LLC). |
| 17. Radiator external face cleaning | According to the equipment manufacturer's specification. |
| 18. Cooling system circuit cleaning | Clean the cooling system circuit every 1000 hours. |
| 19. Radiator filling cap function check | Check radiator pressure cap periodically for proper operation according to the equipment manufacturer's specifications. |
| 20. Electrolyte level check | Replenish with distilled water if necessary. |
| 21. Battery cleaning | Clean the terminals. |
| 22. Battery charge condition | Ammeter registration goes to plus (+) side while engine running. In the lamp type, the lamp is completely being off while engine running. Check charging circuit if the lamp is not off. |

-
- | | |
|--|--|
| 23. Electrolyte gravity check | Check according to the equipment manufacturer's specifications. |
| 24. Starter and generator check and cleaning | Check wear condition of brush and commutator. |
| 25. Wiring and connection check | Check according to the equipment specifications. |
| 26. Preheating condition check | Check preheating condition of the system. |
| 27. Air cleaner element replacement | Change element according to the manufacturer's specifications. |
| 28. Engine starting condition and noise condition | Check engine stability and noise. |
| 29. Exhaust smoke condition | Check exhaust smoke color. |
| 30. Cylinder compression pressure | Check every 1000 hours. |
| 31. Valve clearance check | Incorrect valve clearance will result in increased engine noise and lower engine output. Thereby adversely affecting engine performance.
Check and adjust every 1000 hours. |

9. SIMPLE ENGINE TROUBLESHOOTING

This item contents a simple troubleshooting. When a failure takes place on your ISUZU engine, diagnose the cause referring this troubleshooting. Should the cause of failure cannot be detected or you are unable to manage the failure consult to your machine supply source or nearest ISUZU engine service outlet.

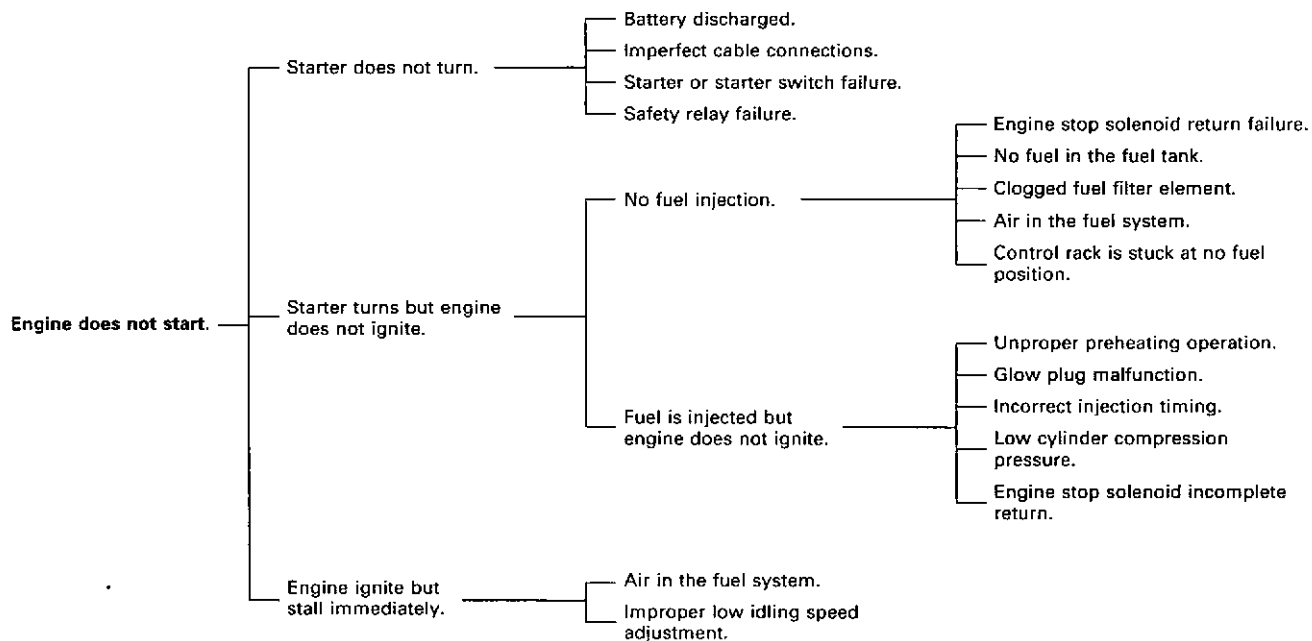

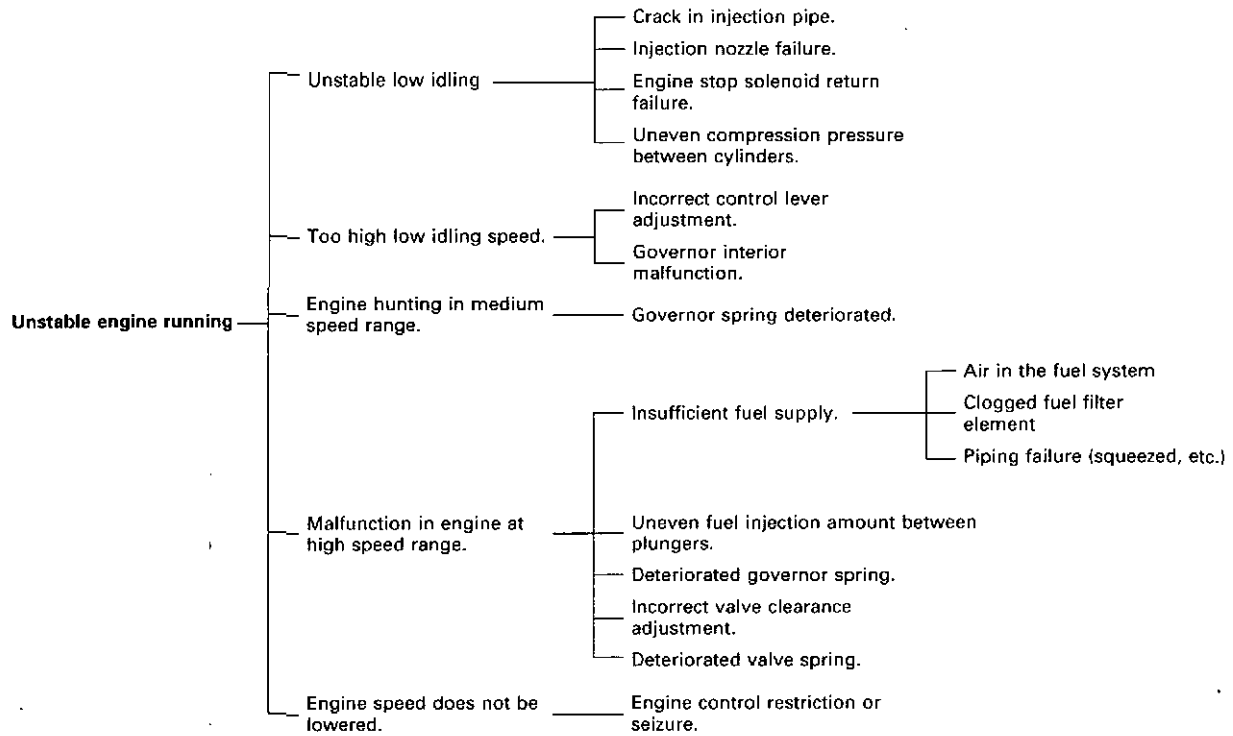

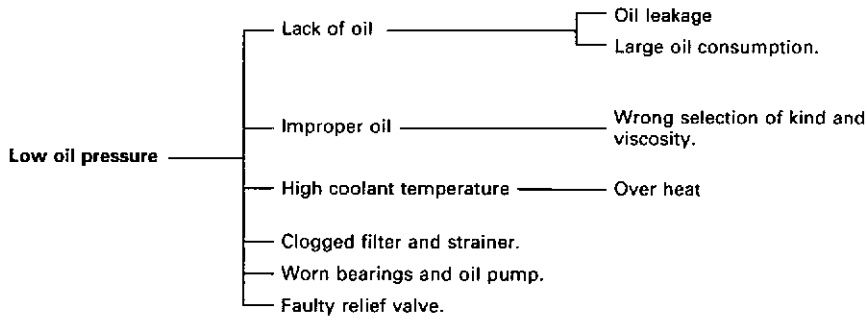
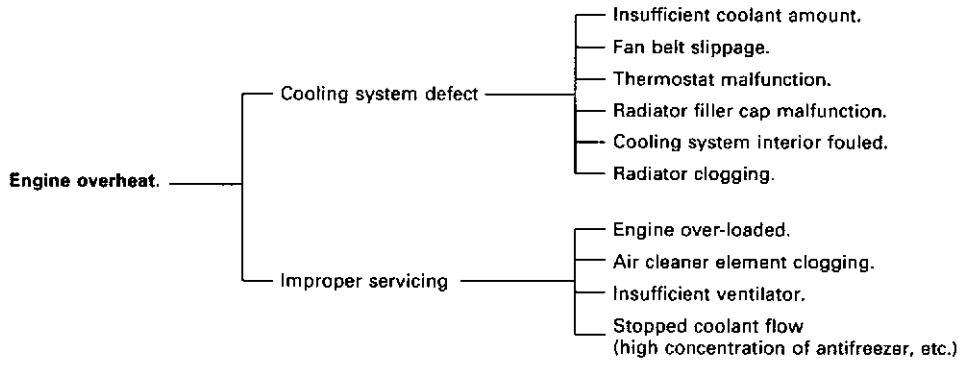

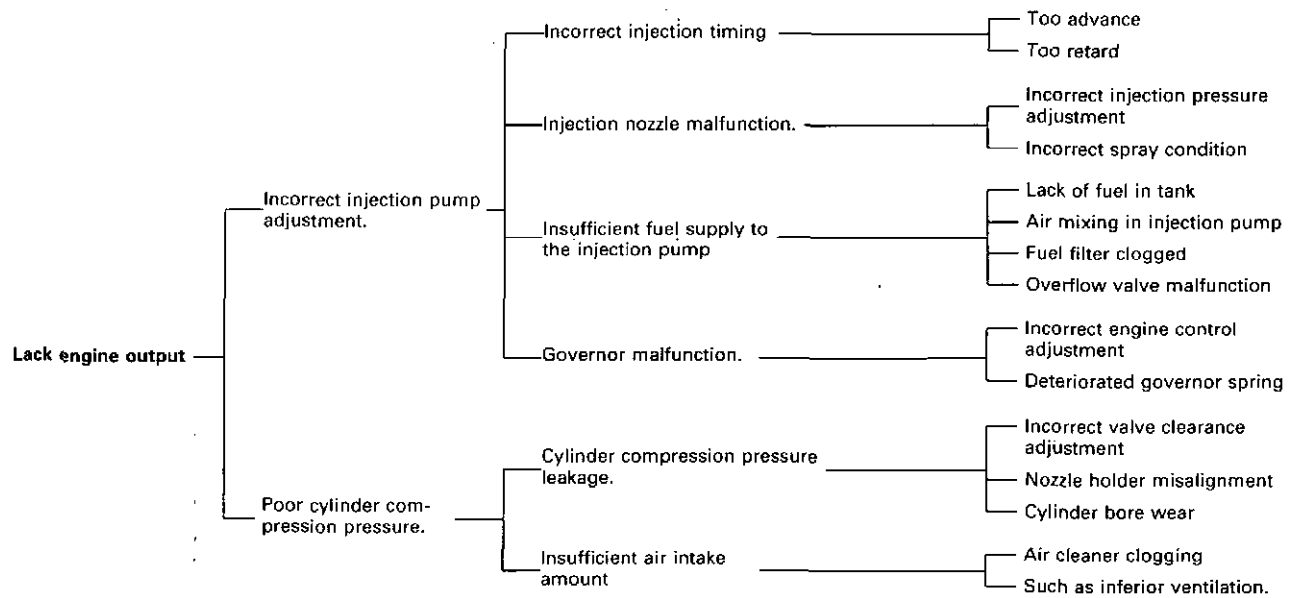

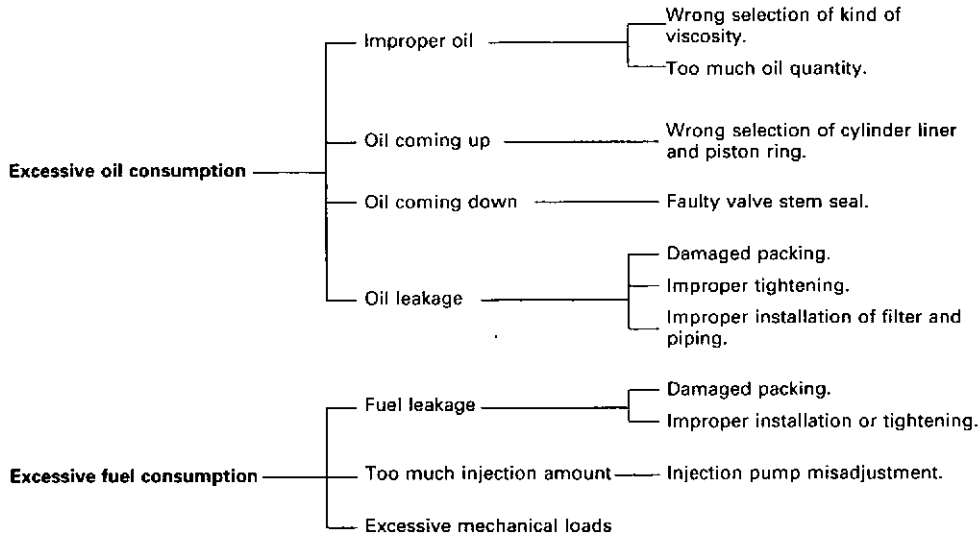

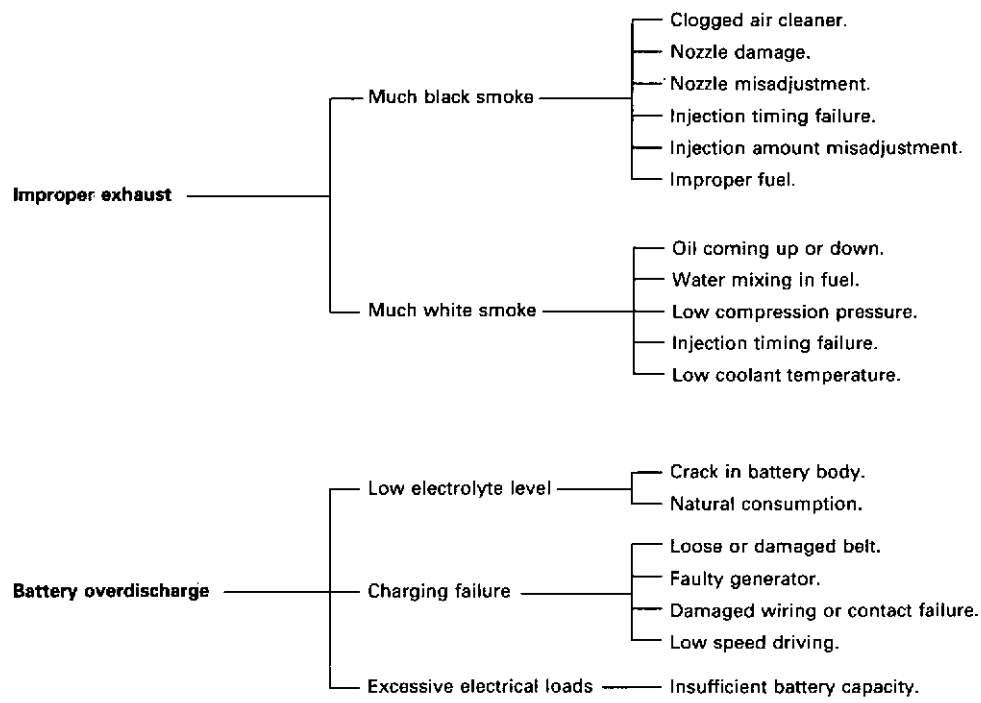

All information, illustrations and specifications contained in this manual are based on the latest product information available at the time of publication. The right is reserved to make changes at any time without notice.

INSTRUCTION MANUAL (INDUSTRIAL)

3LA1, 3LB1, 3LD1

IDE-1100

Issued by

ISUZU MOTORS LIMITED

ENGINE SALES PLANNING OFFICE

6-26-1, Minami-oi, Shinagawa-ku, Tokyo, 140, Japan
TEL 03-5471-1111

604-03-1000K

ISUZU

PRINTED IN JAPAN
IDE-1100