

JOHN DEERE

OPERATOR'S MANUAL

POWERTECH® 2.4 L & 3.0 L OEM
Diesel Engines

OMRG34851 Issue 17JUN03 (English)



POWERTECH™
2.4 L & 3.0 L
4024 and 5030
OEM Diesel Engines

OPERATOR'S MANUAL
2.4 L & 3.0 L OEM Diesel Engines

OMRG34851 Issue 17JUN03 (ENGLISH)

CALIFORNIA
Proposition 65 Warning

Diesel engine exhaust and some of its constituents are known to the State of California to cause cancer, birth defects, and other reproductive harm.

If this product contains a gasoline engine:

 WARNING

The engine exhaust from this product contains chemicals known to the State of California to cause cancer, birth defects or other reproductive harm.

The State of California requires the above two warnings.

John Deere Power Systems

LITHO IN U.S.A.

Introduction

Forward

READ THIS MANUAL carefully to learn how to operate and service your engine correctly. Failure to do so could result in personal injury or equipment damage.

THIS MANUAL SHOULD BE CONSIDERED a permanent part of your engine and should remain with the engine when you sell it.

MEASUREMENTS IN THIS MANUAL are given in both metric and customary U.S. unit equivalents. Use only correct replacement parts and fasteners. Metric and inch fasteners may require a specific metric or inch wrench.

RIGHT-HAND AND LEFT-HAND sides are determined by standing at the drive or flywheel end (rear) of the engine and facing toward the front of the engine.

WRITE ENGINE SERIAL NUMBERS and option codes in the spaces indicated in the Record Keeping Section. Accurately record all the numbers. Your dealer also

needs these numbers when you order parts. File the identification numbers in a secure place off the engine.

SETTING FUEL DELIVERY beyond published factory specifications or otherwise overpowering will result in loss of warranty protection for this engine.

CERTAIN ENGINE ACCESSORIES such as radiator, air cleaner, and instruments are optional equipment on John Deere OEM Engines. These accessories may be provided by the equipment manufacturer instead of John Deere. This operator's manual applies only to the engine and those options available through the John Deere distribution network.

NOTE: This operators manual covers only engines provided to OEM (Outside Equipment Manufacturers). For engines in Deere machines, refer to the machine operators manual.

TX,DH2120 -19-11DEC85-1/1

Engine Owner

John Deere Engine Owner:

Don't wait until you need warranty or other service to meet your local John Deere Engine Distributor or Service Dealer.

Learn who he is and where he is. At your first convenience, go meet him. He'll want to get to know you and to learn what your needs might be.

Aux Utilisateurs De Moteurs John Deere:

N'attendez pas d'être obligé d'avoir recours a votre concessionnaire John Deere ou point de service le plus proche pour vous adresser a lui.

Renseignez-vous des que possible pour l'identifier et le localiser. A la premiere occasion, prenez contact avec lui et faites-vous connaître. Il sera lui aussi heureux de faire votre connaissance et de vous proposer ses services le moment venu.

An Den Besitzer Des John Deere Motors:

Warten Sie nicht auf einen evt. Reparaturfall um den nächstgelegenen John Deere Händler kennen zu lernen.

Machen Sie sich bei ihm bekannt und nutzen Sie sein "Service Angebot".

Proprietario Del Motore John Deere:

Non aspetti fino a quando ha bisogno della garanzia o di un altro tipo di assistenza per incontrarsi con il Suo Concessionario che fornisce l'assistenza tecnica.

Impari a conoscere chi è e dove si trova. Alla Sua prima occasione cerchi d'incontrarlo. Egli desidera farsi conoscere e conoscere le Sue necessità.

Propietario De Equipo John Deere:

No espere hasta necesitar servicio de garantía o de otro tipo para conocer a su Distribuidor de Motores John Deere o al Concesionario de Servicio.

Entérese de quién es, y dónde está situado. Cuando tenga un momento, vaya a visitarlo. A él le gustará conocerlo, y saber cuáles podrían ser sus necesidades.

John Deere MotorÄgare:

Vänta inte med att besöka Din John Deere återförsäljare till dess att Du behöver service eller garanti reparation.

Bekanta Dig med var han är och vem han är. Tag första tillfälle att besöka honom. Han vill också träffa Dig för att få veta vad Du behöver och hur han kan hjälpa Dig.

POWERTECH™ 2.4 L & 3.0 L Diesel Engines

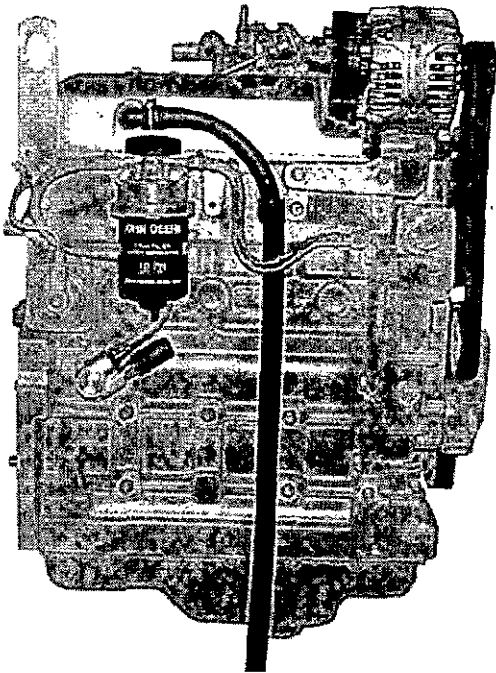

2.4 L Right Side View

RG12861 -JUN-03JUN03

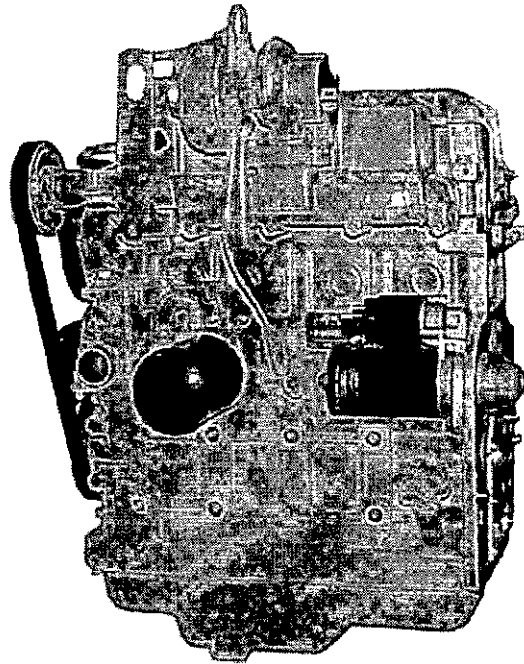

2.4 L Left Side View

RG12860 -JUN-03JUN03

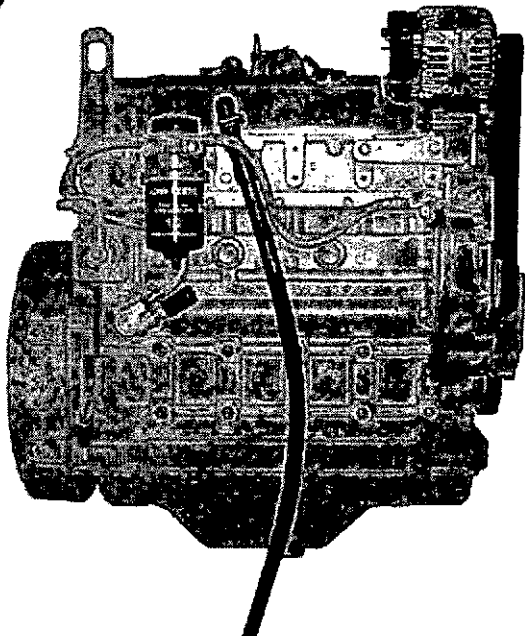

3.0 L Right Side View

RG12962 -JUN-03JUN03

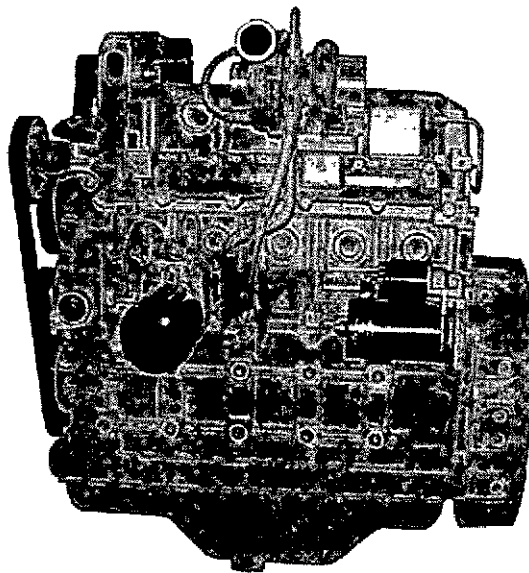

3.0 L Left Side View

RG12963 -JUN-03JUN03

Contents

	Page		Page
Record Keeping			
POWERTECH™ Medallion	01-1	Avoid Excessive Engine Idling	15-8
Engine Serial Number Plate	01-1	Stopping the Engine	15-8
Record Engine Serial Number	01-2	Using a Booster Battery or Charger	15-10
Engine Option Codes	01-3	Lubrication and Maintenance	
Safety			
	05-1	Observe Service Intervals	20-1
Fuels, Lubricants, and Coolant			
Diesel Fuel	10-1	Use Correct Fuels, Lubricants, and Coolant	20-1
Lubricity of Diesel Fuel	10-2	Lubrication and Maintenance Service	
Diesel Fuel Storage	10-3	Interval Chart—Standard Industrial Engines ..	20-2
Bio-Diesel Fuel	10-4	Lubrication & Maintenance/Daily	
Handling And Storing Bio-Diesel Fuel	10-5	Daily Prestarting Checks	25-1
DIESELSCAN Fuel Analysis	10-5	Lubrication & Maintenance/250 Hour/6 Month	
Filling Fuel Tank	10-6	Servicing Fire Extinguisher	30-1
Minimizing the Effect of Cold Weather on		Changing Engine Oil and Replacing Filter	30-1
Diesel Engines	10-7	Checking Engine Mounts	30-4
Diesel Engine Break-In Oil	10-8	Servicing Battery	30-5
Diesel Engine Oil	10-9	Lubrication & Maintenance/500 Hour/12 Month	
Extended Diesel Engine Oil Service		Cleaning Crankcase Vent Tube	35-1
Intervals	10-10	Checking Air Intake System	35-2
Mixing of Lubricants	10-10	Check Engine Speeds	35-2
Oil Filters	10-10	Replacing Fuel Filter Element	35-3
OILSCAN® and COOLSCAN™	10-11	Checking Belt Tensioner Spring Tension	
Alternative and Synthetic Lubricants	10-11	and Belt Wear (Automatic Tensioner)	35-4
Lubricant Storage	10-12	Checking Engine Electrical Ground	
Grease	10-12	Connections	35-6
Diesel Engine Coolant	10-13	Checking Cooling System	35-6
Diesel Engine Coolants, Supplemental		Replenishing Supplemental Coolant	
Additive Information	10-14	Additives (SCAs) Between Coolant	
Testing Diesel Engine Coolant	10-15	Changes	35-7
Supplemental Coolant Additives	10-16	Testing Diesel Engine Coolant	35-9
Operating in Warm Temperature Climates	10-16	Pressure Testing Cooling System	35-10
Disposing of Coolant	10-17	Lubrication & Maint./2000 Hour/24 Month	
Engine Operating Guidelines			
Normal Engine Operation	15-1	Checking Crankshaft Vibration Damper (If	
Break-In Service	15-2	Equipped)	40-1
Auxiliary Gear Drive Limitations	15-3	Flushing and Refilling Cooling System	40-2
Starting The Engine	15-4	Testing Thermostats Opening Temperature	40-4
Cold Weather Starting	15-6		
Warming Engine	15-7		

Continued on next page

All information, illustrations and specifications in this manual are based on the latest information available at the time of publication. The right is reserved to make changes at any time without notice.

COPYRIGHT © 2003
DEERE & COMPANY
Moline, Illinois
All rights reserved
A John Deere ILLUSTRATION® Manual

	Page
Service as Required	
Additional Service Information	45-1
Do Not Modify Fuel System	45-1
Adding Coolant	45-2
Replacing Single Stage Air Cleaner Element	45-3
Replacing Axial Seal Air Cleaner Filter Element	45-4
Replacing Radial Seal Air Cleaner Filter Element	45-6
Replacing Fan and Alternator Belt	45-7
Check Fuses	45-8
Bleed the Fuel System	45-8
Troubleshooting	
General Troubleshooting Information	50-1
Electrical System Schematic	50-2
Engine Troubleshooting	50-3
Storage	
Engine Storage Guidelines	55-1
Preparing Engine for Long Term Storage	55-1
Removing Engine from Long Term Storage	55-2
Specifications	
General OEM Engine Specifications—2.4 L Engines	60-1
General OEM Engine Specifications—3.0 L Engines	60-2
Engine Power Rating and Speed Specifications	60-3
Engine Crankcase Oil Fill Quantities	60-3
Unified Inch Bolt and Cap Screw Torque Values	60-4
Metric Bolt and Cap Screw Torque Values	60-5
Lubrication and Maintenance Records	
Using Lubrication and Maintenance Records	65-1
Daily (Prestarting) Service	65-1
250 Hour/6 Month Service	65-2
500 Hour/12 Month Service	65-3
2000 Hour/24 Month Service	65-4
Service as Required	65-5
Emission System Warranty	
U.S. EPA Emissions Control Warranty Statement	70-1
Emissions Control System Certification Label	70-2

Record Keeping

POWERTECH™ Medallion

A medallion is located on the rocker arm cover which identifies each engine as a John Deere **POWERTECH™** engine.



POWERTECH is a trademark of Deere & Company.

RG41183.000022 -19-10DEC02-1/1

Engine Serial Number Plate

Each engine has a 13-digit John Deere engine serial number. The first two digits identify the factory that produced the engine.

- "PE" indicates the engine was built in Torreon, Mexico

Your engine's serial number plate (A) is located on the left-hand side of cylinder block behind the starter motor.

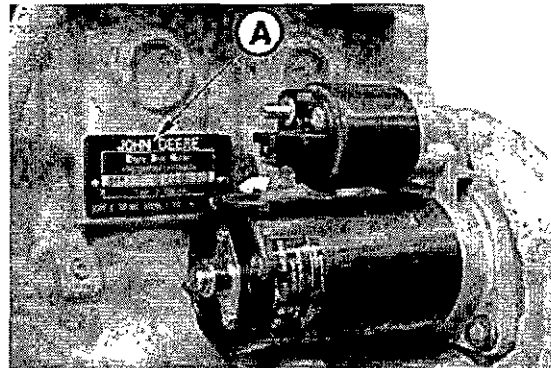

13-Digit Engine Serial Number Plate

RG41183.000025 -19-11DEC02-1/1

Record Engine Serial Number

Record all of the numbers and letters found on your engine serial number plate in the spaces provided below.

This information is very important for repair parts or warranty information.

Engine Serial Number (B)

Engine Model Number (C)

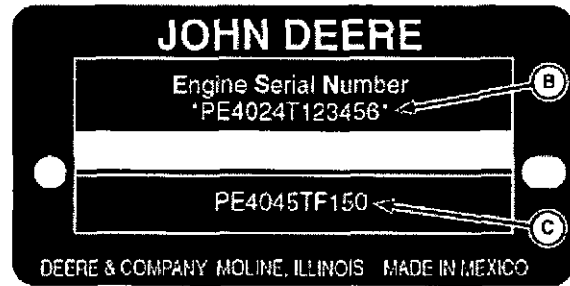

Engine Serial Plate

RG12668 -UN-21JAN03

RG41183,000D026 -19-11DEC02-1/1

Engine Option Codes

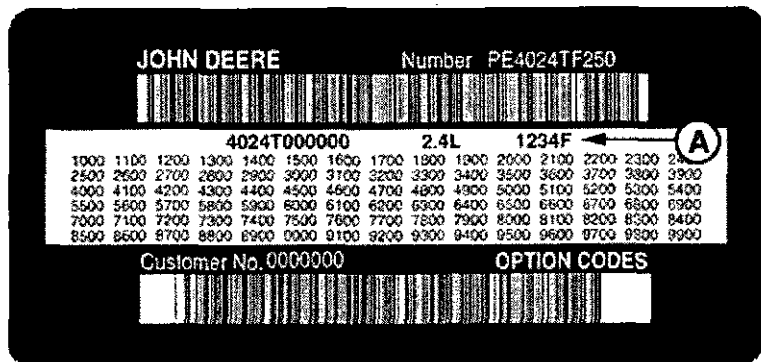

Engine Option Codes

In addition to the serial number plate, OEM engines have an engine option code label affixed to the rocker arm cover. These codes indicate which of the engine options were installed on your engine at the factory. When in need of parts or service, furnish your authorized servicing dealer or engine distributor with these numbers.

The engine option code label includes an engine base code (A). This base code must also be recorded along with the option codes.

The first two digits of each code identify a specific group, such as alternators. The last two digits of each code identify one specific option provided on your engine, such as a 12-volt, 70-amp alternator.

NOTE: These option codes are based on the latest information available at the time of publication. The right is reserved to make changes at any time without notice.

If an engine is ordered without a particular component, the last two digits of that functional group option code will be 99, 00, or XX. The list on the next page shows only the first two digits of the code numbers. For future reference such as ordering repair parts, it is important to have these code numbers available. To ensure this availability, enter the third and fourth digits shown on your engine option code label in the spaces provided on the following page.

Record Keeping

NOTE: Your engine option code label may not contain all option codes if an option has been added after the engine left the producing factory.

If option code label is lost or destroyed, consult your servicing dealer or engine distributor selling the engine for a replacement.

An additional option code label may also be delivered with the engine. Place this sticker or tag, for reference, either on this page or in the engine owner's warranty booklet under **OPTION CODES** title.

Option Codes	Description	Option Codes	Description
11	Rocker Arm Cover	46	Cylinder Block and Camshaft
12	Oil Filler	47	Crankshaft and Bearings
13	Crankshaft Pulley	48	Connecting Rods and Pistons
14	Flywheel Housing	49	Valve Actuating Mechanism
15	Flywheel	50	Oil Pump
16	Fuel Injection System	51	Cylinder Head With Valves
17	Air Inlet	52	Auxiliary Gear Drive
18	Air Cleaner	55	Shipping Stand
19	Oil Pan	56	Paint Option
20	Coolant Pump	57	Coolant Pump Inlet
21	Thermostat Cover	59	Oil Cooler
22	Thermostat	60	Alternator Fan Drive Pulley
23	Fan Drive	62	Alternator Mounting
24	Fan Belt	64	Exhaust Elbow
25	Fan	65	Turbocharger
26	Engine Coolant Heater	66	Coolant Temperature Switch
27	Radiator	67	Speed Sensor
28	Exhaust Manifold	68	Crankshaft Rear Damper
29	Crankcase Vent System	69	Engine Serial Number Plate
30	Starter Motor	74	Air Conditioning (Freon) Compressor
31	Alternator	75	Air Restriction Indicator
32	Instrument Panel	76	Oil Pressure Switch
33	Tachometer	78	Air Compressor
35	Fuel Filter	86	Fan Pulley
36	Front Plate	87	Belt Tensioner
37	Fuel Transfer Pump	88	Oil Filter
39	Thermostat Housing	92	Test Certificate
40	Oil Dipstick	95	Special Equipment (Factory Installed)
43	Starting Aids	97	Special Equipment (Field Installed)
44	Timing Gear Cover	98	Lift Straps for Engine
45	Balancer Shafts	99	Service Only Parts and Kits

Engine Base Code

RG41183.0000027 -19-11DEC02-2/2

Safety

Recognize Safety Information

This is a safety-alert symbol. When you see this symbol on your machine or in this manual, be alert to the potential for personal injury.

Follow recommended precautions and safe operating practices.

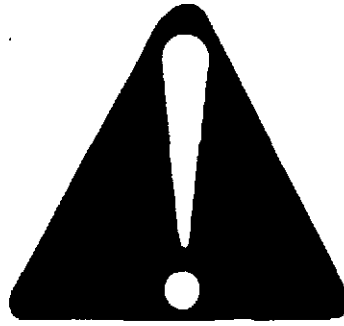

T81389 -19-07DEC88

DX.ALERT -19-28SEP98-1/1

Understand Signal Words

A signal word—DANGER, WARNING, or CAUTION—is used with the safety-alert symbol. DANGER identifies the most serious hazards.

DANGER or WARNING safety signs are located near specific hazards. General precautions are listed on CAUTION safety signs. CAUTION also calls attention to safety messages in this manual.



▲ WARNING

▲ CAUTION

TS187 -19-30SEP88

DX.SIGNAL -19-03MAR93-1/1

Follow Safety Instructions

Carefully read all safety messages in this manual and on your machine safety signs. Keep safety signs in good condition. Replace missing or damaged safety signs. Be sure new equipment components and repair parts include the current safety signs. Replacement safety signs are available from your John Deere dealer.

Learn how to operate the machine and how to use controls properly. Do not let anyone operate without instruction.

Keep your machine in proper working condition. Unauthorized modifications to the machine may impair the function and/or safety and affect machine life.

If you do not understand any part of this manual and need assistance, contact your John Deere dealer.

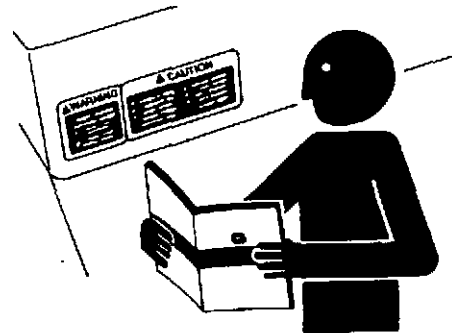

TS201 -19-23AUG88

DX.READ -19-03MAR93-1/1

Replace Safety Signs

Replace missing or damaged safety signs. See the machine operator's manual for correct safety sign placement.

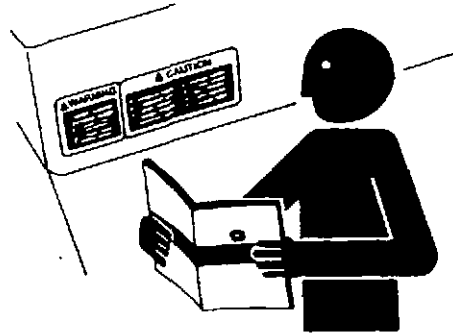

TS201 -UN-23AUG88

DX,SIGNS1 -19-04JUN90-1/1

Prevent Bypass Starting

Avoid possible injury or death from engine runaway.

Do not start engine by shorting across starter terminal. Engine will start with PTO engaged if normal circuitry is bypassed.

Start engine only from operator's station with PTO disengaged or in neutral.

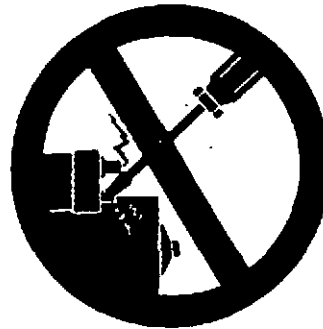

RG5419 -UN-28FEB88

RG,RG34710,7508 -19-30JUN97-1/1

Handle Fuel Safely—Avoid Fires

Handle fuel with care: it is highly flammable. Do not refuel the machine while smoking or when near open flame or sparks.

Always stop engine before refueling machine. Fill fuel tank outdoors.

Prevent fires by keeping machine clean of accumulated trash, grease, and debris. Always clean up spilled fuel.



TS202 -UN-23AUG88

DX,FIRE1 -19-03MAR93-1/1

Prepare for Emergencies

Be prepared if a fire starts.

Keep a first aid kit and fire extinguisher handy.

Keep emergency numbers for doctors, ambulance service, hospital, and fire department near your telephone.

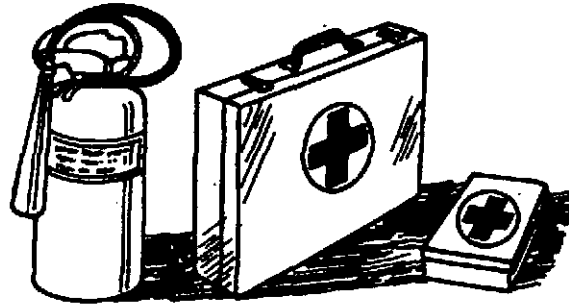

TS291 -JUN-23AUG88

DX,FIRE2 -19-03MAR93-1/1

Handle Fluids Safely—Avoid Fires

When you work around fuel, do not smoke or work near heaters or other fire hazards.

Store flammable fluids away from fire hazards. Do not incinerate or puncture pressurized containers.

Make sure engine is clean of trash, grease; and debris.

Do not store oily rags; they can ignite and burn spontaneously.



TS227 -JUN-23AUG88

DX,FLAME -19-29SEP98-1/1

DO NOT USE Starting Fluids

DO NOT USE ether starting fluids with these glow plug - equipped engines as it could cause an extreme explosion with possible personal injury.

RG41183,0000085 -19-07FEB03-1/1

Service Engines Safely

Tie long hair behind your head. Do not wear a necktie, scarf, loose clothing, or necklace when you work near engine tools or moving parts. If these items were to get caught, severe injury could result.

Remove rings and other jewelry to prevent electrical shorts and entanglement in moving parts.

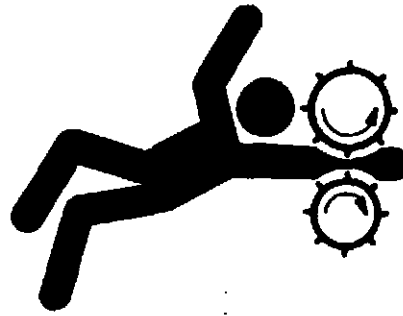

TS228 -UN-23AUG88

DX,LOOSE -19-04JUN90-1/1

Wear Protective Clothing

Wear close fitting clothing and safety equipment appropriate to the job.

Prolonged exposure to loud noise can cause impairment or loss of hearing.

Wear a suitable hearing protective device such as earmuffs or earplugs to protect against objectionable or uncomfortable loud noises.

Operating equipment safely requires the full attention of the operator. Do not wear radio or music headphones while operating machine.

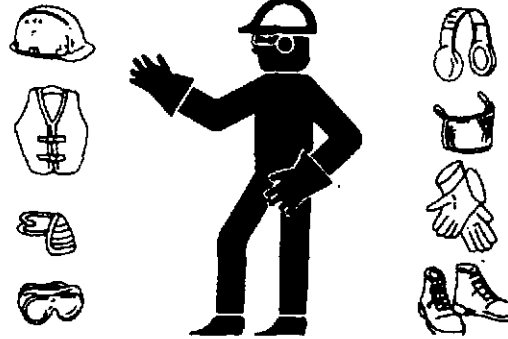

TS206 -UN-23AUG88

DX,WEAR -19-10SEP90-1/1

Protect Against Noise

Prolonged exposure to loud noise can cause impairment or loss of hearing.

Wear a suitable hearing protective device such as earmuffs or earplugs to protect against objectionable or uncomfortable loud noises.



TS207 -UN-23AUG88

DX,NOISE -19-03MAR93-1/1

Handle Chemical Products Safely

Direct exposure to hazardous chemicals can cause serious injury. Potentially hazardous chemicals used with John Deere equipment include such items as lubricants, coolants, paints, and adhesives.

A Material Safety Data Sheet (MSDS) provides specific details on chemical products: physical and health hazards, safety procedures, and emergency response techniques.

Check the MSDS before you start any job using a hazardous chemical. That way you will know exactly what the risks are and how to do the job safely. Then follow procedures and recommended equipment.

(See your John Deere dealer for MSDS's on chemical products used with John Deere equipment.)

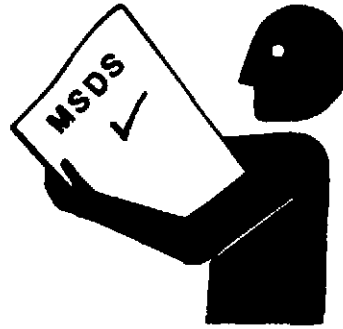

TS1132 -JUN-26NOV90

DX,MSDS,NA -19-03MAR93-1/1

Stay Clear of Rotating Drivelines

Entanglement in rotating driveline can cause serious injury or death.

Keep master shield and driveline shields in place at all times. Make sure rotating shields turn freely.

Wear close fitting clothing. Stop the engine and be sure PTO driveline is stopped before making adjustments, connections, or cleaning out PTO driven equipment.



TS1644 -JUN-22AUG85

DX,PTO -19-12SEP95-1/1

Practice Safe Maintenance

Understand service procedure before doing work. Keep area clean and dry.

Never lubricate, service, or adjust machine while it is moving. Keep hands, feet, and clothing from power-driven parts. Disengage all power and operate controls to relieve pressure. Lower equipment to the ground. Stop the engine. Remove the key. Allow machine to cool.

Securely support any machine elements that must be raised for service work.

Keep all parts in good condition and properly installed. Fix damage immediately. Replace worn or broken parts. Remove any buildup of grease, oil, or debris.

On self-propelled equipment, disconnect battery ground cable (-) before making adjustments on electrical systems or welding on machine.

On towed implements, disconnect wiring harnesses from tractor before servicing electrical system components or welding on machine.



TS218 -UN-23AUG88

DX.SERV -19-17FEB99-1/1

Work In Ventilated Area

Engine exhaust fumes can cause sickness or death. If it is necessary to run an engine in an enclosed area, remove the exhaust fumes from the area with an exhaust pipe extension.

If you do not have an exhaust pipe extension, open the doors and get outside air into the area

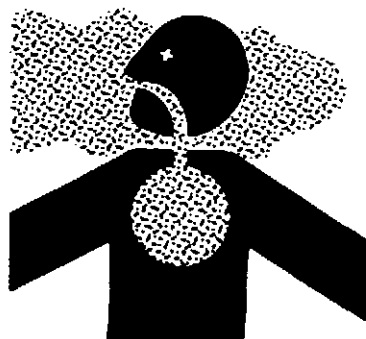

TS220 -UN-23AUG88

DX.AIR -19-17FEB99-1/1

Avoid High-Pressure Fluids

Escaping fluid under pressure can penetrate the skin causing serious injury.

Avoid the hazard by relieving pressure before disconnecting hydraulic or other lines. Tighten all connections before applying pressure.

Search for leaks with a piece of cardboard. Protect hands and body from high pressure fluids.

If an accident occurs, see a doctor immediately. Any fluid injected into the skin must be surgically removed within a few hours or gangrene may result. Doctors unfamiliar with this type of injury should reference a knowledgeable medical source. Such information is available from Deere & Company Medical Department in Moline, Illinois, U.S.A.

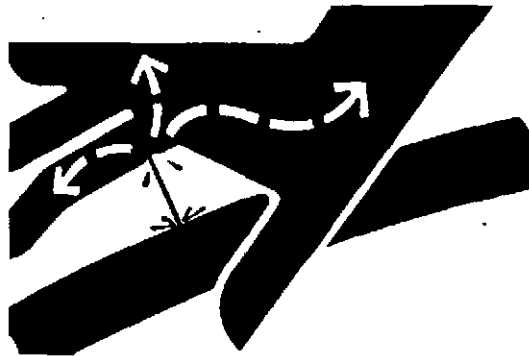

X9811 -JUN-23AUG88

DX,FLUID -19-03MAR93-1/1

Avoid Heating Near Pressurized Fluid Lines

Flammable spray can be generated by heating near pressurized fluid lines, resulting in severe burns to yourself and bystanders. Do not heat by welding, soldering, or using a torch near pressurized fluid lines or other flammable materials. Pressurized lines can be accidentally cut when heat goes beyond the immediate flame area.



TS953 -JUN-15MAY90

DX,TORCH -19-03MAR93-1/1

Remove Paint Before Welding or Heating

Avoid potentially toxic fumes and dust.

Hazardous fumes can be generated when paint is heated by welding, soldering, or using a torch.

Remove paint before heating:

- Remove paint a minimum of 76 mm (3 in.) from area to be affected by heating.
- If you sand or grind paint, avoid breathing the dust. Wear an approved respirator.
- If you use solvent or paint stripper, remove stripper with soap and water before welding. Remove solvent or paint stripper containers and other flammable material from area. Allow fumes to disperse at least 15 minutes before welding or heating.

Do not use a chlorinated solvent in areas where welding will take place.

Do all work in an area that is well ventilated to carry toxic fumes and dust away.

Dispose of paint and solvent properly.

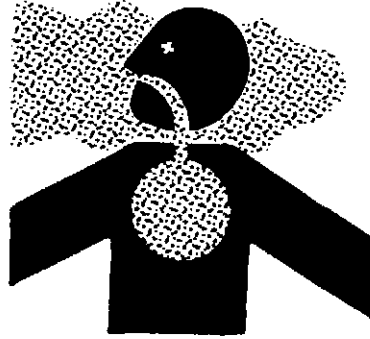

TS220 -UN-23AUG88

DX.PAINT -19-19JUL01-1/1

Install Fan Guards

Rotating cooling system fans can cause serious injury.

Keep fan guards in place at all times during engine operation. Wear close fitting clothes. Stop the engine and be sure fan is stopped before making adjustments or connections, or cleaning near the front of the engine.

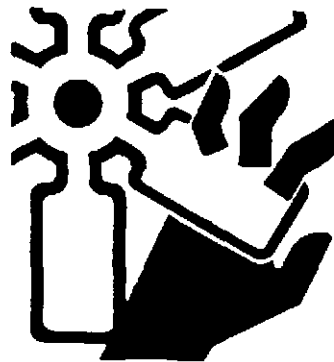

Rotating Fan

TS677 -UN-21SEP89

QUOD006,000009D -19-04DEC02-1/1

Avoid Hot Parts

Avoid skin contact with exhaust manifolds, turbochargers and mufflers. Keep flammable materials clear of the turbocharger.

External dry exhaust parts become very hot during operation. Turbochargers may reach temperatures as high as 500°C (932°F) under full load, and naturally aspired exhaust manifolds may reach 600°C (1112°F) under full load. This may ignite paper, cloth or wooden materials. Parts on engines that have been at full load and reduced to no load idle will maintain approximately 150°C (302°F).



Hot Surface

TS271 -JUN-23AUG88

OUOD006,000008E -19-04DEC02-1/1

Service Cooling System Safely

Explosive release of fluids from pressurized cooling system can cause serious burns.

Shut off engine. Only remove filler cap when cool enough to touch with bare hands. Slowly loosen cap to first stop to relieve pressure before removing completely.

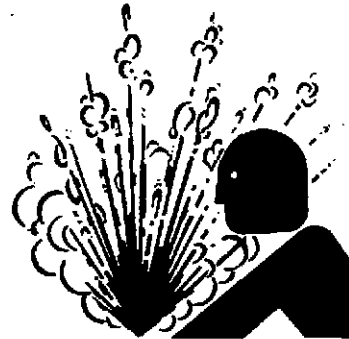

TS281 -JUN-23AUG88

DX,RCAP -19-04JUN90-1/1

Avoid Harmful Asbestos Dust

Avoid breathing dust that may be generated when handling components containing asbestos fibers. Inhaled asbestos fibers may cause lung cancer.

Components in products that may contain asbestos fibers are brake pads, brake band and lining assemblies, clutch plates, and some gaskets. The asbestos used in these components is usually found in a resin or sealed in some way. Normal handling is not hazardous as long as airborne dust containing asbestos is not generated.

Avoid creating dust. Never use compressed air for cleaning. Avoid brushing or grinding material containing asbestos. When servicing, wear an approved respirator. A special vacuum cleaner is recommended to clean asbestos. If not available, apply a mist of oil or water on the material containing asbestos.

Keep bystanders away from the area.

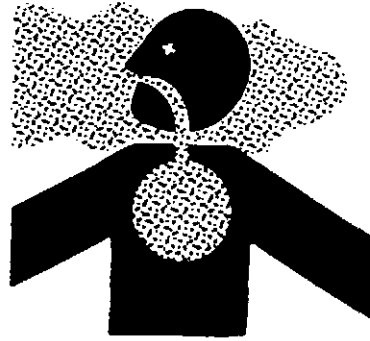

TS220 -UN-23AUG88

DX,DUST -19-15MAR91-1/1

Prevent Battery Explosions

Keep sparks, lighted matches, and open flame away from the top of battery. Battery gas can explode.

Never check battery charge by placing a metal object across the posts. Use a volt-meter or hydrometer.

Do not charge a frozen battery; it may explode. Warm battery to 16°C (60°F).

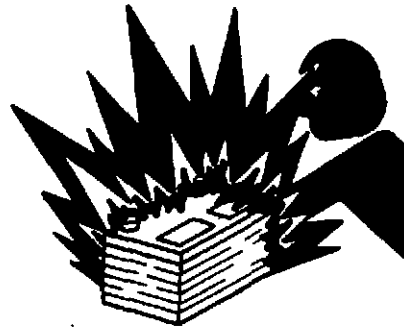

TS204 -UN-23AUG88

DX,SPARKS -19-03MAR93-1/1

Prevent Acid Burns

Sulfuric acid in battery electrolyte is poisonous. It is strong enough to burn skin, eat holes in clothing, and cause blindness if splashed into eyes.

Avoid the hazard by:

1. Filling batteries in a well-ventilated area.
2. Wearing eye protection and rubber gloves.
3. Avoiding breathing fumes when electrolyte is added.
4. Avoiding spilling or dripping electrolyte.
5. Use proper jump start procedure.

If you spill acid on yourself:

1. Flush your skin with water.
2. Apply baking soda or lime to help neutralize the acid.
3. Flush your eyes with water for 15—30 minutes. Get medical attention immediately.

If acid is swallowed:

1. Do not induce vomiting.
2. Drink large amounts of water or milk, but do not exceed 2 L (2 quarts).
3. Get medical attention immediately.

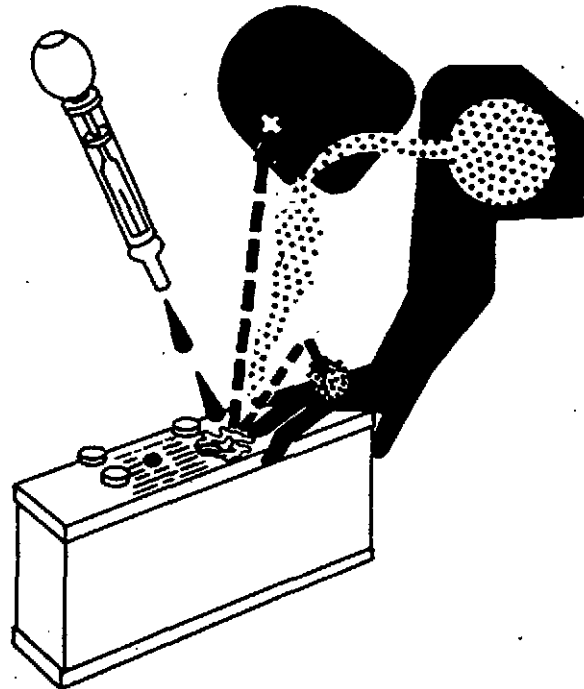

TS203 -JUN-23AUG88

DX,POISON -19-21APR93-1/1

Protect Against High Pressure Spray

Spray from high pressure nozzles can penetrate the skin and cause serious injury. Keep spray from contacting hands or body.

If an accident occurs, see a doctor immediately. Any high pressure spray injected into the skin must be surgically removed within a few hours or gangrene may result. Doctors unfamiliar with this type of injury should reference a knowledgeable medical source. Such information is available from Deere & Company Medical Department in Moline, Illinois, U.S.A.



TS1343 -JUN-18MAR92

DX,SPRAY -19-16APR92-1/1

Dispose of Waste Properly

Improperly disposing of waste can threaten the environment and ecology. Potentially harmful waste used with John Deere equipment include such items as oil, fuel, coolant, brake fluid, filters, and batteries.

Use leakproof containers when draining fluids. Do not use food or beverage containers that may mislead someone into drinking from them.

Do not pour waste onto the ground, down a drain, or into any water source.

Air conditioning refrigerants escaping into the air can damage the Earth's atmosphere. Government regulations may require a certified air conditioning service center to recover and recycle used air conditioning refrigerants.

Inquire on the proper way to recycle or dispose of waste from your local environmental or recycling center, or from your John Deere dealer.

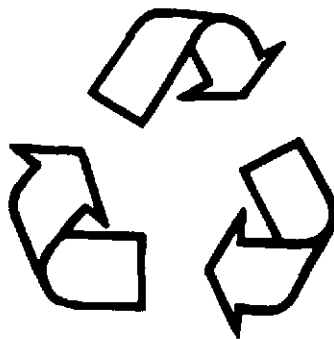

TS11133 -JUN-26NOV90

DX,DRAIN -19-03MAR93-1/1

Live With Safety

Before returning machine to customer, make sure machine is functioning properly, especially the safety systems. Install all guards and shields.



TS231 -19-07OCT88

DX,LIVE -19-25SEP92-1/1

Fuels, Lubricants, and Coolant

Diesel Fuel

Consult your local fuel distributor for properties of the diesel fuel available in your area.

In general, diesel fuels are blended to satisfy the low temperature requirements of the geographical area in which they are marketed.

Diesel fuels specified to EN 590 or ASTM D975 are recommended.

Required fuel properties

In all cases, the fuel must meet the following properties:

Cetane number of 45 minimum. Cetane number greater than 50 is preferred, especially for temperatures below -20°C (-4°F) or elevations above 1500 m (5000 ft).

Cold Filter Plugging Point (CFPP) below the expected low temperature OR **Cloud Point** at least 5°C (9°F) below the expected low temperature.

Fuel lubricity should pass a minimum load level of 3100 grams as measured by ASTM D6078 or, maximum scar diameter of 0.45 mm as measured by ASTM D6079.

Sulfur content:

- Diesel fuel quality and fuel sulfur content must comply with all existing regulations for the area in which the engine operates.
- Sulfur content less than 0.05% (500 ppm) is preferred.
- If diesel fuel with sulfur content greater than 0.05% (500 ppm) is used, crankcase oil service intervals may be affected. (See recommendation for Diesel Engine Oil.)
- DO NOT use diesel fuel with sulfur content greater than 1.0%.

IMPORTANT: DO NOT mix used engine oil or any other type of lubricating oil with diesel fuel.

OUQD002,0000171 -19-18DEC01-1/1

Lubricity of Diesel Fuel

Diesel fuel must have adequate lubricity to ensure proper operation and durability of fuel injection system components.

Diesel fuels for highway use in the United States and Canada require sulfur content less than 0.05% (500 ppm).

Diesel fuel in the European Union requires sulfur content less than 0.05% (500 ppm).

Experience shows that some low sulfur diesel fuels may have inadequate lubricity and their use may reduce performance in fuel injection systems due to inadequate lubrication of injection pump components. The lower concentration of aromatic compounds in these fuels also adversely affects injection pump seals and may result in leaks.

Use of low lubricity diesel fuels may also cause accelerated wear, injection nozzle erosion or corrosion, engine speed instability, hard starting, low power, and engine smoke.

Fuel lubricity should pass a minimum load level of 3100 gram as measured by the ASTM D6078 or maximum scar diameter of 0.45 mm as measured by ASTM D6079.

ASTM D975 and EN 590 specifications do not require fuels to pass a fuel lubricity test.

If fuel of low or unknown lubricity is used, add John Deere PREMIUM DIESEL FUEL CONDITIONER (or equivalent) at the specified concentration.

OUQD002,0000179 -19-18DEC01-1/1

Diesel Fuel Storage



CAUTION: Handle fuel carefully. Do not fill the fuel tank when engine is running.

DO NOT smoke while you fill the fuel tank or service the fuel system.

Fill the fuel tank at the end of each day's operation to prevent water condensation and freezing during cold weather.

IMPORTANT: **DO NOT** store diesel fuel in galvanized containers. Diesel fuel stored in galvanized containers reacts with zinc coating on container to form zinc flakes. If fuel contains water, a zinc gel will also form. The gel and flakes will quickly plug fuel filters, damage injection nozzles and injection pump.

DO NOT use brass-coated containers for fuel storage. Brass is an alloy of copper and zinc.

Store diesel fuel in plastic, aluminum, and steel containers specially coated for diesel fuel storage.

Avoid storing fuel over long periods of time. If fuel is stored for more than a month prior to use, or there is a slow turnover in fuel tank or supply tank, add a fuel conditioner such as John Deere **PREMIUM DIESEL FUEL CONDITIONER** or equivalent to stabilize the fuel and prevent water condensation. John Deere **PREMIUM DIESEL FUEL CONDITIONER** is available in winter and summer formulas. Fuel conditioner also reduces fuel gelling and controls wax separation during cold weather.

IMPORTANT: The fuel tank is vented through the filler cap. If a new filler cap is required, always replace with an original vented cap.

RG, RG34710, 7526 -19-18DEC01-1/1

Bio-Diesel Fuel

Consult your local fuel distributor for properties of the bio-diesel fuel available in your area.

Bio-diesel fuels may be used **ONLY** if the bio-diesel fuel properties meet the latest edition of ASTM D6751, DIN 51606, EN14214 or equivalent specification.

It has been found that bio-diesel blends up to 5% by volume in petroleum diesel fuel (or B5) may improve lubricity and with no harmful effects.

When using a blend of bio-diesel fuel, the engine oil level must be checked daily when the air temperature is -10°C (14°F) or lower. If the oil becomes diluted with fuel, shorten oil change intervals accordingly.

IMPORTANT: Raw pressed vegetable oils are NOT acceptable for use for fuel in any concentration in John Deere engines.

These oils do not burn completely, and will cause engine failure by leaving deposits on injectors and in the combustion chamber.

A major environmental benefit of bio-diesel fuel is its ability to biodegrade. This makes proper storage and handling of bio-diesel fuel especially important. Areas of concern include:

- Quality of new fuel
- Water content of the fuel
- Problems due to aging of the fuel

Potential problems resulting from deficiencies in the above areas when using bio-diesel fuel in concentrations above 5% may lead to the following symptoms:

- Power loss and deterioration of performance
- Fuel leakage
- Corrosion of fuel injection equipment
- Coked and/or blocked injector nozzles, resulting in engine misfire
- Filter plugging
- Lacquering and/or seizure of internal components
- Sludge and sediments
- Reduced service life of engine components

RG41183,0000046 -19-18DEC01-1/1

Handling And Storing Bio-Diesel Fuel

 **CAUTION:** Handle fuel carefully. Do not fill the fuel tank when engine is running.

DO NOT smoke while you fill the fuel tank or service the fuel system.

Fill the fuel tank at the end of each day's operation to prevent water condensation and freezing during cold weather.

Keep all storage tanks as full as practicable to minimize condensation.

Ensure that all fuel tank caps and covers are installed properly to prevent moisture from entering.

Monitor water content of the fuel regularly.

Fuel filter may require more frequent replacement due to premature plugging.

Check engine oil level daily prior to starting engine. A rising oil level may indicate fuel dilution of the engine oil.

IMPORTANT: The fuel tank is vented through the filler cap. If a new filler cap is required, always replace it with an original vented cap.

When fuel is stored for an extended period or if there is a slow turnover of fuel, add a fuel conditioner to stabilize the fuel and prevent water condensation. Contact your fuel supplier for recommendations.

OUOD002.0000176 -19-18DEC01-1/1

DIESELSCAN Fuel Analysis

DIESELSCAN™ is a John Deere fuel sampling program to help you monitor the quality of your fuel source. It verifies fuel type, cleanliness, water content, suitability for cold weather operation, and if fuel is within ASTM specifications. Check with your John Deere dealer for availability of DIESELSCAN kits.

DIESELSCAN is a trademark of Deere & Company

DX,FUEL6 -19-06DEC00-1/1

Filling Fuel Tank

CAUTION: Handle fuel carefully. Do not fill the fuel tank when engine is running.

DO NOT smoke while filling fuel tank or servicing fuel system.

IMPORTANT: The fuel tank is vented through the filler cap. If a new filler cap is required, always replace it with an original vented cap.

Fill fuel tank at the end of each day's operation to prevent condensation in tank. As moist air cools, condensation may form and freeze during cold weather.



TSS202 -JUN-23AUG88

RG, RG34710, 7527 -19-30JUN97-1/1

Minimizing the Effect of Cold Weather on Diesel Engines

John Deere diesel engines are designed to operate effectively in cold weather.

However, for effective starting and cold weather operation, a little extra care is necessary. The information below outlines steps that can minimize the effect that cold weather may have on starting and operation of your engine. See your authorized engine distributor or servicing dealer for additional information and local availability of cold weather aids.

Use Grade No. 1-D Fuel

When temperatures fall below 5°C (40°F), Grade No. 1-D fuel is best suited for cold weather operation. Grade No. 1-D fuel has a lower cloud point and a lower pour point.

Cloud point is the temperature at which wax will begin to form in the fuel and this wax causes fuel filters to plug. **Pour point** is the temperature at which fuel begins to thicken and becomes more resistant to flow through fuel pumps and lines.

NOTE: On an average, Grade No. 1-D fuel has a lower BTU (heat content) rating than Grade No. 2-D fuel. When using Grade No. 1-D fuel you may notice a drop in power and fuel efficiency, but should not experience any other engine performance effects. Check the grade of fuel being used before troubleshooting for low power complaints in cold weather operation.

Glow Plug starting Aids

Glow plugs in the cylinder head are standard equipment to aid in cold weather starting at temperatures below 0°C (32°F). (See Cold Weather Starting in section 15).

Coolant Heaters

Engine block heaters (coolant) are an available option to aid cold weather starting.

Seasonal Viscosity Oil and Proper Coolant Concentration

Use seasonal grade viscosity engine oil based on expected air temperature range between oil changes and a proper concentration of low silicate antifreeze as recommended. (See DIESEL ENGINE OIL and ENGINE COOLANT REQUIREMENTS later in this section).

Diesel Fuel Flow Additive

IMPORTANT: Treat fuel when outside temperature drops below 0°C (32°F). For best results, use with untreated fuel. Follow all recommended instructions on label.

Use John Deere Premium Diesel Fuel Conditioner (Winter) or equivalent to treat fuel during the cold weather season. This winter formulation is a combination diesel fuel conditioner and anti-gel additive.

Winterfronts

Use of fabric, cardboard, or solid winterfronts is not recommended with any John Deere engine. Their use can result in excessive engine coolant, oil, and charge air temperatures. This can lead to reduced engine life, loss of power and poor fuel economy. Winterfronts may also put abnormal stress on fan and fan drive components potentially causing premature failures.

If winterfronts are used, they should never totally close off the grill frontal area. Approximately 25% area in the center of the grill should remain open at all times. At no time should the air blockage device be applied directly to the radiator core.

Radiator Shutters

If equipped with a thermostatically controlled radiator shutter system, this system should be regulated in such a way that the shutters are completely open by

the time the coolant reaches 93°C (200°F) to prevent excessive intake manifold temperatures. Manually controlled systems are not recommended.

If air-to-air aftercooling is used, the shutters must be completely open by the time the intake manifold air temperature reaches the maximum allowable temperature out of the charge air cooler.

For more information, see your John Deere engine distributor or servicing dealer.

RG.RG34710,7529 -19-30JUN97-2/2

Diesel Engine Break-In Oil

New engines are filled at the factory with John DeerePLUS-50™ oil. During the break-in period, add John DeerePLUS-50™15W-40 oil as needed to maintain the specified oil level. (Order TY6389.)

Factory-fill John DeerePLUS-50™ oil is suitable for 250-hour drain interval.

PLUS-50 is a trademark of Deere & Company.

RG39774,0000003 -19-16JUN03-1/1

Diesel Engine Oil

Use oil viscosity based on the expected air temperature range during the period between oil changes.

The following oil is preferred:

- John Deere PLUS-50[®]

The following oils are also recommended:

- John Deere TORQ-GARD SUPREME[®]
- Oils meeting ACEA Specification E4/E5

Other oils may be used if they meet one or more of the following:

- API Service Classification CI-4
- API Service Classification CH-4
- ACEA Specification E3

Multi-viscosity diesel engine oils are preferred.

NOTE: DO NOT use break-in oils in these engines.

Diesel fuel quality and sulfur content must comply with all existing emissions regulations for the area in which the engine operates.

If diesel fuel with sulfur content greater than 0.05% (500 ppm) is used, reduce the oil and filter change interval by 100 hours.

If diesel fuel with sulfur content greater than 0.5% (5000 ppm) is used, reduce the service interval by 50%.

Diesel fuel with sulfur content greater than 1.0% (10,000 ppm) is *not recommended*.

Extended service intervals may apply when John Deere preferred engine oils are used. Consult your John Deere dealer for more information.

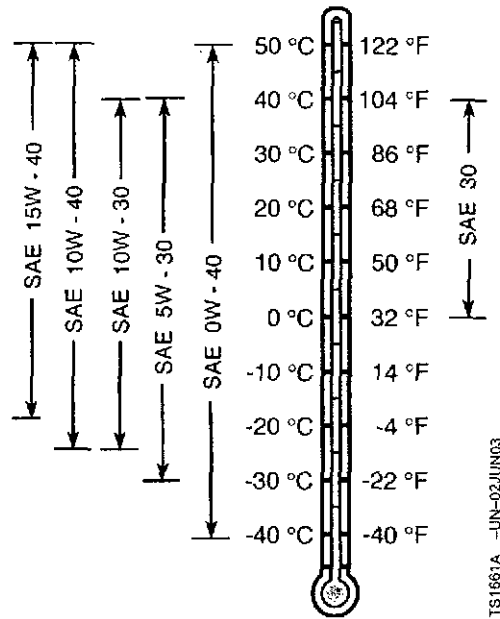

Diesel Engine Oil Viscosity at Various Temperatures

TS1661A -UN-02JUN03

PLUS-50 is a registered trademark of Deere & Company.
TORQ-GARD SUPREME is a trademark of Deere & Company

Extended Diesel Engine Oil Service Intervals

When John Deere PLUS-50[®] or ACEA-E4/E5 oil and the specified John Deere filter are used, the service interval for engine oil and filter changes may be increased by 50% or to every 375 hours..

If other than PLUS-50[®] or ACEA-E4/E5 oil and the specified John Deere filter are used, change the engine oil and filter at the normal service interval.

PLUS-50 is a trademark of Deere & Company

OUOD006,0000069 --19-24SEP02-1/1

Mixing of Lubricants

In general, avoid mixing different brands or types of oil. Oil manufacturers blend additives in their oils to meet certain specifications and performance requirements.

Consult your John Deere engine distributor or servicing dealer to obtain specific information and recommendations.

Mixing different oils can interfere with the proper functioning of these additives and degrade lubricant performance.

DX.LUBMIX --19-18MAR96-1/1

Oil Filters

Filtration of oils is critical to proper operation and lubrication.

Always change filters regularly as specified in this manual.

Use filters meeting John Deere performance specifications.

DX.FILT --19-18MAR96-1/1

OILSCAN® and COOLSCAN™

OILSCAN,[®] OILSCAN PLUS,[®] COOLSCAN™ and, COOLSCAN PLUS™ are John Deere sampling programs to help you monitor machine performance and identify potential problems before they cause serious damage.

Oil and coolant samples should be taken from each system prior to its recommended change interval.

Check with your John Deere engine distributor or servicing dealer for the availability of OILSCAN,[®] OILSCAN PLUS,[®] COOLSCAN™ and, COOLSCAN PLUS™ kits.

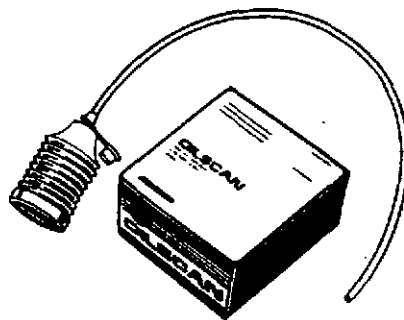

Sampling Programs

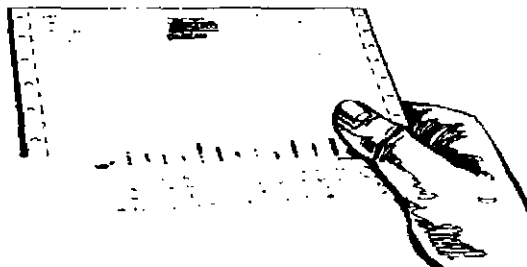

Recommended Change Interval

*OILSCAN is a registered trademark of Deere & Company.
COOLSCAN is a trademark of Deere & Company.
OILSCAN PLUS is a registered trademark of Deere & Company.
COOLSCAN PLUS is a trademark of Deere & Company.*

OUOD902.0000173 -19-23NOV01-1/1

TE629AB -UN-15JUN89

TE629AB -UN-18OCT88

Alternative and Synthetic Lubricants

Conditions in certain geographical areas may require lubricant recommendations different from those printed in this manual.

Some John Deere brand coolants and lubricants may not be available in your location.

Consult your John Deere dealer to obtain information and recommendations.

Synthetic lubricants may be used if they meet the performance requirements as shown in this manual.

The temperature limits and service intervals shown in this manual apply to both conventional and synthetic oils.

Re-refined base stock products may be used if the finished lubricant meets the performance requirements.

DX.ALTER -19-15JUN00-1/1

Lubricant Storage

Your equipment can operate at top efficiency only when clean lubricants are used.

Use clean containers to handle all lubricants.

Whenever possible, store lubricants and containers in an area protected from dust, moisture, and other contamination. Store containers on their side to avoid water and dirt accumulation.

Make certain that all containers are properly marked to identify their contents.

Properly dispose of all old containers and any residual lubricant they may contain.

DX,LUBST -19-18MAR95-1/1

Grease

Use grease based on NLGI consistency numbers and the expected air temperature range during the service interval.

The following greases are preferred:

• John Deere SD POLYUREA GREASE

The following greases are also recommended:

- John Deere HD MOLY GREASE
- John Deere HD LITHIUM COMPLEX GREASE
- John Deere HD WATER RESISTANT GREASE
- John Deere GREASE-GARD

Other greases may be used if they meet the following:

- NLGI Performance Classification GC-LB

IMPORTANT: Some types of grease thickener are not compatible with others. Consult your grease supplier before mixing different types of grease.

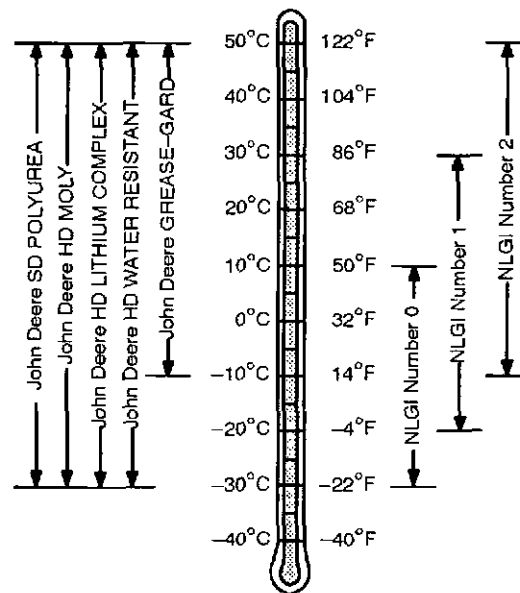

TS1667 -JUN-30JUN99

DX.GREA1 -19-24JAN00-1/1

Diesel Engine Coolant

The engine cooling system is filled to provide year-round protection against corrosion and cylinder liner pitting, and winter freeze protection to -37°C (-34°F).

The following engine coolant is preferred for service:

- John Deere COOL-GARD Prediluted Coolant

The following engine coolant is also recommended:

- John Deere COOL-GARD Coolant Concentrate in a 40 to 60% mixture of concentrate with quality water.

Other low silicate ethylene glycol base coolants may be used if they meet one of the following specifications:

- ASTM D5345 (prediluted coolant)
- ASTM D4985 (coolant concentrate) in a 40 to 60% mixture of concentrate with quality water

Coolants meeting these specifications require use of supplemental coolant additives, formulated for heavy-duty diesel engines, for protection against corrosion and cylinder wall erosion and pitting.

A 50% mixture of ethylene glycol engine coolant in water provides freeze protection to -37°C (-34°F). If

protection at lower temperatures is required, consult your John Deere dealer for recommendations.

Water quality is important to the performance of the cooling system. Distilled, deionized, or demineralized water is recommended for mixing with ethylene glycol base engine coolant concentrate.

IMPORTANT: Do not use cooling system sealing additives or antifreeze that contains sealing additives.

Coolant Drain Intervals

Drain the factory fill engine coolant, flush the cooling system, and refill with new coolant after the first 3 years or 3000 hours of operation. Subsequent drain intervals are determined by the coolant used for service. At each interval, drain the coolant, flush the cooling system, and refill with new coolant.

When John Deere COOL-GARD is used, the drain interval may be extended to 5 years or 5000 hours of operation, provided that the coolant is tested annually AND additives are replenished, as needed, by adding a supplemental coolant additive.

If COOL-GARD is not used, the drain interval is reduced to 2 years or 2000 hours of operation.

DX.COOL3 -19-05FEB99-1/1

Diesel Engine Coolants, Supplemental Additive Information

Engine coolants are a combination of three chemical components: ethylene glycol (antifreeze), inhibiting coolant additives, and quality water.

Coolant Specifications

Some products, including John Deere COOL-GARD Prediluted Coolant, are fully formulated coolants that contain all three components in their correct concentrations. Do not add an initial charge of supplemental coolant additives to these fully formulated products.

Some coolant concentrates, including John Deere COOL-GARD Coolant Concentrate, contain both ethylene glycol antifreeze and inhibiting coolant additives. Mix these products and quality water, but do not add an initial charge of supplemental coolant additives.

Coolants meeting ASTM D5345 (prediluted coolant) or ASTM D4985 (coolant concentrate) require an initial charge of supplemental coolant additives.

Replenish Coolant Additives

The concentration of coolant additives is gradually depleted during engine operation. Periodic replenishment of inhibitors is required, even when John Deere COOL-GARD is used. Follow the recommendations in this manual for the use of supplemental coolant additives.

Why Use Supplemental Coolant Additives?

Operating without proper coolant additives will result in increased corrosion, cylinder wall erosion and pitting, and other damage to the engine and cooling system. A simple mixture of ethylene glycol and water will not give adequate protection.

Use of supplemental coolant additives reduces corrosion, erosion, and pitting. These chemicals reduce the number of vapor bubbles in the coolant and

help form a protective film on cylinder wall surfaces. This film acts as a barrier against the harmful effects of collapsing vapor bubbles.

Avoid Automotive-Type Coolants

Never use automotive-type coolants (such as those meeting ASTM D3306 or ASTM D4656). These coolants do not contain the correct additives to protect heavy-duty diesel engines. They often contain a high concentration of silicates and may damage the engine or cooling system.

Water Quality

Water quality is important to the performance of the cooling system. Distilled, deionized, or demineralized water is recommended for mixing with ethylene glycol base engine coolant concentrate. All water used in the cooling system should meet the following minimum specifications for quality:

Chlorides	<40 mg/L
Sulfates	<100 mg/L
Total Dissolved Solids	<340 mg/L
Total Hardness	<170 mg/L
pH	5.5 to 9.0

Freeze Protection

The relative concentrations of ethylene glycol and water in the engine coolant determine its freeze protection limit.

Ethylene Glycol	Freeze Protection Limit
40%	-24°C (-12°F)
50%	-37°C (-34°F)
60%	-52°C (-62°F)

DO NOT use a coolant-water mixture greater than 60% ethylene glycol.

Testing Diesel Engine Coolant

Maintaining adequate concentrations of glycol and inhibiting additives in the coolant is critical to protect the engine and cooling system against freezing, corrosion, and cylinder wall erosion and pitting.

Test the coolant solution at intervals of 12 month or less and whenever excessive coolant is lost through leaks or overheating.

Coolant Test Strips

Coolant test strips are available from your John Deere dealer. These test strips provide a simple, effective method to check the freeze point and additive levels of your engine coolant.

Compare the results to the supplemental coolant additive (SCA) chart to determine the amount of inhibiting additives in your coolant and whether more John Deere COOLANT CONDITIONER should be added.

COOLSCAN™ and COOLSCAN PLUS™

For a more thorough evaluation of your coolant, perform a COOLSCAN or COOLSCAN PLUS™ analysis. See your John Deere dealer for information.

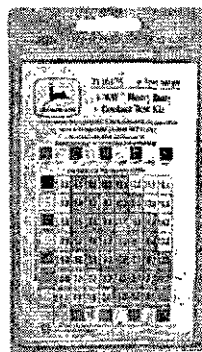

Coolant Test Strips

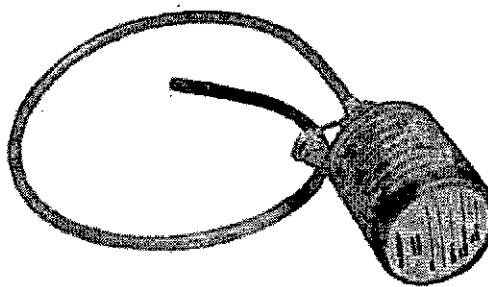

CoolScan Bellows

RG7297 -UN-22SEP98

RG7397 -UN-05DEC97

COOLSCAN is a trademark of Deere & Company
COOLSCAN PLUS is a trademark of Deere & Company.

OUOD002.0008174 -19-18DEC01-1/1

Supplemental Coolant Additives

The concentration of coolant additives is gradually depleted during engine operation. For all recommended coolants, replenish additives between drain intervals by adding a supplemental coolant additive every 12 months or as determined necessary by coolant testing.

John Deere COOLANT CONDITIONER is recommended as a supplemental coolant additive in John Deere engines.

IMPORTANT: Do not add a supplemental coolant additive when the cooling system is drained and refilled with John Deere COOL-GARD.

If other coolants are used, consult the coolant supplier and follow the manufacturer's recommendation for use of supplemental coolant additives.

The use of non-recommended supplemental coolant additives may result in additive drop-out and gelation of the coolant.

Add the manufacturer's recommended concentration of supplemental coolant additive. **DO NOT** add more than the recommended amount.

DX,COOL4 -19-15JUN00-1/1

Operating in Warm Temperature Climates

John Deere engines are designed to operate using glycol base engine coolants.

Always use a recommended glycol base engine coolant, even when operating in geographical areas where freeze protection is not required.

IMPORTANT: Water may be used as coolant in emergency situations only.

Foaming, hot surface aluminum and iron corrosion, scaling, and cavitation will occur when water is used as the coolant, even when coolant conditioners are added.

Drain cooling system and refill with recommended glycol base engine coolant as soon as possible.

DX,COOL6 -19-18MAR96-1/1

Disposing of Coolant

Improperly disposing of engine coolant can threaten the environment and ecology.

Use leakproof containers when draining fluids. Do not use food or beverage containers that may mislead someone into drinking from them.

Do not pour waste onto the ground, down a drain, or into any water source.

Inquire on the proper way to recycle or dispose of waste from your local environmental or recycling center, or from your John Deere engine distributor or servicing dealer.

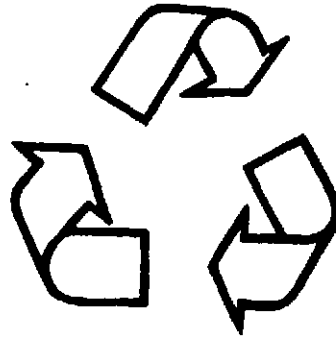

TS1133 -JUN-26NOV90

RG, RG34710, 7543 -19-30JUN97-1/1

Engine Operating Guidelines

Normal Engine Operation

Before starting, fill engine with oil and coolant meeting specifications. (See DIESEL ENGINE OIL and DIESEL ENGINE COOLANT SPECIFICATIONS in Fuels, Lubricants, and Coolant section.)

- Observe engine coolant temperature and engine oil pressure. Temperatures and pressures will vary between engines and with changing operating conditions, temperatures, and loads.
- Normal engine coolant operating temperature range is 90° – 100° C (194° – 212° F). If coolant temperature rises above 105° C (221° F), reduce load on engine. Unless temperature drops quickly, stop engine and determine cause before resuming operation.
- Operate the engine under a lighter load and at slower than normal speed for first 15 minutes after start-up. DO NOT run engine at slow idle.
- Stop engine immediately if there are any signs of part failure. Symptoms that may be early signs of engine problems are:
 - Sudden drop in oil pressure
 - Abnormal coolant temperatures
 - Unusual noise or vibration
 - Sudden loss of power
 - Excessive black exhaust
 - Excessive fuel consumption
 - Excessive oil consumption
 - Fluid leaks

RG41183,000002D -19-16DEC02-1/1

Break-In Service

NOTE: Factory-fill oil is suitable for normal 250-hour drain interval.

Before starting, fill engine with seasonal viscosity grade oil and with coolant meeting specifications. (See DIESEL ENGINE OIL and DIESEL ENGINE COOLANT SPECIFICATIONS in Fuels, Lubricants, and Coolant Section.)

1. During the first 20 hours, avoid prolonged periods of engine idling or sustained maximum load operation. Warm-up engine carefully and operate at normal loads. If engine will idle longer than 5 minutes, stop engine.

IMPORTANT: Do not use break-in oil in this engine.

2. Check oil level daily or every 10 hours during engine break-in period. If oil must be added during this period, use John DeerePLUS-50™oil. (See DIESEL ENGINE OIL in Fuels, Lubricants, and Coolant section.)
3. Watch coolant temperatures (A) closely during break-in period. Also check coolant level daily or every 10 hours and check for leaks.

NOTE: The coolant temperature gauge is an (optional) orderable accessory.

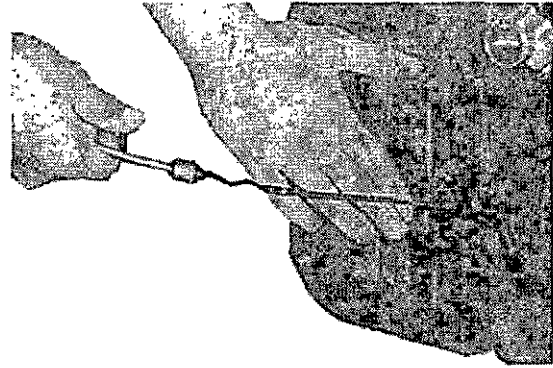

Check Engine Oil Level Daily

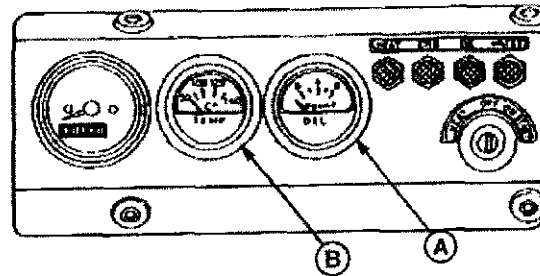

Coolant Temperature Gauge

PLUS-50 is a trademark of Deere & Company.

Continued on next page

RG41183.000002E -19-17JUN03-1/2

4. Check poly-vee belt for proper alignment and seating in pulley grooves.
5. Change oil and filter every 250 hours/6 months. (See CHANGE ENGINE OIL AND FILTER in Lubrication and Maintenance/250 Hour Section.) Fill crankcase with seasonal viscosity grade oil. (See DIESEL ENGINE OIL, in Fuels, Lubricants, and Coolant Section.)

IMPORTANT: DO NOT operate engine when oil level is below ADD mark on dipstick. Check oil level before starting engine for the first time.

A—Oil Filter

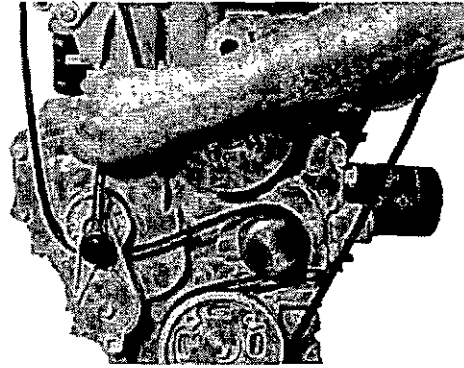

RG12502 -JUN-12DEC02

Automatic Belt Tensioner

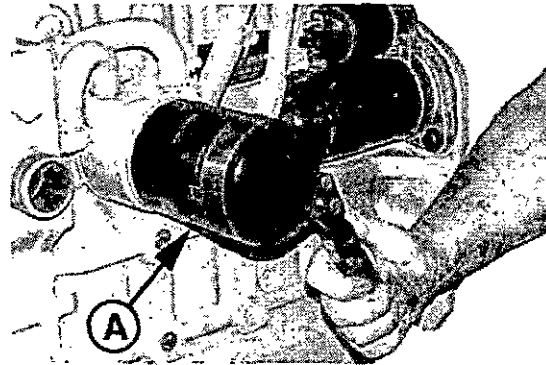

RG12593 -JUN-07FEB03

Engine Oil Filter

RG41183.000002E -19-17JUN03-2/2

Auxiliary Gear Drive Limitations

IMPORTANT: When attaching an air compressor, hydraulic pump, or other accessory to be driven by the auxiliary gear drive (A) (engine timing gear train at front of engine), power requirements of the accessory must be limited to values listed below:

- 30 kW (40 hp) Continuous Operation at 2800 rpm
- 37 kW (50 hp) Intermittent Operation at 2800 rpm

RG41183.0000030 -19-16DEC02-1/1

Starting The Engine

The following instructions apply to the optional controls and instruments available on John Deere Industrial and Generator Power Units only. The controls and instruments for your engine may be different from those shown here. Always follow manufacturer's instructions and familiarize yourself with the correct starting procedure.

CAUTION: Before starting engine in a confined building, install proper outlet exhaust ventilation equipment. Always use safety approved fuel storage and piping.

NOTE: If temperature is below 0° C (32° F), it may be necessary to use cold weather starting aids. (See COLD WEATHER OPERATION, later in this section).

1. Perform all prestarting checks outlined in Lubrication & Maintenance/Daily Section later in this manual.
2. Disengage engine rear driveline (if equipped) or gen set drive.
3. Open the fuel supply shut-off valve, if equipped.
4. Place the speed control lever in the "START" position, if equipped.

IMPORTANT: Do not operate the starter for more than 15 seconds at a time. To do so may overheat the starter. If the engine does not start the first time, wait at least 2 minutes before trying again. If engine does not start after four attempts, see Troubleshooting Section.

5. Turn key switch to "START" position as shown and hold until engine starts. Release key once engine starts; key automatically returns to "ON" position and instrument panel gauges start operating.
6. Warm-up engine for at least 5 minutes before applying a load. (See WARMING-UP ENGINE, later in this section.)

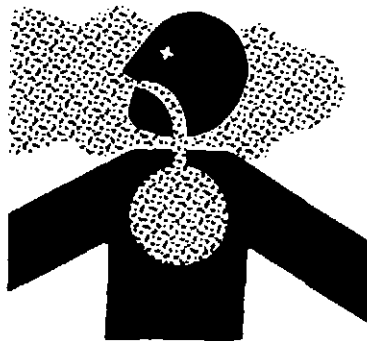

Use Proper Ventilation

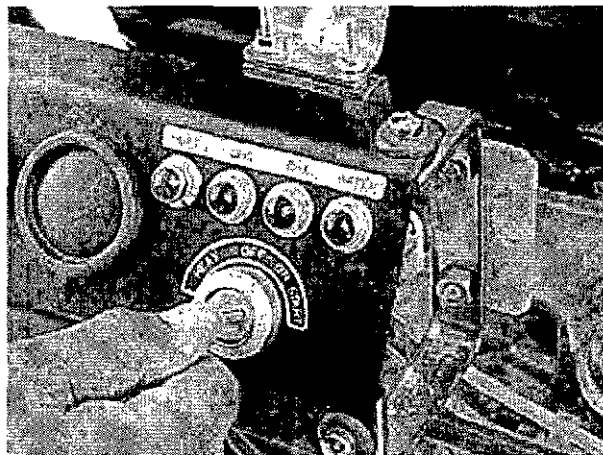

Starting Engine Using Key Switch

TS220 -JUN-23AUG88

RG6660 -JUN-20JAN83

Engine Operating Guidelines

7. Check all gauges for normal operation. If operation is not normal, stop engine immediately and determine cause.

RG41183.0000031 -19-16DEC02-2/2

Cold Weather Starting

When outside temperatures fall below 0°C (32° F) it may be necessary to consider using cold weather starting aids. Engines are equipped with standard glow plugs.

⚠ CAUTION: NEVER USE ETHER as a starting aid with these glow plug-equipped engines as it could cause an explosion and possible personal injury.

Additionally, your POWERTECH™ Engines may be fitted with a block heater, and increased capacity battery and/or lower viscosity oil may also be used. See your local John Deere engine distributor or servicing dealer for recommendations.

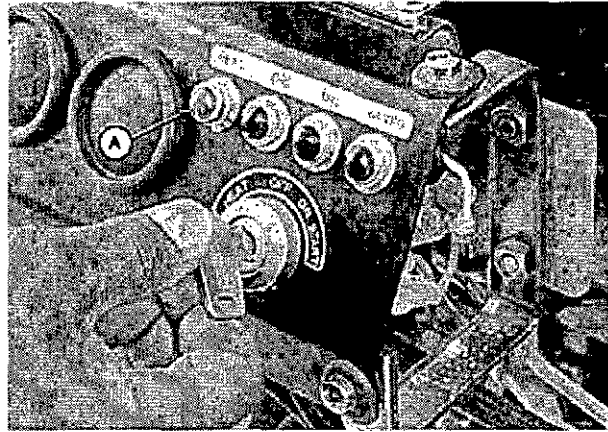

Using Key Switch to Activate Glow Plugs

1. Perform all prestarting checks outlined in Lubrication & Maintenance/Daily Section later in this manual.
2. Disengage engine rear driveline (if equipped) or gen set drive.
3. Open the fuel supply shut-off valve, if equipped.
4. Place the speed control lever in the "START" position, if equipped.
5. Turn key switch to "ON" position and hold at that position for 15 seconds. This activates the glow plugs to warm the combustion chamber.

IMPORTANT: Do not operate the starter for more than 15 seconds at a time. To do so may overheat the starter. If the engine does not start the first time, wait at least 2 minutes before trying again. If engine does not start after four attempts, see Troubleshooting Section.

6. Turn key switch to "START" position and hold until engine starts. Release key once engine starts; key automatically returns to "ON" position and instrument panel gauges start operating.

7. Warm-up engine for at least 5 minutes before applying a load. (See WARMING ENGINE, later in this section.)

RG41163,0000032 -19-16DEC02-2/2

Warming Engine

IMPORTANT: To assure proper lubrication, operate engine at or below 1200 rpm with no load for 1–2 minutes. Extend this period 2–4 minutes when operating at temperatures below freezing.

1. Check oil pressure gauge (A) as soon as engine starts. If gauge needle does not rise above minimum oil pressure specification of 105 kPa (1.05 bar) (15.0 psi) within 5 seconds, stop the engine and determine the cause. Normal engine oil pressure is 345 kPa (3.45 bar) (50 psi) at rated full load speed (1800–2500 rpm) with oil at normal operating temperature of 115° C (240° F). This oil pressure can vary from 35 psi to 65 psi.

NOTE: On certain engines, the oil pressure and coolant temperature gauges are replaced by indicator warning lights. The lights must be "OFF" when engine is running.

2. Watch coolant temperature gauge (B). Do not place engine under full load until it is properly warmed up. The normal engine coolant temperature range is 90°–100° C (194°–212° F).

NOTE: It is a good practice to operate the engine under a lighter load and at lower speeds than normal for the first few minutes after start-up.

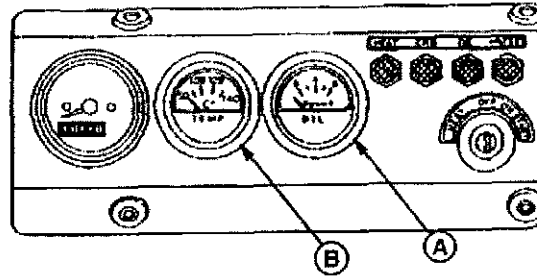

Instrument Panel Gauges

- A—Oil Pressure Gauge
- B—Coolant Temperature Gauge

RG6574 -UN-17FEB03

RG41163,0000033 -19-16DEC02-1/1

Avoid Excessive Engine Idling

Avoid excessive engine idling. Prolonged idling may cause the engine coolant temperature to fall below its normal range. This, in turn, causes crankcase oil dilution, due to incomplete fuel combustion, and permits formation of gummy deposits on valves, pistons, and piston rings. It also promotes rapid accumulation of engine sludge and unburned fuel in the exhaust system.

Once an engine is warmed to normal operating temperatures, engine should be idled at slow idle speed. Slow idle speed for this engine is 900 rpm at factory. If an engine will be idling for more than 5 minutes, stop and restart later.

RG41183.0000034 -19-16DEC02-1/1

Stopping the Engine

IMPORTANT: Stopping the engine immediately when it has been working under load, can result in overheating and accelerated wear of the engine components. **ALWAYS** run the engine at slow idle and no load to allow hot engine parts to cool before shutdown (if possible).

On engines with variable speed governors, remove load from engine and run engine for at least 2 minutes. Run turbocharged engines for 3 to 5 minutes.

On generator set engines with governors locked at a specific speed, remove electrical load from engine (if possible) and run at fast idle and no load for at least 2 minutes.

1. Drop engine speed to slow idle (variable speed governors only).
2. Turn key switch (A) to "OFF" position to stop the engine. After engine stops, close valve on fuel supply to prevent accidental starting.

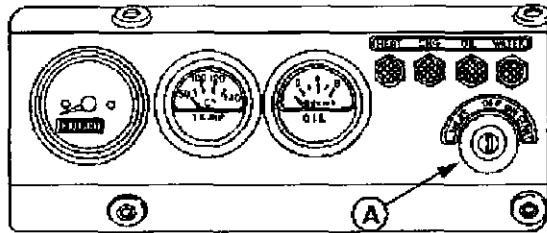

Key Switch on Instrument Panel

RG6574B -JUN-07JAN03

Continued on next page

RG41183.0000035 -19-16DEC02-1/2

IMPORTANT: Make sure that exhaust stack cap (rain cap) is in place when engine is not running. This will prevent water and dirt from entering engine.

3. Fill fuel tank to minimize possible water condensation problems. Filling tanks at end of day drives out moisture-laden air.

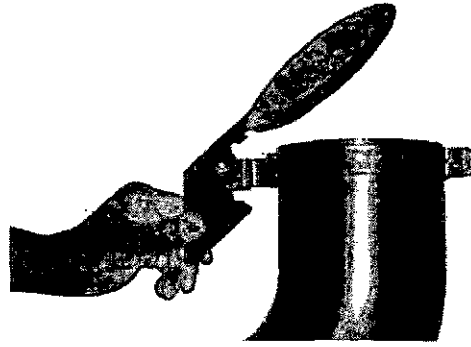

Exhaust Stack Rain Cap

RG10616 -UN-16JUN00

RG41163,0000035 -19-16DEC02-2/2

Using a Booster Battery or Charger

A 12-volt booster battery can be connected in parallel with battery (ies) on the unit to aid in cold weather starting. ALWAYS use heavy duty jumper cables.

CAUTION: Gas given off by battery is explosive. Keep sparks and flames away from battery. Before connecting or disconnecting a battery charger, turn charger off. Make last connection and first disconnection at a point away from battery. Always connect **NEGATIVE (-)** cable last and disconnect this cable first.

WARNING: Battery posts, terminals, and related accessories contain lead and lead compounds, chemicals known to the State of California to cause cancer and reproductive harm. Wash hands after handling.

IMPORTANT: Be sure polarity is correct before making connections. Reversed polarity will damage electrical system. Always connect positive to positive and negative to ground. Always use 12-volt booster battery for 12-volt electrical systems and 24-volt booster battery (ies) for 24-volt electrical systems.

1. Connect booster battery or batteries to produce the required system voltage for your engine application.

NOTE: To avoid sparks, DO NOT allow the free ends of jumper cables to touch the engine.

2. Connect one end of jumper cable to the **POSITIVE (+)** post of the booster battery.

3. Connect the other end of the jumper cable to the **POSITIVE (+)** post of battery connected to starter.

4. Connect one end of the other jumper cable to the **NEGATIVE (-)** post of the booster battery.

5. ALWAYS complete the hookup by making the last connection of the **NEGATIVE (-)** cable to a good ground on the engine frame and away from the battery (ies).

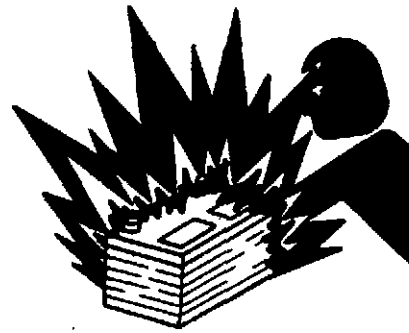

Exploding Battery

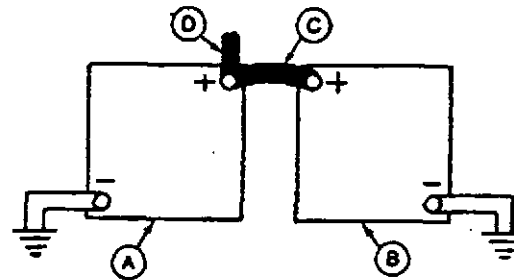

12-Volt System

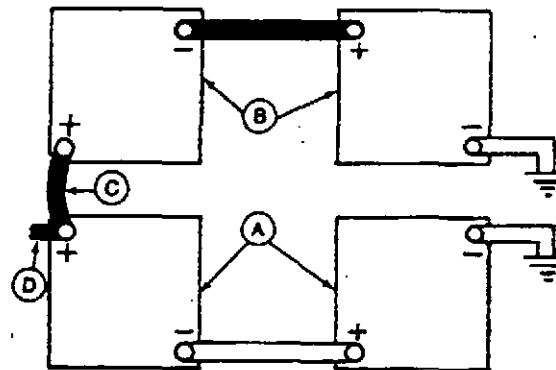

24-Volt System

A—12-Volt Machine Battery (ies)
 B—12-Volt Booster Battery (ies)
 C—Booster Cable
 D—Cable to Starting Motor

TS204 -UN-23AUG88

RG4678 -UN-14DEC88

RG4688 -UN-14DEC88

Engine Operating Guidelines

6. Start the engine. Disconnect jumper cables immediately after engine starts. Disconnect NEGATIVE (-) cable first.

RG.RG34710.5564 -19-20MAY96-2/2

Lubrication and Maintenance

Observe Service Intervals

Using hour meter (A) (if equipped) as guide, perform all services at the hourly intervals indicated on following pages. At each scheduled maintenance interval, perform all previous maintenance operations in addition to the ones specified. Keep a record of hourly intervals and services performed using charts provided in Lubrication and Maintenance Records Section.

IMPORTANT: Recommended service intervals are for normal operating conditions. Service **MORE OFTEN** if engine is operated under adverse conditions. Neglecting maintenance can result in failures or permanent damage to the engine.

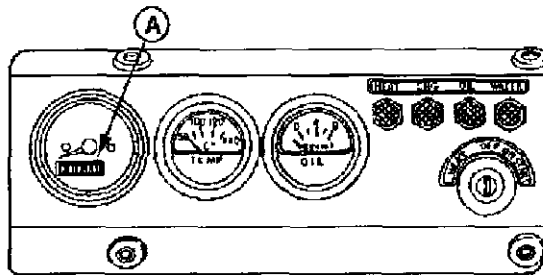

Instrument Panel with Optional Hour Meter

A—Hour Meter

RG6574C -UN-07JAN03

RG41183,0000036 -19-16DEC02-1/1

Use Correct Fuels, Lubricants, and Coolant

IMPORTANT: Use only fuels, lubricants, and coolants meeting specifications outlined in Fuels, Lubricants, and Coolant Section when servicing your John Deere Engine.

Consult your John Deere engine distributor, servicing dealer or your nearest John Deere Parts Network for recommended fuels, lubricants, and coolant. Also available are necessary additives for use when operating engines in tropical, arctic, or any other adverse conditions.



TS100 -UN-23AUG88

DPSG,OUQE003,20 -19-06JAN99-1/1

Lubrication and Maintenance Service Interval Chart—Standard Industrial Engines

NOTE: The service intervals below are for standard industrial engines. See details in Sections which follow these charts.

Item	Lubrication and Maintenance Service Intervals				
	Daily	250 Hour/ 6 Month	500 Hour/ 12 Month	2000 Hour/ 24 Month	As Required
Check Engine Oil and Coolant Level	•				
Check Fuel Filter	•				
Check Air Cleaner Dust Unloader Valve & Indicator ^a	•				
Perform Visual Walkaround Inspection	•				
Service Fire Extinguisher		•			
Change Engine Oil And Replace Oil Filter ^b		•			
Check Engine Mounts		•			
Service Battery		•			
Clean Crankcase Vent Tube			•		
Check Air Intake Hoses, Connections, & System			•		
Check Engine Speeds			•		
Replace Fuel Filter Element			•		
Check Automatic Belt Tensioner and Belt Wear			•		
Check Engine Electrical Ground Connection			•		
Check Cooling System			•		
Coolant Solution Analysis-Add SCAs as required			•		
Pressure Test Cooling System			•		
Check Crankshaft Vibration Damper (If Equipped) ^c				•	
Flush Cooling System ^d				•	
Test Thermostats				•	
Add Coolant					•
Replace Air Cleaner Elements					•
Replace Poly-Vee Belt					•
Check Fuses					•

^aReplace primary air cleaner element when restriction indicator shows a vacuum of 625 mm (25 in.) H₂O.

^bIf PLUS-50 or ACEA - E4/E5 oil is used along with a John Deere oil filter, the oil change interval may be extended by 50 percent to 375 hours.

^cReplace crankshaft damper every 4500 hours or 60 months, whichever occurs first.

^dIf John Deere COOL-GARD is used, the flushing interval may be extended to 3000 hours or 36 months. If John Deere COOL-GARD is used and the coolant is tested annually AND additives are replenished as needed by adding a supplemental coolant additive, the flushing interval may be extended to 5000 hours or 60 months, whichever occurs first.

Lubrication and Maintenance

Item	Lubrication and Maintenance Service Intervals				
	Daily	250 Hour/ 6 Month	500 Hour/ 12 Month	2000 Hour/ 24 Month	As Required
Check Air Compressor (If Equipped)					•
Bleed Fuel System					•

RG41183.0000037 -19-17DEC02-2/2

Lubrication & Maintenance/Daily

Daily Prestarting Checks

Do the following BEFORE STARTING THE ENGINE for the first time each day:

IMPORTANT: DO NOT add makeup oil until the oil level is **BELOW** the "ADD" mark on dipstick. Do not use break-in oil in this engine.

1. Check engine oil level on dipstick. Add as required, using seasonal viscosity grade oil. (See DIESEL ENGINE OIL in Fuels, Lubricants, and Coolant Section for oil specifications.)

Depending on application, oil may be added at left side (A) or rocker arm cover filler cap (C) locations.

After checking oil, hand tighten dipstick used on left-hand oil fillers.

IMPORTANT: DO NOT fill above the top mark on the dipstick. Oil levels anywhere within the crosshatch (D) are considered in the acceptable operating range.

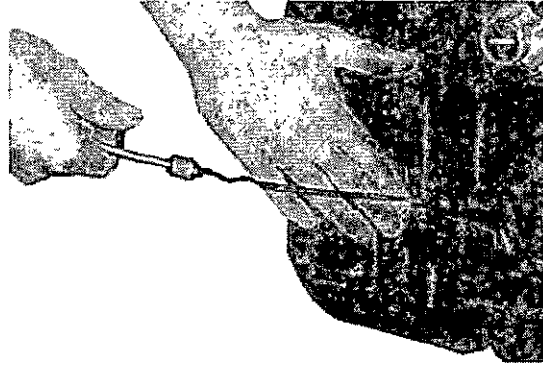

Left Side Oil Dipstick

RG12682 -UN-07FEB03

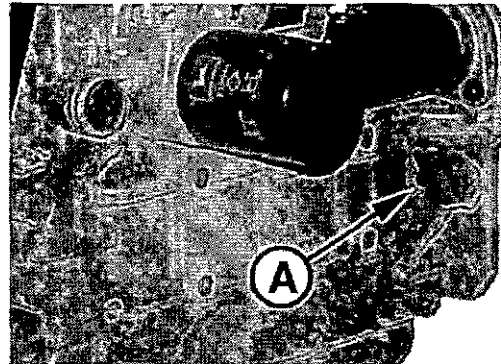

Left Side Oil Filler Cap and Dipstick

RG12779 -UN-07JAN03

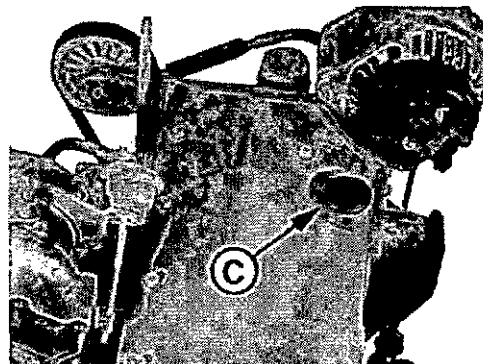

Rocker Arm Cover Filler Cap

RG12781 -UN-17FEB03

RG12780 -UN-07JAN03

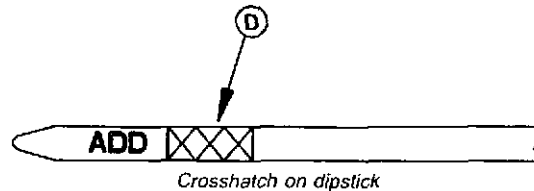

Crosshatch on dipstick

Continued on next page

RG41183,0000039 -19-17DEC02-1/4

⚠ CAUTION: Explosive release of fluids from pressurized cooling system can cause serious burns.

Only remove filler cap when engine is cold or when cool enough to touch with bare hands. Slowly loosen cap to first stop to relieve pressure before removing completely.

2. Check the coolant level when engine is cold. Coolant level should be at bottom of filler neck. Fill radiator (A) with proper coolant solution if level is low. (See ADDING COOLANT in Service As Required Section.) Check overall cooling system for leaks.

NOTE: Refer to your vehicle's operator's manual for recommendations for non-John Deere supplied accessories.

A—Fill Radiator



High-Pressure Fluids

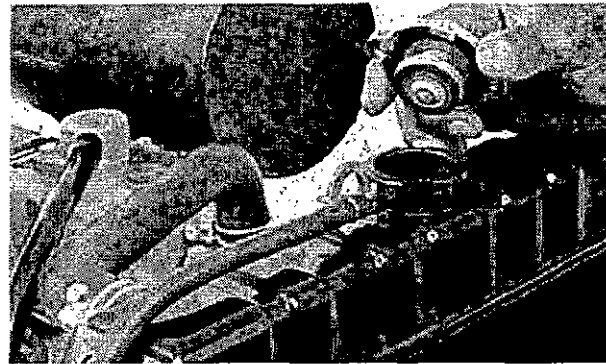

Check Coolant Level in Radiator

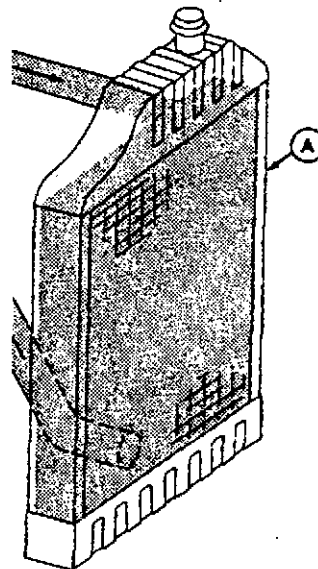

Fill Radiator

RG4675 -UN-14DEC88

TS281 -UN-23AUG88

RG6576 -UN-20JAN93

3. Check the fuel filter for water or debris. If filter is fitted with a see-through bowl, drain as needed based on a daily visual inspection.

IMPORTANT: Drain water into a suitable container and dispose of properly.

- a. Loosen drain plug (B) at bottom of fuel filter or bowl, if equipped, two or three turns.
- b. Loosen air bleed plug (A) two full turns on fuel filter mounting and drain water from bottom until fuel starts to drain out.
- c. When fuel starts to drain out, tighten drain plug securely.

After draining water from the fuel filter, the filter must be primed by bleeding all air from the fuel system.

- a. Operate primer plunger on the fuel filter header (C) until fuel flow is free from air bubbles.
- b. Tighten bleed plug securely, continue operating primer until pumping action is not felt.

If the fuel system needs further bleeding of air, see **BLEEDING FUEL SYSTEM** in Service As Required Section, later in this manual.

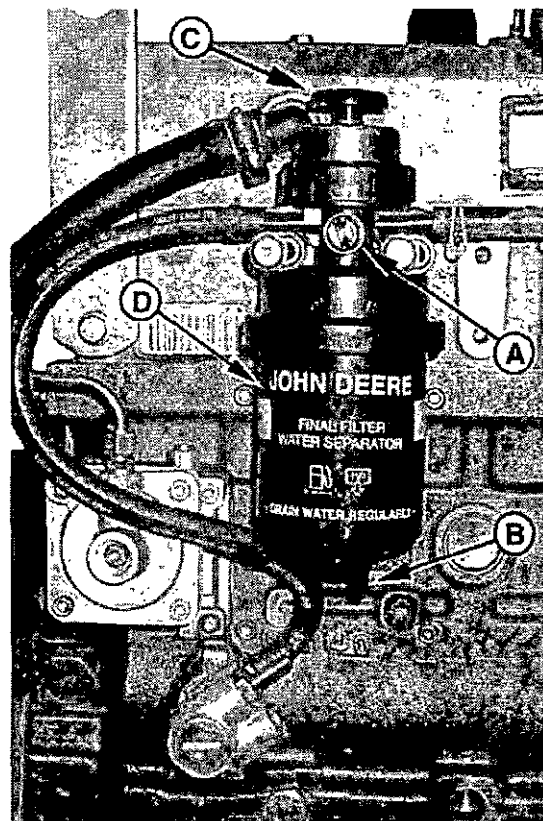

Fuel Transfer Pump and Filter

- A—Air Bleed Plug
- B—Drain Plug
- C—Primer Plunger
- D—Fuel Filter

Continued on next page

RG41183,0000039 -19-17DEC02-3/4

4. If the air cleaner has an automatic dust unloader valve (A), squeeze the unloader valve on air cleaner assembly to clear away any dust buildup.

If equipped with air intake restriction indicator gauge (B), check gauge to determine if air cleaner needs to be serviced.

IMPORTANT: Maximum air intake restriction is 6.25 kPa (0.06 bar) (1.0 psi) (25 in. H₂O). A clogged air cleaner element will cause excessive intake restriction and a reduced air supply to the engine.

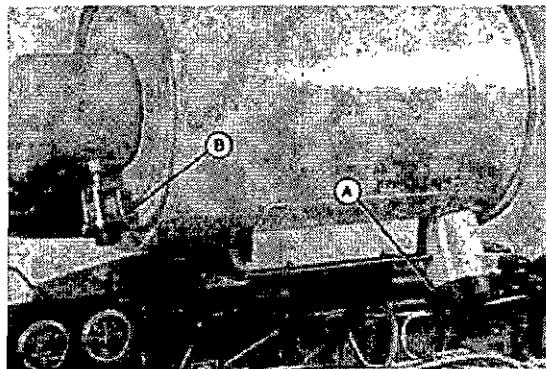

Dust Unloader Valve and Indicator Gauge

5. Make a thorough inspection of the engine compartment. Look for oil or coolant leaks, worn fan and accessory drive belts, loose connections and trash build-up. Remove trash build-up and have repairs made as needed if leaks are found.

NOTE: Wipe all fittings, caps, and plugs before performing any maintenance to reduce the chance of system contamination.

Inspect:

- Radiator for leaks and trash build-up.
- Air intake system hoses and connections for cracks and loose clamps.
- Fan, alternator, and accessory drive belts for cracks, breaks or other damage.
- Coolant pump for coolant leaks.

NOTE: It is normal for a small amount of leakage to occur as the engine cools down and parts contract. Excessive coolant leakage may indicate the need to replace the coolant pump. Contact your engine distributor or servicing dealer for repairs.

6. Turn key switch to "ON" position and check lamps. "WATER" and "HEAT" lamps should be off, while "OIL" and "CHG" lamps should be lit.

Replace lamps as needed. If this does not solve any problems, see your John Deere dealer or distributor.

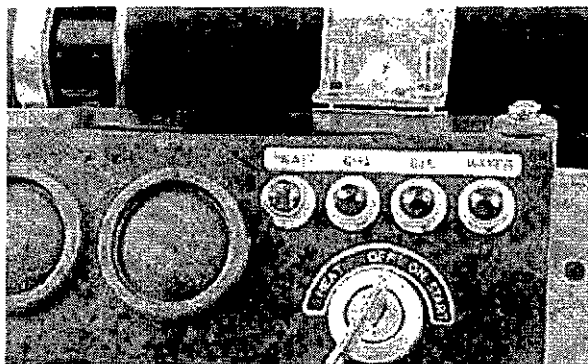

Key Switch in "ON" Position

A—Dust Unloader Valve
B—Air Restriction Indicator

Lubrication & Maintenance/250 Hour/6 Month

Servicing Fire Extinguisher

A fire extinguisher (A) is available from your authorized servicing dealer or engine distributor.

Read and follow the instructions which are packaged with it. The extinguisher should be inspected at least every 250 hours of engine operation or once a month. Once extinguisher is operated, no matter how long, it must be recharged. Keep record of inspections on the tag which comes with the extinguisher instruction booklet.

A—Fire Extinguisher

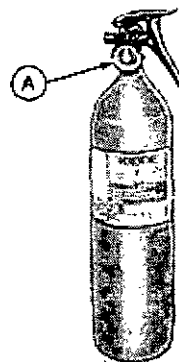

Fire Extinguisher

RW4918 -UN-15DEC88

RG, RG34710.5567 -19-20MAY96-1/1

Changing Engine Oil and Replacing Filter

If John Deere PLUS-50[®] or ACEA - E4/E5 engine oil and a John Deere oil filter are used, the oil and filter change interval may be extended by 50 percent or to 375 hours.

OILSCAN[®] or OILSCAN PLUS[®] is a John Deere sampling program to help you monitor machine performance and identify potential problems before they cause serious damage. OILSCAN[®] and OILSCAN PLUS[®] kits are available from your John Deere engine distributor or servicing dealer. Oil samples should be taken prior to the oil change. Refer to instructions provided with kit.

CAUTION: Metal surfaces of oil pan and drain plug maybe hot to the touch. Use care to prevent burns.

To change engine oil and oil filter:

PLUS-50 is a trademark of Deere & Company.

OILSCAN is a trademark of Deere & Company.

OILSCAN PLUS is a trademark of Deere & Company.

Continued on next page

RG41183.000003A -19-06JAN03-1/3

1. Run engine approximately 5 minutes to warm up oil. Shut engine off.
2. Remove oil pan drain plug (arrow).
3. Drain crankcase oil from engine while warm.
4. Turn filter element (A) counterclockwise using a suitable filter wrench to remove. Discard oil filter element.

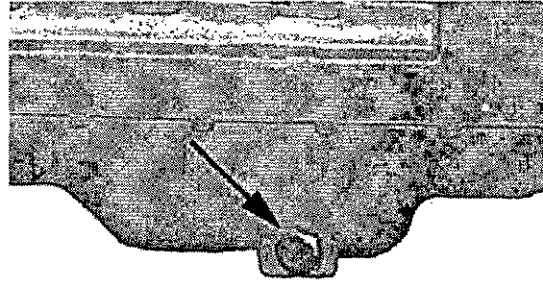

RG12783 -JUN-18FEB03

Oil Pan Drain Plug

NOTE: Depending on engine application, oil filter may have either a vertical or horizontal mounting.

5. Remove oil filter packing and clean filter mounting pad.

IMPORTANT: Filtration of oils is critical to proper lubrication. Always change filter regularly. Use filter meeting John Deere performance specifications.

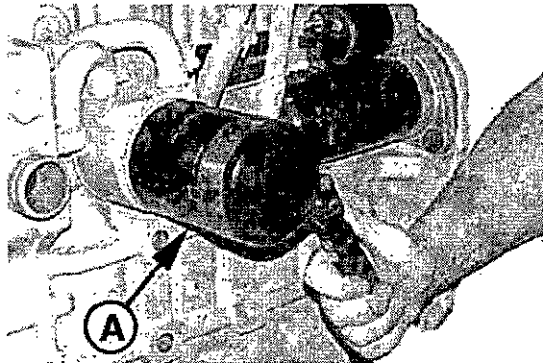

RG12693 -JUN-07FEB03

Removing Horizontal Oil Filter Element

NOTE: Apply a thin coat of engine oil to the entire filter packing. DO NOT use grease.

6. Oil new packing and install new filter element. Hand tighten element according to values printed on filter element. If values are not provided, tighten element by hand approximately 3/4 — 1-1/4 turn after packing contacts filter housing. **DO NOT** overtighten filter element. If a filter wrench is used, be sure it is padded to avoid damaging element.

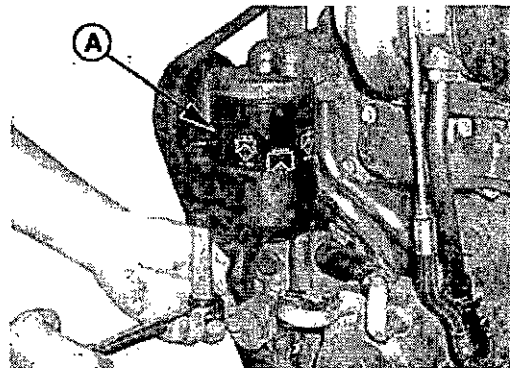

RG12822 -JUN-09FEB03

Removing Optional Vertical Oil Filter Element

7. Install oil pan drain plug with O-ring. If O-ring is damaged, replace it.
8. Tighten drain plug to specifications.

Specification

Oil Pan Drain Plug With O-Ring—
Torque 35 N•m (26 lb ft)

A—Oil Filter Element

Continued on next page

RG41183.000003A -18-06JAN03-2/3

9. Fill engine crankcase with correct John Deere engine oil through rocker arm cover opening (C) or side oil filler (B) depending on engine application. (See DIESEL ENGINE OIL in Fuels, Lubricants, and Coolant Section for determining correct engine oil.)

To determine the correct oil fill quantity for your engine, see ENGINE CRANKCASE OIL FILL QUANTITIES in the Specifications Section of this manual.

IMPORTANT: Immediately after completing any oil change, crank engine for 30 seconds without permitting engine to start. This will help insure adequate lubrication to engine components before engine starts.

NOTE: Crankcase oil capacity may vary slightly. ALWAYS fill crankcase to within crosshatch marks (D) on dipstick. DO NOT overfill.

10. Start engine and run to check for possible leaks.
11. Stop engine and check oil level after 10 minutes. Oil level reading should be within crosshatch marks (D) on dipstick.

- B—Optional Side Oil Fill
- C—Rocker Arm Cover Oil Fill
- D—Crosshatch Marks on Dipstick

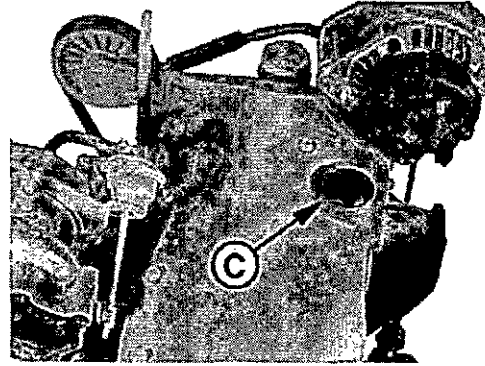

Rocker Arm Cover Oil Fill

RG12780 -UN-07JAN03

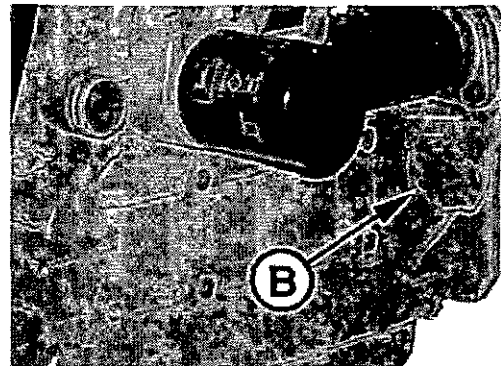

Optional Side Oil Fill

RG12781 -UN-17FEB03

RG12781 -UN-17FEB03

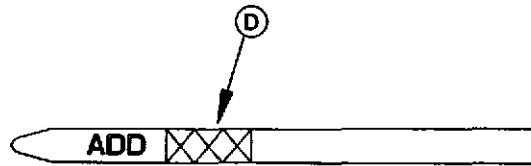

Crosshatch Marks on Dipstick

RG41183.000003A -19-06JAN03-3/3

Checking Engine Mounts

Engine mounting is the responsibility of the vehicle or generator manufacturer. Follow manufacturer's guidelines for mounting specifications.

IMPORTANT: Use only Grade SAE 8 or higher grade of hardware for engine mounting.

1. Check the engine mounting bracket, vibration isolators, and mounting bolts on support frame and engine block for tightness. Tighten as necessary.
2. Inspect overall condition of vibration isolators, if equipped. Replace isolators if rubber has deteriorated or mounts have collapsed, as necessary.

DPSG.RG34710,111 -19-07JAN02-1/1

Servicing Battery

CAUTION: Battery gas can explode. Keep sparks and flames away from batteries. Use a flashlight to check battery electrolyte level.

Never check battery charge by placing a metal object across the posts. Use a voltmeter or hydrometer.

Always remove grounded **NEGATIVE (-)** battery clamp first and replace it last.



Exploding Battery

TS204 -UN-23AUG88

WARNING: Battery posts, terminals, and related accessories contain lead and lead compounds, chemicals known to the State of California to cause cancer and reproductive harm. **Wash hands after handling.**

1. On regular batteries, check electrolyte level. Fill each cell to bottom of filler neck with distilled water.

NOTE: Low-maintenance or maintenance-free batteries should require little additional service. However, electrolyte level can be checked by cutting the center section of decal on dash-line, and removing cell plugs. If necessary, add clean, soft water to bring level to bottom of filler neck.

2. Keep batteries clean by wiping them with a damp cloth. Keep all connections clean and tight. Remove any corrosion, and wash terminals with a solution of 1 part baking soda and 4 parts water. Tighten all connections securely.

NOTE: Coat battery terminals and connectors with a mixture of petroleum jelly and baking soda to retard corrosion.

3. Keep battery fully charged, especially during cold weather. If a battery charger is used, turn charger off before connecting charger to battery(ies). Attach **POSITIVE (+)** battery charger lead to **POSITIVE (+)** battery post. Then attach **NEGATIVE (-)** battery charger lead to a good ground.

CAUTION: Sulfuric acid in battery electrolyte is poisonous. It is strong enough to burn skin, eat holes in clothing, and cause blindness if splashed into eyes.

Avoid the hazard by:

1. Filling batteries in a well-ventilated area.
2. Wearing eye protection and rubber gloves.
3. Avoiding breathing fumes when electrolyte is added.
4. Avoiding spilling or dripping electrolyte.
5. Use proper jump start procedure.

If you spill acid on yourself:

1. Flush your skin with water.
2. Apply baking soda or lime to help neutralize the acid.
3. Flush your eyes with water for 10–15 minutes. Get medical attention immediately.

If acid is swallowed:

1. Drink large amounts of water or milk.
2. Then drink milk of magnesia, beaten eggs, or vegetable oil.
3. Get medical attention immediately.

In freezing weather, run engine at least 30 minutes to assure thorough mixing after adding water to battery.

If necessary to replace battery(ies), replacements must meet or exceed the following recommended capacities at -18°C (0°F):

Specification	
12 Volt Standard Duty Starter—	
Cold Cranking Amps	640
12 Volt Heavy Duty Starter—Cold	
Cranking Amps	800
24 Volt Standard Duty Starter—	
Cold Cranking Amps	570

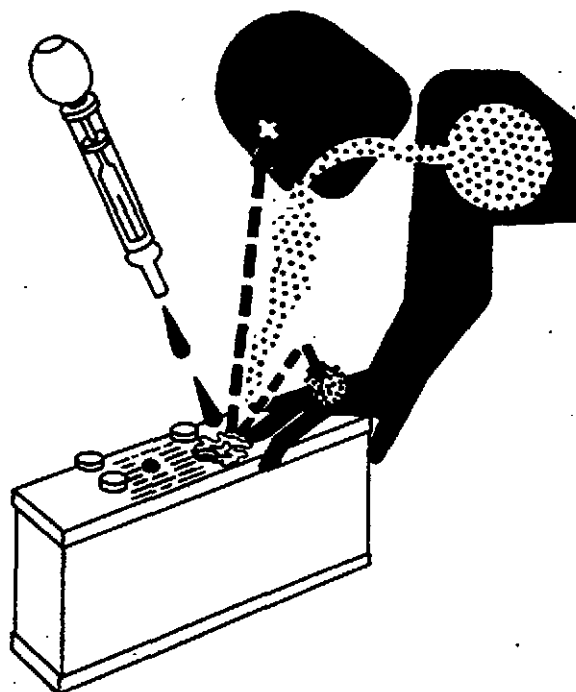

Sulfuric Acid

TS203 -JUN-23AUG88

Lubrication & Maintenance/500 Hour/12 Month

Cleaning Crankcase Vent Tube

If you operate the engine in dusty conditions, clean the tube at shorter intervals.

1. Remove and clean crankcase vent tube (A) by loosening clamp (B) and hose clamp screw.
2. Install the vent tube and hose clamp screw. Tighten hose clamp cap screw to specification.

Specification

Vent Tube Clamp Cap Screw—

Torque 40 N•m (30 lb ft)

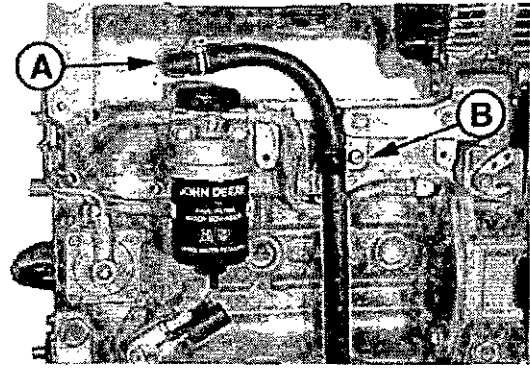

Crankcase Vent Tube and Clamp

RG41183.000003C -19-07JAN03-1/1

Checking Air Intake System

IMPORTANT: The air intake system must not leak. Any leak, no matter how small, may result in internal engine damage due to abrasive dirt and dust entering the intake system.

1. Inspect all intake hoses (piping) for cracks. Replace as necessary.
2. Check clamps (A) on piping which connect the air cleaner, engine and, if present, turbocharger. Tighten clamps as necessary. This will help prevent dirt from entering the air intake system through loose connections causing internal engine damage.
3. If engine has a rubber dust unloader valve (B), inspect the valve on bottom of air cleaner for cracks or plugging. Replace as necessary.

IMPORTANT: ALWAYS REPLACE primary air cleaner element when air restriction indicator shows a vacuum of 625 mm (25 in.) H₂O, is torn, or visibly dirty. See REPLACING AIR CLEANER ELEMENT later in Service As Required section.

4. Test air restriction indicator (C) for proper operation. Replace indicator as necessary.

IMPORTANT: If not equipped with air restriction indicator, replace air cleaner elements at 500 Hours or 12 Months, whichever occurs first.

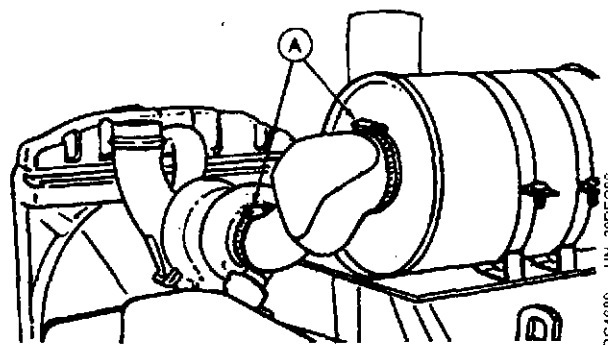

Check Clamps

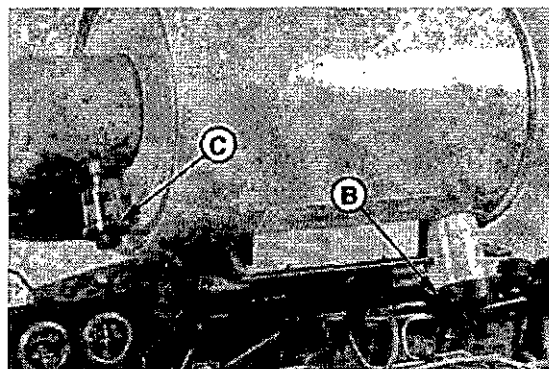

Unloader Valve and Air Restriction Indicator

- A—Clamps
- B—Dust Unloader Valve
- C—Air Restriction Indicator

RG41183.000003D -19-07JAN03-1/1

Check Engine Speeds

Observe tachometer reading (if equipped) and check speeds per specification (See correct speeds listed in ENGINE POWER RATINGS). If speeds require adjustment, contact your John Deere dealer or distributor.

RG41183.000003E -19-07JAN03-1/1

Replacing Fuel Filter Element

CAUTION: Escaping fluid under pressure can penetrate the skin causing serious injury. Relieve pressure before disconnecting fuel or other lines. Tighten all connections before applying pressure. Keep hands and body away from pinholes and nozzles which eject fluids under high pressure. Use a piece of cardboard or paper to search for leaks. Do not use your hand.

If any fluid is injected into the skin, it must be surgically removed within a few hours by a doctor familiar with this type injury or gangrene may result. Doctors unfamiliar with this type of injury may call the Deere & Company Medical Department in Moline, Illinois, or other knowledgeable medical source.

1. Close fuel shut-off valve, if equipped.
 2. Thoroughly clean fuel filter assembly and surrounding area.
 3. Loosen drain plug (B) and drain fuel into a suitable container.
 4. Firmly grasp the filter element (A) and rotate it counterclockwise 1/4 turn. Remove filter element.
 5. Inspect filter mounting base for cleanliness. Clean as required.
 6. Install new filter element by pushing up firmly into mounting base, then turn clockwise until it locks in place. Be sure element is firmly seated in base.
- NOTE: A plug is provided with the new element for plugging the used element.*
7. Open fuel shut-off valve and bleed the fuel system by pressing down in the primer button (D) on top of filter until resistance is felt or fuel flows freely from the bleed plug. Tighten bleed plug (C).

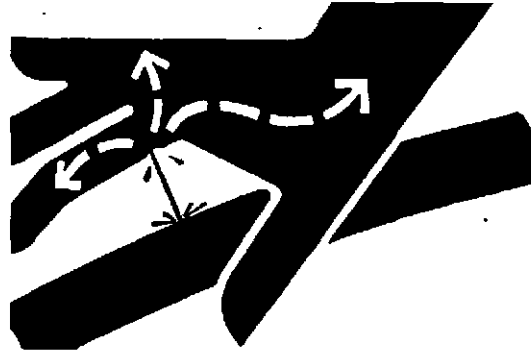

High-Pressure Fluids

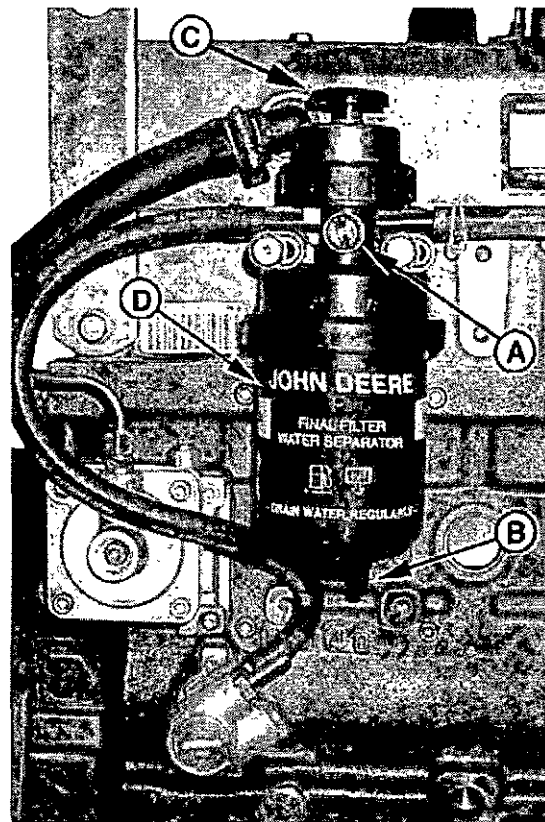

Fuel Filter

- A—Bleed Plug
- B—Drain Plug
- C—Primer Button
- D—Filter Element

X9811 -UN-25AUG88

RG12782A -UN-18FEB03

Checking Belt Tensioner Spring Tension and Belt Wear (Automatic Tensioner)

Belt drive systems equipped with automatic (spring) belt tensioners cannot be adjusted or repaired. The automatic belt tensioner is designed to maintain proper belt tension over the life of the belt. If tensioner spring tension is not within specification, replace tensioner assembly.

RG41183.0000048 -19-08JAN03-1/3

Checking Belt Wear

The belt tensioner is designed to operate within the limit of arm movement when correct belt length and geometry is used.

Visually inspect belt for excessive wear and cracks. See Replacing Fan and Alternator Belt in Section 45.

- A—Belt Tensioner
- B—Poly-Vee Belt

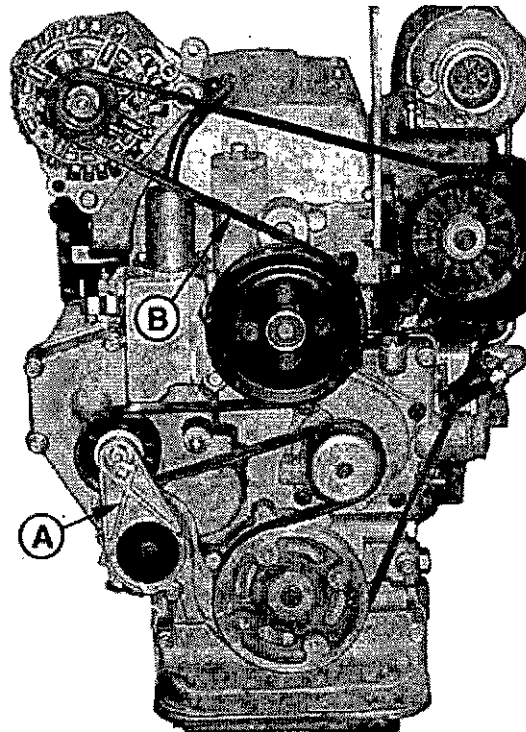

Belt Wear Inspection

RG12972 -UN-05/JUN03

Continued on next page

RG41183.0000048 -19-08JAN03-2/3

Checking Tensioner Spring Tension

A belt tension gauge will not give an accurate measure of the belt tension when automatic spring tensioner is used. Measure tensioner spring tension using a torque wrench and procedure outlined below:

1. Release tension on belt using a breaker bar and socket on tension arm. Remove belt from pulleys.
2. Release tension on tension arm and remove breaker bar.
3. Put a mark (A) on swing arm of tensioner as shown.
4. Measure 21 mm (0.83 in.) from (A) and put a mark (B) on tensioner mounting base.
5. Install torque wrench (C) so that it is aligned with center of pulley and tensioner. Rotate the swing arm with the torque wrench until marks (A and B) are aligned.
6. Record torque wrench measurement and compare with specification below. Replace tensioner assembly as required.

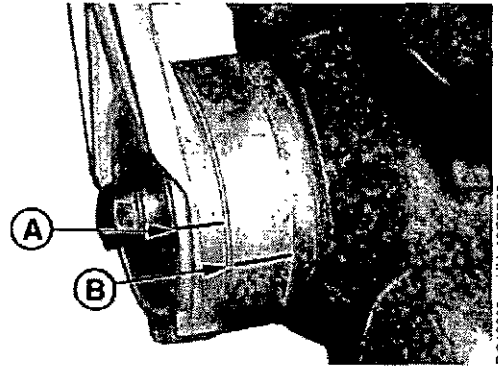

Marks on Tensioner

RG12825 -UN-10FEB03

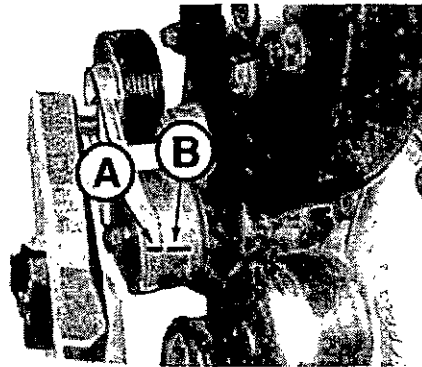

Align Marks

RG12824 -UN-18FEB03

Specification

Spring Tension—Torque 18-22 N•m (13-16 lb-ft)

NOTE: Threads on belt tensioner roller cap screw are LEFT-HAND threads

- A—Mark On Swing Arm
- B—Mark On Tensioner Mounting Base
- C—Torque Wrench

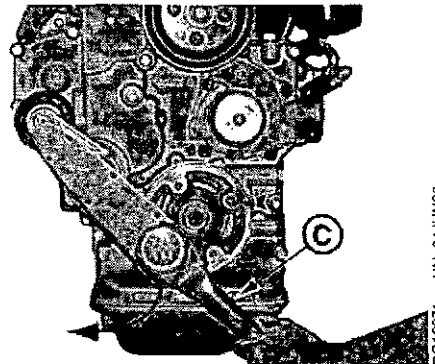

Align Torque Wrench With Pulley And Tensioner

RG12871 -UN-04JUN03

Checking Engine Electrical Ground Connections

Keep all engine ground connections clean and tight to prevent electrical arcing which can damage electrical components.

RG41183.0000049 -19-08JAN03-1/1

Checking Cooling System

⚠ CAUTION: Explosive release of fluids from pressurized cooling system can cause serious burns.

Shut off engine. Only remove filler cap when cool enough to touch with bare hands. Slowly loosen cap to first stop to relieve pressure before removing completely.

IMPORTANT: Air must be expelled from cooling system when system is refilled. Loosen temperature sending unit fitting at rear of cylinder head or plug in thermostat housing to allow air to escape when filling system. Retighten fitting or plug when all the air has been expelled.

1. Visually check entire cooling system for leaks. Tighten all clamps securely.
2. Thoroughly inspect all cooling system hoses for hard, flimsy, or cracked condition. Replace hoses if any of the above conditions are found.



High-Pressure Fluids

TS281 -JUN-23AUG88

RG.RG34710.5580 -19-20MAY96-1/1

Replenishing Supplemental Coolant Additives (SCAs) Between Coolant Changes

IMPORTANT: Do not add supplemental coolant additives when the cooling system is drained and refilled with John Deere COOL-GARD®

NOTE: If system is to be filled with coolant that does not contain SCAs, the coolant must be precharged. Determine the total system capacity and premix with 3% John Deere Coolant Conditioner.

Through time and use, the concentration of coolant additives is gradually depleted during engine operation. Periodic replenishment of inhibitors is required, even when John Deere COOL-GARD® is used. The cooling system must be recharged with additional supplemental coolant additives available in the form of liquid coolant conditioner.

Maintaining the correct coolant conditioner concentration (SCAs) and freeze point is essential in your cooling system to protect against rust, liner pitting and corrosion, and freeze-ups due to incorrect coolant dilution.

John Deere LIQUID COOLANT CONDITIONER is recommended as a supplemental coolant additive in John Deere engines.

DO NOT mix one brand of SCA with a different brand.

Test the coolant solution every 500 hours or 12 months of operation using either John Deere coolant test strips or a COOLSCAN® analysis. If a COOLSCAN® analysis is not available, recharge the system per instructions printed on label of John Deere Liquid Coolant Conditioner.

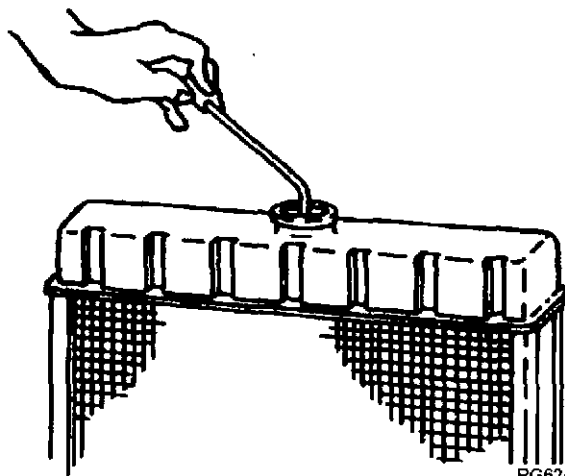

Radiator Coolant Check

RG6241

RG6261 -JUN-08DEC97

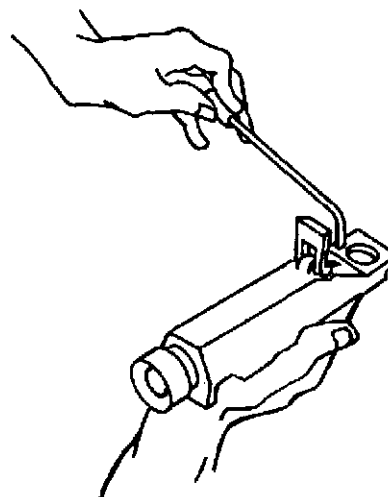

JT07298 Coolant/Battery Tester

RG6262

RG6262 -JUN-06DEC97

COOL-GARD is a registered trademark of Deere & Company
COOLSCAN is a registered trademark of Deere & Company

Continued on next page

DPSG,OUOD002.1921 -19-07JAN02-1/2

IMPORTANT: ALWAYS maintain coolant at correct level and concentration. **DO NOT** operate engine without coolant even for a few minutes.

If frequent coolant makeup is required, the glycol concentration should be checked with JTO7298 Coolant/Battery Tester to ensure that the desired freeze point is maintained. Follow manufacturer's instructions provided with Coolant/Battery Tester.

Add the manufacturer's recommended concentration of supplemental coolant additive. **DO NOT** add more than the recommended amount.

The use of non-recommended supplemental coolant additives may result in additive drop-out and gelation of the coolant.

If other coolants are used, consult the coolant supplier and follow the manufacturer's recommendation for use of supplemental coolant additives.

See DIESEL ENGINE COOLANTS AND SUPPLEMENTAL ADDITIVE INFORMATION for proper mixing of coolant ingredients before adding to the cooling system.

DPSG.OI.OD002.1921 -19-07JAN02-2/2

Testing Diesel Engine Coolant

Maintaining adequate concentrations of glycol and inhibiting additives in the coolant is critical to protect the engine and cooling system against freezing, corrosion, and cylinder liner erosion and pitting.

Test the coolant solution at intervals of 12 months or less and whenever excessive coolant is lost through leaks or overheating.

Coolant Test Strips

Coolant test strips are available from your John Deere dealer. These test strips provide a simple, effective method to check the freeze point and additive levels of your engine coolant.

Compare the results to the supplemental coolant additive (SCA) chart to determine the amount of inhibiting additives in your coolant and whether more John Deere COOLANT CONDITIONER should be added.

COOLSCAN

For a more thorough evaluation of your coolant, perform a COOLSCAN analysis. See your John Deere dealer for information about COOLSCAN.

DX,COOL9 -19-17FE889-1/1

Pressure Testing Cooling System

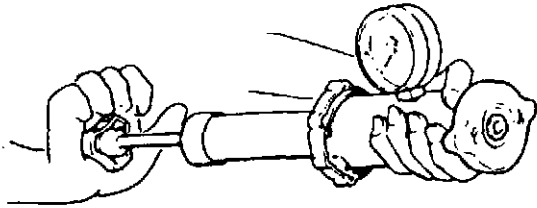

Test Radiator Cap

RG6557 -JUN-20JAN93

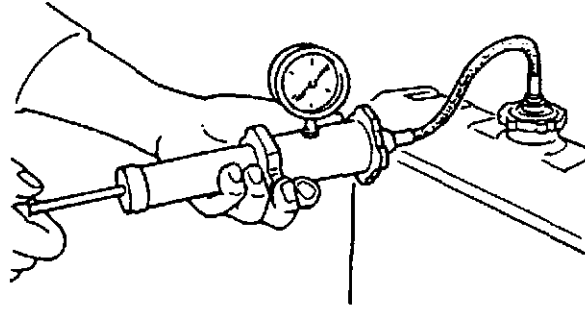

Test Cooling System

RG6558 -JUN-20JAN93

CAUTION: Explosive release of fluids from pressurized cooling system can cause serious burns.

Shut off engine. Only remove filler cap when cool enough to touch with bare hands. Slowly loosen cap to first stop to relieve pressure before removing completely.

Test Radiator Cap

1. Remove radiator cap and attach to D05104ST Tester as shown.
2. Pressurize cap to specification listed. Gauge should hold pressure for 10 seconds within the normal range if cap is acceptable.

If gauge does not hold pressure, replace radiator cap.

Specification

Radiator Cap Holding Pressure
(Not Opening For 10
Seconds)—Pressure..... 70 kPa (0.7 bar) (10 psi)
minimum

3. Remove the cap from gauge, turn it 180°, and retest cap. This will verify that the first measurement was accurate.

Test Cooling System

NOTE: Engine should be warmed up to test overall cooling system.

1. Allow engine to cool, then carefully remove radiator cap.
2. Fill radiator with coolant to the normal operating level.

IMPORTANT: DO NOT apply excessive pressure to cooling system, doing so may damage radiator and hoses.

3. Connect gauge and adapter to radiator filler neck. Pressurize cooling system to specification listed for radiator cap.
4. With pressure applied, check all cooling system hose connections, radiator, and overall engine for leaks.

If leakage is detected, correct as necessary and pressure test system again.

If no leakage is detected, but the gauge indicated a drop in pressure, coolant may be leaking internally within the system or at the block-to-head gasket. Have your engine distributor or servicing dealer correct this problem immediately.

Lubrication & Maint./2000 Hour/24 Month

Checking Crankshaft Vibration Damper (If Equipped)

1. Grasp vibration damper with both hands and attempt to turn it in both directions. If rotation is felt, damper is defective and should be replaced.

IMPORTANT: The vibration damper assembly is not repairable and should be replaced every 4500 hours or 60 months, whichever occurs first.

2. Check vibration damper radial runout by positioning a dial indicator so probe contacts damper outer diameter.
3. Remove starter motor.
4. Rotate crankshaft using JDG1704 Flywheel Turning Tool as shown. This tool is available from your John Deere dealer or distributor.
5. Note dial indicator reading. If runout exceeds specifications given below, replace vibration damper.

Specification

Vibration Damper—Maximum
Radial Runout..... 1.50 mm (0.060 in.)

6. Remove tool and reinstall starter motor. Connect wiring and tighten mounting cap screws to specifications.

Specification

Starter Motor Mounting Cap
Screws—Torque..... 80 N·m (59 lb-ft)

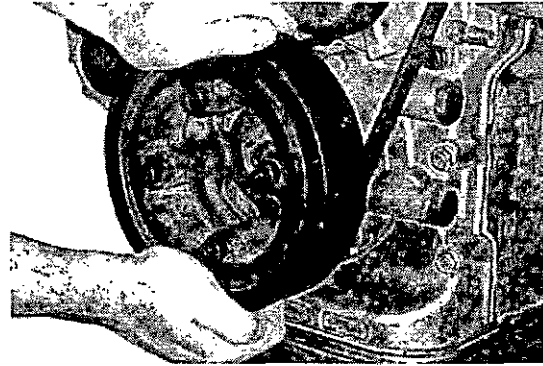

Vibration Damper

RG12917 -JUN-16MAY03

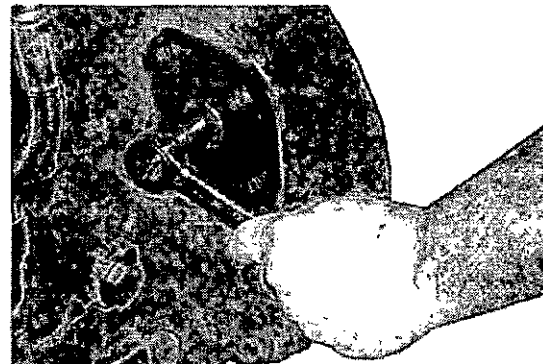

Rotating Crankshaft Using JDG1704

RG12788 -JUN-21JAN03

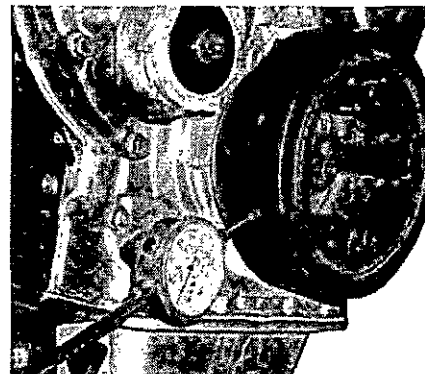

Vibration Damper Radial (Concentricity)

RG12918 -JUN-16MAY03

RG41183.000004B -19-08JAN03-1/1

Flushing and Refilling Cooling System

CAUTION: Explosive release of fluids from pressurized cooling system can cause serious burns.

Shut off engine. Only remove filler cap when cool enough to touch with bare hands. Slowly loosen cap to first stop to relieve pressure before removing completely.

NOTE: When John Deere COOL-GARD is used, the drain interval is 3000 hours or 36 months. The drain interval may be extended to 5000 hours or 60 months of operation, provided that the coolant is tested annually AND additives are replenished, as needed, by adding a supplemental coolant additive (SCA).

If COOL-GARD is not used, the flushing interval is 2000 hours or 24 months of operation.

Drain old coolant, flush the entire cooling system, test thermostats, and fill with recommended clean coolant as follows:

1. Pressure test entire cooling system and pressure cap if not previously done. (See PRESSURE TESTING COOLING SYSTEM, in the Lubrication and Maintenance/500 Hour/12 Month Section.)
2. Slowly open the engine cooling system filler cap or radiator cap to relieve pressure and allow coolant to drain faster.
3. Open engine block drain valve (A) on right side of coolant pump on engine front cover. Drain all coolant from engine block.
4. Open radiator drain valve. Drain all coolant from radiator.
5. Remove coolant hose and thermostat at this time, if not previously done. (See TESTING THERMOSTATS OPENING TEMPERATURE later in this section.)
6. Close all drain valves after coolant has drained.



High-Pressure Fluids

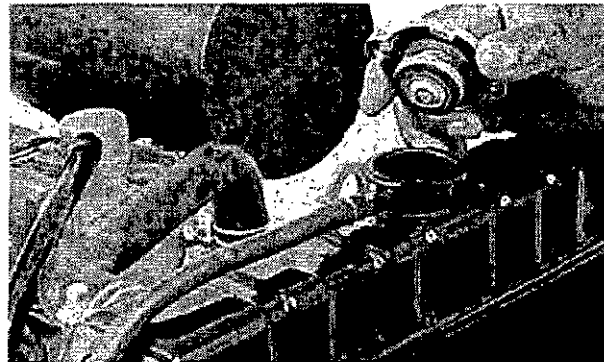

Cooling System Filler Cap

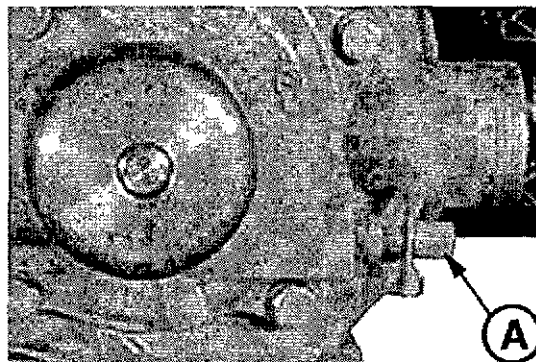

Engine Coolant Drain Valve

A—Engine Coolant Drain Valve

Continued on next page

RG41183,000004F -19-14JAN03-1/3

CAUTION: Do not run engine longer than 10 minutes. Doing so may cause engine to overheat which may cause burns when radiator water is draining.

7. Fill the cooling system with clean water. Run the engine about 10 minutes to stir up possible rust or sediment.
8. Stop engine, pull off lower radiator hose and remove radiator cap. Immediately drain the water from system before rust and sediment settle.
9. After draining water, close drain valves. Reinstall radiator cap and radiator hose and clamp. Fill the cooling system with clean water and a heavy duty cooling system cleaner such as Fleetguard® RESTORE™ and RESTORE PLUS™. These products may be available from your John Deere dealer. Follow manufacturer's directions on label.
10. After cleaning the cooling system, drain cleaner and fill with water to flush the system. Run the engine about 10 minutes, remove radiator cap and pull off lower radiator hose to drain out flushing water.
11. Close all drain valves on coolant pump and radiator. Install thermostat. Reinstall radiator hose and tighten clamps securely.

IMPORTANT: Air must be expelled from cooling system when system is refilled. Loosen temperature sending unit fitting at rear of cylinder head or plug in thermostat housing to allow air to escape when filling system. Retighten fitting or plug after filling cooling system.

12. Refill system with fresh coolant at radiator until coolant touches bottom of filler neck. (See ADDING COOLANT in Service As Required Section.) Install radiator cap.

*Fleetguard is a trademark of Cummins Engine Company, Inc.
RESTORE is a trademark of Fleetguard.
RESTORE PLUS is a trademark of Fleetguard.*

Continued on next page

RG41183.000004F -19-14JAN03-2/3

13. Run engine until it reaches operating temperature. This mixes the solution uniformly and circulates it through the entire system. The normal engine coolant temperature range is 90°—100°C (194° — 212°F).
14. After running engine, check coolant level and entire cooling system for leaks.

RG41183.000004F -19-14JAN03-3/3

Testing Thermostats Opening Temperature

To Remove Thermostat

⚠ CAUTION: Explosive release of fluids from pressurized cooling system can cause serious burns. DO NOT drain coolant until it has cooled below operating temperature. Always loosen radiator pressure cap or drain valve slowly to relieve pressure.

1. Visually inspect area around thermostat housing on top of engine timing gear cover for leaks.
2. Remove radiator pressure cap and partially drain cooling system.
3. Remove coolant hose (shown removed) from thermostat housing.

A—Thermostat Hose Connection

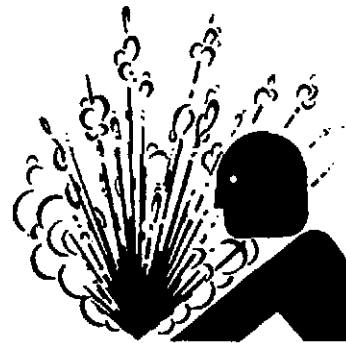

High Pressure Fluids

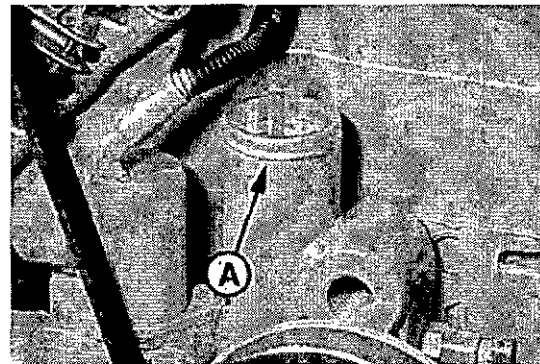

Coolant Hose to Thermostat Housing

Continued on next page

RG41183.0000050 -19-14JAN03-1/4

TS281 -JUN-23AUG88

RG12789 -JUN-21JAN03

4. Remove thermostat from thermostat housing by squeezing handle to release from grooves inside bore and pull out.
5. Clean and check thermostat housing for cracks or damage.

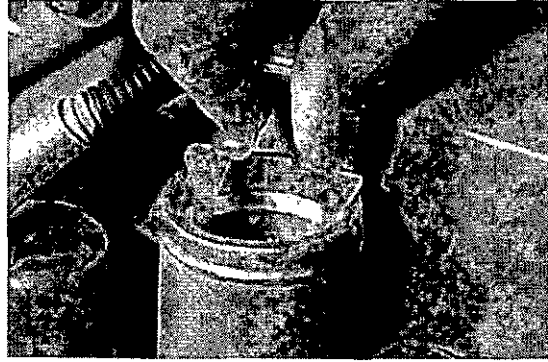

Removing Thermostat from Housing

Continued on next page

RG41183.0000050 -19-14JAN03-2/4

Testing Thermostats Opening Temperature

1. Remove thermostat(s).
2. Visually inspect thermostat(s) for corrosion or damage. If dual thermostats, replace as a matched set as necessary.

CAUTION: DO NOT allow thermostat or thermometer to rest against the side or bottom of container when heating water. Either may rupture if overheated.

3. Suspend thermostat and a thermometer in a container of water.
4. Stir the water as it heats. Observe opening action of thermostat and compare temperatures with the specification below.

NOTE: Due to varying tolerances of different suppliers, initial opening and full open temperatures may vary slightly from specified temperatures.

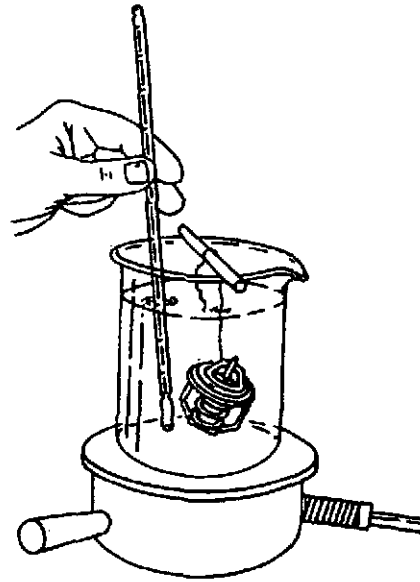

Testing Thermostat Opening Temperature

RG6871 -UN-23NOV97

THERMOSTAT TEST SPECIFICATIONS

Rating	Initial Opening (Range)	Full Open (Nominal)
71°C (160°F)	69—72°C (156—162°F)	84°C (182°F)
77°C (170°F)	74—78°C (166—172°F)	89°C (192°F)
82°C (180°F)	80—84°C (175—182°F)	94°C (202°F)
89°C (192°F)	86—90°C (187—194°F)	101°C (214°F)
90°C (195°F)	89—93°C (192—199°F)	103°C (218°F)
92°C (197°F)	89—93°C (193—200°F)	105°C (221°F)
96°C (205°F)	94—97°C (201—207°F)	100°C (213°F)
99°C (210°F)	96—100°C (205—212°F)	111°C (232°F)

5. Remove thermostat and observe its closing action as it cools. In ambient air the thermostat should close completely. Closing action should be smooth and slow.
6. Replace any defective thermostat.

Continued on next page

RG41183.0000050 -19-14JAN03-3/4

To Install Thermostats

1. Insert thermostat in housing as shown until both tabs (A) are fully engaged in the groove in the housing bore.
2. Install coolant hose to thermostat cover. Tighten clamp.
3. If not already done, fill cooling system and check for leaks.

IMPORTANT: Air must be expelled from cooling system when filling. Loosen temperature sending unit fitting at rear of cylinder head or plug in thermostat housing to allow air to escape when filling system. Tighten fitting or plug when all air has been expelled.

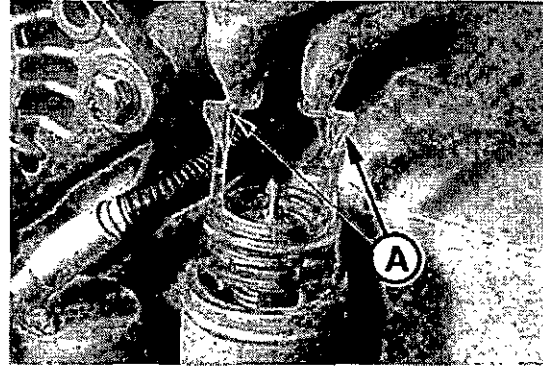

Installing Thermostat

RG12791 -JUN-21JAN03

RG41183,000005D -19-14JAN03-4/4

Service as Required

Additional Service Information

This is not a detailed service manual. If you want more detailed service information, use the form in the back of this manual to order a component technical manual.

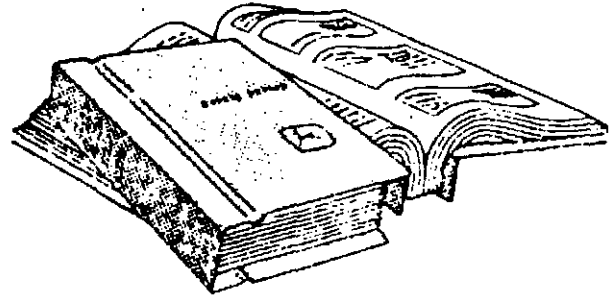

Component Technical Manual

RG4624 -UN-15DEC88

RG, RG34710.5591 -19-20MAY96-1/1

Do Not Modify Fuel System

IMPORTANT: Modification or alteration of the fuel injection system, the injection timing, or the fuel injectors in ways not recommended by the manufacturer will terminate the warranty obligation to the purchaser.

In addition, tampering with fuel system which alters emission-related equipment on engines may result in fines or other penalties, per EPA regulations or other local emission laws.

Do not attempt to service fuel injectors yourself. Special training and special tools are required. (See your authorized servicing dealer or engine distributor.)

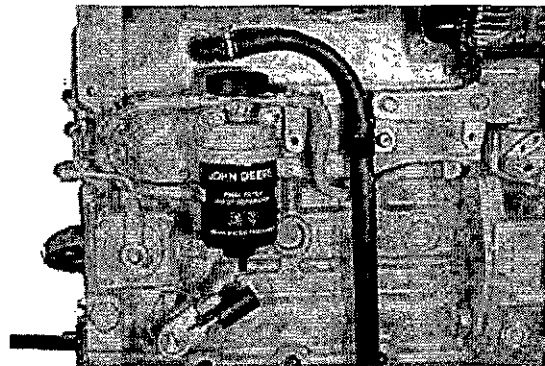

Fuel System

RG12798 -UN-21JAN03

RG41183.0000052 -19-16JAN03-1/1

Adding Coolant

CAUTION: Explosive release of fluids from pressurized cooling system can cause serious burns.

Shut off engine. Only remove filler cap when cool enough to touch with bare hands. Slowly loosen cap to first stop to relieve pressure before removing completely.

IMPORTANT: Never pour cold liquid into a hot engine, as it may crack cylinder head or block. **DO NOT** operate engine without coolant for even a few minutes.

John Deere TY15161 Cooling System Sealer may be added to the radiator to stop leaks. **DO NOT** use any other stop-leak additives in the system.

Air must be expelled from cooling system when coolant is added.

1. Loosen temperature sending unit fitting at rear of cylinder head or plug in side of thermostat housing to allow air to escape when filling system.

IMPORTANT: When adding coolant to the system, use the appropriate coolant solution. (See **ENGINE COOLANT SPECIFICATIONS** in Fuels, Lubricants, and Coolant Section for mixing of coolant ingredients before adding to cooling system.)

Do not overfill cooling system. A pressurized system needs space for heat expansion without overflowing at top of radiator.

2. Remove radiator cap and fill until coolant level touches bottom of radiator filler neck (A).
3. Tighten plugs and fittings when air has been expelled from system.
4. Run engine until it reaches operating temperature.



High-Pressure Fluids

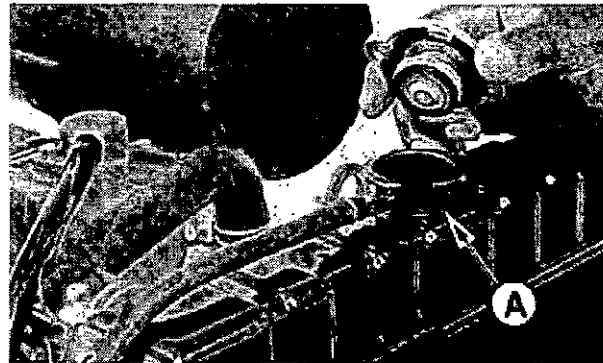

Radiator Filler Neck

TS2R1 -UN-23AUG88

RG6576A -JUN-04JUN03

Replacing Single Stage Air Cleaner Element

IMPORTANT: ALWAYS REPLACE air cleaner when air restriction indicator shows a vacuum of 625 mm (25 in.) H₂O, is torn, or visibly dirty.

NOTE: Refer to manufacturers' instructions for servicing air cleaners not supplied by John Deere. If engine is NOT equipped with an air restriction indicator, replace air filter element every 500 hours of operation or every 12 months, whichever occurs first.

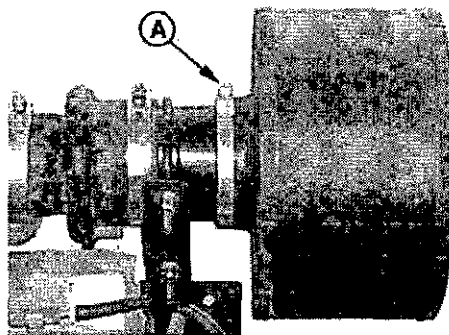

Single Stage Air Filter

RG11319A -UN-06SEP00

1. If equipped, loosen body clamp.
2. Loosen clamp around outlet neck (A).
3. Remove air cleaner.
4. Install new filter so that overlap (B) of air cleaner outlet neck and engine intake pipe is to specification below.

Specification

Air Cleaner Neck to Engine Intake—Overlap..... 38 mm (1.5 in)

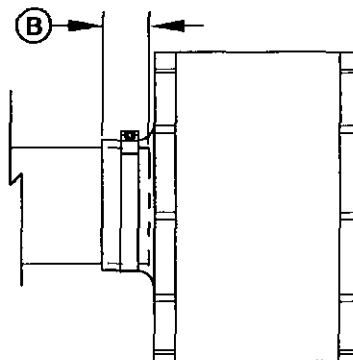

RG11320 -UN-07SEP00

Installation of Single Stage Air Cleaner

A—Outlet Neck Clamp
B—Filter to Engine Overlap

5. Tighten neck clamp (A) to specification below.

Specification

Air Cleaner Neck Clamp—Torque..... 6.8 N·m (60 lb-in.)

IMPORTANT: Do NOT overtighten body clamp. Overtightening may cause crushing of air cleaner body. Tighten body clamp only until snug.

6. If equipped, tighten body clamp until snug.

IMPORTANT: Whenever the air cleaner has been serviced or removed, ALWAYS fully depress the air restriction indicator reset button (if equipped) to assure accurate readings.

7. If equipped, fully depress air restriction indicator reset button and release to reset indicator.

Replacing Axial Seal Air Cleaner Filter Element

IMPORTANT: ALWAYS REPLACE primary air cleaner element when air restriction indicator shows a vacuum of 625 mm (25 in.) H₂O, is torn, or visibly dirty.

NOTE: Refer to manufacturers' instructions for servicing air cleaners not supplied by John Deere. If engine is NOT equipped with an air restriction indicator, replace air filter element every 500 hours of operation or every 12 months, whichever occurs first.

1. Remove wing nut and remove canister cover shown in small illustration inset.
2. Remove wing nut (A) and remove primary element (B) from canister.
3. Thoroughly clean all dirt from inside canister.

NOTE: Some engines may have a dust unloader valve (C) on the air cleaner. If equipped, squeeze valve tip to release any trapped dirt particles.

IMPORTANT: Remove secondary (safety) element (E) ONLY for replacement. DO NOT attempt to clean, wash, or reuse secondary element. Replacement of secondary element is usually necessary ONLY when primary element has a hole in it.

4. To replace secondary element, remove retaining nut (D) and secondary element (E). Immediately replace secondary element with new element to prevent dust from entering air intake system.
5. Install new primary element and tighten wing nut securely. Install cover assembly and tighten retaining wing nut securely.

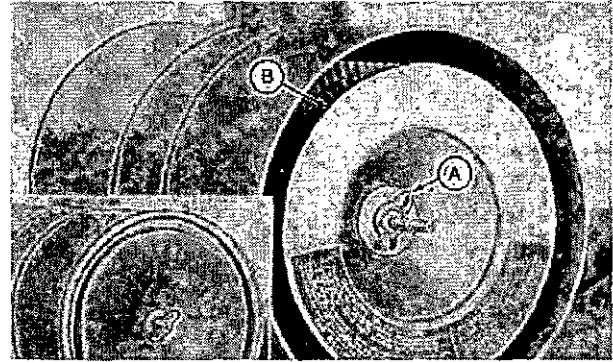

Wing Nut and Primary Element

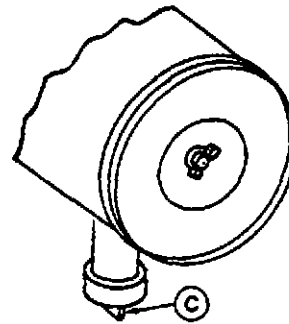

Dust Unloader Valve

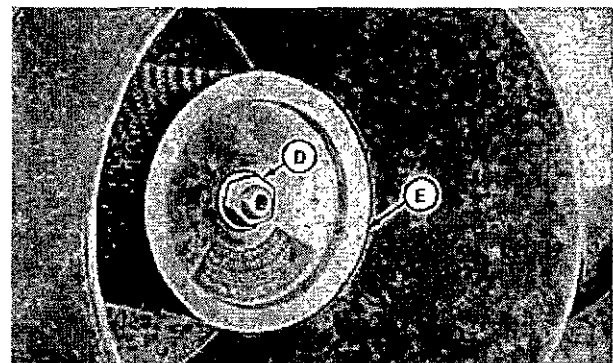

Retaining Nut and Secondary Element

- A—Wing Nut
- B—Primary Element
- C—Dust Unloader Valve
- D—Retaining Nut
- E—Secondary Element

Service as Required

IMPORTANT: Whenever the air cleaner has been serviced or had cover removed, **ALWAYS** fully depress the air restriction indicator reset button (if equipped) to assure accurate readings.

6. If equipped, fully depress air restriction indicator reset button and release to reset indicator.

RG41183,0000054 -19-16JAN03-2/2

Replacing Radial Seal Air Cleaner Filter Element

IMPORTANT: ALWAYS REPLACE primary air cleaner element when air restriction indicator shows a vacuum of 625 mm (25 in.) H₂O, is torn, or visibly dirty.

NOTE: Refer to manufacturers' instructions for servicing air cleaners not supplied by John Deere. If engine is NOT equipped with an air restriction indicator, replace air filter element every 500 hours of operation or every 12 months, whichever occurs first.

1. Unlatch and remove dust cup/cover (A) of air cleaner.
2. Move end of filter (B) back and forth gently to break seal.
3. Pull filter (B) off outlet tube and out of housing.
4. Thoroughly clean all dirt from inside housing and from outlet bore.

IMPORTANT: Remove secondary (safety) element (C) ONLY for replacement. DO NOT attempt to clean, wash, or reuse secondary element. Replacement of secondary element is usually necessary ONLY when primary element has a hole in it.

5. To replace secondary element (C), pull filter element out gently. Immediately replace secondary element with new element to prevent dust from entering air intake system.
6. Install new primary filter element. Apply pressure by hand at outer rim of filter.

IMPORTANT: Do NOT use latches on cover to force filter into air cleaner. Using cover to force filter will damage cleaner housing.

7. Close housing with dust unloader valve aimed down and latch latches.

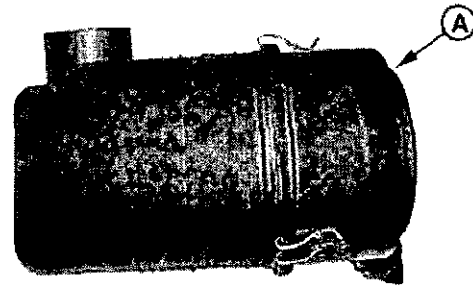

Dust Cup/Cover

RG11321A -JUN-08SEP00

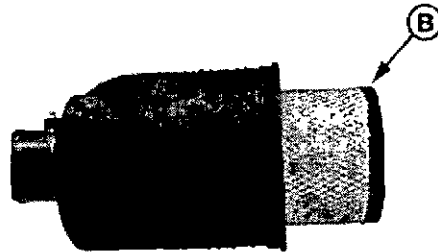

Primary Filter Element

RG11322A -JUN-08SEP00

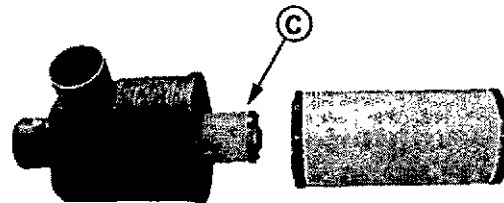

Secondary Filter Element

RG11327A -JUN-08SEP00

- A—Dust Cap/Cover
- B—Primary Filter Element
- C—Secondary Filter Element

Continued on next page

RG41183.0000055 -19-16JAN03-1/2

IMPORTANT: Whenever the air cleaner has been serviced or cover has been removed, **ALWAYS** fully depress the air restriction indicator reset button (if equipped) to assure accurate readings.

8. If equipped, fully depress air restriction indicator reset button and release to reset indicator.

RG41183.000055 -19-16JAN03-2/2

Replacing Fan and Alternator Belt

Refer to CHECKING BELT TENSIONER SPRING TENSION AND BELT WEAR in Lubrication and Maintenance/250 Hour/6 Month Section for additional information on the belt tensioner.

1. Inspect belts for cracks, fraying, or stretched out areas. Replace if necessary.
2. To replace belt, release tension on belt using a 3/8-inch drive arm (B) on tension arm.
3. Remove poly-vee belt from pulleys and discard belt.
4. Install new belt, making sure belt is correctly seated in all pulley grooves. Refer to belt routing at right for your application.
5. Best method to install belt is:
Back-wrap it around the fan pulley (FD), route it over the alternator (A), over top of the idler pulley (I), then down and around the crankshaft pulley (CSP). Finally, use a 3/8-inch drive arm to rotate the tensioner (T) to the tensioned position and slip the belt (back-wrap) over the coolant pump pulley (CP), then release the tensioner.
6. Apply tension to belt with tensioner. Remove drive arm.
7. Start engine and check belt alignment.

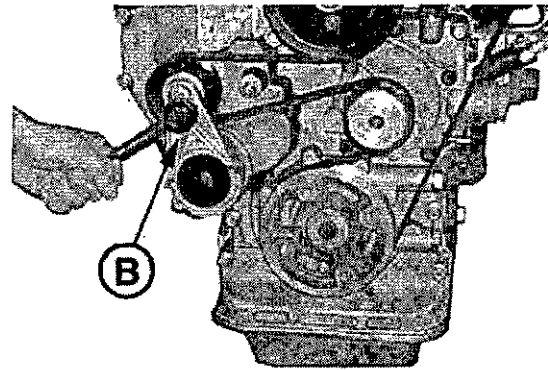

RG12800 -UN-21JAN03

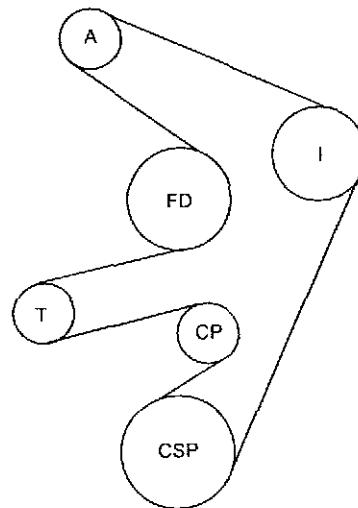

RG12799 -UN-21JAN03

A—Alternator
CSP—Crankshaft Pulley
FD—Fan Drive
I—Idler Pulley
T—Tensioner
CP—Coolant Pump

RG41183.000056 -19-16JAN03-1/1

Check Fuses

Check fuses for electrical system and replace if defective. Refer to manufactures instructions and wiring diagrams for location and types of fuses.

RG41183,0000057 -19-16JAN03-1/1

Bleed the Fuel System

CAUTION: Escaping fluid under pressure can penetrate the skin causing serious injury. Avoid hazards by relieving pressure before disconnecting hydraulic or other lines. Tighten all connections before applying pressure. Search for leaks with a piece of cardboard. Protect hands and body from high pressure fluids.

If an accident occurs, see a doctor immediately. Any fluid injected into the skin must be surgically removed within a few hours or gangrene may result. Doctors unfamiliar with this type of injury may call the Deere & Company Medical Department in Moline, Illinois, or other knowledgeable medical source.

Any time the fuel system has been opened up for service (lines disconnected or filter removed), it will be necessary to bleed air from the system.

The fuel system may be bled at one of several locations. On some engine applications it may be necessary to consult your operator's manual and choose the best location for your engine/machine application.

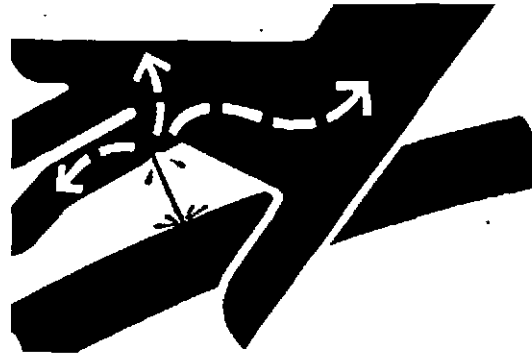

High Pressure Fluids

X9811 -JUN-23AUG88

Continued on next page

RG41183,0000002 -19-27MAY03-1/2

Service as Required

1. Open air bleed vent screw (A) two full turns by hand.
2. Pump the hand primer (B) on filter mounting base until a noticeable amount of fuel and air comes out of vent opening. Continue pumping and close vent screw when fuel starts to flow.
3. Pump the hand primer several times until resistance is felt. Continue pumping and open air bleed vent screw again.
4. Close air bleed vent screw and pump the hand primer several times until resistance is felt again.

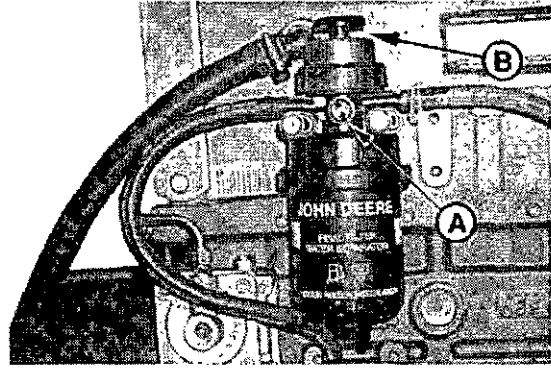

Fuel Filter Bleed Vent Screw and Hand Primer

- A—Bleed Vent Screw
- B—Hand Primer

RG41183,0000002 -19-27MAY03-2/2

Troubleshooting

General Troubleshooting Information

Troubleshooting engine problems can be difficult. An engine wiring diagram is provided in this section to help isolate electrical problems.

Refer to manufactures literature and diagrams for electrical systems not provided by John Deere.

Later in this section is a list of possible engine problems along with possible causes and corrections. The illustrated diagrams and troubleshooting information are of a general nature, final design of the overall system for your engine application may be different. See your engine distributor or servicing dealer if you are in doubt.

A reliable program for troubleshooting engine problems should include the following basic diagnostic thought process:

- Know the engine and all related systems.
- Study the problem thoroughly.
- Relate the symptoms to your knowledge of engine and systems.
- Diagnose the problem starting with the easiest things first.
- Double-check before beginning the disassembly.
- Determine cause and make a thorough repair.
- After making repairs, operate the engine under normal conditions to verify that the problem and cause was corrected.

RG41183.0000058 -19-16JAN03-1/1

Electrical System Schematic

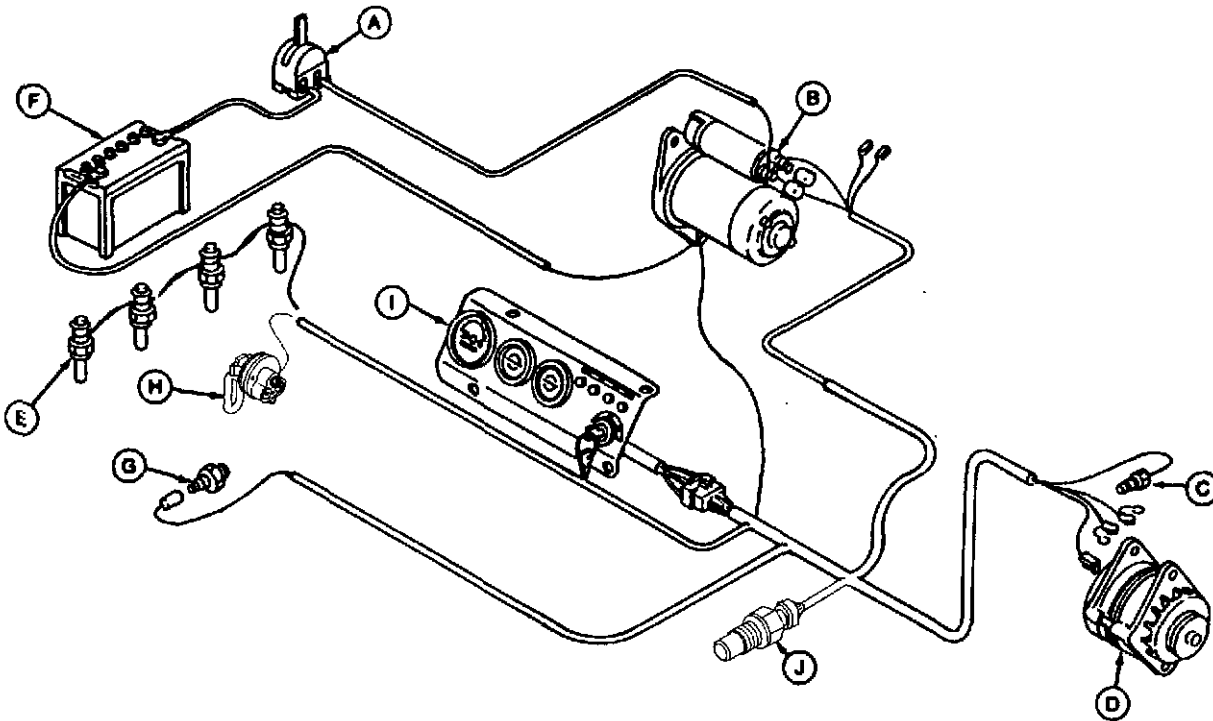

- | | | | |
|---|---------------------------------|-----------------------|----------------------------|
| A—Battery Disconnect Switch
(Optional) | C—Coolant Temperature
Sensor | E—Glow Plug | H—Block Heater |
| B—Starter Motor | D—Alternator | F—Battery | I—Instrument (Gauge) Panel |
| | | G—Oil Pressure Sensor | J—Speed Sensor |

RG12254 -UN-06JUN03

RG41183.0000022 -19-06JUN03-1/1

Engine Troubleshooting

Symptom	Problem	Solution
Engine cranks but will not start	Incorrect starting procedure.	Verify correct starting procedure.
	No fuel.	Check fuel in tank and manual shut-off valve.
	Exhaust restricted.	Check and correct exhaust restriction.
	Fuel filter plugged or full of water.	Replace fuel filter or drain water from filter.
	Unit injection pumps not getting fuel /or air in fuel system.	Check fuel flow at transfer pump or bleed fuel system.
	Faulty injection pumps or nozzles.	Consult authorized diesel repair station for repair or replacement.
Engine hard to start or will not start	Engine starting under load.	Disengage driveline.
	Improper starting procedure.	Review starting procedure.
	No fuel.	Check fuel tank.
	Air in fuel line.	Bleed fuel line.
	Cold weather.	Activate glow plugs.
	Slow starter speed.	See "Starter Cranks Slowly".
	Crankcase oil too heavy.	Use oil of proper viscosity.
	Improper type of fuel.	Consult fuel supplier; use proper type fuel for operating conditions.
	Water, dirt, or air in fuel system.	Drain, flush, fill, and bleed system.
	Clogged fuel filter.	Replace filter element.
	Dirty or faulty injection nozzles.	Have authorized servicing dealer or engine distributor check injectors.
	Injection shut-off not reset.	Turn key switch to "OFF" then to "ON".

Troubleshooting

Symptom	Problem	Solution
Engine knocks	Low engine oil level.	Add oil to engine crankcase.
	Unit injection pumps out of time.	See your authorized servicing dealer or engine distributor.
	Hydraulic valve lifters.	See your authorized servicing dealer or engine distributor.
	Low coolant temperature.	Remove and check thermostat.
	Engine overheating.	See "Engine Overheats".
Engine runs irregularly or stalls frequently	Low coolant temperature.	Remove and check thermostat.
	Clogged fuel filter.	Replace fuel filter element.
	Water, dirt, or air in fuel system.	Drain, flush, fill, and bleed system.
	Dirty or faulty injectors.	Have authorized servicing dealer or engine distributor check injectors.
Below normal engine temperature	Defective thermostat.	Remove and check thermostat.
	Defective temperature gauge or sender.	Check gauge, sender, and connections.

Continued on next page

RG41183.0000059 -19-16JAN03-2/7

Troubleshooting

Symptom	Problem	Solution
Lack of power	Engine overloaded.	Reduce load.
	Intake air restriction.	Service air cleaner.
	Clogged fuel filter.	Replace filter elements.
	Improper type of fuel.	Use proper fuel.
	Overheated engine.	See "Engine Overheats".
	Below normal engine temperature.	Remove and check thermostat.
	Improper valve clearance.	See your authorized servicing dealer or engine distributor.
	Dirty or faulty injectors.	Have authorized servicing dealer or engine distributor check injectors.
	Unit injection pumps out of time	See your authorized servicing dealer or engine distributor.
	Turbocharger not functioning. (Turbocharger engines only.)	See your authorized servicing dealer or engine distributor.
	Leaking exhaust manifold gasket.	See your authorized servicing dealer or engine distributor.
	Defective aneroid control line. (Aneroid engines only.)	See your authorized servicing dealer or engine distributor.
	Restricted fuel hose.	Clean or replace fuel hose.
	Low fast idle speed.	See your authorized servicing dealer or engine distributor.
Low oil pressure	Low oil level.	Add oil.
	Improper type of oil.	Drain, fill crankcase with oil of proper viscosity and quality.

Continued on next page

RG41183.0000059 -19-16JAN03-3/7

Troubleshooting

Symptom	Problem	Solution
High oil consumption	Crankcase oil too light.	Use proper viscosity oil.
	Oil leaks.	Check for leaks in lines, gaskets, and drain plug.
	Restricted crankcase vent tube.	Clean vent tube.
	Defective turbocharger. (Turbocharger engines only.)	See your authorized servicing dealer or engine distributor.
Engine emits white smoke	Improper type of fuel.	Use proper fuel.
	Low engine temperature.	Warm up engine to normal operating temperature.
	Defective thermostat.	Remove and check thermostat.
	Defective fuel injectors.	See your authorized servicing dealer or engine distributor.
	Engine out of time.	See your authorized servicing dealer or engine distributor.
Engine emits black or gray exhaust smoke	Improper type of fuel.	Use proper fuel.
	Clogged or dirty air cleaner.	Service air cleaner.
	Engine overloaded.	Reduce load.
	Fuel injectors dirty.	See your authorized servicing dealer or engine distributor.
	Engine out of time.	See your authorized servicing dealer or engine distributor.
	Turbocharger not functioning. (Turbocharged engines only)	See your authorized servicing dealer or engine distributor.

Continued on next page

RG41183.0000059 -18-16JAN03-4/7

Troubleshooting

Symptom	Problem	Solution
Engine overheats	Engine overloaded.	Reduce load.
	Low coolant level.	Fill radiator to proper level, check radiator and hoses for loose connections or leaks.
	Faulty radiator cap.	Have serviceman check.
	Stretched poly-vee belt or defective belt tensioner.	Check automatic belt tensioner and check belts for stretching. Replace as required.
	Low engine oil level.	Check oil level. Add oil as required.
	Cooling system needs flushing.	Flush cooling system.
	Defective thermostat.	Remove and check thermostat.
	Defective temperature gauge or sender.	Check water temperature with thermometer and replace, if necessary.
	Incorrect grade of fuel.	Use correct grade of fuel.
	High fuel consumption	Improper type of fuel.
Clogged or dirty air cleaner.		Service air cleaner.
Engine overloaded.		Reduce load.
Improper valve clearance.		See your authorized servicing dealer or engine distributor.
Fuel injectors dirty.		See your authorized servicing dealer or engine distributor.
Engine out of time.		See your authorized servicing dealer or engine distributor.
Defective turbocharger. (Turbocharged engines only.)		See your authorized servicing dealer or engine distributor.
Low engine temperature.		Check thermostat.

Continued on next page

RG41183.0000059 -19-16JAN03-57

Troubleshooting

Symptom	Problem	Solution
Undercharged electrical system	Excessive electrical load from added accessories.	Remove accessories or install higher output alternator.
	Excessive engine idling.	Increase engine rpm when heavy electrical load is used.
	Poor electrical connections on battery, ground strap, starter, or alternator.	Inspect and clean or tighten connections as necessary.
	Defective battery.	Test battery.
	Defective alternator.	Test charging system.
Battery uses too much water	Cracked battery case.	Check for moisture and replace as necessary.
	Defective battery.	Test battery.
	Battery charging rate too high.	Test charging system.
Batteries will not charge	Loose or corroded connections.	Clean and tighten connections.
	Sulfated or worn-out batteries.	See your authorized servicing dealer or engine distributor.
	Stretched poly-vee belt or defective belt tensioner.	Adjust belt tension or replace belts.
Starter will not crank	Engine driveline engaged.	Disengage engine driveline.
	Loose or corroded connections.	Clean and tighten loose connections.
	Low battery output voltage.	See your authorized servicing dealer or engine distributor.
	Faulty start circuit relay.	See your authorized servicing dealer or engine distributor.
	Blown main system fuse.	Replace electrical system fuse.
Starter cranks slowly	Low battery output.	See your authorized servicing dealer or engine distributor.
	Crankcase oil too heavy.	Use proper viscosity oil.
	Loose or corroded connections.	Clean and tighten loose connections.

Continued on next page

RG41183.0000059 -19-16JAN03-6/7

Troubleshooting

Symptom	Problem	Solution
Entire electrical system does not function	Faulty battery connection.	Clean and tighten connections.
	Sulfated or worn-out batteries.	See your authorized servicing dealer or engine distributor.
	Blown main system fuse.	Replace electrical system fuse.

RG41183.0000059 -19-16JAN03-7/7

Storage

Engine Storage Guidelines

1. John Deere engines can be stored outside for up to three (3) months with no long term preparation IF COVERED BY WATERPROOF COVERING.
2. John Deere engines can be stored in a standard overseas shipping container for up to three (3) months with no long term preparation.
3. John Deere engines can be stored inside, warehoused, for up to six (6) months with no long term preparation.
4. John Deere engines expected to be stored more than six (6) months, long term storage preparation MUST BE taken. (See PREPARING ENGINE FOR LONG TERM STORAGE, later in this section.)

RG41183,0000066 -19-21JAN03-1/1

Preparing Engine for Long Term Storage

The following storage preparations are good for long term engine storage up to one year. After that, the engine should be started, warmed up, and retreated for an extended storage period.

IMPORTANT: Any time your engine will not be used for over six (6) months, the following recommendations for storing it and removing it from storage will help to minimize corrosion and deterioration.

1. Change engine oil and replace filter. Used oil will not give adequate protection. (See CHANGE ENGINE OIL AND FILTER in Lubrication and Maintenance/250 Hour Section.)
2. Service air cleaner. (See REPLACING AIR CLEANER FILTER ELEMENTS in Service As Required Section.)
3. Draining and flushing of cooling system is not necessary if engine is to be stored only for several months. However, for extended storage periods of a year or longer, it is recommended that the cooling system be drained, flushed, and refilled. Refill with appropriate coolant. (See RECOMMENDED ENGINE COOLANT in Fuels, Lubricants, and Coolant Section and ADDING COOLANT in Service As Required Section.)
4. Remove fan/alternator poly-vee belt, if desired.
5. Remove and clean batteries. Store them in a cool, dry place and keep them fully charged.
6. Disengage the clutch for any driveline.
7. Clean the exterior of the engine with salt-free water and touch up any scratched or chipped painted surfaces with a good quality paint.
8. Coat all exposed (machined) metal surfaces with grease or corrosion inhibitor if not feasible to paint.
9. Seal all openings on engine with plastic bags and tape.
10. Store the engine in a dry protected place. If engine must be stored outside, cover it with a waterproof canvas or other suitable protective material and use a strong waterproof tape.

RG, RG34710, 5612 -19-23NOV01-1/1

Removing Engine from Long Term Storage

Refer to the appropriate section for detailed services listed below or have your authorized servicing dealer or engine distributor perform services that you may not be familiar with.

1. Remove all protective coverings from engine. Unseal all openings in engine and remove covering from electrical systems.
2. Remove the batteries from storage. Install batteries (fully charged) and connect the terminals.
3. Install fan/alternator poly-vee belt if removed.
4. Fill fuel tank.
5. Perform all appropriate prestarting checks. (See DAILY PRESTARTING CHECKS in Lubrication and Maintenance/Daily Section.)
6. Crank engine for 20 seconds with starter (do not allow the engine to start). Wait 2 minutes and crank engine an additional 20 seconds to assure bearing surfaces are adequately lubricated.
7. Start engine and run at low idle and no load for several minutes. Warm up carefully and check all gauges for correct readings before placing engine under load.
8. On the first day of operation after storage, check overall engine for leaks and check all gauges for correct readings.

IMPORTANT: DO NOT operate starter more than 30 seconds at a time. Wait at least 2 minutes for starter to cool before trying again.

RG,RC34710,5613 -19-20MAY96-1/1

Specifications

General OEM Engine Specifications—2.4 L Engines

ITEM	ENGINE	
	4024DF270	4024TF270
Number of Cylinders	4	4
Bore	86 mm (3.39 in.)	86 mm (3.39 in.)
Stroke	105 mm (4.13)	105 mm (4.13)
Displacement	2.4 L (146 cu. in.)	2.44 L (149 cu. in.)
Compression Ratio	19.01:1	18.01:1
Max. Crank Pressure	0.5 kPa (2 H ₂ O)	0.5 kPa (2 H ₂ O)
Governor Regulation	7—10 %	7—10 %
Oil Pressure At Rated Speed, Full Load (±15 psi)	345 kPa (50 psi)	345 kPa (50 psi)
Oil Pressure At Low Idle (Minimum)	105 kPa (15 psi)	105 kPa (15 psi)
Length	541 mm (21.3 in.)	662 mm (26.1 in.)
Width	514 mm (20.2 in.)	541 mm (21.3 in.)
Height	810 mm (31.9 in.)	772 mm (30.4 in.)
Weight	232 kg (511 lb)	251 kg (554 lb)

Engine models listed with numbers ending in "270" are standard industrial engines. Engines with suffix "D" are naturally aspirated while engines with suffix "T" are turbocharged.

RG41183.0000067 -19-21JAN03-1/1

Specifications

General OEM Engine Specifications—3.0 L Engines

ITEM	ENGINE	
	5030TF270	5030HF270
Number of Cylinders	5	5
Bore	86 mm (3.39 in.)	86 mm (3.39 in.)
Stroke	105 mm (4.13 in.)	105 mm (4.13 in.)
Displacement	3.0 L (186 cu. in.)	3.0 L (186 cu. in.)
Compression Ratio	18.0:1	18.0:1
Max. Crank Pressure	0.5 kPa (2 H ₂ O)	0.5 kPa (2 H ₂ O)
Governor Regulation	7—10 %	7—10 %
Oil Pressure At Rated Speed, Full Load (±15 psi)	345 kPa (50 psi)	345 kPa (50 psi)
Oil Pressure At Low Idle (Minimum)	105 kPa (15 psi)	105 kPa (15 psi)
Length	799 mm (31.5 in.)	799 mm (31.5 in.)
Width	566 mm (22.3 in.)	566 mm (22.3 in.)
Height	800 mm (31.5 in.)	800 mm (31.5 in.)
Weight	287 kg (633 lb)	287 kg (633 lb)

Engine models listed with numbers ending in "270" are standard industrial engines. Engines with suffix "D" are naturally aspirated while engines with suffix "T" are turbocharged. Engines with suffix "H" are turbocharged and air-to-air intercooled.

RG41183.0000068 -19-21JAN03-1/1

Specifications

Engine Power Rating and Speed Specifications

NOTE: Specifications are subject to change. Refer to factory DTAC for assistance.

that are different from those preset at the factory.

Engine speeds listed are as preset to factory specification. In some cases, slow idle speed will be reset depending upon specific vehicle application requirements. Refer to your machine technical manual for engine speeds

Power ratings specify flywheel power for a bare engine without the drag effect of a cooling fan or other accessories like an air compressor.

POWER RATINGS ON DYNAMOMETER FOR OEM ENGINES

Engine Model	Fuel System Option Code	Engine Application	Slow Idle (rpm)	Fast Idle (rpm)	Rated Speed at Full Load (rpm)	Power Rating kW (HP)*
4024DF270	1602	Industrial	900	3000	2800	37 (49)
4024TF270	1601	Industrial	900	3000	2800	45 (60)
4024TF270	1603	Industrial	900	3000	2800	49 (66)
5030TF270	1604	Industrial	900	3000	2800	56 (75)
5030TF270	1605	Industrial	900	3000	2800	63 (84)
5030HF270	1606	Industrial	900	3000	2800	74 (99)

*Power rating is under full load and at rated speed listed

RG41183.0000069 -19-21JAN03-1/1

Engine Crankcase Oil Fill Quantities

To determine the option code for the oil fill quantity of your engine, refer to the engine option code label affixed to the rocker arm cover. The first two digits of the code (19) identify the oil pan option group. The last two digits of each code identify the specific oil pan on your engine.

The following table lists engine crankcase oil fill quantities for each "19__" option code for these engines.

Engine Model	Option Code	Crankcase Oil Capacity L (qt)
4024	1901	6.5 (7)
5030	1902	10 (11)

RG41183.000006A -19-21JAN03-1/1

Unified Inch Bolt and Cap Screw Torque Values

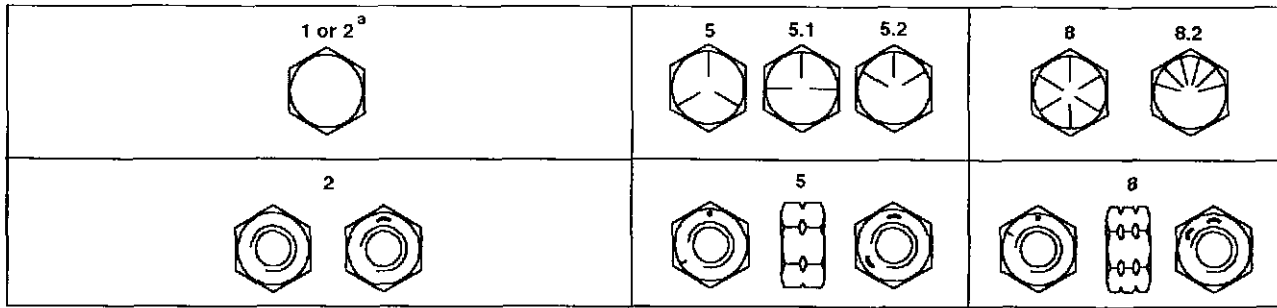

Top, SAE Grade and Head Markings; Bottom, SAE Grade and Nut Markings

Size	Grade 1 (No Mark)		Grade 2 ^a (No Mark)		Grade 5, 5.1 or 5.2		Grade 8 or 8.2	
	Lubricated ^b N·m(lb-ft)	Dry ^c N·m(lb-ft)	Lubricated ^b N·m(lb-ft)	Dry ^c N·m(lb-ft)	Lubricated ^b N·m(lb-ft)	Dry ^c N·m(lb-ft)	Lubricated ^b N·m(lb-ft)	Dry ^c N·m(lb-ft)
1/4	3.8 (2.8)	4.7 (3.5)	6 (4.4)	7.5 (5.5)	9.5 (7)	12 (9)	13.5 (10)	17 (12.5)
5/16	7.7 (5.7)	9.8 (7.2)	12 (9)	15.5 (11.5)	19.5 (14.5)	25 (18.5)	28 (20.5)	35 (26)
3/8	13.5 (10)	17.5 (13)	22 (16)	27.5 (20)	35 (26)	44 (32.5)	49 (36)	63 (46)
7/16	22 (16)	28 (20.5)	35 (26)	44 (32.5)	56 (41)	70 (52)	80 (59)	100 (74)
1/2	34 (25)	42 (31)	53 (39)	67 (49)	85 (63)	110 (80)	120 (88)	155 (115)
9/16	48 (35.5)	60 (45)	76 (56)	95 (70)	125 (92)	155 (115)	175 (130)	220 (165)
5/8	67 (49)	85 (63)	105 (77)	135 (100)	170 (125)	215 (160)	240 (175)	305 (225)
3/4	120 (88)	150 (110)	190 (140)	240 (175)	300 (220)	380 (280)	425 (315)	540 (400)
7/8	190 (140)	240 (175)	190 (140)	240 (175)	490 (360)	615 (455)	690 (510)	870 (640)
1	285 (210)	360 (265)	285 (210)	360 (265)	730 (540)	920 (680)	1030 (760)	1300 (960)
1-1/8	400 (300)	510 (375)	400 (300)	510 (375)	910 (670)	1150 (850)	1450 (1075)	1850 (1350)
1-1/4	570 (420)	725 (535)	570 (420)	725 (535)	1280 (945)	1630 (1200)	2050 (1500)	2600 (1920)
1-3/8	750 (550)	950 (700)	750 (550)	950 (700)	1700 (1250)	2140 (1580)	2700 (2000)	3400 (2500)
1-1/2	990 (730)	1250 (930)	990 (730)	1250 (930)	2250 (1650)	2850 (2100)	3600 (2650)	4550 (3350)

^a Grade 2 applies for hex cap screws (not hex bolts) up to 6 in. (152 mm) long. Grade 1 applies for hex cap screws over 6 in. (152 mm) long, and for all other types of bolts and screws of any length.

^b "Lubricated" means coated with a lubricant such as engine oil, or fasteners with phosphate and oil coatings.

^c "Dry" means plain or zinc plated without any lubrication.

DO NOT use these values if a different torque value or tightening procedure is given for a specific application. Torque values listed are for general use only. Check tightness of fasteners periodically.

Make sure fastener threads are clean and that you properly start thread engagement. This will prevent them from failing when tightening.

Shear bolts are designed to fail under predetermined loads. Always replace shear bolts with identical grade.

Tighten plastic insert or crimped steel-type lock nuts to approximately 50 percent of the dry torque shown in the chart, applied to the nut, not to the bolt head. Tighten toothed or serrated-type lock nuts to the full torque value.

Fasteners should be replaced with the same or higher grade. If higher grade fasteners are used, these should only be tightened to the strength of the original.

Metric Bolt and Cap Screw Torque Values

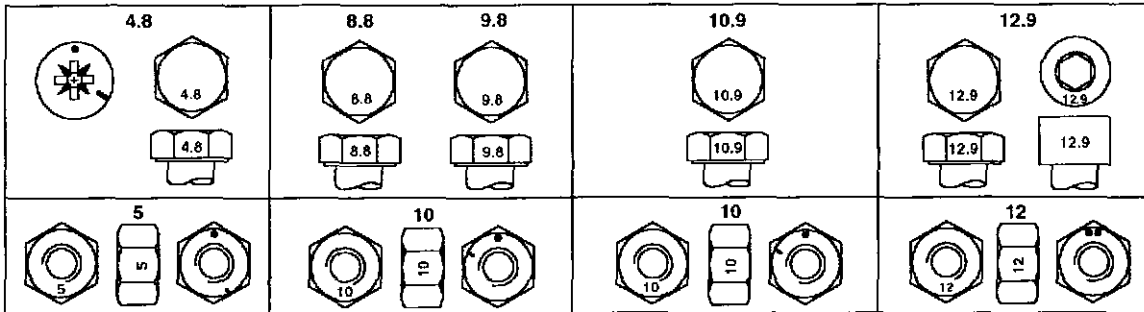

Top, Property Class and Head Markings; Bottom, Property Class and Nut Markings

Size	Class 4.8		Class 8.8 or 9.8		Class 10.9		Class 12.9	
	Lubricated ^a N·m(lb-ft)	Dry ^b N·m(lb-ft)	Lubricated ^a N·m(lb-ft)	Dry ^b N·m(lb-ft)	Lubricated ^a N·m(lb-ft)	Dry ^b N·m(lb-ft)	Lubricated ^a N·m(lb-ft)	Dry ^b N·m(lb-ft)
M6	4.7 (3.5)	6 (4.4)	9 (6.6)	11.5 (8.5)	13 (9.5)	16.5 (12.2)	15.5 (11.5)	19.5 (14.5)
M8	11.5 (8.5)	14.5 (10.7)	22 (16)	28 (20.5)	32 (23.5)	40 (29.5)	37 (27.5)	47 (35)
M10	23 (17)	29 (21)	43 (32)	55 (40)	63 (46)	80 (59)	75 (55)	95 (70)
M12	40 (29.5)	50 (37)	75 (55)	95 (70)	110 (80)	140 (105)	130 (95)	165 (120)
M14	63 (46)	80 (59)	120 (88)	150 (110)	175 (130)	220 (165)	205 (150)	260 (190)
M16	100 (74)	125 (92)	190 (140)	240 (175)	275 (200)	350 (255)	320 (235)	400 (300)
M18	135 (100)	170 (125)	265 (195)	330 (245)	375 (275)	475 (350)	440 (325)	560 (410)
M20	190 (140)	245 (180)	375 (275)	475 (350)	530 (390)	675 (500)	625 (460)	790 (580)
M22	265 (195)	330 (245)	510 (375)	650 (480)	725 (535)	920 (680)	850 (625)	1080 (800)
M24	330 (245)	425 (315)	650 (480)	820 (600)	920 (680)	1150 (850)	1080 (800)	1350 (1000)
M27	490 (360)	625 (460)	950 (700)	1200 (885)	1350 (1000)	1700 (1250)	1580 (1160)	2000 (1475)
M30	660 (490)	850 (625)	1290 (950)	1630 (1200)	1850 (1350)	2300 (1700)	2140 (1580)	2700 (2000)
M33	900 (665)	1150 (850)	1750 (1300)	2200 (1625)	2500 (1850)	3150 (2325)	2900 (2150)	3700 (2730)
M36	1150 (850)	1450 (1075)	2250 (1650)	2850 (2100)	3200 (2350)	4050 (3000)	3750 (2770)	4750 (3500)

^a "Lubricated" means coated with a lubricant such as engine oil, or fasteners with phosphate and oil coatings.

^b "Dry" means plain or zinc plated without any lubrication.

DO NOT use these values if a different torque value or tightening procedure is given for a specific application. Torque values listed are for general use only. Check tightness of fasteners periodically.

Shear bolts are designed to fail under predetermined loads. Always replace shear bolts with identical property class.

Fasteners should be replaced with the same or higher property class. If higher property class fasteners are used, these should only be tightened to the strength of the original.

Make sure fastener threads are clean and that you properly start thread engagement. This will prevent them from failing when tightening.

Tighten plastic insert or crimped steel-type lock nuts to approximately 50 percent of the dry torque shown in the chart, applied to the nut, not to the bolt head. Tighten toothed or serrated-type lock nuts to the full torque value.

Lubrication and Maintenance Records

Using Lubrication and Maintenance Records

Refer to specific Lubrication and Maintenance Section for detailed service procedures.

1. Keep a record of the number of hours you operate your engine by regular observation of hour meter.
2. Check your record regularly to learn when your engine needs service.
3. DO ALL the services within an interval section. Write the number of hours (from your service records) and the date in the spaces provided. For a complete listing of all items to be performed and the

service intervals required, refer to the quick-reference chart near the front of the Lubrication and Maintenance Section.

IMPORTANT: The service recommendations covered in this manual are for the accessories that are provided by John Deere. Follow manufacturer's service recommendations for servicing engine-driven equipment or other accessories not supplied by Deere.

RG.RG34710.5620 --19-20MAY95-1/1

Daily (Prestarting) Service

- Check engine oil level.
- Check coolant level.

IMPORTANT: Drain water by loosening drain plug on fuel/water separator bowl. Premature unit injection pump failure may occur if water is not drained daily.

- Check fuel filter/water separator bowl.
- Check air cleaner dust unloader valve and air restriction indicator, if equipped.
- Visual walkaround inspection.

RG41183.000006B --19-21JAN03-1/1

Lubrication and Maintenance Records

250 Hour/6 Month Service

- Change engine oil and filter.¹
- Service fire extinguisher.
- Service battery.
- Check automatic belt tensioner and belt wear.

Hours									
Date									
Hours									
Date									
Hours									
Date									
Hours									
Date									
Hours									
Date									
Hours									
Date									
Hours									
Date									
Hours									
Date									

¹If John Deere PLUS-50 or ACEA - E4/E5 oil is used along with a John Deere oil filter, the oil and filter change interval may be extended by 50 percent to every 375 hours.

RG41183.000006C -19-21JAN03-1/1

500 Hour/12 Month Service

- Clean crankcase vent tube.
- Check air intake hoses, connections, and system.
- Replace fuel filter element.
- Check automatic belt tensioner and belt wear.
- Check engine electrical ground connection.
- Check cooling system.
- Coolant solution analysis – add SCAs as needed.
- Pressure test cooling system.

Hours									
Date									
Hours									
Date									
Hours									
Date									
Hours									
Date									
Hours									
Date									
Hours									
Date									
Hours									
Date									
Hours									
Date									

RG, RG34710, 5624 -19-07 JAN02-1/1

Lubrication and Maintenance Records

2000 Hour/24 Month Service

- Check crankshaft vibration damper (If equipped). (5030 Engines only).
- Flush cooling system.¹
- Test thermostats.

Hours									
Date									
Hours									
Date									
Hours									
Date									
Hours									
Date									
Hours									
Date									
Hours									
Date									
Hours									
Date									
Hours									
Date									

¹If John Deere COOL-GARD is used, the flushing interval may be extended to 3000 hours, or 36 months. If John Deere COOL-GARD is used and the coolant is tested annually AND additives are replenished as needed by adding a supplemental coolant additive, the flushing interval may be extended to 5000 hours or 60 months, whichever occurs first.

RG41183.000006D -19-21JAN03-1/1

Lubrication and Maintenance Records

Service as Required

- Add coolant
- Service air cleaner.
- Replace poly-vee belts.
- Check fuses
- Bleed fuel system

Hours									
Date									
Hours									
Date									
Hours									
Date									
Hours									
Date									
Hours									
Date									
Hours									
Date									
Hours									
Date									
Hours									
Date									

RG.RG34710.5627 -19-07JAN02-1/1

Emission System Warranty

U.S. EPA Emissions Control Warranty Statement

Emissions control-related parts and components are warranted by John Deere for five years or 3000 hours of operation, whichever occurs first. John Deere further warrants that the engine covered by this warranty was designed, built, and equipped so as to conform at the time of sale with all U.S. emissions standards at the time of manufacture, and that it is free of defects in materials and workmanship which would cause it not to meet these standards within the period of five years or 3000 hours of operation, whichever occurs first.

Warranties stated in this manual refer only to emissions-related parts and components of your engine. The complete engine warranty, less emissions-related parts and components, is provided separately as the "John Deere New Off-Highway Engine Warranty".

RG, RG34710, 7629 -19-30JUN97-1/1

Emissions Control System Certification Label

CAUTION: Statutes providing severe penalties for tampering with emissions controls may apply to the user or dealer.

The emissions warranty described below applies only to those engines marketed by John Deere that have been certified by the United States Environmental Protection Agency (EPA) and/or California Air Resources Board (CARB); and used in the United States and Canada in non-road mobile (self-propelled or portable/transportable¹) equipment. The presence of an emissions label like the one shown signifies that the engine has been certified with the EPA and/or CARB. The EPA and CARB warranties only apply to new engines having the certification label affixed to the engine and sold as stated above in the geographic areas. The presence of an EU number in the third line of the label signifies that the engine has been certified with the European Union countries per Directive 97/68/EC. The emissions warranty does not apply to the EU countries.

NOTE: The hp/kW rating on the engine emissions certification label specifies the gross engine hp/kW, which is flywheel power without fan. In most applications this will not be the same rating as the advertised vehicle hp/kW rating.

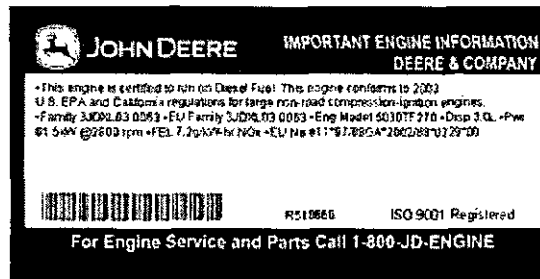

Emissions Label

¹Equipment moved at least once every 12 months.

John Deere Service Literature Available

Technical Information

Technical information is available from John Deere. Some of this information is available in electronic as well as printed form. Order from your John Deere dealer or call **1-800-522-7448**. Please have available the model number, serial number, and name of the product.

Available information includes:

- **PARTS CATALOGS** list service parts available for your machine with exploded view illustrations to help you identify the correct parts. It is also useful in assembling and disassembling.
- **OPERATOR'S MANUALS** providing safety, operating, maintenance, and service information. These manuals and safety signs on your machine may also be available in other languages.
- **OPERATOR'S VIDEO TAPES** showing highlights of safety, operating, maintenance, and service information. These tapes may be available in multiple languages and formats.
- **TECHNICAL MANUALS** outlining service information for your machine. Included are specifications, illustrated assembly and disassembly procedures, hydraulic oil flow diagrams, and wiring diagrams. Some products have separate manuals for repair and diagnostic information. Some components, such as engines, are available in separate component technical manuals
- **FUNDAMENTAL MANUALS** detailing basic information regardless of manufacturer:
 - Agricultural Primer series covers technology in farming and ranching, featuring subjects like computers, the Internet, and precision farming.
 - Farm Business Management series examines "real-world" problems and offers practical solutions in the areas of marketing, financing, equipment selection, and compliance.
 - Fundamentals of Services manuals show you how to repair and maintain off-road equipment.
 - Fundamentals of Machine Operation manuals explain machine capacities and adjustments, how to improve machine performance, and how to eliminate unnecessary field operations.

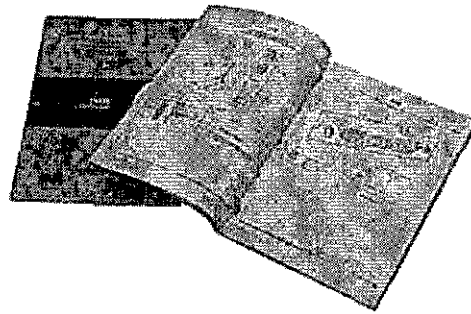

Parts Catalogs

RG9262 -UN-16MAR93

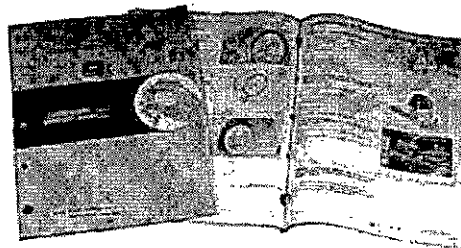

Operator Manuals

RG9260 -UN-16MAR98

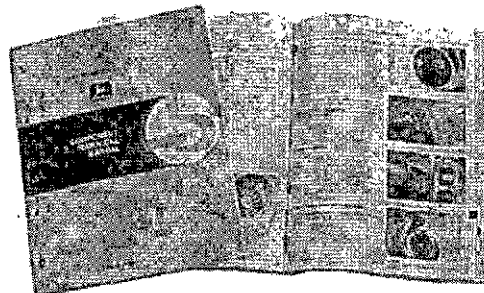

Component Technical Manuals

RG9261 -UN-16MAR98



Fundamental Manuals

TS1663 -UN-10OCT97

DPSG, RG41165, 134 -19-10JUL00-1/1

Publications for this Engine

Technical information is available from John Deere in support of our products. Some of this information is available in electronic as well as printed form. Order from your John Deere dealer or call **1-800-522-7448**. Please have available the model number, and name of the product.

Title	Order Number
POWERTECH 2.4 L and 3.0 L OEM Diesel Engines (English):	
Operation and Maintenance Manual	OMRG34851
Parts Catalogs (OEM Engines Only)	
POWERTECH 2.4 L (4024)	PC9281
POWERTECH 3.0 L (5030)	PC9282
Component Technical Manual: (2.4 & 3.0 L)	CTM301
OEM Engine Accessories	CTM67
Alternators and Starter Motors	CTM77

RG41183,00006F -19-21JAN03-1/1

Index

	Page		Page
A			
Acid burns	30-5	Storage	10-3
Air intake system, check	35-2	Dieselscan fuel analysis	10-5
Alternator		E	
Replacing Belt		Emissions	
Belt Routing	45-7	EPA Statement	70-1
Analysis		Engine coolant	
Dieselscan	10-5	Disposing of	10-17
B			
Batteries		Engine mounts	
Charge/Boost	15-10	Checking	30-4
Service	30-5	Engine oil	
Battery acid burns	30-5	Break-In	10-8
Battery explosion	30-5	Diesel	10-9
Belt tensioner, automatic	35-4	Extended service intervals	10-10
Bio-Diesel fuel	10-4	Quantity	60-3
Bleed fuel system	45-8	F	
C			
Cold weather aids	10-7	Fire extinguisher, service	30-1
Coolant		Fuel	
Adding	45-2	Bio-Diesel	10-4
Additional information	10-14	Diesel	10-1
Analysis	10-11	Dieselscan Analysis	10-5
Diesel engine	10-13	Storage	10-3
Disposing	10-17	Fuel system	
Replenishing supplemental additives	35-7	Bleed	45-8
Supplemental additives	10-16	Fuel System	
Testing	10-15, 35-9	Replace Filter	35-3
Warm temperature climates	10-16	Fuel tank	
Cooling system		Filling	10-6
Adding coolant	45-2	G	
Check	35-6	Grease	
Flush	40-2	Extreme pressure and multipurpose	10-12
Pressure test	35-10	I	
Pressure test radiator cap	35-10	Inch torque values	60-4
Thermostat	40-4	L	
Crankcase vent tube, clean	35-1	Lubricants	
D			
Diesel engine oil	10-9	Mixing	10-10
Diesel fuel	10-1		

