

GENERAC[®]
POWER SYSTEMS, INC.

3.0 LITER

***KIA
DIESEL
ENGINE***

***SERVICE
MANUAL***

FOREWORD

This manual has been published by GENERAC® POWER SYSTEMS, INC. to aid our dealers' mechanics, company service personnel and general consumers when servicing the products described herein.

It is assumed that these personnel are familiar with the servicing procedures for these products, or like or similar products, manufactured and marketed by GENERAC® POWER SYSTEMS, INC. It is also assumed that they have been trained in the recommended servicing procedures for these products, which includes the use of mechanics hand tools and any special tools that might be required.

Proper service and repair is important to the safe, economical and reliable operation of the products described herein. The troubleshooting, testing, service and repair procedures recommended by GENERAC® POWER SYSTEMS, INC. and described in this manual are effective methods of performing such operations. Some of these operations or procedures may require the use of specialized equipment. Such equipment should be used when and as recommended.

We could not possibly know of and advise the service trade of all conceivable procedures or methods by which a service might be performed, nor of any possible hazards and/or results of each procedure or method. We have not undertaken any such wide evaluation. Therefore, anyone who uses a procedure or method not recommended by the manufacturer must first satisfy himself that neither his safety, nor the product's safety, will be endangered by the service or operating procedure selected.

All information, illustrations and specifications contained in this manual are based on the latest product information available at the time of publication. However, GENERAC® POWER SYSTEMS, INC. reserves the right to change, alter or otherwise improve the product at any time without prior notice.

Some components or assemblies of the product described in this manual may not be considered repairable. Disassembly, repair and reassembly of such components may not be included in this manual.

The engines described herein may be used to power a wide variety of products. Service and repair instructions relating to any such products are not covered in this manual. For information pertaining to use of these engines with other products, refer to any owner's or service manuals pertaining to said products.

SERVICE RECOMMENDATIONS A_2
KIA CONTENTS

The 3.0 Liter Diesel Engine has been engineered for use in Generac Power Systems products. The contents of this manual have been reprinted from the original manufacturer's service and repair manual.

3.0 Liter Diesel Engine Service Recommendations

◆ ENGINE OIL RECOMMENDATIONS

The unit has been filled with “break in” engine oil at the factory. Use a high-quality detergent oil classified “For Service CC, SD, SE or SF.” Detergent oils keep the engine cleaner and reduce carbon deposits. Use oil having the following SAE viscosity rating, based on the ambient temperature range anticipated before the next oil change:

Engine Lubrication System:

Type of Oil PumpGear
 Oil FilterFull Flow, Cartridge
 Crankcase Oil Capacity6.0 L (6.3 U.S. qts.)

Temperature	Oil Grade (Recommended)
Above 86° F (30° C)	SAE 40 or 15W-40
32° to 86° F (0° to 30° C)	SAE 30 or 15W-40
Below 32° F (0° C)	SAE 20W or 15W-40
All Seasons	SAE 15W-40

◆ COOLANT

Use a mixture of half low silicate, ethylene glycol base antifreeze and half soft water. Use only soft water and only low silicate antifreeze. If desired, you may add a high quality rust inhibitor to the recommended coolant mixture. When adding coolant, always add the recommended 50-50 mixture.

Cooling System:

Type.....Pressurized, Closed Recovery
 Coolant Capacity
 System.....8.5 L (2.0 U.S. qts.)
 Engine3.4 L (0.9 U.S. qts.)



Do not remove the radiator pressure cap while the engine is hot or serious burns from boiling liquid or steam could result.



Ethylene glycol base antifreeze is poisonous. Do not use your mouth to siphon coolant from the radiator, recovery bottle or any container. Wash your hands thoroughly after handling. Never store used antifreeze in an open container because animals are attracted to the smell and taste of antifreeze even though it is poisonous to them.



Do not use any chromate base rust inhibitor with ethylene glycol base antifreeze, or chromium hydroxide (“green slime”) will form and cause overheating. Engines that have been operated with a chromate base rust inhibitor must be chemically cleaned before adding ethylene glycol base antifreeze. Using any high silicate antifreeze boosters or additives also will cause overheating. We also recommend that you DO NOT use any soluble oil inhibitor for this equipment.

PERIODIC MAINTENANCE SCHEDULE:

SERVICE SCHEDULE

◆ AUTHORIZED OPERATOR MAINTENANCE FUNCTIONS

Every Month or 100 Hours

(whichever comes first)

- Test standby generator system.
- Inspect battery and cables.
- Check engine oil level.
- Check gearbox oil level (if so equipped).
- Check engine coolant level.
- Check generator ground connections.
- Test/inspect starting aids.

Every Three Months or Every 120 Hours

(whichever comes first)

- Inspect and test fuel system and connections.
- Inspect exhaust system.
- Inspect/test fuel supply system.

◆ AUTHORIZED SERVICE TECHNICIAN MAINTENANCE FUNCTIONS

After First 30 Hours of Operation

- Inspect wiring.
- Change engine crankcase oil and oil filter.
- Inspect engine fan belts.
- Inspect battery and cables.

Every Six Months or Every 100 Hours

(whichever comes first)

- Change engine oil and filter.
- Lubricate engine controls.
- Service engine air cleaner.
- Service engine fuel filter.
- Inspect AC generator.
- Test engine safety controls.
- Inspect fan belts.
- Check engine coolant level.
- Inspect engine cooling system hoses.
- Check optional starting aids.
- Check battery.
- Check engine compression.
- Check electrical connections.
- Check/test annunciator panel.
- Perform operational test.

Annually or Every 600 Hours

(whichever comes first)

- Check engine valve clearance.
- Test fuel injection nozzles.
- Test injection timing.
- Inspect all wiring.
- Test engine starter operation.
- Drain water from fuel tank.
- Retorque fan bolts.
- Drain and refill gearbox (if so equipped)

Every Two Years

- Replace all rubber hoses.
- Replace engine fan belts.
- Inspect the Standby Generator System.
- Drain, flush, refill cooling system.

Every 1,000 Operating Hours

- Inspect engine DC alternator.
- Inspect engine starter.
- Retorque engine mounting brackets.
- Remove/test fuel injection pump.
- Remove/test cooling system thermostat.

As Required

- Bleed engine fuel system.

Workshop Manual

K2500-K3000

FOREWORD

This workshop manual was prepared as reference material for the service personnel of authorized Kia dealers to enable them to correctly carry out the task of delivering services and maintenance on Kia vehicles.

In order to ensure that the correct servicing is provided for Kia products, proper servicing as provided. For this purpose, the service personnel should understand the contents of this manual at the same time, are recommended to keep the manual in a place where reference can readily be made.

The information, photographs, drawings and specifications entered in this manual were the best available at the time of printing this manual. All alterations to this manual occurring as the result of modifications will be notified by the issuance of Service Informations or supplementary volumes. It is, therefore, requested that the manual be kept up to date by carefully maintaining a follow-up of these materials.

Kia Ind.

All rights reserved. No part of this book may be reproduced or utilized in any form or by any means, electronic or mechanical, including photocopying, recording, or by any informational storage and retrieval system, without permission in writing.

KIA INDUSTRIAL CO., LTD.
PRINTED IN KOREA JULY, '82

SECTION INDEX	
Name	Section
Engine	1
Lubricating System	2
Cooling System	3
Fuel System	4
Electrical System	5
Clutch	6
Transmission	7
Propeller Shaft	8
Rear Axle	9
Steering	10
Brakes	11
Wheels and Tires	12
Suspension	13
Body	14
Technical Data	T

KIA MOTORS LIBRARY



2000115MNO



000115

000115

IMPORTANT SAFETY NOTICE

The service procedures described in this workshop manual are effective for carrying out the safe and reliable service operations. This manual contains the General Service Instructions as mentioned below and various Notes. It is important to read these instructions and notes carefully in order to minimize the risk of personal injury to service personnel or the possibility that improper service methods will be followed which may damage the vehicle or render it unsafe. It is also important to understand that these instructions and notes do not cover all such risks. Accordingly, anyone who performs service operations must make sure thoroughly prior to commencing service that neither his and his partner's safety nor vehicle safety will be jeopardized by the service method and tools selected.

General Service Instructions

1. If the vehicle is to be jacked up only at the front or rear end, be sure to block the wheels in order to ensure safety.
2. After the vehicle is jacked up, do not fail to support it with stand.
3. Use the fender cover, seat cover and floor cover to keep the car clean and prevent any damage.
4. Before servicing the electrical equipment, disconnect the negative cable at the battery.
5. Always replace gaskets and "O" rings with new ones.
6. Apply sealer to gaskets to prevent leakage.
7. Tighten the bolts and nuts to specified torque using a torque wrench.
8. Some of the service operations require the special tool. Be sure to use the special tool where specified and follow the proper work procedure.

ENGINE

1--A. ENGINE REMOVAL	1 : 1
1--B. ENGINE DISASSEMBLY	1 : 3
1--C. ENGINE INSPECTION AND REPAIR	1 : 8
1-C-1. Cylinder Head Inspection	1 : 8
1-C-2. Replacing Combustion Chamber Insert	1 : 8
1-C-3. Valve Spring Inspection	1 : 9
1-C-4. Valve Inspection	1 : 9
1-C-5. Valve Stem and Guide Inspection	1 : 9
1-C-6. Replacing Valve Guide	1 : 10
1-C-7. Valve Seat Inspection and Refacing	1 : 10
1-C-8. Checking Contact between Valve and Valve Seat	1 : 10
1-C-9. Rocker Arm and Shaft Inspection	1 : 11
1-C-10. Cylinder Block Inspection	1 : 11
1-C-11. Liner Inspection	1 : 11
1-C-12. Checking Piston Clearance	1 : 12
1-C-13. Piston and Piston Ring Inspection	1 : 12
1-C-14. Checking Piston Pin and Bush	1 : 13
1-C-15. Checking Connecting Rod Alignment	1 : 13
1-C-16. Crankshaft and Bearing Inspection	1 : 13
1-C-17. Camshaft Inspection	1 : 14
1-C-18. Checking Idlegear and Spindle	1 : 15
1-C-19. Checking Tappet and Guide Clearance	1 : 15
1-C-20. Checking Push Rod	1 : 16
1-C-21. Cylinder Liner Replacement	1 : 16
1--D. ENGINE ASSEMBLY	1 : 17
1--E. ENGINE INSTALLATION	1 : 26
1--F. CHECKING COMPRESSION PRESSURE	1 : 26
SPECIAL TOOLS	1 : 26

1-A. ENGINE REMOVAL

Remove the engine following order numbered in Figs. 1-1, 1-2 and 1-3.

IMPORTANT : After the vehicle is jack up, do not fail to support it with stands.

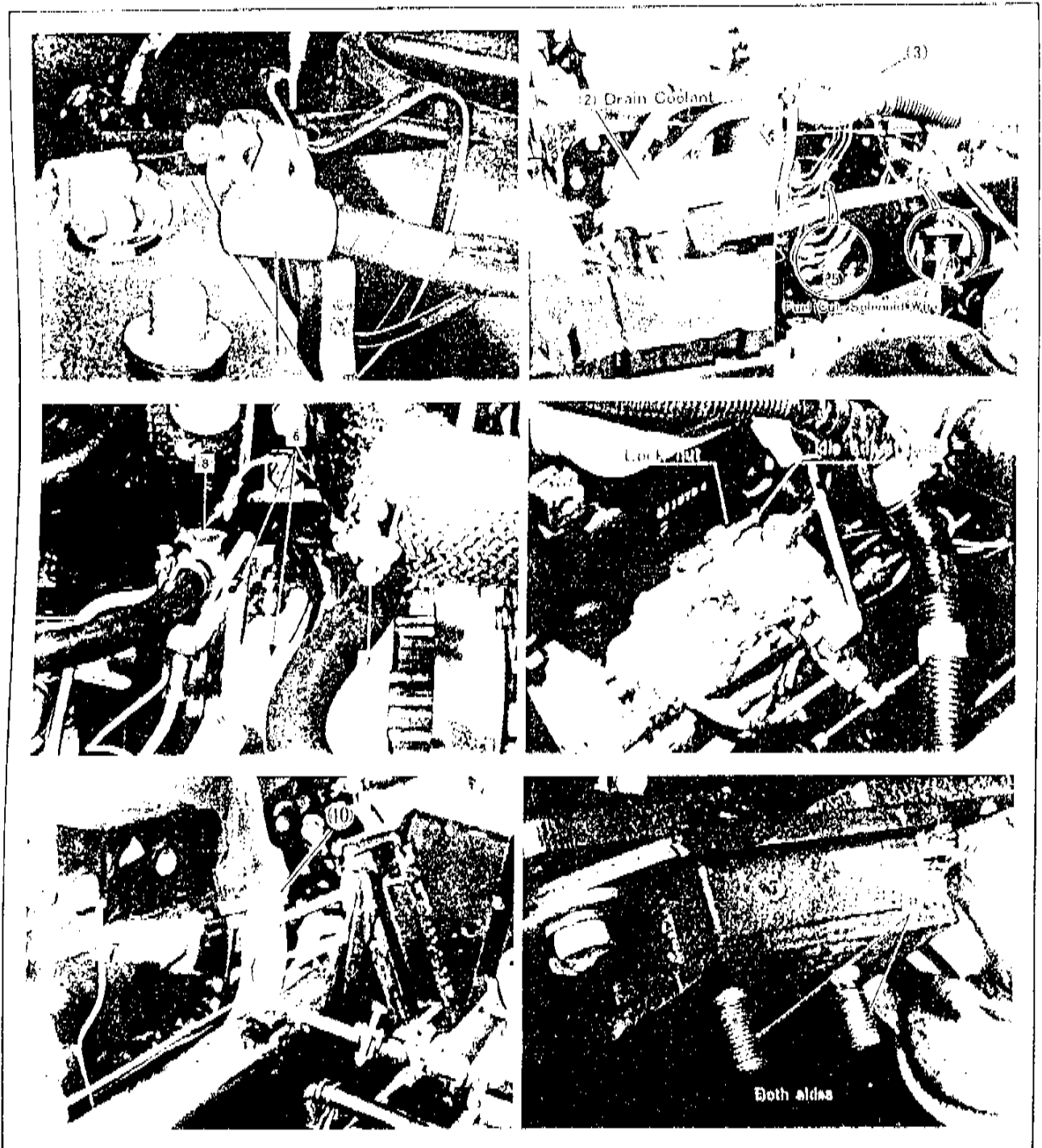

Fig. 1-1

- | | | |
|---------------------------|--------------------------------|------------------|
| 1. Battery negative cable | 6. Wire | 10. Exhaust pipe |
| 2. Draining | water temp unit | 11. Engine mount |
| 3. Air hose | Alternator | |
| 4. Clutch pipe | 7. Water hose, upper and lower | |
| 5. Fuel cut solenoid | 8. Vacuum hose | |
| wire | 9. Control wire | |

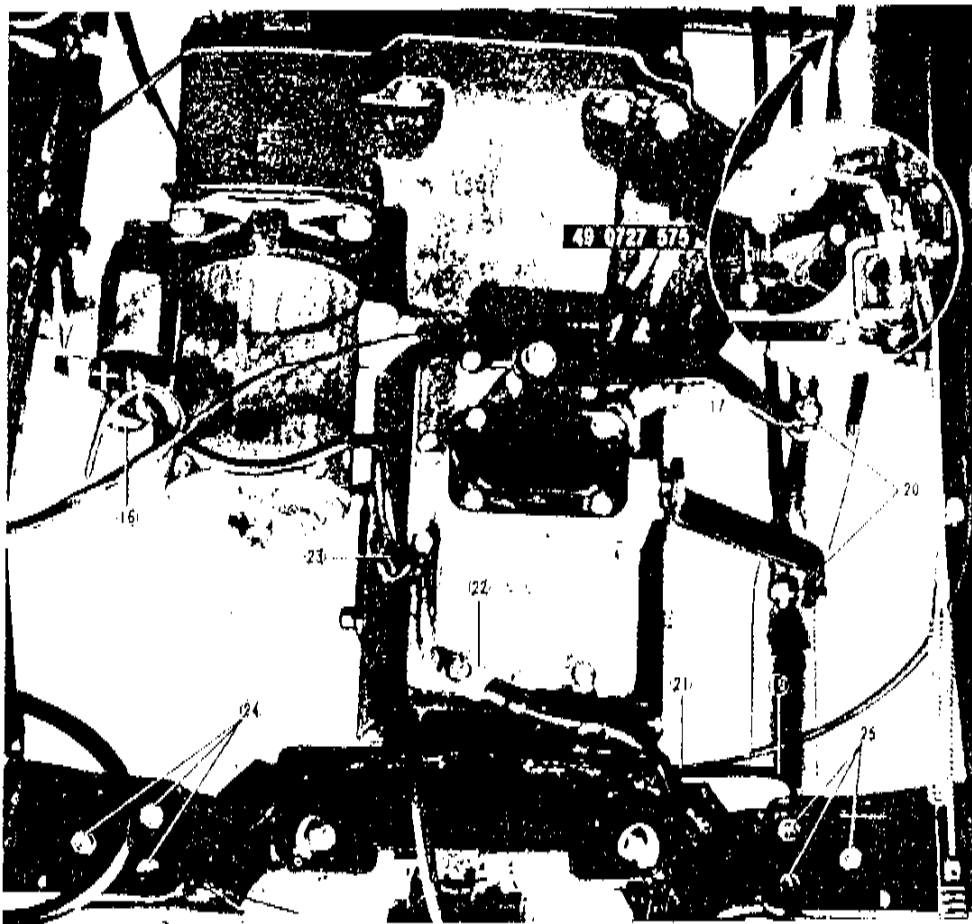

Fig. 1-2

- 15 Tie rod
- 16 Starting motor wire
- 17 Reverse lamp wire
- 18 Fuel hose
- 19 Exhaust pipe bracket
- 20 Changing rods
- 21 Speed meter cable
- 22 Fuse wire
- 23 Wire clip
- 24 Transmission mounting bracket
- 25 Transmission mounting bracket

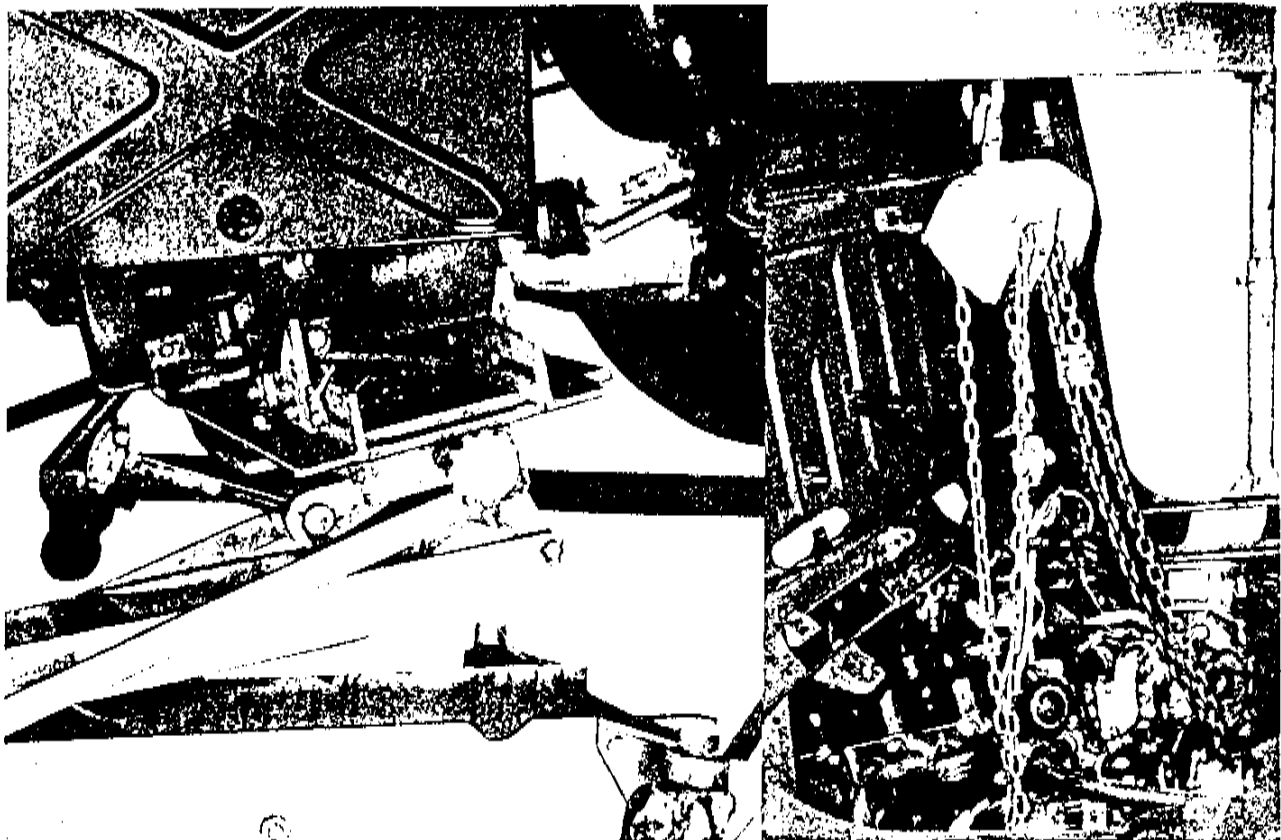

Fig. 1-3

1-B. ENGINE DISASSEMBLY

Disassemble the engine following the order numbered in Figs. 1-4, 1-5, 1-6 and 1-7.

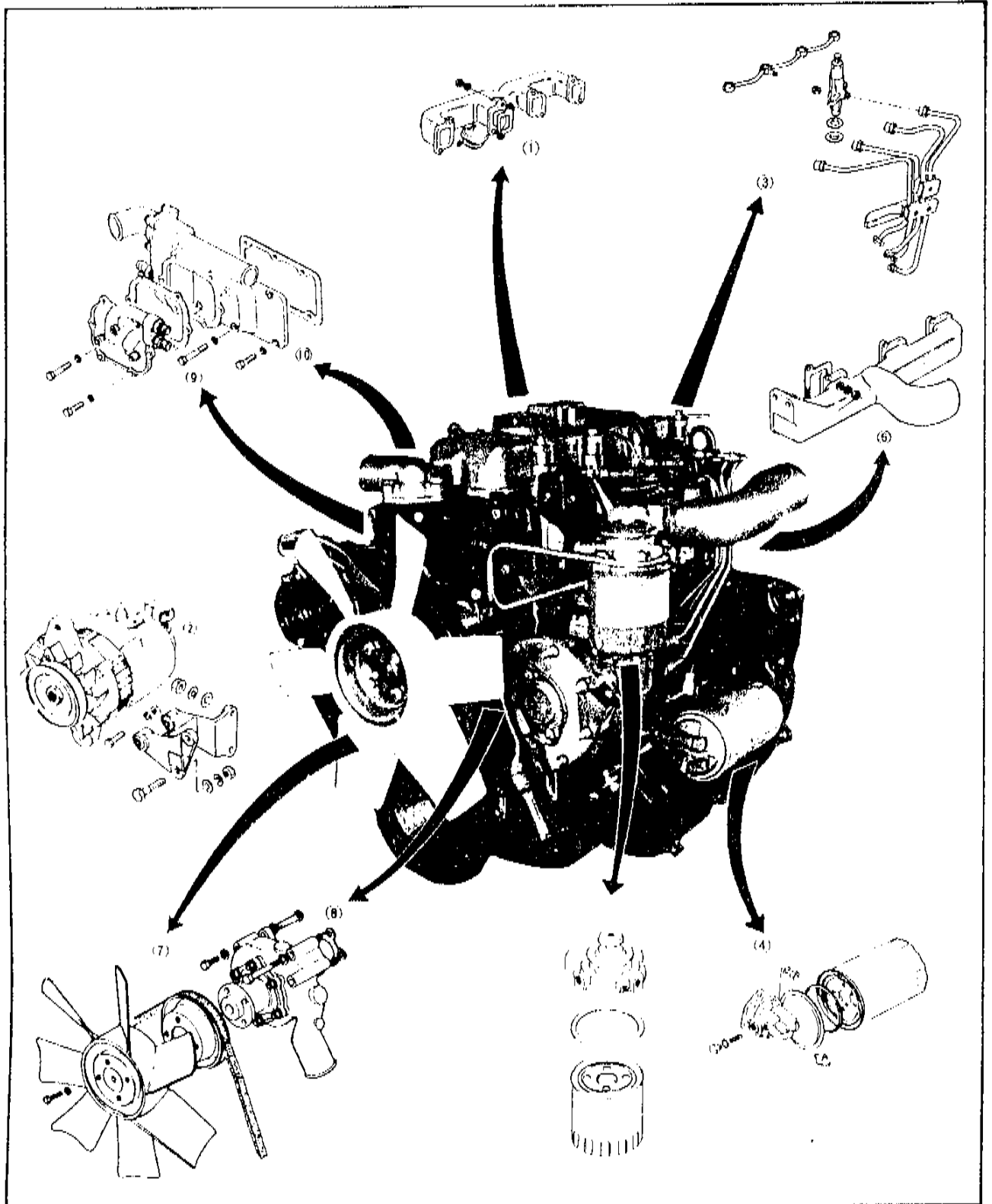

Fig. 1-4

- | | | | |
|-----------------------|--|------------------------------|-------------------------------|
| 1. Exhaust manifold | 3. Injection pipe/nozzle holder/
fuel leak pipe | 5. Fuel filter/pipe assembly | 8. Oil cooler assembly |
| 2. Alternator/bracket | 4. Oil filter/pipe | 6. Intake manifold | 9. Thermostat casing assembly |
| | 7. Cooling fan/belt/pulley
assembly | 10. Water pump assembly | |

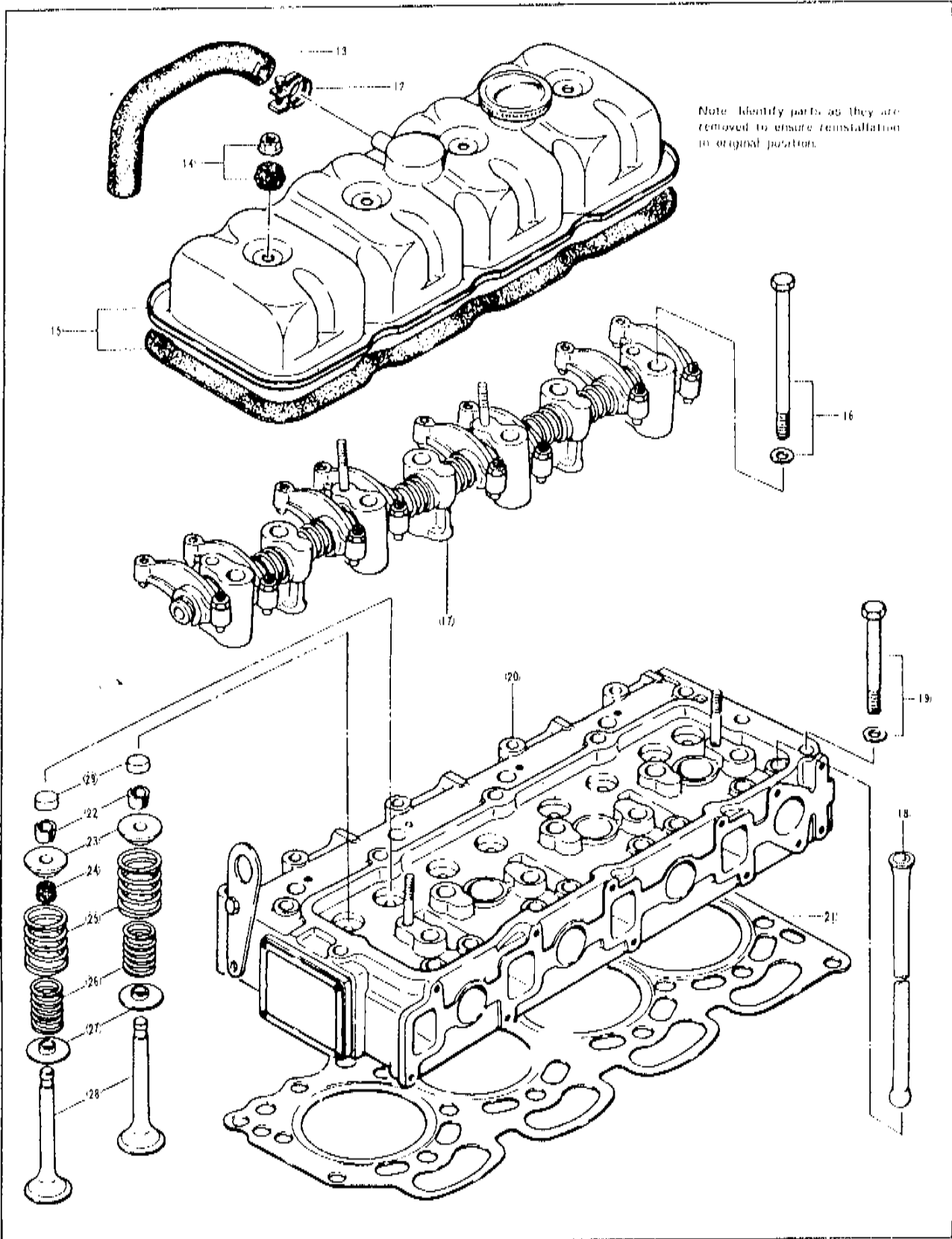

Fig. 1-5

- | | | | |
|-------------------------------|-------------------------------|-----------------------------|------------------------|
| 12. Hose band | 17. Rocker arm assembly | 22. Cotter | 27. Valve spring inner |
| 13. Bleeder hose | 18. Push rod | 23. Valve spring upper seat | 28. IN/EX. Valve |
| 14. Nut/seal washer | 19. Cylinder head bolt/washer | 24. Valve spring outer | 29. Valve Cap. |
| 15. Rocker arm cover/gasket | 20. Cylinder head | 25. Valve spring inner | |
| 16. Cylinder head bolt/washer | 21. Head gasket | 26. Oil deflector | |

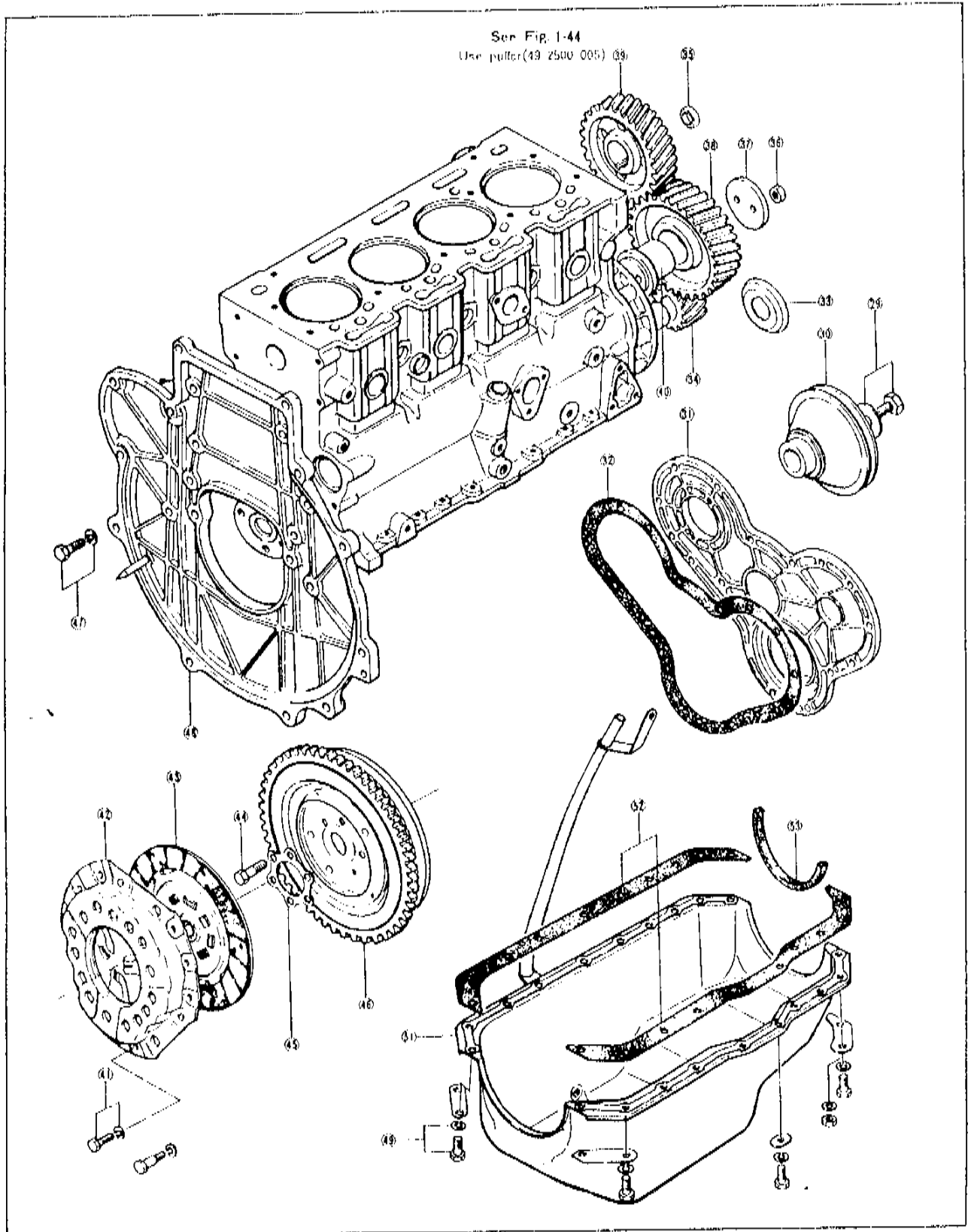

Fig. 1-6

- | | | | | |
|----------------------------|-------------------------------|--|------------------|------------|
| 29. Crank pulley lock bolt | 35. Nut | 41. Bolt/washer | 46. Clutch wheel | 52. Gasket |
| 30. Crank pulley | 36. Nut | 42. Clutch cover/pressure plate assembly | 47. Bolt/washer | 53. Gasket |
| 31. Timing gear cover | 37. Idle gear thrust plate | 43. Clutch disc | 48. End plate | |
| 32. Gasket | 38. Idle gear | 44. Bolt | 49. Bolt/washer | |
| 33. Oil deflector | 39. Injection pump drive gear | 45. Clutch wheel washer | 50. Bleeder pipe | |
| 34. Crank shaft gear | 40. Idle gear spindle | | 51. Oil pan | |

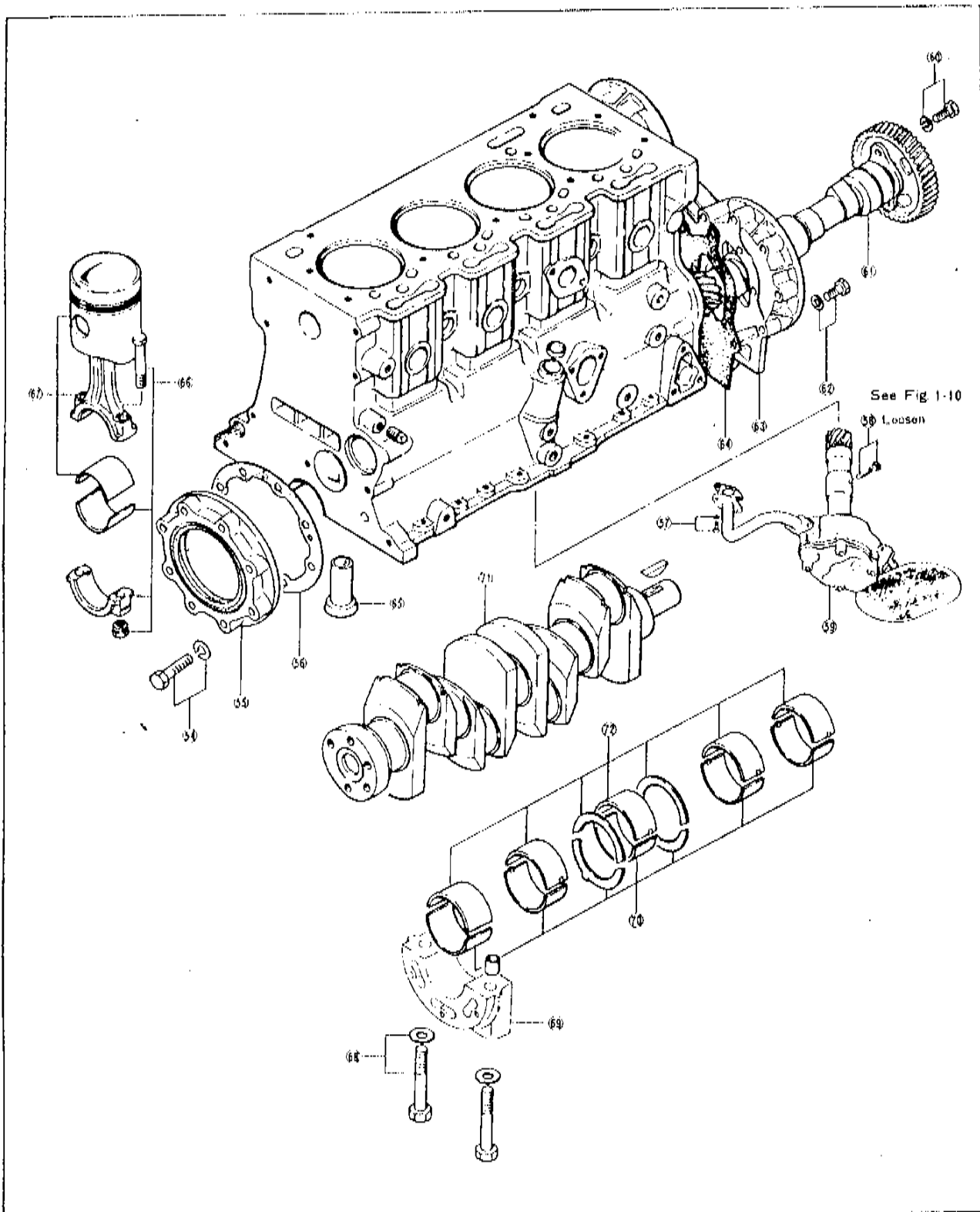

Fig. 1-7

- | | | |
|-----------------------------|---|---------------------------------|
| 54. Bolt/washer | 61. Cam shaft/gear assembly | 68. Main bearing cap bolt |
| 55. Rear oil seal assembly | 62. Bolt/washer | 69. Main bearing cap |
| 56. Gasket | 63. Timing gear case | 70. Main bearing/thrust bearing |
| 57. Bolt/washer | 64. Gasket | 71. Crank shaft |
| 58. Oil pump lock screw/nut | 65. Tappet | 72. Main bearing/thrust bearing |
| 59. Oil pump assembly | 66. Connecting rod cap/bearing/bolt/nut | |
| 60. Bolt/washer | 67. Piston/connecting rod assembly | |

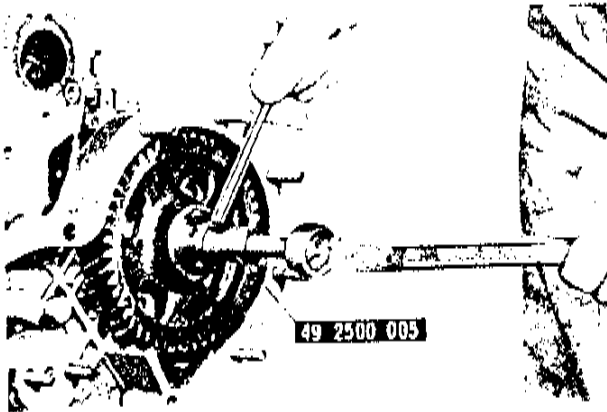

Fig. 1-8

Remove the injection pump gear, using the gear puller (49 2500 005).

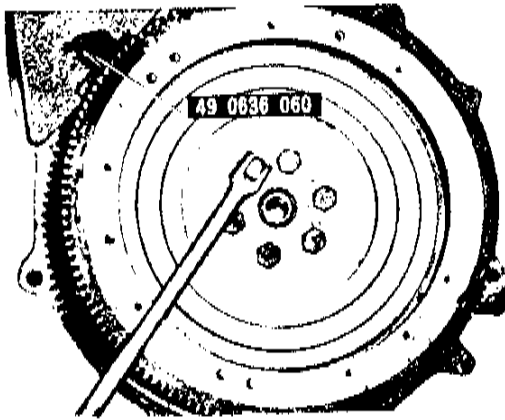

Fig. 1-9

Remove the crank shaft pulley, pressure plate and fly-wheel by using the ring gear brake (49 0636 060).

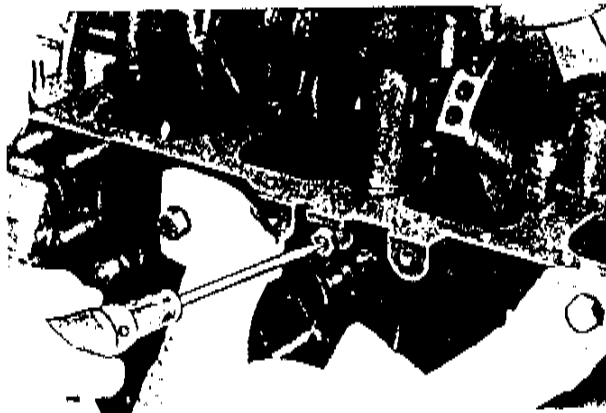

Fig. 1-10

Loosen the lock screw of oil pump and remove the oil pump.

Remove the camshaft and gear.

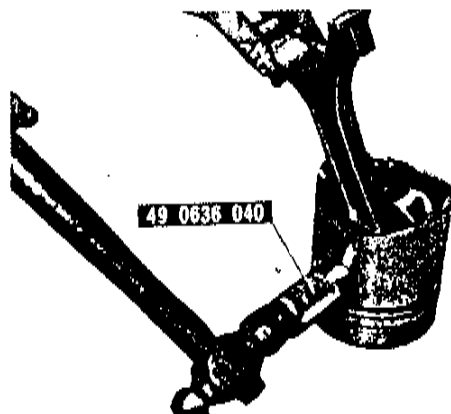

Fig. 1-11

Remove the piston pin by using the piston pin installer (49 0636 060).

1-C. ENGINE INSPECTION AND REPAIR

1-C-1. Cylinder Head Inspection

Check for cylinder head distortion.

If the distortion exceeds limit replace the head.

Max. permissible distortion

(A), (B)	0.1 mm (0.004 in)
(C), (D), (E), (F)	0.25 mm (0.010 in)

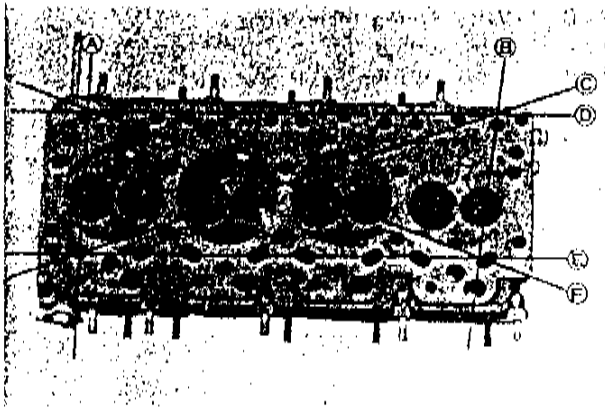

Fig. 1-12

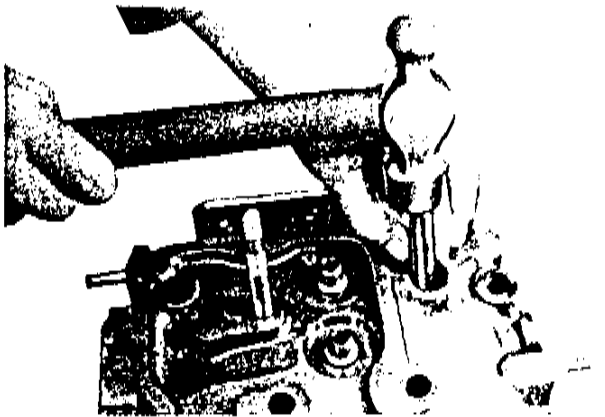

Fig. 1-13

1-C-2. Replacing Combustion Chamber Insert

1. Press out the insert with a suitable mandrel

2. Locate new insert on the cylinder head as shown in Fig. 1-14 with the Welch washer which fits in a recess provided.

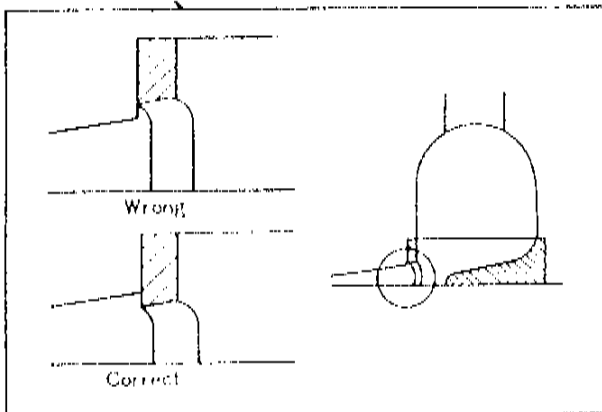

Fig. 1-14

3. Secure the insert by means of expansion the Welch washer.



Fig. 1-15

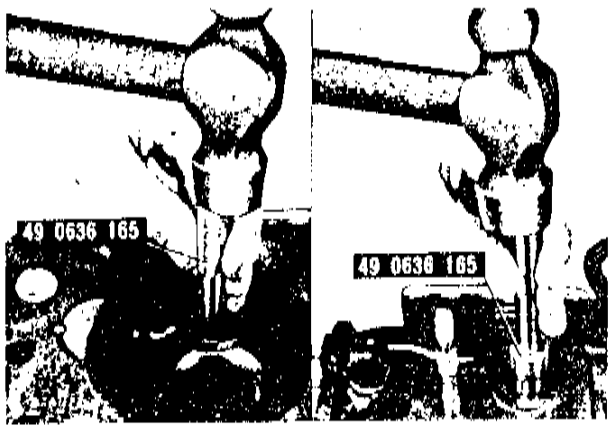

Fig. 1-20

1-C-6. Replacing Valve Guide

1. Press out the guide with the valve guide remover (49 0636 165).
2. Press fit a new guide to the cylinder head, using the valve guide remover and adaptor (49 0636 165) until the adaptor comes in contact with the cylinder head.

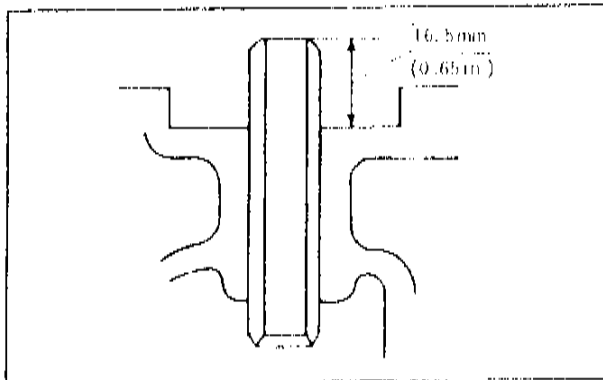

Fig. 1-21

If the adaptor is not available, take care the distance shown in Fig. 1-21 to be 16.5 mm (0.65 in).

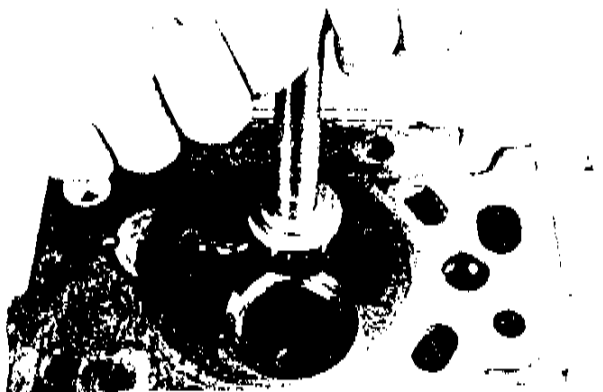

Fig. 1-22

1-C-7. Valve Seat Inspection and Refacing

Inspect the valve seats for cracks, burns, ridges of improper angle and width. When necessary to reface the valve seat, use a valve seat grinder or a valve seat cutter and grind to the specified angle as shown in Fig. 1-23.

Note: If the valve guides are to be replaced, this must be done before refacing the valve seat.

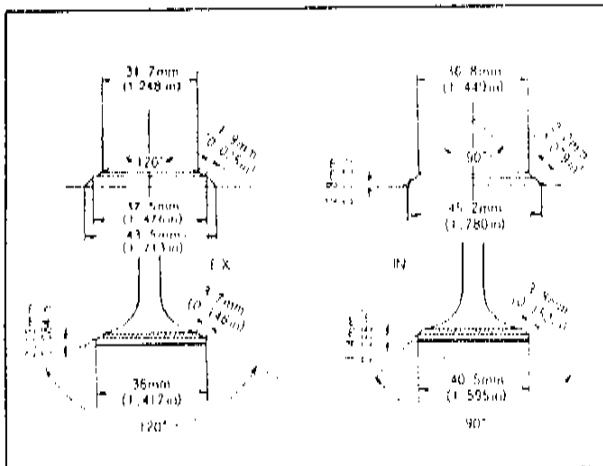

Fig. 1-23

1-C-8. Checking Contact between Valve and Valve Seat

An even transfer indicates accurate valve and valve seat refacing. If uneven, the valve must be lapped into the valve seat using a suitable lapping compound. Next, check its width with a seat width scale or a steel scale placed across the face of the valve seat.

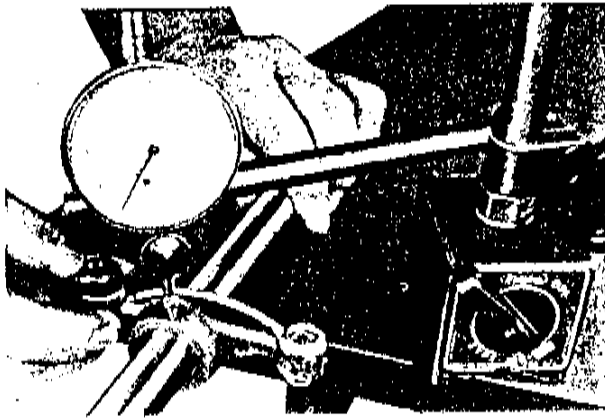

Fig. 1-24

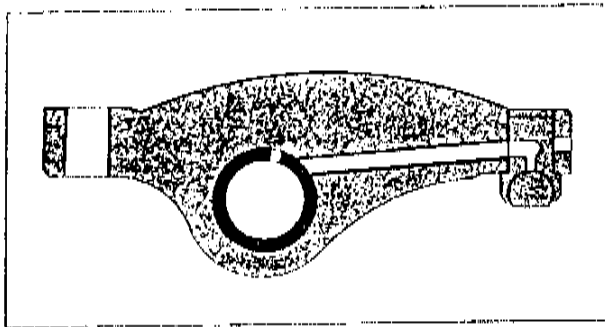

Fig. 1-25

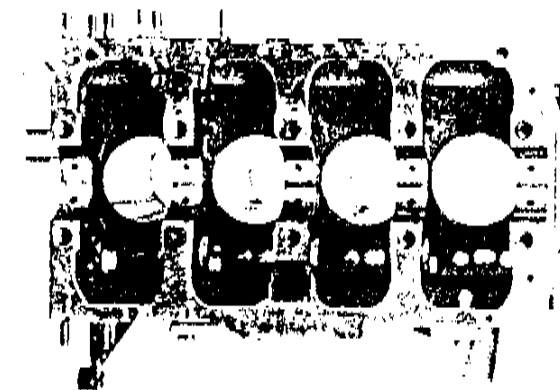

Fig. 1-26

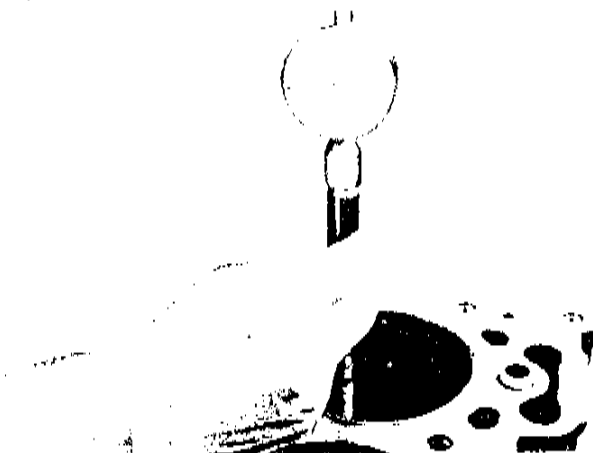

Fig. 1-27

1-C-9. Rocker Arm and Shaft Inspection

Make sure that the oil passage of the rocker arm shaft is open.

1. Check the clearance between the rocker arm bore and shaft. If it is more than specification, replace the rocker arm bush or shaft.

Standard:

0.016 ~ 0.061 mm (0.0006 ~ 0.0024 in)

Limit:

0.070 mm (0.0028 in)

2. To replace the rocker arm bush, proceed as follows:

- 1) Press out the old bush with a suitable mandrel.
- 2) Press fit the new bush, being sure to align the oil holes of the bush and rocker arm.
- 3) Finish the bush with a reamer or pin hole grinder to the correct fit.

1-C-10. Cylinder Block Inspection

Examine the cylinder block for crack and any damage. Examine all machined surfaces of the block for burrs and scores.

Check for cylinder block distortion in the same way as instructed in Par. 1-C-1.

1-C-11. Liner Inspection

Check the cylinder liner bores for wear, scratching and waviness. Measure the diameter of the cylinder liner bore by using a cylinder gauge as shown in Fig. 1-27.

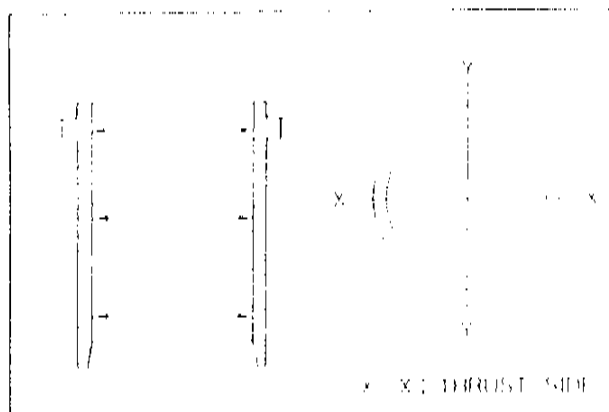

Fig. 1-28

This measurement should be taken in the X-X direction and the Y-Y direction at each of the 3 places, upper, middle and lower, of one cylinder liner, as shown in Fig. 1-28. The difference between the minimum and maximum values out of the 6 measured values is regarded as the amount of wear. If the wear of cylinder liner bore is 0.20 mm (0.008 in) or more, it should be replaced.

Note: Honing and reboring cannot be made on this cylinder liner.

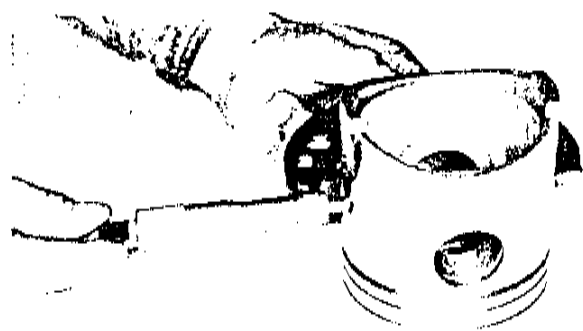

Fig. 1-29

1-C-12. Checking Piston Clearance

Check the clearance between each piston and cylinder by measuring the diameter of the piston and cylinder bore. Refer to Par. 1-C-11 for the bore measurement procedure. Measure the piston diameter at 90 degrees to the pin bore axis and 58.4 mm (2.299 in) below the piston top. If it is excessive the piston or liner must be replaced.

Standard:

0.187 - 0.212 mm (0.0074 - 0.0084 in)

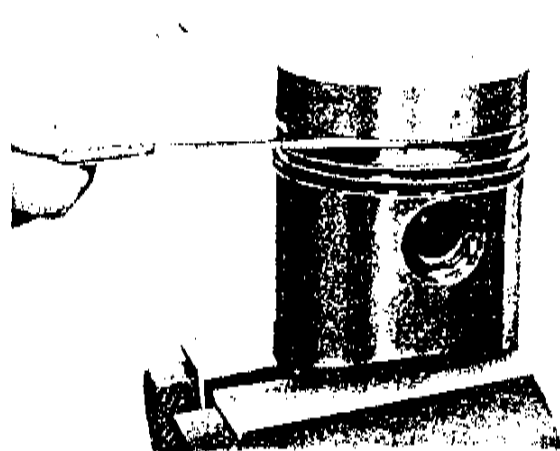

Fig. 1-30

1-C-13. Piston and Piston Ring Inspection

1. Carefully inspect the piston and replace it if it is severely scored, scratched, burned.
2. Check the side clearance of the piston rings at several places. If it exceeds limit, replace the piston ring or piston.

Standard:

0.050 - 0.096 mm (0.0020 - 0.0038 in)

Limit:

0.3 mm (0.012 in)

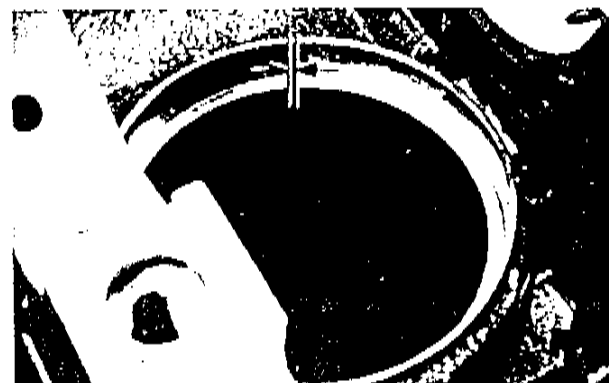

Fig. 1-31

3. Place the piston in the cylinder bore below the ring travel, using a piston head to push the ring in squarely.

Check the piston ring end gap.

If it exceeds limit, the piston ring must be replaced.

Limit: 1.5 mm (0.06 in)

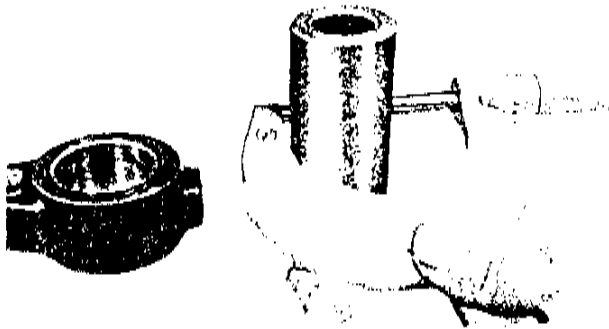

Fig. 1-32

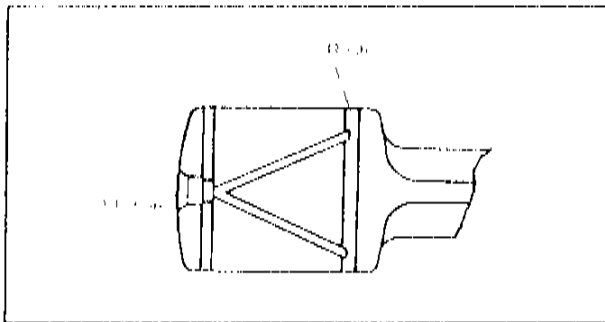

Fig. 1-33



Fig. 1-34

Bearing housing mark	Main journal		Bearing color	Bearing clearance
	Color	Diameter		
"A" Mark	Green	75.812~75.819mm (2.9847~2.9850in)	Green	0.061~0.087mm (0.0024~0.0034in)
	White	75.819~75.825mm (2.9850~2.9852in)	Yellow	0.065~0.090mm (0.0026~0.0035in)
No mark	Green	75.812~75.819mm (2.9847~2.9850in)	Brown	0.060~0.086mm (0.0024~0.0034in)
	White	75.819~75.825mm (2.9850~2.9852in)	Green	0.064~0.089mm (0.0025~0.0035in)
"C" Mark	Green	75.812~75.819mm (2.9847~2.9850in)	Black	0.059~0.085mm (0.0023~0.0033in)
	White	75.819~75.825mm (2.9850~2.9852in)	Brown	0.063~0.087mm (0.0025~0.0034in)

1-C-14. Checking Piston Pin and Bush

1. Check to see that the fit of the bush and piston pin is 0.014 ~ 0.044 mm (0.001 ~ 0.002 in). If it exceeds limit, the bush or piston pin must be replaced.

Limit: 0.05 mm (0.0020 in)

2. To replace the bush, proceed as follows:

- 1) Press out the old bush with a suitable mandrel.
- 2) Press fit the new bush, being sure to align the holes of the bush and connecting rod.
- 3) Finish the bush with a reamer or a pin hole grinder to the correct fit.

1-C-15. Checking Connecting Rod Alignment

Check the connecting rod alignment by using a feeler gauge and an aligner. The standard deflection is less than 0.05 mm per 100 mm (0.0020 in per 4 in). If realignment is necessary, correct by using a press and applying a gradual pressure to the rod.

1-C-16. Crank Shaft and Bearing Inspection

1. Inspect the bearings carefully and replace if they are worn, scored or flacked.

The standard main bearing, main journal and bearing housing are classified into several groups. To obtain the accurate main bearing clearance, the combination of those related parts should be made properly, referring to the table.

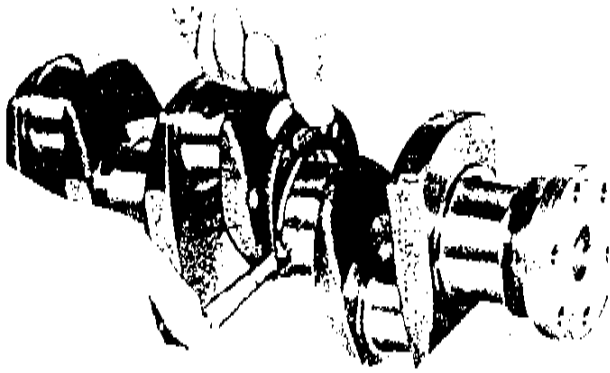

Fig. 1-35

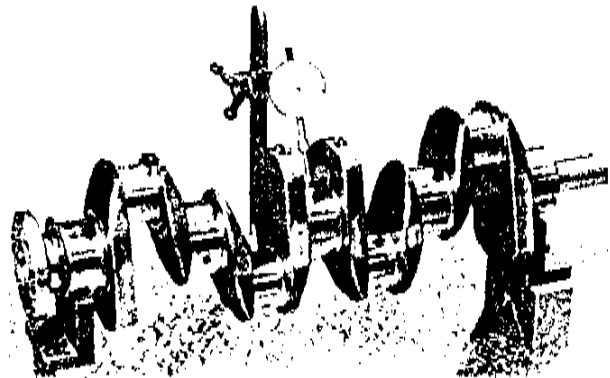

Fig. 1-36

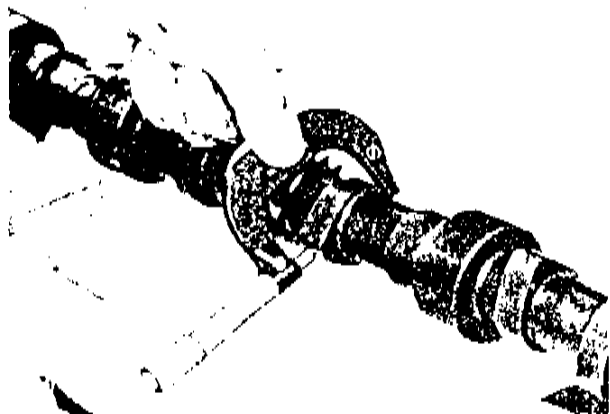

Fig. 1-37

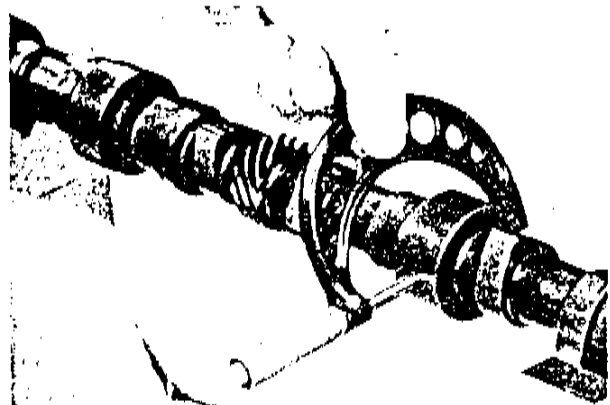

Fig. 1-38

2. Measure the diameter of each crankpin and main journal. If the wear exceeds limit, the crankshaft should be ground to the under size of 0.254 mm (0.01 in) or replaced.

Note: The undersize connecting rod and main journal bearings are 0.254 mm (0.01 in) only.

Crankpin diameter (STD)	Main journal diameter (STD)	Wear Limit
61.112 ~ 61.225 mm (2.4060 ~ 2.4065 in)	75.812 ~ 75.825 mm (2.9847 ~ 2.9852 in)	0.05 mm (0.002 in)

3. Check the crankshaft run-out. If it is not within the specification, correct with a press or replace.

Max. allowable run-out 0.05 mm (0.002 in)

1- C-17. Camshaft Inspection

1. Measure the cam height and replace the camshaft if the wear exceeds limit

	Inlet and Exhaust	
	Standard	Limit
Camheight	42.587 mm (1.6767 in)	42.485 mm (1.6728 in)

2. Measure the diameters of the camshaft journals.

The permissible diameters of the journals are in the following table.

Journal	Permissible Diameter
Front No. 1	51.902 mm (2.0434 in)
No. 2	51.652 mm (2.0336 in)
No. 3	51.402 mm (2.0237 in)
Rear No. 4	51.152 mm (2.0139 in)

Standard clearance:
0.06 ~ 0.12 mm (0.0024 ~ 0.0047 in)

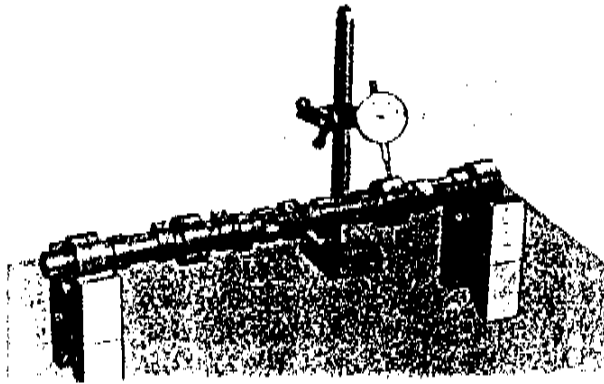

Fig. 1-39

3. Check the camshaft run-out with a dial-indicator. If it is not within specification, correct with a press or replace.

Max. allowable run-out	0.08 mm (0.0031 in)
------------------------------	---------------------

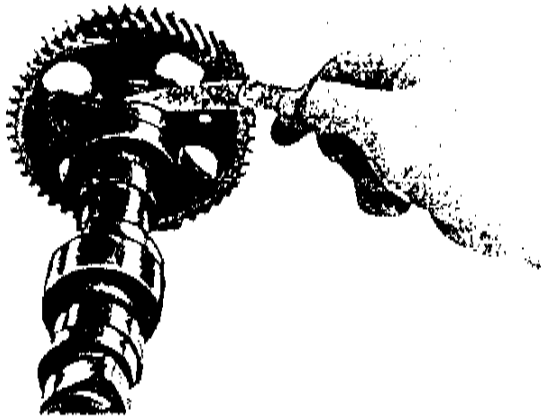

Fig. 1-40

4. Check the end play with a feeler gauge. The permissible limit of end play is 0.3 mm (0.012 in).

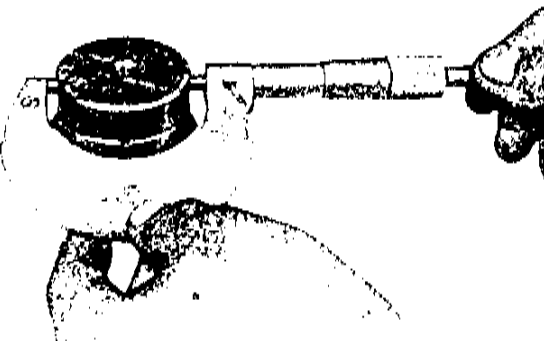

Fig. 1-41

1-C-18. Checking Idle Gear and Spindle
Check for chipped, worn or broken teeth.

Check the clearance between the spindle. If it exceeds limit, replace the spindle or gear.

Standard:	0.034 ~ 0.084 mm (0.0013 ~ 0.0033 in)
Limit:	0.15 mm (0.006 in)

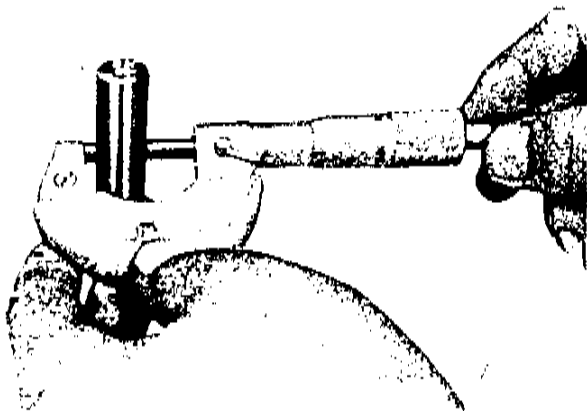

Fig. 1-42

1-C-19. Checking Tappet and Guide Clearance
The standard tappet and guide clearance is 0.039 ~ 0.095 mm (0.0015 ~ 0.0037 in).

Replace if the contact surface of the tappet with the cam is worn abnormally.

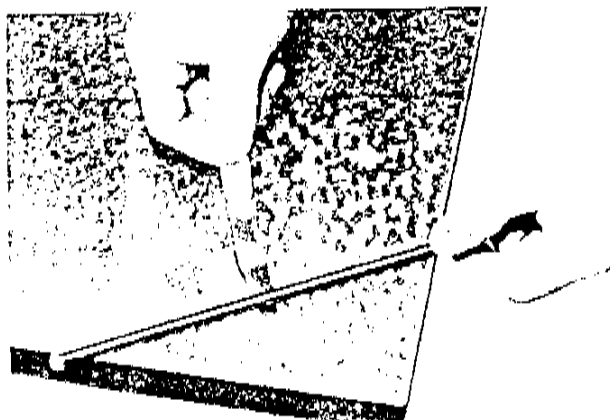

Fig. 1-43

1-C-20. Checking Push Rod

To check the push rod for bend, place the push rod on the surface plate and determine the clearance between the push rod and surface plate with a feeler gauge. If it exceeds 0.19 mm (0.007 in), repair or replace with a new one.

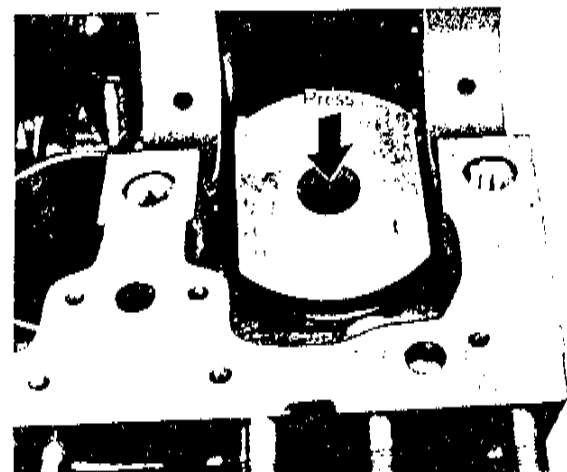

Fig. 1-44

1-C-21. Cylinder Liner Replacement

Removal:

1. Use the liner remover (49 1363 015) and press out the liner.
2. Check the cylinder block bore for any scratches.

Note: Remove the scratches by oil soaked fine emery paper for proper installation liner.

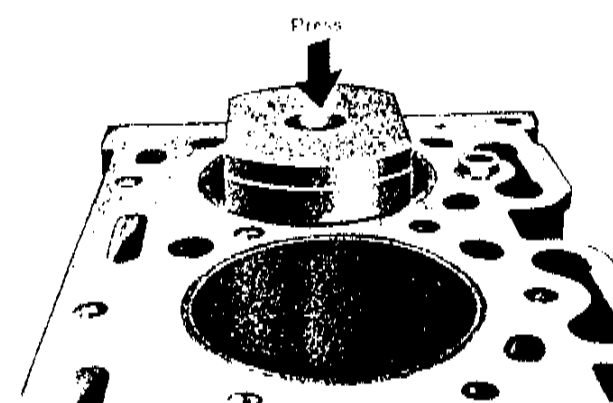

Fig. 1-45

Installation:

1. Press fit liner straight with the same tool, taking special care so as not to distort the liner.

Note:

- 1) New liner supplied as spare parts should be installed with lighter pressure than the removing.
- 2) There is no necessary to hone the cylinder liner bore after installation.

1-D. ENGINE ASSEMBLY

Assemble the engine following the order numbered in Figs. 1-46, 1-47, 1-48 and 1-49.

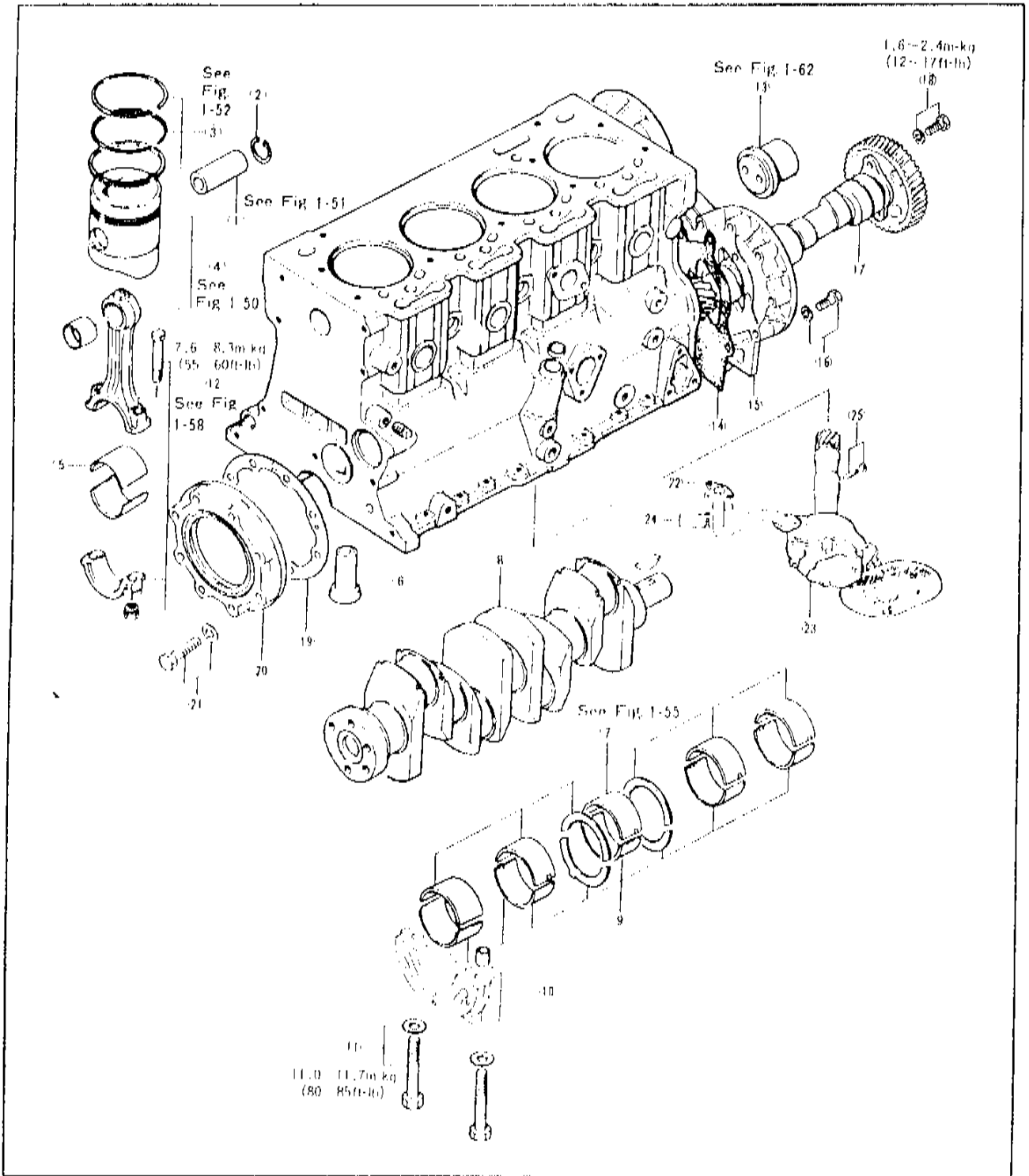

Fig. 1-46

- | | | | |
|-----------------------------------|---|----------------------------|----------------------------|
| 1. Piston pin | 7. Main bearing/thrust bearing | 13. Idle gear spindle | 20. Rear oil seal assembly |
| 2. Clip | 8. Crank shaft | 14. Gasket | 21. Bolt/washer |
| 3. Piston ring | 9. Main bearing/thrust bearing | 15. Timing gear case | 22. Gasket |
| 4. Piston/connecting rod assembly | 10. Main bearing cap | 16. Bolt/washer | 23. Oil pump assembly |
| 5. Connecting rod bearing | 11. Cap bolt | 17. Camshaft/gear assembly | 24. Bolt/washer |
| 6. Tappet | 12. Connecting rod bearing/cap/bolt/nut | 18. Bolt/washer | 25. Lock bolt/nut |
| | | 19. Gasket | |

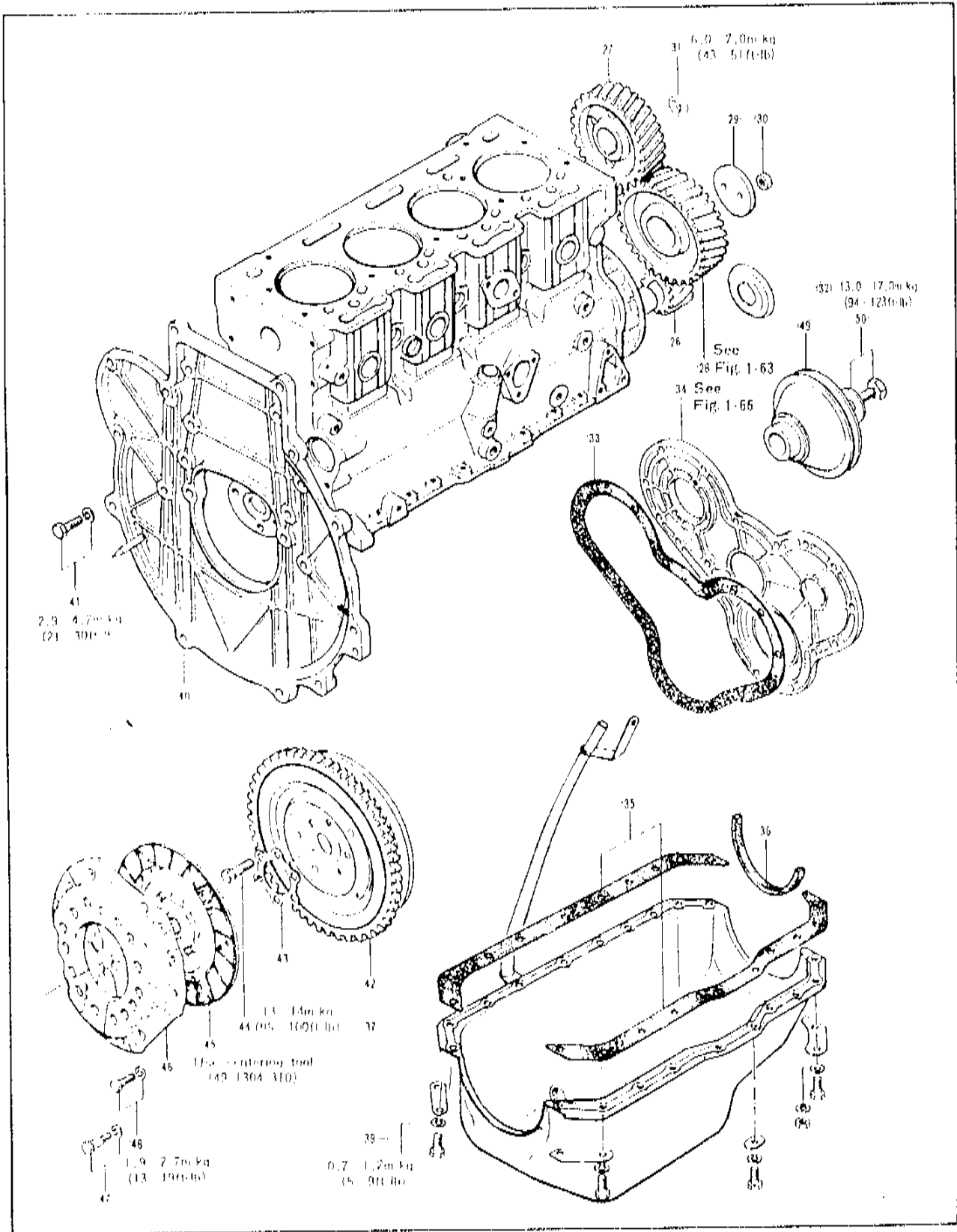

Fig. 1-47

- | | | | | |
|-------------------------------|-----------------------|-------------------------|---------------------------------------|------------------|
| 26. Crank shaft gear | 32. Oil deflector | 39. Bolt/washer | 44. Bolt | 49. Crank pulley |
| 27. Injection pump drive gear | 33. Gasket | 40. End plate | 45. Clutch disc | 50. Bolt |
| 28. Idle gear | 34. Timing gear cover | 41. Bolt/washer | 46. Clutch cover/pressure
assembly | |
| 29. Idle gear thrust plate | 35. Gasket | 42. Clutch wheel | 47. Reamer bolt/washer | |
| 30. Nut | 36. Oil pan gasket | 43. Clutch wheel washer | 48. Bolt/washer | |
| 31. Nut | 37. Oil pan | | | |

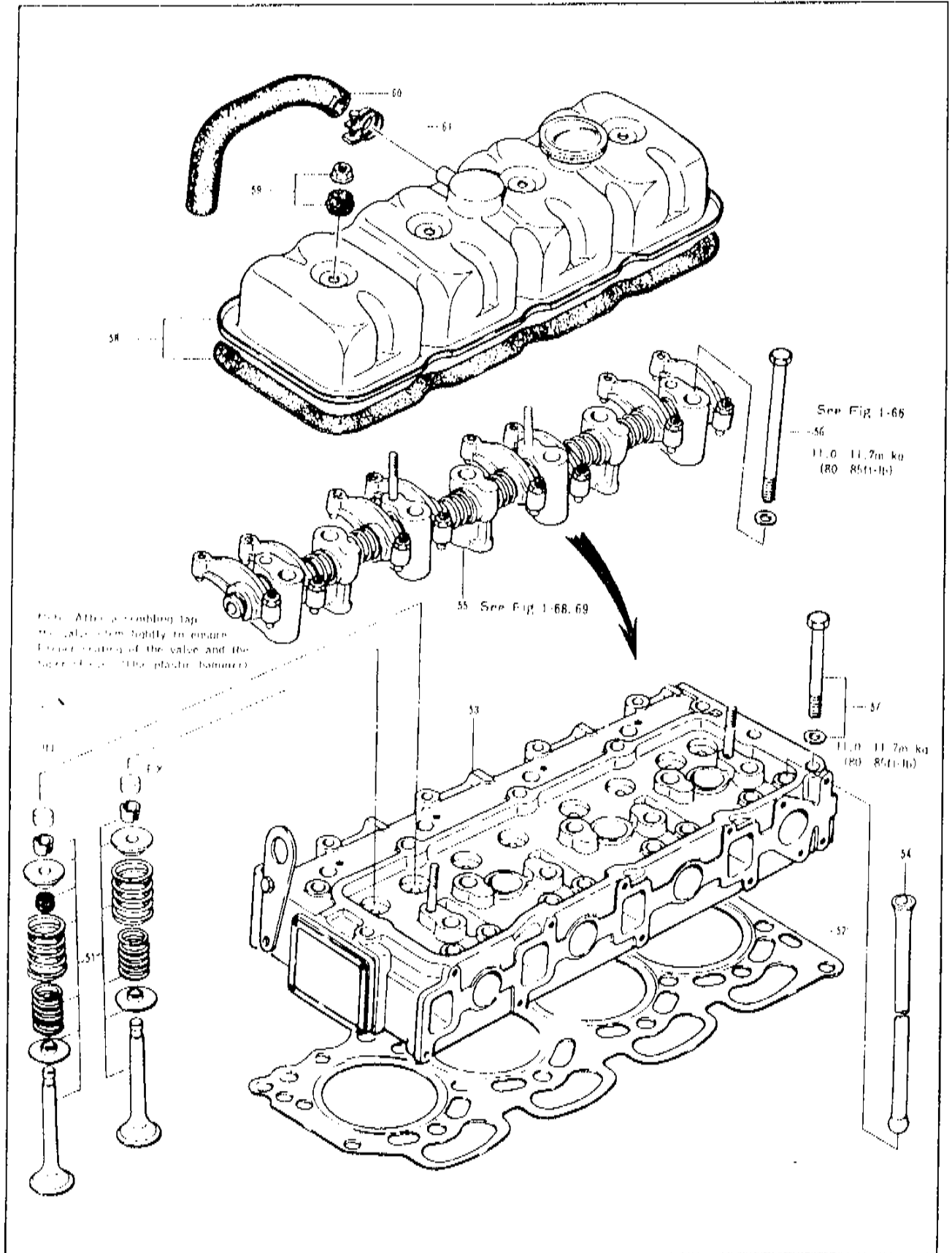

Fig. 1-48

- | | | | |
|---------------------------|-------------------------------|-------------------------------|------------------|
| 51. Valve/spring assembly | 54. Push rod | 57. Cylinder head bolt/washer | 60. Bleeder hose |
| 52. Head gasket | 55. Rocker arm assembly | 58. Rocker arm cover/gasket | 61. Hose band |
| 53. Cylinder head | 56. Cylinder head bolt/washer | 59. Nut/seal washer | |

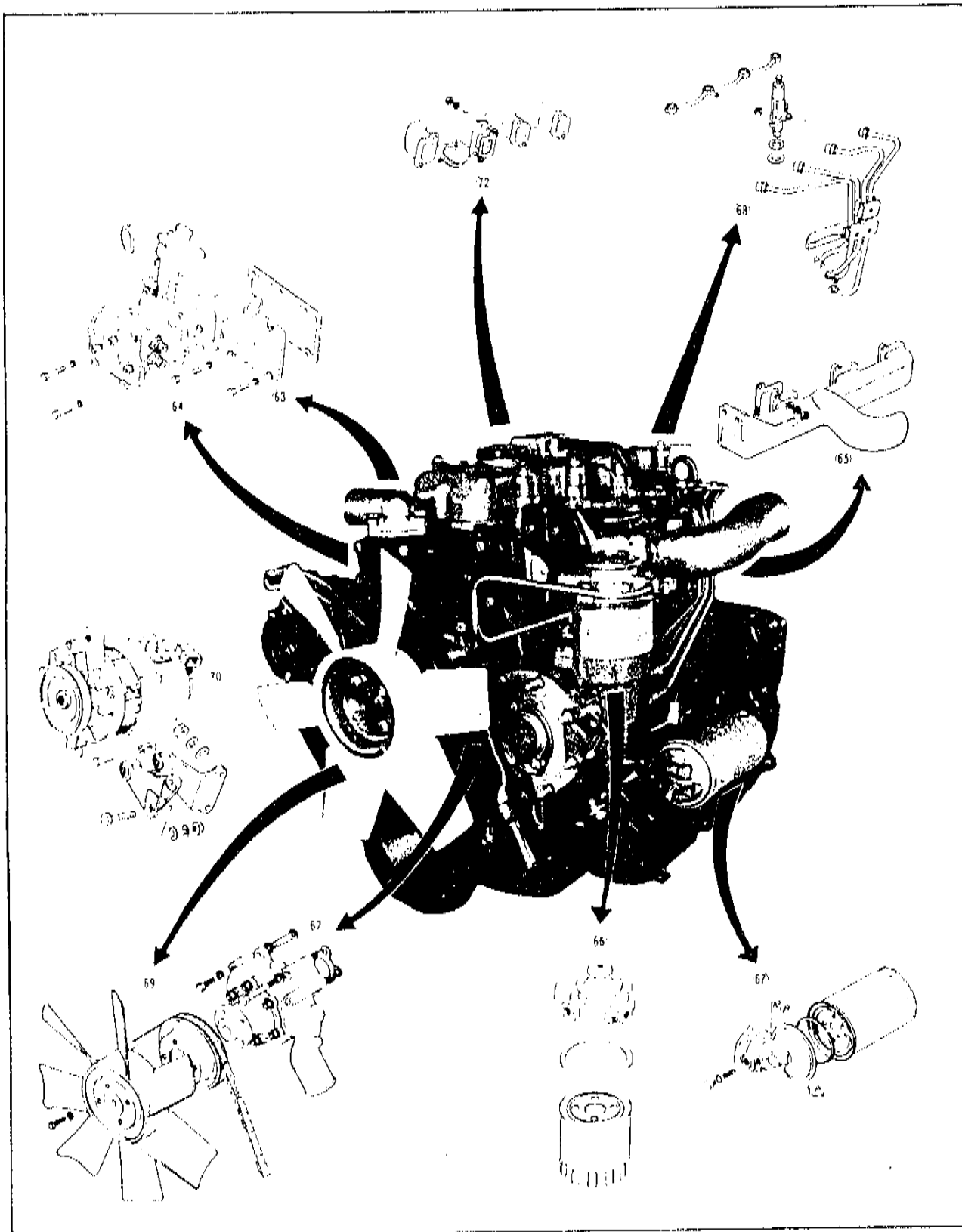

Fig. 1-49

62. Water pump assembly

63. Thermostat casing assembly

64. Oil cooler assembly

65. Intake manifold

66. Fuel filter assembly

67. Oil filter/oil pipe

68. Injection pipe/nozzle holder/
fuel leak pipe

69. Cooling fan/"V" belt/fan pulley

70. Alternator/bracket

72. Exhaust manifold

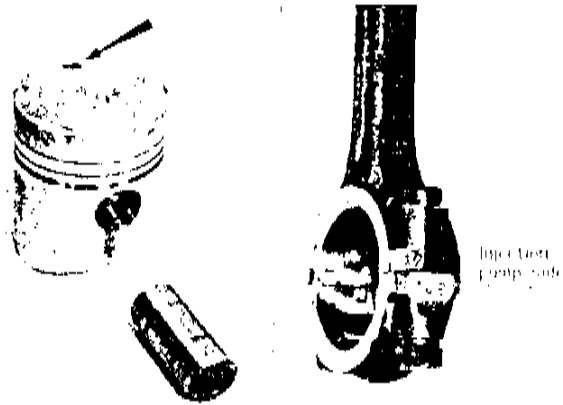

Fig. 1-50

Assemble the piston and connecting rod. Align the direction, piston and connecting rod as shown in Fig. 1-50.

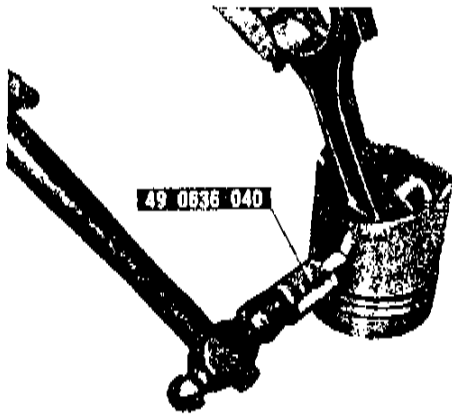

Fig. 1-51

Insert the piston pin with the **installer** (49 0636 040). Preheat the piston, if tightly.

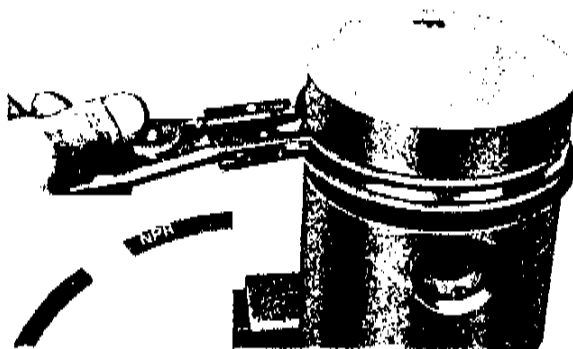

Fig. 1-52

Install the piston rings with the inscription mark upward.

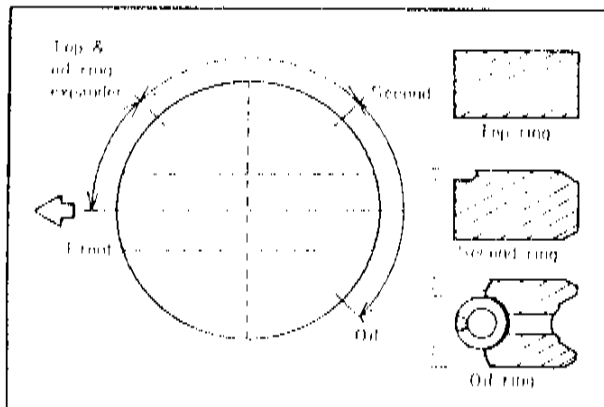

Fig. 1-53

Place the piston rings at about 90° apart as shown in Fig. 1-53.



Fig. 1-54

Install the piston and connecting rod assembly by using the suitable piston guide.

Note: "F" mark of piston top should be faced front.

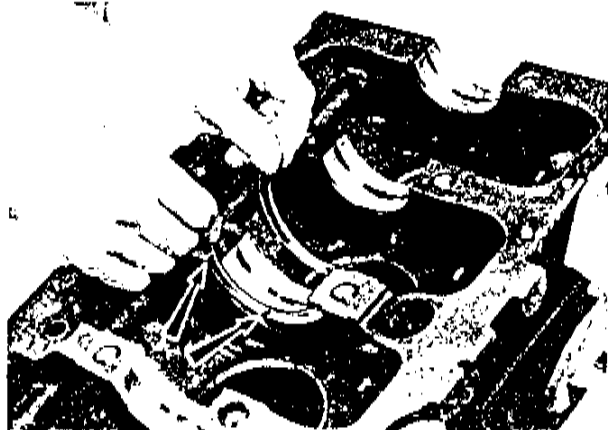

Fig. 1-55

Install the main bearing and thrust washer.

Note: Fit the thrust washer with a oil groove facing outward.

Install the crankshaft and bearing cap.



Fig. 1-56

Checking main bearing oil clearance.

- 1) Place the "Plastigauge" on the main journal in the axial direction.
- 2) Tighten the cap bolts to **11.0 ~ 11.7 m·kg (80 ~ 85 ft·lb)**.

Note: Do not turn the crankshaft.

Compare the flattened width of "Plastigauge" with measuring scale to determine the oil clearance.

Oil clearance:

New 0.059 ~ 0.090 mm (0.0023 ~ 0.0035 in)
Limit 0.12 mm (0.0047 in)

Check the crankshaft end play.

Check the end play with a dial indicator or a feeler gauge. If it exceeds limit, use oversized thrust washer.

Standard:

0.14 ~ 0.39 mm (0.006 ~ 0.015 in)

Limit:

0.4 mm (0.016 in)

Oversized thrust washer:

0.178 mm (0.007 in)

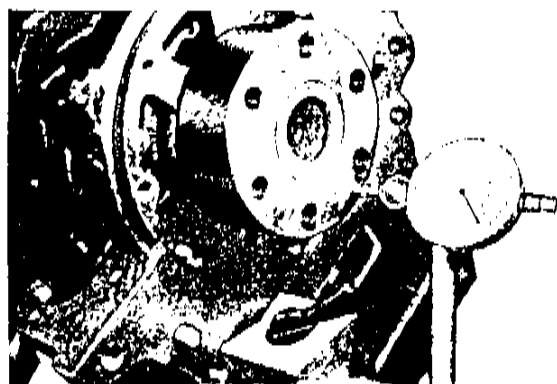

Fig. 1-57

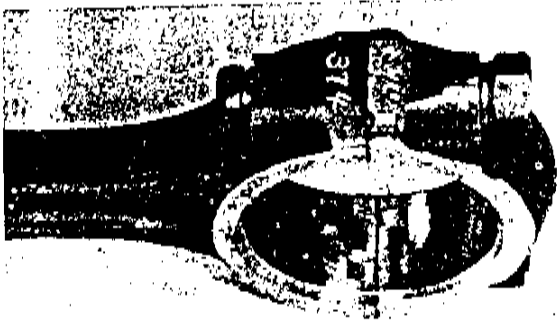

Fig. 1-58

Install the caps to the connecting rods, ensuring that the identification numbers are matched.

Note: After tightening the nut turn the crankshaft and make sure that the rotation is light and smooth.

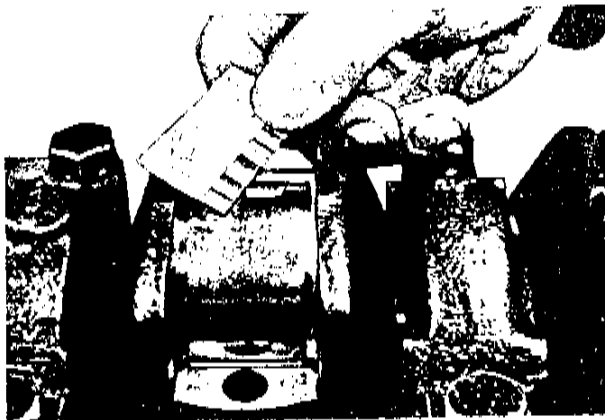

Fig. 1-59

Check the connecting rod oil clearance in the same manner for the main bearing.

Tightening torque of bearing caps 7.6 ~ 8.3 m·kg (55 ~ 60ft·lb)

Oil clearance
New 0.036 ~ 0.076 mm
 (0.0014 ~ 0.0030 in)
Limit 0.10 mm (0.0039 in)

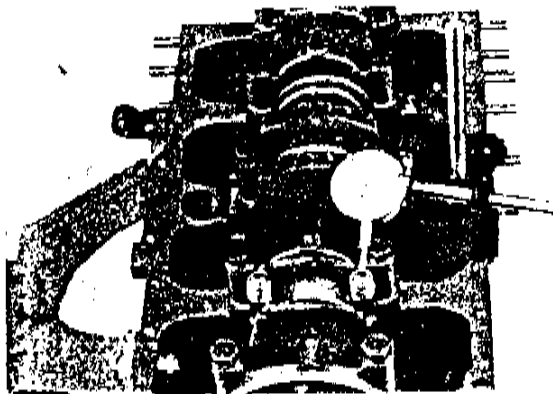

Fig. 1-60

Check the connecting rod side play with a dial-indicator or feeler gauge.

Standard:
 0.239 ~ 0.330 mm (0.009 ~ 0.013 in)
Limit:
 0.4 mm (0.016 in)

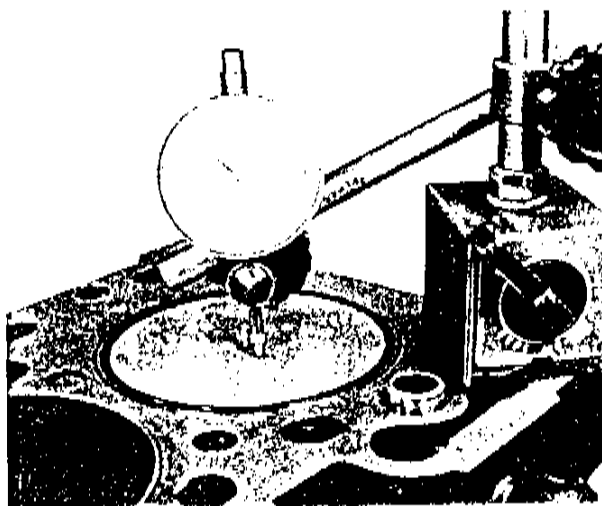

Fig. 1-61

Check the piston height.

When the piston has been replaced with new one, the distance between the cylinder block face and piston crown should be checked to ensure the limit of $-0.05 \sim -0.15$ mm ($-0.002 \sim -0.006$ in), has been maintained when that piston is at top dead center.

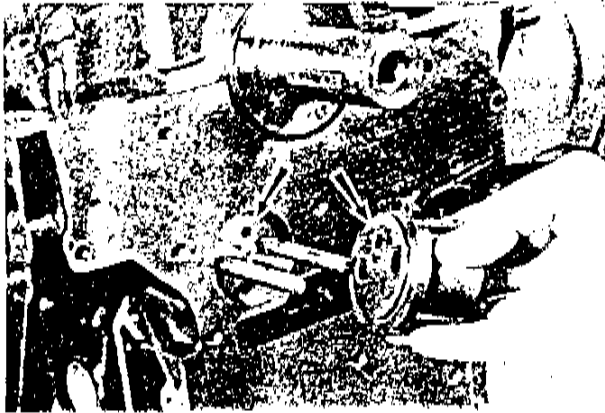

Fig. 1-62

Install the idle gear spindle, aligning the oil hole.

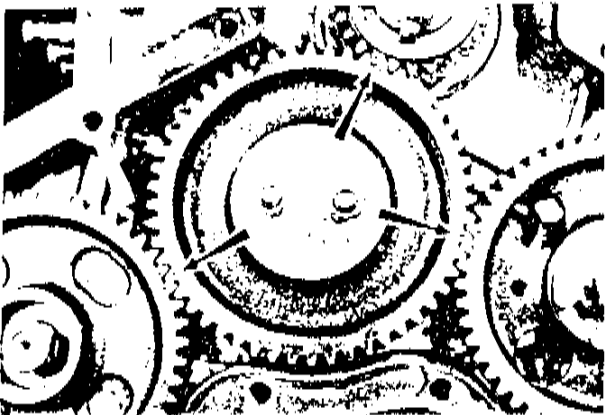

Fig. 1-63

Install the timing gears, aligning the timing marks as shown in Fig. 1-63.

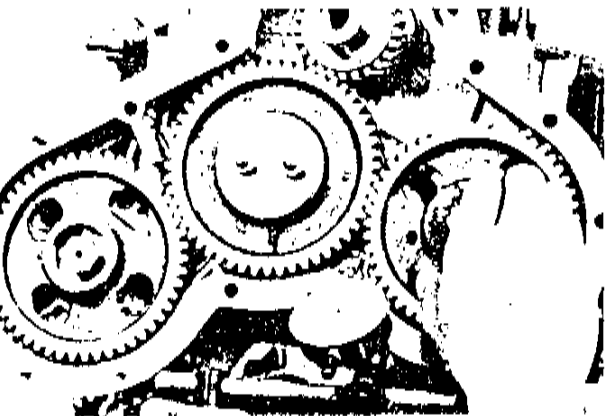

Fig. 1-64

Check the timing gears.

Check the backlash with a dial-indicator or a feeler gauge.

If it exceeds limit, replace with new one.

Standard:

0.1 ~ 0.2 mm (0.004 ~ 0.008 in)

Limit:

0.3 mm (0.012 in)

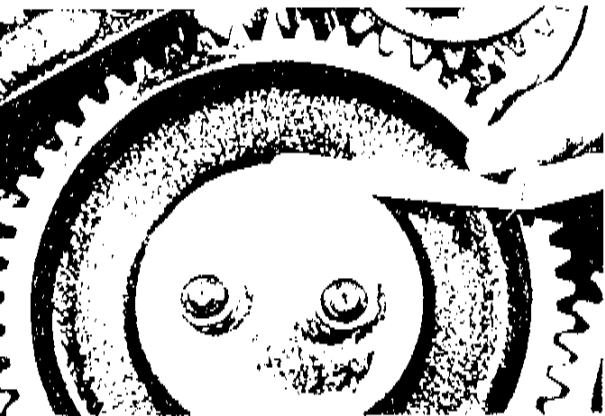

Fig. 1-65

Check the idle gear end play with a feeler gauge.

Standard:

0.15 ~ 0.30 mm (0.006 ~ 0.012 in)

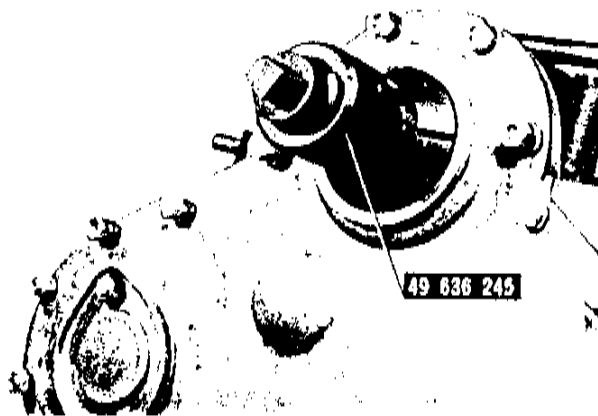

Fig. 1-66

Install the timing gear cover.

Before tightening the nuts and bolts, install the **timing gear cover centering tool** (49 0636 245) in the timing gear cover oil seal as shown in Fig. 1-66.

Note: It is important that centering tool be used to align the timing gear cover so that crankshaft pulley installation will not damage and to prevent oil seal leak.

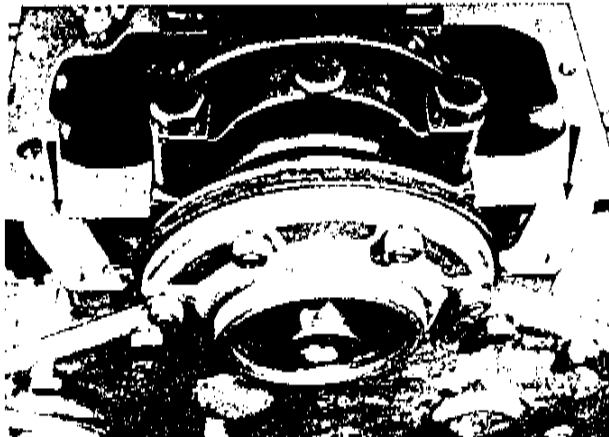

Fig. 1-67

Cut off the excess gaskets along the mounting surfaces of the oil pan.

Before installing the oil pan, make a final internal inspection. Apply a thin coat of gasket past on the oil pan.

Install a new gasket and the oil pan.

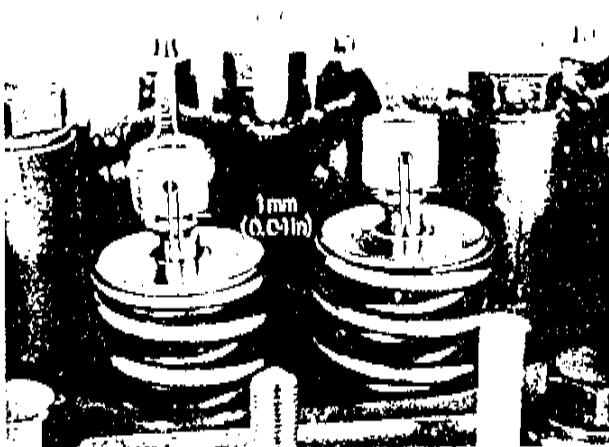

Fig. 1-68

Check the rocker arm offset both of the exhaust and inlet side rocker arms **1 mm (0.04 in)** from the valve stem center.

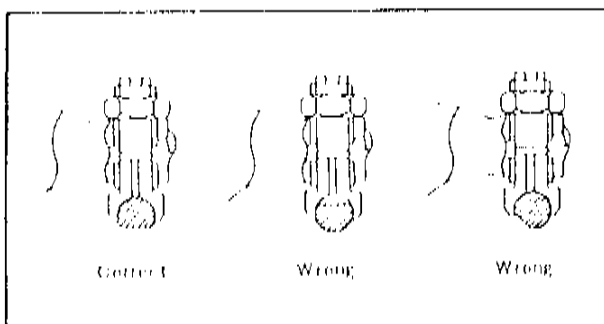

Fig. 1-69

Face the flat surface on the ball on each of the rocker arms downward.

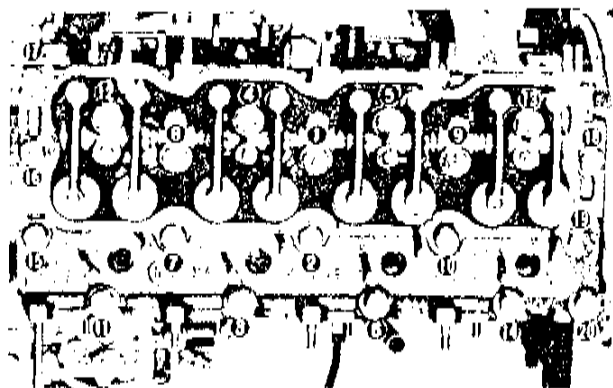

Fig. 1-70

Tighten the cylinder head bolts to **11.0 ~ 11.7 m·kg** (80 ~ 85 ft·lb) in the order shown in Fig. 1-70.

Tighten the nut of the two stud bolts locating the rocker arm shaft.

Adjust the valve clearance to **0.3 mm (0.012 in)** for both inlet and exhaust.

Note: Whenever the engine is overhauled, warm up the engine and readjust the valve clearance after tightening the cylinder head bolts to the specified torque.

1-E. ENGINE INSTALLATION

Carry out the removing operations in the reverse order.

1-F. CHECKING COMPRESSION PRESSURE

1. Before measuring the compression pressure, inspect the valve clearance and the functions of the battery and the starting motor.
2. Run the engine until it obtains normal operating temperature.
3. Disconnect the air hose from the inlet manifold.
4. Remove all injection nozzles.
5. Install the **adaptor** (49 0636 010) in the nozzle hole.
6. Set the fuel stop lever at stop position.
7. Connect the compression tester on the adaptor, one after the other, and turn the engine over with starting motor until the pressure reaches a maximum value.

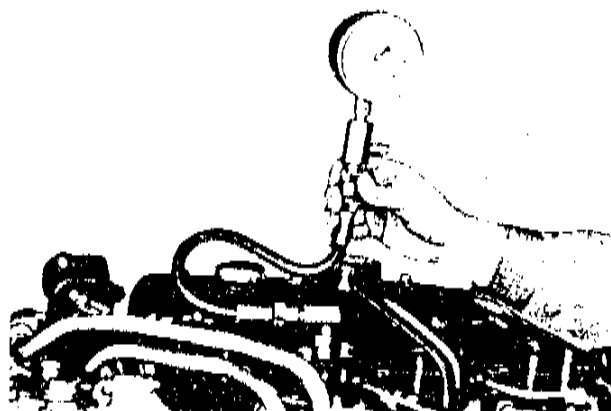

Fig. 1-71

Compression pressure:

Standard	Limit
30.0 kg/cm ² (427 lb/in ²) at 200rpm	27.0 kg/cm ² (384 lb/in ²) at 200rpm

SPECIAL TOOLS

49 0636 010	Adaptor, Compression gauge	49 0107 222A	Pivot, Valve spring lifter
49 0107 680A	Engine stand	49 0636 165	Replacer, Valve guide
49 0636 005	Hanger, Engine stand	49 0636 205	Oil seal replacer, Timing cover
49 2500 005	Puller, Injection pump gear	49 0636 245	Centering tool, Timing cover
49 0636 040	Installer, Piston pin	49 0636 060	Ring gear brake
49 0636 100	Lifter, Valve spring	49 0636 310	Centering tool, Clutch disc

LUBRICATING SYSTEM

2 A. LUBRICATING CIRCUIT	2:1
2 B. OIL PUMP	2:1
2 B 1. Disassembling Oil Pump	2:1
2 B 2. Checking Oil Pump	2:2
2 B 3. Assembling Oil Pump	2:2
2 C. OIL PRESSURE RELIEF VALVE	2:3
2 D. OIL PRESSURE SWITCH	2:3
2 E. CHECKING OIL PRESSURE	2:3
2 F. OIL FILTER	2:3
SPECIAL TOOL	2:3

2-A. LUBRICATING CIRCUIT

1. Oil that has been filtered through the oil filter is forced to the oil cooler and to the main oil gallery and to the main bearings and others through the passages.
2. The cylinder walls, piston pins and bushes are lubricated by splash and oil mist.

3. Oil from the No. 3 main bearing lubricates the oil pump drive shaft and pump driven gear.
4. Oil from the No. 1 camshaft bearing is directed up to the No. 1 rocker arm support through a passage, then passes through inside of the rockers shaft and lubricates rocker arm bush and shaft. Also, oil lubricates the valve stem, and other valve train surface.

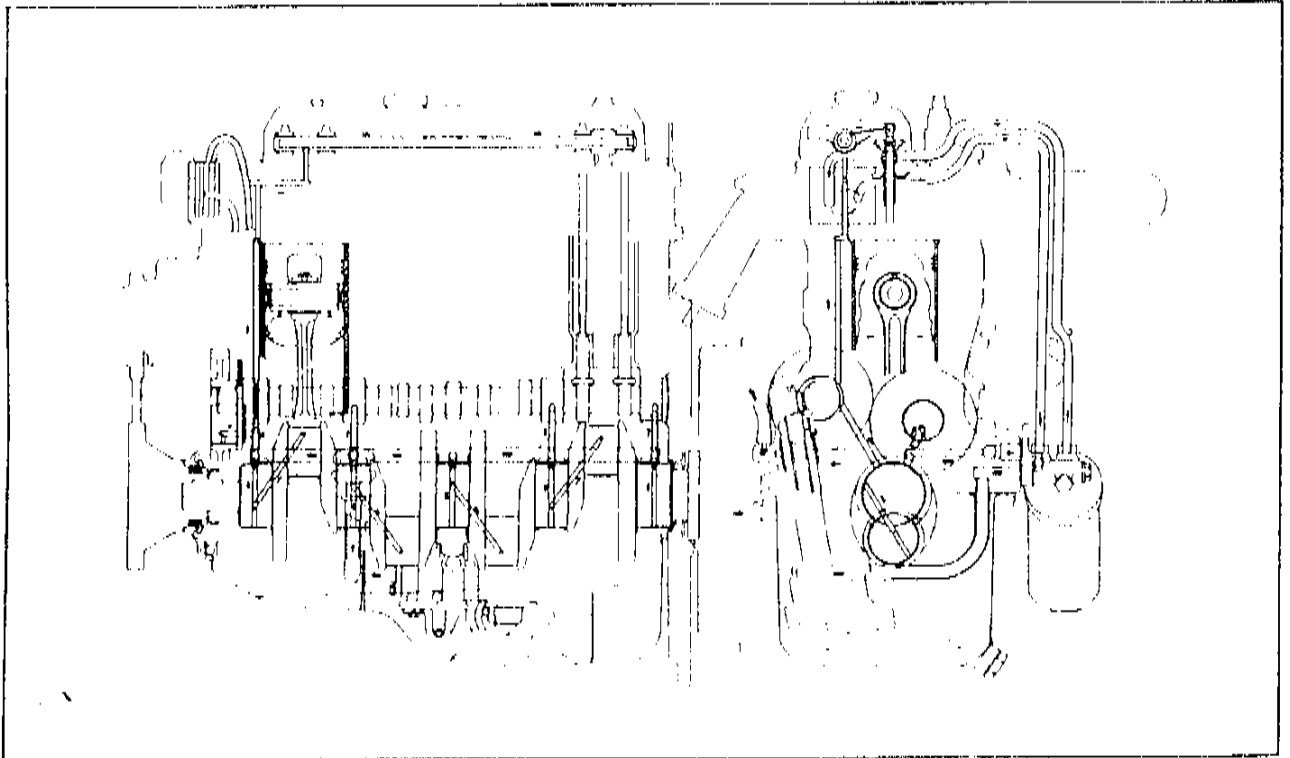

Fig. 2-1

2-B. OIL PUMP

2-B-1. Disassembling Oil Pump

Disassemble the parts in the order numbered below.

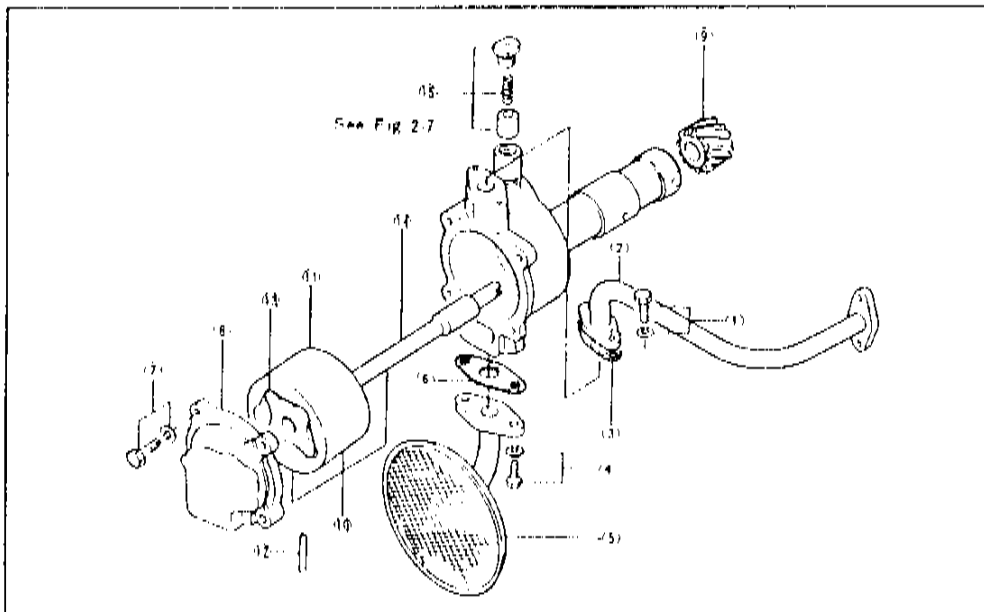

Fig. 2-2

1. Bolt/washer
2. Oil pipe
3. Gasket
4. Bolt/washer
5. Oil strainer
6. Gasket
7. Bolt/washer
8. Cover
9. Drive gear
10. Rotor/shaft assembly
11. Outer rotor
12. Pin
13. Inner rotor
14. Drive shaft
15. Relief valve assembly

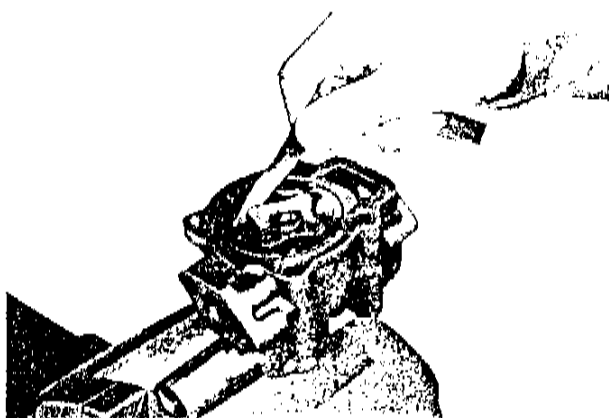

Fig. 2-3

2-B-2. Checking Oil Pump

1. Check the clearance between the lobes of the rotors with a feeler gauge. If the clearance exceeds limit, replace both rotors.

Limit: 0.3 mm (0.012 in)

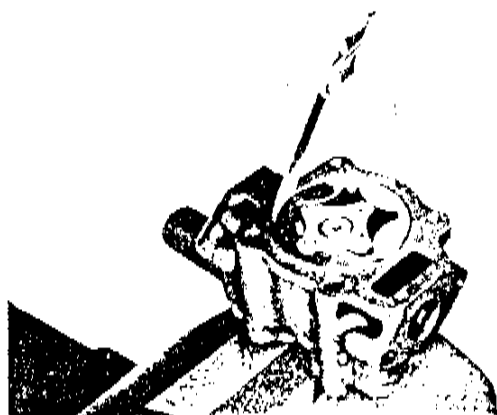

Fig. 2-4

2. Check the clearance between the outer rotor and pump body with a feeler gauge. If the clearance exceeds limit, replace the rotor or pump body.

Limit: 0.3 mm (0.012 in)

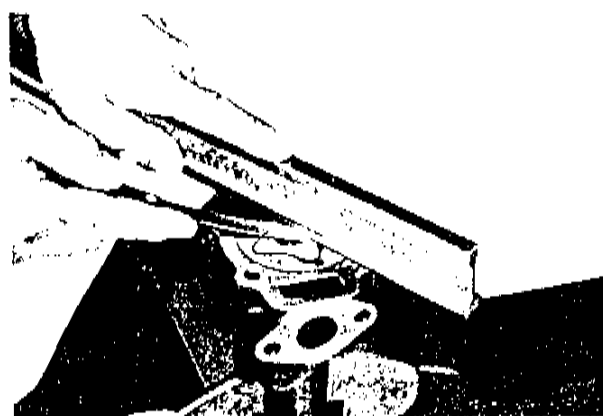

Fig. 2-5

3. Check the end float of the rotors. Place a straight edge across the pump body and measure the clearance between the rotor and straight edge with a feeler gauge.

Then, place a straight edge across the pump cover and measure the clearance between the straight edge and the cover.

If the end float exceeds limit, correct the pump cover by grinding.

Limit: 0.15 mm (0.006 in)

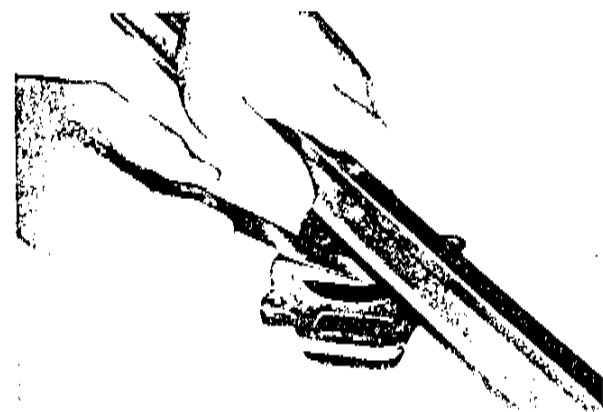

Fig. 2-6

2-B-3. Assembling Oil Pump

Carry out the disassembling operations in the reverse order.

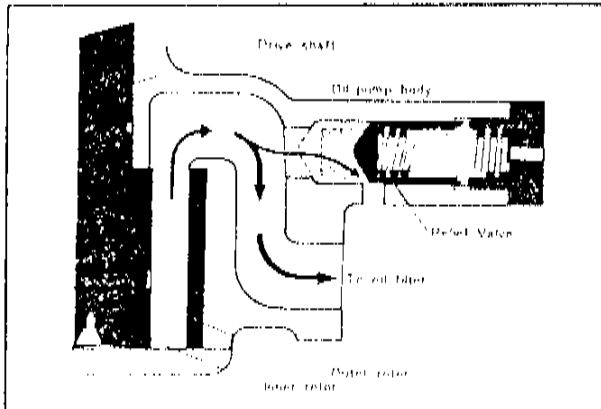

Fig. 2-7

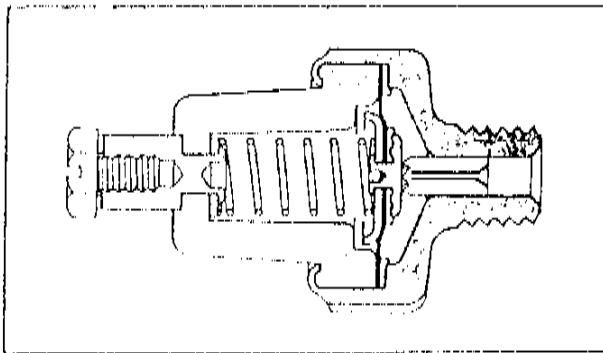

Fig. 2-8

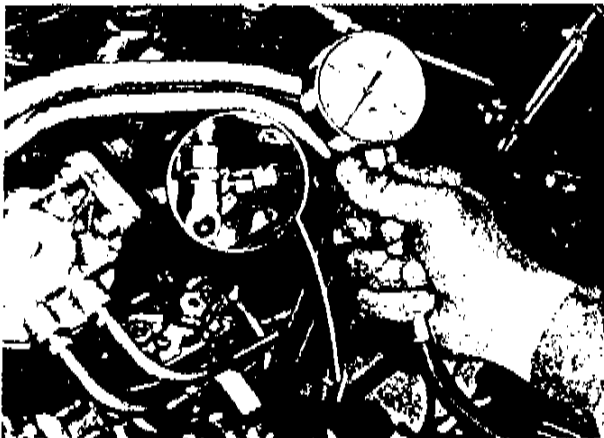

Fig. 2-9

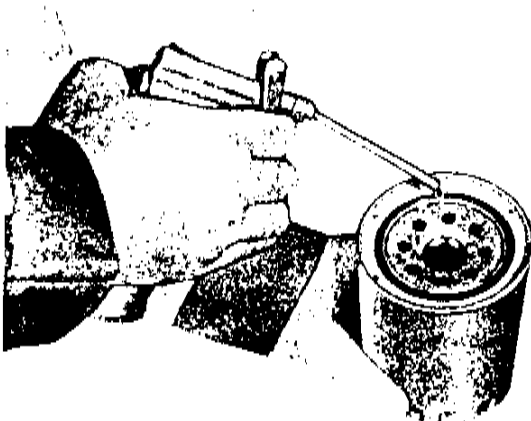

Fig. 2-10

2-C. OIL PRESSURE RELIEF VALVE

When the engine revolution becomes high and excessive oil pressure develops in the system, the relief valve opens to relieve the pressure and to return the excess oil to the oil pan.

Thus, the oil pressure maintains within the maximum pressure of 4.0 kg/cm^2 (57 lb/in^2).

2-D. OIL PRESSURE SWITCH

Safe minimum pressure is 0.4 kg/cm^2 (6 lb/in^2) at idle. If the oil pressure drops below 0.4 kg/cm^2 (6 lb/in^2), the oil pressure warning lamp lights up to indicate some troubles in the lubricating system.

2-E. CHECKING OIL PRESSURE

Warm up the engine to the normal operating temperature. Remove the oil pressure switch and connect the oil pressure gauge (49 0187 280) instead.

The following table shows the normal oil pressure.

Oil pressure: 4.0 kg/cm^2 (57 lb/in^2)
at 3,600 rpm. of engine

2-F. OIL FILTER

The filter cartridge should be replaced at intervals, following the maintenance schedule.

To replace, proceed as follows:

1. Remove the oil filter cartridge with the suitable wrench.
2. Apply oil onto the oil seal on a new filter cartridge.
3. Position the filter and turn clockwise until the gasket surface contacts sealing surface.
- Then, give the filter an additional $5/6$ turn by hand.
4. Start the engine and check that the joints are not leaking. Top up with oil if necessary.

SPECIAL TOOL

49 0187 280

Oil pressure gauge

COOLING SYSTEM

3 A. COOLING CIRCUIT.....	3:1
3 B. ANTI-FREEZE SOLUTION.....	3:1
3 C. RADIATOR.....	3:1
3 C 1. Removing Radiator.....	3:1
3 C 2. Installing Radiator.....	3:1
3 C 3. Radiator Inspection.....	3:2
3 D. THERMOSTAT.....	3:2
3 D 1. Removing Thermostat.....	3:2
3 D 2. Checking Thermostat.....	3:2
3 D 3. Installing Thermostat.....	3:3
3 E. WATER PUMP.....	3:3
3 E 1. Checking Water Pump on Car.....	3:3
3 E 2. Removing Water Pump.....	3:3
3 E 3. Disassembling Water Pump.....	3:4
3 E 4. Assembling Water Pump.....	3:4
3 E 5. Installing Water Pump.....	3:4
3 F. "V" BELT AND TENSION ADJUSTMENT.....	3:4
SPECIAL TOOL.....	3:4

3--A. COOLING CIRCUIT

When the engine gets warm, the coolant flows to the water pump from the outlet in the lower left side of the radiator. After passing through the pump, the

coolant is forced to the cylinder block. After cooling off the cylinder block, the coolant circulates in the cylinder head. Then the coolant flows through the thermostat and back into the radiator.

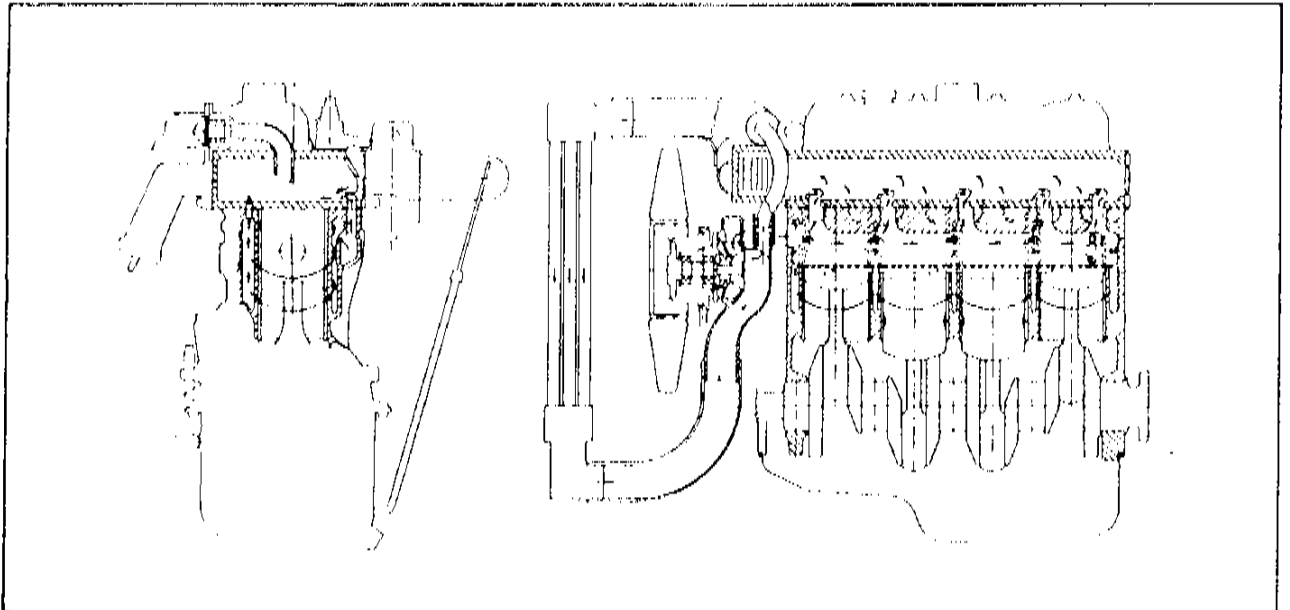

Fig. 3-1

Freezing point (Centigrade)	Mixture percentage (Volume)		Specific gravity of mixture at 20°C (68°F)
	Antifreeze solution	Water	
6.3	15	85	1.022
9.3	20	80	1.029
12.6	25	75	1.037
16.2	30	70	1.044
20.5	35	65	1.051
25.2	40	60	1.058
31.2	45	55	1.066
37.6	50	50	1.073
45.2	55	45	1.080

3--B. ANTIFREEZE SOLUTION

To prevent freezing, add anti-freeze solution to the water which lowers the freezing point of the coolant. Before adding anti-freeze, inspect the cooling system to be sure it is clean and leaktight.

The table shows the percentage of MAZDA genuine anti-freeze solution required to protect the cooling system.

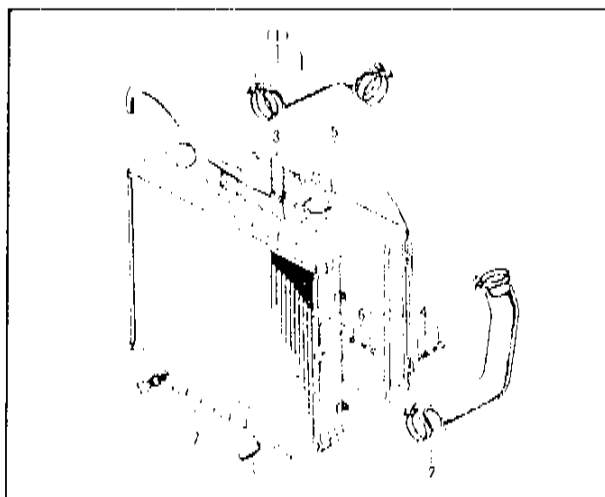

Fig. 3-2

- 1. Upper hose/clamp
- 2. Lower hose/clamp
- 3. Hose/clamp
- 4. Bolt/washer
- 5. Covering
- 6. Bolt/washer
- 7. Radiator

3--C. RADIATOR

3--C--1. Removing Radiator

After draining the cooling system, remove the radiator following the order numbered in Fig. 3-2.

3--C--2. Installing Radiator

Follow the removal procedures in the reverse order.

Note: Fill the cooling system with a mixture of clean soft water (deminalized water) and anti-freeze solution or anti-corrosive solution according to the season and maker's instruction.

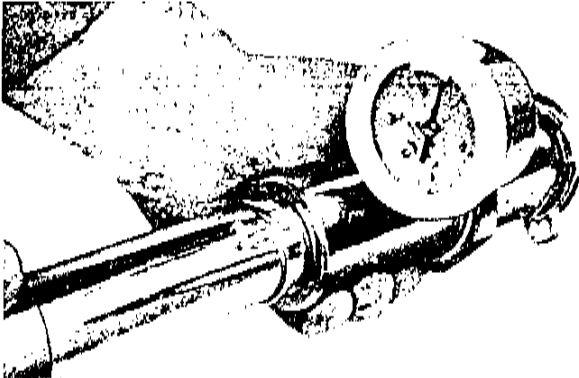

Fig. 3-3

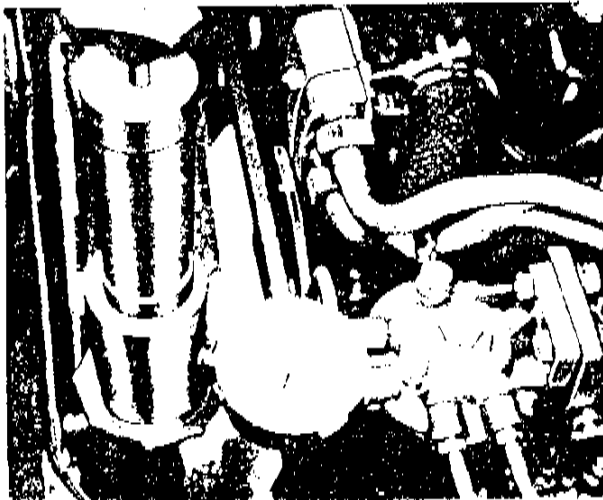

Fig. 3-4



Fig. 3-5

1. Cover 2. Gasket 3. Thermostat

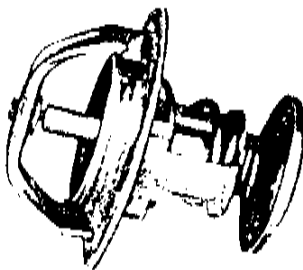

Fig. 3-6

3-C-3. Radiator Inspection

1. Check the pressure cap function. To check, first wet the cap rubber gasket to insure an air tight seal and then attach a tester to the cap.

Valve opening pressure 0.9 kg/cm^2 (13 lb/in^2)

2. Inspect the cooling system for leaks.

- 1) Attach a tester in place of radiator pressure cap.
- 2) Run the engine until it reaches normal operating temperature.
- 3) With the engine running and tester installed, pump up the system to approx. 0.9 kg/cm^2 (13 lb/in^2) and observe the gauge.

Note: Never allow the pressure to build up to more than 1.0 kg/cm^2 (14 lb/in^2).

If pressure drops rapidly, visually inspect all external parts for leaks. If no external leaks appear and pressure continues to drop, inspect the engine oil to determine whether or not coolant is leaking into the crankcase due to a cracked cylinder block or leaking head gasket.

3-D. THERMOSTAT

3-D-1. Removing Thermostat

After draining until the coolant level is below the thermostat housing, remove the thermostat following the orders numbered in Fig. 3-5.

3-D-2. Checking Thermostat

To test the thermostat, place it in water with a thermometer and heat up the water gradually and check the temperature when the thermostat starts to open and when it opens fully. And also measure the lift height when the thermostat is fully opened. If the reading shows a large difference from the specifications, replace with a new thermostat.

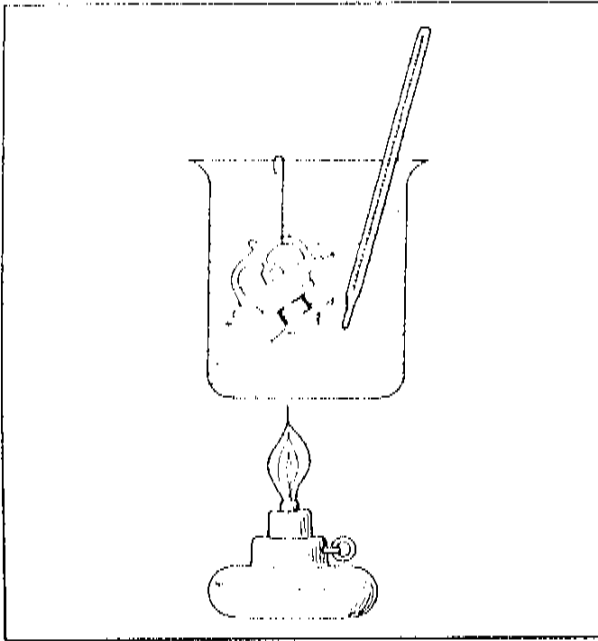

Fig. 3-7

Starts to open	$82^{\circ} \pm 1.5^{\circ}\text{C}$ ($180^{\circ} \pm 2.7^{\circ}\text{F}$)
Fully opens at	95°C (203°F)
Life	8 mm (0.315 in) or more

3-D-3. Installing Thermostat

Follow the removal procedure in the reverse order. Fill the cooling system. Operate the engine and check for leaks.

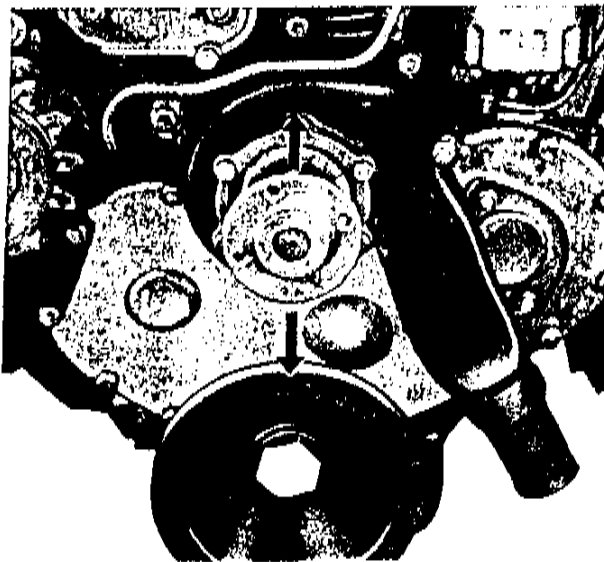

Fig. 3-8

3-E. WATER PUMP

3-E-1. Checking Water Pump on Car

Check the water pump for leaks and excessive play or looseness of the shaft and bearings. If there is evidence of excessive play when the fan blades are manually moved up and down, it shows that the bearings are rough.

If water leaks from the hole located on the pump body, it indicates defective seal necessitating overhaul of the pump.

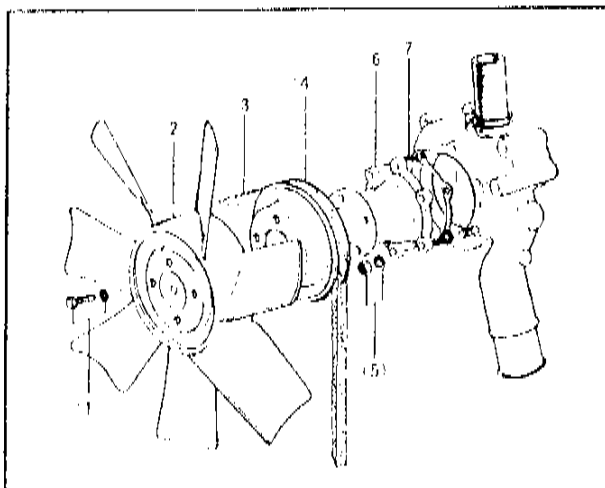

3-E-2. Removing Water Pump

After draining cooling system, remove the water pump following the order numbered in Fig. 3-9.

Fig. 3-9

- 1. Bolt/washer
- 2. Cooling fan
- 3. "V" belt
- 4. Pulley
- 5. Nut/washer
- 6. Water pump
- 7. Gasket

3-E-3. Disassembling Water Pump

Disassemble the parts in the order numbered below.

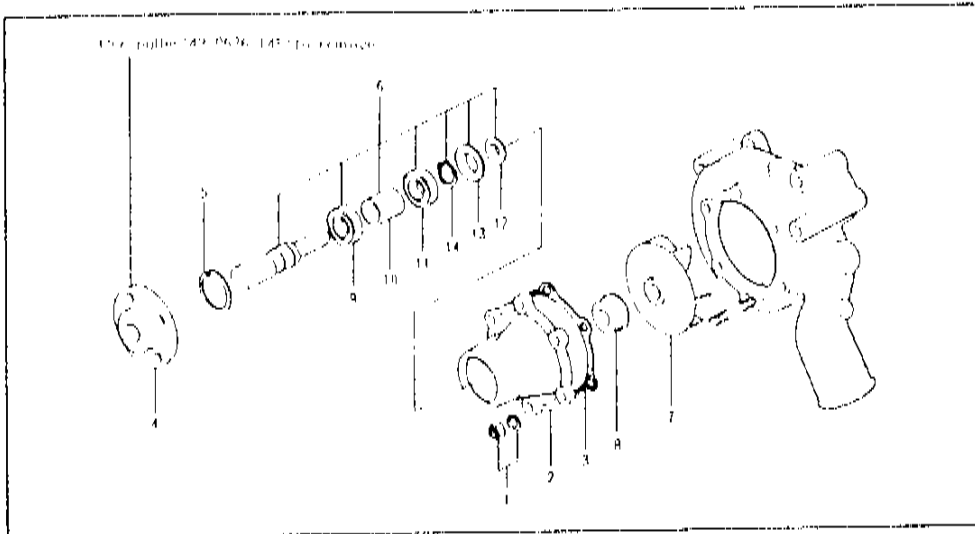
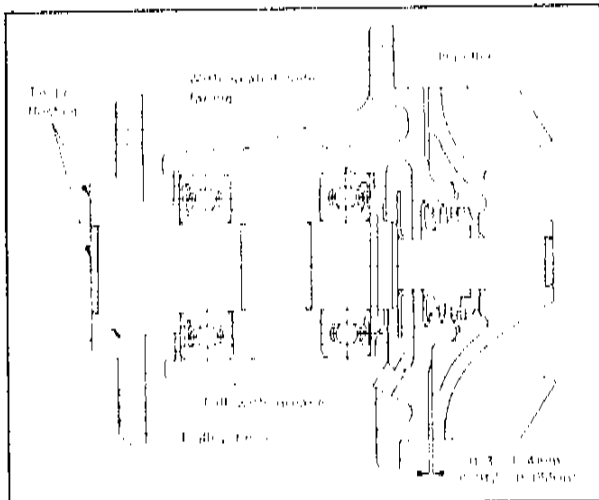

Fig. 3-10

- 1. Nut/washer
- 2. Bearing housing
- 3. Gasket
- 4. Pulley boss
- 5. Snap ring
- 6. Shaft, spacer/bearing assembly
- 7. Impeller
- 8. Seal assembly
- 9. Bearing
- 10. Spacer
- 11. Bearing
- 12. Battle plate
- 13. Dust seal
- 14. Snap ring



3-E-4. Assembling Water Pump

Assemble the water pump in the reverse order of disassembling, take care the cautions in Fig. 3-11.

3-E-5. Installing Water Pump

Install the water pump in the reverse order of removing.

Note:

- 1) Adjust the belt tension, as described in Par. 3-F.
- 2) Fill the cooling system. Operate the engine and check for leaks.

Fig. 3-11

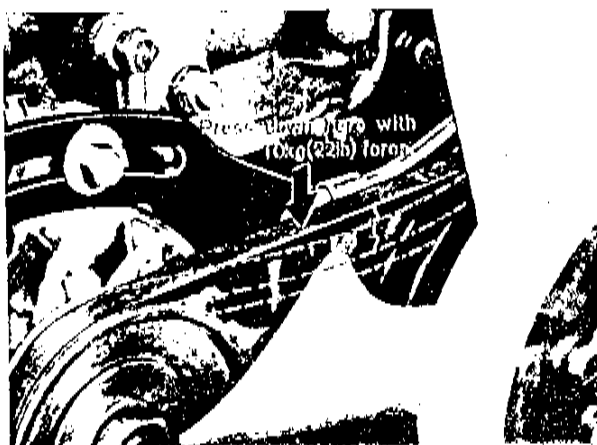

Fig. 3-12

3-F. "V" BELT AND TENSION ADJUSTMENT

- 1. If the belt is broken, glazed, or worn, replace the belt with a new one. If the belt is stretched so that it cannot be tightened sufficiently, install a new belt.
- 2. If the belt is noisy, check the tension of the belt. Also, check for misaligned pulleys.
- 3. When the belt is pressed down with 10 kg (22 lb) force, the belt should deflect the specified amount.

For new belt	10 ~ 13 mm (0.4 ~ 0.5 in)
For used belt	13 ~ 16 mm (0.5 ~ 0.6 in)

SPECIAL TOOL

49 0636 145	Holder, pump pulley
-------------	---------------------

FUEL SYSTEM

4	A. FUEL FLOW SYSTEM	4 : 1
4	B. FUEL FILTER & SEDIMENTOR.....	4 : 1
	4 B 1. Fuel Filter	4 : 1
	4 B 2. Sedimentor	4 : 1
4	C. FUEL INJECTION PUMP.....	4 : 2
	4 C 1. Important Service Points	4 : 2
	4 C 2. Construction of VE Injection Pump.....	4 : 2
	4 C 3. Checking Idle Speed	4 : 5
	4 C 4. Adjusting Idle Speed	4 : 5
	4 C 5. Checking Injection Timing.....	4 : 6
	4 C 6. Adjusting Injection Pump	4 : 7
	4 C 7. Removal	4 : 7
	4 C 8. Installation	4 : 8
	4 C 9. Air-Bleeding Fuel System	4 : 8
4	D. MAGNET VALVE	4 : 9
	4 D 1. Checking	4 : 9
4	E. FUEL INJECTION NOZZLES.....	4 : 10
	4 E 1. Removing Nozzle Holder	4 : 10
	4 E 2. Disassembling Nozzle Holder.....	4 : 10
	4 E 3. Checking Injection Nozzle	4 : 11
	4 E 4. Assembling Injection Nozzle.....	4 : 11
	4 E 5. Testing Injection Nozzle	4 : 11
	4 E 6. Installing Injection Nozzles	4 : 12
4	F. AIR CLEANER	4 : 12
	4 F 1. Removing Air Cleaner Element	4 : 12
	4 F 2. Cleaning Air Cleaner Element	4 : 12
	4 F 3. Installing Air Cleaner Element	4 : 12

4-A. FUEL FLOW SYSTEM

The fuel flow system, as shown in Fig. 4-1.

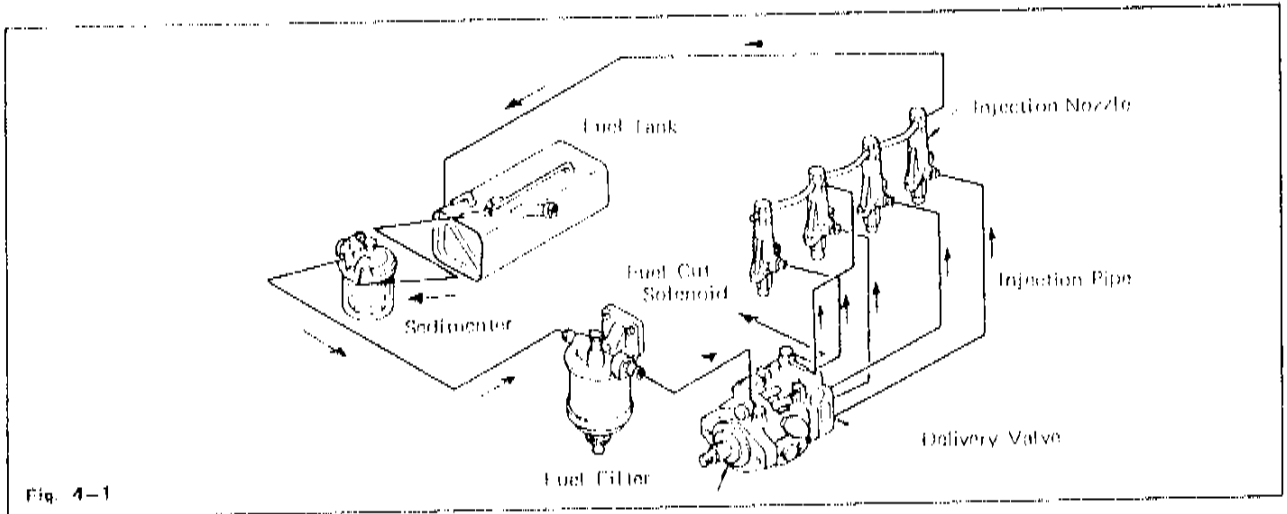

Fig. 4-1

4-B. FUEL FILTER & SEDIMENTOR

4-B-1. Fuel Filter

The element of the filter is sealed in the container as a unit. The element should be replaced at intervals, following the maintenance schedule.

To replace proceed as follows:

1. Remove the fuel filter cartridge with the suitable wrench.
2. Apply fuel onto the oil seal on a new filter cartridge.
3. Position the filter and turn clockwise until the gasket surface contacts ceiling surface.
4. Then, give the filter an additional 2/3 turn by hand.
5. After replacing the filter element, bleed the filter line according to the procedure described in Par. 4-F.
6. Start the engine and check that joints are not leaking.

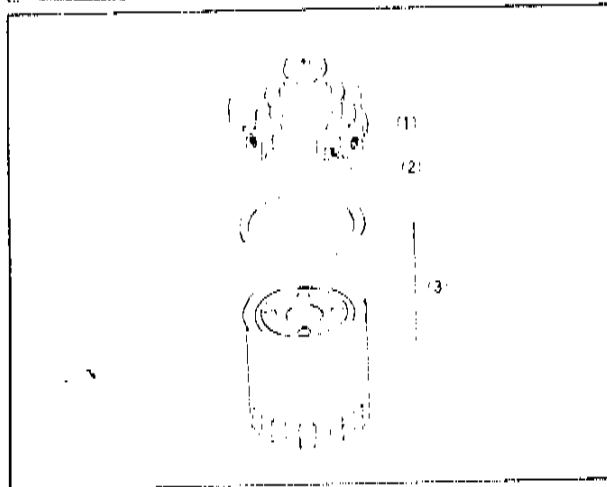

Fig. 4-2

- | | |
|------------------|---------------------|
| 1. Adapter | 3. Filter Cartridge |
| 2. Breeder Screw | |

4-B-2. Sedimentor

Presence of water in the sedimentor can be seen through the transparent plastic bowl. If the red ring floating in the bowl or buzzer is sound, loosen the drain valve of the sedimentor.

When water is drained, air bleeding is not required if the fuel tank is half filled with fuel.

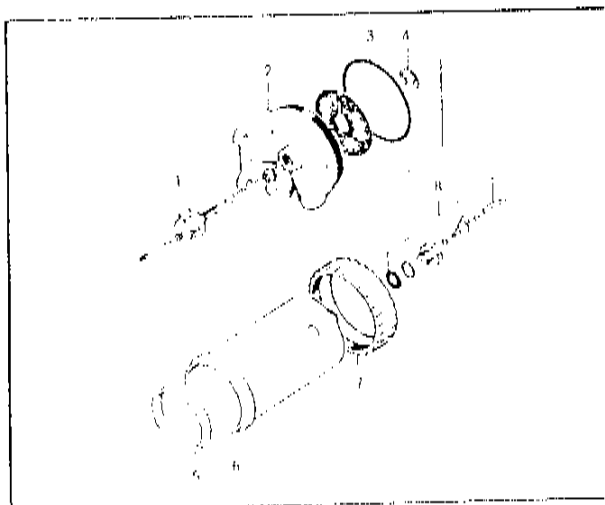

Fig. 4-3

- | | | |
|-------------|----------|--------------------------|
| 1. Detector | 4. Clip | 7. Retainer |
| 2. Cover | 5. Float | 8. Drain plug / "O" ring |
| 3. "O" ring | 6. Bowl | |

4-C. FUEL INJECTION PUMP

4-C-1. Important Service Points

If the inside of the injection pump is disassembled for maintenance, be sure to properly use the checking device such as pump tester, and carefully inspect each component parts.

Disassembly and maintenance should be made at a clean place and the parts should be thoroughly cleaned.

For the disassembling/reassembling, checking and adjusting procedures for the injection pump itself, see the service manual, "Repair Service and Maintenance", prepared by manufacturer of injection pump.



Fig. 4-4

4-C-2. Construction of VE Injection Pump

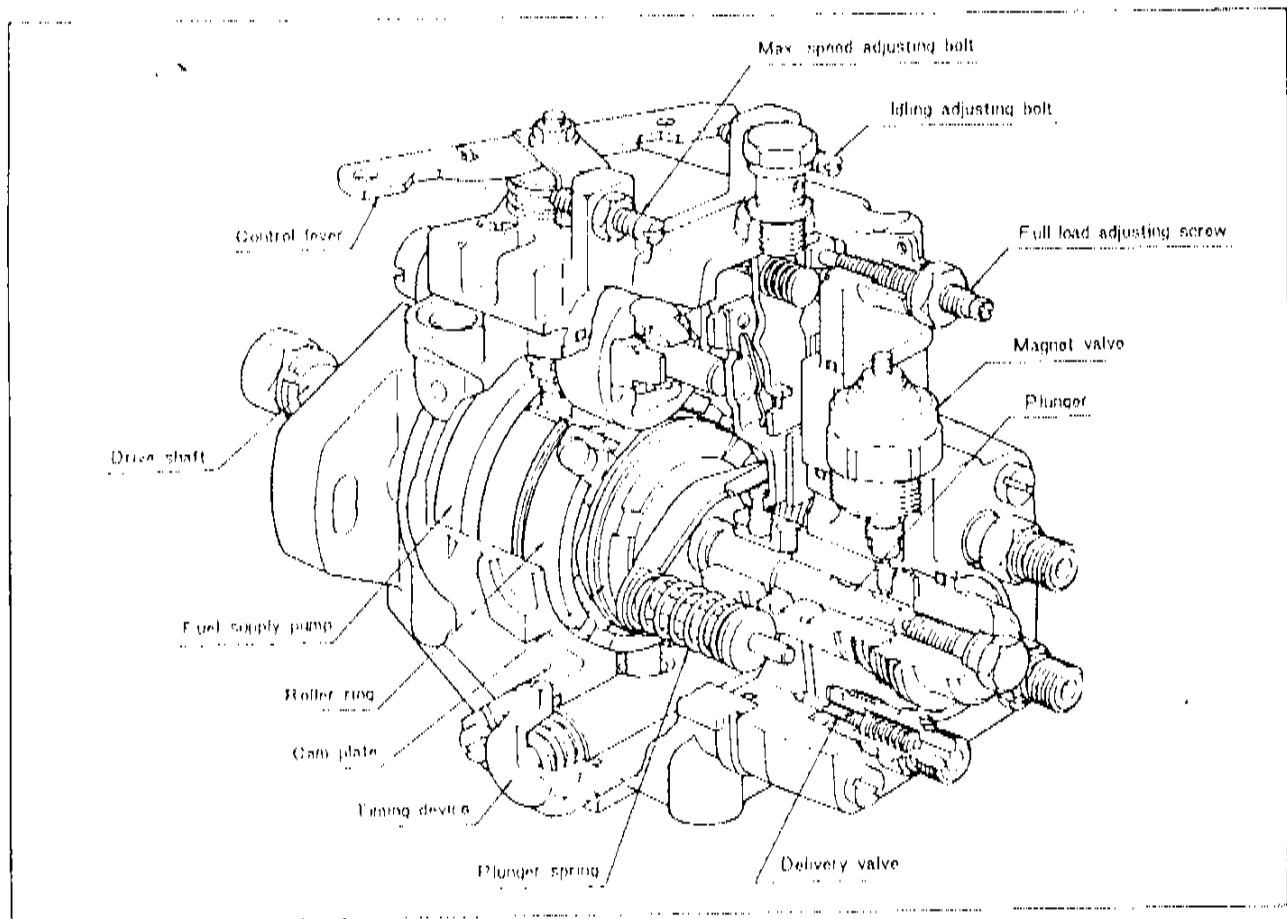

Fig. 4-5

VE TYPE C933 13 800 : 04740-0010 FOR E3000 MA-Engine.

Fig. 4-6

Item	Pump Speed R.P.M.	Fuel Injection Amount mm ³ /Stroke	Chamber Pressure kg/cm ²	Tuner Stroke mm.
Start	100	more than 30	—	—
Start-Idling	30 ~ 210	39.4 ~ 45.4	—	—
Idling	350	41.7 ~ 51.1	—	—
Full load	500	46.5 ~ 50.5	2.3 ~ 2.9	—
"	530 ~ 790	—	—	3.5
"	1000	55.3 ~ 57.3	—	2.3 ~ 3.2
"	1500	52.4 ~ 55.4	5.7 ~ 6.3	4.3 ~ 5.7
"	1800	47.3 ~ 51.1	5.3 ~ 7.5	5.2 ~ 7.4
Governing	2000	11.2 ~ 15.2	—	7.1 ~ 7.8
"	2250	less than 5.0	—	—

Adjustment

NGP	Page 15	Fig. 1-11
Demagnetizer	Fig. 14	—
TC	Page 17	—
Demagnetizer	Fig. 13	Fig. 1-14
TMS	Page 23	—
Demagnetizer	Fig. 14	—

Note: Fuel temperature 40~45°C
Adjust at Speed 1 to Pump Speed.

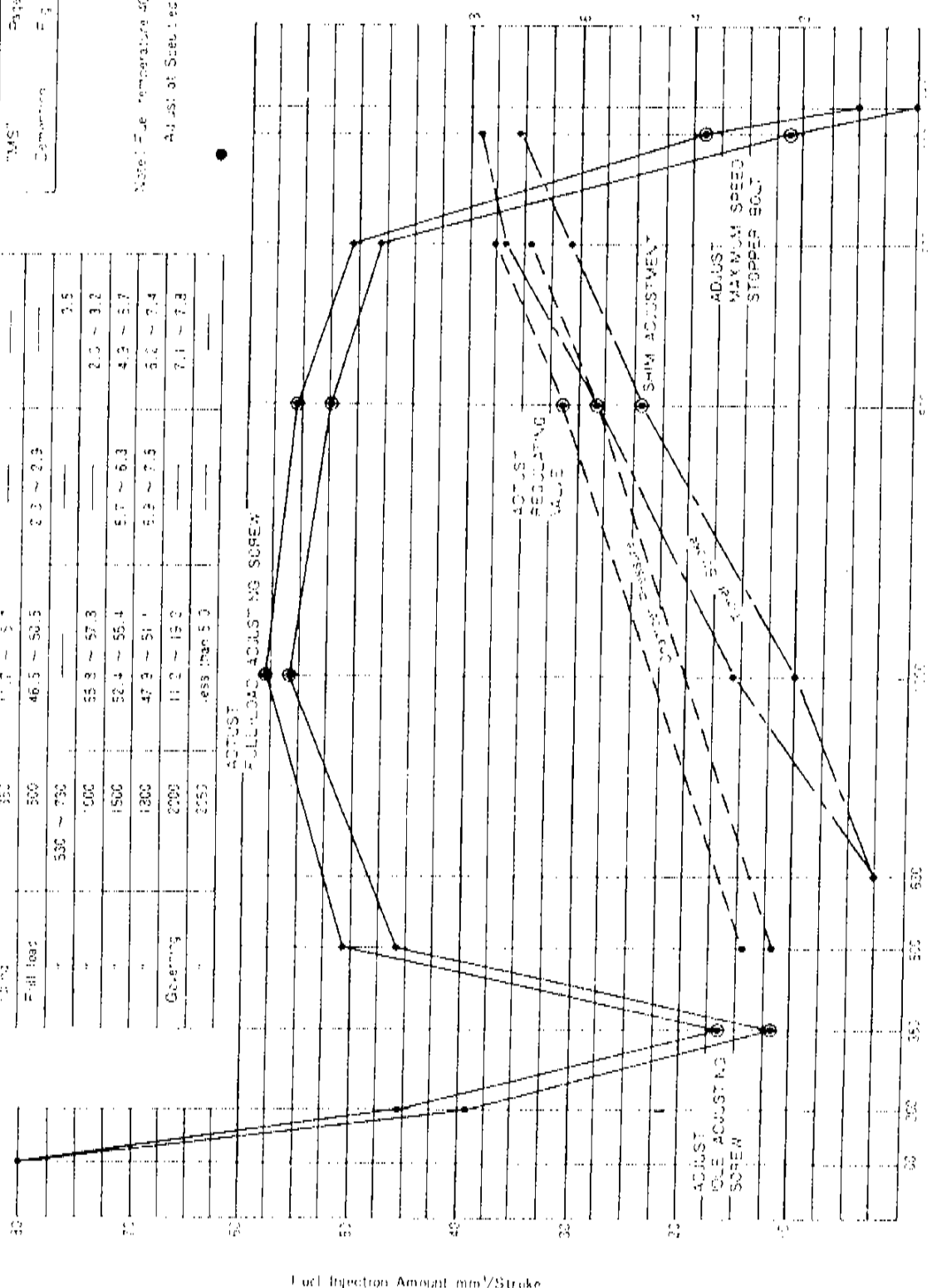

VE TYPE 0911 13 BCC 104740-0000 FOR E2500 1XA-Engine

VE Type 0911 13 BCC 104740-0000

Item	Part No.	Part Name
1	0911-13-001	Injection Pump
2	0911-13-002	Injection Valve
3	0911-13-003	Injection Valve
4	0911-13-004	Injection Valve
5	0911-13-005	Injection Valve
6	0911-13-006	Injection Valve
7	0911-13-007	Injection Valve
8	0911-13-008	Injection Valve
9	0911-13-009	Injection Valve
10	0911-13-010	Injection Valve
11	0911-13-011	Injection Valve
12	0911-13-012	Injection Valve
13	0911-13-013	Injection Valve
14	0911-13-014	Injection Valve
15	0911-13-015	Injection Valve
16	0911-13-016	Injection Valve
17	0911-13-017	Injection Valve
18	0911-13-018	Injection Valve
19	0911-13-019	Injection Valve
20	0911-13-020	Injection Valve

Injection Pump Adjustment

Item	Part No.	Part Name	Adjustment Range
1	0911-13-001	Injection Pump	0.0 ~ 0.1
2	0911-13-002	Injection Valve	0.0 ~ 0.1
3	0911-13-003	Injection Valve	0.0 ~ 0.1
4	0911-13-004	Injection Valve	0.0 ~ 0.1
5	0911-13-005	Injection Valve	0.0 ~ 0.1
6	0911-13-006	Injection Valve	0.0 ~ 0.1
7	0911-13-007	Injection Valve	0.0 ~ 0.1
8	0911-13-008	Injection Valve	0.0 ~ 0.1
9	0911-13-009	Injection Valve	0.0 ~ 0.1
10	0911-13-010	Injection Valve	0.0 ~ 0.1
11	0911-13-011	Injection Valve	0.0 ~ 0.1
12	0911-13-012	Injection Valve	0.0 ~ 0.1
13	0911-13-013	Injection Valve	0.0 ~ 0.1
14	0911-13-014	Injection Valve	0.0 ~ 0.1
15	0911-13-015	Injection Valve	0.0 ~ 0.1
16	0911-13-016	Injection Valve	0.0 ~ 0.1
17	0911-13-017	Injection Valve	0.0 ~ 0.1
18	0911-13-018	Injection Valve	0.0 ~ 0.1
19	0911-13-019	Injection Valve	0.0 ~ 0.1
20	0911-13-020	Injection Valve	0.0 ~ 0.1

Adjust Fuel Temperature 40°~45°C
Adjust at Specified Pump Speed

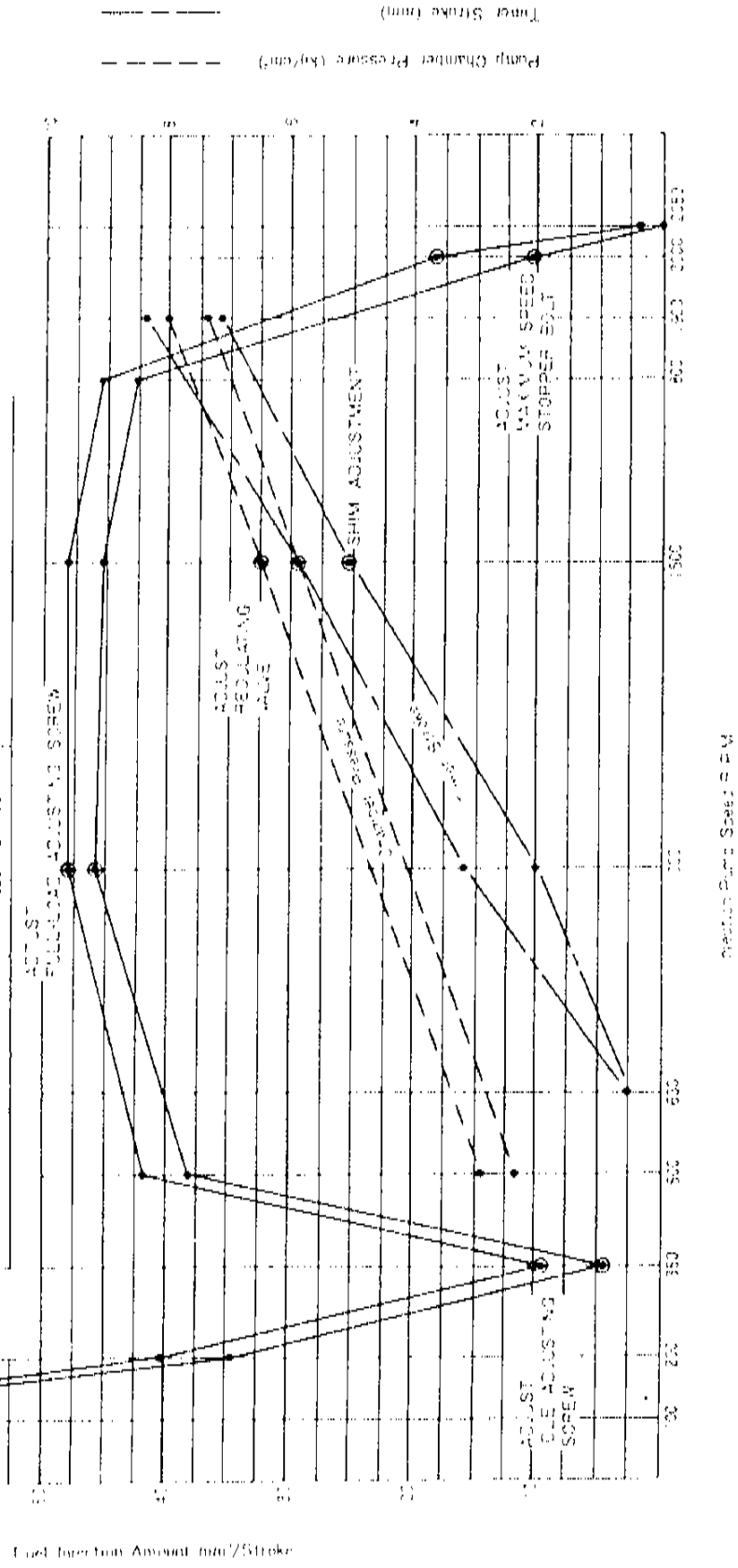

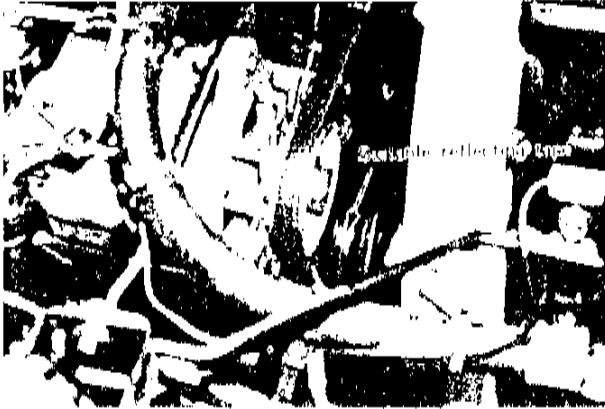

Fig. 4-8



Fig. 4-9

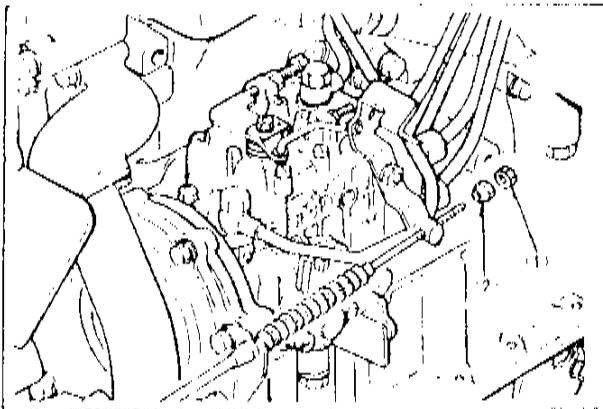

Fig. 4-10

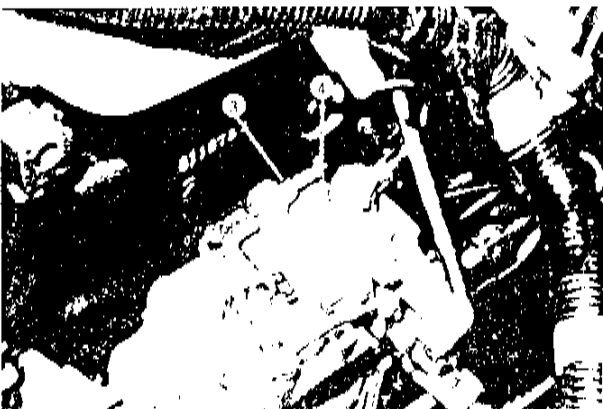

Fig. 4-11

4-C-3. Checking Idle Speed

1. Warm up the engine.
2. Remove any specks on the crankshaft pulley with a waste cloth and place a piece of suitable reflecting tape on the pulley to facilitate use of a photo-electric type tachometer.
3. Start and idle the engine.
4. Aim the light of the tachometer onto the reflecting tape to confirm the engine speed.
5. Adjust the idle speed if the engine speed is not within the specified value.

Standard idling speed:

HA Engine	600 ~ 650 rpm
XA Engine	600 ~ 650 rpm

4-C-4. Adjusting Idle Speed

1. Confirm the play of the accelerator wire.

Permissible play:

1 ~ 3 mm (0.039 ~ 0.118 in)

Note:

- To lengthen the play of the accelerator wire, loosen the lock nut (1) of the wire bracket and tighten the adjust nut (2)

2. Loosen the lock nut (3) of the idle adjust bolt and adjust the play by turning the idle adjust bolt (4).

Note:

- Idle speed will increase when the adjust bolt is turned clockwise and decrease when turned counter clockwise.

3. After the adjustment, race the engine two or three times to inspect the returning of the accelerator wire.

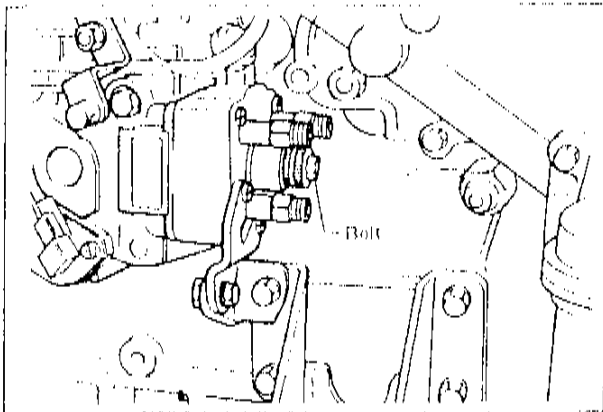

Fig. 4-12

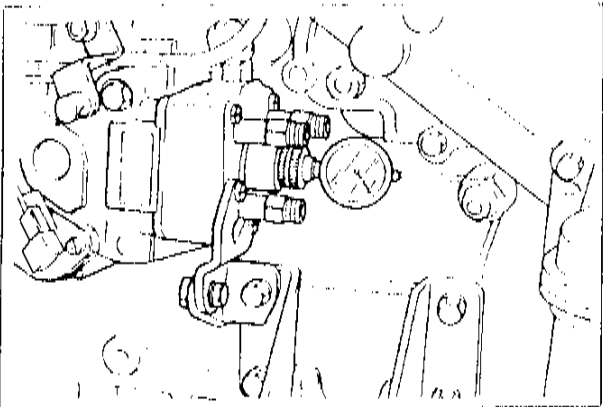

Fig. 4-13

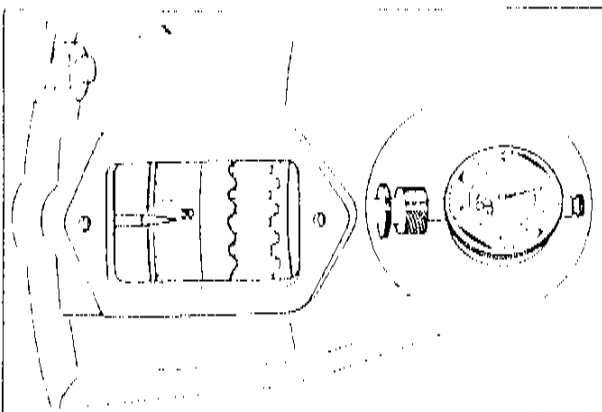

Fig. 4-14

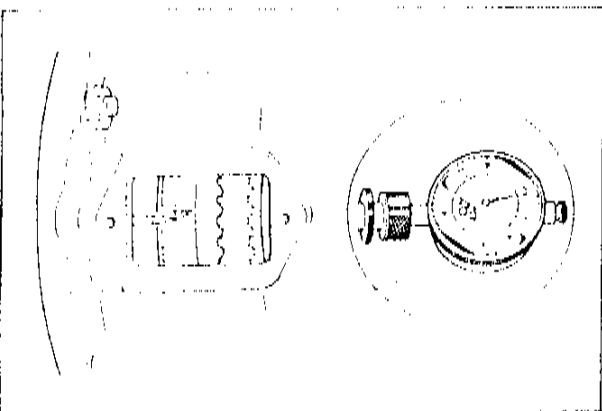

Fig. 4-15

4-C-5. Checking Injection Timing

1. Disconnect the fuel injection pipes from the injection pump.
2. Remove the bolt and gasket installed on the distributor head of the injection pump.

3. Set the measuring device (49 9140 074) on the injection pump.
Make sure that the tip of the feeler needle of the measuring device is in contact with plunger end at this time.

Note:

- The part number of the measuring device specified by Diesel Kiki Co., Ltd. is 157829 - 3520.
- The part number of the measuring device specified by Nippon Denso Co., Ltd. is 95904 - 51260.

1. Set the flywheel ring gear to approximately 30° of BTDC and find the position in which the needle of the dial gauge does not deflect even when the flywheel is turned.
2. When it is confirmed that the dial gauge needle does not deflect, set the needle to "0" on the scale.

6. Turn the flywheel in the normal direction until TDC is indicated.

The injection timing is normal when the dial gauge needle of advanced 1.00 mm ahead of the value set in the above 5.

Beginning of matic injection:

Cam lift 1.00 mm (0.0394 in.).

If the error is more than 1.00 mm, adjust the injection timing.

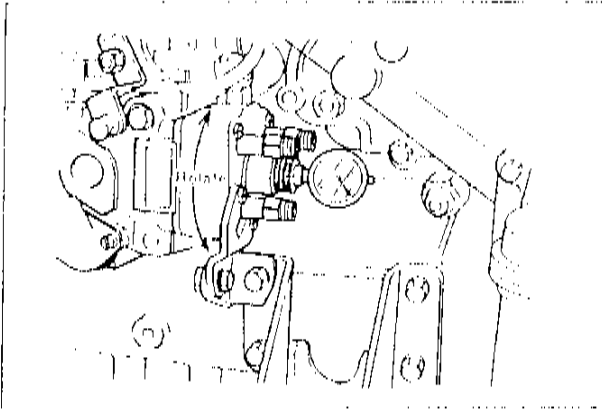

Fig. 4-16

4-C-6. Adjusting Injection Pump

1. If the injection timing is faulty, turn the injection pump to a position in which the dial gauge needle indicates 1.00 mm.

- When the cam lift is larger than 1.00 mm, turn the injection pump all the way in the engine revolving direction once, and then turn it in the reverse direction, adjusting the cam lift to the 1.00 mm point.
- If the cam lift is smaller than 1.00 mm, adjust the lift by turning the pump in the direction inverse to the engine revolving direction.

2. After the adjustment, install the head bolt and gasket.

3. Use a new head bolt and gasket.

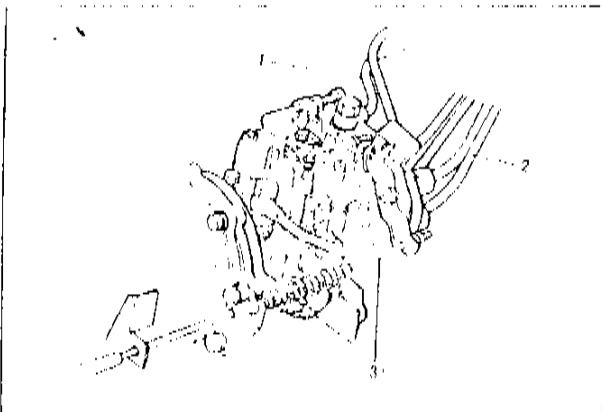

Fig. 4-17

4-C-7. Removal

1. Disconnect both positive and negative terminals of the battery.

2. Remove the upper fan shroud and cooling fan.

3. Remove the air hose.

4. Remove the fuel pipe and fuel injection pipes.

5. Disconnect the accelerator cable from the injection pump.

6. Disconnect the wiring of the magnet valve (for fuel cut).

7. Remove the injection pump cover.

8. Remove the lock nut.

9. Remove the plain washer.

Remove the plain washer with a wire, etc., taking care not to drop it in the gear case.

10. While checking the injection pump shaft key by using a mirror, turn the flywheel through the clutch cover timing hole until the key comes to the top position.

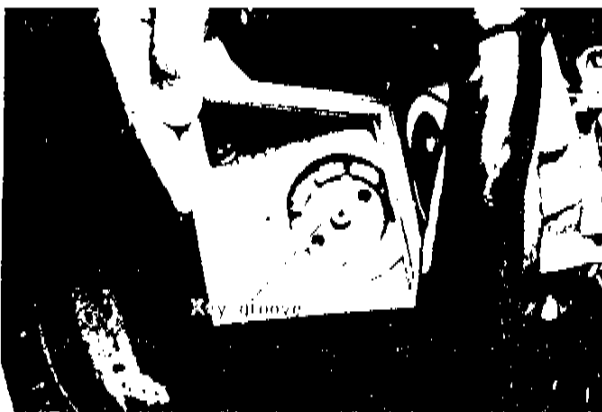

Fig. 4-18



Fig. 4-19

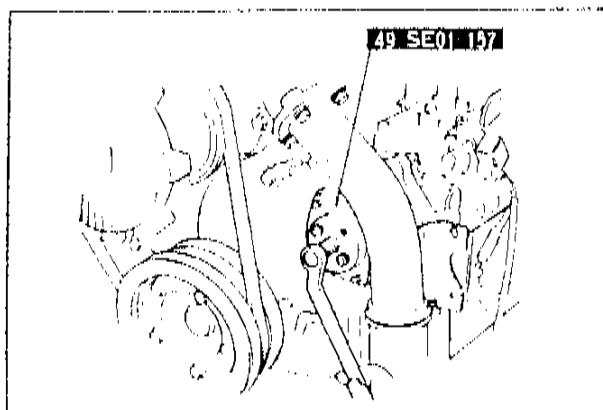

Fig. 4-20

11. Remove the auxiliary bracket tightening bolts used for fixing the lower side of the injection pump.
12. Remove the injection pump mounting nuts.
13. Separate the pump shaft and gear.
 - Set the extractor (49 SE01 157) (Be sure to use the side with M mark at all times).
 - Separate the shaft and gear by tightening the extractor bolts.
14. Remove the injection pump.

Gradually remove the injection pump by pressing the pump gear against the injection pump side, ensuring not to drop the key into the gear case.
15. Remove the extractor.

4-C-8. Installation

Install in the reverse order of removal and pay attention to the following matters.

Note:

- Before installing the key on the drive shaft of the injection pump, lightly tap the key groove of the shaft with a hammer to assure that the key is tightly inserted in the key groove.
- After installing the injection pump, evacuate air.

Drive gear tightening torque:

4.0 – 7.0 m·kg (29 – 51 ft·lb).

4-C-9. Air-Bleeding Fuel System

Whenever the fuel filter is replaced or the sedimentor is cleaned, the filter must be air-bled in the following manner:

1. Loosen the air bleeder screw of fuel filter.
2. Loosen the fuel pump priming plunger by turning counter-clockwise. Then pump the plunger in Up and Down notions.
3. Continue to pump until fuel flows from the air bleeder screw hole free of air bubbles.
4. Depress the fuel pump priming plunger and close the fuel filter air bleeder screw. Secure the priming plunger by turning clockwise.

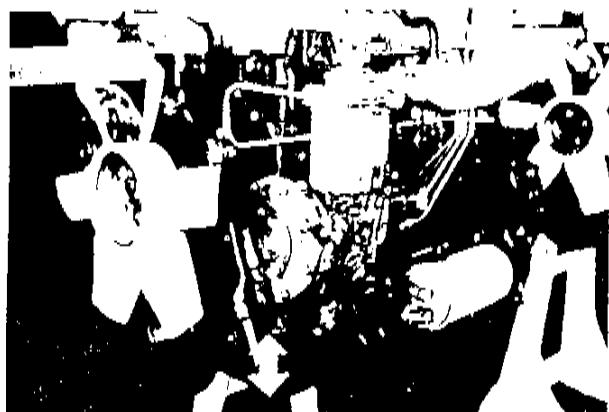

Fig. 4-21

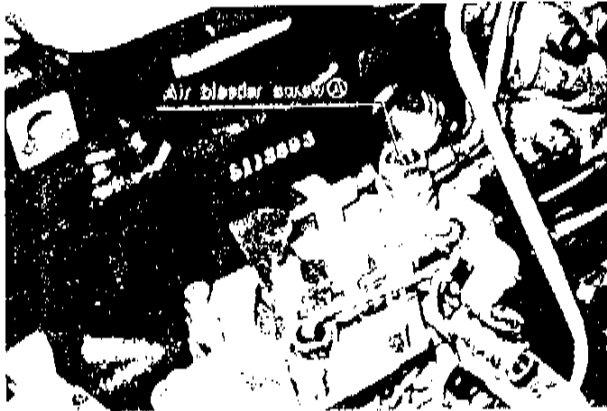

Fig. 4-22

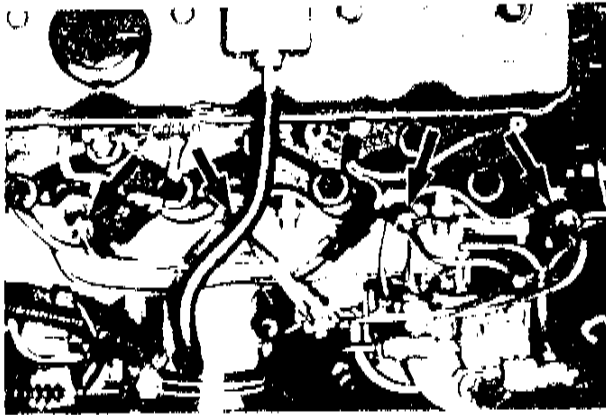

Fig. 4-23

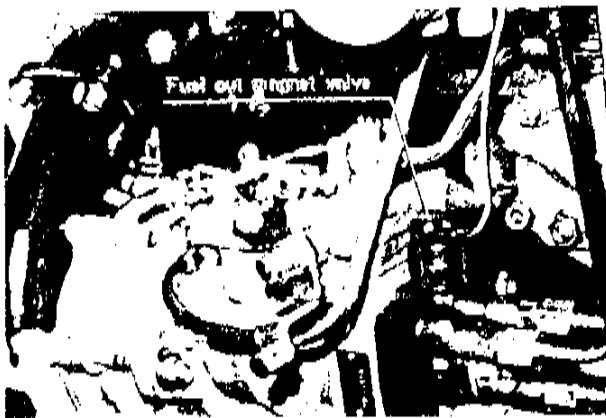

Fig. 4-24

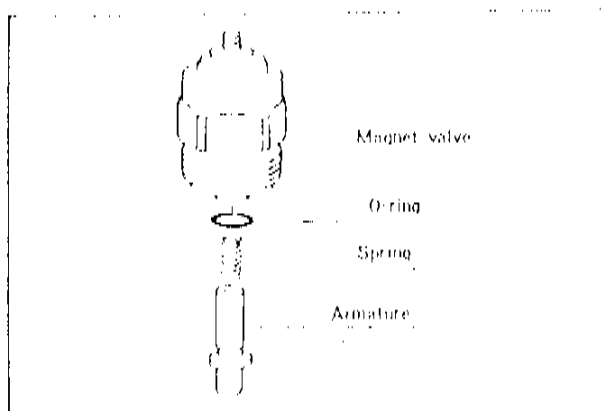

Fig. 4-25

If the engine should run out of fuel during operation and air enters the injection system or whenever the injection pump is removed, the system must be airbled in the following manner:

1. Air-bleed the fuel filter.
2. Loosen the air bleeder screw (A) and operate the fuel pump priming plunger with hand until fuel flows from the air bleeder screw hole free of air bubbles.
3. Close the air bleeder screw (A) with the priming plunger depressed.
4. Loosen the injection pipe nipples on the nozzle holders and crank the engine until fuel flows from the pipes free of air bubbles, and tighten the nipples.

5. Disconnect the injection nozzle side of the injection pipe.

6. Turn the engine switch to the start position, crank the engine and make sure that the fuel flows out of the injection pipe.

4. D. MAGNET VALVE

4-D-1. Checking

The magnet valve is in normal condition; The engine runs smoothly when the engine switch is turned on, but the engine running is stopped when the engine switch is turned off.

If the engine does not stop, check the wiring connection or disconnect the wiring of the magnet valve and check the flow of electric current.

If the electric current is flowing through the coupler when the engine switch is on and is shut off when the switch is off, the engine switch and wiring are in normal condition and the magnet valve is faulty.

When the magnet valve is faulty, replace the part shown in Fig. 4-28 as a complete set.

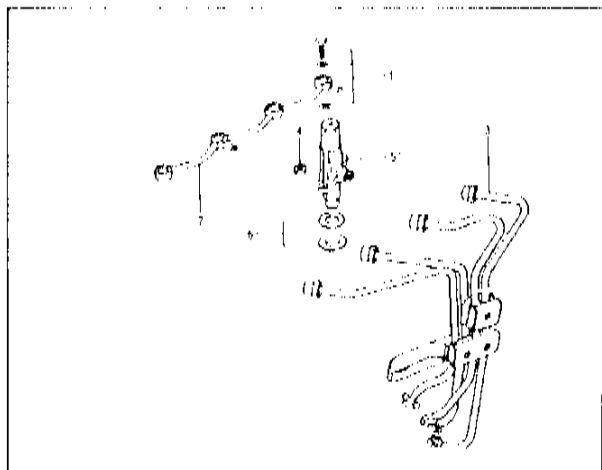

Fig. 4-26

- | | |
|------------------------|-----------------------|
| 1. Joint bolt & Gasket | 4. Nut |
| 2. Fuel leak pipe | 5. Nozzle holder |
| 3. Injection pipe | 6. Gasket & Dust seal |

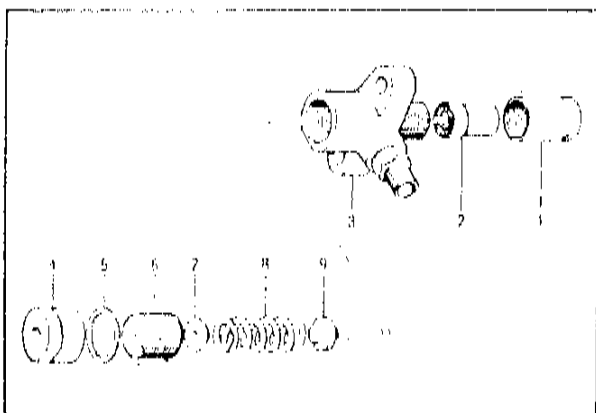

Fig. 4-27

- | | |
|---------------|------------------------|
| 1. Nozzle nut | 6. Spring adjust screw |
| 2. Nozzle | 7. Nozzle spring seat |
| 3. Body | 8. Nozzle spring |
| 4. Cap nut | 9. Push rod |
| 5. Gasket | |

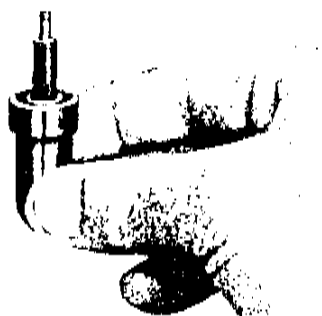

Fig. 4-28

4--E. FUEL INJECTION NOZZLES

As the function of the injection nozzles greatly influences the engine performances, all the injection nozzles must be checked at every 3,000 km (2,000 miles) according to the following method.

4--E-1. Removing Nozzle Holder

Remove the nozzle holder following order numbered in Fig. 4-37.

4--E-2. Disassembling Nozzle Holder

Disassembling nozzle holder following order numbered in Fig. 4-38.

Note:

- 1) Greatest possible care should be taken in handling the nozzles as they are the parts with high precision.
- 2) As the nozzle and the needle valve are in pairs, mixing up of the original combinations must be prevented by disassembling and washing one nozzle assembly after another separately.
- 3) Carbon deposit on the nozzle body must be removed with a piece of hard wood. However, it would be advisable not to clean the surrounding area of the nozzle orifice to avoid possible damage to the orifice. After cleaning, wash the nozzle body in clean gasoline in a container.

Caution:

Never assemble the nozzle needle valve and the nozzle body and slide them on each other in gasoline.

4--E-3. Checking Injection Nozzle

Make sure to needle valve comes down until the valve seat by its weight when it is pushed in the nozzle body about 18 mm (0.70 in).

If it is not so, replace them assembly.

If any defect is found, always replace the needle valve and the nozzle body as a unit.

4--E-4. Assembling Injection Nozzle

Assemble the injection nozzle in the reverse order of disassemble.

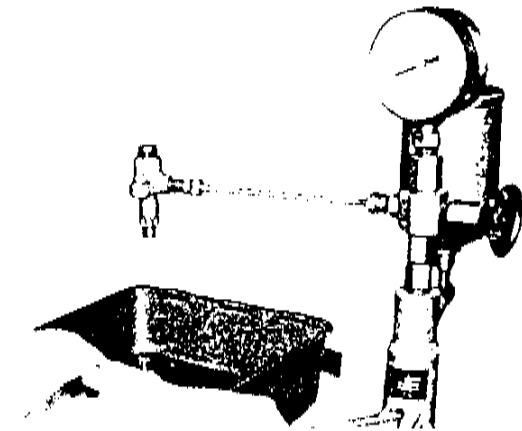

Fig. 4-29

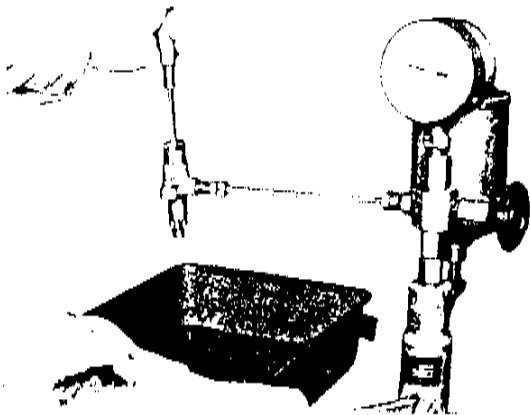

Fig. 4-30

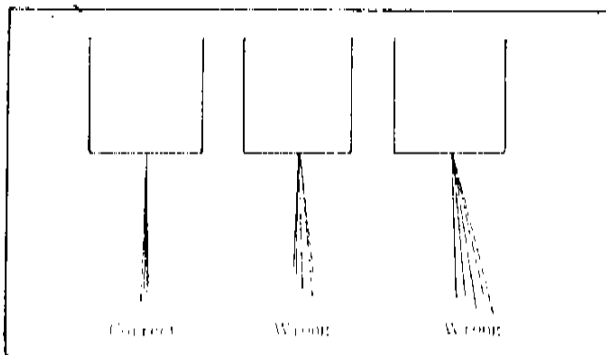

Fig. 4-31

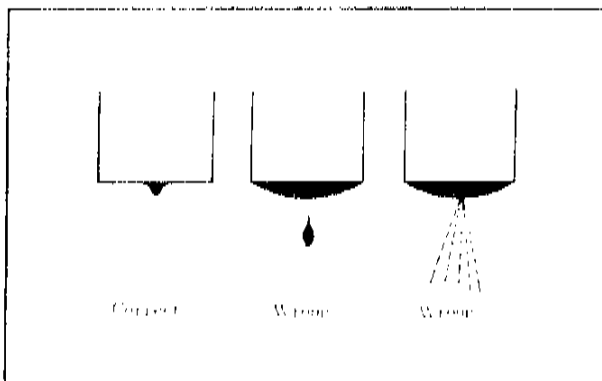

Fig. 4-32

4-E-5. Testing Injection Nozzle

Test the nozzles using light oil under temperature of about 20°C (68°F).

1) Checking Oiltightness of Sliding Portion of Nozzle Needle Valve:

Set the adjusting screw and operate the hand lever to raise the pressure up to 250 kg/cm² (3600 lb/in²) and see how soon the pressure drops from the level to 200 kg/cm² (2800 lb/in²).

If it takes longer than 3 seconds, the oiltightness will be satisfactory. A remarkably quick drop of pressure indicates an excessive clearance at the sliding portion between the needle valve and the nozzle body due to wear, so in such a case replace both needle valve and nozzle body.

2) Checking Injection Starting Pressure:

Operate the hand lever at 60 st/min to check for the pressure under which injection is started. Adjust the pressure to the prescribed value of 135 kg/cm² (1,920 lb/in²) by turning the adjusting screw, and then tighten the cap nut with torque of 3.5 m·kg (25 ft·lb).

3) Checking Oiltightness of Needle Valve Seat:

Operate the hand lever to raise the pressure up to 115 kg/cm² (1635 lb/in²), which is 20 kg/cm² (280 lb/in²) lower than the injection starting pressure. If fuel does not drip from the nozzle orifice under the pressure, oiltightness is satisfactory. Dripping of fuel, on the other hand, is indicative of damage on the needle valve or the valve body, or mal-contact between both. In that event, both needle valve and valve body must be replaced.

Checking Fuel Injection:

Operate the hand lever quickly and verify that fuel is injected correctly from the nozzle orifice in the direction of the nozzle axis.

At fuel injection check, inspect for fuel staying at the nozzle orifice after several times of injection. A large amount of fuel staying there or dripping of fuel therefrom are due to mal-contact between the needle valve and the valve seat. In such a case, renew both nozzle needle valve and nozzle body.



Fig. 4-33

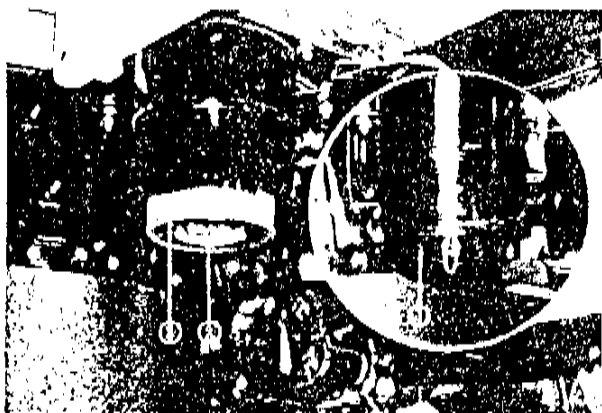

Fig. 4-34

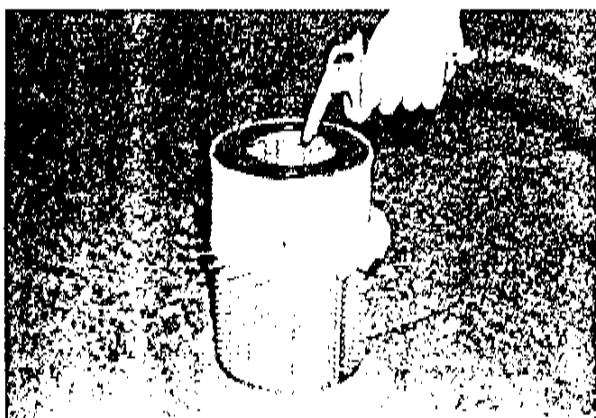

Fig. 4-35

4-E-6. Installing Injection Nozzles

Install the injection nozzle holder in the reverse order of removing.

Note: When installing the nozzle holder, use the new gasket, and tighten the nuts to 1.6 ~ 2.4 m·kg (12 ~ 17 ft·lb).

Fit the fuel pipe to the nozzle holder.

4 F. AIR CLEANER

4-F-1. Removing Air Cleaner Element

Remove in the following order.

1. Air cleaner cover
2. Dust pan
3. Wing nut
4. Element

4-F-2. Cleaning Air Cleaner Element

To clean the element, blow out the dust with compressed air.

4-F-3. Installing Air Cleaner Element

Install in the reverse order of removal.

ELECTRICAL SYSTEM

5 A. SUMMARY	5 : 1
5 A 1. Structural Review	5 : 1
5 A 2. Wiring Diagram	5 : 2
5 A 3. Specification	5 : 3
5 B. TROUBLE SHOOTING	5 : 4
5 C. BATTERY	5 : 5
5 C 1. Checking Battery	5 : 5
5 D. ALTERNATOR	5 : 5
5 D 1. Disassembling Alternator	5 : 5
5 D 2. Alternator Inspection	5 : 6
5 D 3. Assembling Alternator	5 : 7
5 D 4. Precautions on Service	5 : 8
5 D 5. Checking Charging System on Car	5 : 8
5 E. REGULATOR	5 : 8
5 E 1. Checking Regulator Voltage	5 : 8
5 E 2. Adjusting Regulator	5 : 9
5 F. STARTING MOTOR	5 : 9
5 F 1. Checking Starting Circuit	5 : 9
5 F 2. Disassembling Starting Motor	5 : 10
5 F 3. Inspecting Starting Motor	5 : 11
5 F 4. Magnetic Switch Test	5 : 12
5 F 5. Assembling Starting Motor	5 : 13
5 F 6. Testing Starting Motor	5 : 13
5 G. GLOW PLUG	5 : 14
5 G 1. Check Open Circuit of Glow Plug	5 : 14
5 G 2. Removal	5 : 14
5 H. QUICK START SYSTEM	5 : 14
5 H 1. GLOW PLUG RELAY	5 : 15

5-A. SUMMARY

5-A-1. Structural View

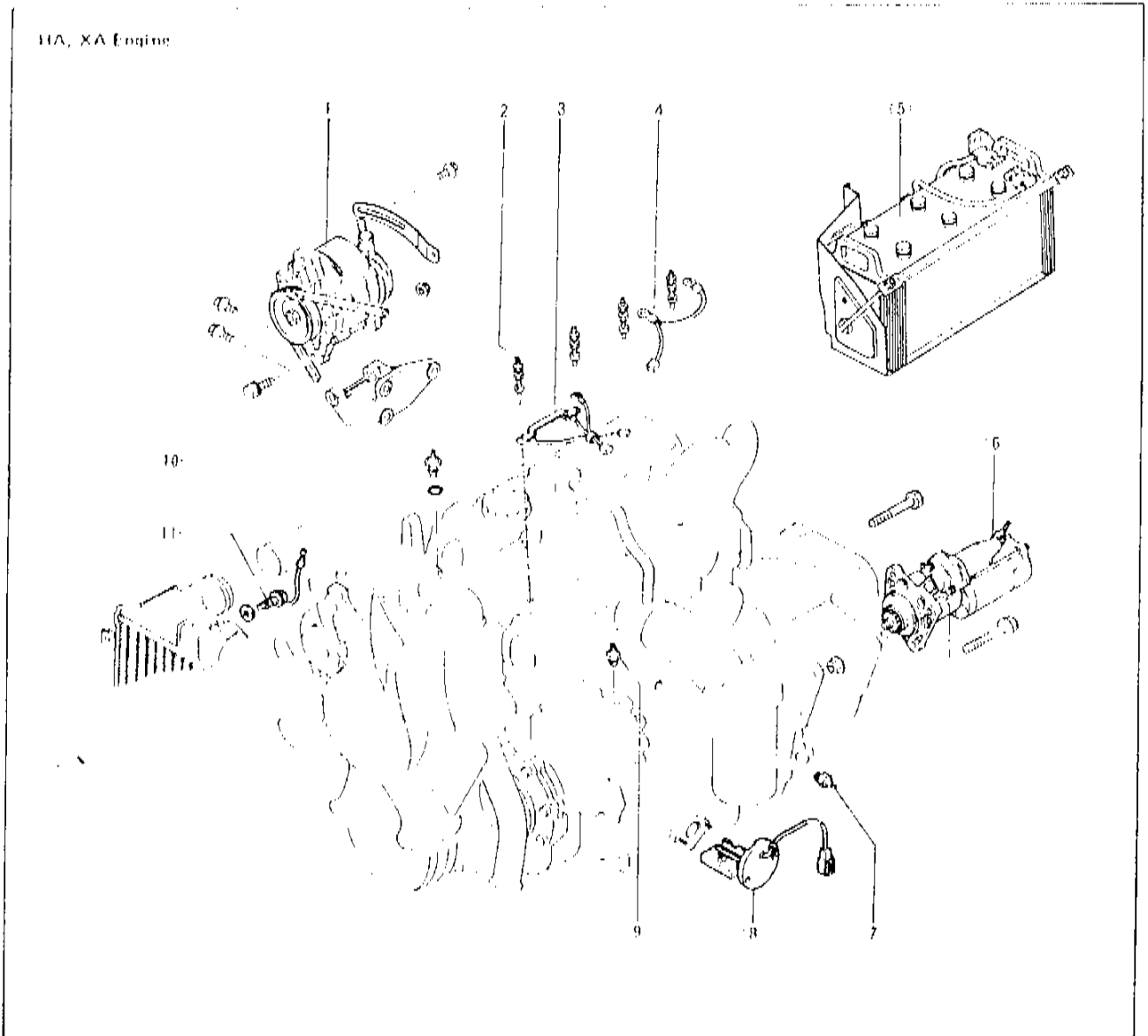

Fig. 5-1

- | | |
|----------------------|-------------------------------------|
| 1. Alternator | 7. Oil pressure switch |
| 2. Glow plug | 8. Oil level sensor |
| 3. External resistor | 9. Magnet valve (Fuel cut solenoid) |
| 4. Glow cord | 10. Water temperature gauge unit |
| 5. Battery | 11. Coolant level sensor |
| 6. Starting motor | |

5-A 3. Specification

				RHD	LHD
Battery	Type (quantity)	HA Engine	12V		N50 or N120 (1)
	Voltage	XA Engine			N50 or N120 (1)
	Capacity (20 hours rate)			12V (24V type vehicle; two batteries in series)	
	Terminal ground			150 amp-hr	
Starting motor	Nominal output	HA Engine	12V	120amp-hr	
		XA Engine		Negative	
Alternator	Nominal output	HA Engine	12V	12V, 2.7kW	12V, 2.7kW
		XA Engine			
Glow plug	Type			12V, 40A	12V, 40A
	Voltage, amperage	HA Engine	12V	Sheathed type	
		XA Engine		10.5V, 16.5A	10.5V, 16.5A

5-B. TROUBLESHOOTING

Trouble	Possible Cause	Action to be Taken
Starting motor does not turn, or turns too slowly to start the engine	<p>Battery and related parts</p> <ul style="list-style-type: none"> • Faulty contact of battery terminals • Faulty grounding of negative cable • Voltage drop caused by discharging • Insufficient voltage caused by faulty battery <p>Engine switch (ignition switch)</p> <ul style="list-style-type: none"> • Faulty contact on engine switch • Loose engine switch wiring and connectors • Broken wire between engine switch and magnetic switch <p>Magnetic switch and related parts</p> <ul style="list-style-type: none"> • Loose wiring and connectors • Faulty contact of magnetic switch contact plate • Broken wire of magnetic switch pull in coil • Broken wire of magnetic switch holding coil <p>Starting motor and related parts</p> <ul style="list-style-type: none"> • Faulty contact of brushes • Fatigued brush spring • Faulty grounding of field coil • Faulty soldering of field coil • Faulty commutator • Faulty grounding of armature • Wear on parts 	<ul style="list-style-type: none"> • Clean and tighten • Clean and repair • Charge • Charge • Replace • Repair • Repair or replace • Repair • Replace • Replace • Replace • Repair replace • Replace • Replace • Repair • Repair • Replace • Replace
Starting motor turns, but the engine does not start	<p>Insufficient battery capacity</p> <p>Quick start system and related parts</p> <ul style="list-style-type: none"> • Faulty glow plug relay control unit • Faulty glow plug relay • Faulty glow plug 	<ul style="list-style-type: none"> • Charge • Replace • Replace • Replace
Starting motor turns, but pinion gear does not mesh with ring gear	<ul style="list-style-type: none"> • Tip of overrunning clutch pinion is worn • Raced overrunning clutch • Faulty sliding surface of spline • Worn bushing • Worn ring gear 	<ul style="list-style-type: none"> • Replace • Replace • Repair or replace • Replace • Replace
Starting motor turns continuously and does not stop	<ul style="list-style-type: none"> • Sticking contact plate of magnetic switch • Layer short of magnetic switch coil • Engine (ignition) switch does not return properly 	<ul style="list-style-type: none"> • Replace • Replace • Replace
Battery discharge	<ul style="list-style-type: none"> • Loose V-belt • Grounded or broken stator coil • Broken rotor coil • Faulty contact between brush and slip ring • Faulty rectifier • Faulty IC regulator • Insufficient or unsuitable battery electrolyte • Faulty battery electrode (internal shortcircuit) • Faulty contact of battery terminal • Excessive electric load 	<ul style="list-style-type: none"> • Adjust • Replace • Replace • Clean or replace • Replace • Replace • Adjust • Replace • Clean, tighten • Check power consumption
Overcharged battery	<ul style="list-style-type: none"> • Faulty IC regulator 	<ul style="list-style-type: none"> • Replace

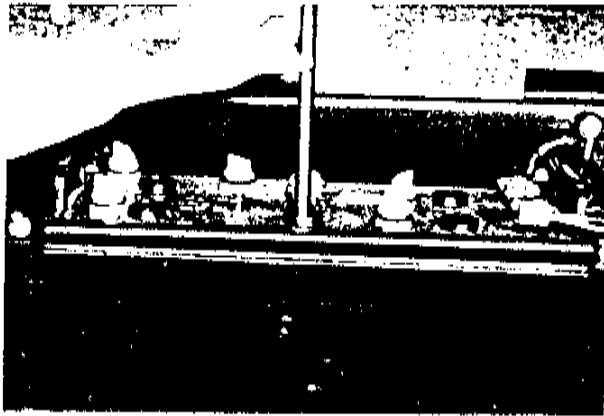

Fig. 5-3

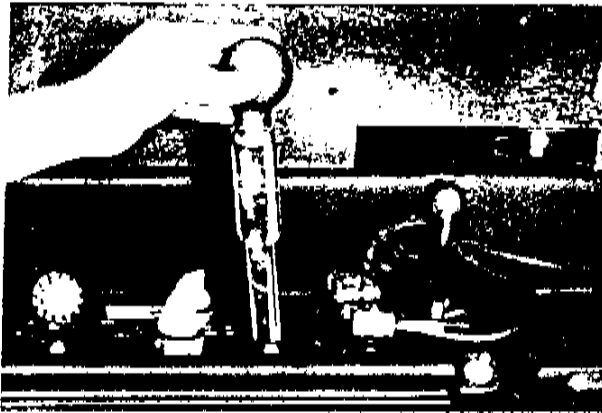

Fig. 5-4

5-C. BATTERY

5-C-1. Checking Battery

1. Check the electrolyte level and add distilled water to maintain the solution 10 ~ 20 mm (0.4 ~ 0.8 in) above the plates.
Do not overfill.

2. Check the specific gravity of the electrolyte with hydrometer.
If the reading is below 1.20, the battery requires recharge.

Note: Always disconnect the battery cable when charging the battery.

3. Check tightness of the terminals to ensure good electrical connections. Clean the terminals and coat the terminals with grease.

5-D. ALTERNATOR

5-D-1. Disassembling Alternator

Disassemble the parts in the order numbered below.

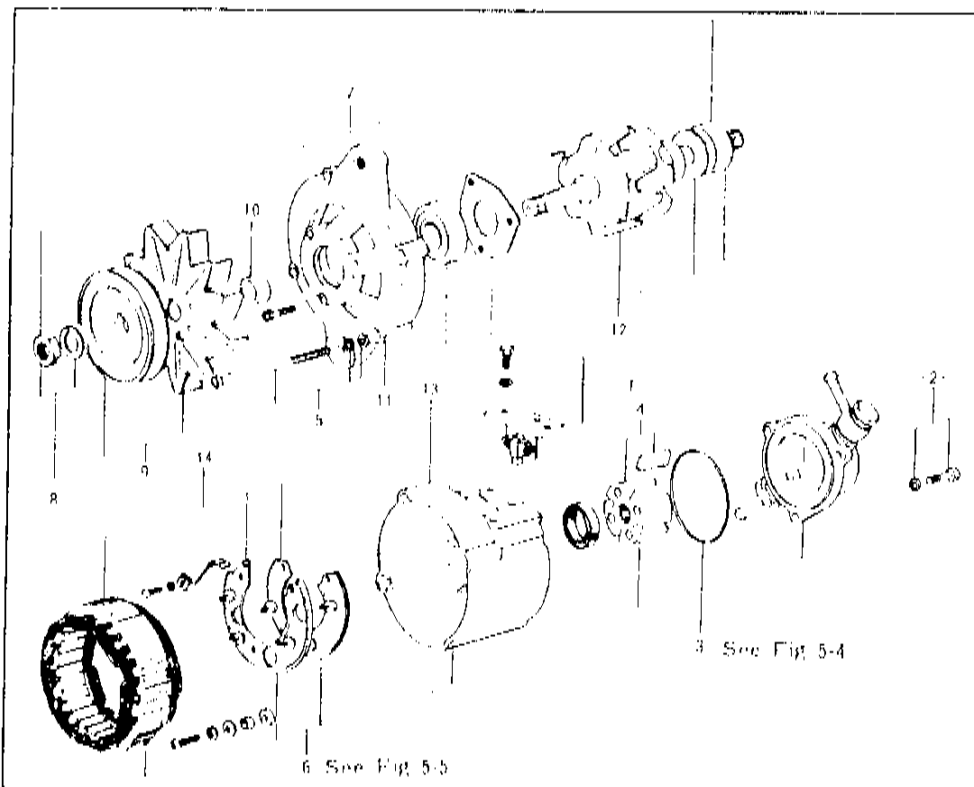

Fig. 5-5

- 1. Brush/holder assembly
- 2. Set bolt
- 3. Vacuum pump
- 4. Rotor/vane
- 5. Through bolt
- 6. Rear housing assembly
- 7. Front housing assembly
- 8. Nut/washer
- 9. Pulley/fan
- 10. Spacer
- 11. Front housing
- 12. Rotor/bearing
- 13. Rear housing
- 14. Stator/heat sink

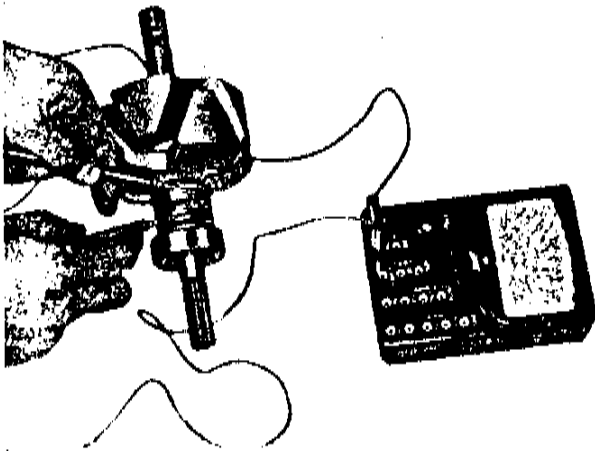

Fig. 5-10

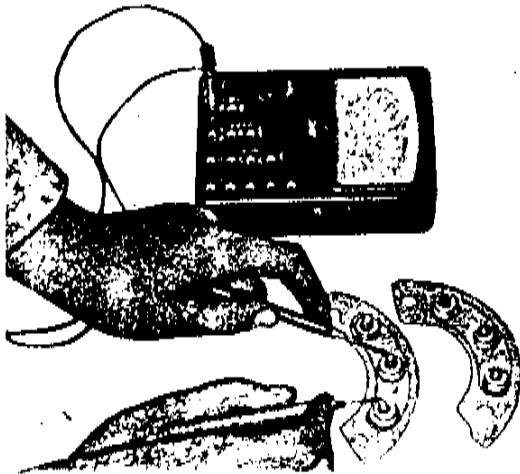

Fig. 5-11

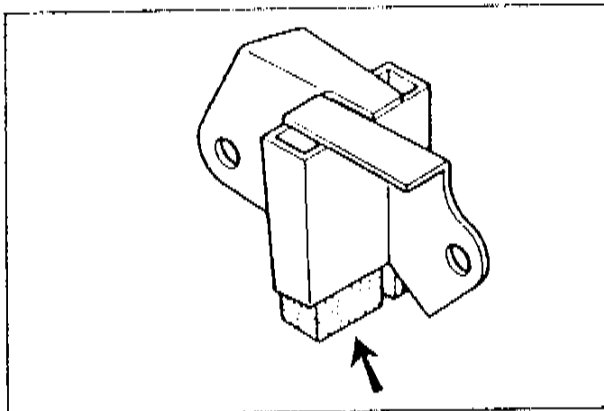

Fig. 5-12

b. Checking rotor

To check for open circuit, place both prods of an ohmmeter on the slip rings. If the reading is 5 ~ 6 ohms, there is no trouble in the rotor.

To check for ground, connect one prod to the slip ring and other prod to the core. If the current flows, the rotor must be repaired or replaced.

c. Checking diodes

To check diode, read the resistance between the lead wire and case with a tester. Then reverse the tester lead and note the reading. If both readings are very low or high, the diode is defective. A good diode will give one low reading and one high reading.

Note: The diodes and heat sink are serviced as an assembly.

d. Checking brushes and springs

The brushes should be replaced when one third of the original length is worn away.

Standard tension
 $350 \pm 52.5\text{gr}$ ($0.8 \pm 0.12\text{lb}$)

If the tension is too low or if excessive corrosion exists, the spring must be replaced.

5-D-3. Assembling Alternator

Assemble the alternator in the reverse order of disassembling.

Note: The soldering of the diode leads should be performed in **less than twenty seconds** as the excessive heat may damage the diode.

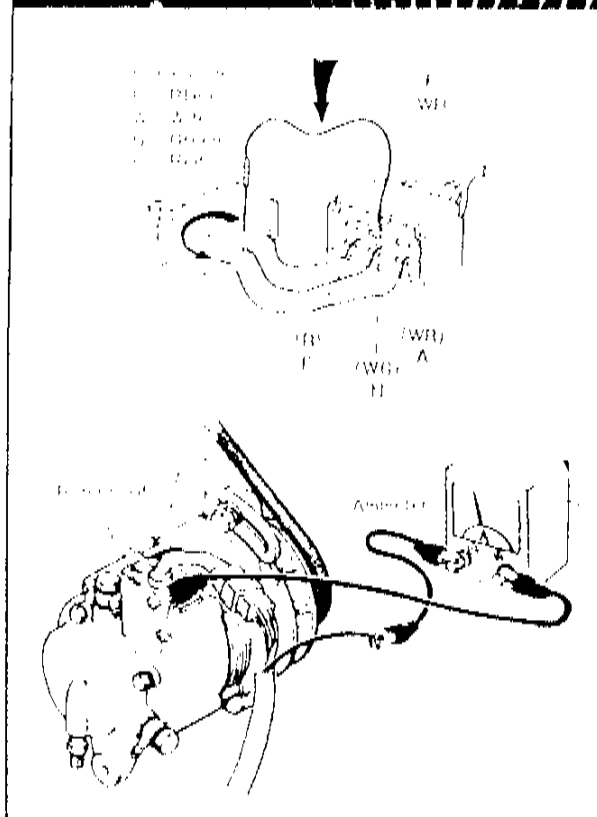
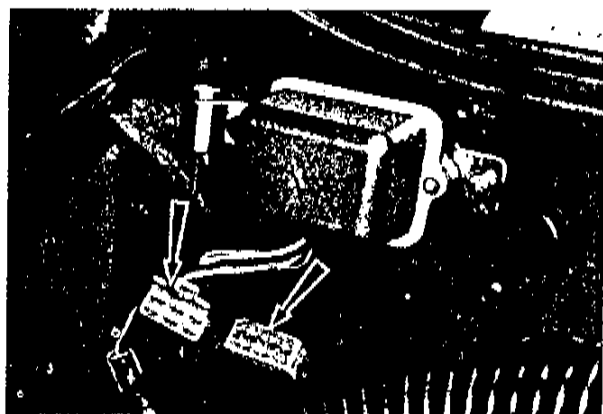

Fig. 5-13

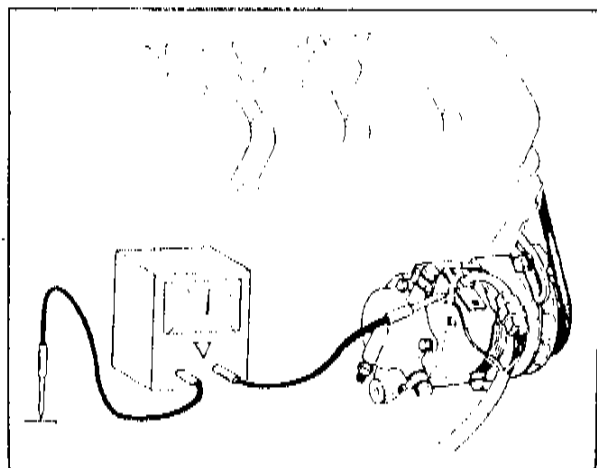

Fig. 5-14

5-D-4. Precautions on Service

When servicing the charging system, observe the following precautions. If not followed, the result will be in serious damage of the system.

1. Do not short across or ground any of the terminals on the alternator.
2. Never operate the alternator on an open circuit (with the field terminal connected and the armature terminal disconnected).
3. Never reverse battery leads, even for an instant, as the reverse polarity current flow will damage the diodes in the alternator.
4. When charging the battery with a fast charger, disconnect the positive cable at the battery.

5-D-5. Checking Charging System on Car

If the electrical system is not charging properly, it is advisable to determine whether the trouble is in the alternator or regulator prior to removing the alternator.

1. Make the checking wire as shown in Fig. 5-11.
2. Holding the engine speed to 2,000 rpm.
3. Disconnect the wire from the "I" terminal and make a short-circuit of the wire to the "A" terminal for a moment.
4. If the meter reading increases remarkably, the trouble is in the regulator and if there is no change in current, it is in alternator.

5-E. REGULATOR

5-E-1. Checking Regulated Voltage

To check, use an almost fully charged battery and connect a volt meter as illustrated, and switch off all accessory parts.

Regulated voltage 14 ~ 15V
 Engine speed 2,000 rpm.

If it is not within the specification, adjust as instructed in Par. 5-C-2.

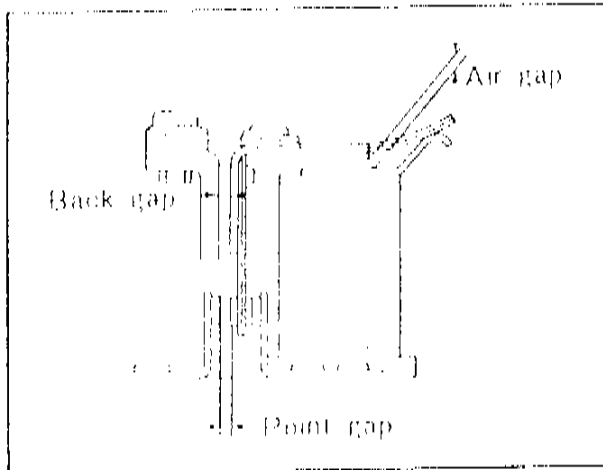

Fig. 5-15

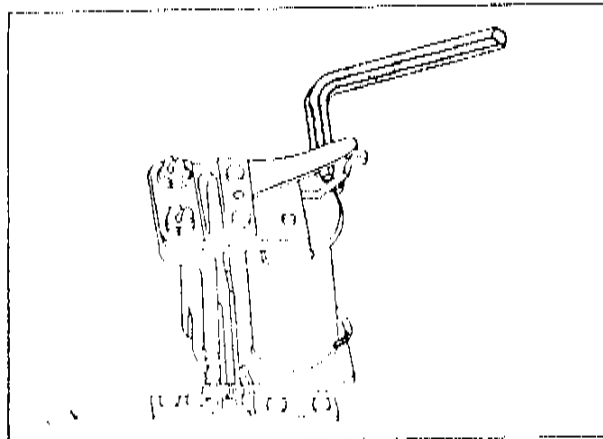

Fig. 5-16

5-E-2. Adjusting Regulator

First, check the air gap, back gap and point gap with a wire gauge. If they are not within the specifications, adjust by bending the stationary contact bracket.

Constant Voltage Relay

Air gap	0.70 ~ 1.30 mm (0.028 ~ 0.051 in)
Point gap	0.30 ~ 0.45 mm (0.012 ~ 0.018 in)
Back gap	0.75 ~ 1.50 mm (0.030 ~ 0.059 in)

Pilot Lamp Relay

Air gap	0.9 ~ 1.4 mm (0.035 ~ 0.055 in)
Point gap	0.7 ~ 1.1 mm (0.028 ~ 0.043 in)
Back gap	0.7 ~ 1.5 mm (0.028 ~ 0.059 in)

After correct gaps are obtained, adjust the voltage setting. Bend the upper plate down to decrease the voltage setting and up to increase the voltage setting.

5-F. STARTING MOTOR

5-F-1. Checking Starting Circuit

When the starting motor fails to operate or does not satisfactorily operate, check the following points before removing the starting motor.

1. Weak battery
2. Corroded or loose battery terminal
3. Loose starting motor terminal
4. Broken or loose wires of the starting circuit
5. Faulty ignition switch

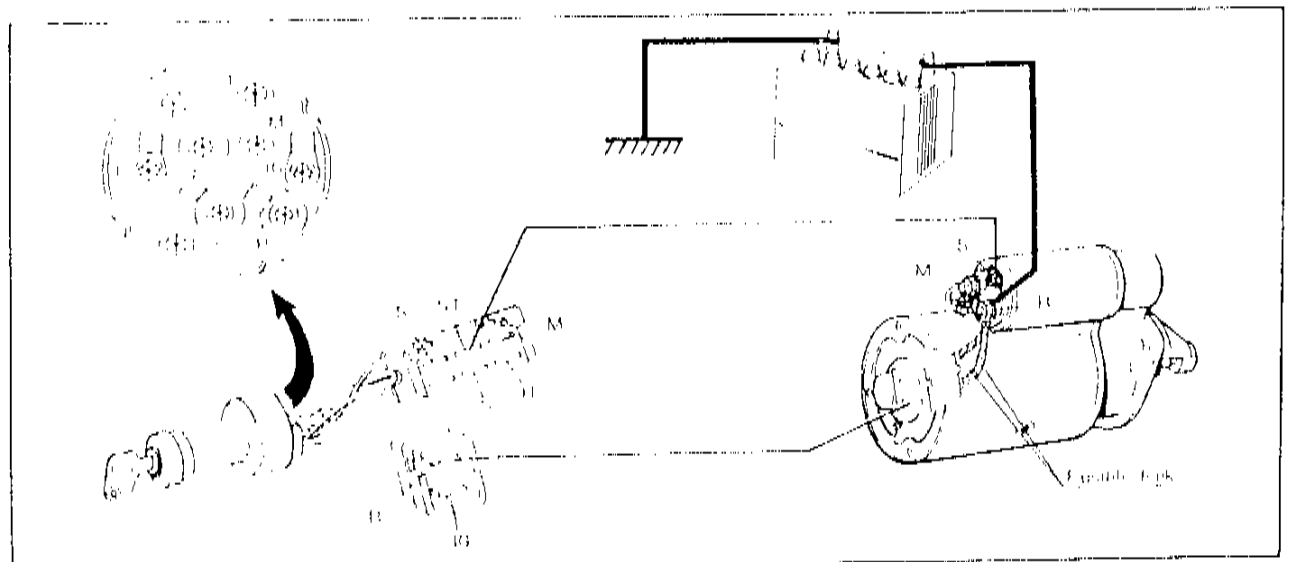

Fig. 5-17

5-F-2. Disassembling Starting Motor

Disassemble the parts in the order numbered below.

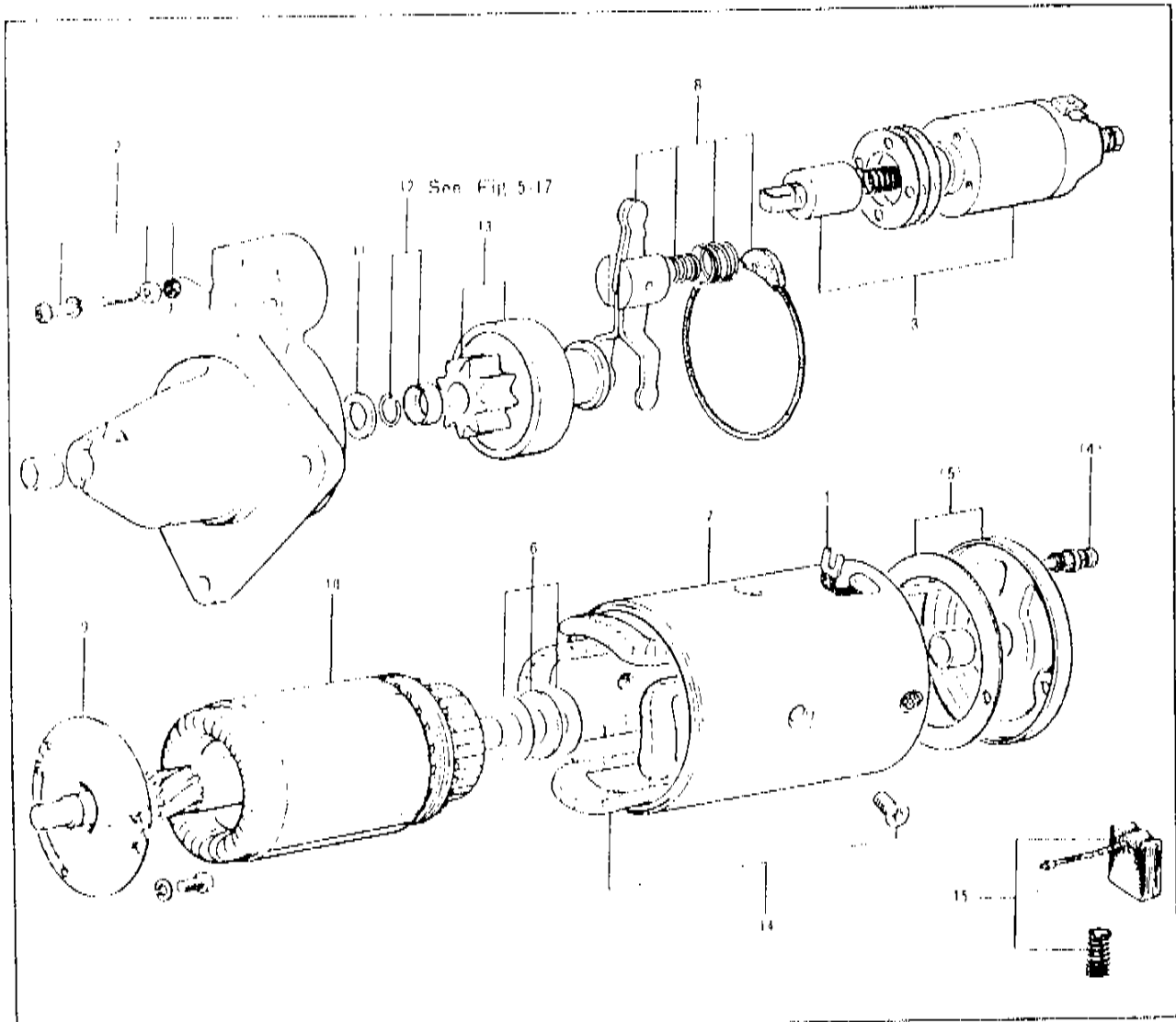

Fig. 5-18

- | | | |
|--------------------------|-------------------------------------|--------------------------------|
| 1. Field strap | 6. Insulator/washer | 11. Stop ring |
| 2. Screw | 7. Yoke assembly | 12. Piston stop collar |
| 3. Magnet switch/plunger | 8. Rubber ring/spring/driving lever | 13. Over running clutch/pinion |
| 4. Through bolt | 9. Center bracket | 14. Screw/pole core |
| 5. Rear cover | 10. Armature assembly | 15. Brush spring/brush |

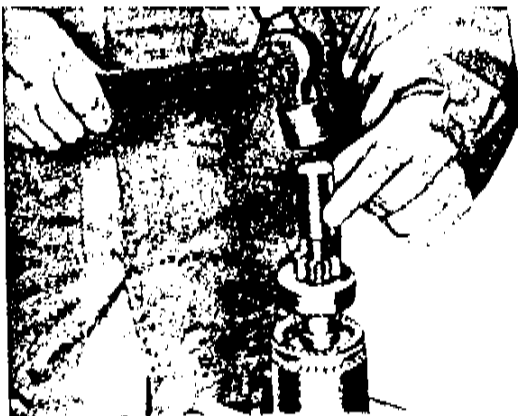

Fig. 5-19

Drive the pinion stop collar toward the armature, and remove the stop ring. Then, slide the stop collar and over-running clutch off the armature shaft.

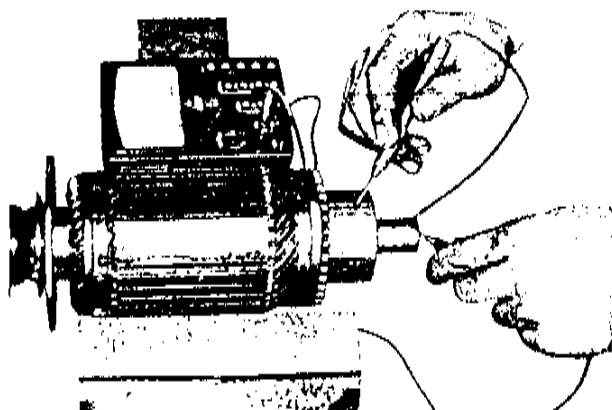

Fig. 5-20

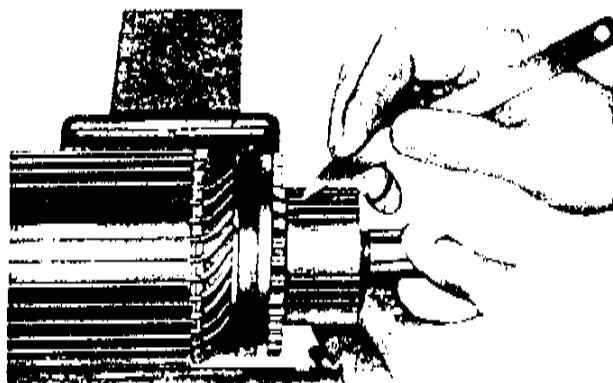

Fig. 5-21

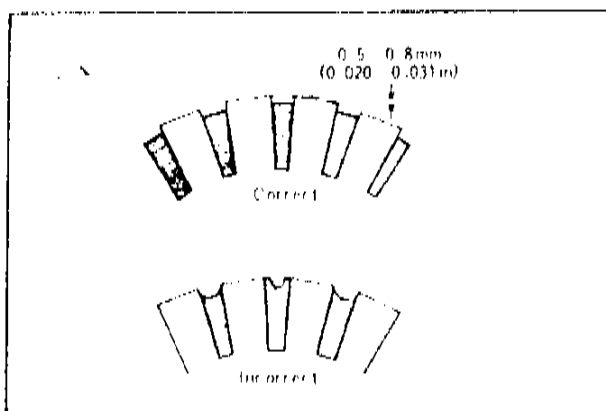

Fig. 5-22

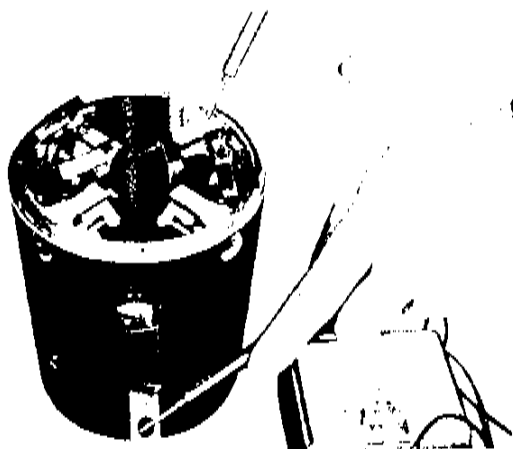

Fig. 5-23

5--F--3. Inspecting Starting Motor

a. Checking armature

Ground test:

Touch one prod of an ohmmeter to each segment and the other prod to the core or shaft.

An infinite reading should be obtained for each segment. If the meter reading is not infinite, the armature windings are shorted to the core and shaft, and the armature must be replaced.

Short-circuit test:

Place an armature against the core of the growler tester, and hold a steel strip on the armature. Then, rotate the armature slowly by hand. If the armature coil is shorted, the steel strip will become magnetized and vibrate. Replace the armature if a short is found.

b. Checking commutator

If the commutator is dirty, discolored or worn, clean it with emery paper and wash with clean solvent. After cleaning, undercut the mica between the segment to the depth of 0.5 ~ 0.8 mm (0.020 ~ 0.031 in) shown in Fig. 5-20.

c. Checking field coil

To test the field coil for ground with a tester, place one prod on the yoke or pole core and the other prod to the field terminal. (for each prod)

If it is grounded, the current will no flow, and the field coil must be repaired or replaced.

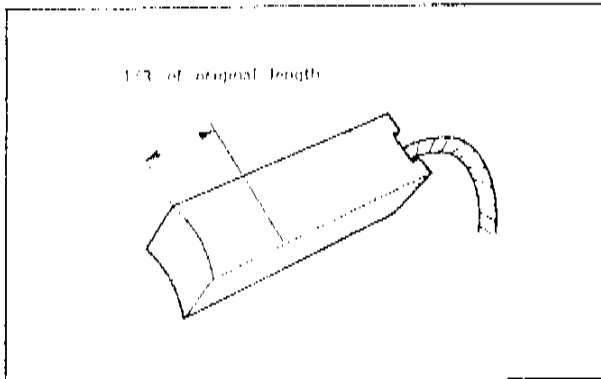

Fig. 5-24

d. **Checking brushes and brush springs**
The brushes should be replaced when one-third of the original length is worn away.

Standard length

19 mm (0.748 in)

Standard tension

2.0 ± 0.3 kg (4.4 \pm 0.661 lb)

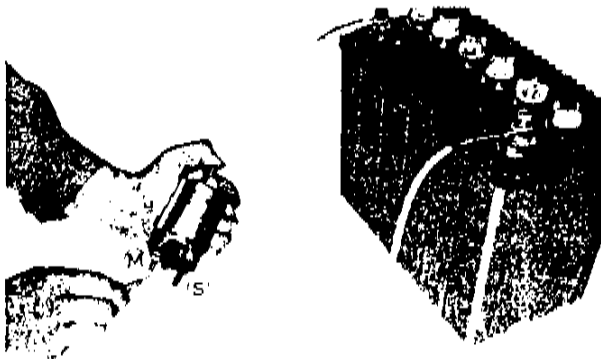

Fig. 5-25

5-F-4. Magnetic Switch Test

a. Pull-in coil test

Apply the specified voltage (12V) between the "S" terminal and "M" terminal. If the magnetic switch is forcefully attached, the pull-in coil is in good condition.

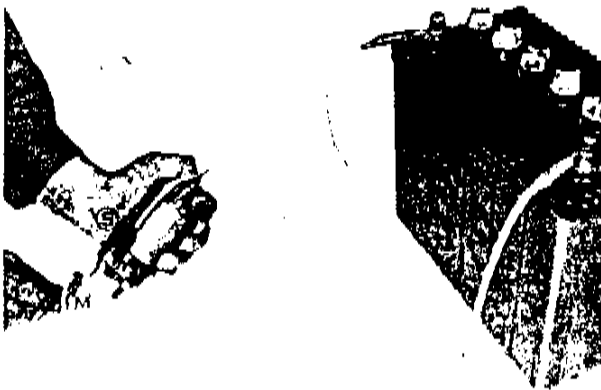

Fig. 5-26

b. Holding coil test

Ground the (M) terminal to the magnetic switch body with lead and impose the specified voltage (12V) upon the "S" terminal to pull in the plunger. If the plunger remains attracted after disconnecting the lead at the (M) terminal, there is no trouble with the holding coil.

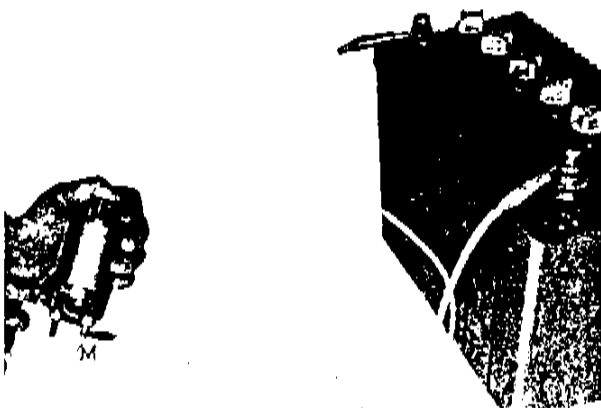

Fig. 5-27

c. Return test

Push in the plunger with hand and apply the specified voltage between the (M) terminal and the magnetic switch body. If the plunger is not attracted, there is no trouble.

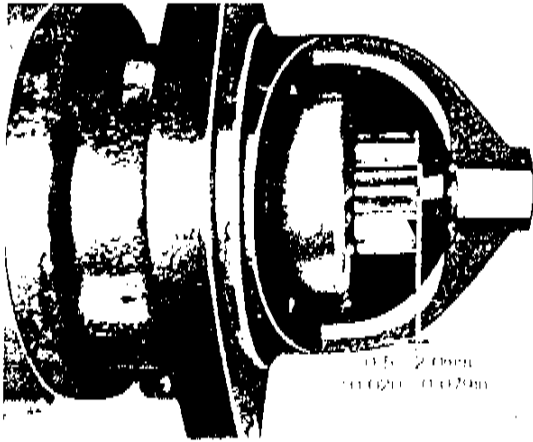

Fig. 5-28

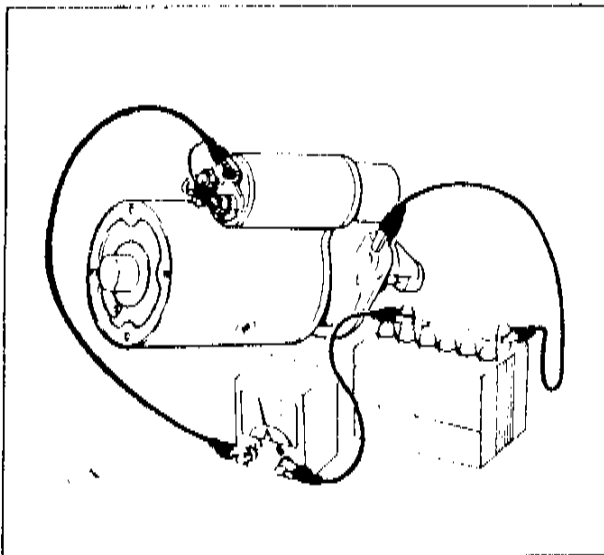

Fig. 5-29

5-F-5. Assembling Starting Motor

To assemble the starting motor, reverse the procedure of Par. 5-D-3.

Note: When the magnetic switch is engaged, the clearance between the pinion and stop collar should be 0.5 ~ 2.0 mm (0.020 ~ 0.079 in).

This clearance can be adjusted by inserting the adjusting washer between the magnetic switch body and the driving housing.

5-F-6. Testing Starting Motor

a. Free running test:

1. Connect an ammeter as illustrated.
2. Apply the battery voltage adjusted to 11.5 volts to the starting motor.
3. Operate the starting motor and take a reading.

Specified current

80A or less at 4,200 rpm. or more

b. Lock resistance test:

Test the lock resistance, following the instructions of the test equipment of manufacturer.

Voltage 3.0V

Current 900A or less

Torque 1.8 m-kp (13 ft-lb)



Fig. 5-30

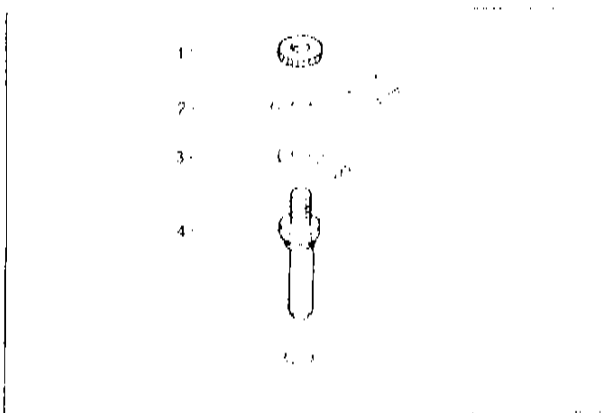

Fig. 5-31

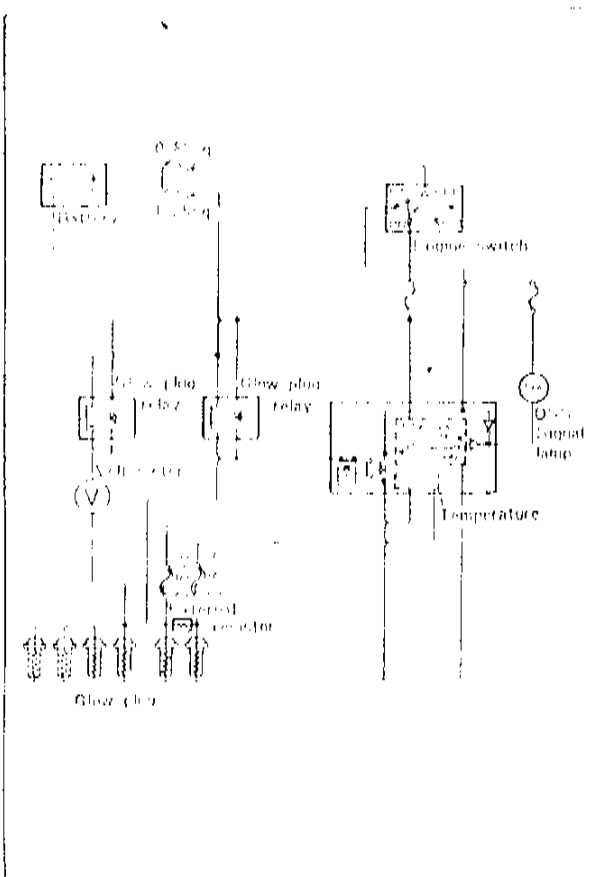

Fig. 5-32

5--G. GLOW PLUG

5--G--1. Checking Open Circuit of Glow Plug

Check the continuity between the positive terminal of the glow plug and cylinder head with a circuit tester. If there is no continuity, replace the glow plug.

5-G--2. Removal

Remove in the following order.

1. Glow plug connector attaching nut.
- Use a suitable driver.
2. Resistor
3. Glow plug connector
4. Glow plug

Note:

Turn the glow plug counter-clockwise and remove it.

5. To install the glow plug, reverse order of removal

5. H. QUICK START SYSTEM

Checking Quick Start System

1. Set a voltmeter to the position as shown in Fig. 5-33.
2. Shift the gear shift lever to the neutral position.
3. Turn on the engine switch and check the following matters:
 - As soon as the engine switch is turned on, the QSS signal lamp lights and the voltmeter indicates the battery voltage.
 - About 3 seconds after the engine switch has been turned on, the QSS signal lamp goes off.
 - About 6 seconds after the engine switch has been on, the voltmeter indicates 0 volt.
 - About 9 seconds after the engine switch has been turned on, the voltmeter indicates the battery voltage.
 - About 10 to 14 seconds after the engine switch is turned on, the voltmeter indicates 0 volt.
4. If the above conditions are all satisfactory, the quick start system is in normal condition.

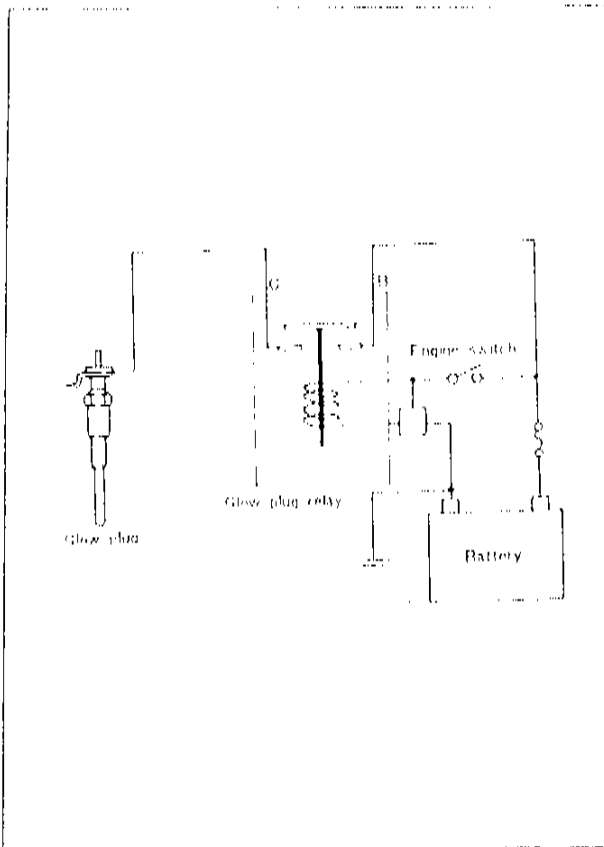

Fig. 5-33

5-1. GLOW PLUG RELAY

Checking Glow Plug Relay

Check continuity between "B" terminal and "C" terminal of glow plug relay when engine switch is "OFF" position.

- If the continuity does not exist, the glow plug relay is correct.
- If the continuity exists, replace the glow plug relay.

Check continuity between "B" terminal and "C" terminal of glow plug relay when engine switch is turned to "ON" position or "START" Position.

- If the continuity exists, the glow plug relay is correct.
- If the continuity does not exist, replace the glow plug relay.

CLUTCH (K3000)

6A A.	CLUTCH PEDAL	6A : 1
	6A A-1. Removing Clutch Pedal	6A : 1
	6A A-2. Checking Clutch Pedal	6A : 1
	6A A-3. Installing Clutch Pedal	6A : 1
	6A A-4. Adjusting Clutch Pedal	6A : 1
6A B.	CLUTCH REMOVAL	6A : 1
6A C.	CLUTCH INSPECTION	6A : 2
	6A C-1. Checking Release Bearing And Fork	6A : 2
	6A C-2. Checking Pressure Plate And Cover Assembly	6A : 2
	6A C-3. Checking Clutch Disk	6A : 2
	6A C-4. Inspecting Flywheel	6A : 3
	6A C-5. Replacing Ring Gear	6A : 3
	6A C-6. Checking Pilot Bearing	6A : 3
6A D.	CLUTCH INSTALLATION	6A : 3
6A E.	CLUTCH MASTER CYLINDER	6A : 4
	6A E-1. Removing Master Cylinder	6A : 4
	6A E-2. Disassembling Master Cylinder	6A : 4
	6A E-3. Checking Master Cylinder	6A : 4
	6A E-4. Assembling Master Cylinder	6A : 4
6A F.	CLUTCH RELEASE CYLINDER	6A : 5
	6A F-1. Removing Clutch Release Cylinder	6A : 5
	6A F-2. Disassembling Release Cylinder	6A : 5
	6A F-3. Checking Clutch Release Cylinder	6A : 5
	6A F-4. Assembling Clutch Release Cylinder	6A : 5
	6A F-5. Installing Clutch Release Cylinder	6A : 5

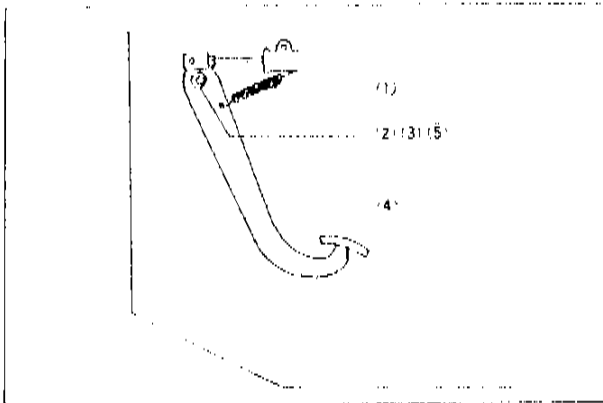

Fig. 6A-1

6A-A. CLUTCH PEDAL

6A-A-1. Removing Clutch Pedal

Remove the clutch Pedal in following order.

1. Clutch pedal return spring.
2. Clutch attaching Bolt and nut.
3. Spacer.
4. Clutch pedal.
5. Bushes.

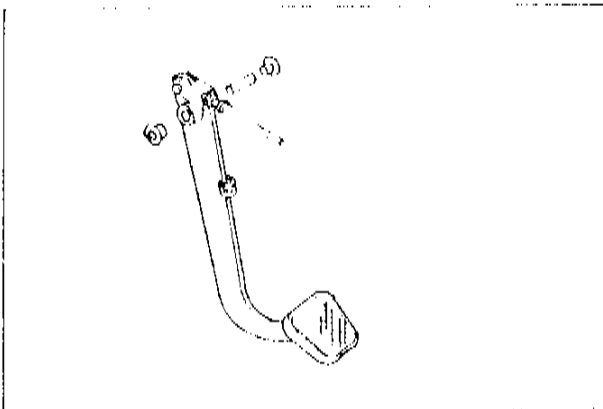

Fig. 6A-2

6A-A-2. Checking Clutch Pedal

Check the Clutch pedal and Bushes for wear or damage. If necessary, repair or replace.

6A-A-3. Install Clutch Pedal

Install the clutch pedal in the order of removing.

Note: Before installing clutch pedal, grease on the Bushes.

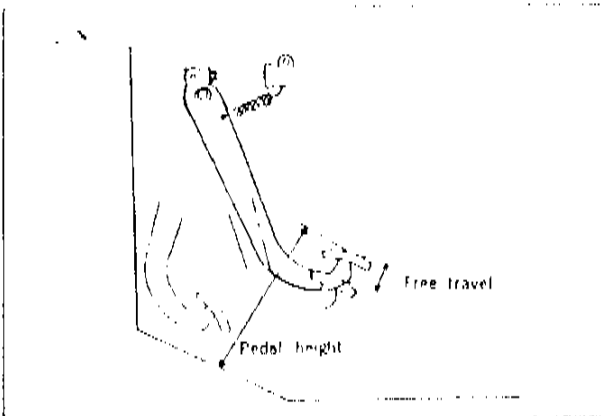

Fig. 6A-3

6A-A-4. Adjusting Clutch Pedal

To adjust the pedal height, loosen the Lock nuts and turn the adjusting bolt until the adjustment is made. Tighten the lock nut after adjustment is completed.

Pedal Height : 175 ~ 180mm

The pedal free travel can be determined by adjusting the push rod after loosening the lock nut.

Pedal Free Travel: 1 ~ 4mm (0.04 ~ 0.16 in.)

Note: Pedal free travel is until the push rod contacts with piston in master cylinder.

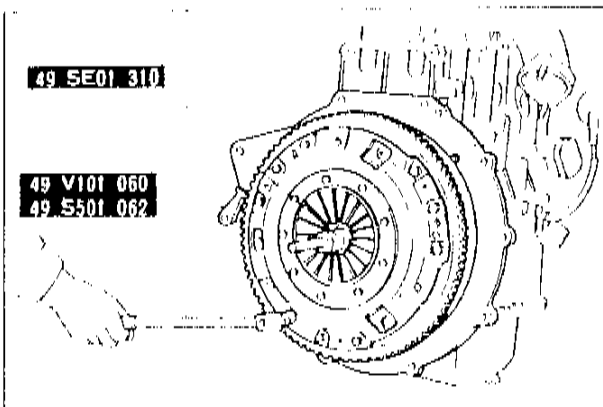

Fig. 6A-4

6A-B. CLUTCH REMOVAL

Remove the transmission as described in Par. 7 A, and remove the clutch following the numerical order.

1. Bolts and reamer bolts.
2. Pressure plate and cover assembly.
3. Clutch disk.

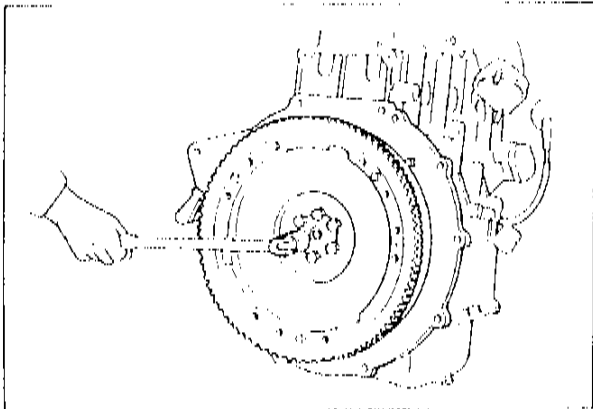

Fig. 6A-5



Fig. 6A-6

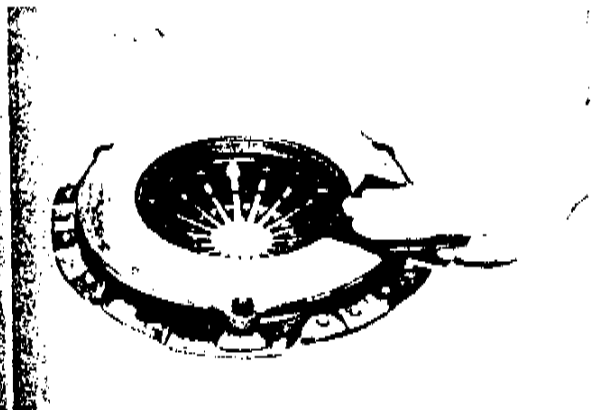

Fig. 6A-7

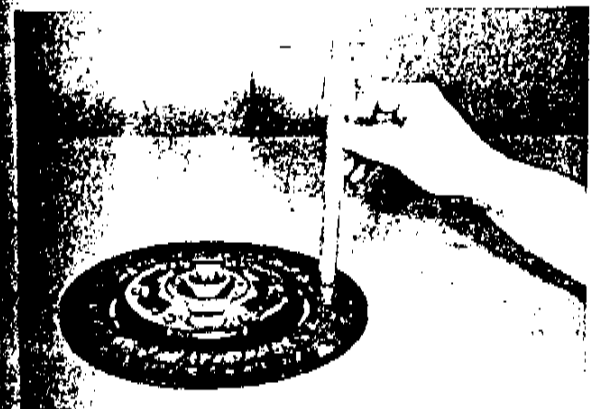

Fig. 6A-8

4. Flywheel attaching bolts.
5. Flywheel wheel.

6A-C. CLUTCH INSPECTION.

6A-C-1. Checking Release Bearing and Fork.

Check the release bearing by hand.
Replace if the bearing feels rough or seems noise when turning.

Check the clutch fork for crack or bend.
If necessary, replace the clutch fork.

6A-C-2. Checking Pressure Plate and Cover Assembly.

Check the contact surface of the pressure plate with clutch facing for wear, damage or wrapage.
If it is slight, correct it by lapping with compound or by turning a lathe. But if severe, replace with a new one.
Check the diaphragm spring and cover and if any wear or damage is found, replace the pressure plate and cover assembly.

6A-C-3. Checking Clutch Disk.

Inspect the clutch disk for wrapage.

Rivet head depth Limit:
0.3mm (0.012 in.)
Run-out Limit :
1.0mm (0.039 in.)

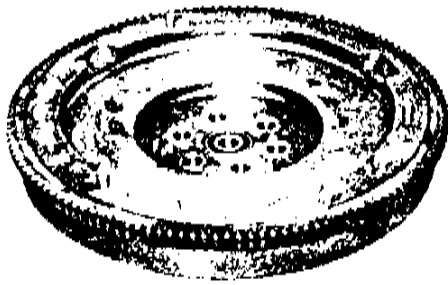

Fig. 6A-9

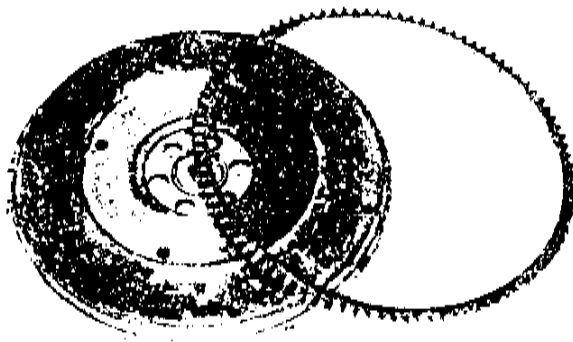

Fig. 6A-10

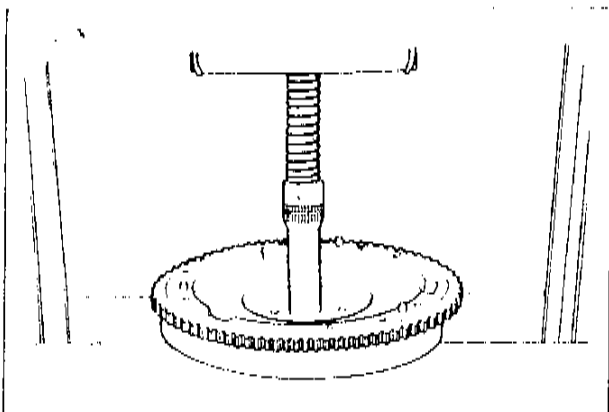

Fig. 6A-11

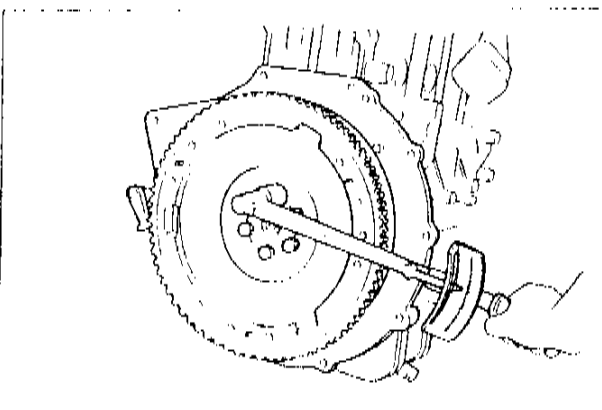

Fig. 6A-12

6A-C-4. Inspecting Flywheel

Inspect the contact surface of the flywheel with the clutch facing for burnt surface or scored surface or rivet grooves.

If it is slight, it can be reconditioned by grinding in a lathe. If the damage is deep the flywheel should be replaced.

Check the ring gear teeth and replace if the ring gear teeth are broken, cranked or seriously burred.

6A-C-5. Replacing Ring Gear

1. Heat the old ring gear remove it from the flywheel.
2. Heat a new ring gear evenly $250 \sim 300^{\circ}\text{C}$ ($480 \sim 570^{\circ}\text{C}$)
3. Place the ring gear on the cold fly wheel.
4. Allow the ring gear to cool slowly to shrink it onto the fly wheel.

6A-C-6. Checking Pilot Bearing.

Check the pilot bearing for roughness, noise or scores.

If necessary, replace the pilot Bearing.

Replacing pilot bearing as followings.

1. Press out the old bearing with suitable tool.
2. Install a new bearing as shown in Fig. 6

6A-D. CLUTCH INSTALLATION

Install the clutch in the reverse order of removing.

When tightening the bolts, use a ring gear brake (49 0636 060) to lock the flywheel.

Tightening torque :

$13 \sim 14\text{Kg} \cdot \text{m}$ ($94 \sim 100\text{ lb}\cdot\text{ft}$)

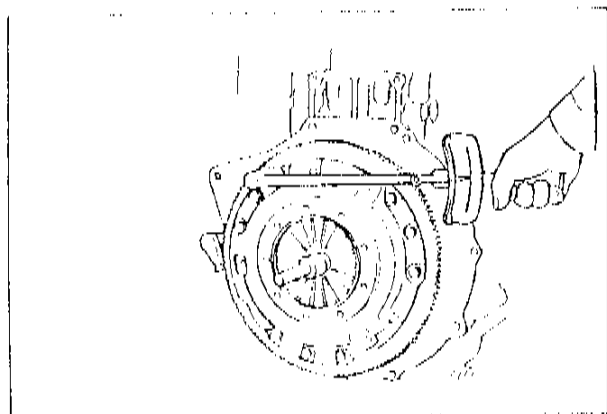

Fig. 6A-13



Fig. 6A-14

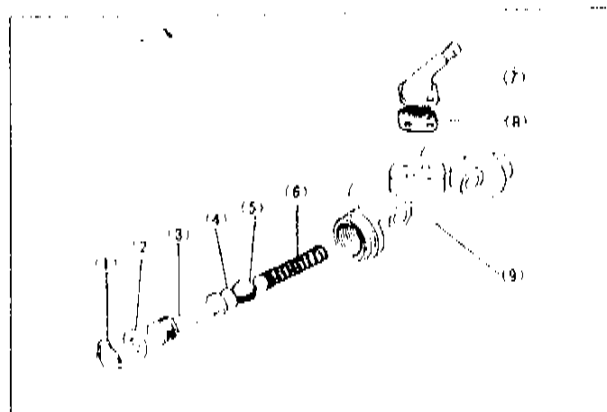

Fig. 6A-15

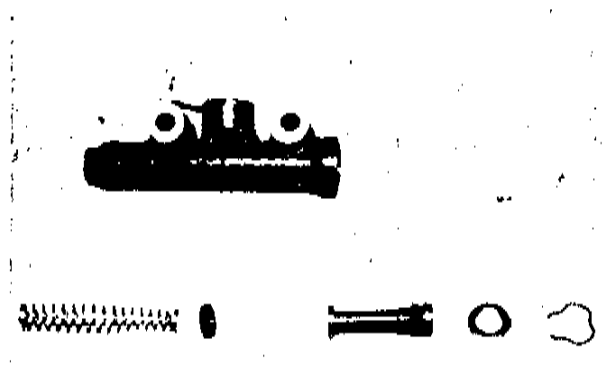

Fig. 6A-16

Hold the clutch disk in its mounting position with the clutch disk centering tool (49 0636 310).
If tool is not available, use a spare main drive shaft.

Install the clutch cover and pressure plate assembly, aligning the reamer hole on the flywheel and the pilot bolt hole on the clutch cover and install the reamer bolts and standard bolts. Then torque the bolts to specifications.

Tightening torque 1.9 ~ 2.7 Kg-m (13 ~ 19ft-lb)

6A-E. CLUTCH MASTER CYLINDER.

6A-E-1. Removing Master Cylinder

Remove in the follow order.

1. Fluid pipe.
2. Fluid hose.
3. Attatching bolt.
4. Master cylinder.

NOTE:

Avoid spilling fluid on the floor.

6A-E-2. Disassembling Master Cylinder.

Disassemble in the following order.

- | | |
|----------------|-----------------------|
| 1. Stop wire | 6. Return spring |
| 2. Stop washer | 7. Union |
| 3. Piston | 8. Packing |
| 4. Spacer | 9. Master cylind Body |
| 5. Primary Cup | |

Note:

Before disassembling, Clean the outside of the master cylinder thoroughly.

6A-E-3. Checking Master Cylinder.

1. Wash the parts in clean alcohol or fluid. Never use gasoline or kerosene. Blow the parts dry with compressed air.
2. Check the piston cup and replace if they are damage, worn, softened or swelled.
3. Examine the cylinder bore and piston for roughness, wear or scoring.

6A-E-4. Assembling Master Cylinder.

Assembl in the reverse order of disassembling.



Fig. 6A-17



Fig. 6A-18

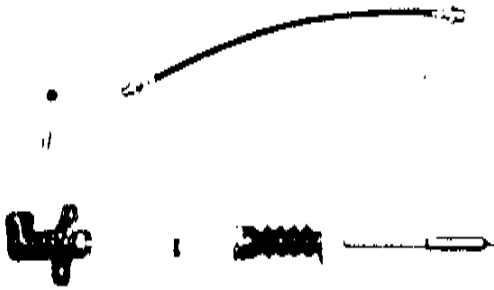

Fig. 6A-19

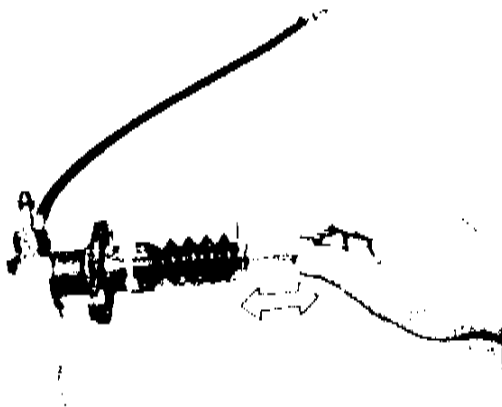

Fig. 6A-20

6A-F. CLUTCH RELEASE CYLINDER.

6A-F-1. Removing Clutch Release Cylinder.
Remove in the following order.

1. Using the Clutch Flare Nut Wrench (49 0259 770A), disconnect the pipe.
2. Attaching Bolt.
3. Release Cylinder.

6A-F-2. Disassembling Release Cylinder.

Disassemble in the following order.

1. Dust boot
2. Release Rod
3. Piston assembly
4. Return spring.

Note:

- Before disassembling, Clean the outside of the release cylinder thoroughly.

6A-F-3. Checking Release Cylinder.

1. Wash the parts in clean alcohol or brake fluid. Never use gasoline or Kerosene. Blow the parts dry with compressed air.
2. Check the piston cups and replace if they are damaged, worn, softened or sweeled.
3. Examine the cylinder bore and piston for wear, roughness or scoring.

6A-F-4. Assembling Release Cylinder

Assembl in the reverse order of disassembling.

Note:

- Before assembling, dip the inner parts in clean brake fluid.

6A-F-5. Installing Release Cylinder.

Install in the reverse order of removing.

Note:

- After installing, bleed the clutch hydraulic system.

TECHNICAL DATA

1. ENGINE	K3000 · K2500
Type	Four cylinder four stroke engine in line, water cooled, overhead valve
Bore K3000 K2500	95 mm (3.74 in) 88.9 mm (3.5 in)
Stroke K3000 K2500	105 mm (4.13 in) 101.6 mm (4.0 in)
Piston displacement K3000 K2500	2977 cc (181.7 cu in) 2522 mm (153.9 cu in)
Compression ratio	21.0 : 1
Compression pressure (at 2000 rpm)	
Standard	30.0 kg/cm ² (427 lb/in ²)
Limit	27.0 kg/cm ² (384 lb/in ²)
Valve clearance	
(Warm engine)	
Inlet	0.30 mm (0.012 in)
Exhaust	0.30 mm (0.012 in)
Cylinder head	
Permissible distortion of cylinder head surface	0.10 mm (0.004 in)
Cylinder head height	82.5 ^{+0.1} ₀ mm (3.248 ^{+0.0039} ₀ in)
Valve seat	
Valve seat angle	
Inlet	45°
Exhaust	30°
Valve seat width	
Inlet	2.0 mm (0.079 in)
Exhaust	2.0 mm (0.079 in)
Valve guide	
Protrusion from cylinder head	16.5 mm (0.6496 in)
Bore diameter	7.988 - 8.014 mm (0.3145 - 0.3155 in)
Stem to guide clearance at limit	0.127 mm (0.005 in)
Valve float	
Overall length	114.5 mm (4.5079 in)
Head diameter	40 ^{+0.1} mm (1.5748 ^{+0.0039} in)
Face angle	45°
Stem diameter	
Standard	7.945 - 7.950 mm (0.3120 - 0.3130 in)
Limit	7.880 mm (0.3102 in)
Valve margin	
Limit	1.35 mm (0.0532 in)
Valve Exhaust	
Overall length	114.6 mm (4.5118 in)
Head diameter	36 ^{+0.13} mm (1.4173 ^{+0.0051} in)
Face angle	30°
Stem diameter	
Standard	7.912 - 7.937 mm (0.3115 - 0.3125 in)
Limit	7.867 mm (0.3097 in)
Valve margin	
Limit	1.35 mm (0.0532 in)
Valve Spring Outer	
Wire diameter	4.5 mm (0.177 in)
Outer coil diameter	38.0 mm (1.496 in)
Free length	
Standard	45.9 mm (1.807 in)
Limit	43.6 mm (1.717 in)
Fitted length	40.3 mm (1.587 in)
Fitted load	
Standard	18.0 ^{+0.9} kg (39.7 ^{+2.0} lb)
Limit	14.5 kg (32.0 lb)

1. ENGINE	K3000 - K2500
Valve spring inner	
Wire diameter	3.5 mm (0.138 in)
Outer coil diameter	27.5 mm (1.083 in)
Free length	
Standard	44.1 mm (1.736 in)
Limit	42.8 mm (1.685 in)
Fitting length	37.8 mm (1.488 in)
Fitting load	
Standard	12.7 ± 0.6 kg (28.0 ± 1.3 lb)
Limit	10.3 kg (22.7 lb)
Rocker arm	
Base on rocker arm	18.258 - 18.278 mm (0.7188 - 0.7196 in)
Rocker arm bushing	
Inner diameter	15.876 - 15.896 mm (0.6250 - 0.6258 in)
Outer diameter	18.288 - 18.309 mm (0.7200 - 0.7208 in)
Rocker arm shaft	
Outer diameter	15.835 - 15.860 mm (0.6234 - 0.6244 in)
Clearance on rocker arm	
Standard	
K3000	0.016 - 0.061 mm (0.0006 - 0.0024 in)
K2500	0.016 - 0.061 mm (0.0006 - 0.0024 in)
Limit	0.07 mm (0.003 in)
Poppet	
Outer diameter	
K3000	14.244 - 14.249 mm (0.5600 - 0.5610 in)
K2500	14.244 - 14.249 mm (0.5600 - 0.5610 in)
Base on cylinder block	14.298 - 14.319 mm (0.5625 - 0.5637 in)
Clearance on cylinder block bore	
Standard	0.039 - 0.095 mm (0.0015 - 0.0037 in)
Limit	0.10 mm (0.004 in)
Crank shaft	
Journal diameter (Standard)	
No. 1 (Front)	51.910 - 51.940 mm (2.0437 - 2.0449 in)
No. 2 (Center)	51.660 - 51.690 mm (2.0339 - 2.0351 in)
No. 3 (Rear)	51.410 - 51.440 mm (2.0240 - 2.0252 in)
No. 4	51.160 - 51.190 mm (2.0142 - 2.0154 in)
Wear limit of journal	0.008 mm (0.0003 in)
Cam elevation	
Inlet	
Standard	42.587 mm (1.6767 in)
Limit	42.485 mm (1.6728 in)
Exhaust	
Standard	42.587 mm (1.6767 in)
Limit	42.485 mm (1.6728 in)
Crankshaft end play	
Standard	0.020 - 0.180 mm (0.001 - 0.007 in)
Limit	0.30 mm (0.012 in)
Crankshaft run out	
Limit	0.080 mm (0.0031 in)

1. ENGINE	K3000 • K2500
Camshaft support bore	
Bore in cylinder block	
No. 1 (Front)	52.000 - 52.030 mm (2.0473 - 2.0485 in)
No. 2 (Center)	51.750 - 51.780 mm (2.0374 - 2.0386 in)
No. 3 (Rear)	51.500 - 51.530 mm (2.0276 - 2.0288 in)
No. 4	51.250 - 51.280 mm (2.0177 - 2.0189 in)
Camshaft to bore clearance	
New	0.060 - 0.120 mm (0.0024 - 0.0047 in)
Limit	0.145 mm (0.0057 in)
Backlash between gears	
Standard	0.10 - 0.20 mm (0.004 - 0.008 in)
Limit	0.30 mm (0.012 in)
Idle gear	
Bore in idle gear boss	48.000 - 48.025 mm (1.8898 - 1.8908 in)
End play	0.15 - 0.30 mm (0.006 - 0.012 in)
Idle gear bushing	
Inner diameter	44.009 - 44.034 mm (1.7327 - 1.7336 in)
Outer diameter	48.043 - 48.068 mm (1.8915 - 1.8925 in)
Idle gear spindle	
Length \times	28.95 - 29.05 mm (1.1398 - 1.1437 in)
Outer diameter	43.950 - 43.975 mm (1.729 - 1.731 in)
Spindle and bushing clearance	
Standard	0.034 - 0.084 mm (0.0013 - 0.0033 in)
Limit	0.15 mm (0.006 in)
Valve timing	
Intake valve opens	14° BTDC
Intake valve closes	44° ABDC
Exhaust valve opens	48° BBDC
Exhaust valve closes	10° ATDC
Cambering rod	
Frameable bend or twist	0.05 mm per 100 mm (0.0020 in per 3.937 in)
Sleeve clearance	
Standard	0.239 - 0.330 mm (0.0094 - 0.0130 in)
Limit	0.4 mm (0.0157 in)
Small end bushing	
Inner diameter	31.763 - 31.788 mm (1.2505 - 1.2515 in)
Outer diameter	35.014 - 35.052 mm (1.3785 - 1.3800 in)
Bore in connecting rod	34.919 - 34.955 mm (1.3748 - 1.3762 in)
Piston pin and small end bushing clearance	
Standard	0.014 - 0.044 mm (0.0006 - 0.0017 in)
Limit	0.05 mm (0.0020 in)

1. ENGINE	K3000 - K2500
Connecting rod bearing Bearing clearance Standard Limit Available undersize bearing	0.036 - 0.076 mm (0.0014 - 0.0030 in) 0.1 mm (0.004 in) 0.254 mm (0.010 in) 0.508 mm (0.020 in) 0.762 mm (0.030 in)
Piston Diameter K3000 K2500	94.825 - 94.851 mm (3.7333 - 3.7344 in) Measure at 90° to the piston pin bore axis and 58.4 mm (2.299 in) below the piston top. 88.885 \pm 0.013 mm (3.5009 in) Measure at 90° to the piston pin bore axis and 25.0 mm (0.787 in) below the piston top.
Piston pin hole bore	31.737 - 31.750 mm (1.2495 - 1.2500 in)
Ring groove width Top Second Oil	2.433 - 2.459 mm (0.0958 - 0.0968 in) 2.433 - 2.459 mm (0.0958 - 0.0968 in) 4.813 - 4.839 mm (0.1895 - 0.1905 in)
Piston and cylinder clearance	0.817 - 0.212 mm (0.0071 - 0.0084 in)
Piston ring Width Top K3000 K2500 Second K3000 K2500 Oil K3000 K2500 Expander oil ring outer diameter Thickness Top K3000 K2500	3.7 - 3.9 mm (0.1457 - 0.1535 in) 2.383 $\begin{matrix} +0 \\ -0.02 \end{matrix}$ mm (0.0937 in) 3.7 - 3.9 mm (0.1457 - 0.1535 in) 2.383 $\begin{matrix} +0 \\ -0.02 \end{matrix}$ mm (0.0937 in) 2.75 - 3.15 mm (0.1083 - 0.1240 in) 4.763 $\begin{matrix} +0 \\ -0.02 \end{matrix}$ mm (0.1873 in) 2.54 - 2.65 mm (0.1004 - 0.1043 in) 2.363 - 2.383 mm (0.0930 - 0.0938 in) 3.5 $\begin{matrix} +0.1 \\ -0.25 \end{matrix}$ mm (0.1377 in)

1. ENGINE	K3000	K2500
Second	2.363 - 2.383 mm (0.0930 - 0.0938 in)	3.5 ^{+0.1} _{-0.25} mm (0.1377 in)
Oil	4.743 - 4.763 mm (0.1867 - 0.1875 in)	2.7 ^{+0.35} _{0.15} mm (0.0983 in)
Side clearance Top	0.050 - 0.096 mm (0.0020 - 0.0038 in)	0.050 - 0.090 mm (0.0020 - 0.0035 in)
Second	0.050 - 0.096 mm (0.0020 - 0.0038 in)	0.040 - 0.080 mm (0.0015 - 0.0031 in)
Oil	0.050 - 0.096 mm (0.0020 - 0.0038 in)	0.030 - 0.070 mm (0.0011 - 0.0027 in)
Side clearance limit End gap Top	0.30 mm (0.0118 in)	0.35 - 0.55 mm (0.0133 - 0.0215 in)
Second	0.4 - 0.6 mm (0.0157 - 0.0236 in)	0.35 - 0.55 mm (0.0133 - 0.0215 in)
Oil	0.4 - 0.53 mm (0.0157 - 0.0209 in)	0.35 - 0.55 mm (0.0133 - 0.0215 in)
End gap limit Ring tension	1.5 mm (0.0591 in)	✦
Top	1.85 ± 0.3 kg (4.08 ± 0.66 lb)	✦
Second	1.85 ± 0.3 kg (4.08 ± 0.66 lb)	✦
Oil	4.47 ± 0.45 kg (9.85 ± 0.99 lb)	✦
Expander oil ring	4.5 ± 0.45 kg (9.92 ± 0.99 lb)	✦
Piston pin	31.744 - 31.749 mm	✦
Diameter	(1.2498 - 1.2500 in)	✦
	- 0.012 - 0.006 mm	✦
	(- 0.0005 - 0.0002 in)	

1. ENGINE	K3000	K2500
Clearance between piston and pin		
Crank pin Maximum diameter Standard	75.812 - 75.825 mm (2.9848 - 2.9953 in)	69.812 - 69.825 mm (2.7485 - 2.7490)
Wear limit Crank pin diameter Standard	61.112 - 61.125 mm (2.4069 - 2.4085 in)	57.112 - 57.125 mm (2.2485 - 2.2490 in)
Wear limit Crank ball end play Standard	0.05 mm (0.0020 in) 0.140 - 0.390 mm (0.0055 - 0.0154 in)	* **
Limit	0.40 mm (0.0157 in)	*
Crank ball run out Limit	0.05 mm (0.0020 in)	*
Main bearing		
Bearing clearance Standard	0.059 - 0.090 mm (0.0023 - 0.0035 in) 0.17 mm (0.0067 in)	* *
Limit		*
Axial clearance between bearing		
Displacement Standard	0.254 mm (0.010 in) 0.508 mm (0.020 in) 0.762 mm (0.030 in)	* * *
Maximum axial protrusion diameter	0.762 mm (0.030 in)	*
Crank pin hole		
Diameter	98.500 - 98.526 mm (3.8780 - 3.8790 in)	96.838 - 96.863 mm (3.8125 - 3.8135 in)
Clearance of bore	0.20 mm (0.0079 in)	*
Wear limit	0.30 mm (0.0089 in)	*
Crank pin run out through cylinder Check	0.654 - 0.730 mm (0.0257 - 0.0287 in)	**
Cylinder bore		
Length	191.092 - 191.350 mm (7.5233 - 7.5336 in)	186.5 - 186.25 mm (7.3425 - 7.3524 in)
Bore diameter	95.025 - 95.050 mm (3.7412 - 3.7422 in)	88.3 - 88.487 mm (3.4803 - 3.4837 in)
Cylinder diameter	98.551 - 98.576 mm (3.8900 - 3.8810 in)	96.914 - 96.899 mm (3.8145 - 3.8155 in)
Crankshaft		
Wear limit Limit	0.20 mm (0.0079 in)	*

2. LUBRICATING SYSTEM	K3000 · K2500	
Oil pressure	3.6 kg/cm ² (51 lb/in ²) and more at 3600 rpm	
Safe minimum pressure at idle	0.3 ± 0.1 kg/cm ² (4.3 ± 1.4 lb/in ²)	
Oil capacity Oil pan	6.0 litres (6.3 U.S. quarts) (5.3 Imp. quarts)	
Lubricant Classification	A.P.I. Service CC 27°C (80°F) or over SAF 30 -1 ~ 27°C (30 ~ 80°F) SAF 20W-20 -18 ~ -1°C (0 ~ 30°F) SAF 10W	
Oil pump		
Rotor rotor and body clearance Standard	0.14 ~ 0.20 mm (0.005 ~ 0.008 in)	
Limit	0.30 mm (0.012 in)	
Clearance between rotor lobes Standard	0.04 ~ 0.20 mm (0.002 ~ 0.008 in)	
Limit	0.30 mm (0.012 in)	
Rotor rod float Standard	0.04 ~ 0.10 mm (0.002 ~ 0.004 in)	
Limit	0.15 mm (0.006 in)	
Clearance between pump shaft and body	0.10 mm (0.004 in)	
3. COOLING SYSTEM	K3000	K2500
Fan belt tension (clock)		
New belt	10 ~ 13 mm (0.39 ~ 0.51 in)	
Used belt	13 ~ 16 mm (0.51 ~ 0.63 in)	
Coolant With heater	14.0 litres (14.8 U.S. quarts) (12.3 Imp. quarts)	12.0 litres (12.6 U.S. quarts) (10.6 Imp. quarts)

3. COOLING SYSTEM	K3000	K2500
Without heater	13.0 litres (13.7 U.S. quarts) (11.4 Imp. quarts)	11.0 litres (11.6 U.S. quarts) (9.7 Imp. quarts)
Mixing ratio		
Mixing percentage		
15°C (3°F) or over	Anti-freeze solution 35%	←
	Water 65%	←
	Gravity 1.054	←
-26°C (-15°F) or over	Anti-freeze solution 45%	←
	Water 55%	←
	Gravity 1.066	←
40°C (104°F) or over	Anti-freeze solution 55%	←
	Water 45%	←
	Gravity 1.078	←
Fan		
Fan diameter	380 ± 2 mm (14.96 ± 0.08 in)	380 ± 3 mm (14.96 ± 0.12 in)
Number of blades	7	←
RPM of crankshaft and fan	1:1.4	←
Thermostat		
Type	Wax pellet	←
Starts to open	82 ± 1.5°C (180 ± 2.7°F)	←
Fully opens at	95°C (203°F)	←
Lift	8 mm (0.315 in) or more	←
Radiator		
Type	Corrugated fin	←
Pressure cap opening	0.9 ± 0.1 kg/cm ² (13 ± 1.4 lb/in ²)	←
4. FUEL SYSTEM	K3000	K2500
Idle speed		
With emission control system	630 ± $\frac{20}{30}$ rpm	←
Without emission control system	630 ± $\frac{20}{30}$ rpm	←
Fuel tank capacity	60 litres (63.4 U.S. quarts) (52.8 Imp. quarts)	←

5. ELECTRICAL SYSTEM

K3000 · K2500

Starting motor

Lock test

Voltage

3.0 volt

Current

900 amp or less

Torque

1.8 m·kg (13.0 ft·lb)

Low pressure test

Voltage

14.5 volt

Current

80 amp or less

Speed

4200 rpm or more

Tipster of brushes

4

Brush length

Standard

19 mm (0.75 in)

Limit

13 mm (0.51 in)

Brush spring pressure

1.7 - 2.3 kg (3.7 - 5.1 lb)

Voltage required to closed solenoid contact

8 volt or less

Air gap depth

0.5 - 0.8 mm (0.020 - 0.031 in)

6. CLUTCH

K3000 · K2500

Type

Single dry plate, diaphragm spring

Clutch pedal

Free play (at pedal pad)

Before push rod contacts piston

1 - 4 mm (0.04 - 0.16 in)

Clutch disc

Disc knee (clutch facing)

3.5 mm (0.138 in)

Lateral run out

Limit

1.0 mm (0.039 in)

Pressure plate

Permissible lateral run out

0.05 mm (0.002 in)

Main cylinder

Bore

15.87 mm (0.625 in)

Clearance between piston and bore

Standard

0.032 - 0.102 mm

Limit

(0.0013 - 0.0040 in)

Limit

0.15 mm (0.006 in)

Release cylinder

Bore

17.46 mm (0.687 in)

Clearance between piston and bore

Standard

0.032 - 0.102 mm

Limit

(0.0013 - 0.0040 in)

Limit

0.15 mm (0.006 in)

7. MANUAL TRANSMISSION

K3000 · K2500

Type

5 speed manual transmission

12. BRAKES

Clearance	0.30 mm (0.0118 in) Measure before pushrod contact with piston
Master cylinder	
Piston	25.40 - 25.45 mm (1.000 - 1.002 in)
Clearance between piston and bore	
Standard	0.030 - 0.035 mm (0.0012 - 0.0014 in)
Limit	0.15 mm (0.006 in)
Lead shoe brake	Two leading shoes
Type	
Bore diameter	
Standard	320 mm (12.598 in)
Limit	321 mm (12.638 in)
Thickness of lining	
Standard	8.5 mm (0.335 in)
Limit	1.0 mm (0.039 in)
Wheel cylinder bore	28.57 mm (1.125 in)
Clearance between piston and bore	
Standard	0.040 - 0.025 mm (0.0016 - 0.0009 in)
Limit	0.15 mm (0.006 in)
Disc shoe brake	
Type	Disc acting two leading shoes
Bore diameter	
Standard	320 mm (12.598 in)
Limit	321 mm (12.638 in)
Thickness of lining	
Standard	8.5 mm (0.335 in)
Limit	1.0 mm (0.039 in)
Wheel cylinder bore	
Clearance between piston and bore	
Standard	25.40 - 25.42 mm (1.000 - 1.001 in)
Limit	0.040 - 0.025 mm (0.0016 - 0.0009 in)
Limit	0.15 mm (0.006 in)
Drum shoe brake	
Bore diameter	
Standard	172 mm (6.7718 in)
Limit	173 mm (6.8113 in)
Thickness of lining	
Standard	4 mm (0.1575 in)
Limit	3 mm (0.0394 in)

TIGHTENING TORQUE

K3000

K2500

Engines		
In-pan	0.7 - 1.2 m.kg (5 - 9 ft.-lb)	←
In-let manifold	1.6 - 2.4 m.kg (12 - 17 ft.-lb)	←
In-shaft manifold	1.6 - 2.4 m.kg (12 - 17 ft.-lb)	←

TIGHTENING TORQUE	K3000	K2500
Companion flange to pinion	24 ~ 28.0 m·kg (174 ~ 200 ft·lb)	
Differential carrier to rear axle shaft housing	4.0 ~ 4.5 m·kg (29 ~ 33 ft·lb)	
Steering		
Steering wheel nut	3 ~ 4 m·kg (22 ~ 29 ft·lb)	
Steering housing to frame	3.8 ~ 4.7 m·kg (27 ~ 34 ft·lb)	
Pitman arm to sector shaft	21.0 ~ 25.0 m·kg (152 ~ 181 ft·lb)	
Steering knuckle arm	15 ~ 25 m·kg (108 ~ 181 ft·lb)	
Tie rod lock nut	9 ~ 12 m·kg (65 ~ 87 ft·lb)	
Drag link to pitman arm	10 ~ 12 m·kg (72 ~ 87 ft·lb)	
Drag link to knuckle arm	10 ~ 12 m·kg (72 ~ 87 ft·lb)	
Brake		
Flexible hose union	2.5 ~ 3.5 m·kg (18 ~ 25 ft·lb)	
Stop light switch	1.4 ~ 1.8 m·kg (10 ~ 13 ft·lb)	
Wheel		
Wheel nut		
K3000	17 ~ 22 m·kg (123 ~ 159 ft·lb)	
Front	22 ~ 27 m·kg (59 ~ 195 ft·lb)	
Rear	17 ~ 22 m·kg (123 ~ 159 ft·lb)	
K2500		
Front		17 ~ 22 m·kg (123 ~ 159 ft·lb)
Rear		15 ~ 17 m·kg (~ 123 ft·lb)
K2500 W/L		
Front		17 ~ 22 m·kg (123 ~ 159 ft·lb)
Rear		15 ~ 17 m·kg (~ 123 ft·lb)

Remove the vacuum pump housing for hydromaster and slide out the rotor and vane assembly.

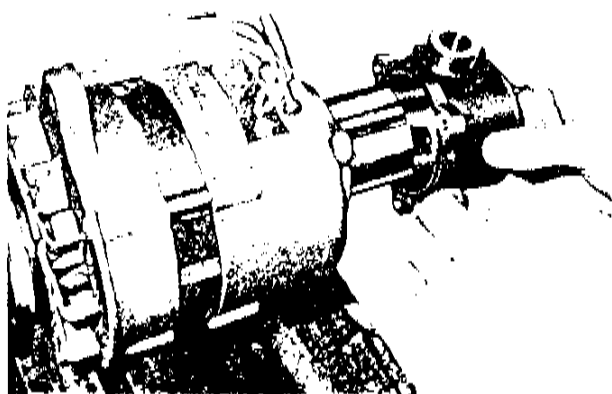

Fig. 5-6

Separate the rear housing assembly.

Remove the heat sink attaching screws and remove the heat sink from the rear housing.

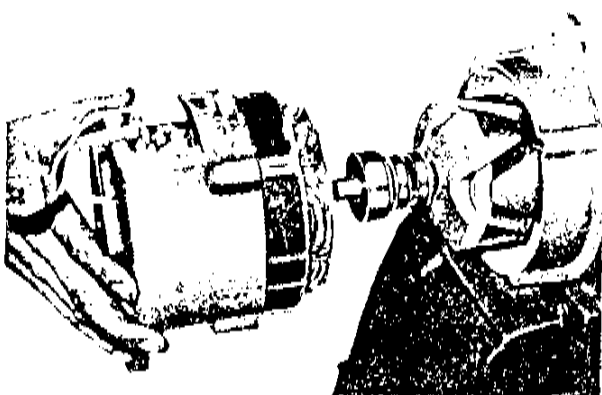

Fig. 5-7

5-D-2. Alternator Inspection

a. Checking stator coil

Check the stator coil. To check for open, connect the prods to each of the two leads. If there is no flow of current, the coil is open circuit and must be repaired or replaced.

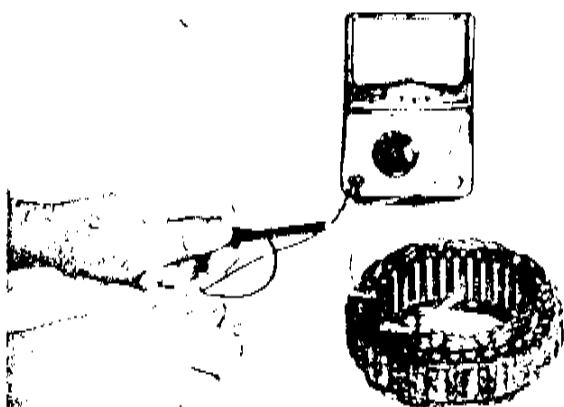

Fig. 5-8

To check for ground, connect one prod to the core and the other to each lead wire.

If a ground is present, the current will flow and the stator coil must be repaired or replaced.

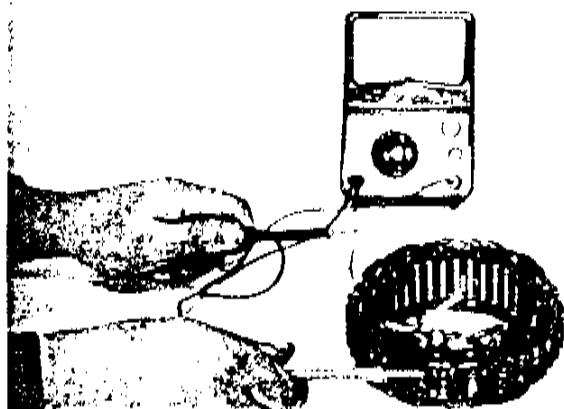

Fig. 5-9

GENERAC[®]
POWER SYSTEMS, INC.

P.O. BOX 310 EAGLE, WI 53119