

Vereinfachte Darstellung, fehlende Angaben siehe CAD-Daten / Representation simplified, missing data see CAD-data

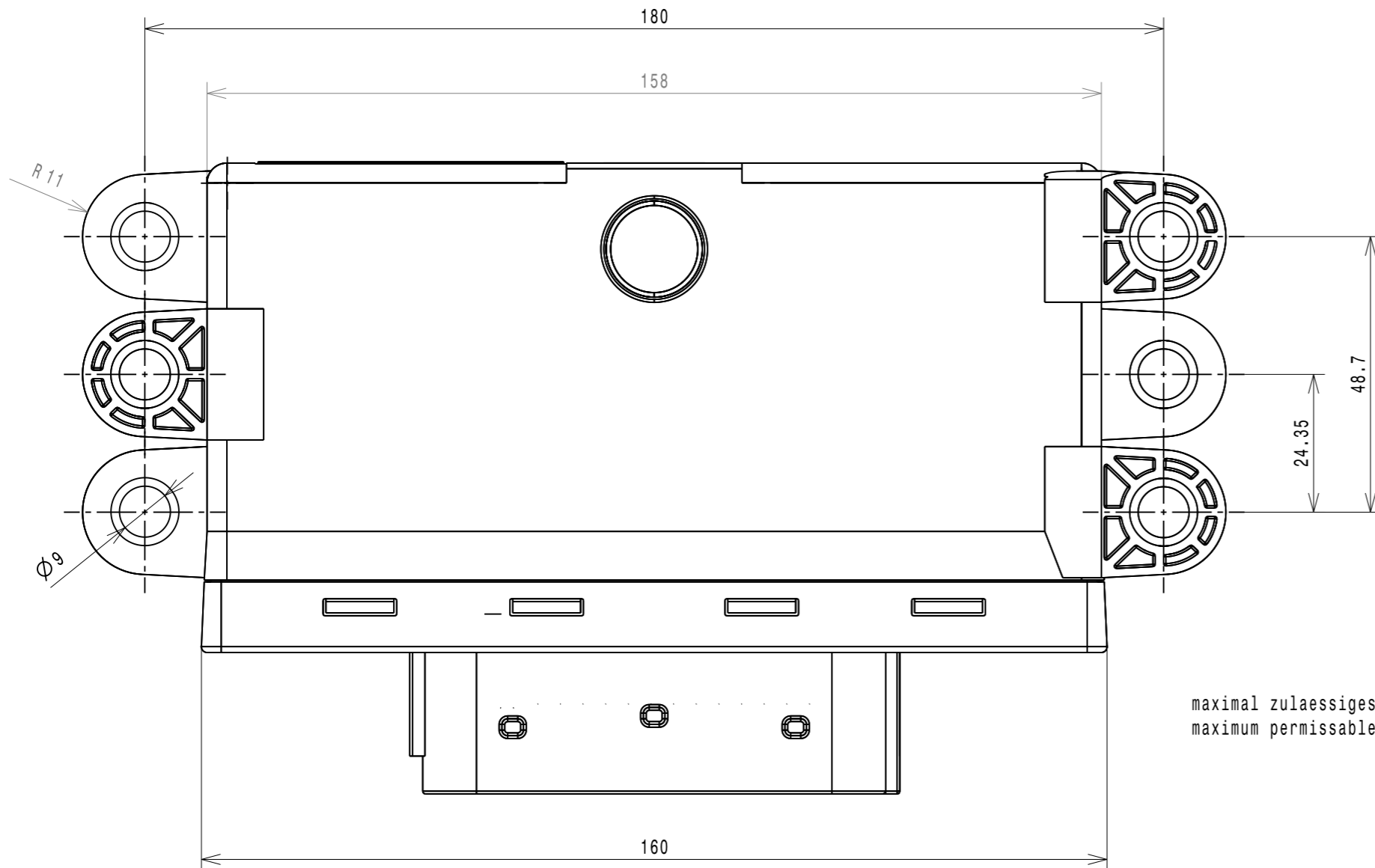
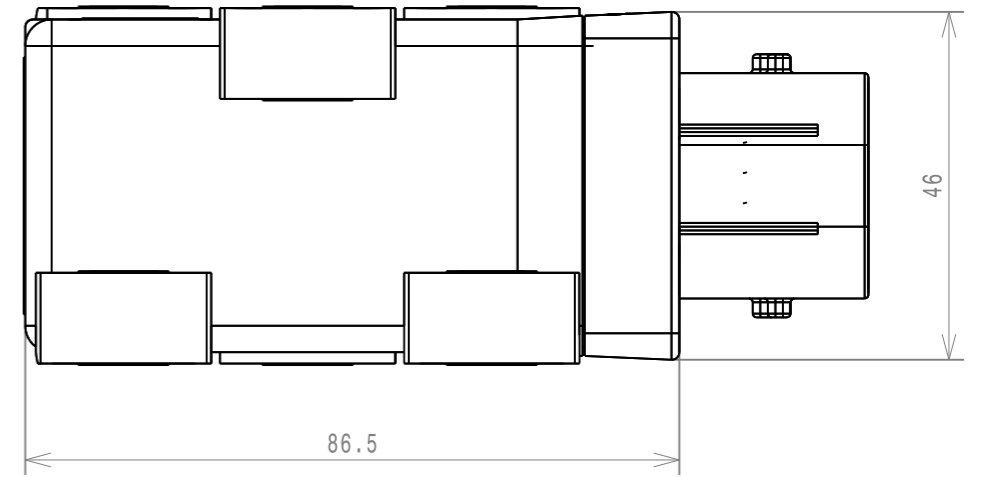
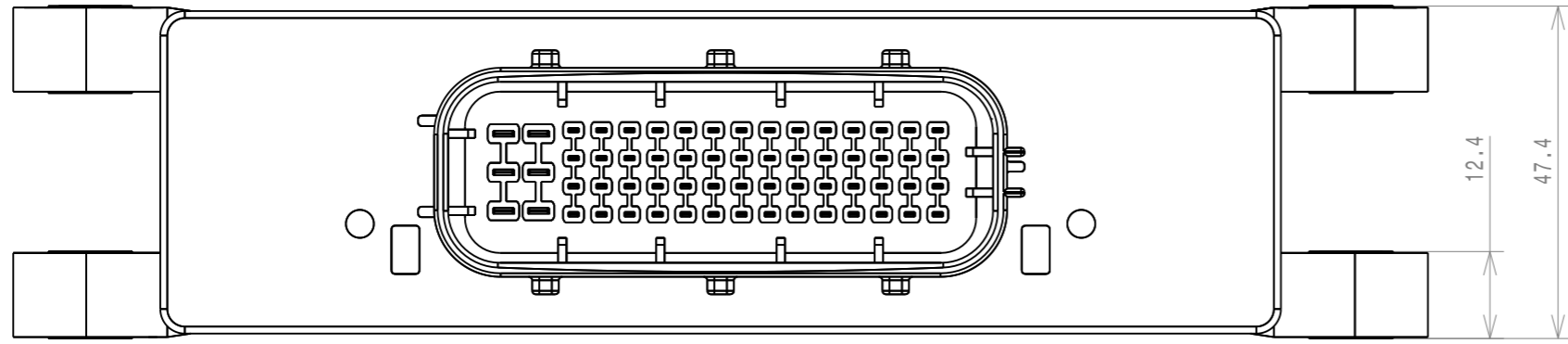

passendes Gegen-Steckergehaeuse A 020 545 66 26
eligible receptabel housing A 020 545 66 26

Schutzart: IP69K / IP67
degree of protection: IP69K / IP67

maximal zulaessiges Anzugsmoment pro Halteauge: 12 Nm
maximum permissable tightening torque per eye: 12 Nm

OM 904 LA, OM 924 LA, OM 906 LA, OM 926 LA, OM 457 LA, OM 460 LA, OM 501 LA, OM 502 LA

Code MJ32

Steuergeraet SCR-Rahmenmodul

lose

Blatt 1 von 3

Control Unit SCR Frame Modul

lose

Page 1 of 3

360 32 001

Vereinfachte Darstellung, fehlende Angaben siehe CAD-Daten / Representation simplified, missing data see CAD-data

