

# DaimlerChrysler

---

## Engine control with MR-PLD

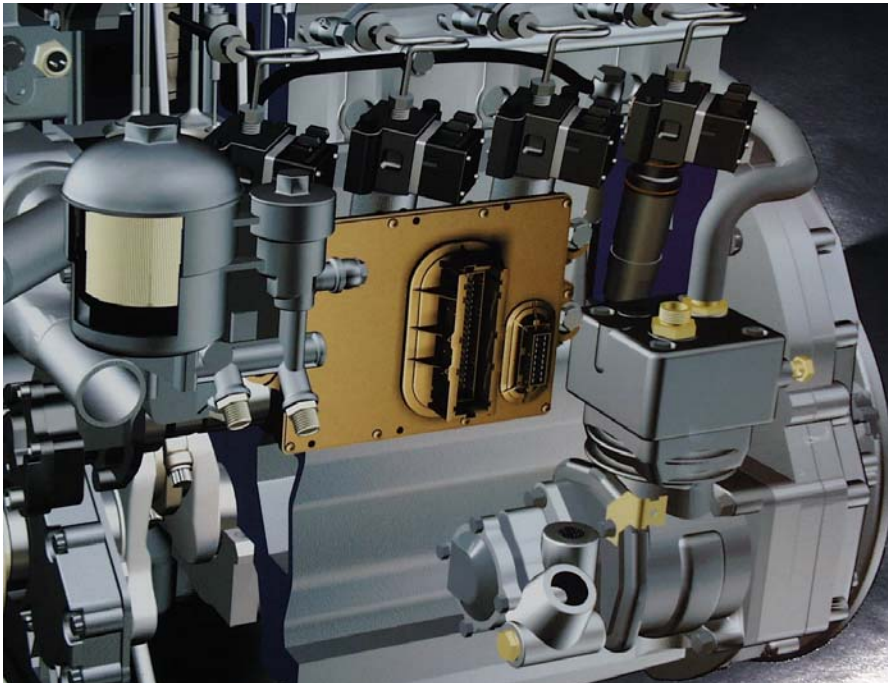

---

**ECU**

**Manual**

## Environment protection



DaimlerChrysler professes itself to an integrated environmental protection, which sets at the causes and on the environment into the business decisions includes all effects of the production processes and the product. Goals are the economical employment of resources and careful handling the natural bases of life, whose preservation serves humans and nature.

Printed in Germany changes of technical details of the controllers and engines opposite the data and illustrations of the available manual are reserved.

Reproduction, duplication or translation, also in part, are not permitted without written permission.

Editorship conclusion:  
Customer service Powertrain Business unit PBE/MSS Responsible for contents: PBE/DEE



Printed on free from chlorine bleached paper

Document name: **PRODUKT DOCUMENTATION MR-PLD**

Project: DC - MR-PLD

Usage: Generally accessible

Validity: ECU versions C3 to D21

Pages: 150

File name: Product documentation MR-PLD\_1.1.pdf

	name	dep.	fon	date	sign
processed	Scheuer, K.	PBE/DEE	52469	02.07.03	
checked					
waned					
responsible	Scheuer, K.	PBE/DEE	52469		

<p><b>DAIMLERCHRYSLER</b></p> <p>Business division</p> <p>PowerSystems / Engines</p> <p>ALL RIGHTS RESERVATIONS</p> <p>- property of the DaimlerChrysler AG -</p>	<p><b>Product documentation</b></p> <p><b>engine elektronik</b></p> <p><b>MR-PLD</b></p>	<p>02. July 2003</p>
<p>Version 1.1</p>	<p>DaimlerChrysler Order-No.:</p>	
<p>This document is in copyright matters protected. Each utilization outside of the close borders of the copyright law is inadmissible without agreement of the DaimlerChrysler AG.</p>		

## LIST OF VERSIONS

version	date	processed	remark / description
1.1	05.02.03	Scheuer, K.	pre version (draft)

## CHANGING US CONDITIONS

version	date	processed	modification
1.1	02.07.03	Scheuer, K.	assimilation to German version 1.1

<p style="text-align: center;"><b>DAIMLERCHRYSLER</b></p> <p style="text-align: center;">Business division</p> <p style="text-align: center;">PowerSystems / Engines</p> <p style="text-align: center;">ALL RIGHTS RESERVATIONS - property of the DaimlerChrysler AG -</p>	<p style="text-align: center;"><b>Product documentation</b></p> <p style="text-align: center;"><b>engine elektronik</b></p> <p style="text-align: center;"><b>MR-PLD</b></p>	<p style="text-align: center;">02. July 2003</p>
<p style="text-align: center;">Version 1.1</p>	<p style="text-align: center;">DaimlerChrysler Order-No.:</p>	
<p>This document is in copyright matters protected. Each utilization outside of the close borders of the copyright law is inadmissible without agreement of the DaimlerChrysler AG.</p>		

---

List of abbreviations .....	10
<b>1. Safety .....</b>	<b>11</b>
1.1. Symbols .....	11
1.2. General information .....	11
1.3. Use for the intended purpose .....	12
1.4. Personnel requirements .....	12
1.5. Conversions and modifications to the MR-PLD .....	12
1.6. Installation .....	12
1.7. Organizational measures.....	12
1.8. Safety precautions for engines with electronic control units .....	13
1.9. DaimlerChrysler original parts .....	14
1.10. Safety and backup running programm.....	14
<b>2. General governor architecture.....</b>	<b>15</b>
2.1. Standard model of engine control (MR-PLD) and vehicle electronics (FRE) .....	15
2.2. Features of the governor and interface module .....	16
2.2.1. VCU (ADM2) as FRE (vehicle electronics).....	16
2.2.2. ADM as FRE (vehicle electronics).....	17
<b>3. MR-PLD engine control (pump-line-nozzle) .....</b>	<b>18</b>
3.1. Brief description of the Diesel engine control unit PLD-MR .....	18
3.2. Control unit - operating principle .....	18
3.2.1. Overview of the telligent engine system BR 500 .....	19
3.2.2. Overview of the telligent engine system BR 900 .....	20
3.2.3. Control unit block diagram.....	21
3.2.4. PLD control unit as engine control (MR-PLD) .....	22
3.3. Functional description .....	23
3.3.1. Configuration.....	23
3.3.2. Flexibility of the concept.....	23
3.3.3. Control unit description of engine electronics MR-PLD .....	24
3.3.3.1. Safeguard /redundancy.....	24
3.3.3.2. Description of the inputs .....	24
3.3.3.3. Description of the outputs .....	24
3.3.4. Compound network between MR-PLD <=> FRE .....	25
3.3.4.1. Communication .....	25
3.3.5. MR-PLD <=> FRE interface functions .....	26
3.3.5.1. Idle-speed control / speed control / maximum engine speed limitation .....	26
3.3.6. Shutoff or throttling of the engine through the FRE (vehicle electronics).....	27
3.3.7. Engine start and stop .....	28
3.3.7.1. Starter control (conditions).....	28
3.3.7.2. Starter protection.....	29
3.3.7.3. Start by the driver .....	29
3.3.7.4. CAN start .....	30
3.3.7.5. Starter reset bridge .....	30
3.3.7.6. Starter driver.....	31
3.3.7.7. Start through the FRE (vehicle control electronics) via CAN .....	32
3.3.7.8. Starting procedure .....	32
3.3.7.9. Service start button at the engine block .....	32
3.3.7.10. Service stop button at the engine block.....	32
3.3.7.11. Engine cranking via the service start and stop button .....	33
3.3.7.12. Rev up to maximum speed via service start button.....	33

---

3.3.7.13. Engine stop.....	33
3.3.8. Plausibility check terminal 50 .....	34
3.3.9. Calculation of injection delivery angle and start of injection.....	35
3.3.10. Controls (PID governor) .....	36
3.3.11. Operating modes .....	37
3.3.11.1. PTO speed control .....	37
3.3.11.2. Controlled operation (normal operation).....	37
3.3.11.3. Immobilizer.....	37
3.3.12. Tow starting of the engine.....	37
3.3.13. Emergency syndrome.....	37
3.4. Mechanical description.....	38
3.4.1. Mechanical layout of PLD engine electronics .....	38
3.4.2. Complete version PLD engine electronics .....	38
3.4.2.1 Fuel cooling .....	39
3.4.2.2 MR-PLD Control Unit.....	39
3.4.2.2.1.MR-PLD - version assignment table.....	41
3.4.3. Technical data .....	41
3.4.4. General testing conditions .....	41
3.5. Electrical description .....	42
3.5.1. System interface diagram .....	42
3.5.1.1. Interface diagram.....	42
3.5.1.2. Socket pin designation MR-PLD control unit (D2.1)/according to pin assignment .	43
3.5.1.3. Pin assignment of MR-PLD control unit (D2.1); function oriented/alphabetical ....	46
3.5.1.4. Voltage supply of control unit MR-PLD (D2.1) .....	50
<del>    3.5.2. ....</del>	<del>xx</del>
<del>        3.5.2.1. ....</del>	<del>xx</del>
<del>        3.5.2.2. ....</del>	<del>xx</del>
<del>        3.5.2.3. ....</del>	<del>xx</del>
3.5.3. Sensor system of the PLD engine control unit (MR-PLD).....	51
3.5.3.1. Control unit internal sensors .....	51
3.5.3.2. Control unit external sensors.....	51
3.5.3.3. Active sensors .....	51
3.5.3.4. Passive sensors .....	52
3.5.3.5. Temperature sensors .....	52
3.5.3.6. Passive oil pressure .....	53
3.5.3.7. Oil level .....	54
3.5.3.8. Camshaft / crankshaft position (inductive).....	55
3.5.3.9. Booster speed 1 / 2.....	55
3.5.3.10. Fan speed.....	56
3.5.4. Digital inputs.....	57
3.5.4.1. Ignition (Terminal 15).....	57
3.5.4.2. Terminal 50 .....	57
3.5.4.3. Service button start/stop .....	58
3.5.4.4. Oil separator.....	59
3.5.5. Proportional valve control.....	60
3.5.5.1. Functional assignment of proportional valves/hardware status D2.1 .....	61
3.5.5.2. Principle block diagram proportional valve control /hardware status D2.1.....	62
3.5.5.3. Functional assignment of the proportional valves/hardware status C3..C6 .....	63
3.5.5.4. Principle block diagram proportional valve control/hardware status C3..C6.....	64
3.5.6. Starter control through the MR-PLD .....	65
3.5.6.1. Main path (self-locking) .....	65
3.5.6.2. Auxiliary path (self conducting).....	65
3.5.6.3. Principle block diagram starter control .....	66
3.5.6.4. Starter relay.....	66
3.5.6.5. Principle block diagram of safety concept of JE-starter .....	67
3.5.7. Serial communication interfaces .....	68

3.5.7.1. CAN data bus (2-wire-interface, standard: ISO 11992) .....	68
3.5.7.2. Diagnostic line (standard: ISO 9141) .....	69
3.5.7.3. Classification of the injector valves .....	69
3.6. Configuration possibilities of the MR-PLD .....	70
3.6.1. Fan type.....	70
3.6.1.1. General connection .....	70
3.6.1.2. Pin assignment of the proportional valve-power stages (PV/Prop) for fan control. ....	70
3.6.1.2.1. Type 0/Linning-clutch (on highway/two-stage) .....	70
3.6.1.2.2. Type 1/Linning-clutch (off highway/two-stage) .....	70
3.6.1.2.2.1. Configuration / fan switch-on threshold (type 1) .....	70
3.6.1.2.3. Type 2 /electrically controlled Viscous-fan .....	72
3.6.1.2.4. Type 3 /Hydrostatic Fan .....	73
3.6.1.2.5. Type 4/Horton-clutch .....	74
3.6.1.2.6. Type 5/one Hydrostatic-fan.....	75
3.6.1.2.7. Type 6/two Hydrostatic-fans.....	76
3.6.2. Starter control .....	77
3.6.2.1. JE-starter .....	77
3.6.2.2. KB-starter.....	78
3.6.2.2.1. KB-starter with starter solenoid relay (2 A) .....	78
3.6.2.2.2. KB-starter without Starter Solenoid Relay (2 A) .....	79
3.6.3. Oil pans .....	80
<b>4. Diagnosis .....</b>	<b>81</b>
4.1. Measured values .....	81
4.1.1. Analogue measured values .....	81
4.1.2. Binary measured values .....	83
4.2. Serial diagnosis interfaces .....	86
4.2.1. Diagnostic line .....	86
4.2.1.1. Fault memory .....	86
4.2.1.2. Operating modes .....	86
4.2.2. CAN data bus systems.....	87
4.2.2.1. Engine-CAN (ISO 11992) .....	87
4.2.2.2. Vehicle CAN .....	87
4.2.3. SAE J1587/SAE J1708 (USA- and partly NAFTA-market).....	88
4.2.4. Configuration of diagnostic interface.....	88
4.2.4.1. MB-truck / Brazil.....	89
4.2.4.2. Europe (ADM / not MB-trucks) .....	90
4.2.4.3. Europe (ADM2 / not MB-Trucks).....	91
4.2.4.4. USA- and partly NAFTA-market .....	92
4.2.5. Diagnosis interface/software description .....	93
4.2.5.1. Fault memory structure .....	93
4.2.5.2. Ground switching.....	93
4.3. Diagnosis unit & application.....	94
4.3.1. minidiag2 .....	94
4.3.1.1. Display/delete fault code memory .....	94
4.3.1.2. Testing routines.....	97
4.3.1.2.1. Voltmeter function.....	97
4.3.1.2.2. Cylinder cutoff.....	98
4.3.1.2.3. Compression check.....	99
4.3.1.2.4. Idle speed balance (hot engine!).....	100
4.3.1.2.5. Impact delay time .....	101
4.3.1.2.6.....	xx
4.3.1.2.7.....	xx
4.3.1.3. Calibration .....	102

4.3.1.3.1.	Single parameters .....	102
4.3.1.3.2.	Data set calibration .....	104
4.3.1.3.3.	Save modified parameter set.....	105
4.3.1.3.4.	Convert modified parameter set.....	106
4.3.1.4.	Program protection .....	107
4.3.2.	Stardiagnose .....	107
4.3.3.	ServiceLink.....	108
4.4.	Diagnosis routines .....	109
4.4.1.	Detailed testing routines.....	109
4.5.	Backup .....	110
4.5.1.	System backup capability .....	110
4.5.1.1.	Microprocessor 1-backup.....	110
4.5.1.1.1.	Crankshaft backup.....	110
4.5.1.1.2.	Camshaft backup .....	110
4.5.1.1.3.	CAN-backup (definition) .....	110
4.5.1.1.4.	CAN-backup, mode 0 (standard-backup) .....	111
4.5.1.1.5.	CAN-backup, mode 1 .....	112
4.5.1.1.6.	CAN-backup, mode 2.....	112
4.5.1.1.7.	CAN data-area check .....	112
4.5.1.1.8.	Nominal engine speed CAN-backup .....	112
4.5.1.1.8.1.	Nominal engine speed CAN-backup mode 0.....	112
4.5.1.1.8.2.	Nominal engine speed CAN-backup mode 1 .....	113
4.5.1.2.	Microprocessor 2-backup.....	113
4.5.2.	Backup functions .....	114
4.5.2.1.	Ambient pressure sensor.....	114
4.5.2.2.	Boost pressure control.....	114
4.5.3.	Sensor-replacement values .....	114
4.5.3.1.	Plausibility limits and sensor replacement values .....	114
4.5.4.	Diagnosis of sensor and backup functions .....	115
4.5.4.1.	Temperature and presure sensors.....	115
4.5.4.2.	Crankshaft sensor .....	115
4.5.4.3.	Camshaft sensor (cylinder 1 recognition).....	116
4.5.5.	Diagnosis of actuators .....	117
4.5.5.1.	MR-PLD injector-/magnetic valves (MV).....	117
4.5.5.2.	MR-PLD proportional valves.....	118
4.5.5.3.	Starter control.....	118
4.6.	Fault codes & repair instructions.....	119
4.6.1.	Fault codes .....	119
4.6.1.1.	Fault priority 0 .....	119
4.6.1.2.	Fault priority 1 .....	119
4.6.1.3.	Fault priority 2 .....	119
4.6.2.	Fault path .....	120
4.6.3.	Fault type .....	122
4.6.4.	Fault codes und repair instructions, high priority .....	124
4.6.5.	Fault codes und repair instructions, mean priority.....	125
4.6.6.	Fault codes und repair instructions, minor priority.....	134
<del>    4.6.7.</del>	<del>.....</del>	<del>xx</del>
<del>    4.6.8.</del>	<del>.....</del>	<del>xx</del>
4.7.	Special measurements .....	138
4.7.1.	General information .....	138
4.7.2.	Actuators.....	138
4.7.2.1.	Solenoid valves: Current modulation curve of the injector valve control/type 1..	138
4.7.2.2.	Solenoid valves: Current modulation curve of the injector valve control/ type 2..	140
<del>    4.7.2.3.</del>	<del>.....</del>	<del>xx</del>
<del>    4.7.3.</del>	<del>.....</del>	<del>xx</del>

**5. Parameters (minidiag2)..... 142**

5.1. MR-PLD Diagnosis version 3 to 5 (up-/download)..... 142

5.2. MR-PLD Diagnosis from version 6 (single parameters)..... 146

A listing follows in the project "MR-PLD" used abbreviations.

Abbreviation	Meaning	Abbreviation	Meaning
ABS	Anti-lock Braking System	LRR	Engine-Smoothness Control
ADR / PTO	PTO speed control / Power Take-off	LK	Slight Vehicle Class (MB-NFZ)
		LS	Low Speed (CAN)
ATG / AT	Automated Transmission	MB	Mercedes Benz
AVD	Compression check	MBR	Engine Brake
BGR	Limitations	<b>MR-PLD</b>	Engine control (Pump-Line-Nozzle System)
BK	exhaust flap		
BR	Engine Type Series (e. g. BR900)		
CAN	Controller Area Network	MS / MTS	Engine protection
		MV	Magnetic Valve
EGR	Exhaust Gas Recirculation	MZA	Mechanical Additional Boost
EMV	Electro-Magnetical-Impulse	n.d.	not difined
EOL	End Of Line		
EZA	Individual cylinder adaption	NFZ	Commercial Vehicle
FB	Start Of Injection	NW	Camshaft
FDOK	Vehicle Documentation System	OM	Oel Engine
FLA	Flame Start Unit	OT / TDC	Top Dead Centre
		PFA	Particle Filter System
<b>FRE</b>	Vehicle control (e. g. VCU, ADM, ADM2, UCV, FR/FMR)	PID	Parameter Identifier
FRT	Free Running Telegramm		
FSP		PV / Prop	Proportional Valve
FW	Injection Delivery Angle	PWM	Pulse Width Modulated
GMA	Basic Moment Adaption	SEG	Segment
HB	High Byte	SG / Stg. /	Electronical Control Unit
		ECU	
		s.n.v.	signal not available
HW	HardWare	SK	Heavy Vehicle Class (MB-NFZ)
ID	IDentifier	STG / MA	Manual Transmission
IES	Intigrated Electronic System	SW	SoftWare
INS / ICU3	Dashboard	TN	(CAN) Attendant
IMO	Industrial Engine (Off-Highway)	TPC	TransPonderCode
KD	Decompression Valve	UT	Bottom Dead Centre
		VTG	Variable Geometry Turbo
		WS	Service System
		WSP	Immobilizer
K-Line	Communication Line (serial)	ZYL / CYL	Cylinder
KW	Crankshaft		
LB	Low Byte		
LL / LLR	Idle / Idle Control		

## 1. Safety

### 1.1. Symbols

The instructions that follow are shown against various symbols.



**risk of injury!**

This symbol appears against all safety instructions that must be complied with in order to avoid a direct risk of danger to life and limb.

---



This symbol is used against all safety instructions that, if disregarded, could give rise to the danger of material damage or malfunctions.

### 1.2. General information

---



**accident and live hazard!**

The engine control unit MR-PLD is essential for defining the functions of the engine and vehicle. Functions such as the exact electric control of injector valves via the magnetic valves, fuel injection, fault recognition, engine safeguards, backup, diagnosis etc. are relevant to safety. Incorrectly performed modifications to the parameters or tampering with the wiring can cause far-reaching changes to the performance of the engine and/or vehicle. This can lead to personal injury and material damage.

---

The control unit MR-PLD has been developed and tested in accordance with the DaimlerChrysler Specifications for Operating Safety and EMC Compatibility. The manufacturer of the vehicle or equipment is solely responsible for the examination and implementation of applicable legal stipulations.

### 1.3. Use for the intended purpose

The DaimlerChrysler engine and the MR-PLD control unit are only to be used for the purpose stated in the contract of purchase. Any other use or an extension of the stated use will be regarded as not conforming to the engines intended purpose.

DaimlerChrysler AG cannot accept any liability for damage resulting from such use. Liability for damage resulting from the engine not having been used for its intended purpose shall rest solely with the manufacturer of the complete machine or vehicle in which the engine is installed. These MR-PLD Operating Instructions and the engine Operating Instructions must be observed.

### 1.4. Personnel requirements

Work on the electrics and programmed parameters should only be carried out by specially skilled persons or those who have received training from DaimlerChrysler, or by specialists employed by a workshop authorized by DaimlerChrysler.

### 1.5. Conversions and modifications to the MR-PLD

Unauthorized modifications to the MR-PLD could affect the operation and safety of the vehicle/machine in which it is installed. No responsibility will be accepted for any resulting damage.

### 1.6. Installation

The guidelines and instructions in Chapter 6 (assembly & connecting) and Chapter 3.5.2 (electric installation) must be observed.

### 1.7. Organizational measures

These Operating Instructions should be handed to personnel entrusted with the operation of the MR-PLD and should, whenever possible, be stored in an easily accessible place.

With the aid of these Operating Instructions, personnel must be familiarized with the operation of the MR-PLD, paying special attention to the safety-relevant instructions applicable to the engine. This applies in particular to personnel who only work on the engine and MR-PLD occasionally.

In addition to these Operating Instructions, comply with local legal stipulations and any other obligatory accident prevention and environmental protection regulations which may apply in the country of operation.

---

## 1.8. Safety precautions for engines with electronic control units

---



### accident hazard!

When the vehicle electrics are first operated, the drive train must be open (transmission in neutral). The engine could start unexpectedly due to incorrect wiring or unsuitable parameter programming. If the drive train is closed (transmission not in neutral), the vehicle could unexpectedly start moving or set the working machine in operation, constituting a risk to life and limb.

---



The safety precautions stated below must be applied at all times in order to avoid damage to the engine, its components and wiring, and to avoid possible personal injury.

- Only start the engine with the batteries securely connected
- Do not disconnect the batteries when the engine is running
- Only start the engine with the engine speed sensor connected.
- Do not start the engine with the aid of a rapid battery charger. If emergency starting is necessary, only start using separate batteries
- The battery terminal clamps must be disconnected before a rapid charger is used. Comply with the operating instructions for the rapid charger
- If electric welding work is to be performed, the batteries must be disconnected and both cables (+ and -) secured together
- Work is only to be performed on the wiring and connectors are only to be plugged/unplugged with the electrical system switched off
- The first time the engine is run, the possibility must be provided to switch off the voltage supply to the MR engine control and to the vehicle electronics (MR-PLD or FRE) in an emergency
- If it is incorrectly wired up, it may no longer be possible to switch the engine off
- Interchanging the poles of the control unit's voltage supply (e.g. by interchanging the battery poles) can damage the control unit beyond repair
- Fasten connectors on the fuel injection system with the specified tightening torque
- Only use properly fitting test lead for measurements on plug connectors (DaimlyerChrysler connector set)



If temperatures in excess of 80°C (e.g. in a drying kiln) are to be expected, the control units must be removed as they could be damaged by such temperatures.



Telephones and two-way radios which are not connected to an external aerial can cause malfunctions in the vehicle electronics and thus jeopardize the engines operating safety.

---

### 1.9. DaimlerChrysler original parts

DaimlerChrysler original parts are subject to the most stringent quality checks and guarantee maximum functional efficiency, safety and retention of value.

Each part is specially designed, produced, selected and approved for DaimlerChrysler. For this reason, we are obliged to disclaim all liability for damage resulting from the use of parts and accessories which do not meet the above requirements.

Germany and various other countries, certain parts (for instance parts relevant to safety) are only officially approved for installation or conversion work if they comply with valid legal stipulations. These regulations are assured to be satisfied by DaimlerChrysler original parts.

If other parts, which have not been tested and approved by DaimlerChrysler, are installed – even if in individual circumstances they have been granted an official operating permit – DaimlerChrysler is unable to assess them or grant an form of warranty, although the company endeavors to monitor market developments as far as possible. The installation of such parts may therefore restrict the validity of the warranty.

### 1.10. Safety and backup running programm

The electronic control units MR-PLD and FRE monitor the engine and carry out self-diagnosis. As soon as a fault is detected it is evaluated and one of the following measures is initiated:

- Faults during operation are indicated by the warning lamps being activated
- Switch-over to a suitable substitute function for continued, albeit restricted engine operation (e.g. constant emergency engine speed)



Have any faults rectified without delay by the responsible DaimlerChrysler Service Station.

Note:

DaimlerChrysler diagnosis testers (hand-held tester (HHT) or Minidiag), which are connected to the 14 pin diagnosis socket (on the unit), can be used to read off the fault codes.

**MR-PLD control unit fault codes and their remedial actions are described in Chapter 4.6.**

Defective units which are still within the period of warranty cover (6 months from DaimlerChrysler dispatch date) must be returned to the DaimlerChrysler field service organization.

**2. General governor architecture**

The electronic governor architecture consists of two components:

1) **Engine control unit (MR)** consisting of PLD (short for pump-line-nozzle system)

2) **Vehicle electronics (FRE)** consisting of the following interface modules:

- FR/FMR (vehicle governor/vehicle engine governor): used in MB Trucks and buses
- ADM/ADM2 (adaptation module): used with MB-engines, IMO (international, but not NAFTA-market)
- VCU (Vehicle Control Unit): used with MB-engines in the NAFTA-market (e.g. Freightliner)
- UCV (Unit Control Vehicle): used with MB-engines in Brasil

*Note: The future interface module CPC (Common Powertrain Controller) shall replace all vehicle controllers and in this documentation the abbreviation FRE (Vehicle Electronics) is used for the different vehicle controls (ADM/ADM2, VCU, FR-FMR, UCV etc.), due to a clear arrangement.*

**2.1. Standard model of engine control (MR-PLD) and vehicle electronics (FRE)**

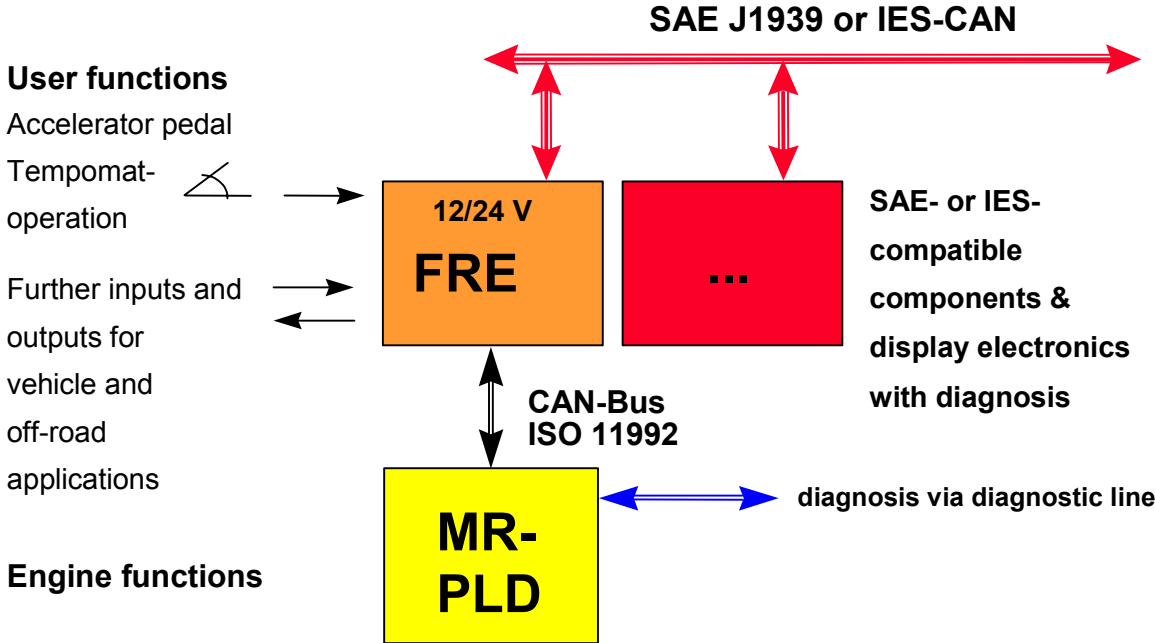

**Block diagram 2.1:** Engine control unit (MR-PLD) and vehicle electronics (FRE)

Note: The application of the High-Speed-CAN (SAE J1939/IES-CAN) depends on the vehicle electronics (FRE)! See also chapter 4.2.2. to 4.2.4.4.

### 2.2. Features of the governor and interface module

#### 2.2.1. VCU (ADM2) as FRE (vehicle electronics)

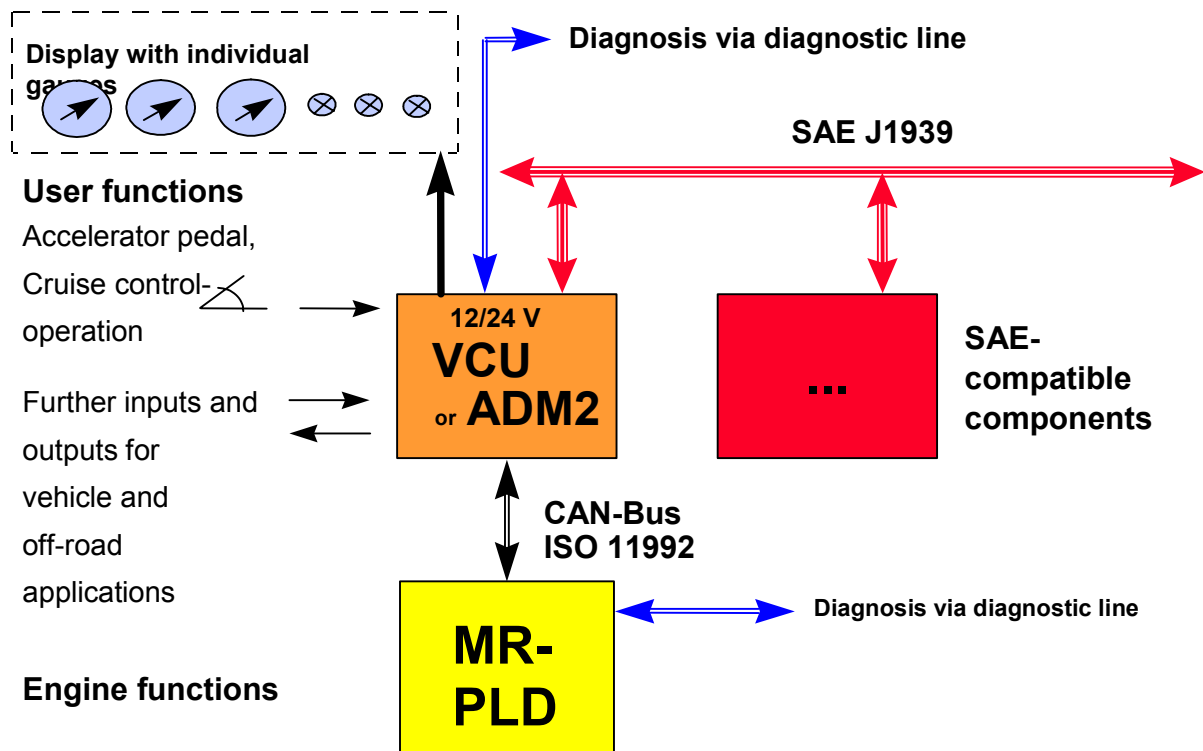

**Block diagram 2.2.1:** Governor architecture with the interface module VCU or ADM2

Note: The application of the High-Speed-CAN (SAE J1939/IES-CAN) depends on the vehicle electronics (FRE)! **See also chapter 4.2.2. to 4.2.4.4.**

- **MR-PLD**

The PLD governor for the electronic Diesel injection has the following features:

- Cylinder-selective injector valve control
- Control, regulation and monitoring of engine functions
- Starter control
- Fault recognition
- Backup operation functions
- Diagnosis
- Communication interfaces with FRE via engine CAN (ISO 11992) and/or diagnostic line (ISO 9141)

- **VCU (ADM2)**

- Implementation of user functions, e.g. accelerator pedal, cruise control, limitations, etc.
- Communication interfaces with MR-PLD via engine CAN (ISO 11992)
- Communication interfaces with vehicle CAN (SAE J1939/IES)
- Conventional display driver: analogue and digital displays
- Diagnosis

## 2.2.2. ADM as FRE (vehicle electronics)

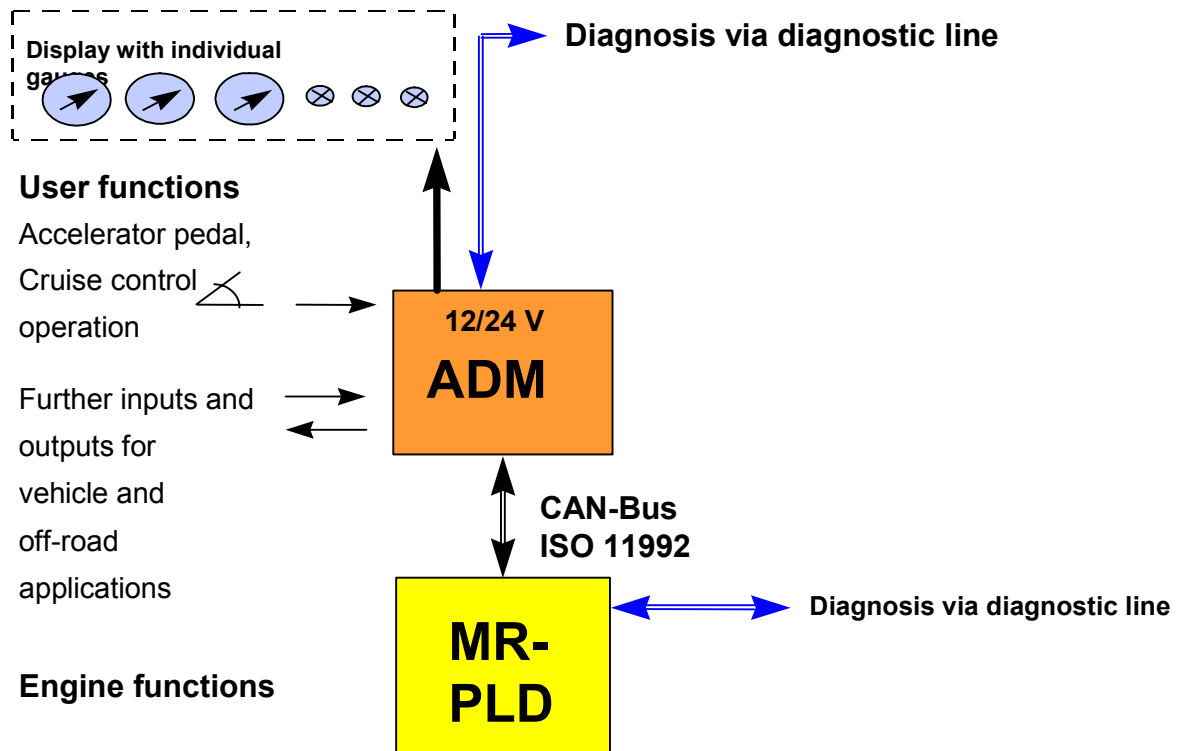

Block diagram 2.2.2.: Governor architecture with interface module ADM

- **ADM**
  - Implementation of user functions, e.g. accelerator pedal, cruise control, limitations, etc.
  - Communication interfaces with MR-PLD via engine CAN (ISO 11992)
  - Conventional display drivers: analogue and digital displays
  - Diagnosis

### 3. MR-PLD engine control (pump-line-nozzle)

#### 3.1. Brief description of the Diesel engine control unit MR-PLD

The engine control unit „MR-PLD“ (pump-line-nozzle system) controls the electronic Diesel-fuel injection and is also designed for the engine series 450, 500 and 900. The main function of the control unit is the exact electric control of the solenoid valves at the injector valves. Regarding this, the optimum start of injection and the necessary injection quantity for the torque (or the desired speed in the case of a PTO speed control operation) demanded by the control unit on the engine side, are calculated and set (mapping specific, through measured engine and ambient conditions).

The control unit also provides further features like fault recognition, possibility of limp-home operating modes, diagnosis and interfaces with other control systems.

#### 3.2. Control unit - operating principle

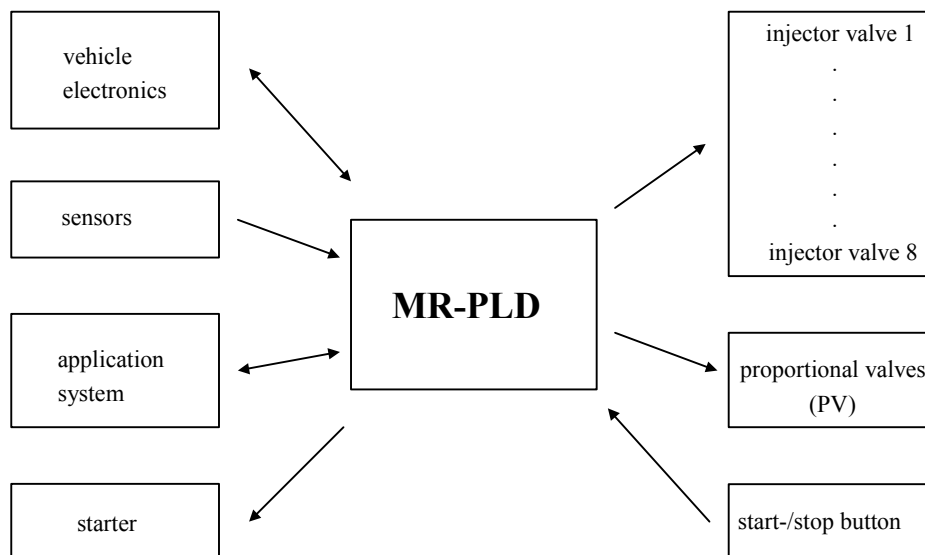

### 3. MR-PLD engine control (pump line nozzle)

#### 3.2.1. Overview of the telligent engine system BR 500

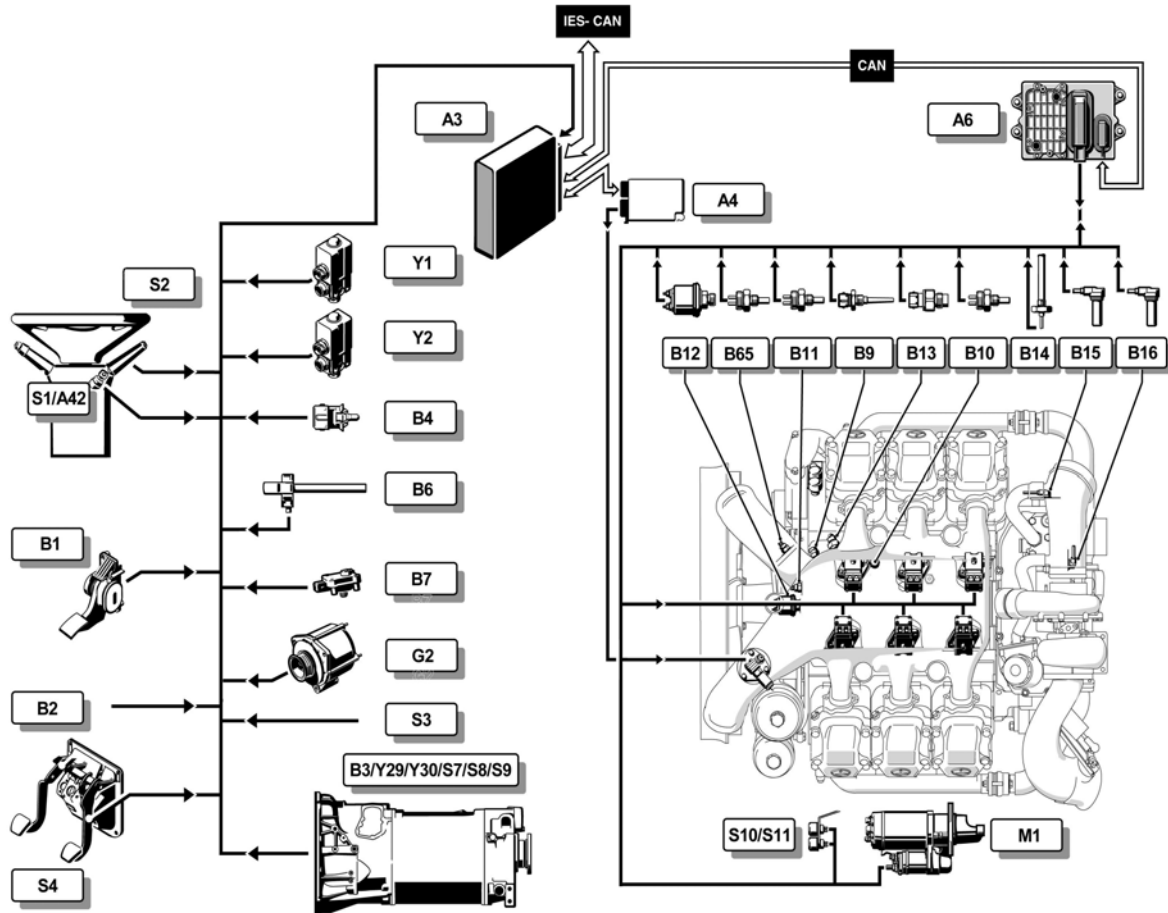

A3	Controller FRE (FR-FMR)	G2	Alternator
A4	Controller Ignition System	M1	Starter
A6	Controller MR-PLD	P1	Speedometer
A42	Electronic to read Transponder Code	S1	Driving Switch
B1	Accelerator Pedal	S2	Lever for Engine Governor / Permanent Brake
B2	Clutch Pedal	S3	Split Switch
B3	Engine Speed Sensor at Counter Shaft	S4	Braking Light Switch
B4	Outside Temperature Sensor	S7	Switch for Reverse Gear
B6	Engine Coolant Level Sensor	S8	Switch for Group Position
B7	Air Filter Inspection Sensor	S9	Switch for Neutral Position
B9	Turbo Charger Temperature Sensor	S10	Push-button Engine Start
B10	Fuel Temperature Sensor	S11	Push-button Engine Stop
B11	Oil Temperature Sensor	Y1	Constant Throttle Magnetic Valve
B12	Oil Pressure Sensor	Y2	Engine Brake Magnetic Valve
B13	Turbo Charger Pressure Sensor	Y29	MS2 Magnetic Valve
B14	Oil Level Sensor	Y30	MS1 Magnetic Valve
B15	Crankshaft Angle Position Sensor		
B16	TDC Sensor Cylinder 1		
B65	Coolant Temperature Sensor		

3.2.2. Overview of the telligent engine system BR 900

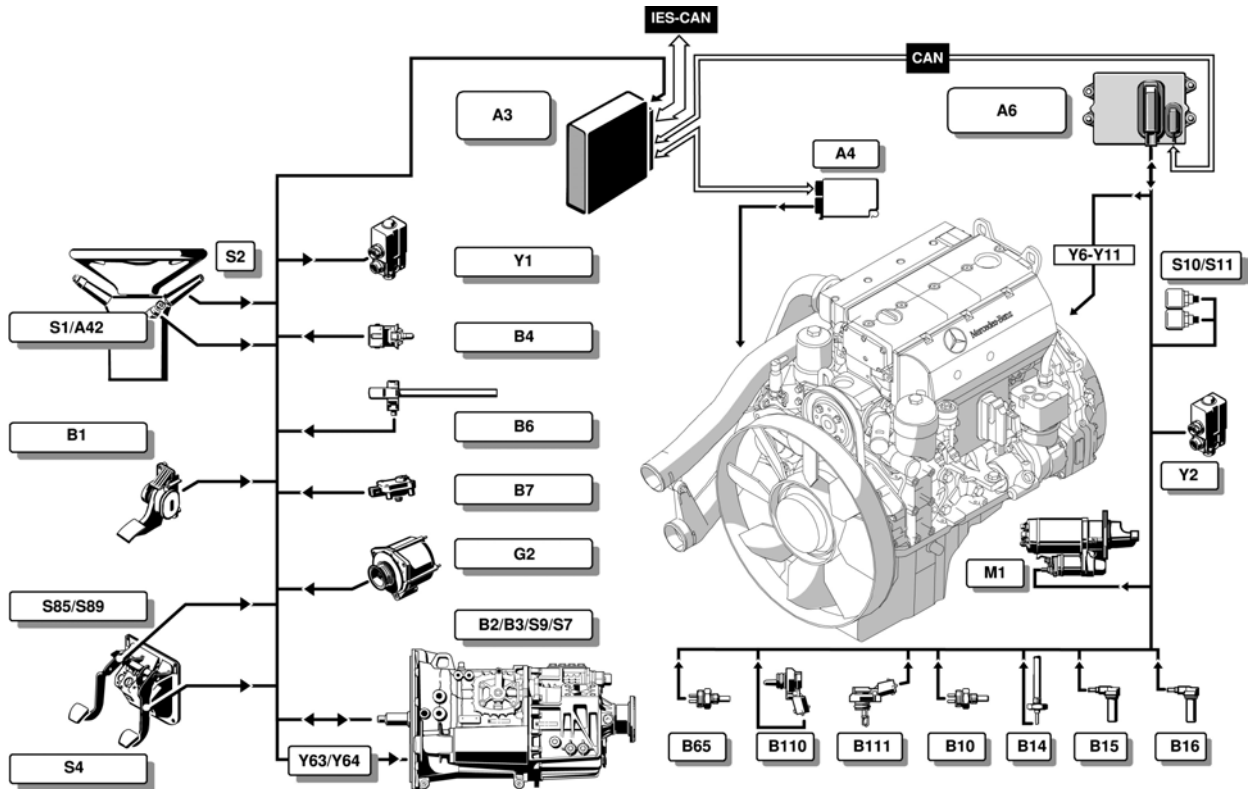

A3	Controller FRE (FR-FMR)	G2	Alternator
A4	Controller Ignition System	M1	Starter
A6	Controller MR-PLD	P1	Speedometer
A42	Electronic to read Transponder Code	S1	Driving Switch
B1	Accelerator Pedal	S2	Lever for Engine Governor / Permanent Brake
B2	Clutch Pedal	S4	Braking Light Switch
B3	Engine Speed Sensor at Counter Shaft	S7	Switch for Reverse Gear
B4	Outside Temperature Sensor	S9	Switch for Neutral Position
B6	Engine Coolant Level Sensor	S10	Push-button Engine Start
B7	Air Filter Inspection Sensor	S11	Push-button Engine Stop
B9	Intake Air Temperature Sensor	S85	Switch 1, Clutch (KUP1) < 15 tons
B10	Fuel Temperature Sensor	S89	Switch 2, Clutch (KUP2) > 15 tons
B14	Oil Level Sensor	Y1	Engine Brake Magnetic Valve (4 cyl.) Exhaust Flap brake (6 cyl.)
B15	Crankshaft Angle Position Sensor	Y2	Constant Throttle Magnetic Valve (6 cyl.)
B16	TDC Sensor Cylinder 1	Y6..11	Pump nozzle unit
B65	Coolant Temperature Sensor	Y63	Split Magnetic Valve
B110	Oil Pressure and Temperature Sensor	Y64	Shift Power Assistant Magnetic Valve G 100
B111	Turbo Charger Air Pressure and Temperature Sensor		

3.2.3. Control unit block diagram

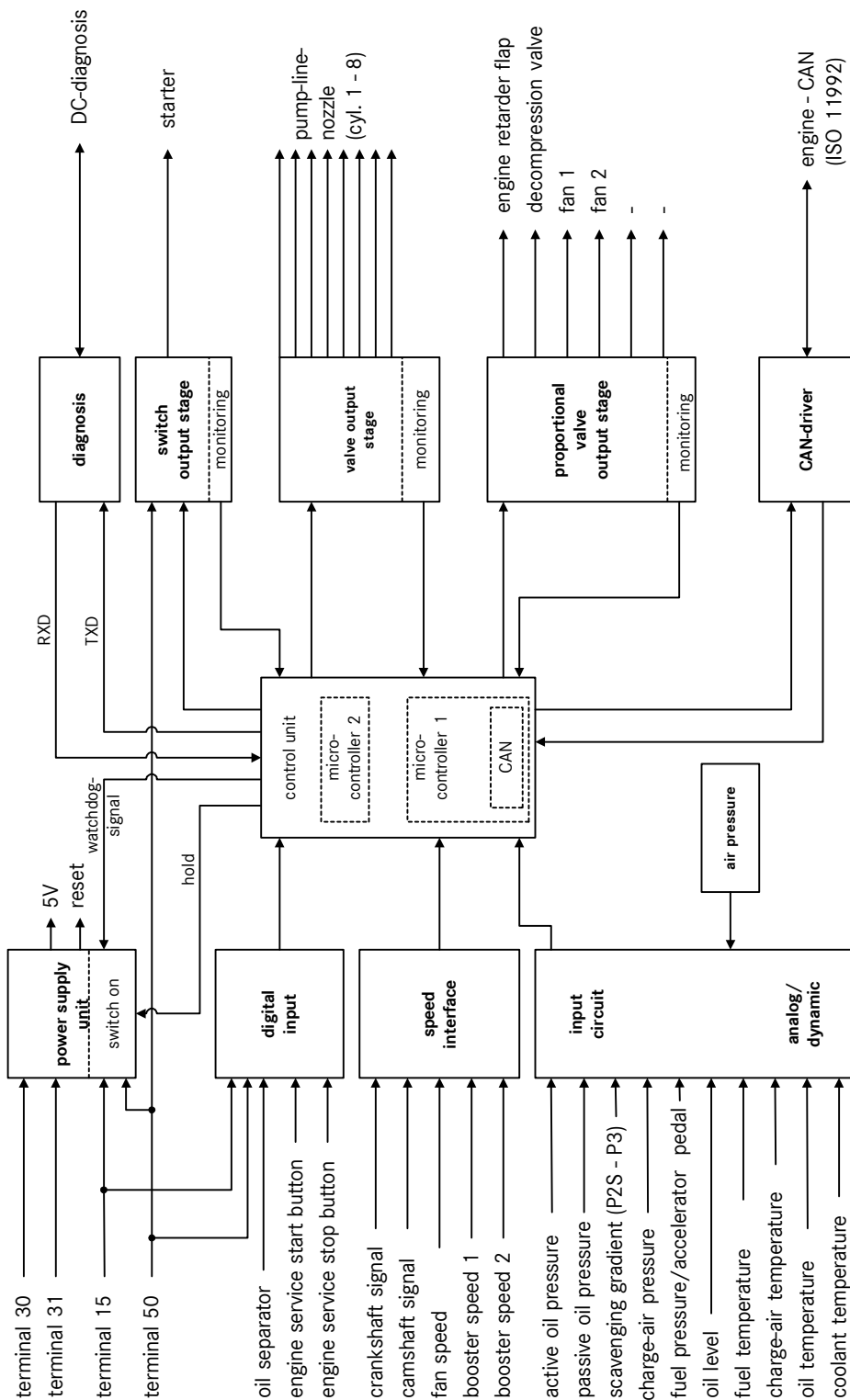

**Note:** On the basis of the control unit the function "hold" is activated, which is responsible for the backup phase of the control unit, if no signal arrives at the power supply unit (switch-on) the control unit switches off.

3.2.4. PLD control unit as engine control (MR-PLD)

ABS	=	Antilock Brake systems
ADR	=	PTO speed control
<b>FRE</b>	=	<b>Vehicle electronics (ADM/ADM2, VCU, FR-FMR etc.)</b>
ASR	=	Anti-slip control
BGR	=	Limitations
FFG	=	Accelerator pedal (operation or speed demand)
FLA	=	Flame start unit
ISO	=	International Organisation for Standardization
IWA	=	Actual value output (for automatic transmission, customer-specific electronics...)
MBR	=	Engine brake
<b>MR-PLD</b>	=	<b>PLD engine control (pump-line-nozzle system)</b>
SAE J1939	=	High-speed CAN (on vehicle side)

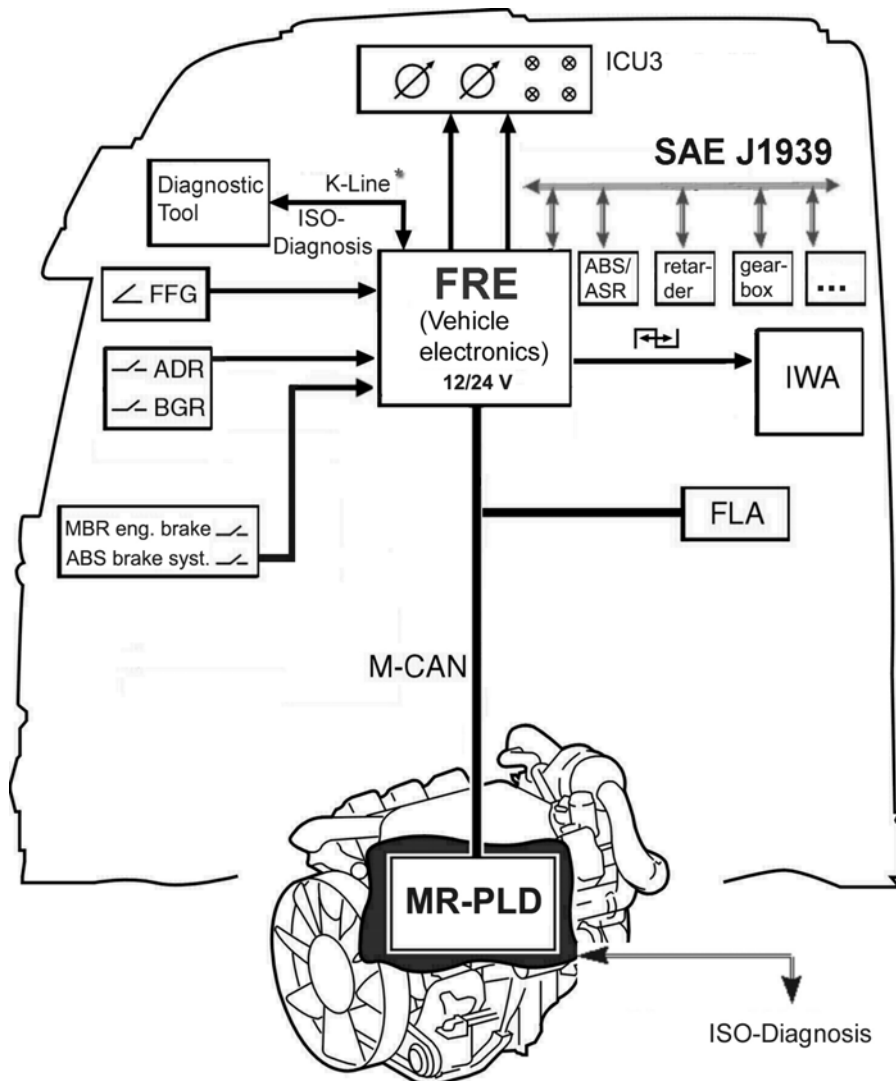

\* K-Line from FR-FMR normally not used!

*Note: In this documentation the abbreviation „FRE“ is used for the different vehicle controls (ADM/ADM2, VCU, FR-FMR, UCV etc.), due to a clear arrangement.*

### 3.3. Functional description

#### 3.3.1. Configuration

The electronic system is divided in two independent subsystems that can be monitored separately.

The cabin mounted control unit “FRE” (vehicle electronics) controls the sensors and actuators attached to the drivers cab or the vehicle frame and involves all functions which are relevant for the vehicle.

The engine mounted control unit MR-PLD controls all sensors and actuators attached to the engine and involves all functions which are important to the engine operation.

The two control units are connected via a bus connection with “one wire capability”. Via this bus connection nominal values and the operating mode of the engine are demanded by the respective FRE (e.g. increase of idle speed, speed-controlled engine operation with programmable desired speed, torque limitation, freely selectable control characteristic, engine braking torque etc.), and in the opposite direction the MR-PLD control unit transmits information about the actual engine operating mode to the FRE (e.g. flame start unit).

#### Advantages:

- the plug connections at the engine are reduced to the connections which are relevant to the engine
- the vehicle connections are located in the uncritical surrounding area of the drivers cab (high degree of acceleration- and temperature load at the engine)
- less connection lines between engine and vehicle (reduced to the EMV-uncritical CAN connection) proves to be of particular advantage in the bus (due to the great distance between the control elements and the engine, like accelerator pedal etc.)
- the computers are only burdened with the functions and tasks of the particular system (the PLD-MR computer is only responsible for the engine management, no load through vehicle functions)
- a modular extension of the system is possible by means of additional units that are connected with the bus system

#### 3.3.2. Flexibility of the concept

Each subsystem is tuned individually and can be tested as a subsystem. Therefore the engine can be replaced by an engine of a different design but with the same category of engine performance, without having to change the configuration in the vehicle-control unit (FRE) (e.g. PLD-MR engine is replaced by Common-Rail engine). 4-, 5-, 6-, and 8-cylinder engines can be operated with the same PLD-MR.

Accessory parts at the engine like “Waste Gate”, fan high speed etc. can be regulated, controlled and connected via 6 PWM outputs at the PLD-MR. An additional digital output is reserved for the starter control!

Functional requests of other electronic systems like ABS, ASR, EPB, EAS, automatic transmission, retarder etc. (data exchange via vehicle-CAN-Bus (e.g. IES-CAN)) are coordinated in the FRE and prepared for the engine electronics (PLD-MR).

### 3.3. Functional description

---

#### 3.3.3. Control unit description of engine electronics MR-PLD

The module MR-PLD engine electronics consists of the control unit and the fuel cooling. The MR-PLD control unit consists of a component circuit board with base plate (planar technique) and a zinc pressure die casting housing. The circuit board/base plate combination is screwed to the housing. The seal between housing and circuit board is achieved by means of a fluid gasket.

The external electrical contact is maintained via a 16 pin and a 55-pin socket. To bring the pressure inside the housing into equilibrium with the ambient pressure, a pressure sensitive membrane is located on the bottom of the housing. The housing has 4 eyelets to accommodate the damping elements and screw them onto the engine. *See also chapter 3.4. Mechanical description.*

##### 3.3.3.1. Safeguard /redundancy:

The MR-PLD is designed as a 2-controller system i.e. in the case of a main controller failure, the limp home controller takes over the control of the magnetic valves at the injector valves. In this case the engine rpm is constant (approx. 1300 rpm). This redundancy (i.e. in the case of the failure of one “functional component”, at least one second operable functional component is available as a safety measure) also applies to solenoid valves (injector valves), speed sensors, starter control and engine CAN-Bus (one wire capability). In addition, the electronics are provided with a “Watch-Dog” circuit, extensive self tests are carried out continuously and in addition a mutual monitoring with the FRE (vehicle electronics) takes place. *See also chapter 4.5. Backup.*

##### 3.3.3.2. Description of the inputs:

- 4 temperature inputs (coolant, oil, fuel, charge air)
- 3 pressure inputs (atmospheric pressure (internal sensor), boost pressure, oil pressure)
- 1 input oil level
- 2 analogue inputs reserve
- 2 binary inputs for service-start- and stop-buttons in engine compartment function: engine start, engine stop, both service-buttons pushed simultaneously => starter is cranking/ no injection, Service-start-bottom release and with running engine operate/ hold => engine again start toward cutoff speed
- 2 inputs for crank-angle and cam-angle sensing  
Bores, slits, teeth (esp. tooth wheel) or noses can be used as markings on engine side (beware polarity!)

##### 3.3.3.3. Description of the outputs:

- 4 / 8 outputs for injector valves (partial assembled) possible for reduction in costs)
- 1 output for starter control
- 6 more PWM-modulated multi-functional outputs for the control of further components like fan high speed, Waste Gate, Viscous-clutch etc.

The assignment of the outputs can be defined by configuration.

*See also chapter 3.5.5. Proportional valve control*

##### Remark:

One of the most important functions is among other things the exact, electric control of the injector valves via the solenoid valves. *See chapter 3.1. “Brief description of the Diesel engine-control unit MR-PLD”.*

### 3.3.4. Compound network between MR-PLD <=> FRE

#### 3.3.4.1. Communication

The FRE makes demands on the MR-PLD via the CAN like e.g.:

- Torque demand through accelerator pedal (controlled operation i.e. normal operation)
- ADR-governor type (5 types altogether, see following chapter 3.3.10.
- in the case of ADR mode: desired speed and max. torque

The MR-PLD sends the following data to the FRE:

- Actual value (sensor values) like speed, temperature, pressure.....
- Feedback of operating mode

***Note: In the case of a total CAN data bus failure e.g. through lead rupture no more communication between FRE and MR-PLD is possible. In this case the MR-PLD switches to a limp-home operating mode. If only one of the two control-/data lines fails, then the communication can still be maintained via the remaining line and ground line (one wire operation). Refer to chapters 4.2.2.1. and 4.5.1.1. for further information about the engine CAN data bus (ISO 11992) and the corresponding limp home functions/performances.***

#### 3.3.5. MR-PLD <=> FRE interface functions

##### 3.3.5.1. Idle-speed control / speed control / maximum engine speed limitation

###### **Speed governor selection:**

The FRE determines the MR-PLD operating mode via the speed governor selection. Governor structures are implemented for the idle-speed control (type 15 (“LL”)) and for the operating speed control (type 0 .. type 5; type 0 is only for DC-engineering!). The MR-PLD informs the FRE about the actual operating mode via the CAN-data bus.

###### **Idle speed control/operation:**

If the FRE does not demand any operating speed control, this implies normal operation. The engine is controlled via the accelerator pedal. Idle-speed and engine limit speed are released via the idle controller or via the maximum speed limiter.

The FRE has the possibility to increase the idle-nominal value by the demand “increment idle speed”. The demand is limited through the PLD-engine limit speed. the MR-PLD transmits the actual idle speed ( $16 \text{ min}^{-1} / \text{Bit}$ ) via the CAN data bus.

###### **Operating speed control:**

If the FRE demands a valid operating speed governor and provides a plausible desired engine speed and a valid desired engine torque for the governor output limitation, it is switched over to operating speed control in the engine-ON operation.

The torque limitation of the governor is limited by the engine-basic torque. The controlled torque by the power-output limitation (corrected limit torque). The desired engine speed is limited by the actual idle speed and the actual maximum speed limitation.

###### **Maximum speed limitation:**

The FRE has the possibility to reduce the applied maximum speed limit to the MR-PLD internal idle speed, through the demand of a valid “maximum speed”.

The engine speed which has been determined in this way, is send back to the FRE as “actual cut-off speed”. Independently of the operating mode the maximum speed limitation restricts the engine speed to the actual maximum value.

#### 3.3.6. Shutoff or throttling of the engine through the FRE (vehicle electronics)

##### Engine brakes:

###### Case 1:

As far as available and configured, the decompression valve (MBR-KD) and the engine retarder flap (MBR-BK) are controlled predominantly by the FRE. The FRE informs the MR-PLD about the status. The MR-PLD has the possibility to demand the decompression valve and/or the engine retarder flap.

###### Case 2:

The mechanical booster is controlled by the MR-PLD. In this case the FRE demands the engine-braking equipment from the MR-PLD. The MR-PLD informs the FRE if the mechanical booster is switched on or available. *Note: Starting from diagnostic version 4 the mechanical loader is no longer realized!*

In both cases no fuel injection takes place in the case of an active braking equipment; the governors are deactivated.

If no braking function is active any more, the injection is still prevented for a certain period of time. Afterwards the FRE-demand torque is released via a factory preset ramp.

##### Engine stop, zero torque quantity:

If engine-stop is send to the MR-PLD via CAN, the injection is prevented.

##### Starter interlock starter actuation, zero torque quantity:

If starter interlock is send to the MR-PLD via CAN, the injection is also prevented and the starter is locked.

#### 3.3.7. Engine start and stop

There are two different types of the engine start control (starter types). A selection is made with the corresponding configuration.

- **Start via MR-PLD** (standard setting / **JE**-Starter)
- **External start** (not via MR-PLD / **KB**-Starter)

##### 3.3.7.1. Starter control (conditions)

With the corresponding configuration the engine control unit (MR-PLD) controls the engine starter via a relay. A redundant power stage is provided for this purpose (multiple protection). Four input signals (starting sources) can initiate the control of the starter:

- Terminal 50 signal, input engine control unit
- Terminal 50 signal from engine CAN
- Signal “external start” from engine CAN
- Service start button at the engine, input engine control unit

Furthermore when starting engine following voltages must be connected parallel to the MR-PLD und FRE:

- Supply voltage terminal 30
- Ignition terminal 15

Once the minimum speed of 50 rpm is reached, the injection is released by the injector valves. The maximum starter speed is different depending upon engine and temperature. When switching on the ignition terminal 15, the initialization period of the governors takes approx. 300 ms. The button for terminal 50 should not be actuated in advance. The voltage supply may drop to a minimum of during the starting procedure. *See also chapter 3.3.7.5. Starter reset bridge*

### 3.3.7.2. Starter protection

For reasons of safety the starter is locked, switched off or disengaged if:

- In the case of a switched off ignition terminal 15, the engine can not be started by the actuation of terminal 50
- The starter control disengages the starter automatically, if the maximum engine speed for the starter operation (set by the factory) is exceeded, and therefore protects the starter from overspeed damage
- The maximum starting period is limited, therefore a starting interlock takes place if the authorized period is exceeded, in order to prevent a burning-out of the starter. After a wait period (for at least one second after the starter switch off) the starting procedure can be executed once again
- A starter lockout exists, as long as the engine speed is above 50 rpm. (cranking state “engine runs”)
- The engine runs and the starter is not engaged (cranking state “engine runs”)
- The starting interlock of CAN is active
- In the case of an automatic transmission an engine start is only possible, if the FRE input “neutral position” is activated

The starter is also locked if the engine control unit (MR-PLD) Parameter is set on KB-starter. In this case the text “starter-typ KB” is displayed in the starter status. A control of the starter is still not possible, if three short circuit events have been detected at the output of the starter driver. In this case the text “starter KS” is already displayed in the starter status when the first event takes place.

For reasons of security the signal which has caused a start has to be cancelled, before a renewed start due to the same signal is possible (interlock).

### 3.3.7.3. Start by the driver

If the starter is not locked, a „start by the driver“ can be initiated via the terminal 50 signal at the input of the engine control unit (MR-PLD). A “start by the driver” has priority over all other starting signals. If the terminal 50 signal of the MR-PLD is present and the signal “terminal 50” of the CAN is not active, the error “terminal 50 inconsistent” is stored in the fault memory after one second and the start is delayed by this period (also refer to paragraph “plausibility check terminal 50”). The terminal 50 signal of the MR-PLD is ignored, if it has already been recognized as ON during the ECU run-up. This prevents an uncontrolled start e.g. due to a bridging between terminal 15- and terminal 50 lead. This does not apply to the event of the starter reset-bridge (also refer to the chapter of the same name).

### 3.3. Functional description

---

#### 3.3.7.4. CAN start

If the starter is not locked, a „CAN start“ can be initiated via the signals “terminal 50” or “external engine start” by the engine-CAN. If the signal terminal 50 from the CAN is present, and the MR-PLD does not recognize the own terminal 50 signal as ON, the error “terminal 50 inconsistent” is stored in the fault memory after one second and the start is delayed by this period (also refer to paragraph “plausibility check terminal 50”). Via the signal “external engine start” from the CAN a start can be initiated directly e.g. via the “programmable special module” (PSM).

#### 3.3.7.5. Starter reset bridge

It is possible that during the cold start, in particular in the case of the 12V-system, the engine control unit (MR-PLD) performs a reset due to the extreme voltage drop and starts once again. In order to secure an engine start in this case, a Starter reset-bridge was implemented.

If the engine start was initiated in a normal way via the terminal 50 signal and no short circuit occurred, the engine control unit stores a corresponding temporary start information. If the engine control unit now detects a “hot start” (control unit starts and detects that the backup phase has not been finished before) and moreover, the temporary start information is recognized, the auxiliary path of the starter is not locked as usual, but is released until the end of the “hot-start”. Once this is reached the starter control is then (with a still valid starting signal) switched over to the main path. The starter remains engaged, and this enables an engine start. Once the control unit-backup phase is terminated, the start information as well as the hot start characteristic are deleted. A further information, which is also only temporary available, deactivates the immobilizer in the case of the Starter reset-bridge, provided that it could have been deactivated before the starting voltage drop.

### 3.3.7.6. Starter driver

The starter driver has a multiple redundancy. The so-called main path consists of two transistors connected in series, which are powered by the battery voltage. In normal function the starter control takes place via this main path.

The so-called auxiliary path is powered via terminal 50 and can be released via terminal 50 in the case of a start, if e.g. the main path is defective. The auxiliary path is also used if the main controller of the engine control unit is defective. Due to the fact that the auxiliary path has no hardware short circuit protection, it is fundamentally used only after the activation of the main path, if furthermore there has been no signal detected via the main path.

The main controller can activate the main path (STA1 and STA2) and disable or release the auxiliary path (STA-NOT). A level measurement at the starter driver output (STA-level) and a short circuit detection (STA-short circuit detection) in the main path serve for the fault recognition.

Starter driver

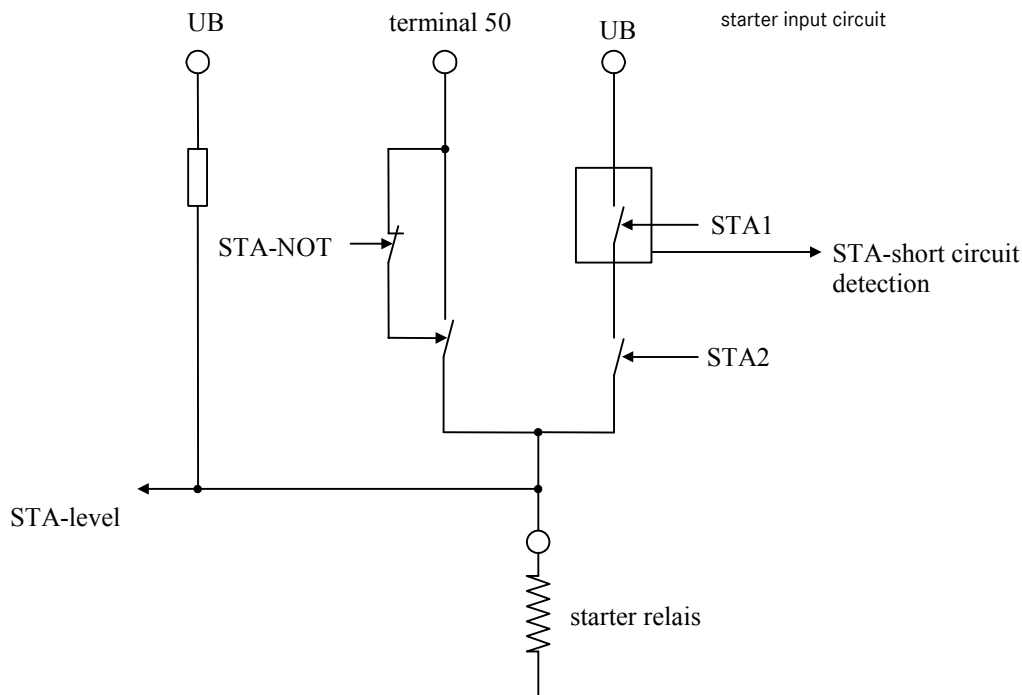

*Note: See also chapter 3.6.2. Starter control*

### 3.3. Functional description

---

#### 3.3.7.7. Start through the FRE (vehicle control electronics) via CAN

The FRE starts the engine directly via CAN, if it transmits a start demand to the MR-PLD via CAN, and the MR-PLD does receive no signal from the service start button at the engine block, or does not recognize the terminal 50 as ON. In this case the engine start is delayed for 1 second, if this is authorized (neutral position).

**Note:** *The FRE has top priority over the MR-PLD, because it is located in the protected area of the drivers cab and is therefore not exposed to external (Temperature, contamination etc.) influences.*

The starter is disengaged if one condition is met or the terminal 50 or the service start button is switched ON and OFF again.

#### 3.3.7.8. Starting procedure

In order to obtain a safe engine start with an as low as possible pollutant emission, the engine start takes place independently of the acceleration pedal position. Starting quantity and beginning of injection are determined temperature- and speed dependent from data maps. If required the starting quantity is increased. An abortion of the start after exceeding the maximum starting time is also intended (starter protection).

#### 3.3.7.9. Service start button at the engine block

If the starter is not locked (*also refer to chapter 3.3.7.2. "starter protection"*), a "button-start" can be initiated via the service start button at the engine block of the engine control unit (MR-PLD), if the ignition is switched on .



**risk of injury!**

***For reasons of safety a start via the service start button at the engine block is prevented by the vehicle electronics (FRE), if the a gear is engaged. A start via the service start button at the engine block is only possible in neutral position of the transmission and if the engine CAN is undamaged (in the CAN-backup and in the case of an operation without CAN no start is possible).***

---

If the service start button at the engine block is pressed, the MR-PLD demands an engine start via the CAN. The FRE checks the permissibility (e.g. neutral position etc.) and confirms the demand. Thereupon the MR-PLD controls the starter.

The starter is disengaged, if the service start button on the engine block is released or the starter safeguard function becomes active (chapter 3.3.7.2. "starter protection"). If the service start button at the engine block is released and the start demand from the CAN (MR-PLD => FRE) is still active, it is ignored until the take-back ("CAN-starting interlock"). Therefore a self-conservation of the starter can be prevented.

#### 3.3.7.10. Service stop button at the engine block

The engine can be shut off via the service stop button at the engine block. The FRE is informed about the shutoff of the engine (engine stop, zero torque quantity).

---

### 3.3.7.11. Engine cranking via the service start and stop button

If the engine is started via the service start button, and the service stop button is pressed simultaneously, the engine can be cranked with the aid of the starter, and no fuel injection takes place. The injection is released again, if either both buttons are released and the engine stops or the service start button at the engine block remains pressed for at least two more seconds, after the stop button has been released.

### 3.3.7.12. Rev up to maximum speed via service start button

The idle speed can be increased up to the actual maximum speed limitation via the service start button at the engine block. On the condition, that the engine has been started via the service start button, and that the button is initially released again. If the service start button at the engine block is then pressed again when the engine is running, the idle demand value increases from actual speed up to maximum engine speed.

If the button is released, the nominal engine speed immediately drops to the original idle speed. Once activated through the service start button at the engine block, the function remains active until the engine stops (engine speed= 0 rpm). If the service start button at the engine block is pressed once again, the nominal value is increased from the actual engine speed up to the actual maximum speed limitation. Therefore no dead time occurs after the actuation of the button, the operator immediately experiences a response of the engine.

### 3.3.7.13. Engine stop

The engine stop can be initiated by the following two possibilities:

- Actuation of the external stop button of the FRE: The button has to remain pressed until the engine stops. The engine starts again, as long as the engine speed is above 50 rpm . As a result the engine is not stopped by a short-time and unintentional actuation of the stop button.
- Ignition terminal 15 off (MR-PLD and FRE):  
After the deactivation of the control input terminal 15 of MR-PLD and FRE, the voltage supply terminal 30 must remain present for approx. 10 s. This enables the store off fault code memory of the fault memory. If terminal 30 is immediately disconnected, it is possible that the data in the fault memory is incorrect or not up-to-date in a subsequent diagnosis of the controllers. If the engine is started once again, a plausibility check of the controllers is carried out and data which may be faulty is corrected.

#### 3.3.8. Plausibility check terminal 50

The fault „terminal 50 inconsistent is detected, if the terminal 50 signal of the MR-PLD and the terminal 50 signal from the CAN are unequal for more than one second. The control of the starter is delayed for this period. The check is not performed:

- in the CAN backup
- if parameters are set on operation without CAN
- if parameters are set on KB-starter (no starter control via MR-PLD)
- in the case of starting interlock from CAN
- if one of the two terminal 50 signals is recognized as „ON“ within the first 500 ms after control unit reset
- if the engine has been started via the service start button at the engine block, but has not (yet) been stopped via the service stop button at the engine block

In these cases the control of the starter is not delayed, as far as authorized.

### 3.3. Functional description

---

#### 3.3.9. Calculation of injection delivery angle and start of injection

- Calculation of start of injection  
Depending on the operating mode the start of injection is calculated for the starting procedure or as a function of the nominal engine torque for the engine-ON operation.
- Begin of injection limitation  
The calculated begin of injection is limited to the current maximum authorized and a minimum authorized value.
- Calculation of injection delivery angle  
The injection delivery angle (which is ,concerning the control duration of the injector valves, a measure for the injection quantity) is calculated on the basis of the pulse-width-map as a function of the corrected nominal engine torque.. Within this angel-synchronous part of torque-control cylinder specific torque corrections are also performed (e.g. by the engine smoothness control etc.)

The actual torque of the engine is controlled via the accelerator pedal (FFG), taking account of the operating point of the engine.

In order not to overload the engine, the driver's torque demand is put through a speed-dependent power-output limitation.

Further limitations are following through the maximum speed limitation, a smoke limitation as function of the engine speed and the calculated air mass and the engine safeguards. Finally a fuel temperature- and an EOL-adjustment takes place.

The injection delivery angle, which is a measure for the injected fuel quantity, is calculated on the basis of a further data map, as a function of the engine speed and the limited torque demand from the driver.

The begin of injection is calculated as a function of the engine speed and the torque demand. Dynamic and static correction functions are implemented for the adaptation to the particular operating conditions.

### 3.3. Functional description

---

#### 3.3.10. Controls (PID governor)

Several governors are implemented for the speed control. The idle speed control is realized through a map based PID-governor. Operating speeds are compensated by further governors with PID structure, whose parameters are adjusted in the data set (can not be changed by configuration).

A characteristic line based PI-controller is also used for the maximum speed limitation.

Notes:

PID-governors are optimized governors. With fixed parameters they can only be adjusted in an optimal way to one (linearized) working point.

P: Proportionally portion: Rough compensating: Correcting variable = offset \* KP

I: Integral portion: Stationary accuracy:

Correcting variable = (offset sum/integrated) \* KI

D: Differential portion: Dynamics (all D-controllers are implemented as D-T1-controllers)

Correcting variable = rate of change of the offset \* KD

**Note: The portions of P, I, D (KP, KI, KD) dependent on the data record!**

type	feature	application
0	PID-governor 1 parameter set (fixed) engine brake can be demanded	Speed-adjustment when switching. Is required if: - exclusive DC-engineering
1	PID governor 2 parameter sets (fixed) for large signal and small signal	ADR  <i>Standard ADR-Regler</i>
2	PID governor Parameters are characteristic-led 1 set of characteristic parameters	High-dynamic applications e.g. concrete pump
3	PID governor 1 parameter set (fixed)	operating speed control 25 % more dynamic than type 1
4	corresponds to type 3	operating speed control 25% lower than type 1
5	corresponds to type 1	operating speed control 50% lower than type 1

### 3.3. Functional description

---

#### 3.3.11. Operating modes

##### 3.3.11.1. PTO speed control

The vehicle control electronics (FRE) demands the operating mode of the PTO speed control. According to the field of application, different speed governors are required.

*For further information refer to chapter 3.3.10. "Controls" or a documentation for the FRE (e.g. ADM2) or ask your responsible service station or DaimlerChrysler.*

##### 3.3.11.2. Controlled operation (normal operation)

The operating mode is called „controlled operation“, if the engine receives signals from the accelerator pedal. *See also chapter 3.3.5.*

##### 3.3.11.3. Immobilizer

The immobilizer works with so-called transponder codes, which are programmed in the vehicle key. In the case of an “active” immobilizer, contact immediately your responsible service station or DaimlerChrysler.

#### 3.3.12. Tow starting of the engine

A tow starting of the engine is possible if the ignition is active. Upon reaching the minimum speed of 50 rpm, the injection is released by the injector valves and the engine can start.

#### 3.3.13. Emergency syndrome

In the case of a defective MR-PLD control unit or with an activated immobilizer, the vehicle can still be moved with the starter. This enables a removal of the vehicle from a danger spot (e.g. railroad embankment) in the case of an emergency.

### 3.4. Mechanical description

#### 3.4.1. Mechanical layout of PLD engine electronics

The complete unit of the PLD engine electronics consists of the **PLD control unit** (MB-number dependent on version) and the fuel cooling, which are screwed together with four fastening screws.

#### 3.4.2. Complete version PLD engine electronics

Mechanical layout of the PLD control unit

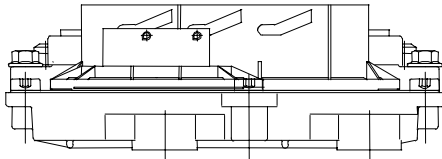

mechanical construct of PLD engine electronics

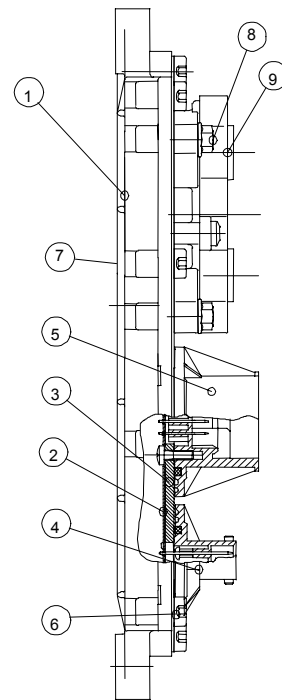
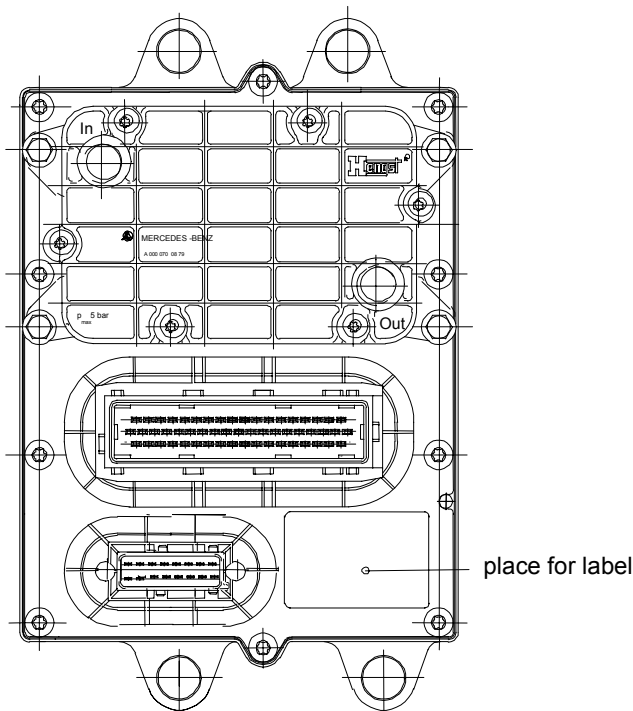

- Pos. 1: casing
- Pos. 2: printed circuit board
- Pos. 3: base plate
- Pos. 4: 16-pin socket
- Pos. 5: 55-pin socket
- Pos. 6: fastening screw
- Pos. 7: type label with bar code
- Pos. 8: fastening screw
- Pos. 9: fuel cooling

## 3.4. Mechanical description

---

### 3.4.2.1. Fuel cooling

If the PLD-delivery item **includes** a fuel cooling, it (pos. 9) is mounted by the supplier.

Specification :	The supplier/or <b>MB</b> is responsible for construction, configuration and testing of the fuel cooling
Fastening screws:	4 pieces
Screw type (Pos. 10):	M6 x 25 - 8.8
Design:	according to MBN 10 143
Tightening torque:	8 Nm $\pm$ 15 %

### 3.4.2.2. MR-PLD Control Unit

The PLD Control Unit consists of a component circuit board (pos. 2) with base plate (pos. 3) and a casing (pos. 1). The complete circuit board is screwed to the housing with 10 screws M6 x 16. The seal between housing and circuit board is achieved by means of a fluid silicon gasket.

The external electrical contact is maintained via a 16 pin and a 55 pin socket (pos. 4 and 5), which are soldered and screwed to the circuit board.

The seal between the pin socket and the base plate is achieved by means of 3-lip silicon gasket rings; between pin socket and plug connection by means of sealing elements in the pin socket or in the plug connection.

The housing has 4 eyelets to accommodate the damping elements and screw them onto the engine. To bring the pressure inside the housing into equilibrium with the ambient pressure, a pressure sensitive membrane is located on the bottom of the housing.

Next to the 16 pin socket a place of 60 mm x 40 mm is provided on the base plate for the MB-internal labeling (e.g. test number, technical control number (TÜV), etc.). The (supplier) labeling of the PLD engine electronics takes place by means of a **type label with bar code** (pos. 7) on the bottom of the housing.

**Example:** type label with bar code

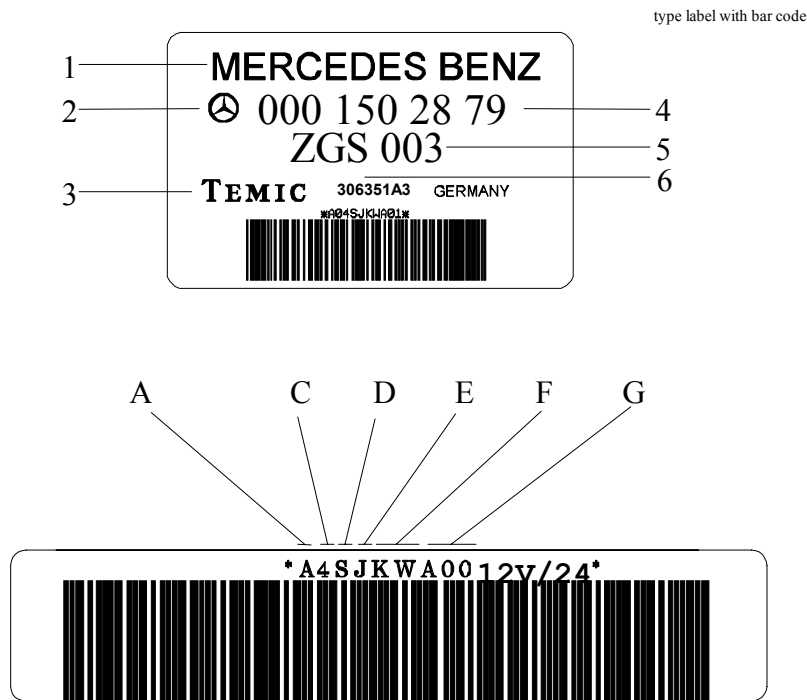

- 1: Trademark Mercedes Benz
- 2: MB star
- 3: Trademark supplier
- 4: MB reference number
- 5: MB design-geometry-status (ZGS)
- 6: Supplier identification number with parts list index

- |   |   |
|---|---|
| <ul style="list-style-type: none"> <li>A: Customer identification A-Z</li> <li>C: Supplier identification number</li> <li>D: Software status</li> <li>E: Year of manufacturing</li> <li>F: Week of manufacturing (three-digit)</li> </ul> | <ul style="list-style-type: none"> <li>A = Daimler Chrysler</li> <li>see assignment table</li> <li>T = XX</li> <li>0...9 (last number of manufacturing year)</li> <li>1. digit: letter A...Z</li> <li>2. digit: number 0...9</li> <li>3. digit: number 0...9</li> </ul> |
|---|---|

In the case of capacity transgression: inversion of digit 1 and 3

### 3.4. Mechanical description

---

#### 3.4.2.2.1. MR-PLD - version assignment table

Designation (Hardware: D21)	12 V/24 V 6/8-cylinder version with fuel cooling	12 V/24V 6/8-cylinder version without fuel cooling	12 V/24V 4-cylinder version without fuel cooling
<b>Temic identification no. with parts list index</b> Mannheim Brazil	00006351xx 00009318xx	00006395xx 00009320xx	00002607xx 00002608xx
MB part number for s/w release <b>56</b>	000 150 31 79	000 446 80 40	000 446 81 40
MB ZGS for s/w release <b>56</b>	001	001	001

#### History PLD-version chart D-Version:

HW	SW	6/8-cylinder version with fuel cooling	6/8-cylinder version without fuel cooling	4-cylinder version without fuel cooling
D0	52A	HMG 541 150 00 79 ZGS001	HMG 541 446 70 40 ZGS001	---
D1	53C	A000 150 25 79 ZGS001	A000 446 70 40 ZGS001	---
D21	53D	A000 150 28 79 ZGS001	A000 446 73 40 ZGS001	---
D21	53G	A000 150 29 79 ZGS001	A000 446 74 40 ZGS001	---
D21	56	A000 150 31 79 ZGS001	A000 446 80 40 ZGS001	---

#### 3.4.3. Technical data

Fastening:	screwed to engine block onto damping elements
Ambient temperature	-40 °C ... +125 °C (according to MBN 22 100)
Vibration load:	max. 3g at 10 Hz - 1000 Hz with damping elements
Degree of protection:	IP69k / IP67
Environment requirements	resistance to all fluids and toxic gases occurring in the engine compartment regarding function and seal
Weight:	approx. 1,5 kg

#### 3.4.4. General testing conditions

The general Mercedes Benz test regulation **MBN 22 100** of September 1992 is the basis for the test conditions. It also contains:

- Environmental tests
- Mechanical test conditions
- Electrical test conditions

### 3.5. Electrical description

#### 3.5.1. System interface diagram

The 55 pin and the 16 pin sockets are the interfaces of the system. In the following block diagram the modules are combined in main groups. The exact pin assignment lists are on the following pages.

##### 3.5.1.1. Interface diagram

###### **engine plug (55 pin)**

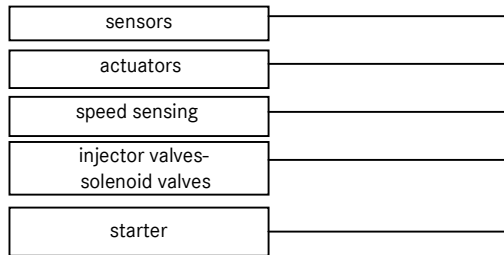

block diagram/interface diagram

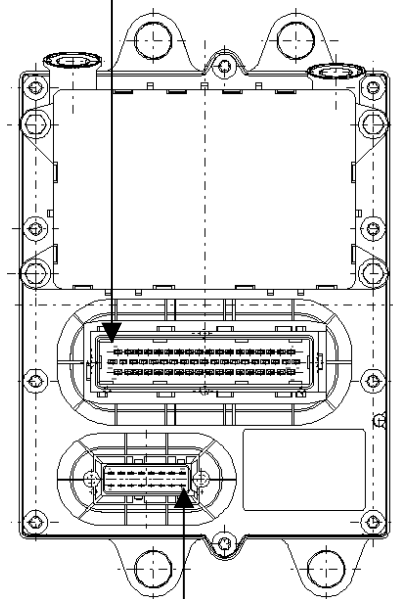

###### **vehicle plug (16 pin)**

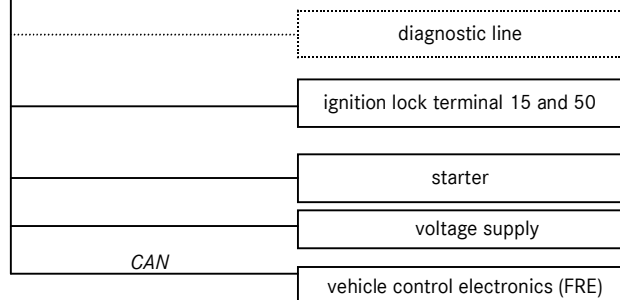

### 3.5. Electrical description

#### 3.5.1.2. Socket pin designation MR-PLD control unit (D2.1)/according to pin assignment

Socket 55 pin (engine plug)				
Pin no.	Designation or description	Type	Abbreviation	In/Out **
0	oil separator diagnosis	signal		I
1	camshaft sensor (-)	feedback		I
2	crankshaft sensor (-)	feedback		I
3	coolant temperature sensor	feedback		I
4	fuel temperature sensor	feedback		I
5	passive oil pressure-/booster-, fan speed sensor	feedback		I
6	active oil pressure sensor	supply		O
7	boost pressure sensor	supply		O
8	booster 2-speed sensor	signal		I
9	injector valves bank 2 ( B-D-F-H )	feedback		O
10	active oil pressure sensor alternative oil combination sensor, each with speed sensor	feedback		I
11	proportional valve - ground	feedback		O
12	proportional valve bank (PV 1...4)*	supply		O
13	optional fuel pressure / P3	supply		
14	scavenging gradient sensor/fan speed sensor	supply		O
15	oil temperature-/scavenging gradient sensor	feedback		I
16	injector valve bank 1( A-C-E-G )	feedback		O
17	fan speed sensor	signal		I
18	starter*	highside control		O
19	crankshaft sensor (+)	signal		I
20	camshaft sensor (+)	signal		I
21	charge-air temperature sensor	feedback		I
22	optional fuel pressure	feedback		
23	boost pressure sensor	feedback		I
24	booster 1-speed sensor	signal		I
25	service engine switch- start	signal		I
26	passive oil pressure sensor	signal		I
27	proportional valve 5	<b>highside control</b>		O

<b>Socket 55 pin (engine plug)</b>				
<b>Pin no.</b>	<b>Designation or description</b>	<b>Type</b>	<b>Abbreviation</b>	<b>In/Out **</b>
28	optional fuel pressure	signal		
29	boost pressure sensor	signal		I
30	service engine switch (start/stop)	supply		O
31	optional scavenging gradient (P2S-P3)	signal		I
32	active oil pressure sensor	signal		I
33	oil level sensor	signal		I
34	coolant-temperature sensor	signal		I
35	service engine switch- stop	signal		I
36	fuel temperature sensor	signal		I
37	injector- /solenoid valve H ( Bank 2 )	highside control		O
38	injector- /solenoid valve F ( Bank 2 )	highside control		O
39	oil temperature sensor	signal		
40	proportional valve 6	lowside control		O
41	proportional valve 3*	lowside control		O
42	proportional valve 6	supply		O
43	proportional valve 4*	lowside control		O
44	injector- /solenoid valve D ( Bank 2 )	highside control		O
45	injector- /solenoid valve B ( Bank 2 )	highside control		O
46	injector- /solenoid valve G ( Bank 1 )	highside control		O
47	injector- /solenoid valve E ( Bank 1 )	highside control		O
48	charge-air temperature sensor	signal		I
49	oil level sensor	feedback		I
50	proportional valve 2	lowside control		O
51	proportional valve 1	lowside control		O
52	proportional valve 2	supply		
53	injector- /solenoid valve C ( Bank 1 )	highside control		O

### 3.5. Electrical description

Socket 55 pin (engine plug)				
Pin no.	Designation or description	Type	Abbreviation	In/Out **
54	injector- /solenoid valve A ( Bank 1 )	highside control		0

\*: signal also on vehicle plug

\*\* : In = input/Out = output

Socket 16 pin (vehicle plug)				
Pin no.	Designation or description	Type	Abbreviation	In/Out **
1	CAN interface	high line	CAN-H	I/O
2	CAN interface	low line	CAN-L	I/O
3	CAN-HF	ground	HF-GND	
4	CAN-HF	ground	HF-GND	
5	battery voltage	battery plus	KL30	
6	battery voltage	battery plus	KL30	
7	NC	-		
8	terminal 50 (start)	signal	KL50	I
9	ground	battery minus	KL31	
10	proportional valve bank (PV1...4)*	supply		0
11	ground	battery minus	KL31	
12	starter*	highside control		0
13	diagnosis via diagnostic line (ISO)	signal		I/O
14	proportional valve 3*	lowside control	PV3	0
15	terminal 15	ignition	KL15	I
16	proportional valve 4*	lowside control	PV4	0

\*: signal also on vehicle plug

\*\* : In = input/Out = output

NC: not connected

## 3.5.1.3. Pin assignment of MR-PLD control unit (D2.1); function oriented/alphabetical

<b>Socket 55 pin (engine plug)</b>				
<b>Pin no.</b>	<b>Designation or description</b>	<b>Type</b>	<b>Abbreviation</b>	<b>In/Out **</b>
<b>Sensors/Activ</b>				
6	active oil pressure sensor	supply		O
32	active oil pressure sensor	signal		I
10	active oil pressure sensor alternative oil combination sensor, each with speed sensor	feedback		I
<b>Sensors/Passive</b>				
26	passive oil pressure sensor	signal		I
5	passive oil pressure-/booster-, fan speed sensor	feedback		I
<b>Sensors</b>				
13	optional fuel pressure / P3	supply		
28	optional fuel pressure	signal		
22	optional fuel pressure	feedback		
34	coolant-temperature sensor	signal		I
3	coolant temperature sensor	feedback		I
19	crankshaft sensor (+)	signal		I
2	crankshaft sensor (-)	feedback		I
36	fuel temperature sensor	signal		I
4	fuel temperature sensor	feedback		I
7	boost pressure sensor	supply		O
29	boost pressure sensor	signal		I
23	boost pressure sensor	feedback		I
48	charge-air temperature sensor	signal		I
21	charge-air temperature sensor	feedback		I
24	booster 1-speed sensor	signal		I
8	booster 2-speed sensor	signal		I
17	fan speed sensor	signal		I
20	camshaft sensor (+)	signal		I
1	camshaft sensor (-)	feedback		I
0	oil separator diagnosis	signal		I
33	oil level sensor	signal		I

### 3.5. Electrical description

<b>Socket 55 pin (engine plug)</b>				
<b>Pin no.</b>	<b>Designation or description</b>	<b>Type</b>	<b>Abbreviation</b>	<b>In/Out **</b>
49	oil level sensor	feedback		I
39	oil temperature sensor	signal		
15	oil temperature-/scavenging gradient sensor	feedback		I
31	optional scavenging gradient (P2S-P3)	signal		I
14	scavenging gradient sensor/fan speed sensor	supply		O
<b>Actuators/Control</b>				
18	starter*	highside control		O
30	service engine switch (start/stop)	supply		O
25	service engine switch- start	signal		I
35	service engine switch- stop	signal		I
11	proportional valve - ground	feedback		O
12	proportional valve bank (PV 1..4)*	supply		O
52	proportional valve 2	supply		
42	proportional valve 6	supply		O
51	proportional valve 1	lowside control		O
50	proportional valve 2	lowside control		O
41	proportional valve 3*	lowside control		O
43	proportional valve 4*	lowside control		O
27	proportional valve 5	<b><u>highside control</u></b>		O
40	proportional valve 6	lowside control		O
16	injector valve bank 1( A-C-E-G )	feedback		O
9	injector valves bank 2 ( B-D-F-H )	feedback		O
54	injector- /solenoid valve A ( Bank 1 )	highside control		O
45	injector- /solenoid valve B ( Bank 2 )	highside control		O
53	injector- /solenoid valve C ( Bank 1 )	highside control		O

Socket 55 pin (engine plug)				
Pin no.	Designation or description	Type	Abbreviation	In/Out **
44	injector- /solenoid valve D ( Bank 2 )	highside control		0
47	injector- /solenoid valve E ( Bank 1 )	highside control		0
38	injector- /solenoid valve F ( Bank 2 )	highside control		0
46	injector- /solenoid valve G ( Bank 1 )	highside control		0
37	injector- /solenoid valve H ( Bank 2 )	highside control		0

\*: signal also on vehicle plug

\*\* : In = input/Out = output

Socket 16 pin (vehicle plug)				
Pin no.	Designation or description	Type	Abbreviation	In/Out **
12	starter*	highside control		0
5	battery voltage	battery plus	KL30	
6	battery voltage	battery plus	KL30	
1	CAN interface	high line	CAN-H	I/O
2	CAN interface	low line	CAN-L	I/O
3	CAN-HF	ground	HF-GND	
4	CAN-HF	ground	HF-GND	
13	diagnosis via diagnostic line (ISO)	signal		I/O
15	terminal 15	ignition	KL15	I
8	terminal 50 (start)	signal	KL50	I
9	ground	battery minus	KL31	
11	ground	battery minus	KL31	
7	NC	-		
10	proportional valve bank (PV1...4)*	supply		0
14	proportional valve 3*	lowside control	PV3	0
16	proportional valve 4*	lowside control	PV4	0

\*: signal also on vehicle plug

\*\* : In = input/Out = output

NC: not connected

## 3.5.1.4. Voltage supply of control unit MR-PLD (D2.1)

<b>1. Voltage versions</b>	<b>24 V</b>	<b>12 V</b>
<b>2. Supply voltage</b>		
Nominal voltage	22 V £ U £ 30 V	11 V £ U £ 16 V
Low voltage	8 £ U < 22 V limited operating range (see MBN 22 100)	6,5 V £ U < 11 V limited operating range (see MBN 22 100)
Overload switch-off	U > 33 V	U > 33 V
<b>3. Polarity/overload protection</b>		
Polarity protection	continuous polarity of terminals 30 and 31 without damage of system constants	continuous polarity of terminals 30, 31 and 15 without damage of system constants
Overload resistance	58 V (see MBN 22 100)	58 V (see MBN 22 100)
Overload resistance	100 V (see SAE J1455)	100 V (see SAE J1455)
<b>4. Current consumption</b>		
Peak power consumption (without solenoid drivers)	32 A, cyclic, depending on engine rpm and series	32 A, cyclic, depending on engine rpm and series
Stand-by voltage supply: terminal 15 off and after completion backup phase	I < 1 mA	I < 1 mA
<b>6. Short circuit recognition thresholds</b>		
ground short	20 A	20 A
Starter to ground	2,5 A	2,5 A
solenoid valve to return line	32 A	32 A
Proportional valve supply to ground	14 A	14 A
Proportional valve to ground	2 A	2 A

### 3.5.3. Sensor system of the PLD engine control unit (MR-PLD)

#### 3.5.3.1. Control unit internal sensors

For the evaluation of the ambient-air pressure there is a pressure sensor located at the control unit. The characteristic curves for the calculation of the atmospheric pressure can not be applied.

#### 3.5.3.2. Control unit external sensors

The calculation variables (characteristic curves, data map, fault-thresholds etc.) can be applied via the data set.

#### 3.5.3.3. Active sensors

##### Sensor input requirements for active sensors:

Active sensors with an operating voltage of 5 Volt are used. These sensor inputs are capable of pulling a current against its 5 V supply by means of a Pull-Up resistor. The sensors may use up to a 20 mA current of the voltage supply. The sensors have a dual power supply laid out to accommodate connection of up to four sensors each (total current load is a maximum of 80 mA).

Voltage limitation is set for currents greater than 80 mA and the short circuit current is at approx. 10 mA due to the characteristic line of the voltage limitation feedback. Therefore the sensor inputs are short-circuit proof.

Principle block diagram of sensor inputs (active sensors)

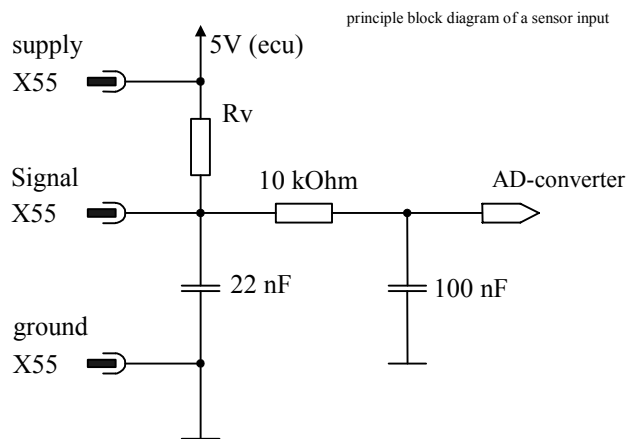

The output voltage range (0.5...4.5 V) of the applied sensors assures the diagnosis capability against line interruption and body contact.

The following specifications refer to the sensor input interface.

Sensor data:

Measured variable	Boost pressure	Active pressure	oil	Fuel pressure	scavenging gradient
$R_v$ in k $\Omega$	10	3		10	10

### 3.5. Electrical description

---

#### 3.5.3.4. Passive sensors

##### Requirements:

The passive sensors applied are temperature sensors on the basis of Negative Temperature Coefficient (NTC) resistance and a pressure sensor (oil) on the basis of a pressure dependent wire resistance. The voltage drop on the sensor resistor, supplied with current by means of a Pull Up Resistor, is used in the evaluation. These inputs are short circuit proof and have diagnostic capability as do the active inputs. The following Pull Up Resistors are integrated in the sensor input circuit.

Principle block diagram of sensor inputs (passive sensors):

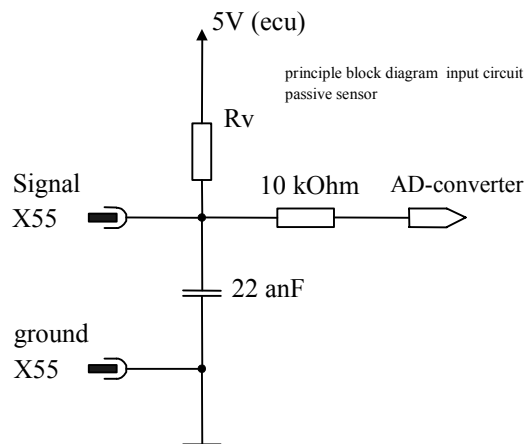

#### 3.5.3.5. Temperature sensors

The following indications are in reference to the sensor input circuit.

Temperature sensor	$R_v$ in $k\Omega$	Deviation in %
Oil temperature sensor	1	1
Coolant temperature sensor	1	1
Charge-air temperature sensor	2,2	5
Fuel temperature sensor	2,2	5

### 3.5.3.6. Passive oil pressure

The Pull Up Resistance of the sensor input circuit for the passive oil pressure is 390  $\Omega$ .

Principle block diagram of a sensor input: passive oil pressure

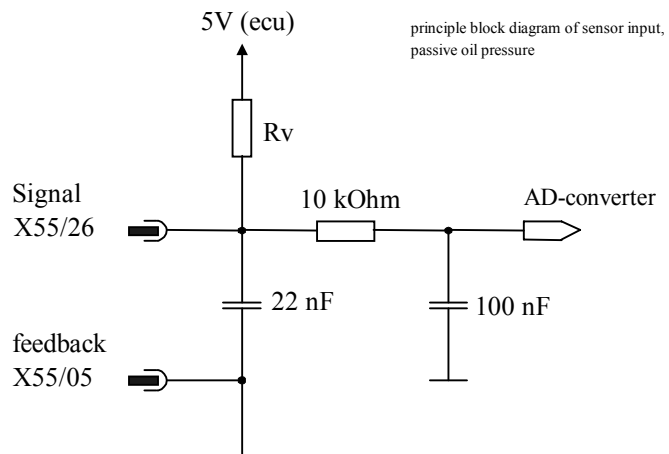

### 3.5. Electrical description

---

#### 3.5.3.7. Oil level

The oil level sensor consists of a hot wire, whose measured resistance is temperature dependent. During the measurement the sensor is heated up for 0.6 sec with 200 mA direct current. The change in voltage is measured on the sensor during the switch-on duration. The value of the change in voltage is a correlation to the oil level. The measurement is repeated every 6 s.

Principle block diagram of an oil level sensor

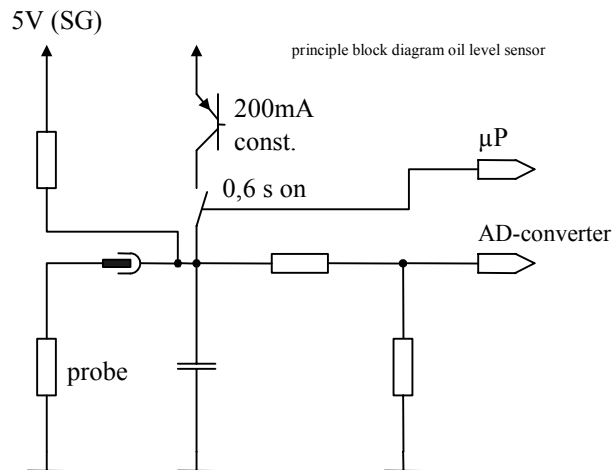

The oil level sensor must suffice to meet the following requirements:

heating current: 200 mA (direct current)

resistance: 22,3 Ω \*

resistance after 0.6 s under current

- at oil level 100%: 23,0 Ω \*

- at oil level 0 %: 28,4 Ω \*

\* at room temperature

The deviation of the constant-current source in the control unit is at < 5%.

### 3.5.3.8. Camshaft / crankshaft position (inductive)

For the computation and evaluation of the actual crankshaft angle and engine rpm, one inductive sensor each is used to generate the **camshaft and crankshaft** signals with the following data:

Specification number: TB speed sensor      011 542 26 17

MB part number:                                    000 153 82 20

Internal resistance:                               $R_i = 1280 \Omega$

Inductive sensor data:

L in mH	R in $\Omega$
630 $\pm 15\%$	1000.....1385

The direct current resistance of the sensors must be within the specified tolerance, to maintain interference suppression and avoid functional errors concerning the diagnostic function. A deviation of the specified inductivity causes uncertainty in position recognition, which is passed on to the begin of injection.

**In the case of an application of other types, you should come to an agreement with the supplier.**

### 3.5.3.9. Booster speed 1 / 2

For the sensing and the evaluation of the booster speed, an inductive input signal is converted into a digital signal.

Minimum input voltage:                        2,2 V

Minimum input speed:                         15000 rpm

Maximum input speed:                        150 000 rpm

Circuit: evaluation booster speed

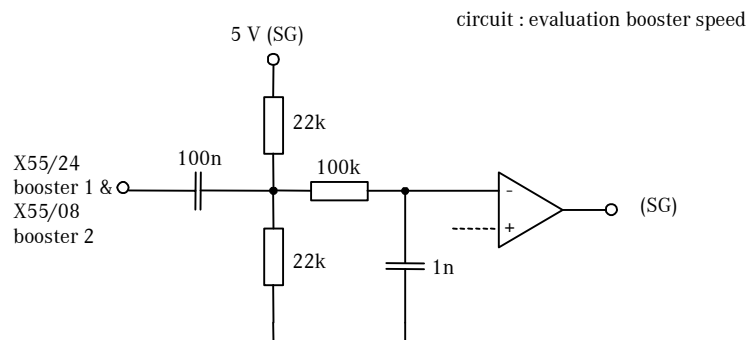

### 3.5. Electrical description

---

#### 3.5.3.10. Fan speed

The fan speed evaluation is realized via a digital input with external ground tipping (e.g. open collector).

Minimum speed: 125 rpm  
Maximum speed: 5000 rpm  
Max. Low-voltage: 0,9 V

Circuit: fan speed evaluation

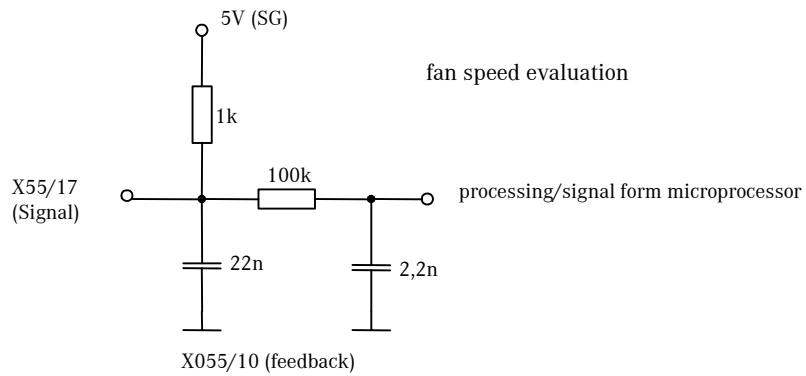

### 3.5.4. Digital inputs

The engine control unit PLD possesses the following digital inputs: terminal 15, terminal 50, oil separator and engine start/stop.

#### 3.5.4.1. Terminal 15

The engine control unit is woken up and starts through the connection of the terminal 15 voltage (terminal 15 ON).

The switching thresholds for a secure detection of the terminal 15-voltage at plug pin 15 of the 16 pin engine plug are:

Terminal 15 ON	Terminal 15 OFF
$> 2/3 U_B$	$< 1/3 U_B$

#### 3.5.4.2. Terminal 50

On account of terminal 50 ON, the starting position of the ignition lock and the transponder code are read in for the immobilizer. The injection is only released with a valid transponder code. The control unit starts due to the terminal 50 signal, if this has not already happened via terminal 15.

##### Example:

- If an open circuit fault exists at terminal 15, the control unit is woken up via terminal 50 ON.

The switching thresholds for a safe detection of the terminal 50 voltage at plug pin 8 of the 16 pin engine plug are:

Terminal 50 ON	Terminal 50 OFF
$> 6,6 V$	$< 2,6 V$

The switching threshold to wake up the control unit via terminal 50 is 9V.

### 3.5. Electrical description

#### 3.5.4.3. Service button start/stop

The service buttons are supplied by the electronic control unit with a tension of 5 V. As trigger levels are considered:

There are two digital inputs (circuit proof against ground), which enable the functions **service button start** and **stop** if the driver's cab is raised. An engine start via the service button at the engine block is only possible in connection with the vehicle control electronics (FRE) and therefore only in the vehicle. The buttons are supplied with a voltage of 5 V by the control unit.

Button	ON	Button	OFF
> 1,8 V		< 1,5 V	

#### Hardware description

The power supply of the pushed button is approx. 10 mA. The button inputs are also short circuit proof against ground and insensitive to contaminating resistance parallel to the buttons. The contaminating resistance can accept values down to 10 k $\Omega$ . If the value falls below 10 k $\Omega$ , the MR-PLD recognizes an open switch as a closed switch (in the case of extreme high degree of contamination/humidity etc.).

Principle block diagram service button start and stop

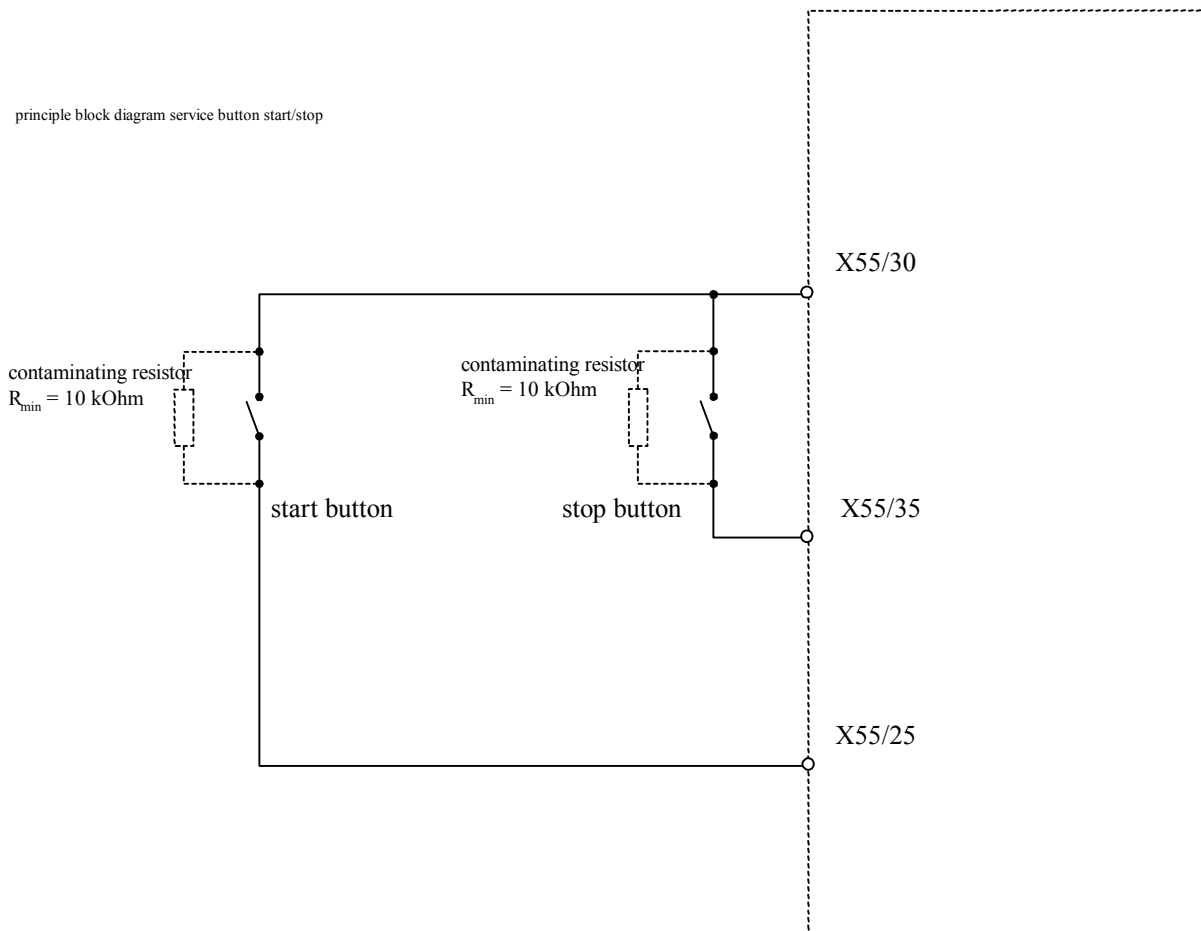

#### 3.5.4.4. Oil separator

The control unit provides an input for the diagnosis of the oil separator. A short circuit of the oil separator is detected. The input circuit is supplied with a voltage of 5 V by the control unit. The switching thresholds are:

U ON	U OFF
> 3,5 V	< 1 V

#### 3.5.5. Proportional valve control

The PLD control unit provides 6 power stages for the proportional valve control. It serves for the control of external setting and switching elements:

Prop. 1:	Engine retarder flap (BK)
Prop. 2:	Decompression valve
Prop. 3:	Fan 1
Prop. 4:	Fan 2
Prop. 5:	-
Prop. 6:	-

Note:

*All proportional valve outputs are designed as multi-functional outputs i.e. the output function can be determined by the configuration. The outputs of the control unit can be pulse width modulated (PWM) or as switch-outputs (b/w) configured. As a result it is not only possible to connect standard proportional valves, but there is for example also the option to control an electro pneumatic converter (EPW).*

**Safety function:**

If a switch is defective\* no valve may be continuously under current – therefore a series connection of 2 switches does exist.

The nominal voltage of a power stage over the entire temperature range is:  $I_{MAX} = 2$  A. The outputs are combined in two groups, in proportional valve bank 1 (PVB1) and proportional valve bank 2 (PVB2).

**Proportional valve bank 1:**

The proportional valves 1,2,3 and 4 are combined in one valve bank (PVB1). The valve bank is supplied with battery voltage via a common circuit. This circuit contains a short circuit- and a level detection. The control of the proportional valves is performed „Lowside“ (low side switch) individually for each valve. The valve bank is switched on if at least one of the proportional valves of this bank is configured.

On account of the compatibility with the C-control unit, the supply voltage is available at X55/12 as well as at X55/52. The difference between the D- and C-control unit is, that the pin assignment for supply and feed-back is reverse. Over X55/11 (PVB2) ground can be referred by the electronic control unit.

The fan functions (PV3 and PV4) are available at the engine plug (55 pin) as well as at the vehicle plug (16 pin).

**Proportional valve bank 2:**

The proportional valves 5 and 6 are combined in one valve bank (PVB2).

The valve bank is also supplied with battery voltage via a common circuit, which also contains a short circuit- and a level detection. The valve bank is switched on if at least one of the proportional valves of this bank is configured.

PV 5 is designed as a Highside switch, the accompanying technical achievement ground lies close X55/11.

PV 6 is designed as a Lowside switch, the provided supply voltage lies close X55/42.

\* through-alloy: ... by fusion developed continuous contact!

## 3.5.5.1. Functional assignment of proportional valves/hardware status D2.1

Output	Function	Current	Feature	Output/pin assignment	Input/pin assignment
PV1	alternative	< 2 A	PWM 120 Hz	lowside control at X55/51 (ground)	* U <sub>SG</sub> -Bank 1: X55/12
	engine retarder flap		digital output		
PV2	alternative	< 2 A	PWM 120 Hz	lowside control at X55/50 (ground)	U <sub>SG</sub> -Bank 1: X55/52
	decompression valve		digital output		
PV3	fan 1	< 2 A	PWM 5...200 Hz	lowside control at X55/41 (ground)	* U <sub>SG</sub> -Bank 1: X55/12
	alternative		digital output		
PV4	fan 2	< 2 A	PWM 5...200 Hz	lowside control at X55/43 (ground)	* U <sub>SG</sub> -Bank 1: X55/12
	alternative		digital output		
PV5	alternative	< 2 A	digital output	** ground: X55/11	highside control at X55/27 (U <sub>SG</sub> -Bank 2)
	alternative				
PV6	alternative	< 2 A	PWM 120 Hz	lowside control at X55/40 via ground: X55/11	U <sub>SG</sub> -Bank2: X55/42
	engine retarder flap		digital output		

\*: Lines in the wiring harness splitted in two banks, together over a plug pin to the electronic control unit

\*\* : Ground, not switched

### 3.5. Electrical description

#### 3.5.5.2. Principle block diagram proportional valve control /hardware status D2.1

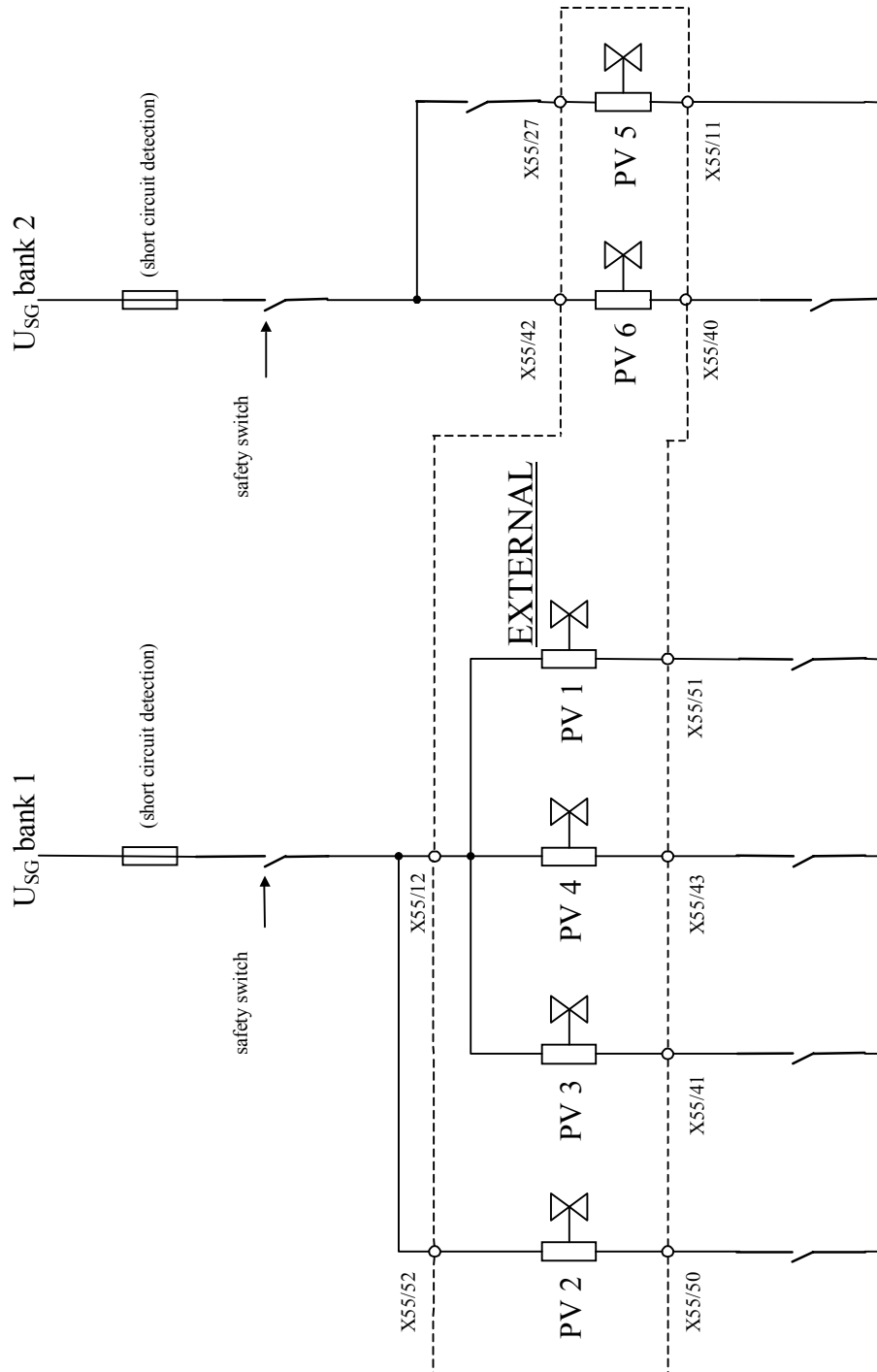

## 3.5.5.3. Functional assignment of the proportional valves/hardware status C3..C6

Output	Function	Current	Feature	Output / pin assignment	Input / pin assignment
PV1	alternative	< 2 A	PWM 120 Hz	* ground : X55/12	highside control at X55/51 (U <sub>SG</sub> -Bank)
	engine retarder flap		digital output		
PV2	alternative	< 2 A	PWM 120 Hz	** ground: X55/52; X55/12	highside control at X55/50 (U <sub>SG</sub> -Bank)
	decompression valve		digital output		
PV3	fan 1	< 2 A	PWM 5...200 Hz	* ground: X55/12	highside control at X55/41 (U <sub>SG</sub> -Bank)
	alternative		digital output		
PV4	fan 2	< 2 A	PWM 5...200 Hz	* ground: X55/12	highside control at X55/43 (U <sub>SG</sub> -Bank)
	alternative		digital output		

\*: Lines in the wiring harness splitted in two banks, together over a plug pin to the electronic control unit

\*\* : Ground X55/52 and X55/12 (ECU-intern bridged)

3.5.5.4. Principle block diagram proportional valve control/hardware status C3..C6

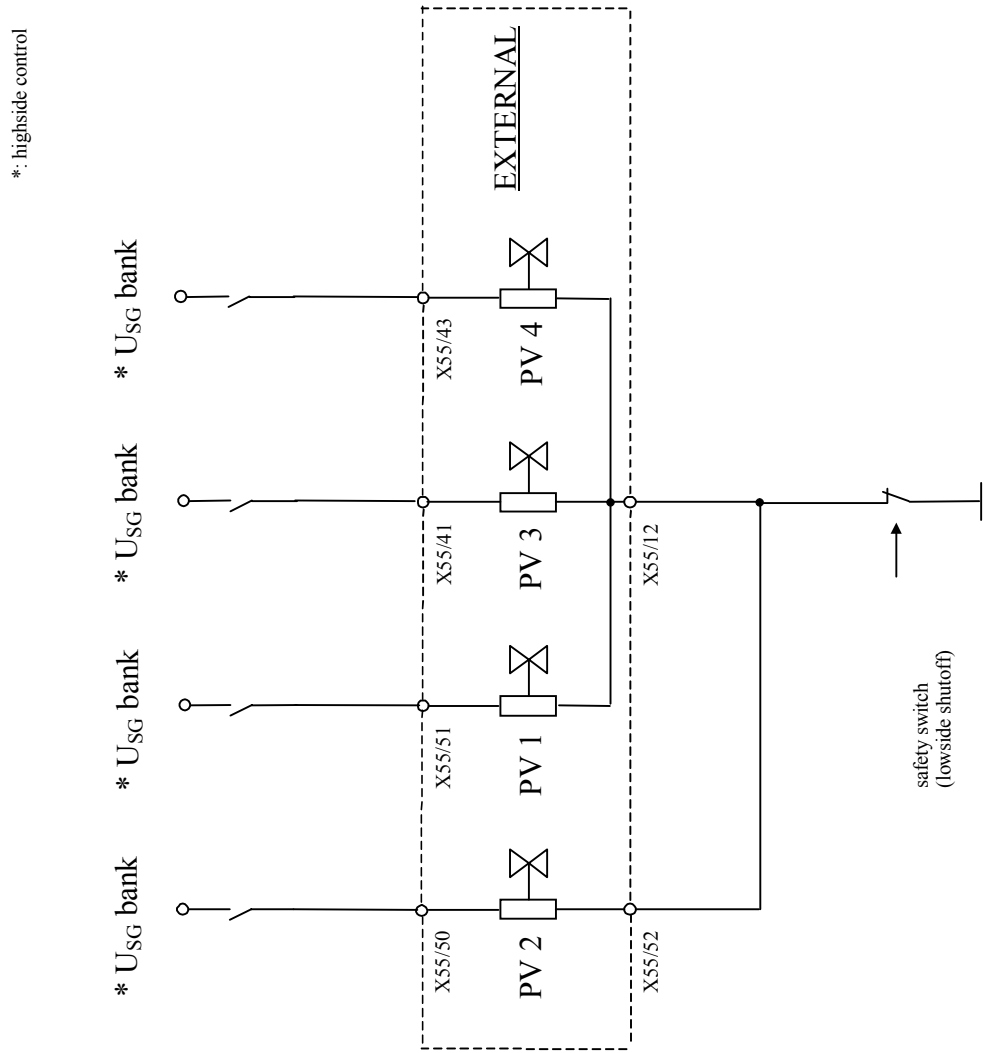

### 3.5.6. Starter control through the MR-PLD

The starter control is performed via a JE-relay (starter solenoid relay mounted to the starter), which is controlled by the starter driver of the MR-PLD control unit.

The starter driver is split into two driver circuits connected in parallel, the main path and the auxiliary path, and is constantly monitored if an open circuit fault or a short circuit is present.

#### 3.5.6.1. Main path (self-locking)

The main path is powered by battery voltage and consists of two semiconductor switches connected in series, each of them has an own power stage circuit. This ensures that the starter can not be controlled unintentionally in the case of a defective \* semiconductor switch.

The main path has also a short circuit detection in series with the two “safety switches”, which cause a signal if a short circuit exists. In this case the main- and the auxiliary path are locked.

#### 3.5.6.2. Auxiliary path (self conducting)

The auxiliary path is powered by terminal 50 and is switched off by the processor via a semiconductor switch if the control unit is faultless. In the case of a control unit failure the starter is controlled via the auxiliary path with “term. 50 ON” (emergency syndrome).

#### **Summary of starter control for main path (A) and auxiliary path (B):**

- A In normal state, the starter is switched off by the control unit, with terminal 50 connected. The control is performed via the main path ( $U_B$ /term. 15).
- B If a control unit failure exists, the starter can be actuated via terminal 50, in order to remove the vehicle e.g. from the railroad embarkment (control via auxiliary path).

*See also chapter 3.5.6.4. safety considerations starter in dependance of terminal 15 and terminal 50 for C- and D-control unit.*

#### **Data:**

Maximum valve current:  $I_{\max} = 2 \text{ A}$

Voltage drop power stage  $U_{\text{End}} = 2 \text{ V}$

\* through-alloy: ... by fusion developed continuous contact

### 3.5. Electrical description

#### 3.5.6.3. Principle block diagram starter control

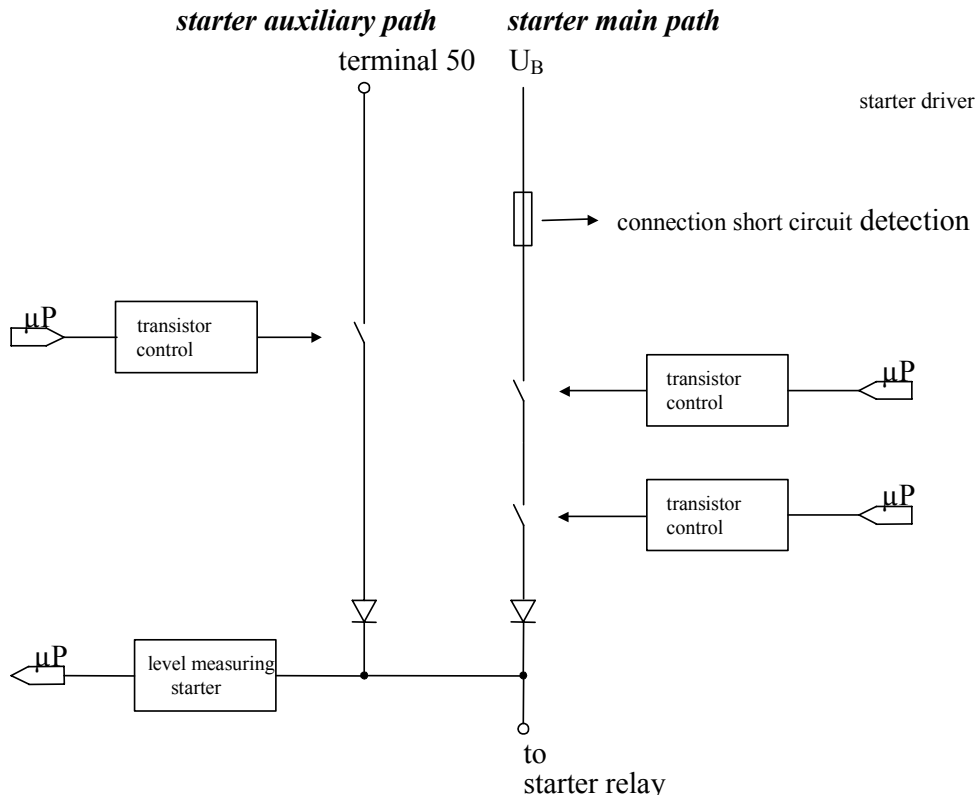

#### 3.5.6.4. Starter relay

The demands on the **starter relay** concerning the internal resistance and inductivity are defined as follows:

if  $R$  the relay internal resistance is at 25°C in ohm  
 and  $L$  the relay inductivity is at 25°C in Henry

then the following applies to the 24V operating-voltage version:

$$\frac{R}{\sqrt{L}} \geq 45 \frac{\sqrt{V}}{\sqrt{As}} \quad \text{or} \quad L \leq \left( \frac{R}{45 \frac{\sqrt{V}}{\sqrt{As}}} \right)^2$$

e.g. with  $R = 30 \Omega$  it turns out to be  $L < 440 \text{ mH}$   
 with  $R = 12 \Omega$  it turns out to be  $L < 70 \text{ mH}$

and for the 12V operating-voltage version:

$$\frac{R}{\sqrt{L}} \geq 22,6 \frac{\sqrt{V}}{\sqrt{As}} \quad \text{or} \quad L \leq \left( \frac{R}{22,6 \frac{\sqrt{V}}{\sqrt{As}}} \right)^2$$

e.g. with  $R = 15 \Omega$  it turns out to be  $L < 440 \text{ mH}$   
 with  $R = 6 \Omega$  it turns out to be  $L < 70 \text{ mH}$

## 3.5.6.5. Principle block diagram of safety concept of JE-starter

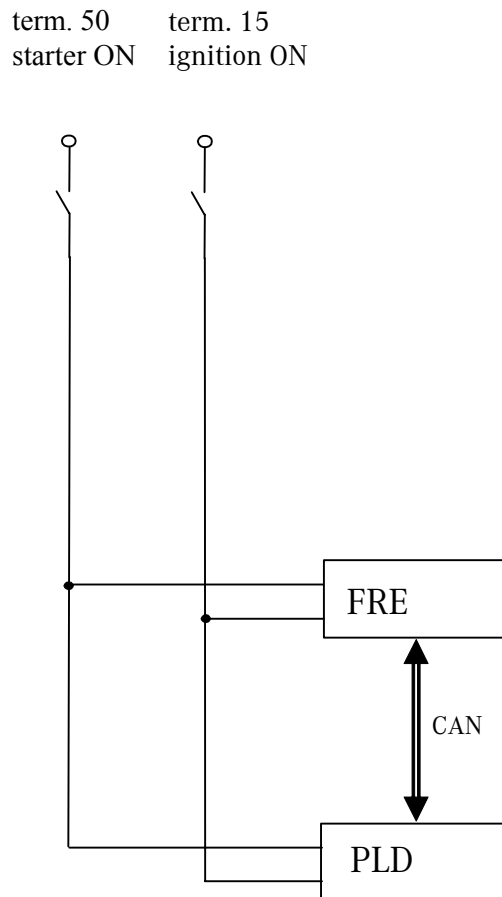
**Explanation:**

The MR-PLD receives the signals „term. 15“and „term. 50“ simultaneously via the engine CAN and directly via the ignition lock. This redundancy makes it possible that e.g. in the case of an CAN-bus failure the vehicle can nevertheless be started via terminal 50 (directly/ignition lock) and can be driven to the next service station (workshop) with an engine speed (ca. 1300 rpm) pre-determined by the main processor (MR-PLD). *See also chapter backup 4.5. and charts above.*

3.5.7. Serial communication interfaces

3.5.7.1. CAN data bus (2-wire-interface, standard: ISO 11992)

The communication takes place via a 2-wire interface (one wire capability) according to ISO 11992. During initialization the operating mode of the physical interface is set up for **two wire** operation.

The communication between MR-PLD and FRE takes place via this CAN Bus. The interface is laid out for signal levels of  $1/3 U_B$  bzw.  $2/3 U_B$  and is operated with 125 kbit/s.

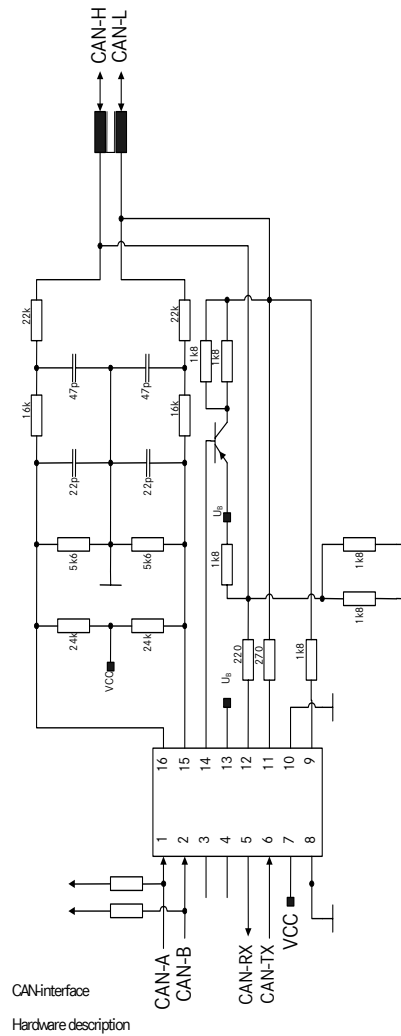

Using the signals CAN-A and CAN-B the interface can be addressed in the following operating conditions:

ASEL	BSEL	Status	Remark
0	0	mute	no function
0	1	one wire CAN-L	limp-home operating mode
1	0	one wire CAN-H	limp-home operating mode
1	1	two wire	normal operation

### 3.5.7.2. Diagnostic line (standard: ISO 9141)

The diagnostic-line is provided for the diagnosis and the data set update. Immediately after the terminal 15 has been switched on, the MR-PLD sends a “Free Running Protocol” via the diagnostic line, so that the “diagnosis information” can be received with suitable diagnosis units (see chapter 4.2.1 diagnostic line).

### 3.5.7.3. Classification of the injector valves

Notes:

## 3.6. Configuration possibilities of the MR-PLD

### 3.6.1. Fan type

#### 3.6.1.1. General connection

Depending on the field of application the connections are mounted on the *engine plug* of the MR-PLD or at the *vehicle plug* of the MR-PLD. For the corresponding parameters refer to chapter 5 parameter list (minidiag2).

**CAUTION:** *The polarity of the control unit outputs of the solenoid drivers change from the C-version to the D2.1-version. There will be a short circuit concerning the additionally connected recovery diodes, if the corresponding polarity of the particular (external) component has not been adjusted!*

#### 3.6.1.2. Pin assignment of the proportional valve-power stages (PV/Prop) for fan control

**Note:**

*The circuits of fan type 0 and 1 are identical. In the case of type 0 all parameters are permanently applied (not adjustable) in the data set and in the case of type 1 particular parameters (fan switch-on thresholds) can be calibrated (EEPROM) via diagnosis units (e.g. minidiag2/Stardiagnose).*

##### 3.6.1.2.1. Type 0/Linning-clutch (on highway/two-stage)

- ECU/D-version: Connection possible via engine- and vehicle plug
- ECU/C-version: Connection only via engine plug
- Connection to PV3 and PV4 (see block diagrams/chart on the following page)

##### 3.6.1.2.2. Type 1/Linning-clutch (off highway/two-stage)

- ECU/D-version: Connection possible via engine- and vehicle plug
- ECU/C-version: Connection only via engine plug
- Connection to PV3 and PV4 (see block diagram/chart on the following page)

##### 3.6.1.2.2.1. Configuration / fan switch-on threshold (type 1)

Parameter	Unit	Range	Resolution	Remark
switch-on threshold charge-air temperature	[°C]	0...150	1.0	stage 1, EEPROM-value configurable
switch-on threshold coolant temperature	[°C]	0...150	1.0	stage 1, EEPROM-value configurable
switch-on threshold charge-air temperature	[°C]	0...150	1.0	stage 2, EEPROM-value configurable
switch-on threshold coolant temperature	[°C]	0...150	1.0	stage 2, EEPROM-value configurable
Delta T charge air according to emission legislation	[°C] [K]	0...150 273...423	1.0	stage 1 & 2, EEPROM-value configurable

### 3.6. Configuration possibilities of the MR-PLD

#### Control unit/C-version:

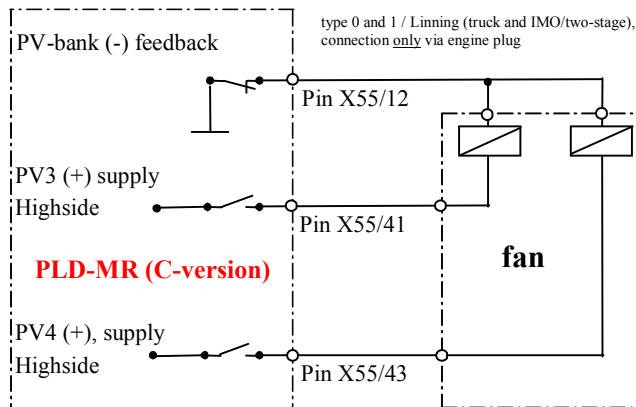

C-version		
Pin X55/12 ground	Pin X55/41 Highside/PV3 (positive voltage controlled)	Pin X55/43 Highside/PV4 (positive voltage controlled)
D-version		
Pin X55/12 or X16/10 supply/ $U_B$	Pin X55/41 or X16/14 Lowside/PV3 (ground controlled)	Pin X55/43 or X16/16 Lowside/PV4 (ground controlled)

#### Control unit/D-version

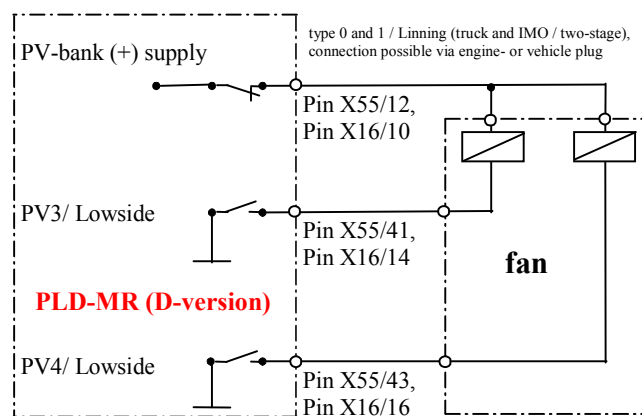

3.6.1.2.3. Type 2 / electrically controlled Viscous-fan

- Connection possible via engine plug
- Connection to PV3, fan + speed sensor (see block diagram/chart)

**Control unit /D-version**

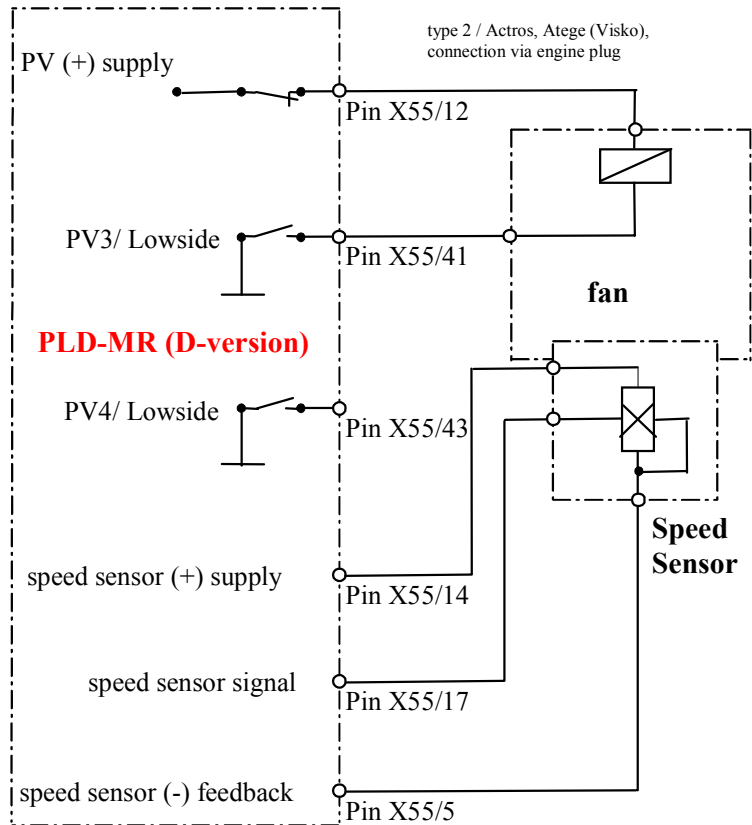

D-version				
Pin X55/12 supply/ $U_B$	Pin X55/41 (PV3) Lowside (ground controlled)	Pin X55/5 speed sensor / feedback	Pin X55/14 speed sensor/ supply, $U_B$	Pin X55/17 speed sensor / signal

### 3.6. Configuration possibilities of the MR-PLD

#### 3.6.1.2.4. Type 3 /Hydrostatic Fan

- Connection possible via engine- and vehicle plug
- Connection to PV3 (see block diagram/chart)

#### Control unit/C-version

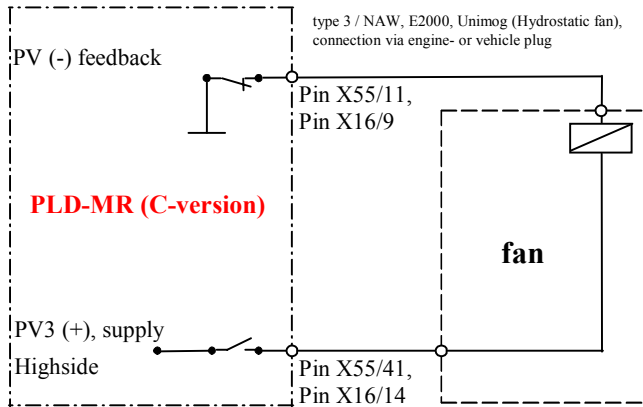

C-version	
X55/11 or X16/9 ground	X55/41 or X16/14 (PV3) Highside (positive voltage controlled)
D-version	
X55/12 or X16/10 supply/ $U_B$	X55/41 or X16/14 (PV3) Lowside (ground controlled)

#### Control unit/D-version:

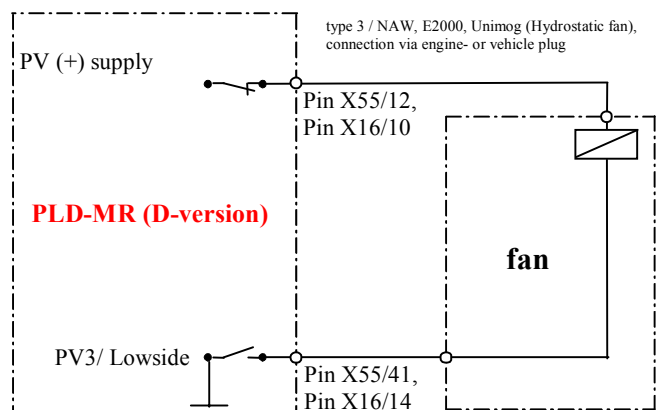

3.6.1.2.5. Type 4/Horton-clutch

- ECU/D-version: Connection possible via engine- and vehicle plug
- ECU/C-version: Connection only via engine plug

**Control unit/C-version:**

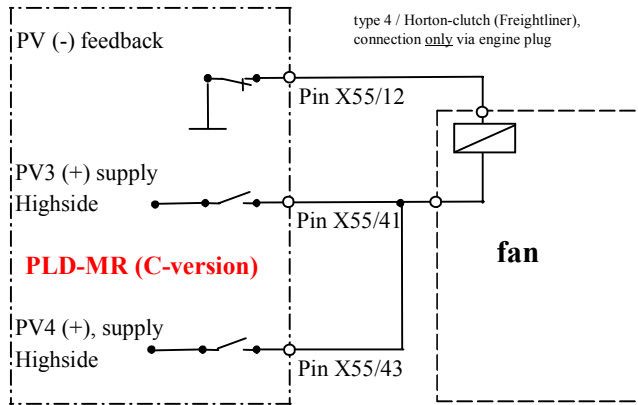

C-version		
X55/12 ground	X55/41 (PV3) Highside (positive voltage controlled)	X55/43 (PV4) Highside (positive voltage controlled)
D-version		
X55/12 or X16/16 supply/ $U_B$	X55/41 or X16/14 Lowside/PV3 (ground controlled)	X55/43 or X16/16 Lowside/PV4 (ground controlled)

**Control unit /D-version**

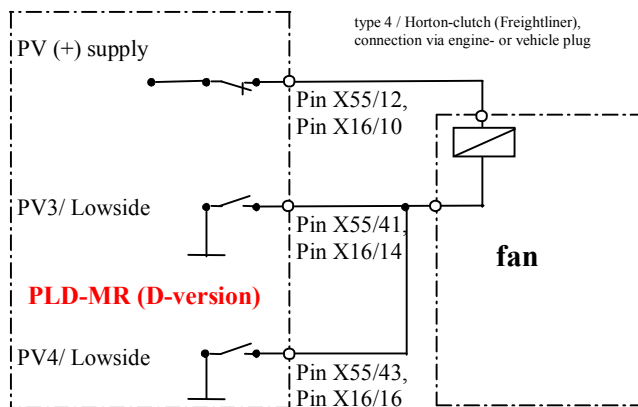

### 3.6. Configuration possibilities of the MR-PLD

#### 3.6.1.2.6. Type 5/one Hydrostatic-fan

- Connection possible via engine- and vehicle plug
- Connection to PV3 (see block diagrams)

#### Control unit/C-version

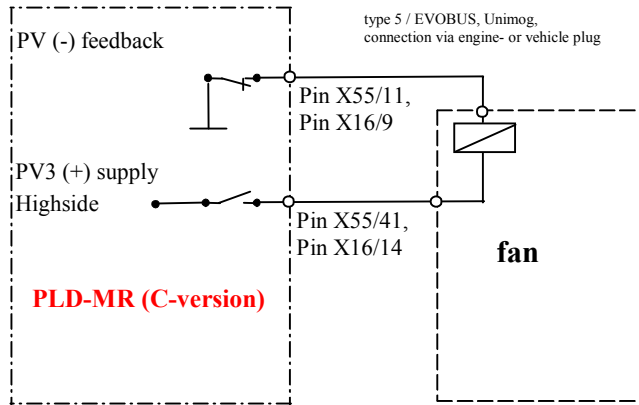

C-version	
X55/11 or X16/9 ground	X55/41 or X16/14 Highside/PV3 (positive voltage controlled)
D-version	
X55/12 or X16/10 supply/ $U_B$	X55/41 or X16/14 Lowside/PV3 (ground controlled)

#### Control unit/D-version:

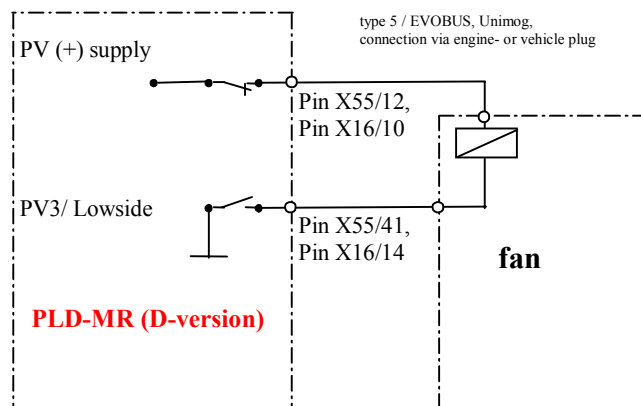

#### 3.6.1.2.7. Type 6/ two Hydrostatic-fans

- ECU/D-version: Connection possible via engine- and vehicle plug
- ECU/C-version: Connection only via engine plug
- Connection to PV3 and PV4 possible (see block diagrams)

#### Control unit /C-version:

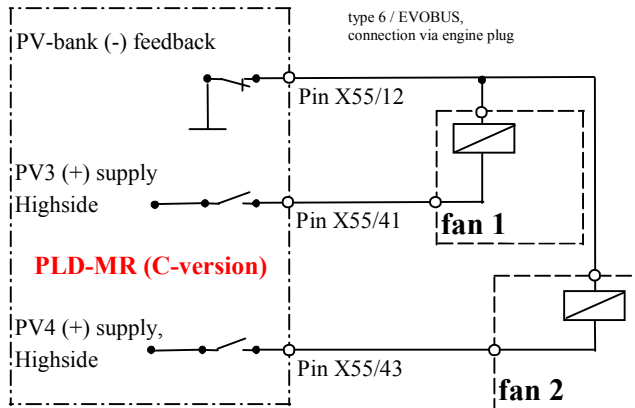

C-version		
X55/12 ground	X55/41 PV3/ fan 1 Highside Positive voltage controlled	X55/43 PV4/ fan 2 Highside Positive voltage controlled
D-version		
X55/12 or X16/10 supply/ $U_B$	X55/41 or X16/14 PV3/ fan 1 Lowside (Ground controlled)	X55/43 or X16/16 PV4/ fan 2 Lowside (Ground controlled)

#### Control unit/D-version:

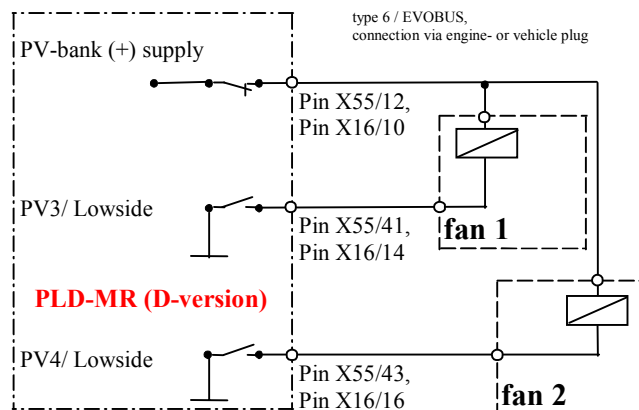

#### 3.6.2. Starter control

##### 3.6.2.1. JE-starter

Two control paths are provided for the starter, so that the starter can still be operated via a parallel path in the case of a failure of one of the power stages (emergency syndrome). *See also chapter 3.3.7.1 Starter control.*

As the engine series are delivered with the parameters set on „JE-starter“ (control via the MR-PLD).

#### Principle block diagram for control unit (JE-mode/parameter = 0)

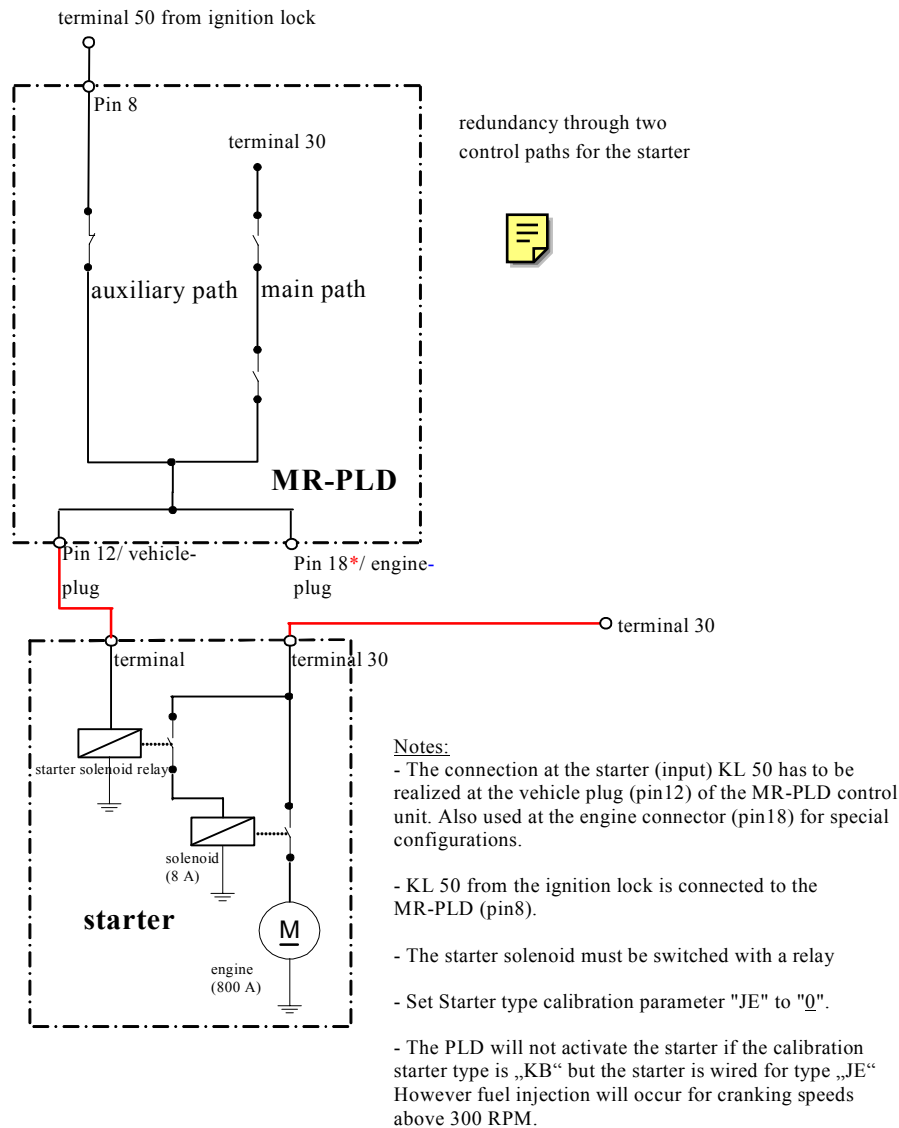

#### 3.6.2.2. KB-starter

For the application of the engine as e.g. stationary machine/aggregate the parameters of the MR-PLD control unit are set on KB-starter. This enables the direct start (without MR-PLD) from the outside.

Principle block diagram for starter control (KB-mode/**parameter=1**

##### 3.6.2.2.1. KB-starter with starter solenoid relay (2 A)

Bemerkung: Motor mit Zündschloss (KL50) oder KL15 ausstellen.

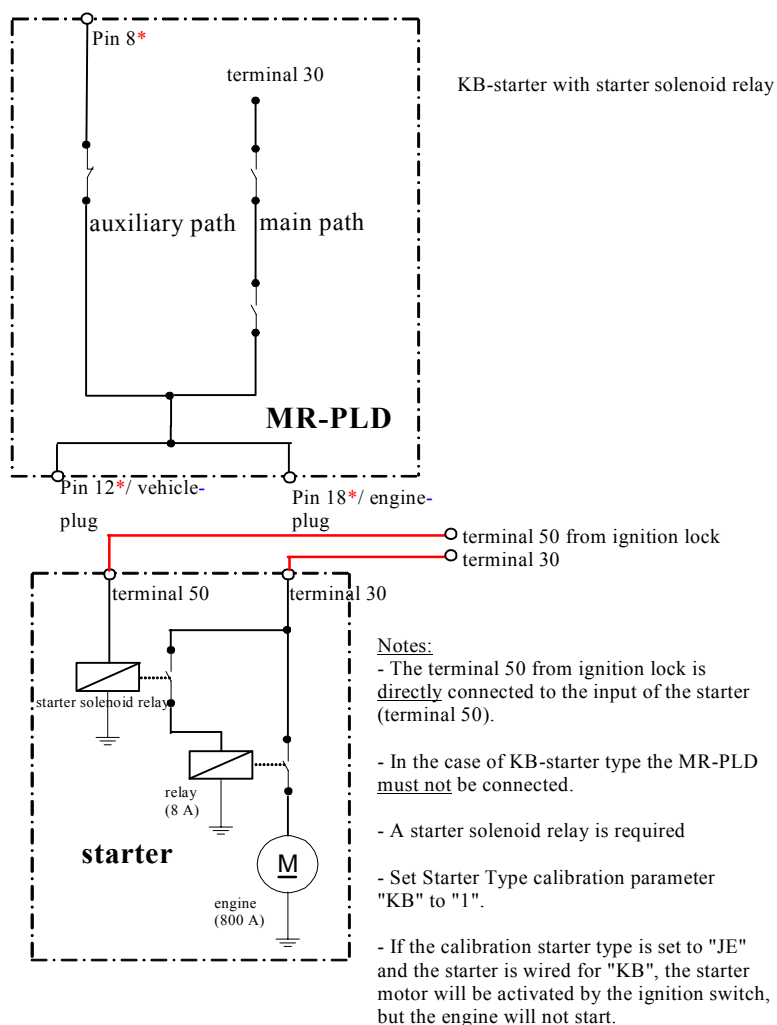

Remark: Shut off engine with ignition lock (terminal 50) or terminal 15.

\*: not connected!

### 3.6. Configuration possibilities of the MR-PLD

#### 3.6.2.2.2. KB-starter without Starter Solenoid Relay (2 A)

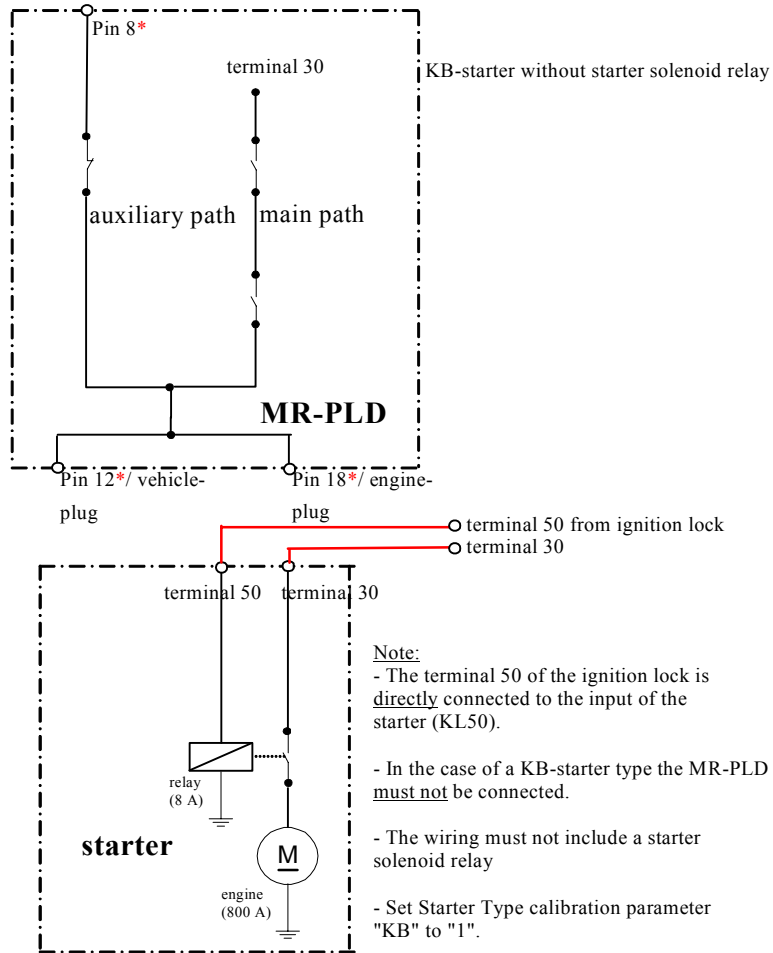

Remark: Shut off engine with ignition lock (terminal 50) or terminal 15.

\*: not connected!

### 3.6.3. Oil pans

Depending on the field of application and the engine type, different oil pans are used. They are calibration-dependant and the parameters have to be set correspondingly. *Turn to DaimlerChrysler for further assistance.*

## 4. Diagnosis

### 4.1. Measured values

The measured values (actual values) are momentary (current) operating values for the engine or for the vehicle/equipment. They can be read off with a diagnosis unit (e.g. minidiag2).

#### 4.1.1. Analogue measured values

Measured value/parameter	Unit	Coding/remark
01 nominal engine torque	Nm	
02 maximum momentary engine torque	Nm	
03 actual engine torque (PLD)	Nm	
04 injection delivery angle (mean of all cylinders)	°crankshaft	
05 measured value/parameter (intern)		
07 actual governing speed	min <sup>-1</sup>	
07 actual engine limit speed	min <sup>-1</sup>	
08 governing speed nominal value (of FRE)	min <sup>-1</sup>	
09 redundant speed (terminal W)	min <sup>-1</sup>	
10 engine speed	min <sup>-1</sup>	
11 speed gradient limitation (of FRE)	min <sup>-1</sup> /s	
12 vehicle speed from (of FRE)	km/h	
13 coolant temperature	°C	
14 fuel temperature	°C	
15 oil level	l	
16 oil temperature	°C	
17 charge-air temperature	°C	
18 boost pressure	mbar	
19 ambient pressure	mbar	
20 oil pressure	mbar	
21 battery voltage	mV	

## 4. Diagnosis

---

Measured value/parameter	Unit	Coding/remark
22 governor type	-	0..6, 8..11 = PTO speed control 15 = idle control
23 engine operating mode	-	0 = engine stop 1 = engine start cut-off 2 = status engine start 3 = idle speed control 4 = pto control 5 = torque demand 6 = CAN limp home status
24 fuel pressure	mbar	not used at the moment
25 scavenging gradient	mbar	not used at the moment
26 fan speed	min <sup>-1</sup>	
27 booster speed 1	min <sup>-1</sup>	
28 booster speed 2	min <sup>-1</sup>	not used at the moment

## 4. Diagnosis

---

### 4.1.2. Binary measured values

No.	Information	Coding
1	Equipment Option	00 = without variable brake 01 = with variable brake 10 = n.d. 11 = signal not available
2	warning buzzer	00 = not demanded 01 = demanded 10 = n.d. 11 = signal not available
	stop lamp	00 = not demanded 01 = demanded 10 = n.d. 11 = signal not available
	CAN status L line	00 = no communication 01 = communication 10 = n.d. 11 = signal not available
	CAN status H line	00 = no communication 01 = communication 10 = n.d. 11 = signal not available
3	status terminal 15 (PLD)	00 = not active 01 = active 10 = n.d. 11 = signal not available
	info terminal 15 (FRE)	00 = not active 01 = active 10 = n.d. 11 = signal not available
	status terminal 50 (PLD)	00 = not active 01 = active 10 = n.d. 11 = signal not available
	status terminal 50 (FRE)	00 = not active 01 = active 10 = n.d. 11 = signal not available

## 4. Diagnosis

---

No.	Information	Coding
4	<p>start button at engine</p> <p>stop button at engine</p> <p>starter actuation</p> <p>starter interlock</p>	<p>00 = not actuated 01 = actuated 10 = n.d. 11 = signal not available</p> <p>00 = not actuated 01 = actuated 10 = n.d. 11 = signal not available</p> <p>00 = not active 01 = active 10 = n.d. 11 = signal not available</p> <p>00 = not active 01 = active 10 = n.d. 11 = signal not available</p>
5	<p>status PWM 1</p> <p>status PWM 2</p> <p>status PWM 3</p> <p>status PWM 4</p>	<p>00 = not active 01 = active 10 = n.d. 11 = signal not available</p> <p>00 = not active 01 = active 10 = n.d. 11 = signal not available</p> <p>00 = not active 01 = active 10 = n.d. 11 = signal not available</p> <p>00 = not active 01 = active 10 = n.d. 11 = signal not available</p>
6	<p>Engine Brake Level 2</p> <p>Engine Brake Level 1</p>	<p>00 = not demanded 01 = demanded 10 = n.d. 11 = signal not available</p> <p>00 = not demanded 01 = demanded 10 = n.d. 11 = signal not available</p>



### 4.2. Serial diagnosis interfaces

Diagnosis interfaces are among other things for the information, fault checking and calibration. Depending on the type of application (vehicle specific) the following interfaces are realized:

- Diagnostic line (ISO 9141)
- CAN data bus system (vehicle: SAE J1939/IES-CAN or engine: ISO 11992)
- SAE J1587/SAE J1708 (USA- & partially NAFTA market)

#### 4.2.1. Diagnostic line

The diagnostic line is an interface via which measured values, errors and parameters (data) can be diagnosed or modified. For the MR-PLD a data set or SW-download is possible via the diagnostic line.

The ISO diagnosis is accomplished via the diagnostic line. The voltage level of the diagnostic line is dependent on the operating voltage of the MR-PLD control unit, in order to achieve a correct voltage adaptation to a RS 232 interface ( $\pm 12V$ ) an external diagnostic line adapter is required.

Ground switching (i.e. the diagnostic line voltage level is switched to ground) allows switching between various operating modes of the diagnostic line or erase fault memory of the control unit.

##### 4.2.1.1. Fault memory

To delete the fault memory a ground switching of  $1,9 \pm 0,02$  s is required, which must be provided by an external test unit.

##### 4.2.1.2. Operating modes

- Free running (monitor operation/default-adjustment, after terminal 15 ON)  
After deleting fault memory, it is switched back to Free Running operation.
- ISO diagnosis (according to ISO standards):  
In order to switch over to dialog operation it is required, that the diagnostic line is grounded for  $1,8 \pm 0,01$ s.
- Application system (only available for DC-engineering)  
With a ground switching of  $1,0 \pm 0,1$  seconds it is switched over to Calibration mode.
- Top dead center output  
In the case of a ground tipping between 4s and 15s the diagnostic line is switched over to the output of a top dead center signal. The voltage level of the K-Line will be switched "high" for every ignition TDC point of cylinder number 1 for a duration of 10 degrees crankshaft rotation.

## 4.2. Serial diagnosis interfaces

---

### 4.2.2. CAN data bus systems

There are different types, e.g. high-speed or low-speed CAN, which differ among other things in the electrical specification, transmission speed and the protocol.

#### 1. Low-Speed-CAN (ISO 11992)

- e.g. engine CAN (MR-PLD <=> FRE)
- depending on operating voltage
- 125 kBaud, 11 Bit Identifier

#### 2. High-Speed-CAN

##### a) IES-CAN for Europe (ISO 11898)

- vehicle CAN (application in MB-truck and Brazil)
- 5 V
- 500 kBaud, at the moment 11 Bit. Identifier, 29 Bit Identifier are possible

##### b) J1939 (SAE-standard)

- Vehicle CAN (application in USA/NAFTA- and partly on EUROPEAN market)
- 5 V
- 250 kBaud, 29 Bit Identifier

#### 4.2.2.1. Engine-CAN (ISO 11992)

Is responsible for the communication between MR-PLD and the FRE (vehicle control electronics).

#### **Special feature is the „one wire capability“!**

If an error is detected during the transfer of the CAN-messages, it is attempted to set up a connection only via one of the two CAN-wires. If this succeeds, an attempt is made to switch back to the two wire operation after ten seconds. If the attempt fails, it is switched back to the previous one-wire operation and always after ten seconds a further attempt to switch back is carried out. The changeover in a possible one wire operation and the switching back into the two wire operation is carried out so fast, that no CAN backup can occur.

#### 4.2.2.2. Vehicle CAN

The vehicle CAN is a communication interface via which amongst other things the measured values, faults and parameters (data) can be read off/or modified.

1. The European vehicle CAN data bus with the DC-designation „IES-CAN“ and the standard ISO 11898 works with 500 kBaud and is operated with 5 V.
2. The American vehicle CAN data bus according to the standard SAE J1939 works with 250 kBaud and is operated with 5 V.

Note: The High-Speed-CAN has no one wire capability!

### 4.2.3. SAE J1587/SAE J1708 (USA- and partly NAFTA-market)

In the USA and partly in the remaining NAFTA-states, the diagnostic interface according to the standard SAE J1587/SAE J1708 is used (2-wire-line).

### 4.2.4. Configuration of diagnostic interface

Different diagnostic concepts are realized, depending on the field of application of the engines (MB-truck-USA-trucks, off highway, etc.).

*Overview of the diagnostic concepts as a exemplary configuration with the example of DC and Brazil:*

#### MB-truck/Brazil

- MR-PLD, FRE (**FR-FMR** for MB-Truck and UCV for Brazil, both 24 V), Low-Speed-CAN (MR-PLD  $\Leftrightarrow$  FR-FMR or UCV), diagnostic line (single wires), High-Speed-CAN (IES-CAN), IES-compatible components and display electronics with diagnosis-interface. Block diagram 4.2.4.1

*Overview of further diagnostic concepts for:*

#### 1.) Europe (not MB-truck)

- a) MR-PLD, FRE (**ADM**, 24V), conventional display, Low-Speed-CAN (MR-PLD  $\Leftrightarrow$  ADM), diagnostic lines (single wires). Block diagram 4.2.4.2
- b) MR-PLD, FRE (**ADM2**, 12/24 V), conventional display, Low-Speed-CAN (MR-PLD  $\Leftrightarrow$  ADM2), diagnostic lines (single wires), High-Speed-CAN (SAE J1939), SAE-compatible components. Block diagram 4.2.4.3

#### 2.) USA- and partly remaining part of NAFTA-market

- MR-PLD, FRE (**VCU**, 12 V), at Freightliner e.g. ICU3 (conventional display), Low-Speed-CAN (MR-PLD  $\Leftrightarrow$  VCU), SAE J1587/SAE J1708 (2-wire-line), High-Speed-CAN (SAE J1939), SAE-compatible components. Block diagram 4.2.4.4

## 4.2. Serial diagnosis interfaces

### 4.2.4.1. MB-truck / Brazil

FRE	=	Vehicle control electronics (FR-FMR or UCV)
MR-PLD	=	Engine control (pump-line-nozzle)
IES-CAN	=	High-Speed-CAN (DC-designation)
INS	=	Display electronics
GM	=	Basic module
DS	=	Diagnostic connector (connected diagnostic line)
KWP	=	Key Word Protocol 2000 NFZ (ISO 14230)

#### Diagnosis:

Diagnosis of MR-PLD via CAN and Gateways and directly via diagnostic line of MR-PLD.

Example of diagnosis via CAN and Gateways:

**Diagnostic line <=> INS/GM <=> High-Speed-CAN <=> FRE <=> Low-Speed-CAN  
<=> MR-PLD**

#### Configuration:

Configuration of the MR-PLD via CAN and Gateways and directly via diagnostic line of MR-PLD (see diagnosis).

#### Programming:

Programming of the MR-PLD software or of the data set via diagnostic line directly at the diagnosis-interface of the MR-PLD.

#### *Block diagram 4.2.4.1*

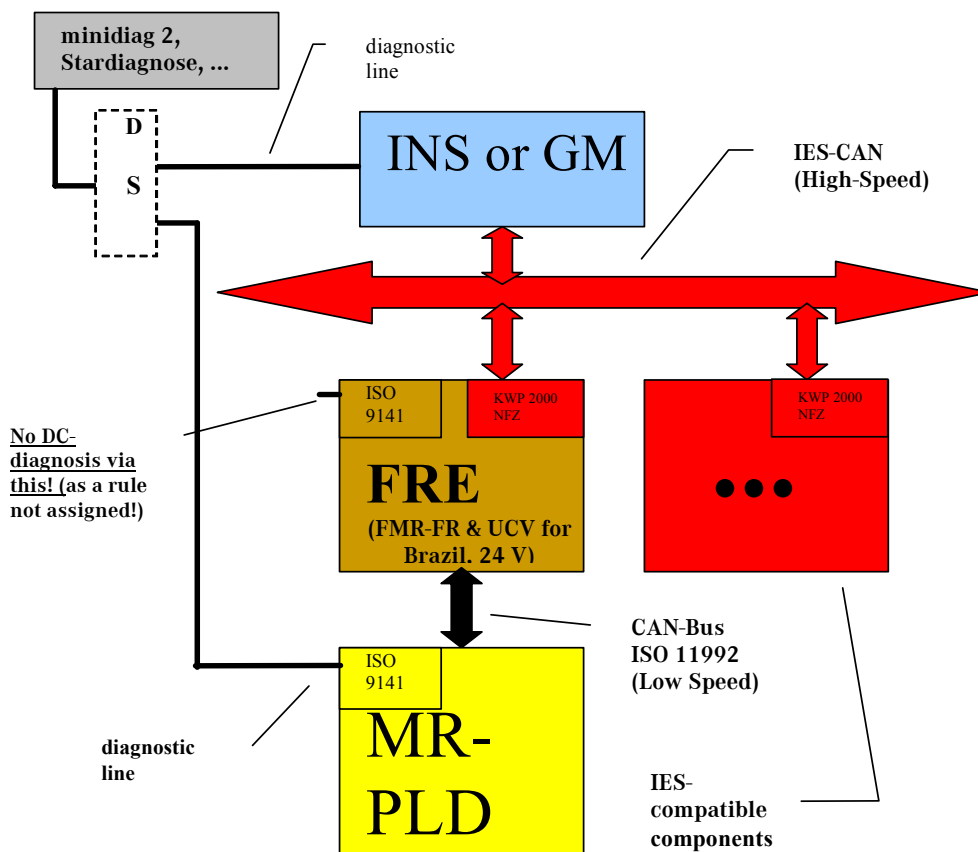

4.2.4.2. Europe (ADM / not MB-trucks)

- FRE = Vehicle control electronics (ADM = adaption module)
- MR-PLD = Engine control (pump-line-nozzle)
- DS = Diagnostic connector (connected diagnostic line)

Diagnosis:

Diagnosis of the MR-PLD via the diagnostic line at the diagnostic-interface of the MR-PLD.

Configuration:

Configuration of the MR-PLD via the diagnostic line at the diagnostic interface of the MR-PLD.

Programming:

Programming of the MR-PLD software or the data set via the diagnostic line at the diagnostic interface of the MR-PLD.

Block diagram: 4.2.4.2

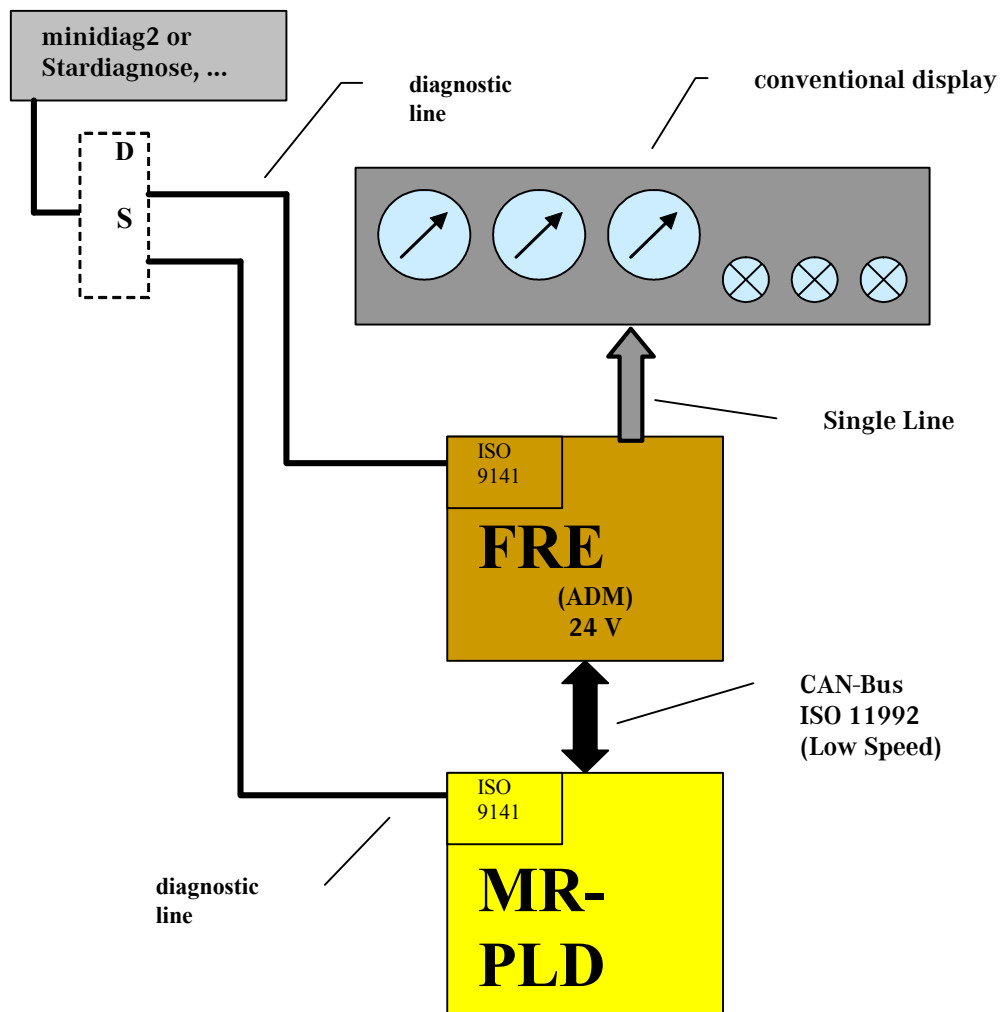

## 4.2. Serial diagnosis interfaces

### 4.2.4.3. Europe (ADM2 / not MB-Trucks)

FRE	=	Vehicle control electronics (ADM2 = adaption module)
MR-PLD	=	Engine control (pump-line-nozzle)
SAE J1939	=	High-Speed-CAN (US-standard)
DS	=	Diagnostic connector (connected diagnostic line)

Diagnosis:

Diagnosis of the MR-PLD via diagnostic line at the diagnostic interface of the MR-PLD.

Configuration:

Configuration of the MR-PLD via diagnostic line at the diagnostic interface of the MR-PLD.

Programming:

Programming of the MR-PLD software or the data set via diagnostic line at the diagnostic interface of the MR-PLD.

Block diagram: 4.2.4.3

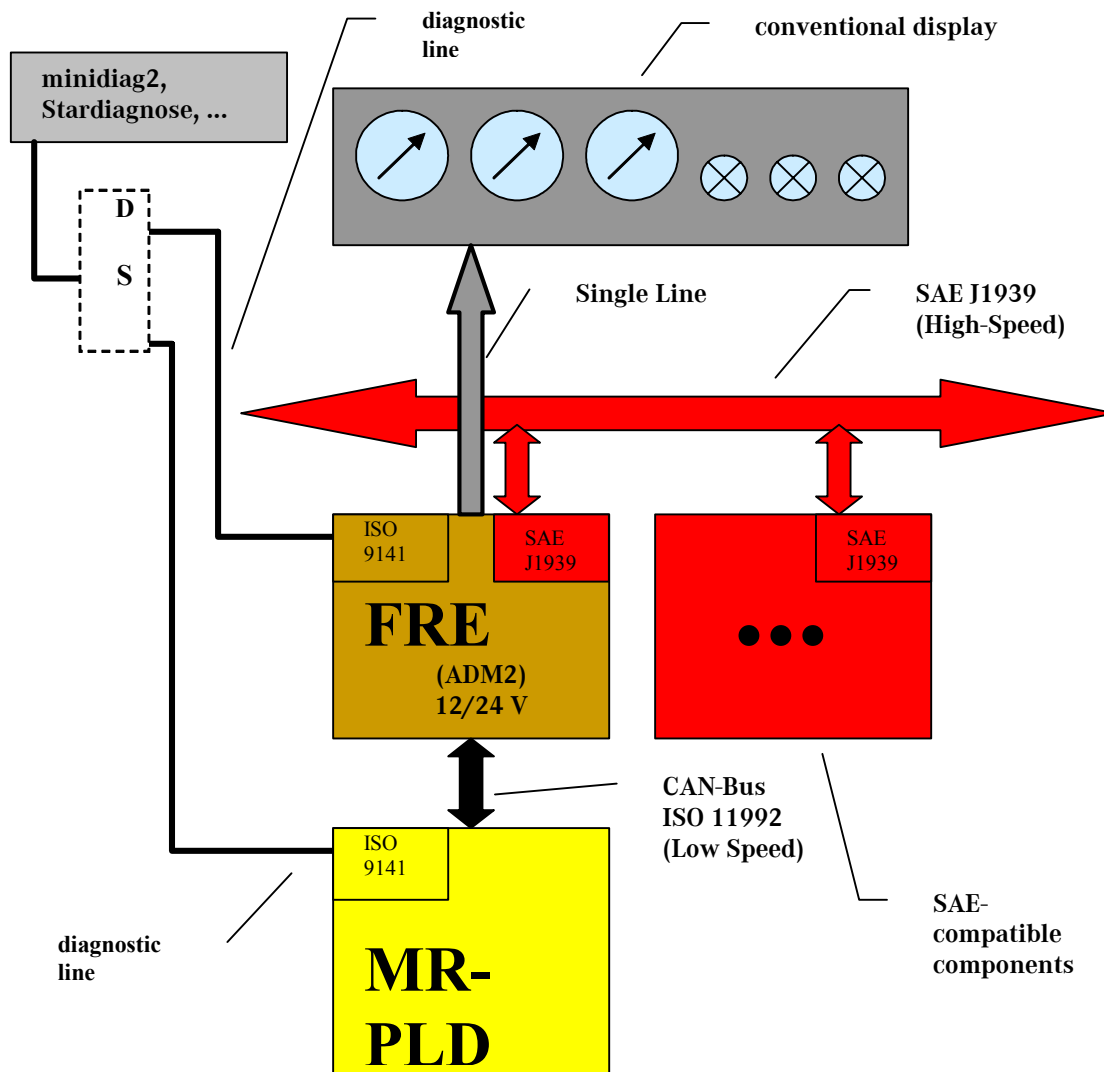

4.2.4.4. USA- and partly NAFTA-market

FRE	=	Vehicle control electronics (VCU = Vehicle Control Unit)
MR-PLD	=	Engine control (pump-line-nozzle)
SAE J1939	=	High-Speed-CAN (US-standard)
SAE J1587/SAE J1708	=	Diagnostic interface (2-wire-line/US-standard) is connected to the diagnostic connector (DS)
ICU3	=	Conventional display
DS	=	Diagnostic connector

Diagnosis

Diagnosis of the MR-PLD via a 2-wire-line, Gateway and CAN (connection diagnostic line of the MR-PLD as a rule not assigned).

Example:

SAE J1587/SAE J1708 <=> FRE <=> Low-Speed-CAN <=> MR-PLD

Configuration:

Configuration of the MR-PLD via a 2-wire-line, Gateway and CAN (see diagnosis).

Programming:

Programming of the MR-PLD via a 2-wire-line, Gateway and CAN (see diagnosis).

Block diagram: 4.2.4.4

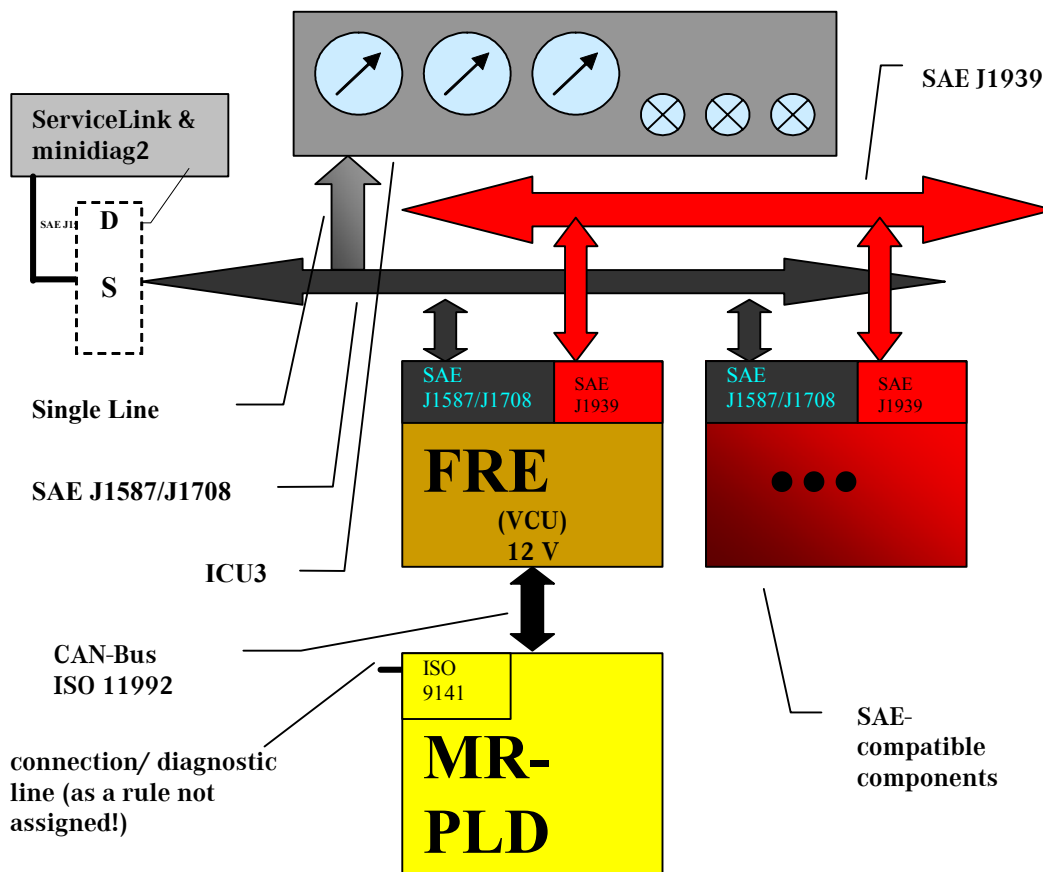

### 4.2.5. Diagnosis interface/software description

#### Diagnosis of PLD engine electronics:

Functions for the monitoring of the engine electronics (sensors, actuator, etc.) are integrated in the PLD-Program, to enable the detection of errors and the introduction of the corresponding substitute measures. A short description of the monitoring functions is stated below.

#### 4.2.5.1. Fault memory structure

Fault recognition is achieved in the individual basic functions (sensor signal processing, actuator control, etc.). The entering of the fault code into the fault memory and the actuation of the fault counter is processed in the main program.

#### 4.2.5.2. Ground switching

*See chapter 4.2.1. diagnostic line*

### 4.3. Diagnosis unit & application

Examples for the application of the diagnosis units:

- Configuration
- Fault tracing and instructions for remedial actions
- Actual value output (measured values)
- Software- or data set-download (MR-PLD)

The most frequently used diagnosis units are:

- minidiag2
- Stardiagnose (DC-engineering/workshop)
- ServiceLink (USA/NAFTA)

#### 4.3.1. minidiag2

The minidiag2 diagnostic and configuration unit is suitable for engine monitoring and vehicle configuration.

Note: This is no operating manual of the diagnosis and configuration unit minidiag2. The following is only a listing of minidiag2 some work instructions and information, which are relevant to the MR-PLD control unit.

##### 4.3.1.1. Display/delete fault code memory

###### Display fault code memory

- Run ecu search routine (see operating instructions minidiag2 on page 13)
- Cursor on required ecu (e.g. PLD)



- The selected ecu functions are then displayed
- Cursor on „diagnosis“



- Cursor on „show fault code memory“



actual fault codes => actually valid (not yet cleared) fault codes. These can not be deleted.

stored fault codes => not actually (possibly already cleared) fault codes. These can be - if required - deleted.

- Cursor on required fault group (e. g. „actual fault code“



### 4.3. Diagnosis unit & application

---

- The fault code of the selected fault group are displayed
- Cursor on required fault code



- The selected fault code, attendant description (consisting of fault names and explanations/remedies) as well as the status of the operating hours counter are displayed.



Display next fault code



Display previous fault code

The operating hours counter indicates the number of operating hours that have elapsed since the last fault code occurrence. The counter can count to a maximum of 255 hours; after reaching this maximum value it will stop counting.

#### Delete fault code memory

- Run ecu search routine (see operating instructions minidiag2 on page 13)
- Cursor on required ecu (e.g. PLD)



- The selected ecu functions are then displayed
- Cursor on „diagnosis“



- Cursor on „show fault code memory“



- Cursor on „delete fault code memory“



- The ecu fault code memory is deleting...
- Wait for next display

Depending upon the state of the fault code memory, one of the two following messages is then shown on the display:

*No more actual (not yet cleared) fault codes in memory. The entire fault code memory has been deleted.*

**or:**

*The fault code memory contains current (not yet cleared) faults.*

Current (not yet cleared) faults can not be deleted.

- After completing work on the fault code memory, turn off the ignition for 6 seconds. Only then will the modified faults be permanently deleted from the ecu.
- After switching off the ignition a countdown is displayed. Switch on after the 6 seconds have elapsed.

## 4.3. Diagnosis unit & application

---

### 4.3.1.2. Testing routines

#### 4.3.1.2.1. Voltmeter function

(only available with control unit selection „PLD“)

The voltmeter functions is provided for the display of the following voltage levels:

<b><u>menu level</u></b>	<b><u>voltage display [mV] of</u></b>
00	Sensor boost pressure
01	Sensor ambient pressure
02	Sensor engine-oil pressure (passive sensor)
03	Sensor fuel pressure
04	Sensor engine-oil level
05	Sensor charge-air temperature
06	Sensor coolant temperature
07	Sensor fuel temperature
08	Sensor engine-oil temperature
09	Sensor volume air flow
10	Battery voltage
11	Sensor engine-oil pressure (active sensor)

In order to read out voltage levels:

- Run ecu search routine (see operating instructions minidiag2 on page 13)
- Cursor on desired control unit (PLD)



- The functions of the selected control unit are displayed
- Cursor on „Routines“



- Select the relevant menu level

### 4.3.1.2.2. Cylinder cutoff

(only available with control unit selection „PLD“)

This function allows to switch cylinders on and off individually.  
„ON“ (switched on) or „OFF“ (switched off) is displayed as value.

- Run ecu search routine (see operating instructions minidiag2 on page 13)
- Cursor on desired control unit (PLD)



- The functions of the selected control unit are displayed (3 routines)
- Cursor on „cylinder cutoff“



In order to switch on and -off

- Select the relevant cylinders with the key <= or => (e.g. “ZYL 3” for the 3. cylinder.)
- Actuate the „OK“ key for switching over between „ON“ and „OFF“.

## 4.3. Diagnosis unit & application

---

### 4.3.1.2.3. Compression check

(only available with control unit selection „PLD“)

The function provides the actual value of the compression pressure (for the desired cylinder) as a percentage of the nominal value.

- Run ecu search routine (see operating instructions minidiag2 on page 13)
- Cursor on desired control unit (PLD)



- The functions of the selected control unit are displayed (3 routines)

In order to read out the actual value:

- Select function „compression check“



In the case of a successful start of the function, the display starts to blink

Note:

In the case of a starting attempt following here upon, no fuel is injected, the injection pumps are switched off.

- Actuate the starter until the starting process stops automatically (approx. 15 seconds).
- "OK! AVD-Werte (value) determined" should be displayed.
- Select the relevant cylinder with the key <= or => and read off the "Avd-Wert" (compression test value) on the display.
- If the function has to be started once again (detect new compression test value) or the engine has to be started after that, the voltage supply must be interrupted for at least 15 seconds (ignition lock in position "0"/ term. 30 and term. 15 off).

### 4.3.1.2.4. Idle speed balance (hot engine!)

(only available with control unit selection „PLD“)

The function provides a correction value (in %) for the selected cylinder. Values which differ greatly from other cylinder values are an indication for a defective cylinder.

Run ecu search routine (see operating instructions minidiag2 on page 13)

- Cursor on desired control unit (PLD)



- The functions of the selected control units are displayed (3 routines)

In order to read out values:

- Select function „idle speed balance“



Select value for relevant cylinder with the key <= or =>

### 4.3. Diagnosis unit & application

---

#### 4.3.1.2.5. Impact delay time

(only available with control unit selection „PLD“)

In order to read out the impact delay time for the cylinders:

- Run ecu search routine (see operating instructions minidiag2 on page 13)
- Cursor on desired control unit (PLD)



- The functions of the selected control unit are displayed (3 routines).

- Select function „impact delay time“



- Select relevant cylinder with the key <= or =>

The display of the impact delay time is in microseconds ( $\mu\text{s}$ ).

Note: Strongly varying impact times can refer to air in the fuel, with 24 V point firm of values a defect.

### 4.3.1.3. Calibration

Two types of calibration are possible with the diagnosis unit minidiag2.

- Single Parameters
- Data set calibration

The moreover changed parameter data from the ecu can be stored in the minidiag2 back, in order to load it later again from the minidiag2 to the PC (chapter 4.3.1.3.3.).

#### 4.3.1.3.1. Single parameters

Individual parameter values are modified.

- Run ecu search routine (see operating instructions minidiag2 on page 13)
- Cursor on desired control unit (PLD)



- The functions of the selected control unit are displayed
- Cursor on „set parameters“



- Cursor on „read/write ecu parameters“



- The parameter groups of the control unit are displayed
- Cursor on desired parameter group



- Parameters of the selected parameter group are displayed
- Cursor on desired parameter



display next parameter



display previous parameter

Displayed values of the selected parameters:

- Enter new value (In the case of an erroneous entry, the incorrect values can be deleted with the key “clear”)



3x 

- Switch off ignition for 6 seconds upon completion of the calibration. Only in this case, the modified parameters are stored permanently in the control unit.
- A countdown is displayed, after the ignition is switched off. Switch the ignition on once again, after the sequence of 6 seconds.

The communication with the control unit is restarted:

If several parameters have to be modified: at first modify all parameters, afterwards switch off ignition for 6 seconds



**No calibration is authorized when the engine is running!**

### 4.3.1.3.2. Data set calibration

A created parameter set is transmitted to a control unit. All parameter values of the control unit are modified simultaneously according to the parameter set.

- Create parameter set with the aid of the PC-program “minidiag2 Assistant” (see operating instructions minidiag2 on page 35)
- Transmit parameter set with the aid of the PC-program „minidiag2 Assistant“ to minidiag2 see operating instructions minidiag2 on page 49)
- Run ecu search routine (see operating instructions minidiag2 on page 13)
- Cursor on the desired control unit (PLD)



- The functions of the selected control unit are displayed
- Cursor on „set parameter“



- Cursor on „select parameter set“



- Cursor on desired client



- Cursor on desired application



- The selected control unit (PLD) is now calibrated according to the parameter set (data set).  
The transmitted parameter groups are displayed.
- The selected control unit (PLD) is now calibrated according to the parameter set (data set).

2x



- Upon completion of the calibration, switch off ignition for 6 seconds. Only in this case the modified parameters are stored permanently in the control unit.
- A countdown is displayed, after the ignition is switched off. Switch the ignition on once again, after the sequence of 6 seconds.

The communication with the control unit is restarted.



**No calibration is authorized when the engine is running!**

### 4.3.1.3.3. Save modified parameter set

Parameter data can be stored from the ecu back to the minidiag2.

#### Part 1 „ecu to minidiag2“:

- Run ecu search routine (see operating instructions minidiag2 on page 13)
- Cursor on required ecu (e. g. PLD)



- Cursor on „set parameters“



- Cursor on „store modified parameterset“



- Enter or select customer name (if available) or accept automatically generated name (Noname)



- Enter „parameter set name“ or accept automatically generated name (Acquired 1)



- Parameter groups are read in and displayed
- The parameter data set is read out/stored by the selected ecu (PLD)

#### Part 2 „Save parameters from minidiag2 to PC“

Step 1: Run the minidiag2 assistant using the „Mdiagass.exe“ in the „Minidiag“ on the PC.

Step 2: Click on „logistic assistant “. The „logistic assistant“ window is opened.

Step 3: Click on „parameter from minidiag2“. Two additional windows open containing information on the parameter data set from the ecu.

Step 4: After confirming by clicking on „OK“ the parameter set is copied to the PC and the procedure is thus concluded.



**No calibration is authorized when the engine is running!**

### 4.3.1.3.4. Convert modified parameter set

With a hardware change (e. g. PLD diagnostic version 5 to 6) it is necessary to convert the parameter set.

- Run ecu search routine (see operating instructions minidiag2 on page 13)
- Cursor on desired control unit (PLD)



- The selected ecu functions are then displayed
- Cursor on „set parameters“



- Push the „scroll downwards“ button



- Select „convert modified parameter set“



- Confirm converting to „DiagVer 6“



- Enter or select customer name (if available) or accept automatically generated name (Noname)



- Enter parameter set name or accept automatically generated name (Acquired1)



- Parameter groups are read in, displayed and then stored

The minidiag2 is now ready to be connected to the PLD diagnostic version 6. The parameter set can be transferred to the ecu (PLD) as described in chapter 4.3.1.3.2.



**No calibration is authorized when the engine is running!**

#### 4.3.1.4. Program protection

*The program protection is provided for the security and for the avoidance of abuse. The immobilizer is an example for this safety concept. The entering of the key-transponder codes, or an activation/deactivation of the immobilizer is only possible with specific tools or programs. Only specialist staff is authorized to modify the data and to take the required measures.*

#### 4.3.2. Stardiagnose

The Stardiagnose is a (internal) DaimlerChrysler service- and diagnostic tool in form of a software program (for Windows NT) with a special hardware. It is particularly useful, that in the case of a failure guided diagnostics with the corresponding instructions (with graphic support) can be performed for each fault code.

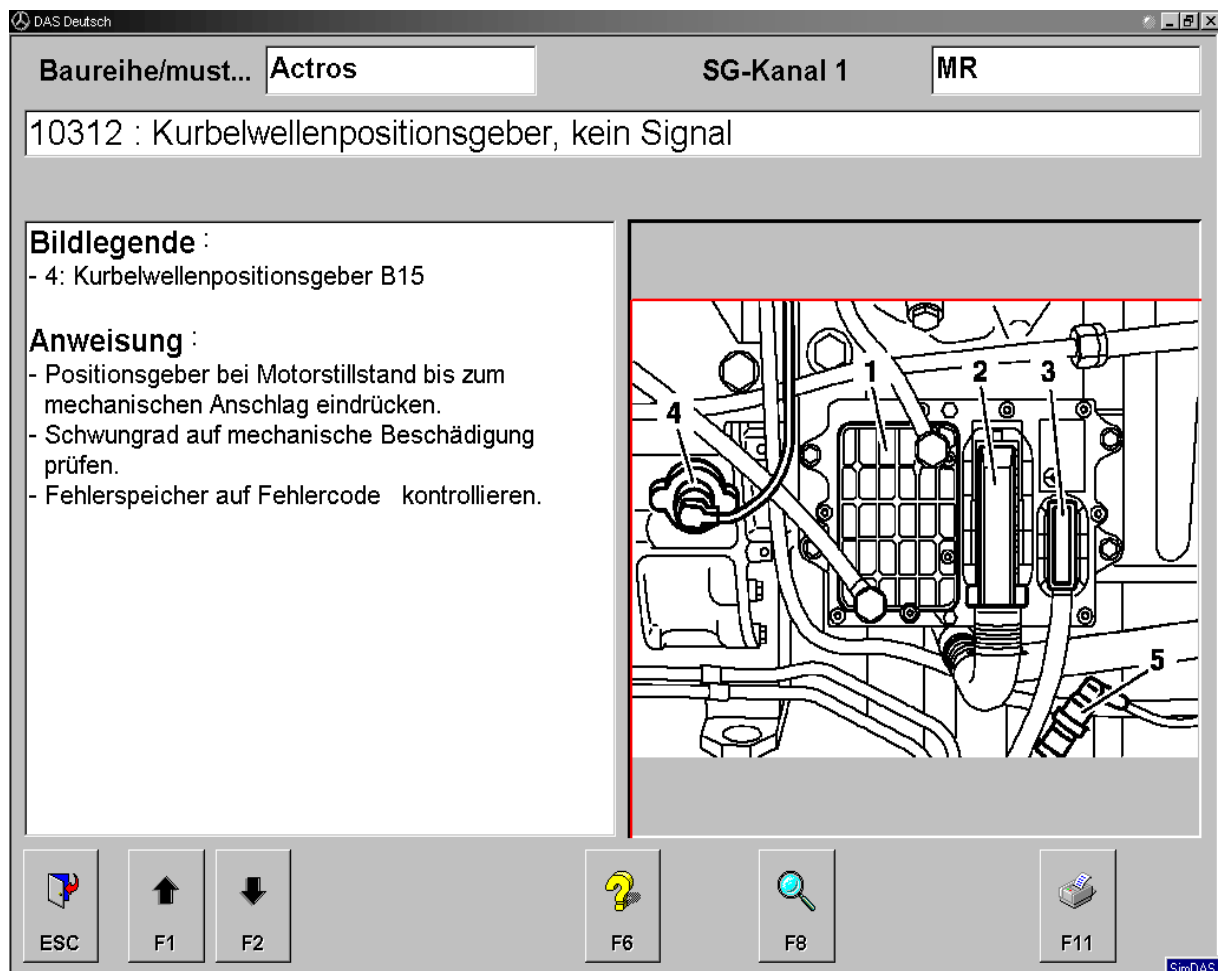

### 4.3.3. ServiceLink

ServiceLink is also a service- and diagnostic tool in the form of a software program (for Windows 9x/2000/XP or other 32-Bit operating systems with a parallel interface), which requires an adapter “MagiKey” for the parallel interface of the PC. ServiceLink is used by Freightliner (USA- and partly in the remaining NAFTA-market).

In contrast to the Stargdiagnose, it is not provided with guided diagnostics. It is a major advantage of ServiceLink, that it can contact the Server of Freightliner, in order to download the data status for the respective control unit (of the relevant engine).



Picture 4.3.3.1 Module "MagiKey" for the **parallel** interface(<http://www.nexiq.com/pdm.asp>)



Picture 4.3.3.2 Module "MagiKey" for the **serial** interface (<http://www.nexiq.com/sdm.asp>)

### **4.4. Diagnosis routines**

The particular diagnosis routines can be realized with a diagnosis- and configuration unit e.g. minidiag2.

#### **4.4.1. Detailed testing routines**

*See chapter 4.3.1.2. testing routines.*

## 4.5. Backup

### 4.5.1. System backup capability

#### 4.5.1.1. Microprocessor 1-backup

##### 4.5.1.1.1. Crankshaft backup

In the case of the crankshaft backup a distinction has to be made, if the system lost the camshaft signal only after a synchronous engine operation, or if the camshaft signal has not yet been detected e.g. during the engine start.

If there is a camshaft signal failure during engine operation, the injection control/control of the injector- and magnetic valves operates without restrictions.

If there is already no camshaft signal during the starting procedure, the control is operated in a double injection mode. Two valves are controlled simultaneously, due to the missing cylinder 1 recognition. The second valve corresponds to the 360° crankshaft displaced cylinder. As a result it is ensured that one cylinder contributes to the combustion, where as no injection takes place at the other cylinder. It is possible that the valve control is more inexact in the double injection mode, because there could be an incorrect evaluation of the cylinder specific rate.

Note: Engine protection are activated in both cases (torque reduction)!

- Upon completion of starting procedure (starting phase – no camshaft signal)
- During the engine operation (synchronization has already taken place)

##### 4.5.1.1.2. Camshaft backup

If there is no crankshaft signal (during starting procedure or engine operation), the system is operated in the camshaft backup. Due to the greater distances of the reference marks (60°), the magnetic valve control operates with more inexact adjustments than with the 10°-information of the crankshaft system.

Note: Engine protection are activated in both cases (torque reduction)!

##### 4.5.1.1.3. CAN-backup (definition)

If the data is not plausible or incorrect, or if the connection via the CAN data bus is interrupted, the speed controlled CAN backup operation is activated.

CAN backup under the condition that:

- No communication is possible via CAN, not even in the one wire operation (hardware error, CAN line defective/broken => MR-PLD does not recognize FRE)
- Data/telegrams on CAN are not valid
- The CAN-module is classified as defective
- The fault is registered in the fault memory of the engine control unit as an active fault (active fault i.e. 1. CAN-fault is present 2. this fault is permanently stored in the fault memory after exceeding a certain period of time and 3. it is switched over to CAN backup)

## 4.5. Backup

---

A differentiation must be made of three different CAN backup operations, which can be set in the MR-PLD control unit **via the FRE** (with a still **intact CAN bus** and valid data).

1. CAN backup, mode 0: standard backup with increased engine speed.
2. CAN backup, mode 1: running during idle, accelerator-pedal interlock.
3. CAN backup, mode 2: disable injection and starter.

### Note:

*The standard CAN backup in mode 0 is activated (is read by the CAN after terminal 15 ON) if from the beginning:*

- *the connection is interrupted*
- *the data/telegrams on the CAN are not valid*

The calibration of the respective CAN backup operation is achieved exclusively in the **vehicle electronics (FRE)**. The following overview provides the required data:

- *parameter: 00 = CAN backup, mode 1*
- *parameter: 01 = CAN backup, mode 2*
- *parameter: 10 = CAN backup, mode 0*
- *parameter: 11 = CAN backup, mode 0*

The system performance of the respective CAN backup operation is described in the following 3 subsidiary points.

### **4.5.1.1.4. CAN-backup, mode 0 (standard-backup)**

If the CAN backup occurs during engine operation, the engine continues running with the actual engine speed, if it is below the applied backup-nominal engine speed. If the actual engine speed is higher, the engine speed is controlled at the backup nominal value. Depending on the EEPROM-calibration the backup nominal engine speed is read out from the application parameter of the backup nominal value for manual transmission or automatic transmission. The torque of the backup- (idle-) governor is limited in dependence on the vehicle speed which was last read by the CAN. The controller is initialized with the actual load.

If the fault occurs during engine standstill or if the engine is shut off in the CAN backup, and the engine is started once again, the engine speed nominal value increases to the applied (STG or ATG) backup speed via a ramp (after starter lockout, starting with actual engine speed). The applied value (constant) is used for the limitation. In both cases the engine-related limitations (smoke, full load etc.) are effective.

### Fault regeneration:

If no CAN fault exists any longer, the CAN backup is terminated and the accelerator pedal is enabled via a ramp (starting with the backup torque). The fault regeneration is terminated, when the alteration of the desired torque is not limited any longer.

### 4.5.1.1.5. CAN-backup, mode 1

The engine speed is controlled at the idle speed of the engine. If the CAN backup occurs during engine operation, then the engine speed drops to the actual idle speed and is controlled at the actual idle speed. If the engine is started in the case of an error, then the engine runs with idle speed after the starter lockout. The applied constant for the CAN backup is used for the torque limitation (in addition to the other engine limitations such as smoke, full load, etc.).

Fault regeneration: See backup mode 0

### 4.5.1.1.6. CAN-backup, mode 2

If the CAN backup is present and the backup mode 2 has been received with an intact communication via the CAN, the injection and the starter are locked and the engine is therefore shut off or not started at all. If terminal 15 is switched off, it is waited for the end of the backup phase, and the control unit is switched on once again, then the control unit runs in the backup mode 0, if the conditions for a CAN backup are still present.

Fault regeneration:

If no CAN fault exists any longer, the CAN backup is terminated and the accelerator pedal is enabled via a ramp (starting with the backup torque), injection (via a ramp) and starter are released again. The engine continues running or can be started in a regular way.

### 4.5.1.1.7. CAN data-area check

During the initialization phase of the engine control unit, the data area of the CAN send and receive buffer is checked. In the case of an error the data is neither read from the CAN nor sent.

The engine can be run in the CAN backup, mode 0. The internal fault "CAN data area defective" is stored in the fault memory of the engine control unit. Corrective action: replace the engine control unit.

### 4.5.1.1.8. Nominal engine speed CAN-backup

In the CAN backup, the idle governor is used as backup governor. The backup nominal value is calculated in dependence on the backup mode.

Depending on the calibration, it is switched over to a backup nominal value for the application of the engine in a truck or in a bus. Both can be applied independently from each other (values in the data set), in the following, the selected value is designated as backup nominal engine speed. Concerning vehicles with an automatic transmission, another (lower) nominal value has to be set if necessary.

#### 4.5.1.1.8.1. Nominal engine speed CAN-backup mode 0

If a CAN backup in mode 0 occurs during engine operation, the nominal governor speed is set to the actual engine speed, if it is smaller than the backup nominal engine speed. If this is not the case, the nominal governor speed is set to the backup nominal value. If the fault occurs, when the engine is not running or the engine is shut off and is restarted in the backup operation, then the nominal governor speed (starting with the engine speed after the starter lockout) is increased to the backup nominal engine speed via a ramp. The nominal governor speed is limited: the lower limit is the actual idle speed and the upper limit is the actual engine limit speed.

## 4.5. Backup

---

### 4.5.1.1.8.2. Nominal engine speed CAN-backup mode 1

During the active CAN backup in mode 1 the engine has to be run with idle speed. The nominal governor speed is therefore set to the actual idle speed.

### 4.5.1.2. Microprocessor 2-backup

If there is a failure of the main processor (microprocessor 1) in the PLD control unit, the backup processor (microprocessor 2) takes over the magnetic valve control. Microprocessor 2 controls the engine speed in a range between 800...1300 rpm. The backup speed is taught in by the main processor. This operating mode can only be terminated by turning the control unit off.

## 4.5.2. Backup functions

### 4.5.2.1. Ambient pressure sensor

If an error of the ambient pressure sensor is registered as active in the fault memory, a replacement value for the ambient pressure is calculated according to the following algorithm.

If the boost pressure sensor is electrically not classified as defective and if it provides plausible signals, the boost pressure is used as ambient pressure, as long as the engine is run with a load and engine speed which is below the applied thresholds. If the current engine-operating point is above the applied thresholds, the boost pressure that has been adopted last is maintained, until the engine runs below the load-/engine speed threshold again. The applied torque- and engine speed thresholds are also used for the plausibility check of the boost pressure sensor.

If the boost pressure sensor is electrically defective or does not provide plausible signals, the applied replacement value is used as ambient pressure. In the case of an error "signal not available" is sent in the cyclic telegram on the CAN.

### 4.5.2.2. Boost pressure control

This function is valid for the engine operation as well as for the engine-trailing throttle state. If the boost pressure sensor is defective, if it delivers a signal which is not plausible, a defective booster path was detected, or one of the faults ("booster set-value deviation" {valence 1}, "booster pressure deviation" or "booster braking power MIN") is active, than the boost pressure control is switched off.

The booster can be controlled in a pre-defined manner, via an applicable constant. Because a controlled booster braking operation is possible no more, the status of the variable engine brake is set on not available and the braking torque characteristic line is calculated no longer.

## 4.5.3. Sensor-replacement values

### 4.5.3.1. Plausibility limits and sensor replacement values

#### **Plausibility limits of the sensor voltages:**

Below the minimum sensor voltage, the error shorted to ground is detected. Above the maximum authorized sensor voltage, the error over voltage is detected. In the case of exceeding or falling below the plausibility limits, an error is stored in the fault memory.

#### **Sensor – replacement values:**

The sensor replacement values are also registered engine-specifically in the data map.

## 4.5. Backup

---

### 4.5.4. Diagnosis of sensor and backup functions

#### 4.5.4.1. Temperature and pressure sensors

**Error recognition: values outside of measuring range:**

After the reading of the sensor voltages, the voltage values are tested to assure they are within the valid range.

If a voltage value is outside of this range, a sporadic error is assumed and the last valid value is used for further calculations. An error is not stored, until the respective sensor value remains in an unauthorized value for a certain period of time.

**Reaction of PLD in case of error:**

Using replacement values.

#### 4.5.4.2. Crankshaft sensor

**Error recognition: crankshaft time-out**

Under normal circumstances, an interrupt is transmitted every 10 degrees crankshaft via the digital crankshaft signal. If this interrupt does not appear over a certain period of time the error “crankshaft time-out” (no crankshaft signal) is stored.

**Reaction of PLD in case of error:**

„Crankshaft time-out“ set in the fault memory and a transition to camshaft backup status takes place. I.e. backup by means of camshaft signal.

**Error recognition: crankshaft sensor polarity:**

If the connection lines of the crankshaft sensor indicate wrong polarity, the error “crankshaft sensor polarity” is stored. Corrective measures through customer service, engine must operate in idle.

*Note: Polarity can only occur after sensor replacement. The error can only be detected by a routine, which is started during the diagnosis by the customer service.*

**Reaction of PLD in case of error:**

None

**Workshop: reverse polarity**

**Error recognition: short circuit to ground and open circuit fault**

**Reaction of PLD in case of error:**

camshaft backup!

### 4.5.4.3. Camshaft sensor (cylinder 1 recognition)

#### **Error recognition: camshaft time-out**

Under normal circumstances, an interrupt of the digital camshaft signal is transmitted every 60 degrees crankshaft and 55 degrees crankshaft before cylinder 1 Top Dead Center (12 + 1 markings). If this interrupt does not appear over a certain period of time, the error "camshaft time-out" (no camshaft signal) is stored.

#### **Reaction of PLD in case of error:**

Transition to crankshaft backup status. I.e. backup by means of crankshaft signal.

#### **Error recognition: camshaft sensor polarity**

If the connection lines of the camshaft sensor indicate wrong polarity, the error „camshaft sensor polarity“ is stored. Corrective measures through customer service; engine must operate in idle.

#### **Reaction of PLD in case of error:**

*(see camshaft sensor reverse voltage protection)*

#### **Error recognition: short circuit to ground and open circuit fault**

#### **Reaction of PLD in case of error:**

Crankshaft backup status!

#### 4.5.5. Diagnosis of actuators

##### 4.5.5.1. MR-PLD injector-/magnetic valves (MV)

**Error recognition: short circuit**

Is only stored as an error, if it has been recognized as such for several times in succession.

**Reaction of PLD in case of error:**

Switch off the magnetic valve affected by the short circuit error. The valve remains deactivated until the control unit is restarted via terminal 15 or the error is deleted in the fault memory. As a result the respective cylinder is switched off.

**Error recognition: no magnetic valve contact**

The magnetic valves are only completely open, when the valve anchor has made magnetic contact. It is therefore essential to determine the time between the electrical switch-on point and the point of magnetic contact on the valve anchor. The MV-starting point must be offset by this period of time to adjust the correct begin of injection. To this purpose, the point in time of the magnetic contact of the valve anchor is detected by the system hardware and a contact signal is released. If this signal lies outside of a defined time reference, an error in point of magnetic contact is recognized.

**Reaction of PLD in case of error:**

If an error in point of magnetic contact is recognized, the last valid point of contact is used.

**Error recognition: interference of solenoid valve control**

After solenoid valve activation, the valve current must exceed a given current threshold after a specified period of time ( $=f(UB)$ ). If this current threshold is not yet surpassed after 1...1,5 ms, a control error is recognized.

**Reaction of PLD in case of error:**

The solenoid valve affected by the control error, remains electrically switched on, but it is possible that it does not open (current too low). Renewed solenoid valve control is attempted in the next working cycle.

**Measures taken by the customer service:**

Control of electrics.

#### 4.5.5.2. MR-PLD proportional valves

##### **Error recognition: short circuit to ground + lead**

If there are several consecutive short circuits in the positive lead during control of a proportional valve, the error „ground short (+lead)“ is stored.

##### **Reaction of PLD in case of error:**

Switch off the proportional valve affected by the short circuit error. The valve remains closed until the control unit is restarted via terminal 15 or the error is deleted in the fault memory.

#### 4.5.5.3. Starter control

##### **Error recognition: short circuit to ground**

If there are several consecutive short circuits (3 times) during the control of the starter, the error „ground short starter control“ is stored.

##### **Reaction of PLD in case of error:**

No further starter control until the next restart via terminal 15 or through the deletion of the error in the fault memory.

##### **Error recognition: open circuit fault**

If there is no starter control, the voltage level of the starter solenoid driver indicates if a open circuit fault exists.

##### **Reaction of PLD in case of error:**

None

## 4.6. Fault codes & repair instructions

### 4.6.1. Fault codes

The fault codes can be read off with a diagnosis unit (e.g. minidiag2).

- The display differentiates between current and non-current faults.
- Current fault codes cannot be cleared.

The fault codes listed apply to the MR-PLD.

The fault codes stored in the control unit describe the priority (valence = „w“), path („pp“) and type („aa“) of the fault which has developed.

**Example of a fault code: 10605**

<b>1</b>		=	<b>fault priority (w)</b>
	<b>06</b>	=	<b>fault path (pp)</b>
		<b>05</b>	= <b>fault type (aa)</b>

In the 5-digit fault code, the first digit (0,1 or 2) indicates the fault priority. Proceed as follows, depending on the fault priority:

#### 4.6.1.1. Fault priority 0

If necessary, these faults can be rectified during the next maintenance service.

#### 4.6.1.2. Fault priority 1

The fault must be rectified as soon as possible.

It can be expected that the running characteristics of the engine will be affected.

The driving and the braking characteristics of the vehicle may have changed if driving mode is active. If working speed governor mode is active, the operating characteristics of the equipment may have changed.

#### 4.6.1.3. Fault priority 2

The fault must be rectified immediately.

The running characteristics of the engine will be affected (emergency running programme).

The driving and braking characteristics of the vehicle will have changed if driving mode is active. If working speed governor mode is active, the operating characteristics of the equipment will have changed.



**Have priority 2 malfunctions rectified immediately in a DaimlerChrysler Service Station or specialist workshop.**

## 4.6. Fault codes & repair instructions

### 4.6.2. Fault path

Fault path (pp)	Description	Remark / Application
00	not assigned	
01	CAN interface	
02	not assigned	
03	crankshaft sensor	
04	camshaft sensor	
05	engine	only if no clear assignment is possible
06	not assigned	
07	carburation system / lambda control	air monitoring, gas monitoring CNG
08	knock sensor	CNG ecu
09	lambda sensor (LSU)	CNG ecu
10	engine-oil temperature sensor	
11	fuel temperature sensor	CNG ecu: gas temperature
12	charge-air temperature sensor	
13	ambient pressure sensor	
14	charge-air pressure sensor	
15	coolant temperature sensor	
16	engine-oil pressure sensor	
17	fuel pressure sensor	fuel monitoring (also in the case of CNG)
18	booster path / boost pressure control	air routing, Wastegate, VTG etc.
19	fuel circulation	fuel pump, fuel filter etc.
20	engine-oil circulation	oil pump etc.
21	coolant circulation	water pump etc.
22	terminal 15 detection (ignition)	
23	terminal 30 detection (supply)	
24	scavenging gradient sensor (P2S-P3)	
25	engine-oil level sensor	
26	speed sensor booster 1	boost pressure control
27	speed sensor booster 2	boost pressure control
28-29	not assigned	
<b>30</b>	<b>fuel pressure sensor**</b>	
31-39	not assigned	
40	control unit internal fault	CAUTION: measure: exchange control unit!
41	not assigned	
42-47	in-gas valves cylinder 1-6	electric circuit, CNG- ECU
48	control MV bank 1	electric circuit
49	control MV bank 2	electric circuit
50	control MV cylinder 1	electric circuit
51	control MV cylinder 2	electric circuit
52	control MV cylinder 3	electric circuit
53	control MV cylinder 4	electric circuit
54	control MV cylinder 5	electric circuit
55	control MV cylinder 6	electric circuit
56	control MV cylinder 7	electric circuit
57	control MV cylinder 8	electric circuit
58-63	ignition output stage cylinder 1-6	electric circuit, CNG- ECU
<b>64</b>	<b>heater flange**</b>	
65	oil separator	
66-68	not assigned	
69	gas shut-off valve	electric circuit, CNG- ECU
70	proportional valve 1	electric circuit
71	proportional valve 3	electric circuit
72	proportional valve 4	electric circuit
73	proportional valve 2	electric circuit
74	proportional valve 5	electric circuit
75	ECU voltage supply	terminal 30 / battery
76	proportional valve 6	electric circuit

77	proportional valve bank 1	electric circuit
78	proportional valve bank 2	electric circuit
79	not assigned	
80	starter/starter control	
81	throttle valve angle sensor B	electric circuit, CNG- ECU
82	throttle valve angle sensor A	electric circuit, CNG- ECU
83	throttle valve-motor	electric circuit, CNG- ECU
84	Lambda sensor (heater circuit)	electric circuit, CNG- ECU
85-89	not assigned	
90	cylinder 1	mechanical/hydraulic fault, e.g. LRR, EZA
91	cylinder 2	mechanical/hydraulic fault, e.g. LRR, EZA
92	cylinder 3	mechanical/hydraulic fault, e.g. LRR, EZA
93	cylinder 4	mechanical/hydraulic fault, e.g. LRR, EZA
94	cylinder 5	mechanical/hydraulic fault, e.g. LRR, EZA
95	cylinder 6	mechanical/hydraulic fault, e.g. LRR, EZA
96	cylinder 7	mechanical/hydraulic fault, e.g. LRR, EZA
97	cylinder 8	mechanical/hydraulic fault, e.g. LRR, EZA
98	not assigned	
99	immobilizer	

*Chart: fault paths (pp)*

*\*\*diagnosis version 6 and newer*

## 4.6. Fault codes & repair instructions

### 4.6.3. Fault type

Fault type (aa)	Description	Remark / Application
00	communication line 1 defective	communication interface (e.g. CAN)
01	communication line 2 defective	communication interface (e.g. CAN)
02	data not plausible	communication interface (e.g. CAN)
03	not assigned	
04	no communication	communication interface (e.g. CAN)
05	shortened to battery voltage (+lead)	plus-lead shorted to battery voltage (e.g. terminal 30)
06	ground short (-lead)	minus-lead shorted to ground
07	shortened to battery voltage (-lead)	minus-lead shorted to battery voltage (e.g. terminal 30)
08	ground short (+lead)	plus-lead shorted to ground
09	open circuit fault	general open circuit
10	signal level too low	crankshaft/camshaft
11	signal assignment not plausible	crankshaft/camshaft
12	signal timeout	generally speed sensor
13	signal polarity wrong	crankshaft/camshaft
14	not assigned	
15	measuring range exceeded	analogue sensor - voltage signal
16	remains under measuring range	analogue sensor - voltage signal
17	measuring value not plausible	analogue sensor
18	booster path defective	
19	signal inconsistent	
20	pressure too high	
21	pressure too low	
22	temperature too high	
23	temperature too low	
24	auxiliary controller / microcontroller 2 defective	internal fault
25	fluid level too high	
26	fluid level too low	
27	control disturbed	injector valves
28	injector valve-solenoid valve shorted	injector valves
<b>29</b>	<b>fill level to high**</b>	
30	engine speed too high	
31	engine speed too low	
32	not assigned	
33	starter relay hangs	starter
34	Highside transistor high-resistance	internal fault, PV-bank1
35	Highside transistor high-resistance	internal fault, PV-bank2
36	Highside transistor high-resistance	internal fault, PV5
37	cylinder number not plausible	internal fault
38	starter driver high-resistance	internal fault
39	starter driver low-resistance	internal fault
40	level-detection starter defective	internal fault, starter
41	transistor defective	internal fault, proportional valves
42	nominal range exceeded	e.g. battery voltage
43	remains under nominal range	e.g. battery voltage
44	limit value achieved	engine-smoothness control
45	limit value achieved	individual cylinder adaptation
46	EZA- Timeou	individual cylinder adaptation
47	fuel map (characteristic data map) defective	internal fault
48	cylinder number <> engine type not plausible	internal fault
49	calibration fault	

50	hardware detection wrong	internal fault
51	EEPROM- read error 1	internal fault
52	EEPROM- read error 2	internal fault
53	EEPROM- read error 3	internal fault
54	CAN data area defective	internal fault
55	AD converter monitoring	internal fault
<b>56</b>	<b>run off control defective</b>	<b>internal fault**</b>
<b>57</b>	<b>power supply defective</b>	<b>internal fault (so far only at CNG)**</b>
<b>58</b>	<b>fuel map data set manipulated</b>	<b>internal fault**</b>
59	not assigned	
60	key number limited to 8	WSP (immobilizer)
61	counter overflow	WSP (immobilizer)
62	not assigned	
63	no signal from redundant source	e.g. WSP : TPC via CAN TPC (TransPonder Code)
64	no signal from signal source	e.g. WSP : TPC via terminal 50
65	valid but incorrect signal code	e.g. WSP: key wrong
66-72	not assigned	
73	limit value achieved	loader ganging governor
74	set value deviation too high	integrator monitoring (e.g. booster)
75	system deviation too high	monitoring system deviation (e.g. booster)
76	limit value not achieved	e.g. boost pressure in booster trailing-throttle
77	control current not within tolerance	e.g. CNG, throttle valve setting-forces too high
78	general actuator fault	e.g. CNG, mechanical throttle valve failure
79	not assigned	
80	knocking combustion	CNG: problem gas quality
81	combustion with misfiring	CNG:
82-85	not assigned	
86	starter does not engage	starter
87-99	not assigned	

Chart: fault types (aa)

\*\*diagnosis version 6 and newer

## 4.6. Fault codes & repair instructions

### 4.6.4. Fault codes und repair instructions, high priority

<b>Fault-No.</b>	<b>Fault</b>	<b>Repair instructions</b>
<b>2 40 53</b>	internal fault EEPROM: Checksum- fault 3 (block production or immobilizer)	- check all affected connectors, plug connections and electric components for damage, loose contact, corrosion etc., and repair if necessary. - if fault code still present, renew and calibrate control unit. - perform functional check
<b>2 48 05</b>	control solenoid valve: shortened to battery voltage Highside bank 1	
<b>2 48 06</b>	control solenoid valve: ground short Lowside bank 1	
<b>2 49 05</b>	control solenoid valve: shortened to battery voltage Highside bank 2	
<b>2 49 06</b>	control solenoid valve: ground short Lowside bank2	
<b>2 50 28</b>	short circuit injector-/ solenoid valve cylinder 1	<p>important note:</p> <ul style="list-style-type: none"> <li>- upon removing mechanical or electrical faults at the injector valves, the engine-smoothness control has to be set to zero.</li> <li>- The engine smoothness control can be set to zero in the menu "controls" in the menu level "check engine smoothness control".</li> <li>- switch off ignition for at least 10s after each testing stage, start engine and read out actual fault.</li> <li>- general visual check (damage, loose contact, corrosion etc.), remove fault if necessary.</li> <li>- check electrical screw connections of the affected injector valve for short circuit.</li> <li>- disconnect electrical screw connections of the affected injector valve.</li> </ul> <p>example for fault code 25028</p> <ul style="list-style-type: none"> <li>- Fault code 25028 not actual: injector valve of the affected cylinder</li> <li>- fault code 25028 remains actual: check electrical supply lines of the respective injector valve(s) for short circuit, repair or replace if necessary.</li> <li>check electrical supply line of the affected injector valve if shorted to battery voltage and ground short, repair or replace if necessary.</li> <li>- if fault code 25028 remains present: replace and program ECU engine control (e.g. MR-PLD)</li> <li>- perform functional check</li> </ul>
<b>2 51 28</b>	short circuit injector-/ solenoid valve cylinder 2	
<b>2 52 28</b>	short circuit injector-/ solenoid valve cylinder 3	
<b>2 53 28</b>	short circuit injector-/ solenoid valve cylinder 4	
<b>2 54 28</b>	short circuit injector-/ solenoid valve cylinder 5	
<b>2 55 28</b>	short circuit injector-/ solenoid valve cylinder 6	
<b>2 56 28</b>	short circuit injector-/ solenoid valve cylinder 7	
<b>2 57 28</b>	short circuit injector-/ solenoid valve cylinder 8	
<b>2 99 65</b>	immobilizer wrong key	<p>note:</p> <ul style="list-style-type: none"> <li>-several attempts were made to start the vehicle with a non-trained key.</li> <li>- wait for the end of the timeout with the ignition switched on, train transponder key after that via the select menu "train transponder key" (FDOC authorization required).</li> <li>- the duration of the timeout depends on the number of the previous starting trials.</li> </ul>

Chart: fault codes and repair instructions, high priority

## 4.6.5. Fault codes und repair instructions, mean priority

<b>Fault-No.</b>	<b>Fault</b>	<b>Repair instructions</b>
<b>1 01 00</b>	CAN connection: CAN-High defective	<ul style="list-style-type: none"> <li>- check wire A6 X1 16/1 - A3 X4 18/1 for open circuit fault, repair or replace if necessary.</li> <li>- switch on ignition</li> <li>- delete fault memory in ECU engine control (e.g. MR-PLD)</li> <li>- delete fault memory in SG FRE</li> <li>- perform functional check</li> </ul>
<b>1 01 01</b>	CAN connection: CAN-Low defective	<ul style="list-style-type: none"> <li>- check wire A6 X1 16/2 - A3 X4 18/1 for open circuit fault, repair or replace if necessary</li> <li>- switch on ignition</li> <li>- delete fault memory in ECU engine control (e.g. MR-PLD)</li> <li>- delete fault memory in SG FRE</li> <li>- perform functional check</li> </ul>
<b>1 01 02</b>	CAN connection: CAN data not plausible	<ul style="list-style-type: none"> <li>- work off actual faults of SG FRE apart from CAN data bus fault codes 10201, 00202 and 10203.</li> <li>- perform functional check</li> </ul>
<b>1 01 04</b>	CAN connection: no connection to CAN	<ul style="list-style-type: none"> <li>- check CAN connection to SG FRE</li> <li>- check cables, connectors, plug connectors and electrical components for damage, correct connection, loose contact and corrosion, repair if necessary.</li> <li>- remove engine CAN bus fault in the SG FRE</li> <li>- perform functional check</li> <li>- communication with the ECU engine control (e.g. MR-PLD) restored: check calibration of ECU engine control (e.g. MR-PLD) for one wire capability.</li> </ul>
<b>1 01 49</b>	CAN connection: parameter fault CAN	<ul style="list-style-type: none"> <li>- check parameters 10 and 13 and correct if necessary.</li> <li>- perform functional check</li> </ul>
<b>1 03 08</b>	crankshaft position sensor: crankshaft sensor ground short	<ul style="list-style-type: none"> <li>- check wire N3/2 - N3/19 and position sensor for ground short, replace if necessary</li> <li>- nominal value 1.2 kOhm</li> </ul>
<b>1 03 09</b>	crankshaft position sensor: crankshaft sensor open circuit fault	<ul style="list-style-type: none"> <li>- check wire N3/2 - N3/19 and position sensor for open circuit fault, replace if necessary</li> <li>- nominal value 1.2 kOhm</li> </ul>
<b>1 03 10</b>	crankshaft position sensor: crankshaft level too low	<ul style="list-style-type: none"> <li>- pull out position sensor while engine is stopped and perform visual check.</li> <li>- remove metal pieces/shavings if necessary.</li> <li>- replace position sensor in the case of mechanical damage (clear stress marks)</li> <li>- replace clamping sleeve of the position sensor if necessary.</li> <li>- press-in speed (position) sensor during engine standstill until mechanical limit stop.</li> <li>- perform functional check</li> </ul>
<b>1 03 11</b>	crankshaft position sensor: crankshaft/camshaft signal assignment not plausible	<ul style="list-style-type: none"> <li>- pull out position sensor during engine standstill and perform visual check.</li> <li>- replace position sensor in the case of mechanical damage (clear stress marks).</li> <li>- check crankshaft- and camshaft position sensor for tight fitting, replace clamping sleeve if necessary.</li> <li>- press in both speed (position) sensor during engine standstill until mechanical limit stop.</li> <li>- check wires at plug connection N3 for damage, correct connection and corrosion, repair if necessary.</li> <li>- check crankshaft- and camshaft position sensor at plug N3 for interchanging.</li> </ul>
<b>1 03 12</b>	crankshaft position sensor: crankshaft timeout - no crankshaft signal	<ul style="list-style-type: none"> <li>- press in speed (position) sensor during engine standstill until mechanical limit stop.</li> <li>- fault code 10309 actual: work off this fault code.</li> <li>- fault code 10312 actual: check crankshaft position sensor, replace if necessary.</li> <li>- nominal value 1.2 kOhm</li> </ul>
<b>1 03 13</b>	crankshaft position sensor: crankshaft sensor wrong polarity	<ul style="list-style-type: none"> <li>- connect the position sensor correctly with the pin N3 of the control unit MR</li> <li>- perform functional check</li> </ul>

## 4.6. Fault codes & repair instructions

<b>1 04 08</b>	camshaft position sensor: camshaft sensor ground short	- check wire N3/1 - N3/20 and position sensor for ground short, replace if necessary. - nominal value: 1.2 kOhm
<b>1 04 09</b>	camshaft position sensor: camshaft sensor open circuit fault	- check wire N3/1 - N3/20 for open circuit, replace if necessary - nominal value: 1.2 kOhm
<b>1 04 12</b>	camshaft position sensor: camshaft time-out (no camshaft signal)	- if fault codes 10408 and 10409 are current, remove them first - pull out position sensor B16 during engine standstill and perform visual check - remove metal pieces/shavings if necessary. - replace position sensor in the case of mechanical damage (clear stress marks). - press in speed (position) sensor during engine standstill until mechanical limit stop.  - perform functional check.
<b>1 04 13</b>	camshaft position sensor: camshaft sensor wrong polarity	- position sensor B16 correctly with pin N3 of the ECU engine control (e.g. MR-PLD) - perform functional check
<b>1 05 30</b>	engine: engine speed too high	- inform about authorized engine speed - delete fault memory
<b>1 11 15</b>	fuel temperature sensor measuring range exceeded	- check wire B10, repair or replace if necessary. - nominal value: 2.4 kOhm (corresponds to 21°C) - check wire N3/36 - B10/1 if shortened to battery voltage and if open circuit fault, repair if necessary.  - check wire N3/4 - B10/2 for open circuit fault, repair if necessary. - perform functional check
<b>1 11 16</b>	fuel temperature sensor remains under measuring range	- check sensor B10, repair or replace if necessary. - nominal value: 2.4 kOhm (corresponds to 21°C) - check wire N3/36 - B10/1 for short circuit to ground, repair if necessary. - perform functional check
<b>1 12 15</b>	boost temperature sensor measuring range exceeded	- check temperature sensor B9, replace if necessary. - nominal value: 2.4 kOhm (corresponds to 21°C) - check wire N4/48 - B9/1 if connected to battery voltage and if open circuit fault, repair if necessary. - check wire N3/21 - B9/2 for open circuit fault, repair if necessary. - perform functional check.
<b>1 12 16</b>	boost temperature sensor remains under measuring range	- check temperature sensor B9, replace if necessary. - nominal value: 2.4 kOhm (corresponds to 21°C) - check wire N3/48 - B9/1 for short circuit to ground, repair if necessary. - perform functional check.
<b>1 14 15</b>	boost pressure sensor measuring range exceeded	- check boost pressure, replace if necessary. - check wire N3/29 - B13/2 for open circuit fault and if shorted to battery voltage, repair if necessary. - check wire N3/23 - B13/1 for open circuit fault, repair if necessary. - perform functional check.
<b>1 14 16</b>	boost pressure sensor remains under measuring range	- unplug the connector from combination sensor. fault codes 01215 and 11415 actual: replace combination sensor. - check wire N3/7 - B13/3 for short circuit to ground, repair if necessary. - check wire N3/29 - B13/2 for short circuit to ground, repair if necessary. - perform functional check.
<b>1 14 17</b>	boost pressure sensor measured value not plausible	- check wire N3/7 - B13/3 for open circuit fault, repair if necessary. - check boost pressure sensor, replace if necessary. - perform functional check.  - if fault code 01315 or 01316 also actual: replace and calibrate ECU engine control (e.g. MR-PLD).

## 4.6. Fault codes & repair instructions

<b>1 15 15</b>	coolant temperature sensor measuring range exceeded	<ul style="list-style-type: none"> <li>- check sensor B65, repair or replace if necessary.</li> <li>- nominal value: 2.4 kOhm (corresponds to 21°C)</li> <li>- check wire N3/34 - B65/1 for open circuit fault or if shortened to battery voltage, repair if necessary.</li> <li>- check wire N3/3 - B65/2 for open circuit fault, repair or replace if necessary.</li> <li>- perform functional check.</li> </ul>
<b>1 15 16</b>	coolant temperature sensor remains under measuring range	<ul style="list-style-type: none"> <li>- check sensor B65, repair or replace if necessary.</li> <li>- nominal value: 2.4 kOhm (corresponds to 21°C)</li> <li>- check wire N3/34 - B65/1 for open circuit fault, repair or replace if necessary.</li> <li>- perform functional check.</li> </ul>
<b>1 16 15</b>	oil pressure sensor measuring range exceeded	<ul style="list-style-type: none"> <li>- check oil pressure sensor, replace if necessary.</li> <li>- check wire N3/26 - B12/K1 for open circuit fault or if shortened to battery voltage, repair if necessary.</li> <li>- check wire N3/5 - B12/K2 for open circuit fault, repair if necessary.</li> <li>- perform functional check.</li> </ul>
<b>1 16 16</b>	oil pressure sensor remains under measuring range	<ul style="list-style-type: none"> <li>- check oil pressure sensor, replace if necessary.</li> <li>- check wire N3/26 - B12/K1 for short circuit to ground, repair if necessary.</li> <li>- perform functional check.</li> </ul>
<b>1 16 17</b>	oil pressure sensor signal not plausible	<ul style="list-style-type: none"> <li>- check oil level, correct if necessary.</li> <li>- check wire N3 55/6 - B110/3 for open circuit fault, repair or replace if necessary.</li> <li>- check oil pressure sensor, replace if necessary.</li> <li>- perform functional check.</li> </ul>
<b>1 17 15</b>	combination input (FPS, P-DK): measuring range exceeded	
<b>1 17 16</b>	combination input (FPS, P-DK): remains under measuring range	
<b>1 17 17</b>	combination input (FPS, P-DK): signal not plausible	
<b>1 18 18</b>	booster path: booster path defective	<ul style="list-style-type: none"> <li>- check tubes and connections between turbocharger, boost air cooler and the boost air tubes for leakage.</li> <li>- check boost air cooler.</li> <li>- perform functional check.</li> </ul>
<b>1 18 20</b>	booster path: boost pressure too high	<ul style="list-style-type: none"> <li>- if fault codes 11415 or 11417 are also present, process them first.</li> <li>- boost pressure system (boost air tubes, boost air cooler) visual check..</li> <li>- perform functional check.</li> </ul>
<b>1 18 73</b>	max. output of booster speed balancing governor	
<b>1 18 74</b>	booster path / boost pressure control: set value deviation too high (with power reduction)	
<b>1 18 75</b>	booster path / boost pressure control: boost pressure deviation too high	
<b>1 18 76</b>	booster path / boost pressure control: braking power too low	
<b>1 19 17</b>	fuel circulation: measured value not plausible	
<b>1 22 19</b>	terminal 15 detection: inconsistency MR<->FR	<ul style="list-style-type: none"> <li>- check fuse F30, replace if necessary.</li> <li>- check wires and plug connectors between S1/1 and A3 X2 18/3 or A6 X1 16/15 for open circuit fault, repair or replace if necessary.</li> <li>- perform functional check.</li> </ul>

## 4.6. Fault codes & repair instructions

<b>1 23 19</b>	terminal 50 detection: inconsistency MR<->FR	- check wires and plug connectors between S1/2 and A3 X1 18/18 for open circuit fault, repair if necessary. - check wires and plug connectors between S1/2 and A6 X1 16/8 for open circuit fault, repair if necessary. - perform functional check.
<b>1 24 15<sup>D)</sup></b>	scavenging gradient sensor (P2S-P3): measuring range exceeded	
<b>1 24 16<sup>D)</sup></b>	scavenging gradient sensor (P2S-P3): remains under measuring range	
<b>1 26 12</b>	no speed booster 1	
<b>1 27 12</b>	no speed booster 2	
<b>1 40 34<sup>D)</sup></b>	internal fault: HS-transistor PVB1 high-resistance	
<b>1 40 35<sup>D)</sup></b>	internal fault: HS-transistor PVB2 high-resistance	
<b>1 40 36<sup>D)</sup></b>	internal fault: HS-transistor PV5 high-resistance	
<b>1 40 38</b>	internal fault: starter driver high-resistance (main path)	
<b>1 40 39</b>	internal fault: starter driver low-resistance (main path or auxiliary path)	- check all affected plugs, plug connectors and electrical components for damage, loose contact, corrosion etc. and repair if necessary. - if fault code is still present, replace and program control unit. - perform functional check.
<b>1 40 41<sup>C)</sup></b>	internal fault: PV- Highside- transistor defective	- check all affected plugs, plug connectors and electrical components for damage, loose contact, corrosion etc. and repair if necessary. - if fault code is still present, replace and program control unit. - perform functional check.
<b>1 40 49</b>	internal fault: parametrization fault	- check all affected plugs, plug connectors and electrical components for damage, loose contact, corrosion etc. and repair if necessary. - if fault code is still present, replace and program control unit. - perform functional check.
<b>1 40 52</b>	internal fault: EEPROM: CKS- fault 2 (groups vehicle parameters)	- check all affected plugs, plug connectors and electrical components for damage, loose contact, corrosion etc. and repair if necessary. - if fault code is still present, replace and program control unit. - perform functional check.
<b>1 40 54</b>	internal fault: CAN-data area defective	- check all affected plugs, plug connectors and electrical components for damage, loose contact, corrosion etc. and repair if necessary. - if fault code is still present, replace and program control unit. - perform functional check.
<b>1 40 58</b>	internal fault: fuel map data set manipulated	An inadmissible change was recognized by the fuel map data set (tuning), which engine operated in the CAN backup mode (backup engine speed).

<b>1 50 26</b>	contact recognition injector-/solenoid valve: no contact cylinder 1	<p>important note:</p> <ul style="list-style-type: none"> <li>- upon removing mechanical or electrical faults at the injector valves, the engine-smoothness control has to be set to zero.</li> <li>- the engine-smoothness control can be set to zero in the menu "controls" at the menu level "check of engine-smoothness control".</li> <li>- if fault code 07543 actual, process this fault code first.</li> <li>- if fuel filter installed: check fuel filter and clean or replace it if necessary.</li> <li>- bleed fuel line, after work at fuel system,.</li> <li>- fault code 15026 remains actual: carry out subsequent checks.</li> <li>- corresponding fault code actual at another cylinder of the same bank: check electrical supply lines of the affected injector valve(s) for short circuit, repair or replace if necessary.</li> <li>- corresponding fault code actual at another cylinder of the same bank: exchange injector valve of the affected cylinder with the injector valve of a cylinder which is not affected. Have the engine run.</li> <li>- fault code moves on (with the injector valve) to the other cylinder. Replace exchanged injector valve.</li> </ul>
<b>1 50 27</b>	control failure injector-/solenoid valve: control cylinder 1 disturbed	<p>important note:</p> <ul style="list-style-type: none"> <li>- upon removing mechanical or electrical faults at the injector valves, the engine-smoothness control has to be set to zero.</li> <li>- the engine-smoothness control can be set to zero in the menu "controls" at the menu level "check engine-smoothness control".</li> <li>- if fault code 07543 actual, process this fault code first.</li> <li>- check screw terminals at the affected injector valve for tight fitting.</li> <li>- check the supply line of the affected injector valve for interruption.</li> <li>- check connectors X1 and N3 of the ECU engine control (e.g. MR-PLD) for correct contacting.</li> <li>- fault code 15027 remains present: exchange injector valve of the affected cylinder with the injector valve of a cylinder which is not affected. Have the engine run.</li> <li>- fault code moves on (with the injector valve) to the other cylinder. Replace exchanged injector valve.</li> </ul>
<b>1 51 26</b>	contact recognition injector-/solenoid valve: no contact cylinder 2	refer to example of fault code 15026...
<b>1 51 27</b>	control failure injector-/solenoid valve: control cylinder 2 disturbed	refer to example of fault code 15027...
<b>1 52 26</b>	contact recognition injector-/solenoid valve: no contact cylinder 3	refer to example of fault code 15026...
<b>1 52 27</b>	control failure injector-/solenoid valve: control cylinder 3 disturbed	refer to example of fault code 15027....
<b>1 53 26</b>	contact recognition injector-/solenoid valve: no contact cylinder 4	refer to example of fault code 15026...
<b>1 53 27</b>	control failure injector-/solenoid valve: control cylinder 4 disturbed	refer to example of fault code 15027...
<b>1 54 26</b>	contact recognition injector-/solenoid valve: no contact cylinder 5	refer to example of fault code 15026...

## 4.6. Fault codes & repair instructions

<b>1 54 27</b>	control failure injector-/solenoid valve: control cylinder 5 disturbed	refer to example of fault code 15027...
<b>1 55 26</b>	contact recognition injector-/solenoid valve: no contact cylinder 6	refer to example of fault code 15026...
<b>1 55 27</b>	control failure injector-/solenoid valve: control cylinder 6 disturbed	refer to example of fault code 15027...
<b>1 56 26</b>	contact recognition injector-/solenoid valve: no contact cylinder 7	refer to example of fault code 15026...
<b>1 56 27</b>	control failure injector-/solenoid valve control cylinder 7 disturbed	refer to example of fault code 15027...
<b>1 57 26</b>	contact recognition injector-/solenoid valve: no contact cylinder 8	refer to example of fault code 15026...
<b>1 57 27</b>	control failure injector-/solenoid valve: control cylinder 8 disturbed	refer to example of fault code 15027...
<b>1 64 09</b>	heater flange: open circuit fault (heater flange defective)	Condition: The heating flange becomes after Kl. 15 uniquely briefly switched on. Here if no break-down of the battery voltage is recognized, the heating flange is classified as defective. Error threshold and cyclic duration are deposited in the data record.
<b>1 70 06</b>	proportional valve 1: short circuit to ground (-lead)	note: ECU engine control (e.g. MR-PLD) wrong calibration.  - check parametrization. - parameter 06 has to be set to NOT ACTIVE - if not, then the data set of ECU engine control (e.g. MR-PLD) is wrong - replace and program ECU engine control (e.g. MR-PLD). - perform functional check.
<b>1 70 07<sup>D)</sup></b>	proportional valve 1: shortened to battery voltage (-lead)	
<b>1 70 09</b>	proportional valve 1: open circuit fault	note: ECU engine control (e.g. MR-PLD) wrong calibration.  - check parametrization. - parameter 06 has to be set to NOT ACTIVE - if not, then the data set of ECU engine control (e.g. MR-PLD) is wrong - replace and program ECU engine control (e.g. MR-PLD). - perform functional check.
<b>1 71 06</b>	proportional valve 3: short circuit to ground (-lead)	note: ECU engine control (e.g. MR-PLD) wrong calibration / short circuit to ground  - check calibration, correct if necessary. Parameter 008 has to be set to NOT ACTIVE.  - if the calibration is OK, check wire N3/41 - Y70/1 for short circuit to ground, repair or replace if necessary.  - if still no fault can be detected, replace and program ECU engine control (e.g. MR-PLD). - perform functional check.
<b>1 71 07<sup>D)</sup></b>	proportional valve 3: shortened to battery voltage (-lead)	

<b>1 71 09</b>	proportional valve 3: open circuit fault	<p>note: ECU engine control (e.g. MR-PLD) wrong calibration/ open circuit fault</p> <ul style="list-style-type: none"> <li>- check calibration, correct if necessary. Parameter 008 has to be set to NOT ACTIVE.</li> </ul> <p>note:</p> <ul style="list-style-type: none"> <li>- if a Linnig-fan is installed, the following calibration applies: parameters 8 and 9 have to be set to ACTIVE. parameter 14 has to be set to "Type 0".</li> </ul> <ul style="list-style-type: none"> <li>- fault code 17109 still actual: check wires N3/41 - Y70/1 and N3/12 - Y70/2 for open circuit fault, repair or replace if necessary.</li> <li>- if no fault can be detected, replace and program ECU engine control (e.g. MR-PLD).</li> <li>- perform functional check.</li> </ul>
<b>1 71 12</b>	fan speed no signal (timeout)	<p>currently not fan speed detection installed.</p> <ul style="list-style-type: none"> <li>- check calibration, correct if necessary. Parameter 14 has to be set to "Type 0".</li> </ul>
<b>1 72 06</b>	proportional valve 4: short circuit to ground (-lead)	<p>note: ECU engine control (e.g. MR-PLD) wrong calibration / short circuit to ground</p> <ul style="list-style-type: none"> <li>- check calibration, correct if necessary. Parameter 009 has to be set to NOT ACTIVE.</li> <li>- if the calibration is OK, check wire N3/43 - Y70/3 for short circuit to ground, repair or replace if necessary.</li> <li>- if still no fault can be detected, replace and program ECU engine control (e.g. MR-PLD).</li> <li>- perform functional check.</li> </ul>
<b>1 72 07<sup>D)</sup></b>	proportional valve 4: shortened to battery voltage (-lead)	
<b>1 72 09</b>	proportional valve 4: open circuit fault	<p>note: ECU engine control (e.g. MR-PLD) wrong calibration / open circuit fault</p> <ul style="list-style-type: none"> <li>- check calibration, correct if necessary. Parameter 009 has to be set to NOT ACTIVE.</li> </ul> <p>note:</p> <ul style="list-style-type: none"> <li>- if a Linnig-fan is installed, the following calibration applies: a) parameters 8 and 9 have to be set to ACTIVE. b) parameter 14 has to be set to "Type 0".</li> </ul> <ul style="list-style-type: none"> <li>- fault code 17209 remains actual: check wires N3/43 - Y71/3 und N3/12 - Y71/4 for open circuit fault, repair or replace if necessary.</li> <li>- if no fault can be detected, replace and program ECU engine control (e.g. MR-PLD)</li> <li>- perform functional check.</li> </ul>
<b>1 73 06</b>	proportional valve 2: short circuit to ground (-lead)	<p>note: ECU engine control (e.g. MR-PLD) wrong calibration</p> <ul style="list-style-type: none"> <li>- check calibration, correct if necessary. Parameter 007 has to be set to NOT ACTIVE.</li> <li>- if not, then the data set of the control unit MR is wrong.</li> <li>- replace and program ECU engine control (e.g. MR-PLD).</li> <li>- perform functional check.</li> </ul>
<b>1 73 07<sup>D)</sup></b>	proportional valve 2: shortened to battery voltage (-lead)	

## 4.6. Fault codes & repair instructions

<b>1 73 09</b>	proportional valve 2: open circuit fault	
<b>1 74 05<sup>D)</sup></b>	proportional valve 5: shortened to battery voltage (+lead)	
<b>1 74 08<sup>D)</sup></b>	proportional valve 5: short circuit to ground (+lead)	
<b>1 76 09<sup>D)</sup></b>	proportional valve 6: open circuit fault	
<b>1 77 05<sup>D)</sup></b>	proportional valve bank 1: shortened to battery voltage (+lead)	
<b>1 77 08<sup>D)</sup></b>	proportional valve bank 1: short circuit to ground (+lead)	
<b>1 78 05<sup>D)</sup></b>	proportional valve bank 2: shortened to battery voltage (+lead)	
<b>1 78 08<sup>D)</sup></b>	proportional valve bank 2: short circuit to ground (+lead)	
<b>1 80 05</b>	starter control : starter relay external current supply	<ul style="list-style-type: none"> <li>- check wire N3/18 - terminal 50 input (terminal 86) of starter relay if shortened to battery voltage, repair or replace if necessary.</li> <li>- check starter relay, replace if necessary.</li> <li>- restore electrical connection(s)</li> </ul>
<b>1 80 08</b>	starter control: short circuit to ground	<ul style="list-style-type: none"> <li>- check wire N3/18 - terminal 50 input (terminal 86) of the starter relay for short circuit to ground, repair or replace if necessary.</li> <li>- check starter relay, replace if necessary.</li> </ul>
<b>1 80 09</b>	starter control: open circuit fault	<ul style="list-style-type: none"> <li>- disconnect battery</li> <li>- check wire N3/18 - terminal 50 input (terminal 86) of the starter relay for open circuit fault, repair or replace if necessary.</li> <li>- check starter relay, replace if necessary.</li> </ul>
<b>1 80 33</b>	starter control: starter relay fixed in closed position	<ul style="list-style-type: none"> <li>- check starter relay, replace if necessary.</li> </ul>
<b>1 80 39</b>	Starter output stage with low impedance (main branch or branch of emergency) or load (relay) also to high resistance and/or to high inductance.	<p>Main branch: During the controller initialization the two transistors of the main branch are alternating switched on briefly. The level at the starter output changes thereby on „High“, the main branch is classified as low impedance.</p> <p>Backup branch: If that changes for clamp 50 signal on „High“ and follows this level change a change of the level at the starter output before the starter output stage was activated, the backup branch is classified as low impedance.</p>
<b>1 80 86</b>	starter control: starter does not engage	<ul style="list-style-type: none"> <li>- check starter electrically and mechanically</li> <li>- perform functional check.</li> </ul>
<b>1 99 60</b>	immobilizer: key number limited to 8	<ul style="list-style-type: none"> <li>- a maximum of eight key- transponder codes can be stored in the ECU engine control (e.g. MR-PLD).</li> <li>- if this number of keys has already been lost, train the new keys via the select menu "train transponder key". This requires a FDOC-authorization.</li> </ul>
<b>1 99 61</b>	immobilizer: counter overflow	<p>note:</p> <ul style="list-style-type: none"> <li>- ECU engine control (e.g. MR-PLD) is unserviceable, because manipulations for the decoding of the transponder codes (immobilizer) have been made at the vehicle.</li> <li>- replace and program ECU engine control (e.g. MR-PLD)</li> <li>- perform functional check.</li> </ul>

<b>1 99 62</b>	immobilizer: X5 has been with drawn	note: - a ECU engine control (e.g. MR-PLD) for applications without immobilizer has been installed in a vehicle with immobilizer. The ECU engine control (e.g. MR-PLD) has activated the immobilizer, i.e. it became unserviceable for the prior application. The SG can only be used for an operation with an immobilizer.  - train transponder key via the select menu "train transponder key". This requires FDOC-authorization. - in the case of power shortage or excessive fuel consumption a new ECU engine control (e.g. MR-PLD) (adjusted to the respective engine) has to be installed.
<b>1 99 63</b>	immobilizer: no TPC via CAN	- fault code 19964 also actual: use spare transponder key in order to start - engine starts with spare key: try to train the defective transponder key via the select menu "train transponder key". if the trial fails, order and train a new transponder code (FDOC authorization required).  - engine does not start with spare key. Check voltage supply and wiring of the readout-electronics, repair if necessary. If no fault is detected, replace readout-electronics of the immobilizer.  - fault code 19964 not actual: check calibration of the SG FRE for immobilizer. - in the SG FRE no parameters are set for the immobilizer: calibrate the SG FRE for immobilizer. - SG FRE is calibrated for immobilizer: check fault memory for actual fault code 12319.  - fault code 12319 actual: check wire of terminal 50 between driving switch and SG FRE for open circuit fault, repair or replace if necessary. - fault code 12319 not actual: work off stored CAN-bus faults.
<b>1 99 64</b>	immobilizer: no TPC via terminal 50	note. - the readout-electronics read the transponder code and sends it permanently to the control units FRE and MR via the wire terminal 50.  - if fault code 19963 actual, process this fault code first.  - check wire of terminal 50 between driving switch and ECU engine control (e.g. MR-PLD) for open circuit fault, repair or replace if necessary.

*Chart: fault codes and repair instructions, mean priority.*

## 4.6. Fault codes & repair instructions

### 4.6.6. Fault codes und repair instructions, minor priority

<b>Fault-No.</b>	<b>Fault</b>	<b>Remark / Repair instructions</b>
<b>0 10 15</b>	oil temperature sensor measuring range exceeded	<ul style="list-style-type: none"> <li>- check oil temperature sensor B11, replace if necessary. nominal value: 2.4 kOhm (corresponds to 21 °C)</li> <li>- check wire N3/39 - B11/1 for open circuit fault and if shortened to battery voltage, repair if necessary.</li> <li>- check wire N3/15 - B11/2 for open circuit fault, repair if necessary.</li> <li>- if fault code is still present: replace and program ECU engine control (e.g. MR-PLD).</li> <li>- perform functional check.</li> </ul>
<b>0 10 16</b>	oil temperature sensor remains under measuring range	<ul style="list-style-type: none"> <li>-check oil temperature sensor B11 and replace if necessary. nominal value: 2.4 kOhm (corresponds to 21 °C)</li> <li>- check wire N3/39 - B11/1 for ground short, repair if necessary.</li> <li>- if fault code still present: replace and program ECU engine control (e.g. MR-PLD).</li> <li>- perform functional check.</li> </ul>
<b>0 13 15</b>	ambient pressure sensor measuring range exceeded	<ul style="list-style-type: none"> <li>- if fault codes 11415 or 11416 are present, remove them first</li> <li>- fault code 01315 remains present: read out actual values 014 and 015 and compare with each other.</li> <li>- actual value inside tolerance band (+/- 10%) while engine stops: replace and program ECU engine control (e.g. MR-PLD).</li> </ul>
<b>0 13 16</b>	ambient pressure sensor remains under measuring range	<ul style="list-style-type: none"> <li>- if fault codes 11415 or 11416 are present, remove them first</li> <li>- fault code 01316 remains present: read out actual values 014 and 015 and compare with each other.</li> <li>- actual value inside tolerance band (+/- 10%) while engine stops: replace and program ECU engine control (e.g. MR-PLD).</li> </ul>
<b>0 18 22</b>	booster path: temperature to high	boost air temperature to high
<b>0 18 74</b>	booster path (control) set value deviation too high	
<b>0 20 20</b>	engine oil circulation pressure too low	
<b>0 20 26</b>	engine oil circulation fluid level too high / too low	
<b>0 21 22</b>	coolant circulation temperature too high	
<b>0 25 09</b>	oil level sensor open circuit fault	<ul style="list-style-type: none"> <li>- check oil level sensor B14, replace if necessary.</li> <li>- check wire N3/33 - B14/1 for open circuit fault, repair or replace if necessary.</li> <li>- check wire N3/49 - B14/2 for open circuit fault, repair or replace if necessary</li> <li>- perform functional check</li> </ul>
<b>0 25 15</b>	oil level sensor measuring range exceeded	<ul style="list-style-type: none"> <li>- check oil level, correct if necessary.</li> <li>- check wire N3/33 - B14/1 if shortened to battery voltage, repair or replace if necessary.</li> <li>- check oil level sensor B14 resistance, replace if necessary</li> <li>- nominal value: 20-25 Ohm</li> <li>- perform functional check.</li> </ul>
<b>0 25 16</b>	oil level sensor remains under measuring range	<ul style="list-style-type: none"> <li>- check oil level, correct if necessary.</li> <li>- check wire N3/33 - B14/1 for ground short, repair or replace if necessary.</li> <li>- check oil level sensor B14 resistance, replace if necessary.</li> <li>- nominal value: 20-25 Ohm</li> <li>- perform functional check.</li> </ul>
<b>0 25 17</b>	oil level sensor measured value not plausible	<ul style="list-style-type: none"> <li>- check oil level during engine standstill, correct if necessary.</li> <li>- check calibration of oil pan type, correct if necessary.</li> <li>- calibration of oil level sensor, correct if necessary.</li> <li>- check cable, plug, plug connections and electrical components for damage, correct connection, loose contact and corrosion, repair if necessary.</li> <li>- check oil level sensor B14 resistance, replace if necessary.</li> <li>- nominal resistance: 22 Ohm when oil pan filled.</li> <li>- perform functional check.</li> </ul>

## 4.6. Fault codes & repair instructions

<b>0 40 24</b>	internal fault: auxiliary controller defective	- check all affected connectors, plug connections and electrical components for damage, loose contact, corrosion etc. and repair if necessary. - if fault code is still present, renew and program control unit - perform functional check.
<b>0 40 37</b>	internal fault: cylinder number implausible	- check all affected connectors, plug connections and electrical components for damage, loose contact, corrosion etc. and repair if necessary. - if fault code is still present, renew and program control unit. - perform functional check.
<b>0 40 38</b>	internal fault: high resistance starter driver (redundant-/auxiliary path)	- if fault code 07543 is present, remove this fault code first. - check all affected connectors, plug connections and electrical components for damage, loose contact, corrosion etc. and repair if necessary. - if fault code is still present, renew and program control unit. - perform functional check.
<b>0 40 40</b>	internal fault: level detection starter defective	- check all affected connectors, plug connections and electrical components for damage, loose contact, corrosion etc. and repair if necessary. - if fault code is still present, renew and program control unit. - perform functional check.
<b>0 40 47</b>	internal fault: characteristic data map defective	- check all affected connectors, plug connections and electrical components for damage, loose contact, corrosion etc. and repair if necessary. - if fault code is still present, renew and program control unit. - perform functional check.
<b>0 40 48</b>	internal fault: cylinder number implausible	- check all affected connectors, plug connections and electrical components for damage, loose contact, corrosion etc. and repair if necessary. - if fault code is still present, renew and program control unit. - perform functional check.
<b>0 40 50</b>	internal fault: incorrect hardware detection	- check all affected connectors, plug connections and electrical components for damage, loose contact, corrosion etc. and repair if necessary. - if fault code is still present, renew and program control unit. - perform functional check.
<b>0 40 51</b>	internal fault: EEPROM: Checksum failure 1 (memory fault)	- check all affected connectors, plug connections and electrical components for damage, loose contact, corrosion etc. and repair if necessary. - if fault code is still present, renew and program control unit. - perform functional check.
<b>0 40 56</b>	internal fault: backup control defective	
<b>0 65 06<sup>D)</sup></b>	oil separator: short circuit to ground diagnostic line	
<b>0 65 64<sup>D)</sup></b>	oil separator: oil separator defective	
<b>0 75 42</b>	battery voltage: nominal range exceeded	possible sources of fault: - generator or governor defective.
<b>0 75 43</b>	battery voltage: remains below nominal range	possible sources of fault: - battery discharged or defective. - generator or governor defective. - fuse F30 at the basic module is defective. - wires of voltage supply are defective.

<b>0 90 44</b>	engine-smoothness control: LRR-limitation cylinder 1	<p>important note:</p> <ul style="list-style-type: none"> <li>- upon removing mechanical or electrical faults at the injector valves, the engine-smoothness control has to be set to zero.</li> <li>- the engine smoothness control can be set to zero in the menu "controls" at the menu level "check of the engine-smoothness control".</li> </ul> <p>note:</p> <ul style="list-style-type: none"> <li>- injection quantity adjustment for the engine-smoothness control for cylinder 1 not within the authorized tolerance (<math>\pm 6\%</math>).</li> <li>- check engine-smoothness control via the select menu "controls".</li> <li>- perform compression check via the select menu "controls".</li> <li>- check tightening torque of the pressure-pipe tube at the injection nozzle. Check pressure-pipe tube for cracks.</li> <li>- exchange the injector valve of the affected cylinder with the injector valve of a cylinder which is not affected.</li> <li>- exchange injection nozzle of the affected cylinder with an injection nozzle of a cylinder which is not affected.</li> </ul>
<b>0 90 45</b>	individual cylinder adaption: EZA-limitation cylinder 1	<p>important note:</p> <ul style="list-style-type: none"> <li>- upon removing mechanical or electrical faults at the injector valves, the engine smoothness control has to be set to zero</li> <li>- the engine smoothness control can be set to zero in the menu "controls" at the menu level "check of the engine-smoothness control".</li> </ul> <ul style="list-style-type: none"> <li>- perform compression check via the select menu "controls".</li> <li>- compression of the affected cylinder &lt; 75 % of the nominal value? Remove mechanical faults (valves, piston ring etc.).</li> <li>- compression is OK: exchange the injector valve of the affected cylinder with the injector valve of a cylinder which is not affected. Have the engine run. Perform individual cylinder adaptation.</li> <li>- the other cylinder is now affected by the deviation: replace the exchanged injector valve.</li> <li>- deviation does not change due to the exchange of the injector valves: check injection nozzle of the affected cylinder and replace if necessary. Check high pressure side tube to injector valve for leakage. Eliminate leakage problem of the affected cylinder.</li> </ul>
<b>0 91 44</b>	engine-smoothness control: LRR-limitation cylinder 2	refer to fault code of example 09044...
<b>0 91 45</b>	individual cylinder adaptation: EZA-limitation cylinder 2	refer to example of fault code 09045...
<b>0 92 44</b>	engine-smoothness control: LRR-limitation cylinder 3	refer to fault code of example 09044....
<b>0 92 45</b>	individual cylinder adaptation: EZA-limitation cylinder 3	refer to example of fault code 09045...
<b>0 93 44</b>	engine-smoothness control: LRR-limitation cylinder 4	refer to fault code of example 09044...
<b>0 93 45</b>	individual cylinder adaption: EZA-limitation cylinder 4	refer to example of fault code 09045...
<b>0 94 44</b>	engine-smoothness control: LRR-limitation cylinder 5	refer to fault code of example 09044...
<b>0 94 45</b>	individual cylinder adaptation: EZA-limitation cylinder 5	refer to example of fault code 09045...
<b>0 95 44</b>	engine-smoothness control: LRR-limitation cylinder 6	refer to fault code of example 09044...
<b>0 95 45</b>	individual cylinder adaption: EZA-limitation cylinder 6	refer to example of fault code 09045...

<b>0 96 44</b>	engine-smoothness control: LRR-limitation cylinder 7	refer to fault code of example 09044...
<b>0 96 45</b>	individual cylinder adaptation: EZA-limitation cylinder 7	refer to example of fault code 09045...
<b>0 97 44</b>	engine-smoothness control: LRR-limitation cylinder 8	refer to fault code of example 09044...
<b>0 97 45</b>	individual cylinder adaptation: EZA-limitation cylinder 8	refer to example of fault code 09045...
<b>0 98 46</b>	individual cylinder adaption: timeout	

*Chart: fault codes and repair instructions, minor priority*

## 4.7. Special measurements

### 4.7.1. General information

Measurements should normally only be carried out with minidiag2/Stardiagnose. Important safety features have to be observed, if a measurement is carried out without a DaimlerChrysler measuring- or diagnosis unit.

The warranty claim expires, if the safety precautions are not applied!

**CAUTION:**

*An external current supply of the actuator outputs is not permissible (only via the MR-PLD)!*

### 4.7.2. Actuators

#### 4.7.2.1. Solenoid valves: measuring of the current modulation curve of the injector valve control/ type 1

If there are clamp-on probes at the two-channel oscilloscope, the current of an injector valve can be measured.

**CAUTION!** *Connecting the positive terminal of the battery with the injector valve is not permissible!*

Connection/measuring type 1:

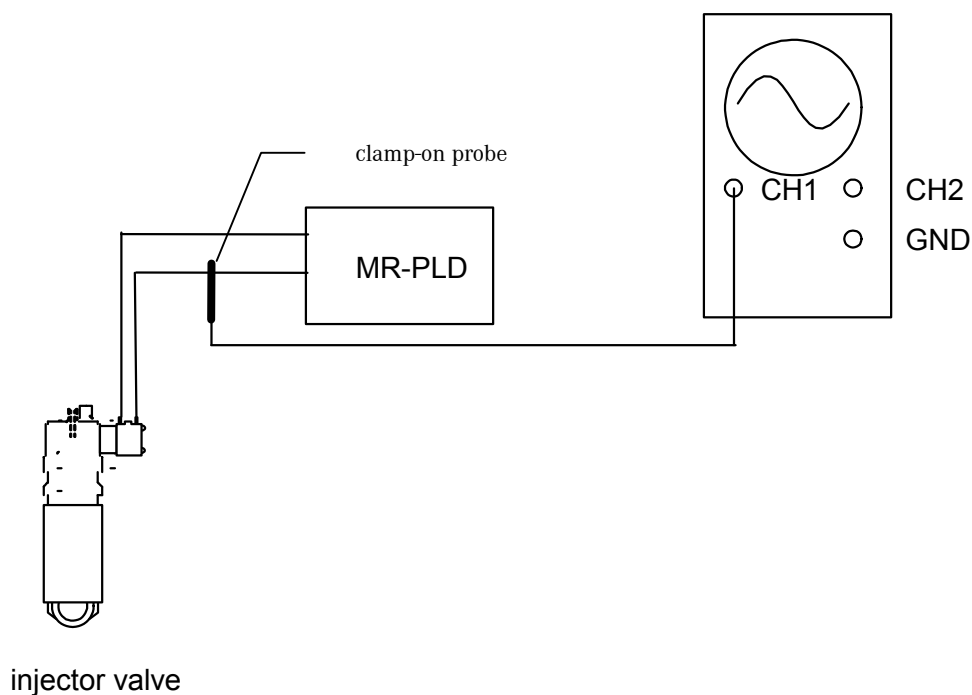

## 4.7. Special measurements

---

### Diagram/measuring type 1

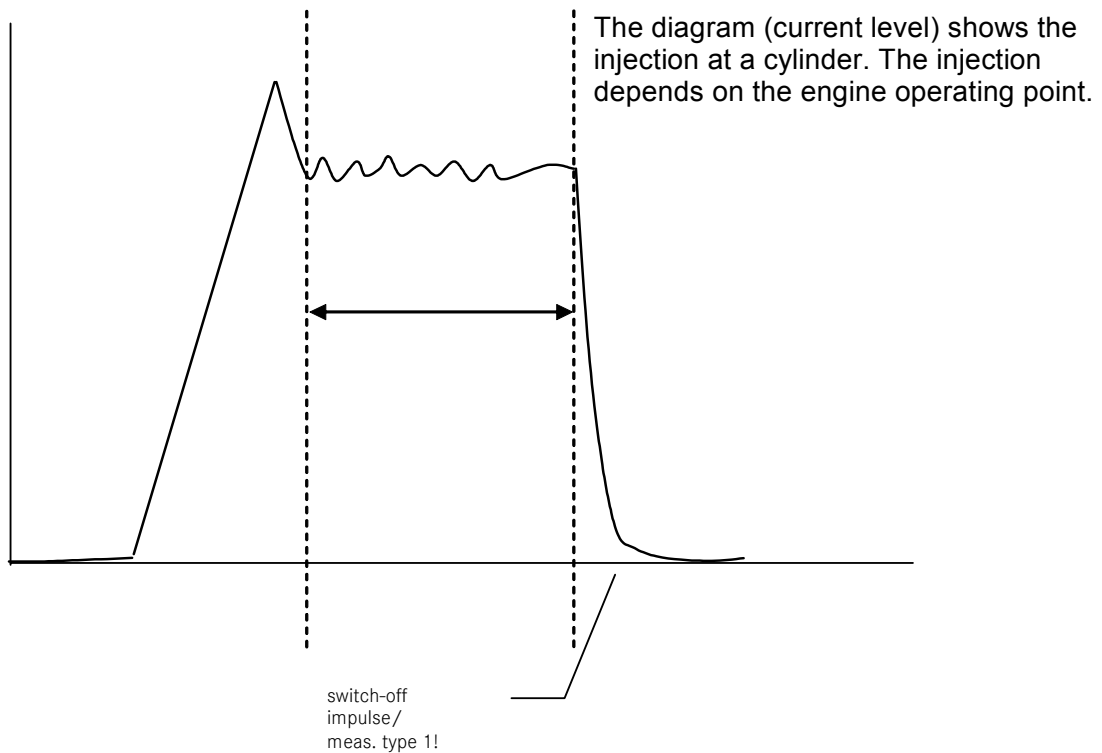

*Note:*

*For this measurement the respective injector valve has to be connected with the engine harness, in order to ensure the current supply through the MR-PLD.*

#### 4.7.2.2. Solenoid valves: measuring of the current modulation curve of the injector valve control/ type 2

With a two-channel oscilloscope the current of an injector valve can be measured, by inverting the voltage level of a measuring channel (CH2) and adding the two channels (CH1 + CH2). During engine standstill (ignition OFF) each of the two terminals of the injector valve is connected with one channel (CH1 and CH2). The ground (GND) of the oscilloscope-wire has to be connected with battery ground.

**CAUTION!** Connecting the positive terminal of the battery with the injector valve is not permissible!

In the case of a correct wiring, the current modulation curve can be measured when the engine is running.

Connection/measuring type 2:

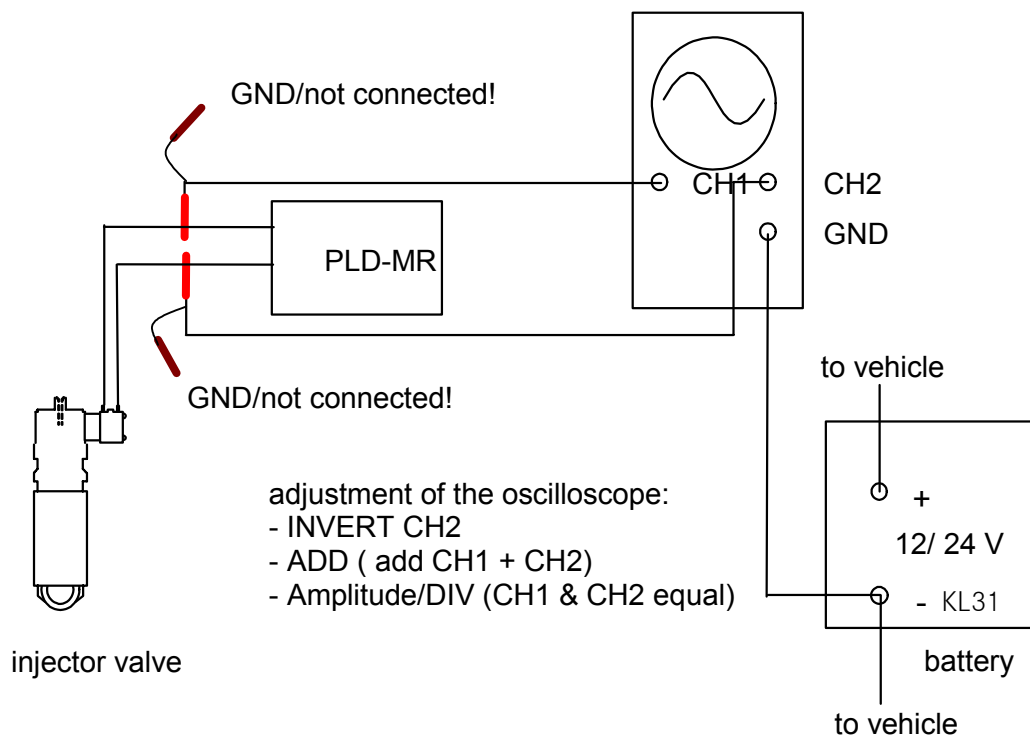

## 4.7. Special measurements

---

### Diagram/measuring type 2

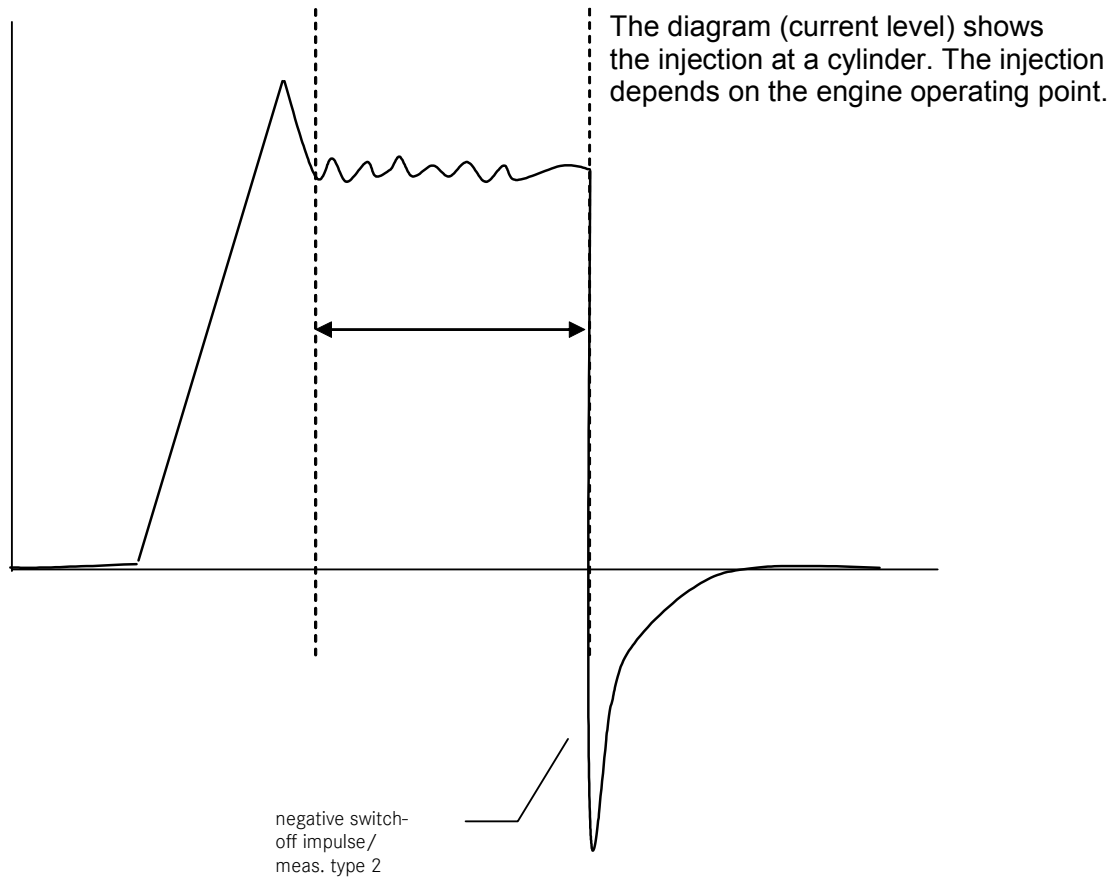

#### Note:

For this measurement the respective injector valve has to be connected with the engine harness, in order to ensure the current supply through the MR-PLD.

## 5. Parameters (minidiag2)

The parameters of the MR-PLD control unit are classified in different groups. Each parameter group corresponds to one area of influence. **Parameters with \* are dependent on data set!**

### 5.1. MR-PLD Diagnosis version 3 to 5 (up-/download)

Parameter group	Parameter	Min	Max	Default	Unit
01 data set code	01/01: data set code				
02 certification code	02/01: certification code				
06 vehicle parameter set 1	06/01: proportional valve 1 0 = no function (def.) 1 = boost pressure control 2 = free 3 = engine retarder flap	0	3	0	-
	06/02: proportional valve 2 0 = no function (def.) 1 = free 2 = free 3 = decompression valve	0	3	0	-
	06/03: proportional valve 3 0 = no function(def.) 1 = fan step1 2 = free 3 = free	0	3	0	-
	06/04: proportional valve 4 0 = no function(def.) 1 = fan step 2 2 = free 3 = free	0	3	0	-
	06/05: engine CAN 1 = engine control for CAN operation 0 = engine control not for CAN operation	0	1	1	-
	06/06: oel temperature sensor 0 = engine without oel temperature sensor 1 = engine with oel temperature sensor	0	1	1	-

## 5. Parameters

Parameter group	Parameter	Min	Max	Default	Unit
06 vehicle parameter set 1	06/07: oel level sensor 0 = type 0 1 = type 2: OM 501, 502 3 = type 3: OM 904 b. Vario	0	3	1	-
	06/08: CAN-one wire operation 0 = no one wire operation 1 = one wire operation	0	1	1	-
	06/09: starter type (JE / KE) 0 = engine ecu controls the starter (JE-mode) 1 = engine ecu controls not the starter (KE-mode)	0	1	0	-
	06/10: immobilizer (WSP) 0 = no WSP blocked 1 = WSP blocked  remark: only with SW49 or earlier!	0	1	1	-
	06/11: gearbox (MB-truck / EvoBus)  manual / automatic transmission: 0 = MB-truck (manual / MT) 1 = EvoBus (automatic / AT)	0	1	0	-
23 scale factor engine start	23/01: scale factor engine start	0	3,5	1	

Parameter group	Parameter	Min	Max	Default	Unit
28 vehicle parameter set 2	28/01: oel pan selection  *type 0 = lorry V6 and V8 *type 1 = Frigo V6 and V8 *type 7 = old V8 with low dome  for OM906: *type 0 = LKN and SKN/R *type 1 = hLA-EVO-BUS *type 2 = E2000-NAW *type 3 = Frigo *type 4 = FLC-Freightliner  *for 904 at Vario = type 0	0	7	0	
	28/02: fan type selection  0 = Linnig; on highway /2-stage 1 = Linnig; off highway /2-stage 2 = on highway, Unimog /Visko 3 = NAW; Econic, Unimog /1 hydro 4 = Horton; Freightliner /1-stage 5 = Bosch; EvoBus, Unimog, off highway /1 hydro 6 = Bosch; EvoBus, Unimog / 2 hydro  PV3 and PV4 to 0 = no fan	0	6	0	
	28/03: fuel temperature compensation  1 = active 0 = not active  Defines, if the torque temperature compensation is performed.	0	1	1	
	28/04: oil pressure sensor type  0 = active absolut pressure sensor 1 = active relative pressure sensor  Using a passive pressure sensor adjustment has no consequence.	0	1	0	
36 switch on threshold on coolant temp. speed 1  ** from diagnosis version 4	36/01: fan speed 1  Temperature at which Electric Fan engages. For Horton (ON/OFF) single stage fan, both 03600 and 03800 should be set the same.	0	97	0	°C
37 switch on threshold on intake air temp. speed 1  ** from diagnosis version 4	37/01: fan speed 1  Temperature at which Electric Fan engages. For 03700 and 03900 should be set the same.	0	150	0	°C

Parametergruppe	Parameter	Bereich Min	Bereich Max	Grundwert	Einheit
38 switch on threshold on coolant temp. speed 2 ** from diagnosis version 4	38/01: fan speed 2  Temperature at which Electric Fan engages. For Horton (ON/OFF) single stage fan, both 03600 and 03800 should be set the same.	0	100	0	°C
39 switch on threshold on intake air temp. speed 2 ** from diagnosis version 4	39/01: fan speed 2  Temperature at which Electric Fan engages. For 03700 and 03900 should be set the same.	0	150	0	°C
48 engine running time counter ** from diagnosis version 5	48/01: hours				
	48/02: minutes				
	48/03: seconds				

Chart: MR-PLD Diagnosis version 3 to 5 (up-/download)

## 5.2. MR-PLD Diagnosis from version 6 (single parameters)

Parameter group	Parameter	Min	Max	Default	Unit
01 engine identification	01/02: gearbox manual / automatic transmission: 0 = MT (manual / default) 1 = AT (automatic)	0	1	0	-
	01/03: starter type (JE / KE) 0 = engine ecu controls the starter (JE-mode) 1 = engine ecu controls not the starter (KE-mode)	0	1	0	-
	01/04: port closing-offset add for engines with CTV port closing-offset add for engines with decompression valve (CTV)? 0 = offset not add (default) 1 = offset add	0	1	0	-
	01/05: boost-pressure sensor characteristic line 0 = characteristic line 1 (3,5 bar sensor) 1 = characteristic line 2 (4 bar sensor)	0	1	0	-
02 CAN configuration	02/01: engine control via CAN 0 = switched off 1 = switched on (default)	0	1	1	-
	02/02: CAN one wire capability 0 = not active 1 = active (default)	0	1	1	-
	02/03: CAN extended 0 = 11 Bit ID (default) 1 = 29 Bit ID	0	1	0	-

Parameter group	Parameter	Min	Max	Default	Unit
03 proportional valves	03/01: proportional valve 1 (PV1) 0 = no function (def.) 1 = boost control 2 = not used 3 = exhaust flap enabled	0	3	0	-
	03/02: proportional valve 2 (PV2) 0 = no function (def.) 1 = not used 2 = not used 3 = decompression valve (constant throttle)	0	3	0	-
	03/03: proportional valve 3 (PV3) 0 = no function (def.) 1 = fan step 1 2 = not used 3 = not used	0	3	0	-
	03/04: proportional valve 4 (PV4) 0 = no function (def.) 1 = fan step 2 2 = not used 3 = characteristic diagram thermostat	0	3	0	-
	03/05: proportional valve 5 (PV5) 0 = no function (def.) 1 = not used 2 = not used 3 = not used	0	3	0	-
	03/06: proportional valve 6 (PV6) 0 = no function (def.) 1 = not used 2 = not used 3 = exhaust flap enabled* 4 = heater flange  *alternative to PV1, if PV1 used for boost control!	0	4	0	-

Parameter group	Parameter	Min	Max	Default	Unit
04 fans	04/01: fan type  0 = Linnig; on highway /2-stage 1 = Linnig; off highway /2-stage 2 = on highway, Unimog /Visko 3 = NAW; Eonic, Unimog /1 hydro 4 = Horton; Freightliner /1-stage 5 = Bosch; EvoBus, Unimog, off highway /1 hydro 6 = Bosch; EvoBus, Unimog / 2 hydro 7 = Horton; Freightliner, off highway /1-stage (PV3) 8 = BorgWarner; on highway /Visko 9 = Bosch; Unimog, Eonic /1 hydro  PV3 and PV4 to 0 = no fan	0	9	0	-
	04/02: switch on threshold on coolant temp. speed 1  remark: only for fan type 1, 4 and 7	0	97	0	°C
	04/03: switch on threshold on intake air temp. speed 1  remark: only for fan type 1, 4 and 7	0	150	0	°C
	04/04: switch on threshold on coolant temp. speed 2  remark: only for fan type 1, 4 and 7	0	100	0	°C
	04/05: switch on threshold on intake air temp. speed 2  remark: only for fan type 1, 4 and 7	0	150	0	°C
	04/06: diff. threshold fan 1  remark: only for fan type 1, 4 and 7	0	60	0	°C
	04/07: switch on threshold on intake air temp. speed 1 at engine brake operation  remark: only for fan type 1, 4 and 7	0	150	0	°C
	04/08: switch on threshold on intake air temp. speed 2 at engine brake operation  remark: only for fan type 1, 4 and 7	0	150	0	°C
	04/09: diff. threshold intake air temp at engine brake operation  remark: only for fan type 1, 4 and 7	0	60	0	°C

Parameter group	Parameter	Min	Max	Default	Unit
06 oil	06/01: oil temperature sensor 0 = oil temperature sensor disabled 1 = oil temperature sensor enabled	0	1	1	-
	06/02: oil level measurement 0 = no function (default) 1 = measurement with running engine 2 = measurement with current and standing engine 3 = measurement with engine switched off  Starting from the engine end number 164012 must be set "type 3" (measurement with engine switched off, ignition ON)!	0	3	0	-
	06/03: select oil pan type  *type 0 = lorry V6 and V8 *type 1 = Frigo V6 and V8 *type 7 = old V8 with low dome  for OM906: *type 0 = LKN and SKN/R *type 1 = hLA-EVO-BUS *type 2 = E2000-NAW *type 3 = Frigo *type 4 = FLC-Freightliner  *for 904 at Vario = type 0	0	7	0	-
	06/04: oil pressure sensor type 0 = active absolut pressure sensor 1 = active relative pressure sensor  Note: Usually only the active absolut pressure sensor is blocked! Using a passive pressure sensor adjustment has no consequence.	0	1	0	-
	06/05: oil pressure switch or sensor 0 = oil pressure sensor blocked (def.) 1 = oil pressure switch blocked	0	1	0	-
	06/06: configuration data of oil pan at EEPROM valid? 0 = configuration data invalid (def.) 1 = configuration data valid	0	1	0	-

Parameter group	Parameter	Min	Max	Default	Unit
08 other factors	08/01: port closing EOL-TDC balancing	-1,5	1,5	0	°KW
	08/02: scale factor engine start	0.00	1,50	1.00	-
	08/03: torque temp. compensation 0 = no torque temp. compensation. 1 = torque temp. compensation (default)	0	1	1	-
	08/04: booster class	0	9	0	-
09 engine service-hour counter	09/01 = engine service-hour counter				
	09/02 = engine service-minutes counter				
	09/03 = engine service-sec. counter				

Chart: MR-PLD Diagnosis from version 6 (single parameters)