

# CAN Struktur bei EM3b

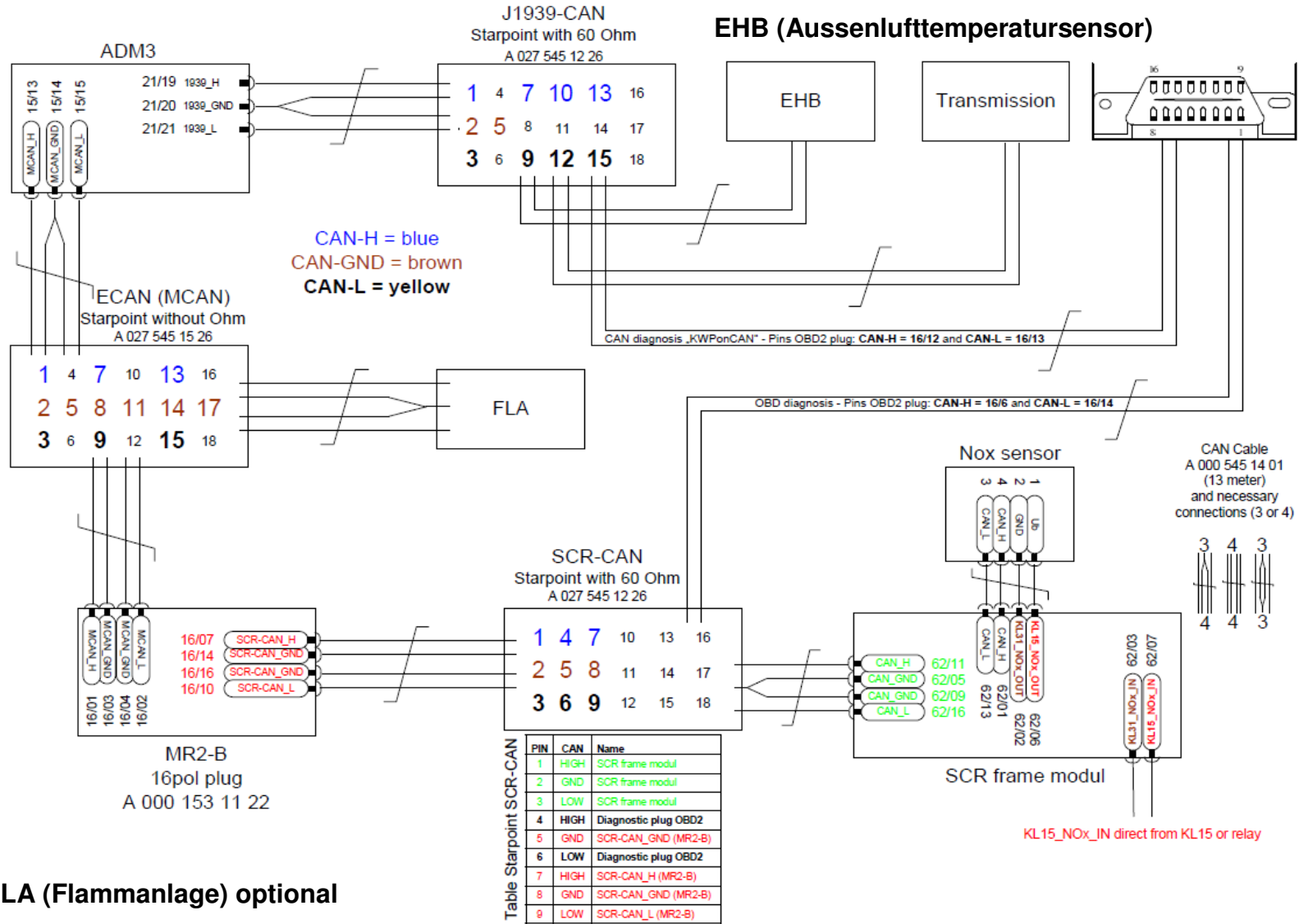

FLA (Flammanlage) optional