

ENGINE	900.9 in MODEL 970, 972, 975, 976 with CODE (MS4) BlueTec 4
ENGINE	900.9 in MODEL 970, 972, 975, 976 with CODE (MS5) BlueTec 5
ENGINE	902.9 in MODEL 970, 972, 974, 975, 976 with CODE (MS4) BlueTec 4
ENGINE	902.9 in MODEL 970, 972, 974, 975, 976 with CODE (MS5) BlueTec 5
ENGINE	924.9 in MODEL 970, 972, 974 with CODE (MS4) BlueTec 4
ENGINE	924.9 in MODEL 970, 972, 974 with CODE (MS5) BlueTec 5
ENGINE	902.9 in MODEL 950.5 /6, 952.5 /6, 953.6, 954.5, 957 with CODE (MS4) BlueTec 4
ENGINE	902.9 in MODEL 950.5 /6, 952.5 /6, 953.6, 954.5, 957 with CODE (MS5) BlueTec 5
ENGINE	926.9 in MODEL 950.5 /6, 952.5 /6, 953.6, 954.5, 957 with CODE (MS4) BlueTec 4
ENGINE	926.9 in MODEL 950.5 /6, 952.5 /6, 953.6, 954.5, 957 with CODE (MS5) BlueTec 5

Location

- 10 Compressed air control unit
- 7.03 Overflow valve (without return flow)
- 30.03 Pressure limiting valve (with purging)
- Y106 SCR air pressure limiter solenoid valve (33.01)

The overflow valve (7.03) is part of the compressed air control unit (10) and is located on the inside of the left longitudinal frame member at the height of the muffler.

Task

The overflow valve (7.03) opens the access to the compressed air ancillary consumer circuit 4 after a certain pressure has been obtained.

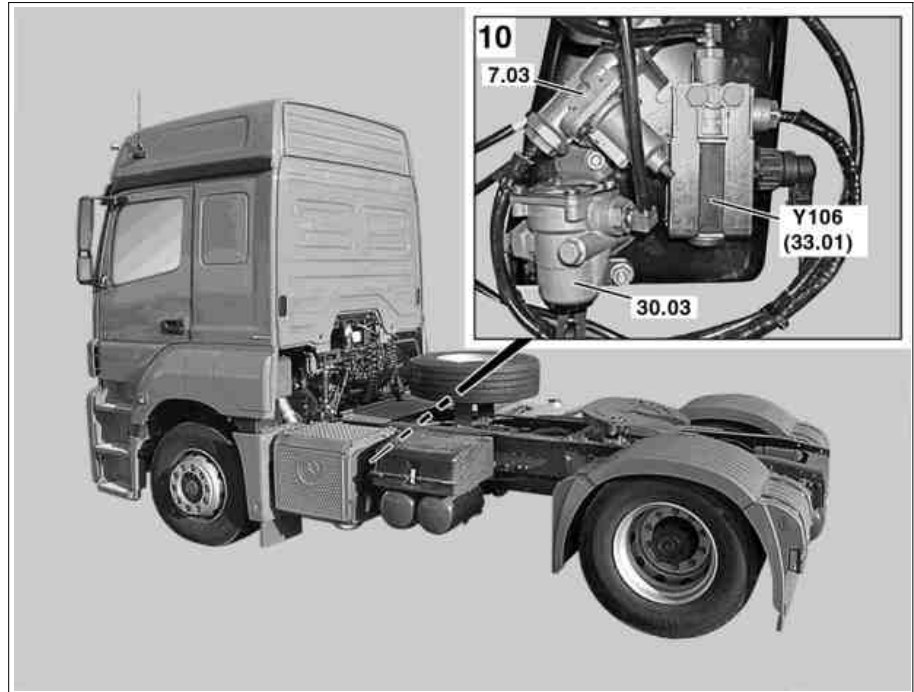

W14.40-1277-06

Design

- 1 Adjusting screw
- 2 Adjuster spring
- 3 Pistons
- 4 Diaphragm
- 5 Bore
- 6 Check valve
- 7 Bore

7.03 Overflow valve (without return flow)

- A Connection (supply line)
- B Connection (working line)

Function

The compressed air passes from the connection (A) into the housing of the overflow valve (7.03) and flows through the hole (7) below the diaphragm (4), which is pressed by the adjuster spring (2) and the piston (3) into its seat. When excess pressure is reached, the force of the adjuster spring (2) is overcome, so that the diaphragm (4) is raised from its seat and the hole (5) released. The compressed air passes directly and after opening of the check valve (6) to the downstream devices positioned in the direction of the arrow.

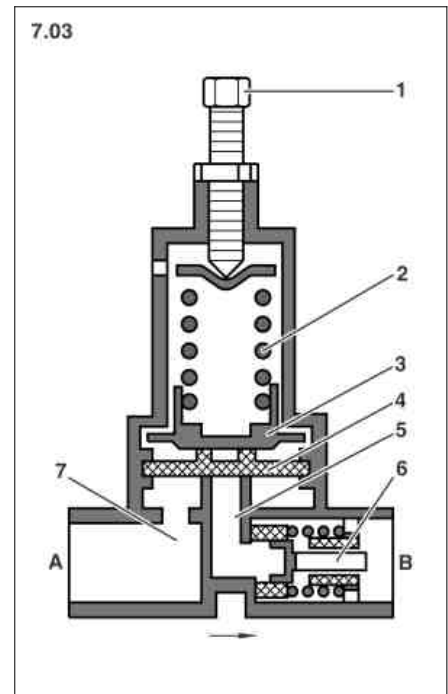

W14.40-1084-03