



COOLING SYSTEM

THERMOSTAT

Available from Mercedes-Benz Industrial Engine Dealers

Degrees	
C	F
71	160
79	174
83	182
+2	+5

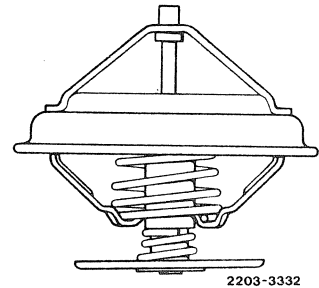

NOTE: All industrial engines except snow grooming operations use 71°C (79°C) thermostat(s)

On double thermostat equipped engines DO NOT INTERMIX 71 - 79 - 83°C units. Equal temp. ranges necessary for proper operation.

THERMOSTAT LOCKED IN OPEN POSITION

- A. 1. Screw M 4x40 Din 84
- 2. Nut M4
- 3. Soldered in open position
- 4. Drill hole into wax insert 3mm bore

OR

- B. Insert copper or brass spacer in area 2 to achieve 8 MM extension of bypass port plate.

To guarantee by-pass sealing, lower plate should be under some spring tension when outlet housing is screwed down tight.

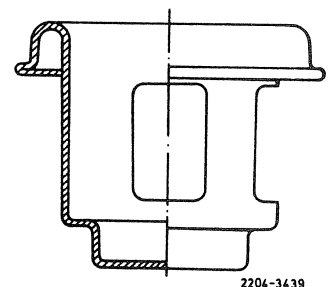
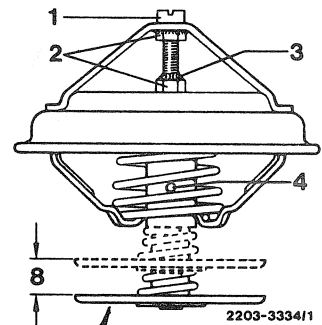

BYPASS INSERT (for testing purposes only)

Part #003 203 7675
 Available from Mercedes-Benz Industrial Engine Dealers