

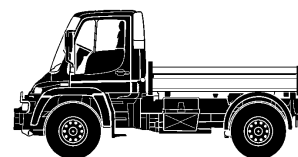

Mercedes-Benz

service information



Group 14/23

SI14.40-G-0011B

06.04.2009

SI14.40-G-0011B	Service Information: Repair solution for pressure reducing valve in pump module of exhaust aftertreatment system	6.4.09
-----------------	--	--------

ENGINES 900.915 /916 /920 /921, 902.923 /924, 924.923

Mechanical wear can result in the internal pneumatic pressure reducing valve of the pump module sticking. This leads to malfunctions in the exhaust aftertreatment system.

On pump modules with part number A 000 140 04 78 in the case of damage an external pneumatic pressure reducing valve can be installed which takes over the function of the internal pressure reducing valve. Consequently the replacement of the complete pump module can be avoided.

ⓘ This repair method can only be used on pump modules with part number A 000 140 04 78.

ⓘ The series production breakpoint of this pump module takes place as of vehicle identification number end no. 211612 (08/2006).

Troubleshooting/diagnosis

In the case of a fault, one of the following fault codes is currently stored in the engine control (MR) control unit:

- MR 1 67 70 "AdBlue pressure drop too low in power-down"
- MR 1 67 21 "AdBlue pressure too low"

The following causes can also lead to these fault codes:

- Incorrect refueling of AdBlue container with diesel fuel
- Defective AdBlue pressure sensor on metering device
- Kinked air lines or AdBlue lines
- Clogged filter screen

For this reason it is absolutely essential to adhere to the test steps specified in Star Diagnosis or in TIPS. The repair method can be used if you encounter the instructions "Replace pump module".

Invoicing

The installation of the external pneumatic pressure reducing valve can be invoiced via damage code 14471 B2 (AdBlue pump module - clogged).

Damage code 47308 (AdBlue shift valve) has been introduced for complaints about the external pneumatic pressure reducing valve.

Shown on model 405

- 1 Pump module
- 2 Pneumatic pressure reducing valve (external)
- 3 AdBlue return connection
- 4 Screw plug (for pneumatic connection)
- 5.1 Scuff protection
- 5.2 Scuff protection

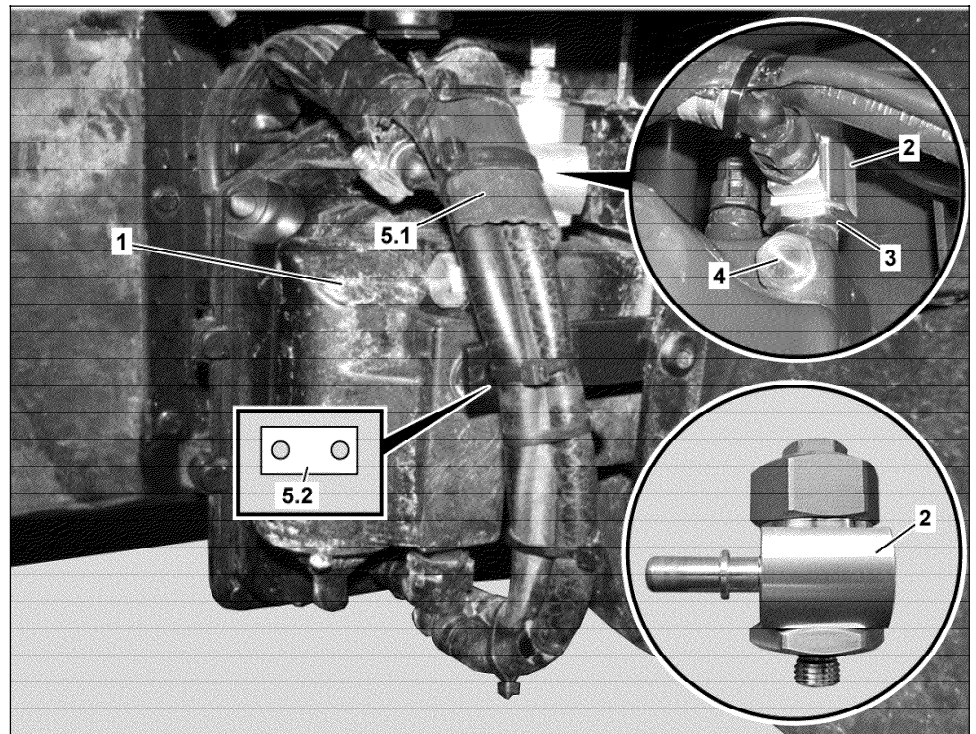

G14.40-3255-06

Illustrated on model 437

- 1 Pump module
- 2 Pneumatic pressure reducing valve (external)
- 3 AdBlue return connection
- 4 Screw plug (for pneumatic connection)
- 5.1 Scuff protection
- 5.2 Scuff protection

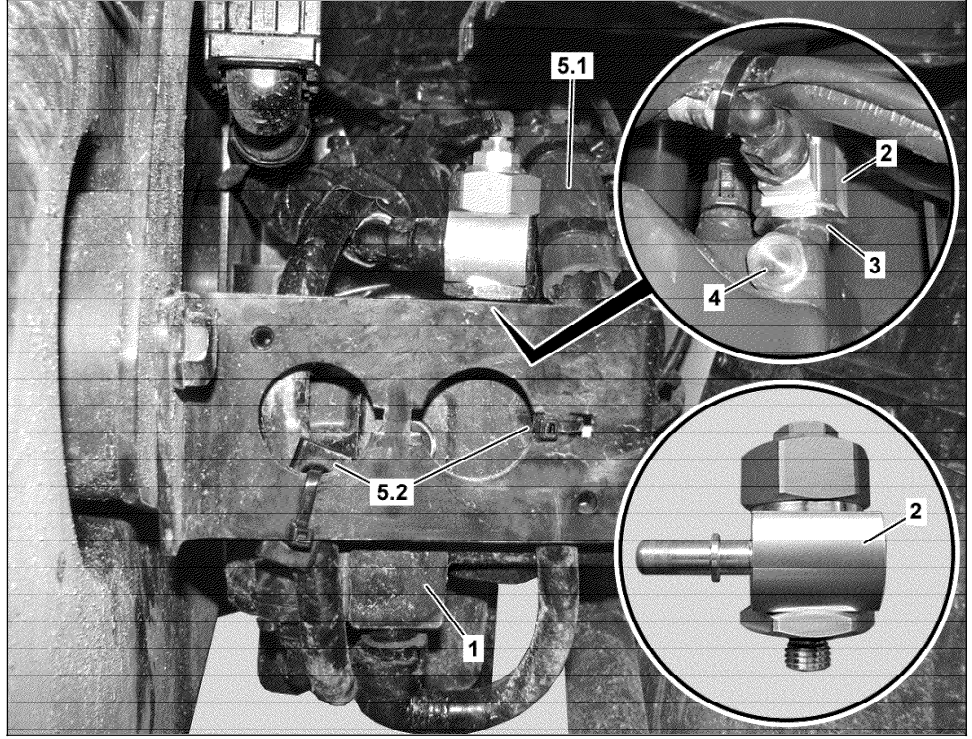

G14.40-3256-06

- 2 Pneumatic pressure reducing valve (external)
- 6 Banjo union
- 7 AdBlue return connection
- 8 Screw-in bushing
- 9 Sleeve
- 10 Hexagon nut
- A Shoulder

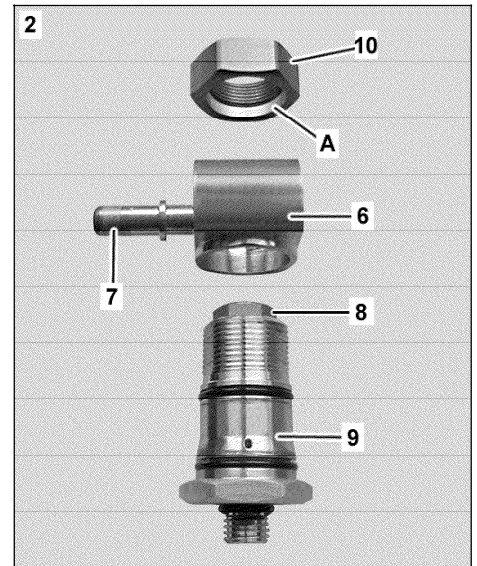

W14.40-1481-02

	Convert pneumatic pressure reducing valve of pump module	Page 4
--	--	---------------















Parts ordering notes

Part no.	Designation	Quantity
A 000 142 03 19	External pneumatic pressure reducing valve	1
A 941 475 17 20	Profile support (as chafe protection)	1
A 418 426 72 40	Bracket (only model 405.050/101/103/121/123/201/221)	1
A 419 426 00 76	Plastic pad (as chafe protection)	

ENGINES 900.915 /916 /920 /921, 902.923 /924, 924.923

Operation no. of operation texts or standard texts and flat rates

Category	Op. no.	Operation text
U	148018	CONVERT PNEUMATIC PRESSURE REDUCING VALVE OF PUMP MODULE (AFTER CHECK)

	Converting		
 Danger!	Risk of accident caused by vehicle starting off by itself when engine is running. Risk of injury caused by contusions and burns during starting procedure or when working near the engine as it is running	Secure vehicle to prevent it from moving by itself. Wear closed and snug-fitting work clothes. Do not touch hot or rotating parts.	AS00.00-Z-0005-01A
 Danger!	Risk of injury to skin and eyes when handling AdBlue. Risk of poisoning from swallowing AdBlue	Only fill AdBlue into suitable and correspondingly marked vessels. Wait for at least 5 minutes before starting any work on the exhaust aftertreatment system. Wear protective clothing and eye protection when handling AdBlue.	AS14.40-Z-0001-01A
 i	Notes on use, material properties and handling of AdBlue®	All engines	AH14.40-N-0001-01A
1	Remove compressed air reservoir over the pump module (1)	Model 405.050/101/103/121/123/201/221 with code (E33) Battery disconnect switch  Remove retaining screw from compressed air reservoir and loosen tensioning strap.	
2	Remove step on top right	Model 437.421/426/431/436	
3	Install external pneumatic pressure reducing valve on pump module		Page 6
		    	BA14.40-N-1027-02F BA14.40-N-1028-02F BA14.40-N-1029-02F BA14.40-N-1030-02F BA14.40-N-1031-02F
 WF	Sealing piece for AdBlue intake line and AdBlue feed line	Engine 457.9, 541.9, 542.9, 900.9, 902.9, 924.9, 926.9	Page 9
 WF	Sealing piece for AdBlue return line	Engine 457.9, 541.9, 542.9, 900.9, 902.9, 924.9, 926.9	Page 9
 WF	Sealing piece for AdBlue feed fitting on pump module and AdBlue feed fitting and return fitting on AdBlue container	Engine 457.9, 541.9, 542.9, 900.9, 902.9, 924.9, 926.9	Page 10
4	Install compressed air reservoir	Model 405.050/101/103/121/123/201/221 with code (E33) Battery disconnect switch  Screw retaining screw into compressed air reservoir and fasten tensioning strap. 	BA00.18-N-1002-01B
5	Install step on top right	Model 437.421/426/431/436  Replace self-locking nuts.	

	Converting		
	Notes on self-locking nuts and bolts	All models	AH00.00-N-0001-01A
6	Start engine and carry out leak test		

 **Compressed air lines**



Number	Designation	Model 405.050/101/ 103/121/123/ 201/221		
BA00.18-N-1002-01B	VOSS "232" compressed-air connection system	M16×1.5	Nm	12
		M22×1.5	Nm	12

 **Exhaust aftertreatment, Blue Tec**

Number	Designation		Engine 900.915/916, 902.923/924	Engine 900.920/921, 924.923
BA14.40-N-1027-02F	Screw plug on pump module	Nm	20	20
BA14.40-N-1028-02F	Sleeve for external pressure reducing valve to pump module	Nm	45	45
BA14.40-N-1029-02F	Hexagon nut on sleeve for external pressure reducing valve	Nm	40	40
BA14.40-N-1030-02F	Screw-in bushing to sleeve for external pressure reducing valve	Nm	30	30
BA14.40-N-1031-02F	Compressed air line to external pressure relief valve	Nm	13	13

Parts ordering notes

Part no.	Designation	Quantity
A 000 142 03 19	External pneumatic pressure reducing valve	1
A 941 475 17 20	Profile support (as chafe protection)	1
A 418 426 72 40	Bracket (only model 405.050/101/103/121/123/201/221)	1
A 419 426 00 76	Plastic pad (as chafe protection)	

SM14.40-G-0010-01B	Install external pneumatic pressure reducing valve on pump module	Engine 900.915/916/920/921, 902.923/924, 924.923	
 WF	Sealing piece for AdBlue intake line and AdBlue feed line	Engine 457.9, 541.9, 542.9, 900.9, 902.9, 924.9, 926.9	WF58.50-W-1440-05A
 WF	Sealing piece for AdBlue return line	Engine 457.9, 541.9, 542.9, 900.9, 902.9, 924.9, 926.9	WF58.50-W-1440-06A
 WF	Sealing piece for AdBlue feed fitting on pump module and AdBlue feed fitting and return fitting on AdBlue container	Engine 457.9, 541.9, 542.9, 900.9, 902.9, 924.9, 926.9	WF58.50-W-1440-07A

 Exhaust aftertreatment, Blue Tec

Number	Designation		Engine 900.915/916, 902.923/924	Engine 900.920/921, 924.923
BA14.40-N-1027-02F	Screw plug on pump module	Nm	20	20
BA14.40-N-1028-02F	Sleeve for external pressure reducing valve to pump module	Nm	45	45
BA14.40-N-1029-02F	Hexagon nut on sleeve for external pressure reducing valve	Nm	40	40
BA14.40-N-1030-02F	Screw-in bushing to sleeve for external pressure reducing valve	Nm	30	30
BA14.40-N-1031-02F	Compressed air line to external pressure relief valve	Nm	13	13

- 1 Detach compressed air line (2) on fitting (3) of pump module (1).
- 2 Loosen AdBlue package and coolant line package.

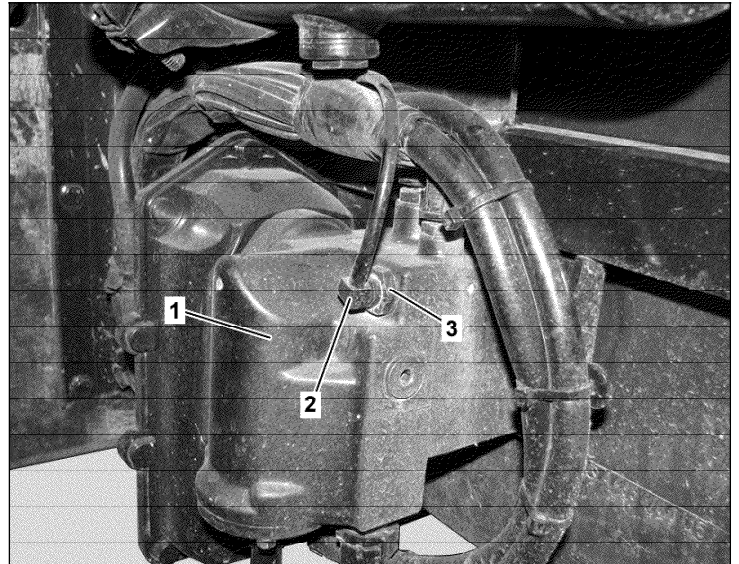

G14.40-3258-11

- 3 Detach AdBlue return line (6) from AdBlue return fitting (9) and seal with sealing piece (7).
- 4 Detach AdBlue feed line (4) from AdBlue feed fitting (8) and seal with sealing piece (5).
i In isolated cases Adblue may flow out of the AdBlue feed fitting (8). If this is the case: Seal AdBlue feed fitting (8) with sealing piece (22).

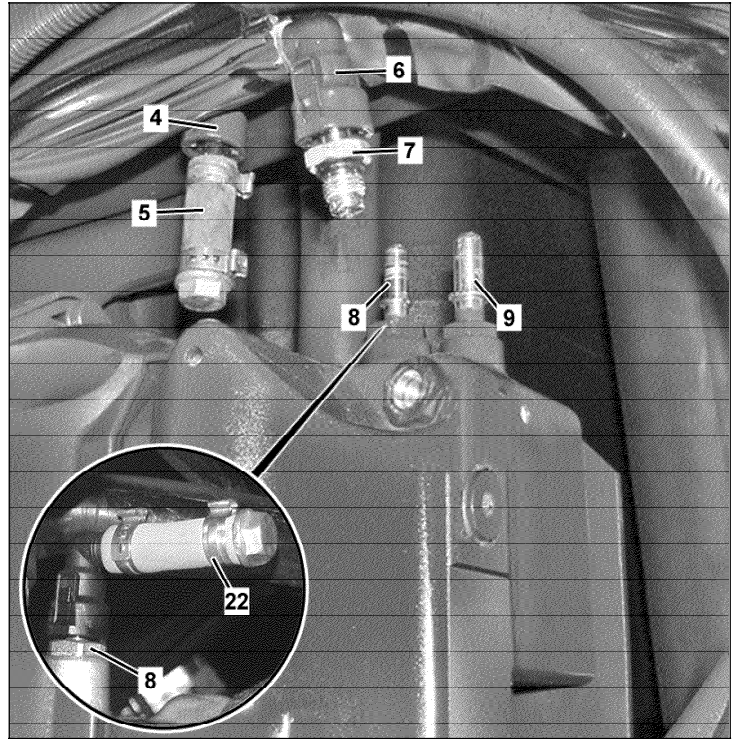

W14.40-1457-12

- 5 Remove fitting (3) from pump module (1).
- 6 Remove internal pressure reducing valve (10) together with coil spring (11) and spring cup (12).
- 7 Remove polymer ball (13).
i The polymer ball (13) is very small and can easily be overlooked. It should be ensured that it does not remain in the pump module (1).

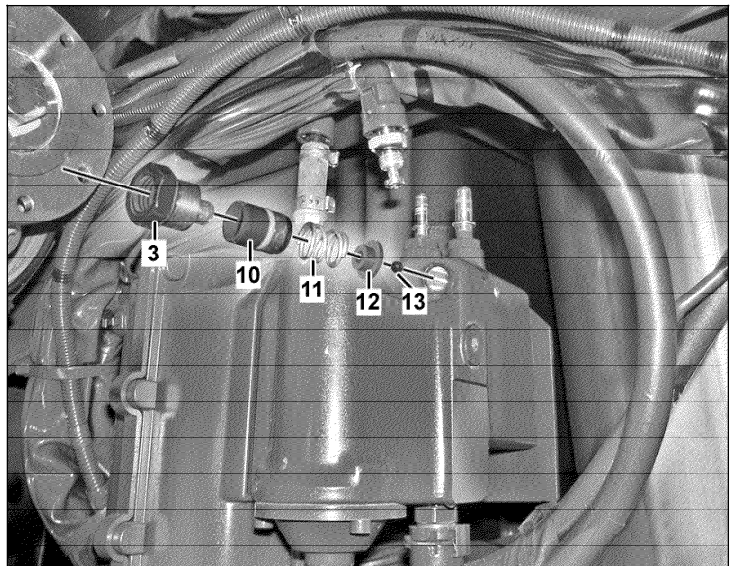

W14.40-1439-11

- 8 Screw the screw plug (14) into the pneumatic connection of the pump module (1) \square Nm.
- 9 Detach AdBlue return connection (9).

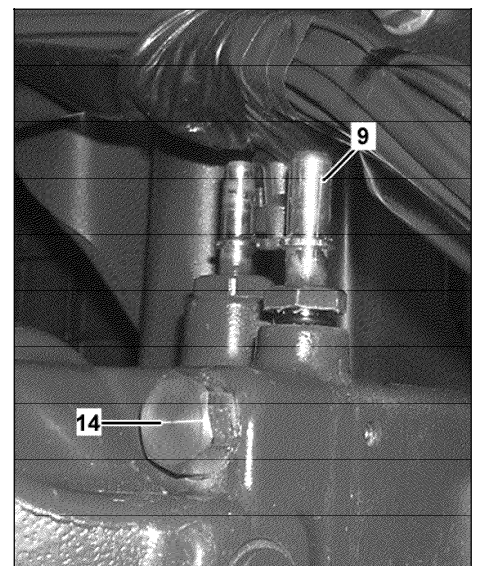

W14.40-1442-02

- 10 Open hexagon nut (17) and displace banjo union (18) upwards slightly
 ⚠ The banjo union (18) must not be turned, otherwise the banjo union (18) and the sleeve (19) will be damaged by the taper on the sleeve (19).

i If the hexagon nut (17) has been unscrewed from the sleeve (19), during assembly it is to be ensured that the shoulder on the inside of the hexagon nut (17) points downwards towards the banjo union (18) **Nm** .

- 11 Install external pneumatic pressure reducing valve (16) on the AdBlue return (15) of the pump module (1) **Nm** .

- 12 Move the banjo union (18) downwards and tighten the hexagon nut (17) **Nm** .

⚠ The banjo union (18) must not be turned, otherwise the banjo union (18) and the sleeve (19) will be damaged by the taper on the sleeve (19).

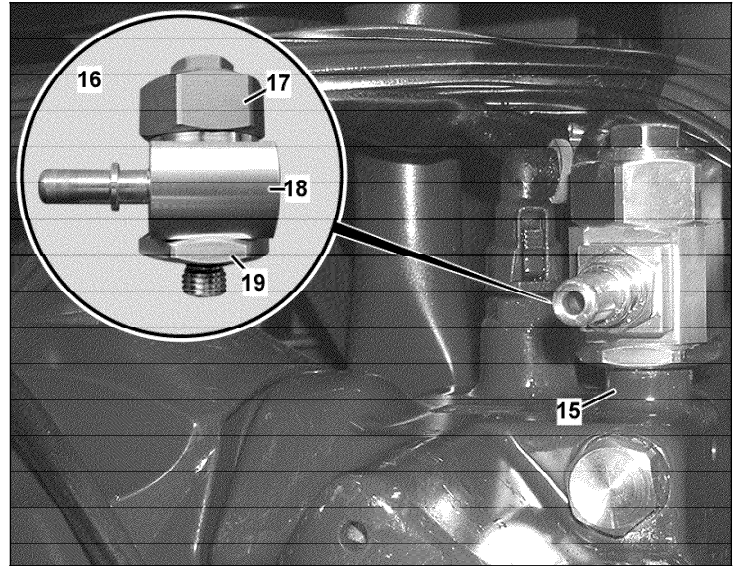

W14.40-1489-11

- 13 Connect the AdBlue feed line (4) to the AdBlue feed fitting (8).

- 14 Turn AdBlue return line (6) through 90° and connect to the external pneumatic pressure reducing valve (16).

- 15 Connect compressed air line (2) to the external pneumatic pressure reducing valve (16) **Nm** .

- 16 Install the chafe protection (20) on the hose line package and fasten with cable ties.

- 17 Install bracket (21) .
i Model 405.

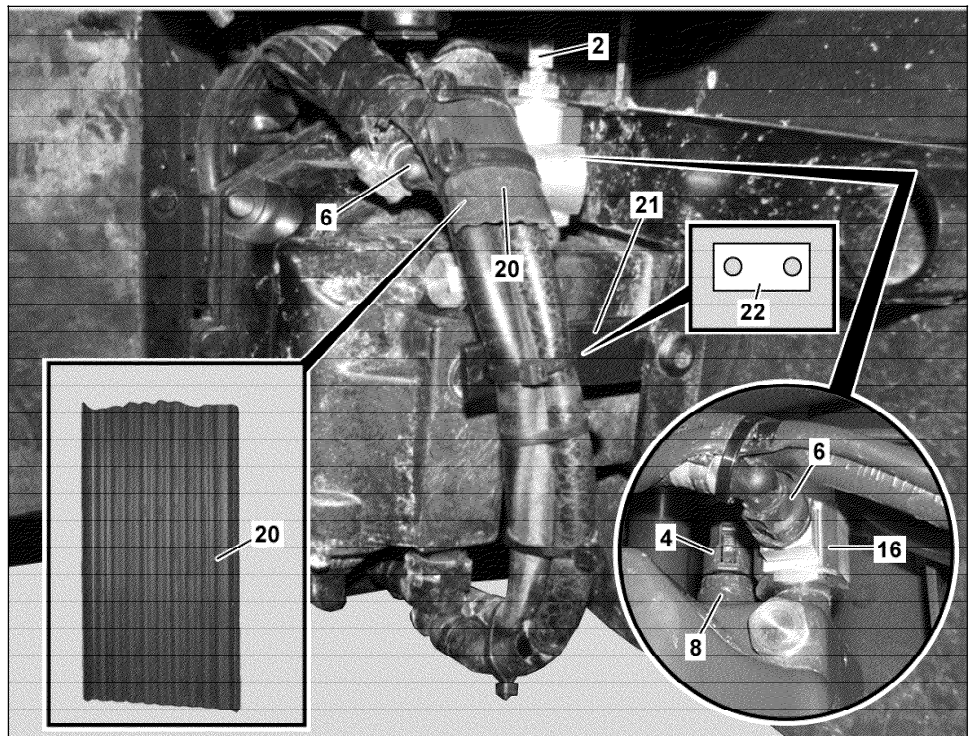

G14.40-3257-06

- 18.1 Fasten the coolant lines to bracket (21) with chafe protection (22) and cable ties.
i Model 405.

- 18.2 Fasten the coolant lines to the installation frame with chafe protection (22) and cable ties.
i Model 437.

- 19 Fasten AdBlue lines and coolant lines with cable ties.
i It is absolutely essential to ensure that the AdBlue lines and coolant lines are always routed together and absolutely free of tension. Possible chafe marks must be avoided.

WF58.50-W-1440-05A	Sealing piece for AdBlue intake line and AdBlue feed line	Engine 457.9, 541.9, 542.9, 900.9, 902.9, 924.9, 926.9	
--------------------	---	--	---

Fabricate a sealing piece (1) out of a piece of AdBlue hose (3), hexagon head bolt (4), a plug connection (2) and two one-ear clamps (5).

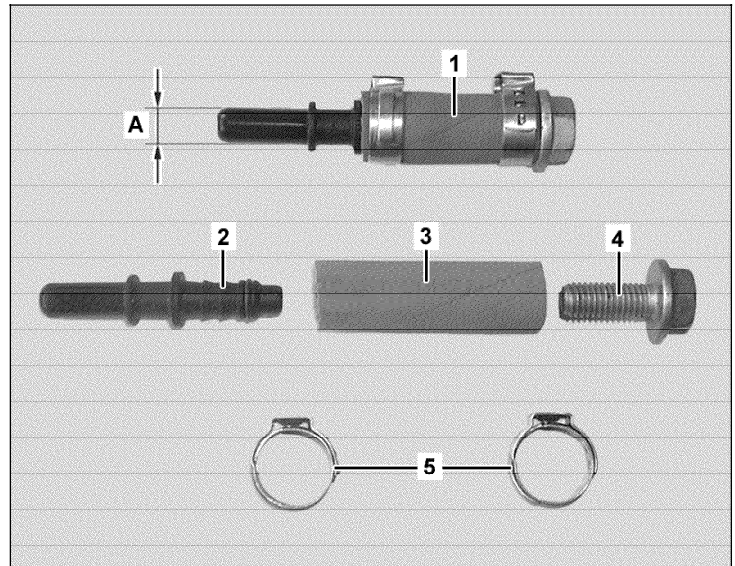

W14.40-1426-11

Parts ordering notes

Part no.	Designation	Quantity
Parts for sealing piece (1)		
A 000 995 62 35	One-ear clamp	2
A 005 997 18 89	Plug connection	1
A 930 476 00 01	AdBlue hose (approx. 50 mm)	1
n304017 008023	Hexagon bolt with collar, M8×20	1

WF58.50-W-1440-06A	Sealing piece for AdBlue return line	Engine 457.9, 541.9, 542.9, 900.9, 902.9, 924.9, 926.9	
--------------------	--------------------------------------	--	---

Modification notes

9.2.09	Diameter of hexagon head bolt and O-ring changed, part numbers added.	Table, parts ordering notes	
--------	---	-----------------------------	--

Cut thread M5 in the fitting (2). After this fabricate sealing piece (1) out of the fitting (2), a hexagon bolt (4), and an O-ring (3).

- 1 Locking piece
- 2 Fitting
- 3 O-ring
- 4 Hexagon bolt

a = dia. 9.52 mm

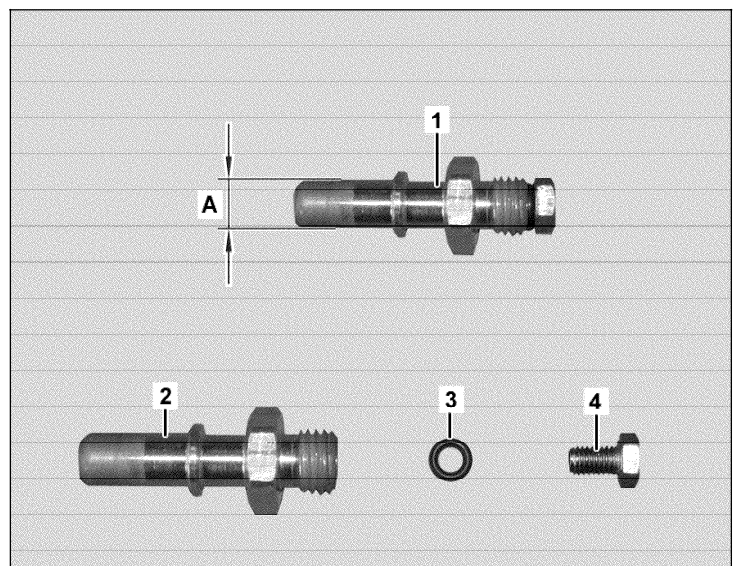

W14.40-1437-11

Parts ordering notes

Part no.	Designation	Quantity
	Parts for sealing piece (1)	
A 002 997 39 71	Fitting	1
A 016 997 35 48	O-ring, 5×1.5	1
N 910142 005000	Hexagon head bolt, M5×10	1

WF58.50-W-1440-07A	Sealing piece for AdBlue feed fitting on pump module and AdBlue feed fitting and return fitting on AdBlue container	Engine 457.9, 541.9, 542.9, 900.9, 902.9, 924.9, 926.9	 WF
--------------------	---	--	--

Fabricate screw cap (1) from a piece of AdBlue hose (3), a hexagon head bolt (4), a plug-in connector (2) and two one-ear clamps (5).

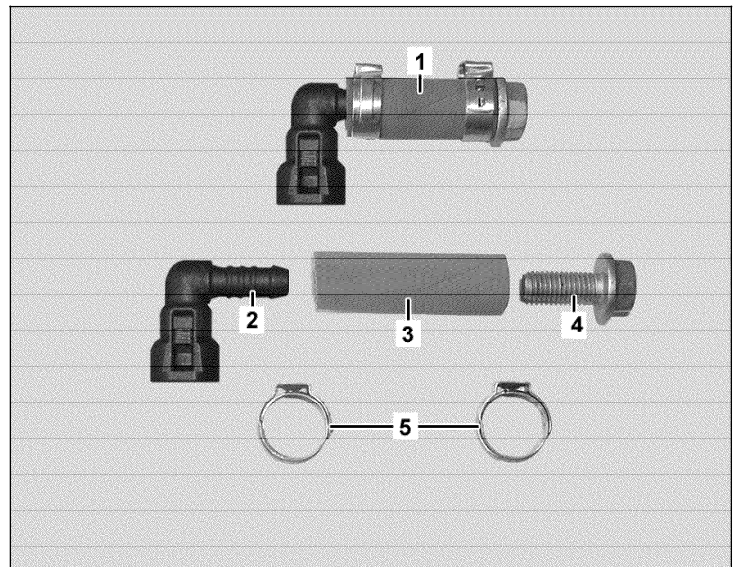

W14.40-1435-11

Parts ordering notes

Part no.	Designation	Quantity
	Parts for sealing piece (1)	
A 000 995 62 35	One-ear clamp	2
A 004 997 94 89	Plug-in connector	1
A 930 476 00 01	AdBlue hose (approx. 50 mm)	1
N 304017 008023	Hexagon bolt with collar, M8×20	1