

# **OPERATION & MAINTENANCE MANUAL**

## **mitsubishi DIESEL ENGINES**

**S2E, S2E2**

**S3E, S3E2, S3F**

**S4E, S4E2, S4F**

**S6E, S6E2, S6F**

**S4E2-T, S4F-T**

**S6E2-T, S6F-T**



**MITSUBISHI  
HEAVY INDUSTRIES, LTD.**

## TABLE OF CONTENTS

	Page
Your engine and Mitsubishi .....	1
Safety – it's up to you .....	2
Operation instructions .....	4
Major components .....	4
New engine initial service .....	6
Controls and instruments .....	7
Walk-around checks .....	8
Starting, running and stopping .....	9
Diesel fuels, cooling water and lubricants .....	11
Operation under extreme conditions .....	16
Maintenance instructions .....	18
Maintenance schedule .....	18
Every 10 hours .....	20
Every 50 hours .....	21
Every 250 hours .....	22
Every 500 hours .....	23
Every 1000 hours .....	27
Troubleshooting .....	29
Specifications .....	35

## YOUR ENGINE AND MITSUBISHI

### SERVICE ASSISTANCE

Your Mitsubishi dealer is vitally interested in your complete satisfaction with Mitsubishi engine you purchased from him. He is anxious to know that all of your service needs are quickly and courteously filled.

**When asking your Mitsubishi dealer for service assistance:**

Give serial number and hour meter reading of your engine, and tell him what is abnormal about your engine, how the engine acted when it began to fail as in detail as possible.

**When transferring your engine to elsewhere from the original place of use registered with Mitsubishi dealer:**

Contact your Mitsubishi dealer to have the registration changed.

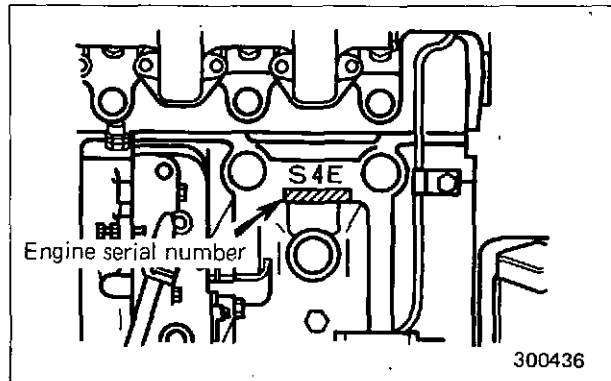

## SAFETY - IT'S UP TO YOU

### Before starting

- ⚠ Before starting and during warm up period, check under and around engine for visual defects – leaks of fuel, oil and coolant, loose or missing part.

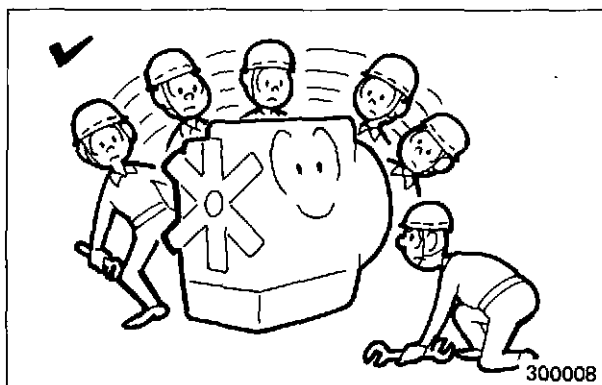

- ⚠ When starting engine, walk around it once more – open eyes and be alert to people and obstacles that may be within operating range.

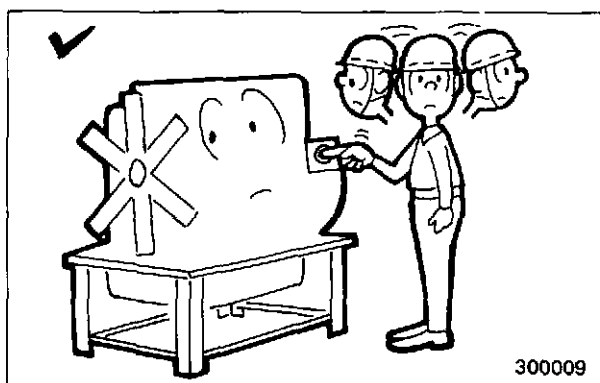

### During operation

- ⚠ Do not touch any moving part of a running engine, or clothing or hair can be caught in moving parts, resulting in personal injury or loss of life.

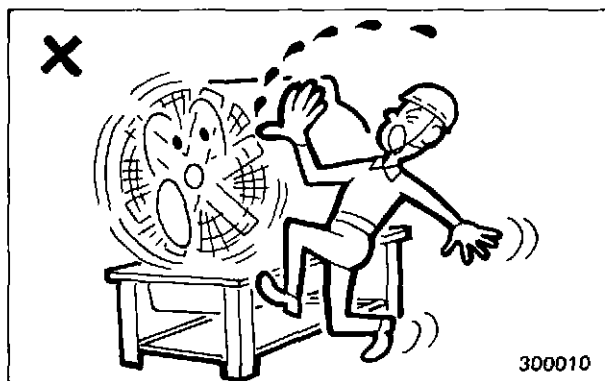

- ⚠ Keep hands off hot parts – turbocharger, exhaust pipe, etc. – during operation or immediately after shutting off engine.

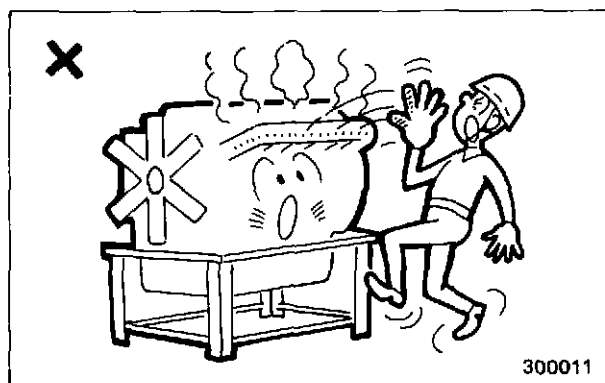

**After operation**

- ⚠ At end of operating period, walk around engine to check for any defects, and make repairs to prepare for the next day.

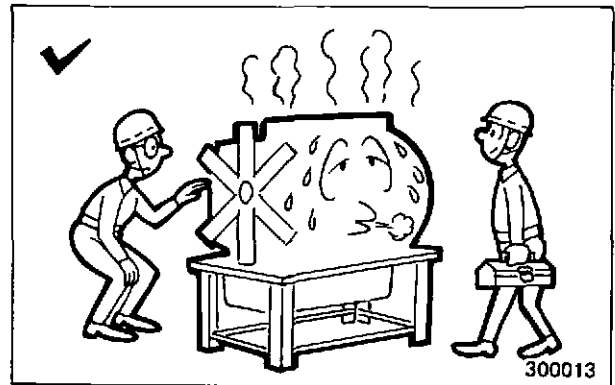

**Maintenance**

- ⚠ Be sure to stop engine, and turn battery main switch off before servicing engine. If necessary to crank engine for inspection, signal to other man to avoid personal injury and accidents.

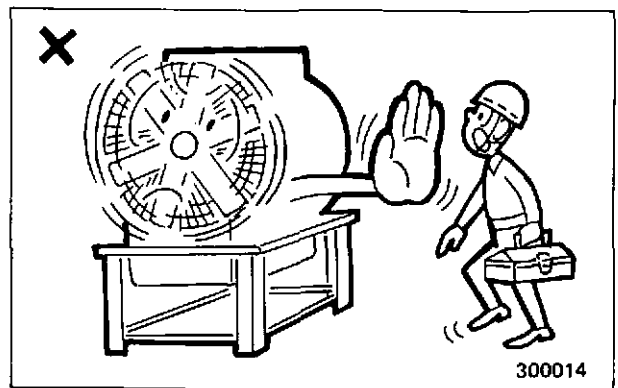

- ⚠ When removing radiator filler cap immediately after shutting off engine, be sure to release pressure to avoid having scalding by hot water or steam spouted out from radiator.

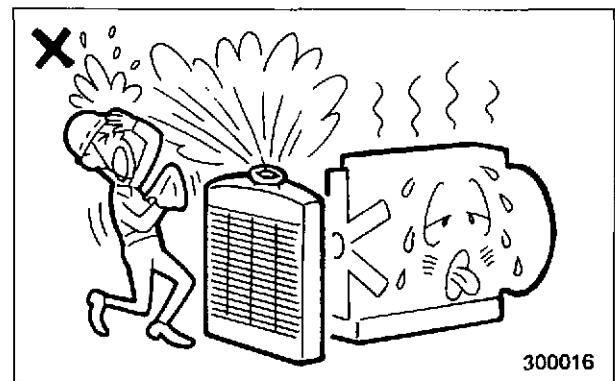

- ⚠ When lifting engine, use slings free of broken strands. Be sure that the crane has enough capacity for engine to be lifted. Make use of hangers provided on engine, and lift it carefully.

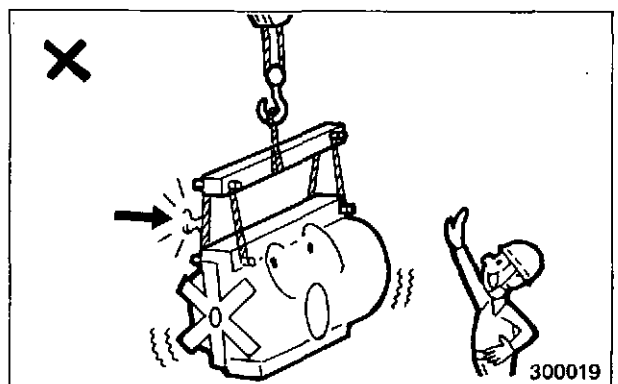

# OPERATION INSTRUCTIONS

## MAJOR COMPONENTS

**[S2E, S2E2]**

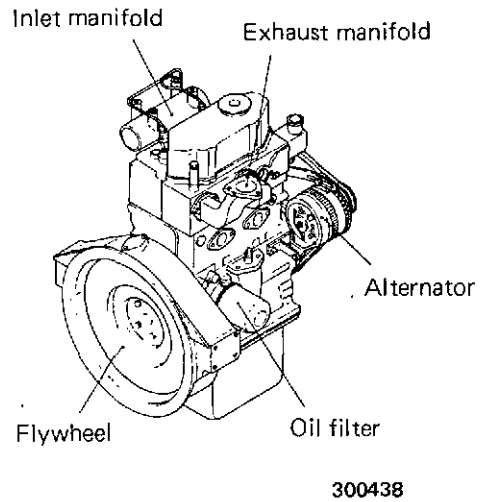
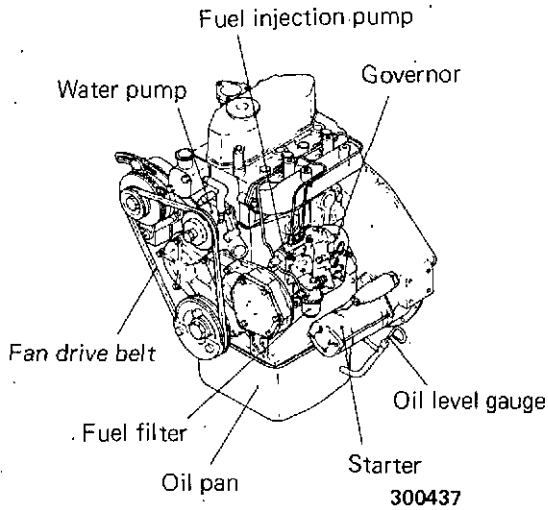

**[S3E, S3E2, S3F]**

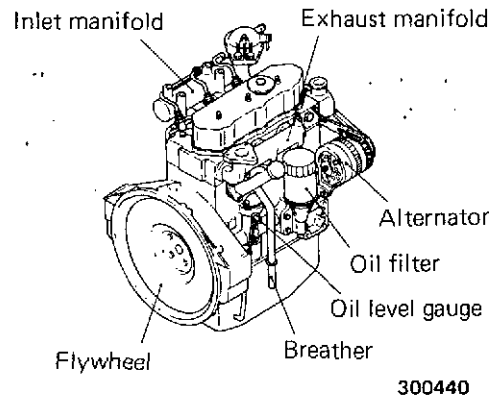
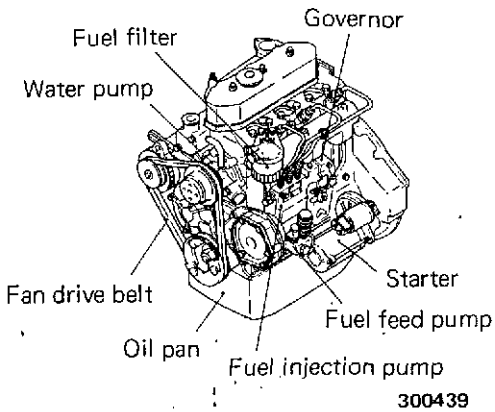

**[S4E, S4E2, S4F]**

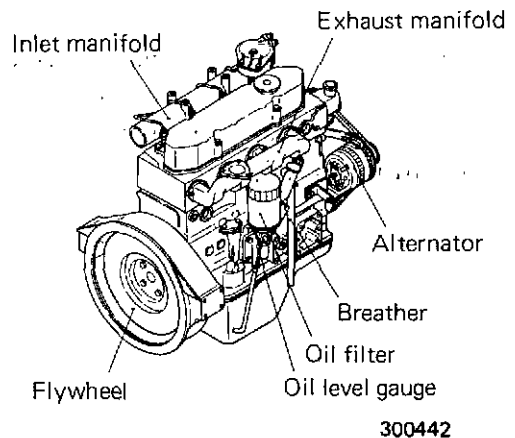
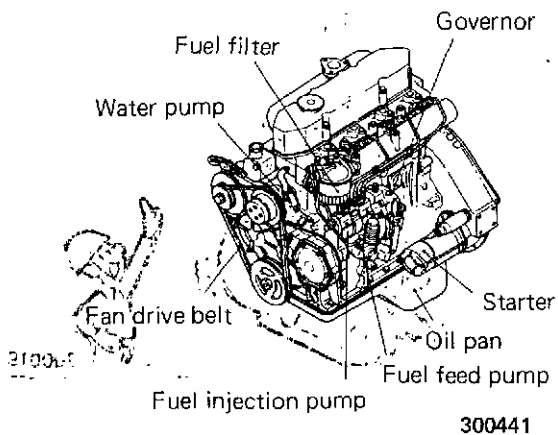

[S4E2-T, S4F-T]

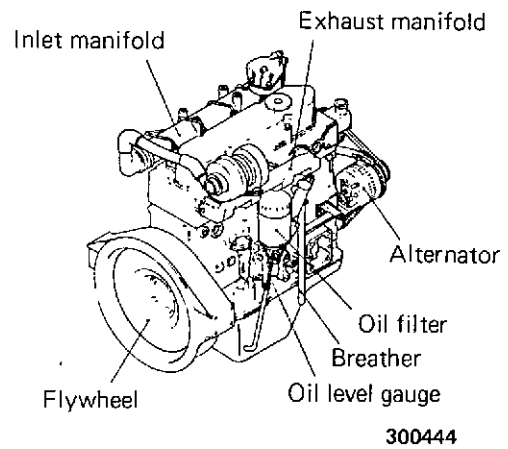
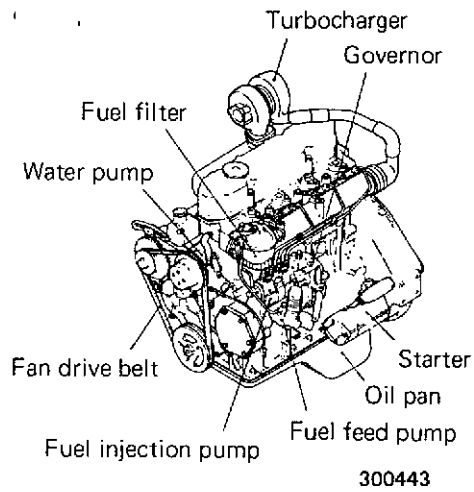

[S6E, S6E2, S6F]

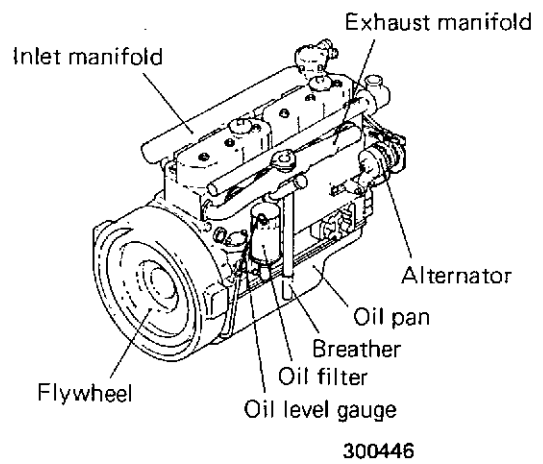
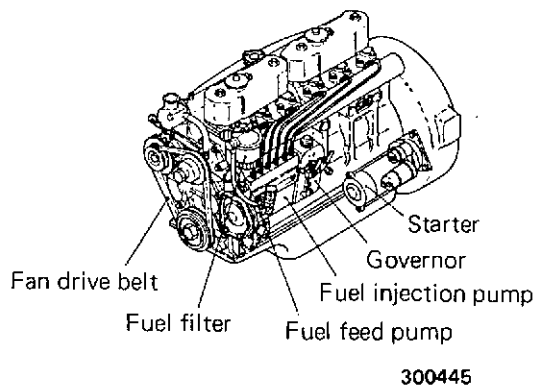

[S6E2-T, S6F-T]

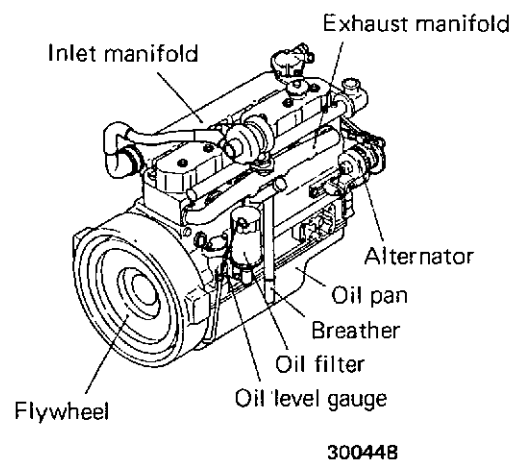
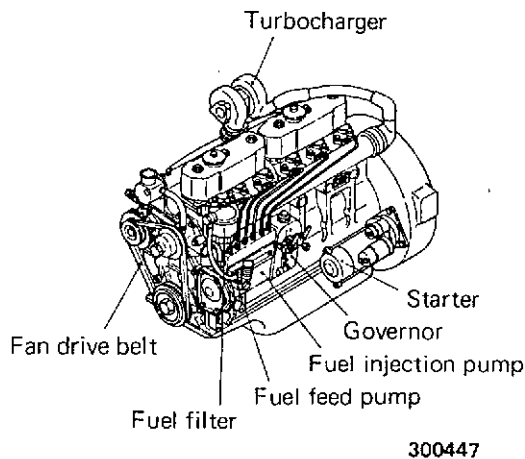

## OPERATION INSTRUCTIONS

### NEW ENGINE INITIAL SERVICE

Anyone charged with the care and operation of the engine is responsible for "new engine initial service" – service for a new or reconditioned engine or an engine which has been

stored for any length of time. Check the following points before starting the engine for the first time. For the second and subsequent services, refer to Maintenance Schedule.

#### Before starting

##### Walk-around checks

- Check for damage or missing parts.
- Check for loose bolts and nuts.

##### Cooling system

- Fill system.
- Check for leaks.
- Check fan drive belt for tension.

##### Fuel system

- Fill tank.
- Prime.
- Check for leaks.

##### Lubrication system

- Fill system.
- Check for leaks.

##### Electrical system

- Check battery electrolyte level and specific gravity.
- Check for loose terminals.
- Check gauges and lamps for operation.

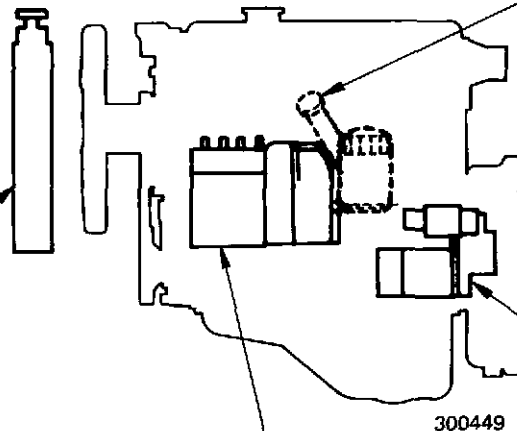

After initial 50 service hours, perform the following services:

Change of engine oil

Change of engine oil filter

Retightening of bolts and nuts

#### NOTE

During break-in period of a new or reconditioned engine, avoid sudden application of load and high-speed operation for engine life.

## CONTROLS AND INSTRUMENTS

Mitsubishi SE-, SE2- & SF-series engines are built to a variety of specifications. The controls and instruments included in this publication are

of a standard-specification engine and may be different from those of your engine. Read and study about items pertinent to your engine.

**Tachometer**

Indicates engine speeds in rpm (revolutions per minute).

**Hour meter**

Records engine operating time. Rely on this meter to measure service intervals.

**Water temperature warning lamp**

Comes on when coolant temperature is abnormally high. If this lamp comes on, check for low coolant level or water leaks.

**Normal coolant temperature**

70 ~ 85°C (158 ~ 185°F)

**Maximum coolant temperature**

100°C (212°F)

Operating the engine above this temperature may cause damage to internal engine parts.

**Alternator not charging warning lamp**

Comes on when starter switch is turned to ON but goes out after engine is started and picks up speeds. If this lamp comes on during operation, check charging system.

**Oil pressure warning lamp**

Comes on when starter switch is turned to ON but goes out after engine is started and picks up speeds. If this lamp comes on during operation, check for low oil level, oil leaks or dirty filter.

**Normal oil pressure**

3 ~ 4 kgf/cm<sup>2</sup> (42.7 ~ 56.9 psi) (at rated rpm)

1 ~ 2 kgf/cm<sup>2</sup> (14.2 ~ 28.4 psi) (at idling)

**Maximum oil temperature**

95°C (203°F) or below [115°C (239°F), max.]

**Heater indicator**

Glows red when starter switch is turned to HEAT.

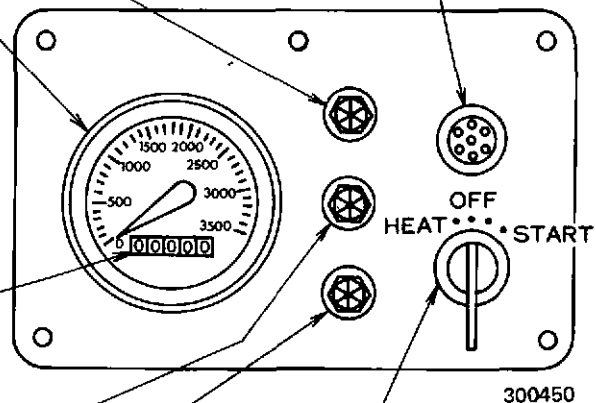
**HEAT**

Turns on glow plugs (SE- & SE2-series) or air heater (SF-series) to facilitate engine starting.

**OFF**

Insert and pull out switch key. All electrical circuits are OFF.

**ON**

Keeps engine running. Charging circuits and lamp circuits are ON.

**START**

Starts engine. Key will return to ON when released.

WALK-AROUND CHECKS

For maximum service life of the engine and safety of the operator, make a thorough walk-around checks before starting the engine for a day's work.

**Radiator**  
Check coolant level in radiator.

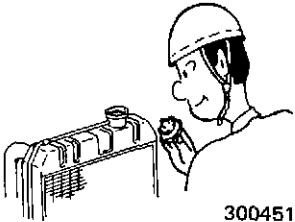

300451

**Fuel control lever**  
Check for smooth movement.

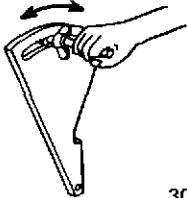

300452

**Battery switch**  
Check for loose battery switch or battery terminals.

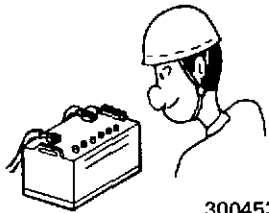

300453

**Engine**  
Check electrical system for loose terminals. Also check for oil and fuel leaks, loose bolts and nuts.

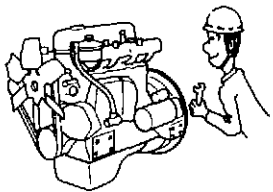

300454

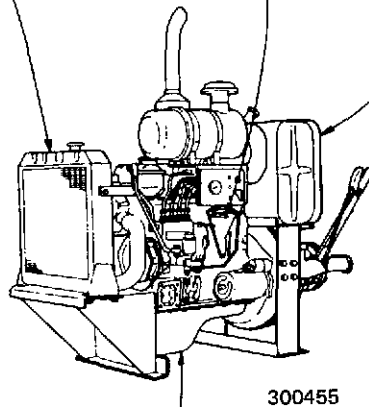

**Fuel tank**  
Check amount of fuel left in tank.

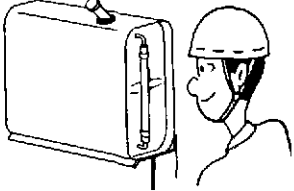

300456

**Engine oil**  
Check to make sure oil level is near by FULL mark.

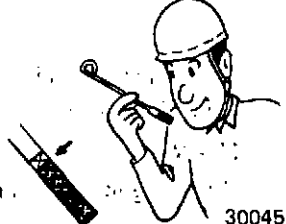

300457

## STARTING, RUNNING AND STOPPING

## Starting

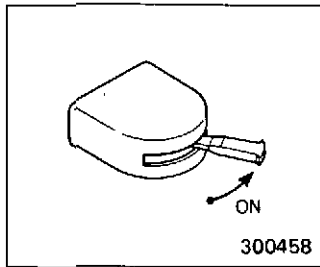

1. Move battery switch to ON.

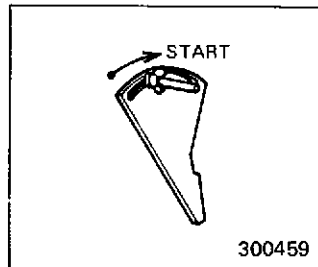

2. Move fuel control lever to START.

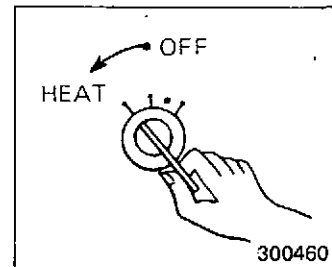

3. Insert key into starter switch, and turn switch to HEAT.

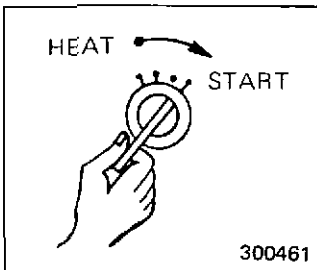

4. Turn starter switch to START to crank engine.

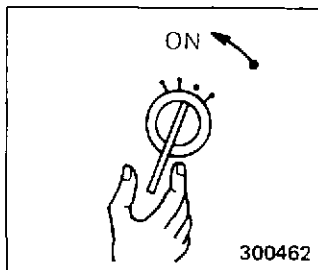

5. Release starter switch as soon as engine starts. Switch will return to ON automatically.



- Disengage clutch by moving clutch control lever to OFF if equipped.
- Do not turn starter switch to START when the engine is running.
- Use glow plugs (SE- & SE2-series engines) for 15 seconds in normal conditions; use them for 30 seconds in cold weather. Use air heater (SF-series) for 20 seconds in normal conditions; use it for 40 seconds in cold weather.
- If the engine fails to start within 30 seconds, wait for a while before cranking it again to allow battery to recover its

strength. In such a case, wait until starter stops rotating and the engine stops "rocking" before turning starter switch to START.

- Do not turn starter switch to OFF when the engine is running.

## OPERATION INSTRUCTIONS

### Warming up and applying load

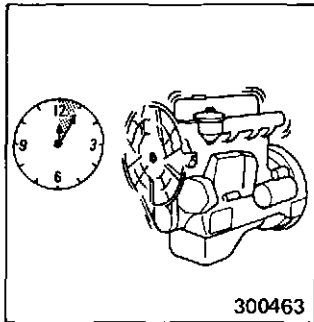

- After starting, warm up engine for about 5 minutes.



Do not warm up engine for more than 15 minutes.

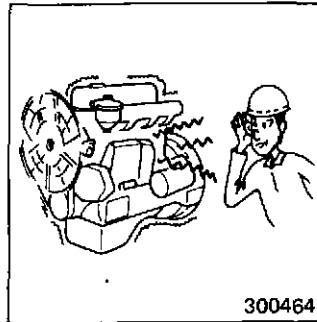

- Apply load and, during operation:
- Check for abnormal noise and vibration.
- Check for abnormal exhaust color.

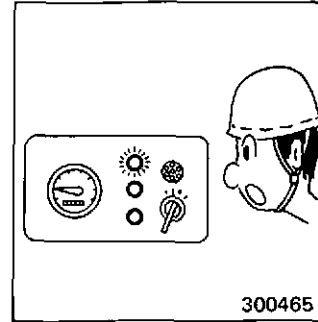

- Observe warning lamps from time to time during operation.

### Stopping

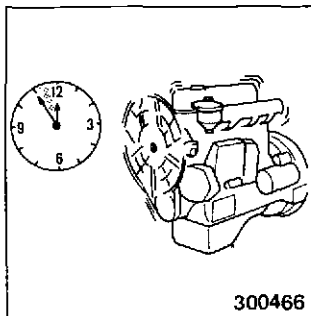

1. Remove load from the engine, and allow it to idle for 3 ~ 5 minutes.

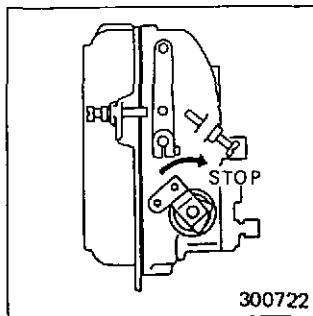

2. Pull engine stop lever to STOP. Engine will stop.

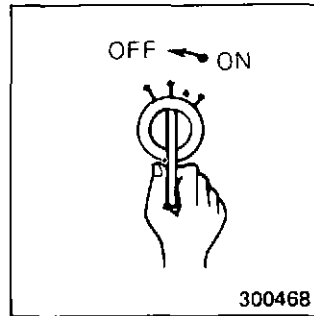

3. Turn starter switch to OFF and pull key from starter switch.

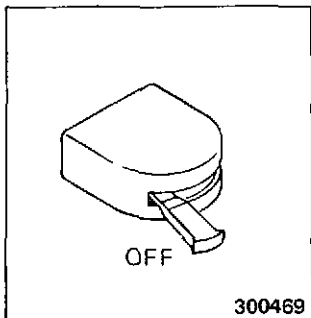

4. Turn battery switch to OFF.



Do not stop the engine immediately after removing load. This practice is undesirable for engine parts and shortens engine life.

## DIESEL FUELS, COOLING WATER AND LUBRICANTS

### DIESEL FUEL

#### Recommended Fuel Oil Properties

Mitsubishi diesel engines have been developed to take advantage of the high energy content of ASTM No. 2 Diesel Fuels. Experience has shown that a Mitsubishi diesel engine will also operate satisfactorily on ASTM No. 1 Diesel Fuels or other fuels with the specifications given in the following table.

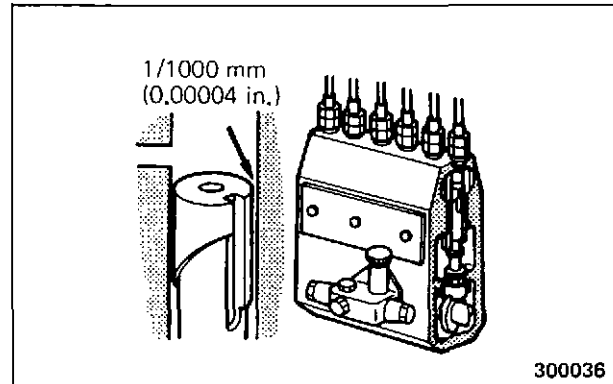

#### Recommended Fuel Oil Specifications

Item	Specification	Remarks
Flash point	50°C (122°F), minimum	JIS-specified diesel fuels: 50°C (122°F), minimum
Distillation temperature (90% point)	380°C (716°F), maximum	BS Class A <sub>1</sub> and A <sub>2</sub> : 357°C (675°F), maximum
Pour point	Below lowest temperature expected to operate at	
Carbon residue (by weight)	1.0%, maximum	JIS-specified A diesel fuel: 4%, maximum ASTM 2-D: 0.35%, maximum on 10% residue
Cetane number	40, minimum	ASTM 2-D: 40, minimum
Viscosity	8 Centistoke, maximum at 50°C (122°F)	JIS-specified A diesel fuel: 20 Centistoke, maximum at 50°C (122°F)
	10.5 Centistoke, maximum at 40°C (104°F)	BS Class A <sub>1</sub> and A <sub>2</sub> : 1.5 to 5.5 Centistoke, maximum at 40°C (104°F)
	16 Centistoke, maximum at 30°C (86°F)	JIS-specified diesel fuel Special No. 1 : 2.7 CentiStoke, maximum at 30°C (86°F)
Sulfur content (by weight)	1%, maximum	BS Class A <sub>2</sub> : 1%, maximum JIS-specified A diesel fuel : 2%, maximum
Water & sediment	0.1%, maximum	BS Class A <sub>1</sub> and A <sub>2</sub> : 0.05%, maximum JIS-specified A diesel fuel : 0.3%, maximum
Ash (by weight)	0.03%, maximum	ASTM 2-D : 0.01%, maximum BS Class A <sub>1</sub> and A <sub>2</sub> : 0.01%, maximum JIS-specified A diesel fuel : 0.05%, maximum
Copper strip corrosion	No. 3 rating, maximum	ASTM 2-D : No. 3 rating, maximum (No. 1, 2, 3)

Mitsubishi will not be liable for lack of power or other trouble of the engine due to use of fuel oil other than those recommended or poor quality fuel oil.

**Care of the fuel supply**

Too much emphasis cannot be placed on the importance of using only clean diesel fuel. The clearance between the plunger and barrel of fuel injection pump and that between needle valve and body of injection nozzle are very small. This makes it evident that invisible particles of dirt which might pass through the filter can damage these finely finished parts.

1. Use a storage tank, and allow fuel to stand at least 24 hours in this tank before pumping it to the diesel fuel tank. Be sure to drain all water and sediment that has settled to the bottom of the storage tank before the diesel fuel tank is refilled. Transfer clean top portion of fuel in storage tank to diesel fuel tank, leaving water and sediment.

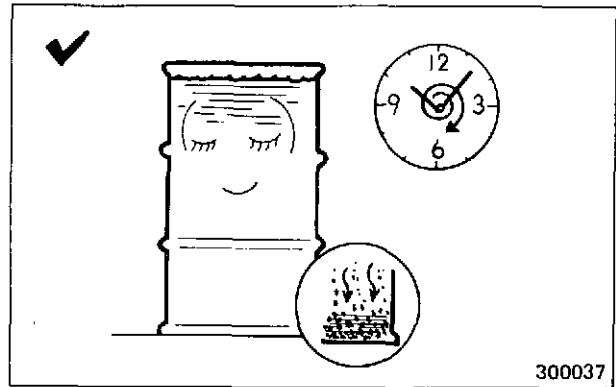

2. Fill the diesel fuel tank at the end of the day. This will drive out moisture-laden air and prevent condensation.

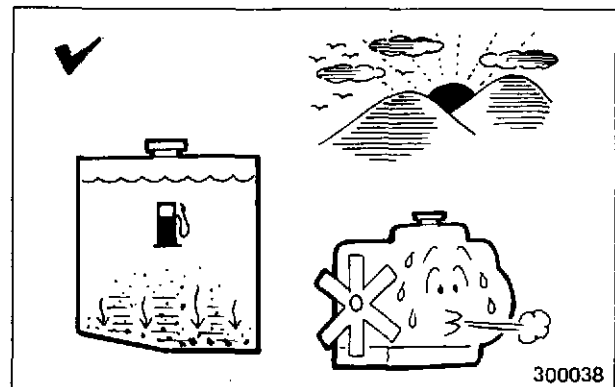

3. When refilling the diesel fuel tank, use clean tools, such as a hand pump, funnels, containers, hoses, etc. Wipe filler cap clean before removing it. When operating the hand pump, keep in mind that there could be water and sediment that has settled to the bottom of storage tank; tap the needed amount of fuel from clean top portion.

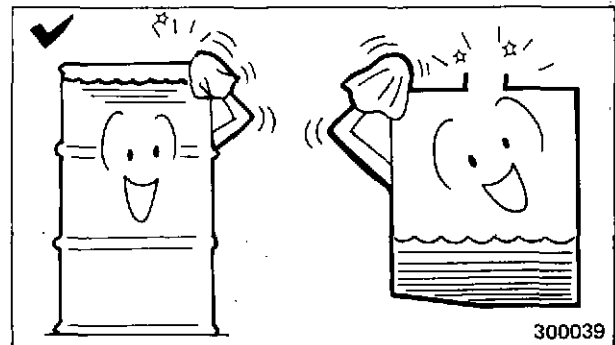

4. Be sure to pour fuel through strainer in the filler opening. Use of a lint-free cheese cloth is a good practice for keeping dirt out.

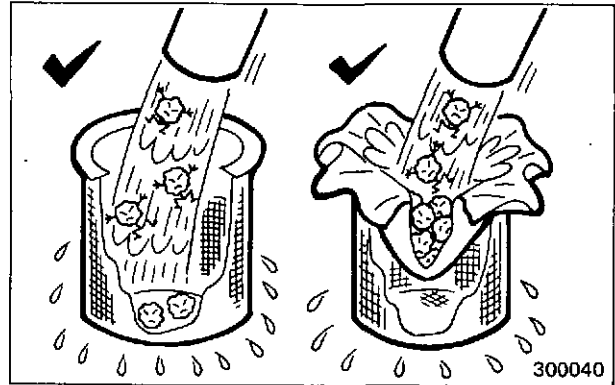

5. Occasionally, open the drain cock of the storage and diesel fuel tank to drain off any water or sediment that may have accumulated. Even clean top portion of fuel oil contains more or less dirt and water. Such dirt and water should be removed before they get inside the engine. This method of cleaning fuel oil is called "draining."

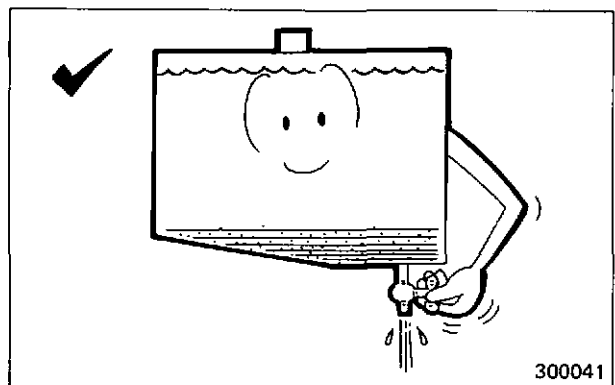

**COOLING WATER**

Water should be clean and free of any corrosive chemicals such as chloride, sulphates and acids. It should be kept slightly alkaline with a pH value range of 8.5 to 10.5. Any water which is suitable for drinking can be treated as described in the following paragraphs for use in an engine.

Maintain the Fleetguard DCA Water Filter on the engine. The filter bypasses a small amount of coolant from the system via a filtering and treating element which must be replaced periodically.

1. In summer, with no antifreeze, fill the system with water.
2. In winter, select an antifreeze and use with water as required by temperature.

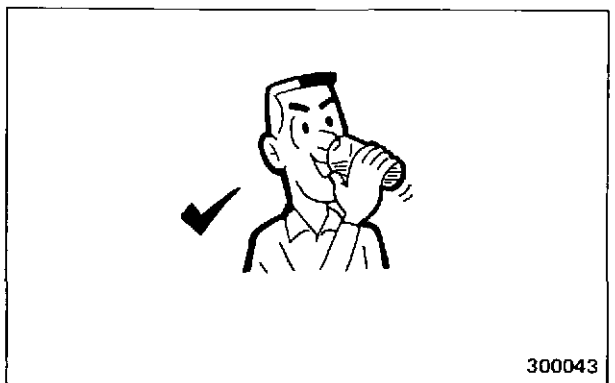
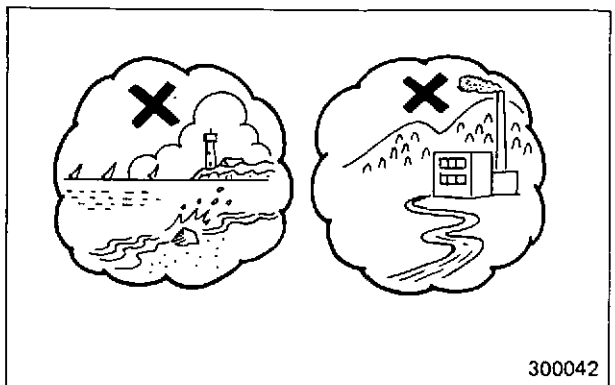

**LUBRICANTS**

**Engine oil**

1. Careful attention to the following information on engine oil and its proper selection will add much to performance, economy and long life of your engine – a high-speed, high-load diesel engine.

Naturally aspirated engines	API Service Classification CC, MIL-L-2104B or equivalent
Turbocharged engines	API Service Classification CD, MIL-L-2104C or MIL-L-2104D or equivalent

API American Petroleum Institute  
 MIL United States Military Specification

2. The Engine Manufacturers Association (EMA) publishes a book entitled "Lubricating Oils Data Book". Copies may be purchased from the Engine Manufacturers Association, 111 E. Wacker Drive, Chicago, Ill., 60601. This book lists commercially available oils by oil company and brand name with the API performance categories met by each brand.

3. Avoid mixing engine oils of different brands. In some cases, different brands are not compatible with each other and, when mixed, can seize parts such as piston rings, cylinder liners, etc. or abnormally wear moving parts. It is best to stick with one and the same brand of engine oil at successive service intervals.

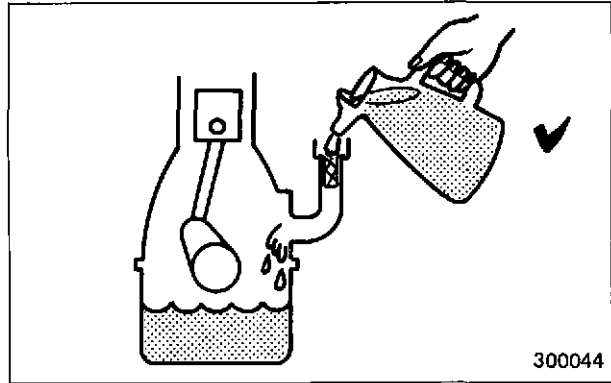

300044

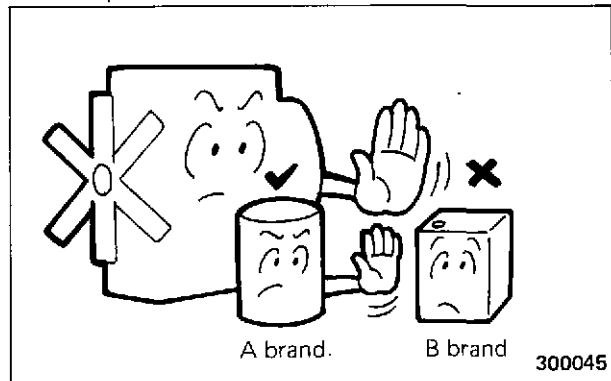

300045

4. To change the oil, drain it out while the engine is still hot after a duty operation: the oil is hot and will rush out, washing out the sludge. After draining, it is recommended to idle the engine for about 5 minutes with a flushing oil in the oil pan and to refill with fresh oil upon draining the flushing oil.

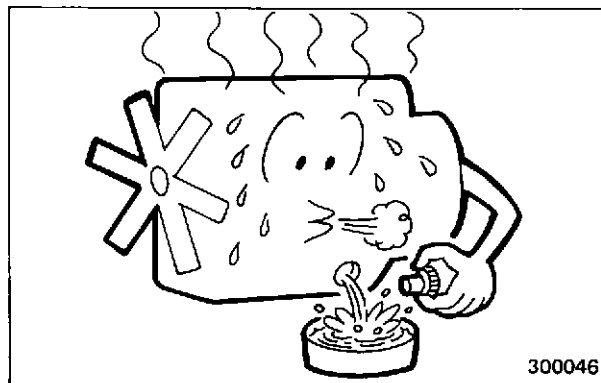

**Selection**

Refer to the following charts in selecting engine oil:

**Starting temperatures and grades of lubricants**

Ambient temperature	-30 (-22)	-20 (-4)	-10 (14)	0 (32)	10 (50)	20 (68)	30 (86)	40 (104)	°C (°F)
Engine oil	SAE10W		SAE 30				SAE40		
	SAE10W-30								

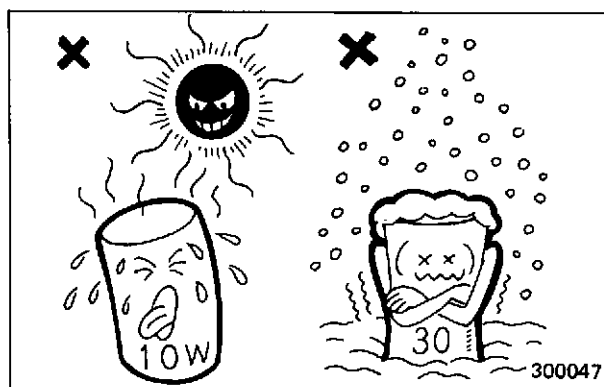

**Grease**

Mitsubishi recommends use of grease meeting the specifications of MIL-G-3545, excluding those of sodium or soda soap thickeners. For consistency of grease to be used, refer to chart below:

Ambient temperature	-20 (-4)	-10 (14)	0 (32)	10 (50)	20 (68)	30 (86)	40 (104)	°C (°F)
Grease	NLGI No.1			NLGI No. 2				

NLGI: National Lubricating Grease Institute

**NOTE**

“Mitsubishi Diamond Multipurpose Grease No. 1” (NLGI No. 1) and “Mitsubishi Diamond Multipurpose Grease No. 2” (NLGI No. 2) or equivalent are recommended.

## OPERATION UNDER EXTREME CONDITIONS

### COLD WEATHER PRECAUTIONS

#### Engine oil and fuel

1. Use engine oil of lower S.A.E. viscosity grade in cold weather (see page 14).
2. Use fuel oil of lower pour point (see page 11).

#### Battery

1. Add distilled water to the battery before starting the engine to prevent electrolyte from freezing.
2. The specific gravity of electrolyte rises as the battery becomes increasingly charged. An electrolyte with S.G. of 1.20 or under freezes at  $-20^{\circ}\text{C}$  ( $-4^{\circ}\text{F}$ ) or so. To avoid such a freeze-up, be sure to keep the battery fully charged at all times, so that the electrolyte S.G. will be 1.26 or over.
3. The lower the temperature, the smaller the capacity of the battery. Try to draw energy from the battery as sparingly as possible, and make necessary provisions for protecting the battery from the deadly chill of the night. A battery with its electrolyte frozen is done with.

#### Cooling water

1. When the temperature is below freezing, use an anti-freeze solution in the cooling system.
2. The larger the proportion of the solution, the lower is the freezing point of the mixture.
3. A commercial anti-freeze solution comes with printed directions. Read them carefully and prepare the mixture in proportions (water and solution) necessary for the lowest freezing temperature expected. This chart will serve as a rough guide for determining the percent proportion of the solution for the mixture:

#### • Anti-freeze solution

- a. Use a permanent-type anti-freeze solution.
- b. When using anti-freeze solution, mix fresh water, anti-freeze solution and rust inhibitor

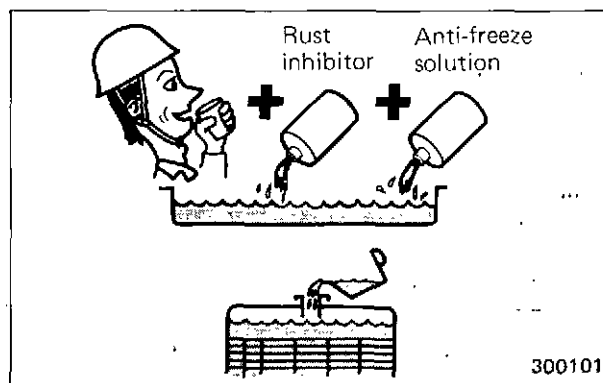
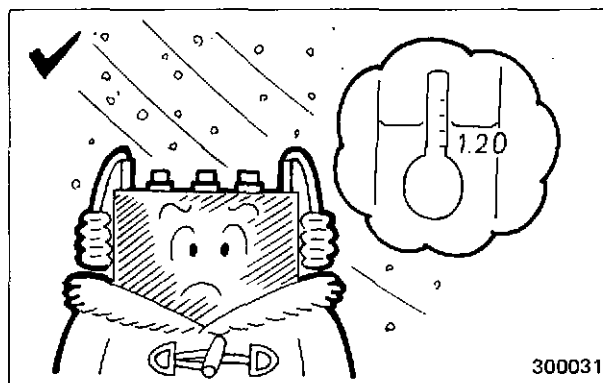
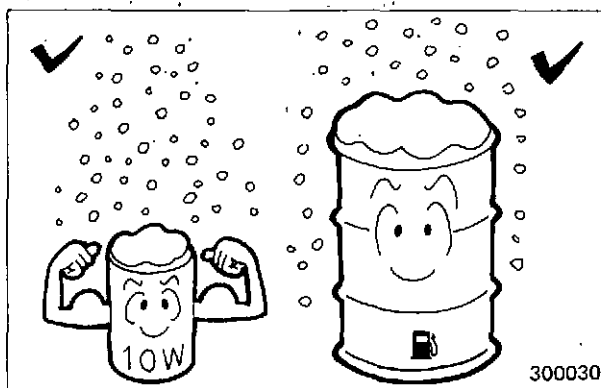

Percent of solution and coolant freezing point (reference)

Anti-freeze solution	0	10	20	30	40	50	60
Freezing point $^{\circ}\text{C}$ ( $^{\circ}\text{F}$ )	0 (32)	-4 (24.8)	-9 (15.8)	-16 (3.2)	-24 (-11.2)	-36 (-32.8)	-45 (-49.0)



The anti-freeze solution is inflammable.  
Be sure to handle it carefully.

in a container, and pour the mixture into radiator.

- c. Before filling up the cooling system with the anti-freeze coolant, flush the system clean.
- d. After the cold season, drain and flush the cooling system and fill it with soft water.

**Operating in cold weather**

- 1. During cold weather, the battery is weak, often resulting in hard starting. If the engine fails to start within 30 seconds, wait about 2 minutes before cranking the engine again.
- 2. After starting the engine, warm it up thoroughly before applying the load.

**At end of operating period**

- 1. Drain out water and sediment that has accumulated in fuel system to prevent freezing.
- 2. Fill the fuel tank fully to drive out moisture-laden air for preventing condensation.

**HOT WEATHER PRECAUTIONS**

**Engine oil**

Use engine oil of higher S.A.E. viscosity grade in hot weather. (See page 15.)

**Battery**

At higher temperatures, the battery is likely to lose its energy by "self-discharging." Remove the battery from the engine, and store it in a cool place.

**Cooling water**

Keep the cooling system filled up at all times. Repair any leaking point upon discovery of such a point. Maintain the water pump, fresh-water cooler and thermostat in the best operable condition.

**Operating in hot weather**

Give particular attention to overheating of the engine by observing the water temperature gauge and oil pressure gauge. When the engine is overheated, remove the load rather slowly, and allow the engine to idle for gradual cooling.

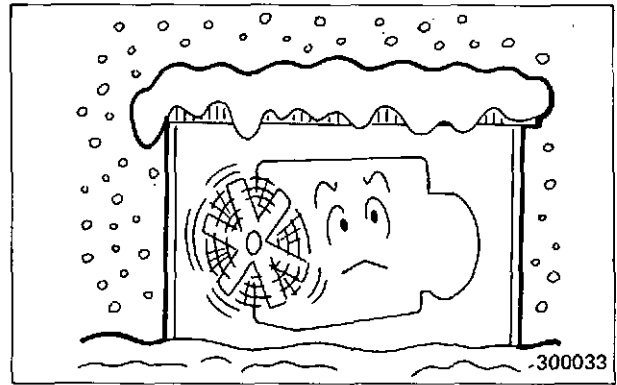

**NOTE**

As starting aids, an oil pan heater, a water heater and a starting burner are available from your Mitsubishi dealer.

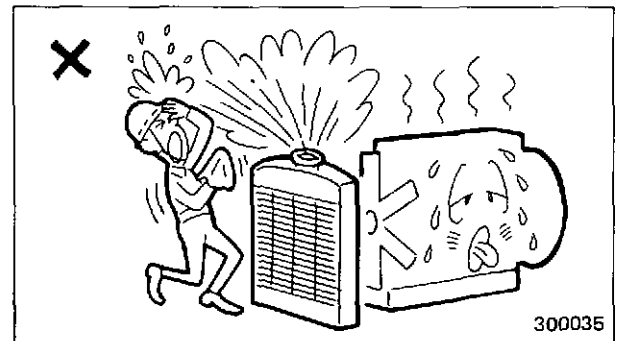
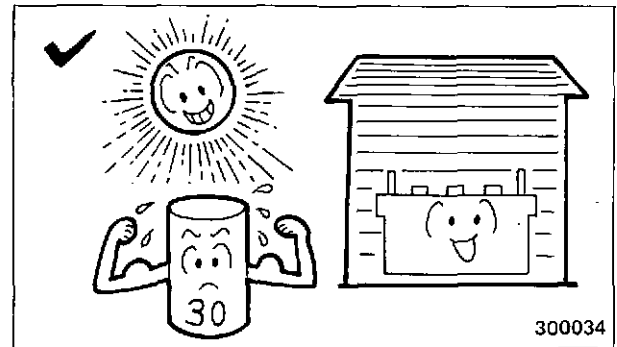

**WARNING**

Shutting off an overheated engine is a dangerous practice. Equally dangerous is an attempt to pour cold water into the radiator: you will have scalding-hot coolant or steam spouted out from the radiator.

## MAINTENANCE INSTRUCTIONS

1. Use hour-meter or calendar intervals whichever occur first.
2. The intervals established in the schedule are for an average job application. Service the engine earlier than scheduled intervals if necessary. (Service intervals depends on application, operating conditions, fuel oil and lubricating oil used in the engine. Adjust the service intervals to meet the actual operating conditions.)

3. Perform previous interval items at multiples of the original requirement.

Example: At 250 hours, also perform those items listed in "10 hours" and "50 hours."

- Check, clean, wash or adjust
- Change
- Ⓢ Rely on your Mitsubishi dealer if necessary.
- \* Item to be performed after initial 50 operating hours of a new or reconditioned engine or placed in service after a long storage

### MAINTENANCE SCHEDULE

Group	Service		Service intervals					Remarks
			Every 10 hours	Every 50 hours	Every 250 hours	Every 500 hours	Every 1000 hours	
Engine proper	Walk-around checks		○					
	Valve clearance	Check and adjust				○		Ⓢ
	Bolts and nuts	Retighten		*			○	Ⓢ
Lubrication system	Crankcase	Check oil level	○					
		Change oil		*	●			Ⓢ
	Oil filter (cartridge type)	Change		*		●		
Fuel system	Fuel tank	Check oil level	○					
		Drain sediment and moisture		○				
	Fuel filter (paper-element type)	Drain sediment and moisture		○				
		Change				●		
	Fuel filter (cartridge type)	Change				●		
	Injection nozzles	Check and adjust					○	Ⓢ

MAINTENANCE INSTRUCTIONS

Group	Service		Service intervals					Remarks
			Every 10 hours	Every 50 hours	Every 250 hours	Every 500 hours	Every 1000 hours	
Cooling system	Coolant	Check level	○					
		Change					●	
	Radiator fins	Clean			○			
	Fan drive belt	Check and adjust tension				○		
	Water pump	Lubricate			○			Ⓢ 2- and 3-cylinder engines only
Air intake system	Air cleaner (paper-element type)	Check indicator		○				
		Clean element				○		Ⓢ
		Change element					●	
	Turbocharger	Check					○	
Electrical system	Battery	Check electrolyte level/specific gravity		○				Check specific gravity at proper intervals
	Alternator	Check					○	Ⓢ
	Starter	Check					○	Ⓢ
Lever ball joint	Lubricate				○		Ⓢ 2- and 3-cylinder engines only	

EVERY 10 HOURS

Walk-around checks

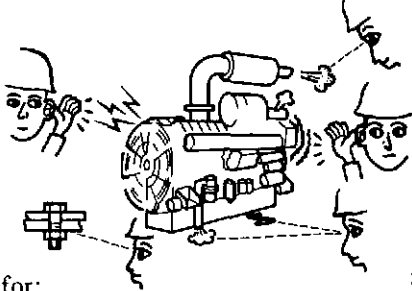

300085

Check for:

- Loose or missing bolts and nuts
- Abnormal vibration, noise and exhaust color
- Water, oil and air leaks
- Broken electric wire and loose terminals
- Loose pipe joints
- Excessive mist from breather

Coolant – Check level

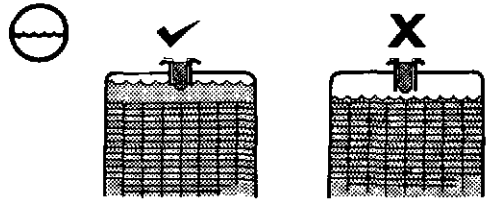

300160

- Remove radiator filler cap and check. Coolant should be visible in filler neck.
- Check level in sight gauge on expansion tank.

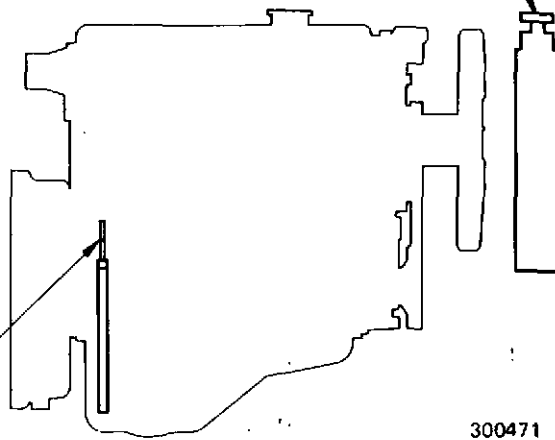

Crankcase – Check oil level

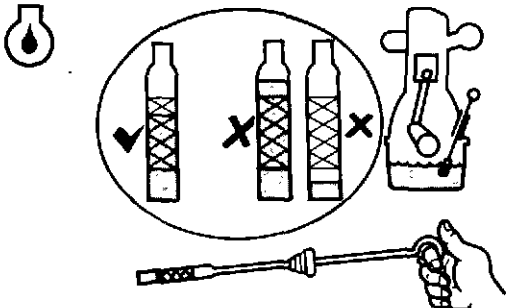

300084

- Maintain oil level in operating range.

Fuel tank – Check oil level

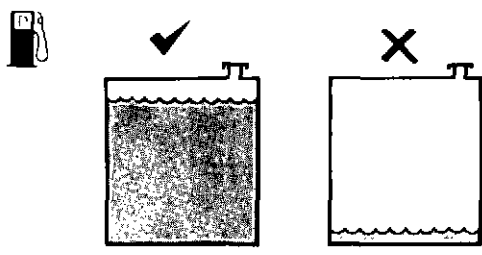

300087

- Be sure to fill up tank at end of operating period.

EVERY 50 HOURS

Fuel tank – Drain sediment and moisture

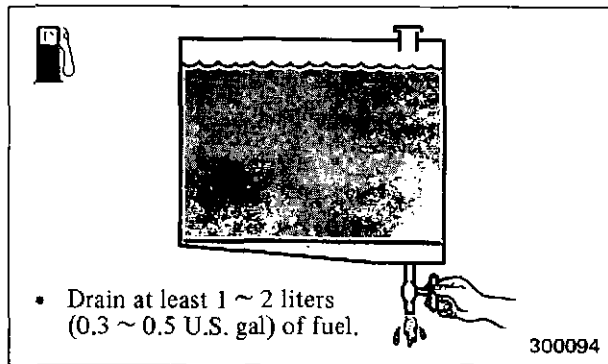

- Drain at least 1 ~ 2 liters (0.3 ~ 0.5 U.S. gal) of fuel.

Air cleaner (paper-element type) – Check indicator

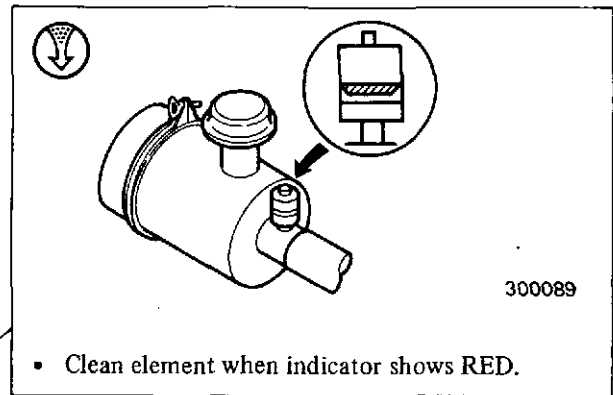

- Clean element when indicator shows RED.

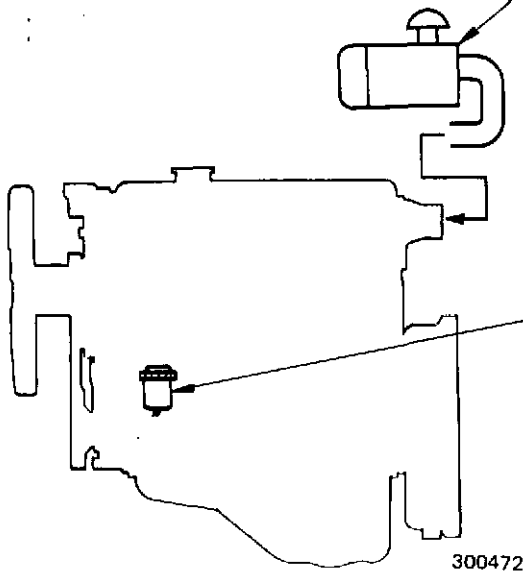

Fuel filter (paper-element type) – Drain sediment and moisture

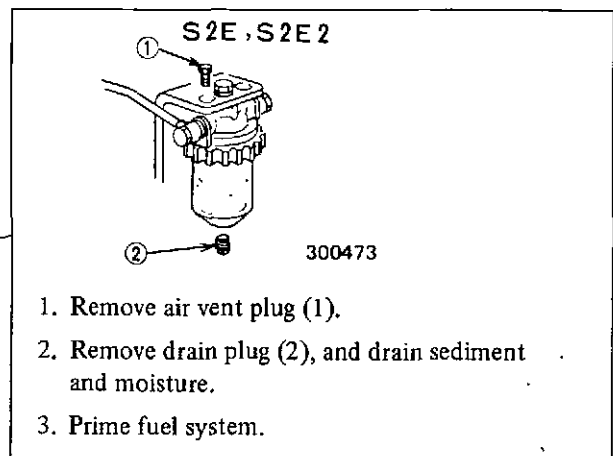

1. Remove air vent plug (1).
2. Remove drain plug (2), and drain sediment and moisture.
3. Prime fuel system.

Battery – Check electrolyte level/specific gravity

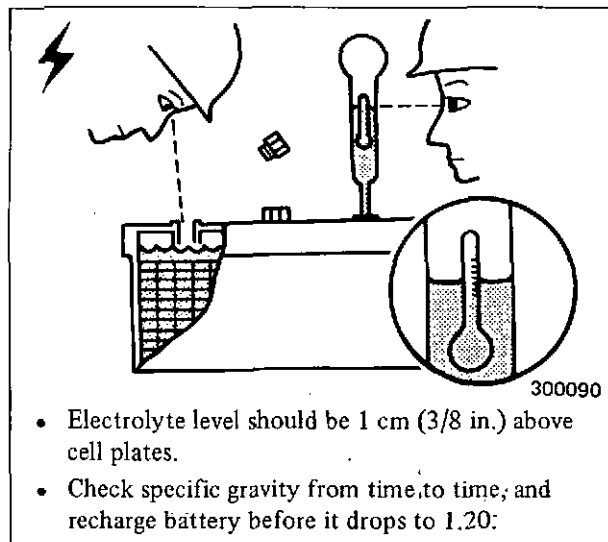

- Electrolyte level should be 1 cm (3/8 in.) above cell plates.
- Check specific gravity from time to time; and recharge battery before it drops to 1.20:

Priming the fuel system

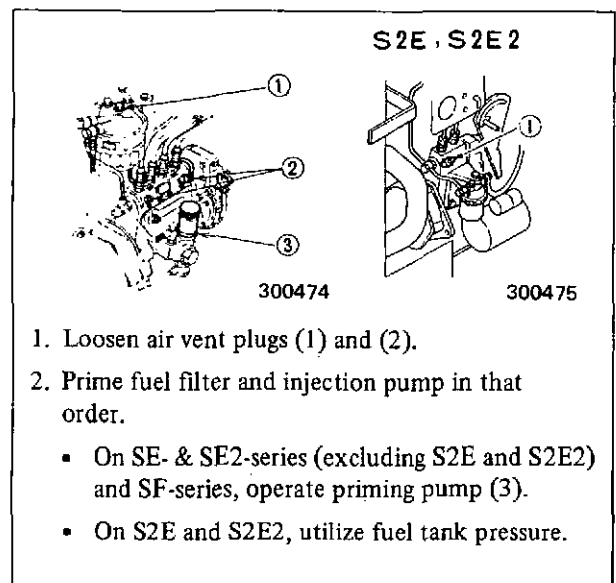

1. Loosen air vent plugs (1) and (2).
2. Prime fuel filter and injection pump in that order.
  - On SE- & SE2-series (excluding S2E and S2E2) and SF-series, operate priming pump (3).
  - On S2E and S2E2, utilize fuel tank pressure.

EVERY 250 HOURS

Radiator fins – Clean

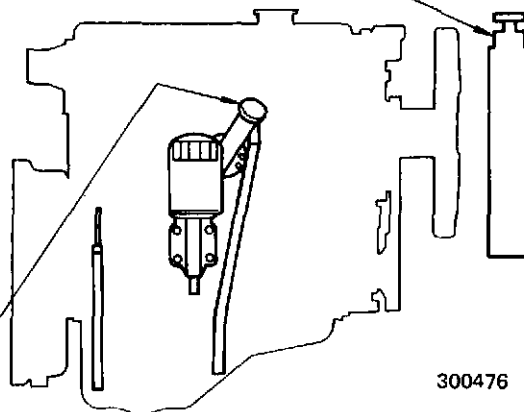
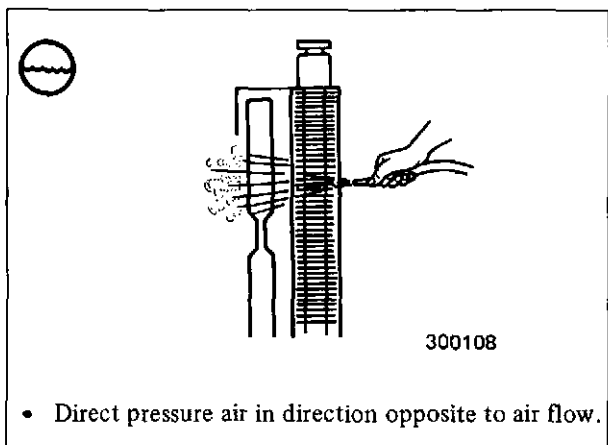

Crankcase – Change oil

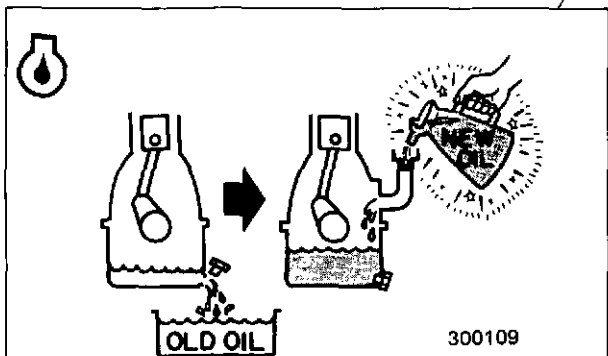

- Drain oil when it is hot – that is, shortly after operation.

	API Service Classification
Naturally aspirated engines	*1 CC or above
Turbocharged engines	*2 CD

\*1 API Service Classification CC, MIL-L-2104B or equivalent

\*2 API Service Classification CD, MIL-L-2104C, MIL-L-2104D or equivalent

Lever ball joint – Lubricate

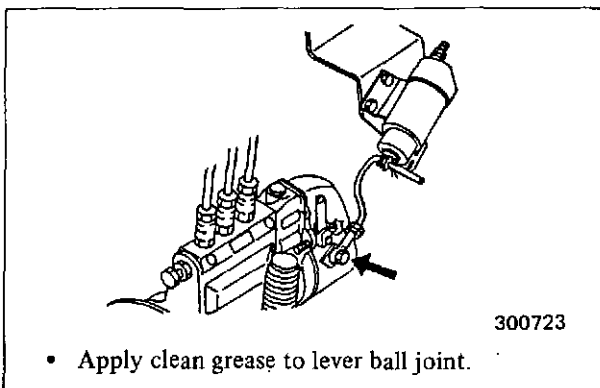

Refill capacities (including oil filters)

Model	Liter (U.S. gal)
S2E, S2E2	5 (1.3)
S3E, S3E2, S3F	7 (1.8)
S4E, S4E2, S4E2-T, S4F, S4F-T	8 (2.1)
S6E, S6E2, S6E2-T, S6F, S6F-T	12 (3.2)

EVERY 500 HOURS

Air cleaner – Clean element

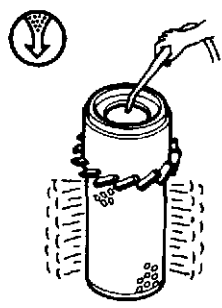

- Use air pressure – 7 kgf/cm<sup>2</sup> (100 psi) maximum.
- Insert light inside clean element and check. Change element if pinholes or tears are found.
- Clean interior of air cleaner case.
- If indicator shows RED shortly after installation of clean element, install new element.

300104

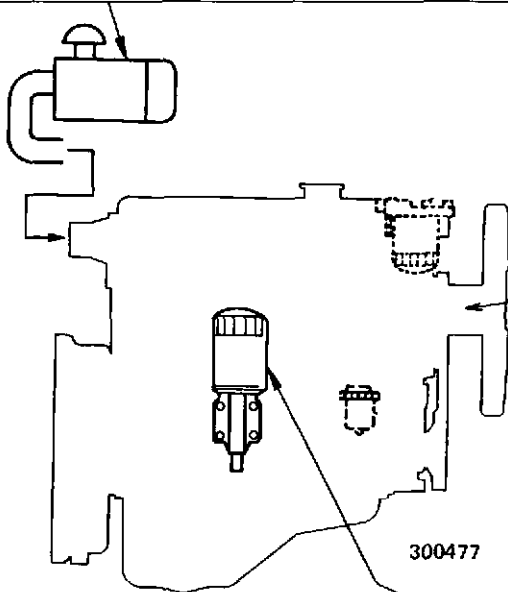

Water pump – Lubricate

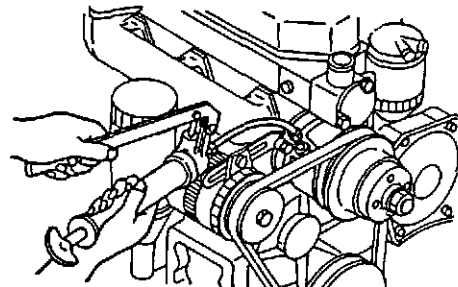

- Add 20 cc (approx. 10 oz) of grease to water pump, using a grease gun.

300724

Oil filter (cartridge type) – Change

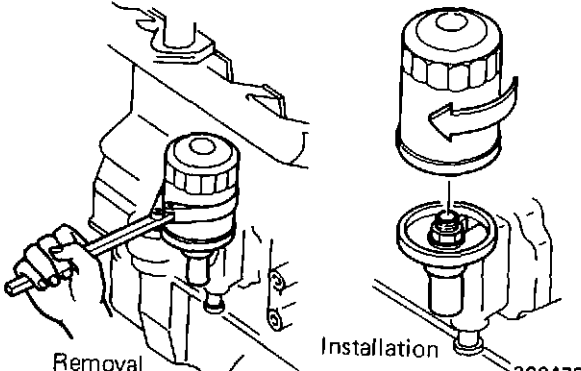

- If metallic particles are found on filter, consult your Mitsubishi dealer.
- When installing new oil filter, apply oil to O-ring, and tighten filter by hands.

300478

**Fuel filter (cartridge type) – Change**

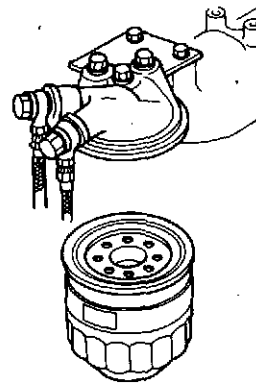

- Use filter wrench to remove filter.
- Before installing new filter, apply fuel to O-ring.
- Install new filter by tightening by hands – without using the wrench.
- Install filter “dry.” Do not add fuel to filter because *unfiltered fuel* will enter injection pump.
- Bleed air out of filter by opening air vent plug and operating priming pump. (See page 21.)

300479

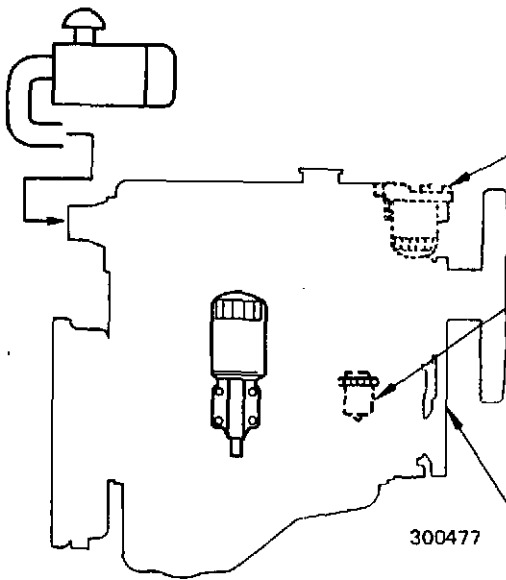

300477

**Fuel filter (paper-element type) – Change**

S2E, S2E2

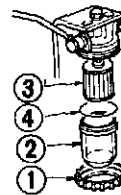

1. Unscrew bolt or ring (1), and remove filter case (2).
2. Clean interior of filter case, and change element (3). Use care when installing element to prevent damage to O-ring (4).
3. Prime fuel system.

300480

**Fan drive belt – Check and adjust tension**

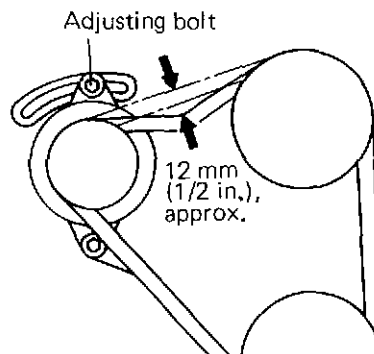

300481

- Deflection should be approximately 12 mm (1/2 in.) when belt is pushed inward with thumb pressure exerted midway between pulleys. Adjust belt by loosening adjusting bolt if necessary.

Valve clearance – Check

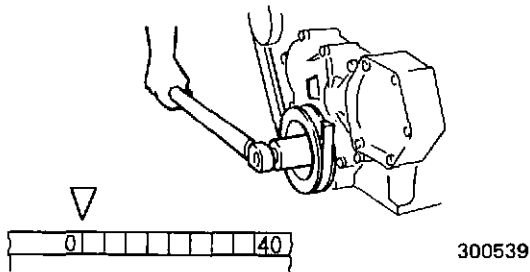

1. Using a wrench at crankshaft pulley nut, turn crankshaft until No. 1 cylinder piston is at top dead center on compression stroke ("0" mark on crankshaft pulley is aligned with pointer).

**NOTE**

Push down on both inlet and exhaust valve rockers for No. 1 cylinder to make sure that they are free.

2. Check both inlet and exhaust valve clearance.

Unit: mm (in.)

	Valve clearance at cold
Inlet valves	0.25 (0.0098)
Exhaust valves	

3. Check valve clearance on the remaining cylinders by turning crankshaft in degrees of angle shown below, one for each cylinder:

Number of cylinder	Sequence	Turning angle
2	1 - 2	180°
3	1 - 3 - 2	240°
4	1 - 3 - 4 - 2	180°
6	1 - 5 - 3 - 6 - 2 - 4	120°

Valve clearance – Adjust

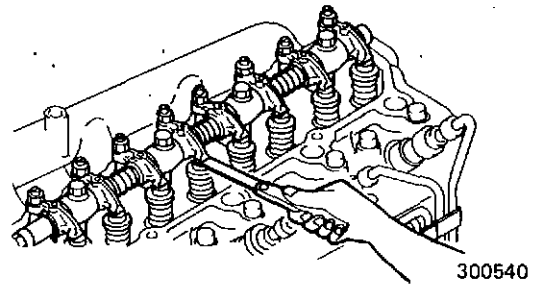

1. If valve clearance is incorrect, adjust it as follows.

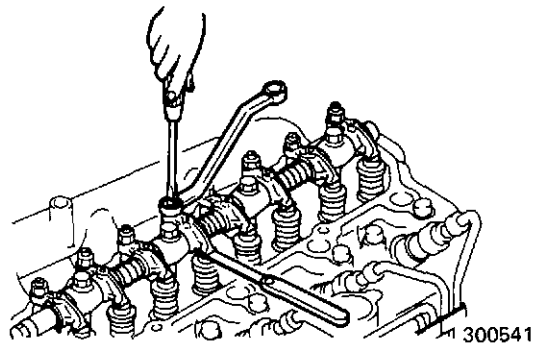

2. Loosen lock nut for adjusting screw, and turn the screw in either direction.
3. Hold adjusting screw, and tighten lock nut.

**NOTE**

After completing adjustment, check to make sure that valve clearance is correct.

**Fuel injection nozzles — Check and adjust**

**Removal**

1. Disconnect injection pipe and leak-off pipe.
2. On SF-series engines, remove gland securing injection nozzle.
3. Remove nozzle and gasket.

**Injection pressure**

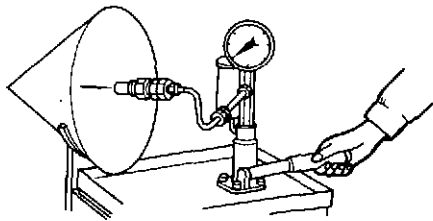

300542

1. Mount injection nozzle on a tester, and push down tester lever slowly to observe pressure at which injection begins.

Unit: kgf/cm<sup>2</sup> (psi)

SE- and SE2-series	120 (1706)
SF-series	220 (3128)

2. Increase or decrease shims used in nozzle holder to adjust injection pressure.

**NOTE**

0.1 mm (0.004 in.) thickness of shim is equivalent to 10 kgf/cm<sup>2</sup> (142 psi) of pressure. Shims are available in 20 different thicknesses from 1 mm (0.04 in.) to 1.95 mm (0.08 in.), increment being 0.05 mm (0.0020 in.).

**Fuel spray pattern**

SE- and SE2-series

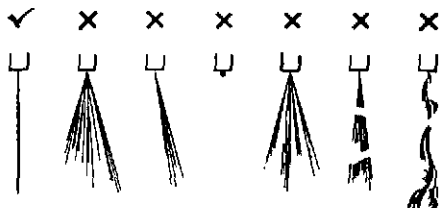

300543

SF-series

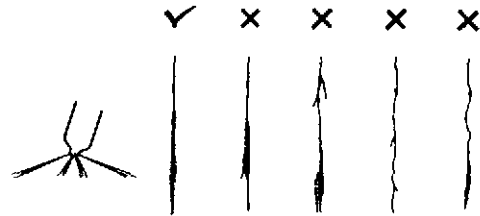

300544

1. Injection nozzle for SE- and SE2-series engines should spray fuel in a straight line when tester lever is operated at a speed of 1 stroke per second.
2. Injection nozzle for SF-series engines should spray fuel from all of the four orifices at the same time, taking a cone shape with an angle of 155° consisting of finely and uniformly atomized fuel particles.

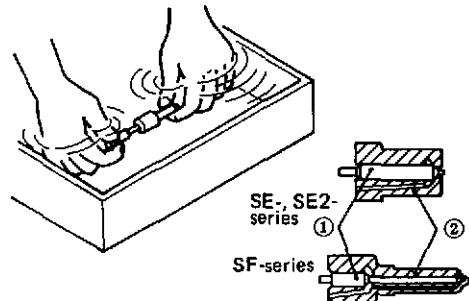

300545

3. If spray pattern is poor, remove nozzle tip, and wash needle valve (1) and body (2) in clean diesel fuel.
4. If spray pattern is still poor even after needle valve and body have been washed, replace nozzle tip.

**NOTE**

When installing a new nozzle tip, remove a coating of rust and corrosion inhibitor from tip, and slide needle valve in body in clean diesel fuel to remove preservative oil.

**Installation**

1. To install, use reverse of removal procedure.
2. After installing nozzle, start engine and make sure that each pipe joint is free from fuel leaks.

EVERY 1000 HOURS

Changing coolant (spring and autumn)

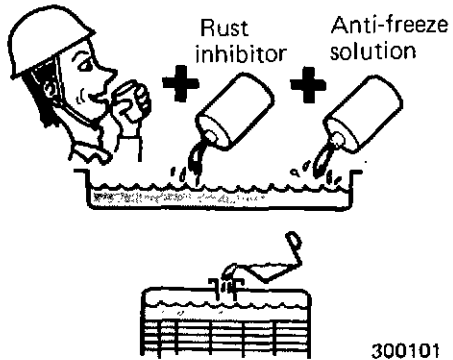

300101

- Normally, change coolant twice a year.
- Use only water that is soft or as free from scale forming minerals as possible.
- In an area with below freezing temperatures in winter, use anti-freeze solution in cooling system in autumn. After cold season, change coolant containing anti-freeze solution with normal one. Use rust inhibitor all the year round.
- In an area without freezing temperatures, change coolant once a year.

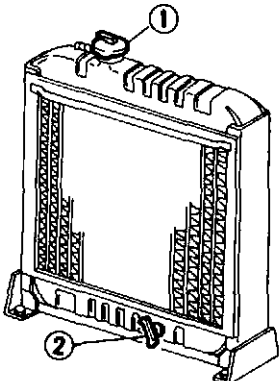

300483

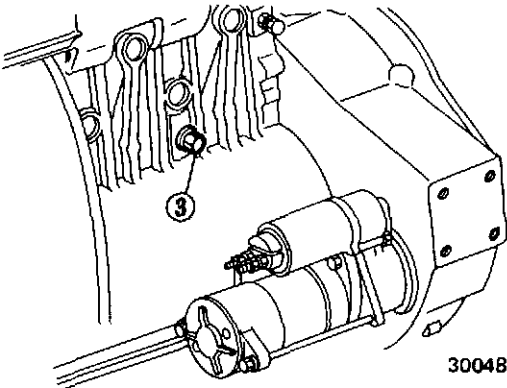

300484

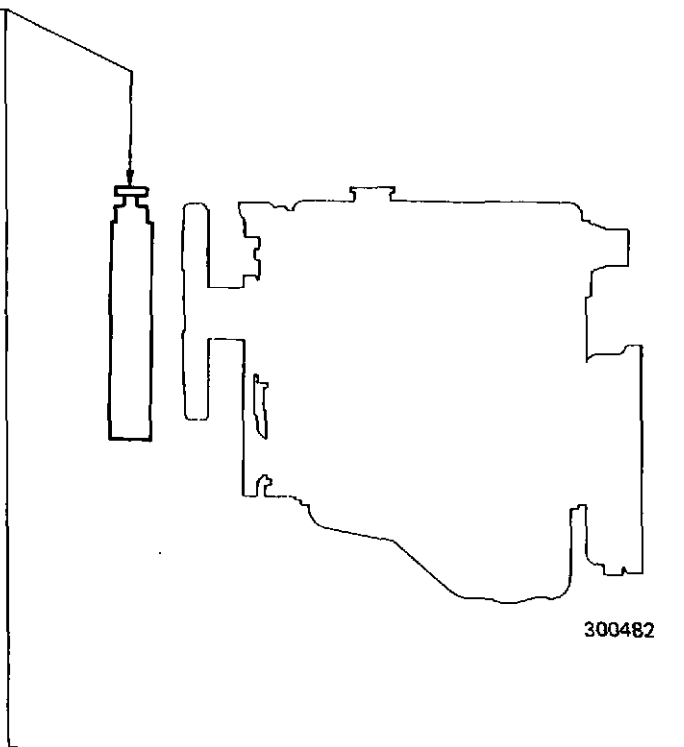

Procedure

1. Start and run engine until water temperature is 70° ~ 85°C (158° ~ 185°F), and stop it.
2. Raise lever of radiator filler cap (1) to relieve pressure, and remove cap.
3. Open drain cock (2) (radiator) and drain cock (3) (engine), and drain coolant.
4. Close drain cocks, and fill system with flushing solvent (which will not attack rubber and metal). Run engine at 800 ~ 900 rpm for about 15 minutes. Stop engine, and drain the solvent.
5. Close drain cocks, and fill system with clean water. Run engine at 800 ~ 900 rpm for about 10 minutes.
6. Stop engine, open drain cocks, and pour water into system until draining water is clean.
7. Close drain cocks, and fill system with soft water up to level.



When using anti-freeze solution, mix fresh water, anti-freeze solution and rust inhibitor in a container, and pour the mixture into radiator.

**Turbocharger – Check**

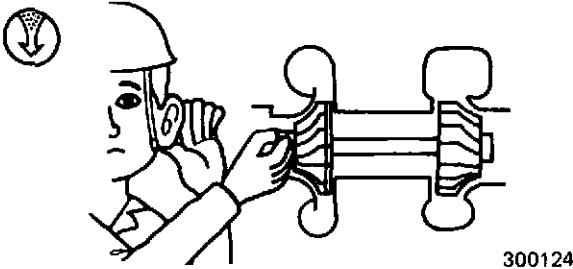

300124

- Spin compressor wheel with fingers to see if it rotates smoothly. Change bearing if the wheel is noisy.

**Air cleaner – Change element**

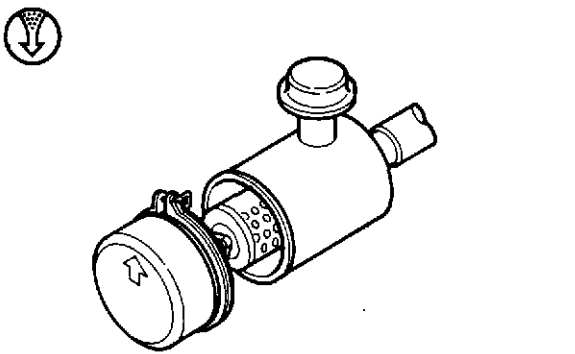

300121

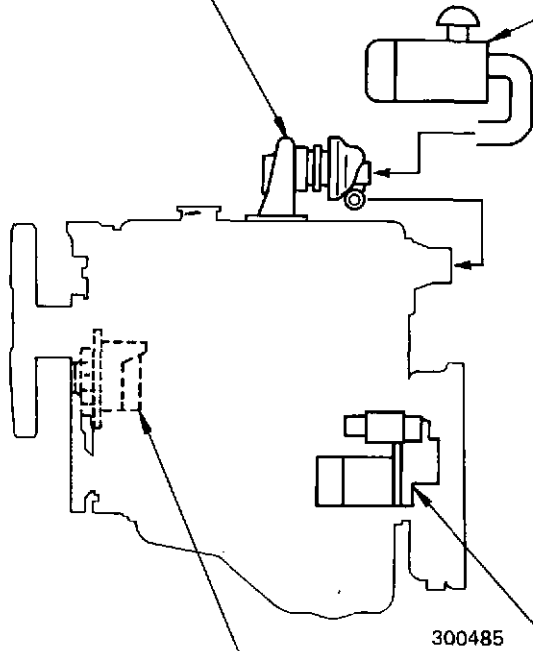

**Bolts and nuts – Retighten**

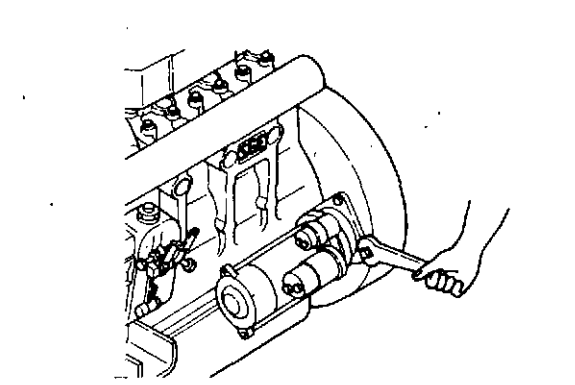

300487

**Alternator – Check**

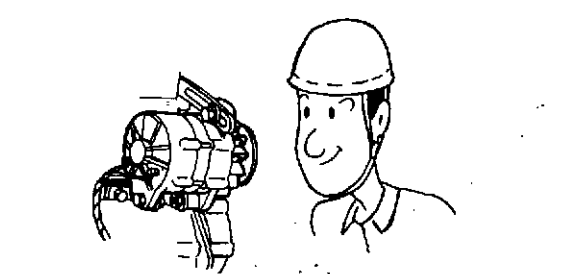

300486

- Check for defects.
- Bearings are factory-lubricated and need no lubrication until overhauling.

**Starter – Check**

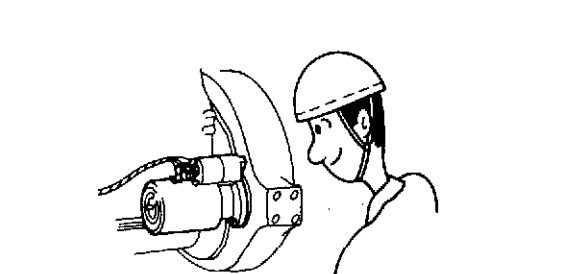

300488

- Check for defects.

## TROUBLESHOOTING

### General instructions

(1) Think before acting

Upon noting an abnormal symptom, recall what you did the last time when you ran across the same symptom. If what you did was correct and successful, do the same. If the symptom noted is new to you, think of possible causes in accordance with the troubleshooting procedure which follows.

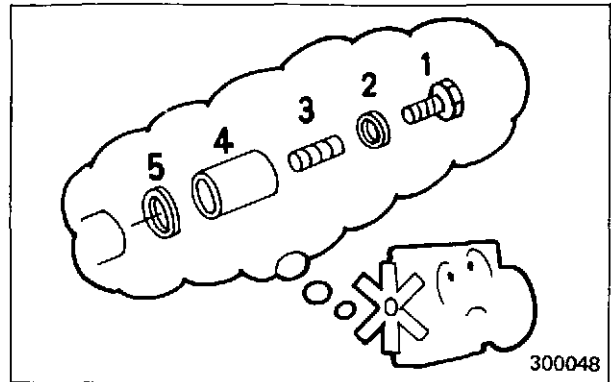

(2) Dust and dirt are often the ultimate causes.

“Wear” is usually a result of abrasive particles. When disconnecting or disassembling a part or component, be sure to keep off dust and dirt.

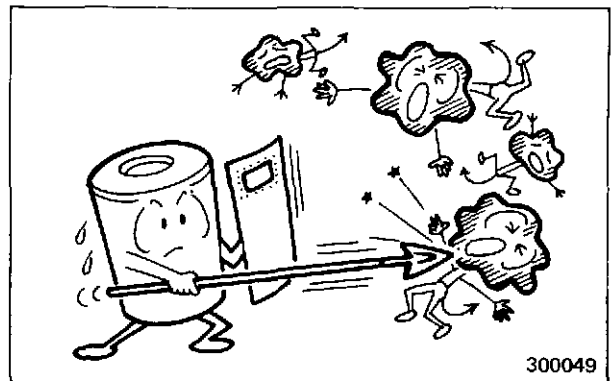

(3) Use genuine Mitsubishi parts.

Use only genuine parts to replace those that have failed or reached the service limit. When ordering, specify the needed replacement parts by referring to the Mitsubishi Parts Catalogues.

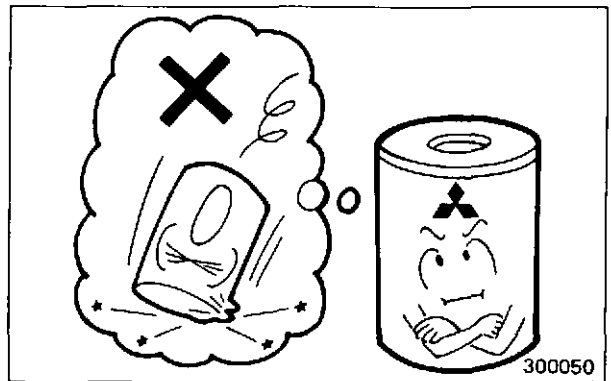

(4) Perform servicing work safely.

Use the right kind of hand tool to carry on each working step in repair work. Avoid injury to yourself and damage to the parts by using improper tool. When lifting or carrying a part too heavy for one person to handle, get another person's help and, if necessary, use a jack or a chain block to avoid personal injury.

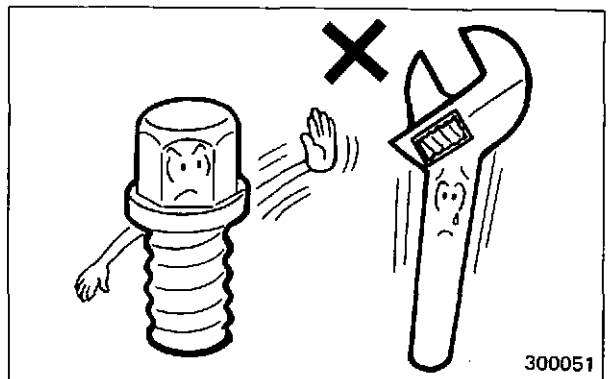

## TROUBLESHOOTING



- Never attempt to break the seals of the governor for maximum speed setting and maximum injection quantity setting.
- The maximum injection quantity of injection pumps has been set on the basis of the output horsepower of each engine verified in the bench test. Never attempt to vary this injection quantity in field.

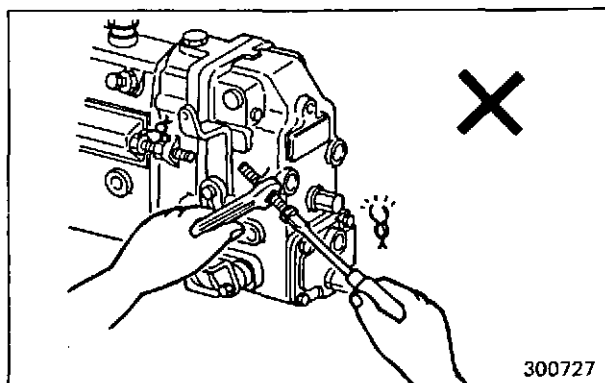

First-aid troubleshooting-1

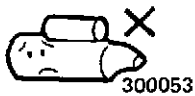

**Starter will not crank engine or cranks slowly, resulting in a failure of engine to start**

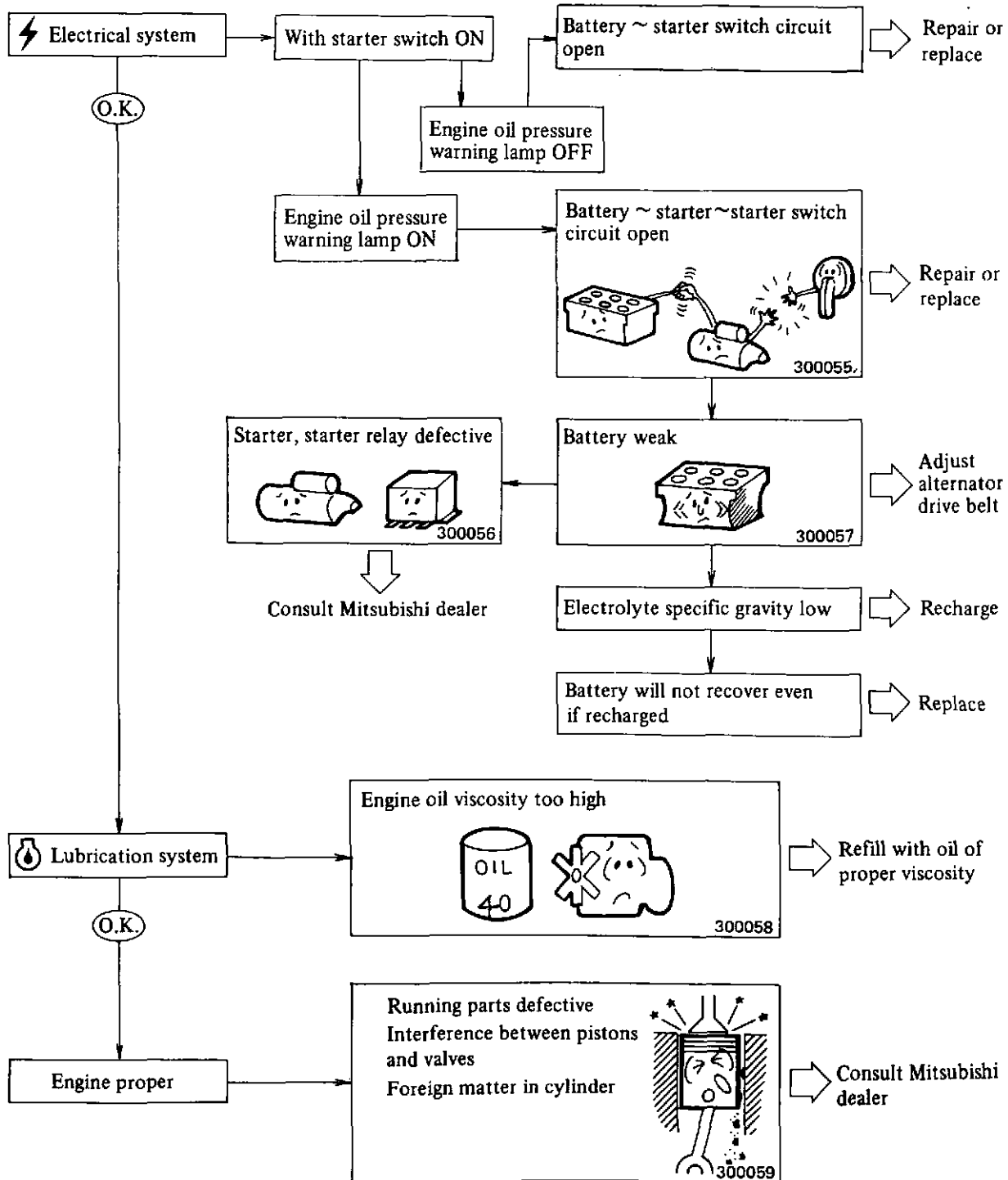

TROUBLESHOOTING

First-aid troubleshooting-2

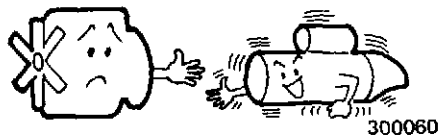



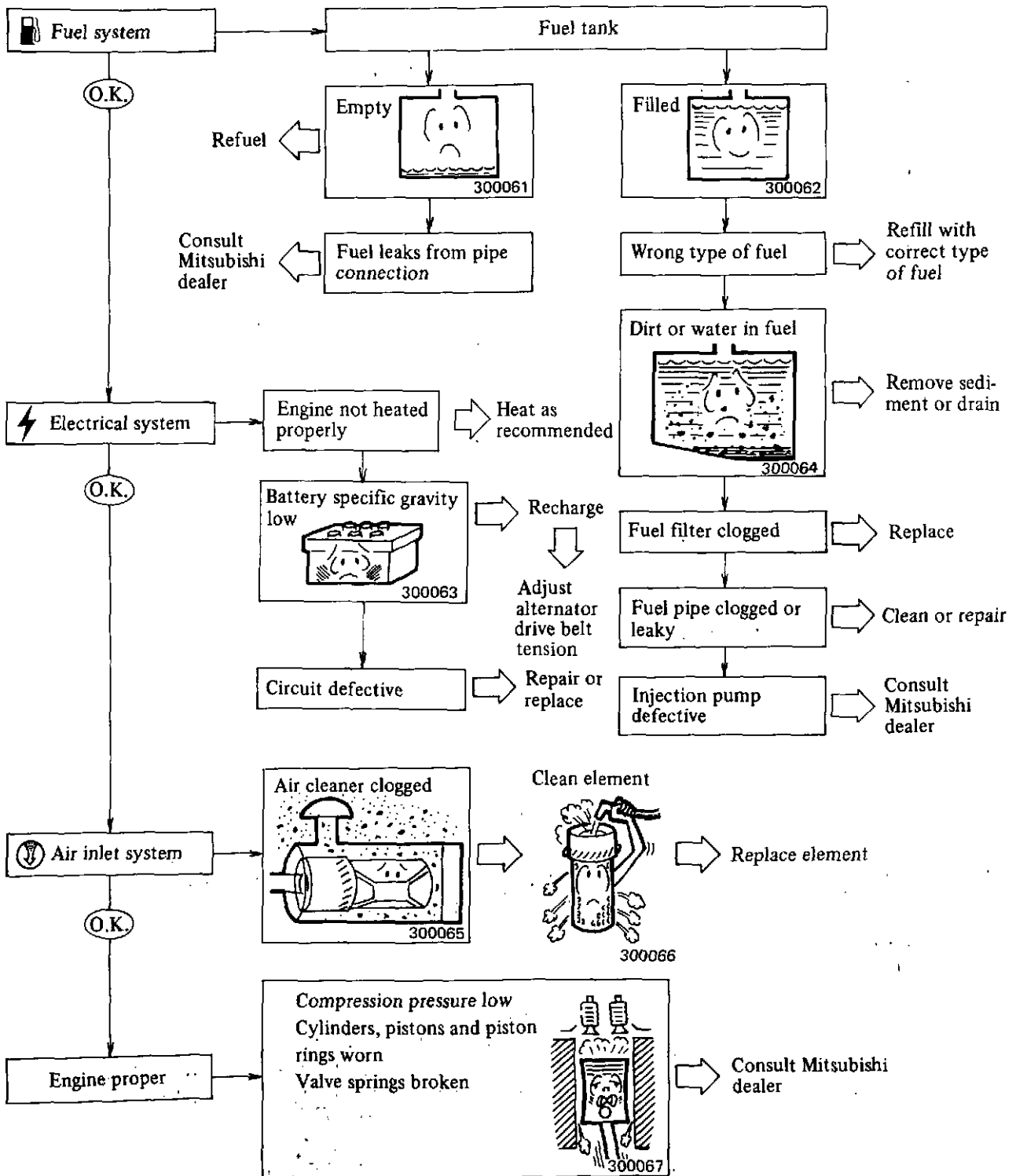

300060



**Starter will crank engine, but engine will not start**



## Others

Complaint	Possible causes	Remedy
<p>Engine lacks power</p>  <p>500040</p>	<ul style="list-style-type: none"> <li>• Incorrect grade of oil</li> <li>• Wrong type of fuel</li> <li>• Insufficient air (air cleaner clogged)</li> <li>• Engine overcooled</li> <li>• Engine overheating</li> <li>• Valve clearance incorrect</li> <li>• Injection pump defective</li> <li>• Injection nozzles defective</li> <li>• Injection timing incorrect</li> <li>• Compression pressure low (cylinders and piston rings worn)</li> </ul>	<ul style="list-style-type: none"> <li>• Use recommended type and SAE number of oil.</li> <li>• Change.</li> <li>• Clean or change element.</li> <li>• Use radiator cover, replace parts.</li> <li>• Flush cooling system or replace parts.</li> <li>• Readjust.</li> <li>* Readjust or replace.</li> <li>* Readjust or replace.</li> <li>* Readjust.</li> <li>* Disassemble and replace parts.</li> </ul>
<p>White or blue exhaust smoke</p>  <p>500041</p>	<ul style="list-style-type: none"> <li>• Too much oil in crankcase</li> <li>• Oil viscosity too low</li> <li>• Engine overcooled</li> <li>• Injection timing incorrect</li> <li>• Compression pressure low</li> <li>• Poor fuel spray from injection nozzles</li> </ul>	<ul style="list-style-type: none"> <li>• Fill only to correct level on gauge.</li> <li>• Refill with correct viscosity of oil.</li> <li>• Use radiator cover, or clean, test and replace thermostat.</li> <li>* Readjust.</li> <li>* Disassemble and replace parts.</li> <li>• Readjust or replace.</li> </ul>
<p>Black or gray exhaust smoke</p>  <p>500042</p>	<ul style="list-style-type: none"> <li>• Wrong type of fuel</li> <li>• Valve clearance incorrect</li> <li>• Injection pump defective</li> <li>• Compression pressure low</li> <li>• Insufficient air (air cleaner clogged)</li> </ul>	<ul style="list-style-type: none"> <li>• Refill with correct type of fuel.</li> <li>• Readjust.</li> <li>* Readjust or replace.</li> <li>* Disassemble and replace parts.</li> <li>• Clean or change element.</li> </ul>
<p>High fuel consumption</p>  <p>500043</p>	<ul style="list-style-type: none"> <li>• Injection pump defective</li> <li>• Injection nozzles defective</li> <li>• Injection timing incorrect</li> <li>• Wrong type of fuel</li> <li>• Compression pressure low</li> <li>• Insufficient air</li> </ul>	<ul style="list-style-type: none"> <li>* Readjust or replace.</li> <li>* Readjust or replace.</li> <li>* Readjust.</li> <li>• Refill with correct type of fuel.</li> <li>* Disassemble and replace parts.</li> <li>• Clean or change air cleaner element. Check turbocharger.</li> </ul>
<p>High oil consumption</p>  <p>500044</p>	<ul style="list-style-type: none"> <li>• Too high oil level in crankcase</li> <li>• Incorrect grade of oil</li> <li>• Oil leaks</li> <li>• Cylinders and piston rings worn</li> </ul>	<ul style="list-style-type: none"> <li>• Maintain oil level in operating range on gauge.</li> <li>• Use recommended type and SAE number of oil.</li> <li>• Retighten or replace.</li> <li>* Disassemble and replace parts.</li> </ul>

## TROUBLESHOOTING

Complaint	Possible causes	Remedy
<p>Engine overheats</p>  <p>500047</p>	<ul style="list-style-type: none"> <li>• Fan belt loose</li> <li>• Lack of coolant</li> <li>• Too low oil level</li> <li>• Water pump defective</li> <li>• Thermostat defective</li> </ul>	<ul style="list-style-type: none"> <li>• Readjust.</li> <li>• Refill.</li> <li>• Maintain oil level in operating range on gauge.</li> <li>* Replace.</li> <li>* Replace.</li> </ul>
<p>Low oil pressure (Oil pressure alarm lamp glows)</p>  <p>500045</p>	<ul style="list-style-type: none"> <li>• Lack of oil</li> <li>• Oil viscosity too low</li> <li>• Oil filter clogged</li> <li>• Oil pump defective</li> <li>• Oil pressure regulating valve defective</li> </ul>	<ul style="list-style-type: none"> <li>• Refill up to level.</li> <li>• Refill with correct viscosity of oil.</li> <li>• Replace element.</li> <li>* Readjust or replace.</li> <li>* Readjust or replace.</li> </ul>

### NOTE

1. Consult your Mitsubishi dealer for items marked with asterisk (\*).
2. Consult your Mitsubishi dealer for any item other than those listed above.
3. When communicating with your Mitsubishi dealer, give model designation, serial number and hour meter reading of your engine.

## SPECIFICATIONS

### SE-series

	S2E	S3E	S4E	S6E
Number of cylinders	2	3	4	6
Bore X stroke mm (in.)	94 X 94 (3.701 X 3.701)			
Combustion chambers	Swirl type			
Direction of rotation	Counterclockwise as viewed from flywheel side			
API service classification of lubricating oil	CC or above			
Refill capacity of lubrication system liter (U.S. gal)	5 (1.3)	7 (1.8)	8 (2.1)	12 (3.2)
Refill capacity of cooling system (engine proper) liter (U.S. gal)	3 (0.8)	4 (1.1)	4.6 (1.2)	6.5 (1.7)
Starting aid	Glow plug			
Turbocharger	-			

### SE2-series

	S2E2	S3E2	S4E2	S4E2-T	S6E2	S6E2-T
Number of cylinders	2	3	4		6	
Bore X stroke mm (in.)	98 X 98 (3.858 X 3.858)					
Combustion chambers	Swirl type					
Direction of rotation	Counterclockwise as viewed from flywheel side					
API service classification of lubricating oil	CC or above			CD	CC or above	CD
Refill capacity of lubrication system liter (U.S. gal)	5 (1.3)	7 (1.8)	8 (2.1)		12 (3.2)	
Refill capacity of cooling system (engine proper) liter (U.S. gal)	3 (0.8)	4 (1.1)	4.6 (1.2)		6.5 (1.7)	
Starting aid	Glow plug					
Turbocharger	-			TC05	-	TC06

SPECIFICATIONS

SF-series

	S3F	S4F	S4F-T	S6F	S6F-T
Number of cylinders	3	4		6	
Bore X stroke mm (in.)	98 X 98 (3.858 X 3.858)				
Combustion chambers	Direct injection type				
Direction of rotation	Counterclockwise as viewed from flywheel side				
API service classification of lubricating oil	CC or above		CD	CC or above	CD
Refill capacity of lubrication system liter (U.S. gal)	7 (1.8)	8 (2.1)		12 (3.2)	
Refill capacity of cooling system (engine proper) liter (U.S. gal)	4 (1.1)	4.6 (1.2)		6.5 (1.7)	
Starting aid	Air heater				
Turbocharger	-		TC05 (TD05)	-	TC06

API Service Classification CC, MIL-L-2104B or equivalent

API Service Classification CD, MIL-L-2104C, MIL-L-2104D or equivalent

