

Engine No. 20003-UP

SERVICE MANUAL

MITSUBISHI DIESEL ENGINE

S12A2



MITSUBISHI
HEAVY INDUSTRIES, LTD.

INTRODUCTION

This Service Manual is written to familiarize you with the maintenance of your Mitsubishi S12A2 Diesel Engine.

Long productive life and efficient performance are the essential qualities required of the engine if it is to fulfil its function of rationalizing power economy. These qualities depend to a great extent on the care exercised in maintenance of the engine.

We hope you read this manual carefully to get to know your new engine and learn how to service it before starting disassembly, inspection and repair, and reassembly.

The description, illustrations and specifications contained in this manual are effective the serial numbers of the engines manufactured at the time this manual was approved for printing.

Mitsubishi reserves the right to change specifications or design without notice and without incurring obligation.

SCOPE

This Service Manual covers the standard-specification model of Mitsubishi S12A2 Diesel Engine and describes, group by group, the specifications, maintenance standards, adjustments, disassembly, inspection and repair, and reassembly of the engine.

The fuel injection pump, governor and turbocharger are described in the separate volume of this manual.

For the non-standard-specification engines such as marine propulsion engines, etc., the supplement has been published to be read together with this manual.

The groups and their contents will be found in "Table of Contents" and the contents of each group in the first page of the group.

The operation and periodical maintenance are described in OPERATION & MAINTENANCE MANUAL, the component parts and ordering of service parts in PARTS CATALOGUE and the construction and function in the various training manuals.

HOW TO USE THIS MANUAL

1. The parts read in the texts or shown in the illustrations are numbered in the disassembling sequence prescribed for each system or assembly.
2. The items to be inspected and disassembled are indicated in in the disassembled view.
3. The maintenance standards to be referred to for inspection and repair are indicated in easy-to-refer passages of the texts and also in GROUP N in a tabulated form.
4. The sequence in which the parts to be reassembled are shown in the form of, for example, ⑤ - ② - ④ - ① below the assembled view.
5. Marks are used in this manual to emphasize important and critical instructions as shown below:
6. Tightening torque in "wet" condition is indicated as [wet]. When indicated as [wet], apply engine oil to the threaded portion of a fastener. Unless indicated as such, the torque is to be considered in "dry" condition.

NOTES, CAUTIONS and WARNINGS

NOTES, CAUTIONS and WARNINGS are used in this manual to emphasize important and critical instructions. They are used for the following conditions:

- NOTE** An operating procedure, condition, etc., which is essential to highlight.
- CAUTION** Operating procedures, practices, etc., which if not strictly observed, will result in damage to or destruction of engine.
- WARNING** Operating procedures, practices, etc., which if not correctly followed, will result in personal injury or loss of life.

DEFINITION OF TERMS

In this manual, the following terms are used in the dimensional and other specifications:

- NOMINAL VALUE Indicates the standard dimension of a part.
- ASSEMBLY STANDARD Indicates the dimension of a part, the dimension to be attained at the time of reassembly or the standard performance. Its value is rounded to the nearest whole number needed for inspection and is different from the design value.
- STANDARD CLEARANCE Indicates the clearance to be obtained between mating parts at the time of reassembly.
- REPAIR LIMIT A part which has reached this limit must be repaired.
- SERVICE LIMIT A part which has reached this limit must be replaced.

TABLE OF CONTENTS

Group	Contents	Group No.
General	External views, Sectional views, Engine serial number location, Engine model and application codes, Specifications, Tips on disassembly and reassembly	1
Maintenance standards	Maintenance standards, Tightening torque, Sealants and lubricants	2
Special tools	Special tool list	3
Overhaul instructions	Determining when to overhaul the engine, Testing the compression pressure	4
Adjustments, bench test, performance tests		5
Engine accessory removal and installation	Removal and installation of turbochargers, air coolers, fuel injection pumps, alternator, starters, etc.	6
Engine proper	Disassembly, inspection and reassembly of engine proper: Cylinder heads, valve mechanism, cylinder liners, pistons, connecting rods, flywheel, timing gears, camshaft, crankcase, crankshaft, main bearings	7
Inlet & exhaust systems	Disassembly and inspection of inlet & exhaust systems: Air cleaners, inlet manifolds & air coolers, exhaust manifolds, air heater	8
Lubrication system	Disassembly, inspection and reassembly of lubrication system: Oil strainer, oil pump, relief valve, oil cooler, oil filters	9
Cooling system	Disassembly, inspection and reassembly of cooling system: Water pump, thermostats, radiator, fan drive	10
Fuel system	Disassembly, inspection and reassembly of fuel system: Fuel filters, fuel injection nozzles, Woodward governor drive	11
Electrical system	Disassembly, inspection and reassembly of electrical system: Starters, alternator	12
Air start systems	Disassembly, inspection and reassembly of air start systems: Air motor, air filter, distributor valve, starter valves, magnetic valve	13
Workshop theory	Precautions for disassembly and reassembly of general parts. Oil seals, O-rings, bearings, lock plates, pins	14

GENERAL

1. GENERAL	2
1.1 S12A2 diesel engine – External views	2
1.2 S12A2 diesel engine – Sectional views	3
1.3 Engine serial number location	4
1.4 Engine model and application codes	4
2. SPECIFICATIONS	5
3. TIPS ON DISASSEMBLY AND REASSEMBLY	9
3.1 Disassembly	9
3.2 Reassembly	9

GENERAL

1. GENERAL

1.1 S12A2 diesel engine - External views

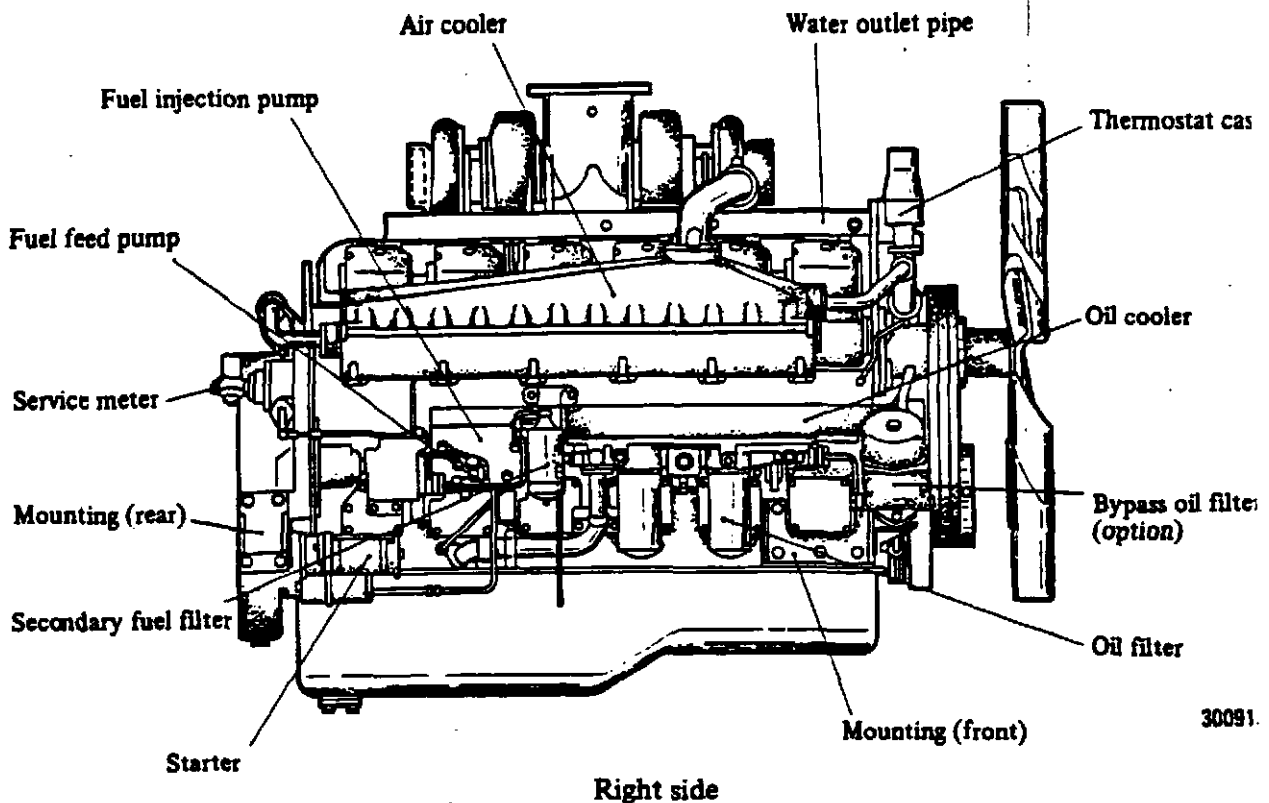
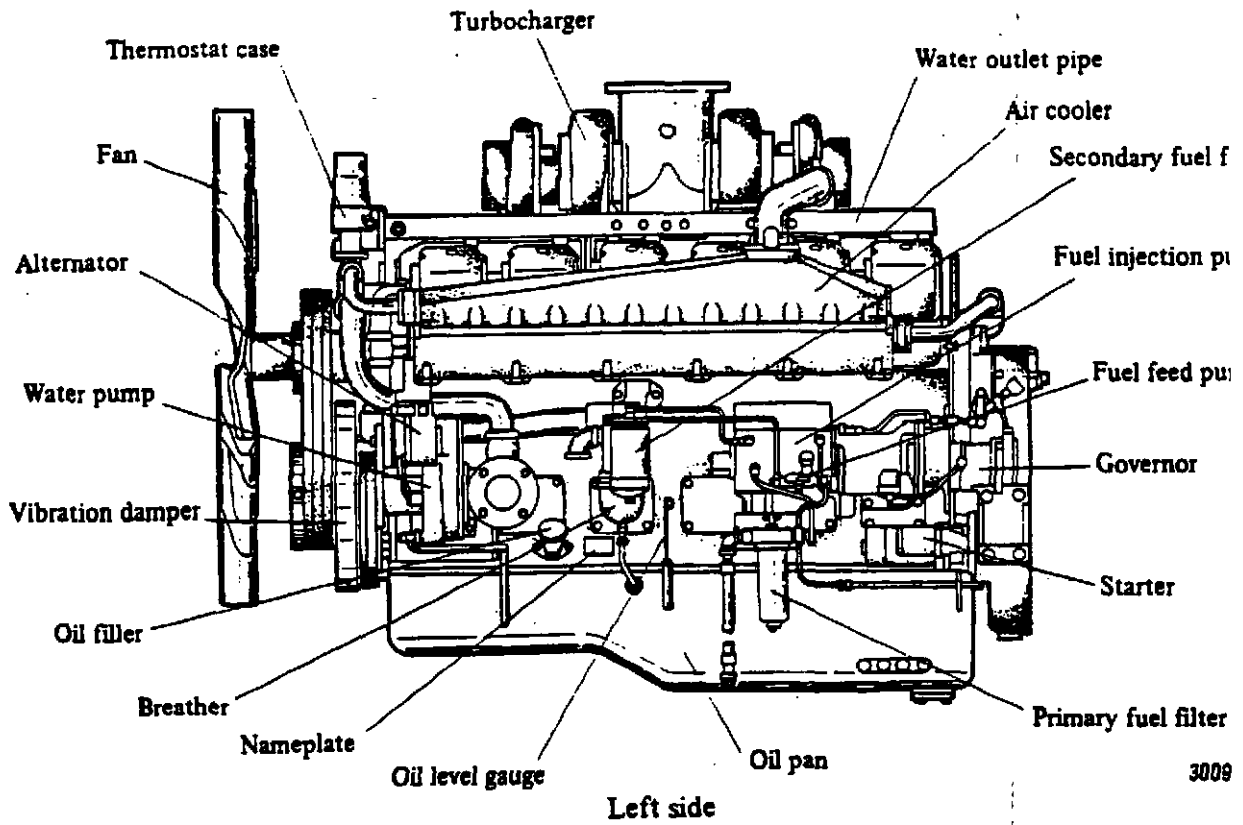

1.2 S12A2 diesel engine - Sectional views

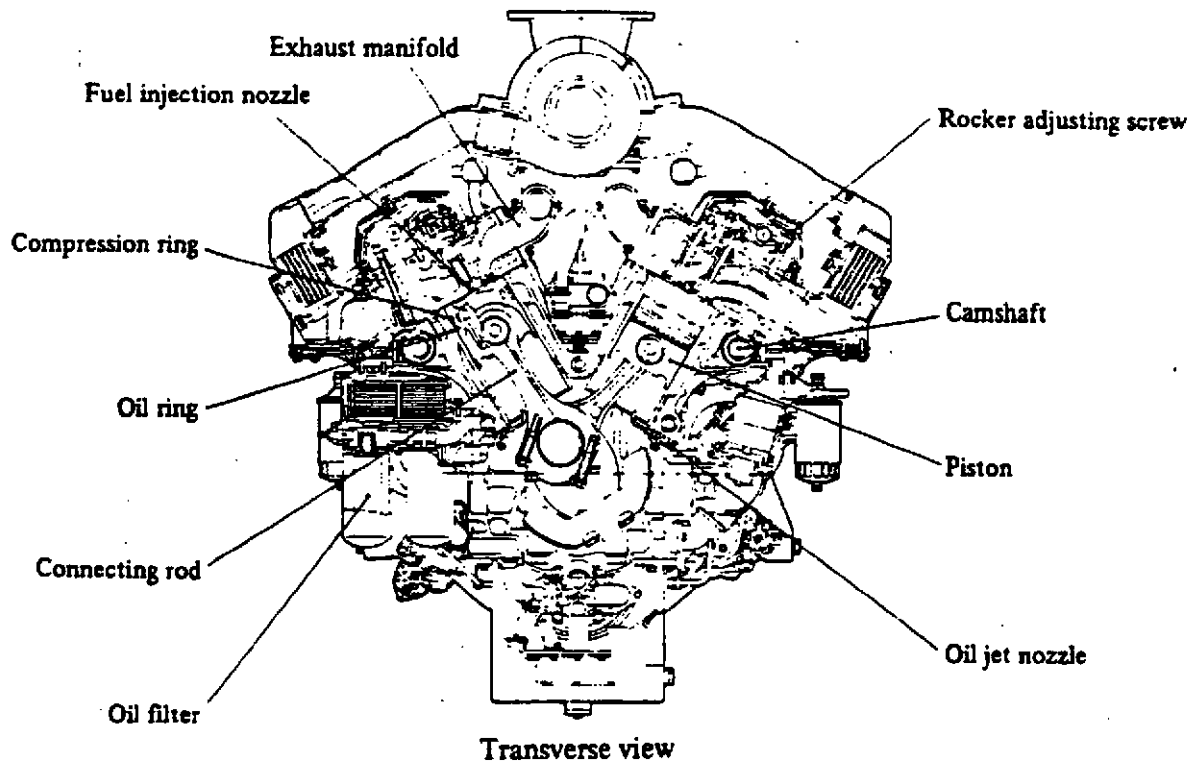

300814

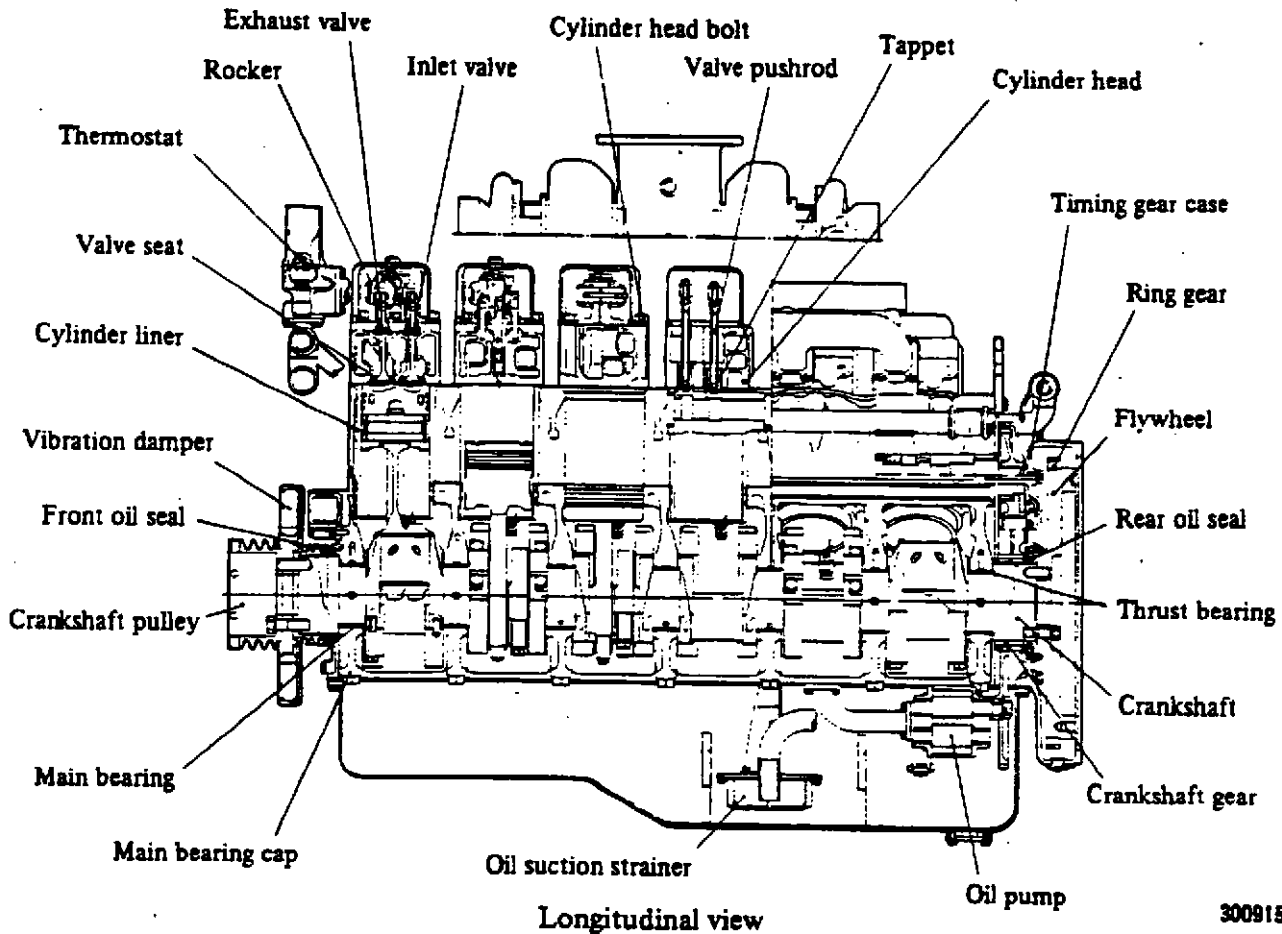

300915

GENERAL

1.3 Engine serial number location

The engine serial number is stamped on the nameplate attached to the left lower side of the engine.

Example: Model Serial number
 S12A2 20003

On the nameplate are also stamped the rated output and speed. The numbers in the illustration show cylinder numbers.

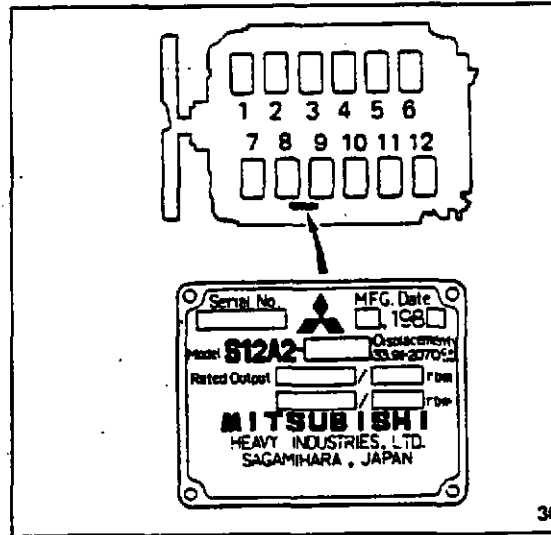

3C

1.4 Engine model and application codes

S □ □ 2 - □ □

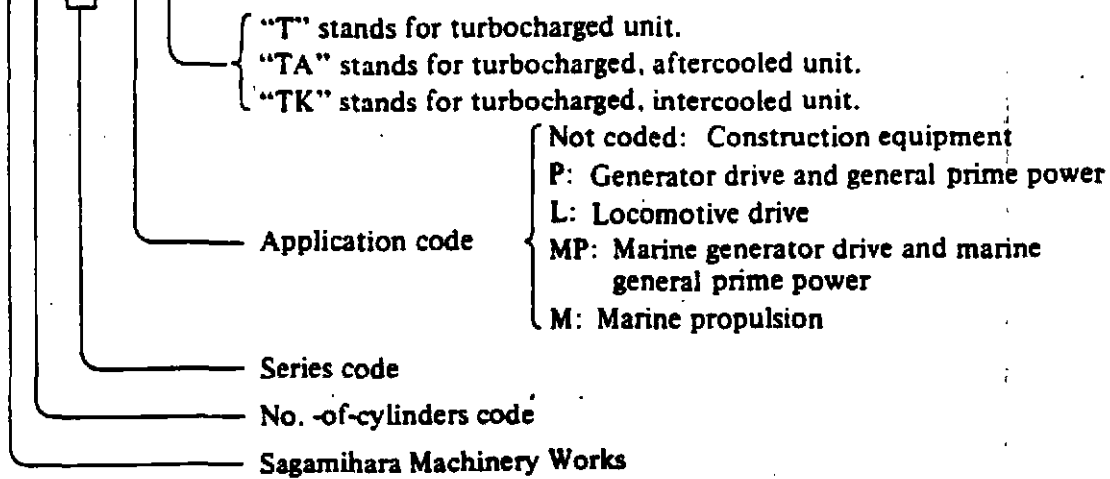

2. SPECIFICATIONS

Model designation		S12A2			
		T	TA	TK	
General	Type	Water-cooled, 4-stroke cycle, turbocharged diesel			
		-	w/aftercooler	w/intercooler	
	No. of cylinders - arrangement	12 - V			
	Combustion chamber type	Direct injection			
	Valve mechanism	Overhead			
	Cylinder bore x stroke	mm (in.)		150 x 160 (5.906 x 6.299)	
	Piston displacement	liter (cu in.)		33.93 (2070.58)	
	Compression ratio	14.5 : 1			
	Fuel	Grade No. 2-D fuel oil (ASTM Specifications)			
	Firing order	1-12-5-8-3-10-6-7-2-11-4-9			
	Direction of rotation	Counterclockwise as viewed from flywheel side			
	Dimensions	Overall length	mm (in.)		1808 (71.2)
		Overall width	mm (in.)		1365 (53.7)
Overall height		mm (in.)		1562 (61.5)	
Weight (dry)	kg (lb)	2850 (6284)	2920 (6439)		
Engine proper	Cylinder liners	Wet type			
	No. of piston rings	Compression rings	2		
		Oil ring	1 (w/spring expander)		
	Valve timing	Inlet valves	Open	55° B.T.D.C.	
			Close	65° A.B.D.C.	
		Exhaust valves	Open	65° B.B.D.C.	
			Close	55° A.T.D.C.	
Engine support	4-point support				
Starting system	Electric-starter, air-motor or direct air starting				
Inlet and exhaust systems	Air cleaner	Type	Paper element type or turbine silencer		
	Turbochargers	Model	4LF (1500/1800 rpm specification) TD13 (2100 rpm specification)	4LF (1500 rpm specification) TD13 (1800 rpm specification) 5MF (2100 rpm specification)	
		No. of units	2		
	Air cooler	Laminated fin-plate type			
Lubrication system	Type	Pressure feed by gear pump			
	Engine oil	Specification	Class CD oil (API Service Classification)		
		Capacity (engine) liter (U.S. gal)	120 (31.7), approx.		
	Oil pump	Type	Gear pump		
Delivery capacity liter (U.S. gal)/min		310 (81.8) (at 1500 engine rpm) 360 (95.0) (at 1800 engine rpm)			

GENERAL

Model designation			S12A2		
			T	TA	TK
Lubrication system	Relief valve	Type	Main gallery pressure detecting type		
		Valve opening pressure kgf/cm ² (psi) [MPa]	5 - 7 (71 - 100) [0.5 - 0.7]		
	Oil cooler	Type	Water-cooled multi-plate type		
	Oil filter	Type	Cartridge type paper element		
	Bypass type oil filter	Type	Centrifugal		
Oil filter alarm	Type	Piston valve with built-in electric contact points			
	Valve opening pressure kgf/cm ² (psi) [MPa]	2.3 - 2.7 (32.7 - 38.4) [0.23 - 0.26] Contact points close at 1.5 - 1.8 (21.3 - 25.6) [0.15 - 0.18]			
Cooling system	Type	Forced circulation			
	Capacity (engine)	liter (U.S. gal)	80 (21), approx.	100 (26.4), approx.	
	Water pump	Type	Centrifugal		
		Delivery capacity liter (U.S. gal)	1000 (264) (at 1500 engine rpm) 1100 (290.4) (at 1800 engine rpm)		
	Water pump belt	Type	Low edge cog belt B type (2-piece set)		
		Manufacturer	Mitsuboshi Belt		
		Outside circumference mm (in.)	1470 (57.87)		
	Thermostats	Type	Wax		
		Valve opening temperature °C (°F)	65 ± 2 (149 ± 3.6) and 71 ± 2 (159.8 ± 3.6)		
	Radiator	Type	Plate fin or corrugated fin		
Cooling fan	Type	Steel-blade, circular-arc type with spider			
Fan belt	Type	Low edge cog belt C type (3-piece set)			
	Manufacturer	Mitsuboshi Belt			
	Outside circumference mm (in.)	1610 (63.39)			
Fuel system	Injection pump	Model	Bosch P type NP-PE6P		
		Manufacturer	Diesel Kiki		
		Plunger outside diameter mm (in.)	12 (0.47)		
		Plunger lead mm (in.)	Right-hand 30 (1.18), 35 (1.38) (timerless specification)		
	Cam lift mm (in.)	12 (0.47)			
Feed pump	Model	Bosch NP-FP/K-PS type			
	Manufacturer	Diesel Kiki			
	Cam lift mm (in.)	4 (0.16)			

Model designation			S12A2		
			T	TA	TK
Fuel system	Governor	Control system	[Mechanical] All speed RSUV	[Hydraulic] Woodward PSG	[Electrical] Woodward EG-3P Barber-Colman DYNA I
	Injection nozzles	Type	Hole type		
		Manufacturer	Diesel Kiki		
		No. of spray holes	8		
		Spray hole diameter, mm (in.), x spray angle, deg	0.27 (0.0106) x 155°	0.26 (0.0102) x 155° (1500 rpm spec.) 0.27 (0.0106) x 155° (1800 rpm spec.) 0.28 (0.0110) x 158° (2100 rpm spec.)	
		Injection pressure kgf/cm ² (psi) [MPa]	220 (3128) [21.6]		
Fuel filter	Wire element type (primary filter) Paper element type (secondary filter)				
Electrical system	Voltage-polarity		24-V - Negative (-) ground		
	Starter	Model	0-23000-3230		
		Manufacturer	Nikko Electric		
		Type	Pinion shift		
		Output V - kW	24 - 6		
		No. of starters	2		
	Alternator	Type	3-phase with silicon-rectifier (add-on type)		
		Manufacturer	Mitsubishi Electric		
		Output V - A	24 - 30		
		Rated voltage generating rpm	rpm	1000, minimum (at 28V)	
		Rated output generating rpm	rpm	5000, maximum (at 27V, 30A)	
	Regulated voltage	V	28.0 - 29.0		
	Magnetic switch	Manufacturer	Sawafuji Electric		
		Relay switch	Operating voltage	V	16, maximum
			Holding voltage	V	8, maximum
Safety coil (b coil)		Operating voltage	V	3, maximum	
		Holding voltage	V	0.05 - 0.15	
Safety coil (c coil)		Operating voltage	V	10.5 - 11.5	
	Holding voltage	V	4, maximum		

GENERAL

Model designation		S12A2		
		T	TA	TK
Electrical system	Battery relay switch	Model	0501-16-0330	
		Manufacturer	Sawafuji Electric	
		Voltage V	24	
		Operating voltage V	14, maximum	
		Holding voltage V	9, minimum	
		Rated coil current		
		When attracting A	5.35	
		When holding A	0.289	
Air-starting systems	Air-motor starting	Model	KSM-20R-15C-2	
		Manufacturer	Kitagawa Kikai Works	
		Type	Pinion shift	
		Nominal output (PS)	10 at 9.5 kgf/cm ² (135.1 psi) [0.93 MPa]	
	Direct-air starting	Air blow-in timing	Valve opens at 3° A.T.D.C. Valve closes at 132° A.T.D.C.	
		Air pressure in ordinary use kgf/cm ² (psi) [MPa]	30 (427) [2.9]	
		Minimum starting air pressure kgf/cm ² (psi) [MPa]	15 (213) [1.5]	

3. TIPS ON DISASSEMBLY AND REASSEMBLY

This Service manual deals with Mitsubishi's recommended procedures to be followed in servicing the Mitsubishi diesel engines and contains information on the special tools and basic safety precautions.

The safety precautions contained herein, however, are not the whole of work. It is the responsibility of the service personnel to know that specific requirements, precautions and work hazards exist and to discuss these with his foreman or supervisor.

Study this manual carefully and observe the following general precautions to help prevent serious injury to the personnel and damage to the engine.

3.1 Disassembly

- (1) Use only right tools and instruments. Serious injury to the personnel and damage to the engine result from the wrong use of tools and instruments.
- (2) Use an overhaul stand or work bench if necessary. Also, use assembly bins to keep the engine parts in order of removal.
- (3) Lay down the disassembled and cleaned parts in the order in which they were removed to save time for reassembling work.
- (4) Pay attention to marks on assemblies, components and parts for their positions or directions. Put on marks, if necessary, to aid reassembly.
- (5) Carefully check each part for any sign of faulty condition during removal or cleaning. The part will tell you how it acted or what was abnormal about it more accurately during removal or cleaning.

- (6) When lifting or carrying a part too heavy or too awkward for one person to handle, get another person's help and, if necessary, use a jack or chain block.

3.2 Reassembly

- (1) Wash all engine parts, except for oil seals, O-rings, rubber sheets, etc., with cleaning solvent and dry them with pressure air.
- (2) Use only right tools and instruments.
- (3) Use only good-quality lubricating oils and greases. Be sure to apply a coat of oil, grease or sealant to parts as specified. (Refer to 3, Group No. 2.)
- (4) Be sure to use a torque wrench to tighten parts for which tightening torque is specified. (Refer to 2, Group No. 2.)
- (5) Replace gaskets and packings with new ones. Apply a proper amount of quick-drying cement to gaskets or packings, if necessary.

MAINTENANCE STANDARDS

1. MAINTENANCE STANDARDS	12
2. TIGHTENING TORQUE	22
2.1 Important bolts and nuts	22
2.2 General bolts and nuts	23
3. SEALANTS AND LUBRICANTS	24

MAINTENANCE STANDARDS

1. MAINTENANCE STANDARDS

Unit: mm

Group	Inspection point		Nominal value	Assembly standard (standard clearance)	Repair limit (clearance)	Service limit (clearance)	Remarks	
General	Maximum rpm		5 - 10% higher than rated rpm		Lower or 15% higher than rated rpm		Check governor setting.	
	Minimum rpm		600 - 650 rpm					
	Compression pressure		24 kgf/cm ² (341 psi) [2.4 MPa] at 120 - 200 rpm, minimum		19 kgf/cm ² (270 psi) [1.9 MPa], minimum		Oil and water temperature: 20 - 30°C (68 - 86°F)	
	Lube oil pressure		5 - 7 kgf/cm ² (71 - 100 psi) [0.5 - 0.7 MPa] (at rated rpm)		4 kgf/cm ² (57 psi) [0.4 MPa], minimum		Oil temperature: 60 ~ 70°C (140 ~ 158°F)	
			2 - 3 kgf/cm ² (28 - 43 psi) [0.2 - 0.3 MPa] (at idling rpm)		1 kgf/cm ² (14 psi) [0.1 MPa], minimum			
	Valve timing (with 2-mm clearance on valve side)		Inlet valve opens 11° B.T.D.C. Inlet valve closes 21° A.B.D.C. Exhaust valve opens 21° B.B.D.C. Exhaust valve closes 11° A.T.D.C. ±2° (crank angle)				Values are only for checking valve timing and are different from actual ones.	
	Valve clearance (cold)		Inlet valves		0.4 (0.016)			
			Exhaust valves		0.5 (0.020)			
	Injection timing		B.T.D.C.	± 1° (crank angle)				Varies according to specifications. Refer to caution plate on No. 1 rocker cover.
	Belt tension	Fan				10 - 15 (3/8 - 5/8)		Measure sag at point indicated by arrow 
Water pump and alternator				10 - 15 (3/8 - 5/8)				
Engine proper	Rockers		Rocker bushing inside diameter	32 (1.26)	32.000 - 32.040 (1.25984 - 1.26141)		32.100 (1.26378)	
			Rocker shaft diameter	32 (1.26)	31.991 - 31.975 (1.25949 - 1.25886)		31.950 (1.25787)	
	Valves	Inlet valves	10 (0.39)	9.960 - 9.940 (0.39213 - 0.39134)		9.910 (0.39016)		
		Exhaust valves	10 (0.39)	9.930 - 9.910 (0.39094 - 0.39016)		9.880 (0.38898)		
	Valve guide inside diameter		10 (0.39)	10.000 - 10.015 (0.39370 - 0.39429)		10.060 (0.39606)	The same for both inlet and exhaust valves.	
	Valve seat angle		30°					
	Valve sinkage			0.2 - -0.2 (0.008 - -0.008)	0.5 (0.020)			
Valve seats and valves	Seat width	Inlet valves		1.93 - 2.23 (0.0760 - 0.0878)	2.5 (0.098)			
		Exhaust valves		1.70 - 2.00 (0.0669 - 0.0787)	2.3 (0.091)			

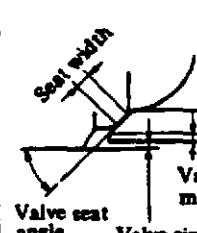

MAINTENANCE STANDARDS

Unit: mm (in.)

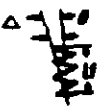
Group	Inspection point		Nominal value	Assembly standard (standard clearance)	Repair limit (clearance)	Service limit (clearance)	Remarks	
Engine proper	Valve seats and valves	Valve margin			3.1 - 2.9 (0.122 - 0.114)		Refacing is permissible up to 2.0 (0.079).	
		Cylinder head bore inside diameter and valve seat outside diameter	Inlet valves	58 (2.28)	(-0.07 - -0.13) ((-0.0028 - -0.0051))			- (minus) indicates interference.
			Exhaust valves	54 (2.13)				
	Valve springs	Free length			67.5 (2.657)		66.2 (2.606)	
		Squareness			$\theta = 1^\circ$, maximum 		$\Delta = 1.5$ (0.059) over the length	
		Length under test force/test force, mm (in.)/ kgf (lbf) [N]			60.0 (2.362)/ 27.8±5% (61.3±5%) [272.6±5%]			
	Valve push-rods	Runout			0.5 (0.020), maximum			
	Cylinder heads	Warpage of gasketed surface			0.03 (0.0012), maximum	0.07 (0.0028)		Regrind slightly.
	Cylinder liners	Inside diameter		150 (5.91)	150.00 - 150.04 (5.9055 - 5.9071)		150.14 (5.9110)	
		Out-of-roundness			0.02 (0.0008), maximum			
		Taper			0.02 (0.0008), maximum			
		Squareness with respect to lower face of flange			0.03 (0.0012), maximum			
		Protrusion of cylinder liner flange above gasketed surface			0.10 - 0.18 (0.0039 - 0.0071)			
	Pistons	Diameter		150 (5.91)	149.82 - 149.78 (5.8984 - 5.8968)		149.68 (5.8929)	Measure diameter in the direction transverse to pin at piston skirt.

MAINTENANCE STANDARDS

Unit: mm

Group	Inspection point		Nominal value	Assembly standard (standard clearance)	Repair limit (clearance)	Service limit (clearance)	Remarks	
Engine proper	Pistons	Variance in weight among pistons per engine		30 g (1.1 oz), maximum				
		Piston pin bore diameter	58 (2.28)	58.002 - 58.012 (2.28354 - 2.28393)		58.020 (2.28425)		
		Protrusion		0.38 - 0.89 (0.0150 - 0.0350)				
	Cylinder head gasket	As-installed thickness	1.8 (0.071)	±0.1 (±0.004)				
	Pistons and cylinder heads	Clearance between piston top and cylinder head		(0.81 - 1.43) ((0.0319 - 0.0563))				
	Piston rings	Gaps	Top		(0.6 - 0.8) ((0.024 - 0.031))		(2.0) ((0.079))	If gauge is not available, check by placing ring a new cylinder
			Second		(0.5 - 0.7) ((0.020 - 0.028))		(2.0) ((0.079))	
			Oil		(0.5 - 0.7) ((0.220 - 0.028))		(2.0) ((0.079))	
	Piston pins	Outside diameter	58 (2.28)	58.000 - 57.987 (2.28346 - 2.28295)		57.970 (2.28228)		
	Connecting rods	Small end bushing inside diameter	58 (2.28)	58.020 - 58.040 (2.28425 - 2.28503)		58.070 (2.28622)		
		Bend and twist		$\frac{C}{D} < \frac{0.05 (0.0020)}{100 (3.9)}$				
		End play (crankpin and big end widths) x 2	54 (2.13)	(0.60 - 0.90) ((0.0236 - 0.0354))		(1.00) ((0.0394))		
		Variance in weight among connecting rods per engine		40 g (1.4 oz), maximum				
		Big-end bore diameter	110 (4.33)	110.000 - 110.022 (4.33070 - 4.33157)		110.047 (4.33255)	To be used in combination w bearing caps.	
	Connecting rod bearings	Thickness of center:					Replace bearing if worn down to service limit. R grind crankpin and use unders bearings are if worn beyond service limit.	
STD		3.0 (0.118)	3.000 - 2.982 (0.11811 - 0.11740)		2.950 (0.11614)			
-0.25 (-0.0098)		3.125 (0.123)	3.125 - 3.107 (0.12303 - 0.12232)		3.075 (0.12106)			
-0.50 (-0.0197)		3.25 (0.128)	3.250 - 3.232 (0.12795 - 0.12724)		3.200 (0.12598)			
-0.75 (-0.0295)		3.375 (0.133)	3.375 - 3.357 (0.13287 - 0.13217)		3.325 (0.13091)			
-1.00 (-0.0394)	3.5 (0.138)	3.500 - 3.482 (0.13780 - 0.13709)		3.450 (0.13583)				
Flywheel	Face runout		0.28 (0.0110), maximum					
	Radial runout		0.13 (0.0051), maximum					

MAINTENANCE STANDARDS

Unit: mm (in.)

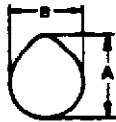
Group	Inspection point		Nominal value	Assembly standard (standard clearance)	Repair limit (clearance)	Service limit (clearance)	Remarks	
Engine proper	Accessory drive	Drive case bore inside diameter	72 (2.83)	71.988 - 72.018 (2.83417 - 2.83535)				
			90 (3.54)	98.985 - 90.020 (3.89704 - 3.54409)				
		Bearing	Diameter	72 (2.83)	72.004 - 71.983 (2.83480 - 2.83397)			
				90 (3.54)	90.005 - 89.980 (3.54350 - 3.54251)			
			Inside diameter	35 (1.38)	34.985 - 35.003 (1.37736 - 1.37807)			
				40 (1.57)	39.985 - 40.003 (1.57421 - 1.57492)			
	Drive shaft diameter	35 (1.38)	35.013 - 35.002 (1.37846 - 1.37803)					
		40 (1.57)	40.013 - 40.002 (1.57531 - 1.57488)					
	Vibration damper	Radial runout (at periphery)		0.5 (0.020), maximum		1.5 (0.059)	Replace every 8000 hours.	
		Face runout		0.5 (0.020), maximum		1.5 (0.059)		
	Timing gears	Backlash		(0.12 - 0.18) ((0.0047 - 0.0071))	(0.30) ((0.0118))	(0.50) ((0.0197))	Replace gears.	
		Idler gear bushing inside diameter	50 (1.97)	50.000 - 50.025 (1.96850 - 1.96948)		50.060 (1.97086)		
		Idler gear shaft diameter	50 (1.97)	49.975 - 49.950 (1.96752 - 1.96653)		49.900 (1.96456)		
		Idler gear end play	53 (2.09)	(0.2 - 0.4) ((0.008 - 0.016))	(0.6) ((0.024))			
	Camshaft	Cam lift (A-B)			7.64 - 7.54 (0.3008 - 0.2968)		6.79 (0.2673)	
Runout			0.05 (0.0020), maximum	0.08 (0.0031)		Runout at center bushing measured with both ends supported. Repair or replace.		
Diameter		No. 1 journal	64 (2.52)	63.94 - 63.92 (2.5173 - 2.5165)		63.87 (2.5146)		
		No. 2 thru No. 7 journals	68 (2.68)	67.94 - 67.92 (2.6748 - 2.6740)		67.87 (2.6720)		
Inside diameter (as installed)		No. 1 bushing	64 (2.52)	64.00 - 64.03 (2.5197 - 2.5209)		64.09 (2.5232)	Replace bushings and ream them if necessary if worn beyond service limit.	
		No. 2 thru No. 7 bushings	68 (2.68)	68.00 - 68.03 (2.6772 - 2.6783)		68.09 (2.6807)		

MAINTENANCE STANDARDS

Unit: mm

Group	Inspection point		Nominal value	Assembly standard (standard clearance)	Repair limit (clearance)	Service limit (clearance)	Remarks
Engine proper	Camshaft	End play		(0.20 - 0.30) ((0.0079 - 0.0118))	(0.40) ((0.0157))		Replace thrust
	Crankshaft	Crankpin diameter	104 (4.09)	-0.08 - -0.10 (-0.0031 - -0.0039)	-0.14 (-0.0055)		
		Journal diameter	130 (5.12)	-0.10 - -0.12 (-0.0039 - -0.0047)	-0.16 (-0.0063)		
		Center-to-center distance between journal and crankpin	80 (3.15)	±0.05 (±0.0020)			
		Parallelism between journals and crankpins		Runout: 0.01 (0.0004), maximum (over crankpin length)	0.03 (0.0012)		
		Out-of-roundness of journals and crankpins		0.01 (0.0004), maximum	0.03 (0.0012)		
		Taper of journals and crankpins		0.01 (0.0004), maximum	0.03 (0.0012)		
		Fillet radius of journals and crankpins		7.0 ⁰ -0.2 ⁰ (0.276 ⁰ -0.008)			
		Hardness of journals and crankpins		Hv > 620			Hs > 75
		Angular error of crankpins		± 0°20'			
	Runout		0.04 (0.0016), maximum	0.10 (0.0039)		Repair or replac	
	Main bearings	End play (thrust journal length)	58 (2.28)	(0.20 - 0.365) ((0.0079 - 0.01437))	(0.50) ((0.0197))	+1.18 (+0.0465) (crankshaft length)	Replace thrust pl worn down to rej limit. Use oversi thrust plate if wo beyond repair lin Oversize thrust pl +0.25, +0.50, +0. (+0.0098, +0.015 +0.0295)
		Thickness of center:					
		STD	3.5 (0.138)	3.500 - 3.482 (0.13780 - 0.13709)		3.450 (0.13583)	Replace bearing if worn down to service limit. Re grind crankpins and use undersi bearings are if worn beyond service limit.
		-0.25 (-0.0098)	3.625 (0.143)	3.625 - 3.607 (0.14272 - 0.14201)		3.575 (0.14075)	
-0.50 (-0.0197)		3.750 (0.148)	3.750 - 3.732 (0.14764 - 0.14693)		3.700 (0.14567)		
-0.75 (-0.0295)	3.875 (0.153)	3.875 - 3.857 (0.15256 - 0.15256)		3.825 (0.15059)			
-1.00 (-0.0394)	4.000 (0.157)	4.000 - 3.982 (0.15748 - 0.15677)		3.950 (0.15551)			

MAINTENANCE STANDARDS

Unit: mm (in.)

Group	Inspection point		Nominal value	Assembly standard (standard clearance)	Repair limit (clearance)	Service limit (clearance)	Remarks	
Engine proper	Crank-case	Warpage of gasketed surface		0.05 (0.0020), maximum	0.20 (0.0079)		Regrind slightly.	
		Main bearing bore diameter	137 (5.39)	137.000 - 137.025 (5.39369 - 5.39467)		137.045 (5.39546)		
Lubrication system	Oil pump	Drive and driven gear backlash		(0.10 - 0.20) ((0.0039 - 0.0079))		(0.40) ((0.0157))		
		Gear radial clearance in case	77 (3.03)	(0.15 - 0.23) ((0.0059 - 0.0091))	(0.35) ((0.0138)) (Tip clearance)			
		Gear end clearance in case	88 (3.46)	(0.13 - 0.20) ((0.0051 - 0.0079))	(0.25) ((0.0098))			
		Shaft diameter	34 (1.34)	33.960 - 33.944 (1.33701 - 1.33638)		33.920 (1.33543)		
		Bushing inside diameter		34.000 - 34.025 (1.33858 - 1.33956)		34.055 (1.34075)		
	Safety valve	Valve opening pressure, kgf/cm ² (psi) [MPa]		8.9 - 9.3 (126.6 - 132.2) [0.87 - 0.91]			Adjust by means of shims.	
	Safety valve spring	Length under test force/test force, mm (in.) / kgf (lbf) [N]		90 (3.54) / 22.5 - 23.5 (49.6 - 51.8) [221 - 226]				
	Bypass valve	Valve opening pressure difference, kgf/cm ² (psi) [MPa]		4.0 - 5.0 (56.9 - 71.1) [0.39 - 0.49]				
	Oil filter alarm	Valve opening pressure difference, kgf/cm ² (psi) [MPa]		2.3 - 2.7 (32.7 - 38.4) [0.23 - 0.26]			Contacts should close at 1.5 to 1.8 (21 to 26) [0.15 to 0.18].	
	Relief valve	Valve opening pressure, kgf/cm ² (psi) [MPa]		5.0 - 7.0 (71.1 - 99.5) [0.49 - 0.69]				
Cooling system	Water pump	Inside diameter of pump case bore to which the bearing outer race is fitted	62 (2.44)	61.988 - 62.018 (2.44047 - 2.44165)				
			72 (2.83)	71.988 - 72.018 (2.83417 - 2.83535)				
		Bearing	Diameter	62 (2.44)	62.004 - 61.983 (2.44110 - 2.44027)			
				72 (2.83)	72.004 - 71.983 (2.83480 - 2.83397)			
			Inside diameter	30 (1.18)	29.987 - 30.003 (1.18059 - 1.18122)			
	Shaft bearing journal diameter	30 (1.18)	30.011 - 30.002 (1.18153 - 1.18118)					

MAINTENANCE STANDARDS

Unit: mm

Group	Inspection point		Nominal value	Assembly standard (standard clearance)	Repair limit (clearance)	Service limit (clearance)	Remarks	
Cooling system	Water pump	Rattle in radial direction		0.010 - 0.025 (0.00039 - 0.00098)		0.045 (0.00177)	Turn it slowly to check. Replace bearing if it fails to rotate smooth	
		Rattle in axial direction				0.25 (0.0098)		
		Vane front face clearance in pump case		(0.6 - 1.4) ((0.024 - 0.055))				
		Vane rear face clearance in pump case		(1.0) ((0.039))				
	Tension pulley	Bearing	Pulley bearing bore inside diameter	52 (2.05)	51.961 - 52.009 (2.04570 - 2.04759)			
			OD	52 (2.05)	52.004 - 51.983 (2.04740 - 2.04657)			
				ID	20 (0.79)	19.987 - 20.003 (0.78689 - 0.78752)		
		Shaft bearing journal diameter	20 (0.79)	20.003 - 19.987 (0.78752 - 0.78689)				
	Thermo-stat	Temperature at which valve starts opening			65 or 71 ± 2°C (149 or 159.8 ± 3.6°F)			Check at atmospheric pressure.
		Temperature at which valve lift is more than 10 (0.39)			80 or 85 ± 2°C (176 or 185 ± 3.6°F)			
	Fan drive	Bearing bore inside diameter		100 (3.94)	99.987 - 100.022 (3.93649 - 3.93787)			
				110 (4.33)	109.987 - 110.022 (4.33019 - 4.33157)			
		Bearing	OD	100 (3.94)	100.005 - 99.980 (3.93720 - 3.93621)			
				110 (4.33)	110.005 - 109.980 (4.33090 - 4.32991)			
			ID	40 (1.57)	39.985 - 40.003 (1.57421 - 1.57492)			
45 (1.77)				44.985 - 45.003 (1.77106 - 1.77177)				
Shaft bearing journal diameter			40 (1.57)	40.013 - 40.002 (1.57531 - 1.57488)				
			45 (1.77)	45.013 - 45.002 (1.77216 - 1.77173)				

MAINTENANCE STANDARDS

Unit: mm (in.)

Group	Inspection point		Nominal value	Assembly standard (standard clearance)	Repair limit (clearance)	Service limit (clearance)	Remarks	
Fuel system	Fuel injection nozzles	Valve opening pressure		220 kgf/cm ² (3128 psi) [21.6 MPa]			Adjusting limit: 225 – 230 kgf/cm ² (3200 – 3271 psi) [22.1 – 22.6 MPa]	
		Spray angle	155° or 158°				Check spray performance with a hand tester [at fuel oil temperature 20°C (68°F)]. Replace the nozzle tip, if the spray pattern is still bad after washing in clean fuel oil.	
	Case bearing bore inside diameter		47 (1.85)	46.989 – 47.014 (1.84996 – 1.85094)				
			80 (3.15)	79.988 – 80.018 (3.14562 – 3.15031)				
			90 (3.54)	89.987 – 90.022 (3.54279 – 3.54417)				
	Cover bearing bore inside diameter		47 (1.85)	46.989 – 47.014 (1.84996 – 1.85094)				
			62 (2.44)	61.988 – 62.018 (2.44047 – 2.44165)				
			72 (2.83)	71.988 – 72.018 (2.83417 – 2.83535)				
	Woodward governor drive	Case side bearings	OD	47 (1.85)	47.003 – 46.986 (1.85051 – 1.84984)			
				80 (3.15)	80.004 – 79.983 (3.14976 – 3.14893)			
				90 (3.54)	90.005 – 89.980 (3.54350 – 3.54251)			
		ID	20 (0.79)	19.987 – 20.003 (0.78689 – 0.78752)				
			40 (1.85)	39.985 – 40.003 (1.57421 – 1.57492)				
			40 (1.85)	39.985 – 40.003 (1.57421 – 1.57492)				
	Cover side bearings	OD	47 (1.85)	47.003 – 46.986 (1.85051 – 1.84984)				
			62 (2.44)	62.004 – 61.983 (2.44110 – 2.44027)				
			72 (2.83)	72.004 – 71.983 (2.83480 – 2.83397)				
		ID	20 (0.79)	19.987 – 20.003 (0.78689 – 0.78752)				
			30 (1.18)	29.987 – 30.003 (1.18059 – 1.18122)				
			35 (1.38)	34.985 – 35.003 (1.37736 – 1.37807)				

MAINTENANCE STANDARDS

Unit: mm

Group	Inspection point		Nominal value	Assembly standard (standard clearance)	Repair limit (clearance)	Service limit (clearance)	Remarks
Fuel system	Woodward governor drive	Driven gear bearing journal diameter	Case side	20 (0.79)	20.011 - 20.002 (0.78783 - 0.78748)		
			Cover side	20 (0.79)	20.011 - 20.002 (0.78783 - 0.78748)		
		Idler gear bearing journal diameter	Case side	40 (1.85)	40.013 - 40.002 (1.57531 - 1.57488)		
			Cover side	30 (1.18)	30.011 - 30.002 (1.18153 - 1.18118)		
		Drive shaft bearing journal diameter	Case side	40 (1.85)	40.013 - 40.002 (1.57531 - 1.57488)		
			Cover side	35 (1.38)	35.013 - 35.002 (1.37846 - 1.37803)		
Electrical system	Starter	Diameter of pinion shaft front side and inside diameter of metal		19 (0.75)	(0.045 - 0.138) ((0.00177 - 0.00543))		(0.25) ((0.0098))
		Diameter of pinion shaft rear side		30 (1.18)	30.011 - 30.002 (1.18153 - 1.18118)		
		Diameter of armature shaft front side		20 (0.79)	20.011 - 20.002 (0.78783 - 0.78748)		
		Diameter of armature shaft rear side		10 (0.39)	10.007 - 10.001 (0.39398 - 0.39374)		
		Commutator outside diameter			39 (1.54)		38 (1.50)
		Armature shaft distortion			0.05 (0.0020)		
		Runout of commutator			0.015 (0.00059), maximum		0.100 (0.00394)
		Mica depth in commutator			0.5 - 0.8 (0.020 - 0.031)	0.2 (0.008)	
		Brush height			20 (0.79)		13 (0.51)
		Brush spring tension (with brush installed), kgf (lbf) [N]			4.0 - 5.0 (8.8 - 11) [39 - 49]		
		Armature end play			0.2 - 0.6 (0.008 - 0.024)		
Pinion shaft end play			0.2 - 0.6 (0.008 - 0.024)				

MAINTENANCE STANDARDS

Unit: mm (in.)

Group	Inspection point	Nominal value	Assembly standard (standard clearance)	Repair limit (clearance)	Service limit (clearance)	Remarks	
Electrical system	Alternator	Slip ring outside diameter		40.8 - 41.2 (1.606 - 1.622)		40.6 (1.598)	
		Brush height		23 (0.91)		8 (0.31)	Up to wear limit line
		Brush spring tension, gf (lbf) [N]		320 - 440 (0.71 - 0.97) [3.14 - 4.31]		200 (0.44) [1.96]	
Air start systems	Distributor valve	Valve height	21.5 (0.846)	21.6 - 21.4 (0.843 - 0.843)	21 (0.83)		
		Shaft clearance in bushing	20 (0.79)	(0.050 - 0.091) ((0.00197 - 0.00358))	(0.300) ((0.01181))		
	Starter valves	Valve clearance in valve guide	13 (0.51)	(0.016 - 0.045) ((0.00063 - 0.00177))	(0.100) ((0.00394))		
		Valve spring free length		30 (1.18)		28 (1.10)	

MAINTENANCE STANDARDS

2. TIGHTENING TORQUE

2.1 Important bolts and nuts

Secured part or component	Thread dia. - pitch	Width across flats	Tightening torque			Remarks
			kgf-m	lbf-ft	N-m	
Cylinder head	20 - 2.5	30	40	290	392	[Wet]
Rocker shaft brackets	12 - 1.75	17	5	36	49	
Main bearing caps	24 - 3	36	60	434	588	[Wet]
Main bearing cap side bolts	16 - 2	22	15	108	147	[Wet]
Timing gear case	12 - 1.75	17	15	108	147	
Oil pan	10 - 1.5	14	4	29	39	
Mounting brackets	18 - 2.5	24	25	181	245	
Connecting rod bearing caps	18 - 1.5	27	30	217	294	[Wet]
Crankshaft pulley and damper	22 - 1.5	32	55	398	539	
Flywheel	22 - 1.5	32	55	398	539	[Wet]
Exhaust manifolds	10 - 1.5	14	6 - 7	43 - 50	59 - 69	
Idler gears	10 - 1.25	14	4	29	39	
Camshaft gear	30 - 1.5	50	30	217	294	Left-hand screw
Fuel injection pump drive gear	30 - 1.5	46	30	217	294	
Idler shaft	12 - 1.75	17	5.5	40	54	
Oil pump drive gear	27 - 1.5	41	30	217	294	
Water pump pulley nut	24 - 1.5	36	25	181	245	
Water pump impeller	22 - 1.5	-	20	145	196	
Fuel injection pump coupling	12 - 1.75	19	8.5 - 9.5	60 - 69	83 - 93	
Fuel injection pump coupling shaft	12 - 1.75	17	8.5 - 9.5	60 - 69	83 - 93	
Gland (injection nozzle holder)	12 - 1.25	17	8	58	78	
Injection nozzle holder set screw cap nuts	16 - 1	22	4 - 5	29 - 36	39 - 49	
Injection nozzle tip retaining nuts	19 - 1	19	6 - 8	43 - 58	59 - 78	

Note: Coat threads of a fastener with engine oil if specified to be [Wet].

2.2 General bolts and nuts

Screw thread		Tightening torque					
Diameter	Pitch	With spring washer			Without spring washer		
		kgf-m	lbf-ft	N-m	kgf-m	lbf-ft	N-m
8	1.0	1.8	13	18	2.2	16	22
	1.25	1.8	13	18	2.1	15	21
10	1.25	3.6	26	35	4.2	30	41
	1.5	3.4	25	33	4.0	29	39
12	1.25	6.5	47	64	7.6	55	75
	1.75	6.0	43	59	7.1	51	70
14	1.5	10.4	75	102	12.2	88	120
	2.0	9.8	71	96	11.5	83	113
16	1.5	15.8	114	155	18.6	135	182
	2.0	15.0	108	147	17.6	127	173
18	1.5	22.9	166	225	26.9	195	264
	2.5	20.7	150	203	24.4	176	239
20	1.5	29.7	215	291	36.6	265	359
	2.5	27.7	200	272	33.8	244	331
22	1.5	39.3	284	385	48.5	351	476
	2.5	37.0	268	363	45.3	328	444
24	1.5	49.7	359	487	61.4	444	602
	3.0	47.7	345	468	58.3	422	572

3. SEALANTS AND LUBRICANTS

Group	Application point		Sealant or lubricant	How to use
Engine proper	Cylinder head sealing caps		Hermeseal S-2	Coat holes in crankcase
	Cylinder liners		ThreeBond 1104	Coat top (joint) of each liner
			Engine oil, soapy water	Apply to rubber packings
	Front cover, oil pan and crankcase	HERDITE		Coat joint surfaces only of both sides of packings
	Rear plate, gear case, oil pan and crankcase			Coat three joint surfaces only of both sides of packing
	Crankcase taper plugs		SEALOCK, LOCTITE	Apply to threads
	Crankcase sealing caps		ThreeBond 1104	
	Oil pan and crankcase		HERDITE	Coat joint surfaces only of both sides of packing
Oil seals		Engine oil	Coat lip of each oil seal	
Lubrication system	Oil pump	Cover and case	ThreeBond 1104	Coat both sides of packing
Cooling system	Water pump	Oil seal, unit seal	Engine oil	Coat lip of inner seal
	Fan drive	Oil seal	Engine oil	Coat lip of oil seal
Others	Taper plugs and cocks not precoated with ThreeBond thread sealants		Vulcanized sealing tape	Wrap threads with 2 turns of tape







SPECIAL TOOLS

Special tool list 26

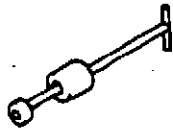
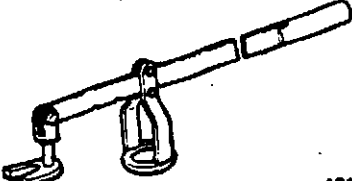



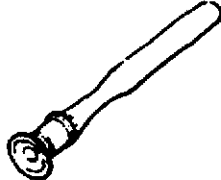

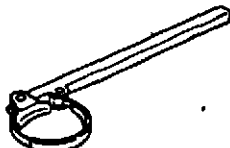
E

SPECIAL TOOLS

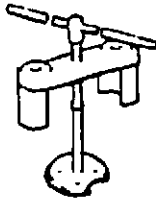
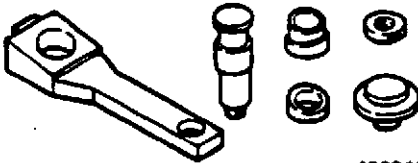



SPECIAL TOOL LIST

Tool name	Part No.	Shape	Use
Nozzle remover	32591 - 00201	 <p style="text-align: right;">400007</p>	Injection nozzle removal
Valve spring pusher	33591 - 04500	 <p style="text-align: right;">400009</p>	Valve spring removal/ installation
Rocker bushing puller	32591 - 02600	 <p style="text-align: right;">400010</p>	Rocker bushing removal/ installation
Valve guide remover	36291 - 04200	 <p style="text-align: right;">400011</p>	Valve guide removal
Valve guide and seal installer	32591 - 10300	 <p style="text-align: right;">400012</p>	Valve guide and valve ste seal installation
Valve lapper	30091 - 08800	 <p style="text-align: right;">400013</p>	Valve lapping
Ring pliers	45191 - 08400	 <p style="text-align: right;">400014</p>	Snap ring removal/ installation
Oil filter wrench	34591 - 00100	 <p style="text-align: right;">401402</p>	Oil filter cartridge, fuel filter cartridge and corrosion resistor cartridge removal



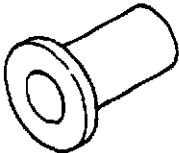

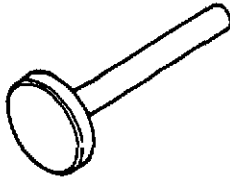
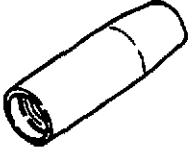
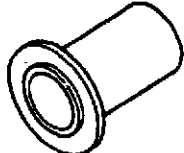

SPECIAL TOOLS

Tool name	Part No.	Shape	Use
Cylinder liner remover	32591 - 04100	 <p style="text-align: right;">400015</p>	Cylinder liner removal
Connecting rod bushing installer	37191 - 08000	 <p style="text-align: right;">400016</p>	Connecting rod bushing removal/installation
Piston ring tool	37191 - 03200	 <p style="text-align: right;">400017</p>	Piston ring removal/installation
Idler bushing puller	32591 - 02500	 <p style="text-align: right;">400018</p>	Idler bushing removal/installation
Piston installer	37191 - 07100	 <p style="text-align: right;">400019</p>	Piston installation
Sleeve installer	32691 - 00510	 <p style="text-align: right;">400020</p>	Oil seal sleeve installation
Installer guide	32691 - 00600	 <p style="text-align: right;">400021</p>	To be used in combination with sleeve installer for oil seal sleeve installation
Turning bar	32091 - 01500	 <p style="text-align: right;">400022</p>	Enging cranking

SPECIAL TOOLS

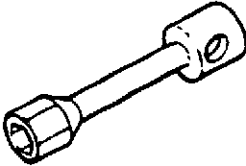
Tool name	Part No.	Shape	Use
Compression gauge adaptor	32591 - 02200	 <p style="text-align: right;">400023</p>	Compression pressure measurement
Bearing installer	32591 - 03600	 <p style="text-align: right;">402930</p>	Water pump bearing installation
Unit seal installer	37191 - 06300	 <p style="text-align: right;">400025</p>	Water pump unit seal installation
Oil seal installer	32591 - 03200	 <p style="text-align: right;">401922</p>	Water pump oil seal installation
Thread cover	37191 - 06600	 <p style="text-align: right;">402931</p>	Water pump shaft installation
Oil seal installer	32591 - 03100	 <p style="text-align: right;">402932</p>	Water pump and fan drive oil seal installation
Compression gauge	33391 - 02100	 <p style="text-align: right;">400902</p>	Compression pressure measurement
Socket	58309 - 73100	 <p style="text-align: right;">400903</p>	Removal/installation of pulley cap nut

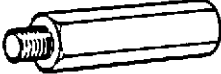
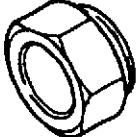
SPECIAL TOOLS

Tool name	Part No.	Shape	Use
Torque wrench	32191 - 03100	 <p>400904</p>	
Adjustable wrench	F9611 - 15000	 <p>400905</p>	
Socket wrench	32591 - 01100	 <p>402933</p>	Cylinder head bolt tightening
Socket	32591 - 02800	 <p>402934</p>	Camshaft connector removal/installation
Oil pump bushing puller	32691 - 02700	 <p>402655</p>	Oil pump bushing removal/installation
Starting valve adaptor	32591 - 01200	 <p>402935</p>	Starting valve removal
Connector	32061 - 31700	 <p>402936</p>	Speeding testing
Screw pin	32061 - 31800	 <p>402937</p>	Speeding testing

SPECIAL TOOLS

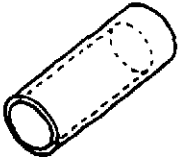
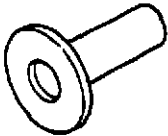
Tool name	Part No.	Shape	Use
Bearing installer	32691 - 04200	 400024	Fan drive bearing installation
Bearing installer	32691 - 04300	 402938	Fan drive bearing installation

OVERHAUL INSTRUCTIONS

1. DETERMINING WHEN TO OVERHAUL THE ENGINE 32
2. TESTING THE COMPRESSION PRESSURE 33

OVERHAUL INSTRUCTIONS

1. DETERMINING WHEN TO OVERHAUL THE ENGINE

Generally, when to overhaul the engine is to be determined by taking into consideration a drop in compression pressure as well as an increase in lubricating oil consumption and excessive blowby gases.

Low power or loss of power, increase in fuel consumption, drop in lubricating oil pressure, hard starting and excessive abnormal noise are also engine troubles. These troubles, however, are not always the result of low compression pressure and give no valid reason for overhauling the engine.

The engine develops troubles of widely different varieties when the compression pressure drops in it. Following are the typical troubles caused by this compression pressure failure:

- (a) Low power or loss of power
- (b) Increase in fuel consumption
- (c) Increase in lubricating oil consumption
- (d) Excessive blowby through breather due to worn cylinder liners, pistons, etc.
- (e) Excessive blowby due to poor seating of worn inlet and exhaust valves
- (f) Hard starting
- (g) Excessive abnormal noise

In most cases, these troubles occur concurrently. Some of them are directly caused by low compression pressure, but others are not. Among the troubles listed above, (b) and (f) are caused by a fuel injection pump improperly adjusted with respect to injection quantity or injection timing, worn

injection pump plungers, faulty injection nozzles, or poor care of the battery, starter and alternator.

The trouble to be considered as most valid reason for overhauling engine is (d) Excessive blowby through breather due to worn cylinder liners, pistons, etc.; in actually determining when to overhaul the engine, it is reasonable to take this trouble into consideration in conjunction with other troubles.

2. TESTING THE COMPRESSION PRESSURE

- (1) Remove the injection nozzle from a cylinder on which the compression pressure is to be measured.
- (2) Attach the adaptor (32591-02200) to the cylinder, and connect a compression gauge (33391-02100) to the adaptor.
- (3) Crank the engine by means of the starter, and read the compression gauge indication when the engine begins to run at the specified speed.
- (4) If the compression pressure is lower than the Repair limit, overhaul the engine.

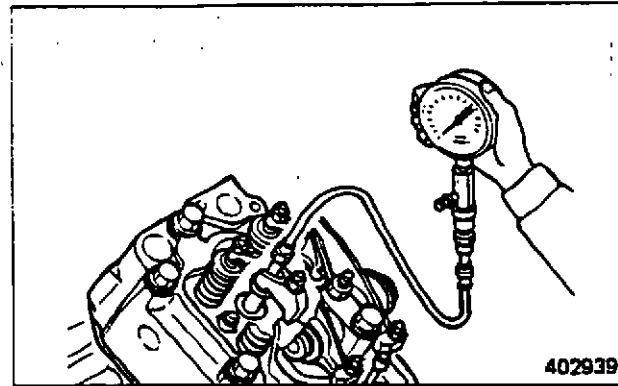

Measuring compression pressure

CAUTION

- (a) Be sure to measure the compression pressure on all cylinders. It is not a good practice to measure the compression pressure on two or three cylinders and judge the compression pressure of the remaining cylinders therefrom.
- (b) The compression pressure varies with change of engine rpm. This makes it necessary to check engine rpm at the time of measuring the compression pressure.

Unit: kgf/cm² (psi) [MPa]

Item	Assembly standard	Repair limit
Compression pressure	24 (341) [2.4], minimum	19 (270) [1.9], maximum

NOTE

Measure the compression pressure with the engine running at 120 -200 rpm.



CAUTION

- (a) It is important to measure the compression pressure at periodical intervals to obtain the data on the gradual change of the pressure.
- (b) The compression pressure would be slightly higher than the Assembly standard in a new or overhauled engine owing to breaking-in of the piston rings, valve seats, etc. It drops as the engine parts wear down.

ADJUSTMENTS, BENCH TEST, PERFORMANCE TESTS

1. ADJUSTMENTS	36
1.1 Valve clearance	36
1.2 Fuel system priming	38
1.3 Fuel injection timing inspection and adjustment	39
1.4 No-load minimum (idling) speed and maximum speed setting inspection and adjustment	41
1.5 Belt inspection and adjustment	48
2. BENCH TEST	48
2.1 Starting up	48
2.2 Inspection after starting up	48
2.3 Bench test (dynamometer test) conditions	49
2.4 Inspection and adjustment after bench test	49
3. PERFORMANCE TESTS	49
3.1 Standard equipment	49
3.2 Test items	49
3.3 Test methods	49

1. ADJUSTMENTS

1.1 Valve clearance

Inspect and adjust the valve clearance when the engine is cold.

Unit: mm (in.)

Item		Assembly standard
Valve clearance (A) (cold)	Inlet valves	0.4 (0.016)
	Exhaust valves	0.5 (0.020)

NOTE

The bridge-to-valve rotator clearance (B) should be more than 0.5 mm (0.020 in.) after the front and rear valve heights have been adjusted. If the clearance is too small, grind the bridge to obtain the specified clearance.

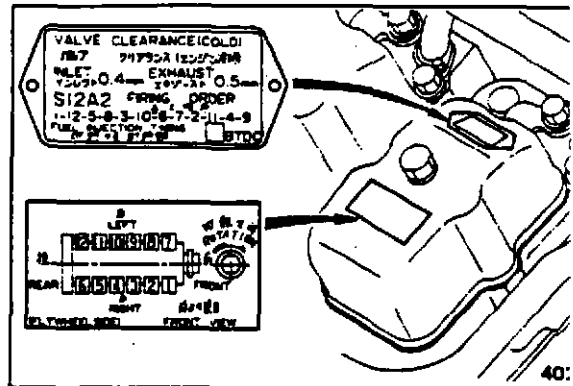
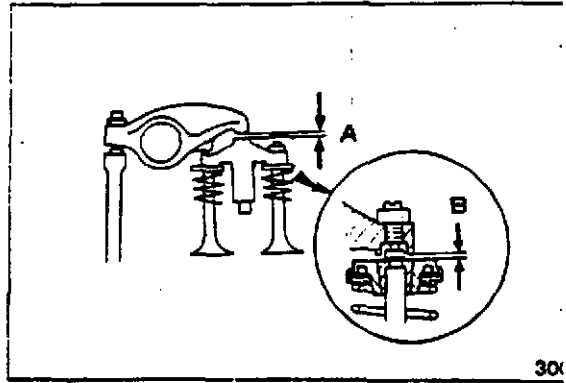

(1) Inspecting valve clearance

- (a) Inspect the valve clearance by the firing order, by turning the crankshaft (60°) in normal direction at a time to bring the piston to its top dead center on compression stroke.

Firing order

S12A2	1-12-5-8-3-10-6-7-2-11-4-9
-------	----------------------------

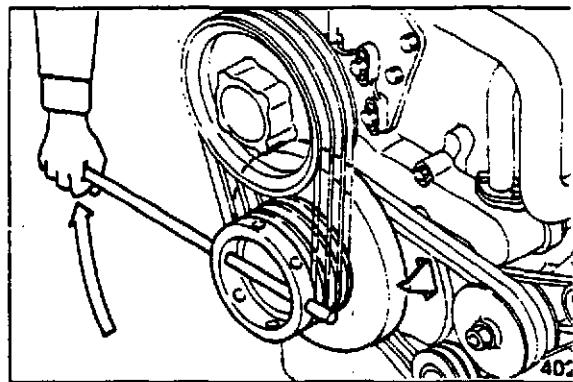

- (b) The top dead center on compression stroke of the piston is identified by the timing mark (provided on the vibration damper) being aligned with the pointer. With the piston so located, the inlet and exhaust valve rocker arms are not being pushed up by their pushrods.

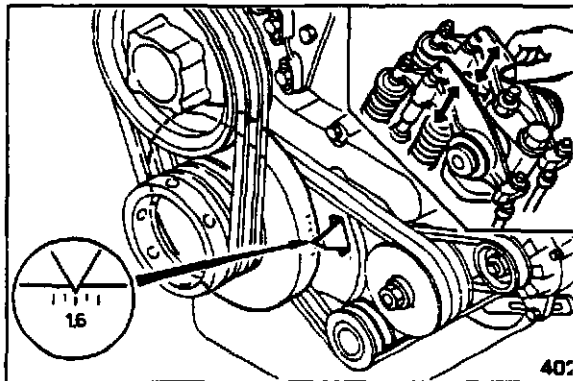

- (c) Insert a feeler gauge into between the rocker arm and bridge cap, and inspect the valve clearance.

(2) Adjusting front and rear valve heights by means of valve bridge

(a) Before adjusting the valve clearance, adjust the front and rear valve heights by means of the bridge (bring the bridge into contact with the valves). If the valve seats are worn, one valve differs from the other in height, producing some clearance between its stem top and bridge to change the valve clearance.

(b) To adjust the valve height, loosen the lock nut, and back off the adjusting screw.

(c) Then, hold the rocker arm by finger, and slowly screw in the adjusting screw until it touches the valve stem top. After making sure, by looking into the hole in the bridge, that the screw is in contact with the stem top, further screw it in about 10° of turn, and tighten the lock nut.

NOTE

If the valve clearance between the bridge and valve rotator is less than 0.5 mm (0.020 in.), the valve cotters are apt to come off. Be sure to maintain 0.5 mm (0.020 in.) or more clearance between the two.

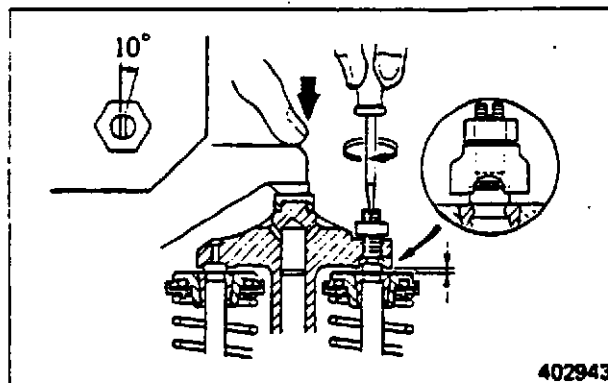

(3) Adjusting valve clearance

(a) Insert a feeler gauge into between the rocker arm and bridge cap, and adjust the clearance by turning the screw in either direction to the extent that the gauge is slightly gripped between the rocker arm and bridge cap.

(b) After adjusting the clearance, tighten the lock nut, and again inspect the clearance, making sure that it is correct.

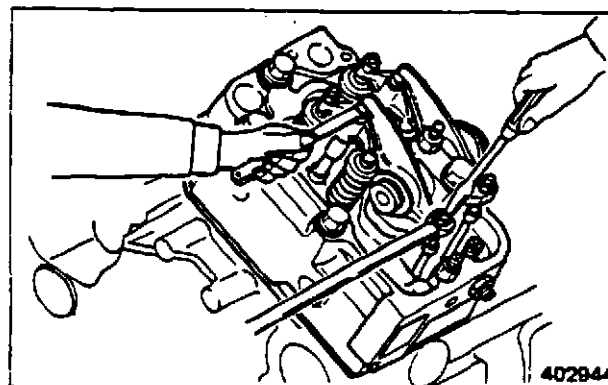

1.2 Fuel system priming

Prime the fuel filters and fuel injection pumps in that order.

(1) Primary filter
(wire-element type)

- (a) Loosen air vent plug (1) at the top of the filter (by turning it about 1.5 rotations).
- (b) Unlock priming pump handle (2) by turning it counterclockwise, and operate the priming pump.
- (c) Tighten the air vent plug when fuel flows from the vent hole without bubbles.

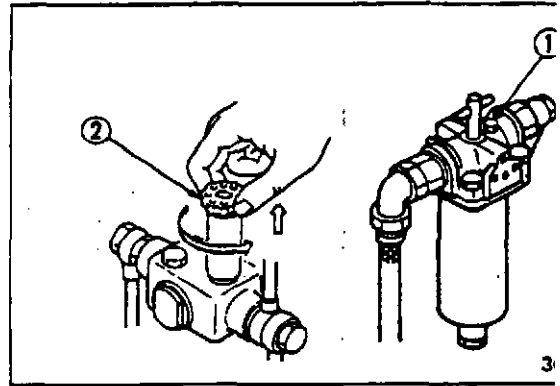

(2) Secondary fuel filter
(paper-element type)

- (a) Loosen air vent plug (1) at the top of the filter (by turning it about 1.5 rotations).
- (b) Unlock priming pump handle (2) by turning it counterclockwise, and operate the priming pump.
- (c) Tighten the air vent plug when fuel flows from the vent hole without bubbles.

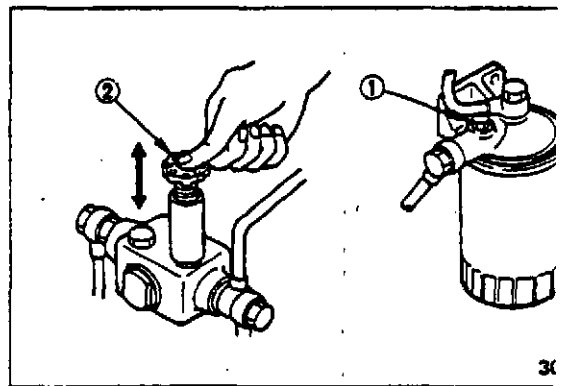

(3) Fuel injection pumps

- (a) Loosen air vent plug (1) (by turning it about 1.5 rotations).
- (b) Operate the priming pump handle (2).
- (c) Tighten the air vent plug when fuel flows from the vent hole without bubbles. Lock the priming pump by turning its handle clockwise while pushing it down before tightening the last vent plug.

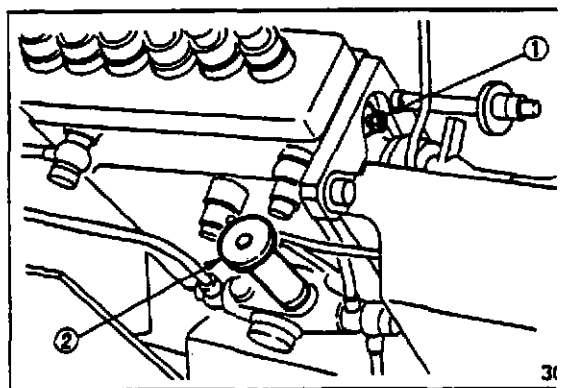



- (a) If all vent plugs are tightened before the priming pump handle is locked, fuel pressure acts on the feed pump, making it impossible to restore the handle.
- (b) Wipe off fuel spilt from the vent holes with cloth.

1.3 Fuel injection timing inspection and adjustment

[Right-hand fuel injection pump]

(1) Fuel injection timing and indication

The injection timing is stamped on the caution plate attached to the No. 1 rocker cover. Be sure to verify the timing by referring to this caution plate. The injection timing for each model of the engine varies according to its output, speed and specification.

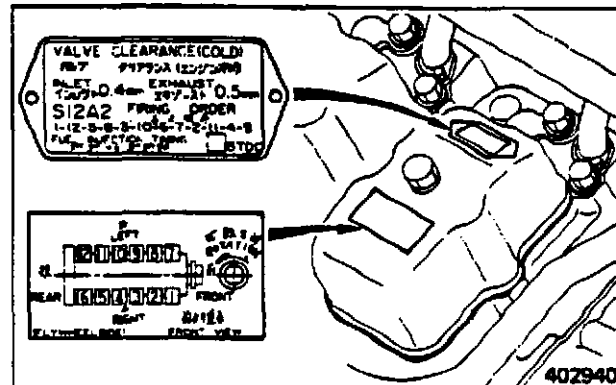

(2) Bringing No. 1 piston to top dead center on compression stroke

- (a) Using turning bar (32091-01500) at the crankshaft pulley, turn the crankshaft in normal direction (clockwise as viewed from the front side of the engine).

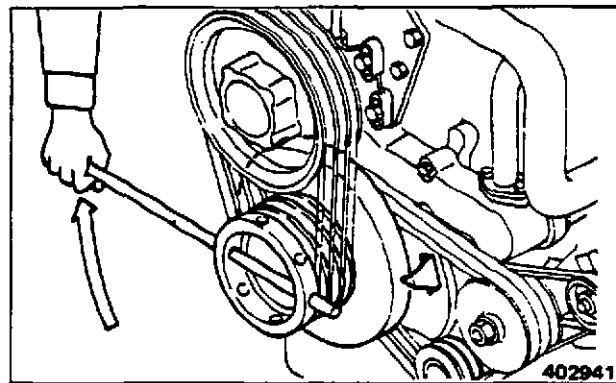

- (b) Stop cranking the engine when the timing mark (1.6) on the vibration damper is aligned with the pointer.
- (c) Move the No. 1 cylinder inlet and exhaust valve rocker arms up and down to make sure that they are not being pushed up by their pushrods.

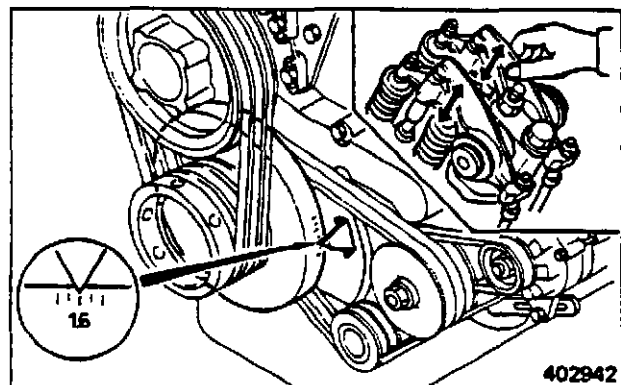

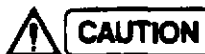

Do not confuse the top dead center on compression stroke for No. 1 cylinder with that for No. 6 cylinder.

(3) Inspecting fuel injection timing

- (a) Once turn the crankshaft about 60° in reverse direction. Then, turn it a little at a time in normal direction to align timing mark (2) on the pump drive coupling with pointer (1) on the pump case.

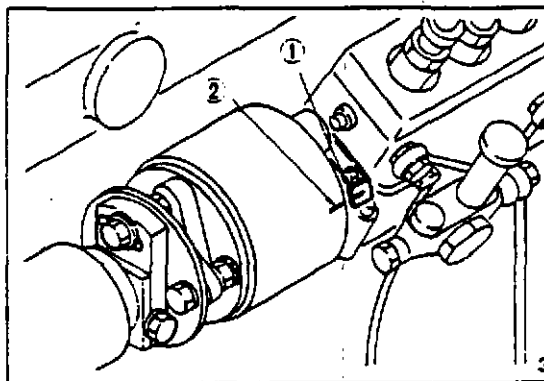

- (b) Read the degrees of an angle (injection timing) on the scale on the vibration damper, indicated by pointer. Minus (-) mark on the scale and BTDC on the caution plate means "BEFORE" top dead center.

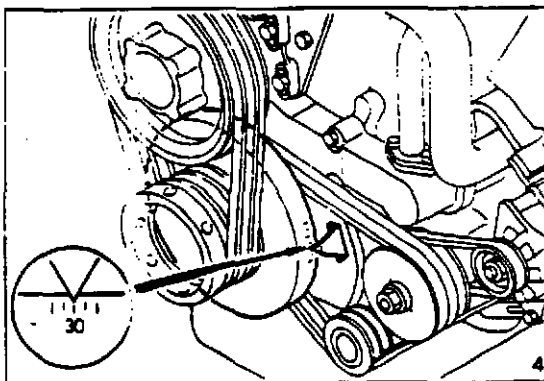

(4) Adjusting fuel injection timing

- (a) Make sure that the timing mark for No. 1 cylinder on the damper is aligned with the pointer.
- (b) Loosen two coupling bolts (1), and displace the injection pump to align pointer (2) on the pump case with timing mark (3) on the coupling. Then, tighten one bolt to the specified torque and, after turning the crankshaft, similarly tighten the other.
- (c) Again inspect the timing by cranking the engine for verification.

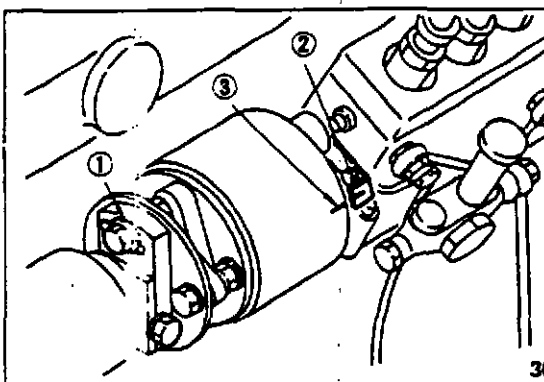

[Left-hand fuel injection pump]

On this pump, the position where the pointer is aligned with the index number "7, 12" on the damper is top dead center on compression stroke of No. 7 cylinder piston. At this position, both inlet and exhaust valves of that cylinder should have clearance as specified. For the subsequent steps, follow the procedure outlined for the right-hand injection pump.

1.4 No-load minimum (idling) speed and maximum speed setting inspection and adjustment



- (a) No-load minimum (idling) speed and maximum speed are set for each engine on the test bench at the factory and the set bolts are sealed. These settings are to be inspected and adjusted at Mitsubishi-authorized service shop only.
- (b) After authorized adjustment of the governor, be sure to seal the stoppers, making them appear as if they were sealed at the factory, if they were broken during adjustment.
- (c) The stoppers are specified to be sealed. Whether the seals are intact or not has important bearing on the validity of claims, if any, under warranty.
- (d) When inspecting and adjusting these settings, be on standby to operate the engine stop lever manually in the event of engine overrun.

or inspection and adjustment, warm up the engine thoroughly until the coolant and oil temperature rises to 70°C (158°F).

Woodward PSG-type governor

(1) Inspecting and adjusting idling speed setting

- (a) Make sure that the speed control lever is in "idling" position, and measure the engine speed (rpm).
- (b) If the idling speed is out of the specified range, reset it by means of adjust screw (1).

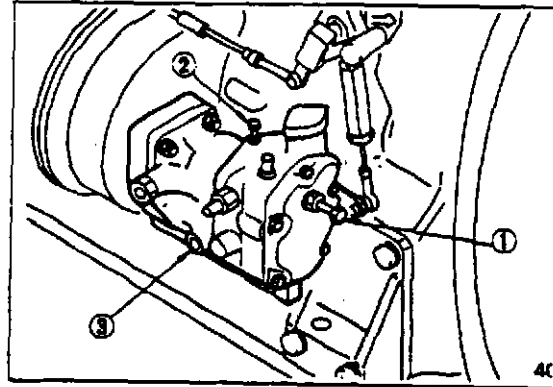

(2) Inspecting and adjusting no-load maximum speed setting

- (a) Move the speed control lever to "maximum speed" position, and measure the engine speed (rpm).
- (b) If the maximum speed is out of the specified range, reset it by means of governor set bolt (2).
- (c) Manually change the engine speed to test the governor for response, verifying the ability of the governor to sense changes in speed and regulate it to the steady-state speed promptly.

(3) Correcting hunting

- (a) If the engine hunts, reset needle valve (3). Open the needle valve by turning it counterclockwise (2 to 3 rotations) until the engine hunts. Keep the engine hunting for about 30 seconds until air is vented from the governor.
- (b) Slowly close the needle valve by turning it clockwise until the engine stops hunting.
- (c) Over-closing of the needle valve will delay speed regulation with respect to changes in load. Be sure to keep the valve backed off at least 1/4 rotation from the fully closed position.
- (d) Seal each set bolt.

Woodward 2301 and 2301A load sharing & speed control devices (for EG-3P governors)

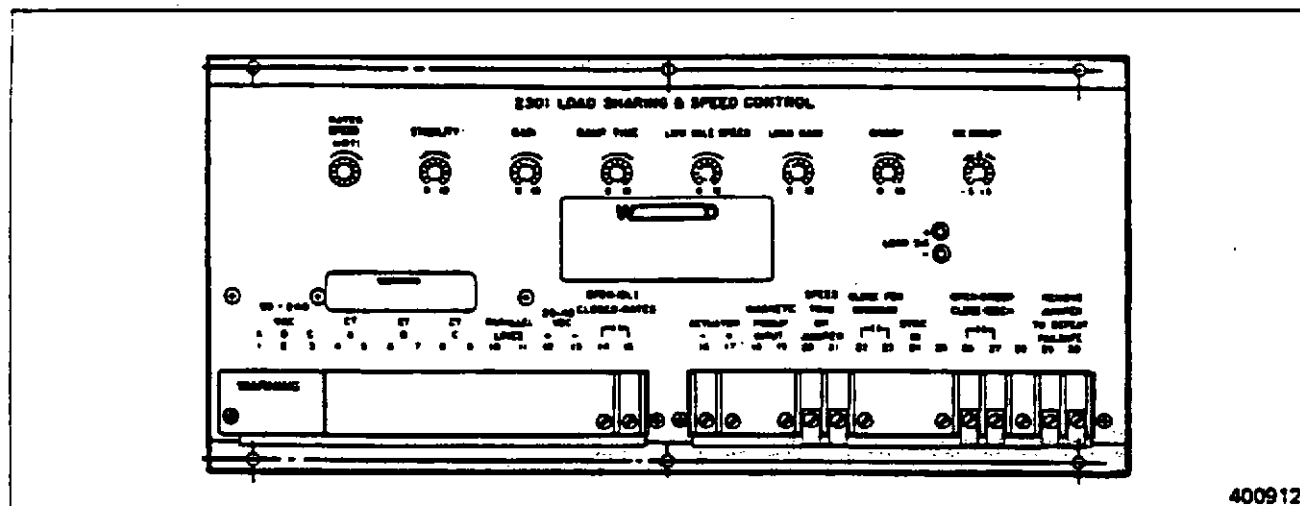

- (1) Adjusting idling speed setting
 - (a) Open the external lamp switch. The engine speed will drop to the speed set by "LOW IDLE SPEED" potentiometer.
 - (b) Set "LOW IDLE SPEED" potentiometer to obtain the specified idling speed.
 - (c) Make sure that the engine speed is above the "minimum injection quantity" position of control rack and is governed as was set by "LOW IDLE SPEED" potentiometer.
 - (d) If the engine speed fluctuates, reset "GAIN" and "STABILITY" potentiometers.

- (2) Adjusting speed setting (no-load rated speed)
 - (a) Set "RATED SPEED" potentiometer so that the engine runs at the rated speed.
 - (b) If the engine speed fluctuates, reset "GAIN" and "STABILITY" potentiometers.

ADJUSTMENTS, BENCH TEST, PERFORMANCE TESTS

(3) Setting "GAIN" and "STABILITY" potentiometers

- (a) Speed of response of the governor can be increased by increasing the gain. To increase the gain for this purpose, turn "GAIN" potentiometer clockwise while observing the voltmeter, until the engine just lacks stability.
- (b) Turn "STABILITY" potentiometer clockwise or counterclockwise until the engine gains stability.
- (c) To verify the engine (governor) stability, change the load on the engine in steps, or quickly move the fuel control linkage. If the stability cannot be gained by turning "STABILITY" potentiometer, turn "GAIN" potentiometer counterclockwise. Turn "GAIN" potentiometer clockwise if low-pitch hunting occurs.



CAUTION

To obtain the optimum performance, turn "GAIN" potentiometer as clockwise as possible, and stop turning it just before the engine lacks stability.

Barber-Colman Dyna 1-type governor

(1) Adjusting speed setting

- (a) Turn the power source switch OFF, and stop the engine.
- (b) Remove top cover from the controller, and make sure that the potentiometers are set as follows:

"A" potentiometer . . . 3 o'clock position

"GAIN" potentiometer

. . . 9 o'clock position

"D" potentiometer . . . 10 o'clock position

"I" potentiometer . . . 8 o'clock position

"L" potentiometer . . . 10 o'clock position
(set at factory)

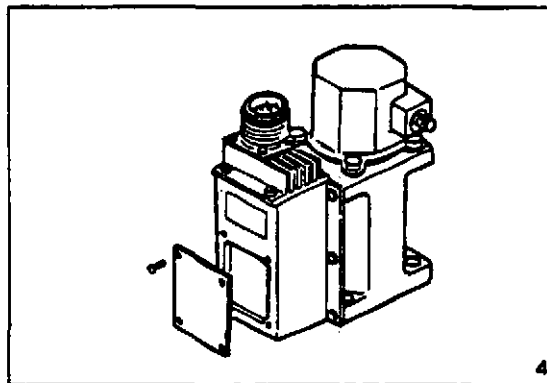

41

- (c) Turn the power source and starter switches ON, and start the engine.
- (d) Turn "SPEED" potentiometer within 20 rotations until the desired engine speed is obtained. This potentiometer can be turned clockwise to increase the speed or counterclockwise to decrease it, but it has no stopper for limiting the rotation in either direction.
- (e) Set the indicated horsepower by means of rack set bolt.

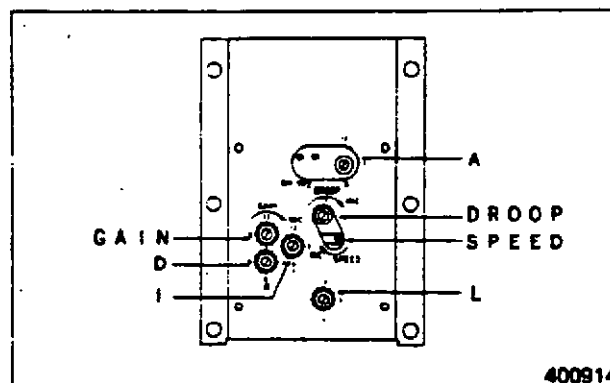

Potentiometer

(2) Correcting hunting

- (a) "A" potentiometer is to be set under no-load condition of the engine. Slowly turn this potentiometer clockwise until the actuator lever quickly vibrates (hunting occurs). Then, slowly turn it counterclockwise until hunting stops. A failure to stop hunting will result in a damage to the actuator.
- (b) If the actuator fails to gain stability (hunting does not stop), slowly turn "GAIN" potentiometer counterclockwise. If the actuator is in stable condition, slowly turn "GAIN" potentiometer clockwise until hunting occurs; then, slowly turn it counterclockwise until hunting stops.
- (c) After setting "GAIN," "A" and "D" potentiometers, turn the power source switch OFF and, when the engine speed is reduced to about 1/2, again turn the power source switch ON. If the engine speed overshoots (jumps up beyond) the setting, turn "I" potentiometer counterclockwise. If the time required to restore to the set speed is too long, turn "I" potentiometer clockwise. Repeat this operation with the engine running under no-load condition.

ADJUSTMENTS, BENCH TEST, PERFORMANCE TESTS

- (d) When "A," "D," "DROOP" and "GAIN" potentiometers are adjusted, the set speed will slightly vary. Set the speed correctly by means of "SPEED" potentiometer. If "DROOP" potentiometer has been turned in the direction of increasing the speed (clockwise), slightly turn "A" potentiometer counterclockwise, and similarly turn "GAIN" potentiometer clockwise.
- (e) Install the top cover to the controller, and seal the cover bolts.

RSUV-type governor

- (1) Inspecting and adjusting idling speed setting
 - (a) Make sure that stop lever (1) is in "idling" position, and measure the engine speed (rpm).
 - (b) If the idling speed is out of the specified range, reset the "idling" position of stop lever.
- (2) Inspecting and adjusting no-load maximum speed setting
 - (a) Move the speed control lever (2) until it touches maximum stopper bolt (3).

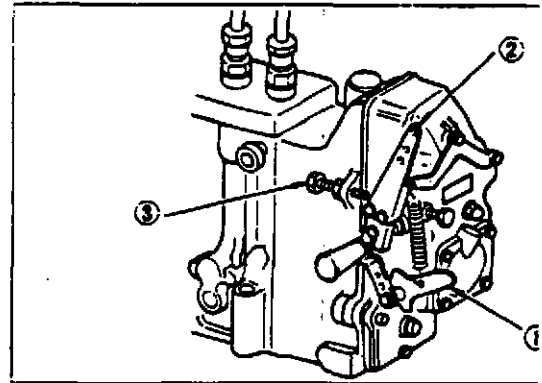

There is a possibility of the engine overrunning in some maximum stopper bolt position. With this possibility kept in mind, operate the control levers while observing the engine rpm.

- (b) Measure the engine rpm. If it is out of the specified range, reset the speed control lever by repositioning its maximum stopper bolt.

- (c) Make sure that the engine will neither stall nor hunt even if the speed control lever is quickly moved from "maximum speed" to "minimum speed" position.

(3) Adjusting idling sub-spring (correcting hunting)

- (a) If the engine hunts during idling run, reset idling sub-spring (4) at the rear side of governor. Set this spring so that it does neither push tension lever nor be apart from it inside the governor.

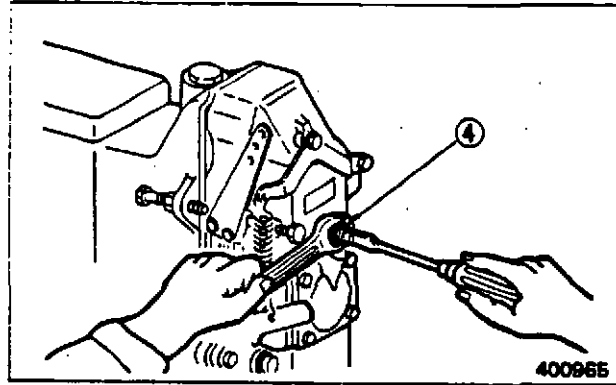

- (b) If the engine still hunts after the idling sub-spring has been reset, inspect the control rack for binding.

CAUTION

If the idling sub-spring is over-corrected, the no-load maximum speed will fluctuate, possibly causing the engine to overrun.

- (c) If the engine hunts during no-load maximum speed operation, it is an indication that the tension of main spring is weak. In such a case, tighten the adjusting screw of swivel lever to increase the tension of main spring. Do not over-tighten this screw; over-tightening will narrow the accuracy of speed regulation, causing the engine to hunt when idling. Set the screw within the specified speed regulation range.

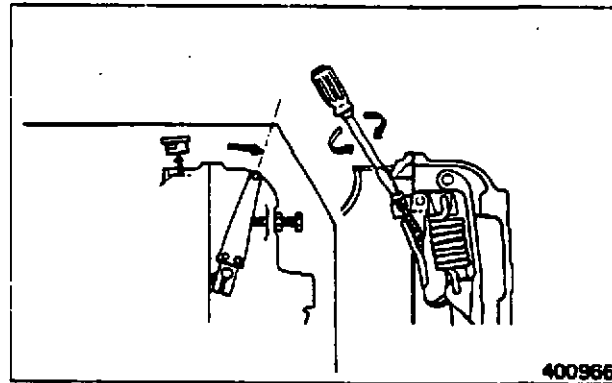

- (d) Seal each set bolt.

1.5 Belt inspection and adjustment

Apply thumb pressure to the belt midway between the pulleys to inspect the belt tension. If the tension is incorrect, make an adjustment by means of adjusting bolts.

Unit: mm (in.)

Item		Assembly standard
Belt tension	Fan	10 - 15 (3/8 - 5/8)
	Water pump and alternator	10 - 15 (3/8 - 5/8)

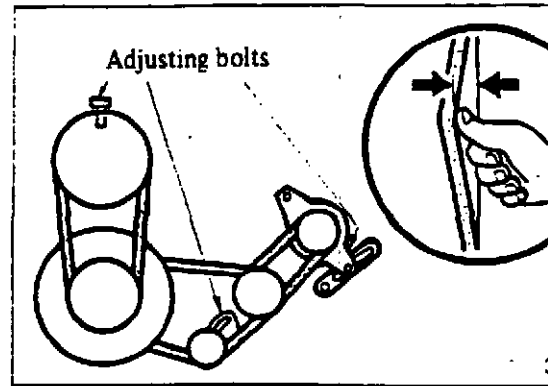

2. BENCH TEST

An overhauled engine should be tested for performance on a dynamometer. This test is also for "breaking-in" of the major running parts of the engine. To test the engine, proceed as follows:

2.1 Starting up

- (1) Inspect the levels in the radiator, oil pan and fuel tank. Prime the fuel and cooling systems to bleed air out.
- (2) Crank the engine with the starter for about 15 seconds to permit lubricating oil to circulate through the engine. For this cranking, do not supply fuel to the engine.
- (3) Slightly move the speed control lever in the direction of increasing fuel injection, and turn the starter switch to START for starting the engine. (Do not move the control lever to "full injection" position.)
- (4) After the engine starts, let it idle under no-load condition by operating the speed control lever.

2.2 Inspection after starting up

After starting up the engine, check the following points. Upon discovery of any faulty condition, immediately stop the engine, and investigate for the cause.

- (1) Lubricating oil pressure: It should be 5 to 7 kgf/cm² (71 to 100 psi) [490 to 686 kPa] at rated speed or 2 to 3 kgf/cm² (28 to 43 psi) [196 to 294 kPa] at idling speed.
- (2) Coolant temperature: It should be 70°C to 85°C (158°F to 185°F).
- (3) Lubricating oil temperature: It should be 60°C to 70°C (140°F to 158°F) when measured in oil pan.
- (4) Leakage of oil, coolant and fuel, especially oil leakage from turbo-charger lubricating oil pipe connections.
- (5) Knocking: It should die away as the coolant temperature rises. No other defects should be noted.
- (6) Exhaust color and abnormal smell

2.3 Bench test (dynamometer test) conditions

Step	Speed (rpm)	Load (PS)	Time (min.)
1	600 - 650	No-load	5
2	1000	No-load	5
3	1200	No-load	10
4	Rated (varies according to specifications)	25%	10
5		50%	10
6		75%	30
7		100%	20

2.4 Inspection and adjustment after bench test

- 1) Retightening of cylinder head bolts
- 2) Adjustment of valve clearance
- 3) Adjustment of injection timing

3. PERFORMANCE TESTS

3.1 Standard equipment

The cooling fan, air cleaner and alternator are the standard equipment of an engine to be tested.

3.2 Test items

- (1) Fuel consumption test
- (2) No-load maximum speed test
- (3) No-load minimum speed test

3.3 Test methods

- (1) Fuel consumption test
 - (a) Engine speed (rpm)
 - (b) Fuel injection quantity
 - (c) Engine output

(2) No-load maximum speed test

For this test, the governor should be set for no-load maximum speed.

(3) No-load minimum speed test

(a) The control lever should be set to the stable minimum speed position. By "stable minimum speed" is meant a minimum speed to which the engine rpm can be quickly dropped from the maximum rpm without stalling.

(b) The no-load minimum speed is specified to be 600 to 650 rpm.

(4) Others

During the performance test, inspect for leakage of gases, coolant, lubricating oil and fuel, noise or hunting.

ENGINE ACCESSORY REMOVAL AND INSTALLATION

1. PREPARATORY STEPS	52
2. ENGINE ACCESSORY REMOVAL	52
3. ENGINE ACCESSORY INSTALLATION	57

ENGINE ACCESSORY REMOVAL AND INSTALLATION

This section explains the procedures and tips for removal and installation of the accessories - the preliminary process to go through for overhauling the engine.

1. PREPARATORY STEPS

- (a) Shut off the fuel supply, and disconnect the starting system from the engine.
- (b) Loosen the water pump and oil cooler drain cocks and drain coolant.
- (c) Loosen the oil pan drain plug, and drain engine oil.
[Oil capacity: 100 liters (26.4 U.S. gal.), approx.]



WARNING

Hot engine oil can cause personal injury if it contacts the skin. Use caution when draining the oil.

2. ENGINE ACCESSORY REMOVAL

(1) Removing fan drive

- (a) Unscrew fan mounting bolts(1), and remove fan (2).
- (b) Remove two flexible lubricating oil pipes (3).
- (c) Loosen bracket mounting bolts (4) and back off belt tension adjusting bolt (5) to slacken V-belt (6).
- (d) Unscrew bracket mounting bolts and remove V-belt and fan drive (7).
- (e) Remove crankshaft pulley (8) and vibration damper (9).
- (f) Disconnect water pipe (10).

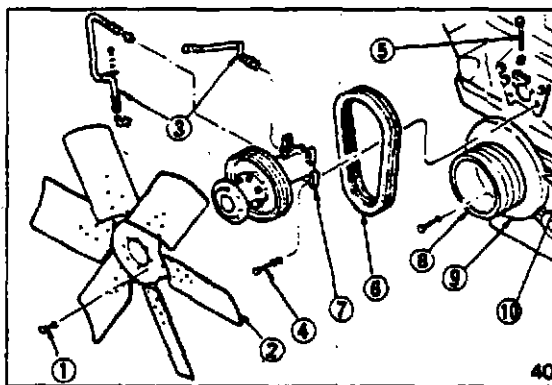

(2) Removing turbochargers

- (a) Disconnect turbocharger lubricating oil pipes (1) and drain pipes (2).
- (b) Unscrew bolts (3) connecting air ducts (4) and air coolers.
- (c) Remove air ducts, exhaust pipe and turbochargers (5).

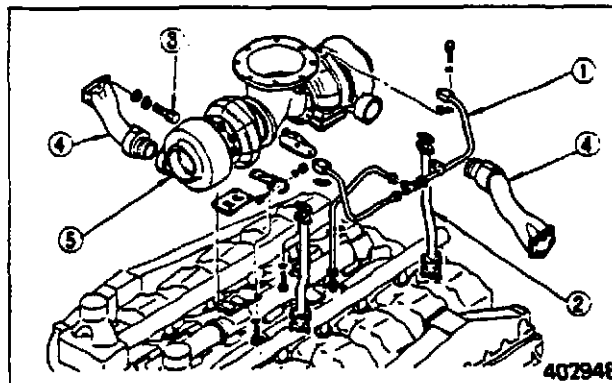

(3) Removing thermostat cases and water pipes

- (a) Remove water pipe connecting couplings (1) (at three places).
- (b) Removing thermostat cases (2) with water pipes.
- (c) Remove water outlet pipes (3) by unscrewing bolts.

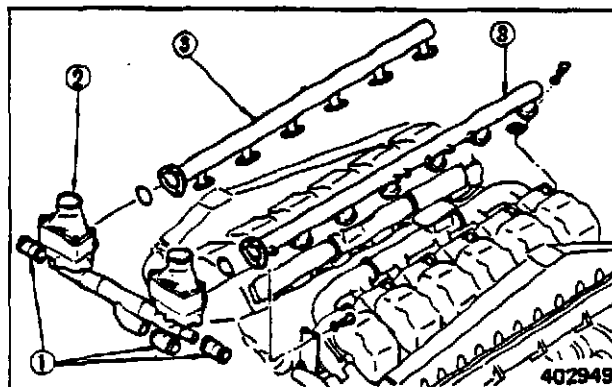

(4) Removing exhaust manifolds

- (a) Remove joints (2) by removing couplings (1).
- (b) Remove exhaust manifolds (3) (4) and gaskets (5) by unscrewing bolts.
- (c) Remove exhaust manifolds (6) and gaskets.

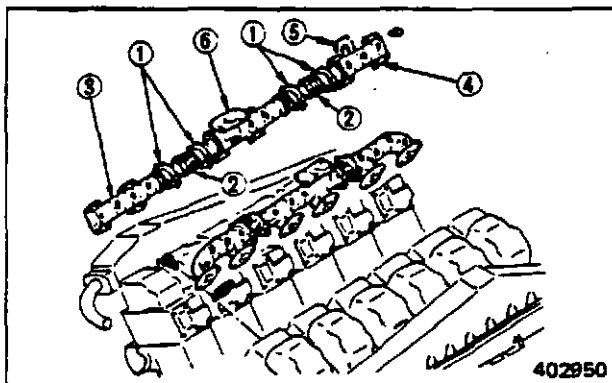

NOTE

When installing the manifolds, place each gasket with its side marked as "TOP" facing the manifold.

ENGINE ACCESSORY REMOVAL AND INSTALLATION

(5) Removing air coolers

- (a) Remove fuel pipe clamps (1).
- (b) Disconnect water pipe (2).
- (c) Remove air coolers (3).

NOTE

Before removing each air cooler, drain coolant from the cooler by opening drain cock at rear water pipe.

[Air cooler weight: 54 kg (119 lb) approx.]

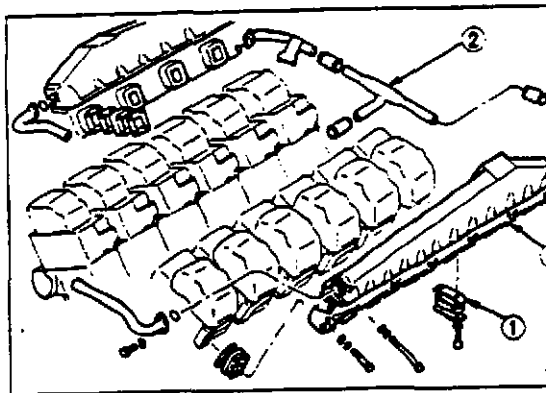

(6) Removing fuel pipes and fuel leak-off pipes

Disconnect and remove fuel pipes (1) (12 pcs) and fuel leak-off pipes (2) (2 pcs).

CAUTION

Be sure to attach rubber caps to openings of the injection pumps and nozzle holders from which fuel injection pipes were disconnected to prevent dust from getting inside the fuel system.

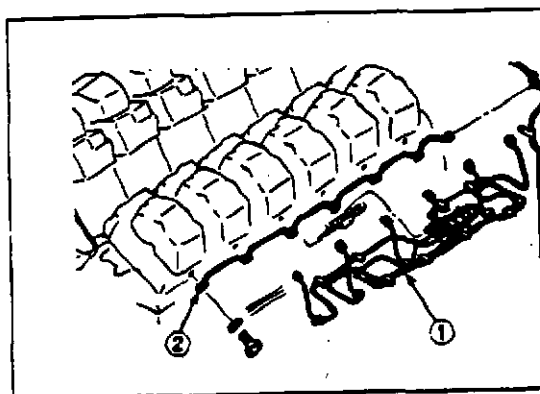

(7) Removing fuel filters

- (a) Disconnect fuel pipes (1).
- (b) Remove fuel filters (3) by unscrewing mounting bolts (2).

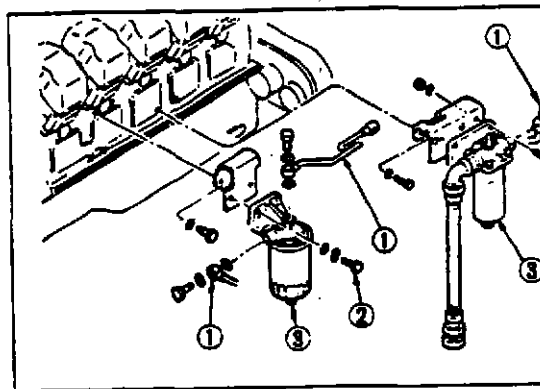

(8) Removing left-hand and right-hand fuel injection pumps

- (a) Disconnect oil pipes (1) from each pump.
- (b) Remove coupling cover (2) from the pump.
- (c) Loosen bolts (3) securing the coupling to the shaft sufficiently.
- (d) Unscrew bolts (4) securing the pump to the engine. Remove pump (5) complete with the coupling by prying it toward the front side of the engine with a bar.

[Weight: 25 kg (55 lb), approx.]

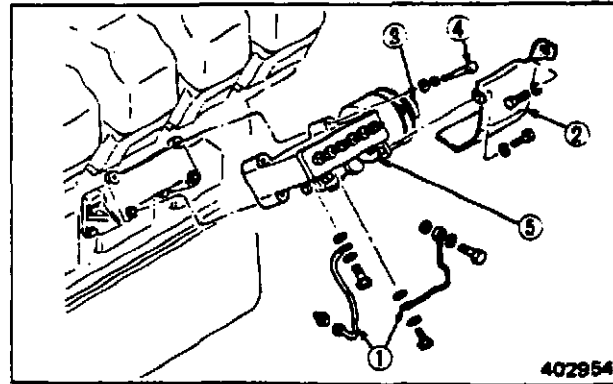

(9) Removing oil filters and oil cooler

- (a) Disconnect harness (1) for the oil filter alarm.
- (b) Using oil filter wrench (34591-00100), remove oil filters (2) (4 pcs).
- (c) Disconnect oil pipe (3).
- (d) Remove oil cooler (5) by unscrewing mounting bolts (4).

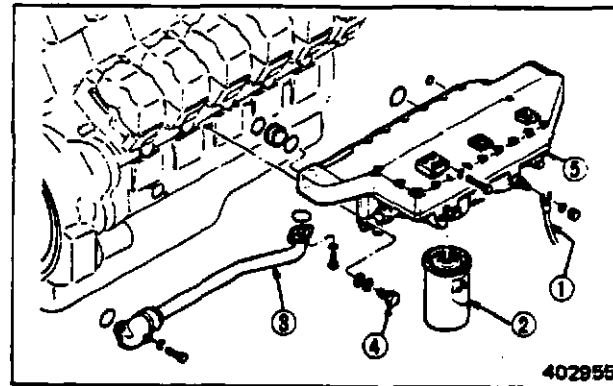

NOTE

Before removing oil filter (2), make a hole in the bottom of the filter to drain oil.

10) Removing bypass oil filter

- (a) Disconnect oil pipes (1).
- (b) Remove bypass oil filter (2) and bracket (3).

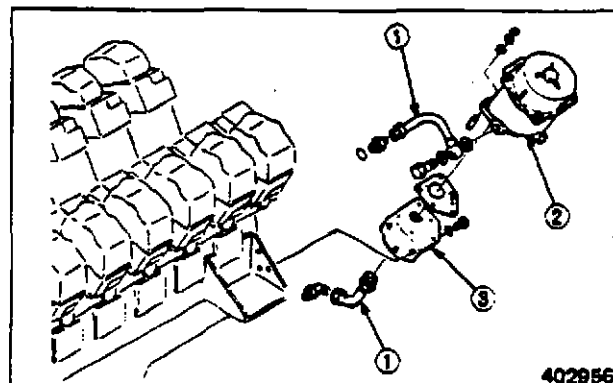

ENGINE ACCESSORY REMOVAL AND INSTALLATION

(11) Removing air breather

- (a) Disconnect oil drain pipe (1).
- (b) Remove air breather (2) by unscrewing mounting bolts.

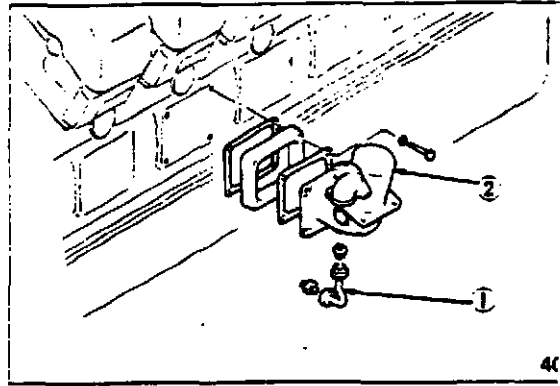

(12) Removing oil filler

- Remove oil filler (1) by unscrewing bolts.

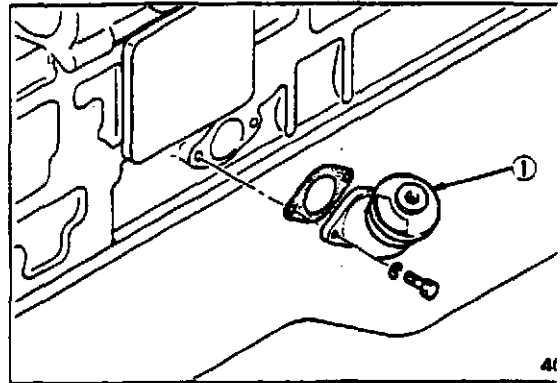

(13) Removing water pump

- (a) Drain coolant from the water pump by loosening drain valve (1).
- (b) Disconnect lubricating oil pipes (2).
- (c) Remove water pump (4) by unscrewing bolts (3).

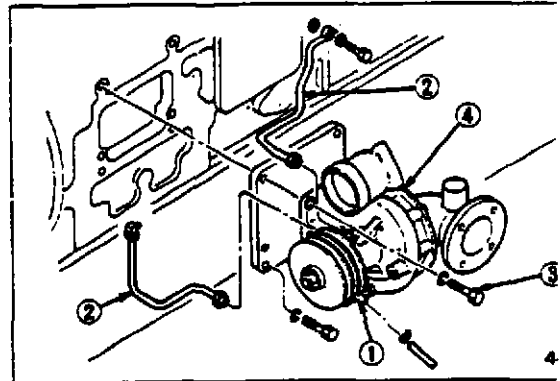

(14) Removing alternator

- (a) Disconnect harness (1), and loosen bolt (2) for belt adjusting boss.
- (b) Remove belt (4) and alternator (5) by unscrewing nut (3).

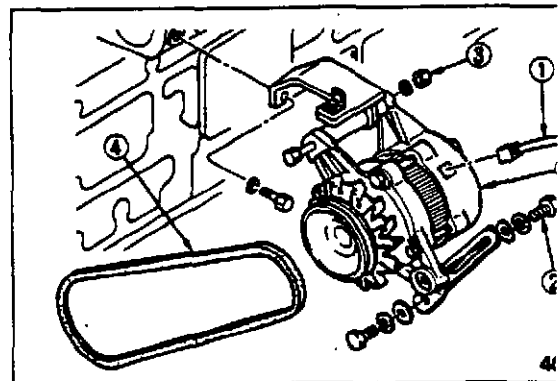

(15) Removing starters

Disconnect harness (1), and remove starter (3) by unscrewing nuts (2).
[Weight: 15.5 kg (34.2 lb), approx.]

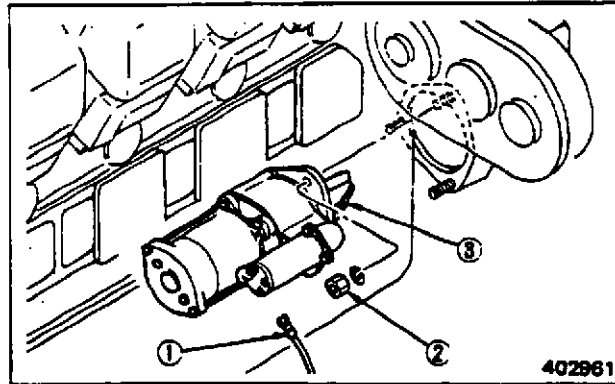

(16) Removing Woodward governor

- (a) Remove lubricating oil pipes (1) and oil filter (2) for Woodward governor.
- (b) Remove Woodward governor (3) by unscrewing mounting nuts.

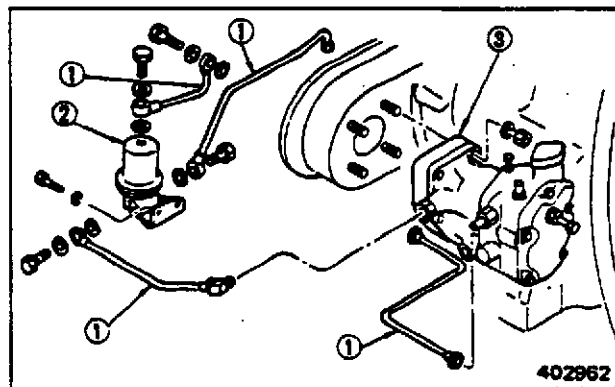

3. ENGINE ACCESSORY INSTALLATION

To install the engine accessories, use reverse of the removal procedures. After installing them, service as follows:

- (a) Refill the engine with recommended oil up to the specified level.
- (b) Refill the cooling system with coolant.
- (c) Check each pipe connection for oil or coolant leaks.
- (d) Prime the fuel system.
- (e) Install the fuel injection pumps as follows. After installing the fuel injection pumps, be sure to inspect and adjust the injection timing. (Refer to 1.3, Group No. 5.)

Fuel Injection Pump Installation

[Right-hand injection pump]

- (a) Turn the crankshaft in normal direction to align the index number "1, 6" on the vibration damper with the pointer.
- (b) Move the No. 1 cylinder inlet and exhaust valve rocker arms to make sure that they are not being pushed up by their pushrods.
- (c) Once turn the crankshaft about 60° in reverse direction. Then, turn it a little at a time in normal direction to align the timing mark on the damper with the pointer.

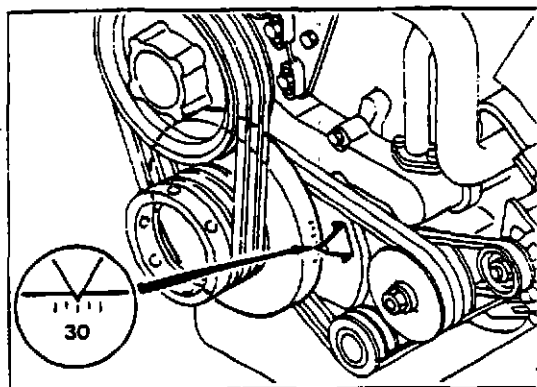
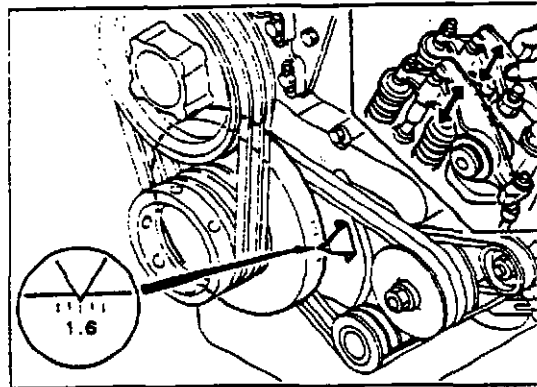

NOTE

Verify the injection timing by referring to the caution plate attached to the No. 1 rocker cover.

- (d) Install the coupling to the injection pump, and align pointer (1) on the pump case with mark (2) on the coupling.
- (e) Fit the key of drive shaft into the keyway of coupling, and push in the injection pump toward the drive case. Tighten bolt (3) securing the coupling to the specified torque.
- (f) Connect the fuel pipes and oil pipes to the injection pump, and install the control link.

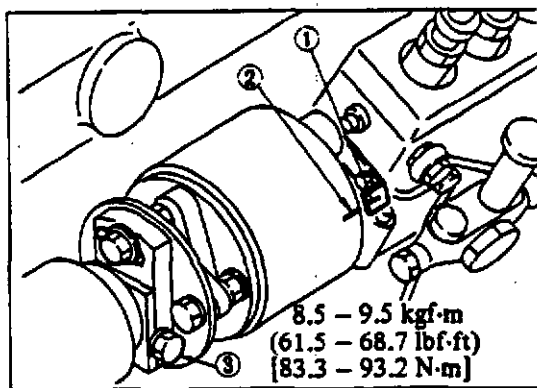

[Left-hand fuel injection pump]

- (a) To install this pump, align the index number "7, 12" on the damper with the pointer. At this position, make sure that both inlet and exhaust valves of No. 7 cylinder piston is at top dead center on compression stroke.

ENGINE PROPER

1. CYLINDER HEADS AND VALVE MECHANISM	62
1.1 Disassembly	62
1.2 Inspection and repair	65
1.3 Reassembly	73
2. CYLINDER LINERS, PISTONS AND CONNECTING RODS	77
2.1 Disassembly	77
2.2 Inspection and repair	81
2.3 Reassembly	90
3. FLYWHEEL, TIMING GEARS AND CAMSHAFT	96
3.1 Disassembly	96
3.2 Inspection and repair	100
3.3 Reassembly	107
4. CRANKCASE, CRANKSHAFT AND MAIN BEARINGS	114
4.1 Disassembly	114
4.2 Inspection and repair	116
4.3 Reassembly	123

1. CYLINDER HEADS AND VALVE MECHANISM

1.1 Disassembly

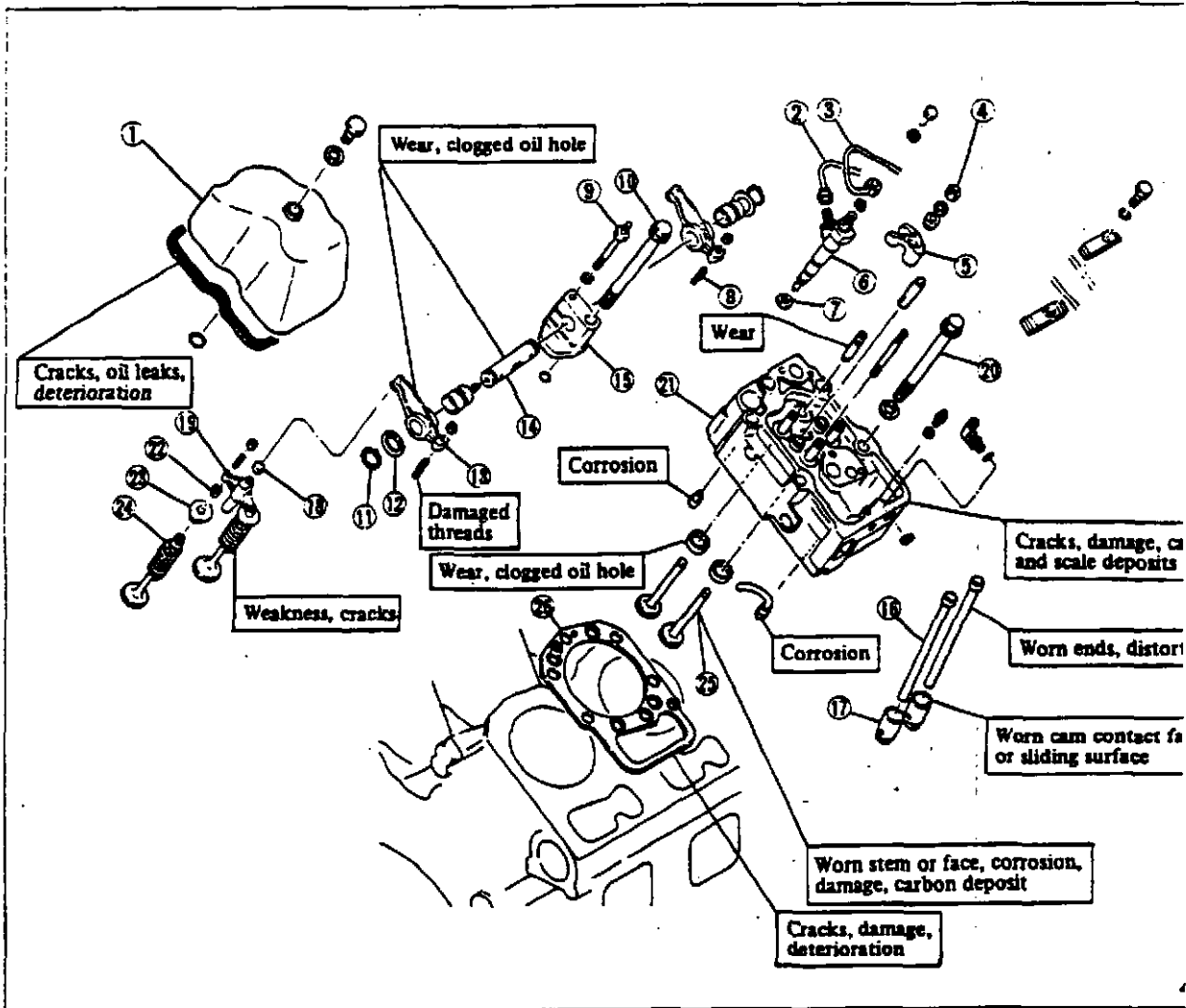

- ① Rocker cover
- ② Fuel leak-off pipe
- ③ Fuel pipe
- ④ Nut, washer
- ⑤ Injection nozzle gland
- ⑥ Injection nozzle
- ⑦ Packing
- ⑧ Adjusting screw
- ⑨ Bolt

- ⑩ Cylinder head bolt
- ⑪ Snap ring
- ⑫ Washer
- ⑬ Rocker
- ⑭ Rocker shaft
- ⑮ Rocker shaft bracket
- ⑯ Valve pushrod
- ⑰ Tappet
- ⑱ Valve bridge cap

- ⑲ Valve bridge
- ⑳ Cylinder head bolt
- ㉑ Cylinder head
- ㉒ Valve cotter
- ㉓ Valve rotator
- ㉔ Valve spring
- ㉕ Valve
- ㉖ Cylinder head gasket

(1) Removing fuel pipes

- (a) Disconnect each fuel injection pipe and fuel leak-off pipe.
- (b) Remove the nozzle-side sealing washers, and set them aside so as not to lose them.

**CAUTION**

Be careful not to let pipe clamp bolts and nuts fall.

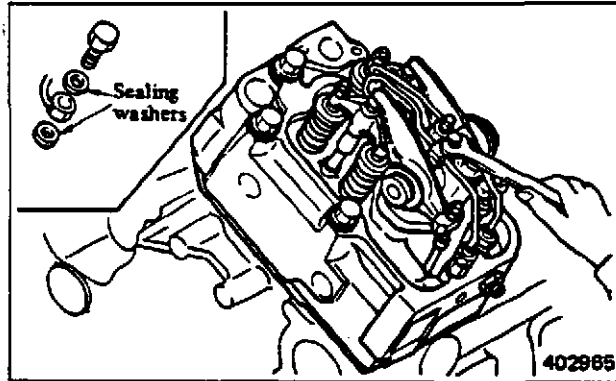
**(2) Removing fuel injection nozzles**

- (a) Using injection nozzle remover (A) (32591-00201), remove each injection nozzle. Take out the gasket left behind in the cylinder head.
- (b) Be careful not to damage the nozzle tip.

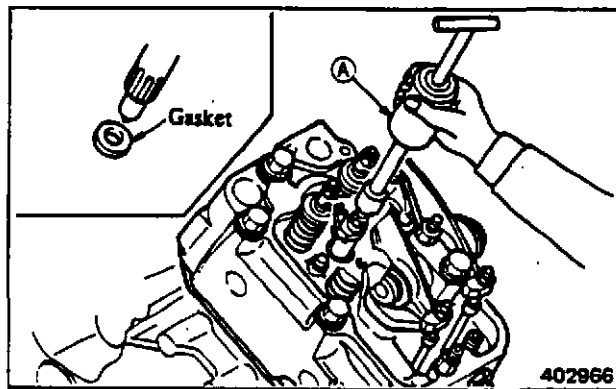
**(3) Removing rocker shaft assemblies**

- (a) Loosen the adjusting screw of each rocker about one rotation in advance.
- (b) Loosen the small-diameter rocker bracket mounting bolt about five rotations first; then remove the large-diameter bolt securing the cylinder head and rocker bracket with a torque wrench.
- (c) Remove each rocker shaft assembly. Keep the shaft assembly and mounting bolts in a set.

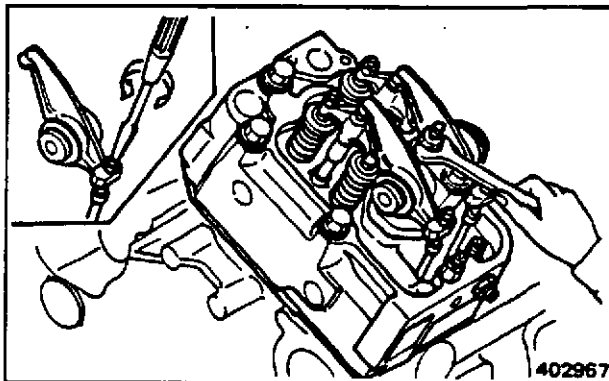
**NOTE**

Be careful not to drop small parts such as bridge caps, bracket O-rings into crankcase through pushrod holes.

(4) Disassembling rocker shaft assemblies

Lay the disassembled rockers in the order removed, and install them in that order at the time of reassembly. This is for insuring the same rocker shaft-to-rocker clearance as before.

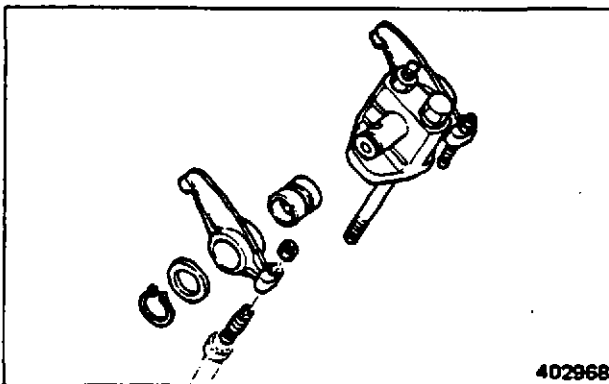

(5) Removing cylinder head assemblies

Each cylinder head is located relative to the crankcase with dowel pins. Lift the head off the crankcase aslant. [Cylinder head weight: 29 kg (64 lb), approx.]



CAUTION

Be careful not to damage the cylinder head and crankcase surfaces when removing the gasket.

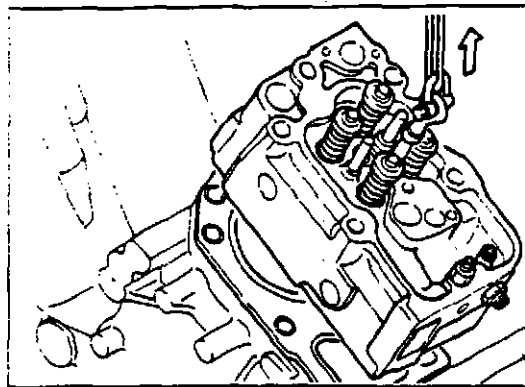

(6) Removing valves and valve springs

Using valve spring pusher (A) (33591-04500), compress the valve spring squarely, and remove the valve cotters, valve spring and valve.

NOTE

If the valves are to be reused, do not change combination of the valve seat and valve guide.

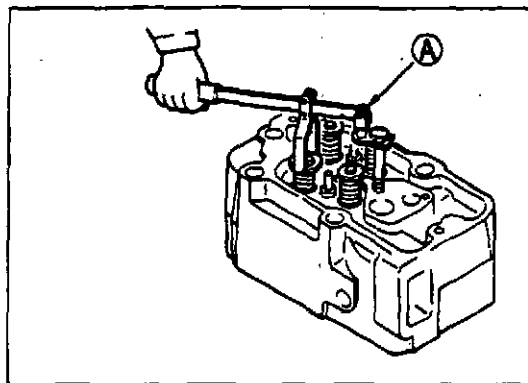

(7) Removing studs, connectors, etc.

Do not remove the following parts from the cylinder head unless absolutely necessary. If any of these parts has been removed, apply sealant to the studded-side threads of the part when installing it to the cylinder head, or install a new part.

- (a) Stud for injection nozzle holder
- (b) Connector for fuel injection pipe
- (c) Connector for fuel leak-off pipe

Do not remove bridge guide (d) except when replacing the valve guide.

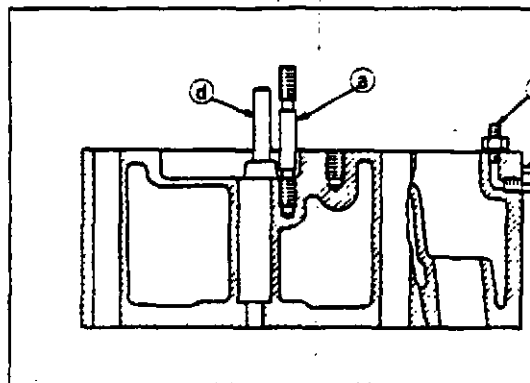

- (b) For subsequent steps, follow the procedure outlined for the right-hand injection pump.

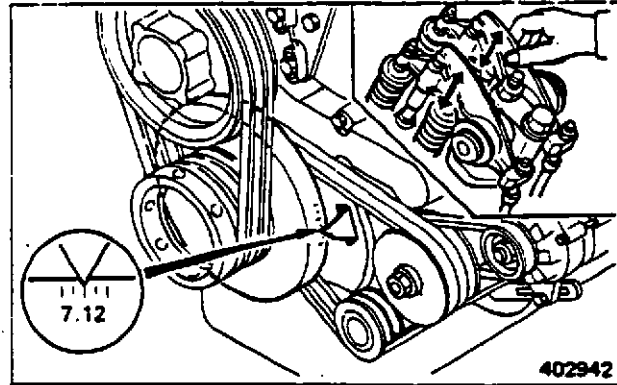

[Adjusting injection quantities of left-hand and right-hand injection pumps]

- (a) To adjust, push in the racks of the pumps all the way to non-injection position, and turn the adjusting rod of the linkage of left-hand injection pump.
- (b) After adjusting, tighten the lock nut of adjusting rod and seal it by passing a wire.

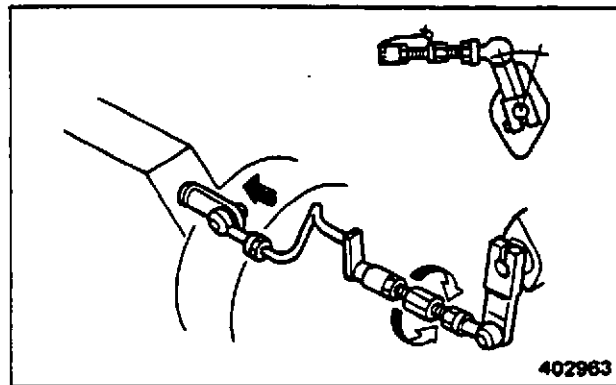

NOTE

When turning the adjusting rod for adjustment, make sure that the rack slides smoothly without any sign of binding. If the rack fails to move smoothly, the governor will not function properly.

1.2 Inspection and repair

Rockers, rocker bushings and rocker shafts

(1) Measuring rocker bushing inside diameter and rocker shaft diameter

If the measurement exceeds the Service limit, replace the bushing and/or shaft.

Unit: mm (in.)

Item	Nominal value	Assembly standard	Service limit
Rocker bushing inside diameter	32 (1.26)	32.000 - 32.040 (1.25984 - 1.26141)	32.100 (1.26378)
Rocker shaft diameter		31.991 - 31.975 (1.25949 - 1.25886)	31.950 (1.25787)

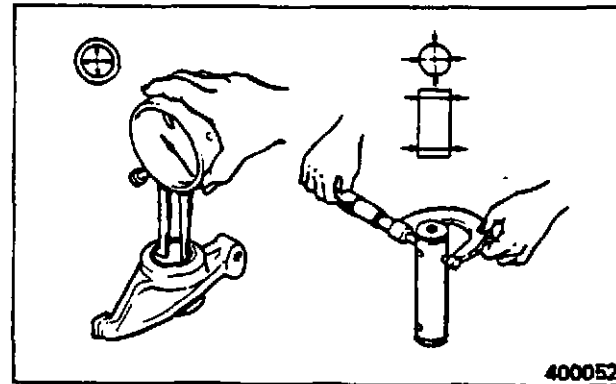

Measuring rocker bushing and rocker shaft

(2) Replacing rocker bushings

Using rocker bushing puller (A) (32591-02600), remove the rocker bushings (worn) for replacement.

- (a) Press a new bushing into the rocker from the internally chamfered side of the bore.
- (b) Align the oil holes in the bushing and rocker.
- (c) After installing the bushing, measure its inside diameter to make sure that it is $32 \begin{smallmatrix} +0.040 \\ 0 \end{smallmatrix}$ mm ($1.26 \begin{smallmatrix} +0.00157 \\ 0 \end{smallmatrix}$ in.). If the diameter is out of this tolerance, refinish it to $32 \begin{smallmatrix} +0.040 \\ 0 \end{smallmatrix}$ mm ($1.26 \begin{smallmatrix} +0.00157 \\ 0 \end{smallmatrix}$ in.) $\frac{3.25}{VV}$ by reaming.

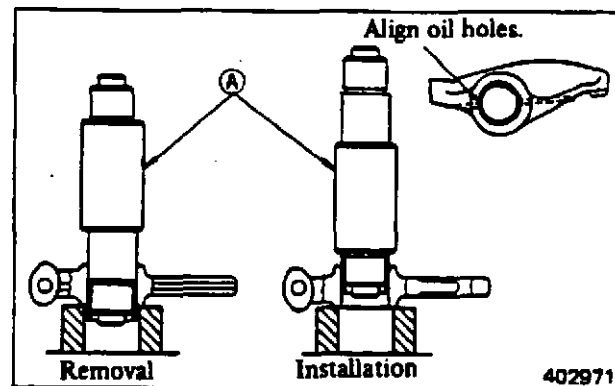

Replacing rocker bushing

ENGINE PROPER

Valve guides and valve stems

(1) Measuring valve stem diameter and valve guide inside diameter

The valve guide wears more rapidly at its both ends than at any other parts. Measure the inside diameter of the guide at its ends and at middle part in two directions. If the Service limit is exceeded, replace the guide.

Unit: mm (in.)

Item		Nominal value	Assembly standard	Service limit
Valve stem diameter	Inlet	10 (0.39)	9.960 - 9.940 (0.39213 - 0.39134)	9.910 (0.39016)
	Exhaust		9.930 - 9.910 (0.39094 - 0.39016)	9.880 (0.38898)
Valve guide inside diameter			10.000 - 10.015 (0.39370 - 0.39429)	10.060 (0.39606)

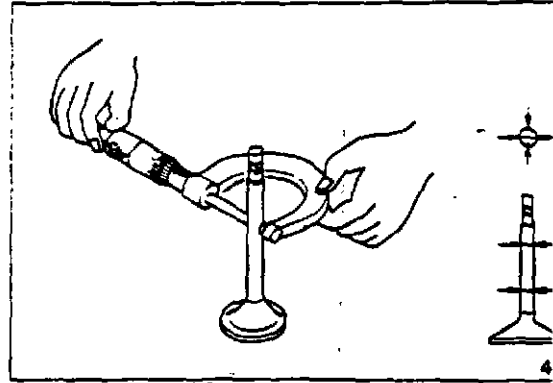

Measuring valve stem

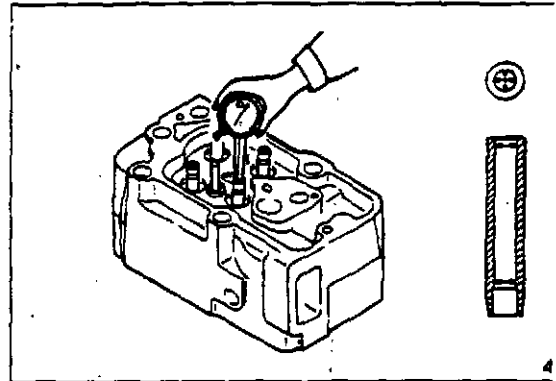

Measuring valve guide

(2) Replacing valve guides and stem seals

- (a) Using valve guide remover (A) (36291-04200), remove the valve guide (worn) for replacement.

NOTE

Be sure to use new stem seals at the time of reassembly.

- (b) Using valve guide and seal installer (B) (32591-10300), install a new guide slowly with a press.

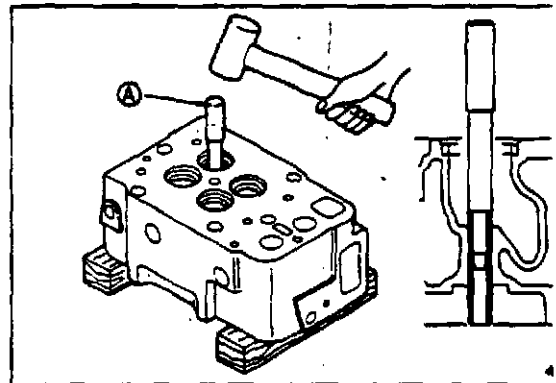

Removing valve guide

CAUTION

- (a) As-installed depth is specified for the valve guide; be sure to use the valve guide and seal installer to secure this depth.
- (b) Do not apply any oil or sealant to the surface of stem seal that comes in contact with the valve guide. When installing the stem seal, coat the seal rubbing surface of the stem with engine oil to insure initial lubrication of the stem seal lip.

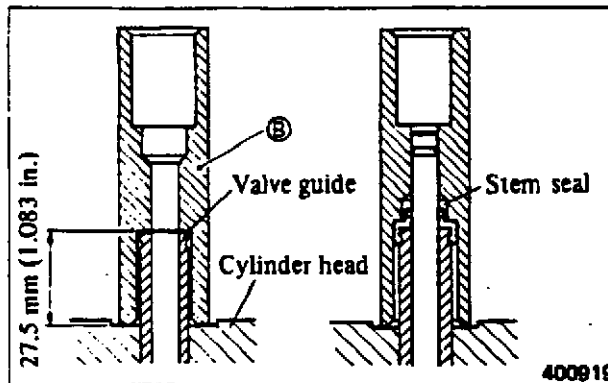

Installing valve guide and stem seal

Valves and valve seats

(1) Inspecting valve face

Coat the valve face lightly with red lead and, using valve lapper (A) (30091-08800), inspect the valve contact with its seat. If the contact is not uniform, or if the valve is defective or the Repair limit is exceeded, repair or replace the valve and valve seat.

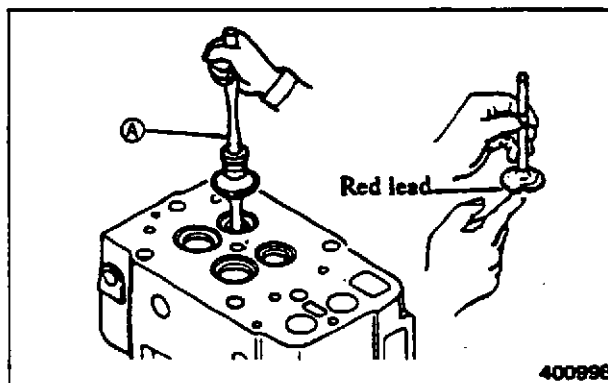

Inspecting valve face

NOTE

- (a) Inspect the valve face after inspecting or replacing the valve guide.
- (b) When pressing the valve coated with red lead into the valve seat, do not rotate the valve.

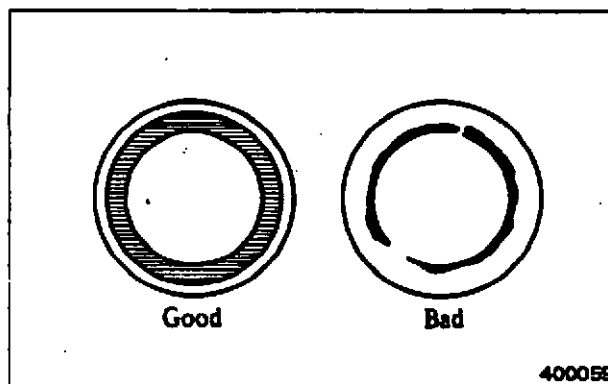

Valve contact with its seat

Unit: mm (in.)

Item		Assembly standard	Repair limit	
Valve seat	Angle	30°	—	
	Valve sinkage	0.2 - -0.2 (0.008 - -0.008)	0.5 (0.020)	
	Width	Inlet	1.93-2.23 (0.0760-0.0878)	2.5 (0.098)
		Exhaust	1.70-2.00 (0.0669-0.0787)	2.3 (0.091)
Valve margin		3.1 - 2.9 (0.122 - 0.114)	2.0 (0.079) by refacing	

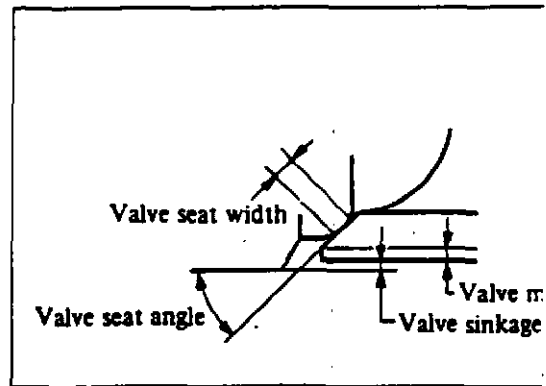

(2) Refacing valves

If the valve face is badly worn, reface it with a valve refacer.

NOTE

- (a) Set a valve refacer at an angle of 30°.
- (b) Grind the valve stock to a minimum. If the margin seems to exceed the Repair limit by grinding, replace the valve.

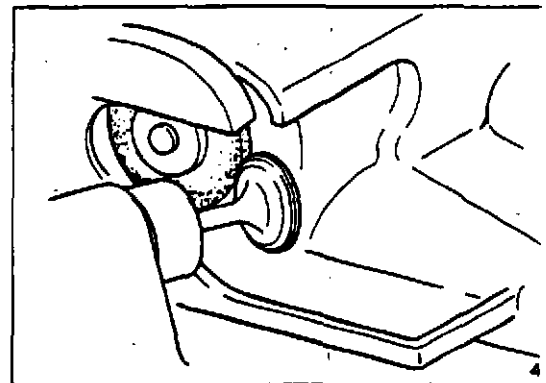

Refacing valve

(3) Refacing valve seats

- (a) Using a valve seat cutter or valve seat grinder, cut the valve seat. After cutting, grind the seat lightly by using sandpaper of #400 grade or so, inserted between the cutter and valve seat.
- (b) Lap the valve in the valve seat.

NOTE

- (a) Cut or grind the valve seat only as necessary for refacing.
- (b) Replace the valve seat if the seat width is more than the Repair limit as a result of wear or cutting.
- (c) Replace the valve seat if the valve sinkage exceeds the Repair limit after refacing.

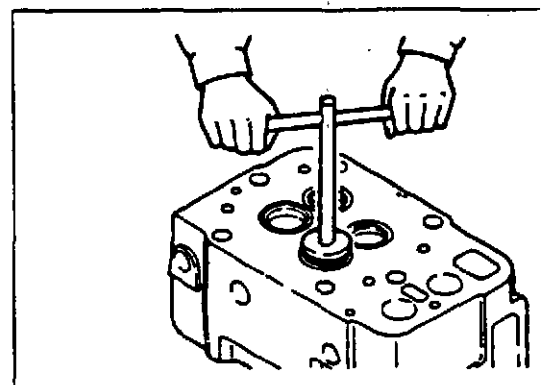

Refacing valve seat

(4) Replacing valve seats

- (a) Weld a stud or the like to the valve seat. Insert a shaft into the valve guide hole from the upper side of cylinder head, and drive the seat off the head as shown.



When welding the stud, be careful not to permit spatters to come in contact with the machined surfaces of cylinder head.

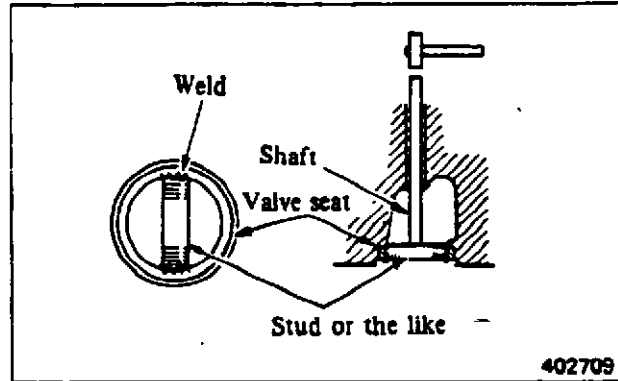

Removing valve seat

402709

- (b) Before inserting a new valve seat, measure the inside diameter of cylinder head bore and the outside diameter of the seat to make sure that clearance (fit) between the two is within the Standard clearance.

Unit: mm (in.)

Item	Nominal value	Standard clearance
Cylinder head bore inside diameter and valve seat outside diameter	Inlet 58 (2.28)	-0.07 - -0.13
	Exhaust 54 (2.13)	(-0.0028 - -0.0051)

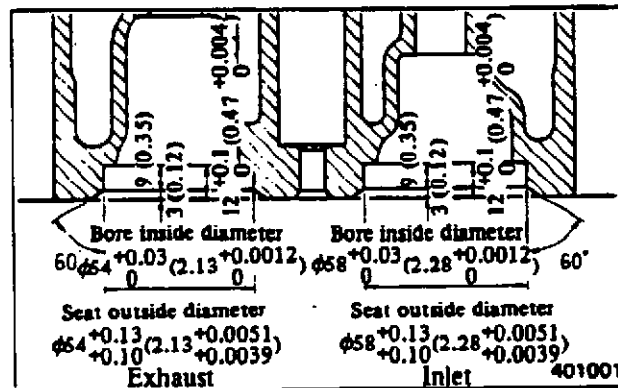

Valve seat dimensions

401001

- (c) Chill the valve seat in liquid nitrogen [about -170°C (-274°F)] more than 4 minutes with the cylinder head kept at normal temperature, or heat the cylinder head to 80°C to 100°C (176°F to 212°F) with the valve seat chilled in ether or alcohol containing dry ice.

- (d) Using the installer, install the valve seat.

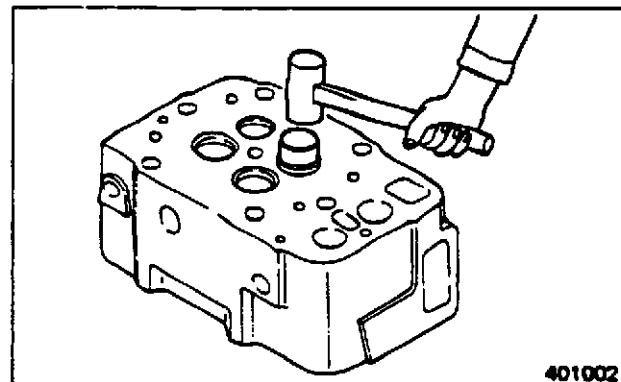

Installing valve seat

401002

ENGINE PROPER

(5) Lapping valves in valve seats

Be sure to lap the valves in the valve seats after the seats have been replaced.

- (a) Coat the valve face lightly with a lapping compound.

NOTE

- (a) Do not permit the compound to come in contact with the valve stem.
- (b) Use the compound of 120 to 150 mesh for initial lapping and the compound of finer than 200 mesh for finish lapping.
- (c) Mixing the compound with a small amount of engine oil will facilitate coating.

- (b) Using valve lapper (A) (30091-08800), lap the valve in the seat. To lap, raise the valve off the seat, and then rotate the valve only a part of turn and strike it against the seat.
- (c) Wash off the compound with diesel fuel.
- (d) Coat the valve face with engine oil, and again lap the valve.
- (e) Check the valve face for contact.

Valve bridges and bridge caps

Check the clearance between the bridge and the rotator (cotter).

- (1) If the clearance is less than 0.5 mm (0.020 in.), check the valve stem top for cupping. When the stem top is badly cupped, replace the valve to obtain more than 0.5 mm (0.020 in.) clearance.
- (2) Check the bridge cap for condition, and replace a badly worn cap.

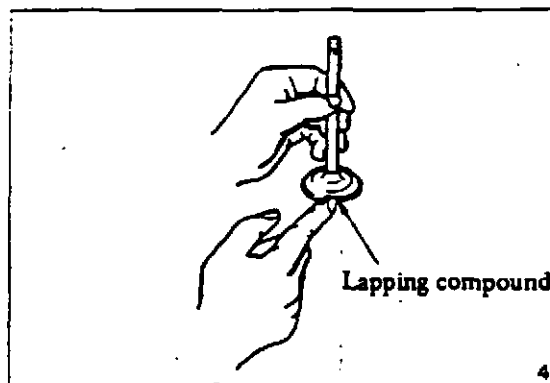

Coating valve with lapping compound

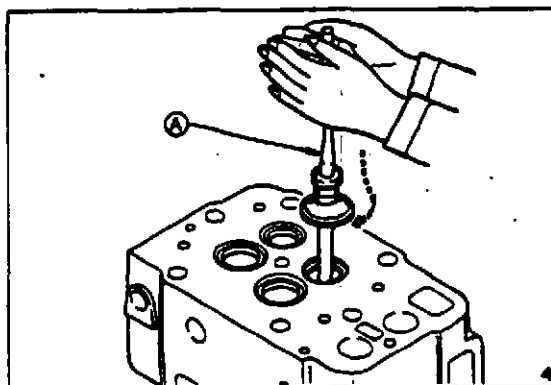

Lapping valve in valve seat

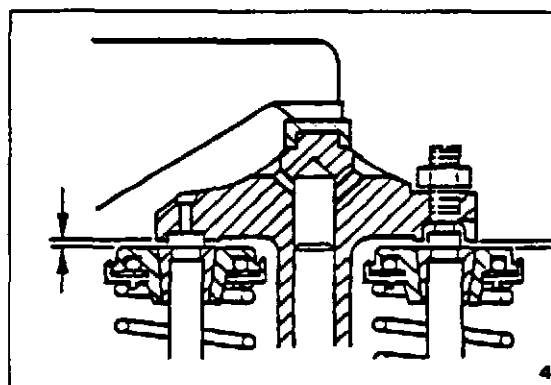

Checking bridge-to-rotator clearance

Valve springs

Measuring squareness and free length

Measure the free length and squareness of each valve spring. If the free length or squareness exceeds the Service limit, replace the spring.

Unit: mm (in.)

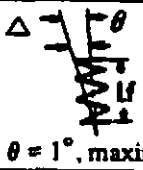
Item	Assembly standard	Service limit
Free length	67.5 (2.657)	66.2 (2.606)
Squareness	 $\theta = 1^\circ$, maximum	$\Delta = 1.5$ (0.059) over the length
Length under test force/test force, mm (in.)/ kgf (lbf) [N]	60.0 (2.362)/ 27.8±5% (61.3±5%) [272.6±5%]	

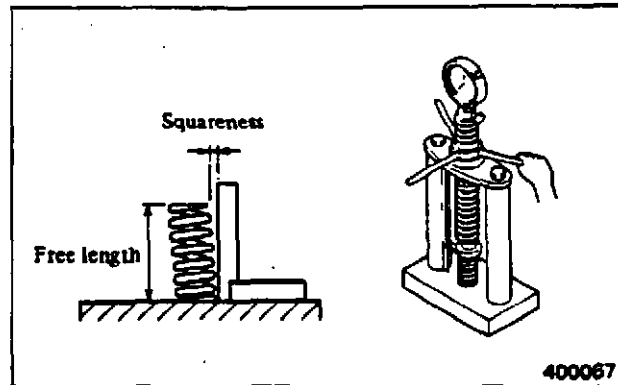

Measuring valve spring

400067

Tappets and valve pushrods

1) Inspecting cam contact face of tappets

Replace the tappets if their cam contact faces are abnormally worn.

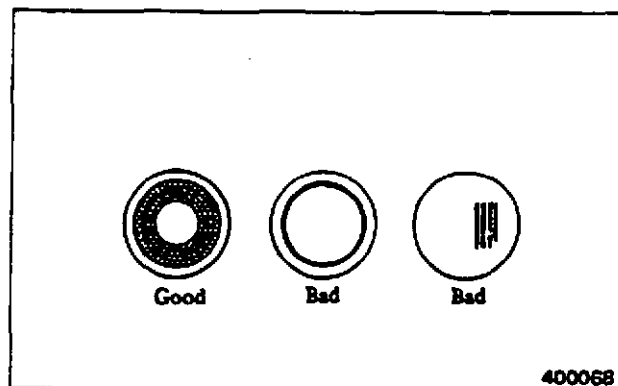

Cam contact face of tappet

400068

2) Inspecting valve pushrods for runout

If the runout exceeds the Assembly standard, replace the pushrods.

Unit: mm (in.)

Item	Assembly standard
Pushrod runout	0.5 (0.020), maximum

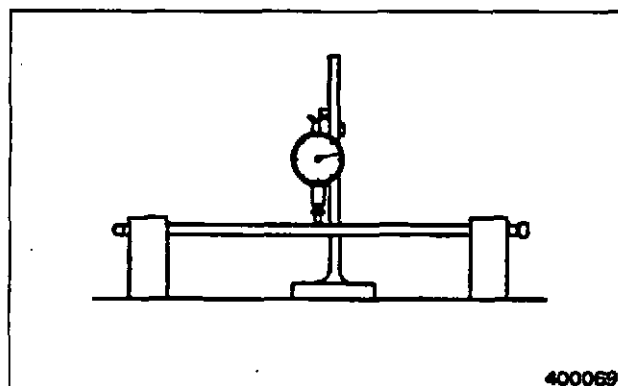

Measuring valve pushrod runout

400069

ENGINE PROPER

Cylinder heads

(1) Measuring gasketed surface warpage

Measure warpage on each head with a straightedge and a feeler gauge. If the warpage exceeds the Repair limit, reface the gasketed surface with a surface grinder.

Unit: mm (in.)

Item	Assembly standard	Repair limit
Cylinder head gasketed surface warpage	0.03 (0.0012), maximum	0.07 (0.0028)

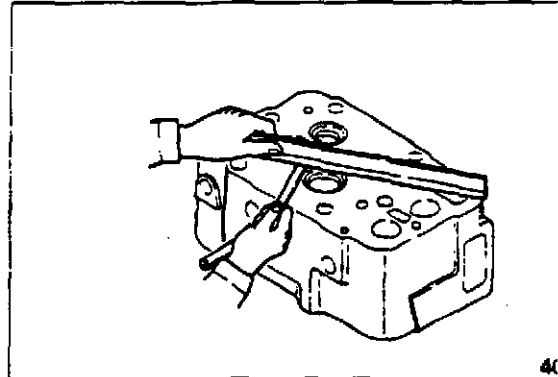

Measuring cylinder head gasketed surface w

(2) Inspecting water directors

Check each water director for corrosion, and replace it if necessary. Using a soft hammer, drive a new director into the cylinder head until it measures 1.0 mm (0.04 in.) sinking from the gasketed surface of the head, with its window positioned as shown.

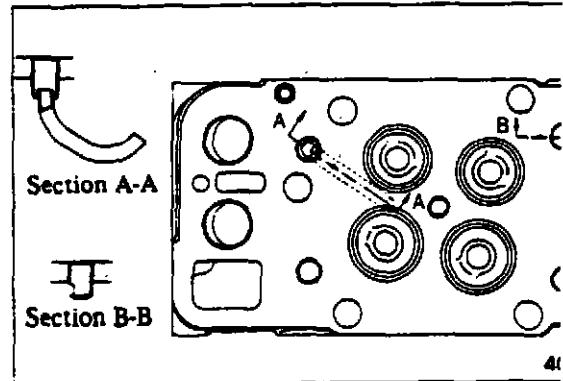

Installing water directors

1.3 Reassembly

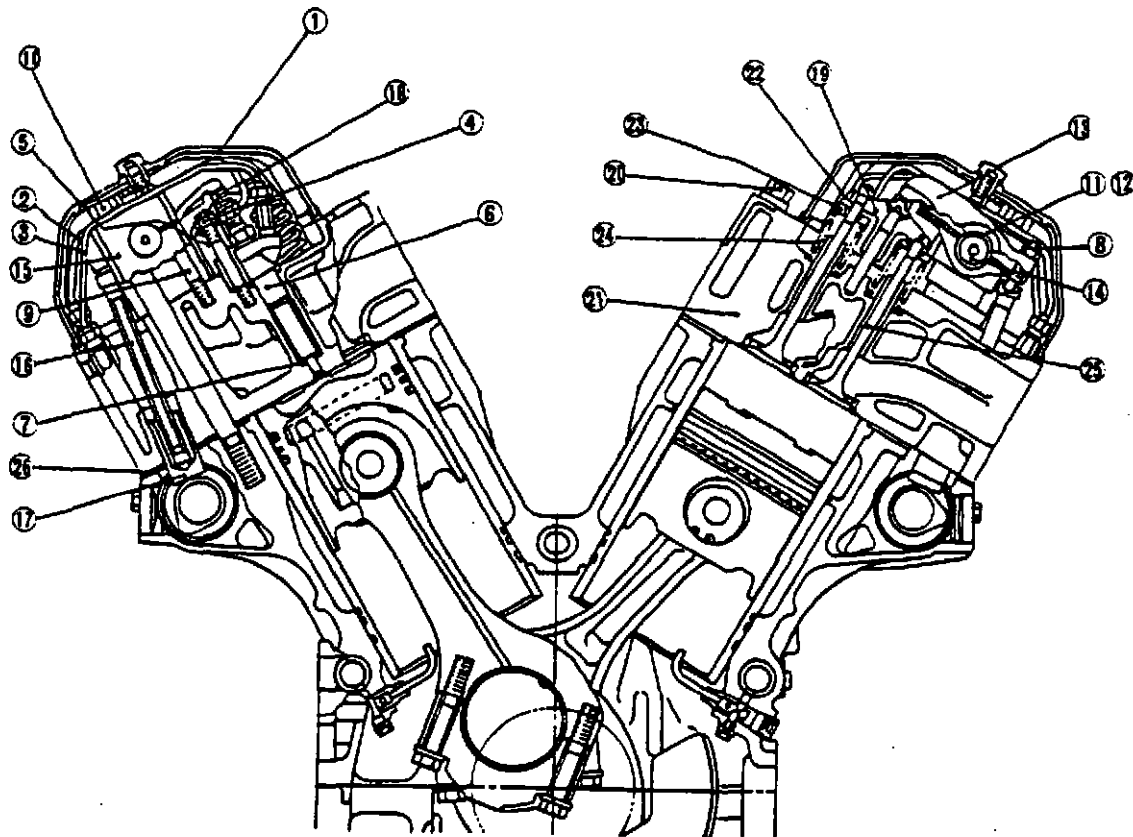

402974

Reassembling sequence

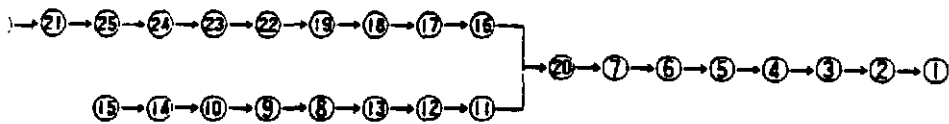

ENGINE PROPER

(1) Installing cylinder head gaskets

- (a) Clean the gasketed surfaces of cylinder head and crankcase thoroughly with a solvent or degreasing solution.
- (b) Place the gaskets on the crankcase, making sure that dowel pins enter their holes in the gaskets.



CAUTION

Do not apply any sealant to the gaskets.

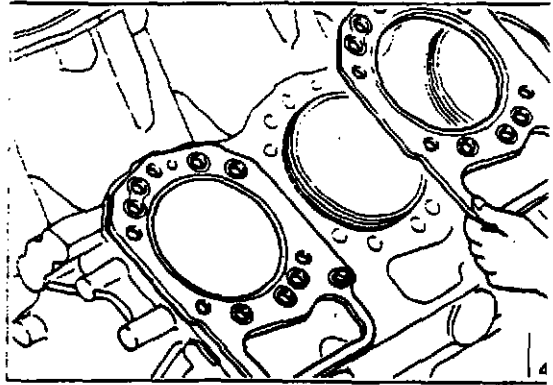

(2) Reassembling cylinder heads

- (a) Coat the valve stems with engine oil, and insert them into the valve guides.
- (b) Install the valve springs and rotators to the valve guides. Compress each valve spring with valve spring pusher (A) (33591-04500), and install the valve cotters to the valve stem.
- (c) Lightly tap on the top of each valve stem with a soft hammer to make sure that the valve spring and cotters are properly installed.

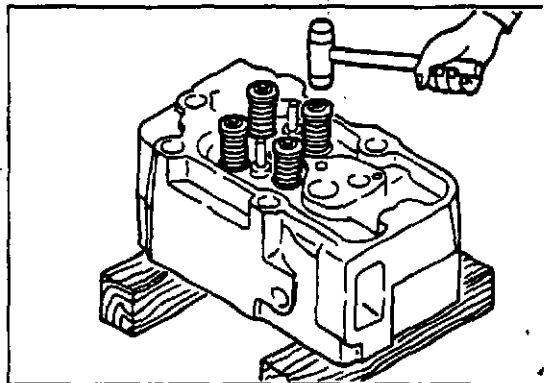
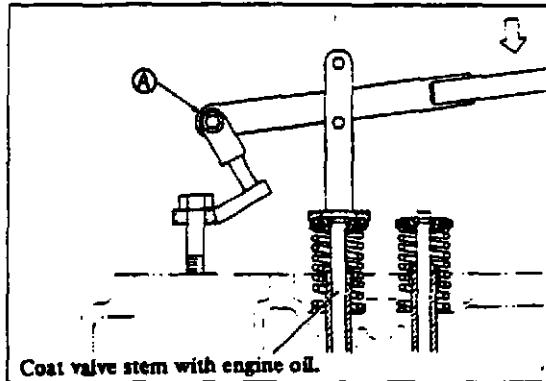

(3) Installing cylinder head assemblies

Place the head assembly on the crankcase with the dowel pins entering their holes. Coat the threads of cylinder head bolts with engine oil, insert the bolts (except one for securing the head and rocker bracket) into the head assembly and tighten the cylinder head bolts temporarily.

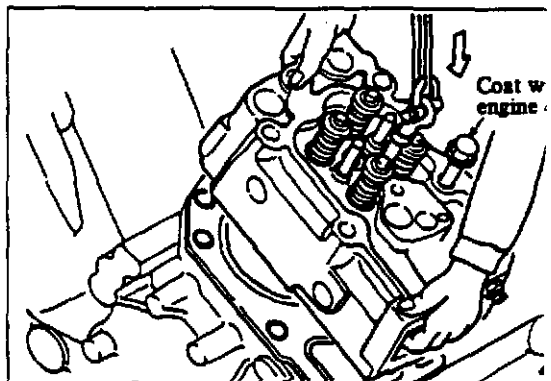



Before installing the cylinder head assembly, measure the protrusion of each piston, making sure that the protrusion is correct. (Refer to (4), Pistons, 2.2, Group No. 7.)

4) Installing valve bridges and caps

- (a) Coat the bridge guides with engine oil, and install the bridges to the guides with the adjusting screw positioned on the exhaust manifold side.
- (b) Coat the bridge contact face of bridge caps with engine oil, and install the caps in position, being careful not to let them fall into the crankcase through pushrod holes.

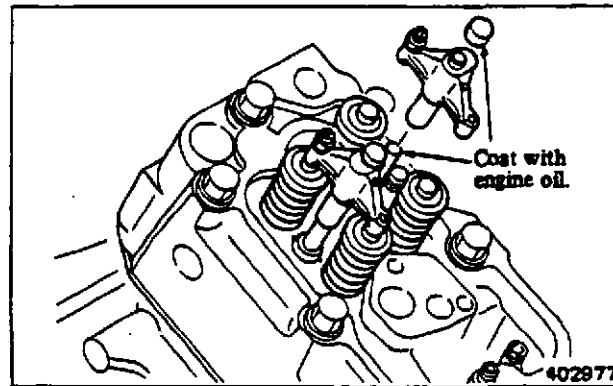

5) Installing tappets and pushrods

Coat the tappets with engine oil, and carefully place them on the camshaft. After that, install the pushrods.

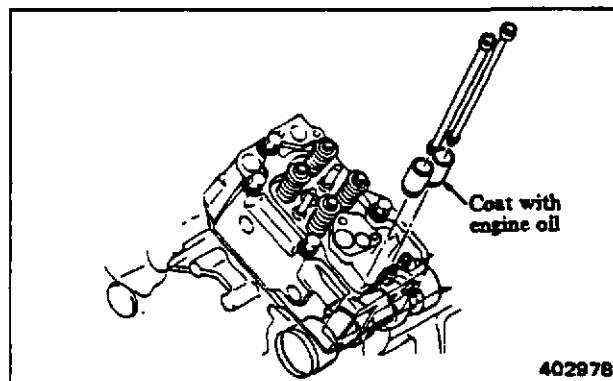

3) Installing rocker shaft assemblies

- (a) Align the notch of rocker shaft with the bolt hole of rocker shaft bracket, and insert the bolt into the bolt hole.
- (b) Insert the long bolt for securing the head and rocker bracket with O-ring through the bolt hole of the rocker bracket into the cylinder head.

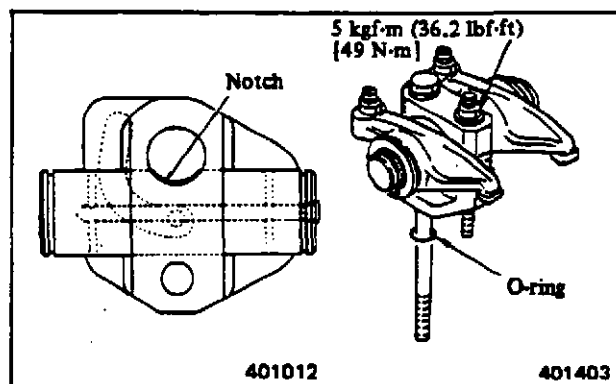

CAUTION

- (a) Move the rocker arm up and down to make sure that the arm is free.
- (b) While tightening the bracket mounting bolts temporarily, install the bracket in place so that rocker tip comes in contact with bridge cap evenly.
- (c) Tighten the long bolt securing the head and rocker bracket first; then tighten the short bolt to the specified torque.

(7) Tightening cylinder head bolts

Tighten the cylinder head bolts to the specified torque in the sequence shown.

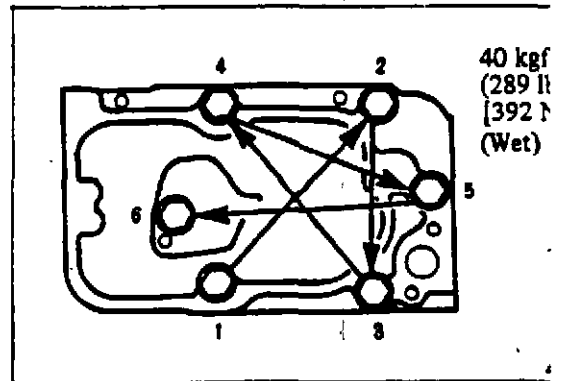

Cylinder head bolt tightening sequence

(8) Installing injection nozzle assemblies

- (a) Install the nozzle assembly to the cylinder head, and connect the injection pipe and leak-off pipe to the assembly.
- (b) Tighten the nozzle gland nut to the specified torque.

NOTE

- (a) When connecting the leak-off pipe, be sure to install the sealing washer to the connection of the pipe.
- (b) When installing each nozzle assembly, be sure to install the gasket.

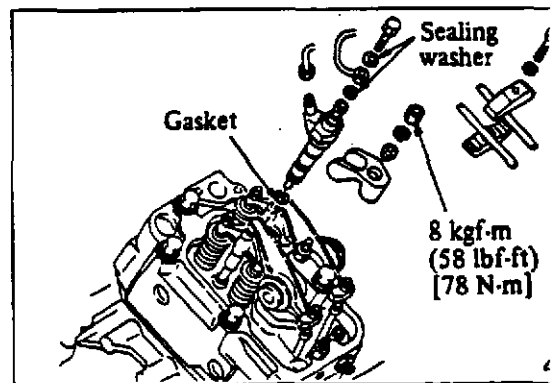

(9) Adjusting valve clearance

Refer to 1.1, Group No. 5.

2. CYLINDER LINERS, PISTONS AND CONNECTING RODS

2.1 Disassembly

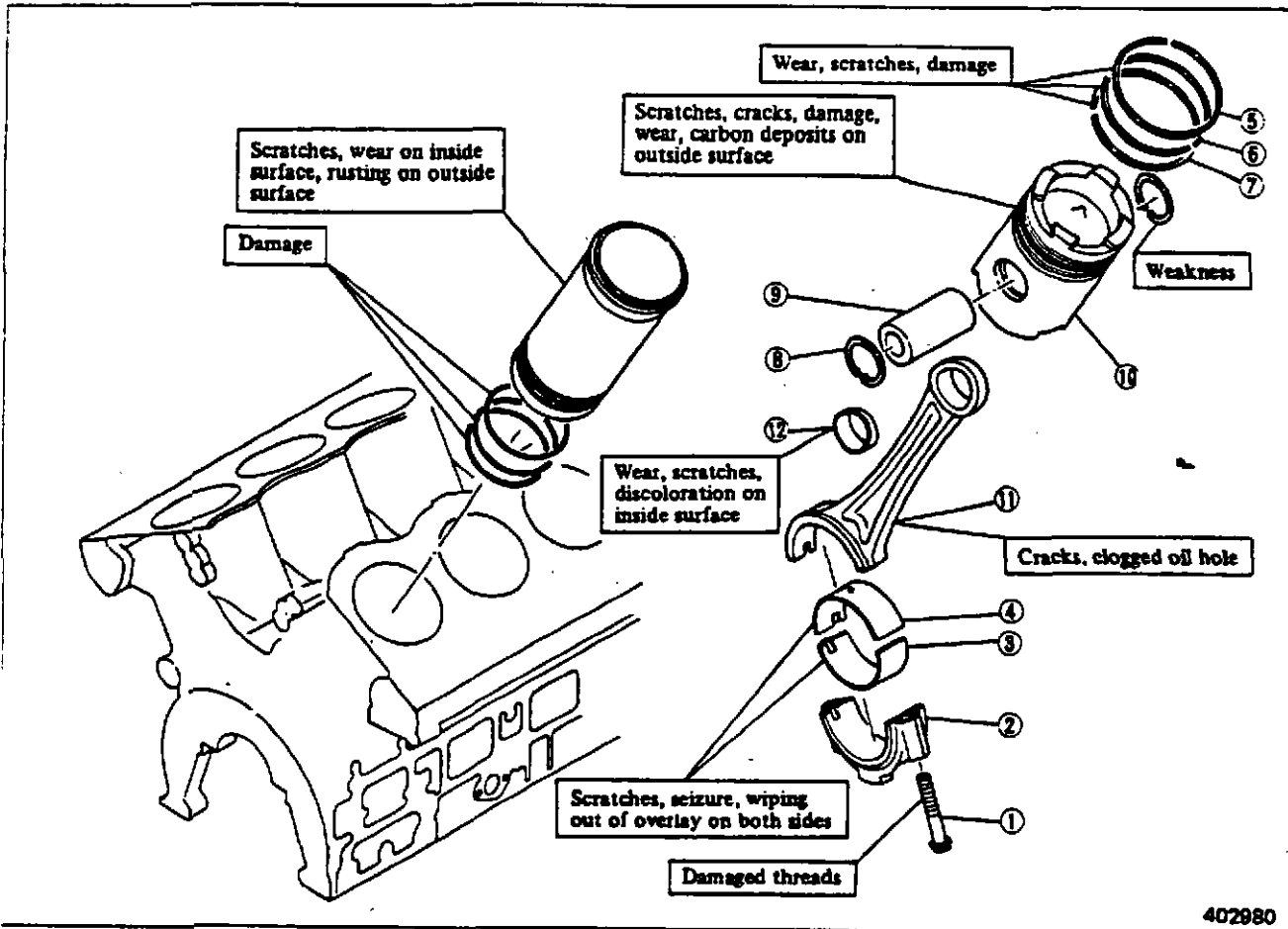

402980

- | | | |
|--------------------------|---------------------------|--------------------------|
| ① Bolt | ⑤ Top compression ring | ⑨ Piston pin |
| ② Connecting rod cap | ⑥ Second compression ring | ⑩ Piston |
| ③ Connecting rod bearing | ⑦ Oil ring | ⑪ Connecting rod |
| ④ Connecting rod bearing | ⑧ Snap ring | ⑫ Connecting rod bushing |

ENGINE PROPER

(1) Removing connecting rod caps

Unscrew the cap bolts, and remove the cap.

NOTE

- (a) Be careful neither to drop the bearings into the oil pan nor to damage them.
- (b) Mark the removed connecting rod bearings for identification of cylinder numbers and for upper and lower shells.

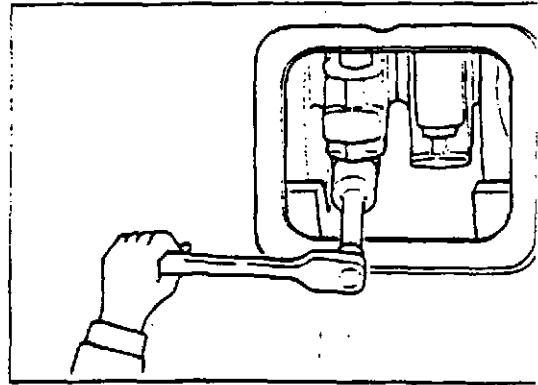

(2) Preparatory step for removing pistons

Remove all carbon deposits from the upper areas of cylinder liner with cloth or oil paper. Carbon deposits, if any, will make it difficult to pull the piston upward.

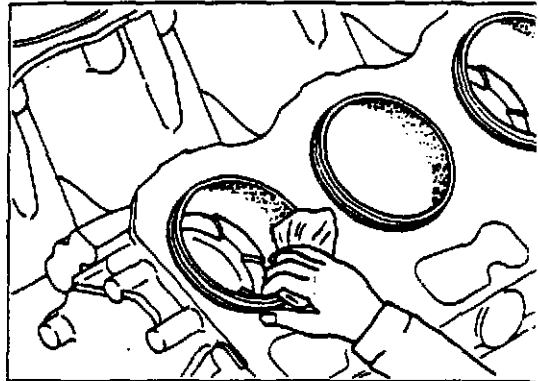

(3) Removing pistons

[Pistons for right bank cylinders]

- (a) Bring the piston assembly (from which the connecting rod bearing cap has been removed) to top dead center by turning the crankshaft.

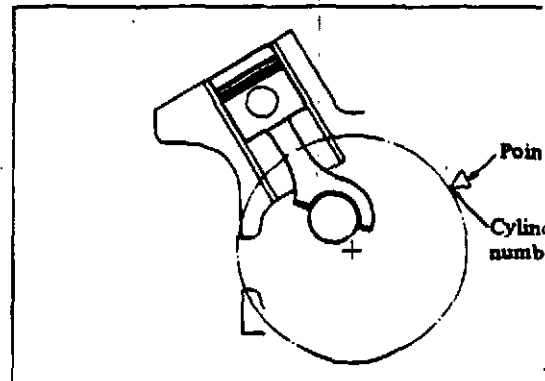

- (b) Turn the crankshaft in reverse direction until the crankpin comes off the connecting rod and the joint of the rod is visible in the inspection hole on the side of crankcase.

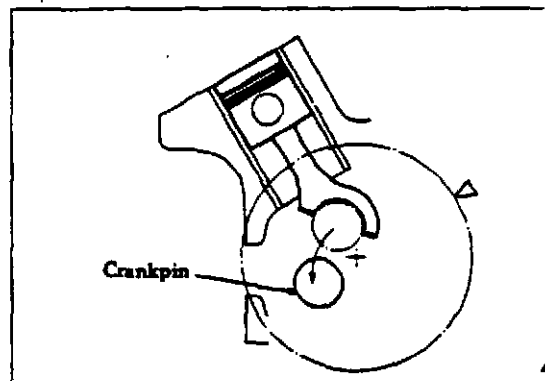

- (c) Cover turning bar (A) (32091-01500) with protective cloth. Put the tip of the bar under the bottom end of connecting rod big end, and pry up the piston assembly just a little by making use of the crankpin as a fulcrum.

CAUTION

Do not insert the turning bar excessively, or the piston assembly cannot be removed. Insert the bar so that it protrudes about 20 mm (0.79 in.) from the bottom end of the big end.

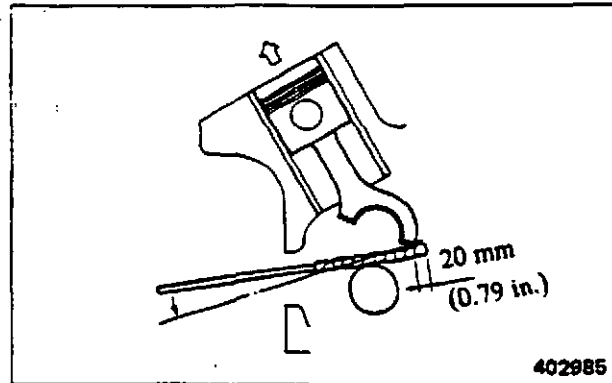

- (d) Turn the crankshaft in normal direction just a little at a time to raise the crankpin (fulcrum) while pushing down on the outer end of the bar to raise the piston assembly.

CAUTION

Raise the piston assembly carefully so that the connecting rod will not interfere with the piston cooling oil jet nozzle.

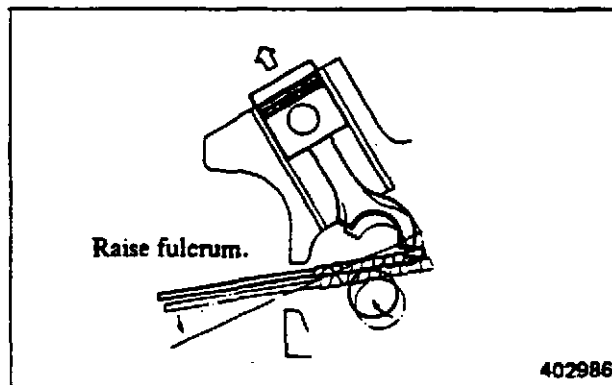

- (e) When the oil ring of the piston comes out of the cylinder liner, lower the piston a little and carefully rest the oil ring on the edge of the liner.

CAUTION

Lower the piston slowly and carefully, or the oil ring will suffer damage.

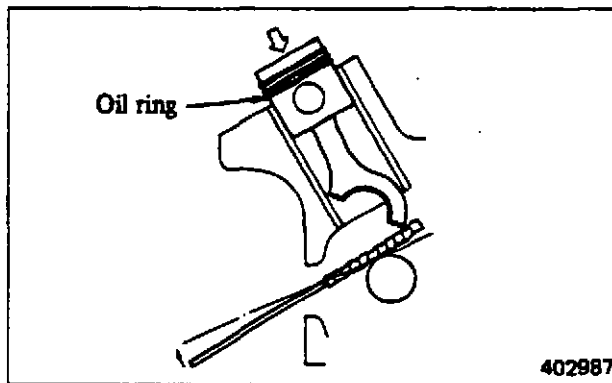

- (f) Hold the compression ring portion of the piston by hands, carefully pull the piston from the cylinder liner, and rest its skirt on the top of crankcase.

- (g) Hold the piston pin portion of the piston by hands, and lift the piston assembly off the liner.

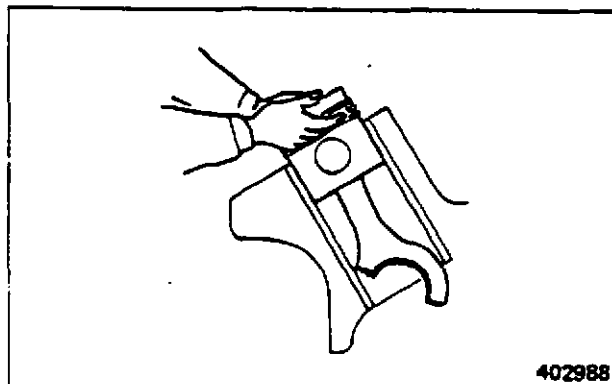

ENGINE PROPER

[Pistons for left bank cylinders]

The procedure is the same as that for removing the pistons for right bank cylinders, the only difference being that the position of crankpin and the direction of crankshaft rotation for removing pistons are reverse.

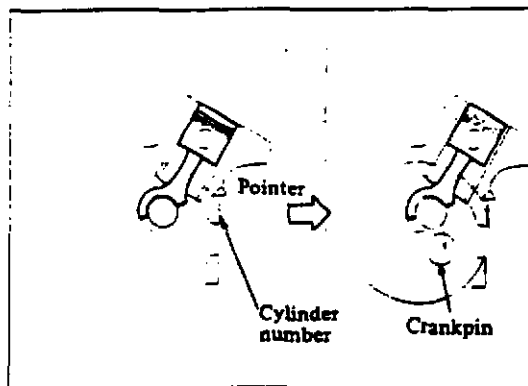

[Use of piston remover]

- (a) Bring a piston assembly to be removed to top dead center by turning the crankshaft.
- (b) Attach piston remover (A) to the top of the piston. Grip the handle of the remover, and lift the piston off the liner.

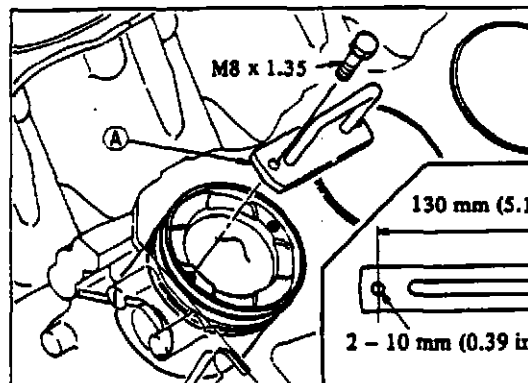

(4) Removing piston rings from piston

Use piston ring tool (A) (37191-03200) to remove the piston rings.

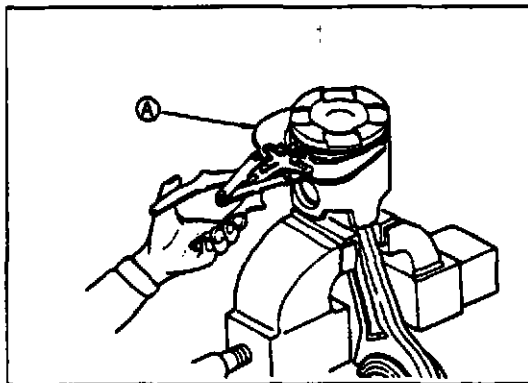

(5) Removing piston pin from piston

- (a) Using ring pliers (A) (45191-08400), remove the snap rings.
- (b) Remove the piston pin to separate the piston from the connecting rod.
- (c) If it is difficult to pull out the pin, heat the piston with a piston heater or in hot water to expand the pin bore.

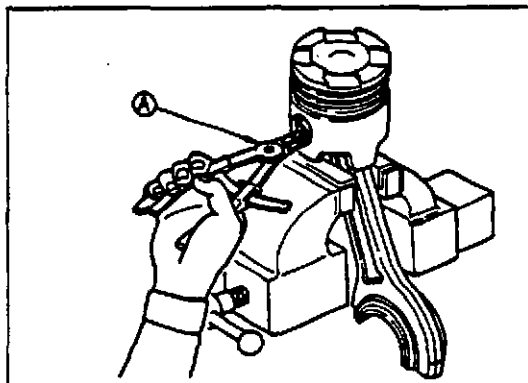

2.2 Inspection and repair

Cylinder liners

(1) Measuring cylinder liner inside diameter

Measure the inside diameter of each liner in two directions, parallel and transverse to the piston pin, at three positions, top (ridged area), middle and bottom as shown. If the measurements exceed the Service limit, replace the liner.

Unit: mm (in.)

Item	Nominal value	Assembly standard	Service limit
Cylinder liner inside diameter	150 (5.91)	150.00 - 150.04 (5.9055 - 5.9071)	150.14 (5.9110)

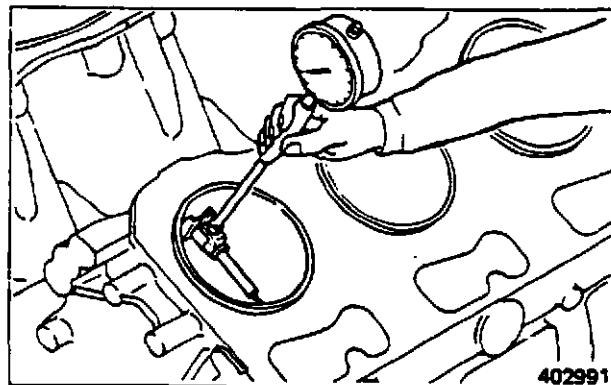

Measuring cylinder liner

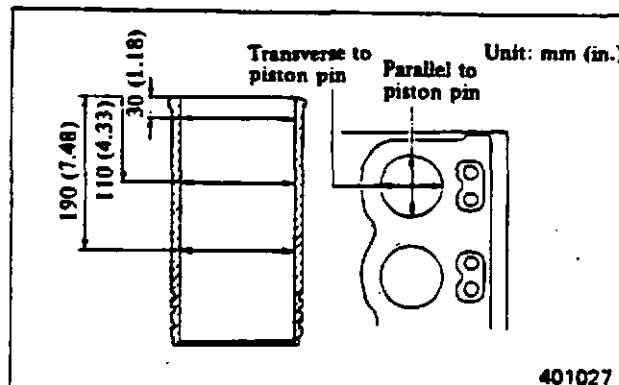

Cylinder liner measuring diagram

(2) Measuring cylinder liner protrusion

Measure protrusion of each liner at its flange with a dial gauge as shown. If the protrusion is not within the Assembly standard range, change the position of the liner relative to its bore, or use the liner in any other bore.

Unit: mm (in.)

Item	Assembly standard
Cylinder liner protrusion at flange	0.10 - 0.18 (0.0039 - 0.0071)

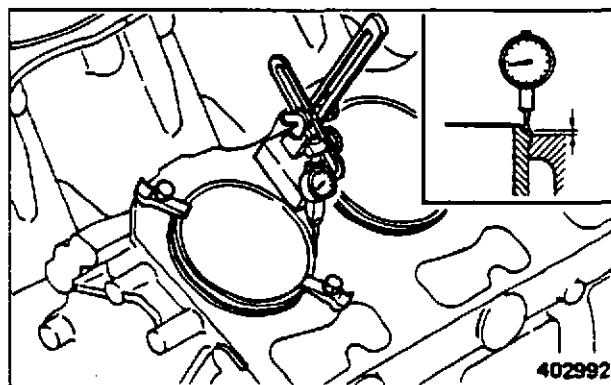

Measuring cylinder liner protrusion



If the protrusion is less than the Assembly standard, the gasket fails to exert sufficient sealing force around the bore, causing exhaust gas leakage.

ENGINE PROPER

- (a) Clean the gasketed surfaces of crankcase and the top of the liners.
- (b) Secure the top of the liner uniformly at two places with clamps and bolts (M20 x 2.5).
- (c) Set up the dial gauge at the top of the liner, and set the gauge pointer to zero (0).
- (d) Measure the protrusion at four places on the top of the liner. Take the average from the four measurements.

(3) Replacing cylinder liners

- (a) Using cylinder liner remover (A) (32591-04100), remove the cylinder liner from the crankcase for replacement.

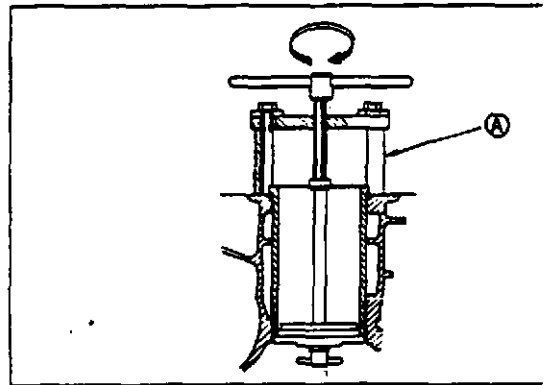

- (b) Attach rubber packings to a new cylinder liner, and carefully insert the liner into the bore of the crankcase.

CAUTION

Coat the joints of cylinder liner and crankcase with ThreeBond 1104. When inserting the liner, coat the rubber packings with engine oil or soapy water to prevent them from twisting.

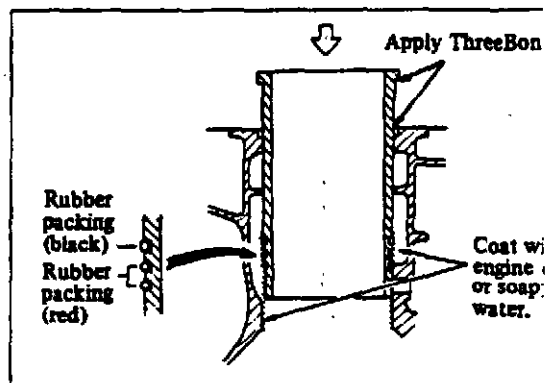

- (c) After inserting the liner into the bore, lightly tap on its top, using installer, to rest its flange in the counterbore formed of the crankcase. After resting the liner, lightly tap on it several times, making sure that it is properly installed.

NOTE

- (a) After installing the liners to all bores, test the liner joints for water-tightness by applying pressure water.
- (b) Check to make sure the protrusion of each liner is within the Assembly standard range.

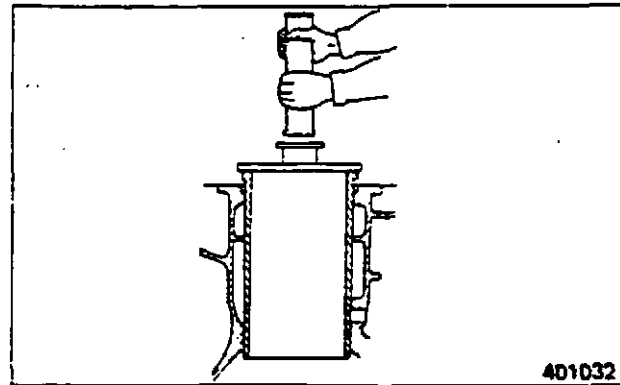

Pistons

Check the combustion chamber and inside surfaces of piston bosses. Replace the piston if any abnormality is found.

1) Measuring piston diameter

- (a) Using a micrometer, measure the diameter of each piston in the direction transverse to the piston pin, at the position shown. If the diameter exceeds the Service limit, replace the piston. If any pistons have to be replaced, select new pistons so that the variance in weight among pistons per engine is within the Assembly standard.

Unit: mm (in.)

Item	Nominal value	Assembly standard	Service limit
Piston diameter	150 (5.91)	149.82 - 149.78 (5.8984 - 5.8968)	149.68 (5.8929)
Variance in weight among pistons per engine	-	±30 g (±1.1 oz), maximum	-

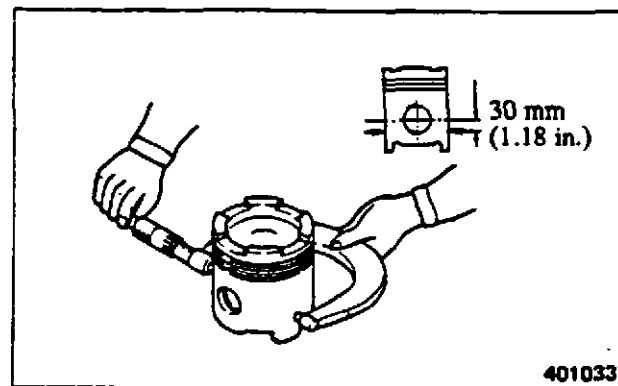

Measuring piston diameter

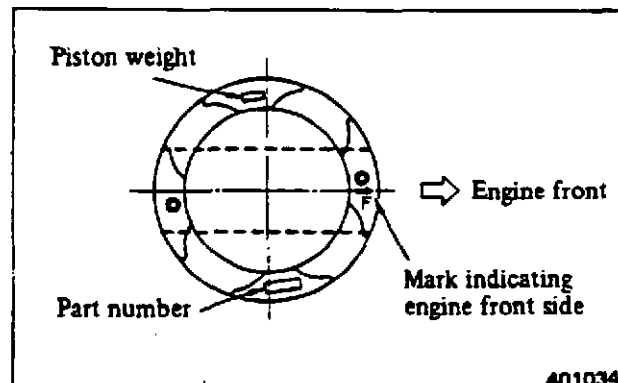

Piston weight stamp location

- (b) The piston weight is stamped on the top of each piston.

ENGINE PROPER

(2) Inspecting piston ring grooves

Check the piston ring grooves for wear and damage, and replace the piston if necessary.

Check Ni-Resist insert for cracks. Replace the piston if the insert is cracked.

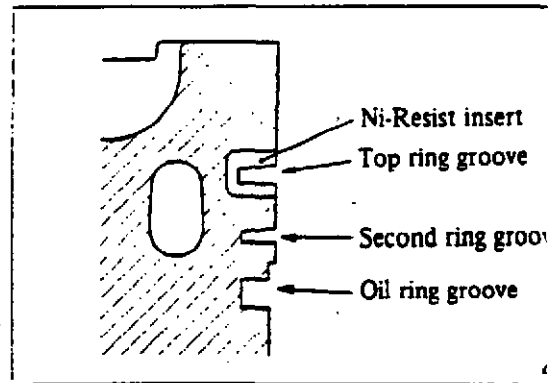

Inspecting piston ring grooves

(3) Measuring piston pin bore diameter

Using a caliper gauge or cylinder gauge, measure the piston pin bore diameter. If the diameter exceeds the Service limit, replace the piston.

Unit: mm (in.)

Item	Nominal value	Assembly standard	Service limit
Piston pin bore diameter	58 (2.28)	58.002 - 58.012 (2.28354 - 2.28393)	58.020 (2.28425)

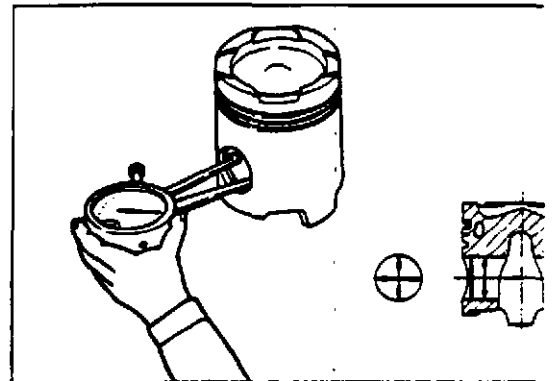

Measuring piston pin bore diameter

(4) Measuring piston protrusion

Measure protrusion of each piston and, if it is not within the Assembly standard range, inspect the various parts for clearance.

- Determine the top dead center of piston with a dial gauge.
- Set up the dial gauge at the top of crankcase, and set the gauge pointer to zero (0).
- Measure the protrusion at four places on the piston head, and average the four measurements to determine the protrusion. Subtract the piston protrusion from the as-installed thickness of cylinder head gasket to determine the clearance between the piston top and cylinder head.

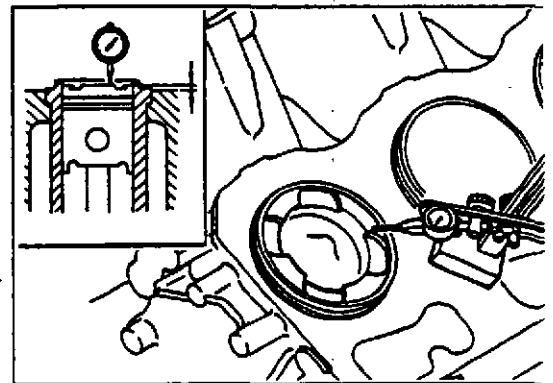

Measuring piston protrusion

Unit: mm (in.)

Item	Assembly standard (Standard clearance)
Piston protrusion	0.38 - 0.89 (0.0150 - 0.0350)
As-installed thickness of cylinder head gasket	1.8 ± 0.1 (0.071 ± 0.004)
Clearance between piston top and cylinder head	(0.81 - 1.43) ((0.0319 - 0.0563))

CAUTION

Keeping the piston protrusion within the Assembly standard range is important not only for engine performance but also for prevention of interference of the valves with the pistons.

Piston rings

(1) Measuring gaps

Place the rings in a new or master cylinder liner, and measure the gap of each ring. If the gap of any ring exceeds the Service limit, replace all rings as a set.

Inside diameter of master cylinder liner:
150 ± 0 mm (5.91 ± 0 in.).

NOTE

- (a) Using a piston, place the piston ring in the liner by pushing it squarely.
- (b) The oversizes of piston rings are 0.50 mm (0.020 in.), 0.75 mm (0.030 in.) and 1.00 mm (0.039 in.).

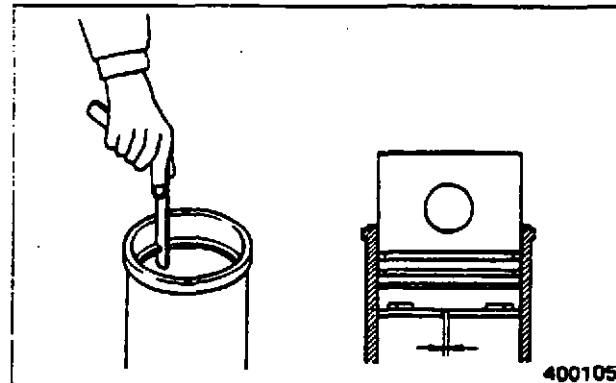

Measuring piston ring gap

400105

Unit: mm (in.)

Item	Standard clearance	Service limit
Piston ring gaps	Top (0.024 - 0.031)	2.0 (0.079)
	Second (0.020 - 0.028)	
	Oil (0.020 - 0.028)	

Piston pins

Measuring piston pin diameter

Using a micrometer, measure the outside diameter of each piston pin. If the outside diameter exceeds the Service limit, replace the pin.

Unit: mm (in.)

Item	Nominal value	Assembly standard	Service limit
Piston pin outside diameter	58 (2.28)	58.000 - 57.987 (2.28346 - 2.28295)	57.970 (2.28228)

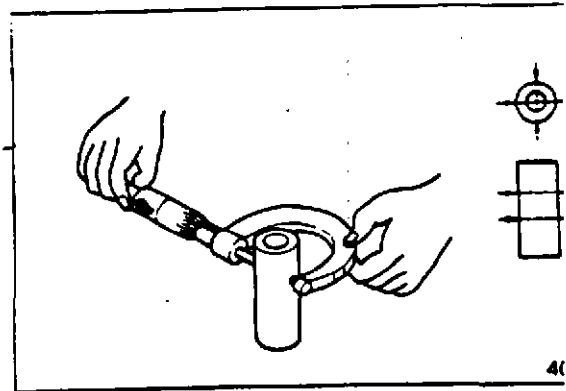

Measuring piston pin diameter

Connecting rods, connecting rod bearings and small-end bushings

(1) Measuring small-end bushing inside diameter

Using a cylinder gauge, measure the inside diameter of each bushing. If the inside diameter exceeds the Service limit, replace the bushing.

Unit: mm (in.)

Item	Nominal value	Assembly standard	Service limit
Connecting rod small-end bushing inside diameter	58 (2.28)	58.020 - 58.040 (2.28425 - 2.28504)	58.070 (2.28622)

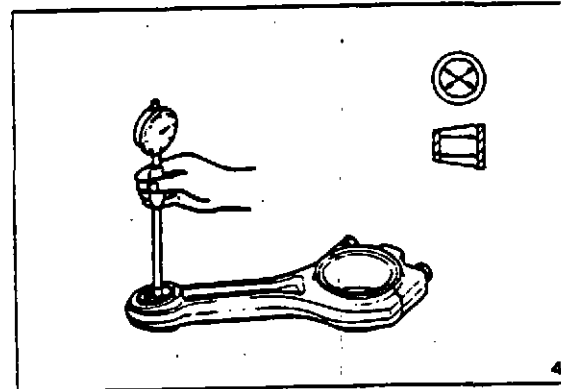

Measuring connecting rod small-end bushing inside diameter

(2) Replacing connecting rod small-end bushings

(a) Using connecting rod bushing installer (A) (37191-08000), remove the bushing, as shown, for replacement.

(b) When installing a new bushing, align oil holes in the bushing and connecting rod.

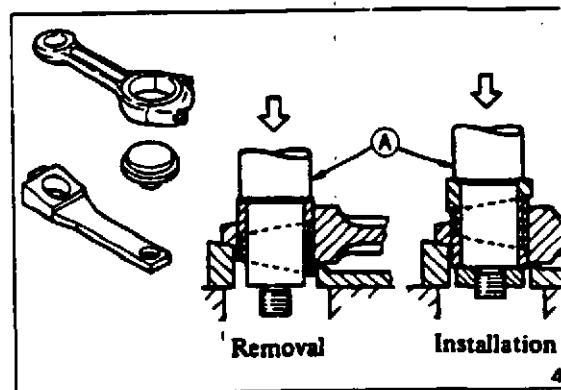

Replacing connecting rod small-end bushing

- (c) After installing the bushing, finish its inside diameter to $58^{+0.040}_{+0.030}$ mm ($2.28^{+0.00157}_{+0.00079}$ in.) ± 0.00157 and its parallelism with respect to the big-end bearing to 0.05 mm (0.0020 in.) by reaming.
- (d) After installing the bushing, insert the piston pin, and make sure that the pin rotates freely without rattling.

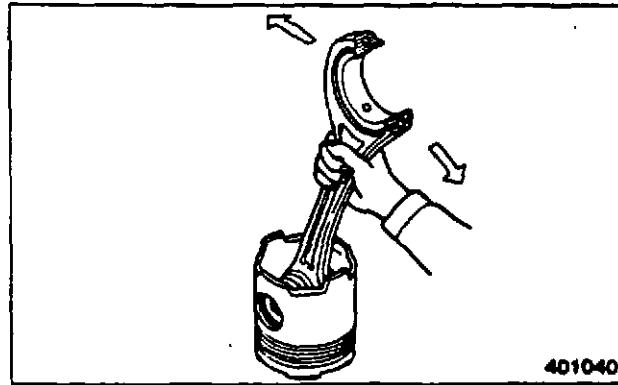

(3) Inspecting connecting rods for bend and twist

- (a) Measure "C" and "l." If the measurement at "C" is larger than 0.05 mm (0.0020 in.) per 100 mm (3.9 in.) of "l," straighten the rod with a press.

NOTE

To inspect for bend, install the cap to connecting rod, and tighten the cap bolts to the specified torque.

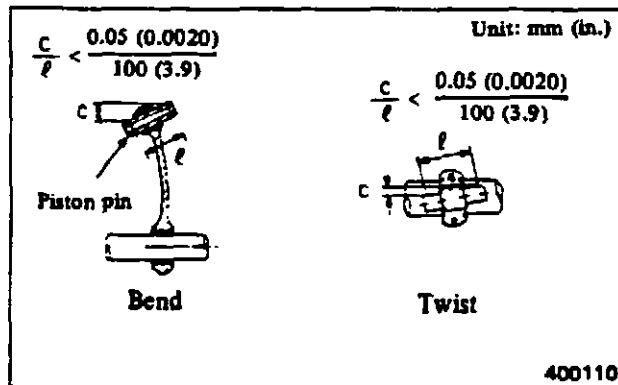

Inspecting connecting rod

- (b) To inspect the rod installed to the piston, place the piston on a surface plate, insert a round bar corresponding to the crankpin in diameter into the big end bore, and measure the heights "A" and "B" of the bar.

Unit: mm (in.)

Item	Assembly standard
Connecting rod bend and twist (C/D)	0.05/100 (0.0020/3.9), maximum

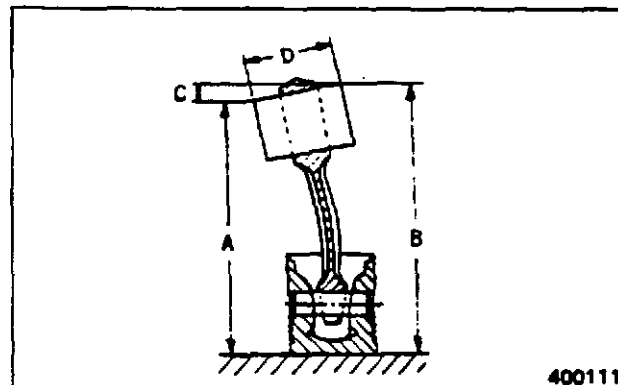

Inspecting connecting rod installed to piston

ENGINE PROPER

(4) Inspecting connecting rod big-end bearings

Inspect each bearing shell for wiped overlay, scratching, seizure, pitting and other defects. If any of these defects is present, replace the shell.

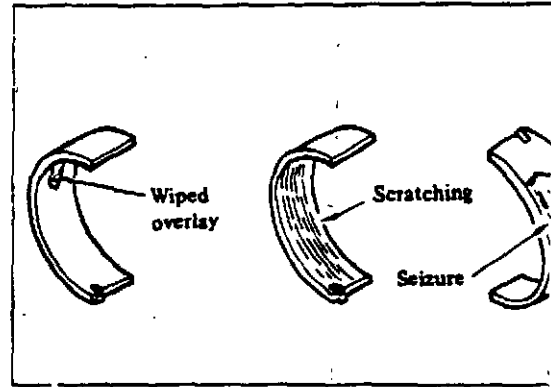

(5) Measuring connecting rod end play

Install the connecting rod to its crankpin, and tighten its cap bolts to the specified torque. Then, using a feeler gauge, measure the end play. If the end play exceeds the Service limit, replace the connecting rod.

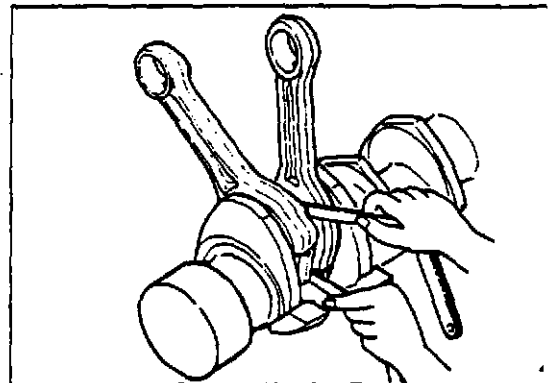

Measuring connecting rod end play

Unit: mm (in.)

Item	Nominal value	Standard clearance [Nominal]	Service limit
Connecting rod end play [widths of connecting rod and crankpin] x 2	54 (2.13)	0.60 - 0.90 (0.0236 - 0.0354)	1.00 (0.0394)

(6) Variance in weight among connecting rods per engine

When replacing connecting rods, make sure that the variance in weight among connecting rods per engine is within the Assembly standard shown below.

Item	Assembly standard
Variance in weight among connecting rods per engine	40 g (1.4 oz), maximum

(7) Measuring connecting rod big-end bore diameter

Measure the bore in two positions, front and rear, and in two directions. If the diameter exceeds the Service limit, replace the connecting rod.

Unit: mm (in.)

Item	Nominal value	Assembly standard	Service limit
Connecting rod big-end bore diameter	110 (4.33)	110.000 - 110.022 (4.33070 - 4.33157)	110.047 (4.33255)

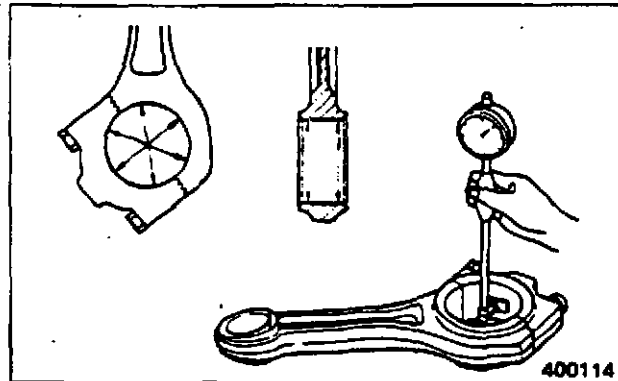

Measuring connecting rod big-end bore diameter

(8) Measuring connecting rod bearing thickness

Using a ball-point type micrometer, measure the center of each bearing shell. If the thickness exceeds the Service limit, on either upper or lower shell, replace both shells as a set.

Unit: mm (in.)

Item	Nominal value	Assembly standard	Service limit
Connecting rod bearing thickness	Standard	3.000 - 2.982 (0.11811 - 0.11740)	2.950 (0.11614)
	-0.25 (-0.0098)	3.125 - 3.107 (0.12303 - 0.12232)	3.075 (0.12106)
	-0.50 (-0.0197)	3.250 - 3.232 (0.12795 - 0.12724)	3.200 (0.12598)
	-0.75 (-0.0295)	3.375 - 3.357 (0.13287 - 0.13217)	3.325 (0.13091)
	-1.00 (-0.0394)	3.500 - 3.482 (0.13780 - 0.13709)	3.450 (0.13583)

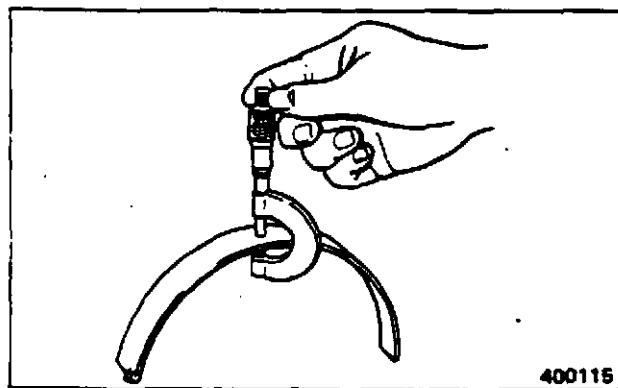

Measuring connecting rod bearing thickness

NOTE

Four undersizes are available for the connecting rod bearings; namely, -0.25 mm (-0.0098 in.), -0.50 mm (-0.0197 in.), -0.75 mm (-0.0295 in.) and -1.00 mm (-0.0394 in.).

2.3 Reassembly

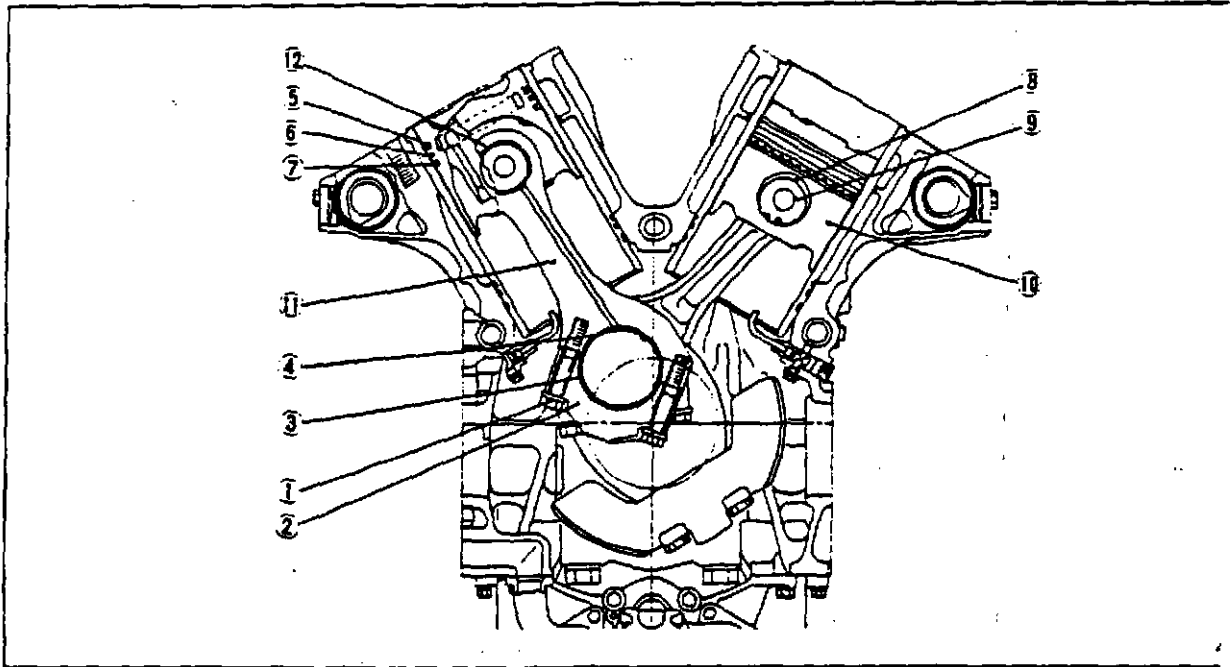

Reassembling sequence

11-12-10-9-8-7-6-5-4-3-2-1

(1) Reassembling pistons on connecting rods

- (a) Heat the piston with a piston heater or in hot water.
- (b) Coat the piston pin with engine oil, and insert it into position through the connecting rod.
- (c) Install the connecting rod to the piston with the matching marks on its big end on the side of the camshaft.
- (d) Using ring pliers (A) (45191-08400), install the snap rings to the grooves in the pistons. Make sure that the rings are not fatigued and that they are fitted in their grooves properly.

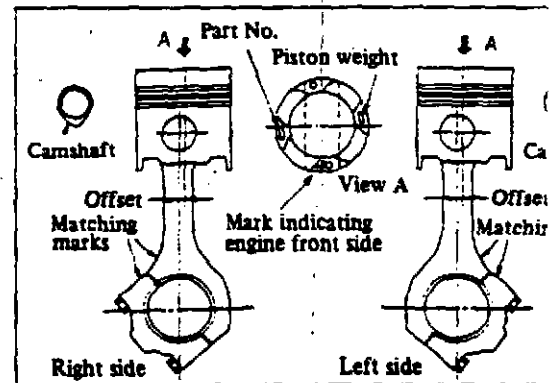

Matching marks on connecting rod

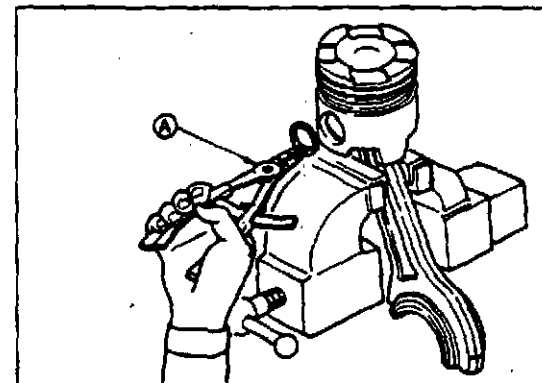

NOTE

Position the ends of both snap rings at the bottom of pin bore.

(2) Installing piston rings

- (a) Using piston ring tool (37191-03200), install the piston rings to the piston.

**CAUTION**

Top piston ring is marked "RN" and second piston ring "R" near the gap on the side to be up when installed on the piston. If the ring is installed with this mark down, excessive oil consumption or overheating will occur.

- (b) Install the oil ring with its gap positioned at 180° to that of coil spring.

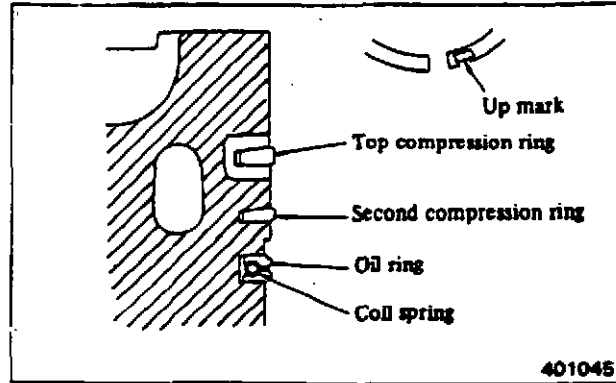

Piston and piston rings

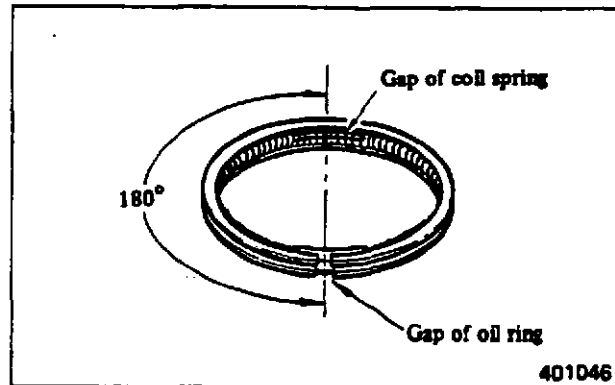
**3) Preparatory steps for installing pistons****(a) Pistons for right bank cylinders**

Turn the crankshaft in normal direction until the number (stamped on the damper) of a cylinder to which the piston is to be installed is at the position of approx. 50° before top dead center.

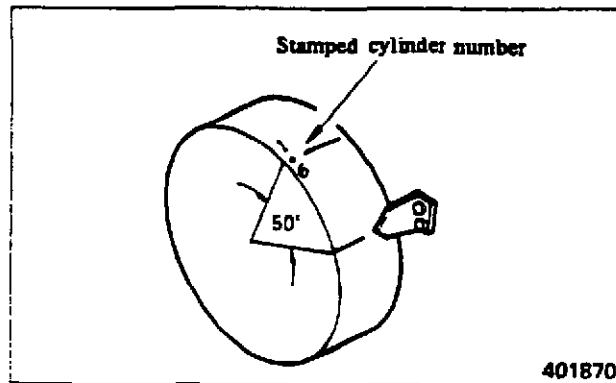
**(b) Pistons for left bank cylinders**

Turn the crankshaft in normal direction until the number of a cylinder to which the piston is to be installed is at the position of about 50° after top dead center.

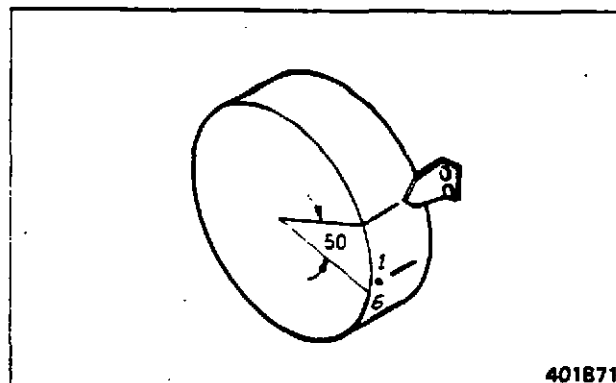

ENGINE PROPER

- (c) Clean the cylinder liner bore surface and crankpin by wiping with cloth, and coat it with engine oil.

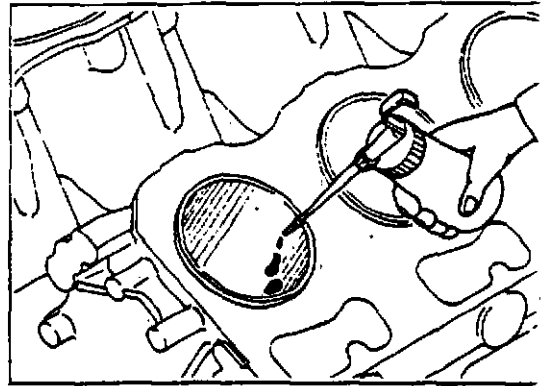

- (4) Installing connecting rod bearing upper shells

Install the upper shell of the bearing in the rod by fitting its locking lip in the recess provided in the rod. Coat the inside surface of the shell with engine oil. Make sure the oil holes in the rod and bearing are aligned.

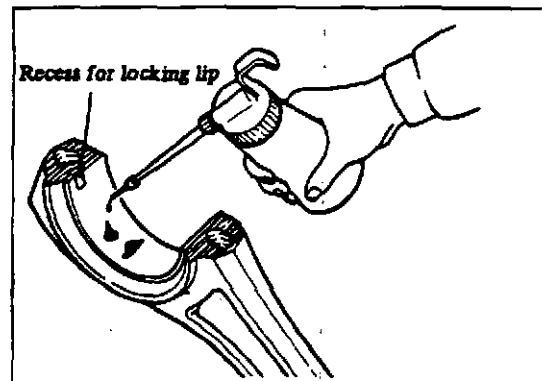

- (5) Inserting pistons

- (a) Put the connecting rod in the cylinder liner, and carefully rest the piston on the top of crankcase.



- (a) Make sure that the arrow of mark \overline{F} on the top of piston points forward.
- (b) When putting the connecting rod in the liner, keep it away from the oil jet nozzle by observing the rod through the inspection hole of crankcase.

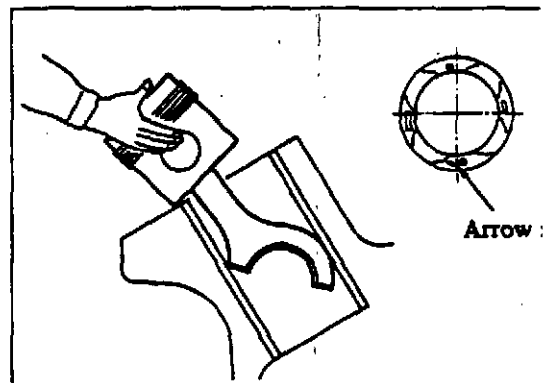

- (b) Coat the piston rings with engine oil, and position the ring gaps as shown.

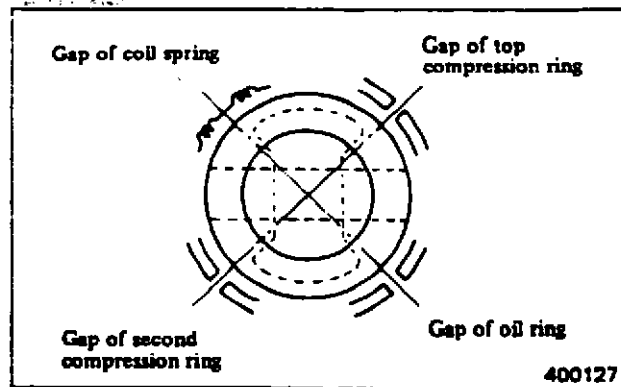

- (c) Hold the compression ring portion of the piston by hands, and carefully insert the piston into the cylinder liner.

NOTE

- (a) Be careful not to get your little finger pinched between the oil ring and cylinder liner.
- (b) Slowly insert the piston, being careful not to damage the oil ring.
- (d) After making sure that the piston ring gaps are positioned properly, coat the rings with engine oil, and clamp them, using piston installer (A) (37191-07100). At this time, coat the inside surface of the installer with engine oil.

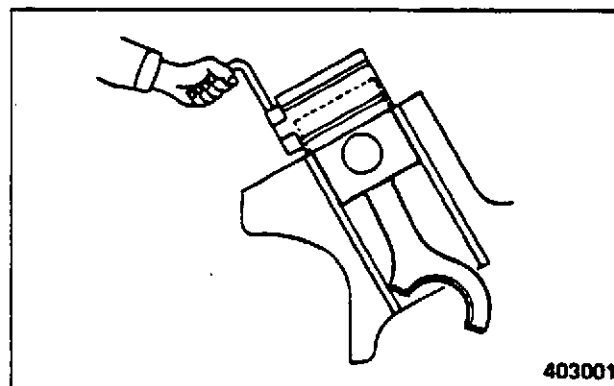
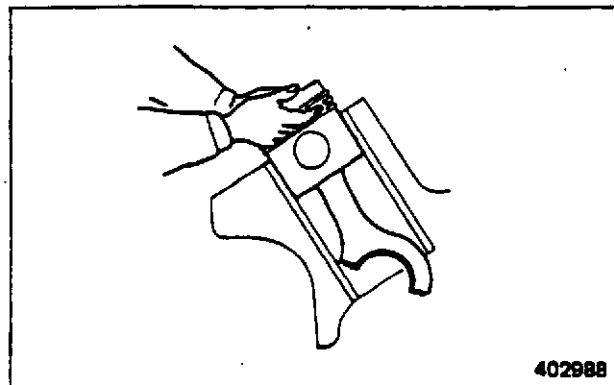

- (e) Lightly tap on the piston head with a soft hammer to insert the piston into the cylinder liner. If the piston will not go into the liner, move the big end of connecting rod back and forth through the inspection hole of crankcase.

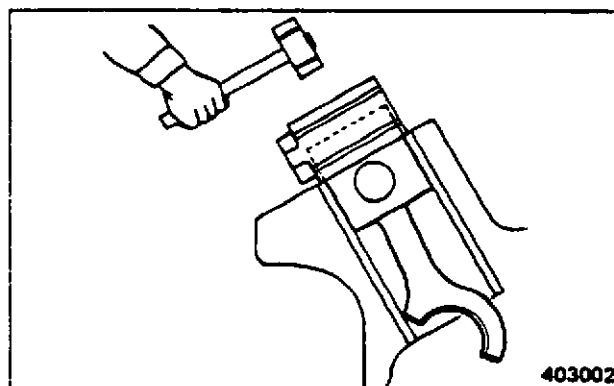

ENGINE PROPER

- (f) Make sure the upper shell of the bearing is properly positioned in the connecting rod big end, by inserting the hand through the inspection hole of crankcase.

If the bearing shell is slightly out of place, repositin it by pushing it up by the hand.

(6) Installing connecting rod cap bolts

- (a) Coat the threads of cap bolts and the inside surface of lower shells of connecting rod bearings with engine oil.

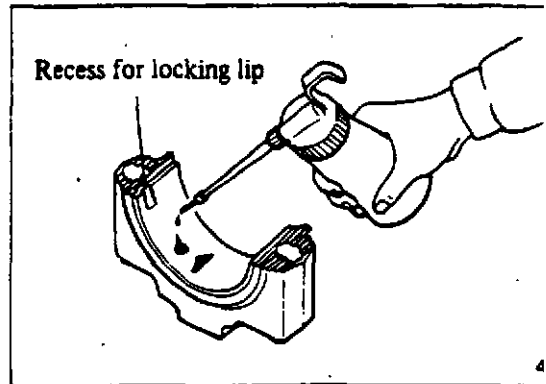

- (b) Install each cap in position. Hold upper end of the cap by hand, and tighten the bolt at the lower end first. This will help prevent dropping the cap into the oil pan. Coat the threads of bolts with engine oil, and tighten the bolts temporarily.

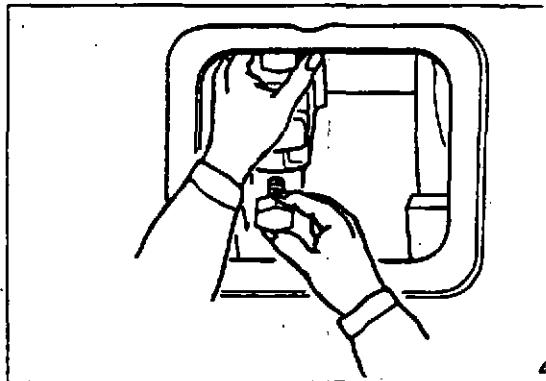

- (c) With cap bolts tightened temporarily, touch the joint between the cap and rod, making sure that the cap is normally held in place, and tighten the bolts to the specified torque.



Make sure that matching marks on the cap and rod are on the same side.

- (d) Temporarily tighten the cap bolts of the rod installed later, and press it squarely toward the rod already installed by tapping. Move the big end of this rod in the thrust direction, making sure that it has correct end play.

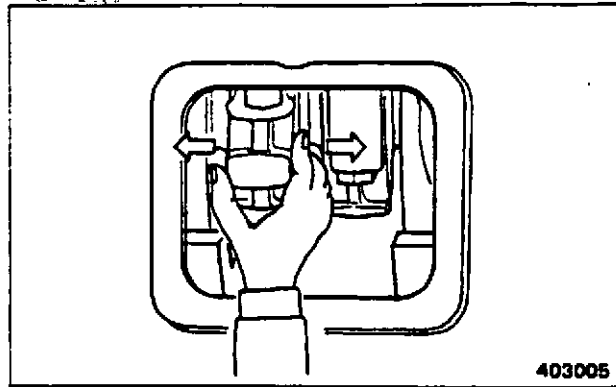

403005

- (e) Tighten the cap bolts to the specified torque.

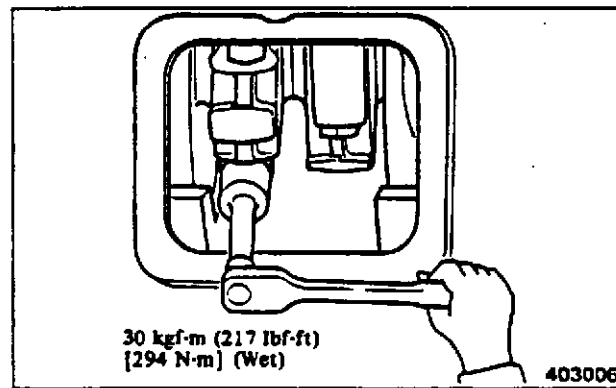

30 kgf-m (217 lbf-ft)
[294 N-m] (Wet)

403006

- (f) Using a feeler gauge, measure the end play of connecting rod, making sure that the end play is equal on both top and bottom sides of the crankpin. (Refer to 2.2, Group No. 7.)

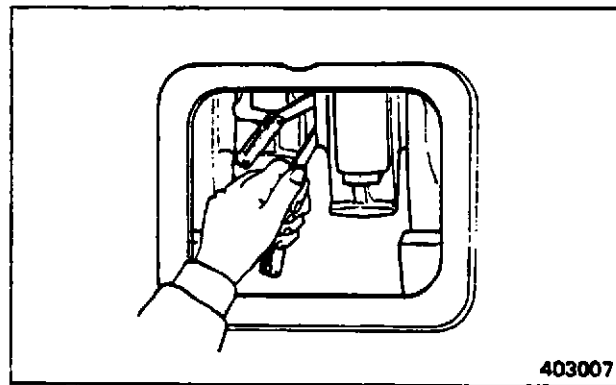

403007

Measuring connecting rod end play

NOTE

Before installing the cylinder head, measure the protrusion of piston, making sure that it is correct. (Refer to (4), Pistons, 2.2, Group No. 7.)

3. FLYWHEEL, TIMING GEARS AND CAMSHAFT

3.1 Disassembly

Flywheel side

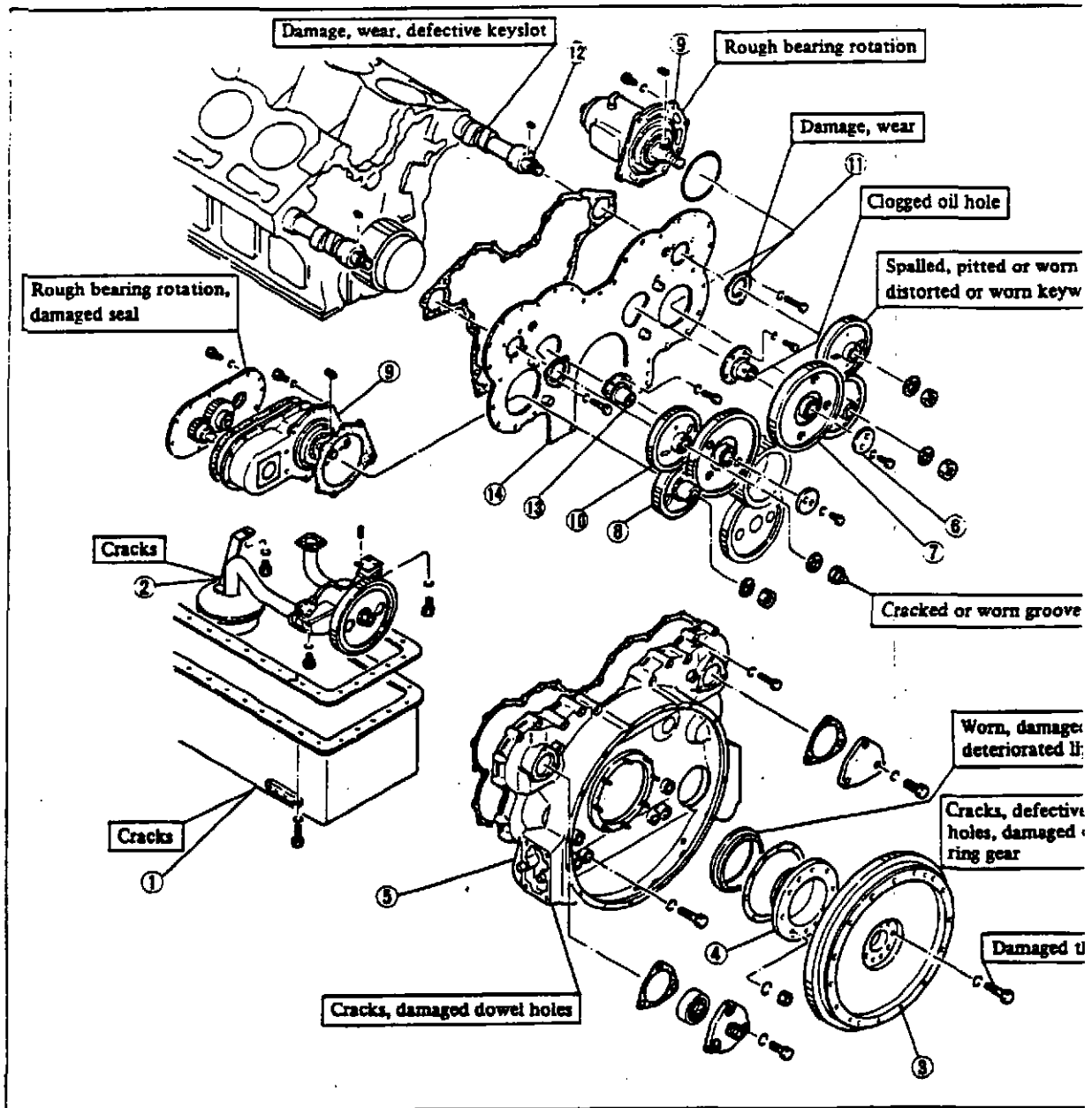

- | | | |
|------------------------------------|----------------------------------|--------------------|
| ① Oil pan | ⑤ Timing gear case | ⑩ Camshaft gear |
| ② Oil strainer, oil pipe, oil pump | ⑥ Thrust plate | ⑪ Thrust plate |
| ③ Flywheel | ⑦ Idler gear | ⑫ Camshaft |
| ④ Oil seal retainer, oil seal | ⑧ Fuel injection pump drive gear | ⑬ Idler gear shaft |
| | ⑨ Accessory drive | ⑭ Rear plate |

Vibration damper side

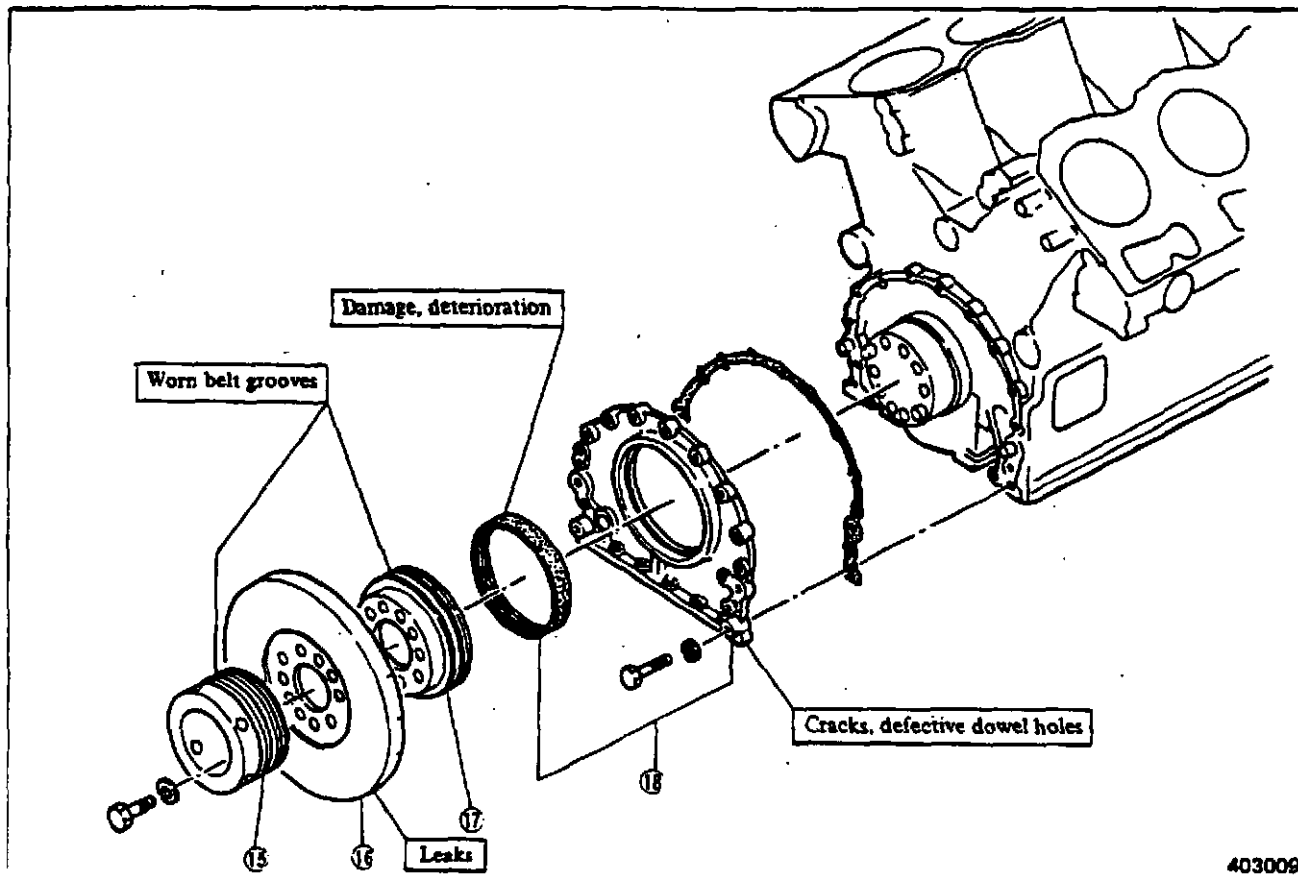

- ⑮ Pulley (for fan)
⑯ Vibration damper

- ⑰ Pulley (for water pump)
⑱ Front cover, oil seal

(1) Removing flywheel

- (a) Attach a sling to the flywheel.
- (b) Unscrew the mounting bolts.
- (c) Screw jacking bolts [M12 x 1.75] into the holes in the flywheel uniformly, and remove the flywheel. [Flywheel weight: 75 kg (165 lb), approx.]

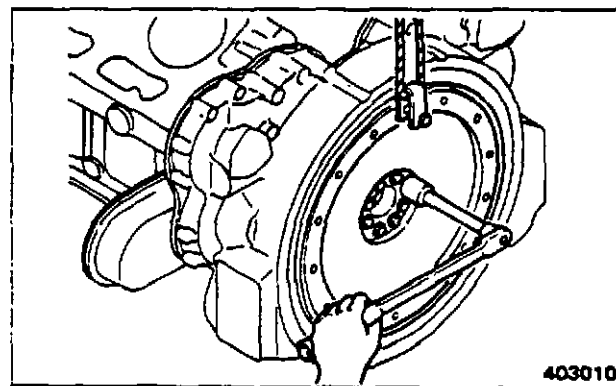

CAUTION

- (a) When removing the flywheel, be careful not to drop or bump it against a hard object.
- (b) The ring gear is shrinkage-fitted to the flywheel. Do not remove the gear except when it has to be replaced.

ENGINE PROPER

(2) Removing oil seal retainer

- (a) Unscrew the mounting nuts.
- (b) Screw jacking bolts (2 - M10 x 1.5) into the holes in the retainer uniformly, and remove the retainer, being careful not to damage the oil seal.

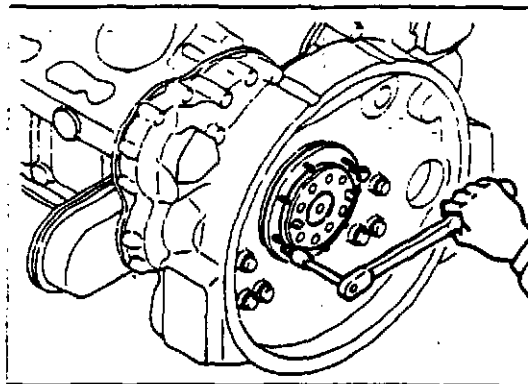

(3) Removing accessory drive cover for Woodward governor

- (a) Unscrew the mounting bolts.
- (b) Screw jacking bolts (2 - M8 x 1.25) into the holes in the cover uniformly, and remove the cover, being careful not to damage the oil seal.

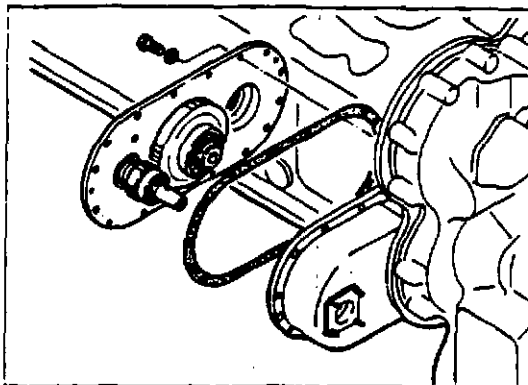

(4) Removing timing gear case

- (a) Attach slings to the timing gear case.
- (b) Unscrew the mounting bolts, and remove the timing gear case. [Timing gear case weight: 100 kg (221 lb), approx.]

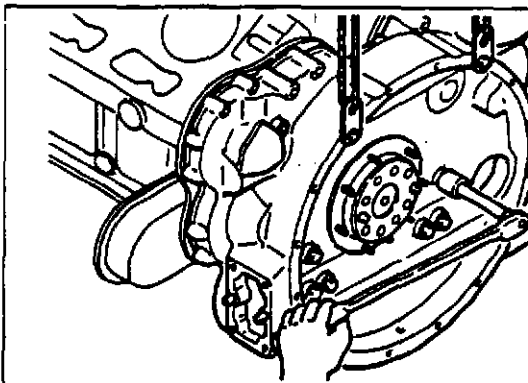

(5) Measuring backlash and end play

Measure the backlash and end play of each gear to obtain the data for parts replacement.
(Refer to 3.2, Group No. 7.)

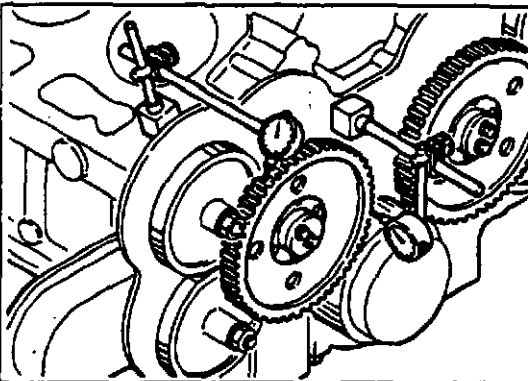

(6) Removing idler gears (left and right)

Align the pointer with the mark for top dead center on compression stroke of No. 1 cylinder. Unscrew thrust plate mounting bolts, and remove the gear.

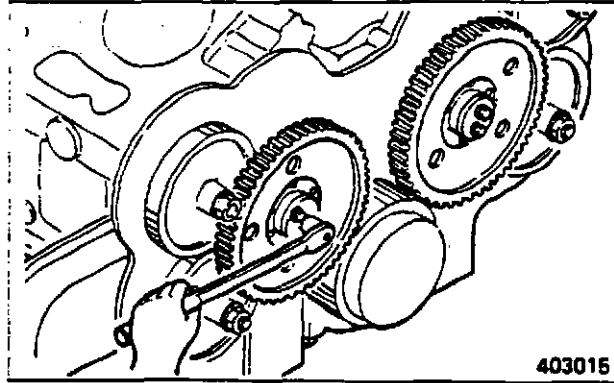
**(7) Removing fuel injection pump drive gears (left and right)**

Straighten the lock washer of nut securing the gear, unscrew the nut and, using a puller, remove the gear.

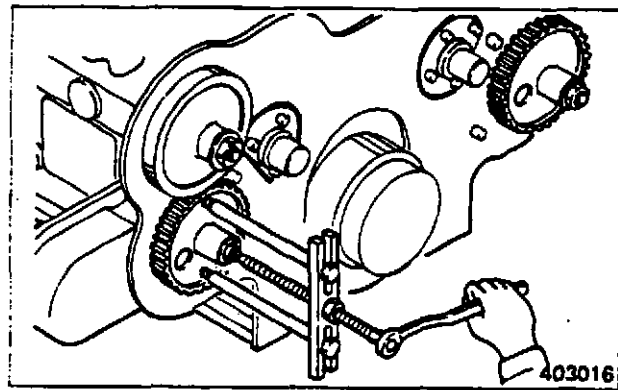
**(8) Removing accessory drives (left and right)**

Unscrew bolts and nuts securing the drive to the rear plate, and remove the drive.

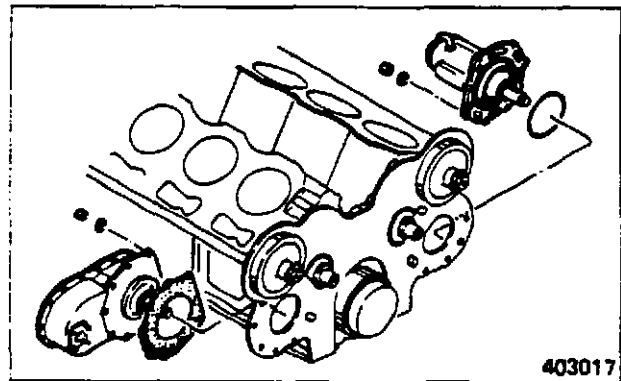
**(9) Removing camshaft gears (left and right)**

Straighten the lock washer of nut (having left-hand threads) securing the gear. Unscrew the nut with socket (32591-02800), and remove the gear with a puller.

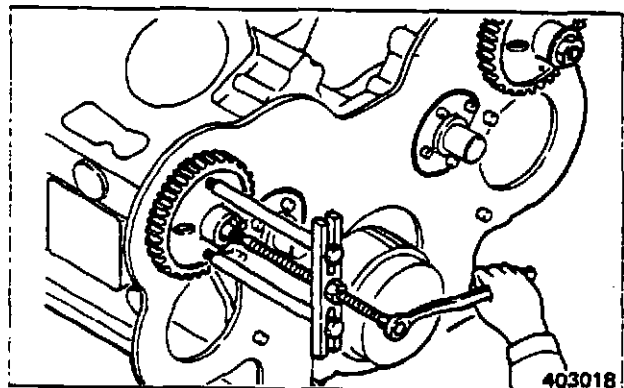

(10) Removing camshafts (left and right)

Unscrew the thrust plate mounting bolts, and pull out the camshaft from the crankcase.



When pulling the camshaft, support it with a bar-like tool inserted through the inspection hole of crankcase to prevent damage to the cam surfaces and bushings.

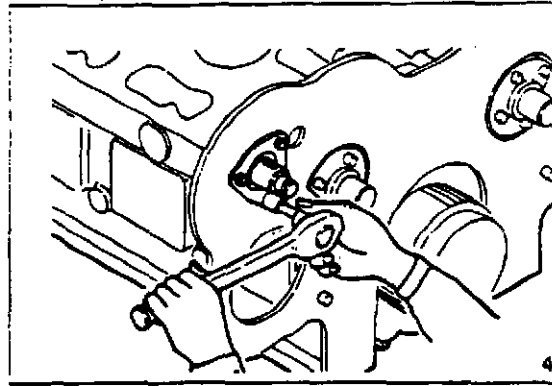

(11) Removing front cover

- (a) Unscrew the mounting bolts.
- (b) Screw jacking bolts (2 - M10 x 1.5) into the holes in the cover uniformly, and remove the cover, being careful not to damage the oil seal.

NOTE

The front cover is to be removed with the pointer. Before removing the cover, mark the pointer installation position.

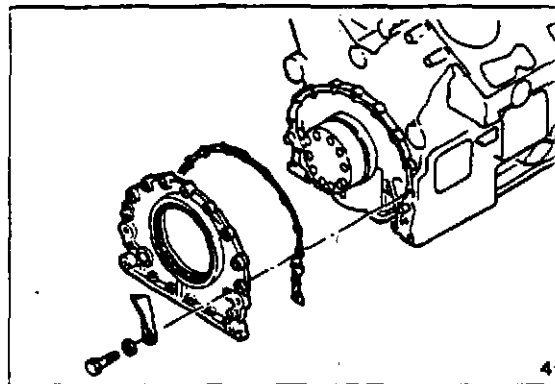

3.2 Inspection and repair

Flywheel and ring gear

Measuring flywheel face and radial runouts

Measure the runouts with the flywheel installed to the crankshaft. If the runouts exceed the Assembly standard, check for loose bolts or obstacles lodged between the mounting faces of the flywheel and crankshaft.

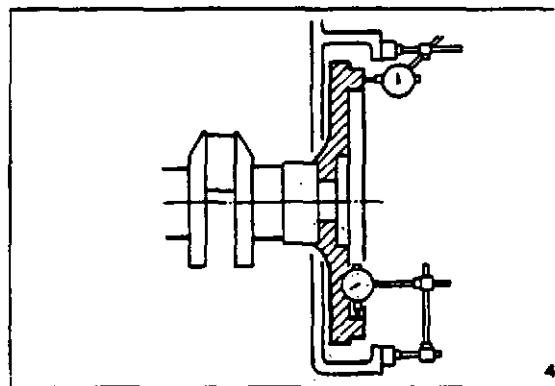

Measuring flywheel runouts

Unit: mm (in.)

	Item	Assembly standard
Flywheel	Face runout	0.28 (0.0110), maximum
	Radial runout	0.13 (0.0051), maximum

Accessory drives

- (1) Check the bearing for smooth rotation. Replace the bearing if it rotates erratically or hums.
- (2) Check the fit of drive shaft in the bearing, and replace an excessively worn part.
- (3) Check the fit of the bearing in the drive case, and replace an excessively worn part.
- (4) Check the drive shaft and oil seal, and replace a defective part.

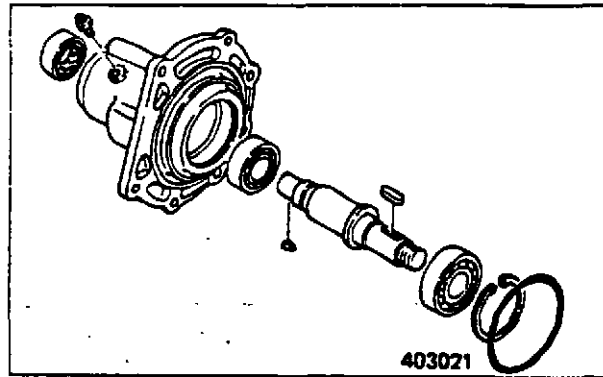

Unit: mm (in.)

Item		Nominal value	Assembly standard
Drive case bore inside diameter		72 (2.83)	71.988 - 72.018 (2.83417 - 2.83535)
		90 (3.54)	89.985 - 90.020 (3.54271 - 3.54409)
Bearing	Diameter	72 (2.83)	72.004 - 71.983 (2.83480 - 2.83397)
		90 (3.54)	90.005 - 89.980 (3.54350 - 3.54251)
	Inside diameter	35 (1.38)	34.985 - 35.003 (1.37736 - 1.37807)
		40 (1.57)	39.985 - 40.003 (1.57421 - 1.57492)
Drive shaft diameter		35 (1.38)	35.013 - 35.002 (1.37846 - 1.37803)
		40 (1.57)	40.013 - 40.002 (1.57531 - 1.57488)

Vibration damper and crankshaft pulley

(1) Inspecting vibration damper

- (a) Visually inspect exterior for torn, swelling and cracks around bolt hole of disc and leakage of silicone (damping) fluid.
- (b) With the damper installed to the engine, measure the radial and face runouts of the inertia mass of the damper by turning the crankshaft slowly, with a dial gauge set up on the periphery of the damper as shown. If the runouts exceed the Service limit, replace the damper. The damper should be replaced every 8000 operating hours even if there is no evidence of defects.

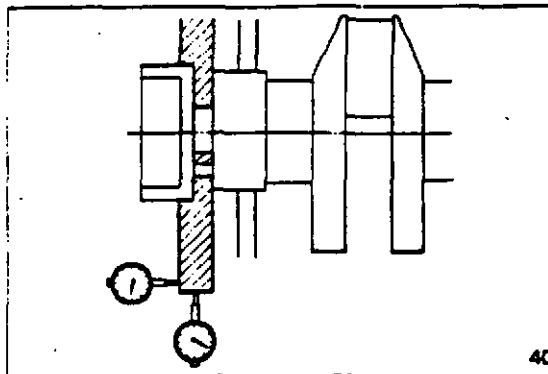

Measuring damper runouts

Unit: mm (in.)

Item		Assembly standard	Service limit
Vibration damper	Radial runout	0.5 (0.020), maximum	1.5 (0.059)
	Face runout		

(2) Inspecting crankshaft pulley

Inspect the V-belt groove for wear. Wrap a new belt around the pulley, pressing it in the groove as far as it goes, and see if the top surface of the belt is above the top of the pulley.

If the top surface of the belt (or the belts for the pulleys having two or more grooves) is uniformly above the top of the pulley all the way around, it is not necessary to replace the pulley.

If the top surface of the belt sinks into the groove more than 1.6 mm (0.063 in.), replace the pulley.

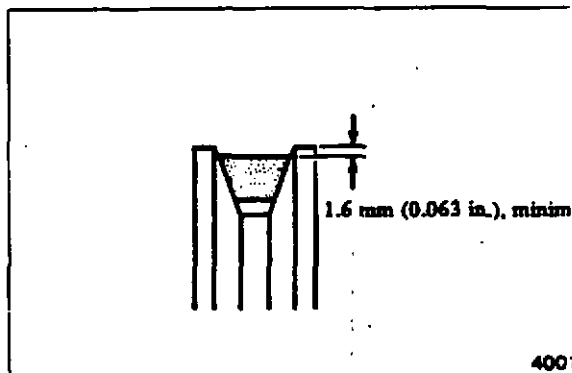

Inspecting V-belt groove in crankshaft pulley

Timing gears

Measuring backlash

Set up a dial gauge so that it contacts with the pitch circle of the gear and move one gear back and forth to measure the backlash between the gears. If the dial gauge is not available, measure the backlash by inserting a feeler gauge between the teeth of the gears. If the backlash exceeds the Service limit, replace a worn gear.

Unit: mm (in.)

Item	Standard clearance	Repair limit	Service limit
Timing gear backlash	0.12 - 0.18 (0.0047 - 0.0071)	0.30 (0.0118)	0.50 (0.0197)

NOTE

Temporarily tighten the bolts and nuts securing the left and right accessory drives at eight places before measuring timing gear backlash.

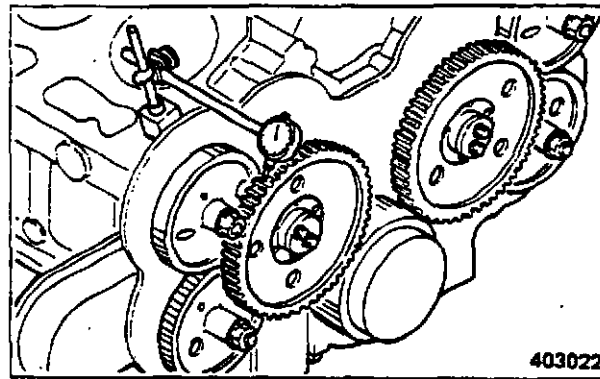

Measuring timing gear backlash

403022

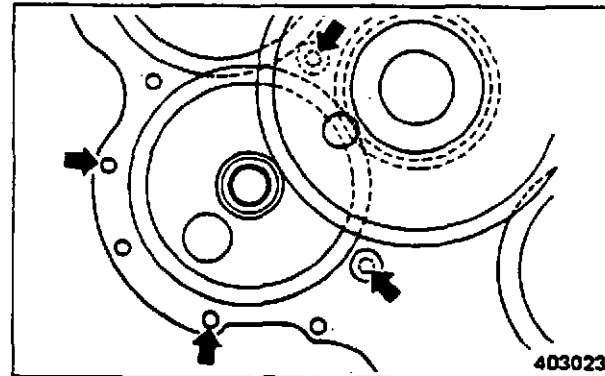

403023

Idler gears, idler gear bushings and idler gear shafts

- (1) Measuring idler gear bushing inside diameter and idler gear shaft diameter

If the diameter exceeds the Service limit, replace the bushing or shaft whichever is worn.

Unit: mm (in.)

Item	Nominal value	Assembly standard	Service limit
Idler gear bushing inside diameter	50 (1.97)	50.000 - 50.025 (1.96850 - 1.96948)	50.060 (1.97086)
Idler gear shaft diameter		49.975 - 49.950 (1.96752 - 1.96653)	49.900 (1.96456)

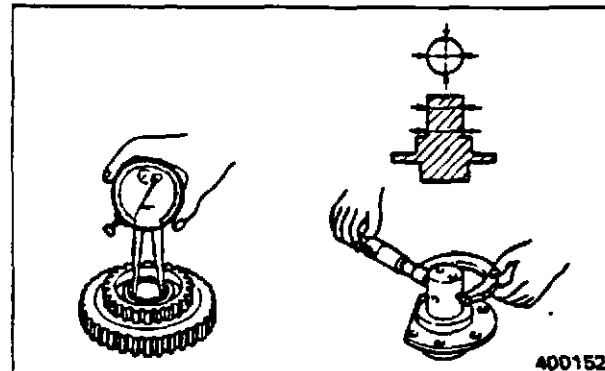

Measuring idler gear bushing and shaft

400152

ENGINE PROEPR

(2) Measuring idler gear end play

Measure the end play with a feeler gauge or a dial gauge. If the end play exceeds the Repair limit, replace the thrust plate.

Unit: mm (in.)

Item	Standard clearance	Repair limit
Idler gear end play	0.2 - 0.4 (0.008 - 0.016)	0.6 (0.024)

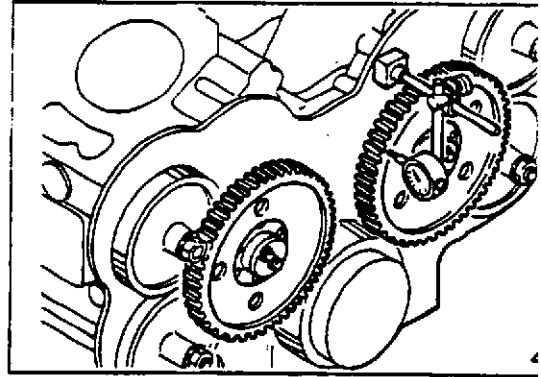

Measuring idler gear end play

(3) Replacing idler gear bushings

- (a) Using idler bushing puller (A) (32591-02500), remove the existing bushing.
- (b) Install a new bushing to the gear by pressing it from the large gear side until the end face of the bushing is flush with that of gear boss.
- (c) After installing the bushing, make sure that its inside diameter is within the Assembly standard. If it is less than the Assembly standard, ream the bushing to the inside diameter of $50^{+0.025}$ mm ($1.97^{+0.00098}$ in.) $\frac{1.5S}{VVV}$.

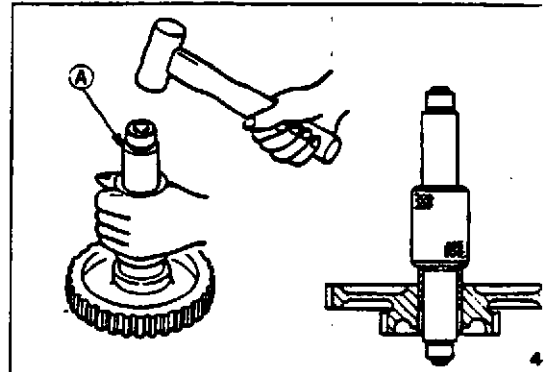

Replacing idler gear bushing

Camshafts and camshaft bushings

(1) Measuring cam lift

Using a micrometer, measure the diameters "A" and "B" on each cam to determine the loss in cam lift. If the cam lift is less than the Service limit, replace the camshaft.

Unit: mm (in.)

Item	Assembly standard	Service limit
Cam lift (A - B)	7.64 - 7.54 (0.3008 - 0.2968)	6.79 (0.2673)

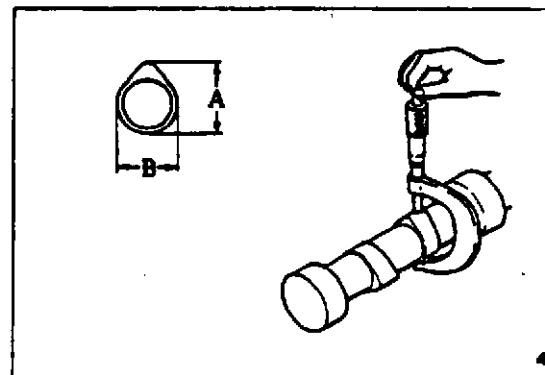

Measuring cam lift

(2) Measuring camshaft runout

If the runout exceeds the Repair limit, straighten the camshaft by means of a press, or replace it with a new one.



Set up a dial gauge on the camshaft, and turn the camshaft. Take one half (1/2) of the gauge indication as the runout.

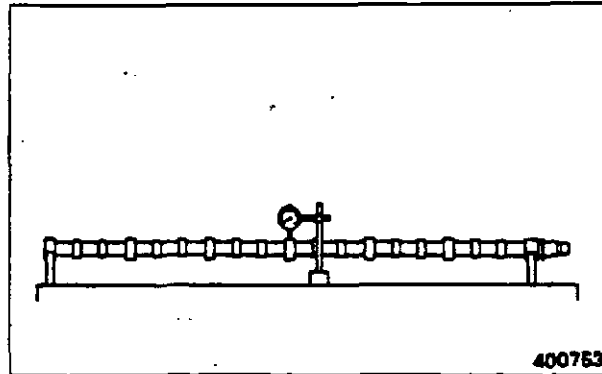

400753

Measuring camshaft runout

Unit: mm (in.)

Item	Assembly standard	Repair limit
Camshaft runout	0.05 (0.0020), maximum	0.08 (0.0031)

(3) Measuring camshaft journal diameter

Using a micrometer, measure each camshaft journal in two directions at right angles to each other. If the diameter exceeds the Service limit, replace the camshaft.

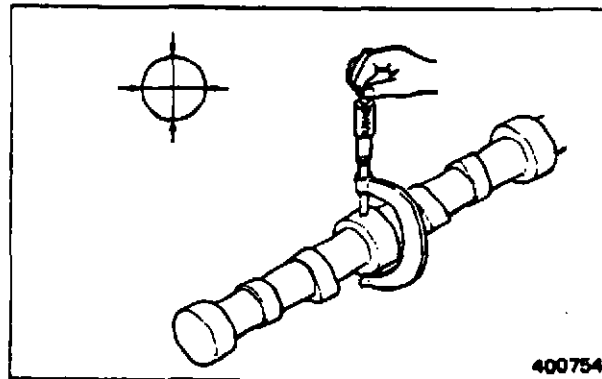

400754

Measuring camshaft journal diameter

Unit: mm (in.)

Item		Nominal value	Assembly standard	Service limit
Camshaft journal diameter	No.1	64 (2.52)	63.94 - 63.92 (2.5173 - 2.5165)	63.87 (2.5146)
	No.2	68 (2.68)	67.94 - 67.92 (2.6748 - 2.6740)	67.87 (2.6720)
	No.7			

ENGINE PROPER

(4) Measuring camshaft bushing inside diameter

Using a cylinder gauge, measure the inside diameter of camshaft bushings fitted to the crankcase. If the inside diameter exceeds the Service limit, replace the bushings.

Unit: mm (in.)

Item		Nominal value	Assembly standard	Service limit
Camshaft bushing inside diameter	No.1	64 (2.52)	64.00 - 64.03 (2.5197 - 2.5209)	64.09 (2.5232)
	No.2	68 (2.68)	68.00 - 68.03 (2.6772 - 2.6783)	68.09 (2.6807)
	No.7			

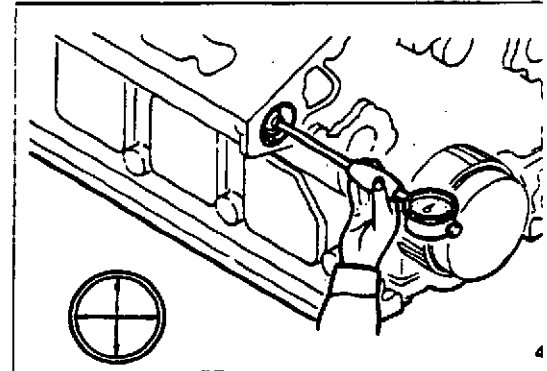

Measuring camshaft bushing inside diameter

(5) Measuring camshaft end play

Using a dial gauge, measure the end play of camshaft to which the camshaft gear is installed. If the end play exceeds the Service limit, replace the thrust plate.

Unit: mm (in.)

Item	Standard clearance	Service limit
Camshaft end play	0.20 - 0.30 (0.0079 - 0.0118)	0.40 (0.0157)

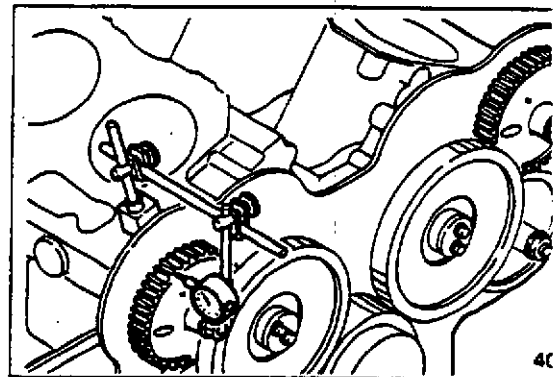

Measuring camshaft end play

(6) Replacing camshaft bushings

Install the bushings in the crankcase, and secure them in place with set screws. Before tightening the screws, make sure that the screw holes in the bushings and crankcase are aligned and that the oil holes in the bushings are aligned with those leading to the oil gallery in the crankcase.

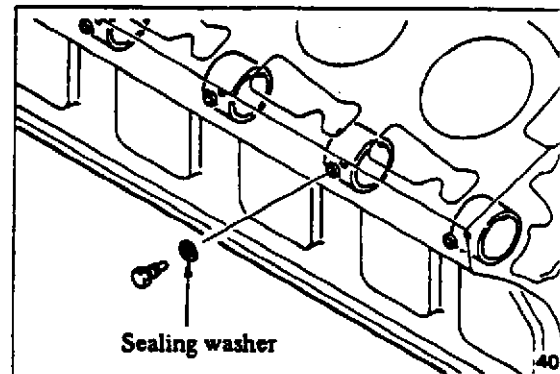

Replacing camshaft bushings

3.3 Reassembly

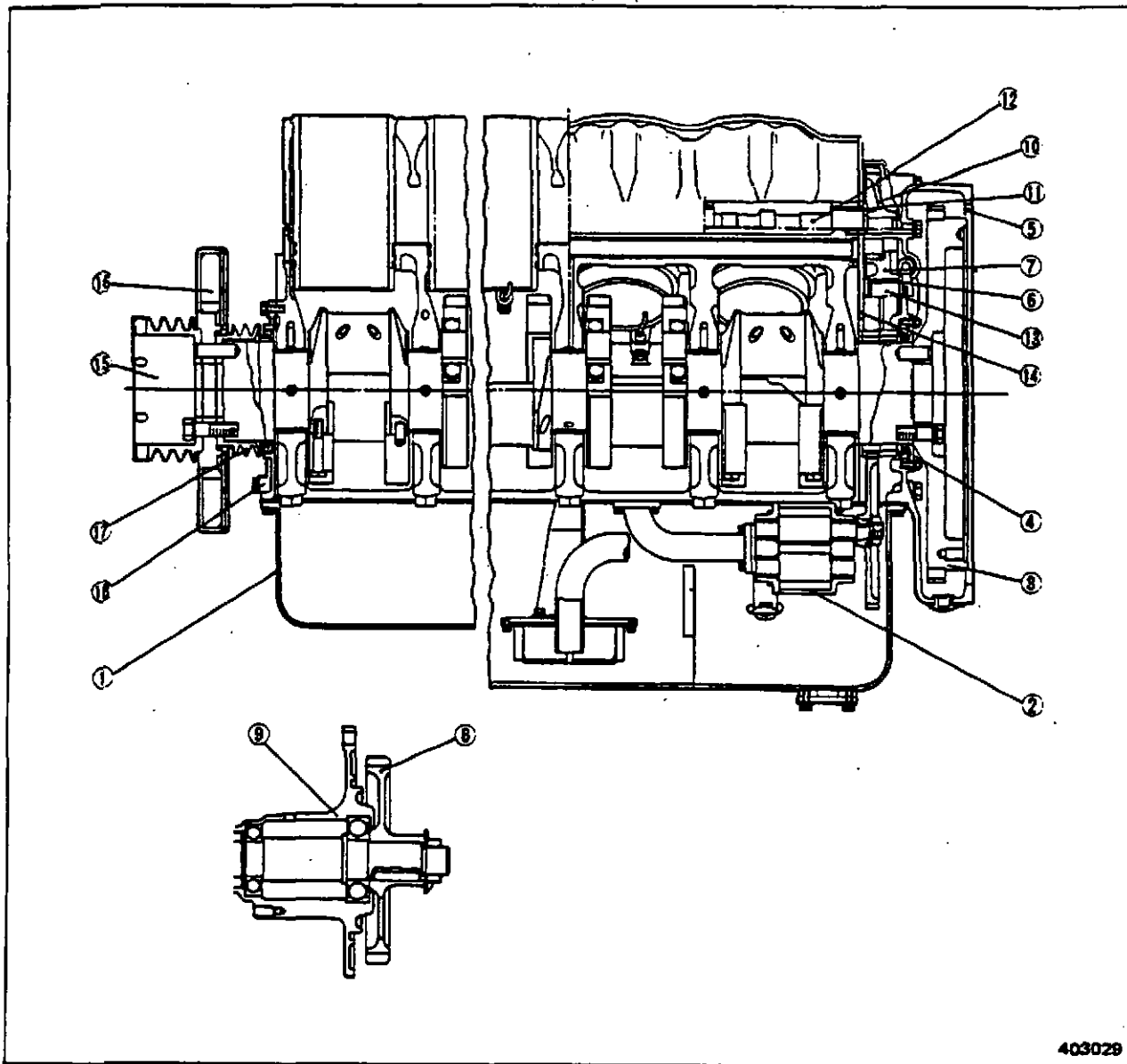

403029

Reassembling sequence

- 18 → 17 → 16 → 15 → 14 → 13 → 12 → 11 → 10 → 9 → 8 → 7 → 6 → 5 → 4 → 3 → 2 → 1

ENGINE PROPER

(1) Installing front cover and pointer

- (a) Install the oil seal to the front cover.
- (b) Apply sealant (HERDITE) to the front cover mounting surface of crankcase, and place the packing in position. Apply the same sealant to the packing, and install the front cover and pointer.
- (c) Replace the dowel pins if worn, or if the front cover has been replaced.
- (d) Tighten the front cover mounting bolts uniformly.
- (e) Make sure that the lower end of front cover is flush with the bottom of crankcase. Cut off the excess of the packing neatly along the edge of the cover.

(When the pointer has been out of place)

To determine the top dead center on compression stroke of No. 1 cylinder, for example, bring the mark on the flywheel to the position where it is at equal distances from two marks punched on the timing gear case.

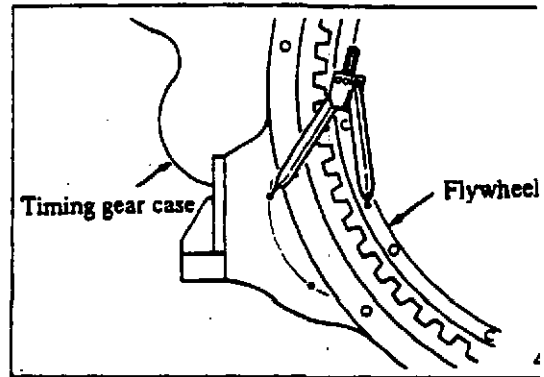
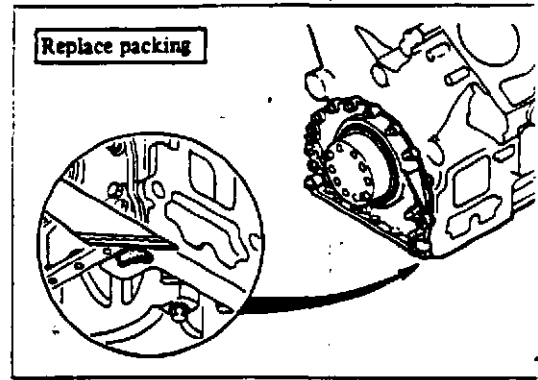

(2) Installing pulley and vibration damper

- (a) Tighten the pulley and damper mounting bolts to the specified torque.
- (b) Inspect the damper for radial and face runouts.
(Refer to 3.2, Group No. 7.)

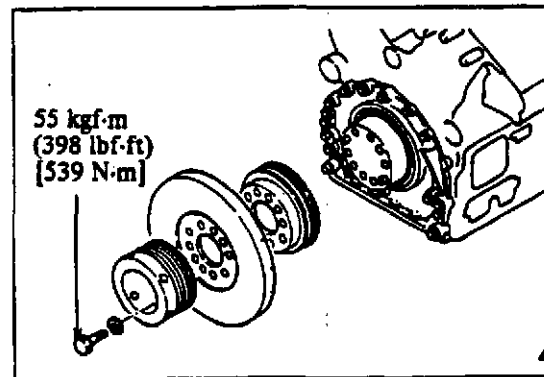

(3) Installing rear plate

- (a) Apply sealant (HERDITE) to the rear plate mounting surface of crankcase, and place the packing in position. Apply the same sealant to the packing, and install the rear plate to the crankcase.
- (b) Replace the dowel pins if worn, or if the rear plate has been replaced.
- (c) Make sure that the lower end of rear plate is flush with the bottom of crankcase. Cut off the excess of the packing neatly along the edge of the plate.

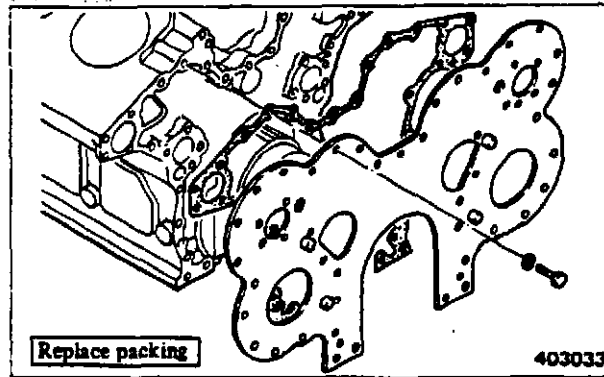
**(4) Cranking engine**

Turn the crankshaft to bring No. 1 cylinder piston to top dead center on compression stroke.

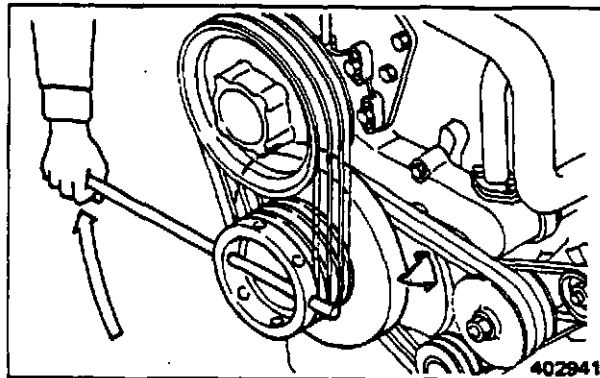
**(5) Installing idler gear shafts (left and right)**

- (a) Drive in the idler gear shaft, using a guide bolt.
- (b) Tighten the idler gear shaft mounting bolts to the specified torque.

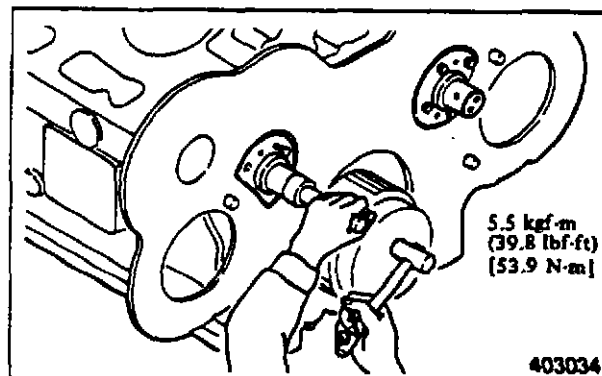
**(6) Installing camshafts (left and right)**

- (a) Insert the camshaft into the crankcase, and install the thrust plate.
- (b) Check and make sure that the camshaft turns smoothly.

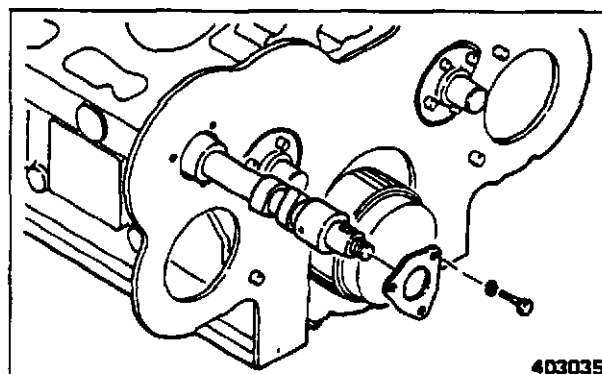

ENGINE PROPER

(7) Installing camshaft gears

Using socket (32591-02800), tighten the nut to the specified torque, and bend the lock washer against the flat of the nut.

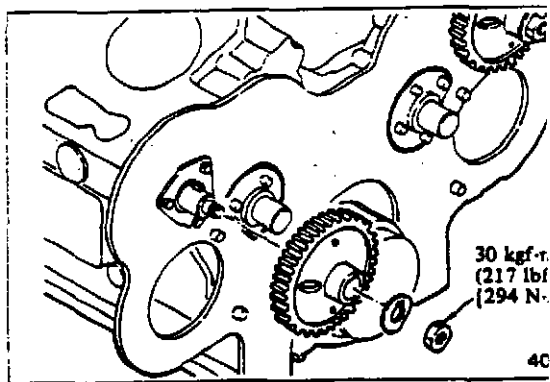

(8) Installing accessory drives

Attach the packing and O-ring to the mounting flange of drive case, and install the case to the rear plate.

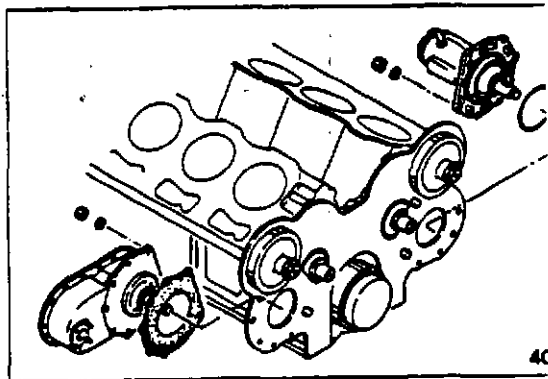

(9) Installing fuel injection pump drive gears

- (a) Attach the injection pump drive gear to the drive shaft fitted with woodruff key by aligning the matching mark with that on the camshaft gear.
- (b) Tighten the nut to the specified torque, and bend the lock washer against the flat of the nut.

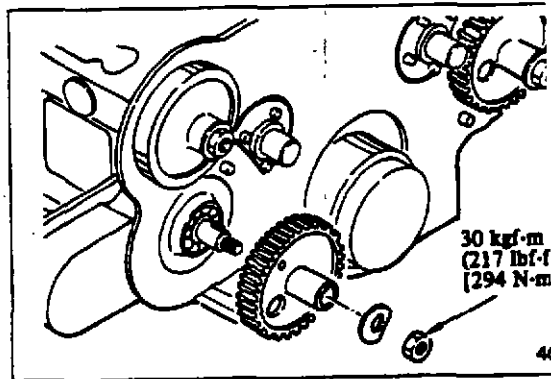

- (c) Align the matching marks on the timing gears as shown at right.

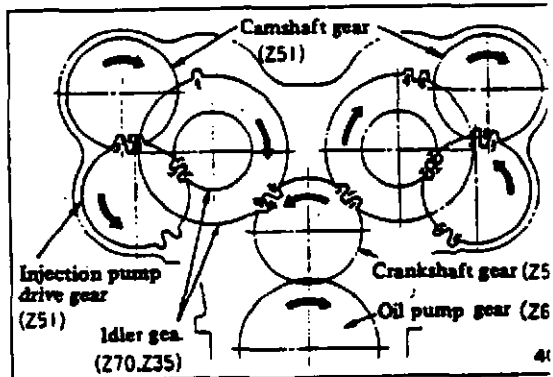

Timing gear train (as seen from flywheel side)
(Aligning the matching marks with No. 1 cylinder piston at top dead center on compression stroke)

(10) Installing idler gears

- (a) Install the idler gear by aligning its matching mark with that on the crankshaft gear and injection pump drive gear, and install the thrust plate.
- (b) Tighten the thrust plate mounting bolts to the specified torque.

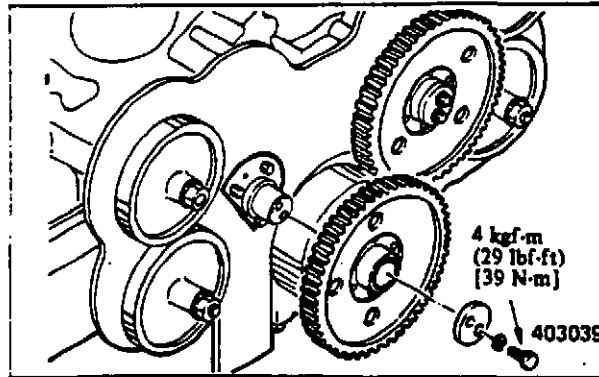

(11) Inspecting and adjusting timing gears after installation.

After installing the timing gears, be sure to inspect and adjust them as follows:

(Inspecting timing gear backlash and end play)

After installing the timing gears, inspect the backlash between the gears in mesh and the end play of each gear. (Refer to 3.2, Group No. 7.)

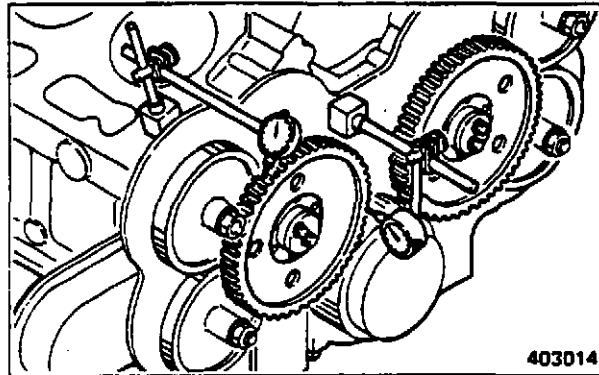

Inspecting valve timing)

It is not necessary to inspect the valve timing, provided that all matching marks on the timing gears are aligned. Inspect the timing for verification as follows:

Using a 2 mm (0.08 in.) feeler gauge, add 2 mm (0.08 in.) clearance to the inlet and exhaust valves of No. 1 cylinder. Then, insert a 0.05 mm (0.0020 in.) feeler gauge into between the top of bridge cap and rocker, and slowly turn the crankshaft, trying to find a position where the feeler gauge is firmly gripped (the valve starts opening) and a position where the gauge is just ungripped (the valve starts closing). Check to make sure that these positions coincide with the angular positions shown in the valve timing diagram with 2 mm (0.08 in.) clearance added to valves.

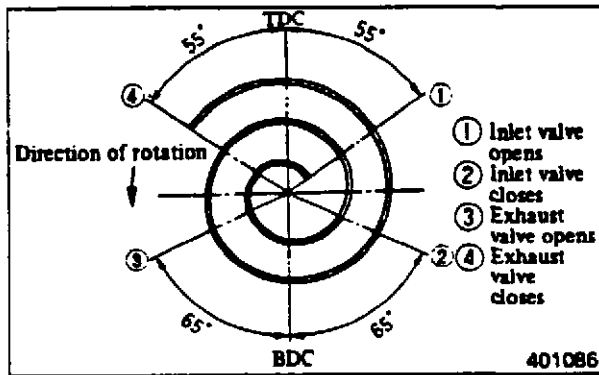

Valve timing diagram

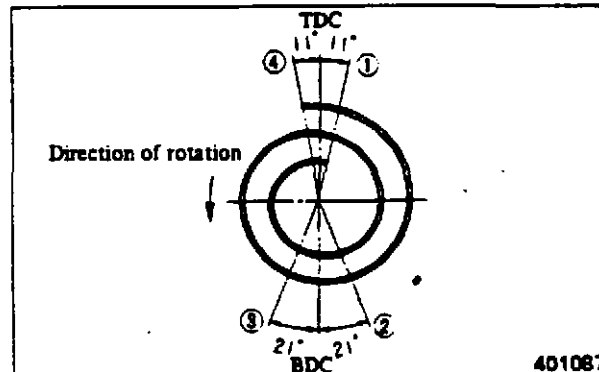

Valve timing diagram with 2mm (0.08 in.) clearance added to valves

ENGINE PROPER.

(12) Installing timing gear case

- (a) Replace the dowel pins if worn, or if the gear case has been replaced.
- (b) Tighten the gear case mounting bolts uniformly to the specified torque.

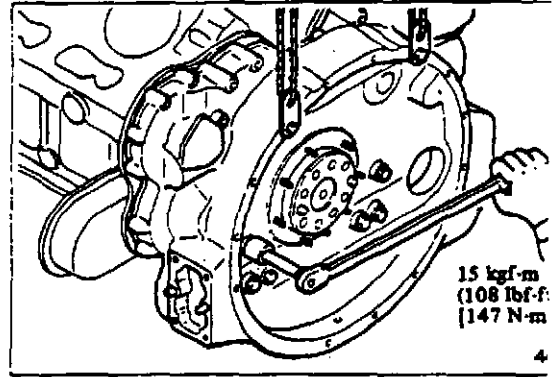

(13) Installing accessory drive cover for Woodward governor

Install the drive cover to which idler gear and driven gear are installed to the drive case.

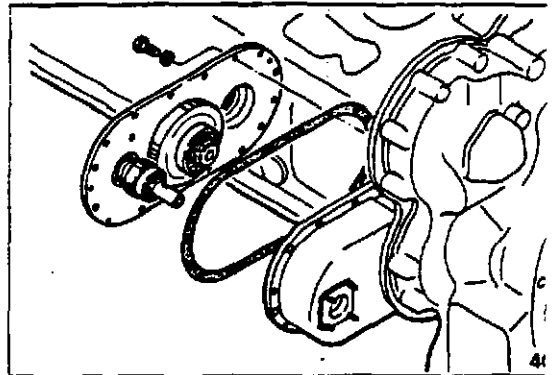

(14) Installing oil seal retainer

Install the oil seal to the retainer, and install the retainer to the gear case, being careful not to fold or damage the seal lip.

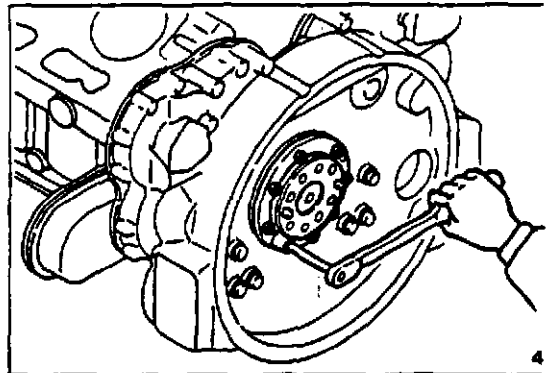

(15) Installing flywheel

- (a) Install the flywheel, making sure that the dowel pins enter their holes.
- (b) Coat the threads of flywheel mounting bolts with MOLYKOTE, and tighten the bolts to the specified torque.
- (c) Inspect the face and radial runouts of the flywheel.
(Refer to 3.2, Group No. 7.)

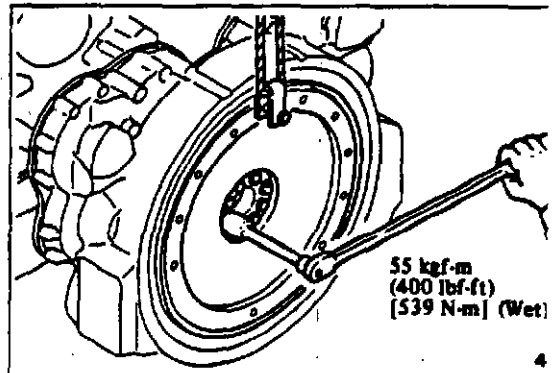

(16) Installing oil pump and oil strainer

Measure the backlash between crankshaft gear and oil pump drive gear. If the backlash is too small, adjust it by fitting shims to the pump gear mounting face.

(Refer to 3.2, Group No. 7 for backlash specification.)

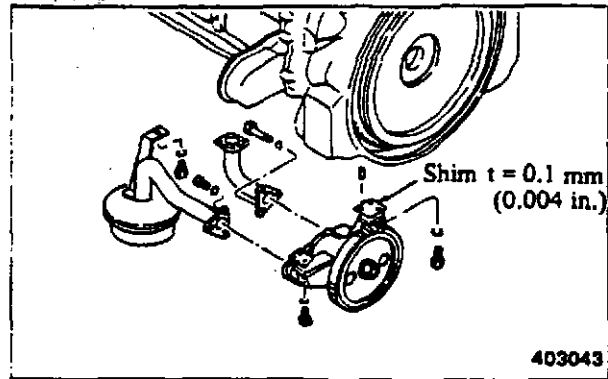
**(17) Installing oil pan**

- (a) Fit the packing to the oil pan by applying sealant (HERDITE) to the separated portions (4 places).
- (b) Tighten the oil pan mounting bolts uniformly to the specified torque.

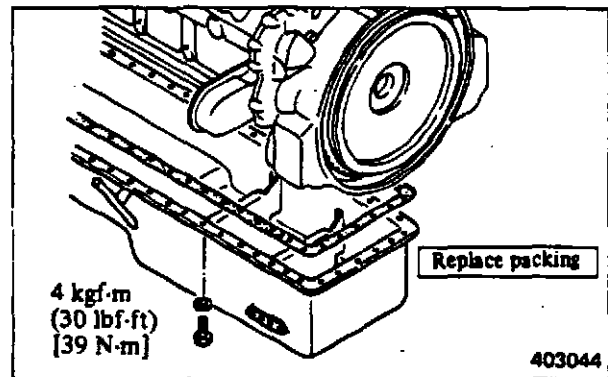

4. CRANKCASE, CRANKSHAFT AND MAIN BEARINGS

4.1 Disassembly

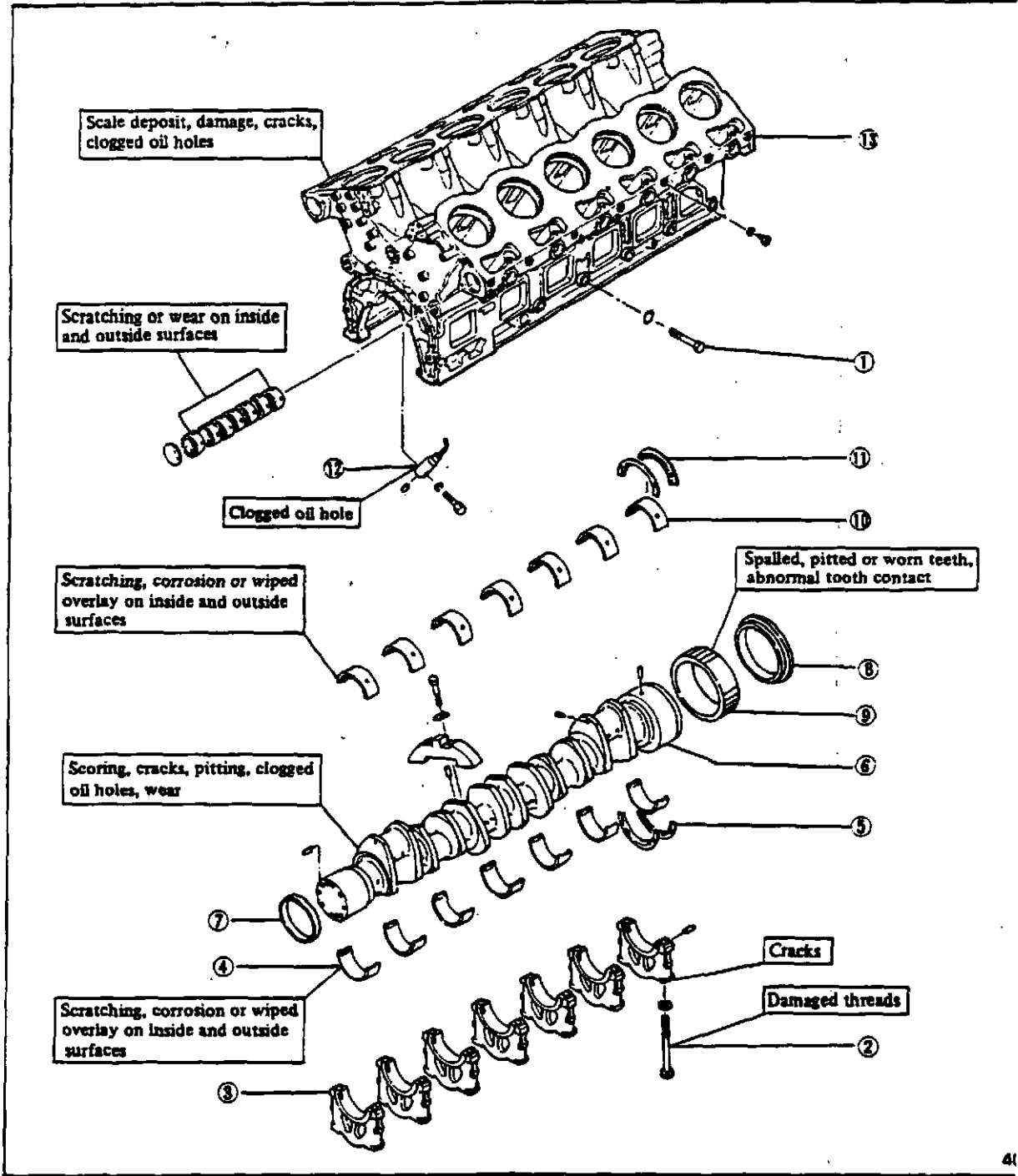

- | | | |
|------------------------------|------------------------------|------------------|
| ① Side bolt | ⑥ Crankshaft | ⑪ Thrust plate |
| ② Bolt | ⑦ Sleeve | ⑫ Oil jet nozzle |
| ③ Main bearing cap | ⑧ Oil slinger | ⑬ Crankcase |
| ④ Main bearing (lower shell) | ⑨ Crankshaft gear | |
| ⑤ Thrust plate | ⑩ Main bearing (upper shell) | |

(1) Turning crankcase upside down

Using a chain block and shackles, lay the crankcase on its side. Then, attach wire ropes to the crankcase, and turn it upside down.

[Crankcase and crankshaft weight: 1010 kg (2230 lb), approx.]

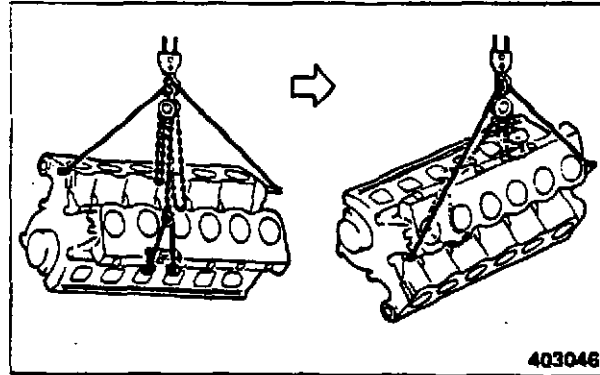

403046

(2) Removing main bearing caps

(a) Unscrew the cap bolts and side bolts. Using a cap remover, remove the main bearing caps.

(b) Remove the thrust plates from the No. 7 bearing cap, being careful not to damage the thrust plates.

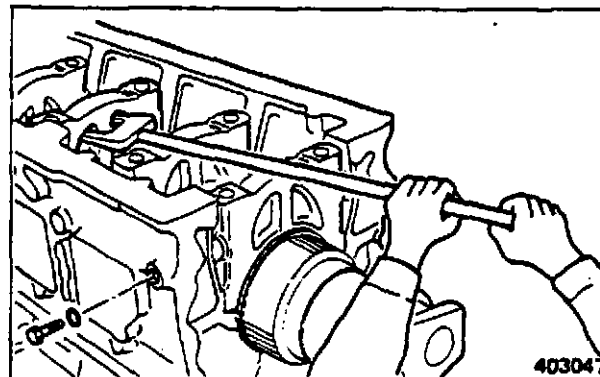

403047

(3) Removing crankshaft

(a) Remove the upper halves of thrust plates while rotating the crankshaft slowly.

(b) Carefully lift the crankshaft off the crankcase, keeping it horizontal.

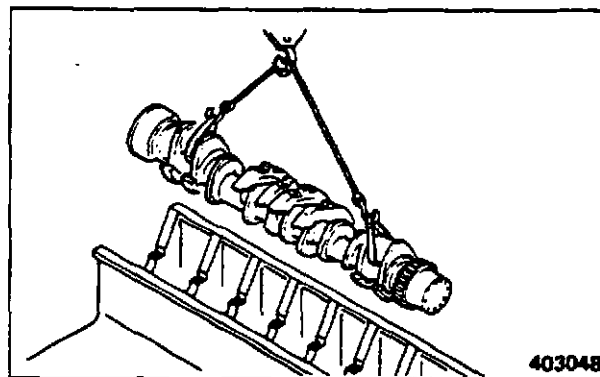

403048

(4) Removing oil jet nozzles

Remove the nozzles only when their oil holes are clogged or defective.

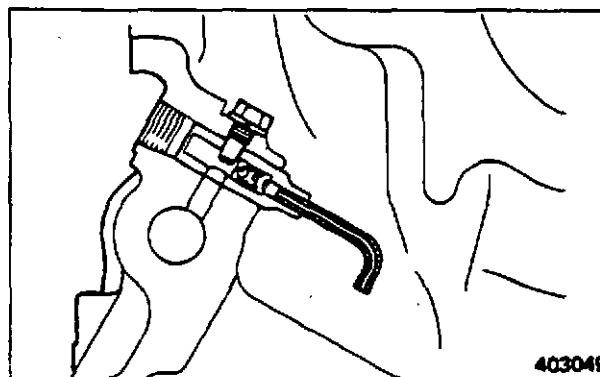

403049

ENGINE PROPER

4.2 Inspection and repair

Crankshaft

(1) Measuring crankpin and journal diameters

(a) Using a micrometer, measure the crankpin and journal diameters. If the diameter exceeds the Repair limit, grind them to the next undersize [-0.25 mm (-0.0098 in.), -0.50 mm (-0.0197 in.), -0.75 mm (-0.0295 in.) or -1.00 mm (-0.0394 in.)].

(b) Measure the crankpins and journals to determine the amount of out-of-roundness and taper.

(c) If the -1.00 mm (0.0394 in.) undersize journals and crankpins exceed the Repair limit, replace the crankshaft.

Unit: mm (in.)

Item	Nominal value	Assembly standard	Repair limit
Crankpin diameter	104 (4.09)	-0.08 -- -0.10 (-0.0031 - -0.0039)	-0.14 (-0.0055)
Journal diameter	130 (5.12)	-0.10 -- -0.12 (-0.0039 - -0.0047)	-0.16 (-0.0063)
Out-of-roundness and taper of crankpins and journals		0.01 (0.0004), maximum	0.03 (0.0012)
Fillet radius		7.0 ⁰ -0.2 (0.276 ⁰ -0.008)	
Hardness		Hv > 620	

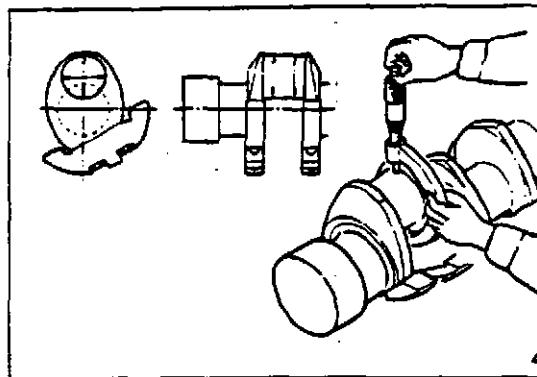

Measuring crankpin diameter

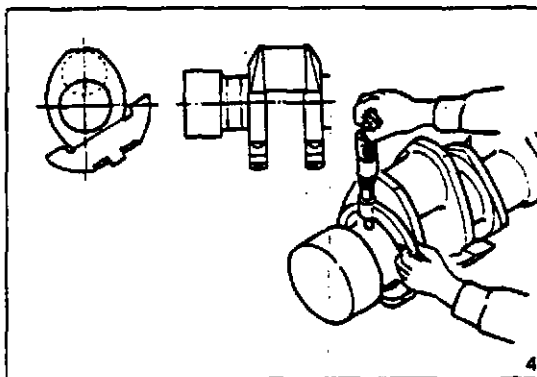

Measuring journal diameter

(2) Grinding crankshaft

If the crankshaft is refinished in compliance with any grinding dimension of the undersizes and the bearings are replaced by the undersize ones, it is not necessary to check the bearing contact pattern.

Crankshaft refinishing dimensions

Unit: mm (in.)

	Undersize	Finishing dimension	Out-of-roundness	Taper
Crankpin diameters	0.25 (0.0098)	103.67 - 103.65 (4.0815 - 4.0807)	0.01 (0.0004), maximum	0.01 (0.0004), maximum
	0.50 (0.0197)	103.42 - 103.40 (4.0716 - 4.0709)		
	0.75 (0.0295)	103.17 - 103.15 (4.0618 - 4.0610)		
	1.00 (0.0394)	102.92 - 102.90 (4.0520 - 4.0512)		
Journal diameters	0.25 (0.0098)	129.65 - 129.63 (5.1043 - 5.1035)		
	0.50 (0.0197)	129.40 - 129.38 (5.0945 - 5.0937)		
	0.75 (0.0295)	129.15 - 129.13 (5.0846 - 5.0838)		
	1.00 (0.0394)	128.90 - 128.88 (5.0748 - 5.0740)		

When grinding the crankpins and journals, be sure to produce the same fillet radius as the original one. They should have a hardness of 620 or more in terms of Vickers Hardness Number. If necessary, reharden the crankpins and journals, and inspect them for cracks by conducting a magnalux (magnetic particle) test. After grinding, finish the journals and crankpins to $\frac{0.8S}{VV}$ to $\frac{1.0S}{VV}$.

(3) Measuring crankshaft end play

- (a) Install the thrust plates in position, and secure the bearing cap. Under this condition, measure the end play. If the end play exceeds the Standard clearance, replace the thrust plates.
- (b) If the end play still exceeds the Repair limit even after new thrust plates have been installed, replace the plates with the next oversize ones. There are three oversizes for the thrust plates; namely, +0.25 mm (+0.0098 in.), +0.50 mm (+0.0197 in.) and +0.75 mm (+0.0295 in.). Generally, the rear journal is likely to be worn more rapidly than the front journal. This means that replacement of the rear thrust plates will, in most cases, gain the purpose.

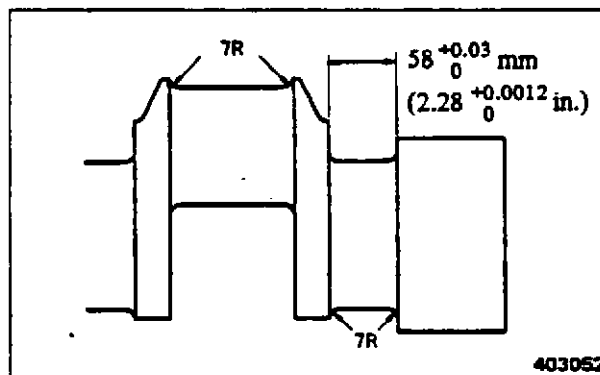

Measuring thrust bearing journal length

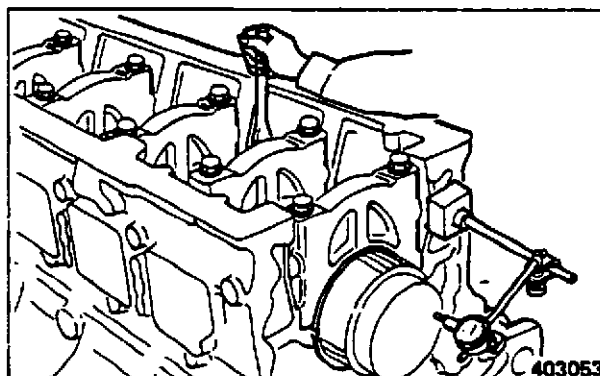

Measuring crankshaft end play

ENGINE PROPER

Unit: mm (in.)

Item	Standard clearance	Repair limit
Crankshaft end play	0.20 – 0.365 (0.0079 – 0.01437)	0.50 (0.0197)

Crankshaft journal grinding dimensions for
oversize thrust plates

Unit: mm (in.)

Item	Oversizes for journal or thrust plates	Oversizes for journal and thrust plates	Tolerance
Standard size	-	58 (2.28)	+0.03 0 (+0.0012, 0)
+0.25 (+0.0098) oversize	58.25 (2.2933)	58.50 (2.3031)	
+0.50 (+0.0197) oversize	58.50 (2.3031)	59.00 (2.3228)	
+0.75 (+0.0295) oversize	58.75 (2.3130)	59.50 (2.3425)	

(4) Measuring crankshaft runout

Support the crankshaft on its journals in V-blocks, and measure the runout at the center journal, using a dial gauge. Depending on the amount of runout, repair the crankshaft by grinding or straightening with a press. If the runout exceeds the Repair limit, replace the crankshaft.

Unit: mm (in.)

Item	Assembly standard	Repair limit
Crankshaft runout	0.04 (0.0016), maximum	0.10 (0.0039)

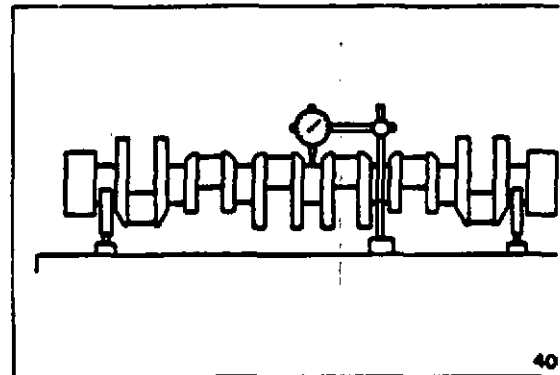

Measuring crankshaft runout

(5) Replacing oil seal sleeve

Replace the sleeve as follows if it is pitted, scratched or distorted to such an extent of causing oil leakage.

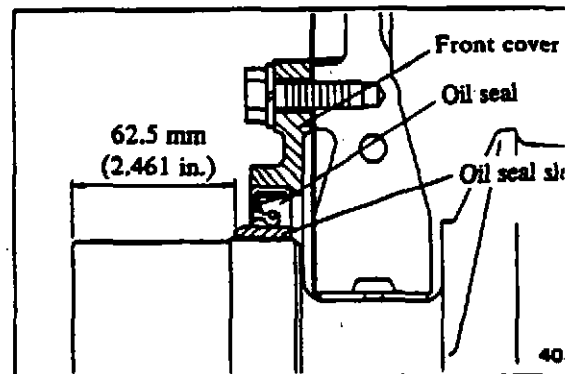

(Removing sleeve)

Give hammer blows to the sleeve at three places by holding a chisel at right angles to the sleeve surface and, when the sleeve loses tension, remove it from the crankshaft.



Be careful not to damage the crankshaft by the chisel.

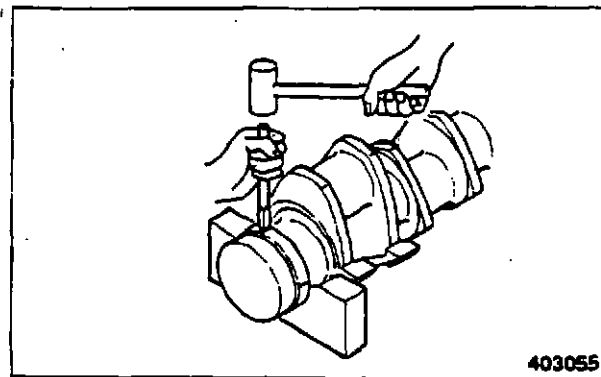

403055

(Installing sleeve)

Coat the inside surface of a new sleeve with oil or MOLYKOTE, and install the sleeve, using a sleeve installer.

Tool name	Part number
Sleeve installer	32691-00510
Installer guide	32691-00600

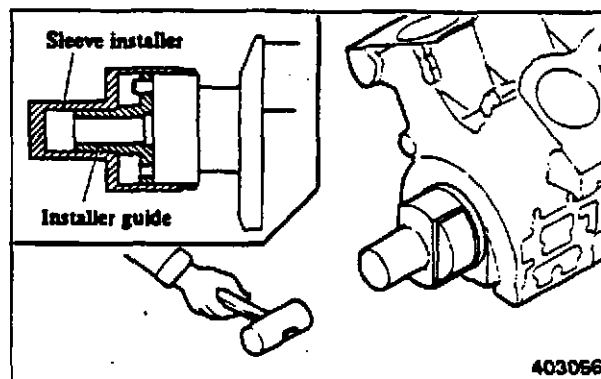

403056

(6) Replacing rear oil seal slinger

If the slinger is pitted, scratched or distorted to such an extent as to cause oil leakage, replace it with a new one as follows:

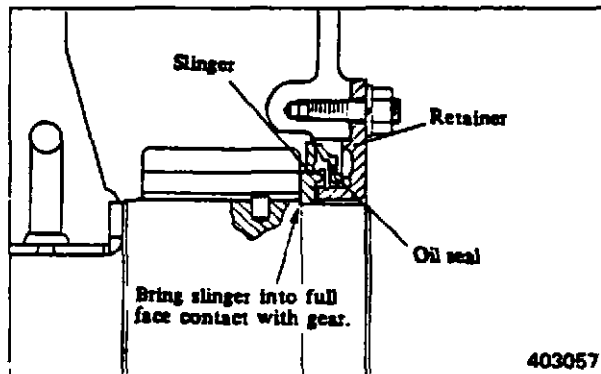

403057

(Removing slinger)

Using a gear puller, remove the slinger from the crankshaft.

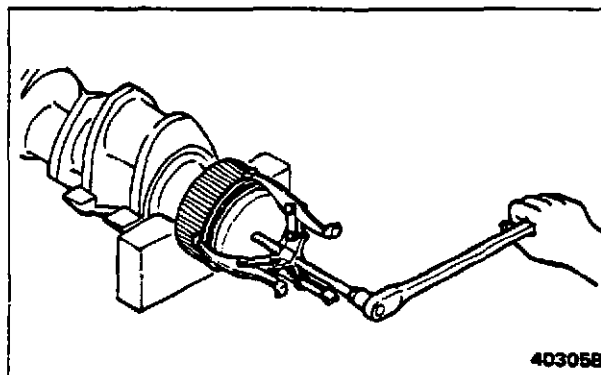

403058

(Installing slinger)

Fit the slinger heated above 110°C (230°F) to the tip of the installer. Press the slinger until it touches the gear.

If the installer gets fast halfway, give the blows of a copper hammer to the center or shoulder of the installer. Coat the seal lip with engine oil.

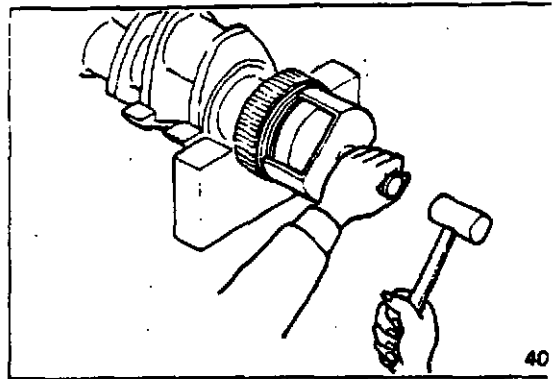

(7) Replacing (removing) crankshaft gear

(Removing the gear)

Using gear puller, remove the gear from the crankshaft.

NOTE

Do not remove the gear by driving with a hammer.

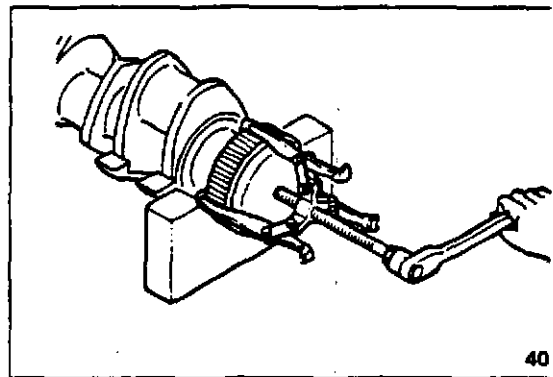

(Installing gear)

(a) Measure the diameter of crankshaft and the inside diameter of crankshaft gear to make sure that the fit is 0.106 to 0.171 mm (0.00417 to 0.00673 in.).

(b) Heat the gear up to 180 to 200°C (356 to 392°F).

(c) Drive the gear onto the crankshaft by giving light blows of a copper hammer to the end face of the gear, making sure that the crankshaft dowel pin enters the notch in the gear.

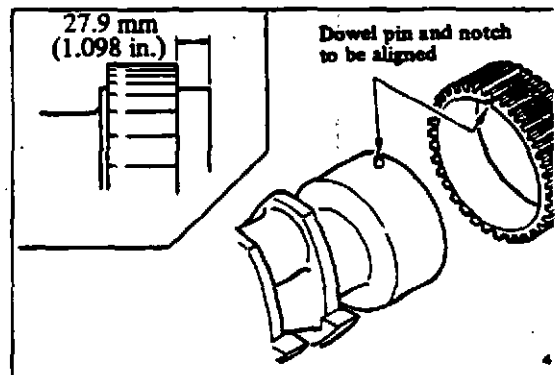

Main bearings

(1) Inspection

Inspect each bearing shell for abnormal contact, scratching, corrosion, wiped overlay and other defects. Also check for a sign of poor seating in the bore of the crankcase or bearing cap.

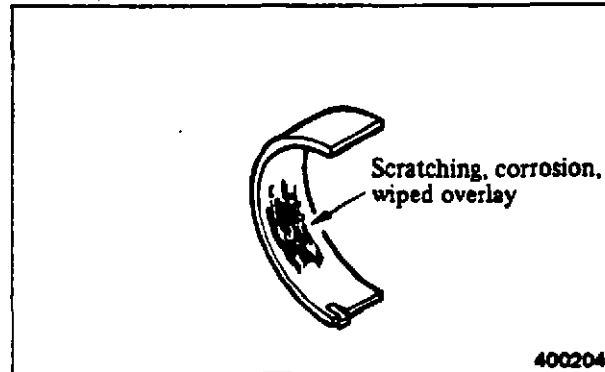

(2) Measuring bearing thickness

Using a ball-point type micrometer, measure the center of each bearing shell. If the thickness exceeds the Service limit on any of the upper and lower shells, replace the upper and lower shells as a set.

Unit: mm (in.)

Item	Nominal value	Assembly standard	Service limit
Main bearing thickness (center portion)	Standard	3.500 - 3.482 (0.13780 - 0.13709)	3.450 (0.13583)
	-0.25 (-0.0098)	3.625 - 3.607 (0.14272 - 0.14201)	3.575 (0.14075)
	-0.50 (-0.0197)	3.750 - 3.732 (0.14764 - 0.14693)	3.700 (0.14567)
	-0.75 (-0.0295)	3.875 - 3.857 (0.15256 - 0.15185)	3.825 (0.15059)
	-1.00 (-0.0394)	4.000 - 3.982 (0.15748 - 0.15677)	3.950 (0.15551)

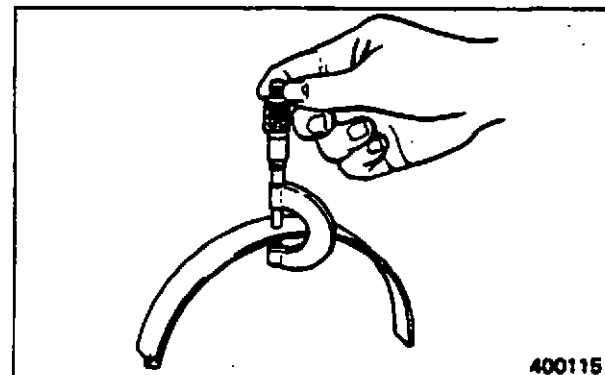
**NOTE**

Four undersizes are available for the main bearings; namely, -0.25 mm (-0.0098 in.), -0.50 mm (-0.0197 in.), -0.75 mm (-0.0295 in.) and -1.00 mm (-0.0394 in.).

ENGINE PROPER

(3) Replacing main bearings

If the thickness exceeds the Service limit, either replace the main bearings as above, or refinish the crankshaft and use undersize bearings. If the crankshaft is refinished in compliance with any of the undersizes, it is not necessary to check the bearing contact pattern.

Crankcase

(1) Measuring gasketed surface warpage

Measure warpage with a straightedge and feeler gauge. If the warpage exceeds the Assembly standard, reface the gasketed surfaces with a surface grinder.

Unit: mm (in.)

Item	Assembly standard	Repair limit
Crankcase gasketed surface warpage	0.05 (0.0020), maximum	0.20 (0.0079)

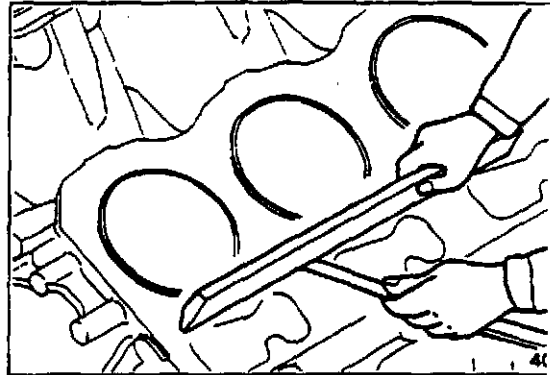

Measuring crankcase gasketed surfaces

NOTE

Do not grind the crankcase more than are necessary for removing warpage to prevent the piston protrusion from exceeding the Assembly standard. (Refer to (4), Pistons, 2.2, Group No. 7.)

(2) Measuring main bearing bore diameter

Secure each bearing cap to the specified torque, and measure the bore diameter in the criss-cross directions.

Unit: mm (in.)

Item	Nominal value	Assembly standard	Service limit
Main bearing bore diameter	137 (5.39)	137.000 - 137.025 (5.39369 - 5.39467)	137.045 (5.39546)

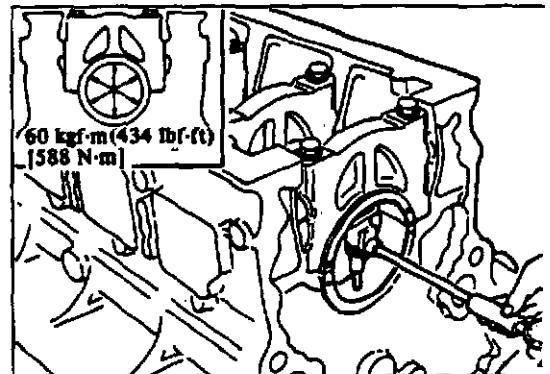

Measuring main bearing bore diameter

4.3 Reassembly

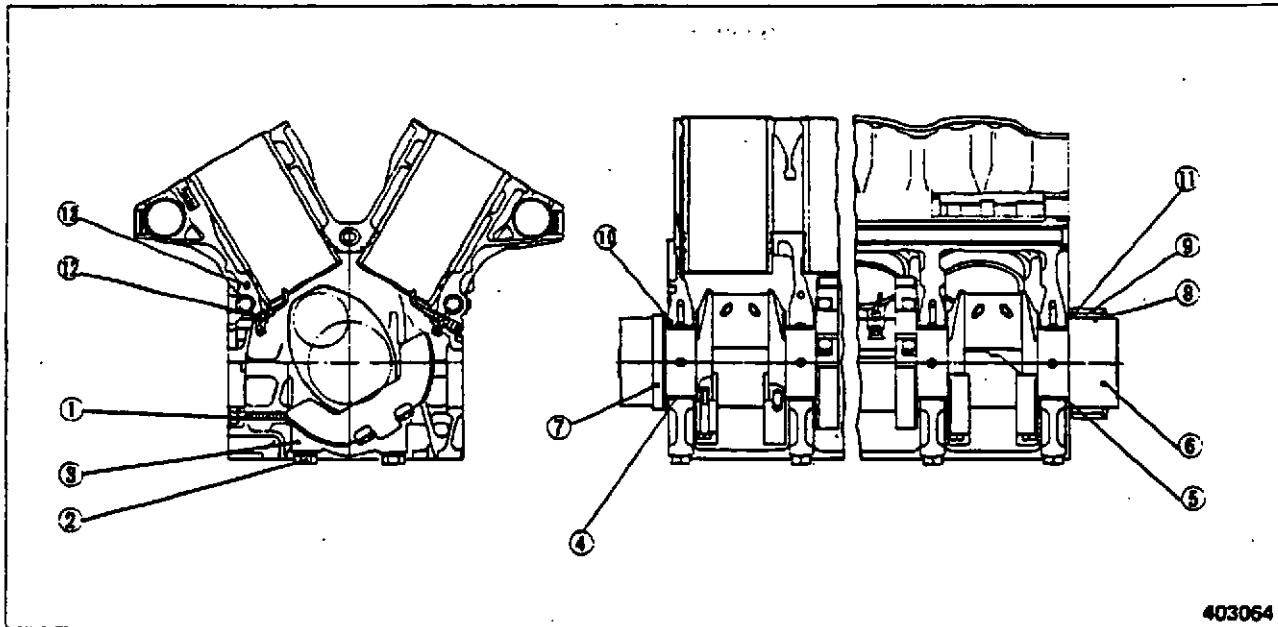

403064

Reassembling sequence

13-12-11-10-5-4-3-2-1
 6-7-9-8

(1) Installing main bearings

- (a) Install each upper shell of main bearing in the crankcase by fitting its locking lip in the recess. The oil holes in the bearings and crankcase will be aligned when the bearings are so installed.
- (b) Lightly coat the inside surface of the shells with engine oil.

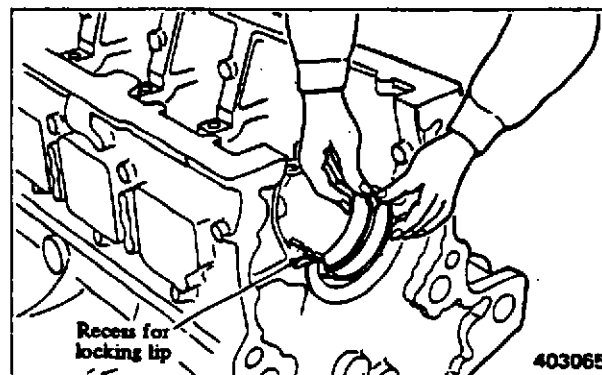

403065

(2) Installing crankshaft

- (a) Wash the crankshaft with cleaning solvent, and dry it by applying a blast of pressure air.

NOTE

After washing the crankshaft, make sure that the oil holes are clean and free from dirt or foreign matter.

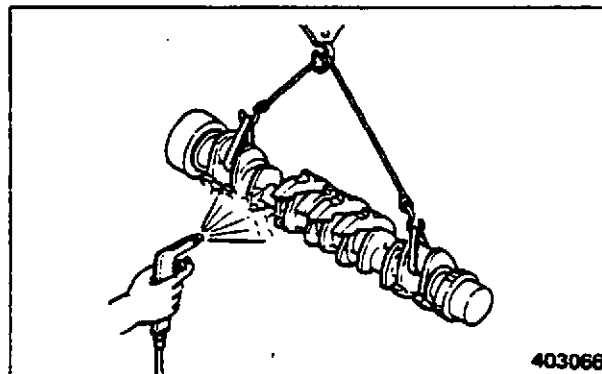

403066

ENGINE PROPER

(3) Replacing main bearings

If the thickness exceeds the Service limit, either replace the main bearings as above, or refinish the crankshaft and use undersize bearings. If the crankshaft is refinished in compliance with any of the undersizes, it is not necessary to check the bearing contact pattern.

Crankcase

(1) Measuring gasketed surface warpage

Measure warpage with a straightedge and feeler gauge. If the warpage exceeds the Assembly standard, reface the gasketed surfaces with a surface grinder.

Unit: mm (in.)

Item	Assembly standard	Repair limit
Crankcase gasketed surface warpage	0.05 (0.0020), maximum	0.20 (0.0079)

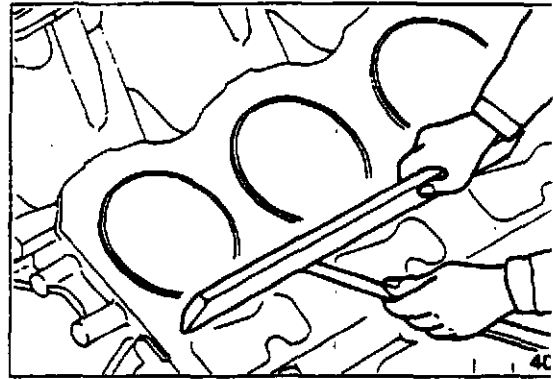

Measuring crankcase gasketed surfaces

NOTE

Do not grind the crankcase more than are necessary for removing warpage to prevent the piston protrusion from exceeding the Assembly standard. (Refer to (4), Pistons, 2.2, Group No. 7.)

(2) Measuring main bearing bore diameter

Secure each bearing cap to the specified torque, and measure the bore diameter in the criss-cross directions.

Unit: mm (in.)

Item	Nominal value	Assembly standard	Service limit
Main bearing bore diameter	137 (5.39)	137.000 - 137.025 (5.39369 - 5.39467)	137.045 (5.39546)

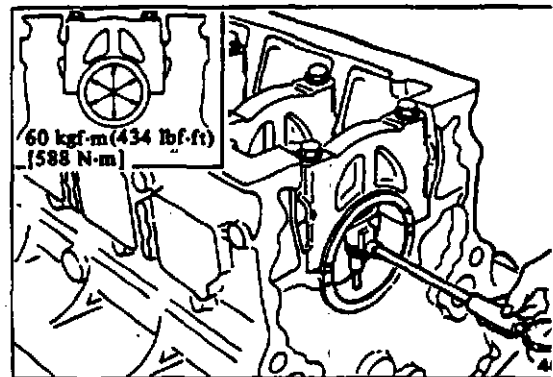

Measuring main bearing bore diameter

(5) Installing bearing cap bolts

- (a) Temporarily tighten bearing cap bolts coated with engine oil. Tighten left and right bolts alternately to the specified torque.
- (b) Tighten left and right side bolts alternately to the specified torque.
- (c) Make sure that the crankshaft rotates smoothly.

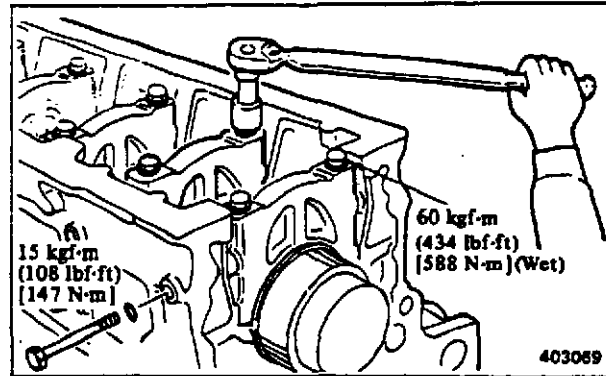
**(6) Measuring crankshaft end play**

- (a) Tighten No. 1 thru No. 6 bearing cap bolts and side bolts to the specified torque, with No. 7 cap bolts being temporarily tightened, and measure the end play.
- (b) After tightening the No.7 cap bolts, make sure that the end play is correct.
- (c) Again make sure that all cap bolts and side bolts are tightened to the specified torque. (Refer to 4.2, Group 7.)

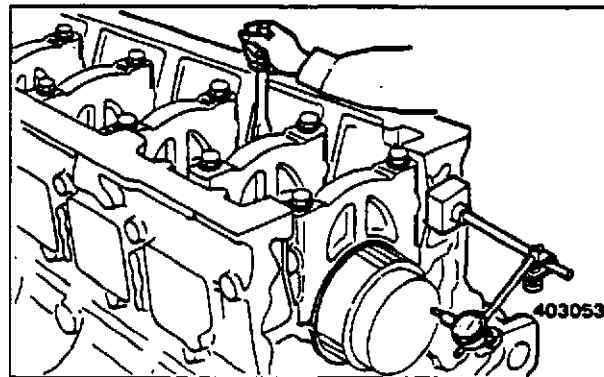

INLET & EXHAUST SYSTEMS

1. DESCRIPTION	128
2. PAPER-ELEMENT TYPE AIR CLEANER	128
Disassembly and inspection	128
3. INLET MANIFOLDS AND AIR COOLER	129
3.1 Disassembly	129
3.2 Inspection	129
4. EXHAUST MANIFOLDS	131
Disassembly and inspection	131
5. AIR HEATER	131
Inspection	131

1. DESCRIPTION

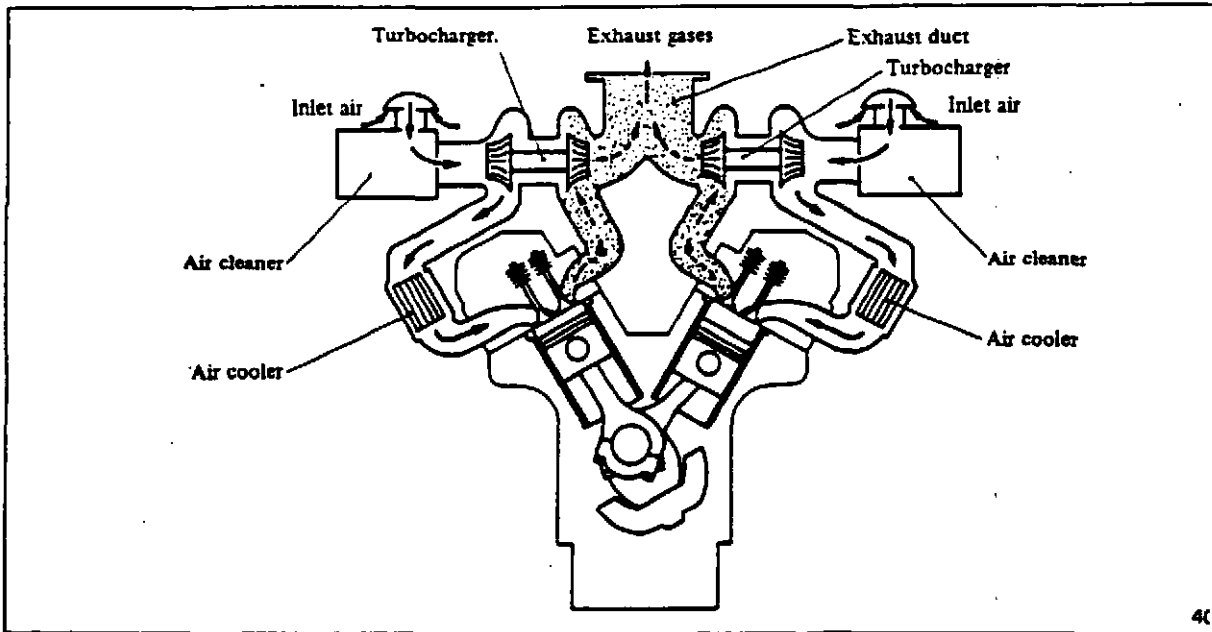

4c

2. PAPER-ELEMENT TYPE AIR CLEANERS

Disassembly and inspection

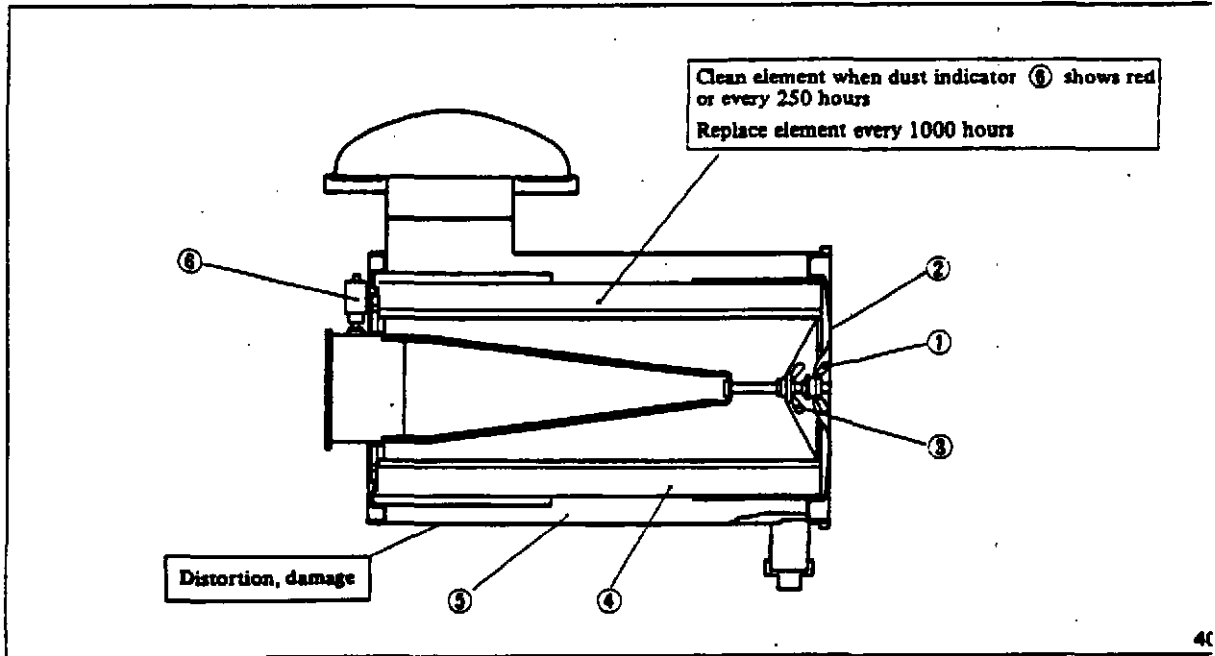

4c

- | | | |
|------------|------------|--------------------|
| ① Wing nut | ③ Wing nut | ⑤ Air cleaner body |
| ② Cover | ④ Element | ⑥ Dust indicator |

CAUTION

When removing the air cleaner for servicing, be sure to stop the engine and cover the air inlet port to prevent dirt from entering the engine.

3. INLET MANIFOLDS AND AIR COOLERS

3.1 Disassembly

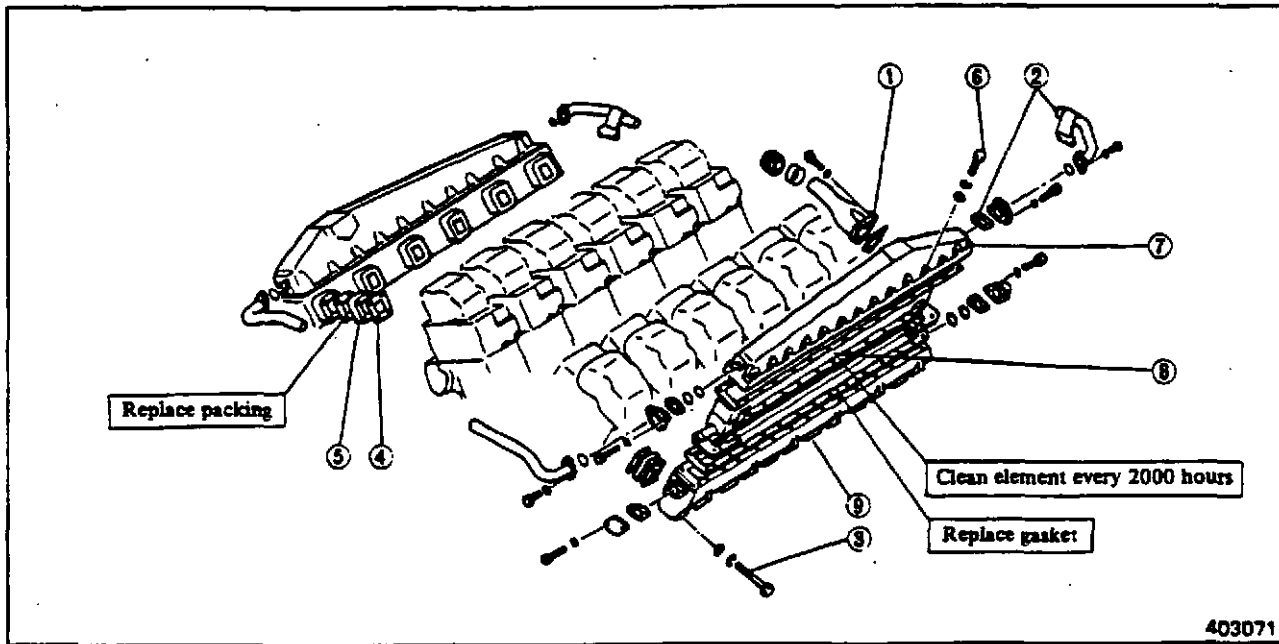

- | | | |
|-----------------------|-----------|------------------------|
| ① Air duct | ④ Packing | ⑦ Inlet manifold cover |
| ② Water pipe, packing | ⑤ Spacer | ⑧ Element, gasket |
| ③ Bolts | ⑥ Bolt | ⑨ Inlet manifold |

3.2 Inspection

(1) Cleaning air coolers

- (a) Remove dirt buildup from the air cooler by directing pressure air of 3 to 5 kgf/cm² (43 to 71 psi) [0.3 to 0.5 MPa] maximum in the direction opposite to the air flow. Then, inspect the cooler for corrosion and cracks.

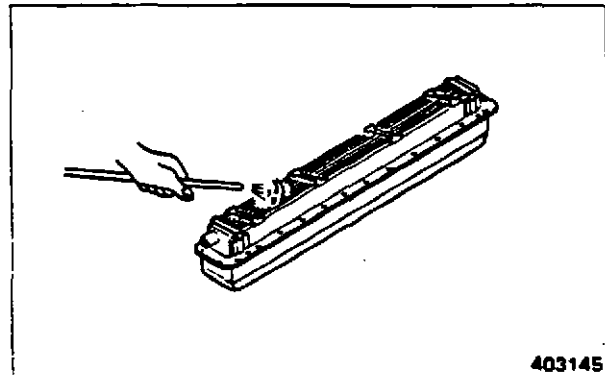

INLET & EXHAUST SYSTEMS

- (b) Wash the fresh-water or sea-water pipes in water and caustic soda or soda lime, and remove scale deposits by inserting a 3 mm (1/8 in.) diameter bar into each pipe.
- (c) Every 500 hours, replace the zinc rods if sea water is used in the cooler.

(2) Inspecting air coolers for airtightness

Immerse the air cooler in water, and apply pressure air of 6 kgf/cm² (85 psi) [0.6 MPa] to the coolant side to inspect for air leakage.



CAUTION

Fresh-water type air cooler differs from sea-water type air cooler in construction and material. With this kept in mind, carefully handle the air cooler.

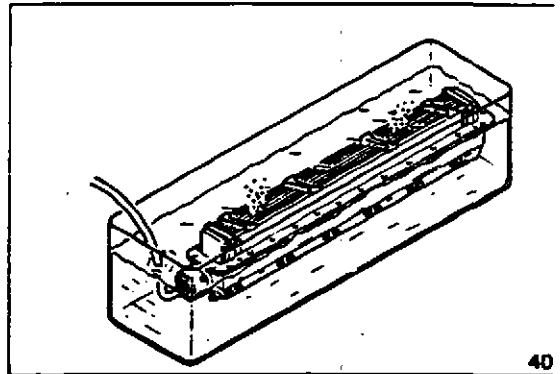

4. EXHAUST MANIFOLDS

Disassembly and inspection

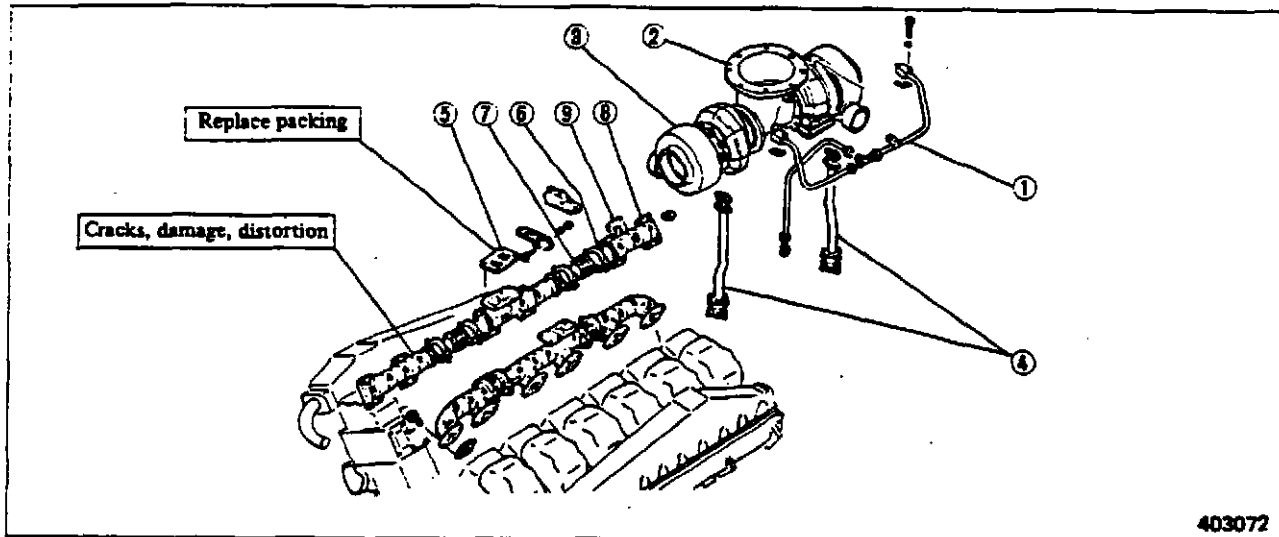

403072

- | | | |
|----------------|--------------|--------------------|
| ① Oil pipe | ④ Drain pipe | ⑦ Flexible joint |
| ② Exhaust pipe | ⑤ Gasket | ⑧ Exhaust manifold |
| ③ Turbocharger | ⑥ Coupling | ⑨ Gasket |

NOTE

- (a) Place each gasket with "TOP" mark on the exhaust manifold side.
- (b) If any of the gaskets has to be replaced, replace all gaskets at a time.

5. AIR HEATER

Inspection

- (a) Using an ammeter or a test lamp, check to make sure that the current flows to the heater when the starter switch is turned to HEAT position and that the current is cutoff when the switch is turned to ON or OFF position.

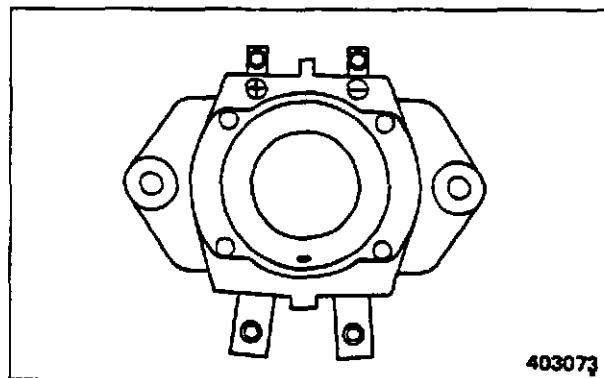

403073

INLET & EXHAUST SYSTEMS

(b) Check to make sure that the indicator takes 45 to 55 seconds to glow red after the starter switch is turned to HEAT position. If the indicator glows red too early or it fails to glow red, check the indicator and air heater for short or open circuit. The ohmic values of the air heater circuit components are as shown below:

(c) Replace the battery relay switch if the resistance measured by touching tester prods to the positive (+) and negative (-) terminals of the switch is out of the Assembly standard.

Unit: Ω

	Item	Assembly standard
Resistance	Indicator	12.2
	Air heater	$0.135 \pm 10\%$
	Battery relay switch	$64 \pm 5\%$

NOTE

To measure the resistance, touch the black (negative) prod to the positive (+) terminal of the switch and the red (positive) prod to the negative (-) terminal.

LUBRICATION SYSTEM

1. DESCRIPTION	134
2. OIL PUMP, OIL STRAINER AND SAFETY VALVE	135
2.1 Disassembly	135
2.2 Inspection	136
2.3 Reassembly	139
3. OIL COOLER, OIL FILTERS, OIL FILTER ALARM AND RELIEF VALVE	140
3.1 Disassembly	140
3.2 Inspection	141
3.3 Reassembly	143
4. BYPASS TYPE OIL FILTER	144
4.1 Disassembly	144
4.2 Inspection	145
4.3 Reassembly	145

LUBRICATION SYSTEM

1. DESCRIPTION

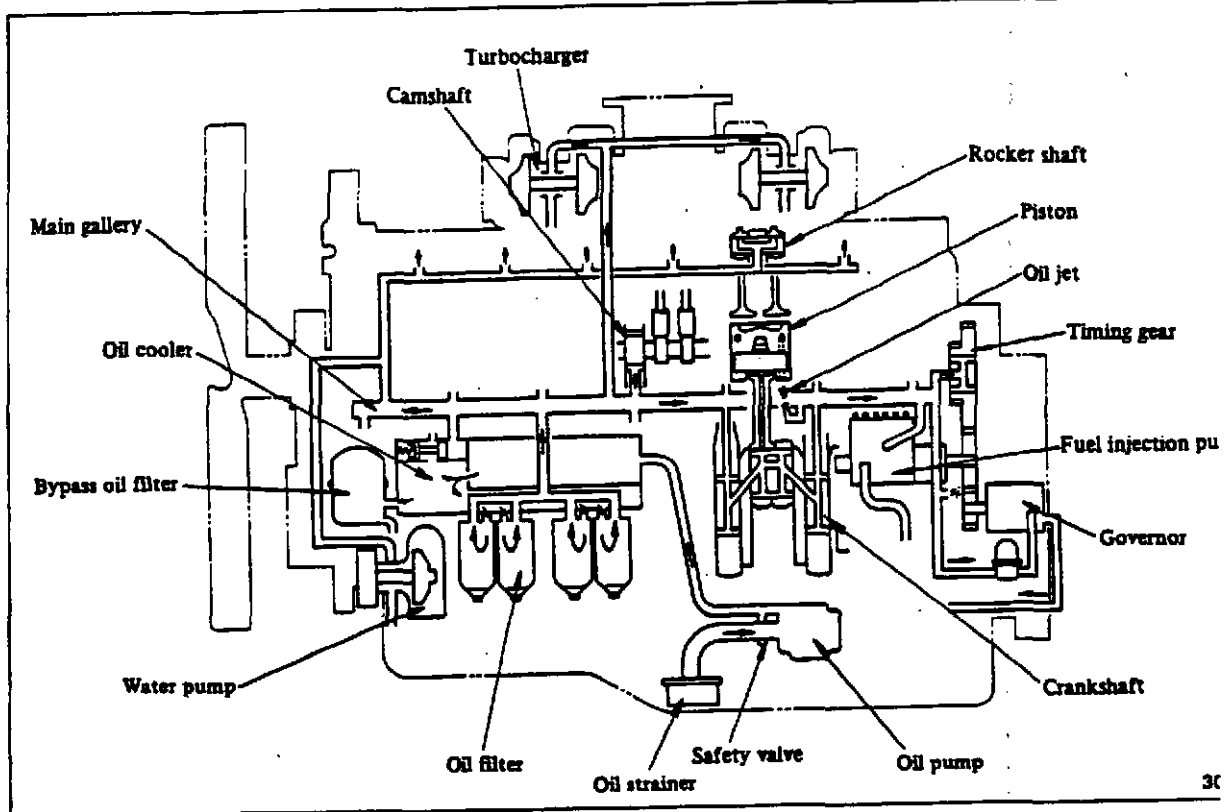

2. OIL PUMP, OIL STRAINER AND SAFETY VALVE

2.1 Disassembly

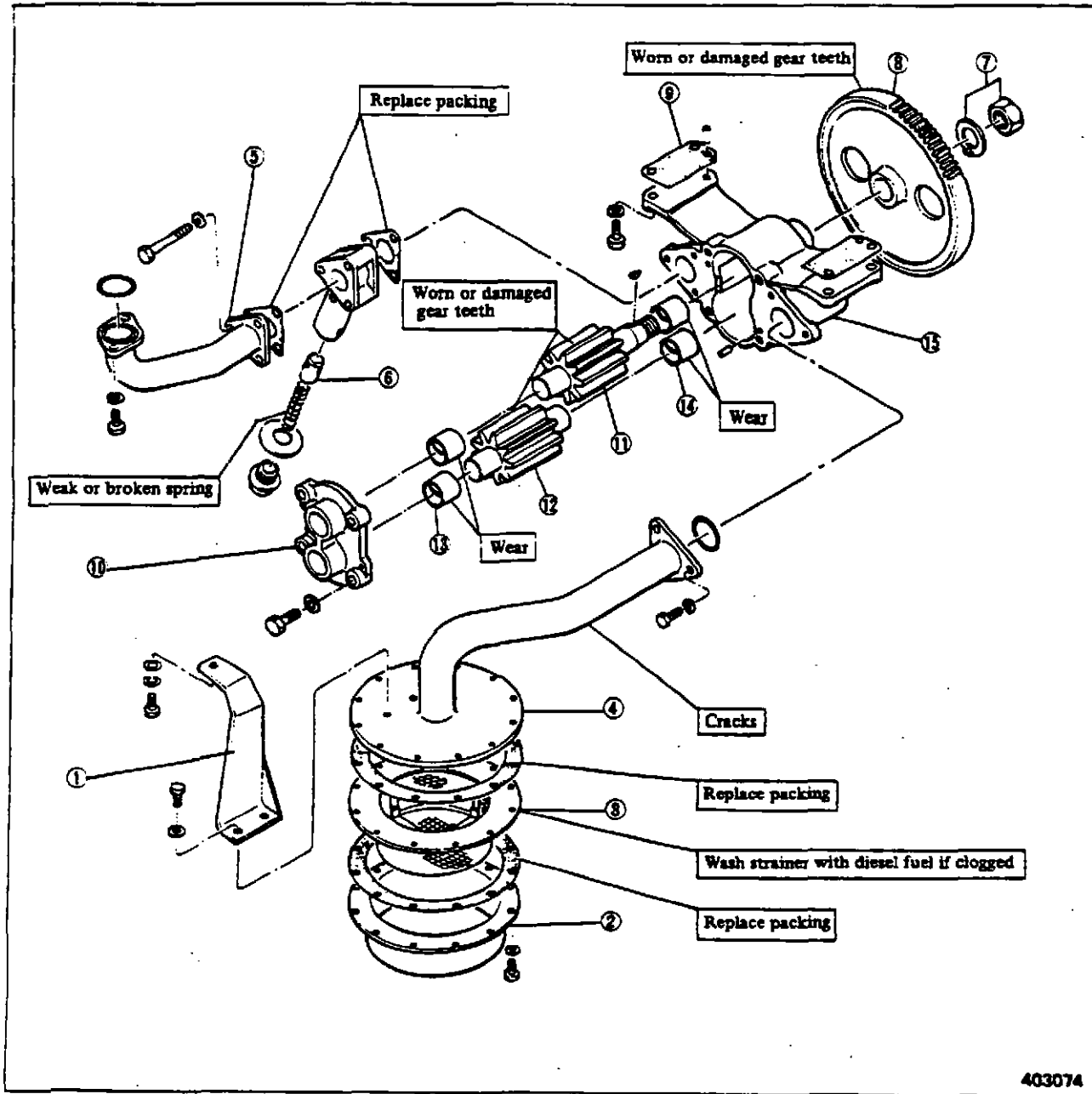

403074

- | | | |
|---------------------|-------------------------|--------------------|
| ① Support | ⑥ Safety valve assembly | ⑪ Pump drive gear |
| ② Plate | ⑦ Nut, washer | ⑫ Pump driven gear |
| ③ Oil strainer | ⑧ Oil pump gear | ⑬ Bushing |
| ④ Oil strainer pipe | ⑨ Shim | ⑭ Bushing |
| ⑤ Oil pipe | ⑩ Oil pump cover | ⑮ Oil pump case |

LUBRICATION SYSTEM

2.2 Inspection

(1) Measuring oil pump gear backlash

If the backlash exceeds the Service limit, replace the gears.

Unit: mm (in.)

Item	Standard clearance	Service limit
Oil pump gear backlash	0.10 - 0.20 (0.0039 - 0.0079)	0.40 (0.0157)

(2) Measuring pump gear tip clearance

Using a feeler gauge, measure the clearance. If the clearance exceeds the Service limit, replace the gears or case whichever is badly worn.

Unit: mm (in.)

Item	Nominal value	Standard clearance	Service limit
Pump gear tip clearance	77 (3.03)	0.15 - 0.23 (0.0059 - 0.0091)	0.35 (0.0138)

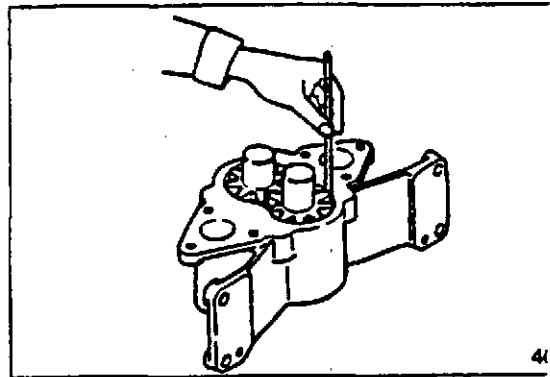

Measuring pump gear tip clearance

(3) Measuring pump gear end clearance

Using a dial gauge, measure the clearance. If the clearance exceeds the Service limit, replace the gears or case whichever is badly worn.

Unit: mm (in.)

Item	Nominal value	Standard clearance	Service limit
Pump gear end clearance	88 (3.46)	0.13 - 0.20 (0.0051 - 0.0079)	0.25 (0.0098)

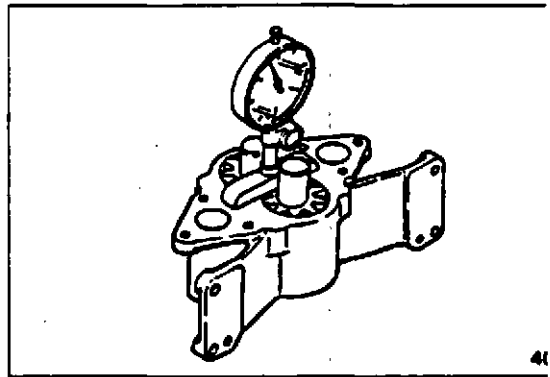

Measuring pump gear end clearance

(4) Measuring drive and driven gear shaft and bushing diameters

(a) Check gear teeth, and replace gears if defective.

(b) If the diameter exceeds the Service limit, replace the gears.

Unit: mm

Item	Nominal value	Assembly standard	Serv lim
Shaft diameter	34 (1.34)	33.960 - 33.944 (1.33701 - 1.33638)	33.5 (1.33)
Bushing inside diameter		34.000 - 34.025 (1.33858 - 1.33956)	34.0 (1.34)

(5) Replacing oil pump bushings

- (a) Use oil pump bushing puller (A) (32691-02700) to remove and install the bushings.
- (b) After pressing a new bushing into position, finish its inside diameter to 34H7 $+0.025$ mm (1.34 $+0.00098$ in.) $\frac{1.6S}{\sqrt{V}}$ $\begin{matrix} 0 \\ 0 \end{matrix}$

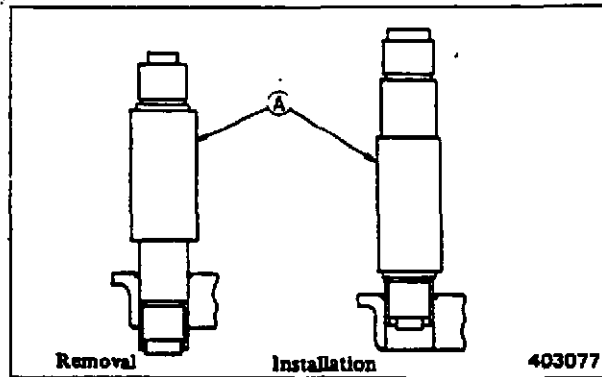

Replacing oil pump bushing

NOTE

When pressing the bushings, position their joints as shown.

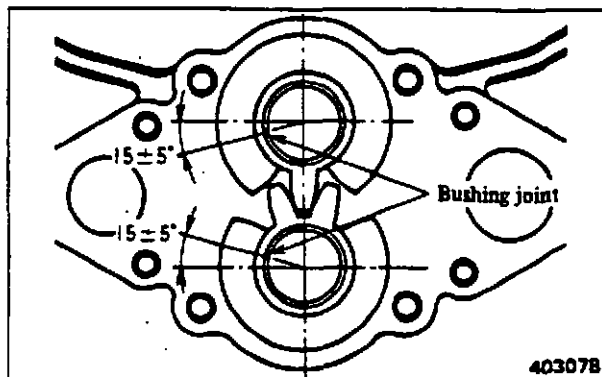

Oil pump bushing joint positions

(6) Inspecting safety valve

Measure the valve opening pressure. If the pressure is higher or lower than the Assembly standard, increase or decrease the thickness of shim inserted between the spring and spring cap nut. 2 mm (0.08 in.) thickness of shim will vary the pressure by about 1 kgf/cm² (14.2 psi) [0.1 MPa].

Item	Assembly standard
Safety valve opening pressure kgf/cm ² (psi) [MPa]	8.9 - 9.3 (126.6 - 132.2) [0.87 - 0.91]
Safety valve spring length under test force/test force mm (in.)/kgf (lbf) [N]	90 (3.54)/ 22.5 - 23.5 (49.6 - 51.8) [221 - 230]

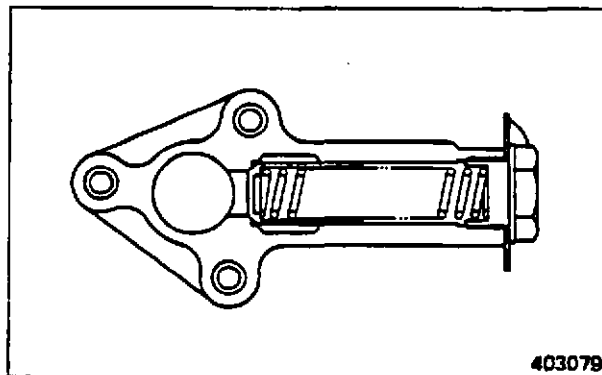

LUBRICATION SYSTEM

(7) Adjusting backlash between crankshaft gear and oil pump drive gear

After installing the pump to the crankcase, measure the backlash. If the backlash exceeds the Assembly standard, insert shim (32635-00900) [thickness: 1 mm (0.04 in.)] between the pump mount and crankcase.

Unit: mm (in.)

Item	Assembly standard
Backlash between crankshaft gear and oil pump drive gear	0.12 - 0.18 (0.0047 - 0.0071)

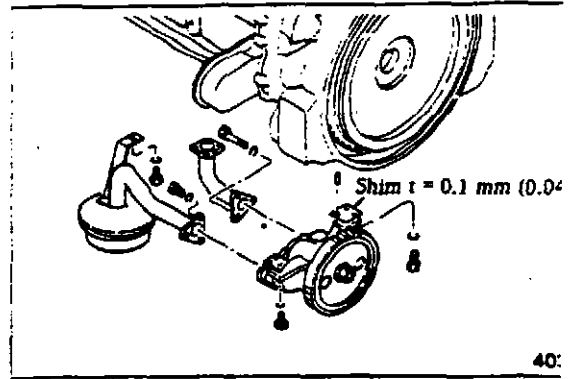

40:

2.3 Reassembly

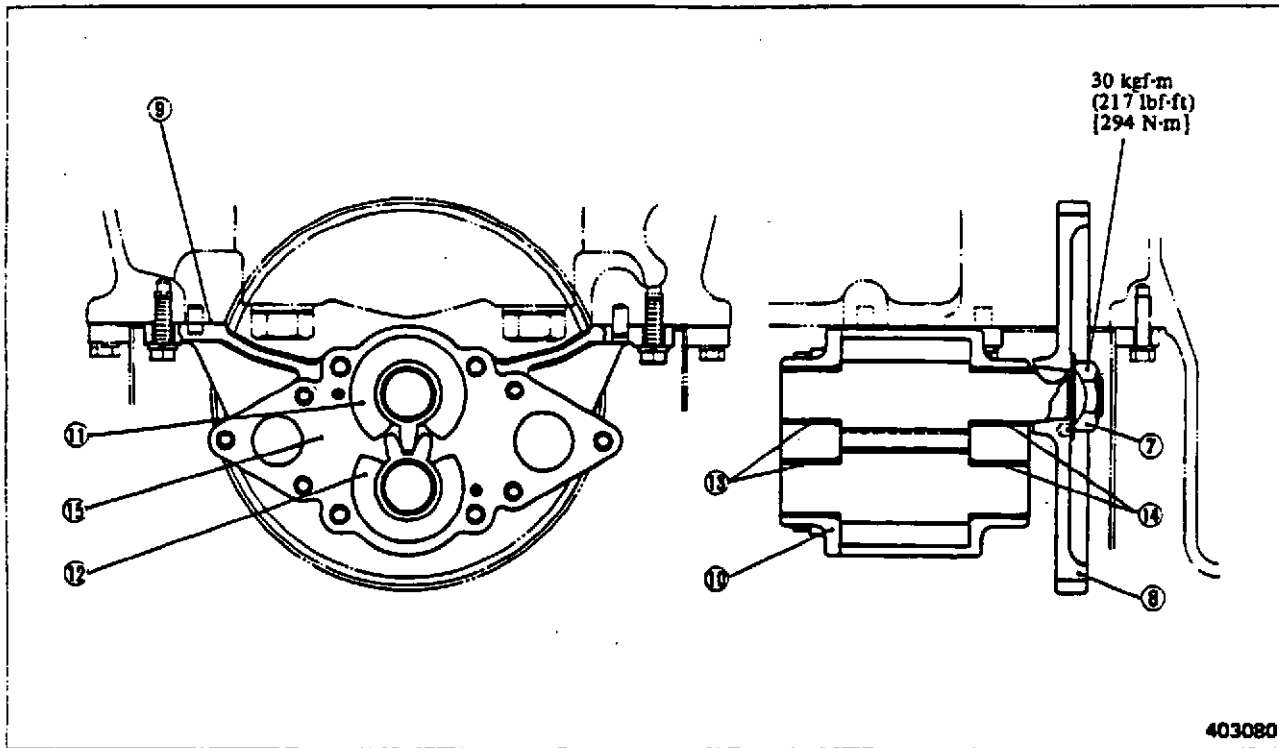

Reassembling sequence

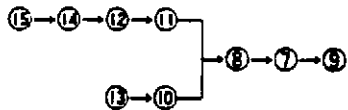

NOTE

Coat the pump parts with engine oil before installing them.

3. OIL COOLER, OIL FILTERS, OIL FILTER ALARM AND RELIEF VALVE

3.1 Disassembly

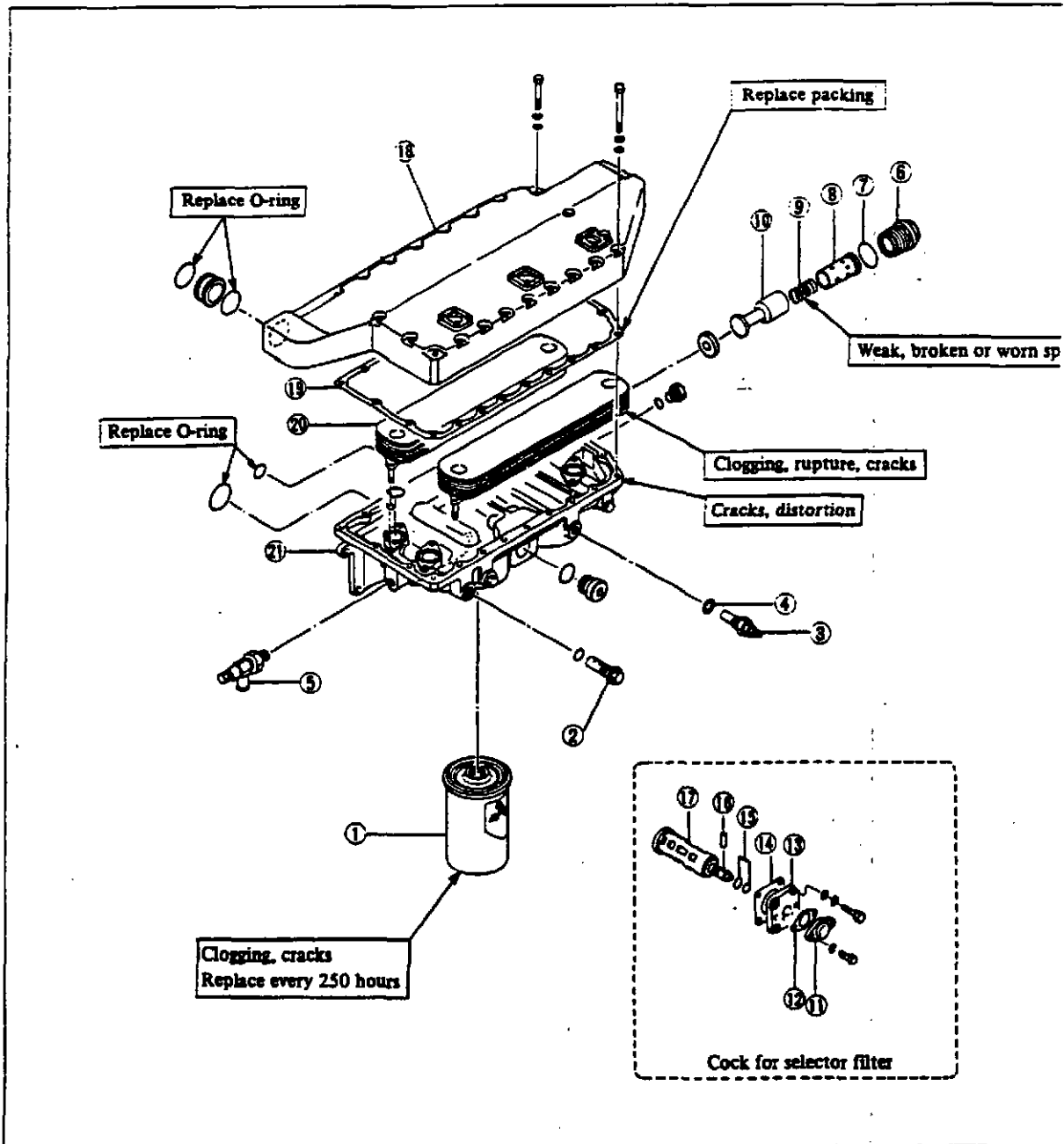

- ① Oil filter (cartridge type)
- ② Bypass valve
- ③ Oil filter alarm
- ④ Washer
- ⑤ Drain cock
- ⑥ Relief valve plug
- ⑦ O-ring

- ⑧ Relief valve sleeve
- ⑨ Relief valve spring
- ⑩ Relief valve
- ⑪ Cover
- ⑫ Packing
- ⑬ Cover
- ⑭ Packing

- ⑮ O-ring
- ⑯ Pin
- ⑰ Cock
- ⑱ Oil cooler case
- ⑲ Gasket
- ⑳ Oil cooler element
- ㉑ Oil cooler cover

3.2 Inspection

(1) Inspecting oil cooler element

Check the element for rupture or cracks by applying 15 kgf/cm² (213 psi) [1.5 MPa] pressure air to the element. Replace the element if it shows a sign of leakage.

(2) Inspecting bypass valve

Measure the valve opening pressure and, if it exceeds the Assembly standard, replace the valve.

Unit: kgf/cm² (psi) [MPa]

Item	Assembly standard
Pressure difference across bypass valve that makes it open	4.0 - 5.0 (57 - 71) [0.4 - 0.5]

(3) Inspecting oil filter

When replacing the paper element, sample about 500 cm³ (31 cu in.) of oil and check for presence of metal particles. If any metal particles are found, unfold the pleats of the element, and check the color and shape of the particles trapped in the pleats to locate the cause.

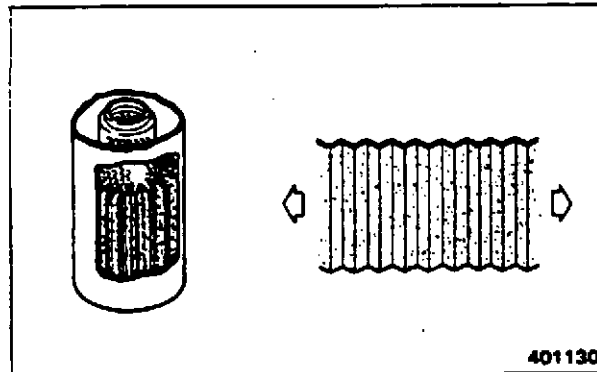

401130

(4) Inspecting oil filter alarm

- (a) Using a tester, test the alarm for insulation and continuity. Disassemble and repair the alarm if defective with respect to insulation or continuity. Replace the alarm if the bakelite and rubber insulators are deteriorated or damaged.

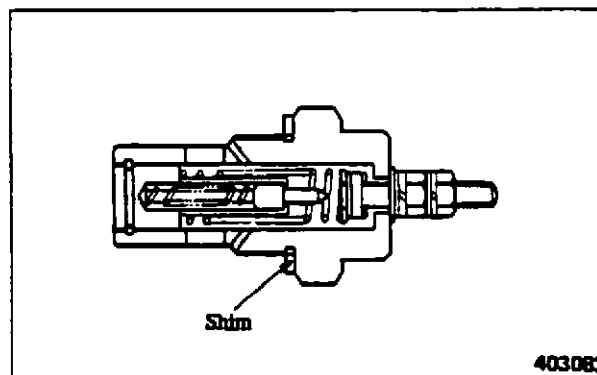

403082

LUBRICATION SYSTEM

- (b) If the valve opening pressure is out of the Assembly standard, adjust it by inserting shims. 1 mm (0.04 in.) thickness of shim corresponds to a change in pressure of 0.07 kgf/cm² (1.00 psi) [6.9 kPa].

Unit: kgf/cm² (psi) [MPa]

Item	Assembly standard
Pressure difference across oil filter alarm that makes its valve open	2.3 - 2.7 (32.7 - 38.4) [0.23 - 0.26]
Pressure difference across oil filter alarm that makes its contacts close	1.5 - 1.8 (21.3 - 25.6) [0.15 - 0.18]

(5) Measuring relief valve pressure

- (a) Remove the taper plug on the lower side of oil cooler, and attach a pressure gauge.
- (b) Warm up the engine until the oil temperature rises to 70°C to 90°C (158°F to 194°F).
- (c) Measure the oil pressure at idling speed and at maximum speed.

Unit: kgf/cm² (psi) [MPa]

Item	Assembly standard
Relief valve opening pressure	5 - 7 (71 - 100) [0.5 - 0.7]

3.3 Reassembly

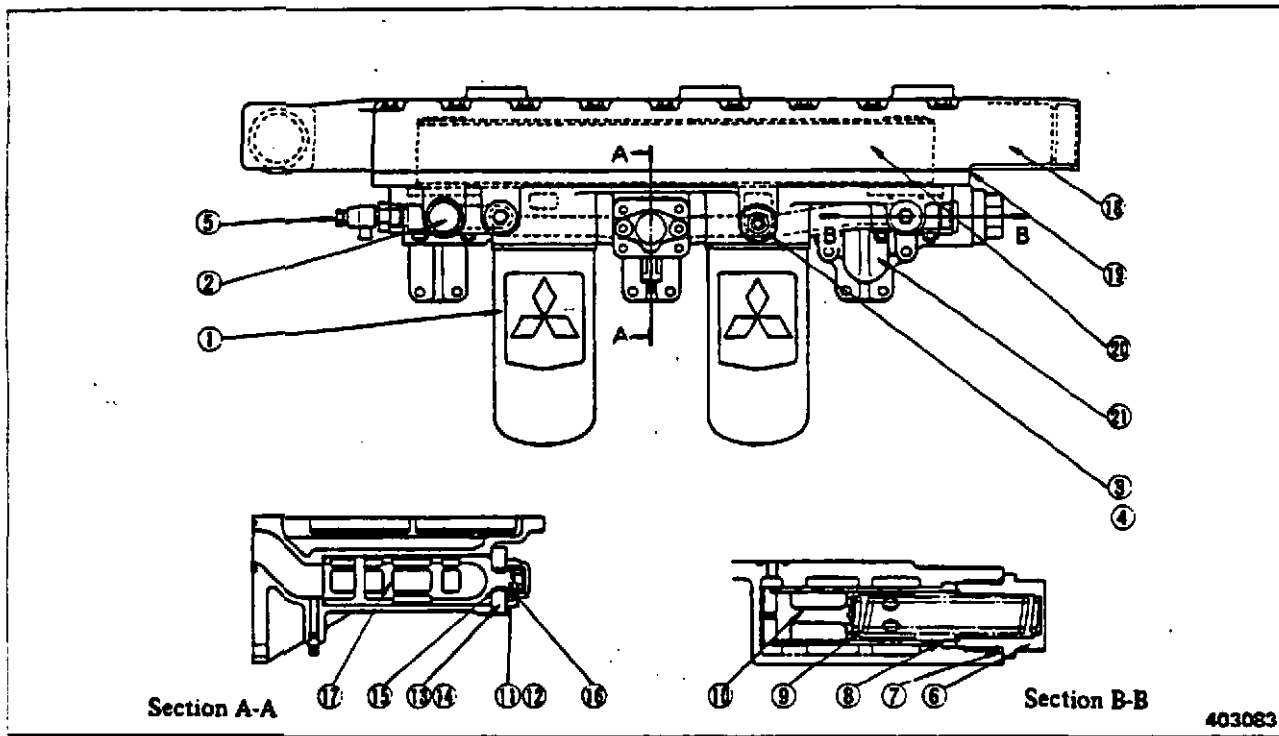

Reassembling sequence

21 → 20 → 19 → 18 → 17 → 15 → 14 → 13 → 16 → 12 → 11 → 8 → 10 → 9 → 7 → 6 → 5 → 4 → 3 → 2 → 1



CAUTION

Replace packings and O-rings during reassembly.

4.2 Inspection

- (1) If the cover assembly, body and bushings are badly worn, replace them as an assembly.
- (2) Disassemble the rotor, and wash it in diesel fuel with a soft brush.
- (3) After washing, direct 3 to 5 kgf/cm² (43 to 71 psi) [0.3 to 0.5 MPa] pressure air to air dry. Clean the nozzle port of the pipe thoroughly.

4.3 Reassembly

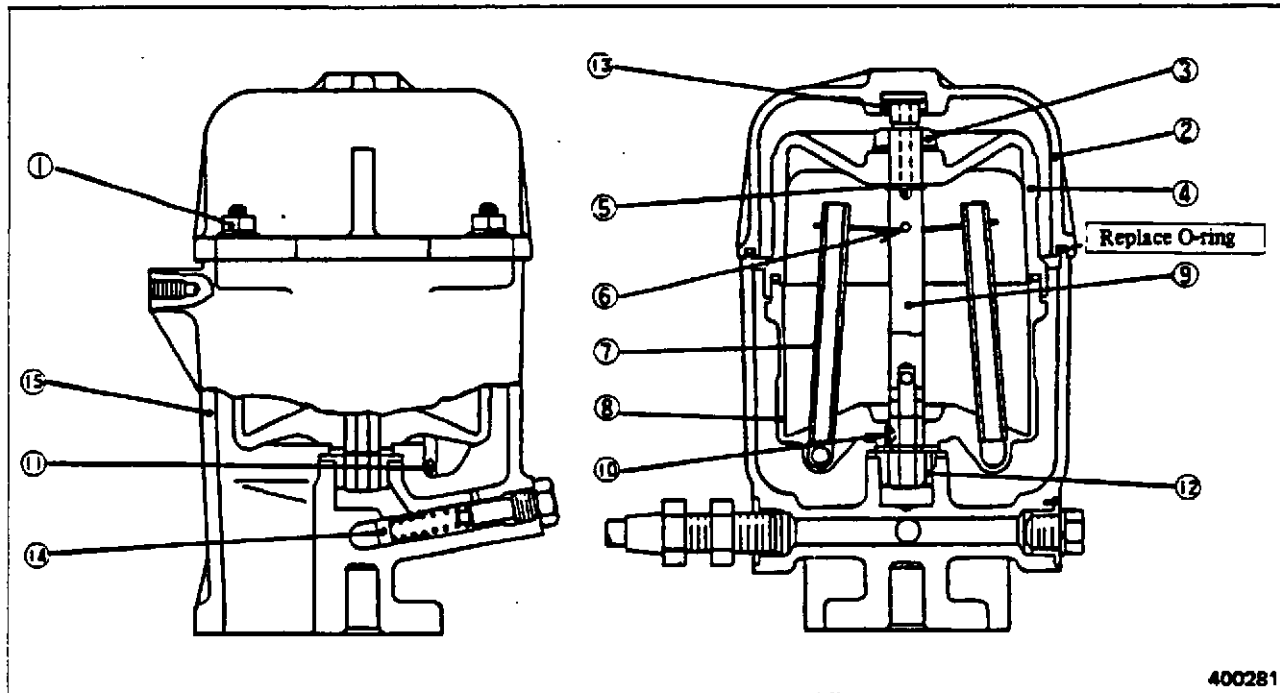

Reassembling sequence

- 15 → 14 → 12 → 9 → 10 → 11 → 8 → 7 → 6 → 5 → 4 → 3 → 13 → 2 → 1

COOLING SYSTEM

1. COOLING SYSTEM WITH RADIATOR	148
2. COOLING SYSTEM WITH REMOTE WATER SUPPLY	148
3. WATER PUMP AND TENSION PULLEY	149
3.1 Disassembly	149
3.2 Inspection	150
3.3 Reassembly	152
4. THERMOSTATS	154
4.1 Disassembly	154
4.2 Inspection	154
5. RADIATOR	155
Inspection	155
6. FAN DRIVE	156
6.1 Disassembly	156
6.2 Inspection	157
6.3 Reassembly	158

COOLING SYSTEM

1. COOLING SYSTEM WITH RADIATOR

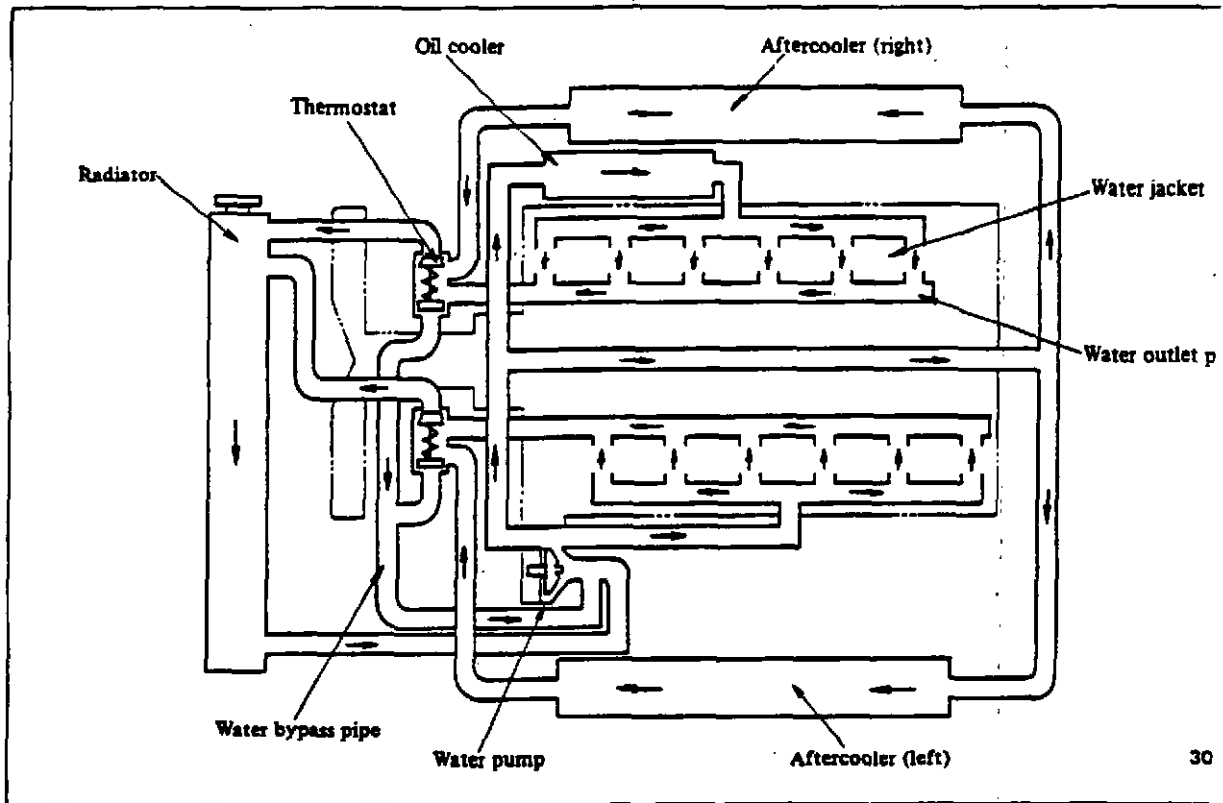

2. COOLING SYSTEM WITH REMOTE WATER SUPPLY

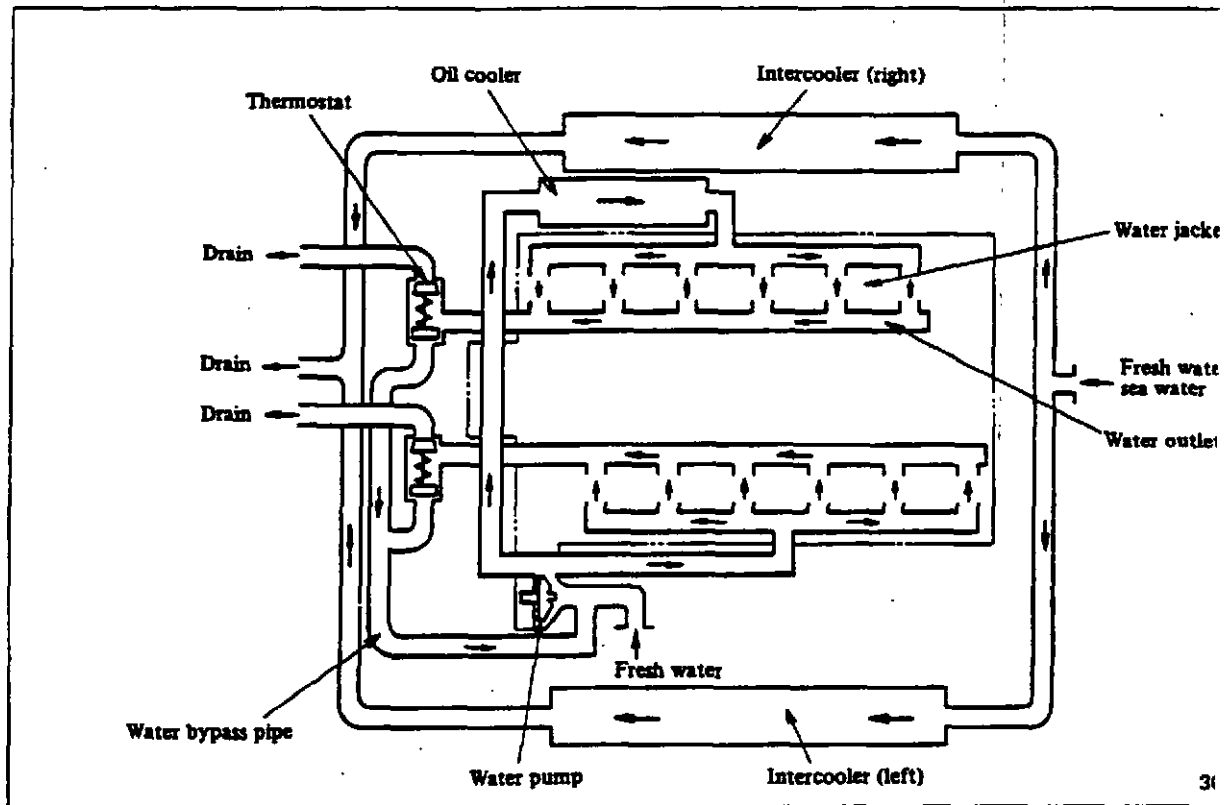

3. WATER PUMP AND TENSION PULLEY

3.1 Disassembly

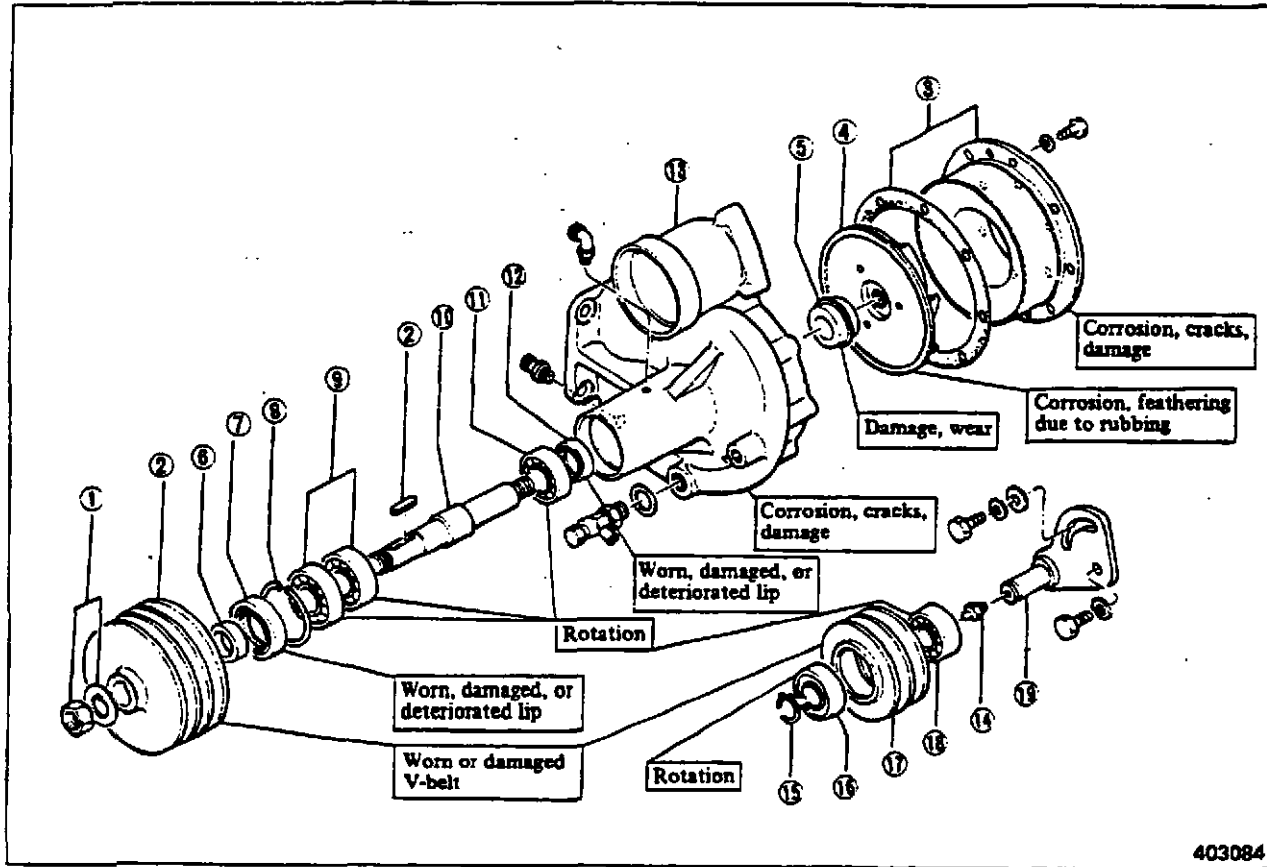

- | | | |
|-----------------------------|--------------------|------------------|
| ① Nut, lock washer | ⑧ Snap ring | ⑮ Snap ring |
| ② Water pump pulley, key | ⑨ Ball bearing | ⑯ Ball bearing |
| ③ Water pump cover, packing | ⑩ Water pump shaft | ⑰ Tension pulley |
| ④ Impeller | ⑪ Ball bearing | ⑱ Ball bearing |
| ⑤ Unit seal | ⑫ Oil seal | ⑲ Shaft |
| ⑥ Spacer | ⑬ Water pump case | |
| ⑦ Oil seal | ⑭ Grease fitting | |

COOLING SYSTEM

(1) Inspecting water pump on engine

Touch the drain port located at the bottom of the pump with the finger. If the port is oozing water, inspect the unit seal for condition. If it is oozing oil, the oil seal would be defective.

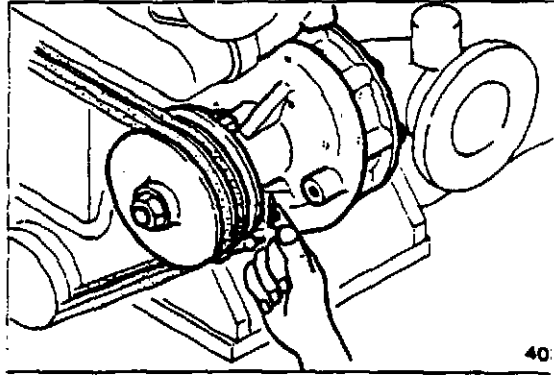

40

(2) Removing water pump shaft

Remove the snap ring for the front bearing. Using a press or soft hammer, drive out the pump shaft complete with the bearing toward the pulley side.



Be careful not to damage the water pump shaft and impeller during removal of the impeller from the shaft.

3.2 Inspection

Water pump

Measure the inside diameter of the pump case bore to which the bearing outer race is fitted and the diameter of the pump shaft on which the bearing inner race is fitted. Replace the bearing, case or shaft whichever is badly worn or damaged.

Unit: mm (in.)

Item	Nominal value	Assembly standard	
Inside diameter of pump case bore to which the bearing outer race is fitted	62 (2.44)	61.988 - 62.018 (2.44047 - 2.44165)	
	72 (2.83)	71.988 - 72.018 (2.83417 - 2.83535)	
Bearing	Diameter	62 (2.44)	62.004 - 61.983 (2.44110 - 2.44027)
		72 (2.83)	72.004 - 71.983 (2.83480 - 2.83397)
	Inside diameter	30 (1.18)	29.987 - 30.003 (1.18059 - 1.18122)
Diameter of pump shaft on which the bearing inner race is fitted	30 (1.18)	30.011 - 30.002 (1.18153 - 1.18118)	

Tension pulley

Measure the inside diameter of the pulley bore to which the bearing outer race is fitted and the diameter of the shaft on which the bearing inner race is fitted. Replace the bearing, pulley or shaft whichever is badly worn or damaged.

Unit: mm (in.)

Item	Nominal value	Assembly standard	
Inside diameter of pulley to which bearing outer race is fitted	52 (2.05)	51.961 - 52.009 (2.04570 - 2.04759)	
Bearing	Diameter	52 (2.05)	52.004 - 51.983 (2.04740 - 2.04657)
	Inside diameter	20 (0.79)	19.987 - 20.003 (0.78689 - 0.78752)
Diameter of shaft on which bearing inner race is fitted	20 (0.79)	20.003 - 19.987 (0.78752 - 0.78689)	

COOLING SYSTEM

3.3 Reassembly

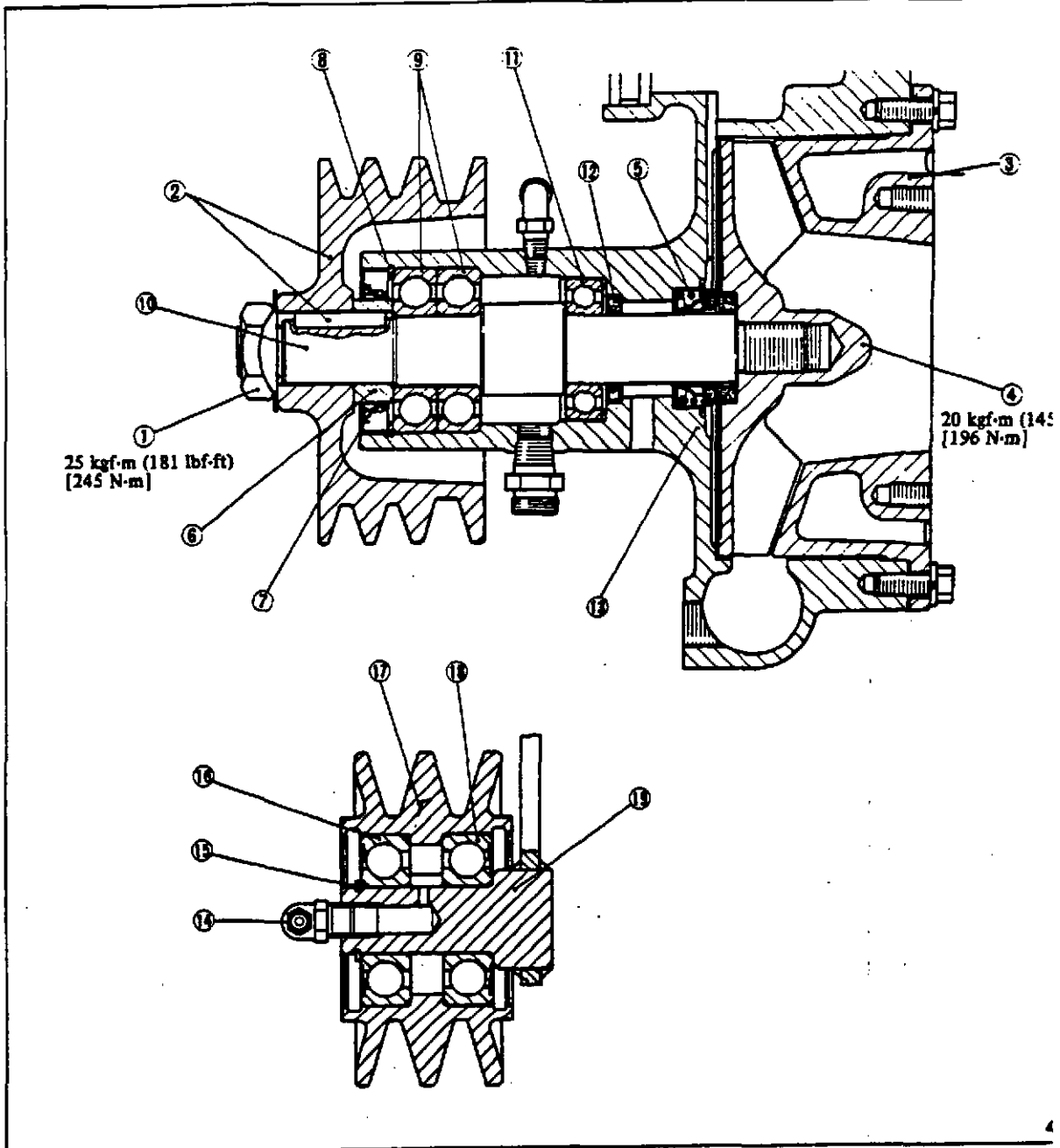

Reassembling sequence

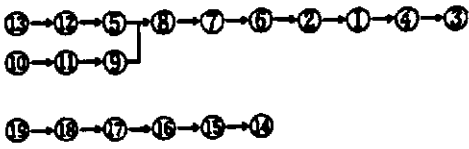

- (1) Using oil seal installer (A) (32591-03200), press in the oil seal.

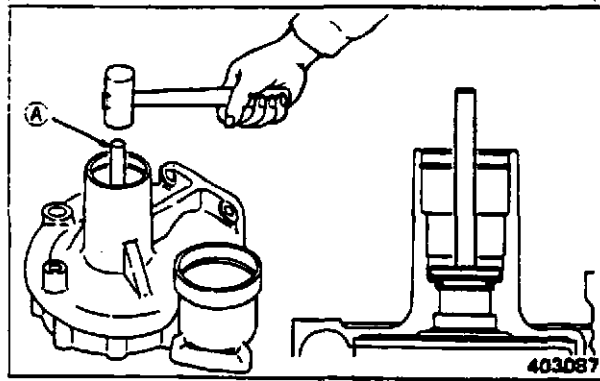

- (2) Using unit seal installer (B) (37191-06300), press in the unit seal. Be sure to replace the unit seal if it has been removed during disassembly.

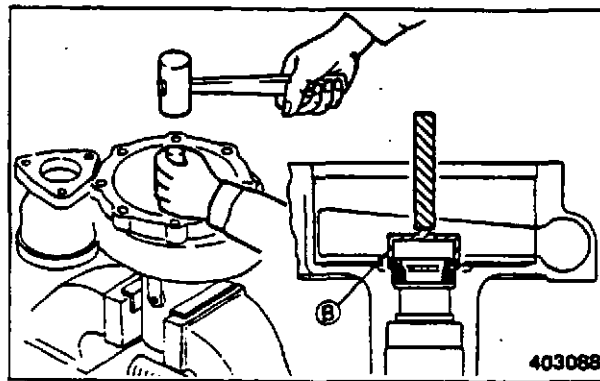

- (3) Attach thread cover (C) (37191-06600) to the pump shaft complete with ball bearing. Using installer (D) (32591-03600), press the pump shaft into the pump case.

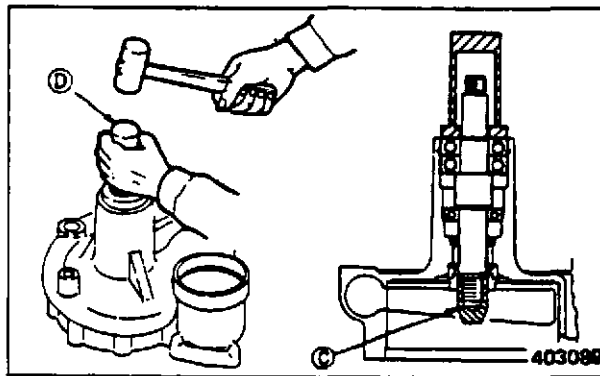

- 4) Using oil seal installer (E) (32591-03100), press in the outer oil seal into the pump case.

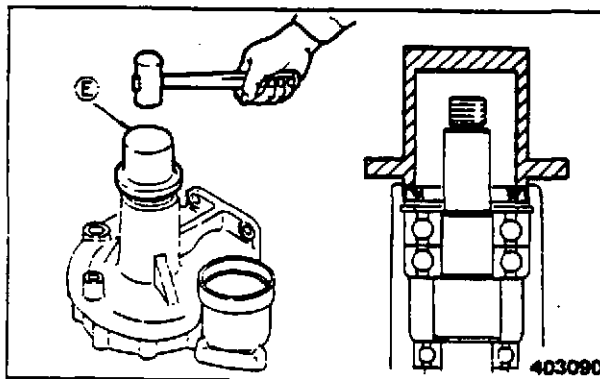

COOLING SYSTEM

4. THERMOSTATS

4.1 Disassembly

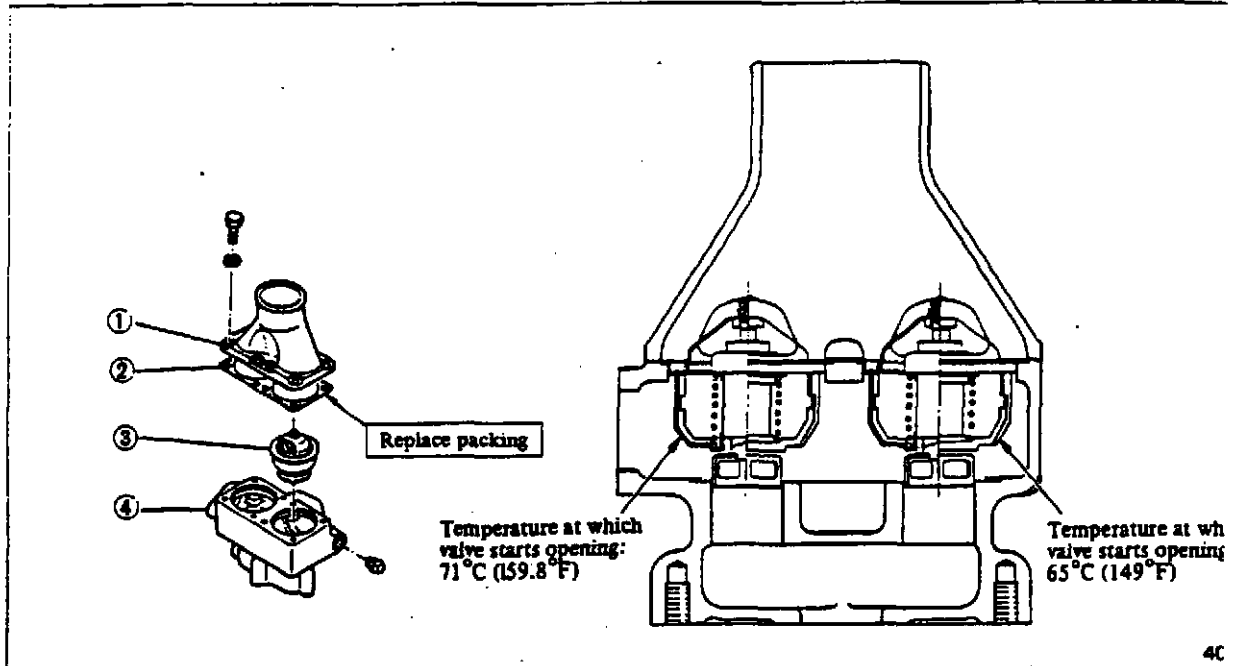

- ① Case cover
- ② Packing

- ③ Thermostat
- ④ Thermostat case

4.2 Inspection

Place the thermostat in a water tub, and test it for thermostatic action by heating the tub to raise the water temperature. If the valve fails to operate properly, replace the thermostat.

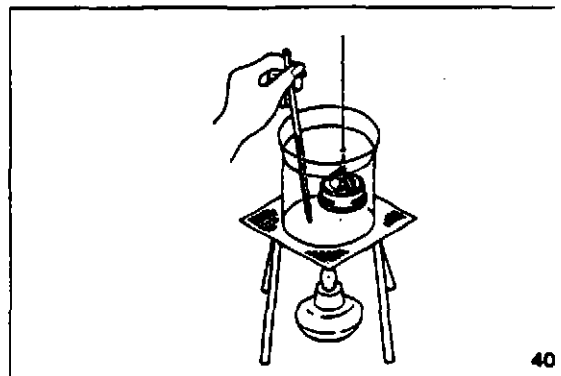

Item	Assembly standard	
	A	B
Temperature at which valve starts opening	$65 \pm 2^{\circ}\text{C}$ ($149 \pm 3.6^{\circ}\text{F}$)	$71 \pm 2^{\circ}\text{C}$ ($159.8 \pm 3.6^{\circ}\text{F}$)
Temperature at which valve opens fully	$80 \pm 2^{\circ}\text{C}$ ($176 \pm 3.6^{\circ}\text{F}$)	$85 \pm 2^{\circ}\text{C}$ ($185 \pm 3.6^{\circ}\text{F}$)
Valve lift	10 mm (0.39 in.), minimum	

NOTE

- (a) Stir the water in the tub with a stick to maintain its temperature uniform during test.
- (b) Be sure to place the thermostat in correct position by ascertaining the valve opening temperature stamped on its mounting flange at reassembly.

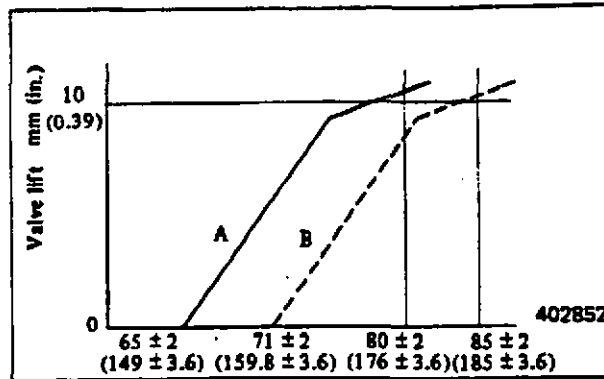

Thermostat performance curve

5. RADIATOR

Inspection

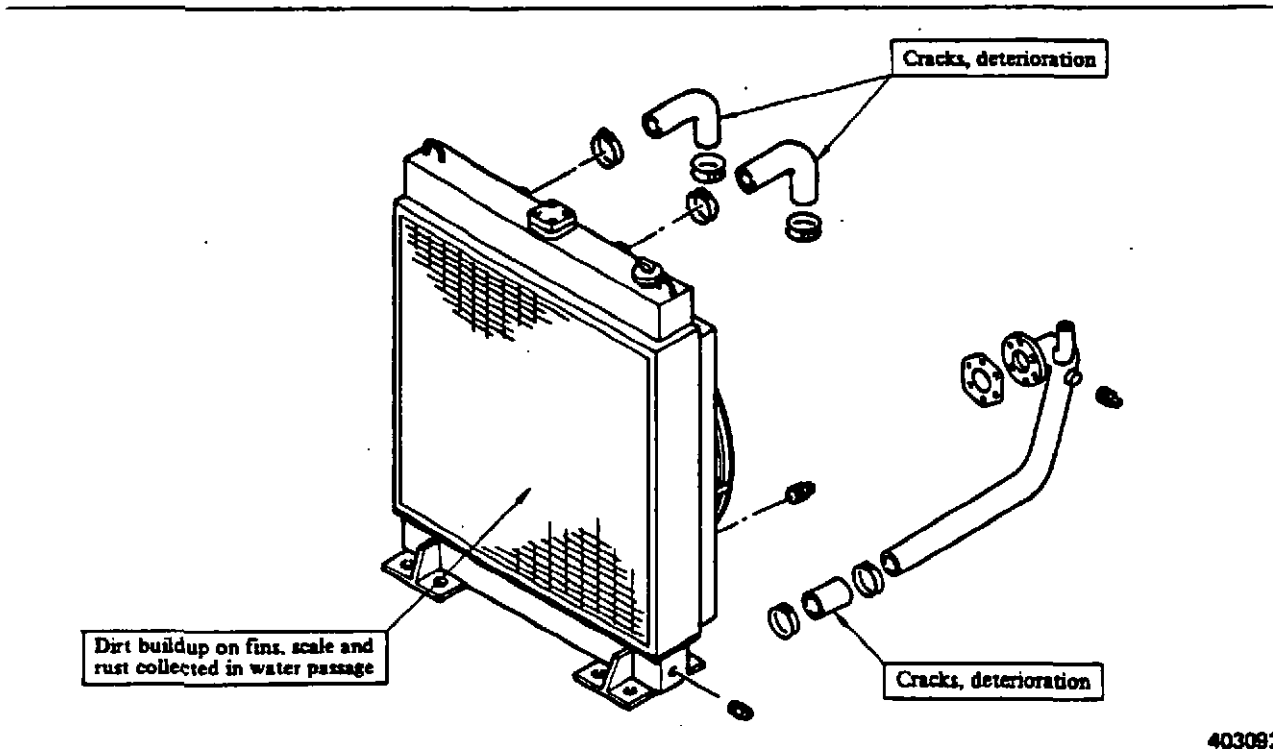

COOLING SYSTEM

6. FAN DRIVE

6.1 Disassembly

<Pressure-lubricated type>

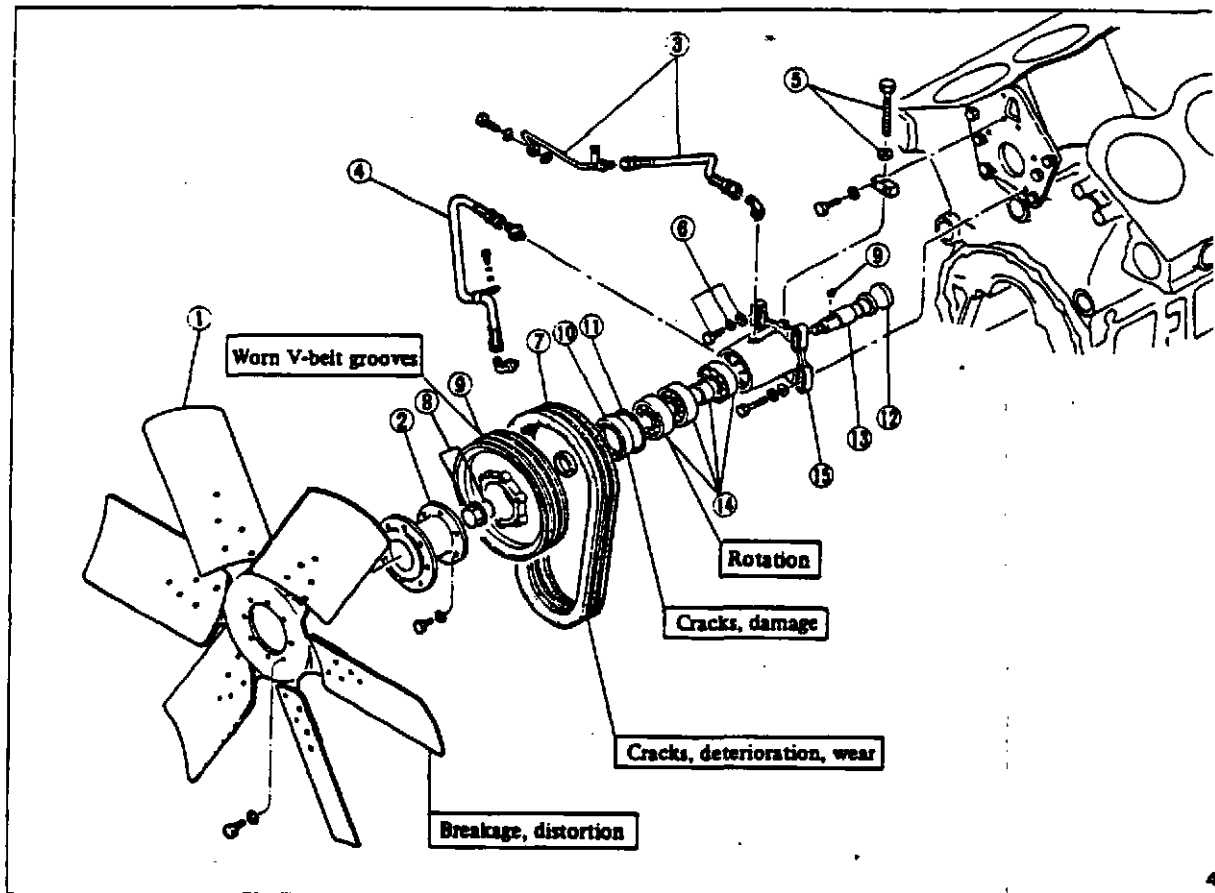

- | | |
|-------------------------------------|------------------------|
| ① Fan | ⑨ Pulley, sleeve, key |
| ② Spacer | ⑩ Oil seal, |
| ③ Flexible pipe | ⑪ Snap ring |
| ④ Flexible pipe | ⑫ Sealing cap |
| ⑤ Adjusting bolt, nut | ⑬ Shaft |
| ⑥ Bolt, spring washer, plain washer | ⑭ Ball bearing, spacer |
| ⑦ Belt | ⑮ Bracket |
| ⑧ Cap nut, O-ring | |

CAUTION

If any one of the fan blades is broken, the fan vibrates excessively, making the opposite blade fragile. With this kept in mind, carefully inspect each blade for cracks and distortion.

6.2 Inspection

Measure the inside diameter of the bracket to which the bearing outer race is fitted and the diameter of the shaft on which the bearing inner race is fitted. Replace the bearing, shaft or bracket whichever is badly worn or damaged.

Unit: mm (in.)

Item		Nominal value	Assembly standard
Inside diameter of bracket bore to which bearing outer race is fitted		100 (3.94)	99.987 - 100.022 (3.93649 - 3.93787)
		110 (4.33)	109.987 - 110.022 (4.33019 - 4.33157)
Bearing	Diameter	100 (3.94)	100.005 - 99.980 (3.93720 - 3.93621)
		110 (4.33)	110.005 - 109.980 (4.33090 - 4.32991)
	Inside diameter	40 (1.57)	39.985 - 40.003 (1.57421 - 1.57492)
		45 (1.77)	44.985 - 45.003 (1.77106 - 1.77177)
Diameter of shaft on which bearing inner race is fitted		40 (1.57)	40.013 - 40.002 (1.57531 - 1.57488)
		45 (1.77)	45.013 - 45.002 (1.77216 - 1.77173)

6.3 Reassembly

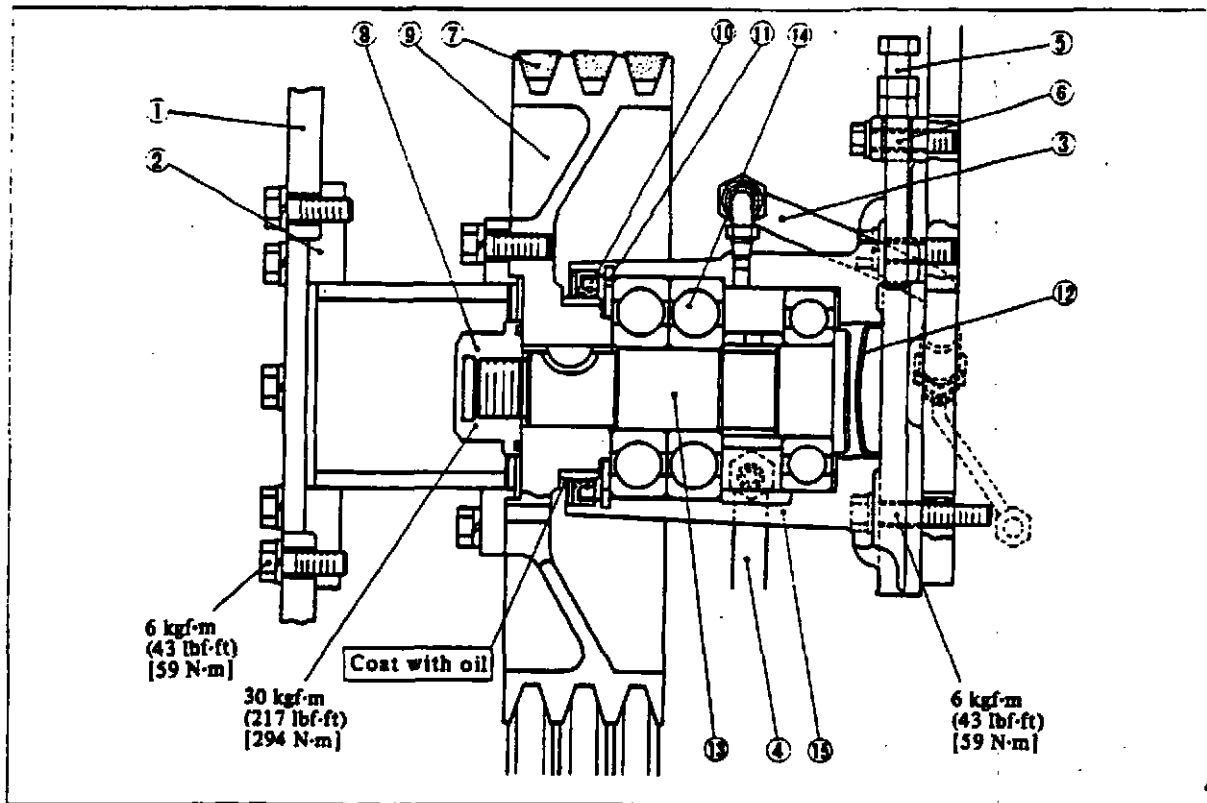

Reassembling sequence

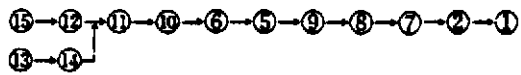

- (1) Using bearing installer (A) (32691-04200), press the bearing onto the shaft.

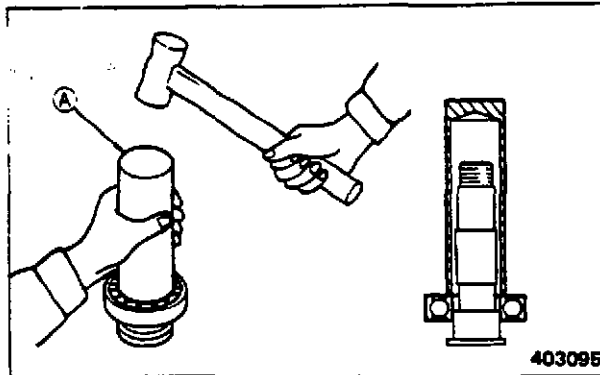

- (2) Press the shaft into the bracket. Using bearing installer (B) (32691-04300), press the bearings to the shaft and bracket.

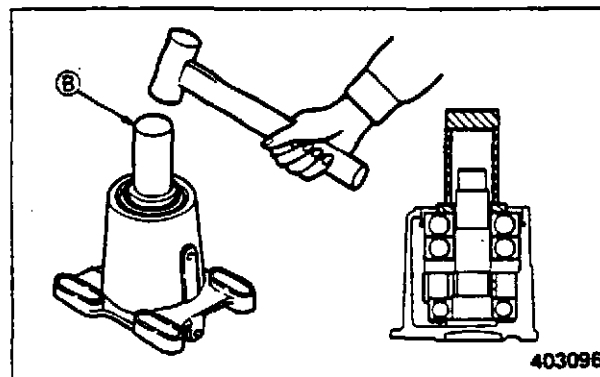

- (3) Using oil seal installer (C) (32591-03100), press the oil seal into the bracket.

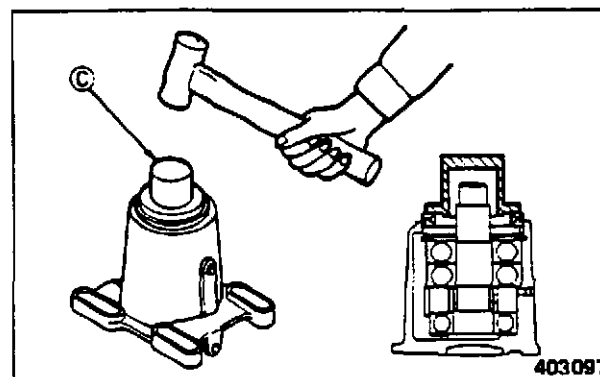

FUEL SYSTEM

1. DESCRIPTION	162
2. FUEL FILTERS	163
2.1 Disassembly and inspection	163
2.2 Reassembly	164
3. FUEL INJECTION NOZZLES	165
3.1 Disassembly	165
3.2 Inspection and adjustment	165
3.3 Reassembly	167
4. WOODWARD GOVERNOR DRIVE	168
4.1 Disassembly	168
4.2 Inspection	169
4.3 Reassembly	170

FUEL SYSTEM

1. DESCRIPTION

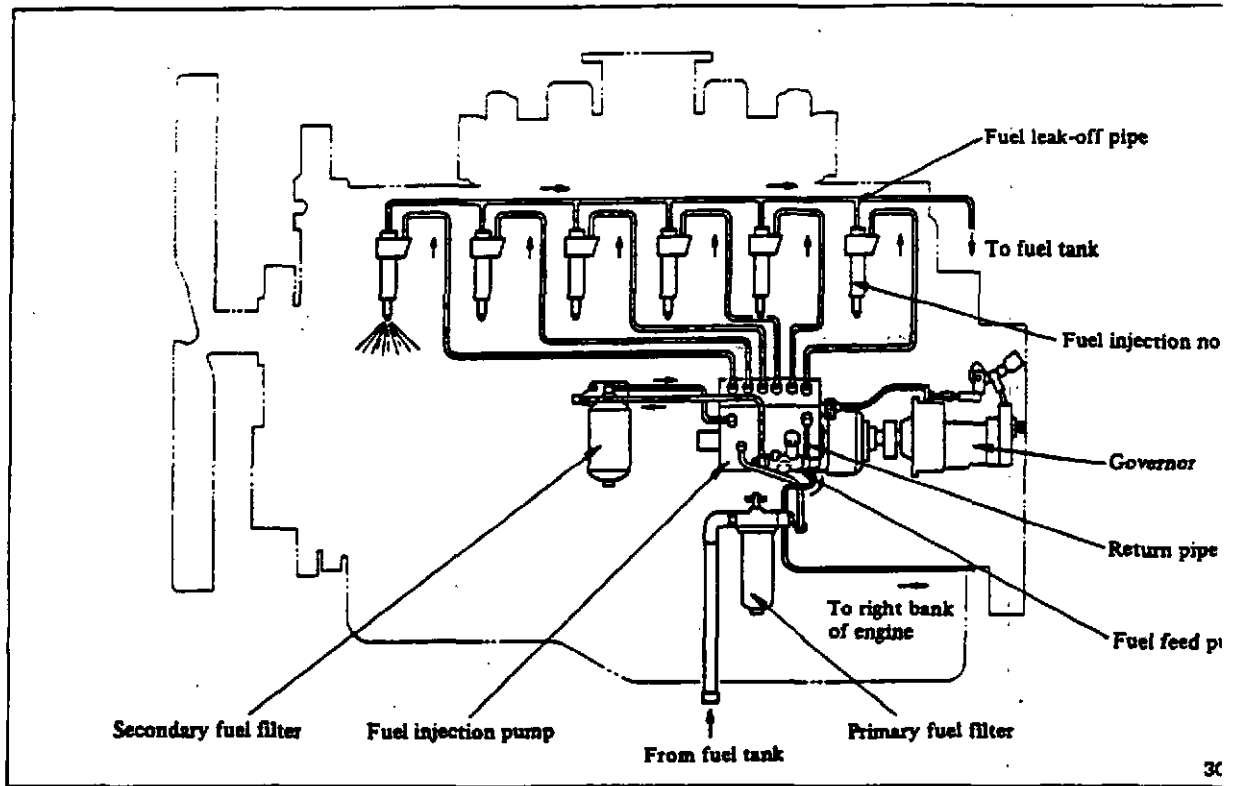

2. FUEL FILTERS

2.1 Disassembly and inspection

(Cartridge type)

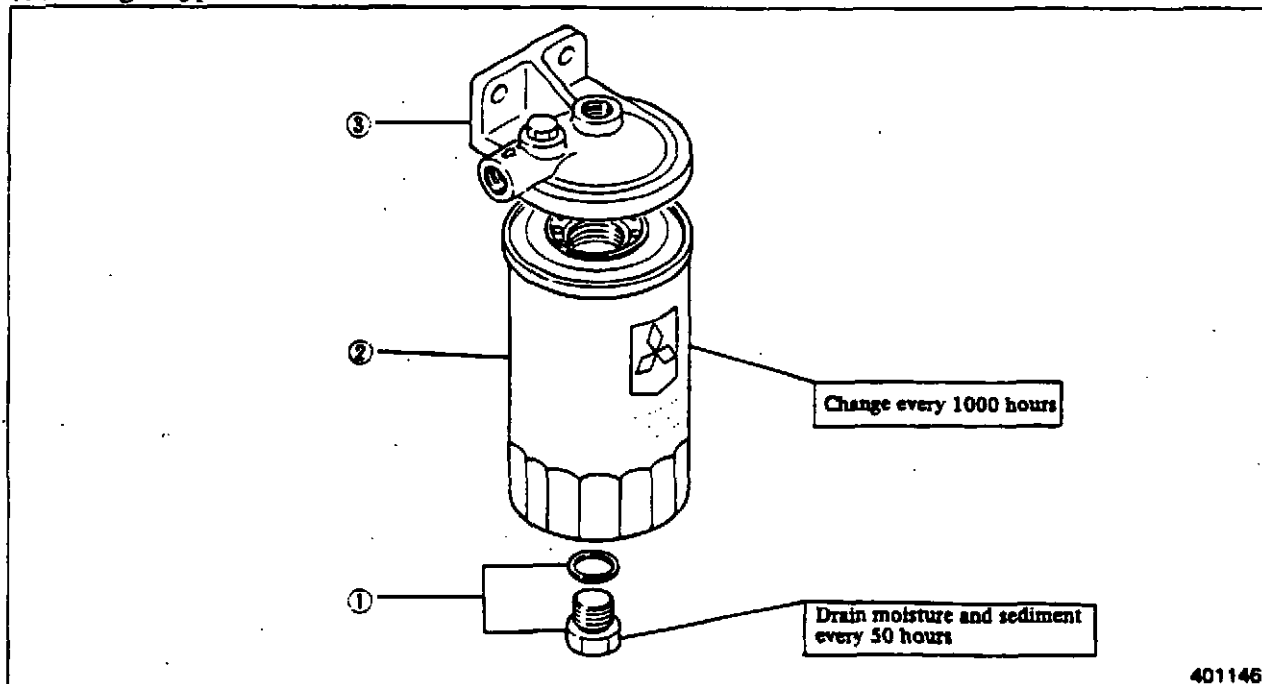

401146

① Plug, gasket

② Cartridge filter

③ Filter bracket

(Wire-element type)

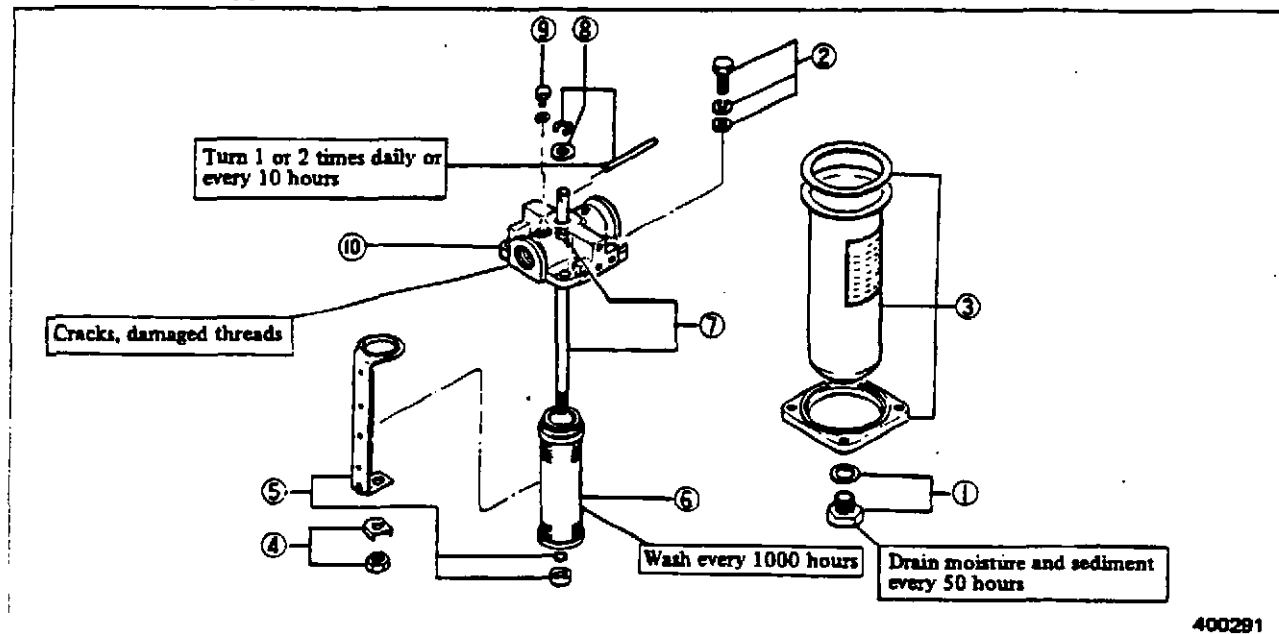

400291

① Plug, gasket

② Bolt, spring washer, plain washer

③ Flange, filter case, packing

④ Washer, nut

⑤ Plate assembly, collar, O-ring

⑥ Element

⑦ Rod, O-ring

⑧ Ring, washer, handle

⑨ bolt, gasket

⑩ Cover

FUEL SYSTEM

2.2 Reassembly (Cartridge type)

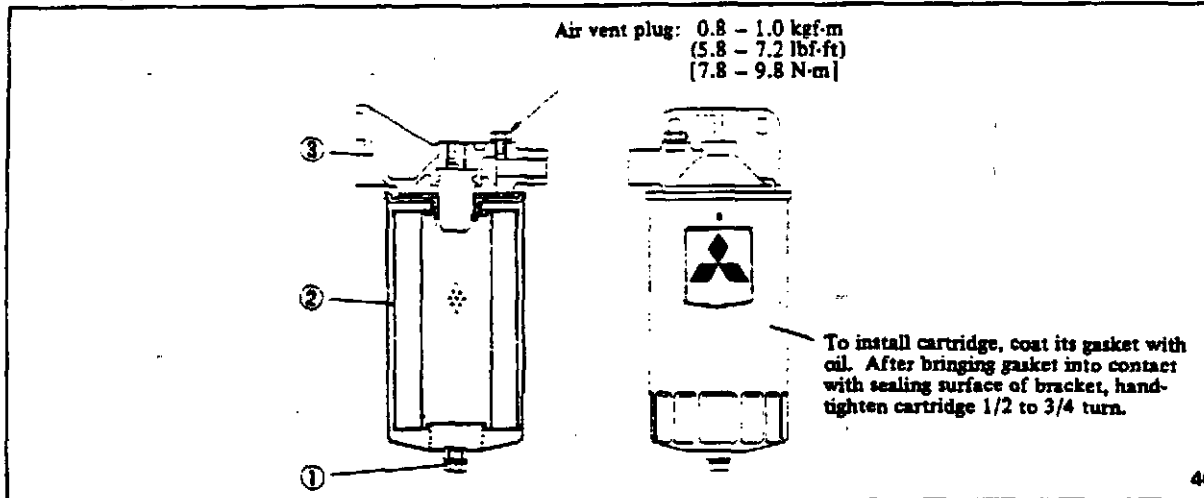

Reassembling sequence

③→②→①

(Wire-element type)

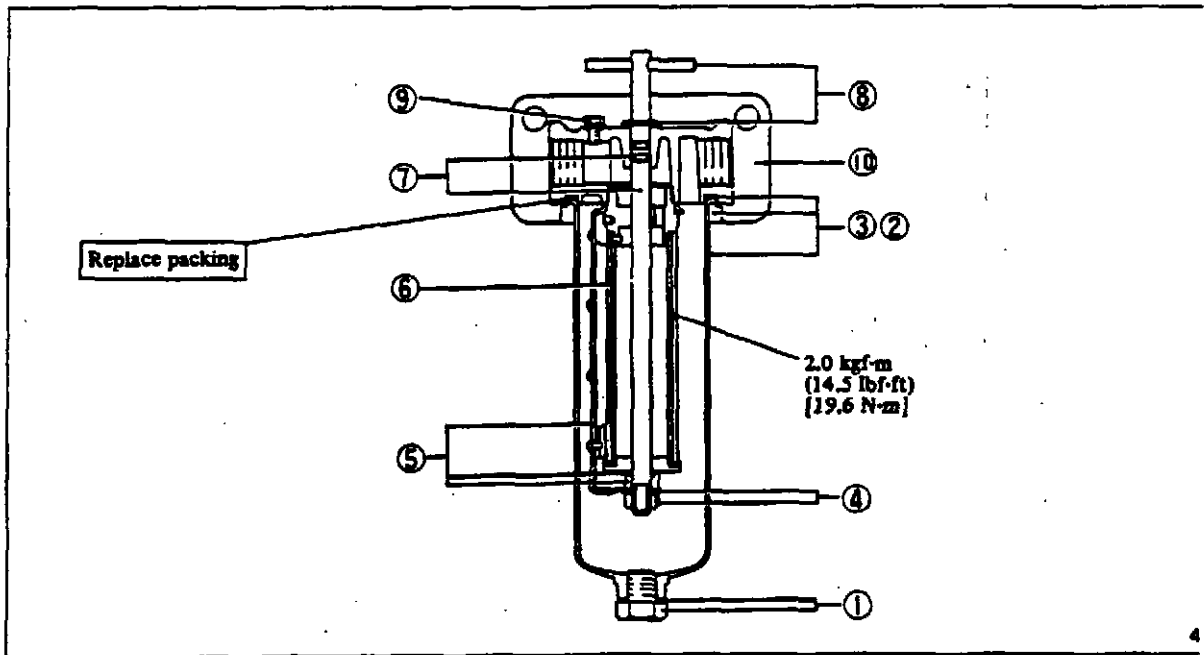

Reassembling sequence

⑨→⑧→⑦→⑥→⑤→④→③→②→①



CAUTION

After installing the fuel filter on engine, start the engine, and make sure that the filters are free from fuel leakage.

3. FUEL INJECTION NOZZLES

3.1 Disassembly

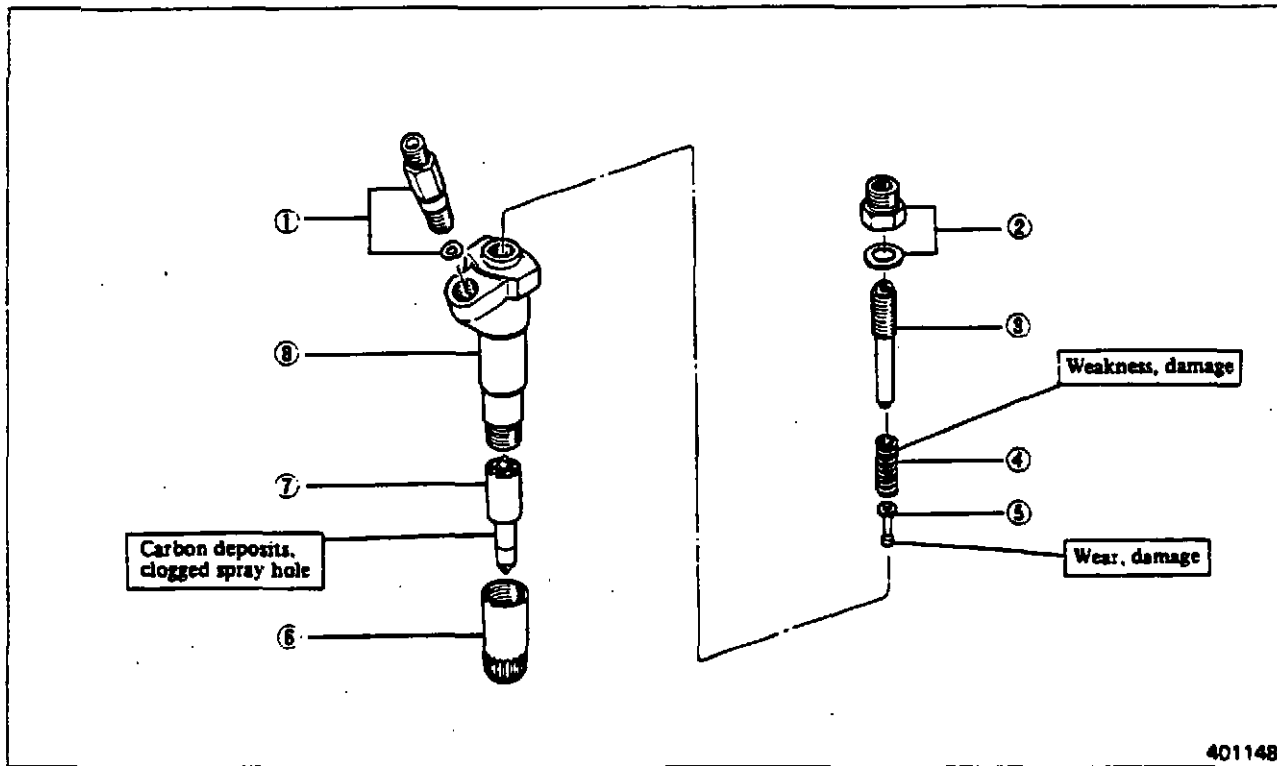

401148

- ① Inlet connector, gasket
- ② Cap nut, gasket
- ③ Adjusting screw
- ④ Nozzle spring
- ⑤ Pushrod
- ⑥ Retaining nut
- ⑦ Nozzle tip
- ⑧ Nozzle holder

3.2 Inspection and adjustment

(1) Injection pressure

- (a) Install the nozzle on the tester. Operate the handle of the tester at a rate of about 1 stroke per second to observe the pressure at which fuel injection begins.

Unit: kgf/cm² (psi) [MPa]

Item	Assembly standard	Adjusting limit
Injection pressure (valve opening pressure)	220 (3128) [21.6]	225 - 230 (3200 - 3271) [22.1 - 22.6]

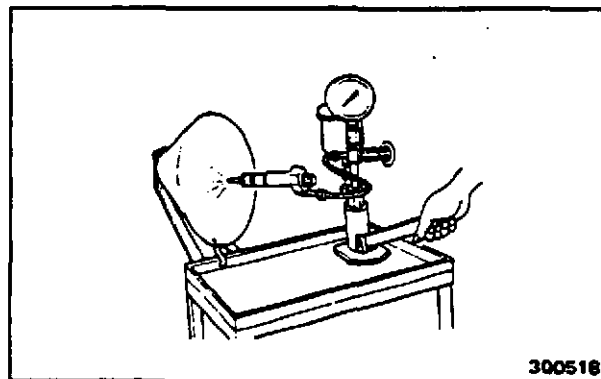

300516



WARNING

During injection testing never attempt to touch the spray hole of injection nozzle.

FUEL SYSTEM

- (b) To adjust the injection pressure, remove cap nut (1) from the nozzle holder, and turn adjusting screw (2) in either direction with a screwdriver.
- (c) After completing the adjustment, tighten the cap nut to the specified torque.
- (d) Recheck the injection pressure, making sure that it is correct.

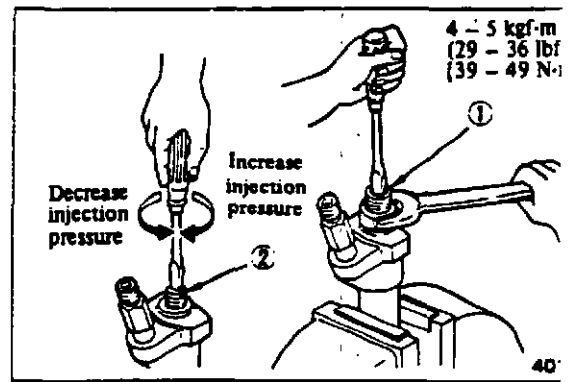

(2) Spray pattern

- (a) At the time of testing the injection pressure, inspect each nozzle for clogged spray hole and fuel leaks from the hole. Also examine spray pattern. If the nozzle is faulty, wash or replace the nozzle tip.
- (b) When tested on the nozzle tester, the nozzle should spray fuel from its eight orifices at the same time in a good straight cone of 155 or 158 degrees, consisting of finely atomized fuel particles without any large droplets, and should terminate with no dribble at the tip.

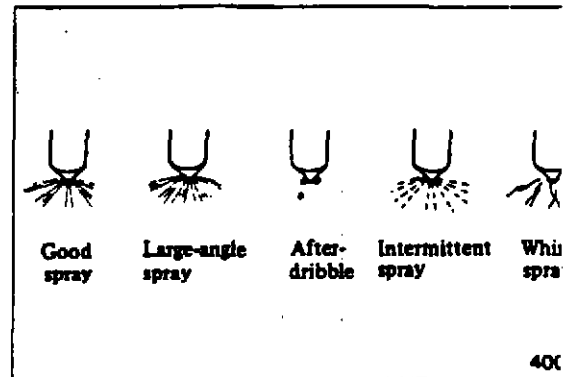

Possible spray patterns

(3) Washing or replacing nozzle tip

- (a) The nozzle tip is spring loaded. Remove the cap nut and, with a screwdriver, loosen the adjusting screw to such an extent that it can be loosened by the hand.
- (b) Loosen retaining nut (1), remove the nozzle tip and wash the needle valve and body.

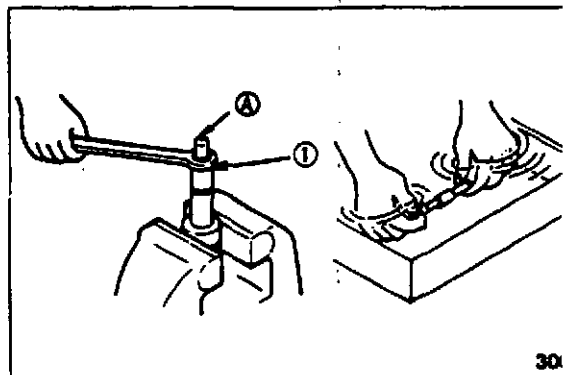
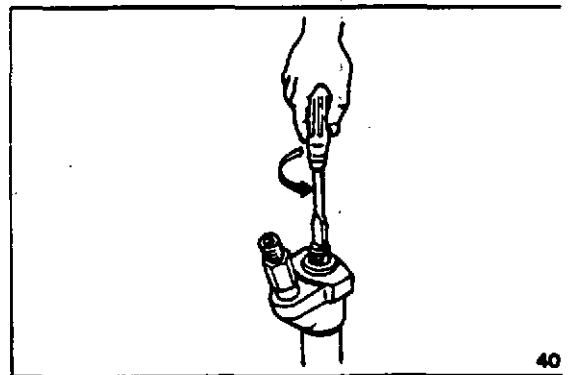

When pulling out the nozzle tip, be careful not to damage its tip (A).

- (c) Wash the nozzle tip in clean gasoline. After washing, assemble the needle valve and body in clean diesel fuel.

CAUTION

The needle valve and body are finely finished. Do not change the combination or set of the valve and body.

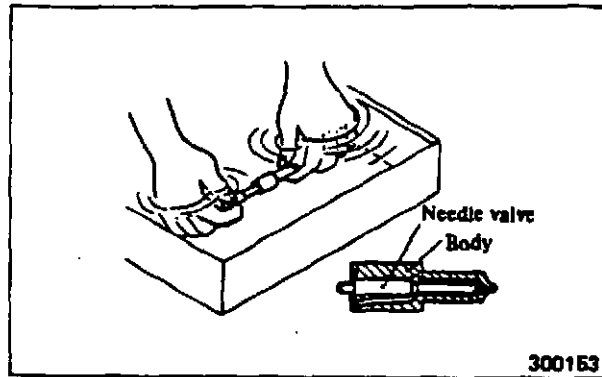

- (d) Tighten the retaining nut to the specified torque.
- (e) If the spray pattern is still bad after the nozzle has been adjusted and cleaned, replace the nozzle tip.

NOTE

New nozzle tips are coated with vaseline for preservation. Be sure to wash them two times, first in gasoline and then in diesel fuel to be used, before assembling them.

3.3 Reassembly

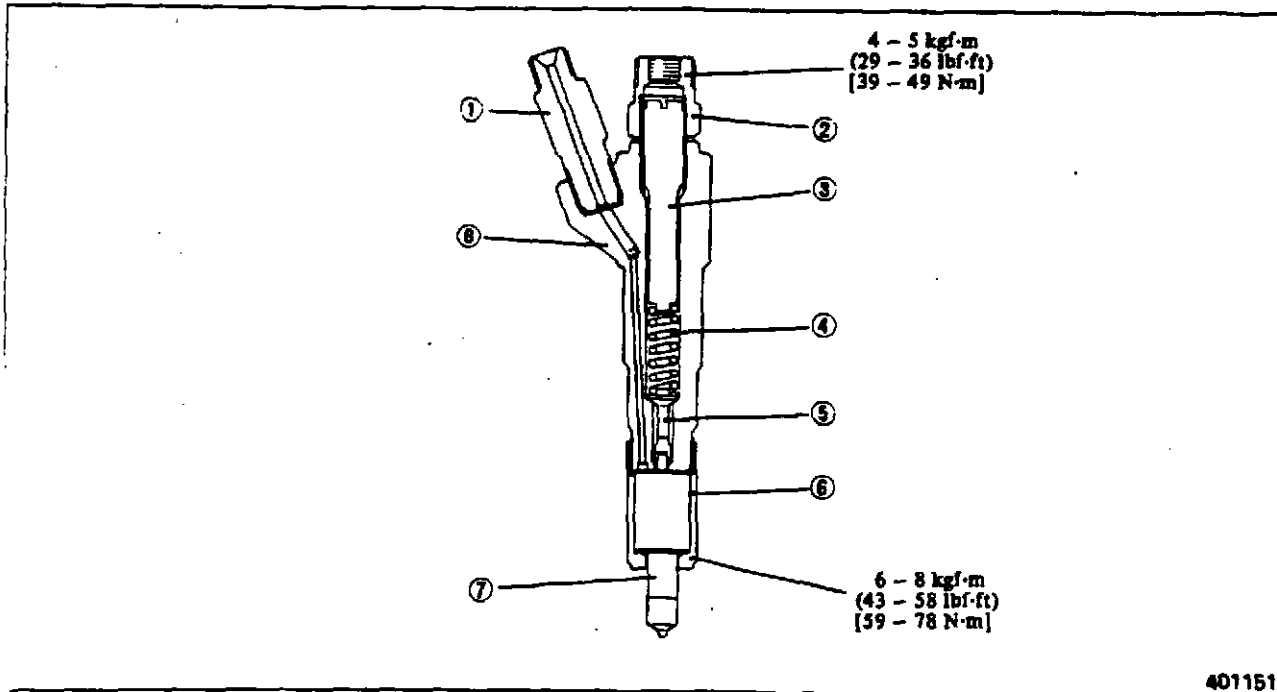

401151

Reassembling sequence

③→⑦→⑥→⑤→④→③→②→①

FUEL SYSTEM

4. WOODWARD GOVERNOR DRIVE

4.1 Disassembly

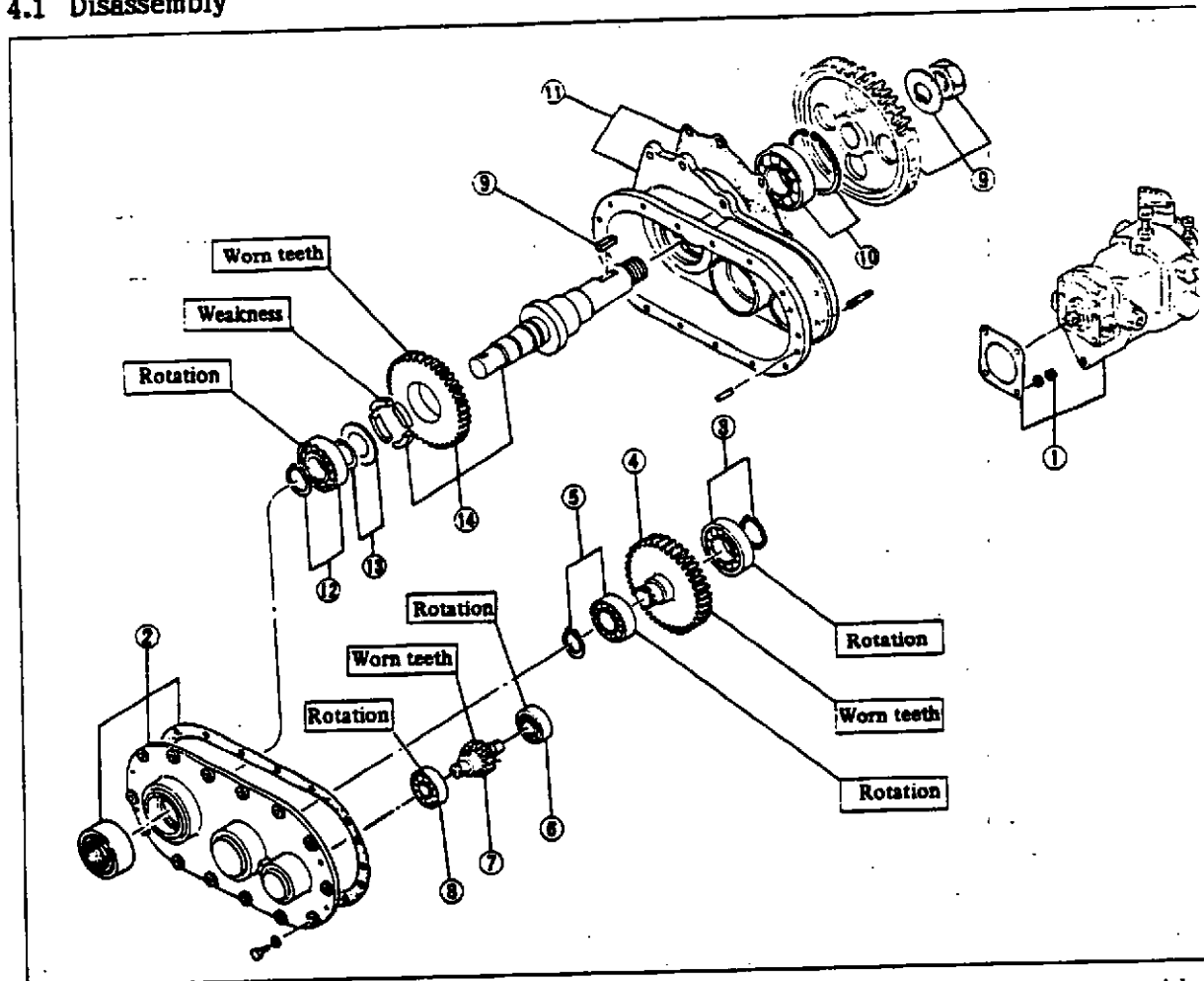

- ① Woodward governor, nut, washer, packing
- ② Drive cover, packing, oil seal
- ③ Ball bearing, snap ring
- ④ Idler gear
- ⑤ Ball bearing, snap ring

- ⑥ Ball bearing
- ⑦ Driven gear
- ⑧ Ball bearing
- ⑨ Fuel injection pump drive gear, nut, washer, key
- ⑩ Ball bearing, snap ring

- ⑪ Drive case, packing
- ⑫ Ball bearing, snap ring
- ⑬ Washer, snap ring
- ⑭ Drive shaft, drive gear, rubber, pin

4.2 Inspection

Rotate each bearing to check for rotation. Replace the bearing if its rotation is not smooth.

Check the fit of bearings on the drive shaft, idler gear and driven gear. Replace the shaft or bearings whichever are badly worn.

Check the fit of bearings in the drive case and drive cover, and replace a worn part, if any.

Check the drive shaft and oil seal for defect, and replace them if necessary.

Unit: mm (in.)

Item			Nominal value	Assembly standard	Item			Nominal value	Assembly standard
Inside diameters of case bores to which bearing outer races are fitted			47 (1.85)	46.989 - 47.014 (1.84996 - 1.85094)	Bearings	Cover side	Inside diameters	20 (0.79)	19.987 - 20.003 (0.78689 - 0.78752)
			80 (3.15)	79.988 - 80.018 (3.14913 - 3.15031)				30 (1.18)	29.987 - 30.003 (1.18059 - 1.18122)
			90 (3.54)	89.987 - 90.022 (3.54279 - 3.54417)				35 (1.38)	34.985 - 35.003 (1.37736 - 1.37807)
Inside diameters of cover bores to which bearing outer races are fitted			47 (1.85)	46.989 - 47.014 (1.84996 - 1.85094)	Diameters of driven gear on which bearing inner races are fitted		Case side	20 (0.79)	20.011 - 20.002 (0.78783 - 0.78748)
			62 (2.44)	61.988 - 62.018 (2.44047 - 2.44165)			Cover side	20 (0.79)	20.011 - 20.002 (0.78783 - 0.78748)
			72 (2.83)	71.988 - 72.018 (2.83417 - 2.83535)	Diameters of idler gear on which bearing inner races are fitted		Case side	40 (1.57)	40.013 - 40.002 (1.57531 - 1.57488)
Bearings	Case side	Outside diameters	47 (1.85)	47.003 - 46.986 (1.85051 - 1.84984)			Cover side	30 (1.18)	30.011 - 30.002 (1.18153 - 1.18118)
			80 (3.15)	80.004 - 79.983 (3.14976 - 3.14893)	Diameters of drive shaft on which bearing inner races are fitted		Case side	40 (1.57)	40.013 - 40.002 (1.57531 - 1.57488)
			90 (3.54)	90.005 - 89.980 (3.54350 - 3.54251)			Cover side	35 (1.38)	35.013 - 35.002 (1.37846 - 1.37803)
			20 (0.79)	19.987 - 20.003 (0.78689 - 0.78752)					
			40 (1.57)	39.985 - 40.003 (1.57421 - 1.57492)					
			40 (1.57)	39.985 - 40.003 (1.57421 - 1.57492)					
	Cover side	Outside diameters	47 (1.85)	47.003 - 46.986 (1.85051 - 1.84984)					
			62 (2.44)	62.004 - 61.983 (2.44110 - 2.44027)					
			72 (2.83)	72.004 - 71.983 (2.83480 - 2.83397)					

FUEL SYSTEM

4.3 Reassembly

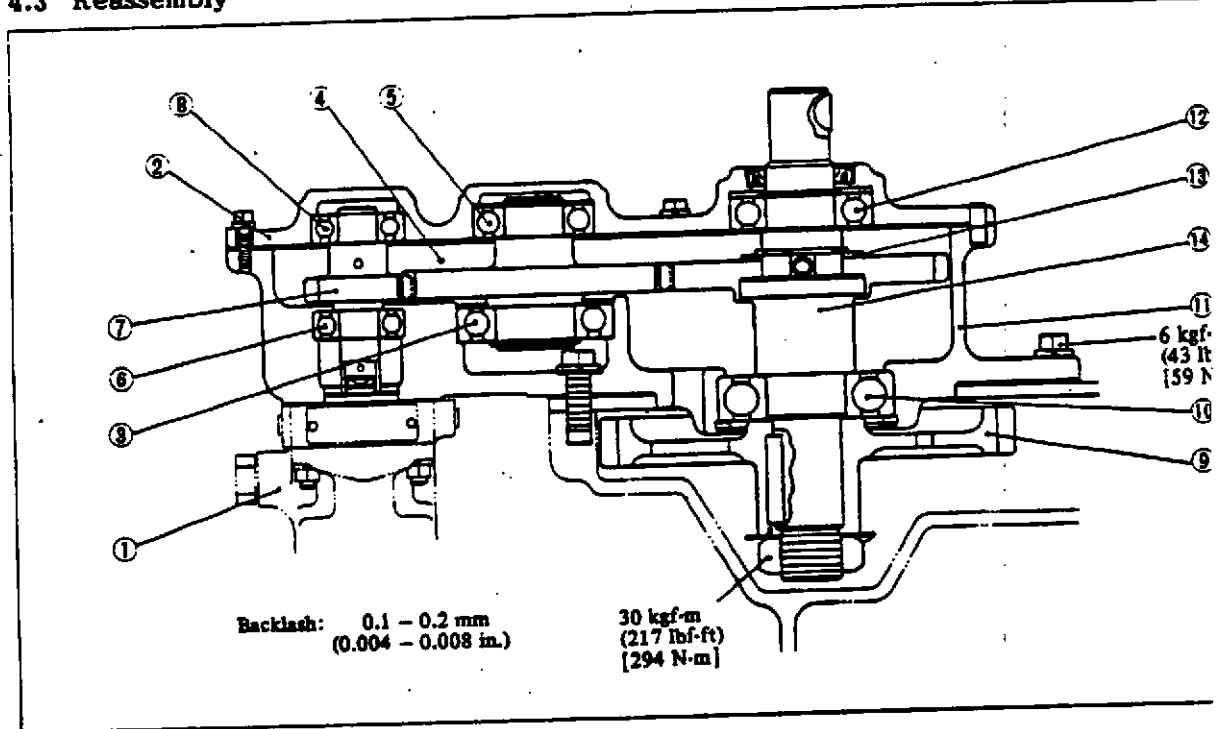

Reassembling sequence

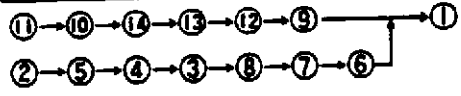

(1) Installing rubber

After pressing drive gear onto the drive shaft, install pin and rubber.

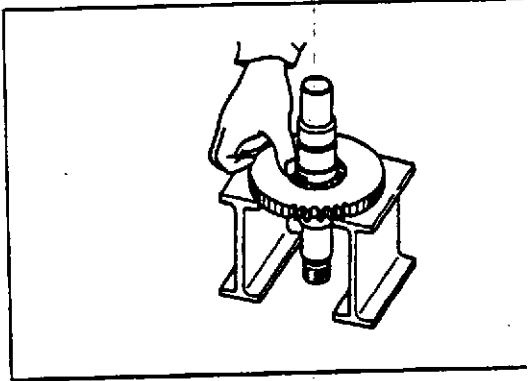

(2) Installing drive gear

Press the drive gear assembly into the drive case.

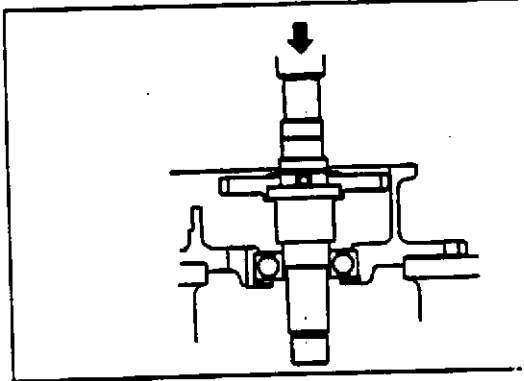

ELECTRICAL SYSTEM

1. DESCRIPTION	172
2. STARTERS	173
2.1 Disassembly	173
2.2 Inspection and repair	176
2.3 Reassembly	179
3. ALTERNATOR	183
3.1 Disassembly	183
3.2 Inspection and repair	184
3.3 Reassembly	186

ELECTRICAL SYSTEM

1. DESCRIPTION

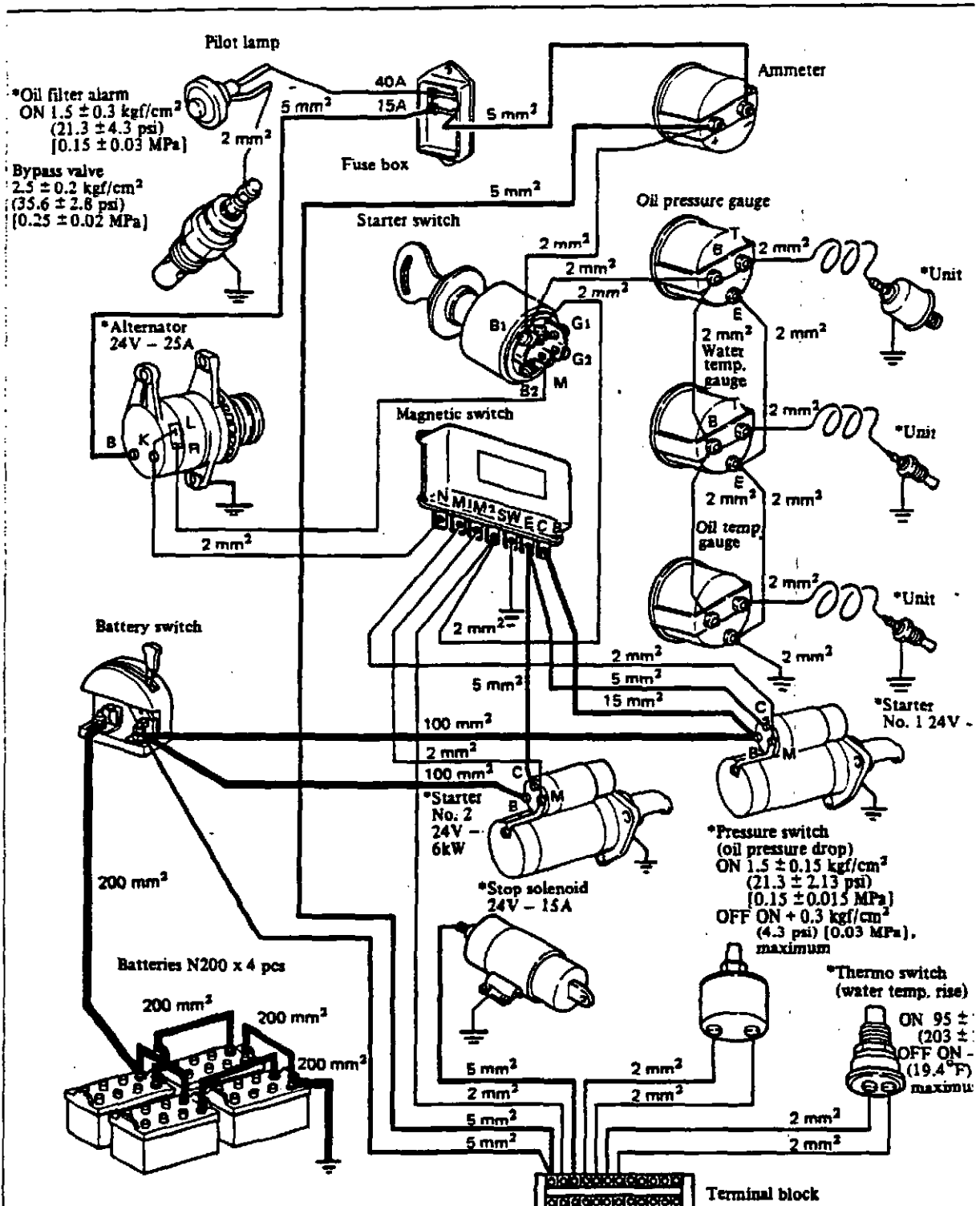

Remarks: (a) The circuit shown above is for standard model. The circuit varies from one specification and application of the engine to another.

(b) Wiring involved in the circuit is to be prepared in field.

(c) Items bearing asterisk (*) belong to the engine. Items bearing no mark are to be supplied individually.

Wiring diagram

2. STARTERS

2.1 Disassembly

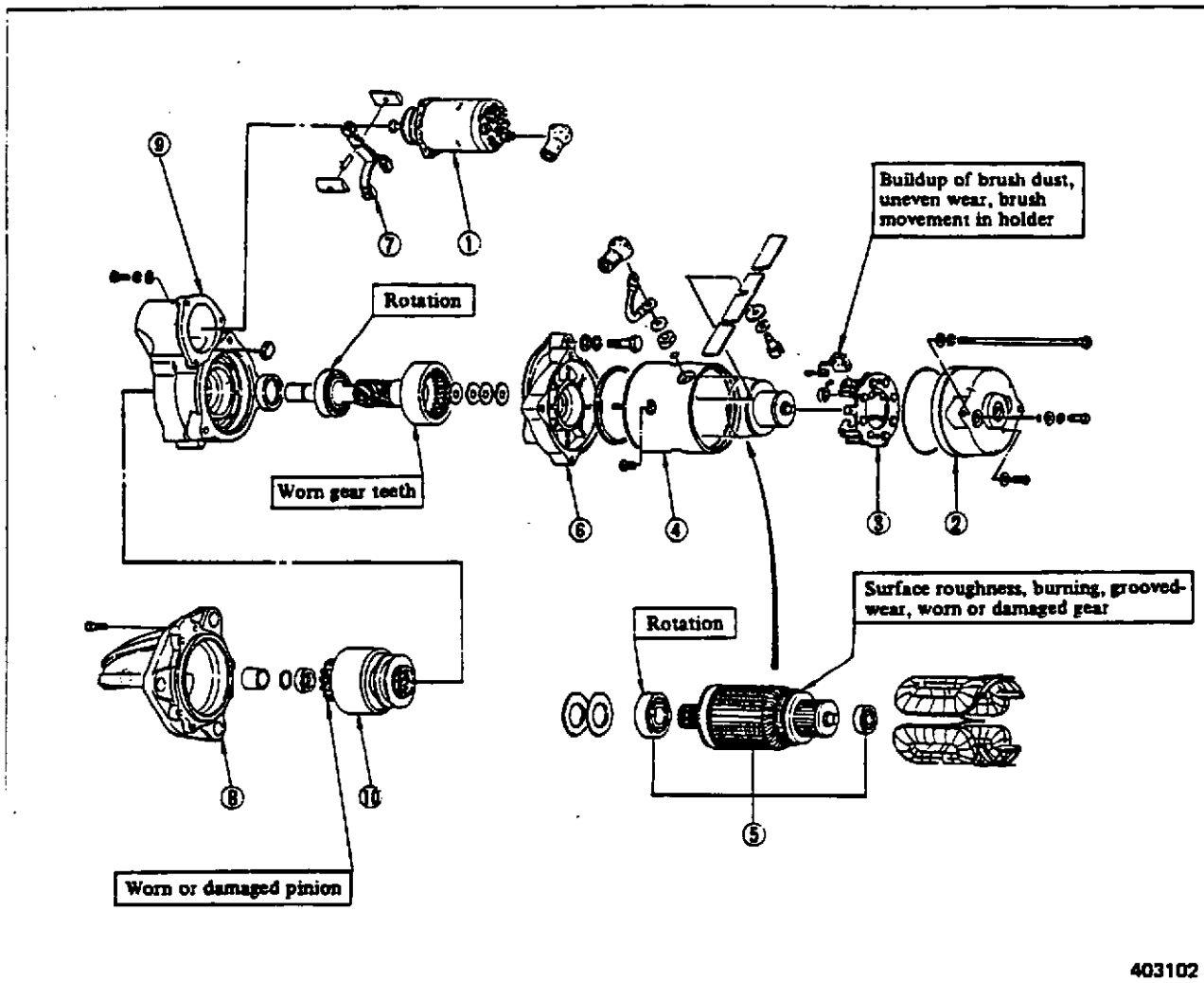

403102

- | | |
|----------------------------|--------------------------|
| ① Magnetic switch assembly | ⑥ Center bracket |
| ② Rear bracket | ⑦ Lever assembly |
| ③ Brush holder assembly | ⑧ Front bracket |
| ④ Yoke assembly | ⑨ Pinion case |
| ⑤ Armature assembly | ⑩ Pinion clutch assembly |

ELECTRICAL SYSTEM

- (1) Disconnect lead wire, and remove magnetic switch assembly.

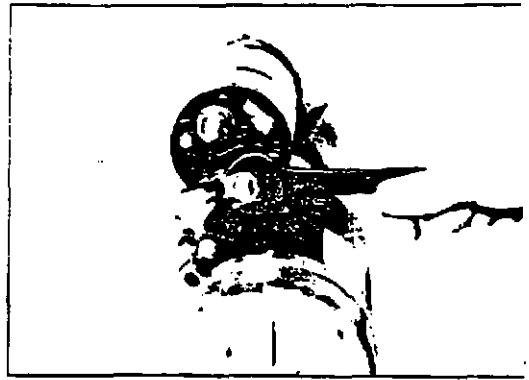

- (2) Unscrew through bolts and brush holder attaching screws, and remove rear bracket.

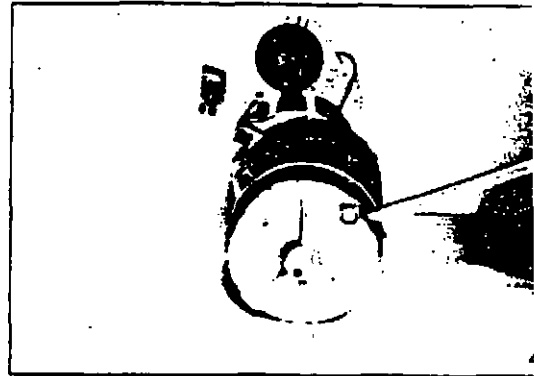

- (3) Remove brushes from brush holder assembly, and remove yoke.

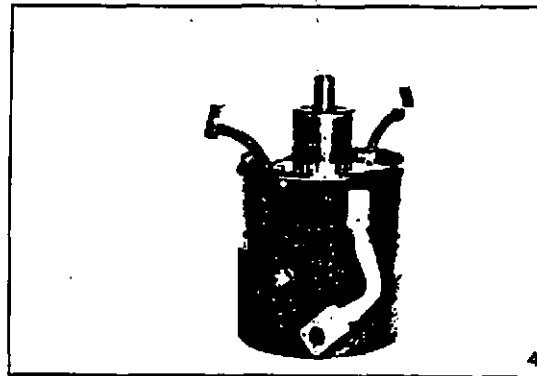

- (4) Pull out armature assembly.

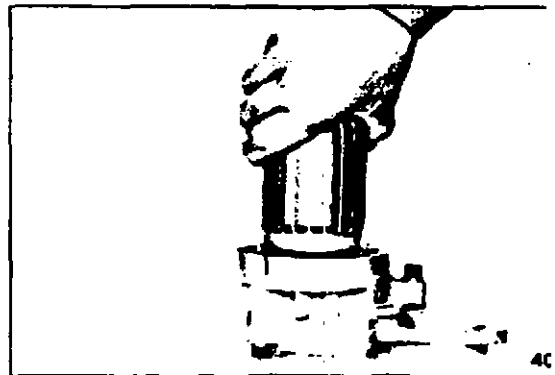

(5) Remove center bracket.

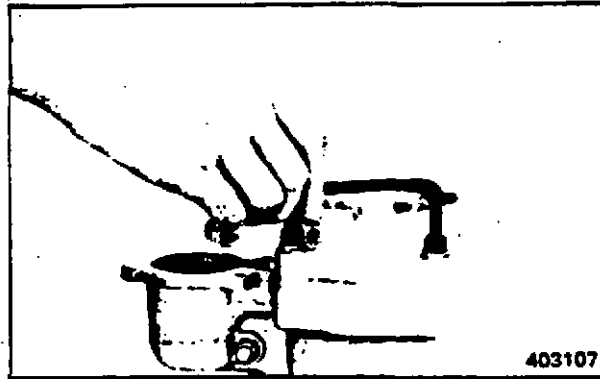

(6) Remove lever pin, inner housing and shift lever from pinion case.

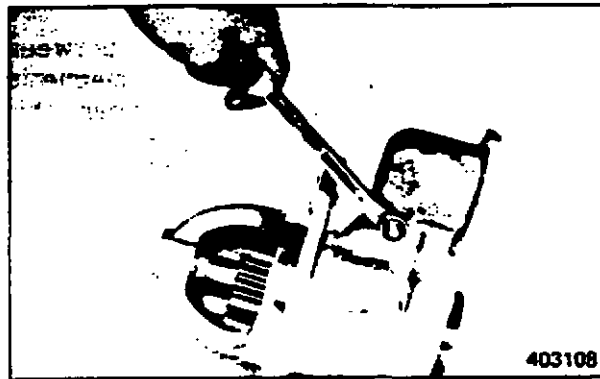

(7) Using a jig, remove pinion stopper, and remove overrunning clutch from pinion shaft.

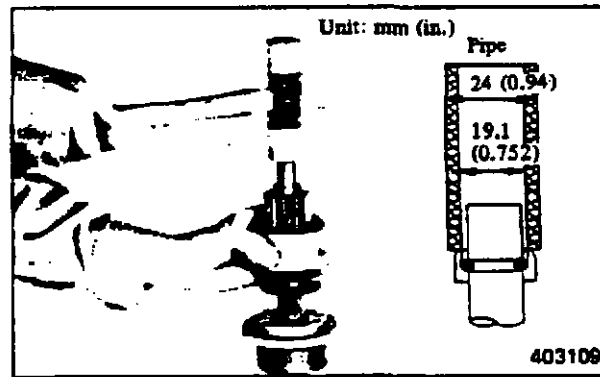

NOTE

To remove pinion shaft bearing for replacement, use a bearing puller of the type shown.

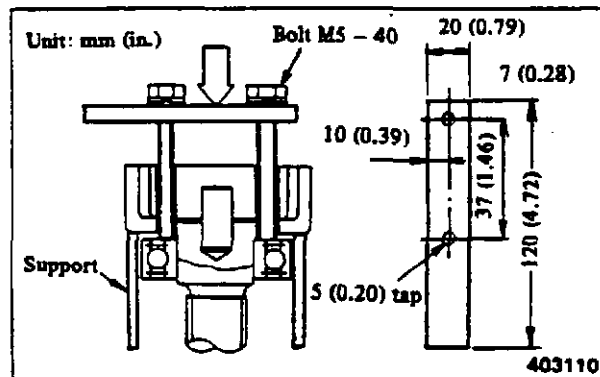

Pinion shaft bearing puller

ELECTRICAL SYSTEM

2.2 Inspection and repair

Magnetic switch

(1) Testing magnetic switch coil

- (a) Test the pressure coil and holding coil for open circuit. The coils are open-circuited if there is no continuity between the terminal "M" of magnetic switch and the case.

(Resistance: 1.16 ohms, approx.)

- (b) Apply a voltage of 24 volts between the terminal "M" of magnetic switch and the case. Under this condition, push in the plunger by hand. The plunger should be attracted when the hand is released.

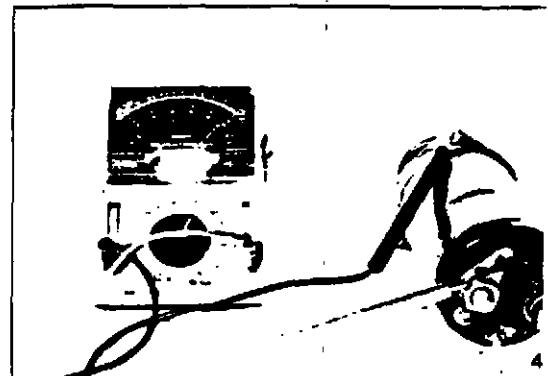
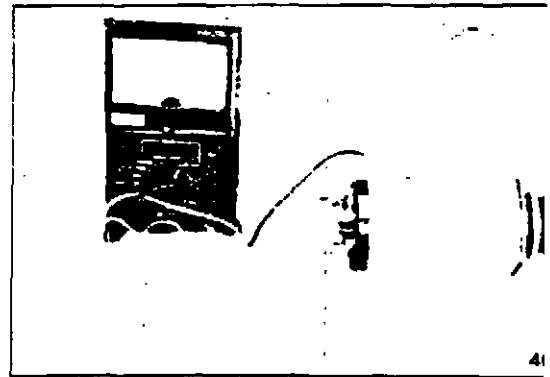

(2) Testing magnetic switch contact points

Measure the load current flowing through the starter. If the voltage drop between the terminals "B" and "M" exceeds 0.3 volt per 100 amperes of current, polish or replace the contact points.



If the starter switch is turned to OFF during voltage measurement, the battery voltage is directly applied to the voltmeter and damage it. With this kept in mind, be sure to turn the starter switch to ON before measuring the voltage and turn it to OFF after measuring the voltage.



Under no circumstances should only the magnetic switch be tested.

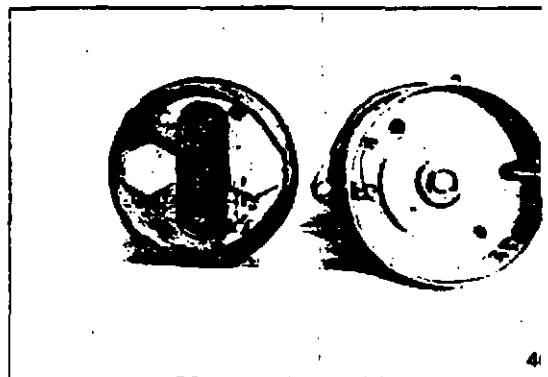

Armature

(1) Inspecting armature shaft for runout

Measure the runout with a dial gauge. If the runout exceeds the Assembly standard, repair or replace the armature.

Unit: mm (in.)

Item	Assembly standard
Armature shaft runout	0.05 (0.0020)

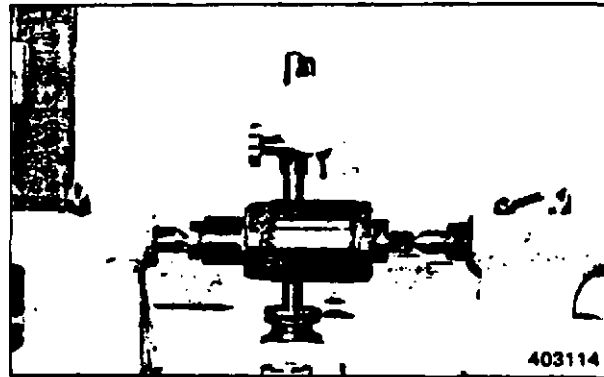

(2) Inspecting commutator

(a) Check the commutator surface for condition. If the surface is rough, polish it with #400 to #600 sandpaper.

Also check the commutator for runout with a dial gauge. Replace the commutator if the runout exceeds the Service limit.

Unit: mm (in.)

Item	Assembly standard	Service limit
Commutator runout	0.015 (0.00059)	0.100 (0.00394)

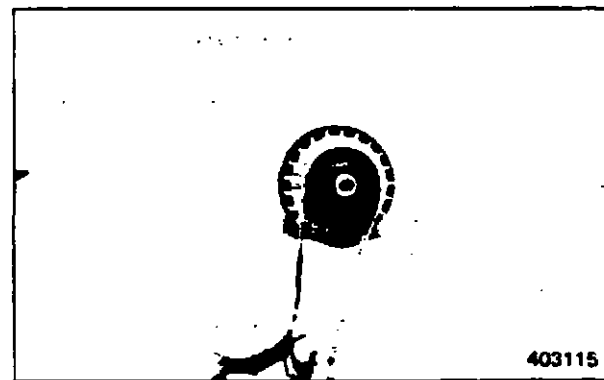

(b) Measuring mica depth

Using a depth gauge, measure the depth of each mica undercut. If the depth exceeds the Repair limit, recondition the mica.

Unit: mm (in.)

Item	Assembly standard	Repair limit
Commutator mica depth	0.5 - 0.8 (0.020 - 0.031)	0.2 (0.008)

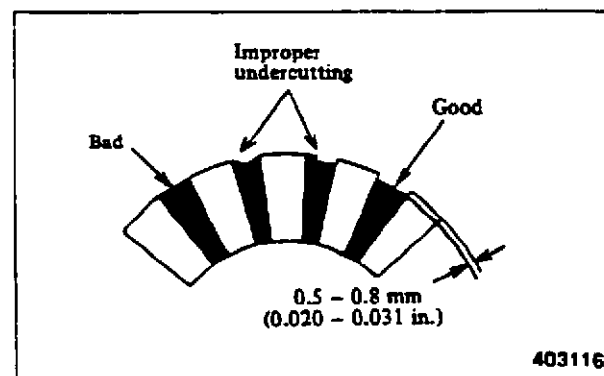

ELECTRICAL SYSTEM

(3) Testing armature

- (a) Test the armature for short circuits on a growler. If the hacksaw blade vibrates against the core, replace the armature.
- (b) If there is continuity between the commutator and shaft, replace the armature.

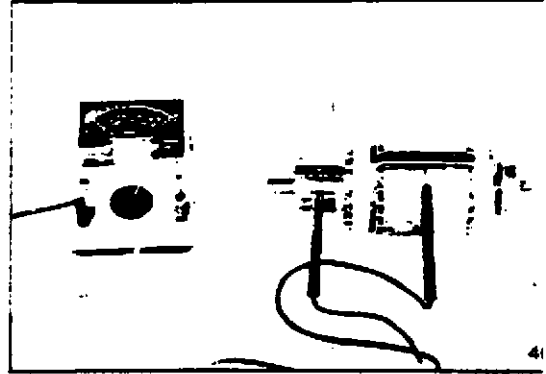

Field coil

(1) Testing for open circuits

If there is no continuity between the terminal "M" of field coil and the brush-side lead wire, replace the field coil.

(Shunt coil resistance: 4.3 ohms, approx.)

- (2) If there is continuity between the field coil and yoke, replace the field coil.

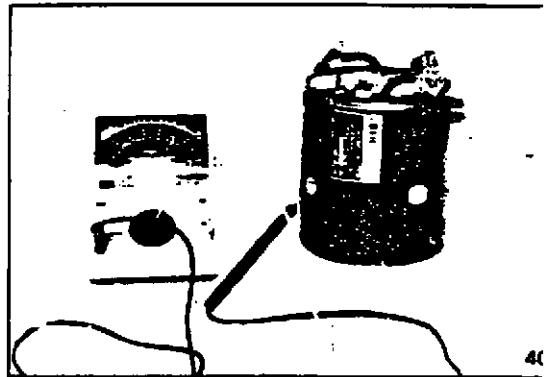

NOTE

To test, remove the negative (-) terminal of shunt coil from the yoke.

Overrunning clutch

The clutch is in good condition if it rotates freely in one direction when turned by hand.

Check the pinion teeth for wear or damage, and replace the pinion if they are damaged.

CAUTION

Do not immerse the overrunning clutch in cleaning solvent when cleaning the clutch. This will cause grease to flow out from inside the clutch, resulting in seizure of clutch parts.

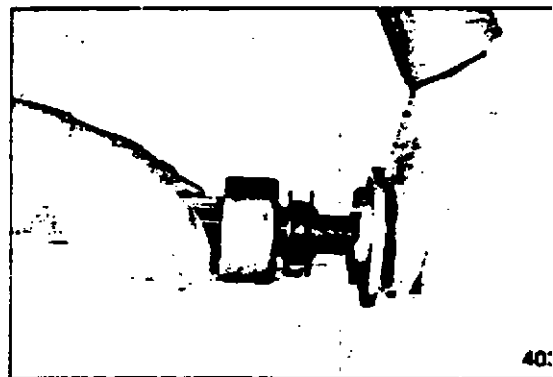

Brushes

(1) Inspecting for wear

Unit: mm (in.)

Item	Assembly standard	Service limit
Brush height	20 (0.78)	13 (0.51)

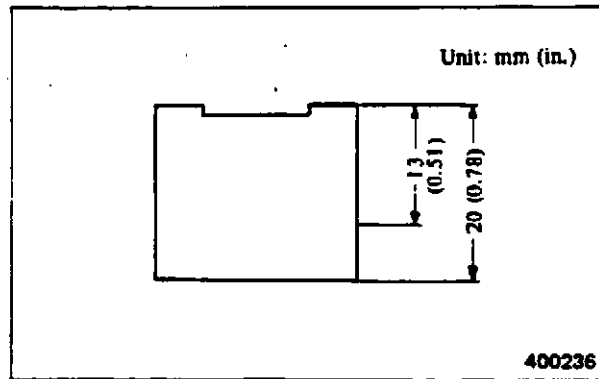

(2) Testing brush spring tension

Unit: kgf (lbf) [N]

Item	Assembly standard
Brush spring tension	4.0 – 5.0 (8.8 – 11.0) [39.2 – 49.0]

2.3 Reassembly

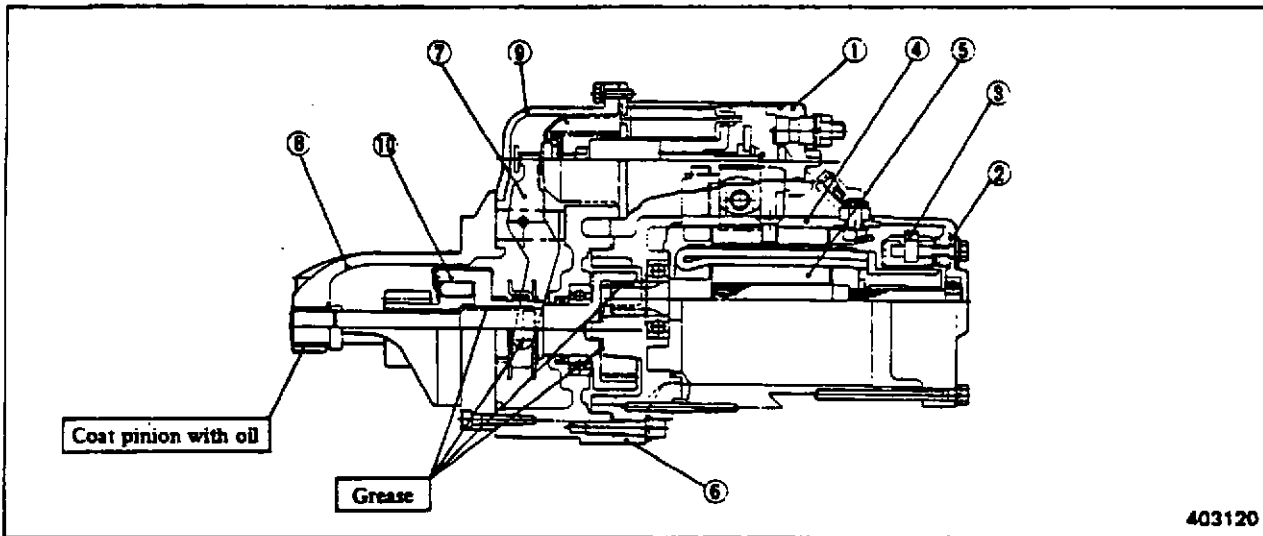

Reassembling sequence

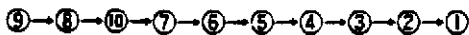

ELECTRICAL SYSTEM

- (1) Install center bracket, overrunning clutch and pinion stopper to pinion shaft, and insert the shaft into position by tapping with a plastic hammer.

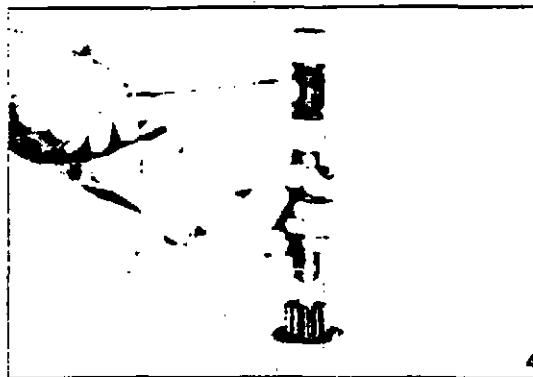

- (2) Install shift lever and pinion shaft to front bracket by aligning matching mark on shift lever.



- (3) Install armature and yoke to center bracket, making sure that dowel pin enters its hole.

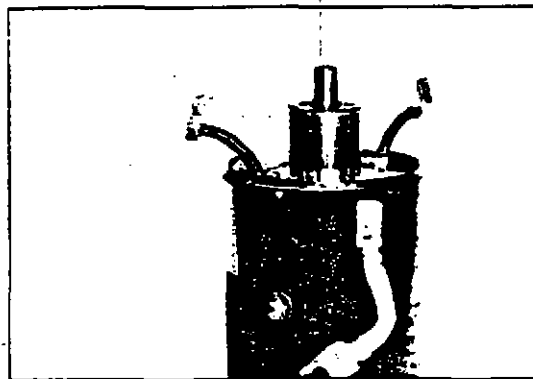

- (4) Install brushes and brush holders.

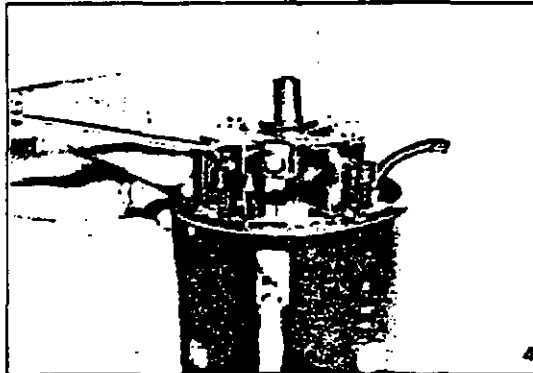

NOTE

Install positive (+) side brush and negative (-) side brush as shown.

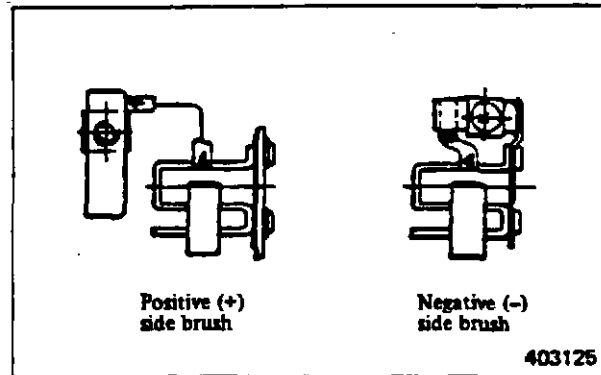

- (5) Install rear bracket to yoke by aligning matching marks, secure brush holders with bolts, and tighten through bolts.

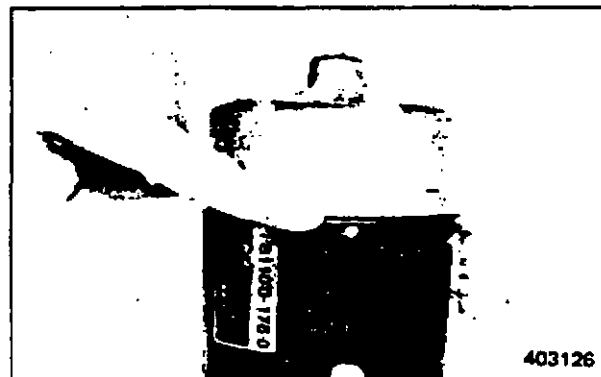

- (6) Measure the end play of armature. If the end play exceeds the Assembly standard, adjust it on the rear side.

Test the motor to make sure that the voltage and current are below 24 volts and 90 amperes respectively.

Unit: mm (in.)

Item	Assembly standard
Armature end play	0.2 - 0.6 (0.008 - 0.024)

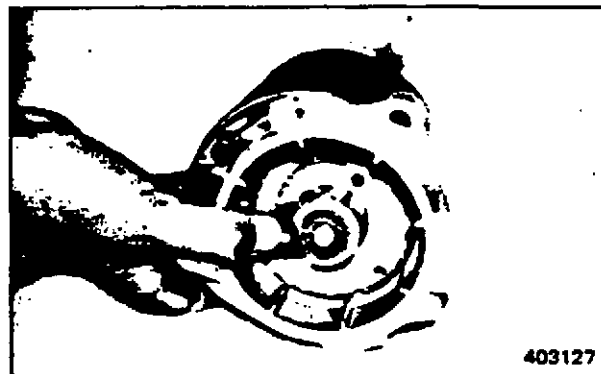

- (7) Liberally coat internal gear with grease, and install pinion shaft to the gear.

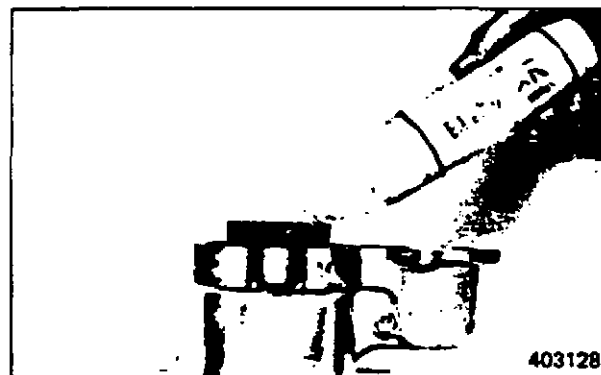

ELECTRICAL SYSTEM

- (8) Measure the end play of pinion shaft. If the end play exceeds the Assembly standard, adjust it on the internal gear side.

Unit: mm (in.)

Item	Assembly standard
Pinion shaft end play	0.2 - 0.6 (0.008 - 0.024)

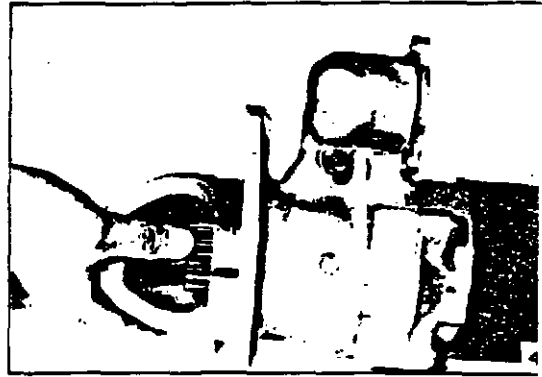

- (9) Install magnetic switch. Apply a voltage of 24 volts between the terminals "C" and "E," connect lead wire and energize the circuit between the terminals "M" and "E" (within 1 second). After the pinion has shifted, measure how much the pinion returns. If the measurement is not 1.5 to 5 mm (0.06 to 0.20 in.), make an adjustment by means of magnetic switch adjusting screw.



- (10) Secure lead wire.

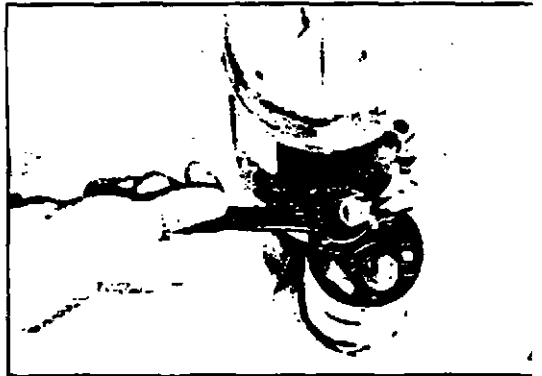

3. ALTERNATOR

3.1 Disassembly

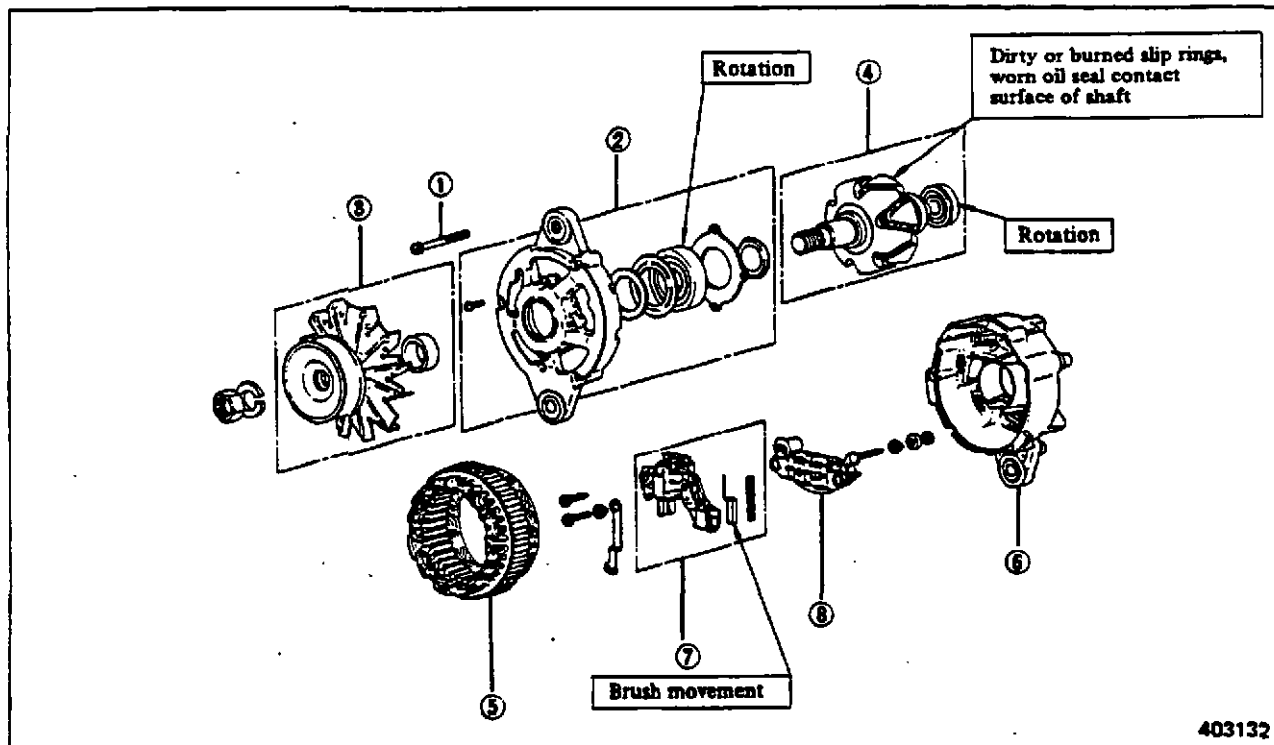

- | | |
|--------------------------|----------------------|
| ① Set screw | ⑤ Stator |
| ② Front bracket assembly | ⑥ Rear bracket |
| ③ Pulley assembly | ⑦ Regulator assembly |
| ④ Rotor assembly | ⑧ Rectifier assembly |

CAUTION

When undoing the soldered connections of lead wires extending from the stator coil, using a soldering iron, make it quickly by gripping the wires with a needle-nose pliers to prevent heating the diode rectifier.

ELECTRICAL SYSTEM

3.2 Inspection and repair

(1) Stator

(a) Testing stator coil for open circuits

If there is no continuity among four lead wires, replace the stator.

(b) Testing stator coil for grounding

If there is continuity between the coil and core, replace the stator.

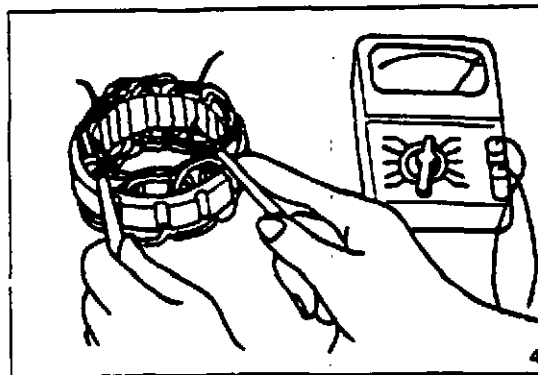

(2) Rotor

(a) Testing rotor coil for open circuits

If there is no continuity between the slip rings, replace the rotor.

(b) Testing rotor coil for grounding

If there is continuity between the slip rings and shaft (or core), replace the rotor.

(c) Measure slip ring outside diameter

Using a calipers, measure the outside diameter of each slip ring. If the diameter exceeds the Service limit, replace the slip ring.

Unit: mm (in.)

Item	Assembly standard	Service limit
Slip ring outside diameter	40.8 - 41.2 (1.606 - 1.622)	40.6 (1.598)

(3) Brushes and brush springs

(a) Wear of brushes

Unit: mm (in.)

Item	Assembly standard	Service limit
Brush height	23 (0.91)	8 (0.31)

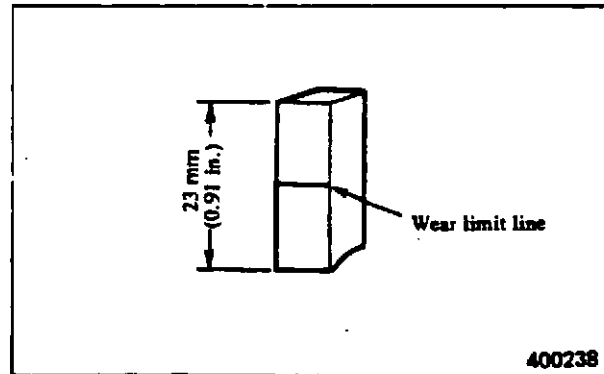

(b) Brush spring tension

Unit: gf (lbf) [N]

Item	Assembly standard	Service limit
Brush spring tension	320 - 440 (0.71 - 0.97) [3.14 - 4.31]	200 (0.44) [1.96]

(4) Diodes

(a) Main diode

If there is continuity between the diode lead wire and heat sink in both directions, replace the rectifier assembly.

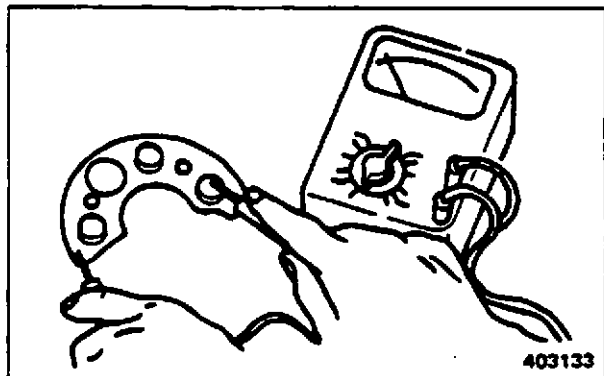

(b) Auxiliary diode

If the diode is short- or open-circuited, replace the heat sink assembly.

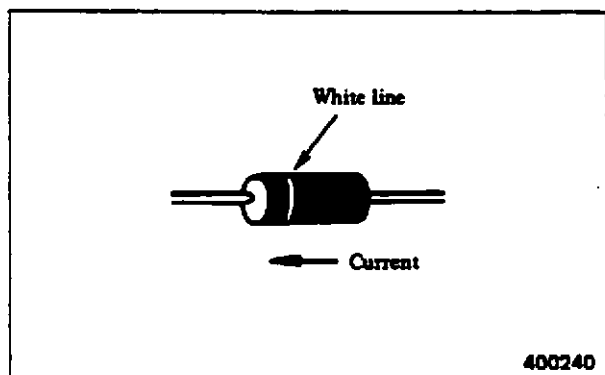

ELECTRICAL SYSTEM

3.3 Reassembly

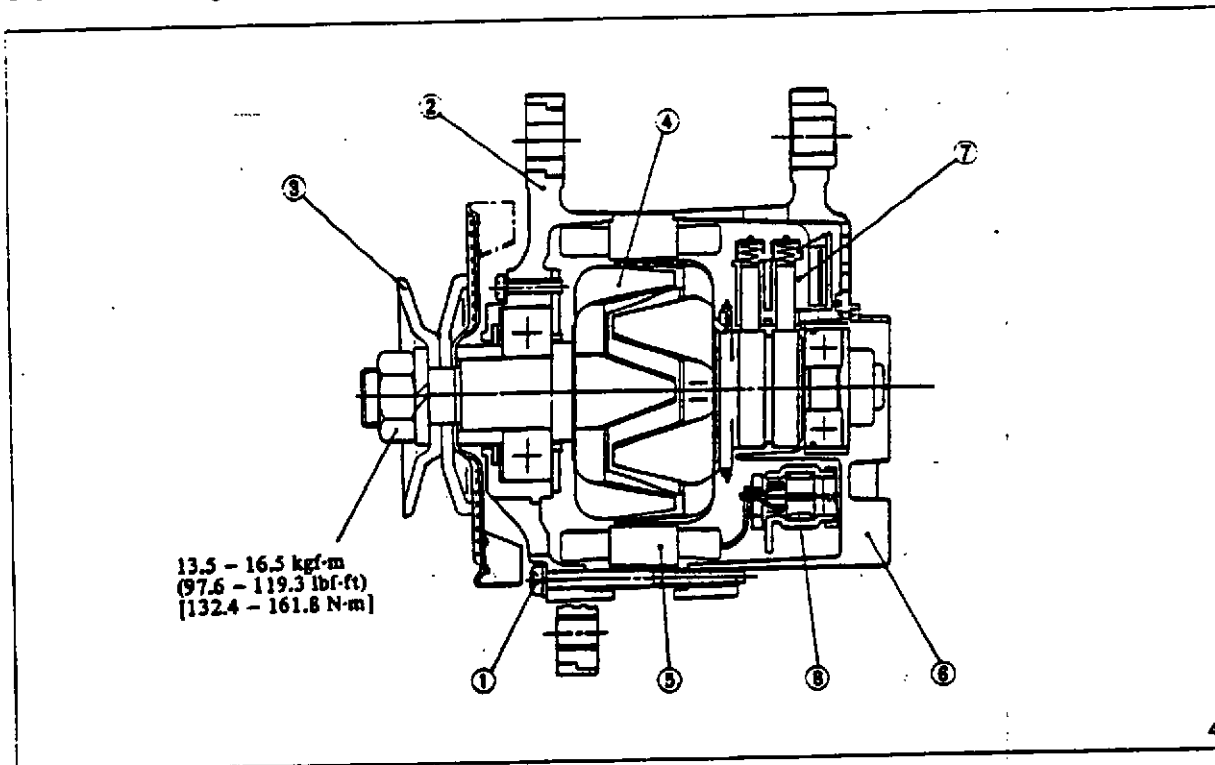

Reassembling sequence

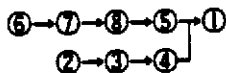

(1) Tightening pulley nut

Tighten the nut to 13.5 to 16.5 kgf-m.
(97.6 to 119.3 lbf-ft) [132.4 to 161.8
N·m] torque.

(2) Holding brush for installing rotor

Push the brush into the holder, and hold it there, using a piece of wire as shown at right. Then, install the rotor. Be sure to remove the wire after installing the rotor.

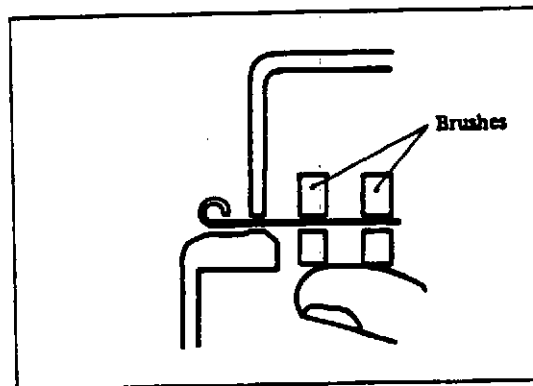

AIR START SYSTEMS

1. AIR MOTOR SYSTEM	188
2. AIR MOTOR	189
2.1 Disassembly and reassembly	189
2.2 Inspection	189
3. AIR FILTER	190
Inspection	190
4. OILER	190
Inspection	190
5. AIR TANK (FOR AIR MOTOR SYSTEM)	191
Inspection	191
6. DIRECT AIR START SYSTEM	192
7. DISTRIBUTOR VALVE	192
7.1 Disassembly	192
7.2 Inspection	193
7.3 Reassembly	193
8. STARTER VALVES	194
8.1 Disassembly	194
8.2 Inspection	195
8.3 Reassembly	195
9. MAGNETIC VALVE	196
Inspection	196
10. AIR FILTER	196
Inspection	196
11. AIR TANK (FOR DIRECT AIR START SYSTEM)	197
Inspection	197

AIR START SYSTEMS

1. AIR MOTOR SYSTEM

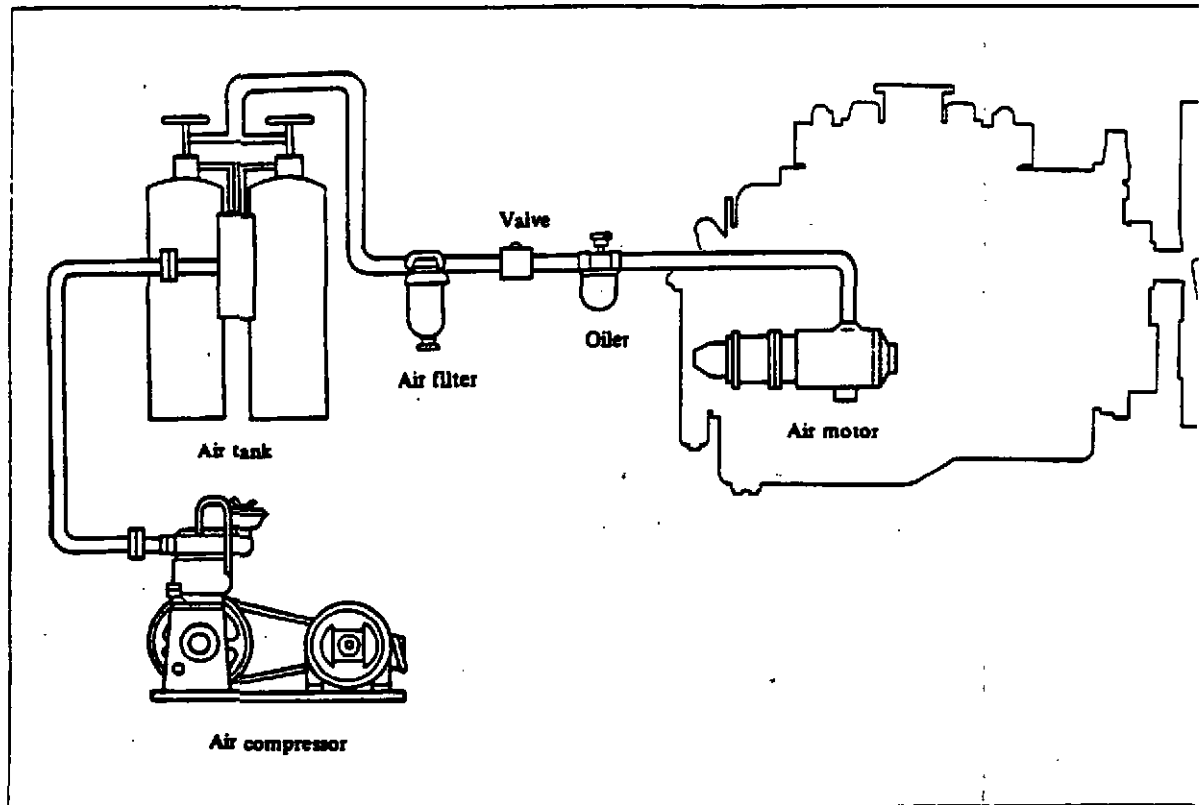

2. AIR MOTOR

2.1 Disassembly and reassembly

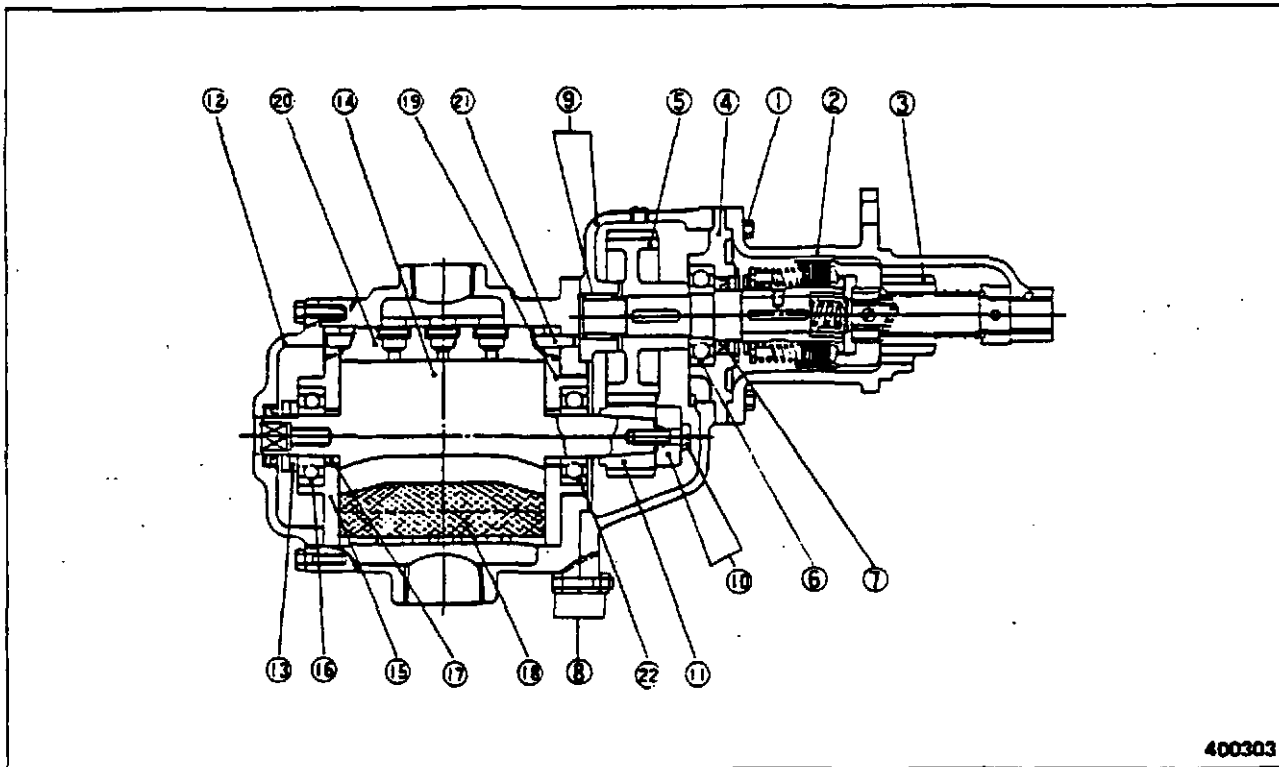

400303

- | | | |
|-------------------|------------------------------------|------------------------|
| ① Bolt | ⑨ Gear case, needle roller bearing | ⑯ Ball bearing |
| ② Pinion case | ⑩ Bolt, washer | ⑰ Rotor adjusting ring |
| ③ Clutch assembly | ⑪ Drive gear | ⑱ Vane |
| ④ Gear case cover | ⑫ Upper cover | ⑲ Cylinder lower cover |
| ⑤ Driven gear | ⑬ Bearing retaining nut | ⑳ Cylinder |
| ⑥ Bearing | ⑭ Rotor | ㉑ Dowel pin |
| ⑦ Oil seal | ⑮ Cylinder upper cover | ㉒ Ball bearing |
| ⑧ Nut | | |

NOTE

Do not remove the rotor adjusting ring from the rotor.

2.2 Inspection

Wash and inspect the air motor parts for wear or damage. Replace the defective parts if any. The clutch assembly and pinion assembly should be replaced as an assembly.

Reassembling sequence

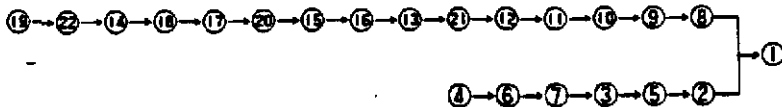

AIR START SYSTEMS

3. AIR FILTER

Inspection

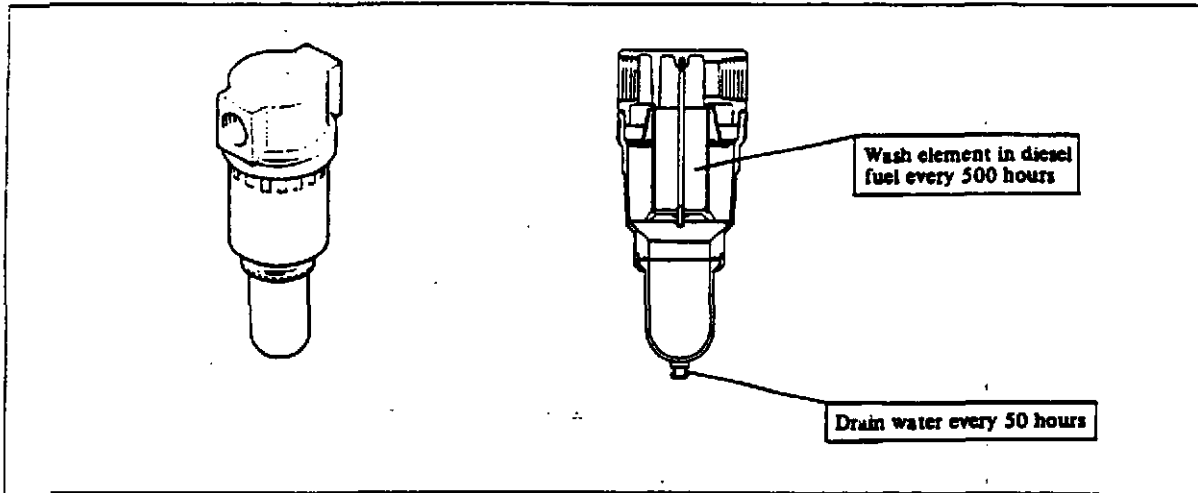

4. OILER

Inspection

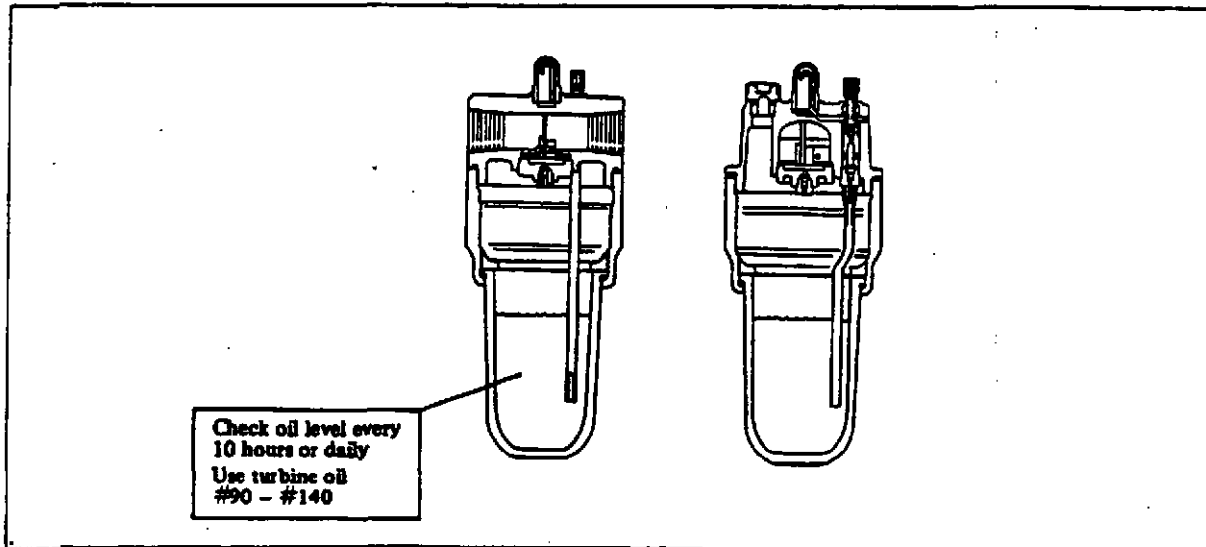

5. AIR TANK (FOR AIR MOTOR SYSTEM)

Inspection

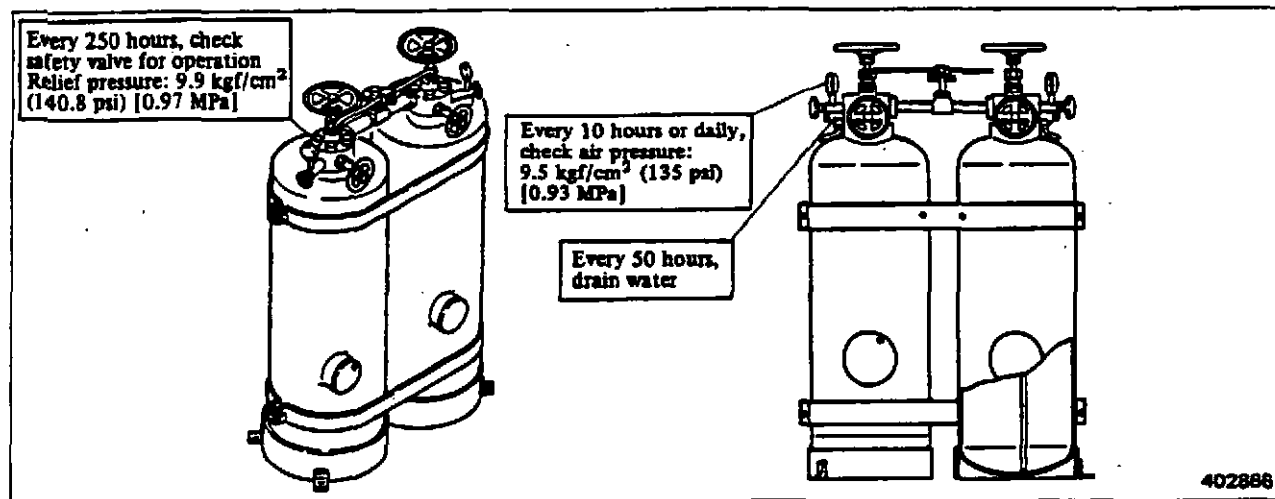

6. DIRECT AIR START SYSTEM

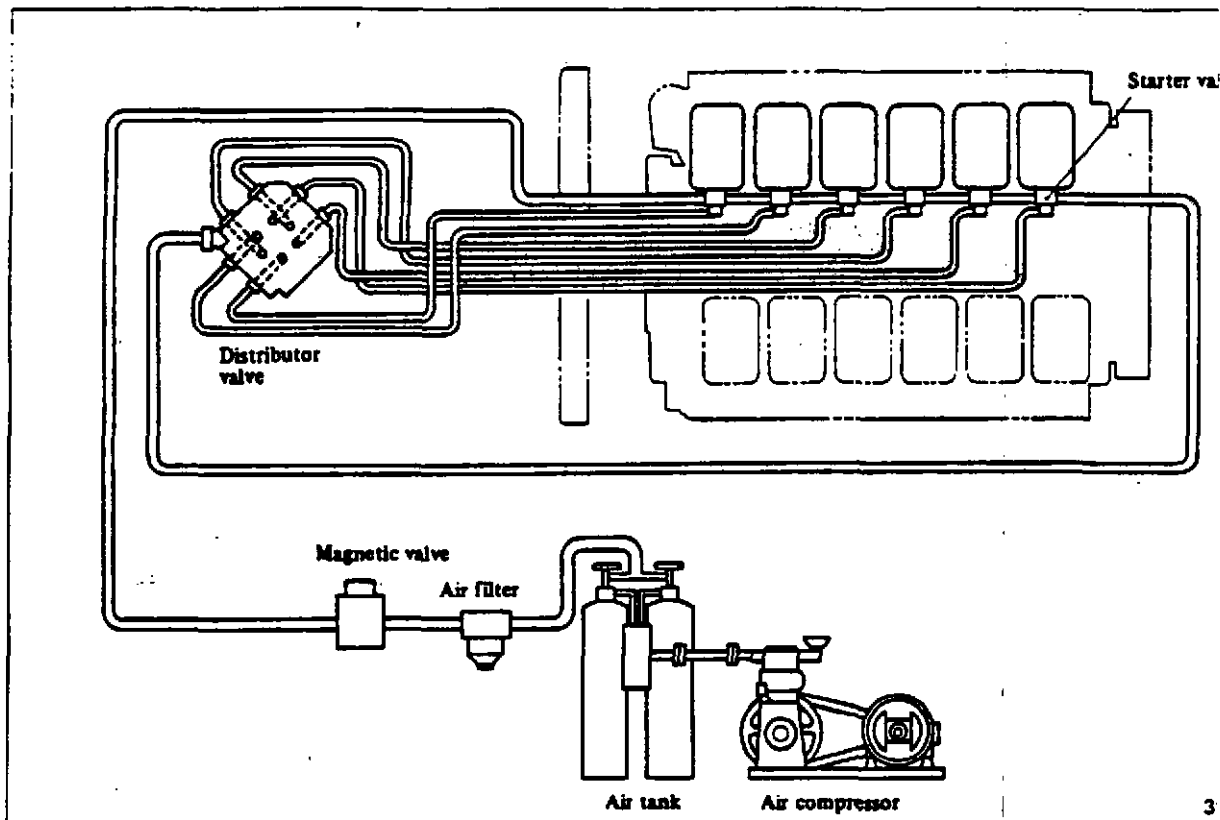

7. DISTRIBUTOR VALVE

7.1 Disassembly

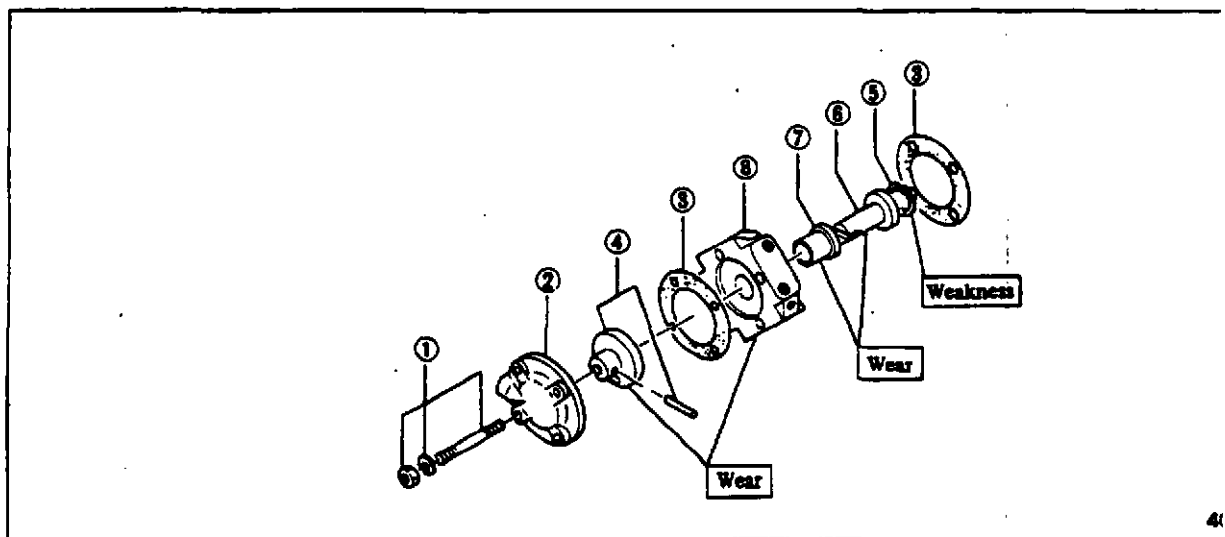

- ① Stud, spring washer, nut
- ② Case cover
- ③ Packing
- ④ Lock pin, distributor valve

- ⑤ Snap ring
- ⑥ Distributor shaft
- ⑦ Bushing
- ⑧ Distributor case

7.2 Inspection

(1) Measuring distributor valve height

If the height exceeds the Service limit, replace the valve.

Unit: mm (in.)

Item	Nominal value	Assembly standard	Service limit
Distributor valve height	21.5 (0.846)	21.6 - 21.4 (0.850 - 0.843)	21 (0.83)

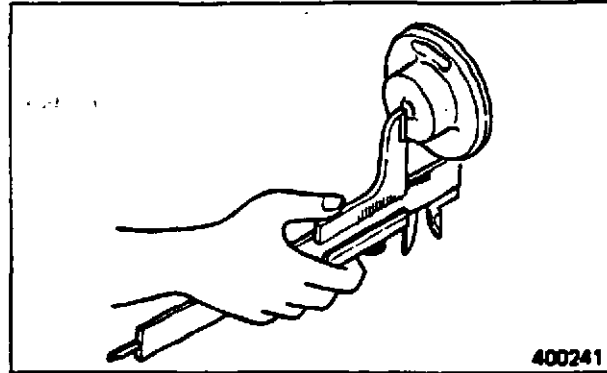

(2) Measuring distributor shaft clearance in bushing

Measure the diameter of the shaft and the inside diameter of the bushing to determine the clearance. If the clearance exceeds the Service limit, replace the bushing.

Unit: mm (in.)

Item	Nominal value	Standard clearance	Service limit
Distributor shaft clearance in bushing	20 (0.79)	0.050 - 0.091 (0.00197 - 0.00358)	0.300 (0.01181)

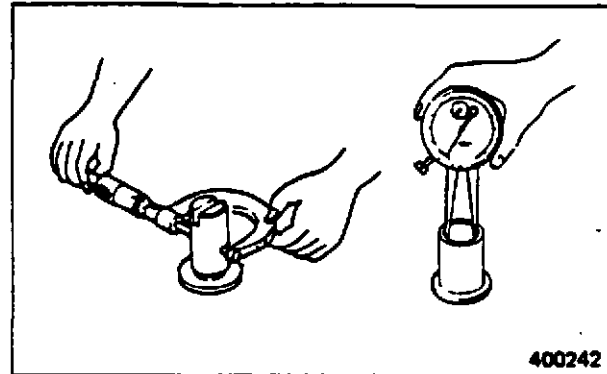

(3) Check valve lock pin and replace it if worn excessively.

7.3 Reassembly

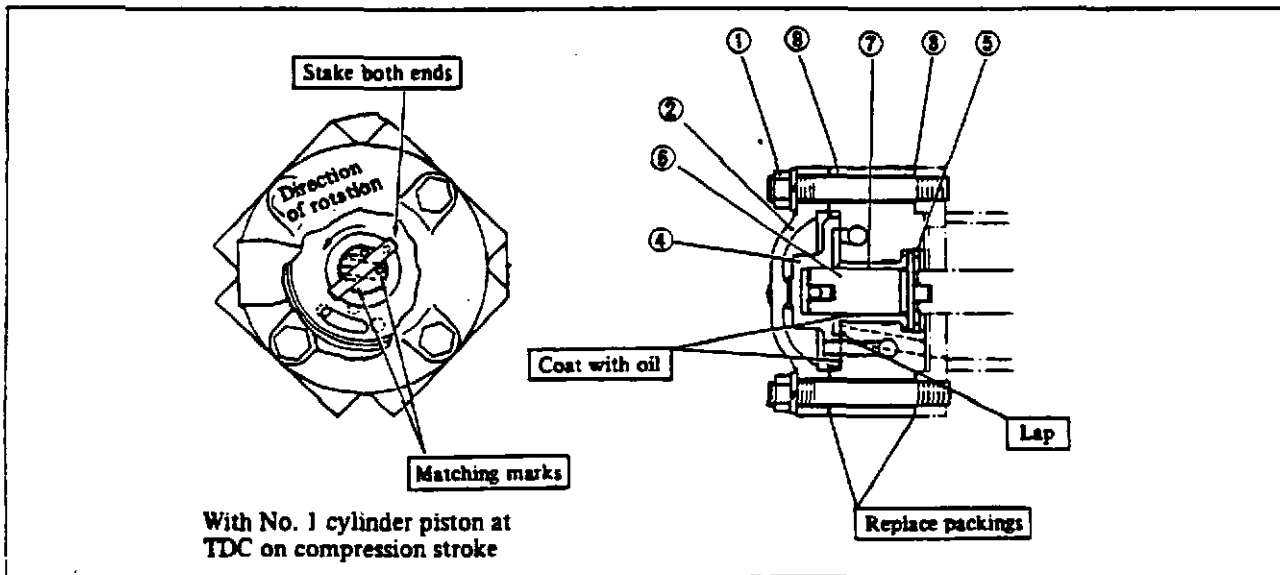

Reassembling sequence

⑧→⑦→⑥→⑤→④→③→②→①

NOTE

- (a) Stake the lock pin end in such a manner as to prevent it from interfering with the inside surface of the case.
- (b) When reassembling and installing the distributor valve, be sure to align the matching marks. If the marks are not aligned, the valve timing (at which the air is blown into the cylinders) could be off by 360°, resulting in a failure to start the engine.

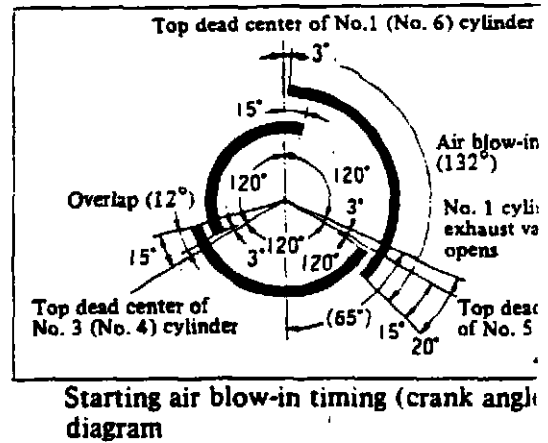

8. STARTER VALVES

8.1 Disassembly

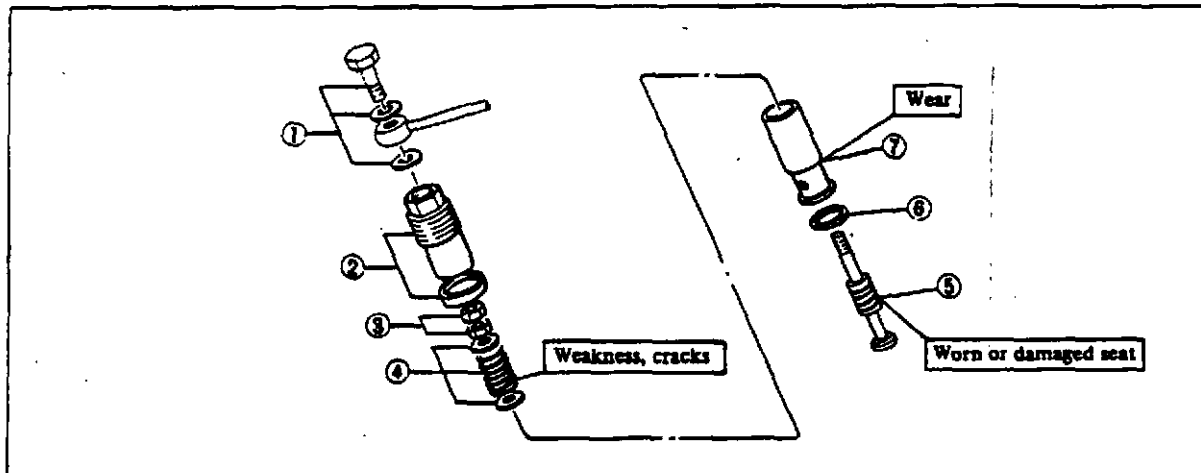

- ① Eye bolt, gasket, air pipe
- ② Retaining screw, packing
- ③ Nut
- ④ Retainer, valve spring, washer

- ⑤ Starter valve
- ⑥ Packing
- ⑦ Starter valve guide

NOTE

To remove starter valve from cylinder head, remove retaining screw, attach starting adaptor (A) (32591-01200) to the threaded portion of starter valve and, using nozzle remover, pull out the valve.

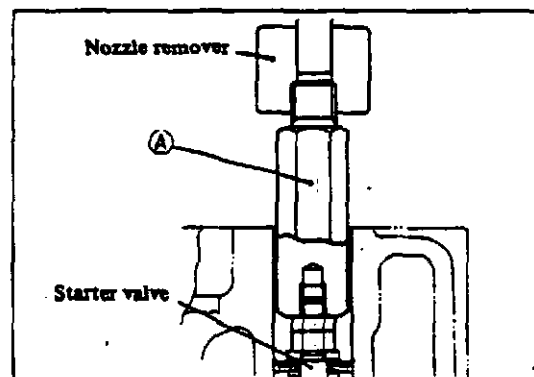

8.2 Inspection

(1) Measuring starter valve clearance in guide

Using a micrometer, measure the clearance. If the clearance exceeds the Service limit, replace the parts.

Unit: mm (in.)

Item	Nominal value	Standard clearance	Service limit
Starter valve clearance in guide	13 (0.51)	0.016 - 0.045 (0.00063 - 0.00177)	0.100 (0.00394)

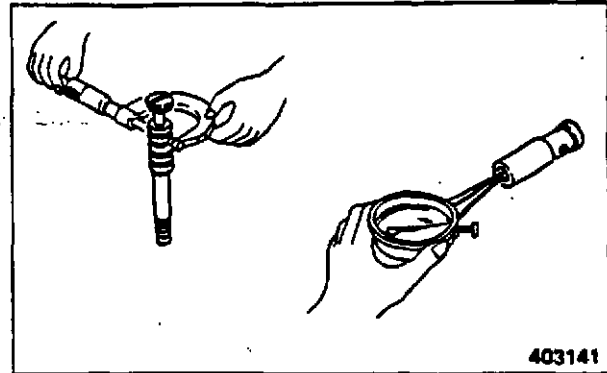

(2) Measuring valve spring free length

Using a calipers, measure the free length. If the free length exceeds the Service limit, replace the spring.

Unit: mm (in.)

Item	Assembly standard	Service limit
Valve spring free length	30 (1.18)	28 (1.10)

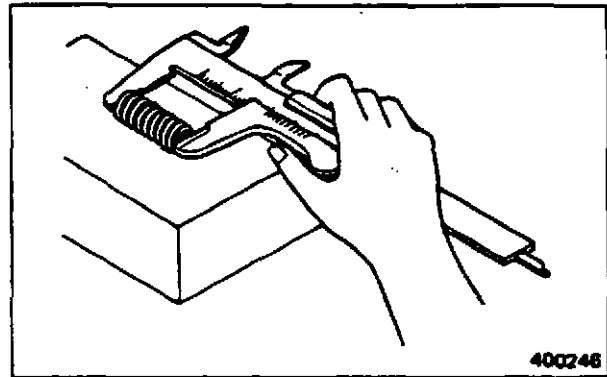

8.3 Reassembly

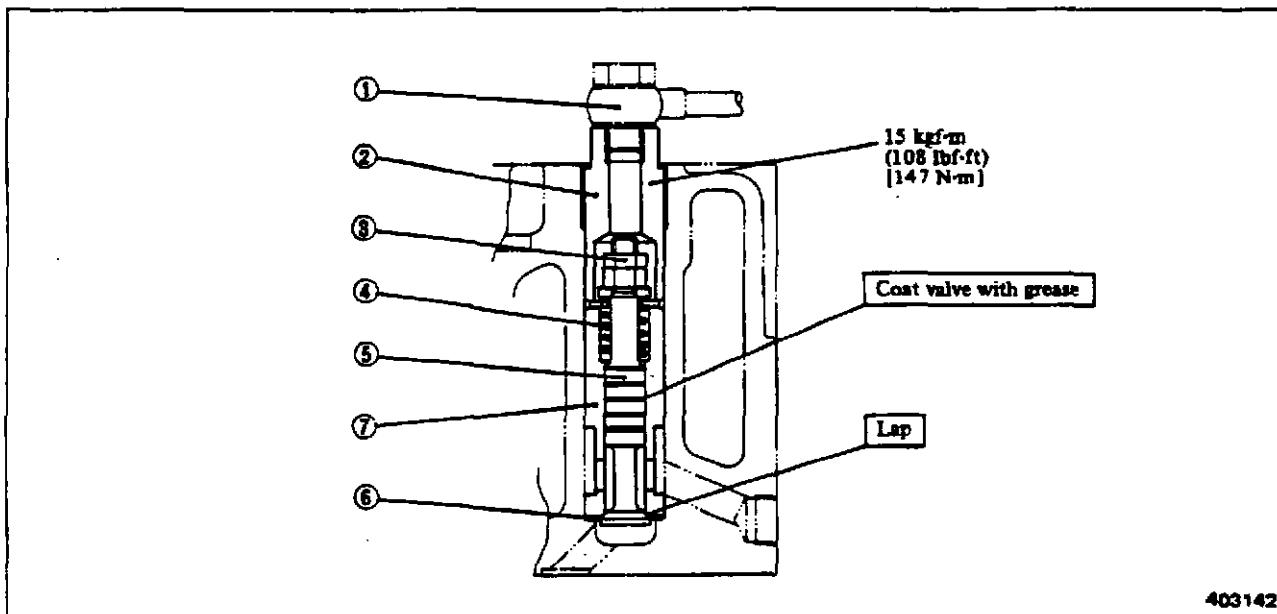

Reassembling sequence



AIR START SYSTEMS

9. MAGNETIC VALVE

Inspection

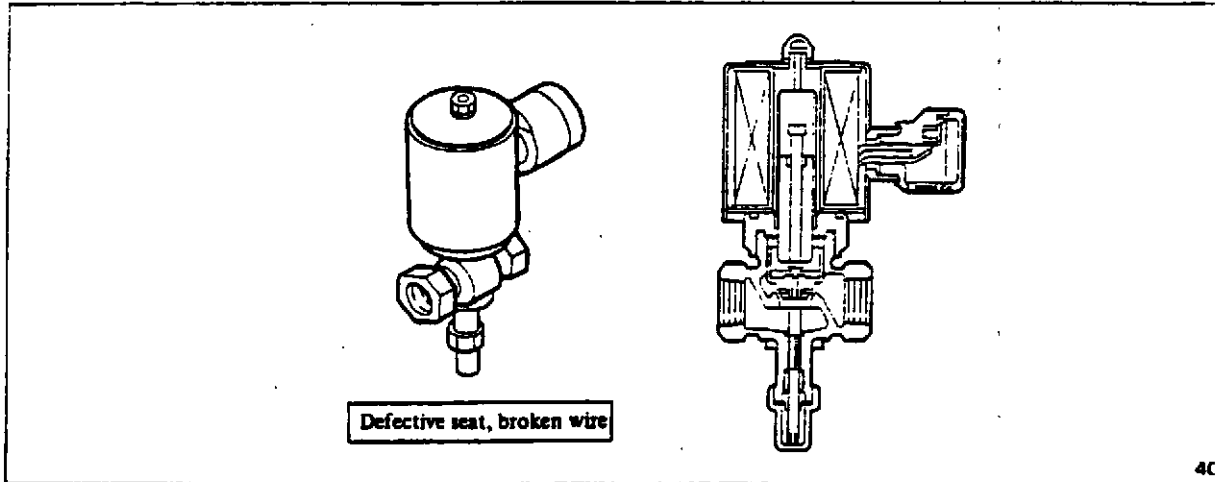

10. AIR FILTER

Inspection

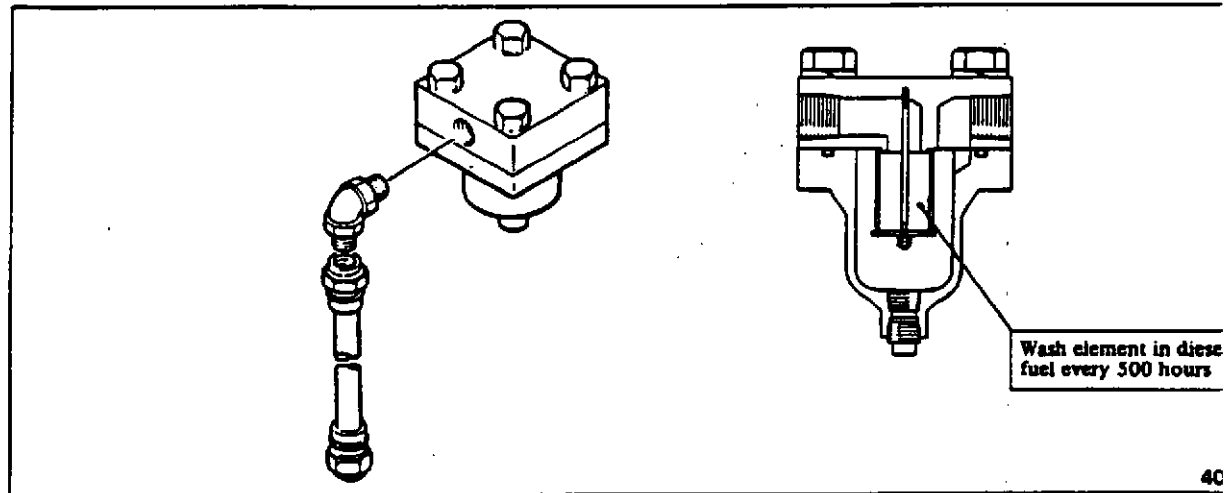

11. AIR TANK (FOR DIRECT AIR START SYSTEM)

Inspection

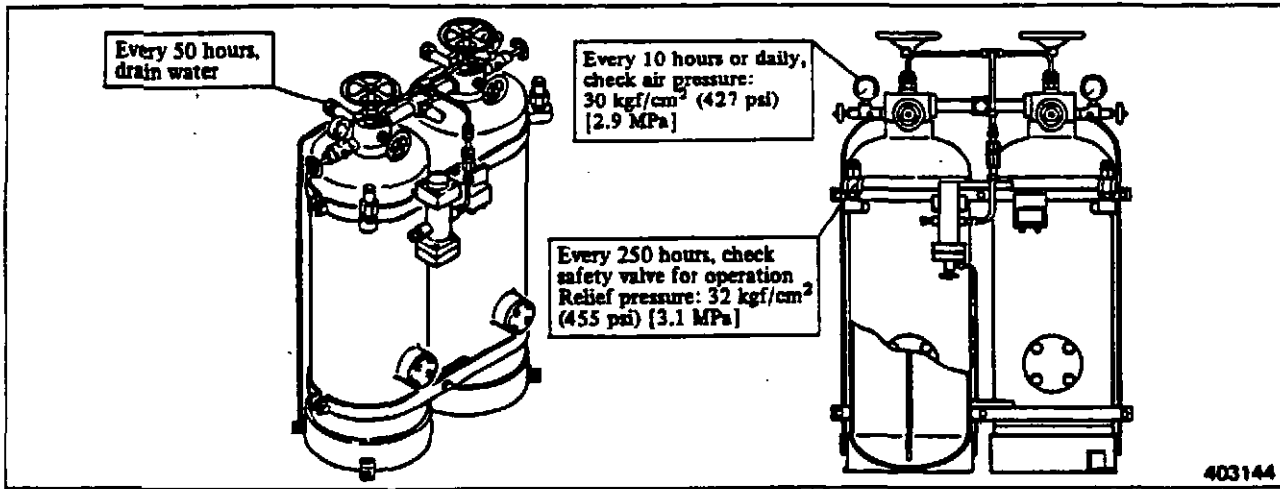

WORKSHOP THEORY

1. PRECAUTIONS FOR DISASSEMBLY AND REASSEMBLY	200
1.1 Oil seals	200
1.2 O-rings	201
1.3 Bearings	201
1.4 Lock plates	202
1.5 Split pins and spring pins	202

WORKSHOP THEORY

1. PRECAUTIONS FOR DISASSEMBLY AND REASSEMBLY

1.1 Oil seals

When installing oil seals, carefully observe the following points:

(1) Driving oil seals into housings

- (a) Make sure that seal lip is not damaged, and position it correctly with respect to oil compartment.
- (b) Apply a small amount of grease to the surface of oil seal to be fitted into housing bore.
- (c) Using a tool of the type shown to guide seal lip, drive oil seal squarely. Never give any hammer blows directly to oil seal since this will damage the seal, resulting in oil leakage.

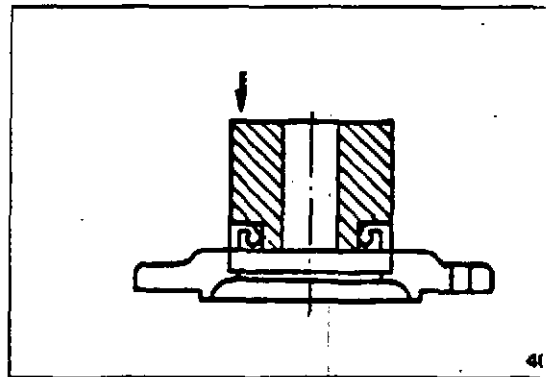

Oil seal driver

(2) Driving oil seals onto shafts

- (a) Apply a thin coat of grease to oil seal lip.
- (b) Use an oil seal guide of the type shown when driving oil seal over stepped portion, splines, threads or keyway to prevent damage to seal lip.

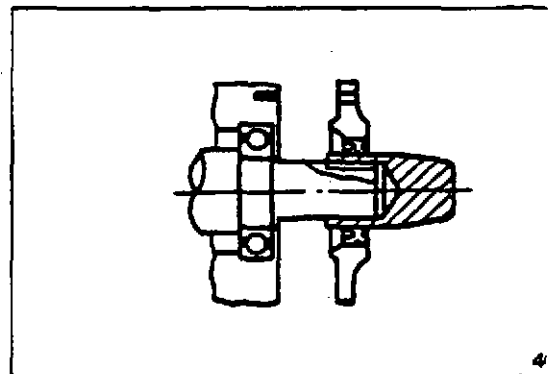

Oil seal guide

1.2 O-rings

Use an O-ring guide of the type shown when installing O-ring over stepped portion, splines, threads or keyway to prevent damage to the ring. Apply a thin coat of grease to O-ring.

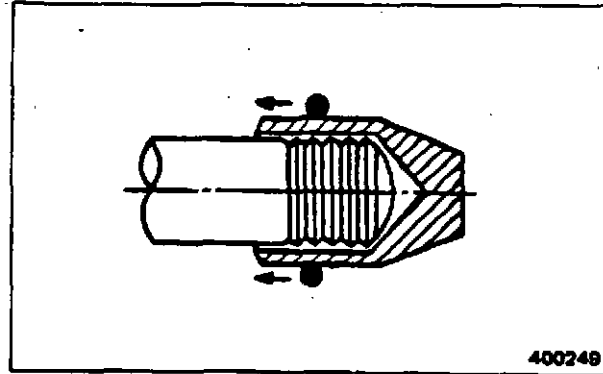

400249

O-ring guide

1.3 Bearings

(1) When installing a rolling bearing, be sure to give a push to the race, inner or outer, by which the bearing is fitted. Be sure to use a bearing driver of the type shown.

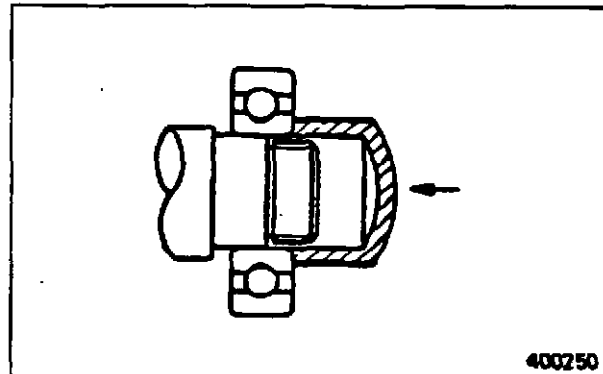

400250

Bearing driver

(2) Use a press whenever possible to minimize shock to bearing and to assure proper installation.

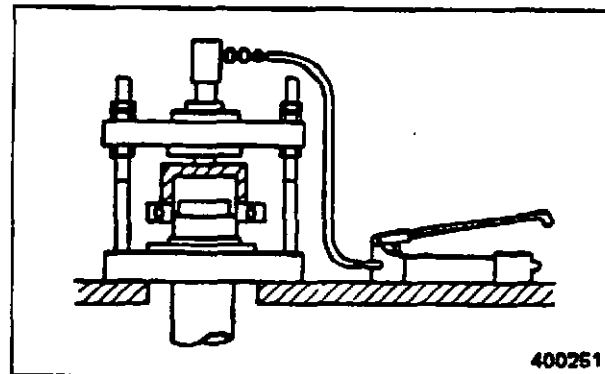

400261

Bearing installation by a press

WORKSHOP THEORY

1.4 Lock plates

Bend lock plate against one of the flats of nut or bolt head as shown.

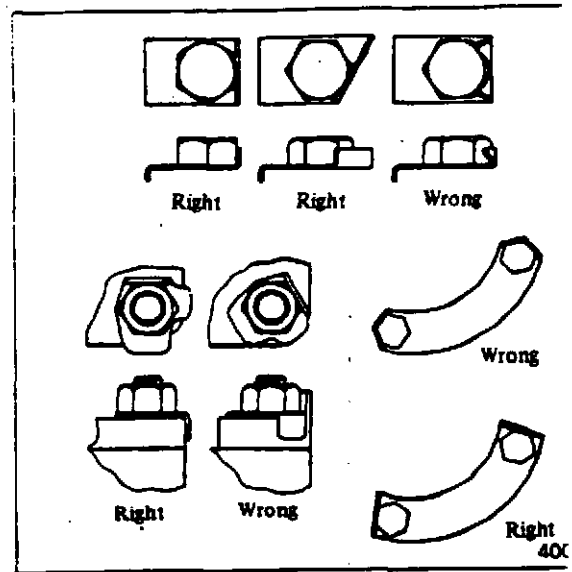

Bending lock plates

1.5 Split pins and spring pins

Generally, split pins are to be replaced at the time of disassembly. Insert the pin fully and spread it properly. Drive each spring pin into position so that it may not get out of place after subsequent installation of parts has been completed.

