

OPERATION & MAINTENANCE MANUAL

**MITSUBISHI
DIESEL ENGINE**

S16R-YIPTA-2

for **MITSUBISHI ENGINE NORTH AMERICA, INC.**

The operator and supervisor are requested to read this Operation and Maintenance Manual carefully before operating the engine or conducting inspection and maintenance.

Never operate the engine or conduct maintenance work without completely understanding this manual.

February 2006



**MITSUBISHI
HEAVY INDUSTRIES, LTD.**

FOREWORD

This operation and maintenance manual contains detailed operation, inspection and maintenance information of the Mitsubishi Engines.

Please read this manual thoroughly before proceeding with operation, inspection, and maintenance work for correct use and servicing.

Failure to follow directions in this manual may result in serious accidents.

Limited warranty

The manufacturer will repair or replace parts returned to the manufacturer when the manufacturer judges that the parts are defective in material and/or workmanship after conducting inspection.

The manufacturer's warranty is limited to the compensation work of repair or replacement of parts.

The coverage of the warranty is effective to the original purchaser only. Those who are transferred the ownership are not provided with the warranty.

-
- The manufacturer makes no warranties, either expressed or implied, except as provided in this manual, including, but not limited to, warranties as to marketability, merchantability, fitness for a particular purpose or use, or against infringement of any patent.
 - The manufacturer will not be liable for any damages or consequential damages, including, but not limited to, damages or other costs resulting from any abuse, misuse, misapplication of the engine and devices supplied by the manufacturer.
 - The manufacturer will not be liable for any damages or personal injuries resulting from any modification, without the manufacturer's written permission, of the engine and devices supplied by the manufacturer.
 - The manufacturer will not be liable for any damages or production losses caused by the use of fuel, engine oil and/or long life coolant (LLC) that are not recommended by the manufacturer.
-

Important information

- To avoid potential hazard, accident prevention activities must be planned methodically and conducted continually by considering all aspects of engine operation, maintenance and inspection. Everyone including managers and supervisors should actively participate, recognize one's role and organize oneself and one's work to ensure a safe environment.
- The foremost safety objective is to prevent accidents which may result in injury or death, or equipment damage.
- Always observe laws or regulations by the local or federal/national government.
- The manufacturer cannot foresee all potential danger of the engine, potential danger resulting from human error and others, or danger caused by a specific environment in which the engine is used. Since there are many actions that cannot be performed or must not be performed, it is impossible to indicate every caution in this manual or on warning labels. As such, it is extremely important to follow directions in this manual and also to take general safety measures when operating, maintaining and inspecting the engine.
- This manual has been prepared for people whose native language is English. When the engine is used by individuals whose native language is not English, the customer is requested to provide thorough safety guidance to the operators. Also add safety, caution and operating signs that describe the original warning label statements in the native language of the operators.
- The engine must be operated, maintained and inspected only by qualified persons who have thorough knowledge of engines and their danger and also who have received risk aversion training.
- To prevent an accident, do not attempt to carry out any operation other than those described in this manual, or do not use the engine for any unapproved purpose.
- When the ownership of the engine is transferred, be sure to provide this manual with the engine to the new owner. Also inform the manufacturer of the name and address of the new owner of the engine.
- This manual is copyrighted and all rights are reserved. No part of this manual including illustrations and technical reference may be reproduced, photocopied, translated, or reproduced in any electronic medium or machine readable form without prior written consent from the manufacturer.
- The contents in this manual are subject to change at any time without notice for improvement of the engine.
- Pictures or illustrations of the engine in this manual may differ from those of your engines.
- Please note that, depending on specifications, items described in this manual may differ from those on your engine in shape, or may not be installed on your engine.
- Please contact your Mitsubishi dealer if you need more information or if you have any questions.
- If you lost or damaged this manual, obtain a new copy at your Mitsubishi dealer as soon as possible.

Warnings

The following two means are used to call the attention of the operators and maintenance personnel to potential dangers of the engine.

- Warning statements in the manual
- Warning labels affixed on the engine

Warning statements

The warning statements in this manual describe potential danger in operating, inspecting or maintaining the engine by using the following five classifications to indicate the degree of potential hazard. Failure to follow these directions can lead to serious accidents which can result in personal injury, or death in the worst case.



Indicates a highly hazardous situation which, if not avoided, will result in death or serious injury.



Indicates a potentially hazardous situation which, if not avoided, could result in death or serious injury.



Indicates a potentially hazardous situation which, if not avoided, may result in minor or moderate injury.



Indicates a potentially hazardous situation which, if not avoided, can result in property damage.

Note:

Indicates important information or information which is useful for engine operation.

Units of measurement

Measurements are based on the International System of Units (SI), and they are converted to the metric system units in this manual using the following conversion rates.

- Pressure: 1 MPa = 10.197 kgf/cm²
- Torque: 1 N·m = 0.10197 kgf·m
- Force: 1 N = 0.10197 kgf
- Horsepower: 1 kW = 1.341 HP = 1.3596 PS
- Meter of mercury: 1 kPa = 0.75 cmHg
- Meter of water: 1 kPa = 10.197 cmH₂O (cmAq)
- Engine speed: 1 min⁻¹ = 1 rpm

Abbreviations, standards and others

- API = American Petroleum Institute
- ASTM = American Society for Testing and Materials
- JIS = Japanese Industrial Standards
- MIL = Military Specifications and Standards (U.S.)
- MSDS = Material Safety Data Sheet
- SAE = Society of Automotive Engineers (U.S.)
- LLC = Long Life Coolant

CONTENTS

Chapter 1

BASIC SAFETY PRECAUTIONS

Warning fire and explosion	1-1
Keep flames away	1-1
Keep engine and surrounding area clean and clear ..	1-1
Never open crankcase when engine is hot.....	1-1
Check for fuel, oil and exhaust gas leaks	1-1
Use flameproof light.....	1-1
Do not short electrical wires.....	1-1
Keep fire extinguishers and first-aid kit handy.....	1-1
Warning stay clear of all rotating and moving parts	1-2
Install protective covers around rotating parts	1-2
Check work area for safety.....	1-2
Watch out for rotating and moving parts while engine is in operation.....	1-2
Lock out and tag out	1-2
Always stop engine before inspection and maintenance	1-2
Always remove turning tools from the engine.....	1-2
Warning be careful of burns	1-3
Do not touch engine during operation or immediately after operation.....	1-3
Do not open radiator filler cap when the engine is hot1-3	
Add coolant only after coolant temperature is lowered1-3	
Do not remove heat protection covers.....	1-3
Warning be careful of exhaust fume poisoning	1-3
Perform engine operation in a well-ventilated area ..	1-3
Warning protect ears from noises.....	1-3
Wear earmuff.....	1-3
Warning be careful when lifting engine	1-4
Lift engine carefully.....	1-4
Do not climb onto engine	1-4
Always prepare secure platform	1-4
Caution be careful of handling engine oil and LLC	1-4
Use only specified fuel, engine oil and coolant (LLC)1-4	
Handle LLC carefully	1-4
Properly dispose of drained oil and LLC.....	1-4
Caution service battery.....	1-5
Handle battery carefully	1-5
Caution when abnormality occurs	1-5
If engine overheats, conduct cooling operation before stopping engine	1-5

If engine stops due to abnormality, exercise caution when restarting.....	1-5
If engine oil pressure drops, stop engine immediately1-5	
If V-belt breaks, stop engine immediately.....	1-5
Caution other cautions	1-6
Never modify engine.....	1-6
Never break seals.....	1-6
Perform all specified pre-operation inspections and periodic inspections	1-6
Perform engine break-in	1-6
Warm up engine before use	1-6
Never operate engine under overload condition.....	1-6
Conduct cooling operation before stopping engine ...	1-6
Do not splash water on engine	1-6
Conduct proper maintenance of air cleaner or pre-cleaner.....	1-7
Observe safety rules at workplace.....	1-7
Wear proper work clothes and protective gear.....	1-7
Use appropriate tools for maintenance work	1-7
Do not operate starter for prolonged time.....	1-7
Do not turn off battery switch while engine is operating	1-7
Cautions concerning transportation.....	1-7
Caution about warning labels.....	1-8
Maintain and inspect warning labels.....	1-8

Chapter 2

NAME OF PARTS

Engine external view.....	2-1
Left view	2-1
Right view	2-1
Equipment and instrument.....	2-2
Manual stop lever	2-2
Stop solenoid.....	2-2
Instruments.....	2-2
Revolution pickup	2-3
Engine protection devices	2-3
Engine protection devices	2-3
Oil filter alarm switch.....	2-3
Using turning gear.....	2-4
Cautions regarding exhaust emission control	2-5

**Chapter 3
OPERATION**

Preparation for operating new or overhauled engine3-1

Preparation of fuel system 3-1

Filling fuel tank 3-1

Bleeding fuel system..... 3-2

Bleeding fuel filter 3-2

Fuel injection pump..... 3-3

Priming pump cap tightening method 3-3

Preparation of lubrication system..... 3-4

Filling engine with engine oil..... 3-4

Preparation of cooling system..... 3-5

Filling cooling system with coolant..... 3-5

Checking battery 3-6

Checking battery electrolyte level 3-6

Checking specific gravity of battery electrolyte..... 3-6

Test operation 3-7

Starting and stopping..... 3-7

Inspection 3-7

Normal engine operation3-8

Preparations for operation (pre-start inspection) 3-8

External inspection 3-8

Checking fuel tank oil level 3-9

Checking engine oil level..... 3-9

Checking coolant level..... 3-10

Checking air cleaner..... 3-10

Starting..... 3-11

Warming-up operation..... 3-11

Checking engine oil pressure 3-11

External inspection during warming-up..... 3-11

Operation 3-12

Inspection during operation..... 3-12

Stopping..... 3-13

Emergency stop 3-13

Inspection after stopping..... 3-13

**Chapter 4
FUEL**

Recommended fuel4-1

Handling fuel.....4-1

**Chapter 5
ENGINE OIL**

Properties of engine oil and their influence on engine performance 5-1

Main properties of engine oil..... 5-1

Dispersibility 5-1

Acid neutralization ability..... 5-1

Viscosity 5-1

Recommended engine oil 5-2

Selection of oil viscosity 5-2

Genuine engine oil 5-2

Engine oil in the market 5-3

Handling engine oil 5-3

Service limits of engine oil 5-4

Definition of properties of engine oil.... 5-4

Viscosity 5-4

Total base number 5-4

Total acid number 5-4

Water..... 5-4

Flash point..... 5-4

Insolubles 5-4

Engine oil analysis service..... 5-5

How to order engine oil sampling tool set 5-5

**Chapter 6
COOLANT AND LLC**

Recommended coolant..... 6-1

Long life coolant (LLC)..... 6-1

Genuine LLC..... 6-1

LLC in the market..... 6-2

Maintenance of LLC 6-2

Replacement intervals of LLC.....6-2

LLC concentration.....6-2

Importance of LLC..... 6-3

Characteristics of LLC additive and important notes 6-3

Examples of abnormalities caused by LLC 6-3

Pitting on iron parts.....6-3

Corrosion of aluminum parts.....6-3

Pitting and clogging of radiator6-3

Chapter 7 PERIODIC MAINTENANCE CHART

How to use periodic maintenance chart	7-1
Periodic maintenance chart	7-1
Periodic maintenance chart for regular use engine	7-1
Periodic maintenance chart for emergency engine	7-1
Periodic maintenance chart for general-use engine	7-1
Definition of regular use engine, emergency engine and general-use engine	7-2
Regular use engine	7-2
Emergency engine	7-2
General-use engine	7-2
Periodic maintenance chart for regular use engine	7-3
Periodic maintenance chart for emergency engine	7-5
Periodic maintenance chart for general-use power supply engine	7-8

Chapter 8 PERIODIC INSPECTION AND MAINTENANCE PROCEDURES

Engine body periodic inspection and maintenance	8-1
Visual inspection	8-1
Checking pipe	8-2
Checking and replacing high pressure fuel injection pipe and clamp seat	8-2
Checking and replacing low pressure fuel pipe, oil pipe and clip	8-2
Checking V-belt and adjusting belt tension	8-3
Checking V-belt	8-3
Adjusting V-belt tension (Alternator side)	8-3
Checking damper	8-4
Visual checking of damper	8-4
Damper temperature management	8-4
Fuel system periodic inspection and maintenance	8-5
Draining fuel tank	8-5
Checking fuel control linkage ball joints	8-5
Changing fuel filter	8-6

Lubricating system periodic inspection and maintenance	8-7
Changing engine oil, oil filters and bypass oil filter	8-7
Draining engine oil	8-7
Changing oil filters and bypass oil filter	8-8
Refilling engine oil	8-9
Checking engine oil for mixing of fuel and water	8-9
Cooling system periodic inspection and maintenance	8-10
Changing coolant	8-10
Draining coolant	8-10
Cleaning cooling system	8-11
Refilling coolant	8-11
Checking and cleaning radiator fins	8-12
Inlet exhaust system periodic inspection and maintenance	8-13
Checking turbocharger	8-13
Draining water from exhaust muffler	8-13
Cleaning, checking and replacing pre-cleaner	8-14
Cleaning, checking, replacing air cleaner element	8-15
Electrical system periodic inspection and maintenance	8-16
Checking starter	8-16
Checking alternator	8-16
Checking battery	8-17
Checking battery electrolyte level	8-17
Checking specific gravity of battery electrolyte	8-17

Chapter 9 LONG-TERM STORAGE

Long-term storage	9-1
Storing engine in non-operable condition for 3 months or more	9-1
Preparation for storage	9-1
Recommended rust-preventive oil and corrosion inhibitor	9-1
Maintenance during storage	9-1
Using engine after storage	9-2

Storing engine in operable condition for 3 months or more9-2
 Operating engine for maintenance purpose..... 9-2

**Chapter 10
 TRANSPORTATION**

Lifting engine carefully 10-1

**Chapter 11
 TROUBLESHOOTING**

General precautions 11-1
 Contact your mitsubishi dealer for repair service..... 11-1
 Consideration before work 11-1
 Cautions against contamination 11-1
 Cautions regarding parts handling 11-1
 Work safety 11-1
 How to troubleshoot..... 11-2
 Starters do not crank or crank slowly, resulting in start failure 11-2
 Starters crank, but engine does not start 11-2
 Other problems and countermeasures11-3
 Engine output is low 11-3
 Exhaust smoke is white or blue 11-3
 Exhaust smoke is black or dark gray 11-4
 Fuel consumption is high 11-4
 Engine oil consumption is high..... 11-4
 Engine overheats 11-5
 Engine oil pressure is faulty 11-5
 When fuel has run out 11-5

**Chapter 12
 MAIN SPECIFICATIONS**

Main specifications 12-1

List of Illustrations

Fig.1-1 Warning labels 1-8
 Fig.2-1 Left view2-1
 Fig.2-2 Right view2-1
 Fig.2-3 Manual stop lever.....2-2
 Fig.2-4 Stop solenoid2-2
 Fig.2-5 Revolution pickup.....2-3
 Fig.2-6 Oil filter alarm switch.....2-3
 Fig.2-7 Turning gear position (engine in operation) .2-4
 Fig.2-8 Turning gear position (shaft pushed in).....2-4
 Fig.2-9 Turning gear position (turning shaft)2-4
 Fig.2-10 Tamper-proof equipment.....2-5
 Fig.3-1 How to use priming pump3-2
 Fig.3-2 Bleeding fuel filter3-2
 Fig.3-3 Fuel injection pump3-3
 Fig.3-4 Priming pump cap tightening method.....3-3
 Fig.3-5 Priming pump cap packing.....3-3
 Fig.3-6 Oil filler and oil level gage3-4
 Fig.3-7 Pouring engine oil on valve mechanisms and chamber3-4
 Fig.3-8 Coolant drain cock on the engine.....3-5
 Fig.3-9 Coolant drain cock on the water pump.....3-5
 Fig.3-10 Radiator coolant level.....3-5
 Fig.3-11 Coolant level in reserve tank.....3-5
 Fig.3-12 Checking battery electrolyte level3-6
 Fig.3-13 Checking specific gravity of electrolyte3-6
 Fig.3-14 Oil filler and oil level gage3-9
 Fig.3-15 Radiator cap.....3-10
 Fig.3-16 Radiator coolant level.....3-10
 Fig.3-17 Reserve tank coolant level.....3-10
 Fig.3-18 Checking air cleaner3-10
 Fig.3-19 Manual stop lever.....3-13
 Fig.4-1 Recommended fuel4-1
 Fig.4-2 Recommended fuel according to air temperature.....4-1
 Fig.5-1 Recommended engine oil5-2
 Fig.5-2 Recommended oil viscosity according to air temperature.....5-2
 Fig.5-3 Jukoil cojera,new mariner5-2
 Fig.5-4 Engine oil sampling tool set5-5
 Fig.6-1 GLASSY - LLC6-1

Fig.8-1 Checking and replacing high pressure fuel injection pipe and oil pipe..... 8-2

Fig.8-2 Checking and replacing low pressure fuel pipe 8-2

Fig.8-3 Adjusting V-belt tension 8-3

Fig.8-4 Checking damper 8-4

Fig.8-5 Damper temperature management..... 8-4

Fig.8-6 Draining water from fuel tank 8-5

Fig.8-7 Inspecting fuel control linkage for looseness.....8-5

Fig.8-8 Removing fuel control linkage 8-5

Fig.8-9 Changing fuel filters 8-6

Fig.8-10 Fuel filter 8-6

Fig.8-11 Oil filters and bypass oil filter 8-8

Fig.8-12 Oil filter..... 8-8

Fig.8-13 Oil filler and oil level gage 8-9

Fig.8-14 Radiator cap..... 8-10

Fig.8-15 Draining coolant (engine main parts) 8-10

Fig.8-16 Draining coolant (water pump side) 8-10

Fig.8-17 Radiator..... 8-11

Fig.8-18 Reserve tank..... 8-11

Fig.8-19 Cleaning radiator fins 8-12

Fig.8-20 Checking turbocharger..... 8-13

Fig.8-21 Draining water from exhaust muffler 8-13

Fig.8-22 Cleaning pre-cleaner..... 8-14

Fig.8-23 Removing air cleaner element 8-15

Fig.8-24 Cleaning air cleaner element 8-15

Fig.8-25 Checking air cleaner element..... 8-15

Fig.8-26 Air cleaner indicator 8-15

Fig.8-27 Checking starter..... 8-16

Fig.8-28 Checking alternator 8-16

Fig.8-29 Checking battery electrolyte level 8-17

Fig.8-30 Checking specific gravity of electrolyte 8-17

Fig.10-1 Hangers for lifting (left side) 10-1

Fig.10-2 Hangers for lifting (right side)..... 10-1

List of Tables

Table 3-1 Specific gravity of electrolyte.....3-6

Table 3-2 Standard values at rated speed.....3-12

Table 4-1 Recommended fuel 4-1

Table 4-2 Recommended and limit values of fuel property4-2

Table 5-1 Service limit for engine oil properties.....5-4

Table 5-2 Engine oil sampling tool sets.....5-5

Table 6-1 Water quality standards.....6-1

Table 6-2 Recommended LLC concentration (for reference only)6-2

Table 7-1 Periodic maintenance chart for regular use engine.....7-3

Table 7-2 Periodic maintenance chart for emergency engine.....7-5

Table 7-3 Periodic maintenance chart for general-use engine.....7-8

Table 8-1 Thermo label for temperature management.....8-4

Table 8-2 Specific gravity of electrolyte8-17

Table 9-1 Recommended rust-preventive oil and corrosion inhibitor.....9-1

Table 11-1 Starters Do Not Crank or Crank Slowly, Resulting in Start Failure¹1-2

Table 11-2 Starters Crank, But Engine Does Not Start¹1-2

Table 11-3 Engine Output is Low11-3

Table 11-4 Exhaust Smoke is White or Blue11-3

Table 11-5 Exhaust Smoke is Black or Dark Gray ..11-4

Table 11-6 Fuel Consumption is High11-4

Table 11-7 Engine Oil Consumption is High.....11-4

Table 11-8 Engine Overheats.....11-5

Table 11-9 Engine Oil Pressure is Faulty11-5

Table 12-1 Main specifications12-1

Chapter 1 BASIC SAFETY PRECAUTIONS

Warning fire and explosion

Keep flames away

Store fuel and engine oil in a well-ventilated designated area.

Make sure that the caps of fuel and engine oil containers are tightly closed.

Do not use flames, do not smoke, or do not work near heater or other fire hazards where fuel or oil is handled or when cleaning solvent is being used for washing parts.

Wipe off spilled fuel, oil and LLC immediately and thoroughly. Spilled fuel, oil and LLC may ignite and cause a fire.

Keep engine and surrounding area clean and clear

Keep the engine and the surrounding area free of dust, dirt and foreign materials, as they may easily ignite and cause a fire or may cause engine overheat. Clean the top surface of the battery after performing maintenance work. Dust on the battery may ignite and cause a short-circuit. The engine must be installed at least 1 m [3.3 ft.] away from structures and other equipment to avoid possible fire hazards due to engine heat.

Never open crankcase when engine is hot

If the cover is opened while the engine is still hot, fresh air enters crankcase and oil mist can ignite due to engine heat and may result in the explosion of the engine. Never open the engine crankcase cover while the engine is hot. Wait at least 10 minutes after the engine has stopped. Open the cover after the engine becomes cool.



Check for fuel, oil and exhaust gas leaks

Inspect fuel, oil and exhaust pipes regularly for damage and loose. If a fuel, oil and exhaust gas leak is found, repair the leakage immediately. Spilled fuel or oil on a hot surface of the engine, or exhaust gas discharged directly to a combustible material may cause a fire and result in personal injury and/or damage to equipment.

Use flameproof light

When inspecting fuel, engine oil, coolant, battery electrolyte, etc., use a flameproof light. An ordinary light, if it accidentally broken, may ignite and cause an explosion.

Do not short electrical wires

Before inspecting or servicing any electrical component, disconnect the ground cable from the (-) negative battery terminal to prevent a short-circuit and a risk of fire.

Loose terminals or damaged cables/wires can cause a short-circuit that may result in fire. Before operating the engine, inspect the cables and wires, and repair or replace if necessary.

Keep fire extinguishers and first-aid kit handy

Keep fire extinguishers handy, and be familiarized with their usage.

Keep first-aid kits at the designated place with easy access by anyone at any time.

Establish response procedures to follow in the event of fire or accident. Provide emergency evacuation route and contact points and means of communication in case of emergency.



Warning stay clear of all rotating and moving parts

Install protective covers around rotating parts

Make sure the protective covers of the engine are correctly installed. Repair any damaged or loose covers. When the engine is coupled to the radiator or other equipment, install protective covers around the exposed connecting belt and coupling. Never remove protective covers of rotating parts such as the damper cover, camshaft cover or rocker cover while the engine is operating.

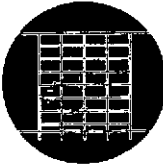

Check work area for safety

Before starting the engine, check to make sure that no one is near the engine, no tools are left behind on the floor or on the engine. Verbally notify persons around the engine or in the work area when starting the engine.

When the starter device is posted with a sign that prohibits startup operation, do not operate the engine.

Watch out for rotating and moving parts while engine is in operation

Do not touch or come close to rotating and moving parts (output shaft, flywheel, fan belts and pulleys) of the engine while the engine is running. Keep flappy and loose objects away from rotating parts to avoid entanglement.



Entanglement of your body or tools in rotating and moving parts will result in serious injury.

Lock out and tag out

Before starting inspection or maintenance work, be sure to lock out and tag out the engine. Lockout and tagout are effective methods of cutting off machines and equipment from energy sources. To lock out and tag out, pull out the key from the starter switch, turn off the battery switch, and post a "Do Not Operate" tag on the starter switch. The starter key switch should be kept by the person performing the inspection and maintenance. For the air starter system, close the main valve of the air tank, and post a "Do Not Open the Valve" tag.

Always stop engine before inspection and maintenance

Be sure to stop the engine before proceeding with inspection and maintenance work. Never attempt to adjust the engine parts while the engine is running. Attempting any work on running engine can cause a severe accident.

Always remove turning tools from the engine

Be sure to remove all turning tools used during maintenance and inspection work. If the engine is started with turning tools or gears left on the engine, it can cause a severe accident and result in not only engine damage but also personal injury or death.

Warning be careful of burns

Do not touch engine during operation or immediately after operation

Do not touch any parts of the engine during operation or immediately after operation to avoid burns. To conduct maintenance and inspection work, wait until the engine have cooled sufficiently by checking the temperature gage.



Do not open radiator filler cap when the engine is hot

Never open the radiator filler cap while the engine is running or immediately after the engine is stopped. The engine coolant is hot during engine operation and immediately after operation. If the radiator filler cap is opened when the coolant is at operating temperature, steam and hot coolant may blow out and result in burns. When opening the cap, stop the engine and allow the coolant temperature to lower sufficiently. Cover the cap with a cloth or use thick rubber glove, and then slowly open the cap. When closing the cap, be sure to tighten securely.

Add coolant only after coolant temperature is lowered

Do not add coolant immediately after the engine stops. Wait until the coolant temperature lowers sufficiently to avoid a risk of burns.

Do not remove heat protection covers

The high-temperature exhaust components are installed with heat protection covers. Do not remove these heat protection covers. If the covers must be removed during inspection and maintenance work, be sure to reinstall them after the inspection and maintenance work is completed.

Warning be careful of exhaust fume poisoning

Perform engine operation in a well-ventilated area

Exhaust gas from the engine contains carbon monoxide and other toxic substances. Do not operate the engine in an enclosed area (inside a warehouse, tunnel, etc.) or in an area where all sides are blocked, as exhaust gas is hazardous. If the engine must be operated in an enclosed area, discharge the exhaust gas to the outside and provide adequate ventilation. Connect exhaust duct to the exhaust pipe to discharge exhaust gas to the outside, and make sure exhaust gas does not leak from the duct joints. Make sure the exhaust gas is not discharged directly to surrounding buildings, plants or living passersby.

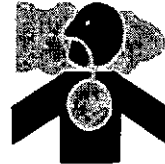

Warning protect ears from noises

Wear earmuff

Be sure to wear earmuff or earplugs when entering the engine room. The earmuff or earplugs can be quite useful to protect ears from various engine noises.



⚠ Warning be careful when lifting engine

Lift engine carefully

To lift the engine, use slings capable of supporting the weight of the engine. Attach appropriate slings to the hangers on the engine. Keep the engine balanced during lifting by considering the center of gravity of the engine. Keep the angle formed by slings attached to hangers within 60°. If the angle exceeds this limit, excessive load is imposed on the hangers and may damage the hangers and result in a serious accident. If slings come in contact with the engine, place a cloth or other soft padding to avoid damage to the engine and slings.



Do not climb onto engine

Never climb onto the engine. To work on parts located on the upper part of the engine, use a ladder, stand, or other stable platform.

Climbing on the engine may not only damage engine parts but also cause parts to fall off and result in personal injury.

Always prepare secure platform

Use a stable work platform to stand on when working on the upper part of the engine and other hard-to-reach places. Standing on a feeble stand or parts box may result in personal injury. Do not put obstacles on the platform.



⚠ Caution be careful of handling engine oil and LLC

Use only specified fuel, engine oil and coolant (LLC)

Use fuel, oil and LLC specified in this manual, and handle them carefully. Use of any other fuel, oil or LLC, and improper handling may cause various engine problems and malfunctions. Obtain the MSDSs issued by the fuel, oil and LLC suppliers, and follow the directions in the MSDSs for proper handling.

Handle LLC carefully

Wear safety mask and rubber gloves when handling LLC. Avoid contact with skin and eyes to prevent personal injury.

If LLC is accidentally swallowed, induce vomiting immediately and seek medical attention at once.

If LLC enter eyes, flush immediately with plenty of water and seek medical attention at once. If LLC is spilled on skin or clothes, wash immediately with plenty of water.

Keep flammable materials away from LLC to prevent a risk of fire. Never use open flames or generate sparks near LLC, as they can cause a fire.

Coolant containing LLC is a hazardous material. For disposal of the coolant, observe applicable law or regulations, or contact your Mitsubishi dealer.

Properly dispose of drained oil and LLC

Do not discharge engine oil, used cleaning oil or LLC into conventional sewage.

Prepare drip pan or other containers to receive oil and LLC drained from the engine. Do not discharge them directly in the ground.

For disposal of used oil and LLC, observe applicable law or regulations, or contact your Mitsubishi dealer.

⚠ Caution service battery

Handle battery carefully

- Batteries release flammable hydrogen gas and oxygen. Never use open flames or generate sparks near the battery since open flames or sparks can cause an explosion.
- Do not use the battery when the fluid surface is lower than the minimum required level. Using a battery with a low electrolyte level may result in an explosion.
- Do not short the battery terminals with a tool or other metal object.
- When disconnecting battery cables, remove the cable from the (-) negative terminal first. When reconnecting cables, attach the cable to the (+) positive terminal first.
- Charge the battery in a well-ventilated area, with all filling hole plugs removed.
- Make sure the cable clamps are securely installed on the battery terminals. A loose cable clamp can cause sparks that may result in an explosion.
- Before servicing electrical components or conducting electric welding, set the battery switch to the [OFF] position or disconnect the cable from the (-) negative battery terminal to cut off the electrical current.
- Battery electrolyte contains dilute sulfuric acid. Careless handling of the battery may result in loss of sight and burns.
- Wear safety goggles and rubber gloves when working with the battery (filling of fluid, charging, etc.)
- If battery electrolyte is spilled on skin or clothes, wash immediately with lots of water. Then, use soap to clean thoroughly.
- If battery electrolyte enters eyes, flush immediately with lots of fresh water and seek medical attention at once.
- If battery electrolyte is accidentally swallowed, gargle with plenty of water, and then drink lots of water. Seek medical attention at once.



⚠ Caution when abnormality occurs

If engine overheats, conduct cooling operation before stopping engine

If the engine overheats, do not stop the engine immediately. Abrupt stopping of an overheated engine may cause the coolant temperature to rise and result in seizing of the engine. If the engine overheats, operate the engine at low idling speed (cooling operation), and stop the engine after the coolant temperature lowers sufficiently. Do not add coolant immediately after stopping the engine. Adding coolant to a hot engine may cause damage to the cylinder head due to sudden change in temperature. Add coolant gradually after the engine cools to the room temperature.

If engine stops due to abnormality, exercise caution when restarting

If the engine stops due to an abnormality, do not restart the engine immediately. If the engine stops with an alarm, check and correct the cause of the problem before restarting. Operating the engine without correcting the problem may result in serious engine problems.

If engine oil pressure drops, stop engine immediately

If the engine oil pressure decreases, stop the engine immediately, and inspect the lubricating system including the oil level and pump. Operating the engine with low oil pressure may cause seizing of bearings and other parts.

If V-belt breaks, stop engine immediately

If V-belt breaks, stop the engine immediately. Continued operation of the engine without V-belt in place causes an engine overheating and could be result in burns due to blowout of steam from reserve tank or radiator.

Caution other cautions

Never modify engine

Unauthorized modification of the engine will void the manufacturer's warranty. Modification of the engine may not only cause engine damage but may result in personal injury as well. If there is a need to modify the engine, contact your Mitsubishi dealer.

Never break seals

To ensure proper engine operation, the fuel control links are sealed to prevent accidental change of the injection volume and rotation speed settings. Operating the engine without these seals in place can cause problems described below, and also invalidates the warranty.

- Rapid wear of sliding and rotating parts
- Engine damage such as seizing of engine parts
- Considerably increased consumption of fuel and lubricating oil
- Degradation of engine performance due to improper balance between fuel injection volume and governor operation or overrun of engine which will be result in serious accident.

Perform all specified pre-operation inspections and periodic inspections

Conduct the pre-operation inspections and periodic inspections as described in this manual. Failure to conduct the specified inspections may cause various engine problems, damage to parts, and serious accidents.

Perform engine break-in

To break in a new engine, operate the engine at a speed lower than rated speed under light load during the first 50 hours of operation. Operating a new engine under heavy load or severe conditions during the break-in period will shorten the service life of the engine.

Warm up engine before use

When starting auxiliary devices such as water heater and engine oil priming pump is not installed, let the engine idle for 5 to 10 minutes before operating the engine for work. Warm-up operation circulates lubricants in the engine and contributes to a longer service life and economical operation. Do not conduct warm-up operation for prolonged period of time. Prolonged warm-up operation causes carbon build-up in the cylinders that lead to incomplete combustion.

Never operate engine under overload condition

If the engine shows an overload condition such as back exhaust smoke, reduce the load immediately to operate the engine at appropriate output and load. Overloading causes not only high fuel consumption but also excessive carbon deposits inside the engine. Carbon deposits cause various problems and will shorten the service life of the engine.

Conduct cooling operation before stopping engine

Before stopping the engine, let it idle at low speed for 5 to 6 minutes to cool down. Stopping the engine immediately after high-load operation will cause engine parts to heat up and shorten the service life of the engine. During cooling operation, check the engine for abnormalities.

Do not splash water on engine

Do not allow water such as rain to enter the engine through the air inlet or exhaust openings. Do not wash the engine while it is in operation, as the water enters the engine. If the engine is started with water inside the combustion chambers, water hammering occurs and damages the engine, and may result in serious accidents.

Conduct proper maintenance of air cleaner or pre-cleaner

The major cause of abnormal wear on engine parts is due to the dust from intake air. Worn parts result in an increase of oil consumption, decrease of output, and starting difficulties. Conduct maintenance of the air cleaner or pre-cleaner as described below to ensure optimum air filtering performance.

- Do not conduct maintenance of the air cleaner or pre-cleaner while the engine is in operation. Without the air cleaner/pre-cleaner, the turbocharger can suck foreign particles into the engine and it could result in serious accidents.
- When removing the air cleaner/pre-cleaner, use care to prevent dust trapped in the air cleaner from entering the engine.
- If the air cleaner is equipped with a dust indicator, conduct maintenance whenever the clog warning sign appears. While servicing the air cleaner, do not allow dust to enter the air cleaner and do not damage or deform the element.

Observe safety rules at workplace

Observe the safety rules established at your workplace when operating and maintaining the engine. Do not operate the engine if you are feeling ill. Operation of the engine with reduced awareness may cause improper operations that could result in accidents. In such a case, inform your supervisor of your condition. When working in a team of two or more persons, use specified hand signals to communicate among the workers.

Wear proper work clothes and protective gear

Wear a hardhat, face shield, safety shoes, dust protective mask, gloves and other protective gear as needed.

When handling compressed air, wear safety goggles, a hardhat, gloves and other necessary protective gears. Without the proper protective gear, the compressed air may cause personal injury.

Use appropriate tools for maintenance work

Use appropriate tools according to the type of maintenance work, and use them correctly.

If a tool is damaged, replace with a new one.

Do not operate starter for prolonged time

Do not use the starter for more than 10 seconds at a time. If the engine does not start, wait for at least 30 seconds before cranking again.

Continuous operation of the starter will cause the battery to discharge as well as the starter to seize.

Do not turn off battery switch while engine is operating

Do not turn off the battery switch while the engine is in operation.

Turning the battery switch off while the engine is in operation causes the operation of instruments to stop, and may deteriorate the alternator diode and regulator.

Cautions concerning transportation

When transporting the engine using a truck, consider the engine weight, width and height to ensure safety.

Abide by the pertinent laws and regulations.

Caution about warning labels

Maintain and inspect warning labels

Make sure all warning labels are legible.

If the description and/or illustration on a warning label is illegible, clean or replace the label.

To clean warning labels, use a cloth, water and soap. Do not use solvents, gasoline or other chemicals to clean warning labels, as chemicals may cause the labels to peel off.

If warning labels are damaged or missing, install new labels.

If a part of the engine with warning label is replaced with a new part, also install the new warning label to the new part.

To obtain replacement warning labels, contact your Mitsubishi dealer.

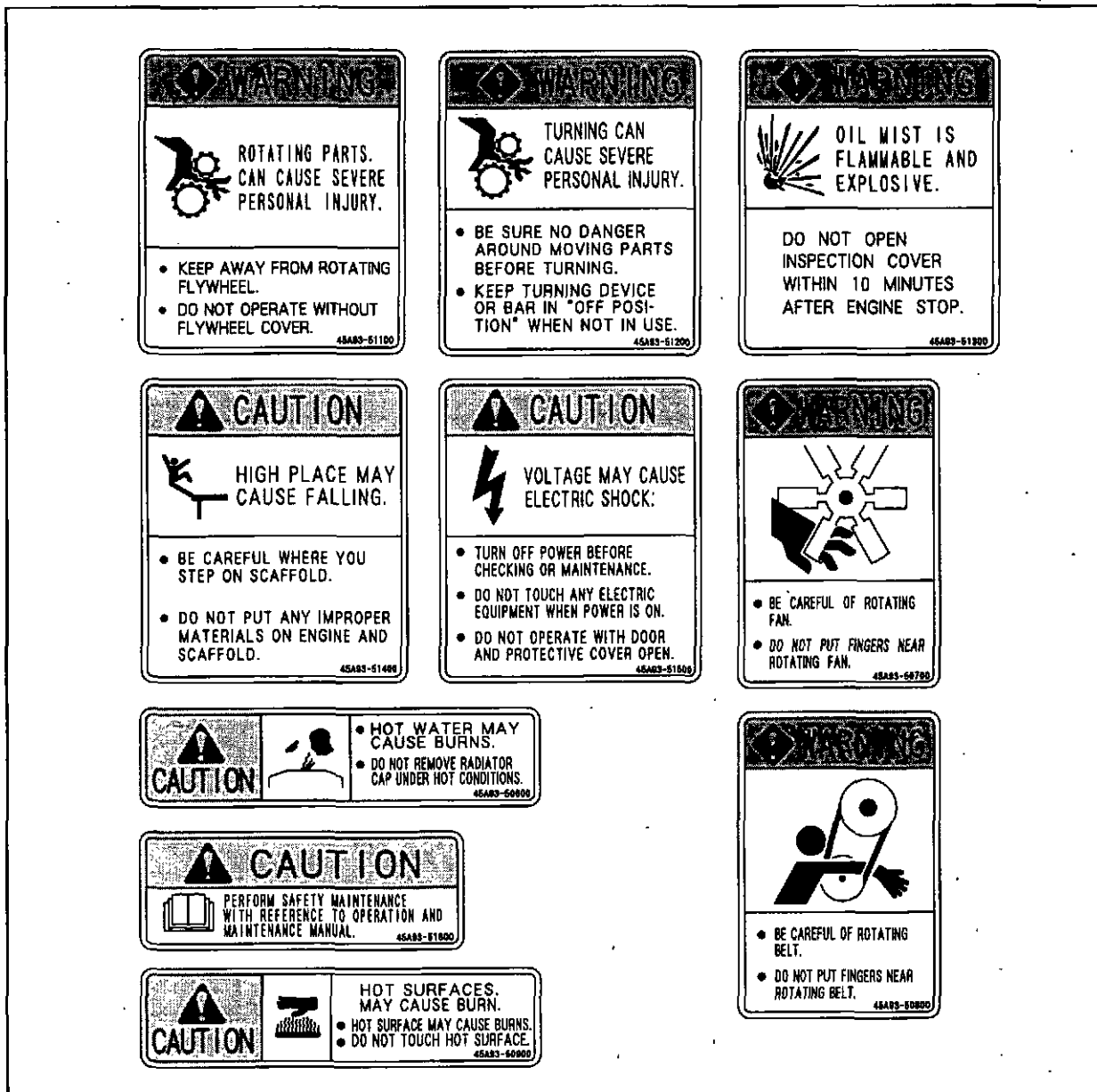

Fig.1-1 Warning labels

Chapter 2 NAME OF PARTS

Engine external view

The external views shown below are the standard type of engine.
The external view changes based on the type and attachments.

Left view

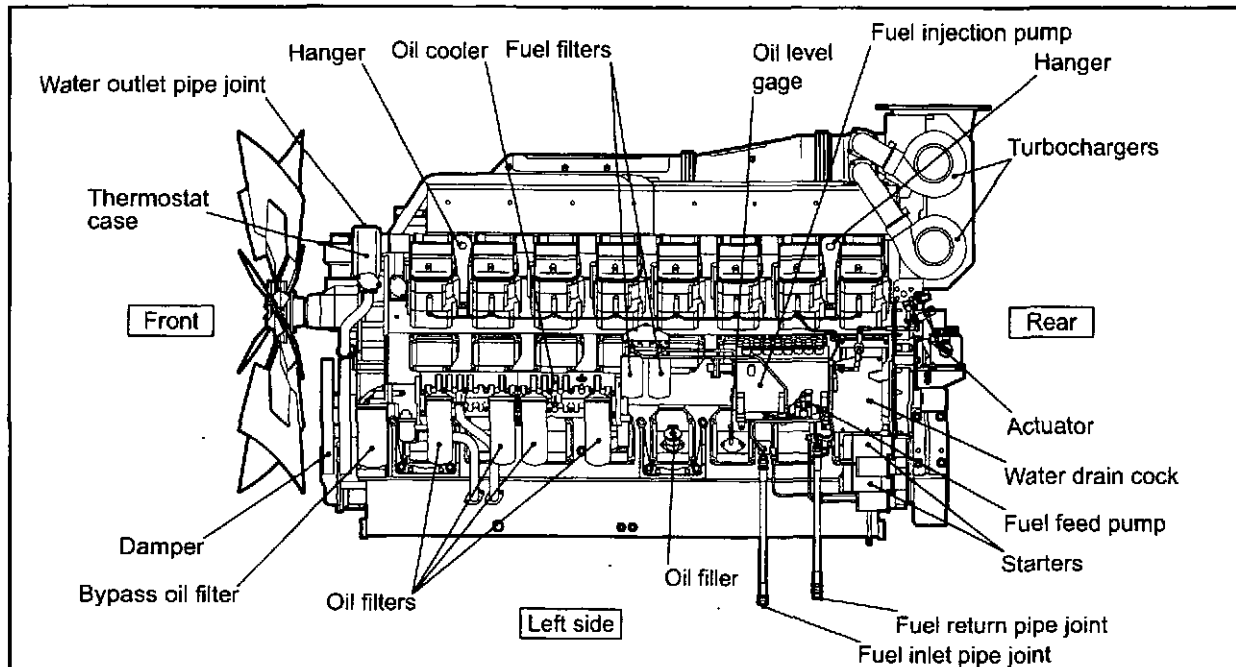

Fig.2-1 Left view

Right view

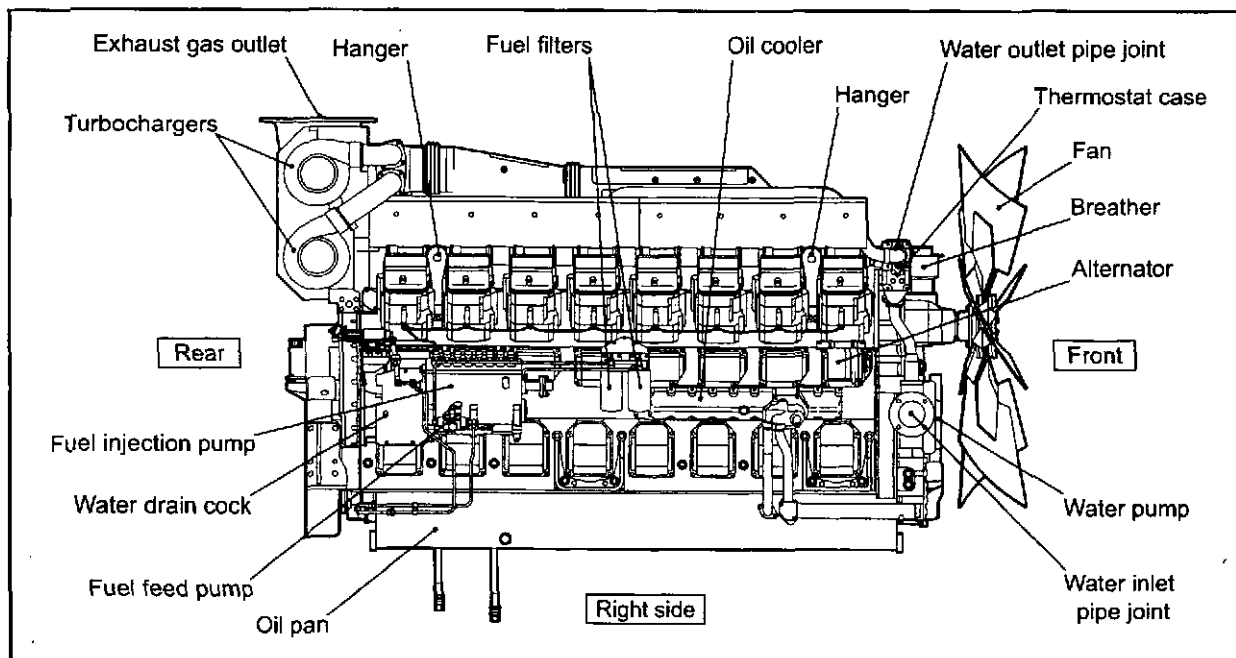

Fig.2-2 Right view

Equipment and instrument

Manual stop lever

Use the manual stop lever to shut down the engine in the event of an emergency. If the starter switch fails to stop engine operation, use the manual stop lever.

When the lever is moved in the [STOP] direction, the engine stops operation.

If the engine continues a operation even after the manual stop lever is operated, cut off the fuel supply to stop the engine.

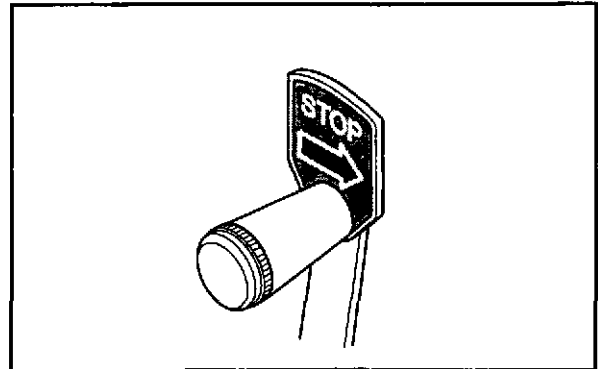

Fig.2-3 Manual stop lever

Stop solenoid

The stop solenoid operates for normal shutdown of engine operation. The stop solenoid moves the rack of the fuel injection pump to stop fuel injection, thus shutting down the engine operation.

The "RUN-ON" type solenoid sets the start switch to the "OFF" position by de-energizing the stop solenoid and pushing the rod out by internal spring power which makes the rack of the fuel injection pump move to the non-injection direction.

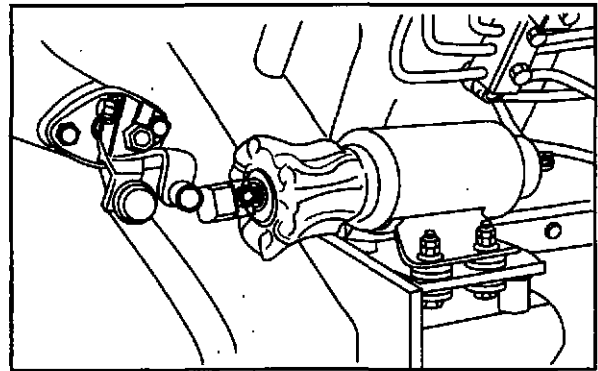

Fig.2-4 Stop solenoid

Instruments

This section describes about devices which transmit signals to necessary instruments of the engine in operation.

Please read carefully and understand functions of each device.

Revolution pickup

The revolution pickup is installed in the timing gear case to detect the engine speed.

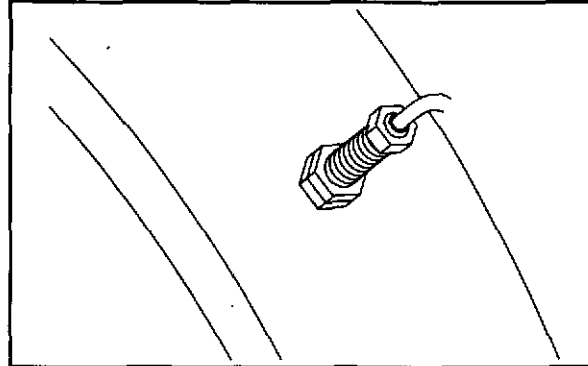

Fig.2-5 Revolution pickup

Engine protection devices

The engine protection devices activate an alarm when an abnormality occurs in the engine in order to protect the engine and prevent serious problems and accidents. When a protection device is activated, stop the engine, examine the cause of the abnormality, and take corrective measures.

If the cause of the problem is not detected, contact your Mitsubishi dealer. Protection devices on the engine and their types (setting values) and shapes change depending on the engine specifications. The typical protection devices are shown below:

Engine protection devices

Oil filter alarm switch

The oil filter alarm switch activates the alarm system when the oil filter is clogged.

The switch is activated when the difference of pressures measured at before and after oil filter reaches the limit.

When the alarm sign is given, immediately replace the oil filter with a new filter. Also renew the engine oil.

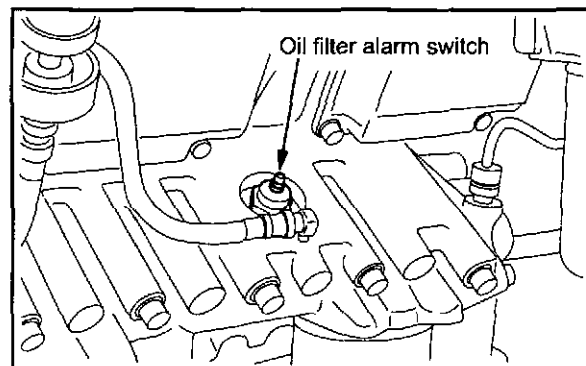

Fig.2-6 Oil filter alarm switch

Using turning gear

WARNING

Before starting the engine, make sure that the turning gear is pulled out in the original position. Starting the engine with the turning gear pushed in not only damages the ring gear but also may result in personal injury.

1. Loosen the two bolts, and remove the plate from the shaft groove.

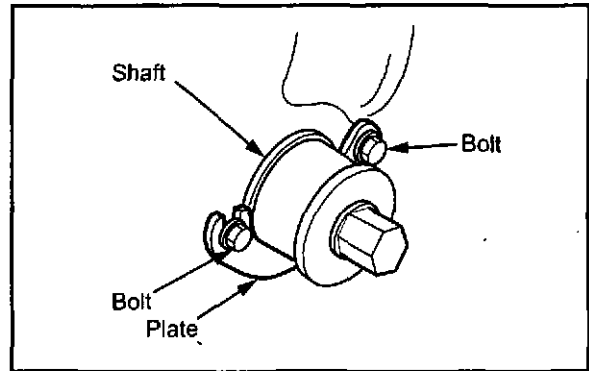

Fig.2-7 Turning gear position (engine in operation)

2. Push in the shaft fully to engage it with the ring gear.

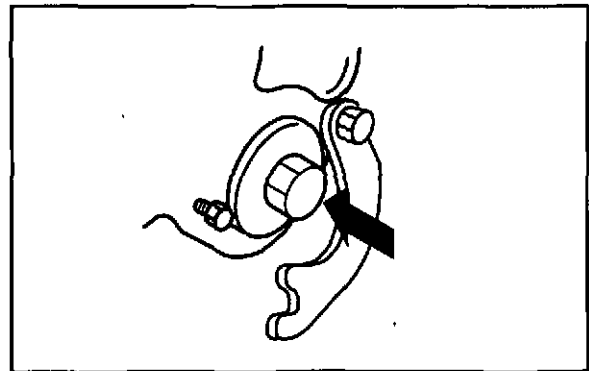

Fig.2-8 Turning gear position (shaft pushed in)

3. Using a socket wrench and a ratchet handle, turn the shaft.
4. After turning, pull out the shaft, insert the plate in the shaft groove, and tighten the bolts.

CAUTION

Make sure the plate is securely installed in the shaft groove.

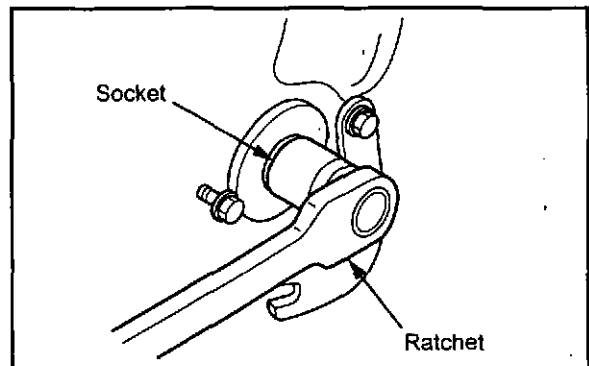

Fig.2-9 Turning gear position (turning shaft)

Cautions regarding exhaust emission control

Do not modify any part of the engine. Alteration or adjustment of parts connected with the exhaust emission control performance not only adversely affects the engine performance but also results in non-compliance with the EPA regulations. It also invalidates the manufacturer's warranty. The following parts in the engine are specially designed to ensure proper exhaust emission control.

- Turbocharger
- Cylinder head
- Camshaft
- Piston
- Fuel injection nozzle
- Fuel injection pump
- Boost sensor
- Tamper-proof equipment

If any of the above parts is removed and replaced with a nonconforming product, the engine will fail to comply with the EPA regulations and provide poor emission control performance. The exhaust emission control system of the engine should be serviced only by an authorized Mitsubishi dealer.

To maintain the exhaust emission control performance, be sure to conduct maintenance according to the direction in this manual.

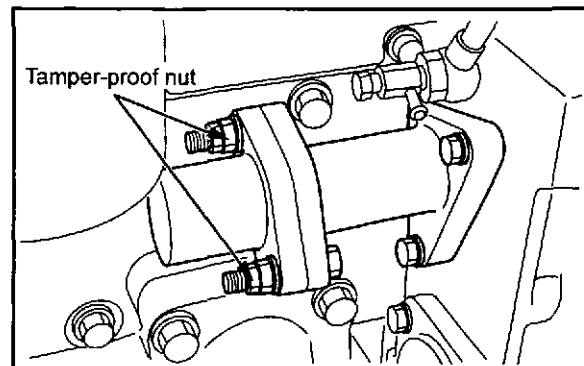

Fig.2-10 Tamper-proof equipment

Chapter 3 OPERATION

Preparation for operating new or overhauled engine

Before proceeding with operation of a new or overhauled engine, conduct the inspections described in this section. For second operation onward, follow the instructions described in the "Normal engine operation" (3-8).

Preparation of fuel system

CAUTION

When handling fuel, do not use open flames or heaters. Wipe off any spilled fuel completely. Spilled fuel is highly flammable and can cause a fire.

CAUTION

Do not remove the strainer when filling the fuel tank. Use the fuel specified in "FUEL" (4-1).

Filling fuel tank

1. Make sure the insides of the fuel tank and fuel pipes are thoroughly clean.
2. Fill fuel tank with fuel.
3. Remove the fuel feed pipe and the drain plug from the fuel inlet of engine, and check the discharged fuel for foreign particles such as dust.
4. Reinstall the drain plug and the fuel feed pipe.
5. Refill fuel tank until fuel level gage indicates "FULL."

Bleeding fuel system

WARNING

When fuel overflow from the air vent plug, wipe thoroughly with a cloth. Spilled fuel is a fire hazard. After bleeding, lock the priming pump cap securely. If the cap is not locked tightly, the priming pump can be damaged, causing fuel leakage that may lead to a fire. To lock the priming pump cap, follow the procedure described on the following page.

CAUTION

Do not close all air vent plugs before locking the priming pump cap, as the priming pump cap will not return to the original position due to internal pressure.

Bleed air at fuel filters and then at the fuel injection pump. Bleeding from upstream to downstream makes the job effective.

Bleeding fuel filter

CAUTION

If air vent plugs, thread portion of bracket, or sealing washers are damaged, replace them with new ones.

1. Loosen the air vent plug on the fuel filter intake for the left bank cylinder about 1.5 turns.
2. Turn the priming pump cap counterclockwise to unlock, and prime the fuel filter.
3. When the fuel from the air vent plug becomes free from air bubbles, stop priming and tighten the air vent plug to the specified torque.
4. Loosen the air vent plug on the fuel filter outlet for the left bank cylinder about 1.5 turns, and bleed as described above.
5. Bleed the fuel filters for the right bank cylinders as described above.

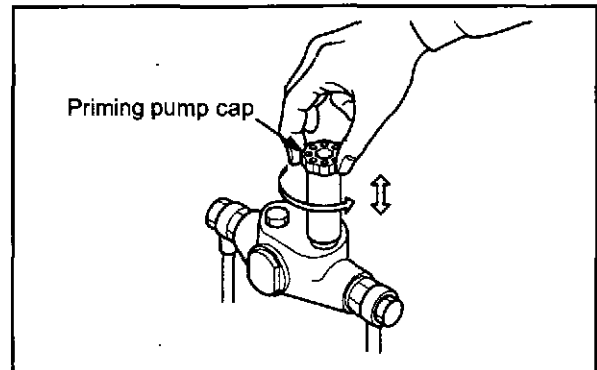

Fig.3-1 How to use priming pump

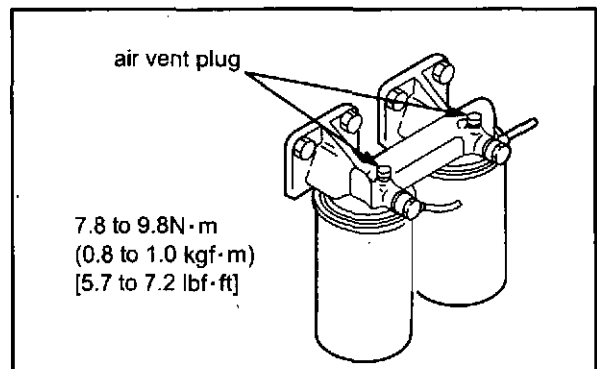

Fig.3-2 Bleeding fuel filter

Fuel injection pump

1. Loosen the air vent cock on the fuel injection pump about 1.5 turns.
2. Move the priming pump cap up and down until the fuel flow from the air vent cock is free from air bubbles. Push and turn the priming pump cap clockwise to lock in the original position when the fuel flows is free from bubbles.
3. Tighten the air vent plug on the fuel injection pump.
4. Repeat the same procedure to fuel injection pump on the other side.

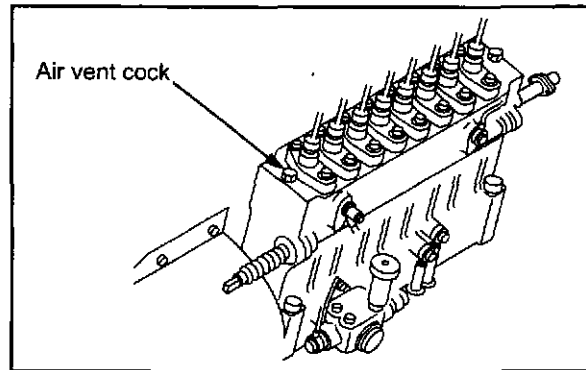

Fig.3-3 Fuel injection pump

Priming pump cap tightening method

CAUTION

Never fail to tighten the priming pump cap to the specified angle ($90\pm 10^\circ$). If the priming pump cap is not firmly tightened, internal thread will be worn due to engine vibration, resulting in sudden ejection of the cap to cause fuel flow-out. Or if the priming pump cap is excessively tightened (turned 120° or more), the head of the priming pump can be damaged.

1. Finger tighten the priming pump cap.
2. Mark this position on the cap to facilitate the following steps:
3. Tighten the cap further by $90\pm 10^\circ$ with a wrench. Note that the cap will be tightened by 70 to 90° with full force of hand at the above step 1.
4. Make sure the head packing is not protruding.

Note: If the head packing is protruding, loosen the priming pump cap. Check the packing for damage and retighten the cap. If damaged, consult your Mitsubishi dealer.

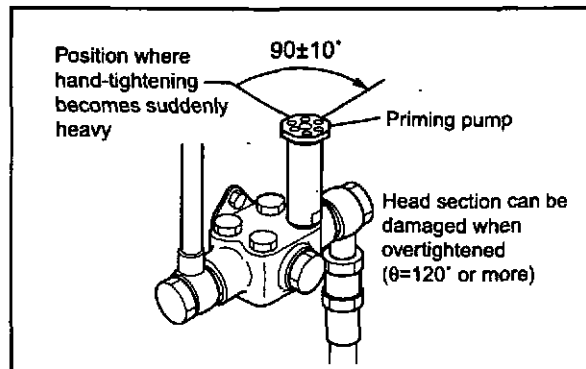

Fig.3-4 Priming pump cap tightening method

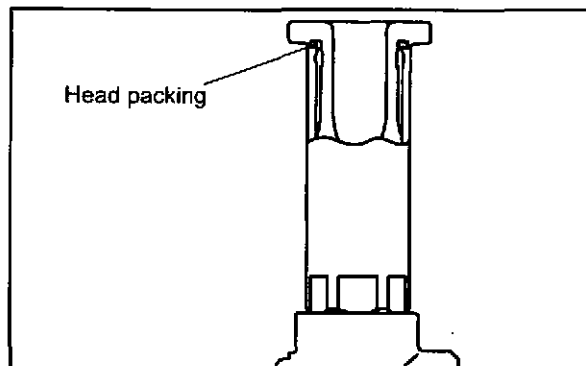

Fig.3-5 Priming pump cap packing

Preparation of lubrication system

Filling engine with engine oil

1. Remove the cap from the oil filler.
2. Fill engine with the specified engine oil to the specified level.

Note: For engine oil, refer to "ENGINE OIL" (5-1).
For engine oil capacity, refer to "MAIN SPECIFICATIONS" (12-1).

3. Remove the rocker covers of all the cylinders. Lubricate the valve mechanisms and fill the camshaft oil bath with engine oil from the cylinder head.

Oil capacity per cylinder: 800cm³

4. Reinstall the rocker covers.
5. Check the oil level of oil pan as described below:
 - Pull out the oil level gage and wipe it clean with a cloth.
 - Reinsert the oil level gage all the way in the oil level guide and then pull it out again.
 - The oil level is correct if it is between maximum, and minimum level marks.
 - Add the specified engine oil if it is lower the minimum level mark.
6. Check the oil pan and other parts for oil leaks. Repair the oil leakage if any.
7. Shut off fuel and crank the engine with the starter for 10 seconds to circulate oil throughout the engine. After 1 minute of rest period, start cranking again to circulate oil throughout the engine for another 10 seconds.
8. Check the oil level with the oil level gage again, and add oil if necessary.

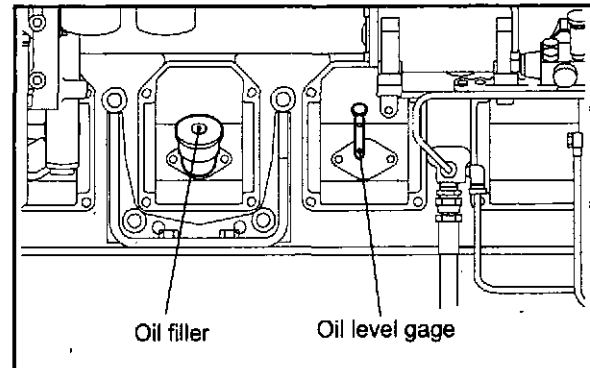

Fig.3-6 Oil filler and oil level gage

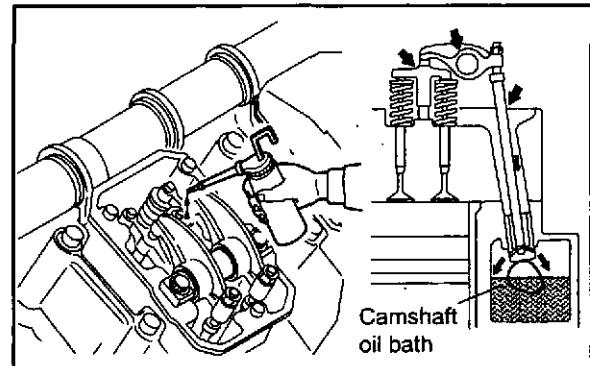

Fig.3-7 Pouring engine oil on valve mechanisms and chamber

CAUTION

To crank the engine, shut off the fuel supply to the engine and operate the starters. When conducting the above cranking operation, also check the items to be inspected for the cooling system by cranking.

Preparation of cooling system

Filling cooling system with coolant

1. Make sure the drain cocks on the engine and water pump are securely tightened.
2. Remove the radiator cap, and fill the radiator tank with undiluted LLC.

Note: Determine the quantities of LLC based on the coolant capacity and the LLC concentration chart.

For the coolant, refer to "COOLANT AND LLC" (6-1)

For the coolant capacity, refer to "MAIN SPECIFICATIONS" (12-1).

3. Pour in water (soft water with minimal impurities, such as tap water) slowly to the full level.
- Note: For absolute air bleeding, loosen the air vent cock on the upper section of thermostat when adding water.
4. Check the radiator and other parts for coolant leaks. Repair leakage if found.
 5. Install the radiator cap securely.
 6. Shut off fuel and crank the engine with the starter for 10 seconds.
 7. After about 1 minute of rest period, start cranking again for another 10 seconds to bleed air from the water pump.

CAUTION

To crank the engine, shut off the fuel supply to the engine and operate the starters. When conducting the above cranking operation, also check the items to be inspected for the lubricating system by cranking.

8. Check the coolant level in the radiator.
9. When a reserve tank is equipped, fill the reserve tank with the coolant to the [FULL] level.

CAUTION

Always use the coolant with the same LLC concentration for refilling.

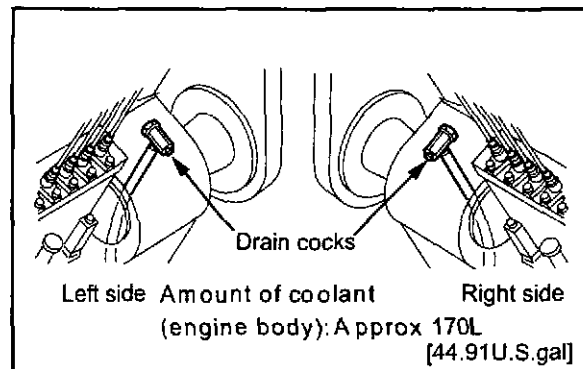

Fig.3-8 Coolant drain cock on the engine

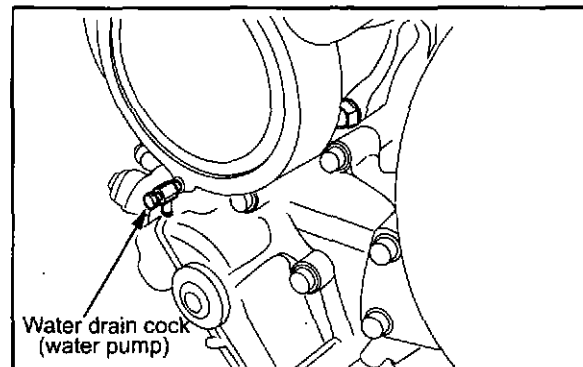

Fig.3-9 Coolant drain cock on the water pump

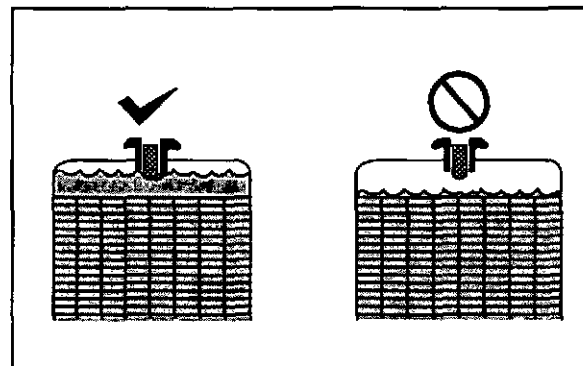

Fig.3-10 Radiator coolant level

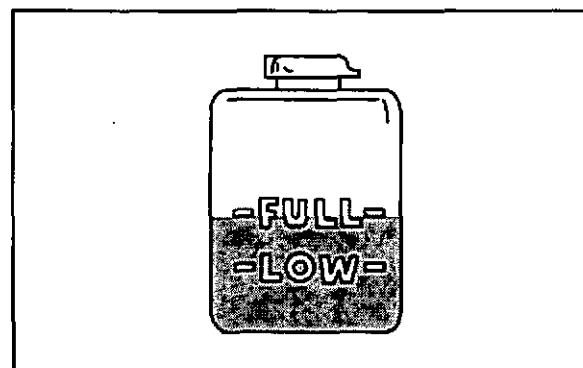

Fig.3-11 Coolant level in reserve tank

Checking battery

WARNING

If battery electrolyte is spilled on your skin, flush immediately with plenty of water. If battery electrolyte enters the eyes, flush them immediately with lots of fresh water and seek medical attention at once. Do not use open flames or other fire hazards near the battery. When handling the battery, be careful of sparks generated by accidental shorting. For other cautions in handling the battery, refer to "Caution service battery" (1-5).

Checking battery electrolyte level

Battery electrolyte evaporates during use and the fluid level gradually decreases. The correct fluid surface level is between the LOWER LEVEL and UPPER LEVEL lines. For the battery without level lines, the correct fluid surface level is about 10 to 15 mm [0.394 to 0.591 in.] above the top of the plates. If the fluid level is low, remove the caps and add distilled water to the proper level.

Note: When adding distilled water, pour in carefully.

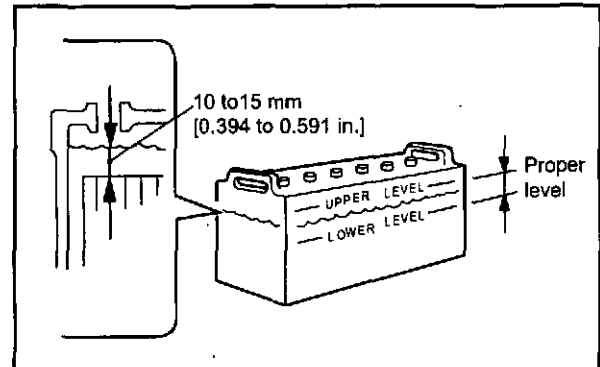

Fig.3-12 Checking battery electrolyte level

Checking specific gravity of battery electrolyte

Check the specific gravity of the electrolyte. If the specific gravity measured at 20°C [68°F] is lower than 1.22, then charge the battery.

Table 3-1 Specific gravity of electrolyte

Specific gravity at 20°C [68°F]	Condition	Remedy
From 1.26 to 1.28	Fully charged	-
From 1.22 to 1.25	Charged	Charge
Less than 1.22	Discharged	Charge

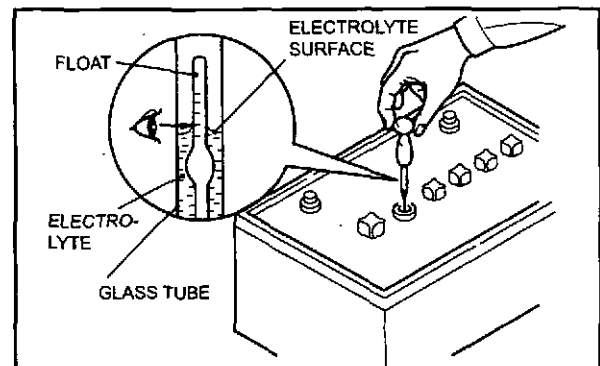

Fig.3-13 Checking specific gravity of electrolyte

Test operation

To conduct a test operation, follow the procedures below.

Note: For engine operation, refer to "Normal engine operation" (3-8).

Starting and stopping

1. Start the engine.
2. Operate the engine at low idling speed under no load for 5 to 10 minutes for a warm-up operation.
3. Stop the engine.

Inspection

1. Leave the engine be stopped for about 30 minutes.
2. During this period, check the engine and surrounding area for leaks of fuel, engine oil or coolant.
3. At 30 minutes after the engine stop, check the oil level with the oil level gauge.
4. If the oil level is low, add engine oil from the oil filler. Be sure to use the engine oil of the same brand and type.
5. Open the radiator cap, and check the coolant level.

CAUTION

Remove the radiator cap only after the engine is cooled to the room temperature. Place a cloth over the cap, and loosen the cap about a half-turn to release internal pressure. Opening the radiator cap while the engine is hot causes steam and hot coolant to splash out that may result in skin burns.

6. If the coolant level is low, add coolant to the specified level.
7. When a reserve tank is equipped, add coolant to the [FULL] level.

CAUTION

Always use the coolant with the same LLC concentration for refilling.

Normal engine operation

This section of the manual covers the procedures for the engine operation in normal condition.

CAUTION

If any engine abnormality is observed during operation, stop the engine and correct the problem, or contact your Mitsubishi dealer.

Preparations for operation (pre-start inspection)

Before starting the engine, always conduct the following inspection.

External inspection

CAUTION

Be sure to keep combustible materials away from the engine, especially from the hot engine parts such as exhaust manifolds, or the battery. Check for fuel and oil leaks. Clean the top of battery with a wet cloth before starting engine, as dust on the battery can easily ignite. If any abnormality is found, be sure to repair or contact your Mitsubishi dealer.

Inspect the engine exterior as described below.

1. Make sure there is no combustible material near the engine or battery. Also, check to make sure the engine and battery are clean. If combustible materials or dust are found near the engine or battery, remove them.
2. Check the electrical wiring to such components as starters and alternator for loose.
3. Check the entire engine for leaks of fuel, engine oil and coolant. If leaks are found, repair the leak, or contact your Mitsubishi dealer.
4. Make sure the following valves, plugs and cocks are open or closed properly:
 - Fuel feed valve: Open
 - Coolant drain cock (plug): Closed
 - Oil drain valve: Closed
 - Air supply valve (air tank): Open

Checking fuel tank oil level

WARNING

When working around fuel, make sure there are no open flames, heaters or other fire hazards. Wipe off any spilled fuel completely. Spilled fuel can ignite and cause a fire.

CAUTION

Do not remove the strainer when filling the fuel tank.
Use fuel specified in "FUEL" (4-1).

Make sure the fuel tank is full. If the fuel level is low, refill the tank to the "FULL" level.

Checking engine oil level

1. Pull out the oil level gauge and wipe it with a cloth.
2. Insert the oil level gauge fully into the oil level gauge guide, then pull out the gauge again.
3. The correct oil level is between the MAXIMUM and MINIMUM marks on the oil level gauge.
4. If the oil level is low, remove the oil filler cap and add engine oil of the specified type to the MAXIMUM level.
5. Install the oil filler cap after a refill.
6. Check the oil pan and other parts for oil leaks.

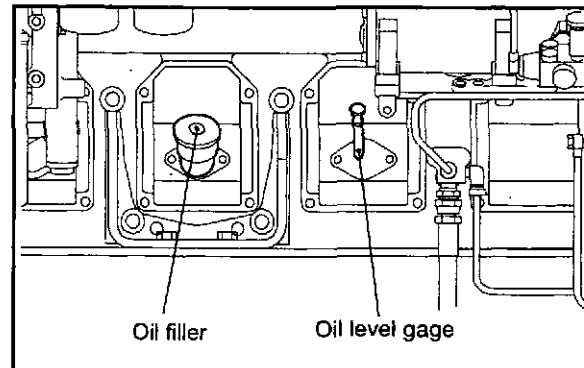

Fig.3-14 Oil filler and oil level gage

Checking coolant level

WARNING
 Remove the radiator cap only after the engine is cooled to the room temperature. Place a cloth over the cap, and loosen the cap about a half-turn or stand the lever to the upright position to release internal pressure. Opening the radiator cap while the engine is hot causes steam and hot coolant to splay out that may result in skin burns.

1. Open the radiator cap and check the coolant level.
2. If the coolant level is low, add coolant to the specified level.

CAUTION
 Always use the coolant with the same LLC concentration.

Note: Determine the quantities of LLC based on the coolant capacity and the LLC concentration chart.

For the coolant, refer to "COOLANT AND LLC" (6-1). For the coolant capacity, refer to "MAIN SPECIFICATIONS" (12-1).

3. If a reserve tank is equipped, fill the reserve tank with coolant up to the [FULL] line level.

Checking air cleaner

1. Check the air cleaner indicator for the element clog.
2. If the element is clogged, the red signal mark is visible.
3. Immediately clean or replace the air cleaner element when the signal turns red.

Note: For cleaning of the air cleaner element, refer to "Cleaning, checking, replacing air cleaner element" (8-15).

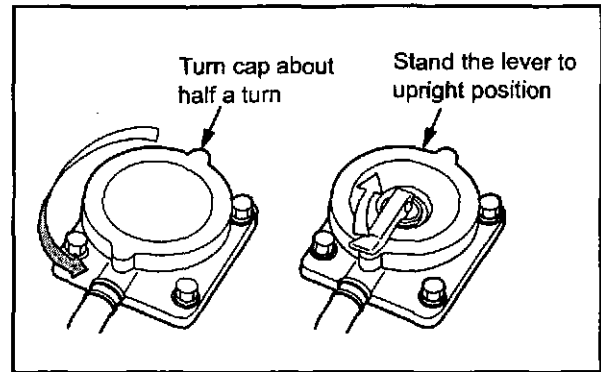

Fig.3-15 Radiator cap



Fig.3-16 Radiator coolant level

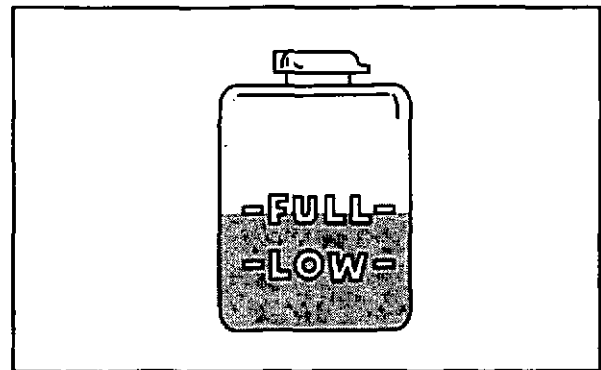

Fig.3-17 Reserve tank coolant level

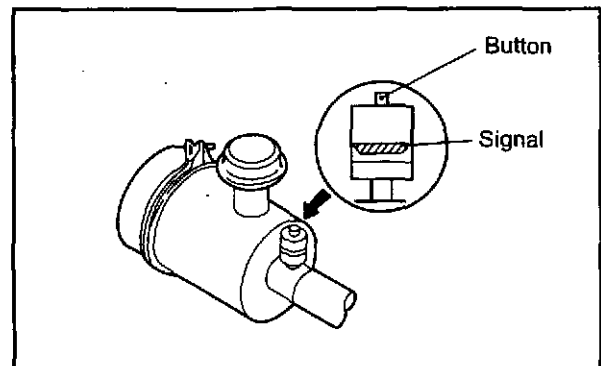

Fig.3-18 Checking air cleaner

Starting

The starting method changes based on application and specifications. Start the engine according to the specified procedure.

WARNING

Before starting the engine, check to make sure no one is near the engine and tools are not left on or near the engine. In loud voice, notify people in the area when starting the engine.

CAUTION

Do not apply load to the engine at starting. (Disengage the clutch if installed.)

Warming-up operation

WARNING

Do not approach rotating parts during operation. Entanglement by rotating parts can cause serious injury.

CAUTION

Do not conduct warm-up operation for prolonged period of time.

Prolonged warm-up operation causes carbon buildup in the cylinders that leads to incomplete combustion. Do not turn the battery switch to OFF. Turning off the battery switch while the engine is in warm-up operation not only stops the instrument operations but also may deteriorates the alternator diode and regulator. Never turn the key to START position during warm-up operation, as it damages starter.

During warming-up operation, do not operate the engine under overload (if overloaded, the black smoke is exhausted). Operating the engine under overload not only increases fuel consumption but also generates excessive carbon deposits inside the engine which considerably shorten the engine service life.

After the engine starts, operate the engine under no load at low idling speed for 5 to 10 minutes to warm up.

Checking engine oil pressure

During warming-up operation, check if the oil pressure is in the range of standard value.

Also, make sure the oil pressure gage is operating properly.

Note: The oil pressure gage may indicate higher level than normal level immediately after the engine starts, due to the low oil temperature. The pressure gradually lowers to the normal level as the oil temperature rises.

External inspection during warming-up

Visually check the external view of the engine for leaks of fuel, engine oil and coolant, or leaks of exhaust gas from joints.

Operation

WARNING

Do not approach rotating parts during operation. Entanglement by rotating parts can cause serious injury.

CAUTION

Do not touch any hot part of the engine such as exhaust pipes during operation or immediately after shut down. A hot engine can cause burns.

CAUTION

Always provide adequate ventilation in the engine room. If air supply to the engine room is not sufficient, the room temperature rises and can affect engine output and performance.

For the first 50 hours, operate the engine under light load at lower speed than the normal operation for break-in operation.

Operating the engine under heavy load or severe conditions during the break-in period can shorten the service life of the engine.

Do not turn the battery switch to OFF when the engine is in operation. Turning off the battery switch during operation not only stops the battery charge but also causes malfunctioning of instruments and deteriorates the alternator diode and regulator.

Never turn the key to the START position during operation. The starter may be damaged.

After the warm-up operation, start applying load to the engine.

Inspection during operation

Carefully check the exterior of engine such as piping joints for leaks.

Check for abnormal engine noises or vibrations such as knocking.

Check the color of exhaust gas from the exhaust muffler.

Note: For abnormal exhaust gas conditions, refer to "Other problems and countermeasures" (11-3).

Check the instruments and gages for proper operation and make sure they indicate normal values.

Table 3-2 Standard values at rated speed

Item	Standard value
Engine oil pressure gage	0.49 to 0.64 MPa (5 to 6.5 kgf/cm ²) [71 to 92 psi]
Coolant temperature	70 to 90°C [158 to 194 °F]

Note (a) When the oil pressure drops below 0.29 MPa (3 kgf/cm²) [42.7 psi] in normal operation, or below 0.10 MPa (1 kgf/cm²) [14.2 psi] at low idling, stop the engine immediately. Be sure to locate the cause of problem and correct it before restarting the engine.

(b) When the high temperature alarm switch is activated in normal operation, change the engine operation immediately to low idling operation until the engine temperature decreases to normal operating level. Then, operate the engine for another 5 or 6 minutes for cooling before stopping the engine. Be sure to locate the cause of problem and correct it before restarting the engine.

Stopping

CAUTION

The sudden engine stop at high speed operation creates a local abnormal high temperature rise, and shortens the service life of engine. Except in an emergency, be sure to conduct cooling operation for 5 to 6 minutes at low idling speed before stopping the engine. During the cooling operation, check the engine for abnormalities. Never accelerate the engine right before the shut down.

Do not restart the engine immediately after abnormal shut down.

When the engine stops with alarms, be sure to locate the cause of the problem and correct the problem before restarting the engine. And after restarting the operation, check the engine for abnormalities again. If abnormalities still exist, contact your Mitsubishi dealer.

Engine stopping method changes depending on the specifications.

Follow the instructions according to the specifications of the equipment.

Emergency stop

CAUTION

When stopping the engine by pulling the manual stop lever, continue to pull the lever until the engine stops completely. If not, the engine may start again.

To stop the engine in an emergency, pull the manual lever fully in the direction of arrow and continue to pull the lever until the engine stops completely.

Note: When the engine does not stop with the manual lever, cut the fuel supply.

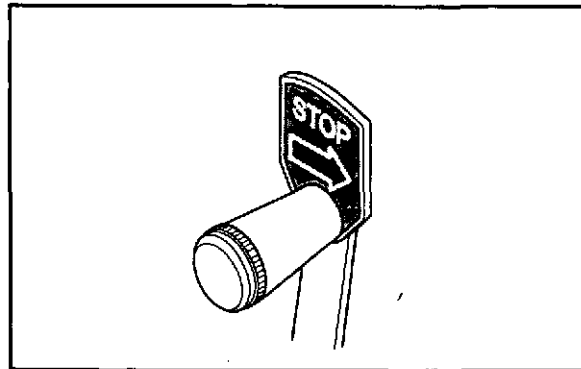

Fig.3-19 Manual stop lever

Inspection after stopping

Inspect the engine for leaks of fuel, oil or coolant. If any leak are found, repair the leakage or contact your Mitsubishi dealer.

Chapter 4 FUEL

Recommended fuel

WARNING

Use recommended fuel specified in this manual.
Do not refill fuel tank more than the specified level, as it may result in a fire.

Use fuel that meets the values specified in the table of "Recommended and limit values of fuel property" (4-2)

Use a diesel oil that meet "JIS K2204, Diesel Oil" or equivalent.

It is necessary to use fuel that has a pour point suitable for the ambient temperature. Choose the fuel type from the chart on the right.

Table 4-1 Recommended fuel

Standard	Classification
JIS K2204	TYPE 1, TYPE 2, TYPE 3
ASTM D975	No. 1-D, No. 2-D
BS 2869	CLASS-A1, CLASS A-2
DIN 51601	DIESEL-FUEL
ISO 8217	DMX-CLASS

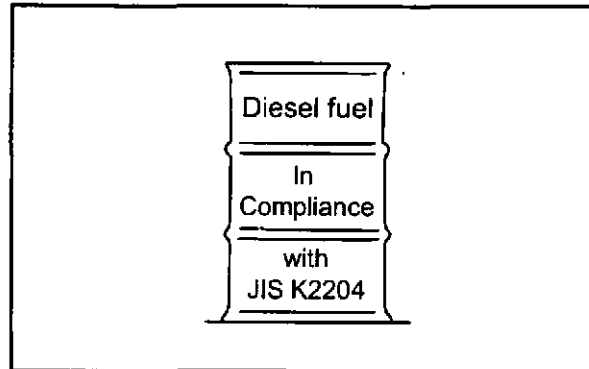

Fig.4-1 Recommended fuel

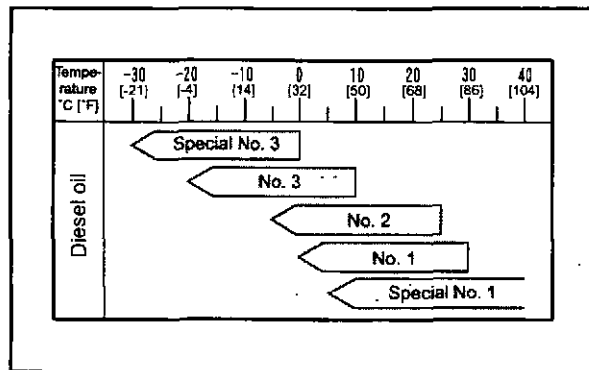

Fig.4-2 Recommended fuel according to air temperature

Handling fuel

When using fuel in a storage tank, leave it to sit for more than 24 hours so that dust and water can settle at the bottom. Then, use the upper clean fuel.

Fill up the fuel tank or service tank at the end of each day of operation. This prevents water from mixing with fuel in the tank and also gives time for dust and water to separate and settle at the bottom of the tank.

Before refilling, clean the areas around the caps thoroughly and remove the caps from the drum and tank. Also clean your hands and the hose before refueling. When using a hand-operated pump, be careful not to pump water or sediment accumulated at the bottom of the storage tank.

Be sure to use a strainer when filling fuel tank. For a complete filtration, it is recommended to use of a clean lint-free cloth together with the strainer.

Table 4-2 Recommended and limit values of fuel property

Property		Limit value	Remark	Recommend value
Flash point		As stipulated by regulation	As stipulated by regulation	JIS K2204 Diesel fuel: 50°C or higher
Distillation	Initial boiling point	170°C [338°F] or higher	170°C [338°F] or higher	JIS K2254
	90% boiling point	330 to 380°C [626 to 716°F]	330 to 380°C [626 to 716°F]	
Pour point		6°C [10.8°F] or more below ambient temperature		JIS K2269
Cloud point		Ambient temperature or below		
Carbon residue (10% residual oil)		0.4 weight % or lower	1.0 weight % or lower	JIS K2270
Cetane number		45 or higher	45 or higher	
Cetane index (new)		45 or higher	45 or higher	JIS K2280-1996
Kinetic viscosity		2.0 mm ² /s [0.0031 in ²] or higher (30°C [86°F]) 8.0 mm ² /s [0.0124 in ²] or lower (50°C [122°F]) 10.5 mm ² /s [0.0163 in ²] or lower (40°C [104°F]) 16.0 mm ² /s [0.0248 in ²] or lower (30°C [86°F])		
Sulfur content		0.2 weight % or lower	1.0 weight % or lower	JIS K2541 0.05 weight % (same as diesel fuel) is recommended.
Water and sediment		0.1 volume % or lower	0.1 volume % or lower	JIS K2275
Ash		0.03 weight % or lower	0.03 weight % or lower	JIS K2272
Copper plate corrosion (100°C [212°F], 3 hrs.)		No.3 or lower	No.3 or lower	ASTM - No.3 JIS K2513 - Discoloration No.3
Specific gravity (15°C [59°F])		0.83 to 0.87	0.80 to 0.87	
Coking test		Should not be carbonized more than 75% at 250°C [482°F]	Should not be carbonized 100% at 250°C [482°F]	Fed791B (U.S.) 250°C [482°F]×24Hr 230°C [446°F]×24Hr 180°C [356°F]×48Hr
		Should not be evaporated more than 55% at 230°C [446°F]		
		Should not be turn to tar at 180°C [356°F]		
Aromatics content (HPLC method)		38 weight % or lower	38 weight % or lower	JIS K 2536 Total of aromatic content
Asphaltene		0.1 weight % or lower	0.1 weight % or lower	ICP analysis (U.K.)
Particulate contaminant		5.0 mg / L or lower	5.0 mg / L or lower	JIS B9931 Including foreign substances in the fuel pipe lines

Chapter 5 ENGINE OIL

Properties of engine oil and their influence on engine performance

Engine oil plays a role of lubrication of engine and has a great influence on the performance and durability of engine

Distinctive differences of engine oil from other oils are that engine oil lubricates hot sections adjacent to the combustion chamber and is strongly affected by the combustion products. Engine oils, therefore, are required to have cooling, sealing, deterging, and neutralizing abilities in addition to the lubricating function. Because diesel engines especially produce acid products such as sulfuric acid due to sulfur content of fuel and soot due to imperfect combustion that contaminates oils, engine oils for diesel engines must have capabilities not only to withstand severe lubricating conditions, but also to neutralize acids products to prevent them from agglomeration and deposition. The function of performance required for engine oils is shown below:

- Good detergent dispersability for at high temperature application for the prevention of contamination and deposition of sludge and soot.
- Excellent acid neutralizing capability to inhibit oxidation due to sulfur content of fuel.
- Good oxidation stability that withstands the long hours at high temperature.
- Appropriate viscosity to maintain lubricity and low-temperature startability.
- Good rust and corrosion resistance to water.
- Good foam resistance to prevent the lubricating quality from lowering due the oxidation.

Main properties of engine oil

Dispersibility

Engine oil performance degrades through the oxidation and also by external causes. Acid products such as sulfuric acid due to sulfur content of fuel become insoluble sludge. Incomplete combustion of fuel creates soot in oil.

Those sludge and soot in oil are accumulated in the groove or on inner surface of piston ring and will result in seizure or wear of piston ring, or it will lower heat

transfer of piston ring drastically. Dispersibility of engine oil is to disperse sludge and soot in oil in order to prevent from the deposition.

Acid neutralization ability

Compared to gasoline fuel, diesel oil or A-fuel oil produces more sulfuric acid due to high sulfur content in fuel during combustion, and the sulfuric acid contaminates the oil. To neutralize the sulfuric acid, engine oils are required to have an excellent neutralizing ability. Engine oils for diesel engines usually contain a detergent metal agent that has high neutralization ability.

Viscosity

Viscosity is the measure of oil's resistance to flow. In general, the viscosity of a simple liquid decreases with increasing temperature and vice versa. This characteristic of viscosity directly relates to low-temperature startability, lubricity, fuel consumption by friction loss, and oil consumption.

For identification of an oil's viscosity, SAE (Society Automotive Engineers) numbers are widely used. (The viscosity of engine oil identified by the number of SAE shows thick and thin of viscosity at particular temperature.)

The characteristics of engine oils are identified not only by viscosity number that shows thick and thin of viscosity at particular temperature, but also by viscosity index that shows the changes in oil viscosity with changes in temperature. When viscosity index of oil is high, which means the change of viscosity due to temperature is small.

Viscosity index (VI)-100 of oil is generally used for application of diesel engine. Oils indicated by, for instance, VI-100 is called single grade oil, which falls under one range of viscosity. There is also oils that called multigrade oil which viscosity fall under two range of viscosity and they are indicated by, for instance, SAE 15W-40, which means that at lower temperature, oil has 15W grade, and also has 40 grade at higher temperature. ("W" indicates the suitability of oil for colder temperature). In other word, 15W-40 indicated by oil demonstrates SAW15 grade of viscosity at lower temperature and 40 grade viscosity at higher temperature.

Recommended engine oil

CAUTION

Use only recommended engine oils in this manual. Never use other oils. The use of inappropriate or inferior oils will result in sticking of piston ring, seizure between piston and cylinder, or premature wear of bearings and moving parts, and significantly shortens the service life of engine.

Many oil standards, which established through special engine tests, are available to determine the quality of oil depending application of engines and operating conditions. Among those standards, SAE viscosity grades and API (American Petroleum Institute) service classifications are mostly used to classify engine oils. SAE specifies the viscosity only while API service classification indicates quality level of engine oil. Seven grades from CA to CF-4 are provided for diesel engine oil. For Mitsubishi diesel engine, CD or CF graded oils is recommended as they are suitable for supercharging and high load application.

In addition, CE grade oil is established for the use with fuel of 0.5 % sulfur content or less and CF-4 for the use of fuel of 0.2% sulfur content or less. Thus when using A-fuel oil, do not use CE or CF-4 graded oil.

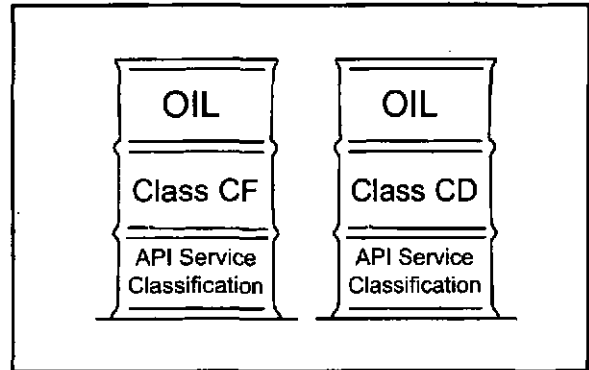

Fig.5-1 Recommended engine oil

Selection of oil viscosity

Use the following chart to select the appropriate oil viscosity according to the ambient temperature.

Excessively high oil viscosity causes power loss and an abnormal rise of oil temperature, while excessively low oil viscosity accelerates wear due to inadequate lubrication, and also causes a decrease in engine output due to leakage of combustion gas.

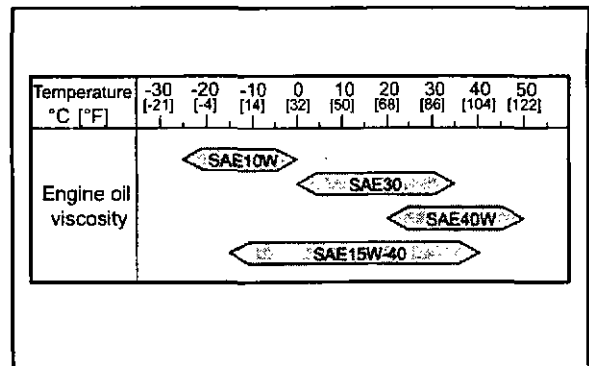

Fig.5-2 Recommended oil viscosity according to air temperature

Genuine engine oil

Mitsubishi Heavy Industries, Ltd. offers the best suited oils, which yielded from many tests, to Mitsubishi diesel engines. We highly recommend the use of our genuine engine oil. For land use engine, "JUKCOIL Cojera 15W-40 or 15W-30" and for marine engine, "JUKOIL New Mariner 15W-40 or 15W-30" are available.

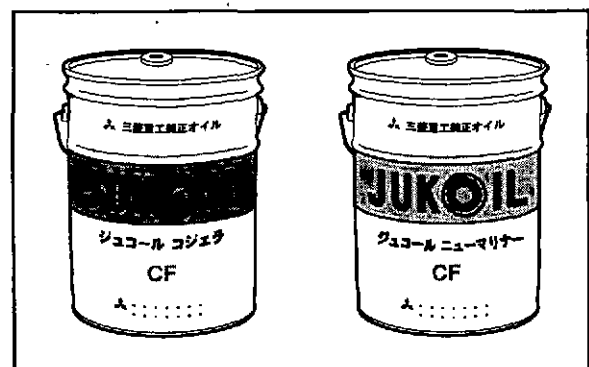

Fig.5-3 Jukoil cojera,new mariner

Engine oil in the market

Mitsubishi Heavy Industries, Ltd. does not warrant the engine if oils in the market are used.

The quality and performance of commercially available oils as well as their components variations are in the responsibility of engine oil suppliers. Before purchasing commercial oils, be sure to discuss the suitability of engine oil with the oil supplier.

Handling engine oil

WARNING

Before filling engine with engine oil, stop the engine and make sure there are no open flames and other fire hazards near the engine. Leaked or spilled oil on hot surfaces or electrical components can cause a fire. Wipe off any spilled oil immediately and thoroughly. After filling, securely close the filler cap.

CAUTION

Never mix different brands of engine oil. Mixing different brands of engine oil may cause a chemical reaction by additives in the engine oil that could degrade the engine oil quality.

When handling oil of more than the legally specified quantities, be sure to have the work performed by a service station in compliance with the legal regulations.

When removing oil from the engine or oil can, use an oil pump. Do not suck oil with the mouth to siphon.

Be sure to close the cap on the oil can after use.

Keep oil in a well-ventilated place and out of direct sunlight.

Be sure to obtain the MSDS (material safety data sheet) of the engine oil used and follow the instructions of the MSDS.

Service limits of engine oil

Engine oil degrades by the use and by lapse of time.

Be sure to renew engine oil if a property exceeds the limit.

Table 5-1 Service limit for engine oil properties

Property	Unit	Service limit	Test Method
Viscosity	cst@100C	Within +30 and -15% of new oil	JIS K2283
Total base number	mgKOH/g	2.0 or more with hydrochloric acid (HCL) method 1/2 of new oil or more with perchloric acid (PCA) method	JIS K2501
Total acid number	mgKOH/g	Up to +3.0 of new oil	JIS K2501
Water content	Vol %	0.2 or less	JIS K2501.
Flash point (open cup)	°C	180 or more	JIK K2275
Pentane insolubles	Wt %	0.5 or less	Comply with ASTM D893
Pentane insolubles coagulated	Wt %	3.0 or less	Comply with ASTM D893

Definition of properties of engine oil

Viscosity

Viscosity is a basic physical property of engine and considered as the most important aspect of oil when evaluating.

Contamination of oil by blow-by gas and deterioration of oil by its natural aging degrade the performance of viscosity that will cause the deposition of sludge in the interval engine and oil filter clogging. Contamination of oil by fuel and sheared molecules of viscosity index improver in oil also degrade the performance of viscosity that will cause insufficient lubrication and friction/wear of engine parts.

Total base number

Total base number (TBN) shows the ability to neutralize acids such as organic acid due to the engine oil oxidation, or sulfuric acid or sulfuric acid due to sulfur content of fuel.

Because TBN indicates the amount of dispersant detergent in oil, it can be used to estimate consumption of basic dispersant detergent. The ability to disperse sludge declines as dispersant detergent is being used up.

Total acid number

Total acid number in oil increases as the organic acid is being derived by the engine oil oxidation, or sulfuric acid or sulfuric acid derived by the combustion of sulfur content of fuel, or the oil is contaminated with imperfect combustion products. The increase of total

acid number will result in corrosion or wear of inner parts of engine (such as cylinder liner or metals) derived by sulfur content, and piston ring seizure by sludge.

Water

Water in oil promotes corrosion/wear, and decreases lubricity in sliding parts.

Flash point

Flash point is lowered by contamination by fuels. Flash point is measured to check the dilution of fuel. The dilution of fuel reduces oil film, and causes insufficient lubrication that will cause friction or wear of engine parts.

Insolubles

Insolubles include acid products of engine oil, imperfect combustion products, sludge or soot, metal abrasive particles and dust. Insolubles are an indication of degradation/contamination of oil.

Dispersant detergent, which is one of additives in engine oil, absorbs sludge particles, and disperses them as fine particles in oil.

Total insolubles density and remaining dispersibility can be obtained by measuring insolubles and coagulated insolubles (using chemical specialities to stop action of disperse detergent and to collect the sludge dispersed in oil) and by which, piston ring seizure or premature wear can be prevented before occurring.

Engine oil analysis service

For a long term service life of engine, Mitsubishi Heavy Industries, Ltd. offers an engine oil analysis service. The service includes special oil sampling tools, the sample oil analysis and the result data.

The engine oil analysis service provides the following information:

- The quantity of fine metal powder in engine oil due to abrasion, by which worn parts can be located.
- Water, LLC, or salt that should not be in engine oil can be detected.
- Engine oil deteriorating conditions, with that, appropriate engine oil renewal intervals, operating conditions, proper inspection and maintenance schedule can be planned.

The engine oil analysis service can diagnose the internal condition of an engine, which used to require engine dis-assembly. It is highly recommended to take advantage of our engine oil analysis service as you can learn the engine condition before any malfunctions are appeared on the engine.

How to order engine oil sampling tool set

The oil sampling pump is reusable, but oil sampling bottle and suction pipe must be replaced each time. For replacing tools, order them through the regular part supply system. The analysis fee is included in the price of the sampling bottle. Therefore, if you sample the oil in other bottles, you will not receive our analysis service. Also, note that optional analysis requires addition charge.

Table 5-2 Engine oil sampling tool sets

Product name	Part no.	Remarks
Engine oil sampling set	36291-19100	Contains oil sampling pump, pipes and bottles
Oil sample bottle set	36291-00098	1 Carton: 6 bottles Includes suction pipes and oil sample data labels

Oil sampling bottle set: 1 carton: 6 bottles includes suction pipes and analyzing data of sample oil

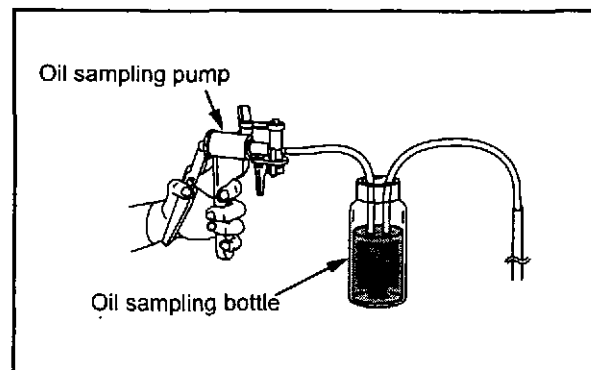

Fig.5-4 Engine oil sampling tool set

Chapter 6 COOLANT AND LLC

Recommended coolant

Use soft water (e.g. tap water) for the engine cooling system. The water quality must meet the requirements in the Table below. Basically, the water quality should be within the recommended value, however, within limit is acceptable.

Table 6-1 Water quality standards

Item	Chemical symbol	Unit	Recommended	Limit	Main adverse effect	
					Corrosion and rust	Scale formation
pH (25°C [77°F])	-	-	6.5 to 8.0	6.5 to 8.5	○	○
Electrical conductivity (25°C [77°F])	-	mS/m	<25	<40	○	○
Total hardness	CaCO ₃	ppm	<95	<100	-	○
M alkalinity	CaCO ₃	ppm	<70	<150	-	○
Chlorine ion	Cl ⁻	ppm	<100	<100	○	-
Sulfuric acid ion	SO ₄ ⁴⁻	ppm	<50	<100	○	-
Total iron	Fe	ppm	<1.0	<1.0	-	○
Silica	SiO ₂	ppm	-	<50	-	○
Residue from evaporation	-	ppm	<250	<400	-	○

Note: Figures in parentheses are the standard value. In addition to the items specified above, turbidity is specified to be below 15 mg/liter.

Long life coolant (LLC)

CAUTION

Should LLC be accidentally swallowed, induce vomiting immediately and seek medical attention.

If LLC should enter eyes, flush immediately with plenty of water and seek medical attention.

Be sure to use long life coolant (LLC) as coolant, because it prevents not only freezing of coolant but also rusting of the cooling system.

Use an all-season, non-amine type LLC.

Recommended brands of LLC are shown in the chart below.

Genuine LLC

Mitsubishi Heavy Industries, Ltd. recommends the use of our genuine long life coolant "GLASSY," which is the most appropriate coolant for Mitsubishi diesel engine.

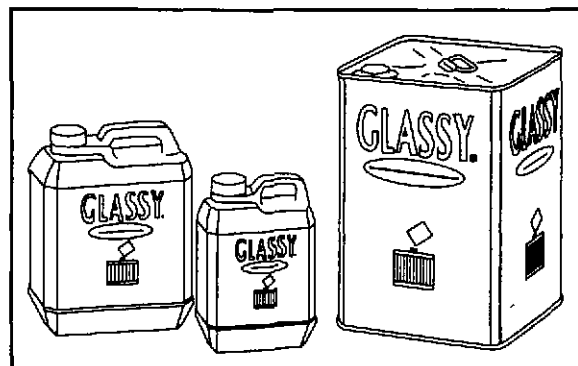

Fig.6-1 GLASSY - LLC

LLC in the market

CAUTION

Never mix Mitsubishi genuine LLC with other brand LLC. Mixing with other brand LLC degrades the performance of the genuine LLC

Mitsubishi Heavy Industries, Ltd. does not warrant the engine if LLC of other brand is used.

The quality and performance of commercially available LLCs as well as their components variations are in the responsibility of LLC suppliers.

Before purchasing commercial LLC, be sure to discuss the suitability of LLC with the LLC supplier.

Use only all-season LLC (non-amine type). Do not use antifreeze alone instead of LLC.

Maintenance of LLC

CAUTION

LLC is toxic. Never dispose of coolant containing LLC drained from engine into regular sewage. For disposal of used coolant, consult your Mitsubishi dealer.

Replacement intervals of LLC

CAUTION

Be sure to renew LLC (coolant) at the specified intervals in this manual. Failure to renew LLC may cause malfunctions due to cavitation

The coolant containing LLC recommended in this manual should be renewed every 8000 hours or 2 years, whichever comes first, for a regular-use or general-purpose engine. For an emergency-use engine, renew coolant every 2 years.

LLC concentration

When determining the LLC concentration, provide a margin of 5°C [9°F] below the expected lowest temperature in your region. Maintain the LLC concentration between 30 and 60% throughout the year.

LLC of less than 30% concentration does not provide sufficient corrosion protection. If the LLC concentration is as low as several percent, it may accelerate corrosion. LLC of more than 60% concentration can adversely affect its freeze protection characteristic and cause the engine to overheat easily.

When adding coolant, do not add plain water. Always use coolant having the same LLC concentration.

Table 6-2 Recommended LLC concentration
(for reference only)

Lowest ambient temperature °C (°F)	up to -15 [5]	up to -24 [-11]	up to -36 [-32]	up to -43 [-45]
LLC concentration (%)	30	40	50	55

Note: The concentration above is based on the Mitsubishi genuine GLASSY long life coolant.

For determining the accurate LLC concentration, refer to the instructions for the LLC used.

Importance of LLC

Today's trend is toward smaller and more lightweight engines offering greater output, lower fuel consumption and lower exhaust emission level.

Conditions to which engine coolant is subjected, therefore, are becoming severer due to longer operating hours, higher coolant temperature and higher coolant circulating speed.

Many different materials such as steel, aluminum, copper, solder and rubber are used in the cooling system, and they are also subjected to the severe conditions described above.

Those materials have different ionization characteristics, and this difference accelerates corrosion through the medium of engine coolant.

To prevent such a problem, the use of LLC (long life coolant) is very important.

Characteristics of LLC additive and important notes

LLC contains several chemicals in such proportions as to produce chemical reactions that suppress corrosion (ionization) of engine parts in contact with the coolant.

LLC loses its effectiveness by hours of use as well as lapse of time.

Moreover, if the chemicals are not well proportioned to match the metals used in the cooling system, certain chemicals in the LLC become rapidly used up and result in dissolution of metals instead of protecting metals from corrosion.

Consequently, other corrosion preventing chemicals react with dissolving metals and accelerate corrosion. This condition generates more severe corrosion than when plain soft water is used. This is a typical problem caused by the use of inappropriate LLC.

Examples of abnormalities caused by LLC

Pitting on iron parts

Amines are generally effective in suppressing the rusting of ferrous metals, but they are said to cause problems for copper parts.

Dissolved copper (copper corrosion) in the cooling system deposits on iron parts and the copper deposits cause a corrosion and then pitting on iron parts that has a high ionization characteristics due to galvanic or local-cell action.

Corrosion of aluminum parts

Silicate is highly effective in protecting aluminum against rusting. However, it is unstable in a solution in which pH is 9 or lower, and can turn to gel and precipitate in the solution. For this reason, the pH is usually specified to be about 10 to ensure a high alkaline level.

This means, after silicate is used up, the high alkalinity causes chemical attacks on aluminum. To prevent this problem, proper maintenance of the coolant is required.

(Example)

Rapid wear of mechanical seals in the water pump due to secondary effects of silicate gel formed.
Corrosion of aluminum parts after silicate is consumed.

Pitting and clogging of radiator

When LLC deteriorates or when its concentration in the coolant is too low, the anti-corrosion performance of LLC lowers and results in the corrosion of metals. Brass and solder tend to corrode faster than other metals, and corrosion of these metals is said to cause water leakage and clogs.

(Example)

Holes and clogs in radiator

Chapter 7 PERIODIC MAINTENANCE CHART

How to use periodic maintenance chart

Periodic inspection not only extends the service life of the engine but also serves to ensure safe operation. Be sure to conduct inspections and maintenance according to the periodic maintenance chart. The maintenance chart shows the standard service intervals. If you notice any abnormalities such as abnormal noise, black exhaust smoke, white exhaust smoke, extremely high temperature of exhaust gas, abnormal vibration, and fuel, oil or exhaust gas leakage, make sure to conduct the inspection and maintenance work, regardless of recommended service intervals in the "Periodic Maintenance Chart."

Note: Appropriate service intervals vary depending on the usage and operating conditions as well as consumption of fuel, oil and coolant. Check the operating record of the engine to determine the most appropriate service intervals. (Feel free to consult your Mitsubishi dealer regarding service intervals.)

Perform service on items at multiples of the original requirement. For example, at 1000 service hours, also service those items listed under every 250 service hours and every 50 service hours.

Items marked with * in the maintenance chart require special tools or large equipment. For the servicing of those items, contact your Mitsubishi dealer.

Periodic maintenance chart

Appropriate service intervals vary depending on the engine specifications. Perform all the daily inspection and maintenance work in accordance with one of the following maintenance charts, depending on the engine application; regular-use, emergency, or general-purpose engine.

Periodic maintenance chart for regular use engine

For regular use engines, perform the periodic inspection and maintenance work in accordance with the "Periodic Maintenance Chart for Engine in Regular Use."

Periodic maintenance chart for emergency engine

For emergency engines, perform the periodic inspection and maintenance work in accordance with the "Periodic Maintenance Chart for Emergency Engine." Due to the nature of application, an emergency engine is subject to demanding operating conditions such as a quick startup and immediate supply of power, not to mention reliable operation in the event of an emergency. Therefore, be sure to perform not only the daily inspection work but also the following operations for maintenance purposes.

Once every week: Operate the engine under no load (for 3 to 5 minutes). (When operating the engine for the adjustment of peripheral devices, limit the operating time to 10 minutes.)

Once every month: Operate the engine under load (for 15 to 30 minutes with more than 1/2 of rated load). If the engine cannot be operated under load every month, operate the engine under load (more than 1/2 of rated load) for more than 2 hours once a year. During the engine maintenance operation, check startup conditions such as oil pressure, exhaust color, and vibration

Periodic maintenance chart for general-use engine

If the engine is used for general purpose power supply, other than the above usage, perform maintenance work in accordance with the "Periodic Maintenance Chart for General-Use Power Supply Engine."

Definition of regular use engine, emergency engine and general-use engine

Regular use engine

An engine operated with a constant base load for the purpose of generating electric power, which is used independently or in combination with commercial power supply. An engine operated under a fluctuating load throughout a day for supplying rated electric power in lieu of commercial power.

Emergency engine

An engine used for emergency power generation at the time of such as failure of main power or commercial power supply.

General-use engine

An engine used for applications other than power generators, for example, pumping engines, marine engines, and industrial vehicle engines that are operated under constant or cyclically varying load and speed.

Periodic maintenance chart for regular use engine

Table 7-1 Periodic maintenance chart for regular use engine (1 / 2)

Service item		Page
Every 50 service hours or every month	Draining fuel tank	8-5
First 50 service hours for new or reconditioned engine	Retightening the bolts and nuts	*
	Changing engine oil, oil filters and bypass oil filter (It is recommended to analyze the engine oil properties at the same time) (The oil filters must be changed when the filter alarm lights)	8-7
Every 250 service hours or every year	Changing engine oil, oil filters and bypass oil filter (It is recommended to analyze the engine oil properties at the same time) (The oil filters must be changed when the filter alarm lights)	8-7
First 250 service hours for new or reconditioned engine	Checking and adjusting valve clearances (Also inspect the valve mechanisms at the same time)	*
Every 1000 service hours	Checking V-belt and adjusting belt tension	8-3
	Changing fuel filter	8-6
Every 2000 service hours	Checking V-belt	8-3
	Inspecting ball joints of fuel control system	*
	Checking and adjusting valve clearances (Also check the valve mechanisms at the same time)	*
	Checking and adjusting fuel injection timing	*
	Changing fuel injection nozzle tips (Check the spray condition and adjust the fuel injection pressure after replacement)	*
	Checking movement of rack (During operation of the fuel injection pump (including the governor))	*
	Checking pipe	8-2
Every 4000 service hours	Overhaul the top end of the engine Remove the cylinder head, and inspect and service the combustion chambers. <ul style="list-style-type: none"> • Inspect the connecting rod • Visually inspect top surfaces of each piston • Inspect the cylinder liner surfaces 	*
	Checking damper	8-4
	Checking turbocharger	8-13
	Checking starter	8-16
	Checking alternator	8-16
	Checking protective devices for proper operation	*
	Replacing unit seals and oil seals in the water pump	*
	Checking LLC concentration in the coolant	*

Table 7-1 Periodic maintenance chart for regular use engine (2 / 2)

	Service item	Page
Every 8000 service hours	Conduct a major overhaul Disassemble engine: clean, check and change major parts [Parts to be changed] <i>Inlet and exhaust valve seats, inlet and exhaust valves, valve rotators, valve cotters, rocker arm adjusting screws, valve push rods, bridge caps, camshaft bushings, main bearings, cylinder liners, main bearing cap bolts and washers, piston rings, connecting rod bearings, damper, crankcase thrust plate and consumable items (gaskets, oil seals, O-rings, etc)</i> [In every other major overhaul, replace the following parts in addition to the parts listed above] Cylinder head bolts, valve guides, valve bridge guides, valve bridges, valve springs, tappets, camshaft thrust plates, rocker bushings, thrust plates, pistons, piston pins, connecting rod bolts, connecting rod bushings, rocker bushings, clamp seat, high pressure fuel injection pipe, low pressure fuel pipe assembly, oil pipe assembly, oil pipe, etc	*
	Inspection and testing of fuel injection pump (Replace parts, if necessary)	*
	Inspection and testing of governor (Replace parts, if necessary)	*
	Correction or replacement of protective devices high coolant temperature, low oil pressure, overspeeding, starting failure, water supply failure, under-voltage, overvoltage, overcurrent, low coolant level in tank, low fuel level in tank, low air pressure in tank, etc	*
	Checking the auxiliary devices for proper operation water heater, oil heater, oil priming pump, fuel transfer pump, governor motor, etc	*
Every 2 years	Changing coolant	8-10
When required	Bleeding fuel system	3-2
	Checking and cleaning radiator fins	8-12
	Cleaning, checking, replacing air cleaner element	8-15
	Cleaning the inside of the engine breathers	*
	Inspecting or replacing the stop solenoid	*
	Inspecting or replacing the couplings	*
	Inspecting the vibration-isolating rubber	*

Periodic maintenance chart for emergency engine

Table 7-2 Periodic maintenance chart for emergency engine (1 / 3)

Service item		Page	
Every week	External inspection	3-8	
	Filling fuel tank	3-1	
	Checking engine oil level	3-9	
	Checking coolant level	3-10	
	Conducting an engine maintenance operation (Operate the engine under no load for 5 to 10 minutes) Check for ease of starting, color of exhaust smoke, abnormal vibration, abnormal noise, abnormal smell and gauge indication " (oil pressure gauge, coolant temperature gauge, oil temperature gauge, exhaust temperature gauge, tachometer, etc)"	*	
Every month	Inspecting ball joints of fuel control system	*	
	Checking engine oil for mixing of fuel and water	8-9	
	Checking battery electrolyte level	8-17	
	Conducting engine maintenance operation (Operate the engine with more than 1/2 load for 15 to 30 minutes) Check for ease of starting, color of exhaust smoke, abnormal vibration, abnormal noise, abnormal smell and gauge indication (oil pressure gauge, coolant temperature gauge, oil temperature gauge, exhaust temperature gauge, tachometer, etc) Check fuel injection pump and hydraulic and electronic governor rack movement"	*	
Every 6 months	Checking LLC concentration in the coolant	*	
	Cleaning the inside of the coolant tank	*	
Every year	Basic block	Checking V-belt and adjusting belt tension	8-3
		Checking external bolts and nuts for tightness, and retighten if necessary	*
		Checking damper	8-4
		Inspection and adjustment of valve clearance (Inspect the parts related to valve mechanism at the same time)	*
		Checking vibration-isolating rubber	*
		Checking foundation bolts	*
		Inspection or replacement of couplings	*
	Fuel system	Inspection and adjustment of fuel injection nozzle spray condition and spray pressure	*
		Inspection and adjustment of fuel injection timing	*

Table 7-2 Periodic maintenance chart for emergency engine (2 / 3)

	Service item	Page	
Every year	Lubrication system	Analyzing engine oil properties	*
		Inspection and adjustment of engine oil pressure (Maintenance operation)	*
	Cooling system	Checking water pump	*
		Inspection, disassembly and cleaning of electromagnetic valve and pressure reducing valve of the cooling system	*
		Inspection, disassembly and cleaning of strainer (including with/ball tap) of cooling water	*
		Analyzing coolant properties (when only soft water is used) (Change coolant according to the analysis results)	*
	Air inlet system	Cleaning, checking, replacing air cleaner element	8-15
	Electrical system	Checking starter	8-16
		Checking alternator	8-16
		Checking specific gravity of battery electrolyte	8-17
		Checking air heater	*
		Checking protection devices for proper operation High coolant temperature, low oil pressure, overspeeding, starting failure, water supply failure, undervoltage, overvoltage, overcurrent, low coolant level in tank, low fuel level in tank, low air pressure in tank, etc	*
		Checking auxiliary devices for proper operation Engine control, fuel transfer pump, governor motor, room ventilating fan, solenoid, storage pump, water tank ball tap, water heater, oil heater, oil priming pump, etc	*
Every 2 years	Checking fuel control linkage ball joints	8-5	
	Changing fuel filter	8-6	
	Changing engine oil, oil filters and bypass oil filter (It is recommended to analyze the engine oil properties at the same time) (The oil filters must be changed when the filter alarm lights)	8-7	
	Changing coolant	8-10	
	Checking turbocharger	8-13	
	Draining water from exhaust muffler	8-13	
	Checking thermostat	*	
Every 4 years	Draining fuel tank	8-5	
	Checking and cleaning radiator fins	8-12	
	Cleaning, checking, replacing air cleaner element	8-15	
	Checking oil cooler for soiling, clogging and leakage	*	
	Checking oil pump for discoloration and other external defects	*	
	Inspection and testing of fuel injection pump (Replace parts if necessary)	*	
	Inspection and testing of governor (Replace parts if necessary)	*	
	Changing the rubber hoses	*	
	Repair or replacement of instruments Oil pressure gauge, coolant temperature gauge, oil temperature gauge and tachometer	*	

Table 7-2 Periodic maintenance chart for emergency engine (3 / 3)

	Service item	Page
Every 8 years	Inspection and replacement of main engine parts (major overhaul) Inlet and exhaust valves and valve seats (lapping), valve guides, pistons, piston rings, connecting rod metals, connecting rod bushings, cylinderliners and crankshaft (If the parts for No.1 and No.2 cylinders are found defective, change the parts for all cylinders.)	*
	Replacement of damper	*
	Repair or replacement of oil pump	*
	Replacement of fuel injection nozzle tips (Adjust the spray condition and spray pressure after replacement)	*
	Replacement of rubber parts and O-rings	*
	Replacement of unit seal, oil seal of the water pump	*
	Disassembly and checking turbocharger	*
	Disassembly and cleaning of air cooler	*
	Repair or replacement of vibration-isolating rubber	*
	Repair or replacement of couplings	*
	Adjustment or replacement of governor motor	*
	Adjustment or replacement of air ventilation fan of the room	*
	Inspection or replacement of stop solenoid	*
	Adjustment or replacement of ball tap of water tank	*
Replacement of other consumables	*	

Periodic maintenance chart for general-use power supply engine

Table 7-3 Periodic maintenance chart for general-use engine

	Service item	Page
Every 50 service hours or every month	Draining fuel tank	8-5
After first 50 service hours for new engine	Retightening external bolts and nuts for looseness	*
	Changing engine oil, oil filters and bypass oil filter (It is recommended to analyze engine oil properties at the same time) (Change the oil filters whenever the filter alarm turns on)	8-7
Every 250 service hours or every year	Checking V-belt and adjusting belt tension	8-3
	Changing engine oil, oil filters and bypass oil filter (It is recommended to analyze engine oil properties at the same time) (Change the oil filters whenever the filter alarm turns on.)	8-7
	Checking and cleaning radiator fins	8-12
	Draining water from exhaust muffler	8-13
First 250 service hours for new engine	Inspection and adjustment of valve clearances (Check the valve mechanism and parts at the same time)	*
Every 1000 service hours or every 2 years	Changing fuel filter	8-6
	Retightening external bolts and nuts	*
	Inspection and adjustment of valve clearances (Check the valve mechanism and parts at the same time)	*
	Inspection and adjustment of fuel injection timing	*
	Replacement of fuel injection nozzle tips (Inspect and adjust spray condition and fuel injection pressure after replacement)	*
Every 2000 service hours or every 3 years	Checking damper	8-4
	Inspecting ball joints of fuel control system	*
	Checking air cooler	*
	Checking pipe	8-2
Every 4000 service hours or every 5 years	Overhaul the top end of the engine Remove the cylinder head, and inspect and service the combustion chambers <ul style="list-style-type: none"> • Disassemble, inspect and service the cylinder head • Inspect the intake and exhaust valves, and lap the valves against seats • Visually inspect the top surface of each piston • Inspect the cylinder liner surfaces 	*
Every 8000 service hours	Conduct a major overhaul Disassemble engine: check and change major parts	*
Every 2 years	Changing coolant	8-10
When required	Bleeding fuel system	3-2
	Cleaning, checking, replacing air cleaner element	8-15

Chapter 8 PERIODIC INSPECTION AND MAINTENANCE PROCEDURES

Engine body periodic inspection and maintenance

Visual inspection

▲ CAUTION

Check the engine exterior carefully, especially around batteries and hot engine parts such as exhaust manifold and other exhaust gas passages for combustible materials, fuel leaks, or oil leaks, as they can ignite and cause a fire. Before starting the engine, clean the top surface of the battery with a wet cloth, as the dust on the battery can easily ignite and cause explosion. If an abnormality is found, be sure to repair it or contact your Mitsubishi dealer.

Inspect the engine exterior as described below.

1. Make sure there is no combustible material near the engine or battery. Also, check to make sure the engine and battery are clean. If combustible materials or waste are found near the engine or battery, remove them.
2. Check the electrical wiring to such components as starter and alternator for loose.
3. Check the entire engine for leakage of fuel, engine oil or coolant. If leaks are found, repair the leakage or contact your Mitsubishi dealer.
4. Make sure the following valves, plugs and cocks are open or closed properly.
 - Fuel feed valve: Open
 - Coolant drain cock (plug): Closed
 - Oil drain valve: Closed

Checking pipe

Checking and replacing high pressure fuel injection pipe and clamp seat

Visual inspection in every 2000 service hours

Check clamp seat cracks and high pressure fuel injection pipe metal contact with clamp. If defective, replace the clamp seat with a new one. Replace the high pressure fuel injection pipe with a new one as needed.

In every major overhaul

Replace clamp seat with a new one. Also, check high pressure fuel injection pipe metal contact with clamp. If defective, replace the high pressure fuel injection pipe with a new one.

In every other major overhaul

Replace all clamp seats and high pressure fuel injection pipes with new ones.

Checking and replacing low pressure fuel pipe, oil pipe and clip

Visual inspection in every 2000 service hours

Loosen clamp fixing bolt and check clip wear and pipe metal contact with clamp. If defective, replace the pipe assembly with a new one.

In every other major overhaul

Replace the pipe assembly with a new one.

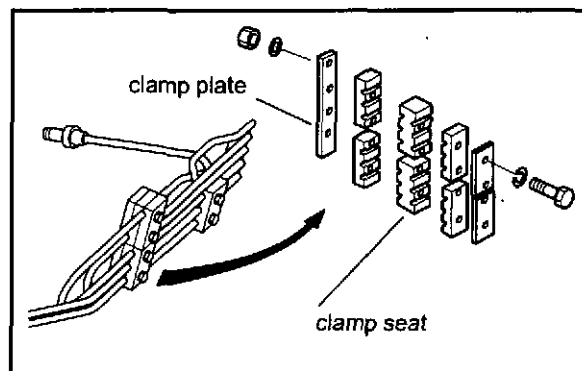

Fig.8-1 Checking and replacing high pressure fuel injection pipe and clamp seat

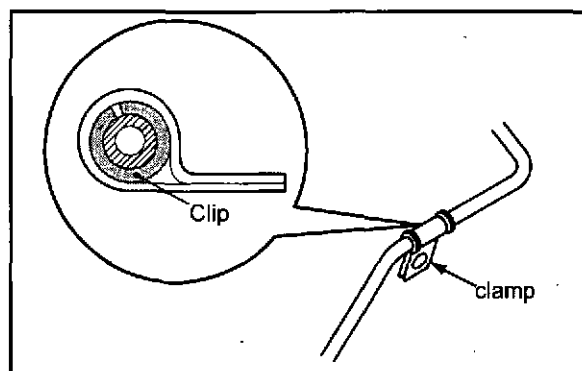

Fig.8-2 Checking and replacing low pressure fuel pipe and, oil pipe and clip

Checking V-belt and adjusting belt tension

CAUTION

If defects such as cuts or surface separations are found on V-belt during inspection, replace V-belt. Keep oil and grease away from the belt, since they may cause the belt to slip and shorten the service life.

Excessive V-belt tension can cause rapid wear of the alternator bearing and shorten the service life of the belt.

Adjust belt tension accurately by following the procedures below.

Checking V-belt

1. Inspect V-belt for defects such as wear, cuts or surface separations. If defects are found, replace V-belt with a new belt.
2. Inspect belt tension as instructed below:
Push the belt downward with about $49 \pm 5 \text{ N}$ [$5 \pm 0.5 \text{ kgf}$] pressure midway between pulleys. If the deflection is $7 \pm 1 \text{ mm}$ [$0.28 \pm 0.04 \text{ in.}$] for new belt and $9 \pm 1 \text{ mm}$ [$0.35 \pm 0.04 \text{ in.}$] for retightening, the tension is correct. If the tension is out of the specified value, adjust belt tension.

Adjusting V-belt tension (Alternator side)

1. Remove alternator front cover and V-belt cover.
2. Loosen all the retaining bolts on the alternator and adjusting rod.
3. Loosen the upper and lower lock nuts on the adjusting rod.

Note: The lower nut on the adjusting rod has left-hand threads.

4. Turn the adjusting rod to adjust V-belt tension.
5. After the tension adjustment, tighten the upper and lower lock nuts.
6. Tighten all the retaining bolts on the alternator and adjusting rod.
7. Reinstall belt cover and alternator front cover.

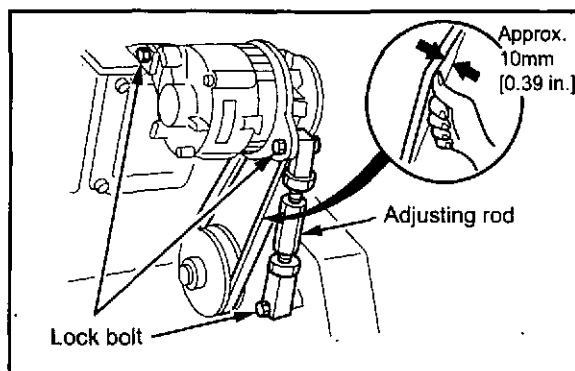

Fig.8-3 Adjusting V-belt tension

Checking damper

Visual checking of damper

CAUTION
When installing a protective cover to damper, do not use a cover that encloses the damper. The closed cover can cause damper deterioration due to heat.

Check damper for oil leakage and defects such as scratches, deformation, discoloration and peeling of paint. Check carefully for swelling on the cover (use a scale), oil leaks from the shim, discoloration and peeling of paint due to heat.

Note: If defect is found on damper, contact your Mitsubishi dealer.

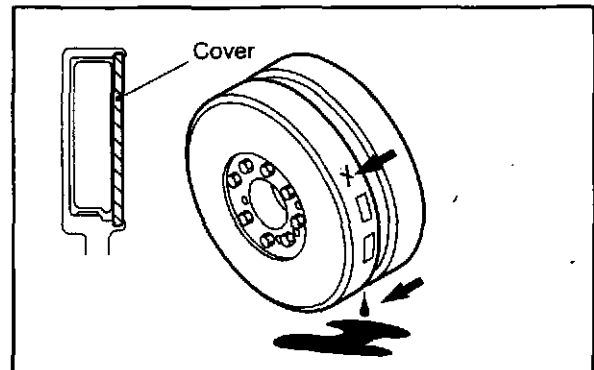

Fig.8-4 Checking damper

Damper temperature management

For making damper function well, heat of damper must be dissipated from its surface to prevent excessive damper heating. Before the shipment of engines, Mitsubishi Heavy Industries, Ltd. inspects each engine to ensure proper operating temperature of damper. However, since damper temperature changes with the ambient conditions, it is important to observe the following instructions and provide sufficient ventilation for damper by considering factors such as layout of equipment.

- In the case of viscous damper of regular use engine, make sure the temperature of the outside damper surface does not exceed 90°C [194°F] after the engine operation at the rated output for 1 hour, and for emergency engine 100°C [212°F]. In the case of viscous rubber damper of regular use engine, make sure the temperature does not exceed 80°C [176°F], and for emergency engine 90°C [194°F]. It is recommended to use the thermo label for the temperature management of damper in regular use engine.
- When installing a safety cover to damper, check ventilation carefully and make sure the damper temperature remains below the temperature specified above, with the cover in place.

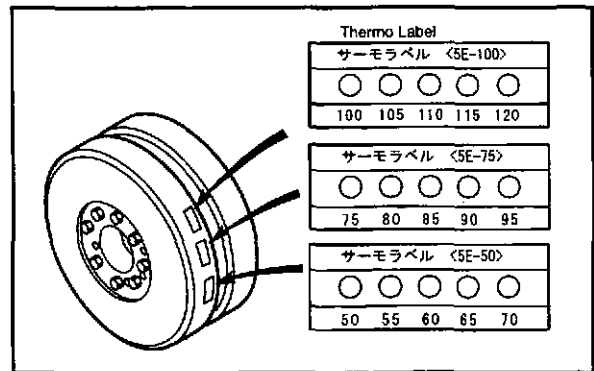

Fig.8-5 Damper temperature management

Table 8-1 Thermo label for temperature management

Parts name	Parts No.	Temperature measuring range
Thermo label 75-95	32522-04100	75 to 95°C [167 to 203°F]
Thermo label 100-120	32522-04200	100 to 120°C [212 to 248°F]
Thermo label 50-70	32522-04300	50 to 70°C [122 to 158°F]

Fuel system periodic inspection and maintenance

Draining fuel tank

WARNING

When handling fuel, make sure there are no open flames or other fire hazards near the engine. Wipe off any spilled fuel completely. Spilled fuel can ignite and cause fire.

CAUTION

Do not remove the strainer when filling the fuel tank.

Use fuel specified in "FUEL" (4-1).

If fuel get mixed with foreign particles such as dust, dirt, or water, it can cause not only decrease of output but also defect of the fuel system. To avoid such a problem, drain fuel tank as described below.

1. Prepare a oil pan (capacity of 2 liters or more) under the drain cock of fuel tank.
2. Open the drain cock of fuel tank and drain fuel at least 1 to 2 liters.
3. Make sure that water and foreign particles discharged with fuel. Close the drain cock.

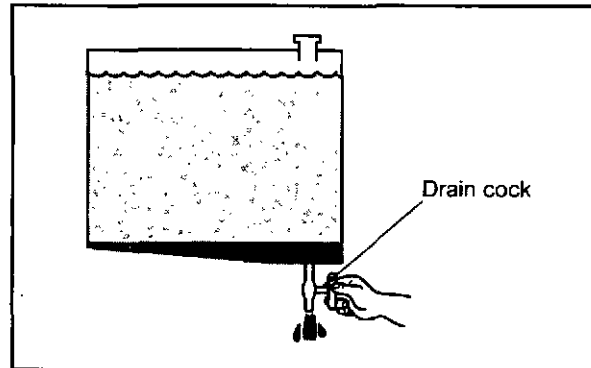

Fig.8-6 Draining water from fuel tank

Checking fuel control linkage ball joints

Check ball joints in the fuel control linkage for play. If the amount of play is 0.1 mm [0.004 in.] or more, replace the ball joints.

CAUTION

If the sealed ball joints found loosened, contact your Mitsubishi dealer. If the seal on the ball joint is broken, the warranty is invalidated.

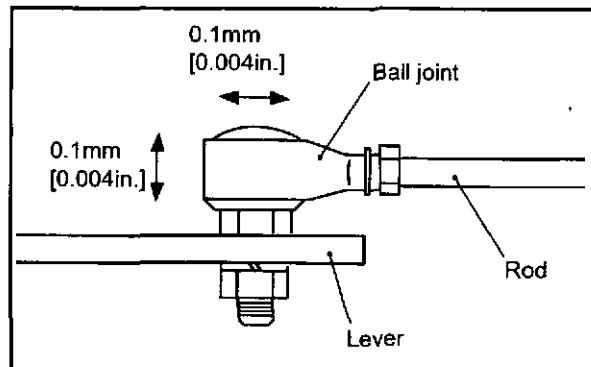

Fig.8-7 Inspecting fuel control linkage for looseness

If the ball joints are integrated in the control linkage, replace the control linkage when the ball joints have loosened. When installing ball joints, be sure to tighten the nuts firmly.

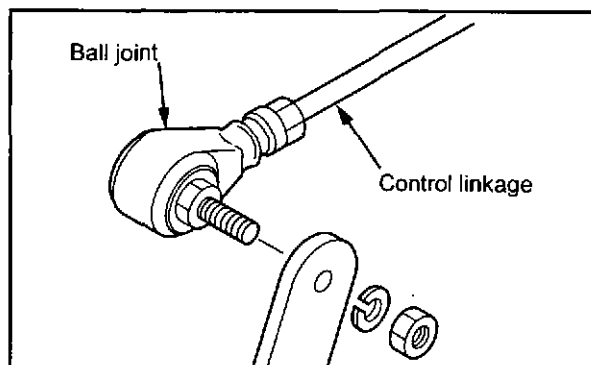

Fig.8-8 Removing fuel control linkage

Changing fuel filter

WARNING

When handling fuel, make sure there are no open flames or other fire hazards near the engine. Wipe off any spilled fuel completely. Spilled fuel can ignite and cause a fire.

1. Clean the area around the fuel filters.
2. Place a drip pan under the fuel filters.
3. Using a filter wrench, remove the fuel filters.
4. Wipe off fuel on the fuel filter cartridge mounting surface of the filter bracket with a cloth.
5. Check new fuel filters for proper seating of the gaskets.

WARNING

Do not use the filter that has dent on its case. It may damage the filter, or may cause a fuel leak, which could result in a fire during operation.

6. Apply clean fuel to the gaskets on new fuel filters.
7. Install fuel filters.

CAUTION

Do not use the filter wrench for the installation of fuel filters. Do not dent or scratch the fuel filter surfaces.

8. After installing the new fuel filter, bleed the fuel filter.

Note: For bleeding fuel filter, refer to "Bleeding fuel system" (3-2).

9. Start the engine and let it idle for several minutes.
10. Check the fuel filter mounting sections for fuel leakage. If fuel leakage is found, loosen the fuel filter and check the gaskets for damage. If there is no gasket damage, retighten the fuel filter.

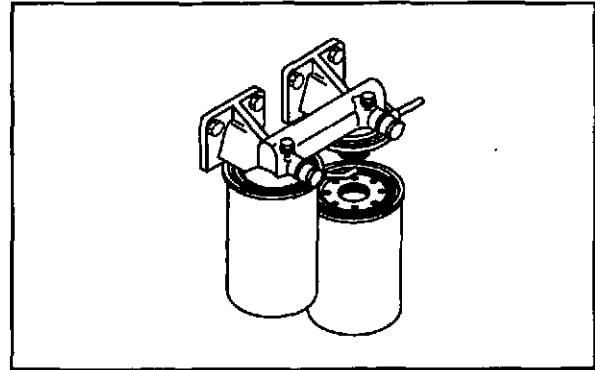

Fig.8-9 Changing fuel filters

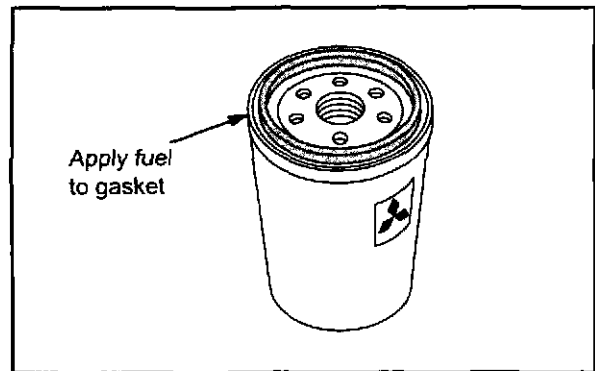

Fig.8-10 Fuel filter

Lubricating system periodic inspection and maintenance

Changing engine oil, oil filters and bypass oil filter

CAUTION

To drain oil or change oil filters, wear gloves. Hot engine oil and parts can cause burns.

CAUTION

Disposal of discharged oil is legally restricted. Contact your Mitsubishi dealer for the disposal of waste oil.

When changing engine oil, renew oil filters and bypass oil filter. Also it is recommended to conduct an analysis of engine oil properties at the time of engine oil change.

Never wash and reuse oil filters, as their elements are paper type.

When replacing filters, always replace gaskets with new ones.

Draining engine oil

After the engine has stopped, drain engine oil from the engine oil drain port.

Note: Sucking-up draining should be avoided.

Changing oil filters and bypass oil filter

WARNING

Do not use the filter that has dent on its case. It may damage the filter, or may cause an oil leak, which could result in a fire during operation.

CAUTION

Do not use the filter wrench to install filters. Use hands to prevent filters from damaging.

1. Clean the area around the oil filters.
2. Place a drip pan under oil filters and a bypass oil filter.
3. Using a filter wrench, remove oil filters and a bypass oil filter.

Note: Disassemble the removed oil filter and bypass oil filter and check elements for metal particles. If metal particles are found, contact your Mitsubishi dealer. Change oil filters and a bypass oil filter whenever the filter alarm turns on.

4. Wipe off oil on the oil filter mounting surface of the filter bracket with a cloth.
5. Check new oil filters and a bypass filter for proper seating of the gaskets.
6. Apply clean engine oil to the gaskets on new oil filters and a bypass oil filter.
7. Install oil filters and a bypass oil filter. When the gasket contacts the mounting surface of the filter bracket, further rotate 3/4 to a full turn.

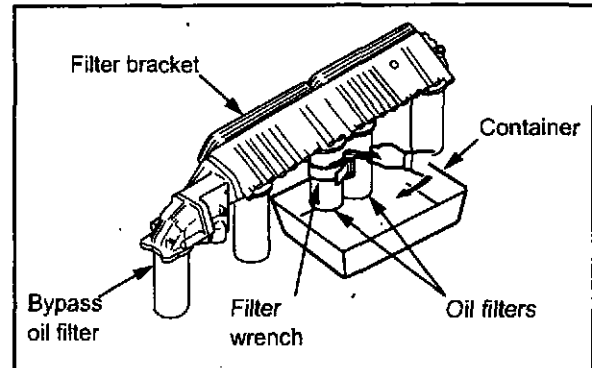

Fig.8-11 Oil filters and bypass oil filter

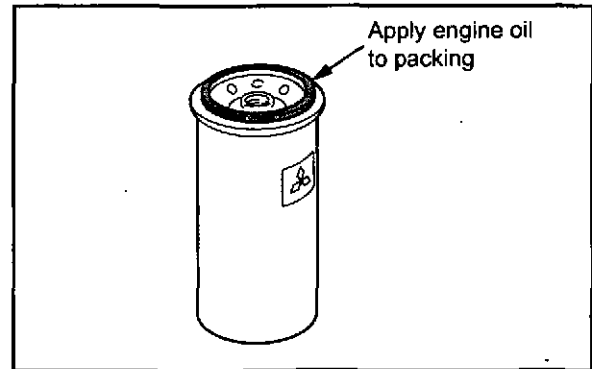

Fig.8-12 Oil filter

Refilling engine oil

CAUTION

To crank the engine, shut off the fuel supply to the engine and operate the starters.

1. Reinstall the drain plug.
2. Remove the oil filler cap.
3. Fill the engine oil pan with specified engine oil to the specified level.

Note: For engine oil, refer to "ENGINE OIL" (5-1).

For engine oil capacity, refer to "MAIN SPECIFICATIONS" (12-1).

4. Check the oil level in the oil pan as follows:
Pull out the oil level gauge and wipe it with a cloth. Insert the oil level gauge fully into the oil level gauge guide, then pull the gauge out again. The oil level should be between the MAXIMUM and MINIMUM marks on the oil level gauge.
5. If the oil level is low, add engine oil of the specified type.
6. Check the oil pan and other parts for oil leakage. Repair any oil leakage found.
7. Shut off the fuel supply and crank the engine for about 10 seconds or less using the starters, and wait for about 1 minute.
8. Perform the above cranking operation again to circulate oil in the engine.
9. Check the oil level with the oil level gauge again, and add oil to the specified level.

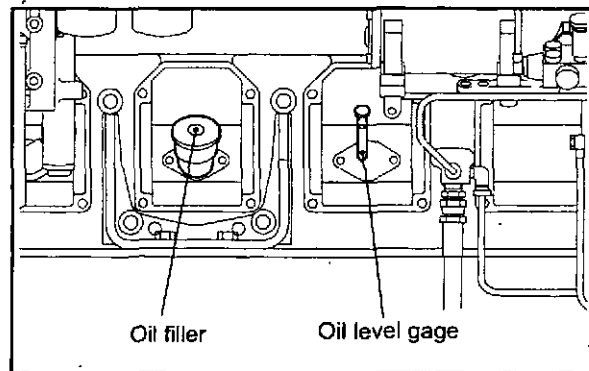

Fig.8-13 Oil filler and oil level gage

Checking engine oil for mixing of fuel and water

CAUTION

If the engine continues to operate with engine oil with mixed with fuel or water, the engine oil viscosity decreases and this can cause serious accidents such as seizing of bearings.

Sample 1 to 2 L [0.26 to 0.53 U. S. gal] of engine oil, and check for abnormal odor and discoloration to determine the mixing of fuel and water.

If fuel is mixed with the engine oil, the oil smells like fuel.

If water is mixed with the engine oil, the color of oil turns to milky white.

If fuel and/or water is mixed with the engine oil, locate and correct the cause of it, or if correction of the cause is difficult, contact your Mitsubishi dealer.

Cooling system periodic inspection and maintenance

Changing coolant

WARNING

To remove the radiator cap, wait until the engine is cooled to the room temperature. Place a cloth over the cap, and loosen the cap about a half-turn or stand the lever to upright position to release internal pressure. Opening the radiator cap while the engine is hot causes steam and hot coolant to blow out and can result in skin burns. Coolant containing LLC drained from the engine is toxic. Never dispose of coolant into regular sewage. For disposal of used coolant, consult your Mitsubishi dealer.

CAUTION

The service life of LLC is 2 years. Be sure to renew coolant at least once every 2 years.

Draining coolant

1. When draining coolant immediately after engine operation, let the engine idle at low idling speed for 5 to 6 minutes to lower the coolant temperature to 70 to 80°C [158 to 176°F].
2. Open the radiator cap.
3. Place coolant receiving cans under the drain cocks on the engine, and open the drain cocks to drain coolant.

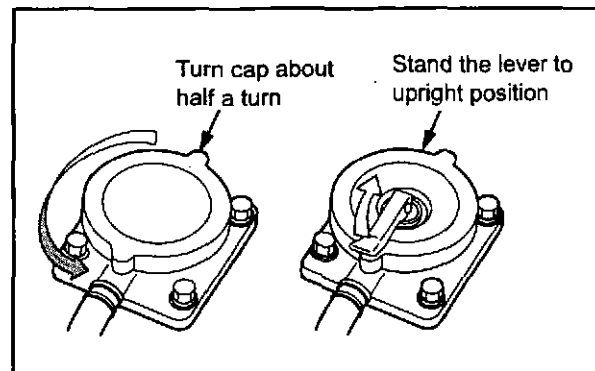

Fig.8-14 Radiator cap

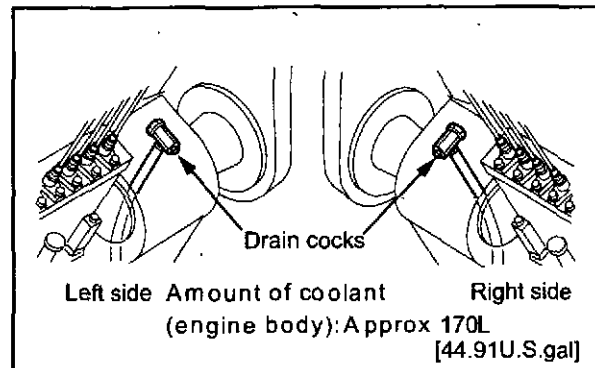

Fig.8-15 Draining coolant (engine main parts)

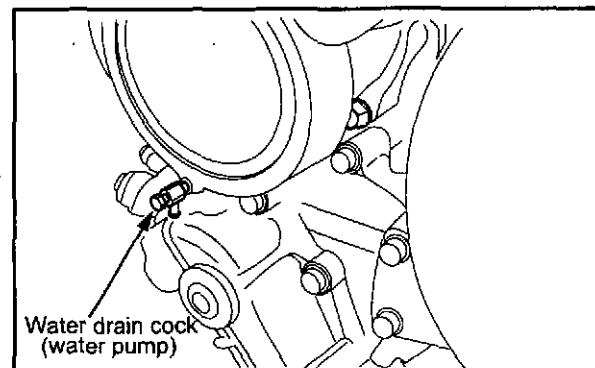

Fig.8-16 Draining coolant (water pump side)

Cleaning cooling system

1. Close drain cocks and plugs.
2. Pour in a cleaning solution (non-corrosive solution to rubber and metals) in the cooling system, and operate the engine at 800 to 900 min^{-1} for about 15 minutes, then drain the cleaning solution.
3. Close drain cocks and plugs.
4. Pour in fresh water, and operate the engine at 800 to 900 min^{-1} for about 10 minutes. Repeat rinsing until the draining water becomes clear and clean.

Refilling coolant

1. Make sure drain cocks and plugs are closed tightly.
2. Remove radiator cap, and pour in undiluted LLC.

Note: Determine the amounts of LLC and water to be added by using the LLC concentration chart. For coolant, refer to "COOLANT AND LLC" (6-1).

For coolant capacity, refer to "MAIN SPECIFICATIONS" (12-1).

3. Pour in water (soft water with minimal impurities, such as tap water) slowly to the full level.
4. Check radiator and other parts for coolant leakage. If coolant leakage is found, repair it.
5. When coolant reaches the full level, close the radiator cap securely.
6. Shut off the fuel supply and crank the engine for about 10 seconds or less using the starters. Wait for about 1 minute, then repeat the above cranking operation again to remove air from the water pump.

CAUTION

To crank the engine, shut off the fuel supply to the engine and operate the starters.

7. Check the coolant level in the radiator.
If a reserve tank is equipped, fill the reserve tank with coolant to the full level as well.

CAUTION

When adding coolant, use the coolant having the same LLC concentration as the coolant already in the radiator.

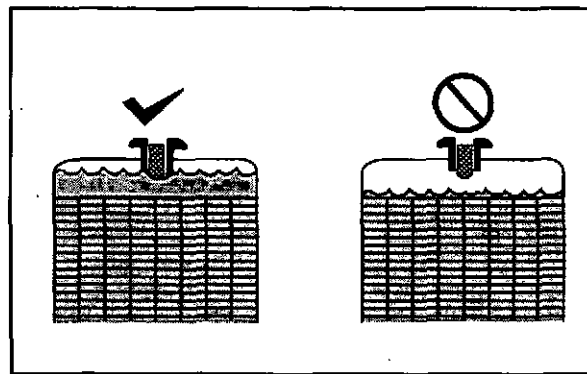

Fig.8-17 Radiator

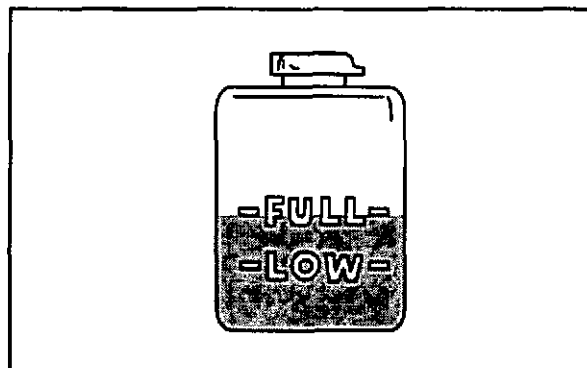

Fig.8-18 Reserve tank

Checking and cleaning radiator fins

Check radiator fins for holes and cracks.

To clean radiator fins, blow compressed air from the opposite direction to the normal air flow.

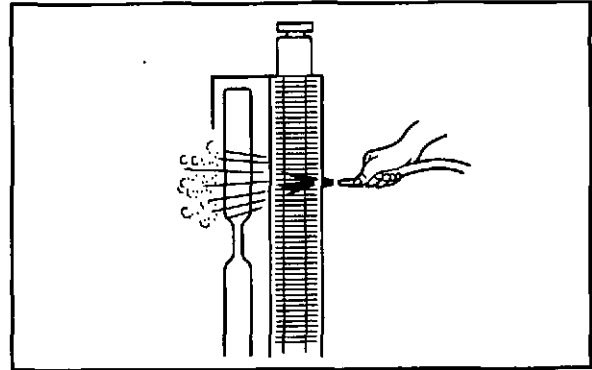

Fig.8-19 Cleaning radiator fins

Inlet exhaust system periodic inspection and maintenance

Checking turbocharger

CAUTION

Check turbocharger when engine is cold. Also make sure the compressor wheel is not rotating when checking turbocharger.

CAUTION

If the color of exhaust gas is abnormal, also conduct inspections of the turbocharger.

Disconnect the pipe from the air inlet side. Hold the compressor wheel nut by hand and turn the wheel to check for loose and abnormal noise. Replace the bearings if loose or abnormal noise is found.

Note: For replacement of the bearing, consult your Mitsubishi dealer.

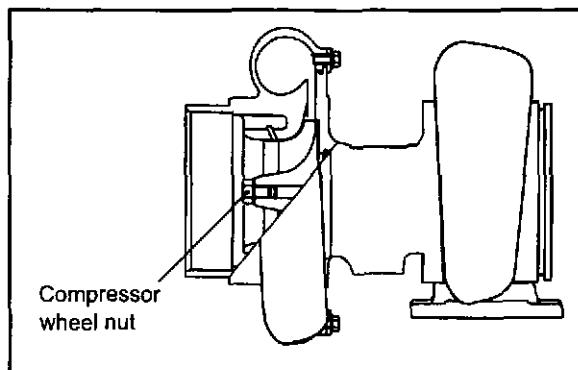

Fig.8-20 Checking turbocharger

Draining water from exhaust muffler

CAUTION

Never touch the exhaust muffler immediately after the engine stops, as it is extremely hot. To drain water, wait until the exhaust muffler becomes cool.

Remove the drain plug and allow water to drain from the exhaust muffler.

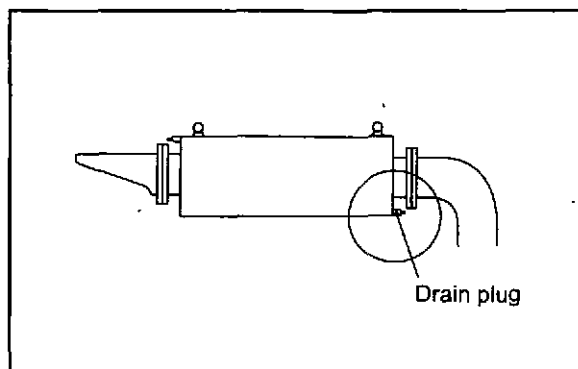

Fig.8-21 Draining water from exhaust muffler

Cleaning, checking and replacing pre-cleaner

CAUTION

Never service the pre-cleaner while the engine is running. Servicing the pre-cleaner while the engine is in operation can cause foreign particles to enter the engine and result in rapid wear of parts which leads a shorter service life of engine.

The pre-cleaner is equipped to the silencer of the turbocharger to remove dust from intake air and keep the engine clean for optimum performance. Be sure to clean the pre-cleaner as described below.

1. Remove the pre-cleaner from the silencer, and hand-wash the pre-cleaner with a mild detergent.
2. Rinse the pre-cleaner with fresh water.
3. After drying thoroughly, check the pre-cleaner for defects. If defects are found, replace the pre-cleaner with new one.
4. After cleaning, checking or replacement, reinstall the pre-cleaner.

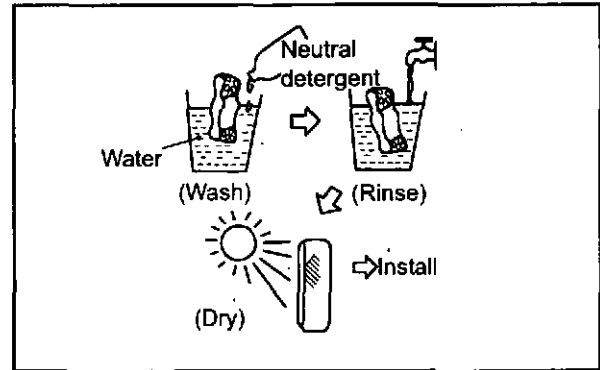

Fig.8-22 Cleaning pre-cleaner

Cleaning, checking, replacing air cleaner element

CAUTION

Never service the air cleaner while the engine is running. Servicing the air cleaner while the engine is in operation can cause foreign particles to enter the engine and result in rapid wear of parts that leads to a shorter service life of engine. Never knock or hit the element.

When using compressed air, wear protective gear such as safety glasses, hard hat and gloves. Working without protective gear can result in a severe personal injury.

1. Remove the air cleaner cap or wing nut.
2. Remove the air cleaner element from the body.
3. Blow compressed air (0.69 MPa (7 kgf/cm²) [100 psi] or lower) onto the inside surface of the element to remove dust and other contaminants.
4. To remove dust stuck on the element, blow dry compressed air onto the outside surface from a distance. Blow compressed air on the inside surface toward outside along the pleats. Then, blow compressed air on the outside and inside surface again.
5. After cleaning, place a light bulb to illuminate inside the element to check for defects such as cuts, pinholes or a local wear.
6. If defects are found, replace the air cleaner element with a new one.
7. After cleaning, checking or replacing the air cleaner element, reinstall the air cleaner element to the body.

CAUTION

If defects such as cuts, pinholes or a local wear are found in the element or if the air cleaner indicator shows red sign soon after the cleaned element is installed, replace the filter element with new element.

Reset the indicator by pressing the reset button after the clean or new element is installed when the indicator shows a red sign.

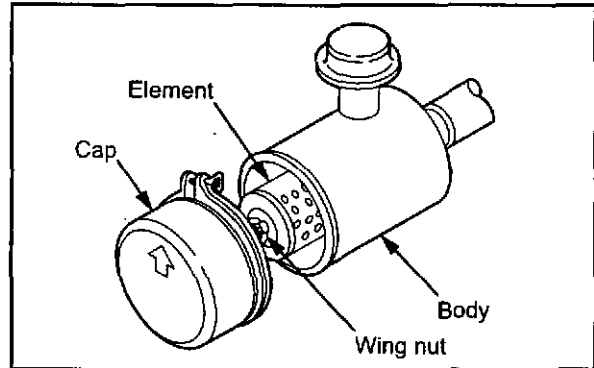

Fig.8-23 Removing air cleaner element

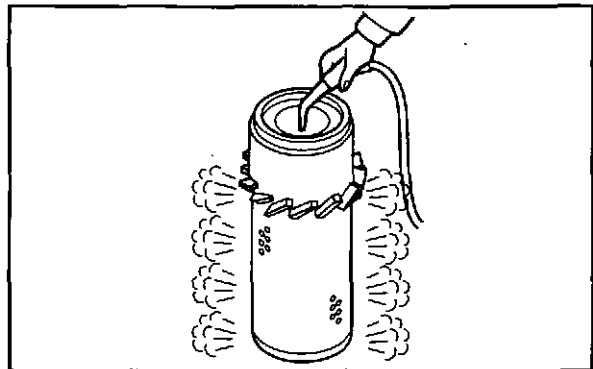

Fig.8-24 Cleaning air cleaner element

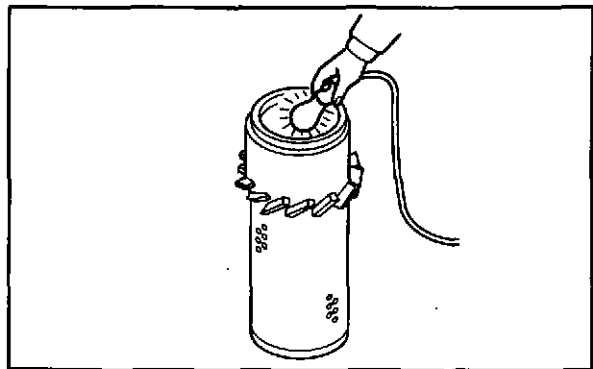

Fig.8-25 Checking air cleaner element

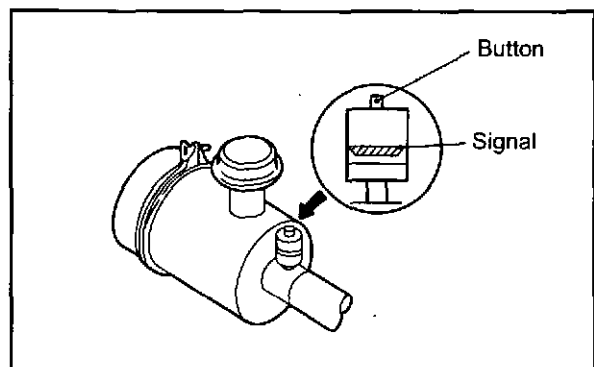

Fig.8-26 Air cleaner indicator

Electrical system periodic inspection and maintenance

Checking starter

Visually check the starter for damage.

If the starter are dusty, blow off dust using compressed air.

Note: If defects are found in the starter, contact your Mitsubishi dealer.

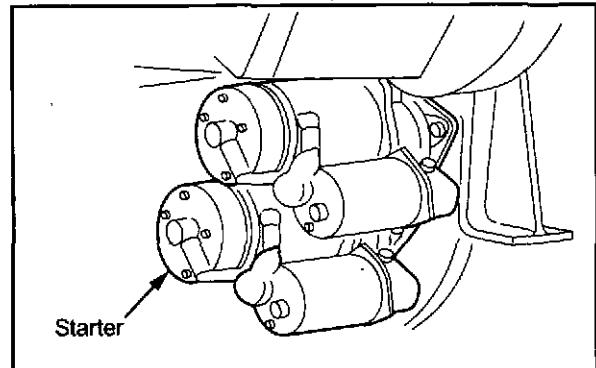

Fig.8-27 Checking starter

Checking alternator

Visually check the alternator for damage.

If the alternator is dusty, blow off dust using compressed air.

Remove V-belt, and turn the pulley with hands to make sure it rotates smoothly.

Note: If defects are found in the alternator, contact your Mitsubishi dealer.

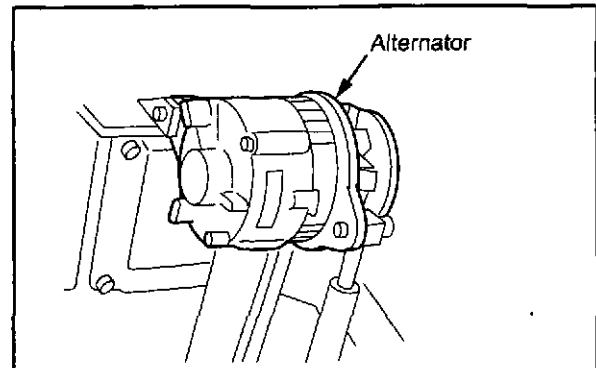

Fig.8-28 Checking alternator

Checking battery

WARNING

If battery electrolyte is spilled on your skin, flush immediately with plenty of water. If battery electrolyte enters the eyes, flush them immediately with lots of fresh water and seek medical attention at once. Do not use open flames or other fire hazards near the battery. When handling the battery, be careful of sparks generated by accidental shorting. For other cautions in handling the battery, refer to "Caution service battery" (1-5).

Checking battery electrolyte level

Battery electrolyte evaporates during use and the fluid level gradually decreases. The correct fluid surface level is between the LOWER LEVEL and UPPER LEVEL lines. For the battery without level lines, the correct fluid surface level is about 10 to 15 mm [0.394 to 0.591 in.] above the top of the plates. If the fluid level is low, remove the caps and add distilled water to the proper level.

Note: When adding distilled water, pour in carefully.

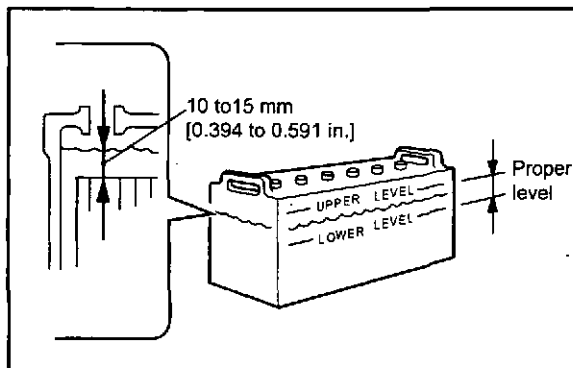

Fig.8-29 Checking battery electrolyte level

Checking specific gravity of battery electrolyte

Check the specific gravity of the electrolyte. If the specific gravity measured at 20°C [68°F] is lower than 1.22, then charge the battery.

Table 8-2 Specific gravity of electrolyte

Specific gravity at 20°C [68°F]	Condition	Remedy
From 1.26 to 1.28	Fully charged	-
From 1.22 to 1.26	Charged	Charge
Less than 1.22	Discharged	Charge

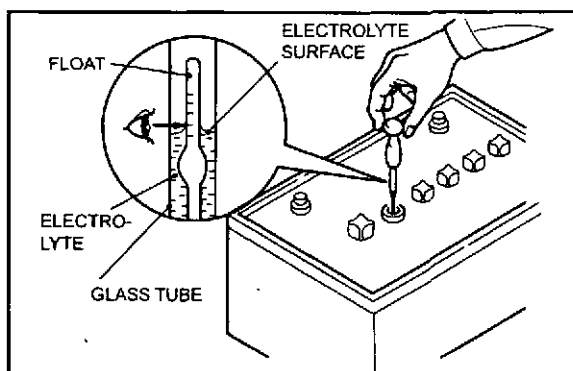

Fig.8-30 Checking specific gravity of electrolyte

Chapter 9 LONG-TERM STORAGE

Long-term storage

The following describes how to store the engine in a non-operable condition for three months or more and in an operable condition for three months or more. If the engine has been left unattended for three months or more, the internal engine parts can rust that may cause damage to the engine. When storing the engine for an extended period of time, be sure to follow the directions below.

Storing engine in non-operable condition for 3 months or more

Preparation for storage

1. Drain engine oil, and pour in rust-preventive oil (NP-10-2) into the engine.
2. Prepare a fuel mixture containing 50% rust-preventive oil (NP-9), and fill the fuel tank with it.
3. Operate the engine at a speed of 800 to 1000 min^{-1} (idling) for 5 to 10 minutes under no load.
4. Immediately before stopping the engine, spray volatile corrosion inhibitor (V.C.I.) through the inlet port to prevent rust on the air intake system.
5. With the engine stopped, drain the fuel mixture from the fuel tank.
6. Apply rust-preventive oil (NP-3) liberally on the exposed sections of the machining.
7. Seal air inlet, exhaust outlet, breather and other openings with an adhesive cloth tape.
8. Loosen V-belt.
9. Wrap adhesive cloth tape on the terminals of the starters and alternator, and seal the openings. Cover these sections with polyethylene sheet or processed polyethylene paper, and place desiccants in the polyethylene covers.
10. Disconnect cables from the battery terminals, and charge the battery. Clean the terminals, apply a thin coat of grease to the terminals, and store the battery in a cool and dry room.
11. Cover the entire engine.

- Note (a) Store the engine in a well-ventilated indoor area.
- (b) No need to drain coolant since it contains LLC. (Add LLC to increase the concentration between 30 and 60%.)
- (c) Post a sign at an easily noticeable place to warn that the rust-preventive oil in the engine must be replaced with engine oil, and the fuel tank must be filled with fuel before operating the engine.
- (d) A new engine oil can substitute for rust-preventive oil (NP-10-2).

Recommended rust-preventive oil and corrosion inhibitor

Table 9-1 Recommended rust-preventive oil and corrosion inhibitor

JIS No.	Recommended product	Application
K2246	NP-3 Nippon Oil Corporation Anti Rust P-1400	Prevention of rust on exposed machine surfaces
	NP-9 Nippon Oil Corporation Anti Rust P-2400	Prevention of rust on fuel system
	NP-10-2 Nippon Oil Corporation Anti Rust P-230	Prevention of rust on lubricating system
Z1519	- Ryokou Kagaku V.C.I.Diana volatile corrosion inhibitor	Prevention of rust on air intake system

Maintenance during storage

Charge the battery once a month.

First, check the battery electrolyte for correct level and then charge the battery.

Using engine after storage

1. Remove the cover from the engine.
2. Connect a fully charged battery.
3. Remove the covers from the starters and alternator.
4. Adjust the tension of V-belt.

Note: For the adjustment of V-belt tension, refer to "Adjusting V-belt tension" (8-3).

5. Remove sealing tapes from the openings of the engine.
6. Drain rust-preventive oil, and pour in appropriate engine oil.

Note: For engine oil, refer to "ENGINE OIL" (5-1)

7. Fill the fuel tank with fuel, and bleed the fuel system.

Note: For bleeding fuel system.

8. Inspect the entire engine.
9. Remove the rocker covers, and lubricate the valve mechanisms.
10. Shut off the fuel supply and crank the engine for about 10 seconds, and repeat this cranking 3 times at intervals of about 1 minute.

CAUTION

To crank the engine, shut off the fuel supply to the engine and operate the starters.

11. Make sure the engine oil pressure rises.
12. Start the engine

Note: For starting the engine, refer to "Starting" (3-11).

13. Conduct a warm-up operation for sufficient duration.
14. Apply load and increase the engine speed to the rated speed.

Storing engine in operable condition for 3 months or more

When the engine is not operated during storage of three months or more, internal engine parts can rust and lose oil film. As a result, the engine can seize when it is started after storage. To prevent such a risk, the engine must be operated periodically during storage.

Operating engine for maintenance purpose

Operate the engine for maintenance purpose at least once a month as described below.

1. With fuel shut off (press the engine stop button in order to shut off fuel injection), operate the starters twice at intervals of about 15 seconds and check to see if the engine oil pressure increases.
2. After the engine starts, operate under no load for 5 to 10 minutes.

Note: For engine operation, refer to "OPERATION" (3-1).

Chapter 10 TRANSPORTATION

Lifting engine carefully

WARNING

To lift the engine, use wire ropes, shackles and slings capable of supporting the weight of the engine.

Attach slings to the hangers provided on the engine to lift the engine.

Keep the engine balanced during lifting by considering the engine's center of gravity.

Keep the angle formed by slings attached to hangers within 60°. If the angle exceeds this limit, excessive load is applied on the hangers and may damage the hangers.

Attach wire ropes to the hanger after removing the pipe cover and the insulator near the hanger for lifting.

To prevent wire ropes from contacting the engine, place a cloth or other soft padding to prevent damage to the engine and wire ropes.

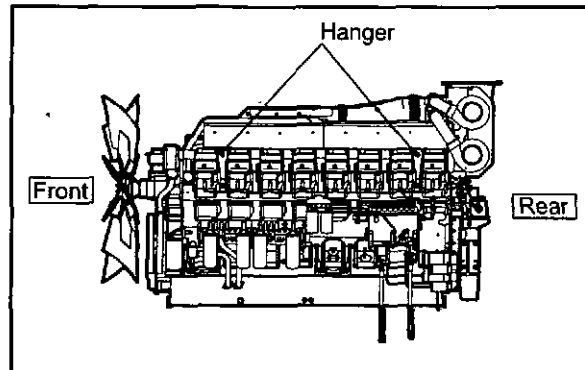

Fig.10-1 Hangers for lifting (left side)

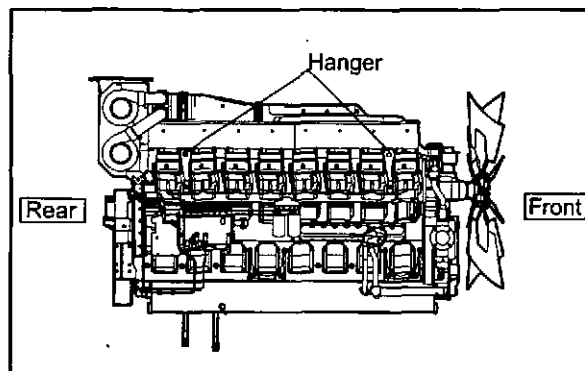

Fig.10-2 Hangers for lifting (right side)

Chapter 11 TROUBLESHOOTING

General precautions

Contact your Mitsubishi dealer for repair service

Repairing a malfunctioning engine may require special equipment or involve potentially dangerous work, except for relatively simple procedures such as the change and addition of fuel, engine oil and coolant. In the event of the engine failure, contact your Mitsubishi dealer.

Consideration before work

Before troubleshooting, consider possible causes of the problem and try to see if the same problem has occurred in the past.

Check the parts that may be causing the problem in the most efficient order.

When disassembling a component, pay close attention to the disassembly sequence so that you can reassemble the component in reverse order of disassembly.

Cautions against contamination

Dust and foreign particles are the most common cause of rapid wear of parts.

When disassembling a component, take measures to prevent dust and foreign particles from entering the component being disassembled.

Cautions regarding parts handling

Handle parts carefully.

When replacing parts, use only genuine parts by referring to the parts catalog.

Work safety

Be sure to use wrenches of correct size. Using a wrench of a wrong size not only damages nuts but can also cause the personal injury.

Use correct tools and perform work with utmost caution.

Be sure to accurately estimate the weight of the part being dismantled. If the removed part is unlikely heavy than you have estimated, it may fall down during lifting and can result in the damage to the parts or personal injury.

How to troubleshoot

Starters do not crank or crank slowly, resulting in start failure

Table 11-1 Starters Do Not Crank or Crank Slowly, Resulting in Start Failure

	Cause	Remedy
Electrical system	Blown fuse	Change fuse
	Faulty wire connection between battery and starter switch	Connect wire correctly
	Faulty wire connection between battery, starters and starter switch	Connect wire correctly
	Insufficiently charged battery	Inspect and adjust V-belt tension. Refer to "Checking V-belt and adjusting belt tension" (8-3).
	Specific gravity of battery fluid too low	Charge battery
	Faulty battery	Install new battery.
	Faulty starter or starter relay	Consult a Mitsubishi dealer
Lubricating system	Oil viscosity too high	Use appropriate engine oil, Refer to "ENGINE OIL" (5-1)
Fuel system	Air in fuel system	Bleed fuel system, Refer to "FUEL" (4-1)
	Low fuel level	Add fuel
	Clogged fuel filters	Change fuel filters, Refer to "Changing fuel filter" (8-6)
	Faulty fuel feed pump	Consult a Mitsubishi dealer
	Faulty fuel injection pump	Consult a Mitsubishi dealer
Engine mechanical	Faulty moving parts (Interference between valves and pistons, or foreign items in cylinders)	Consult a Mitsubishi dealer

Starters crank, but engine does not start

Table 11-2 Starters Crank, But Engine Does Not Start

	Cause	Remedy
Fuel system	Empty fuel tank	Add fuel, and bleed fuel system, Refer to "FUEL" (4-1)
	Damaged fuel pipe	Consult a Mitsubishi dealer
	Loose fuel pipe connection	Tighten connection, Consult a Mitsubishi dealer
	Improper fuel	Use proper fuel, Refer to "FUEL" (4-1)
	Dust or water mixed in fuel	Remove dust or water from fuel tank, Refer to "Draining fuel tank" (8-5)
	Clogged fuel filters	Replace fuel filters, Refer to "Changing fuel filter" (8-6)
	Faulty fuel feed pump	Consult a Mitsubishi dealer
	Faulty fuel injection pump	Consult a Mitsubishi dealer
Air intake system	Clogged air cleaner	Clean pre-cleaner, Refer to "Cleaning, checking, replacing air cleaner element" (8-15)
Engine mechanical	Compression pressure low (damaged cylinder liner, piston or piston ring, or faulty valve seat or nozzle packing seal)	Consult a Mitsubishi dealer

Other problems and countermeasures

Engine output is low

Table 11-3 Engine Output is Low

Cause	Remedy
Engine oil viscosity too high	Use engine oil of appropriate viscosity according to ambient temperature. Refer to "ENGINE OIL" (5-1)
Improper fuel	Use proper fuel. Refer to "FUEL" (4-1)
Insufficient air intake (clogged air cleaner)	Clean air cleaner element, or replace if necessary. Refer to "Cleaning, checking, replacing air cleaner element" (8-15)
Engine overcooling	Cover the radiator or consult a Mitsubishi dealer
Clogged fuel filter	Replace fuel filters. Refer to "Changing fuel filter" (8-6)
Insufficient cooling (overheating)	Consult a Mitsubishi dealer
Incorrect valve clearance	Consult a Mitsubishi dealer
Faulty fuel feed pump	Consult a Mitsubishi dealer
Faulty fuel injection pump	Consult a Mitsubishi dealer
Faulty fuel injection nozzles	Consult a Mitsubishi dealer
Incorrect fuel injection timing	Consult a Mitsubishi dealer
Low compression pressure (worn cylinder liners, worn piston rings, etc)	Consult a Mitsubishi dealer

Exhaust smoke is white or blue

Table 11-4 Exhaust Smoke is White or Blue

Cause	Remedy
Excessive amount of engine oil	Maintain correct oil level. Refer to "Preparation of lubrication system" (3-4)
Engine oil viscosity too high	Use engine oil of appropriate viscosity according to ambient temperature. Refer to "ENGINE OIL" (5-1)
Overcooling	Cover the radiator or consult your Mitsubishi dealer
Faulty thermostat(water temperature does not rise)	Consult a Mitsubishi dealer
Faulty fuel injection nozzles (uneven injection among cylinders)	Consult a Mitsubishi dealer
Incorrect fuel injection timing	Consult a Mitsubishi dealer
Low compression pressure (worn piston liners, worn piston rings, etc)	Consult a Mitsubishi dealer
Improper fuel (low cetane number)	Use proper fuel. Refer to "FUEL" (4-1)

Exhaust smoke is black or dark gray

Table 11-5 Exhaust Smoke is Black or Dark Gray

Cause	Remedy
Improper fuel	Use proper fuel. Refer to "FUEL" (4-1)
Incorrect valve clearance	Consult a Mitsubishi dealer
Faulty fuel feed pump	Consult a Mitsubishi dealer
Low compression pressure (worn piston liners, worn piston rings, etc)	Consult a Mitsubishi dealer
Insufficient intake air (improper ventilation, clogged air cleaner)	Clean air cleaner element, or replace if necessary. Refer to "Cleaning, checking, replacing air cleaner element" (8-15)
Incorrect fuel injection timing	Consult a Mitsubishi dealer
Faulty fuel injection nozzles	Consult a Mitsubishi dealer
Faulty fuel injection pump	Consult a Mitsubishi dealer

Fuel consumption is high

Table 11-6 Fuel Consumption is High

Cause	Remedy
Faulty fuel feed pump	Consult a Mitsubishi dealer
Faulty fuel injection pump	Consult a Mitsubishi dealer
Incorrect fuel injection timing	Consult a Mitsubishi dealer
Improper fuel	Use proper fuel. Refer to "FUEL" (4-1)
Low compression pressure (worn piston liners, worn piston rings, etc)	Consult a Mitsubishi dealer
Insufficient intake air (improper ventilation, clogged air cleaner)	Clean air cleaner element, or replace if necessary. Refer to "Cleaning, checking, replacing air cleaner element" (8-15)

Engine oil consumption is high

Table 11-7 Engine Oil Consumption is High

Cause	Remedy
Excessive amount of engine oil	Maintain correct oil level. Refer to "Preparation of lubrication system" (3-4)
Engine oil viscosity too low	Use engine oil of appropriate viscosity according to ambient temperature. Refer to "ENGINE OIL" (5-1)
Engine oil leakage	Consult a Mitsubishi dealer
Worn cylinder liners, worn piston rings	Consult a Mitsubishi dealer
Worn valve stem seals	Consult a Mitsubishi dealer

Engine overheats

Table 11-8 Engine Overheats

Cause	Remedy
Radiator, heat exchanger leakage	Consult a Mitsubishi dealer
Low coolant level	Add coolant
Faulty water pump	Consult a Mitsubishi dealer
Faulty thermostat	Consult a Mitsubishi dealer

Engine oil pressure is faulty

Table 11-9 Engine Oil Pressure is Faulty

Cause	Remedy
Insufficient amount of engine oil	Maintain correct oil level. Refer to "Preparation of lubrication system" (3-4)
Engine oil viscosity too low	Use engine oil of appropriate viscosity according to ambient temperature. Refer to "ENGINE OIL" (5-1)
Clogged oil filter	Replace oil filters. Refer to "Changing engine oil, oil filters and bypass oil filter" (8-7)
Faulty oil pump	Consult a Mitsubishi dealer
Faulty relief valve	Consult a Mitsubishi dealer
Faulty oil pressure sensor	Consult a Mitsubishi dealer

Note: If the problem cannot be corrected easily or when a problem other than those listed above occurs, consult a Mitsubishi dealer.

When ordering replacement parts, provide the engine serial number. When requesting repair, provide the engine serial number and service hour meter reading.

When fuel has run out

When fuel runs out during engine operation and the engine has stopped, restart engine as described below.

- Return the starter switch to the OFF position.
- Add fuel to the fuel tank.
For filling fuel tank, refer to "Draining fuel tank" (8-5).
- Bleed the fuel system.
For bleeding fuel system, refer to "Bleeding fuel system" (3-2).
- Restart the engine.
For starting engine, refer to "Preparations for operation (pre-start inspection)" (3-8).

Chapter 12 MAIN SPECIFICATIONS

Main specifications

Table 12-1 Main specifications

Item	Specification
Engine model	S16R-Y1PTA-2
Type	Water-cooled 4-stroke cycle, turbocharged diesel, air cooler
Number of cylinders, arrangement	16-V
BorexStroke (mm [in.])	170x180 [6.70x7.10]
Total displacement (L [cu.in.])	65.37 [3985]
Combustion type	Direct injection
Compression ratio	15.0:1
Firing order	1-9-6-14-2-10-4-12-8-16-3-11-7-15-5-13
Rotation direction	Counterclockwise as viewed from flywheel
Dimensions (LxWxH (mm) [in.])	Approx. 3223x1455x1810 [127x57x71]
Dry weight (kg [lb.])	Approx. 6200 [13669]
Fuel	Diesel fuel
Fuel injection pump	Mitsubishi PS8 type
Fuel filter	Cartridge-type paper element, spin-on type
Fuel injection nozzle	Hole type
Initial fuel injection pressure (MPa (kgf/cm ²) [psij])	34.3 (350) [4979]
Lubricating system	Forced circulation type (pressure feed by oil pump)
Lubrication oil	Class CD or CF oil (API service classification)
Engine oil capacity (liter [U.S.gallon])	Oil pan: Approx. 200 [52.83] Whole engine: Approx. 230 [60.76]
Oil filter	Paper element (equipped with bypass filter, spin-on type)
Oil cooler	Water cooled multi-plate (equipped with crankcase)
Cooling system	Force water cooling
Cooling water capacity (liter [U.S.gallon])	Approx. 170 [44.91] (in engine only)
Starting system	Electrical start
Starter	24 V - 7.5 kWx2
Alternator	24 V - 30 A
Turbocharger	Mitsubishi TD10x4

