

# **OPERATION & MAINTENANCE MANUAL**

**MITSUBISHI  
DIESEL ENGINE**

**S16R-Y2PTAW**

**for EPA Tier2**

The operator and supervisor are requested to read this Operation and Maintenance Manual carefully before operating the engine or conducting inspection and maintenance.

Never operate the engine or conduct maintenance work without completely understanding this manual.

**January 2007**



---

# FOREWORD

This operation and maintenance manual contains detailed operation, inspection and maintenance information for Mitsubishi engines.

Please read this manual thoroughly before proceeding with operation, inspection, and maintenance work for correct use and servicing.

Failure to follow directions in this manual may result in serious accidents.

## Limited warranty

The manufacturer will repair or replace parts returned to the manufacturer when the manufacturer judges after inspection that the parts are defective in material and/or workmanship.

The manufacturer's warranty is limited to the repair work or replacement of parts for the defective parts only.

The warranty coverage is effective for the original purchaser only. Those to whom ownership is later transferred are not provided with the warranty.

- 
- The manufacturer makes no warranties, either expressed or implied, except as provided in this manual, including, but not limited to, warranties as to marketability, merchantability, fitness for a particular purpose or use, or against infringement of any patent.
  - The manufacturer will not be liable for any damages or consequential damages, including, but not limited to, damages or other costs resulting from any abuse, misuse, misapplication of the engine and devices supplied by the manufacturer.
  - The manufacturer will not be liable for any damages or personal injuries resulting from any modification, without the manufacturer's written permission, of the engine and devices supplied by the manufacturer.
  - The manufacturer will not be liable for any damages or production losses caused by the use of fuel, engine oil and/or long life coolant (LLC) that are not recommended by the manufacturer.
-

## Important information

- To avoid potential hazard, accident prevention activities must be planned methodically and conducted continually by considering all aspects of engine operation, maintenance and inspection. All related personnel, including managers and supervisors, should actively participate, recognize their roles and organize themselves and their work to ensure a safe environment.
- The foremost safety objective is to prevent accidents that may result in injury or death, or equipment damage.
- Always observe laws or regulations of the local or federal/national government.
- The manufacturer cannot foresee all potential dangers of the engine, potential danger resulting from human error and other causes, or danger caused by a specific environment in which the engine is used. Since there are many actions that cannot be performed or must not be performed, it is impossible to indicate every caution in this manual or on warning labels. As such, it is extremely important to follow directions in this manual and also to take general safety measures when operating, maintaining and inspecting the engine.
- This manual has been prepared for people whose native language is English. When the engine is used by individuals whose native language is not English, the customer is requested to provide thorough safety guidance to the operators. Also add safety, caution and operating signs that describe the original warning label statements in the native language of the operators.
- The engine must be operated, maintained and inspected only by qualified persons who have thorough knowledge of engines and their dangers and who also have received risk avoidance training.
- To prevent an accident, do not attempt to carry out any operation other than those described in this manual, and do not use the engine for any unapproved purpose.
- When the ownership of the engine is transferred, be sure to provide this manual with the engine to the new owner. Also inform the manufacturer of the name and address of the new owner of the engine.
- This manual is copyrighted and all rights are reserved. No part of this manual, including illustrations and technical references, may be reproduced, photocopied, translated, or reproduced in any electronic medium or machine readable form without prior written consent from the manufacturer.
- The contents in this manual are subject to change at any time without notice, for improvement of the engine.
- Pictures or illustrations of the product in this manual may differ from those of product you have.
- Please note that, depending on specifications, items described in this manual may differ in shape, or may not be installed on the product you have.
- Please contact your Mitsubishi dealer if you need more information or if you have any questions.
- If you lose or damage this manual, obtain a new copy at your Mitsubishi dealer as soon as possible.

## Warning Indication

The following two means are used to call the attention of the operators and maintenance personnel to potential dangers of the engine.

- Warning statements in the manual
- Warning labels affixed on the engine

### Warning statements

The warning statements in this manual describe potential danger in operating, inspecting or maintaining the engine, using the following five classifications to indicate the degree of potential hazard. Failure to follow these directions could lead to serious accidents which could result in personal injury, or death in the worst case.



Indicates an imminently hazardous situation which, if not avoided, will result in death or serious injury.



Indicates a potentially hazardous situation which, if not avoided, could result in death or serious injury.



Indicates a potentially hazardous situation which, if not avoided, may result in minor or moderate injury.



Indicates a potentially hazardous situation which, if not avoided, can result in property damage.

Note: Indicates important information or information which is useful for engine operation.

## Units of measurement

Measurements are based on the International System of Units (SI), and they are converted to the metric system units in this manual using the following conversion rates.

- Pressure: 1 MPa = 10.197 kgf/cm<sup>2</sup>
- Torque: 1 N·m = 0.10197 kgf·m
- Force: 1 N = 0.10197 kgf
- Horsepower: 1 kW = 1.341 HP = 1.3596 PS
- Meter of mercury: 1 kPa = 0.75 cmHg
- Meter of water: 1 kPa = 10.197 cmH<sub>2</sub>O (cmAq)
- Engine speed: 1 min<sup>-1</sup> = 1 rpm

## Abbreviations, standards and others

- API = American Petroleum Institute
- ASTM = American Society for Testing and Materials
- JIS = Japanese Industrial Standards
- MIL = Military Specifications and Standards (U.S.A.)
- MSDS = Material Safety Data Sheet
- SAE = Society of Automotive Engineers (U.S.A.)
- LLC = Long Life Coolant

# CONTENTS

## Chapter 1

### BASIC SAFETY PRECAUTIONS

Fire and explosion .....	1-1
Keep flames away .....	1-1
Keep engine surrounding area tidy and clean..	1-1
Avoid accessing crankcase until engine cools.	1-1
Care for fuel, oil and exhaust gas leakage.....	1-1
Use explosion-proof lighting apparatus.....	1-1
Prevent electrical wires from short-circuiting....	1-1
Keep fire extinguishers and a first-aid kit handy	1-1
Stay clear of all rotating and moving parts .....	1-2
Install protective covers around rotating parts .	1-2
Check the work area for safety .....	1-2
Stay clear of moving parts during engine running .....	1-2
Lockout and Tagout .....	1-2
Keep engine stopped during servicing .....	1-2
Always restore engine turning tools after use ..	1-2
Be careful of burns .....	1-3
Do not touch the engine during or immediately after operation .....	1-3
Do not open the radiator filler cap when the engine is hot .....	1-3
Add coolant only after the coolant temperature dropped .....	1-3
Never remove heat shields .....	1-3
Be careful of exhaust fume poisoning .	1-3
Operate the engine in a well-ventilated area....	1-3
Protect ears from noise .....	1-3
Wear ear plugs.....	1-3
Be careful to prevent the engine from falling .....	1-4
Lift engine carefully .....	1-4
Do not climb onto the engine .....	1-4
Always prepare stable scaffold .....	1-4
Be careful when handling fuel, engine oil and LLC.....	1-4
Use only specified fuel, engine oil and long-life coolant (LLC).....	1-4
Handle LLC (long life coolant) carefully .....	1-4

Proper disposal of waste oil and coolant (LLC)	1-4
Service battery .....	1-5
Handle the battery correctly .....	1-5
When an abnormality occurs .....	1-5
Do not add coolant immediately after a sudden stop due to overheating.....	1-5
Avoid immediate restart after abnormal stop....	1-5
Avoid continuous engine operation at low oil pressure .....	1-5
If the fan belt breaks, stop the engine immediately .....	1-5
Other cautions.....	1-6
Never modify engine .....	1-6
Never break the seals .....	1-6
Perform all specified pre-operation inspections and periodic inspections.....	1-6
Break-in the engine .....	1-6
Warm up the engine before use.....	1-6
Never operate the engine in an overloaded condition.....	1-6
Conduct cooling operation before stopping the engine .....	1-6
Protection of the engine against water entry....	1-6
Properly maintain the air cleaner and pre-cleaner	1-7
Observe safety rules at work site .....	1-7
Work clothing and protective gear.....	1-7
Use of tools optimum for each work.....	1-7
Do not operate the starter for a prolonged time	1-7
Do not turn off the battery switch during operation .....	1-7
Cautionary instructions for transporting the engine .....	1-7
About warning labels.....	1-8
Maintenance of warning labels.....	1-8

## Chapter 2

### NAME OF PARTS

Engine external view.....	2-1
Left view .....	2-1
Right view.....	2-1

Equipment and instrument.....	2-2
Manual stop lever.....	2-2
Stop solenoid .....	2-2
Instruments.....	2-2
Revolution pickup.....	2-2
Engine protection devices .....	2-3
Oil filter alarm switch.....	2-3
Air cleaner indicator .....	2-3
Using turning gear .....	2-4
Cautions regarding exhaust emission control.....	2-5

### Chapter 3 OPERATION

Preparation for operating new or overhauled engine .....	3-1
Preparation of fuel system .....	3-1
Filling fuel tank .....	3-1
Bleeding the fuel system.....	3-2
Bleeding the fuel filter .....	3-2
Fuel injection pump.....	3-3
Priming pump cap tightening method .....	3-3
Preparation of lubrication system.....	3-4
Filling engine with engine oil.....	3-4
Preparation of cooling system.....	3-5
Filling main cooling system with coolant.....	3-5
Filling inter cooler cooling system with coolant.....	3-6
Cranking the engine after filling cooling system .....	3-6
Inspecting the battery.....	3-7
Inspecting battery electrolyte level.....	3-7
Inspecting specific gravity of battery electrolyte .....	3-7
Test operation .....	3-8
Starting and stopping .....	3-8
Inspection .....	3-8
Normal engine operation .....	3-9
Preparations for operation (pre-start inspection) .....	3-9
External inspection .....	3-9
Checking the fuel tank oil level .....	3-10
Checking the engine oil level.....	3-10
Checking the coolant level.....	3-11
Checking the fuel control link.....	3-11
Checking the air cleaner .....	3-12

Starting.....	3-13
Warming-up operation.....	3-13
Checking engine oil pressure .....	3-13
External inspection during warm-up .....	3-13
Operation .....	3-14
Inspection during operation.....	3-14
Stopping .....	3-15
Emergency stop .....	3-15
Inspection after stopping .....	3-15

### Chapter 4 FUEL

Recommended fuel.....	4-1
Handling fuel .....	4-1

### Chapter 5 ENGINE OIL

Properties of engine oil and its influence on engine performance ...	5-1
Main properties of engine oil .....	5-1
Dispersibility .....	5-1
Acid neutralization ability.....	5-1
Viscosity .....	5-1
Recommended engine oil .....	5-2
Selection of oil viscosity .....	5-2
Genuine engine oil .....	5-2
Other brands of engine oil.....	5-3
Handling engine oil .....	5-3
Service limits of engine oil .....	5-4
Definition of properties of engine oil....	5-4
Viscosity .....	5-4
Total base number .....	5-4
Total acid number .....	5-4
Water.....	5-4
Flash point.....	5-4
Insolubles .....	5-4
Engine oil analysis service.....	5-5
How to order engine oil sampling tool'set .....	5-5

**Chapter 6**

**COOLANT AND LLC**

Recommended coolant..... 6-1  
 Long life coolant (LLC) ..... 6-1  
 Genuine LLC ..... 6-1  
 Other brands of LLC..... 6-2  
 Maintenance of LLC ..... 6-2  
 Replacement intervals of LLC..... 6-2  
 LLC concentration..... 6-2  
 Importance of LLC..... 6-3  
 Characteristics of LLC additive and important notes ..... 6-3  
 Examples of abnormalities caused by LLC..... 6-3  
 Pitting of iron parts..... 6-3  
 Corrosion of aluminum parts..... 6-3  
 Pitting and clogging of the radiator ..... 6-3

**Chapter 7**

**MAINTENANCE SCHEDULE**

How to use the maintenance schedule 7-1  
 Maintenance schedule ..... 7-1  
 Maintenance schedule for regular use engine ..... 7-1  
 Maintenance schedule for emergency engine ..... 7-1  
 Maintenance schedule for general-use engine ..... 7-1  
 Definition of regular use engine, emergency engine and general-use engine ..... 7-2  
 Regular use engine..... 7-2  
 Emergency engine..... 7-2  
 General-use engine ..... 7-2  
 Maintenance schedule for regular use engine..... 7-3  
 Maintenance schedule for emergency engine..... 7-5  
 Maintenance schedule for general-use engine..... 7-8

**Chapter 8**

**PERIODIC INSPECTION AND MAINTENANCE PROCEDURES**

Engine body periodic inspection and maintenance..... 8-1  
 Visual inspection ..... 8-1

Inspecting pipe ..... 8-2  
 Inspecting and replacing high pressure fuel injection pipe and clamp seat..... 8-2  
 Inspecting and replacing low pressure fuel pipe, oil pipe and clip ..... 8-2  
 Inspecting V-belt and adjusting belt tension..... 8-3  
 Inspecting V-belt..... 8-3  
 Adjusting V-belt tension (Alternator side) ..... 8-3  
 Adjusting V-belt tension (Inter cooler water pump side)..... 8-3  
 Checking damper ..... 8-4  
 Visual checking of damper..... 8-4  
 Damper temperature management..... 8-4  
**Fuel system periodic inspection and maintenance ..... 8-5**  
 Draining water from the fuel tank ..... 8-5  
 Inspecting fuel control linkage ball joint..... 8-5  
 Changing the fuel filter ..... 8-6  
**Lubricating system periodic inspection and maintenance ..... 8-7**  
 Changing engine oil, oil filters and bypass oil filter ..... 8-7  
 Draining engine oil ..... 8-7  
 Changing oil filter and bypass oil filter..... 8-8  
 Refilling engine oil ..... 8-9  
 Checking engine oil for mixing of fuel and water 8-9  
**Cooling system periodic inspection and maintenance ..... 8-10**  
 Changing the coolant ..... 8-10  
 Draining the coolant ..... 8-10  
 Cleaning the cooling system ..... 8-11  
 Filling main cooling system with coolant ..... 8-12  
 Filling inter cooler cooling system with coolant 8-13  
 Cranking the engine after filling cooling system 8-13  
 Checking and cleaning the radiator fins..... 8-14  
**Inlet exhaust system periodic inspection and maintenance ..... 8-15**  
 Inspecting turbocharger ..... 8-15  
 Draining water from the exhaust muffler ..... 8-15  
 Cleaning, inspecting and replacing pre-cleaner 8-16  
 Cleaning, inspecting, and replacing the air cleaner element..... 8-17

Electrical system periodic inspection  
and maintenance ..... 8-18

Inspecting starters ..... 8-18

Inspecting alternator ..... 8-18

Inspecting the battery ..... 8-19

Inspecting battery electrolyte level ..... 8-19

Inspecting specific gravity of battery electrolyte ..... 8-19

**Chapter 9**

**LONG-TERM STORAGE**

Long-term storage ..... 9-1

Storing the engine in a non-operable  
condition for 3 months or more ..... 9-1

Preparation for storage ..... 9-1

Recommended rust-preventive oil and  
corrosion inhibitor ..... 9-1

Maintenance during storage ..... 9-1

Using the engine after storage ..... 9-2

Storing the engine in an operable  
condition for 3 months or more ..... 9-2

Operating the engine for maintenance ..... 9-2

**Chapter 10**

**TRANSPORTATION**

Lift the engine carefully ..... 10-1

**Chapter 11**

**TROUBLESHOOTING**

General precautions ..... 11-1

Contact your Mitsubishi dealer  
for repair service ..... 11-1

Considerations before work ..... 11-1

Cautions against contamination ..... 11-1

Cautions regarding parts handling ..... 11-1

Work safety ..... 11-1

How to troubleshoot ..... 11-2

The starter does not crank or cranks slowly,  
resulting in start failure ..... 11-2

The starter cranks,  
but the engine does not start ..... 11-2

**Other problems and countermeasures 11-3**

Engine output is low ..... 11-3

Exhaust smoke is white or blue ..... 11-3

Exhaust smoke is black or dark gray ..... 11-4

Fuel consumption is high ..... 11-4

Engine oil consumption is high ..... 11-4

Engine overheats ..... 11-5

Engine oil pressure is faulty ..... 11-5

When fuel has run out ..... 11-5

**Chapter 12**

**MAIN SPECIFICATIONS**

Main specifications ..... 12-1

## List of Illustrations

Fig. 1-1 Warning labels .....	1-8	Fig. 4-2 Recommended fuel according to ambient temperature .....	4-1
Fig. 2-1 Left view .....	2-1	Fig. 5-1 Recommended engine oil .....	5-2
Fig. 2-2 Right view .....	2-1	Fig. 5-2 Recommended oil viscosity according to ambient temperature .....	5-2
Fig. 2-3 Manual stop lever .....	2-2	Fig. 5-3 JUKOIL Cojera, New Mariner .....	5-2
Fig. 2-4 Stop solenoid .....	2-2	Fig. 5-4 Engine oil sampling tool set .....	5-5
Fig. 2-5 Revolution pickup .....	2-2	Fig. 6-1 GLASSY - LLC .....	6-1
Fig. 2-6 Oil filter alarm switch .....	2-3	Fig. 8-1 Inspecting and replacing high pressure fuel injection pipe and oil pipe .....	8-2
Fig. 2-7 Air cleaner indicator .....	2-3	Fig. 8-2 Inspecting and replacing low pressure fuel pipe .....	8-2
Fig. 2-8 Turning gear position (engine in operation) .....	2-4	Fig. 8-3 Adjusting V-belt tension (alternator side) .....	8-3
Fig. 2-9 Turning gear position (shaft pushed in) .....	2-4	Fig. 8-4 Adjusting V-belt tension (inter cooler water pump side) .....	8-3
Fig. 2-10 Turning gear position (turning shaft) .....	2-4	Fig. 8-5 Checking damper .....	8-4
Fig. 2-11 Tamper-proof equipment .....	2-5	Fig. 8-6 Damper temperature management .....	8-4
Fig. 3-1 How to use priming pump .....	3-2	Fig. 8-7 Draining water from fuel tank .....	8-5
Fig. 3-2 Bleeding fuel filter .....	3-2	Fig. 8-8 Inspecting fuel control linkage for looseness .....	8-5
Fig. 3-3 Fuel injection pump .....	3-3	Fig. 8-9 Removing fuel control linkage .....	8-5
Fig. 3-4 Priming pump cap tightening method .....	3-3	Fig. 8-10 Changing fuel filters .....	8-6
Fig. 3-5 Priming pump cap packing .....	3-3	Fig. 8-11 Fuel filter .....	8-6
Fig. 3-6 Oil filler and oil level gauge .....	3-4	Fig. 8-12 Oil filters and bypass oil filter .....	8-8
Fig. 3-7 Pouring engine oil on valve mechanisms and chamber .....	3-4	Fig. 8-13 Oil filter .....	8-8
Fig. 3-8 Coolant drain cock - engine body .....	3-5	Fig. 8-14 Oil filler and oil level gauge .....	8-9
Fig. 3-9 Coolant drain cock - water pump .....	3-5	Fig. 8-15 Coolant drain cock - inter cooler .....	8-10
Fig. 3-10 Air vent plug - main cooling system .....	3-5	Fig. 8-16 Radiator cap .....	8-10
Fig. 3-11 Radiator coolant level .....	3-5	Fig. 8-17 Coolant drain cock - engine body .....	8-10
Fig. 3-12 Coolant drain cock - inter cooler .....	3-6	Fig. 8-18 Coolant drain cock - water pump .....	8-10
Fig. 3-13 Coolant drain cock - inter cooler water pump .....	3-6	Fig. 8-19 Coolant drain cock - inter cooler water pump .....	8-10
Fig. 3-14 Air vent cock and plug - inter cooler cooling system .....	3-6	Fig. 8-20 Coolant drain cock - engine body .....	8-12
Fig. 3-15 Radiator coolant level .....	3-6	Fig. 8-21 Coolant drain cock - water pump .....	8-12
Fig. 3-16 Checking battery electrolyte level .....	3-7	Fig. 8-22 Air vent plug - main cooling system .....	8-12
Fig. 3-17 Checking specific gravity of electrolyte .....	3-7	Fig. 8-23 Radiator coolant level .....	8-12
Fig. 3-18 Oil filler and oil level gauge .....	3-10	Fig. 8-24 Coolant drain cock - inter cooler .....	8-13
Fig. 3-19 Radiator cap .....	3-11	Fig. 8-25 Coolant drain cock - inter cooler water pump .....	8-13
Fig. 3-20 Radiator coolant level .....	3-11	Fig. 8-26 Air vent cock and plug - inter cooler cooling system .....	8-13
Fig. 3-21 Reserve tank coolant level .....	3-11	Fig. 8-27 Radiator coolant level .....	8-13
Fig. 3-22 Checking fuel control link .....	3-11		
Fig. 3-23 Checking air cleaner .....	3-12		
Fig. 3-24 Manual stop lever .....	3-15		

Fig. 8-28Cleaning radiator fins..... 8-14  
 Fig. 8-29Checking turbocharger ..... 8-15  
 Fig. 8-30Draining water from exhaust muffler..... 8-15  
 Fig. 8-31Cleaning pre-cleaner ..... 8-16  
 Fig. 8-32Removing air cleaner element..... 8-17  
 Fig. 8-33Cleaning air cleaner element..... 8-17  
 Fig. 8-34Checking air cleaner element..... 8-17  
 Fig. 8-35Air cleaner indicator..... 8-17  
 Fig. 8-36Checking starter ..... 8-18  
 Fig. 8-37Inspecting alternator ..... 8-18  
 Fig. 8-38Checking battery electrolyte level..... 8-19  
 Fig. 8-39Checking specific gravity of electrolyte..... 8-19  
 Fig. 10-1Hangers for lifting ..... 10-1  
 Fig. 10-2The center of gravity for the engine..... 10-1

**List of Tables**

Table 3-1 Specific gravity of electrolyte.....3-7  
 Table 3-2 Standard values at rated speed.....3-14  
 Table 4-1 Recommended fuel .....4-1  
 Table 4-2 Recommended and limit values of  
 fuel property.....4-2  
 Table 5-1 Service limit for engine oil properties.....5-4  
 Table 5-2 Engine oil sampling tool sets .....5-5  
 Table 6-1 Water quality standards.....6-1  
 Table 6-2 Recommended LLC concentration  
 (for reference only) .....6-2  
 Table 7-1 Maintenance schedule  
 for regular use engine.....7-3  
 Table 7-2 Maintenance schedule  
 for emergency engine.....7-5  
 Table 7-3 Maintenance schedule  
 for general-use engine.....7-8  
 Table 8-1 Thermo label for temperature  
 management.....8-4  
 Table 8-2 Specific gravity of electrolyte .....8-19  
 Table 9-1 Recommended rust-preventive  
 oil and corrosion inhibitor.....9-1  
 Table 11-1 The Starter Does Not Crank or Cranks Slowly,  
 Resulting in Start Failure .....11-2  
 Table 11-2 The Starter Cranks, But the Engine  
 Does Not Start.....11-2  
 Table 11-3 Engine Output is Low .....11-3  
 Table 11-4 Exhaust Smoke is White or Blue .....11-3  
 Table 11-5 Exhaust Smoke is Black or Dark Gray ..11-4  
 Table 11-6 Fuel Consumption is High .....11-4  
 Table 11-7 Engine Oil Consumption is High.....11-4  
 Table 11-8 Engine Overheats.....11-5  
 Table 11-9 Engine Oil Pressure is Faulty .....11-5  
 Table 12-1 Main specifications .....12-1

# Chapter 1 BASIC SAFETY PRECAUTIONS

## WARNING

### Fire and explosion

#### Keep flames away

Store fuel and engine oil in a well ventilated designated area.

Make sure that the caps of fuel and engine oil containers are tightly closed.

Do not use flames, do not smoke, and do not work near a heater or other fire hazard where fuel or oil is handled or when cleaning solvent is being used for washing parts.

Wipe off spilled fuel, oil and LLC immediately and thoroughly. Spilled fuel, oil and LLC may ignite and cause a fire.



#### Keep engine surrounding area tidy and clean

Do not leave combustible or explosive materials, such as fuel, engine oil and LLC, near the engine. Such substances can cause fire or explosion.

Remove dust, dirt and other foreign materials accumulated on the engine and surrounding parts thoroughly. Such materials can cause fire or the engine to overheat. In particular, clean the top surface of the battery thoroughly. Dust can cause a short-circuit.

Always operate the engine at a position at least 1 m [3.28 ft.] away from buildings and other equipment to prevent possible fire caused by engine heat.

#### Avoid accessing crankcase until engine cools

Do not attempt to open the side cover of the crankcase before the engine cools down. Wait at least 10 minutes after stopping the engine.

Opening the cover when the engine is hot allows fresh air to flow into the crankcase, which can cause oil mist to ignite and explode.

#### Care for fuel, oil and exhaust gas leakage

If any fuel, oil or exhaust gas leakage is found, immediately take corrective measures to stop it.

Such leakages, if left uncorrected, can cause fuel or engine oil to reach hot engine surfaces or hot exhaust gas to contact flammable materials, possibly leading to personal injury and/or damage to equipment.

#### Use explosion-proof lighting apparatus

When inspecting fuel, engine oil, coolant, battery electrolyte, etc., use a flameproof light. An ordinary light, if accidentally broken, may ignite and cause an explosion.

#### Prevent electrical wires from short-circuiting

Avoid inspecting or servicing the electrical system with the ground cable connected to the battery. Otherwise, a fire could result from short-circuiting. Be sure to disconnect the battery cable from the negative (-) terminal before beginning with the work procedure.

Short-circuits, possibly resulting in fire, may be caused by a loose terminal or damaged cable/wire. Inspect the terminals, cables and wires, and repair or replace the faulty parts before beginning with the service procedure.

#### Keep fire extinguishers and a first-aid kit handy

Keep fire extinguishers handy, and become familiar with their usage.

Keep a first-aid kit at the designated place where it is easily accessible by anyone at any time.

Establish response procedures to follow in the event of fire or accident. Provide an emergency evacuation route and contact points and means of communication in case of emergency.



**WARNING**

## Stay clear of all rotating and moving parts

### Install protective covers around rotating parts

Make sure the protective covers of the engine are correctly installed. Repair any damaged or loose covers.

Never remove the protective covers of rotating parts during operation.

When the engine is coupled to the radiator or other equipment, install protective covers around the exposed connecting belt and coupling.

Never remove protective covers.



### Check the work area for safety

Before starting the engine, check to make sure no one is near the engine and tools are not left on or near the engine. Verbally notify persons within the immediate area when starting the engine.

When the starter device is posted with a sign that prohibits startup operation, do not operate the engine.

### Stay clear of moving parts during engine running

Do not approach rotating or sliding parts of the engine when the engine is in operation.

Keep objects likely to be caught by rotating parts away from such parts.

If any part of the clothing or outfitting is caught by a rotating part, serious bodily injuries could result.



### Lockout and Tagout

Be sure to lockout and tagout before starting inspection and maintenance.

Lockout and tagout are effective methods of cutting off machines and equipment from energy sources.

To accomplish the lockout/tagout, remove the starter switch key, set the battery switch to OFF and attach a "Do Not Run" or similar caution tag to the starter switch. The starter switch key must be kept by the person who performs inspection and maintenance during the work.

In the case of pneumatic starting type, close the main valve of the air tank and post a tag saying "Do Not Open the Valve" or the like.

### Keep engine stopped during servicing

Be sure to stop the engine before proceeding to inspection and service procedure. Never attempt to make adjustments on the engine parts while the engine is running. Rotating parts such as belt can entangle your body and cause serious injuries.

### Always restore engine turning tools after use

Do not forget to remove the tools which have been used for turning the engine during inspection or servicing, after the procedure is finished. Remember also that the turning gear must be returned to the operating condition before starting the engine.

Starting the engine with the turning tools inserted or with the turning gear in engagement can lead to not only engine damage but also personal injuries.

**WARNING****Be careful of burns****Do not touch the engine during or immediately after operation**

To avoid burns, do not touch the engine during or immediately after operation.

To conduct maintenance and inspection work, wait until the engine has cooled sufficiently by checking the temperature gauge.

**Do not open the radiator filler cap when the engine is hot**

Never open the radiator filler cap while the engine is running or immediately after the engine is stopped.

The engine coolant is hot during engine operation and immediately after operation.

If the radiator filler cap is opened when the coolant is at operating temperature, steam and hot coolant may blow out and result in burns.

When opening the cap, stop the engine and allow the coolant temperature to lower sufficiently. Cover the cap with a cloth or use thick rubber glove, and then slowly open the cap. When closing the cap, be sure to tighten securely.

**Add coolant only after the coolant temperature dropped**

Do not add coolant immediately after the engine stops. Wait until the coolant temperature lowers sufficiently to avoid a risk of burns.

**Never remove heat shields**

The exhaust system, which becomes extremely hot while the engine is operating, is provided with various heat shields. Do not remove these heat shields. If any of these heat shields have been removed owing to unavoidable circumstances during the work, be sure to restore them after the work is completed.

**WARNING****Be careful of exhaust fume poisoning****Operate the engine in a well-ventilated area**

If the engine is installed in an enclosed area, and the exhaust gas is ducted outside, ensure that there is no exhaust gas leak from duct joints.

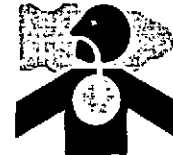

When the engine is used for a mobile generator set, never run the engine in an enclosed area (such as a warehouse and tunnel), or near the wall, structure, or equipment where the ventilation is bad. When the engine must be operated in an enclosed area, provide sufficient ventilation, and discharge exhaust gas to the outside. Make sure the exhaust gas is not discharged directly to surrounding buildings, plants or living passersby.

Exhaust gas from the engine contains carbon monoxide and other harmful substances. Operating the engine in an ill-ventilated area can produce gas poisoning.

**WARNING****Protect ears from noise****Wear ear plugs**

Always wear ear plugs when entering the machine room (engine room). Combustion sound and mechanical noise generated by the engine can cause hearing problems.



**WARNING****Be careful to prevent the engine from falling****Lift engine carefully**

To lift the engine, always use a correct wire rope capable of withstanding the engine weight.

Attach the wire rope to the lifting hangers provided on the engine using a correct sling.

During lifting process, keep the engine in a well-balanced position by taking the center of gravity of the engine into consideration.

Keep the angle formed by slings attached to hangers within 60 degrees. If the angle exceeds this limit, excessive load is imposed on the hangers and this may damage the hangers and result in a serious accident.

If the wire rope contacts the engine directly, place a cloth or other soft padding to avoid damage to the engine and wire rope.

**Do not climb onto the engine**

Do not climb onto the engine, nor step on any engine parts located on the lateral sides.

To work on parts located on the upper section of engine, use a ladder, stool, etc., that was firmly secured.

Climbing on the engine may not only damage engine parts but also cause parts to fall off and result in personal injuries.

**Always prepare stable scaffold**

When working on the upper part of the engine and other hard-to-reach places, use a stable work platform.

Standing on a decrepit stool or parts box may result in personal injury. Do not place any unnecessary objects on a work platform.

**CAUTION****Be careful when handling fuel, engine oil and LLC****Use only specified fuel, engine oil and long-life coolant (LLC)**

Use fuel, oil and LLC specified in this manual, and handle them carefully.

Use of any other fuel, oil or LLC, or improper handling may cause various engine problems and malfunctions.

Obtain the Material Safety Data Sheet (MSDS) issued by the fuel, oil and LLC suppliers, and follow the directions in the MSDSs for proper handling.

**Handle LLC (long life coolant) carefully**

When handling LLC, always wear rubber gloves and a protective face mask. If LLC or cooling water containing LLC comes into contact with your skin or eyes, or if it is swallowed, you would suffer from inflammation, irritation or poisoning.

Should LLC be accidentally swallowed, induce vomiting immediately and seek medical attention. Should LLC enter your eyes, flush them immediately with plenty of water and seek medical attention. If LLC splashes onto your skin or clothing, wash it away immediately with plenty of water.

Keep flames away from LLC. The LLC can catch flames, causing a fire.

**Proper disposal of waste oil and coolant (LLC)**

Do not discharge waste engine oil or coolant into sewerage, river, lake or other similar places. Such a way of disposal is strictly prohibited by laws and regulations.

Dispose of waste oil, coolant and other environmentally hazardous waste in accordance with the applicable law and regulations, or consult a Mitsubishi dealer.

**CAUTION****Service battery****Handle the battery correctly**

- Never use flames or allow sparks to generate near the battery. The battery releases flammable hydrogen gas and oxygen gas. Any flames or sparks in the vicinity could cause an explosion.
- Do not use the battery the fluid level of which is lowered below the lower limit line. Sustained use of the battery could result in an explosion.
- Do not short the battery terminals with a tool or other metal object.
- When disconnecting battery cables, always remove the cable from the negative (-) terminal first. When reconnecting the cables, attach the cable to the positive (+) terminal first.
- Charge the battery in a well-ventilated area, with all filling hole plugs removed.
- Make sure the cable clamps are securely installed on the battery terminals. A loose cable clamp can cause sparks that may result in an explosion.
- Before servicing electrical components or conducting electric welding, set the battery switch to the [Open/OFF] position or disconnect the cable from the negative (-) battery terminal to cut off the electrical current.
- Electrolyte (battery fluid) contains dilute sulfuric acid. Careless handling of the battery can lead to the loss of sight and/or skin burns. Also, keep the battery fluid off the mouth.
- Wear protective goggles and rubber gloves when working with the battery (when adding water, charging, etc.).
- If electrolyte is spilled onto the skin or clothing, immediately wash it away with lots of water. Use soap to thoroughly clean.
- The battery fluid can cause blindness if splashing into the eyes. If it gets into the eyes, immediately flush it away with plenty of clean fresh water, and seek immediate medical attention.
- If the battery fluid is accidentally swallowed, gargle with plenty of water, then drink lots of water, and seek immediate medical attention.

**CAUTION****When an abnormality occurs****Do not add coolant immediately after a sudden stop due to overheating**

If the engine stops suddenly or if you have no choice but to stop the engine suddenly due to overheating, do not add coolant immediately.

Adding water while the engine is hot can damage parts such as cylinder heads due to a sudden drop of temperature. Add coolant gradually after the engine has completely cooled.

**Avoid immediate restart after abnormal stop**

If the engine stops abnormally, do not restart the engine immediately. If the engine stops with an alarm, check and remedy the cause of the problem before restarting. Sustained use of the engine without any remedy could result in serious engine problems.

**Avoid continuous engine operation at low oil pressure**

If an abnormal engine oil pressure drop is indicated, stop the engine immediately, and inspect the lubrication system to locate the cause. Continuous engine operation with low oil pressure could cause bearings and other parts to seize.

**If the fan belt breaks, stop the engine immediately**

If the fan belt breaks, stop the engine immediately. Continuous engine operation with the broken fan belt could cause the engine to overheat and thereby the coolant to boil into steam, which may gush out from the reserve tank or radiator, and cause personal injuries.

**CAUTION**

## Other cautions

### Never modify engine

Unauthorized modification of the engine will void the manufacturer's warranty.

Modification of the engine may not only cause engine damage but also produce personal injuries.

### Never break the seals

To ensure proper engine operation, the fuel control links are sealed to prevent accidental change of the injection volume and rotation speed settings. Operating the engine without these seals in place can cause the problems described below, and also invalidates the warranty.

- Rapid wear of sliding and rotating parts
- Engine damage such as seizing of engine parts
- Considerably increased consumption of fuel and lubricating oil
- Degradation of engine performance due to improper balance between fuel injection volume and governor operation or overrunning of the engine which could result in a serious accident.

### Perform all specified pre-operation inspections and periodic inspections

Conduct the pre-operation inspections and periodic inspections as described in this manual.

Failure to conduct the specified inspections may cause various engine problems, damage to parts, and serious accidents.

### Break-in the engine

To break in new engines or overhauled engines, operate the engine at a speed lower than the rated speed in a light load condition during the first 50 hours of operation.

Operating new engines or overhauled engines in a severe condition during the break-in period shortens the service life of the engine.

### Warm up the engine before use

When starting auxiliary devices, such as a water heater and an engine oil priming pump, are not installed, let the engine idle for 5 to 10 minutes before operating the engine for work. Warm-up operation circulates lubricants in the engine and contributes to a longer service life and economical operation. Do not conduct warm-up operation for prolonged period of time.

Prolonged warm-up operation causes carbon build-up in the cylinders that leads to incomplete combustion.

### Never operate the engine in an overloaded condition

If the engine shows an overloaded condition such as black exhaust smoke, reduce the load immediately to operate the engine at an appropriate output and load. Overloading causes not only high fuel consumption but also excessive carbon deposits inside the engine. Carbon deposits cause various problems and will shorten the service life of the engine.

### Conduct cooling operation before stopping the engine

Before stopping the engine, let it idle at low speed for 5 to 6 minutes to cool down.

Stopping the engine immediately after high-load operation will cause engine parts to heat up and shorten the service life of the engine.

During cooling operation, check the engine for abnormalities.

### Protection of the engine against water entry

Do not allow rainwater, etc. to enter the engine through the air inlet or exhaust openings.

Do not wash the engine while it is operating. Cleaning fluid (water) can be sucked into the engine.

Starting the engine with water inside the combustion chambers can cause the water hammer action which may result in internal engine damage and serious accidents.

## Properly maintain the air cleaner and pre-cleaner

The major cause of abnormal wear on engine parts is dust from intake air. Worn parts produce many problems such as an increase of oil consumption, decrease of output, and starting difficulties. For effective removal of dust from intake air, maintain the air cleaner or pre-cleaner according to the following instructions.

- Do not maintain the air cleaner/pre-cleaner while the engine is operating. Operating the engine without the air cleaner/pre-cleaner allows foreign matters to enter the turbocharger and could result in serious damage.
- Remove the air cleaner/pre-cleaner slowly to prevent dust accumulated on the element from falling off. After removing the air cleaner or pre-cleaner, immediately cover the opening (inlet port of air cleaner; port in body for pre-cleaner) with plastic sheet or similar means to prevent dust from entering the engine.
- Air cleaners equipped with a dust indicator will issue an alarm if the element gets clogged. Service the cleaner as soon as possible if an alarm is issued.

## Observe safety rules at work site

Observe the safety rules established at your workplace when operating and maintaining the engine.

Do not operate the engine if you are feeling ill.

Operation of the engine with reduced awareness may cause improper operation that could result in accidents. In such a case, inform your supervisor of your condition.

When working in a team of two or more people, use specified hand signals to communicate among workers.

## Work clothing and protective gear

Wear a hardhat, face shield, safety shoes, dust mask, gloves and other protective gear as needed.

When handling compressed air, wear safety goggles, a hardhat, gloves and other necessary protective gear. Works without wearing proper protective gear could result in serious injuries.

## Use of tools optimum for each work

Always keep in mind to select most appropriate tools for the work to be performed and use them correctly. If tools are damaged, replace them with new tools.

## Do not operate the starter for a prolonged time

Do not operate the starter for more than 10 seconds at a time even if the engine does not start. Wait for at least 30 seconds before next engine cranking. Continuous operation of the starter will drain the battery power and cause seizing of the starter.

## Do not turn off the battery switch during operation

If the battery switch is turned OFF when the engine is running, not only various meters will stop working but also the alternator may have its diode and transistor deteriorated.

## Cautionary instructions for transporting the engine

When transporting the engine on a truck, consider the engine weight, width and height to ensure safety.

Abide by road traffic law, road vehicles act, vehicle restriction ordinance and other pertinent laws.

**CAUTION**

## About warning labels

### Maintenance of warning labels

Make sure all warning/caution labels are legible.

Clean or replace the warning/caution labels the description and/or illustration of which cannot be seen clearly. For cleaning the warning/caution labels, use a cloth, water and soap. Do not use cleaning solvents, gasoline or other chemicals to prevent the letters from getting blurred or the adhesion from being weakened.

Replace damaged or fractured labels with new ones.

If any engine part on which a warning label is attached is replaced with a new one, attach a new identical warning label to the new part.

To obtain replacement warning labels, contact a Mitsubishi dealer.

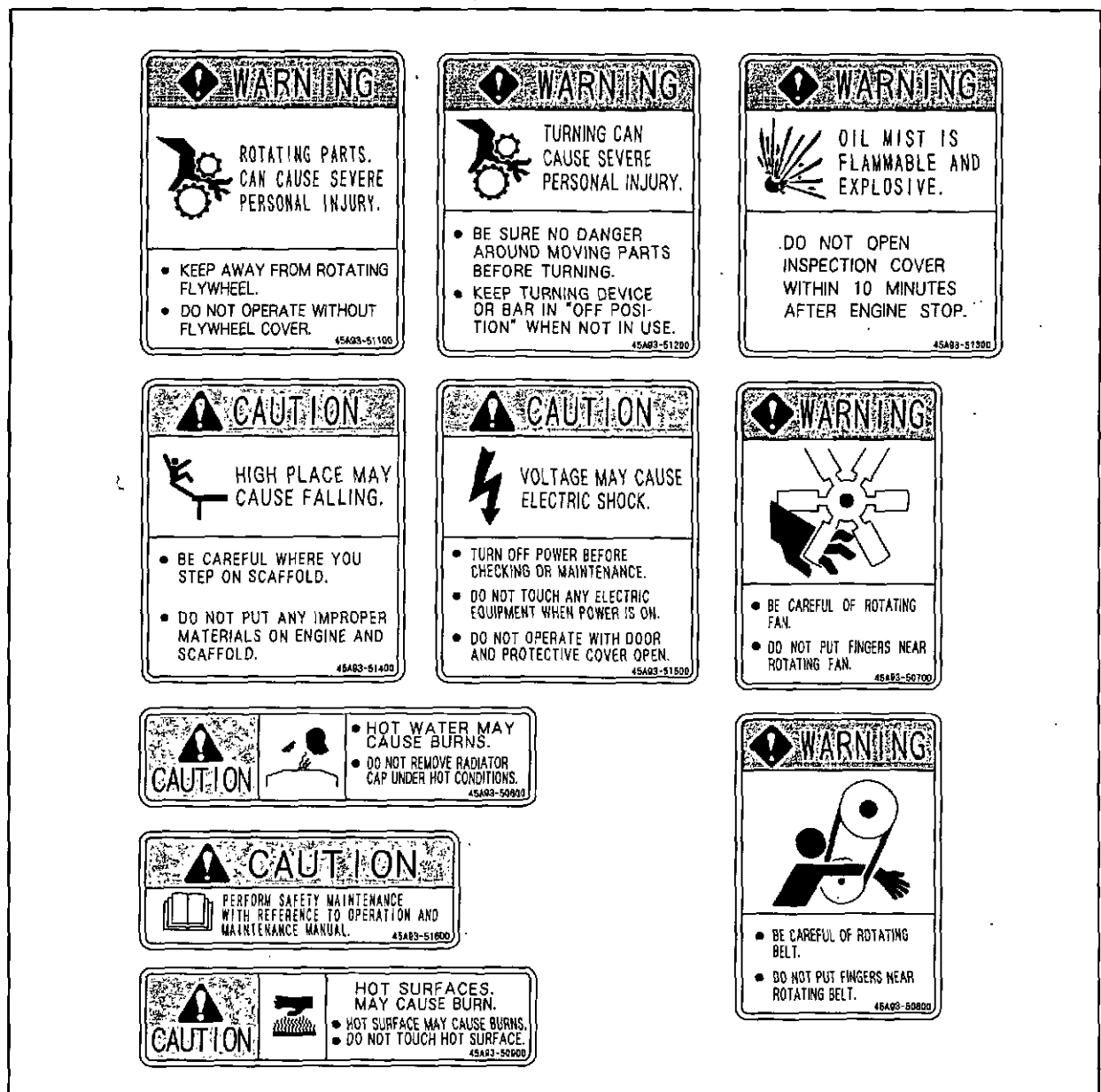

Fig. 1-1 Warning labels

# Chapter 2 NAME OF PARTS

## Engine external view

The external views shown below are the standard type of engine.  
The external view changes based on the type and attachments.

### Left view

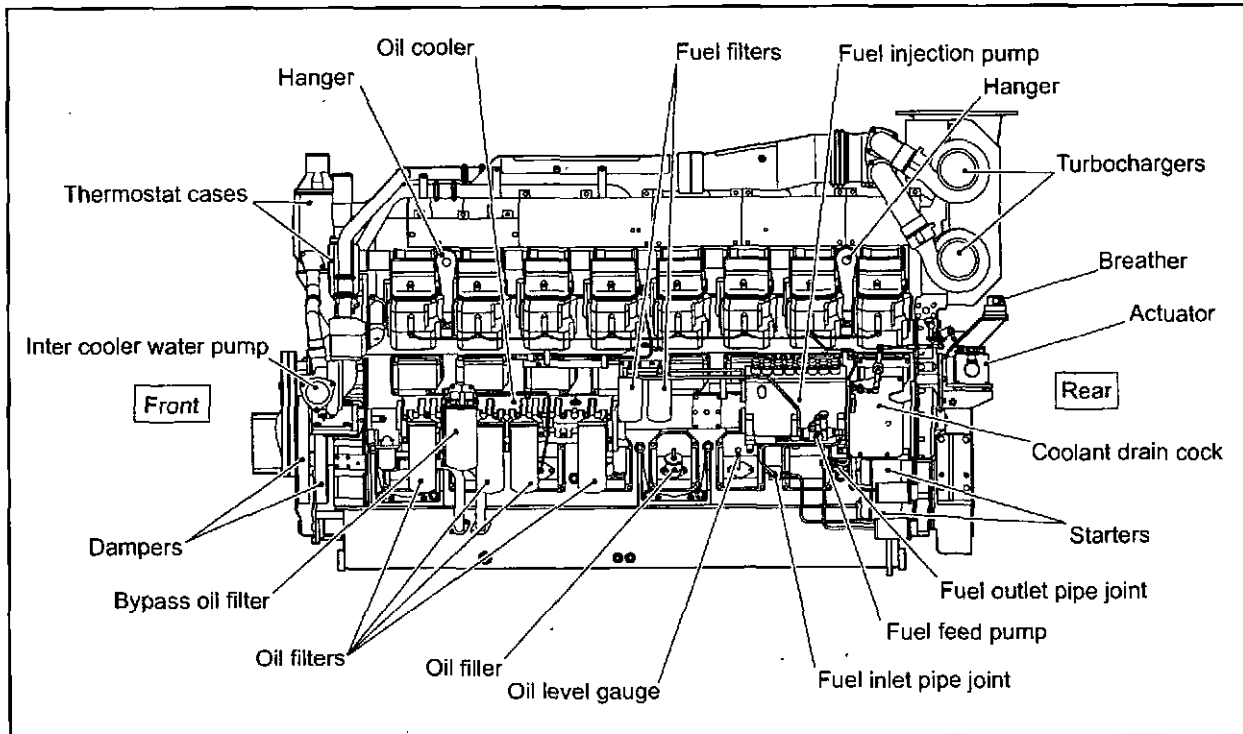

Fig. 2-1 Left view

### Right view

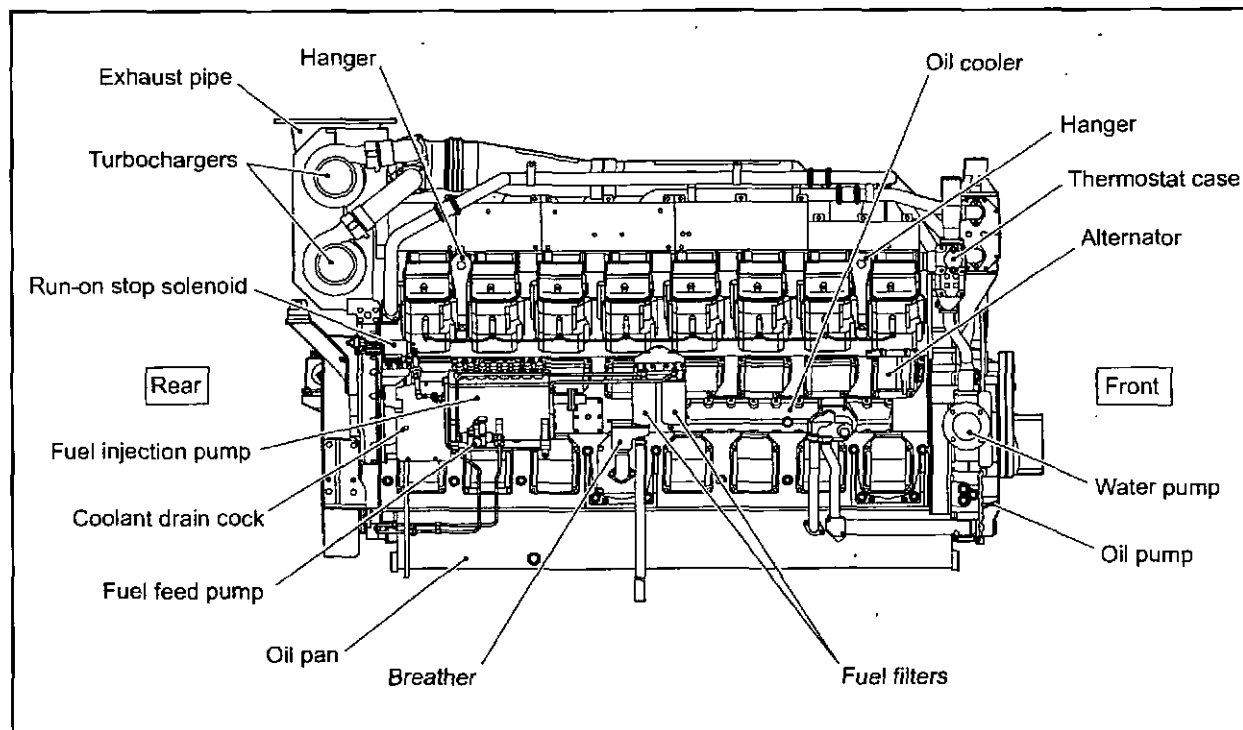

Fig. 2-2 Right view

## Equipment and instrument

### Manual stop lever

Use the manual stop lever to shut down the engine in the event of an emergency. If the starter switch fails to stop engine operation, use the manual stop lever.

When the manual stop lever, which is located in the fuel control link, is moved in the [STOP] direction, the engine stops.

If the engine continues to operate even after the manual stop lever is moved in the STOP position, cut off the fuel supply to stop the engine.

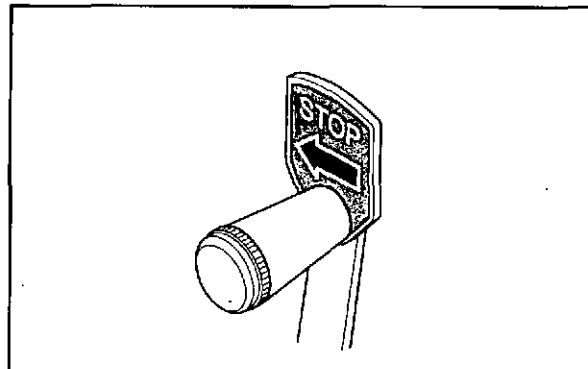

Fig. 2-3 Manual stop lever

### Stop solenoid

The stop solenoid operates for normal shutdown of engine operation. The stop solenoid moves the rack of the fuel injection pump to stop fuel injection, thus shutting down the engine operation.

The "RUN-ON" type solenoid sets the starter switch to the "OFF" position by de-energizing the stop solenoid and pushing the rod out by internal spring power which makes the rack of the fuel injection pump move to the non-injection direction.

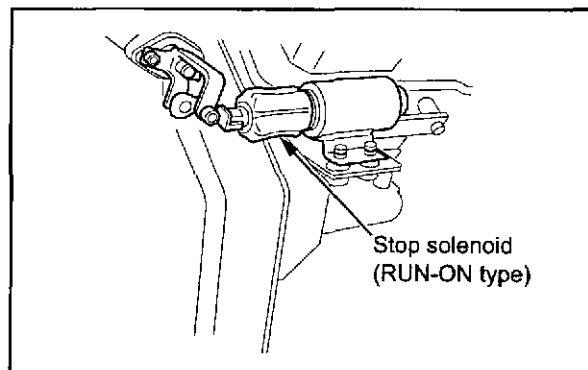

Fig. 2-4 Stop solenoid

## Instruments

This section describes the devices which transmit signals to the instruments that are necessary for operation. Be sure to understand the function of each device before proceeding with operation.

### Revolution pickup

The revolution pickup is installed in the timing gear case to detect the engine speed.

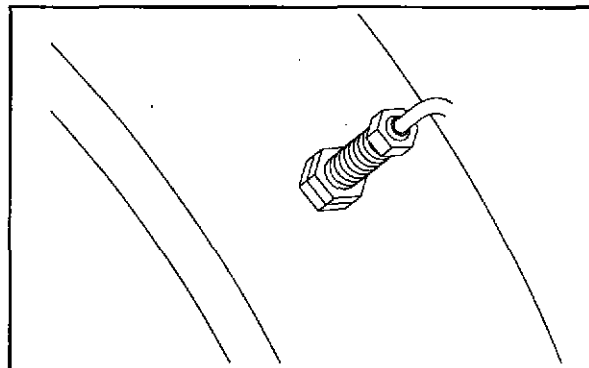

Fig. 2-5 Revolution pickup

## Engine protection devices

The engine protection devices activate an alarm when an abnormality occurs in the engine to protect the engine against serious problems and accidents. When a protection device is activated, stop the engine, inspect the cause of abnormality, and take corrective measures.

If the cause is unidentified, contact your local Mitsubishi dealer.

Protection devices on the engine, their types (set value) and shapes vary depending on the specifications. The functions of typical protection devices are described below:

### Oil filter alarm switch

The oil filter alarm switch activates the alarm system when the oil filter is clogged.

The switch is activated when the difference of pressures measured at before and after oil filter reaches the specified value.

When the alarm sign is given, immediately replace the oil filter with a new filter. Also renew the engine oil.

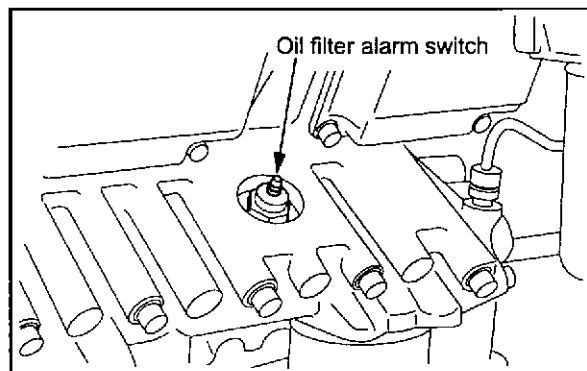

Fig. 2-6 Oil filter alarm switch

### Air cleaner indicator

When the air cleaner element is clogged and the difference of pressures measured at before and after air cleaner becomes abnormally high, the air cleaner indicator shows a red sign.

Immediately clean the element or replace with a new element when the red sign appears.

After cleaning or replacing the air cleaner, press the button on the top of the indicator to reset the alarm signal. When serving the air cleaner, use care to prevent dust from entering the air cleaner. Also do not damage nor distort the element.

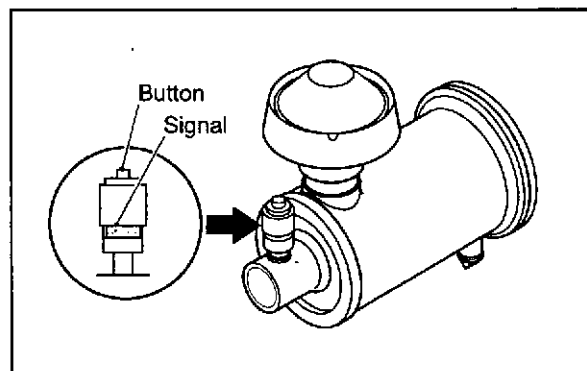

Fig. 2-7 Air cleaner indicator

## Using turning gear

**WARNING**

Before starting the engine, make sure that the turning gear is pulled out in the original position. Starting the engine with the turning gear pushed in not only damages the ring gear but also may result in personal injury.

1. Loosen the two bolts, and remove the plate from the shaft groove.

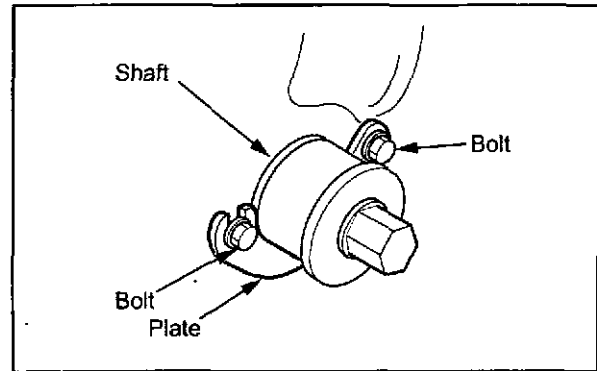

Fig. 2-8 Turning gear position (engine in operation)

2. Push in the shaft fully to engage it with the ring gear.

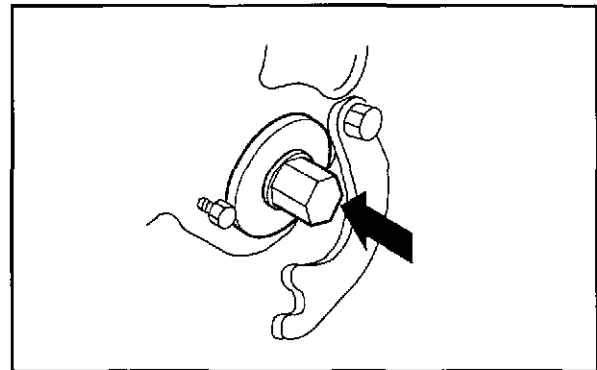

Fig. 2-9 Turning gear position (shaft pushed in)

3. Using a socket wrench and a ratchet handle, turn the shaft.
4. After turning, pull out the shaft, insert the plate in the shaft groove, and tighten the bolts.

**CAUTION**

Make sure the plate is securely installed in the shaft groove.

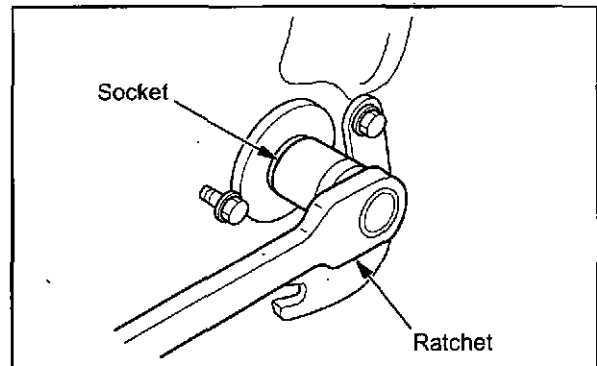

Fig. 2-10 Turning gear position (turning shaft)

## Cautions regarding exhaust emission control

Do not modify any part of the engine. Alteration or adjustment of parts connected with the exhaust emission control performance not only adversely affects the engine performance but also results in non-compliance with the EPA regulations. It also invalidates the manufacturer's warranty. The following parts in the engine and the fuel injection timing are specially designed to ensure proper exhaust emission control.

- Turbocharger
- Cylinder head
- Camshaft
- Piston
- Fuel injection nozzle
- Fuel injection pump
- Tamper-proof equipment
- Inter cooler
- Engine controller
- Inter cooler water pump

Use proper radiator for inter cooler which satisfies the service condition specified in the specification.

If any of the above parts is removed and replaced with a nonconforming product, the engine will fail to comply with the EPA regulations and provide poor emission control performance. The exhaust emission control system of the engine should be serviced only by an authorized Mitsubishi dealer.

To maintain the exhaust emission control performance, be sure to conduct maintenance according to the direction in this manual.

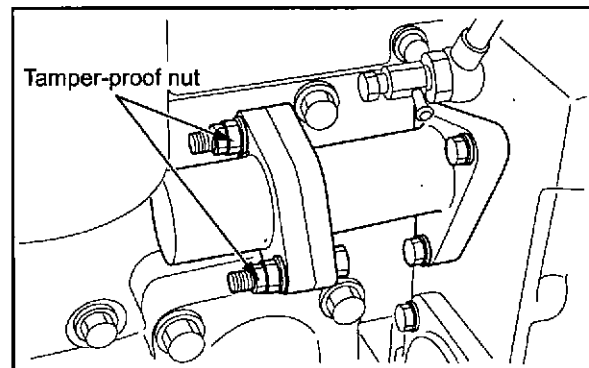

Fig. 2-11 Tamper-proof equipment

---

# Chapter 3 OPERATION

## Preparation for operating new or overhauled engine

Before proceeding with operation of a new or overhauled engine, conduct the inspections described in this section. For second operation onward, follow the instructions described in the "Normal engine operation" (3-9).

### Preparation of fuel system

---

**CAUTION**

---

When handling fuel, do not use open flames or heaters. Wipe off any spilled fuel completely. Spilled fuel is highly flammable and can cause a fire.

---

**CAUTION**

---

Do not remove the strainer when filling the fuel tank. Use the fuel specified in "FUEL" (4-1).

---

### Filling fuel tank

1. Make sure the insides of the fuel tank and fuel pipes are thoroughly clean.
2. Fill fuel tank with fuel.
3. Remove the fuel feed pipe and the drain plug from the fuel inlet of engine, and check the discharged fuel for foreign particles such as dust.
4. Reinstall the drain plug and the fuel feed pipe.
5. Refill fuel tank until fuel level gauge indicates "FULL".

## Bleeding the fuel system

### **WARNING**

When fuel overflows from the air vent plug, wipe thoroughly with a cloth. Spilled fuel is a fire hazard. After bleeding, lock the priming pump cap securely. If the cap is not locked tightly, the priming pump can be damaged, causing a fuel leak that could lead to a fire. To lock the priming pump cap, follow the procedure described on the following page.

### **CAUTION**

Do not close all air vent plugs before locking the priming pump cap, as the priming pump cap will not return to the original position due to internal pressure.

Bleed air at fuel filters and then at the fuel injection pump. Bleeding from upstream to downstream is effective for this job.

## Bleeding the fuel filter

### **CAUTION**

If air vent plugs, the thread portion of the bracket, or sealing washers are damaged, replace them with new ones.

1. Loosen the air vent plug on the fuel filter intake for the left bank cylinder about 1.5 turns.
2. Turn the priming pump cap counterclockwise to unlock, and prime the fuel filter.
3. When the fuel from the air vent plug becomes free from air bubbles, stop priming and tighten the air vent plug to the specified torque.
4. Loosen the air vent plug on the fuel filter outlet for the left bank cylinder about 1.5 turns, and bleed as described above.
5. Bleed the fuel filters for the right bank cylinders as described above.

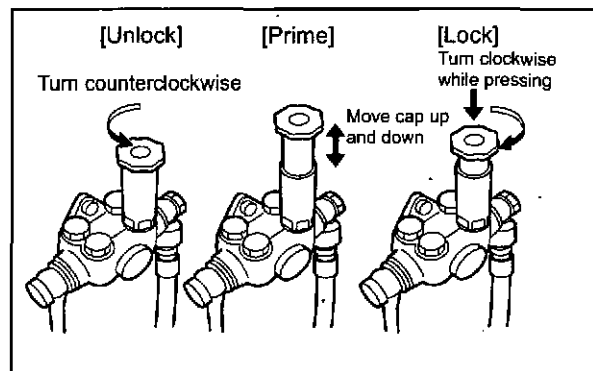

Fig. 3-1 How to use priming pump

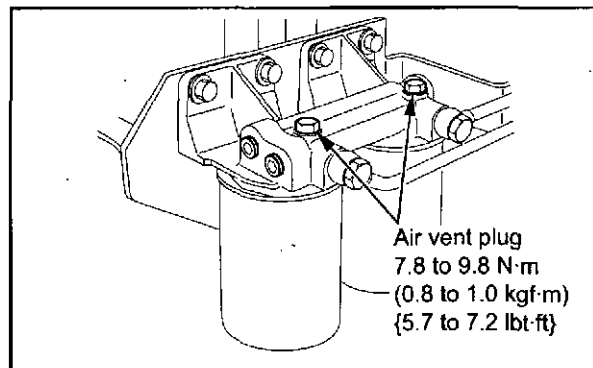

Fig. 3-2 Bleeding fuel filter

### Fuel injection pump

1. Loosen the air vent plug on the fuel injection pump about 1.5 turns.
2. Move the priming pump cap up and down until the fuel flow from the air vent plug is free from air bubbles. Push and turn the priming pump cap clockwise to lock in the original position when the fuel flows is free from bubbles.
3. Tighten the air vent plug on the fuel injection pump.
4. Repeat the same procedure to fuel injection pump on the other side.

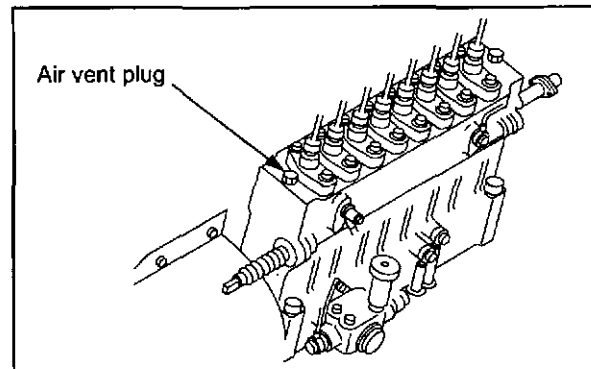

Fig. 3-3 Fuel injection pump

### Priming pump cap tightening method

**CAUTION**  
 Never fail to tighten the priming pump cap to the specified angle ( $90 \pm 10^\circ$ ). If the priming pump cap is not firmly tightened, internal thread will be worn due to engine vibration, resulting in sudden ejection of the cap to cause fuel flow-out. Or if the priming pump cap is excessively tightened (turned  $120^\circ$  or more), the head of the priming pump can be damaged.

1. Finger tighten the priming pump cap.

Note: Mark this position on the cap to facilitate the following steps:

2. Tighten the cap further by  $90 \pm 10^\circ$  with a wrench.

Note: Note that the cap will be tightened by 70 to  $90^\circ$  with full force of hand at the above step 1.

3. Make sure the head packing is not protruding.

Note: If the head packing is protruding, loosen the priming pump cap. Check the packing for damage and retighten the cap.

If the packing is damaged, consult your Mitsubishi dealer, as the priming pump needs to be changed.

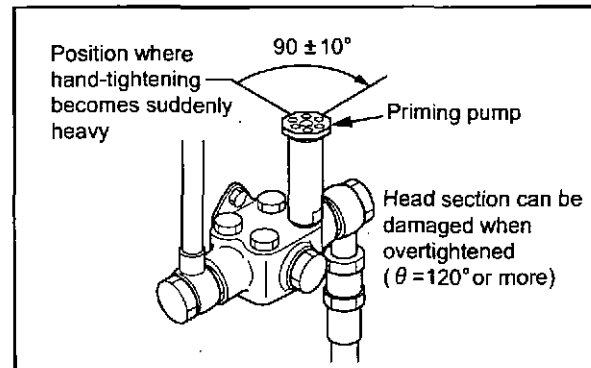

Fig. 3-4 Priming pump cap tightening method

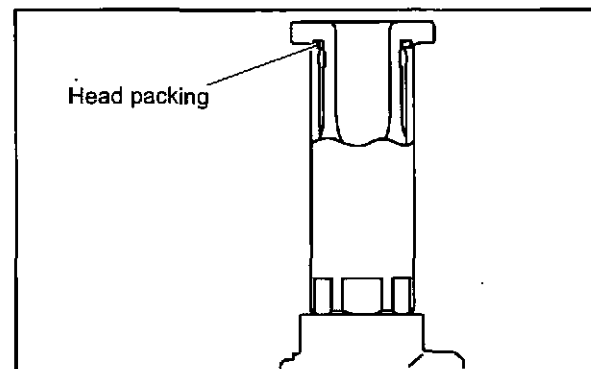

Fig. 3-5 Priming pump cap packing

## Preparation of lubrication system

### Filling engine with engine oil

1. Remove the cap from the oil filler.
2. Fill engine with the specified engine oil to the specified level.

Note: For engine oil, refer to "ENGINE OIL" (5-1).

For engine oil capacity, refer to "MAIN SPECIFICATIONS" (12-1).

3. Remove the rocker covers of all the cylinders. Lubricate the valve mechanisms and fill the camshaft oil bath with engine oil from the cylinder head.

Oil capacity per cylinder: 800cm<sup>3</sup>

4. Reinstall the rocker covers.
5. Check the oil level of oil pan as described below:
  - Pull out the oil level gauge and wipe it clean with a cloth.
  - Reinsert the oil level gauge all the way in the oil level guide and then pull it out again.
  - The oil level is correct if it is between maximum and minimum level marks.
  - Add the specified engine oil if it is lower than minimum level mark.
6. Check the oil pan and other parts for oil leaks. Repair the oil leakage if any.
7. Shut off fuel and crank the engine with the starter for 10 seconds to circulate oil throughout the engine. After 1 minute of rest period, start cranking again to circulate oil throughout the engine for another 10 seconds.
8. Check the oil level with the oil level gauge again, and add oil if necessary.

### CAUTION

To crank the engine, shut off the fuel supply to the engine and operate the starters. When conducting the above cranking operation, also check the items to be inspected for the cooling system by cranking.

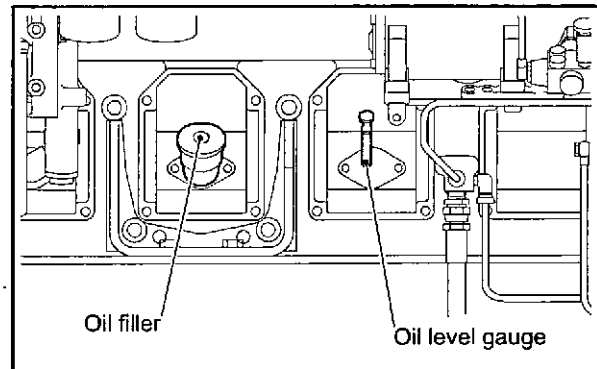

Fig. 3-6 Oil filler and oil level gauge

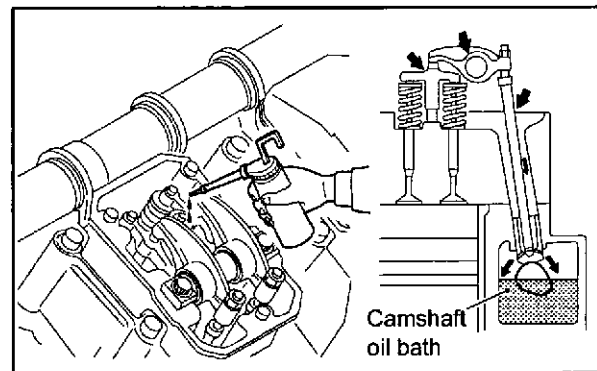

Fig. 3-7 Pouring engine oil on valve mechanisms and chamber

## Preparation of cooling system

### Filling main cooling system with coolant

1. Make sure the drain cocks on the engine and water pump are securely tightened.
2. Remove the radiator cap, and fill the radiator tank with undiluted LLC.

Note: Determine the quantities of LLC based on the coolant capacity and the LLC concentration chart.

For the coolant, refer to "COOLANT AND LLC" (6-1).

For the coolant capacity, refer to "MAIN SPECIFICATIONS" (12-1).

3. Pour in water (soft water with minimal impurities, such as tap water) slowly to the full level.

Note: For absolute air bleeding, loosen the air vent plug on the upper section of thermostat when adding water.

4. Check the radiator and other parts for coolant leaks. Repair leakage if found.
5. Install the radiator cap securely.

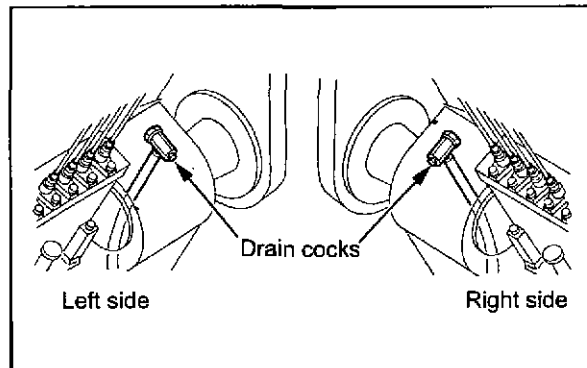

Fig. 3-8 Coolant drain cock - engine body

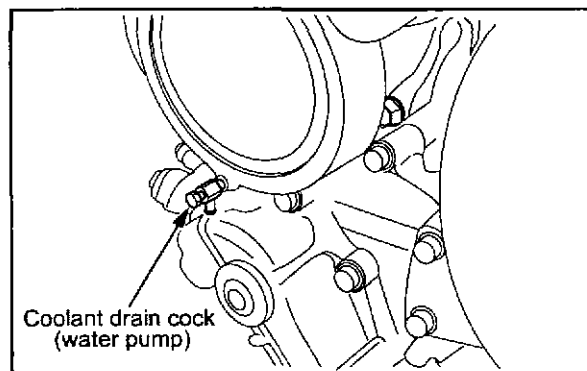

Fig. 3-9 Coolant drain cock - water pump

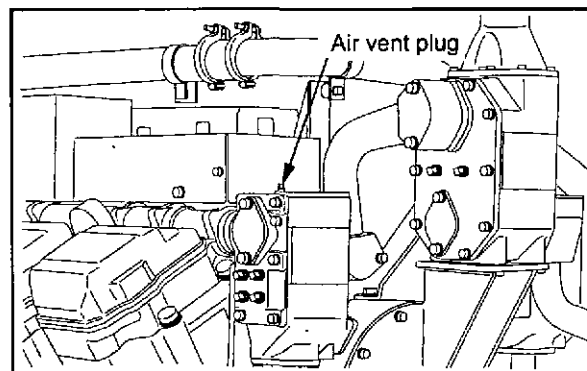

Fig. 3-10 Air vent plug - main cooling system

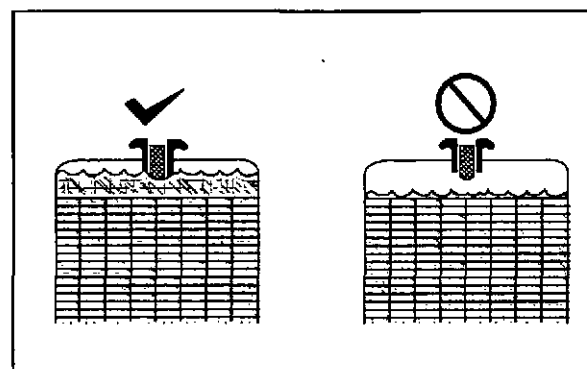

Fig. 3-11 Radiator coolant level

### Filling inter cooler cooling system with coolant

1. Make sure the drain cocks on the engine and water pump are securely tightened.
2. Remove the radiator cap, and fill the radiator tank with undiluted LLC.

Note: Determine the quantities of LLC based on the coolant capacity and the LLC concentration chart.

For the coolant, refer to "COOLANT AND LLC" (6-1).

For the coolant capacity, refer to "MAIN SPECIFICATIONS" (12-1).

3. Pour in water (soft water with minimal impurities, such as tap water) slowly to the full level.

Note: For absolute air bleeding, loosen the air vent on the upper section of thermostat when adding water.

4. Check the radiator and other parts for coolant leaks. Repair leakage if found.
5. Install the radiator cap securely.

### Cranking the engine after filling cooling system

Be sure to fill both main cooling system and inter cooler cooling system with coolant before cranking the engine.

1. Shut off fuel and crank the engine with the starter for 10 seconds.
2. After about 1 minute of rest period, start cranking again for another 10 seconds to bleed air from the water pump.

#### CAUTION

To crank the engine, shut off the fuel supply to the engine and operate the starters. When conducting the above cranking operation, also check the items to be inspected for the lubricating system by cranking.

3. Check the coolant level in the radiator.
4. When a reserve tank is equipped, fill the reserve tank with the coolant to the [FULL] level.

#### CAUTION

Always use the coolant with the same LLC concentration for refilling.

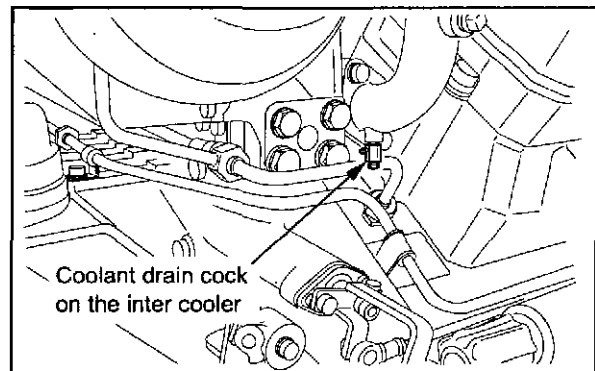

Fig. 3-12 Coolant drain cock - inter cooler

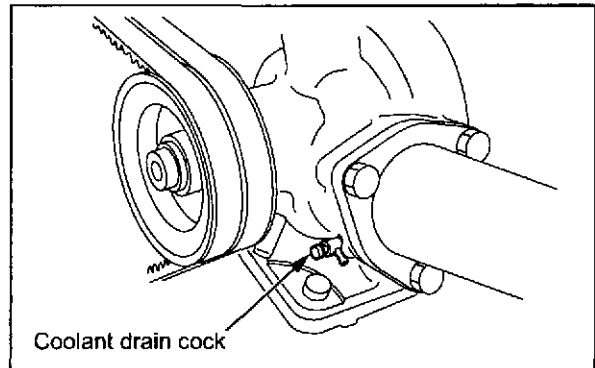

Fig. 3-13 Coolant drain cock - inter cooler water pump

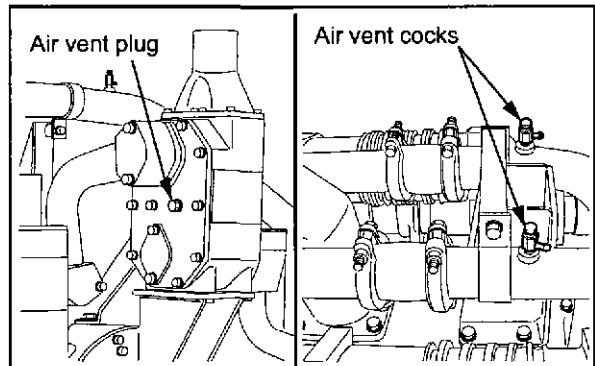

Fig. 3-14 Air vent cock and plug - inter cooler cooling system

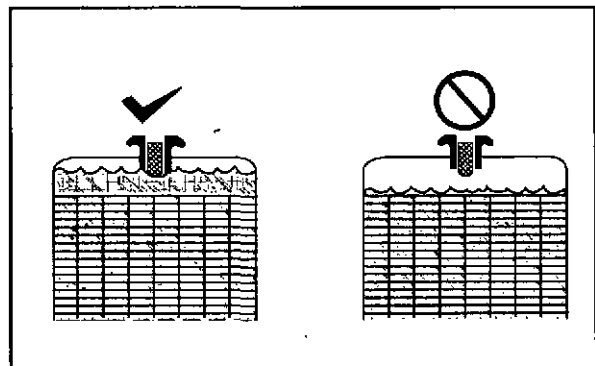

Fig. 3-15 Radiator coolant level

## Inspecting the battery

### WARNING

If battery electrolyte is spilled on your skin, flush immediately with plenty of water. If battery electrolyte enters the eyes, flush them immediately with lots of fresh water and seek medical attention at once. Do not use open flames or other fire hazards near the battery. When handling the battery, be careful of sparks generated by accidental shorting. For other cautions in handling the battery, refer to "Service battery" (1-5).

### Inspecting battery electrolyte level

Battery electrolyte evaporates during use and the fluid level gradually decreases. The correct fluid surface level is between the LOWER LEVEL and UPPER LEVEL lines. For the battery without level lines, the correct fluid surface level is about 10 to 15 mm [0.394 to 0.591 in.] above the top of the plates. If the fluid level is low, remove the caps and add distilled water to the proper level.

Note: When adding distilled water, pour in carefully.

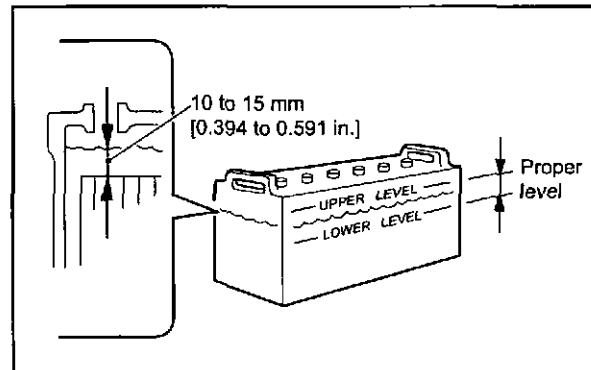

Fig. 3-16 Checking battery electrolyte level

### Inspecting specific gravity of battery electrolyte

Check the specific gravity of the electrolyte. If the specific gravity measured at 20°C [68°F] is lower than 1.22, then charge the battery.

Table 3-1 Specific gravity of electrolyte

Specific gravity at 20°C [68°F]	Condition	Remedy
From 1.26 to 1.28	Fully charged	-
From 1.22 to 1.26	Charged	Charge
Less than 1.22	Discharged	Charge

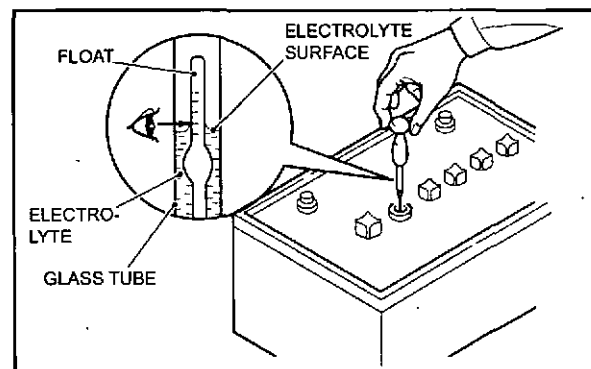

Fig. 3-17 Checking specific gravity of electrolyte

## Test operation

To conduct a test operation, follow the procedures below.

Note: For engine operation, refer to "Normal engine operation" (3-9).

## Starting and stopping

1. Start the engine.
2. Operate the engine at low idling speed under no load for 5 to 10 minutes for a warm-up operation.
3. Stop the engine.

## Inspection

1. Leave the engine be stopped for about 30 minutes.
2. During this period, check the engine and surrounding area for leaks of fuel, engine oil or coolant.
3. At 30 minutes after the engine stop, check the oil level with the oil level gauge.
4. If the oil level is low, add engine oil from the oil filler. Be sure to use the engine oil of the same brand and type.
5. Open the radiator cap, and check the coolant level.

---

**CAUTION**

Remove the radiator cap only after the engine is cooled to the room temperature. Place a cloth over the cap, and loosen the cap about a half-turn to release internal pressure. Opening the radiator cap while the engine is hot causes steam and hot coolant to splash out that may result in skin burns.

---

6. If the coolant level is low, add coolant to the specified level.
7. When a reserve tank is equipped, add coolant to the [FULL] level.

---

**CAUTION**

Always use the coolant with the same LLC concentration for refilling.

---

## Normal engine operation

This section of the manual covers the procedures for the engine operation in normal condition.

---

**CAUTION**

---

If any engine abnormality is observed during operation, stop the engine and correct the problem, or contact your Mitsubishi dealer.

---

## Preparations for operation (pre-start inspection)

Before starting the engine, always conduct the following inspection.

### External inspection

---

**CAUTION**

---

Be sure to keep combustible materials away from the engine, especially from the hot engine parts such as exhaust manifolds, or the battery. Check for fuel and oil leaks. Clean the top of the battery with a wet cloth before starting the engine, as dust on the battery can easily ignite. If any abnormality is found, be sure to repair it or contact your Mitsubishi dealer.

---

Inspect the engine exterior as described below.

1. Make sure there is no combustible material near the engine or battery. Also, check to make sure that the engine and battery are clean. If combustible materials or dust are found near the engine or battery, remove them.
2. Check the electrical wiring for such components as the starter and alternator for looseness.
3. Check the entire engine for leaks of fuel, engine oil or coolant. If a leak is found, repair the leak, or contact your Mitsubishi dealer.
4. Make sure the following valves, plugs and cocks are open or closed properly:
  - Fuel feed valve: Open
  - Coolant drain cock (plug): Closed
  - Oil drain valve: Closed

### Checking the fuel tank oil level

**WARNING**

When working around fuel, make sure there are no open flames, heaters or other fire hazards. Wipe off any spilled fuel completely. Spilled fuel can ignite and cause a fire.

**CAUTION**

Do not remove the strainer when filling the fuel tank.

Use fuel specified in "FUEL" (4-1).

Make sure the fuel tank is full. If the fuel level is low, refill the tank to the "FULL" level.

### Checking the engine oil level

1. Pull out the oil level gauge and wipe it clean using a cloth.
2. Insert the oil level gauge fully into the oil level gauge guide, then pull out the gauge again.
3. The correct oil level is between the MAXIMUM and MINIMUM marks on the oil level gauge.
4. If the oil level is low, remove the oil filler cap and add engine oil of the specified type to the MAXIMUM level.
5. Refasten the oil filler cap after refilling.
6. Check the oil pan and other parts for oil leaks.

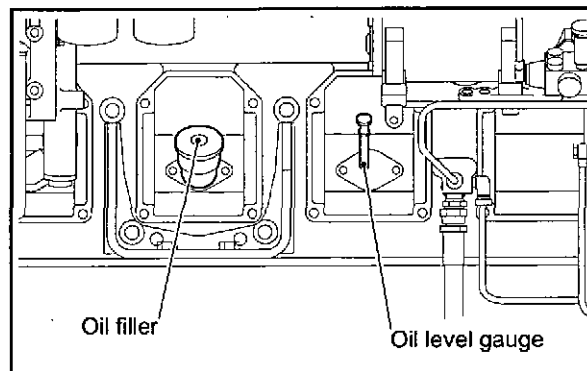

Fig. 3-18 Oil filler and oil level gauge

## Checking the coolant level

### **WARNING**

Remove the radiator cap only after the engine has cooled to room temperature. Place a cloth over the cap, and loosen the cap about a half-turn or stand the lever to the upright position to release internal pressure. Opening the radiator cap while the engine is hot causes steam and hot coolant to spray out and may result in skin burns.

1. Open the radiator cap and check the coolant level for both main cooling system and inter cooler cooling system.
2. If the coolant level is low, add coolant to the specified level.

### **CAUTION**

Always use the coolant with the same LLC concentration.

Note: Determine the quantities of LLC based on the coolant capacity and the LLC concentration chart.

For the coolant, refer to "COOLANT AND LLC" (6-1). For the coolant capacity, refer to "MAIN SPECIFICATIONS" (12-1).

3. If a reserve tank is equipped, fill the reserve tank with coolant up to the [FULL] line level.

## Checking the fuel control link

Check fuel control link for smooth movement. Also check boll joint for loose and play.

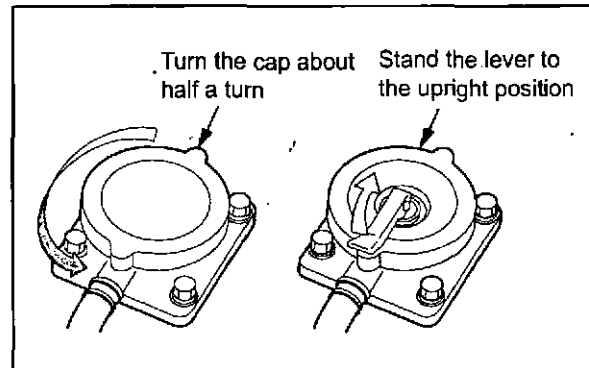

Fig. 3-19 Radiator cap

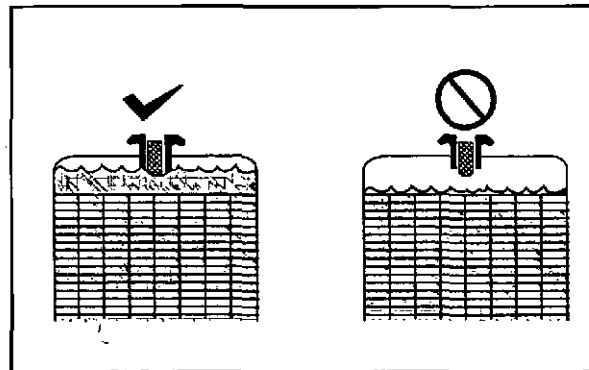

Fig. 3-20 Radiator coolant level

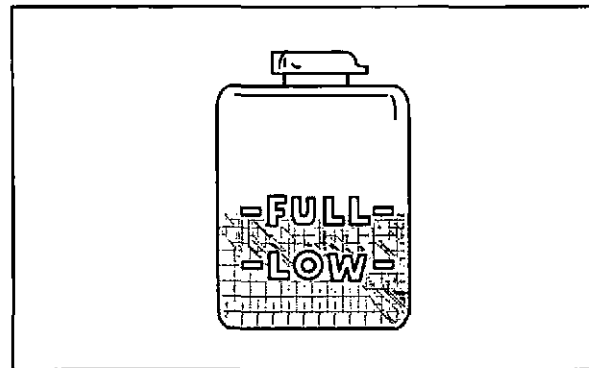

Fig. 3-21 Reserve tank coolant level

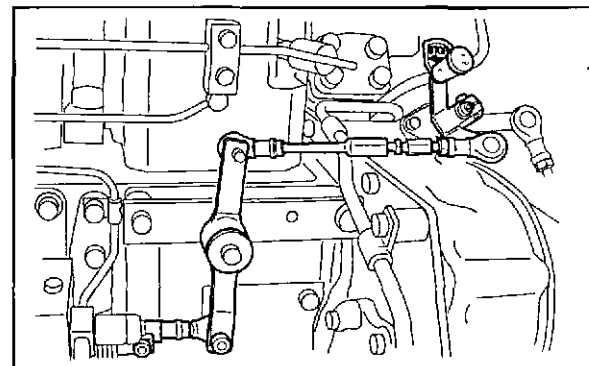

Fig. 3-22 Checking fuel control link

### Checking the air cleaner

1. Check the air cleaner indicator for the element clog.
2. If the element is clogged, the red signal mark is visible.
3. Immediately clean or replace the air cleaner element when the signal turns red.

Note: For cleaning of the air cleaner element, refer to "Cleaning, inspecting, and replacing the air cleaner element" (8-17).

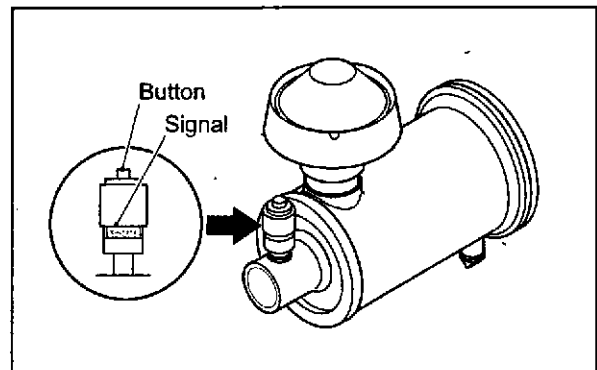

Fig. 3-23 Checking air cleaner

## Starting

The starting method changes based on the application and specifications. Start the engine according to the specified procedure.

### **WARNING**

Before starting the engine, check to make sure no one is near the engine and that tools are not left on or near the engine. In a loud voice, notify people in the area when starting the engine.

### **CAUTION**

A long and continuous operation of the starter drains the battery power, and it can also burn the starter. Do not apply a load to the engine at starting. (Disengage the clutch if installed.)

Do not use the starter for more than 10 seconds at a time. When the engine does not start, wait for more than 30 seconds before cranking again.

## Warming-up operation

### **WARNING**

Do not approach rotating parts during operation. Entanglement by rotating parts can cause serious injury.

### **CAUTION**

Do not conduct warm-up operation for a prolonged period of time.

Prolonged warm-up operation causes carbon buildup in the cylinders that leads to incomplete combustion. Do not turn the battery switch to OFF. Turning off the battery switch while the engine is in warm-up operation not only stops the instrument operations but also may deteriorate the alternator diode and regulator. Never turn the key to the START position during warm-up operation, as it damages starter. During warming-up operation, do not operate the engine in an overloaded condition (if overloaded, black smoke is exhausted). Operating the engine in an overloaded condition not only increases fuel consumption but also generates excessive carbon deposits inside the engine which considerably shortens the service life of the engine.

After the engine starts, operate the engine in a no load condition at high idling speed for 5 to 10 minutes to warm up the engine.

## Checking engine oil pressure

During warming-up operation, check if the oil pressure is in the range of standard value.

Also, make sure the oil pressure gauge is operating properly.

Note: The oil pressure gauge may indicate a higher level than normal level immediately after the engine starts, due to the low oil temperature.

The pressure gradually lowers to the normal level as the oil temperature rises.

## External inspection during warm-up

Visually check the external view of the engine for leaks of fuel, engine oil and coolant, or leaks of exhaust gas from joints.

## Operation

### WARNING

Do not approach rotating parts during operation. Entanglement by rotating parts can cause serious injury.

### CAUTION

Do not touch any hot part of the engine such as exhaust pipes during operation or immediately after shut down. A hot engine can cause burns.

### CAUTION

Always provide adequate ventilation in the engine room. If air supply to the engine room is not sufficient, the room temperature rises and can affect engine output and performance.

For the first 50 hours, operate the engine under a light load for break-in operation.

Operating the engine under heavy load or severe conditions during the break-in period can shorten the service life of the engine.

Do not turn the battery switch to OFF when the engine is in operation. Turning off the battery switch during operation not only stops the battery charge but also causes malfunctioning of instruments and deteriorates the alternator diode and regulator.

Never turn the key to the START position during operation. The starter may be damaged.

After the warm-up operation, start applying load to the engine.

## Inspection during operation

Carefully check the exterior of engine such as piping joints for leaks.

Check for abnormal engine noises or vibrations such as knocking.

Check the color of exhaust gas from the exhaust muffler.

Note: For abnormal exhaust gas conditions, refer to "Other problems and countermeasures" (11-3).

Check the instruments and gauges for proper operation and make sure they indicates normal values.

Table 3-2 Standard values at rated speed

Item		Standard value
Engine oil pressure gauge		0.49 to 0.64 MPa {5 to 6.5 kgf/cm <sup>2</sup> } [71 to 92 psi]
Coolant temperature	Main cooling system	70 to 90°C [158 to 194°F]
	Inter cooler cooling system	40 to 70°C [104 to 158°F]

Note (a) When the oil pressure drops below 0.29 MPa {3 kgf/cm<sup>2</sup>} [42.7 psi] in normal operation, or below 0.10 MPa {1 kgf/cm<sup>2</sup>} [14.2 psi] at low idling, stop the engine immediately. Be sure to locate the cause of problem and correct it before restarting the engine.

(b) When the high temperature alarm switch is activated in normal operation, change the engine operation immediately to low idling operation until the engine temperature decreases to the normal operating level. Then, operate the engine for another 5 or 6 minutes for cooling before stopping the engine. Be sure to locate the cause of problem and correct it before restarting the engine.

## Stopping

### CAUTION

Stopping the engine suddenly during high speed operation creates a local abnormal high temperature rise, and shortens the service life of engine. Except in an emergency, be sure to conduct the cooling operation for 5 to 6 minutes at low idling speed before stopping the engine. During the cooling operation, check the engine for abnormalities. Never accelerate the engine right before shutting it down.

Do not restart the engine immediately after abnormal shut down.

When the engine stops with alarms, be sure to locate the cause of the problem and correct the problem before restarting the engine. After restarting the operation, check the engine for abnormalities again. If abnormalities still exist, contact your Mitsubishi dealer.

The engine stopping method changes depending on the specifications.  
Follow the instructions according to the specifications of the equipment.

## Emergency stop

### CAUTION

When stopping the engine by pulling the manual stop lever, continue to pull the lever until the engine stops completely. If not, the engine may start again.

To stop the engine in an emergency, pull the manual stop lever fully in the direction of arrow and continue to pull the lever until the engine stops completely.

Note: When the engine does not stop with the manual lever, cut the fuel supply.

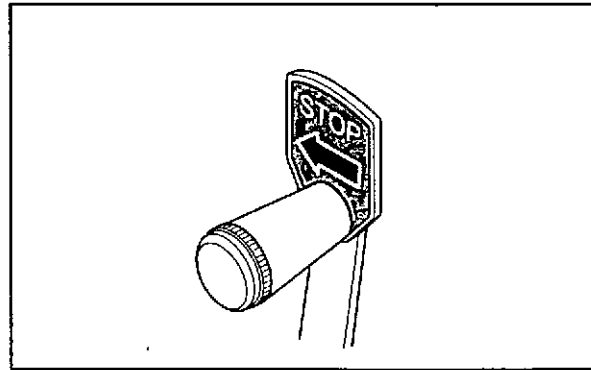

Fig. 3-24 Manual stop lever

## Inspection after stopping

Inspect the engine for leaks of fuel, oil or coolant. If any leak is found, repair the leak or contact your Mitsubishi dealer.

# Chapter 4 FUEL

## Recommended fuel

**WARNING**

Use the recommended fuel specified in this manual. Do not refill the fuel tank more than the specified level, as it may result in a fire.

Use fuel that meets the values specified in the table of "Recommended and limit values of fuel property" (4-2)

Use a diesel oil that meets "JIS K2204, Diesel Oil" or its equivalent.

It is necessary to use fuel that has a pour point suitable for the ambient temperature. Choose the fuel type from the chart on the right.

Table 4-1 Recommended fuel

Standard	Classification
JIS K2204	TYPE 1, TYPE 2, TYPE 3
ASTM D975	No. 1-D, No. 2-D
BS 2869	CLASS-A1, CLASS A-2
DIN 51601	DIESEL-FUEL
ISO 8217	DMX-CLASS

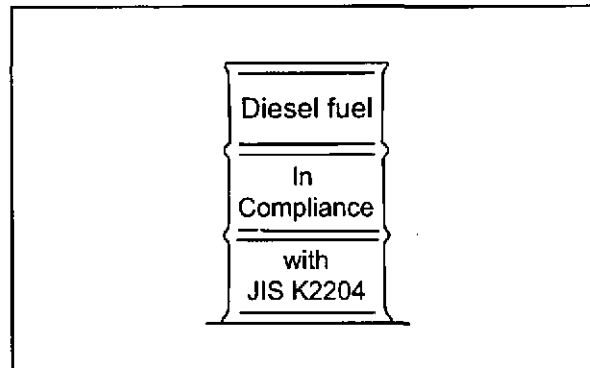

Fig. 4-1 Recommended fuel

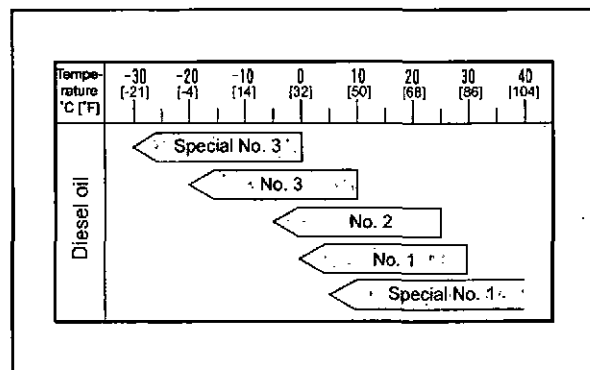

Fig. 4-2 Recommended fuel according to ambient temperature

## Handling fuel

When using fuel stored in a storage tank, leave it to sit for more than 24 hours so that dust and water can settle at the bottom. Then, use the upper clean fuel.

Fill up the fuel tank or service tank at the end of each day of operation. This prevents water from mixing with fuel in the tank and also gives time for dust and water to separate and settle at the bottom of the tank.

Before refilling, clean the areas around the caps thoroughly and remove the caps from the drum and tank. Also clean your hands and the hose before refueling. When using a hand-operated pump, be careful not to pump water or sediment accumulated at the bottom of the storage tank.

Be sure to use a strainer when filling fuel tank. For a complete filtration, it is recommended to use a clean lint-free cloth together with the strainer.

Table 4-2 Recommended and limit values of fuel property

Property		Recommend value	Limit value	Remarks
Flash point		As stipulated by regulation	As stipulated by regulation	JIS K2204, 2205 Diesel fuel: 50°C or higher
Distillation	Initial boiling point	170°C [338°F] or higher	170°C [338°F] or higher	JIS K2254
	90% boiling point	330 to 380°C [626 to 716°F]	330 to 380°C [626 to 716°F]	
Pour point		6°C [10.8°F] or lower degrees below ambient temperature		JIS K2269
Cloud point		Ambient temperature or below		
Carbon residue (10% residual oil)		0.4 weight % or lower	1.0 weight % or lower	JIS K2270
Cetane number		45 or higher	45 or higher	
Cetane index (new)		45 or higher	45 or higher	JIS K2280-1996
Kinetic viscosity		2.0 mm <sup>2</sup> /s [0.0031 in <sup>2</sup> ] or higher (30°C [86°F]) 8.0 mm <sup>2</sup> /s [0.0124 in <sup>2</sup> ] or lower (50°C [122°F]) 10.5 mm <sup>2</sup> /s [0.0163 in <sup>2</sup> ] or lower (40°C [104°F]) 16.0 mm <sup>2</sup> /s [0.0248 in <sup>2</sup> ] or lower (30°C [86°F])		
Sulfur content		0.2 weight % or lower	1.0 weight % or lower	JISK25410.05 weight % (same as diesel fuel) is recommended.
Water and sediment		0.01 volume % or lower	0.01 volume % or lower	JIS K2275
Ash		0.03 weight % or lower	0.03 weight % or lower	JIS K2272
Copper plate corrosion (100°C [212°F], 3 hrs.)		No.3 or lower	No.3 or lower	ASTM - No.3 JIS K2513 - Discoloration No.3
Specific gravity (15°C [59°F])		0.83 to 0.87	0.80 to 0.87	
Coking test		Should not be more than 75% carbonized at 250°C [482°F]	Should not be 100% carbonized at 250°C [482°F]	Fed791B (U.S.A.) 250°C [482°F]×24Hr 230°C [446°F]×24Hr 180°C [356°F]×48Hr
		Should not be more than 55% evaporated at 230°C [446°F]		
		Should not turn to tar at 180°C [356°F]		
Aromatics content (HPLC method)		38 weight % or lower	38 weight % or lower	JIS K 2536 Total of aromatic content
Asphaltene		0.1 weight % or lower	0.1 weight % or lower	ICP analysis (U.K.)
Particulate contaminant		18/15/6	18/15/6	ISO 4406 Including foreign substances in the fuel pipe lines

# Chapter 5 ENGINE OIL

## Properties of engine oil and its influence on engine performance

Engine oil lubricates the engine and greatly influences the performance and durability of the engine.

Distinctive differences of engine oil from other oils are that engine oil lubricates hot sections adjacent to the combustion chamber and is strongly affected by the combustion products. Engine oils, therefore, are required to have cooling, sealing, deterging, and neutralizing abilities in addition to the lubricating function. Because diesel engines especially produce acid products such as sulfuric acid due to the sulfur content of the fuel and soot due to imperfect combustion that contaminates oils, engine oils for diesel engines must have capabilities not only to withstand severe lubricating conditions, but also to neutralize acid products to prevent them from agglomerating and depositing. The function of performance required for engine oils is shown below:

- Good detergent dispersability for high temperature applications, for preventing contamination and deposition of sludge and soot.
- Excellent acid neutralizing capability to inhibit oxidation due to sulfur content of fuel.
- Good oxidation stability that withstands long hours at high temperature.
- Appropriate viscosity to maintain lubricity and low-temperature startability.
- Good rust and corrosion resistance to water.
- Good foam resistance to prevent the lubricating quality from lowering due to oxidation.

## Main properties of engine oil

### Dispersibility

Engine oil performance degrades through oxidation and also by external causes. Acid products such as sulfuric acid due to sulfur content of fuel become insoluble sludge. Incomplete combustion of fuel creates soot in oil.

This sludge and soot in oil are accumulated in the groove or on the inner surface of piston rings and will result in seizure or wear of the piston rings, or it will lower heat transfer of the piston rings drastically. Dispersibility of engine oil is to disperse sludge and soot in oil in order to prevent it from the depositing.

### Acid neutralization ability

Compared to gasoline fuel, diesel oil or A-fuel oil produces more sulfuric acid due to the high sulfur content in the fuel during combustion, and the sulfuric acid contaminates the oil. To neutralize the sulfuric acid, engine oils are required to have excellent neutralizing ability. Engine oils for diesel engines usually contain a detergent metal agent that has high neutralization ability.

### Viscosity

Viscosity is the measure of oil's resistance to flow. In general, Oils flow with difficulty at lower temperatures, and flow smoothly at high temperatures. This property of viscosity directly relates to low-temperature startability, lubricity, fuel consumption by friction loss, and oil consumption.

For identification of an oil's viscosity, SAE (Society Automotive Engineers) numbers are widely used. (The viscosity of engine oil identified by the number of SAE shows the thickness or thinness of viscosity at particular temperature.)

The property of engine oils is identified not only by viscosity number that shows the thickness or thinness of viscosity at particular temperature, but also by viscosity index that shows the changes in oil viscosity with changes in temperature. When the viscosity index of oil is high, it means the change of viscosity due to temperature is small.

The viscosity index (VI)-100 of oil is generally applied to diesel engine oil. Oils indicated by, for instance, VI-100 are called single grade oil, which fall under one range of viscosity. There are also oils called "multi-grade oil" for which viscosity falls under two ranges of viscosity and they are indicated by, for instance, SAE 15W-40, which means that at a lower temperature, the oil has 15W grade, and at a higher temperature it has a 40 grade. ("W" indicates the suitability of oil for colder temperature). In other words, 15W-40 indicated on oil demonstrates SAW15 grade of viscosity at a lower temperature and 40 grade viscosity at higher temperature.

## Recommended engine oil

### CAUTION

Use only the engine oils recommended in this manual. Never use other oils. The use of inappropriate or inferior oils will result in sticking of piston rings, seizure between piston and cylinder, or premature wear of bearings and moving parts, and significantly shortens the service life of the engine.

Many oil standards, which are established through special engine tests, are available to determine the quality of oil depending on the engines to which they will be applied and on operating conditions. Among those standards, SAE viscosity grades and API (American Petroleum Institute) service classifications are mostly used to classify engine oils. SAE specifies the viscosity only, while the API service classification indicates the quality level of engine oil.

There are several categories of diesel engine oils. For Mitsubishi diesel engine, CD or CF graded oils are recommended as they are suitable for supercharging and high load application.

In addition, CE grade oil is established for the use with the fuel of 0.5 % sulfur content or less and CF-4 for the use of the fuel of 0.2% sulfur content or less. Thus when using the fuel oil A, do not use CE or CF-4 graded oil.

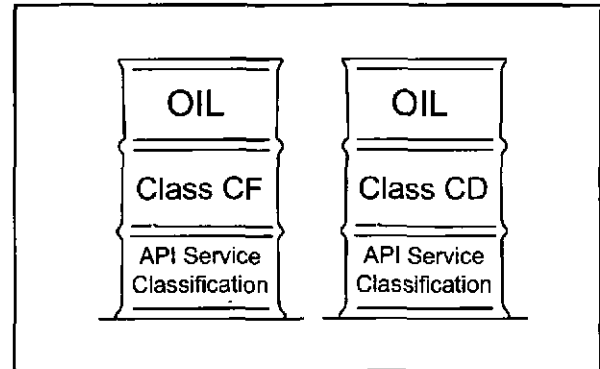

Fig. 5-1 Recommended engine oil

## Selection of oil viscosity

Use the following chart to select the appropriate oil viscosity according to the ambient temperature.

Excessively high oil viscosity causes power loss and an abnormal rise of oil temperature, while excessively low oil viscosity accelerates wear due to inadequate lubrication, and also causes a decrease in engine output due to leakage of combustion gas.

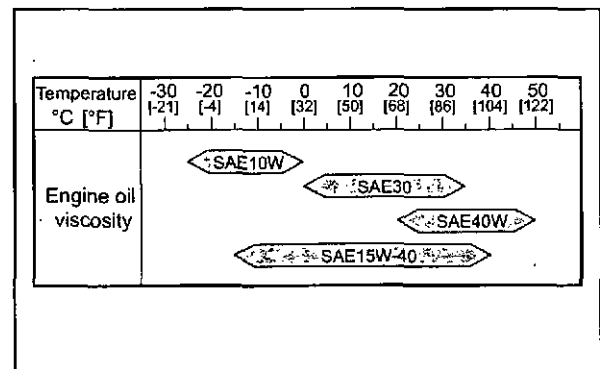

Fig. 5-2 Recommended oil viscosity according to ambient temperature

## Genuine engine oil

Mitsubishi Heavy Industries, Ltd. offers the best suited oils, which yielded from many tests, to Mitsubishi diesel engines. We highly recommend the use of our genuine engine oil. For land use engine, "JUKOIL Cojera 15W-40 or 30" and for marine engine, "JUKOIL New Mariner 15W-40 or 30" are available.

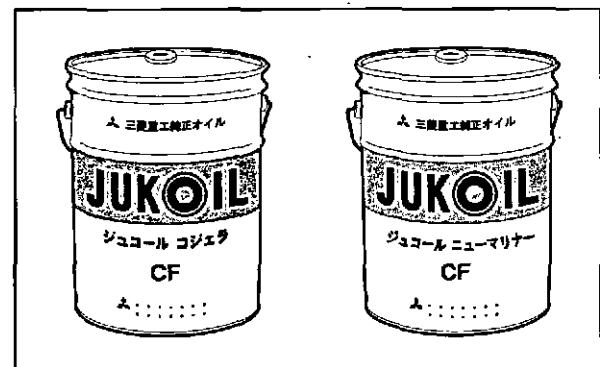

Fig. 5-3 JUKOIL Cojera, New Mariner

## Other brands of engine oil

Mitsubishi Heavy Industries, Ltd. does not warrant the engine if other brands of oil are used.

The quality and performance of commercially available oils as well as their components variations are the responsibility of engine oil suppliers. Before purchasing commercial oils, be sure to discuss the suitability of the engine oil with the oil supplier.

## Handling engine oil

### **WARNING**

Before filling the engine with engine oil, stop the engine and make sure there are no open flames and other fire hazards near the engine. Leaked or spilled oil on hot surfaces or electrical components can cause a fire. Wipe off any spilled oil immediately and thoroughly. After filling, securely close the filler cap.

### **CAUTION**

Never mix different brands of engine oil. Mixing different brands of engine oil may cause a chemical reaction of additives in the engine oil that could degrade the engine oil quality.

When handling oil in greater than the legally specified quantities, be sure to have the work performed by a service station in compliance with the law.

When removing oil from the engine or oil can, use an oil pump. Do not suck oil with the mouth to siphon it.

Be sure to close the cap on the oil can after use.

Keep oil in a well-ventilated place and out of direct sunlight.

Be sure to obtain the MSDS (material safety data sheet) of the engine oil used and follow the instructions of the MSDS.

## Service limits of engine oil

Engine oil degrades through the use and by lapse of time.

Be sure to renew the engine oil if any of the properties below exceeds the limit.

Table 5-1 Service limit for engine oil properties

Property	Service limit	Test Method	
Viscosity	cst@100°C [212 °F]	Within +30 and -15% of new oil	JIS K2283
Total base number	mgKOH/g	2.0 or more with hydrochloric acid (HCL) method 1/2 of new oil or more with perchloric acid (PCA) method	JIS K2501
Total acid number	mgKOH/g	Up to +3.0 of new oil	JIS K2501
Water content	Vol %	0.2 or less	JIS K2275
Flash point (open cup)	°C[°F]	180[356] or more	JIK K2265
Pentane insolubles	Wt %	0.5 or less	Comply with ASTM D893
Pentane insolubles coagulated	Wt %	3.0 or less	Comply with ASTM D893

## Definition of properties of engine oil

### Viscosity

Viscosity is a basic physical property of engine oil and is considered as the most important aspect when evaluating oil.

Contamination of oil by blow-by gas and deterioration of oil by its natural aging degrade the performance of viscosity, which will cause the deposition of sludge inside the engine and oil filter clogging. Contamination of oil by fuel and sheared molecules of viscosity index improver in oil also degrade the performance of viscosity, which will cause insufficient lubrication and friction/wear of engine parts.

### Total base number

Total base number (TBN) shows the ability to neutralize acids such as organic acid due to engine oil oxidation, or sulfurous or sulfuric acid due to the sulfur content of fuel.

Because TBN indicates the amount of dispersant detergent in oil, it can be used to estimate consumption of basic dispersant detergent. The ability to disperse sludge declines as dispersant detergent is used up.

### Total acid number

The total acid number in oil increases as the organic acid is being derived by the engine oil oxidation, or sulfurous acid or sulfuric acid derived by the combustion of sulfur content of fuel, or the oil becomes contaminated with imperfect combustion products. An

increase in the total acid number will result in corrosion or wear of the inner parts of the engine (such as cylinder liners or metal) due to sulfur content, and piston ring seizure due to sludge.

### Water

Water in oil promotes corrosion/wear, and decreases lubricity in sliding parts.

### Flash point

The flash point is lowered by contamination with fuels. Flash point is measured to check the dilution of fuel. The dilution of fuel reduces oil film, and causes insufficient lubrication that will cause friction or wear of engine parts.

### Insolubles

Insolubles include acid products of engine oil, imperfect combustion products, sludge or soot, metal abrasive particles and dust. Insolubles are an indication of degradation/contamination of oil.

Dispersant detergent, which is an additive in engine oil, absorbs sludge particles, and disperses them as fine particles in oil.

Total insolubles density and remaining dispersibility can be obtained by measuring insolubles and coagulated insolubles (using chemical specialities to stop action of disperse detergent and to collect the sludge dispersed in oil) by which piston ring seizure or premature wear can be prevented before it occurs.

## Engine oil analysis service

For a long term service life of engine, Mitsubishi Heavy Industries, Ltd. offers an engine oil analysis service. The service includes special oil sampling tools, the sample oil analysis and the result data.

The engine oil analysis service provides the followings:

- The quantity of fine metal powder in engine oil due to abrasion, by which worn parts can be located.
- Water, LLC, or salt that should not be in engine oil can be detected.
- Engine oil deteriorating conditions, by which appropriate engine oil renewal intervals, operating conditions, proper inspection and maintenance schedule can be planned.

The engine oil analysis service can diagnose the internal condition of the engine, which is necessary when disassembling the engine. It is highly recommended to take advantage of our engine oil analysis service so that you can learn the engine condition before any malfunction occurs to the engine.

## How to order engine oil sampling tool set

The oil sampling pump is reusable, but oil sampling bottle and suction pipe must be replaced each time. For replacing tools, order them through the regular part supply system. The analysis fee is included in the price of the sampling bottle. Therefore, if you sample the oil in other bottles, you will not receive our analysis service. Also, note that optional analysis requires additional charge.

Table 5-2 Engine oil sampling tool sets

Product name	Part no.	Remarks
Engine oil sampling set	36291-19100	Contains oil sampling pump, pipes and bottles
Oil sample bottle set	36291-00098	1 Carton: 6 bottles Includes suction pipes and oil sample data labels

Oil sampling bottle set: 1 carton: 6 bottles includes suction pipes and analyzing data of sample oil

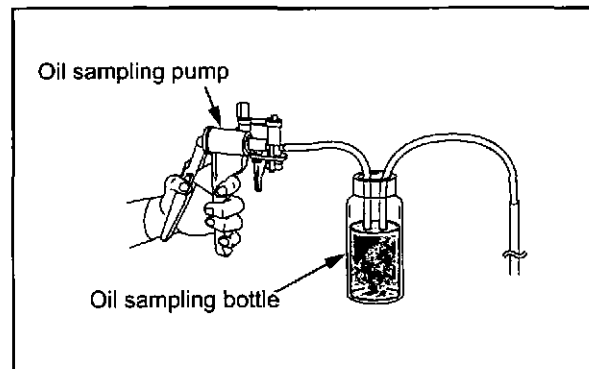

Fig. 5-4 Engine oil sampling tool set

# Chapter 6 COOLANT AND LLC

## Recommended coolant

Use soft water for the engine cooling system. The water quality must meet the requirements in the Table below. Basically, the water quality should be within the recommended value, however, up to the limit is acceptable.

Table 6-1 Water quality standards

Item	Chemical symbol	Unit	Recommended	Limit	Main adverse effect	
					Corrosion (and rust)	Scale (formation)
pH (25°C [77°F])	-	-	6.5 to 8.0	6.5 to 8.5	○	○
Electrical conductivity (25°C [77°F])	-	mS/m	<25	<40	○	○
Total hardness	CaCO <sub>3</sub>	ppm	<95	<100	-	○
M alkalinity	CaCO <sub>3</sub>	ppm	<70	<150	-	○
Chlorine ion	Cl <sup>-</sup>	ppm	<100	<100	○	-
Sulfuric acid ion	SO <sub>4</sub> <sup>2-</sup>	ppm	<50	<100	○	-
Total iron	Fe	ppm	<1.0	<1.0	-	○
Silica	SiO <sub>2</sub>	ppm	-	<50	-	○
Residue from evaporation	-	ppm	<250	<400	-	○

Note: Figures in parentheses are the standard value. In addition to the items specified above, turbidity is specified to be below 15 mg/liter.

## Long life coolant (LLC)

### CAUTION

Should LLC be accidentally swallowed, induce vomiting immediately and seek medical attention.

If LLC should enter the eyes, flush immediately with plenty of water and seek medical attention.

Be sure to use long life coolant (LLC) as coolant, because it prevents not only freezing of coolant but also rusting of the cooling system.

Use an all-season, non-amine type LLC.

## Genuine LLC

Mitsubishi Heavy Industries, Ltd. recommends the use of our genuine long life coolant "GLASSY", which is the most appropriate coolant for the Mitsubishi diesel engine.

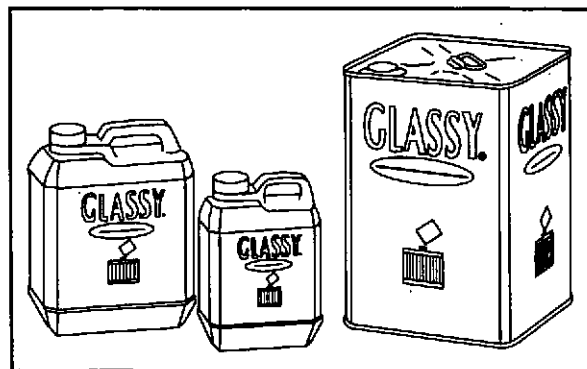

Fig. 6-1 GLASSY - LLC

## Other brands of LLC

### CAUTION

Never mix genuine Mitsubishi LLC with other brands of LLC. Mixing with other brands of LLC degrades the performance of the genuine Mitsubishi LLC

Mitsubishi Heavy Industries, Ltd. does not warrant the engine if LLC of another brand is used.

The quality and performance of commercially available LLCs as well as their component variations are the responsibility of LLC suppliers.

Before purchasing commercial LLC, be sure to discuss the suitability of LLC with the LLC supplier.

Use only all-season LLC (non-amine type). Do not use antifreeze alone instead of LLC.

## Maintenance of LLC

### CAUTION

LLC is toxic. Never dispose of coolant containing LLC drained from engine into regular sewage. For disposal of used coolant, consult your Mitsubishi dealer.

## Replacement intervals of LLC

### CAUTION

Be sure to renew LLC (coolant) at the intervals specified in this manual. Failure to renew LLC may cause malfunctions due to cavitation

The coolant containing LLC recommended in this manual should be renewed every 8000 hours or 2 years, whichever comes first, for a regular-use or general-purpose engine.

## LLC concentration

When determining the LLC concentration, provide a margin of 5°C [9°F] below the expected lowest temperature in your region. Maintain the LLC concentration between 30 and 60% throughout the year.

LLC of less than 30% concentration does not provide sufficient corrosion protection. If the LLC concentration is a few percentage points lower than 30%, it may accelerate corrosion. LLC of more than 60% concentration can adversely affect its freezing protection characteristic and cause the engine to overheat easily. When adding coolant, do not add plain water. Always use coolant with the same LLC concentration.

Table 6-2 Recommended LLC concentration  
(for reference only)

Lowest ambient temperature (°C [°F])	up to -15 [5]	up to -24 [-11]	up to -36 [-32]	up to -43 [-45]
LLC concentration (%)	30	40	50	55

Note: The concentration above is based on genuine Mitsubishi GLASSY long life coolant.

For determining the accurate LLC concentration, refer to the instructions for the LLC used.

## Importance of LLC

Today's trend is toward smaller and lighter engines offering greater output, lower fuel consumption and lower exhaust emission levels.

Conditions to which engine coolant is subjected, therefore, are becoming severer due to longer operating hours, higher coolant temperature and higher coolant circulating speed.

Many different materials such as steel, aluminum, copper, solder and rubber are used in the cooling system, and they are also subjected to the severe conditions described above.

Those materials have different ionization characteristics, and this difference accelerates corrosion through the medium of engine coolant.

To prevent such a problem, the use of LLC (long life coolant) is very important.

## Characteristics of LLC additive and important notes

LLC contains several chemicals in such proportions as to produce chemical reactions that suppress corrosion (ionization) of engine parts in contact with the coolant.

LLC loses its effectiveness by hours of use as well as lapse of time.

Moreover, if the chemicals are not well proportioned to match the metals used in the cooling system, certain chemicals in the LLC become rapidly used up and result in dissolution of metals instead of protecting metals from corrosion.

Consequently, other corrosion preventing chemicals react with dissolving metals and accelerate corrosion. This condition generates more severe corrosion than when plain soft water is used. This is a typical problem caused by the use of inappropriate LLC.

## Examples of abnormalities caused by LLC

### Pitting of iron parts

Amines are generally effective in suppressing the rusting of ferrous metals, but they are said to cause problems for copper parts.

Dissolved copper (copper corrosion) in the cooling system deposits on iron parts and the copper deposits cause corrosion and then pitting on iron parts that have a high ionization characteristics due to galvanic or local-cell action.

### Corrosion of aluminum parts

Silicate is very effective in protecting aluminum against rusting. However, it is unstable in a solution in which the pH is 9 or lower, and can turn to gel and precipitate in the solution. For this reason, the pH is usually specified to be about 10 to ensure a high alkaline level.

This means, after silicate is used up, the high alkalinity causes chemical attacks on aluminum. To prevent this problem, proper maintenance of the coolant is required.

Example:

Rapid wear of mechanical seals in the water pump due to secondary effects of silicate gel formed.

Corrosion of aluminum parts after silicate is consumed.

### Pitting and clogging of the radiator

When LLC deteriorates or when its concentration in the coolant is too low, the anti-corrosion performance of LLC lowers and results in the corrosion of metals.

Brass and solder tend to corrode faster than other metals, and corrosion of these metals is said to cause water leakage and clogs.

Example:

Holes and clogs in radiator

# Chapter 7 MAINTENANCE SCHEDULE

## How to use the maintenance schedule

Periodic inspection not only extends the service life of the engine but also serves to ensure safe operation. Be sure to conduct inspections and maintenance according to the maintenance schedule. The maintenance schedule shows the standard service intervals. If you notice any abnormalities such as abnormal noise, black exhaust smoke, white exhaust smoke, extremely high temperature of exhaust gas, abnormal vibration, and fuel, oil or exhaust gas leakage, make sure to conduct the inspection and maintenance work, regardless of recommended service intervals in the "Maintenance schedule".

Note: Appropriate service intervals vary depending on the usage and operating conditions as well as consumption of fuel, oil and coolant. Check the operating record of the engine to determine the most appropriate service intervals. (Feel free to consult your Mitsubishi dealer regarding service intervals.)

Service the items at multiples of the original requirement. For example, at 1000 service hours, also service those items listed under every 250 service hours and every 50 service hours.

Items marked with \* in the maintenance schedule require special tools or large equipment. For the servicing of those items, contact your Mitsubishi dealer.

### Maintenance schedule

Appropriate service intervals vary depending on the engine specifications. Perform all the daily inspection and maintenance work in accordance with one of the following maintenance schedules, depending on the engine application; regular-use, emergency, or general-purpose engine.

#### Maintenance schedule for regular use engine

For regular use engines, perform the periodic inspection and maintenance work in accordance with the "Maintenance schedule for engine in regular use".

### Maintenance schedule for emergency engine

For emergency engines, perform the periodic inspection and maintenance work in accordance with the "Maintenance schedule for emergency engine". Due to the nature of application, an emergency engine is subject to demanding operating conditions such as a quick startup and immediate supply of power, not to mention reliable operation in the event of an emergency. Therefore, be sure to perform not only the daily inspection work but also the following operations for maintenance purposes.

Once every week : Operate the engine under no load (for 3 to 5 minutes). (When operating the engine for the adjustment of peripheral devices, limit the operating time to 10 minutes.)

Once every month : Operate the engine under load (for 15 to 30 minutes with more than 1/2 of rated load).

If the engine cannot be operated under load every month, operate the engine under load (more than 1/2 of rated load) for more than 2 hours once a year. During the engine maintenance operation, check startup conditions such as oil pressure, exhaust color, and vibration.

### Maintenance schedule for general-use engine

If the engine is used for general purpose power supply, other than the above usage, perform maintenance work in accordance with the "Maintenance schedule for general-use engine".

## **Definition of regular use engine, emergency engine and general-use engine**

### **Regular use engine**

An engine operated with a constant base load for the purpose of generating electric power, which is used independently or in combination with commercial power supply. An engine operated under a fluctuating load throughout a day for supplying rated electric power in lieu of commercial power.

### **Emergency engine**

An engine used for emergency power generation at the time of such as failure of main power or commercial power supply.

### **General-use engine**

An engine used for applications other than power generators, for example, pumping engines, marine engines, and industrial vehicle engines that are operated varying load and speed.

## Maintenance schedule for regular use engine

Table 7-1 Maintenance schedule for regular use engine (1 / 2)

	Service item	Page
Every 50 service hours or every month	Draining water from the fuel tank	8-5
First 50 service hours for new or reconditioned engine	Retightening the bolts and nuts	*
	Changing engine oil, oil filters and bypass oil filter (It is recommended to analyze the engine oil properties at the same time) (The oil filters must be changed when the filter alarm lights)	8-7
Every 250 service hours or every year	Changing engine oil, oil filters and bypass oil filter (It is recommended to analyze the engine oil properties at the same time) (The oil filters must be changed when the filter alarm lights)	8-7
First 250 service hours for new or reconditioned engine	Inspecting and adjusting valve clearance (Also inspect the valve mechanisms at the same time)	*
Every 1000 service hours	Inspecting V-belt and adjusting belt tension	8-3
	Changing the fuel filter	8-6
Every 2000 service hours	Inspecting V-belt	8-3
	Inspecting fuel control linkage ball joint	8-5
	Inspecting and adjusting valve clearance (Also check the valve mechanisms at the same time)	*
	Inspecting and adjusting fuel injection timing	*
	Changing fuel injection nozzle tips (Check the spray condition and adjust the fuel injection pressure after replacement)	*
	Checking movement of rack (During operation of the fuel injection pump (including the governor))	*
	Inspecting pipe	8-2
Every 4000 service hours	Overhaul the top end of the engine Remove the cylinder head, and inspect and service the combustion chambers. • Inspect the connecting rod • Visually inspect top surfaces of each piston • Inspect the cylinder liner surfaces	*
	Checking damper	8-4
	Inspecting turbocharger	8-15
	Inspecting starters	8-18
	Inspecting alternator	8-18
	Checking protective devices for proper operation	*
	Replacing unit seals and oil seals in the water pump	*
Checking LLC concentration in the coolant	*	

Table 7-1 Maintenance schedule for regular use engine (2 / 2)

	Service item	Page
Every 8000 service hours	Conduct a major overhaul Disassemble engine-clean, check and change major parts [Parts to be changed] Inlet and exhaust valve seats, inlet and exhaust valves, valve rotators, valve cotters, rocker arm adjusting screws, valve push rods, bridge caps, camshaft bushings, main bearings, cylinder liners, main bearing cap bolts and washers, piston rings, connecting rod bearings, damper, crankcase thrust plate and consumable items (gaskets, oil seals, O-rings, etc) [In second overhaul, replace the following parts in addition to the parts listed above] Cylinder head bolts, valve guides, valve bridge guides, valve bridges, valve springs, tappets, camshaft thrust plates, rocker bushings, thrust plates, pistons, piston pins, connecting rod bolts, connecting rod bushings, rocker bushings, Cclamp seat, high pressure fuel injection pipe, low pressure fuel pipe assembly, oil pipe assembly, oil pipe, etc	*
	Inspecting and testing fuel injection pump (Replace parts, if necessary)	*
	Inspecting and testing governor (Replace parts, if necessary)	*
	Correction or replacement of protective devices high coolant temperature, low oil pressure, overspeeding, starting failure, water supply failure, undervoltage, overvoltage, overcurrent, low coolant level in tank, low fuel level in tank, low air pressure in tank, etc	*
	Inspecting the auxiliary devices for proper operation water heater, oil heater, oil priming pump, fuel transfer pump, governor motor, etc	*
Every 2 years	Changing the coolant	8-10
When required	Bleeding the fuel system	3-2
	Checking and cleaning the radiator fins	8-14
	Cleaning, inspecting and replacing pre-cleaner	8-16
	Cleaning, inspecting, and replacing the air cleaner element	8-17
	Cleaning the inside of the engine breathers	*
	Inspecting or replacing the stop solenoid	*
	Inspecting or replacing the couplings	*
	Inspecting the vibration-isolating rubber	*

## Maintenance schedule for emergency engine

Table 7-2 Maintenance schedule for emergency engine (1 / 3)

Service item		Page	
Every week	External inspection	3-9	
	Filling fuel tank	3-1	
	Checking the engine oil level	3-10	
	Checking the coolant level	3-11	
	Check air cooler for water leaks	*	
	Conducting an engine maintenance operation (Operate the engine under no load for 5 to 10 minutes) Check for ease of starting, color of exhaust smoke, abnormal vibration, abnormal noise, abnormal smell and gauge indication " (oil pressure gauge, coolant temperature gauge, oil temperature gauge, exhaust temperature gauge, tachometer, etc)" Bleeding fuel system	*	
Every month	Inspecting fuel control linkage ball joint	8-5	
	Clean fuel filter (wire element type) - turn handle one or two times	-	
	Checking engine oil for mixing of fuel and water	8-9	
	Inspecting battery electrolyte level (checking voltage)	8-19	
	Conducting engine maintenance operation (Operate the engine with more than 1/2 load for 15 to 30 minutes) Check for ease of starting, color of exhaust smoke, abnormal vibration, abnormal noise, abnormal smell and gauge indication (oil pressure gauge, coolant temperature gauge, oil temperature gauge, exhaust temperature gauge, tachometer, etc) Inspecting fuel injection pump and hydraulic and electronic governor rack movement"	*	
	Checking LLC concentration in the coolant	*	
Every 6 months	Cleaning the inside of the coolant tank	*	
Every year	Basic block	Inspecting V-belt and adjusting belt tension	8-3
		Checking external bolts and nuts for tightness, and retighten if necessary	*
		Checking damper	8-4
		Inspecting and adjusting valve clearance (Inspect the parts related to valve mechanism at the same time)	*
		Checking vibration-isolating rubber	*
		Checking foundation bolts	*
		Inspection or replacement of couplings	*
	Fuel system	Drain water and sediment from fuel tank	*
		Drain water from fuel filter (wire element type)	*
		Inspecting and adjusting fuel injection nozzle spray condition and spray pressure	*
		Inspecting and adjusting fuel injection timing	*
		Inspecting high pressure fuel injection pipe clamp seat, low pressure fuel pipe clip	*

Table 7-2 Maintenance schedule for emergency engine (2 / 3)

		Service item	Page
Every year	Lubrication system	Analyzing engine oil properties	*
		Inspection and adjustment of engine oil pressure (Maintenance operation)	*
		Inspecting low pressure oil pipe clip	*
	Cooling system	Checking water pump	*
		Inspection, disassembly and cleaning of electromagnetic valve and pressure reducing valve of the cooling system	*
		Inspection, disassembly and cleaning of strainer (including with/ball tap) of cooling water	*
		Analyzing coolant properties (when only soft water is used) (Change coolant according to the analysis results)	*
	Air inlet system	Cleaning, inspecting, and replacing the air cleaner element	8-17
		Cleaning, inspecting and replacing pre-cleaner	8-16
	Electrical system	Inspecting starters	8-18
		Inspecting alternator	8-18
		Inspecting specific gravity of battery electrolyte	8-19
		Checking air heater	*
		Inspecting protection devices for proper operation High coolant temperature, low oil pressure, overspeeding, starting failure, water supply failure, undervoltage, overvoltage, overcurrent, low coolant level in tank, low fuel level in tank, low air pressure in tank, etc	*
		Checking auxiliary devices for proper operation Engine control, fuel transfer pump, governor motor, room ventilating fan, solenoid, storage pump, water tank ball tap, water heater, oil heater, oil priming pump, etc	*
	Every 2 years	Changing the fuel filter	8-6
		Changing engine oil, oil filters and bypass oil filter (It is recommended to analyze the engine oil properties at the same time) (The oil filters must be changed when the filter alarm lights)	8-7
Changing the coolant		8-10	
Inspecting turbocharger		8-15	
Draining water from the exhaust muffler		8-15	
Inspecting thermostat		*	
Clean fuel filter (wire element type)		*	
Draining water from the fuel tank		8-5	
Cleaning the inside of the engine breathers	*		

Table 7-2 Maintenance schedule for emergency engine (3 / 3)

	Service item	Page
Every 4 years	Checking and cleaning the radiator fins	8-14
	Cleaning, inspecting, and replacing the air cleaner element	8-17
	Checking oil cooler for soiling, clogging and leakage	*
	Checking oil pump for discoloration and other external defects	*
	Inspecting and testing fuel injection pump (Replace parts if necessary)	*
	Inspecting and testing governor (Replace parts if necessary)	*
	Changing the rubber hoses	*
	Repair or replacement of instruments Oil pressure gauge, coolant temperature gauge, oil temperature gauge and tachometer	*
Every 8 years	Inspection and replacement of main engine parts (major overhaul) Inlet and exhaust valves and valve seats (lapping), valve guides, pistons, piston rings, connecting rod metals, connecting rod bushings, cylinderliners and crankshaft (If the parts for No.1 and No.2 cylinders are found defective, change the parts for all cylinders.)	*
	Replacement of damper	*
	Repair or replacement of oil pump	*
	Replacement of fuel injection nozzle tips (Adjust the spray condition and spray pressure after replacement)	*
	Replacement of rubber parts and O-rings	*
	Replacement of unit seal, oil seal of the water pump	*
	Disassembly and inspecting turbocharger	*
	Disassembly and cleaning of air cooler	*
	Repair or replacement of vibration-isolating rubber	*
	Repair or replacement of couplings	*
	Adjusting or replacing governor motor	*
	Adjustment or replacement of air ventilation fan of the room	*
	Inspection or replacement of stop solenoid	*
	Adjustment or replacement of ball tap of water tank	*
Replacement of other consumables	*	
Inspecting high pressure fuel injection pipe	*	

## Maintenance schedule for general-use engine

Table 7-3 Maintenance schedule for general-use engine (1 / 2)

	Service item	Page
Every 50 service hours or every month	Draining water from the fuel tank	8-5
After first 50 service hours for new engine	Retightening external bolts and nuts for looseness	*
	Changing engine oil, oil filters and bypass oil filter (It is recommended to analyze engine oil properties at the same time) (Change the oil filters whenever the filter alarm turns on)	8-7
Every 250 service hours or every year	Changing engine oil, oil filters and bypass oil filter (It is recommended to analyze engine oil properties at the same time) (Change the oil filters whenever the filter alarm turns on.)	8-7
	Inspecting V-belt and adjusting belt tension	8-3
	Checking and cleaning the radiator fins	8-14
	Draining water from the exhaust muffler	8-15
First 250 service hours for new engine	Inspecting and adjusting valve clearance (Check the valve mechanism and parts at the same time)	*
Every 1000 service hours or every 2 years	Changing the fuel filter	8-6
Every 2000 service hours or every 3 years	Retightening external bolts and nuts	*
	Inspecting and adjusting valve clearance (Check the valve mechanism and parts at the same time)	*
	Inspecting and adjusting fuel injection timing	*
	Replacement of fuel injection nozzle tips (Inspect and adjust spray condition and fuel injection pressure after replacement)	*
	Inspecting operation of protection devices	*
	Inspecting pipe	8-2
Every 4000 service hours or every 5 years	Overhaul the top end of the engine Remove the cylinder head, and inspect and service the combustion chambers <ul style="list-style-type: none"> <li>• Disassemble, inspect and service the cylinder head</li> <li>• Inspect the intake and exhaust valves, and lap the valves against seats</li> <li>• Visually inspect the top surface of each piston</li> <li>• Inspect the cylinder liner surfaces</li> </ul>	*
	Inspecting fuel control linkage ball joint	8-5
	Visual checking of damper	8-4
	Cleaning air cooler	*
Every 8000 service hours	Conduct a major overhaul Disassemble engine-clean, check and change major parts	*
	Inspecting and testing fuel injection pump (Replace parts, if necessary)	*
	Inspecting and testing governor (Replace parts, if necessary)	*
	Correction or replacement of protective devices High coolant temperature, low oil pressure, overspeeding, starting failure, water supply failure, undervoltage, overvoltage, overcurrent. low coolant level in tank, low fuel level in tank, low air pressure in tank, etc	*
	Inspecting the auxiliary devices for proper operation Water heater, oil heater, oil priming pump, fuel transfer pump, governor motor, etc	*

Table 7-3 Maintenance schedule for general-use engine (2 / 2)

	Service item	Page
Every 2 years	Changing the coolant	8-10
When required	Bleeding the fuel system	3-2
	Cleaning, inspecting and replacing pre-cleaner	8-16
	Cleaning, inspecting, and replacing the air cleaner element	8-17

---

# Chapter 8 PERIODIC INSPECTION AND MAINTENANCE PROCEDURES

## Engine body periodic inspection and maintenance

### Visual inspection

---

**CAUTION**

---

Check the engine exterior carefully, especially around batteries and hot engine parts such as exhaust manifold and other exhaust gas passages for combustible materials, fuel leaks, or oil leaks, as they can ignite and cause a fire. Before starting the engine, clean the top surface of the battery with a wet cloth, as the dust on the battery can easily ignite and cause explosion. If an abnormality is found, be sure to repair it or contact your Mitsubishi dealer.

---

Inspect the engine exterior as described below.

1. Make sure there is no combustible material near the engine or battery. Also, check to make sure the engine and battery are clean. If combustible materials or waste are found near the engine or battery, remove them.
2. Check the electrical wiring to such components as starter and alternator for loose.
3. Check the entire engine for leakage of fuel, engine oil or coolant. If leaks are found, repair the leakage or contact your Mitsubishi dealer.
4. Make sure the following valves, plugs and cocks are open or closed properly.
  - Fuel feed valve: Open
  - Coolant drain cock (plug): Closed
  - Oil drain valve: Closed

## Inspecting pipe

### Inspecting and replacing high pressure fuel injection pipe and clamp seat

Check clamp seat cracks and high pressure fuel injection pipe metal contact with clamp plate. If defective, replace the clamp seat with a new one. Replace the high pressure fuel injection pipe with a new one as needed.

### Inspecting and replacing low pressure fuel pipe, oil pipe and clip

Loosen clamp fixing bolt and check clip wear and pipe metal contact with clamp. If defective, replace the pipe assembly with a new one.

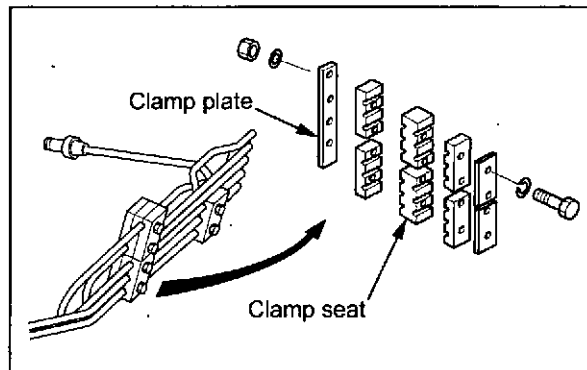

Fig. 8-1 Inspecting and replacing high pressure fuel injection pipe and oil pipe

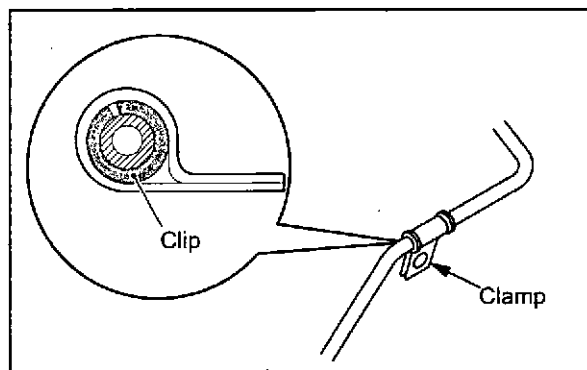

Fig. 8-2 Inspecting and replacing low pressure fuel pipe

## Inspecting V-belt and adjusting belt tension

### CAUTION

If defects such as cuts or surface separations are found on V-belt during inspection, replace V-belt. Keep oil and grease away from the belt, since they may cause the belt to slip and shorten the service life.

Excessive V-belt tension can cause rapid wear of the alternator bearing and shorten the service life of the belt. Adjust belt tension accurately by following the procedures below.

### Inspecting V-belt

1. Inspect V-belt for defects such as wear, cuts or surface separations. If defects are found, replace V-belt with a new belt.
2. Inspect belt tension as instructed below:  
Push the belt downward with  $49 \pm 5 \text{ N}$  [ $5 \pm 0.5 \text{ kgf}$ ] force midway between pulleys. If the deflection is  $7 \pm 1 \text{ mm}$  [ $0.28 \pm 0.04 \text{ in.}$ ] for new belt and  $9 \pm 1 \text{ mm}$  [ $0.35 \pm 0.04 \text{ in.}$ ] for retightening, the tension is correct. If the tension is out of the specified value, adjust belt tension.

### Adjusting V-belt tension (Alternator side)

1. Remove alternator front cover and V-belt cover.
2. Loosen all the retaining bolts on the alternator and adjusting rod.
3. Loosen the upper and lower lock nuts on the adjusting rod.

Note: The lower nut on the adjusting rod has left-hand threads.

4. Turn the adjusting rod to adjust V-belt tension.
5. After the tension adjustment, tighten the upper and lower lock nuts.
6. Tighten all the retaining bolts on the alternator and adjusting rod.
7. Reinstall belt cover and alternator front cover.

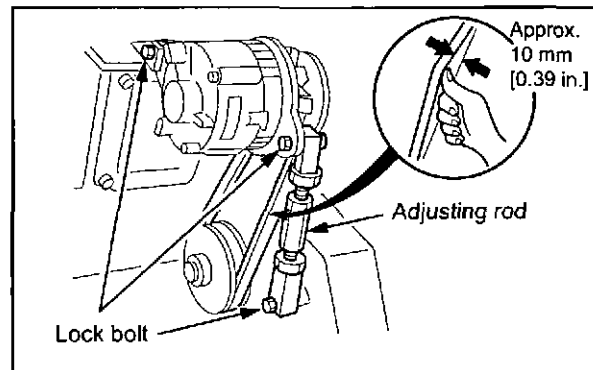

Fig. 8-3 Adjusting V-belt tension (alternator side)

### Adjusting V-belt tension (Inter cooler water pump side)

1. Loosen all the retaining bolts on the tension pulley sliding plate.
2. Loosen the lock nuts on the adjusting bolt.
3. Turn the adjusting bolt to adjust V-belt tension.
4. Retighten all the retaining bolts on the tension pulley sliding plate.
5. Retighten the lock nuts on the adjusting bolt.

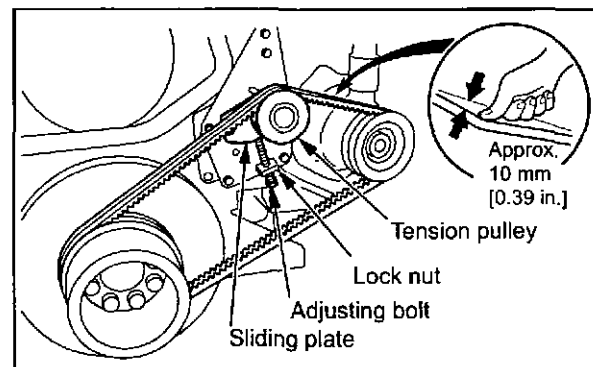

Fig. 8-4 Adjusting V-belt tension  
(inter cooler water pump side)

## Checking damper

### Visual checking of damper

#### CAUTION

When installing a protective cover to damper, do not use a cover that encloses the damper. The closed cover can cause damper deterioration due to heat.

Check damper for oil leakage and defects such as scratches, deformation, discoloration and peeling of paint. Check carefully for swelling on the cover (use a scale), oil leaks from the shim, discoloration and peeling of paint due to heat.

Note: If defect is found on damper, contact your Mitsubishi dealer.

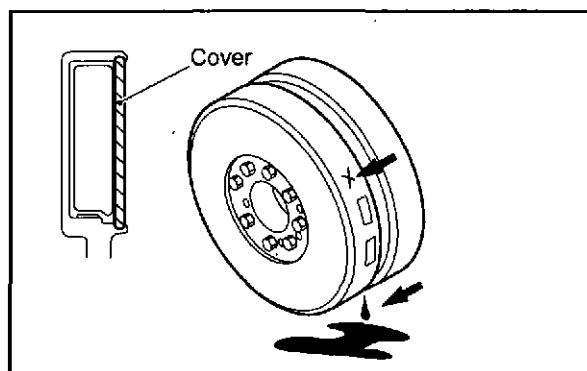

Fig. 8-5 Checking damper

### Damper temperature management

For making damper function well, heat of damper must be dissipated from its surface to prevent excessive damper heating. Before the shipment of engines, Mitsubishi Heavy Industries, Ltd. inspects each engine to ensure proper operating temperature of damper. However, since damper temperature changes with the ambient conditions, it is important to observe the following instructions and provide sufficient ventilation for damper by considering factors such as layout of equipment.

- In the case of viscous damper of emergency engine, make sure the temperature of the outside damper surface does not exceed 100°C [212°F] after the engine operation at the rated output for 1 hour. In the case of viscous rubber damper of emergency engine, make sure the temperature does not exceed 90°C [194°F]. It is recommended to use the thermo label for the temperature management of damper in emergency engine.
- When installing a safety cover to damper, check ventilation carefully and make sure the damper temperature remains below the temperature specified above, with the cover in place.

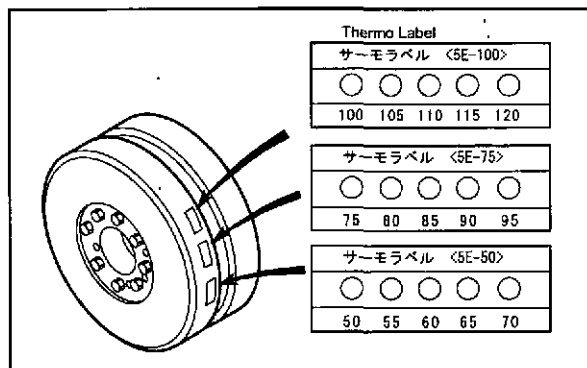

Fig. 8-6 Damper temperature management

Table 8-1 Thermo label for temperature management

Parts name	Parts No.	Temperature measuring range
Thermo label 100-120	32522-04211 20 labels set : 32522-04200	100 to 120°C [212 to 248°F]
Thermo label 75-95	32522-04111 20 labels set : 32522-04100	75 to 95°C [167 to 203°F]
Thermo label 50-70	32522-04311 20 labels set : 32522-04300	50 to 70°C [122 to 158°F]

## Fuel system periodic inspection and maintenance

### Draining water from the fuel tank

#### WARNING

When handling fuel, make sure there are no open flames or other fire hazards near the engine. Wipe off any spilled fuel completely. Spilled fuel can ignite and cause fire.

#### CAUTION

Do not remove the strainer when filling the fuel tank.

Use fuel specified in "FUEL" (4-1).

If fuel gets mixed with particles of foreign matter such as dust, dirt, or water, it can cause not only decrease of output but also defect of the fuel system. To avoid such a problem, drain fuel tank as described below.

1. Prepare a oil pan (capacity of 2 liters or more) under the drain cock of fuel tank.
2. Open the drain cock of fuel tank and drain fuel at least 1 to 2 liters.
3. Make sure that water and particles of foreign matter discharged with fuel. Close the drain cock.

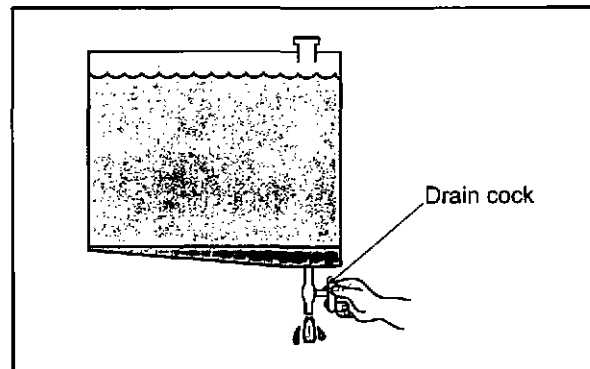

Fig. 8-7 Draining water from fuel tank

### Inspecting fuel control linkage ball joint

Check ball joints in the fuel control linkage for play. If the amount of play is 0.1 mm [0.004 in.] or more, replace the ball joint with the new one.

#### CAUTION

If the sealed ball joints found loosened, contact your Mitsubishi dealer. If the seal on the ball joint is broken, the warranty is invalidated.

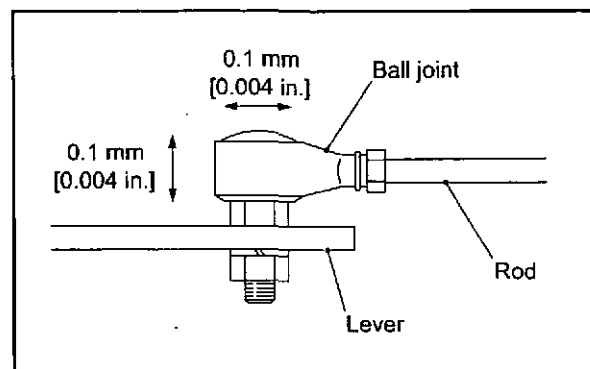

Fig. 8-8 Inspecting fuel control linkage for looseness

If the ball joints are integrated in the control linkage, replace the control linkage when the ball joints have loosened. When installing ball joints, be sure to tighten the nuts firmly.

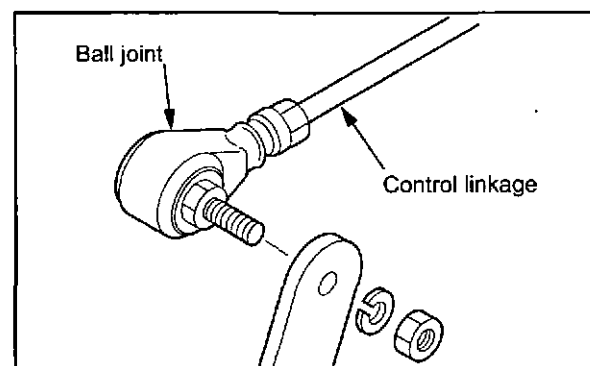

Fig. 8-9 Removing fuel control linkage

## Changing the fuel filter

**WARNING**

When handling fuel, make sure there are no open flames or other fire hazards near the engine.

Wipe off any spilled fuel completely. Spilled fuel could ignite and cause a fire.

1. Clean the area around the fuel filters.
2. Place a drip pan under the fuel filters.
3. Using a filter wrench, remove the fuel filters.
4. Wipe off fuel on the fuel filter cartridge mounting surface of the filter bracket with a cloth.
5. Check new fuel filters for proper seating of the gasket.

**WARNING**

Do not use a filter that has dent on its case.

It may damage the filter, or may cause a fuel leak, which could result in a fire during operation.

6. Apply clean fuel to the gasket on the new fuel filter.
7. Install the fuel filter.

**CAUTION**

Do not use a filter wrench to install the fuel filter. Do not dent or scratch the fuel filter surfaces.

8. After installing the new fuel filter, bleed the fuel filter.

Note: For bleeding the fuel filter, refer to "Bleeding the fuel filter" (3-2).

9. Start the engine and let it idle for several minutes.
10. Make sure that there is no fuel leak during the engine operation.

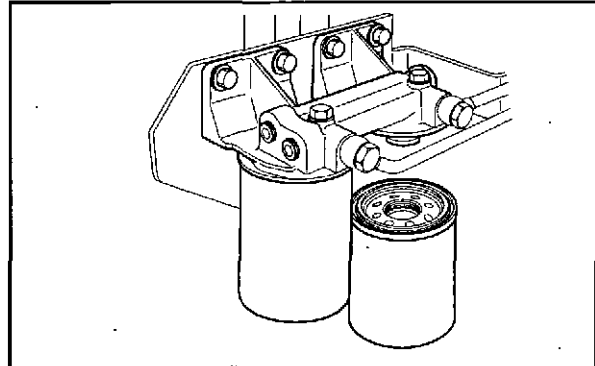

Fig. 8-10 Changing fuel filters

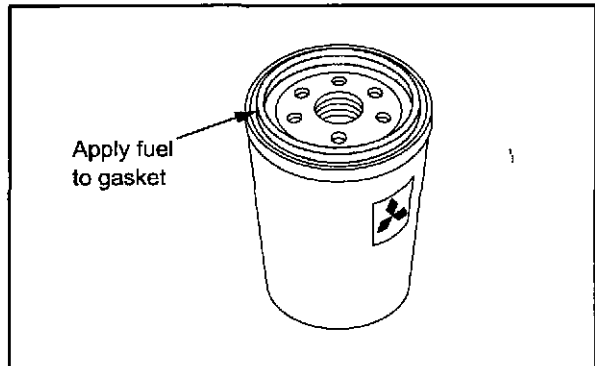

Fig. 8-11 Fuel filter

## Lubricating system periodic inspection and maintenance

### Changing engine oil, oil filters and bypass oil filter

---

**CAUTION**

To drain oil or change oil filters, wear gloves. Hot engine oil and parts can cause burns.

---

---

**CAUTION**

Disposal of discharged oil is legally restricted. Contact your Mitsubishi dealer for the disposal of waste oil.

When changing engine oil, renew oil filters and bypass oil filter. Also it is recommended to conduct an analysis of engine oil properties at the time of engine oil change.

Never wash and reuse oil filters, as their elements are paper type.

When replacing filters, always replace gasket with new ones.

---

### Draining engine oil

After the engine has stopped, drain engine oil from the engine oil drain port.

Note: Draining by suction should be avoided.

## Changing oil filter and bypass oil filter

### WARNING

Do not use the filter that has dent on its case. It may damage the filter, or may cause an oil leak, which could result in a fire during operation.

### CAUTION

Do not use the filter wrench to install filters. Use hands to prevent filters from damaging.

1. Clean the area around the oil filters.
2. Place a drip pan under oil filters and a bypass oil filter.
3. Using a filter wrench, remove oil filters and a bypass oil filter.

Note: Disassemble the removed oil filter and bypass oil filter and check elements for metal particles. If metal particles are found, contact your Mitsubishi dealer. Change oil filters and a bypass oil filter whenever the filter alarm turns on.

4. Wipe off oil on the oil filter mounting surface of the filter bracket with a cloth.
5. Check new oil filters and a bypass filter for proper seating of the gasket.
6. Apply clean engine oil to the gasket on new oil filters and a bypass oil filter.
7. Install oil filters and a bypass oil filter. When the gasket contacts the mounting surface of the filter bracket, further rotate  $3/4$  to a full turn.

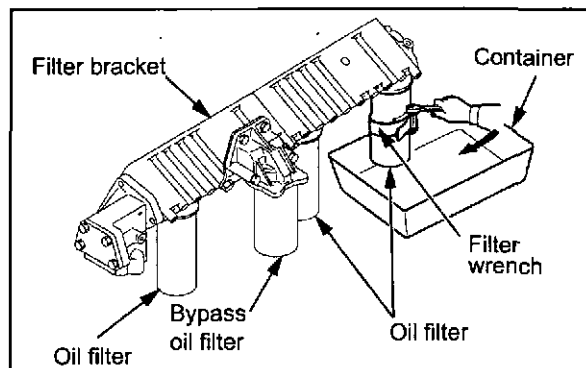

Fig. 8-12 Oil filters and bypass oil filter

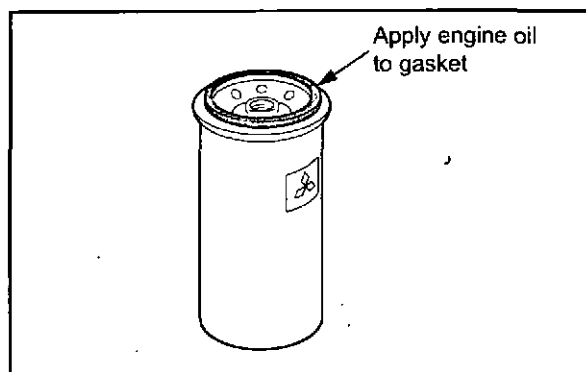

Fig. 8-13 Oil filter

## Refilling engine oil

1. Make sure that the engine oil drain plug is closed.
2. Remove the oil filler cap.
3. Fill the engine oil pan with specified engine oil to the specified level.

Note: For engine oil, refer to "ENGINE OIL" (5-1). For engine oil capacity, refer to "MAIN SPECIFICATIONS" (12-1).

4. Check the oil level in the oil pan as follows: Pull out the oil level gauge, and wipe it with a cloth.
5. Insert the oil level gauge fully into the oil level gauge guide, then pull the gauge out again. The oil level should be between the MAXIMUM and MINIMUM marks on the oil level gauge. If the oil level is low, add engine oil of the specified type.
6. Check the oil pan and other parts for oil leakage. Repair any oil leakage found.
7. Shut off the fuel supply and crank the engine for about 10 seconds or less using the starters, and wait for about 1 minute.
8. Perform the above cranking operation again to circulate oil in the engine.

### CAUTION

To crank the engine, shut off the fuel supply to the engine and operate the starters.

9. Check the oil level with the oil level gauge again, and add oil to the specified level.

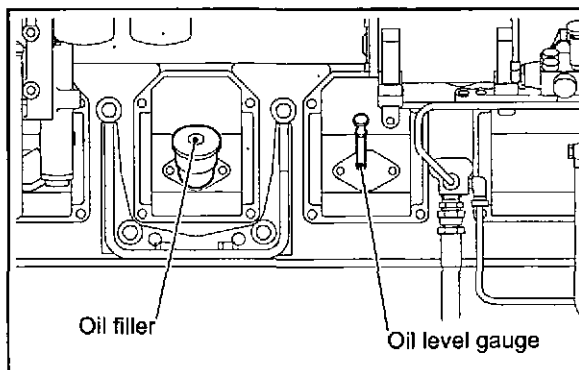

Fig. 8-14 Oil filler and oil level gauge

## Checking engine oil for mixing of fuel and water

### CAUTION

If the engine continues to operate with engine oil with mixed with fuel or water, the engine oil viscosity decreases and this can cause serious accidents such as seizing of bearings.

Sample 1 to 2 liter [0.26 to 0.53 U.S.gal] of engine oil, and check for abnormal odor and discoloration to determine the mixing of fuel and water.

If fuel is mixed with the engine oil, the oil smells like fuel.

If water is mixed with the engine oil, the color of oil turns to milky white.

If fuel and/or water is mixed with the engine oil, locate and correct the cause of it, or if correction of the cause is difficult, contact your Mitsubishi dealer.

## Cooling system periodic inspection and maintenance

### Changing the coolant

#### WARNING

Do not remove the radiator cap until the engine has cooled to the room temperature. When removing the radiator cap, place a cloth over the cap, and loosen the cap about a half-turn or stand the lever to the upright position to release internal pressure. Never open the radiator cap while the engine is hot, as it causes steam and hot coolant to blow out and can result in serious burns. Coolant (containing LLC) drained from the engine is toxic. Do not dispose of coolant into regular sewage. For disposal of used coolant, consult your Mitsubishi dealer.

#### CAUTION

The service life of LLC is 2 years. Be sure to change coolant at least once every 2 years.

### Draining the coolant

1. When draining coolant immediately after engine operation, let the engine idle at low idling speed for 5 to 6 minutes to lower the coolant temperature to 70 to 80°C [158 to 176°F].
2. Open the radiator cap.
3. Place coolant receiving cans under the drain cocks on the engine, and open the drain cocks to drain the coolant.

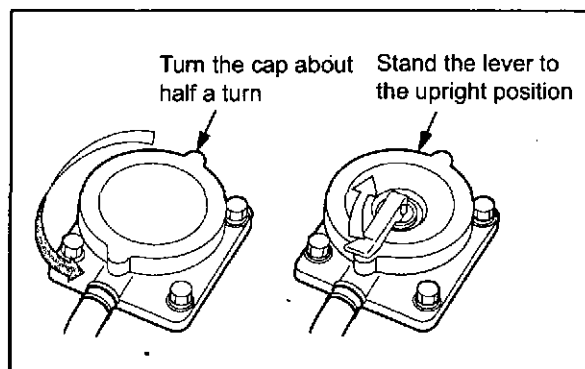

Fig. 8-16 Radiator cap

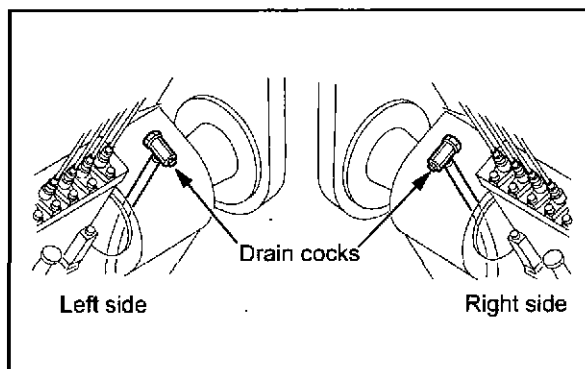

Fig. 8-17 Coolant drain cock - engine body

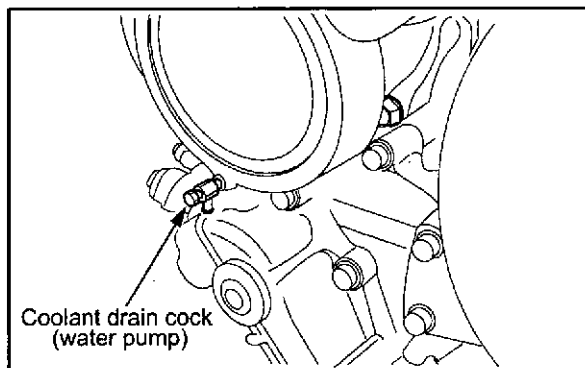

Fig. 8-18 Coolant drain cock - water pump

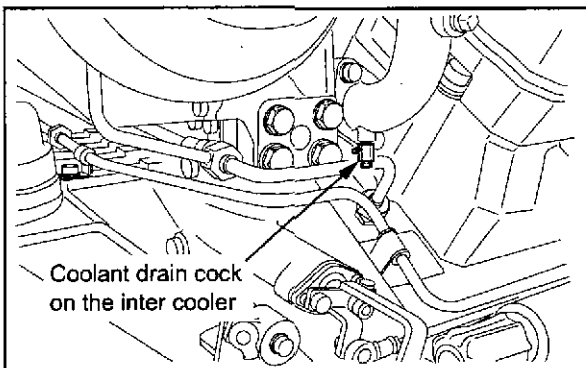

Fig. 8-15 Coolant drain cock - inter-cooler

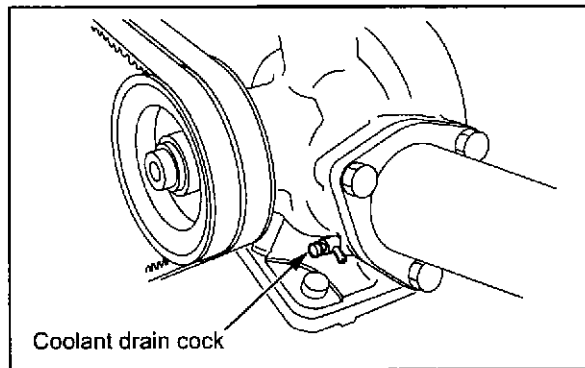

Fig. 8-19 Coolant drain cock - inter-cooler water pump

## **Cleaning the cooling system**

1. Close drain cocks and plugs.
2. Pour in a cleaning solution (a solution that is non-corrosive to rubber and metals) in the cooling system, and operate the engine at 800 to 900  $\text{min}^{-1}$  for about 15 minutes, then drain the cleaning solution.
3. Close drain cocks and plugs.
4. Pour in fresh water, and operate the engine at 800 to 900  $\text{min}^{-1}$  for about 10 minutes. Repeat rinsing until the draining water becomes clear and clean.

## Filling main cooling system with coolant

1. Make sure the drain cocks on the engine and water pump are securely tightened.
2. Remove the radiator cap, and fill the radiator tank with undiluted LLC.

Note: Determine the quantities of LLC based on the coolant capacity and the LLC concentration chart.

For the coolant, refer to "COOLANT AND LLC" (6-1).

For the coolant capacity, refer to "MAIN SPECIFICATIONS" (12-1).

3. Pour in water (soft water with minimal impurities, such as tap water) slowly to the full level.

Note: For absolute air bleeding, loosen the air vent plug on the upper section of thermostat when adding water.

4. Check the radiator and other parts for coolant leaks. Repair leakage if found.
5. Install the radiator cap securely.

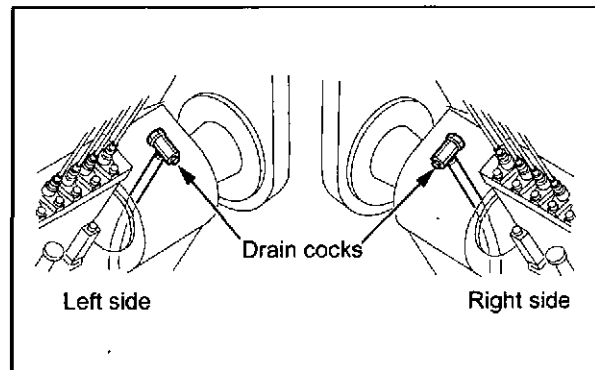

Fig. 8-20 Coolant drain cock - engine body

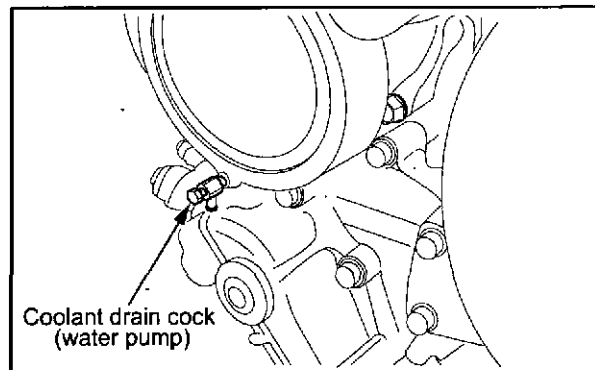

Fig. 8-21 Coolant drain cock - water pump

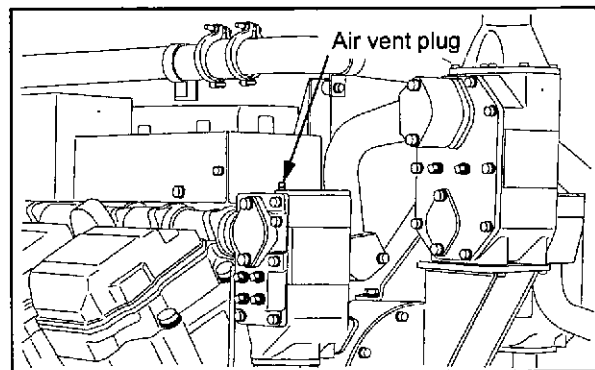

Fig. 8-22 Air vent plug - main cooling system

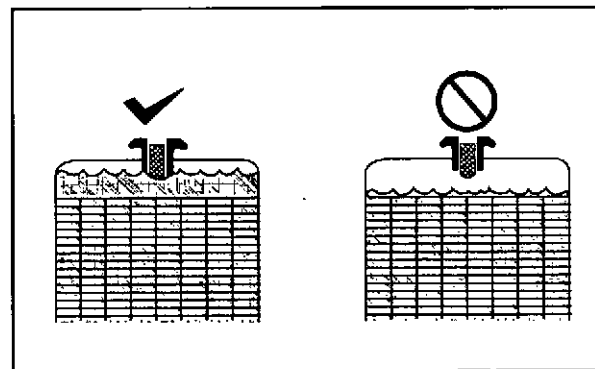

Fig. 8-23 Radiator coolant level

## Filling inter cooler cooling system with coolant

1. Make sure the drain cocks on the engine and water pump are securely tightened.
2. Remove the radiator cap, and fill the radiator tank with undiluted LLC.

Note: Determine the quantities of LLC based on the coolant capacity and the LLC concentration chart.

For the coolant, refer to "COOLANT AND LLC" (6-1).

For the coolant capacity, refer to "MAIN SPECIFICATIONS" (12-1).

3. Pour in water (soft water with minimal impurities, such as tap water) slowly to the full level.

Note: For absolute air bleeding, loosen the air vent on the upper section of thermostat when adding water.

4. Check the radiator and other parts for coolant leaks. Repair leakage if found.
5. Install the radiator cap securely.

## Cranking the engine after filling cooling system

Be sure to fill both main cooling system and inter cooler cooling system with coolant before cranking the engine.

1. Shut off fuel and crank the engine with the starter for 10 seconds.
2. After about 1 minute of rest period, start cranking again for another 10 seconds to bleed air from the water pump.

### CAUTION

To crank the engine, shut off the fuel supply to the engine and operate the starters. When conducting the above cranking operation, also check the items to be inspected for the lubricating system by cranking.

3. Check the coolant level in the radiator.
4. When a reserve tank is equipped, fill the reserve tank with the coolant to the [FULL] level.

### CAUTION

Always use the coolant with the same LLC concentration for refilling.

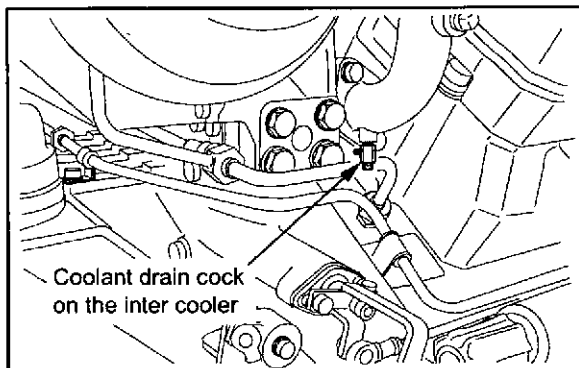

Fig. 8-24 Coolant drain cock - inter cooler

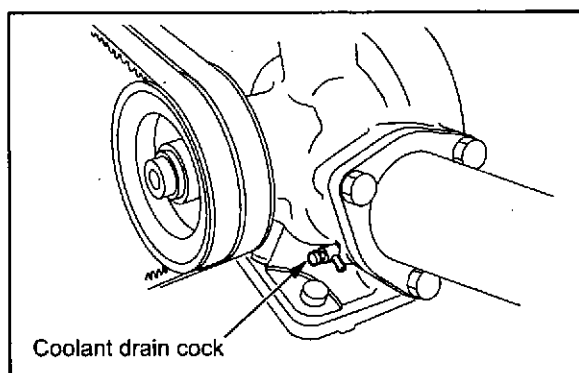

Fig. 8-25 Coolant drain cock - inter cooler water pump

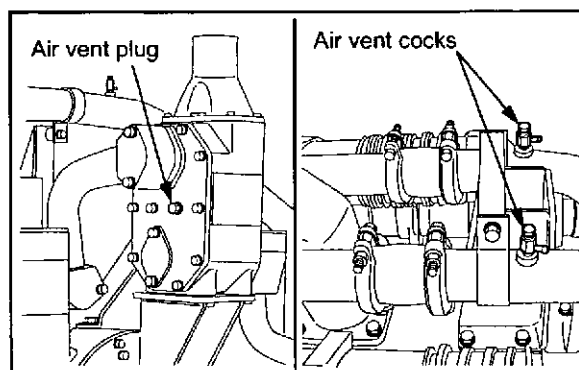

Fig. 8-26 Air vent cock and plug - inter cooler cooling system

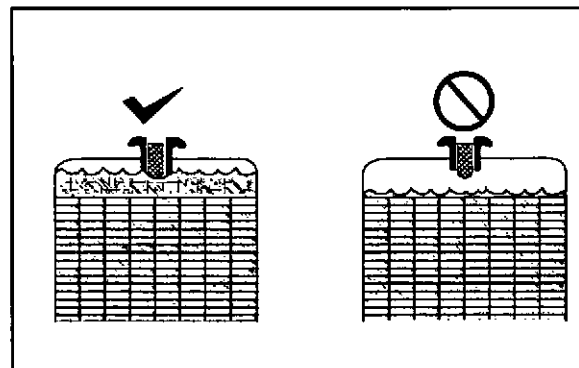

Fig. 8-27 Radiator coolant level

## Checking and cleaning the radiator fins

Check the radiator fins for holes and cracks.

To clean the radiator fins, blow compressed air from the opposite direction of the normal air flow.

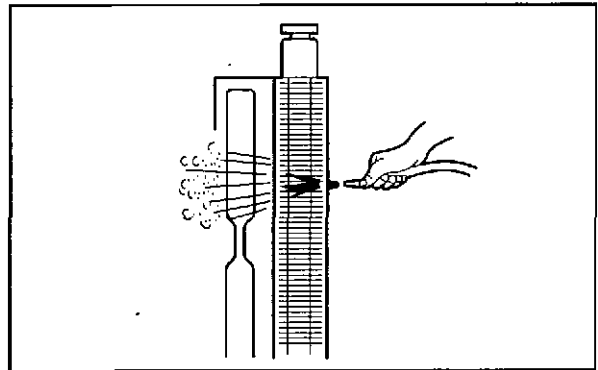

Fig. 8-28 Cleaning radiator fins

## Inlet exhaust system periodic inspection and maintenance

### Inspecting turbocharger

#### **CAUTION**

Check the turbocharger when the engine is cold. Also, make sure that the compressor wheel is not rotating when checking the turbocharger.

#### **CAUTION**

If the color of the exhaust gas is abnormal, also inspect the turbocharger.

Disconnect the pipe from the air inlet side. Hold the *compressor wheel nut* by hand and turn the wheel to check for looseness or abnormal noise. Replace the bearings if looseness or abnormal noise is found.

Note: For replacement of the bearing, consult your Mitsubishi dealer.

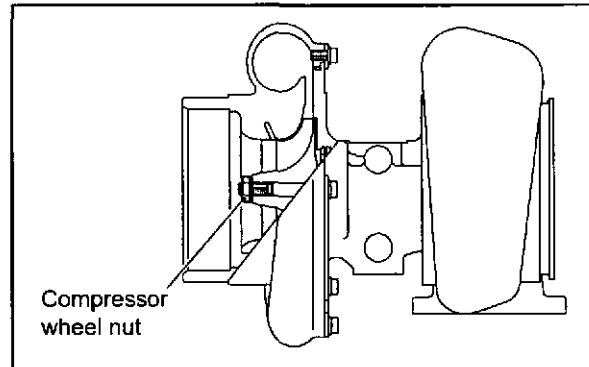

Fig. 8-29 Checking turbocharger

### Draining water from the exhaust muffler

#### **CAUTION**

Never touch the exhaust muffler immediately after the engine stops, as it is extremely hot. To drain water, wait until the exhaust muffler cools.

Remove the drain plug and allow water to drain from the exhaust muffler.

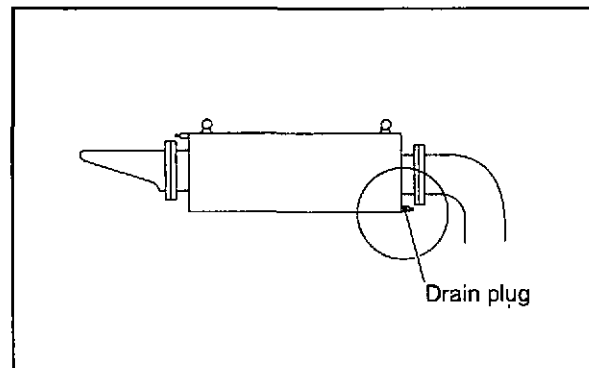

Fig. 8-30 Draining water from exhaust muffler

## Cleaning, inspecting and replacing pre-cleaner

### CAUTION

Never service the pre-cleaner while the engine is running. Servicing the pre-cleaner while the engine is in operation can cause foreign particles to enter the engine and result in rapid wear of parts which leads a shorter service life of engine.

The pre-cleaner is equipped to the silencer of the turbocharger to remove dust from intake air and keep the engine clean for optimum performance. Be sure to clean the pre-cleaner as described below.

1. Remove the pre-cleaner from the silencer, and hand-wash the pre-cleaner with a mild detergent.
2. Rinse the pre-cleaner with fresh water.
3. After drying thoroughly, inspect the pre-cleaner for defects. If defects are found, replace the pre-cleaner with new one.

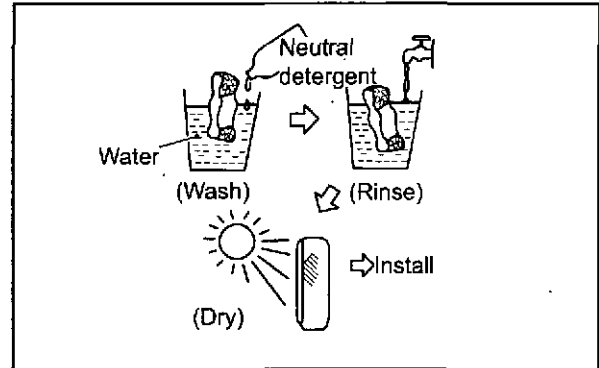

Fig. 8-31 Cleaning pre-cleaner

## Cleaning, inspecting, and replacing the air cleaner element

### CAUTION

Never service the air cleaner while the engine is running. Servicing the air cleaner while the engine is in operation can cause particles of foreign matter to enter the engine and result in rapid wear of parts leading to a shorter service life of the engine. Never knock or hit the element.

When using compressed air, wear protective gear such as safety glasses, a hard hat and gloves. Working without protective gear can result in a severe personal injury.

1. Remove the air cleaner cap and wing nut.
2. Remove the air cleaner element from the body.
3. Blow compressed air (0.69 MPa {7 kgf/cm<sup>2</sup>} [100 psi] or lower) onto the inside surface of the element to remove dust and other contaminants.
4. To remove dust stuck on the element, blow dry compressed air onto the outside surface from a distance. Blow compressed air on the inside surface toward the outside along the pleats. Then, blow compressed air on the outside and inside surface again.
5. After cleaning, hold the element near a light bulb to illuminate the inside, to check for defects such as cuts, pinholes or local wear.
6. If any defect is found, replace the air cleaner element with a new one.
7. Reinstall the air cleaner element to the engine.

### CAUTION

If defects such as cuts, pinholes or local wear are found in the element, or if the air cleaner indicator shows a red sign soon after the cleaned element is installed, replace the filter element with new element.

Reset the indicator by pressing the reset button to erase a red sign after installing the clean or new element.

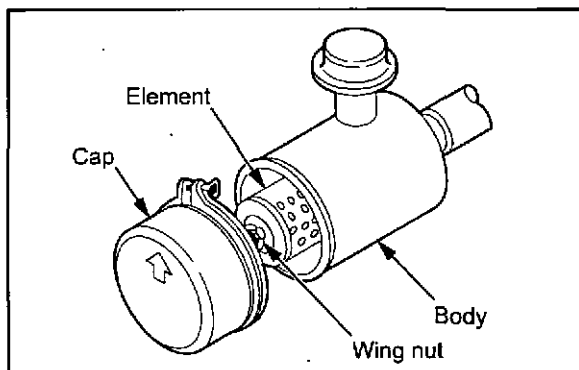

Fig. 8-32 Removing air cleaner element

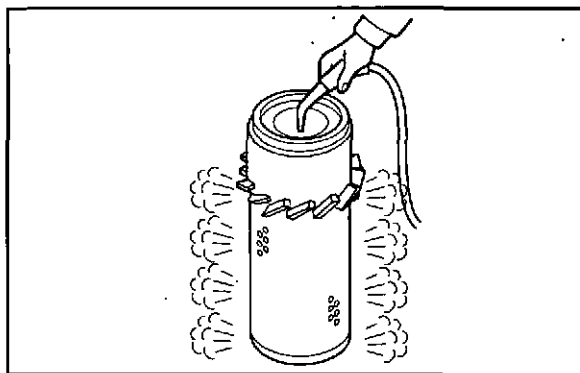

Fig. 8-33 Cleaning air cleaner element

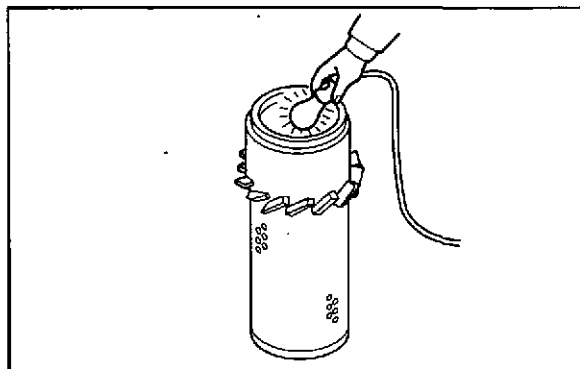

Fig. 8-34 Checking air cleaner element

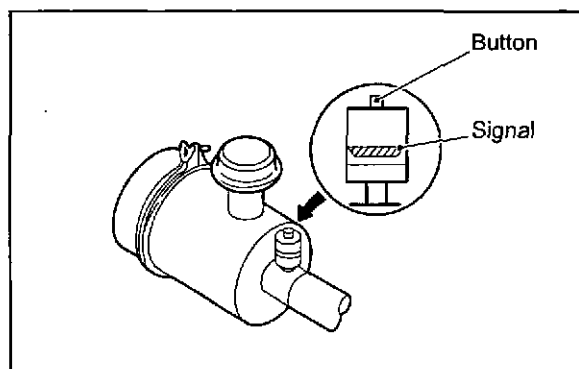

Fig. 8-35 Air cleaner indicator

## Electrical system periodic inspection and maintenance

### Inspecting starters

Check the exterior of the starters for damage.  
If the starters are dusty, blow dirt using compressed air.

Note: If the starters are defective, consult a Mitsubishi dealer.

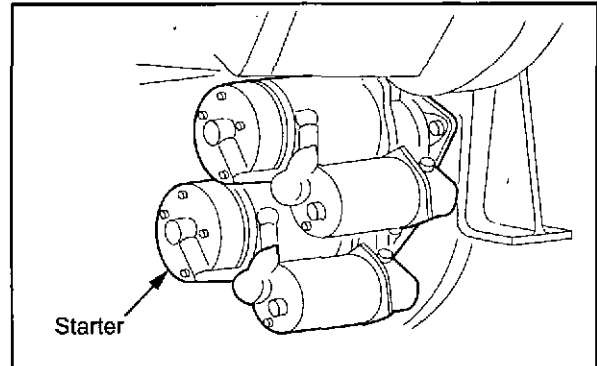

Fig. 8-36 Checking starter

### Inspecting alternator

Visually check the alternator for damage.  
If the alternator is dusty, blow off dust using compressed air.  
Remove the belt, and turn the pulley by hand to make sure that it rotates smoothly.

Note: If defects are found in the alternator, contact your Mitsubishi dealer.

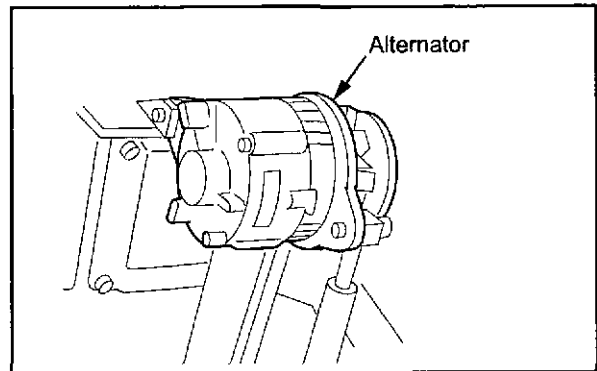

Fig. 8-37 Inspecting alternator

## Inspecting the battery

### WARNING

If battery electrolyte is spilled on your skin, flush immediately with plenty of water. If battery electrolyte enters the eyes, flush them immediately with lots of fresh water and seek medical attention at once. Do not use open flames or other fire hazards near the battery. When handling the battery, be careful of sparks generated by accidental shorting. For other cautions in handling the battery, refer to "Service battery" (1-5).

### Inspecting battery electrolyte level

Battery electrolyte evaporates during use and the fluid level gradually decreases. The correct fluid surface level is between the LOWER LEVEL and UPPER LEVEL lines. For the battery without level lines, the correct fluid surface level is about 10 to 15 mm [0.394 to 0.591 in.] above the top of the plates. If the fluid level is low, remove the caps and add distilled water to the proper level.

*Note: When adding distilled water, pour in carefully.*

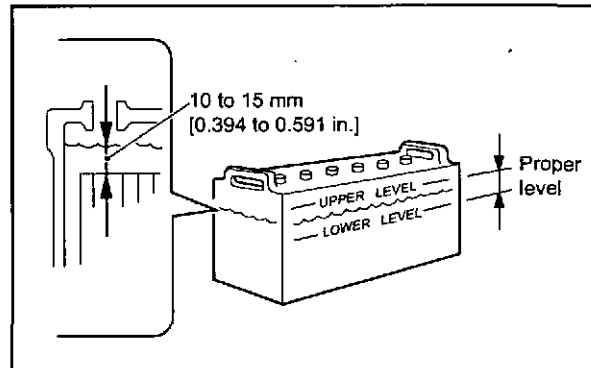

Fig. 8-38 Checking battery electrolyte level

### Inspecting specific gravity of battery electrolyte

Check the specific gravity of the electrolyte. If the specific gravity measured at 20°C [68°F] is lower than 1.22, then charge the battery.

Table 8-2 Specific gravity of electrolyte

Specific gravity at 20°C [68°F]	Condition	Remedy
From 1.26 to 1.28	Fully charged	-
From 1.22 to 1.26	Charged	Charge
Less than 1.22	Discharged	Charge

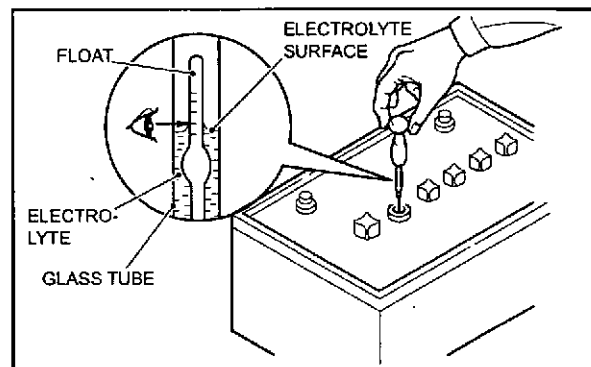

Fig. 8-39 Checking specific gravity of electrolyte

# Chapter 9 LONG-TERM STORAGE

## Long-term storage

The following describes how to store the engine in a non-operable condition for three months or more and in an operable condition for three months or more. If the engine has been left unattended for three months or more, the internal engine parts can rust, and that may cause damage to the engine. When storing the engine for an extended period of time, be sure to follow the directions below.

## Storing the engine in a non-operable condition for 3 months or more

### Preparation for storage

1. Drain engine oil, and pour rust-preventive oil (NP-10-2) into the engine.
2. Prepare a fuel mixture containing 50% rust-preventive oil (NP-9), and fill the fuel tank with it.
3. Operate the engine at a speed of 800 to 1000  $\text{min}^{-1}$  (idling) for 5 to 10 minutes under no load.
4. Immediately before stopping the engine, spray volatile corrosion inhibitor (V.C.I.) through the inlet port to prevent rust on the air intake system.
5. With the engine stopped, drain the fuel mixture from the fuel tank.
6. Apply rust-preventive oil (NP-3) liberally on the exposed sections of the machining.
7. Seal the air inlet, exhaust outlet, breather and other openings with an adhesive cloth tape.
8. Loosen the V-belt.
9. Wrap adhesive cloth tape on the terminals of the starters and alternator, and seal the openings. Cover these sections with polyethylene sheet or processed polyethylene paper, and place desiccants in the polyethylene covers.
10. Disconnect the cables from the battery terminals, and charge the battery. Clean the terminals, apply a thin coat of grease to the terminals, and store the battery in a cool and dry room.
11. Cover the entire engine.

- Note:
- (a) Store the engine in a well-ventilated indoor area.
  - (b) It is not necessary to drain coolant since it contains LLC. (Add LLC to increase the concentration to between 30 and 60%.)
  - (c) Post a sign at an easily noticeable place to warn that the rust-preventive oil in the engine must be replaced with engine oil, and the fuel tank must be filled with fuel before operating the engine for the first time after storage.
  - (d) New engine oil can substitute for rust-preventive oil (NP-10-2).

### Recommended rust-preventive oil and corrosion inhibitor

Table 9-1 Recommended rust-preventive oil and corrosion inhibitor

JIS No.	Recommended product	Application
K2246	NP-3 Nippon Oil Corporation Anti Rust P-1400	Prevention of rust on exposed machine surfaces
	NP-9 Nippon Oil Corporation Anti Rust P-2400	Prevention of rust in fuel system
	NP-10-2 Nippon Oil Corporation Anti Rust P-230	Prevention of rust in lubricating system
Z1519	- Ryokou Kagaku V.C.I. Diana volatile corrosion inhibitor	Prevention of rust in air intake system

### Maintenance during storage

Charge the battery once a month.

First, check the battery electrolyte for correct level and then charge the battery.

## Using the engine after storage

1. Remove the cover from the engine.
2. Connect a fully charged battery.
3. Remove the covers from the starters and alternator.
4. Adjust the tension of V-belt.

Note: For the adjustment of V-belt tension, refer to "Adjusting V-belt tension (Alternator side)" (8-3).

5. Remove sealing tapes from the openings of the engine.
6. Drain rust-preventive oil, and pour in appropriate engine oil.

Note: For engine oil, refer to "ENGINE OIL" (5-1)

7. Fill the fuel tank with fuel, and bleed the fuel system.

Note: For bleeding fuel system, refer to "Bleeding the fuel system" (3-2).

8. Inspect the entire engine.
9. Remove the rocker covers, and lubricate the valve mechanisms.
10. Shut off the fuel supply and crank the engine for about 10 seconds. Then repeat this cranking 3 times at intervals of about 1 minute.

### **CAUTION**

To crank the engine, shut off the fuel supply to the engine and operate the starter.

11. Make sure the engine oil pressure rises.
12. Start the engine

Note: For starting the engine, refer to "Starting" (3-13).

13. Conduct a warm-up operation for a sufficient duration.
14. Apply load and increase the engine speed to the rated speed.

## Storing the engine in an operable condition for 3 months or more

When the engine is not operated during storage of three months or more, internal engine parts can rust and lose oil film. As a result, the engine can seize when it is started after storage. To prevent such a risk, the engine must be operated periodically during storage.

## Operating the engine for maintenance

Operate the engine for maintenance at least once a month as described below.

1. With the fuel shut off (press the engine stop button to shut off the fuel injection), operate the starter twice at intervals of about 15 seconds and check to see if the engine oil pressure increases.
2. After the engine starts, operate under no load for 5 to 10 minutes.

Note: For engine operation, refer to "OPERATION" (3-1).

# Chapter 10 TRANSPORTATION

## Lift the engine carefully



To lift the engine, use wire ropes, shackles and slings capable of supporting the weight of the engine.

Attach slings to the hangers provided on the engine to lift the engine.

Keep the engine balanced during lifting by considering the engine's center of gravity.

Keep the angle formed by slings attached to hangers within  $60^\circ$ . If the angle exceeds this limit, excessive load is applied on the hangers and may damage the hangers.

Attach wire ropes to the hanger after removing the pipe cover and the insulator near the hanger for lifting. To prevent wire ropes from contacting the engine, place a cloth or other soft padding to prevent damage to the engine and wire ropes.

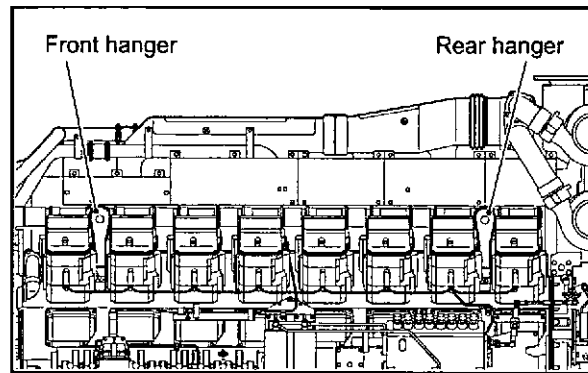

Fig. 10-1 Hangers for lifting

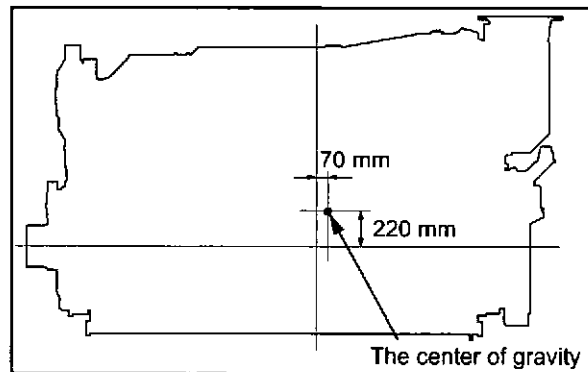

Fig. 10-2 The center of gravity for the engine

---

# Chapter 11 TROUBLESHOOTING

## General precautions

### Contact your Mitsubishi dealer for repair service

Repairing a malfunctioning engine may require special equipment or involve potentially dangerous work, except for relatively simple procedures such as the change and addition of fuel, engine oil and coolant. In the event of the engine failure, contact your Mitsubishi dealer.

### Considerations before work

Before troubleshooting, consider possible causes of the problem and try to find out if the same problem has occurred in the past.

Check the parts that may be causing the problem in the most efficient order.

When disassembling a component, pay close attention to the disassembly sequence so that you can reassemble the component in reverse order of disassembly.

### Cautions against contamination

Dust and particles of foreign matter are the most common cause of rapid wear of parts.

When disassembling a component, take measures to prevent dust and foreign particles from entering the component being disassembled.

### Cautions regarding parts handling

Handle parts carefully.

When replacing parts, use only genuine parts by referring to the parts catalog.

### Work safety

Be sure to use wrenches of the correct size. Using a wrench of the wrong size not only damages nuts but can also cause the personal injury.

Use correct tools and perform work with utmost caution.

Be sure to accurately estimate the weight of the part being dismantled. If the removed part is much heavier than you have estimated, it may fall down during lifting and can result in the damage to the parts or personal injury.

## How to troubleshoot

### The starter does not crank or cranks slowly, resulting in start failure

Table 11-1 The Starter Does Not Crank or Cranks Slowly, Resulting in Start Failure

	Cause	Remedy
Electrical system	Blown fuse	Change fuse
	Faulty wiring connection between battery and starter switch	Connect wire correctly
	Faulty wiring connection between battery, starter and starter switch	Connect wire correctly
	Insufficiently charged battery	Inspect and adjust V-belt tension. Refer to "Inspecting V-belt and adjusting belt tension" (8-3).
	Specific gravity of battery fluid too low	Charge battery
	Faulty battery	Install new battery
	Faulty starter or starter relay	Consult a Mitsubishi dealer
Lubricating system	Oil viscosity too high	Use appropriate engine oil. Refer to "ENGINE OIL" (5-1).
Fuel system	Air in fuel system	Bleed fuel system. Refer to "Bleeding the fuel system" (3-2).
	Low fuel level	Add fuel
	Clogged fuel filters	Change fuel filters. Refer to "Changing the fuel filter" (8-6).
	Faulty fuel feed pump	Consult a Mitsubishi dealer
	Faulty fuel injection pump	Consult a Mitsubishi dealer
Engine mechanical	Faulty moving parts (interference between valves and pistons, or foreign matter in cylinders)	Consult a Mitsubishi dealer

### The starter cranks, but the engine does not start

Table 11-2 The Starter Cranks, But the Engine Does Not Start

	Cause	Remedy
Fuel system	Empty fuel tank	Add fuel, and bleed fuel system. Refer to "FUEL" (4-1).
	Damaged fuel pipe	Consult a Mitsubishi dealer
	Loose fuel pipe connection	Tighten connection. Consult a Mitsubishi dealer
	Improper fuel	Use proper fuel. Refer to "FUEL" (4-1).
	Dust or water mixed in fuel	Remove dust or water from fuel tank. Refer to "Draining water from the fuel tank" (8-5).
	Clogged fuel filters	Replace fuel filters. Refer to "Changing the fuel filter" (8-6).
	Faulty fuel feed pump	Consult a Mitsubishi dealer
	Faulty fuel injection pump	Consult a Mitsubishi dealer
Air intake system	Clogged air cleaner or pre-cleaner	Clean air cleaner or pre-cleaner. Refer to "Cleaning, inspecting and replacing pre-cleaner" (8-16).
Engine mechanical	Compression pressure low (damaged cylinder liner, piston or piston ring, or faulty valve seat or nozzle packing seal)	Consult a Mitsubishi dealer

## Other problems and countermeasures

### Engine output is low

Table 11-3 Engine Output is Low

Cause	Remedy
Engine oil viscosity too high	Use engine oil of appropriate viscosity according to ambient temperature. Refer to "ENGINE OIL" (5-1).
Improper fuel	Use proper fuel. Refer to "FUEL" (4-1).
Insufficient air intake (clogged air cleaner)	Clean air cleaner element, or replace if necessary. Refer to "Cleaning, inspecting, and replacing the air cleaner element" (8-17).
Engine overcooling	Cover the radiator or consult a Mitsubishi dealer
Clogged fuel filter	Replace fuel filters. Refer to "Changing the fuel filter" (8-6).
Insufficient cooling (overheating)	Consult a Mitsubishi dealer
Incorrect valve clearance	Consult a Mitsubishi dealer
Faulty fuel feed pump	Consult a Mitsubishi dealer
Faulty fuel injection pump	Consult a Mitsubishi dealer
Faulty fuel injection nozzles	Consult a Mitsubishi dealer
Incorrect fuel injection timing	Consult a Mitsubishi dealer
Low compression pressure (worn cylinder liners, worn piston rings, etc.)	Consult a Mitsubishi dealer

### Exhaust smoke is white or blue

Table 11-4 Exhaust Smoke is White or Blue

Cause	Remedy
Excessive amount of engine oil	Maintain correct oil level. Refer to "Draining engine oil" (8-7).
Engine oil viscosity too high	Use engine oil of appropriate viscosity according to ambient temperature. Refer to "ENGINE OIL" (5-1).
Overcooling	Cover the radiator or consult your Mitsubishi dealer
Faulty thermostat (water temperature does not rise)	Consult a Mitsubishi dealer
Faulty fuel injection nozzles (uneven injection among cylinders)	Consult a Mitsubishi dealer
Incorrect fuel injection timing	Consult a Mitsubishi dealer
Low compression pressure (worn piston liners, worn piston rings, etc.)	Consult a Mitsubishi dealer
Improper fuel (low cetane number)	Use proper fuel. Refer to "FUEL" (4-1).

**Exhaust smoke is black or dark gray**

Table 11-5 Exhaust Smoke is Black or Dark Gray

Cause	Remedy
Improper fuel	Use proper fuel. Refer to "FUEL" (4-1).
Incorrect valve clearance	Consult a Mitsubishi dealer
Faulty fuel feed pump	Consult a Mitsubishi dealer
Low compression pressure (worn piston liners, worn piston rings, etc.)	Consult a Mitsubishi dealer
Insufficient intake air (improper ventilation, clogged air cleaner)	Clean air cleaner element, or replace if necessary. Refer to "Cleaning, inspecting, and replacing the air cleaner element" (8-17).
Incorrect fuel injection timing	Consult a Mitsubishi dealer
Faulty fuel injection nozzles	Consult a Mitsubishi dealer
Faulty fuel injection pump	Consult a Mitsubishi dealer

**Fuel consumption is high**

Table 11-6 Fuel Consumption is High

Cause	Remedy
Faulty fuel feed pump	Consult a Mitsubishi dealer
Faulty fuel injection pump	Consult a Mitsubishi dealer
Incorrect fuel injection timing	Consult a Mitsubishi dealer
Improper fuel	Use proper fuel. Refer to "FUEL" (4-1).
Low compression pressure (worn piston liners, worn piston rings, etc.)	Consult a Mitsubishi dealer
Insufficient intake air (improper ventilation, clogged air cleaner)	Clean air cleaner element, or replace if necessary. "Cleaning, inspecting, and replacing the air cleaner element" (8-17)

**Engine oil consumption is high**

Table 11-7 Engine Oil Consumption is High

Cause	Remedy
Excessive amount of engine oil	Maintain correct oil level. Refer to "Draining engine oil" (8-7).
Engine oil viscosity too low	Use engine oil of appropriate viscosity according to ambient temperature. Refer to "ENGINE OIL" (5-1).
Engine oil leakage	Consult a Mitsubishi dealer
Worn cylinder liners, worn piston rings	Consult a Mitsubishi dealer
Worn valve stem seals	Consult a Mitsubishi dealer

## Engine overheats

Table 11-8 Engine Overheats

Cause	Remedy
Radiator, heat exchanger leakage	Consult a Mitsubishi dealer
Low coolant level	Add coolant
Faulty water pump	Consult a Mitsubishi dealer
Faulty thermostat	Consult a Mitsubishi dealer

## Engine oil pressure is faulty

Table 11-9 Engine Oil Pressure is Faulty

Cause	Remedy
Insufficient amount of engine oil	Maintain correct oil level. Refer to "Draining engine oil" (8-7).
Engine oil viscosity too low	Use engine oil of appropriate viscosity according to ambient temperature. Refer to "ENGINE OIL" (5-1).
Clogged oil filter	Replace oil filters. Refer to "Changing engine oil, oil filters and bypass oil filter" (8-7).
Faulty oil pump	Consult a Mitsubishi dealer
Faulty relief valve	Consult a Mitsubishi dealer
Faulty oil pressure sensor	Consult a Mitsubishi dealer

**Note:** If the problem cannot be corrected easily or when a problem other than those listed above occurs, consult a Mitsubishi dealer.

When ordering replacement parts, provide the engine serial number. When requesting repair, provide the engine serial number and service hour meter reading.

## When fuel has run out

When fuel runs out during engine operation and the engine has stopped, restart the engine as described below.

1. Return the starter switch to the OFF position.
2. Add fuel to the fuel tank.  
For filling fuel tank, refer to "Draining water from the fuel tank" (8-5).
3. Bleed the fuel system.  
For bleeding fuel system, refer to "Bleeding the fuel system" (3-2).
4. Restart the engine.  
For starting the engine, refer to "Preparations for operation (pre-start inspection)" (3-9).

# Chapter 12 MAIN SPECIFICATIONS

## Main specifications

Table 12-1 Main specifications

Item	Specification
Engine model	S16R-Y2PTAW
Type	Water-cooled 4-stroke cycle, turbocharged diesel, air cooler
Number of cylinders, arrangement	16-V
Bore × Stroke (mm [in.])	170 × 180 [6.70 × 7.10]
Total displacement (L [cu.in.])	65.37 [3985]
Combustion type	Direct injection
Compression ratio	14.5 : 1
Firing order	1-9-6-14-2-10-4-12-8-16-3-11-7-15-5-13
Rotation direction	Counterclockwise as viewed from flywheel
Dimensions (L × W × H (mm) [in.])	Approx. 3045.5 × 1467 × 1810 [120 × 58 × 71]
Dry weight (kg [lb.])	Approx. 6530 [14396]
Fuel	Diesel fuel
Fuel injection pump	Mitsubishi PS8 type
Fuel filter	Cartridge-type paper element, spin-on type
Fuel injection nozzle	Hole type
Initial fuel injection pressure (MPa (kgf/cm <sup>2</sup> ) [psi])	34.3 (350) [4979]
Lubricating system	Forced circulation type (pressure feed by oil pump)
Lubrication oil	Class CD or CF oil (API service classification)
Engine oil capacity (liter [U.S.gallon])	Oil pan: Approx. 200 [52.83] Whole engine: Approx. 230 [60.76]
Oil filter	Paper element (equipped with bypass filter, spin-on type)
Oil cooler	Water cooled multi-plate (equipped with crankcase)
Cooling system	Forced cooling type
Cooling water capacity (liter [U.S.gallon])	Main cooling system : Approx. 142 [37.5] (in engine only) Inter cooler cooling system : Approx. 28 [7.4] (in engine only)
Starting system	Electrical start
Starter	24 V - 7.5 kW × 2
Alternator	24 V - 30 A
Turbocharger	Mitsubishi TD10 × 4

