

MITSUBISHI

ENGINE NORTH AMERICA

SQ - SERIES

24 to 47.5 HP



Model		S4Q	S4Q2	
Specifications	Type	4-cycle, water-cooled, diesel engine		
		Naturally Aspirated		
	Cylinder Arrangement - Bore x Stroke (mm)	88 X 95	88 X 103	
	Engine Configuration	Inline 4 Cyl.		
	Total Displacement - Liters	2.311	2.505	
	Combustion System	Swirl Chamber - IDI		
	Dry Weight kg / lbs.	195 / 430		
	Starting System	Electric starting with cell starter		
	Fuel Oil	Diesel fuel oil (ASTM No. 2-D)		
Power Unit	Continuous	1500 rpm	N/A	20.2 (27.0)
	Power Rating	1800 rpm		24.6 (33.0)
	Output	2000 rpm		27.6 (37.0)
	kWm (HP)	2200 rpm		30.2 (40.5)
	kWm (HP)	2500 rpm		33.1 (44.5)
	One-hour	1500 rpm	N/A	21.7 (29.0)
	Power Rating	1800 rpm		26.1 (35.0)
	Output	2000 rpm		29.1 (39.0)
	kWm (HP)	2200 rpm		32.0 (43.0)
	kWm (HP)	2500 rpm		☆ 35.3 (47.3)
Generators	Prime Power	50Hz 1500 rpm	18.0 (24.0)	19.9 (26.5)
	kWm (HP)	60Hz 1800 rpm	22.1 (29.6)	23.9 (32.0)
	Stand-By	50Hz 1500 rpm	19.9 (26.5)	21.7 (29.0)
	kWm (HP)	60Hz 1800 rpm	☆ 24.1 (32.3)	☆ 26.1 (35.0)

☆ EPA CERTIFICATION

CONSTRUCTION

- Ribbed thin-wall cast iron crankcase for added strength and durability.
- Internal crankcase breather for reduced emissions.
- Extra large bearing surfaces for low bearing loads and long life.

LUBRICATION

- Full flow spin-on cartridge filter.
- Forced circulation by trochoid gear pump.
- Oil Capacity: 1.72 gal (6.5 lit.)

FUEL & COMBUSTION SYSTEMS

- Bosch style fuel injection pump.
- Indirect injection combustion system for low noise and emissions.
- Cylinder head is a cross-flow, pre-chamber design to increase efficiency of combustion.

MOUNTING

- Standard crankcase side mounting pads for flexible mounting arrangements.
- Rear engine support available from side mounting pads on SAE 4 housing.

COOLING

- Forced circulation by centrifugal pump.
- Cooling packages available for ambient temperatures up to 122°F (50°C).
- Cooling Fan (Std. Eq.): Variable Speed (VS) - Suction Generator Drive (GD) - Pusher

ELECTRIC SYSTEM

- Starter: 12V, 2.0kW
- Alternator: 12V, 50 amp with integral regulator
- Glow Plugs: 12V
- High water temperature and low oil pressure switches.
- Stop Solenoid: 12V, energized to stop (ETS) solenoid. Energize to run (ETR) available June 2000.

GOVERNING

- Mechanical governing is provided for either variable or constant speeds.

DRIVES

- SAE 4 flywheel housing and 7.5 inch flywheel (GD & VS models).
- Rotation direction: counter-clockwise, facing the flywheel end.
- Limited power hydraulic drives are available for mounting at the gear end.

SQ-SERIES

TECHNICAL DATA

S4Q

Available in Generator Drive Configuration Only.

S4Q2

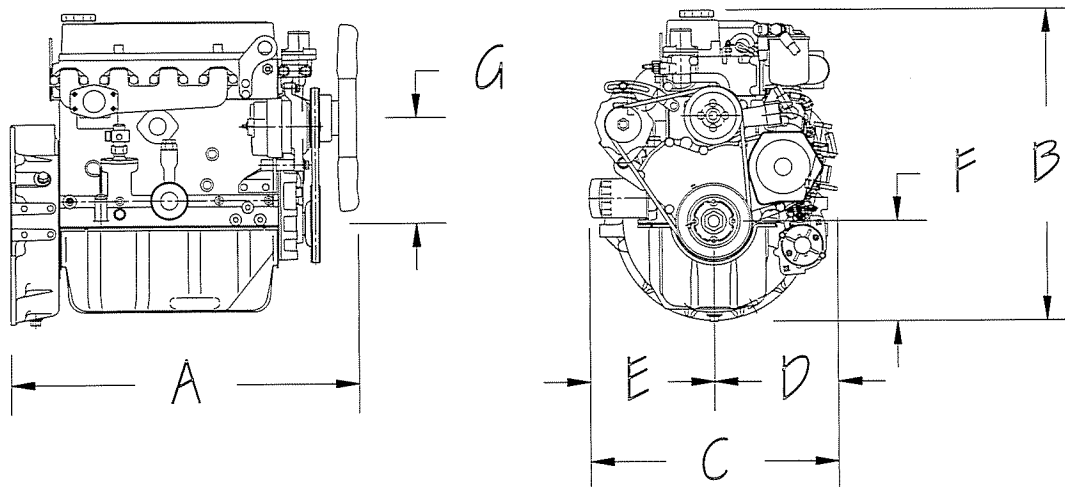
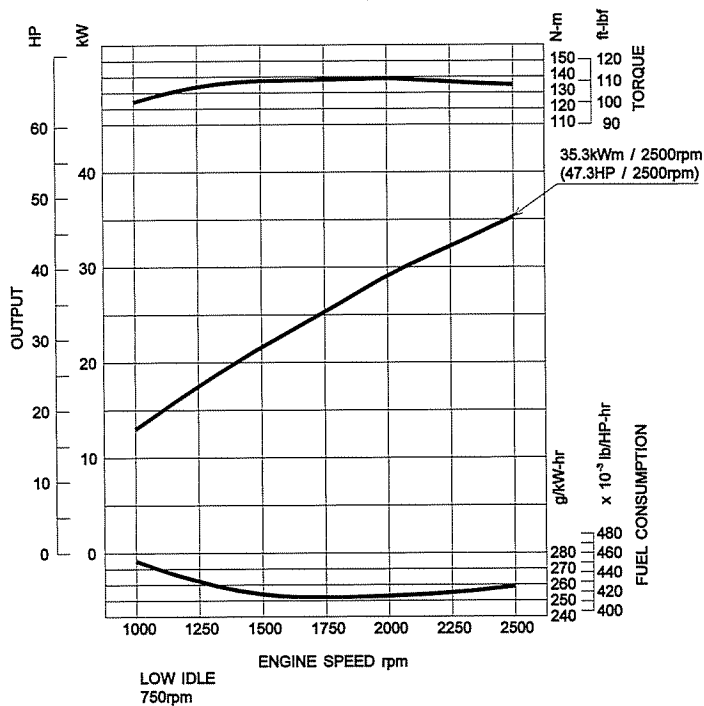

	A	B	C	D	E	F	G
S4Q/2	27.81	24.91	19.9	9.94	9.96	8.0	8.46

General dimensions are in inches.

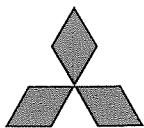

MITSUBISHI ENGINE NORTH AMERICA, INC.

1250 Greenbriar Drive, Ste. E
Addison, IL 60101-1065
(630) 268-0750
Fax (630) 268-9293
www.mitsubishi-engine.com

Your Distributor Is:

