

Engine Mechanical - 5.7L

Specifications

Fastener Tightening Specifications

Application	Specification	
	Metric	English
Accelerator Control Cable Bracket Bolt and Nut	12 N•m	106 lb in
Belt Idler Pulley Bolt	50 N•m	37 lb ft
Camshaft Retainer Bolt	12 N•m	106 lb in
Camshaft Sprocket Bolt	25 N•m	18 lb ft
Connecting Rod Nut		
First Pass	27 N•m	20 lb ft
Final Pass	55 degrees	
Crankshaft Balancer Bolt	95 N•m	70 lb ft
Crankshaft Bearing Cap Bolt and Stud (Preferred Method)		
First Pass (Two Bolt Type Bearing Cap)	20 N•m	15 lb ft
Final Pass (Two Bolt Type Bearing Cap)	73 degrees	
First Pass (Four Bolt Type Bearing Cap)	20 N•m	15 lb ft
Final Pass Outboard Bolt (Four Bolt Type Bearing Cap)	43 degrees	
Final Pass Inboard Bolt and Stud (Four Bolt Type Bearing Cap)	73 degrees	
Crankshaft Bearing Cap Bolt and Stud (Optional Strategy)		
Two Bolt Type Bearing Cap	105 N•m	77 lb ft
Inboard Bolt and Stud (Four Bolt Type Bearing Cap)	105 N•m	77 lb ft
Outboard Bolt (Four Bolt Type Bearing Cap)	90 N•m	66 lb ft
Crankshaft Oil Deflector Nut	40 N•m	30 lb ft
Crankshaft Position Sensor Bolt	9 N•m	80 lb in
Crankshaft Pulley Bolt	58 N•m	43 lb ft
Crankshaft Rear Oil Seal Housing Nut and Bolt	12 N•m	106 lb ft
Crankshaft Rear Oil Seal Housing Retainer Stud	6 N•m	53 lb in
Cylinder Head Bolt (Preferred Method)		
All Bolts First Pass in Sequence	30 N•m	22 lb ft
Long Bolts Final Pass in Sequence	75 degrees	
Medium Bolts Final Pass in Sequence	65 degrees	
Short Bolts Final Pass in Sequence	55 degrees	
Cylinder Head Bolt (Optional On-Vehicle Strategy)		
First Pass in Sequence	35 N•m	26 lb ft
Second Pass in Sequence	60 N•m	44 lb ft
Final Pass in Sequence	90 N•m	66 lb ft
Cylinder Head Core Hole Plug	20 N•m	15 lb ft
Distributor Cap Bolt	2.4 N•m	21 lb in
Distributor Clamp Bolt	25 N•m	18 lb ft
Drive Belt Tensioner Bolt	50 N•m	37 lb ft
EGR Valve Bolt		
First Pass	10 N•m	89 lb in
Final Pass	30 N•m	22 lb ft

Fastener Tightening Specifications (cont'd)

Application	Specification	
	Metric	English
EGR Valve Pipe Nut at Intake Manifold	25 N•m	18 lb ft
EGR Valve Pipe Nut at Exhaust Manifold	30 N•m	22 lb ft
EGR Valve Pipe Clamp Bracket Bolt	25 N•m	18 lb ft
Engine Block Coolant Drain Hole Plug	20 N•m	15 lb ft
Engine Block Oil Gallery Plug	20 N•m	15 lb ft
Engine Coolant Temperature (ECT) Sensor	20 N•m	15 lb ft
Engine Flywheel Bolt	100 N•m	74 lb ft
Engine Front Cover Bolt	12 N•m	106 lb in
Engine Lift Bracket Bolt (Special Tool J 41427)	15 N•m	11 lb ft
Engine Lift Front Bracket Stud	35 N•m	26 lb ft
Engine Mount Bolt (Through-bolt) to Engine Mount Bracket	95 N•m	70 lb ft
Engine Mount Bolt to Engine Mount Frame Bracket	58 N•m	43 lb ft
Engine Mount Bracket Bolt to Engine	54 N•m	40 lb ft
Engine Mount Bracket Bolt to Frame	45 N•m	33 lb ft
Engine Mount Heat Shield to Engine Mount Bracket	6 N•m	53 lb in
Engine Mount Nut (Through-Bolt)	68 N•m	50 lb ft
Engine Oil Pressure Gauge Sensor	30 N•m	22 lb ft
Engine Oil Pressure Gauge Sensor Fitting (Plus Required Angle)	15 N•m	11 lb ft
Engine Wiring Harness Bracket Nut	12 N•m	106 lb in
Evaporitive Emission (EVAP) Canister Purge Solenoid Valve Stud	10 N•m	89 lb in
Exhaust Manifold Bolt		
First Pass	15 N•m	11 lb ft
Final Pass	30 N•m	22 lb ft
Fan and Water Pump Pulley Bolt	25 N•m	18 lb ft
Fuel Pipe Bracket Bolt	6 N•m	53 lb in
Fuel Pipe Retainer Nut	3 N•m	27 lb in
Generator and Drive Belt Tensioner Bracket Bolt and Nut to Engine	41 N•m	30 lb ft
Generator and Drive Belt Tensioner Bracket Stud to Engine	20 N•m	15 lb ft
Ignition Coil Stud	12 N•m	106 lb in
Knock Sensor	20 N•m	15 lb ft
Lower Intake Manifold Bolt		
First Pass in Sequence	3 N•m	27 lb in
Second Pass in Sequence	12 N•m	106 lb in
Final Pass in Sequence	15 N•m	11 lb ft
Oil Filter Adapter Bolt	25 N•m	18 lb ft
Oil Filter Fitting	35 N•m	26 lb ft
Oil Level Indicator Tube Bolt	25 N•m	18 lb ft
Oil Pan Drain Plug	25 N•m	18 lb ft
Oil Pan Stud (Front)	6 N•m	53 lb in
Oil Pan Stud Nut	25 N•m	18 lb ft
Oil Pan Bolt or Stud	12 N•m	106 lb in
Oil Pump Bolt to Rear Crankshaft Bearing Cap		

Fastener Tightening Specifications (cont'd)

Application	Specification	
	Metric	English
Generator and Drive Belt Tensioner Bracket Stud Nut	41 N•m	30 lb ft
Ground Wire Bolt to Rear of Left Side Cylinder Head	16 N•m	12 lb ft
Ground Wire Nut to Rear of Right Side Cylinder Head	16 N•m	12 lb ft
Heater Hose Bracket Bolt to Generator and Drive Belt Tensioner Bracket	25 N•m	18 lb ft
Ignition Coil Stud	12 N•m	106 lb in
Knock Sensor	20 N•m	15 lb ft
Lower Intake Manifold Stud		
First Pass in Sequence	3 N•m	27 lb in
Second Pass in Sequence	12 N•m	106 lb in
Final Pass in Sequence	15 N•m	11 lb ft
Oil Cooler Pipe Bracket to Oil Pan Bolt	12 N•m	106 lb in
Oil Filter Fitting	55 N•m	41 lb ft
Oil Level Indicator Tube Bolt	12 N•m	106 lb in
Oil Pan Baffle Bolt	12 N•m	106 lb in
Oil Pan Bolt and Nut	25 N•m	18 lb ft
Oil Pan Drain Plug	25 N•m	18 lb ft
Oil Pan Skid Plate Bolt	20 N•m	15 lb ft
Oil Pump Bolt to Rear Crankshaft Bearing Cap	90 N•m	66 lb ft
Oil Pump Cover Bolt	12 N•m	106 lb in
Power Steering Pump Bracket Bolt to Engine	41 N•m	30 lb ft
Power Steering Pump Bracket Bolt to Engine	20 N•m	15 lb in
Power Steering Pump Bracket Stud Nut	41 N•m	30 lb ft
Power Steering Pump Bolt	50 N•m	37 lb ft
Power Steering Pump Nut to Engine (Rear Bracket to Engine)	41 N•m	30 lb ft
Power Steering Pump Rear Bracket Nut	50 N•m	37 lb ft
Secondary Air Injection (AIR) Check Valve Pipe Bracket Bolt to Exhaust Manifold	10 N•m	89 lb in
Secondary Air Injection (AIR) Check Valve Pipe Stud Nut	25 N•m	18 lb ft
Spark Plug		
Initial Installation (NEW Cylinder Head)	30 N•m	22 lb ft
All Subsequent Installations	15 N•m	11 lb ft
Spark Plug Wire Support Bolt	12 N•m	106 lb in
Starter Motor Wiring Harness/Transmission Cooler Pipe Bracket to Oil Pan Bolt	9 N•m	80 lb in
Throttle Body Stud	9 N•m	80 lb in
Transmission to Oil Pan Bolt	47 N•m	35 lb ft
Transmission Cover Bolt	12 N•m	106 lb in
Upper Intake Manifold Stud		
First Pass	5 N•m	44 lb in
Final Pass	9 N•m	80 lb in
Valve Lifter Pushrod Guide Bolt	16 N•m	12 lb ft
Valve Rocker Arm Bolt	30 N•m	22 lb ft
Valve Rocker Arm Cover Bolt	12 N•m	106 lb in

Fastener Tightening Specifications (cont'd)

Application	Specification	
	Metric	English
First Pass	20 N•m	15 lb ft
Final Pass	65 degrees	
Oil Pump Cover Bolt	12 N•m	106 lb in
Power Steering Pump Bolt	50 N•m	37 lb ft
Power Steering Pump Bracket Bolt to Engine	41 N•m	30 lb ft
Power Steering Pump Bracket Stud to Engine	20 N•m	15 lb ft
Power Steering Pump Bracket Stud Nut	41 N•m	30 lb ft
Power Steering Pump Nut to Engine	41 N•m	30 lb ft
Power Steering Pump Rear Bracket Nut	50 N•m	37 lb ft
Spark Plug		
Initial Installation (NEW Cylinder Head)	30 N•m	22 lb ft
All subsequent installations	15 N•m	11 lb ft
Spark Plug Wire Support Bolt	12 N•m	106 lb in
Square Socket Plug (Engine Block Oil Gallery)	20 N•m	15 lb ft
Throttle Body Stud	9 N•m	80 lb in
Transmission Cover Bolts	12 N•m	106 lb in
Upper Intake Manifold Stud		
First Pass	5 N•m	44 lb in
Final Pass	10 N•m	89 lb in
Valve Lifter Guide Retainer Bolts	25 N•m	18 lb ft
Valve Rocker Arm Cover Bolts	12 N•m	106 lb in
Water Outlet Stud	25 N•m	18 lb ft
Water Pump Bolt	45 N•m	33 lb ft

Engine Mechanical Specifications

Application	Specification	
	Metric	English
General Data		
Engine Type	V8	
Displacement	4.3L	350 CID
RPO (VIN Code)	L31 (R)	
Bore	101.63 mm	4.0012 in
Stroke	88.39 mm	3.480 in
Compression Ratio	9.4:1	
Firing Order	1-8-4-3-6-5-7-2	
Spark Plug Gap	1.52 mm	0.060 in
Oil Pressure (Minimum) at Normal Operating Temperature	42 kPa at 1,000 engine rpm 125 kPa at 2,000 engine rpm 166 kPa at 4,000 engine rpm	6.0 psig at 1,000 engine rpm 18.0 psig at 2,000 engine rpm 24.0 psig at 4,000 engine rpm
Camshaft		
End Play	0.05-0.30 mm	0.002-0.012 in
Journal Diameter	47.440-47.490 mm	1.8677-1.8696 in
Journal Diameter Out-of-Round	0.025 mm (Maximum)	0.0010 in (Maximum)
Lobe Lift (Exhaust)	7.20-7.30 mm	0.283-0.287 in
Lobe Lift (Intake)	6.97-7.07 mm	0.274-0.278 in
Runout	0.065 mm (Maximum)	0.0026 in (Maximum)
Connecting Rod		
Connecting Rod Bearing Clearance (Production)	0.033-0.078 mm	0.0013-0.0031 in
Connecting Rod Bearing Clearance (Service)	0.025-0.063 mm	0.0010-0.0025 in
Connecting Rod Side Clearance	0.15-0.68 mm	0.006-0.027 in
Connecting Rod Journal Diameter	53.304-53.334 mm	2.0986-2.0998 in
Connecting Rod Journal Taper (Production)	0.007 mm (Maximum)	0.0003 in (Maximum)
Connecting Rod Journal Taper (Service)	0.025 mm (Maximum)	0.0010 in (Maximum)
Connecting Rod Journal Out-of-Round (Production)	0.007 mm (Maximum)	0.0003 in (Maximum)
Connecting Rod Journal Out-of-Round (Service)	0.025 mm (Maximum)	0.0010 in (Maximum)
Crankshaft		
Crankshaft Bearing Clearance (Journal #1-Production)	0.018-0.053 mm	0.0007-0.0021 in
Crankshaft Bearing Clearance (Journal #2, #3 and #4-Production)	0.030-0.068mm	0.0012-0.0027 in
Crankshaft Bearing Clearance (Journal #5-Production)	0.020-0.060 mm	0.0008-0.0024 in
Crankshaft Bearing Clearance (Journal #1-Service)	0.025-0.051 mm	0.0010-0.0020 in
Crankshaft Bearing Clearance (Journal #2, #3 and #4-Service)	0.025-0.064 mm	0.0010-0.0025 in
Crankshaft Bearing Clearance (Journal #5-Service)	0.038-0.063 mm	0.0015-0.0025 in
Crankshaft End Play	0.050-0.20 mm	0.002-0.008 in
Crankshaft Journal Diameter (Journal #1)	62.189-62.212 mm	2.4484-2.4493 in
Crankshaft Journal Diameter (Journal #2 and #3)	62.181-62.207 mm	2.4481-2.4491 in
Crankshaft Journal Diameter (Journal #5)	62.185-62.207 mm	2.4482-2.4491 in
Crankshaft Journal Out-of-Round (Production)	0.005 mm (Maximum)	0.0002 in (Maximum)
Crankshaft Journal Out-of-Round (Service)	0.025 mm (Maximum)	0.0010 in (Maximum)
Crankshaft Journal Taper (Production)	0.005 mm (Maximum)	0.0002 in (Maximum)
Crankshaft Journal Taper (Service)	0.025 mm (Maximum)	0.0010 in (Maximum)
Crankshaft Runout at Rear Flange	0.038mm (Maximum)	0.0015 in (Maximum)
Cylinder Bore		
Diameter	101.618-101.643 mm	4.0007-4.0017 in
Out-of-Round (Production)	0.025 mm (Maximum)	0.0010 in (Maximum)
Out-of-Round (Service)	0.05 mm (Maximum)	0.002 in (Maximum)
Taper (Production-Relief Side)	0.025 mm (Maximum)	0.0010 in (Maximum)

Engine Mechanical Specifications (cont'd)

Taper (Production-Thrust Side)	0.012 mm (Maximum)	0.0005 in (Maximum)
Taper (Service Limit)	0.025 mm (Maximum)	0.0010 in (Maximum)
Cylinder Head		
Surface Flatness (Engine Block Deck)	0.10 mm (Maximum)	0.004 in (Maximum)
Surface Flatness (Exhaust Manifold Deck)	0.05 mm (Maximum)	0.002 in (Maximum)
Surface Flatness (Intake Manifold Deck)	0.10 mm (Maximum)	0.004 in (Maximum)
Exhaust Manifold		
Surface Flatness (Flange to Flange)	0.25 mm (Maximum)	0.010 in (Maximum)
Surface Flatness (Individual Flange)	0.05 mm (Maximum)	0.002 in (Maximum)
Piston		
Piston Bore Clearance (Production)	0.018-0.053 mm	0.0007-0.002 in
Piston Bore Clearance (Service)	0.018-0.053 mm	0.0007-0.002 in
Piston Pin		
Clearance in Piston (Production)	0.013-0.023 mm	0.0005-0.0009 in
Clearance in Piston (Service)	0.013-0.025 mm	0.0005-0.0010 in
Diameter	23.545-23.548 mm	0.9270-0.9271 in
Fit in Connecting Rod	0.021-0.040 mm (Interference)	0.0008-0.0016 in (Interference)
Piston Rings (End Gap Measured in Cylinder Bore)		
Piston Compression Ring Gap (Production-Top Groove)	0.25-0.40 mm	0.098-0.015 in
Piston Compression Ring Gap (Production- 2nd Groove)	0.46-0.66 mm	0.018-0.025 in
Piston Compression Ring Gap (Service -Top Groove)	0.25-0.50 mm	0.009-0.019 in
Piston Compression Ring Gap (Service - 2nd Groove)	0.46-0.80 mm	0.018-0.031 in
Piston Compression Ring Groove Clearance (Production-Top Groove)	0.030-0.070 mm	0.0012-0.0027 in
Piston Compression Ring Groove Clearance (Production- 2nd Groove)	0.040-0.080 mm	0.0015-0.003 in
Piston Compression Ring Groove Clearance (Service-Top Groove)	0.030-0.090 mm	0.0012-0.0035 in
Piston Compression Ring Groove Clearance (Service-2nd Groove)	0.040-0.100 mm	0.0015-0.0040 in
Piston Oil Ring Gap (Production)	0.25-0.76 mm	0.009-0.029 in
Piston Oil Ring Gap (Service)	0.25-0.90 mm	0.009-0.035 in
Piston Oil Ring Groove Clearance (Production)	0.046-0.096 mm	0.0018-0.0037 in
Piston Oil Ring Groove Clearance (Service)	0.046-0.100 mm	0.0018-0.0039 in
Valve System		
Valve Face Angle	45 Degrees	
Valve Head Edge Margin	0.79 mm (Minimum)	0.031 in (Minimum)
Valve Lash	Rotate the Valve Rocker Arm Nut Clockwise 360 degrees (1 Turn) from Zero Lash	
Valve Lifter	Hydraulic Roller	
Valve Rocker Arm Ratio	1.5:1	
Valve Seat Angle	46 Degrees	
Valve Seat Runout	0.05 mm (Maximum)	0.002 in (Maximum)
Valve Seat Width (Exhaust-Heavy Duty)	1.50-2.56 mm	0.059-0.101 in
Valve Seat Width (Exhaust-Light Duty)	1.65-2.49 mm	0.065-0.098 in
Valve Seat Width (Intake)	1.02-1.65 mm	0.040-0.065 in
Valve Spring Free Length	51.3 mm	2.02 in
Valve Spring Installed Height (Exhaust)	42.92-43.43 mm	1.67-1.70 in
Valve Spring Installed Height (Intake)	42.92-43.43 mm	1.67-1.70 in
Valve Spring Pressure (Closed)	338-374 N at 43.2 mm	76-84 lb at 1.70 in
Valve Spring Pressure (Open)	832-903 N at 32.3 mm	187-203 lb at 1.27 in
Valve Stem Clearance (Exhaust-Production)	0.025-0.069 mm	0.0010-0.0027 in
Valve Stem Clearance (Intake-Production)	0.025-0.069 mm	0.0010-0.0027 in
Valve Stem Clearance (Exhaust-Service)	0.025-0.094 mm	0.0010-0.0037 in
Valve Stem Clearance (Intake-Service)	0.025-0.094 mm	0.0010-0.0037 in
Valve Stem Diameter	8.661-8.679 mm	0.3410-0.3416 in
Valve Stem Oil Seal Installed Height (Measured from the Top of the Large Valve Guide Bevel to the Bottom of the Valve Stem Oil Seal)	1-2 mm	0.03937-0.07874 in

GM SPO Group Numbers

Application	GM SPO Group Number
Accelerator Control Cable Bracket	3.454
Belt Idler Pulley (Grooved)	1.062
Belt Idler Pulley (Smooth)	1.062
Camshaft Bearing	0.539
Camshaft Retainer	0.529
Camshaft Sprocket	0.736
Camshaft Sprocket Locator Pin	0.738
Camshaft Timing Chain	0.724
Clutch Pilot Bearing	0.649
Connecting Rod	0.603
Connecting Rod Bearing Kit	0.616
Crankshaft Balancer	0.659
Crankshaft Bearing Kit	0.096
Crankshaft Front Oil Seal	0.213
Crankshaft Oil Deflector	1.430
Crankshaft Rear Oil Seal	0.137
Crankshaft Rear Oil Seal Housing	0.137
Crankshaft Rear Oil Seal Housing Retainer Stud	0.137
Crankshaft Rear Oil Seal Housing Gasket	0.137
Crankshaft Rear Oil Seal Retainer Stud	0.137
Crankshaft Position Sensor	2.383
Crankshaft Position Sensor Reluctor Ring	2.383
Crankshaft Position Sensor Seal (O-ring)	2.383
Crankshaft Pulley	0.659
Crankshaft Sprocket	0.728
Cylinder Head	0.269
Cylinder Head Gasket	0.289
Distributor	2.361
Distributor Cap	2.367
Distributor Clamp	2.363
Distributor Gasket	2.363
Dowel Pin (Cylinder Head Locator)	8.939
Dowel Straight Pin (Transmission Locator)	8.939
Drive Belt Tensioner	1.060
EGR Valve	3.670
EGR Valve Gasket	3.680
EGR Valve Pipe	3.675
EGR Valve Pipe Fitting	3.680
Evaporative Emission Canister Purge Solenoid Valve	3.130
Evaporative Emission Canister Purge Solenoid Valve Harness	3.145
Engine Block	N.S.
Engine Block Core Hole Plug	0.034
Engine Block Oil Gallery Plug	1.531
Engine Camshaft	0.519
Engine Coolant Heater	1.152
Engine Coolant Temperature Sensor	1.150
Engine Coolant Temperature Gauge Sensor	1.150
Engine Coolant Thermostat	1.246
Engine Coolant Thermostat Seal (O-ring)	1.252
Engine Crankshaft	0.646
Engine Flywheel	0.666
Engine Front Cover	0.206
Engine Mount	0.029

GM SPO Group Numbers (cont'd)

Application	GM SPO Group Number
Engine Mount Bracket	0.029
Engine Mount Bracket Spacer	0.029
Engine Oil Pressure Gauge Sensor	1.800
Engine Oil Pressure Gauge Sensor Fitting	1.800
Engine Piston Kit (Piston and Pin)	0.629
Engine Wiring Harness Bracket	2.559
Exhaust Manifold	3.601
Exhaust Manifold Gasket	3.270
Exhaust Valve	0.297
Expansion Cup Plug (Camshaft Rear Bearing Hole)	8.970
Fan & Water Pump & A/C Compressor & Generator & Power Steering Pump Belt	1.066
Fan & Water Pump & Generator & Power Steering Pump Belt	1.066
Fan & Water Pump Pulley	1.062
Flywheel Locator Pin	0.669
Front Groove Pin (Crankshaft Balancer Weight)	8.940
Fuel Pipe (Included in Fuel Injection Feed and Return Pipe Kit Only)	3.163
Fuel Pipe Retainer Bracket (Included in Fuel Injection Feed and Return Pipe Kit Only)	3.163
Fuel Injector (O-ring) Seal Kit	3.331
Fuel Meter Body	3.374
Generator & Drive Belt Tensioner Bracket	1.060
Ignition Coil	2.170
Ignition Coil Wire Harness	2.240
Intake Valve	0.296
Knock Sensor	2.383
Lower Intake Manifold (Included in Lower Intake Manifold Kit Only)	3.265
Lower Intake Manifold Gasket Kit	3.270
MAP Sensor	3.682
MAP Sensor Seal	3.682
Oil Fill Cap	1.758
Oil Filter	1.836
Oil Filter Adapter	1.840
Oil Filter Adapter Gasket	1.840
Oil Filter Adapter Seal (O-ring)	1.844
Oil Filter Bypass Valve	1.837
Oil Filter Fitting	1.855
Oil Level Indicator	1.516
Oil Level Indicator Tube	1.516
Oil Pan Drain Plug	1.453
Oil Pan Drain Plug Seal (O-ring)	1.456
Oil Pan Gasket	1.429
Oil Pan Kit with Gasket	1.426
Oil Pan Reinforcement	1.426
Oil Pump	1.652
Oil Pump Cover	1.723
Oil Pump Drive Shaft	1.639
Oil Pump Drive Shaft Retainer	1.639
Oil Pump Pressure Relief Valve	1.609
Oil Pump Pressure Relief Valve Spring	1.609
Oil Pump Pressure Relief Valve Spring Bore Plug	1.609
Oil Pump Pressure Relief Valve Spring Straight Pin	1.609
Oil Pump Screen	1.656
PCV Tube	1.762
PCV Valve	1.745

GM SPO Group Numbers (cont'd)

Application	GM SPO Group Number
PCV Valve Cover	1.745
PCV Valve Elbow	1.762
PCV Valve Grommet	1.745
PCV Valve Hose	1.762
Pin (Oil Pump Locator)	1.723
Piston (with Pin)	0.629
Piston Ring Kit	0.643
Power Steering Pump Bracket	6.606
Secondary Air Injection (AIR) Check Valve	3.670
Secondary Air Injection (AIR) Check Valve Gasket	3.680
Secondary Air Injection (AIR) Check Valve (Crossover) Pipe	3.675
Secondary Air Injection (AIR) Pipe	3.675
Spark Plug	2.270
Spark Plug Wire	2.240
Spark Plug Wire Retainer	2.251
Spark Plug Wire Shield	2.251
Spark Plug Wire Support	2.251
Spring Type S Pin (Crankshaft Rear Oil Seal Housing Locator)	8.940
Square Socket Plug (Engine Block Oil Gallery)	8.971
Throttle Body	3.335
Throttle Body to Upper Manifold Gasket (Included in Service Kits Only)	N.S.
Upper Intake Manifold (Included in Upper Intake Manifold Kit Only)	3.625
Upper Intake Manifold to Lower Intake Manifold Gasket (Included in Intake Manifold Seal Kit)	3.270
Valve Lifter	0.459
Valve Lifter Guide	0.439
Valve Lifter Guide Retainer	0.439
Valve Pushrod	0.426
Valve Rocker Arm (Included in the Valve Rocker Arm Kit only)	N.S.
Valve Rocker Arm Ball (Included in the Valve Rocker Arm Kit only)	N.S.
Valve Rocker Arm Ball Stud	0.429
Valve Rocker Arm Cover	0.386
Valve Rocker Arm Cover Gasket	0.423
Valve Rocker Arm Kit (Includes the Valve Rocker Arm, the Valve Rocker Arm Ball and the Valve Rocker Arm Nut)	0.333
Valve Rocker Arm Nut	0.429
Valve Spring	0.303
Valve Spring Cap	0.309
Valve Stem Key	0.310
Valve Stem Oil Seals	0.308
Water Outlet	1.153
Water Pump Gasket	1.079
Water Pump Inlet Hose	1.097
Water Pump Kit (Includes the Water Pump Gaskets)	1.069
Woodruff Key (Crankshaft Balancer)	8.960

Sealers, Adhesives and Lubricants

Application	Type of Material	GM Part Number
Camshaft Retainer Bolt	Threadlock	12345382
Crankshaft Balancer Keyway	Adhesive	12346141
Cylinder Head Bolt	Sealant	12346004
Engine Block to the Crankshaft Rear Oil Seal Housing Junction at the Oil Pan Sealing Surfaces	Adhesive	12346141
Engine Block to the Engine Front Cover Junction at the Oil Pan Sealing Surfaces	Adhesive	12346141
Engine Block at the Lower Intake Manifold Sealing Surfaces	Adhesive	12346141
Engine Block Coolant Drain Hole Plug	Sealant	12346004
Engine Block Core Hole Plug	Threadlock	12345382
Engine Block Oil Gallery Plug	Sealant	12346004
Engine Coolant Temperature (ECT) Sensor	Sealant	12346004
Engine Coolant Temperature (ECT) Gauge Sensor	Sealant	12346004
Engine Oil	SAE 5W-30 Oil	12345610
Engine Oil Pressure Gauge Sensor	Sealant	12346004
Engine Oil Pressure Gauge Sensor Fitting	Sealant	12346004
Engine Oil Supplement	Lubricant	1052367
Evaporative Emission (EVAP) Canister Purge Solenoid Valve Stud	Threadlock	12345382
Exhaust Manifold Bolt	Threadlock	12345382
Expansion Cup Plug (Camshaft Rear Bearing Hole)	Sealant	12346004
Expansion Cup Plug (Engine Block Core Hole)	Sealant	12346004
Fuel Pipe Bolt	Threadlock	12345382
Knock Sensor	Sealant	12346004
Lower Intake Manifold Bolt	Threadlock	12345382
Oil Level Indicator Tube	Sealant	12346004
Oil Pump Screen Tube	Sealant	12346004
Throttle Body Stud	Threadlock	12345382
Upper Intake Manifold Stud	Threadlock	12345382
Valve Rocker Arm Ball Stud	Lubricant	1052271
Valve Train Component Prelube	Lubricant	12345501
Water Pump Bolt	Sealant	12346004

Diagnostic Information and Procedures

Base Engine Misfire Diagnosis

Checks	Action
	<p>Engine Performance diagnosis procedures are covered in Engine Controls and should be consulted for diagnosis of any Drivability, Emissions or Malfunctioning Indicator Lamp (MIL) concerns.</p> <p>The following diagnosis covers common concerns and possible causes.</p> <p>When the proper diagnosis is made, the concern should be corrected by adjustment, repair or replacement as required. Refer to the appropriate section of the service manual for each specific procedure.</p> <p>This diagnostic table will assist in engine misfire diagnosis due to a mechanical concern such as a faulty engine camshaft, worn or damaged bearings or bent valve pushrod.</p> <p>This table will not isolate a crossed fuel injector wire, faulty fuel injector or any other drivability component failure that may cause a misfire.</p> <p>The Powertrain On-Board Diagnostic System checks must be performed first.</p> <p>When using this table to make a Base Engine Misfire diagnosis, begin with the preliminary information below and then proceed to the specific category.</p>
Preliminary	<ol style="list-style-type: none"> 1. Perform DTC P0300 before proceeding with Base Engine Misfire Diagnosis information. DTC P0300 will assist in determining which cylinder or cylinders are misfiring. 2. Perform a visual inspection of the following: <ul style="list-style-type: none"> • A loose or improperly installed engine flywheel or crankshaft balancer • Worn, damaged or misaligned accessory drive system components 3. Listen to the engine for any abnormal internal engine noises. 4. Inspect the engine for acceptable oil pressure. 5. Verify if the engine has excessive oil consumption. 6. Verify if the engine has excessive coolant consumption. 7. Perform a compression test on the engine.
Intake Manifold Leaks	<p>An intake manifold that has a vacuum leak may cause a misfire.</p> <p>Inspect for the following:</p> <ul style="list-style-type: none"> • Improperly installed or damaged vacuum hoses • Faulty or improperly installed lower intake manifold and/or gaskets • Cracked or damaged lower intake manifold • Improperly installed MAP sensor The sealing grommet of the MAP sensor should not be torn or damaged • Improperly installed throttle body or damaged gasket • Warped intake manifold • Warped or damaged cylinder head sealing surface
Coolant Consumption	<p>Coolant consumption may or may not cause the engine to overheat.</p> <p>Inspect for the following:</p> <ul style="list-style-type: none"> • External coolant leaks • Faulty cylinder head gasket • Warped cylinder head • Cracked cylinder head • Damaged engine block
Oil Consumption	<p>Oil consumption may or may not cause the engine to misfire.</p> <ol style="list-style-type: none"> 1. Remove the spark plugs and inspect for an oil fouled spark plug. 2. Perform a cylinder compression test. 3. If the compression test indicates worn valves or valve guides, inspect the following: <ul style="list-style-type: none"> • Worn, brittle or improperly installed valve stem oil seals • Worn valve guides • Worn valve stems • Worn or burnt valves or valve seats 4. If the compression test indicates worn or damaged piston rings, inspect the following: <ul style="list-style-type: none"> • Broken or improperly seated piston rings • Excessive piston ring end gap • Excessive cylinder bore wear or taper • Cylinder damage • Piston damage

Base Engine Misfire Diagnosis (cont'd)

Checks	Action
Abnormal Internal Engine Noises	<ol style="list-style-type: none"> 1. Start the engine and determine if the noise is timed to the engine camshaft speed or the crankshaft speed. 2. Using a timing light, two knocks per flash is the crankshaft speed and one knock per flash is the engine camshaft speed. 3. If the noise is timed to the engine camshaft speed, inspect the following: <ul style="list-style-type: none"> • Missing or loose valve train components • Worn or loose valve rocker arms • Worn or bent valve pushrods • Faulty valve springs • Bent or burnt valves • Worn engine camshaft lobes • Worn or damaged camshaft timing chain and/or sprockets <p>Important: A slight COLD knock or piston slapping noise could be considered normal if not present after the engine has reached normal operating temperatures. If the knock is timed to the crankshaft speed, inspect the following:</p> <ul style="list-style-type: none"> • Worn crankshaft or connecting rod bearings • Piston ro cylinder damage • Worn piston or piston pin • Faulty connecting rod • Excessive carbon build-up on the top of the piston
No Abnormal Internal Engine Noise	<ol style="list-style-type: none"> 1. Inspect for a worn or improperly installed camshaft timing chain and/or sprockets. 2. Remove the valve rocker arm cover on the side of the engine with the cylinder that is misfiring. 3. Inspect for the following: <ul style="list-style-type: none"> • Loose valve rocker arm studs • Bent valve push rods • Faulty valve springs • Faulty valve lifters (bleeding down) • Worn or improperly seated valves • Worn engine camshaft lobes

Engine Compression Test

1. Disconnect the positive ignition coil wire plug from ignition coil.
 2. Disconnect the fuel injector electrical connector.
 3. Remove all the spark plugs.
 4. Block the throttle plate wide open.
 5. Charge the battery if the battery is not fully charged.
 6. Start with the compression gauge at zero. Then crank the engine through four compression strokes (four puffs).
 7. Make the compression check the same for each cylinder. Record the reading.
The minimum compression in any one cylinder should not be less than 70 percent of the highest cylinder. No cylinder should read less than 690 kPa (100 psi). For example, if the highest pressure in any one cylinder is 1035 kPa (150 psi), the lowest allowable pressure for any other cylinder would be 725 kPa (105 psi). (1035 x 70% = 725) (150 x 70% = 105).
 8. If some cylinders have low compression, inject approximately 15 ml (one tablespoon) of engine oil into the combustion chamber through the spark plug hole.
 9. Install the removed parts.
 10. Connect the disconnected components.
- Normal - Compression builds up quickly and evenly to the specified compression for each cylinder.
 - Piston Rings Leaking - Compression is low on the first stroke. Then compression builds up with the following strokes but does not reach normal. Compression improves considerably when you add oil.
 - Valves Leaking - Compression is low on the first stroke. Compression usually does not build up on the following strokes. Compression does not improve much when you add oil.
 - If two adjacent cylinders have lower than normal compression, and injecting oil into the cylinders does not increase the compression, the cause may be a head gasket leaking between the two cylinders.

Engine Noise Diagnosis

Symptoms	Cause
<p>When diagnosing engine noise complaints, use the following steps to isolate the source of the engine noise:</p> <ul style="list-style-type: none"> • Determine the type of noise For example, is the noise a light rattle/tapping or a low rumble/knocking? • The exact operating condition under which the noise exists Note factors such as ambient temperature, the amount of engine warm-up time, the engine temperature, the engine RPM and other specifics. • At what rate the noise occurs, and at what location on the engine Engine noises are generally synchronized to either engine speed (crankshaft, engine flywheel, connecting rods, crankshaft balancer or pistons and related components) or one-half engine speed (valve train noise such as valve rocker arms, valve lifters and camshaft timing chain). Determine the rate at which the noise is occurring. • Compare the engine sounds to other engines, and make sure you are not trying to correct a normal condition. 	
<p>Noise on Start-Up but Only Lasts a Few seconds</p>	<ul style="list-style-type: none"> • Improper oil viscosity. Install the recommended oil viscosity for the expected temperatures. • Worn or dirty valve lifters • Excessive piston-to-cylinder bore clearance • Excessive piston pin-to-bore clearance • Excessive crankshaft bearing clearance
<p>Knocks Cold and Continues for 1 to 2 Minutes</p>	<ul style="list-style-type: none"> • Loose or broken crankshaft balancer or accessory drive components • Excessive piston-to-bore clearance A cold piston knock which appears in 1.5 minutes should be considered acceptable. • A cold engine knock usually disappears when the specific cylinders secondary ignition circuit is grounded out.
<p>Intermittent Noise on Idle, Disappearing When Engine Speed is Increased</p>	<ul style="list-style-type: none"> • Improper oil viscosity. Install the recommended oil viscosity for the expected temperatures. • Lower than specified oil pressure Install an oil pressure gauge and measure the engine oil pressure. • Dirty or worn valve lifter
<p>Valve Train Noise (Rattle/Tapping)</p>	<p>The following conditions may cause valve train noise:</p> <ul style="list-style-type: none"> • Lower than specified oil pressure • Worn or faulty oil pump • Loose oil pump-to-engine block bolt • Loose valve rocker arm attachments • Worn valve rocker arms and/or valve pushrods • Broken valve spring • Sticking valves • Worn, dirty or faulty valve lifters • Worn engine camshaft lobes • Worn valve guides or valve stems • Bent, broken or damaged timing chain sprocket teeth
<p>Knocks Hot at Idle (Rumble/Knocking)</p>	<p>The following conditions may cause a knocking noise:</p> <ul style="list-style-type: none"> • Malfunctioning accessory drive system components • Loose or broken crankshaft balancer • Detonation or spark knock Check for proper operation of the cooling, knock and ignition control components. • Refer to diagnostic information in Engine Controls • Excessive connecting rod bearing clearance • Excessive piston pin-to-bore clearance • Bent connecting rod • Excessive crankshaft bearing clearance • Loose torque converter bolts (if equipped) • Cracked or damaged engine flywheel • Exhaust leak at the exhaust manifold • Combustion chamber deposits
<p>Exhaust System Noise and/or Leakage</p>	<p>Exhaust system noise and/or leakage may be caused by the following conditions:</p> <ul style="list-style-type: none"> • Improperly installed or misaligned exhaust system components • A cracked or broken exhaust manifold • Damaged or worn exhaust manifold gaskets and/or seals • Burnt or rusted out exhaust system components • Broken or loose exhaust clamps and/or brackets

Valve Train Diagnosis

General Information

Symptoms	Cause
<ul style="list-style-type: none"> A light tapping noise at 1/2 engine speed, or any varying frequency, may indicate a valve train problem. Tapping noises will typically increase with increased engine speed. Before attempting to diagnose a valve train noise, check for the proper engine oil level and then allow the engine to obtain normal operating temperature. Following this procedure will bring all engine components to a normal state of expansion. Sit in the driver's seat, then operate the engine at various speeds and listen for any abnormal engine noise. 	
Valve Train Noise	<ul style="list-style-type: none"> Low engine oil pressure A worn or faulty oil pump A loose or plugged oil pump screen Loose valve rocker arm attachments (causing excessive valve lash) A worn or damaged valve rocker arm ball A worn valve rocker arm and/or valve pushrod A broken valve spring Sticking valves Valve lifters worn, dirty or faulty A broken valve lifter guide Engine camshaft lobes worn Worn valve guides or valve stems Bent valve pushrods Excessive free play in the camshaft timing chain Bent, broken or damaged camshaft sprocket teeth

Diagnostic Table

Step	Action	Value(s)	Yes	No
DEFINITION: A light tapping noise at 1/2 engine speed, or any varying frequency.				
1	Is there valve train noise?	—	Go to Step 2	System OK
2	Check for a high engine oil level. An engine with the engine oil level above the FULL mark on the oil level indicator allows the crankshaft counterweights to churn the engine oil into foam. When the foamy engine oil is pumped into the valve lifters, the valve lifters become noisy. A solid column of engine oil ensures proper valve lifter operation. Is the engine oil level too high?	—	Go to Step 3	Go to Step 4
3	Drain the engine oil to the proper level. Is the tapping noise gone?	—	System OK	Go to Step 6
4	Check for a low engine oil level. An engine with the engine oil level below the ADD mark on the oil level indicator may allow the oil pump to pump air at high engine RPM. Is the engine oil level below the ADD mark on the oil level indicator?	—	Go to Step 5	Go to Step 6
5	Add the engine oil as required. Is the tapping noise gone?	—	System OK	Go to Step 6
6	Check for the proper engine oil pressure. Refer to <i>Engine Mechanical Specifications and Oil Pressure Diagnosis and Testing</i> . Is the engine oil pressure within specifications?	41.4 kPa (6 psi)	Go to Step 11	Go to Step 7

Diagnostic Table (cont'd)

Step	Action	Value(s)	Yes	No
7	Check the oil pump screen for damage or a loose fit to the oil pump. Is the oil pump screen loose or is the oil pump screen damaged?	—	Go to Step 8	Go to Step 9
8	Repair as required. Is the tapping noise gone?	—	System OK	Go to Step 9
9	Check for a damaged oil pump or loose bolts. Refer to <i>Oil Pump Clean and Inspect</i> . Is the oil pump damaged or are the bolts loose?	—	Go to Step 10	Go to Step 11
10	Repair as required. Is the tapping noise gone?	—	System OK	Go to Step 11
11	Remove and inspect the valve lifters, the valve rocker arms and the valve pushrods. Refer to <i>Valve Rocker Arm and Pushrods Clean and Inspect</i> and <i>Valve Lifters and Guides Clean and Inspect</i> . Are the components worn or damaged?	—	Go to Step 12	Go to Step 13
12	Replace the components as required. Is the tapping noise gone?	—	System OK	Go to Step 13
13	Perform an engine camshaft lobe lift test. Refer to <i>Camshaft and Bearings Clean and Inspect</i> . Is the engine camshaft lobes within specifications?	—	Go to Step 15	Go to Step 14
14	Replace the engine camshaft and valve lifters. Is the tapping noise gone?	—	System OK	Go to Step 15
15	Remove the engine front cover and inspect the camshaft timing chain and sprockets for excessive wear or damage. Refer to <i>Timing Chain and Sprockets Clean and Inspect</i> . Are the components worn or damaged?	—	Go to Step 17	Go to Step 16
16	Replace the components as required. Is the tapping noise gone?	—	System OK	Go to Step 17
17	Perform a complete disassembly of the engine and inspect all components. Are the components worn or damaged?	—	Go to Step 18	System OK
18	Replace the components as required. Did you complete the worn or damaged component replacement?	—	System OK	—

Oil Consumption Diagnosis

Excessive oil consumption (not due to leaks) is the use 1.9 liters (2 quarts) of engine oil within 3,200 kilometers (2,000 miles). However, during initial engine break-in periods 4,828-6,437 kilometers (3,000-4,000 miles) oil consumption may exceed 1.9 liters (2 quarts) or more. The causes of excessive oil consumption include the following conditions:

- External oil leaks. Tighten the bolts and/or replace gaskets and oil seals as necessary.
- Incorrect oil level or improper reading of oil level indicator. With the vehicle on a level surface, allow adequate drain down time and check for the correct oil level.
- Improper oil viscosity. Use a recommended SAE viscosity for the prevailing temperatures.
- Continuous high speed operation and/or severe usage.
- Crankcase ventilation system restrictions or malfunctioning components. Possible improper PCV valve.
- Valve guides and/or valve stem oil seals worn, damaged or the seal omitted. Ream the valve guides and install oversize service valves and/or new valve stem oil seals.
- Piston rings broken, improperly installed, worn or not seated properly. Allow adequate time for the piston rings to seat. Replace broken or worn piston rings as necessary.
- Piston improperly installed or mis-fitted.

Oil Pressure Diagnosis and Testing

1. With the vehicle on a level surface, allow adequate drain down time (2-3 minutes) and measure for a low engine oil level.
Add the recommended grade engine oil, and fill the crankcase until the oil level measures FULL on the oil level indicator.
2. Operate the engine and verify low or no oil pressure on the vehicle oil pressure gauge or the oil indicator light.
Listen for a noisy valve train or a knocking noise.
3. Inspect for the following:
 - Engine oil diluted by moisture or unburned fuel mixtures
 - Improper engine oil viscosity for the expected temperature
 - Incorrect or faulty oil pressure gauge sensor
 - Incorrect or faulty oil pressure gauge
 - Plugged oil filter
 - Malfunctioning oil filter bypass valve

4. Remove the oil pressure gauge sensor or another engine block oil gallery plug.
5. Install an oil pressure gauge.
6. Start the engine and then allow the engine to reach normal operation temperature.
7. Measure the engine oil pressure at the following RPM:

Specification

- 7.1. 42 kPa (6psig) (minimum) at 1,000 RPM
- 7.2. 125 kPa (18 psig) (minimum) at 2,000 RPM
- 7.3. 166 kPa (24 psig) (minimum) at 4,000 RPM
8. If the engine oil pressure is below minimum specifications, inspect the engine for one or more of the following:
 - Oil pump worn or dirty
 - Malfunctioning oil pump pressure relief valve
 - Oil pump screen loose, plugged or damaged
 - Excessive bearing clearance
 - Cracked, porous or restricted oil galleries
 - Engine block oil gallery plugs missing or incorrectly installed
 - Broken valve lifters

Oil Leak Diagnosis

Step	Action	Value(s)	Yes	No
<p>Important: You can repair most fluid leaks by first visually locating the leak, repairing or replacing the component, or by resealing the gasket surface. Once the leak is identified, determine the cause of the leak. Repair the cause of the leak as well as the leak itself.</p>				
1	<ol style="list-style-type: none"> Operate the vehicle until it reaches normal operating temperature. Park the vehicle on a level surface, over a large sheet of paper or other clean surface. Wait (15 minutes) Check for drippings. <p>Are drippings present?</p>	—	Go to Step 2	System OK
2	Can you identify the type of fluid and the approximate location of the leak?	—	Go to Step 10	Go to Step 3
3	<ol style="list-style-type: none"> Visually inspect the suspected area. Use a small mirror to assist in looking at hard to see areas. Check for leaks at the following locations: <ul style="list-style-type: none"> Sealing surfaces Fittings Cracked or damaged components <p>Can you identify the type of fluid and the approximate location of the leak?</p>	—	Go to Step 10	Go to Step 4
4	<ol style="list-style-type: none"> Completely clean the entire engine and surrounding components. Operate the vehicle for several kilometers (miles) at normal operating temperature and at varying speeds. Park the vehicle on a level surface, over a large sheet of paper or other clean surface. Wait (15 minutes). Identify the type of fluid and the approximate location of the leak. <p>Can you identify the type of fluid and the approximate location of the leak?</p>	—	Go to Step 10	Go to Step 5
5	<ol style="list-style-type: none"> Visually inspect the suspected area. Use a small mirror to assist in looking at hard to see areas. Check for leaks at the following locations: <ul style="list-style-type: none"> Sealing surfaces Fittings Cracked or damaged components <p>Can you identify the type of fluid and the approximate location of the leak?</p>	—	Go to Step 10	Go to Step 6
6	<ol style="list-style-type: none"> Completely clean the entire engine and surrounding components. Apply an aerosol-type powder (baby powder, foot powder, etc.) to the suspected area. 			

Oil Leak Diagnosis (cont'd)

Step	Action	Value(s)	Yes	No
	3. Operate the vehicle for several kilometers (miles) at normal operating temperature and at varying speeds.			
6	4. Identify the type of fluid and the approximate location of the leak, from the discolorations in the powder surface. Can you identify the type of fluid and the approximate location of the leak?	—	Go to Step 10	Go to Step 7
7	1. Visually inspect the suspected area. Use a small mirror to assist in looking at hard to see areas. 2. Check for leaks at the following locations: <ul style="list-style-type: none"> • Sealing surfaces • Fittings • Cracked or damaged components Can you identify the type of fluid and the approximate location of the leak?	—	Go to Step 10	Go to Step 8
8	Use <i>J 28428-E</i> , Dye and Light Kit, in order to identify the type of fluid and the approximate location of the leak. Refer to manufacturer's instructions when using the tool. Can you identify the type of fluid and the approximate location of the leak?	—	Go to Step 10	Go to Step 9
9	1. Visually inspect the suspected area. Use a small mirror to assist in looking at hard to see areas. 2. Check for leaks at the following locations: <ul style="list-style-type: none"> • Sealing surfaces • Fittings • Cracked or damaged components Can you identify the type of fluid and the approximate location of the leak?	—	Go to Step 10	System OK
10	1. Inspect the engine for mechanical damage. Special attention should be shown to the following areas: <ul style="list-style-type: none"> • Higher than recommended fluid levels • Higher than recommended fluid pressures • Plugged or malfunctioning fluid filters or pressure bypass valves • Plugged or malfunctioning engine ventilation system • Improperly tightened or damaged fasteners • Cracked or porous components • Improper sealants or gaskets where required • Improper sealant or gasket installation • Damaged or worn gaskets or seals • Damaged or worn sealing surfaces 2. Inspect the engine for customer modifications. Is there mechanical damage, or customer modifications to the engine?	—	Go to Step 11	System OK
11	Repair or replace all damaged or modified components. Does the engine still leak oil?	—	Go to Step 1	—

Symptoms - Drive Belt

Important: Review the system operation in order to familiarize yourself with the system functions. Refer to *Drive Belt System Description*.

Visual/Physical Inspection

- Inspect for aftermarket devices which could affect the operation of the drive belts.
- Inspect the easily accessible or visible system components for obvious damage or conditions which could cause the symptom.
- Inspect the drive belt for excessive wear, shredding or missing sections.
- Inspect the drive belt for contamination of excessive dirt, oil, coolant or other substances that may affect the drive belt operation.

Intermittent

- Drive belt symptoms may be from intermittent

failure of an accessory drive component.

- Drive belt symptoms may occur from changes in load of the accessory drive components.
- Ambient temperatures, moisture or engine operating temperature can affect the drive belt operation.

Symptoms List

Refer to a symptom diagnostic procedure from the following list in order to diagnose the symptom:

- *Drive Belt Chirping Diagnosis*
- *Drive Belt Squeal Diagnosis*
- *Drive Belt Whine Diagnosis*
- *Drive Belt Rumbling Diagnosis*
- *Drive Belt Vibration Diagnosis*
- *Drive Belt Falls Off Diagnosis*
- *Drive Belt Excessive Wear Diagnosis*

Drive Belt Chirping Diagnosis

Diagnostic Aids

The symptom may be intermittent due to moisture on the drive belt(s) or the pulleys. It may be necessary to spray a small amount of water on the drive belt(s) in order to duplicate the customer's concern. If spraying water on the drive belt(s) duplicates the symptom, cleaning the belt pulleys may be the probable solution.

A loose or improper installation of a body component, a suspension component or other items of the vehicle may cause the chirping noise.

Test Description

The number(s) below refer to the step number(s) on the diagnostic table.

2. The noise may not be engine related. This step is to verify that the engine is making the noise. If the engine is not making the noise, do not proceed further with this table.
3. The noise may be an internal engine noise. Removing the drive belt and operating the engine for a brief period will verify the noise is related to the drive belt. When removing the drive belt(s), the water pump may not be operating and the engine may overheat. Also DTCs may set when the engine is operating with the drive belt removed.
4. Inspect all drive belt pulleys for pilling. Pilling is the small balls or pills or it can be strings in the drive belt grooves from the accumulation of rubber dust.

6. Misalignment of the pulleys may be caused from improper mounting of the accessory drive component, incorrect installation of the accessory drive component pulley or the pulley bent inward or outward from a previous repair. Test for a misaligned pulley using a straight edge in the pulley grooves across two or three pulleys. If a misaligned pulley is found, refer to that accessory drive component for the proper installation procedure for that pulley.
10. Inspecting of the fasteners can eliminate the possibility that a wrong bolt, nut, spacer or washer was installed.
12. Inspecting the pulleys for being bent should include inspecting for a dent or other damage to the pulleys that would prevent the drive belt from not seating properly in all of the pulley grooves or on the smooth surface of a pulley when the back side of the belt is used to drive the pulley.
14. Replacing the drive belt when it is not damaged or there is not excessive pilling will only be a temporary repair.

Drive Belt Chirping Diagnosis

Step	Action	Value(s)	Yes	No
<p>Notice: Refer to <i>Belt Dressing Notice</i> in Cautions and Notices.</p> <p>DEFINITION: The following items are indications of chirping:</p> <ul style="list-style-type: none"> • A high pitched noise that is heard once per revolution of the drive belt or a pulley. • It usually occurs on cold damp mornings. 				
1	Did you review the Drive Belt Symptom operation and perform the necessary inspections?	—	Go to Step 2	Go to <i>Symptoms - Drive Belt</i>
2	Verify that there is a chirping noise. Does the engine make the chirping noise?	—	Go to Step 3	Go to Diagnostic Aids
3	1. Remove the drive belt. 2. Operate the engine for no longer than 30 to 40 seconds. Does the chirping noise still exist?	—	Go to <i>Engine Noise Diagnosis</i>	Go to Step 4
4	Inspect for severe pilling exceeding 1/3 of the belt groove depth. Does the belt grooves have pilling?	—	Go to Step 5	Go to Step 6
5	Clean the drive belt pulleys with a suitable wire brush. Did you complete the repair?	—	Go to Step 15	Go to Step 6
6	Inspect for misalignment of the pulleys. Are any of the pulleys misaligned?	—	Go to Step 7	Go to Step 8
7	Replace or repair any misaligned pulleys. Did you complete the repair?	—	Go to Step 15	Go to Step 8
8	Inspect for bent or cracked brackets. Did you find any bent or cracked brackets?	—	Go to Step 9	Go to Step 10
9	Replace any bent or cracked brackets. Did you complete the repair?	—	Go to Step 15	Go to Step 10
10	Inspect for improper, loose or missing fasteners Did you find the condition?	—	Go to Step 11	Go to Step 12
11	Tighten any loose fasteners. Replace any improper or missing fasteners. Refer to <i>Fastener Tightening Specifications</i> . Did you complete the repair?	—	Go to Step 15	Go to Step 12
12	Inspect for a bent pulley. Did you find the condition?	—	Go to Step 13	Go to Step 14
13	Replace the bent pulley. Did you complete the repair?	—	Go to Step 15	Go to Step 14
14	Replace the drive belt. Refer to <i>Drive Belt Replacement</i> . Did you complete the repair?	—	Go to Step 15	Go to Diagnostic Aids
15	Operate the system in order to verify the repair. Did you correct the condition?	—	System OK	Go to Step 3

Drive Belt Squeal Diagnosis

Diagnostic Aids

A loose or improper installation of a body component, a suspension component or other items of the vehicle may cause the chirping noise.

If the noise is intermittent, verify the accessory drive components by varying their loads making sure they are operated to their maximum capacity. An overcharged A/C system, power steering system with a pinched hose or wrong fluid or a generator failing are suggested items to inspect.

Test Description

The number(s) below refer to the step number(s) on the diagnostic table.

2. The noise may not be engine related. This step is to verify that the engine is making the noise. If the engine is not making the noise, do not proceed further with this table.
3. The noise may be an internal engine noise. Removing the drive belt and operating the engine for a brief period will verify the noise is related to the drive belt. When removing the drive belt(s), the water pump may not be operating and the engine may overheat. Also DTCs may set when the engine is operating with the drive belt removed.
4. This test is to verify that an accessory drive component does not have a seized bearing. With the belt removed, test the bearings in the

accessory drive components for turning smoothly. Also test the accessory drive components with the engine operating by varying the load on the components to verify that the components operate properly.

5. This test is to verify that the drive belt tensioner operates properly. If the drive belt tensioner is not operating properly, proper belt tension may not be achieved to keep the drive belt from slipping, which could cause a squeal noise.
6. This test is to verify that the drive belt(s) is not too long, which would prevent the drive belt tensioner from working properly. Also, if an incorrect length drive belt was installed, it may not be routed properly and may be turning an accessory drive component in the wrong direction.
7. Misalignment of the pulleys may be caused from improper mounting of the accessory drive component, incorrect installation of the accessory drive component pulley or the pulley bent inward or outward from a previous repair. Test for a misaligned pulley using a straight edge in the pulley grooves across two or three pulleys. If a misaligned pulley is found, refer to that accessory drive component for the proper installation procedure for that pulley.
8. This test is to verify that the pulleys are the correct diameter or width. Using a known good vehicle compare the pulley sizes.

Drive Belt Squeal Diagnosis

Step	Action	Value(s)	Yes	No
<p>Notice: Refer to <i>Belt Dressing Notice</i> in Cautions and Notices.</p> <p>DEFINITION: The following items are indications of drive belt squeal:</p> <ul style="list-style-type: none"> • A loud screeching noise that is caused by a slipping drive belt (this is unusual for a drive belt with multiple ribs) • The noise occurs when a heavy load is applied to the drive belt, such as an air conditioning compressor engagement, snapping the throttle or slipping on a seized pulley or a faulty accessory drive component. 				
1	Did you review the Drive Belt Symptom operation and perform the necessary inspections?	—	Go to Step 2	Go to <i>Symptoms - Drive Belt</i>
2	Verify that there is a squeal noise. Does the engine make the squeal noise?	—	Go to Step 3	Go to Diagnostic Aids
3	1. Remove the drive belt(s). 2. Operate the engine for no longer than 30 to 40 seconds. Does the chirping noise still exist?	—	Go to <i>Engine Noise Diagnosis</i>	Go to Step 4
4	Inspect for an accessory drive component seized bearing or faulty accessory drive component. Did you find and correct the condition?	—	Go to Step 9	Go to Step 5

Drive Belt Squeal Diagnosis (cont'd)

Step	Action	Value(s)	Yes	No
5	Test the drive belt tensioner for proper operation. Refer to <i>Drive Belt Tensioner Diagnosis</i> . Did you find and correct the condition?	—	Go to Step 9	Go to Step 6
6	Inspect for the correct drive belt length. Refer to <i>Drive Belt Replacement</i> . Did you find and correct the condition?	—	Go to Step 9	Go to Step 7
7	Inspect for a misalignment of a pulley. Did you find and correct the condition?	—	Go to Step 9	Go to Step 8
8	Inspect for the correct pulley size. Did you find and correct the condition?	—	Go to Step 9	Go to Diagnostic Aids
9	Operate the system in order to verify the repair. Did you correct the condition?	—	System OK	Go to Step 3

Drive Belt Whine Diagnosis

Diagnostic Aids

The drive belt(s) will not cause the whine noise.

If the whine noise is intermittent, verify the accessory drive components by varying their loads making sure they are operated to their maximum capacity. An overcharged A/C system, power steering system with a pinched hose or wrong fluid or a generator failing are suggested items to inspect.

Test Description

The number(s) below refer to the step number(s) on the diagnostic table.

- 3. This test is to verify that the noise is being

caused by the drive belt(s) or the accessory drive components. When removing the drive belt(s), the water pump may not be operating and the engine may overheat. Also DTCs may set when the engine is operating with the drive belt(s) removed.

- 4. The inspection should include checking the drive belt tensioner and the drive belt idler pulley bearings. The drive belt(s) may have to be installed and the accessory drive components operated separately by varying their loads. Refer to the suspected accessory drive component for the proper inspection and replacement procedure.

Drive Belt Whine Diagnosis

Step	Action	Value(s)	Yes	No
Notice: Refer to <i>Belt Dressing Notice</i> in Cautions and Notices.				
DEFINITION: A high pitched continuous noise that may be caused by an accessory drive component failed bearing.				
1	Did you review the Drive Belt Symptom operation and perform the necessary inspections?	—	Go to Step 2	Go to <i>Symptoms-Drive Belt</i>
2	Verify that there is a whine noise. Does the engine make the whine noise?	—	Go to Step 3	Go to Diagnostic Aids
3	1. Remove the drive belt(s). 2. Operate the engine for no longer than 30 to 40 seconds. Does the whine noise still exist?	—	Go to <i>Engine Noise Diagnosis</i>	Go to Step 4
4	Inspect for a failed accessory drive component bearing. Did you find and repair the condition?	—	Go to Step 5	Go to Diagnostic Aids
5	Operate the system in order to verify the repair. Did you correct the condition?	—	System OK	—

Drive Belt Rumbling Diagnosis

Diagnostic Aids

Vibration from the engine operating may cause a body component or another part of the vehicle to make rumbling noise.

The drive belt(s) may have a condition that can not be seen or felt. Sometimes replacing the drive belt may be the only repair for the symptom.

If replacing the drive belt(s), completing the diagnostic table, and the noise is only heard when the drive component with a failure. Varying the load on the different accessory drive components may aid in identifying which component is causing the rumbling noise.

Test Description

The number(s) below refer to the step number(s) on the diagnostic table.

2. This test is to verify that the symptom is present during diagnosing. Other vehicle components may cause a similar symptom.
3. This test is to verify that the drive belt(s) is causing the rumbling noise. Rumbling noise may be confused with an internal engine noise due to the similarity in the description. Remove only one drive belt at a time if the vehicle has multiple drive belts. When removing the drive belt the water pump may not be operating and the engine may overheat. Also, DTC's may set when the engine is operating with the drive belt removed.
4. Inspecting the drive belt(s) is to ensure that it is not causing the noise. Small cracks across the ribs of the drive belt will not cause the noise. Belt separation is identified by the plies of the belt separating and may be seen at the edge of the belt, or felt as a lump in the belt.
5. Small amounts of pilling is a normal condition and acceptable. When the pilling is severe, the drive belt does not have a smooth surface for proper operation.

Drive Belt Rumbling Diagnosis

Step	Action	Value(s)	Yes	No
<p>Notice: Refer to <i>Belt Dressing Notice</i> in Cautions and Notices.</p> <p>DEFINITION:</p> <ul style="list-style-type: none"> • A low pitch tapping, knocking or thumping noise heard at or just above idle. • Heard once per revolution of the drive belt or a pulley. • Rumbling may be caused from: <ul style="list-style-type: none"> - Pilling, the accumulation of rubber dust that forms small balls (pills) or strings in the drive belt pulley groove - The separation of the drive belt - A damaged drive belt 				
1	Did you review the Drive Belt Symptom operation and perform the necessary inspections?	—	Go to Step 2	Go to <i>Symptoms-Drive Belt</i>
2	Verify that there is a rumbling noise. Does the engine make the rumbling noise?	—	Go to Step 3	Go to Diagnostic Aids
3	1. Remove the drive belt(s). 2. Operate the engine for no longer than 30 to 40 seconds. Does the rumbling noise still exist?	—	Go to <i>Engine Noise Diagnosis</i>	Go to Step 4
4	Inspect the drive belt(s) for damage, separation or sections of missing ribs. Did you find and repair the condition?	—	Go to Step 7	Go to Step 5
5	Inspect for severe pilling of more than 1/3 of the drive belt pulley grooves. Did you find severe pilling?	—	Go to Step 6	Go to Step 7
6	1. Clean the drive belt pulleys using a suitable wire brush. 2. Reinstall the drive belt. Refer to <i>Drive Belt Replacement</i> . Did you complete the repair?	—	Go to Step 8	Go to Step 7

Drive Belt Rumbling Diagnosis (cont'd)

Step	Action	Value(s)	Yes	No
7	Install a new drive belt. Refer to <i>Drive Belt Replacement</i> . Did you complete the replacement?	—	Go to Step 8	—
8	Operate the system in order to verify the repair. Did you correct the condition?	—	System OK	Go to Diagnostic Aids

Drive Belt Vibration Diagnosis

Diagnostic Aids

The accessory drive components can have an affect on engine vibration. Such as, but not limited to the A/C system overcharged, the power steering system restricted or the incorrect fluid or an extra load on the generator. To help identify an intermittent or an improper condition, vary the loads on the accessory drive components.

Test Description

The number(s) below refer to the step number(s) on the diagnostic table.

- 2. This test is to verify that the symptom is present during diagnosing. Other vehicle components may cause a similar symptom such as the exhaust system or the drivetrain.
- 3. This test is to verify that the drive belt(s) or accessory drive components may be causing the vibration. When removing the drive belt the water pump may not be operating and the engine may overheat. Also, DTC's may set when the engine is operating with the drive belt removed.

- 4. The drive belt(s) may cause a vibration. While the drive belt(s) is removed, inspect the condition of the belt.
- 6. Inspecting of the fasteners can eliminate the possibility that a wrong bolt, nut, spacer or washer was installed.
- 8. This step should only be performed if the fan is driven by the drive belt. Inspect the engine cooling fan for bent, twisted, loose or cracked blades. Inspect the fan clutch for smoothness, ease of turning. Inspect for a bent fan shaft or bent mounting flange.
- 9. This step should only be performed if the water pump is driven by the drive belt. Inspect the water pump shaft for being bent. Also inspect the water pump bearings for smoothness and excessive play. Compare the water pump with a known good water pump.
- 10. Accessory drive component brackets that are bent, cracked or loose may put extra strain on that accessory component causing it to vibrate.

Drive Belt Vibration Diagnosis

Step	Action	Value(s)	Yes	No
Notice: Refer to <i>Belt Dressing Notice</i> in Cautions and Notices.				
DEFINITION:				
<ul style="list-style-type: none"> • The vibration is engine-speed related. • The vibration may be sensitive to accessory load. 				
1	Did you review the Drive Belt Symptom operation and perform the necessary inspections?	—	Go to Step 2	Go to <i>Symptoms-Drive Belt</i>
2	Verify that the vibration is engine related. Does the engine make the vibration?	—	Go to Step 3	Go to Diagnostic Aids
3	1. Remove the drive belt(s). 2. Operate the engine for no longer than 30 to 40 seconds. Does the rumbling noise still exist?	—	Go to <i>Engine Related Vibration</i>	Go to Step 4
4	Inspect the drive belt(s) for wear, damage, debris build-up and missing drive belt ribs. Did you find any of these conditions?	—	Go to Step 5	Go to Step 6

Drive Belt Vibration Diagnosis (cont'd)

Step	Action	Value(s)	Yes	No
5	Install a new drive belt. Refer to <i>Drive Belt Replacement</i> . Did you complete the replacement?	—	Go to Step 11	—
6	Inspect for improper, loose or missing fasteners. Did you find any of these conditions?	—	Go to Step 7	Go to Step 8
7	Tighten any loose fasteners. Replace improper or missing fasteners. Refer to <i>Fastener Tightening Specifications</i> . Did you complete the repair?	—	Go to Step 11	—
8	Inspect for damaged fan blades or bent fan clutch shaft, if the fan is belt driven. Refer to <i>Fan Clutch Replacement</i> in Engine Cooling. Did you find and correct the condition?	—	Go to Step 11	Go to Step 9
9	Inspect for bent water pump shaft, if the water pump is belt driven. Refer to <i>Water Pump Replacement (4.3L Engine)</i> in Engine Cooling. Did you find and correct the condition?	—	Go to Step 11	Go to Step 10
10	Inspect for bent or cracked brackets. Did you find and correct the condition?	—	Go to Step 11	Go to Diagnostic Aids
11	Operate the system in order to verify the repair. Did you correct the condition?	—	System OK	Go to Step 3

Drive Belt Falls Off Diagnosis

Diagnostic Aids

If the drive belt(s) repeatedly falls off the drive belt pulleys, this is because of pulley misalignment.

An extra load that is quickly applied and released by an accessory drive component may cause the drive belt to fall off the pulleys. Verify the accessory drive components operate properly.

If the drive belt(s) is the incorrect length, the drive belt tensioner may not keep the proper tension on the drive belt.

Test Description

The number(s) below refer to the step number(s) on the diagnostic table.

- This inspection is to verify the condition of the drive belt. Damage may have occurred to the drive belt when the drive belt fell off. The drive belt may have been damaged, which caused the drive belt to fall off. Inspect the belt for cuts, tears, sections of ribs missing or damaged belt plies.
- Misalignment of the pulleys may be caused from improper mounting of the accessory drive

component, incorrect installation of the accessory drive component pulley or the pulley bent inward or outward from a previous repair. Test for a misaligned pulley using a straight edge in the pulley grooves across two or three pulleys. If a misaligned pulley is found, refer to that accessory drive component for the proper installation procedure of that pulley.

- Inspecting the pulleys for being bent should include inspecting for a dent or other damage to the pulleys that would prevent the drive belt from not seating properly in all of the pulley grooves or on the smooth surface of a pulley when the back side of the belt is used to drive the pulley.
- Accessory drive component brackets that are bent or cracked will let the drive belt fall off.
- Inspecting of the fasteners can eliminate the possibility that a wrong bolt, nut, spacer or washer was installed. Missing, loose or the wrong fasteners may cause pulley misalignment from the bracket moving under load. Over tightening of the fasteners may cause misalignment of the accessory component bracket.

Drive Belt Falls Off Diagnosis

Step	Action	Value(s)	Yes	No
Notice: Refer to <i>Belt Dressing Notice</i> in Cautions and Notices.				
DEFINITION: The drive belt falls off the pulleys or may not ride correctly on the pulleys.				
1	Did you review the Drive Belt Symptom operation and perform the necessary inspections?	—	Go to Step 2	Go to <i>Symptoms-Drive Belt</i>
2	Inspect for a damaged drive belt. Did you find the condition?	—	Go to Step 3	Go to Step 4
3	Install a new drive belt. Refer to <i>Drive Belt Replacement</i> . Does the drive belt continue to fall off?	—	Go to Step 4	System OK
4	Inspect for misalignment of the pulleys. Did you find and repair the condition?	—	Go to Step 12	Go to Step 5
5	Inspect for a bent or dented pulley. Did you find and repair the condition?	—	Go to Step 12	Go to Step 6
6	Inspect for a bent or cracked bracket. Did you find and repair the condition?	—	Go to Step 12	Go to Step 7
7	Inspect for improper, loose or missing fasteners. Did you find loose or missing fasteners?	—	Go to Step 8	Go to Step 9
8	Tighten any loose fasteners. Replace improper or missing fasteners. Refer to <i>Fastener Tightening Specifications</i> . Does the drive belt continue to fall off?	—	Go to Step 9	System OK
9	Test the drive belt tensioner for operating correctly. Refer to <i>Drive Belt Tensioner Diagnosis</i> . Does the drive belt tensioner operate correctly?	—	Go to Step 11	Go to Step 10
10	Replace the drive belt tensioner. Refer to <i>Drive Belt Tensioner Replacement</i> . Does the drive belt continue to fall off?	—	Go to Step 11	System OK
11	Inspect for failed drive belt idler and drive belt tensioner pulley bearings. Did you find and repair the condition?	—	Go to Step 12	Go to Diagnostic Aids
12	Operate the system in order to verify the repair. Did you correct the condition?	—	System OK	Go to Step 2

Drive Belt Excessive Wear Diagnosis

Diagnostic Aids

Excessive wear on a drive belt(s) is usually caused by an incorrect installation or the wrong drive belt for the application.

Minor misalignment of the drive belt pulleys will not cause excessive wear, but will probably cause the drive belt(s) to make a noise or to fall off.

Excessive misalignment of the drive belt pulleys will cause excessive wear but may also make the drive belt(s) fall off.

Test Description

The number(s) below refer to the step number(s) on the diagnostic table.

- This inspection is to verify the drive belt(s) is correctly installed on all of the drive belt pulleys. Wear on the drive belt(s) may be caused by mis-positioning the drive belt(s) by one groove on a pulley.
- The installation of a drive belt that is too wide or too narrow will cause wear on the drive belt. The drive belt ribs should match all of the grooves on all of the pulleys.
- This inspection is to verify the drive belt(s) is not contacting any parts of the engine or body while the engine is operating. There should be sufficient clearance when the drive belt accessory drive components load varies. The drive belt(s) should not come in contact with an engine or a body component when snapping the throttle.

Drive Belt Excessive Wear Diagnosis

Step	Action	Value(s)	Yes	No
Notice: Refer to <i>Belt Dressing Notice</i> in Cautions and Notices.				
DEFINITION: Wear at the outside ribs of the drive belt due to an incorrectly installed drive belt.				
1	Did you review the Drive Belt Symptom operation and perform the necessary inspections?	—	Go to Step 2	Go to <i>Symptoms-Drive Belt</i>
2	Inspect the drive belt(s) for the proper installation. Refer to <i>Drive Belt Replacement</i> . Did you find the condition?	—	Go to Step 5	Go to Step 3
3	Inspect for the proper drive belt. Did you find this condition?	—	Go to Step 5	Go to Step 4
4	Inspect for the drive belt rubbing against a bracket, hose or wiring harness. Did you find and repair the condition?	—	Go to Step 6	Go to Diagnostic Aids
5	Replace the drive belt. Refer to <i>Drive Belt Replacement</i> . Did you complete the replacement?	—	Go to Step 6	—
6	Operate the system in order to verify the repair. Does the drive belt continue to fall off?	—	System OK	—

Drive Belt Tensioner Diagnosis

Inspection Procedure

Notice: Allowing the drive belt tensioner to snap into the free position may result in damage to the tensioner.

1. Remove the drive belt. Refer to *Drive Belt Replacement*.
2. Position a hex-head socket on the drive belt tensioner pulley bolt head.
3. Move the drive belt tensioner through its full travel.
 - The movement should feel smooth
 - There should be no binding
 - The tensioner should return freely
4. If any binding is observed, replace the drive belt tensioner. Refer to *Drive Belt Tensioner Replacement*.
5. Install the drive belt. Refer to *Drive Belt Replacement*.

Important: Movement of the drive belt tensioner while the engine is operating is a normal operating condition. Do not replace the drive belt tensioner for this normal condition.

Visual Identification

Dissassembled Views

Intake Manifolds and Components

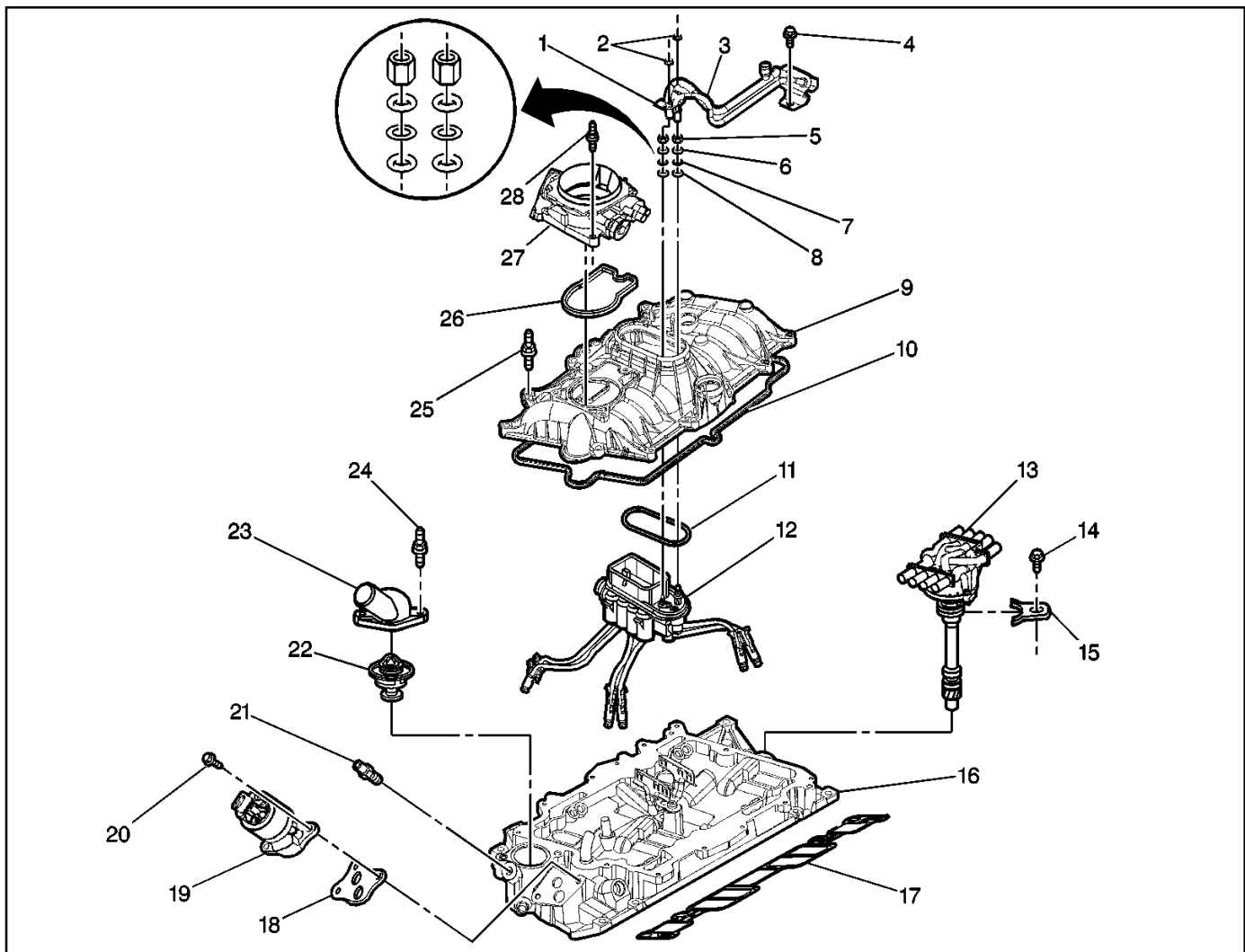

66997

Legend

- | | |
|--|-----------------------------------|
| (1) Fuel Pipe Retainer Bracket | (14) Hex Bolt (Distributor Clamp) |
| (2) Fuel Pipe Retainer Bracket Nuts | (15) Distributor Clamp |
| (3) Fuel Pipe | (16) Lower Intake Manifold |
| (4) Fuel Pipe Attachment Screw | (17) Lower Intake Manifold Gasket |
| (5) Fuel Seal Retainer | (18) EGR Valve Gasket |
| (6) Fuel Seal (Yellow O-ring) | (19) EGR Valve |
| (7) Spacer Ring (Flat Washer) | (20) EGR Valve Bolt |
| (8) Fuel Seal (Black O-ring) | (21) Engine Coolant Sensor |
| (9) Upper Manifold | (22) Engine Coolant Thermostat |
| (10) Upper Intake Manifold to Lower Intake Manifold Gasket | (23) Water Outlet |
| (11) Fuel Meter Body Seal | (24) Water Outlet Stud |
| (12) Fuel Meter Body | (25) Upper Intake Manifold Stud |
| (13) Distributor Assembly | (26) Throttle Body Gasket |
| | (27) Throttle Body |
| | (28) Throttle Body Attaching Stud |

Front of Engine

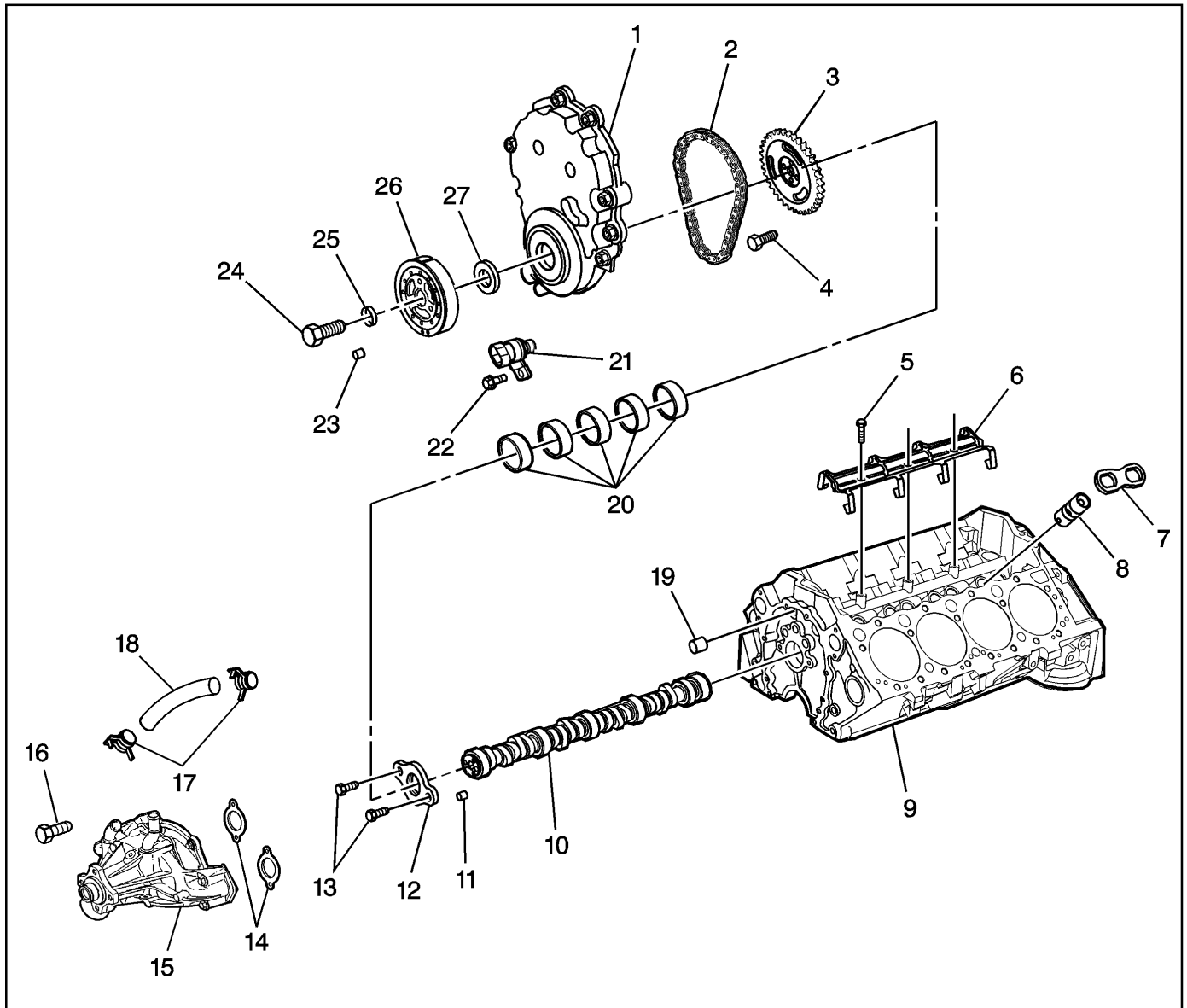

182828

Legend

- | | |
|--------------------------------------|---|
| (1) Engine Front Cover | (15) Water Pump |
| (2) Camshaft Timing Chain | (16) Water Pump Bolt |
| (3) Camshaft Sprocket | (17) Water Pump Inlet Hose Clamp |
| (4) Camshaft Sprocket Bolt | (18) Water Pump Inlet Hose |
| (5) Valve Lifter Guide Retainer Bolt | (19) Engine Block Oil Gallery Plug |
| (6) Valve Lifter Guide Retainer | (20) Camshaft Bearings |
| (7) Valve Lifter Guide | (21) Crankshaft Position Sensor |
| (8) Valve Lifter | (22) Crankshaft Position Sensor Bolt |
| (9) Engine Block | (23) Front Groove Pin (Crankshaft Balancer) |
| (10) Engine Camshaft | (24) Crankshaft Balancer Bolt |
| (11) Camshaft Sprocket Locator Pin | (25) Crankshaft Balancer Bolt Washer |
| (12) Camshaft Retainer | (26) Crankshaft Balancer |
| (13) Camshaft Retainer Bolt | (27) Crankshaft Front Oil Seal |
| (14) Water Pump Gasket | |

Cylinder Head and Exhaust Manifold Area

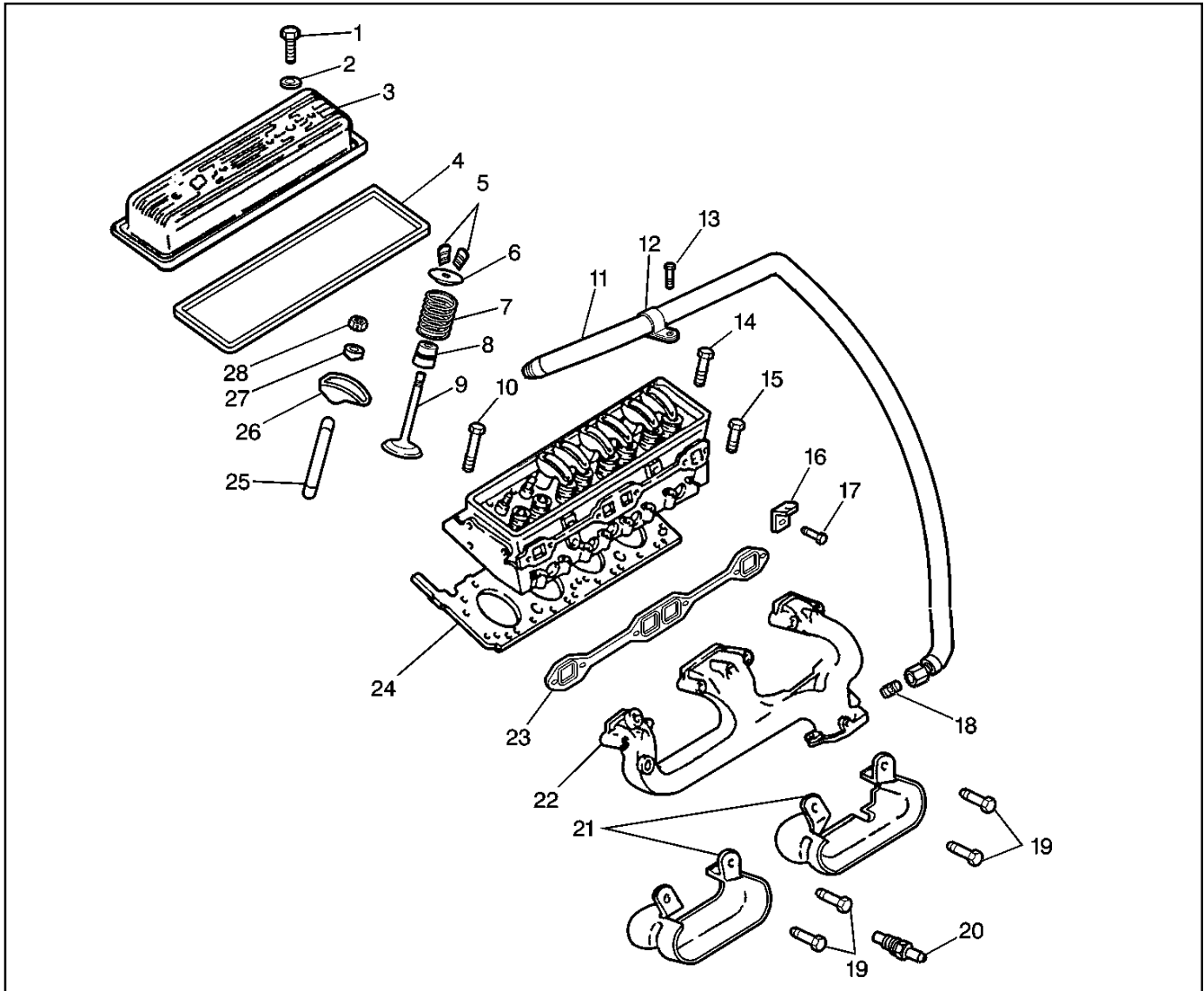

182825

Legend

- | | |
|--|--|
| (1) Valve Rocker Arm Cover Bolt | (16) Spark Plug Wire Support Bracket |
| (2) Valve Rocker Arm Cover Bolt Washer | (17) Spark Plug Wire Support Bracket Bolt |
| (3) Valve Rocker Arm Cover | (18) EGR Valve Pipe Fitting |
| (4) Valve Rocker Arm Cover Gasket | (19) Exhaust Manifold Bolts |
| (5) Valve Stem Keys | (20) Engine Coolant Temperature (ECT) Gauge Sensor |
| (6) Valve Spring Cap | (21) Spark Plug Wire Shields |
| (7) Valve Spring | (22) Exhaust Manifold |
| (8) Valve Stem Oil Seal | (23) Exhaust Manifold Gasket |
| (9) Valve | (24) Cylinder Head Gasket |
| (10) Cylinder Head Bolt (Long) | (25) Valve Pushrod |
| (11) EGR Valve Pipe | (26) Valve Rocker Arm |
| (12) EGR Valve Pipe Clamp | (27) Valve Rocker Arm Ball |
| (13) EGR Valve Pipe Clamp Bracket Bolt | (28) Valve Rocker Arm Nut |
| (14) Cylinder Head Bolt (Medium) | |
| (15) Cylinder Head Bolt (Short) | |

Cylinder Block and Components

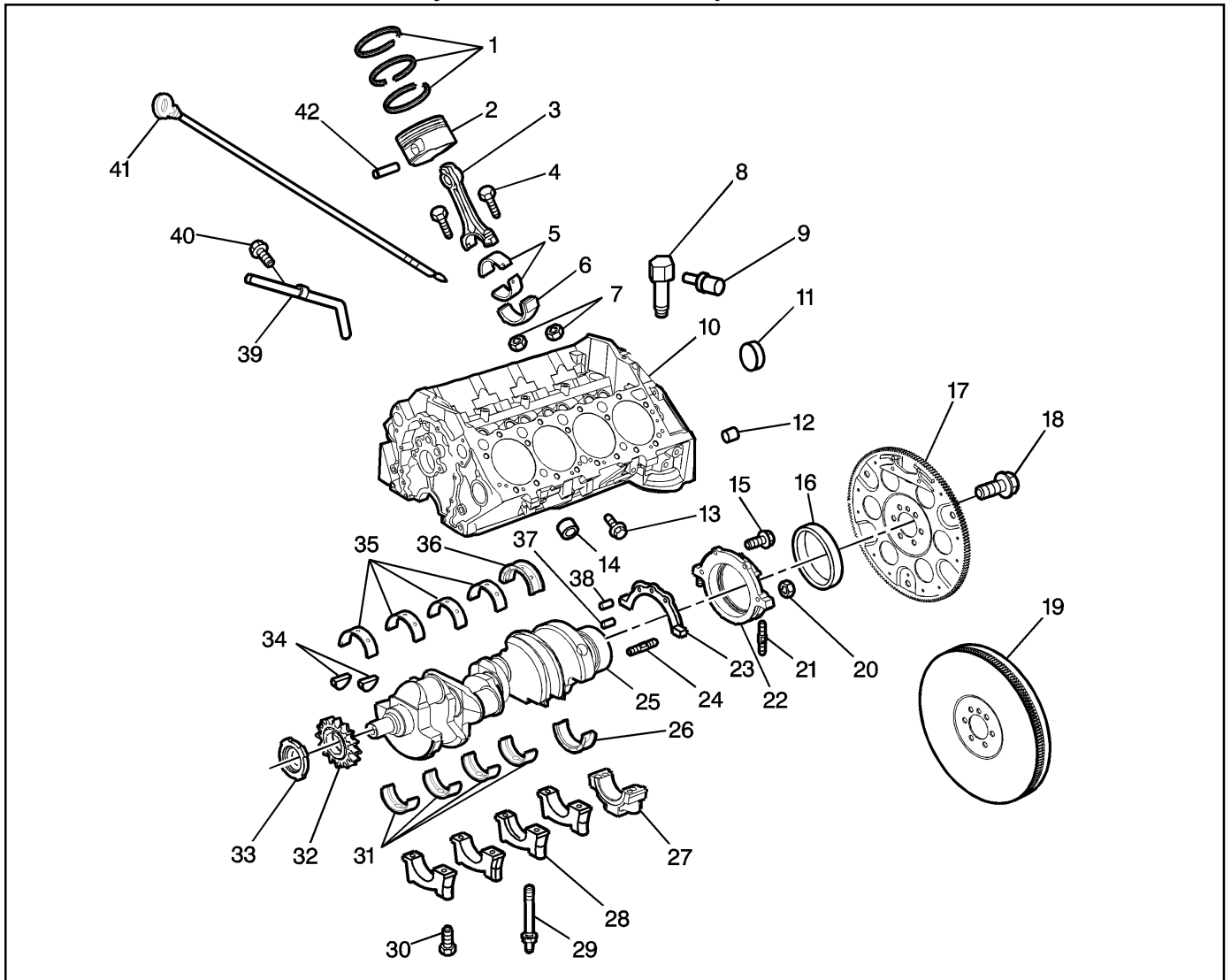

317429

Legend

- | | |
|--|---|
| (1) Piston Ring Kit | (16) Crankshaft Rear Oil Seal |
| (2) Piston | (17) Engine Flywheel (Automatic Transmission) |
| (3) Connecting Rod | (18) Flywheel Bolt |
| (4) Connecting Rod Bolt | (19) Engine Flywheel (Manual Transmission) |
| (5) Connecting Rod Bearings | (20) Crankshaft Rear Oil Seal Housing Nut |
| (6) Connecting Rod Cap | (21) Crankshaft Rear Oil Seal Housing Stud |
| (7) Hex Nut (Connecting Rod) | (22) Crankshaft Rear Oil Seal Housing |
| (8) Engine Oil Pressure Gauge Sensor Fitting | (23) Crankshaft Rear Oil Seal Housing Gasket |
| (9) Engine Oil Pressure Gauge Sensor | (24) Crankshaft Rear Oil Seal Housing |
| (10) Engine Block | (25) Crankshaft |
| (11) Expansion Cup Plug (Camshaft Rear Bearing Hole) | (26) Crankshaft Bearing (Rear Thrust Bearing) |
| (12) Dowel Straight Pin (Transmission Locator) | (27) Crankshaft Bearing Cap (Rear) |
| (13) Engine Block Coolant Drain Hole Plug | (28) Crankshaft Bearing Cap |
| (14) Engine Block Core Hole Plug | (29) Crankshaft Bearing Cap Stud |
| (15) Crankshaft Rear Oil Seal Housing Bolt | (30) Crankshaft Bearing Cap Bolt |
| | (31) Crankshaft Bearings |

6-34 Marine/Industrial 5.7L**Engine**

- | | |
|---|---|
| (32) Crankshaft Sprocket | (38) Spring Type S Pin (Crankshaft Rear Oil Seal Housing Locator) |
| (33) Crankshaft Position Sensor Reluctor Ring | |
| (34) Woodruff Keys (Crankshaft Balancer) | (39) Oil Level Indicator Tube |
| (35) Crankshaft Bearing | (40) Oil Level Indicator Tube Bolt |
| (36) Crankshaft Bearing (Rear Thrust Bearing) | (41) Oil Level Indicator |
| (37) Flywheel Locator Pin | (42) Piston Pin |

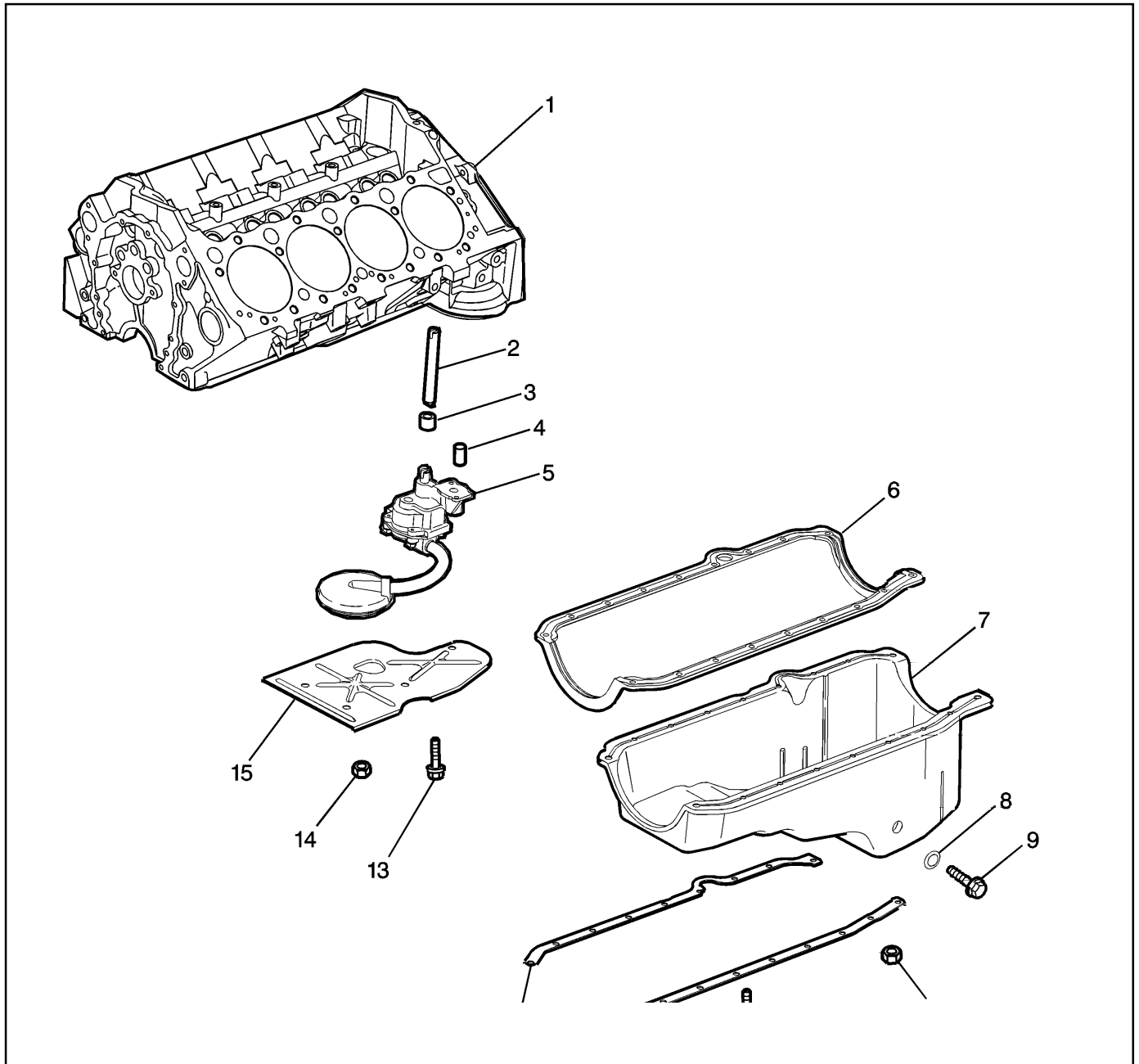

182829

Legend

- | | |
|--------------------------------------|------------------------------------|
| (1) Engine Block | (9) Oil Pan Drain Plug |
| (2) Oil Pump Driveshaft | (10) Oil Pan Nut |
| (3) Oil Pump Driveshaft Retainer | (11) Oil Pan Bolt |
| (4) Pin (Oil Pump Locator) | (12) Oil Pan Reinforcement |
| (5) Oil Pump | (13) Crankshaft Oil Deflector Bolt |
| (6) Oil Pan Gasket | (14) Crankshaft Oil Deflector Nut |
| (7) Oil Pan | (15) Crankshaft Oil Deflector |
| (8) Oil Pan Drain Plug Seal (O-ring) | |

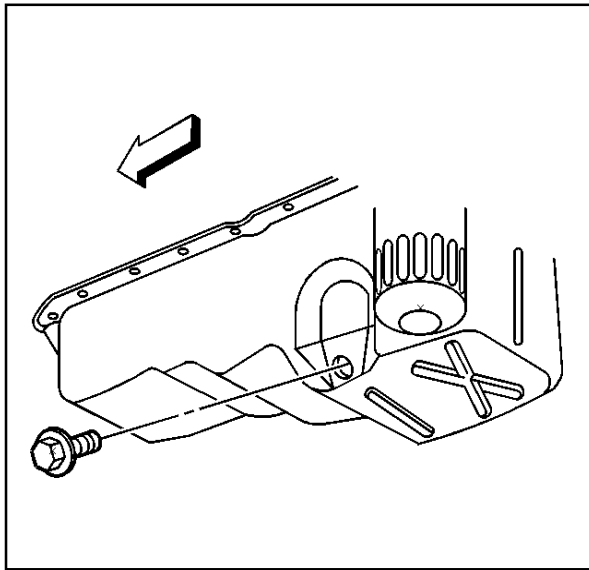

182850

Draining Fluids and Oil Filter Removal

1. Remove the oil pan drain plug and allow the engine oil to drain into a suitable container.

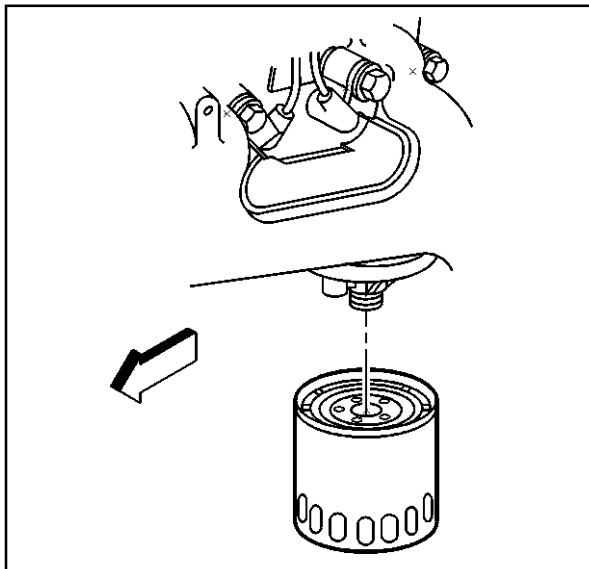

316766

2. Remove the oil filter and discard.

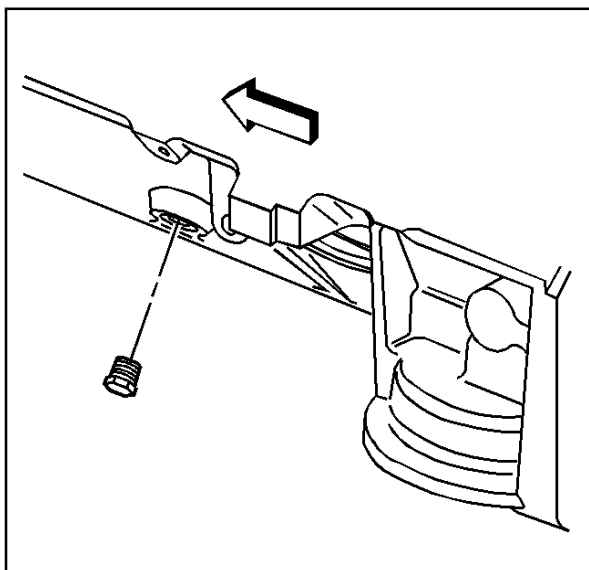

316798

3. Remove the engine block coolant drain hole plug and allow the coolant to drain into a suitable container.

4. Remove the knock sensor and allow the coolant to drain into a suitable container.

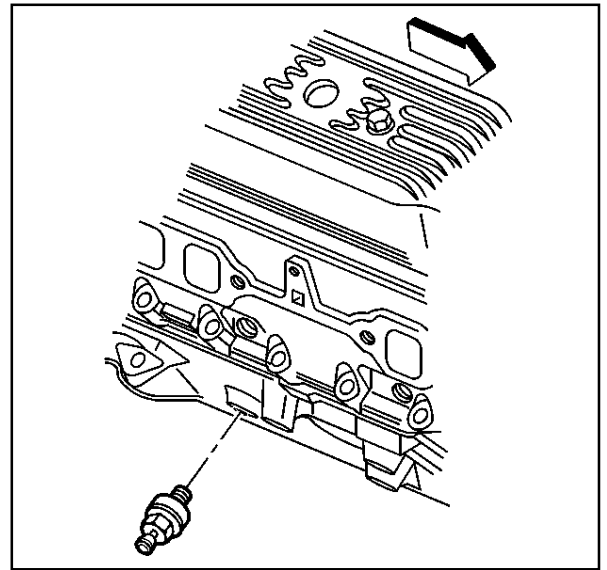

182837

Engine Flywheel Removal

1. Remove the engine flywheel bolts.
2. Remove the engine flywheel.

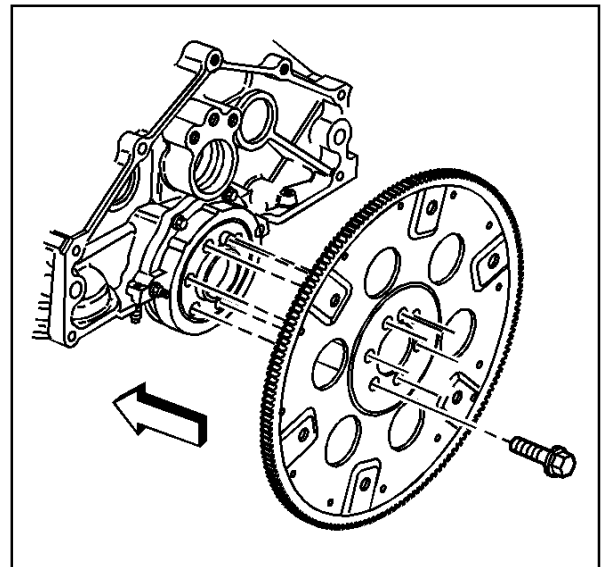

522146

Exhaust Manifold Removal (Left)

Notice: Twist the spark plug boot one-half turn in order to release the boot. Pull on the spark plug boot only. Do not pull on the spark plug wire or the wire could be damaged.

1. Remove the spark plug wires from the spark plugs.
 - 1.1. Rotate the spark plug wire boot one-half turn.
 - 1.2. Pull outward on the spark plug wire boot to release from the spark plug.
2. Remove the bolts and the spark plug wire supports.

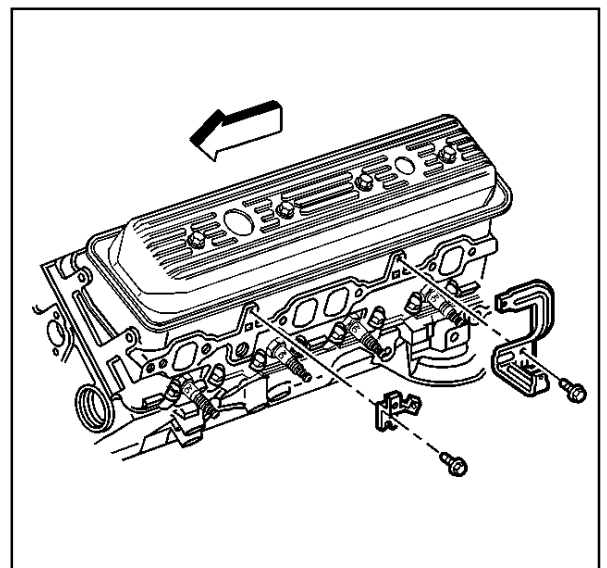

317185

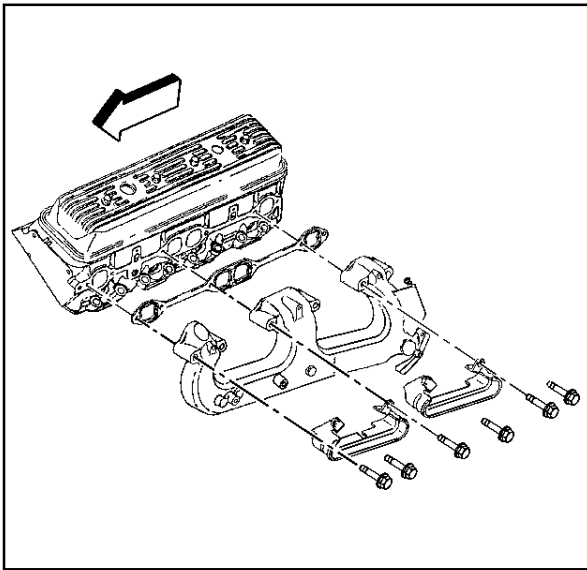

64925

3. Remove the exhaust manifold bolts.
4. Remove the spark plug wire shields.
5. Remove the exhaust manifold.
6. Remove and discard the exhaust manifold gasket.

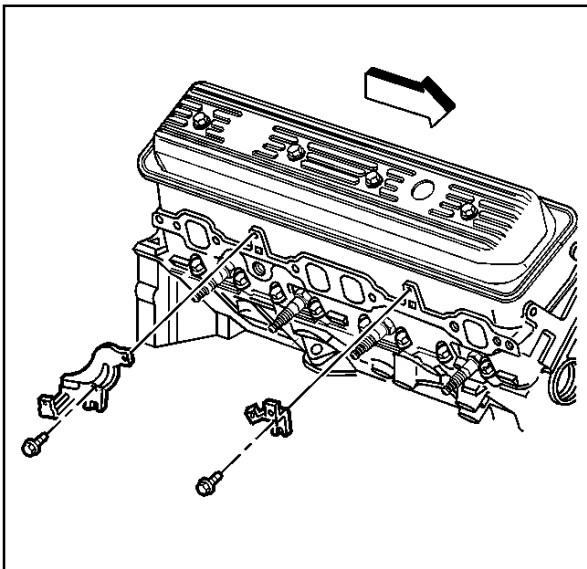

317179

Exhaust Manifold Removal (Right)

Notice: Twist the spark plug boot one-half turn in order to release the boot. Pull on the spark plug boot only. Do not pull on the spark plug wire or the wire could be damaged.

1. Remove the spark plug wires from the spark plugs.
 - 1.1. Rotate the spark plug wire boot one-half turn.
 - 1.2. Pull outward on the spark plug wire boot to release from the spark plug.
2. Remove the bolts and the spark plug wire supports.

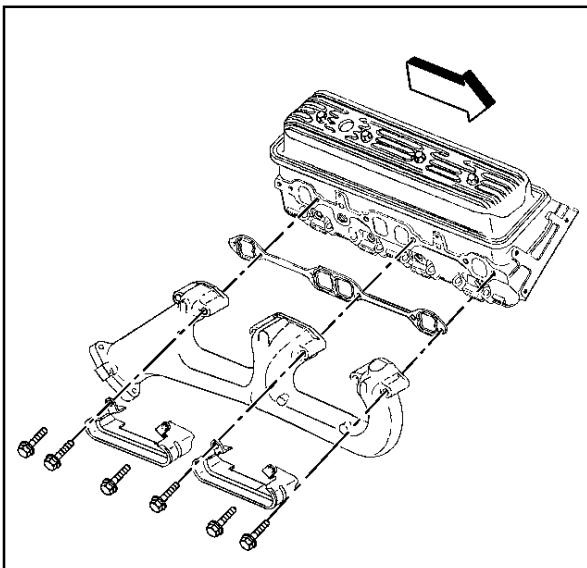

69032

3. Remove the exhaust manifold bolts.
4. Remove the spark plug wire shields.
5. Remove the exhaust manifold.
6. Remove and discard the exhaust manifold gasket.

Oil Level Indicator and Tube Removal

1. Remove the oil level indicator tube bolt.
2. Remove the oil level indicator tube from the engine block.

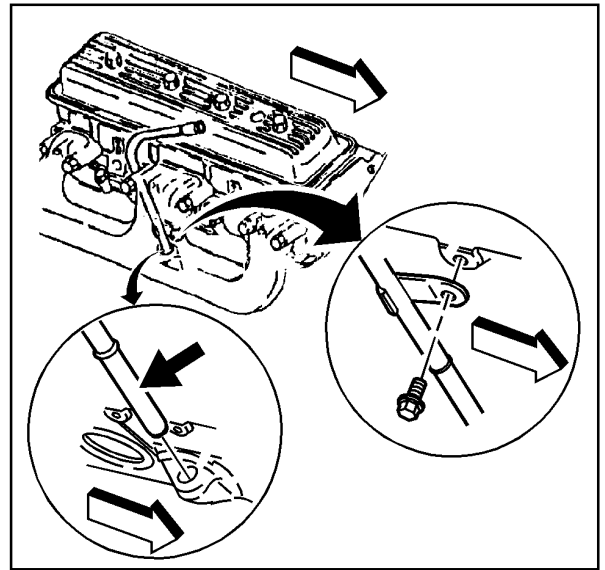

500691

Water Pump Removal

Tools Required

J 41240 Fan Clutch Remover and Installer

1. Remove the bolts and the fan and water pump pulley using the *J 41240*.

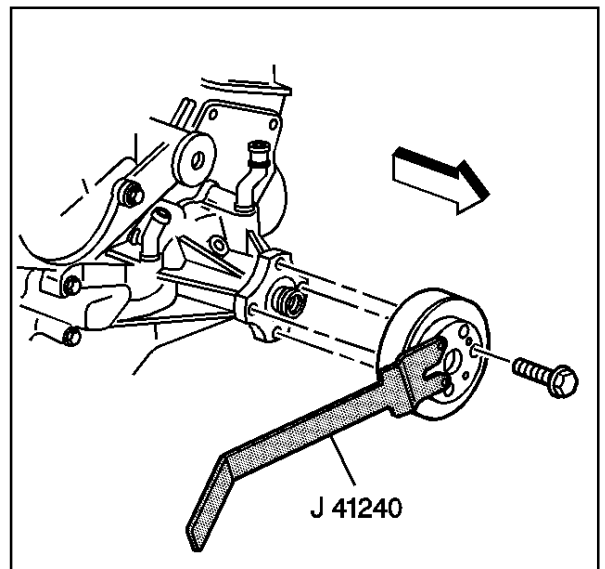

317191

2. Remove the clamps and the water pump inlet hose.

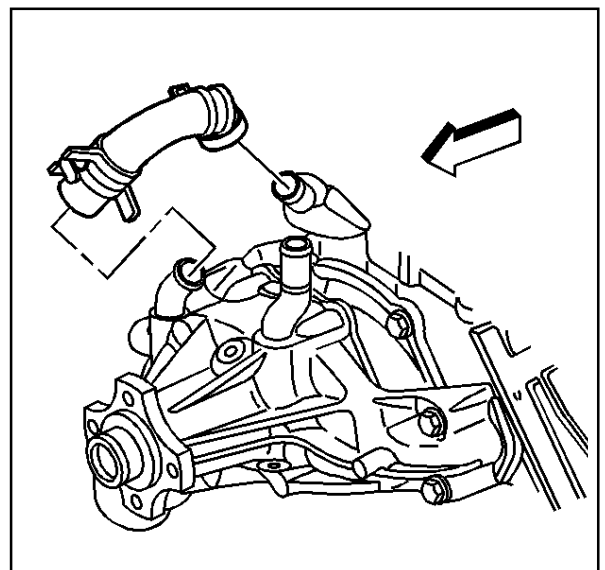

182853

**This page
was
intentionally
left blank**

3. Remove the water pump bolts.
4. Remove the water pump.
5. Remove the water pump gaskets.
6. Discard the water pump gaskets.

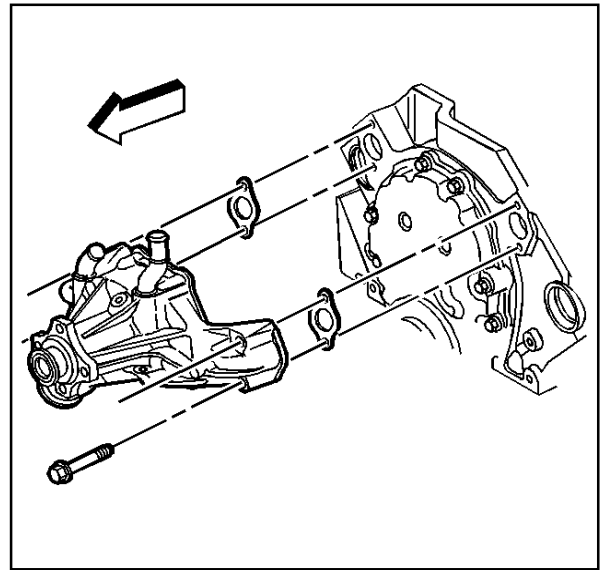

69011

Crankshaft Balancer Removal

Tools Required

J 23523-F Balancer Remover and Installer

1. Remove the crankshaft balancer bolt and washer.

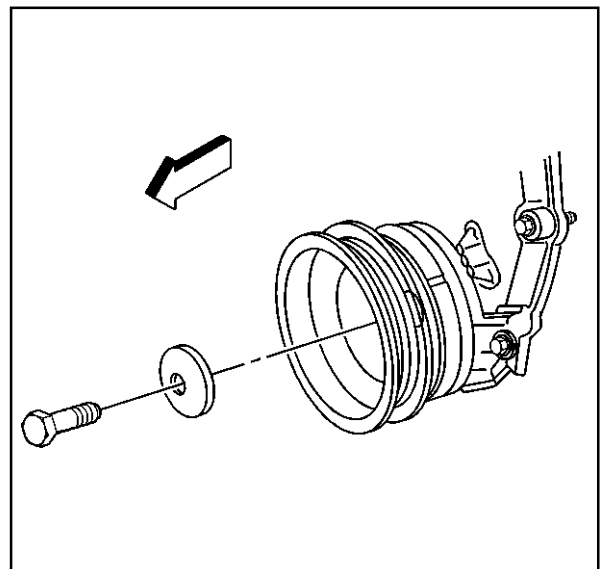

173172

2. Remove the bolts and the crankshaft pulley.

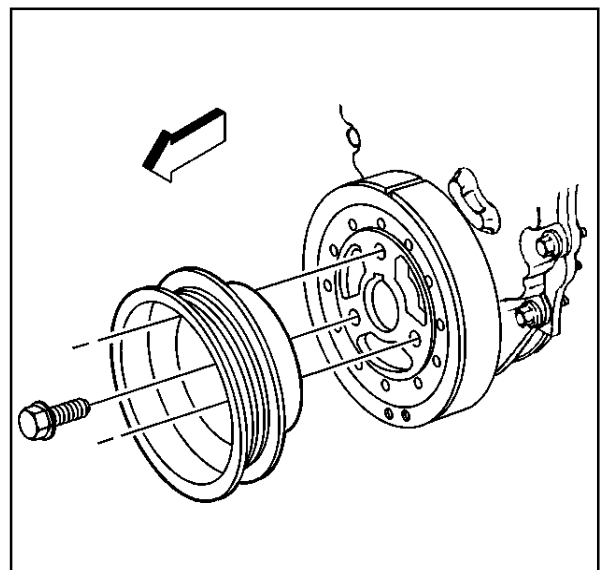

188055

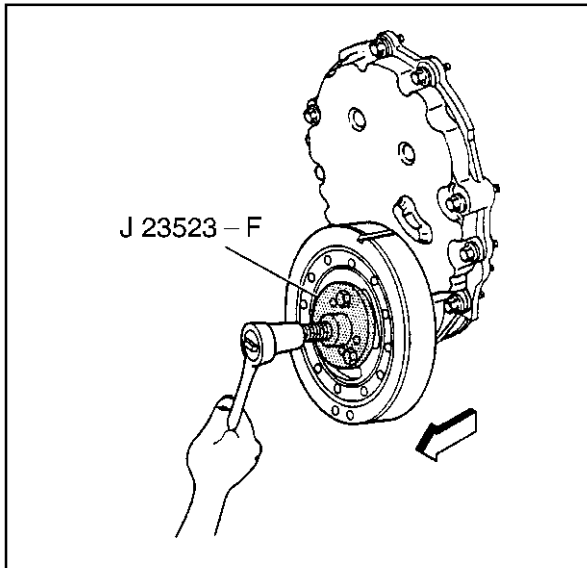

66878

Notice: Refer to *Fastener Notice* in Cautions and Notices.

3. Use the J23523-F in order to remove the crankshaft balancer.

- 3.1. Install the J 23523-F plate and bolts onto the crankshaft balancer.

Tighten

Tighten the bolts to 25 N•m (18 lb ft).

- 3.2. Install the J 23523-F forcing screw into the plate.
- 3.3. Rotate the J 23523-F forcing screw clockwise in order to remove the crankshaft balancer.
4. Remove the J 23523-F from the crankshaft balancer.

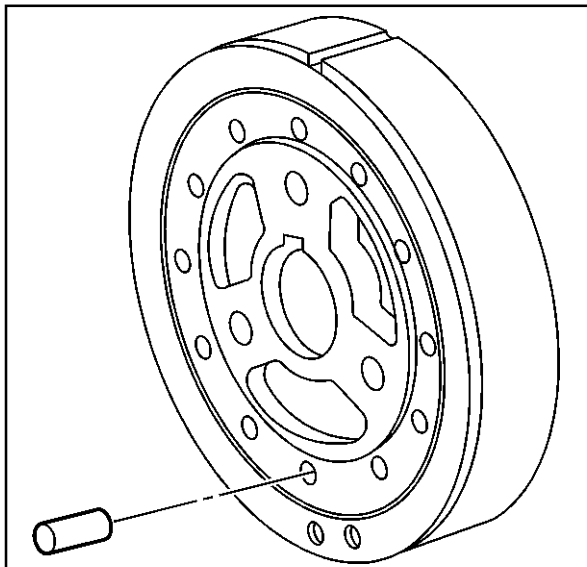

182849

5. Note the position of any front groove pins (crankshaft balancer weights) (if applicable).

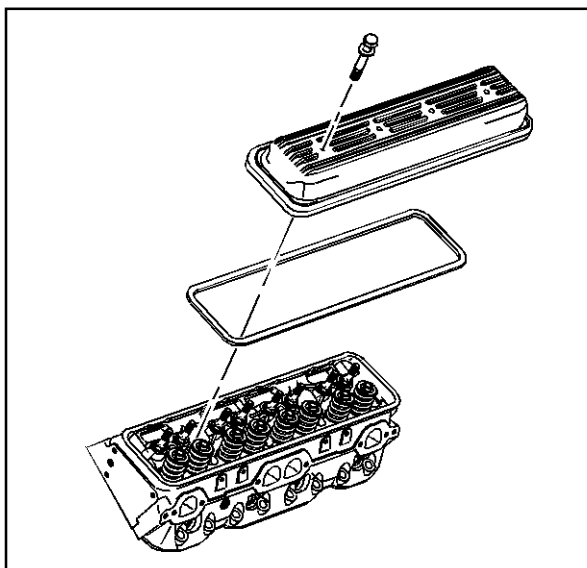

39119

Valve Rocker Arm Cover Removal (Left)

1. Remove the valve rocker arm cover bolts and washers.
2. Remove the valve rocker arm cover.
3. Remove the valve rocker arm cover gasket.
4. Discard the valve rocker arm cover gasket.

Valve Rocker Arm Cover Removal (Right)

1. Remove the valve rocker arm cover bolts and washers.
2. Remove the valve rocker arm cover.
3. Remove the valve rocker arm cover gasket.
4. Discard the valve rocker arm cover gasket.

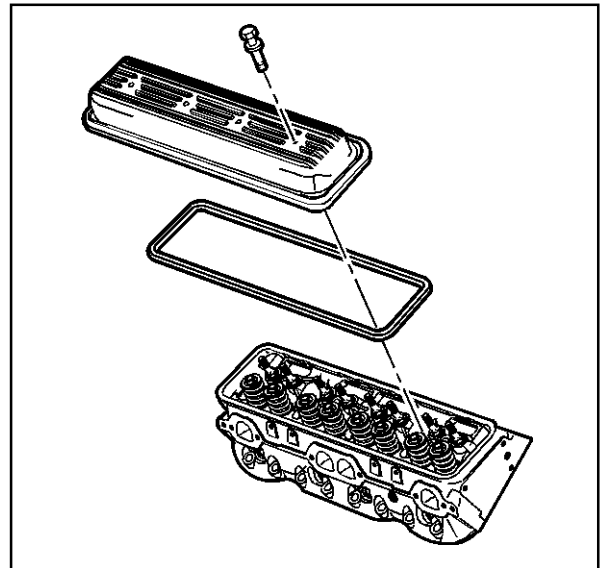

182833

Distributor Removal

1. Remove the ignition coil wire harness from the ignition coil and distributor cap.

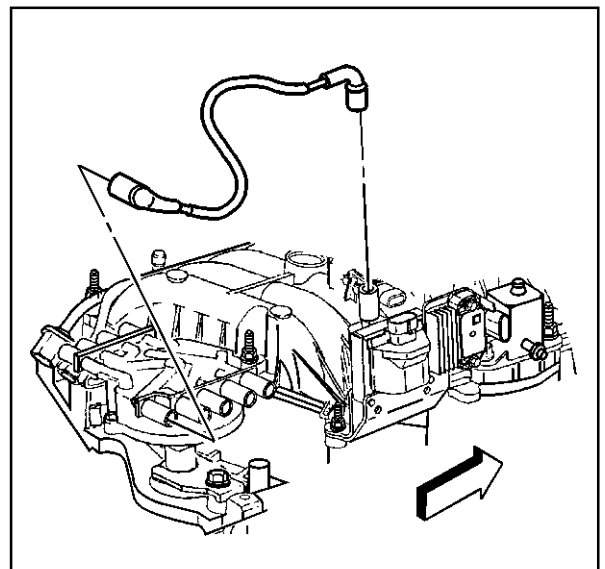

341359

2. Remove the distributor clamp bolt.
3. Remove the distributor and the distributor clamp.

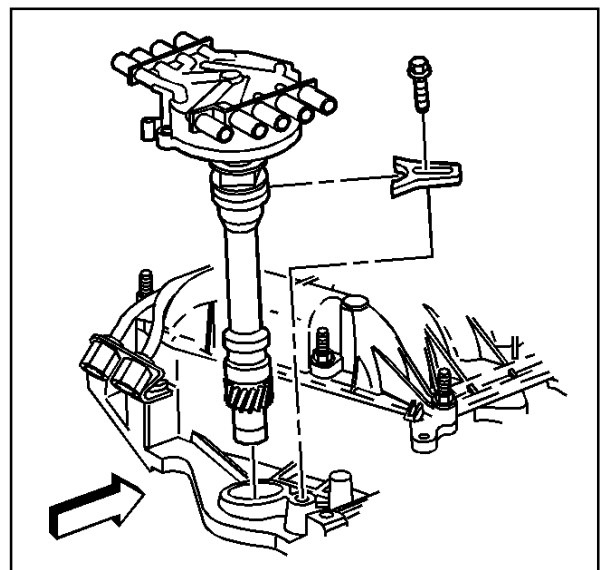

69303

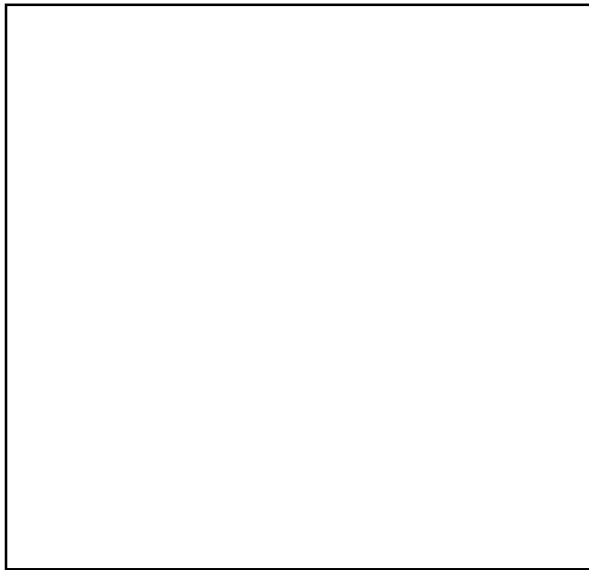

523516

4. Remove the distributor gasket and discard.

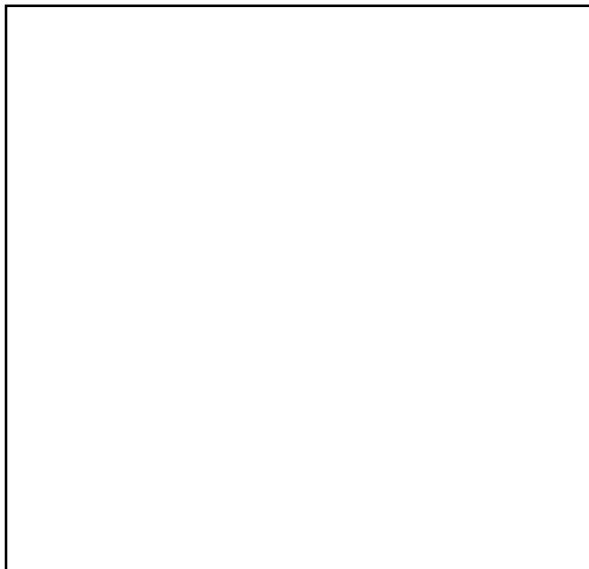

317211

Intake Manifold Removal

1. Remove the evaporative emission canister purge solenoid valve harness.
 - 1.1. Push the quick disconnect clip and hold in place.
 - 1.2. Pull outward on the harness elbow.



66456

2. Remove the lower intake manifold bolts.

Important: The intake manifold may be removed as an assembly. Do not remove the specific intake manifold components unless component service is required.

Do not allow dirt or debris to enter the fuel system. Ensure that the ends of the fuel system are properly sealed.

Do not disassemble the fuel injection unit, unless service is required.

3. Remove the intake manifold assembly.
4. Remove and discard the lower intake manifold gaskets.

Valve Rocker Arm and Push Rod Removal

Important: Mark, sort and organize the components so that the components can be reinstalled to the original location.

1. Remove the following components from the cylinder head:
 - The valve rocker arm nuts (1)
 - The valve rocker arm balls (2)
 - The valve rocker arms (3)

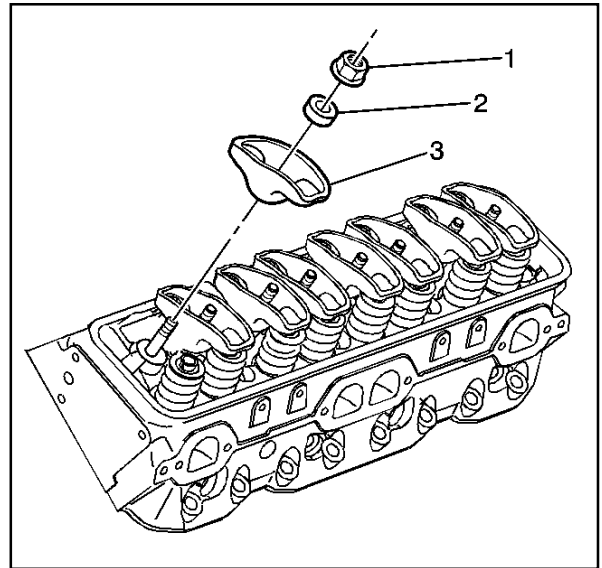

182835

2. Remove the valve pushrods.

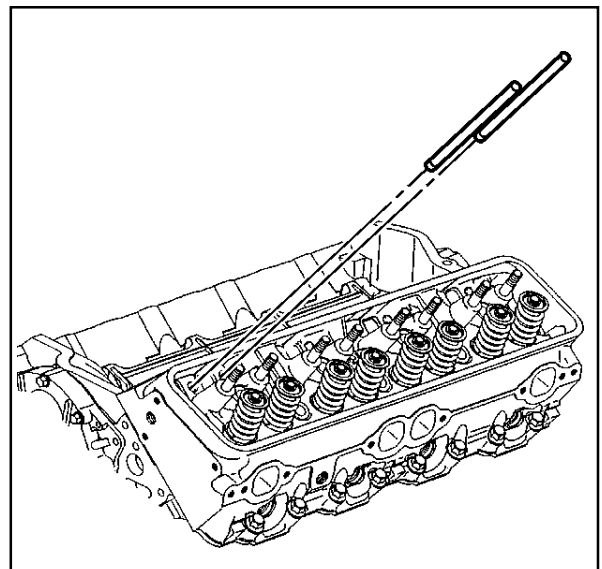

22766

Cylinder Head Removal (Left)

1. Remove the engine coolant temperature gauge sensor.

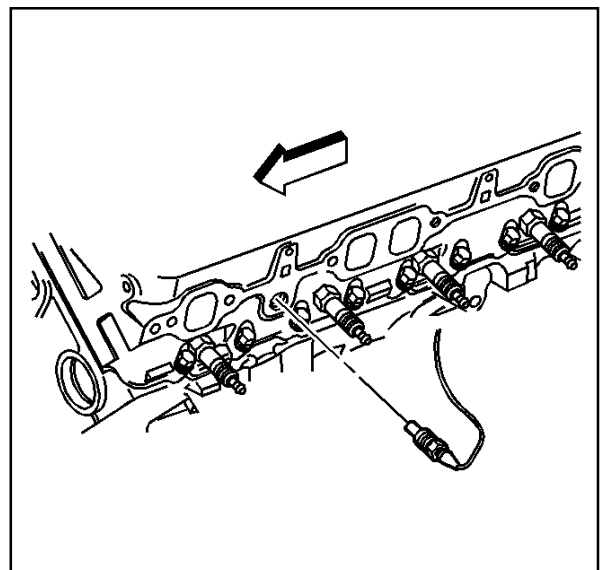

521828

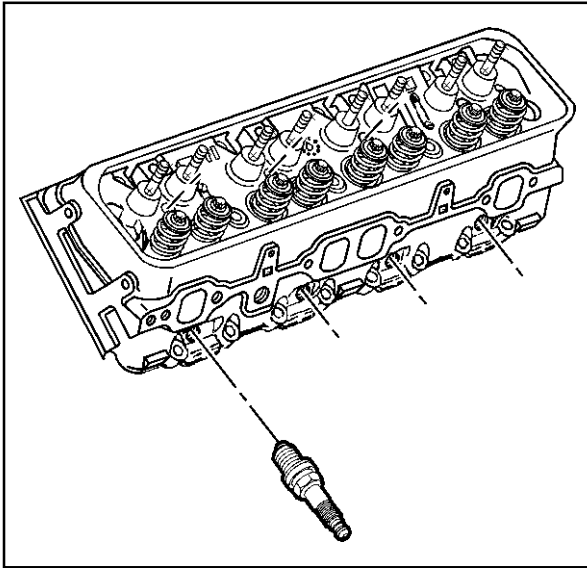

317307

2. Remove and discard the spark plugs.

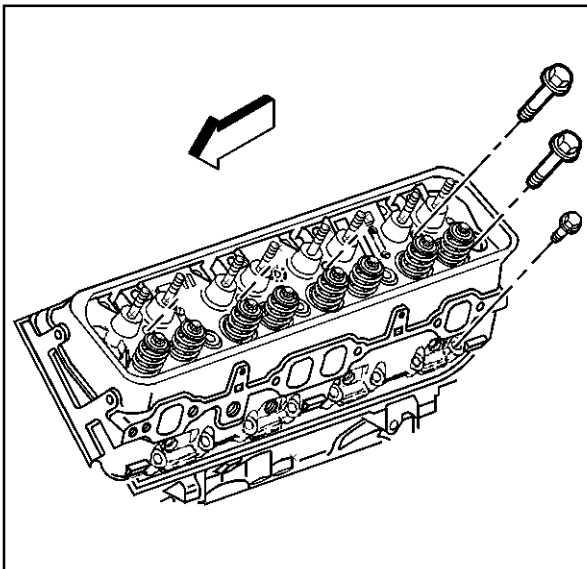

317217

3. Remove the cylinder head bolts.

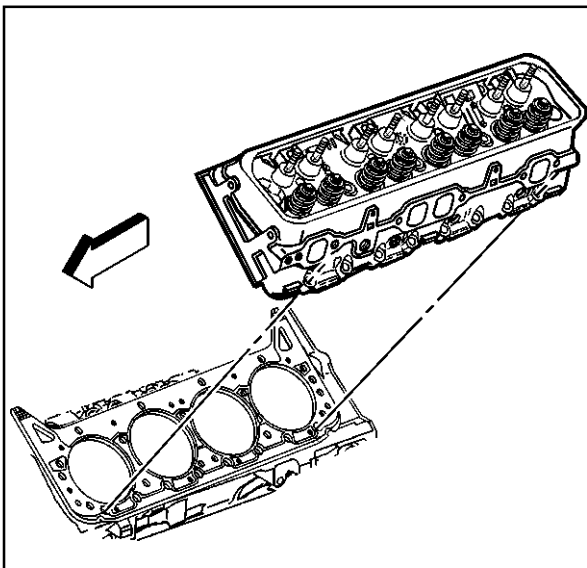

317227

Notice: After removal, place the cylinder head on two wood blocks to prevent damage.

4. Remove the cylinder head.

5. Remove and discard the cylinder head gasket.

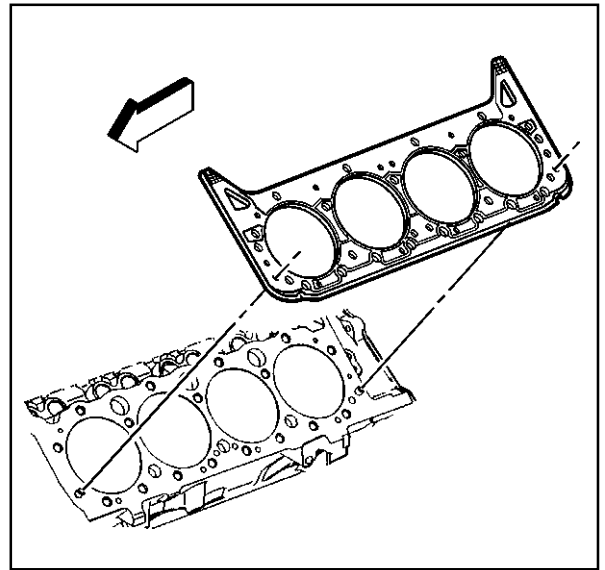

317233

6. Remove the dowel pin (cylinder head locator)(if required).

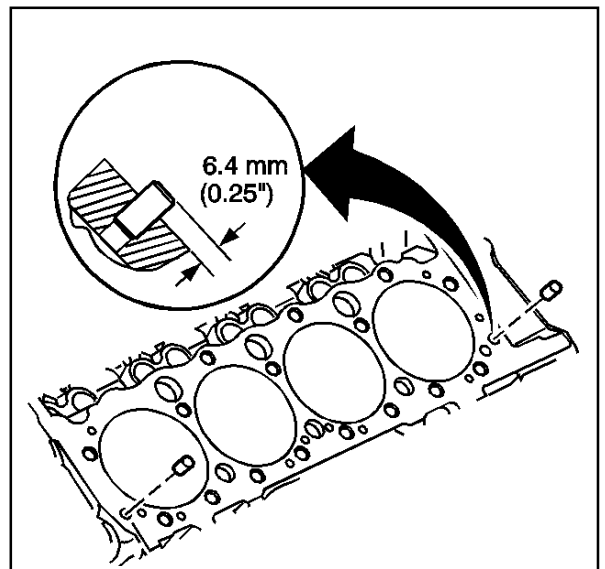

182846

Cylinder Head Removal (Right)

1. Remove and discard the spark plugs.

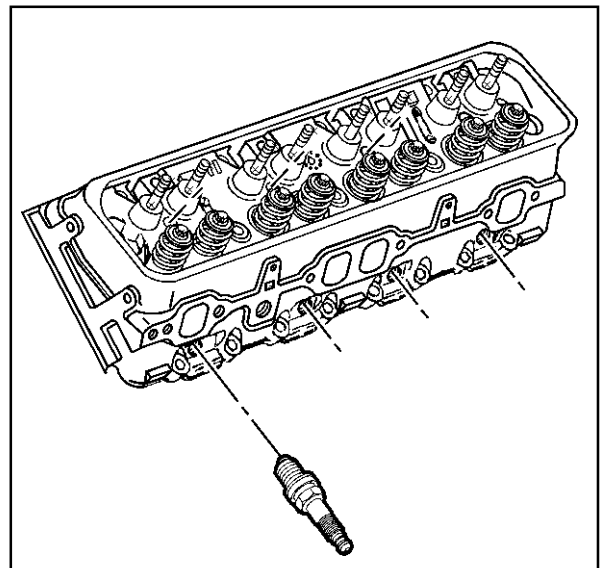

317307

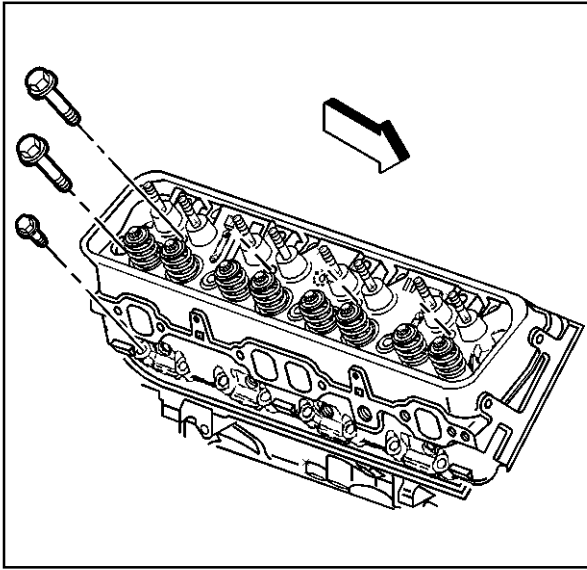

317239

2. Remove the cylinder head bolts.

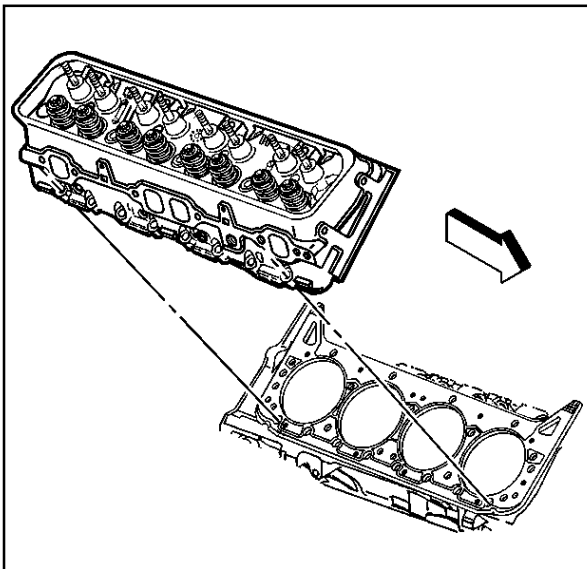

317246

Notice: After removal, place the cylinder head on two wood blocks to prevent damage.

3. Remove the cylinder head.

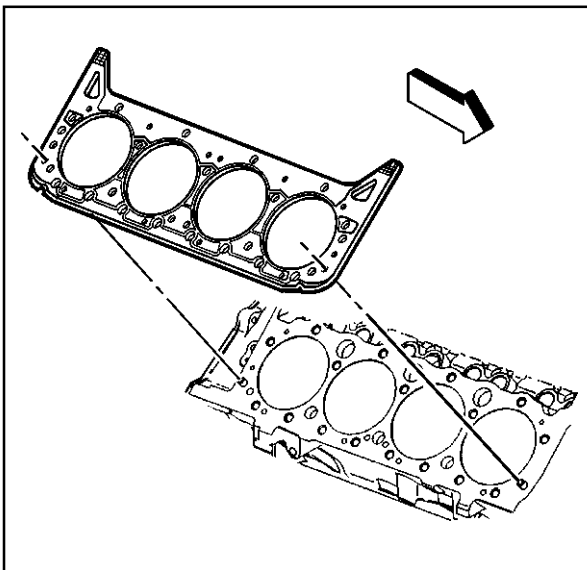

317255

4. Remove and discard the cylinder head gasket.

5. Remove the dowel pin (cylinder head locator)(if required).

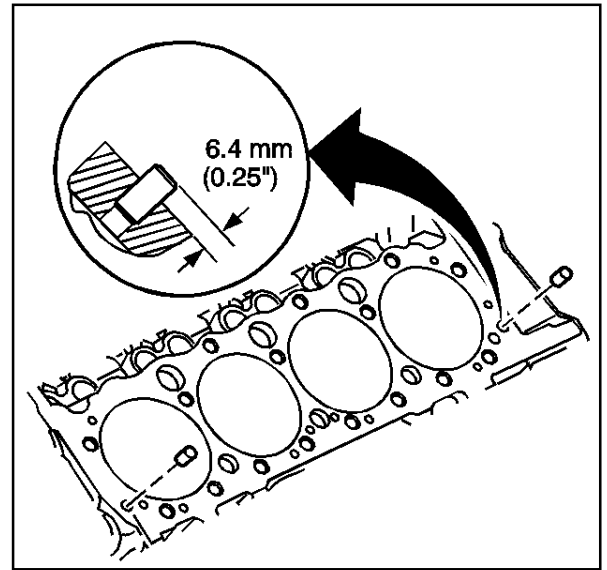

182846

Valve Lifter Removal

Tools Required

J 3049-A Valve Lifter Remover

1. Remove the bolts and valve lifter guide retainer.

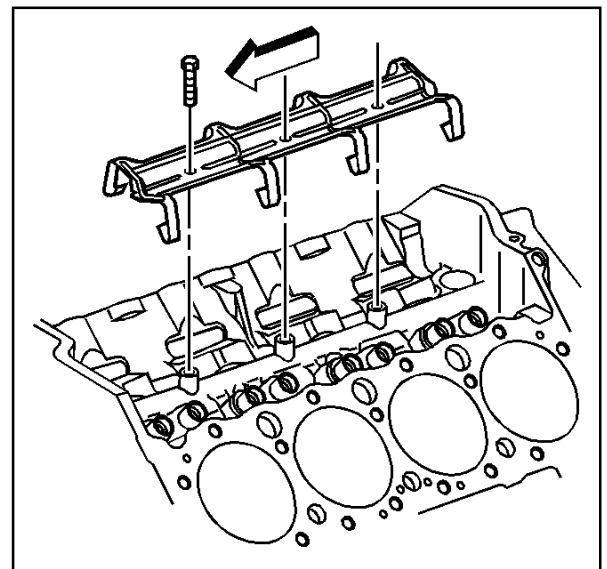

11508

Important: Place the valve lifters in the rack in the upright position in order to maintain the oil inside the valve lifter.

2. Remove the valve lifter guides and valve lifters.
Place the components in a rack so that the components can be reinstalled to the original location.

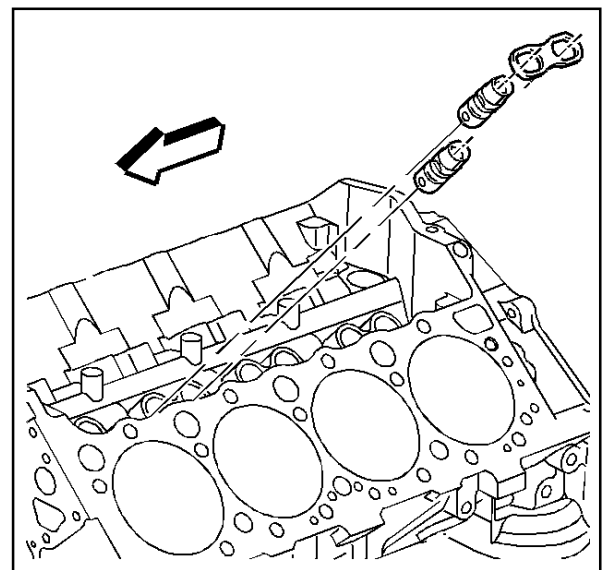

11509

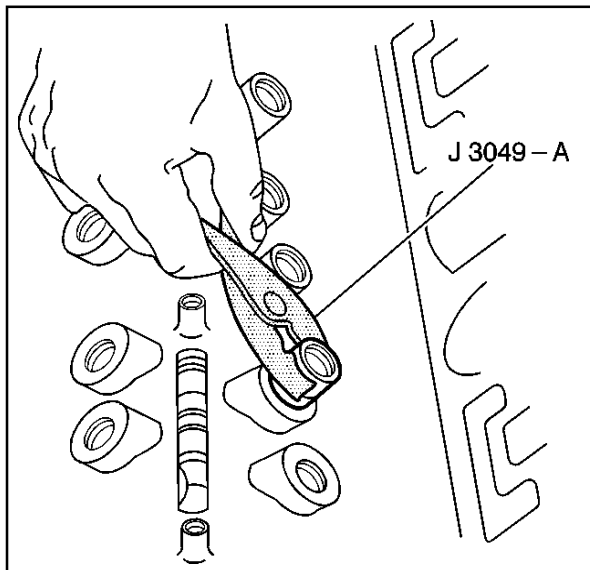

31350

Important: Some valve lifters may be stuck in the valve lifter bores because of gum or varnish deposits and may require the use of *J 3049-A* for removal.

3. Use the J 3049-A in order to remove the stuck valve lifters.

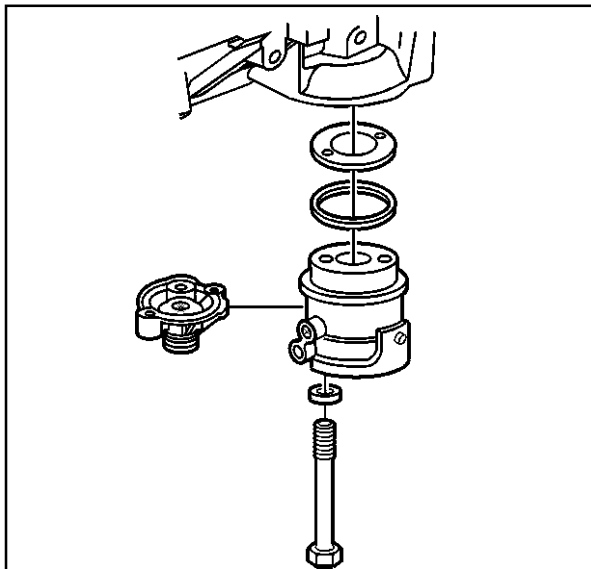

39122

Oil Filter Adapter Removal

1. Remove the oil filter adapter bolts and washers (if applicable).
2. Remove the oil filter adapter.
3. Remove the oil filter adapter seal (O-ring) and the oil filter adapter gasket (if applicable).
4. Discard the oil filter adapter seal (O-ring) and the oil filter adapter gasket (if applicable).

Oil Pan Removal

1. Remove the oil pan bolts and nuts.
2. Remove the oil pan reinforcements.
3. Remove the oil pan.
4. Remove and discard the oil pan gasket.

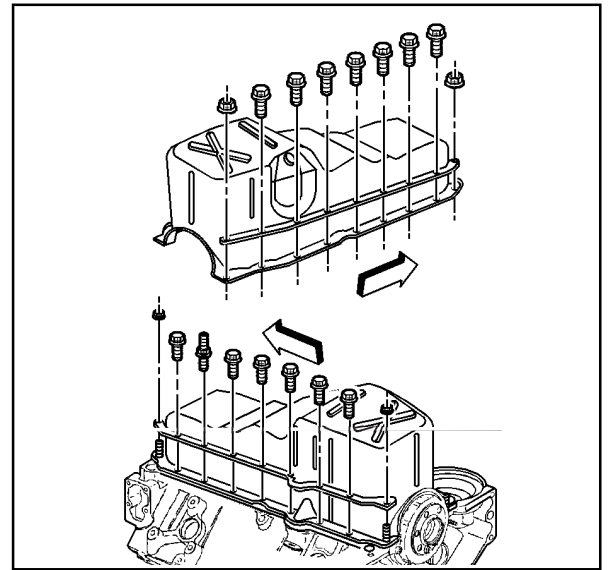

182851

5. Remove the oil pan studs.

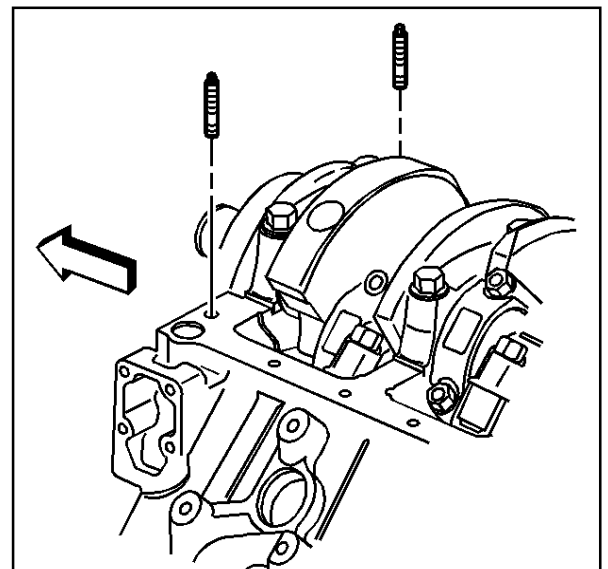

521817

Oil Pump, Pump Screen and Deflector Removal

1. Remove the nuts (6) and the crankshaft oil deflector (2).
2. Remove the oil pump bolt (1).
3. Remove the oil pump (3), the oil pump driveshaft (5) and the oil pump driveshaft retainer (4).
4. Separate the oil pump (3), the oil pump driveshaft (5) and the oil pump driveshaft retainer (4).

Important: Always install a NEW oil pump driveshaft retainer during assembly.

5. Discard the oil pump driveshaft retainer.

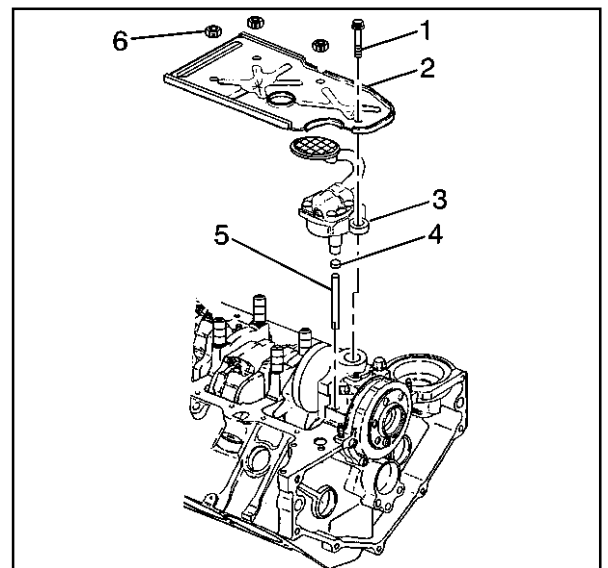

11438

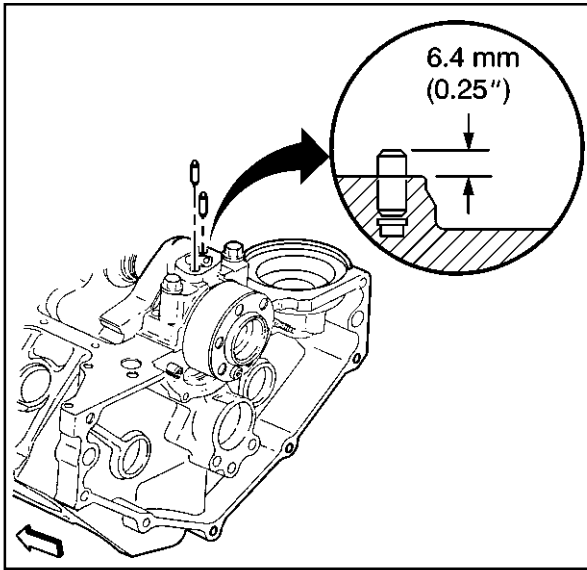

182852

6. Inspect the pins (oil pump locator) for damage, replace the pins if required.

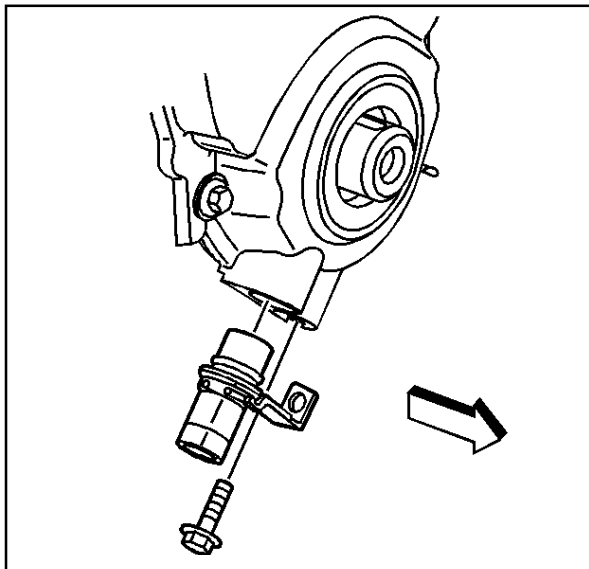

11485

Engine Front Cover Removal

1. Remove the crankshaft position sensor bolt.
2. Remove the crankshaft position sensor.

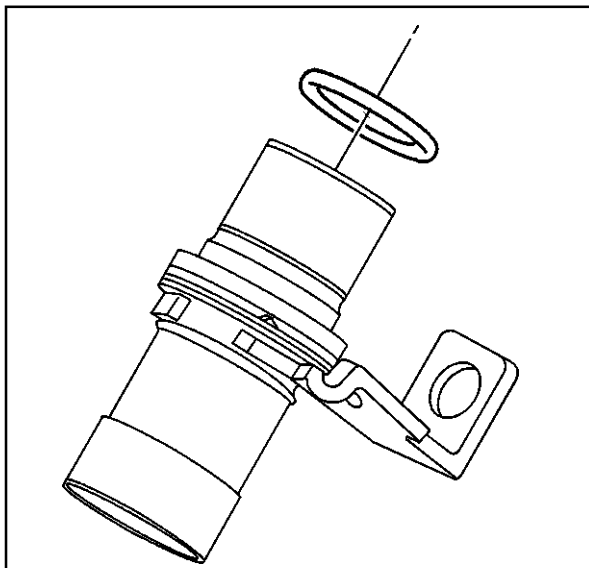

387759

Important: Always install a NEW crankshaft position sensor seal (O-ring) during assembly.

3. Remove the crankshaft position sensor seal (O-ring).
4. Discard the crankshaft position sensor seal (O-ring).

Engine

Marine/Industrial 5.7L 6-53

5. Remove the engine front cover bolts.
6. Remove the engine front cover and gasket.

Important: DO NOT reuse the composite engine front cover and gasket. Always install a NEW engine front cover and gasket.

7. Discard the engine front cover and gasket.

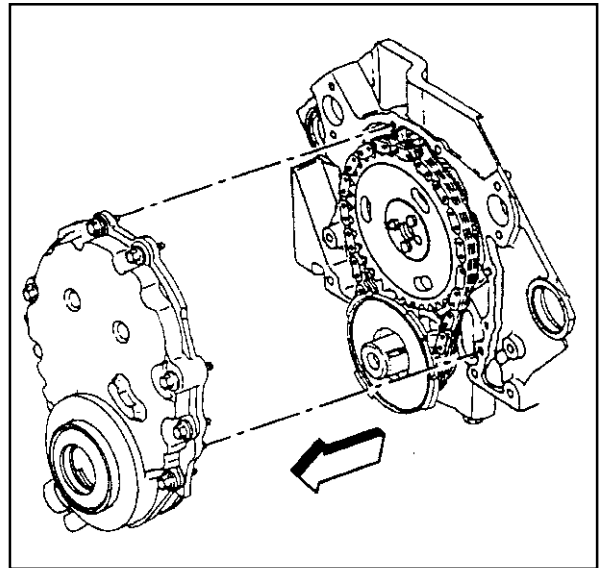

69010

Timing Chain and Sprockets Removal

Tools Required

J 5825-A Crankshaft Gear Remover

1. Remove the crankshaft position sensor reluctor ring.

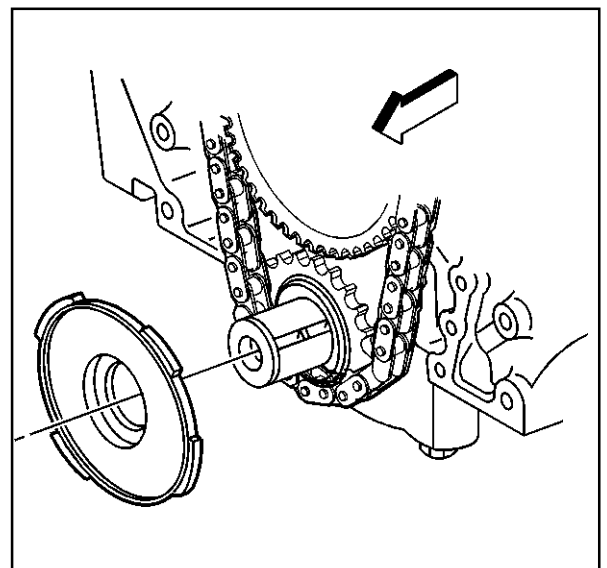

69450

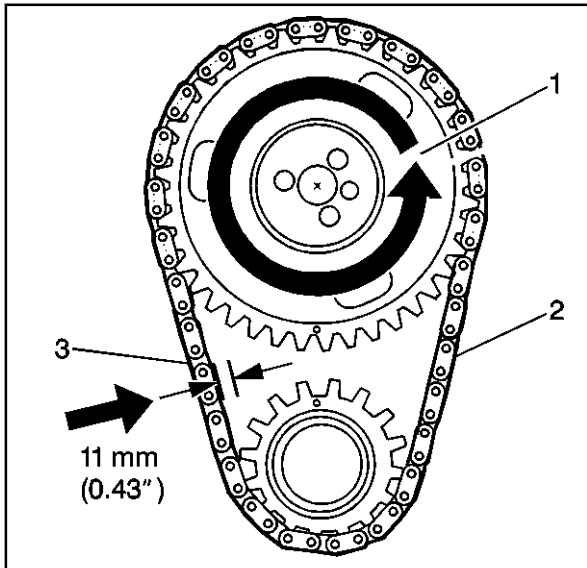

341357

2. Check the camshaft timing chain free play.
 - 2.1. Rotate the camshaft sprocket (1) counterclockwise until all slack is removed from the camshaft timing chain (2).
 - 2.2. Measure the free play on the slack side (3) of the camshaft timing chain.

If the camshaft timing chain can be moved side to side in excess of 11 mm (0.43 in), replacement of the camshaft timing chain and the sprockets is recommended during assembly.

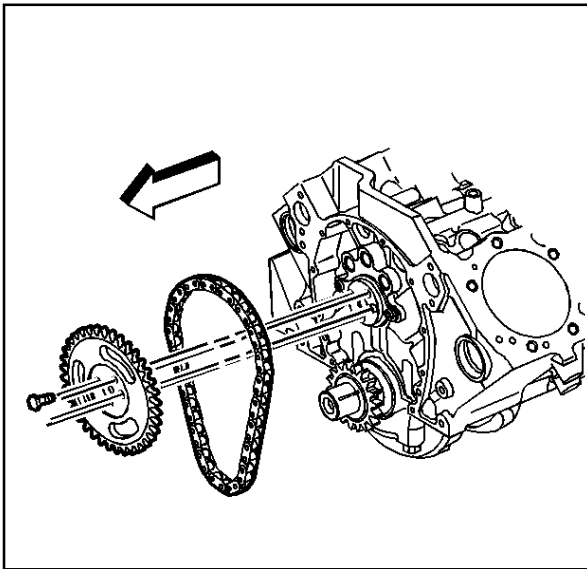

500645

3. Remove the camshaft sprocket bolts.
4. Remove the camshaft sprocket.
5. Remove the camshaft timing chain.

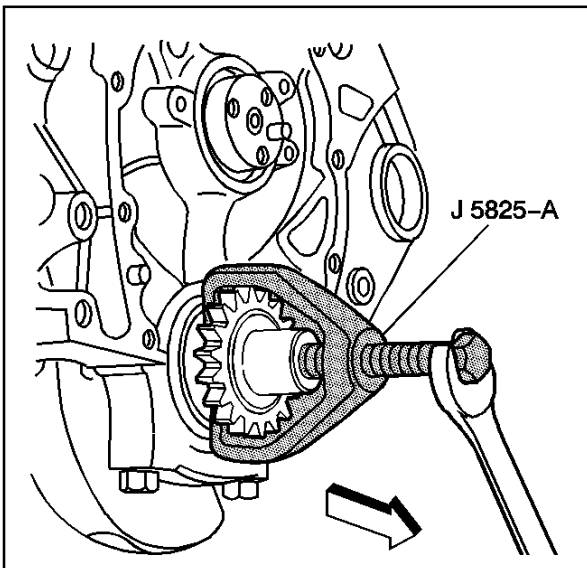

11506

Caution: Refer to Safety Glasses Caution in Cautions and Notices.

6. Remove the crankshaft sprocket using the J 5825-A.

7. Remove the woodruff keys (crankshaft balancer)(if required).

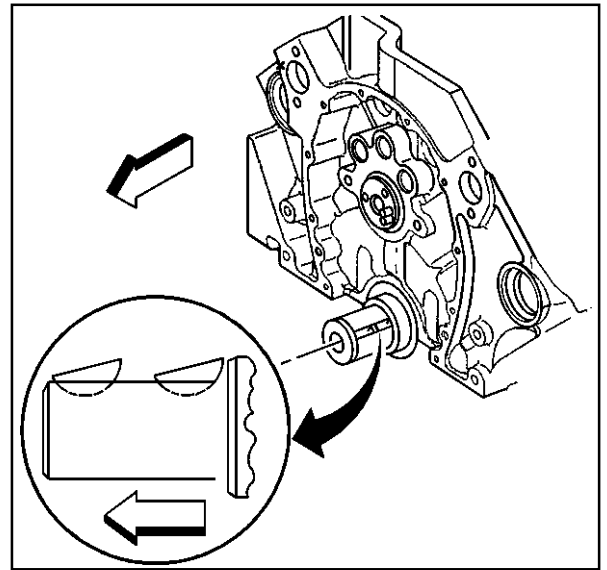

182847

Camshaft Removal

1. Remove the bolts and the camshaft retainer.

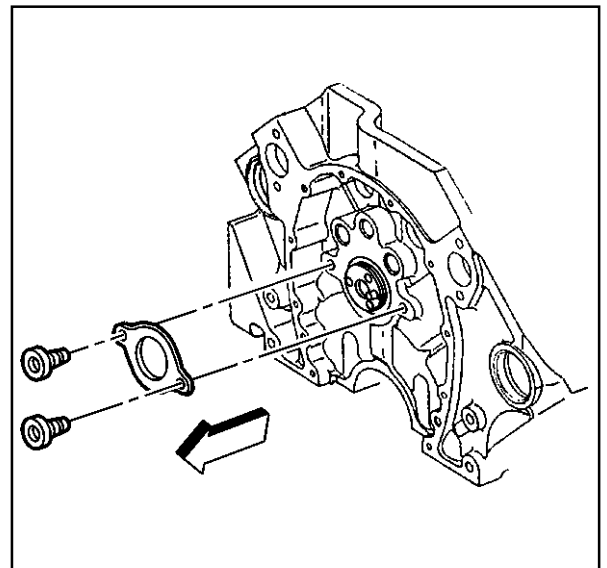

182836

Notice: All camshaft journals are the same diameter, so care must be used in removing or installing the camshaft to avoid damage to the camshaft bearings.

2. Remove the engine camshaft.
 - 2.1. Install the three 5/16-18 x 4.0 inch bolts in the engine camshaft front bolt holes.
 - 2.2. Using the bolts as a handle, carefully rotate and pull the engine camshaft out of the camshaft bearings.
 - 2.3. Remove the bolts from the front of the engine camshaft.

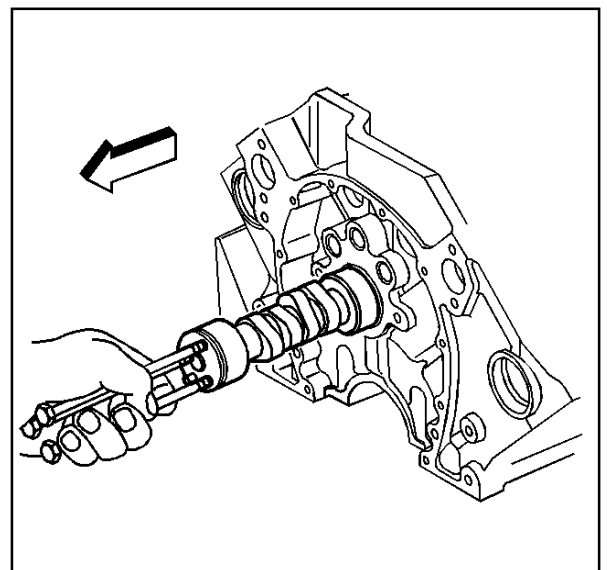

69013

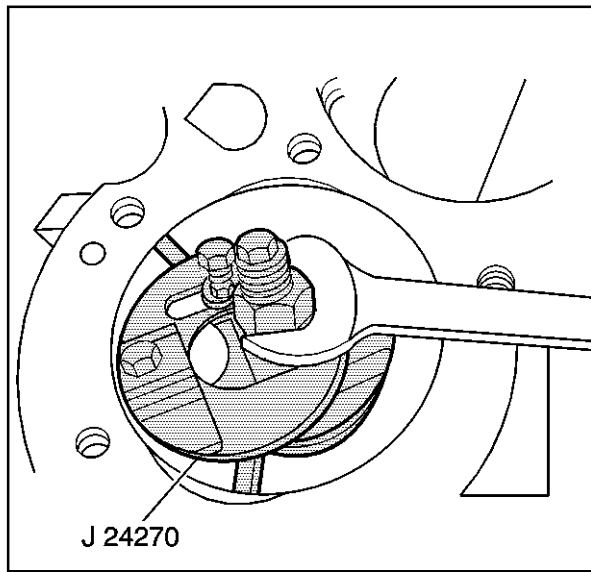

Piston, Connecting Rod, and Bearing Removal

Tools Required

J 5239 Connecting Rod Bolt Guide Set

J 24270 Cylinder Bore Ridge Reamer

Caution: *Wear safety glasses in order to avoid eye damage.*

1. Remove the ring ridge.
 - 1.1. Turn the crankshaft until the piston is at the bottom of the stroke.
 - 1.2. Place a cloth on top of the piston.
 - 1.3. Use the J 24270 to remove all of the cylinder ring ridge.
 - 1.4. Turn the crankshaft so the piston is at the top of the stroke.
 - 1.5. Remove the cloth.
 - 1.6. Remove the cutting debris.

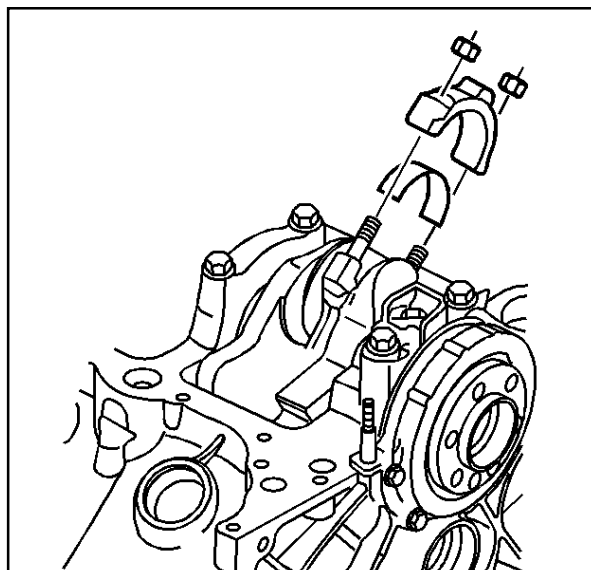

Important: Place matchmarks or numbers on the connecting rods and the connecting rod caps.

2. Remove the connecting rod nuts.
3. Remove the connecting rod cap.

4. Use the J 5239 in order to protect the crankshaft journals and remove the connecting rod and the piston out of the top of the engine block.

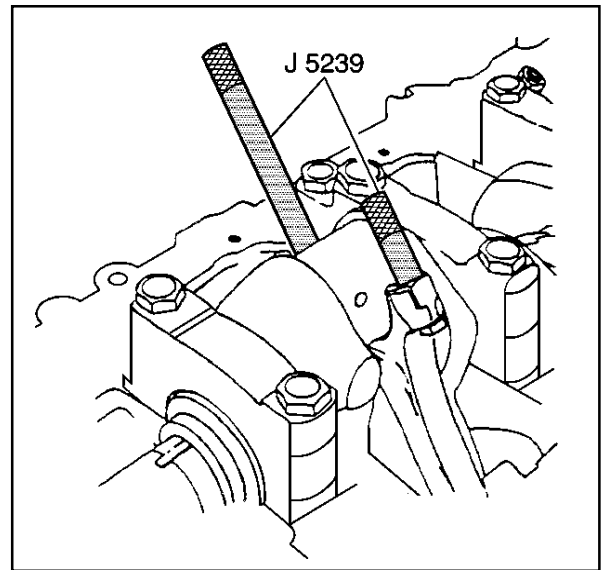

31373

Important: Always assemble the connecting rod caps to the matching connecting rods.

5. Remove the connecting rod bearings.
 - 5.1. Keep the connecting rod bearings with the original connecting rod and connecting rod cap.
 - 5.2. Wipe the oil from the connecting rod bearings.
 - 5.3. Wipe the oil from the crankpins.

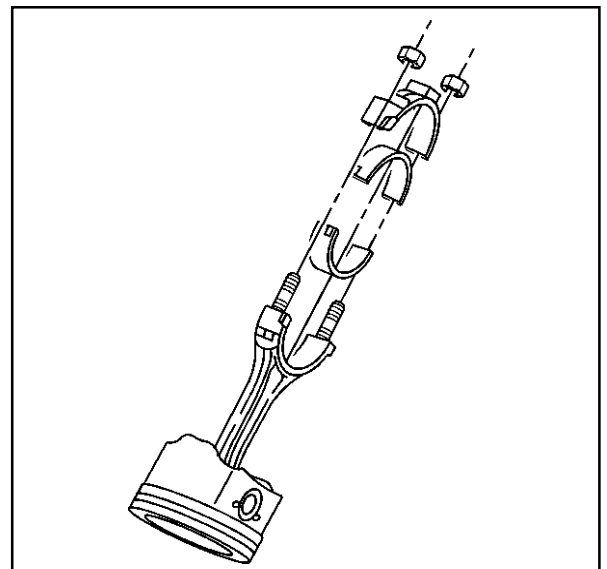

188017

Crankshaft Rear Oil Seal and Housing Removal

1. Remove the crankshaft rear oil seal from the crankshaft rear oil seal housing.

Insert a suitable tool into the access notches and then carefully pry the crankshaft rear oil seal from the crankshaft rear oil seal housing.
2. Discard the crankshaft rear oil seal.

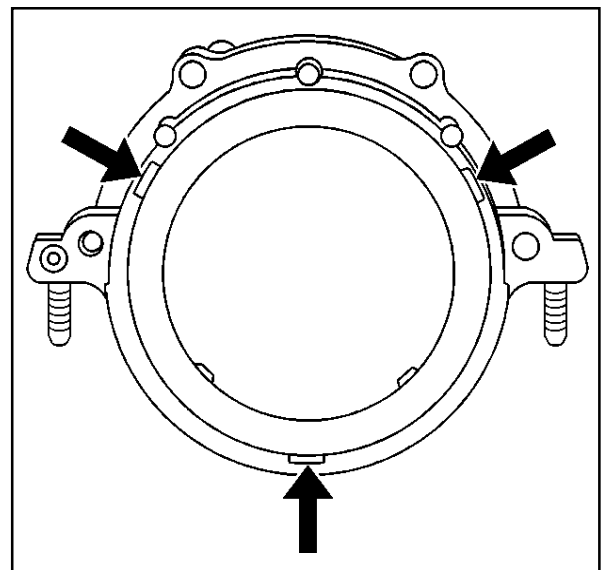

31379

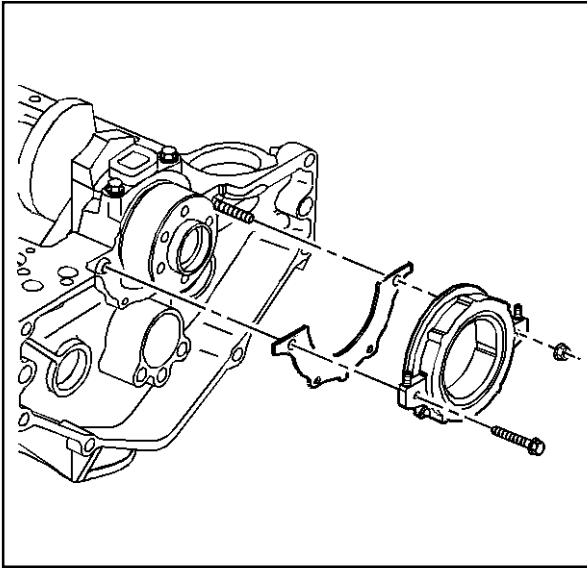

11479

3. Remove the crankshaft rear oil seal housing nut and bolts.
4. Remove the crankshaft rear oil seal housing.
5. Remove the crankshaft rear oil seal housing gasket.
6. Discard the crankshaft rear oil seal housing gasket.
7. Remove the rear oil seal housing retainer stud from the engine block.

Crankshaft and Bearings Removal

1. Mark or identify the crankshaft bearing cap locations, direction and positions for assembly.
2. Remove the crankshaft bearing cap bolts.
3. Remove the crankshaft bearing caps.

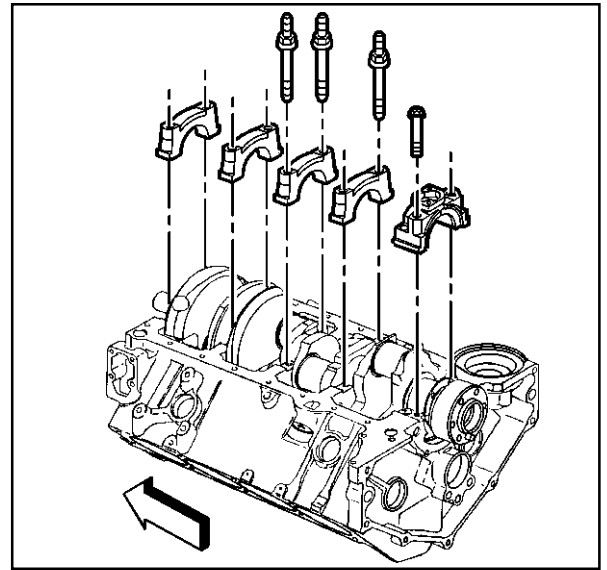

317268

4. Remove the crankshaft.

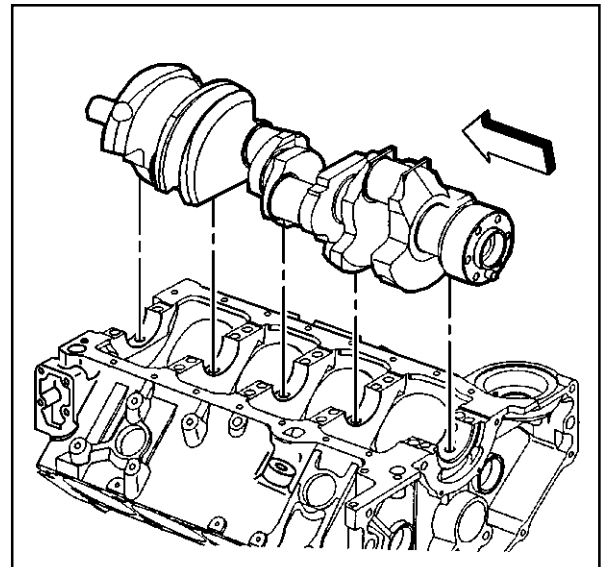

317351

5. Remove the crankshaft bearings from the crankshaft bearing caps.

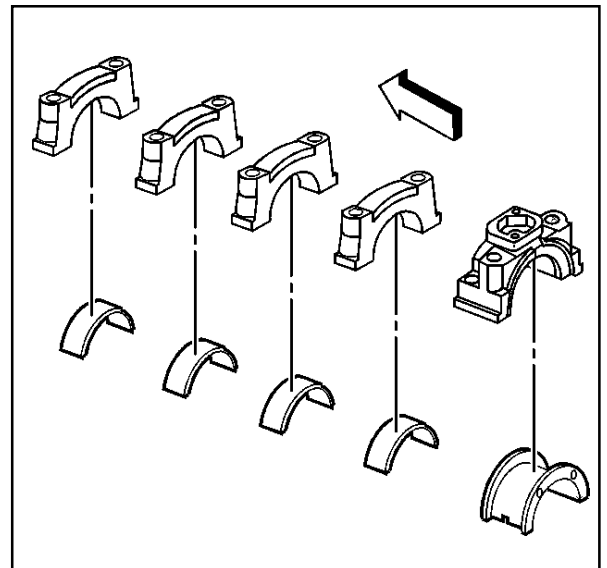

317295

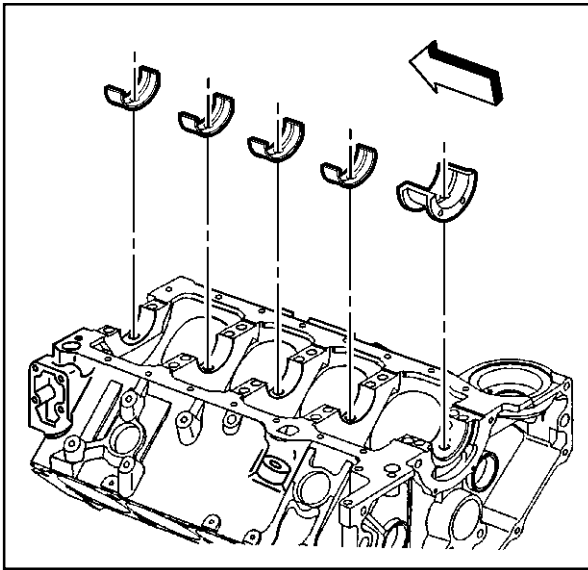

317292

6. Remove the crankshaft bearings from the engine block.

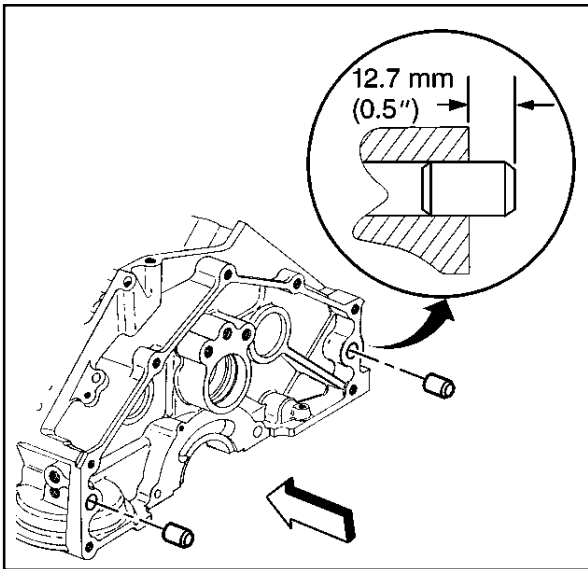

182855

Engine Block Plug Removal

Tools Required

J 41712 Oil Pressure Switch Socket

Caution: Refer to Safety Glasses Caution in Cautions and Notices.

1. Remove the transmission locator pins (if required).

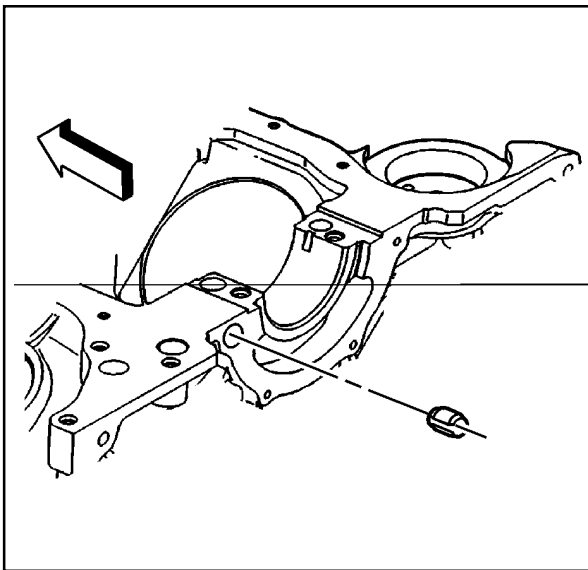

521820

2. Remove the S type pin (crankshaft rear oil seal housing)(if required).

- 3. Remove the expansion cup plug (camshaft rear bearing hole).

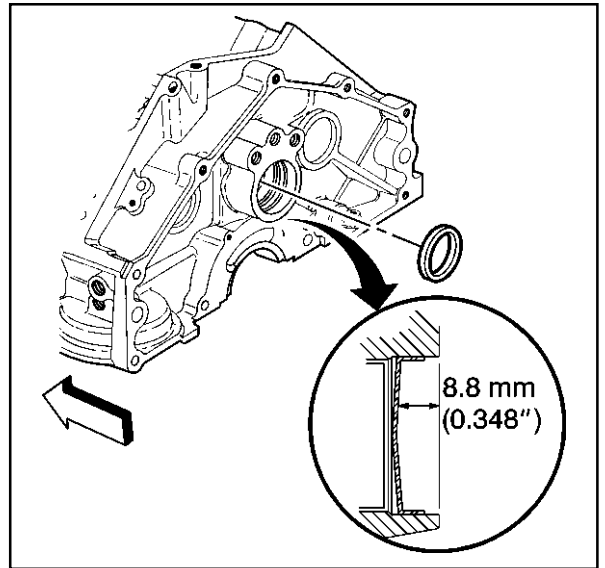

182854

- 4. Remove the engine oil pressure gauge sensor using the J 41712.

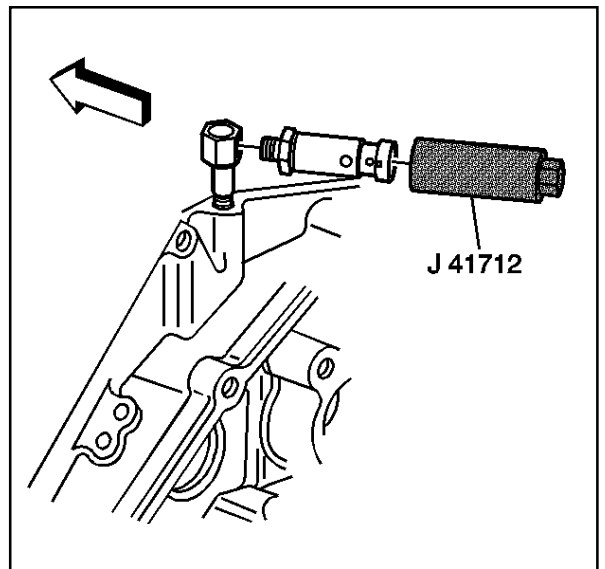

333649

- 5. Remove the engine oil pressure sensor gauge fitting.

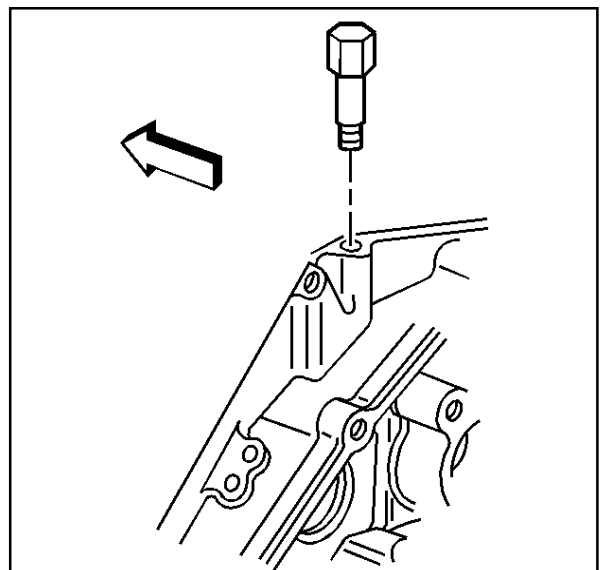

333652

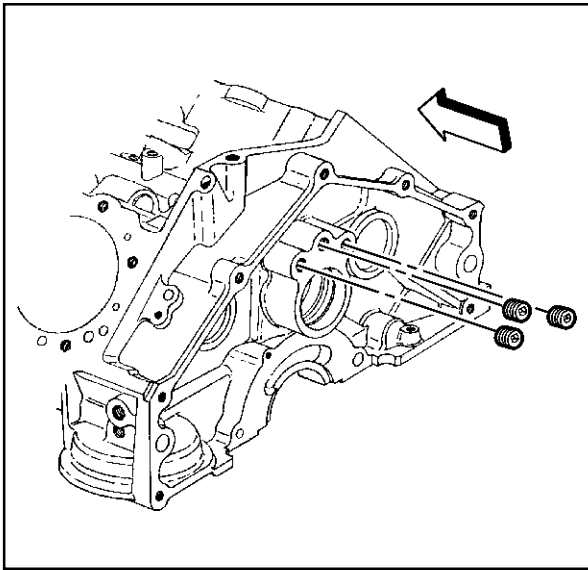

69847

6. Remove the square socket plugs (engine block oil gallery) from the rear of the engine block.

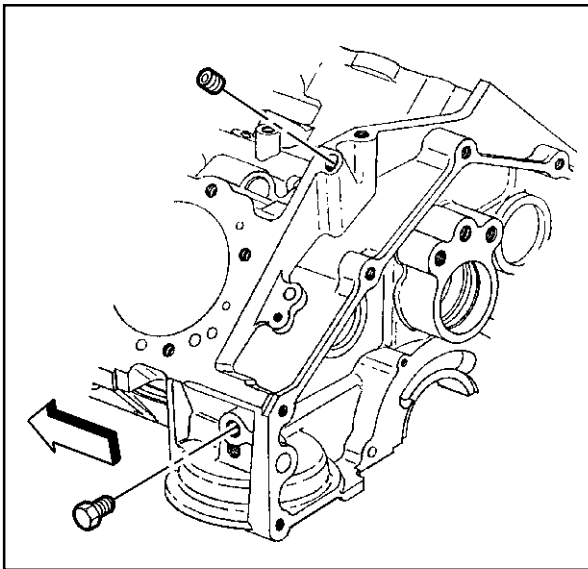

182841

7. Remove the left side rear and left rear top engine block oil gallery plugs.

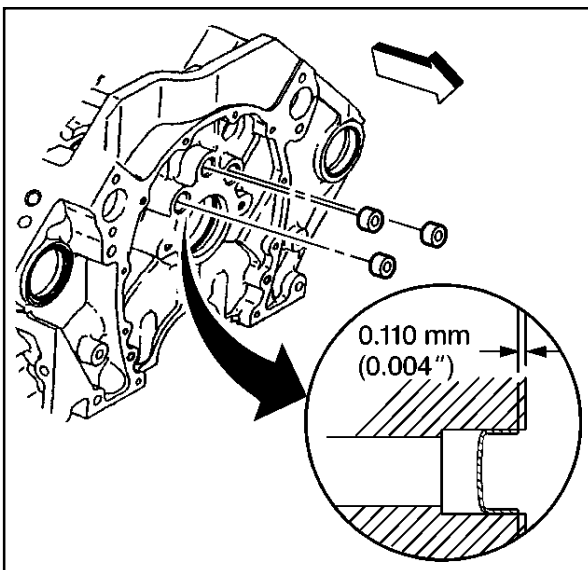

182838

8. Remove the engine block oil gallery plugs (front) from the engine block and discard.
Insert a 3/8 x 26 in. rod into the rear oil gallery holes in order to drive out the front engine block oil gallery plugs.

9. Remove the engine block core hole plugs.
 - 9.1. Use a suitable tool in order to drive the engine block core hole plugs into the coolant jacket.
 - 9.2. Use a suitable tool in order to pull the engine block core hole plugs from the coolant jacket.
 - 9.3. Discard the engine block core hole plugs.

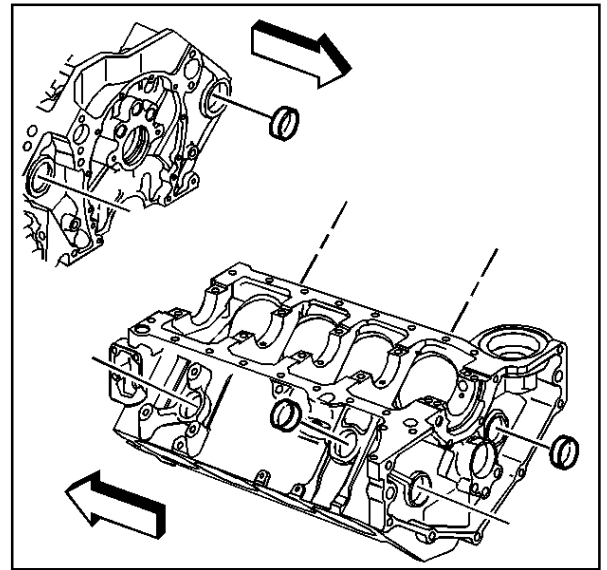

500648

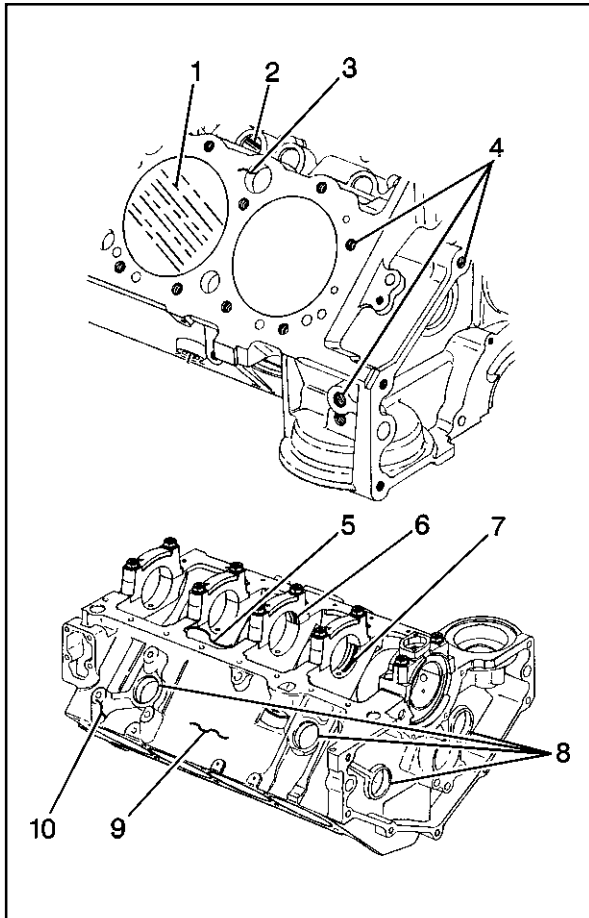

317297

Engine Block Clean and Inspect

Tools Required

J 8087 Cylinder Bore Gauge

Caution: Refer to Safety Glasses Caution in Cautions and Notices.

1. Clean all the remaining sealing or gasket material from the sealing surfaces.
2. Clean the engine block with cleaning solvent.
3. Flush the engine block with clean water or steam.
4. Clean the cylinder bores.
5. Clean the oil galleries and the oil passages.
6. Clean the scale and the deposits from the coolant passages.

Notice: Clean all debris, dirt and coolant from the engine block cylinder head bolt holes. Failure to remove all foreign material may result in damaged threads, improperly tightened fasteners or damage to the components.

7. Clean the engine block cylinder head bolt holes.
8. After cleaning the engine block, spray or wipe the cylinder bores and the machined surfaces with clean engine oil.
9. Inspect the following areas:
 - Coolant jackets (3) for cracks
 - Cylinder bores (1) for scratches or gouging
 - Valve lifter bores (2) for excessive scoring or wear
 - Threaded holes (4) for damage
 - Crankshaft bearing webs (5) for cracks
 - Crankshaft bearing caps (6) and the crankshaft bearing bores (7) for damage
 - The crankshaft bearing bores should be round and uniform when measuring the inside diameter (ID).
 - The surface where the crankshaft bearings contact the crankshaft bearing bore should be smooth.
 - If a crankshaft bearing cap is damaged and requires replacement, replace the crankshaft bearing cap first, then rebore the engine block crankshaft bearing bores and check for proper alignment. Finally, check the crankshaft for the proper clearances.
 - Engine block core hole plug bores (8) for damage
 - Engine block (9) for cracks or damage
 - Engine mount bosses (10) for damage

10. Measure the cylinder bores for taper and out-of-round.
 - 10.1. Depress the plunger on the J 8087 7 mm (0.275 in) or until the J 8087 enters the cylinder bore.
 - 10.2. Center the J 8087 in the cylinder bore and turn the indicator dial to 0.
 - 10.3. Move the J 8087 up and down the cylinder bore to determine the cylinder bore taper. Refer to *Engine Mechanical Specifications*.
 - 10.4. Turn the J 8087 to different points around the cylinder bore to determine the cylinder bore out-of-round condition. Refer to *Engine Mechanical Specifications*.

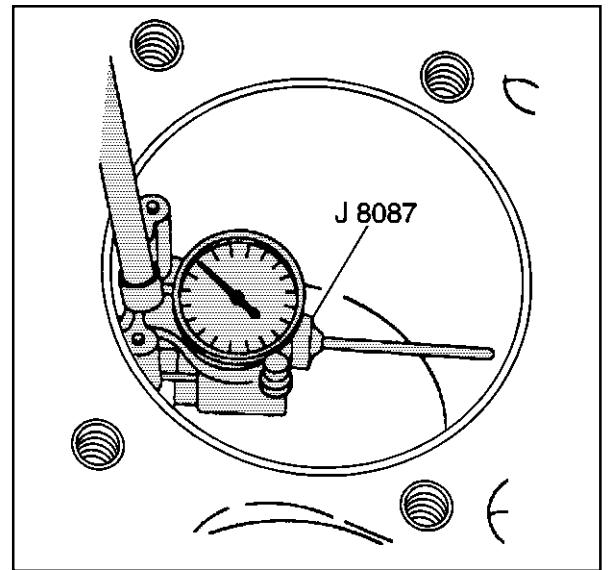

4972

Cylinder Boring and Honing

Honing Procedure

Caution: Refer to Safety Glasses Caution in Cautions and Notices.

1. When honing the cylinder bores, follow the manufacturer's recommendations for equipment use, cleaning and lubrication.
 - Use only clean sharp stones of the proper grade for the amount of material to be removed.
 - Dull, dirty stones cut unevenly and generate excessive heat.
 - DO NOT hone to a final grade with a coarse or medium-grade stone.
 - Leave sufficient metal so that all the stone marks will be removed with the fine grade stones.
 - Perform the final honing with a fine-grade stone and hone the cylinder bore in a cross-hatch pattern at 45-65 degrees to obtain the proper clearance.
2. During the honing operation, thoroughly check the cylinder bore.
 - Repeatedly check the cylinder bore fit with the selected piston.
 - All measurements of the piston or cylinder bore should be made with the components at normal room temperature.
3. When honing to eliminate taper in the cylinder bore, use full strokes the complete length of the cylinder bore.
4. Repeatedly check the measurement at the top, the middle and the bottom of the cylinder bore.
 - The finish marks should be clean but not sharp.
 - The finish marks should be free from imbedded particles or torn or folded material.

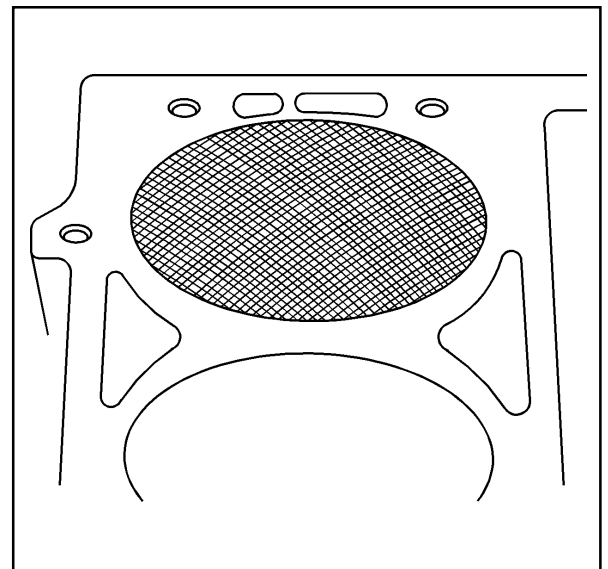

186747

5. By measuring the selected piston at the sizing point and then by adding the average of the clearance specification, the final cylinder bore honing dimension required can be determined.
6. When finished, the reconditioned cylinder bores should have less than or meet the specified out-of-round and taper requirements.
7. After the final honing and before the piston is checked for fit, clean the cylinder bore with hot water and detergent.
 - 7.1. Scrub the cylinder bores with a stiff bristle brush.
 - 7.2. Rinse the cylinder bores thoroughly with clean hot water.
 - 7.3. Dry the cylinder bores with a clean rag.
 - 7.4. Do not allow any abrasive material to remain in the cylinder bores.
 - Abrasive material may cause premature wear of the new piston rings and the cylinder bores.
 - Abrasive material will contaminate the engine oil and may cause premature wear of the bearings.
8. Perform final measurements of the piston and the cylinder bore.
9. Permanently mark the top of the piston for the specified cylinder to which it has been fitted.
10. Apply clean engine oil to each cylinder bore in order to prevent rusting.

Boring Procedure

Caution: Refer to Safety Glasses Caution in Cautions and Notices.

1. Before starting the honing or reboring operation, measure all the new pistons with the micrometer contacting at points exactly 90 degrees from the piston pin centerline.
2. File the top of the cylinder block in order to remove any dirt or burrs before using any type of boring bar.
3. Follow the instructions furnished by the manufacturer regarding the use of the boring equipment.
4. When reboring the cylinders, make sure all the crankshaft bearing caps are installed in the original position and direction.
5. Tighten the crankshaft bearing caps to the proper torque specifications in order to avoid distortion of the cylinder bores in the final assembly.
6. When making the final cut with the boring bar, leave 0.03 mm (0.001 in) on the cylinder bore diameter for finish honing. This gives the required position to the cylinder clearance specifications. (Carefully perform the honing and boring operation in order to maintain the specified clearances between the pistons, the piston rings and the cylinder bores).

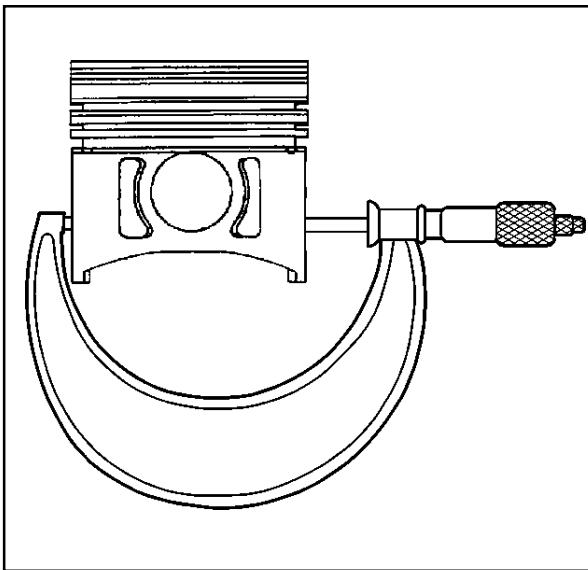

188016

Piston and Connecting Rod Disassemble

Tools Required

J 24086-C Piston Pin Remover/Installer

Caution: Refer to Safety Glasses Caution in Cautions and Notices.

1. Remove the piston rings from the pistons.

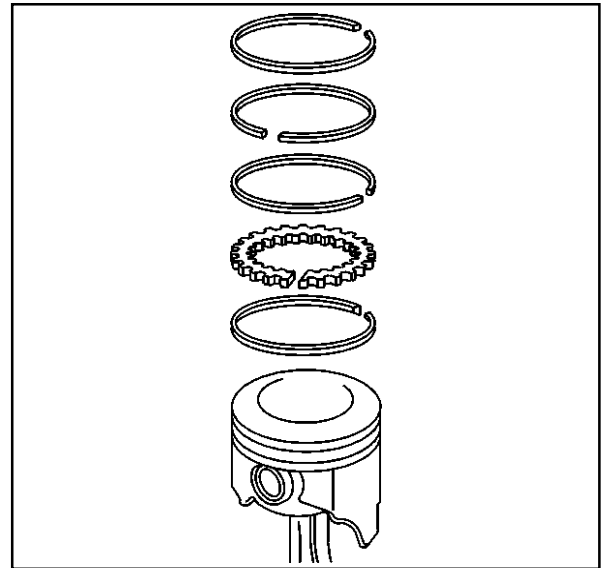

4967

2. Press the piston pin from the connecting rod using the J 24086-C.
The piston pin has an interference fit into the connecting rod, and is full floating in the piston.

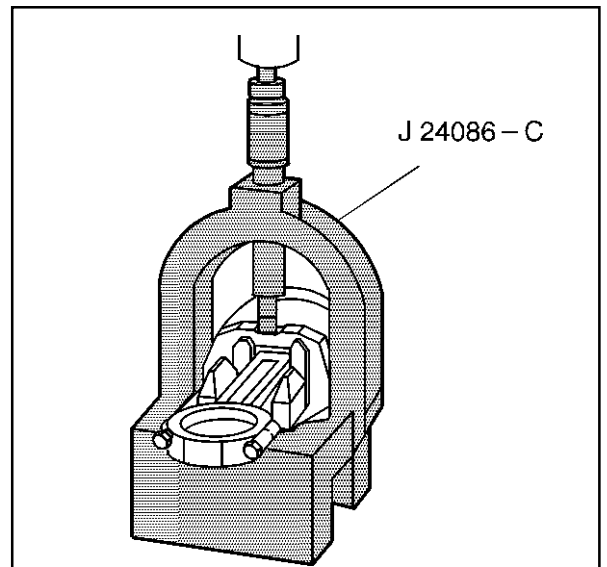

4965

3. Mark, separate and organize the parts for assembly.

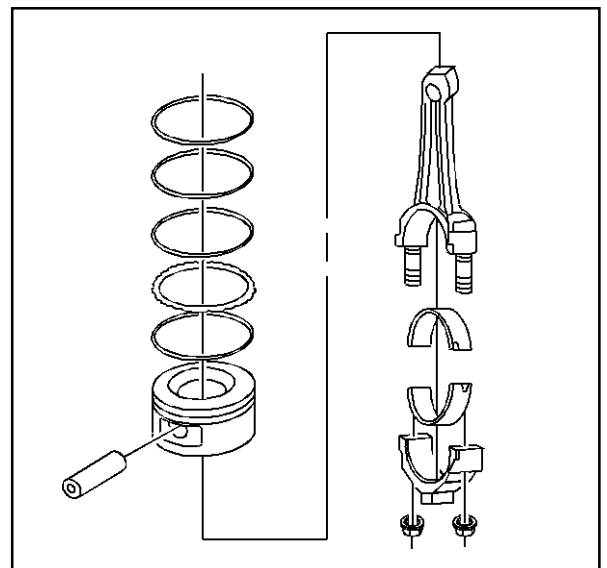

34671

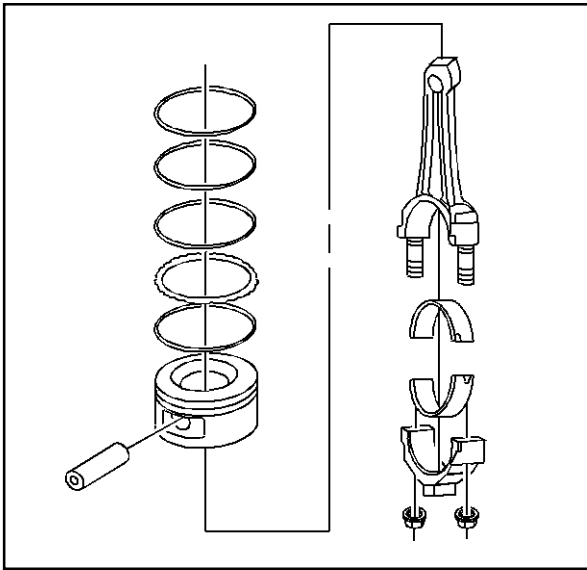

34671

Piston, Connecting Rod and Bearings Clean/Inspect

Important: Measurement of all components should be taken with the components at room temperature.

Do not use a wire brush in order to clean any part of the piston.

Caution: Refer to *Safety Glasses Caution in Cautions and Notices*.

1. Clean the piston and connecting rod in solvent.
2. Dry the components with compressed air.

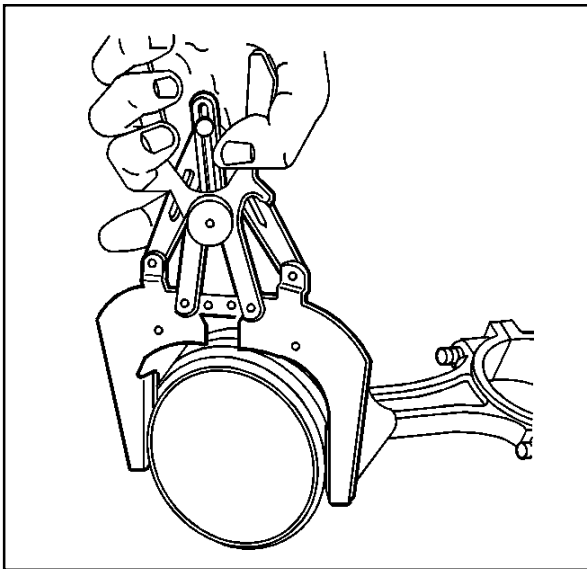

4977

3. Clean the piston ring grooves with a suitable ring groove cleaning tool.

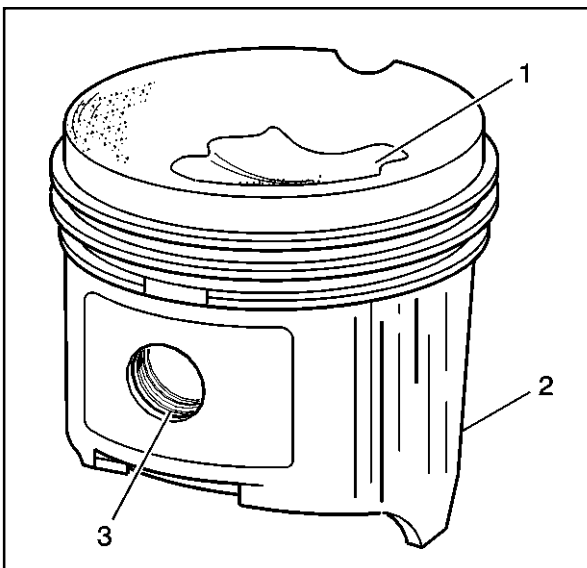

156168

4. Clean the piston oil lubrication holes and slots.
5. Inspect the piston for the following:
 - Eroded areas (1) on the top of the piston
 - Scuffed or damaged skirt (2)
 - Damage to the pin bore (3)
 - Cracks in the piston ring lands, the piston skirt or the pin bosses
 - Piston ring grooves for nicks, burrs or other warpage which may cause the piston ring to bind
6. Inspect the piston pin for scoring, wear or other damage

7. Measure the piston ring-to-piston ring groove side clearance.
 - 7.1. Insert the edge of the piston ring into the piston ring groove.
 - 7.2. Roll the piston ring completely around the piston.
 - If binding is caused by a distorted piston ring groove, MINOR imperfections may be removed with a fine file.
 - If binding is caused by a distorted piston ring, replace the piston ring.

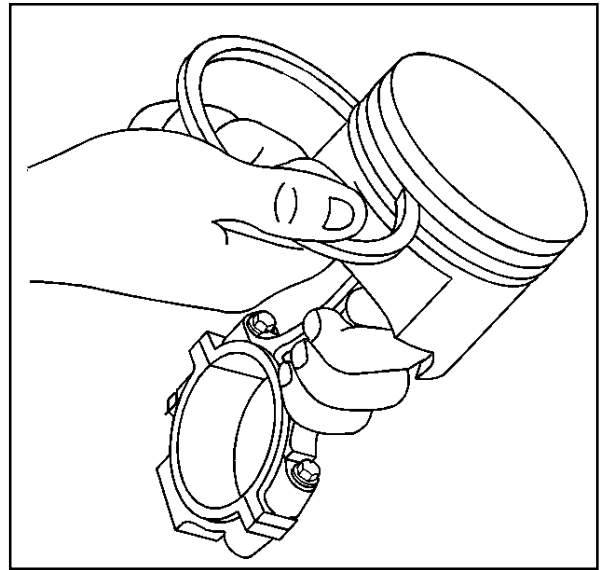

4969

8. Measure the piston ring side clearance with a feeler gauge.
 - If the side clearance is too small, try another piston ring set.
 - If the proper piston ring-to-piston ring groove clearance cannot be achieved, replace the piston and pin assembly.
9. To determine the proper piston ring side clearance, refer to *Engine Mechanical Specifications*.

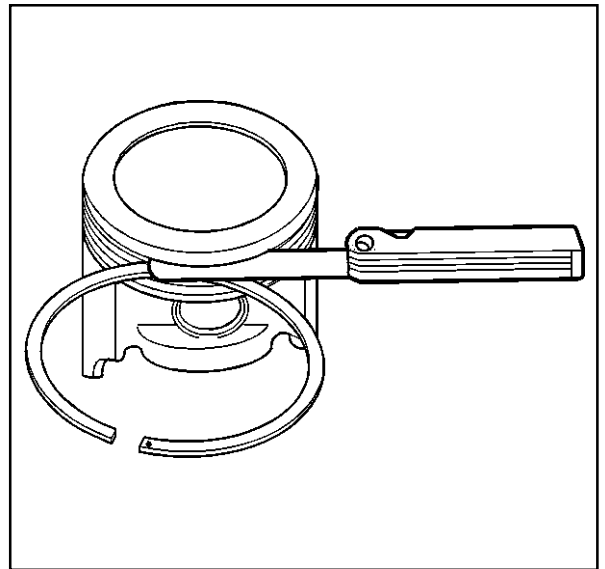

22934

10. To determine piston pin-to-bore clearance, use a micrometer and measure the piston pin.

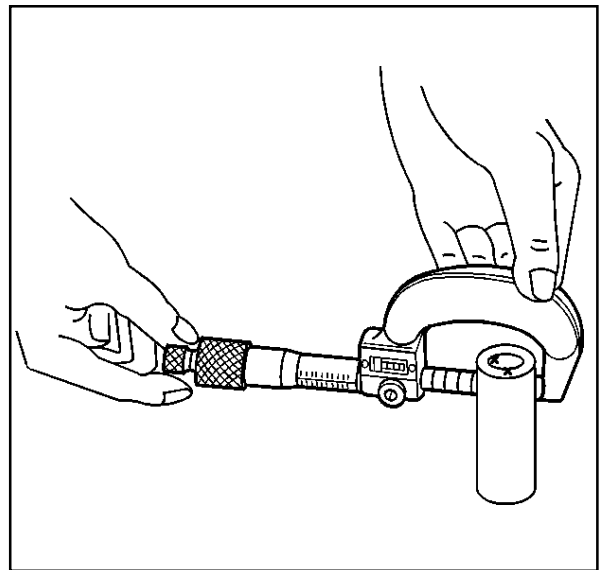

4976

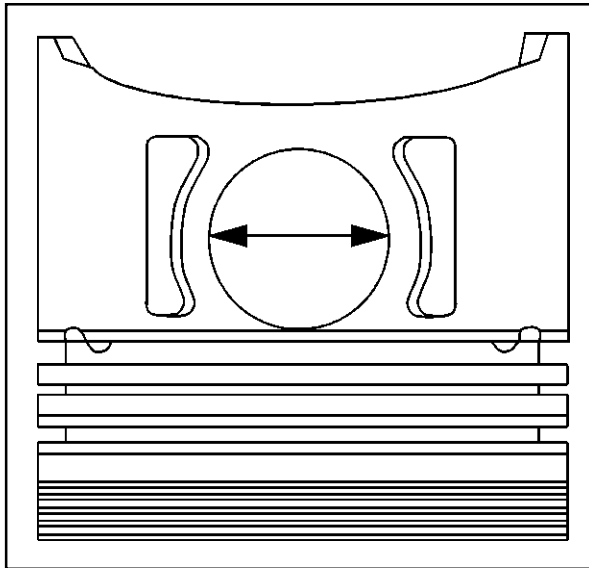

4975

11. To determine piston pin-to-bore clearance, use an inside micrometer and measure the piston pin bore.
12. To determine the piston pin-to-bore clearance, subtract the piston pin diameter from the piston pin bore diameter. Refer to *Engine Mechanical Specifications*.

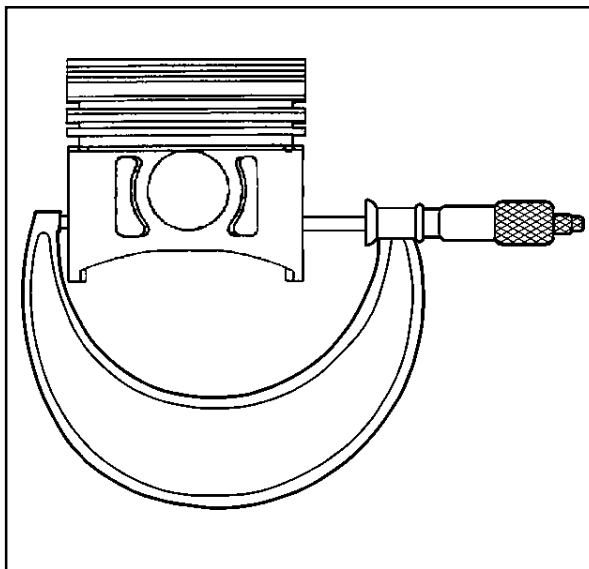

188016

13. Measure the piston with a micrometer at a right angle to the piston pin bore, measure the piston at 11 mm (0.433 in) from the bottom of the skirt. Refer to *Engine Mechanical Specifications*.

If the piston is not within specifications, replace the piston and pin as an assembly.

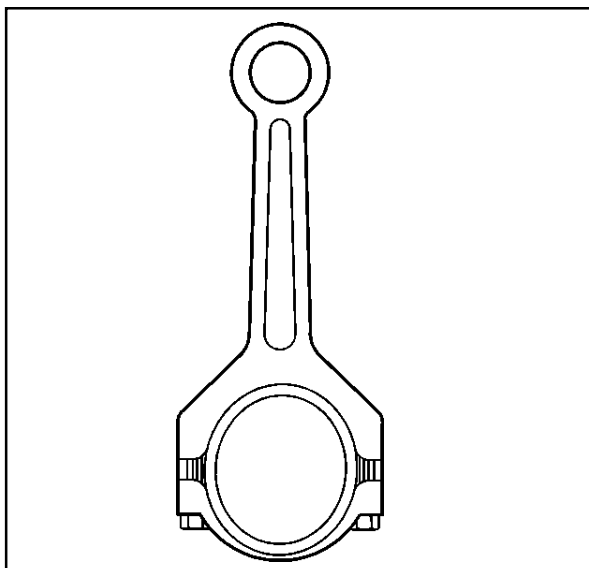

156167

14. Inspect the connecting rod for an out-of-round bearing bore. Refer to *Engine Mechanical Specifications*.

15. Inspect the connecting rod for twisting.
16. Inspect the connecting rod for damage to the bearing cap and bolt threads.

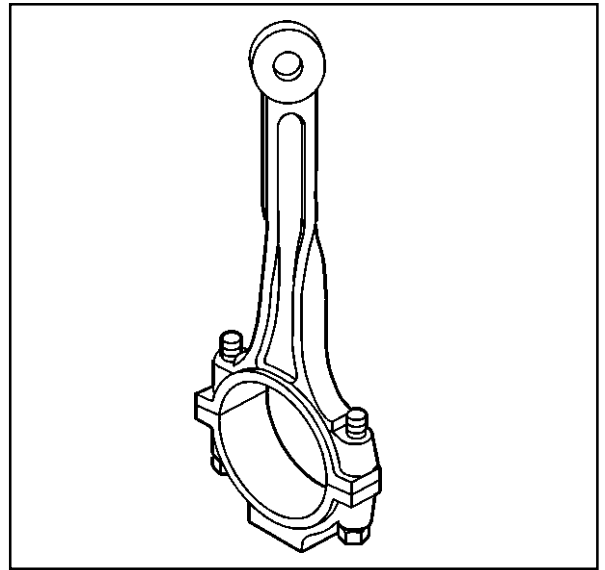

156169

17. Measure the piston compression ring end gap.

Important: Fit each compression ring to the cylinder in which it will be used.

18. Place the compression ring into the cylinder bore.
 - 18.1. Push the compression ring into the cylinder bore to approximately 6.5 mm (0.25 in) above the ring travel. The ring must be square to the cylinder wall.
 - 18.2. Use a feeler gauge in order to measure the end gap. Select another size ring set if the end gap exceeds specifications. Refer to *Engine Mechanical Specifications*.

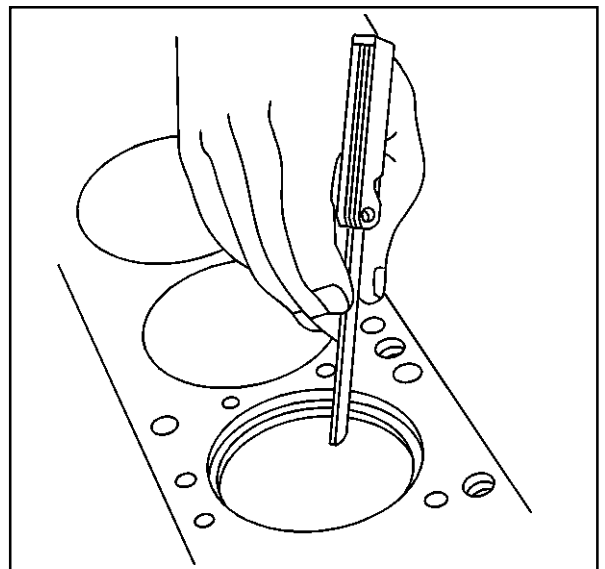

4968

Piston Selection

Tools Required

J 8087 Cylinder Bore Gauge

Important: Measurements of all components should be taken with the components at normal room temperature.

For proper piston fit, the engine block cylinder bores should not have excessive wear or taper.

A used piston and piston pin set may be reinstalled if, after cleaning and inspection, the piston and piston pin are within specifications.

1. Use the J 8087 in order to measure the cylinder bore diameter. Measure at a point 64 mm (2.5 in) from the top of the cylinder bore and 90 degrees to the crankshaft centerline.

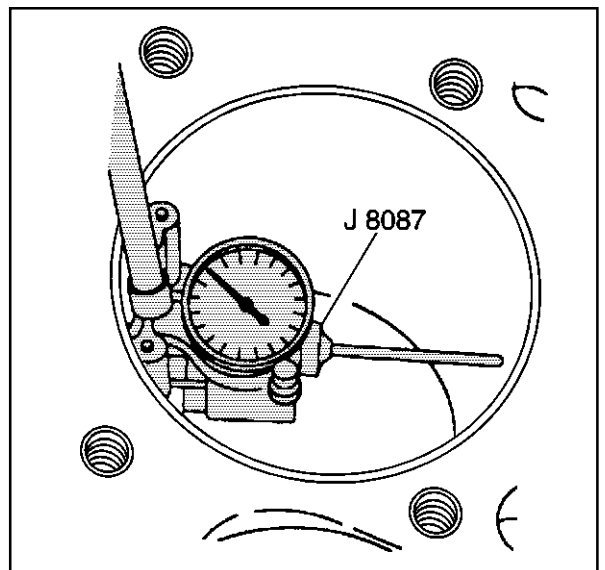

4972

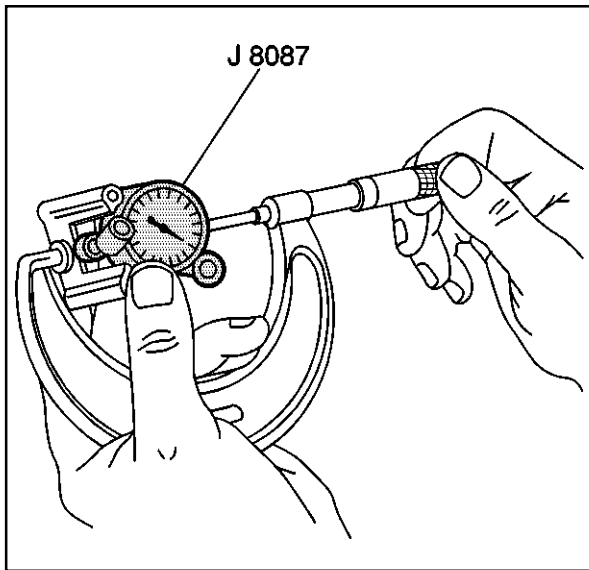

4974

2. Measure the J 8087 with a micrometer and record the reading.

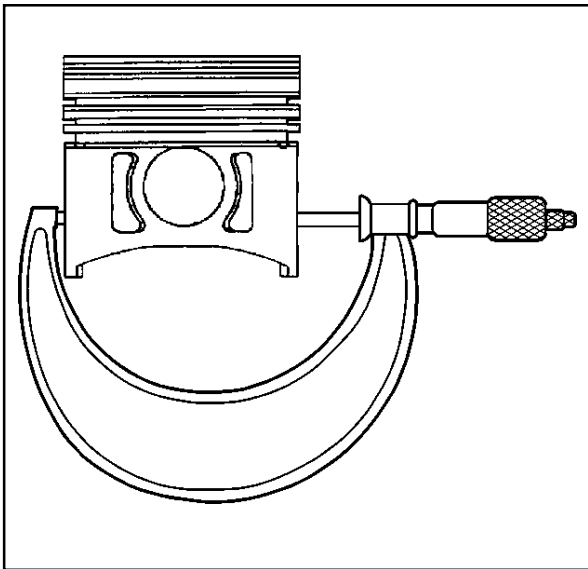

188016

3. With a micrometer or caliper at a right angle to the piston pin bore, measure the piston 11 mm (0.433 in) from the bottom of the skirt.
4. Subtract the piston diameter from the cylinder bore diameter in order to determine piston-to-bore clearance.

Specification

Piston-to-bore clearance 0.018-0.068 mm (0.0007-0.0026 in).

5. If the proper clearance cannot be obtained, then select another piston and measure the clearances.
If the proper fit cannot be obtained, the cylinder bore may require honing or boring.
6. When the piston-to-cylinder bore clearance is within specifications, permanently mark the top of the piston for installation into the proper cylinder.

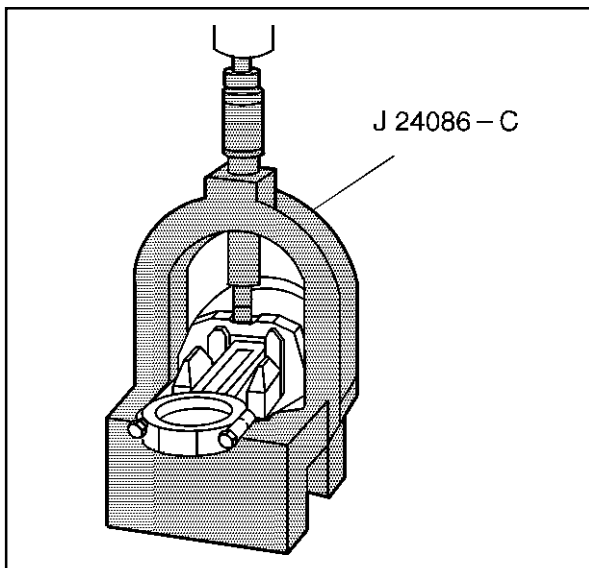

4965

Piston and Connecting Rod Assemble

Tools Required

J 24086-C Piston Pin Remover/Installer

Caution: Avoid contact with HOT components. Wear safety glasses and protective gloves to avoid personal injury.

Notice: Applying excessive heat to the connecting rod may damage or distort the rod. Rod temperature SHOULD NOT exceed 315°C (600°F). At this temperature, the end of the connecting rod will turn a straw color upon visual inspection.

Notice: After the J 24086-C installer hub bottoms on the support assembly, DO NOT exceed 35,000 kPa (5,000 psi) or the tool may be damaged.

Important: When assembling the piston and connecting rod, the mark on the top of the piston must point to the front of the engine block. The left bank connecting rods should have the flange face toward the front of the engine block. The right bank connecting rods should have the flange face toward the rear of the engine block.

The piston pin has an interference fit into the connecting rod and is full floating in the piston.

1. Install the piston pin and connecting rod assembly.
 - 1.1. Lubricate the piston pin bores with clean engine oil.
 - 1.2. Use a torch and apply MILD heat to the piston pin end of the connecting rod.
 - 1.3. Use the J 24086-C in order to press the piston pin into the piston and connecting rod assembly.
 - 1.4. Inspect for the proper installation of the piston and piston pin. The piston must move freely on the piston pin with no binding or interference.

Notice: Use a piston ring expander to install the piston rings. The rings may be damaged if expanded more than necessary.

2. Install the piston rings onto the piston.
 - 2.1. Install the oil control piston ring spacer.
 - 2.2. Install the lower oil control piston ring.
 - 2.3. Install the upper oil control piston ring.
 - 2.4. Install the lower compression piston ring.

The mark on the side of the piston ring should face the top of the piston.
 - 2.5. Install the upper compression piston ring.

The mark on the side of the piston ring should face the top of the piston.

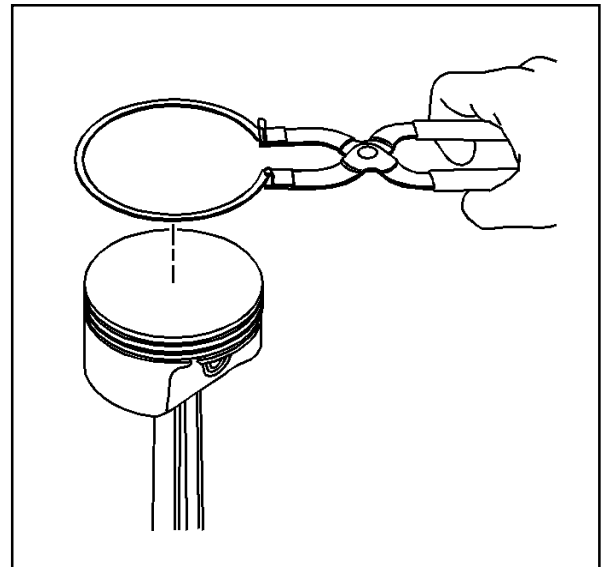

490763

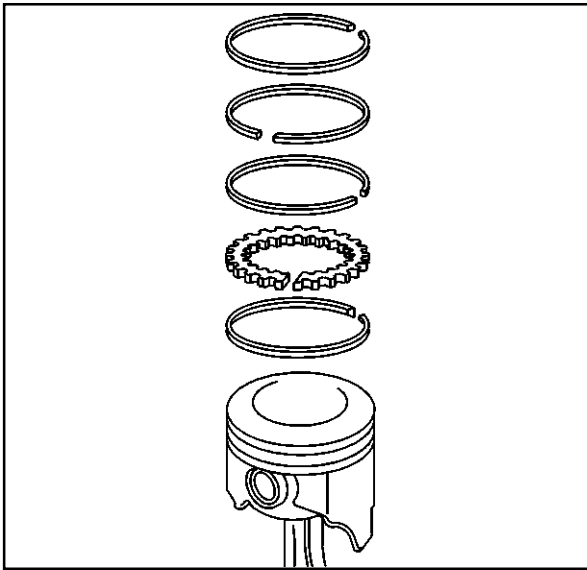

4967

3. Space the compression piston ring end gaps 120 degrees apart.
4. Space the oil control piston ring end gaps a minimum of 90 degrees apart.

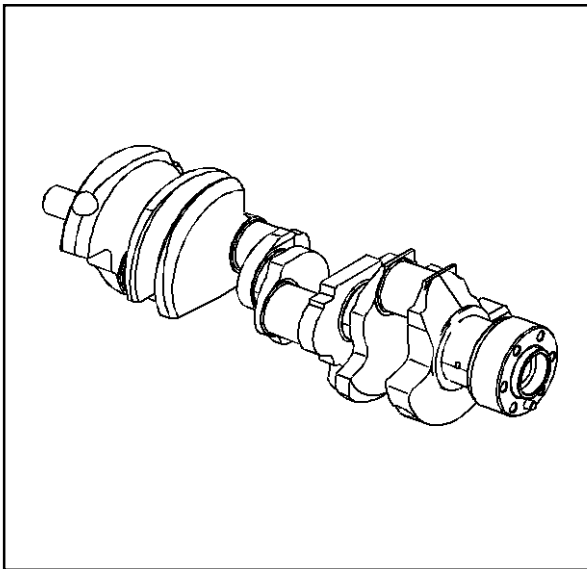

59918

Crankshaft and Bearings Clean and Inspect

Tools Required

J 7872 Magnetic Base Dial Indicator

J 36660 Electronic Torque Angle Meter

Caution: Refer to **Safety Glasses Caution in Cautions and Notices.**

Important: Use care when handling the crankshaft. Avoid damage to the crankshaft bearing surfaces.

1. Clean the crankshaft in cleaning solvent. Remove all sludge or restrictions from the oil passages.
2. Clean the crankshaft bearings in cleaning solvent. Wipe the crankshaft bearings clean with a soft cloth, do not scratch the crankshaft bearing surfaces.
3. Dry the crankshaft with compressed air.

4. Inspect the crankshaft for the following:
- Crankshaft journals (1) should be smooth with no evidence of scoring or damage.
 - Deep grooves (2)
 - Scratches or uneven wear (3)
 - Pitted surfaces (4)
 - Wear or damage to the thrust journal surfaces
 - Scoring or damage to the rear seal surface
 - Restrictions to the oil passages
 - Damage to the threaded bolt holes

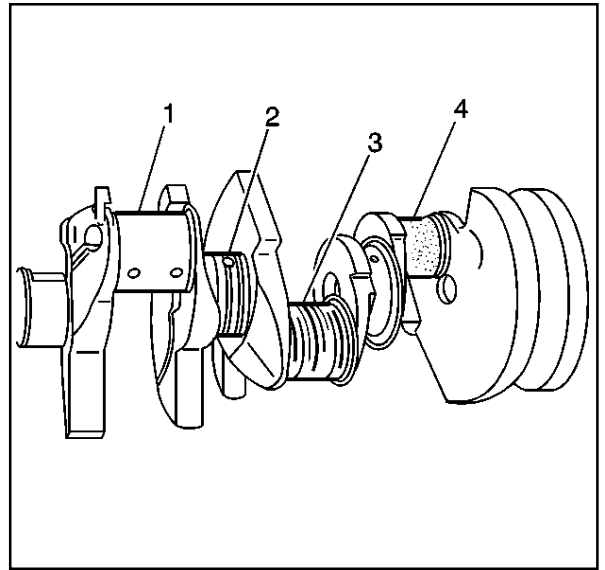

156170

5. Inspect the crankshaft balancer key (1), the keyway (2) and the threaded hole (3) for damage.
 Repair or replace the crankshaft as necessary.

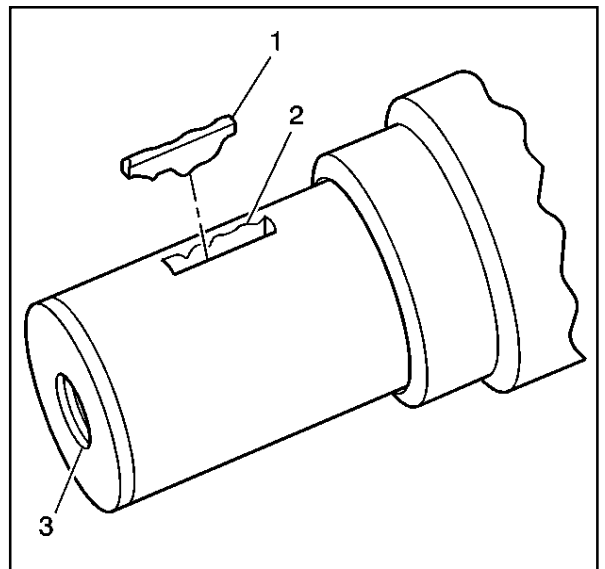

188090

6. Measure the crankpins for out-of-round and taper. Refer to *Engine Mechanical Specifications*.

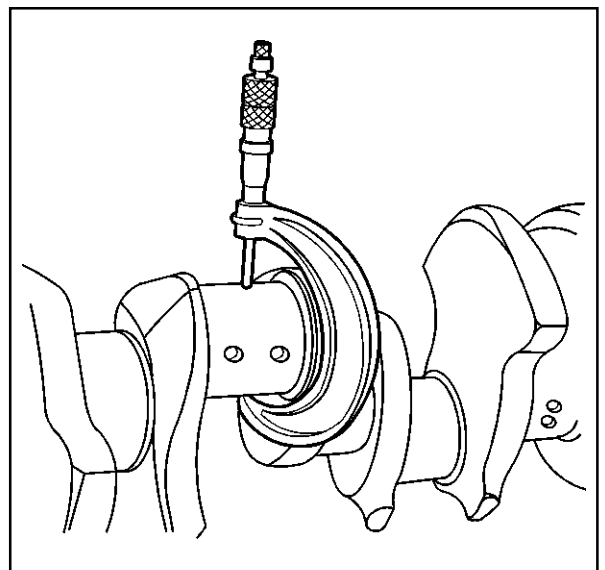

188015

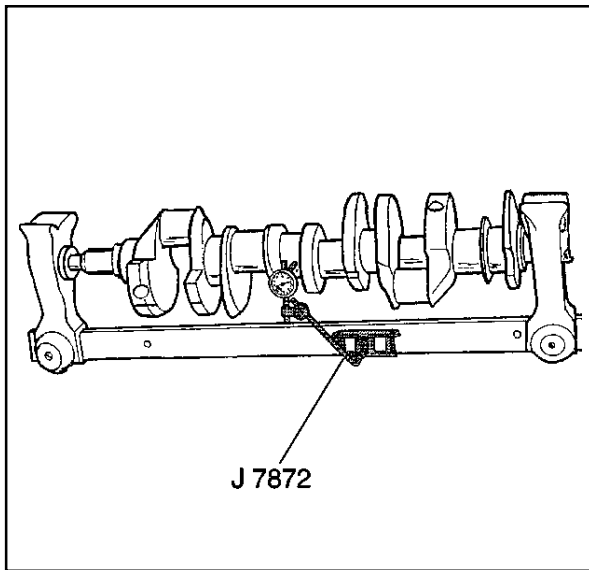

35210

7. Use a suitable support to support the crankshaft on the front and rear journals.
8. Use the J 7872 in order to measure the crankshaft journal runout.

The crankshaft runout should not exceed 0.038 mm (0.0015 in).

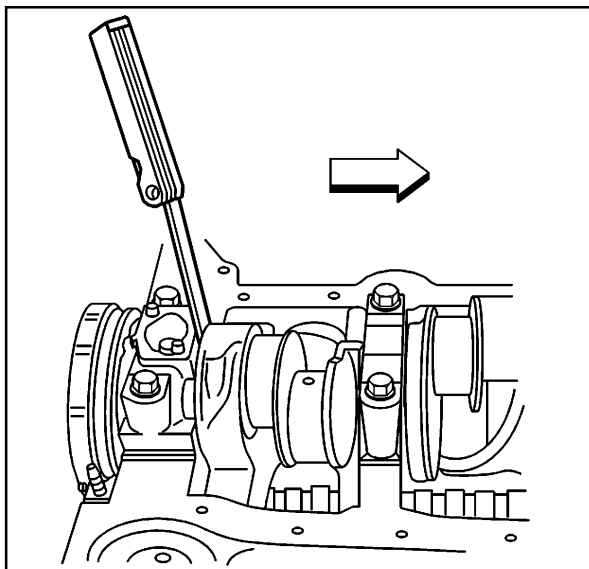

188467

9. Measure the crankshaft end play.

Important: In order to properly measure the crankshaft end play, the crankshaft, the crankshaft bearings and the crankshaft bearing caps, the crankshaft bearing cap bolts must be installed into the engine block and the bolts tightened to specifications.

Firmly thrust the crankshaft first rearward, then forward. This will align the crankshaft rear bearings and the crankshaft thrust surfaces.

- 9.1. With the crankshaft pushed forward, insert a feeler gauge between the crankshaft and the crankshaft bearing surface and then measure the clearance. Refer to *Engine Mechanical Specifications*.
- 9.2. If the correct end play cannot be obtained, verify that the correct size crankshaft bearing has been installed. Refer to *Engine Mechanical Specifications*.
- 9.3. Inspect the crankshaft for binding. Turn the crankshaft to check for binding. If the crankshaft does not turn freely, then loosen the crankshaft bearing cap bolts, one bearing cap at a time, until the tight crankshaft bearing is located.

Burrs on the crankshaft bearing cap, foreign matter between the crankshaft bearing and the engine block or crankshaft bearing cap or a faulty crankshaft bearing could cause a lack of clearance at the crankshaft bearing.

10. Inspect the crankshaft bearings for craters or pockets. Flattened sections on the crankshaft bearing halves also indicate fatigue.

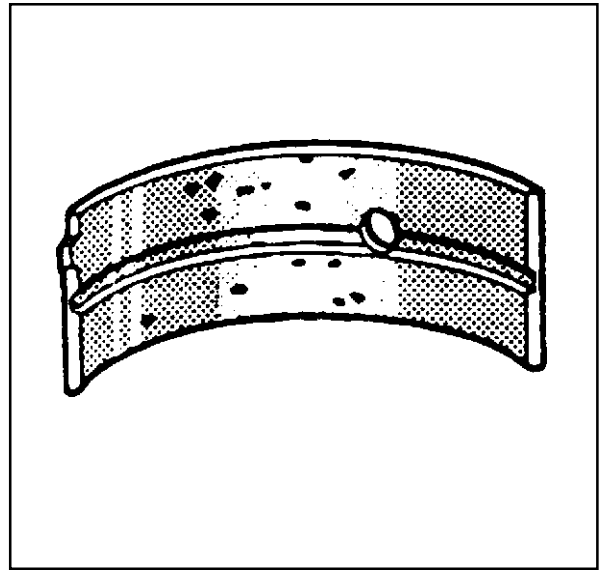

52051

11. Inspect the crankshaft bearings for excessive scoring or discoloration.
12. Inspect the crankshaft bearings for dirt or debris imbedded into the crankshaft bearing material.

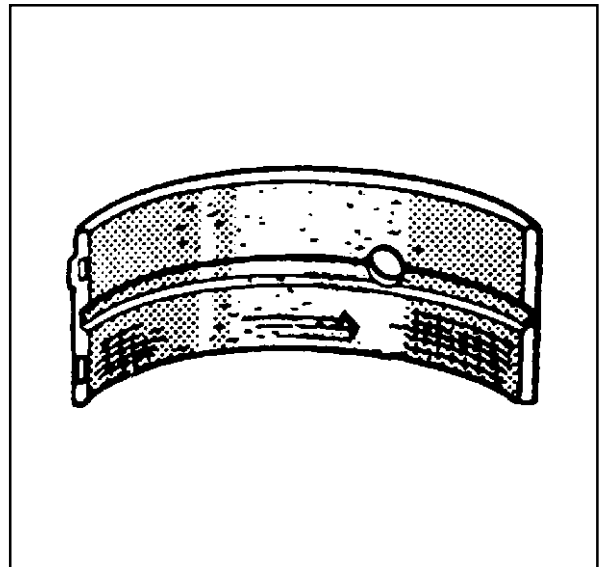

52053

13. Inspect the crankshaft bearings for improper seating indicated by bright, polished sections of the crankshaft bearings.
 - If the lower half of the crankshaft bearing is worn or damaged, both the upper and lower halves of the crankshaft bearing should be replaced.
 - Generally, if the lower half of the crankshaft bearing is suitable for use, the upper half of the crankshaft bearing should also be suitable for use.

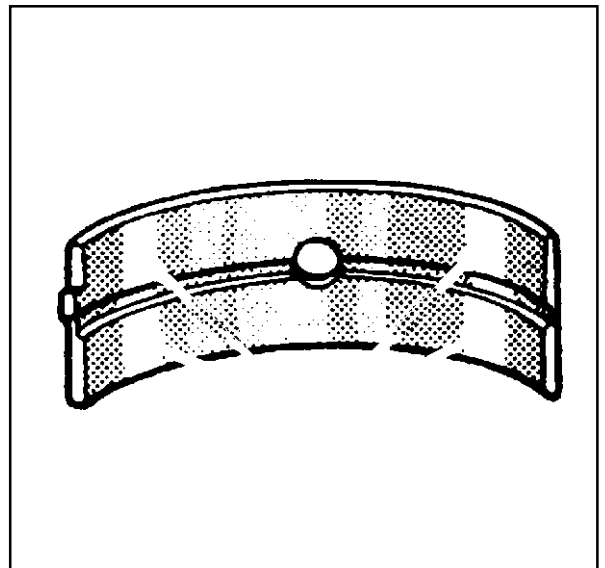

52056

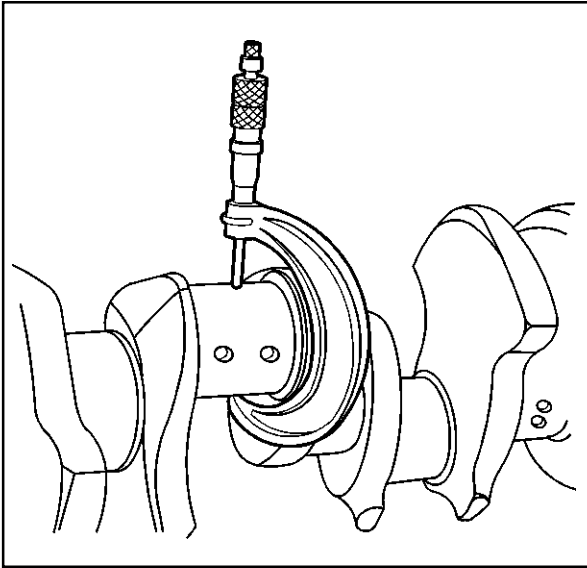

188015

Bearing Clearance Measuring Procedures

The crankshaft bearings are of the precision insert type and do not use shims for adjustment. If the clearances are excessive, then new upper and lower crankshaft bearings will be required. The service crankshaft bearings are available in the standard size and an undersize.

The selective fitting of the crankshaft bearings are necessary in production in order to obtain close tolerances. For this reason, in one journal bore you may use one-half of a standard crankshaft bearing with one-half of an undersize crankshaft bearing.

Important: Do not use the plastic gauge method to measure connecting rod bearing clearances. The plastic gauge method for measuring connecting rod bearing clearances will result in unreliable measurements. Use only the micrometer method to correctly determine the connecting rod bearing clearances.

In order to determine the correct replacement crankshaft bearing size, the crankshaft bearing clearance must be measured accurately. Either the micrometer or plastic gauge method may be used; however, the micrometer method gives more reliable results and is preferred.

Micrometer Method for Crankshaft Bearings

1. Measure the crankshaft journal diameter with a micrometer in several places, approximately 90 degrees apart, and then average the measurements.
2. Determine the taper and the out-of-round of the crankshaft journal. Refer to *Engine Mechanical Specifications*.

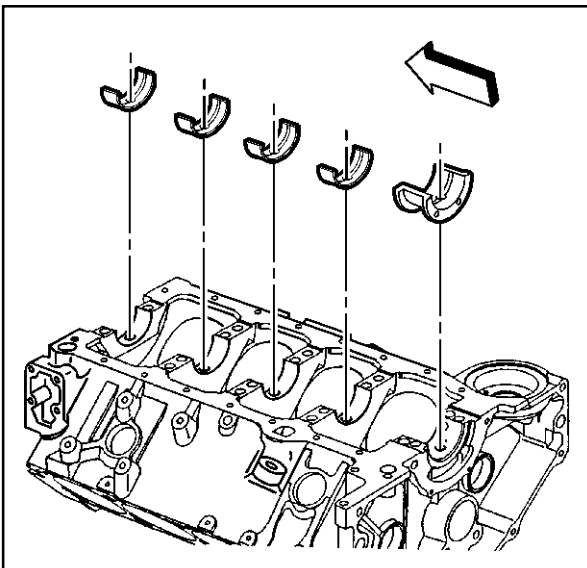

317292

3. Install the crankshaft bearings into the engine block.

4. Install the crankshaft bearings into the crankshaft bearing caps.

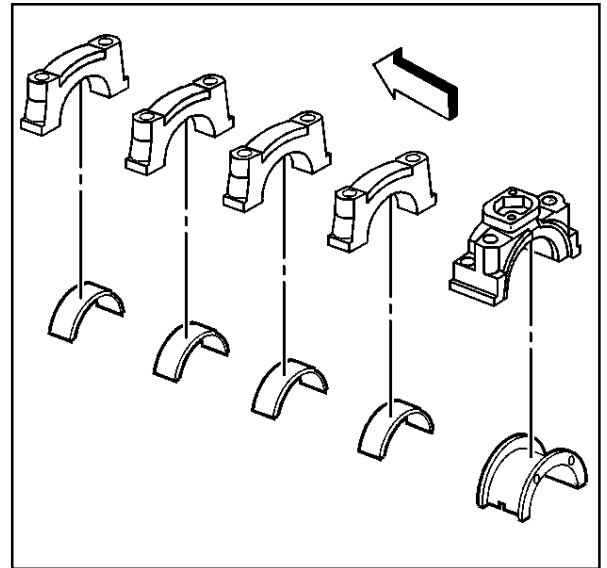

317295

5. Install the crankshaft bearing caps in the original positions and with the arrow on the crankshaft bearing caps in the direction of the front of the engine block.

Notice: Refer to *Fastener Notice* in Cautions and Notices.

6. Install the crankshaft bearing cap bolts.

Tighten

- 6.1. Tighten the crankshaft bearing cap bolts and the crankshaft bearing cap studs on the first pass to 20 N•m (15 lb ft).
- 6.2. Tighten the crankshaft bearing cap bolts and the crankshaft bearing cap studs (two bolt caps) on the final pass an additional 73 degrees using the J 36660.
- 6.3. Tighten the crankshaft bearing cap outboard bolts and the crankshaft bearing cap outboard studs (four bolt caps) on the final pass an additional 43 degrees using the J 36660.
- 6.4. Tighten the crankshaft bearing cap inboard bolts and the crankshaft bearing cap inboard studs (four bolt caps) on the final pass an additional 73 degrees using the J 36660.

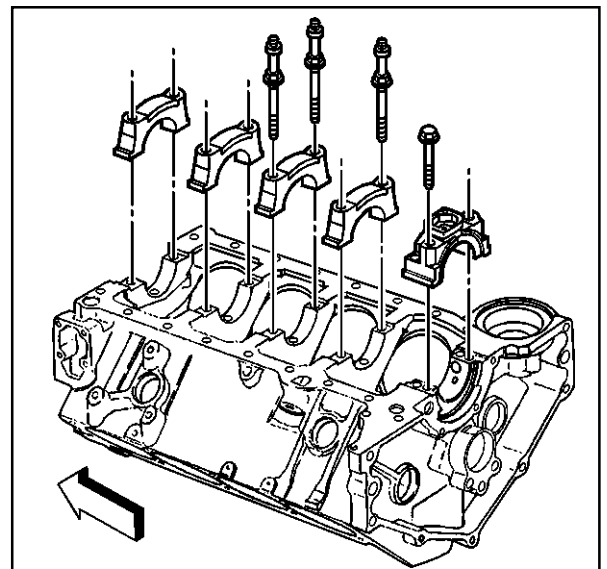

353070

7. Measure the crankshaft bearing inside diameter (ID) at the top and the bottom using an inside micrometer.
8. In order to determine the crankshaft bearing clearance, subtract the journal diameter from the crankshaft bearing ID.
9. Compare the crankshaft bearing clearance to the specifications. Refer to *Engine Mechanical Specifications*.
10. If the crankshaft bearing clearances exceeds specifications, install the new crankshaft bearings as follows:
 - 10.1. Measure the crankshaft bearing inside diameter (ID) at the top and the bottom using an inside micrometer.
 - 10.2. Compare the crankshaft bearing clearance to the specifications. Refer to *Engine Mechanical Specifications*.
11. Replace or repair the crankshaft if the proper clearances cannot be obtained.

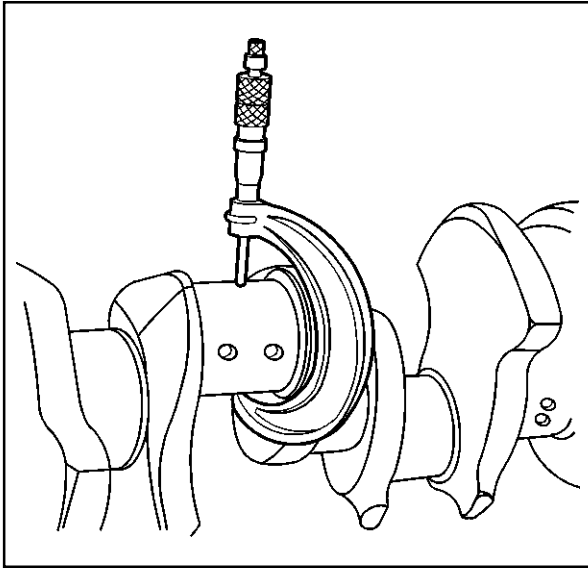

188015

Micrometer Method for Connecting Rod Bearings

Notice: Do not shim, scrape or file bearing inserts. Do not touch the bearing surface of the insert with bare fingers. Skin oil and acids will etch the bearing surface.

1. Measure the crankpin diameter with a micrometer in several places, approximately 90 degrees apart, and then average the measurements.
2. Determine the taper and the out-of-round. Refer to *Engine Mechanical Specifications*.
3. Install the connecting rod bearings into the connecting rod cap and the connecting rod.

Notice: Refer to *Fastener Notice* in Cautions and Notices.

4. Install the connecting rod caps and the nuts.

Tighten

- 4.1. Tighten the connecting rod nuts on the first pass, evenly to 27 N•m (20 lb ft).
- 4.2. Tighten the connecting rod nuts on the final pass an additional 55 degrees using the J 36660.
5. Measure the connecting rod bearing inside diameter (ID) at the top and the bottom using an inside micrometer.
6. Compare the connecting rod bearing clearance to the specifications. Refer to *Engine Mechanical Specifications*.
7. If the connecting rod bearing clearance is within specifications, the connecting rod bearing is satisfactory.
 - Replace the connecting rod bearing if the clearance is not within specifications.
 - Always replace both the upper and the lower connecting rod bearings as an assembly.
8. A standard or undersize connecting rod bearing combination may result in the proper clearance. If the proper connecting rod bearing clearance cannot be achieved using the standard or the undersize connecting rod bearings, it will be necessary to replace or repair the crankshaft.

Plastic Gauge Method for Crankshaft Bearings

1. Install the crankshaft bearings into the engine block.

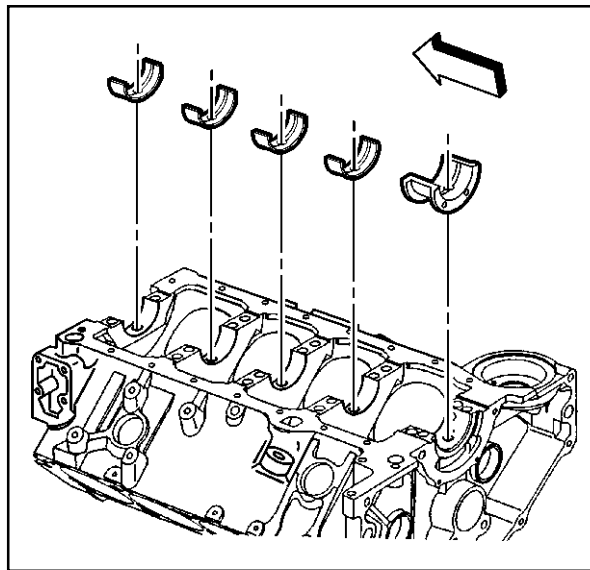

317292

2. Install the crankshaft.

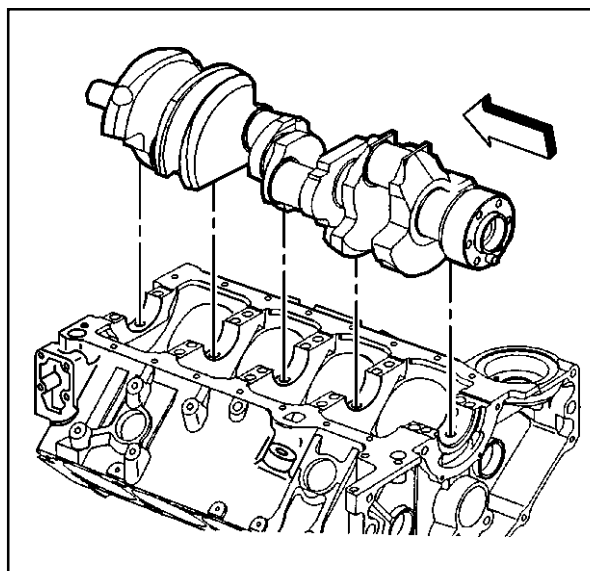

317351

3. Install the gauging plastic the full width of the journal.

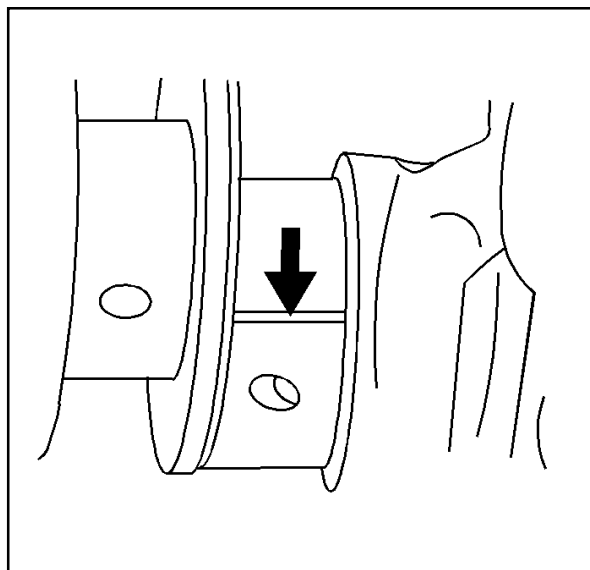

500655

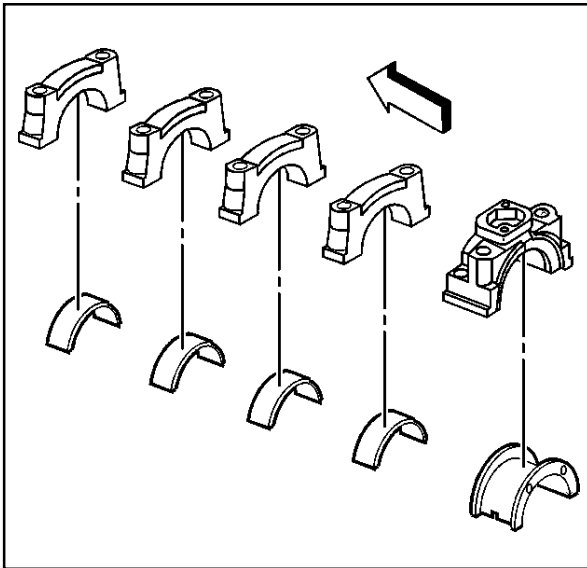

317295

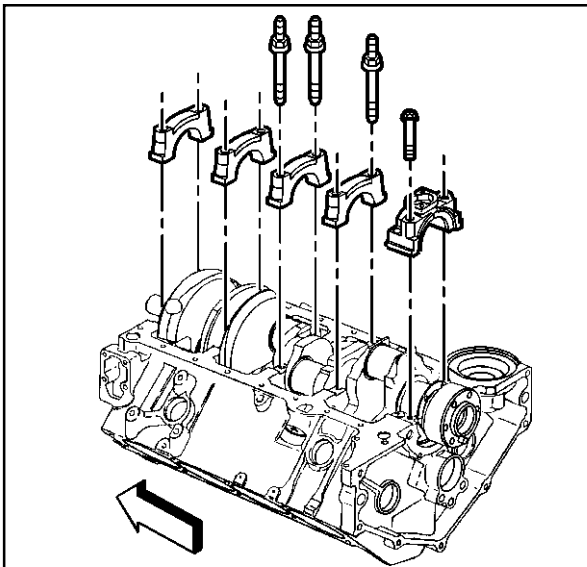

317268

4. Install the crankshaft bearings into the crankshaft bearing caps.

5. Install the crankshaft bearing caps in the original positions and with the arrow on the crankshaft bearing caps in the direction of the front of the engine block.

Notice: Refer to *Fastener Notice* in Cautions and Notices.

6. Install the crankshaft bearing cap bolts and the crankshaft bearing cap studs.

Tighten

- 6.1. Tighten the crankshaft bearing cap bolts and the crankshaft bearing cap studs on the first pass to 20 N•m (15 lb ft).
- 6.2. Tighten the crankshaft bearing cap bolts and the crankshaft bearing cap studs (two bolt caps) on the final pass an additional 73 degrees using the J 36660.
- 6.3. Tighten the crankshaft bearing cap outboard bolts and the crankshaft bearing cap outboard studs (four bolt caps) on the final pass an additional 43 degrees using the J 36660.
- 6.4. Tighten the crankshaft bearing cap inboard bolts and the crankshaft bearing cap inboard studs (four bolt caps) on the final pass an additional 73 degrees using the J 36660.
7. Remove the crankshaft bearing cap bolts.
8. Remove the crankshaft bearing caps. The gauging plastic may adhere to either the crankshaft bearing journal or the crankshaft bearing surface.

9. Without removing the gauging plastic, measure the compressed width at the widest point using the graduated scale on the edge of the gauging plastic envelope.
If the flattened gauging plastic tapers toward the middle or the ends, there may be a difference in clearance indicating taper, low spot or other irregularity of the crankshaft bearing or the crankshaft bearing journal.

 - Normally the crankshaft bearing journals wear evenly and are not out-of-round. However, if a crankshaft bearing is being fitted to an out-of-round 0.0254 mm (0.0010 in) (maximum) crankshaft bearing journal, be sure to fit to the maximum diameter of the crankshaft bearing journal. If the crankshaft bearing is fitted to the minimum diameter and the crankshaft bearing journal is excessively out-of-round, the interference between the crankshaft bearing and the crankshaft bearing journal will result in rapid crankshaft bearing failure.
 - If the crankshaft bearing clearance is within specifications, the crankshaft bearing is satisfactory. If the clearance is not within specifications, replace the crankshaft bearing.
Always replace both the upper and lower crankshaft bearings as a unit.
 - A standard or undersize crankshaft bearing combination may result in the proper clearance. If the proper crankshaft bearing clearance cannot be achieved using the standard or the undersize crankshaft bearings, it may be necessary to repair or replace the crankshaft.

Notice: Do not shim, scrape or file bearing inserts. Do not touch the bearing surface of the insert with bare fingers. Skin oil and acids will etch the bearing surface.

10. Remove the flattened gauging plastic.
11. Measure the remaining crankshaft bearing journals.

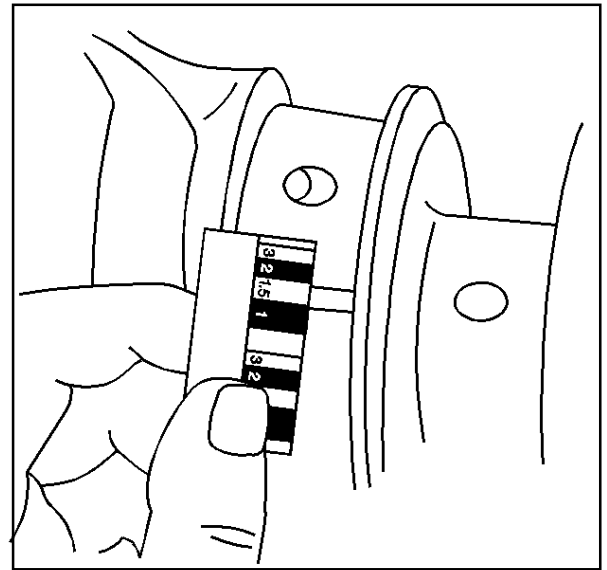

500656

Connecting Rod Side Clearance Measuring Procedure

1. Insert a feeler gauge between the connecting rod caps and measure the connecting rod side clearance. Refer to *Engine Mechanical Specifications*.
2. Connecting rod side clearances may also be measured with a dial indicator set.

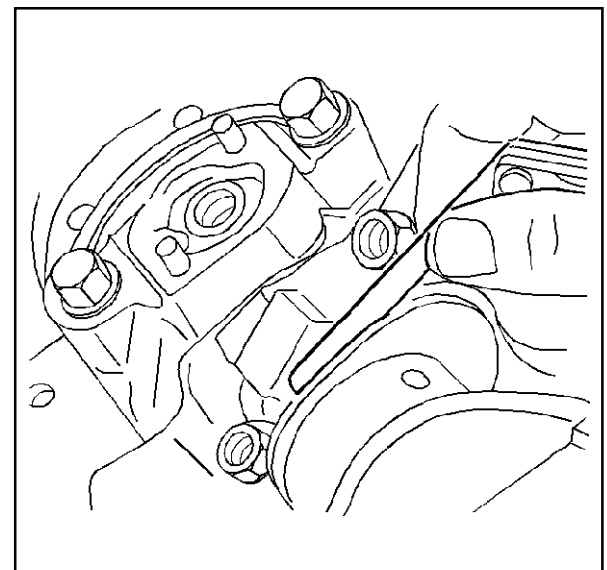

5163

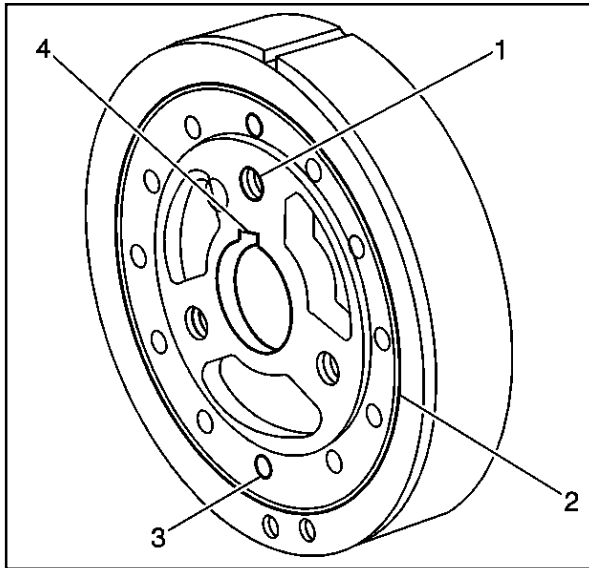

334038

Crankshaft Balancer Clean and Inspect

Caution: Refer to Safety Glasses Caution in Cautions and Notices.

1. Clean the crankshaft balancer in cleaning solvent.
2. Dry the crankshaft balancer with compressed air.
3. Inspect the crankshaft balancer for the following:
 - Worn or damaged bolt hole threads (1)
 - Worn, chunking or deteriorated rubber (2) between the hub and outer ring
 - Loose or improperly installed balance weights (3)

A properly installed front groove pin should be installed until flush or below flush with the face of the crankshaft balancer.

 - Worn or damaged keyway (4)

Important: A crankshaft front oil sealing surface with excessive scoring, grooves, rust or other damage must be replaced.

- Worn, grooved or damaged crankshaft front oil sealing surface

Minor imperfections on the crankshaft balancer crankshaft front oil seal surface may be removed with a polishing compound or fine grade emery cloth.

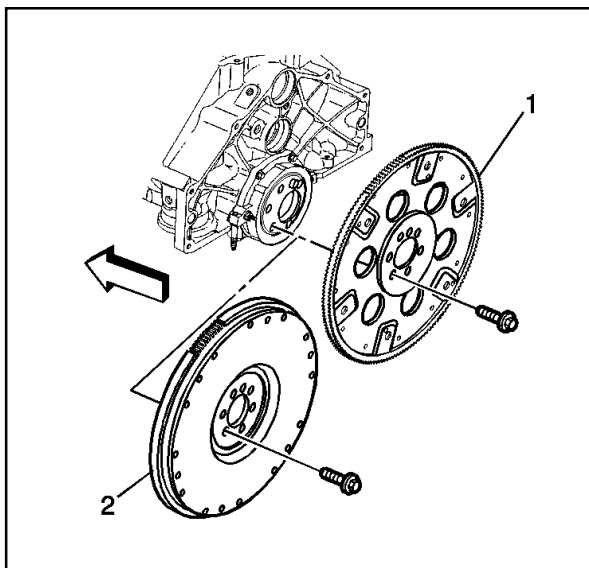

69012

Engine Flywheel Clean and Inspect

Caution: Refer to Safety Glasses Caution in Cautions and Notices.

1. Clean the engine flywheel (1) or (2) in cleaning solvent.
2. Dry the engine flywheel with compressed air.

3. Inspect the engine flywheel (automatic transmission) (if equipped) for the following:

- Stress cracks around the engine flywheel-to-torque converter bolt hole locations (1)
- Missing balance weights
- Stress cracks around the engine flywheel-to-crankshaft bolt hole locations (2) or (3)

Important: Do not attempt to repair the welded areas (if present) that retain the ring gear to the engine flywheel plate. Always install a NEW engine flywheel.

- Welded areas that retain the ring gear onto the engine flywheel for cracking (4) (if present)
- Damaged ring gear teeth (5)

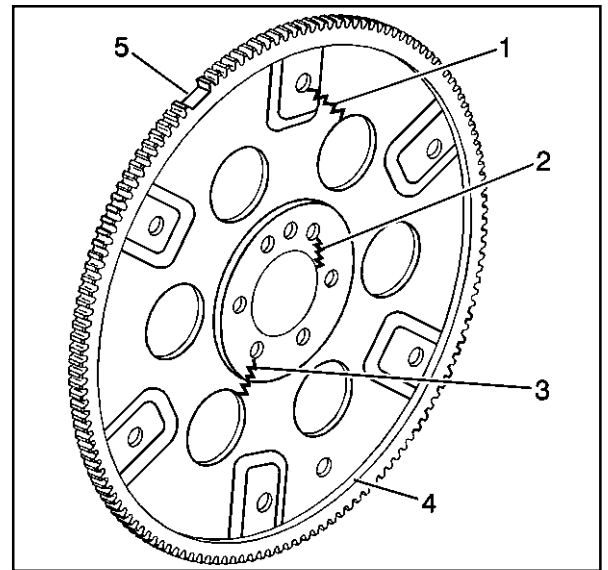

381965

4. Inspect the engine flywheel (manual transmission) (if equipped) for loose or improperly installed flywheel weights (if applicable).

A properly installed flywheel weight should be installed until flush or below flush with the face of the engine flywheel.

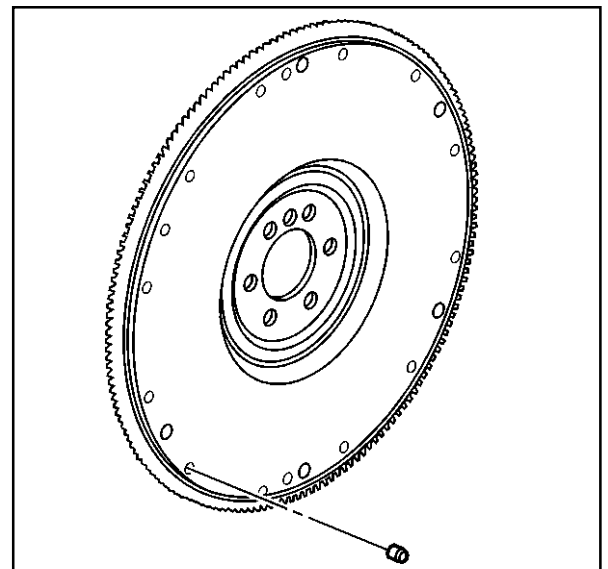

64126

5. Inspect the engine flywheel (manual transmission) (if equipped) for the following:

- Pitted friction surface (1)
- Scoring or grooves (2)
- Rust or other surface damage (3)
- Damaged ring gear teeth (4)
- Loose or improperly positioned ring gear

The ring gear has an interference fit onto the engine flywheel and the ring gear should be positioned completely flat against the flange of the engine flywheel.

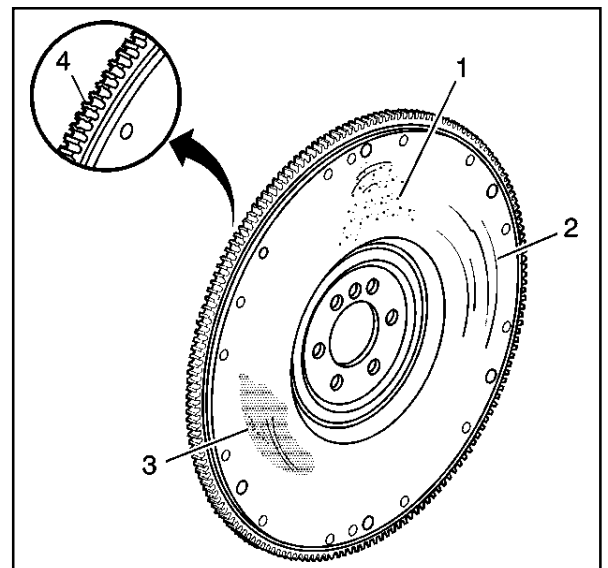

188086

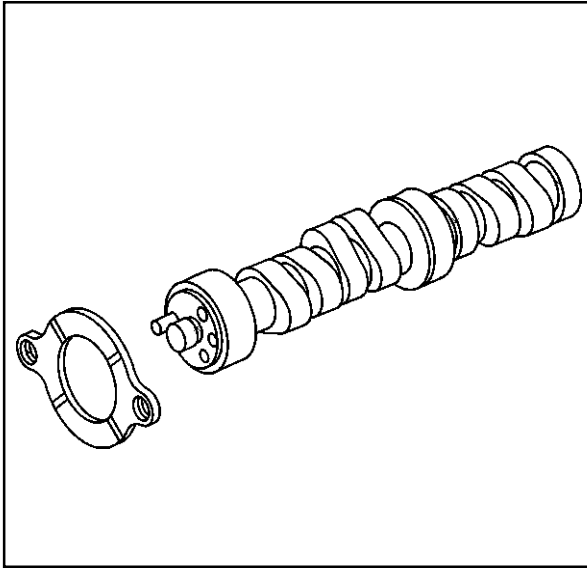

334499

Camshaft and Bearings Clean and Inspect

Tools Required

J 7872 Magnetic Base Dial Indicator

Caution: Refer to *Safety Glasses Caution in Cautions and Notices.*

1. Clean the engine camshaft in cleaning solvent.
2. Dry the engine camshaft with compressed air.
3. Inspect the camshaft retainer plate for damage.
If the camshaft retainer plate is damaged, replace as necessary.
4. Inspect the camshaft bearings for correct fit into the engine block camshaft bearing bores.

The camshaft bearings have an interference fit to the engine block camshaft bearing bores and must not be loose in the engine block camshaft bearing bores.

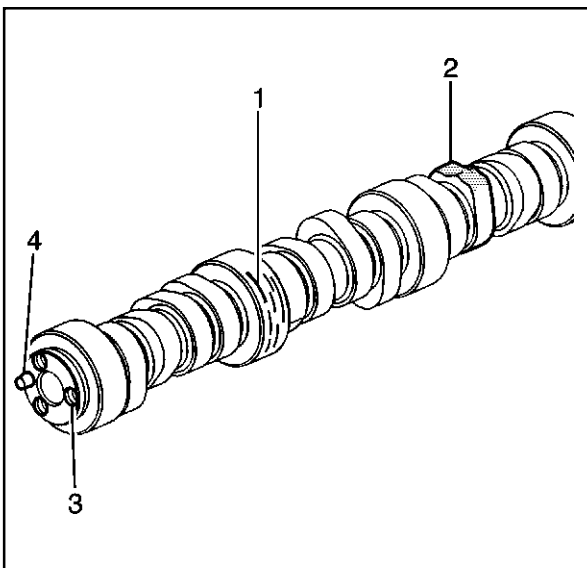

188095

Important: If any camshaft bearing is excessively worn or scored, replace all the camshaft bearings.

5. Inspect the camshaft bearings for excessive wear or scoring.
6. Inspect the engine camshaft for the following:
 - Worn, scored or damaged bearing journals (1)
 - Worn engine camshaft lobes (2)
 - Damaged bolt hole threads (3)
 - Damaged camshaft sprocket locator pin (4)

7. Measure the engine camshaft journals with a micrometer.
If the camshaft journals are more than 0.025 mm (0.0010 in) out-of-round, then replace the engine camshaft.

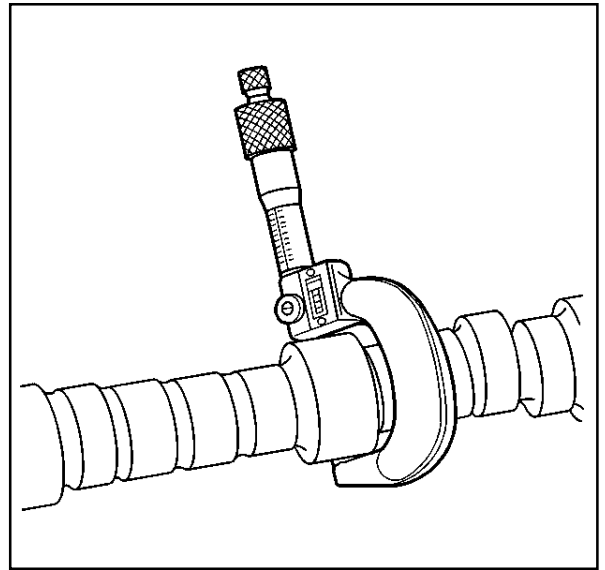

188014

8. Measure for a bent engine camshaft or excessive engine camshaft runout using the J 7872.
 - 8.1. Mount the engine camshaft in a suitable stand between centers.
 - 8.2. Use the J 7872 in order to check the intermediate engine camshaft journals.
If the runout exceeds 0.065 mm (0.0026 in), the engine camshaft is bent and must be replaced.
9. Measure the engine camshaft lobe lift using the J 7872.
 - 9.1. Place the engine camshaft on the V-blocks.
 - 9.2. Use the J 7872 in order to measure the engine camshaft lobe lift.
10. Replace the engine camshaft if the engine camshaft lobe lift is not within specifications. Refer to *Engine Mechanical Specifications*.

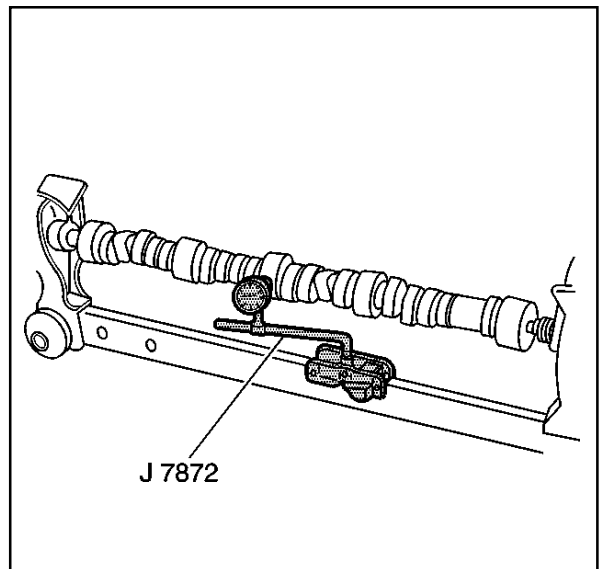

188012

Camshaft Bearing Removal

Tools Required

J 33049 Camshaft Bearing Service Kit

1. Select the cone (1), the handle (10), the expanding driver (4-8), the washer (2 or 3) and the expander assembly (15) from the J 33049.
2. Assemble the J 33049.

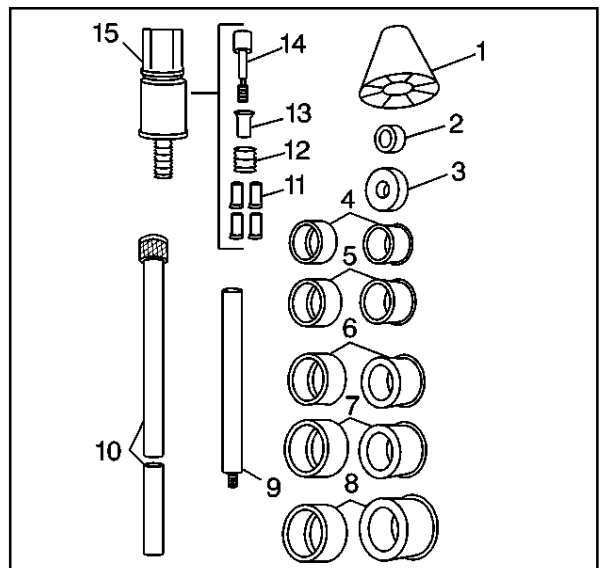

66100

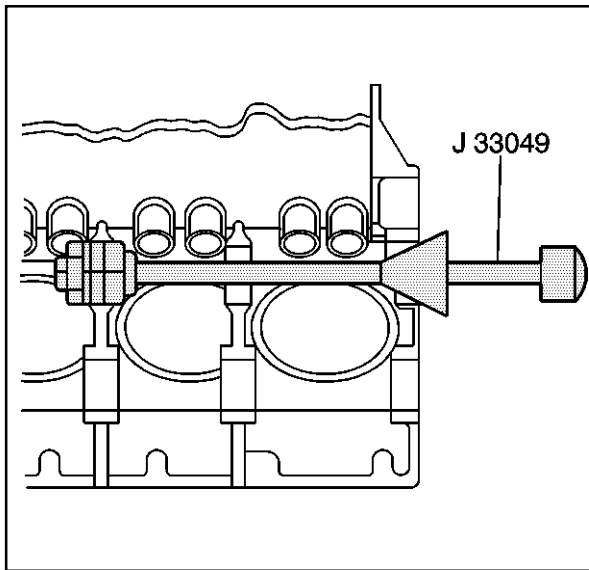

4985

Important: A loose camshaft bearing may be caused by an enlarged, out-of-round or damaged engine block camshaft bearing bore.

Important: Always remove the camshaft inner bearings #2, #3 and #4 first. The camshaft outer bearings #1 and #5 serve as a guide for the J 33049.

Caution: Refer to *Safety Glasses Caution in Cautions and Notices*.

3. Remove the camshaft inner bearings #2, #3 and #4.
 - 3.1. Insert the J 33049 through the front of the engine block and into the camshaft inner bearing #2.
 - 3.2. Tighten the J 33049 expander assembly nut until snug.
 - 3.3. Push the J 33049 guide cone into the camshaft front bearing in order to align the J 33049.
 - 3.4. Drive the camshaft inner bearing #2 from the camshaft inner bearing bore #2.
 - 3.5. Loosen the J 33049 expander assembly nut.
 - 3.6. Remove the camshaft inner bearing #2 from the J 33049 expander assembly.
 - 3.7. Insert the J 33049 expander assembly into the camshaft inner bearing #3.
 - 3.8. Tighten the J 33049 expander assembly nut until snug.
 - 3.9. Push the J 33049 guide cone into the camshaft front bearing in order to align the J 33049.
 - 3.10. Drive the camshaft inner bearing #3 from the camshaft inner bearing bore #3.
 - 3.11. Loosen the J 33049 expander assembly nut.
 - 3.12. Remove the camshaft inner bearing #3 from the J 33049 expander assembly.
 - 3.13. Insert the J 33049 expander assembly into the camshaft inner bearing #4.
 - 3.14. Tighten the J 33049 expander assembly nut until snug.
 - 3.15. Push the J 33049 guide cone into the camshaft front bearing in order to align the J 33049.
 - 3.16. Drive the camshaft inner bearing #4 from the camshaft inner bearing bore #4.
 - 3.17. Loosen the J 33049 expander assembly nut.
 - 3.18. Remove the camshaft inner bearing #4 from the J 33049 expander assembly.
4. Remove the J 33049 from the engine block.

5. Remove the camshaft outer bearings #1 and #5.
 - 5.1. Insert the J 33049 into the camshaft outer bearing #1.
 - 5.2. Tighten the J 33049 expander assembly nut until snug.
 - 5.3. Drive the camshaft outer bearing #1 from the camshaft outer bearing bore #1.
 - 5.4. Loosen the J 33049 expander assembly nut.
 - 5.5. Remove the camshaft outer bearing #1 from the J 33049 expander assembly.
 - 5.6. Remove the J 33049 from the engine block.
 - 5.7. Insert the J 33049 expander assembly into the camshaft outer bearing #5.
 - 5.8. Tighten the J 33049 expander assembly nut until snug.
 - 5.9. Drive the camshaft outer bearing #5 from the camshaft outer bearing bore #5.
 - 5.10. Loosen the J 33049 expander assembly nut.
 - 5.11. Remove the camshaft outer bearing #5 from the J 33049 expander assembly.
6. Remove the J 33049 from the engine block.
7. Discard the camshaft bearings.

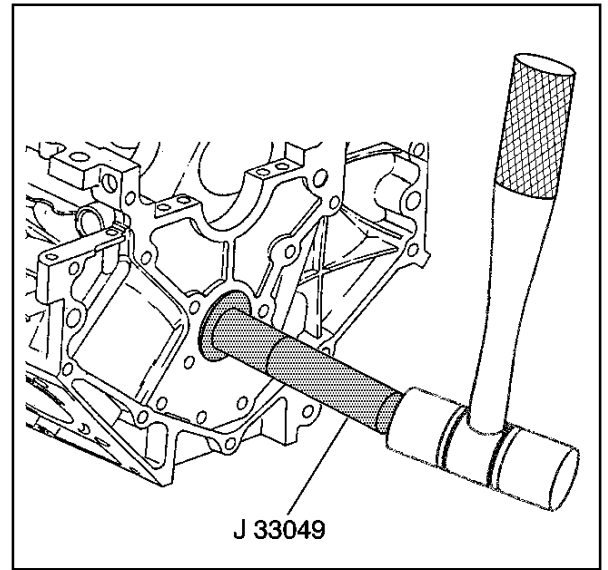

63219

Camshaft Bearing Installation

Tools Required

J 33049 Camshaft Bearing Service Kit

Important: Always install the camshaft outer bearings #1 and #5 first. The camshaft outer bearings serve as a guide for the J 33049 and help center the camshaft inner bearings during the installation process.

Look to ensure that the camshaft bearing lubrication hole or holes align with the oil gallery hole or holes in the engine block. On some engines, the oil gallery holes may be difficult to see. Verify that the camshaft bearing lubrication holes and the oil gallery holes are aligned.

1. Select the handle (10), the expanding driver (4-8), the washer (2 or 3) and the expander assembly (15) from the J 33049.
2. Assemble the J 33049.

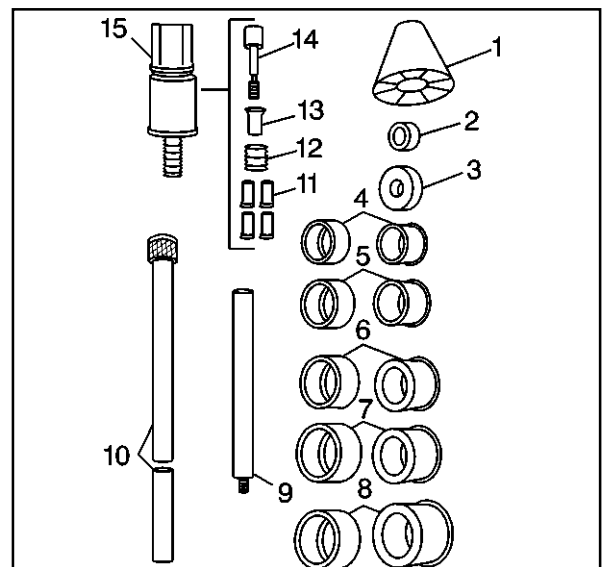

66100

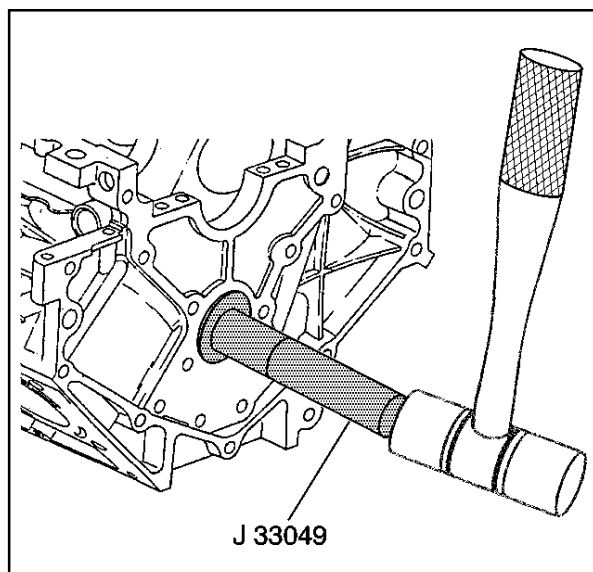

63219

Caution: Refer to Safety Glasses Caution in Cautions and Notices.

Important: The camshaft bearing lubrication holes must align with the oil gallery holes in the engine block.

After installation of the camshaft bearings, always inspect the camshaft bearing lubrication holes for proper alignment with the oil gallery holes.

An improperly aligned camshaft bearing lubrication hole and oil gallery hole will restrict oil flow to the camshaft bearing and the camshaft journal.

3. Install the NEW camshaft outer bearings #5 and #1.
 - 3.1. Install the NEW camshaft outer bearing #4 onto the J33049 expander assembly.
 - 3.2. Tighten the J 33049 expander assembly nut until snug.
 - 3.3. Align the camshaft outer bearing #5 lubrication hole with the oil gallery hole in the camshaft outer bearing bore #5 at the rear of the engine block.
 - 3.4. Drive the camshaft outer bearing #5 into the camshaft outer bearing bore #5 at the rear of the engine block.
 - 3.5. Loosen the J 33049 expander assembly nut.
 - 3.6. Remove the camshaft outer bearing #5 from the J33049 expander assembly.
 - 3.7. Install the NEW camshaft outer bearing #1 onto the J33049 expander assembly.
 - 3.8. Tighten the J 33049 expander assembly nut until snug.
 - 3.9. Align the camshaft outer bearing #1 lubrication hole with the oil gallery hole in the camshaft outer bearing bore #1 at the front of the engine block.
 - 3.10. Drive the camshaft outer bearing #1 into the camshaft outer bearing bore #1 at the front of the engine block.
 - 3.11. Loosen the J 33049 expander assembly nut.
 - 3.12. Carefully slide the J 33049 into the engine block until the J 33049 expander assembly is positioned between the camshaft inner bearing bore #3 and the camshaft inner bearing bore #4.

Important: The camshaft bearing lubrication holes must align with the oil gallery holes in the engine block.

After installation of the camshaft bearings, always inspect the camshaft bearing lubrication holes for proper alignment with the oil gallery holes.

An improperly aligned camshaft bearing lubrication hole and oil gallery hole will restrict oil flow to the camshaft bearing and the camshaft journal.

4. Install the NEW camshaft inner bearings #4, #3 and #2.
 - 4.1. Install the NEW camshaft inner bearing #4 onto the J33049 expander assembly.
 - 4.2. Tighten the J 33049 expander assembly nut until snug.
 - 4.3. Align the camshaft inner bearing #4 lubrication hole with the oil gallery hole in the camshaft inner bearing bore #4 of the engine block.
 - 4.4. Push the J 33049 guide cone into the camshaft front bearing bore #1 in order to align the J 33049.
 - 4.5. Drive the camshaft inner bearing #4 into the camshaft inner bearing bore #4.
 - 4.6. Loosen the J 33049 expander assembly nut.
 - 4.7. Carefully slide the J 33049 until the J 33049 expander assembly is positioned between the camshaft inner bearing bore #3 and the camshaft inner bearing bore #2.
 - 4.8. Install the NEW camshaft inner bearing #3 onto the J33049 expander assembly.
 - 4.9. Tighten the J 33049 expander assembly nut until snug.
 - 4.10. Align the camshaft inner bearing #3 lubrication hole with the oil gallery hole in the camshaft inner bearing bore #3 of the engine block.
 - 4.11. Push the J 33049 guide cone into the camshaft front bearing bore #1 in order to align the J 33049.
 - 4.12. Drive the camshaft inner bearing #3 into the camshaft inner bearing bore #3.
 - 4.13. Loosen the J 33049 expander assembly nut.
 - 4.14. Carefully slide the J 33049 until the J 33049 expander assembly is positioned between the camshaft inner bearing bore #2 and the camshaft outer bearing bore #1.
 - 4.15. Install the NEW camshaft inner bearing #2 onto the J33049 expander assembly.
 - 4.16. Tighten the J 33049 expander assembly nut until snug.
 - 4.17. Align the camshaft inner bearing #2 lubrication hole with the oil gallery hole in the camshaft inner bearing bore #2 of the engine block.
 - 4.18. Push the J 33049 guide cone into the camshaft front bearing bore #1 in order to align the J 33049.
 - 4.19. Drive the camshaft inner bearing #2 into the camshaft inner bearing bore #2.
 - 4.20. Loosen the J 33049 expander assembly nut.

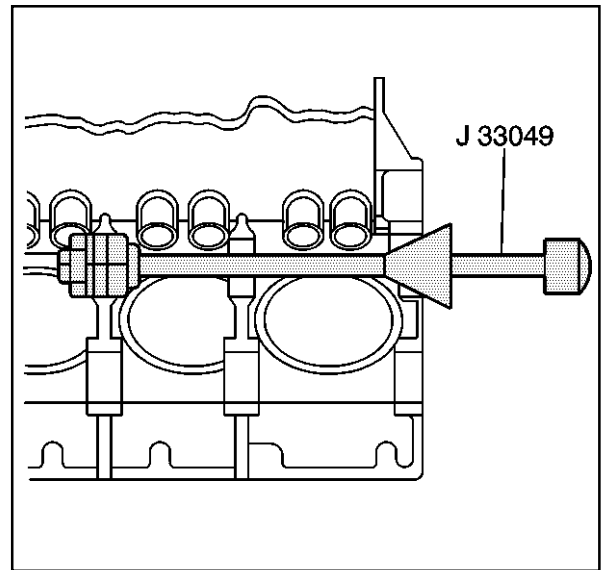

4985

- Carefully remove the J 33049 from the engine block.

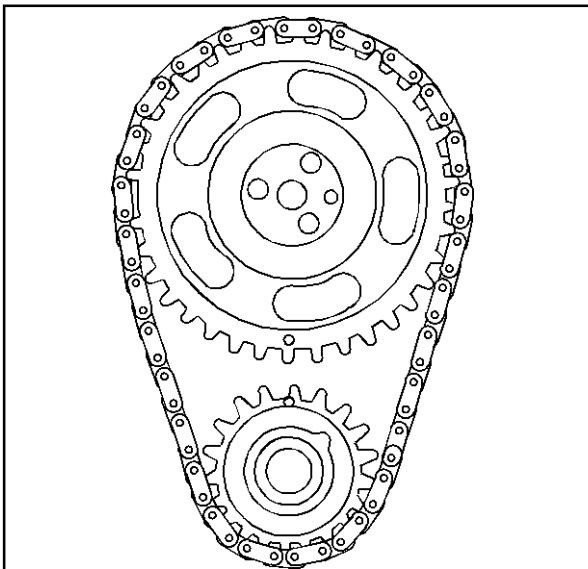

11503

Timing Chain and Sprockets Clean and Inspect

Caution: Refer to Safety Glasses Caution in Cautions and Notices.

- Clean the components with cleaning solvent.
- Dry the components with compressed air.
- Inspect the camshaft timing chain for binding or wear.

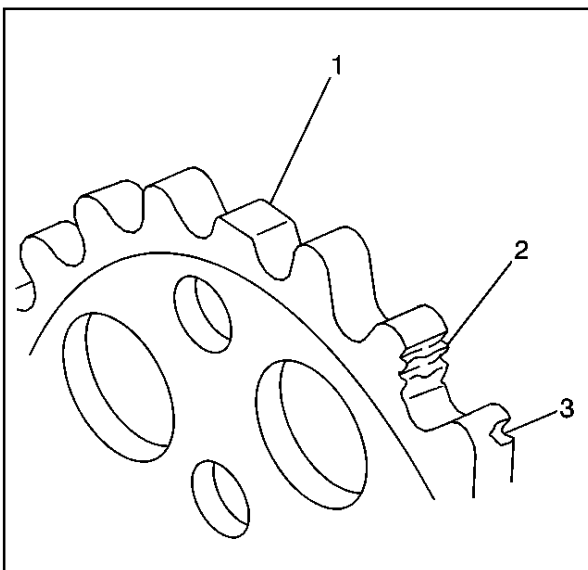

188097

- Inspect the camshaft sprocket and the crankshaft sprocket for the following:
 - Broken teeth (1)
 - Damaged teeth (2)
 - Chipped teeth (3)
 - Worn teeth
 - Uneven wear on the edge of the teeth
 - Worn valleys between the sprocket teeth
 - Crankshaft sprocket keyway for wear
 - Woodruff key (crankshaft sprocket) for wear or damage

Valve Rocker Arm and Push Rods Clean and Inspect

Important: Parts that are to be reused must be marked, sorted and organized for assembly.

1. Mark, sort and organize the components for assembly.

Caution: Refer to Safety Glasses Caution in Cautions and Notices.

2. Clean the components with cleaning solvent.
3. Dry the components with compressed air.
4. Inspect the valve rocker arm components for the following:

- Wear or scoring of the valve rocker arm (3) ball area
- Valve rocker arm (3) pushrod sockets and valve stem contact surfaces

The contact surfaces should be smooth with no scoring or excessive wear.

- Valve rocker arm ball (2) for wear or scoring
- The contact surfaces should be smooth with no scoring or excessive wear.

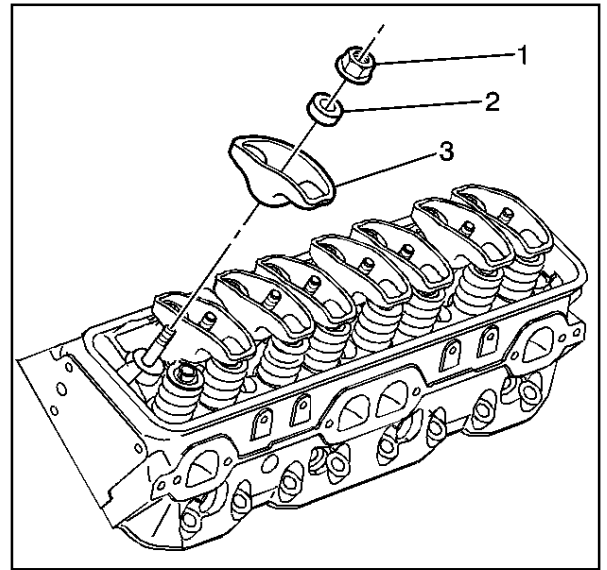

182835

5. Inspect the valve push rods for the following:
 - Restriction of the oil passage (1)
 - Wear or scoring of the end contact surfaces (2). The end contact surfaces must be smooth with no scoring or excessive wear.
 - Shaft for bends (3).

Roll the valve pushrod on a flat surface to determine if the valve pushrod is bent.

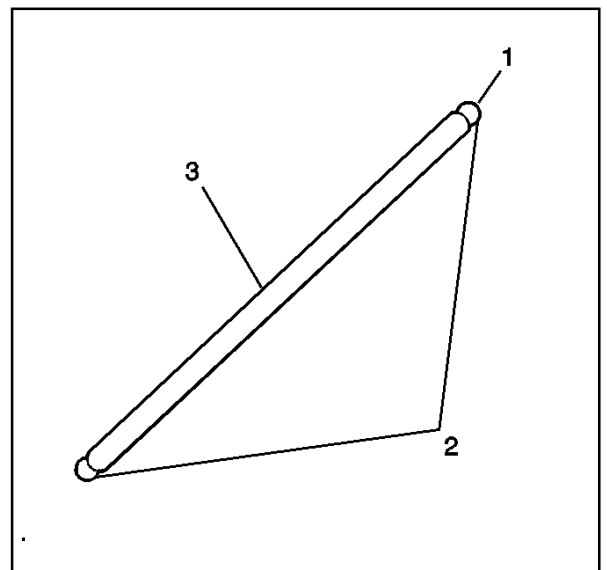

488857

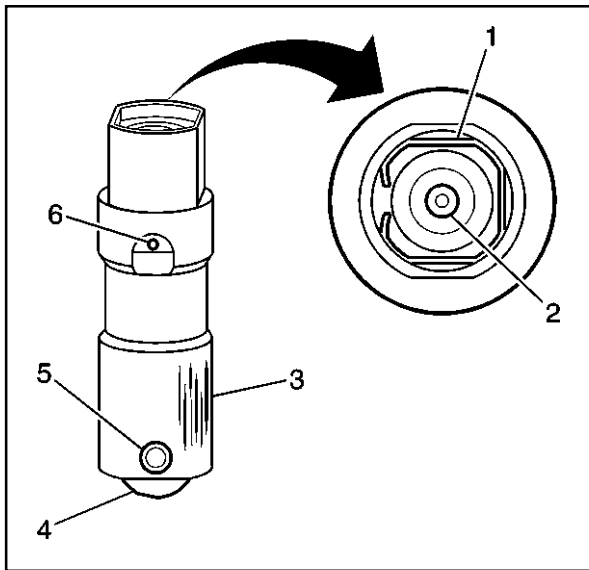

178485

Valve Lifters and Guides Clean and Inspect

Important: Components that are to be reused must be marked, sorted and organized for assembly.

1. Mark, sort and organize the components for assembly.

Caution: Refer to *Safety Glasses Caution in Cautions and Notices*.

2. Clean the components with cleaning solvent.
3. Dry the components with compressed air.
4. Inspect the valve lifter for the following:

- Broken or damaged clip (1)
- Worn valve pushrod socket (2)
- Wear or scuffing (3)

If the valve lifter shows wear or scuffing, inspect the engine block valve lifter bores for wear or damage

- Worn roller (4)
- Loose or damaged pin (5)
- Plugged oil hole (6)

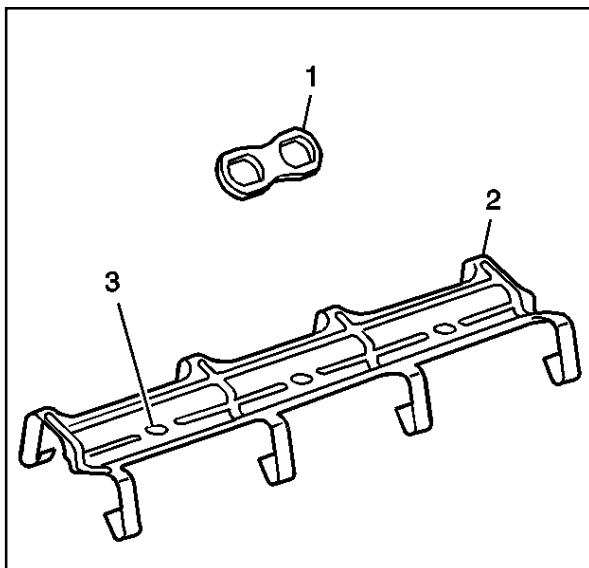

521834

5. Inspect the valve lifter guides (1) for the following:

- Excessive wear (1)
- Cracks or damage

6. Inspect the valve lifter guide retainer for the following:

- Wear, damage or stress cracking in the leg areas (2)
- Wear or damage in the bolt holes (3)

Cylinder Head Disassemble

Tools Required

J 8062 Valve Spring Compressor

Caution: Compressed valve springs have high tension against the valve spring compressor. Valve springs that are not properly compressed by or released from the valve spring compressor can be ejected from the valve spring compressor with intense force. Use care when compressing or releasing the valve spring with the valve spring compressor and when removing or installing the valve stem keys. Failing to use care may cause personal injury.

Caution: Refer to Safety Glasses Caution in Cautions and Notices.

1. Use the J 8062 in order to compress the valve springs.

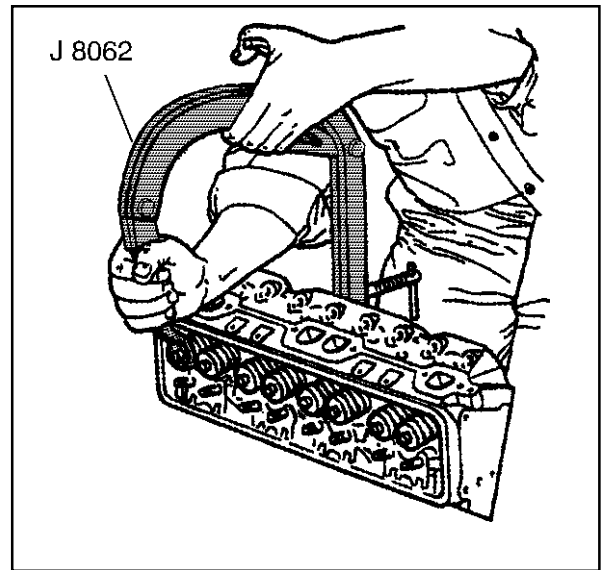

34468

Important: Mark, sort and organize the components so that the components can be reinstalled in their original location and position.

2. Remove the valve stem keys (1).
3. Remove the J 8062 from the cylinder head.
4. Remove the valve spring cap (2).
5. Remove the valve spring (3).
6. Remove the valve stem oil seal (4).
7. Discard the valve stem oil seal.
8. Remove the valve.

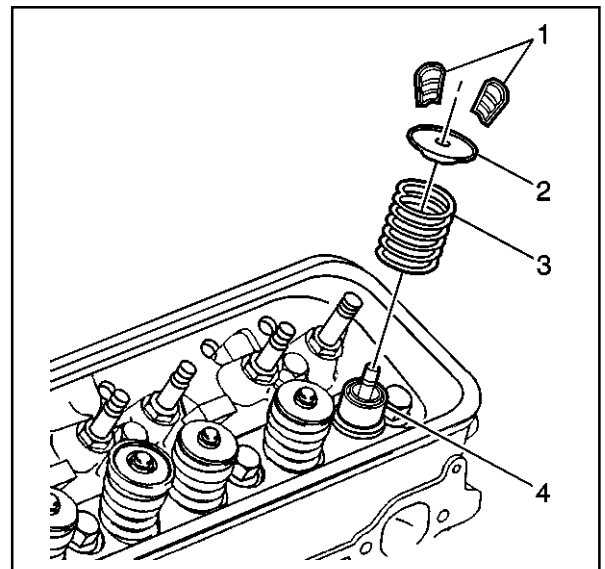

334505

Cylinder Head Clean and Inspect

Tools Required

J 8001 Dial Indicator Set

J 8089 Carbon Removing Brush

J 9666 Valve Spring Tester

Caution: Refer to Safety Glasses Caution in Cautions and Notices.

1. Clean the valve stems and cylinder heads on a buffing wheel.
2. Clean the following components in cleaning solvent:
 - Valve stem keys (1)
 - Valve spring cap (2)
 - Valve spring (3)
 - Cylinder head

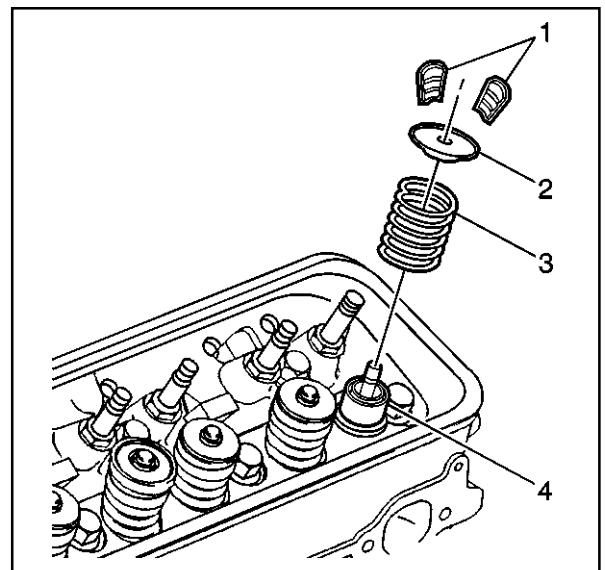

334505

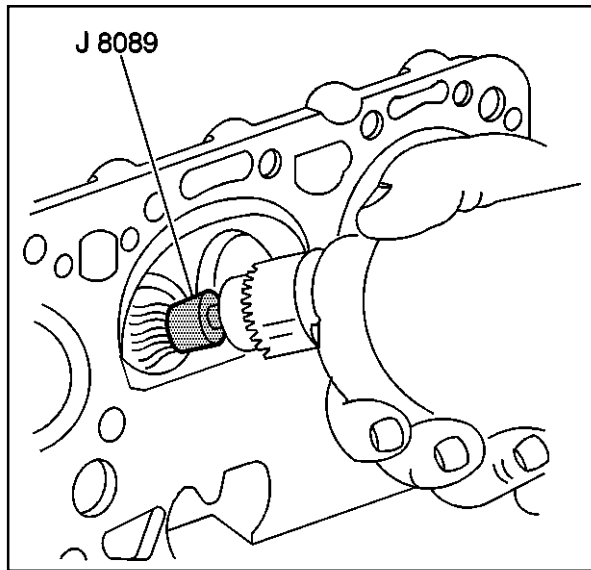

4957

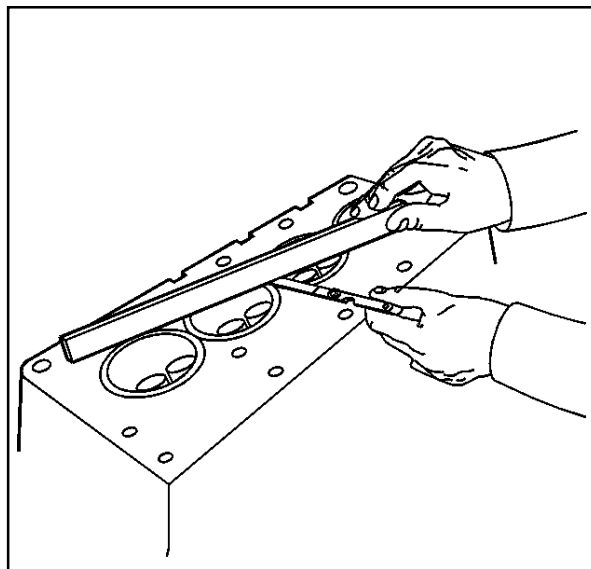

64318

3. Dry the components with compressed air.
4. Use the J 8089 to clean the carbon from the cylinder head combustion chambers.
Be careful not to scuff the combustion chambers.
5. Inspect the cylinder head for the following:
 - Damage to the gasket surfaces
 - Damage to the threaded bolt holes
 - Burnt or eroded areas in the combustion chambers
 - Cracks in the exhaust ports and combustion chambers
 - External cracks in the water chambers
 - Restrictions in the intake or exhaust passages
 - Restrictions in the cooling system passages
 - Rusted, damaged or leaking core plugs
6. Measure the cylinder head for warpage with a straight edge and feeler gauge
 - A cylinder head block deck with warpage in excess of 0.10 mm (0.004 in) within a 152.4 mm (6.0 in) area must be repaired or replaced.
 - A cylinder head exhaust manifold deck with warpage in excess of 0.05 mm (0.002 in) must be repaired or replaced.
 - A cylinder head intake manifold deck with warpage in excess of 0.10 mm (0.004 in) must be repaired or replaced.

- 7. Use the J 9666 in order to measure the valve spring.
Replace the valve spring if the valve spring tension is less than 338 N (76 lb) at 43.2 mm (1.70 in).

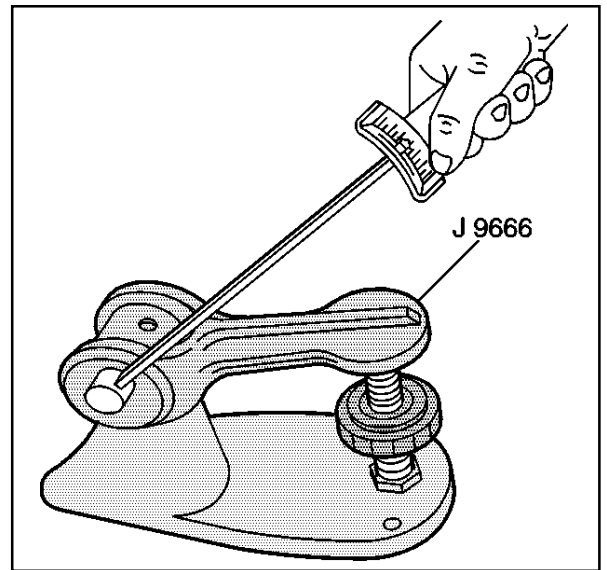

4960

- 8. Inspect the valve springs for squareness.

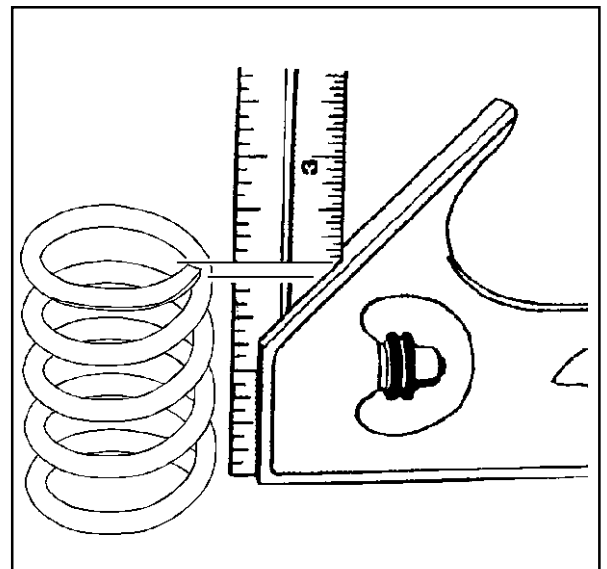

40075

- 9. Valve stems (1) with excessive valve guide (2) clearance must be repaired or the cylinder head replaced.

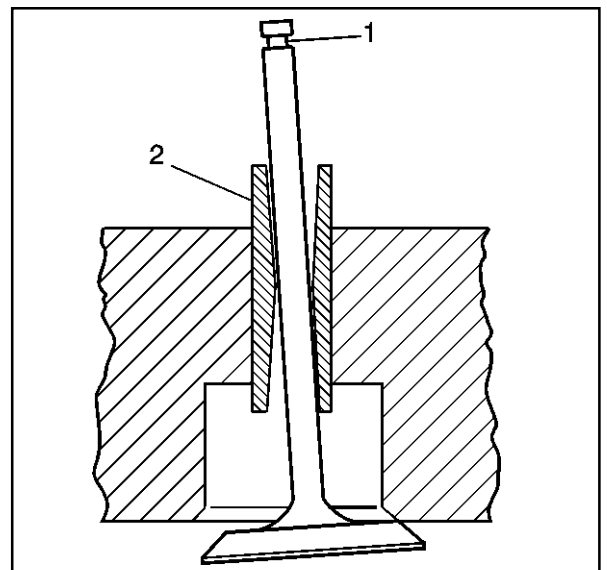

156172

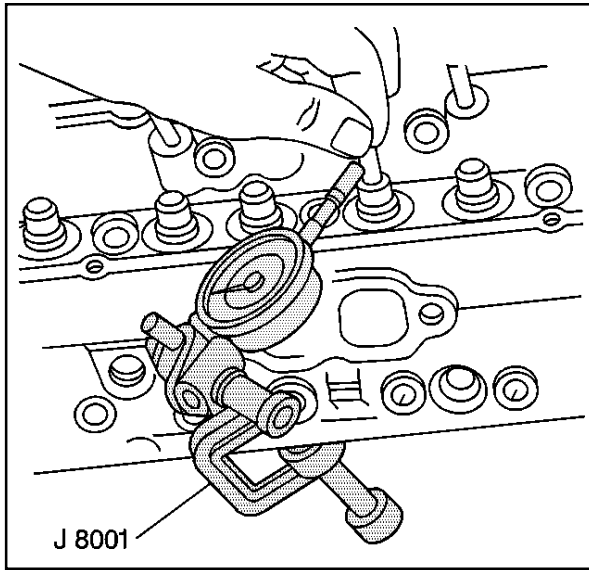

10. Measure the valve stem-to-guide clearance.

Excessive valve stem-to-guide clearance may cause an excessive oil consumption and may also cause a valve to break. Insufficient clearance will result in noisy and sticky functioning of the valve and will disturb the engine assembly smoothness.

- 10.1. Clamp the J 8001 on the exhaust port side of the cylinder head.
- 10.2. Position the dial indicator so that the movement of the valve stem from side to side (crosswise to the cylinder head) will cause a direct movement of the dial indicator stem.

The dial indicator stem must contact the side of the valve stem just above the valve guide.

- 10.3. Drop the valve head about 1.6 mm (0.063 in) off the valve seat.
- 10.4. Use light pressure and move the valve stem from side to side in order to obtain a valve stem-to-guide clearance reading. Refer to *Engine Mechanical Specifications*.

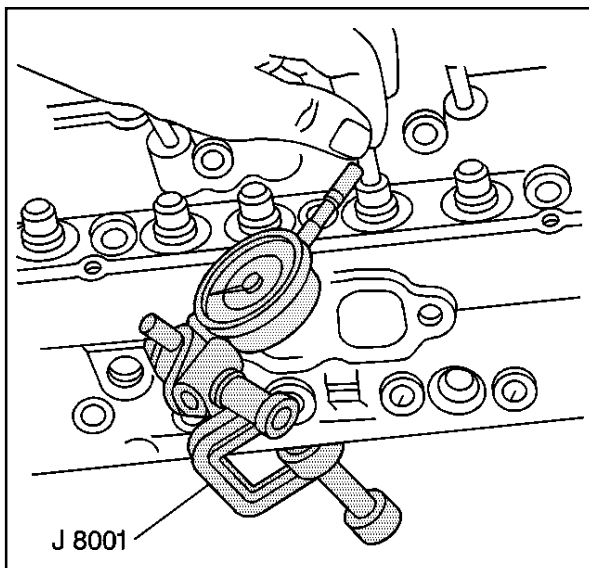

Valve Guide Reaming/Valve and Seat Grinding

Tools Required

J 5830-02 Valve Guide Reamer Set

J 8001 Dial Indicator Set

1. Measure the valve stem-to-guide clearance. Refer to *Cylinder Head Clean and Inspect*.

2. Improper valve stem (1) to valve guide (2) clearance may cause excessive oil consumption.

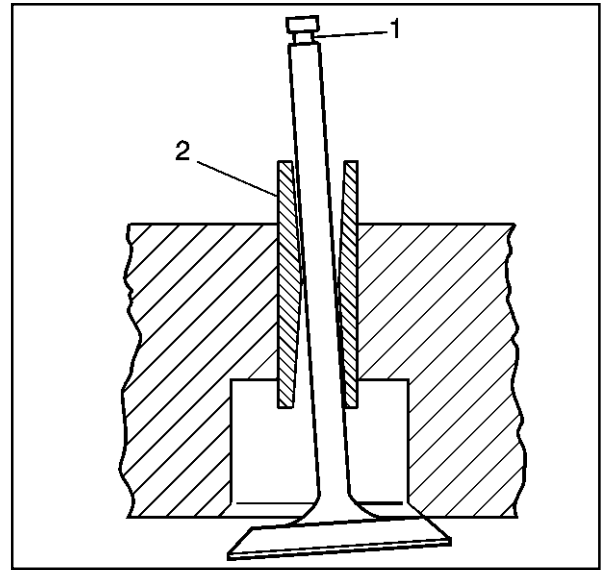

156172

Caution: Refer to Safety Glasses Caution in Cautions and Notices.

Important: Exhaust valves with excessive valve stem-to-guide clearance must be replaced with the available service valve that has an 0.0774 mm (0.0305 in) oversize valve stem. The intake valves are NOT available with oversize valve stems. Replace the cylinder head if after using a NEW intake valve in order to measure the valve stem-to-guide clearance, the valve stem-to-guide clearance is not within specifications.

3. Use the J 5830-3 in order to ream the exhaust valve guide in order to achieve the correct valve stem-to-guide clearance.
4. Always recondition the exhaust valve seat after reaming the exhaust valve guide bores and installing new exhaust valves.

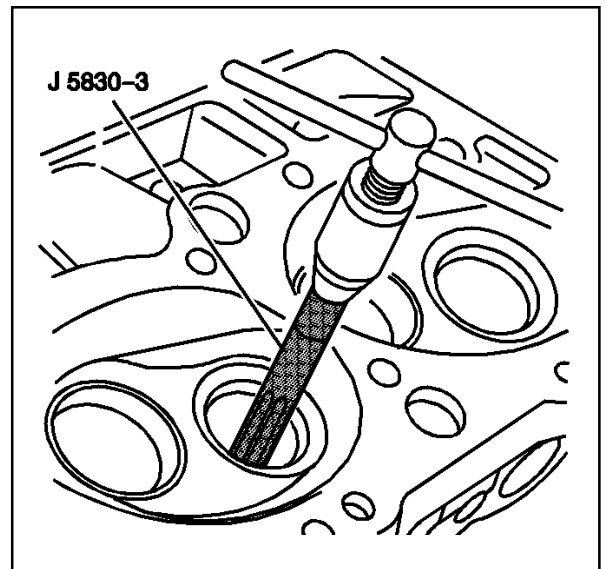

480556

5. Inspect the valves for the following:
 - Burnt or damaged areas (1)
 - Undersize margin (2)
 - Bent stem (3)
 - Scoring or other damage to the stem (4)
 - Worn key groove (5)
 - Worn stem tip (6)

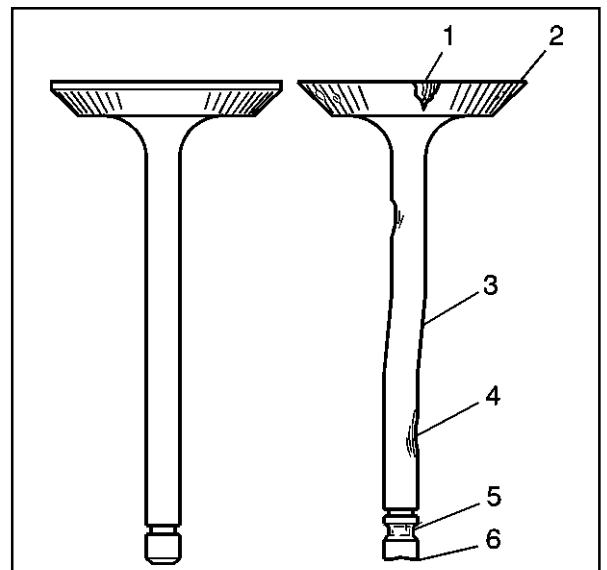

156174

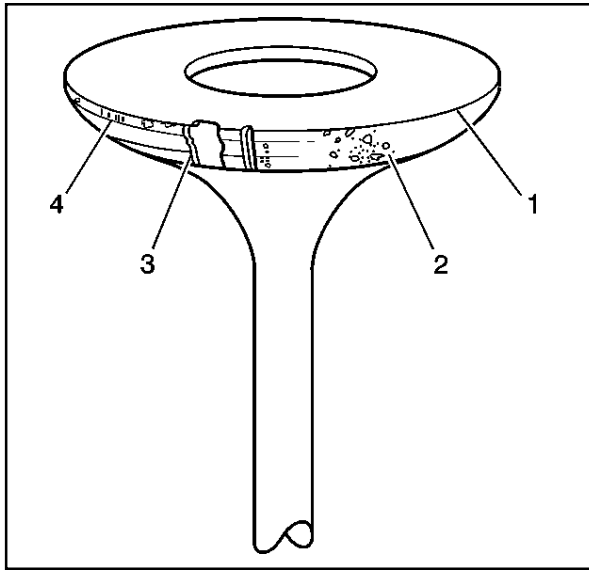

156173

6. Inspect the valve contact surface for the following:

- Undersized margin (1)
- Pitted surfaces (2)
- Burnt or eroded areas (3)
- Acceptable edge (margin) (4)

Valves with excessive damage must be replaced.

Minor imperfections of the valve or valve seat may be repaired.

7. Reconditioning of the valves and valve seats:

- The valves must seat perfectly for the engine to deliver optimum power and performance.
- Cooling the valve heads is another important factor. Good contact between each valve and valve seat in the cylinder head is necessary to insure that the heat in the valve head is properly carried away.
- Regardless of what type of equipment is used, it is essential that the valve guide bores are free from carbon or dirt in order to ensure the proper centering of the pilot in the valve guide.

The valve seats should be concentric to within 0.05 mm (0.002 in) total indicator reading.

- Reface pitted valves on a valve refacing machine in order to ensure the correct relationship between the valve head and the valve stem.

Replace the valve if the valve stem is excessively worn or warped.

Replace the valve if the edge margin (4) of the valve head is less than 0.79 mm (0.031 in) thick after grinding.

- Several different types of equipment are available for reconditioning valves and valve seats. Follow the equipment manufacturer's recommendations for equipment use to attain the proper results.

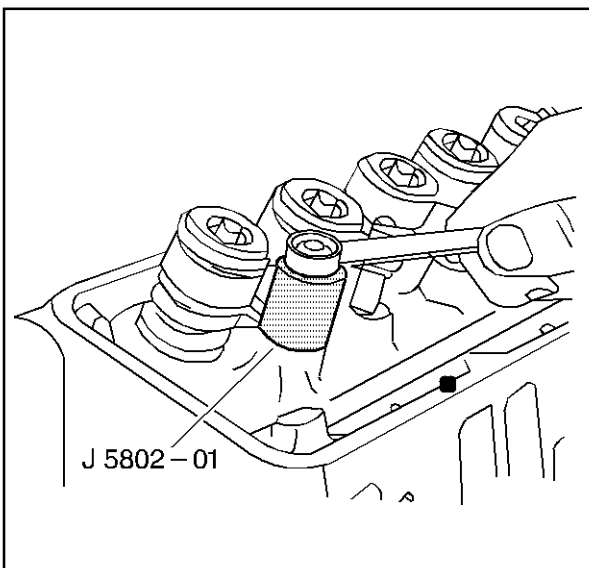

66507

Valve Rocker Arm Stud Removal**Tools Required**

J 5802-01 Rocker Arm Stud Remover

Valve rocker arm ball studs that have damaged threads or are loose in cylinder heads should be replaced.

Valve rocker arm ball studs are pressed into the cylinder head.

New valve rocker arm ball studs are available in 0.0762 mm (0.003 in) and 0.3302 mm (0.013 in) oversize.

1. Place the *J 5802-01* over the valve rocker arm ball stud to be removed.
2. Install a nut and a flat washer.
3. Rotate the nut clockwise to remove the valve rocker arm ball stud.

Valve Rocker Arm Stud Installation

Tools Required

J 5715 Reamer (0.0762 mm (0.003 in))

J 6036 Reamer (0.03302 mm (0.013 in))

J 6880 Rocker Arm Stud Installer

Caution: Refer to *Safety Glasses Caution in Cautions and Notices*.

Important: Valve rocker arm ball studs that have damaged threads or are loose in cylinder heads should be replaced. New valve rocker arm ball studs are available in 0.0762 mm (0.003 in) and 0.03302 mm (0.013 in) oversize.

1. Ream the hole to the proper size for the replacement oversize valve rocker arm ball stud.
Use J 5715 for 0.0762 mm (0.003 in) oversize valve rocker arm ball studs, or J 6036 for 0.03302 mm (0.013 in) oversize valve rocker arm ball studs.
2. Apply lubricant GM P/N 1052271 or equivalent to the lower end (press-fit end) of the valve rocker arm ball stud.
3. Use the J 6880 and a hammer to install the valve rocker arm ball stud into place.
The valve rocker arm ball stud is installed to proper depth when the J 6880 bottoms onto the cylinder head.

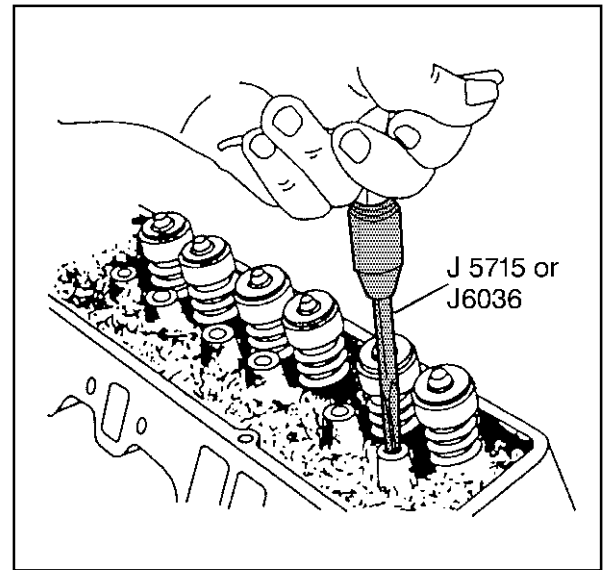

66509

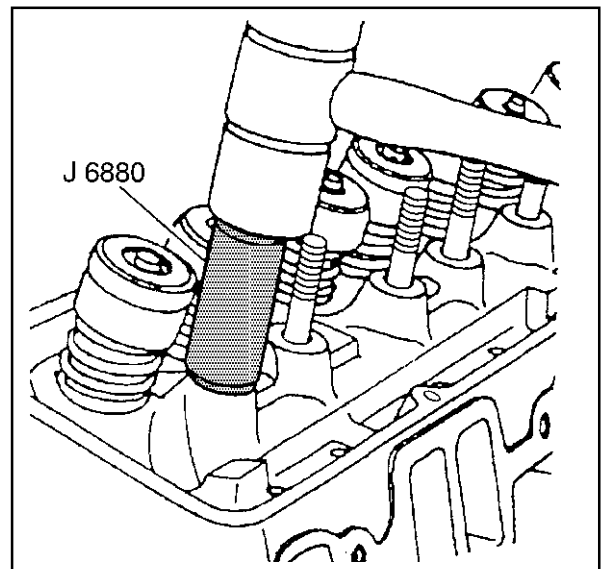

66504

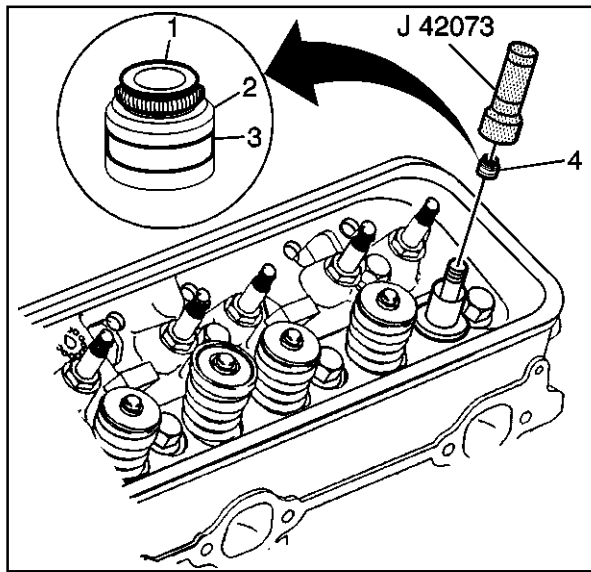

200320

Cylinder Head Assemble

Tools Required

J 8062 Valve Spring Compressor

J 42073 Valve Stem Seal Installer

Important: The exhaust valve oil stem seal has the letters EX (1) molded into the top of the seal. The exhaust valve oil stem seal material is brown in color (2) with a white stripe (3) painted onto the outside diameter of the seal, or the material may be red in color (2) with no paint stripe. The intake valve oil seal is black in color.

1. Assemble the valve into the proper valve guide.
2. Select the proper valve stem oil seal for the specific valve guide.
3. Lubricate the valve stem oil seal and the outside diameter of the valve guide with clean engine oil.

4. Assemble the valve stem oil seal onto the valve stem.

Caution: Refer to Safety Glasses Caution in Cautions and Notices.

5. Install the valve stem oil seal onto the valve guide using the J 42073.

Install the valve stem oil seal onto the valve guide until the J 42073 bottoms against the valve spring seat.

6. Inspect the valve stem oil seal. The valve stem oil seal should not be bottomed against the valve guide.

There should be a 1-2 mm (0.03937-0.07874 in) gap between the bottom edge of the valve stem oil seal and the valve guide.

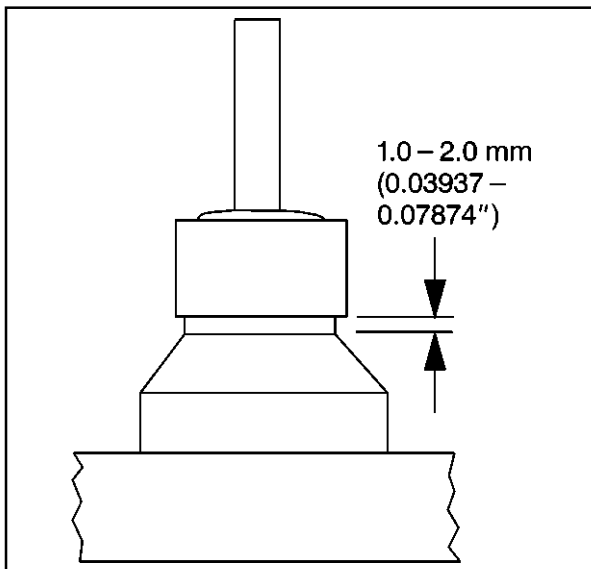

36373

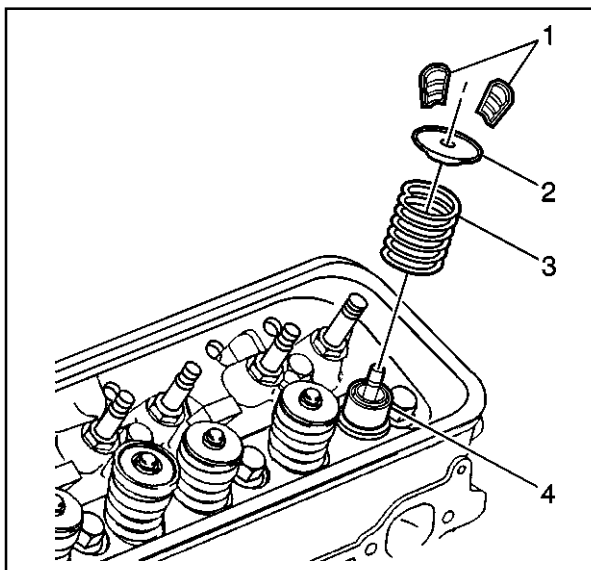

334505

7. Install the valve spring (3).

8. Install the valve spring cap (2) onto the valve spring (3) and over the valve stem.

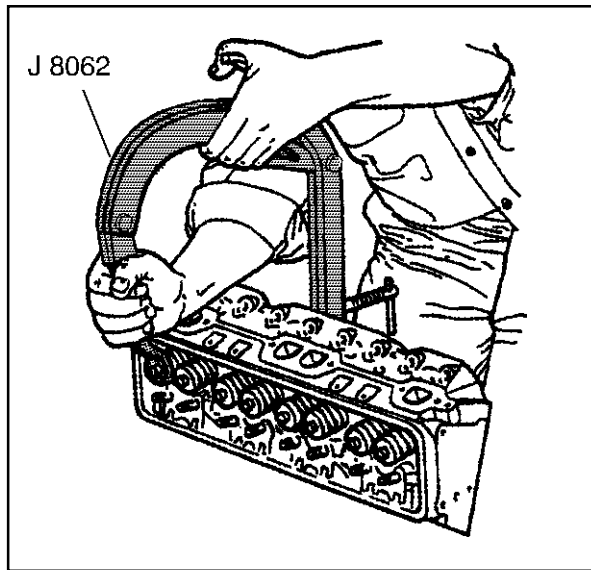

34468

Caution: Compressed valve springs have high tension against the valve spring compressor. Valve springs that are not properly compressed by or released from the valve spring compressor can be ejected from the valve spring compressor with intense force. Use care when compressing or releasing the valve spring with the valve spring compressor and when removing or installing the valve stem keys. Failing to use care may cause personal injury.

Caution: Refer to Safety Glasses Caution in Cautions and Notices.

9. Use the J 8062 in order to compress the valve springs.
10. Install the valve stem keys.
 - 10.1 Use grease in order to hold the valve stem keys in place while disconnecting the J 8062.
 - 10.2. Ensure that the valve stem keys seat properly in the upper groove of the valve stem.
 - 10.3. Tap the end of the valve stem with a plastic-faced hammer in order to seat the valve stem keys, if necessary.

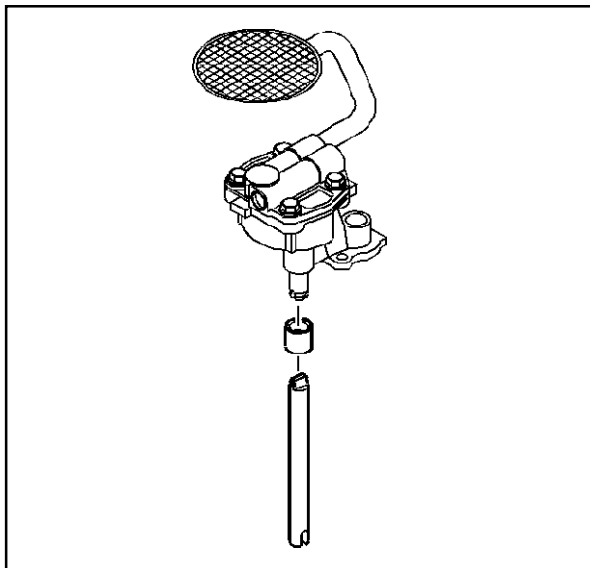

5274

Oil Pump Disassemble

1. Remove the oil pump driveshaft and oil pump driveshaft retainer.

2. Remove the oil pump screen (if necessary).
 - The oil pump screen has a press fit into the oil pump cover.
 - DO NOT remove the oil pump screen from the pipe. The pipe and oil pump screen are serviced as a complete assembly.

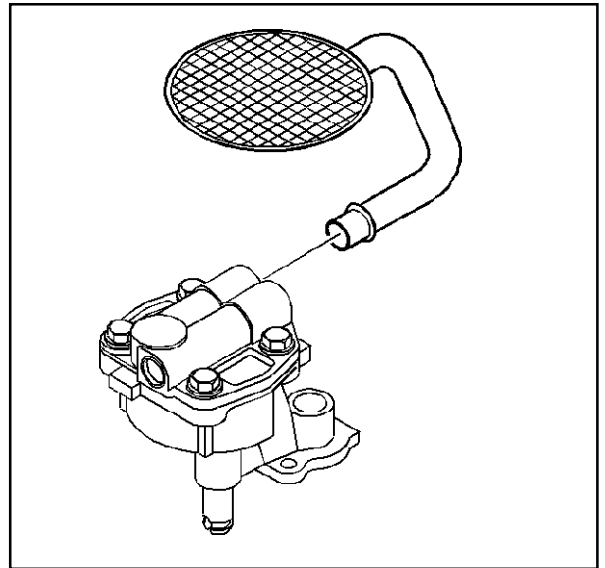

5275

3. Remove the oil pump cover bolts.

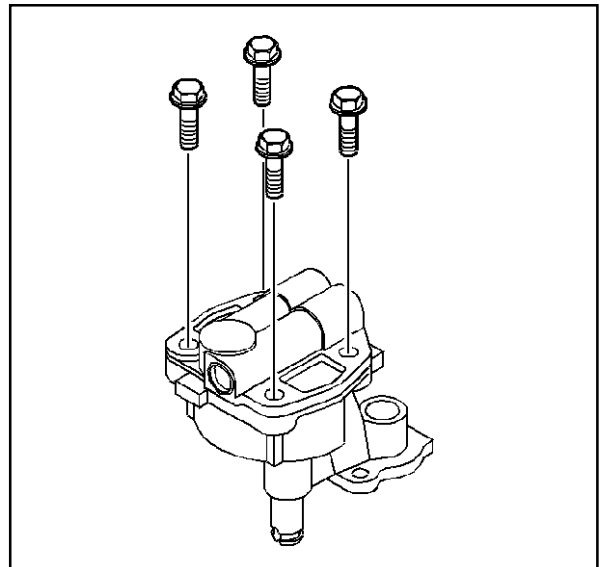

5276

4. Remove the oil pump cover.

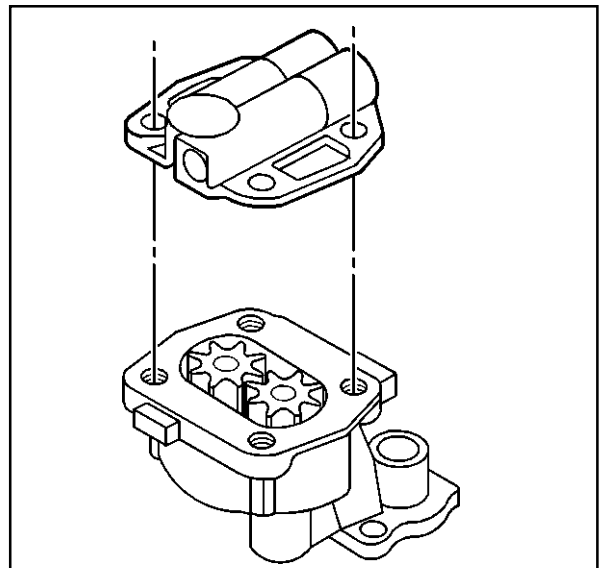

5277

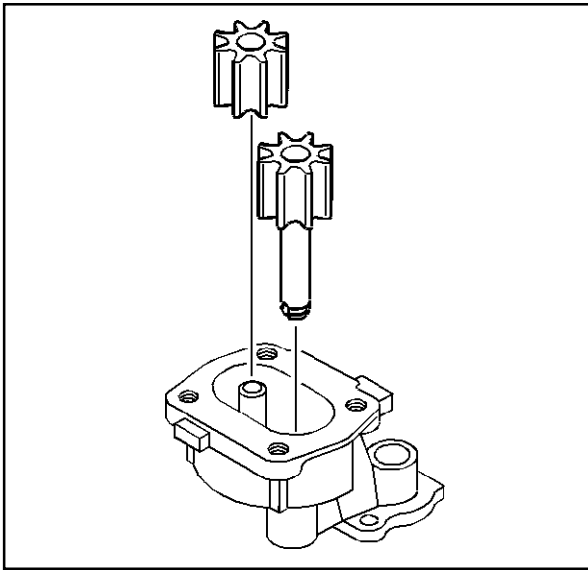

5278

5. Remove the oil pump drive gear and the oil pump driven gear.
6. Matchmark the gear teeth for assembly.

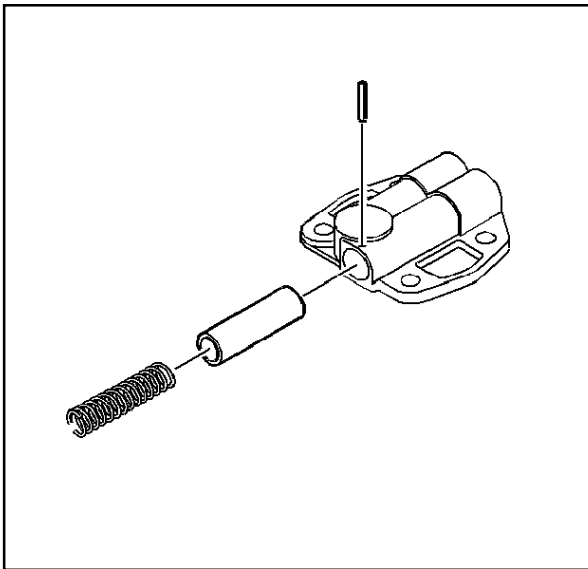

30401

Caution: Refer to Safety Glasses Caution in Cautions and Notices.

7. Remove the following items:
 - 7.1. The oil pump pressure relief valve spring straight pin
 - 7.2. The oil pump pressure relief spring
 - 7.3. The oil pump pressure relief valve

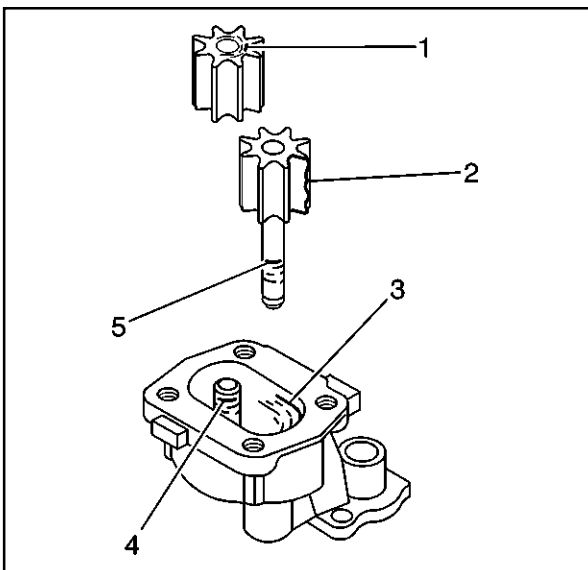

186750

Oil Pump Clean and Inspect

Caution: Refer to Safety Glasses Caution in Cautions and Notices.

1. Clean the oil pump components in cleaning solvent.
2. Dry the components with compressed air.
3. Inspect the oil pump for the following conditions:
 - Scoring on the top of the gears (1)
 - Damaged gears (2) for the following:
 - Chipping
 - Galling
 - Wear
 - Scoring, damage or casting imperfections to the body (3)
 - Damaged or scored gear shaft (4)
 - Damaged or scored gear shaft (5)

- Damaged bolt hole threads
 - Worn oil pump driveshaft bore
 - Damaged or sticking oil pump pressure relief valve (minor imperfections may be removed with a fine oil stone)
 - Collapsed or broken oil pump pressure relief valve spring
4. If the oil pump is to be reused, install a NEW oil pump pressure relief valve spring.
 5. During oil pump installation, install a NEW oil pump driveshaft retainer.

Oil Pump Assemble

Tools Required

J 21882 Oil Suction Pipe Installer

1. Apply clean engine oil GM P/N 12345610 or equivalent to the oil pump pressure relief valve, oil pump pressure relief valve spring and oil pump body.

Caution: Refer to Safety Glasses Caution in Cautions and Notices.

Important: Replace the oil pump pressure relief valve spring when you reuse the oil pump.

2. Install the following items:
 - 2.1. The oil pump pressure relief valve
 - 2.2. The oil pump pressure relief valve spring
 - 2.3. The oil pump pressure relief valve spring straight pin

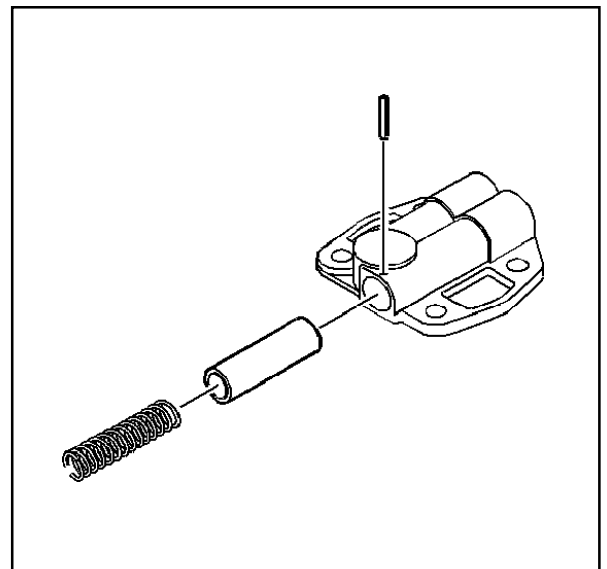

30401

3. Apply clean engine oil GM P/N 12345610 or equivalent to the oil pump drive gear, the oil pump driven gear and the oil pump body internal surfaces.
4. Install the oil pump drive gear and the oil pump driven gear into the oil pump body.
 - 4.1. Align the matchmarks on the oil pump drive and driven gears.
 - 4.2. Install the smooth side of the oil pump drive and driven gears toward the oil pump cover.

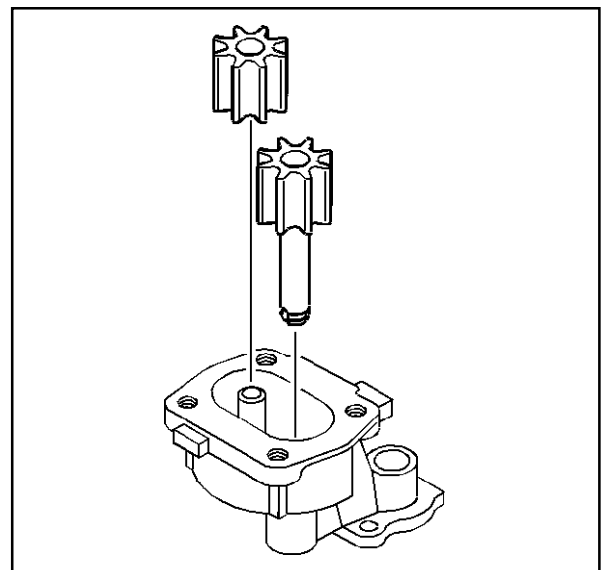

5278

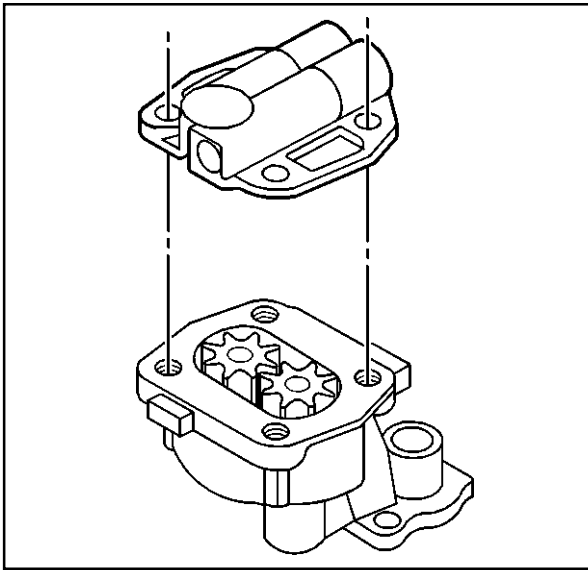

5277

4. Install the oil pump cover.

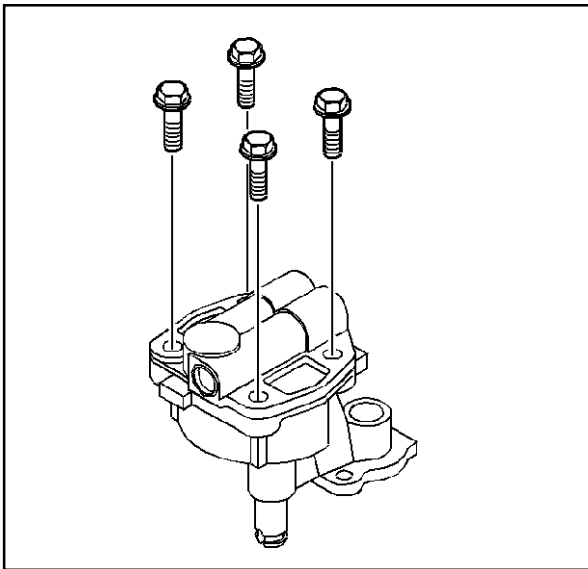

5276

Notice: Refer to *Fastener Notice* in Cautions and Notices.

5. Install the oil pump cover bolts.

Tighten

Tighten the bolts to 12 N•m (106 lb in).

6. Inspect the oil pump for smoothness of operation by turning the oil pump driveshaft by hand.

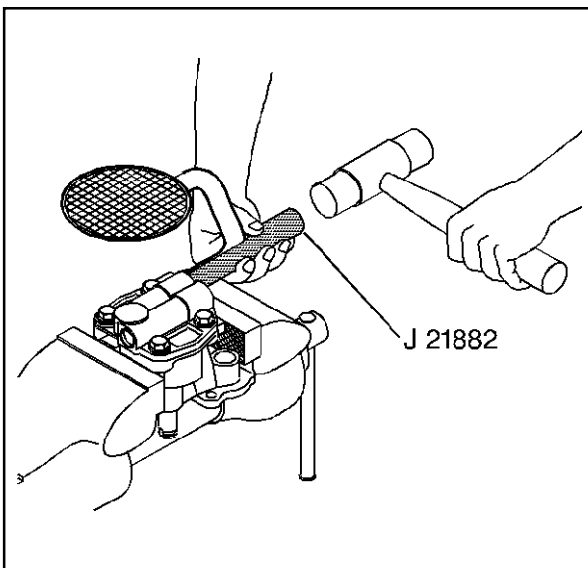

5280

7. Install the oil pump screen.

- 7.1. If removed, replace the oil pump screen.

The oil pump screen must have a good press fit into the oil pump body.

- 7.2. Mount the oil pump in a soft jawed vise.

- 7.3. Apply sealant GM P/N 12346004 or equivalent to the end of the oil pump screen pipe.

- 7.4. Use the J 21882 and a soft-faced hammer in order to tap the oil pump screen into the pump body.

The oil pump screen must align parallel with the bottom of the oil pan when the oil pan is installed.

Important: Install a NEW oil pump driveshaft retainer during assembly.

8. Install the oil pump driveshaft and the NEW oil pump driveshaft retainer.

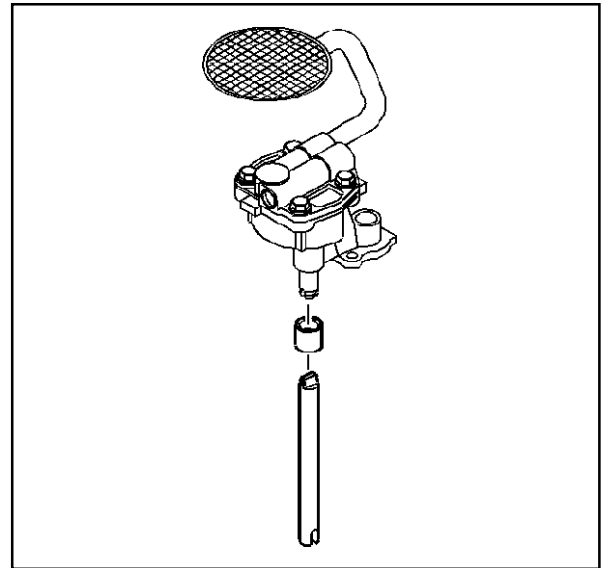

5274

Valve Rocker Arm Cover Clean and Inspect

Caution: Refer to *Safety Glasses Caution in Cautions and Notices*.

1. Clean the valve rocker arm cover in cleaning solvent.
2. Dry the valve rocker arm cover with compressed air.
3. Inspect the valve rocker arm cover for the following:
 - Damage to the PCV valve grommet (1)
 - Dents or damage to the exterior of the valve rocker arm cover (2)
 - A dented or damaged valve rocker arm cover may interfere with the valve rocker arms.
 - Gouges or damage to the sealing surface (3)
 - Damage to the bolt holes (4)
 - Restrictions to the ventilation system passages

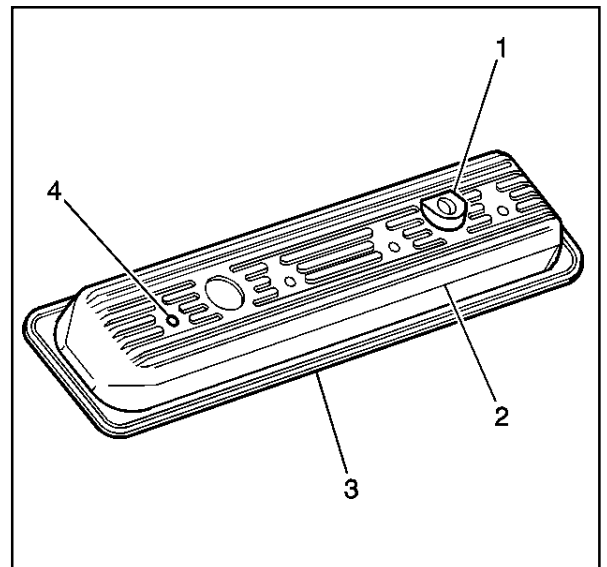

333657

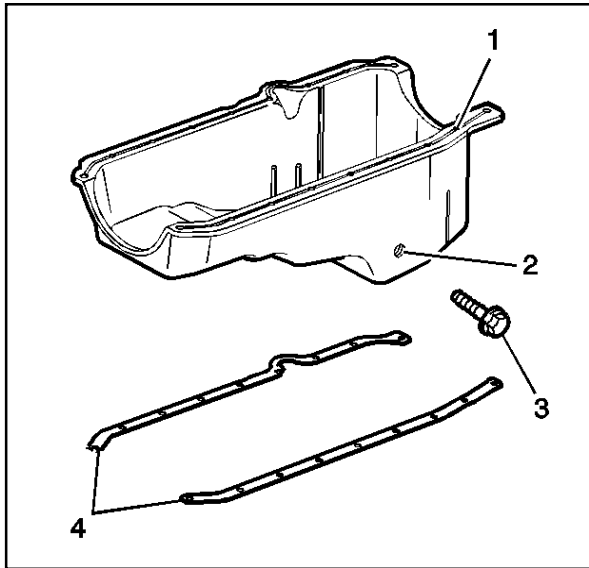

521835

Oil Pan Clean and Inspect

Caution: Refer to Safety Glasses Caution in Cautions and Notices.

1. Clean the oil pan and the oil pan baffle in cleaning solvent.
2. Dry the oil pan and the oil pan baffle with compressed air.
3. Inspect the oil pan for the following:
 - Gouges or damage to the oil pan sealing surfaces (1)
 - The oil pan drain plug hole for damaged threads (2)
 - Damaged oil pan drain plug threads (3)
 - Damage to the oil pan reinforcements (4)
 - Damage to the oil pan baffle
 - Dents or damage to the exterior of the oil pan

An oil pan that is dented may interfere with the proper position of the oil pump screen, or may not distribute oil properly in the oil pan sump area.

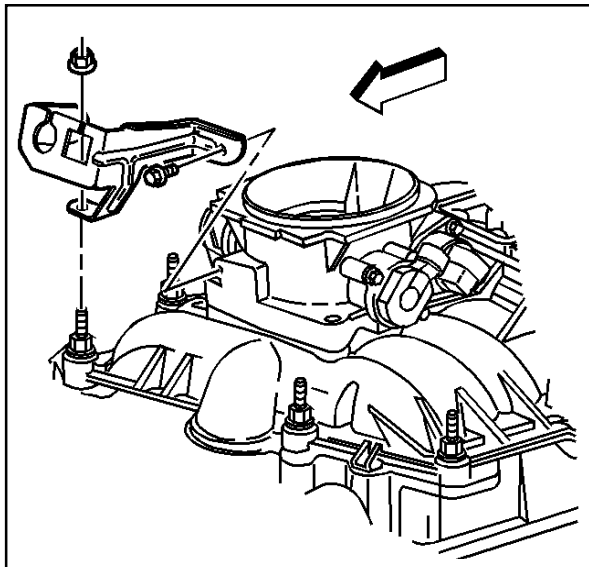

500661

Intake Manifold Disassemble

1. Remove the bolt, the nut and the accelerator control cable bracket.

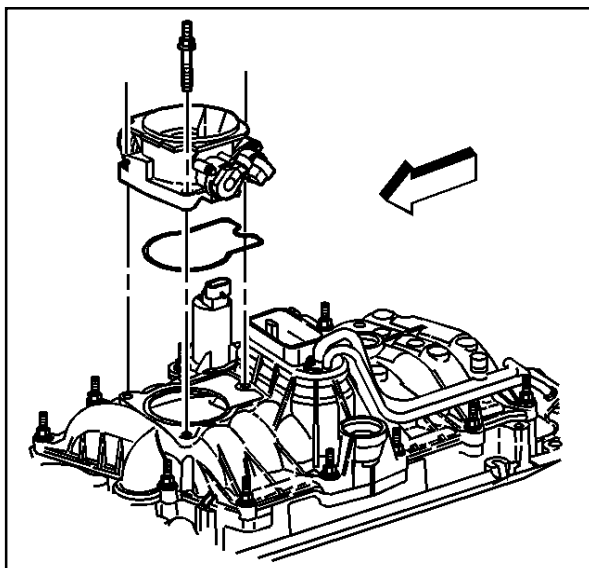

500667

2. Remove the throttle body attaching studs.
3. Remove the throttle body.
4. Remove the throttle body upper intake manifold gasket.
5. Discard the throttle body to upper intake manifold gasket.

6. Remove the water outlet studs.
7. Remove the water outlet.
8. Remove the engine coolant thermostat.

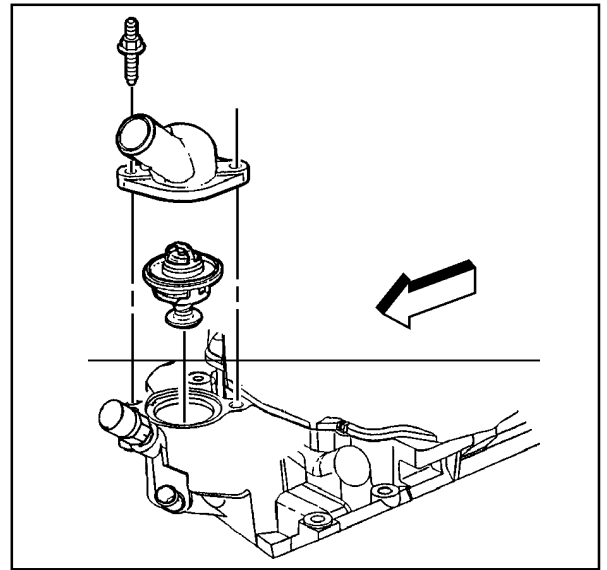

500671

Important: Note the position and direction of the exhaust gas recirculation (EGR) valve before removal. It is possible to improperly install the EGR valve 180 degrees from the original position.

9. Remove the exhaust gas recirculation (EGR) valve bolts.

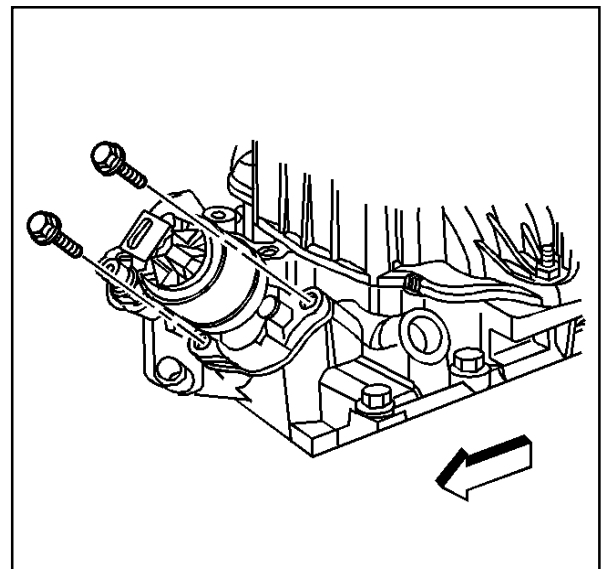

480563

Notice: The Linear EGR valve is an electrical component. DO NOT soak in any liquid cleaner or solvent because damage may result.

10. Remove the EGR valve and EGR valve gasket from the lower intake manifold.
11. Discard the EGR valve gasket.

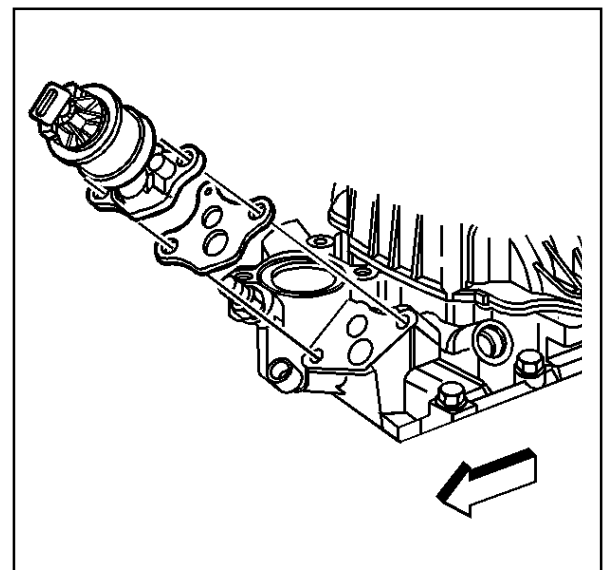

480565

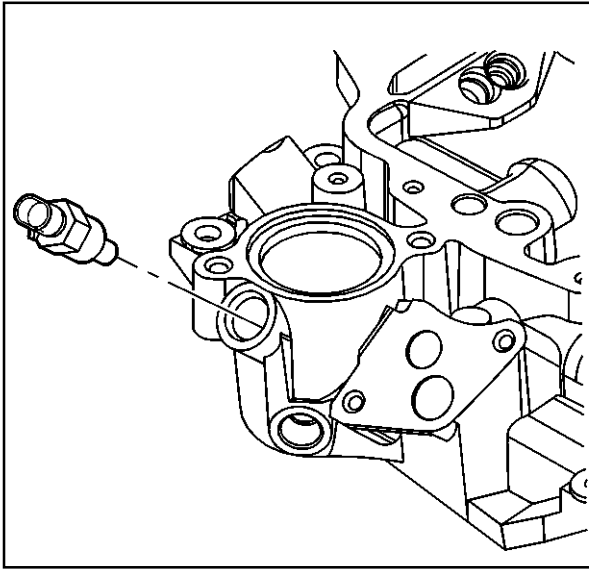

10932

12. Remove the engine coolant temperature (ECT) sensor from the lower intake manifold.

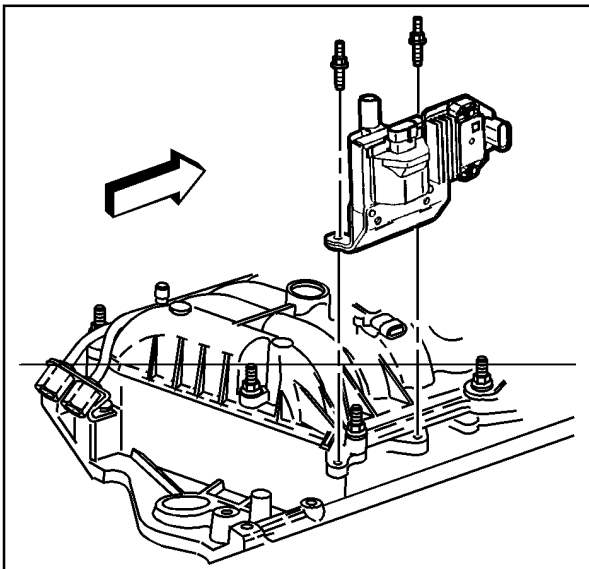

500674

13. Remove the studs and the ignition coil.

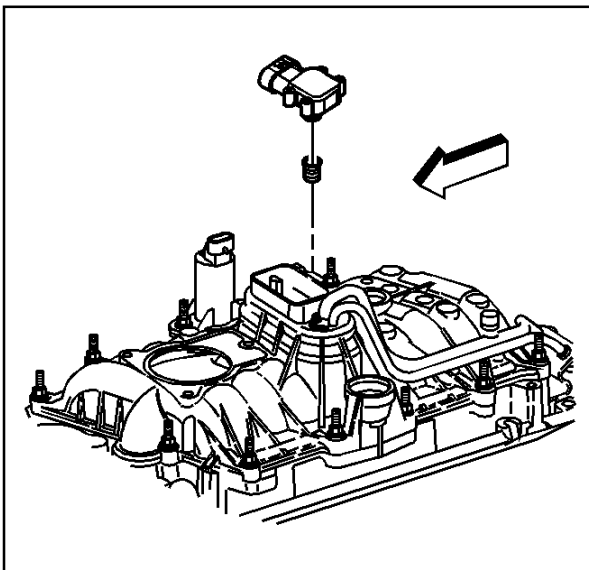

500677

14. Remove the manifold absolute pressure (MAP) sensor from the upper intake manifold.
15. Remove the MAP sensor seal from the MAP sensor.
16. Discard the MAP sensor seal.

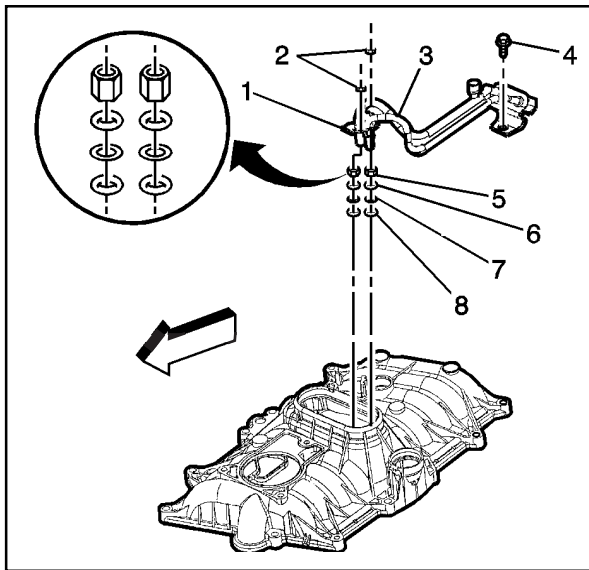

500679

17. Remove the fuel pipe bolt (4).
18. Remove the nuts (2) and the fuel pipe retainer (1).
19. Remove the fuel pipe (3).
20. Remove and discard the fuel seal retainers (5).
21. Remove and discard the fuel seals (6) (yellow O-rings).
22. Remove and discard the spacer rings (7) (flat washers).
23. Remove and discard the fuel seals (8) (black O-rings).

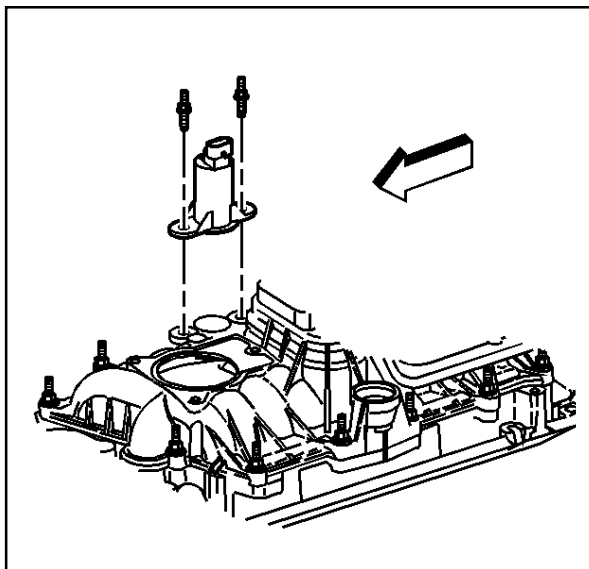

500680

24. Remove the studs and the evaporative emission (EVAP) canister purge solenoid valve.
25. Remove the nut and the engine wiring harness bracket.

26. Remove the upper intake manifold studs (1).
27. Remove the upper intake manifold (2).
28. Remove the upper intake manifold to lower intake manifold gasket (3).
29. Discard the upper intake manifold to lower intake manifold gasket (3).
30. Remove the fuel meter body seal (4) and discard.
31. Remove the 8 poppet nozzles from the lower intake manifold bores.
32. Remove the fuel meter body (5) from the lower intake manifold (6).

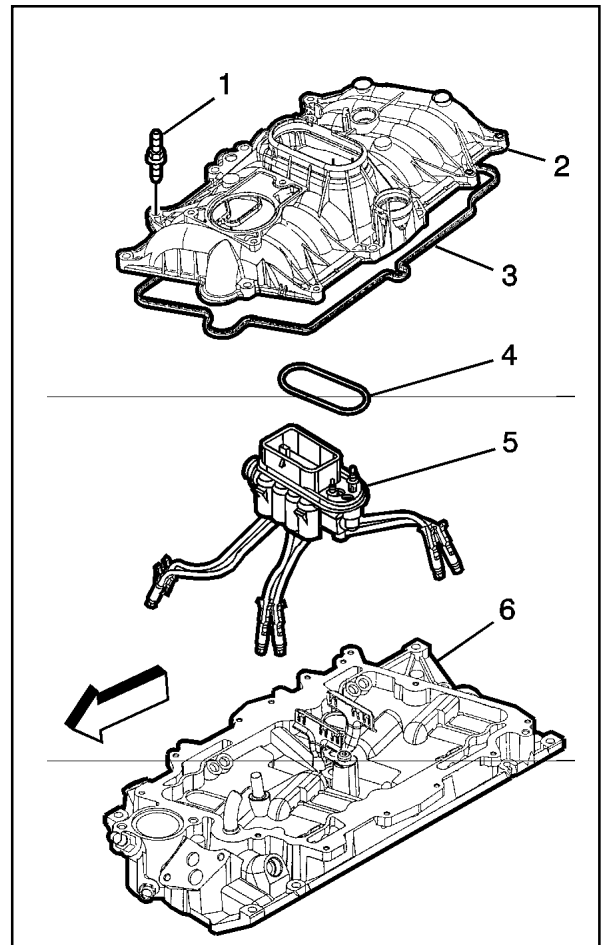

500681

Intake Manifold Clean and Inspect

Caution: Refer to Safety Glasses Caution in Cautions and Notices.

1. Clean the upper intake manifold in cleaning solvent.
2. Dry the upper intake manifold with compressed air.

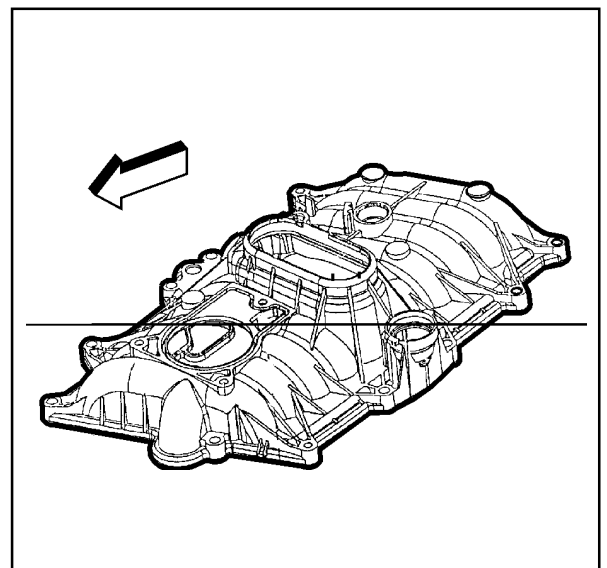

500682

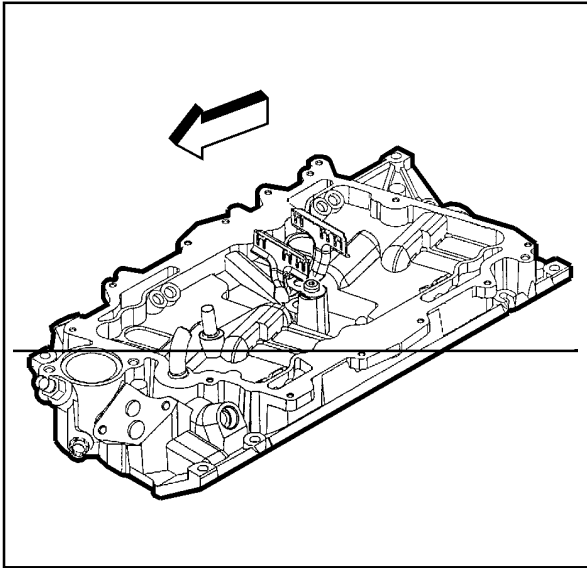

500684

3. Clean the lower intake manifold in cleaning solvent.
4. Dry the lower intake manifold with compressed air.

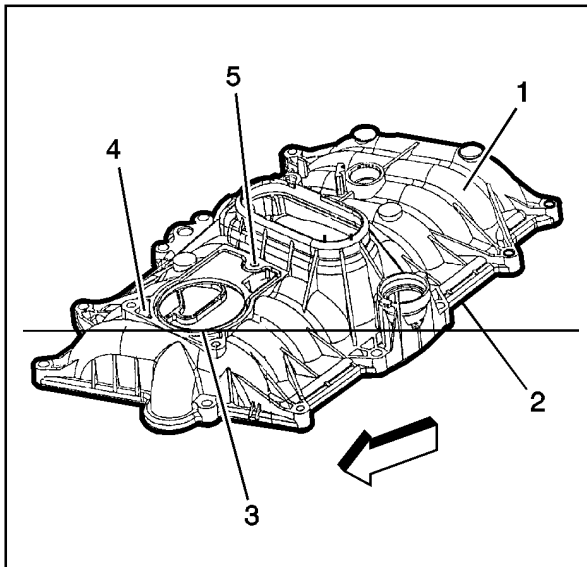

500685

5. Inspect the upper intake manifold for the following:
 - Cracks or other damage to the exterior (1)
 - Cracking or damage in the gasket grooves (2) and (3)
 - Damage to the throttle body mounting surface (4)
 - Loose or damaged bolt hole thread inserts (5)

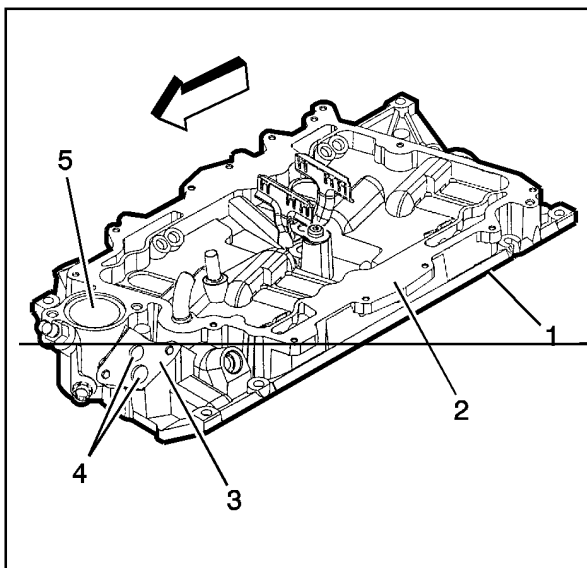

500686

6. Inspect the lower intake manifold for the following:
 - Damage to the gasket sealing surfaces (1), (2) and (3)
 - Restricted exhaust gas recirculation (EGR) system passages
 - Restricted cooling system passages (5)
 - Cracks or damage
 - Damage to the threaded bolt holes

Intake Manifold Assemble

1. Install the fuel meter body (5) into the lower intake manifold (6).
2. Install the 8 poppet nozzles into the lower intake manifold (6).
3. Inspect the poppet nozzles in order to ensure that the poppet nozzles are firmly seated and locked in the lower intake manifold bores.
4. Install a NEW fuel meter body seal (4) into the groove on the fuel meter body (5).
5. Install the NEW upper intake manifold to lower intake manifold gasket (3) into the groove of the upper intake manifold (2).
6. Install the upper intake manifold (2) onto the lower intake manifold (6).

Notice: Refer to *Fastener Notice* in Cautions and Notices.

7. If reusing the fasteners, apply threadlock GM P/N 12345382 or equivalent to the threads of the upper intake manifold attaching studs (1).
8. Install the upper intake manifold attaching studs (1).

Tighten

- 8.1. Tighten the upper intake manifold attaching studs on the first pass to 5 N•m (44 lb in).
- 8.2. Tighten the upper intake manifold attaching studs on the final pass to 10 N•m (89 lb in).

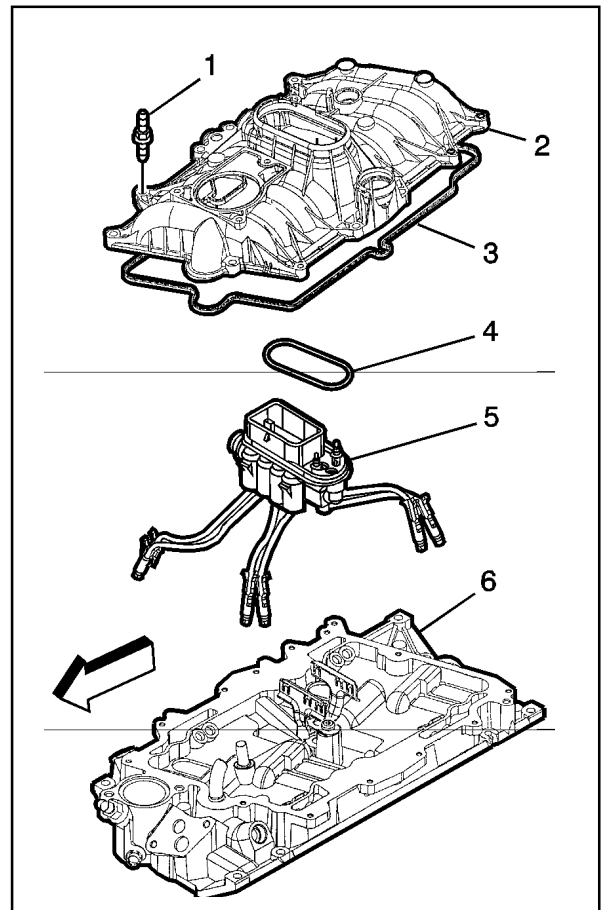

500681

9. If reusing the fasteners, apply threadlock GM P/N 12345382 or equivalent to the threads of the evaporative emission (EVAP) canister purge solenoid valve studs.
10. Install the EVAP canister purge solenoid valve and studs.

Tighten

Tighten the EVAP canister purge solenoid valve studs to 10 N•m (89 lb in).

11. Install the engine wiring harness bracket and nut.

Tighten

Tighten the engine wiring harness bracket nut to 12 N•m (106 lb in).

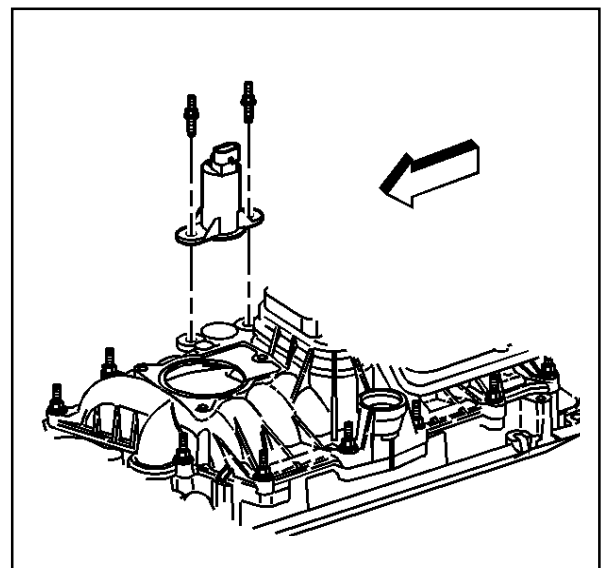

500680

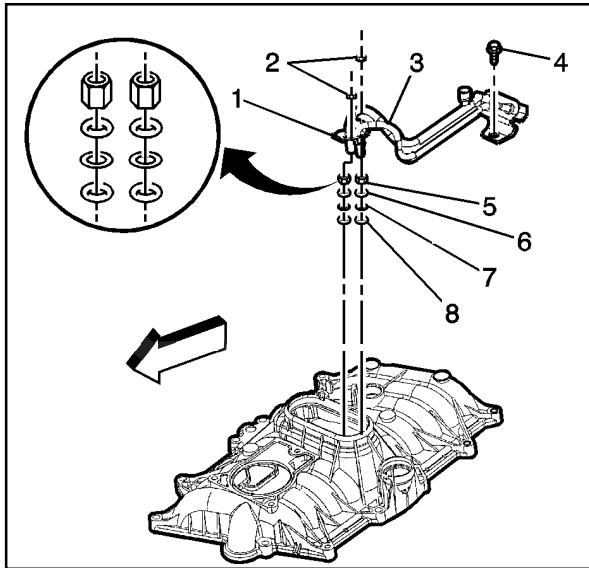

500679

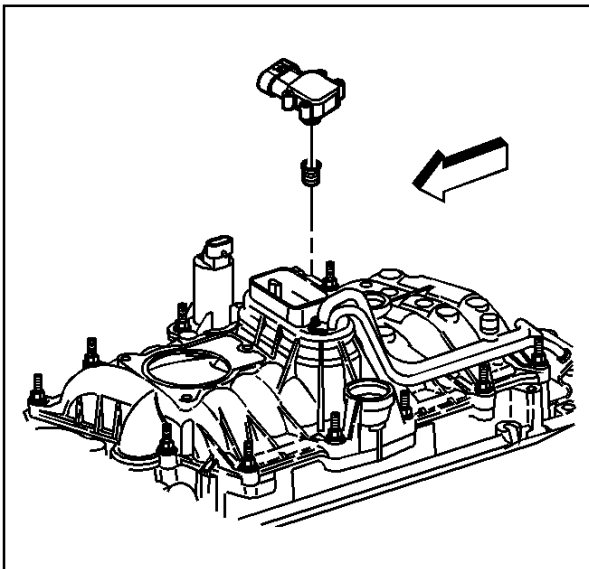

500677

12. Install the NEW fuel seals (8) (black O-rings) into the fuel meter body.
13. Install the NEW spacer rings (7) (flat washers) into the fuel meter body.
14. Install the NEW fuel seals (6) (yellow O-rings) into the fuel meter body.
15. Install the NEW fuel seal retainers (5) into the fuel meter body.
16. Install the fuel pipe (3) into the fuel meter body.
17. Install the fuel pipe retainer (1) and the nuts (2).
18. If reusing the fastener, apply threadlock GM P/N 12345382 or equivalent to the threads of the fuel pipe bolt (4).
19. Install the fuel pipe bolt (4).

Tighten

- 19.1. Tighten the fuel pipe retainer nuts (2) to 3 N•m (27 lb in).
- 19.2. Tighten the fuel pipe bolt (4) to 6 N•m (53 lb in).
20. Install a NEW manifold absolute pressure (MAP) sensor seal onto the MAP sensor.
21. Apply a small amount (1 drop) of clean engine oil to the MAP sensor seal.
22. Install the MAP sensor into the upper intake manifold.

23. Install the ignition coil and studs.

Tighten

Tighten the ignition coil studs to 12 N•m (106 lb in).

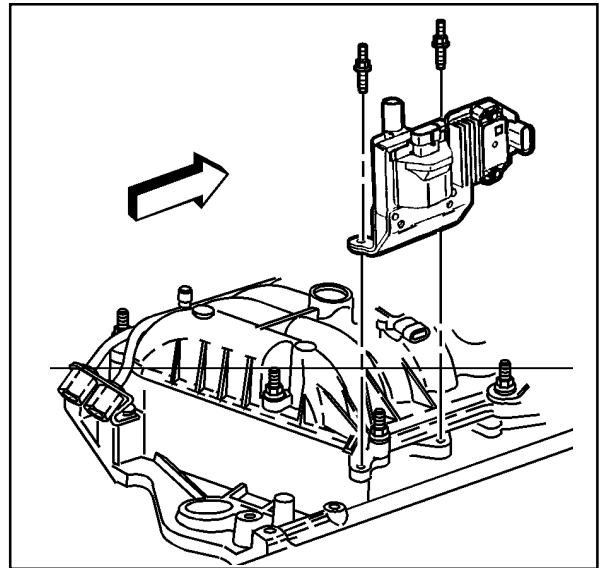

500674

24. If reusing the engine coolant temperature (ECT) sensor, apply sealant GM P/N 12346004 or equivalent to the threads of the ECT sensor.

25. Install the ECT sensor into the front of the lower intake manifold.

Tighten

Tighten the ECT sensor to 20 N•m (15 lb ft).

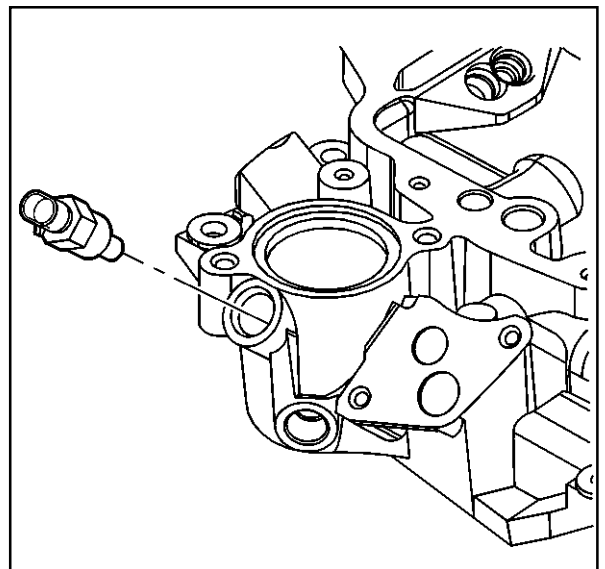

10932

Important: The exhaust gas recirculation (EGR) valve must be installed in the original orientation.

26. Install the NEW EGR valve gasket and the EGR valve.

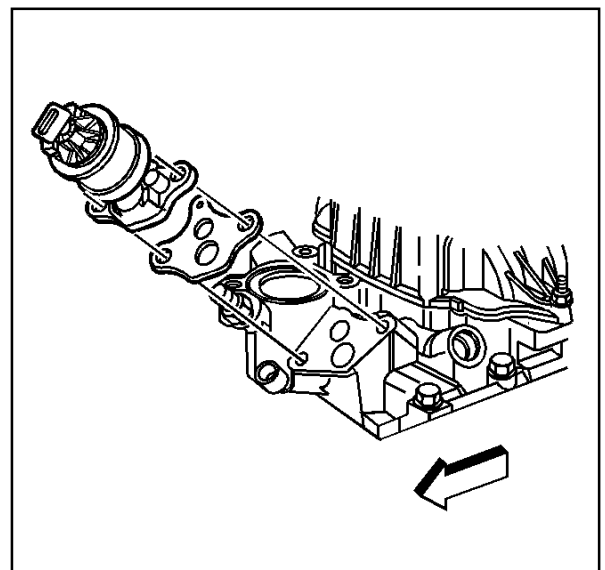

480565

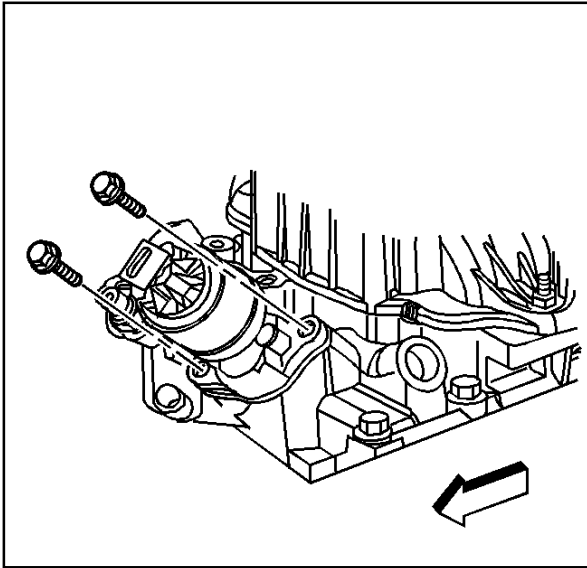

480563

27. Install the EGR valve bolts.

Tighten

- 27.1. Tighten the EGR valve bolts on the first pass to 10 N•m (88 lb in).
 27.2. Tighten the EGR valve bolts on the final pass to 30 N•m (22 lb ft).

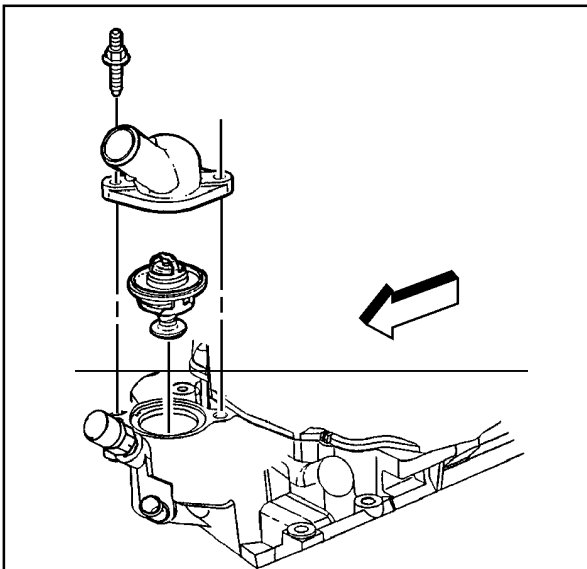

500671

28. Install the engine coolant thermostat.
 29. Install the water outlet.
 30. Install the water outlet studs.

Tighten

Tighten the water outlet studs to 25 N•m (18 lb ft).

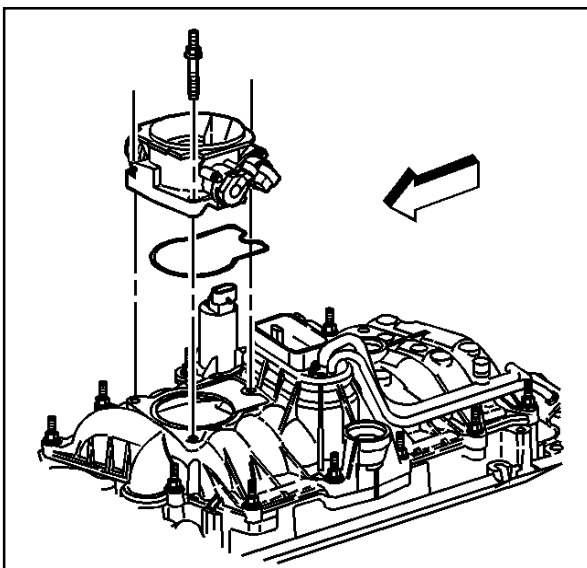

500667

31. Install a NEW throttle body gasket into the groove in the upper intake manifold.
 32. Install the throttle body onto the upper intake manifold.
 33. If reusing the fasteners, apply threadlock GM P/N 12345382 or equivalent to the threads of the throttle body attaching studs.
 34. Install the throttle body attaching studs.

Tighten

Tighten the throttle body attaching studs to 9 N•m (80 lb in).

35. Install the accelerator control cable bracket, the bolt and the nut.

Tighten

Tighten the accelerator control cable bracket bolt and nut to 12 N•m (106 lb in).

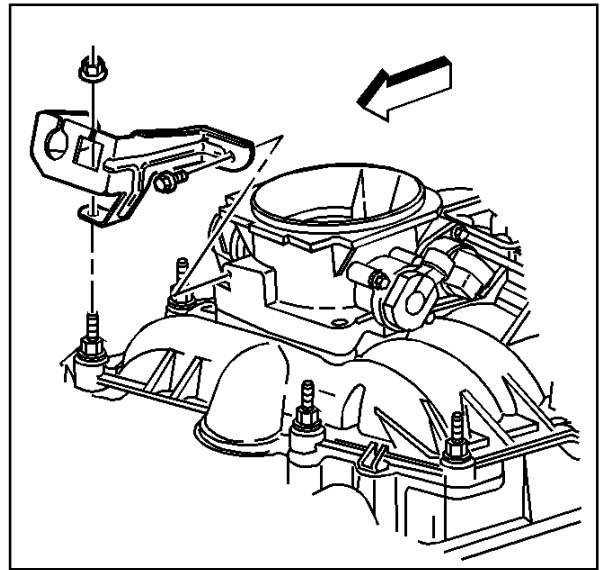

500661

Exhaust Manifold Clean and Inspect

Caution: Refer to Safety Glasses Caution in Cautions and Notices.

1. Clean the exhaust manifolds in cleaning solvent.
2. Dry the components with compressed air.
3. Inspect the exhaust manifolds for the following:
 - Damage to the gasket sealing surfaces (1)
 - Damage to the exhaust gas recirculation (EGR) pipe fitting (2) (left manifold).
 - Damage to the take down bolt hole threads (3)
 - Restrictions within exhaust passages
 - Broken or damaged exhaust manifold heat shields (4) (if applicable)
 - Damaged or cracked exhaust manifold

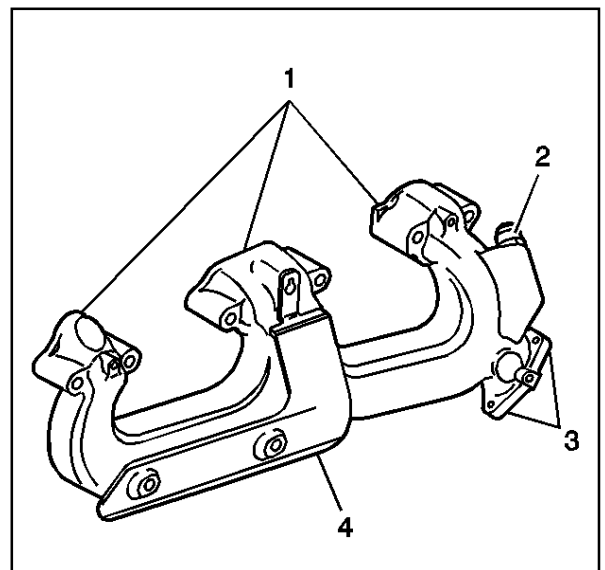

521830

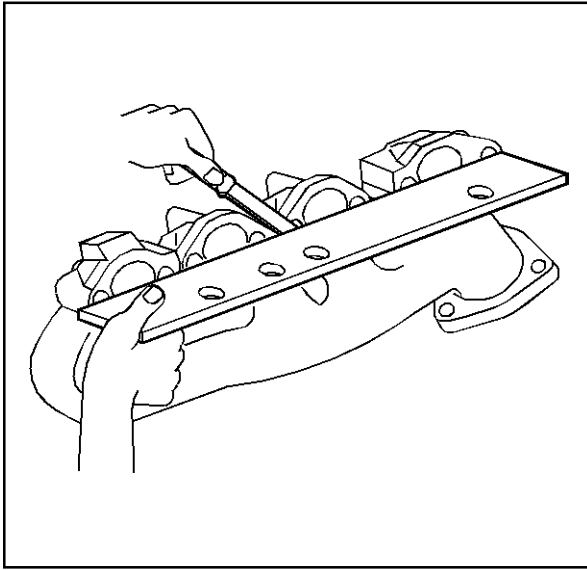

66607

4. Measure the alignment or surface flatness of the exhaust manifold flanges using a straight edge and a feeler gauge. Refer to *Engine Mechanical Specifications*.

If the surface flatness is not within the specifications, the exhaust manifold is warped and must be replaced.

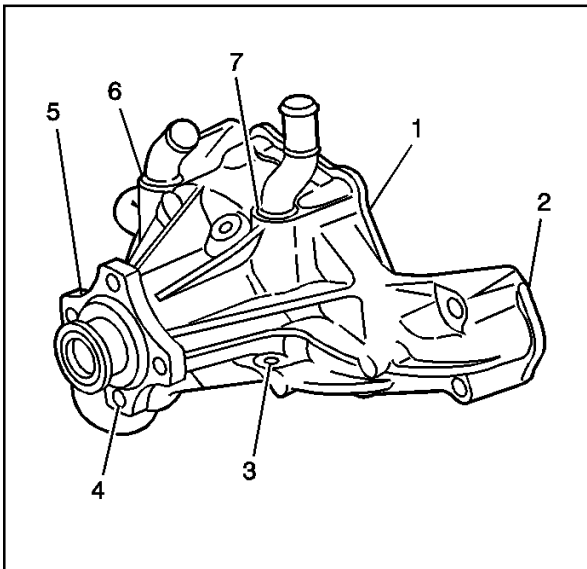

480571

Water Pump Clean and Inspect

Caution: Refer to *Safety Glasses Caution in Cautions and Notices*.

1. Remove all the old gasket material from the water pump sealing surfaces.
2. Clean all the dirt and any debris from the water pump.
3. Inspect the water pump for the following:
 - Leakage or damage to the housing cover or gasket (1)
 - Excessive scratches or gouging to the gasket sealing surfaces (2)
 - Leakage from the water pump vent hole (3)

A stain around the vent hole is acceptable. If leakage occurred (dripping) with the engine operating and the cooling system pressurized, then replace the water pump.
 - Damaged bolt hole threads (4)
 - Excessive side-to-side movement of the water pump shaft (5)
 - Leakage around the water inlet pipe (6)
 - Leakage around the heater hose pipe (7)
 - Restrictions within the internal coolant passages

Thread Repair

General purpose thread repair kits are available commercially.

Caution: Refer to *Safety Glasses Caution in Cautions and Notices*.

Important: Refer to the thread repair kit manufacturer's instructions regarding the size of the drill and which tap to use.

Always avoid any buildup of chips. Back out the tap every few turns and remove the chips.

Determine the size, the pitch and the depth of the damaged thread.

1. Adjust the stop collars on the cutting tool as needed. Tap the stop collars to the required depths.
2. Drill out the damaged thread.
3. Remove the chips.
4. Apply clean engine oil to the top thread.
5. Use the tap in order to cut new thread.
6. Clean the thread.
7. Screw the thread insert onto the mandrel of the thread insert installer. Engage the tang of the thread insert onto the end of the mandrel.

Important: The thread insert should be flush to 1 turn below the surface.

8. Lubricate the thread insert with clean engine oil (except when installing in aluminum) and install the thread insert.
9. If the tang of the thread insert does not break off when backing out the thread insert installer, break off the tang using a drift punch.

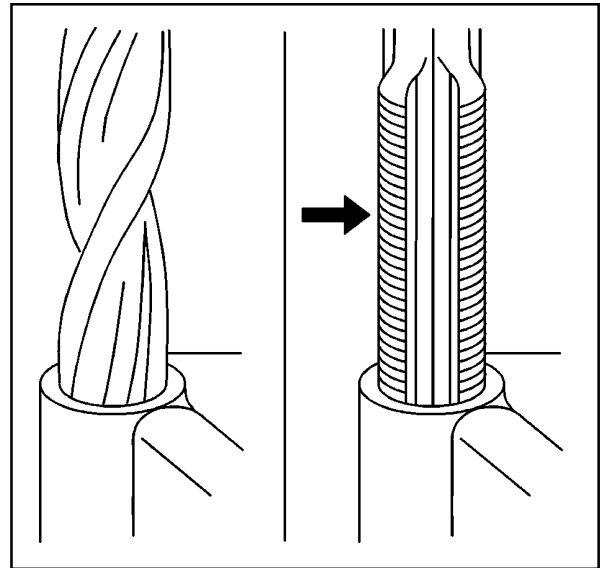

4962

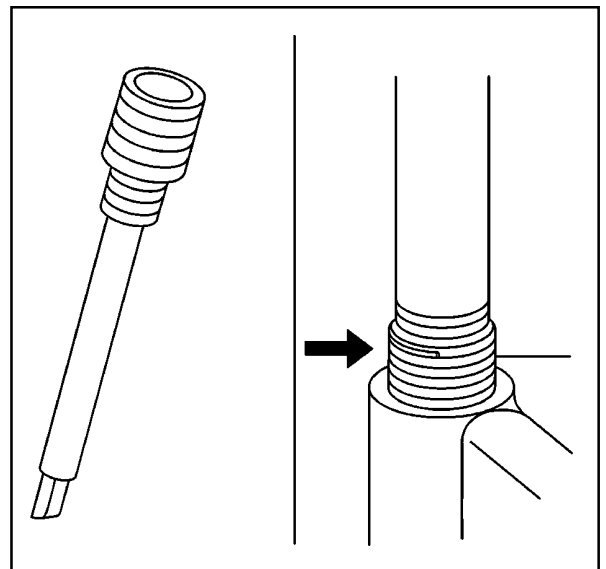

4963

Service Prior to Assembly

- Dirt will cause premature wear of the rebuilt engine. Clean all the components.
- Use the proper tools to measure the components when checking for excessive wear. Components not within the manufacturer's specification must be repaired or replaced.
- When the components are re-installed into an engine, return the components to the original location, position and direction.
- During assembly, lubricate all the moving parts with clean engine oil (unless otherwise specified). The engine oil will provide the initial lubrication when the engine is first started.

**This page left
intentionally
blank**

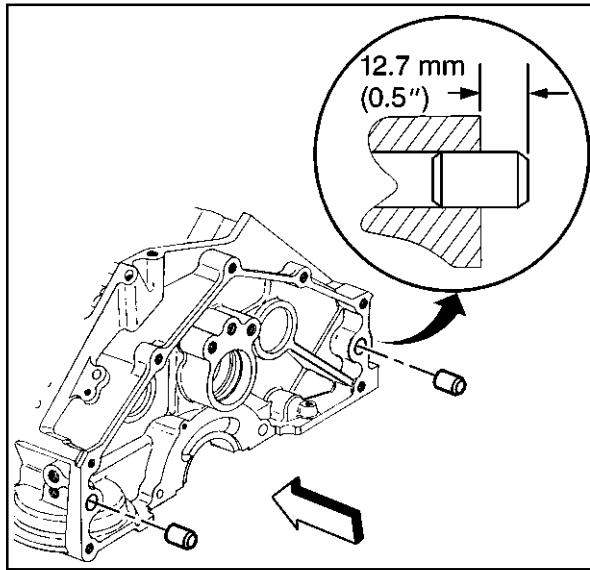

182855

Engine Block Plug Installation

Tools Required

J 41712 Oil Pressure Switch Socket

Caution: Refer to Safety Glasses Caution in Cautions and Notices.

1. Install the transmission locator pins (if required).
A properly installed transmission locator pin will protrude 12.7 mm (0.5 in) from the rear face of the engine block.

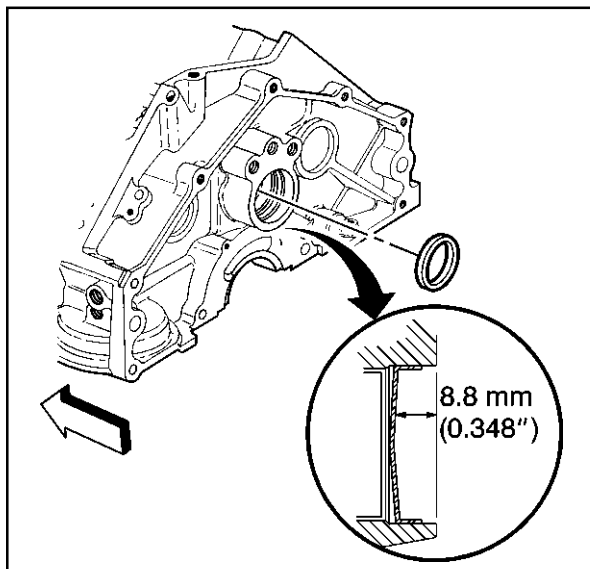

182854

2. Apply sealant GM P/N 12346004 or equivalent to the outside diameter of the NEW expansion cup plug (camshaft rear bearing hole).
3. Install the NEW expansion cup plug (camshaft rear bearing hole).
A properly installed expansion cup plug will be installed 8.8 mm (0.348 in) into the rear of the engine block.

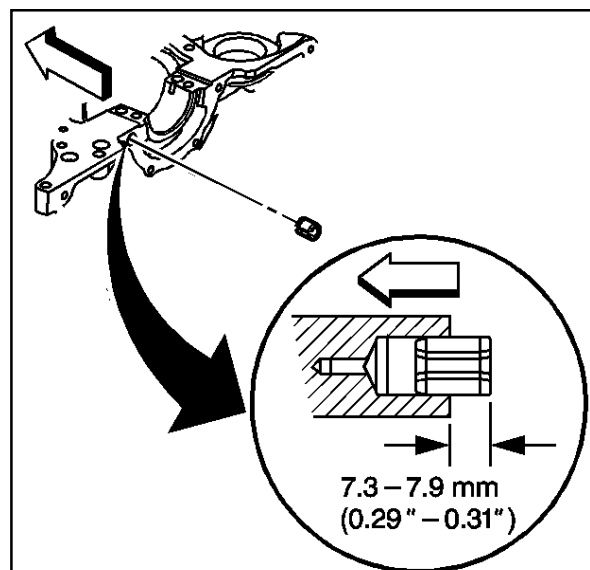

521836

4. Install the S type pin (crankshaft rear oil seal housing locator).

Notice: Refer to *Fastener Notice* in Cautions and Notices.

5. Apply sealant GM P/N 12346004 or equivalent to the threads of the left side rear and left rear top engine oil gallery plugs.
6. Install the left side rear and left rear top engine oil gallery plugs.

Tighten

Tighten the left side rear and left rear top oil gallery plugs to 20 N·m (15 lb ft).

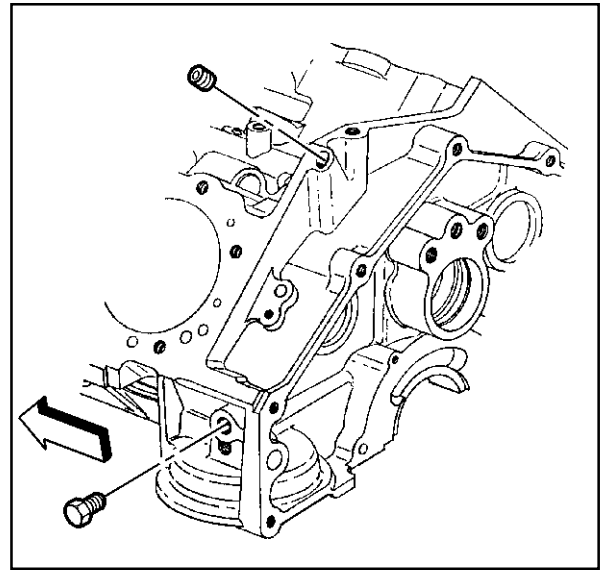

182841

7. Apply sealant GM P/N 12346004 or equivalent to the threads of the square socket plugs (engine block oil gallery).
8. Install the square socket plugs.

Tighten

Tighten the square socket plugs to 20 N·m (15 lb ft).

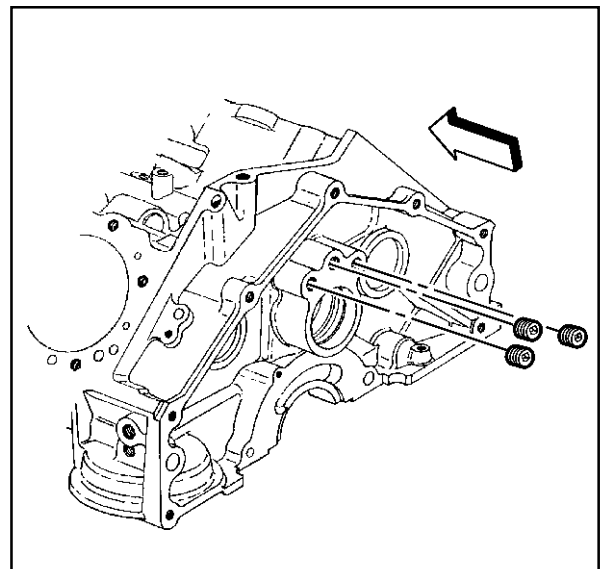

69847

9. Apply sealant GM P/N 12346004 or equivalent to the outside diameter of the NEW engine block oil gallery plugs.
10. Install the NEW engine block oil gallery plugs.
A properly installed engine block oil gallery plug must be installed below flush with the front face of the engine block.

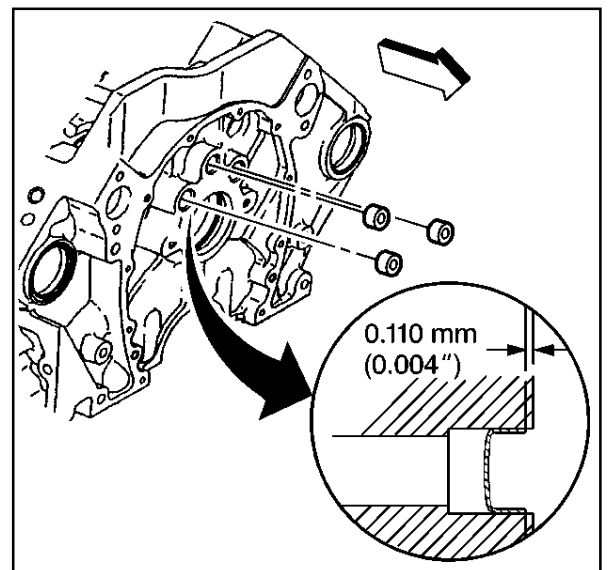

182838

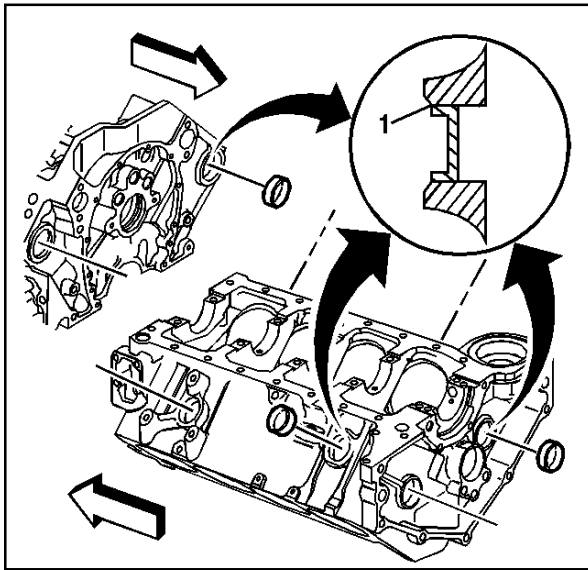

500653

11. Apply threadlock GM P/N 12345382 or equivalent to the threads of the outside diameter of the NEW engine block core hole plugs.
12. Install the NEW engine block core hole plugs.
A properly installed engine block core hole plug must be installed flush with the bottom of the chamfer (1) of the engine block core hole.

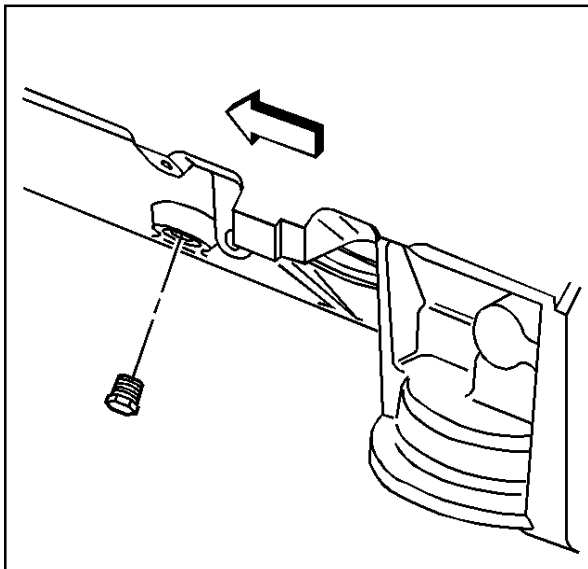

316798

13. Apply sealant GM P/N 12346004 or equivalent to the threads of the engine block coolant drain hole plug.
14. Install the engine block coolant drain hole plug.

Tighten

Tighten the engine block coolant drain hole plug to 20 N·m (15 lb ft).

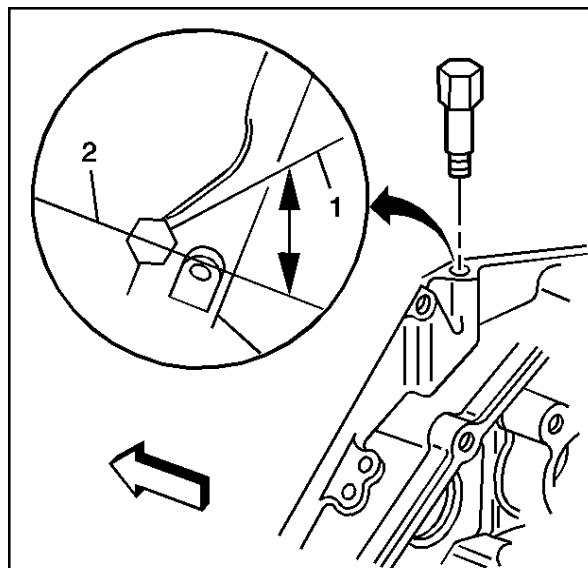

333659

15. Apply sealant GM P/N 12346004 or equivalent to the threads of the engine oil pressure sensor fitting.
- Important:** Do not loosen the oil pressure sensor fitting after the initial torque has been obtained.
16. Install the engine oil pressure sensor fitting.
- Tighten**
- Tighten the engine oil pressure sensor fitting to 15 N·m (11 lb ft).
- Important:** Do not rotate the engine oil pressure sensor fitting more than 359 degrees after the initial torque has been obtained.
17. Rotate the engine oil pressure sensor fitting clockwise to the proper position (1), 50 degrees from the centerline (2).

Engine

Marine/Industrial 5.7L 6-129

18. Apply sealant GM P/N 12346004 or equivalent to the threads of the engine oil pressure gauge sensor.
19. Install the engine oil pressure gauge sensor using the J 41712.

Tighten

Tighten the engine oil pressure gauge sensor to 30 N·m (22 lb ft).

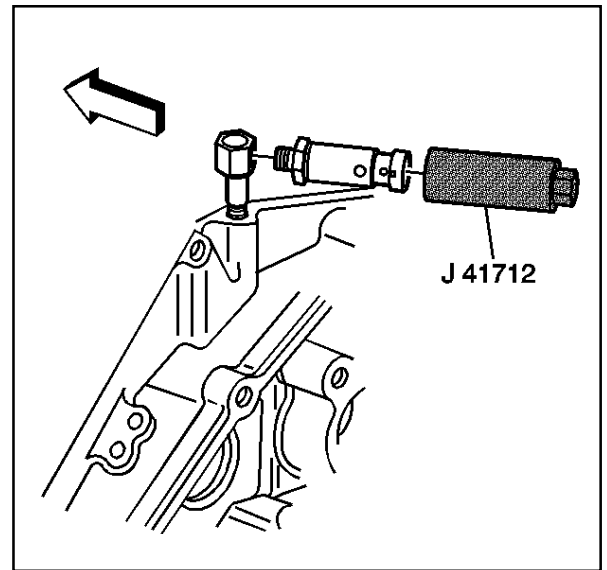

333649

20. Apply sealant GM P/N 12346004 or equivalent to the threads of the knock sensor.
21. Install the knock sensor.

Tighten

Tighten the knock sensor to 19 N·m (14 lb ft).

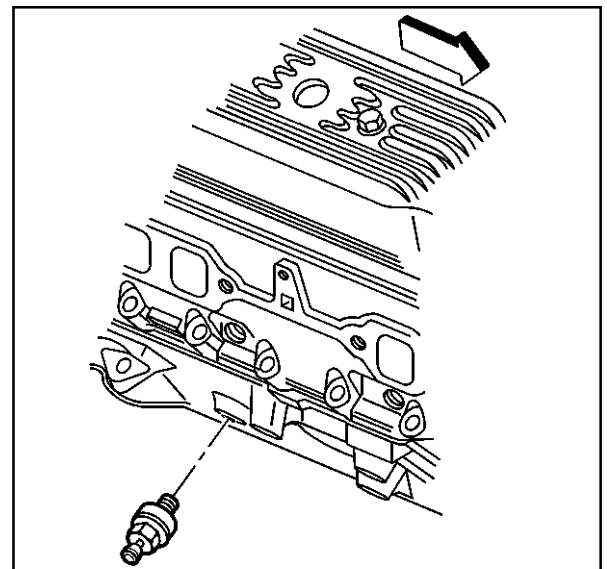

182837

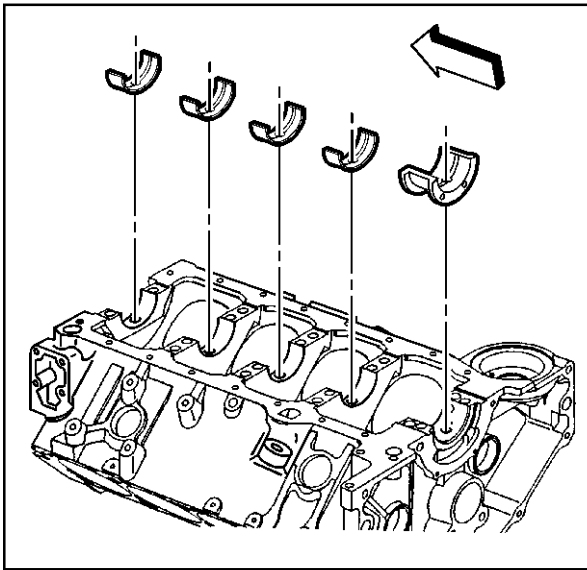

317292

Crankshaft and Bearings Installation

Tools Required

J 36660 Electronic Torque Angle Meter

1. Install the crankshaft bearings into the engine block.
2. Apply clean engine oil to the crankshaft bearings.

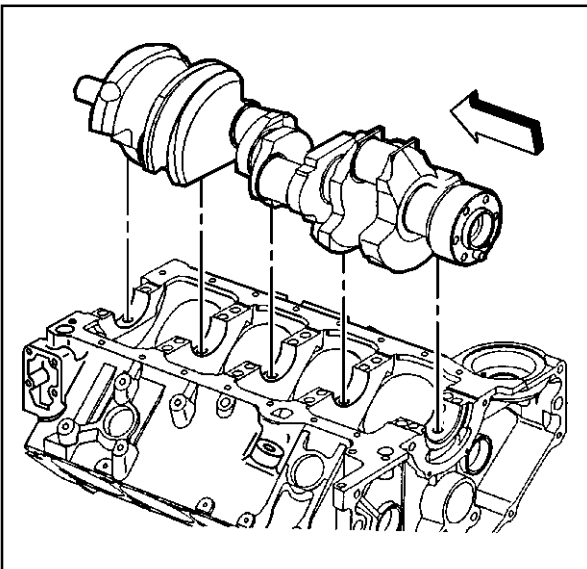

317351

3. Apply clean engine oil to the crankshaft bearing journals.
4. Install the crankshaft.

5. Install the crankshaft bearings into the crankshaft bearing caps.
6. Apply clean engine oil to the crankshaft bearings.

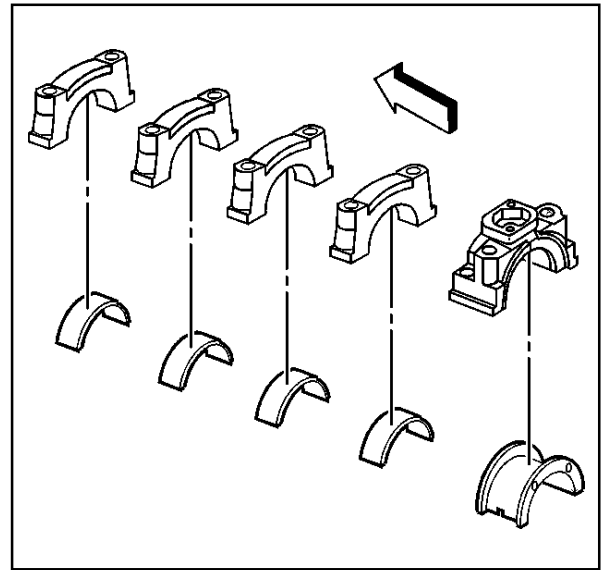

317295

7. Install the crankshaft bearing caps in the original position and with the arrow on the crankshaft bearing caps in the direction of the front of the engine block.

Notice: Refer to *Fastener Notice* in Cautions and Notices.

8. Install the crankshaft bearing cap bolts and the crankshaft bearing cap studs.
9. Thrust the crankshaft rearward in order to set and align the crankshaft thrust bearings and the crankshaft bearing caps.
10. Thrust the crankshaft forward in order to align the rear faces of the crankshaft thrust bearings.
11. Look to ensure that the crankshaft bearing caps are fully seated in the engine block crankshaft bearing cap channel and that the crankshaft bearing caps are centered on the engine block bulkheads.
11. Tighten the crankshaft bearing cap bolts and the crankshaft bearing cap studs.

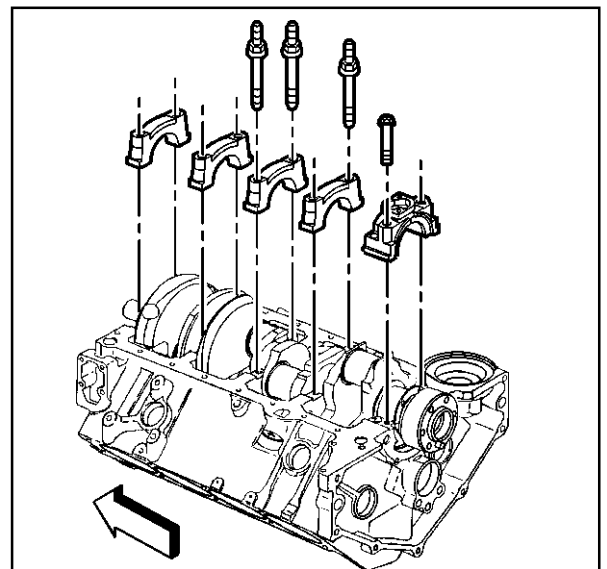

317268

Tighten

- 11.1. Tighten the crankshaft bearing cap bolts and the crankshaft bearing cap studs on the first pass to 20 N•m (15 lb ft).
- 11.2. Tighten the crankshaft bearing cap bolts and the crankshaft bearing cap studs (two bolt caps) on the final pass to 73 degrees using the J 36660.
- 11.3. Tighten the bearing cap outboard bolts (four bolt caps) on the final pass to 43 degrees using the J 36660.
- 11.4. Tighten the bearing cap inboard bolts and the bearing cap inboard studs (four bolt caps) on the final pass to 73 degrees using J 36660.

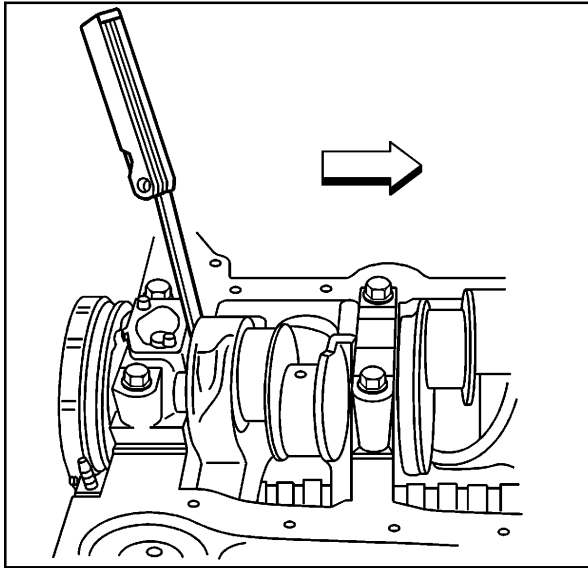

188467

12. Measure the crankshaft end play.
 - 12.1. Firmly thrust the crankshaft rearward, and then forward.
This will align the crankshaft rear bearing thrust surfaces.
 - 12.2. With the crankshaft pushed forward, insert a feeler gauge between the crankshaft and the crankshaft rear bearing thrust surface to measure the clearance.

Specification

Crankshaft end play 0.05-0.20 mm (0.002-0.008 in)

13. Rotate the crankshaft in order to check for binding.
A bent crankshaft or lack of proper crankshaft bearing clearance may cause binding.
14. If the crankshaft does not turn freely, loosen the crankshaft bearing cap bolts on 1 crankshaft bearing cap at a time in order to determine the location of the binding.
A lack of proper crankshaft bearing clearance may be caused by the following:
 - Burrs on the crankshaft bearing cap
 - Foreign material between the crankshaft bearing and the engine block
 - Foreign material between the crankshaft bearing and the crankshaft bearing cap
 - Damaged crankshaft bearing
 - Improper size crankshaft bearing

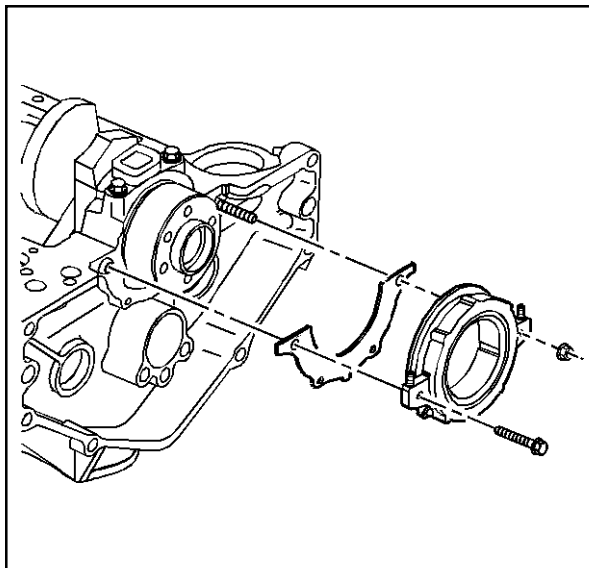

11479

Crankshaft Rear Oil Seal and Housing Installation**Tools Required**

J 35621-B Rear Main Seal Installer

Notice: Refer to *Fastener Notices* in Cautions and Notices.

1. Install the crankshaft rear oil seal housing retainer stud.

Tighten

Tighten the crankshaft rear oil seal housing retainer stud to 6 N•m (53 lb in).

Important: Always use a NEW crankshaft rear oil seal housing gasket when installing the crankshaft rear oil seal housing.

2. Install the NEW crankshaft rear oil seal housing gasket and the crankshaft rear oil seal housing onto the crankshaft rear oil seal housing retainer stud.
3. Install the crankshaft rear oil seal housing nut and bolts.

Tighten

Tighten the crankshaft rear oil seal housing nut and bolts to 12 N•m (106 lb in).

4. Apply a small amount (2 to 3 drops) of clean engine oil GM P/N 1234610 or equivalent to the bore of the crankshaft rear oil seal housing.
5. Inspect the outside diameter of the engine flywheel pilot flange for imperfections or rust.
Minor imperfections and/or rust may be removed with a fine grade emery cloth.
6. Apply a small amount (2 to 3 drops) of clean engine oil GM P/N 1234610 or equivalent to the outside diameter of the engine flywheel pilot flange.
7. Apply a small amount (1 drop) of clean engine oil GM P/N 1234610 or equivalent to the outside diameter of the flywheel locator pin.
8. Apply a small amount (2 to 3 drops) of clean engine oil GM P/N 1234610 or equivalent to the crankshaft seal surface.
9. Inspect the J 35621-B flange for imperfections that may damage the crankshaft rear oil seal.
Minor imperfections may be removed with a fine grade emery cloth.

Important: DO NOT allow oil or any other lubricants to contact the seal lip of the crankshaft rear oil seal.

10. Remove the installation guide from the NEW crankshaft rear oil seal.
11. Apply a small amount (2 to 3 drops) of clean engine oil GM P/N 1234610 or equivalent to the outside diameter of the NEW crankshaft rear oil seal.
12. Install the NEW crankshaft rear oil seal onto the J 35621-B.

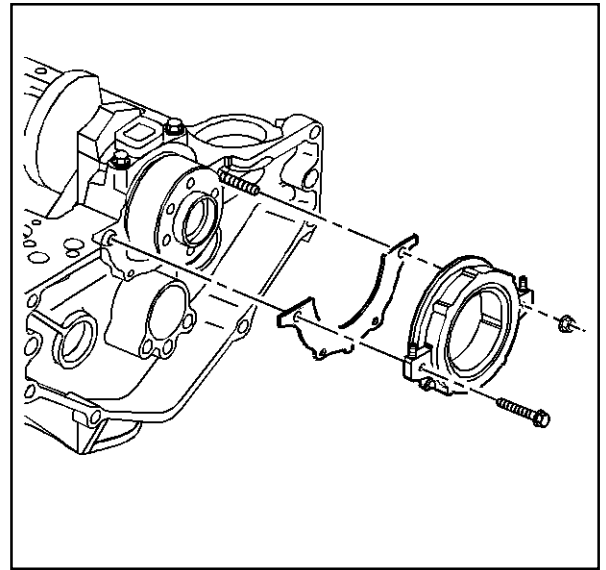

11479

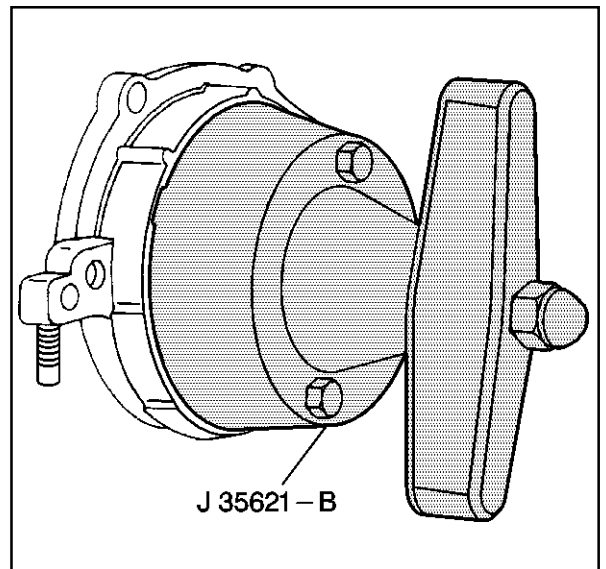

334550

13. Install the J 35621-B onto the rear of the crankshaft and hand tighten the tool bolts until snug.

Notice: Proper alignment of the crankshaft rear oil seal is critical. Install the crankshaft rear oil seal near to flush and square to the crankshaft rear oil seal housing. Failing to do so may cause the crankshaft rear oil seal or the crankshaft rear oil seal installation tool to fail.

Important: A properly installed crankshaft rear oil seal will be near to flush and square to the crankshaft rear oil seal housing.

14. Install the crankshaft rear oil seal onto the crankshaft and into the crankshaft rear oil seal housing.
 - 14.1. Turn the J 35621-B wing nut clockwise until the crankshaft rear oil seal is installed near to flush and square to the crankshaft rear oil seal housing. Increased resistance will be felt when the crankshaft rear oil seal has reached the bottom of the crankshaft rear oil seal housing bore.
 - 14.2. Turn the J 35621-B wing nut counterclockwise to release the J 35621-B from the crankshaft rear oil seal.
15. Remove the J 35621-B from the crankshaft.
16. Wipe off any excess engine oil with a clean rag.

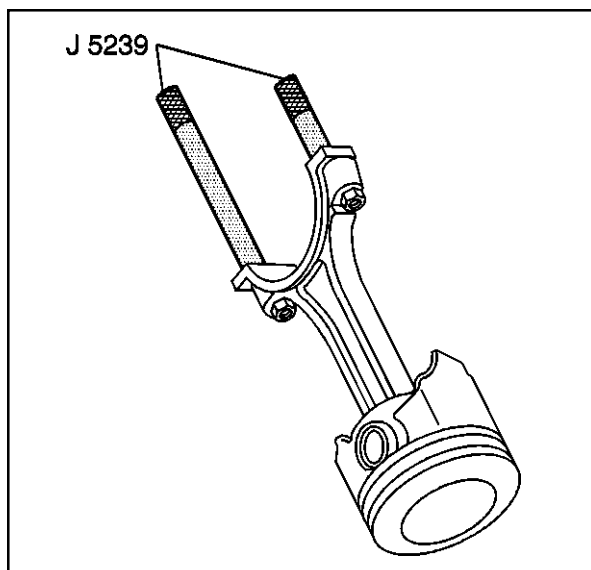

387765

Piston, Connecting Rod and Bearing Installation

Tools Required

J 5239 Connecting Rod Bolt Guide Set

J 8037 Ring Compressor

J 36660 Electronic Torque Angle Meter

1. Apply clean engine oil to the following components:
 - The piston
 - The piston rings
 - The cylinder bore
 - The bearing surfaces
2. Install the J 5239 onto the connecting rod bolts.

3. Install the J 8037 onto the piston and compress the piston rings.

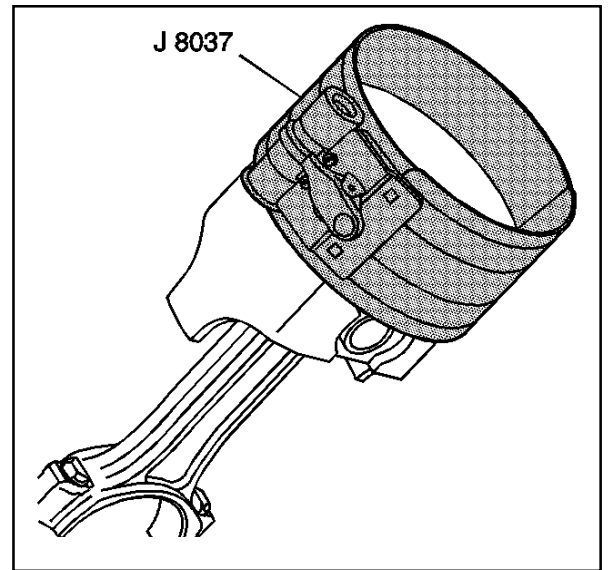

480573

Important: The mark on the top of the piston must face the front of the engine block.

When assembled, the flanges on the connecting rod and connecting rod cap should face to the front of the engine block on the left bank, and to the rear of the engine block on the right bank.

4. Install the piston and connecting rod assembly, and the J 8037 into the proper cylinder bore.

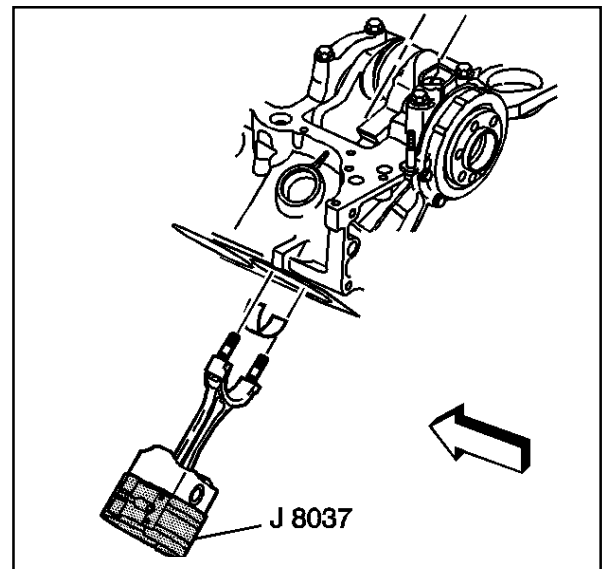

492144

5. Use the J 8037 and the J 5239 and lightly tap the top of the piston with a wooden hammer handle.
 - 5.1. Hold the J 8037 firmly against the engine block until all of the piston rings have entered the cylinder bore.
 - 5.2. Use the J 5239 in order to guide the connecting rod onto the crankshaft journal.

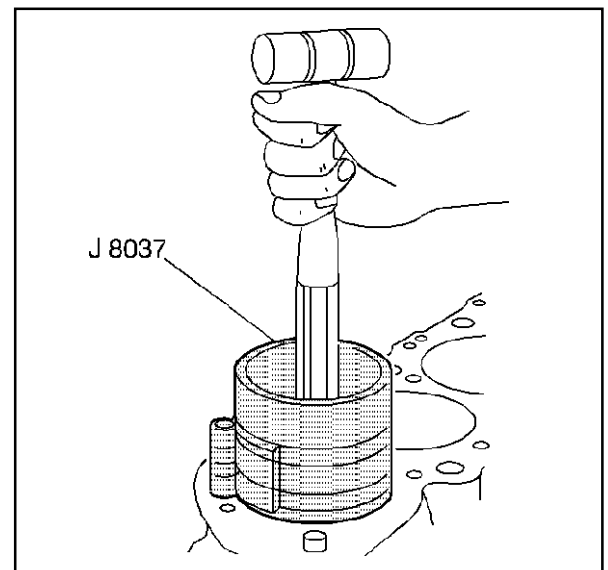

5159

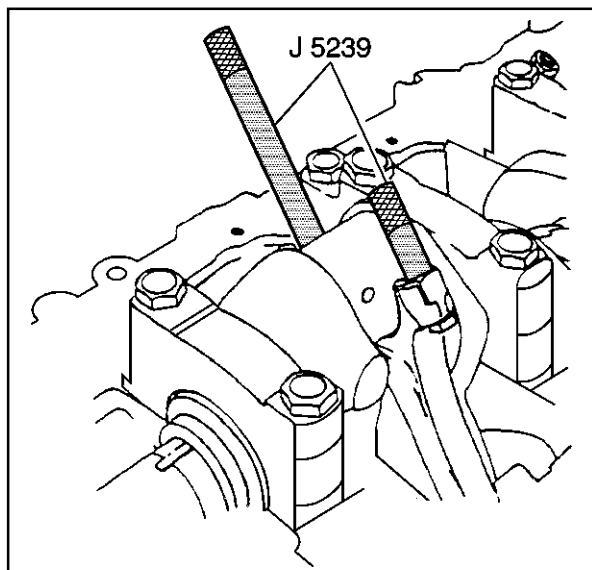

31373

6. Remove the J 5239.

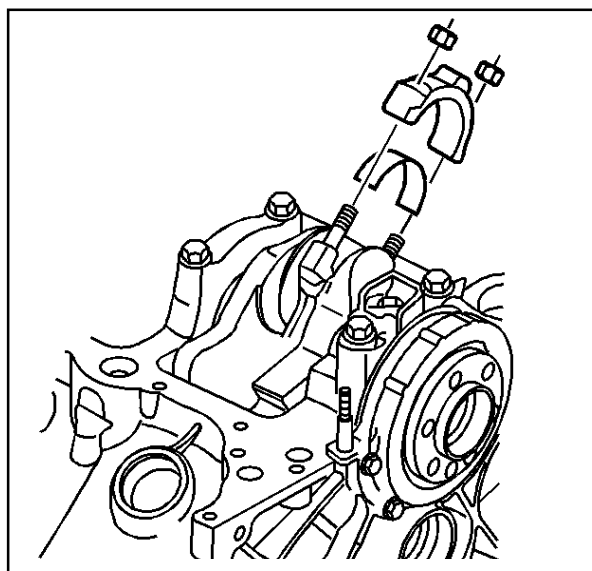

480549

Notice: Refer to *Fastener Notice* in Cautions and Notices.

7. Install the connecting rod caps, bearings and nuts.

Tighten

- 7.1. Tighten the nuts evenly on the first pass to 27 N•m (20 lb ft).
- 7.2. Use the J 36660 in order to tighten the nuts on the final pass to 70 degrees.

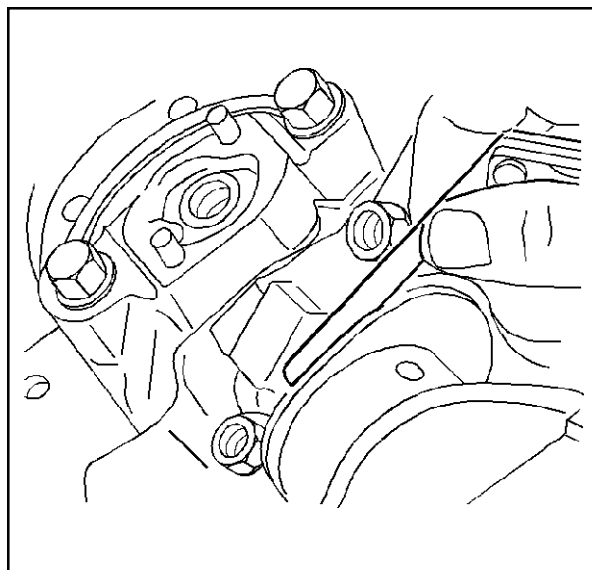

5163

8. After the piston and connecting rod assemblies have been installed, then lightly tap each connecting rod assembly (parallel to the crankpin) in order to ensure that the connecting rods have side clearance.
9. Use a feeler gauge or a dial indicator to measure the connecting rod side clearance between the connecting rod caps. The connecting rod side clearance should be 0.15-0.68 mm (0.006-0.027 in).

Camshaft Installation

1. Apply clean engine oil GM P/N 12345610 or equivalent, or engine oil supplement GM P/N 1052367 or equivalent to the following components:
 - The engine camshaft lobes
 - The camshaft bearing journals
 - The camshaft bearings
2. Install three 5/16-18 x 4.0 in. bolts into the engine camshaft front bolt holes.

Notice: All camshaft journals are the same diameter, so care must be used in removing or installing the camshaft to avoid damage to the camshaft bearings.

3. Use the bolts as a handle in order to install the engine camshaft.
4. Remove the 3 bolts from the front of the engine camshaft.

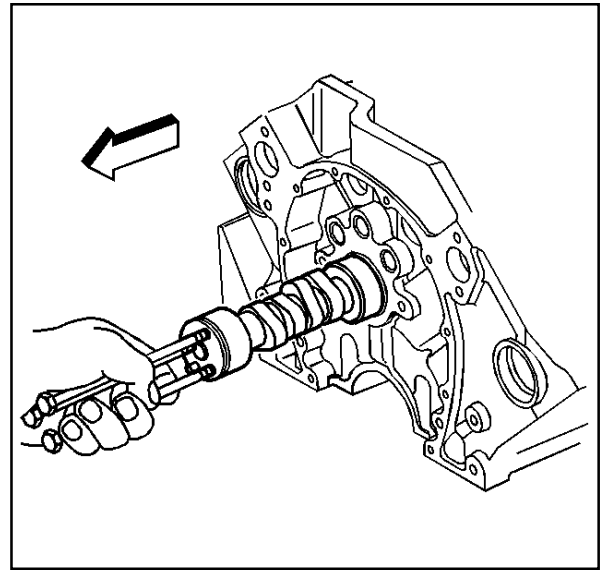

69013

Notice: Refer to *Fastener Notice* in Cautions and Notices.

5. If reusing the fasteners, apply threadlock GM P/N 12345382 or equivalent to the threads of the camshaft retainer bolts.
6. Install the camshaft retainer and bolts.
Tighten the camshaft retainer bolts to 12 N•m (106 lb in).

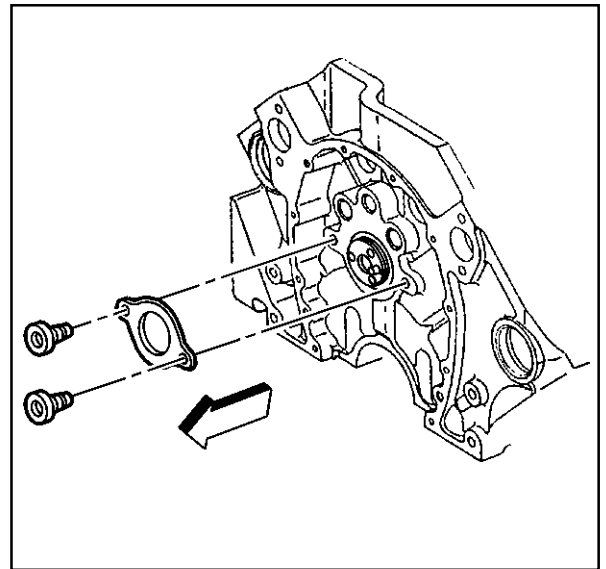

182836

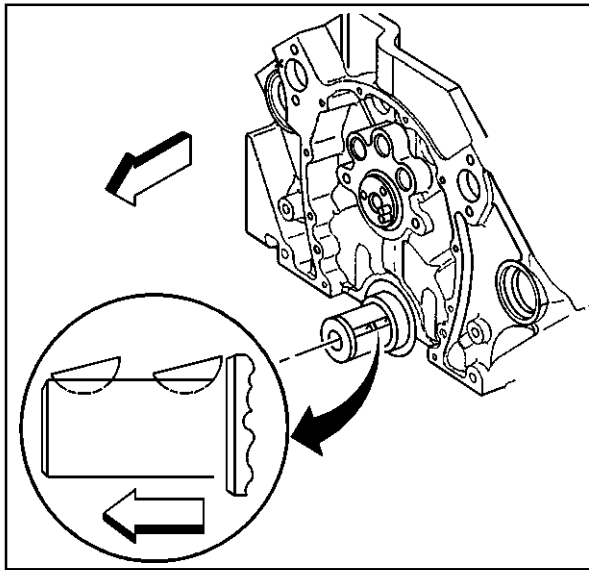

182847

Timing Chain and Sprockets Installation

Tools Required

J 5590 Installer

1. Install the woodruff keys (crankshaft balancer) into the crankshaft keyway.

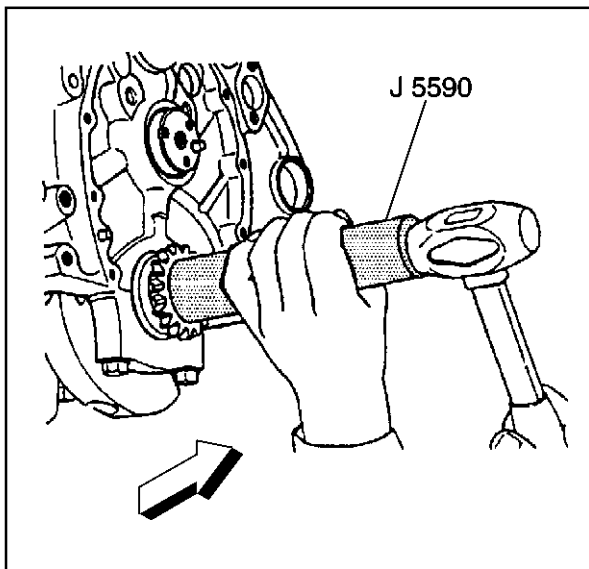

32066

2. Align the keyway of the crankshaft sprocket with the woodruff key (crankshaft balancer).

Caution: Refer to Safety Glasses Caution in Cautions and Notices.

3. Use the J 5590 in order to install the crankshaft sprocket.
4. Rotate the crankshaft until the crankshaft sprocket alignment mark is in the 12 o'clock position.

5. Install the camshaft sprocket and the camshaft timing chain. Install the camshaft sprocket with the alignment mark in the 6 o'clock position.

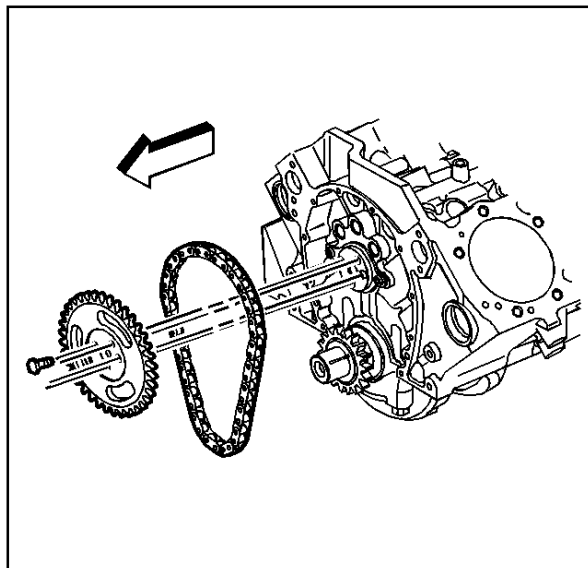

500645

Important: Do not use a hammer to install the camshaft sprocket onto the camshaft. To do so may dislodge the expansion cup plug (camshaft rear bearing hole) and/or damage the camshaft.

6. Rotate the camshaft until the camshaft and crankshaft sprocket alignment marks are in the proper position.

Notice: Refer to *Fastener Notice* in Cautions and Notices.

7. Install the camshaft sprocket bolts.

Tighten

Tighten the camshaft sprocket bolts to 25 N·m (18 lb ft).

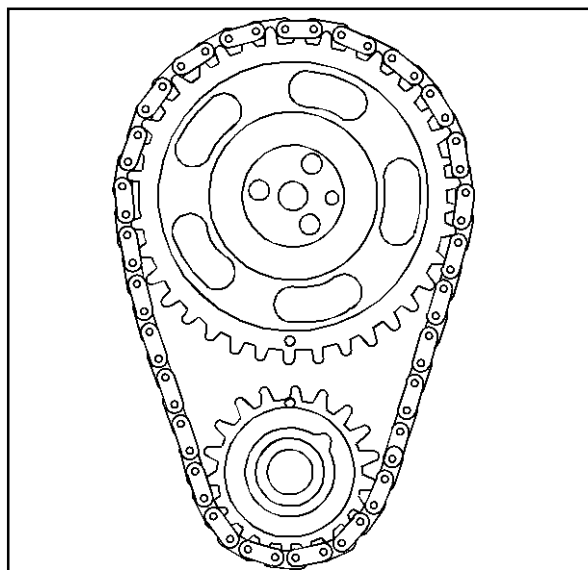

11503

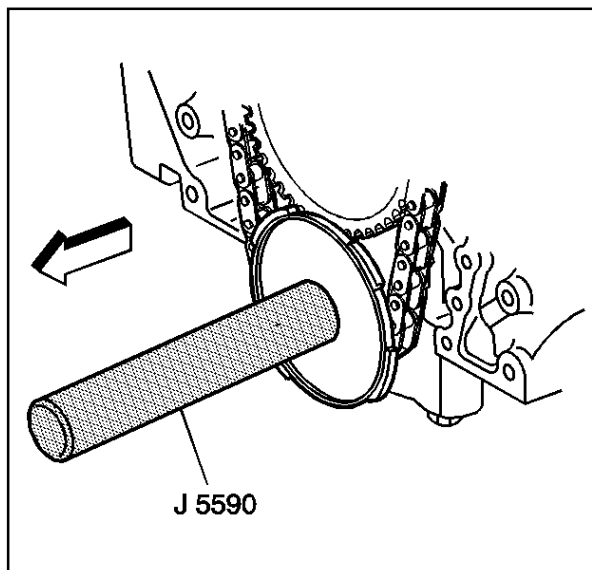

521825

Important: Align the keyway on the crankshaft position sensor reluctor ring with the woodruff key (crankshaft balancer) in the crankshaft, and install the crankshaft position sensor reluctor ring onto the crankshaft until completely seated against the crankshaft sprocket.

8. Install the crankshaft position sensor reluctor ring.
 - 8.1. Align the keyway on the crankshaft position sensor reluctor ring with the woodruff key (crankshaft balancer) in the crankshaft.
 - 8.2. Use the J 5590 in order to push the crankshaft position sensor reluctor ring onto the crankshaft until completely seated against the crankshaft sprocket.

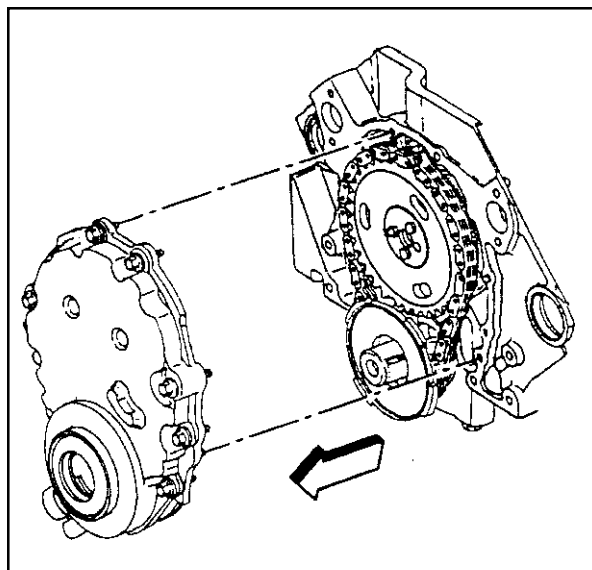

69010

Engine Front Cover Installation

Important: Once the composite engine front cover is removed, DO NOT reinstall the engine front cover. Always install a NEW engine front cover.

1. Install the NEW engine front cover.

Notice: Refer to *Fasteners Notice* in Cautions and Notices.

2. Install the engine front cover bolts.

Tighten

Tighten the engine front cover bolts to 12 N•m (106 lb in).

Important: DONOT reuse the original crankshaft position sensor seal (o-ring). When installing the crankshaft position sensor, be sure the crankshaft position sensor is fully seated and held stationary in the engine front cover crankshaft position sensor bore. A crankshaft position sensor that is not completely seated will cock in the engine front cover and may result in erratic engine operation.

3. Lubricate the NEW crankshaft position sensor seal (O-ring) with clean engine oil.
4. Install the NEW crankshaft position sensor seal (O-ring) onto the crankshaft position sensor.

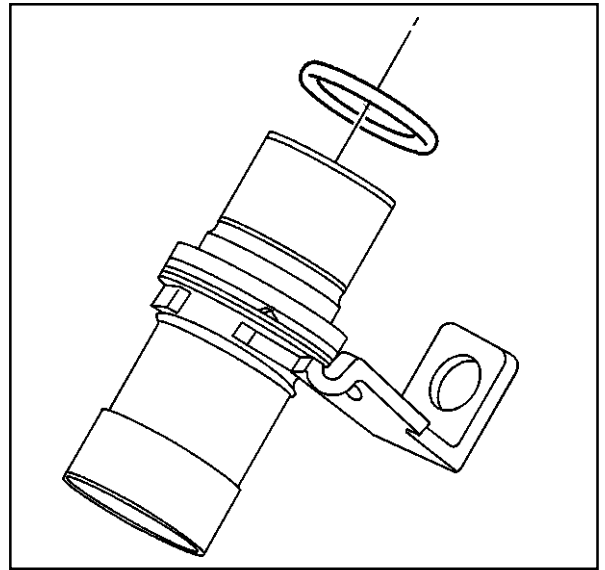

387759

5. Install the crankshaft position sensor until fully seated into the engine front cover.
6. Install the crankshaft position sensor bolt.

Tighten

Tighten the crankshaft position bolt to 9 N•m (80 lb in).

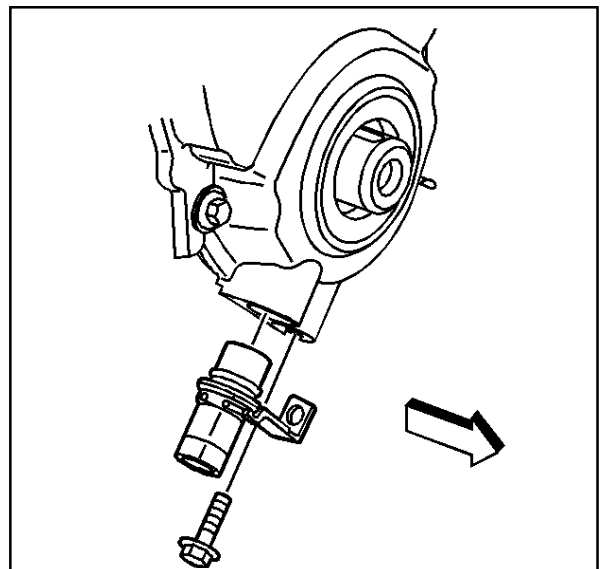

11485

Oil Pump, Pump Screen and Deflector Installation

Tools Required

J 36660 Electronic Torque Angle Meter

1. Inspect for properly installed pins (oil pump locator).

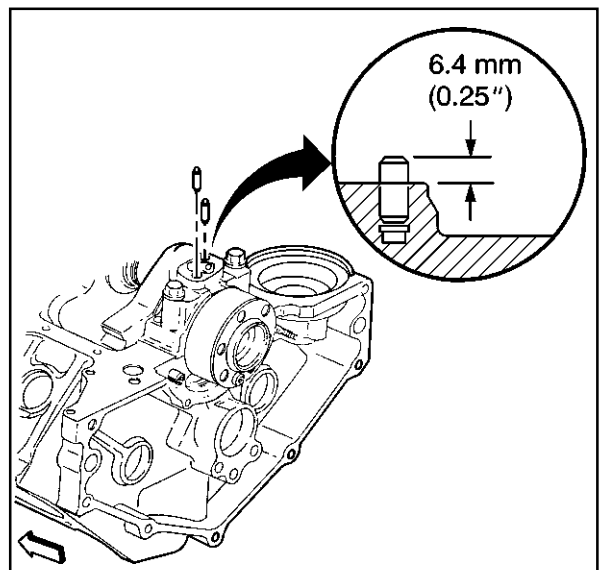

182852

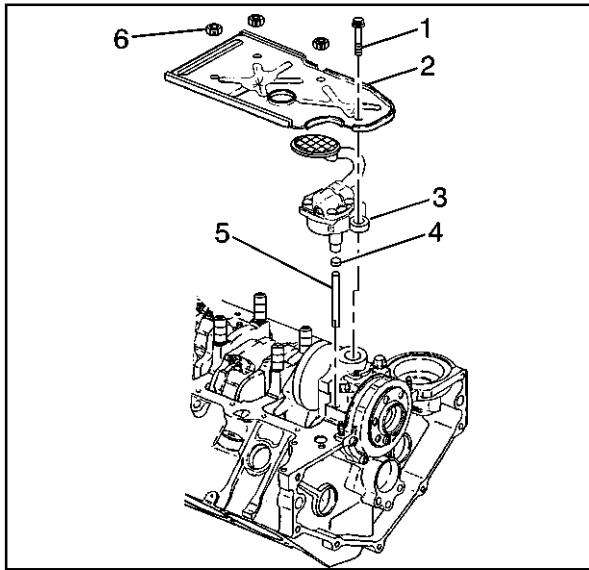

11438

Important: DO not reuse the oil pump driveshaft retainer (4).

During assembly, install a NEW oil pump driveshaft retainer.

2. Assemble the oil pump (3), the oil pump driveshaft (5) and a NEW oil pump driveshaft retainer (4).
3. Install the oil pump (3).
Position the oil pump onto the pins.
4. Install the crankshaft oil deflector (2) and the nuts (6).
5. Install the bolt (1) attaching the oil pump to the rear crankshaft bearing cap.

Tighten

- Tighten the oil pump bolt on the first pass to 20 N·m (15 lb ft).
- Tighten the oil pump bolt on the final pass to 65 degrees using the J 36660.
- Tighten the crankshaft oil deflector nuts to 40 N·m (30 lb ft).

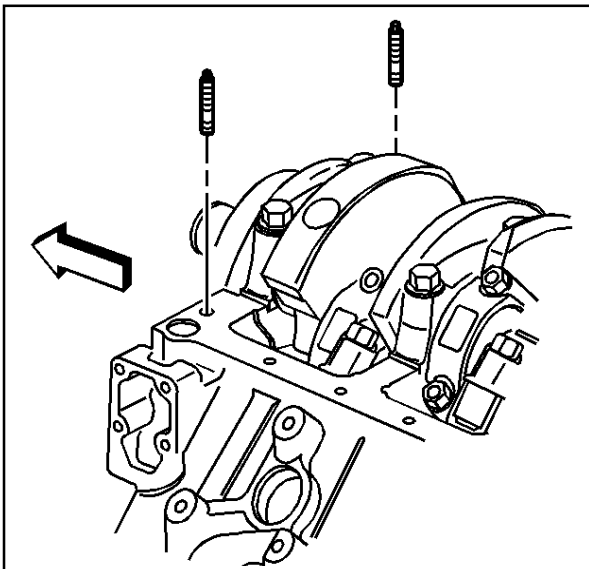

521817

Oil Pan Installation

Notice: Refer to *Fastener Notice* in Cautions and Notices.

1. Install the oil pan studs into the engine block.

Tighten

Tighten the oil pan studs to 6 N·m (53 lb in).

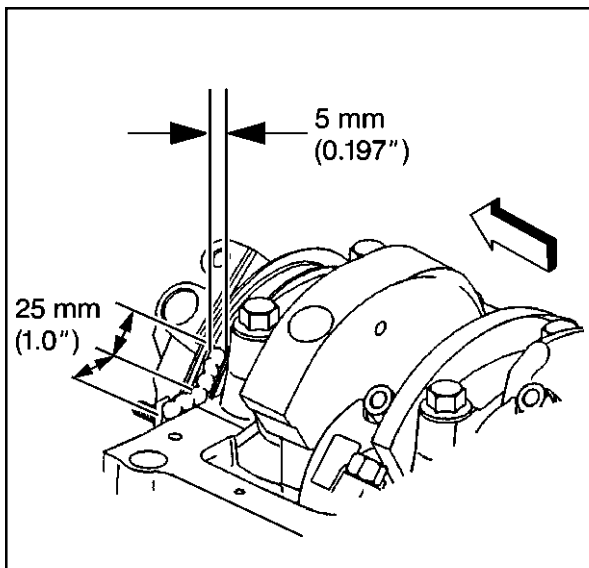

317310

2. Apply a 5 mm (0.197 in) wide and 25 mm (1.0 in) long bead of adhesive GM P/N 12346141 or equivalent to both the right and left sides of the engine front cover to engine block junction at the oil pan sealing surfaces.

3. Apply a 5 mm (0.197 in) wide and 25 mm (1.0 in) long bead of adhesive GM P/N 12346141 or equivalent to both the right and left sides of the crankshaft rear oil seal housing to engine block junction at the oil pan sealing surfaces.

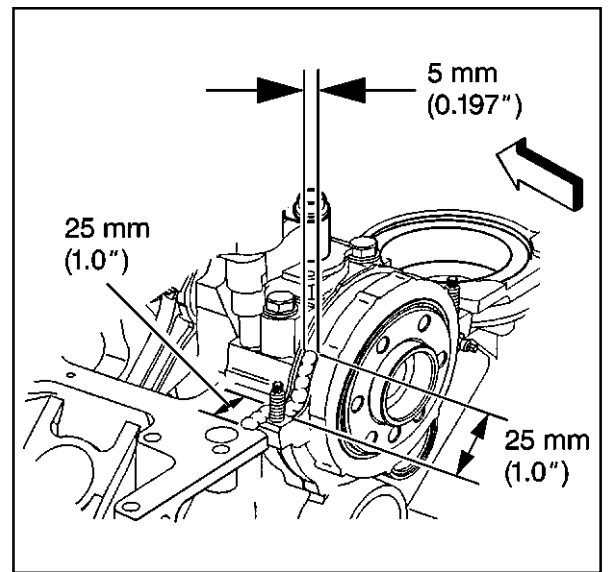

317313

Important: Always install a NEW oil pan gasket.

The oil pan gasket and oil pan must be installed and the fasteners tightened while the adhesive is still wet to the touch.

4. Install the NEW oil pan gasket.
5. Install the oil pan.
Press the oil pan gasket into the grooves of the engine front cover and crankshaft rear oil seal housing.
6. Install the oil pan reinforcements.
7. Install the nuts and the bolts.

Tighten

- 7.1. Tighten the oil pan bolts to 12 N·m (106 lb in).
- 7.2. Tighten the oil pan nuts to 25 N·m (18 lb ft).

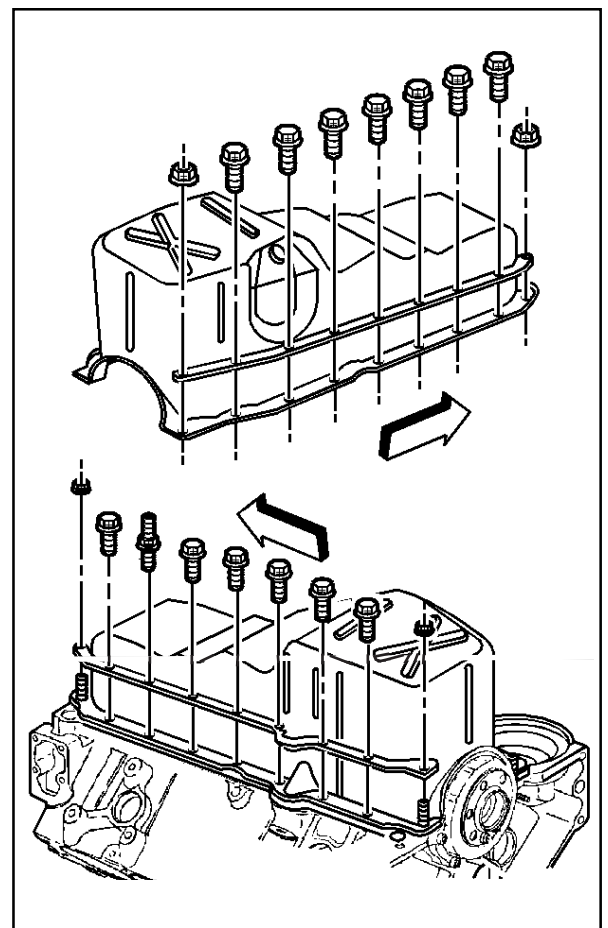

182851

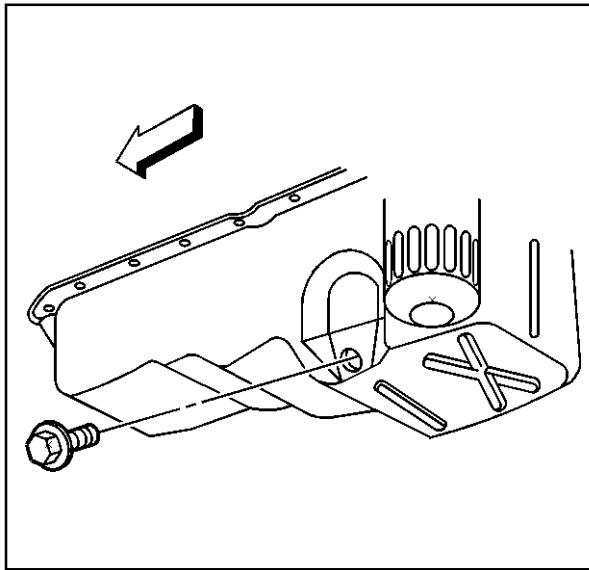

182850

8. Install a NEW oil pan drain plug seal (O-ring) onto the oil pan drain plug.
9. Install the oil pan drain plug into the oil pan.

Tighten

Tighten the oil pan drain plug to 25 N•m (18 lb ft).

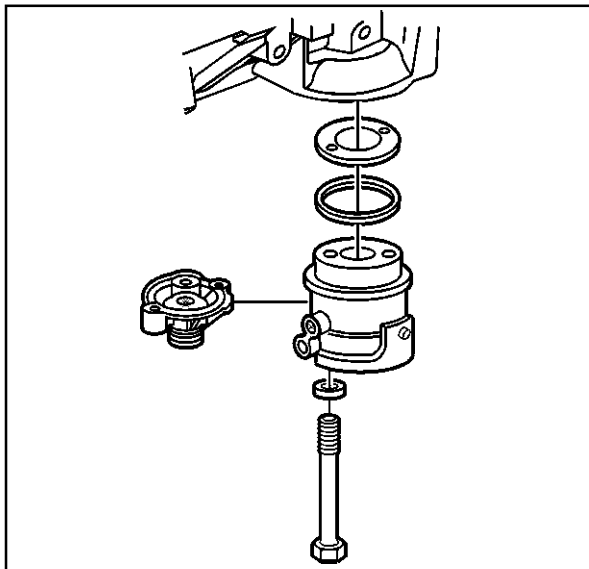

39122

Oil Filter Adapter Installation

1. Apply clean engine oil GM P/N 12345610 or equivalent to the NEW oil filter adapter seal (O-ring) (if applicable).
2. Install the NEW oil filter adapter seal into the groove in the oil filter adapter (if applicable).
3. Install the NEW oil filter adapter gasket (if applicable) and the oil filter adapter.

Notice: Refer to *Fastener Notice* in Cautions and Notices.

4. Install the oil filter adapter flat washers (if applicable) and the oil filter adapter bolts.

Tighten

Tighten the oil filter adapter bolts to 25 N•m (18 lb ft).

Crankshaft Balancer Installation

Tools Required

J 23523-F Balancer Remover and Installer

1. Look to ensure that the front groove pin (crankshaft balancer) is installed in the proper location (if applicable).

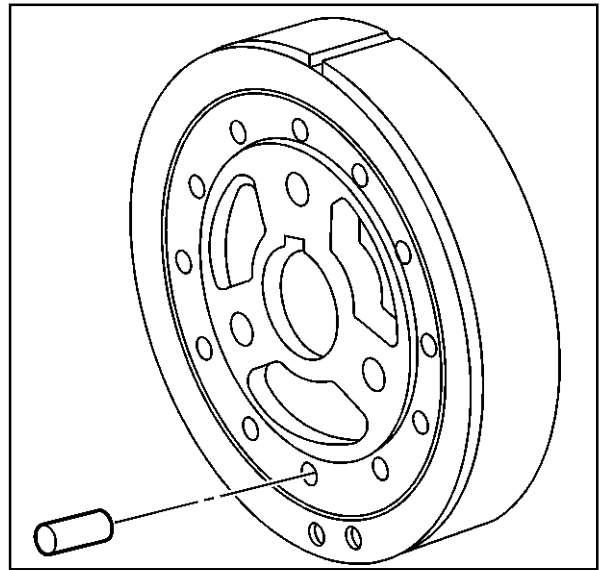

182849

Notice: The inertial weight section of the crankshaft balancer is assembled to the hub with a rubber type material. The correct installation procedures (with the proper tool) must be followed or movement of the inertial weight section of the hub will destroy the tuning of the crankshaft balancer.

2. Apply a small amount of adhesive GM P/N 12346141 or equivalent onto the crankshaft balancer keyway in order to seal the crankshaft balancer keyway and crankshaft joint.
3. Align the keyway of the crankshaft balancer with the woodruff key (crankshaft balancer).
4. Install the crankshaft balancer onto the end of the crankshaft.

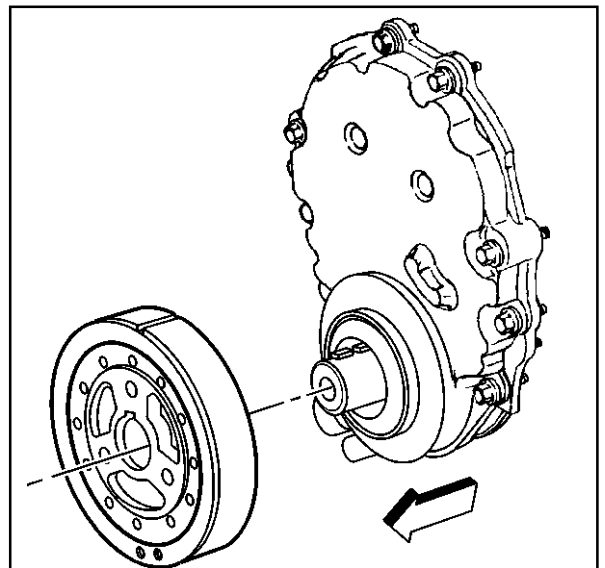

182832

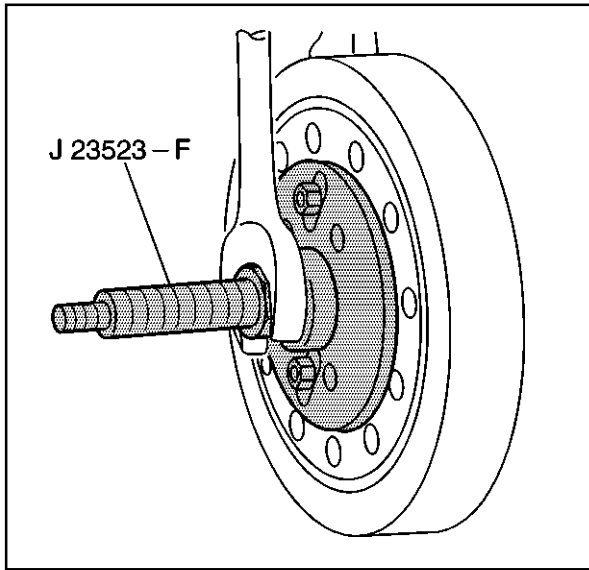

4065

5. Use the J 23523-F in order to press the crankshaft balancer onto the crankshaft.

5.1. Install the J 23523-F plate and bolts onto the front of the crankshaft balancer.

Tighten

Tighten the J 23523-F plate bolts to 25 N•m (18 lb ft).

5.2. Install the J 23523-F screw into the end for the crankshaft.

5.3. Install the J 23523-F bearing, the washer and the nut onto the J 23523-F screw.

5.4. Rotate the J 23523-F nut clockwise until the crankshaft balancer hub is completely seated against the crankshaft position sensor reluctor ring.

6. Remove the J 23523-F.

Notice: Refer to *Fastener Notice* in Cautions and Notices.

7. Install the crankshaft pulley and bolts.

Tighten

Tighten the crankshaft pulley bolts to 58 N•m (43 lb ft).

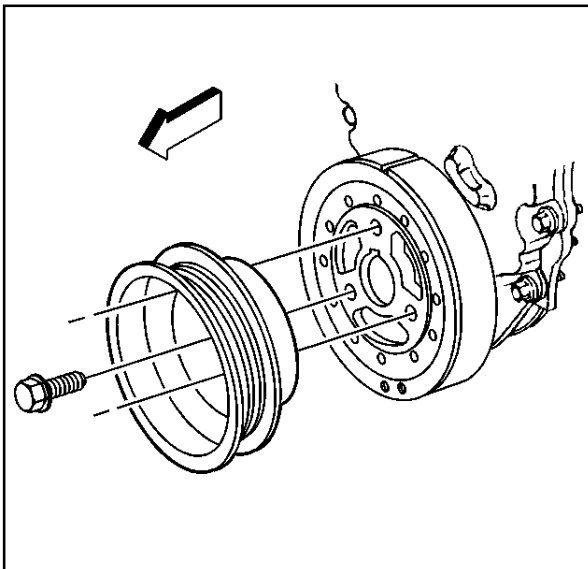

188055

8. Ensure that the crown of the crankshaft balancer washer (2) is faced away from the engine.

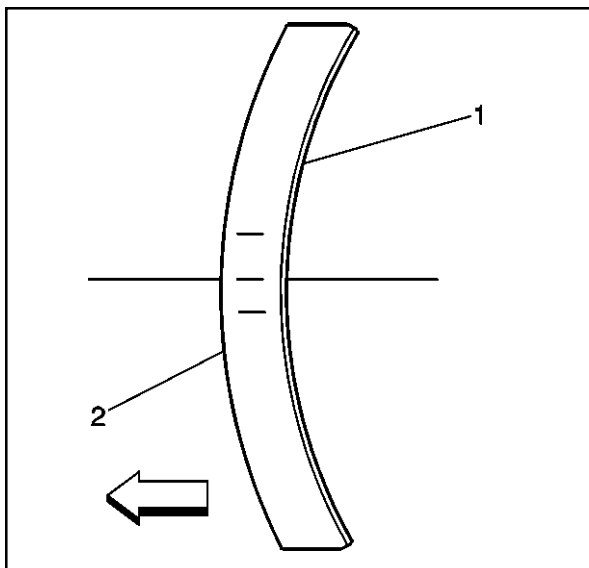

342203

9. Install the crankshaft balancer washer and the bolt.

Tighten

Tighten the crankshaft balancer bolt to 95 N•m (70 lb ft).

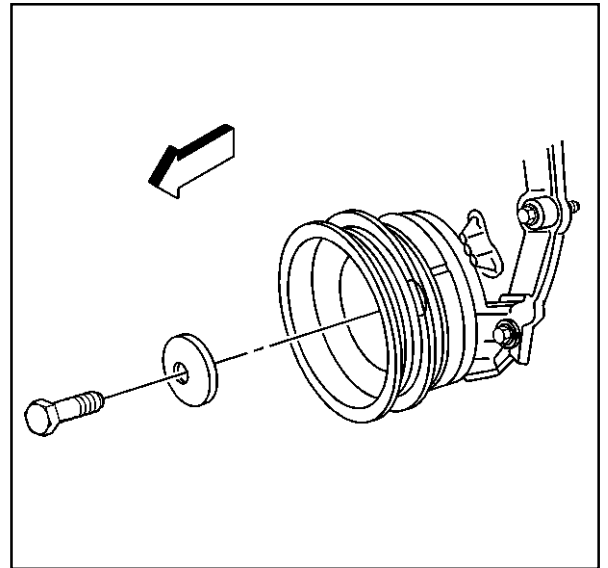

173172

Valve Lifter Installation

1. Apply lubricant GM P/N 12345501 or equivalent to the valve lifter rollers.

Important: If reusing the valve lifters, install the valve lifters in the original positions.

2. Install the valve lifters.

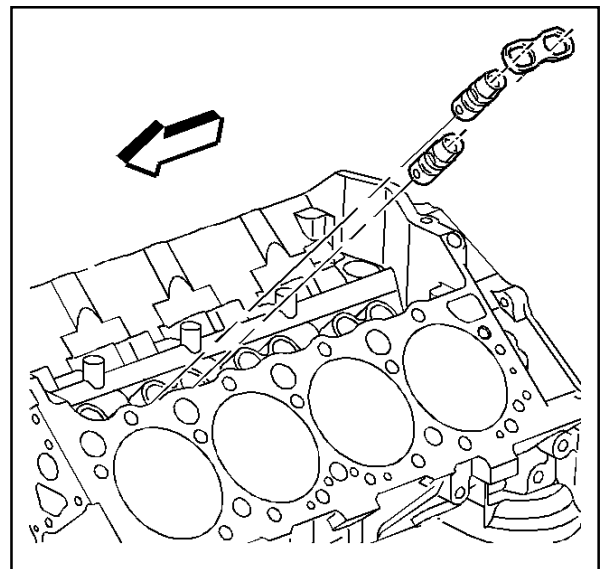

11509

Notice: Refer to *Fastener Notice* in Cautions and Notices.

3. Install the valve lifter guides.
4. Install the valve lifter guide retainer.
5. Install the valve lifter guide retainer bolts.

Tighten

Tighten the valve lifter guide retainer bolts to 25 N•m (18 lb ft).

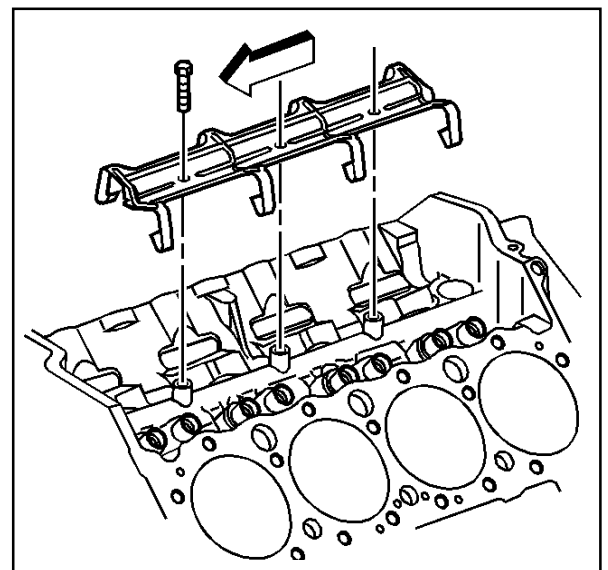

11508

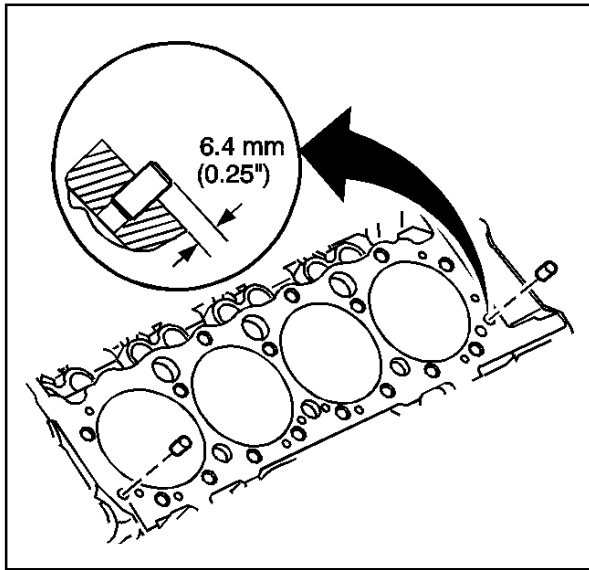

182846

Cylinder Head Installation (Left)

Tools Required

J 36660 Electronic Torque Angle Meter

1. Clean the cylinder head gasket surfaces on the engine block.
2. Inspect the dowel pins (cylinder head locators) for proper installation.
3. Clean the cylinder head gasket surfaces on the cylinder head.

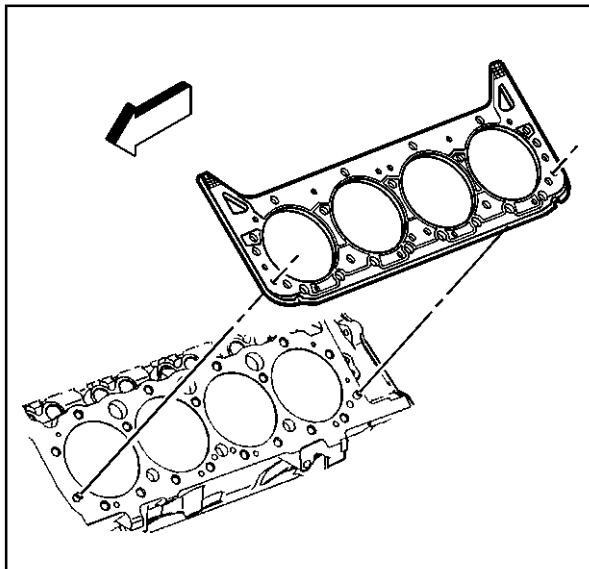

317233

Important: Do not use any type of sealer on the cylinder head gasket (unless specified).

4. Install the NEW cylinder head gasket in position over the dowel pins (cylinder head locators).

The cylinder head gasket is not directional and may be installed using either side facing the engine block.

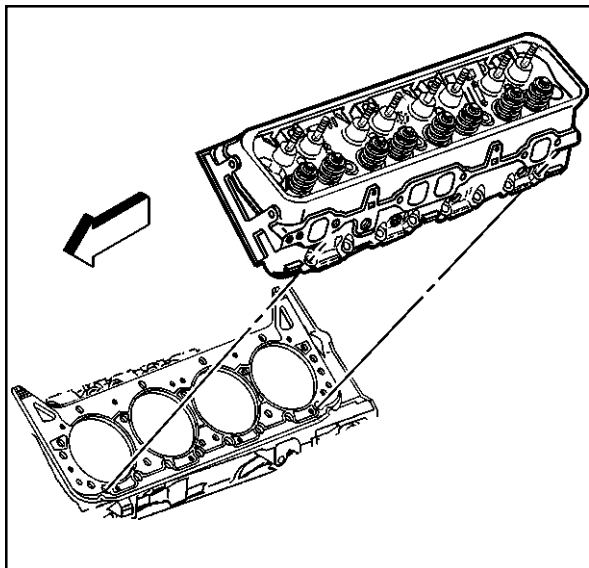

317227

5. Install the cylinder head onto the engine block.
Guide the cylinder head carefully into place over the dowel pins and the cylinder head gasket.

6. Apply sealant GM P/N 12346004 or equivalent to the threads of the cylinder head bolts.

Notice: Refer to *Fastener Notice* in Cautions and Notices.

7. Install the cylinder head bolts.

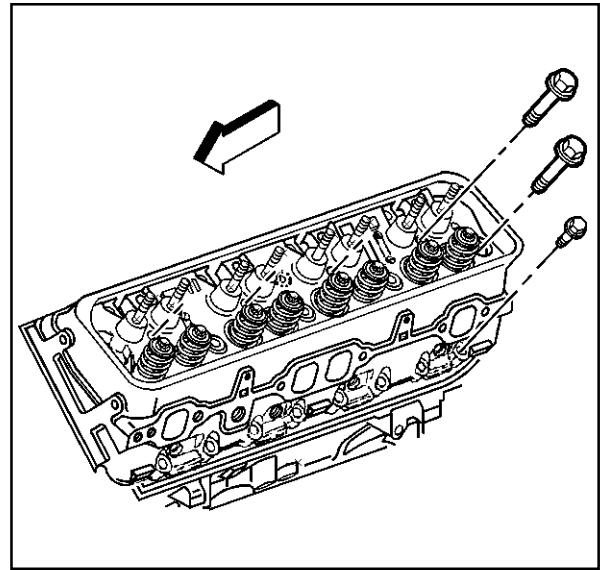

317217

8. Tighten the cylinder head bolts in sequence on the first pass.

Tighten

Tighten the bolts in sequence on the first pass to 30 N•m (22 lb ft).

9. Use the J 36660 in order to tighten the cylinder head bolts in sequence on the final pass.

Tighten

- Tighten the long bolts (1, 2, 5, 6, 9, 10 and 13) on the final pass in sequence to 75 degrees.
- Tighten the medium bolts (14 and 17) on the final pass in sequence to 65 degrees.
- Tighten the short bolts (3, 4, 7, 8, 11, 12, 15 and 16) on the final pass in sequence to 55 degrees.

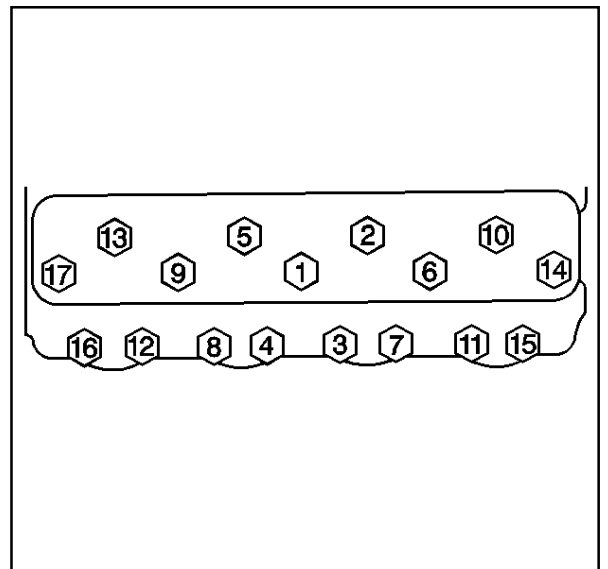

500687

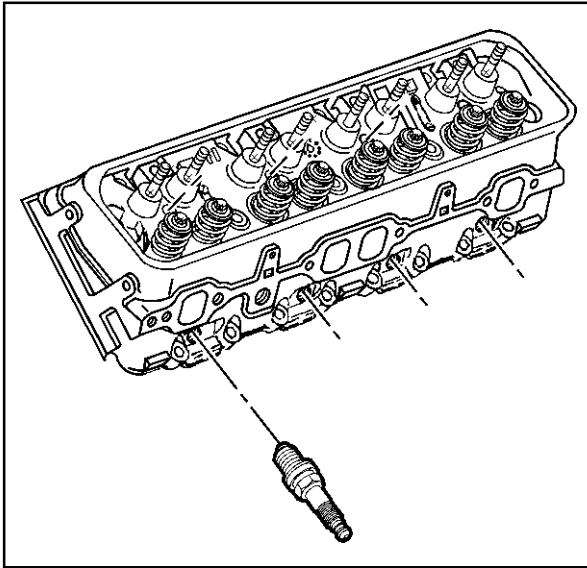

317307

10. Measure the NEW spark plugs for the proper gap.
Adjust the spark plug gap if necessary.

Specification

Spark plug gap to 1.52 mm (0.060 in)

11. Install the spark plugs.

Tighten

- Tighten the spark plugs for a USED cylinder head to 15 N•m (11 lb ft)
- Tighten the spark plugs for the initial installation of a NEW cylinder head to 30 N•m (22 lb ft).

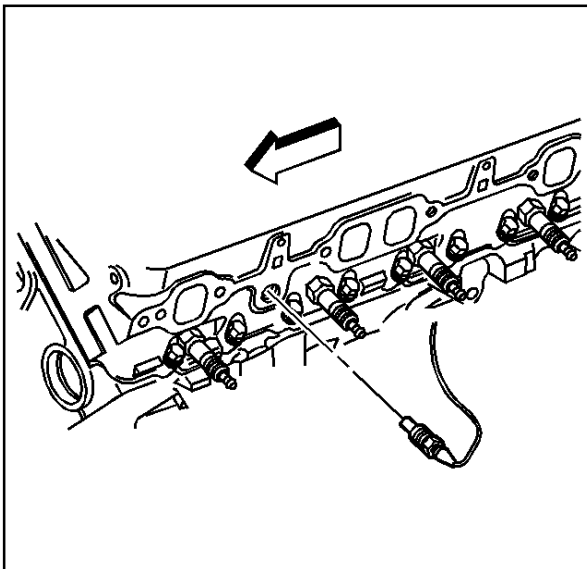

521828

12. If reusing the engine coolant temperature gauge sensor (if applicable), apply sealant GM P/N 12346004 or equivalent to the threads of the engine coolant temperature gauge sensor.
13. Install the engine coolant temperature gauge sensor (if applicable).

Tighten

Tighten the engine coolant temperature gauge sensor to 20 N•m (15 lb ft).

Cylinder Head Installation (Right)

Tools Required

J 36660 Electronic Torque Angle Meter

1. Clean the cylinder head gasket surfaces on the engine block.
2. Inspect the dowel pins (cylinder head locators) for proper installation.
3. Clean the cylinder head gasket surfaces on the cylinder head.

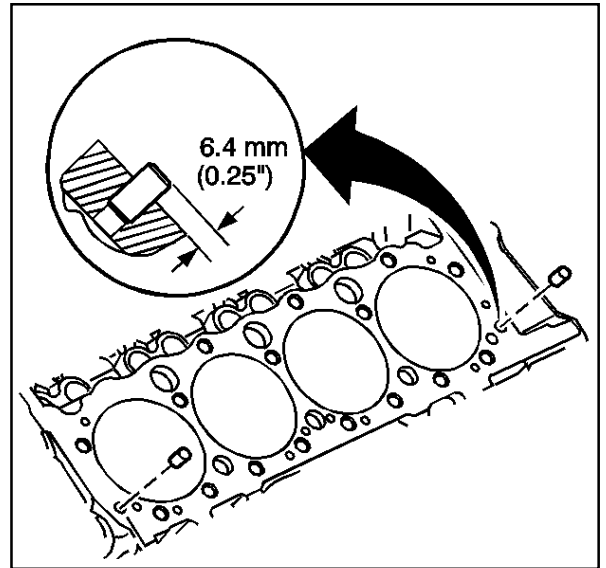

182846

Important: Do not use any type of sealer on the cylinder head gasket (unless specified).

4. Install the NEW cylinder head gasket in position over the dowel pins (cylinder head locators).

The cylinder head gasket is not directional and may be installed using either side facing the engine block.

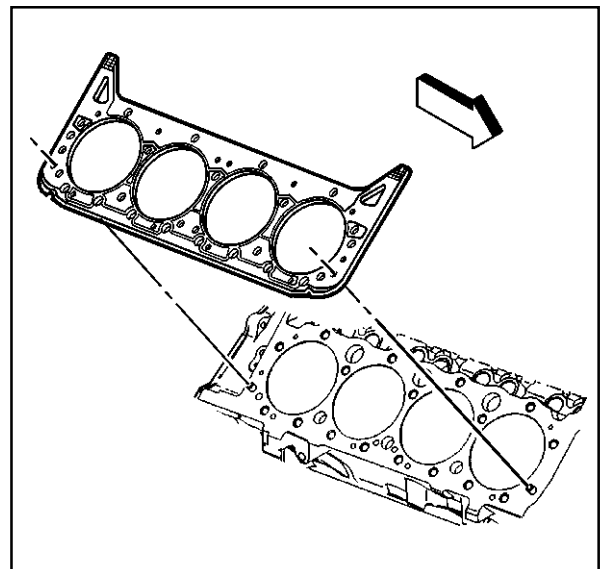

317255

5. Install the cylinder head onto the engine block.
Guide the cylinder head carefully into place over the dowel pins and the cylinder head gasket.

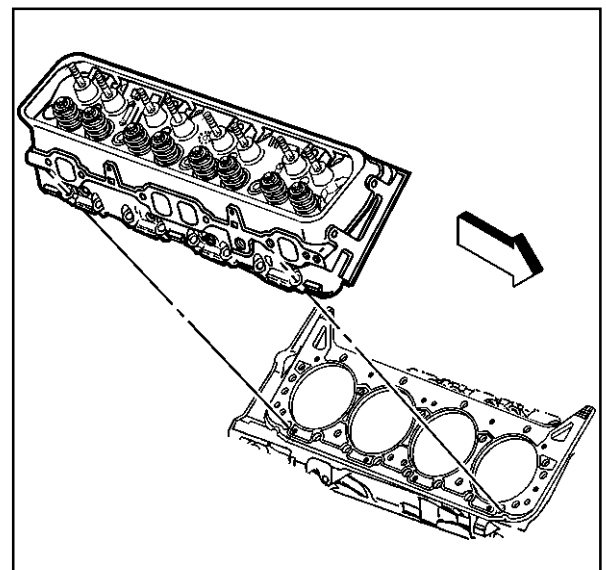

317246

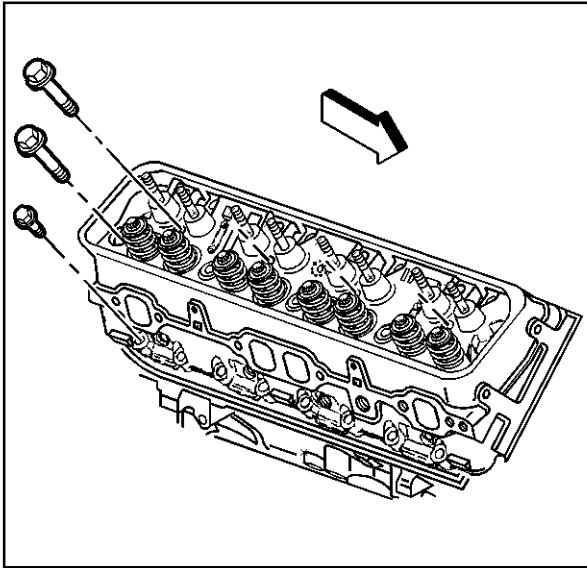

317239

6. Apply sealant GM P/N 12346004 or equivalent to the threads of the cylinder head bolts.

Notice: Refer to *Fastener Notice* in Cautions and Notices.

7. Install the cylinder head bolts.

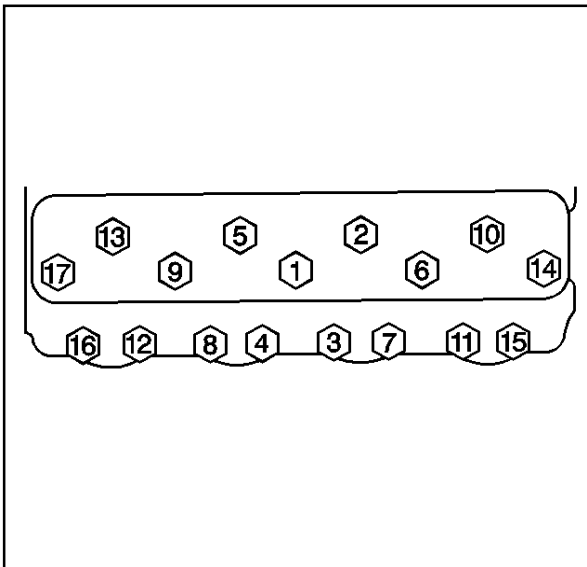

500687

8. Tighten the cylinder head bolts in sequence on the first pass.

Tighten

Tighten the bolts in sequence on the first pass to 30 N•m (22 lb ft).

9. Use the J 36660 in order to tighten the cylinder head bolts in sequence on the final pass.

- Tighten the long bolts (1, 2, 5, 6, 9, 10 and 13) on the final pass in sequence to 75 degrees.
- Tighten the medium bolts (14 and 17) on the final pass in sequence to 65 degrees.
- Tighten the short bolts (3, 4, 7, 8, 11, 12, 15 and 16) on the final pass in sequence to 55 degrees.

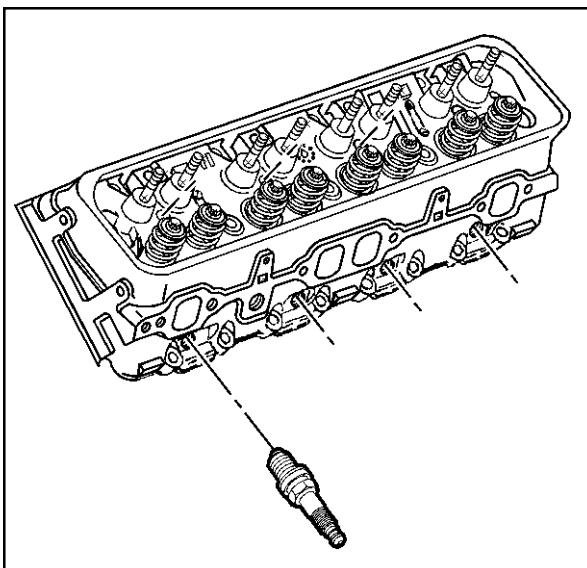

317307

10. Measure the NEW spark plugs for the proper gap. Adjust the spark plug gap if necessary.

Specification

Spark plug gap to 1.52 mm (0.060 in)

11. Install the spark plugs.

Tighten

- Tighten the spark plugs for a USED cylinder head to 15 N•m (11 lb ft)
- Tighten the spark plugs for the initial installation of a NEW cylinder head to 30 N•m (22 lb ft).

Valve Rocker Arm and Push Rod Installation

Important: Be sure to keep parts in order. Parts must be reinstalled into the original location and position.

1. Apply prelude GM P/N 12345501 or equivalent to the valve rocker arm and the valve rocker arm ball surfaces.

Important: Be sure that the valve pushrods seat in the valve lifter sockets.

2. Install the valve pushrods.

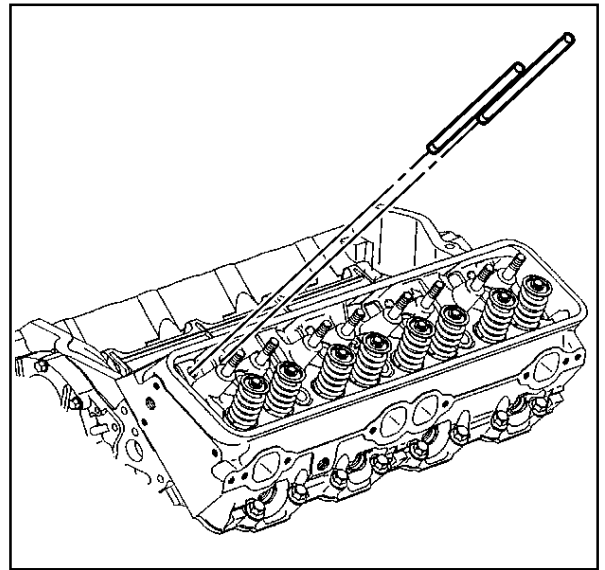

22766

3. Install the following components:
 - 1.1. The valve rocker arm nuts (1)
 - 1.2. The valve rocker arm balls (2)
 - 1.3. The valve rocker arms (3)

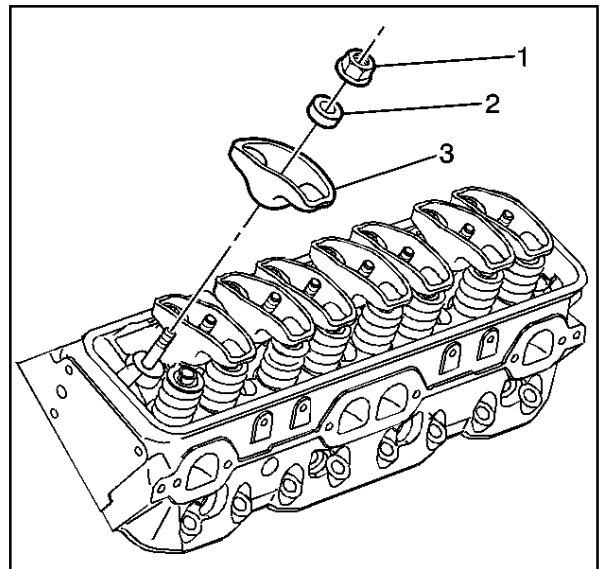

182835

Valve Lash Adjustment

1. Turn the valve rocker arm nuts clockwise until all of the valve lash is removed.
2. Turn the crankshaft clockwise until the alignment mark on the crankshaft balancer is aligned with the notch in the engine front cover tab.
3. Look at number 1 cylinder valves as the crankshaft balancer alignment mark approaches the notch in the engine front cover tab. If a valve moves as the alignment mark moves into position, the engine is in the number 6 firing position. If this happens, turn the crankshaft clockwise one revolution in order to reach the number 1 cylinder firing position.

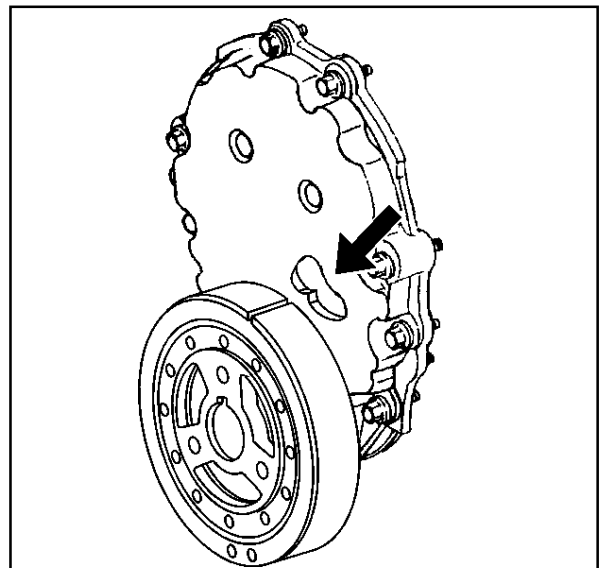

195336

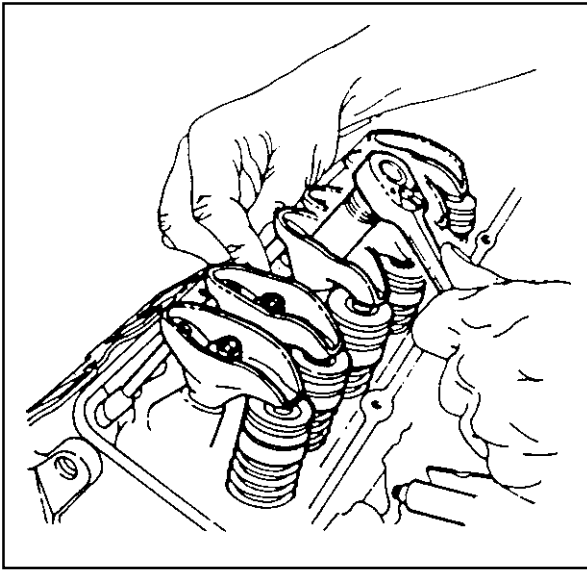

22759

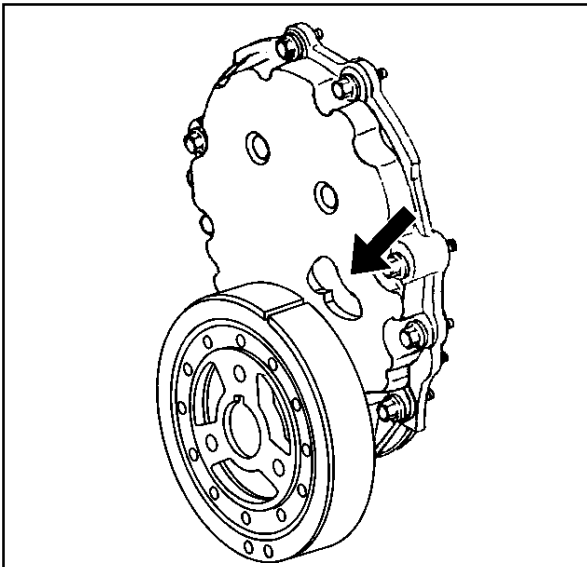

195336

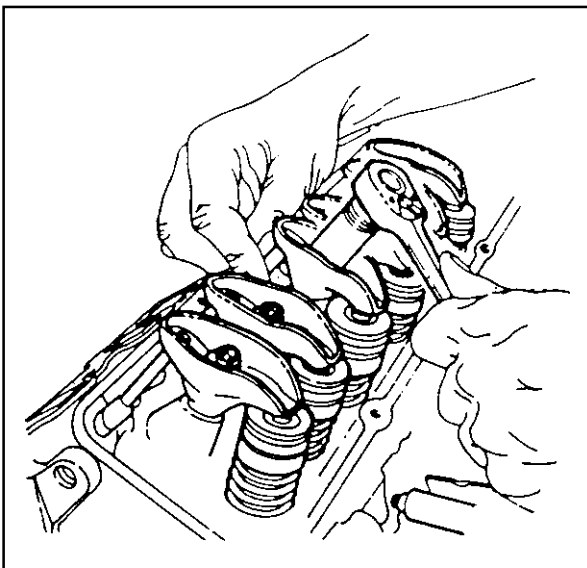

22759

4. With the engine in the number 1 cylinder firing position, adjust the exhaust valves for cylinders number 1, 3, 4 and 8 and the intake valves for cylinders number 1, 2, 5 and 7.
 - 4.1. Turn the valve rocker arm nut counter clockwise until the valve lash is felt in the valve pushrod.
 - 4.2. Turn the valve rocker arm nut clockwise until all the valve lash is removed (zero valve lash).
Zero valve lash can be felt by moving the valve pushrod up and down between your thumb and forefinger until there is no more up and down movement of the valve pushrod.
 - 4.3. When all the valve lash is removed, then turn the valve rocker arm nut clockwise 1 additional turn (360 degrees).

5. Turn the crankshaft clockwise 1 revolution until the alignment mark on the crankshaft balancer is aligned with the notch in the engine front cover tab.

6. With the engine in the number 6 cylinder firing position, adjust the exhaust valves for cylinders number 2, 5, 6 and 7 and the intake valves for cylinders number 3, 4, 6 and 8.
 - 6.1. Turn the valve rocker arm nut counter clockwise until the valve lash is felt in the valve pushrod.
 - 6.2. Turn the valve rocker arm nut clockwise until all the valve lash is removed (zero valve lash).
Zero valve lash can be felt by moving the valve pushrod up and down between your thumb and forefinger until there is no more up and down movement of the valve pushrod.
 - 6.3. When all the valve lash is removed, then turn the valve rocker arm nut clockwise 1 additional turn (360 degrees).

Intake Manifold Installation

Notice: Applying excessive amounts of sealant may prohibit the intake manifold gaskets from sealing properly.

1. Apply a 4.0 mm (0.157 in) patch of adhesive GM P/N 12346141 or equivalent to the cylinder head side of the lower intake manifold gasket at each end.

Important: The lower intake manifold gasket must be installed while the adhesive is still wet to the touch.

2. Install the lower intake manifold gasket onto the cylinder head.

Use the gasket locator pins in order to properly seat the lower intake manifold gasket on the cylinder head.

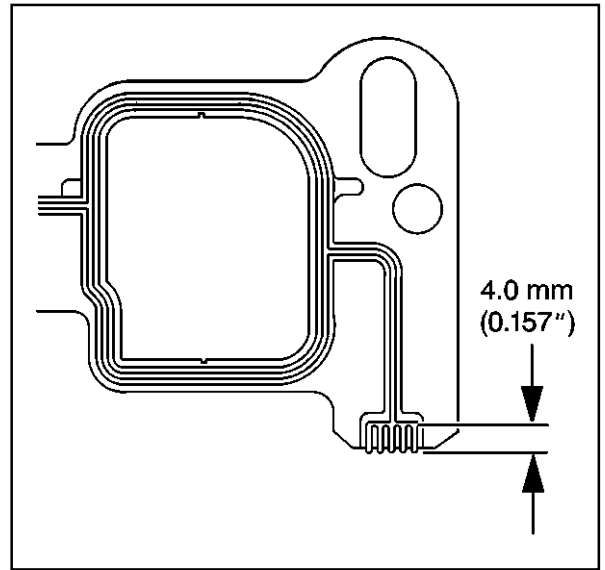

38512

Notice: Care must be used to apply the correct amount of sealant onto the gaskets. Applying excessive amounts of sealant may prohibit the intake manifold gaskets from sealing properly.

Important: The lower intake manifold must be installed and the fasteners tightened while the adhesive is still wet to the touch.

3. Apply a 5.0 mm (0.197 in) bead of adhesive GM P/N 12346141 or equivalent to the front top of the engine block. Extend the adhesive bead 13 mm (0.50 in) onto each lower intake manifold gasket.

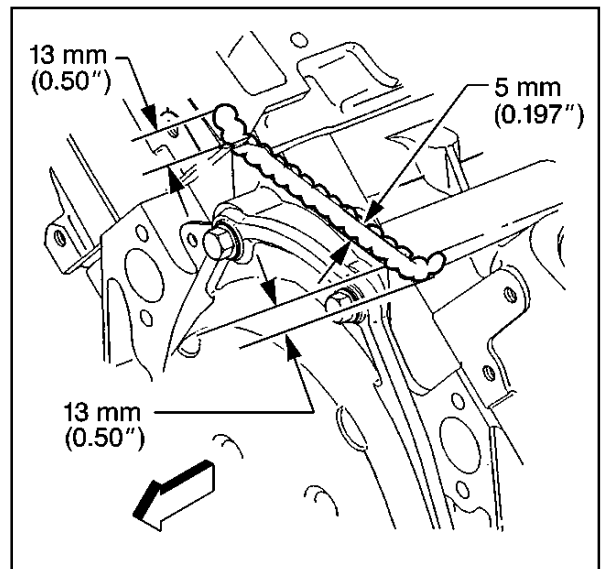

26744

4. Apply a 5.0 mm (0.197 in) bead of adhesive GM P/N 12346141 or equivalent to the rear top of the engine block. Extend the adhesive bead 13 mm (0.50 in) onto each lower intake manifold gasket.

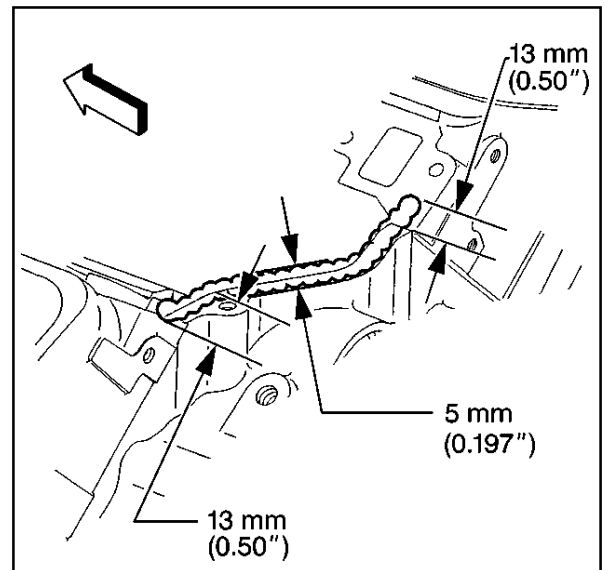

26743

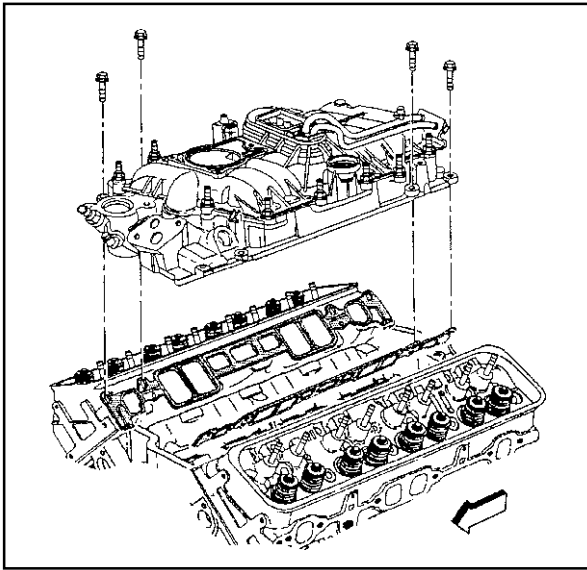

66456

5. Install the lower intake manifold onto the engine block.

Notice: Refer to *Fastener Notice* in Cautions and Notices.

6. If reusing the fasteners, apply threadlock GM P/N 12345382 or equivalent to the threads of the lower intake manifold bolts.
7. Install the lower intake manifold bolts.

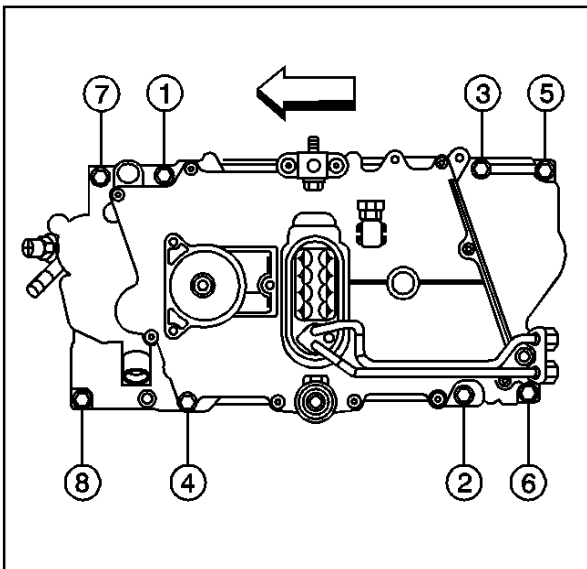

500689

Notice: Proper lower intake manifold fastener tightening sequence and torque is critical. Always follow the tightening sequence, and torque the intake manifold bolts using the 3 step method. Failing to do so may distort the crankshaft bearing bore alignment and cause damage to the crankshaft bearings.

8. Tighten the lower intake manifold bolts.

Tighten

- 8.1. Tighten the bolts in sequence (1-8) on the first pass to 3 N•m (27 lb in).
- 8.2. Tighten the bolts in sequence (1-8) on the first pass to 12 N•m (106 lb in).
- 8.3. Tighten the bolts in sequence (1-8) on the first pass to 15 N•m (11 lb ft).

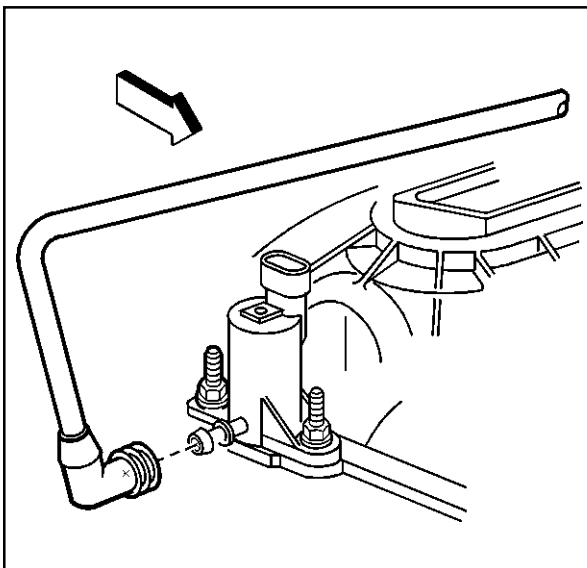

317211

9. Connect the evaporative emission (EVAP) canister solenoid valve harness.
 - 9.1. Push the elbow inward until the quick connect snaps into place.
 - 9.2. Pull the elbow outward in order to ensure proper connection.

Distributor Installation

1. Bring cylinder number one piston to Top Dead Center (TDC) of the compression stroke.

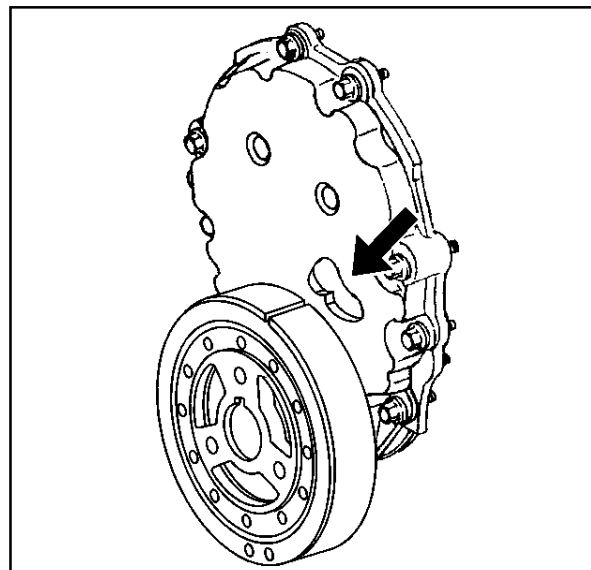

195336

2. Remove the distributor cap bolts and discard.
3. Remove the distributor cap.

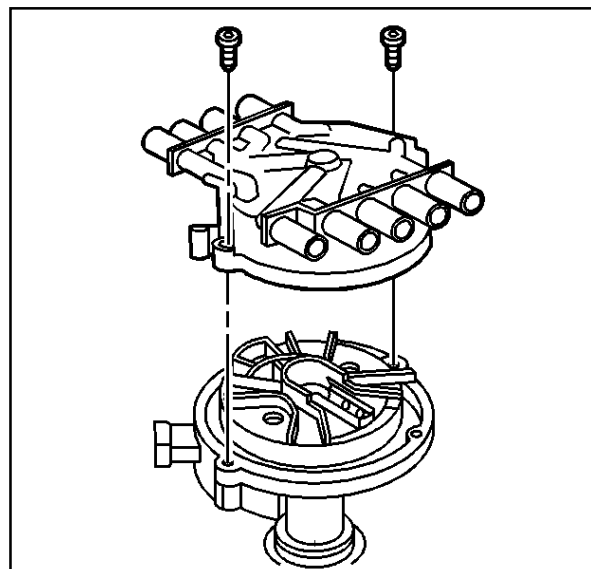

500690

4. Install a NEW distributor gasket onto the distributor.

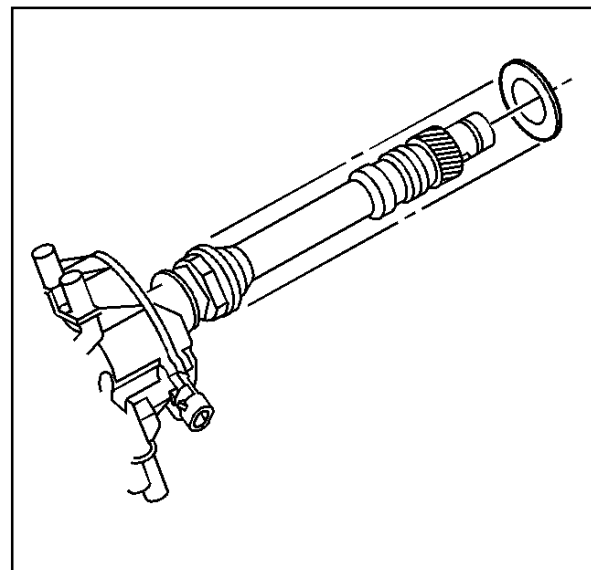

523516

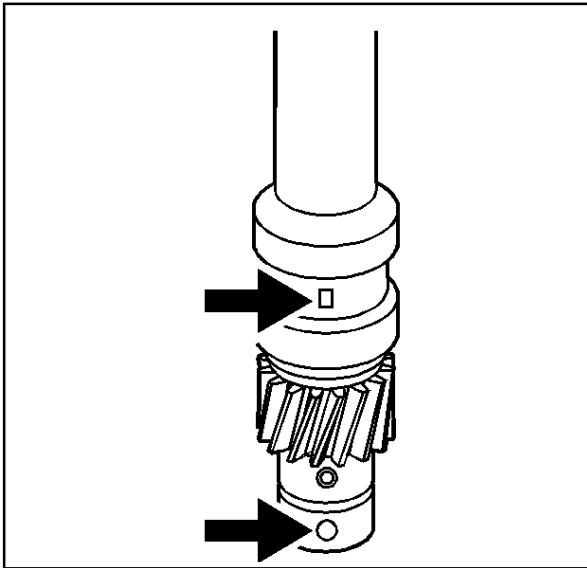

492137

4. Align the indent hole on the driven gear with the paint mark on the distributor housing.
5. Ensure that the distributor rotor segment points to the cap hold area.

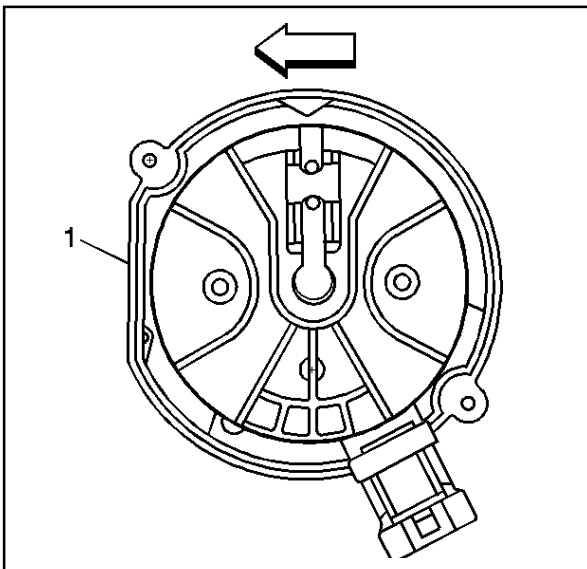

523746

6. Align the slotted tang in the oil pump driveshaft with the distributor driveshaft.
Rotate the oil pump driveshaft with a screwdriver if necessary.
7. Align the flat (1) in the distributor housing toward the front of the engine.
8. Install the distributor and distributor clamp.

9. Once the distributor is fully seated, align the distributor rotor segment with the number 8 pointer that is cast into the distributor base.
10. If the distributor rotor segment does not come with a few degrees of the number 6 pointer (1), the gear mesh between the distributor and camshaft may be off a tooth or more. Repeat the procedure again in order to achieve proper alignment.

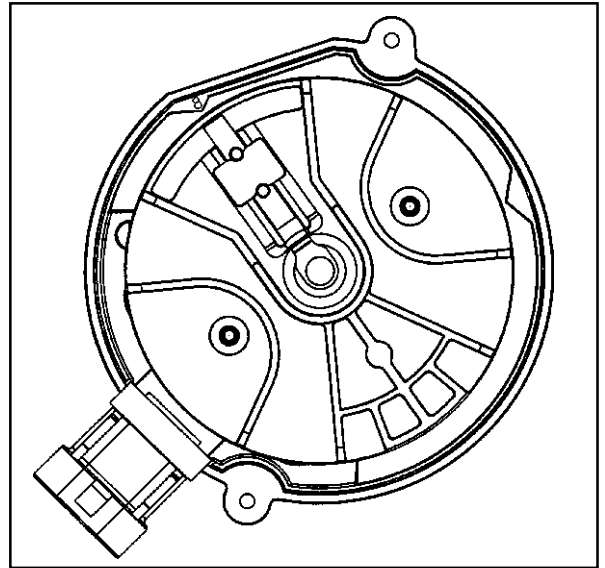

68505

Notice: Refer to *Fastener Notice* in Cautions and Notices.

11. Install the distributor clamp bolt.

Tighten

Tighten the distributor clamp bolt to 25 N·m (18 lb ft).

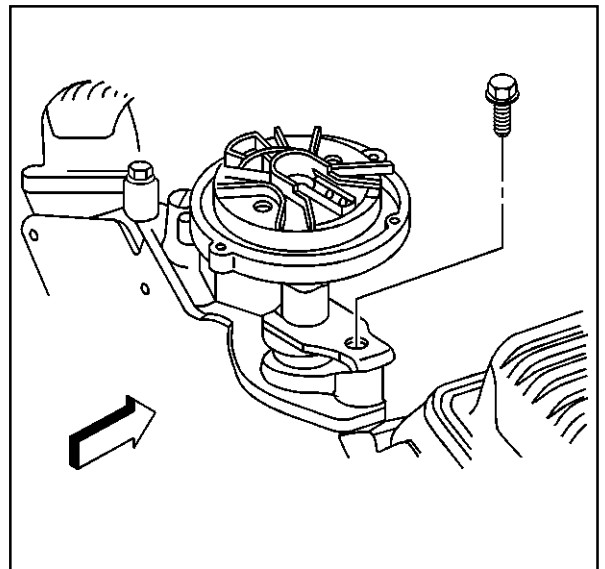

366609

12. Install the distributor cap onto the distributor.
13. Install the NEW distributor cap bolts. Do not overtighten the NEW distributor cap bolts.

Tighten

Tighten the distributor cap bolts to 2.4 N·m (21 lb in).

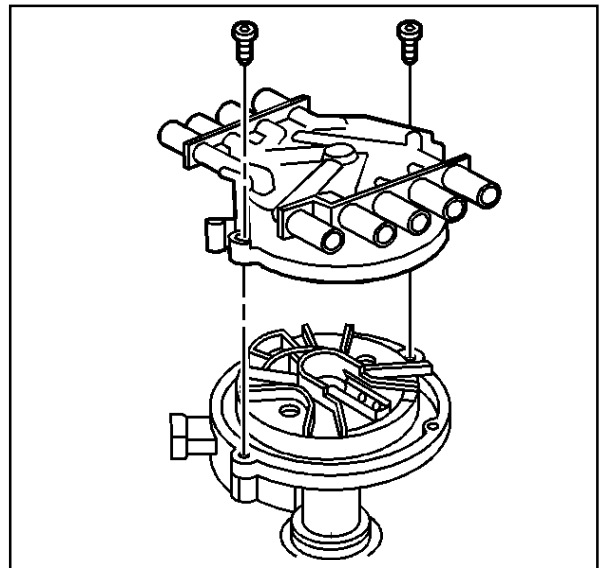

500690

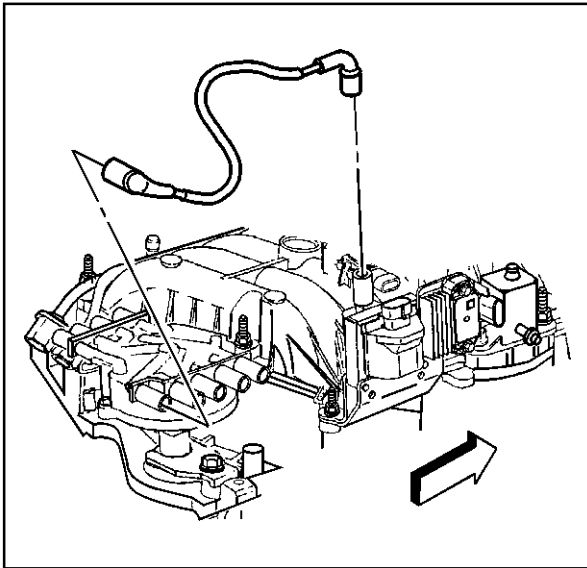

341359

14. Install the ignition coil wire harness.

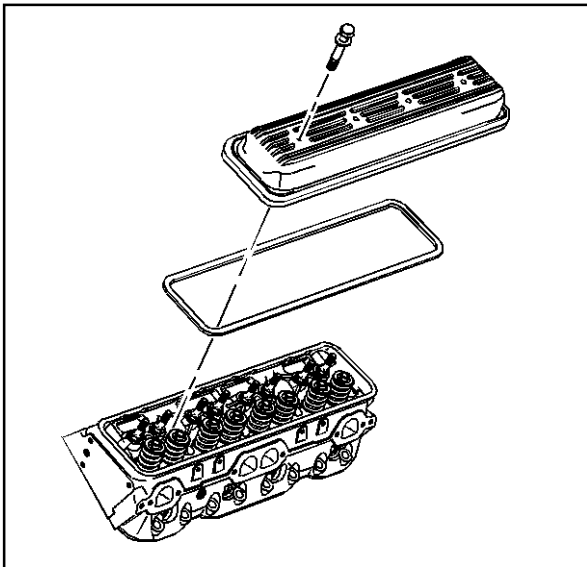

39119

Valve Rocker Arm Cover Installation (Left)

Important: Always install a NEW valve rocker arm cover gasket.

1. Install the NEW valve rocker arm cover gasket.
2. Install the valve rocker arm cover.

Notice: Refer to *Fastener Notice* in Cautions and Notices.

3. Install the valve rocker arm cover washers and bolts.

Tighten

Tighten the bolts to 12 N·m (106 lb in).

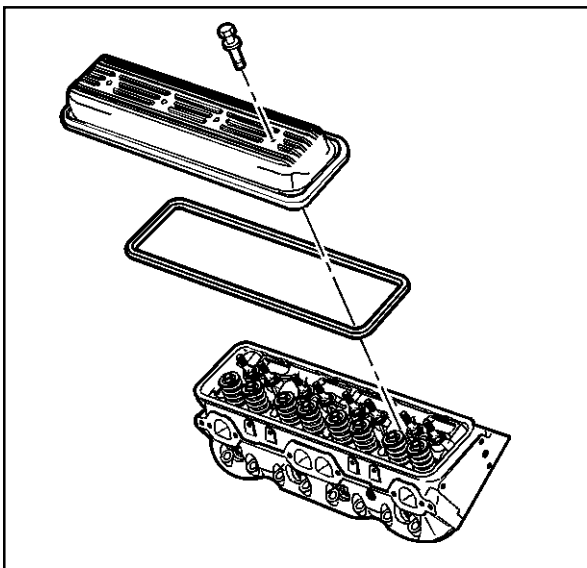

182833

Valve Rocker Arm Cover Installation (Right)

Important: Always install a NEW valve rocker arm cover gasket.

1. Install the NEW valve rocker arm cover gasket.
2. Install the valve rocker arm cover.

Notice: Refer to *Fastener Notice* in Cautions and Notices.

3. Install the valve rocker arm cover washers and bolts.

Tighten

Tighten the bolts to 12 N·m (106 lb in).

Water Pump Installation

Tools Required

J 41240 Fan Clutch Remover and Installer

1. If reusing the fasteners, apply sealant GM P/N 12346004 or equivalent to the threads of the water pump bolts.
2. Install the water pump and the NEW water pump gaskets.

Notice: Refer to *Fastener Notice* in Cautions and Notices.

3. Install the water pump bolts.

Tighten

Tighten the water pump bolts to 45 N·m (33 lb ft).

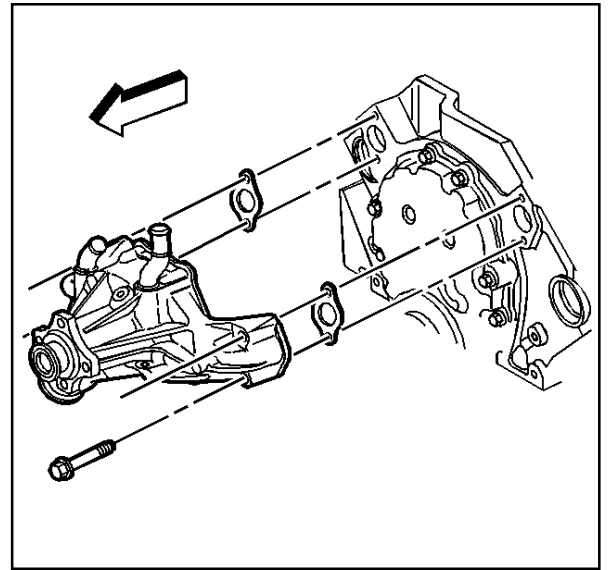

69011

Important: After final assembly, the water pump inlet hose clamp tangs (water pump end) must point forward and the upper tang should be level with the outside diameter of the water pump inlet hose.

4. Install the water pump inlet hose and the water pump inlet hose clamps.

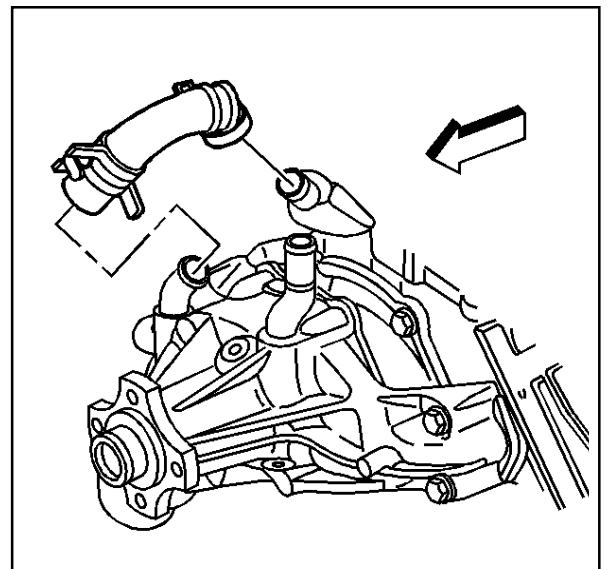

182853

5. Install the fan and water pump pulley and bolts using the J 41240.

Tighten

Tighten the fan and water pump pulley bolts to 25 N·m (18 lb ft).

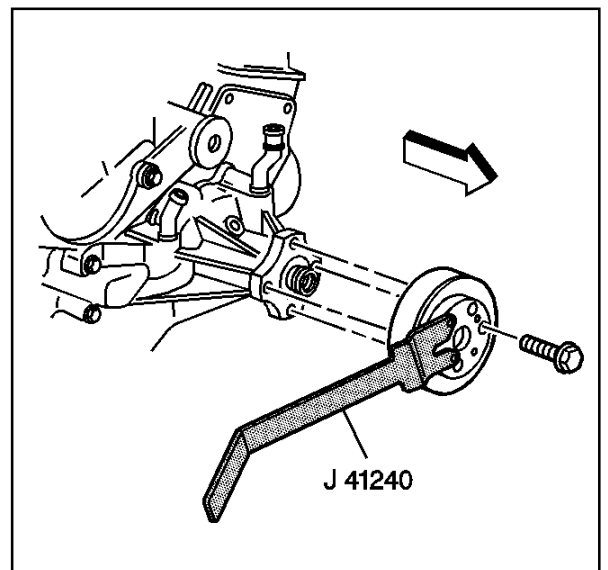

317191

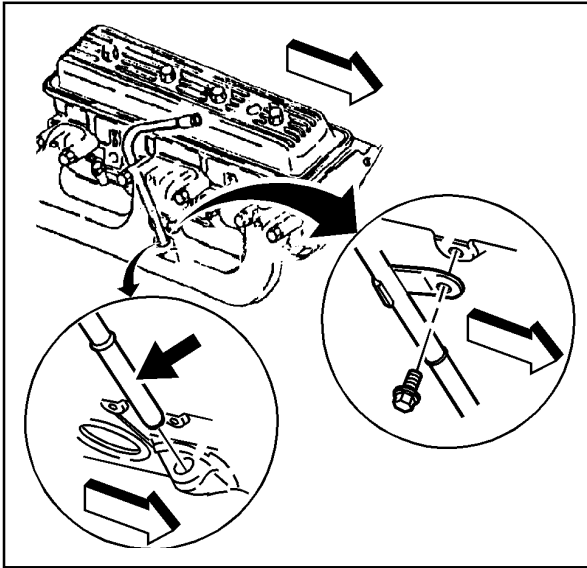

500691

Oil Level Indicator and Tube Installation

1. Apply sealant GM P/N 12346004 or equivalent around the oil level indicator tube 13 mm (0.50 in) below the tube bead.
2. Install the oil level indicator tube into the engine block. Rotate the oil level indicator tube into position.

Notice: Refer to *Fastener Notice* in Cautions and Notices.

3. Install the oil level indicator tube bolt.

Tighten

Tighten the oil level indicator tube bolt to 25 N•m (18 lb ft).

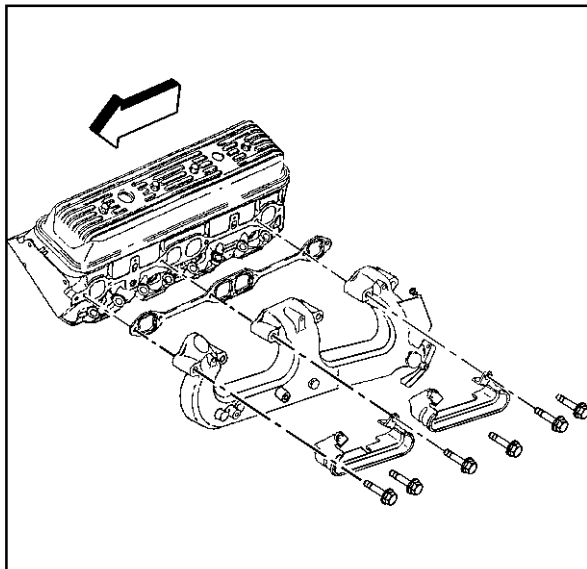

64925

Exhaust Manifold Installation (Left)

1. Install the NEW exhaust manifold gasket.
2. Install the exhaust manifold.
3. Install the spark plug wire shields.
4. Apply threadlock GM P/N 12345493 or equivalent to the threads of the exhaust manifold bolts.

Notice: Refer to *Fastener Notice* in Cautions and Notices.

5. Install the exhaust manifold bolts and stud.

Tighten

- 5.1. Tighten the exhaust manifold bolts on the first pass to 15 N•m (11 lb ft).
- 5.2. Tighten the exhaust manifold bolts on the final pass to 30 N•m (22 lb ft).

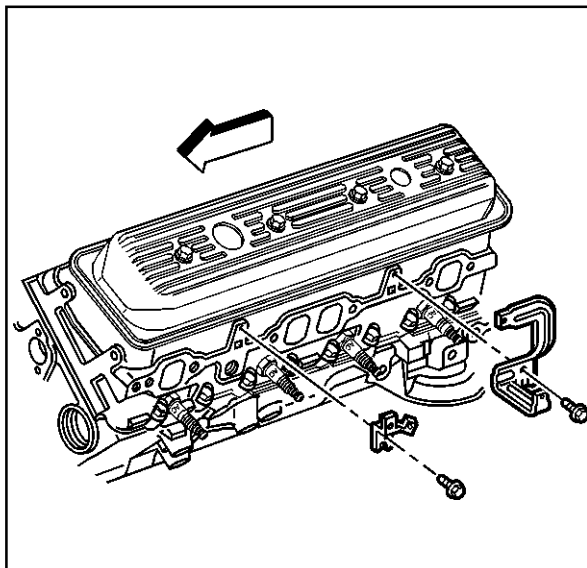

317185

6. Install the spark plug wire supports and bolts.

Tighten

Tighten the bolts to 12 N•m (106 lb in).

7. Install the spark plug wires onto the spark plugs.

Exhaust Manifold Installation (Right)

1. Install the NEW exhaust manifold gasket.
2. Install the exhaust manifold.
3. Install the spark plug wire shields.
4. Apply threadlock GM P/N 12345493 or equivalent to the threads of the exhaust manifold bolts.

Notice: Refer to *Fastener Notice* in Cautions and Notices.

5. Install the exhaust manifold bolts and stud.

Tighten

- 5.1. Tighten the exhaust manifold bolts on the first pass to 15 N•m (11 lb ft).
- 5.2. Tighten the exhaust manifold bolts on the final pass to 30 N•m (22 lb ft).

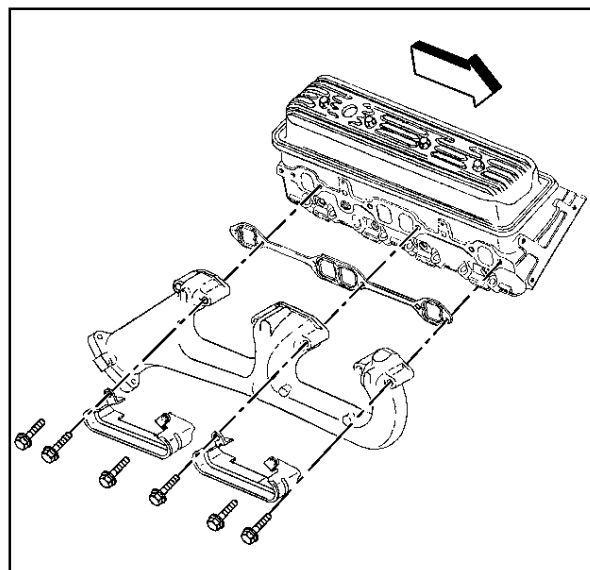

69032

6. Install the spark plug wire supports and bolts.

Tighten

Tighten the bolts to 12 N·m (106 lb in).

7. Install the spark plug wires onto the spark plugs.

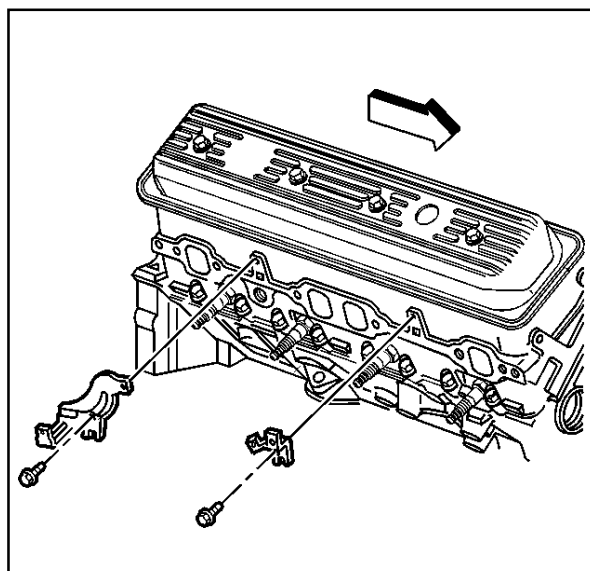

317179

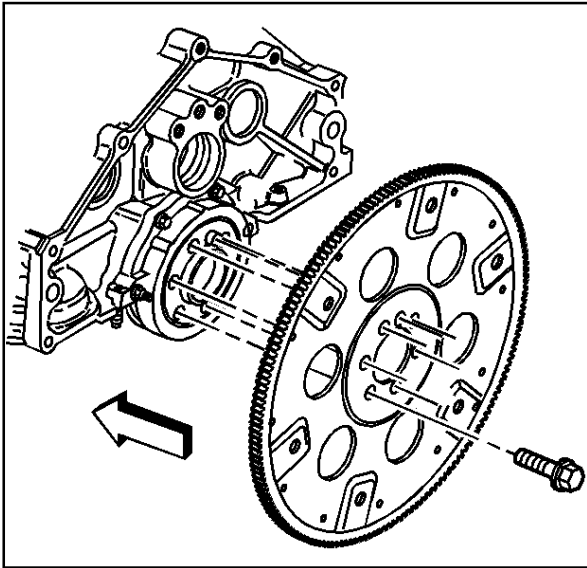

522146

Engine Flywheel Installation

1. Install the engine flywheel to the crankshaft.
2. Align the engine flywheel locator hole to the pin.

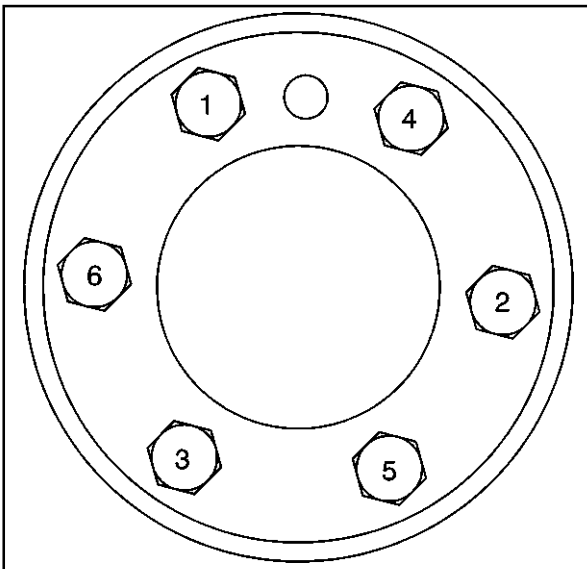

63174

Notice: Refer to *Fastener Notice* in Cautions and Notices.

3. Install the engine flywheel bolts.

Tighten

Tighten the engine flywheel bolts in sequence (1-6) to 100 N•m (74 lb ft).

Engine Set-Up and Testing

After overhaul, the engine must be tested before it is installed in the vehicle. If a suitable test stand is not available, the following procedures can be used after the engine is installed in the vehicle.

1. Fill the crankcase with the proper quantity and grade of engine oil.
2. Add engine oil supplement GM P/N 1052367 or equivalent to the engine oil.

Notice: DO NOT use cooling system seal tabs (or similar compounds) unless otherwise instructed. The use of cooling system seal tabs (or similar compounds) may restrict coolant flow through the passages of the cooling system or the engine components. Restricted coolant flow may cause engine overheating and/or damage to the cooling system or the engine components/assembly.

3. Fill the cooling system with the proper quantity and grade of coolant.
4. With the ignition OFF or disconnected, crank the engine several times. Listen for any unusual noises or evidence that any of the parts are binding.
5. Start the engine and listen for unusual noises.
6. Check the vehicle oil pressure gauge or light and confirm that the engine has acceptable oil pressure.
If necessary, install an oil pressure gauge and measure the engine oil pressure.
7. Operate the engine at about 1,000 RPM until the engine has reached normal operating temperature.
8. Listen for improperly adjusted or sticking valves, sticking valve lifters or other unusual noises.
9. Inspect for oil and/or coolant leaks while the engine is operating.
10. Verify that the distributor is properly positioned.
11. Perform a final inspection for the proper engine oil and coolant levels.

Description and Operation

Engine Component Description

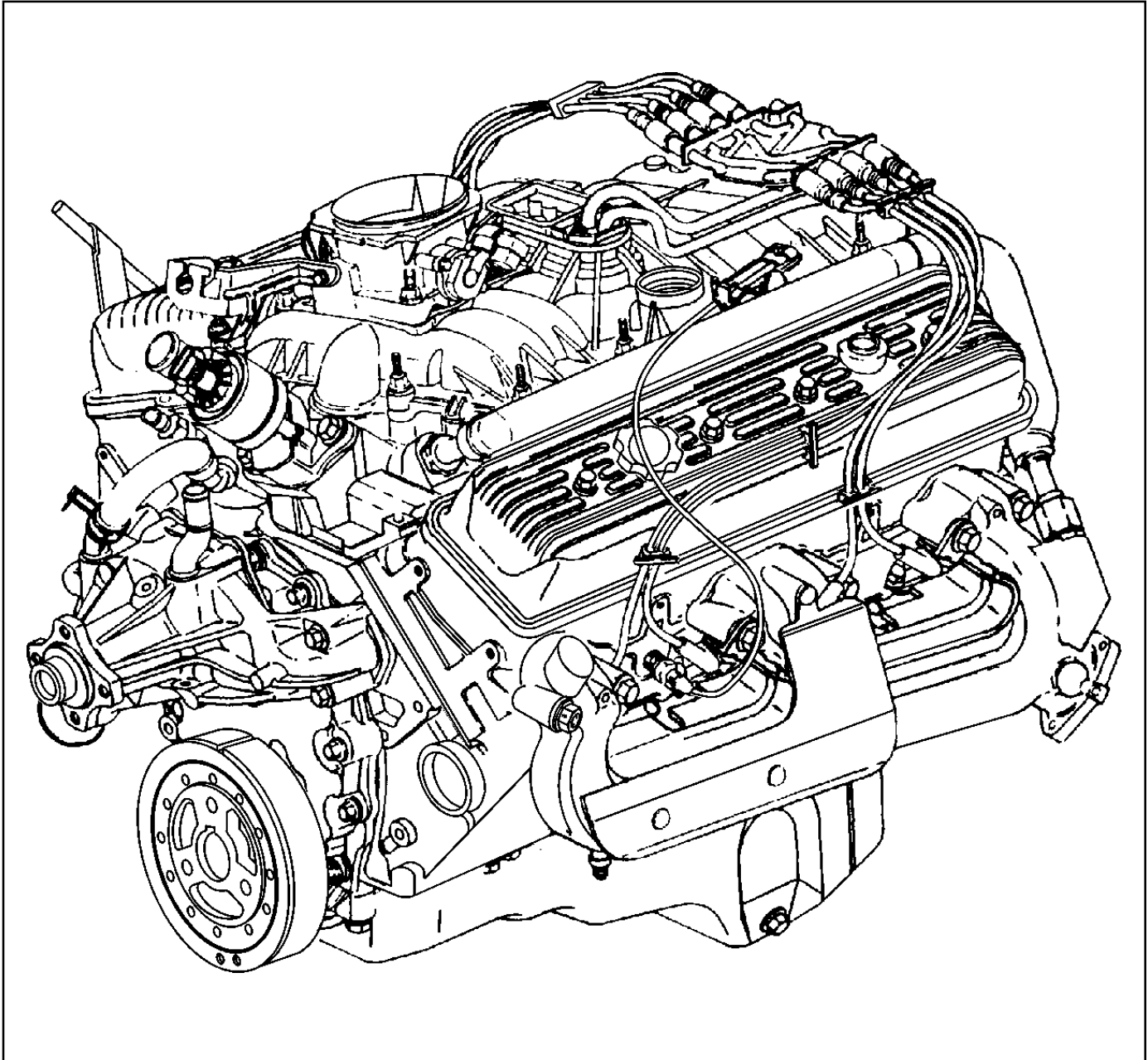

182830

Engine Block

The cast iron engine block has eight cylinders arranged in a V shape with four cylinders in each bank. The engine block is a one piece casting with the cylinders encircled by coolant jackets.

Cylinder Head

The cast iron cylinder heads have one intake and one exhaust valve for each cylinder. A spark plug is located between the valves in the side of the cylinder head. The valve guides and seats are integral to the cylinder head. The 5.7L heavy duty applications have pressed in exhaust valve seats.

Camshaft

The steel camshaft is supported by five bearings pressed into the engine block. The camshaft timing chain sprocket mounted to the front of the camshaft is driven by the crankshaft sprocket through a camshaft timing chain.

Motion from the engine camshaft is transmitted to the valves by hydraulic roller valve lifters, valve pushrods and ball-pivot type valve rocker arms.

Crankshaft

The cast nodular iron crankshaft is supported by five crankshaft bearings. The crankshaft bearings are retained by the crankshaft bearing caps, which are machined with

the engine block for proper alignment and clearances. Light duty 5.7L engines have two bolts per crankshaft bearing cap. The heavy duty 5.7L engines have four bolts per crankshaft bearing cap, on bearing caps 2, 3, and 4. The number five crankshaft bearing at the rear of the engine is the end thrust bearing. The four connecting rod journals (two connecting rods per journal) are spaced 90 degrees apart. The crankshaft position sensor reluctor ring has four lugs used for crankshaft timing and is constructed of powdered metal. The crankshaft position sensor reluctor ring has a slight interference fit onto the crankshaft and an internal keyway for correct positioning.

Piston and Connecting Rod Assemblies

The cast aluminum pistons use two compression rings and one oil control assembly. The piston is a low friction, lightweight design with a flat top and barrel shaped skirt. The piston pins are chromium steel. The piston pins have a floating fit in the piston and are retained by a press fit in the connecting rod. The connecting rods are made out of either forged powdered metal or forged steel. The connecting rods are machined with the rod cap installed for proper clearances and alignments.

Valve Train

The valve train is a ball pivot type. Motion is transmitted from the camshaft through the hydraulic roller valve lifters and tubular valve pushrods to the valve rocker arms. The valve rocker arm pivots on a ball in order to open the valve. The hydraulic roller valve lifters keep all parts of the valve train in constant contact. The valve rocker arm ball is retained on the valve rocker arm ball stud with a locking nut. The valve rocker arm ball studs are pressed into the cylinder head.

Intake Manifold

The intake manifold is a two-piece design. The upper portion is made from a composite material and the lower portion is cast aluminum. The throttle body attaches to the upper manifold. The lower manifold has an exhaust gas recirculation (EGR) port cast into the manifold for mixture. The (EGR) valve bolts into the lower intake manifold. The Central Sequential Multiport Fuel Injection system uses multiple fuel injectors to meter and distribute fuel to each engine cylinder. The Central (SFI) is retained by a bracket bolted to the lower intake manifold. The fuel meter body also houses the pressure regulator. Metal inlet and outlet fuel lines and nylon delivery tubes connect to the Central (SFI) unit. The delivery tubes independently distribute fuel to each cylinder through nozzles located at the port entrance of each manifold runner where the fuel is atomized.

Drive Belt System Description

The drive belt system consists of the following components:

- The drive belt
- The drive belt tensioner
- The drive belt idler pulley
- The crankshaft balancer pulley
- The accessory drive component mounting brackets
- The accessory drive components
 - The power steering pump, if belt driven
 - The generator
 - The A/C compressor, if equipped
 - The engine cooling fan, if belt driven
 - The water pump, if belt driven
 - The vacuum pump, if belt driven
 - The air compressor, if belt driven

The drive belt system may use one belt or two belts. The drive belt is thin so that it can bend backwards and has several ribs to match the grooves in the pulleys. There also may be a V-belt style belt used to drive certain accessory drive components. The drive belts are made of different types of rubbers (chloroprene or EPDM) and have different layers or plys containing either fiber cloth or cords for reinforcement.

Both sides of the drive belt may be used to drive the different accessory drive components. When the back side of the drive belt is used to drive a pulley, the pulley is smooth.

The drive belt is pulled by the crankshaft balancer pulley across the accessory drive component pulleys. The spring loaded drive belt tensioner keeps constant tension on the drive belt to prevent the drive belt from slipping. The drive belt tensioner arm will move when loads are applied to the drive belt by the accessory drive components and the crankshaft.

The drive belt system may have an idler pulley, which is used to add wrap to the adjacent pulleys. Some systems use an idler pulley in place of an accessory drive component when the vehicle is not equipped with the accessory.

New Product Information

The purpose of New Product Information is to highlight or indicate important product changes from the previous model year.

Changes may include one or more of the following items:

- Torque values and/or fastener tightening strategies
- Changed engine specifications
- New sealants and/or adhesives
- Disassembly and assembly procedure revisions
- Engine mechanical diagnostic procedure revisions
- New special tools required
- A component comparison from the previous year

Torque Values and/or Fastener Tightening Strategies

- Cylinder head bolts, the crankshaft bearing cap bolts and the connecting rod bolts apply a torque angle strategy.
In an on-vehicle situation where a torque angle meter may not fit into the vehicle packaging, a three step tightening process may be followed using a torque wrench.
- Certain fasteners should not be reused. Bolts, studs or other fasteners that must be replaced will be called out in the specific service procedures.

Changed Engine Specifications

Engine mechanical specifications remain the same as the 1999 products.

New Sealants and/or Adhesives

No new sealants or adhesives have been added.

Disassembly and Assembly Procedure Revisions and Additions

No revisions or additions.

Engine Mechanical Diagnostic Procedure Revisions

- Valve Train diagnostic information is now provided in table form.
Potential or probable causes are supplied for each specific concern.
- Engine Noise diagnostic information is now provided in table form.
Potential or probable causes are supplied for each specific concern.

New Special Tools Required

No new special tools are required.

Engine Identification

The Vehicle Identification Number (VIN) is located on the left side rear of the engine block (near the transmission bellhousing) and typically is a nine digit number stamped onto the engine at the vehicle assembly plant.

- The first digit identifies the division.
- The second digit identifies the model year.
- The third digit identifies the assembly plant.
- The fourth through ninth digits are the last six digits of the Vehicle Identification Number (VIN).

Lubrication

Right Side View

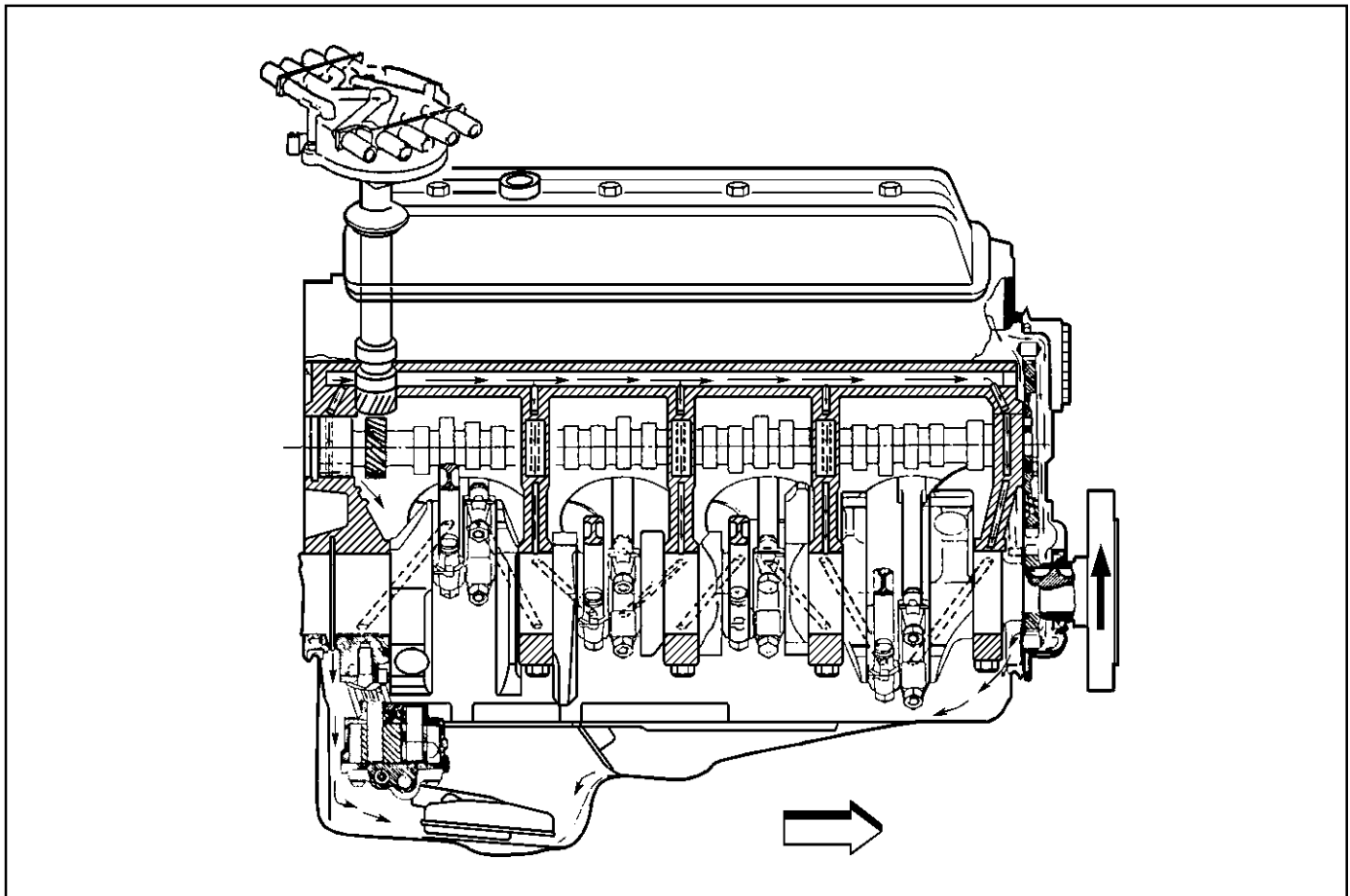

67757

Front View

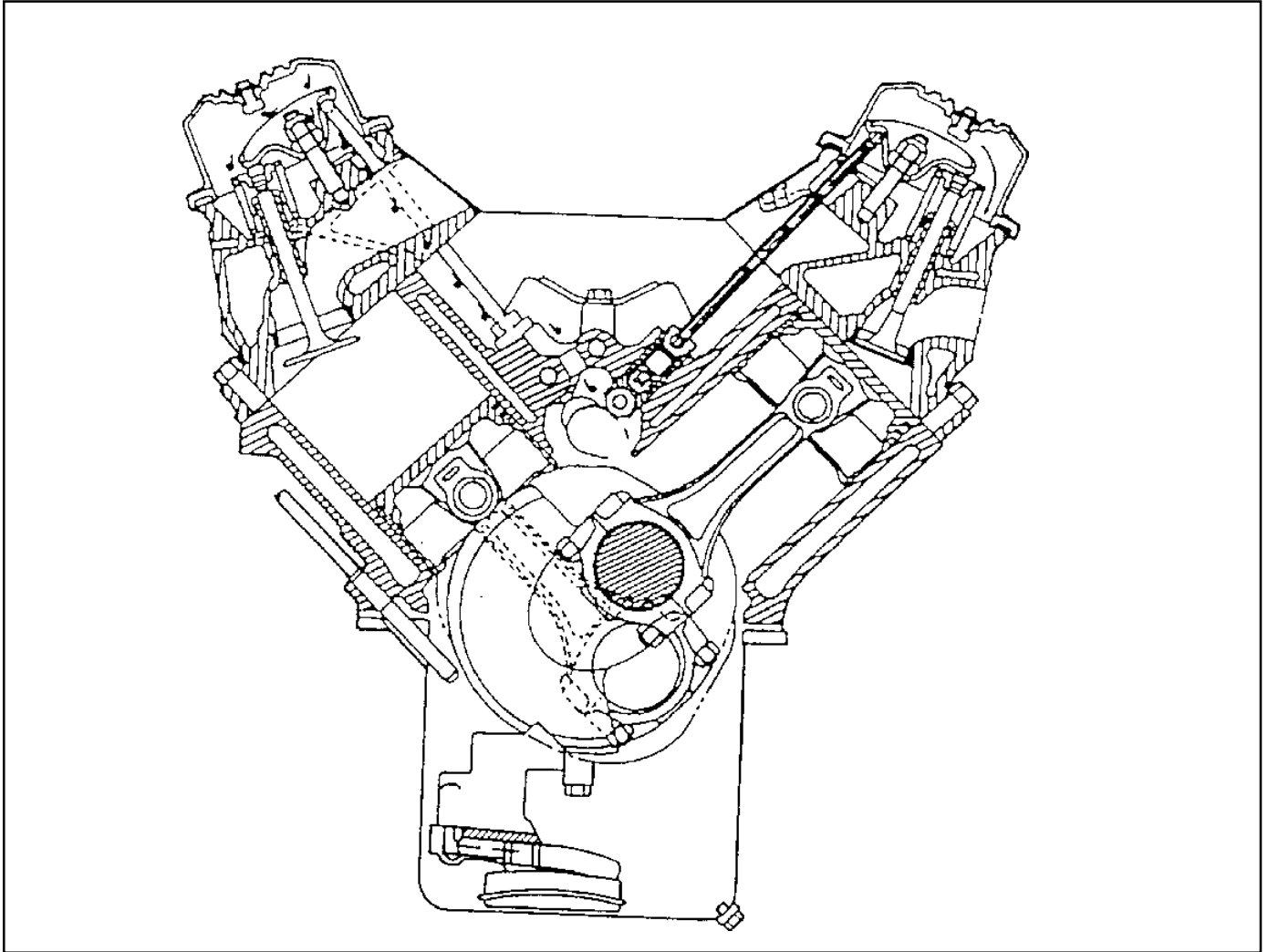

67753

The gear-type oil pump is driven through an extension driveshaft. The extension driveshaft is driven by the distributor which is gear driven by the camshaft. The oil is drawn from the oil pan through a pickup screen and tube. Pressurized oil is delivered through internal passages in order to lubricate the camshaft and the crankshaft bearings and to provide lash control in the hydraulic valve lifters. Oil is metered from the valve lifters through the valve pushrods in order to lubricate the valve rocker arms and valve rocker arm ball pivots. Oil returning to the oil pan from the cylinder heads and the camshaft front bearing, lubricates the camshaft timing chain and the crankshaft and the camshaft sprockets.

Cleanliness and Care

- Throughout this section, it should be understood that proper cleaning and protection of machined surfaces and friction areas is part of the repair procedure. This is considered standard shop practice even if not specifically stated.
- When any internal engine parts are serviced, care and cleanliness is important.
- When components are removed for service, the components should be marked, organized or retained in a specific order for re-assembly.
- At the time of installation, the components should be installed in the same location and with the same mating surface as when removed.
- An automobile engine is a combination of many machined, honed, polished and lapped surfaces with tolerances that are measured in millimeters or thousandths of an inch. The surfaces should be protected to avoid component damage.
- Apply a liberal amount of clean engine oil to friction areas during assembly.
- Proper lubrication will protect and lubricate friction areas during initial operation. retained in a specific order for re-assembly.

Replacing Engine Gaskets

Gasket Reuse and Applying Sealant

- Do not reuse any gasket unless specified.
- Gaskets that can be reused will be identified in the service procedure.
- Do not apply sealant to any gasket or sealing surface unless specified in the service procedure.

Separating Components

- Use a rubber mallet in order to separate the components.
- Bump the part sideways in order to loosen the components.
- Bumping of the component should be done at bends or reinforced areas of the component to prevent distortion of the components.

Cleaning Gasket Surfaces

- Use care to avoid gouging or scraping the sealing surfaces.
- Use a plastic or wood scraper in order to remove all the sealant from the components.
Do not use any other method or technique to remove the sealant or the gasket material from a part.
- Do not use abrasive pads, sand paper or power tools to clean the gasket surfaces.
 - These methods of cleaning can cause damage to the component sealing surfaces.
 - Abrasive pads also produce a fine grit that the oil filter cannot remove from the engine oil.
This fine grit is abrasive and can cause internal engine damage.

Assembling Components

- Assemble components using only the sealant (or equivalent) that is specified in the service procedure.
- Sealing surfaces must be clean and free of debris or oil.
- Specific components such as crankshaft oil seals or valve stem oil seals may require lubrication during assembly.
- Components requiring lubrication will be identified in the service procedure.
- Apply only the amount of sealant specified in the service procedure to a component.
- Do not allow the sealant to enter into any blind threaded holes, as the sealant may prevent the fastener from clamping properly or cause component damage when tightened.

- Tighten fasteners to the proper specifications. DO NOT overtighten the fasteners.

Use of RTV and Anaerobic Sealer

Sealant Types

Important: The correct sealant and amount of sealant must be used in the proper location to prevent oil leaks, coolant leaks or the loosening of the fasteners. DO NOT interchange the sealants. Use only the sealant (or equivalent) as specified in the service procedure.

The following 2 major types of sealant are commonly used in engines:

- Aerobic sealant [Room Temperature Vulcanizing (RTV)]
- Anaerobic sealant, which include the following:
 - Gasket eliminator
 - Pipe
 - Threadlock

Aerobic Type Room Temperature Vulcanizing (RTV) Sealant

Aerobic type Room Temperature Vulcanizing (RTV) sealant cures when exposed to air. This type of sealant is used where 2 components (such as the intake manifold and the engine block) are assembled together.

Use the following information when using RTV sealant:

- Do not use RTV sealant in areas where extreme temperatures are expected. These areas include:
 - The exhaust manifold
 - The head gasket
 - Any other surfaces where a different type of sealant is specified in the service procedure
- Always follow all the safety recommendations and the directions that are on the RTV sealant container.
- Use a plastic or wood scraper in order to remove all the RTV sealant from the components.

Important: Do not allow the RTV sealant to enter any blind threaded holes, as it may prevent the fasteners from clamping properly or cause damage when the fastener is tightened.

The surfaces to be sealed must be clean and dry.

- Use a RTV sealant bead size as specified in the service procedure.
- Apply the RTV sealant bead to the inside of any bolt hole areas.
- Assemble the components while the RTV sealant is still wet to the touch (within 3 minutes). Do not wait for the RTV sealant to skin over.
- Tighten the fasteners in sequence (if specified) and to the proper torque specifications. DO NOT overtighten

the fasteners.

Anaerobic Type Gasket Eliminator Sealant

Anaerobic type gasket eliminator sealant cures in the absence of air. This type of sealant is used where 2 rigid parts (such as castings) are assembled together. When 2 rigid parts are disassembled and no sealant or gasket is readily noticeable, then the 2 parts were probably assembled using an anaerobic type gasket eliminator sealant.

Use the following information when using gasket eliminator sealant:

- Always follow all the safety recommendations and directions that are on the gasket eliminator sealant container.
- Apply a continuous bead of gasket eliminator sealant to one flange.

The surfaces to be sealed must be clean and dry.

Important: Do not allow the gasket eliminator sealant to enter any blind threaded holes, as the gasket eliminator sealant may prevent the fasteners from clamping properly, seating properly or cause damage when the fastener is tightened.

Apply the gasket eliminator sealant evenly to get a uniform thickness of the gasket eliminator sealant on the sealing surface.

Important: Gasket eliminator sealed joint fasteners that are partially torqued and the gasket eliminator sealant allowed to cure more than 5 minutes, may result in incorrect shimming and sealing of the joint.

- Tighten the fasteners in sequence (if specified) and to the proper torque specifications. DO NOT overtighten the fasteners.
- After properly tightening the fasteners, remove the excess gasket eliminator sealant from the outside of the joint.

Anaerobic Type Threadlock Sealant

Anaerobic type threadlock sealant cures in the absence of air. This type of sealant is used for threadlocking and sealing of bolts, fittings, nuts and studs. This type of sealant cures only when confined between 2 close fitting metal surfaces.

Use the following information when using threadlock sealant:

- Always follow all safety recommendations and directions that are on the threadlock sealant container.
- The threaded surfaces must be clean and dry.
- Apply the threadlock sealant as specified on the threadlock sealant container.

Important: Fasteners that are partially torqued and then the threadlock sealant allowed to cure more than five minutes, may result in incorrect clamp load of assembled

components.

Tighten the fastener in sequence (if specified) and to the proper torque specification. DO NOT overtighten the fasteners.

Anaerobic Type Pipe Sealant

Anaerobic type pipe sealant cures in the absence of air and remains pliable when cured. This type of sealant is used where 2 parts are assembled together and require a leak proof joint.

Use the following information when using pipe sealant:

- Do not use pipe sealant in areas where extreme temperatures are expected. These areas include:
 - The exhaust manifold
 - The head gasket
 - Surfaces where a different sealant is specified
- Always follow all the safety recommendations and directions that are on the pipe sealant container.
- The surfaces to be sealed must be clean and dry.
- Use a pipe sealant bead of the size or quantity as specified in the service procedure.

Important: Do not allow the pipe sealant to enter any of the blind threaded holes, as the pipe sealant may prevent the fastener from clamping properly, or cause component damage when the fastener is tightened.

- Apply the pipe sealant bead to the inside of any bolt hole areas.
- Apply a continuous bead of pipe sealant to 1 sealing surface.
- Tighten the fasteners in sequence (if specified) and to the proper torque specifications. DO NOT overtighten the fasteners.

Separating Parts

Important: Many internal engine components will develop specific wear patterns on their friction surfaces.

When disassembling the engine, internal components MUST be separated, marked and organized in a way to ensure reinstallation to the original location and position.

Mark or identify the following components:

- Piston to the specific cylinder bore
- Piston rings to the specific cylinder bore
- Connecting rod to the crankshaft journal
- Connecting rod to connecting rod cap
- Crankshaft bearings and connecting rod bearings
- Engine camshaft and valve lifters
- Valve lifters, valve rocker arms and valve rocker arm supports
- Valve to the valve guide

- Valve spring to cylinder head location
- Engine block bearing cap location and direction
- Oil pump drive and driven gears

Tools and Equipment

Special tools are listed and illustrated throughout this section with a complete listing at the end of the section. The tools (or equivalents) are specially designed to quickly and safely accomplish the operations for which the tools are intended. The use of special tools will also minimize possible damage to engine components. Some precision measuring tools are required for inspection of certain critical components. Torque wrenches and a torque angle meter are necessary for the proper tightening of various fasteners.

To properly service the engine assembly, the following items should be readily available:

- Approved eye protection and safety gloves
- A clean, well-lit, work area
- A suitable parts cleaning tank
- A compressed air supply
- Trays or storage containers to keep parts and fasteners organized
- An adequate set of hand tools
- Approved engine repair stand
- An approved engine lifting device that will adequately support the weight of the components

**This page left
intentionally
blank**

Special Tools and Equipment

Illustration	Tool Number/Description
	<p>J 3049-A Valve Lifter Remover</p>
	<p>J 5239 Connecting Rod Bolt Guide Set</p>
	<p>J 5590 Installer</p>
	<p>J 5715 or J 6036 Reamer</p>
	<p>J 5802-01 Rocker Arm Stud Remover</p>

Illustration	Tool Number/Description
	<p>J 5825-A Crankshaft Gear Remover</p>
	<p>J 5830-02 Valve Guide Reamer Set</p>
	<p>J 5892-D Valve Spring Compressor</p>
	<p>J 6880 Rocker Arm Stud Installer</p>
	<p>J 7872 Magnetic Base Dial Indicator</p>

Engine

Marine/Industrial 5.7L 6-175

Illustration	Tool Number/Description
	<p>J 8001 Dial Indicator Set</p>
	<p>J 8037 Ring Compressor</p>
	<p>J 8062 Valve Spring Compressor</p>
	<p>J 8087 Cylinder Bore Gauge</p>
	<p>J 8089 Carbon Removing Brush</p>

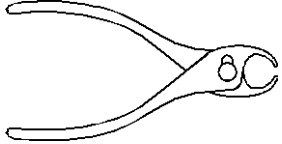
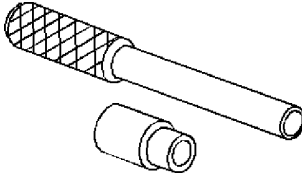
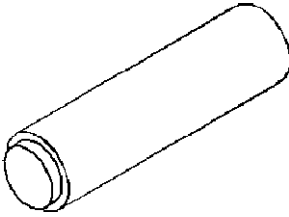
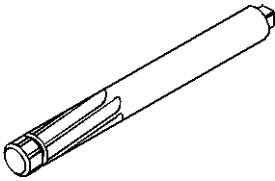
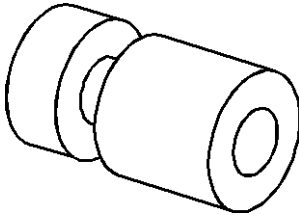
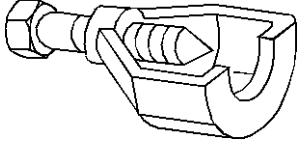
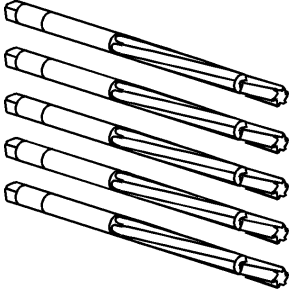
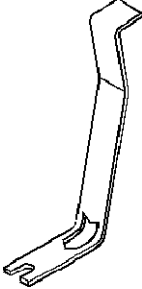
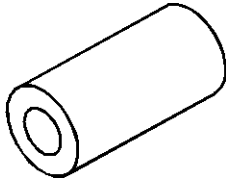
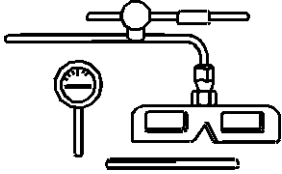
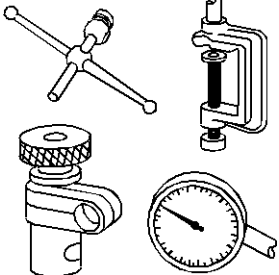
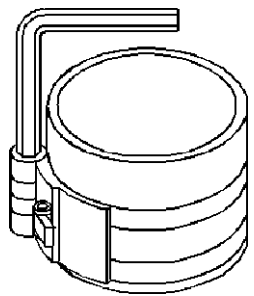
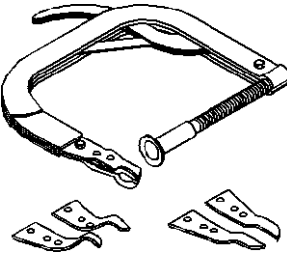
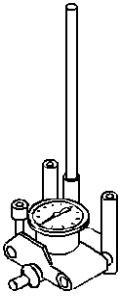
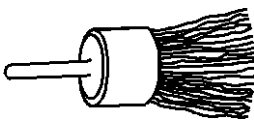
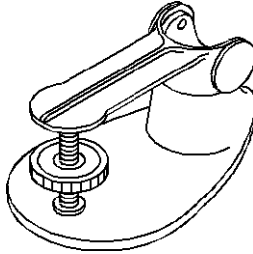
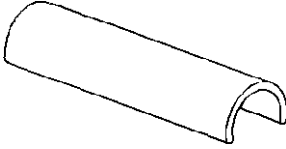
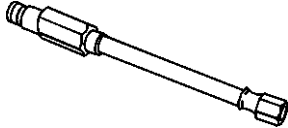
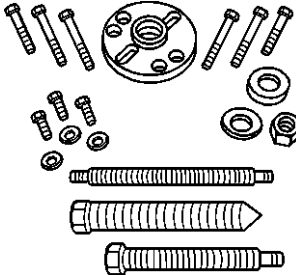
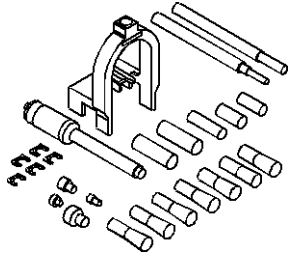
Illustration	Tool Number/Description
	<p>J 9666 Valve Spring Tester</p>
	<p>J 21882 Oil Suction Pipe Installer</p>
	<p>J 22794 Spark Plug Port Adapter</p>
	<p>J 23523-F Balancer Remover and Installer</p>
	<p>J 24086-C Piston Pin Remover/ Installer Set</p>

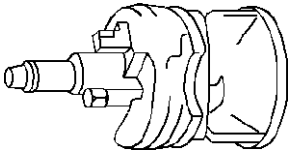
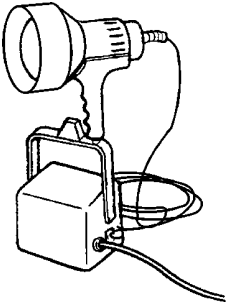
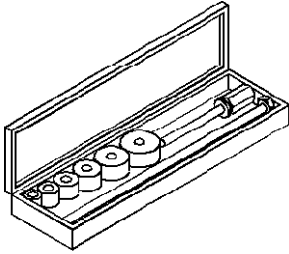
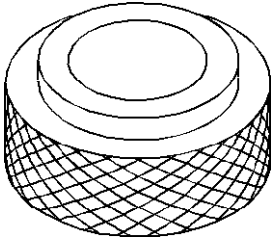
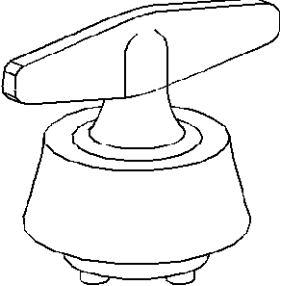
Illustration	Tool Number/Description
	<p>J 24270 Cylinder Bore Ridge Reamer</p>
	<p>J 28428-E High Intensity Black Light Kit</p>
	<p>J 33049 Camshaft Bearing Service Set</p>
	<p>J 35468 Cover Aligner/Seal Installer</p>
	<p>J 35621-B Rear Main Seal Installer</p>

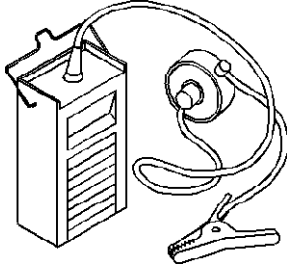
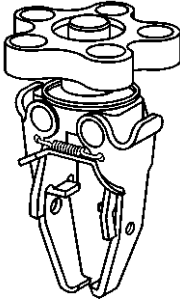
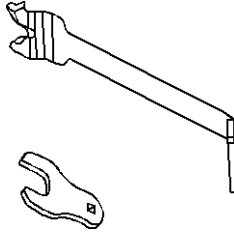
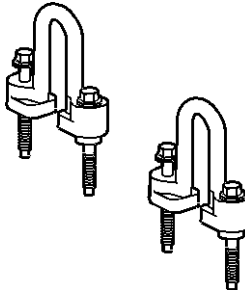
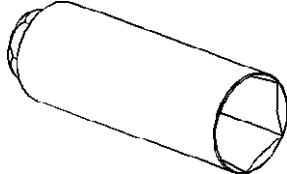
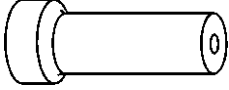
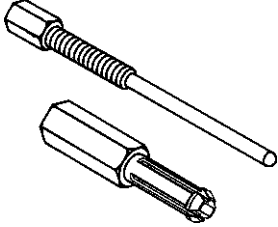
Illustration	Tool Number/Description
	<p>J 36660 Electronic Torque Angle Meter</p>
	<p>J 38606 Valve Spring Compressor</p>
	<p>J 41240 Fan Clutch Remover and Installer</p>
	<p>J 41427 Engine Lift Brackets</p>
	<p>J 41712 Oil Pressure Switch Socket</p>

Illustration	Tool Number/Description
	<p>J 42073 Valve Stem Seal Installer</p>
	<p>J 43276 Clutch Pilot Bearing Remover</p>