

Original Issue  
Dated January 2004  
Publication Number 8.1LESM

# 8.1L

## INDUSTRIAL ENGINE SERVICE MANUAL



Vortec 8100  
2004 8.1L V8 (L18)



**No part of this publication may be reproduced without the written permission of Power Solutions, Inc. At the time of publication, all of the information included in this publication is accurate to the best of our knowledge. Power Solutions, Inc., cannot be responsible for information that has changed after this book was published.**

# Engine

## Engine Mechanical - 8.1L

### Specifications

#### Fastener Tightening Specifications

*Engine Mechanical - 8.1L:Specifications:Fastener Tightening Specifications*

Application	Specification	
	Metric	English
Accessory Drive Belt Tensioner Bolt	50♦&newtonm;	37♦lb♦ft
Air Cleaner Outlet Duct Clamp	4♦&newtonm;	35♦lb♦in
Air Conditioning (A/C) Belt Tensioner Bolt	50♦&newtonm;	37♦lb♦ft
Battery Cable Channel Bolt	9♦&newtonm;	80♦lb♦in
Camshaft Position Sensor Bolt	12♦&newtonm;	106♦lb♦in
Camshaft Retainer Bolt	12♦&newtonm;	106♦lb♦in
Camshaft Sprocket Bolt	30♦&newtonm;	22♦lb♦ft
Connecting Rod Nut - First Pass	30♦&newtonm;	22♦lb♦ft
Connecting Rod Nut - Final Pass	90♦Degrees	
Crankshaft Balancer Bolt	255♦&newtonm;	189♦lb♦ft
Crankshaft Bearing Cap Inner Bolts - First Pass	30♦&newtonm;	22♦lb♦ft
Crankshaft Bearing Cap Inner Bolts - Final Pass	90♦Degrees	
Crankshaft Bearing Cap Outer Bolts/Studs - First Pass	30♦&newtonm;	22♦lb♦ft
Crankshaft Bearing Cap Outer Bolts/Studs - Final Pass	80♦Degrees	
Crankshaft Oil Deflector Nut	50♦&newtonm;	37♦lb♦ft
Crankshaft Position Sensor Bolt	12♦&newtonm;	106♦lb♦in
Crossbar Bolt	100♦&newtonm;	74♦lb♦ft
Cylinder Head Bolts - In Sequence		
First Pass	30♦&newtonm;	22♦lb♦ft

Second Pass	30♦&newtonm; + 120♦Degrees	22♦lb♦ft + 120♦Degrees
Final Pass - Long Bolts #1, 2, 3, 6, 7, 8, 9, 10, 11, 14, 16, 17	60♦Degrees	
Final Pass - Medium Bolts #15, 18	45♦Degrees	
Final Pass - Short Bolts #4, 5, 12, 13	30♦Degrees	
Cylinder Head Coolant Hole Plug	50♦&newtonm;	37♦lb♦ft
Drive Belt Idler Pulley Bolt	50♦&newtonm;	37♦lb♦ft
EGR Cover Nut	22♦&newtonm;	16♦lb♦ft
EGR Cover Stud	7♦&newtonm;	62♦lb♦in
Engine Block Coolant Drain M28 Plug - Left Front	60♦&newtonm;	44♦lb♦ft
Engine Block Coolant Drain Plug - Sides	30♦&newtonm;	22♦lb♦ft
Engine Block Heater	50♦&newtonm;	37♦lb♦ft
Engine Block Oil Gallery Front Plug	20♦&newtonm;	15♦lb♦ft
Engine Block Oil Gallery Rear Plug	30♦&newtonm;	22♦lb♦ft
Engine Block Oil Gallery Side Plug	30♦&newtonm;	22♦lb♦ft
Engine Block Oil Gallery Top Plug	20♦&newtonm;	15♦lb♦ft
Engine Coolant Temperature (ECT) Sensor	50♦&newtonm;	37♦lb♦ft
Engine Coolant Temperature (ECT) Sensor Bracket Bolt	50♦&newtonm;	37♦lb♦ft
Engine Harness Bolt	5♦&newtonm;	44♦lb♦in
Engine Harness Ground Bolt	16♦&newtonm;	12♦lb♦ft
Engine Harness Stud	10♦&newtonm;	89♦lb♦in
Engine Mount Bolt-to-Engine Bracket	50♦&newtonm;	37♦lb♦ft
Engine Mount-to-Engine Bracket Bolt	50♦&newtonm;	37♦lb♦ft
Engine Mount Frame Bracket Thru Bolt	75♦&newtonm;	55♦lb♦ft
Engine Mount Frame Side Mount Bolt	65♦&newtonm;	50♦lb♦ft
Engine Shield Bolt	20♦&newtonm;	15♦lb♦ft
Engine Sight Shield Bracket Nut	5♦&newtonm;	44♦lb♦in
Engine Wiring Harness Bolt	16♦&newtonm;	12♦lb♦ft

EVAP Purge Valve Bolt	8♦&newtonm;	71♦lb♦in
Exhaust Manifold Center Bolt	35♦&newtonm;	26♦lb♦ft
Exhaust Manifold Nut	16♦&newtonm;	12♦lb♦ft
Exhaust Manifold Stud	20♦&newtonm;	15♦lb♦ft
Exhaust Manifold Heat Shield Bolt	25♦&newtonm;	18♦lb♦ft
Exhaust Manifold Heat Shield Nut	25♦&newtonm;	18♦lb♦ft
Flywheel Bolt - First Pass	40♦&newtonm;	30♦lb♦ft
Flywheel Bolt - Second Pass	80♦&newtonm;	59♦lb♦ft
Flywheel Bolt - Final Pass	100♦&newtonm;	74♦lb♦ft
Front Cover Bolt - First Pass	6♦&newtonm;	53♦lb♦in
Front Cover Bolt - Final Pass	12♦&newtonm;	106♦lb♦in
Fuel Rail Bolt/Stud	12♦&newtonm;	106♦lb♦in
Heater Hose Bracket Bolt	50♦&newtonm;	37♦lb♦ft
Hood Hinge Bolt	25♦&newtonm;	18♦lb♦ft
Ignition Coil Bolt	12♦&newtonm;	106♦lb♦in
Ignition Coil Wiring Harness Bolt	12♦&newtonm;	106♦lb♦in
Intake Manifold Bolts - In Sequence - First Pass	5♦&newtonm;	44♦lb♦in
Intake Manifold Bolts - In Sequence - Second Pass	8♦&newtonm;	71♦lb♦in
Intake Manifold Bolts - In Sequence - Third Pass	12♦&newtonm;	106♦lb♦in
Intake Manifold Bolt - In Sequence - Final Pass	15♦&newtonm;	11♦lb♦ft
J 42847 Flywheel Holding Tool Bolt	50♦&newtonm;	37♦lb♦ft
Knock Sensor	20♦&newtonm;	15♦lb♦ft
Knock Sensor Heat Shield Bolt	12♦&newtonm;	106♦lb♦in
Lift Bracket Bolt	40♦&newtonm;	30♦lb♦ft
MAP Sensor Bolt	12♦&newtonm;	106♦lb♦in
Oil Cooler Hose Fittings	23♦&newtonm;	17♦lb♦ft
Oil Fill Tube Bolt	12♦&newtonm;	106♦lb♦in
Oil Filter	38♦&newtonm;	28♦lb♦ft

Oil Filter Fitting	66♦&newtonm;	49♦lb♦ft
Oil Level Indicator Tube Bolt	25♦&newtonm;	18♦lb♦ft
Oil Level Sensor	20♦&newtonm;	15♦lb♦ft
Oil Pan Bolt - First Pass	10♦&newtonm;	89♦lb♦in
Oil Pan Bolt - Final Pass	25♦&newtonm;	18♦lb♦ft
Oil Pan Drain Plug	28♦&newtonm;	21♦lb♦ft
Oil Pan Skid Plate Bolt	20♦&newtonm;	15♦lb♦ft
Oil Pressure Gage Sensor	30♦&newtonm;	22♦lb♦ft
Oil Pump Bolt	75♦&newtonm;	56♦lb♦ft
Oil Pump Cover Bolt	12♦&newtonm;	106♦lb♦in
Oil Pump Drive Bolt	25♦&newtonm;	18♦lb♦ft
Power Steering Pump Bracket Bolt/Nut	50♦&newtonm;	37♦lb♦ft
Power Steering Pump Bracket Stud	20♦&newtonm;	15♦lb♦ft
Spark Plug	30♦&newtonm;	22♦lb♦ft
Thermostat Housing Bolt/Stud	30♦&newtonm;	22♦lb♦ft
Throttle Body Nut	10♦&newtonm;	89♦lb♦in
Throttle Body Stud	12♦&newtonm;	106♦lb♦in
Valve Lifter Guide Retainer Bolt	25♦&newtonm;	18♦lb♦ft
Valve Rocker Arm Cover Bolt - First Pass	6♦&newtonm;	53♦lb♦in
Valve Rocker Arm Cover Bolt - Final Pass	12♦&newtonm;	106♦lb♦in
Valve Rocker Arm Nut	35♦&newtonm;	26♦lb♦ft
Valve Rocker Arm Stud	50♦&newtonm;	37♦lb♦ft
Water Crossover Bolt	50♦&newtonm;	37♦lb♦ft
Water Pump Bolt - First Pass	25♦&newtonm;	18♦lb♦ft
Water Pump Bolt - Final Pass	50♦&newtonm;	37♦lb♦ft
Water Pump Pulley Bolt	25♦&newtonm;	18♦lb♦ft

## Specifications

### Engine Mechanical Specifications

## Engine Mechanical Specifications: Engine Mechanical - 8.1L

Application	Specification	
	Metric	English
General		
Engine Type	V-8	
Displacement	8.1L	496♦CID
RPO	L18	
VIN	G	
Bore	107.950♦mm	4.250♦in
Stroke	111.00♦mm	4.370♦in
Compression Ratio	9.1:1	
Firing Order	1-8-7-2-6-5-4-3	
Spark Plug Gap	1.52♦mm	0.060♦in
Block		
Crankshaft Main Bearing Bore Diameter	74.6060–74.6220♦mm	2.9372–2.9379♦in
Cylinder Bore Diameter - Production	107.950–107.968♦mm	4.2500–4.2507♦in
Cylinder Bore Diameter - Service	107.940–107.990♦mm	4.2496–4.2516♦in
Cylinder Bore Out-of-Round - Production, Maximum Minus Minimum Bore Diameter	0.0180♦mm	0.0007♦in
Cylinder Bore Out-of-Round - Service, Maximum Minus Minimum Bore Diameter	0.050♦mm	0.002♦in
Cylinder Bore Taper - Production	0.0180♦mm	0.0007♦in
Cylinder Bore Taper - Service Thrust Axis	0.050♦mm	0.002♦in
Cylinder Bore Taper - Service Pin Axis	0.050♦mm	0.002♦in
Cylinder Head Deck Height - from Centerline of Crankshaft	259.875–260.125♦mm	10.231–10.241♦in
Cylinder Head Deck Surface Flatness - Entire Face	0.100♦mm	0.004♦in
Cylinder Head Deck Surface Flatness - Within 150♦mm (6♦in)	0.050♦mm	0.002♦in

Valve Lifter Bore Diameter	21.417–21.443♦mm	0.843–0.844♦in
Camshaft		
Camshaft Bearing Inside Diameter	49.5480–49.5730♦mm	1.9507–1.9517♦in
Camshaft Journal Diameter	49.4720–49.5220♦mm	1.9477–1.9497♦in
Camshaft Lobe Lift - Exhaust	6.973–7.075♦mm	0.2745–0.2785♦in
Camshaft Lobe Lift - Intake	6.924–7.026♦mm	0.2726–0.2766♦in
Camshaft Runout - Production	0.051♦mm	0.002♦in
Camshaft Runout - Service	0.076♦mm	0.003♦in
Connecting Rod		
Connecting Rod Bearing Clearance - Production	0.033–0.068♦mm	0.0013–0.0027♦in
Connecting Rod Bearing Clearance - Service	0.033–0.081♦mm	0.0013–0.0032♦in
Connecting Rod Side Clearance	0.384–0.686♦mm	0.0151–0.0270♦in
Crankshaft		
Connecting Rod Journal Diameter	55.854–55.870♦mm	2.1990–2.1996♦in
Connecting Rod Journal Out-of-Round - Production	0.0102♦mm	0.0004♦in
Connecting Rod Journal Taper - Production	0.0102♦mm	0.0004♦in
Crankshaft End Play	0.127–0.350♦mm	0.0050–0.0138♦in
Crankshaft Main Bearing Clearance - #1, #2, #3, #4 Production	0.022–0.057♦mm	0.0008–0.0022♦in
Crankshaft Main Bearing Clearance - #5 Production	0.034–0.069♦mm	0.0013–0.0027♦in
Crankshaft Main Bearing Clearance - #1, #2, #3, #4 Service	0.022–0.089♦mm	0.0008–0.0035♦in
Crankshaft Main Bearing Clearance - #5 Service Limit	0.035–0.102♦mm	0.0014–0.0040♦in
Crankshaft Main Journal Diameter	69.805–69.822♦mm	2.7482–2.7489♦in
Crankshaft Main Journal Out-of-Round - Production	0.0102♦mm	0.0004♦in
Crankshaft Main Journal Taper - Production	0.0102♦mm	0.0004♦in
Crankshaft Runout - Production	0.050♦mm	0.0020♦in

Crankshaft Runout - Service	0.065♦mm	0.0026♦in
Cylinder Head		
Cylinder Head Height/Thickness	259.875–260.125♦mm	10.231–10.241♦in
Surface Flatness - Block Deck	0.050♦mm	0.002♦in
Surface Flatness - Exhaust Manifold Deck	0.102♦mm	0.004♦in
Surface Flatness - Intake Manifold Deck	0.080♦mm	0.003♦in
Exhaust Manifold		
Surface Flatness	0.254♦mm	0.010♦in
Lubrication System		
Oil Capacity - Without Filter	5.7L	6♦Qts
Oil Pressure - Minimum	34♦kPa @ 1,000♦RPM	5♦psi @ 1,000♦RPM
Oil Pressure - Minimum	69♦kPa @ 2,000♦RPM	10♦psi @ 2,000♦RPM
Piston Rings		
Piston Ring End Gap		
First Compression Ring - Production	0.300–0.450♦mm	0.012–0.018♦in
First Compression Ring - Service	0.450–0.675♦mm	0.018–0.027♦in
Second Compression Ring - Production	0.450–0.650♦mm	0.017–0.025♦in
Second Compression Ring - Service	0.675–0.975♦mm	0.026–0.039♦in
Oil Control Ring - Production	0.249–0.759♦mm	0.0098–0.0299♦in
Oil Control Ring - Service	0.373–1.138♦mm	0.015–0.045♦in
Piston Ring to Groove Clearance		
First Compression Ring	0.031–0.074♦mm	0.0012–0.0029♦in
Second Compression Ring	0.031–0.074♦mm	0.0012–0.0029♦in
Oil Control Ring	0.051–0.203♦mm	0.002–0.008♦in
Piston and Pins		
Piston		

Piston Diameter	Not Measurable	Not Measurable
Piston to Bore Clearance	Interference Fit	Interference Fit
Pin		
Piston Pin Clearance to Connecting Rod Bore	0.049–0.020♦mm Interference	0.00019–0.0007♦in Interference
Piston Pin Diameter	26.416–26.419♦mm	1.0400–1.0401♦in
Valve System		
Valves		
Valve Face Angle - Exhaust	45♦degrees	
Valve Face Angle - Intake	45♦degrees	
Valve Head Diameter - Exhaust	43.69♦mm	1.72♦in
Valve Head Diameter - Intake	55.63♦mm	2.19♦in
Valve Lash - Exhaust	Net Lash	Net Lash
Valve Lash - Intake	Net Lash	Net Lash
Valve Seat Angle - Exhaust	46♦degrees	
Valve Seat Angle - Intake	46♦degrees	
Valve Seat Runout - Exhaust	0.0500♦mm	0.002♦in
Valve Seat Runout - Intake	0.0500♦mm	0.002♦in
Valve Seat Width - Exhaust	1.651–2.159♦mm	0.060–0.095♦in
Valve Seat Width - Intake	0.800–1.200♦mm	0.030–0.060♦in
Valve Stem Diameter - Exhaust	9.431–9.449♦mm	0.3713–0.3720♦in
Valve Stem Diameter - Intake	9.436–9.454♦mm	0.3715–0.3722♦in
Valve Stem-to-Guide Clearance - Production Exhaust	0.030–0.079♦mm	0.0012–0.0031♦in
Valve Stem-to-Guide Clearance - Production Intake	0.025–0.074♦mm	0.0010–0.0029♦in
Valve Stem-to-Guide Clearance - Service Exhaust	0.030–0.104♦mm	0.0012–0.0041♦in
Valve Stem-to-Guide Clearance - Service Intake	0.025–0.099♦mm	0.0010–0.0039♦in

Rocker Arms		
Valve Rocker Arm Ratio	1.70:1	
Valve Springs		
Valve Spring Free Length	56.35♦mm	2.218♦in
Valve Spring Installed Height	45.923–46.685♦mm	1.808–1.838♦in
Valve Spring Load - Closed	381–419♦&newtonm; @ 45.923♦mm	86–94♦lb @ 1.808♦in
Valve Spring Load - Open	962–1058♦&newtonm; @ 33.985♦mm	216–236♦lb @ 1.338♦in

## Specifications

### Sealers, Adhesives, and Lubricants

*Engine Mechanical - 8.1L:Specifications:Sealers, Adhesives, and Lubricants*

Application	Type of Material	GM Part Number	
		United States	Canada
Block Heater Threads	Sealant	12346004	10953480
Camshaft Rear Bearing Hole Plug	Sealant	12377901	10953504
Crankshaft Position Sensor Bolt	Thread Adhesive	12345493	10953488
Crankshaft Rear Bearing Cap	Sealant	1052942	10953466
Cylinder Head Bolt Threads	Sealant	12346004	10953480
Cylinder Head Coolant Hole Plug	Sealant	12346004	10953480
Engine Block Coolant Drain Plugs	Sealant	12346004	10953480
Engine Block Oil Gallery Plugs	Sealant	12346004	10953480
Engine Coolant Temperature (ETC) Sensor Threads	Sealant	12346004	10953480
Engine Front Cover	Sealant	12346286	10953472
Engine Oil Supplement	Lubricant	1052367	992869
Intake Manifold	Sealant	12346141	10953433
Intake Manifold Bolt Threads	Thread Adhesive	12345382	10953489
Intake Manifold Engine Block/Cylinder Head	Sealant	12346141	10953433
Knock Sensor Threads	Sealant	12346004	10953480

Oil Cooler Hose Fittings	Sealant	12346004	10953480
Oil Fill Tube	Sealant	9985409	9985409
Oil Pan Corners	Sealant	12346286	10953472
Oil Pressure Sensor Threads	Sealant	12346004	10953480
Purge Solenoid Bolt	Thread Adhesive	12345493	10953488
Valve Rocker Arm Stud Threads	Sealant	12346004	10953480
Water Pump Bolt Threads	Sealant	12346004	10953480

## Component Locator

### Disassembled Views

#### Intake Manifold/Upper Engine

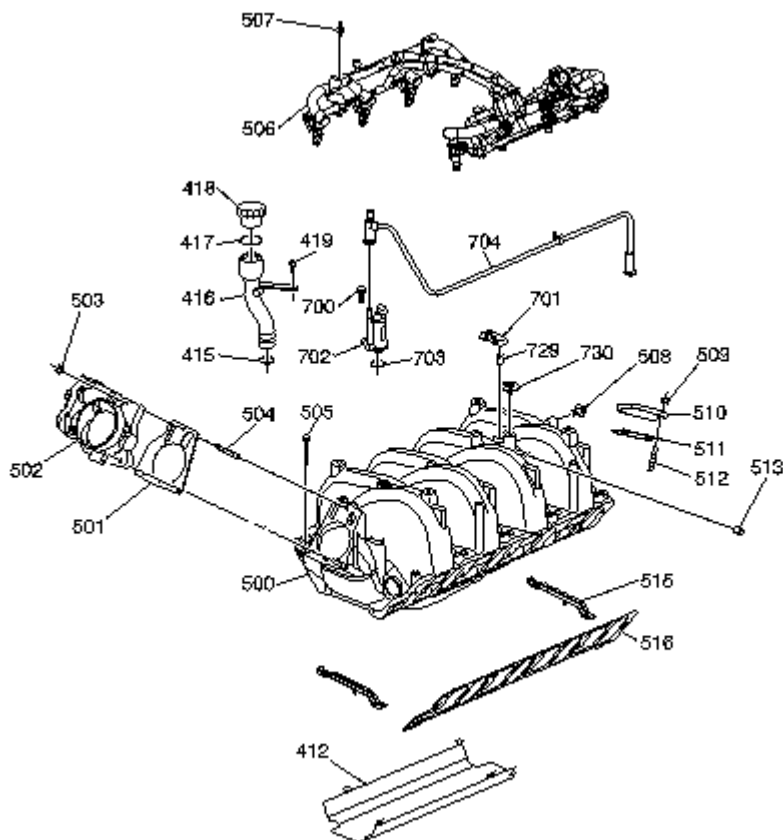

- 412. *Splash Shield*
- 415. *Oil Fill Tube O-ring*
- 416. *Oil Fill Tube*
- 417. *Oil Fill Cap O-ring*
- 418. *Oil Fill Cap*
- 419. *Oil Fill Tube Bolt*
- 500. *Intake Manifold*
- 501. *Throttle Body Gasket*

- 502. Throttle Body
- 503. Throttle Body Nut
- 504. Throttle Body Stud
- 505. Intake Manifold Bolt
- 506. Fuel Rail with Injectors
- 507. Fuel Rail Bolt/Stud
- 508. Intake Manifold Plug
- 509. EGR Cover Nut
- 510. EGR Cover
- 511. EGR Cover Gasket
- 512. EGR Cover Stud
- 513. Vacuum Fitting Plug
- 515. Intake Gasket - End Seal
- 516. Intake Gasket - Side
- 700. EVAP Valve Bolt
- 701. MAP Sensor
- 702. EVAP Valve
- 703. EVAP Valve O-ring
- 704. EVAP Tube
- 729. MAP Sensor Grommet
- 730. MAP Sensor Bolt

### Cylinder Head/Upper Engine

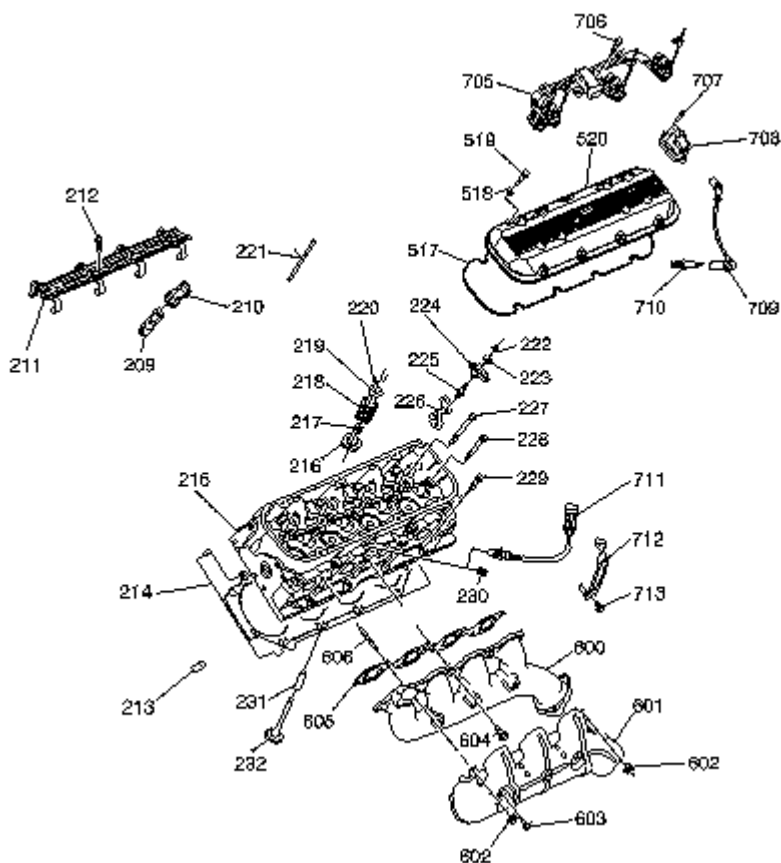

- 209. Valve Lifter
- 210. Valve Lifter Guide
- 211. Valve Lifter Retainer
- 212. Valve Lifter Retainer Bolt

- 213. *Cylinder Head Locating Pin*
- 214. *Cylinder Head Gasket*
- 215. *Cylinder Head*
- 216. *Valve Rotator*
- 217. *Valve Stem Oil Seal*
- 218. *Valve Spring*
- 219. *Valve Spring Cap*
- 220. *Valve Stem Keys*
- 221. *Pushrod*
- 222. *Rocker Arm Nut*
- 223. *Rocker Arm Ball*
- 224. *Rocker Arm*
- 225. *Rocker Arm Bolt/Stud*
- 226. *Pushrod Guide*
- 227. *Cylinder Head Bolt - Long*
- 228. *Cylinder Head Bolt - Medium*
- 229. *Cylinder Head Bolt - Short*
- 230. *Cylinder Head Coolant Plug*
- 231. *Valve Guide - Exhaust*
- 232. *Valve*
- 517. *Valve Cover Gasket*
- 518. *Valve Cover Bolt Grommet*
- 519. *Valve Cover Bolt*
- 520. *Valve Cover*
- 600. *Exhaust Manifold*
- 601. *Exhaust Manifold Heat Shield*
- 602. *Exhaust Manifold Nut*
- 602. *Exhaust Manifold Nut*
- 603. *Exhaust Manifold Heat Shield Bolt*
- 604. *Exhaust Manifold Bolt*
- 605. *Exhaust Manifold Gasket*
- 606. *Exhaust Manifold Stud*
- 705. *Ignition Coil Wire Harness*
- 706. *Ignition Coil Wire Harness Bolt*
- 707. *Ignition Coil Bolt*
- 708. *Ignition Coil*
- 709. *Spark Plug Wire*
- 710. *Spark Plug*
- 711. *Engine Coolant Temperature (ECT) Sensor*
- 712. *ECT Sensor Bracket*
- 713. *ECT Sensor Bracket Bolt*

### **Front of Engine**

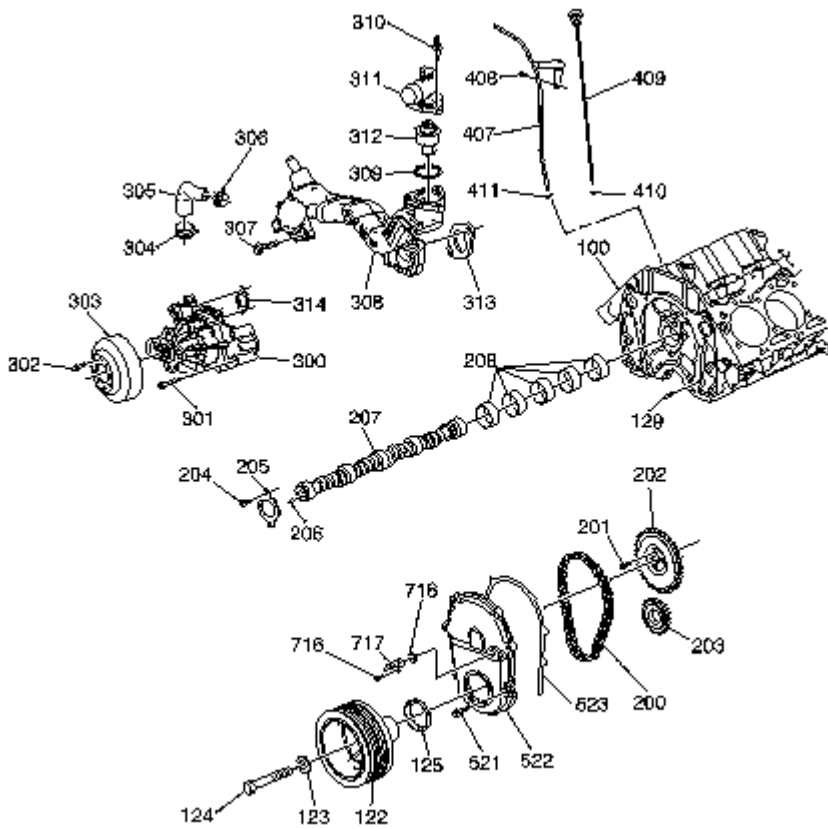

- 100. Engine Block
- 122. Crankshaft Balancer
- 123. Crankshaft Balancer Bolt Washer
- 124. Crankshaft Balancer Bolt
- 125. Crankshaft Front Oil Seal
- 129. Front Cover Locating Pin
- 200. Timing Chain
- 201. Camshaft Sprocket Bolt
- 202. Camshaft Sprocket
- 203. Crankshaft Sprocket
- 204. Camshaft Retainer Bolt
- 205. Camshaft Retainer
- 206. Camshaft Sprocket Locating Pin
- 207. Camshaft
- 208. Camshaft Bearings
- 300. Water Pump
- 301. Water Pump Bolt
- 302. Water Pump Pulley Bolt
- 303. Water Pump Pulley
- 304. Water Pump Bypass Hose Clamp
- 305. Water Pump Bypass Hose
- 306. Water Pump Bypass Hose Clamp
- 307. Water Crossover Bolt
- 308. Water Crossover
- 309. Thermostat O-ring
- 310. Thermostat Housing Bolt/Stud

- 311. Thermostat Housing
- 312. Thermostat
- 313. Water Crossover Gasket
- 314. Water Pump Gasket
- 408. Oil Level Indicator Tube Bolt
- 407. Oil Level Indicator Tube
- 409. Oil Level Indicator
- 410. Oil Level Indicator O-ring
- 411. Oil Level Indicator Tube O-ring
- 521. Front Cover Bolt
- 522. Front Cover
- 523. Front Cover Gasket
- 716. Camshaft Position Sensor Bolt
- 717. Camshaft Position Sensor
- 718. Camshaft Position Sensor O-ring

### Rear of Engine

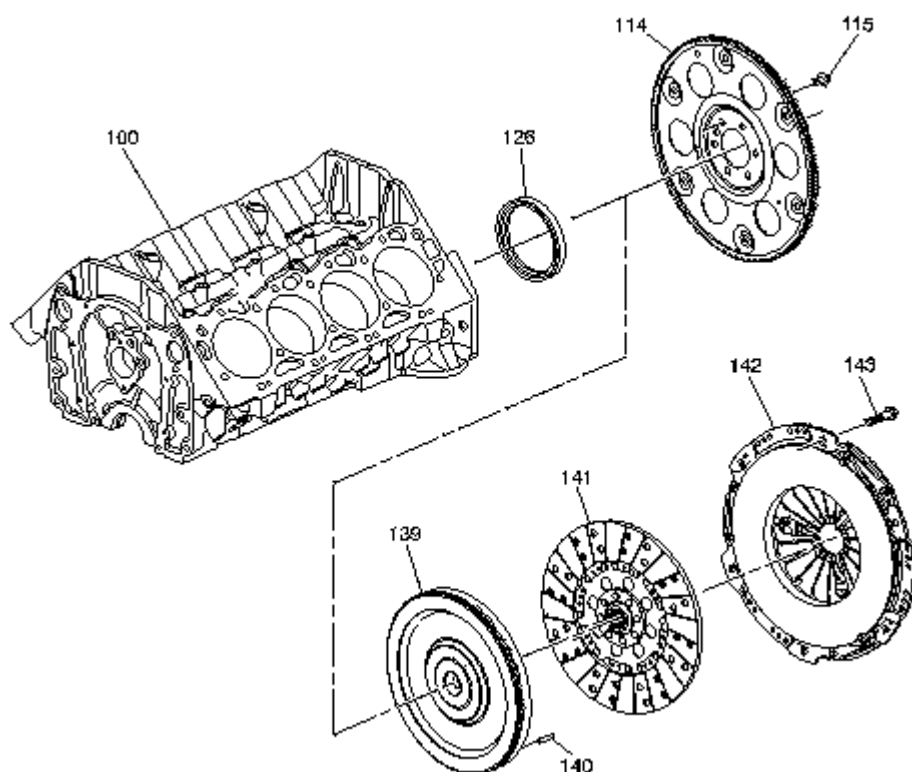

- 100. Engine Block
- 114. Flywheel – Automatic Transmission
- 115. Flywheel Bolt
- 126. Crankshaft Rear Oil Seal
- 139. Flywheel – Manual Transmission
- 140. Pressure Plate Locating Pin – Manual Transmission
- 141. Clutch Disc – Manual Transmission
- 142. Pressure Plate – Manual Transmission
- 143. Pressure Plate Bolt – Manual Transmission

## Lower Engine Assembly

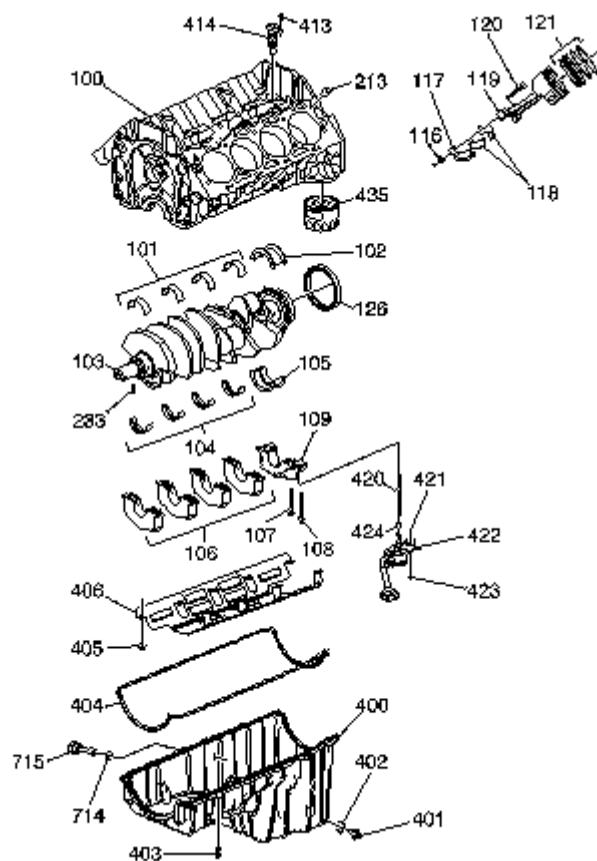

- 100. Engine Block
- 101. Crankshaft Main Bearings – Upper
- 102. Crankshaft Thrust Bearing – Upper
- 103. Crankshaft
- 104. Crankshaft Main Bearings – Lower
- 105. Crankshaft Thrust Bearings – Lower
- 106. Crankshaft Bearing Cap
- 107. Crankshaft Bearing Cap Bolt
- 108. Crankshaft Bearing Cap Bolt/Stud
- 109. Crankshaft Bearing Cap – Thrust
- 116. Connecting Rod Nut
- 117. Connecting Rod Cap
- 118. Connecting Rod Bearings
- 119. Piston and Connecting Rod Assembly
- 120. Connecting Rod Bolt
- 121. Piston Rings
- 126. Crankshaft Rear Oil Seal
- 213. Cylinder Head Locating Pin
- 233. Crankshaft Sprocket Locating Pin
- 400. Oil Pan
- 401. Oil Pan Drain Plug
- 402. Oil Pan Drain Plug O-ring
- 403. Oil Pan Bolt
- 404. Oil Pan Gasket
- 405. Crankshaft Oil Deflector Nut

- 406. Crankshaft Oil Deflector
- 413. Oil Pump Drive Bolt
- 414. Oil Pump Drive
- 420. Oil Pump Driveshaft
- 421. Oil Pump Locating Pin
- 422. Oil Pump
- 423. Oil Pump Bolt
- 424. Oil Pump Driveshaft Retainer
- 435. Oil Filter
- 714. Oil Level Sensor O-ring
- 715. Oil Level Sensor

### Engine Block Plugs/Sensors

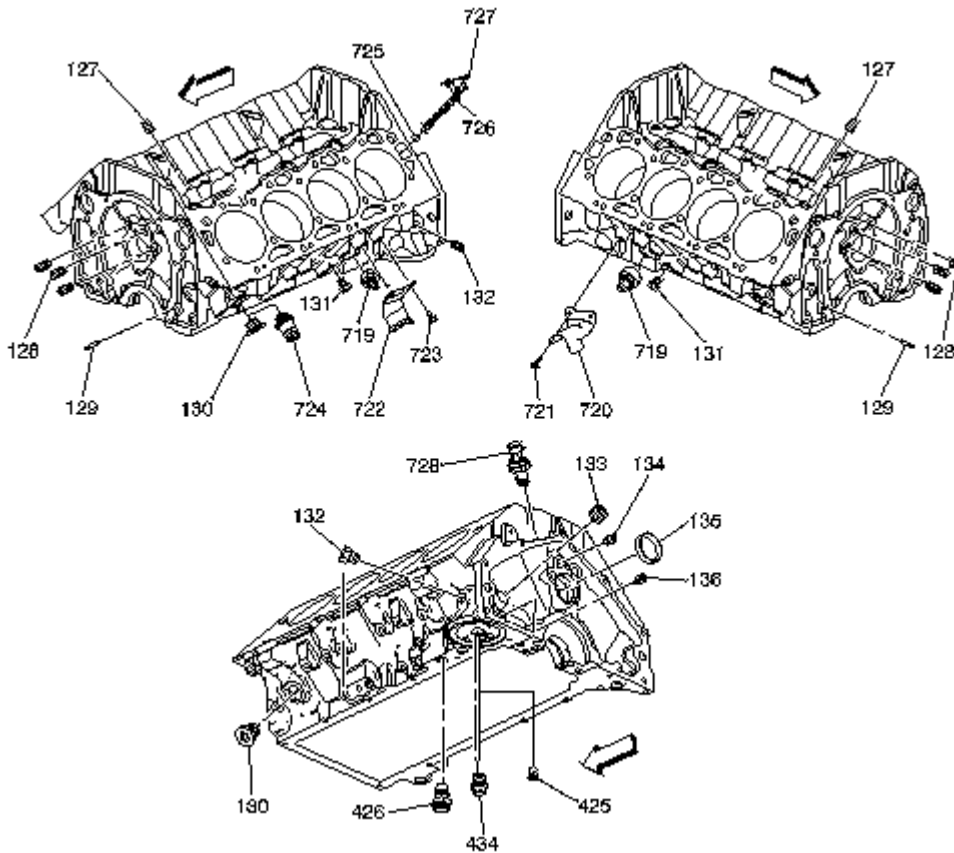

- 127. Oil Gallery Plug – Top
- 127. Oil Gallery Plug – Top
- 128. Oil Gallery Plug – Front
- 128. Oil Gallery Plug – Front
- 129. Front Cover Locating Pin
- 129. Front Cover Locating Pin
- 130. Coolant Drain Plug
- 130. Coolant Drain Plug
- 131. Oil Gallery Plug – Side
- 131. Oil Gallery Plug – Side
- 132. Oil Gallery Plug – Left Side Rear
- 132. Oil Gallery Plug – Left Side Rear
- 133. Oil Gallery Plug – Rear
- 134. Oil Gallery Plug – Rear

- 135. Camshaft Hole Plug
- 136. Oil Gallery Plug – Rear
- 425. Oil Filter Bypass Valve
- 426. Oil Cooler Fitting
- 434. Oil Filter Fitting
- 719. Knock Sensor
- 719. Knock Sensor
- 720. Knock Sensor Heat Shield – Right
- 721. Knock Sensor Heat Shield Bolt
- 722. Knock Sensor Heat Shield – Left
- 723. Knock Sensor Heat Shield Bolt
- 724. Block Coolant Heater
- 725. Crankshaft Position Sensor O-ring
- 726. Crankshaft Position Sensor
- 727. Crankshaft Position Sensor Bolt
- 728. Oil Pressure Sensor

### Oil Pump Assembly

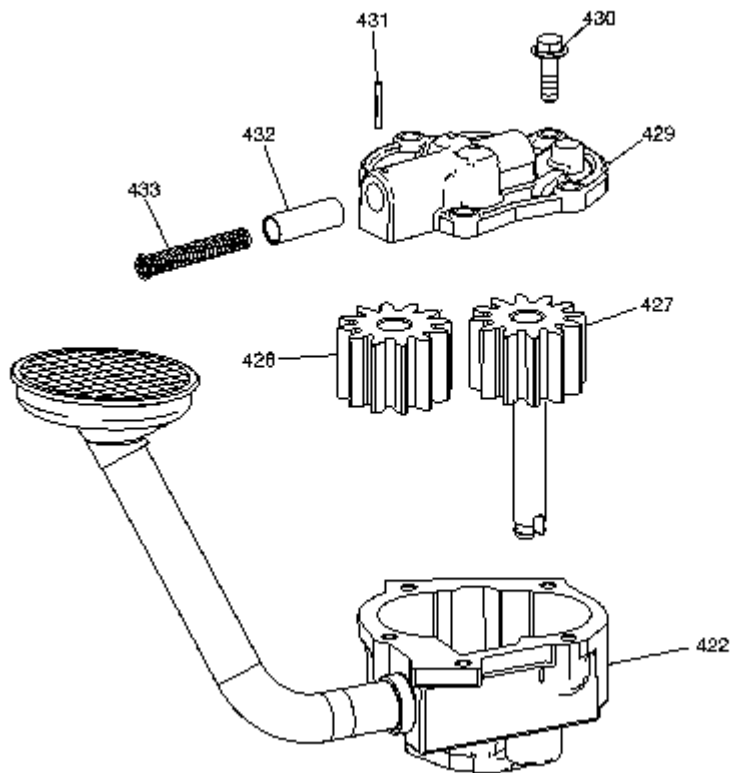

- 422. Oil Pump with Pickup Screen
- 427. Drive Gear
- 428. Driven Gear
- 429. Oil Pump Cover
- 430. Oil Pump Cover Bolt
- 431. Pressure Relief Valve/Spring Pin
- 432. Pressure Relief Valve
- 433. Pressure Relief Valve Spring

## Component Locator

### Engine Identification

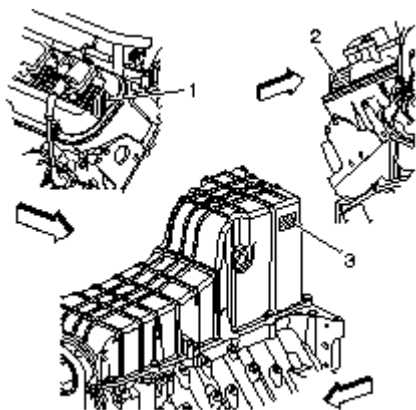

The engine identification number is located in three locations. There are labels on the front of the right rocker arm cover♦(1), the rear of the left rocker arm cover♦(2), and the right side of the engine oil pan♦(3). The engine identification number is used to track and identify the engine prior to installation in a vehicle.

The Vehicle Identification Number (VIN) Derivative is located on the left rear side of the engine block and is a nine digit number stamped or laser etched onto the engine at the vehicle assembly plant. If reading the identification number from the left, the following information can be obtained:

- The first digit identifies the division.
- The second digit identifies the model year.
- The third digit identifies the assembly plant.
- The fourth through ninth digits are the last six digits of the Vehicle Identification Number (VIN).

## Diagnostic Information and Procedures

### Diagnostic Starting Point - Engine Mechanical

*Engine Mechanical - 8.1L:Diagnosis:Diagnostic Starting Point - Engine Mechanical*

Begin the system diagnosis by reviewing the [Disassembled Views](#) , [Engine Component Description](#) , [Lubrication Description](#) , [New Product Information](#) , and the [Drive Belt System Description](#) . Reviewing the description and operation information will help you determine the correct symptom diagnostic procedure when a malfunction exists. Reviewing the description and operation information will also help you determine if the condition described by the customer is normal operation. Refer to [Symptoms - Engine Mechanical](#) in order to identify the correct procedure for diagnosing the system and where the procedure is located.

## Diagnostic Information and Procedures

### Symptoms - Engine Mechanical

*Engine Mechanical - 8.1L:Diagnosis:Symptoms - Engine Mechanical*

### Strategy Based Diagnostics

1. Perform a [Diagnostic System Check - Engine Controls](#) in Engine Controls – 8.1L before using the symptom tables, if applicable.
2. Review the system operations in order to familiarize yourself with the system functions. Refer to [Disassembled Views](#) , [Engine Component Description](#) , [Drive Belt System Description](#) , [Lubrication Description](#) and [New Product Information](#) .

All diagnosis on a vehicle should follow a logical process. Strategy based diagnostics is a uniform approach for repairing all systems. The diagnostic flow may always be used in order to resolve a system problem. The diagnostic flow is the place to start when repairs are necessary. For a detailed explanation, refer to [Strategy Based Diagnosis](#) in General Information.

## Visual/Physical Inspection

- Inspect for aftermarket devices which could affect the operation of the Engine. Refer to *Checking Aftermarket Accessories* in Wiring Systems.
- Inspect the easily accessible or visible system components for obvious damage or conditions which could cause the symptom.
- Check for the correct oil level, proper oil viscosity, and correct filter application.
- Verify the exact operating conditions under which the concern exists. Note factors such as engine RPM, ambient temperature, engine temperature, amount of engine warm-up time, and other specifics.
- Compare the engine sounds, if applicable, to a known good engine and make sure you are not trying to correct a normal condition.

## Intermittent

Test the vehicle under the same conditions that the customer reported in order to verify the system is operating properly.

## Symptom List

Refer to a symptom diagnostic procedure from the following list in order to diagnose the symptom:

- *Base Engine Misfire without Internal Engine Noises*
- *Base Engine Misfire with Abnormal Internal Lower Engine Noises*
- *Base Engine Misfire with Abnormal Valve Train Noise*
- *Base Engine Misfire with Coolant Consumption*
- *Base Engine Misfire with Excessive Oil Consumption*
- *Engine Noise on Start-Up, but Only Lasting a Few Seconds*
- *Upper Engine Noise, Regardless of Engine Speed*
- *Lower Engine Noise, Regardless of Engine Speed*
- *Engine Noise Under Load*
- *Engine Will Not Crank - Crankshaft Will Not Rotate*
- *Coolant in Combustion Chamber*
- *Coolant in Engine Oil*
- *Oil Consumption Diagnosis*
- *Oil Pressure Diagnosis and Testing*
- *Oil Leak Diagnosis*
- *Cylinder Leakage Test*
- *Engine Compression Test*
- *Drive Belt Chirping Diagnosis*
- *Drive Belt Squeal Diagnosis*
- *Drive Belt Whine Diagnosis*
- *Drive Belt Rumbling Diagnosis*
- *Drive Belt Vibration Diagnosis*

- [Drive Belt Falls Off Diagnosis](#)
- [Drive Belt Excessive Wear Diagnosis](#)

## Diagnostic Information and Procedures

### Base Engine Misfire without Internal Engine Noises

*Engine Mechanical - 8.1L:Diagnosis:Base Engine Misfire without Internal Lower Engine Noises*

Cause	Correction
<p>Abnormalities such as severe cracking, bumps, or missing areas in the accessory drive belt</p> <p>Abnormalities in the accessory drive system and/or components may cause engine RPM variations and lead to a misfire DTC. A misfire code may be present without an actual misfire condition.</p>	<p>Replace the drive belt. Refer to <a href="#">Drive Belt Replacement - Accessory</a> .</p>
<p>Worn, damaged, or mis-aligned accessory drive components or excessive pulley runout</p> <p>A misfire code may be present without an actual misfire condition.</p>	<p>Inspect the components, repair or replace as required.</p>
<p>Loose or improperly installed engine flywheel or crankshaft balancer</p> <p>A misfire code may be present without an actual misfire condition.</p>	<p>Repair or replace the flywheel and/or balancer as required. Refer to <a href="#">Engine Flywheel Replacement</a> or <a href="#">Crankshaft Balancer Replacement</a> .</p>
<p>Restricted exhaust system</p> <p>A severe restriction in the exhaust flow can cause significant loss of engine performance and may set a DTC. Possible causes of restrictions include collapsed or dented pipes or plugged mufflers and/or catalytic converters.</p>	<p>Repair or replace as required.</p>
<p>Improperly installed or damaged vacuum hoses</p>	<p>Repair or replace as required.</p>
<p>Improper sealing between the intake manifold and cylinder heads or throttle body</p>	<p>Replace the intake manifold, gaskets, cylinder heads and/or throttle body as required.</p>
<p>Improperly installed or damaged MAP sensor</p> <p>The sealing grommet of the MAP sensor should not be torn or damaged.</p>	<p>Repair or replace the MAP sensor as required.</p>
<p>Worn or loose rocker arms</p>	<p>Repair or replace the valve rocker arms as required.</p>
<p>Worn or bent push rods</p>	<p>Replace the push rods.</p>
<p>Sticking valves</p> <p>Carbon buildup on the valve stem can cause the valve not to close properly.</p>	<p>Repair or replace as required.</p>
<p>Excessively worn or mis-aligned timing chain</p>	<p>Repair or replace the timing chain, camshaft retainer and sprockets as required.</p>
<p>Worn camshaft lobes</p>	<p>Replace the camshaft and valve lifters.</p>
<p>Excessive oil pressure</p> <p>A lubrication system with excessive oil pressure may lead to excessive valve lifter pump-up and loss of compression.</p>	<ul style="list-style-type: none"> <li>• Perform an oil pressure test. Refer to <a href="#">Oil Pressure Diagnosis and Testing</a> .</li> </ul>

	<ul style="list-style-type: none"> <li>• Repair or replace the oil pump as required.</li> </ul>
<p>Faulty cylinder head gaskets and/or cracking or other damage to the cylinder heads and engine block cooling system passages.</p> <p>Coolant consumption may or may not cause the engine to overheat.</p>	<ul style="list-style-type: none"> <li>• Inspect for spark plugs saturated by coolant. Refer to <a href="#">Spark Plug Inspection</a> in Engine Controls – 8.1L.</li> <li>• Perform a pressure test to the cooling system. Refer to <a href="#">Loss of Coolant</a> in Engine Cooling.</li> <li>• Inspect the cylinder heads, engine block, and/or head gaskets. Refer to <a href="#">Coolant in Combustion Chamber</a>.</li> <li>• Repair or replace as required.</li> </ul>
<p>Worn piston rings</p> <p>Oil consumption may or may not cause the engine to misfire.</p>	<ul style="list-style-type: none"> <li>• Inspect the spark plugs for oil deposits. Refer to <a href="#">Spark Plug Inspection</a> in Engine Controls – 8.1L.</li> <li>• Inspect the cylinders for a loss of compression. Refer to <a href="#">Engine Compression Test</a>.</li> <li>• Perform cylinder leak down and compression testing to identify the cause. Refer to <a href="#">Cylinder Leakage Test</a>.</li> <li>• Repair or replace as required.</li> </ul>
<p>A damaged crankshaft reluctor wheel</p> <p>A damaged crankshaft reluctor wheel can result in different symptoms depending on the severity and location of the damage.</p> <ul style="list-style-type: none"> <li>• Systems with electronic communications, DIS or coil per cylinder, and SEVERE reluctor ring damage may exhibit periodic loss of crankshaft position, stop delivering a signal, and then re-sync the crankshaft position.</li> <li>• Systems with electronic communication, DIS or coil per cylinder, and SLIGHT reluctor ring damage may exhibit no loss of crankshaft position and no misfire may occur. However, a P0300 DTC may be set.</li> <li>• Systems with mechanical communications and SEVERE reluctor ring damage may cause additional pulses and effect fuel and spark delivery to the point of generating a P0300 DTC or P0336.</li> </ul>	<p>Replace the sensor and/or crankshaft reluctor wheel as required.</p>

## Diagnostic Information and Procedures

### Base Engine Misfire with Abnormal Internal Lower Engine Noises

*Engine Mechanical - 8.1L:Diagnosis:Base Engine Misfire with Abnormal Internal Lower Engine Noises*

Cause	Correction
<p>Abnormalities such as severe cracking, bumps or missing areas in the accessory drive belt</p> <p>Abnormalities in the accessory drive system and/or components may cause engine RPM variations, noises similar to a faulty lower engine and also lead to a misfire condition. A misfire code may be present without an actual misfire condition.</p>	<p>Replace the drive belt. Refer to <a href="#">Drive Belt Replacement - Accessory</a>.</p>

Worn, damaged, or mis-aligned accessory drive components or excessive pulley runout A misfire code may be present without an actual misfire condition.	Inspect the components, repair or replace as required.
Loose or improperly installed engine flywheel or crankshaft balancer A misfire code may be present without an actual misfire condition.	Repair or replace the flywheel and/or balancer as required. Refer to <i>Engine Flywheel Replacement</i> or <i>Crankshaft Balancer Replacement</i> .
Worn piston rings Oil consumption may or may not cause the engine to misfire.	<ul style="list-style-type: none"> <li>Inspect the spark plugs for oil deposits. Refer to <i>Spark Plug Inspection</i> in Engine Controls – 8.1L.</li> <li>Inspect the cylinders for a loss of compression. Refer to <i>Engine Compression Test</i>.</li> <li>Perform cylinder leak down and compression testing to determine the cause. Refer to <i>Cylinder Leakage Test</i>.</li> <li>Repair or replace as required.</li> </ul>
Worn Crankshaft Thrust Bearings Severely worn thrust surfaces on the crankshaft and/or thrust bearing may permit fore and aft movement of the crankshaft and create a DTC without an actual misfire condition.	<ul style="list-style-type: none"> <li>Check the crankshaft endplay.</li> <li>Replace the crankshaft and/or bearings as required.</li> </ul>

## Diagnostic Information and Procedures

### Base Engine Misfire with Abnormal Valve Train Noise

*Engine Mechanical - 8.1L:Diagnosis:Base Engine Misfire with Abnormal Valve Train Noise*

Cause	Correction
Worn or loose rocker arms	Repair or replace the valve rocker arms as required.
Worn or bent push rods	Replace the push rods.
Sticking valves Carbon buildup on the valve stem can cause the valve not to close properly.	Repair or replace as required.
Excessively worn or mis-aligned timing chain	Repair or replace the timing chain, camshaft retainer and sprockets as required.
Worn camshaft lobes	Replace the camshaft and valve lifters.
Sticking lifters	Replace as required.

## Diagnostic Information and Procedures

### Base Engine Misfire with Coolant Consumption

*Engine Mechanical - 8.1L:Diagnosis:Base Engine Misfire with Coolant Consumption*

Cause	Correction
Faulty cylinder head gaskets and/or cracking or other damage to the	

cylinder heads and engine block cooling system passages.

Coolant consumption may or may not cause the engine to overheat.

- Inspect for spark plugs saturated by coolant. Refer to [Spark Plug Inspection](#) in Engine Controls - 8.1L.
- Perform a pressure test to the cooling system. Refer to [Loss of Coolant](#) in Engine Cooling.
- Perform a cylinder leak down test. Refer to [Cylinder Leakage Test](#).
- Inspect the cylinder heads and engine block for damage to the coolant passages and/or a faulty head gasket. Refer to [Coolant in Combustion Chamber](#).
- Repair or replace as required.

## Diagnostic Information and Procedures

### Base Engine Misfire with Excessive Oil Consumption

*Engine Mechanical - 8.1L:Diagnosis:Base Engine Misfire with Excessive Oil Consumption*

Cause	Correction
Leaking intake gaskets	Repair or replace the intake manifold bolts and/or gaskets as required.
Worn valves, valve guides and/or valve stem oil seals	<ul style="list-style-type: none"> <li>• Inspect the spark plugs for oil deposits. Refer to <a href="#">Spark Plug Inspection</a> in Engine Controls – 8.1L.</li> <li>• Repair or replace as required.</li> </ul>
Worn piston rings Oil consumption may or may not cause the engine to misfire.	<ul style="list-style-type: none"> <li>• Inspect the spark plugs for oil deposits. Refer to <a href="#">Spark Plug Inspection</a> in Engine Controls – 8.1L.</li> <li>• Inspect the cylinders for a loss of compression. Refer to <a href="#">Engine Compression Test</a>.</li> <li>• Perform cylinder leak down and compression testing to determine the cause. Refer to <a href="#">Cylinder Leakage Test</a>.</li> <li>• Repair or replace as required.</li> </ul>

## Diagnostic Information and Procedures

### Engine Noise on Start-Up, but Only Lasting a Few Seconds

*Engine Mechanical - 8.1L:Diagnosis:Engine Noise on Start-Up, but Only Lasting a Few Seconds*

Cause	Correction
<p><b>Important:</b> A cold piston knock which disappears in 1.5 minutes should be considered acceptable. A cold engine knock usually disappears when the specific cylinder's secondary ignition circuit is grounded out during diagnosis.</p> <p>A light rattle/tapping noise may indicate a valve train, upper engine, concern, or a low rumble/knocking may indicate a crankshaft or piston, lower engine, concern.</p>	
Incorrect oil level Too high an oil level will cause aeration within the oil	Add or remove oil as required to achieve proper level.

Incorrect oil filter without anti-drainback feature	Install the correct oil filter.
Incorrect oil viscosity	<ul style="list-style-type: none"> <li>• Drain the oil.</li> <li>• Install the correct viscosity oil.</li> </ul>
High valve lifter leak down rate	Replace the valve lifters as required.
Worn crankshaft thrust bearing	<ul style="list-style-type: none"> <li>• Check the crankshaft endplay.</li> <li>• Inspect the thrust bearing and crankshaft.</li> <li>• Repair or replace as required.</li> </ul>
Damaged or faulty oil filter by-pass valve	<ul style="list-style-type: none"> <li>• Inspect the oil filter by-pass valve for proper operation.</li> <li>• Repair or replace as required.</li> </ul>

## Diagnostic Information and Procedures

### Upper Engine Noise, Regardless of Engine Speed

*Engine Mechanical - 8.1L:Diagnosis:Upper Engine Noise, Regardless of Engine Speed*

Cause	Correction
<p><b>Important:</b> A cold piston knock which disappears in 1.5 minutes should be considered acceptable. A cold engine knock usually disappears when the specific cylinder's secondary ignition circuit is grounded out during diagnosis. A light rattle/tapping noise may indicate a valve train, upper engine, concern.</p>	
Plugged oil filter	Replace the oil filter.
Low oil pressure	<ul style="list-style-type: none"> <li>• Verify proper oil level.</li> <li>• Perform an oil pressure test. Refer to <a href="#">Oil Pressure Diagnosis and Testing</a>.</li> <li>• Repair or replace as required.</li> </ul>
Loose and/or worn valve rocker arm attachments	<ul style="list-style-type: none"> <li>• Inspect the valve rocker arm stud, nut or bolt.</li> <li>• Repair or replace as required.</li> </ul>
Worn valve rocker arm	Replace the valve rocker arm.
Worn pushrod guide plate	Replace as required.
Bent or damaged push rod	Inspect the following components, and replace as required: <ul style="list-style-type: none"> <li>• The valve rocker arm</li> <li>• The valve push rod</li> <li>• The valve lifter</li> </ul>
Improper lubrication to the valve rocker arms	Inspect the following components, and repair or replace as required: <ul style="list-style-type: none"> <li>• The valve rocker arm</li> </ul>

	<ul style="list-style-type: none"> <li>• The valve push rod</li> <li>• The valve lifter</li> <li>• The oil filter bypass valve</li> <li>• The oil pump and pump screen</li> <li>• The engine block oil galleries</li> </ul>
Broken valve spring	Replace the valve spring.
Worn and/or damaged valve rotators	Replace the valve rotators as required.
Worn or dirty valve lifters	Replace the valve lifters.
Stretched or broken timing chain and/or damaged sprocket teeth	Replace the timing chain and sprockets.
Worn engine camshaft lobes	<ul style="list-style-type: none"> <li>• Inspect the engine camshaft lobes.</li> <li>• Replace the camshaft and valve lifters as required.</li> </ul>
Worn valve guides or valve stems	Inspect the following components, and repair as required: <ul style="list-style-type: none"> <li>• The valves</li> <li>• The valve guides</li> </ul>
Stuck valves Carbon on the valve stem or valve seat may cause the valve to stick.	Inspect the following components, and repair as required: <ul style="list-style-type: none"> <li>• Use GM Top Engine Cleaner, GM♦P/N♦1050002, (Canadian♦P/N♦992872), to eliminate carbon deposits following manufacturer's instructions</li> <li>• The valves</li> <li>• The valve guides</li> </ul>

## Diagnostic Information and Procedures

### Lower Engine Noise, Regardless of Engine Speed

*Engine Mechanical - 8.1L:Diagnosis:Lower Engine Noise, Regardless of Engine Speed*

Cause	Correction
<p><b>Important:</b> A cold piston knock which disappears in 1.5♦minutes should be considered acceptable. A cold engine knock usually disappears when the specific cylinder's secondary ignition circuit is grounded out during diagnosis. A low rumble/knocking may indicate a crankshaft or piston, lower engine, concern.</p>	
Low oil pressure	<ul style="list-style-type: none"> <li>• Verify proper oil level.</li> <li>• Perform an oil pressure test. Refer to <a href="#">Oil Pressure Diagnosis and Testing</a> .</li> <li>• Repair or replace damaged components as required.</li> </ul>
Worn accessory drive components Abnormalities such as severe cracking, bumps or missing areas in the	<ul style="list-style-type: none"> <li>• Inspect the accessory drive system.</li> </ul>

accessory drive belt and/or misalignment of system components.	<ul style="list-style-type: none"> <li>• Repair or replace as required.</li> </ul>
Loose or damaged crankshaft balancer	<ul style="list-style-type: none"> <li>• Inspect the crankshaft balancer.</li> <li>• Repair or replace as required.</li> </ul>
Detonation or spark knock	Verify the correct operation of the ignition controls system. Refer to <a href="#">Detonation/Spark Knock</a> in Engine Controls - 8.1L.
Loose torque converter bolts, automatic transmission only	<ul style="list-style-type: none"> <li>• Inspect the torque converter bolts and flywheel.</li> <li>• Repair or replace as required.</li> </ul>
Loose or damaged flywheel	Repair or replace the flywheel.
Damaged oil pan, contacting the oil pump screen An oil pan that has been damaged may improperly position the oil pump screen, preventing proper oil flow to the oil pump.	<ul style="list-style-type: none"> <li>• Inspect the oil pan.</li> <li>• Inspect the oil pump screen.</li> <li>• Repair or replace as required.</li> </ul>
Oil pump screen loose, damaged or restricted	<ul style="list-style-type: none"> <li>• Inspect the oil pump screen.</li> <li>• Repair or replace as required.</li> </ul>
Excessive piston-to-cylinder bore clearance	<ul style="list-style-type: none"> <li>• Inspect the piston and cylinder bore.</li> <li>• Repair as required.</li> </ul>
Excessive piston pin-to-bore clearance	<ul style="list-style-type: none"> <li>• Inspect the piston, piston pin, and the connecting rod.</li> <li>• Repair or replace as required.</li> </ul>
Excessive connecting rod bearing clearance	Inspect the following components, and repair as required: <ul style="list-style-type: none"> <li>• The connecting rod bearings</li> <li>• The connecting rods</li> <li>• The crankshaft</li> <li>• The crankshaft journals</li> </ul>
Excessive crankshaft bearing clearance	Inspect the following components, and repair as required: <ul style="list-style-type: none"> <li>• The crankshaft bearings</li> <li>• The crankshaft journals</li> </ul>
Incorrect piston, piston pin and connecting rod installation Pistons must be installed with the mark or dimple on the top of the piston facing the front of the engine. Piston pins must be centered in the connecting rod pin bore.	<ul style="list-style-type: none"> <li>• Verify the pistons, piston pins and connecting rods are installed correctly.</li> <li>• Repair as required.</li> </ul>

## Diagnostic Information and Procedures

### Engine Noise Under Load

*Engine Mechanical - 8.1L:Diagnosis:Engine Noise Under Load*

Cause	Correction
<p><b>Important:</b> A cold piston knock which disappears in 1.5 minutes should be considered acceptable. A cold engine knock usually disappears when the specific cylinder's secondary ignition circuit is grounded out during diagnosis. A low rumble/knocking may indicate a crankshaft or piston, lower engine, concern.</p>	
Low oil pressure	<ul style="list-style-type: none"> <li>• Perform an oil pressure test. Refer to <i>Oil Pressure Diagnosis and Testing</i>.</li> <li>• Repair or replace as required.</li> </ul>
Detonation or spark knock	Verify the correct operation of the ignition controls. Refer to <i>Detonation/Spark Knock</i> in Engine Controls - 8.1L.
Loose torque converter bolts or improperly installed torque converter, automatic transmission only	<ul style="list-style-type: none"> <li>• Inspect the torque converter bolts and flywheel.</li> <li>• Verify correct installation of the torque converter.</li> <li>• Repair as required.</li> </ul>
Cracked flywheel, automatic transmission	<ul style="list-style-type: none"> <li>• Inspect the flywheel bolts and flywheel.</li> <li>• Repair as required.</li> </ul>
Excessive connecting rod bearing clearance	Inspect the following components, and repair as required: <ul style="list-style-type: none"> <li>• The connecting rod bearings</li> <li>• The connecting rods</li> <li>• The crankshaft</li> </ul>
Excessive crankshaft bearing clearance	Inspect the following components, and repair as required: <ul style="list-style-type: none"> <li>• The crankshaft bearings</li> <li>• The crankshaft journals</li> <li>• The cylinder block crankshaft bearing bore</li> </ul>

**Diagnostic Information and Procedures****Engine Will Not Crank - Crankshaft Will Not Rotate***Engine Mechanical - 8.1L:Diagnosis:Engine Will Not Crank - Crankshaft Will Not Rotate*

Cause	Correction
Seized accessory drive system component or starter motor	<ol style="list-style-type: none"> <li>1. Remove accessory drive belt or belts and/or starter motor.</li> <li>2. Rotate crankshaft by hand at the balancer or flywheel location.</li> </ol>
Broken timing chain	<ul style="list-style-type: none"> <li>• Inspect timing chain, gears and crankshaft sprocket locating pin.</li> <li>• Repair as required.</li> </ul>
Seized camshaft	

	<ul style="list-style-type: none"> <li>Inspect camshaft and camshaft bearings.</li> <li>Repair as required.</li> </ul>
Bent valve in cylinder head	<ul style="list-style-type: none"> <li>Inspect valves and cylinder heads.</li> <li>Repair as required.</li> </ul>
Hydraulically locked cylinder: <ul style="list-style-type: none"> <li>Coolant/antifreeze in cylinder</li> <li>Oil in cylinder</li> <li>Fuel in cylinder</li> </ul>	<ol style="list-style-type: none"> <li>Remove spark plugs and check for fluid.</li> <li>Inspect for a sticking fuel injector.</li> <li>Inspect for broken head gasket or gaskets.</li> <li>Inspect for cracked engine block or cylinder head.</li> </ol>
Seized automatic transmission torque converter	<ol style="list-style-type: none"> <li>Remove the torque converter bolts.</li> <li>Rotate crankshaft by hand at the balancer or flywheel location.</li> </ol>
Seized manual transmission	<ol style="list-style-type: none"> <li>Disengage the clutch.</li> <li>Rotate crankshaft by hand at the balancer or flywheel location.</li> </ol>
Material in cylinder: <ul style="list-style-type: none"> <li>Broken valve</li> <li>Piston material</li> <li>Foreign material</li> </ul>	<ul style="list-style-type: none"> <li>Inspect cylinder and cylinder head for damaged components and/or foreign materials.</li> <li>Repair or replace as required.</li> </ul>
Seized crankshaft or connecting rod bearings	<ul style="list-style-type: none"> <li>Inspect crankshaft and connecting rod bearings.</li> <li>Repair as required.</li> </ul>
Bent or broken connecting rod	<ul style="list-style-type: none"> <li>Inspect connecting rods.</li> <li>Repair as required.</li> </ul>
Broken crankshaft	<ul style="list-style-type: none"> <li>Inspect crankshaft.</li> <li>Repair as required.</li> </ul>

## Diagnostic Information and Procedures

### Coolant in Combustion Chamber

Cause	Correction
<p>DEFINITION: Excessive white smoke and/or coolant type odor coming from the exhaust pipe may indicate coolant in the combustion chamber. Low coolant levels, an inoperative cooling fan, or a faulty thermostat may lead to an "overtemperature" condition which may cause engine component damage.</p>	
<ol style="list-style-type: none"> <li>A slower than normal cranking speed may indicate coolant entering the combustion chamber. Refer to <a href="#">Engine Will Not Crank - Crankshaft Will Not Rotate</a>.</li> <li>Remove the spark plugs and inspect for spark plugs saturated by coolant or coolant in the cylinder bore.</li> <li>Inspect by performing a cylinder leak-down test. During this test, excessive air bubbles within the coolant may indicate a faulty gasket or damaged component. Refer to <a href="#">Cylinder Leakage Test</a>.</li> </ol>	

4. Inspect by performing a cylinder compression test. Two cylinders "side-by-side" on the engine block, with low compression, may indicate a failed cylinder head gasket. Refer to [Engine Compression Test](#) .

Faulty cylinder head gasket	Replace the head gasket and components as required. Refer to <a href="#">Cylinder Head Cleaning and Inspection</a> and <a href="#">Cylinder Head Replacement - Left</a> or <a href="#">Cylinder Head Replacement - Right</a> .
Cracked cylinder head	Replace the cylinder head and gasket.
Cracked engine block	Replace the components as required.
Cylinder head or engine block porosity	Replace the components as required.
Warped cylinder head	Machine the cylinder head to the proper flatness, if applicable and replace the cylinder head gasket. Refer to <a href="#">Cylinder Head Cleaning and Inspection</a> .
Defective external oil cooler	Replace the components as required.

## Diagnostic Information and Procedures

### Coolant in Engine Oil

Cause	Correction
<p>DEFINITION: Foamy or discolored oil or an engine oil "overfill" condition may indicate coolant entering the engine crankcase. Low coolant levels, an inoperative cooling fan, or a faulty thermostat may lead to an "overtemperature" condition which may cause engine component damage. Contaminated engine oil and oil filter should be changed.</p> <p>1. Inspect the oil for excessive foaming or an overfill condition. Oil diluted by coolant may not properly lubricate the crankshaft bearings and may lead to component damage. Refer to <a href="#">Lower Engine Noise, Regardless of Engine Speed</a> .</p> <p>2. Inspect by performing a cylinder leak-down test. During this test, excessive air bubbles within the cooling system may indicate a faulty gasket or damaged component. Refer to <a href="#">Cylinder Leakage Test</a> .</p> <p>3. Inspect by performing a cylinder compression test. Two cylinders "side-by-side" on the engine block with low compression may indicate a failed cylinder head gasket. Refer to <a href="#">Engine Compression Test</a> .</p>	
Faulty cylinder head gasket	Replace the head gasket and components as required. Refer to <a href="#">Cylinder Head Cleaning and Inspection</a> and <a href="#">Cylinder Head Replacement - Left</a> or <a href="#">Cylinder Head Replacement - Right</a> .
Cracked cylinder head	Replace the cylinder head and gasket.
Cracked cylinder liner or engine block	Replace the components as required.
Cylinder head, block, or manifold porosity	Replace the components as required.
Warped cylinder head	Machine the cylinder head to proper flatness, if applicable, and replace the cylinder head gasket. Refer to <a href="#">Cylinder Head Cleaning and Inspection</a> .
Faulty external engine oil cooler	Replace the components as required.

## Diagnostic Information and Procedures

### Engine Compression Test

*Engine Mechanical - 8.1L:Diagnosis:Engine Compression Test*

1. Disconnect the ignition coil wire harness connector at the front of the engine on the left cylinder bank and at the rear of the engine at the right cylinder bank.

2. Disconnect the fuel injector electrical harness connector at the rear of the intake manifold.
3. Remove all the spark plugs.
4. Block the throttle plate wide open.
5. Charge the battery if the battery is not fully charged.
6. Start with the compression gauge at zero. Then crank the engine through four compression strokes (four puffs).
7. Make the compression check the same for each cylinder. Record the reading.

The minimum compression in any one cylinder should not be less than 70 percent of the highest cylinder. No cylinder should read less than 690♦kPa (100♦psi). For example, if the highest pressure in any one cylinder is 1035♦kPa (150♦psi), the lowest allowable pressure for any other cylinder would be 725♦kPa (105♦psi). (1035♦x♦70%♦=♦725) (150♦x♦70%♦=♦105).

8. If some cylinders have low compression, inject approximately 15♦ml (one tablespoon) of engine oil into the combustion chamber through the spark plug hole.
  - Normal — Compression builds up quickly and evenly to the specified compression for each cylinder.
  - Piston Rings Leaking — Compression is low on the first stroke. Then compression builds up with the following strokes but does not reach normal. Compression improves considerably when you add oil.
  - Valves Leaking — Compression is low on the first stroke. Compression usually does not build up on the following strokes. Compression does not improve much when you add oil.
  - If two adjacent cylinders have lower than normal compression, and injecting oil into the cylinders does not increase the compression, the cause may be a head gasket leaking between the two cylinders.

## Diagnostic Information and Procedures

### Cylinder Leakage Test

#### Tools Required

*J 35667-A* Cylinder Head Leakdown Tester or equivalent

**Important:** A leakage test may be performed in order to measure cylinder/combustion chamber leakage. High cylinder leakage may indicate one or more of the following:

- Worn or burnt valves
- Broken valve springs
- Stuck valve lifters
- Incorrect valve lash
- Damaged piston
- Worn piston rings
- Worn or scored cylinder bore
- Damaged cylinder head gasket
- Cracked or damaged cylinder head
- Cracked or damaged engine block

**Caution:** Refer to *Battery Disconnect Caution* in *Cautions and Notices*.

1. Disconnect the battery ground negative cable.
2. Remove the spark plugs. Refer to *Spark Plug Replacement* in Engine Controls – 8.1L.
3. Rotate the crankshaft to place the piston in the cylinder being tested at Top Dead Center (TDC) of the compression stroke.
4. Install the *J 35667-A* or equivalent.

**Important:** It may be necessary to hold the crankshaft balancer bolt to prevent the crankshaft from rotating.

5. Apply shop air pressure to the *J 35667-A* and adjust according to the manufacturers instructions.
6. Record the cylinder leakage value. Cylinder leakage that exceeds 25 percent is considered excessive and may require component service. In excessive leakage situations, inspect for the following conditions:
  - Air leakage sounds at the throttle body or air inlet hose that may indicate a worn or burnt intake valve or a broken valve spring.
  - Air leakage sounds at the exhaust system tailpipe that may indicate a worn or burnt exhaust valve or a broken valve spring.
  - Air leakage sounds from the crankcase, oil level indicator tube, or oil fill tube that may indicate worn piston rings, a damaged piston, a worn or scored cylinder bore, a damaged engine block or a damaged cylinder head.
  - Air bubbles in the cooling system may indicate a damaged cylinder head or a damaged cylinder head gasket.
7. Perform the leakage test on the remaining cylinders and record the values.

## Diagnostic Information and Procedures

### Oil Consumption Diagnosis

*Engine Mechanical - 8.1L:Diagnosis:Oil Consumption*

Excessive oil consumption, not due to leaks, is the use of more than 0.95 liter (1 quart) of engine oil within 379 liters (100 gallons) of fuel used. However, during initial engine break-in periods 5000–6500 kilometers (3,000–4,000 miles) oil consumption may exceed 1.9 liters (2 quarts) or more per 379 liters (100 gallons) of fuel used. The causes of excessive oil consumption include the following conditions:

- External oil leaks. Tighten bolts and/or replace gaskets and oil seals as necessary.
- Incorrect oil level or improper reading of oil level indicator. With the vehicle on a level surface, allow adequate drain down time and check for the correct oil level.
- Improper oil viscosity. Use recommended SAE viscosity for the prevailing temperatures.
- Continuous high speed driving and/or severe usage.
- Crankcase ventilation system restrictions or malfunctioning components.
- Valve guides and/or valve stem oil seals worn, or the seal omitted. Ream guides and install oversize service valves and/or new valve stem oil seals.
- Piston rings broken, improperly installed, worn, or not seated properly. Allow adequate time for rings to seat. Replace broken or worn rings as necessary.
- Piston improperly installed or piston size is incorrectly selected.

## Diagnostic Information and Procedures

### Oil Pressure Diagnosis and Testing

*Engine Mechanical - 8.1L:Diagnosis:Oil Pressure Diagnosis and Testing*

1. With the vehicle on a level surface, allow adequate drain down time, 2–3 minutes, and measure for the proper engine oil level. Too high an oil level will cause aeration within the oil.

Add the recommended grade engine oil GM P/N 12345610, (Canadian P/N 993193), or equivalent, and fill the crankcase until the oil level measures FULL on the oil level indicator.

2. Operate the engine and verify low or no oil pressure on the vehicle oil pressure gage or oil indicator light.
  - Listen for a noisy valve train or knocking noise.
3. Inspect for the following:
  - Engine oil diluted by moisture or unburned fuel mixtures

- Improper engine oil viscosity for the expected temperature
  - Incorrect or faulty oil pressure gage sensor
  - Incorrect or faulty oil pressure gage
  - Plugged oil filter
  - Malfunctioning oil filter bypass valve
4. Remove the oil pressure gage sensor or another engine block oil gallery plug.
5. Install an oil pressure gage and measure the engine oil pressure.
6. If the engine oil pressure is below specifications, inspect the engine for one or more of the following:
- Oil pump worn or dirty
  - Malfunctioning oil pump pressure relief valve
  - Oil pump screen loose, plugged, or damaged
  - Excessive bearing clearance or worn bearings
  - Cracked, porous or restricted oil galleries
  - Engine block oil gallery plugs missing or incorrectly installed
  - Broken valve lifters

## Diagnostic Information and Procedures

### Oil Leak Diagnosis

*Engine Mechanical - 8.1L:Diagnosis:Oil Leak*

Step	Action	Yes	No
<p><b>Important:</b> You can repair most fluid leaks by first visually locating the leak, repairing or replacing the component, or by resealing the gasket surface. Once the leak is identified, determine the cause of the leak. Repair the cause of the leak as well as the leak itself.</p>			
1	<p>1. Operate the vehicle until it reaches normal operating temperature.</p> <p>2. Park the vehicle on a level surface, over a large sheet of paper or other clean surface.</p> <p>3. Wait 15♦minutes.</p> <p>4. Check for drippings.</p> <p>Are drippings present?</p>	Go to <a href="#">Step♦2</a>	System OK
2	Can you identify the type of fluid and the approximate location of the leak?	Go to <a href="#">Step♦10</a>	Go to <a href="#">Step♦3</a>
3	<p>1. Visually inspect the suspected area. Use a small mirror to assist in looking at hard to see areas.</p> <p>2. Check for leaks at the following locations:</p> <ul style="list-style-type: none"> <li>• Sealing surfaces</li> <li>• Fittings</li> <li>• Cracked or damaged components</li> </ul> <p>Can you identify the type of fluid and the approximate location of the leak?</p>	Go to <a href="#">Step♦10</a>	Go to <a href="#">Step♦4</a>
4	<p>1. Completely clean the entire engine and surrounding components.</p> <p>2. Operate the vehicle for several kilometers – miles at normal operating temperature and at varying speeds.</p> <p>3. Park the vehicle on a level surface, over a large sheet of paper or other clean surface.</p>		

	<p>4. Wait 15♦minutes.</p> <p>5. Identify the type of fluid, and the approximate location of the leak.</p> <p>Can you identify the type of fluid and the approximate location of the leak?</p>	Go to <a href="#">Step♦10</a>	Go to <a href="#">Step♦5</a>
5	<p>1. Visually inspect the suspected area. Use a small mirror to assist in looking at hard to see areas.</p> <p>2. Check for leaks at the following locations:</p> <ul style="list-style-type: none"> <li>• Sealing surfaces</li> <li>• Fittings</li> <li>• Cracked or damaged components</li> </ul> <p>Can you identify the type of fluid and the approximate location of the leak?</p>	Go to <a href="#">Step♦10</a>	Go to <a href="#">Step♦6</a>
6	<p>1. Completely clean the entire engine and surrounding components.</p> <p>2. Apply an aerosol-type powder, baby powder, foot powder, etc., to the suspected area.</p> <p>3. Operate the vehicle for several kilometers (miles) at normal operating temperature and at varying speeds.</p> <p>4. Identify the type of fluid, and the approximate location of the leak, from the discolorations in the powder surface.</p> <p>Can you identify the type of fluid and the approximate location of the leak?</p>	Go to <a href="#">Step♦10</a>	Go to <a href="#">Step♦7</a>
7	<p>1. Visually inspect the suspected area. Use a small mirror to assist in looking at hard to see areas.</p> <p>2. Check for leaks at the following locations:</p> <ul style="list-style-type: none"> <li>• Sealing surfaces</li> <li>• Fittings</li> <li>• Cracked or damaged components</li> </ul> <p>Can you identify the type of fluid and the approximate location of the leak?</p>	Go to <a href="#">Step♦10</a>	Go to <a href="#">Step♦8</a>
8	<p>Use <i>J 28428-E</i> High Intensity Black Light Kit in order to identify the type of fluid, and the approximate location of the leak. Refer to the manufacturer's instructions when using the tool.</p> <p>Can you identify the type of fluid and the approximate location of the leak?</p>	Go to <a href="#">Step♦10</a>	Go to <a href="#">Step♦9</a>
9	<p>1. Visually inspect the suspected area. Use a small mirror to assist in looking at hard to see areas.</p> <p>2. Check for leaks at the following locations:</p> <ul style="list-style-type: none"> <li>• Sealing surfaces</li> <li>• Fittings</li> <li>• Cracked or damaged components</li> </ul> <p>Can you identify the type of fluid and the approximate location of the leak?</p>	Go to <a href="#">Step♦10</a>	System OK
	<p>1. Inspect the engine for mechanical damage. Special attention should be shown to the following areas:</p> <ul style="list-style-type: none"> <li>• Higher than recommended fluid levels</li> <li>• Higher than recommended fluid pressures</li> <li>• Plugged or malfunctioning fluid filters or pressure bypass valves</li> </ul>		

10	<ul style="list-style-type: none"> <li>• Plugged or malfunctioning engine ventilation system</li> <li>• Improperly tightened or damaged fasteners</li> <li>• Cracked or porous components</li> <li>• Improper sealants or gaskets where required</li> <li>• Improper sealant or gasket installation</li> <li>• Damaged or worn gaskets or seals</li> <li>• Damaged or worn sealing surfaces</li> </ul> <p>2. Inspect the engine for customer modifications.</p> <p>Is there mechanical damage, or customer modifications to the engine?</p>	Go to <b>Step♦11</b>	System OK
11	<p>Repair or replace all damaged or modified components.</p> <p>Does the engine still leak oil?</p>	Go to <b>Step♦1</b>	System OK

## Diagnostic Information and Procedures

### Crankcase Ventilation System Inspection/Diagnosis

A plugged positive crankcase ventilation (PCV) pipe/passage way may cause:

- Rough idle
- Stalling or slow idle speed
- Oil leaks
- Sludge in the engine

## Diagnostic Information and Procedures

### Drive Belt Chirping Diagnosis

*Engine Mechanical - 8.1L:Diagnosis:Drive Belt Chirping Diagnosis*

#### Diagnostic Aids

The chirping noise may be intermittent due to moisture on the drive belt(s) or the accessory drive pulley(s). In order to duplicate the customers concern, it may be necessary to spray a small amount of water onto the drive belt(s). If spraying water onto the drive belt(s) duplicates the symptom, cleaning the accessory drive pulley(s) may be the most probable solution.

A loose or improper installation of a body or suspension component, or other item(s) on the vehicle may also cause the chirping noise.

#### Test Description

The number(s) below refer to the step(s) in the diagnostic table.

**2.** The chirping noise may not be engine related. This step is to verify that the engine is making the noise. If the engine is not making the noise do not proceed further with this table.

**3.** The noise may be an internal engine noise. Remove the drive belt(s) and operate the engine for a few seconds, this will verify if the chirping noise is related to the drive belt(s) or not. With the drive belt(s) removed the water pump will not operate and the engine may overheat. Also diagnostic trouble codes (DTCs) may set when the engine is operated with the drive belt(s) removed.

**4.** Inspect all drive belt(s) for signs of pilling. Pilling is the small balls, pills or strings in the drive belt grooves caused from the accumulation of rubber dust.

**6.** Misalignment of the accessory drive pulley(s) may be caused from improper mounting or incorrect installation of an accessory drive component, or the pulley may be bent inward or outward from a previous repair. Test for a misaligned accessory drive pulley using a straight edge in the pulley grooves across two or three pulleys. If a misaligned pulley is found, refer to that accessory drive

component for the proper removal and installation procedure for that pulley.

10. Inspection of the fasteners can eliminate the possibility that a incorrect bolt, nut, spacer, or washer was installed.

12. Inspection of the accessory drive pulley(s) should include inspecting for bends, dents or other damage to the pulley(s) that would prevent the drive belt(s) from not seating properly in the pulley grooves or on the smooth surface of the pulley when the back side of the drive belt is used to drive the pulley.

14. Replacing the drive belt(s) when it is not damaged or there is not excessive pilling will only be a temporary repair.

Step	Action	Yes	No
<p><b>Notice: Refer to <i>Belt Dressing Notice</i> in Cautions and Notices.</b></p> <p>DEFINITION: The following items are indications of chirping:</p> <ul style="list-style-type: none"> <li>A high pitched noise that is heard once per revolution of the drive belt(s) or a accessory drive pulley.</li> <li>Chirping may occur on cold damp start up conditions and will subside once the vehicle reaches normal operating temperature.</li> </ul>			
1	Did you review the Symptoms - Engine Mechanical diagnostic information and perform the necessary inspections?	Go to <a href="#">Step ♦2</a>	Go to <a href="#">Symptoms - Engine Mechanical</a>
2	Verify that there is a chirping noise. Does the engine make the chirping noise?	Go to <a href="#">Step♦3</a>	Go to Diagnostic Aids
3	<p>1. Remove the drive belt(s). Refer to <a href="#">Drive Belt Replacement - Accessory</a> or <a href="#">Drive Belt Replacement - Air Conditioning</a> .</p> <p>2. Operate the engine for no longer than 30 to 40 seconds.</p> <p>Does the chirping noise still exist?</p>	Go to <a href="#">Engine Noise on Start-Up, but Only Lasting a Few Seconds</a>	Go to <a href="#">Step♦4</a>
4	Inspect for severe drive belt pilling exceeding 1/3 of the drive belt groove depth. Do the drive belt grooves have pilling?	Go to <a href="#">Step♦5</a>	Go to <a href="#">Step♦6</a>
5	Clean the accessory drive belt pulley(s) with a suitable wire brush. Were the accessory drive pulley(s) cleaned?	Go to <a href="#">Step♦15</a>	—
6	Inspect for misaligned accessory drive pulley(s). Is there a misaligned accessory drive pulley(s)?	Go to <a href="#">Step♦7</a>	Go to <a href="#">Step♦8</a>
7	Replace and/or repair the misaligned accessory drive pulley(s). were the misaligned accessory drive pulley(s) replaced and/or repaired?	Go to <a href="#">Step♦15</a>	—
8	Inspect for a bent or cracked accessory drive bracket(s). Did you find any bent or cracked accessory drive bracket(s)?	Go to <a href="#">Step♦9</a>	Go to <a href="#">Step♦10</a>
9	Replace any bent and/or cracked accessory drive bracket(s). Was the bent and/or cracked accessory drive bracket(s) replaced?	Go to <a href="#">Step♦15</a>	Go to <a href="#">Step♦10</a>
10	Inspect for incorrect, loose and/or missing fasteners. Were there any incorrect, loose, and/or missing fasteners found?	Go to <a href="#">Step♦11</a>	Go to <a href="#">Step♦12</a>
11	Replace any incorrect and/or missing fasteners. Tighten any loose fasteners. Refer to <a href="#">Fastener Tightening Specifications</a> .		—

	Were the fasteners replaced and/or tightened?	Go to <a href="#">Step♦15</a>	
12	Inspect for a bent accessory drive pulley(s). Was a bent accessory drive pulley(s) found?	Go to <a href="#">Step♦13</a>	Go to <a href="#">Step♦14</a>
13	Replace the bent accessory drive pulley(s). Was the bent accessory drive pulley(s) replaced?	Go to <a href="#">Step♦15</a>	—
14	Replace the drive belt(s). Refer to <a href="#">Drive Belt Replacement - Accessory</a> or <a href="#">Drive Belt Replacement - Air Conditioning</a> . Was the drive belt(s) replaced?	Go to <a href="#">Step♦15</a>	—
15	1. Clear any codes. 2. Run the engine in order to verify the repair. Does the chirping noise still exist?	—	System OK

## Diagnostic Information and Procedures

### Drive Belt Squeal Diagnosis

*Engine Mechanical - 8.1L:Diagnosis:Drive Belt Squeal Diagnosis*

#### Diagnostic Aids

A loose or improper installation of a body, or suspension component, or other item(s) on the vehicle may cause the squeal noise.

If the squeal noise is intermittent, verify that it is not the accessory drive component(s) by varying their load(s) making sure they are operating to their maximum capacity. An overcharged air conditioning (A/C) system, a power steering system restriction or the incorrect fluid, or a failing generator are suggested items to inspect.

#### Test Description

The number(s) below refer to the step(s) in the diagnostic table.

- The squeal may not be engine related. This step is to verify that the engine is making the noise. If the engine is not making the noise do not proceed further with this table
- The squeal may be an internal engine noise. Remove the drive belt(s) and operate the engine for a few seconds, this will verify if the squealing noise is related to the drive belt(s) or an accessory drive component. With the drive belt(s) removed the water pump will not operate and the engine may overheat. Also diagnostic trouble codes (DTCs) may set when the engine is operated with the drive belt(s) removed.
- This test is to verify that an accessory drive component(s) does not have a seized bearing. With the belt(s) removed, test the bearings in the accessory drive component(s) for smooth operation. Also test the accessory drive component(s) with the engine operating by varying the load on the accessory drive component(s) to verify that the component(s) is operating properly.
- This test is to verify that the drive belt(s) tensioner(s) is operating properly. If the drive belt(s) tensioner(s) is not operating properly, proper belt tension may not be achieved to keep the drive belt(s) from slipping which could cause a squeal noise.
- This test is to verify that the drive belt(s) is not too long, which would prevent the drive belt(s) tensioner(s) from operating properly. Also if the incorrect length drive belt(s) was installed, it may not be routed correctly and may be turning an accessory drive component in the incorrect direction.
- Misalignment of the accessory drive pulley(s) may be caused from improper mounting or incorrect installation of a accessory drive component, or the pulley may be bent inward or outward from a previous repair. Test for a misaligned pulley using a straight edge in the pulley grooves across two or three pulleys. If a misaligned pulley is found, refer to that accessory drive component for the proper removal and installation procedure for that pulley.
- Inspect the accessory drive pulley(s) to verify that they are the correct diameter or width. Using a known good vehicle, compare the accessory drive pulleys.

--	--	--	--

Step	Action	Yes	No
<p><b>Notice:</b> Refer to <i>Belt Dressing Notice</i> in <b>Cautions and Notices</b>.</p> <p>DEFINITION: The following items are indications of drive belt squeal:</p> <ul style="list-style-type: none"> <li>A loud screeching noise that is caused by a slipping drive belt(s) (this is unusual for a drive belt with multiple ribs)</li> <li>The squeal occurs when a heavy load is applied to the drive belt(s), such as an A/C compressor engagement, snapping the throttle, slipping on a seized pulley, or a faulty accessory drive component.</li> </ul>			
1	Did you review the Symptoms - Engine Mechanical diagnostic information and perform the necessary inspections?	Go to <a href="#">Step♦2</a>	Go to <i>Symptoms - Engine Mechanical</i>
2	Verify that there is a squeal noise. Does the engine make the squeal noise?	Go to <a href="#">Step♦3</a>	Go to Diagnostic Aids
3	<ol style="list-style-type: none"> <li>Remove the drive belt(s). Refer to <i>Drive Belt Replacement - Accessory</i> or <i>Drive Belt Replacement - Air Conditioning</i>.</li> <li>Operate the engine for no longer than 30 to 40 seconds.</li> </ol> Does the squealing noise still exist?	Go to <i>Engine Noise on Start-Up, but Only Lasting a Few Seconds</i>	Go to <a href="#">Step♦4</a>
4	Inspect for a seized accessory drive component bearing or a faulty accessory drive component. Did you find and correct the condition?	Go to <a href="#">Step♦9</a>	Go to <a href="#">Step♦5</a>
5	Inspect the drive belt tensioner for proper operation. Refer to <i>Drive Belt Tensioner Diagnosis</i> . Did you find and correct the condition?	Go to <a href="#">Step♦9</a>	Go to <a href="#">Step♦6</a>
6	Check for the correct length drive belt(s). Did you find and correct the condition?	Go to <a href="#">Step♦9</a>	Go to <a href="#">Step♦7</a>
7	Inspect for misaligned pulley. Did you find and correct the condition?	Go to <a href="#">Step♦9</a>	Go to <a href="#">Step♦8</a>
8	Inspect for an incorrect size pulley. Did you find and correct the condition?	Go to <a href="#">Step♦9</a>	—
9	<ol style="list-style-type: none"> <li>Install the drive belt(s). Refer to <i>Drive Belt Replacement - Accessory</i> or <i>Drive Belt Replacement - Air Conditioning</i>.</li> <li>Clear any codes.</li> <li>Run the engine in order to verify the repair.</li> </ol> Does the squealing noise still exist?	—	System OK

## Diagnostic Information and Procedures

### Drive Belt Whine Diagnosis

*Engine Mechanical - 8.1L:Diagnosis:Drive Belt Whine Diagnosis*

#### Diagnostic Aids

The drive belt(s) will not cause the whine.

If the whine is intermittent, verify that it is not the accessory drive component(s) by varying their loads, making sure they are

operating to their maximum capacity. An overcharged air conditioning (A/C) system, a power steering system restriction or the incorrect fluid, or a failing generator are suggested items to inspect.

## Test Description

The number(s) below refer to the step(s) in the diagnostic table.

3. This test is to verify that the whine is being caused by the accessory drive component(s). Remove the drive belt (s) and operate the engine for a few seconds, this will verify if the whining noise is related to the accessory drive component. With the drive belt(s) removed the water pump will not operate and the engine may overheat. Also diagnostic trouble codes (DTCs) may set when the engine is operate with the drive belt(s) removed.

4. The inspection should include checking the drive belt tensioner and the drive belt idler pulley bearings. The drive belt(s) may have to be installed and the accessory drive components operated separately by varying their loads. Refer to the suspected accessory drive component for the proper removal and installation procedure.

Step	Action	Yes	No
<b>Notice: Refer to <i>Belt Dressing Notice</i> in Cautions and Notices.</b>			
DEFINITION: A high pitched continuous noise that may be caused by an accessory drive component failed bearing.			
1	Did you review the Symptoms - Engine Mechanical diagnostic information and perform the necessary inspections?	Go to <a href="#">Step♦2</a>	Go to <a href="#">Symptoms - Engine Mechanical</a>
2	Verify that there is a whining noise. Does the engine make the whining noise?	Go to <a href="#">Step♦3</a>	Go to Diagnostic Aids
3	1. Remove the drive belt(s). Refer to <a href="#">Drive Belt Replacement - Accessory</a> or <a href="#">Drive Belt Replacement - Air Conditioning</a> . 2. Operate the engine for no longer than 30 to 40 seconds. Does the whining noise still exist?	Go to <a href="#">Engine Noise on Start-Up, but Only Lasting a Few Seconds</a>	Go to <a href="#">Step♦4</a>
4	1. Inspect for a failed accessory drive component bearing. 2. Install the drive belt(s). Refer to <a href="#">Drive Belt Replacement - Accessory</a> or <a href="#">Drive Belt Replacement - Air Conditioning</a> . Did you find and correct the condition?	Go to <a href="#">Step♦5</a>	—
5	1. Clear any codes. 2. Run the engine in order to verify the repair. Does the whining noise still exist?	—	System OK

## Diagnostic Information and Procedures

### Drive Belt Rumbling Diagnosis

*Engine Mechanical - 8.1L:Diagnosis:Drive Belt Rumbling Diagnosis*

### Diagnostic Aids

Vibration from the engine operating may cause a body component or another part of the vehicle to make rumbling noise.

The drive belt(s) may have a condition that can not be seen or felt. Sometimes replacing the drive belt(s) may be the only repair for the symptom.

If after replacing the drive belt(s) and completing the diagnostic table, the rumbling is only heard with the drive belt(s) installed, there might be an accessory drive component failure. Varying the load on the different accessory drive component(s) may aid in identifying which component is causing the rumbling noise.

## Test Description

The number(s) below refer to the step(s) in the diagnostic table.

2. This test is to verify that the symptom is present during diagnosing. Other vehicle components may cause a similar symptom.

3. This test is to verify that the drive belt(s) is causing the rumbling. Rumbling may be confused with an internal engine noise due to the similarity in the description. Remove only one drive belt at a time if the vehicle has multiple drive belts. Operate the engine for a few seconds, this will verify if the rumbling noise is related to the drive belt(s) or not. With the drive belt(s) removed the water pump will not operate and the engine may overheat. Also diagnostic trouble codes (DTCs) may set when the engine is operated with the drive belt(s) removed.

4. Inspect the drive belt(s) to ensure that the drive belt(s) is not the cause of the noise. Small cracks across the ribs of the drive belt(s) will not cause the noise. Belt separation is identified by the plys of the belt separating, this may be seen at the edge of the belt or felt as a lump in the belt.

5. Small amounts of pilling is a normal condition and acceptable. When the pilling is severe the drive belt(s) does not have a smooth surface for proper operation.

Step	Action	Yes	No
<p><b>Notice: Refer to <i>Belt Dressing Notice</i> in Cautions and Notices.</b></p> <p>DEFINITION:</p> <ul style="list-style-type: none"> <li>• A low pitch tapping, knocking, or thumping noise heard at or just above idle.</li> <li>• Heard once per revolution of the drive belt(s) or pulley(s).</li> <li>• Rumbling may be caused from: <ul style="list-style-type: none"> <li>– Pilling, the accumulation of rubber dust that forms small balls (pills) or strings in the drive belt(s) pulley groove</li> <li>– The separation of the drive belt(s)</li> <li>– A damaged drive belt(s)</li> </ul> </li> </ul>			
1	Did you review the Symptoms - Engine Mechanical diagnostic information and perform the necessary inspections?	Go to <a href="#">Step♦2</a>	Go to <i>Symptoms - Engine Mechanical</i>
2	Verify that there is a rumbling noise. Does the engine make the rumbling noise?	Go to <a href="#">Step♦3</a>	Go to Diagnostic Aids
3	<ol style="list-style-type: none"> <li>1. Remove the drive belt(s). Refer to <i>Drive Belt Replacement - Accessory</i> or <i>Drive Belt Replacement - Air Conditioning</i>.</li> <li>2. Operate the engine for no longer than 30 to 40 seconds.</li> </ol> Does the rumbling noise still exist?	Go to <i>Engine Noise on Start-Up, but Only Lasting a Few Seconds</i>	Go to <a href="#">Step♦4</a>
4	Inspect the drive belt(s) for damage, separation, or sections of missing ribs. Were any of these conditions found?	Go to <a href="#">Step♦7</a>	Go to <a href="#">Step♦5</a>
5	Inspect for severe pilling of more than 1/3 of the drive belt groove depth. Do the drive belt grooves have pilling?	Go to <a href="#">Step♦6</a>	Go to <a href="#">Step♦7</a>
6	<ol style="list-style-type: none"> <li>1. Clean the drive belt pulleys using a suitable wire brush.</li> <li>2. Reinstall the drive belt(s). Refer to <i>Drive Belt Replacement - Accessory</i> or <i>Drive Belt Replacement - Air Conditioning</i>.</li> </ol> Did you complete the repair?	Go to <a href="#">Step♦8</a>	—
7	Install a new drive belt(s). Refer to <i>Drive Belt Replacement - Accessory</i> or <i>Drive Belt Replacement - Air Conditioning</i> . Did you complete the replacement?	Go to <a href="#">Step♦8</a>	—

8	<ol style="list-style-type: none"> <li>1. Clear any codes.</li> <li>2. Run the engine in order to verify the repair.</li> </ol> Does the rumbling noise still exist?	—	System OK
---	--	---	-----------

## Diagnostic Information and Procedures

### Drive Belt Vibration Diagnosis

Engine Mechanical - 8.1L:Diagnosis:Drive Belt Vibration Diagnosis

#### Diagnostic Aids

The accessory drive components may have an affect on engine vibration. An overcharged air conditioning (A/C) system, a power steering system restriction, or the incorrect fluid, or an extra load on the generator. To help identify an intermittent or an improper condition, vary the loads on the accessory drive components.

#### Test Description

The number(s) below refer to the step(s) in the diagnostic table.

**2.** This test is to verify that the vibration is present during diagnosing. Other vehicle components may cause a similar symptom such as the exhaust system, or the drivetrain.

**3.** This test is to verify that the drive belt(s) or accessory drive components may be causing the vibration. Remove the drive belt(s) and operate the engine for a few seconds, this will verify if the vibration is related to the drive belt(s) or not. With the drive belt(s) removed the water pump will not operate and the engine may overheat. Also diagnostic trouble codes (DTCs) may set when the engine is operated with the drive belt(s) removed.

**4.** The drive belt(s) may cause a vibration. While the drive belt(s) is removed this is the best time to inspect the condition of the drive belt(s).

**6.** Inspection of the fasteners can eliminate the possibility that a incorrect bolt, nut, spacer, or washer was installed.

**8.** This step should only be performed if the fan is driven by the drive belt(s). Inspect the engine cooling fan for bent, twisted, loose, or cracked blades. Inspect the fan clutch for smooth operation. Inspect for a bent fan shaft or bent mounting flange.

**9.** Inspect the water pump drive shaft for being bent. Also inspect the water pump bearings for smooth operation and excessive play. Compare the water pump with a known, good water pump.

**10.** Accessory drive component brackets that are bent, cracked, or loose may put an extra strain on that accessory drive component causing it to vibrate.

Step	Action	Yes	No
<p><b>Notice:</b> Refer to <i>Belt Dressing Notice</i> in <b>Cautions and Notices</b>.</p> <p>DEFINITION: The following items are indications of drive belt vibration:</p> <ul style="list-style-type: none"> <li>• The vibration is engine-speed related.</li> <li>• The vibration may be sensitive to accessory load.</li> </ul>			
1	Did you review the Symptoms - Engine Mechanical diagnostic information and perform the necessary inspections?	Go to <a href="#">Step♦2</a>	Go to <i>Symptoms - Engine Mechanical</i>
2	Verify that the vibration is engine related. Does the engine make the vibration?	Go to <a href="#">Step♦3</a>	Go to Diagnostic Aids
3	<ol style="list-style-type: none"> <li>1. Remove the drive belt(s). Refer to <i>Drive Belt Replacement - Accessory</i> or <i>Drive Belt Replacement - Air Conditioning</i>.</li> <li>2. Operate the engine for no longer than 30 to 40 seconds.</li> </ol> Does the engine still make the vibration?	Go to <i>Engine Noise on Start-Up, but Only Lasting a Few Seconds</i>	Go to <a href="#">Step♦4</a>

4	Inspect the drive belt(s) for wear, damage, debris build-up and missing drive belt ribs. Were any of these conditions found?	Go to <a href="#">Step♦5</a>	Go to <a href="#">Step♦6</a>
5	Install a new drive belt(s). Refer to <a href="#">Drive Belt Replacement - Accessory</a> or <a href="#">Drive Belt Replacement - Air Conditioning</a> . Did you complete the replacement?	Go to <a href="#">Step♦11</a>	—
6	Inspect for incorrect, loose or missing fasteners. Were any of these conditions found?	Go to <a href="#">Step♦7</a>	Go to <a href="#">Step♦8</a>
7	Replace the incorrect or missing fasteners. Tighten any loose fasteners. Refer to <a href="#">Fastener Tightening Specifications</a> . Were the fasteners replaced and/or tightened?	Go to <a href="#">Step♦11</a>	—
8	Inspect for damaged fan blades or a bent fan clutch shaft. Did you find and correct the condition?	Go to <a href="#">Step♦11</a>	Go to <a href="#">Step♦9</a>
9	Inspect for a bent water pump drive shaft. Did you find and correct the condition?	Go to <a href="#">Step♦11</a>	Go to <a href="#">Step♦10</a>
10	Inspect for bent or cracked accessory drive bracket(s). Did you find and correct the condition?	Go to <a href="#">Step♦11</a>	—
11	1. Clear any codes. 2. Run the engine in order to verify the repair. Did you correct the condition?	—	System OK

## Diagnostic Information and Procedures

### Drive Belt Falls Off Diagnosis

*Engine Mechanical - 8.1L:Diagnosis:Drive Belt Falls Off Diagnosis*

#### Diagnostic Aids

If the drive belt(s) repeatedly falls off the accessory drive pulley(s), this may be caused by a pulley misalignment.

An extra load that is quickly applied or released by an accessory drive component may cause the drive belt(s) to fall off. Verify that the accessory drive component(s) are operating properly.

If the drive belt(s) is the incorrect length, the drive belt tensioner(s) may not maintain the proper tension on the drive belt(s).

#### Test Description

The number(s) below refer to the step(s) in the diagnostic table.

**2.** This inspection is to verify the condition of the drive belt(s). Damage may have occurred to the drive belt(s) when the drive belt(s) fell off the pulleys. Inspect the drive belt(s) for cuts, tears, sections of ribs missing, or damaged belt plies.

**4.** Misalignment of the accessory drive pulley(s) may be caused from improper mounting or incorrect installation of a accessory drive component, or the pulley may be bent inward or outward from a previous repair. Test for a misaligned pulley using a straight edge in the pulley grooves across two or three pulleys. If a misaligned pulley is found, refer to that accessory drive component for the proper removal and installation procedure of that pulley.

**5.** Inspection of the accessory drive pulley(s) should include inspecting for bends, dents, or other damage that would prevent the

drive belt from seating properly in the pulley grooves or on the smooth surface of a pulley when the back side of the belt(s) is used to drive the pulley.

6. Accessory drive component brackets that are bent or cracked will also cause the drive belt(s) to fall off.

7. Inspection of the fasteners can eliminate the possibility that a incorrect bolt, nut, spacer, or washer was installed. Missing, loose, or incorrect fasteners may cause pulley misalignment from the accessory drive bracket(s) moving under load. Over tightening the fasteners may cause misalignment of the accessory component bracket(s).

Step	Action	Yes	No
<b>Notice: Refer to <i>Belt Dressing Notice</i> in Cautions and Notices.</b>			
DEFINITION: The drive belt(s) falls off the pulleys or may not ride correctly on the pulleys.			
1	Did you review the Symptoms - Engine Mechanical diagnostic information and perform the necessary inspections?	Go to <a href="#">Step♦2</a>	Go to <a href="#">Symptoms - Engine Mechanical</a>
2	Inspect for a damaged drive belt(s). Was a damaged drive belt(s) found?	Go to <a href="#">Step♦3</a>	Go to <a href="#">Step♦4</a>
3	Install a new drive belt(s). Refer to <a href="#">Drive Belt Replacement - Accessory</a> or <a href="#">Drive Belt Replacement - Air Conditioning</a> . Does the drive belt(s) continue to fall off?	Go to <a href="#">Step♦4</a>	System OK
4	Inspect for a misaligned accessory drive pulley(s). Did you find and correct the condition?	Go to <a href="#">Step♦12</a>	Go to <a href="#">Step♦5</a>
5	Inspect for a bent or dented accessory drive pulley(s). Did you find and correct the condition?	Go to <a href="#">Step♦12</a>	Go to <a href="#">Step♦6</a>
6	Inspect for a bent or a cracked accessory drive bracket(s). Did you find and correct the condition?	Go to <a href="#">Step♦12</a>	Go to <a href="#">Step♦7</a>
7	Inspect for incorrect, loose and/or missing fasteners. Were there any incorrect, loose and/or missing fasteners?	Go to <a href="#">Step♦8</a>	Go to <a href="#">Step♦9</a>
8	Replace and incorrect and/or missing fasteners. Tighten any loose fasteners. Refer to <a href="#">Fastener Tightening Specifications</a> . Does the drive belt continue to fall off?	Go to <a href="#">Step♦9</a>	System OK
9	Test the drive belt tensioner for correct operation. Refer to <a href="#">Drive Belt Tensioner Diagnosis</a> . Does the drive belt tensioner operate correctly?	Go to <a href="#">Step♦11</a>	Go to <a href="#">Step♦10</a>
10	Replace the drive belt tensioner. Refer to <a href="#">Drive Belt Tensioner Replacement - Accessory</a> or <a href="#">Drive Belt Tensioner Replacement - Air Conditioning</a> . Does the drive belt continue to fall off?	Go to <a href="#">Step♦11</a>	System OK
11	Inspect for a failed drive belt idler(s) and/or tensioner pulley(s) bearing. Did you find and repair the condition?	Go to <a href="#">Step♦12</a>	—
12	Run the engine in order to verify the repair.	—	

Does the drive belt still fall off?	System OK
-------------------------------------	-----------

## Diagnostic Information and Procedures

### Drive Belt Excessive Wear Diagnosis

*Engine Mechanical - 8.1L:Diagnosis:Drive Belt Excessive Wear Diagnosis*

#### Diagnostic Aids

Excessive wear on a drive belt(s) is usually caused by incorrect installation or the incorrect drive belt(s) for the application.

Minor misalignment of the accessory drive pulley(s) will not cause excessive wear, but will probably cause the drive belt(s) to make a noise or fall off.

Excessive misalignment of the accessory drive pulley(s) will cause excessive wear and may also make the drive belt(s) fall off.

#### Test Description

The number(s) below refer to the step(s) in the diagnostic table.

**2.** This inspection is to verify that the drive belt(s) is correctly installed on all of the accessory drive pulley(s). Wear on the drive belt(s) may be caused by mis-positioning the drive belt(s) by one or more grooves on a pulley(s).

**3.** The installation of a drive belt(s) that is too wide or too narrow will cause wear on the drive belt(s). The drive belt(s) ribs should match all of the grooves on the pulleys.

**4.** This inspection is to verify the drive belt(s) is not contacting any part of the engine or body while the engine is operating. There should be sufficient clearance when the accessory drive components load varies. The drive belt(s) should not come in contact with an engine or a body component when snapping the throttle.

Step	Action	Yes	No
<b>Notice: Refer to <i>Belt Dressing Notice</i> in Cautions and Notices.</b>			
DEFINITION: Wear at the outside ribs of the drive belt(s) due to incorrect installation of the drive belt(s).			
1	Did you review the Symptoms - Engine Mechanical diagnostic information and perform the necessary inspections?	Go to <a href="#">Step♦2</a>	Go to <a href="#">Symptoms - Engine Mechanical</a>
2	Inspect the drive belt(s) for proper installation. Is the drive belt(s) installed properly?	Go to <a href="#">Step♦5</a>	Go to <a href="#">Step♦3</a>
3	Inspect for the correct drive belt(s). Is the correct drive belt installed?	Go to <a href="#">Step♦5</a>	Go to <a href="#">Step♦4</a>
4	Inspect the drive belt(s) for signs of rubbing against a bracket, hose, or wiring harness. Was the drive belt(s) rubbing against anything?	Go to <a href="#">Step♦6</a>	Go to Diagnostic Aids
5	Replace the drive belt(s). Refer to <a href="#">Drive Belt Replacement - Accessory</a> or <a href="#">Drive Belt Replacement - Air Conditioning</a> . Did you complete the replacement?	Go to <a href="#">Step♦6</a>	—
6	Run the engine in order to verify the repair. Is there still excessive drive belt wear?	—	System OK

## Diagnostic Information and Procedures

## Drive Belt Tensioner Diagnosis

*Engine Mechanical - 8.1L:Diagnosis:Drive Belt Tensioner Diagnosis*

**Notice:** Allowing the drive belt tensioner to snap into the free position may result in damage to the tensioner.

1. Remove the drive belt(s). Refer to *Drive Belt Replacement - Accessory* or *Drive Belt Replacement - Air Conditioning* .
2. Position a hex-head socket on the belt tensioner pulley bolt head.
3. Move the drive belt tensioner through its full travel.
  - The movement should feel smooth.
  - There should be no binding.
  - The tensioner should return freely.
4. If any binding is observed, replace the drive belt tensioner(s). Refer to *Drive Belt Tensioner Replacement - Accessory* or *Drive Belt Tensioner Replacement - Air Conditioning* .
5. Install the drive belt(s). Refer to *Drive Belt Replacement - Accessory* or *Drive Belt Replacement - Air Conditioning* .

## Repair Instructions

### Drive Belt Replacement - Accessory

*Engine Mechanical - 8.1L:Repair:Drive Belt Replacement - Accessory*

#### Removal Procedure

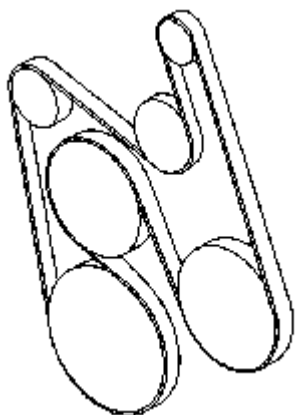

1. Install a breaker bar with hex-head socket to the drive belt tensioner bolt.
2. Rotate the drive belt tensioner clockwise in order to relieve tension on the belt.
3. Remove the belt from the pulleys and the drive belt tensioner.
4. Slowly release the tension on the drive belt tensioner.
5. Remove the breaker bar and socket and from the drive belt tensioner bolt.
6. Clean and inspect the belt surfaces of all the pulleys.

#### Installation Procedure

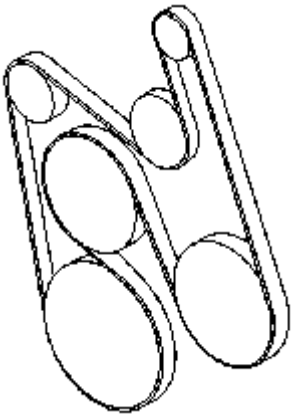

1. Route the drive belt around all the pulleys except the idler pulley.
2. Install the breaker bar with hex-head socket to the belt tensioner bolt.
3. Rotate the belt tensioner clockwise in order to relieve the tension on the tensioner.
4. Install the drive belt under the idler pulley.
5. Slowly release the tension on the belt tensioner.
6. Remove the breaker bar and socket from the belt tensioner bolt.
7. Inspect the drive belt for proper installation and alignment.

## Repair Instructions

### Drive Belt Replacement - Air Conditioning

*Engine Mechanical - 8.1L:Repair:Drive Belt Replacement - Air Conditioning*

#### Removal Procedure

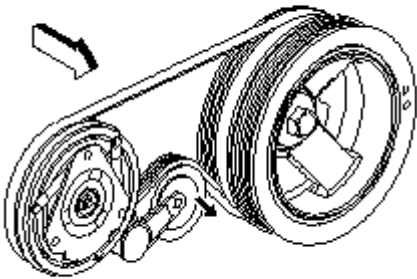

1. Remove the accessory drive belt. Refer to [Drive Belt Replacement - Accessory](#) .
2. Install a breaker bar into the air conditioning (A/C) belt tensioner adapter opening.
3. Rotate the A/C belt tensioner clockwise in order to relieve tension on the belt.
4. Remove the A/C belt from the pulleys.
5. Slowly release the tension on the A/C belt tensioner.
6. Remove the breaker bar from the A/C belt tensioner.
7. Clean and inspect the belt surfaces of all the pulleys.

#### Installation Procedure

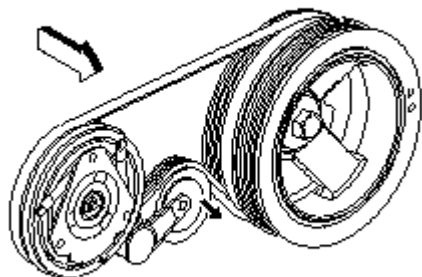

1. Install the A/C belt around the crankshaft balancer.
2. Install the breaker bar into the A/C drive belt tensioner adapter opening
3. Rotate the A/C belt tensioner clockwise in order to relieve tension on the tensioner.
4. Install the A/C belt over the idler pulley.
5. Install the A/C belt around the A/C compressor pulley.
6. Slowly release the tension on the A/C belt tensioner.
7. Remove the breaker bar from the A/C belt tensioner.
8. Inspect the A/C belt for proper installation and alignment.
9. Install the accessory drive belt. Refer to [Drive Belt Replacement - Accessory](#) .

## Repair Instructions

### Drive Belt Tensioner Replacement - Accessory

Engine Mechanical - 8.1L:Repair:Drive Belt Tensioner Replacement - Accessory

#### Removal Procedure

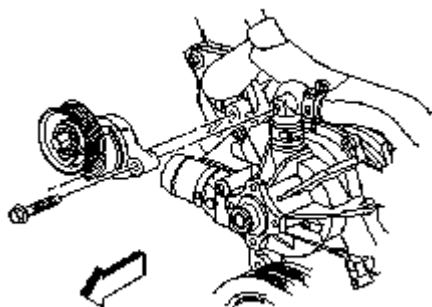

1. Remove the accessory drive belt. Refer to [Drive Belt Replacement - Accessory](#) .
2. Remove the drive belt tensioner bolts.
3. Remove the drive belt tensioner.

#### Installation Procedure

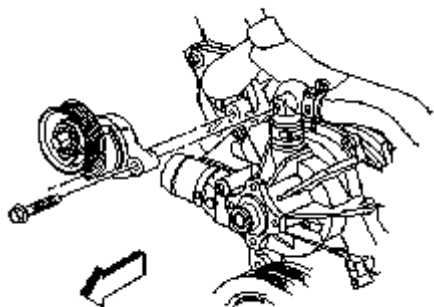

1. Install the drive belt tensioner.
2. Install the drive belt tensioner bolts.

**Notice:** Refer to *Fastener Notice in Cautions and Notices*.

3. Tighten the drive belt tensioner bolts.

**Tighten:** Tighten the accessory drive belt tensioner bolts to 50♦&newtonm; (37♦lb♦ft).

4. Install the accessory drive belt. Refer to *Drive Belt Replacement - Accessory* .

## Repair Instructions

### Drive Belt Tensioner Replacement - Air Conditioning

*Engine Mechanical - 8.1L:Repair:Drive Belt Tensioner Replacement - Air Conditioning*

#### Removal Procedure

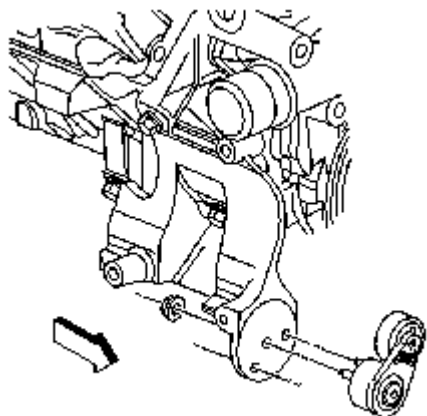

1. Remove the air conditioning (A/C) drive belt. Refer to *Drive Belt Replacement - Air Conditioning*
2. Remove the A/C belt tensioner bolts.
3. Remove the A/C belt tensioner.

#### Installation Procedure

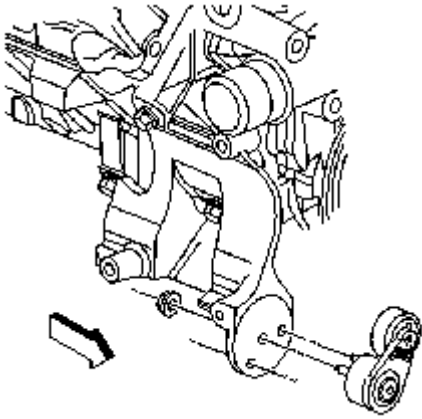

1. Install the A/C belt tensioner.

**Notice:** Refer to *Fastener Notice in Cautions and Notices*.

2. Install the A/C belt tensioner bolts.

**Tighten:** Tighten the A/C belt tensioner bolts to 50♦&newtonm; (37♦lb♦ft).

3. Install the A/C drive belt. Refer to *Drive Belt Replacement - Air Conditioning* .

## Repair Instructions

### Drive Belt Idler Pulley Replacement

*Engine Mechanical - 8.1L:Repair:Drive Belt Idler Pulley Replacement*

#### Removal Procedure

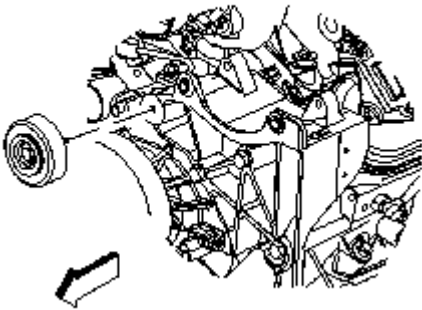

1. Loosen the drive belt idler pulley bolt.
2. Remove the accessory drive belt. Refer to *Drive Belt Replacement - Accessory* .
3. Remove the drive belt idler pulley.

#### Installation Procedure

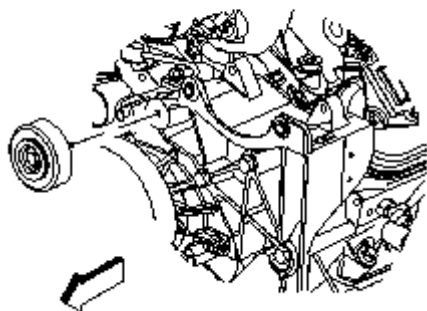

1. Install the drive belt idler pulley and bolt to the generator bracket.

Snug the bolt finger tight.

**Notice:** Refer to *Fastener Notice in Cautions and Notices*.

2. Install the accessory drive belt. Refer to *Drive Belt Replacement - Accessory*.

**Tighten:** Tighten the drive belt idler pulley bolt to 50♦&newtonm; (37♦lb♦ft).

## Repair Instructions

### Engine Mount Inspection

*Engine Mechanical - 8.1L:Repair:Engine Mount Inspection*

**Notice:** Broken or deteriorated mounts can cause misalignment and destruction of certain drive train components. When a single mount breaks, the remaining mounts are subjected to abnormally high stresses.

**Notice:** When raising or supporting the engine for any reason, do not use a jack under the oil pan, any sheet metal, or the crankshaft pulley. Due to the small clearance between the oil pan and the oil pump screen, jacking against the oil pan may cause the pan to be bent against the pump screen. This will result in a damaged oil pickup unit.

1. Measure the engine movement at the engine mount in order to check for damage to the rubber portions of the mount.
  - 1.1. Apply the park brake.
  - 1.2. Start the engine.
  - 1.3. Firmly apply and hold the primary brakes.
  - 1.4. Have an assistant stand to the side of the vehicle in order to observe for engine movement.
  - 1.5. Slightly load the engine, shifting from drive to reverse a few times
  - 1.6. If the engine moves more than 24♦mm (0.945♦in) from the at rest position, in either direction, check for loose engine mount bolts.
2. If the engine mount bolt torque is within specifications, check the condition of the engine mount.
3. Replace the engine mount if any of the following conditions exist:
  - Heat check cracks cover the rubber cushion surface.
  - The rubber cushion is separated from the metal plate of the mount.
  - There is a split through the rubber cushion.

## Repair Instructions

### Engine Mount Replacement - Left

*Engine Mechanical - 8.1L:Repair:Engine Mount Replacement - Left*

### Removal Procedure

**Notice:** When raising or supporting the engine for any reason, do not use a jack under the oil pan, any sheet metal, or the crankshaft pulley. Due to the small clearance between the oil pan and the oil pump screen, jacking against the oil pan may cause the pan to be bent against the pump screen. This will result in a damaged oil pickup unit.

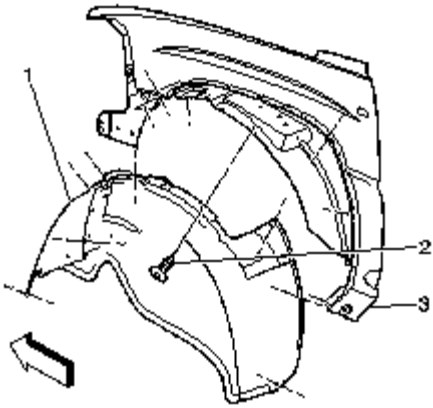

1. If vehicle is a 2 wheel drive (2WD), raise the vehicle to a height to work through the front wheelhouse opening.
2. If vehicle is a 4 wheel drive (4WD), raise the vehicle in order to remove the front tires and wheels.
3. Remove the left front tire and wheel. Refer to *Tire and Wheel Removal and Installation* in Tires and Wheels.
4. Remove the wheelhouse inner panel push pin retainers (2).
5. Remove the wheelhouse inner panel (1).

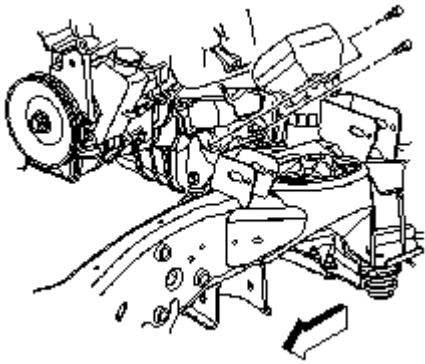

6. Working through the wheelhouse opening, remove the engine mount heat shield bolts.
7. Remove the engine mount heat shield.

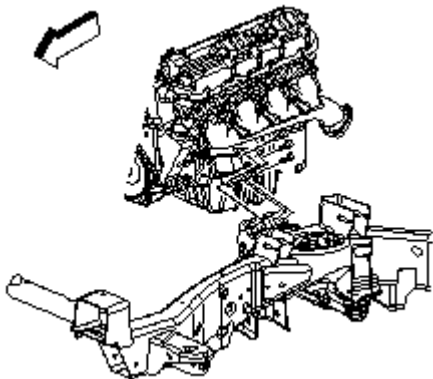

8. Remove the engine mount-to-engine mount bracket bolt.

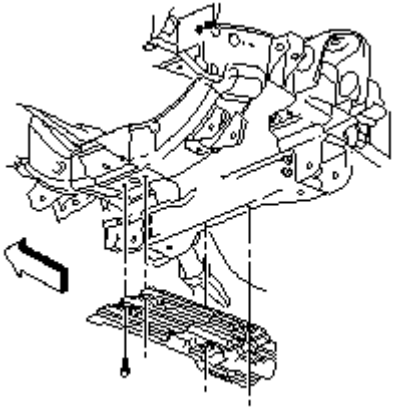

9. if equipped, remove the oil pan skid plate bolts and plate.

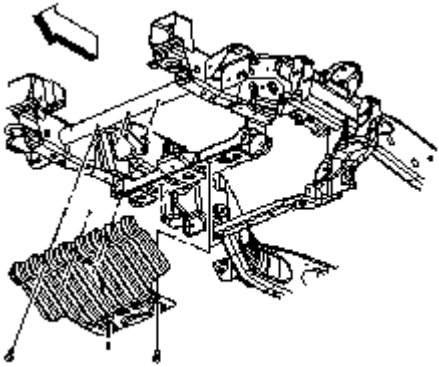

10. Remove the engine shield bolts and shield.

**Important:** When raising the engine only raise it enough to separate the engine mount from the engine mount bracket.

11. Raise the engine with a suitable jack in order to remove the engine mount and bracket.

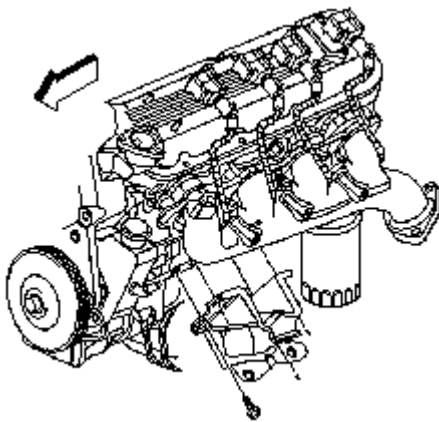

12. Remove the engine mount-to-engine bolts.

13. Remove the engine mount.

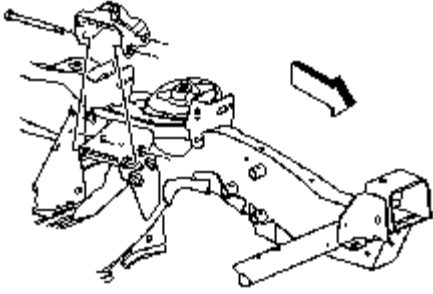

14. Remove the engine mount bracket through bolts.

15. Remove the engine mount bracket.

## Installation Procedure

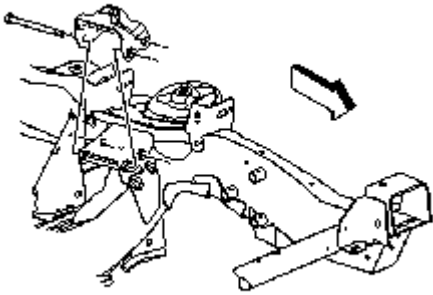

1. Install the engine mount bracket onto the frame.

2. Loosely install the engine mount bracket through bolts.

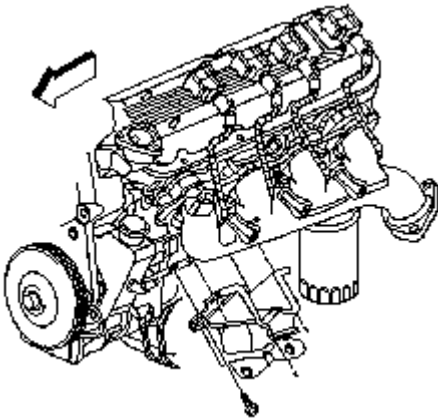

3. Position the engine mount to engine.

4. Loosely install the engine mount-to-engine bolts.

**Notice:** Refer to *Fastener Notice in Cautions and Notices*.

5. Tighten the engine mount bracket through bolts and engine mount-to-engine bolts.

**Tighten:**

- Tighten the engine mount bracket through bolts to 75♦&newtonm; (55♦lb♦ft).
- Tighten the engine mount-to-engine bolts to 50♦&newtonm; (37♦lb♦ft).

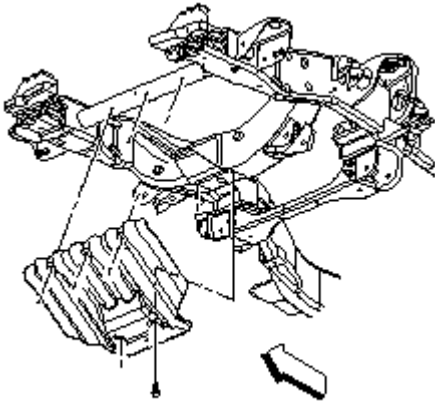

6. Install the engine shield and bolts.

**Tighten:** Tighten the engine shield bolts to 20♦&newtonm; (15♦lb♦ft).

7. Lower the engine.

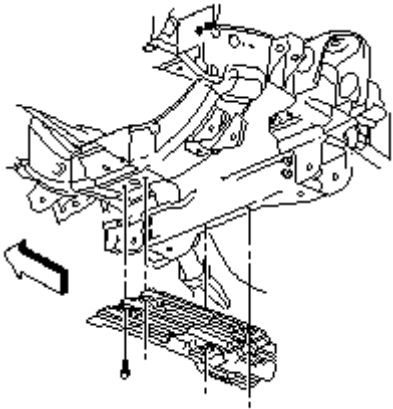

8. if equipped, install the oil pan skid plate and bolts.

**Tighten:** Tighten the oil pan skid plate bolts to 20♦&newtonm; (15♦lb♦ft).

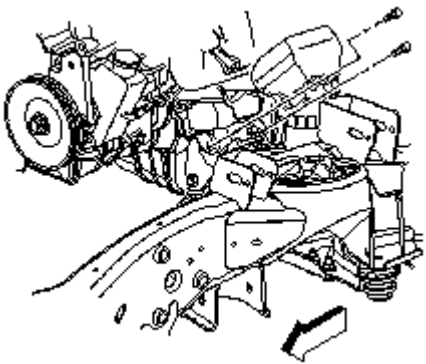

9. Install the engine mount heat shield.

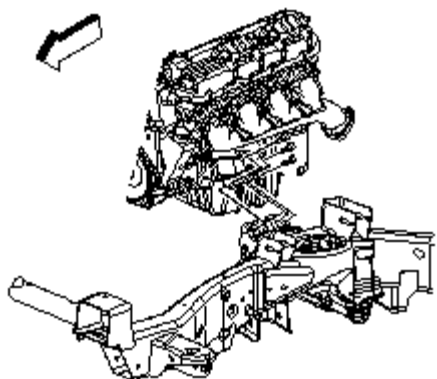

10. Install the engine mount-to-engine mount bracket bolts.

**Tighten:** Tighten the engine mount-to-engine mount bracket bolts to 65♦&newtonm; (48♦lb♦ft).

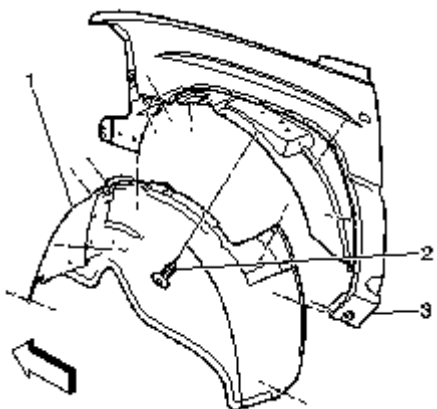

11. Install the wheelhouse inner panel (1).

12. Install the wheelhouse inner panel push pin retainers (2).

13. Install the left front tire and wheel. Refer to *Tire and Wheel Removal and Installation* in Tires and Wheels.

14. Lower the vehicle.

## Repair Instructions

### Engine Mount Replacement - Right

*Engine Mechanical - 8.1L:Repair:Engine Mount Replacement - Right*

#### Removal Procedure

**Notice:** When raising or supporting the engine for any reason, do not use a jack under the oil pan, any sheet metal, or the crankshaft pulley. Due to the small clearance between the oil pan and the oil pump screen, jacking against the oil pan may cause the pan to be bent against the pump screen. This will result in a damaged oil pickup unit.

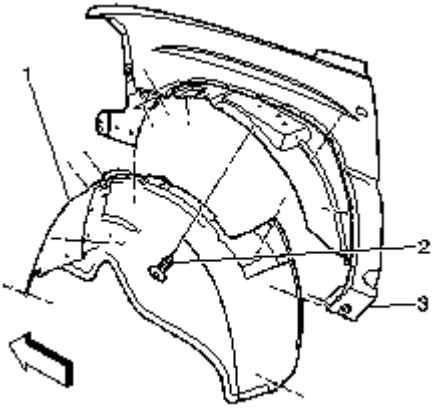

1. If vehicle is a 2 wheel drive (2WD), raise the vehicle to a height to work through the front wheelhouse opening.
2. If vehicle is a 4 wheel drive (4WD), raise the vehicle in order to remove the front tires and wheels.
3. Remove the left front tire and wheel. Refer to [Tire and Wheel Removal and Installation](#) in Tires and Wheels.
4. Remove the wheelhouse inner panel push pin retainers (2).
5. Remove the wheelhouse inner panel (1).

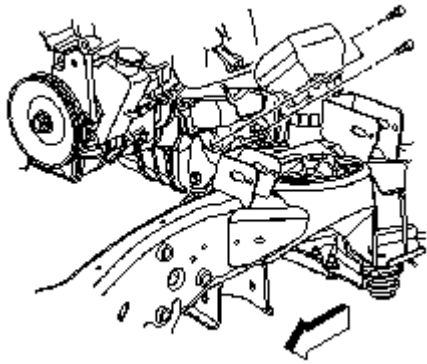

6. Working through the wheelhouse opening, remove the engine mount heat shield bolts (left side shown, right side similar).
7. Remove the engine mount heat shield.

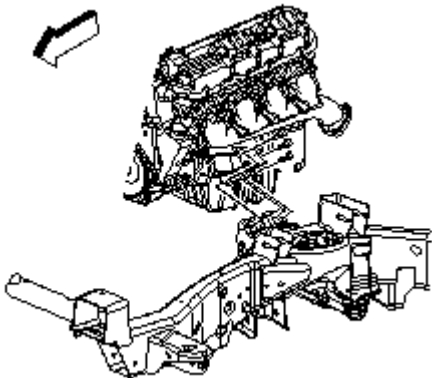

8. Remove the engine mount-to-engine mount bracket bolt (left side shown, right side similar).

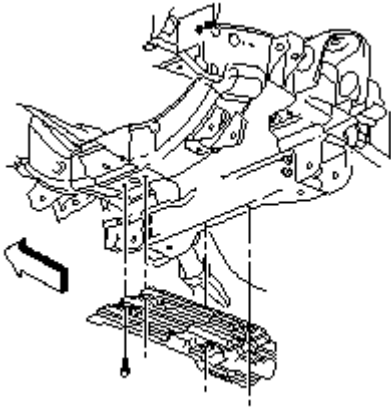

9. Remove the oil pan skid plate bolts and plate, if equipped.

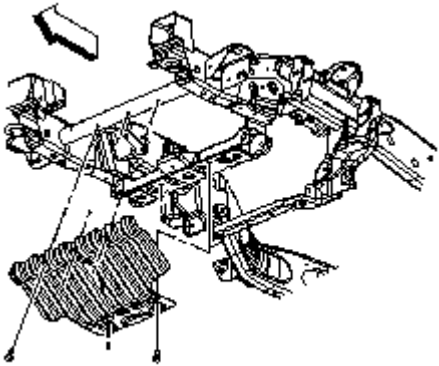

10. Remove the engine shield bolts and shield.

**Important:** When raising the engine only raise it enough to separate the engine mount from the engine mount bracket.

11. Raise the engine with a suitable jack in order to remove the engine mount and bracket.

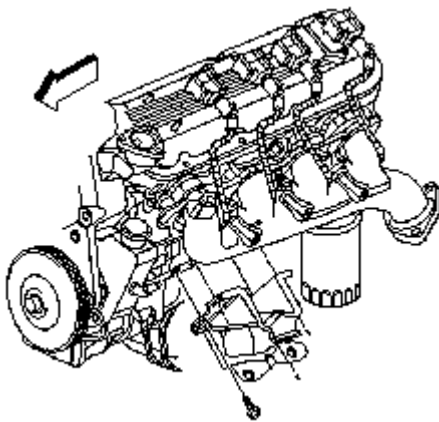

12. Remove the engine mount-to-engine bolts (left side shown, right side similar).  
13. Remove the engine mount.

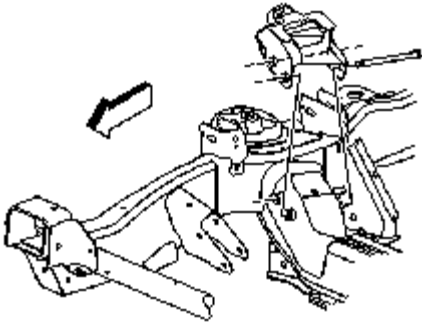

14. Remove the engine mount bracket through bolts.

15. Remove the engine mount bracket.

## Installation Procedure

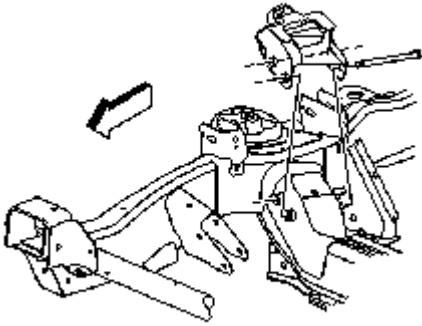

1. Install the engine mount bracket onto the frame.

2. Loosely install the engine mount bracket through bolts.

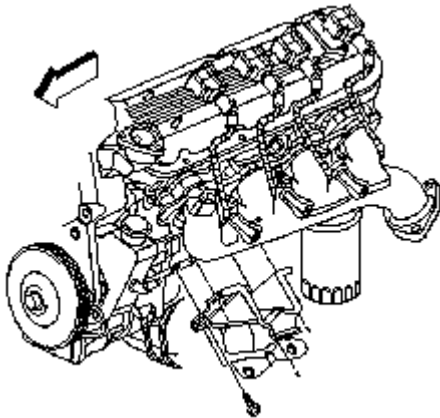

3. Position the engine mount to engine (left side shown, right side similar).

4. Loosely install the engine mount-to-engine bolts.

**Notice:** Refer to *Fastener Notice in Cautions and Notices*.

5. Tighten the engine mount bracket through bolts and engine mount-to-engine bolts.

**Tighten:**

- Tighten the engine mount bracket through bolts to 75♦&newtonm; (55♦lb♦ft).
- Tighten the engine mount-to-engine bolts to 50♦&newtonm; (37♦lb♦ft).

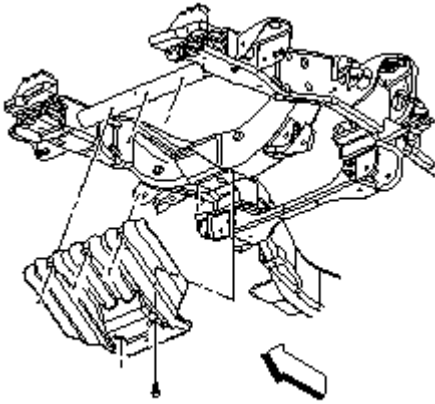

6. Install the engine shield and bolts.

**Tighten:** Tighten the engine shield bolts to 20♦&newtonm; (15♦lb♦ft).

7. Lower the engine.

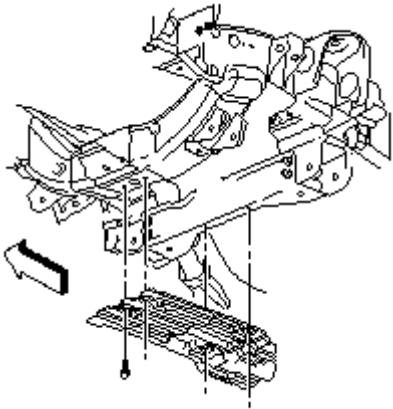

8. if equipped, install the oil pan skid plate and bolts.

**Tighten:** Tighten the oil pan skid plate bolts to 20♦&newtonm; (15♦lb♦ft).

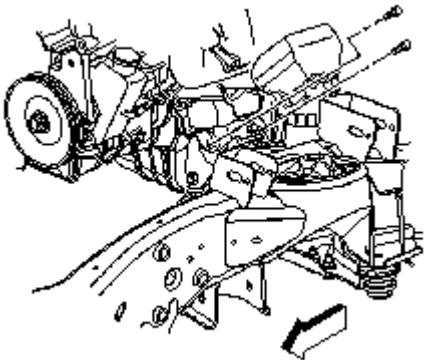

9. Install the engine mount heat shield (left side shown, right side similar).

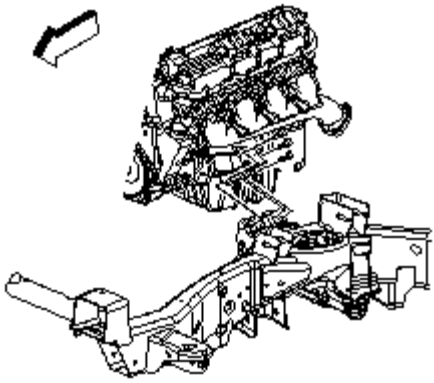

10. Install the engine mount-to-engine mount bracket bolts (left side shown, right side similar).

**Tighten:** Tighten the engine mount-to-engine mount bracket bolts to 65♦&newtonm; (48♦lb♦ft).

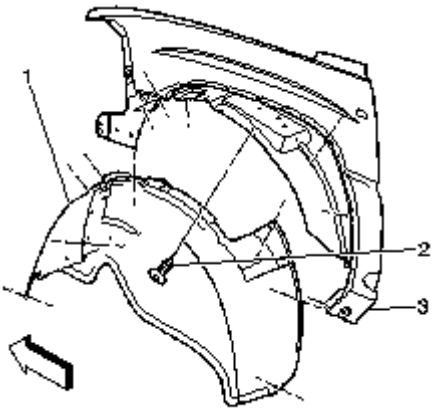

11. Install the wheelhouse inner panel (1).

12. Install the wheelhouse inner panel push pin retainers (2).

13. Install the left front tire and wheel. Refer to *Tire and Wheel Removal and Installation* in Tires and Wheels.

14. Lower the vehicle.

## Repair Instructions

### Engine Sight Shield Replacement

*Engine Mechanical - 8.1L:Repair:Engine Sight Shield Replacement*

#### Removal Procedure

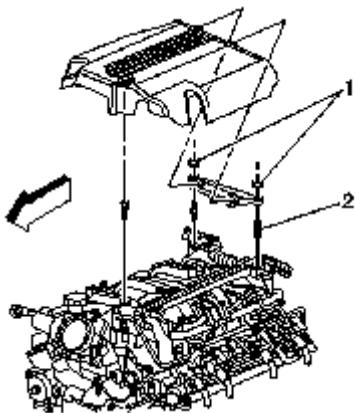

1. Unsnap the intake manifold sight shield from the stud.
2. Remove the sight shield from the sight shield bracket.
3. Remove the sight shield bracket retainer nuts♦(1), if necessary.
4. Remove the sight shield bracket from the studs♦(2), if necessary.

## Installation Procedure

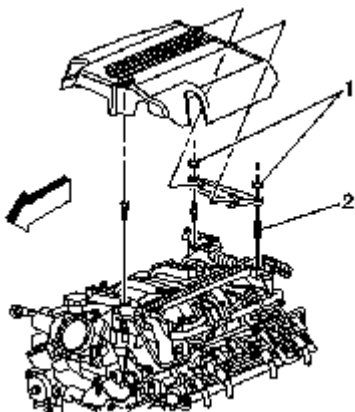

1. Install the sight shield bracket to the studs♦(2), if necessary.

**Notice:** Refer to *Fastener Notice in Cautions and Notices*.

2. Install the sight shield bracket nuts♦(1), if necessary.

**Tighten:** Tighten the nuts to 5♦&newtonm; (44♦lb♦in).

**Notice:** Use care when installing the engine sight shield to avoid contacting the manifold absolute pressure (MAP) sensor wire harness connector. Loss of engine performance or engine damage may result.

3. Install the intake manifold sight shield to the bracket.
4. Snap the intake manifold sight shield onto the stud.

## Repair Instructions

### Intake Manifold Replacement

*Engine Mechanical - 8.1L:Repair:Intake Manifold Replacement*

#### Removal Procedure

**Important:** The intake manifold, throttle body, fuel rail, and injectors may be removed as an assembly. If not servicing the individual components, remove the manifold as a complete assembly.

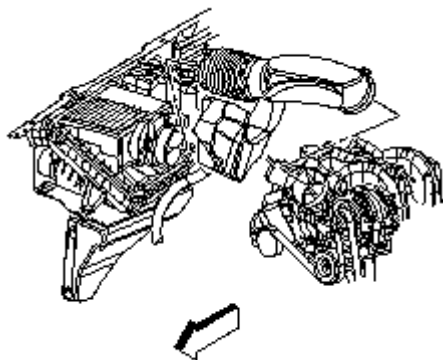

1. Loosen the clamps at the throttle body and air cleaner.
2. Remove the air cleaner outlet duct.

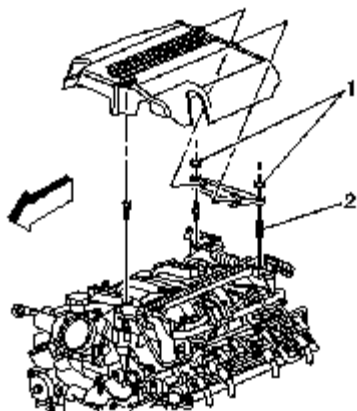

3. Unsnap the intake manifold sight shield from the stud.
4. Remove the sight shield from the bracket.
5. Remove the sight shield bracket nuts (1) and bracket, if necessary.
6. Relieve the fuel system pressure. Refer to [Fuel Pressure Relief Procedure](#) in Engine Controls - 8.1L.
7. Disconnect the fuel feed and return pipes. Refer to [Quick Connect Fitting\(s\) Service \(Metal Collar\)](#) in Engine Controls - 8.1L.

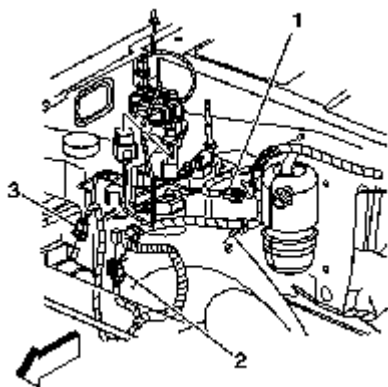

8. Disconnect the engine harness clips from the studs on the front of dash.
9. Disconnect the engine harness clip from the wheelhouse splash shield.
10. Disconnect the following electrical connectors:

- Pressure cycling switch♦(1)
- Surge tank switch♦(2)
- Mass airflow (MAF) sensor♦(3)

11. Reposition the engine harness branch to top of engine.

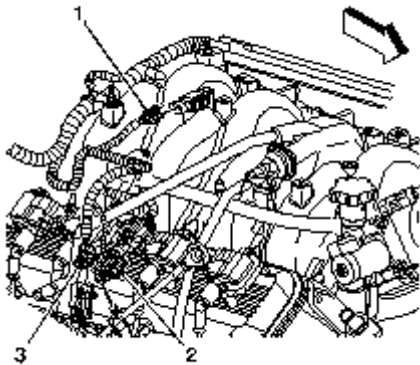

12. Remove the connector position assurance (CPA) retainer at the ignition coil harness.

13. Disconnect the following electrical connectors:

- Manifold absolute pressure (MAP) sensor♦(1)
- Ignition coil harness♦(2)
- Engine coolant temperature (ECT) sensor♦(3)

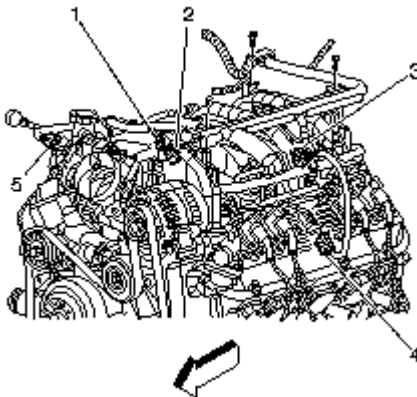

14. Remove the engine harness bolt and studs

15. Remove the CPA retainer at the ignition coil harness.

16. Disconnect the following electrical connectors:

- Generator♦(2)
- Injector harness♦(3)
- Ignition coil harness♦(4)
- Electronic throttle control (ETC)♦(5)
- Purge valve solenoid♦(1)

17. Reposition the engine harness to the drivers side of the engine compartment.

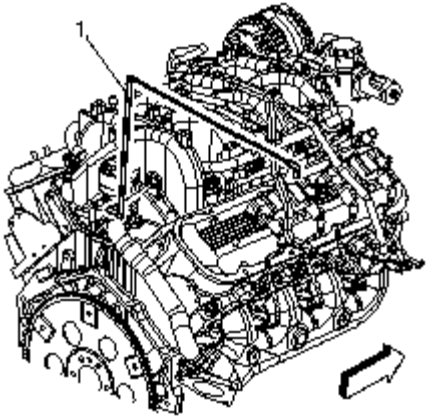

18. Remove the bypass valve vacuum hose♦(1) from the intake manifold.

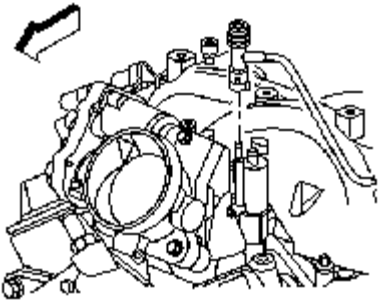

19. Disconnect the evaporative emission (EVAP) tube from the purge solenoid.

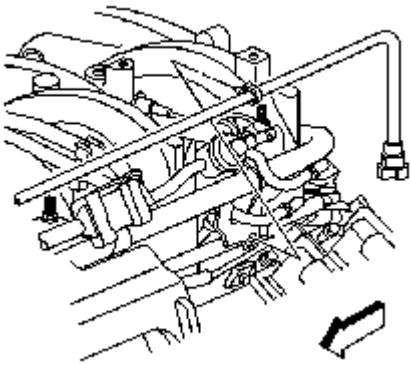

20. Unclip the EVAP tube from the fuel rail.

21. Disconnect the EVAP tube from the vent pipe at the rear of the engine.

22. Remove the EVAP tube.

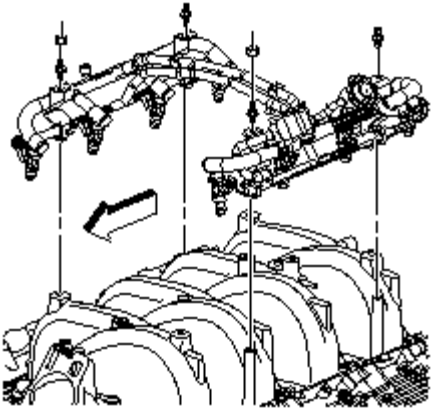

23. If replacing the intake manifold, remove the fuel rail studs.
24. Remove the fuel rail.

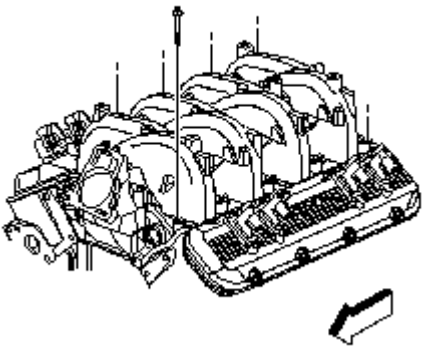

- Important:** Do not attempt to loosen the manifold by prying under the gasket surface with any tool.
25. Remove the intake manifold bolts.

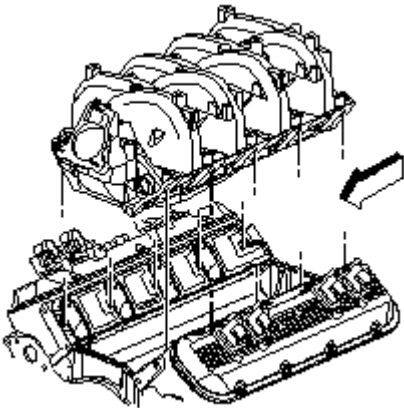

26. Remove the intake manifold.

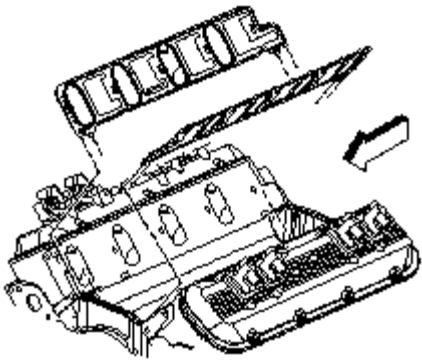

**Important:** The intake manifold gaskets are not reusable.

27. Remove and discard the intake manifold side gaskets.

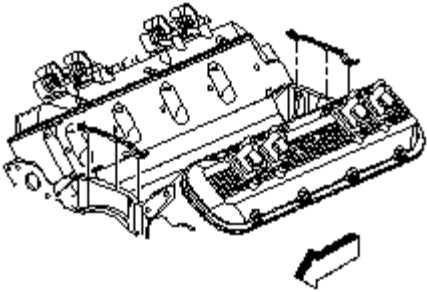

28. Remove and discard the intake manifold end seals.

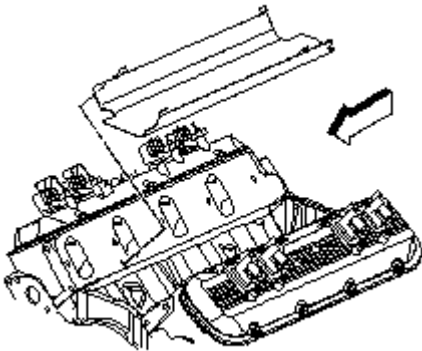

**Important:** The splash shield is secured using a snap-in fit. Do not distort the splash shield. The splash shield is reusable.

29. Remove the splash shield.

30. If replacing the intake manifold, refer to [Intake Manifold Disassemble](#) .

31. Clean and inspect the intake manifold. Refer to [Intake Manifold Cleaning and Inspection](#) .

## Installation Procedure

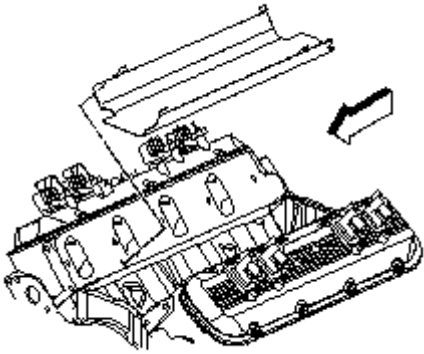

1. If replacing the intake manifold, refer to [Intake Manifold Assemble](#) .
2. Install the splash shield.

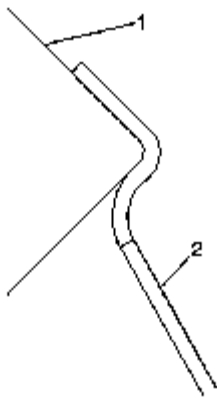

3. Ensure the splash shield♦(2) snap fits between the cylinder heads♦(1).

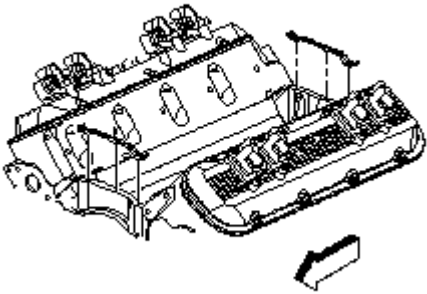

4. Install the NEW intake manifold end seals.

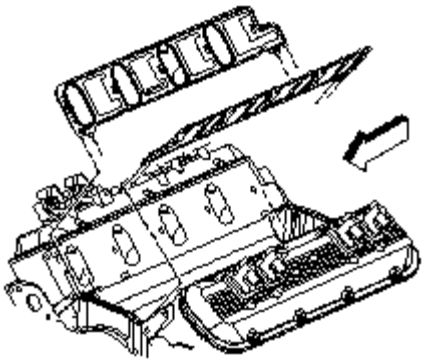

5. Install the NEW intake manifold side gaskets.

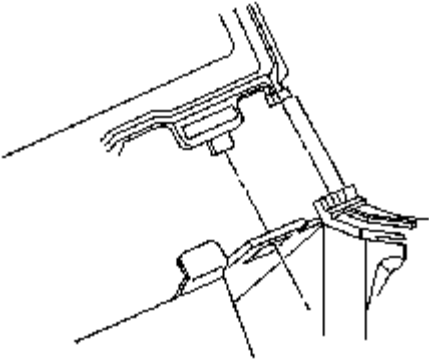

6. Ensure the intake manifold gasket tabs align with the hole in the head gasket.

7. Ensure the intake manifold gasket tabs align with the slot in the intake manifold end seals.

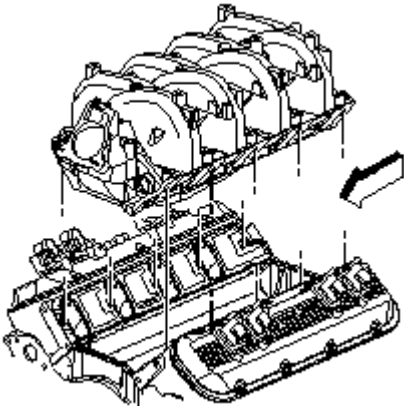

8. Install the intake manifold.

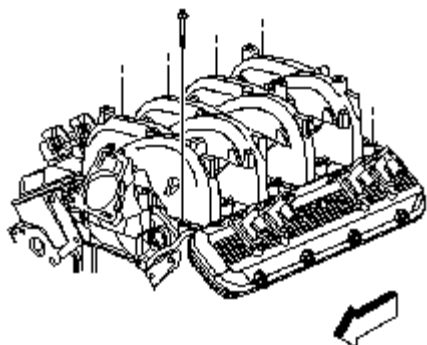

9. Apply threadlock, GM P/N 12345382 (Canadian P/N 10953489), or equivalent to a minimum of eight threads of the intake manifold bolts.

10. Install the intake manifold bolts.

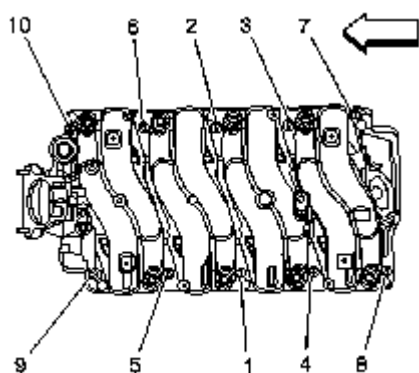

**Notice:** Refer to *Fastener Notice in Cautions and Notices*.

11. Tighten the intake manifold bolts in the sequence shown, using four passes.

**Tighten:**

12. Tighten the bolts a first pass to 5♦&newtonm; (44♦lb♦in).
13. Tighten the bolts a second pass to 8♦&newtonm; (71♦lb♦in).
14. Tighten the bolts a final pass to 12♦&newtonm; (106♦lb♦in).

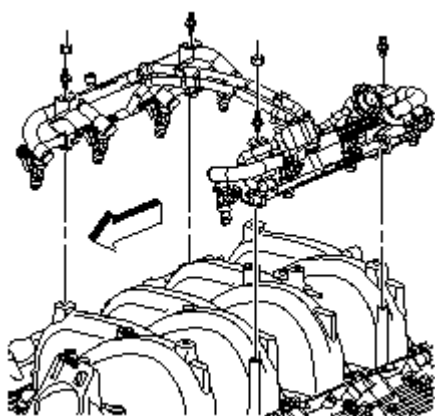

**Important:** Lubricate the fuel injector O-ring seals with clean engine oil and install onto the spray tip of each injector.

15. If replacing the intake manifold, install the fuel rail.

16. Install the fuel rail studs.

**Tighten:** Tighten the studs to 12♦&newtonm; (106♦lb♦in).

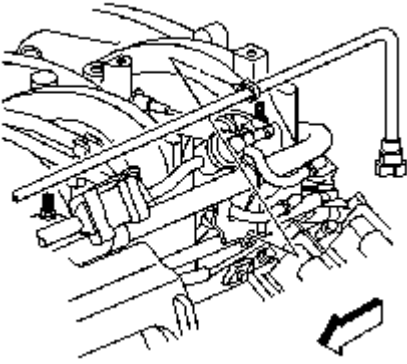

17. Install the EVAP tube.

18. Connect the EVAP tube to the vent pipe at the rear of the engine.

19. Clip the EVAP tube to the fuel rail.

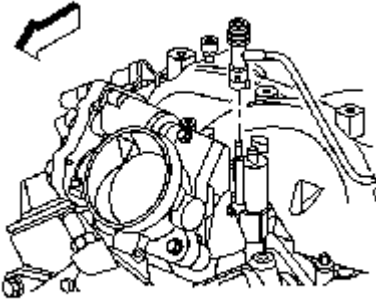

20. Connect the EVAP tube to the purge solenoid.

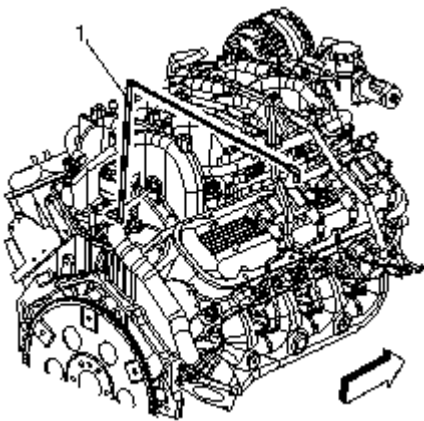

21. Install the bypass valve vacuum hose♦(1) to the intake manifold.

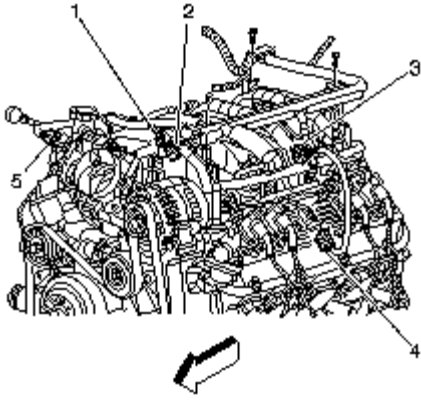

**22.** Position the engine harness over the engine compartment.

**23.** Connect the following electrical connectors:

- Generator♦(2)
- Injector harness♦(3)
- Ignition coil harness♦(4)
- ETC♦(5)
- Purge valve solenoid (1)

**24.** Install the CPA retainer at the ignition coil harness.

**25.** Install the engine harness bolt and studs

**Tighten:**

- Tighten the bolt to 5♦&newtonm; (44♦lb♦in).
- Tighten the studs to 10♦&newtonm; (89♦lb♦in).

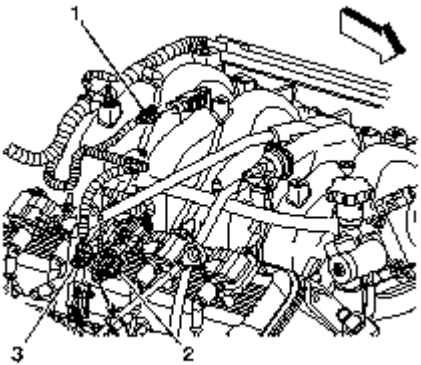

**26.** Connect the following electrical connectors:

- MAP sensor♦(1)
- Ignition coil harness♦(2)
- ECT sensor♦(3)

**27.** Install the CPA retainer at the ignition coil harness.

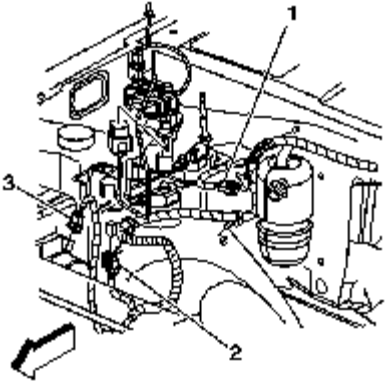

28. Position engine harness branch over the top of engine.

29. Connect the following electrical connectors:

- Pressure cycling switch♦(1)
- Surge tank switch♦(2)
- MAF sensor♦(3)

30. Connect the engine harness clip to the wheelhouse splash shield.

31. Connect the engine harness clips to the studs on the front of dash.

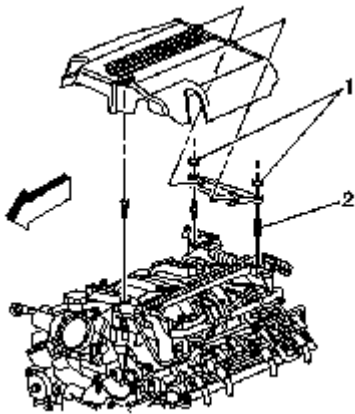

32. Connect the fuel feed and return pipes.

33. Install the sight shield bracket and nuts♦(1).

**Tighten:** Tighten the nuts to 5♦&newtonm; (44♦lb♦in).

34. Install the sight shield to the bracket.

35. Snap the intake manifold sight shield to the stud.

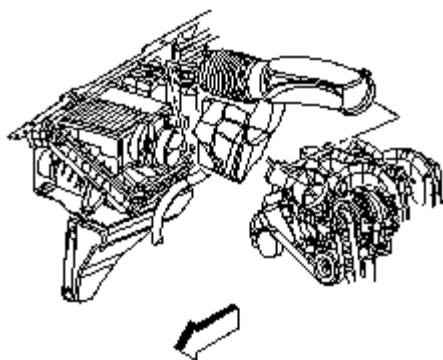

36. Install the air cleaner outlet duct.

37. Tighten the clamps at the throttle body and air cleaner.

**Tighten:** Tighten the clamps to 4♦&newtonm; (35♦lb♦in).

## Repair Instructions

### Valve Rocker Arm Cover Replacement - Left

Engine Mechanical - 8.1L:Repair:Valve Rocker Arm Cover Replacement - Left

#### Removal Procedure

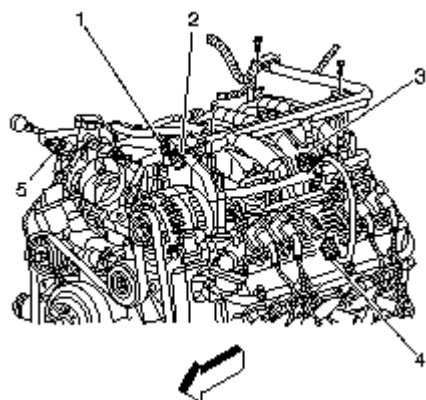

1. Remove the engine sight shield. Refer to [Engine Sight Shield Replacement](#) .

2. Remove the connector position assurance (CPA) retainer from the ignition coil electrical connector.

3. Disconnect the ignition coil harness electrical connector (4).

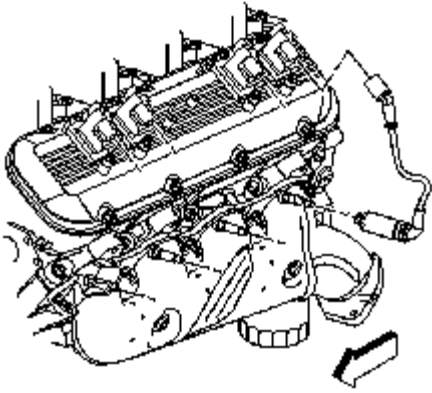

**Important:** Twist the spark plug boot one-half turn in order to release the boot. Pull on the spark plug boot only. Do not pull on the spark plug wire or the wire could be damaged.

4. Remove the spark plug wires from the spark plugs and ignition coils.

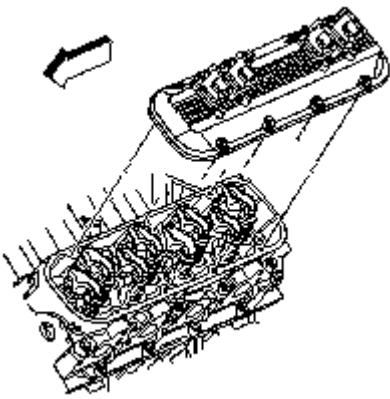

5. Remove the valve rocker arm cover bolts.

6. Remove the valve rocker arm cover.

**Important:** Valve rocker arm cover gaskets are reusable. Replace the gasket only if damaged.

7. Inspect the valve rocker arm cover gasket for cuts or damage.

8. Clean and inspect the valve rocker arm cover. Refer to [Valve Rocker Arm Cover Cleaning and Inspection](#).

## Installation Procedure

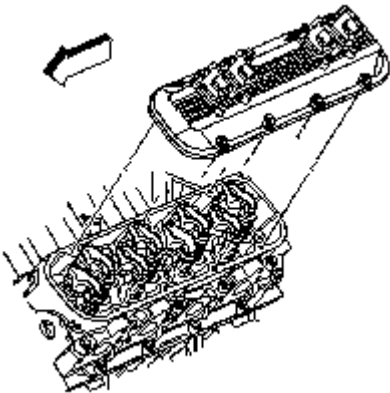

1. Install a new valve rocker arm cover gasket if the gasket was removed from the rocker arm cover.

2. Install the valve rocker arm cover.
3. Install the valve rocker arm cover bolts.

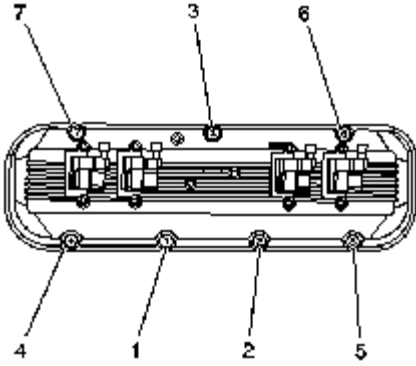

**Notice:** Refer to *Fastener Notice in Cautions and Notices*.

4. Tighten the valve rocker arm cover bolts in the sequence shown, using two passes as shown.

**Tighten:**

- Tighten the bolts a first pass to 6♦&newtonm; (53♦lb♦in).
- Tighten the bolts a final pass to 12♦&newtonm; (106♦lb♦in).

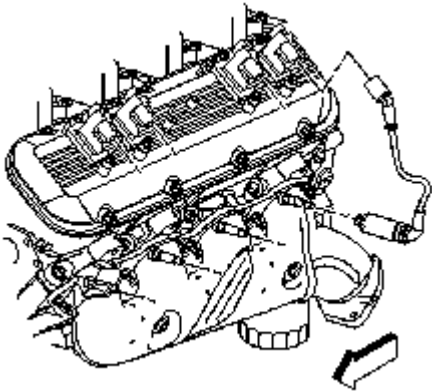

**Important:** Fully install the spark plug wire by pushing on the exposed end of the spark plug boot. Do not push the spark plug wire on to the spark plug by using the metal heat shield.

5. Install the spark plug wires to the spark plugs and ignition coils.

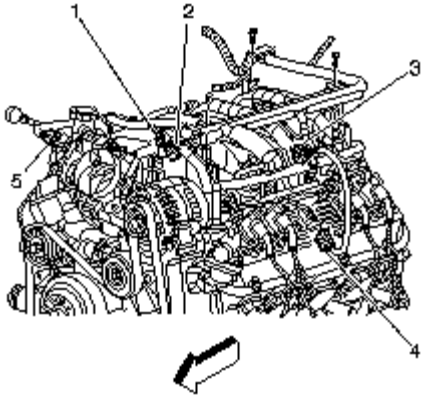

6. Connect the ignition coil harness electrical connector (4).
7. Install the CPA retainer to the ignition coil electrical connector.
8. Install the engine sight shield. Refer to [Engine Sight Shield Replacement](#) .

## Repair Instructions

### Valve Rocker Arm Cover Replacement - Right

*Engine Mechanical - 8.1L:Repair:Valve Rocker Arm Cover Replacement - Right*

#### Removal Procedure

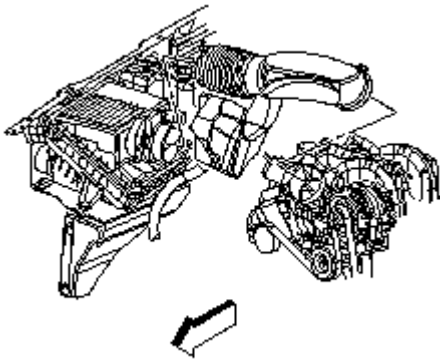

1. Remove the engine sight shield. Refer to [Engine Sight Shield Replacement](#) .
2. Loosen the clamps at the throttle body and air cleaner.
3. Remove the air cleaner outlet duct.

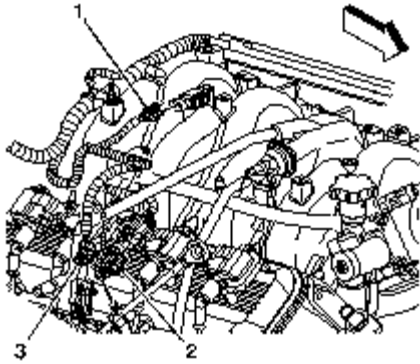

4. Remove the connector position assurance (CPA) retainer from the ignition coil electrical connector (2).
5. Disconnect the ignition coil harness electrical connector (2).
6. Disconnect the engine coolant temperature (ECT) sensor electrical connector (3).

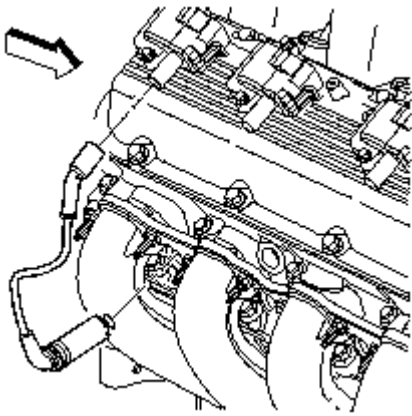

**Important:** Twist the spark plug boot one-half turn in order to release the boot. Pull on the spark plug boot only. Do not pull on the spark plug wire or the wire could be damaged.

7. Remove the spark plug wires from the ignition coils.

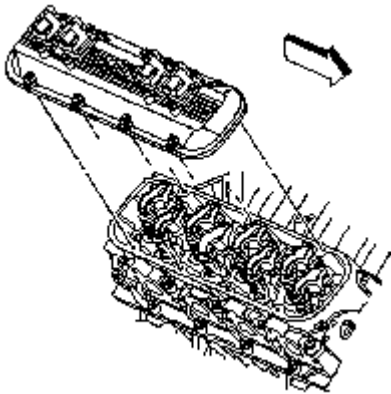

8. Loosen the valve rocker arm cover bolts.
9. Remove the valve rocker arm cover.

**Important:** The valve rocker arm cover gasket may be reused if not removed from the valve rocker arm cover.

10. Replace the valve rocker arm cover gasket if it is cut or damaged.
11. Clean and inspect the valve rocker arm cover. Refer to [Valve Rocker Arm Cover Cleaning and Inspection](#).

## Installation Procedure

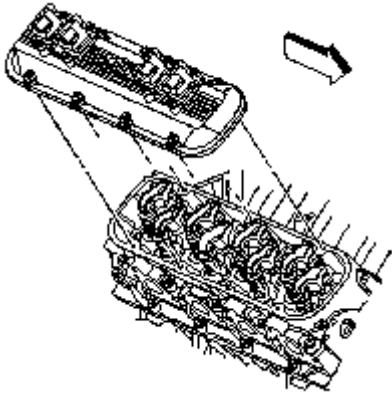

1. Install a NEW valve rocker arm cover gasket, if necessary.
2. Install the valve rocker arm cover.

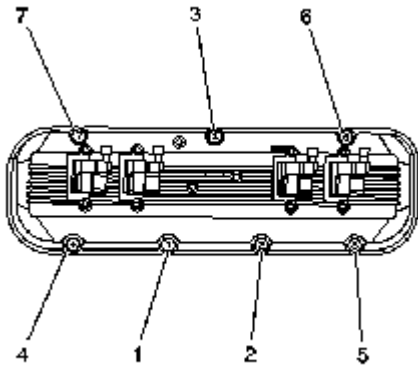

**Notice:** Refer to *Fastener Notice in Cautions and Notices*.

3. Tighten the valve rocker arm cover bolts in sequence using two passes as shown.

**Tighten:**

4. Tighten the bolts a first pass to 6♦&newtonm; (53♦lb♦in).
5. Tighten the bolts a final pass to 12♦&newtonm; (106♦lb♦in).

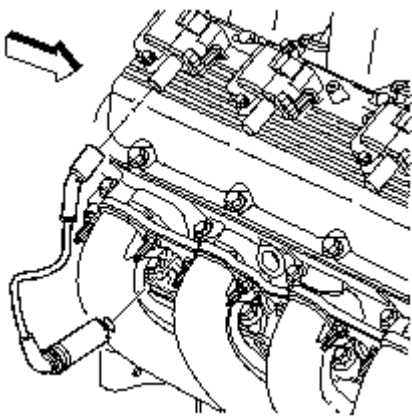

6. Install the spark plug wires to the ignition coils.

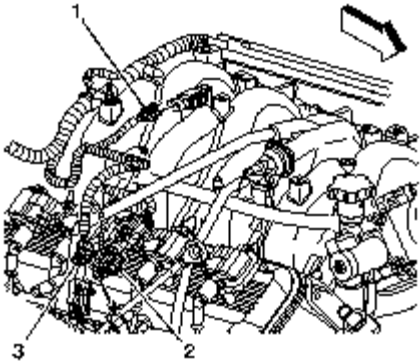

7. Connect the ECT sensor electrical connector (3).
8. Connect the ignition coil harness electrical connector (2).
9. Install the CPA retainer to the ignition coil electrical connector (2).

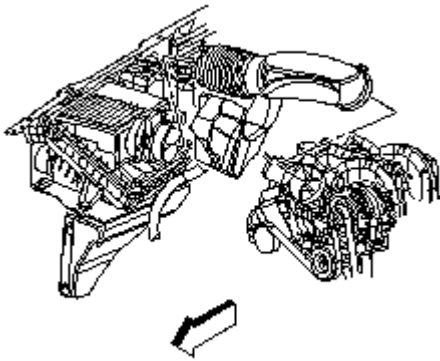

10. Install the air cleaner outlet duct.
11. Tighten the clamps at the throttle body and air cleaner.  
**Tighten:** Tighten the clamps to 4♦&newtonm; (35♦lb♦in).
12. Install the engine sight shield. Refer to *Engine Sight Shield Replacement* .

## Repair Instructions

### Valve Rocker Arm and Push Rod Replacement

*Engine Mechanical - 8.1L:Repair:Valve Rocker Arm and Push Rod Replacement*

#### Removal Procedure

**Important:** Mark, organize, and sort the cylinder head components. Return the components to their original location during reassembly.

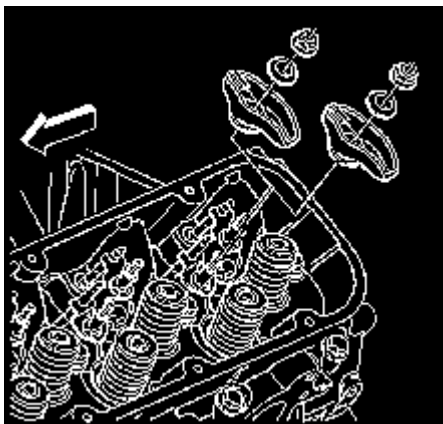

1. Remove the valve rocker arm cover. Refer to [Valve Rocker Arm Cover Replacement - Left](#) and/or [Valve Rocker Arm Cover Replacement - Right](#).

2. Remove the valve rocker arm nuts, the valve rocker arm balls, and valve rocker arms.

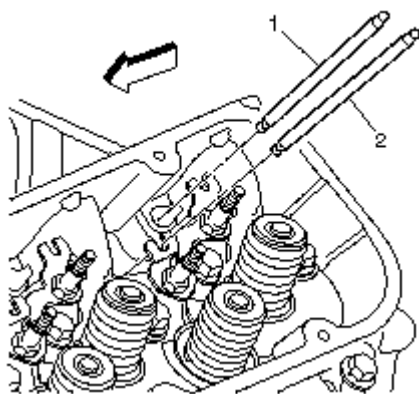

**Important:** The exhaust valve pushrods (2) are longer than the intake valve pushrods (1).

3. Remove the valve pushrods.

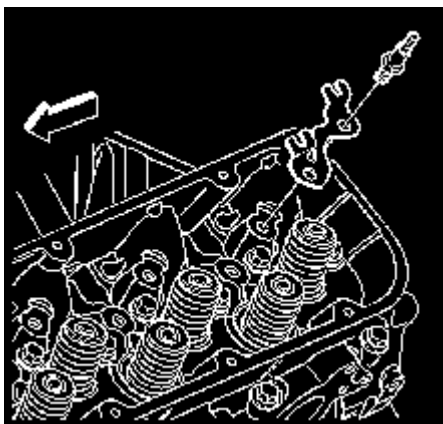

4. Remove the valve rocker arm studs and pushrod guides.

5. Clean and inspect the valve rocker arms and pushrods. Refer to [Valve Rocker Arm and Push Rods Cleaning and Inspection](#).

## Installation Procedure

**Important:** Be sure to keep parts in order. Parts must be put back from where they were removed.

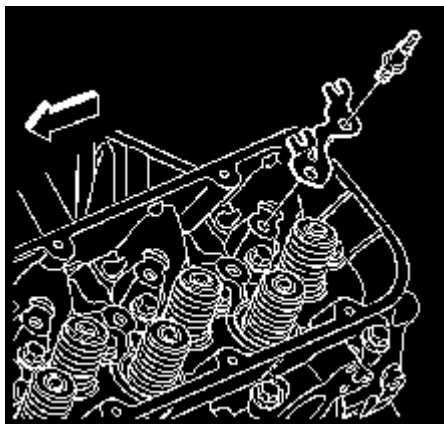

1. Apply sealant GM♦P/N♦12346004 (Canadian♦P/N♦10953480), or equivalent to the valve rocker arm stud-to-cylinder head threads.

**Notice:** Refer to *Fastener Notice in Cautions and Notices*.

2. Install the pushrod guides and valve rocker arm studs.

**Tighten:** Tighten the studs to 50♦&newtonm; (37♦lb♦ft).

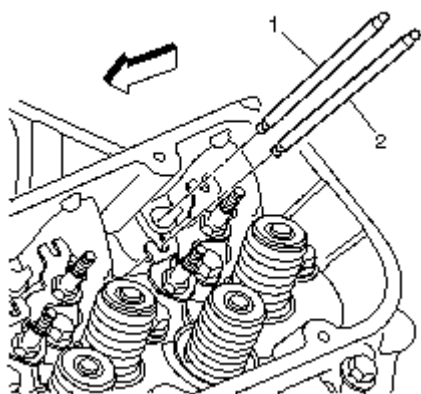

**Important:** The exhaust valve pushrods (2) are longer than the intake valve pushrods (1).

3. Install the valve pushrods.

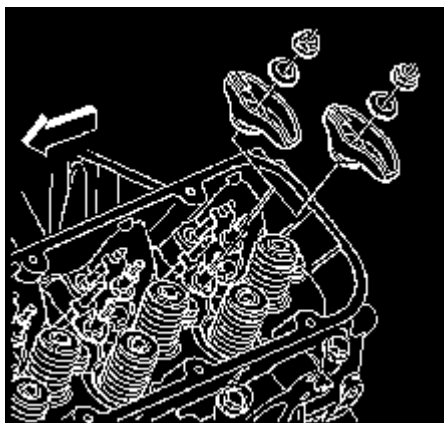

4. Coat the valve rocker arm and valve rocker arm ball bearing surfaces with lubricant GM♦P/N♦12345501 (Canadian♦P/N♦992704), or equivalent.

5. Install the valve rocker arms, the valve rocker arm balls, and the valve rocker arm nuts.

**Tighten:** Tighten the nuts slowly to 35♦&newtonm; (26♦lb♦ft) while guiding the tips of the rocker arms over the tips of the valves.

6. Install the valve rocker arm cover. Refer to [Valve Rocker Arm Cover Replacement - Left](#) or [Valve Rocker Arm Cover Replacement - Right](#).

## Repair Instructions

### Valve Stem Oil Seal and Valve Spring Replacement

Engine Mechanical - 8.1L:Repair:Valve Stem Oil Seal and Valve Spring Replacement

#### Tools Required

- [J 5892-D](#) Valve Spring Compressor
- [J 22794](#) Spark Plug Port Adapter
- [J 43105](#) Valve Stem Seal Installer

#### Removal Procedure

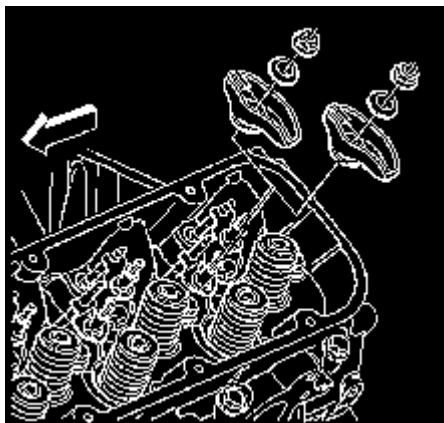

1. Remove the valve rocker arms and pushrods. Refer to [Valve Rocker Arm and Push Rod Replacement](#).

**Important:** Rotate the piston in the cylinder being serviced to the bottom of its stroke, to ensure that the engine does not rotate when the compressed air is applied.

2. Rotate the crankshaft until both valves are closed before installing the compressed air into the cylinder.

3. Remove the spark plug from the cylinder being serviced. Refer to [Spark Plug Replacement](#) in Engine Controls - 8.1L.

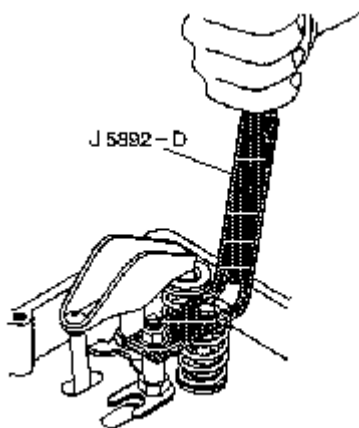

4. Remove the valve stem keys as followed:

- 4.1. Install the [J 22794](#) into the spark plug hole.
- 4.2. Apply compressed air into the cylinder in order to hold the valves closed.
- 4.3. Lightly tap the valve spring cap to loosen the valve stem keys.

4.4. Install the *J 5892-D* to the cylinder head.

4.5. Install the valve rocker arm nut.

**Important:** Tighten the valve rocker arm nut enough to hold *J 5892-D* in place.

4.6. Using *J 5892-D* compress the valve spring.

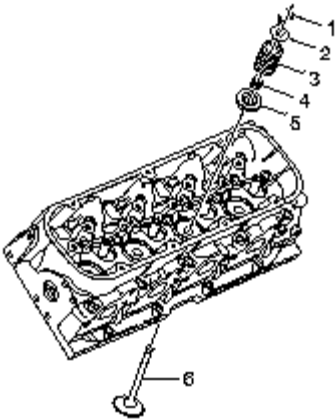

5. Remove the valve stem keys (1).

**Important:** Do not release the compressed air from the cylinder being worked on. The valve will fall into the cylinder bore.

6. Slowly release the *J 5892-D*.

7. Remove the *J 5892-D* from the cylinder head.

8. Remove the valve spring cap (2) and valve spring (3).

9. Remove the valve stem oil seal (4).

## Installation Procedure

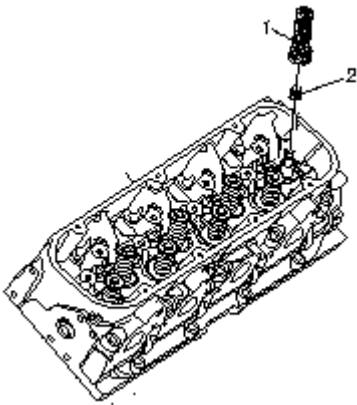

1. Lubricate the valve stem and outside diameter of the valve guide seal with clean engine oil.

2. Lubricate the rotators with clean engine oil.

**Important:** When installing valve seals, *J 43105* must be used to achieve correct installation. Failure to use *J 43105* may cause excessive oil consumption.

3. Install the valve stem oil seal (2) over the valve tip and onto the valve guide using *J 43105*. Tap the valve stem seal onto the valve guide until the *J 43105* fully seats the seal.

4. Install the valve spring cap and the spring.

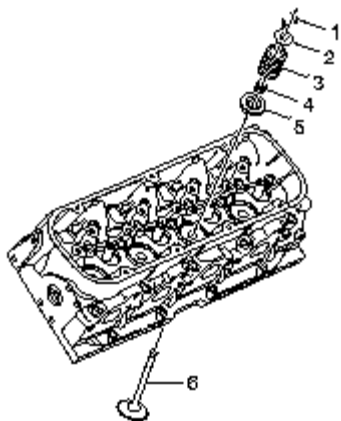

**Important:** When installing valve springs, the small end of the valve spring must be installed up.

5. Install the valve spring (3).
6. Install the valve spring cap (2).

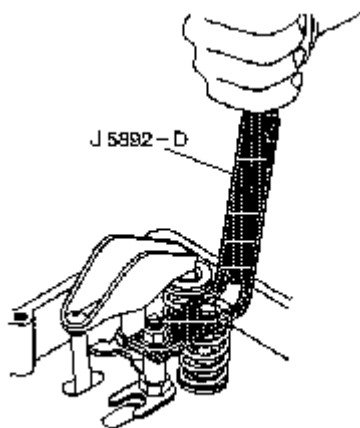

7. Using *J 5892-D* compress the valve spring.
8. Install the valve stem keys as follows:
  - 8.1. Apply a small amount of clean grease to hold the valve stem keys in place.
  - 8.2. Carefully release the *J 5892-D*. Make sure the valve stem keys do not move.
  - 8.3. Remove the *J 5892-D* from the valve assembly.
  - 8.4. Remove the compressed air from the cylinder being worked on.
9. Install the spark plug. Refer to [Spark Plug Replacement](#) in Engine Controls - 8.1L.

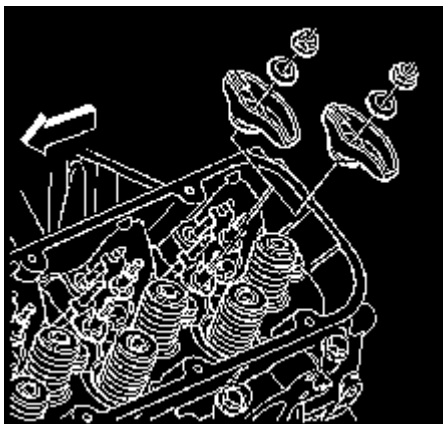

10. Install the valve rocker arms and pushrods. Refer to [Valve Rocker Arm and Push Rod Replacement](#).

## Repair Instructions

### Valve Lifter Replacement

Engine Mechanical - 8.1L:Repair:Valve Lifter Replacement

#### Tools Required

J 3049-A Valve Lifter Remover

#### Removal Procedure

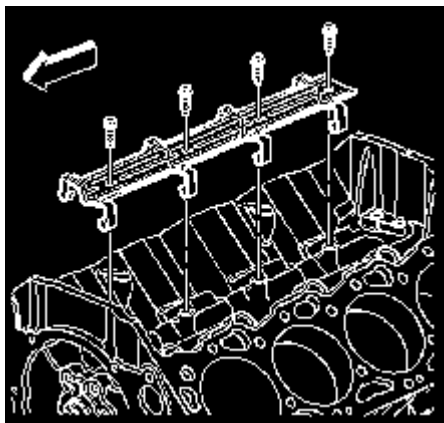

1. Remove the intake manifold. Refer to [Intake Manifold Replacement](#) .
2. Remove the valve rocker arms and pushrods. Refer to [Valve Rocker Arm and Push Rod Replacement](#) .
3. Remove the valve lifter guide retainer bolts and retainer.

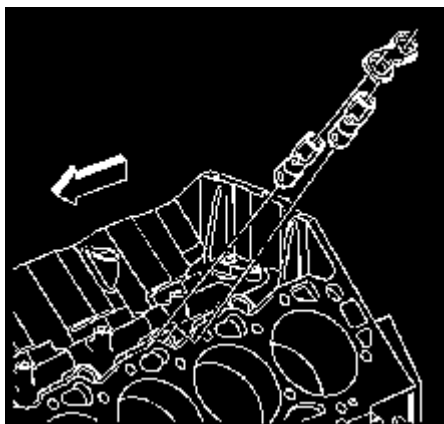

4. Remove the valve lifter guides.  
**Important:** Mark, sort, or organize the valve lifters and guides for installation in their original location.
5. Remove the valve lifters.

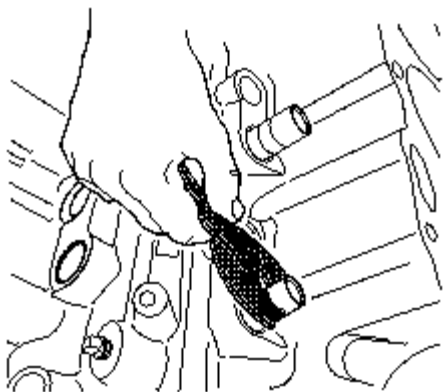

6. Some valve lifter may be stuck in their bore due to gum or varnish deposits, These lifters can be removed using *J 3049-A* .

7. Clean and inspect the valve lifters. Refer to *Valve Lifters and Guides Cleaning and Inspection* in Engine Mechanical - 8.1L Unit Repair.

## Installation Procedure

**Important:** If a new camshaft is installed, replace all the valve lifters.

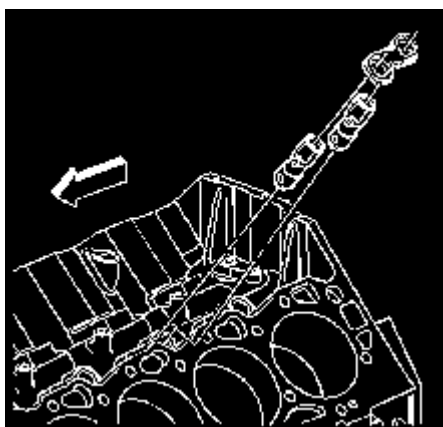

1. Coat the valve lifter rollers with lubricant GM♦U.S.♦P/N♦12345501, Canada♦P/N♦992704, or equivalent.

**Important:** If reusing the valve lifters, install the lifters in their original location. The valve lifter guide retainer must contact all of the valve lifter guides. If the lifter guide retainer is bent, the valve lifter guide retainer must be replaced.

2. Install the valve lifters.

3. Install the valve lifter guides over the flats on the valve lifters, making sure the rollers of the valve lifters are properly aligned with the camshaft lobes.

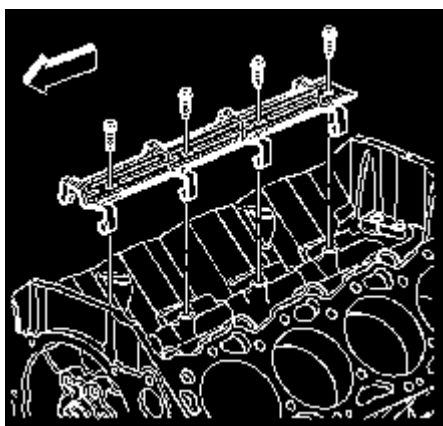

4. Install the valve lifter guide retainer.

**Notice:** Refer to *Fastener Notice in Cautions and Notices*.

5. Install the valve lifter guide retainer bolts.

**Tighten:** Tighten the valve lifter guide retainer bolts to 25♦&newtonm; (18♦lb♦ft).

6. Install the valve rocker arms and pushrods. Refer to *Valve Rocker Arm and Push Rod Replacement*.

Install the intake manifold. Refer to *Intake Manifold Replacement*.

## Repair Instructions

### Oil Level Indicator and Tube Replacement

*Engine Mechanical - 8.1L:Repair:Oil Level Indicator and Tube Replacement*

#### Removal Procedure

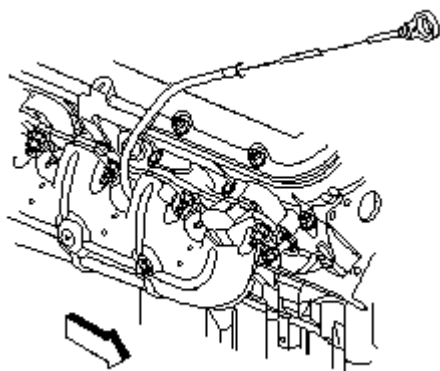

1. Remove the oil level indicator from the indicator tube.

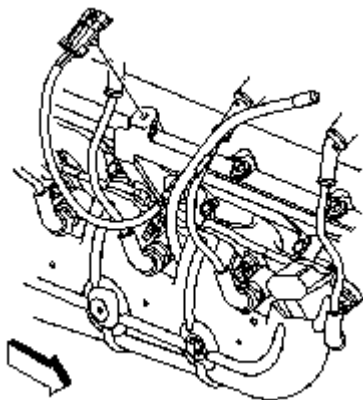

2. Disconnect the engine coolant temperature (ECT) sensor electrical connector.

3. Remove the ECT sensor connector from the indicator tube.

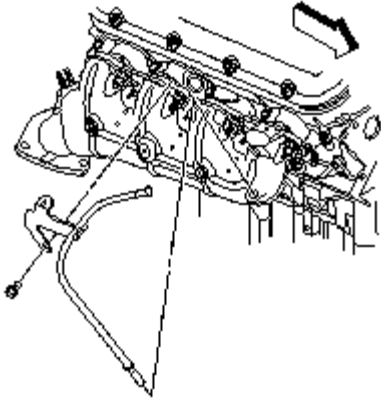

4. Remove the indicator tube bolt.
5. Remove the indicator tube bracket.
6. Remove the O-ring seal from the indicator tube.

## Installation Procedure

**Important:** Make sure the indicator tube does not come in contact with spark plug wires. Ensure that the spark plug wires are routed around the indicator tube.

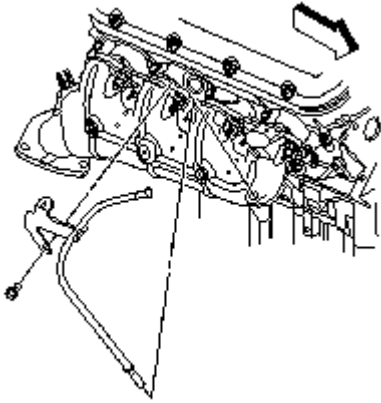

1. Install a NEW O-ring seal onto the indicator tube.
2. Install the indicator tube into the oil pan.
3. Align the indicator tube bracket with the bolt hole in the block.

**Notice:** Refer to *Fastener Notice in Cautions and Notices*.

4. Install the indicator tube bolt.

**Tighten:** Tighten the bolt to 50♦&newtonm; (37♦lb♦ft).

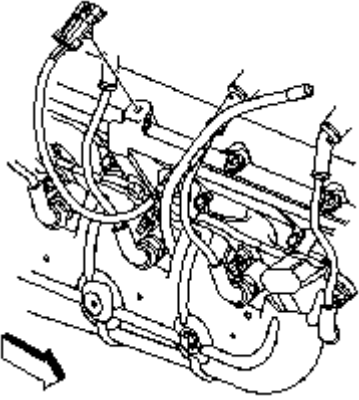

5. Install the ECT sensor connector to the indicator tube.
6. Connect the ECT sensor electrical connector.

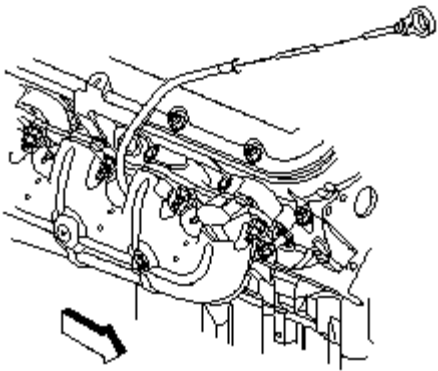

7. Install the oil level indicator to the indicator tube.

## Repair Instructions

### Cylinder Head Replacement - Left

*Engine Mechanical - 8.1L:Repair:Cylinder Head Replacement - Left*

#### Tools Required

*J 45059* Angle Meter

#### Removal Procedure

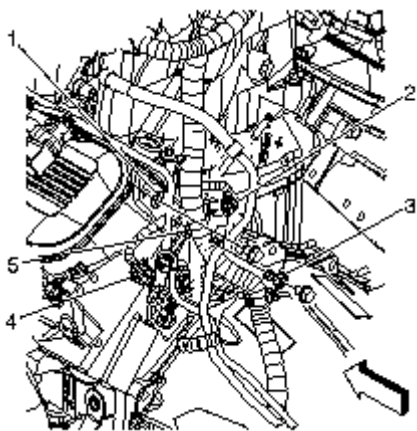

1. Remove the intake manifold. Refer to [Intake Manifold Replacement](#) .
2. Remove the water crossover. Refer to [Water Crossover Replacement \(8.1L Engine\)](#) in Engine Cooling.
3. Remove the valve rocker arms and pushrods. Refer to [Valve Rocker Arm and Push Rod Replacement](#) .
4. Remove the engine harness ground bolts.
5. Reposition the engine harness grounds (1 and 5) and ground strap (4) from the cylinder head.

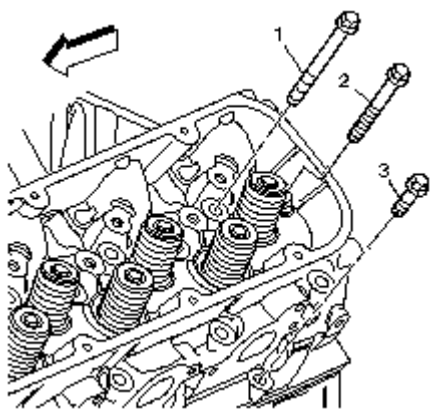

6. Remove the exhaust manifold. Refer to [Exhaust Manifold Replacement - Left \(4.3L Engine\)](#) [Exhaust Manifold Replacement - Left \(4.8L, 5.3L, and 6.0L Engine\)](#) [Exhaust Manifold Replacement - Left \(6.6L \(LB7\) Engine\)](#) [Exhaust Manifold Replacement - Left \(8.1L Engine\)](#) in Engine Exhaust.
7. Remove and discard the cylinder head bolts (1, 2, and 3).

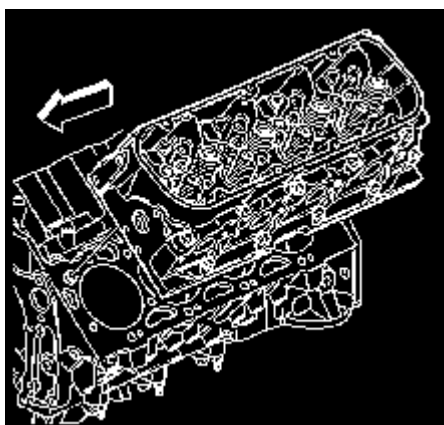

**Important:** Place the cylinder head on two wood blocks to prevent damage to the sealing surfaces.

8. Remove the cylinder head.

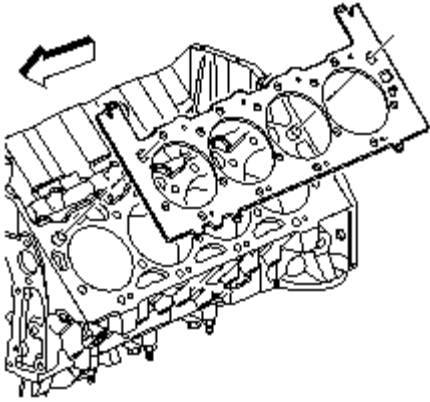

9. Remove and discard the cylinder head gasket.

10. Clean and inspect the cylinder head. Refer to [Cylinder Head Cleaning and Inspection](#) .

## Installation Procedure

**Important:** Make sure the threaded holes in the engine block are clean and not damaged. Do not use sealer on any engines that use a composition type gasket. Align the cylinder head gasket locating marks to face up. Ensure that the head gasket tabs are located over the numbers 1 and 2 cylinders for correct installation.

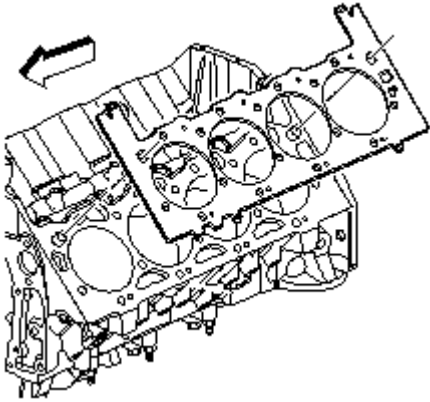

1. Place a NEW cylinder head gasket into position.

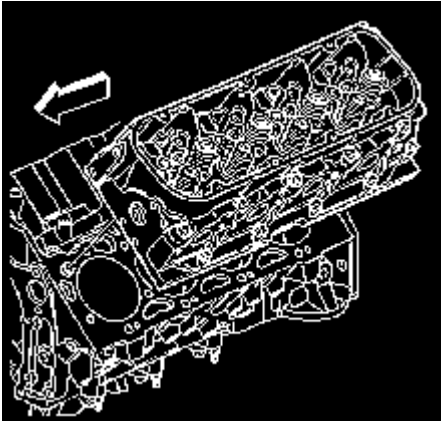

2. Install the cylinder head.

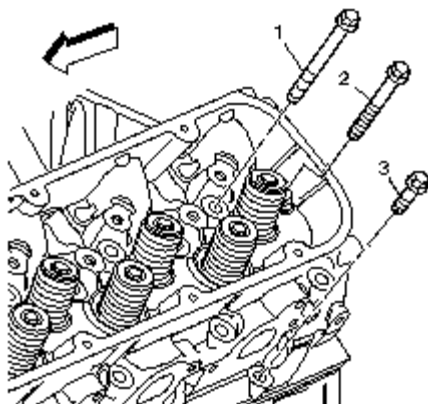

**Notice:** Do not reuse the cylinder head bolts. NEW cylinder head bolts must be used. The cylinder head bolts are torque-to-yield bolts and cannot be reused once the initial torque is applied. During the initial torque of the cylinder head bolt the cylinder head bolt is stretched to achieve proper clamp load. Proper clamp load will not be achieved if a used cylinder head bolt is torqued again. A stretched cylinder head bolt can also break when torqued. Failure to replace the used cylinder head bolts with NEW cylinder head bolts can lead to improper clamp loads and extensive engine damage.

**Important:** The sealer must be applied to a minimum of eight threads starting at the point of the cylinder head bolt.

3. If not pre-applied to the NEW cylinder head bolts, apply sealant GM♦P/N♦12346004 (Canadian♦P/N♦10953480), or equivalent to the cylinder head bolts.

4. Install the cylinder head bolts (1, 2, and 3).

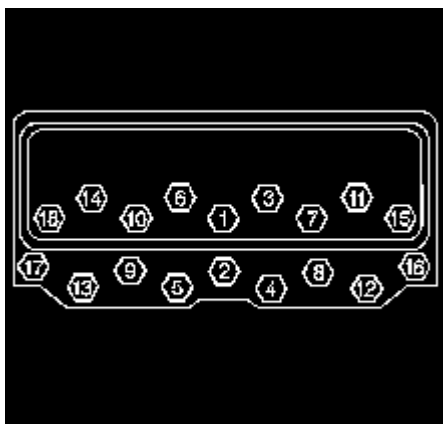

**Notice:** Refer to *Fastener Notice in Cautions and Notices*.

**Important:** The long bolts are used in locations 1, 2, 3, 6, 7, 8, 9, 10, 11, 14, 16, and 17. The medium length bolts are used in locations 15 and 18. The short bolts are used in locations 4, 5, 12, and 13.

5. Tighten the cylinder head bolts.

**Tighten:**

6. Tighten the bolts a first pass in sequence to 30♦&newtonm; (22♦lb♦ft)

7. Tighten the bolts a second pass in sequence to 30 ♦&newtonm; (22♦lb♦ft) then an additional 120 degrees using J 45059 .

8. Tighten the bolts (1, 2, 3, 6, 7, 8, 9, 10, 11, 14, 16, 17) an additional 60 degrees, bolts (15, and 18) an additional 45 degrees, and bolts (4, 5, 12, and 13) an additional 30 degrees a final pass in sequence using J 45059 .

9. Install the exhaust manifold. Refer to *Exhaust Manifold Replacement - Left (4.3L Engine) Exhaust Manifold Replacement - Left (4.8L, 5.3L, and 6.0L Engine) Exhaust Manifold Replacement - Left (6.6L (LB7) Engine) Exhaust Manifold Replacement - Left (8.1L Engine)* in Engine Exhaust.

10. Install the water crossover. Refer to *Water Crossover Replacement (8.1L Engine)* in Engine Cooling.

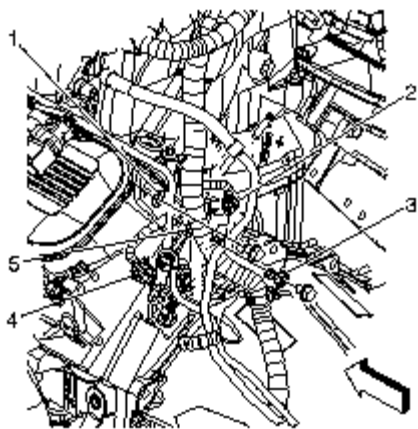

11. Position the engine harness grounds (1 and 5) and ground strap (4) to the cylinder head.
12. Install the engine harness ground bolts.

**Tighten:** Tighten the bolts to 16♦&newtonm; (12♦lb♦ft).

13. Install the valve rocker arms and pushrods. Refer to [Valve Rocker Arm and Push Rod Replacement](#).
14. Install the intake manifold. Refer to [Intake Manifold Replacement](#).

## Repair Instructions

### Cylinder Head Replacement - Right

*Engine Mechanical - 8.1L:Repair:Cylinder Head Replacement - Right*

#### Tools Required

*J 45059* Angle Meter

#### Removal Procedure

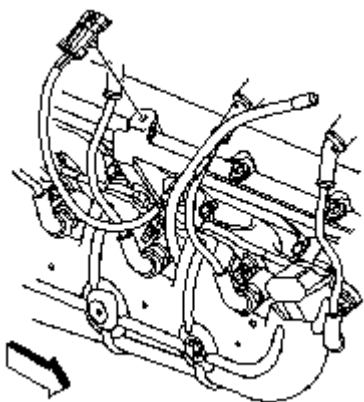

1. Drain the cooling system. Refer to [Draining and Filling Cooling System](#) in Engine Cooling.
2. Remove the intake manifold. Refer to [Intake Manifold Replacement](#).
3. Remove the valve rocker arms and pushrods. Refer to [Valve Rocker Arm and Push Rod Replacement](#).
4. Remove the engine coolant temperature (ECT) sensor clip from the bracket.
5. Remove the ECT sensor from the cylinder head.

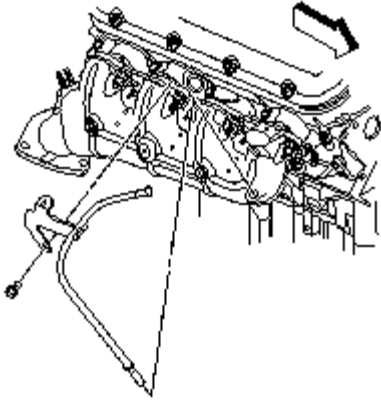

6. Remove the indicator tube bolt.
7. Remove the indicator tube bracket.
8. Remove the O-ring seal from the indicator tube.

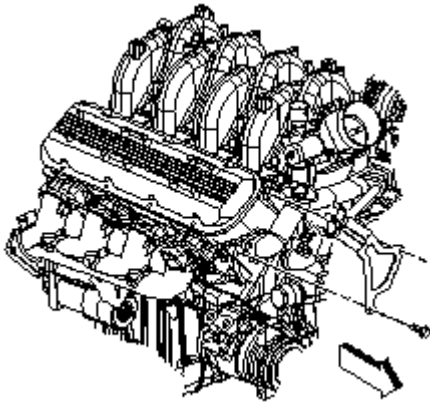

9. Remove the heater inlet and outlet hoses from the hose bracket.
10. Remove the heater hose bracket bolts and bracket from the cylinder head.
11. Remove the water crossover. Refer to [Water Crossover Replacement \(8.1L Engine\)](#) in Engine Cooling.
12. Remove the exhaust manifold. Refer to [Exhaust Manifold Replacement - Right \(4.3L Engine\)](#) [Exhaust Manifold Replacement - Right \(4.8L, 5.3L, and 6.0L Engines\)](#) [Exhaust Manifold Replacement - Right \(6.6L \(LB7\) Engine\)](#) [Exhaust Manifold Replacement - Right \(8.1L Engine\)](#) in Engine Exhaust.

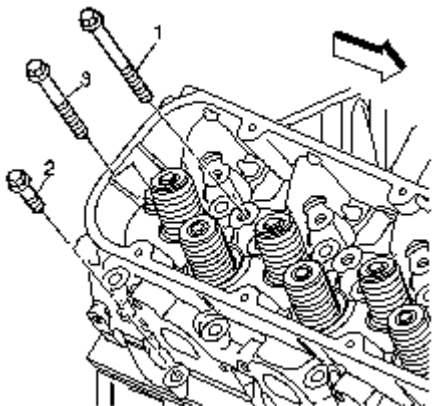

13. Remove and discard the cylinder head bolts (1, 2, and 3).

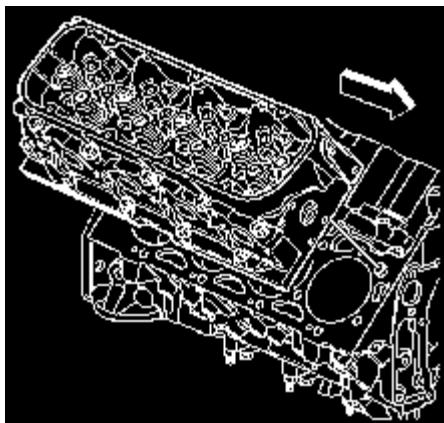

**Important:** Place the cylinder head on two wood block to prevent damage to the sealing surface.

14. Remove the cylinder head.

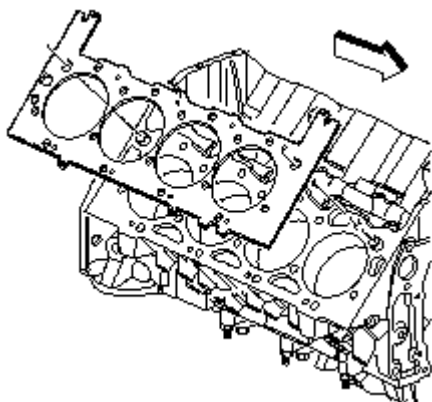

15. Remove and discard the cylinder head gasket.

16. Clean and inspect the cylinder head. Refer to [Cylinder Head Cleaning and Inspection](#) .

## Installation Procedure

**Important:** Make sure the threaded holes in the engine block are clean and not damaged. Do not use sealer on any engines that use a composition type gasket. Align the cylinder head gasket locating mark to face up. Ensure that the head gasket tabs are located over the numbers 1 and 2 cylinders for correct installation.

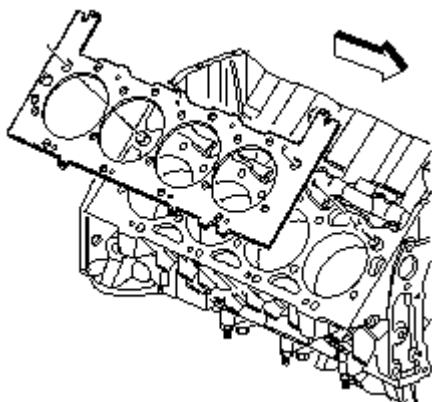

1. Place a NEW cylinder head gasket into position.

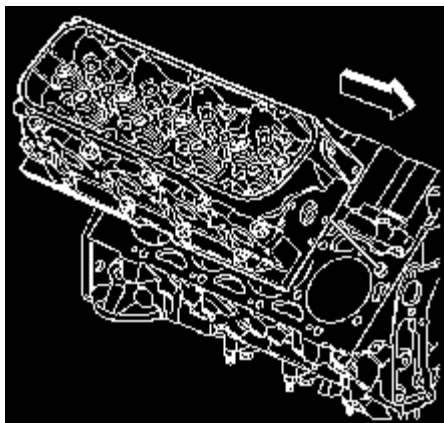

2. Install the cylinder head.

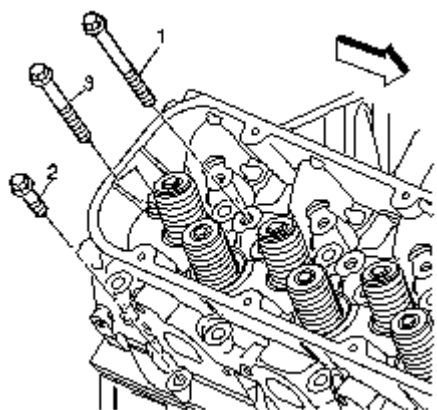

**Notice:** Do not reuse the cylinder head bolts. NEW cylinder head bolts must be used. The cylinder head bolts are torque-to-yield bolts and cannot be reused once the initial torque is applied. During the initial torque of the cylinder head bolt the cylinder head bolt is stretched to achieve proper clamp load. Proper clamp load will not be achieved if a used cylinder head bolt is torqued again. A stretched cylinder head bolt can also break when torqued. Failure to replace the used cylinder head bolts with NEW cylinder head bolts can lead to improper clamp loads and extensive engine damage.

**Important:** The sealer must be applied to a minimum of eight threads starting at the point of the cylinder head bolt.

3. If not pre-applied to the new cylinder heads bolts, apply sealant GM♦P/N♦12346004 (Canadian♦P/N♦10953480) or equivalent to the cylinder head bolts.

4. Install the cylinder head bolts (1, 2, and 3).

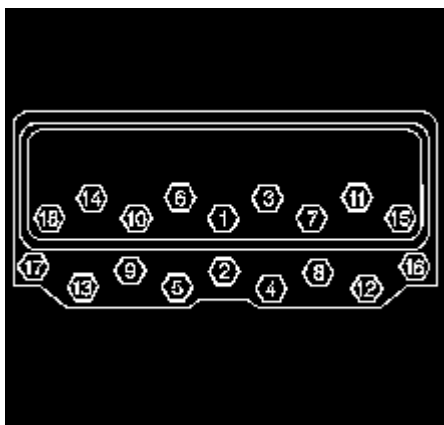

**Notice:** Refer to *Fastener Notice in Cautions and Notices*.

**Important:** The long bolts are used in locations 1, 2, 3, 6, 7, 8, 9, 10, 11, 14, 16, and 17. The medium length bolts are

used in locations 15 and 18. The short bolts are used in locations 4, 5, 12, and 13.

5. Tighten the cylinder head bolts.

**Tighten:**

6. Tighten the cylinder head bolts a first pass in sequence to 30♦&newtonm; (22♦lb♦ft).

7. Tighten the cylinder head bolts a second pass in sequence to 30♦&newtonm; (22♦lb♦ft) then an additional 120 degrees using *J 45059*.

8. Tighten the bolts (1, 2, 3, 6, 7, 8, 9, 10, 11, 14, 16, and 17) an additional 60 degrees, bolts (15, and 18) an additional 45 degrees, and bolts (4, 5, 12, and 13) an additional 30 degrees a final pass using *J 45059*.

9. Install the exhaust manifold. Refer to *Exhaust Manifold Replacement - Right (4.3L Engine)* *Exhaust Manifold Replacement - Right (4.8L, 5.3L, and 6.0L Engines)* *Exhaust Manifold Replacement - Right (6.6L (LB7) Engine)* *Exhaust Manifold Replacement - Right (8.1L Engine)* in Engine Exhaust.

10. Install the water crossover. Refer to *Water Crossover Replacement (8.1L Engine)* in Engine Cooling.

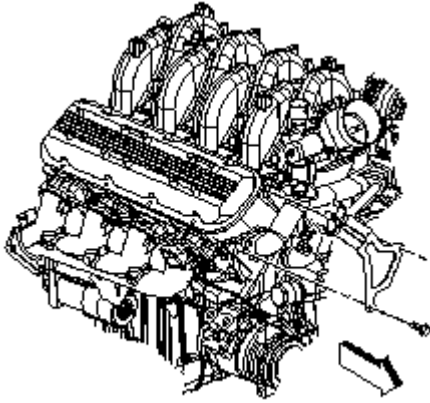

11. Install the heater hose bracket and bolts to the cylinder head.

**Tighten:** Tighten the heater hose bracket bolts to 50♦&newtonm; (37♦lb♦ft).

12. Install the heater inlet and outlet hoses to the hose bracket.

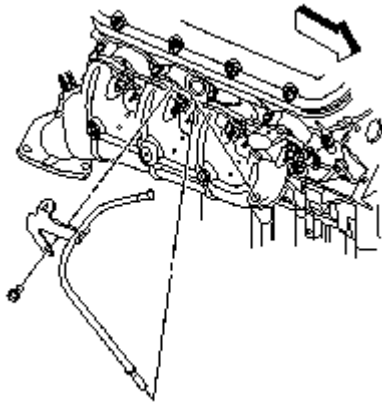

13. Install a NEW O-ring seal onto the indicator tube.

14. Install the indicator tube into the oil pan.

15. Align the indicator tube bracket with the bolt hole in the block.

16. Install the indicator tube bolt.

**Tighten:** Tighten the bolt to 50♦&newtonm; (37♦lb♦ft).

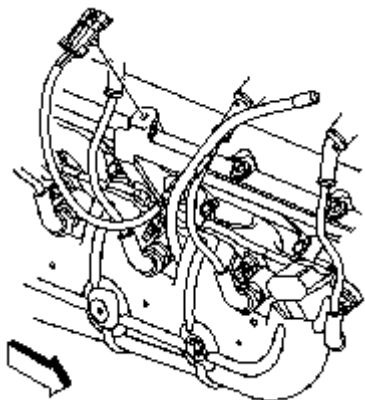

17. Apply sealant GM♦P/N♦12346004 (Canadian♦P/N♦10953480) or equivalent to the threads of the ECT sensor.

18. Install the ECT sensor to the cylinder head.

**Tighten:** Tighten the ECT sensor to 20♦&newtonm; (15♦lb♦ft).

19. Install the ECT sensor clip to the bracket.

20. Install the valve rocker arms and pushrods. Refer to [Valve Rocker Arm and Push Rod Replacement](#) .

21. Install the intake manifold. Refer to [Intake Manifold Replacement](#) .

22. Drain the cooling system. Refer to [Draining and Filling Cooling System](#) in Engine Cooling.

## Repair Instructions

### Crankshaft Balancer Replacement

*Engine Mechanical - 8.1L:Repair:Crankshaft Balancer Replacement*

#### Tools Required

- [J 38416-B](#) Harmonic Balancer Remover
- [J 42845](#) Crankshaft Balancer Installer
- [J 42846](#) Crankshaft Balancer Protector Button
- [J 42847](#) Flywheel Holding Tool

#### Removal Procedure

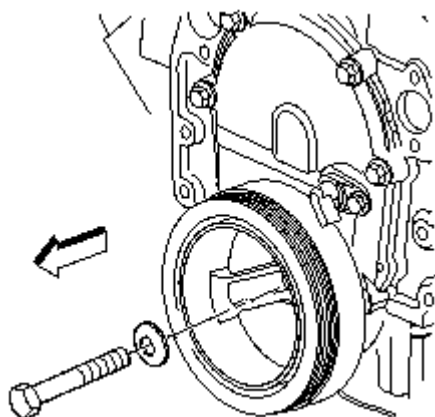

1. Remove the air conditioning (A/C) belt. Refer to [Drive Belt Replacement - Air Conditioning](#) .

2. Remove the fan. Refer to [Fan Replacement](#) in Engine Cooling.

3. Remove the starter motor. Refer to [Starter Motor Replacement \(4.3L Engine\) Starter Motor Replacement \(4.8L, 5.3L, and 6.0L](#)

Engines) Starter Motor Replacement (6.6L (LB7) Engine) Starter Motor Replacement (6.6L (LLY) Engine) Starter Motor Replacement (8.1L Engine) in Engine Electrical.

**Notice:** Refer to **Fastener Notice in Cautions and Notices.**

**Important:** Ensure that the teeth of the flywheel holding tool engage the engine flywheel teeth.

4. Install the *J 42847* to the starter bolt holes.

**Tighten:** Tighten the *J 42847* bolts to 50♦&newtonm; (37♦lb♦ft).

5. Remove the crankshaft balancer bolt and washer.

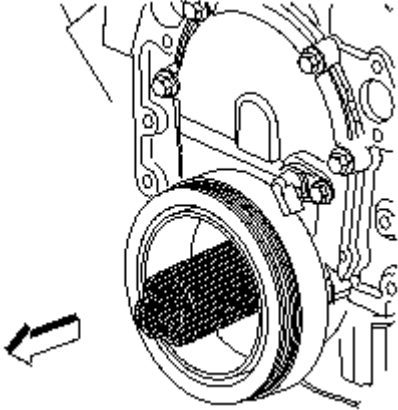

6. Install the *J 42846* onto the end of the crankshaft.

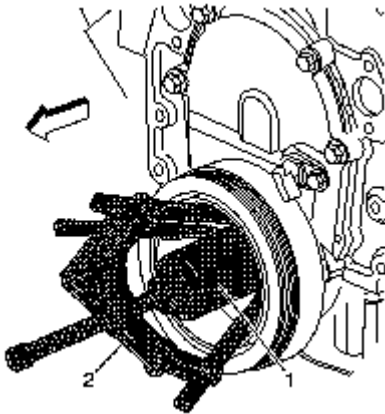

7. Install the *J 38416-B* (2) onto the *J 42846* (1) in order to remove the crankshaft balancer. Place the legs of the *J 38416-B* into the recesses cast into the backside of the balancer inner hub.

8. Tighten the center screw of the *J 38416-B* until the crankshaft balancer is clear of the crankshaft nose.

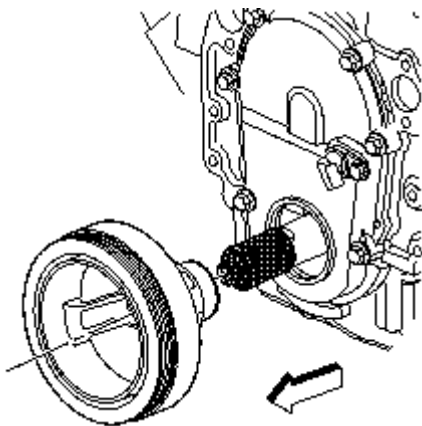

9. Remove the crankshaft balancer.

10. Remove the *J 42846* from the end of the crankshaft.

## Installation Procedure

### Important:

- The balancer should be positioned onto the end of the crankshaft as straight as possible prior to tool installation.
- Apply grease or clean engine oil to the inside of the crankshaft balancer or the end of the crankshaft, to prevent galling during assembly.

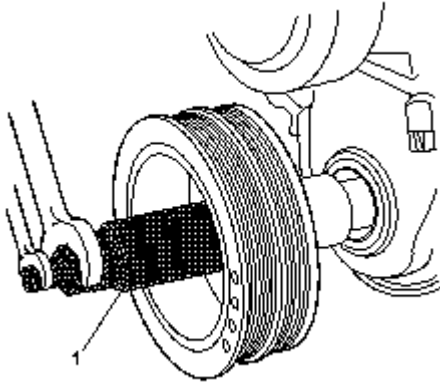

1. Install the balancer onto the end of the crankshaft.
2. Install [J 42845](#) to the crankshaft balancer.

**Important:** Apply the lubricant that comes with [J 42845](#) each time the tool is used. Failure to lubricate the [J 42845](#) may prevent the balancer from installing completely.

3. Using [J 42845](#) install the balancer.
4. Tighten the [J 42845](#) until the crankshaft balancer is completely seated against the crankshaft sprocket.

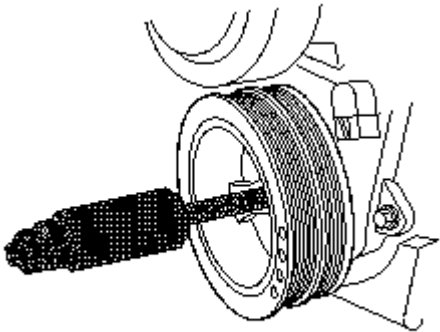

5. Remove the [J 42845](#) from the crankshaft.

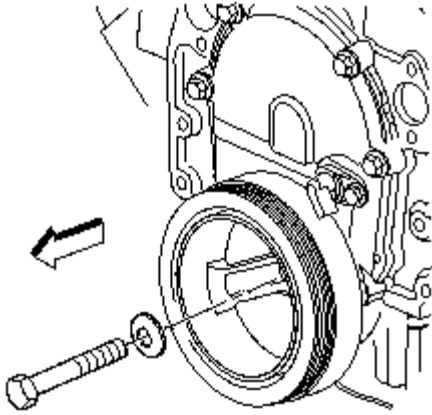

**Notice:** Refer to *Fastener Notice in Cautions and Notices*.

6. Install the crankshaft bolt and washer to the crankshaft.

**Tighten:** Tighten the crankshaft balancer bolt to 255♦&newtonm; (189♦lb♦ft).

7. Remove the *J 42847*.

8. Install the starter motor. Refer to *Starter Motor Replacement (4.3L Engine)* *Starter Motor Replacement (4.8L, 5.3L, and 6.0L Engines)* *Starter Motor Replacement (6.6L (LB7) Engine)* *Starter Motor Replacement (6.6L (LLY) Engine)* *Starter Motor Replacement (8.1L Engine)* in Engine Electrical.

9. Install the fan. Refer to *Fan Replacement* in Engine Cooling.

10. Install the A/C belt. Refer to *Drive Belt Replacement - Air Conditioning*.

## Repair Instructions

### Crankshaft Front Oil Seal Replacement

*Engine Mechanical - 8.1L:Repair:Crankshaft Front Oil Seal Replacement*

#### Tools Required

*J 42851* Front Cover Oil Seal Installer

#### Removal Procedure

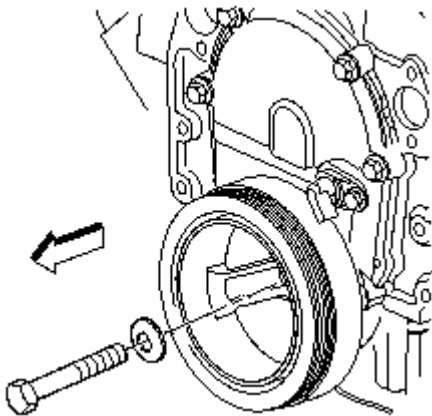

1. Remove the crankshaft balancer. Refer to *Crankshaft Balancer Replacement*.

**Important:** Use care as not to damage the engine front cover or the crankshaft sealing area when removing the crankshaft front cover oil seal.

2. Remove the crankshaft front cover oil seal.

#### Installation Procedure

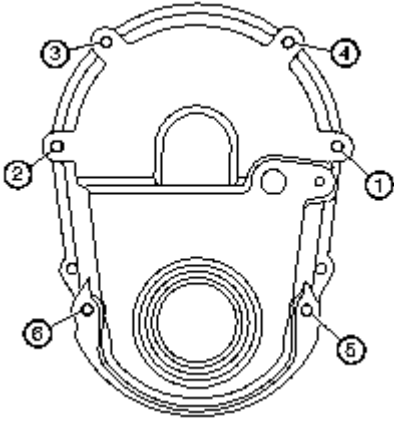

1. Coat the crankshaft front cover oil seal with clean engine oil.
2. Using [J 42851](#) install the oil seal.
3. Remove the [J 42851](#) .
4. Install the crankshaft balancer. Refer to [Crankshaft Balancer Replacement](#) .

## Repair Instructions

### Engine Front Cover Replacement

*Engine Mechanical - 8.1L:Repair:Engine Front Cover Replacement*

#### Tools Required

[J 42851](#) Front Cover Oil Seal Installer

#### Removal Procedure

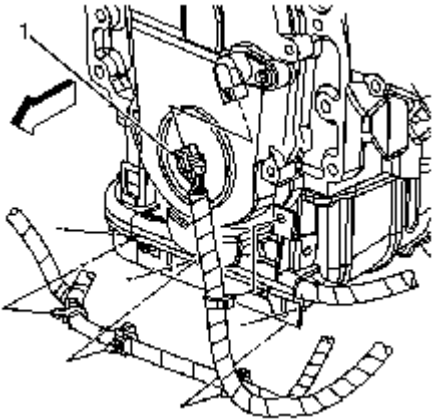

1. Remove the water pump. Refer to [Water Pump Replacement \(4.3L Engine\)](#) [Water Pump Replacement \(4.8L, 5.3L, and 6.0L Engines\)](#) [Water Pump Replacement \(6.6L \(LB7\) Engine\)](#) [Water Pump Replacement \(6.6L \(LLY\) Engine\)](#) [Water Pump Replacement \(8.1L Engine\)](#) in Engine Cooling.
2. Remove the crankshaft balancer. Refer to [Crankshaft Balancer Replacement](#) .
3. Disconnect the camshaft position (CMP) sensor electrical connector (1).
4. Remove the engine harness clips from the battery cable channel.

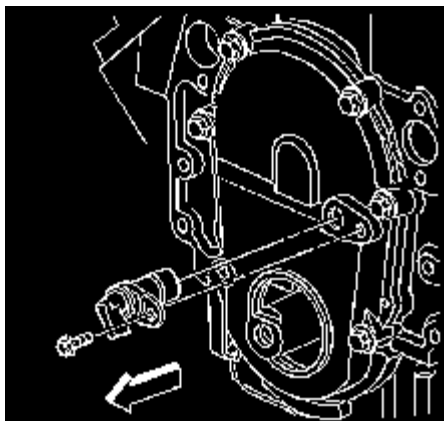

5. Remove the CMP sensor bolt.
6. Remove the CMP sensor.

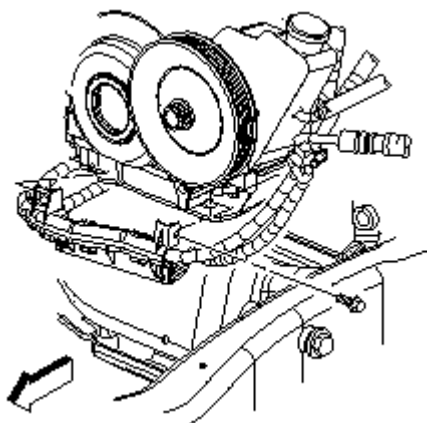

7. Remove the battery cable channel bolt.
8. Remove and reposition the battery cable channel.

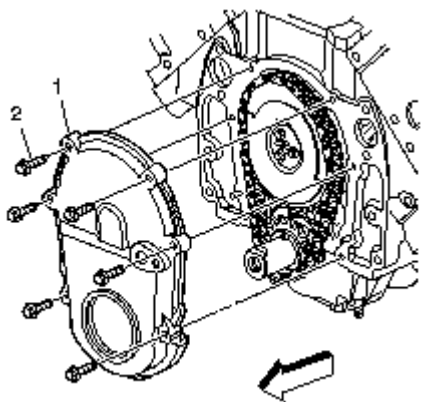

9. Remove the engine front cover bolts (2).
10. Remove the engine front cover (1).
- Important:** The engine front cover gasket is reusable.
11. Remove the engine front cover gasket.
12. Remove the crankshaft front oil seal from the front cover.

## Installation Procedure

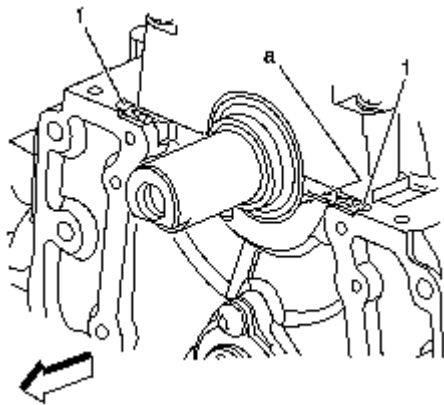

1. Install a NEW crankshaft front oil seal using *J 42851*.
2. Lubricate the sealing surface of the crankshaft front oil seal with clean engine oil.

**Important:** The engine front cover must be installed and the fasteners tightened while the sealant is still wet to the touch.

3. Apply sealant GM P/N 12346286 (Canadian P/N 10953472) or equivalent in 2 places (1) on the engine block where the front cover meets the oil pan.

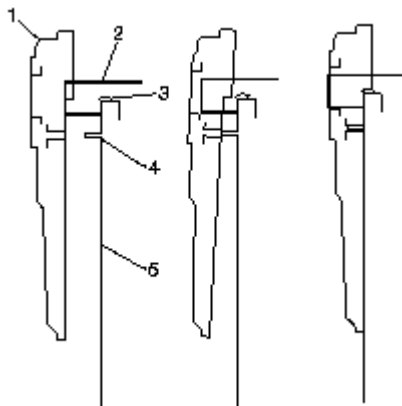

4. Install the engine front cover gasket into the front cover.

**Important:** The following method must be used when installing the engine front cover. Failure to follow the instructions will push the sealant out, which may cause an oil leak.

5. Install the front cover and gasket.
  - 5.1. Hold the front cover (1) up to the crankshaft (2).
  - 5.2. Lift the front cover (1) while sliding the cover over the crankshaft (2).
  - 5.3. Slide the front cover towards the engine block (5) while keeping the cover raised.
  - 5.4. Lower the cover down over the dowel pin (4), allowing the front cover to rest on the sealant (3).

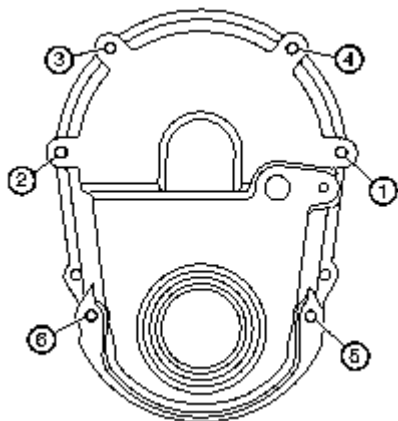

6. Install the engine front cover bolts.

**Notice:** Refer to *Fastener Notice in Cautions and Notices*.

7. Tighten the engine front cover bolts.

**Tighten:**

8. Tighten the engine front cover bolts in sequence a first pass to 6♦&newtonm; (53♦lb♦in).
9. Tighten the engine front cover bolts in sequence a final pass to 12♦&newtonm; (106♦lb♦in).

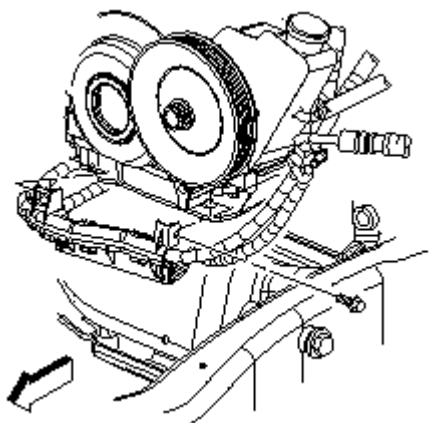

10. Position the battery cable channel into place.

11. Install the battery cable channel bolt.

**Tighten:** Tighten the battery cable channel bolt to 9♦&newtonm; (80♦lb♦in).

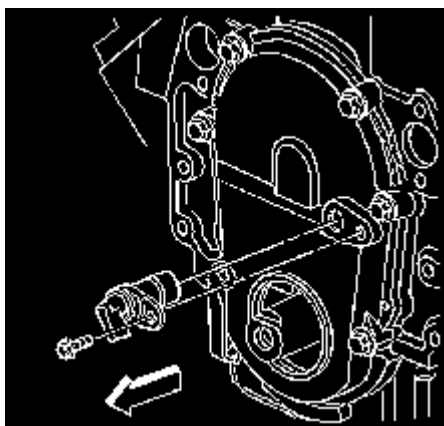

12. Inspect the CMP sensor O-ring for cuts, cracks, tears or damage. Replace as needed.

13. Apply a light film of clean engine oil to the CMP sensor O-ring.

**14.** Install the CMP sensor.

Install the CMP sensor bolt.

**Tighten:** Tighten the CMP sensor bolt to 12♦&newtonm; (106♦lb♦in).

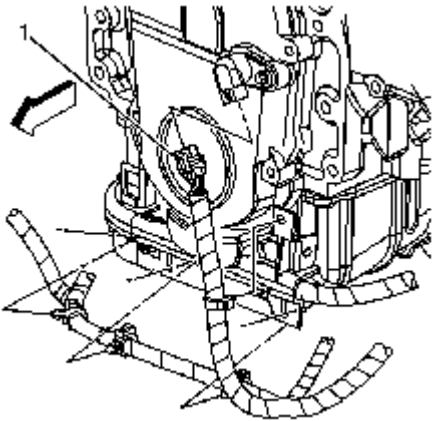
**15.** Install the engine harness clips to the battery cable channel.**16.** Connect the CMP sensor electrical connector (1).**17.** Install the crankshaft balancer. Refer to [Crankshaft Balancer Replacement](#) .

**18.** Install the water pump. Refer to [Water Pump Replacement \(4.3L Engine\)](#) [Water Pump Replacement \(4.8L, 5.3L, and 6.0L Engines\)](#) [Water Pump Replacement \(6.6L \(LB7\) Engine\)](#) [Water Pump Replacement \(6.6L \(LLY\) Engine\)](#) [Water Pump Replacement \(8.1L Engine\)](#) in Engine Cooling.

## Repair Instructions

### Timing Chain and Sprockets Replacement

*Engine Mechanical - 8.1L:Repair:Timing Chain and Sprockets Replacement*

#### Tools Required

- [J 22102](#) Crankshaft Sprocket Installer
- [J 42846](#) Crankshaft Protector Button

#### Removal Procedure

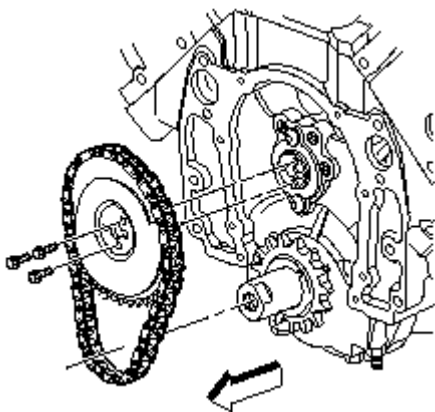
**1.** Remove the engine front cover. Refer to [Engine Front Cover Replacement](#) .**2.** Aligned the timing marks on the camshaft and crankshaft sprockets.**3.** Remove the camshaft sprocket bolts.**4.** Remove the camshaft sprocket and timing chain.

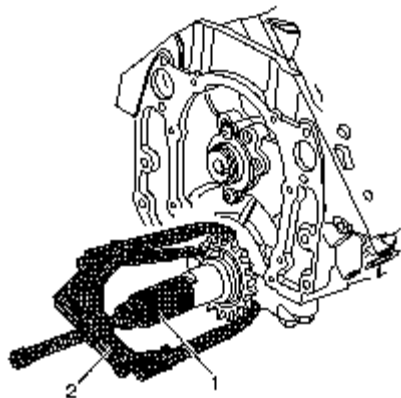

5. Install the *J 42846* (1) into the end of the crankshaft.
6. Remove the crankshaft sprocket using a suitable three jaw puller.
7. Clean and inspect the timing chain and sprockets. Refer to *Timing Chain and Sprockets Cleaning and Inspection* .

## Installation Procedure

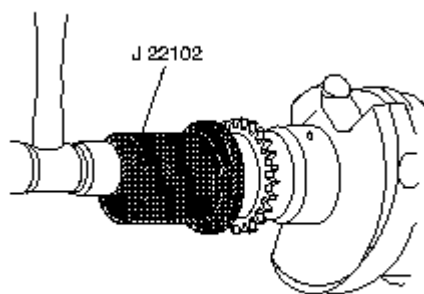

1. Use the *J 22102* in order to install the crankshaft sprocket.  
Align the keyway of the crankshaft sprocket with the crankshaft pin.
2. Remove the *J 22102* .
3. Rotate the crankshaft until the crankshaft sprocket alignment mark is in the 12 o'clock position.

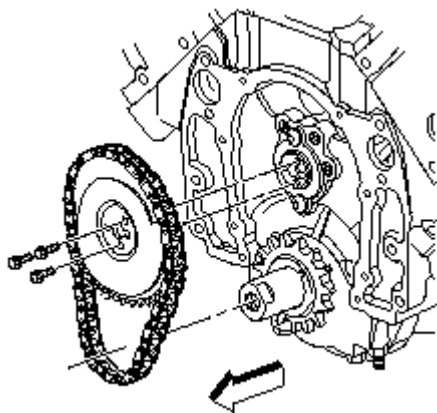

### Important:

- Install the camshaft sprocket with the alignment mark in the 6 o'clock position.

- The sprocket teeth must mesh with the timing chain in order to prevent damage to the camshaft retainer.
- Do not use a hammer to install the camshaft sprocket onto the camshaft. To do so may damage the camshaft.

4. Install the camshaft sprocket and timing chain.

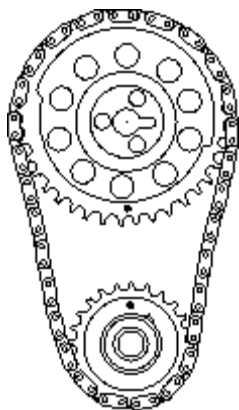

5. Ensure that the crankshaft sprocket is aligned at the 12 o'clock position and the camshaft sprocket is aligned at the 6 o'clock position.

**Notice:** Refer to *Fastener Notice in Cautions and Notices*.

6. Install the camshaft sprocket bolts.

**Tighten:**

7. Tighten the bolts a first pass to 30♦&newtonm; (22♦lb♦ft).
8. Tighten the bolts a final pass to 30♦&newtonm; (22♦lb♦ft).

9. Install the engine front cover. Refer to *Engine Front Cover Replacement* .

## Repair Instructions

### Oil Pump Drive Replacement

*Engine Mechanical - 8.1L:Repair:Oil Pump Drive Replacement*

#### Removal Procedure

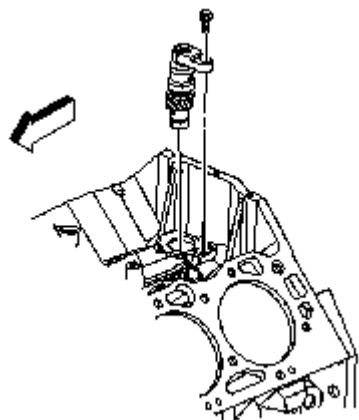

1. Remove the intake manifold. Refer to *Intake Manifold Replacement* .
2. Remove the oil pump drive bolt.
3. Remove the oil pump drive.
4. Clean and inspect the oil pump drive. Refer to *Oil Pump Drive Cleaning and Inspection*

#### Installation Procedure

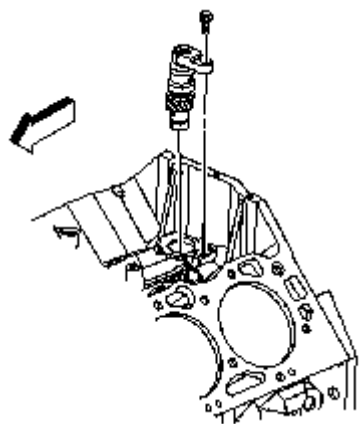

1. Apply grease to the oil pump drive gear for ease of assembly.

**Important:** Correct alignment of the oil pump drive and oil pump driveshaft is critical. Make sure both components mate correctly, or engine damage may occur.

2. Line up the oil pump drive, making sure that the oil pump is fully seated in the engine block.

**Notice:** Refer to *Fastener Notice in Cautions and Notices*.

3. Install the oil pump, making sure that the oil pump drive is fully seated in the engine block.

**Tighten:** Tighten the bolt to 25•&newtonm; (18•lb•ft).

4. Install the intake manifold. Refer to *Intake Manifold Replacement* .

## Repair Instructions

### Camshaft Replacement

*Engine Mechanical - 8.1L:Repair:Camshaft Replacement*

#### Removal Procedure

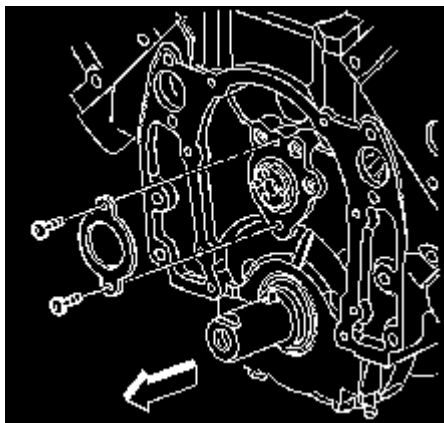

1. Remove the grille. Refer to *Grille Replacement (GMC) Grille Replacement (Chevrolet)* in Exterior Trim.
2. Remove the air conditioning (A/C) condenser. Refer to *Condenser Replacement* in Heating, Ventilation and Air Conditioning.
3. Remove the valve lifters. Refer to *Valve Lifter Replacement* .
4. Remove the timing chain and sprocket. Refer to *Timing Chain and Sprockets Replacement* .
5. Remove the camshaft retainer bolts.
6. Remove the camshaft retainer.

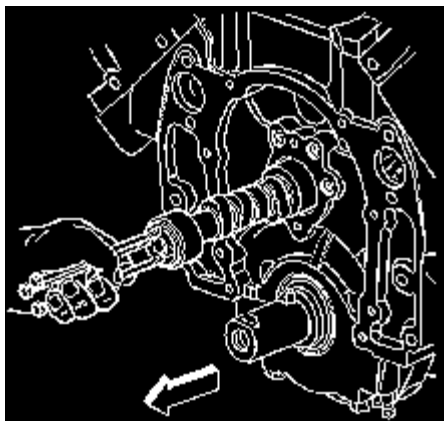

7. Install three 8 - 1.25 x 100mm bolts into the camshaft front bolt holes.
8. Using the bolts as a handle, carefully rotate and pull the camshaft out of the engine block.
9. Remove the bolts from the front of the camshaft.
10. Clean and inspect the camshaft. Refer to *Camshaft and Bearings Cleaning and Inspection* .

## Installation Procedure

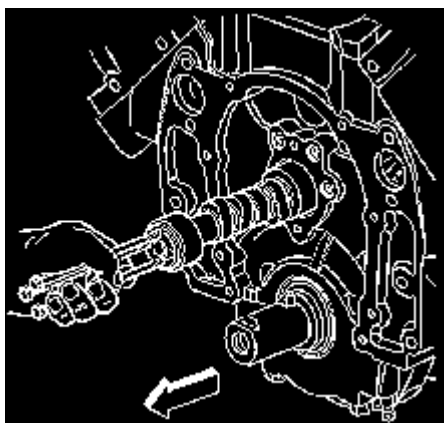

1. Apply lubricant GM P/N 12345501 (Canadian P/N 992704), or equivalent to the following components:
  - The camshaft lobes
  - The camshaft bearing journals
  - The camshaft bearings

**Notice: All camshaft journals are the same diameter, so care must be used in removing or installing the camshaft to avoid damage to the camshaft bearings.**

2. Install three 8 - 1.25 x 100mm bolts into the camshaft threaded bolt holes.
3. Using the bolts as a handle, carefully install the camshaft.
4. Remove the bolts from the front of the camshaft.

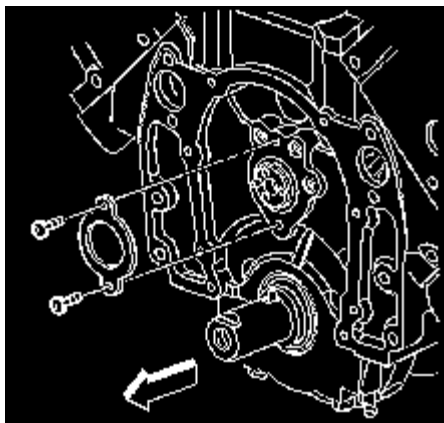

**Notice:** Refer to *Fastener Notice in Cautions and Notices*.

5. Install the camshaft retainer and bolts.

**Tighten:** Tighten the bolts to 12♦&newtonm; (106♦lb♦in).

6. Install the timing chain and sprocket. Refer to *Timing Chain and Sprockets Replacement* .

7. Install the valve lifters. Refer to *Valve Lifter Replacement* .

8. Install the A/C condenser. Refer to *Condenser Replacement* in Heating, Ventilation and Air Conditioning.

9. Install the grille. Refer to *Grille Replacement (GMC) Grille Replacement (Chevrolet)* in Exterior Trim.

## Repair Instructions

### Oil Filter Adapter and Bypass Valve Assembly Replacement

*Engine Mechanical - 8.1L:Repair:Oil Filter Adapter and Valve Assembly Replacement*

#### Removal Procedure

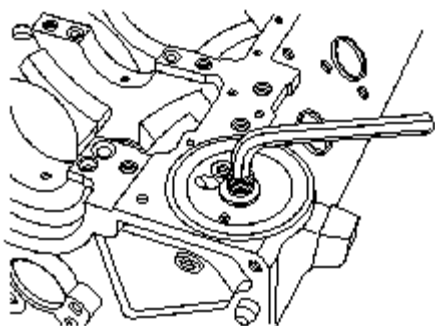

1. Remove the engine oil filter. Refer to *Engine Oil and Oil Filter Replacement* .

2. Loosen the oil filter fitting using a hex wrench.

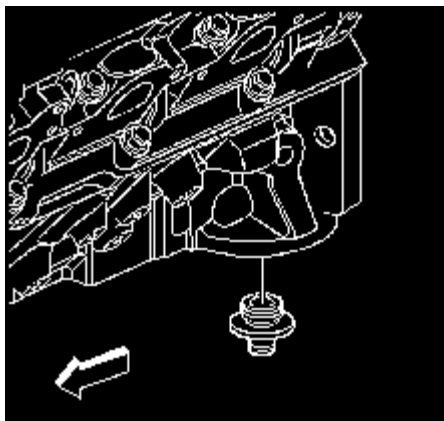

3. Remove the oil filter fitting.

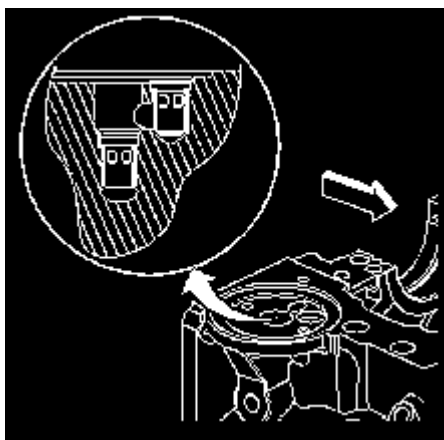

4. Remove the oil filter bypass valves.

Unstake the tangs on the oil bypass valves and remove with long nose pliers.

5. Discard the oil bypass valves.

## Installation Procedure

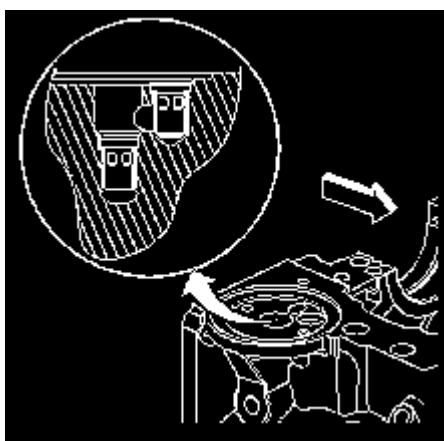

1. Install NEW oil bypass valves. Stake the tangs on the new oil bypass valves.

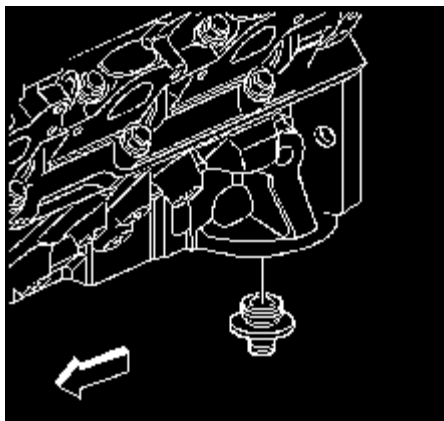

2. Inspect the oil filter fitting, replace as necessary.

**Notice:** Refer to *Fastener Notice in Cautions and Notices*.

3. Install the oil filter fitting.

**Tighten:** Tighten the oil filter fitting to 66♦&newtonm; (49♦lb♦ft).

4. Install the oil filter. Refer to *Engine Oil and Oil Filter Replacement* .

## Repair Instructions

### Oil Pan Replacement

*Engine Mechanical - 8.1L:Repair:Oil Pan Replacement*

#### Removal Procedure

**Important:** Do not raise the engine by the crankshaft balancer to perform this service procedure. Damage to the crankshaft balancer or the crankshaft may occur.

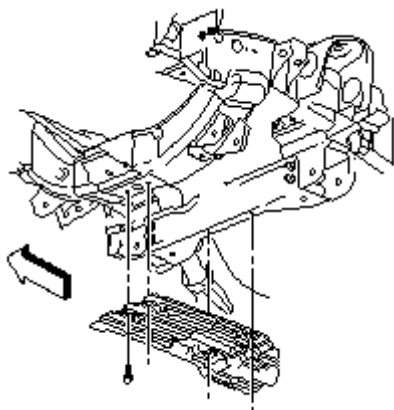

1. Remove the front differential, if equipped with four wheel drive (4WD). Refer to *Differential Carrier Assembly Replacement in Front Drive Axle*.

2. Remove the starter motor. Refer to *Starter Motor Replacement (4.3L Engine) Starter Motor Replacement (4.8L, 5.3L, and 6.0L Engines) Starter Motor Replacement (6.6L (LB7) Engine) Starter Motor Replacement (6.6L (LLY) Engine) Starter Motor Replacement (8.1L Engine)* in Engine Electrical.

3. Remove the oil pan skid plate bolts.

4. Remove the oil pan skid plate.

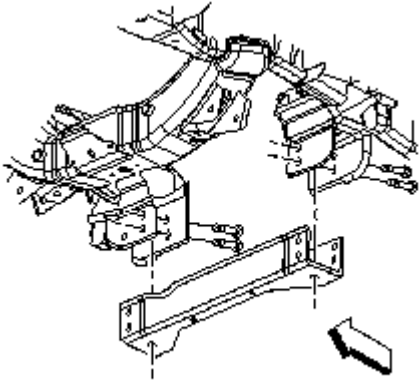

5. If equipped with two wheel drive (2WD), remove the crossbar bolts.
6. Remove the crossbar.

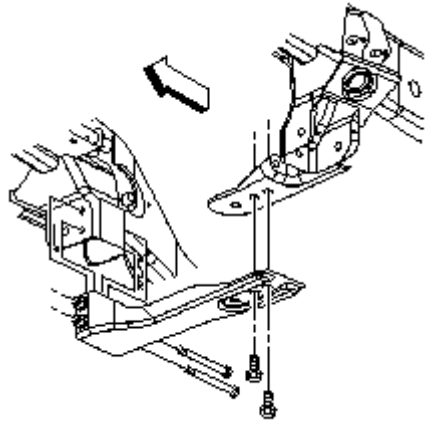

7. If equipped with 4WD, remove the crossbar bolts.
8. Remove the crossbar.

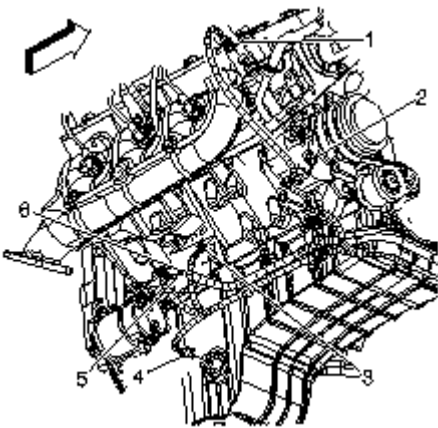

9. Drain the engine oil. Refer to [Engine Oil and Oil Filter Replacement](#).
10. Remove the oil level indicator. Refer to [Oil Level Indicator and Tube Replacement](#).
11. Disconnect the oil level sensor electrical connector (4).
12. Remove the engine harness clip from the oil pan.

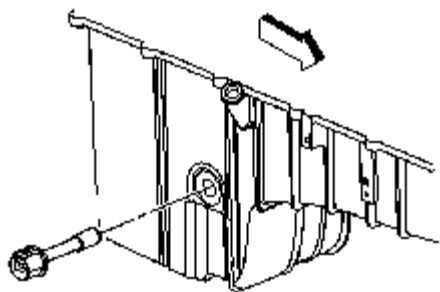

**13.** Remove the oil level sensor from the oil pan.

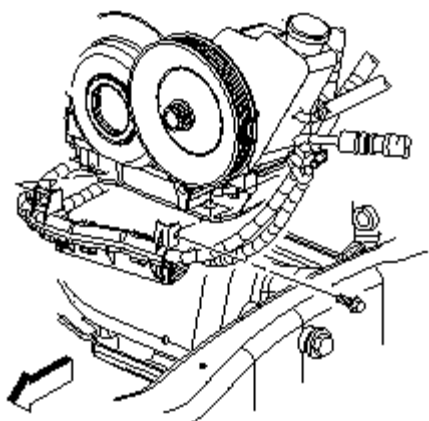

**14.** Remove the battery cable channel bolt.

**15.** Remove and reposition the battery cable channel.

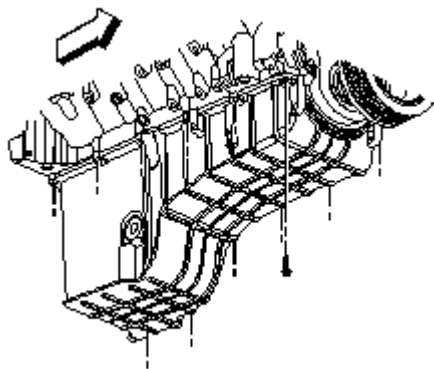

**16.** Remove the oil pan bolts.

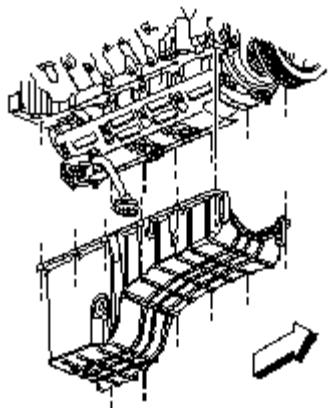

**Important:** The oil pan gasket is reusable if not cut or damaged.

17. Remove the oil pan (1) and gasket (2).

## Installation Procedure

**Important:** The oil pan must be installed within 5 minutes of the sealer being applied or the sealer will begin to cure, causing an inadequate seal.

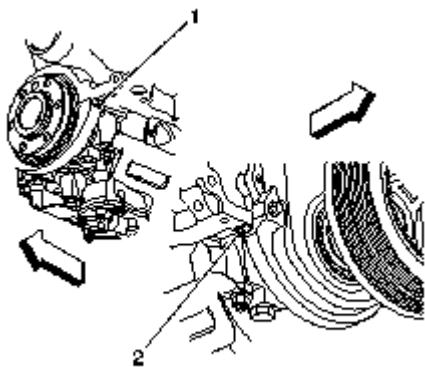

1. Apply sealant GM♦2346286 (Canadian♦P/N♦10953472), or equivalent to the sides of the front (2) and rear (1) crankshaft bearing caps, on both the left and right sides (4♦locations total).

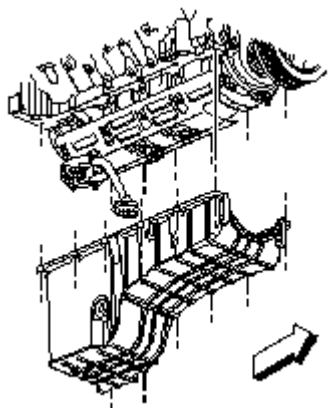

2. Install a NEW oil pan gasket into the oil pan groove, if required.  
3. Install the oil pan.

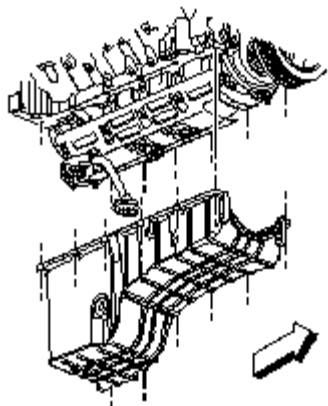

4. Install the oil pan bolts.

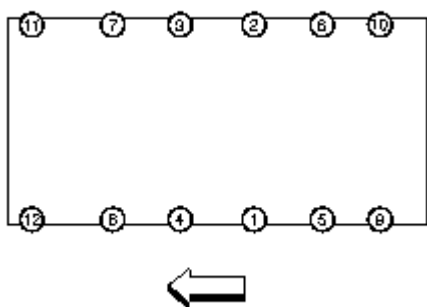

**Notice:** Refer to *Fastener Notice in Cautions and Notices.*

5. Tighten the oil pan bolts.

**Tighten:**

6. Tighten the bolts a first pass in sequence to 10♦&newtonm; (89♦lb♦in).
7. Tighten the bolts a final pass in sequence to 25♦&newtonm; (18♦lb♦ft).

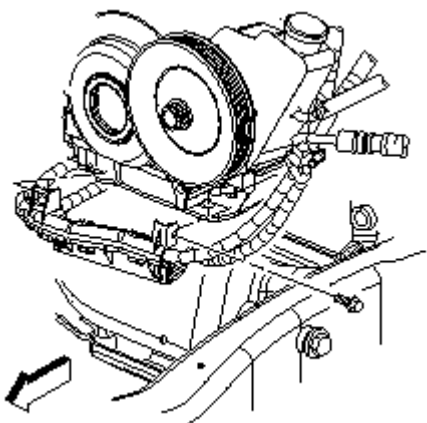

8. Position the battery cable channel into place.

9. Install the battery cable channel bolt.

**Tighten:** Tighten the bolt to 9♦&newtonm; (80♦lb♦in).

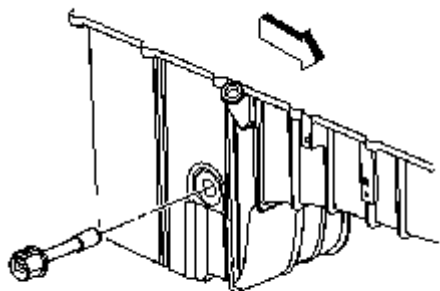

10. Install the oil level sensor to the oil pan.

**Tighten:** Tighten the sensor to 20♦&newtonm; (15♦lb♦ft).

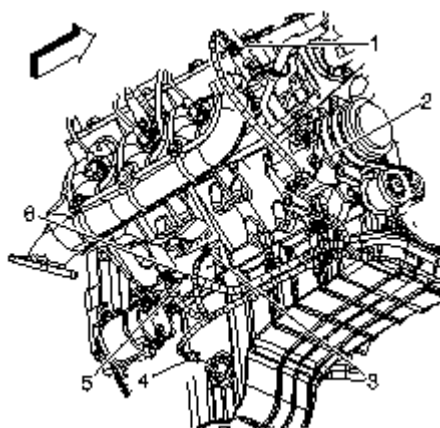

11. Install the engine harness clip to the oil pan.

12. Connect the oil level sensor electrical connector (4).

13. Install the oil level indicator. Refer to [Oil Level Indicator and Tube Replacement](#) .

14. Fill the engine with oil. Refer to [Engine Oil and Oil Filter Replacement](#) .

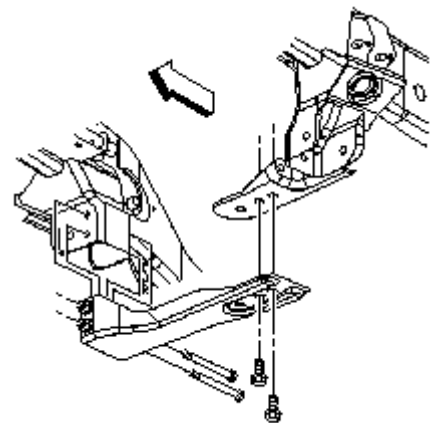

15. If equipped with 4WD, install the crossbar.

16. Install the crossbar bolts.

**Tighten:** Tighten the bolts to 100♦&newtonm; (74♦lb♦ft).

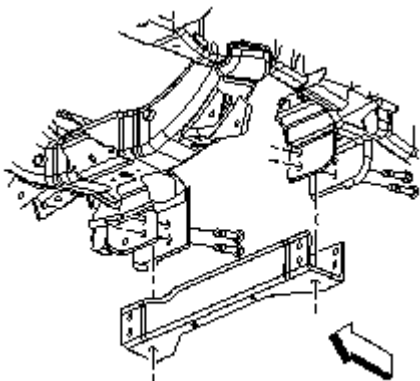

17. If equipped with 2WD, install the crossbar.

18. Install the crossbar bolts.

**Tighten:** Tighten the bolts to 100♦&newtonm; (74♦lb♦ft).

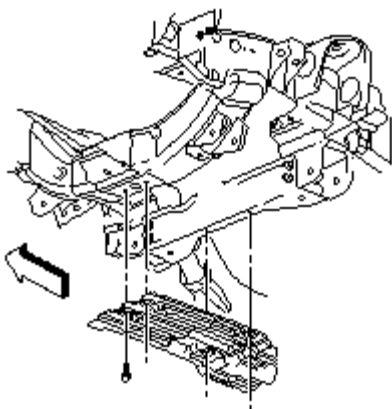

19. Install the oil pan skid plate.

20. Install the oil pan skid plate bolts.

**Tighten:** Tighten the bolts to 20♦&newtonm; (15♦lb♦ft).

21. Install the starter motor. Refer to *Starter Motor Replacement (4.3L Engine)* *Starter Motor Replacement (4.8L, 5.3L, and 6.0L Engines)* *Starter Motor Replacement (6.6L (LB7) Engine)* *Starter Motor Replacement (6.6L (LLY) Engine)* *Starter Motor Replacement (8.1L Engine)* in Engine Electrical.

22. Install the front differential, if equipped with 4WD. Refer to *Differential Carrier Assembly Replacement* in Front Drive Axle.

## Repair Instructions

### Engine Oil Pressure Sensor and/or Switch Replacement

*Engine Mechanical - 8.1L:Repair:Engine Oil Pressure Sensor and/or Switch Replacement*

#### Tools Required

J 41712 Oil Pressure Sensor Socket

#### Removal Procedure

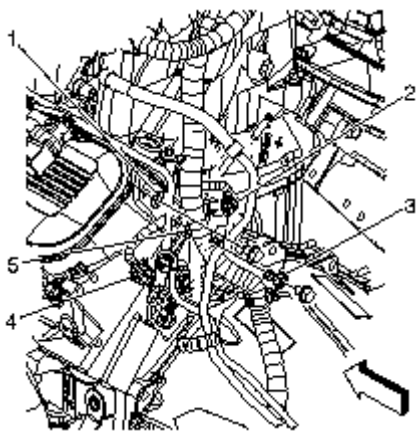

1. Remove the engine sight shield. Refer to [Engine Sight Shield Replacement](#).
2. Disconnect the oil pressure sensor electrical connector (2).

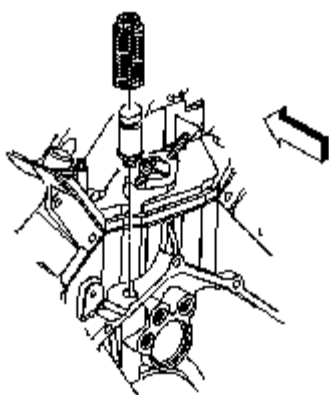

3. Using [J 41712](#) or equivalent, remove the oil pressure sensor.

## Installation Procedure

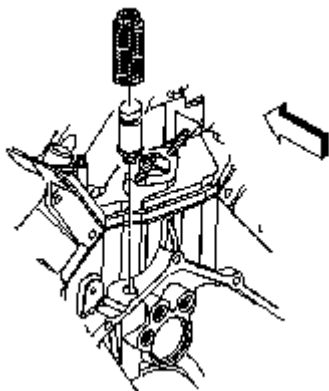

1. Apply sealant GM P/N 12346004 (Canadian P/N 10953480), or equivalent, to the threads of the oil pressure sensor.

**Notice:** Refer to [Fastener Notice in Cautions and Notices](#).

2. Using [J 41712](#) or equivalent, install the oil pressure sensor.

**Tighten:** Tighten the sensor to 30 newtonm; (22 lb-ft).

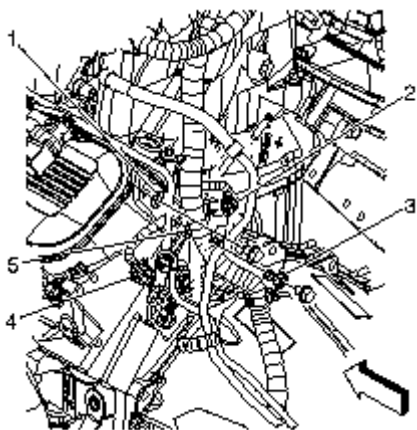

3. Connect the oil pressure sensor electrical connector (2).

4. Install the engine sight shield. Refer to [Engine Sight Shield Replacement](#) .

## Repair Instructions

### Engine Oil Level Sensor and/or Switch Replacement

*Engine Mechanical - 8.1L:Repair:Engine Oil Level Sensor and/or Switch Replacement*

#### Removal Procedure

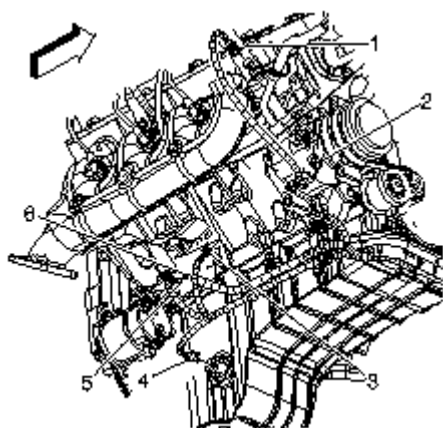

1. Drain the engine oil. Refer to [Engine Oil and Oil Filter Replacement](#) .

2. Disconnect the oil level sensor electrical connector (4).

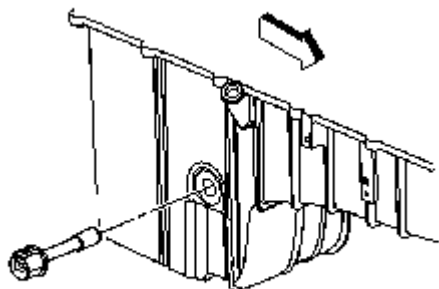

3. Remove the oil level sensor from the oil pan.

## Installation Procedure

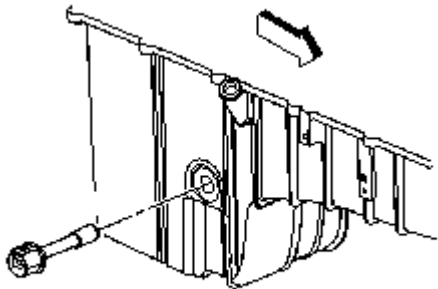

**Notice:** Refer to *Fastener Notice in Cautions and Notices*.

1. Install the oil level sensor to the oil pan.

**Tighten:** Tighten the sensor to 20♦&newtonm; (15♦lb♦ft).

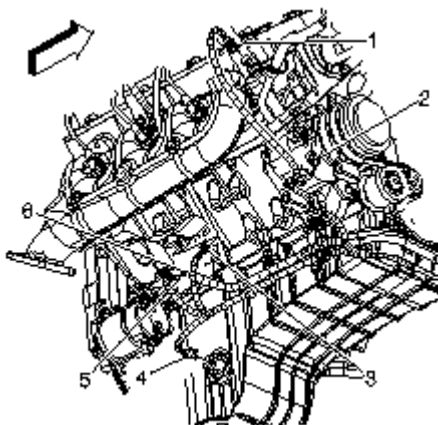

2. Connect the oil level sensor electrical connector (4).
3. Fill the engine oil. Refer to *Engine Oil and Oil Filter Replacement*.

## Repair Instructions

### Oil Pump Replacement

*Engine Mechanical - 8.1L:Repair:Oil Pump Replacement*

## Removal Procedure

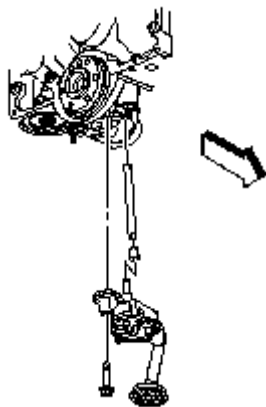

1. Remove the oil pan. Refer to [Oil Pan Replacement](#) .
2. Remove the oil pump bolt.
3. Remove and separate the oil pump, retainer, and driveshaft.
4. Discard the driveshaft retainer.

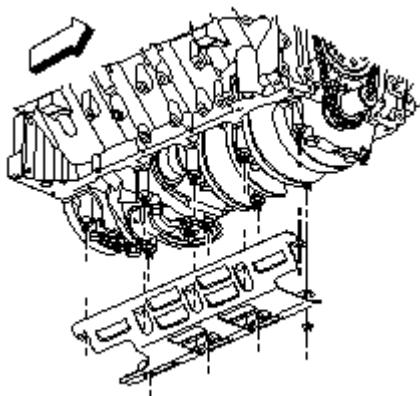

5. Remove the crankshaft oil deflector nuts.
6. Remove the crankshaft oil deflector.
7. Clean and inspect the oil pump. Refer to [Oil Pump Cleaning and Inspection](#) .

## Installation Procedure

**Important:** When installing the oil pump, always replace the retainer between the oil pump and the shaft.

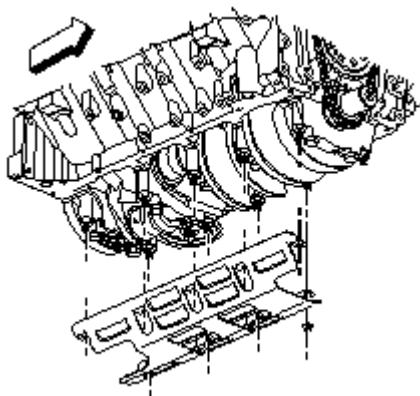

1. Install the crankshaft oil deflector.

**Notice:** Refer to *Fastener Notice in Cautions and Notices*.

2. Install the crankshaft oil deflector nuts.

**Tighten:** Tighten the nuts to 50♦&newtonm; (37♦lb♦ft).

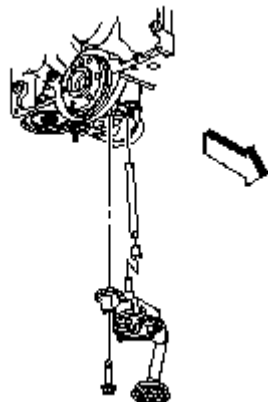

**Important:** During assembly, install NEW oil pump driveshaft retainer. Slightly heat the retainer above room temperature for ease of installation onto the oil pump driveshaft.

3. Assemble the oil pump, driveshaft and a NEW retainer.
4. Install the oil pump assembly. Position the oil pump onto the locating pins.
5. Install the oil pump bolt.

**Tighten:** Tighten the bolts to 75♦&newtonm; (56♦lb♦ft).

6. Install the oil pan. Refer to *Oil Pan Replacement*.

## Repair Instructions

### Crankshaft Rear Oil Seal Replacement

*Engine Mechanical - 8.1L:Repair:Crankshaft Rear Oil Seal Replacement*

#### Tools Required

- *J 43320* Crankshaft Rear Seal Puller
- *J 42849* Crankshaft Rear Seal Installer

#### Removal Procedure

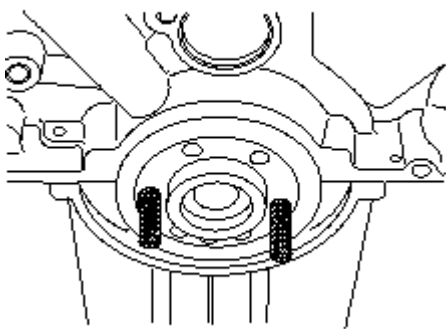

1. Remove the flywheel. Refer to *Engine Flywheel Replacement*.

2. Install the guide pins from *J 43320* into the crankshaft.

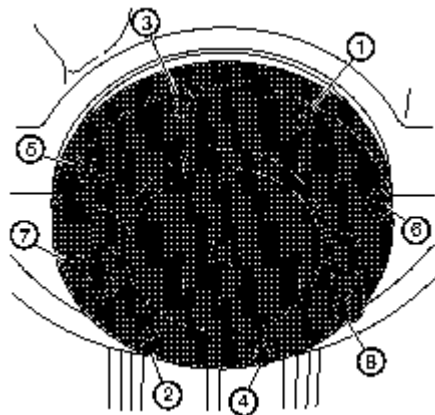

3. Install the *J 43320* over the guide pins.
4. Using a suitable drill, insert eight of the self-drilling sheet metal screws into the rear crankshaft seal, using a criss-cross pattern. The self-tapping screws are included with the *J 43320*.

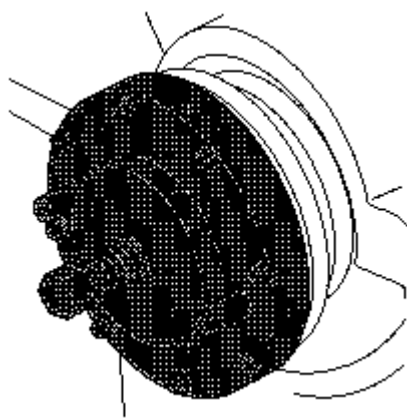

5. Thread the center bolt of *J 43320* into the crankshaft to remove the seal.
6. Remove the guide pins from the crankshaft.

## Installation Procedure

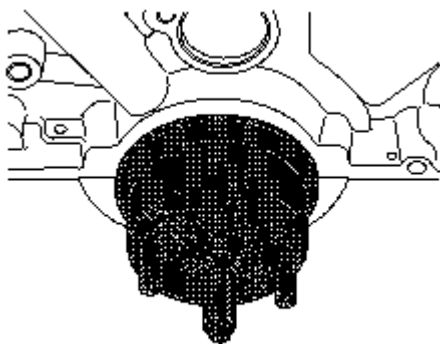

1. Make sure the crankshaft is free of grit, loose rust, and burrs. Correct as needed.
2. Apply a very light film of oil onto the crankshaft sealing surface. DO NOT apply oil to the sealing surface of the engine block.
3. Install the seal onto *J 42849*.
4. Position the *J 42849* against the crankshaft. Thread the attaching screws into the tapped holes in the crankshaft.
5. Tighten the screws securely with a screwdriver in order to ensure that the seal is installed squarely over the crankshaft.

6. Rotate the center nut until the *J 42849* bottoms.
7. Remove the *J 42849* .
8. Install the flywheel. Refer to *Engine Flywheel Replacement* .

## Repair Instructions

### Engine Flywheel Replacement

*Engine Mechanical - 8.1L:Repair:Engine Flywheel Replacement*

#### Removal Procedure

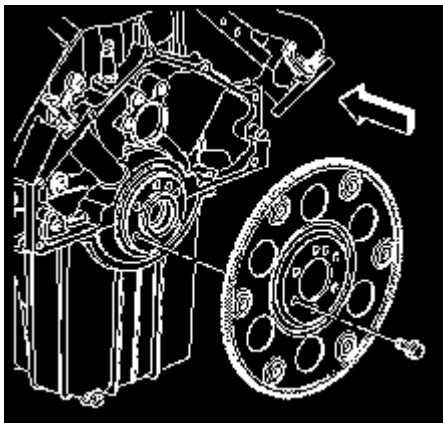

1. If equipped with a automatic transmission, remove the transmission. Refer to *Transmission Replacement* in Automatic Transmission - 4L80-E, or *Transmission Replacement (With 6.6L (LB7) Engine)* *Transmission Replacement (With 8.1L (L18) Engine)* in Automatic Transmission - Allison.
2. Remove the engine flywheel bolts.
3. Remove the engine flywheel.

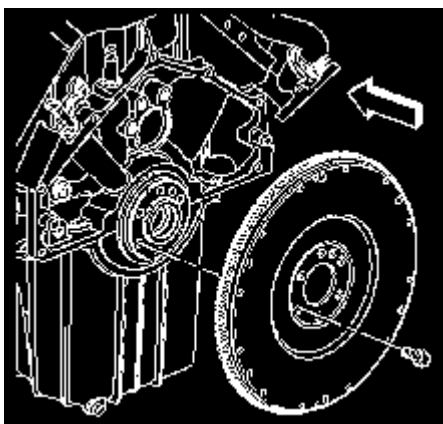

4. If equipped with a manual transmission, remove the clutch assembly. Refer to *Clutch Assembly Replacement* in Clutch.
5. Remove the engine flywheel bolts.
6. Remove the engine flywheel.
7. Clean and inspect the engine flywheel. Refer to *Engine Flywheel Cleaning and Inspection (AT)* *Engine Flywheel Cleaning and Inspection (MT)* .

#### Installation Procedure

**Important:** Make sure the flywheel is installed correctly. "Engine Side" is stamped on the flywheel to aid with installation.

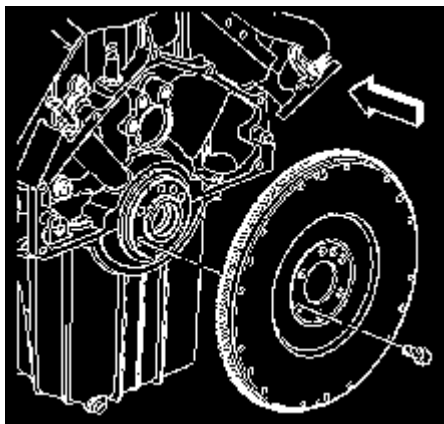

1. If equipped with a manual transmission, Install the engine flywheel.

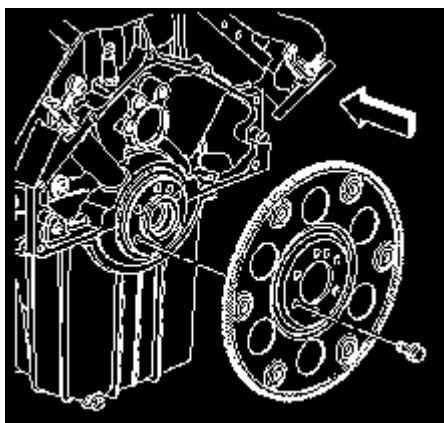

2. If equipped with a automatic transmission, Install the engine flywheel.

**Notice:** Refer to *Fastener Notice in Cautions and Notices*.

3. Install the engine flywheel bolts.

**Tighten:**

4. Tighten the bolts a first pass to 40♦&newtonm; (30♦lb♦ft).
5. Tighten the bolts a second pass to 80♦&newtonm; (59♦lb♦ft).
6. Tighten the bolts a final pass to 100♦&newtonm; (74♦lb♦ft).

7. If equipped with a manual transmission, install the clutch assembly. Refer to *Clutch Assembly Replacement* in Clutch.

8. If equipped with a automatic transmission, install the transmission. Refer to *Transmission Replacement* in Automatic Transmission - 4L80-E, or *Transmission Replacement (With 6.6L (LB7) Engine) Transmission Replacement (With 8.1L (L18) Engine)* in Automatic Transmission - Allison.

## Repair Instructions

### Engine Replacement

*Engine Mechanical - 8.1L:Repair:Engine Replacement*

#### Tools Required

J 36857 Engine Lift Brackets

### Removal Procedure

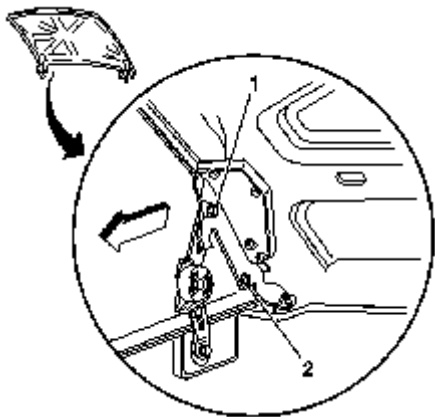

1. Open the hood.
2. Place fender covers over both fenders.
3. Raise the hood to the service position, perform the following:
  - 3.1. Remove the hood hinge bolts (1).
  - 3.2. Raise the hood until vertical.
  - 3.3. Install the hood hinge bolts until snug in the service position (2).

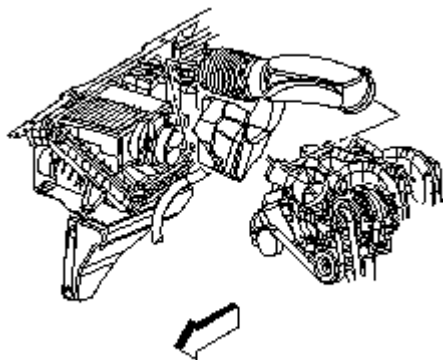

4. Loosen the clamps at the throttle body and air cleaner.
5. Remove the air cleaner outlet duct.

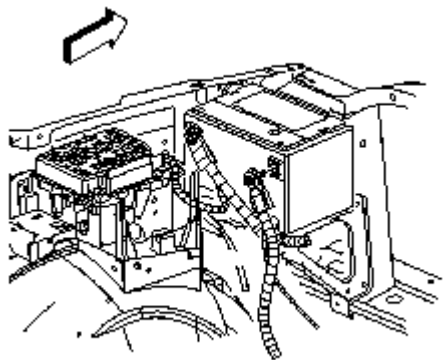

6. Disconnect the battery negative cable. Refer to [Battery Negative Cable Disconnect/Connect Procedure \(Single Battery\)](#) [Battery Negative Cable Disconnect/Connect Procedure \(Auxiliary Battery\)](#) in Engine Electrical.
7. Disconnect the positive battery cable.

8. Remove the ignition coils. Refer to [Ignition Coil\(s\) Replacement](#) in Engine Controls - 8.1♦L.

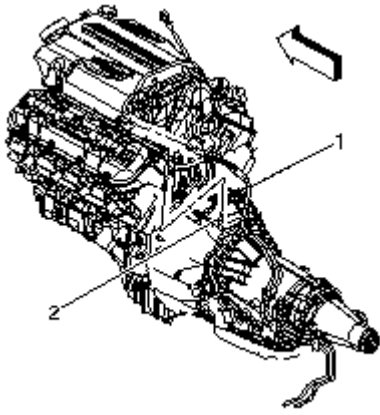

9. Relieve the fuel system pressure. Refer to [Fuel Pressure Relief Procedure](#) in Engine Controls - 8.1♦L.

10. Disconnect the fuel feed pipe (1) from the fuel rail. Refer to [Quick Connect Fitting\(s\) Service \(Metal Collar\)](#) in Engine Controls - 8.1♦L.

11. Remove the air conditioning (A/C) compressor. Refer to [Compressor Replacement \(L18\) Compressor Replacement \(LB7\) Compressor Replacement \(LR4, LM7, and LQ4\)](#) in Heating, Ventilation and Air Conditioning.

12. Remove the radiator. Refer to [Radiator Replacement \(EXC 8.1L\) Radiator Replacement \(8.1L\)](#) in Engine Cooling.

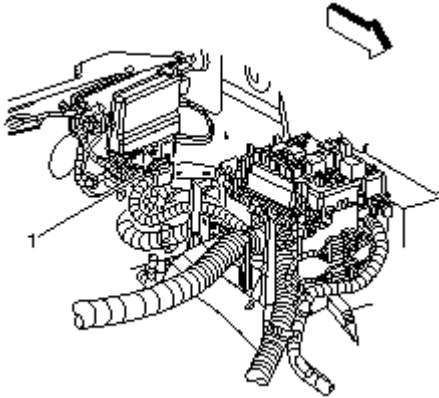

13. Disconnect the throttle actuator control (TAC) module electrical connector (1).

14. Remove the vacuum lines from the engine, as required.

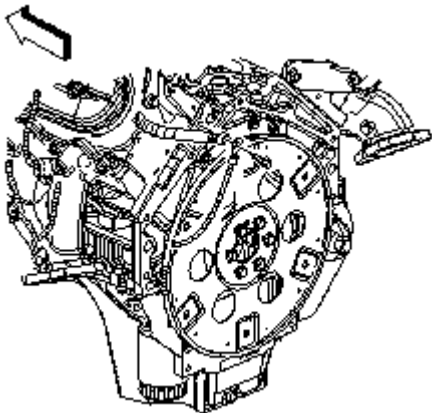

15. Remove the ground cable bolt at the engine block.

16. Remove the generator. Refer to [Generator Replacement \(4.3L Engine\) Generator Replacement \(4.8L, 5.3L, and 6.0L Engines\) Generator Replacement \(6.6L \(LB7\) Engine\) Generator Replacement \(6.6L \(LLY\) Engine\) Generator Replacement \(8.1L](#)

*Engine*) in Engine Electrical.

17. Remove the engine electrical harness and tie out of the way.
18. Raise and suitably support the vehicle safety stands. Refer to *Lifting and Jacking the Vehicle* in General Information.
19. Remove the starter motor. Refer to *Starter Motor Replacement (4.3L Engine) Starter Motor Replacement (4.8L, 5.3L, and 6.0L Engines) Starter Motor Replacement (6.6L (LB7) Engine) Starter Motor Replacement (6.6L (LLY) Engine) Starter Motor Replacement (8.1L Engine)* in Engine Electrical.
20. Remove the hoses from the power steering pump. Refer to *Power Steering Cooler Pipe/Hose Replacement (Without Hydroboost) Power Steering Cooler Pipe/Hose Replacement (Rack and Pinion) Power Steering Cooler Pipe/Hose Replacement (With Hydroboost) Power Steering Cooler Pipe/Hose Replacement (Parallel Hybrid Truck)* in Power Steering System.
21. Remove the exhaust manifold pipe. Refer to *Exhaust Manifold Pipe Replacement (6.0L, 6.6L (LB7), and 8.1L Engines)* in Engine Exhaust.
22. Remove the catalytic converter. Refer to *Catalytic Converter Replacement (4.3L, 4.8L, and 5.3L Engines) Catalytic Converter Replacement (6.0L and 8.1L Engines)* in Engine Exhaust.

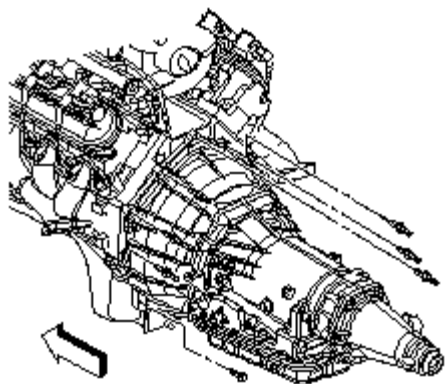

23. Remove the torque converter bolts, if equipped.
24. Remove the clutch pressure plate bolts, if equipped.
25. Remove the bolts from the transmission to the engine.
  - For the automatic transmission, refer to *Transmission Replacement* in Automatic Transmission - 4L80-E or *Transmission Replacement (With 6.6L (LB7) Engine) Transmission Replacement (With 8.1L (L18) Engine)* in Automatic Transmission - Allison.
  - For the manual transmission, refer to *Transmission Replacement* in Manual Transmission - NV 4500 or *Transmission Replacement* in Manual Transmission - ZF S6-650.
26. Remove the engine oil cooler lines from the engine block. Refer to *Engine Oil Cooler Hose/Pipe Replacement* in Engine Cooling.

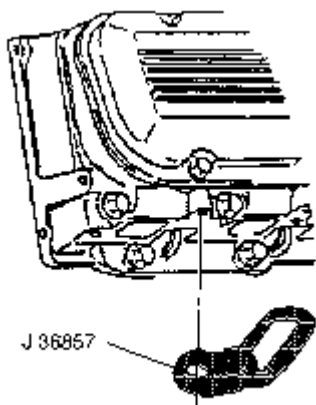

27. Attach *J 36857* to the rear of the right cylinder head and to the front of the left cylinder head.

**Notice:** Refer to *Fastener Notice in Cautions and Notices*.

28. Install the attaching bolt and washer. Use GM♦P/N♦9428217 with GM♦P/N♦15650963.

**Tighten:** Tighten the lift bracket bolts to 40♦&newtonm; (30♦lb♦ft).

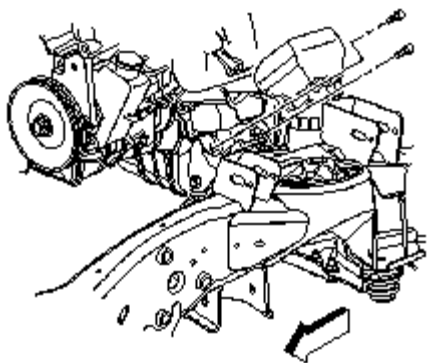

29. Remove the engine mount heat shield bolts and shields.

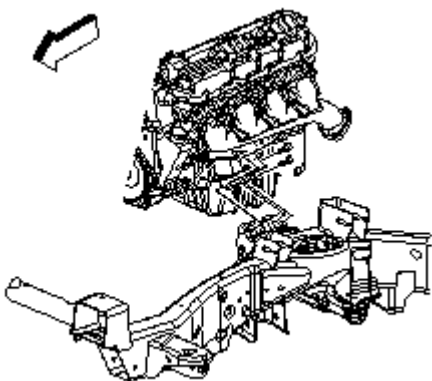

30. Remove the engine mount to engine mount bracket bolts.

31. Remove the engine using a suitable lifting devise.

32. Install the engine onto a suitable engine stand.

33. Remove the generator mounting bracket. Refer to [Generator Bracket Replacement \(4.3L Engine\)](#) [Generator Bracket Replacement \(4.8L, 5.3L, and 6.0L Engines\)](#) [Generator Bracket Replacement \(6.6L \(LB7\) Engine\)](#) [Generator Bracket Replacement \(6.6L \(LLY\) Engine\)](#) [Generator Bracket Replacement \(8.1L Engine\)](#) in Engine Electrical.

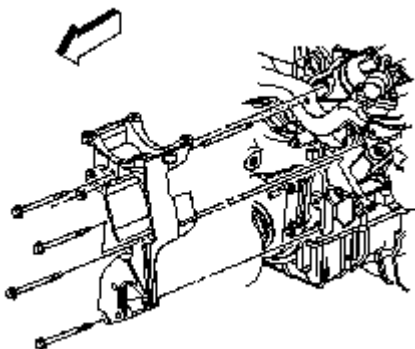

34. Remove the A/C compressor/power steering pump bracket from the cylinder head.

35. Remove the lift brackets from the cylinder head.

## Installation Procedure

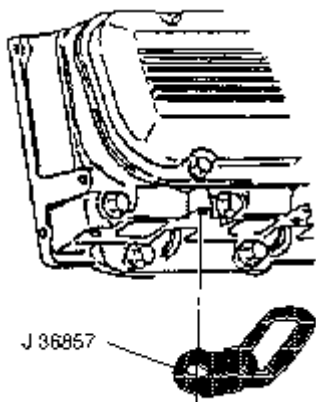

1. Attach *J 36857* to the rear of the right cylinder head and to the front of the left cylinder head.

**Notice:** Refer to *Fastener Notice in Cautions and Notices*.

2. Install the attaching bolt and washer. Use GM♦P/N♦9428217 with GM♦P/N♦15650963.

**Tighten:** Tighten the lift bracket bolts to 40♦&newtonm; (30♦lb♦ft).

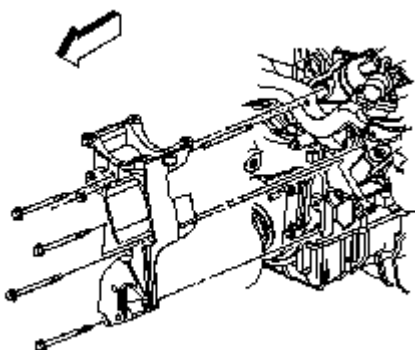

3. Install the air compressor/power steering mounting bracket to the engine block.

**Tighten:** Tighten the power steering pump bracket bolts and nut to 50♦&newtonm; (37♦lb♦ft).

4. Install the generator bracket. Refer to *Generator Bracket Replacement (4.3L Engine)* *Generator Bracket Replacement (4.8L, 5.3L, and 6.0L Engines)* *Generator Bracket Replacement (6.6L (LB7) Engine)* *Generator Bracket Replacement (6.6L (LLY) Engine)* *Generator Bracket Replacement (8.1L Engine)* in Engine Electrical.

5. Remove the engine using a suitable lifting devise.

6. Install the engine into the vehicle.

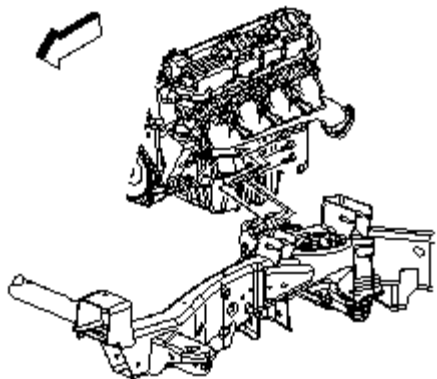

7. Install the engine mount to engine mount bracket bolts.

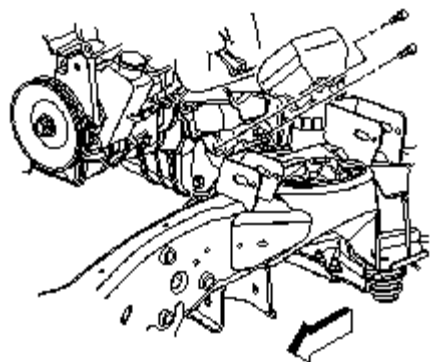

8. Install the engine mount heat shield and bolts.

9. Remove the engine lift hooks from the cylinder heads.

10. Raise the vehicle and support with safety stands.

11. Install the engine oil cooler lines to the engine block. Refer to [Engine Oil Cooler Hose/Pipe Replacement](#) in Engine Cooling.

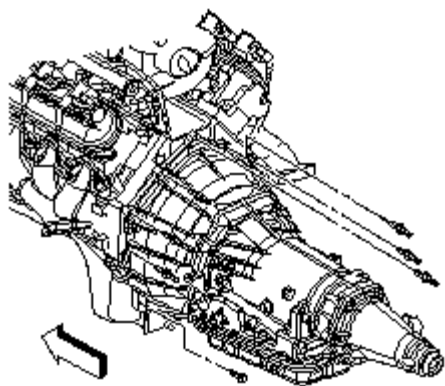

12. Install the bolts from the transmission to the engine.

- For the automatic transmission, refer to [Transmission Replacement](#) in Automatic Transmission - 4L80-E or [Transmission Replacement \(With 6.6L \(LB7\) Engine\)](#) [Transmission Replacement \(With 8.1L \(L18\) Engine\)](#) in Automatic Transmission - Allison.
- For the manual transmission, refer to [Transmission Replacement](#) in Manual Transmission - NV 4500 or [Transmission](#)

*Replacement* in Manual Transmission - ZF S6-650.

13. Install the clutch pressure plate bolts, if equipped.
14. Install the torque converter bolts, if equipped.
15. Install the catalytic converter. Refer to *Catalytic Converter Replacement (4.3L, 4.8L, and 5.3L Engines) Catalytic Converter Replacement (6.0L and 8.1L Engines)* in Engine Exhaust.
16. Install the exhaust manifold pipe. Refer to *Exhaust Manifold Pipe Replacement (6.0L, 6.6L (LB7), and 8.1L Engines)* in Engine Exhaust.
17. Install the hoses to the power steering pump. Refer to *Power Steering Cooler Pipe/Hose Replacement (Without Hydroboost) Power Steering Cooler Pipe/Hose Replacement (Rack and Pinion) Power Steering Cooler Pipe/Hose Replacement (With Hydroboost) Power Steering Cooler Pipe/Hose Replacement (Parallel Hybrid Truck)* in Power Steering System.
18. Install the starter motor. Refer to *Starter Motor Replacement (4.3L Engine) Starter Motor Replacement (4.8L, 5.3L, and 6.0L Engines) Starter Motor Replacement (6.6L (LB7) Engine) Starter Motor Replacement (6.6L (LLY) Engine) Starter Motor Replacement (8.1L Engine)* in Engine Electrical.
19. Lower the vehicle.
20. Route the engine electrical harness.
21. Install the generator. Refer to *Generator Replacement (4.3L Engine) Generator Replacement (4.8L, 5.3L, and 6.0L Engines) Generator Replacement (6.6L (LB7) Engine) Generator Replacement (6.6L (LLY) Engine) Generator Replacement (8.1L Engine)* in Engine Electrical.

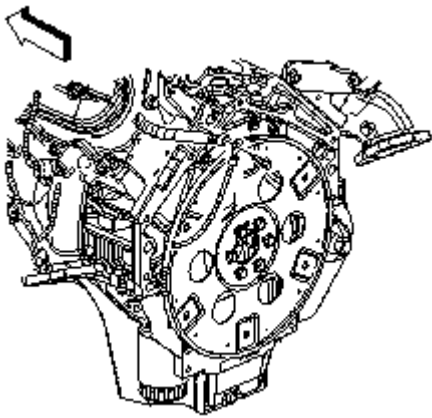

22. Install the ground cable bolt at the engine block.

**Tighten:** Tighten the engine wiring harness bolt to 16♦&newtonm; (12♦lb♦ft).

23. Install the vacuum lines to the engine.

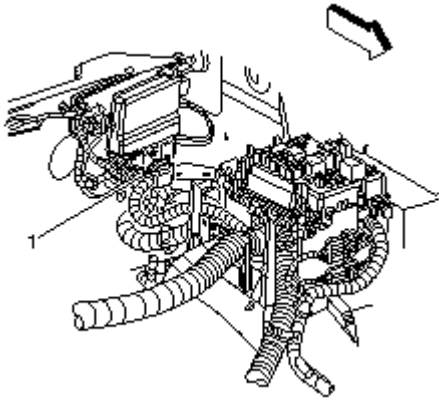

24. Connect the TAC module electrical connector (1).
25. Install the radiator. Refer to *Radiator Replacement (EXC 8.1L) Radiator Replacement (8.1L)* in Engine Cooling.
26. Install the A/C compressor. Refer to *Compressor Replacement (L18) Compressor Replacement (LB7) Compressor Replacement (LR4, LM7, and LQ4)* in Heating, Ventilation and Air Conditioning.

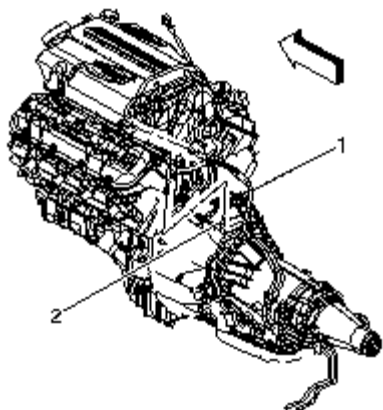

27. Connect the fuel feed pipe (1) to the fuel rail.
28. Install the ignition coils. Refer to *Ignition Coil(s) Replacement* in Engine Controls - 8.1♦L.
29. Connect the positive battery cable.
30. Connect the battery negative cable. Refer to *Battery Negative Cable Disconnect/Connect Procedure (Single Battery) Battery Negative Cable Disconnect/Connect Procedure (Auxiliary Battery)* in Engine Electrical.

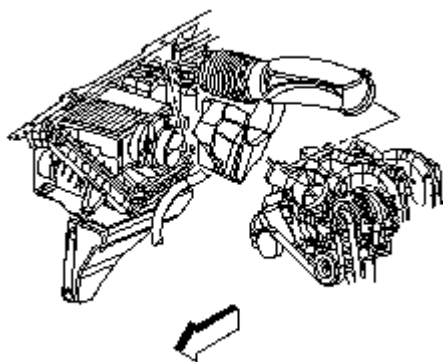

31. Install the air cleaner outlet duct.
32. Tighten the clamps at the throttle body and air cleaner.
33. Remove fender covers from both fenders.

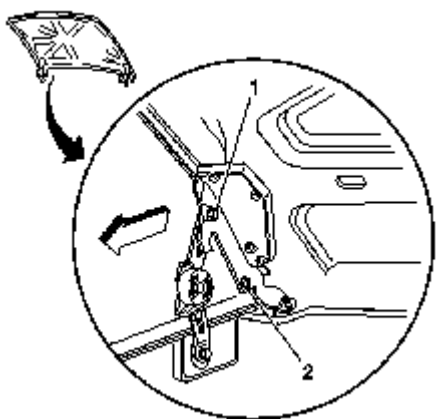

34. Remove the hood hinge bolts from the service position (2).
35. Lower the hood to the normal position.
36. Install the hood hinge bolts.

**Tighten:** Tighten the hood hinge bolts to 25♦&newtonm; (18♦lb♦ft).

37. Before starting a new engine or one that has been repaired, complete the following procedure.

37.1. Prelube the engine. Refer to [Engine Prelubing](#) .

37.2. Remove the fuel pump fuse and disconnect the coil harness connectors, then crank the engine until oil pressure is present.

37.3. Crank the engine several times. Listen for any unusual noises or evidence that any of the parts are binding.

37.4. Install the fuel pump fuse and connect the coil harness connectors and start the engine and listen for unusual noises.

37.5. Check the vehicle oil pressure gauge or light and confirm that the engine has acceptable oil pressure. If necessary install an oil pressure gauge and measure the oil pressure.

37.6. Run the engine at about 1000♦RPM until the engine has reached normal operating temperature.

37.7. Inspect for oil and or coolant leaks while the engine is running.

37.8. Stop the engine and perform a final inspection for the proper engine oil and coolant levels.

37.9. The final step is to perform the crankshaft position (CKP) sensor variation learn procedure. Refer to [CKP System Variation Learn Procedure](#) in Engine Controls - 8.1♦L.

## Repair Instructions

### Engine Oil and Oil Filter Replacement

*Engine Mechanical - 8.1L:Repair:Engine Oil and Oil Filter Replacement*

#### Removal Procedure

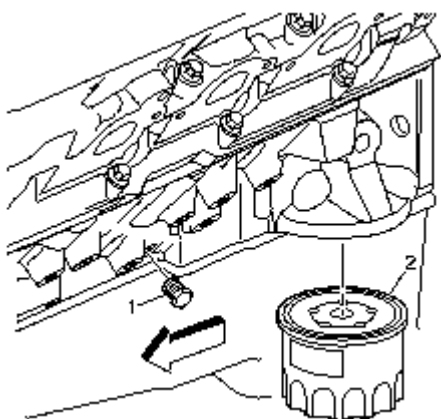

1. Raise and suitably support the vehicle with safety stands. Refer to [Lifting and Jacking the Vehicle](#) in General Information.
2. Remove the oil pan drain plug and allow the engine oil to drain completely.
3. Clean the oil pan drain plug surface.
4. Remove the oil filter (2) from the engine block and allow the engine oil to drain completely.
5. Clean the oil filter surface.

#### Installation Procedure

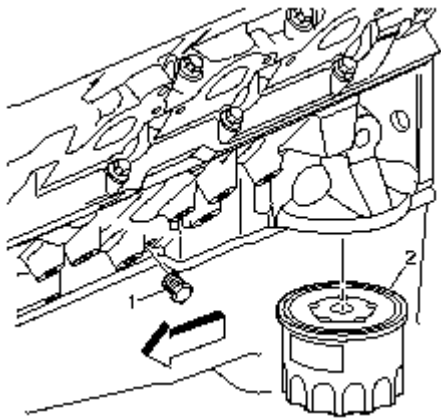

1. Install a new oil filter (2) to the engine block. Tighten the oil filter per the oil filter manufacturers instruction printed on the oil filter box.

**Notice:** Refer to *Fastener Notice in Cautions and Notices*.

2. Install the oil pan drain plug.

**Tighten:** Tighten the oil pan drain plug to 28♦&newtonm; (21♦lb♦ft).

3. Lower the vehicle.

4. Fill the engine with oil. Refer to *Fluid and Lubricant Recommendations* in Maintenance and Lubrication.

## Repair Instructions

### Draining Fluids and Oil Filter Removal

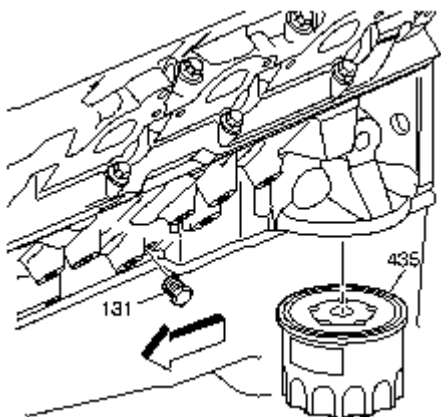

1. Remove the oil pan drain plug.

2. Drain the engine oil.

3. Remove the oil filter♦(435).

4. Remove the left engine coolant drain hole plug♦(131) and the right engine coolant drain hole plug.

5. Drain the engine coolant.

## Repair Instructions

### Crankshaft Balancer Removal

#### Tools Required

- [J 38416-B](#) Harmonic Balancer Remover
- [J 42846](#) Crankshaft Protector Button

- [J 42847](#) Flywheel Holding Tool

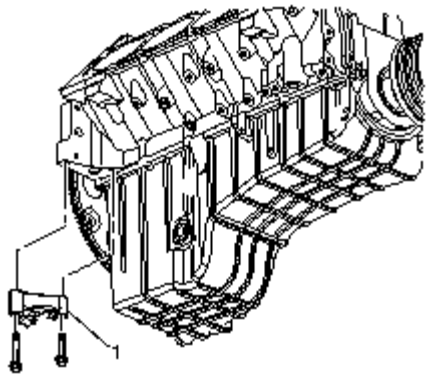

**Notice:** Refer to *Fastener Notice in Cautions and Notices*.

**Important:** Ensure that the teeth of the flywheel holding tool engage the engine flywheel teeth.

1. Install the [J 42847](#) (1) to the starter bolt holes.

**Tighten:** Tighten the [J 42847](#) bolts to 50♦&newtonm; (37♦lb♦ft).

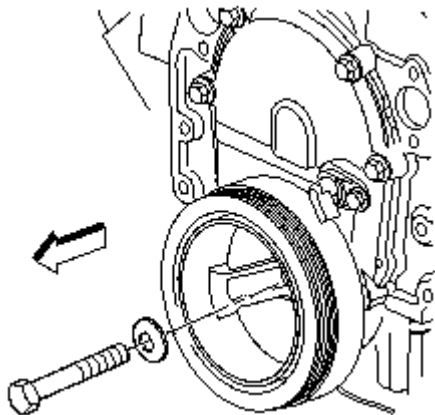

2. Remove the crankshaft balancer bolt and washer.

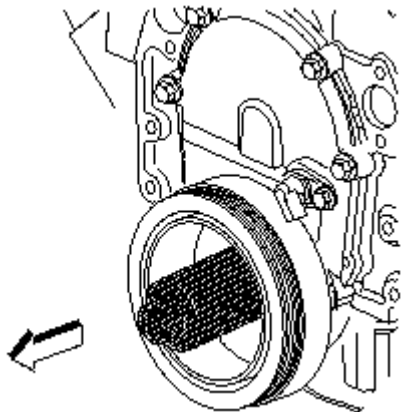

3. Install the [J 42846](#) onto the end of the crankshaft.

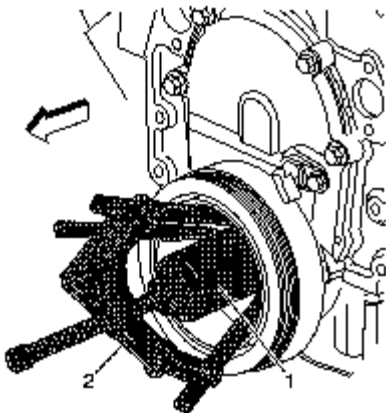

4. Install the *J 38416-B* (2) in order to remove the crankshaft balancer. Place the legs of the *J 38416-B* into the recesses cast into the backside of the balancer inner hub.

5. Tighten the center screw of the *J 38416-B* until the crankshaft balancer is removed from the end of the crankshaft.

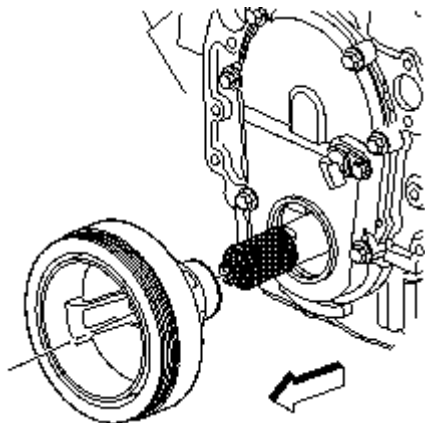

6. Remove the *J 38416-B*.

7. Remove the crankshaft balancer.

8. Remove the *J 42846* from the end of the crankshaft.

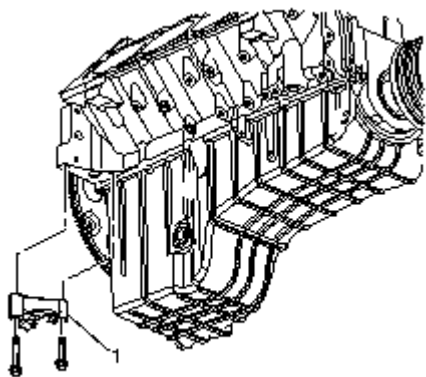

9. Remove the *J 42847* (1).

## Repair Instructions

### Engine Flywheel Removal (AT)

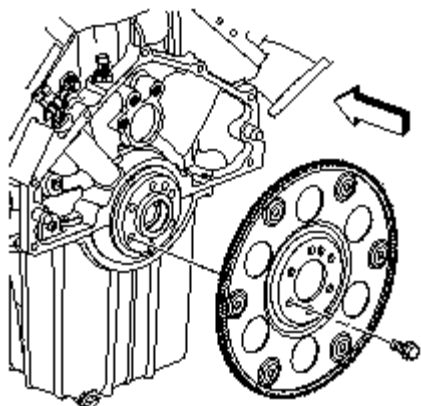

1. Remove the engine flywheel bolts.
2. Remove the engine flywheel.

## Repair Instructions

### Engine Flywheel Removal (MT)

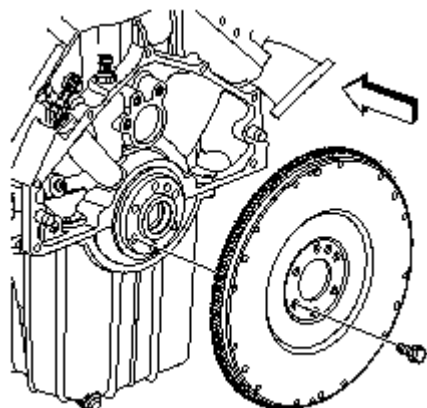

**Important:** The flywheel may need to be tapped with a non-metallic mallet from the engine side due to a slight interference fit to the crankshaft.

1. Remove the engine flywheel bolts.
2. Remove the engine flywheel.

## Repair Instructions

### Crankshaft Rear Oil Seal Removal

#### Tools Required

J 43320 Crankshaft Rear Seal Puller

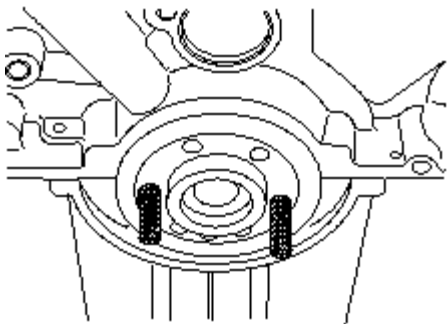

1. Install the *J 43320* guide pins into the crankshaft.

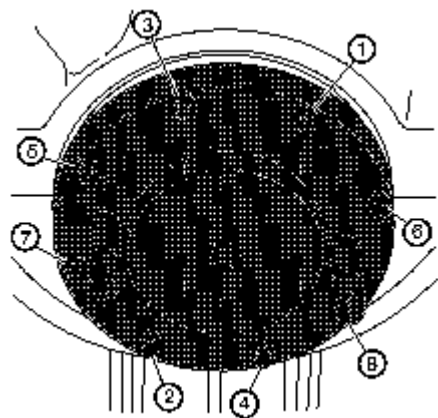

2. Install the *J 43320* over the guide pins.

3. Using a suitable drill, insert eight of the self-drilling sheet metal screws♦(1–8) into the rear crankshaft seal, using a criss-cross pattern. The self-drilling screws are included with the *J 43320* .

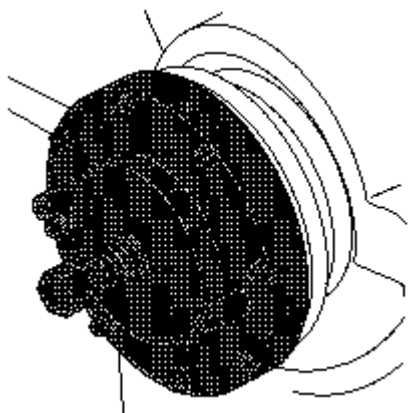

4. Thread the center bolt of *J 43320* into the crankshaft to remove the seal.

5. Remove the *J 43320* guide pins from the crankshaft.

## Repair Instructions

### Clutch Pilot Bearing Removal

#### Tools Required

*J 43276* Clutch Pilot Bearing Remover

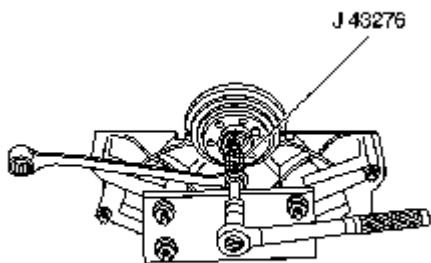

**Caution:** Refer to *Safety Glasses Caution in Cautions and Notices*.

**Notice:** When using the J♦43276 Clutch Pilot Bearing Remover, always secure the J♦43276-1 Clutch Pilot Bearing Remover tool body using a wrench. Do not allow the J♦43276-1 tool body to rotate. Failing to do so causes damage to the J♦43276-1 tool body.

1. Remove the clutch pilot bearing using the *J 43276* .
  - 1.1. Install the J♦43276-1 tool body into the clutch pilot bearing.
  - 1.2. Using a wrench secure the J♦43276-1 tool body.
  - 1.3. Insert the J♦43276-2 forcing screw into the J♦43276-1 tool body.
  - 1.4. Rotate the J♦43276-2 forcing screw clockwise into the J♦43276-1 tool body until the clutch pilot bearing is completely removed from the crankshaft.
  - 1.5. Rotate the J♦43276-2 forcing screw counterclockwise to remove the J♦43276-2 forcing screw from the J♦43276-1 tool body.
  - 1.6. Remove the J♦43276-1 tool body from the clutch pilot bearing.
2. Discard the clutch pilot bearing.

## Repair Instructions

### Oil Level Indicator and Tube Removal

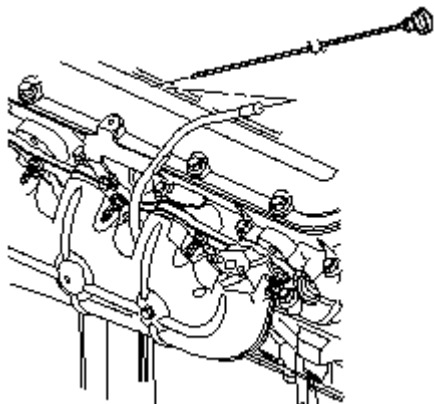

1. Remove the oil level indicator from the oil level indicator tube.

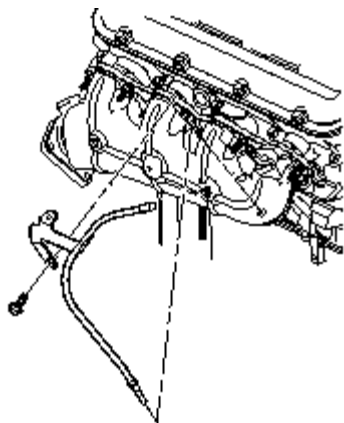

2. Remove the oil level indicator tube bolt.
3. Remove the oil level indicator tube from the oil pan.
4. Remove the O-ring seal from the oil level indicator tube.

## Repair Instructions

### Exhaust Manifold Removal - Left

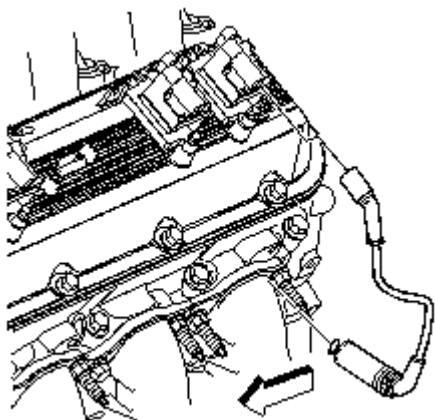

**Notice:** Twist the spark plug boot one-half turn in order to release the boot. Pull on the spark plug boot only. Do not pull on the spark plug wire or the wire could be damaged.

1. Remove the spark plug wires from the spark plugs and ignition coils.

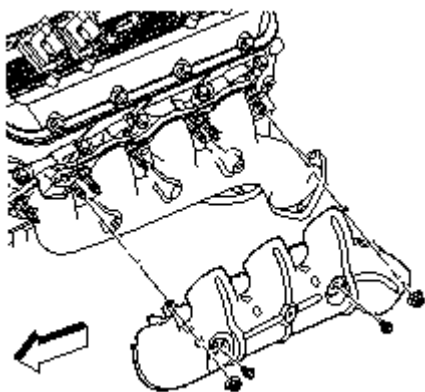

2. Remove the exhaust manifold heat shield bolts and nuts.

3. Remove the exhaust manifold heat shield.

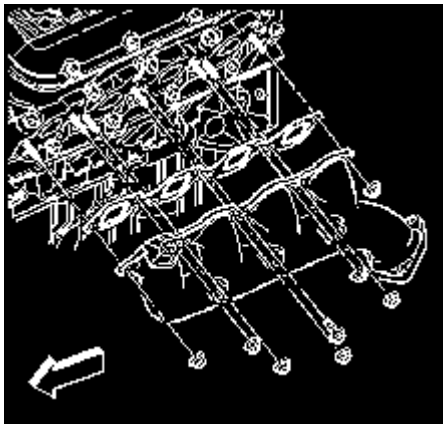

4. Remove the exhaust manifold nuts and center bolt.

5. Remove the exhaust manifold.

6. Remove the exhaust manifold gasket.

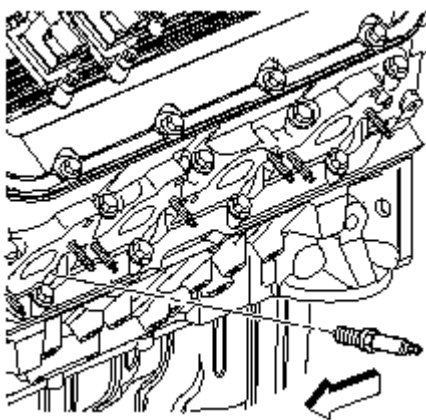

7. Remove the spark plugs, if required.

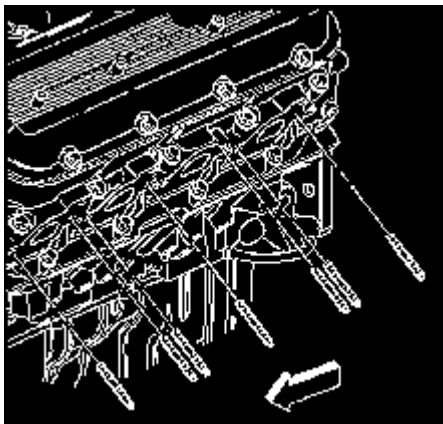

8. Remove the exhaust manifold studs, if required.

## Repair Instructions

### Exhaust Manifold Removal - Right

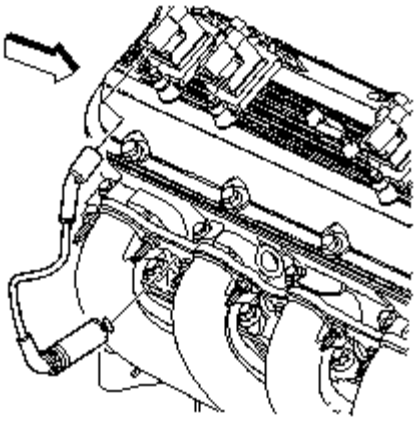

**Notice:** Twist the spark plug boot one-half turn in order to release the boot. Pull on the spark plug boot only. Do not pull on the spark plug wire or the wire could be damaged.

1. Remove the spark plug wires from the spark plugs and ignition coils.

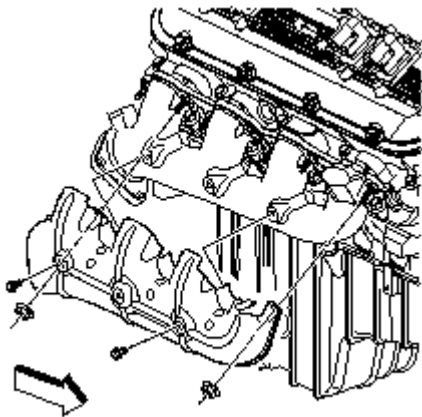

2. Remove the exhaust manifold heat shield bolts and nuts.
3. Remove the exhaust manifold heat shield.

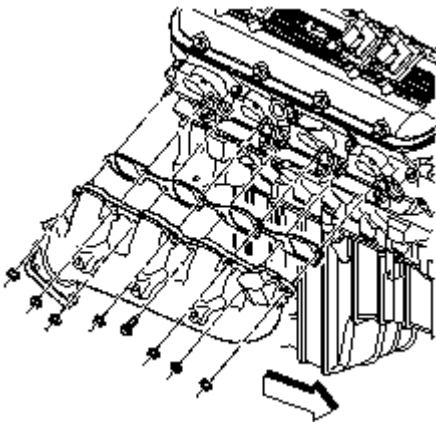

4. Remove the exhaust manifold nuts and center bolt.
5. Remove the exhaust manifold.
6. Remove the exhaust manifold gasket.

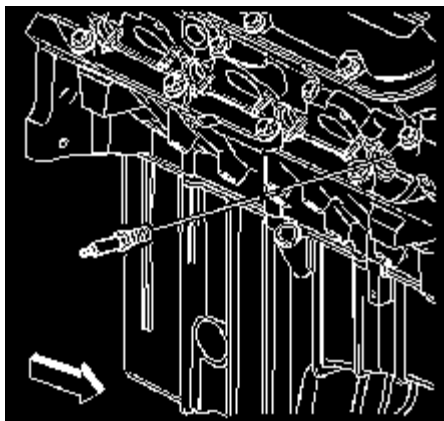

7. Remove the spark plugs, if required.

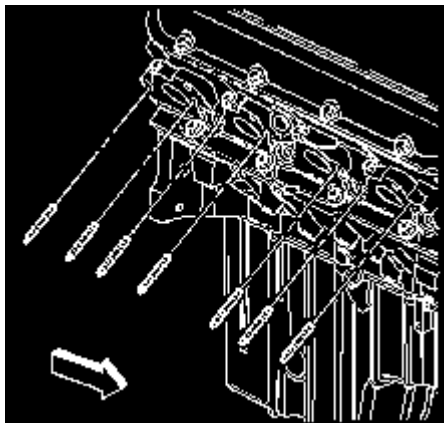

8. Remove the exhaust manifold studs, if required.

## Repair Instructions

### Water Crossover Removal

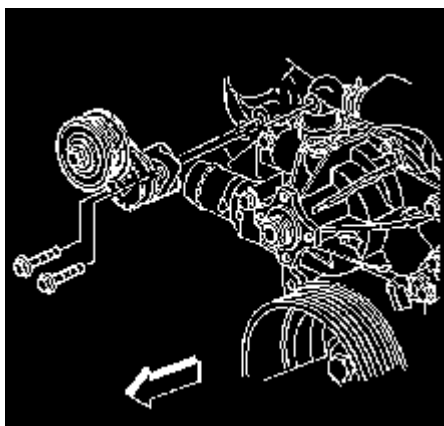

1. Remove the drive belt tensioner bolts.
2. Remove the drive belt tensioner.

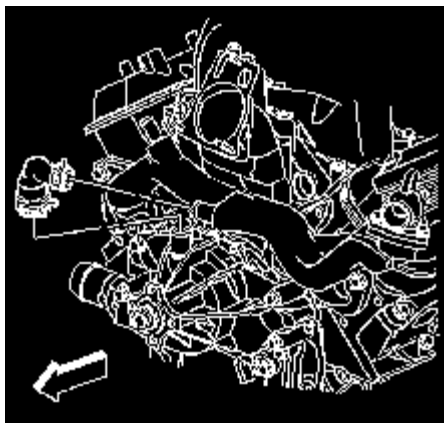

3. Remove the coolant bypass hose and clamps.

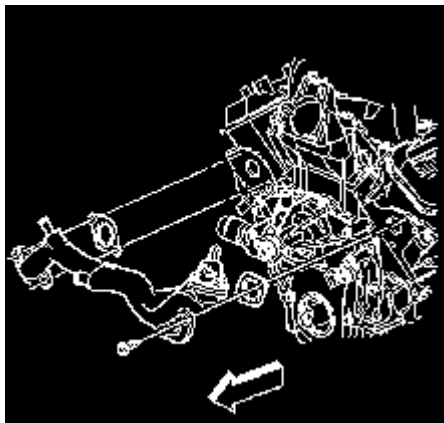

4. Remove the coolant crossover bolts.

5. Remove the coolant crossover.

6. Remove the coolant crossover gaskets.

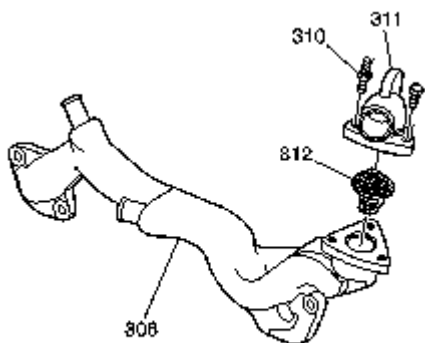

7. Remove the thermostat housing bolts/studs♦(310).

8. Remove the thermostat housing♦(311).

9. Remove the thermostat♦(312) from the coolant crossover♦(308).

## Repair Instructions

### Water Pump Removal

#### Tool Required

### J 41240 Fan Clutch Remover and Installer

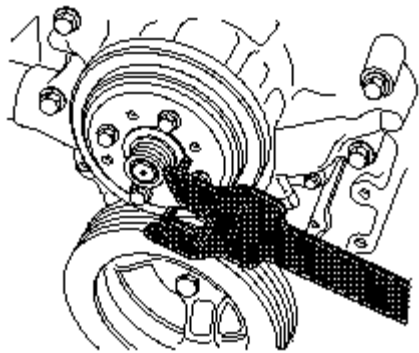

1. Use the *J 41240* to retain the water pump pulley.

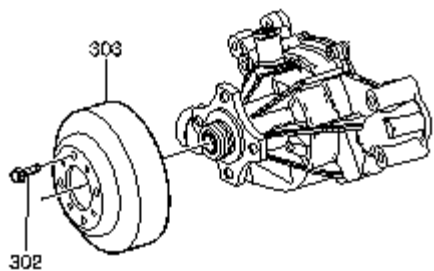

2. Remove the water pump pulley bolts♦(302) and pulley♦(303).

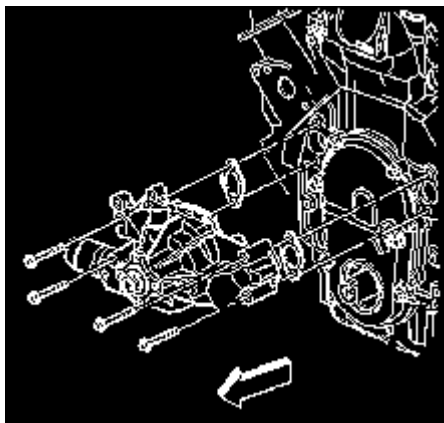

3. Remove the water pump bolts.
4. Remove the water pump.
5. Remove the water pump gaskets.

## Repair Instructions

### Intake Manifold Removal

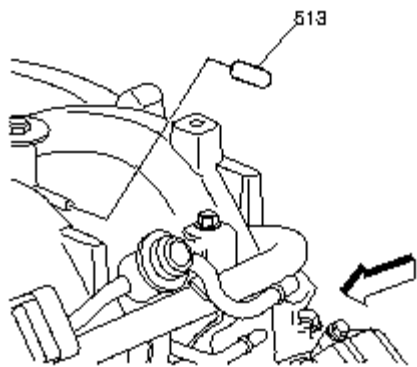

1. Remove the vacuum plug♦(513), if required.

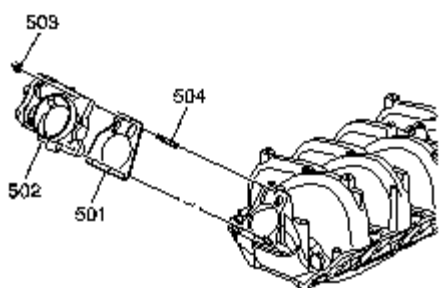

2. Remove the throttle body nuts♦(503).

3. Remove the throttle body♦(502) and gasket♦(501).

4. Remove the studs♦(504), if required.

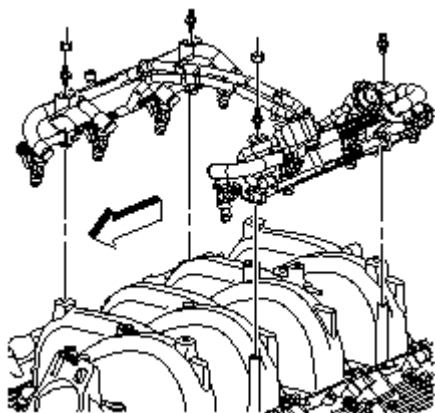

5. Remove the fuel injection fuel rail bolts/studs.

6. Remove the fuel injection fuel rail with injectors.

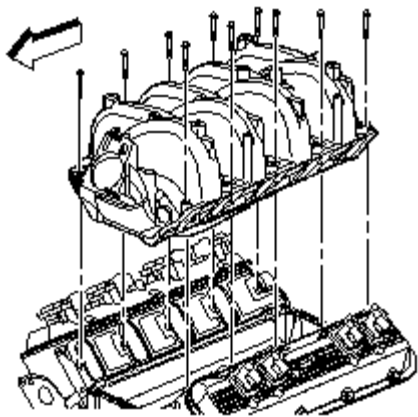

7. Remove the intake manifold bolts.

**Important:** Do not attempt to loosen the manifold by prying under the gasket surface with any tool.

8. Remove the intake manifold.

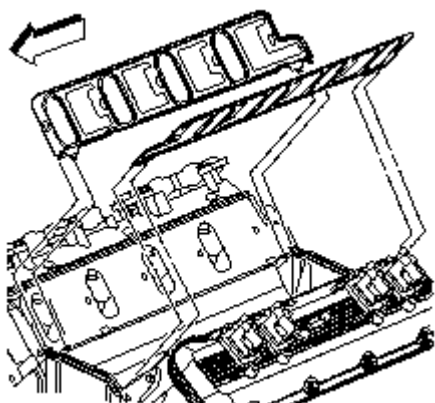

**Important:** The intake manifold gaskets are not reusable.

9. Remove and discard the intake manifold side gaskets.

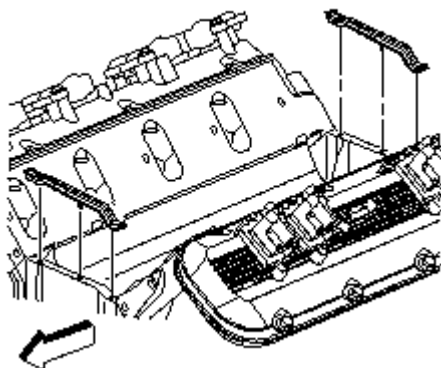

10. Remove and discard the intake manifold end seals.

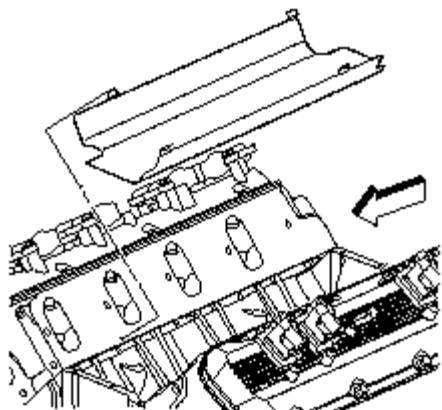

**Important:** The splash shield is secured using a snap-in fit. Do not distort the splash shield. The splash shield is reusable.

11. Remove the splash shield.

## Repair Instructions

### Valve Rocker Arm Cover Removal - Left

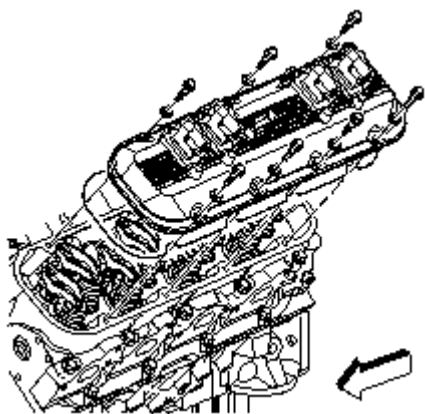

1. Remove the valve rocker arm cover bolts.
2. Remove the valve rocker arm cover.

**Important:** The valve rocker arm cover gasket may be reused if not removed from valve rocker arm cover.

3. Replace the valve rocker arm cover gasket if it is cut or damaged.

## Repair Instructions

### Valve Rocker Arm Cover Removal - Right

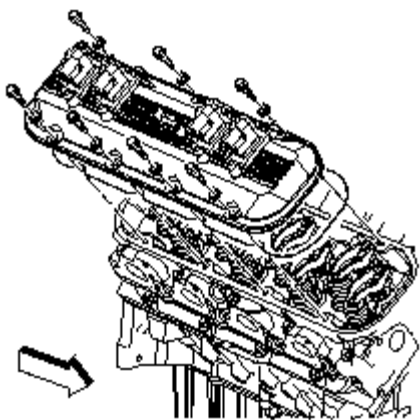

1. Remove the valve rocker arm cover bolts.
2. Remove the valve rocker arm cover.

**Important:** The valve rocker arm cover gasket may be reused if not removed from the valve rocker arm cover.

3. Replace the valve rocker arm cover gasket if it is cut or damaged.

## Repair Instructions

### Valve Rocker Arm and Push Rod Removal

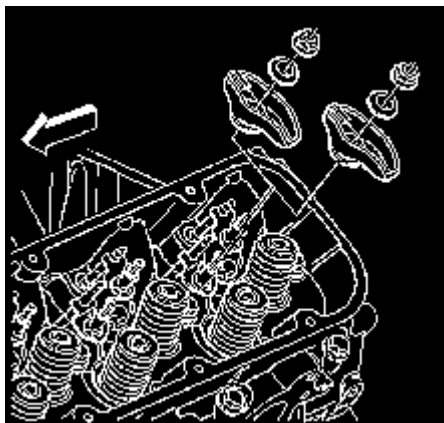

**Important:** Mark, organize and sort the cylinder head components. Return the components to their original location during reassembly. Make an organizer rack from a piece of wood.

1. Remove the valve rocker arm nuts, the valve rocker arm balls and the valve rocker arms.

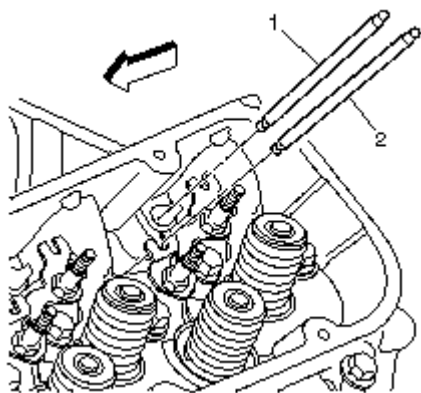

**Important:** The exhaust valve push rods (2) are longer than the intake valve push rods (1).

2. Remove the valve push rods.

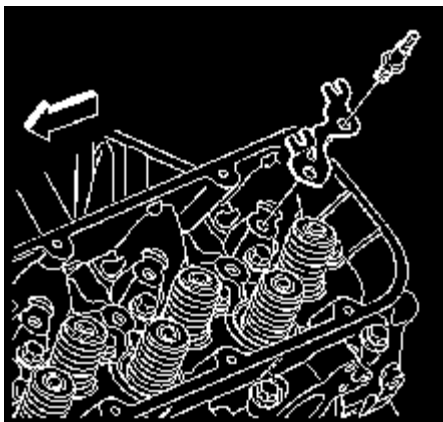

3. Remove the valve rocker arm studs and push rod guides.

## Repair Instructions

### Cylinder Head Removal - Left

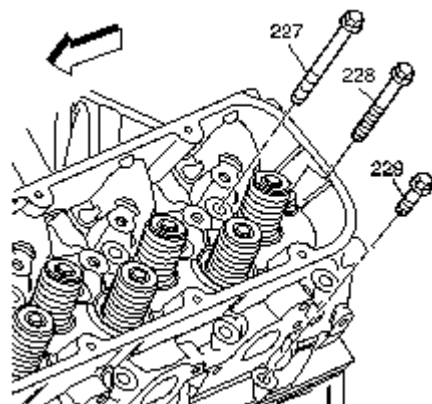

1. Remove and discard the eighteen cylinder head bolts (227, 228, 229).

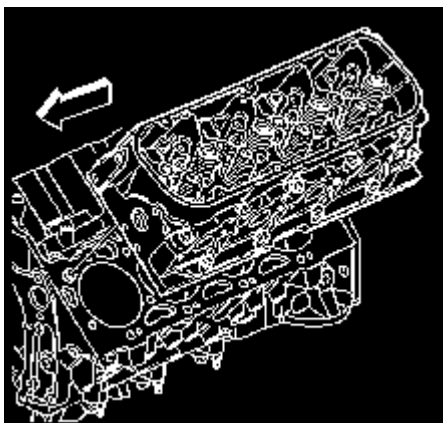

**Notice:** After removal, place the cylinder head on two wood blocks to prevent damage to the sealing surfaces.

2. Remove the cylinder head.

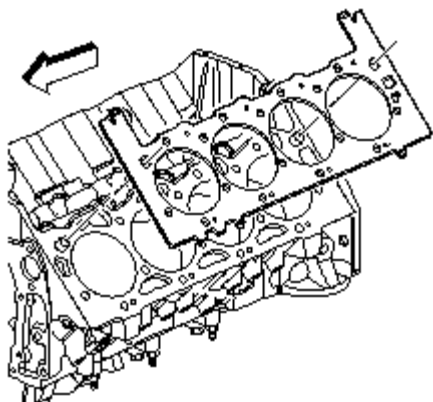

3. Remove the cylinder head gasket.
4. Discard the cylinder head gasket.

## Repair Instructions

### Cylinder Head Removal - Right

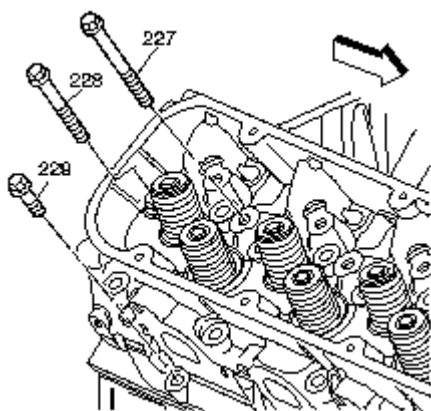

1. Remove and discard the eighteen cylinder head bolts (227, 228, 229).

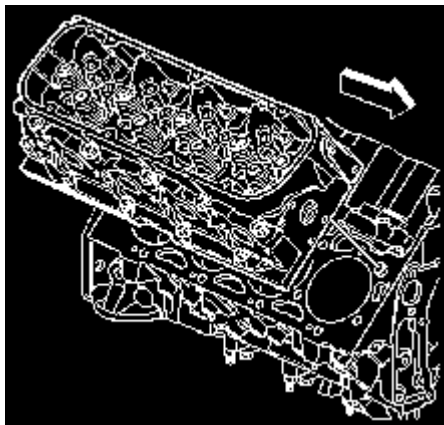

**Notice:** After removal, place the cylinder head on two wood blocks to prevent damage to the sealing surfaces.

2. Remove the cylinder head.

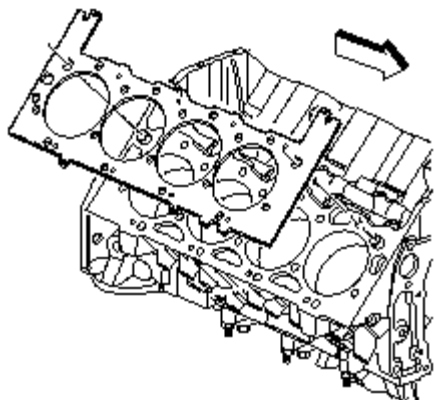

3. Remove the cylinder head gasket.
4. Discard the cylinder head gasket.

## Repair Instructions

### Valve Lifter Removal

#### Tools Required

*J 3049-A* Valve Lifter Remover

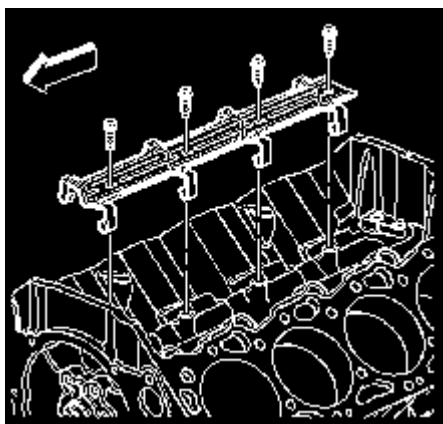

**Important:** Mark, sort, or organize the valve lifters and guides for return to their original location during assembly.

1. Remove the valve lifter guide retainer bolts and retainer.

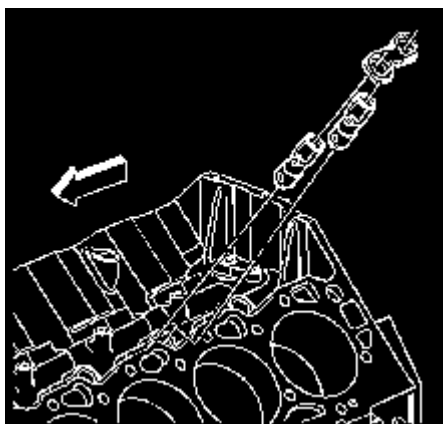

2. Remove the valve lifter guides.

**Important:** Place the valve lifters in the organizer rack or tag them in a way to ensure they can be returned to the valve lifter bore from which they were removed.

3. Remove the valve lifters.

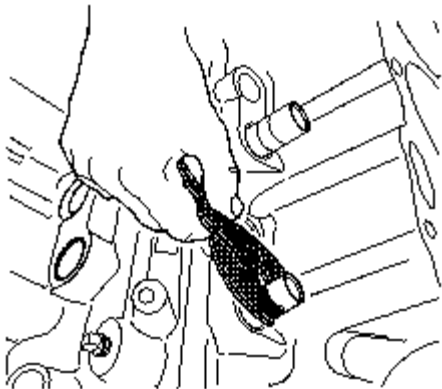

4. Some valve lifters may be stuck in their bore due to gum or varnish deposits. These valve lifters can be removed using [J 3049-A](#).

## Repair Instructions

### Oil Pump Drive Removal

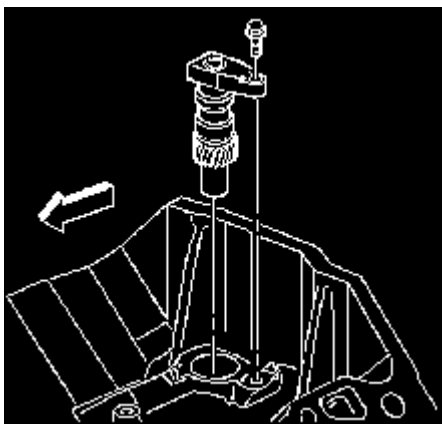

1. Remove the oil pump drive bolt.
2. Remove the oil pump drive.

## Repair Instructions

### Oil Pan Removal

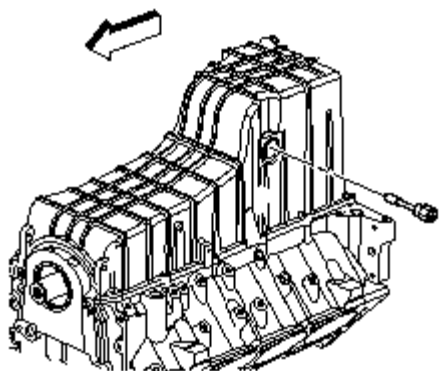

1. Remove the oil level sensor from the oil pan.

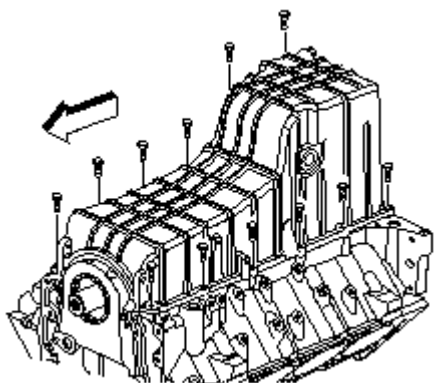

2. Remove the oil pan bolts.

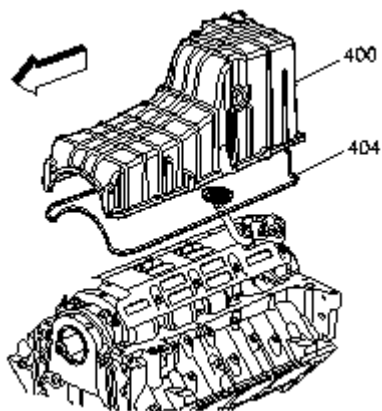

**Important:** The oil pan gasket is reusable if not cut or damaged.

3. Remove the oil pan (400) and the oil pan gasket (404).

## Repair Instructions

### Oil Pump, Pump Screen and Deflector Removal

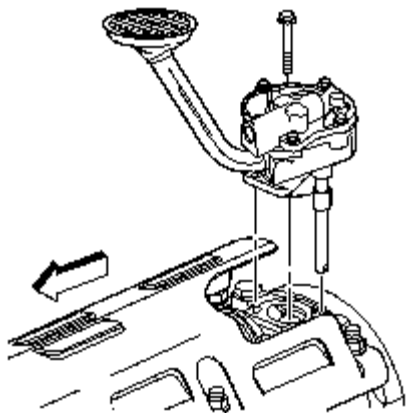

1. Remove the bolt that attaches the oil pump to the crankshaft rear bearing cap.
2. Remove the oil pump, driveshaft and retainer from the crankshaft rear bearing cap.

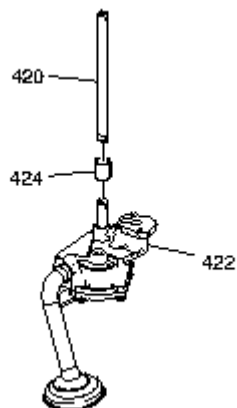

3. Separate the oil pump♦(422), driveshaft♦(420) and retainer♦(424).
4. Discard the driveshaft retainer♦(424).

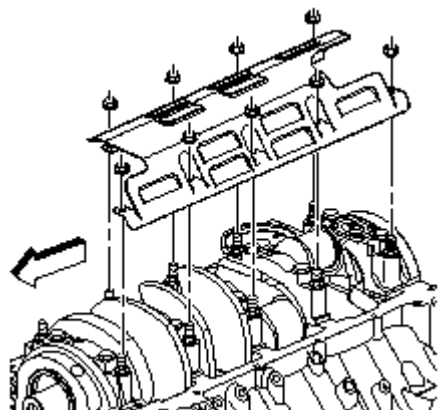

5. Remove the crankshaft oil deflector nuts.
6. Remove the crankshaft oil deflector.

## Repair Instructions

### Engine Front Cover Removal

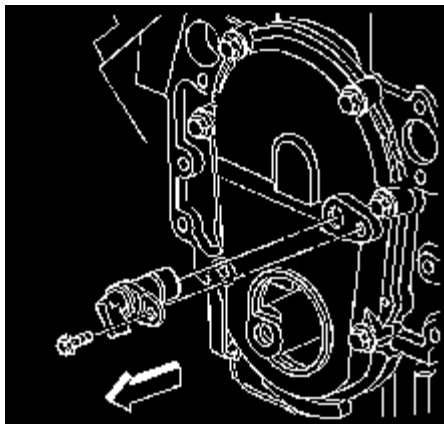

**Notice:** This component is initially installed using a self-tapping bolt(s). Care should be taken when removing and/or installing the self-tapping bolt(s). Failure to use care when removing and/or installing the self-tapping bolt(s) can lead to damage and unnecessary replacement of the self-tapping bolt(s) and/or the component the self-tapping bolt(s) is threaded into.

1. Remove the camshaft position sensor bolt.
2. Remove the camshaft position sensor.
3. Inspect the camshaft position sensor O-ring for cuts, cracks, tears or damage. Replace the O-ring as required.

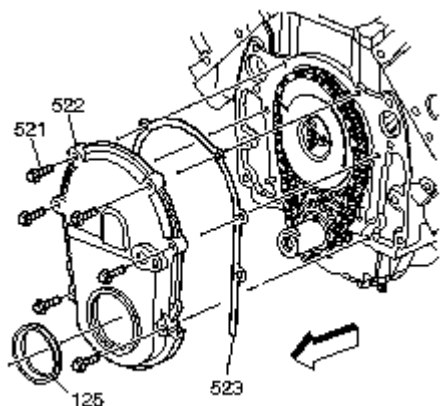

4. Remove the engine front cover bolts♦(521).
5. Remove the engine front cover♦(522).
- Important:** The engine front cover gasket is reusable.
6. Remove the engine front cover gasket♦(523).
7. Remove the crankshaft front oil seal♦(125) from the engine front cover.

## Repair Instructions

### Timing Chain and Sprockets Removal

#### Tools Required

J 42846 Crankshaft Protector Button

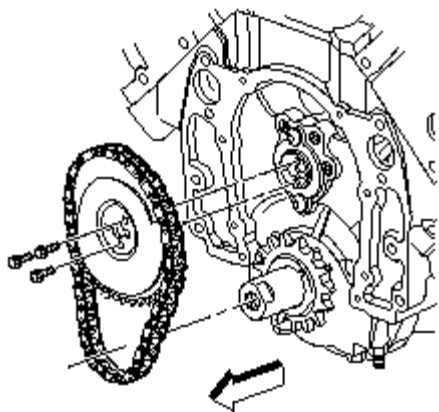

1. Measure the camshaft timing chain free play. If the chain can be moved back and forth in excess of 16♦mm (0.625♦in), replace the chain and sprockets.
2. Remove the camshaft sprocket bolts.
3. Remove the camshaft sprocket and the timing chain.

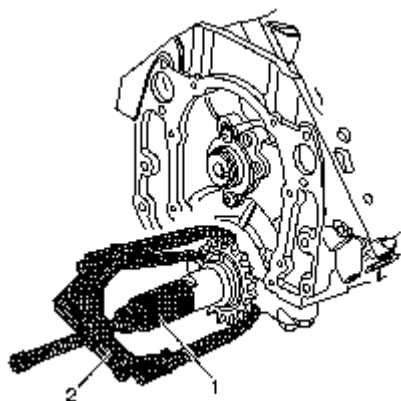

4. Install the *J 42846* ♦(1) into the end of the crankshaft.
5. Remove the crankshaft sprocket using a three jaw puller♦(2).

## Repair Instructions

### Camshaft Removal

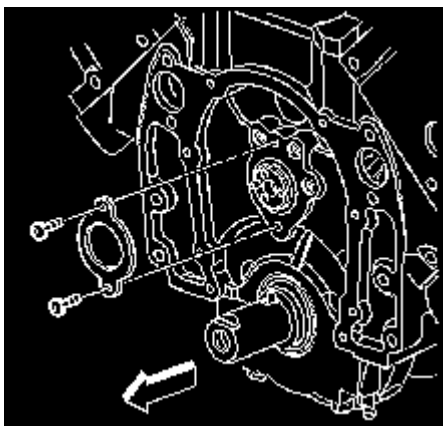

1. Remove the camshaft retainer bolts.
2. Remove the camshaft retainer.

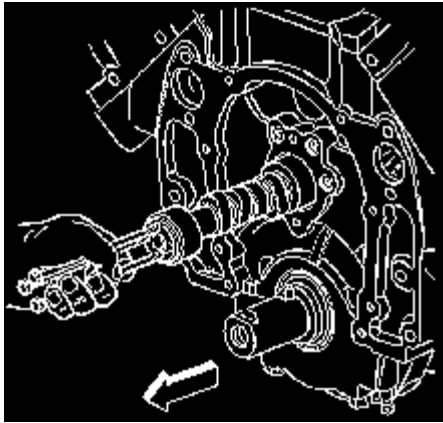

3. Install three 8-1.25 x 100mm bolts in the camshaft front bolt holes.

**Notice:** All camshaft journals are the same diameter, so care must be used in removing or installing the camshaft to avoid damage to the camshaft bearings.

4. Using the bolts as a handle, carefully rotate and pull the camshaft out of the engine block.

5. Remove the bolts from the front of the camshaft.

## Repair Instructions

### Piston, Connecting Rod, and Bearing Removal

#### Tools Required

- *J 24270* Cylinder Bore Ridge Reamer
- *J 42846* Crankshaft Protector Button

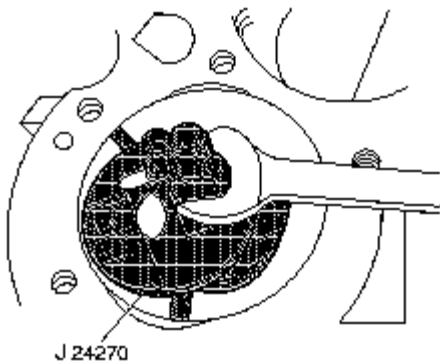

**Important:** Do not remove the excessive material from the cylinder bore. Excessive removal of material may require cylinder boring to the next oversize.

1. Remove the cylinder bore ridge as necessary.

1.1. Install the *J 42846* onto the front of the crankshaft in order to rotate the crankshaft.

1.2. Rotate the crankshaft until the piston is at the bottom of the stroke (BDC).

1.3. Place a cloth on top of the piston.

1.4. Perform the cutting operation with a *J 24270*. Refer to the manufacturer's instructions before using the *J 24270*.

1.5. Remove the *J 24270*.

1.6. Rotate the crankshaft until the piston is at top dead center (TDC).

1.7. Remove the cloth and the cuttings.

1.8. Repeat the procedure for each piston.

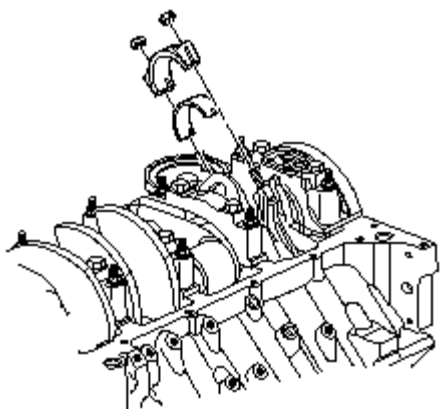

**Important:** Place matching marks or numbers on the connecting rods and the connecting rod caps. The connecting rod caps must be assembled to their original connecting rods.

**Important:** When connecting rod bearings are removed, NEW bearings must be installed during assembly.

2. Remove the connecting rod nuts.

3. Remove the connecting rod cap and the connecting rod lower bearing.

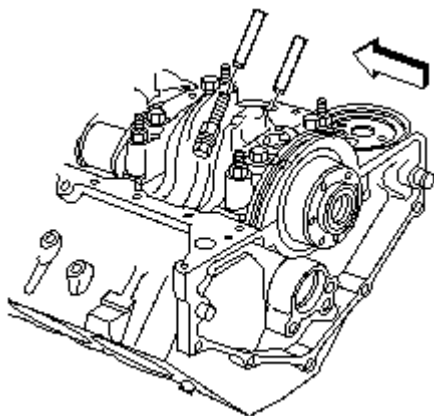

4. Install rubber fuel line onto the connecting rod bolts to prevent contact with the crankshaft journal.

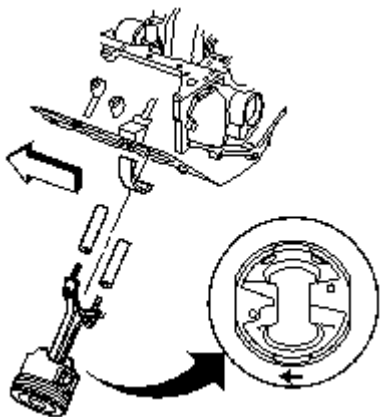

5. Remove the piston, connecting rod, and connecting rod upper bearing.

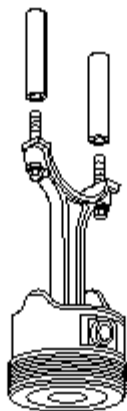

6. Remove the rubber fuel line from the connecting rod bolts.
7. Remove the remaining piston and the connecting rod assemblies.
8. Remove the *J 42846* from the front of the crankshaft.

## Repair Instructions

### Crankshaft and Bearings Removal

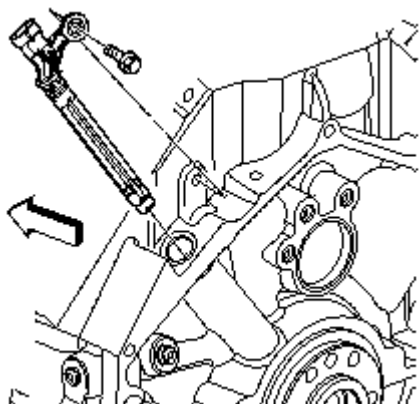

**Notice:** In order to prevent damage to the crankshaft position sensor reluctor wheel/ring care must be used when removing or installing this component.

**Important:** The crankshaft position sensor is designed to contact the reluctor wheel of the crankshaft. Wear may be noticeable on the end of the sensor.

1. Remove the crankshaft position sensor bolt.
2. Apply penetrating oil to the crankshaft position sensor-to-engine block mating surface. Allow the penetrating oil to soak for several minutes, to help loosen the O-ring from the engine block.
3. Twist the sensor to loosen the O-ring seal. When removing the sensor, pull the sensor straight out of the engine block at the same angle the sensor was installed.
4. Inspect both crankshaft position sensor O-ring for cuts, cracks, tears or damage. Replace the O-ring as needed.

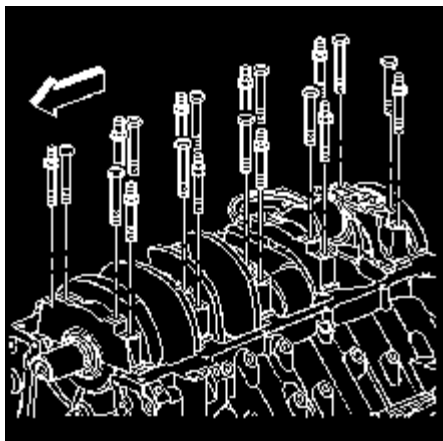

**Important:** Crankshaft bearing caps are machined with the engine block for the proper clearances. Mark or identify each crankshaft bearing cap location and direction before removal. Crankshaft bearing caps must be installed in their original locations.

5. Remove the crankshaft bearing cap bolts and studs.

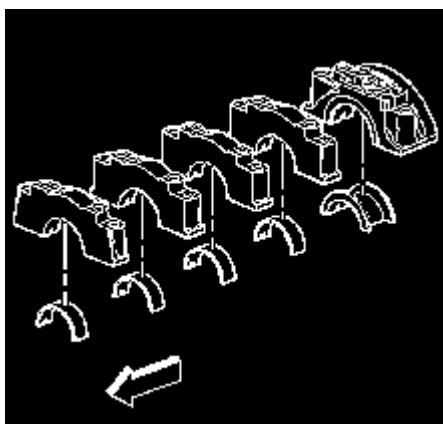

6. Remove the crankshaft bearing caps.

7. Remove the crankshaft lower bearings from the crankshaft bearing caps.

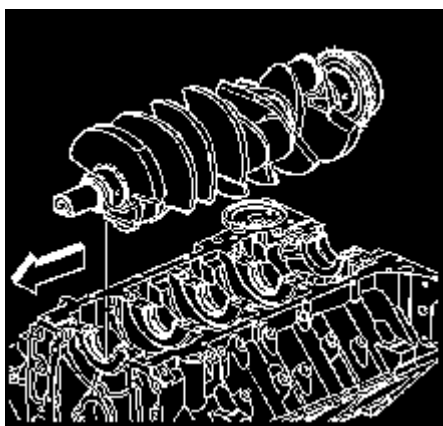

**Important:** Care should be taken when removing the crankshaft so that the crankshaft position sensor reluctor ring is not damaged.

8. Remove the crankshaft.

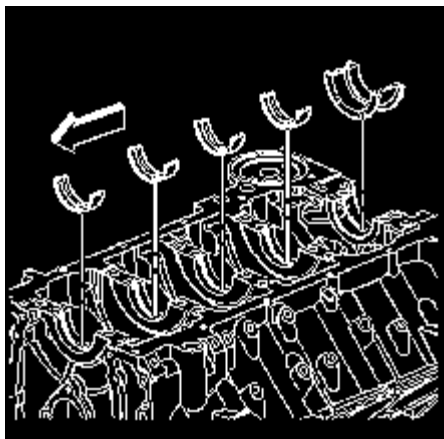

9. Remove the crankshaft upper bearings from the engine block.

## Repair Instructions

### Oil Filter Adapter Removal

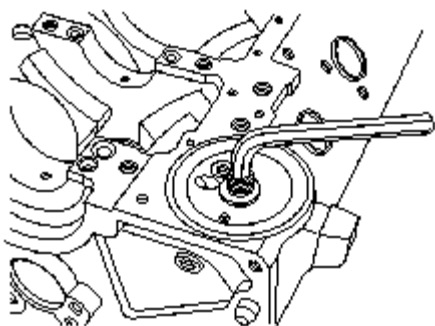

1. Loosen the oil filter fitting, using a hex wrench.

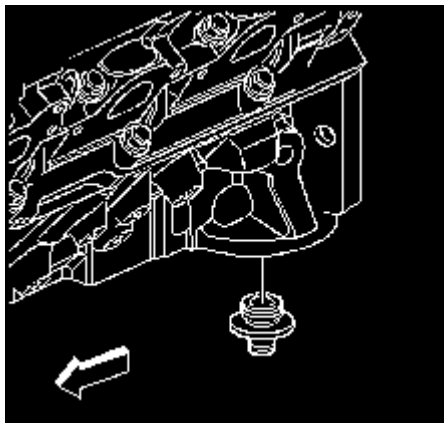

2. Remove the oil filter fitting.

3. Inspect the oil filter fitting, replace if necessary.

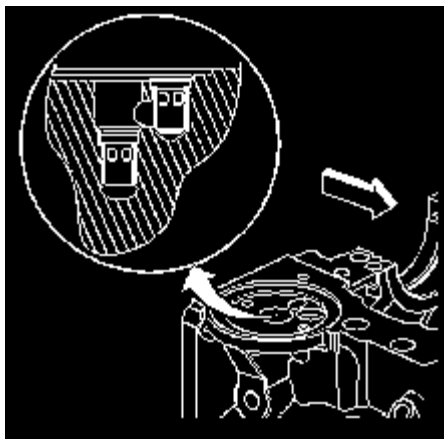

4. Remove the oil bypass valves (if required). Unstake the tangs on the oil bypass valves and remove with long nose pliers.
5. Discard the oil bypass valves, if removed.

## Repair Instructions

### Engine Block Plug Removal

#### Tools Required

*J 41712* Oil Pressure Switch Socket

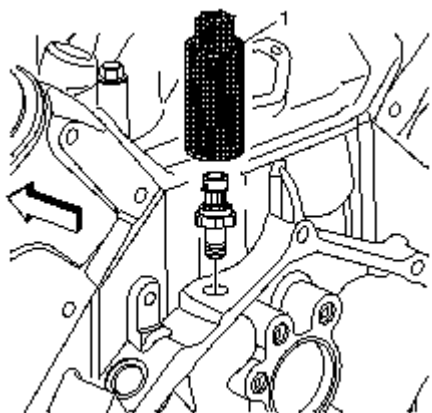

1. Remove the oil pressure switch using *J 41712* (1).

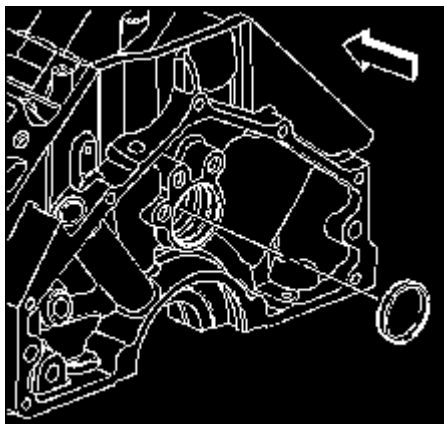

2. Remove the camshaft rear bearing hole plug:

- 2.1. Obtain a suitable self-threading screw.
- 2.2. Drill a hole into the plug.
- 2.3. Install the self-threading screw.
- 2.4. Pull on the plug until it has left the bore.

**Important:** Use care not to damage the camshaft bearings.

2.5. An alternate method to remove the plug would be to insert a long shaft or bar through the front of the engine and drive the plug from the bore.

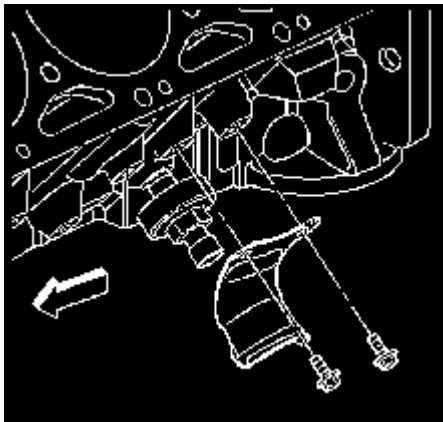

3. Remove the left side knock sensor heat shield bolts.
4. Remove the left side knock sensor heat shield.

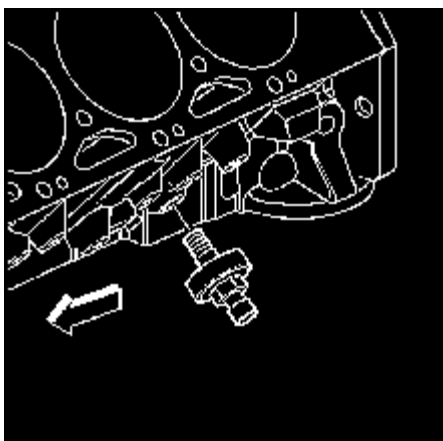

5. Remove the left side knock sensor.

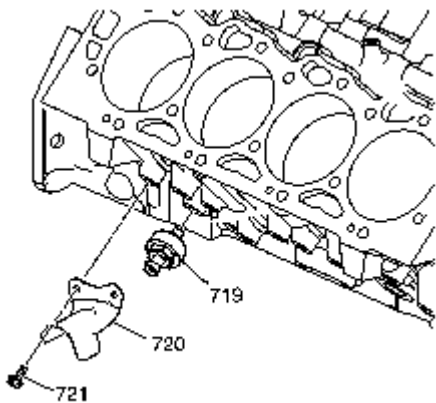

6. Remove the right side knock sensor heat shield♦(720) and bolts♦(721).
7. Remove the right side knock sensor♦(719).

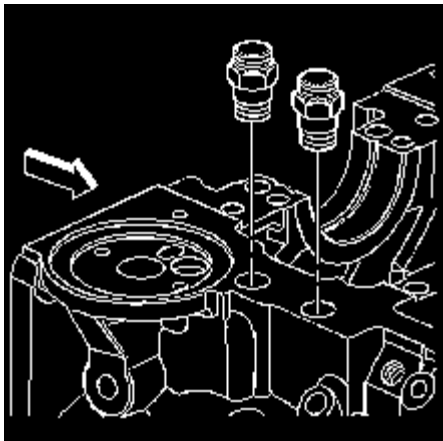

8. Remove the engine block oil cooler hose fittings.

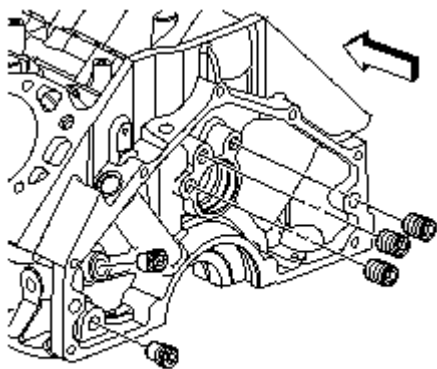

9. Remove the rear oil gallery plugs.

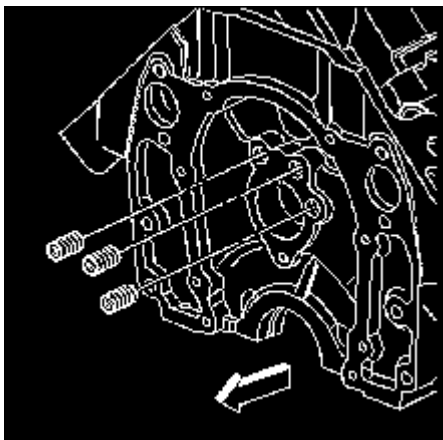

10. Remove the front oil gallery plugs.

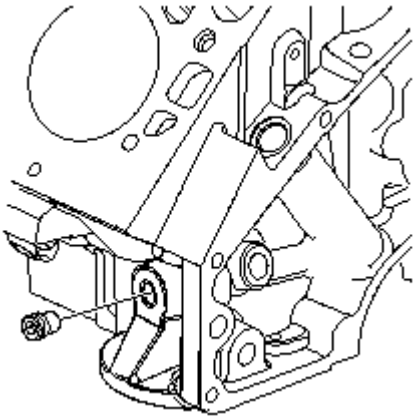

11. Remove the left side oil gallery plug.

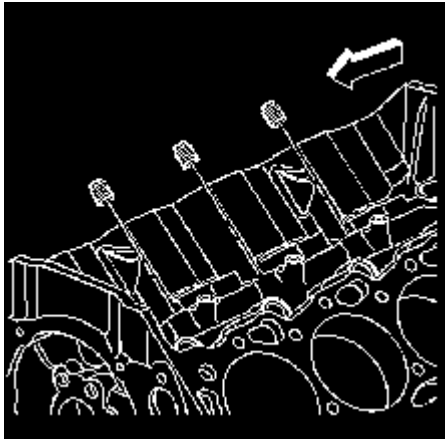

12. Remove the top oil gallery plugs.

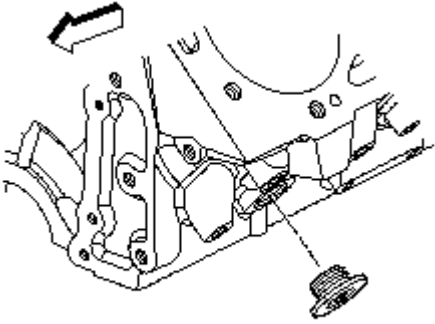

13. Remove the engine coolant hole plug.

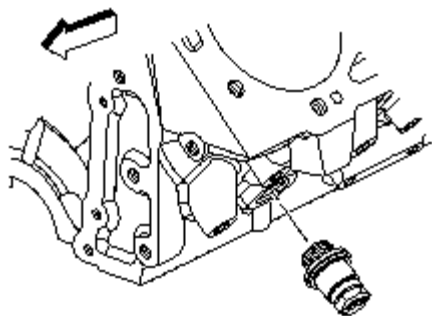

14. Remove the engine block heater, if equipped.

## Repair Instructions

### Camshaft Bearing Removal

#### Tools Required

[J 33049](#) Camshaft Bearing Service Set

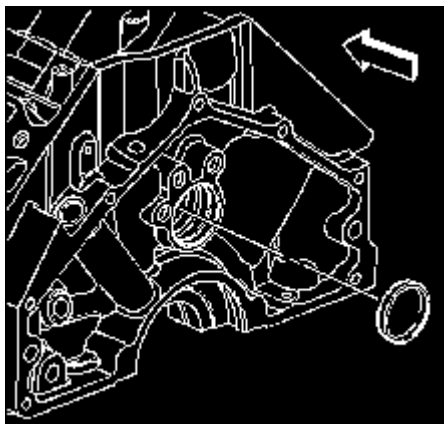

1. Remove the rear camshaft plug, if not previously removed.

Insert a long bar through the front of the engine and drive the plug out of the rear bore.

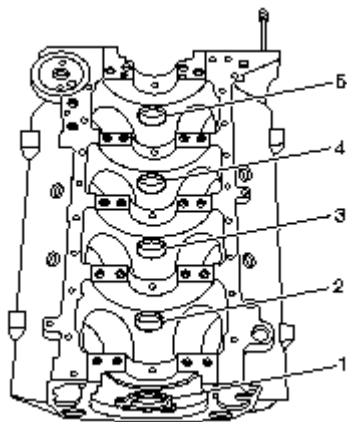

**Important:** A loose camshaft bearing may be caused by an enlarged, out-of-round, or damaged engine block bearing bore.

2. Prior to bearing removal, inspect the camshaft bearings for loose fit in the engine block bearing bores (positions♦1–5) .

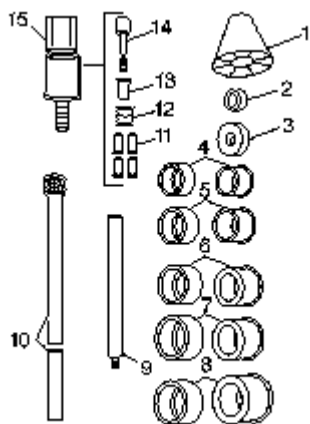

3. Select the expanding driver♦(4–8) and washer♦(2 or 3) from the *J 33049* .

4. Assemble the *J 33049* .

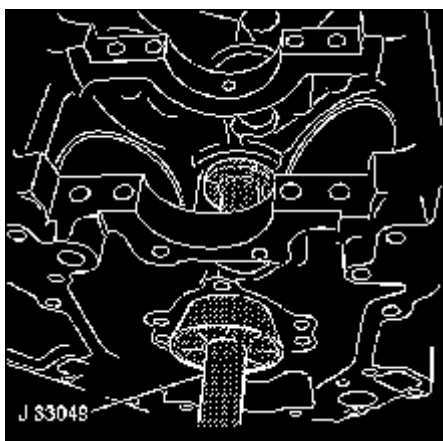

**Important:** Remove the inner bearings in positions♦2, 3, and 4 first. The outer bearings in positions♦1 and 5 serve as a guide for the *J 33049* .

5. Insert the *J 33049* through the front of the engine block and into the bearing.  
 6. Tighten the expander assembly nut until snug.  
 7. Push the guide cone into the front camshaft bearing in position♦1 to align the *J 33049* .  
 8. Drive the inner bearings in positions♦2, 3, and 4 from their block bores.

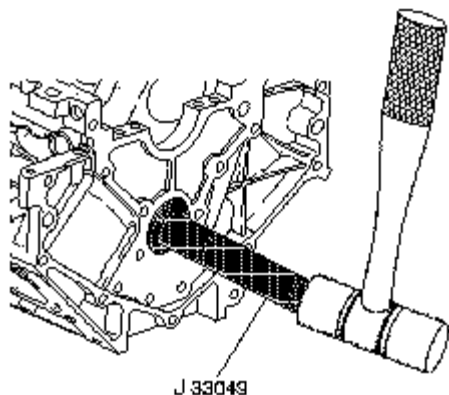

9. Assemble the *J 33049* handle, expanding driver, and washer.  
 10. Insert the *J 33049* into the outer camshaft bearings.

11. Drive the outer bearings from the bore.

## Repair Instructions

### Engine Block Cleaning and Inspection

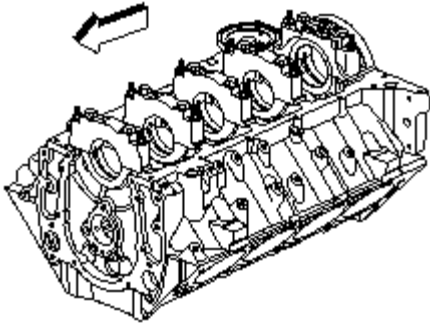

1. Boil the cylinder block in caustic solution.
2. Flush the cylinder block with clean water or steam.
3. Clean the following areas:
  - All gasket surfaces; Refer to [Replacing Engine Gaskets](#)
  - Cylinder bores, remove excessive cylinder ring ridge as required
  - Main bearing caps
  - Oil galleries, remove all sludge or restrictions
  - Scale deposits from the coolant passages
  - All dirt or debris from threaded bolt holes

**Caution:** Refer to [Safety Glasses Caution in Cautions and Notices](#).

4. Dry the block with compressed air.
5. Lubricate the cylinder bores with clean engine oil to prevent rusting.
6. Inspect the engine block for the following conditions:

- Gasket surfaces for deep gouges or other damage
- Crankshaft bearing bores for wear

The surfaces where the crankshaft bearings contact the crankshaft bearing bore must be smooth.

All crankshaft bearing bores must be round and uniform in inside diameter (ID) at all the bearing supports.

If a crankshaft bearing cap is damaged and requires replacement, refer to [Crankshaft and Bearings Cleaning and Inspection](#).

- Camshaft bearing bores for wear or damage
- Valve lifter bores for scuffing or wear
- Engine block for cracks or other damage
- Cylinder walls for scoring or gouges
- Coolant jackets for cracks
- Crankshaft bearing webs for cracks

- Engine mount bosses for damage
- The oil passages for restrictions

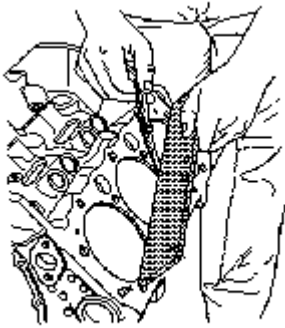

7. Inspect the engine block cylinder head deck for flatness using a straight edge and a feeler gage. The surface must be flat within 0.100♦mm (0.004♦in).

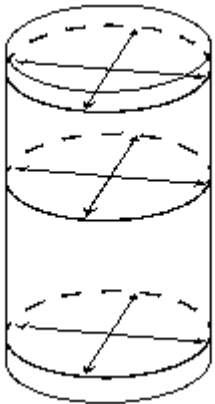

8. Use a bore gage and measure the cylinder bore for taper, out-of-round and oversize. Slide the bore gage up and down throughout the length of the cylinder bore. Check the bore both parallel and perpendicular to the centerline of the crankshaft at the top, center and bottom of the bore. A cylinder bore that measures 107.940–107.990♦mm (4.249–4.251♦in) may be serviced with a standard size piston/connecting rod assembly. A cylinder bore that exceeds the maximum diameter must be serviced with an oversized piston/connecting rod assembly.

## Repair Instructions

### Cylinder Boring and Honing

#### Boring Procedure

**Important:** The coating on the piston allows for an interference fit between the cylinder and the bore. The piston diameter can NOT be measured accurately because the piston coating is not a consistent thickness. Do NOT measure the piston diameter.

To select the correct piston for installation, the cylinder bore must be measured. If the cylinder bore diameter is within service specifications, install the original piston/connecting rod assembly or a new, standard size piston/connecting rod assembly. A used piston/connecting rod assembly may be reinstalled if, after cleaning and inspection, the piston is not damaged. If the cylinder bore is NOT within specifications, the cylinder must be resized to accept a new, oversized piston.

**Important:** If you do not check the cylinder block, the boring bar may be tilted, this may result in incorrect rebored cylinder wall to crankshaft angle.

1. Before you use any type of boring bar, clean the top of the cylinder block in order to remove any dirt or burrs.

2. Carefully follow the instructions furnished by the manufacturer regarding use of equipment.
3. When you rebore cylinders, make sure all crankshaft bearing caps are in place.
  - Tighten the bearing caps to the proper torque in order to avoid distortion of the bores in the final assembly.
  - The crankshaft must be removed prior to cylinder boring.
4. When you take the final cut with a boring bar, leave 0.03♦mm (0.001♦in) on the diameter for finish honing. This gives the required position to the cylinder clearance specifications. (Carefully perform the honing and boring operation in order to maintain the specified clearances between pistons, rings, and cylinder bores).

## Honing Procedure

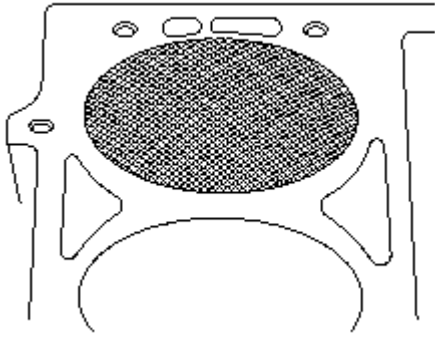

**Important:** Always remove all bearings and components from engine block before cleaning, boring or honing the engine block.

1. When honing the cylinders, follow the manufacturer's recommendations for equipment use, cleaning, and lubrication.
  - Use only clean, sharp stones of the proper grade for the amount of material you remove.
  - Dull, dirty stones cut unevenly and generate excessive heat.
  - Do not hone to a final grade with a coarse or medium-grade stone.
  - Leave sufficient metal so that all stone marks may be removed with fine grade stones.
  - The re-honed surface finish should be 0.25–0.50♦micrometer (10–20♦microinch).
  - Perform final honing with a fine-grade stone and hone the cylinder in a cross hatch pattern at 20 to 30♦degrees to obtain the proper clearance.
2. During the honing operation, thoroughly clean the cylinder bore.
  - Repeatedly check the cylinder bore for fit with the selected oversized piston.
  - All measurements of the cylinder bore should be made with the components at normal room temperature.
3. To eliminate taper in the cylinder, when honing, make full strokes of the hone in the cylinder. Repeatedly check the measurement at the top, the middle, and the bottom of the bore.
  - The finish marks should be clean but not sharp.
  - The finish marks should be free from embedded particles and torn or folded metal.
4. When finished, the reconditioned cylinder bores should have less than or meet the specified out-of-round or taper requirements.
5. After final honing and before the piston is checked for fit, clean the bores with hot water and detergent.
  - 5.1. Scrub the bores with a stiff bristle brush and rinse the bores thoroughly with hot water. Do not allow any abrasive material to remain in the cylinder bores.
 

Abrasive material may cause premature wear of new piston rings and cylinder bores.

Abrasive material will contaminate the engine oil and may cause premature wear of the bearings.

5.2. After washing the cylinder bore, dry the bore with a clean shop towel.

6. Perform final measurements of the cylinder bore.
7. Permanently mark the piston for the specific cylinder to which it has been fitted.
8. Apply clean engine oil to each cylinder bore in order to prevent rusting.

## Repair Instructions

### Crankshaft and Bearings Cleaning and Inspection

#### Tools Required

- *J 7872* Magnetic Base Dial Indicator
- *J 43690* Rod Bearing Clearance Checking Tool
- *J 43690-100* Rod Bearing Clearance Checking Tool - Adapter Kit
- *J 45059* Angle Meter

#### Crankshaft Inspection

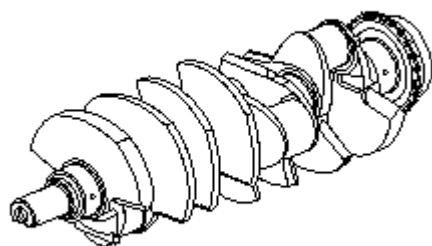

**Important:** Use care when handling the crankshaft. Avoid damage to the bearing surfaces.

1. Clean the crankshaft in solvent. Remove all sludge or restrictions from the oil passages.

**Caution:** Refer to **Safety Glasses Caution in Cautions and Notices.**

2. Dry the crankshaft and bearings with compressed air.

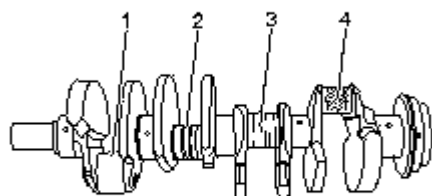

3. Inspect the crankshaft for the following conditions:

- Crankshaft journals♦(1) should be smooth with no evidence of scoring or damage

- Deep grooves♦(2)
- Scratches or uneven wear♦(3)
- Pitted surfaces♦(4)
- Wear or damage to the thrust journal surfaces
- Scoring or damage to the rear seal surface
- Restrictions to oil passages
- Damage to threaded bolt holes

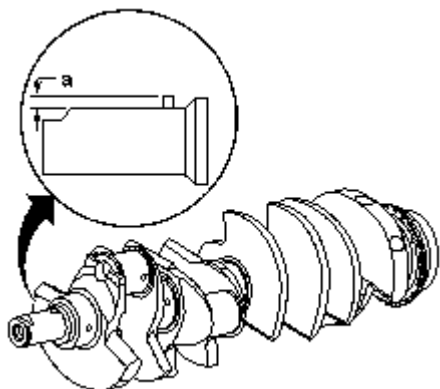

**Important:** The crankshaft pin is a pressed-in-place roll pin. The pin only needs to be removed from the crankshaft if the pin is damaged.

4. Inspect the crankshaft pin for damage:

- Measure for proper installed height♦(a). Correct height should be 2.00–2.25♦mm (0.078–0.088♦in).
- Replace the crankshaft pin if it is damaged.

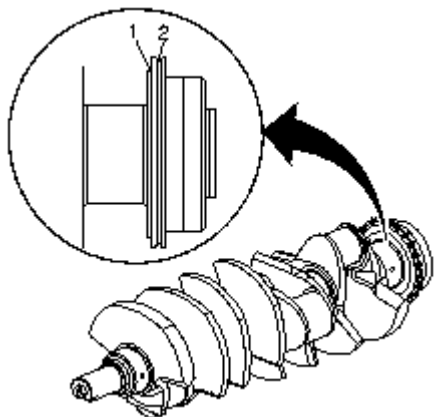

**Important:** Do NOT attempt to remove the crankshaft reluctor wheels. If the reluctor wheels are damaged and/or removed, the crankshaft must be replaced.

5. Inspect the reluctor wheels for cracked, bent or broken teeth.

- Measure between the crankshaft shoulder and the front reluctor wheel♦(1).
- Measure between the front and rear reluctor wheels♦(2).
- The maximum allowable gap is 0.15♦mm (0.006♦in).

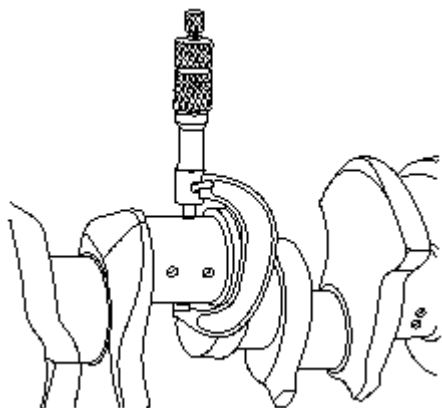

6. Measure the crankshaft main journals and the crankpins for out-of-round and taper.

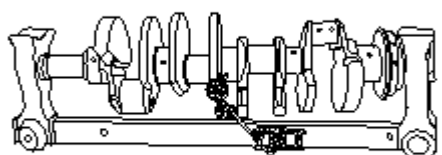

7. Using a suitable fixture, support the crankshaft.

7.1. Measure the crankshaft runout using *J 7872*.

7.2. Crankshaft runout should not exceed 0.051 mm (0.002 in).

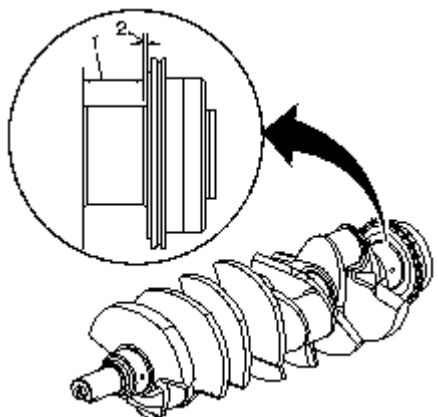

8. Inspect the crankshaft thrust wall surface for wear (1) and/or excessive runout (2). Refer to *Engine Mechanical Specifications*.

## Crankshaft and Connecting Rod Bearing Inspection

**Important:** The crankshaft and connecting rod bearings should be inspected only to determine what kind of damage or failure has occurred. Always install NEW bearings once the bearings have been removed.



1. Inspect the bearings for craters or pockets. Flattened sections on the bearing halves also indicate fatigue.



2. Inspect the bearings for excessive scoring or discoloration.
3. Inspect the bearings for dirt or debris embedded into the bearing material.

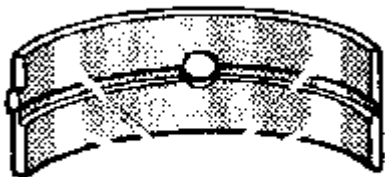

4. Inspect the bearings for improper seating indicated by bright, polished sections of the bearings.

## **Crankshaft and Connecting Rod Bearing Clearance Measurement**

The crankshaft and connecting rod bearings are of the precision insert type and do not use shims for adjustment. Crankshafts with journals that measure less than minimum specifications must be replaced.

### **Micrometer Method for Crankshaft Bearings**

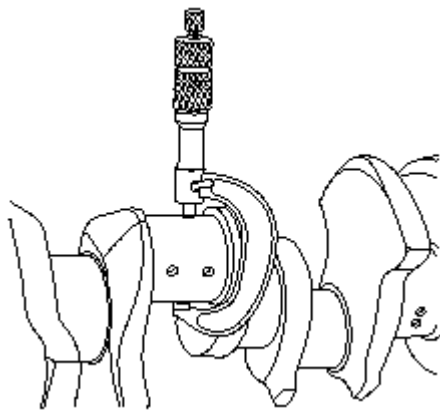

**Important:** When bearings are removed, NEW bearings must be installed during reassembly.

1. Measure the crankshaft main journal diameter with a micrometer in several places along the length approximately 90° degrees apart, minimum of 4 places, and average the measurements.
2. Determine the taper and the out-of-round. Refer to *Engine Mechanical Specifications* .

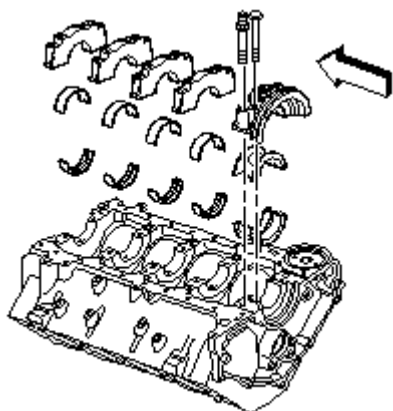

3. Install the NEW crankshaft bearings into the crankshaft bearing caps and the engine block.

**Notice:** Refer to *Fastener Notice in Cautions and Notices*.

**Important:** Tighten the inner crankshaft bearing cap bolts before tightening the outer crankshaft bearing cap studs.

4. Install the bearing cap bolts and studs.

**Tighten:**

5. Tighten the bearing cap 1–5 inner bolts a first pass to 30♦&newtonm; (22♦lb♦ft).
6. Tighten the bearing cap 1–5 outer studs a first pass to 30♦&newtonm; (22♦lb♦ft).
7. Tighten the bearing cap 1–5 inner bolts a final pass an additional 90♦degrees using the *J 45059*.
8. Tighten the bearing cap 1–5 outer studs a final pass an additional 80♦degrees using the *J 45059*.

9. Measure the crankshaft bearing inside diameter (ID) using an inside micrometer. Measure at a minimum of four places and average the measurements.
10. In order to determine the crankshaft bearing clearance, subtract the crankshaft journal diameter from the crankshaft bearing ID.
11. Compare the crankshaft bearing clearance to the specifications. Refer to *Engine Mechanical Specifications* .
12. If the crankshaft bearing clearances exceeds specifications, install undersize crankshaft bearings to achieve the correct clearance.
13. Measure the new crankshaft bearing inside diameter (ID) using an inside micrometer.
14. Replace the crankshaft if the proper clearances cannot be obtained with standard size bearings.

## Micrometer Method for Connecting Rod Bearings

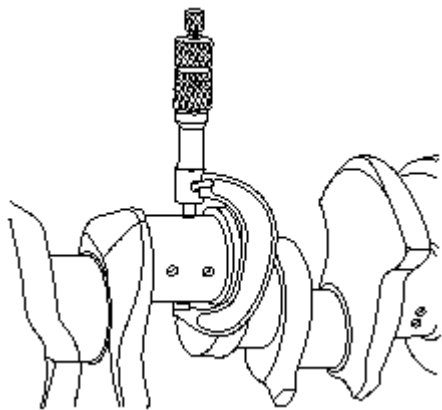

**Important:** When bearings are removed, NEW bearings must be installed during reassembly.

1. Measure the crankpin diameter with a micrometer in several places along the length, approximately 90 degrees apart, minimum of 4 places, and average the measurements.
2. Determine the taper and the out-of-round. Refer to *Engine Mechanical Specifications*.
3. Install the NEW connecting rod bearings into the connecting rod cap and the connecting rod.

**Notice:** Refer to *Fastener Notice in Cautions and Notices*.

**Important:** Use the original connecting rod nuts for clearance measurement. During final assembly new connecting rod nuts must be used to obtain correct fastener tightening.

4. Install the connecting rod cap and the original, used, nuts.

**Tighten:**

5. Tighten the connecting rod nuts a first pass to 30 newtonm; (22 lb-ft).
6. Tighten the connecting rod nuts a second pass an additional 90 degrees using the J 45059.
7. Measure the connecting rod bearing inside diameter (ID) using an inside micrometer.
8. Compare the connecting rod bearing clearance specifications. Refer to *Engine Mechanical Specifications*.
9. If the connecting rod bearing clearances exceed specifications, replace components as required.

## Plastic Gage Method for Crankshaft Bearings

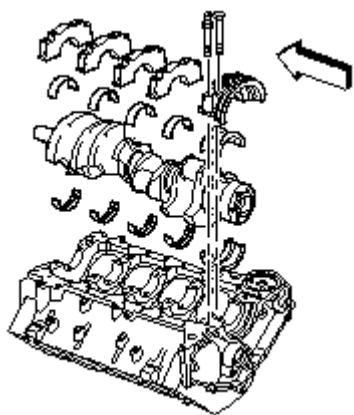

**Important:** When bearings are removed, NEW bearings must be installed during reassembly.

1. Install the crankshaft and the new crankshaft bearings into the block, making sure not to damage the reluctor rings of the crankshaft.

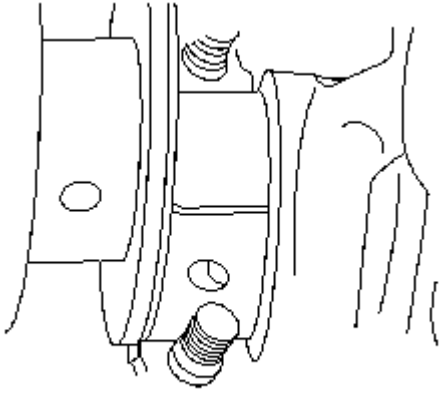

2. Install the gaging plastic the full width of the crankshaft journal.

**Notice:** Refer to *Fastener Notice in Cautions and Notices*.

**Important:** Tighten the inner crankshaft bearing cap bolts before tightening the outer crankshaft bearing cap studs. The crankshaft journal and the crankshaft bearing surface must be free from oil to obtain a correct measurement. Do not allow the crankshaft to rotate while performing the measurement, or an incorrect measurement will be obtained.

3. Install the bearing cap bolts and studs.

**Tighten:**

4. Tighten the bearing cap 1–5 inner bolts a first pass to 30♦&newtonm; (22♦lb♦ft).
5. Tighten the bearing cap 1–5 outer studs a first pass to 30♦&newtonm; (22♦lb♦ft).
6. Tighten the bearing cap 1–5 inner bolts a final pass an additional 90♦degrees using the *J 45059*.
7. Tighten the bearing cap 1–5 outer studs a final pass an additional 80♦degrees using the *J 45059*.

8. Remove the crankshaft bearing cap bolts and the crankshaft bearing caps. The gaging plastic may adhere to either the crankshaft journal or the crankshaft bearing surfaces.

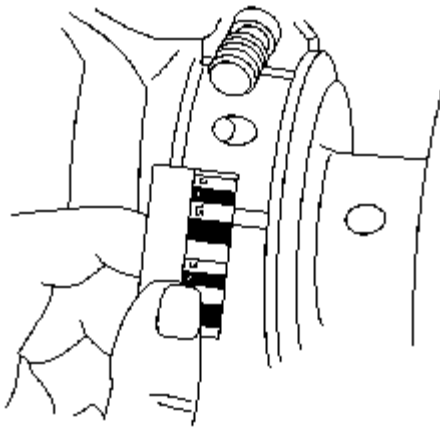

9. On the edge of the gaging plastic envelope there is a graduated scale. Without removing the gaging plastic, measure the compressed width at the widest point.

10. If the flattened gaging plastic tapers toward the middle or the ends, there may be a difference in clearance indicating taper, low spot or other irregularity of the crankshaft bearing or the crankshaft journal.

- Normally the crankshaft journals wear evenly and are not out-of-round. However, if a crankshaft bearing is being fitted to an out-of-round 0.0254♦mm (0.001♦in maximum) crankshaft journal, be sure to fit to the maximum diameter of the crankshaft journal.
- If the crankshaft bearing is fitted to the minimum diameter and the crankshaft journal is excessively out-of-round, the interference between the crankshaft bearing and the crankshaft journal will result in rapid crankshaft bearing failure.

11. Compare the crankshaft bearing clearance to the specifications. Refer to *Engine Mechanical Specifications* .
12. If the crankshaft bearing clearances exceeds specifications, replace components as required.
13. Measure the new crankshaft bearing inside diameter (ID) using the same method.
14. Replace the crankshaft if the proper clearances cannot be obtained with standard size bearings.
15. Remove the flattened gaging plastic.
16. Measure the remaining crankshaft journals.

## Plastic Gage Method for Connecting Rod Bearings

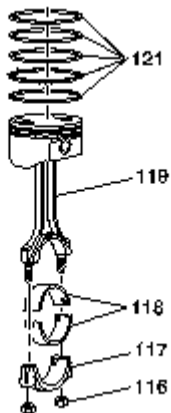

**Important:** When bearings are removed, NEW bearings must be installed during reassembly.

1. Install the connecting rod bearings (118) into the connecting rod (119) and the connecting rod cap (117).
2. Using rubber fuel line over the connecting rod bolts, install the piston and connecting rod assembly onto the crankpin journal.

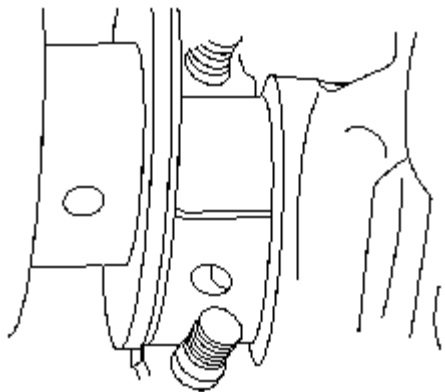

3. Install the gaging plastic the full width of the crankpin journal.

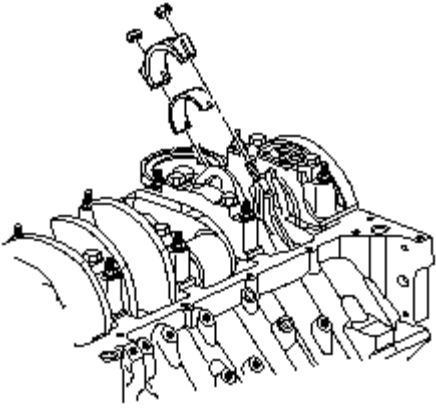

**Notice: Refer to *Fastener Notice in Cautions and Notices.***

**Important:** Use the original connecting rod nuts for clearance measurement. During final assembly, new connecting rod nuts must be used to obtain correct fastener tightening.

4. Install the connecting rod cap and the original, used, nuts.

**Tighten:**

5. Tighten the connecting rod nuts a first pass to 30♦newtonm; (22♦lb♦ft).
6. Tighten the connecting rod nuts a second pass an additional 90♦degrees using the *J 45059*.

7. Remove the connecting rod nuts and cap. The gaging plastic may adhere to either the crankpin journal or the connecting rod bearing surface.

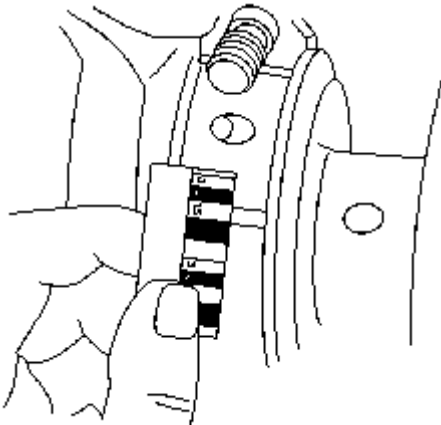

8. On the edge of the gaging plastic envelope there is a graduated scale. Without removing the gaging plastic, measure the compressed width at the widest point.

If the flattened gaging plastic tapers toward the middle or the ends, there may be a difference in clearance indicating taper, low spot or other irregularity of the crankshaft bearing or the crankpin journal.

9. Normally the crankpin journals wear evenly and are not out-of-round. However, if a connecting rod bearing is being fitted to an out-of-round 0.0254♦mm (0.001♦in maximum) crankpin journal, be sure to fit to the maximum diameter of the crankpin journal. If the connecting rod bearing is fitted to the minimum diameter and the crankpin journal is excessively out-of-round, the interference between the connecting rod bearing and the crankpin journal will result in rapid connecting rod bearing failure.

10. Compare the connecting rod bearing clearance to the specifications. Refer to *Engine Mechanical Specifications* .

11. If the connecting rod bearing clearances exceed specifications, replace components as required.

12. Remove the flattened gaging plastic.

13. Measure the remaining crankpin journals.

## Measuring Crankshaft End Play

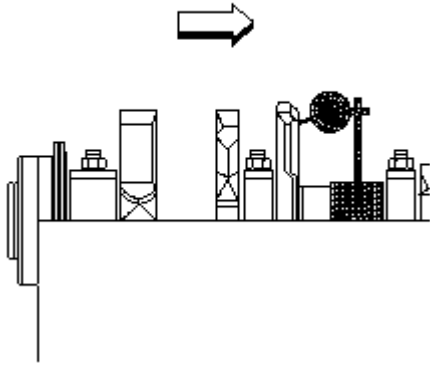

**Important:** In order to properly measure the crankshaft end play, the crankshaft, bearings, bearing caps and fasteners must be installed into the engine block and the bolts tightened to specifications. Refer to [Crankshaft and Bearings Installation](#).

1. Install the [J 7872](#) or equivalent to the cylinder block, with the dial indicator plunger against one of the counterweights of the crankshaft.
2. Firmly thrust the end of the crankshaft first rearward then forward. This will line up the rear crankshaft bearing and the crankshaft thrust surfaces.
3. With the crankshaft pushed forward, zero the dial indicator. Move the crankshaft rearward and read the endplay measurement on the dial indicator. An optional method is to insert a feeler gage between the crankshaft and the bearing surface and measure the clearance. Refer to [Engine Mechanical Specifications](#).
4. If the correct end play cannot be obtained, inspect the crankshaft thrust wall surface or surfaces for wear and/or excessive runout.
5. Inspect the crankshaft for binding. Turn the crankshaft to check for binding. If the crankshaft does not turn freely, loosen the crankshaft bearing bolts and studs, one cap at a time, until the tight bearing is located. The following condition or conditions could cause a lack of clearance at the bearing:
  - Burrs on the crankshaft bearing cap
  - Foreign matter between the crankshaft bearing and the block or the crankshaft bearing cap
  - A faulty crankshaft bearing

## Measuring Connecting Rod Side Clearance

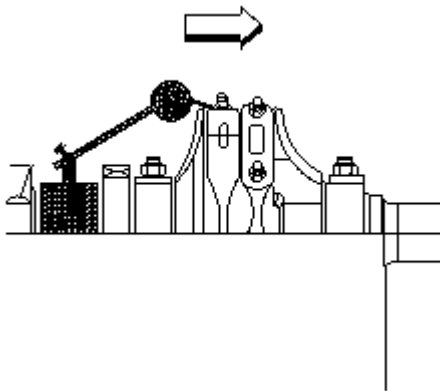

**Important:** In order to properly measure the connecting rod side clearance, the piston/connecting rod assembly and bearings must be installed into the engine block and the connecting rod nuts tightened to specifications. Refer to [Piston, Connecting Rod, and Bearing Installation](#).

1. Install the [J 7872](#) or equivalent to the cylinder block, with the dial indicator plunger against the side of the pair of connecting rods.
2. With the connecting rods pushed forward, zero the dial indicator. Firmly move the pair of connecting rods side to side and read

the measurement on the dial indicator. An optional method is to insert a feeler gage between the connecting rod caps and measure the connecting rod side clearance. Refer to *Engine Mechanical Specifications* .

## Measuring Connecting Rod Bearing Clearance – Using J♦43690/J♦43690-100

Tools *J 43690* and adapter kit *J 43690-100* have been developed as a more accurate method to measure connecting rod bearing clearances. The instructions below provide an overview of tool set-up and usage. For more detailed information, refer to the tool instruction sheets as supplied by the tool manufacturer.

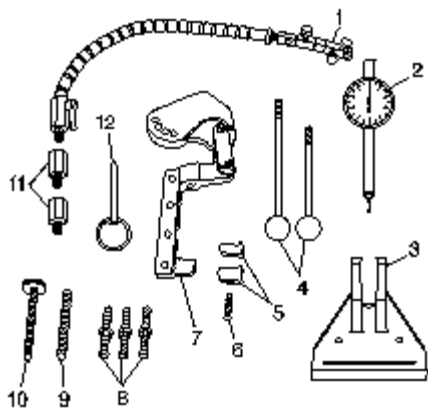

### J 43690 Rod Bearing Clearance Checking Tool

- J♦43690-20 Swivel Base♦(1)
- J♦43690-19 Dial Indicator♦(2)
- J♦43690-2 Base♦(3)
- J♦43690-5, -6 Handle♦(4)
- J♦43690-10, -11 Foot♦(5)
- 280307 Screw♦(6)
- J♦43690-1 Pivot Arm Assembly♦(7)
- J♦43690-3, -7, -8 Screws♦(8)
- 280319 Screw♦(9)
- 280311 Screw♦(10)
- J♦43690-17, -18 Adapter♦(11)
- 280310 Pin♦(12)

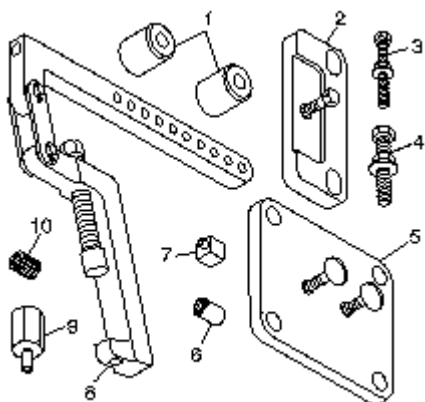

## J 43690-100 Rod Bearing Clearance Checking Tool – Adapter Kit

- J♦43690-104 Spacer♦(1)
- J♦43690-105 Retainer Plate♦(2)
- 505478 Bolt♦(3)
- 511341 Bolt♦(4)
- J♦43690-106 Retainer Plate♦(5)
- J♦43690-107 Cap♦(6)
- J♦43690-102 Foot♦(7)
- J♦43690-101 Pivot Arm Assembly♦(8)
- J♦43690-103 Adapter♦(9)
- 505439 Adapter♦(10)

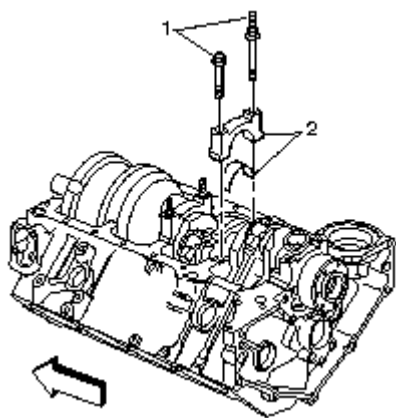

**Important:** The crankshaft must be secure with no movement or rotation in order to obtain an accurate reading.

1. Rotate the crankshaft until the journal/connecting rod to be measured is in the 12♦o'clock position.
2. Remove a bearing cap bolts♦(1).
3. Remove the bearing half and bearing cap♦(2).
4. Insert a piece of paper card stock onto the crankshaft journal.
5. Install the bearing half and cap♦(2) and bolts♦(1). Refer to *Fastener Tightening Specifications* .

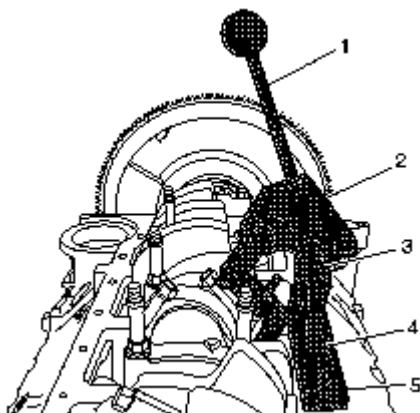

6. Install the following:
  - 6.1. J♦43690-2♦(5)
  - 6.2. J♦43690-8♦(4)

6.3. J♦43690-1♦(2)

6.4. 280310♦(3)

6.5. J♦43690-5♦(1)

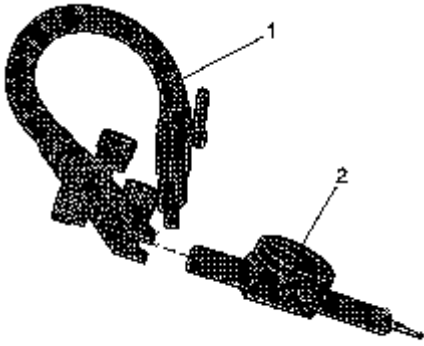

7. Install the swivel base♦(1) and dial indicator♦(2).

8. Adjust per the manufacturers instructions and measure the connecting rod bearing clearance.

A connecting rod with a clearance in excess of 0.081♦mm (0.0032♦in) is considered excessive. Service components as required.

## Repair Instructions

### Crankshaft Balancer Cleaning and Inspection

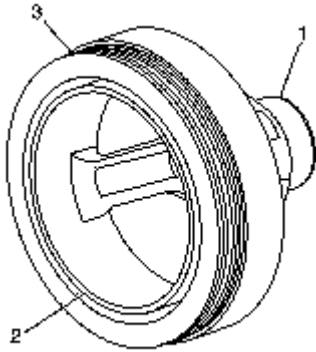

1. Clean the crankshaft balancer in solvent.

**Caution: Refer to Safety Glasses Caution in Cautions and Notices.**

2. Dry the crankshaft balancer with compressed air.

3. Inspect the crankshaft balancer for the following:

- Damaged belt grooves♦(3)
- Debris in the belt grooves♦(3)
- Worn, grooved, or damaged hub seal surface♦(1)

Minor imperfections on the hub seal surface may be removed with a polishing compound or fine grade of emery cloth.

A crankshaft balancer hub seal surface with excessive scoring, grooves, rust or other damage must be replaced.

- Worn, chunking or deteriorated rubber between the hub and pulley♦(2)

4. Repair or replace the crankshaft balancer as necessary.

## Repair Instructions

### Engine Flywheel Cleaning and Inspection (AT)

1. Clean the engine flywheel in solvent.

**Caution:** Refer to *Safety Glasses Caution* in *Cautions and Notices*.

2. Dry the engine flywheel with compressed air.

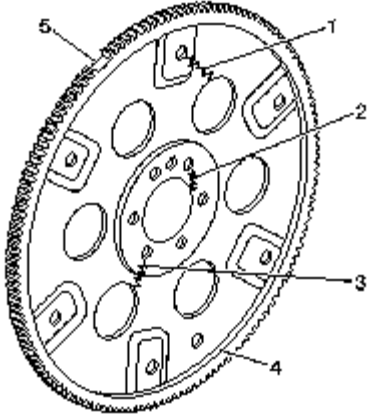

3. Inspect the engine flywheel for the following conditions:

- Stress cracks around the engine flywheel-to-torque converter mounting bolt hole locations♦(1) and/or engine flywheel-to-crankshaft♦(2, 3)

**Important:** Do not attempt to repair the welded areas that retain the ring gear to the engine flywheel plate. Install a new engine flywheel.

- Cracks at welded areas that retain the ring gear onto the engine flywheel♦(4)
- Damaged or missing ring gear teeth♦(5)

## Repair Instructions

### Engine Flywheel Cleaning and Inspection (MT)

1. Clean the engine flywheel in solvent.

**Caution:** Refer to *Safety Glasses Caution* in *Cautions and Notices*.

2. Dry the engine flywheel with compressed air.

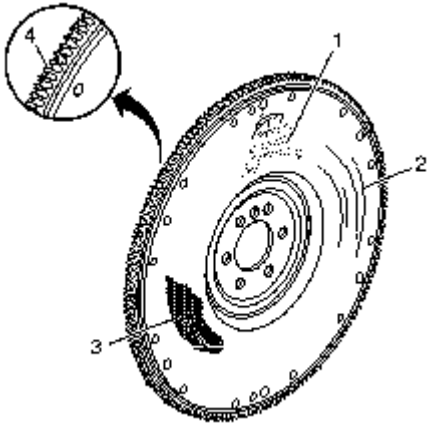

3. Inspect the manual transmission engine flywheel for the following conditions:

- Pitted surface♦(1)
- Scoring or grooves♦(2)
- Rust or other surface damage♦(3)
- Damaged ring gear teeth♦(4)
- Loose or improperly positioned ring gear

The ring gear has an interference fit onto the engine flywheel and should be positioned completely against the flange of the engine flywheel.

## Repair Instructions

### Piston and Connecting Rod Disassemble

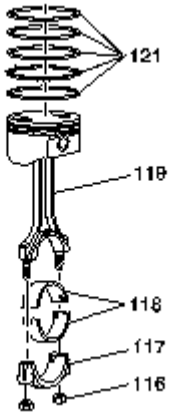

**Important:** The piston and connecting rod are only serviced as an assembly. If a new piston or connecting rod is required, a complete piston/connecting rod assembly must be used.

**Important:** New connecting rod nuts must be used when the pistons are reinstalled in the engine.

Remove the piston rings♦(121) from the piston.

## Repair Instructions

### Piston, Connecting Rod, and Bearings Cleaning and Inspection

**Important:** The piston diameter can NOT be measured due to the piston coating. Do NOT measure the piston diameter.

**Important:** Measurement of all components should be taken with the components at room temperature.

Do not use a wire brush in order to clean any part of the piston.

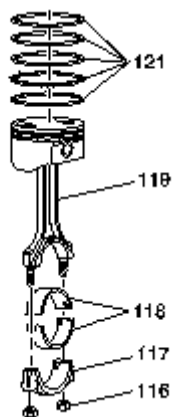

1. Clean the piston and connecting rod (119) and connecting rod cap (117) in solvent.

**Caution:** Refer to **Safety Glasses Caution in Cautions and Notices.**

2. Dry the components with compressed air.

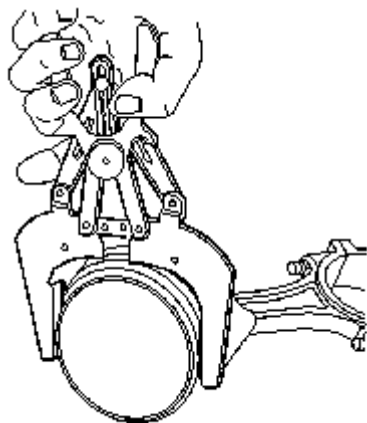

3. Clean the piston ring grooves with a suitable ring groove cleaning tool.
4. Clean the piston oil lubrication holes and slots.

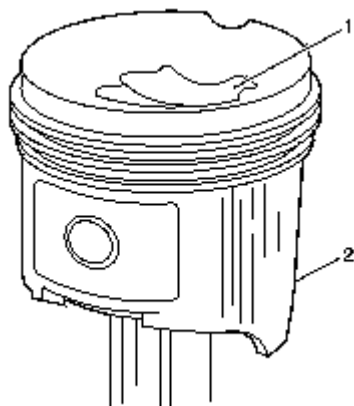

5. Inspect the piston for the following conditions:
  - Eroded areas (1) on the top of the piston

- Scuffed or damaged skirt♦(2)
- Cracks in the piston ring lands, the piston skirt, or the pin bosses
- Piston ring grooves for nicks, burrs, or other warpage which may cause the piston ring to bind

6. Inspect the piston pin for scoring, wear or other damage.

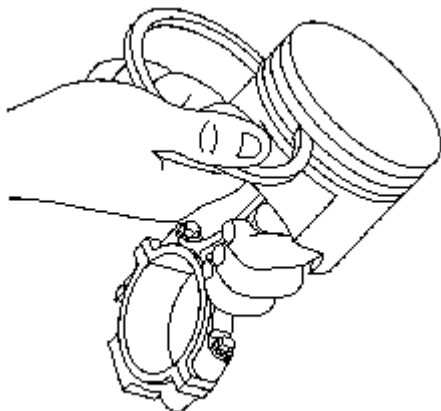

7. Measure the piston ring-to-piston ring groove side clearance. Refer to [Engine Mechanical Specifications](#) .

7.1. Insert the edge of the piston ring into the piston ring groove.

Roll the piston ring completely around the piston.

7.2. If binding is caused by a distorted piston ring groove, MINOR imperfections may be removed with a fine file.

7.3. If binding is caused by a distorted piston ring, replace the piston ring.

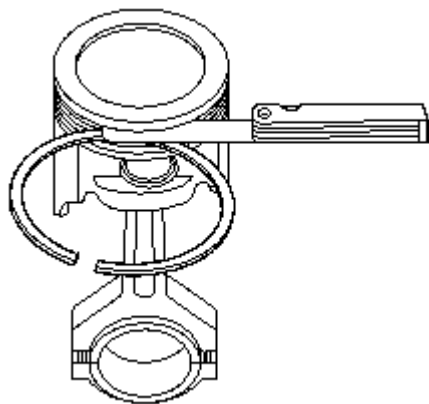

8. Measure the piston ring side clearance with a feeler gage.

9. If the side clearance is too small, try another piston ring set. Refer to [Engine Mechanical Specifications](#) .

10. If the proper piston ring-to-piston ring groove clearance cannot be achieved, replace the piston and pin assembly.

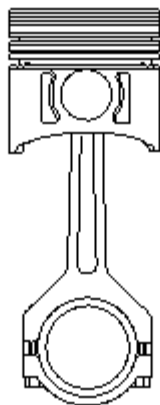

11. Inspect the connecting rod for an out-of-round bearing bore.

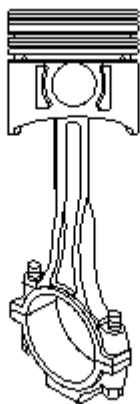

12. Inspect the connecting rod for twisting.

13. Inspect the connecting rod for damage to the connecting rod bolt threads.

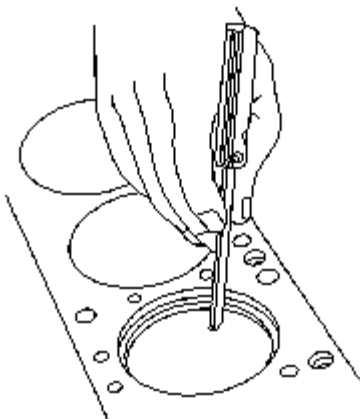

**Important:** Fit each compression ring to the cylinder in which it will be used.

14. Measure the piston compression ring end gap.

14.1. Place the compression ring into the cylinder bore.

14.2. Push the compression ring into the cylinder bore to approximately 6.5♦mm (0.25♦in) above the ring travel.

The ring must be square to the cylinder wall.

14.3. Use a feeler gage in order to measure the end gap.

14.4. Select another size ring set if the end gap exceeds specifications.

## Repair Instructions

### Piston and Connecting Rod Assemble



**Notice:** Use a piston ring expander to install the piston rings. The rings may be damaged if expanded more than necessary.

1. Install the lower oil control piston ring spacer onto the piston.

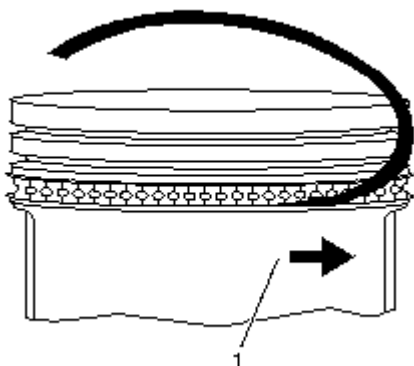

2. Install the lower oil control piston ring onto the piston♦(1).

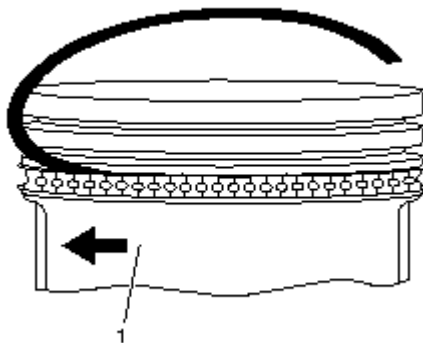

3. Install the upper oil control piston ring onto the piston♦(1).

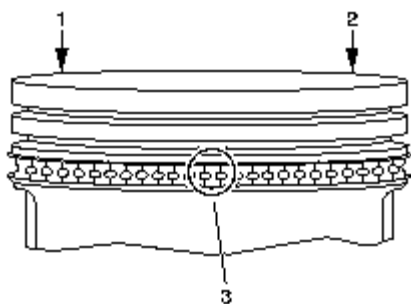

4. Space the oil control piston ring end gaps a minimum of 90° apart (1, 2, 3).

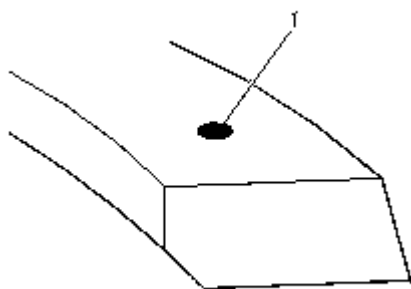

5. Install the lower compression piston ring onto the piston (1). The mark on the side of the piston ring should face the top of the piston.

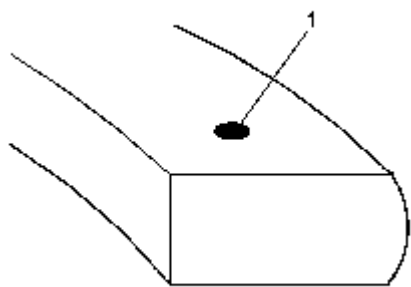

6. Install the upper compression piston ring onto the piston. The mark (1) on the side of the piston ring should face the top of the piston.

7. Space the compression piston ring end gaps 120° apart.

## Repair Instructions

### Camshaft and Bearings Cleaning and Inspection

#### Tools Required

J 7872 Magnetic Base Dial Indicator

1. Clean the camshaft in solvent.

**Caution: Refer to *Safety Glasses Caution in Cautions and Notices.***

2. Dry the camshaft with compressed air.

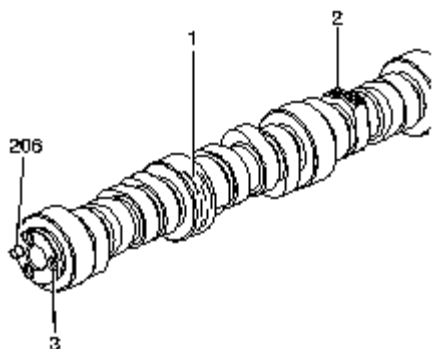

3. Inspect the camshaft retainer plate for damage.

4. Inspect the camshaft for the following conditions:

- Camshaft bearing journals♦(1) that are:

Worn

Scored

Damaged

- Worn camshaft lobes♦(2)
- Damaged sprocket bolt threads♦(3)
- Damaged sprocket pin♦(206)

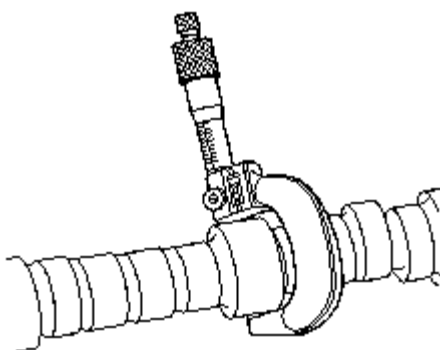

5. Measure the camshaft journals with a micrometer. Refer to *Engine Mechanical Specifications* .

6. Measure for excessive camshaft runout using *J 7872*.

6.1. Mount the camshaft in a suitable fixture.

6.2. Use the *J 7872* in order to measure for a bent camshaft. Refer to *Engine Mechanical Specifications* .

7. Replace the camshaft if runout exceeds specifications.

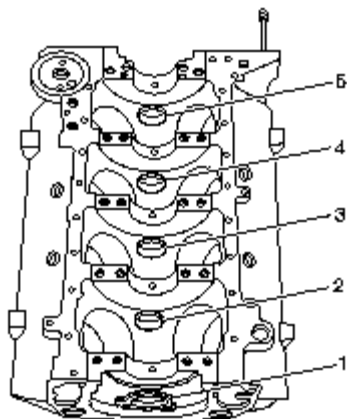

8. Inspect the camshaft bearings, 1–5, for serviceability.

9. Replace the camshaft bearings if necessary. Refer to [Camshaft Bearing Removal](#) and [Camshaft Bearing Installation](#).

## Repair Instructions

### Camshaft Bearing Installation

#### Tools Required

[J 33049](#) Camshaft Bearing Service Set

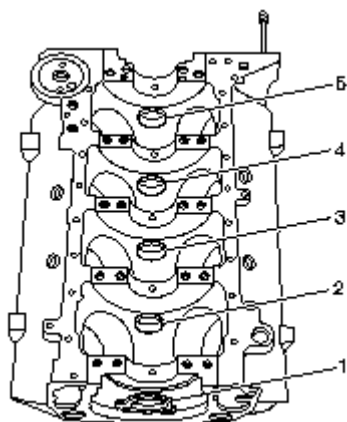

**Important:** The outer camshaft bearings (positions 1 and 5) must be installed first. These bearings serve as guides for the tool and help center the inner bearings during the installation process.

Ensure the correct camshaft bearing fits into the proper bore. The camshaft bearing bores may vary in size.

Ensure that the camshaft bearing lubrication hole or holes align with the oil gallery hole or holes in the block. On some engines, the oil holes may be difficult to see. Verify that the holes are aligned.

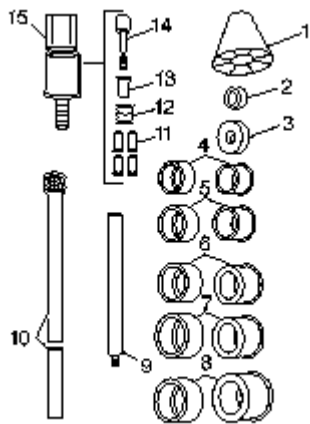

1. Assemble the tool handle♦(10), expanding driver♦(4–8), and washer♦(2 or 3).

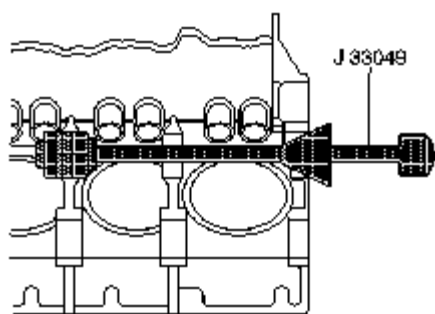

2. Insert the *J 33049* tool into the engine block end camshaft bearings.

**Notice:** Do not shim, scrape, or file bearing inserts. Do not touch the bearing surface of the insert with bare fingers. Skin oil and acids will etch the bearing surface.

**Important:** An improperly aligned camshaft bearing oil gallery hole will restrict oil flow to the bearing and the camshaft journal.

3. Drive the end bearings into the bore.

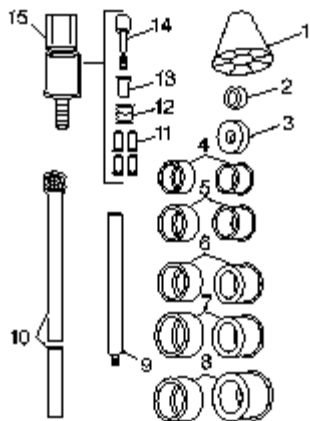

4. Select the expanding driver♦(4–8) and washer♦(2 or 3) from the *J 33049*.
5. Assemble the tool.

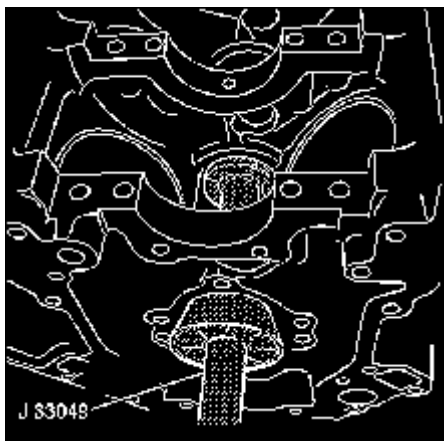

6. Insert the *J 33049* tool through the front of the engine block and to the inner bearing bores.
7. Install the bearing onto the expanding driver.
8. Tighten the expander assembly nut until the tool is snug in the bearing.

**Important:** The camshaft bearing oil holes must align with the oil galleries in the engine block.

After installation of the camshaft bearings, inspect the camshaft bearing oil holes for proper alignment with the oil galleries.

An improperly aligned camshaft bearing oil gallery hole will restrict oil flow to the bearing and the camshaft journal.

9. Align the oil lubrication hole in the bearing with the oil galleries in the engine block.
10. Push the guide cone into the front camshaft bearing bore to align the tool.
11. Drive the bearing into the bore.

## Repair Instructions

### Timing Chain and Sprockets Cleaning and Inspection

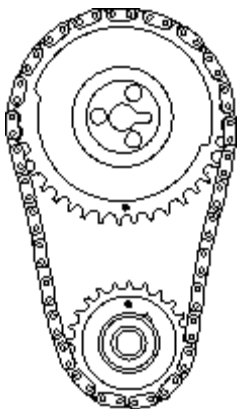

1. Clean the camshaft timing components in solvent.

**Caution:** Refer to *Safety Glasses Caution in Cautions and Notices*.

2. Dry the components with compressed air.
3. Inspect the camshaft timing chain for binding or wear.

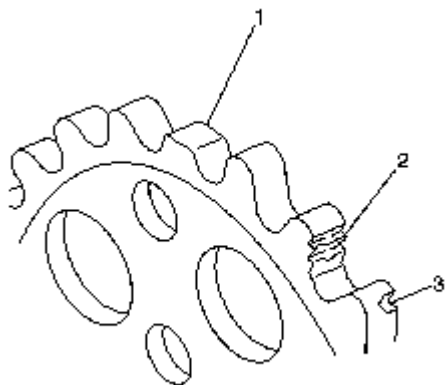

**Important:** If the sprocket or sprockets must be replaced, replace both sprockets to ensure that timing chain centerline alignment is maintained.

4. Inspect the camshaft and crankshaft sprockets for the following conditions:

- Worn teeth♦(1)
- Damaged teeth♦(2)
- Chipped teeth♦(3)
- Uneven wear on one edge of the teeth
- Worn valleys between the sprocket teeth
- Crankshaft sprocket keyway for wear

## Repair Instructions

### Valve Rocker Arm and Push Rods Cleaning and Inspection

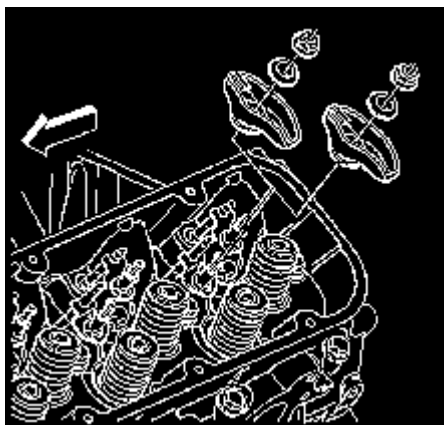

**Important:** Parts that are to be reused must remain sorted or organized in order to return them to their original location.

1. Clean the components with cleaning solvent.

**Caution:** Refer to **Safety Glasses Caution in Cautions and Notices.**

2. Dry the components with compressed air.

3. Inspect the valve rocker arms for wear or scoring in the ball area.

4. Inspect the valve rocker arm push rod sockets and valve stem tip mating surfaces.

5. Inspect the valve rocker arm ball for wear or scoring.

These surfaces should be smooth with no scoring or exceptional wear.

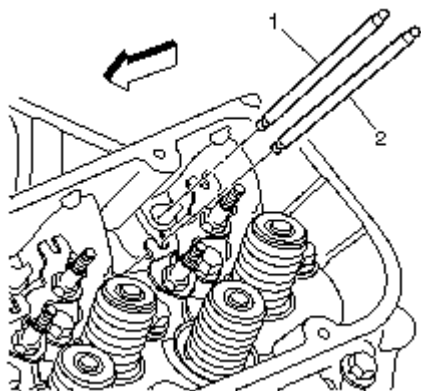

6. Inspect the push rods♦(1, 2) for worn or scored ends.

These surfaces should be smooth with no scoring or exceptional wear.

7. Inspect the push rods for bends. Roll the push rods on a flat surface to determine if the push rod is bent. If it rolls smoothly, it is OK. If the push rod does not roll smoothly, replace the push rod.

8. Inspect the push rod oil passages for restrictions.

- Clean out the push rod tube with compressed air.
- Inspect by looking through the push rod tube for obstructions. A clear push rod will allow light through.
- Replace push rod(s) that cannot be cleaned out.

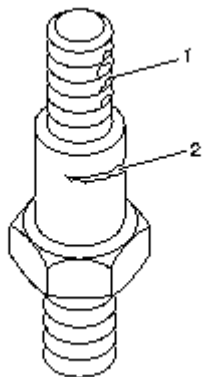

**Important:** A light contact mark on the rocker arm stud is normal. A noticeable groove in the rocker arm stud is excessive wear and the rocker arm stud should be replaced.

9. Inspect the rocker arm studs for the following conditions:

- Damaged threads♦(1)
- Excessive wear or damage made from contact between the rocker arm and rocker arm stud♦(2)

10. Valve rocker arm studs with excessive wear and/or damage must be replaced.

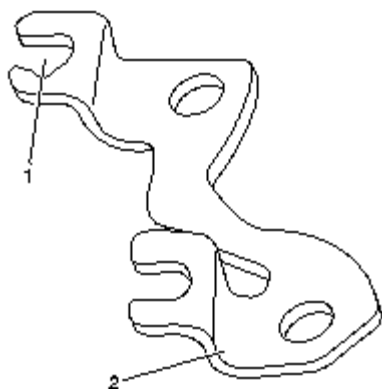

11. Inspect the push rod guides for the following conditions:

- Wear between the push rod and the push rod guide♦(1)
- Bent push rod guide♦(2)
- Cracks

12. Push rod guides with excessive wear and/or damage must be replaced.

## Repair Instructions

### Valve Lifters and Guides Cleaning and Inspection

**Caution:** Refer to *Safety Glasses Caution in Cautions and Notices*.

**Important:** Parts that are to be reused must remain sorted or organized in order to return them to their original location.

1. Dry the components with compressed air.

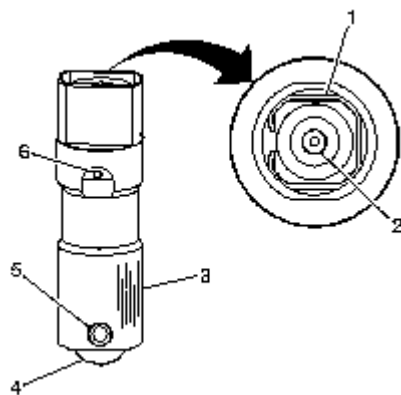

2. Inspect the valve lifters for the following:

- A damaged, mispositioned or broken clip♦(1)
- A scored or worn pushrod socket♦(2)
- A severely scuffed or worn lifter body♦(3)

If the valve lifter body shows scuffing or wear, inspect the engine block valve lifter bores for wear or damage.

- Flat spots on the roller♦(4)
- A loose pin♦(5)
- A plugged oil hole♦(6)

3. If flat spots are found on the lifter(s), inspect the corresponding lobe on the camshaft for damage.

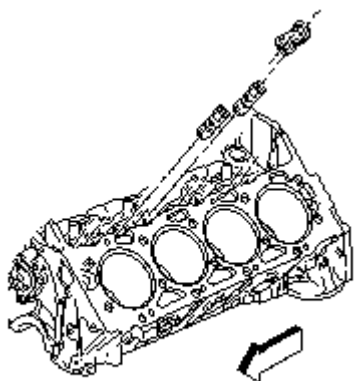

4. Inspect the valve lifter guides for the following:

- Excessive guide slot side wear
- Cracks or damage

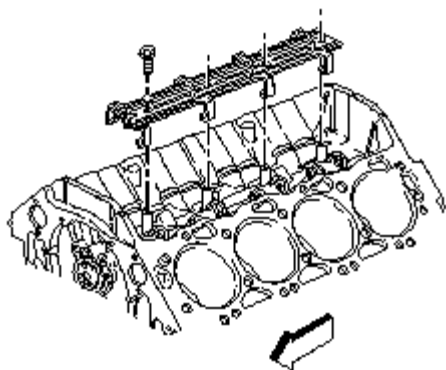

5. Inspect the valve lifter guide retainer for the following:

- Wear, damage, or stress cracking in the leg areas
- Wear or damage around the retainer bolt holes

## Repair Instructions

### Cylinder Head Disassemble

#### Tools Required

*J 8062* Valve Spring Compressor - Head Off

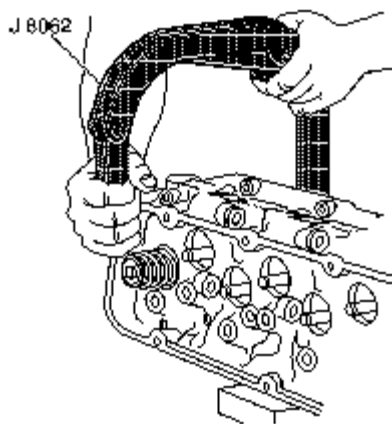

**Caution:** Refer to *Safety Glasses Caution* in *Cautions and Notices*.

**Caution:** Compressed valve springs have high tension against the valve spring compressor. Valve springs that are not properly compressed by or released from the valve spring compressor can be ejected from the valve spring compressor with intense force. Use care when compressing or releasing the valve spring with the valve spring compressor and when removing or installing the valve stem keys. Failing to use care may cause personal injury.

**Important:** Mark, sort, or organize components for return to their original locations.

1. Use *J 8062* in order to compress the valve springs.

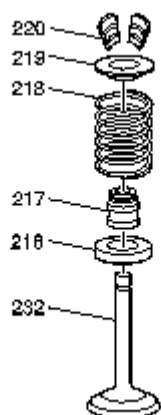

2. Remove the valve stem keys♦(220).
3. Release and remove *J 8062*.
4. Remove the cap♦(219).
5. Remove the valve spring♦(218).
6. Remove the valve stem seal♦(217) from the valve guide.
7. Remove the valve rotator♦(216).

**Important:** In order to prevent damage to the valve guide, small burrs on the valve tip and at the stem key groove that interfere with the valve removal can be lightly filed with a fine file or stone to facilitate valve removal.

8. Remove the valve♦(232).

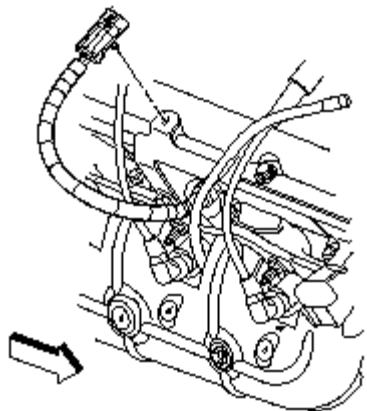

9. Disconnect the engine coolant temperature (ECT) sensor from the bracket.
10. Remove the ECT sensor from the cylinder head.
11. Remove the ECT sensor bracket and bolt.

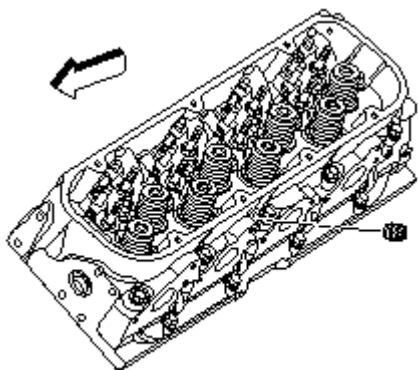

12. Remove the cylinder head coolant hole plug from the cylinder head.

## Repair Instructions

### Cylinder Head Cleaning and Inspection

#### Tools Required

- *J 8089* Carbon Removal Brush
- *J 9666* Valve Spring Tester
- *J 8001* Dial Indicator Set

#### Cleaning Procedure

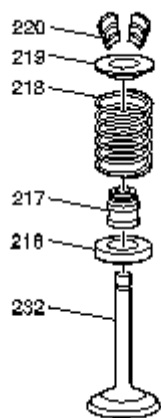

**Caution:** Refer to *Safety Glasses Caution in Cautions and Notices*.

**Important:** Mark, sort, or organize components for return to their original locations.

1. Clean the valve stems and heads on a buffing wheel.
2. Clean the following components in solvent:

- Valve stem keys♦(220)
- Valve spring cap♦(219)
- Valve spring♦(218)
- Valve Rotators♦(216)
- Valve♦(232)
- Cylinder head

**Caution:** Refer to *Safety Glasses Caution in Cautions and Notices*.

3. Dry the components with compressed air.

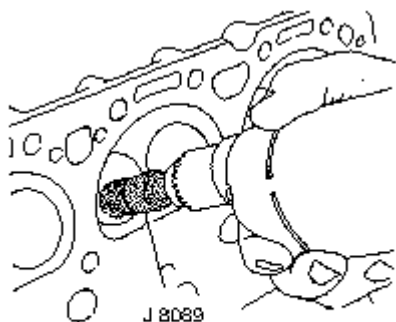

**Important:** Be careful not to damage the chamber or the valve seat.

4. Use the *J 8089* in order to clean the carbon from the combustion chambers.

## Visual Inspection Procedure

Inspect the cylinder head for the following conditions:

- Damaged gasket surfaces
- Damage to threaded bolt holes

- Burnt or eroded areas in the combustion chamber
- Cracks in the exhaust ports and combustion chambers
- External cracks in the water chamber
- Restrictions in the intake or exhaust passages
- Restrictions in the cooling system passages

## Flatness Measurement Procedure

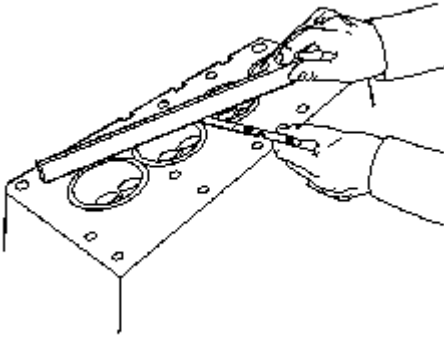

1. Measure the cylinder head for warpage with a straight edge and feeler gage.

- A cylinder head block deck with warpage in excess of 0.050 mm (0.002 in) within a 150.0 mm (6.0 in) area must be repaired or replaced.
- A cylinder head exhaust manifold deck with an overall warpage in excess of 0.102 mm (0.004 in) must be repaired or replaced.
- A cylinder head intake manifold deck with warpage in excess of 0.080 mm (0.003 in) must be repaired or replaced.

2. A cylinder head block deck can be resurfaced up to 0.305 mm (0.012 in) maximum removal.

**Important:** Excessive cylinder head resurfacing will affect compression ratio and emission control.

3. A cylinder head that requires excessive resurfacing must be replaced.

## Valve Inspection Procedure

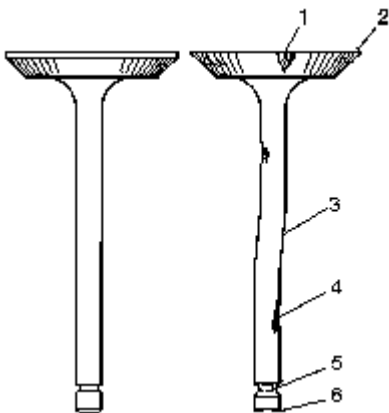

1. Inspect the valves for the following conditions:

- Burnt or damaged areas (1)

- Undersized valve margin♦(2)
- Bent stem♦(3)
- Scoring or other damage to the stem♦(4)
- Worn key groove♦(5)
- Worn stem tip♦(6)

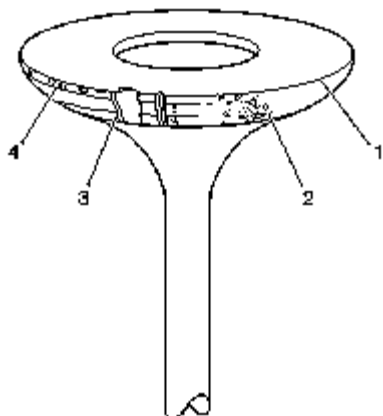

2. Inspect the valve contact surface for the following conditions:

- Undersized margin♦(1)
- Pitted surface♦(2)
- Burnt or eroded areas♦(3)
- Acceptable edge, margin♦(4)

**Important:** Minor imperfections of the valve may be corrected during reconditioning.

3. Valves with excessive damage must be replaced.

## Valve Spring Inspection and Measurement

1. Inspect the valve springs for broken coils or coil ends.

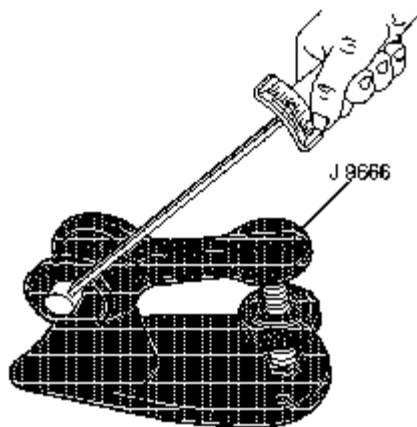

2. Use the *J 9666* in order to measure the valve spring force. Refer to *Engine Mechanical Specifications* .

**Important:** Add a maximum of one shim up to 0.726♦mm (0.030♦in) thick to increase tension.

3. If the valve spring tension is low, use a shim to increase tension.

4. Recheck the valve spring tension, a valve spring that does not meet specification must be replaced.

## Valve Guide Measurement Procedure

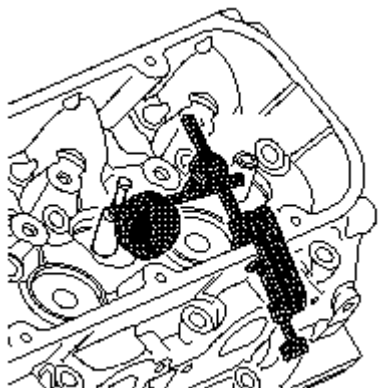

**Important:** Excessive valve stem-to-guide clearance may cause an excessive oil consumption and may also cause a valve to break. Insufficient clearance will result in noisy and sticky functioning of the valve and will disturb the engine assembly smoothness.

1. Measure the valve stem-to-guide clearance.

1.1. Clamp the *J 8001* on the exhaust port side of the cylinder head.

**Important:** The indicator stem must contact the side of the valve stem just above the valve guide.

1.2. Locate the indicator so that the movement of the valve stem from side to side, crosswise to the cylinder head, will cause a direct movement of the indicator stem.

1.3. Drop the valve head about 1.6 mm (0.064 in) off the valve seat.

1.4. Use light pressure when moving the valve stem from side to side in order to obtain a clearance reading. Refer to *Engine Mechanical Specifications*.

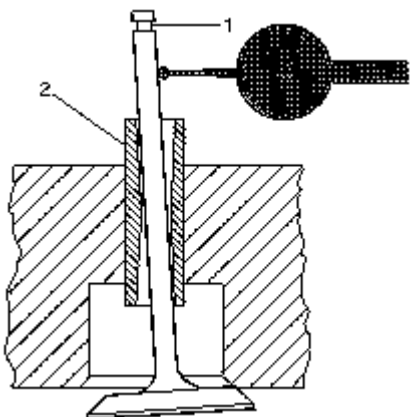

2. Valve guide (2) with excessive clearance must be repaired. Refer to *Valve Guide Reaming/Valve and Seat Grinding*.

3. Replace the cylinder head if the valve guide cannot be repaired or reamed to accept an oversize valve stem.

## Repair Instructions

### Valve Guide Reaming/Valve and Seat Grinding

#### Valve Guide Reaming Procedure for Oversized Valve Stems

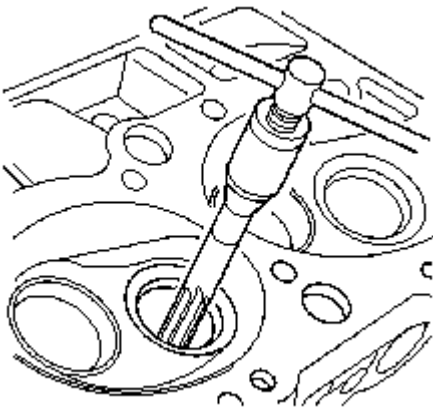

**Notice:** The exhaust valve guides are replaceable components and must be serviced properly. The exhaust valve guide must be pressed out and into the cylinder head in the proper directions. The old exhaust valve guide must be removed by pressing out towards the combustion chamber side of the cylinder head. The new exhaust valve guide must be installed by pressing from the combustion chamber side of the cylinder head. Failure to press the exhaust valve guide out and into the cylinder head in the proper directions will damage the cylinder head.

1. Ream the valve guide as necessary to achieve proper valve stem-to-guide clearance with the new, oversized valve stems.
2. Always recondition the valve seat after reaming the valve guide bores or installing new valves.
3. Replace the cylinder head if the valve guide cannot be repaired or reamed to accept an oversize valve stem.

## Valve Reconditioning Procedure

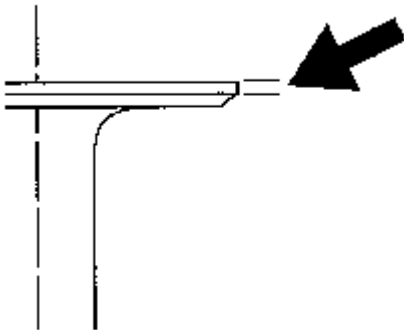

1. Replace the valve if the valve stem shows excessive wear or is warped.

**Important:** Several different types of equipment are available for reconditioning valves. Use the manufacturers recommendations of equipment to attain the proper results.

2. Reface pitted valves on a valve refacing machine in order to insure the correct relationship between the head and the stem.
3. Replace the valve if the edge of the head is less than 0.79mm (0.031in) thick after grinding.

## Valve Seat Reconditioning Procedure

**Important:** Several different types of equipment are available for reconditioning valve seats. Use the manufacturers recommendations of equipment to attain the proper results.

**Important:** Always recondition the valve seat after reaming the valve guide bores or installing new valves.

1. Recondition the valve seats.
2. The valves must seat perfectly for the engine to deliver optimum power and performance.
3. Ensure that the valve seat and valve are not shrouded after valve seat reconditioning. Adequate flow past the valve seat and

valve is essential for cooling the valve head and valve seat area.

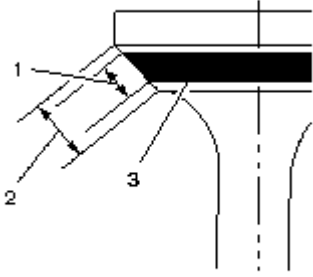

4. Correct contact (1) between each valve and its seat in the cylinder head is also essential to ensure that the heat in the valve head is properly carried away.

**Important:** Regardless of what type of equipment is used, it is essential that the valve guide bores are free from carbon or dirt to ensure the proper centering of the pilot in the guide.

5. The valve seats should be concentric to within 0.050 mm (0.002 in) total indicator runout.

## Repair Instructions

### Cylinder Head Assemble

#### Tools Required

- J 8062 Valve Spring Compressor
- J 43105 Valve Stem Seal Installer

#### Checking Valve Spring Installed Height

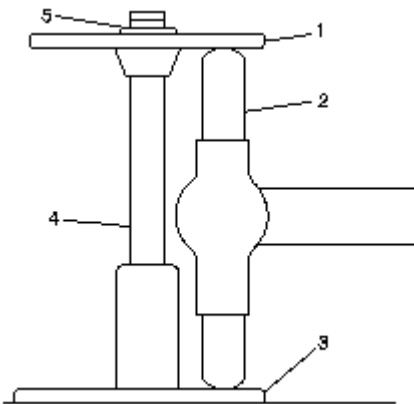

1. Install the valve rotator (3), the valve (4), the valve spring cap (1) and the valve stem keys (5) into the cylinder head.

2. Using a snap gage or inside micrometer, measure the distance from the top of the valve rotator to the bottom of the valve spring cap. Refer to *Engine Mechanical Specifications* for proper valve spring installed height specifications.

#### Important:

- Never shim the spring to obtain an installed height under the specified amount.
- Install the valve spring seat shims under the rotator, between the rotator and the cylinder head spring seat.
- Add a maximum of one valve spring seat shim, up to 0.726 mm (0.030 in) thick to achieve the valve spring

installed height specification.

- The combination of valve spring seat shims to correct valve spring installed height and valve spring tension should not exceed 1.524♦mm (0.060♦in) thick.

3. Install a valve spring seat shim if the valve spring installed height measurement is above the specification.
4. Recheck the valve spring installed height, replace the cylinder head if the valve spring installed height cannot be obtained.

## Valve Installation

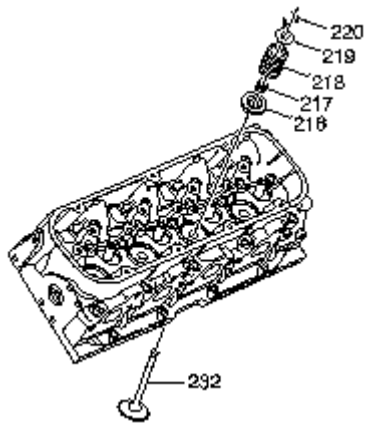

**Caution:** Refer to **Safety Glasses Caution** in **Cautions and Notices**.

**Caution:** Compressed valve springs have high tension against the valve spring compressor. Valve springs that are not properly compressed by or released from the valve spring compressor can be ejected from the valve spring compressor with intense force. Use care when compressing or releasing the valve spring with the valve spring compressor and when removing or installing the valve stem keys. Failing to use care may cause personal injury.

1. Lubricate the valve stems♦(232) with clean engine oil.
2. Insert the valves into their proper locations.
3. Install the necessary valve spring shims onto the cylinder head, if applicable.
4. Lubricate the rotators♦(216) with clean engine oil.
5. Install the rotators over the guide and on top of the cylinder head or valve spring shims, if applicable.

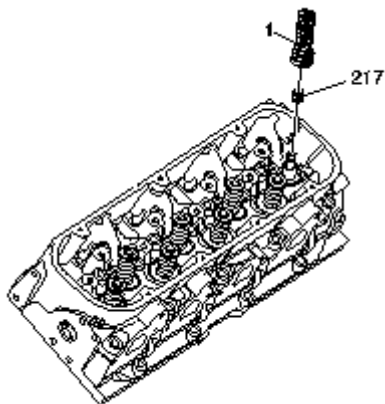

**Important:** When installing valve stem oil seals onto the valve guides, be careful not to tear the seal lip.

**Important:** When installing valve seals, *J 43105* must be used to achieve correct installation. Failure to use *J 43105* may cause excessive oil consumption.

6. Lubricate the valve stem seal and the outside diameter of the valve guide with clean engine oil.
7. Install the valve stem oil seals♦(217) over the valve tip and onto the valve guides using *J 43105* ♦(1). Tap the valve stem seal onto the valve guide until the *J 43105* fully seats the seal.

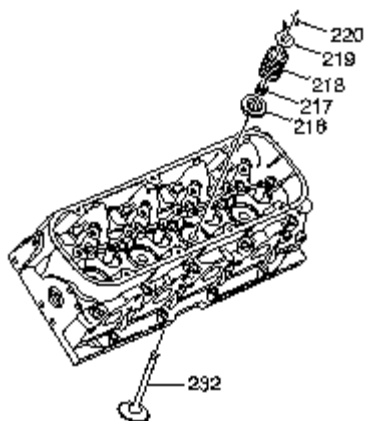

**Important:** When installing valve springs, the small end of the valve spring must be installed up.

8. Install the valve springs♦(218).
9. Install the valve spring caps♦(219).

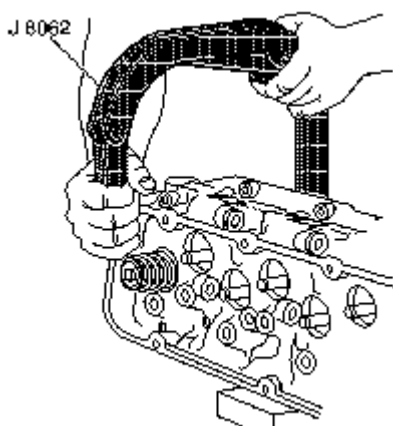

10. Use the *J 8062* in order to compress the valve spring. Compress the spring enough to clearly see the valve stem key grooves of the valve.

11. Install the valve stem keys.

- Use grease to hold the keys in place.
- Ensure that the keys seat properly in the upper groove of the valve stem.

12. Release and remove the *J 8062* .

13. Lightly tap the end of the valve stem with a plastic-faced hammer to seat the keys.

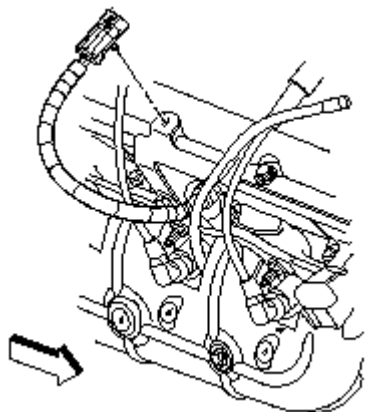

14. Apply sealant GM♦P/N♦12346004, (Canadian♦P/N♦10953480), or equivalent to the threads of the engine coolant temperature

(ECT) sensor.

**Notice:** Refer to *Fastener Notice in Cautions and Notices*.

15. Install the ECT sensor into the right cylinder head.

**Tighten:** Tighten the ECT sensor to 50♦&newtonm; (37♦lb♦ft).

16. Install the ECT sensor bracket and bolt.

**Tighten:** Tighten the ECT sensor bracket bolt to 50♦&newtonm; (37♦lb♦ft).

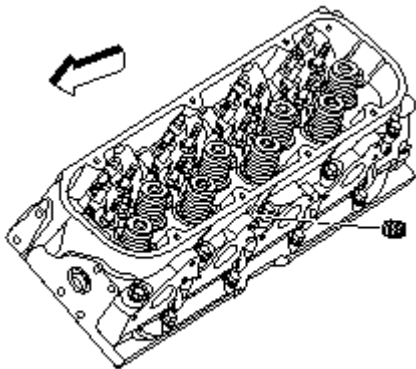

17. Apply sealant GM♦P/N♦12346004, (Canadian♦P/N♦10953480), or equivalent to the threads of the cylinder head coolant hole plug.

18. Install the cylinder head coolant hole plug into the left cylinder head.

**Tighten:** Tighten the cylinder head coolant hole plug to 50♦&newtonm; (37♦lb♦ft).

## Repair Instructions

### Oil Pump Disassemble

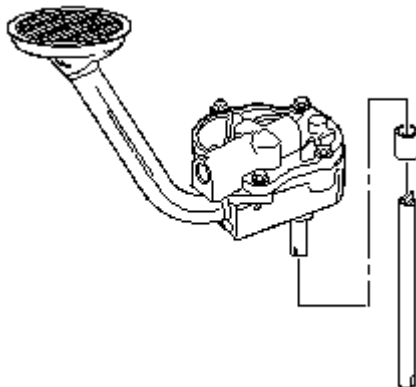

**Important:** The oil pump pipe has a press fit into the oil pump. DO NOT remove the pipe from the oil pump. The pipe and oil pump are serviced as a complete assembly.

1. Remove the oil pump driveshaft and retainer.

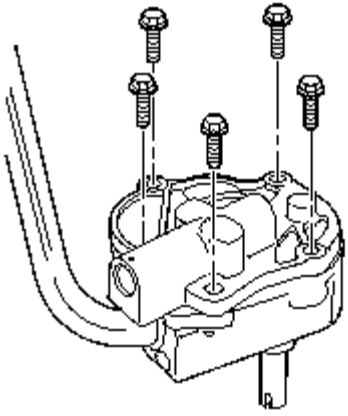

2. Remove the oil pump cover bolts.

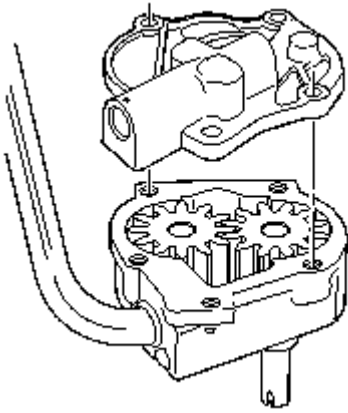

3. Remove the pump cover.

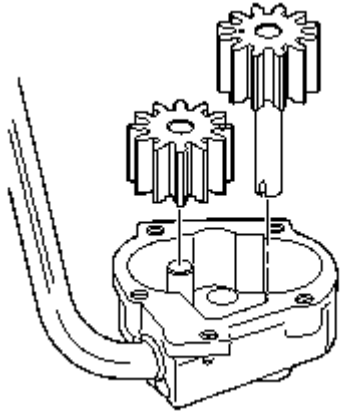

4. Remove the drive gear and the driven gear. Matchmark the gear teeth for assembly.

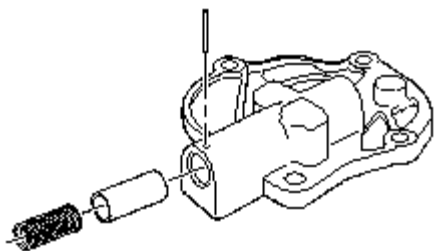

5. Remove the following items:

- 5.1. The retaining pin
- 5.2. The pressure relief spring
- 5.3. The pressure relief valve

## Repair Instructions

### Oil Pump Cleaning and Inspection

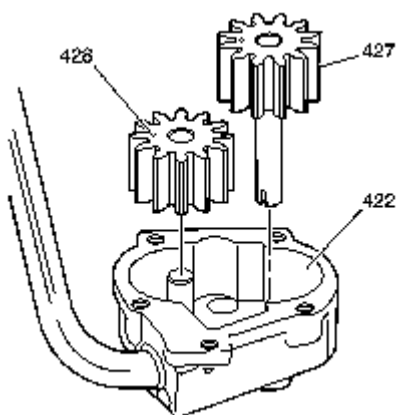

**Caution: Refer to Safety Glasses Caution in Cautions and Notices.**

1. Clean the oil pump components in cleaning solvent.
2. Dry the components with compressed air.
3. Inspect the gears♦(427, 428) for the following:
  - Scoring
  - Chipping
  - Galling
  - Excessive wear
4. Inspect the oil pump housing♦(422) for the following:
  - Damaged bolt hole threads
  - Worn oil pump driveshaft bore
  - Scoring or excessive wear within the housing
  - Worn driven gear shaft

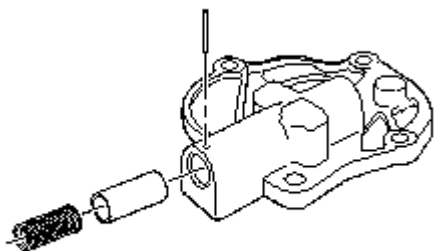

5. Inspect for a collapsed pressure relief spring.

6. Inspect the pressure relief valve for scoring or wear. The valve should move freely within the bore of the housing.

## Repair Instructions

### Oil Pump Assemble

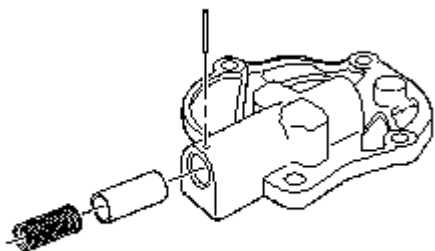

**Important:** Replace the pressure relief valve spring when reusing the oil pump.

1. Install the following items:

- 1.1. The pressure relief valve
- 1.2. The pressure relief spring
- 1.3. The retaining pin

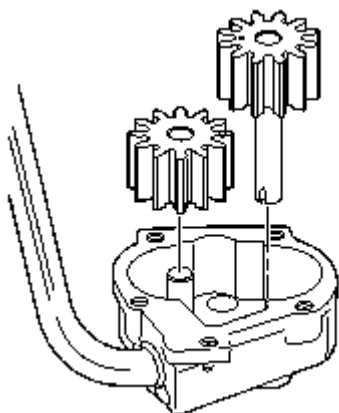

2. Coat the drive gear, the driven gear and the housing gear surfaces with clean engine oil.

3. Install the drive gear and the driven gear into the pump body. Align the matching marks on the gears. Install the smooth side of the gear toward the pump cover.

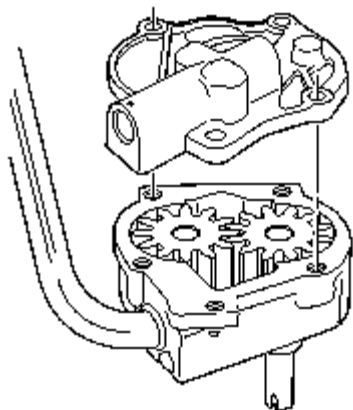

4. Install the oil pump cover.

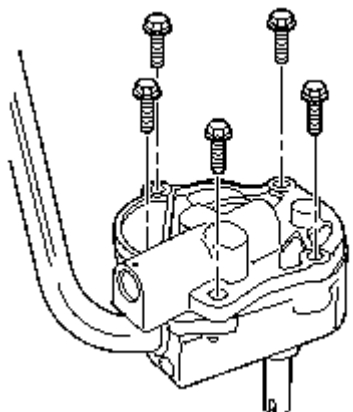

**Notice:** Refer to *Fastener Notice in Cautions and Notices.*

5. Install the oil pump cover bolts.

**Tighten:** Tighten the oil pump cover bolts to 12  $\text{N}\cdot\text{m}$ ; (106  $\text{lb}\cdot\text{in}$ ).

6. Inspect the oil pump for smoothness of operation by turning the oil pump driveshaft by hand.

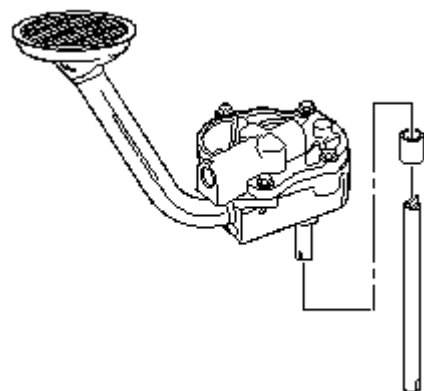

**Notice:** Ensure the oil pump driveshaft is inspected for wear and/or damage, and replaced if necessary. An excessively worn or damaged oil pump driveshaft may fail causing severe engine damage.

7. Install the oil pump driveshaft and the new retainer.

## Repair Instructions

## Oil Pump Drive Cleaning and Inspection

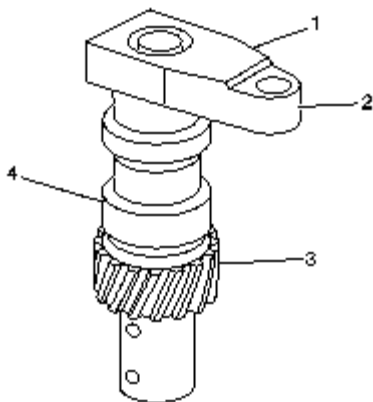

**Caution:** Refer to **Safety Glasses Caution in Cautions and Notices.**

1. Clean the oil pump drive in cleaning solvent.
2. Dry the oil pump drive with compressed air.
3. Inspect the oil pump drive♦(1) for the following conditions:
  - Excessive play in the oil pump drive bearing
  - Damage to the oil pump drive clamp bolt hole♦(2)
  - Damaged gear♦(3) for the following:
    - Chipping
    - Galling
    - Wear
    - Damage to the oil pump drive shaft tang
4. Damage to the oil pump drive body♦(4).
5. If the oil pump drive is to be reused, lubricate the bearing with clean engine oil, and apply grease to all gear teeth♦(3).

## Repair Instructions

### Valve Rocker Arm Cover Cleaning and Inspection

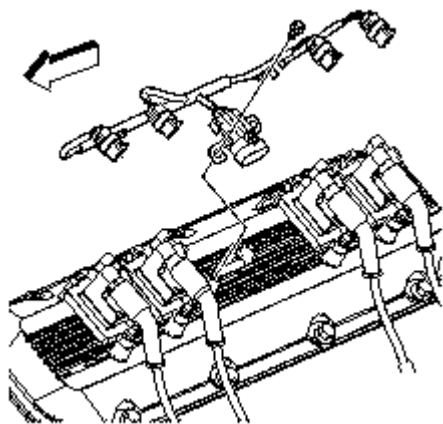

**Notice:** In order to ensure correct reinstallation, mark the ignition wiring harness connectors for cylinders one and

three, and cylinders six and eight prior to disconnection. Failure to reconnect the ignition wiring harness connectors to the proper ignition coils may result in serious engine damage.

**Notice:** This component is initially installed using a self-tapping bolt(s). Care should be taken when removing and/or installing the self-tapping bolt(s). Failure to use care when removing and/or installing the self-tapping bolt(s) can lead to damage and unnecessary replacement of the self-tapping bolt(s) and/or the component the self-tapping bolt(s) is threaded into.

1. Remove the white wiring harness clip locks.
2. Disconnect the ignition coil wiring harness from the ignition coils.
3. Remove the ignition coil wiring harness retainer bolts.
4. Open the 2 wiring harness retainers and remove the ignition coil wiring harness.

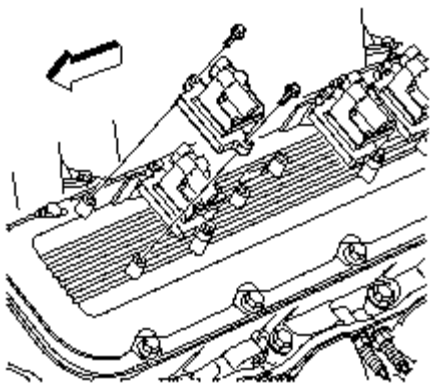

5. Remove the ignition coil bolts.
6. Remove the ignition coils.

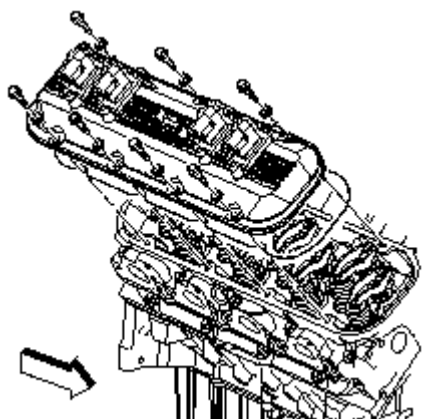

**Caution:** Refer to **Safety Glasses Caution in Cautions and Notices.**

**Important:** Do not clean or submerge the ignition coils in solvent.

Remove the ignition coils before cleaning the cover in solvent. To prevent damage to the gasket, minimize solvent contact with the gaskets.

7. Clean the valve rocker arm cover in solvent.
8. Dry the covers with compressed air.
9. Inspect the covers for the following:
  - Gouges or damage to the sealing surfaces
  - Cracking or damage to the valve cover gasket
  - Debris or damage to the bolt hole threads

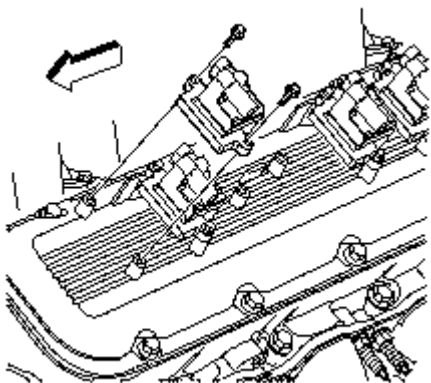

**Notice:** This bolt is a self-tapping bolt. If installing this bolt into a new component, installation of the bolt may be difficult. Ensure that the bolt is not over-torqued during the initial installation (thread cutting). Failure to limit torque can lead to bolt failure.

10. Install the ignition coils.

**Notice:** Refer to *Fastener Notice* in *Cautions and Notices*.

11. Install the ignition coil bolts.

**Tighten:** Tighten the ignition coil bolts to 12♦&newtonm; (106♦lb♦in).

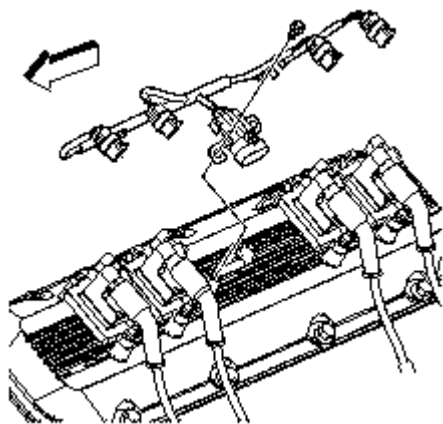

12. Install and secure the ignition coil wiring harness into the 2 wiring harness retainers.

13. Install the ignition coil wiring harness retainer bolts.

**Tighten:** Tighten the ignition coil wiring harness retainer bolts to 12♦&newtonm; (106♦lb♦in).

14. Connect the ignition coil wiring harness to the ignition coils, making sure the connectors for cylinders 1 and 3, and cylinders 6 and 8 are connected to the corresponding ignition coils.

15. Install the white wiring harness clip locks.

## Repair Instructions

### Oil Pan Cleaning and Inspection

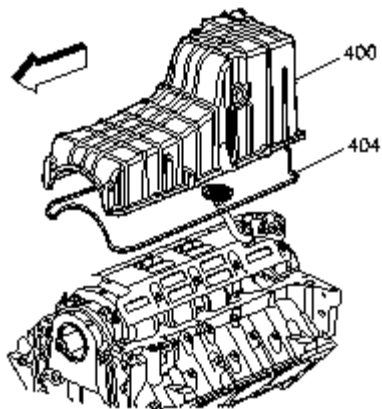

1. Remove the oil pan gasket♦(404) from the groove in the oil pan♦(400).
2. Clean the oil pan in solvent.

**Caution: Refer to Safety Glasses Caution in Cautions and Notices.**

3. Dry with compressed air.
4. Inspect the oil pan for the following conditions:
  - The drain plug hole for damaged threads
  - Gouges or damage to the oil pan sealing surfaces
  - Cracks or damage to the exterior of the oil pan
  - Damage to the oil level indicator tube area
  - Damage to the oil pan gasket

## Repair Instructions

### Intake Manifold Disassemble

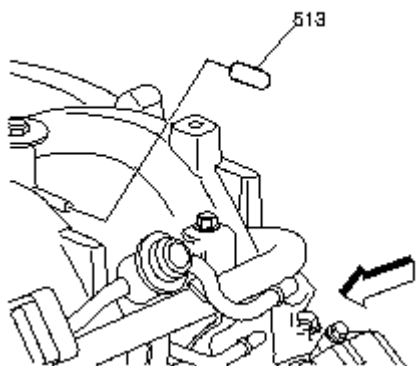

1. Remove the vacuum plug♦(513).

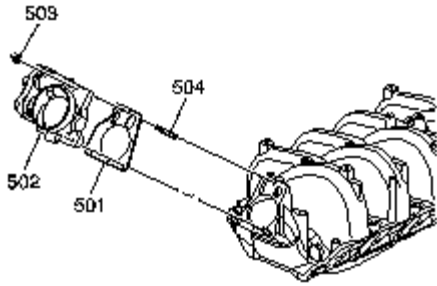

2. Remove the throttle body nuts♦(503).
3. Remove the throttle body♦(502) and gasket♦(501).
4. Discard the gasket.
5. Remove the throttle body studs♦(504), if required.

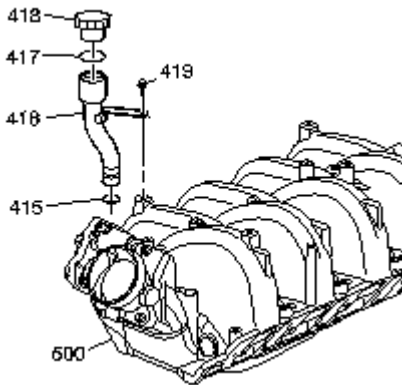

6. Remove the oil fill cap♦(418).
7. Remove the oil fill tube♦(416) and bolt♦(419).

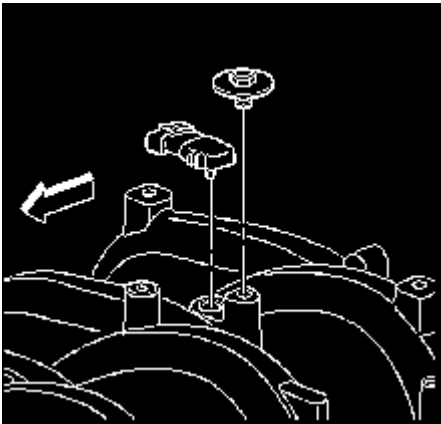

8. Remove the MAP sensor bolt and MAP sensor.
9. Inspect the MAP sensor grommet for damage.

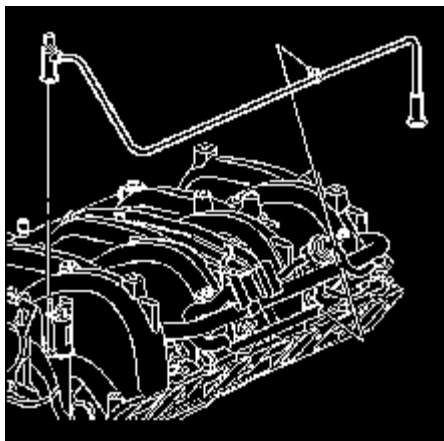

10. Remove the EVAP tube.

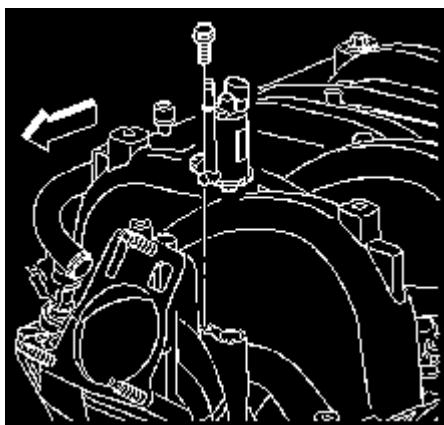

11. Remove the EVAP purge valve and bolt.

12. Inspect the O-ring seal for damage. Replace as needed.

## Repair Instructions

### Intake Manifold Cleaning and Inspection

**Important:** Do not reuse the lower intake manifold gaskets or end seals.

1. Clean the intake manifold in an approved solvent.

- Clean debris out of all bolt holes. Clean the intake manifold gasket sealing surfaces.
- Clean all intake manifold ports.

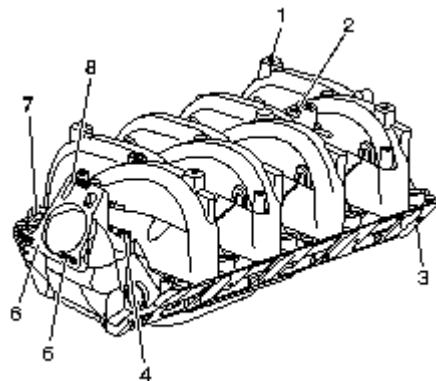

**Caution: Refer to *Safety Glasses Caution in Cautions and Notices.***

2. Dry the intake manifold with compressed air.

3. Inspect the following:

- The intake manifold bolt holes♦(1) for cracks and/or damage
- The MAP sensor sealing surface♦(2) for damage
- The purge solenoid sealing surface♦(4) for damage. The purge solenoid bolt has a sealer that may come off during removal of the bolt. Ensure all sealant is removed from the bolt hole.
- The intake manifold-to-cylinder head sealing surfaces♦(3) for damage
- The throttle body studs♦(5) for damage. Replace as necessary.
- The throttle body mounting surface♦(6) for damage
- The oil fill tube hole♦(7) for signs of leakage. Reseal as necessary.
- PCV port♦(8) for debris or varnish buildup

## Repair Instructions

### Intake Manifold Assemble

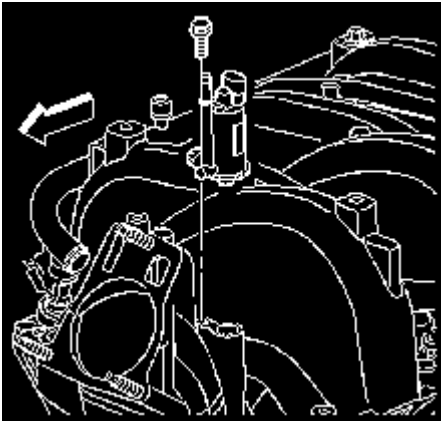

1. Apply a very light film of clean engine oil to the EVAP valve O-ring seal.

2. Install the EVAP valve.

3. Apply thread sealer GM♦P/N♦12345493, (Canadian♦P/N♦10953488), or equivalent to the threads of the purge solenoid bolt.

**Notice: Refer to *Fastener Notice in Cautions and Notices.***

4. Install the EVAP valve bolt.

**Tighten:** Tighten the bolt to 8♦&newtonm; (71♦lb♦in).

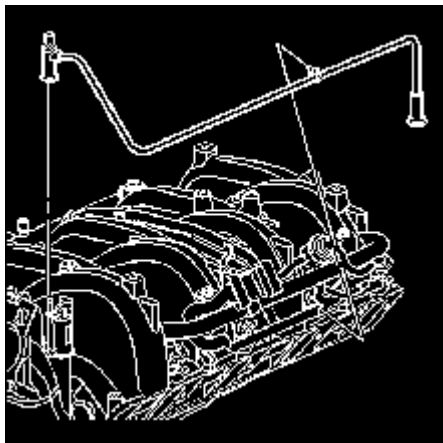

5. Install the EVAP tube.

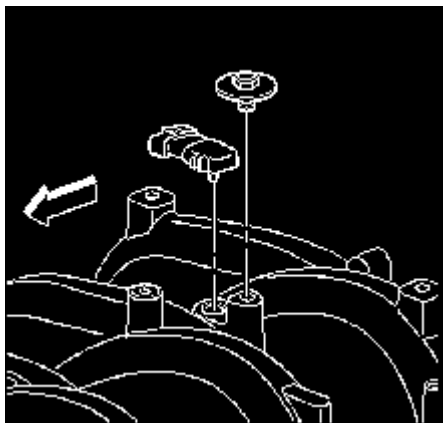

**Important:** Lubricate the port of the MAP sensor with clean engine oil. Avoid dipping the sensor port directly into the lubricant or using a solid type of lubricant, as they may block the vacuum port signal.

6. Install the MAP sensor.

7. Install the MAP sensor bolt.

**Tighten:** Tighten the MAP sensor bolt to 12♦&newtonm; (106♦lb♦in).

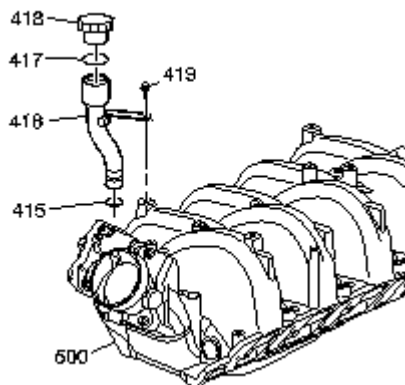

8. Lubricate the O-ring seal♦(415) of the oil fill tube with clean engine oil.

9. Install the oil fill tube♦(416).

10. Install the oil fill tube bolt♦(419).

**Tighten:** Tighten the oil fill tube bolt to 12♦&newtonm; (106♦lb♦in).

11. Install the oil fill cap♦(418).

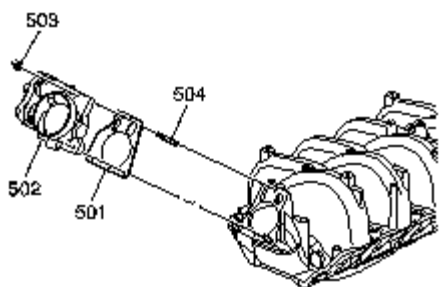

12. Install the throttle body gasket♦(501).
13. Install the throttle body♦(502).
14. Install the throttle body nuts♦(503).

**Tighten:** Tighten the throttle body nuts to 10♦&newtonm; (89♦lb♦in).

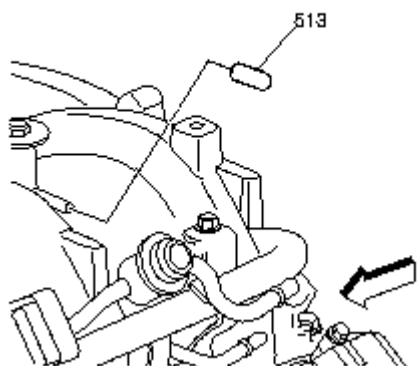

15. Install the vacuum plug♦(513).

## Repair Instructions

### Exhaust Manifold Cleaning and Inspection

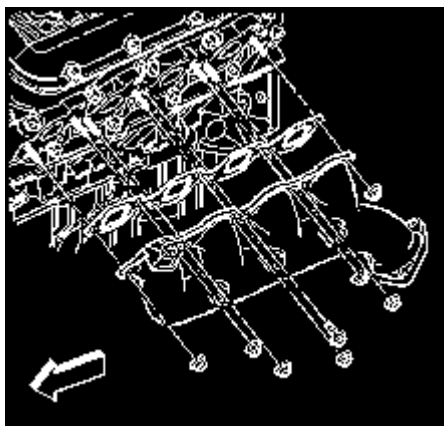

1. Clean the exhaust manifolds in solvent.

**Caution:** Refer to *Safety Glasses Caution* in *Cautions and Notices*.

2. Dry the components with compressed air.
3. Inspect the exhaust manifolds for the following:
  - Damage to the gasket sealing surfaces
  - Damage to the exhaust manifold studs
  - Broken or damaged heat shields
  - Cracks in the exhaust manifold
  - Restrictions within the exhaust passages

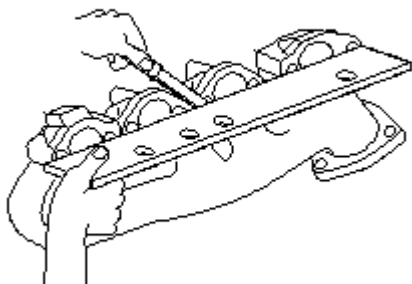

4. Measure the alignment or surface flatness of the exhaust manifold flanges, using a straight edge and a feeler gage. Exhaust manifold surface flatness must not exceed 0.254 mm (0.01 in).

5. If the surface flatness is not within specifications, the exhaust manifold is warped and must be replaced.

## Repair Instructions

### Water Crossover Cleaning and Inspection

#### Cleaning Procedure

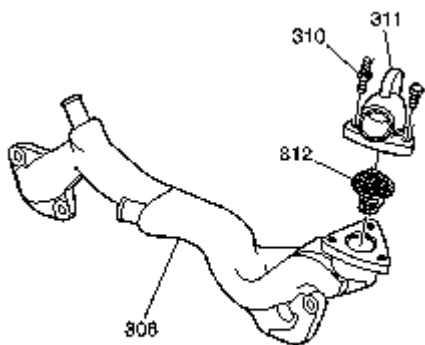

1. Clean the water crossover (308) and thermostat housing (311) in solvent.

**Caution: Refer to Safety Glasses Caution in Cautions and Notices.**

2. Dry the components with compressed air.

#### Inspection Procedure

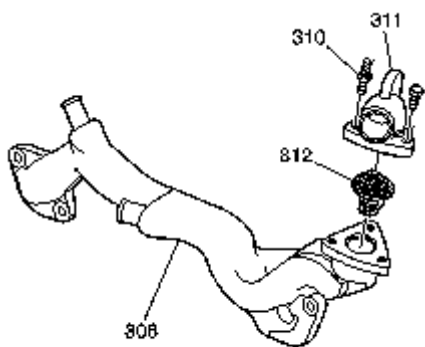

1. Inspect the water crossover♦(308) for the following:
  - Corrosion or damage to the gasket sealing surfaces
  - Corrosion or damage to the bypass hose fitting
  - Corrosion or damage to the heater hose fitting
  - Corrosion or damage to the threads of the water outlet
2. Inspect the thermostat housing♦(311) for corrosion or damage.

## Repair Instructions

### Water Pump Cleaning and Inspection

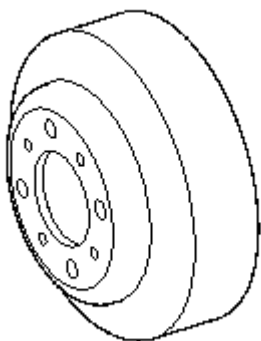

1. Inspect the water pump pulley for damage at the belt contact area and the pulley-to-water pump mounting surface.

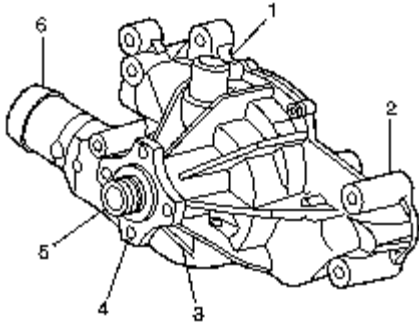

**Important:** Do not immerse the water pump in solvent. The solvent may enter the water pump's permanently lubricated bearings and cause premature bearing failure.

2. Clean all excess dirt and debris from the water pump housing.

3. Inspect the water pump for the following:

- Leakage at the hose fitting♦(1)
- Leakage at the water pump weep hole♦(3)
  - A stain around the weep hole is acceptable. If leakage occurs, dripping with the engine running and the cooling system pressurized, replace the water pump.
- Gasket sealing surfaces♦(2) for excessive scratches or gouging
- Restrictions within the internal coolant passages♦(6)
- Excessive side-to-side play in the pulley shaft
  - If the shaft end play exceeds 0.381♦mm (0.015♦in), replace the water pump.

- Rotate the pump shaft by hand and inspect for roughness of operation

If the hub wobbles, is noisy or feels rough when rotated, replace the water pump.

The shaft and fan hub must turn straight and smoothly.

- Damage to threaded bolt holes♦(4)
- Damage to the fan clutch mounting threads♦(5)

## Repair Instructions

### Thread Repair

#### Tools Required

*J 39345* Thread Repair Kit

The following procedure is used to accomplish proper and durable thread repairs in the cylinder head and the cylinder block, using the *J 39345*.

**Important:** Take appropriate precautions to assure that machining chips will not remain inside the engine. For example, block all intake passages, oil drainback holes and exhaust passages with a towel or tape before performing thread repairs.

1. Select the proper size drill as indicated in the schematic charts found in Thread Repair Specifications for the hole being repaired.
2. Drill out the damaged threads to the original depth or completely through for through holes.

**Caution:** Refer to **Safety Glasses Caution in Cautions and Notices.**

3. Apply compressed air with a shop towel wrapped around the air spout, in order to retain the chips forced out of the hole.
4. Select the correct size tap, using the appropriate chart for the hole being repaired.
5. Coat the tap and the hole with spray machining oil.
6. Tap the hole to the original depth. In order to clean the threads, reverse the rotation of the tap periodically.
7. Use solvent to clean out all of the chips.
8. Apply compressed air with a shop towel wrapped around the air spout, in order to retain the chips forced out of the hole.
9. Tap the hole again to clean the threads. The tap should thread in with little resistance.

**Important:** Make sure all of the chips are cleared from the hole.

10. Use solvent to clean out all of the chips.
11. Apply compressed air with a shop towel wrapped around the air spout, in order to retain the chips forced out of the hole.
12. Use a flashlight to confirm that all of the chips are removed from the hole.
13. Continue to clean the hole until all of the chips are cleared.
14. Install the heli-coil insert as follows:
  - 14.1. In order to determine the correct size installation tool and length insert, refer to the appropriate picture and chart.
  - 14.2. Screw the insert on the mandrel of the installation tool until the driving tang is fully engaged in the driving contour.
  - 14.3. Coat the insert with spray machining oil.
  - 14.4. Install the insert as follows:
    - 14.4.1. Slide the prewinder over the mandrel and insert.
    - 14.4.2. Rotate the mandrel clockwise until 1 or 2 threads of the insert are threaded into the prewinder.
    - 14.4.3. Place the insert in position on the threaded hole being repaired.
    - 14.4.4. Rotate the mandrel clockwise until the insert is flush with the top surface of the threaded hole.
    - 14.4.5. Remove the prewinder except when repairing cylinder head bolts.
    - 14.4.6. Continue to install the insert until reaching the original thread depth.
    - 14.4.7. Remove the mandrel.
  - 14.5. Remove the driving tang from the thread insert as follows. The tang must be removed in order to allow passage of the fastener through the insert.
    - 14.5.1. Place the square end of the punch, no chamfer, on the tang after installation.
    - 14.5.2. Strike the punch sharply with the hammer. The tang will break off at the notch.
15. Clean the hole using compressed air. Take appropriate steps to assure that chips are not blown into the engine.

## Repair Instructions

### Service Prior to Assembly

- Dirt will cause premature wear of the rebuilt engine. Clean all the components.
- Use the proper tools to measure the components when checking for excessive wear. Components not within the manufacturer's specification must be repaired or replaced.
- When the components are reinstalled into an engine, return the components to their original location, position, and direction.
- During assembly, lubricate all the moving parts with clean engine oil (unless otherwise specified). This will provide initial lubrication when the engine is first started.

## Repair Instructions

### Engine Prelubing

#### Tools Required

J 45299 Engine Preluber

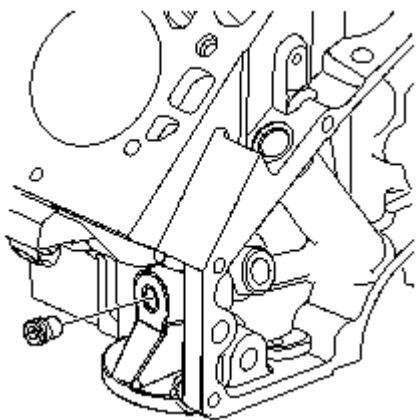

**Important:** A constant and continuous flow of clean engine oil is required in order to properly prime the engine. Be sure to use an approved engine oil as specified in the owners manual.

1. Remove the engine oil filter, fill with clean engine oil.

**Notice:** Refer to *Fastener Notice in Cautions and Notices*.

2. Install the oil filter.

**Tighten:** Tighten the oil filter to 38♦&newtonm; (28♦lb♦ft).

3. Locate the oil gallery plug on the left side of the engine block above the oil filter housing.

4. Install the 1/4 - 18 adapter P/N♦509373.

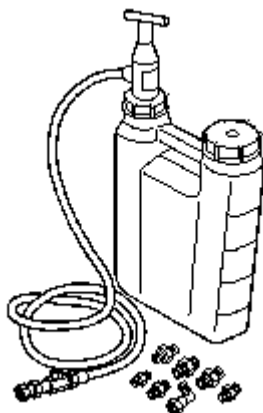

5. Install the flexible hose to the adapter and open the valve.

6. Pump the handle on the [J 45299](#) in order to flow a minimum of 1–1.9♦liters (1–2♦quarts) of engine oil. Observe the flow of engine oil through the flexible hose and into the engine assembly.

7. Close the valve and remove the flexible hose and adapter from the engine.

8. Install the gallery plug to the engine.

**Tighten:** Tighten the oil gallery plug to 30♦&newtonm; (22♦lb♦ft).

9. Top-off the engine oil to the proper level.

## Repair Instructions

### Engine Block Plug Installation

#### Tools Required

[J 41712](#) Oil Pressure Switch Socket

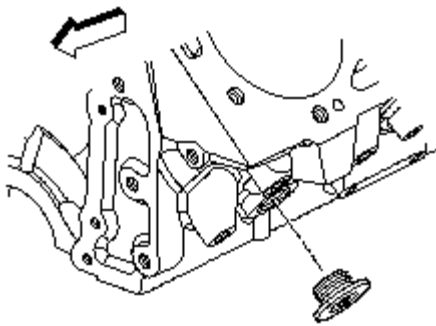

**Notice: Refer to *Fastener Notice in Cautions and Notices.***

1. Apply sealant GM♦P/N♦12346004, (Canadian♦P/N♦10953480), or equivalent to the threads of the coolant hole plug.
2. Install the engine coolant hole plug into the block.

**Tighten:** Tighten the engine coolant hole plug to 60♦&newtonm; (40♦lb♦ft).

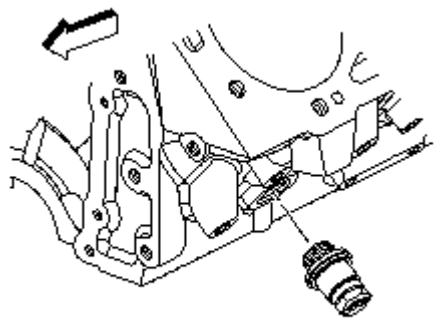

3. Apply sealant GM♦P/N♦12346004, (Canadian♦P/N♦10953480), or equivalent to the threads of the engine block heater, if applicable.

4. Install the engine block heater into the block.

**Tighten:** Tighten the engine block heater to 50♦&newtonm; (37♦lb♦ft).

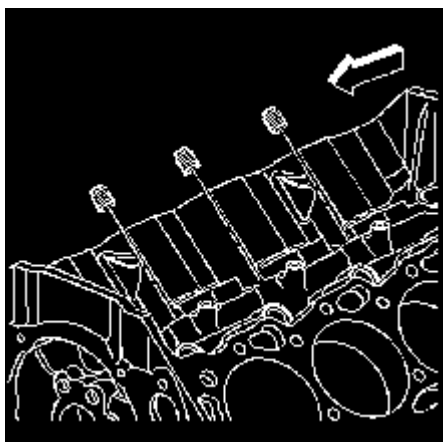

5. Apply sealant GM♦P/N♦12346004, (Canadian♦P/N♦10953480), or equivalent to the threads of the oil gallery plugs.
6. Install the engine block top oil gallery plugs.

**Tighten:** Tighten the top oil gallery plugs to 20♦&newtonm; (15♦lb♦ft).

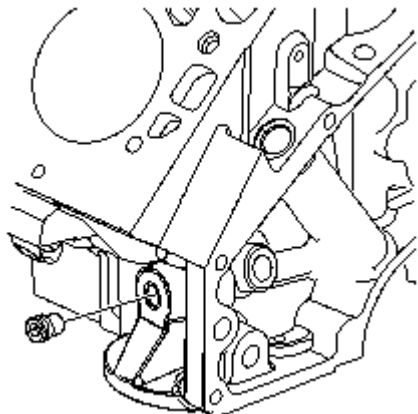

7. Apply sealant GM♦P/N♦12346004, (Canadian♦P/N♦10953480), or equivalent to the threads of the oil gallery plug.

8. Install the engine block left side oil gallery plug.

**Tighten:** Tighten the left oil gallery plug to 30♦&newtonm; (22♦lb♦ft).

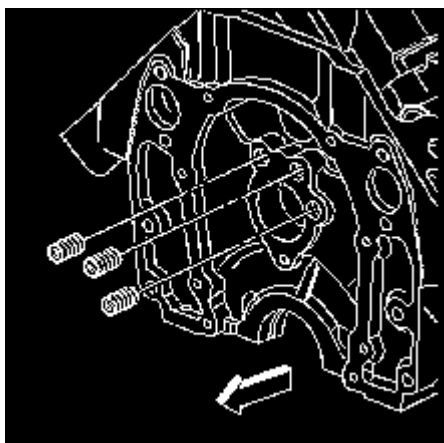

9. Apply sealant GM♦P/N♦12346004, (Canadian♦P/N♦10953480), or equivalent to the threads of the oil gallery plugs.

10. Install the front oil gallery plugs.

**Tighten:** Tighten the front oil gallery plugs to 30♦&newtonm; (22♦lb♦ft).

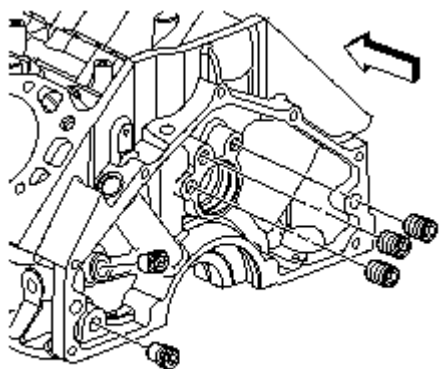

11. Apply sealant GM♦P/N♦12346004, (Canadian♦P/N♦10953480), or equivalent to the threads of the oil gallery plugs.

12. Install the rear oil gallery plugs.

**Tighten:** Tighten the rear oil gallery plugs to 20♦&newtonm; (15♦lb♦ft).

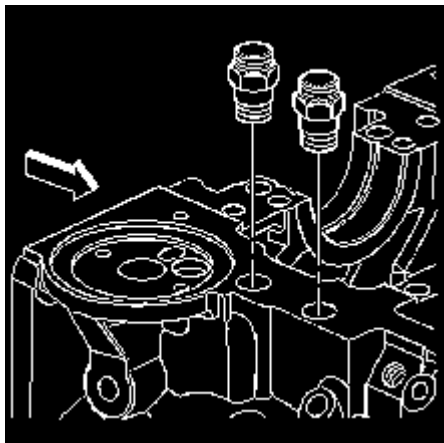

13. Apply sealant GM P/N 12346004, (Canadian P/N 10953480), or equivalent to the threads of the engine block oil cooler hose fittings.

14. Install the engine block oil cooler hose fittings.

**Tighten:** Tighten the engine block oil cooler hose fittings to 23 N·m; (17 lb·ft).

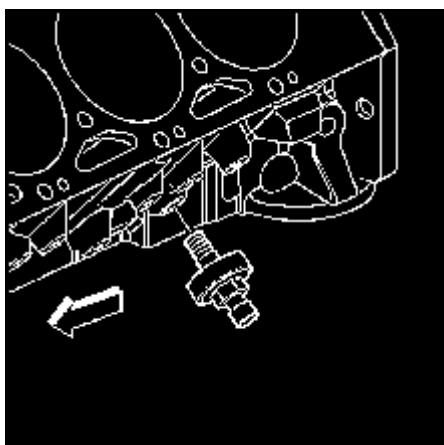

**Important:** Do not overtighten the knock sensor.

15. Install the left knock sensor to the engine block.

**Tighten:** Tighten the left knock sensor to 20 N·m; (15 lb·ft).

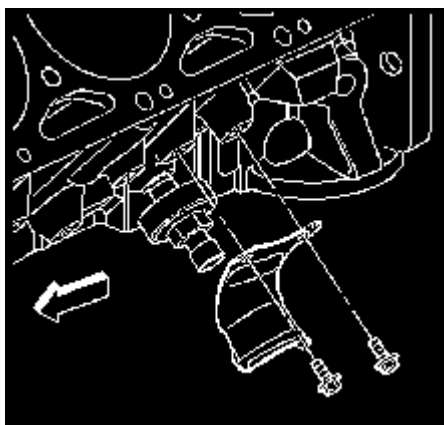

16. Install the left side knock sensor heat shield.

17. Install the left side knock sensor heat shield bolts.

**Tighten:** Tighten the bolts to 12 N·m; (106 lb·in).

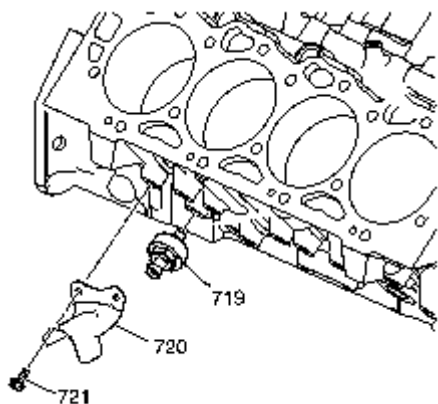

**Important:** Do not overtighten the knock sensor.

18. Install the right knock sensor (719) to the engine block.

**Tighten:** Tighten the right side knock sensor to 20 N·m; (15 lb·ft).

19. Install the right side knock sensor heat shield (720) and bolts (721).

**Tighten:** Tighten the bolts to 12 N·m; (106 lb·in).

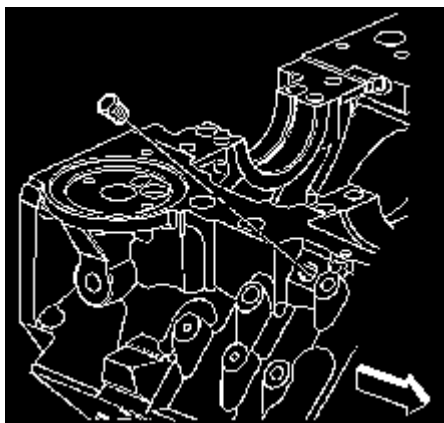

20. Apply sealant GM P/N 12346004, (Canadian P/N 10953480), or equivalent to the threads of the engine block coolant drain hole plugs.

21. Install the engine block coolant drain hole plugs.

**Tighten:** Tighten the coolant drain hole plugs to 30 N·m; (22 lb·ft).

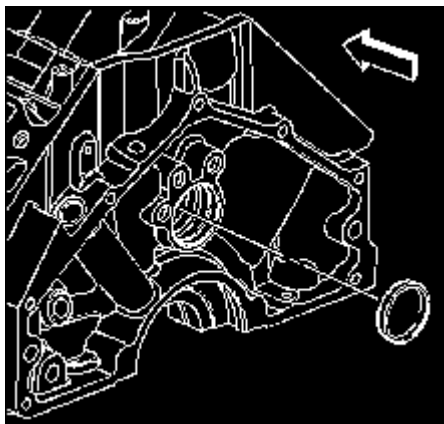

22. Apply sealer GM P/N 12377901, (Canadian P/N 10953504), to the outside diameter of the new camshaft rear bearing hole plug.

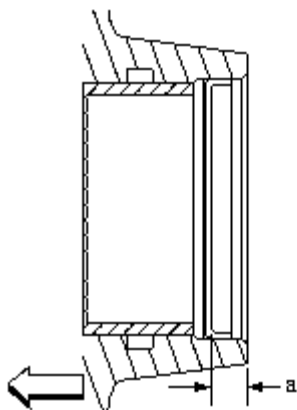

23. Install the NEW camshaft rear bearing hole plug to the proper depth of (a)  $7.600-6.200$  mm ( $0.299-0.244$  in).

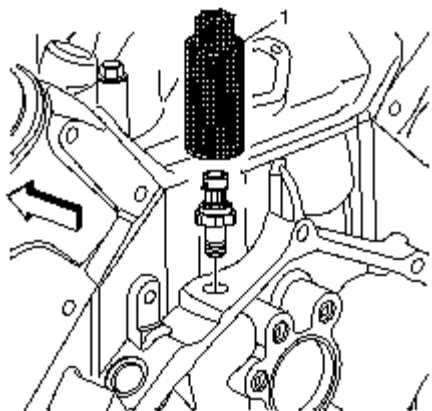

24. Apply sealant GM P/N 12346004, (Canadian P/N 10953480), or equivalent to the threads of the oil pressure sensor.  
 25. Install the oil pressure sensor.

**Tighten:** Using the J 41712 (1), tighten the oil pressure sensor to  $30$  newtonm; ( $22$  lb ft).

## Repair Instructions

### Oil Filter Adapter Installation

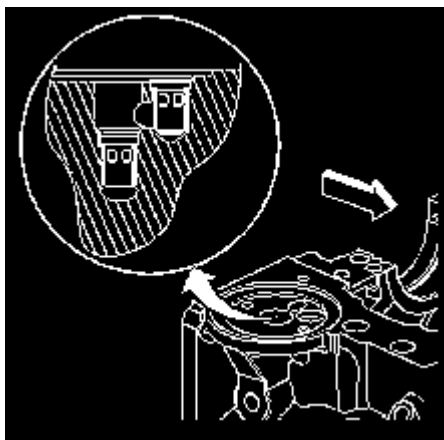

1. If removed, install the new oil bypass valves. Stake the tangs on the oil bypass valves.

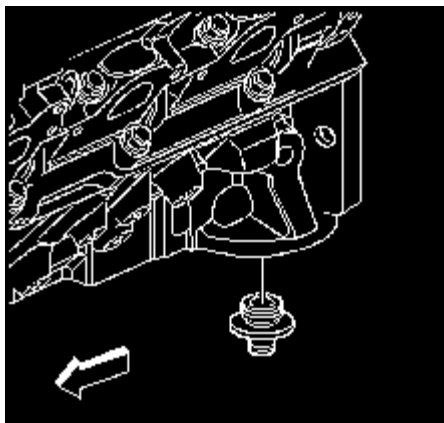

**Notice:** Refer to *Fastener Notice in Cautions and Notices*.

2. Install the oil filter fitting.

**Tighten:** Tighten the oil filter fitting to 66♦&newtonm; (49♦lb♦ft).

## Repair Instructions

### Crankshaft and Bearings Installation

#### Tools Required

- *J 8001* Dial Indicator Set
- *J 45059* Angle Meter

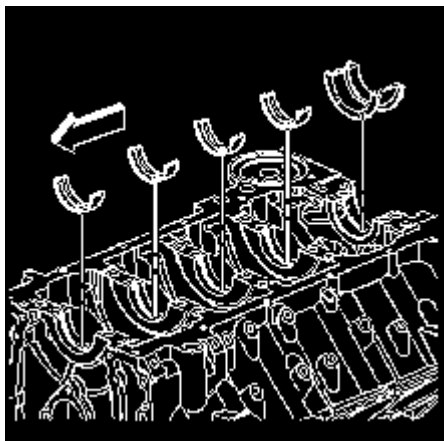

#### Important:

- Lubricate the crankshaft bearings and crankshaft with clean engine oil.
- If undersized bearings are used, ensure that the bearings are fitted to the proper journals.

1. Install the crankshaft upper bearings into the block. Apply clean engine oil to the bearing surfaces.

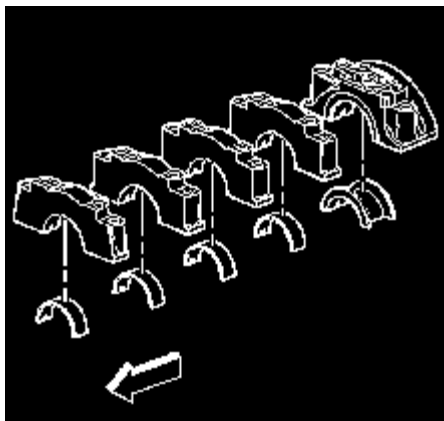

2. Install the crankshaft lower bearings into the crankshaft bearing caps. Apply clean engine oil to the bearing surfaces.

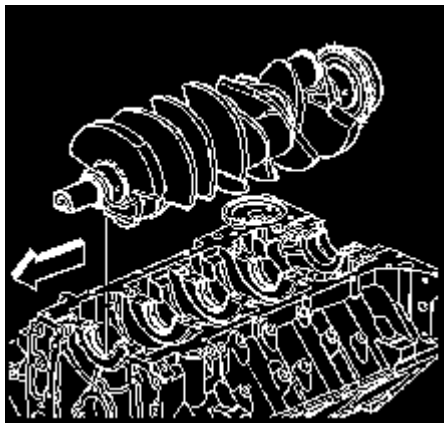

**Notice:** In order to prevent damage to the crankshaft position sensor reluctor wheel/ring care must be used when removing or installing this component.

3. Install the crankshaft.

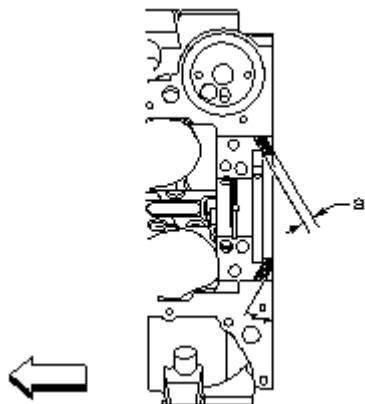

**Important:** The bearing caps must be seated within 60 minutes of the sealer being applied. The bearing cap fasteners must be tightened within 5 minutes of the bearing caps being installed onto the engine block.

4. Apply a (a) 13 mm (0.500 in) light film of sealant GM P/N 1052942, (Canadian P/N 10953466), or equivalent to the rear bearing cap sealing face or to the rear bearing cap channel of the engine block. Apply the sealant to the bearing cap mating surface and bearing cap channel from the rear seal bore to the oil pan surface.

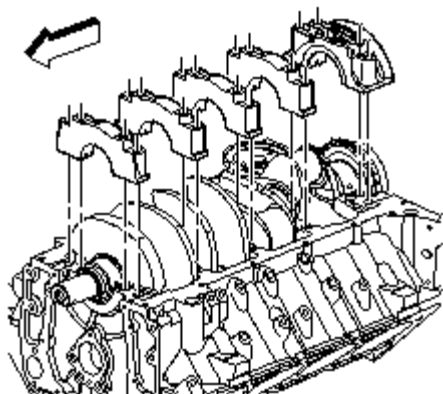

**Notice:** In order to prevent the possibility of cylinder block or crankshaft bearing cap damage, the crankshaft bearing caps are tapped into the cylinder block cavity using a brass, lead, or a leather mallet before the attaching bolts are installed. Do not use attaching bolts to pull the crankshaft bearing caps into the seats. Failure to use this process may damage a cylinder block or a bearing cap.

**Notice:** The crankshaft position sensor reluctor wheel/ring is not serviced separately. Do not repair the crankshaft position sensor reluctor wheel/ring. If the crankshaft position sensor reluctor ring is damaged, the crankshaft assembly must be replaced.

**Important:** Ensure that the triangle symbols on the crankshaft bearing caps are facing the front of the engine.

5. Install the crankshaft bearing caps in the location the caps were marked and originally removed from.

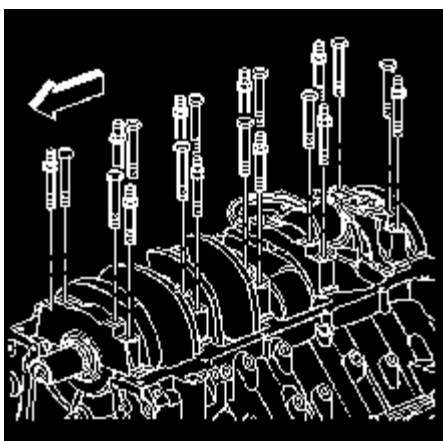

**Notice:** Refer to *Fastener Notice in Cautions and Notices*.

**Important:** Tighten the crankshaft bearing cap inner bolts before tightening the crankshaft bearing cap outer studs.

6. Install the bearing cap bolts and studs.

**Tighten:**

7. Tighten the bearing cap 1–4 inner bolts a first pass to 30♦&newtonm; (22♦lb♦ft).
8. Tighten the bearing cap 1–4 outer studs a first pass to 30♦&newtonm; (22♦lb♦ft).
9. Tighten the bearing cap 1–4 inner bolts a final pass an additional 90♦degrees using the *J 45059*.
10. Tighten the bearing cap 1–4 outer studs a final pass an additional 80♦degrees using the *J 45059*.
11. Tighten the bearing cap 5♦bolts and studs to 30♦&newtonm; (22♦lb♦ft).
12. Loosen the bearing cap 5♦bolts and studs.
13. Tighten the bearing cap 5♦bolts and studs to 5♦&newtonm; (44♦lb♦in).

14. Thrust the crankshaft firmly rearward.

15. Thrust the crankshaft firmly forward.

**Tighten:**

16. Tighten the bearing cap 5 inner bolts a first pass to 30 newtonm; (22 lbft).
17. Tighten the bearing cap 5 outer studs a first pass to 30 newtonm; (22 lbft).
18. Tighten the bearing cap 5 inner bolts a final pass an additional 90 degrees using the J 45059.
19. Tighten the bearing cap 5 outer bolts a final pass an additional 80 degrees using the J 45059.

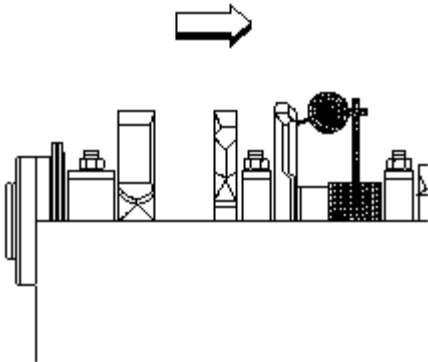

20. Measure the crankshaft end play as follows:

**20.1.** Install the J 8001 or equivalent to the cylinder block, with the dial indicator plunger against one of the counterweights of the crankshaft.

**20.2.** Firmly thrust the end of the crankshaft first rearward then forward. This will line up the rear crankshaft bearing and the crankshaft thrust surfaces.

**20.3.** With the crankshaft pushed forward, zero the dial indicator. Move the crankshaft rearward, and read the end play measurement on the dial indicator. An optional method is to insert a feeler gage between the crankshaft and the bearing surface and measure the clearance. Refer to *Engine Mechanical Specifications* .

**20.4.** If the correct end play cannot be obtained, inspect for the following conditions:

Verify that the correct size crankshaft bearing has been installed. Refer to *Engine Mechanical Specifications* .

Inspect the crankshaft thrust wall surface or surfaces for wear and/or excessive runout. Refer to *Engine Mechanical Specifications* .

**20.5.** Inspect the crankshaft for binding. Turn the crankshaft to check for binding. If the crankshaft does not turn freely, loosen the crankshaft bearing bolts and studs, one cap at a time, until the tight bearing is located. The following condition or conditions could cause a lack of clearance at the bearing:

Burrs on the crankshaft bearing cap

Foreign material between the bearing and the block

Foreign material between the bearing and the bearing cap

A faulty crankshaft bearing

Improper size bearing

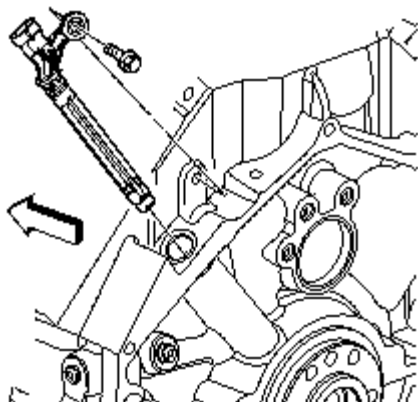

**Important:**

- Ensure that the crankshaft position sensor is fully seated against the crankshaft reluctor ring. The upper flange on the sensor **MAY NOT** seat against the engine block.
- The crankshaft position sensor bolt has a thread sealant applied to the threads. The thread sealant may have come off during the removal of the bolt. Ensure that the bolt hole is clean of any debris before installing the crankshaft sensor bolt.

**21.** Inspect both crankshaft position sensor O-rings for cuts, cracks, tears or damage. Replace the O-rings as needed. Lubricate the crankshaft position sensor O-rings with clean engine oil.

**22.** Install the crankshaft position sensor into the block.

There may be a slight resistance as the O-rings seat into the engine block.

**23.** Apply thread adhesive GM♦P/N♦12345493, (Canadian♦P/N♦10953488), or equivalent to the crankshaft position sensor bolt.

**24.** Install the crankshaft position sensor bolt.

**Tighten:** Tighten the crankshaft position sensor bolt to 12♦&newtonm; (106♦lb♦in).

## Repair Instructions

### Piston, Connecting Rod, and Bearing Installation

#### Tools Required

- *J 8037* Piston Ring Compressor
- *J 8087* Cylinder Bore Gage
- *J 45059* Angle Meter

#### Piston Selection

**Important:** The coating on the piston allows for an interference fit between the cylinder and the bore. The piston diameter can **NOT** be measured accurately because the piston coating is not a consistent thickness. Do **NOT** measure the piston diameter.

To select the correct piston for installation, the cylinder bore must be measured. If the cylinder bore diameter is within service specifications, install the original piston/connecting rod assembly or a new, standard size piston/connecting rod assembly. A used piston/connecting rod assembly may be reinstalled if, after cleaning and inspection, the piston is not damaged. If the cylinder bore is **NOT** within specifications, the cylinder must be resized to accept a new, oversized piston.

For proper piston fit, the engine block cylinder bores should not have excessive wear or taper.

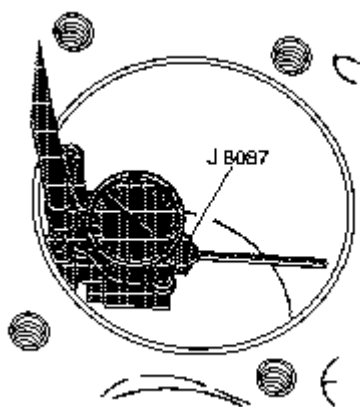

1. Inspect the engine block cylinder bore. Refer to [Engine Block Cleaning and Inspection](#) .
2. Inspect the piston/connecting rod assembly for damage. Refer to [Piston, Connecting Rod, and Bearings Cleaning and Inspection](#) .
3. Use the *J 8087* and measure the cylinder bore diameter. Refer to [Engine Block Cleaning and Inspection](#) .

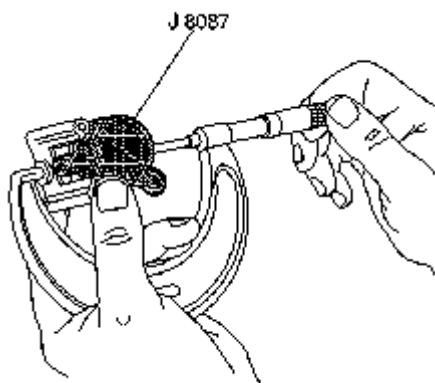

4. Measure the *J 8087* with a micrometer and record the reading.
5. Compare the cylinder bore measurement to the specifications. Refer to [Engine Mechanical Specifications](#) .
  - 5.1. If the cylinder bore is within specifications, select the original piston or a new, original size piston.
  - 5.2. If the cylinder bore is not within specifications, select the next oversized piston/connecting rod assembly, then bore and hone the cylinder bore to fit the oversize piston.

## Piston Installation

1. Coat the following components with clean engine oil:
  - The piston
  - The piston rings
  - The cylinder bore
  - The bearing surfaces

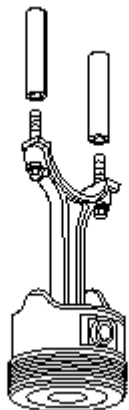

2. Install rubber fuel line onto the connecting rod bolts.

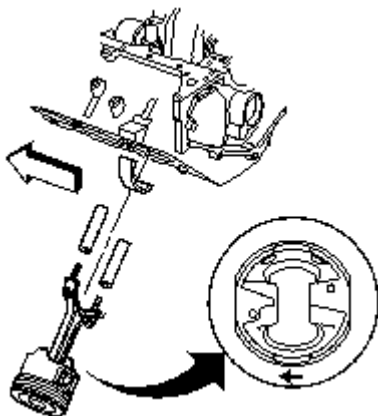

**Important:** The mark on the top of the piston must face the front of the engine block. When assembled, the flanges on the connecting rod and cap should face to the front of block on the left bank and to the rear of block on the right bank.

3. Install the piston, connecting rod and upper connecting rod bearing through the top of the engine block.

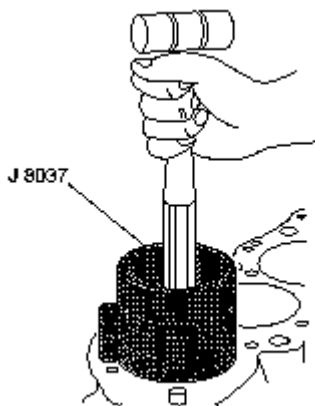

4. Install the *J 8037* onto the piston and compress the piston rings.
5. Use the *J 8037* and lightly tap the top of the piston with a wooden hammer handle.
6. Hold the *J 8037* firmly against the engine block until all of the piston rings have entered the cylinder bore.

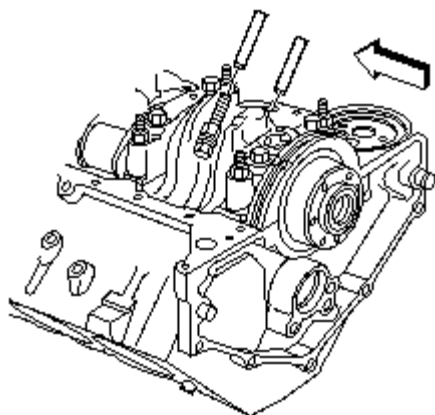

7. Use the rubber fuel line in order to guide the connecting rod onto the crankshaft journal.
8. Remove the rubber fuel line.

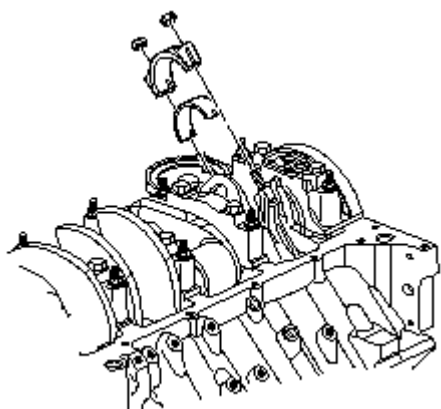

9. Install the connecting rod cap and lower connecting rod bearing.

**Notice:** Refer to *Fastener Notice in Cautions and Notices*.

**Important:** When installing the piston/connecting rod assembly, NEW connecting rod nuts must be installed.

10. Install the new connecting rod nuts.

**Tighten:**

11. Tighten the connecting rod nuts a first pass to 30♦&newtonm; (22♦lb♦ft).
12. Tighten the connecting rod nuts an additional 90♦degrees using the J 45059.

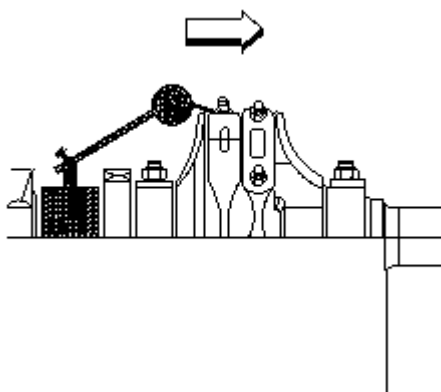

13. Once the piston and connecting rod assemblies have been installed, lightly tap each connecting rod assembly, parallel to the crankpin, in order to make sure that they have side clearance.

14. Use a feeler gage or a dial indicator to measure the side clearance between the connecting rod caps. The rod side clearance

should be 0.384–0.686♦mm (0.0151–0.0270♦in).

## Repair Instructions

### Camshaft Installation

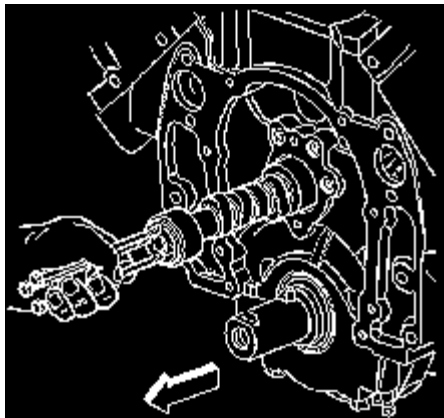

1. Lubricate the following components with clean engine oil.

- The camshaft lobes
- The camshaft bearing journals
- The camshaft bearings

**Notice:** All camshaft journals are the same diameter, so care must be used in removing or installing the camshaft to avoid damage to the camshaft bearings.

2. Install the three 8–1.25 x 100♦mm bolts in the camshaft front bolt holes.
3. Using the bolts as a handle, install the camshaft.
4. Remove the three bolts from the front of the camshaft.

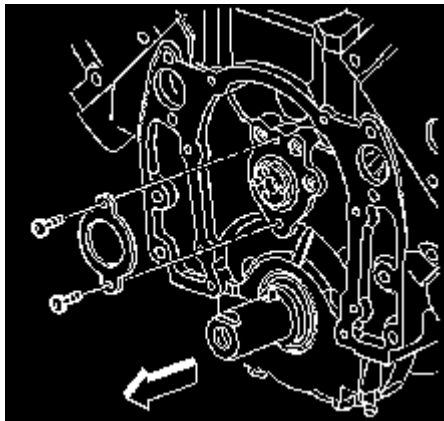

5. Install the camshaft retainer.

**Notice:** Refer to *Fastener Notice in Cautions and Notices*.

6. Install the camshaft retainer bolts.

**Tighten:** Tighten the camshaft retainer bolts to 12♦&newtonm; (106♦lb♦in).

## Repair Instructions

### Timing Chain and Sprockets Installation

#### Tools Required

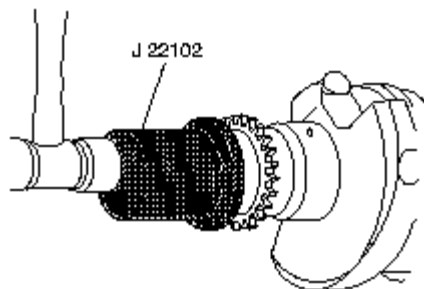
*J 22102* Front Cover Aligner and Seal Installer

1. Use the *J 22102* in order to install the crankshaft sprocket.

Align the keyway of the crankshaft sprocket with the crankshaft pin.

2. Inspect the sprocket pin for proper installation. Refer to *Crankshaft and Bearings Cleaning and Inspection*.
3. Rotate the crankshaft until the crankshaft sprocket alignment mark is in the 12 o'clock position.

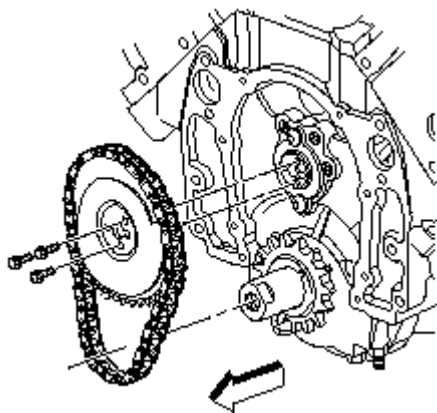

**Notice:** Do not hammer the camshaft sprocket onto the camshaft. To do so may dislodge the rear camshaft plug and damage the camshaft.

**Important:** Install the camshaft sprocket with the alignment mark in the 6 o'clock position.

**Important:** The sprocket teeth must mesh with the timing chain in order to prevent damage to the camshaft retainer.

4. Install the camshaft sprocket and timing chain.

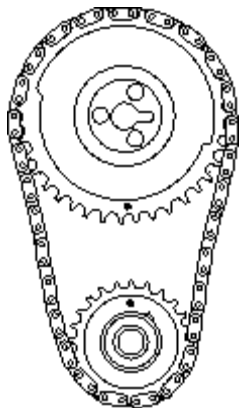

5. Look to ensure that the crankshaft sprocket is aligned at the 12 o'clock position and the camshaft sprocket is aligned at the

6 o'clock position.

**Notice:** Refer to *Fastener Notice in Cautions and Notices*.

6. Install camshaft sprocket bolts.

**Tighten:** Tighten the three camshaft sprocket bolts to 30 N·m; (22 lb·ft).

## Repair Instructions

### Engine Front Cover Installation

#### Tools Required

*J 42851* Front Cover Oil Seal Installer

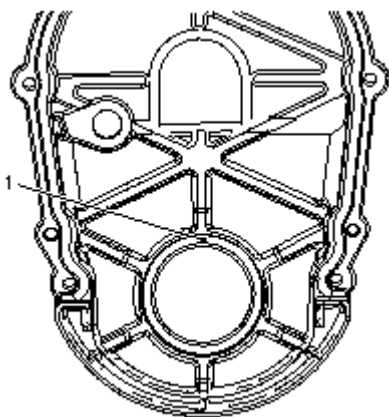

1. Lubricate the outer sealing surface of the crankshaft front oil seal lightly with clean engine oil. DO NOT lubricate the inner portion of the seal.

2. Position the NEW crankshaft front oil seal in the engine front cover so that the mark (1) on the rear of the seal is in the 12 o'clock position.

Second design oil seals will not have an alignment mark on the rear face. The seal may be installed in any position.

3. Install the crankshaft front oil seal using the *J 42851*.

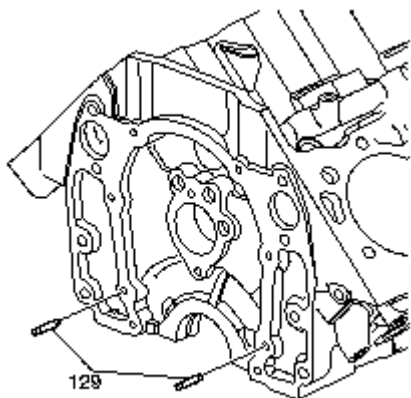

4. Install the front cover locating pins (129), if required.

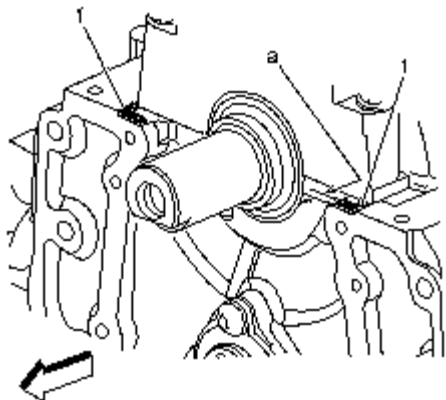

**Important:** The engine front cover must be installed and the fasteners tightened while the sealant is still wet to the touch.

5. Apply a 3–4 mm (0.12–0.16 in) bead of sealant (a) GM P/N 12346286, (Canadian P/N 10953472), or equivalent in 2 sealant points (1) on the engine block where the front cover meets the oil pan.

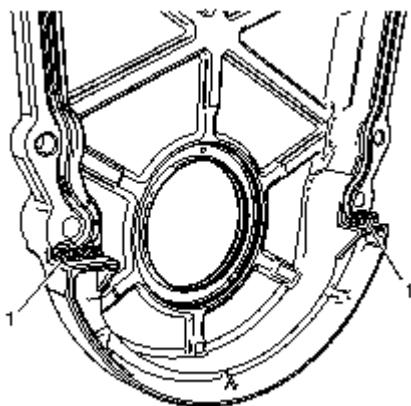

6. Apply a 3–4 mm (0.12–0.16 in) bead of sealant GM P/N 12346286, (Canadian P/N 10953472), or equivalent in 2 sealant points (1) across the flange where the gasket ends at the bottom of the front cover.

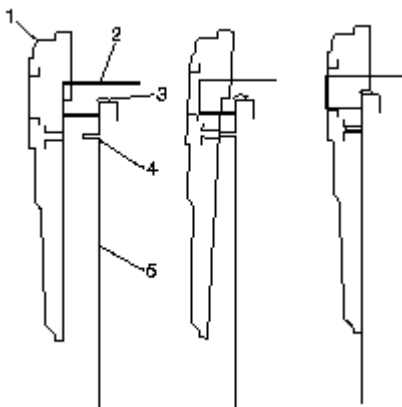

7. Install the engine front cover gasket into the front cover.

**Important:** The following method must be used when installing the engine front cover. Failure to follow the instructions will push the sealant out, which may cause an oil leak.

8. Install the engine front cover.

- 8.1. Hold the front cover (1) up to the crankshaft (2).
- 8.2. Lift the front cover (1) while sliding the cover over the crankshaft (2).
- 8.3. Slide the front cover towards the engine block (5) while keeping the cover raised.
- 8.4. Lower the cover down over the dowel pin (4), allowing the front cover to rest on the sealant (3).

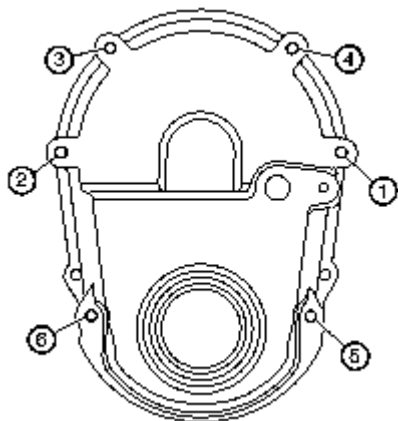

**Notice:** Refer to *Fastener Notice in Cautions and Notices*.

9. Install the engine front cover bolts.

**Tighten:**

- Tighten the engine front cover bolts in sequence a first pass to 6♦&newtonm; (53♦lb♦in).
- Tighten the engine front cover bolts in sequence a final pass to 12♦&newtonm; (106♦lb♦in).

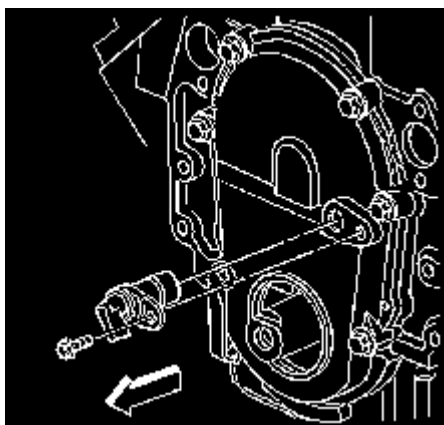

10. Inspect the camshaft position sensor O-ring for cuts, cracks, tears or damage. Replace the O-ring as needed.

11. Apply a light film of clean engine oil to the camshaft position sensor O-ring.

12. Install the camshaft position sensor.

**Notice:** This bolt is a self-tapping bolt. If installing this bolt into a new component, installation of the bolt may be difficult. Ensure that the bolt is not over-torqued during the initial installation (thread cutting). Failure to limit torque can lead to bolt failure.

13. Install the camshaft position sensor bolt.

**Tighten:** Tighten the camshaft position sensor bolt to 12♦&newtonm; (106♦lb♦in).

## Repair Instructions

### Oil Pump, Pump Screen and Deflector Installation

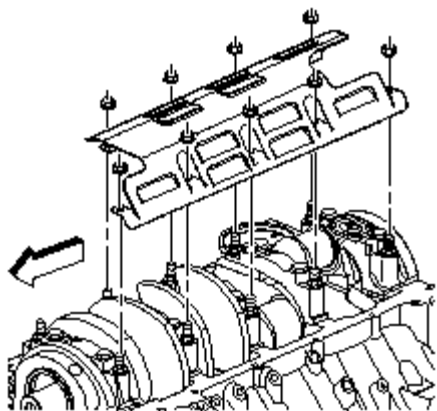

1. Install the crankshaft oil deflector.

**Notice:** Refer to *Fastener Notice in Cautions and Notices*.

2. Install the crankshaft oil deflector nuts.

**Tighten:** Tighten the crankshaft oil deflector nuts to 50♦&newtonm; (37♦lb♦ft).

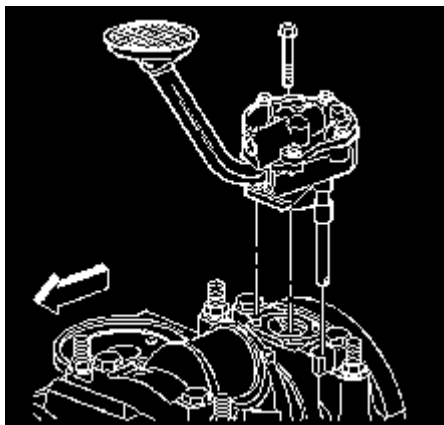

**Important:** During assembly, install a NEW oil pump driveshaft retainer. Slightly heat retainer above room temperature for ease of installation onto the oil pump driveshaft.

3. Install clean engine oil into the oil pump through the outlet oil hole. Rotate the pump in both directions to prime and lubricate.

4. Assemble the oil pump, driveshaft, and a NEW retainer.

5. Install the oil pump assembly.

Position the oil pump onto the locating pins.

6. Install the bolt attaching the oil pump to the rear crankshaft bearing cap.

**Tighten:** Tighten the oil pump bolt to 75♦&newtonm; (55♦lb♦ft).

7. Pour clean engine oil into the oil pump pickup screen.

## Repair Instructions

### Oil Pan Installation

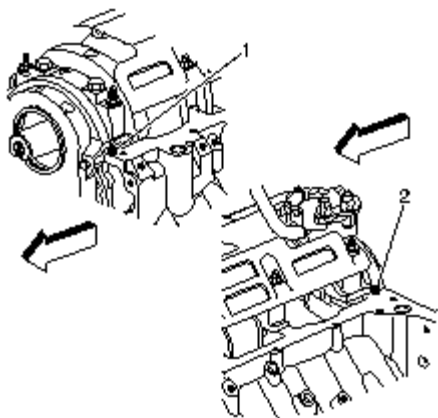

**Important:** The oil pan must be installed within five minutes of the sealer being applied or the sealer will begin to cure, causing an inadequate seal.

1. Apply sealant GM P/N 12346286, (Canadian P/N 10953472), to the side of the front cover (1) and rear (2) crankshaft bearing cap, on both the left and right sides, 4 locations total.

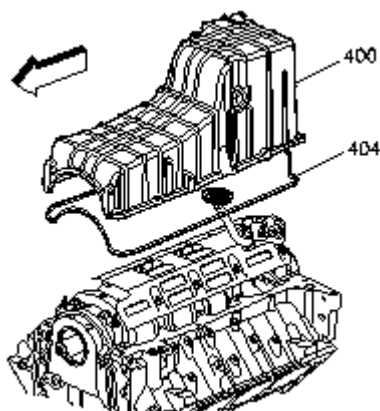

2. Install the new oil pan gasket (404) into the oil pan groove.
3. Install the oil pan (400).

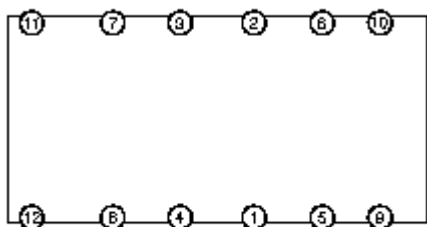

**Notice:** Refer to *Fastener Notice in Cautions and Notices*.

4. Install the oil pan bolts (1-12).
5. Tighten the oil pan bolts in sequence.

**Tighten:**

- Tighten the oil pan bolts a first pass in sequence to 10 newtonm; (89 lb-in).

- Tighten the oil pan bolts a final pass in sequence to 25♦&newtonm; (18♦lb♦ft).

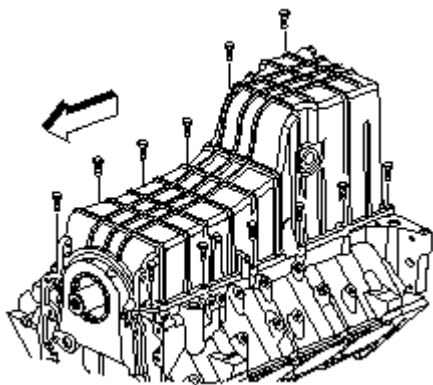

6. Install the oil pan drain plug.

**Tighten:** Tighten the oil pan drain plug to 28♦&newtonm; (21♦lb♦ft).

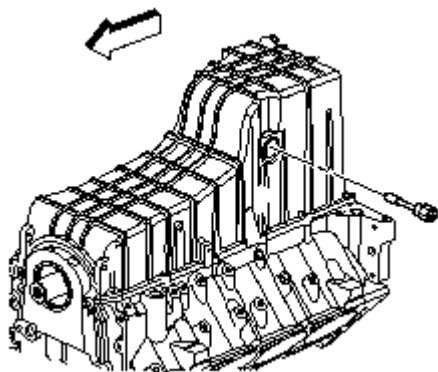

7. Lubricate the oil level sensor O-ring with engine oil.

8. Install the oil level sensor.

**Tighten:** Tighten the oil level sensor to 20♦&newtonm; (15♦lb♦ft).

## Repair Instructions

### Oil Pump Drive Installation

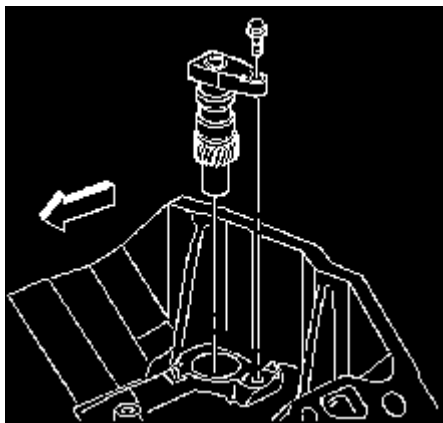

1. Apply grease to the oil pump drive gear for ease of assembly.

**Notice:** Ensure both components are aligned correctly or serious engine damage will occur.

2. Line up the oil pump drive gear with the oil pump drive shaft.
3. Install the oil pump drive, making sure that the oil pump drive is fully seated in the engine block.

**Notice:** Refer to *Fastener Notice in Cautions and Notices*.

4. Install the oil pump drive bolt.

**Tighten:** Tighten the oil pump drive bolt to 25♦&newtonm; (18♦lb♦ft).

## Repair Instructions

### Valve Lifter Installation

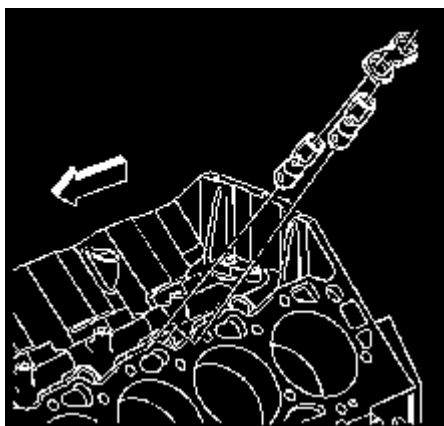

**Important:** If a new camshaft is installed, replace all the valve lifters.

1. Coat the valve lifter rollers with clean engine oil.

**Important:** If reusing the valve lifters, install in their original location. The valve lifter guide retainer must contact all of the valve lifter guides. If the valve lifter guide retainer is bent, the valve lifter guide retainer must be replaced.

2. Install the valve lifters.
3. Install the valve lifter guides over the flats on the valve lifters, making sure the rollers of the valve lifters are properly aligned with the camshaft lobes.

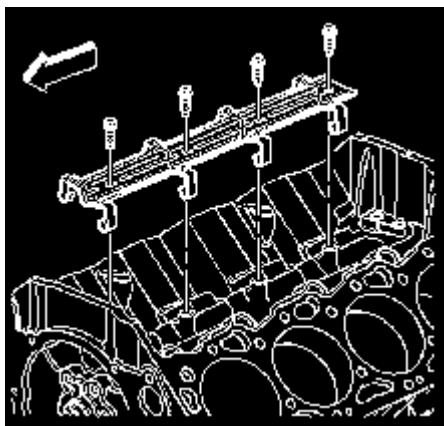

4. Install the valve lifter guide retainer.

**Notice:** Refer to *Fastener Notice in Cautions and Notices*.

5. Install the valve lifter guide retainer bolts.

**Tighten:** Tighten the valve lifter guide retainer bolts to 25♦&newtonm; (18♦lb♦ft).

## Repair Instructions

## Cylinder Head Installation - Left

### Tools Required

J 45059 Angle Meter

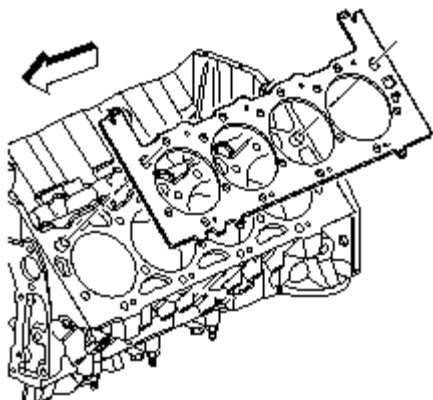

**Notice:** Do not use a sealant or adhesive when installing this component. Use of a sealant or adhesive can cause improper sealing. A component that is not sealed properly can leak leading to extensive engine damage.

1. Place the cylinder head gasket in position over the cylinder head locating pins.

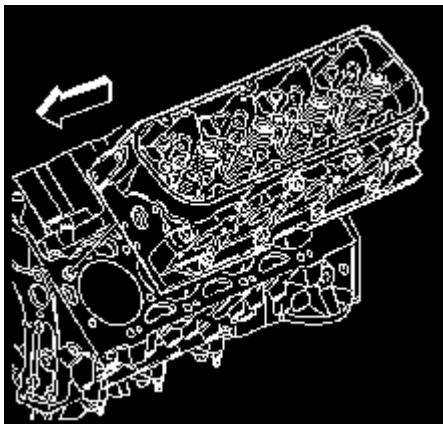

**Important:** Guide the cylinder head carefully into place over the locating pins and the cylinder head gasket.

2. Install the cylinder head to the block.

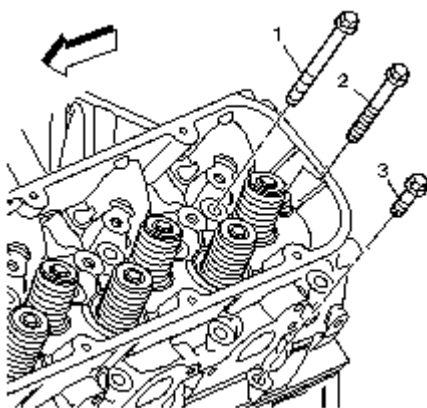

**Notice:** Do not reuse the cylinder head bolts. NEW cylinder head bolts must be used. The cylinder head bolts are torque-to-yield bolts and cannot be reused once the initial torque is applied. During the initial torque of the cylinder

head bolt the cylinder head bolt is stretched to achieve proper clamp load. Proper clamp load will not be achieved if a used cylinder head bolt is torqued again. A stretched cylinder head bolt can also break when torqued. Failure to replace the used cylinder head bolts with NEW cylinder head bolts can lead to improper clamp loads and extensive engine damage.

**Important:** The sealer must be applied to a minimum of eight threads starting at the point of the cylinder head bolt.

3. If not pre-applied to the new cylinder head bolts, apply sealer GM♦P/N♦12346004, (Canadian♦P/N♦10953480), or equivalent to the cylinder head bolts. Refer to Use of RTV and Anaerobic Sealer.

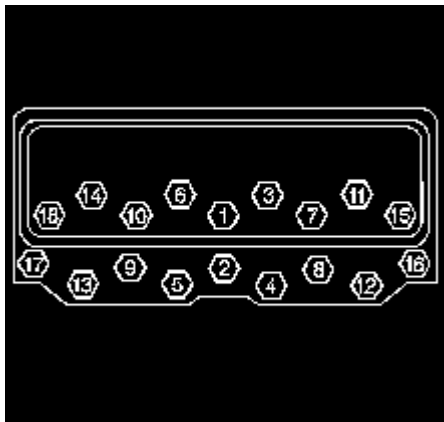

**Notice:** Refer to *Fastener Notice* in *Cautions and Notices*.

**Notice:** Do not reuse a cylinder head gasket once the initial clamping loads are applied. The initial tightening sequence procedure of the cylinder head bolts compresses the cylinder head gasket. If any bolt must be loosened once the initial sequence is started the cylinder head gasket must be replaced. Failure to replace the cylinder head gasket can lead to cylinder head bolt breakage or cylinder head gasket failure. A broken cylinder head bolt or failed cylinder head gasket can lead to extensive engine damage.

**Notice:** The cylinder head bolt tightening sequence must be followed. The final angle tightening sequence of the cylinder head bolts varies depending on the length of the cylinder head bolt. Failure to angle tighten the specific length bolt the proper number of degrees can lead to cylinder head bolt failure or improper clamping load of the cylinder head gasket. Cylinder head bolt or cylinder head gasket failure can lead to extensive engine damage.

**Important:** The long bolts are used in locations 1, 2, 3, 6, 7, 8, 9, 10, 11, 14, 16 and 17. The medium length bolts are used in locations 15 and 18. The short bolts are used in locations 4, 5, 12 and 13.

4. Install the cylinder head bolts.

**Tighten:**

5. Tighten the bolts a first pass in sequence to 30♦&newtonm; (22♦lb♦ft).

6. Retighten the bolts in a second pass in sequence to 30♦&newtonm; (22♦lb♦ft), then an additional 120♦degrees using the *J 45059*.

7. Tighten the bolts, 1, 2, 3, 6, 7, 8, 9, 10, 11, 14, 16, 17, an additional 60♦degrees, bolts, 15 and 18, an additional 45♦degrees, and bolts, 4, 5, 12, 13, an additional 30♦degrees a final pass in sequence using the *J 45059*.

## Repair Instructions

### Cylinder Head Installation - Right

#### Tools Required

*J 45059* Angle Meter

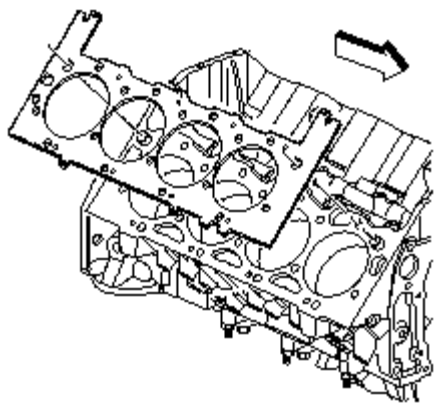

**Notice:** Do not use a sealant or adhesive when installing this component. Use of a sealant or adhesive can cause improper sealing. A component that is not sealed properly can leak leading to extensive engine damage.

1. Place the cylinder head gasket in position over the cylinder head locating pins.

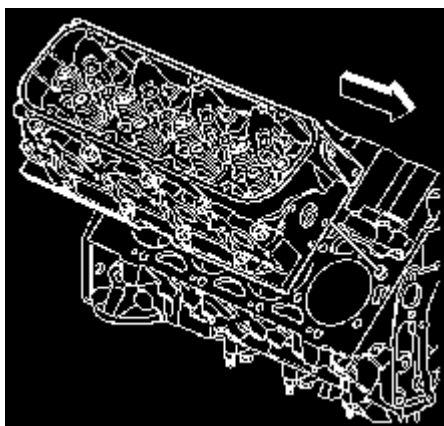

**Important:** Guide the cylinder head carefully into place over the locating pins and the cylinder head gasket.

2. Install the cylinder head to the block.

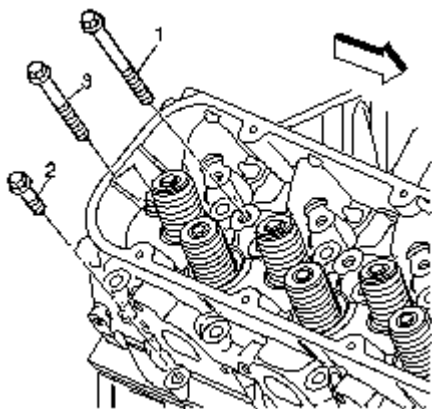

**Notice:** Do not reuse the cylinder head bolts. NEW cylinder head bolts must be used. The cylinder head bolts are torque-to-yield bolts and cannot be reused once the initial torque is applied. During the initial torque of the cylinder head bolt the cylinder head bolt is stretched to achieve proper clamp load. Proper clamp load will not be achieved if a used cylinder head bolt is torqued again. A stretched cylinder head bolt can also break when torqued. Failure to replace the used cylinder head bolts with NEW cylinder head bolts can lead to improper clamp loads and extensive engine damage.

**Important:** The sealer must be applied to a minimum of eight threads starting at the point of the cylinder head bolt.

3. If not pre-applied to the new cylinder head bolts (1–3), apply sealer GM P/N 12346004, (Canadian P/N 10953480), or equivalent to the cylinder head bolts. Refer to Use of RTV and Anaerobic Sealer.

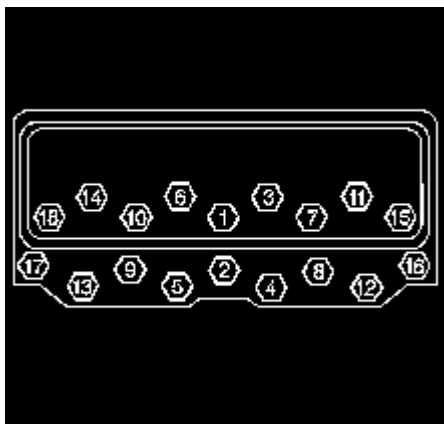

**Notice:** Refer to *Fastener Notice* in *Cautions and Notices*.

**Notice:** Do not reuse a cylinder head gasket once the initial clamping loads are applied. The initial tightening sequence procedure of the cylinder head bolts compresses the cylinder head gasket. If any bolt must be loosened once the initial sequence is started the cylinder head gasket must be replaced. Failure to replace the cylinder head gasket can lead to cylinder head bolt breakage or cylinder head gasket failure. A broken cylinder head bolt or failed cylinder head gasket can lead to extensive engine damage.

**Notice:** The cylinder head bolt tightening sequence must be followed. The final angle tightening sequence of the cylinder head bolts varies depending on the length of the cylinder head bolt. Failure to angle tighten the specific length bolt the proper number of degrees can lead to cylinder head bolt failure or improper clamping load of the cylinder head gasket. Cylinder head bolt or cylinder head gasket failure can lead to extensive engine damage.

**Important:** The long bolts are used in locations 1, 2, 3, 6, 7, 8, 9, 10, 11, 14, 16 and 17. The medium length bolts are used in locations 15 and 18. The short bolts are used in locations 4, 5, 12 and 13.

4. Install the cylinder head bolts.

**Tighten:**

5. Tighten the bolts a first pass in sequence to 30 N·m; (22 lb·ft).
6. Re-tighten the bolts a second pass in sequence to 30 N·m; (22 lb·ft), then an additional 120 degrees using the *J 45059*.
7. Tighten the bolts, 1, 2, 3, 6, 7, 8, 9, 10, 11, 14, 16, 17, an additional 60 degrees, bolts, 15 and 18, an additional 45 degrees, and bolts, 4, 5, 12, 13, an additional 30 degrees a final pass in sequence using the *J 45059*.

## Repair Instructions

### Valve Rocker Arm and Push Rod Installation

**Important:** Keep the parts in order. Parts must be put back from where they were removed.

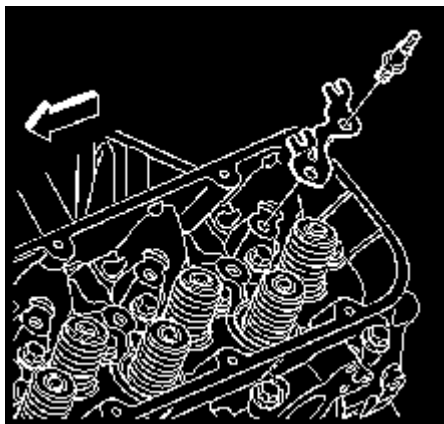

1. Apply sealer GM P/N 12346004, (Canadian P/N 10953480), or equivalent to the valve rocker arm stud-to-cylinder head threads.

Apply the sealer to a minimum of 6 threads.

**Notice:** Refer to *Fastener Notice in Cautions and Notices*.

2. Install the push rod guides and valve rocker arm studs onto the cylinder head.

**Tighten:** Tighten the valve rocker arm studs to 50 newtonm; (37 lb-ft).

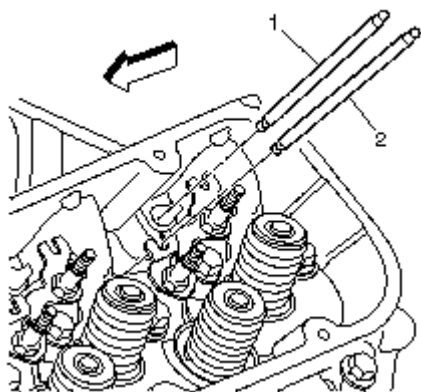

**Important:** The 8.1L engine uses different length intake and exhaust valve push rods.

The exhaust valve push rods (2) are longer than the intake valve push rods (1).

3. Install the valve push rods.

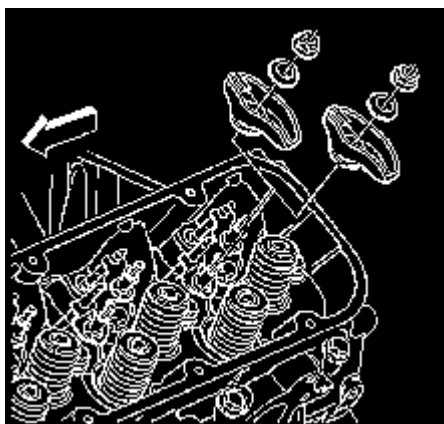

4. Coat the valve rocker arm and valve rocker arm ball bearing surfaces with clean engine oil.

5. Install the valve rocker arms, the valve rocker arm balls and the valve rocker arm nuts.

**Tighten:** Tighten the valve rocker arm nuts slowly, to 35♦&newtonm; (26♦lb♦ft), while guiding the tips of the rocker arms over the tips of the valves.

## Repair Instructions

### Intake Manifold Installation

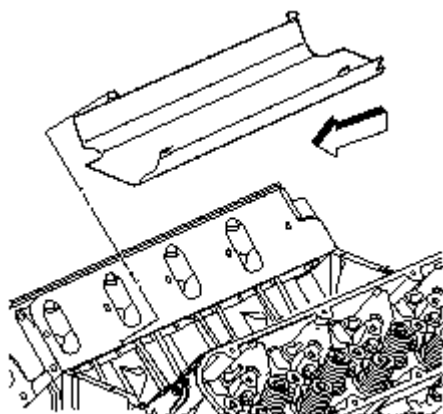

1. Install the splash shield.

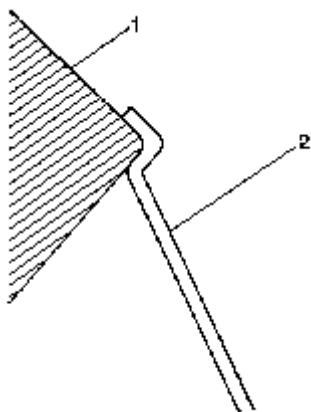

2. Ensure the splash shield♦(2) snap fits between the cylinder heads♦(1).

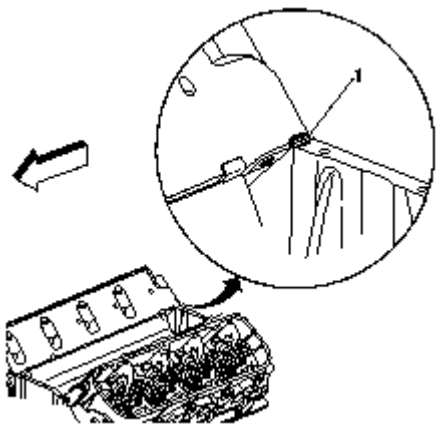

3. Apply a 5♦mm (0.2♦in) bead of GM♦P/N♦12346141 (Canadian♦P/N♦10953433) sealer♦(1) to the 4♦engine block/cylinder head locations.

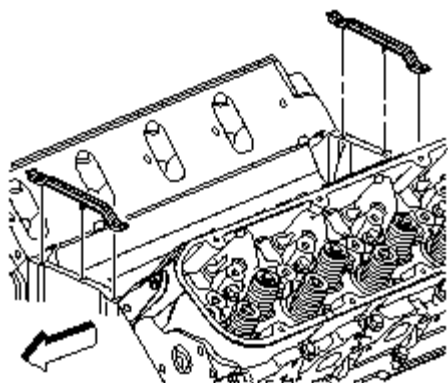

4. Install the new intake manifold end seals.

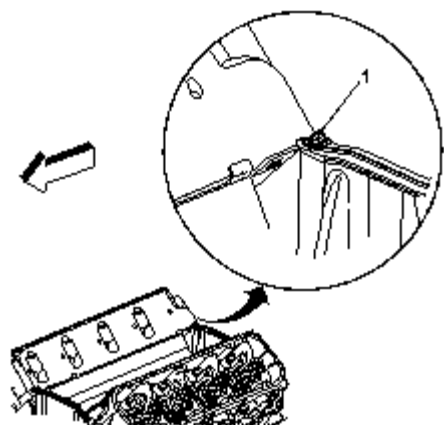

5. Apply a 5mm (0.2in) bead of GM P/N 12346141 (Canadian P/N 10953433) sealer (1) onto the end seals at the 4 engine block/cylinder head locations.

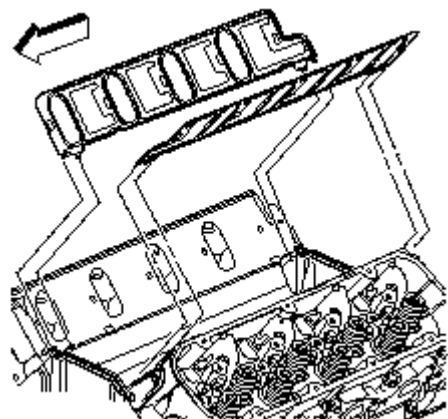

6. Install the new intake manifold side gaskets onto the cylinder heads.

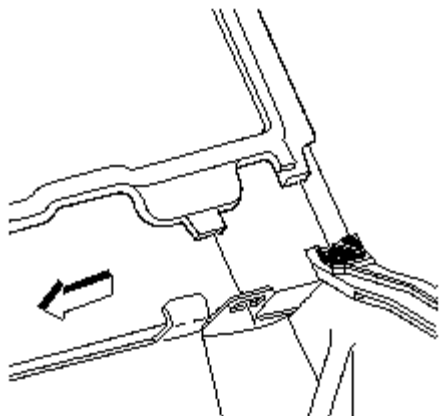

7. Ensure the intake manifold gasket tabs align with the hole in the head gasket.

8. Ensure the intake manifold gasket tabs align with the slot in the intake manifold end seals.

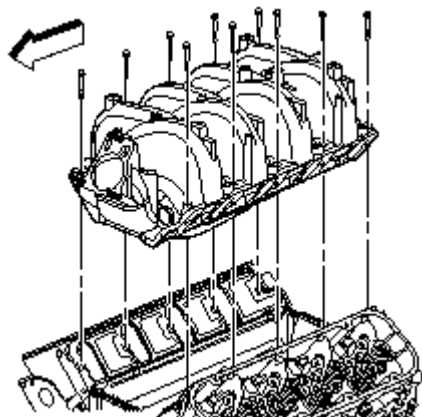

9. Install the intake manifold onto the engine block.

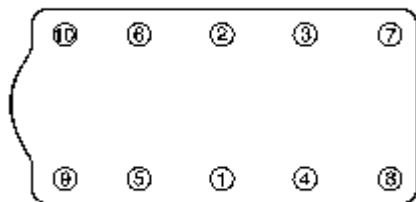

**Notice:** Ensure the intake manifold does not shift as the intake manifold bolts are tightened in the proper sequence. Failure to follow the entire intake manifold bolt tightening sequence exactly, may result in an oil leak and serious engine damage.

**Important:** The entire intake manifold tightening sequence must be promptly completed due to the anaerobic thread adhesive. The final pass of the tightening sequence must be completed before the adhesive starts to cure, or false torque readings and ineffective thread locking may result.

**Important:** DO NOT reuse intake manifold bolts. Install NEW intake manifold bolts during assembly.

10. Install the NEW intake manifold bolts.

**Notice: Refer to *Fastener Notice in Cautions and Notices.***

11. Tighten the intake manifold bolts in sequence, using 4 passes.

**Tighten:**

12. Tighten the intake manifold bolts a first pass in sequence to 5 N·m; (44 lb·in).
13. Tighten the intake manifold bolts a second pass in sequence to 8 N·m; (71 lb·in). Inspect the intake manifold joints for signs of intake manifold shifting. Correct as required.
14. Tighten the intake manifold bolts a third pass in sequence to 12 N·m; (106 lb·in).
15. Tighten the intake manifold bolts a final pass in sequence to 15 N·m; (111 lb·ft).

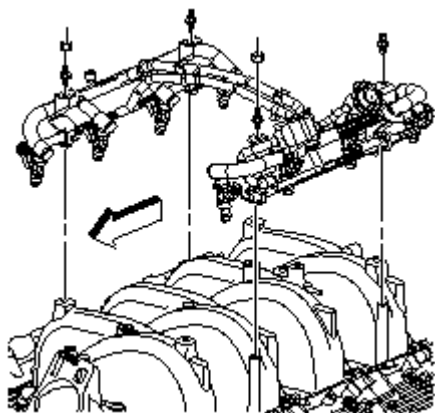

**Important:** Lubricate the injector O-ring seals with clean engine oil and install onto the spray tip end of each injector.

16. Install the fuel injection fuel rail with injectors.

17. Install the fuel injection fuel rail bolts/studs.

**Tighten:** Tighten the fuel injection fuel rail bolts/studs to 12 N·m; (106 lb·in).

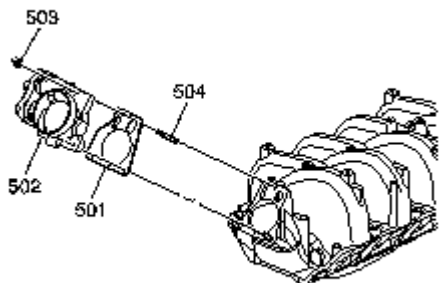

18. Install the throttle body gasket (501) and throttle body (502).

19. Install the throttle body nuts (503).

**Tighten:** Tighten the throttle body nuts to 10 N·m; (89 lb·in).

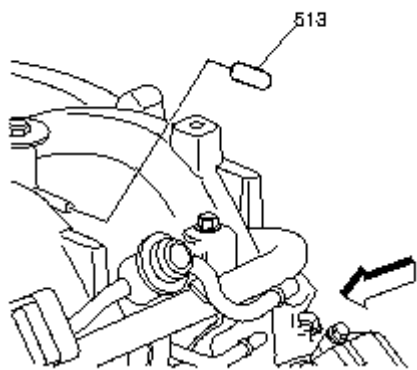

20. Install the vacuum plug♦(513).

## Repair Instructions

### Valve Rocker Arm Cover Installation - Left

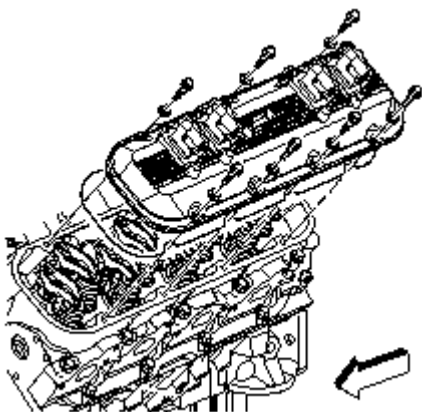

1. Install a new valve rocker arm cover gasket if the gasket was removed from the valve rocker arm cover.
2. Install the valve rocker arm cover.
3. Install the valve rocker arm cover bolts.

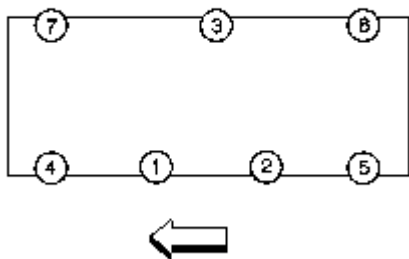

**Notice:** Refer to *Fastener Notice in Caution and Notices*.

4. Tighten the valve rocker arm cover bolts in sequence using 2♦passes.

**Tighten:**

- Tighten the valve rocker arm cover bolts a first pass to 6♦&newtonm; (54♦lb♦in).
- Tighten the valve rocker arm cover bolts a final pass to 12♦&newtonm; (106♦lb♦in).

## Repair Instructions

### Valve Rocker Arm Cover Installation - Right

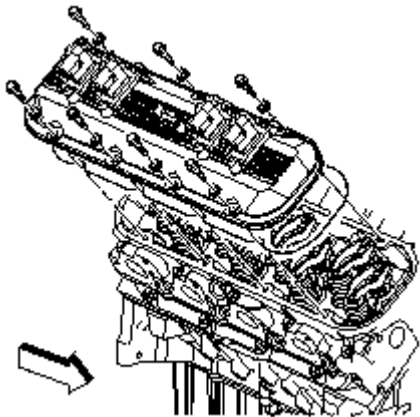

1. Install a new valve rocker arm cover gasket if the gasket was removed from the valve rocker arm cover.
2. Install the valve rocker arm cover.
3. Install the valve rocker arm cover bolts.

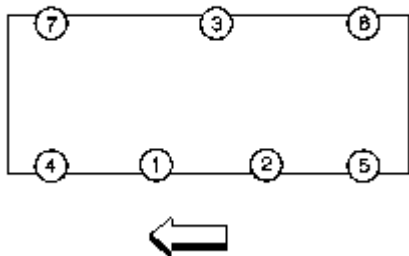

**Notice:** Refer to *Fastener Notice in Caution and Notices*.

4. Tighten the valve rocker arm cover bolts in sequence using 2♦passes.

#### Tighten:

- Tighten the valve rocker arm cover bolts a first pass to 6♦&newtonm; (54♦lb♦in).
- Tighten the valve rocker arm cover bolts a final pass to 12♦&newtonm; (106♦lb♦in).

## Repair Instructions

### Water Pump Installation

#### Tools Required

J 41240 Fan Clutch Remover and Installer

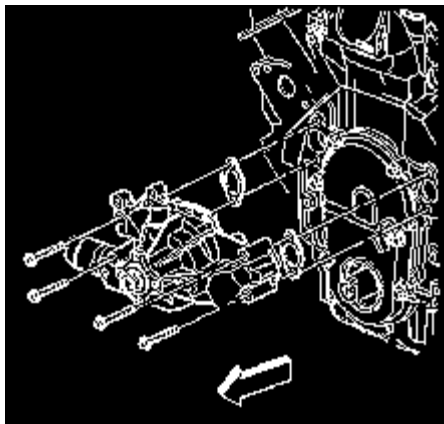

1. Install the water pump and gaskets.

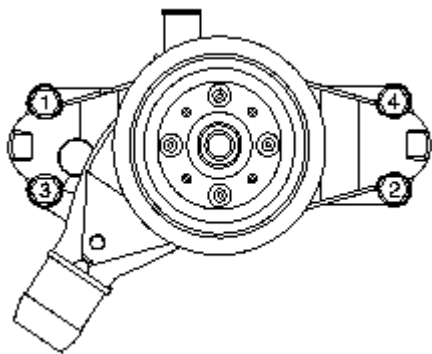

**Notice:** Refer to *Fastener Notice in Cautions and Notices.*

2. Install the water pump bolts.

**Tighten:**

- Tighten the water pump bolts a first pass to 25♦&newtonm; (18♦lb♦ft).
- Tighten the water pump bolts a final pass to 50♦&newtonm; (37♦lb♦ft).

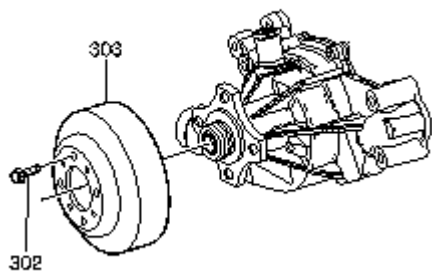

3. Install the water pump pulley♦(303) and bolts♦(302).

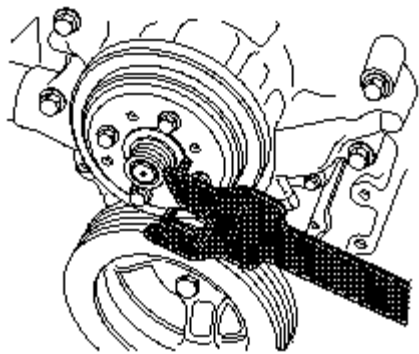

4. Use the *J 41240* in order to retain the water pump pulley.

**Tighten:** Tighten the water pump pulley bolts to 25♦&newtonm; (18♦lb♦ft).

## Repair Instructions

### Water Crossover Installation

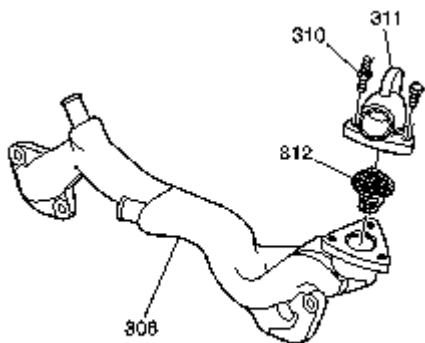

1. Install the thermostat♦(312) with the seal into the water crossover♦(308).
2. Install the thermostat housing♦(311).

**Notice:** Refer to *Fastener Notice in Cautions and Notices*.

3. Install the thermostat housing bolts♦(310).

**Tighten:** Tighten the bolts to 30♦&newtonm; (22♦lb♦ft).

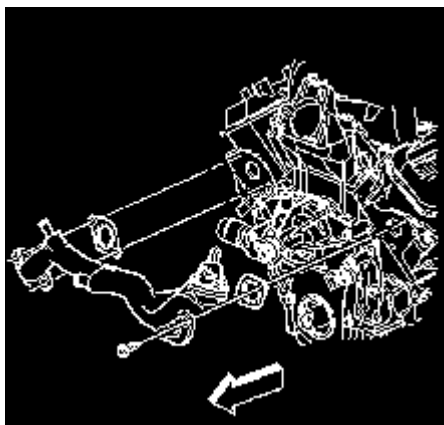

4. Install the gaskets and the water crossover.
5. Install the bolts.

**Tighten:** Tighten the water crossover bolts to 50♦&newtonm; (37♦lb♦ft).

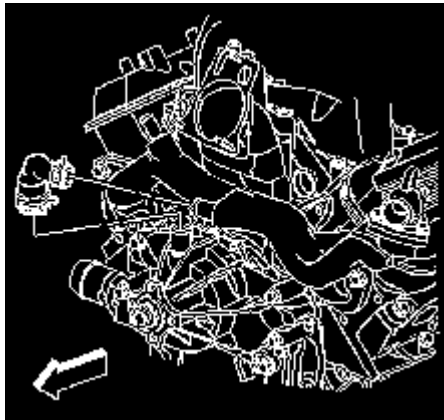

**Important:** Properly position the bypass hose clamps to avoid water pump pulley interference.

6. Install the thermostat bypass hose and clamps.

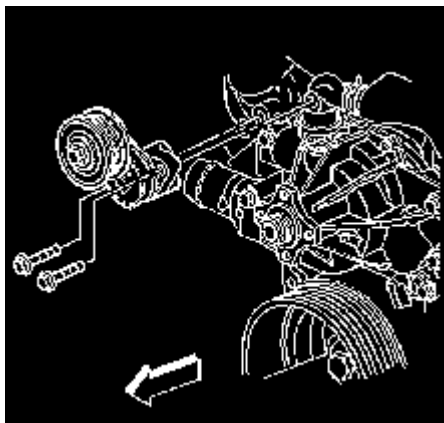

7. Install the drive belt tensioner.
8. Install the drive belt tensioner bolts.

**Tighten:** Tighten the drive belt tensioner bolts to 50♦&newtonm; (37♦lb♦ft).

## Repair Instructions

### Exhaust Manifold Installation - Left

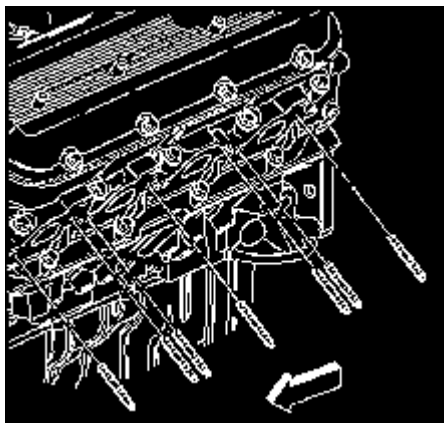

**Notice: Refer to *Fastener Notice in Cautions and Notices.***

1. Install the exhaust manifold studs into the cylinder head, if necessary.

**Tighten:** Tighten the exhaust manifold studs to 20♦&newtonm; (15♦lb♦ft).

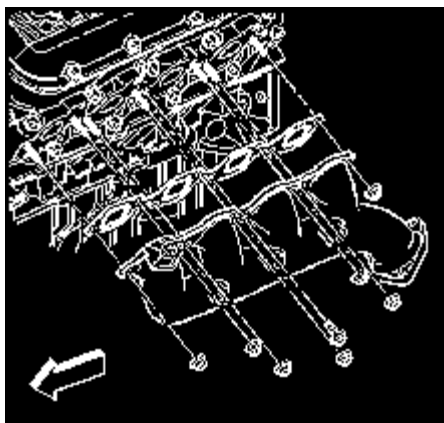

2. Install the NEW left exhaust manifold gasket.
3. Install the left exhaust manifold.
4. Install the left exhaust manifold nuts and center bolt.

**Tighten:**

- Tighten the left exhaust manifold center bolt to 35♦&newtonm; (26♦lb♦ft).
- Tighten the left exhaust manifold nuts to 16♦&newtonm; (12♦lb♦ft).

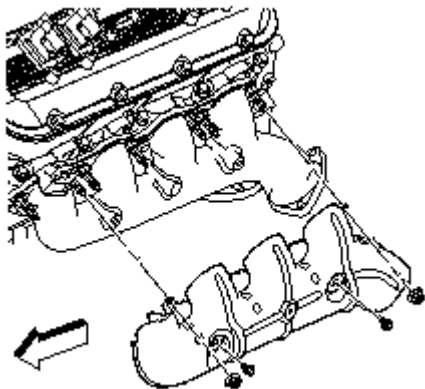

5. Install the left exhaust manifold heat shield.
6. Install the left exhaust manifold heat shield bolts and nuts.

**Tighten:** Tighten the left exhaust manifold heat shield bolts and nuts to 25♦&newtonm; (18♦lb♦ft).

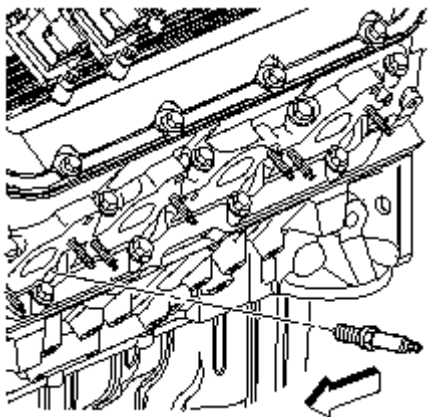

7. Install the left spark plugs.

**Tighten:** Tighten the left spark plugs to 30♦&newtonm; (22♦lb♦ft).

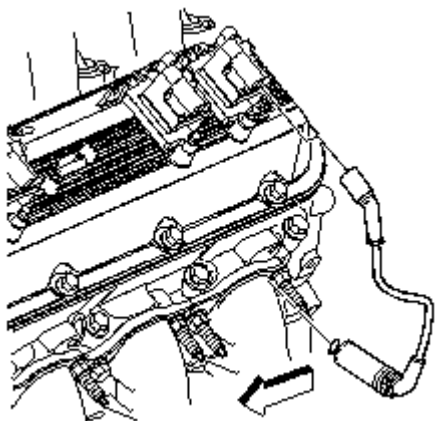

**Important:** Fully install the spark plug wire by pushing on the exposed end of the spark plug boot. Do not push the spark plug wire on to the spark plug by using the metal heat shield.

8. Install the left spark plug wires to the spark plugs and ignition coils.

## Repair Instructions

### Exhaust Manifold Installation - Right

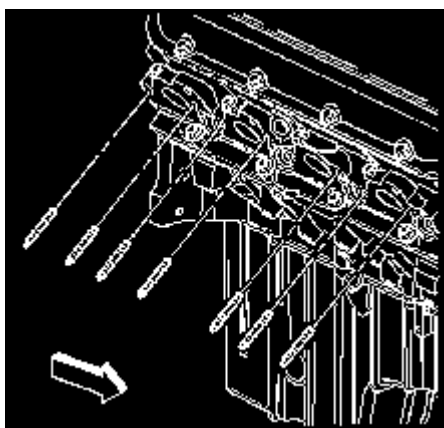

**Notice:** Refer to *Fastener Notice* in *Cautions and Notices*.

1. Install the exhaust manifold studs into the cylinder head, if necessary.

**Tighten:** Tighten the exhaust manifold studs to 20♦&newtonm; (15♦lb♦ft).

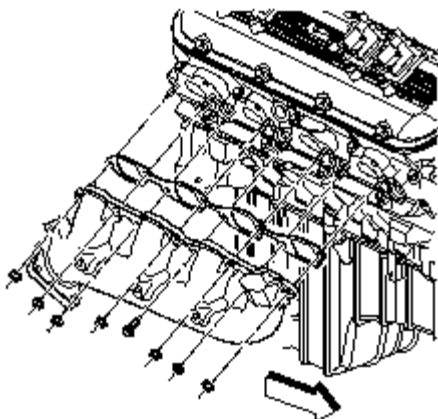

2. Install the NEW right exhaust manifold gasket.

3. Install the right exhaust manifold.

4. Install the right exhaust manifold nuts and center bolt.

**Tighten:**

- Tighten the right exhaust manifold center bolt to 35♦&newtonm; (26♦lb♦ft).
- Tighten the right exhaust manifold nuts to 16♦&newtonm; (12♦lb♦ft).

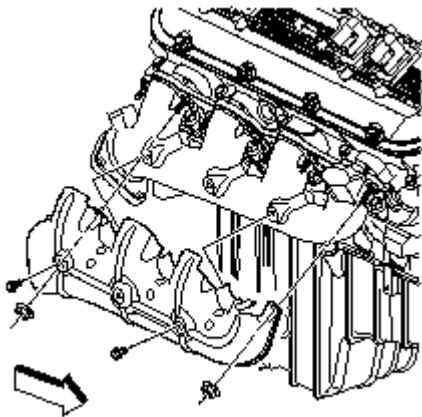

5. Install the right exhaust manifold heat shield.

6. Install the right exhaust manifold heat shield bolts and nuts.

**Tighten:** Tighten the right exhaust manifold heat shield bolts and nuts to 25♦&newtonm; (18♦lb♦ft).

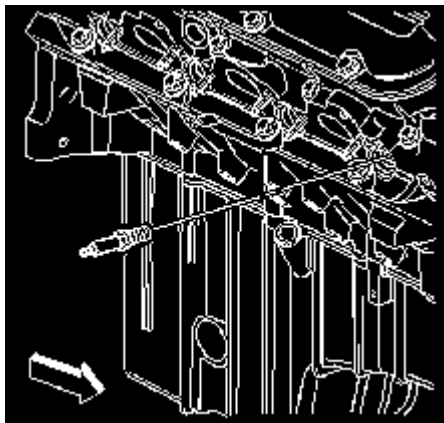

7. Install the right spark plugs.

**Tighten:** Tighten the right spark plugs to 30♦&newtonm; (22♦lb♦ft).

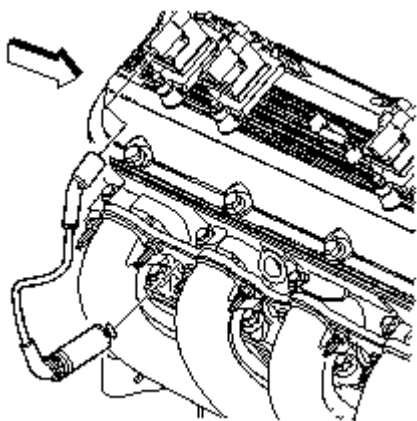

**Important:** Fully install the spark plug wire by pushing on the exposed end of the spark plug boot. Do not push the spark plug wire on to the spark plug by using the metal heat shield.

8. Install the right spark plug wires to the spark plugs and ignition coils.

## Repair Instructions

### Oil Level Indicator and Tube Installation

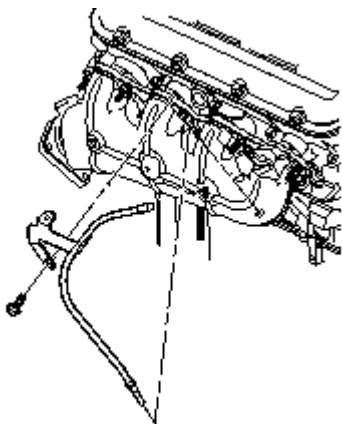

**Important:** Ensure that the oil level indicator tube does not come in contact with the spark plug wires. Route the spark plug wires around the oil level indicator tube.

1. Install a NEW O-ring seal onto the oil level indicator tube.
2. Install the oil level indicator tube into the oil pan.
3. Install the oil level indicator tube bracket to the exhaust manifold stud.

**Notice:** Refer to *Fastener Notice in Cautions and Notices*.

4. Install the oil level indicator tube bracket bolt.

**Tighten:** Tighten the oil level indicator tube bolt to 25♦&newtonm; (18♦lb♦ft).

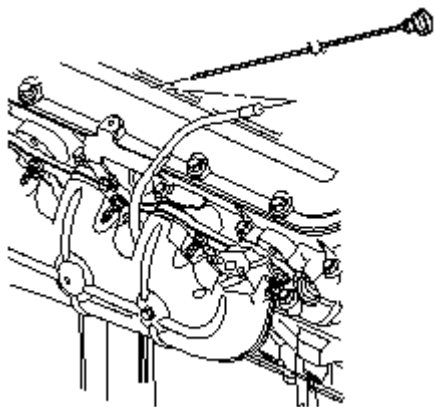

5. Install the oil level indicator into the oil level indicator tube.

## Repair Instructions

### Clutch Pilot Bearing Installation

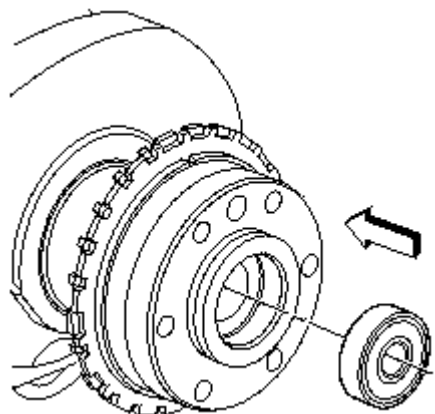

**Caution:** Refer to *Safety Glasses Caution in Cautions and Notices*.

1. Install the NEW clutch pilot bearing.

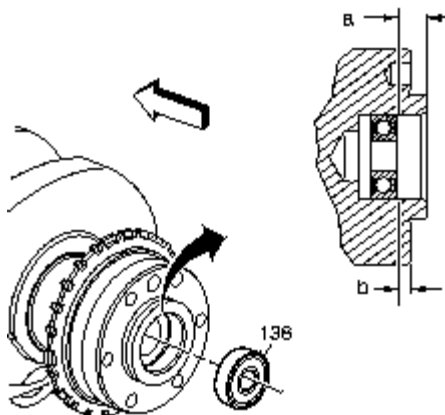

**Important:** Make sure the bearing is installed parallel to the rear of the crankshaft.

2. Measure to ensure the proper installation depth is obtained. The bearing (138) should be (a) 14.650–15.650 mm (0.577–0.616 in) from the lip of the crankshaft, or (b) 6.400–7.400 mm (0.252–0.291 in) from the crankshaft flange.

## Repair Instructions

### Crankshaft Rear Oil Seal Installation

#### Tools Required

*J 42849* Crankshaft Rear Seal Installer

**Important:** Crankshaft rear oil seal and engine flywheel installation requires adequate space for installation. If the engine stand does not allow suitable space to use the *J 42849*, install the crankshaft rear oil seal and engine flywheel with the engine properly supported on the floor.

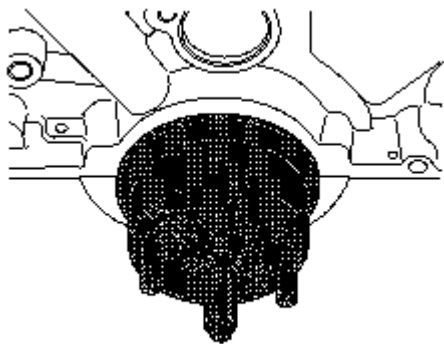

1. Make sure the crankshaft rear chamfer is free of grit, loose rust, and burrs. Correct as needed.
2. Apply a very light film of oil onto the crankshaft sealing surface.  
DO NOT apply oil to the sealing surface of the engine block.
3. Install the seal on the *J 42849*.
4. Position *J 42849* against the crankshaft. Thread the attaching screws into the tapped holes in the crankshaft.
5. Tighten the screws securely with a screwdriver in order to ensure that the seal is installed squarely over the crankshaft.
6. Rotate the center nut until the *J 42849* bottoms.
7. Remove the *J 42849*.

## Repair Instructions

### Engine Flywheel Installation (AT)

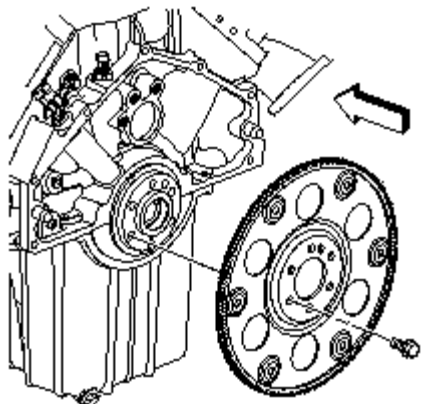

**Important:** Make sure the flywheel is installed correctly. Engine Side is stamped on the flywheel to assist with installation.

1. Install the engine flywheel.

**Notice:** Refer to *Fastener Notice in Cautions and Notices*.

2. Install the engine flywheel bolts.

Tighten the fasteners following a criss cross pattern.

**Tighten:**

- Tighten the engine flywheel bolts a first pass to 40♦&newtonm; (30♦lb♦ft).
- Tighten the engine flywheel bolts a second pass to 80♦&newtonm; (59♦lb♦ft).
- Tighten the engine flywheel bolts a final pass to 100♦&newtonm; (74♦lb♦ft).

## Repair Instructions

### Engine Flywheel Installation (MT)

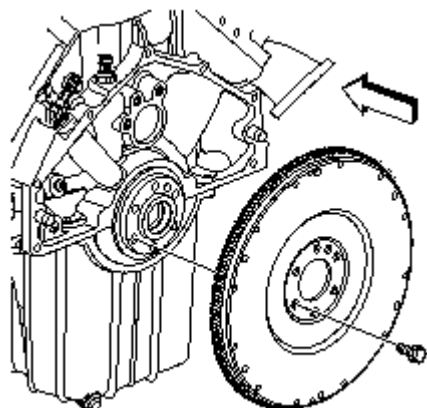

1. Install the engine flywheel.

**Notice:** Refer to *Fastener Notice in Cautions and Notices*.

2. Install the engine flywheel bolts.

Tighten the fasteners following a criss cross pattern.

**Tighten:**

- Tighten the engine flywheel bolts a first pass to 40♦&newtonm; (30♦lb♦ft).

- Tighten the engine flywheel bolts a second pass to 80♦&newtonm; (59♦lb♦ft).
- Tighten the engine flywheel bolts a final pass to 100♦&newtonm; (74♦lb♦ft).

## Repair Instructions

### Crankshaft Balancer Installation

#### Tools Required

- J 42845 Crankshaft Balancer Installer
- J 42847 Flywheel Holding Tool

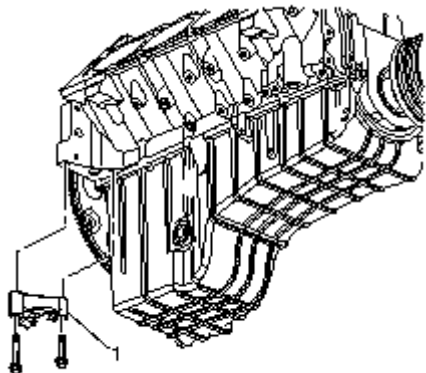

**Notice:** Refer to *Fastener Notice in Cautions and Notices.*

#### Important:

- Ensure that the teeth of the flywheel holding tool engage the engine flywheel teeth.
- The balancer should be positioned onto the end of the crankshaft as straight as possible prior to tool installation.

1. Install the J 42847 ♦(1) to the starter bolt holes.

**Tighten:** Tighten the J 42847 bolts to 50♦&newtonm; (37♦lb♦ft).

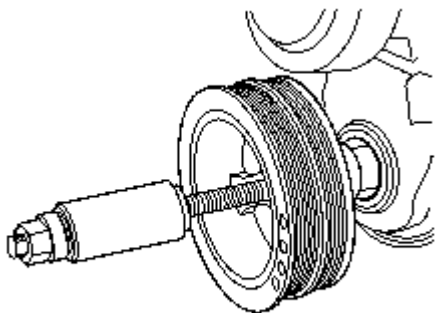

**Important:** Apply grease or clean engine oil to the inside of the crankshaft balancer or the end of the crankshaft, to prevent galling during assembly.

2. Install the balancer onto the end of the crankshaft.

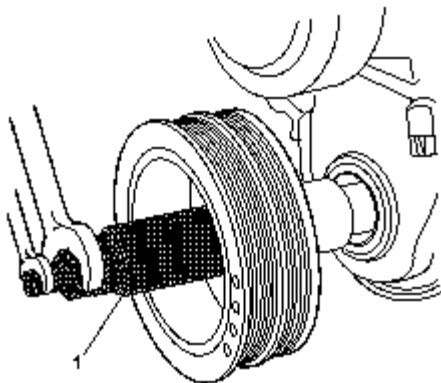

**Important:** Apply the lubricant that comes with *J 42845* each time the tool is used. Failure to lubricate *J 42845* may prevent the balancer from installing completely.

- Use the *J 42845* ♦(1) in order to install the balancer.

**Notice:** Ensure the crankshaft balancer is installed to the proper depth. The crankshaft balancer nose must be seated against the crankshaft sprocket. Failure to install the crankshaft balancer properly may result in improper torque to the crankshaft balancer bolt. An improperly torqued crankshaft balancer bolt may loosen causing serious engine damage.

- Tighten the *J 42845* until the crankshaft balancer is completely seated against the crankshaft sprocket.

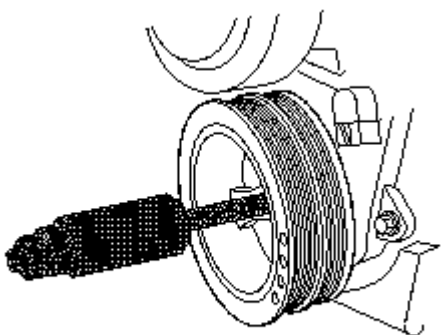

- Remove the *J 42845* from the crankshaft.

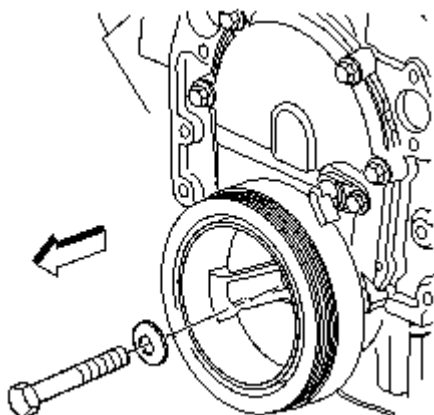

- Install the crankshaft balancer washer and bolt.

**Tighten:** Tighten the crankshaft balancer bolt to 255♦&newtonm; (189♦lb♦ft).

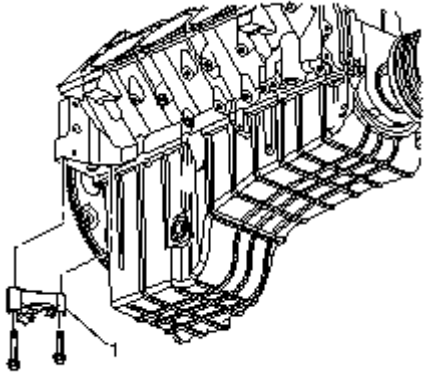

7. Remove the *J 42847* ♦(1).

## Description and Operation

### Crankcase Ventilation System Description

*Engine Mechanical - 8.1L:Description:Crankcase Ventilation System Description*

The crankcase ventilation system has no serviceable components so routine maintenance of the system is not required.

A closed crankcase ventilation system is used in order to provide a more complete scavenging of crankcase vapors. The air cleaner supplies the fresh air through a filter to the crankcase. The crankcase mixes the fresh air blow-by gases. This mixture then passes through a pipe/passage located in the intake manifold.

## Description and Operation

### Drive Belt System Description

*Engine Mechanical - 8.1L:Description:Drive Belt System Description*

The drive belt system consists of the following components:

- The drive belt
- The drive belt tensioner
- The drive belt idler pulley
- The crankshaft balancer pulley
- The accessory drive component mounting brackets
- The accessory drive components
  - The power steering pump, if belt driven
  - The generator
  - The A/C compressor, if equipped
  - The engine cooling fan, if belt driven
  - The water pump, if belt driven
  - The vacuum pump, if equipped
  - The air compressor, if equipped

The drive belt system may use 1 belt or 2 belts. The drive belt is thin so that it can bend backwards and has several ribs to match the grooves in the pulleys. There also may be a V-belt style belt used to drive certain accessory drive components. The drive belts are made of different types of rubbers — chloroprene or EPDM — and have different layers or plies containing either fiber cloth or cords for reinforcement.

Both sides of the drive belt may be used to drive the different accessory drive components. When the back side of the drive belt is used to drive a pulley, the pulley is smooth.

The drive belt is pulled by the crankshaft balancer pulley across the accessory drive component pulleys. The spring loaded drive belt tensioner keeps constant tension on the drive belt to prevent the drive belt from slipping. The drive belt tensioner arm will move when loads are applied to the drive belt by the accessory drive components and the crankshaft.

The drive belt system may have an idler pulley, which is used to add wrap to the adjacent pulleys. Some systems use an idler pulley in place of an accessory drive component when the vehicle is not equipped with the accessory.

## Description and Operation

### Engine Component Description

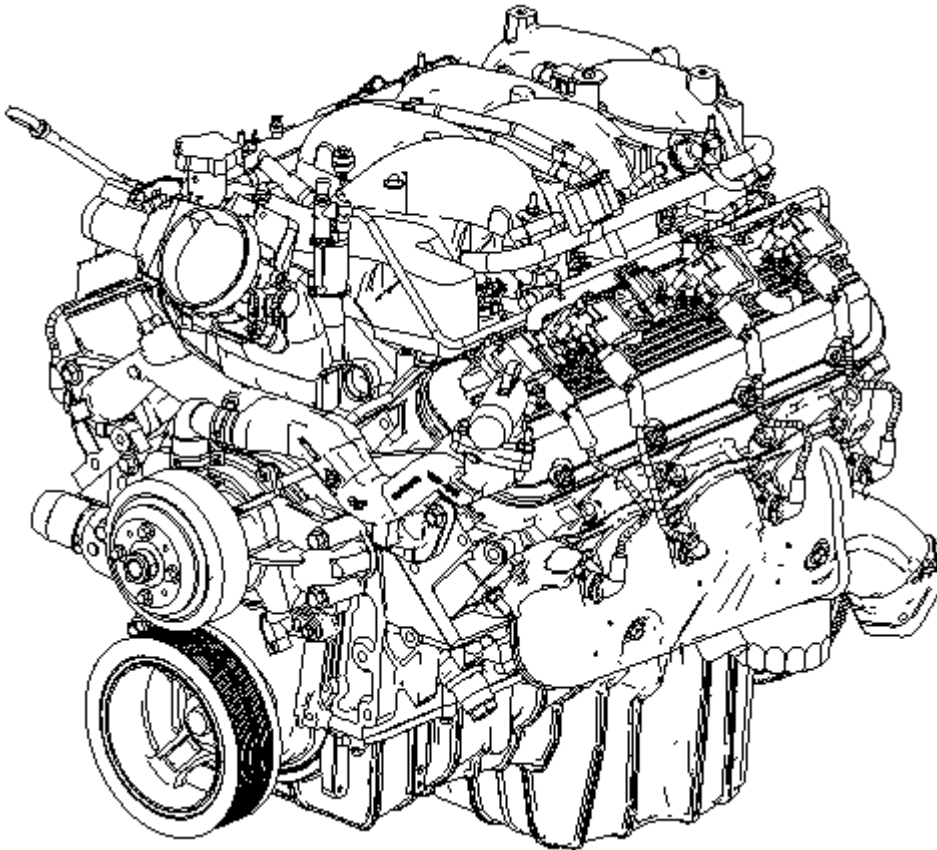

### Cylinder Block

The engine block is made of cast iron and it has eight cylinders arranged in a V shape with four cylinders in each bank. The engine block is a one piece casting with the cylinders encircled by coolant jackets.

### Cylinder Head

The cylinder heads are made of cast iron and have parent metal intake valve guides and intake valve seats. The cast iron exhaust valve guides and powdered metal valve seats are pressed into the exhaust ports. A spark plug is located between the valves in the side of the cylinder head. The water crossover pipe attaches to the front of each cylinder head.

### Camshaft

A steel camshaft is supported by five bearings pressed into the engine block. The camshaft sprocket is mounted to the front of the camshaft and is driven by the crankshaft sprocket through a camshaft timing chain.

Motion from the camshaft is transmitted to the valves by hydraulic roller valve lifters, valve push rods, and ball-pivot type rocker arms. A spiral gear machined into the camshaft near the rear journal drives a shaft assembly which operates the oil pump driveshaft assembly. Ignition synchronization with the camshaft is provided by a physical feature integral with the camshaft sprocket.

## Crankshaft

The crankshaft is made of cast nodular iron. The crankshaft is supported by five crankshaft bearings. The crankshaft bearings are retained by the crankshaft bearing caps. The crankshaft bearing caps are machined with the engine block for proper alignment and clearance. The crankshaft bearing caps are retained by two bolts and two studs each. The number five crankshaft bearing at the rear of the engine block is the end thrust bearing. The four connecting rod journals, two rods per journal, are spaced 90 degrees apart. The crankshaft position sensor reluctor ring is pushed onto the rear of the crankshaft. The crankshaft position sensor reluctor is constructed of powdered metal. The reluctor ring has an interference fit onto the crankshaft and an internal keyway for correct positioning.

## Pistons and Connecting Rods

The pistons are cast aluminum alloy that use two compression rings and one oil control ring assembly. The piston pins are a floating fit in the pistons and the piston pins are retained by a press fit in the connecting rod assembly. The pistons are coated in order to create an interference fit into the cylinder. The connecting rods are forged steel and have precision insert type crankpin bearings. The piston and connecting rod is only serviced as an assembly.

## Valve Train

The valve train is a ball pivot type. Motion is transmitted from the camshaft through the hydraulic roller valve lifters and tubular valve push rods to the valve rocker arms. The valve rocker arm pivots on a ball in order to open the valve. The hydraulic roller valve lifters keep all parts of the valve train in constant contact. Each valve lifter acts as an automatic adjuster and maintains zero lash in the valve train. This eliminates the need for periodic valve adjustment. The valve rocker arm stud and nut retains the valve rocker arm and ball seat. The valve rocker arm stud is threaded into the cylinder head. The valve stem seal is pressed over the valve guide of the cylinder head.

## Intake Manifold

The intake manifold is a one-piece design. The intake manifold is made of cast aluminum. The throttle body is attached to the front of the intake manifold. The fuel rail assembly with eight separate fuel injectors is retained to the intake manifold by four studs. The fuel injectors are seated in their individual manifold bores with O-ring seals to provide sealing. A Manifold Absolute Pressure (MAP) sensor is mounted on the top of the intake manifold and sealed by an O-ring seal. The MAP sensor is held in place with a retainer bolt. The evaporative emission canister solenoid is located in the front of the intake manifold. The positive crankcase ventilation (PCV) system is internally cast into the intake manifold. There is not a PCV valve. A splash shield is installed under the intake manifold. The shield prevents hot oil from contacting the bottom of the intake manifold, maintaining air inlet charge density.

## Exhaust Manifold

The two exhaust manifolds are constructed of cast stainless steel. The exhaust manifolds direct exhaust gases from the combustion chambers to the exhaust system.

## Description and Operation

### New Product Information

The purpose of New Product Information is to highlight important technical changes from the previous model year.

Changes may include one or more of the following items:

- Torque values and/or fastener tightening strategies
- Changed engine specifications
- New sealants and/or adhesives
- Disassembly and assembly procedure revisions
- Engine mechanical diagnostic procedure revisions
- New special tools required
- A component comparison from the previous year

## Torque Values and/or Fastener Tightening Strategies

No torque or fastener tightening changes from the previous year. Refer to [Fastener Tightening Specifications](#) .

## Changed Engine Specifications

No changed engine specifications. Refer to [Engine Mechanical Specifications](#) .

## New Sealants and/or Adhesives

No sealant or adhesive changes from the previous year. Refer to [Sealers, Adhesives, and Lubricants](#) .

## Engine Mechanical Diagnostic Procedure Revisions

All diagnosis on a vehicle should follow a logical process. Strategy based diagnostics is a uniform approach for repairing all systems. The diagnostic flow may always be used in order to resolve a system problem. The diagnostic flow is the place to start when repairs are necessary. For a detailed explanation, refer to [Strategy Based Diagnosis](#) in General Information or [Diagnostic Starting Point - Engine Mechanical](#) in Engine Mechanical.

## New Special Tools Required

- A variety of new tools have been developed to assist in engine disassembly, assembly and on-vehicle service. Refer to [Special Tools](#) .
- Angle Meter [J 45059](#) has been developed to provide technicians with a convenient method to tighten bolts that require the torque angle tightening strategy.

## A Component Comparison from the Previous Year

- The exhaust gas recirculation system (EGR) has been removed. Refer to [Disassembled Views](#) .
- The front cover is now aligned to the engine block with 2♦front cover locating pins.

## Description and Operation

### Lubrication Description

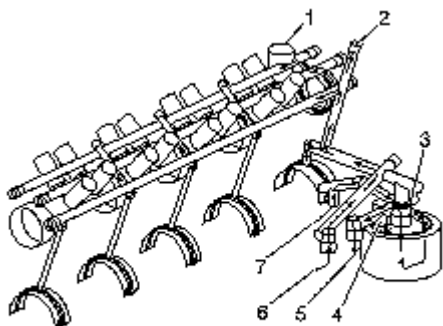

The gear-type oil pump is driven through an extension driveshaft. The extension driveshaft is driven by the oil pump drive, which is gear driven by the camshaft. The oil is drawn from the oil pan through a pickup screen and tube, into the oil pump♦(7). Pressurized oil flows through the oil filter, into the oil cooler♦(5), back into the engine♦(6), up to the oil pressure gage port♦(2) and rear crankshaft bearing, and is then distributed to the upper oil galleries. Oil must flow around the oil pump drive♦(1) in order to reach the right side valve lifters properly. The oil is delivered through internal passages in order to lubricate camshaft and crankshaft bearings and to provide lash control in the hydraulic valve lifters. Oil is metered from the valve lifters through the valve push rods in order to lubricate the valve rocker arms and ball pivots. Oil returning to the oil pan from the cylinder heads and the front camshaft bearing, lubricates the camshaft timing chain and the crankshaft and the camshaft sprockets. There are two bypass valves located in the engine block, above the oil filter. The oil filter bypass valve♦(4) and the oil cooler bypass valve♦(3).

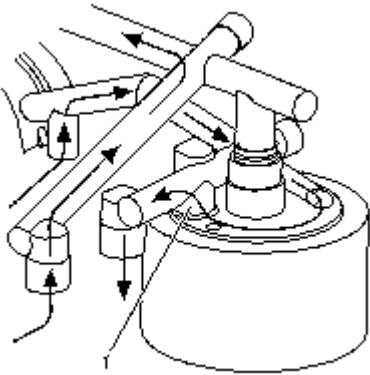

If the oil filter becomes plugged, the pressurized oil is diverted around the top of the oil filter. The oil filter bypass valve♦(1) is forced open, allowing the oil to continue on to the oil cooler and engine oil passages. No oil filtration occurs because the oil is not allowed into the oil filter.

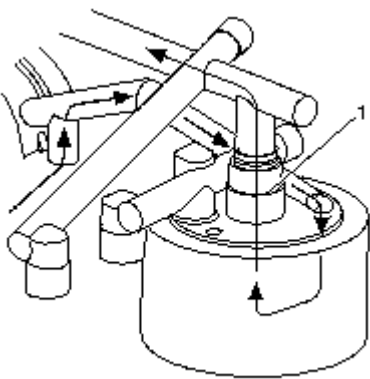

If the oil cooler flow becomes blocked, either from a plugged oil cooler or blocked or kinked oil cooler line, the oil cooler bypass valve♦(1) is forced open, allowing oil to flow directly into the engine oil passages. Oil does not flow into or out of the engine oil cooler.

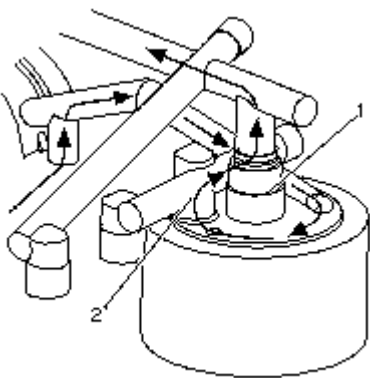

If both the oil filter and the oil cooler are plugged, the pressurized oil is routed around the top of the oil filter, through the oil filter bypass valve♦(2), through the oil cooler bypass valve♦(1) and directly into the engine oil passages. Lubrication still occurs, but the oil is not filtered or directed through the oil cooler.

## Description and Operation

### Cleanliness and Care

- Throughout this section, it should be understood that proper cleaning and protection of machined surfaces and friction areas is part of the repair procedure. This is considered standard shop practice even if not specifically stated.
- When any internal engine parts are serviced, care and cleanliness is important.
- When components are removed for service, they should be marked, organized or retained in a specific order for reassembly.
- At the time of installation, components should be installed in the same location and with the same mating surface as when removed.
- An automobile engine is a combination of many machined, honed, polished and lapped surfaces with tolerances that are measured in millimeters or thousandths of an inch. These surfaces should be covered or protected to avoid component damage.
- A liberal coating of clean engine oil should be applied to friction areas during assembly.
- Proper lubrication will protect and lubricate friction surfaces during initial operation.

## Description and Operation

### Separating Parts

**Important:** Many internal engine components will develop specific wear patterns on their friction surfaces.

When disassembling the engine, internal components **MUST** be separated, marked or organized in a way to ensure reinstallation to original location and position.

Separate, mark, or organize the following components:

- Piston to the specific cylinder bore
- Piston rings to the piston
- Connecting rod to the crankshaft journal
- Connecting rod to the bearing cap
- Crankshaft and connecting rod bearings
- Camshaft and valve lifters
- Valve lifters, guides, pushrods, pivot supports and rocker arms
- Valve to the valve guide
- Valve spring and shim to the cylinder head location
- Engine block crankshaft bearing cap location and direction
- Oil pump drive and driven gears

## Description and Operation

### Replacing Engine Gaskets

#### Gasket Reuse and Applying Sealant

- Do not reuse any gasket unless specified.
- Gaskets that can be reused will be identified in the service procedure.
- Do not apply sealant to any gasket or sealing surface unless specified in the service procedure.

### Separating Components

- Use a rubber mallet in order to separate the components.
- Bump the part sideways in order to loosen the components.
- Bumping of the component should be done at bends or reinforced areas of the component to prevent distortion of the components.

## Cleaning Gasket Surfaces

- Use care to avoid gouging or scraping the sealing surfaces.
- Use a plastic or wood scraper in order to remove all the sealant from the components.  
Do not use any other method or technique to remove the sealant or the gasket material from a part.
- Do not use abrasive pads, sand paper, or power tools to clean the gasket surfaces.
  - These methods of cleaning can cause damage to the component sealing surfaces.
  - Abrasive pads also produce a fine grit that the oil filter cannot remove from the engine oil.  
This fine grit is an abrasive and can cause internal engine damage.

## Assembling Components

- Assemble components using only the sealant (or equivalent) that is specified in the service procedure.
- Sealing surfaces must be clean and free of debris or oil.
- Specific components such as crankshaft oil seals or valve stem oil seals may require lubrication during assembly.
- Components requiring lubrication will be identified in the service procedure.
- Apply only the amount of sealant specified in the service procedure to a component.
- Do not allow the sealant to enter into any blind threaded holes, as the sealant may prevent the fastener from clamping properly or cause component damage when tightened.
  - Important:** Do not overtighten the fasteners.
- Tighten the fasteners to the proper specifications.

## Description and Operation

### Use of RTV and Anaerobic Sealer

#### Sealant Types

**Important:** The correct sealant and amount of sealant must be used in the proper location to prevent oil leaks, coolant leaks, or the loosening of the fasteners. DO NOT interchange the sealants. Use only the sealant (or equivalent) as specified in the service procedure.

The following 2 major types of sealant are commonly used in engines:

- Aerobic sealant (Room Temperature Vulcanizing (RTV))
- Anaerobic sealant, which include the following:
  - Gasket eliminator
  - Pipe
  - Threadlock

#### Aerobic Type Room Temperature Vulcanizing (RTV) Sealant

Aerobic type Room Temperature Vulcanizing (RTV) sealant cures when exposed to air. This type of sealant is used where 2

components (such as the intake manifold and the engine block) are assembled together.

Use the following information when using RTV sealant:

- Do not use RTV sealant in areas where extreme temperatures are expected. These areas include:
  - The exhaust manifold
  - The head gasket
  - Any other surfaces where a different type of sealant is specified in the service procedure
- Always follow all the safety recommendations and the directions that are on the RTV sealant container.
- Use a plastic or wood scraper in order to remove all the RTV sealant from the plastic and aluminum components.
  - Important:** Do not allow the RTV sealant to enter any blind threaded holes, as it may prevent the fasteners from clamping properly or cause damage when the fastener is tightened.
- The surfaces to be sealed must be clean and dry.
- Use a RTV sealant bead size as specified in the service procedure.
- Apply the RTV sealant bead to the inside of any bolt holes areas.
- Assemble the components while the RTV sealant is still wet to the touch (within 3♦minutes). Do not wait for the RTV sealant to skin over.
- Tighten the fasteners in sequence (if specified) and to the proper torque specifications. DO NOT overtighten the fasteners.

## Anaerobic Type Gasket Eliminator Sealant

Anaerobic type gasket eliminator sealant cures in the absence of air. This type of sealant is used where 2 rigid parts (such as castings) are assembled together. When 2 rigid parts are disassembled and no sealant or gasket is readily noticeable, then the 2♦parts were probably assembled using an anaerobic type gasket eliminator sealant.

Use the following information when using gasket eliminator sealant:

- Always follow all the safety recommendations and directions that are on the gasket eliminator sealant container.
- Apply a continuous bead of gasket eliminator sealant to one flange.
  - The surfaces to be sealed must be clean and dry.
  - Important:** Do not allow the gasket eliminator sealant to enter any blind threaded holes, as the gasket eliminator sealant may prevent the fasteners from clamping properly, seating properly, or cause damage when the fastener tightened.
- Apply the gasket eliminator sealant evenly to get a uniform thickness of the gasket eliminator sealant on the sealing surface.
  - Important:** Gasket eliminator sealed joint fasteners that are partially torqued and the gasket eliminator sealant allowed to cure more than five minutes, may result in incorrect shimming and sealing of the joint.
- Tighten the fasteners in sequence (if specified) and to the proper torque specifications. DO NOT overtighten the fasteners.
- After properly tightening the fasteners, remove the excess gasket eliminator sealant from the outside of the joint.

## Anaerobic Type Threadlock Sealant

Anaerobic type threadlock sealant cures in the absence of air. This type of sealant is used for threadlocking and sealing of bolts, fittings, nuts, and studs. This type of sealant cures only when confined between 2 close fitting metal surfaces.

Use the following information when using threadlock sealant:

- Always follow all safety recommendations and directions that are on the threadlock sealant container.
- The threaded surfaces to be sealed must be clean and dry.
- Apply the threadlock sealant as specified on the threadlock sealant container.
  - Important:** Fasteners that are partially torqued and then the threadlock sealant allowed to cure more than five minutes, may result in incorrect clamp load of assembled components.

- Tighten the fasteners in sequence (if specified) and to the proper torque specifications. DO NOT overtighten the fasteners.

## Anaerobic Type Pipe Sealant

Anaerobic type pipe sealant cures in the absence of air and remains pliable when cured. This type of sealant is used where 2 parts are assembled together and require a leak proof joint.

Use the following information when using pipe sealant:

- Do not use pipe sealant in areas where extreme temperatures are expected. These areas include:
  - The exhaust manifold
  - The head gasket
  - Surfaces where a different sealant is specified
- Always follow all the safety recommendations and the directions that are on the pipe sealant container.
- The surfaces to be sealed must be clean and dry.
- Use a pipe sealant bead of the size or quantity as specified in the service procedure.

**Notice: Do not allow the sealant to enter a blind hole. The sealant may prevent the fastener from achieving proper clamp load, cause component damage when the fastener is tightened, or lead to component failure.**

- Apply the pipe sealant bead to the inside of any bolt hole areas.
- Apply a continuous bead of pipe sealant to 1 sealing surface.
- Tighten the fasteners in sequence (if specified) and to the proper torque specifications. DO NOT overtighten the fasteners.

## Description and Operation

### Tools and Equipment

*Engine Mechanical - 8.1L:Description:Tools and Equipment*

• Special tools are listed and illustrated throughout this section with a complete listing at the end of the section. These tools (or their equivalents) are specially designed to quickly and safely accomplish the operations for which they are intended. The use of these special tools will also minimize possible damage to engine components. Some precision measuring tools are required for inspection of certain critical components. Torque wrenches and a torque angle meter are necessary for the proper tightening of various fasteners.





- To properly service the engine assembly, the following items should be readily available:
  - Approved eye protection and safety gloves
  - A clean, well-lit, work area
  - A suitable parts cleaning tank
  - A compressed air supply
  - Trays or storage containers to keep parts and fasteners organized
  - An adequate set of hand tools
  - Approved engine repair stand
  - An approved engine lifting device that will adequately support the weight of the components





## Special Tools and Equipment



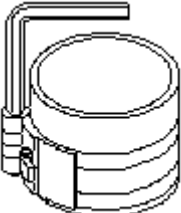
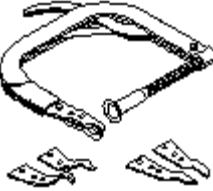

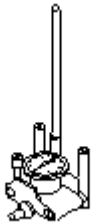
### Special Tools

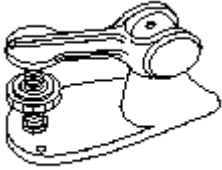
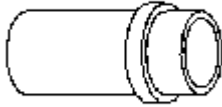
*Engine Mechanical - 8.1L:Tools:Special Tools*

Illustration	Tool Number/Description

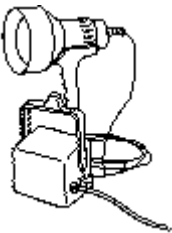
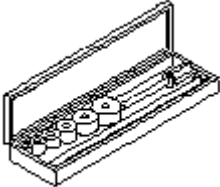

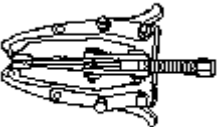
 A pair of long-handled pliers with a curved tip, used for removing valve lifters.	<p>J♦3049-A Valve Lifter Remover</p>
 A long, thin metal tool with a curved end, used for compressing valve springs.	<p>J♦5892-C Valve Spring Compressor</p>
 A dial indicator with a magnetic base and a long, thin stem, used for measuring surface flatness.	<p>J♦7872 Magnetic Base Dial Indicator</p>
 A set of dial indicators, including a dial indicator with a magnetic base, a dial indicator with a long stem, and a dial indicator with a short stem.	<p>J♦8001 Dial Indicator Set</p>
 A cylindrical tool with a handle and a piston ring, used for compressing piston rings.	<p>J♦8037 Piston Ring Compressor</p>
 A curved metal tool with a handle and a head, used for compressing valve springs.	<p>J♦8062 Valve Spring Compressor - Head Off</p>

	J♦8087 Cylinder Bore Gage
	J♦8089 Carbon Removal Brush
	J♦9666 Valve Spring Tester
	J♦22102 Front Cover Aligner and Seal Installer
	J♦22794 Spark Plug Port Adapter
	J♦24270 Cylinder Bore Ridge Reamer

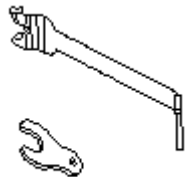
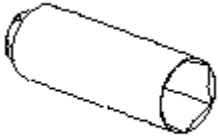
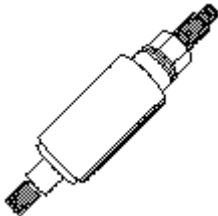
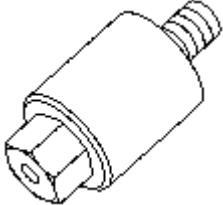
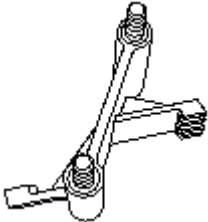
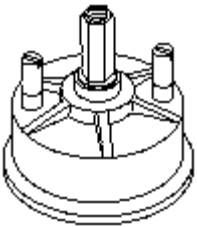
 A high-intensity black light with a large lens and a carrying case.	<p>J♦28428-E High Intensity Black Light</p>
 A set of camshaft bearings in a carrying case.	<p>J♦33049 Camshaft Bearing Service Set</p>
 A cylinder head leakdown tester in a carrying case.	<p>J♦35667-A Cylinder Head Leakdown Tester</p>
 An engine lift bracket with a hook and a handle.	<p>J♦36857 Engine Lift Bracket</p>
 A harmonic balancer remover tool with a handle and a hook.	<p>J♦38416-B Harmonic Balancer Remover</p>
 A thread repair kit in a carrying case.	<p>J♦39345 Thread Repair Kit</p>

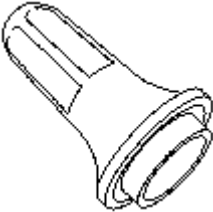
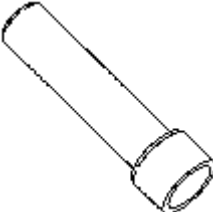
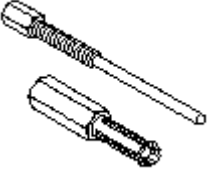
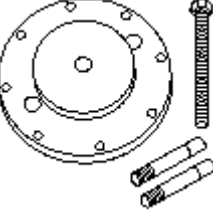
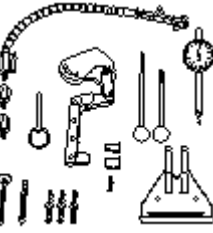
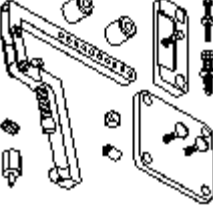
	J♦41240 Fan Clutch Wrench
	J♦41712 Oil Pressure Switch Socket
	J♦42845 Crankshaft Balancer Installer
	J♦42846 Crankshaft Protector Button
	J♦42847 Flywheel Holding Tool
	J♦42849 Crankshaft Rear Seal Installer
	J♦42851

	<p>Front Cover Oil Seal Installer</p>
	<p>J♦43105 Valve Stem Seal Installer</p>
	<p>J♦43276 Clutch Pilot Bearing Remover</p>
	<p>J♦43320 Crankshaft Rear Seal Puller</p>
	<p>J♦43690 Rod Bearing Clearance Checking Tool</p>
	<p>J♦43690-100 Rod Bearing Clearance Checking Tool - Adapter Kit</p>
	<p>J♦45059</p>

 <p>An illustration of a rectangular angle meter. The front panel features a circular dial with a needle, a small window, and the text 'ANGLE METER' and '0-120°'. There are also some smaller markings and a small circular indicator at the bottom.</p>	<p>Angle Meter</p>
 <p>An illustration of an engine pre-luber. It consists of a rectangular reservoir with a pump handle on top, connected to a flexible hose with a spray nozzle. A small circular cap is also shown next to the reservoir. The text 'J45299' and 'ENGINE PRE-LUBER' is visible on the reservoir.</p>	<p>J45299 Engine Pre-Luber</p>