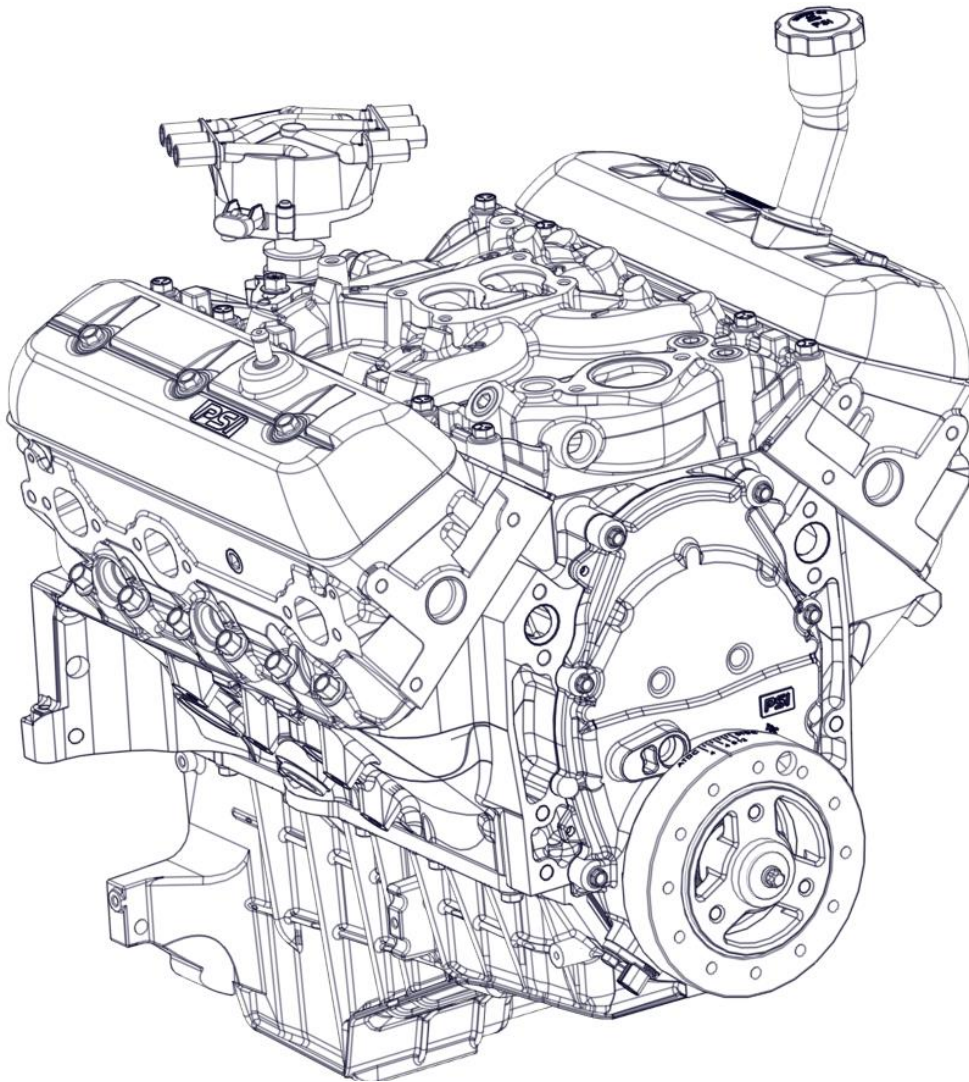




**POWER SOLUTIONS
INTERNATIONAL**

POWER SOLUTIONS INTERNATIONAL 4X INDUSTRIAL ENGINE



Revision A



**POWER SOLUTIONS
INTERNATIONAL**

No part of this publication may be reproduced without the written permission of Power Solutions, Inc. At the time of publication, all of the information included in this publication is accurate to the best of our knowledge. Power Solutions, Inc., cannot be responsible for information that has changed after this book was published.

Engine Mechanical - 4.3L

Specifications

Fastener Tightening Specifications

Torque Specifications			
Fastener	Specification (SAE)	Specification (Metric)	Lube/Sealant
Main Cap	15 ft-lbf + 73°	20.3 N-m + 73°	ARP Ultra-Torque
Rod Bolts	20 ft-lbf + 70°	27.1 N-m + 70°	ARP Ultra-Torque
Cam Retainer Bolts	106 in-lbf	12 N-m	-
Cam Gear Bolts	18 ft-lbf	24.4 N-m	-
Oil Pump Bolt	66 ft-lbf	89.5 N-m	Red Thread Sealant
Oil Pan	18 ft-lbf	24.4 N-m	Blue Thread Sealant
Oil Filter Adapter	41 ft-lbf	55.6 N-m	-
Timing Cover	106 in-lbf	12 N-m	-
Balancer Bolt	15 ft-lbf + 35°	20.3 N-m + 35°	-
Cylinder Head Bolts - Long	22 ft-lbf + 75°	29.8 N-m + 75°	PTFE Thread Sealant
Cylinder Head Bolts - Medium	22 ft-lbf + 65°	29.8 N-m + 65°	PTFE Thread Sealant
Cylinder Head Bolts - Short	22 ft-lbf + 55°	29.8 N-m + 55°	PTFE Thread Sealant
Lifter Hold Down Bolts	12 ft-lbf (144 in-lbf)	16.3 N-m	Blue Thread Sealant
Intake Bolts	27 in-lbf + 106 in-lbf + 132 in-lbf	3.1 N-m + 12 N-m + 14.9 N-m	Oil
Rocker Arm Bolts	30 ft-lbf	40.70 N-m	Assembly Lube
Valve Cover Bolts	106 in-lbf	12 N-m	-
Crank Sensor Bolt	106 in-lbf	12 N-m	-
Water Pump	35 ft-lbf	47.5 N-m	-
Flywheel	74 ft-lbf	100.3 N-m	Red Thread Sealant
Flex Plate	74 ft-lbf	100.3 N-m	Blue Thread Sealant
Bell Housing	35 ft-lbf	47.5 N-m	Blue Thread Sealant
Exhaust Manifold	35 ft-lbf	47.5 N-m	-
NPT Plugs Iron 1/4" - 3/4"	150 in-lbs + 3/4 turn	17 N-m + 3/4 turn	PTFE Thread Sealant
Oil Pan Baffle	92 in-lbf	10.4 N-m	-
Oil Pan Drain Bolt	18 ft-lbf	24.4 N-m	Dry
Starter Bolts	40 ft-lbf	54.2 N-m	-
Block Drain Plug	22 ft-lbf + 1/2 turn	29.8 N-m + 1/2 turn	PTFE Thread Sealant
Balancer Shaft Retainer Bolt	106 in-lbf	12 N-m	-
Bolt, Rear Oil Crossover Cover	8 ft-lbs (96 in-lbf)	10.9 N-m	-
Long R Cr Shf Oil Seal Hsg Bolt	106 in-lbf	12 N-m	-
Short R Cr Shf Oil Seal Hsg Bolt	106 in-lbf	12 N-m	-

Fastener	Specification (SAE)	Specification (Metric)	Lube/Sealant
Nut, R Cr Shf Oil Seal Hsg	106 in-lbf	12 N-m	-
Stud and Nut, R Cr Shf Oil Seal Hsg	106 in-lbf	12 N-m	-
Retainer, R Cr Shf Oil Seal Hsg	53 in-lbf	6 N-m	-
NPT Plugs Iron 1/4-3/4	150 in-lbf	17 N-m	PTFE Thread Sealant
Spark Plug	22 ft-lbf	29.8 N-m	Dry

Engine Mechanical Specifications

Clearance			
Application		Specification (SAE)	Specification (Metric)
Block	Bore, Cylinder	4.0016 - 4.0008	101.641 - 101.620
	Stroke	3.4799	88.389
	Out-of-Round, Cylinder Bore	0.002	0.05
	Taper, Cylinder Bore	0.0138	0.35
	Flatness, Head Deck Surface	0.002	0.05
		0.0020 Across 5.906 in	0.051 Across 150 mm
		0.0010 Between bolts	0.025 Between Bolts
		0.0010 Across 0.984 in	0.025 Across 25 mm
	Diameter, Main Bores	2.6411 ± 0.0005	67.084 ± 0.013
	Diameter, Camshaft Bearing Bore (1)	2.0200 ± 0.0005	51.308 ± 0.013
	Diameter, Camshaft Bearing Bore (2)	2.0100 ± 0.0005	51.054 ± 0.013
	Diameter, Camshaft Bearing Bore (3)	2.0000 ± 0.0005	50.800 ± 0.013
	Diameter, Camshaft Bearing Bore (4)	2.0200 ± 0.0005	51.308 ± 0.013
	Freeze Plug Press (Steel)	0.0140 - 0.0240	0.356 - 0.610
	Freeze Plug Press, Cam Tunnel (Steel)	0.0075 - 0.0135	0.191 - 0.343
	Crank to Camshaft Centerline	4.6409 ± 0.0100	117.879 ± 0.254
	Height, Deck	9.0270 - 9.0250	229.286 - 229.235
Height, China Rail	9.9350 - 9.9150	252.349 - 251.841	
Piston & Accessories	Clearance, Piston Dome to Block Deck	0.015	0.38
	Diameter, Skirt	3.9993 - 3.9999	101.582 - 101.597
	Gap, Top Ring (@4.0010 Gage Diameter)	0.0100 - 0.0160	0.254 - 0.406
	Gap, 2nd Ring (@4.0010 Gage Diameter)	0.0180 - 0.0260	0.457 - 0.660
	Gap, Oil Control Ring (@4.0000 Gage Diameter)	0.0100 - 0.030 0	0.254 - 0.762
	Bore, Wrist Pin	0.9281 - 0.9287	23.574 - 23.589
	Diameter, Pin	0.9280 - 0.9274	23.571 - 23.556
	Tension, Oil Ring	7.5 lbf - 12.5 lbf	33.4 N - 55.6 N
	Clearance, Piston to Bore	0.0009 - 0.0023	0.023 - 0.058
	Weight, Piston	1.1288 lbf ± 0.0110 lbf	5.021 N ± 0.049 N
	Diameter (Dial) , Piston Gage	3.9940 ± 0.0118	101.448 ± 0.300
Connecting Rod	Clearance, Small End (Bearing to Wrist Pin)	0.0005 - 0.0011	0.013 - 0.028
	Clearance, Big End (Crank Pin to Bearing)	0.0015 - 0.0031	0.038 - 0.079
	Rod Side Clearance, Big End Side	0.0059 - 0.0138	0.150 - 0.351
	Diameter, Big End (No Bearing)	2.3752 ± 0.0004	60.330 ± 0.010
	Width, Big End	0.8925 ± 0.0019	22.670 ± 0.048

	Weight, Connecting Rod	1.1288 ± 0.0110	28.672 ± 0.280
	Distance, Big to Small End Centerline	5.7000 ± 0.0030	144.780 ± 0.076
Crankshaft	Diameter, Connecting Rod (PIN) Journal	2.2493 ± 0.0006	57.132 ± 0.015
	Out-of-Round, Connecting Rod (PIN) Journal	0.0003	0.008
	Cylindricity, Connecting Rod (PIN) Journal	0.0003	0.008
	Width, Connecting Rod (PIN)	0.9043 - 0.9004	22.970 - 22.870
	Diameter, Main Journal (#1 - #3)	2.4489 ± 0.0005	62.202 ± 0.013
	Diameter, Main Journal (#4 ONLY)	2.4489 ± 0.0006	62.202 ± 0.015
	Runout, Main Journal	0.0004	0.01
	Cylindricity, Main Bearing (#4)	0.0002	0.005
	Width, Main Bearing (#4)	1.7205 - 1.7197	43.701 - 43.680
	Clearance, Main Bearing (#1-3)	0.0011 - .0023	0.028 - 0.058
	Clearance, Main Bearing (#4)	0.0011 - .0028	0.028 - 0.071
	End Play (Fully Assembled)	0.0020 - .0079	0.051 - 0.203
	Crank Sprocket Interference	0.0090 - 0.0129	0.229 - 0.330
	Harmonic Damper Interference	0.0049 - 0.0075	0.124 - 0.191
	Diameter, Snout	1.2400 - 1.2379	31.496 - 31.445

Camshaft	Diameter, Journal	1.8697 - 1.8677	47.490 - 47.440
	Runout, Journal	Max = 0.002	Max = 0.05
	Bearing Clearance, #1-4	0.0010 - 0.0052	0.025 - 0.132
	End float (Fully Assembled)	0.0010 - 0.0089	0.025 - 0.226
	Diameter, Base Circle	1.2594 - 1.2554	31.989 - 31.887
	Lobe Lift, Exhaust	0.243	6.74
	Lobe Lift, Intake	0.265	6.16
Cylinder Head	Flatness, Head Deck Surface	0.0020 Across 5.906	0.051 Across 150 mm
		0.0012 Between Bolts	0.03 Between Bolts
		0.0001 Across 0.984	0.025 Across 25 mm
	Surface Finish Rz, Head Deck	0.787 µin	0.020 µm
	Surface Finish Rmax, Head Deck	0.984 µin	0.025 µm
	Leakage Rate, Combustion Chamber	1 inch Hg/3 sec @ 34 inch Hg	3.4 kPa/3 sec @ 115.1 kpa
	Volume, Combustion Chamber	3.8354 in ³	62.851 cc
	Ratio, Compression	9.6:1 - 10:1	
	Valve Seat Runout, Intake	Max = 0.002	Max = 0.05
	Valve Seat Runout, Exhaust	Max = 0.002	Max = 0.05
Valves	Diameter, Valve Stem, Intake	0.3413 ± 0.0004	8.669 ± 0.010
	Valve Stem to Guide Clearance, Intake	0.0005 - 0.0019	0.013 - 0.048
	Valve Guide Cylindricity, Intake	0.0005	0.013
	Valve Seat Runout, Intake	Max = 0.002	Max = 0.05
	Valve Seat Face Angle, Intake	45° ± 0.25°	
	Head Deck to Valve Seat Gage Point, Intake	0.6630 - 0.6430	16.840 - 16.332
	Diameter, Valve Stem, Exhaust	0.3409 ± 0.0004	8.659 ± 0.102

	Valve Stem to Guide Clearance, Exhaust	0.0009 - 0.0023	0.023 - 0.058
	Application	Specification (SAE)	Specification (Metric)
	Valve Guide Cylindricity, Exhaust	0.0005	0.013
	Valve Seat Runout, Exhaust	Max = 0.002	Max = 0.05
	Valve Seat Face Angle, Exhaust	45° ± 0.25°	
	Head Deck to Valve Seat Gage Point, Exhaust	0.6071	15.42
	Valve Guide Cylindricity, Exhaust	Max = 0.0005	Max = 0.013
Valve Spring	Valve Spring Load, Installed Height, Intake	100 lbf - 110 lbf	445 N - 489 N
	Valve Spring Load, Installed Height, Exhaust	100 lbf - 110 lbf	445 N - 489 N
	I.D. (Minimum), Valve Spring	0.605 ± 0.010	15.37 ± 0.25
	Valve Spring Installed Height, Intake	1.8	45.72
	Valve Spring Installed Height, Exhaust	1.8	45.72
Hydraulic Lifter	Preload, Lifter	0.0300 - 0.0701	0.762 - 1.781
	Clearance, Lifter to Bore	0.0024 - 0.0011	0.061 - 0.028
	Diameter, Lifter	0.8424 ± 0.0004	21.397 ± 0.010
Push Rod	Length, Intake	7.7125 - 7.4125	195.898 - 188.520
	Length, Exhaust	7.2449 - 7.2252	184.020 - 183.520
	Diameter, Oiling Hole	0.0750 - 0.0810	1.905 - 2.057
	Diameter, Ball	0.3070 - 0.3170	7.798 - 8.052
IGN	Gap, Spark Plug	0.03	0.76
	Dry Fill (Naturally Aspirated)	5.0 qt	4.73 L
	Drain and Fill (Naturally Aspirated)	4.5 qt	4.26 L
Rocker	Rocker Ratio	1.7	
Harmonic Balancer	Diameter, Damper I.D.	1.2447 - 1.2459	31.615 - 31.646

Diagnostic Information and Procedures

Base Engine Misfire Diagnosis

Checks	Action
<p>Engine Performance diagnosis procedures are covered in Engine Controls and should be consulted for diagnosis of any Drivability, Emissions or Malfunctioning Indicator Lamp (MIL) concerns.</p> <p>The following diagnosis covers common concerns and possible causes.</p> <p>When the proper diagnosis is made, the concern should be corrected by adjustment, repair or replacement as required. Refer to the appropriate section of the service manual for each specific procedure.</p> <p>This diagnostic table will assist in engine misfire diagnosis due to a mechanical concern such as a faulty engine camshaft, worn or damaged bearings or bent valve pushrod.</p> <p>This table will not isolate a crossed fuel injector wire, faulty fuel injector or any other drivability component failure that may cause a misfire.</p> <p>The Powertrain On-Board Diagnostic System checks must be performed first.</p> <p>When using this table to make a Base Engine Misfire diagnosis, begin with the preliminary information below and then proceed to the specific category.</p>	
<p>Preliminary</p>	<ol style="list-style-type: none"> 1. Perform DTC P0300 before proceeding with Base Engine Misfire Diagnosis information. DTC P0300 will assist in determining which cylinder or cylinders are misfiring. 2. Perform a visual inspection of the following: <ul style="list-style-type: none"> • A loose or improperly installed engine flywheel or crankshaft balancer • Worn, damaged or misaligned accessory drive system components 3. Listen to the engine for any abnormal internal engine noises. 4. Inspect the engine for acceptable oil pressure. 5. Verify if the engine has excessive oil consumption. 6. Verify if the engine has excessive coolant consumption. 7. Perform a compression test on the engine.
<p>Intake Manifold Leaks</p>	<p>An intake manifold that has a vacuum leak may cause a misfire.</p> <p>Inspect for the following:</p> <ul style="list-style-type: none"> • Improperly installed or damaged vacuum hoses • Faulty or improperly installed lower intake manifold and/or gaskets • Cracked or damaged lower intake manifold • Improperly installed MAP sensor The sealing grommet of the MAP sensor should not be torn or damaged • Improperly installed throttle body or damaged gasket • Warped intake manifold • Warped or damaged cylinder head sealing surface
<p>Coolant Consumption</p>	<p>Coolant consumption may or may not cause the engine to overheat.</p> <p>Inspect for the following:</p> <ul style="list-style-type: none"> • External coolant leaks • Faulty cylinder head gasket • Warped cylinder head • Cracked cylinder head • Damaged engine block
<p>Oil Consumption</p>	<p>Oil consumption may or may not cause the engine to misfire.</p> <ol style="list-style-type: none"> 1. Remove the spark plugs and inspect for an oil fouled spark plug. 2. Perform a cylinder compression test. 3. If the compression test indicates worn valves or valve guides, inspect the following: <ul style="list-style-type: none"> • Worn, brittle or improperly installed valve stem oil seals • Worn valve guides • Worn valve stems • Worn or burnt valves or valve seats 4. If the compression test indicates worn or damaged piston rings, inspect the following: <ul style="list-style-type: none"> • Broken or improperly seated piston rings • Excessive piston ring end gap • Excessive cylinder bore wear or taper • Cylinder damage • Piston damage

Base Engine Misfire Diagnosis (cont'd)

Checks	Action
Abnormal Internal Engine Noises	<ol style="list-style-type: none"> 1. Start the engine and determine if the noise is timed to the engine camshaft speed or the crankshaft speed. 2. Using a timing light, two knocks per flash is the crankshaft speed and one knock per flash is the engine camshaft speed. 3. If the noise is timed to the engine camshaft speed, inspect the following: <ul style="list-style-type: none"> • Missing or loose valve train components • Worn or loose valve rocker arms • Worn or bent valve pushrods • Faulty valve springs • Bent or burnt valves • Worn engine camshaft lobes • Worn or damaged camshaft timing chain and/or sprockets <p>Important: A slight COLD knock or piston slapping noise could be considered normal if not present after the engine has reached normal operating temperatures.</p> <p>If the knock is timed to the crankshaft speed, inspect the following:</p> <ul style="list-style-type: none"> • Worn crankshaft or connecting rod bearings • Piston to cylinder damage • Worn piston or piston pin • Faulty connecting rod • Excessive carbon build-up on the top of the piston
No Abnormal Internal Engine Noise	<ol style="list-style-type: none"> 1. Inspect for a worn or improperly installed camshaft timing chain and/or sprockets. 2. Remove the valve rocker arm cover on the side of the engine with the cylinder that is misfiring. 3. Inspect for the following: <ul style="list-style-type: none"> • Loose valve rocker arm studs • Bent valve push rods • Faulty valve springs • Faulty valve lifters (bleeding down) • Worn or improperly seated valves • Worn engine camshaft lobes

Engine Compression Test

approximately 15 ml (one tablespoon) of engine

1. Disconnect the positive ignition coil wire plug from ignition coil.
2. Disconnect the fuel injector electrical connector.
3. Remove all the spark plugs.
4. Block the throttle plate wide open.
5. Charge the battery if the battery is not fully charged.
6. Start with the compression gauge at zero. Then crank the engine through four compression strokes (four puffs).
7. Make the compression check the same for each cylinder. Record the reading.

The minimum compression in any one cylinder should not be less than 70 percent of the highest cylinder. No cylinder should read less than 690 kPa (100 psi). For example, if the highest pressure in any one cylinder is 1035 kPa (150 psi), the lowest allowable pressure for any other cylinder would be 725 kPa (105 psi).

(1035 x 70% = 725) (150 x 70% = 105).

8. If some cylinders have low compression, inject

oil into the combustion chamber through the spark plug hole.

- Normal - Compression builds up quickly and evenly to the specified compression for each cylinder.
- Piston Rings Leaking - Compression is low on the first stroke. Then compression builds up with the following strokes but does not reach normal. Compression improves considerably when you add oil.
- Valves Leaking - Compression is low on the first stroke. Compression usually does not build up on the following strokes. Compression does not improve much when you add oil.
- If two adjacent cylinders have lower than normal compression, and injecting oil into the cylinders does not increase the compression, the cause may be a head gasket leaking between the two cylinders.

9. Install the removed parts.

10. Connect the disconnected components.

Engine Noise Diagnosis

Symptoms	Cause
<p>When diagnosing engine noise complaints, use the following steps to isolate the source of the engine noise: Determine</p> <ul style="list-style-type: none"> • the type of noise For example, is the noise a light rattle/tapping or a low rumble/knocking? • The exact operating condition under which the noise exists Note factors such as ambient temperature, the amount of engine warm-up time, the engine temperature, the engine RPM and other specifics. • At what rate the noise occurs, and at what location on the engine Engine noises are generally synchronized to either engine speed (crankshaft, engine flywheel, connecting rods, crankshaft balancer or pistons and related components) or one-half engine speed (valve train noise such as valve rocker arms, valve lifters and camshaft timing chain). Determine the rate at which the noise is occurring. • Compare the engine sounds to other engines, and make sure you are not trying to correct a normal condition. 	
Noise on Start-Up but Only Lasts a Few seconds	<ul style="list-style-type: none"> • Improper oil viscosity. Install the recommended oil viscosity for the expected temperatures. • Worn or dirty valve lifters • Excessive piston-to-cylinder bore clearance • Excessive piston pin-to-bore clearance • Excessive crankshaft bearing clearance
Knocks Cold and Continues for 1 to 2 Minutes	<ul style="list-style-type: none"> • Loose or broken crankshaft balancer or accessory drive components • Excessive piston-to-bore clearance A cold piston knock which appears in 1.5 minutes should be considered acceptable. • A cold engine knock usually disappears when the specific cylinders secondary ignition circuit is grounded out.
Intermittent Noise on Idle, Disappearing When Engine Speed is Increased	<ul style="list-style-type: none"> • Improper oil viscosity. Install the recommended oil viscosity for the expected temperatures. • Lower than specified oil pressure Install an oil pressure gauge and measure the engine oil pressure. • Dirty or worn valve lifter
Valve Train Noise (Rattle/Tapping)	<p>The following conditions may cause valve train noise:</p> <ul style="list-style-type: none"> • Lower than specified oil pressure • Worn or faulty oil pump • Loose oil pump-to-engine block bolt • Loose valve rocker arm attachments • Worn valve rocker arms and/or valve pushrods • Broken valve spring • Sticking valves • Worn, dirty or faulty valve lifters • Worn engine camshaft lobes • Worn valve guides or valve stems • Bent, broken or damaged timing chain sprocket teeth
Knocks Hot at Idle (Rumble/Knocking)	<p>The following conditions may cause a knocking noise:</p> <ul style="list-style-type: none"> • Malfunctioning accessory drive system components • Loose or broken crankshaft balancer • Detonation or spark knock Check for proper operation of the cooling, knock and ignition control components. • Refer to diagnostic information in Engine Controls • Excessive connecting rod bearing clearance • Excessive piston pin-to-bore clearance • Bent connecting rod • Excessive crankshaft bearing clearance • Loose torque converter bolts (if equipped) • Cracked or damaged engine flywheel • Exhaust leak at the exhaust manifold • Combustion chamber deposits

•
•
•
•
•

Exhaust System Noise and/or Leakage	Exhaust system noise and/or leakage may be caused by the following conditions: Improperly installed or misaligned exhaust system components A cracked or broken exhaust manifold Damaged or worn exhaust manifold gaskets and/or seals Burnt or rusted out exhaust system components Broken or loose exhaust clamps and/or brackets
-------------------------------------	--

Valve Train Diagnosis

General Information

Symptoms	Cause
<ul style="list-style-type: none"> A light tapping noise at 1/2 engine speed, or any varying frequency, may indicate a valve train problem. Tapping noises will typically increase with increased engine speed. Before attempting to diagnose a valve train noise, check for the proper engine oil level and then allow the engine to obtain normal operating temperature. Following this procedure will bring all engine components to a normal state of expansion. Sit in the driver's seat, then operate the engine at various speeds and listen for any abnormal engine noise. 	
Valve Train Noise	<ul style="list-style-type: none"> Low engine oil pressure A worn or faulty oil pump A loose or plugged oil pump screen Loose valve rocker arm attachments (causing excessive valve lash) A worn or damaged valve rocker arm ball A worn valve rocker arm and/or valve pushrod A broken valve spring Sticking valves Valve lifters worn, dirty or faulty A broken valve lifter guide Engine camshaft lobes worn Worn valve guides or valve stems Bent valve pushrods Excessive free play in the camshaft timing chain Bent, broken or damaged camshaft sprocket teeth

Diagnostic Table

Step	Action	Value(s)	Yes	No
DEFINITION: A light tapping noise at 1/2 engine speed, or any varying frequency.				
1	Is there valve train noise?	—	Go to Step 2	System OK
2	Check for a high engine oil level. An engine with the engine oil level above the FULL mark on the oil level indicator allows the crankshaft counterweights to churn the engine oil into foam. When the foamy engine oil is pumped into the valve lifters, the valve lifters become noisy. A solid column of engine oil ensures proper valve lifter operation. Is the engine oil level too high?	—	Go to Step 3	Go to Step 4
3	Drain the engine oil to the proper level. Is the tapping noise gone?	—	System OK	Go to Step 6
4	Check for a low engine oil level. An engine with the engine oil level below the ADD mark on the oil level indicator may allow the oil pump to pump air at high engine RPM. Is the engine oil level below the ADD mark on the oil level indicator?	—	Go to Step 5	Go to Step 6
5	Add the engine oil as required. Is the tapping noise gone?	—	System OK	Go to Step 6

6	Check for the proper engine oil pressure. Refer to <i>Engine Mechanical Specifications</i> and <i>Oil Pressure Diagnosis and Testing</i> . Is the engine oil pressure within specifications?	41.4 kPa (6 psi)	Go to Step 11	Go to Step 7
---	---	---------------------	---------------	--------------

Diagnostic Table (cont' d)

Step	Action	Value(s)	Yes	No
7	Check the oil pump screen for damage or a loose fit to the oil pump. Is the oil pump screen loose or is the oil pump screen damaged?	—	Go to Step 8	Go to Step 9
8	Repair as required. Is the tapping noise gone?	—	System OK	Go to Step 9
9	Check for a damaged oil pump or loose bolts. Refer to <i>Oil Pump Clean and Inspect</i> . Is the oil pump damaged or are the bolts loose?	—	Go to Step 10	Go to Step 11
10	Repair as required. Is the tapping noise gone?	—	System OK	Go to Step 11
11	Remove and inspect the valve lifters, the valve rocker arms and the valve pushrods. Refer to <i>Valve Rocker Arm and Pushrods Clean and Inspect</i> and <i>Valve Lifters and Guides Clean and Inspect</i> . Are the components worn or damaged?	—	Go to Step 12	Go to Step 13
12	Replace the components as required. Is the tapping noise gone?	—	System OK	Go to Step 13
13	Perform an engine camshaft lobe lift test. Refer to <i>Camshaft and Bearings Clean and Inspect</i> . Is the engine camshaft lobes within specifications?	—	Go to Step 15	Go to Step 14
14	Replace the engine camshaft and valve lifters. Is the tapping noise gone?	—	System OK	Go to Step 13
15	Remove the engine front cover and inspect the camshaft timing chain and sprockets for excessive wear or damage. Refer to <i>Timing Chain and Sprockets Clean and Inspect</i> . Are the components worn or damaged?	—	Go to Step 17	Go to Step 16
16	Replace the components as required. Is the tapping noise gone?	—	System OK	Go to Step 17
17	Perform a complete disassembly of the engine and inspect all components. Are the components worn or damaged?	—	System OK	Go to Step 11
18	Replace the components as required. Did you complete the worn or damaged component replacement?	—	System OK	—

Oil Consumption

Excessive oil consumption (not due to leaks) is the use 1.9 liters (2 quarts) of engine oil within 3,200 kilometers (2,000 miles). However, during initial engine break-in periods 4,828-6,437 kilometers (3,000-4,000 miles) oil consumption may exceed 1.9 liters (2 quarts) or more. The causes of excessive oil consumption include the following conditions:

- External oil leaks. Tighten the bolts and/or replace gaskets and oil seals as necessary.
- Incorrect oil level or improper reading of oil level indicator. With the vehicle on a level surface, allow adequate drain down time and check for the correct oil level.
- Improper oil viscosity. Use a recommended SAE viscosity for the prevailing temperatures.
- Continuous high speed operation and/or severe usage.
- Crankcase ventilation system restrictions or malfunctioning components. Possible improper PCV valve.
- Valve guides and/or valve stem oil seals worn, damaged or the seal omitted. Ream the valve guides and install oversize service valves and/or new valve stem oil seals.
- Piston rings broken, improperly installed, worn or not seated properly. Allow adequate time for the piston rings to seat. Replace broken or worn piston rings as necessary.
- Piston improperly installed or miss-fitted.

Oil Pressure Diagnosis and Testing

1. With the vehicle on a level surface, allow adequate drain down time (2-3 minutes) and measure for a low engine oil level.
Add the recommended grade engine oil, and fill the crankcase until the oil level measures FULL on the oil level indicator.
2. Operate the engine and verify low or no oil pressure on the vehicle oil pressure gauge or the oil indicator light.
Listen for a noisy valve train or a knocking noise.
3. Inspect for the following:
 - Engine oil diluted by moisture or unburned fuel mixtures
 - Improper engine oil viscosity for the expected temperature
 - Incorrect or faulty oil pressure gauge sensor
 - Incorrect or faulty oil pressure gauge
 - Plugged oil filter
 - Malfunctioning oil filter bypass valve

4. Remove the oil pressure gauge sensor or another engine block oil gallery plug.
5. Install an oil pressure gauge.
6. Start the engine and then allow the engine to reach normal operation temperature.
7. Measure the engine oil pressure at the following RPM:

Specification

- 7.1. 42 kPa (6psig) (minimum) at 1,000 RPM
 - 7.2. 125 kPa (18 psig) (minimum) at 2,000 RPM
 - 7.3. 166 kPa (24 psig) (minimum) at 4,000 RPM
8. If the engine oil pressure is below minimum specifications, inspect the engine for one or more of the following:
 - Oil pump worn or dirty
 - Malfunctioning oil pump pressure relief valve
 - Oil pump screen loose, plugged or damaged
 - Excessive bearing clearance
 - Cracked, porous or restricted oil galleries
 - Engine block oil gallery plugs missing or incorrectly installed
 - Broken valve lifters

Oil Leak Diagnosis

Step	Action	Value(s)	Yes	No
<p>Important: You can repair most fluid leaks by first visually locating the leak, repairing or replacing the component, or by resealing the gasket surface. Once the leak is identified, determine the cause of the leak. Repair the cause of the leak as well as the leak itself.</p>				
1	<ol style="list-style-type: none"> 1. Operate the vehicle until it reaches normal operating temperature. 2. Park the vehicle on a level surface, over a large sheet of paper or other clean surface. 	—	<i>Go to Step 2</i>	System OK
2	Can you identify the type of fluid and the approximate location of the leak?	—	<i>Go to Step 10</i>	<i>Go to Step 3</i>
3	<ol style="list-style-type: none"> 1. Visually inspect the suspected area. Use a small mirror to assist in looking at hard to see areas. 2. Check for leaks at the following locations: <ul style="list-style-type: none"> • Sealing surfaces • Fittings • Cracked or damaged components <p>Can you identify the type of fluid and the approximate location of the leak?</p>	—	<i>Go to Step 10</i>	<i>Go to Step 4</i>
4	<ol style="list-style-type: none"> 1. Completely clean the entire engine and surrounding components. 2. Operate the vehicle for several kilometers (miles) at normal operating temperature and at varying speeds. 3. Park the vehicle on a level surface, over a large sheet of paper or other clean surface. 4. Wait (15 minutes). 5. Identify the type of fluid and the approximate location of the leak. <p>Can you identify the type of fluid and the approximate location of the leak?</p>	—	<i>Go to Step 10</i>	<i>Go to Step 5</i>
5	<ol style="list-style-type: none"> 1. Visually inspect the suspected area. Use a small mirror to assist in looking at hard to see areas. 2. Check for leaks at the following locations: <ul style="list-style-type: none"> • Sealing surfaces • Fittings • Cracked or damaged components <p>Can you identify the type of fluid and the approximate location of the leak?</p>	—	<i>Go to Step 10</i>	<i>Go to Step 6</i>

6	<ol style="list-style-type: none">1. Completely clean the entire engine and surrounding components.2. Apply an aerosol-type powder (baby powder, foot powder, etc.) to the suspected area.3. Operate the vehicle for several kilometers (miles) at normal operating temperature and at varying speeds.5. Identify the type of fluid and the approximate location of the leak, from the discolorations in the powder surface.			
---	---	--	--	--

Oil Leak Diagnosis (cont' d)

Step	Action	Value(s)	Yes	No
6	Can you identify the type of fluid and the approximate location of the leak?	—	Go to Step 10	Go to Step 4
7	1. Visually inspect the suspected area. Use a small mirror to assist in looking at hard to see areas. 2. Check for leaks at the following locations: <ul style="list-style-type: none"> • Sealing surfaces • Fittings • Cracked or damaged components Can you identify the type of fluid and the approximate location of the leak?	—	Go to Step 10	Go to Step 8
8	Use <i>J 28428-E</i> , Dye and Light Kit, in order to identify the type of fluid and the approximate location of the leak. Refer to manufacturer's instructions when using the tool. Can you identify the type of fluid and the approximate location of the leak?	—	Go to Step 10	Go to Step 9
9	1. Visually inspect the suspected area. Use a small mirror to assist in looking at hard to see areas. 2. Check for leaks at the following locations: <ul style="list-style-type: none"> • Sealing surfaces • Fittings • Cracked or damaged components Can you identify the type of fluid and the approximate location of the leak?	—	Go to Step 10	System OK
10	1. Inspect the engine for mechanical damage. Special attention should be shown to the following areas: <ul style="list-style-type: none"> • Higher than recommended fluid levels • Higher than recommended fluid pressures • Plugged or malfunctioning fluid filters or pressure bypass valves • Plugged or malfunctioning engine ventilation system • Improperly tightened or damaged fasteners • Cracked or porous components • Improper sealants or gaskets where required • Improper sealant or gasket installation • Damaged or worn gaskets or seals • Damaged or worn sealing surfaces 2. Inspect the engine for customer modifications. Is there mechanical damage, or customer modifications to the engine?	—	Go to Step 11	System OK
11	Repair or replace all damaged or modified components. Does the engine still leak oil?	—	Go to Step 1	—

Symptoms - Drive Belt

Important: Review the system operation in order to familiarize yourself with the system functions. Refer to *Drive Belt System Description*.

Visual/Physical Inspection

- Inspect for aftermarket devices which could affect the operation of the drive belts.
- Inspect the easily accessible or visible system components for obvious damage or conditions which could cause the symptom.
- Inspect the drive belt for excessive wear, shredding or missing sections.
- Inspect the drive belt for contamination of excessive dirt, oil, coolant or other substances that may affect the drive belt operation.

Intermittent

- Drive belt symptoms may be from intermittent

Failure of an accessory drive component.

- Drive belt symptoms may occur from changes in load of the accessory drive components.
- Ambient temperatures, moisture or engine operating temperature can affect the drive belt operation.

Symptoms List

Refer to a symptom diagnostic procedure from the following list in order to diagnose the symptom:

- *Drive Belt Chirping Diagnosis*
- *Drive Belt Squeal Diagnosis*
- *Drive Belt Whine Diagnosis*
- *Drive Belt Rumbling Diagnosis*
- *Drive Belt Vibration Diagnosis*
- *Drive Belt Falls Off Diagnosis*
- *Drive Belt Excessive Wear Diagnosis*

Drive Belt Chirping Diagnosis

Diagnostic Aids

The symptom may be intermittent due to moisture on the drive belt(s) or the pulleys. It may be necessary to spray a small amount of water on the drive belt(s) in order to duplicate the customer's concern. If spraying water on the drive belt(s) duplicates the symptom, cleaning the belt pulleys may be the probable solution.

A loose or improper installation of a body component, a suspension component or other items of the vehicle may cause the chirping noise.

Test Description

The number(s) below refer to the step number(s) on the diagnostic table.

2. The noise may not be engine related. This step is to verify that the engine is making the noise. If the engine is not making the noise, do not proceed further with this table.
3. The noise may be an internal engine noise. Removing the drive belt and operating the engine for a brief period will verify the noise is related to the drive belt. When removing the drive belt(s), the water pump may not be operating and the engine may overheat. Also DTCs may set when the engine is operating with the drive belt removed.
4. Inspect all drive belt pulleys for pilling. Pilling is the small balls or pills or it can be strings in the drive belt grooves from the accumulation of

rubber dust.

6. Misalignment of the pulleys may be caused from improper mounting of the accessory drive component, incorrect installation of the accessory drive component pulley or the pulley bent inward or outward from a previous repair. Test for a misaligned pulley .using a straight edge in the pulley grooves across two or three pulleys. If a misaligned pulley is found, refer to that accessory drive component for the proper installation procedure for that pulley.
10. Inspecting of the fasteners can eliminate the possibility that a wrong bolt, nut, spacer or washer was installed.
12. Inspecting the pulleys for being bent should include inspecting for a dent or other damage to the pulleys that would prevent the drive belt from not seating properly in all of the pulley grooves or on the smooth surface of a pulley when the back side of the belt is used to drive the pulley.
14. Replacing the drive belt when it is not damaged or there is not excessive pilling will only be a temporary repair.

Drive Belt Chirping Diagnosis

Step	Action	Value(s)	Yes	No
<p>Notice: Refer to <i>Belt Dressing Notice</i> in Cautions and Notices.</p> <p>DEFINITION: The following items are indications of chirping:</p> <ul style="list-style-type: none"> • A high pitched noise that is heard once per revolution of the drive belt or a pulley. • It usually occurs on cold damp mornings. 				
1	Did you review the Drive Belt Symptom operation and perform the necessary inspections?	—	Go to Step 2	Go to <i>Symptoms - Drive Belt</i>
2	Verify that there is a chirping noise. Does the engine make the chirping noise?	—	Go to Step 3	Go to Diagnostic Aids
3	1. Remove the drive belt. 2. Operate the engine for no longer than 30 to 40 seconds. Does the chirping noise still exist?	—	Go to <i>Engine Noise Diagnosis</i>	Go to Step 4
4	Inspect for severe pilling exceeding 1/3 of the belt groove depth. Does the belt grooves have pilling?	—	Go to Step 5	Go to Step 6
5	Clean the drive belt pulleys with a suitable wire brush. Did you complete the repair?	—	Go to Step 15	Go to Step 6
6	Inspect for misalignment of the pulleys. Are any of the pulleys misaligned?	—	Go to Step 7	Go to Step 8
7	Replace or repair any misaligned pulleys. Did you complete the repair?	—	Go to Step 15	Go to Step 8
8	Inspect for bent or cracked brackets. Did you find any bent or cracked brackets?	—	Go to Step 9	Go to Step 10
9	Replace any bent or cracked brackets. Did you complete the repair?	—	Go to Step 15	Go to Step 10
10	Inspect for improper, loose or missing fasteners Did you find the condition?	—	Go to Step 11	Go to Step 12
11	Tighten any loose fasteners. Replace any improper or missing fasteners. Refer to <i>Fastener Tightening Specifications</i> . Did you complete the repair?	—	Go to Step 15	Go to Step 12
12	Inspect for a bent pulley. Did you find the condition?	—	Go to Step 13	Go to Step 14
13	Replace the bent pulley. Did you complete the repair?	—	Go to Step 15	Go to Step 14
14	Replace the drive belt. Refer to <i>Drive Belt Replacement</i> . Did you complete the repair?	—	Go to Step 15	Go to Diagnostic Aids
15	Operate the system in order to verify the repair. Did you correct the condition?	—	System OK	Go to Step 3

Drive Belt Squeal Diagnosis

Diagnostic Aids

A loose or improper installation of a body component, a suspension component or other items of the vehicle may cause the chirping noise.

If the noise is intermittent, verify the accessory drive components by varying their loads making sure they are operated to their maximum capacity. An overcharged A/C system, power steering system with a pinched hose or wrong fluid or a generator failing are suggested items to inspect.

Test Description

The number(s) below refer to the step number(s) on the diagnostic table.

2. The noise may not be engine related. This step is to verify that the engine is making the noise. If the engine is not making the noise, do not proceed further with this table.
3. The noise may be an internal engine noise. Removing the drive belt and operating the engine for a brief period will verify the noise is related to the drive belt. When removing the drive belt(s), the water pump may not be operating and the engine may overheat. Also DTCs may set when the engine is operating with the drive belt removed.
4. This test is to verify that an accessory drive component does not have a seized bearing. With the belt removed, test the bearings in the

accessory drive components for turning smoothly. Also test the accessory drive components with the engine operating by varying the load on the components to verify that the components operate properly.

5. This test is to verify that the drive belt tensioner operates properly. If the drive belt tensioner is not operating properly, proper belt tension may not be achieved to keep the drive belt from slipping, which could cause a squeal noise.
6. This test is to verify that the drive belt(s) is not too long, which would prevent the drive belt tensioner from working properly. Also, if an incorrect length drive belt was installed, it may not be routed properly and may be turning an accessory drive component in the wrong direction.
7. Misalignment of the pulleys may be caused from improper mounting of the accessory drive component, incorrect installation of the accessory drive component pulley or the pulley bent inward or outward from a previous repair. Test for a misaligned pulley using a straight edge in the pulley grooves across two or three pulleys. If a misaligned pulley is found, refer to that accessory drive component for the proper installation procedure for that pulley.
8. This test is to verify that the pulleys are the correct diameter or width. Using a known good vehicle compare the pulley sizes.

Drive Belt Squeal Diagnosis

Step	Action	Value(s)	Yes	No
<p>Notice: Refer to <i>Belt Dressing Notice</i> in Cautions and Notices.</p> <p>DEFINITION: The following items are indications of drive belt squeal:</p> <ul style="list-style-type: none"> • A loud screeching noise that is caused by a slipping drive belt (this is unusual for a drive belt with multiple ribs) • The noise occurs when a heavy load is applied to the drive belt, such as an air conditioning compressor engagement, snapping the throttle or slipping on a seized pulley or a faulty accessory drive component. 				
1	Did you review the Drive Belt Symptom operation and perform the necessary inspections?	—	Go to Step 2	Go to <i>Symptoms - Drive Belt</i>
2	Verify that there is a squeal noise. Does the engine make the squeal noise?	—	Go to Step 3	Go to Diagnostic Aids
3	1. Remove the drive belt(s). 2. Operate the engine for no longer than 30 to 40 seconds. Does the chirping noise still exist?	—	Go to <i>Engine Noise Diagnosis</i>	Go to Step 4
4	Inspect for an accessory drive component seized bearing or faulty accessory drive component. Did you find and correct the condition?	—	Go to Step 9	Go to Step 5

Drive Belt Squeal Diagnosis (cont' d)

Step	Action	Value(s)	Yes	No
5	Test the drive belt tensioner for proper operation. Refer to <i>Drive Belt Tensioner Diagnosis</i> . Did you find and correct the condition?	—	Go to Step 9	Go to Step 6
6	Inspect for the correct drive belt length. Refer to <i>Drive Belt Replacement</i> . Did you find and correct the condition?	—	Go to Step 9	Go to Step 7
7	Inspect for a misalignment of a pulley. Did you find and correct the condition?	—	Go to Step 9	Go to Step 8
8	Inspect for the correct pulley size. Did you find and correct the condition?	—	Go to Step 9	Go to Diagnostic Aids
9	Operate the system in order to verify the repair. Did you correct the condition?	—	System OK	Go to Step 3

Drive Belt Whine Diagnosis

Diagnostic Aids

The drive belt(s) will not cause the whine noise.

If the whine noise is intermittent, verify the accessory drive components by varying their loads making sure they are operated to their maximum capacity. An overcharged A/C system, power steering system with a pinched hose or wrong fluid or a generator failing are suggested items to inspect.

Test Description

The number(s) below refer to the step number(s) on the diagnostic table.

- This test is to verify that the noise is being

caused by the drive belt(s) or the accessory drive components. When removing the drive belt(s), the water pump may not be operating and the engine may overheat. Also DTCs may set when the engine is operating with the drive belt(s) removed.

- The inspection should include checking the drive belt tensioner and the drive belt idler pulley bearings. The drive belt(s) may have to be installed and the accessory drive components operated separately by varying their loads. Refer to the suspected accessory drive component for the proper inspection and replacement procedure.

Drive Belt Whine Diagnosis

Step	Action	Value(s)	Yes	No
Notice: Refer to <i>Belt Dressing Notice</i> in Cautions and Notices.				
DEFINITION: A high pitched continuous noise that may be caused by an accessory drive component failed bearing.				
1	Did you review the Drive Belt Symptom operation and perform the necessary inspections?	—	Go to Step 2	Go to <i>Symptoms-Drive Belt</i>
2	Verify that there is a whine noise. Does the engine make the whine noise?	—	Go to Step 3	Go to Diagnostic Aids
3	1. Remove the drive belt(s). 2. Operate the engine for no longer than 30 to 40 seconds. Does the whine noise still exist?	—	Go to <i>Engine Noise Diagnosis</i>	Go to Step 4
4	Inspect for a failed accessory drive component bearing. Did you find and repair the condition?	—	Go to Step 5	Go to Diagnostic Aids
9	Operate the system in order to verify the repair. Did you correct the condition?	—	System OK	—

Drive Belt Rumbling Diagnosis

Diagnostic Aids

Vibration from the engine operating may cause a body component or another part of the vehicle to make rumbling noise.

The drive belt(s) may have a condition that cannot be seen or felt. Sometimes replacing the drive belt may be the only repair for the symptom.

If replacing the drive belt(s), completing the diagnostic table, and the noise is only heard when the drive component with a failure. Varying the load on the different accessory drive components may aid in identifying which component is causing the rumbling noise.

Test Description

The number(s) below refer to the step number(s) on the diagnostic table.

2. This test is to verify that the symptom is present during diagnosing. Other vehicle components may cause a similar symptom.
3. This test is to verify that the drive belt(s) is causing the rumbling noise. Rumbling noise may be confused with an internal engine noise due to the similarity in the description. Remove only one drive belt at a time if the vehicle has multiple drive belts. When removing the drive belt the water pump may not be operating and the engine may overheat. Also, DTC's may set when the engine is operating with the drive belt removed.
4. Inspecting the drive belt(s) is to ensure that it is not causing the noise. Small cracks across the ribs of the drive belt will not cause the noise. Belt separation is identified by the plies of the belt separating and may be seen at the edge of the belt, or felt as a lump in the belt.
5. Small amounts of pilling is a normal condition and acceptable. When the pilling is severe, the drive belt does not have a smooth surface for proper operation.

Drive Belt Rumbling Diagnosis

Step	Action	Value(s)	Yes	No
<p>Notice: Refer to <i>Belt Dressing Notice</i> in Cautions and Notices.</p> <p>DEFINITION:</p> <ul style="list-style-type: none"> • A low pitch tapping, knocking or thumping noise heard at or just above idle. • Heard once per revolution of the drive belt or a pulley. • Rumbling may be caused from: <ul style="list-style-type: none"> - Pilling, the accumulation of rubber dust that forms small balls (pills) or strings in the drive belt pulley groove - The separation of the drive belt - A damaged drive belt 				
1	Did you review the Drive Belt Symptom operation and perform the necessary inspections?	—	Go to Step 2	Go to <i>Symptoms-Drive Belt</i>
2	Verify that there is a rumbling noise. Does the engine make the rumbling noise?	—	Go to Step 3	Go to Diagnostic Aids
3	1. Remove the drive belt(s). 2. Operate the engine for no longer than 30 to 40 seconds. Does the rumbling noise still exist?	—	Go to <i>Engine Noise Diagnosis</i>	Go to Step 4
4	Inspect the drive belt(s) for damage, separation or sections of missing ribs. Did you find and repair the condition?	—	Go to Step 7	Go to Step 5
5	Inspect for severe pilling of more than 1/3 of the drive belt pulley grooves. Did you find severe pilling?	—	Go to Step 6	Go to Step 7
6	1. Clean the drive belt pulleys using a suitable wire brush. 2. Reinstall the drive belt. Refer to <i>Drive Belt Replacement</i> . Did you complete the repair?	—	Go to Step 8	Go to Step 7

Drive Belt Rumbling Diagnosis (cont'd)

Step	Action	Value(s)	Yes	No
7	Install a new drive belt. Refer to <i>Drive Belt Replacement</i> . Did you complete the replacement?	—	Go to Step 8	—
8	Operate the system in order to verify the repair. Did you correct the condition?	—	System OK	Go to Diagnostic Aids

Drive Belt Vibration Diagnosis

Diagnostic Aids

The accessory drive components can have an effect on engine vibration. Such as, but not limited to the A/C system overcharged, the power steering system restricted or the incorrect fluid or an extra load on the generator. To help identify an intermittent or an improper condition, vary the loads on the accessory drive components.

Test Description

The number(s) below refer to the step number(s) on the diagnostic table.

2. This test is to verify that the symptom is present during diagnosing. Other vehicle components may cause a similar symptom such as the exhaust system or the drivetrain.
3. This test is to verify that the drive belt(s) or accessory drive components may be causing the vibration. When removing the drive belt the water pump may not be operating and the engine may overheat. Also, DTC's may set when the engine is operating with the drive belt removed.
4. The drive belt(s) may cause a vibration. While the drive belt(s) is removed, inspect the condition of the belt.
6. Inspecting of the fasteners can eliminate the possibility that a wrong bolt, nut, spacer or washer was installed.
8. This step should only be performed if the fan is driven by the drive belt. Inspect the engine cooling fan for bent, twisted, loose or cracked blades. Inspect the fan clutch for smoothness, ease of turning. Inspect for a bent fan shaft or bent mounting flange.
9. This step should only be performed if the water pump is driven by the drive belt. Inspect the water pump shaft for being bent. Also inspect the water pump bearings for smoothness and excessive play. Compare the water pump with a known good water pump.
10. Accessory drive component brackets that are bent, cracked or loose may put extra strain on that accessory component causing it to vibrate.

Drive Belt Vibration Diagnosis

Step	Action	Value(s)	Yes	No
Notice: Refer to <i>Belt Dressing Notice</i> in Cautions and Notices. DEFINITION: <ul style="list-style-type: none"> • The vibration is engine-speed related. • The vibration may be sensitive to accessory load. 				
1	Did you review the Drive Belt Symptom operation and perform the necessary inspections?	—	Go to Step 2	Go to <i>Symptoms-Drive Belt</i>
2	Verify that the vibration is engine related. Does the engine make the vibration?	—	Go to Step 3	Go to Diagnostic Aids
3	1. Remove the drive belt(s). 2. Operate the engine for no longer than 30 to 40 seconds. Does the rumbling noise still exist?	—	Go to <i>Engine Related Vibration in Vibration and Diagnosis</i>	Go to Step 4

4	Inspect the drive belt(s) for wear, damage, debris build-up and missing drive belt ribs. Did you find any of these conditions?	—	<i>Go to Step 5</i>	<i>Go to Step 6</i>
---	---	---	---------------------	---------------------

Drive Belt Vibration Diagnosis (cont' d)

Step	Action	Value(s)	Yes	No
5	Install a new drive belt. Refer to <i>Drive Belt Replacement</i> . Did you complete the replacement?	—	Go to Step 11	—
6	Inspect for improper, loose or missing fasteners. Did you find any of these conditions?	—	Go to Step 5	Go to Step 6
7	Tighten any loose fasteners. Replace improper or missing fasteners. Refer to <i>Fastener Tightening Specifications</i> . Did you complete the repair?	—	Go to Step 11	—
8	Inspect for damaged fan blades or bent fan clutch shaft, if the fan is belt driven. Refer to <i>Fan Clutch Replacement</i> in Engine Cooling. Did you find and correct the condition?	—	Go to Step 11	Go to Step 9
9	Inspect for bent water pump shaft, if the water pump is belt driven. Refer to <i>Water Pump Replacement (4.3L Engine)</i> in Engine Cooling. Did you find and correct the condition?	—	Go to Step 11	Go to Step 10
10	Inspect for bent or cracked brackets. Did you find and correct the condition?	—	Go to Step 11	Go to Diagnostic Aids
11	Operate the system in order to verify the repair. Did you correct the condition?	—	System OK	Go to Step 3

Drive Belt Falls Off Diagnosis

Diagnostic Aids

If the drive belt(s) repeatedly falls off the drive belt pulleys, this is because of pulley misalignment.

An extra load that is quickly applied and released by an accessory drive component may cause the drive belt to fall off the pulleys. Verify the accessory drive components operate properly.

If the drive belt(s) is the incorrect length, the drive belt tensioner may not keep the proper tension on the drive belt.

Test Description

The number(s) below refer to the step number(s) on the diagnostic table.

2. This inspection is to verify the condition of the drive belt. Damage may have occurred to the drive belt when the drive belt fell off. The drive belt may have been damaged, which caused the drive belt to fall off. Inspect the belt for cuts, tears, sections of ribs missing or damaged belt plies.
4. Misalignment of the pulleys may be caused from improper mounting of the accessory drive

component, incorrect installation of the accessory drive component pulley or the pulley bent inward or outward from a previous repair. Test for a misaligned pulley using a straight edge in the pulley grooves across two or three pulleys. If a misaligned pulley is found, refer to that accessory drive component for the proper installation procedure of that pulley.

5. Inspecting the pulleys for being bent should include inspecting for a dent or other damage to the pulleys that would prevent the drive belt from not seating properly in all of the pulley grooves or on the smooth surface of a pulley when the back side of the belt is used to drive the pulley.
6. Accessory drive component brackets that are bent or cracked will let the drive belt fall off.
7. Inspecting of the fasteners can eliminate the possibility that a wrong bolt, nut, spacer or washer was installed. Missing, loose or the wrong fasteners may cause pulley misalignment from the bracket moving under load. Over tightening of the fasteners may cause misalignment of the accessory component bracket.

Drive Belt Falls Off Diagnosis

Step	Action	Value(s)	Yes	No
Notice: Refer to <i>Belt Dressing Notice</i> in Cautions and Notices.				
DEFINITION: The drive belt falls off the pulleys or may not ride correctly on the pulleys.				
1	Did you review the Drive Belt Symptom operation and perform the necessary inspections?	—	Go to Step 2	Go to <i>Symptoms-Drive Belt</i>
2	Inspect for a damaged drive belt. Did you find the condition?	—	Go to Step 3	Go to Step 4
3	Install a new drive belt. Refer to <i>Drive Belt Replacement</i> . Does the drive belt continue to fall off?	—	Go to Step 4	System OK
4	Inspect for misalignment of the pulleys. Did you find and repair the condition?	—	Go to Step 12	Go to Step 5
5	Inspect for a bent or dented pulley. Did you find and repair the condition?	—	Go to Step 12	Go to Step 6
6	Inspect for a bent or cracked bracket. Did you find and repair the condition?	—	Go to Step 12	Go to Step 7
7	Inspect for improper, loose or missing fasteners. Did you find loose or missing fasteners?	—	Go to Step 8	Go to Step 9
8	Tighten any loose fasteners. Replace improper or missing fasteners. Refer to <i>Fastener Tightening Specifications</i> . Does the drive belt continue to fall off?	—	Go to Step 9	System OK
9	Test the drive belt tensioner for operating correctly. Refer to <i>Drive Belt Tensioner Diagnosis</i> . Does the drive belt tensioner operate correctly?	—	Go to Step 11	Go to Step 10
10	Replace the drive belt tensioner. Refer to <i>Drive Belt Tensioner Replacement</i> . Does the drive belt continue to fall off?	—	Go to Step 11	System OK
11	Inspect for failed drive belt idler and drive belt tensioner pulley bearings. Did you find and repair the condition?	—	Go to Step 12	Go to Diagnostic Aids
12	Operate the system in order to verify the repair. Did you correct the condition?	—	System OK	Go to Step 2

Drive Belt Excessive Wear Diagnosis

the diagnostic table.

Diagnostic Aids

Excessive wear on a drive belt(s) is usually caused by an incorrect installation or the wrong drive belt for the application.

Minor misalignment of the drive belt pulleys will not cause excessive wear, but will probably cause the drive belt(s) to make a noise or to fall off.

Excessive misalignment of the drive belt pulleys will cause excessive wear but may also make the drive belt(s) fall off.

Test Description

The number(s) below refer to the step number(s) on

2. This inspection is to verify the drive belt(s) is correctly installed on all of the drive belt pulleys. Wear on the drive belt(s) may be caused by mis-positioning the drive belt(s) by one groove on a pulley.
3. The installation of a drive belt that is too wide or too narrow will cause wear on the drive belt. The drive belt ribs should match all of the grooves on all of the pulleys.
4. This inspection is to verify the drive belt(s) is not contacting any parts of the engine or body while the engine is operating. There should be sufficient clearance when the drive belt accessory drive components load varies. The drive belt(s) should not come in contact with an engine or a body component when snapping the throttle.

Drive Belt Excessive Wear Diagnosis

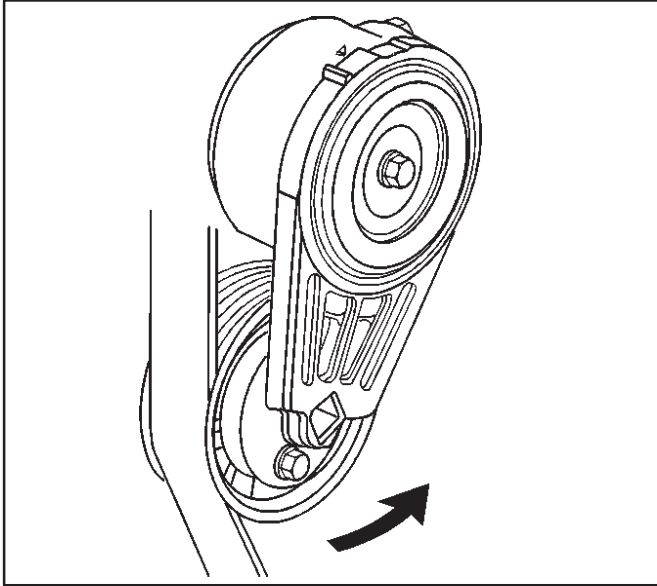
Step	Action	Value(s)	Yes	No
<p>Notice: Refer to <i>Belt Dressing Notice</i> in Cautions and Notices.</p> <p>DEFINITION: Wear at the outside ribs of the drive belt due to an incorrectly installed drive belt.</p>				
1	Did you review the Drive Belt Symptom operation and perform the necessary inspections?	—	<i>Go to Step 2</i>	<i>Go to Symptoms-Drive Belt</i>
2	Inspect the drive belt(s) for the proper installation. Refer to <i>Drive Belt Replacement</i> . Did you find the condition?	—	<i>Go to Step 5</i>	<i>Go to Step 3</i>
3	Inspect for the proper drive belt. Did you find this condition?	—	<i>Go to Step 5</i>	<i>Go to Step 4</i>
4	Inspect for the drive belt rubbing against a bracket, hose or wiring harness. Did you find and repair the condition?	—	<i>Go to Step 6</i>	<i>Go to Diagnostic Aids</i>
5	Replace the drive belt. Refer to <i>Drive Belt Replacement</i> . Did you complete the replacement?	—	<i>Go to Step 6</i>	—
6	Operate the system in order to verify the repair. Does the drive belt continue to fall off?	—	System OK	—

Drive Belt Tensioner Diagnosis

Inspection Procedure

Important

When the engine is operating the drive belt tensioner arm will move. Do not replace the drive belt tensioner because of movement in the drive belt tensioner arm.

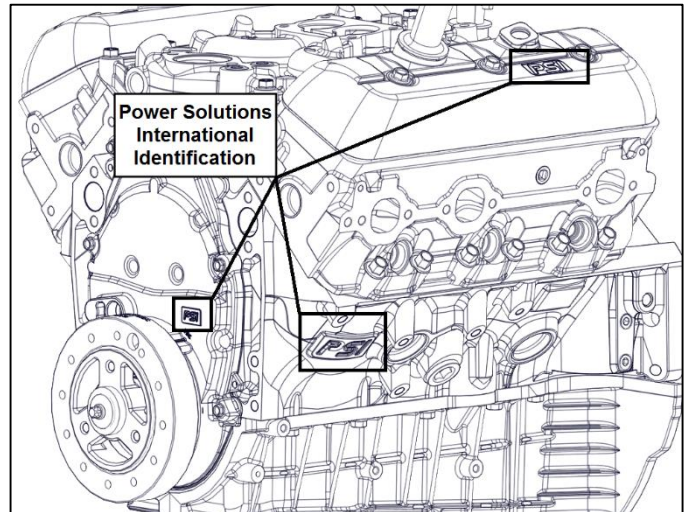


1. Remove the drive belt.
2. Position a 3/8 inch drive wrench on the drive belt tensioner arm and rotate the arm counterclockwise.
3. Move the drive belt tensioner through its full travel.
 - The movement should feel smooth
 - There should be no binding
 - The tensioner should return freely
4. If any binding is observed, replace the drive belt tensioner
5. Install the drive belt.

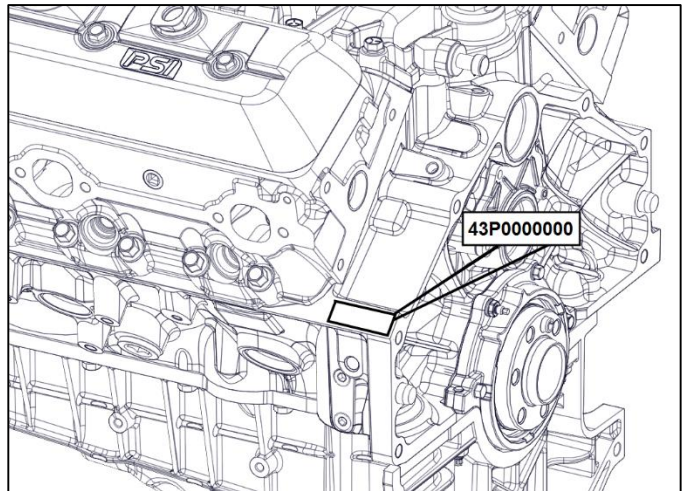
Notice: Allowing the drive belt tensioner to snap into the free position may result in damage to the tensioner.

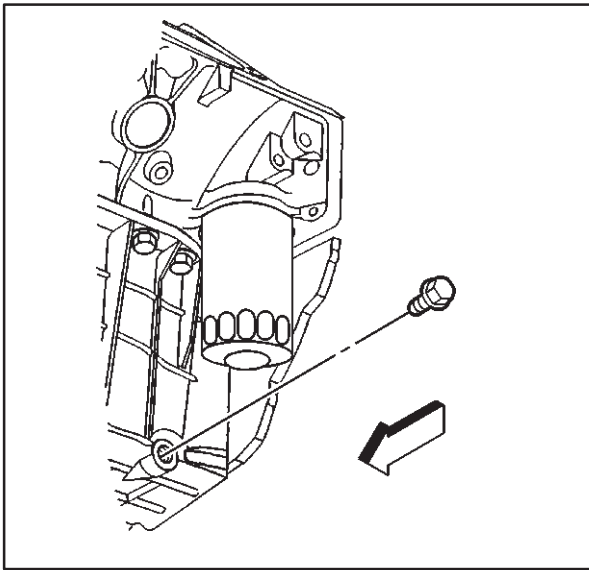
Engine Identification

A Power Solutions International (PSI) 4.3 Liter engine will be identified with PSI branding throughout the engine. "PSI" will be found on the valve covers, timing cover, engine block, and oil pan.



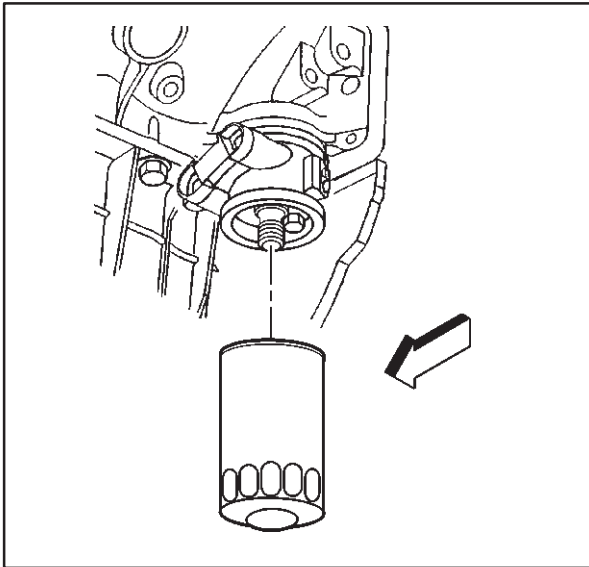
The engine serial number is located on the valve cover of the engine as well as stamped into the left rear of the engine block. It will be formatted 43P followed by a sequence of numbers.



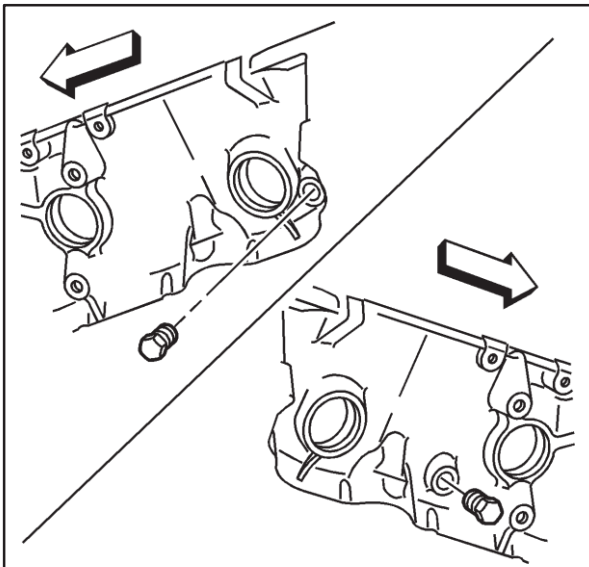


Draining Fluids and Oil Filter Removal

1. Remove the oil pan drain plug and allow the engine oil to drain into a suitable container.



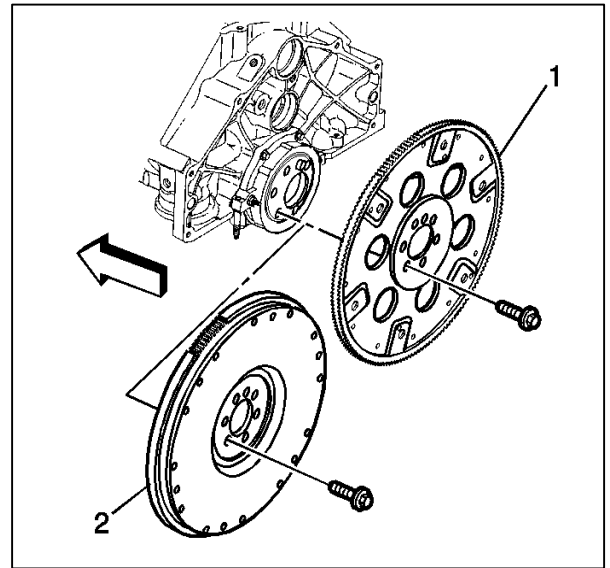
2. Remove the oil filter (if applicable).
3. Discard the oil filter (if applicable).



4. Remove both the engine block coolant drain hole plugs and allow the coolant to drain into a suitable container.

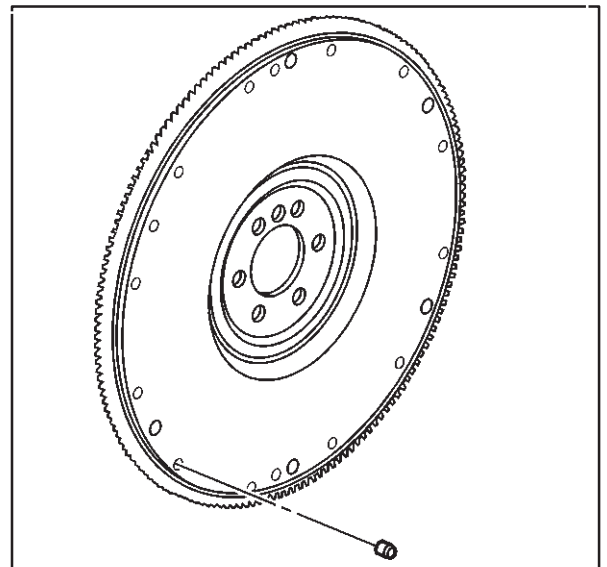
Engine Flywheel Removal

1. Remove the engine flywheel bolts.
2. Remove the engine flywheel (automatic transmission) (1), if applicable.
3. Remove the engine flywheel (manual transmission) (2), if applicable.



Important: If replacing the engine flywheel (manual transmission), then NEW flywheel weights must be installed into the NEW engine flywheel in the same location as the old flywheel weights in the old engine flywheel.

4. Note the position of any flywheel weights for assembly (if applicable).



Clutch Pilot Bearing Removal

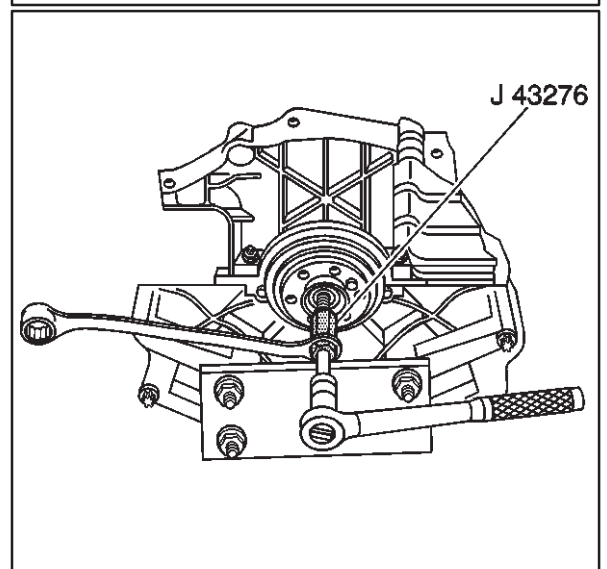
Tools Required

J 43276 Clutch Pilot Bearing Remover

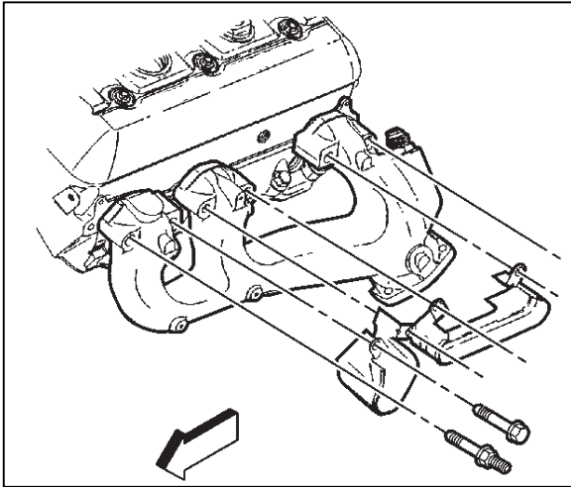
Caution: Refer to Safety Glasses Caution in Cautions and Notices

Notice: When using the J 43276 Clutch Pilot Bearing Remover, always secure the J 43276-1 Clutch Pilot Bearing Remover tool body using a wrench. Do not allow the J 43276-1 Clutch Pilot Bearing Remover tool body to rotate. Failing to do so will cause damage to the J 43276-1 Clutch Pilot Bearing Remover tool body.

1. Remove the clutch pilot bearing using the J 43276
 - 1.1. Install the J 43276 tool body into the clutch pilot bearing.



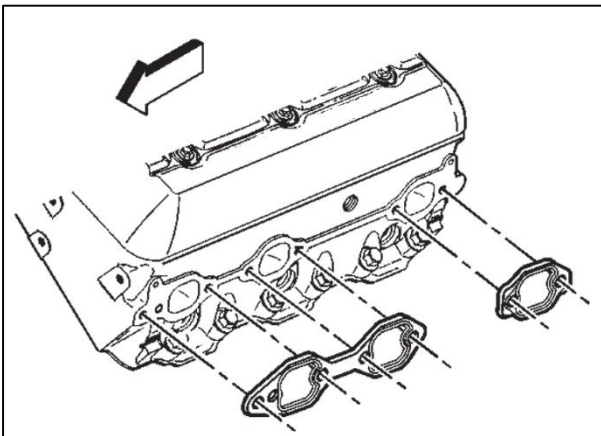
- 1.2. Using a wrench secure the J 43276-1 tool body.
- 1.3. Insert the J 43276-2 forcing screw into the J 43276-1 tool body.
- 1.4. Rotate the J 43276-2 forcing screw clockwise into the J 43276-1 tool body until the clutch pilot bearing is completely removed from the crankshaft.
- 1.5. Rotate the J 43276-2 forcing screw counterclockwise to remove the J 43276-2 forcing screw from the J 43276-1 tool body.
- 1.6. Remove the J 43276-1 tool body from the clutch pilot bearing.
2. Discard the clutch pilot bearing.



Exhaust Manifold Removal (Left)

Notice: Twist the spark plug boot one-half turn in order to release the boot. Pull on the spark plug boot only. Do not pull on the spark plug wire or the wire could be damaged.

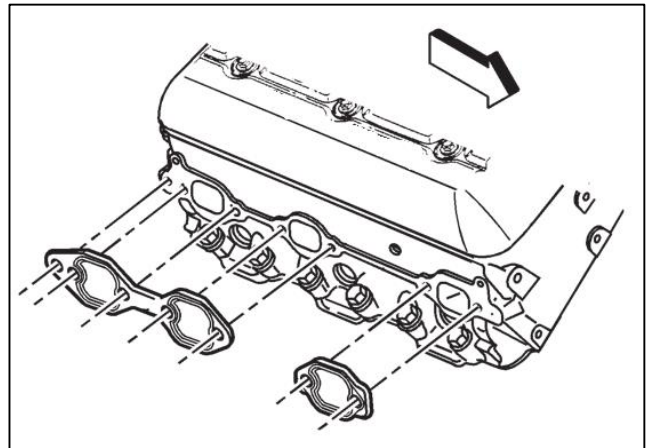
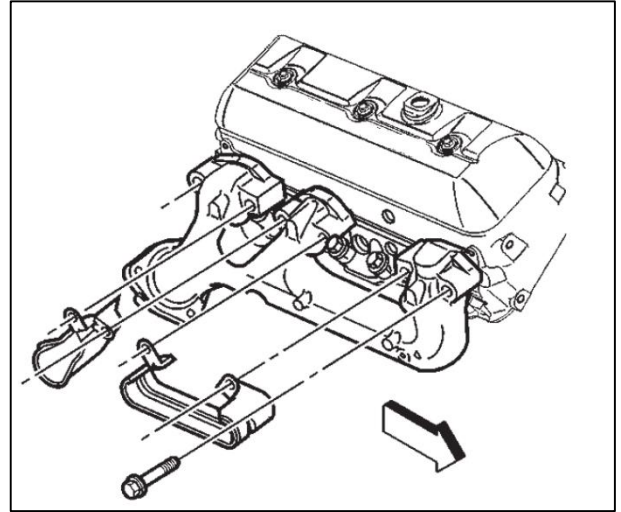
1. Remove the spark plug wires from the spark plugs.
 - 1.1. Rotate the spark plug wire boot one-half turn.
 - 1.2. Pull outward on the spark plug wire boot to release from the spark plug.
2. Remove the spark plug wires from the spark plug wire retainers.
3. Remove the exhaust manifold bolts and the stud.
4. Remove the spark plug wire shields (if applicable) and the exhaust manifold.
5. Remove and discard the exhaust manifold gaskets.



Exhaust Manifold Removal (Right)

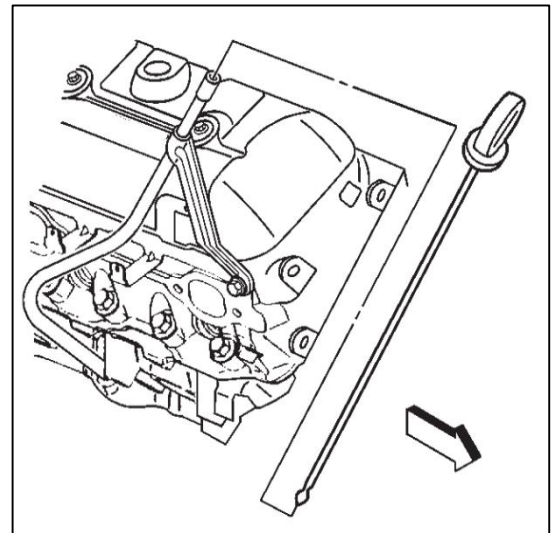
Notice: Twist the spark plug boot one-half turn in order to release the boot. Pull on the spark plug boot only. Do not pull on the spark plug wire or the wire could be damaged.

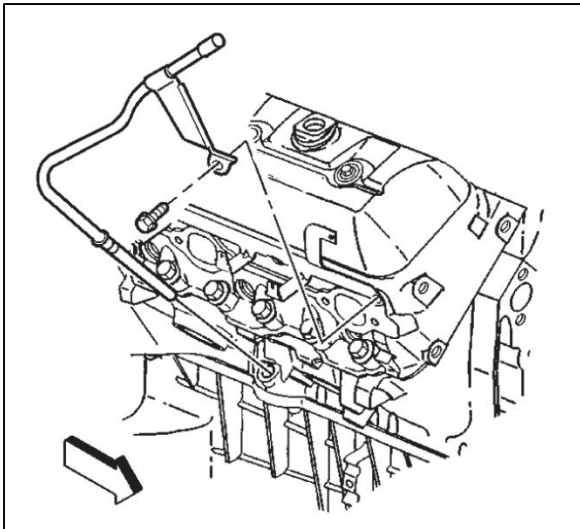
1. Remove the spark plug wires from the spark plugs.
 - 1.1. Rotate the spark plug wire boot one-half turn.
 - 1.2. Pull outward on the spark plug wire boot to release from the spark plug.
2. Remove the spark plug wires from the spark plug wire retainers.
3. Remove the exhaust manifold bolts and the stud.
4. Remove the spark plug wire shields (if applicable) and the exhaust manifold.
5. Remove and discard the exhaust manifold gaskets.



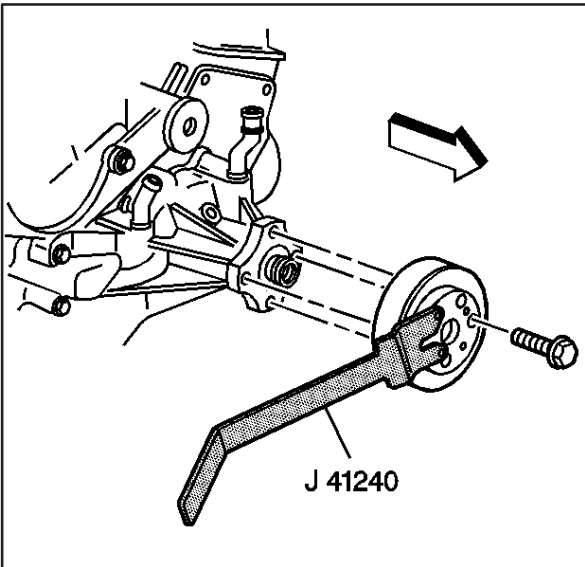
Oil Level Indicator and Tube Removal

1. Remove the oil level indicator from the oil level indicator tube, if applicable.



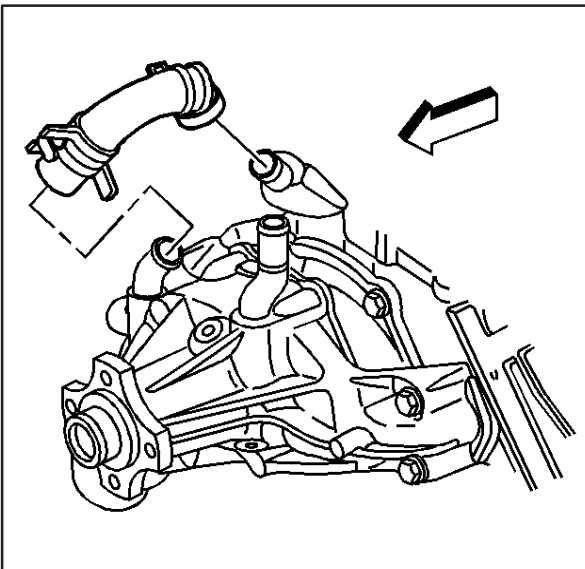


2. Remove the oil level indicator tube bolt.
3. Remove the oil level indicator tube from the engine block.



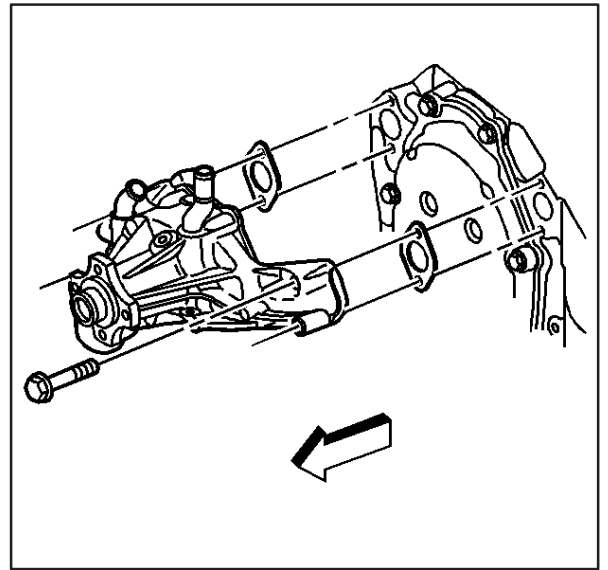
Water Pump Removal

1. Remove the bolts and the fan and water pump pulley using the



2. Remove the clamps and water pump inlet hose.

3. Remove the water pump bolts.
4. Remove the water pump.
5. Remove the water pump gaskets.
6. Discard the water pump gaskets.

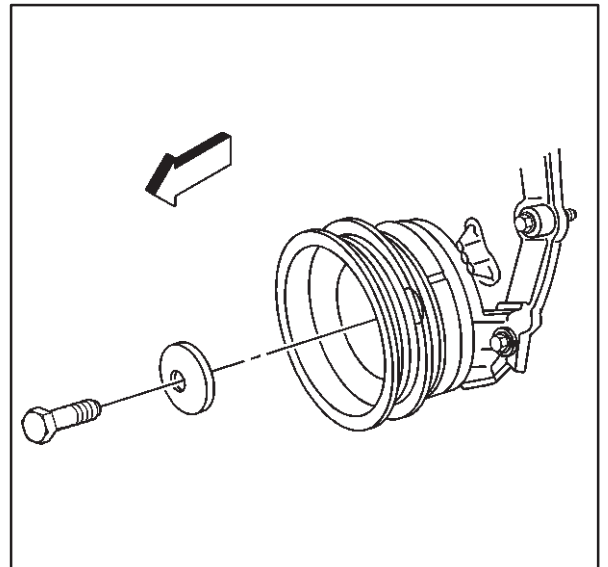


Crankshaft Balancer Removal

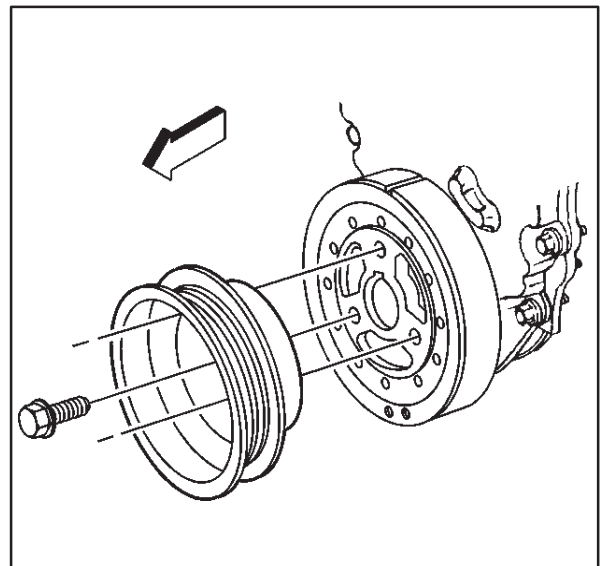
Tools Required

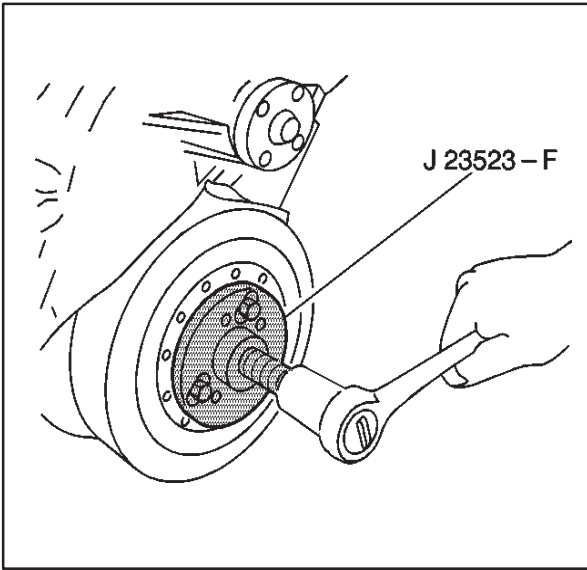
J23523-F Balancer Remover and Installer

1. Remove the crankshaft balancer bolt and washer.



2. Remove the bolts and the crankshaft pulley.





Notice: Refer to *Fastener Notice* in Cautions and Notices.

3. Use the J23523-F in order to remove the crankshaft balancer.

- 3.1. Install the J 23523-F plate and bolts onto the crankshaft balancer.

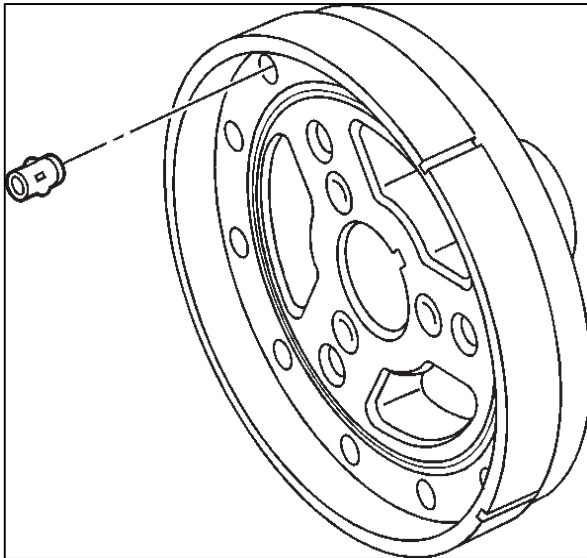
Tighten

Tighten the bolts to 25 N•m (18 lb ft.).

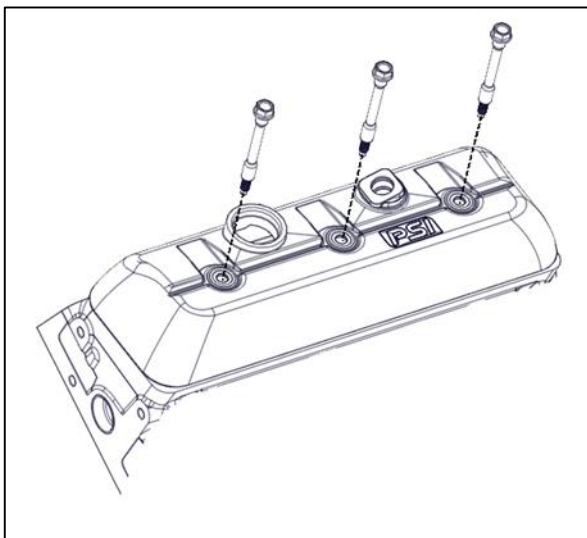
- 3.2. Install the J 23523-F forcing screw into the plate.

- 3.3. Rotate the J 23523-F forcing screw clockwise in order to remove the crankshaft balancer.

4. Remove the J 23523-F from the crankshaft balancer.



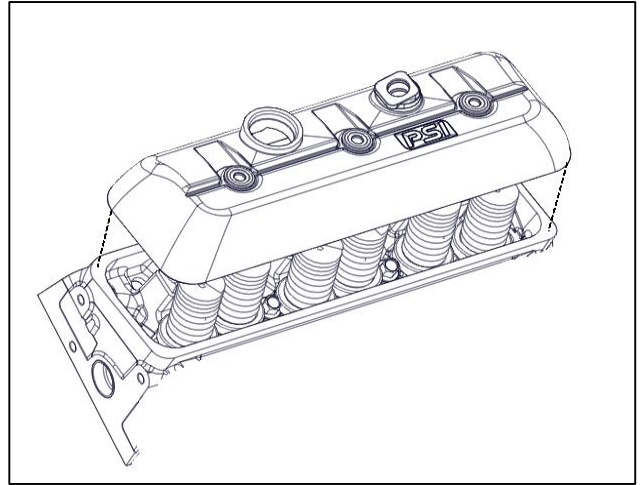
5. Note the position of any front groove pins (crankshaft balancer) (if applicable)



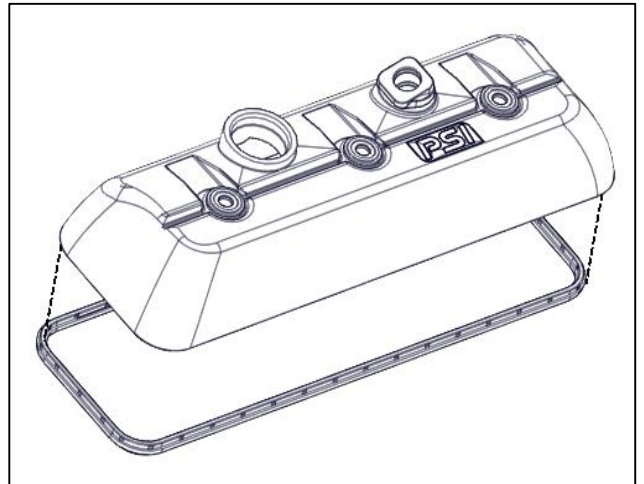
Valve Rocker Arm Cover Removal (Left)

1. Remove the valve rocker arm cover bolts.
2. Remove the valve rocker arm cover bolt grommets.
3. Discard the valve rocker arm cover bolt grommets.

4. Remove the valve rocker arm cover.

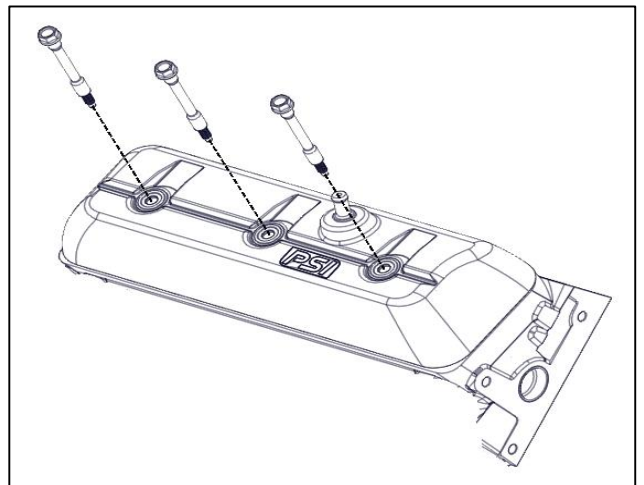


5. Remove the valve rocker arm cover gasket.
6. Discard the valve rocker arm cover gasket.

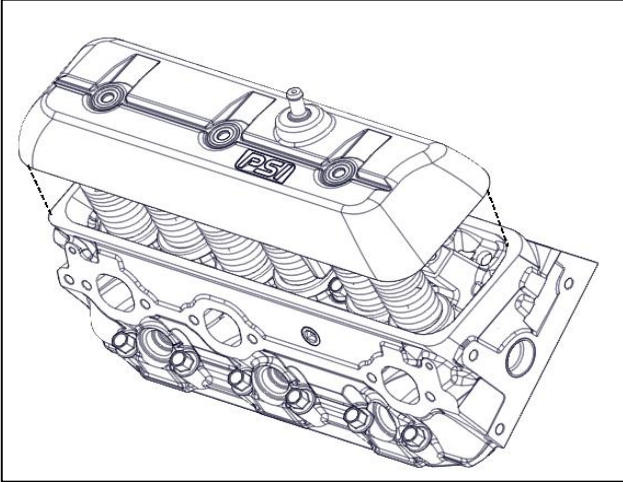


Valve Rocker Arm Cover Removal (Right)

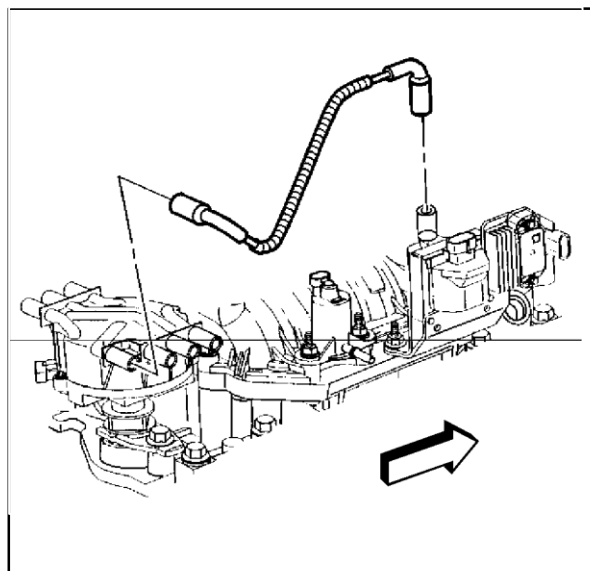
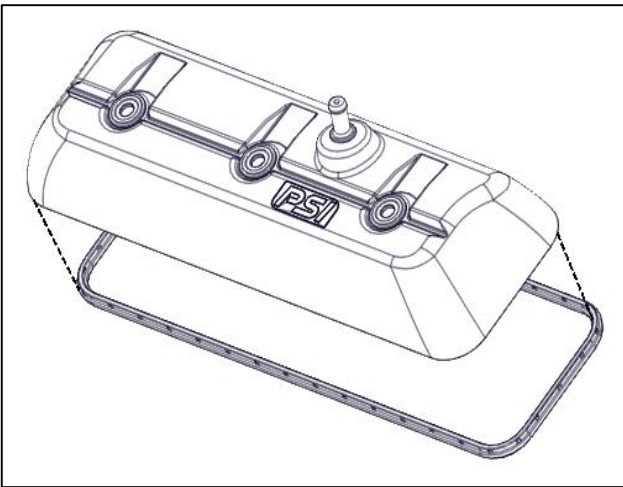
1. Remove the valve rocker arm cover bolts.
2. Remove the valve rocker arm cover bolt grommets.
3. Discard the valve rocker arm cover bolt grommets.



-
4. Remove the valve rocker arm cover.



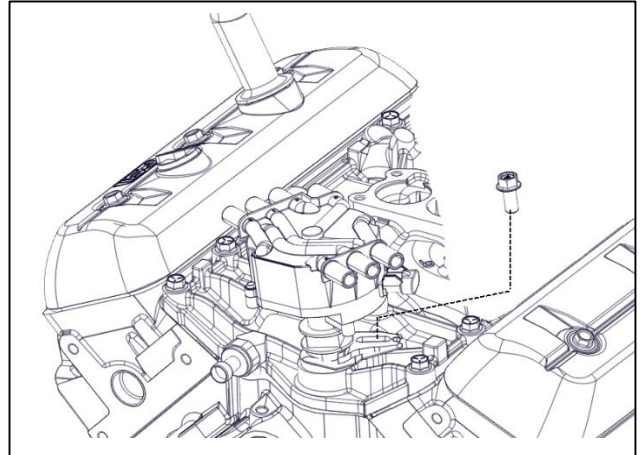
5. Remove the valve rocker arm cover gasket.
6. Discard the valve rocker arm cover gasket.



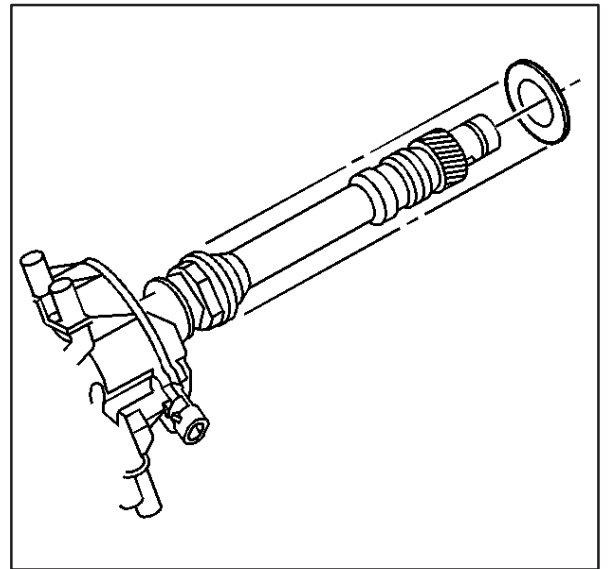
Distributor Removal

1. Remove the ignition coil wire harness from the ignition coil and distributor cap.

2. Remove the distributor clamp bolt.
3. Remove the distributor and the distributor clamp.

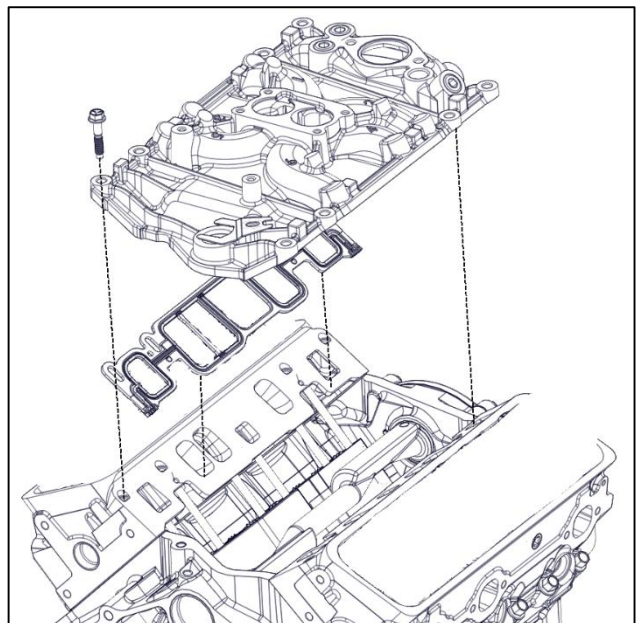


4. Remove the distributor gasket and discard.



Intake Manifold Removal

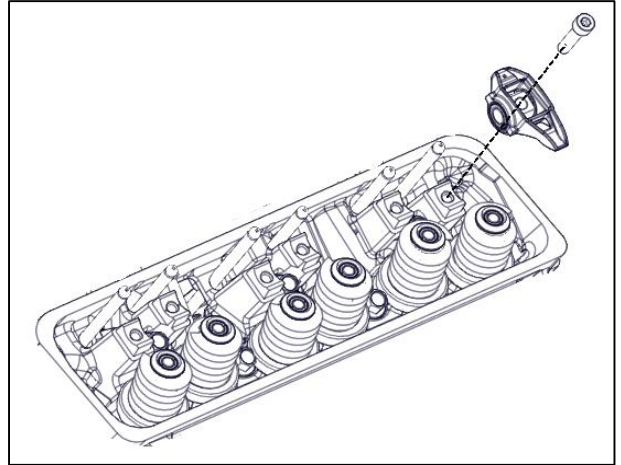
1. Remove the engine coolant temperature (ECT) sensor wire connector (if equipped) from the engine wiring harness bracket.
2. Remove the lower intake manifold bolts.
3. Remove the intake manifold assembly.
4. Remove and discard the lower intake manifold gaskets.



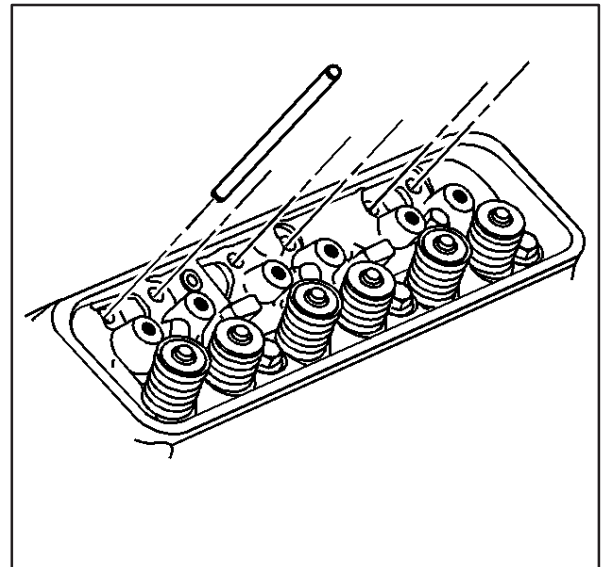
Valve Rocker Arm and Push Rod Removal

Important: Mark, sort and organize all the components for assembly.

1. Remove the valve rocker arms.

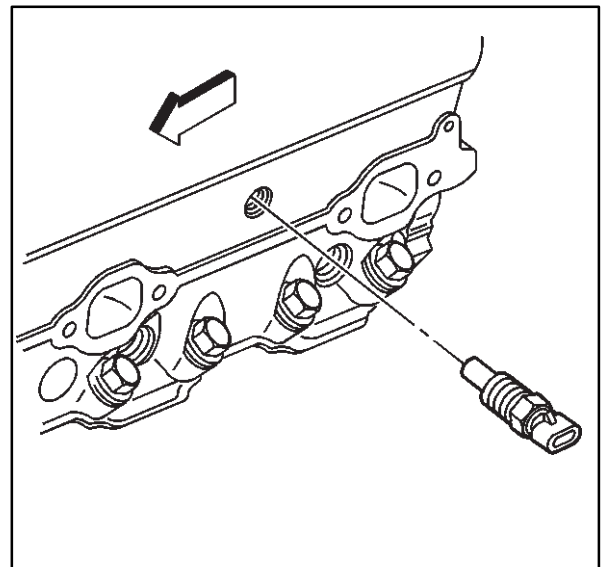


2. Remove the valve pushrods.

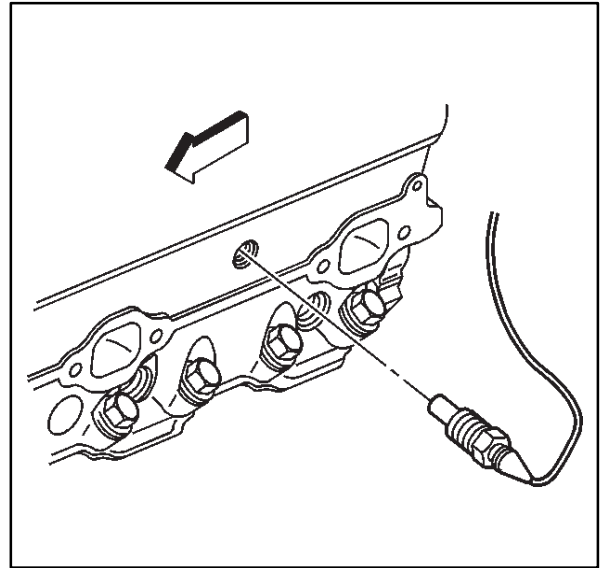


Cylinder Head Removal (Left)

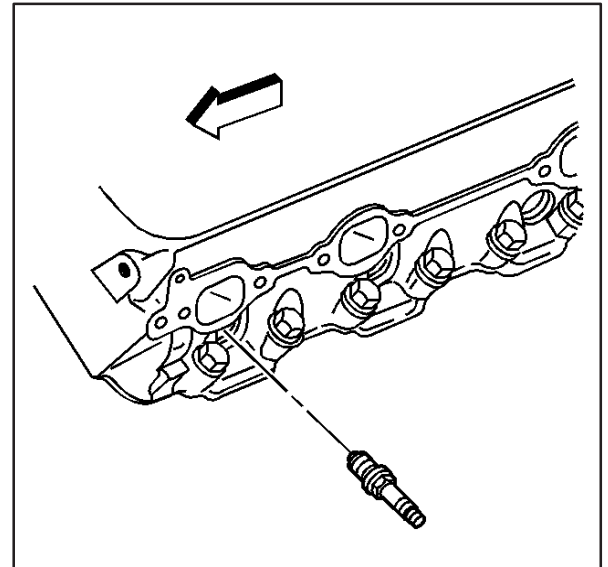
1. Remove the engine coolant temperature sensor (if applicable).



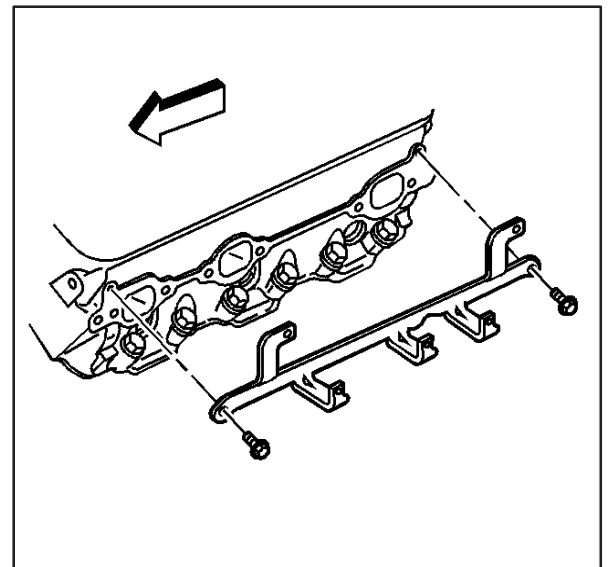
2. Remove the engine coolant temperature gauge sensor (if applicable).

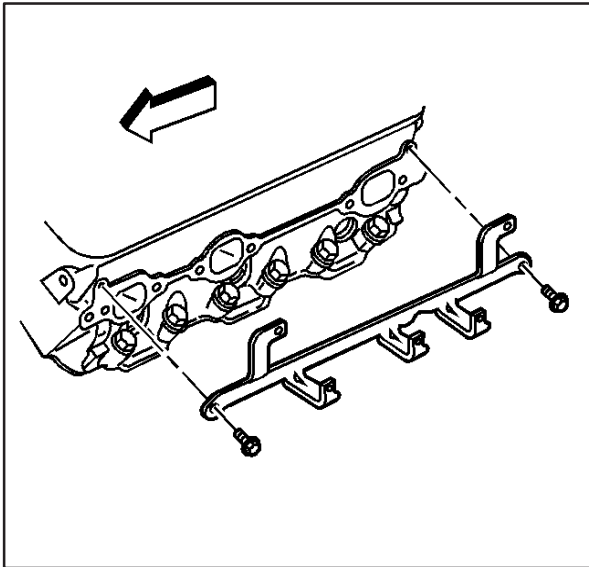


3. Remove the spark plugs.

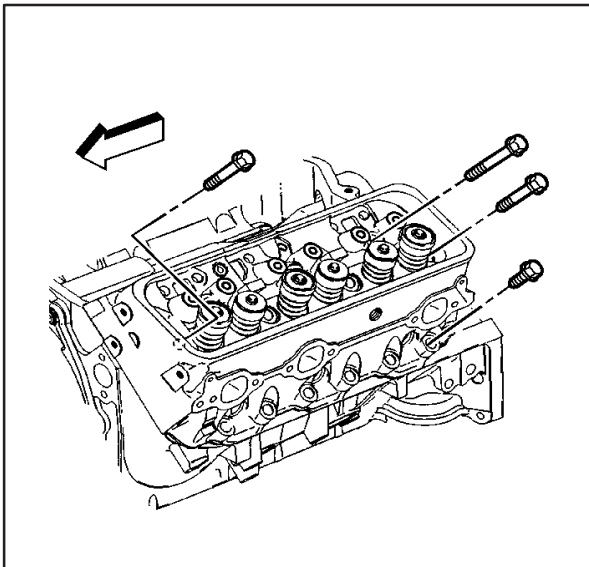


4. Remove the bolts and the spark plug wire support.

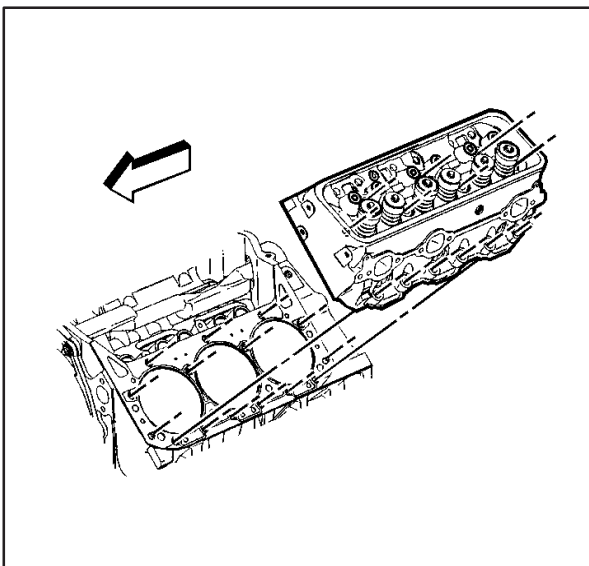




5. Remove the bolts and the spark plug wire support.



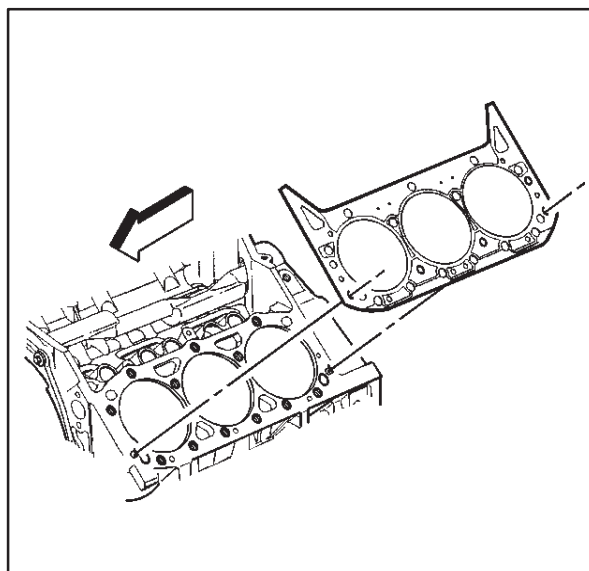
6. Remove the cylinder head bolts.



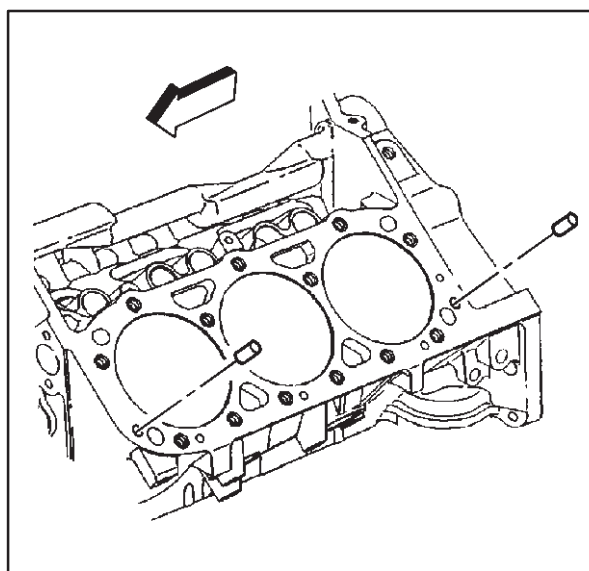
Notice: After removal, place the cylinder head on two wood blocks to prevent damage.

7. Remove the cylinder head.

8. Remove and discard the cylinder head gasket.

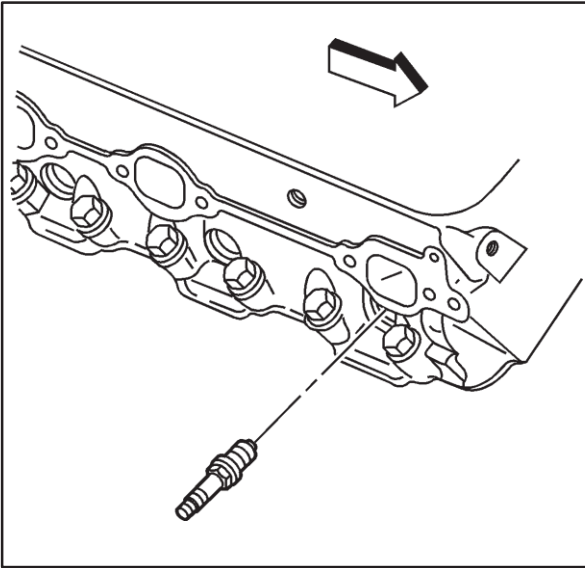


9. Remove the dowel pins (cylinder head locator) (if required).

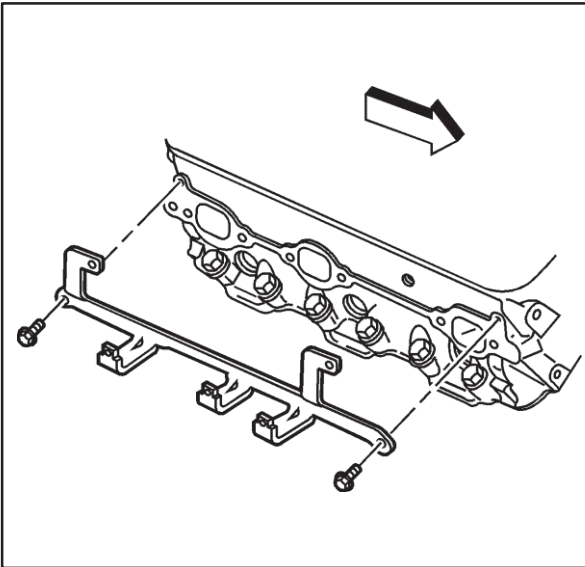


Cylinder Head Removal (Right)

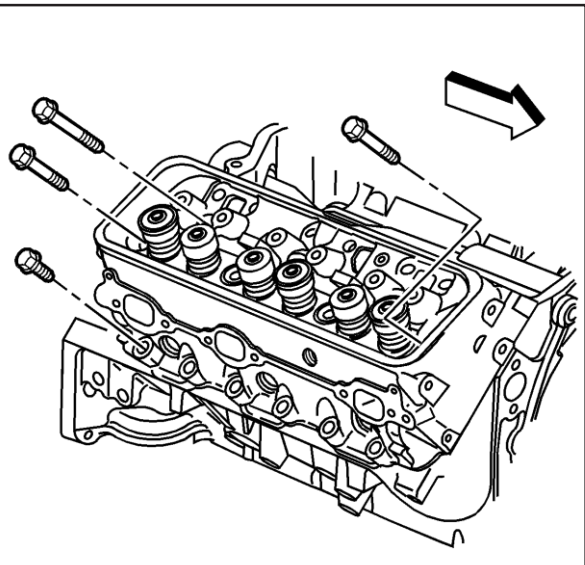
1. Remove the spark plugs.



2. Remove the bolts and the spark plug wire support.

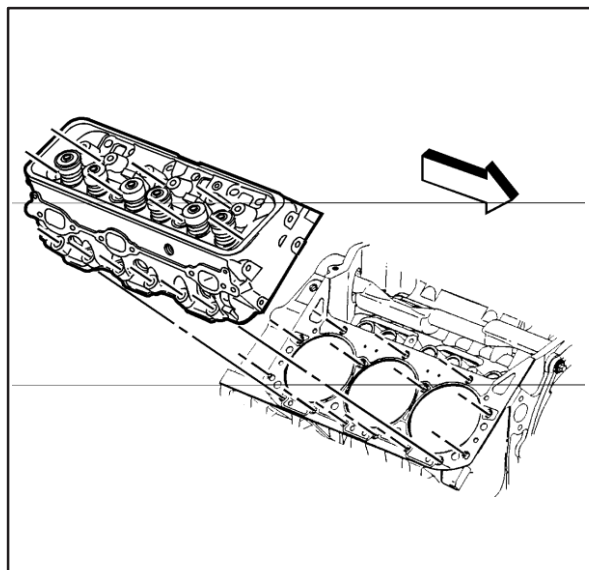


3. Remove the cylinder head bolts.

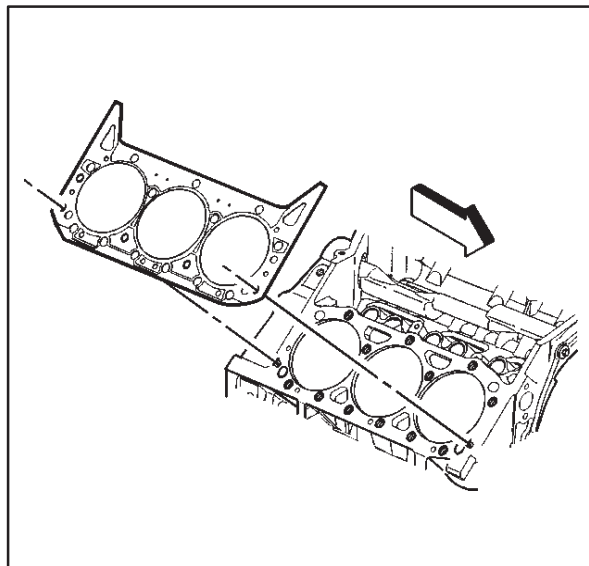


Notice: After removal, place the cylinder head on two wood blocks to prevent damage.

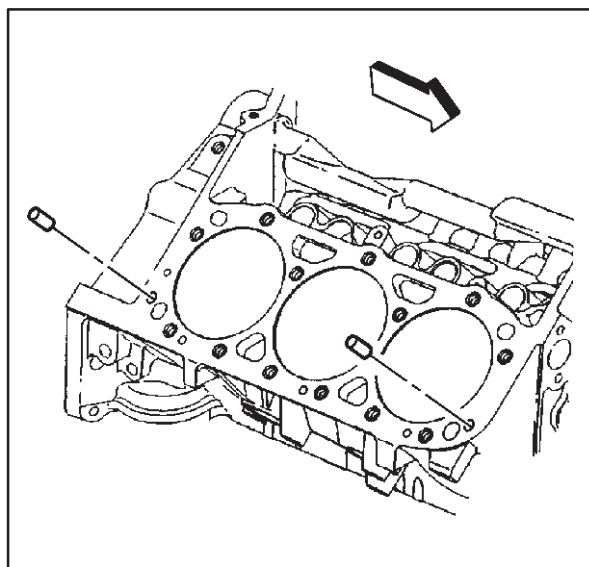
4. Remove the cylinder head.

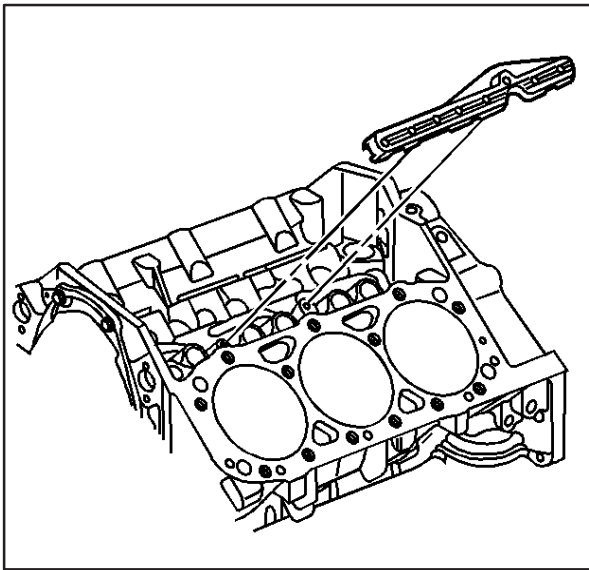


5. Remove and discard the cylinder head gasket.



6. Remove the dowel pins (cylinder head locator) (if required).





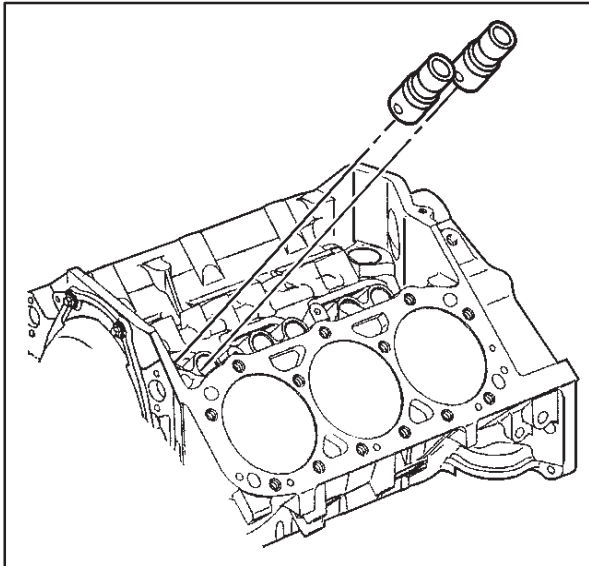
Valve Lifter Removal

Tools Required

J 3049-A Valve Lifter Remover

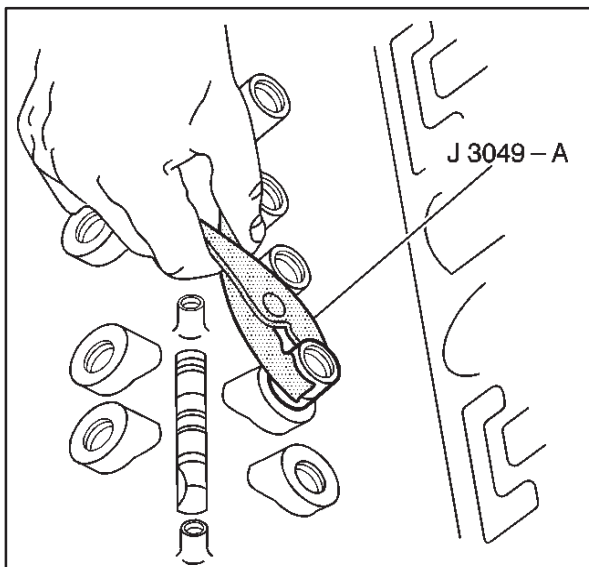
Important: Place the components in a rack so that the components can be reinstalled to their original location.

1. Remove the bolts and the valve lifter pushrod guide.



Important: Place the valve lifters in the rack in the upright position in order to maintain the oil inside the valve lifters.

2. Remove the valve lifters.

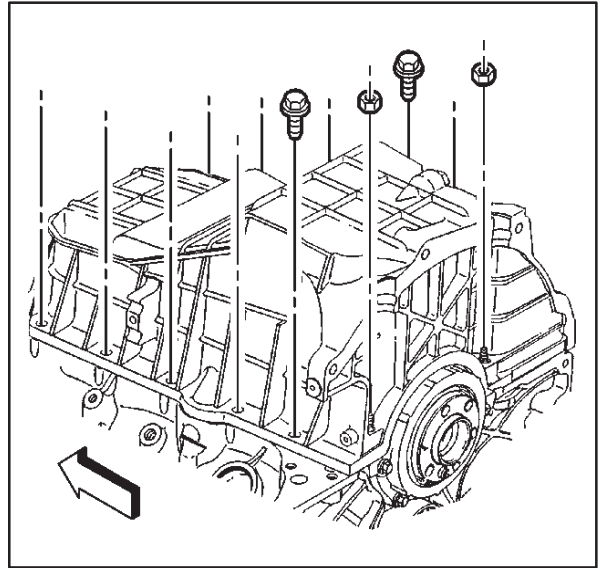


Important: Some valve lifters may be stuck in the valve lifter bores because of gum or varnish deposits and may require the use of *J 3049-A* for removal.

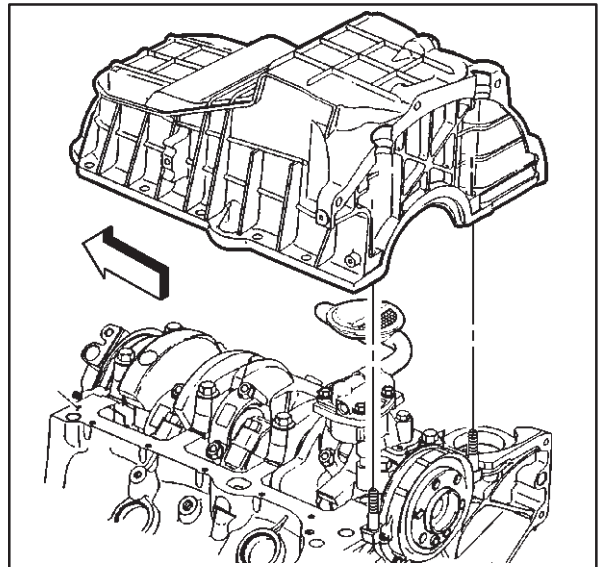
3. Use the *J 3049-A* in order to remove the stuck valve lifters.

Oil Pan Removal

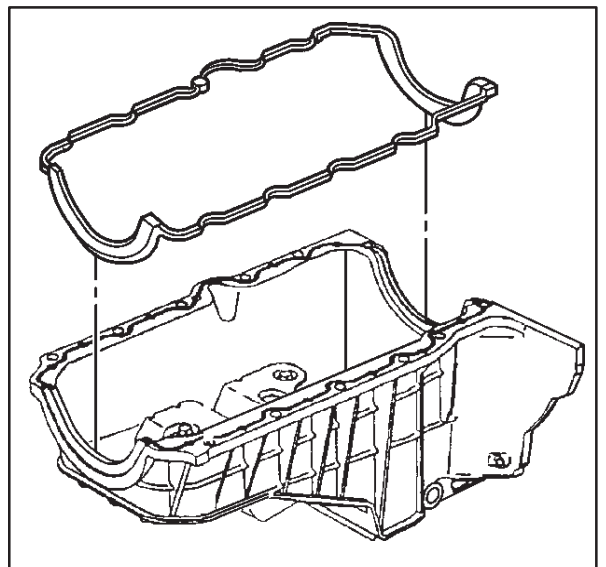
1. Remove the oil pan bolts and nuts.



2. Remove the oil pan.

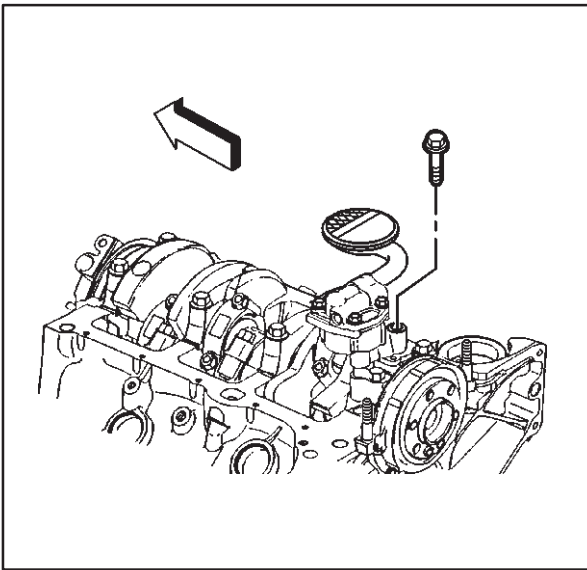


1. Remove the oil pan gasket.
2. Discard the oil pan gasket.

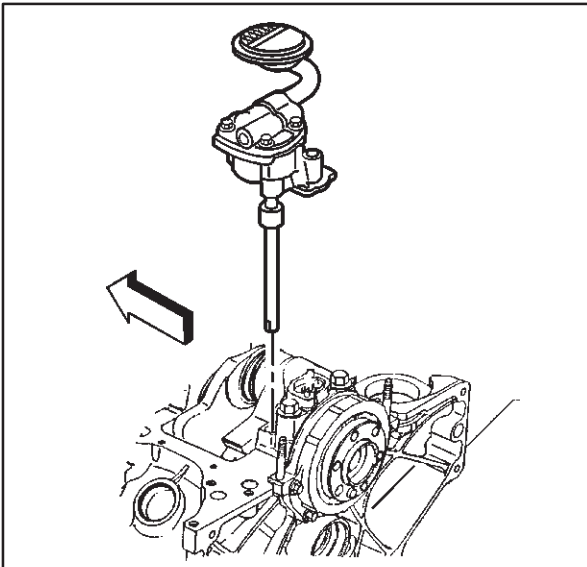


Oil Pump Removal

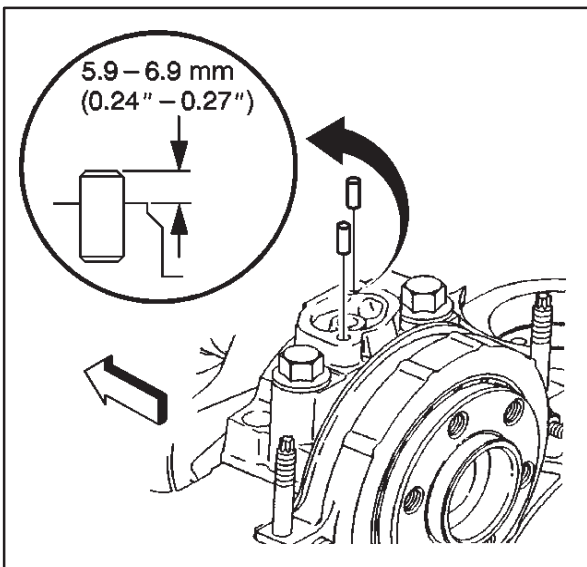
1. Remove the oil pump bolt.



2. Remove the oil pump.

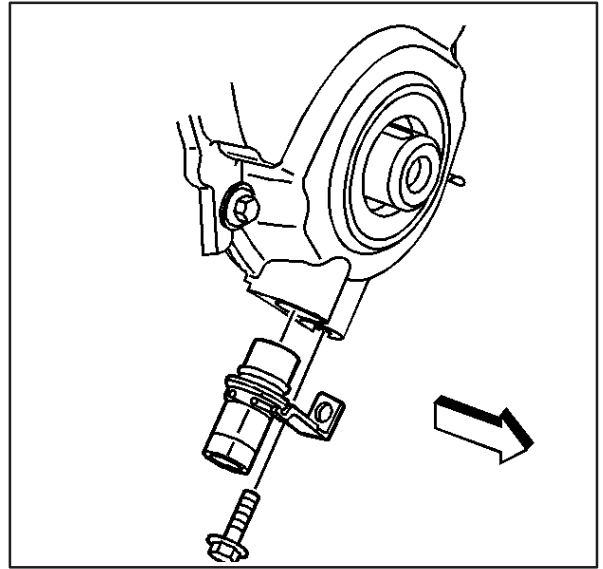


3. Inspect the pins (oil pump locator) for damage, and replace the pins if required.

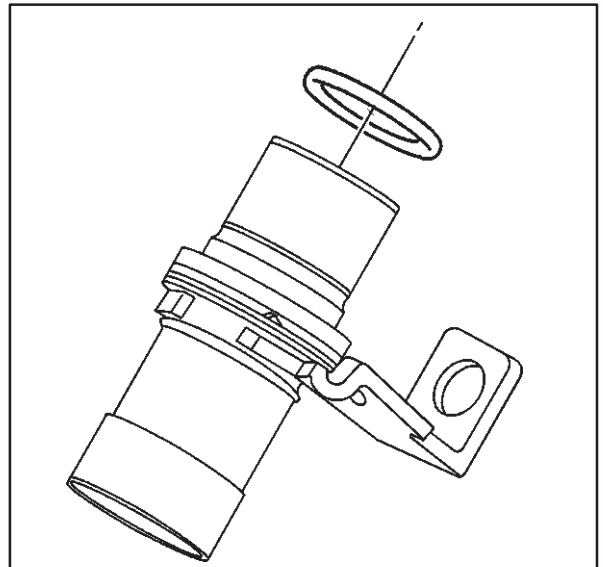


Engine Front Cover Removal

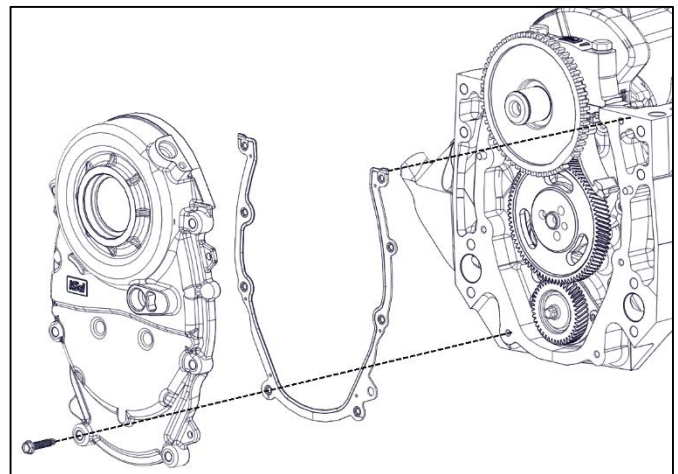
1. Remove the crankshaft position sensor bolt.
2. Remove the crankshaft position sensor.

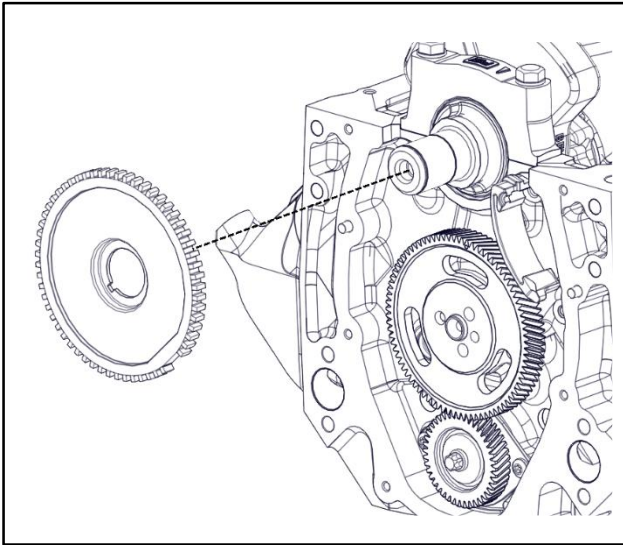


3. Remove the crankshaft position sensor seal (O-ring).
4. Discard the crankshaft position sensor seal (O-



1. Remove the engine front cover bolts.
2. Remove the engine front cover.
3. Discard the engine front cover seal.



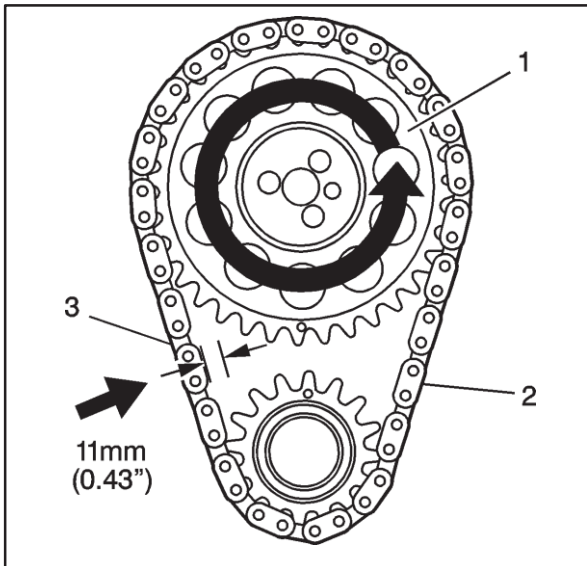


Timing Chain and Sprockets Removal

Tools Required

J 5825-A Crankshaft Gear Remover

1. Remove the crankshaft position sensor reluctor ring.



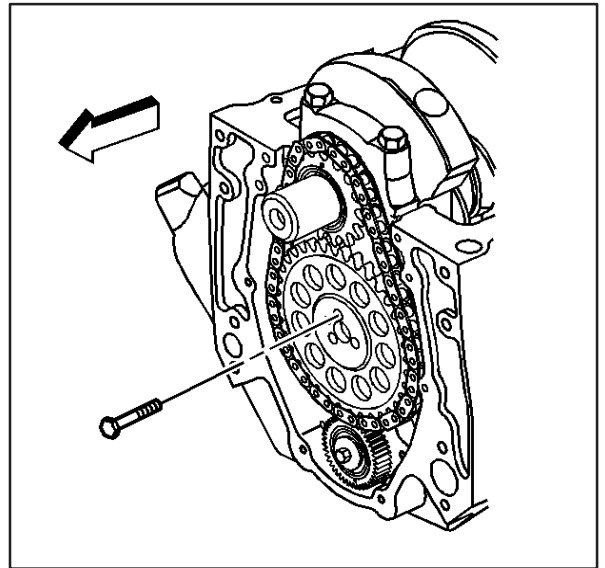
2. Check the camshaft timing chain free play.

- 2.1. Rotate the camshaft sprocket (1) counterclockwise until all slack is removed from the camshaft timing chain (2).

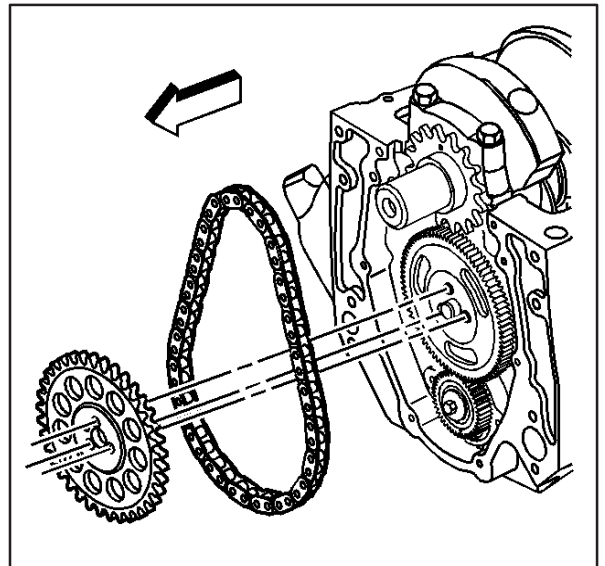
- 2.2. Measure the free play on the slack side (3) of the camshaft timing chain.

If the camshaft timing chain can be moved side to side in excess of 11 mm (0.43 in), replacement of the camshaft timing chain and the sprockets is recommended during assembly.

3. Remove the camshaft sprocket bolts.

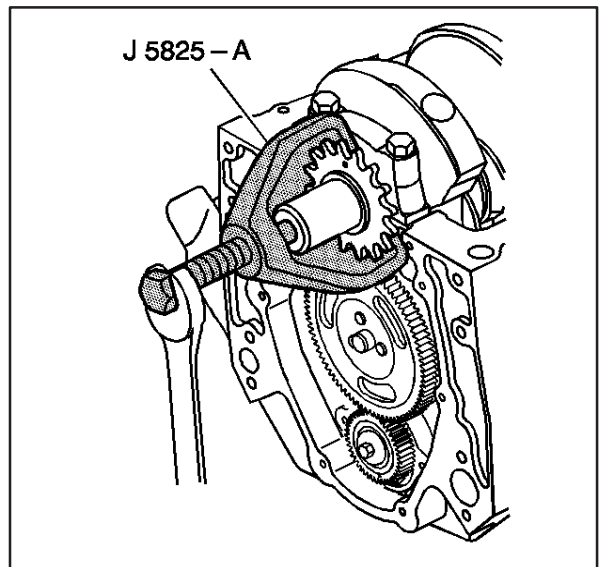


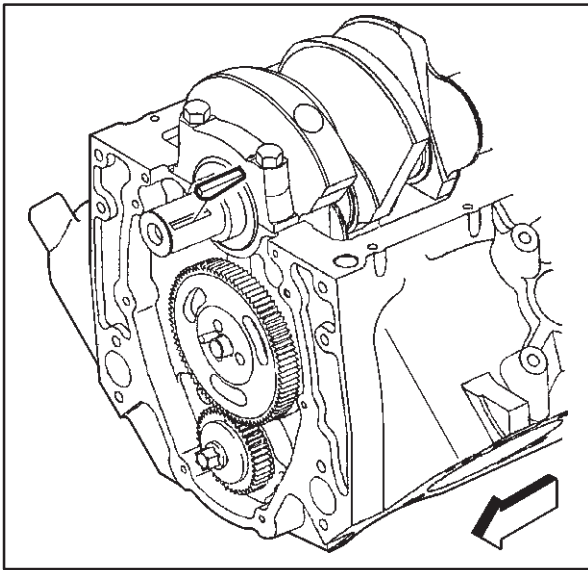
4. Remove the camshaft sprocket and the camshaft timing chain.



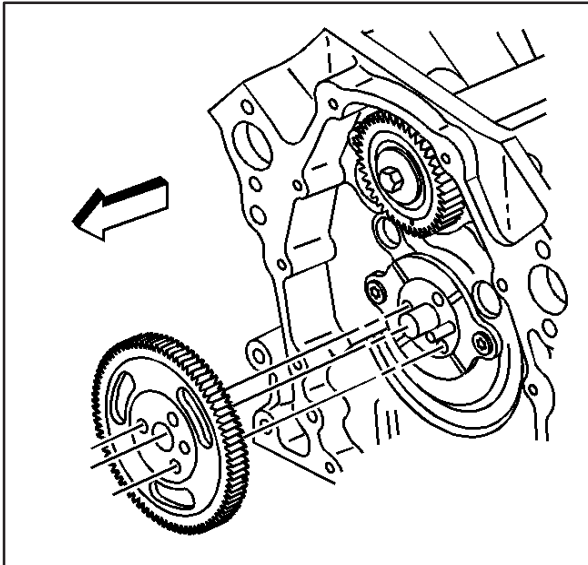
Caution: Refer to Safety Glasses Caution in Cautions and Notices.

5. Remove the crankshaft sprocket using the J 5825-A.



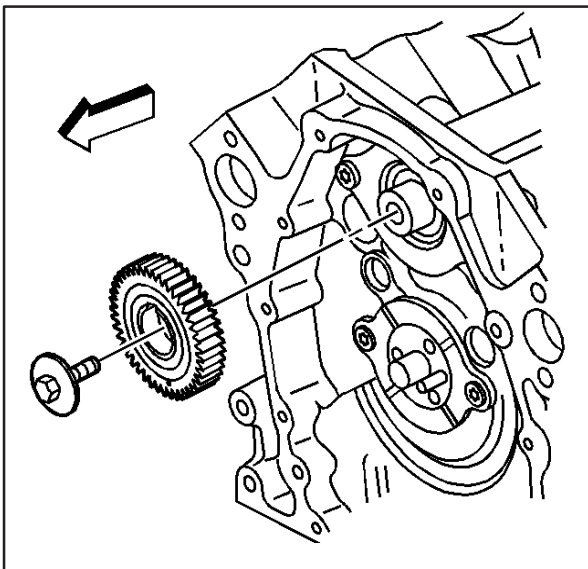


6. Remove the crankshaft balancer key.



Balance Shaft Removal

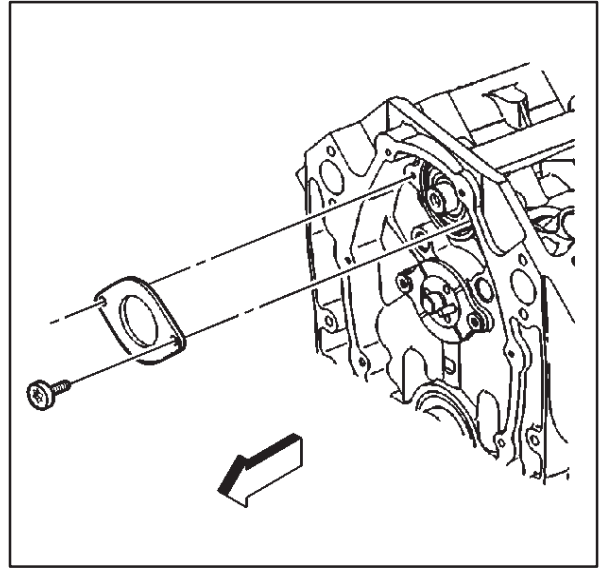
1. Remove the balancer shaft drive gear.



Important: The balance shaft drive and balance shaft driven gears are serviced as a set. The set includes the balance shaft driven gear bolt.

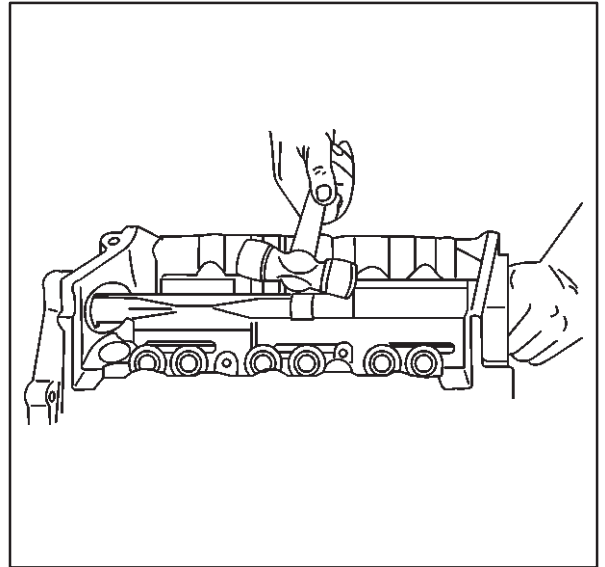
2. Remove the balance shaft driven gear bolt from the balance shaft.
 - 2.1. Use a wrench in order to secure the balance shaft.
Place the wrench onto the balance shaft near to the balance shaft front bearing.
 - 2.2. Remove the balance shaft bolt.
 - 2.3. Remove the wrench from the balance shaft.
3. Remove the balance shaft driven gear from the balance shaft.

4. Remove the bolts and the balance shaft retainer.



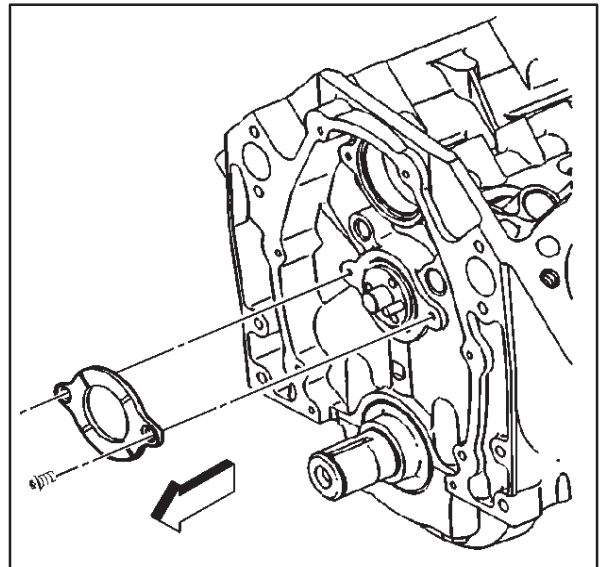
Important: The balance shaft and the balance shaft front bearing are serviced only as a package. Do not remove the balance shaft front bearing from the balance shaft.

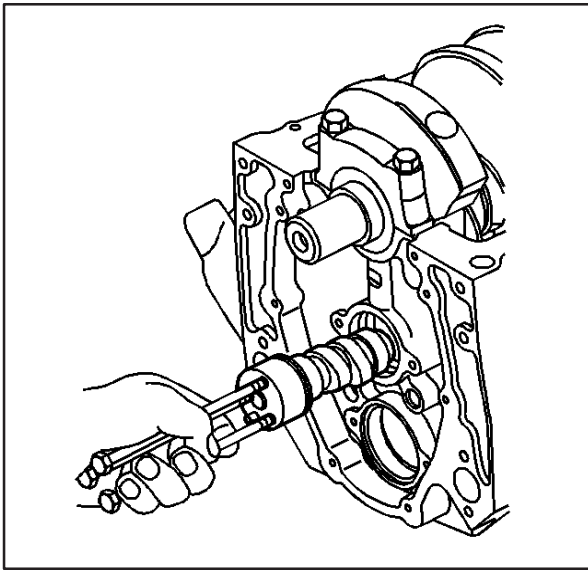
5. Use a soft-faced hammer in order to remove the balance shaft from the engine block.



Camshaft Removal

1. Remove the camshaft retainer bolts and





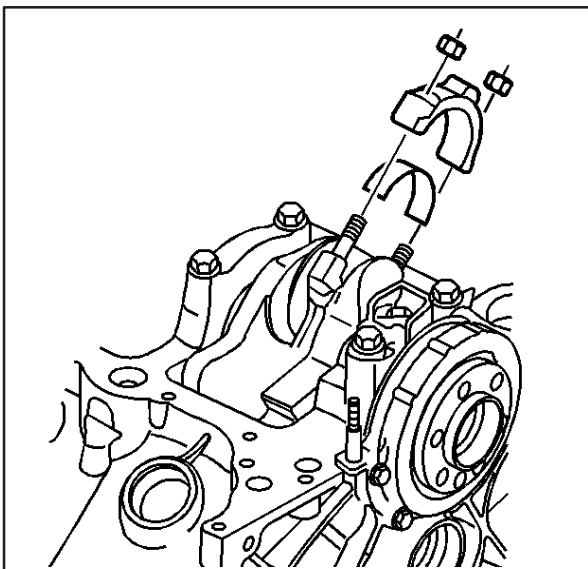
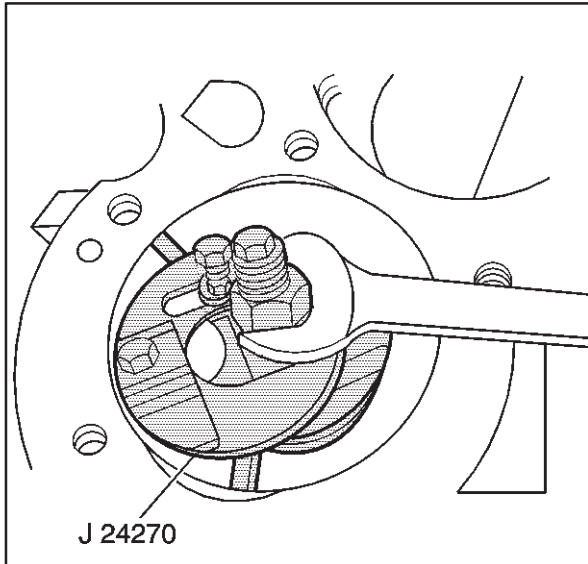
Notice: All camshaft journals are the same diameter, so care must be used in removing or installing the camshaft to avoid damage to the camshaft bearings.

2. Remove the engine camshaft.
 - 2.1. Install the three 5/16-18 x 4.0 inch bolts into the engine camshaft front bolt holes.
 - 2.2. Using the bolts as a handle, carefully rotate and pull the engine camshaft out of the camshaft bearings.
 - 2.3. Remove the bolts from the front of the engine camshaft.

Piston, Connecting Rod, and Bearing Removal

Tools Required

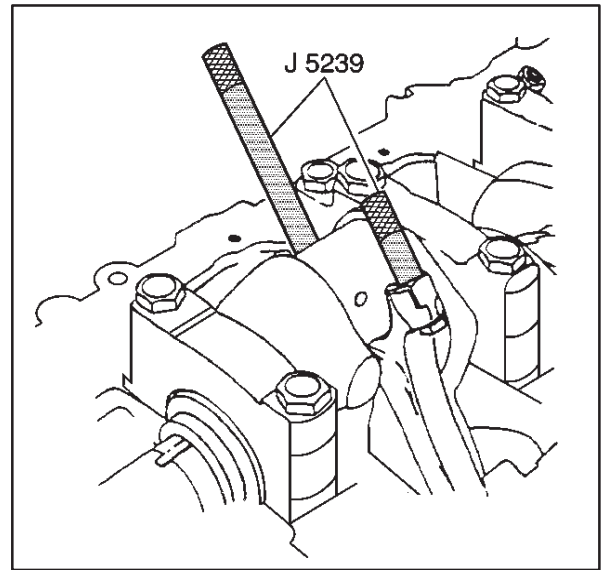
- J 5239 Connecting Rod Bolt Guide Set
- J 24270 Cylinder Bore Ridge Reamer
 1. Use the J 24270 in order to remove the cylinder ring ridge.
 - 1.1. Turn the crankshaft until the piston is at the bottom of the stroke.
 - 1.2. Place a cloth on top of the piston.
 - 1.3. Use the J 24270 to remove all of the cylinder ring ridge.
 - 1.4. Turn the crankshaft so the piston is at the top of the stroke.
 - 1.5. Remove the cloth.
 - 1.6. Remove the cutting debris.



Important: Place match marks or numbers on the connecting rods and the connecting rod caps, also indicate direction on both.

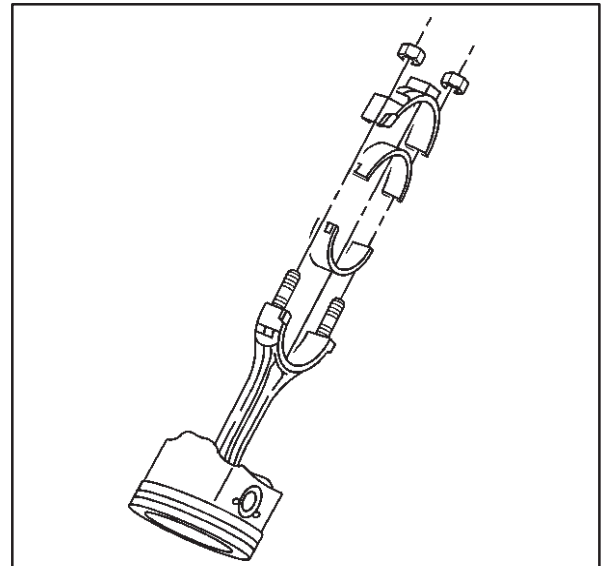
2. Remove the connecting rod nuts.
3. Remove the connecting rod cap.

4. Use the J 5239 in order to protect the crankshaft journals and remove the connecting rod and the piston out of the top of the engine block.



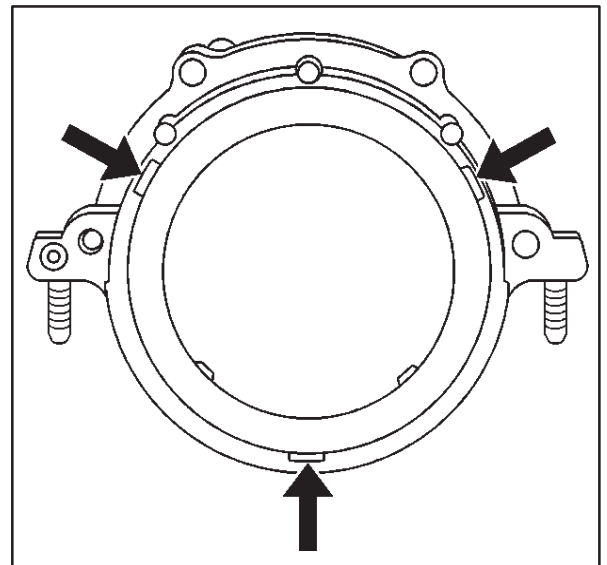
Important: Always assemble the connecting rod caps to the matching connecting rods.

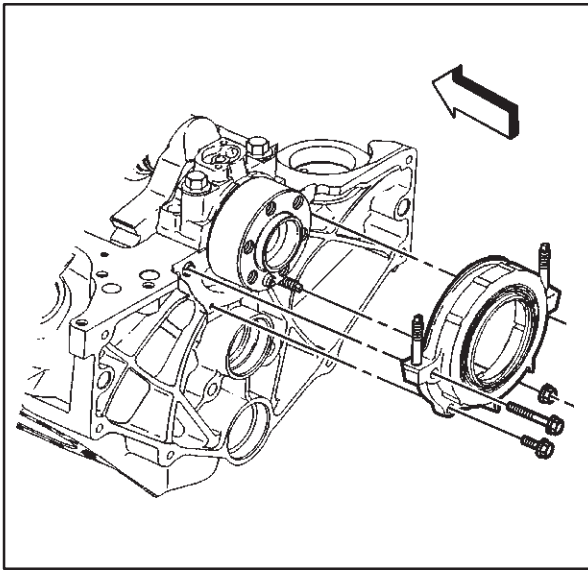
5. Remove the connecting rod bearings.
 - 5.1. Keep the connecting rod bearings with the original connecting rod and connecting rod cap.
 - 5.2. Wipe the oil from the connecting rod bearings.
 - 5.3. Wipe the oil from the crankpins.



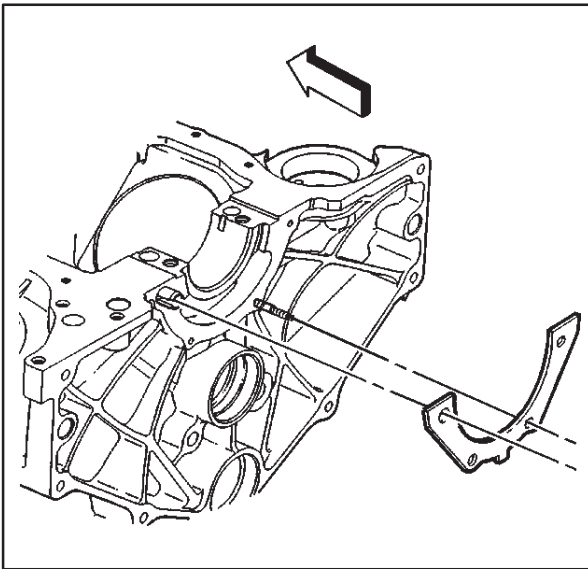
Crankshaft Rear Oil Seal and Housing Removal

1. Remove the crankshaft rear oil seal from the crankshaft rear oil seal housing.
2. Insert a suitable tool into the access notches and then carefully pry the crankshaft rear oil seal from the crankshaft rear oil seal housing.
3. Discard the crankshaft rear oil seal.

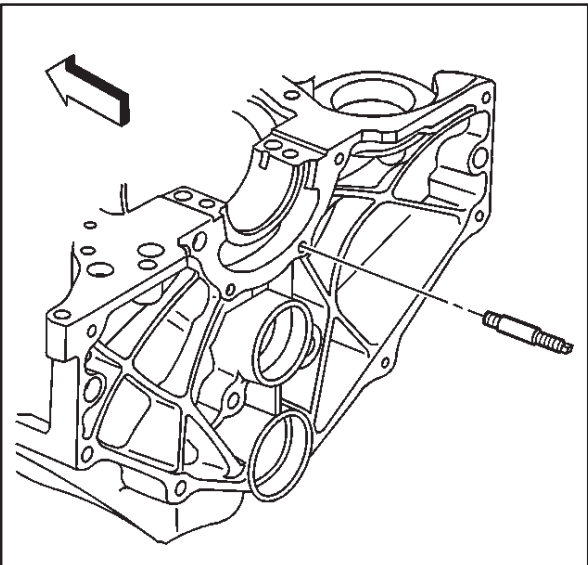




4. Remove the crankshaft rear oil seal housing nut and bolts.
5. Remove the crankshaft rear oil seal housing.



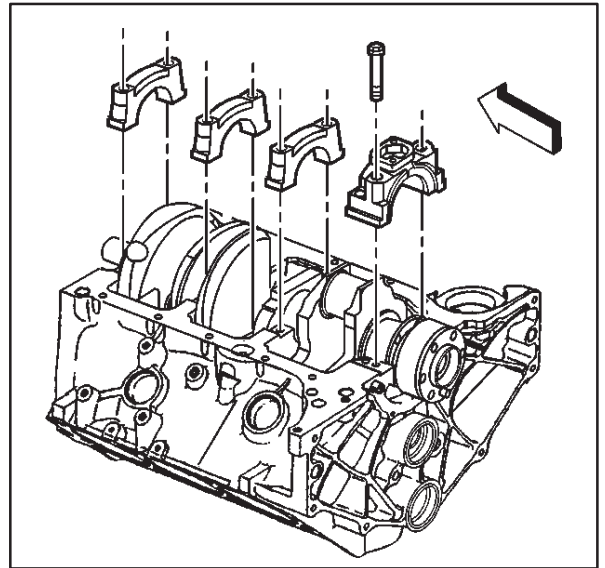
6. Remove the crankshaft rear oil seal housing gasket.
7. Discard the crankshaft rear oil seal housing gasket.



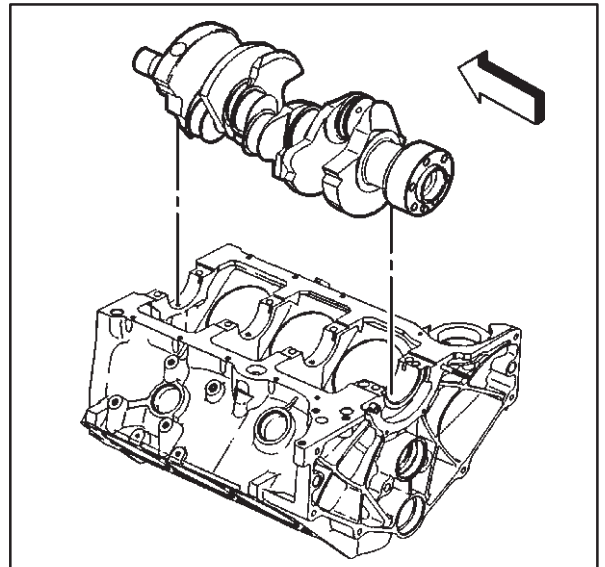
8. Remove the crankshaft rear oil seal housing retainer stud from the engine block.

Crankshaft and Bearings Removal

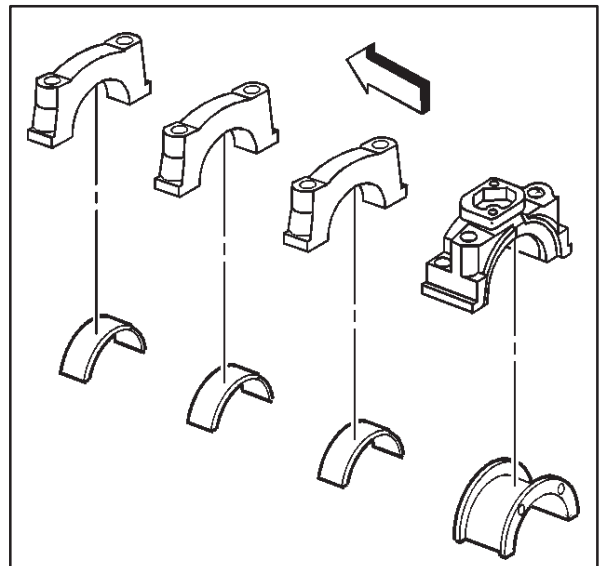
1. Mark or identify the crankshaft bearing cap locations, direction and positions for assembly.
2. Remove the crankshaft bearing cap bolts.
3. Remove the crankshaft bearing caps.

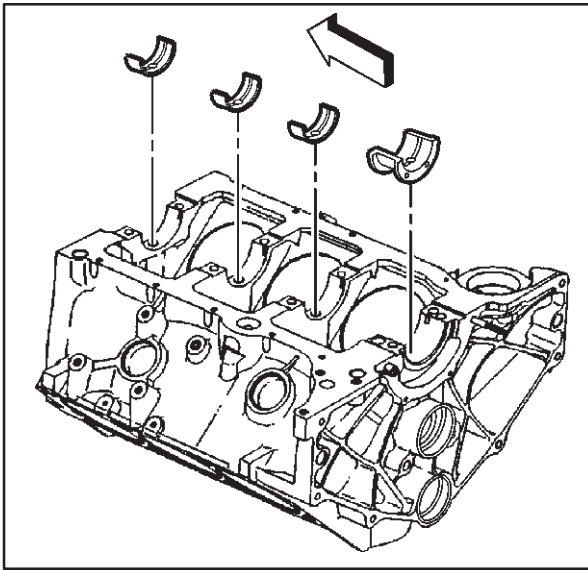


4. Remove the crankshaft.



5. Remove the crankshaft bearings from the crankshaft bearing caps.





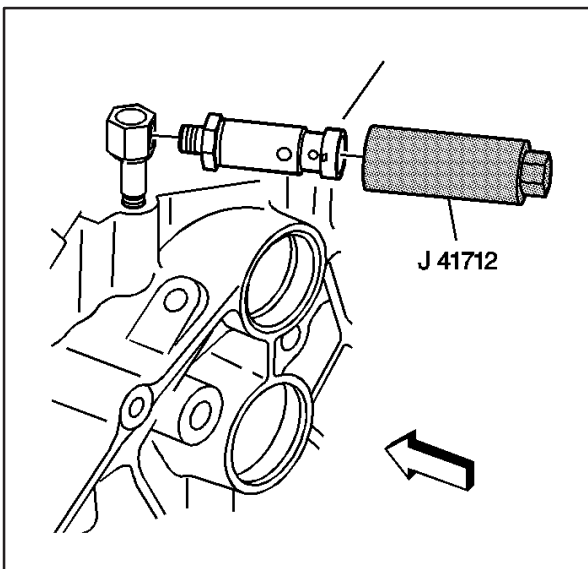
6. Remove the crankshaft bearings from the engine block.

Engine Block Plug Removal

Tools Required

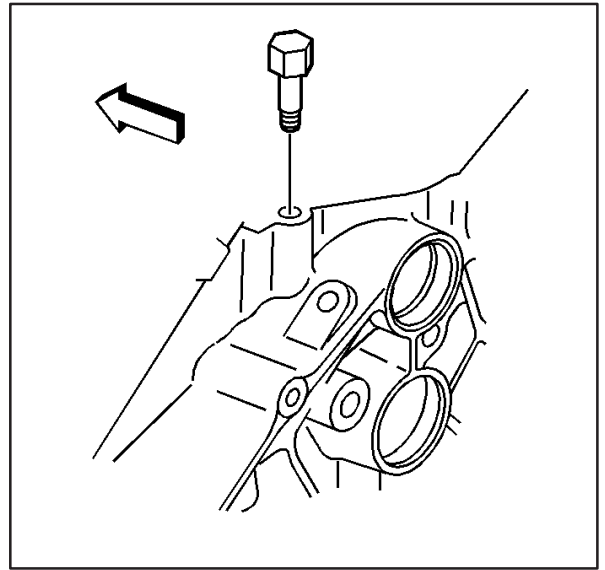
J 41712 Oil Pressure Switch Socket

Caution: Refer to Safety Glasses Caution in Cautions and Notices.

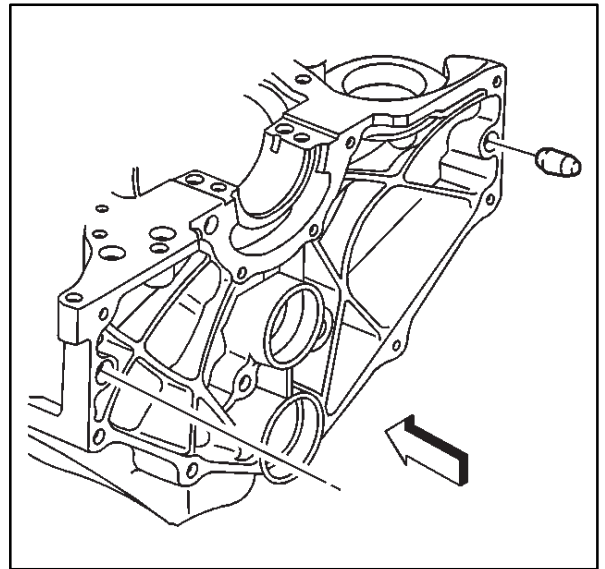


1. Remove the engine oil pressure gauge sensor using the J 41712.

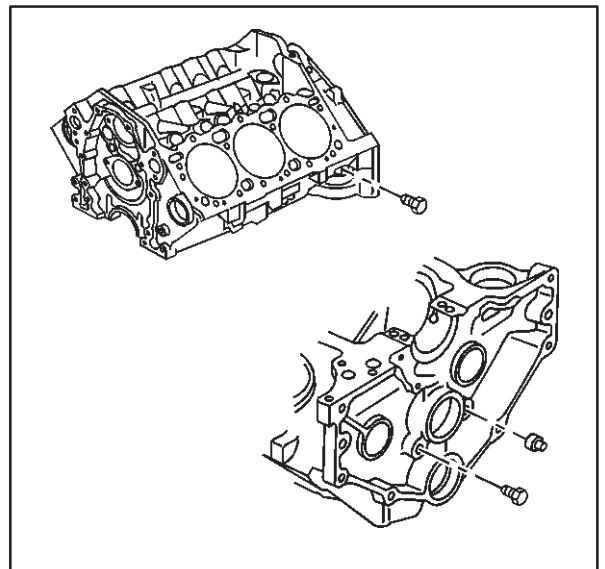
2. Remove the engine oil pressure sensor fitting.

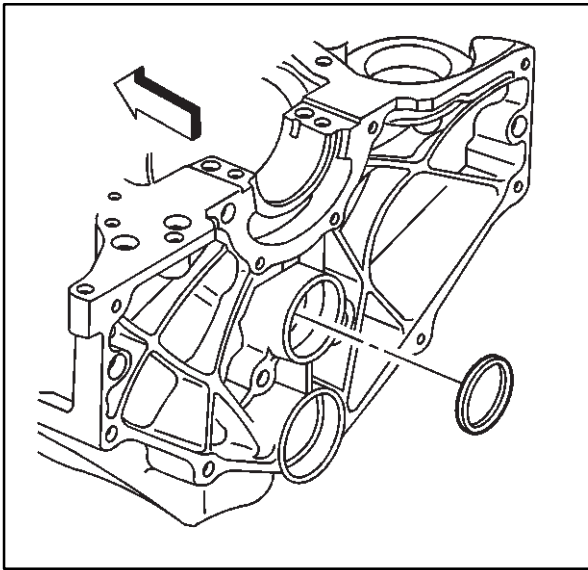


3. Remove the dowel straight pins (transmission locator) (if required).

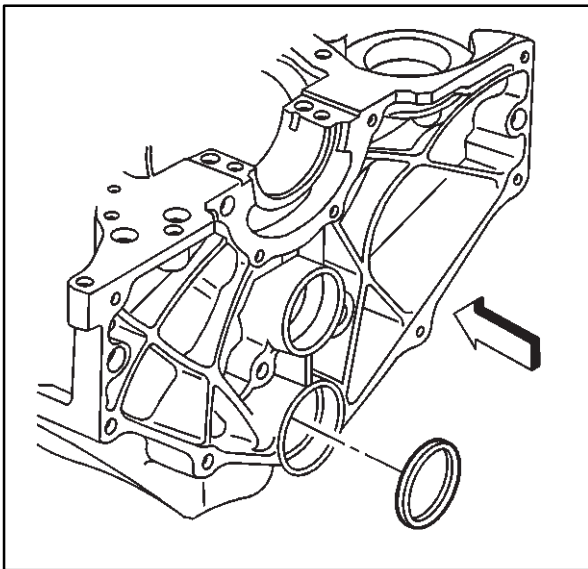


4. Remove the engine block left side oil gallery plug.
5. Remove the rear crossover cover. Discard O-Ring.

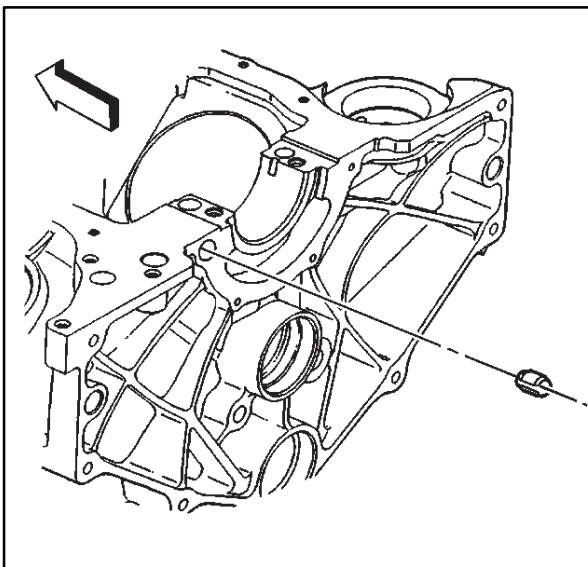




6. Remove the expansion cup plug (camshaft rear bearing hole) and discard.

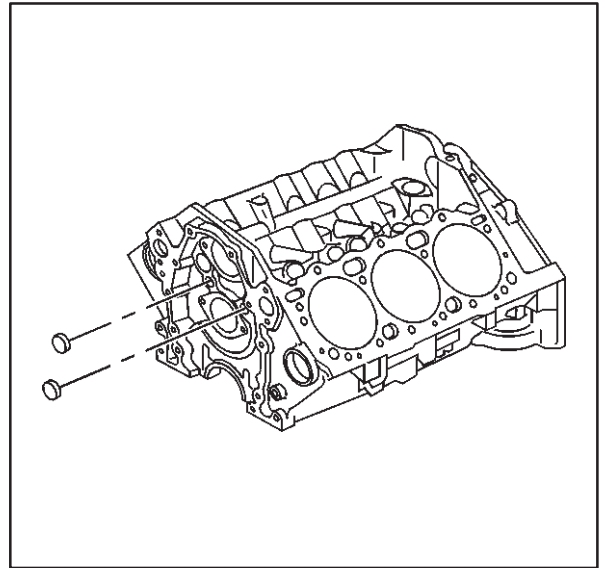


7. Remove the expansion cup plug (balance shaft rear bearing hole) and discard.

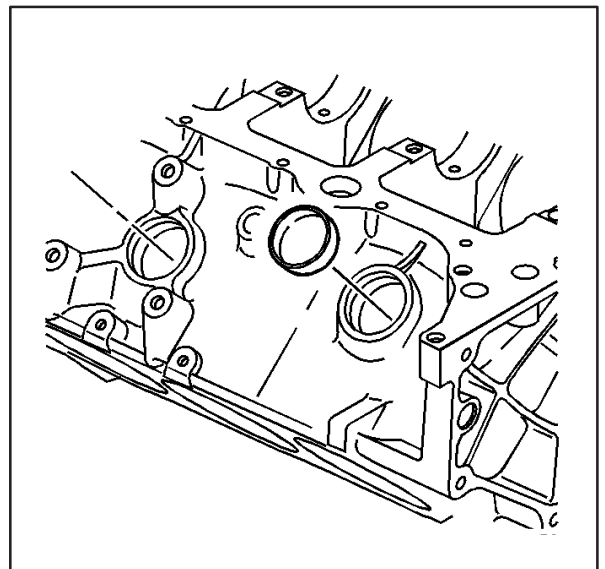


8. Remove the spring type S pin (crankshaft rear oil seal housing locator) (if required).

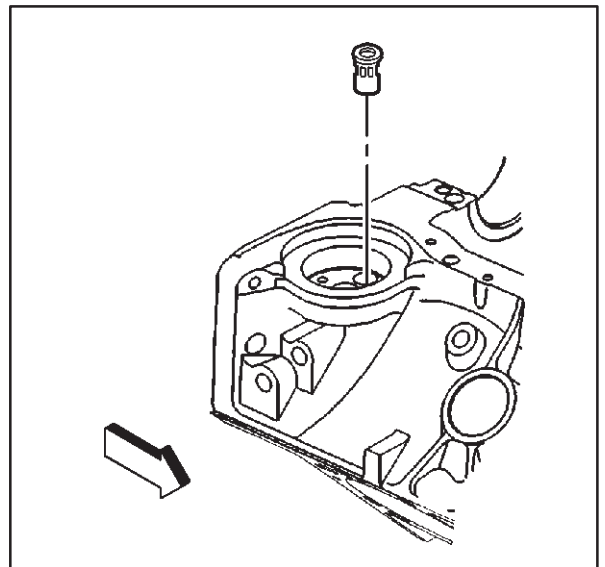
9. Remove the front oil gallery plugs or balls from the front of the engine block and discard.
10. Insert a 3/8 x 26 in. rod into the rear oil gallery holes in order to drive out the front oil gallery plugs or balls.

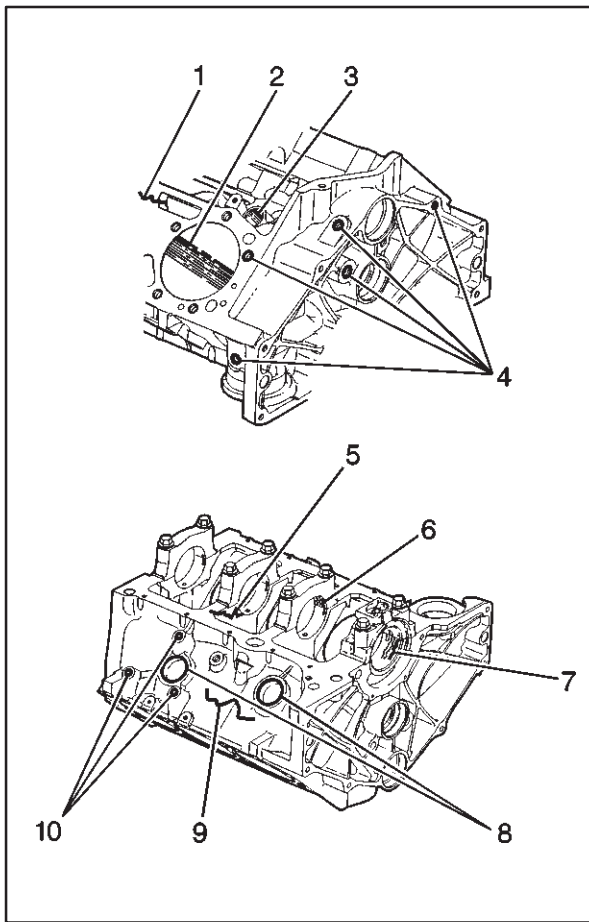


11. Remove the engine block core hole plugs.
 - 11.1. Use a suitable tool in order to drive the engine block core hole plugs into the coolant jacket.
 - 11.2. Use a suitable tool in order to pull the engine block core hole plugs from the coolant jacket.
 - 11.3. Discard the engine block core hole plugs.



12. Remove the oil filter bypass valve and discard.





Engine Block Clean and Inspect

Tools Required

J 8087 Cylinder Bore Gauge

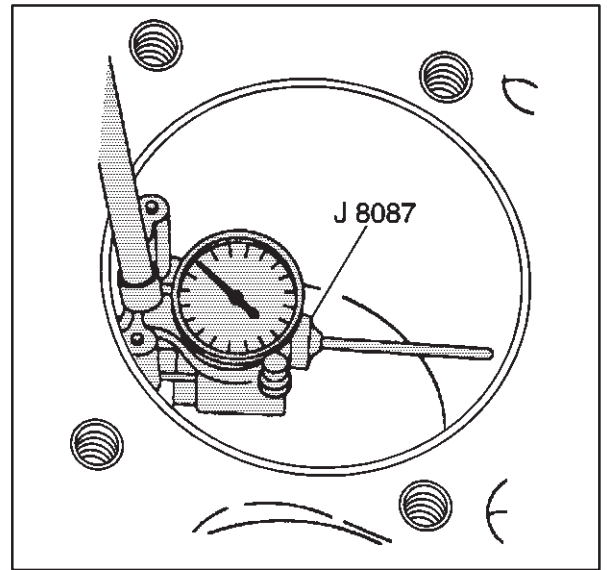
Caution: Refer to Safety Glasses Caution in Cautions and Notices.

1. Clean all the remaining sealing or gasket material from the sealing surfaces.
2. Clean the engine block with cleaning solvent.
3. Flush the engine block with clean water or steam.
4. Clean the cylinder bores.
5. Clean the oil galleries and the oil passages.
6. Clean the scale and the deposits from the coolant passages.

Notice: Clean all debris, dirt and coolant from the engine block cylinder head bolt holes. Failure to remove all foreign material may result in damaged threads, improperly tightened fasteners or damage to the components.

7. Clean the engine block cylinder head bolt holes.
8. After cleaning the engine block, spray or wipe the cylinder bores and the machined surfaces with clean engine oil.
9. Inspect the following areas:
 - Coolant jackets (1) for cracks
 - Cylinder bores (2) for scratches or gouging
 - Valve lifter bores (3) for excessive scoring or wear
 - Threaded holes (4) for damage
 - Crankshaft bearing webs (5) for cracks
 - Crankshaft bearing caps (6) and the crankshaft bearing bores (7) for damage
 - The crankshaft bearing bores should be round and uniform when measuring the inside diameter (ID).
 - The surface where the crankshaft bearings contact the crankshaft bearing bore should be smooth.
 - If a crankshaft bearing cap is damaged and requires replacement, replace the crankshaft bearing cap first, then rebores the engine block crankshaft bearing bores and check for proper alignment. Finally, check the crankshaft for the proper clearances.
 - Engine block core hole plug bores (8) for damage
 - Engine block (9) for cracks or damage
 - Engine mount bosses (10) for damage

10. Measure the cylinder bores for taper and out-of-round.
 - 10.1. Depress the plunger on the J 8087 7 mm (0.275 in) or until the J 8087 enters the cylinder bore.
 - 10.2. Center the J 8087 in the cylinder bore and turn the indicator dial to 0.
 - 10.3. Move the J 8087 up and down the cylinder bore to determine the cylinder bore taper. Refer to *Engine Mechanical Specifications*.
 - 10.4. Turn the J 8087 to different points around the cylinder bore to determine the cylinder bore out-of-round condition. Refer to *Engine Mechanical Specifications*.

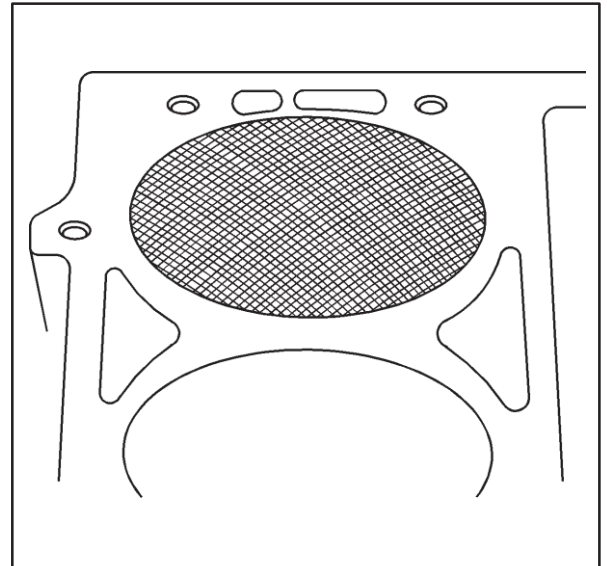


Cylinder Boring and Honing

Honing Procedure

Caution: Refer to Safety Glasses Caution in Cautions and Notices.

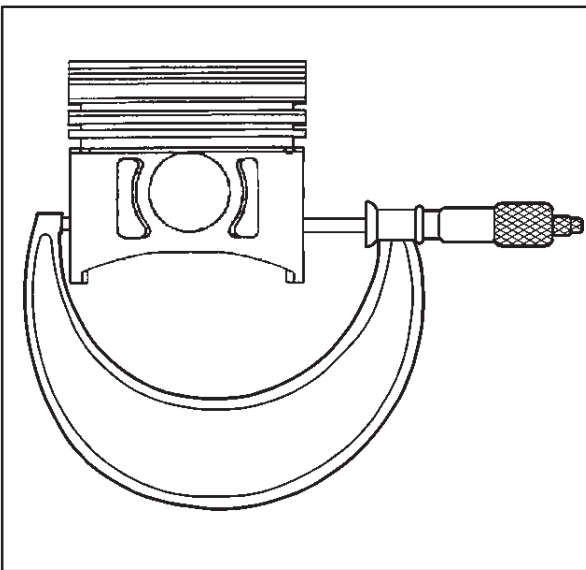
1. When honing the cylinder bores, follow the manufacturer's recommendations for equipment use, cleaning and lubrication.
 - Use only clean sharp stones of the proper grade for the amount of material to be removed.
 - Dull, dirty stones cut unevenly and generate excessive heat.
 - DO NOT hone to a final grade with a coarse or medium-grade stone.
 - Leave sufficient metal so that all the stone marks will be removed with the fine grade stones.
 - Perform the final honing with a fine-grade stone and hone the cylinder bore in a cross-hatch pattern at 45-65 degrees to obtain the proper clearance.
2. During the honing operation, thoroughly check the cylinder bore.
 - Repeatedly check the cylinder bore fit with the selected piston.
 - All measurements of the piston or cylinder bore should be made with the components at normal room temperature.
3. When honing to eliminate taper in the cylinder bore, use full strokes the complete length of the cylinder bore.
4. Repeatedly check the measurement at the top, the middle and the bottom of the cylinder bore.
 - The finish marks should be clean but not sharp.
 - The finish marks should be free from imbedded particles or torn or folded material.



5. By measuring the selected piston at the sizing point and then by adding the average of the clearance specification, the final cylinder bore honing dimension required can be determined.
6. When finished, the reconditioned cylinder bores should have less than or meet the specified out-of-round and taper requirements.
7. After the final honing and before the piston is checked for fit, clean the cylinder bore with hot water and detergent.
 - 7.1. Scrub the cylinder bores with a stiff bristle brush.
 - 7.2. Rinse the cylinder bores thoroughly with clean hot water.
 - 7.3. Dry the cylinder bores with a clean rag.
 - 7.4. Do not allow any abrasive material to remain in the cylinder bores.
 - Abrasive material may cause premature wear of the new piston rings and the cylinder bores.
 - Abrasive material will contaminate the engine oil and may cause premature wear of the bearings.
8. Perform final measurements of the piston and the cylinder bore.
9. Permanently mark the top of the piston for the specified cylinder to which it has been fitted.
10. Apply clean engine oil to each cylinder bore in order to prevent rusting.

Boring Procedure

Caution: Refer to Safety Glasses Caution in Cautions and Notices.



1. Before starting the honing or reboring operation, measure all the new pistons with the micrometer contacting at points exactly 90 degrees from the piston pin centerline.
2. File the top of the cylinder block in order to remove any dirt or burrs before using any type of boring bar.
3. Follow the instructions furnished by the manufacturer regarding the use of the boring equipment.
4. When reboring the cylinders, make sure all the crankshaft bearing caps are installed in the original position and direction.
5. Tighten the crankshaft bearing caps to the proper torque specifications in order to avoid distortion of the cylinder bores in the final assembly.
6. When making the final cut with the boring bar, leave 0.03 mm (0.001 in) on the cylinder bore diameter for finish honing. This gives the required position to the cylinder clearance specifications. (Carefully perform the honing and boring operation in order to maintain the specified clearances between the pistons, the piston rings and the cylinder bores).

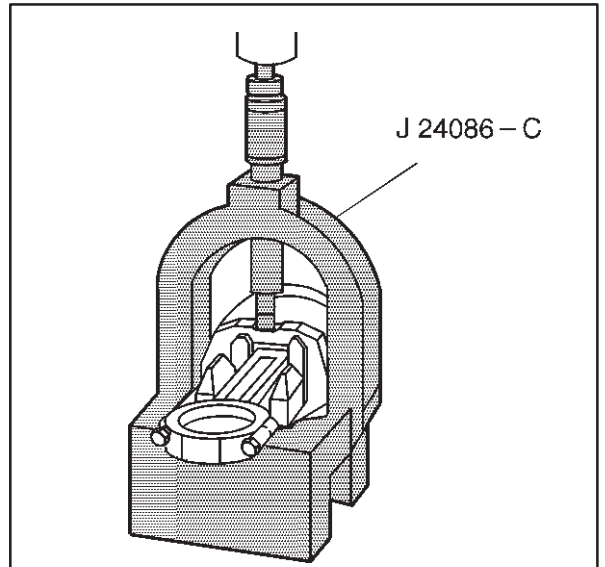
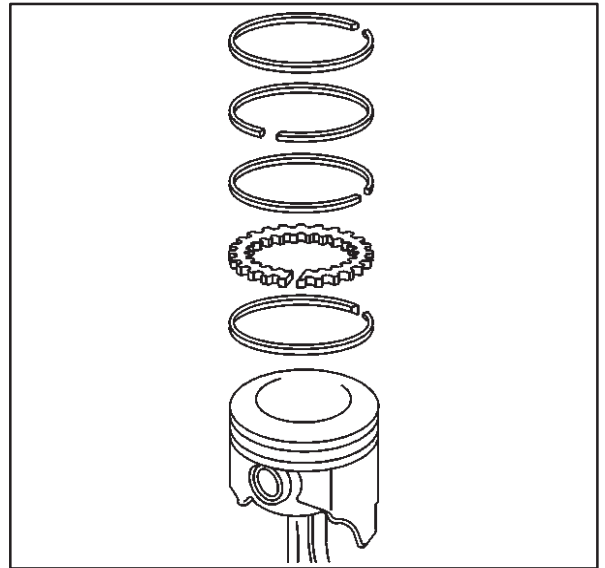
Piston and Connecting Rod Disassemble

Tools Required

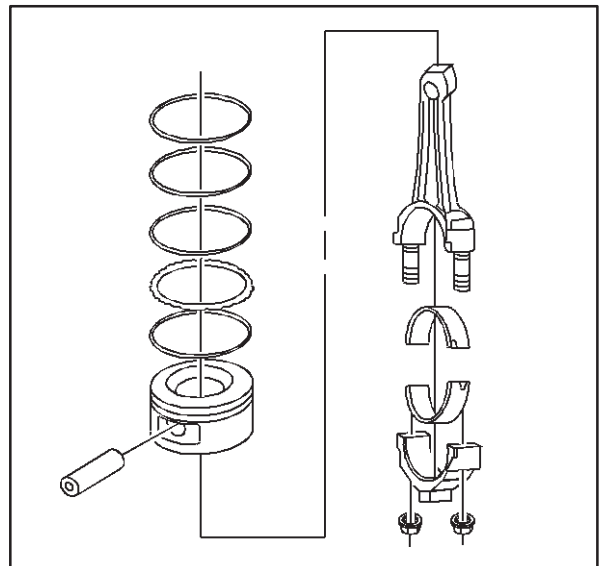
J 24086-C Piston Pin Remover/Installer

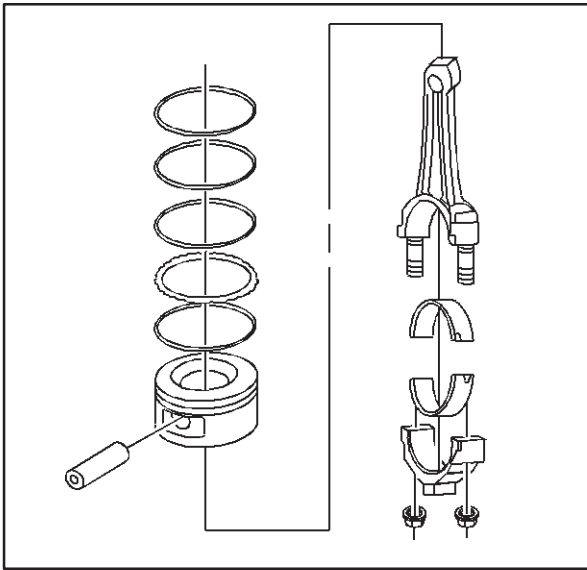
Caution: Refer to Safety Glasses Caution in Cautions and Notices.

1. Remove the piston rings from the pistons.
2. Press the piston pin from the connecting rod using the J 24086-C.
3. The piston pin has an interference fit into the connecting rod, and is full floating in the piston.



4. Mark, separate and organize the parts for assembly.





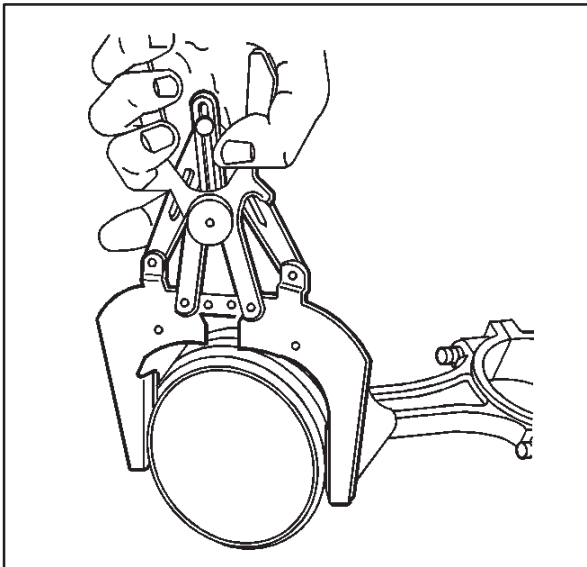
Piston, Connecting Rod and Bearings Clean/Inspect

Important: Measurement of all components should be taken with the components at room temperature.

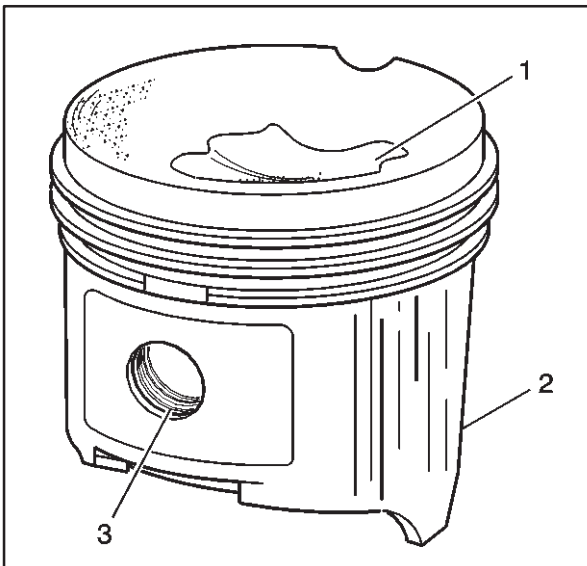
Do not use a wire brush in order to clean any part of the piston.

Caution: Refer to Safety Glasses Caution in Cautions and Notices.

1. Clean the piston and connecting rod in solvent.
2. Dry the components with compressed air.

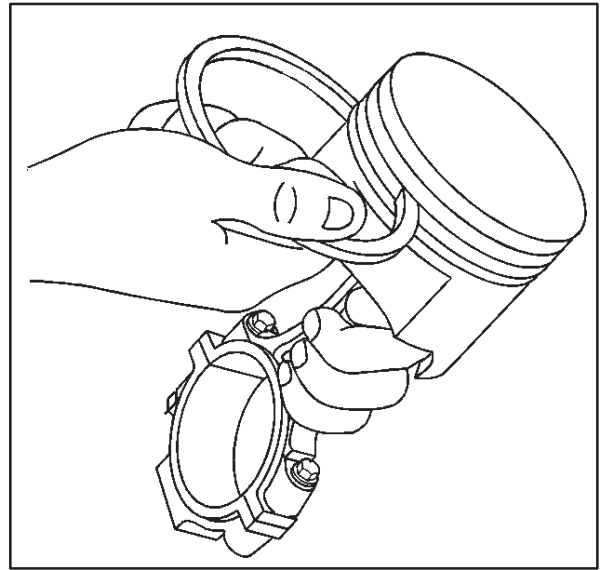


3. Clean the piston ring grooves with a suitable ring groove cleaning tool.

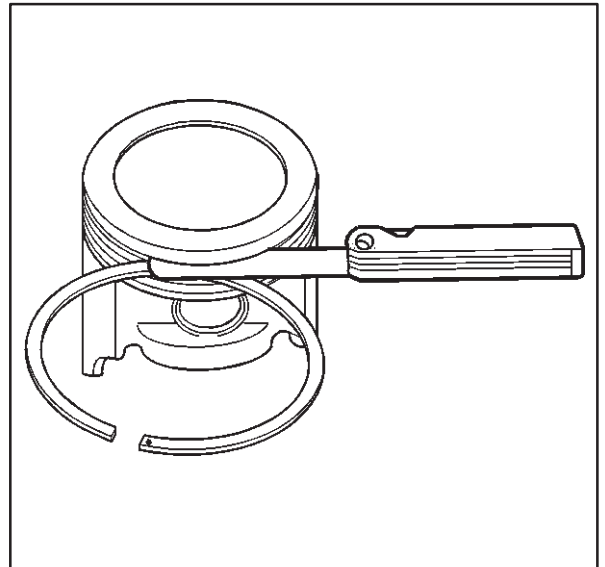


4. Clean the piston oil lubrication holes and slots.
5. Inspect the piston for the following:
 - Eroded areas (1) on the top of the piston
 - Scuffed or damaged skirt (2)
 - Damage to the pin bore (3)
 - Cracks in the piston ring lands, the piston skirt or the pin bosses
 - Piston ring grooves for nicks, burrs or other warpage which may cause the piston ring to bind
6. Inspect the piston pin for scoring, wear or other damage

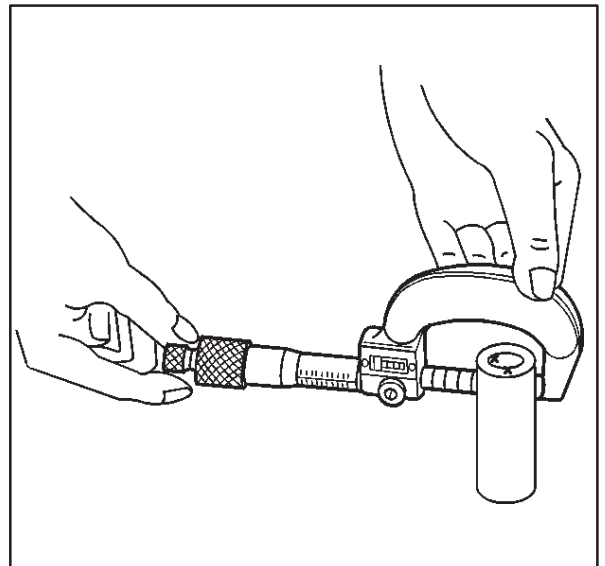
7. Measure the piston ring-to-piston ring groove side clearance.
 - 7.1. Insert the edge of the piston ring into the piston ring groove.
 - 7.2. Roll the piston ring completely around the piston.
 - If binding is caused by a distorted piston ring groove, MINOR imperfections may be removed with a fine file.
 - If binding is caused by a distorted piston ring, replace the piston ring.

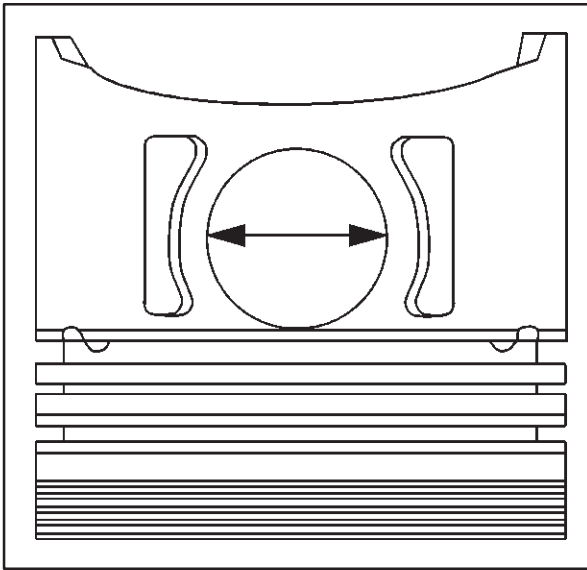


8. Measure the piston ring side clearance with a feeler gauge.
9. If the side clearance is too small, try another piston ring set.
10. If the proper piston ring-to-piston ring groove clearance cannot be achieved, replace the piston and pin assembly.
11. To determine the proper piston ring side clearance, refer to *Engine Mechanical Specifications*.

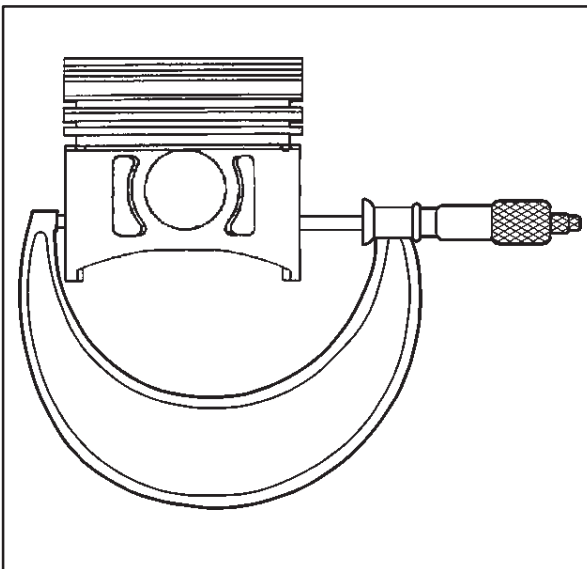


12. To determine piston pin-to-bore clearance, use a micrometer and measure the piston pin.

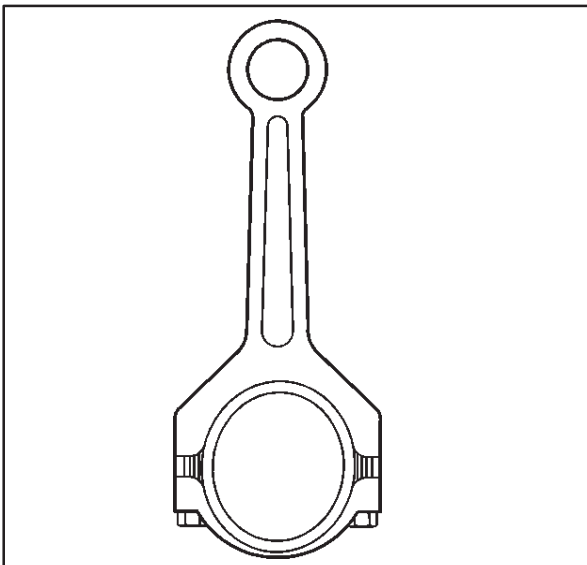




13. To determine piston pin-to-bore clearance, use an inside micrometer and measure the piston pin bore.
14. To determine the piston pin-to-bore clearance, subtract the piston pin diameter from the piston pin bore diameter. Refer to *Engine Mechanical Specifications*.

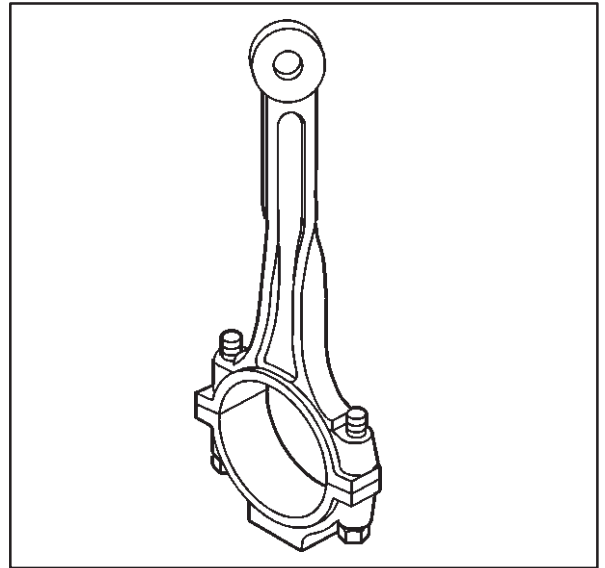


15. Measure the piston with a micrometer at a right angle to the piston pin bore, measure the piston at 11 mm (0.433 in) from the bottom of the skirt. Refer to *Engine Mechanical Specifications*.
If the piston is not within specifications, replace the piston and pin as an assembly.



16. Inspect the connecting rod for an out-of-round bearing bore. Refer to *Engine Mechanical Specifications*.

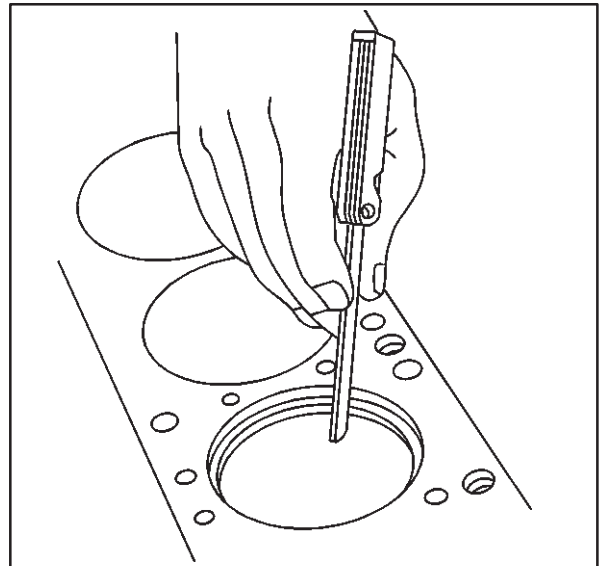
17. Inspect the connecting rod for twisting.
18. Inspect the connecting rod for damage to the bearing cap and bolt threads.



19. Measure the piston compression ring end gap.

Important: Fit each compression ring to the cylinder in which it will be used.

20. Place the compression ring into the cylinder bore.
 - 20.1. Push the compression ring into the cylinder bore to approximately 6.5 mm (0.25 in) above the ring travel. The ring must be square to the cylinder wall.
 - 20.2. Use a feeler gauge in order to measure the end gap.
 - 20.3. Select another size ring set if the end gap exceeds specifications. Refer to *Engine Mechanical Specifications*.



Piston Selection

Tools Required

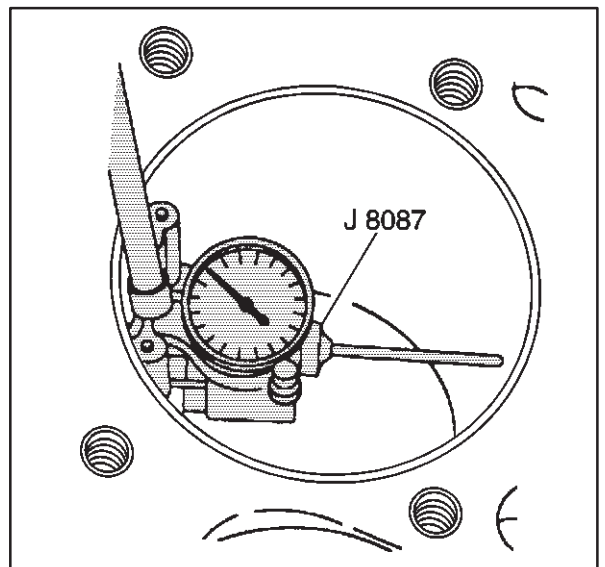
J 8087 Cylinder Bore Gauge

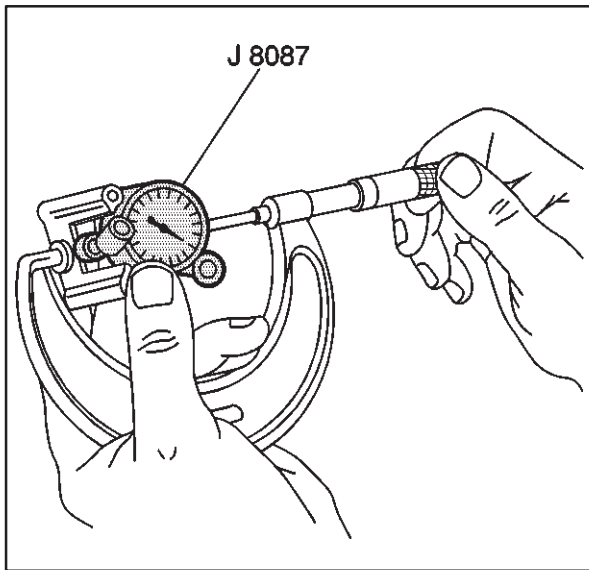
Important: Measurements of all components should be taken with the components at normal room temperature.

For proper piston fit, the engine block cylinder bores should not have excessive wear or taper.

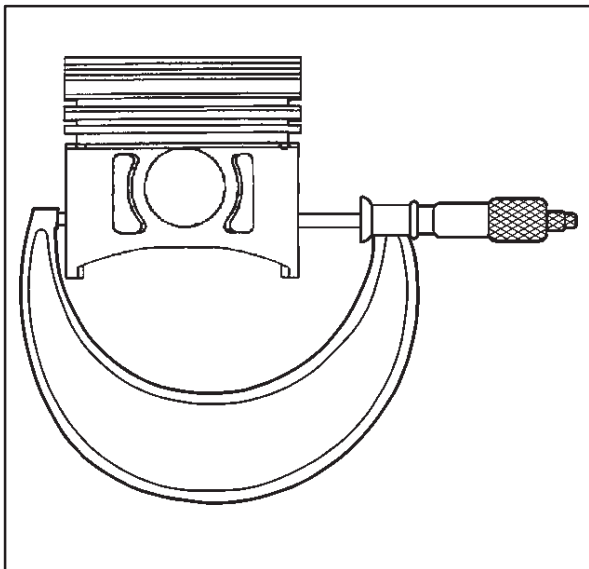
A used piston and piston pin set may be reinstalled if, after cleaning and inspection, the piston and piston pin are within specifications.

1. Use the J 8087 in order to measure the cylinder bore diameter. Measure at a point 64 mm (2.5 in) from the top of the cylinder bore and 90 degrees to the crankshaft centerline.

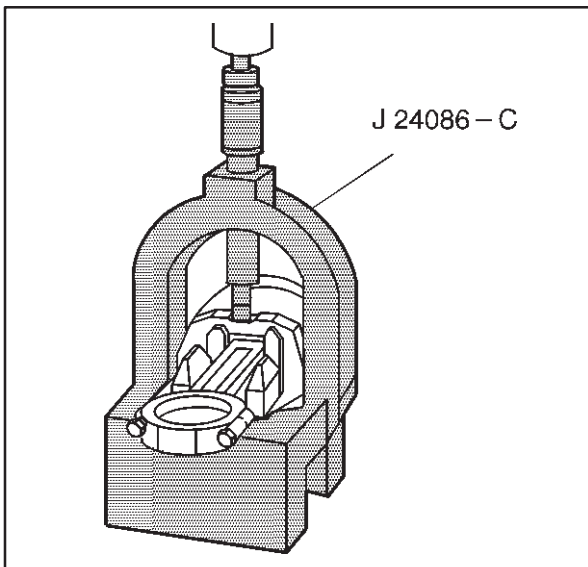




2. Measure the J 8087 with a micrometer and record the reading.



3. With a micrometer or caliper at a right angle to the piston pin bore, measure the piston 11 mm (0.433 in) from the bottom of the skirt.
4. Subtract the piston diameter from the cylinder bore diameter in order to determine piston-to-bore clearance. Refer to *Engine Mechanical Specifications*.
5. If the proper clearance cannot be obtained, then select another piston and measure the clearances.
If the proper fit cannot be obtained, the cylinder bore may require honing or boring.
6. When the piston-to-cylinder bore clearance is within specifications, permanently mark the top of the piston for installation into the proper cylinder.



Piston and Connecting Rod Assemble

Tools Required

J 24086-C Piston Pin Remover/Installer

Caution: Avoid contact with **HOT** components. Wear safety glasses and protective gloves to avoid personal injury.

Notice: Applying excessive heat to the connecting rod may damage or distort the rod. Rod temperature SHOULD NOT exceed 315°C (600°F). At this temperature, the end of the connecting rod will turn a straw color upon visual inspection.

Notice: After the J 24086-C installer hub bottoms on the support assembly, DO NOT exceed 35,000 kPa (5,000 psi) or the tool may be damaged.

Important: When assembling the piston and connecting rod, the mark on the top of the piston must point to the front of the engine block. The left bank connecting rods should have the flange face toward the front of the engine block. The right bank connecting rods should have the flange face toward the rear of the engine block.

The piston pin has an interference fit into the connecting rod and is full floating in the piston.

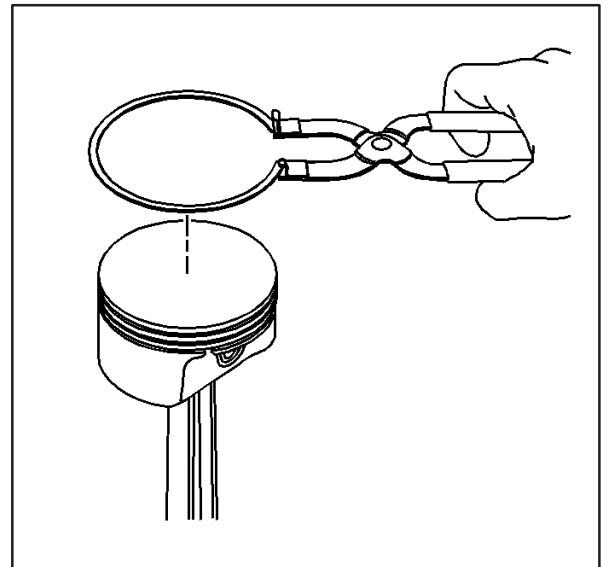
1. Install the piston pin and connecting rod assembly.
 - 1.1. Lubricate the piston pin bores with clean engine oil.
 - 1.2. Use a torch and apply MILD heat to the piston pin end of the connecting rod.
 - 1.3. Use the J 24086-C in order to press the piston pin into the piston and connecting rod assembly.
 - 1.4. Inspect for the proper installation of the piston and piston pin. The piston must move freely on the piston pin with no binding or interference.

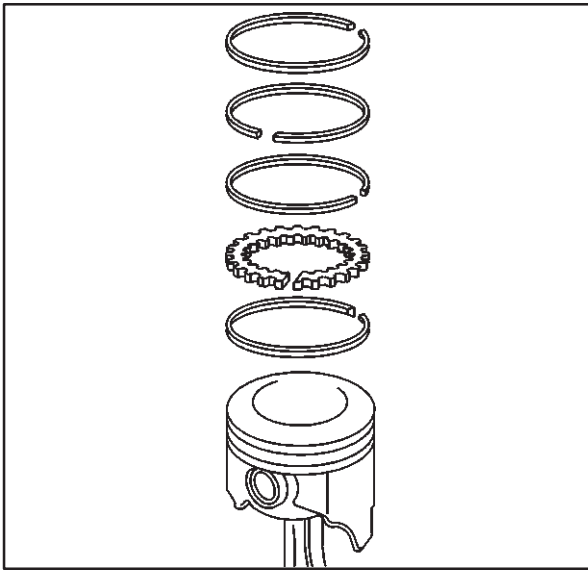
Notice: Use a piston ring expander to install the piston rings. The rings may be damaged if expanded more than necessary.

2. Install the piston rings onto the piston.
 - 2.1. Install the oil control piston ring spacer.
 - 2.2. Install the lower oil control piston ring.
 - 2.3. Install the upper oil control piston ring.
 - 2.4. Install the lower compression piston ring.

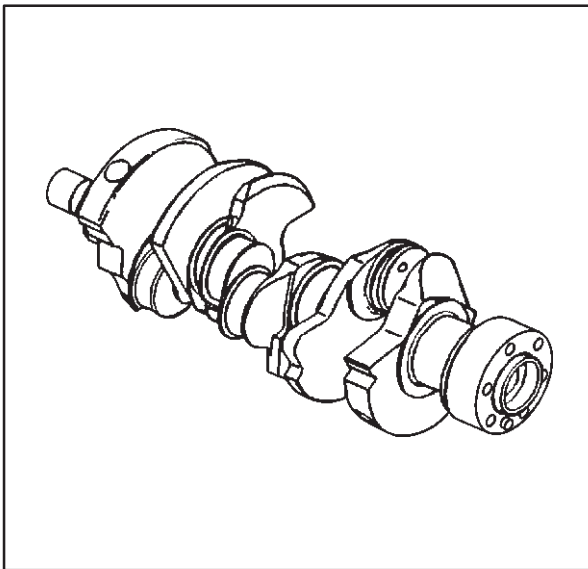
The mark on the side of the piston ring should face the top of the piston.
 - 2.5. Install the upper compression piston ring.

The mark on the side of the piston ring should face the top of the piston.





3. Space the compression piston ring end gaps 120 degrees apart.
4. Space the oil control piston ring end gaps a minimum of 90 degrees apart.



Crankshaft and Bearings Clean and Inspect

Tools Required

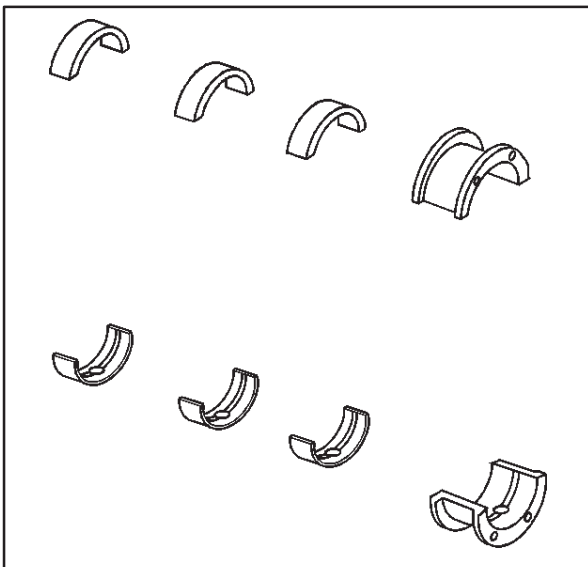
J 7872 Magnetic Base Dial Indicator

J 36660 Electronic Torque Angle Meter

Caution: Refer to Safety Glasses Caution in Cautions and Notices.

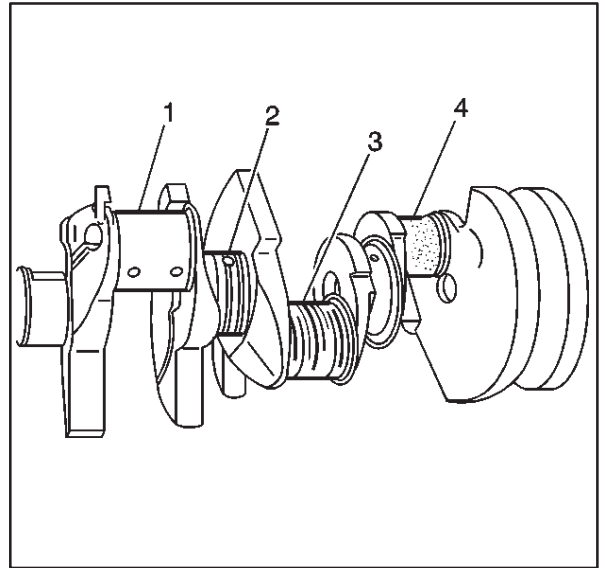
Important: Use care when handling the crankshaft. Avoid damage to the crankshaft bearing surfaces.

1. Clean the crankshaft in cleaning solvent. Remove all sludge or restrictions from the oil passages.
2. Dry the crankshaft with compressed air.

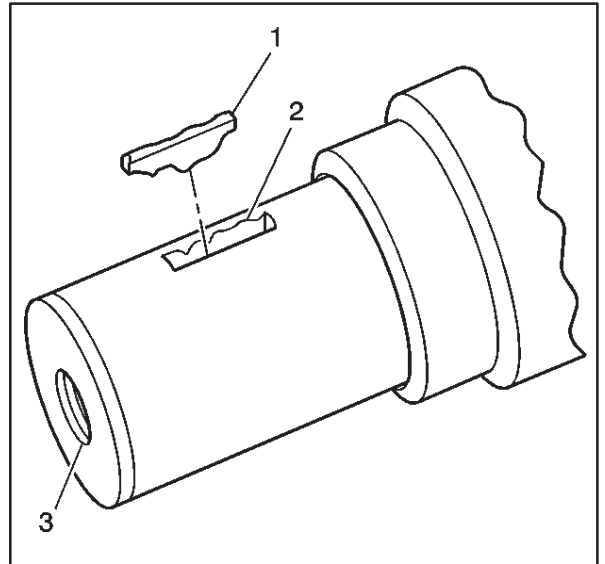


3. Clean the crankshaft bearings in cleaning solvent. Wipe the crankshaft bearings clean with a soft cloth, do not scratch the crankshaft bearing surface.
4. Dry the crankshaft bearings with compressed air.

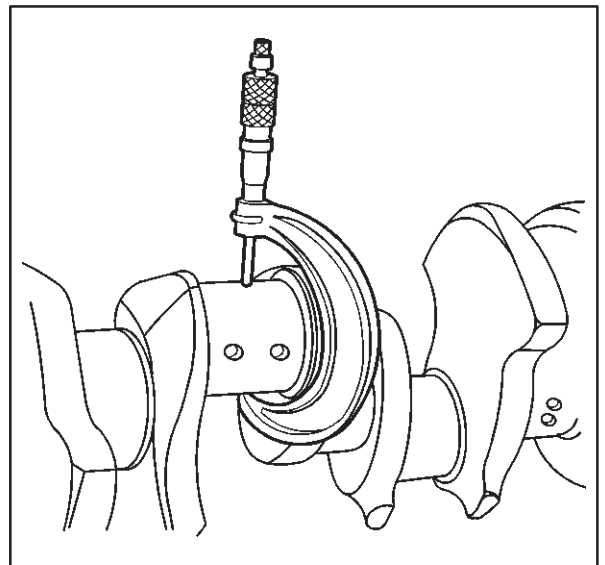
5. Inspect the crankshaft for the following:
- Crankshaft journals (1) should be smooth with no evidence of scoring or damage.
 - Deep grooves (2)
 - Scratches or uneven wear (3)
 - Pitted surfaces (4)
 - Wear or damage to the thrust journal surfaces
 - Scoring or damage to the rear seal surface
 - Restrictions to the oil passages
 - Damage to the threaded bolt holes

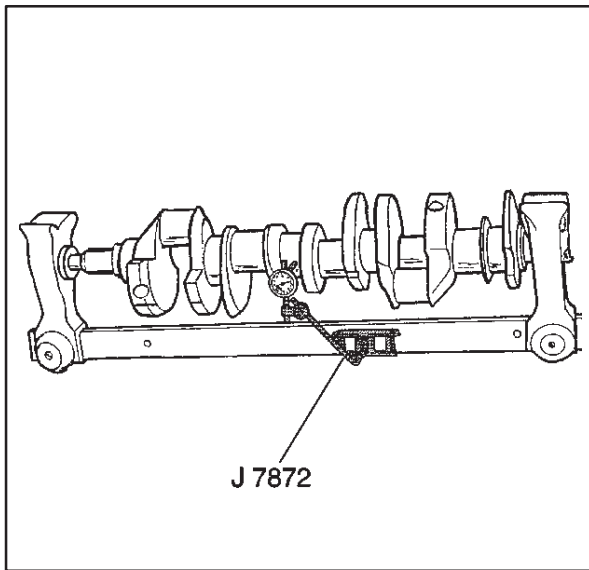


6. Inspect the crankshaft balancer key (1), the keyway (2) and the threaded hole (3) for damage.
Repair or replace the crankshaft as necessary.



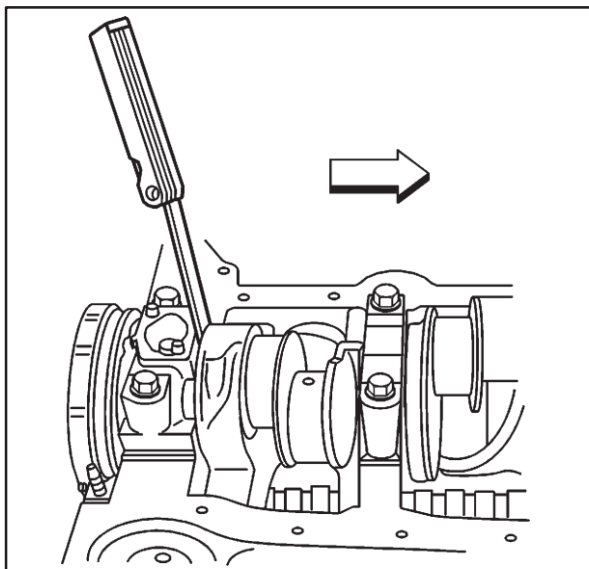
7. Measure the crankpins for out-of-round and taper. Refer to *Engine Mechanical Specifications*.





8. Use a suitable support to support the crankshaft on the front and rear journals.
9. Use the J 7872 in order to measure the crankshaft journal runout.

The crankshaft runout should not exceed 0.025 mm (0.0040 in).



10. Measure the crankshaft end play.

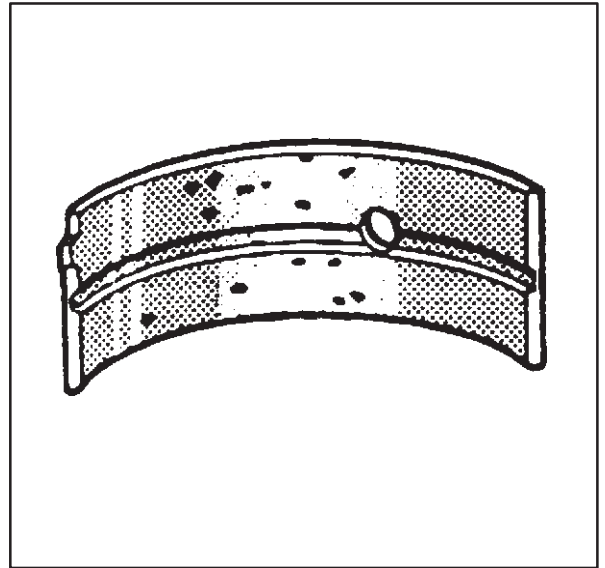
Important: In order to properly measure the crankshaft end play, the crankshaft, the crankshaft bearings and the crankshaft bearing caps, the crankshaft bearing cap bolts must be installed into the engine block and the bolts tightened to specifications.

Firmly thrust the crankshaft first rearward, then forward. This will align the crankshaft rear bearings and the crankshaft thrust surfaces.

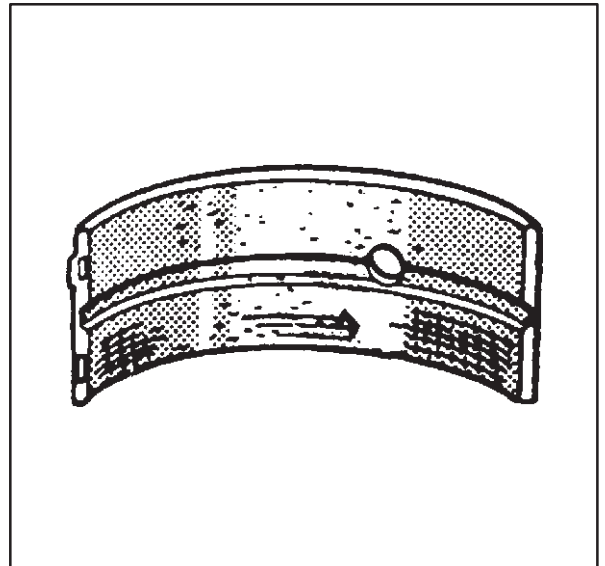
- 10.1. With the crankshaft pushed forward, insert a feeler gauge between the crankshaft and the crankshaft bearing surface and then measure the clearance. Refer to *Engine Mechanical Specifications*.
- 10.2. If the correct end play cannot be obtained, verify that the correct size crankshaft bearing has been installed. Refer to *Engine Mechanical Specifications*.
- 10.3. Inspect the crankshaft for binding. Turn the crankshaft to check for binding. If the crankshaft does not turn freely, then loosen the crankshaft bearing cap bolts, one bearing cap at a time, until the tight crankshaft bearing is located.

Burrs on the crankshaft bearing cap, foreign matter between the crankshaft bearing and the engine block or crankshaft bearing cap or a faulty crankshaft bearing could cause a lack of clearance at the crankshaft bearing.

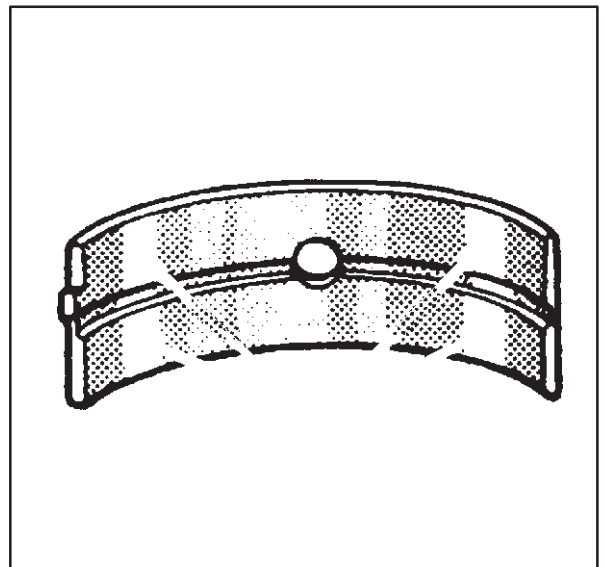
11. Inspect the crankshaft bearings for craters or pockets. Flattened sections on the crankshaft bearing halves also indicate fatigue.

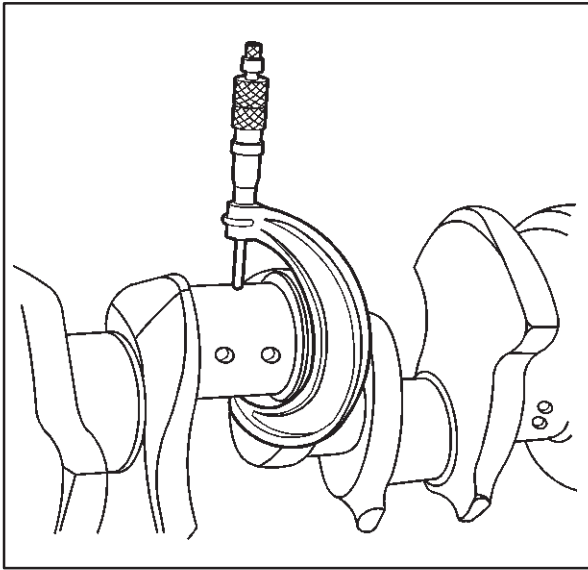


12. Inspect the crankshaft bearings for excessive scoring or discoloration.
13. Inspect the crankshaft bearings for dirt or debris imbedded into the crankshaft bearing material.



14. Inspect the crankshaft bearings for improper seating indicated by bright, polished sections of the crankshaft bearings.
- If the lower half of the crankshaft bearing is worn or damaged, both the upper and lower halves of the crankshaft bearing should be replaced.
 - Generally, if the lower half of the crankshaft bearing is suitable for use, the upper half of the crankshaft bearing should also be suitable for use.





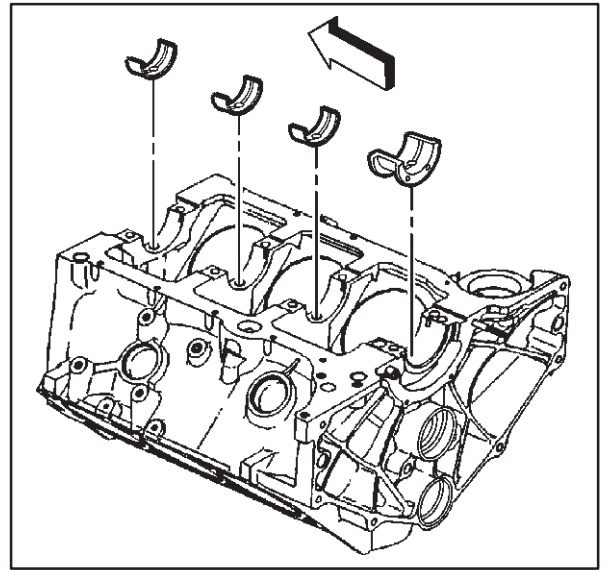
Measuring Crankshaft Bearing Clearances

- The crankshaft bearings are of the precision insert type and do not use shims for adjustment. If the clearances are excessive, then new upper and lower crankshaft bearings will be required. The service crankshaft bearings are available in the standard size and an undersize.
- The selective fitting of the crankshaft bearings are necessary in production in order to obtain close tolerances. For this reason, in one journal bore you may use one-half of a standard crankshaft bearing with one-half of an undersize crankshaft bearing
- In order to determine the correct replacement crankshaft bearing size, the crankshaft bearing clearance must be measured accurately. Either the micrometer or plastic gauge method may be used; however, the micrometer method gives more reliable results and is preferred. When checking connecting rod bearing clearances, the plastic gauge method will result in unreliable measurements. The use of J 43690 is preferred.
- Normally the crankshaft bearing journals wear evenly and are not out-of-round. However, if a crankshaft bearing is being fitted to an out-of-round crankshaft bearing journal, be sure to fit to the maximum diameter of the crankshaft bearing journal. If the crankshaft bearing is fitted to the minimum diameter and the crankshaft bearing journal will result in rapid crankshaft bearing failure.
- If the crankshaft bearing clearance is within specifications, the crankshaft bearing is satisfactory. If the clearance is not within specifications, replace the crankshaft bearing. Always replace both the upper and lower crankshaft bearings as a set.
- A standard or oversize crankshaft bearing combination may result in the proper clearance. If the proper crankshaft bearing clearance cannot be achieved using the standard or the undersize crankshaft bearings, it may be necessary to repair or replace the crankshaft.

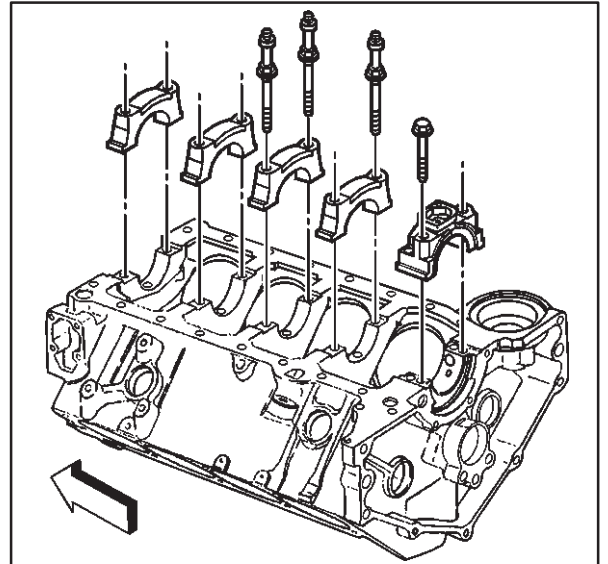
Micrometer Method for Crankshaft Bearings

1. Measure the crankshaft journal diameter with a micrometer in several places, approximately 90 degrees apart, and then average the measurements.
2. Determine the taper and the out-of-round of the crankshaft journal. Refer to *Engine Mechanical Specifications*.

3. Install the crankshaft bearings into the engine block or connecting rod assembly.



4. Install the bearing cap bolts and tighten to specifications.
5. Measure the bearing inside diameter (ID) at two points 90 degrees apart. Average the measurements.
6. In order to determine the bearing clearance, subtract the average journal diameter from the average bearing inside diameter.
7. Compare the readings to specifications. Refer to *Engine Mechanical Specifications*.
8. Replace bearing halves as required to obtain the proper bearing clearances.



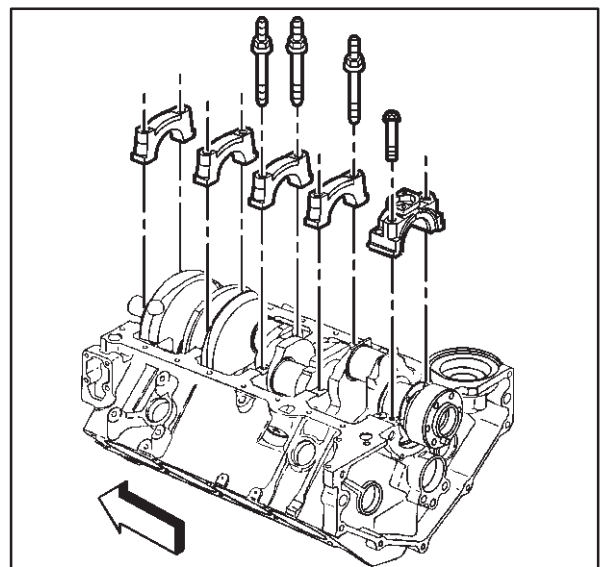
Measuring Connecting Rod Bearing Clearances (J 43690 Method)

1. Remove the oil pan and other necessary components to gain access to the connecting rods. Remove the oil pump, screen and deflector (when applicable).
2. Rotate the crankshaft until the crankshaft journal/connecting rod to be measured is in the 10 o'clock position.

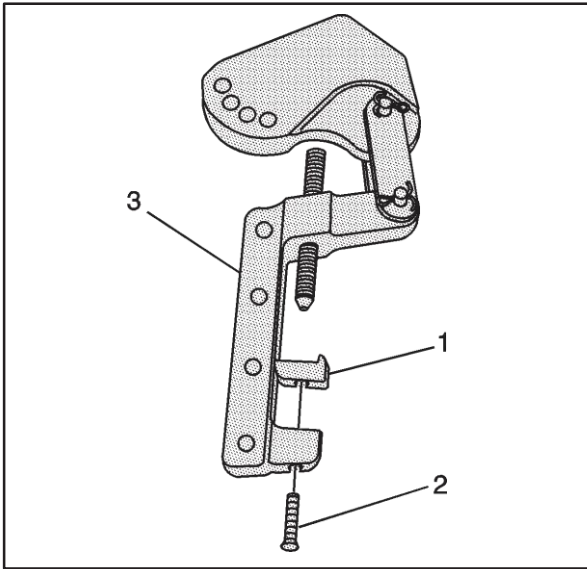
Important: The crankshaft must be secure with no movement or rotation in order to obtain an accurate reading. Remove an intermediate bearing cap (as required) in order to secure the crankshaft and allow measurement of connecting rod bearing clearances.

3. Remove the bearing cap bolts (1), cap (2) and bearing half.

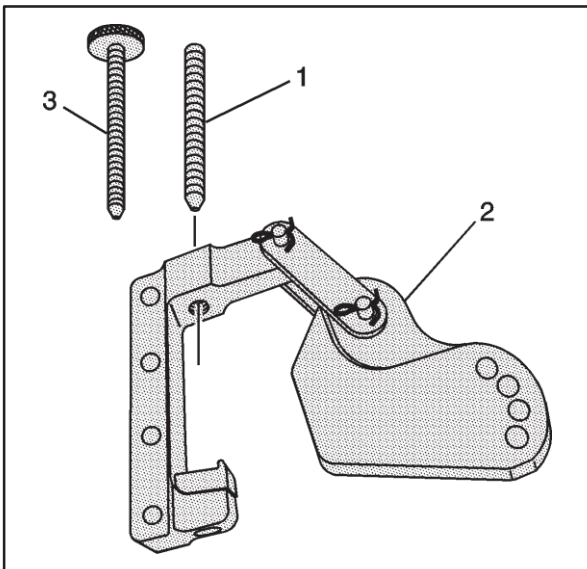
Notice: Refer to *Fastener Notice* in Cautions and Notices.



-
4. Insert a piece of paper card stock onto the crankshaft journal. Install the bearing half, bearing cap and bolts. Refer to *Fastener Tightening Specifications*.

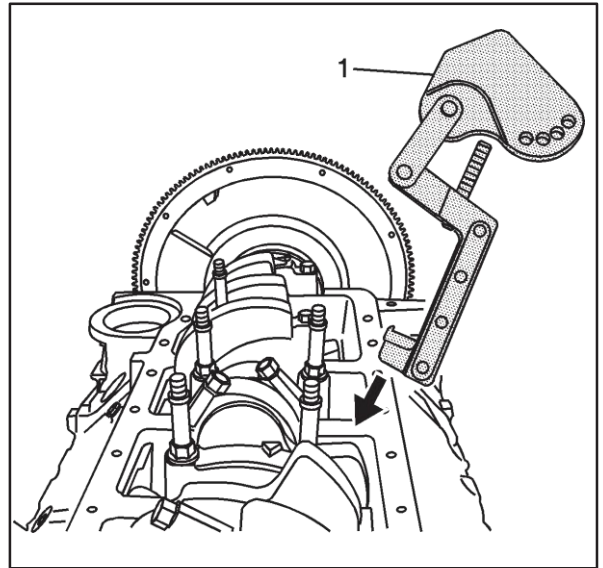


5. Install the foot (1) and bolt (2) to the pivot arm assembly (3). Tighten the bolt until snug.

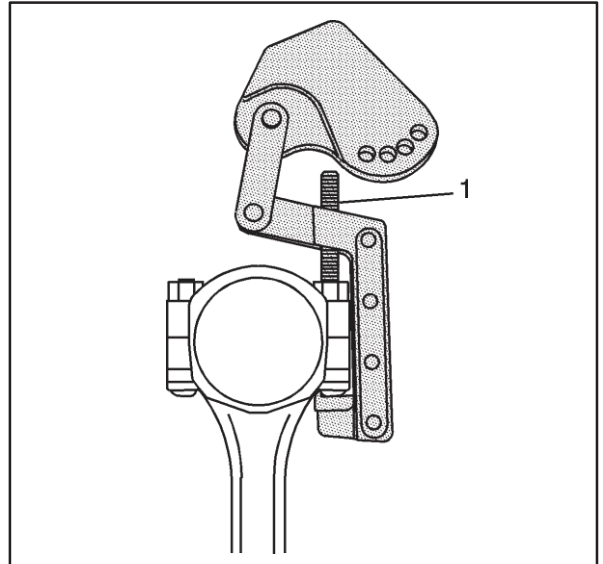


6. Install the screw (1 or 3) to the pivot arm assembly (2).

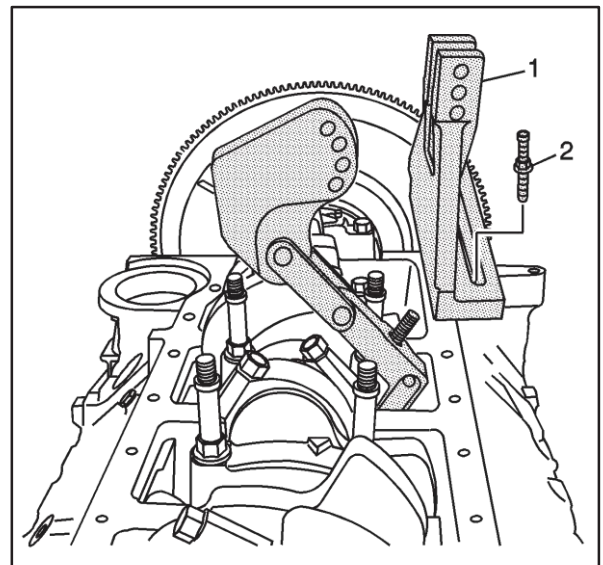
7. Install the pivot arm assembly (1) onto the connecting rod.

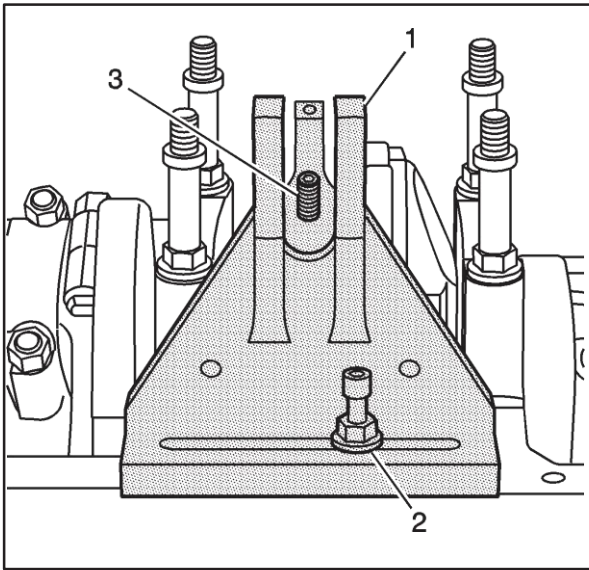


- 8. Position the foot of the pivot arm assembly over the large end of the connecting rod bolt.
- 9. Position the screw (1) onto the small end of the connecting rod bolt and tighten securely.

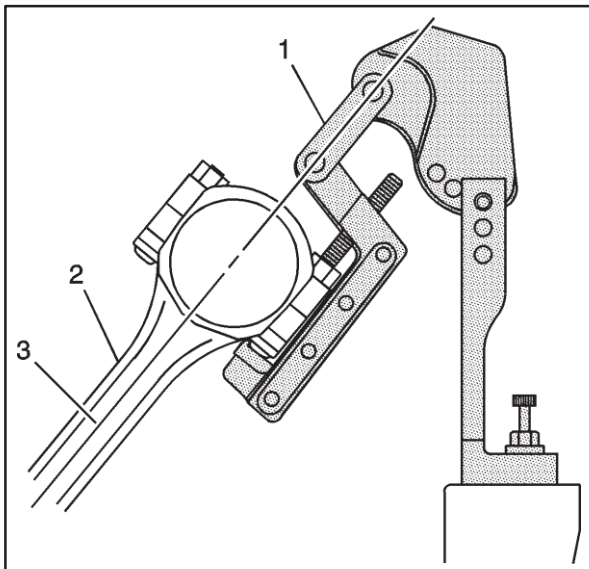


10. Install the base (1) and bolt (2) to the oil pan rail.

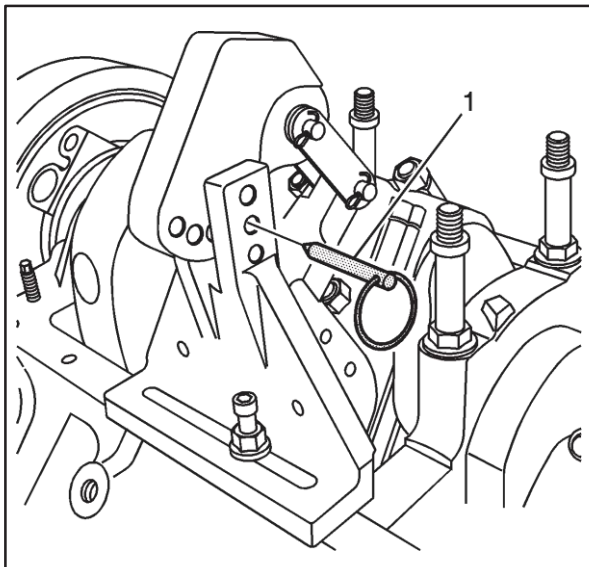




11. Align the center of the base (1) with the screw (3) of the pivot arm assembly. Tighten the bolt (2) until snug.

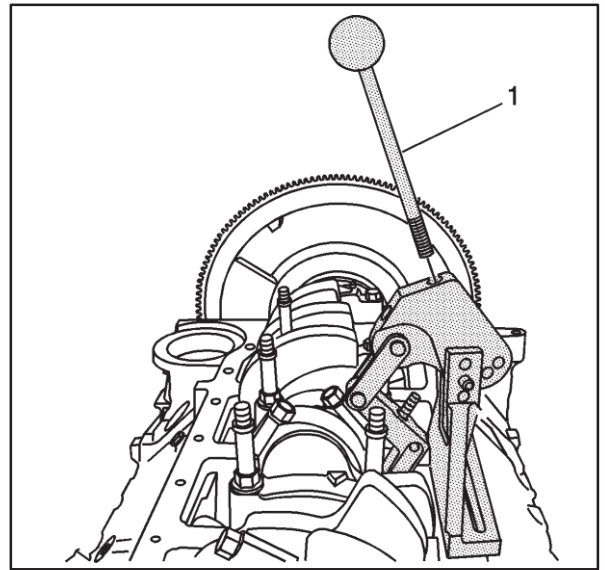


12. Align the link (1) of the pivot arm assembly on a plane (3) equal to that of the connecting rod beam (2).

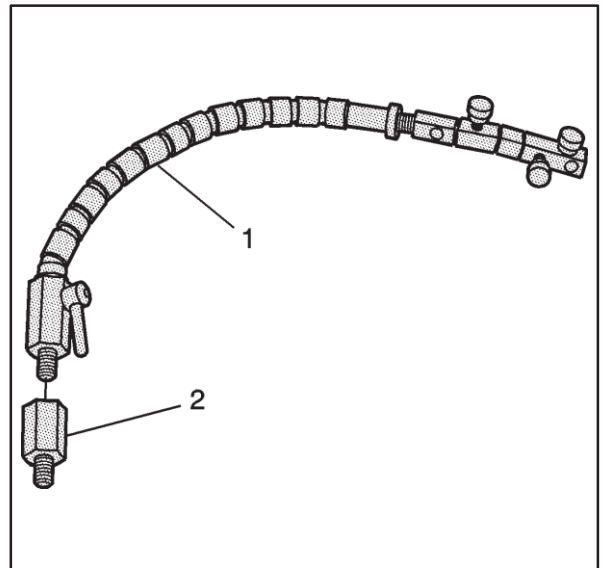


13. With the link of the pivot arm assembly aligned to the beam of the connecting rod, position the pivot arm to the base and insert the pin (1).

14. Install the handle (1) to the pivot arm assembly.

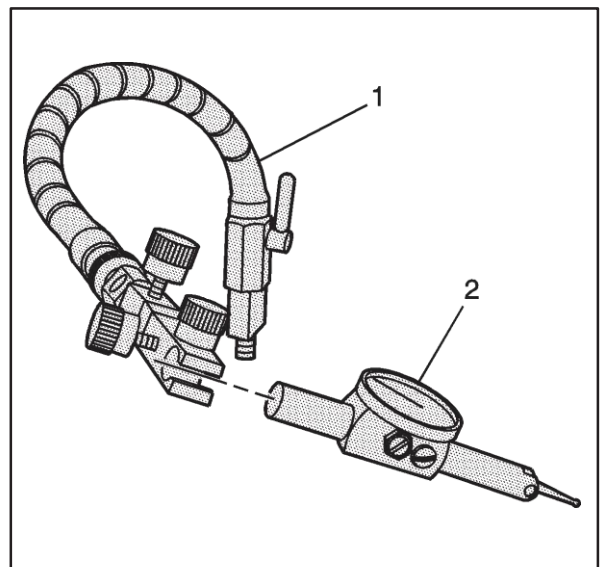


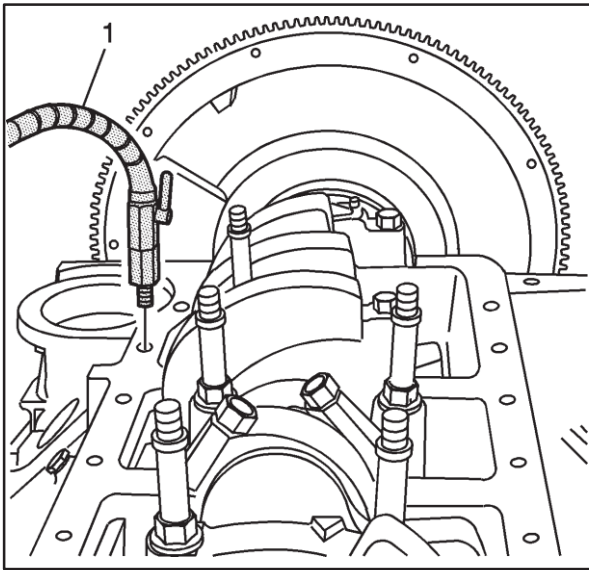
15. Select the adapter (2) (as required) and install to the swivel base (1). Tighten until snug.



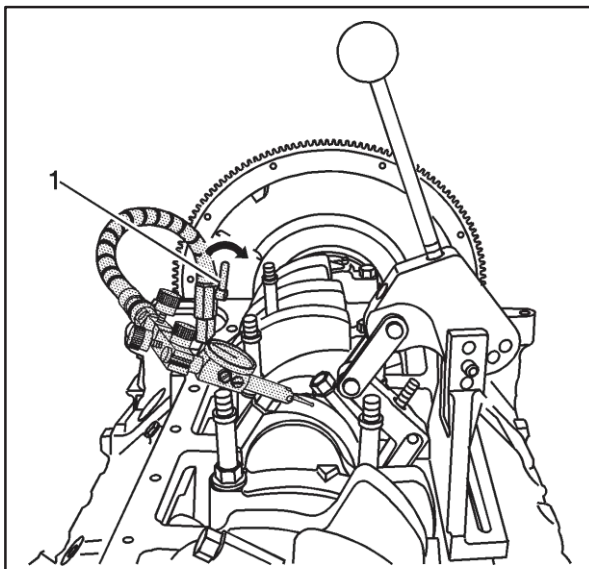
Important: The clamp of the swivel base and the shaft of the indicator should be free of oil or other debris. A loose or improperly clamped indicator may indicate incorrect readings.

16. Install the indicator (2) to the swivel base (1). Tighten the clamp of the base until snug.

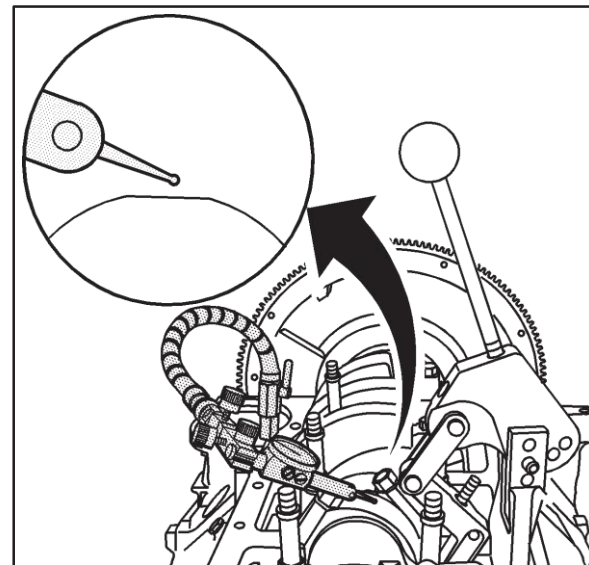




17. Install the swivel base (1) to the oil pan rail of the engine block. Tighten until snug.

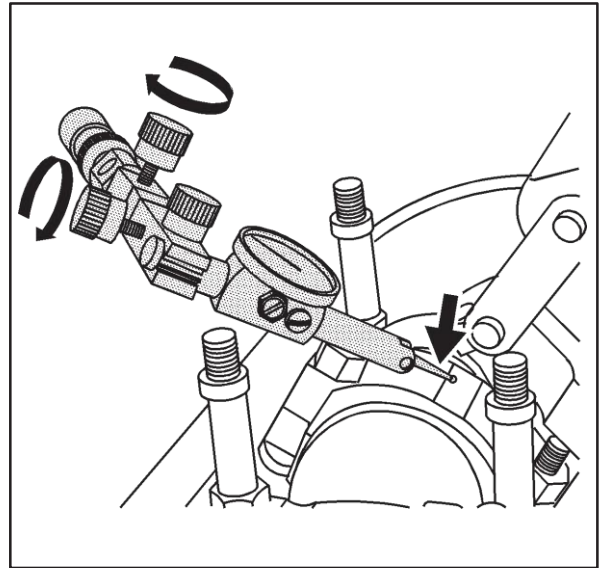


18. Adjust the swivel base as required and position the indicator tip slightly above the connecting rod cap. Lock the swivel base in position by rotating the locking lever (1). Do not allow the tip of the indicator to contact the connecting rod at this time.

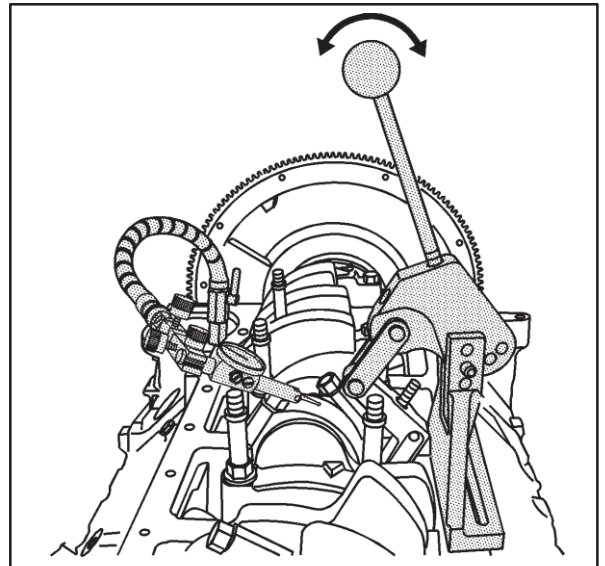


19. The tip of the indicator should be positioned above and NOT in contact with the cap end of the connecting rod.

20. Rotate the fine adjustment knobs on the dial indicator end of the swivel base to position the tip of the indicator in contact with the connecting rod.



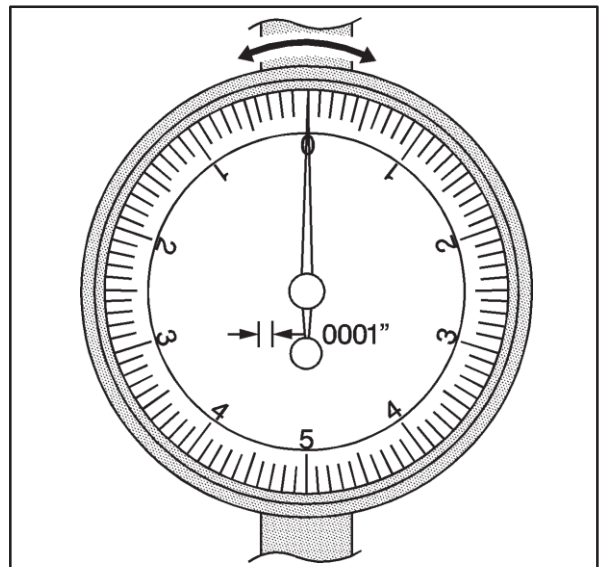
21. Lightly actuate the handle of the pivot arm assembly (multiple times in both directions) to ensure the oil film is removed from the journal.

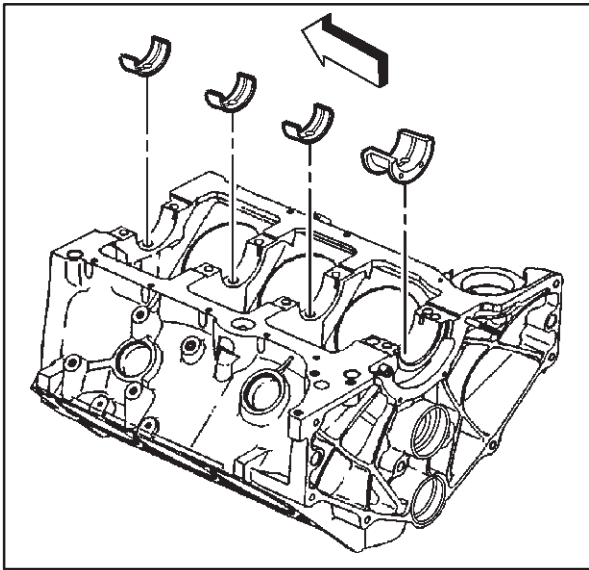


22. Load the handle in the forward position and zero the dial indicator. Load the handle multiple times in both directions and record the reading.

Important: During this procedure, card stock may enter the crankshaft journal oil galleries. Be sure to remove all card stock from the bearing journal and oil galleries prior to reassembly.

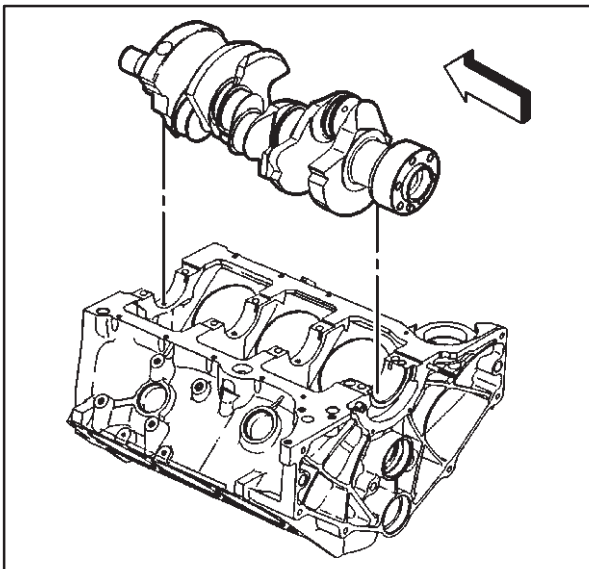
23. Remove the bearing cap bolts, cap and paper stock.
24. Replace the bearing halves as required to obtain the proper bearing clearances.
25. Install the bearings, cap and bolts. Refer to *Fastener Tightening Specifications*.



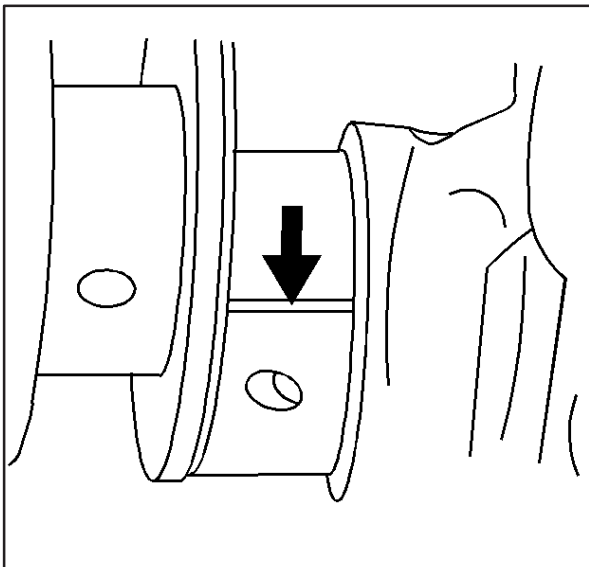


Measuring Crankshaft Bearing Clearances (Plastic Gauge Method)

1. Install the crankshaft bearings into the engine block.

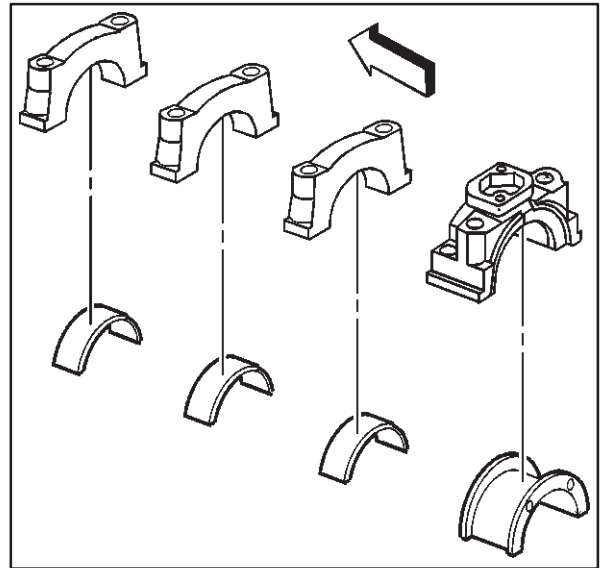


2. Install the crankshaft.



3. Install the gauging plastic the full width of the journal.

4. Install the crankshaft bearings into the crankshaft bearing caps.



5. Install the crankshaft bearing caps in the original positions and with the arrow on the crankshaft bearing caps in the direction of the front of the engine block.

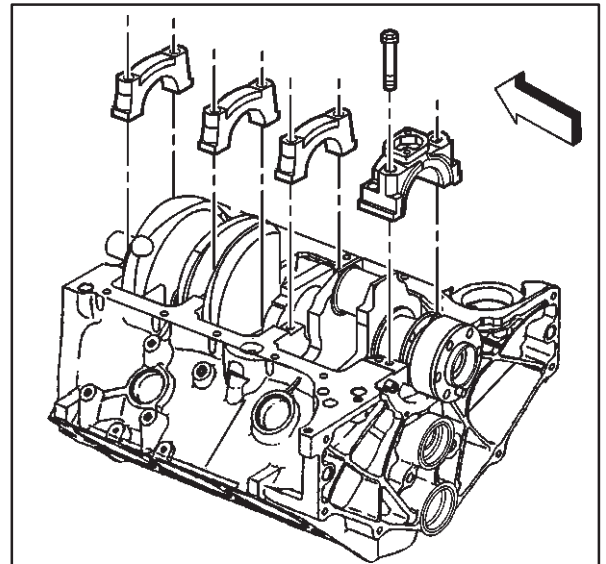
Notice: Refer to *Fastener Notice* in Cautions and Notices.

6. Install the crankshaft bearing cap bolts.

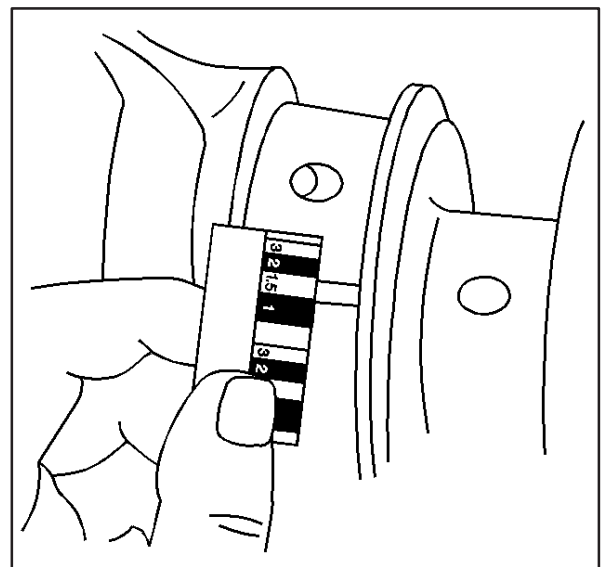
Tighten

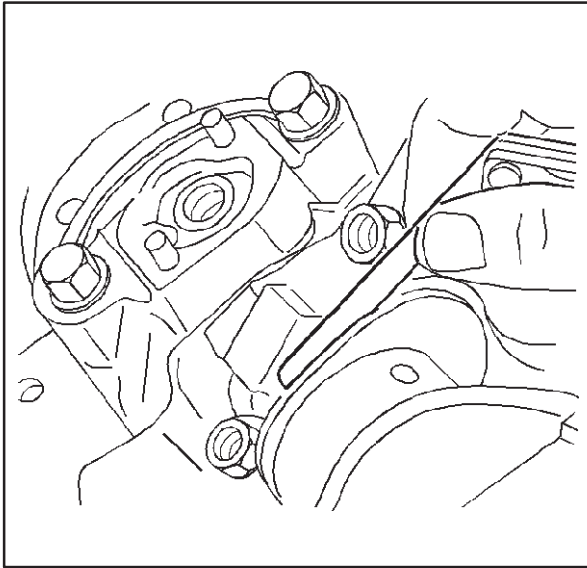
- 6.1. Tighten the crankshaft bearing cap bolts on the first pass to 20 N•m (15 lb ft.).
- 6.2. Tighten the crankshaft bearing cap bolts on the final pass an additional 73 degrees using the J 36660.

7. Remove the crankshaft bearing cap bolts.
8. Remove the crankshaft bearing caps. The gauging plastic may adhere to either the crankshaft bearing journal or the crankshaft bearing surface.



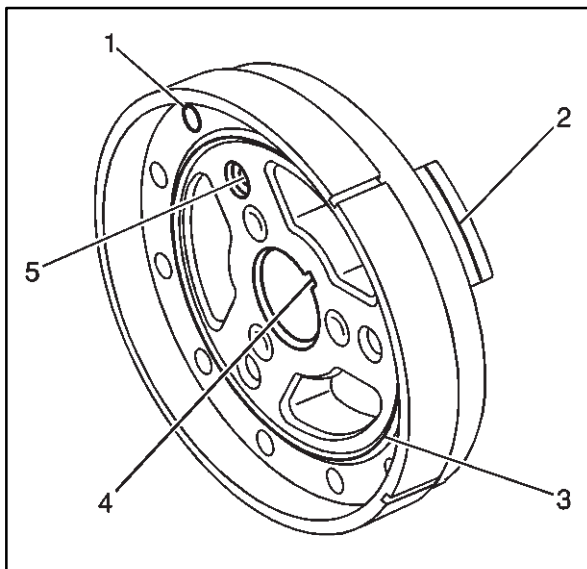
9. Without removing the gauging plastic, measure the compressed width at the widest point using the graduated scale on the edge of the gauging plastic envelope.
If the flattened gauging plastic tapers toward the middle or the ends, there may be a difference in clearance indicating taper, low spot or other irregularity of the crankshaft bearing or the crankshaft bearing journal.
10. Remove the flattened gauging plastic.
11. Measure the remaining crankshaft bearing journals.





Measuring Connecting Rod Bearing Side Clearance

1. Insert a feeler gauge between the connecting rod caps and measure the connecting rod side clearance. Refer to *Engine Mechanical Specifications*.
2. Connecting rod side clearances may also be measured with a dial indicator set.



Crankshaft Balancer Clean and Inspect

Caution: Refer to *Safety Glasses Caution in Cautions and Notices*.

1. Clean the crankshaft balancer in cleaning solvent.
2. Dry the crankshaft balancer with compressed air.
3. Inspect the crankshaft balancer for the following:

- Loose or improperly installed front groove pin (1) (if applicable)

A properly installed front groove pin should be installed until flush or below flush with the face of the crankshaft balancer.

Important: A crankshaft front oil sealing surface with excessive scoring, grooves, rust or other damage must be replaced.

- Worn, grooved or damaged crankshaft front oil sealing surface (2)

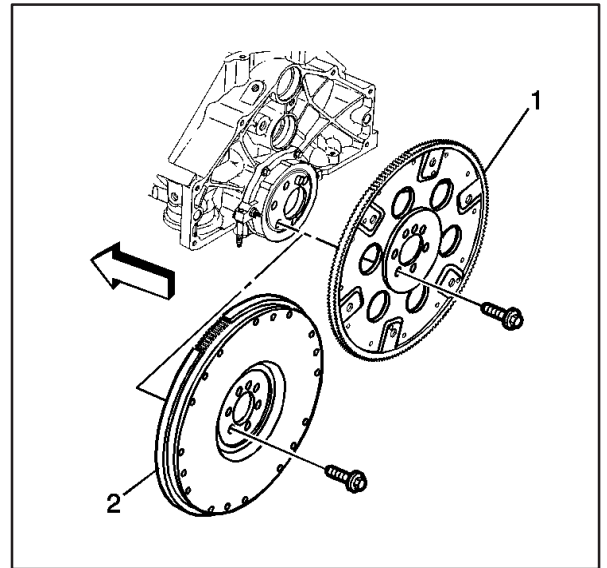
Minor imperfections on the crankshaft balancer crankshaft front oil seal surface may be removed with a polishing compound or fine grade emery cloth.

- Worn, chunking or deteriorated rubber (3) between the hub and the outer ring
- Worn or damaged keyway (4)
- Worn or damaged bolt hole threads (5)

Engine Flywheel Clean and Inspect

Caution: Refer to Safety Glasses Caution in Cautions and Notices.

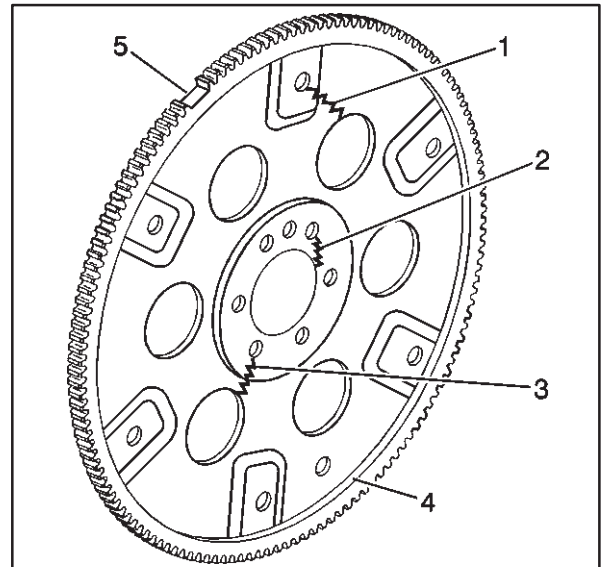
1. Clean the engine flywheel (1) or (2) in cleaning solvent.
2. Dry the engine flywheel with compressed air.

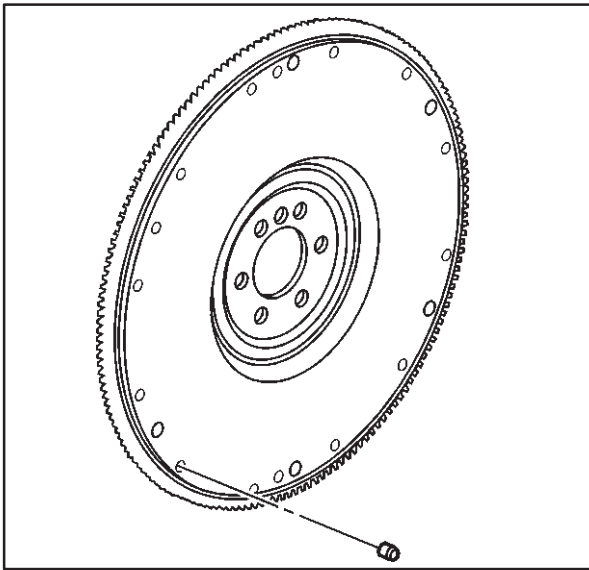


3. Inspect the engine flywheel (automatic transmission) (if equipped) for the following:
 - Stress cracks around the engine flywheel-to-torque converter bolt hole locations (1)
 - Missing balance weights
 - Stress cracks around the engine flywheel-to-crankshaft bolt hole locations (2) or (3)

Important: Do not attempt to repair the welded areas (if present) that retain the ring gear to the engine flywheel plate. Always install a NEW engine flywheel.

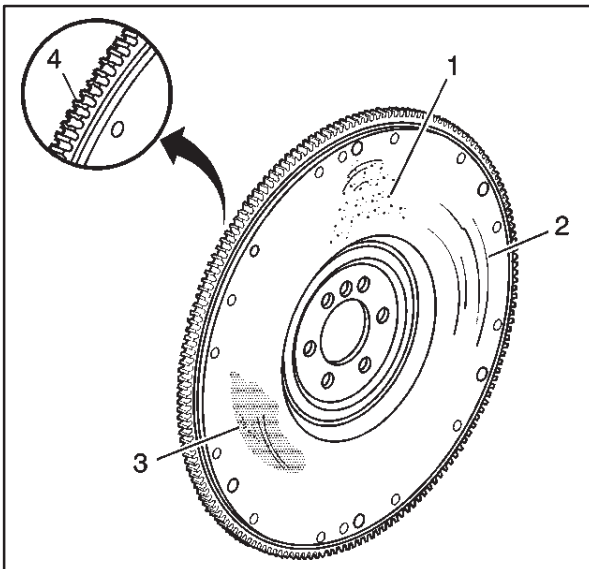
- Welded areas that retain the ring gear onto the engine flywheel for cracking (4) (if present)
- Damaged ring gear teeth (5)





4. Inspect the engine flywheel (manual transmission) (if equipped) for loose or improperly installed flywheel weights (if applicable).

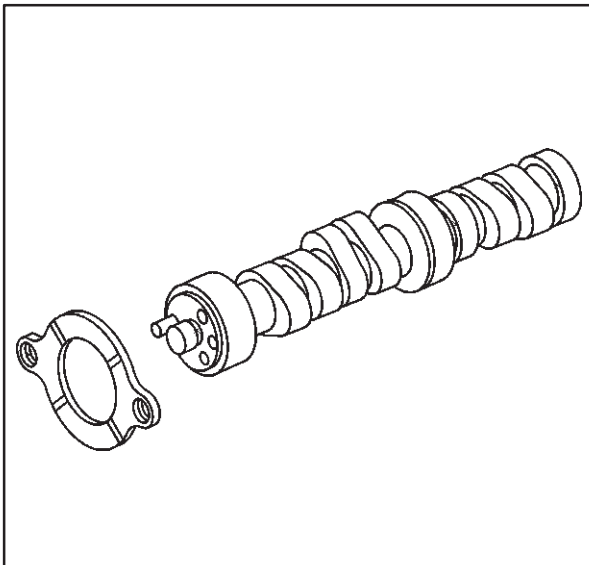
A properly installed flywheel weight should be installed until flush or below flush with the face of the engine flywheel.



5. Inspect the engine flywheel (manual transmission) (if equipped) for the following:

- Pitted friction surface (1)
- Scoring or grooves (2)
- Rust or other surface damage (3)
- Damaged ring gear teeth (4)
- Loose or improperly positioned ring gear

The ring gear has an interference fit onto the engine flywheel and the ring gear should be positioned completely flat against the flange of the engine flywheel.



Camshaft and Bearings Clean and Inspect

Tools Required

J 7872 Magnetic Base Dial Indicator

Caution: Refer to Safety Glasses Caution in Cautions and Notices.

1. Clean the engine camshaft in cleaning solvent.
2. Dry the engine camshaft with compressed air.
3. Inspect the camshaft retainer plate for damage.

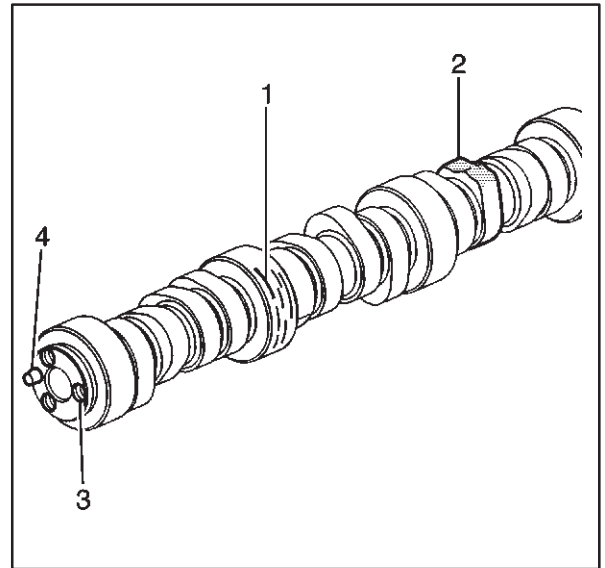
If the camshaft retainer plate is damaged, replace as necessary.

4. Inspect the camshaft bearings for correct fit into the engine block camshaft bearing bores.

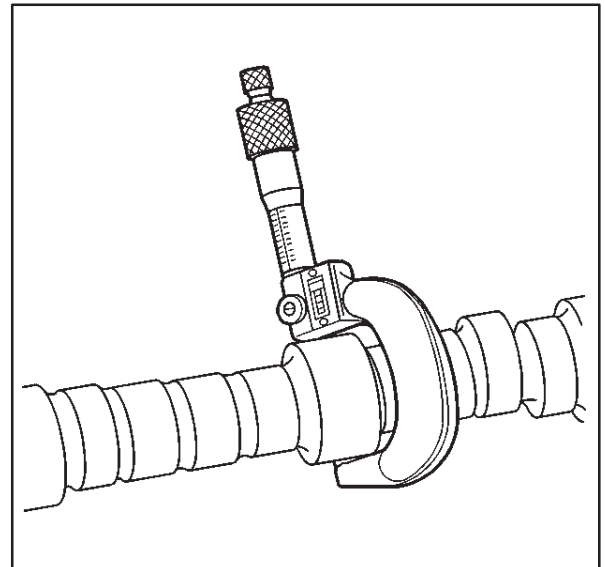
The camshaft bearings have an interference fit to the engine block camshaft bearing bores and must not be loose in the engine block camshaft bearing bores.

Important: If any camshaft bearing is excessively worn or scored, replace all the camshaft bearings.

5. Inspect the camshaft bearings for excessive wear or scoring.
6. Inspect the engine camshaft for the following:
 - Worn, scored or damaged bearing journals (1)
 - Worn engine camshaft lobes (2)
 - Damaged bolt hole threads (3)
 - Damaged camshaft sprocket locator pin (4)



7. Measure the engine camshaft journals with a micrometer.
If the camshaft journals are more than 0.05 mm (0.0020 in) out-of-round, then replace the engine camshaft.



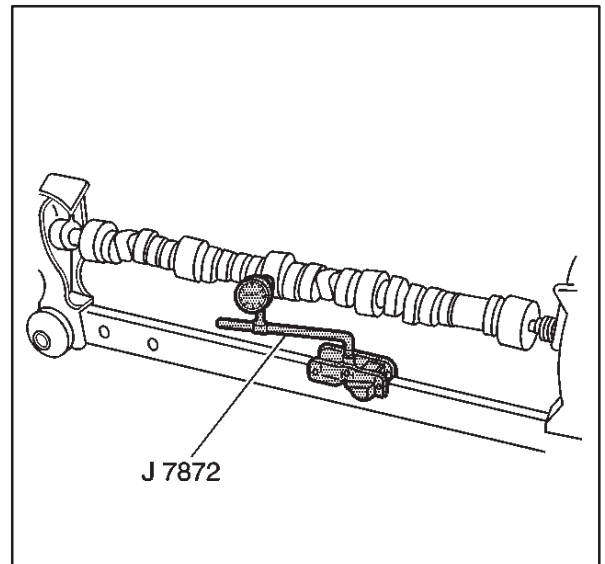
8. Measure for a bent engine camshaft or excessive engine camshaft runout using the J 7872.

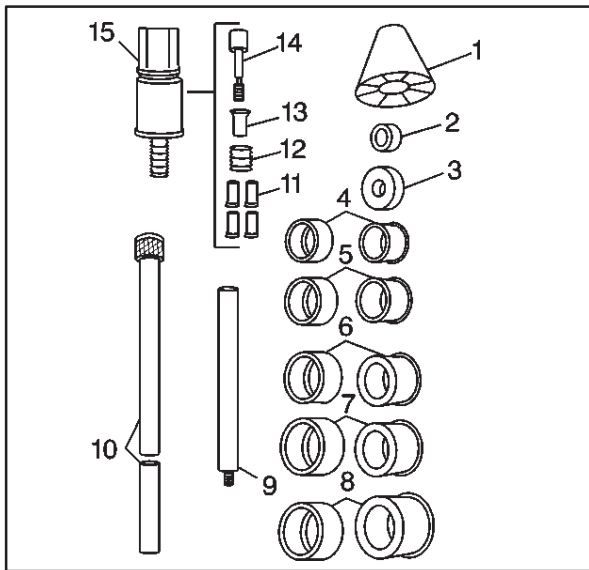
- 8.1. Mount the engine camshaft in a suitable stand between centers.
- 8.2. Use the J 7872 in order to check the intermediate engine camshaft journals.

9. Measure the engine camshaft lobe lift using the J 7872.

- 9.1. Place the engine camshaft on the V-blocks.
- 9.2. Use the J 7872 in order to measure the engine camshaft lobe lift.

10. Replace the engine camshaft if the engine camshaft lobe lift is not within specifications. Refer to *Engine Mechanical Specifications*.



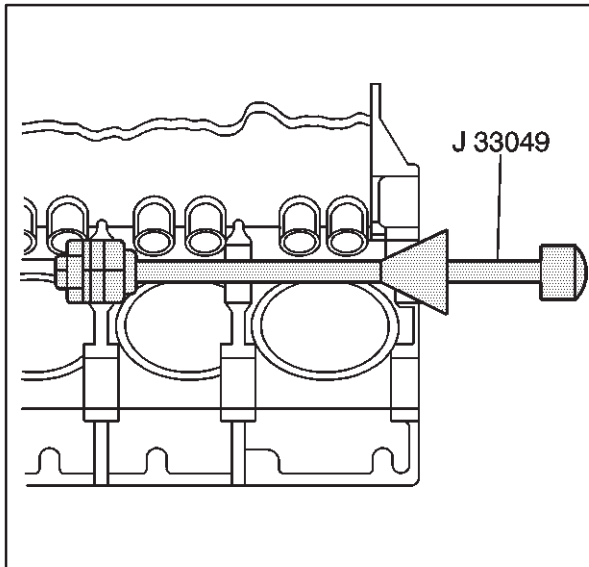


Camshaft Bearing Removal

Tools Required

J 33049 Camshaft Bearing Service Kit

1. Select the cone (1), the handle (10), the expanding driver (4-8), the washer (2 or 3) and the expander assembly (15) from the J 33049.
2. Assemble the J 33049.



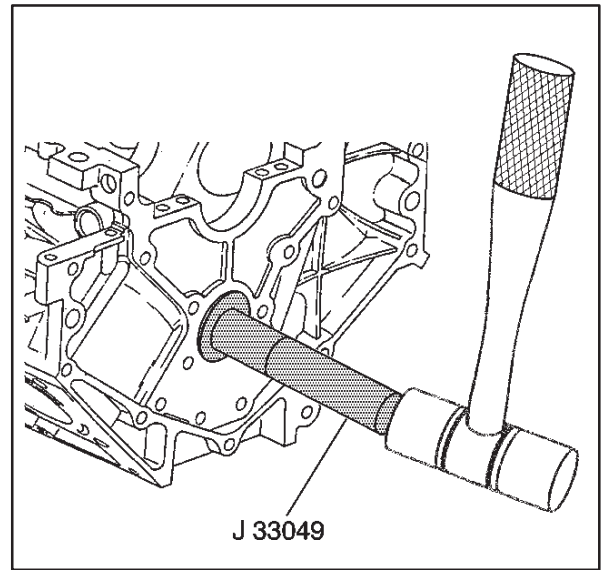
Important: A loose camshaft bearing may be caused by an enlarged, out-of-round or damaged engine block camshaft bearing bore.

Important: Always remove the camshaft inner bearings #2 and #3 first. The camshaft outer bearings #1 and #4 serve as a guide for the J 33049.

Caution: Refer to Safety Glasses Caution in Cautions and Notices.

3. Remove the camshaft inner bearings #2 and #3.
 - 3.1. Insert the J 33049 through the front of the engine block and into the camshaft inner bearing #2.
 - 3.2. Tighten the J 33049 expander assembly nut until snug.
 - 3.3. Push the J 33049 guide cone into the camshaft front bearing in order to align the J 33049.
 - 3.4. Drive the camshaft inner bearing #2 from the camshaft inner bearing bore #2.
 - 3.5. Loosen the J 33049 expander assembly nut.
 - 3.6. Remove the camshaft inner bearing #2 from the J 33049 expander assembly.
 - 3.7. Insert the J 33049 expander assembly into the camshaft inner bearing #3.
 - 3.8. Tighten the J 33049 expander assembly nut until snug.
 - 3.9. Push the J 33049 guide cone into the camshaft front bearing in order to align the J 33049.
 - 3.10. Drive the camshaft inner bearing #3 from the camshaft inner bearing bore #3.
 - 3.11. Loosen the J 33049 expander assembly nut.
 - 3.12. Remove the camshaft inner bearing #3 from the J 33049 expander assembly.

4. Remove the J 33049 from the engine block.
5. Remove the camshaft outer bearings #1 and #4.
 - 5.1. Insert the J 33049 into the camshaft outer bearing #1.
 - 5.2. Tighten the J 33049 expander assembly nut until snug.
 - 5.3. Drive the camshaft outer bearing #1 from the camshaft outer bearing bore #1.
 - 5.4. Loosen the J 33049 expander assembly nut.
 - 5.5. Remove the camshaft outer bearing #1 from the J 33049 expander assembly.
 - 5.6. Remove the J 33049 from the engine block.
 - 5.7. Insert the J 33049 expander assembly into the camshaft outer bearing #4.
 - 5.8. Tighten the J 33049 expander assembly nut until snug.
 - 5.9. Drive the camshaft outer bearing #4 from the camshaft outer bearing bore #4.
 - 5.10. Loosen the J 33049 expander assembly nut.
 - 5.11. Remove the camshaft outer bearing #4 from the J 33049 expander assembly.
6. Remove the J 33049 from the engine block.
7. Discard the camshaft bearings.

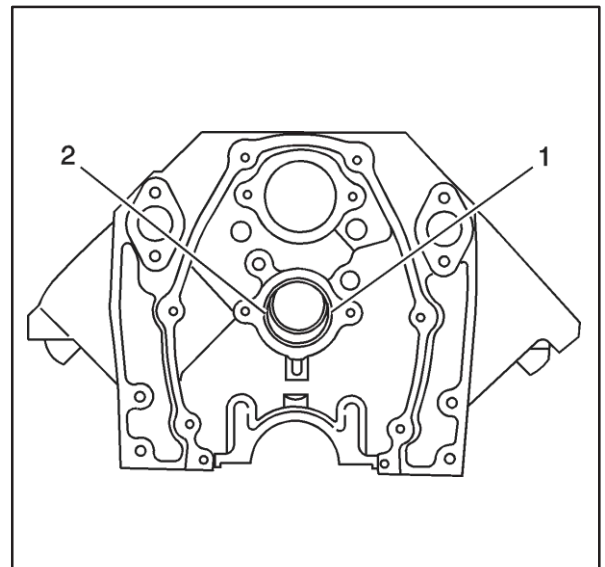


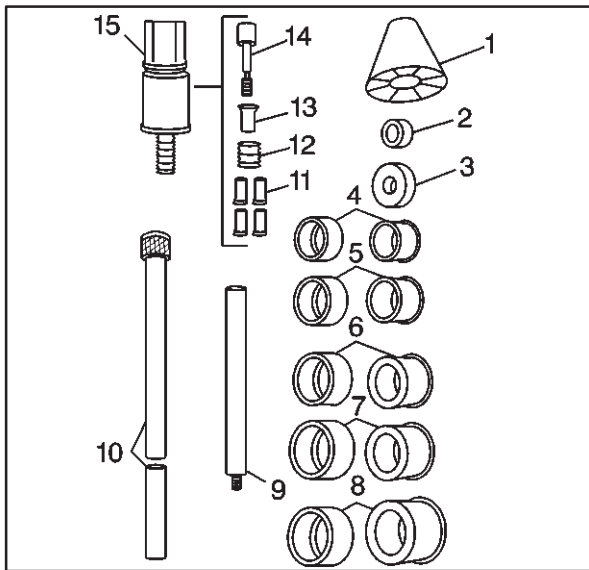
Camshaft Bearing Installation

Tools Required

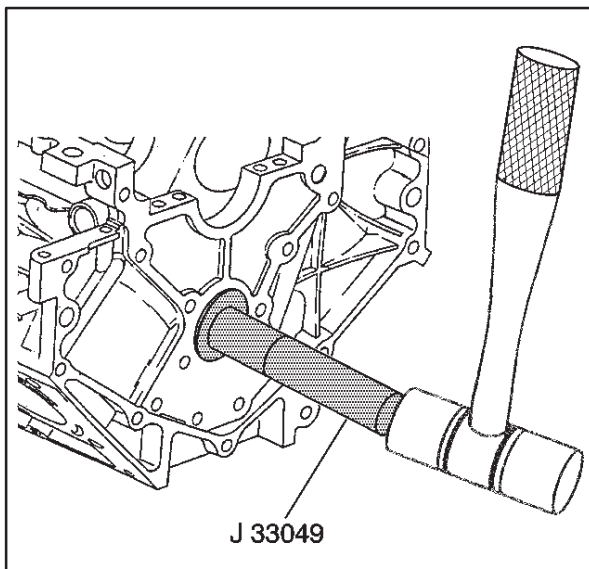
J 33049 Camshaft Bearing Service Kit

Important: When installing the camshaft bearings, always look in order to ensure that the camshaft bearing lubrication hole is located above the 3 o'clock position (1) or the 9 o'clock position (2). The proper positioning of the camshaft bearing lubrication hole is in order to ensure the best lubrication of the engine camshaft journals.





1. Select the handle (10), the expanding driver (4-8), the washer (2 or 3) and the expander assembly (15) from the J 33049.
2. Assemble the J 33049.



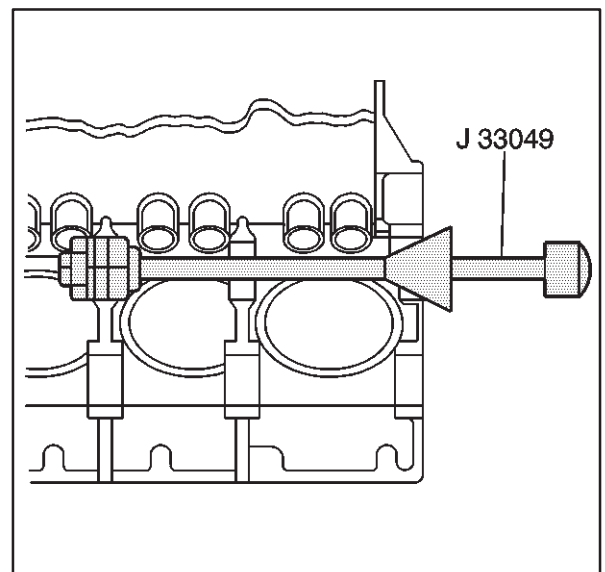
Caution: Refer to Safety Glasses Caution in Cautions and Notices.

Important: The camshaft bearings vary in size. When ordering the new camshaft bearings, be sure to order the correct camshaft bearings for the application to be serviced.

Always install the camshaft outer bearings #1 and #4 first. The camshaft outer bearings serve as a guide for the J 33049 and help center the camshaft inner bearings during the installation process.

3. Install the NEW camshaft outer bearings #4 and #1.
 - 3.1. Install the NEW camshaft outer bearing #4 onto the J33049 expander assembly.
 - 3.2. Tighten the J 33049 expander assembly nut until snug.
 - 3.3. Align the lubrication hole of the camshaft outer bearing #4 above the 3 o'clock position or the 9 o'clock position of the camshaft outer bearing bore #4 at the rear of the engine block.
 - 3.4. Drive the camshaft outer bearing #4 into the camshaft outer bearing bore #4 at the rear of the engine block.
 - 3.5. Loosen the J 33049 expander assembly nut.
 - 3.6. Remove the camshaft outer bearing #4 from the J33049 expander assembly.
 - 3.7. Install the NEW camshaft outer bearing #1 onto the J33049 expander assembly.
 - 3.8. Tighten the J 33049 expander assembly nut until snug.
 - 3.9. Align the lubrication hole of the camshaft outer bearing #1 above the 3 o'clock position or the 9 o'clock position of the camshaft outer bearing bore #1 at the front of the engine block.
- 3.10. Drive the camshaft outer bearing #1 into the camshaft outer bearing bore #1 at the front of the engine block.
- 3.11. Loosen the J 33049 expander assembly nut.
- 3.12. Carefully slide the J 33049 into the engine block until the J 33049 expander assembly is positioned between the camshaft inner bearing bores.

4. Install the NEW camshaft inner bearings #3 and #2.
 - 4.1. Install the NEW camshaft inner bearing #3 onto the J33049 expander assembly.
 - 4.2. Tighten the J 33049 expander assembly nut until snug.
 - 4.3. Align the lubrication hole of the camshaft inner bearing #3 above the 3 o'clock position or the 9 o'clock position of the camshaft inner bearing bore #3 of the engine block.
 - 4.4. Push the J 33049 guide cone into the camshaft front bearing bore #1 in order to align the J 33049.
 - 4.5. Drive the camshaft inner bearing #3 into the camshaft inner bearing bore #3 of the engine block.
 - 4.6. Loosen the J 33049 expander assembly nut.
 - 4.7. Carefully slide the J 33049 until the J 33049 expander assembly is positioned between the camshaft inner bearing bore #2 and the camshaft outer bearing bore #1.
 - 4.8. Install the NEW camshaft inner bearing #2 onto the J33049 expander assembly.
 - 4.9. Tighten the J 33049 expander assembly nut until snug.
 - 4.10. Align the lubrication hole of the camshaft inner bearing #2 above the 3 o'clock position or the 9 o'clock position of the camshaft inner bearing bore #2 of the engine block.
 - 4.11. Push the J 33049 guide cone into the camshaft front bearing bore #1 in order to align the J 33049.
 - 4.12. Drive the camshaft inner bearing #2 into the camshaft inner bearing bore #2 of the engine block.
 - 4.13. Loosen the J 33049 expander assembly nut.
5. Carefully remove the J 33049 from the engine block.



Balance Shaft Bearing and/or Bushing Removal

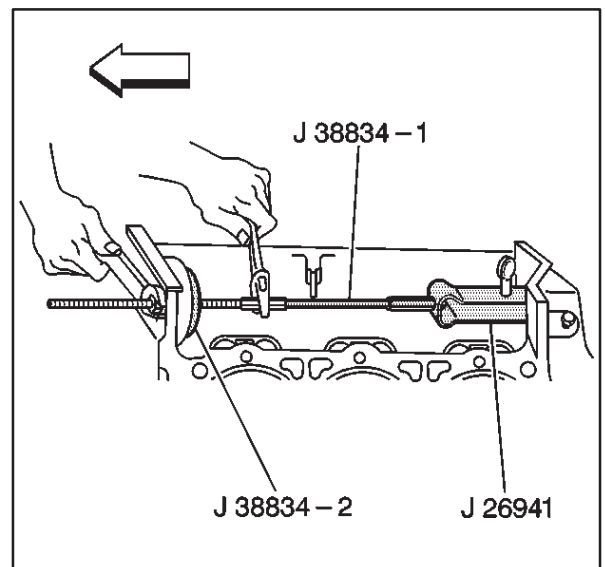
Tools Required

J 26941 Bushing/Bearing Remover

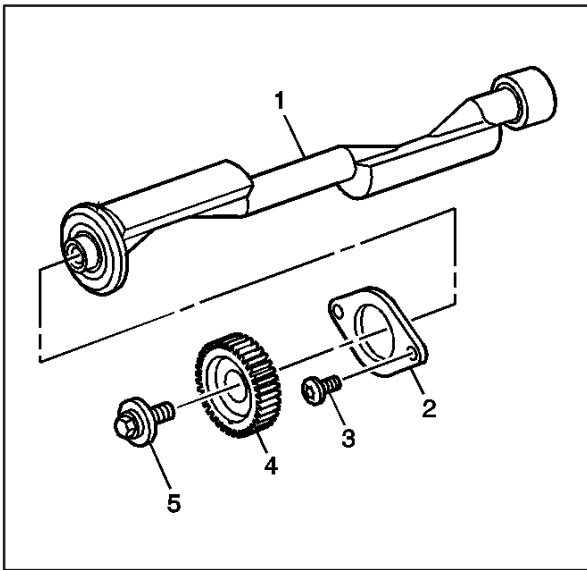
J 38834 Balance Shaft Service Kit

Caution: Refer to *Safety Glasses Caution in Cautions and Notices*.

1. Use the J 38834 and the J 26941 in order to remove the balance shaft rear bearing.
 - 1.1. Install the J 26941 legs behind the balance shaft rear bearing and secure.
 - 1.2. Install the J 38834-1 with the short threaded end through the balance shaft bore in the front of the engine block.
 - 1.3. Install the J 38834-1 into the J 26941.



- 1.4. Slide the J 38834-2 onto the J 38834-1 and into the balance shaft bore of the engine block.
 - 1.5. Install the J 38834 bearing, washer and nut onto the J 38834-1.
 - 1.6. Using a wrench, secure the J 38834-1 and then rotate the J 38834 nut clockwise until the balance shaft rear bearing is removed from the engine block.
 - 1.7. Remove the J 26941 from the balance shaft rear bearing.
2. Discard the balance shaft rear bearing.



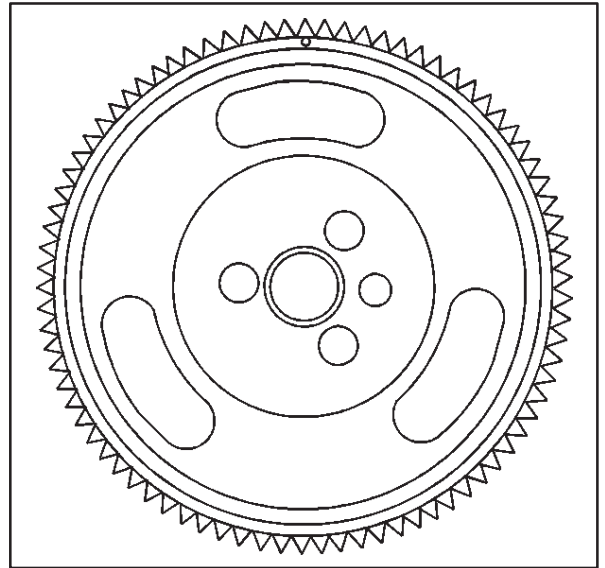
Balance Shaft Clean and Inspect

Caution: Refer to Safety Glasses Caution in Cautions and Notices.

Important: The balance shaft and the balance shaft front bearing are serviced only as an assembly. Do not remove the balance shaft front bearing from the balance shaft.

1. Clean the following components in cleaning solvent:
 - The balance shaft (1)
 - The balance shaft retainer (2)
 - The balance shaft rear bearing
 - The balance shaft driven gear (4)
 - The balance shaft drive gear
2. Dry the following components with compressed air:
 - The balance shaft (1)
 - The balance shaft retainer (2)
 - The balance shaft rear bearing
 - The balance shaft driven gear (4)
 - The balance shaft drive gear
3. Inspect the balance shaft bearings for the following:
 - Front ball bearing for damage or wear
 - Front ball bearing for smoothness of operation
 - Rear sleeve bearing for wear, scoring or other damage
4. Inspect the balance shaft (1) for the following:
 - Wear or scoring on the rear bearing journal
 - Damaged bolt hole threads
 - Damaged to the balance shaft driven gear locator pin
5. Inspect the balance shaft retainer (2) for wear or damage.
6. Inspect the balance shaft retainer bolts (3) for damaged threads.
7. Inspect the driven gear (4) for the following:
 - Excessive wear or damage
 - Nicks, burrs or scoring

8. Inspect the driven gear bolt (5) for damaged threads.
9. Inspect the balance shaft drive gear for the following:
 - Excessive wear or damage
 - Nicks, burrs or scoring



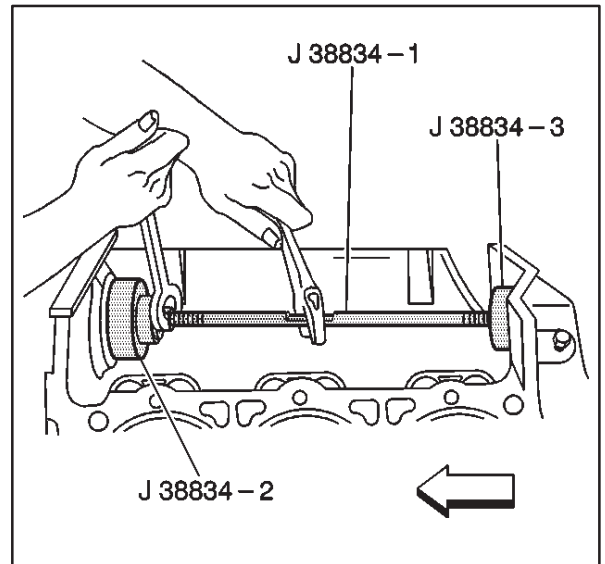
Balance Shaft Bearing and/or Bushing Installation

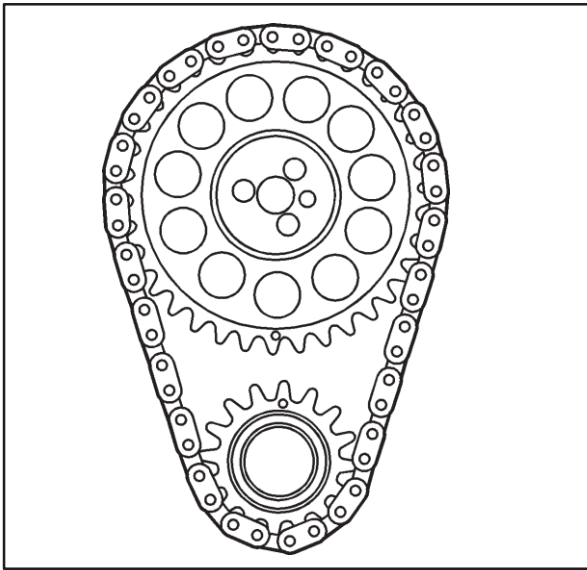
Tools Required

J 38834 Balance Shaft Service Kit

Caution: Refer to Safety Glasses Caution in Cautions and Notices.

1. Use the J 38834 in order to install the balance shaft rear bearing.
 - 1.1. Install the J 38834-3 onto the short threaded end of the J 38834-1.
 - 1.2. Install the J 38834 nut, the washer and the bearing on the long threaded end of the J 38834-1.
 - 1.3. Install the J 38834-2 onto the J 38834-1 so that the smaller diameter of the J 38834-2 will be facing the front of the engine block.
 - 1.4. Install the J 38834-2 on the inside of the balance shaft front bearing bore.
 - 1.5. Lubricate the NEW balance shaft rear bearing with clean engine oil.
 - 1.6. Install the balance shaft rear bearing onto the J 38834-2.
 - 1.7. Align the balance shaft rear bearing for installation.
 - 1.8. Using a wrench, secure the J 38834-1 into place.
 - 1.9. Rotate the J 38834 nut until the balance shaft rear bearing is properly and completely pushed into the balance shaft rear bearing bore.
2. Remove the J 38834.

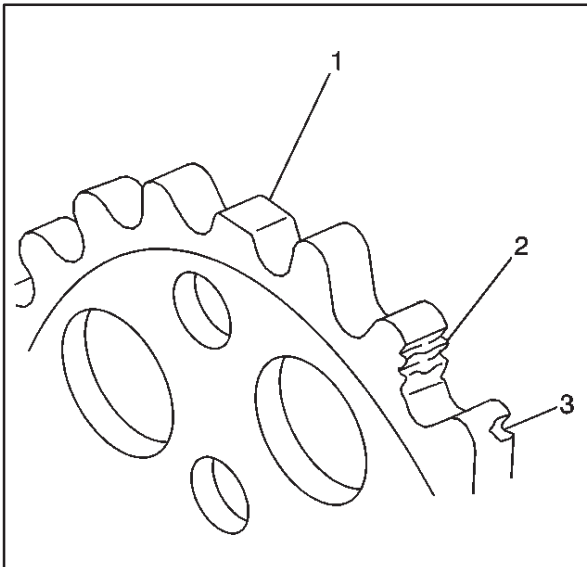




Timing Chain and Sprockets Clean and Inspect

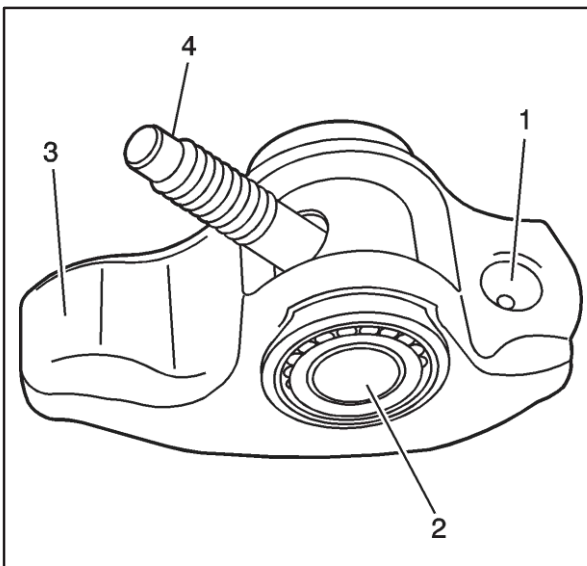
Caution: Refer to Safety Glasses Caution in Cautions and Notices.

1. Clean the components with cleaning solvent.
2. Dry the components with compressed air.
3. Inspect the camshaft timing chain for binding or wear.



4. Inspect the camshaft sprocket and the crankshaft sprocket for the following:

- Broken teeth (1)
- Damaged teeth (2)
- Chipped teeth (3)
- Worn teeth
- Uneven wear on the edge of the teeth
- Worn valleys between the sprocket teeth
- Crankshaft sprocket keyway for wear



Valve Rocker Arm and Push Rods Clean and Inspect

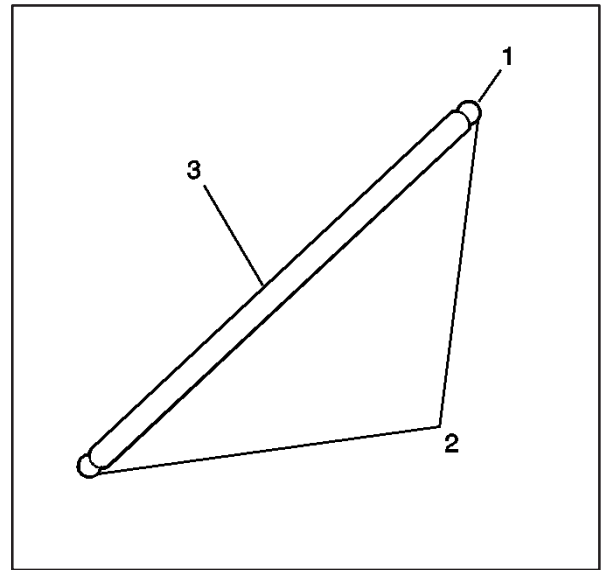
Important: Parts that are to be reused must be marked, sorted and organized for assembly.

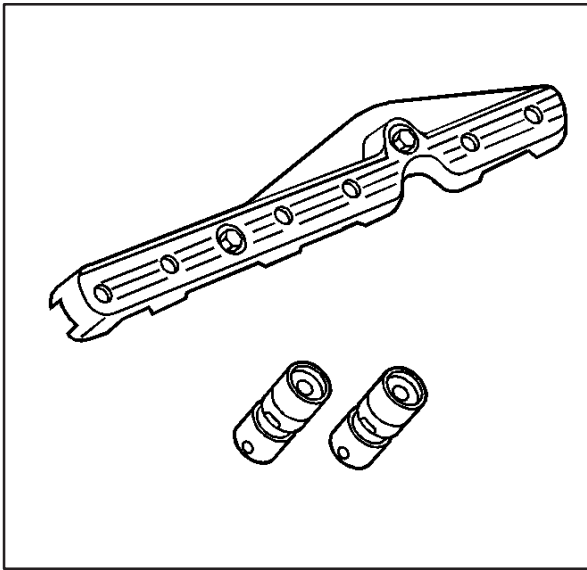
1. Mark, sort and organize the components for assembly.

Caution: Refer to Safety Glasses Caution in Cautions and Notices.

2. Clean the components with cleaning solvent.
3. Dry the components with compressed air.
4. Inspect the valve rocker arm components for the following:
 - Valve rocker arm valve push rod socket contact surface (1). The contact surface must be smooth with no scoring or excessive wear.
 - Valve rocker arm roller pivot for binding or damage (2)
 - Valve rocker arm valve stem contact surface (3)
 - Valve rocker arm bolt threads for damage (4)

5. Inspect the valve push rods for the following:
- Restriction of the oil passage (1)
 - Wear or scoring of the end contact surfaces (2). The end contact surfaces must be smooth with no scoring or excessive wear.
 - Shaft for bends (3). Roll the valve pushrod on a flat surface to determine if the valve pushrod is bent.





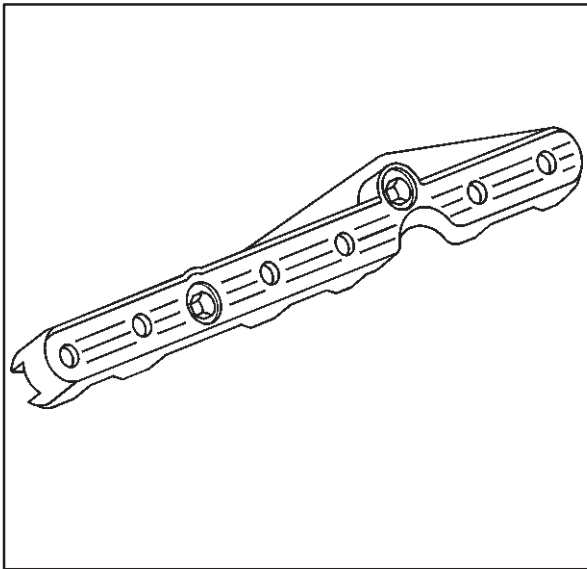
Valve Lifters and Guides Clean and Inspect

Important: Parts that are to be reused must be marked, sorted and organized for assembly.

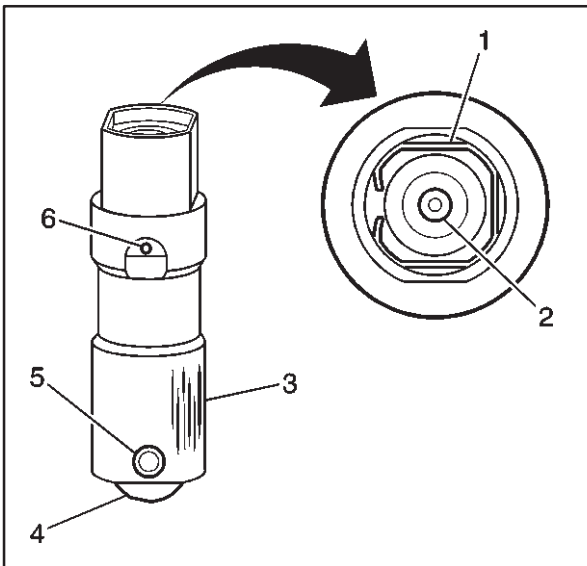
1. Mark, sort and organize the components for assembly.

Caution: Refer to *Safety Glasses Caution in Cautions and Notices*.

2. Clean the components with cleaning solvent.
3. Dry the components with compressed air.



4. Inspect the valve lifter pushrod guides for excessive wear.
5. Inspect the valve lifter pushrod guides for cracks or damage.



6. Inspect the valve lifter for the following:

- Broken or damaged clip (1)
- Worn pushrod socket (2)
- Scuffed or worn lifter body (3)

If the valve lifter shows scuffing or wear, inspect the engine block valve lifter bores for wear.

- Worn roller (4)
- Loose or damaged pin (5)
- Plugged oil hole (6)

Cylinder Head Disassemble

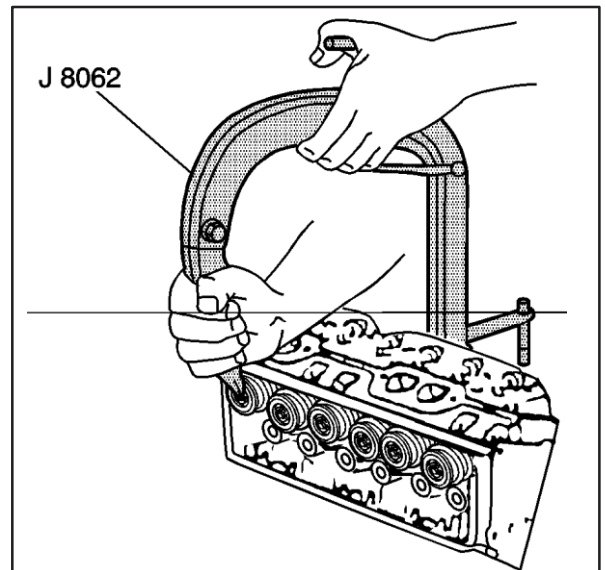
Tools Required

J 8062 Valve Spring Compressor

Caution: Compressed valve springs have high tension against the valve spring compressor. Valve springs that are not properly compressed by or released from the valve spring compressor can be ejected from the valve spring compressor with intense force. Use care when compressing or releasing the valve spring with the valve spring compressor and when removing or installing the valve stem keys. Failing to use care may cause personal injury.

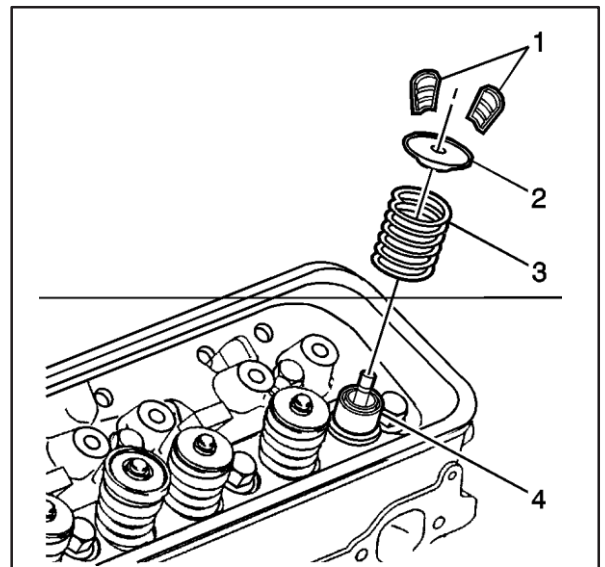
Caution: Refer to Safety Glasses Caution in Cautions and Notices.

1. Use the J 8062 in order to compress the valve springs.



Important: Mark, sort and organize the components so that the components can be reinstalled in their original location and position.

2. Remove the valve stem keys (1).
3. Remove the J 8062 from the cylinder head.
4. Remove the valve spring cap (2).
5. Remove the valve spring (3).
6. Remove the valve stem oil seal (4).
7. Discard the valve stem oil seal.
8. Remove the valve.



Cylinder Head Clean and Inspect

Tools Required

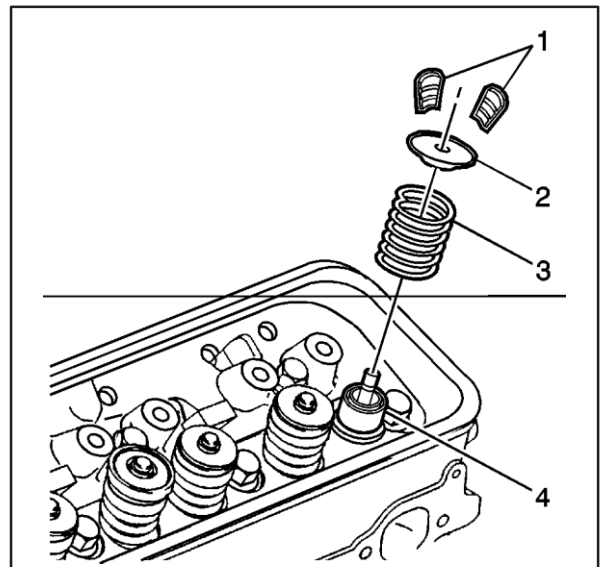
J 8001 Dial Indicator Set

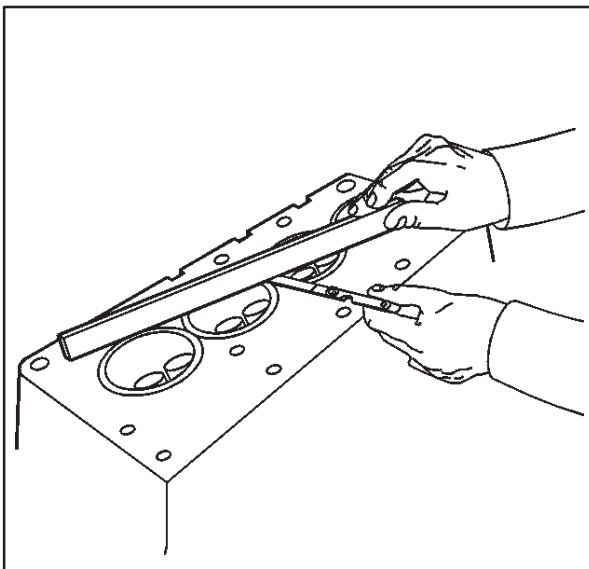
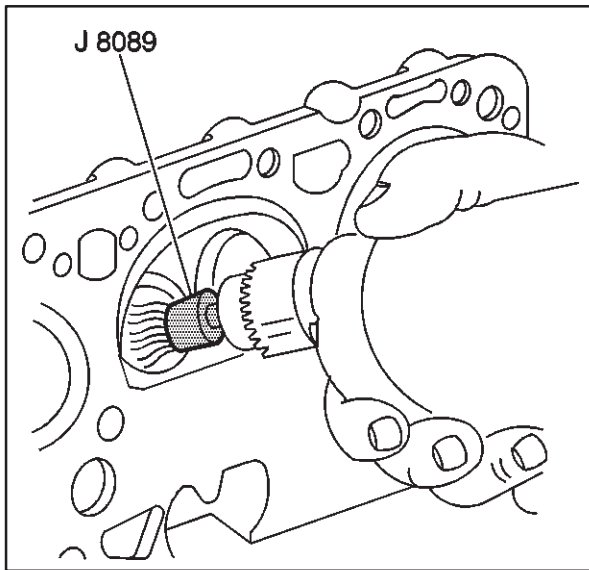
J 8089 Carbon Removing Brush

J 9666 Valve Spring Tester

Caution: Refer to Safety Glasses Caution in Cautions and Notices.

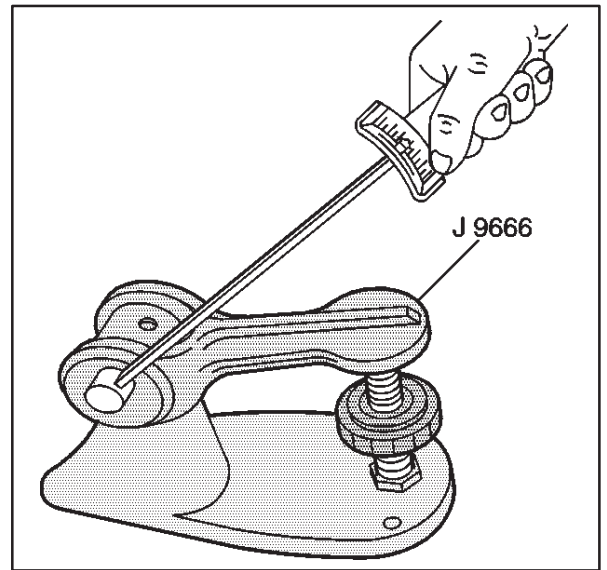
1. Clean the valve stems and cylinder heads on a buffing wheel.
2. Clean the following components in cleaning solvent:
 - Valve stem keys (1)
 - Valve spring cap (2)
 - Valve spring (3)
 - Cylinder head



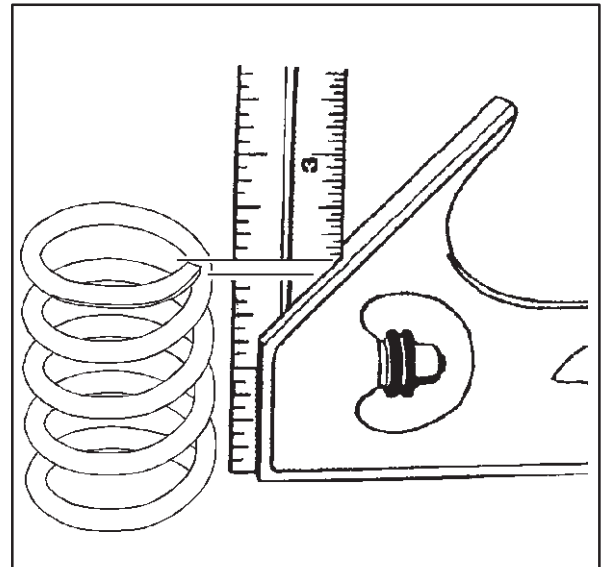


3. Dry the components with compressed air.
4. Use the J 8089 to clean the carbon from the cylinder head combustion chambers.
Be careful not to scuff the combustion chambers.
5. Inspect the cylinder head for the following:
 - Damage to the gasket surfaces
 - Damage to the threaded bolt holes
 - Burnt or eroded areas in the combustion chambers
 - Cracks in the exhaust ports and combustion chambers
 - External cracks in the water chambers
 - Restrictions in the intake or exhaust passages
 - Restrictions in the cooling system passages
 - Rusted, damaged or leaking core plugs
6. Measure the cylinder head for warpage with a straight edge and feeler gauge
 - A cylinder head block deck with warpage in excess of 0.10 mm (0.004 in) within a 152.4 mm (6.0 in) area must be repaired or replaced.
 - A cylinder head exhaust manifold deck with warpage in excess of 0.05 mm (0.002 in) within a 152.4 mm (6.0 in) area must be repaired or replaced.
 - A cylinder head intake manifold deck with warpage in excess of 0.10 mm (0.004 in) within a 152.4 mm (6.0 in) area must be repaired or replaced.

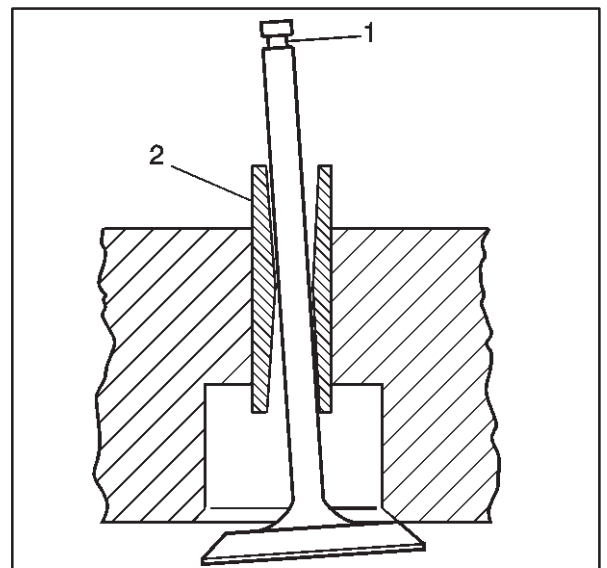
7. Use the J 9666 in order to measure the valve spring.
Replace the valve spring if the valve spring tension is less than 445 N (100 lb) at 43.2 mm (1.80 in).

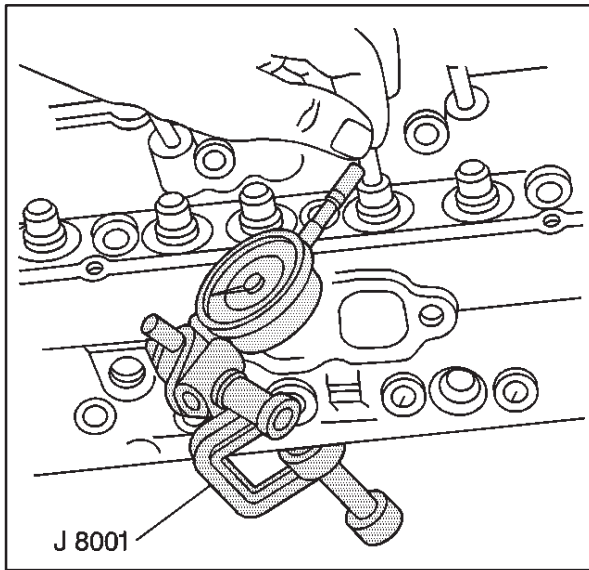


8. Inspect the valve springs for squareness.

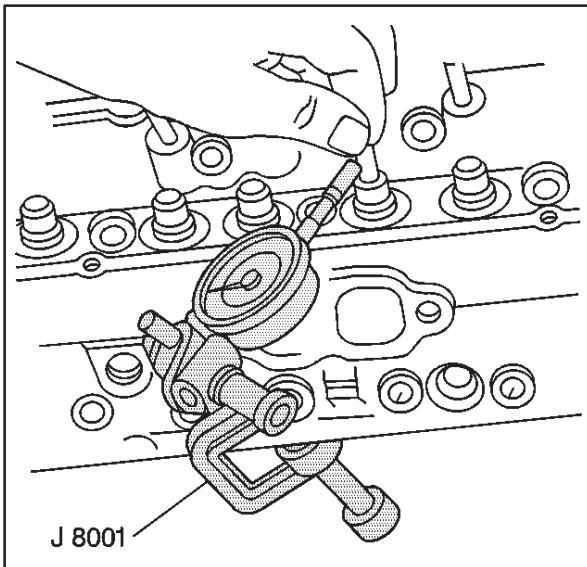


9. Valve stems (1) with excessive valve guide (2) clearance must be repaired or the cylinder head replaced





10. Measure the valve stem-to-guide clearance.
Excessive valve stem-to-guide clearance may cause an excessive oil consumption and may also cause a valve to break. Insufficient clearance will result in noisy and sticky functioning of the valve and will disturb the engine assembly smoothness.
 - 10.1. Clamp the J 8001 on the exhaust port side of the cylinder head.
 - 10.2. Position the dial indicator so that the movement of the valve stem from side to side (crosswise to the cylinder head) will cause a direct movement of the dial indicator stem.
The dial indicator stem must contract the side of the valve stem just above the valve guide.
 - 10.3. Drop the valve head about 1.6 mm (0.063 in) off the valve seat.
 - 10.4. Use light pressure and move the valve stem from side to side in order to obtain a valve stem-to-guide clearance reading. Refer to *Engine Mechanical Specifications*.



Valve Guide Reaming/Valve and Seat Grinding

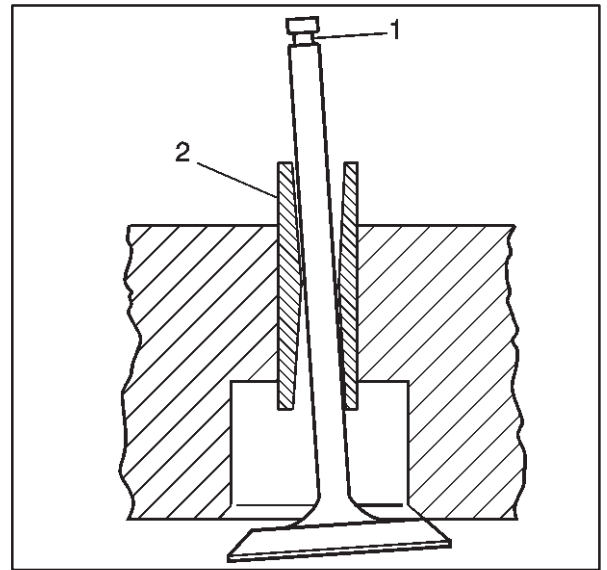
Tools Required

J 5830-02 Valve Guide Reamer Set

J 8001 Dial Indicator Set

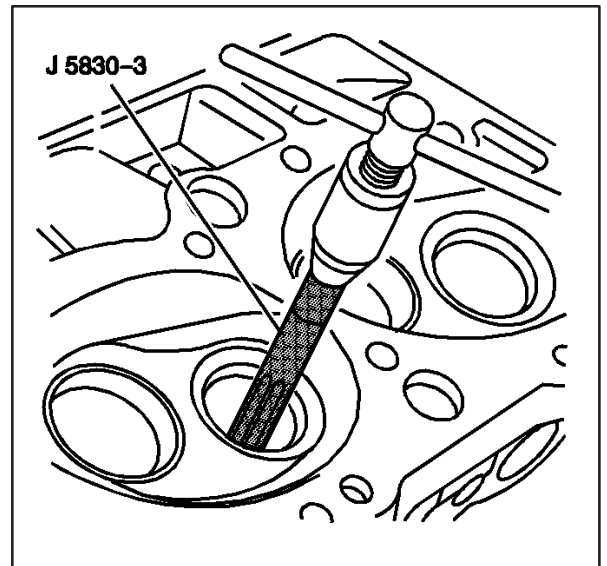
1. Measure the valve stem-to-guide clearance. Refer to *Cylinder Head Clean and Inspect*.

2. Improper valve stem (1) to valve guide (2) clearance may cause excessive oil consumption.

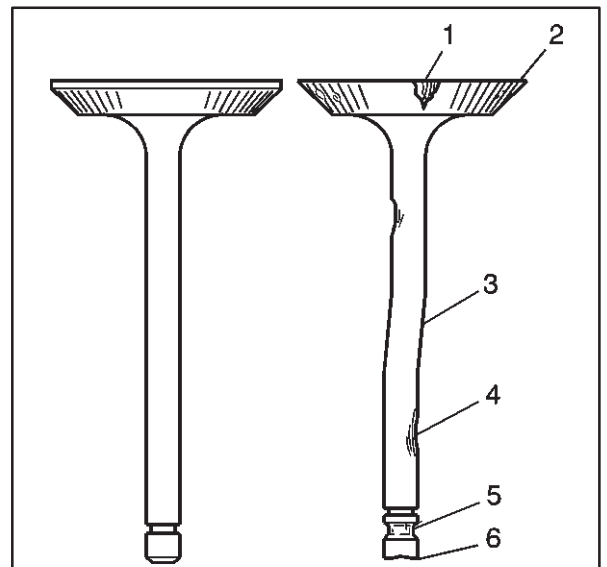


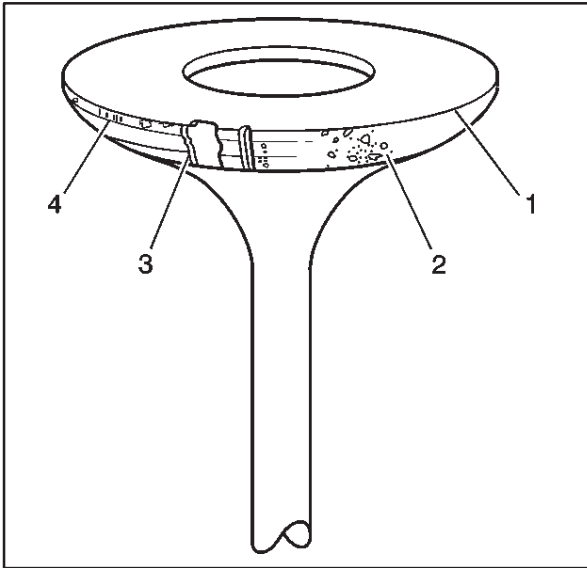
Caution: Refer to Safety Glasses Caution in Cautions and Notices.

3. Use the J 5830-3 in order to ream the exhaust valve guide in order to achieve the correct valve stem-to-guide clearance.
4. Always recondition the exhaust valve seat after reaming the exhaust valve guide bores and installing new exhaust valves.



5. Inspect the valves for the following:
 - Burnt or damaged areas (1)
 - Undersize margin (2)
 - Bent stem (3)
 - Scoring or other damage to the stem (4)
 - Worn key groove (5)
 - Worn stem tip (6)





6. Inspect the valve contact surface for the following:

- Undersized margin (1)
- Pitted surfaces (2)
- Burnt or eroded areas (3)
- Acceptable edge (margin) (4)

Valves with excessive damage must be replaced.

Minor imperfections of the valve or valve seat may be repaired.

7. Reconditioning of the valves and valve seats:

- The valves must seat perfectly for the engine to deliver optimum power and performance.
- Cooling the valve heads is another important factor. Good contact between each valve and valve seat in the cylinder head is necessary to insure that the heat in the valve head is properly carried away.
- Regardless of what type of equipment is used, it is essential that the valve guide bores are free from carbon or dirt in order to ensure the proper centering of the pilot in the valve guide.

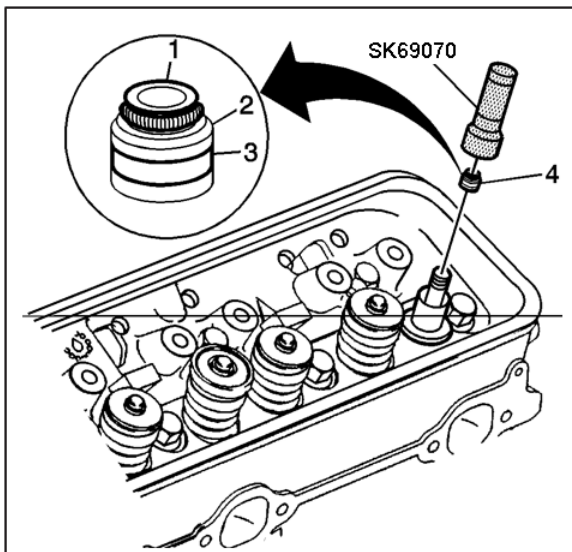
The valve seats should be concentric to within 0.05 mm total indicator reading.

- Reface pitted valves on a valve refacing machine in order to ensure the correct relationship between the valve head and the valve stem.

Replace the valve if the valve stem is excessively worn or warped.

Replace the valve if the edge margin (4) of the valve head is less than 0.79 mm (0.031 in) thick after grinding.

- Several different types of equipment are available for reconditioning valves and valve seats. Follow the equipment manufacturer's recommendations for equipment use to attain the proper results.



Cylinder Head Assemble

Tools Required

J 8062 Valve Spring Compressor

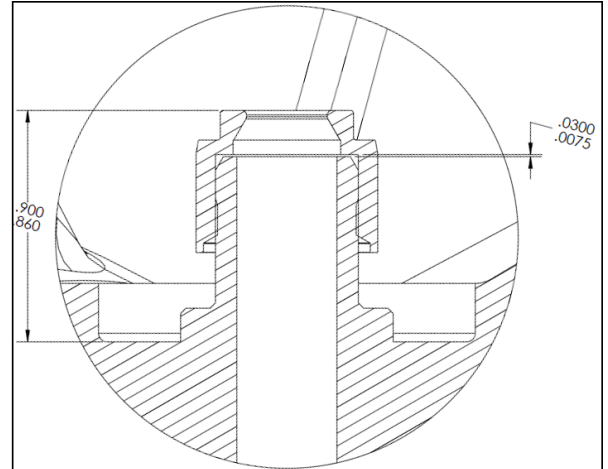
SK69070 Valve Stem Seal Installer

1. Assemble the valve into the proper valve guide.
2. Select the proper valve stem oil seal for the specific valve guide.
3. Lubricate the valve stem oil seal and the outside diameter of the valve guide with clean engine oil.

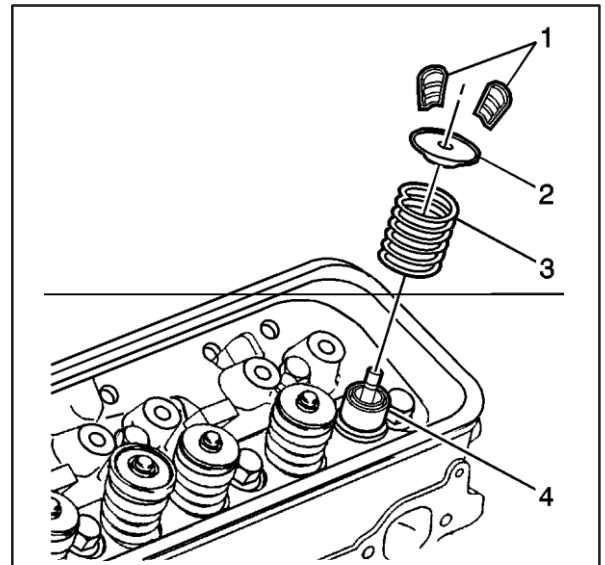
4. Assemble the valve stem oil seal onto the valve stem.

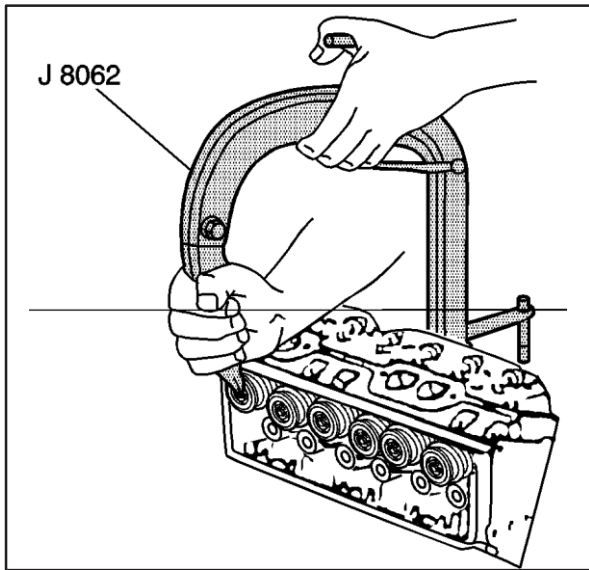
Caution: Refer to Safety Glasses Caution in Cautions and Notices.

5. Install the valve stem oil seal onto the valve guide using the special tool SK69070.
6. Inspect the valve stem oil seal. The valve stem oil seal should not be bottomed against the valve guide.
The distance measured between the top of the seal and the bottom of the head should be between 0.860"-0.900" as shown on the image.



7. Install the valve spring (3).
8. Install the valve spring cap (2) onto the valve spring (3) and over the valve stem.

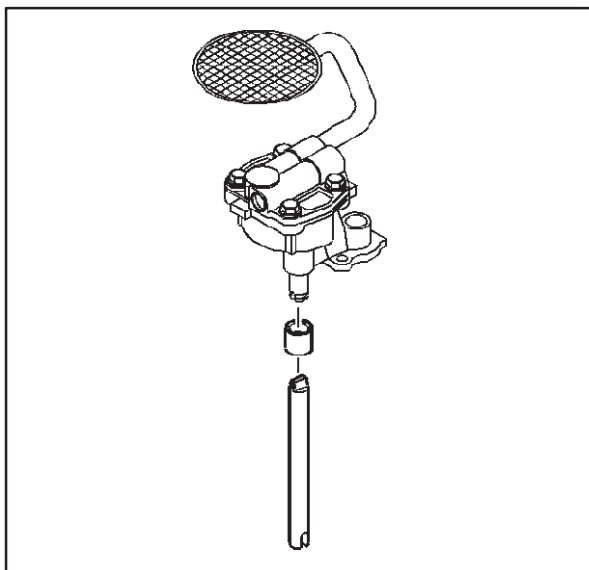




Caution: Compressed valve springs have high tension against the valve spring compressor. Valve springs that are not properly compressed by or released from the valve spring compressor can be ejected from the valve spring compressor with intense force. Use care when compressing or releasing the valve spring with the valve spring compressor and when removing or installing the valve stem keys. Failing to use care may cause personal injury.

Caution: Refer to Safety Glasses Caution in Cautions and Notices.

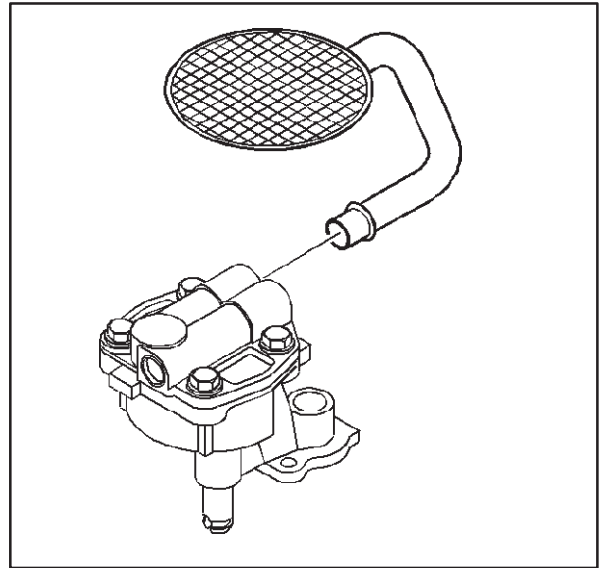
9. Use the J 8062 in order to compress the valve springs.
10. Install the valve stem keys.
 - 10.1 Use grease in order to hold the valve stem keys in place while disconnecting the J 8062.
 - 10.2. Look to ensure that the valve stem keys seat properly in the upper groove of the valve stem.
 - 10.3. Tap the end of the valve stem with a plastic-faced in order to seat the valve stem keys, if necessary.



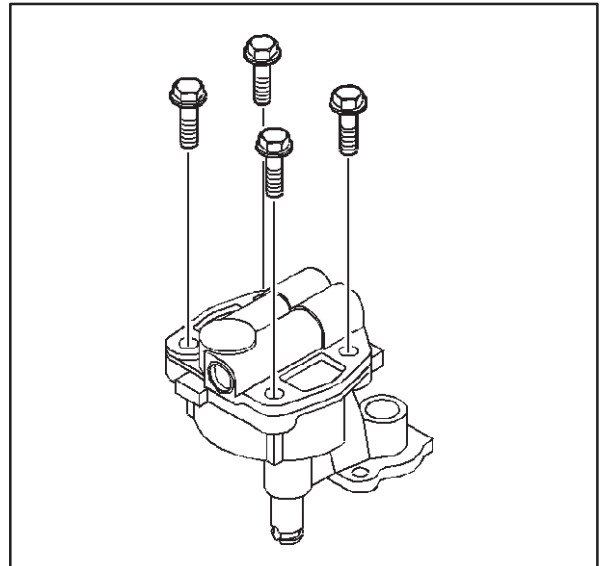
Oil Pump Disassemble

1. Remove the oil pump driveshaft and oil pump driveshaft retainer.

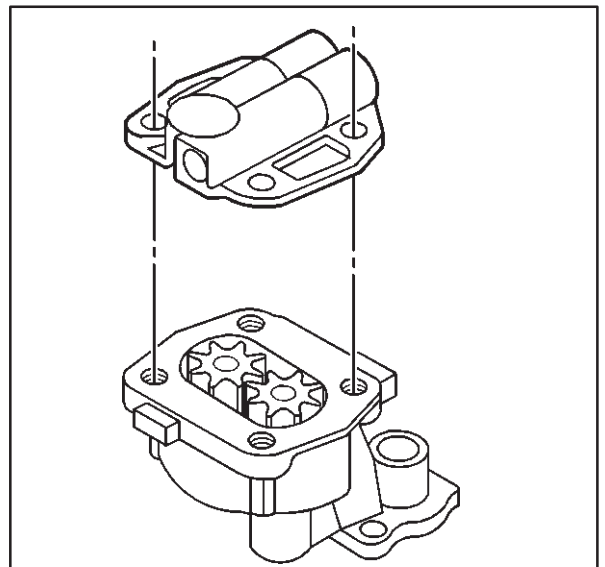
2. Remove the oil pump screen (if necessary).
 - The oil pump screen has a press fit into the oil pump cover.
 - DO NOT remove the oil pump screen from the pipe. The pipe and oil pump screen are serviced as a complete assembly.

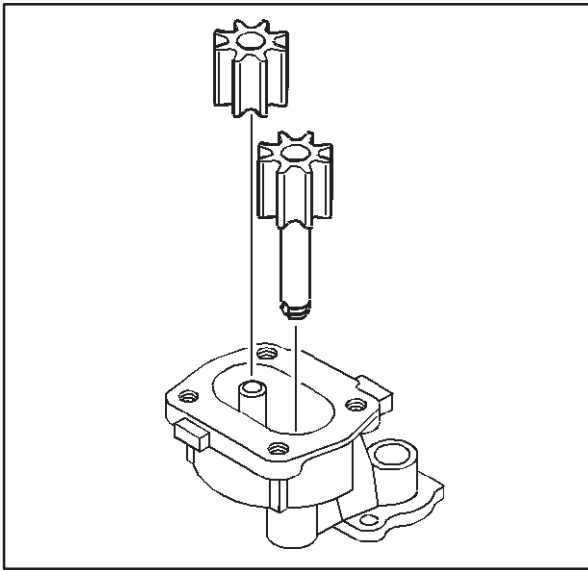


3. Remove the oil pump cover bolts.

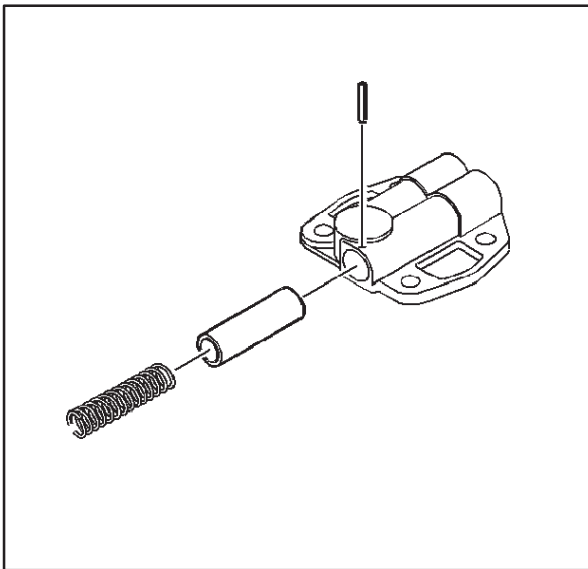


4. Remove the oil pump cover.



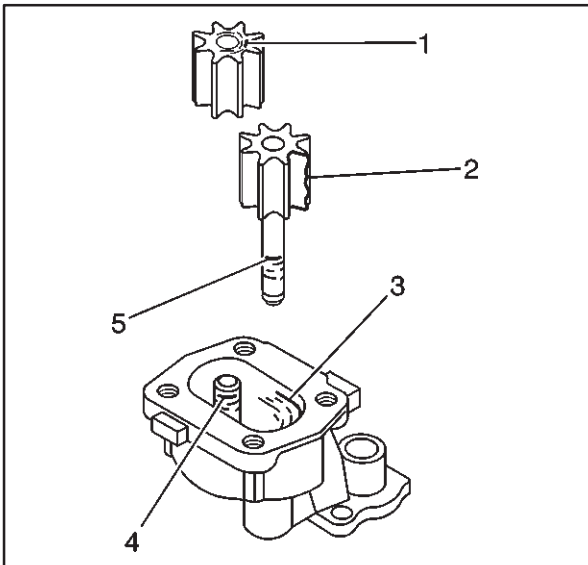


5. Remove the oil pump drive gear and the oil pump driven gear.
6. Matchmark the gear teeth for assembly.



Caution: Refer to Safety Glasses Caution in Cautions and Notices.

7. Remove the following items:
 - 7.1. The oil pump pressure relief valve spring straight pin
 - 7.2. The oil pump pressure relief spring
 - 7.3. The oil pump pressure relief valve



Oil Pump Clean and Inspect

Caution: Refer to Safety Glasses Caution in Cautions and Notices.

1. Clean the oil pump components in cleaning solvent.
 2. Dry the components with compressed air.
3. Inspect the oil pump for the following conditions:
 - Scoring on the top of the gears (1)
 - Damaged gears (2) for the following:
 - Chipping
 - Galling
 - Wear
 - Scoring, damage or casting imperfections to the body (3)
 - Damaged or scored gear shaft (4)
 - Damaged or scored gear shaft (5)

- Damaged bolt hole threads
 - Worn oil pump driveshaft bore
 - Damaged or sticking oil pump pressure relief valve (minor imperfections may be removed with a fine oil stone)
 - Collapsed or broken oil pump pressure relief valve spring
4. If the oil pump is to be reused, install a NEW oil pump pressure relief valve spring.
 5. During oil pump installation, install a NEW oil pump driveshaft retainer.

Oil Pump Assemble

Tools Required

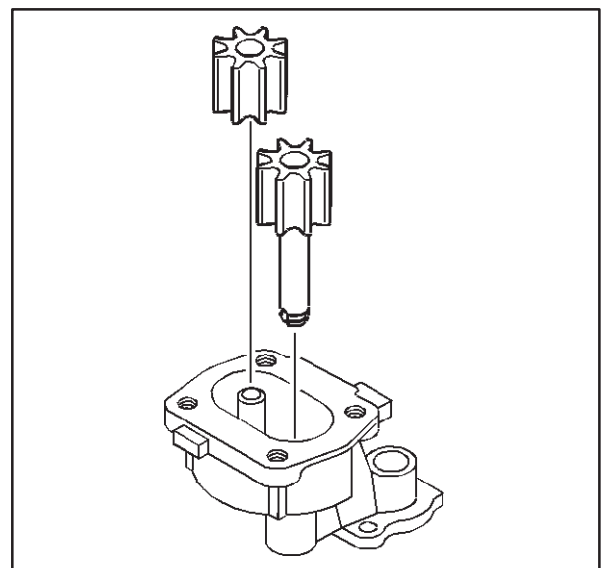
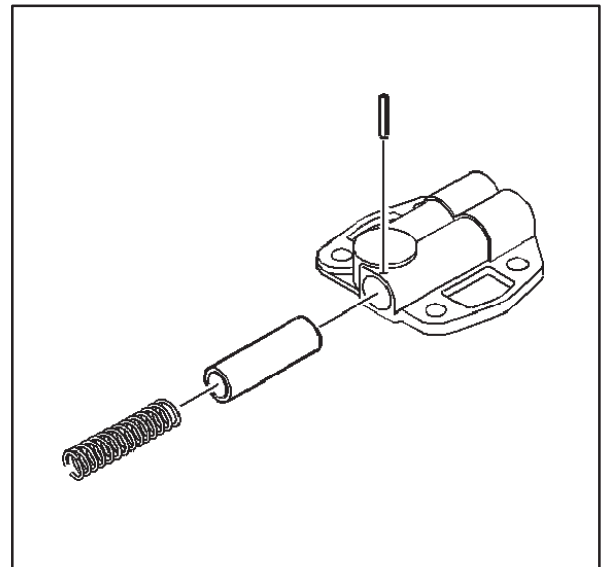
J 21882 Oil Suction Pipe Installer

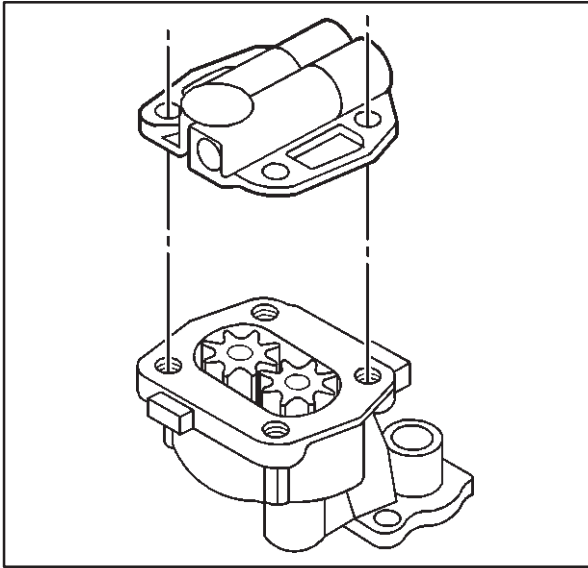
1. Apply clean engine oil GM P/N 12345610 or equivalent to the oil pump pressure relief valve, oil pump pressure relief valve spring and oil pump body.

Caution: Refer to Safety Glasses Caution in Cautions and Notices.

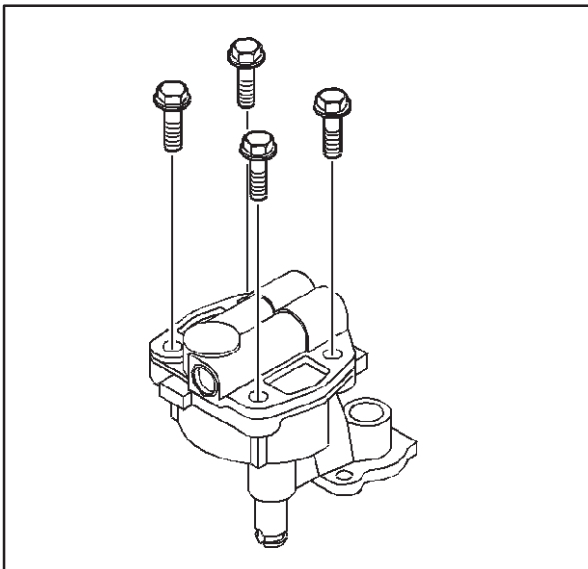
Important: Replace the oil pump pressure relief valve spring when you reuse the oil pump.

2. Install the following items:
 - 2.1. The oil pump pressure relief valve
 - 2.2. The oil pump pressure relief valve spring
 - 2.3. The oil pump pressure relief valve spring straight pin
3. Apply clean engine oil GM P/N 12345610 or equivalent to the oil pump drive gear, the oil pump driven gear and the oil pump body internal surfaces.
4. Install the oil pump drive gear and the oil pump driven gear into the oil pump body.
 - 4.1. Align the matchmarks on the oil pump drive and driven gears.
 - 4.2. Install the smooth side of the oil pump drive and driven gears toward the oil pump cover.





4. Install the oil pump cover.



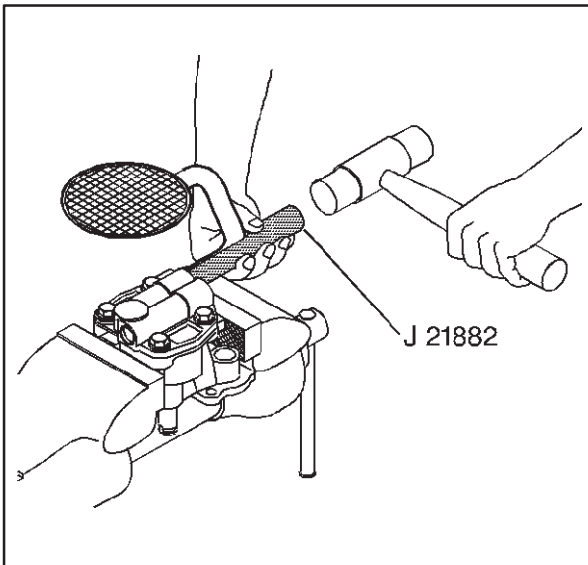
Notice: Refer to *Fastener Notice* in Cautions and Notices.

5. Install the oil pump cover bolts.

Tighten

Tighten the bolts to 12 N•m (106 lb in).

6. Inspect the oil pump for smoothness of operation by turning the oil pump driveshaft by hand.



7. Install the oil pump screen.

- 7.1. If removed, replace the oil pump screen.

The oil pump screen must have a good press fit into the oil pump body.

- 7.2. Mount the oil pump in a soft jawed vise.

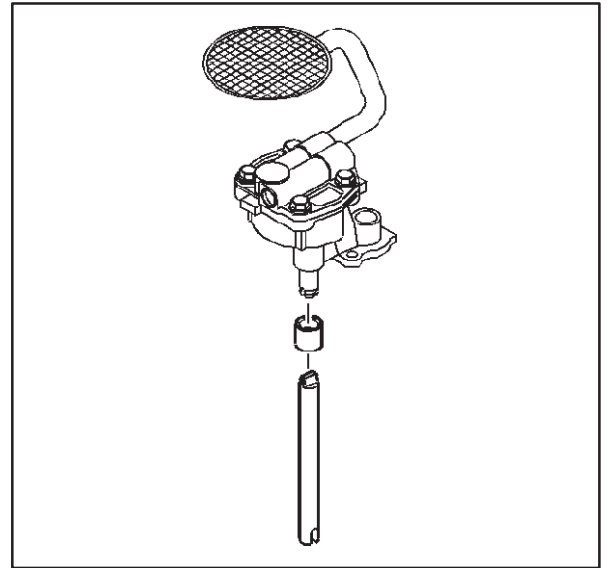
- 7.3. Apply PTFE Thread Sealant or equivalent to the end of the oil pump screen pipe.

- 7.4. Use the J 21882 and a soft-faced hammer in order to tap the oil pump screen into the pump body.

The oil pump screen must align parallel with the bottom of the oil pan when the oil pan is installed.

Important: Install a NEW oil pump driveshaft retainer during assembly.

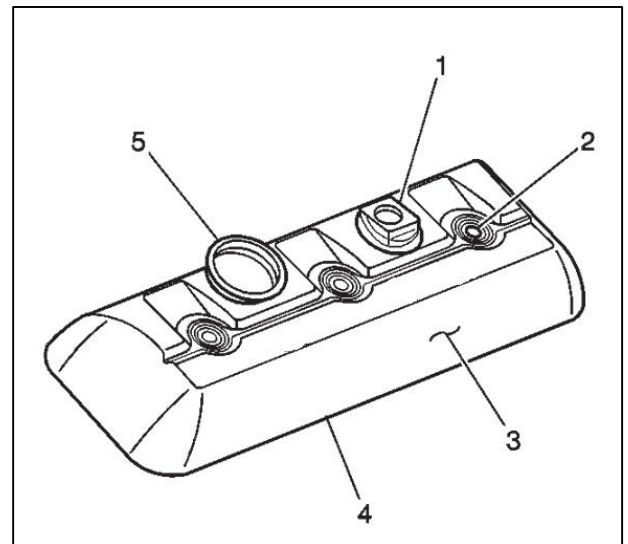
8. Install the oil pump driveshaft and the NEW oil pump driveshaft retainer.

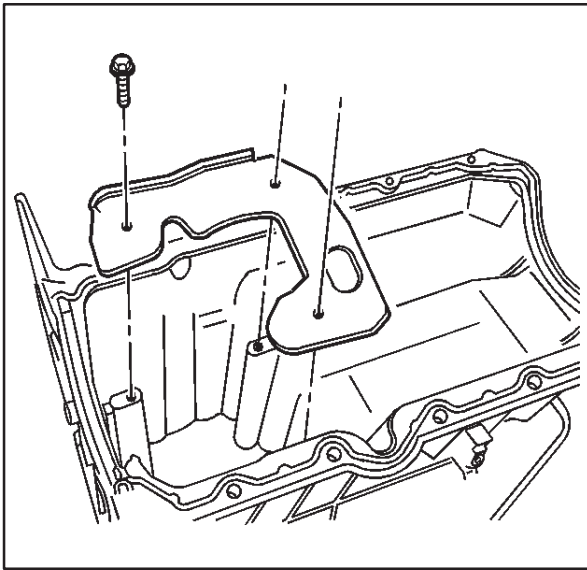


Valve Rocker Arm Cover Clean and Inspect

Caution: Refer to *Safety Glasses Caution in Cautions and Notices*.

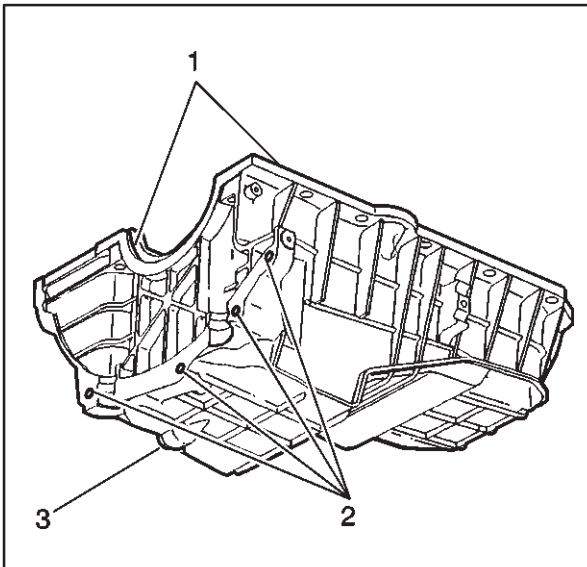
1. Clean the valve rocker arm cover in cleaning solvent.
2. Dry the valve rocker arm cover with compressed air.
3. Inspect the valve rocker arm cover for the following:
 - Damage to the PCV valve grommet (1)
 - Damage to the bolt holes (2)
 - A damaged valve rocker arm cover may interfere with the valve rocker arms.
 - Damage to the exterior of the valve rocker arm cover (3)
 - Gouges or damage to the sealing surface (4)
 - Damage to the oil fill tube grommet (5)
 - Restrictions to the ventilation system passages





Oil Pan Clean and Inspect

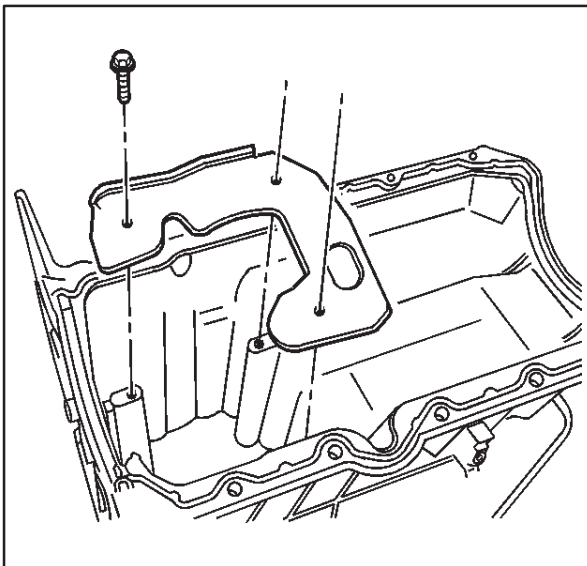
1. Remove the oil pan baffle bolts and the oil pan baffle.



Caution: Refer to *Safety Glasses Caution in Cautions and Notices*.

2. Clean the oil pan and the oil pan baffle in cleaning solvent.
3. Dry the oil pan and the oil pan baffle with compressed air.
4. Inspect the oil pan for the following:
 - Gouges or damage to the oil pan sealing surfaces (1)
 - Damage to the threaded holes (2)
 - Damaged oil pan drain hole threads (3)
 - Damage to the oil pan baffle
 - Damage to the exterior of the oil pan

A damaged oil pan may interfere with the proper position of the oil pump screen, or may not distribute oil properly in the oil pan sump area.



Notice: Refer to *Fastener Notice* in Cautions and Notices.

5. Install the oil pan baffle and the bolts.

Tighten

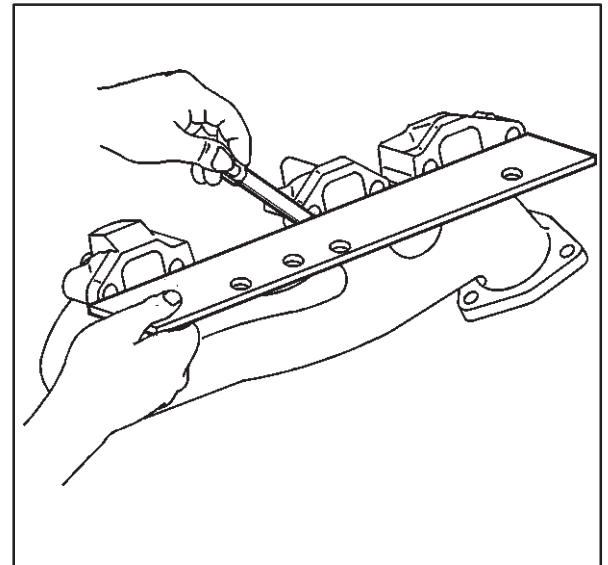
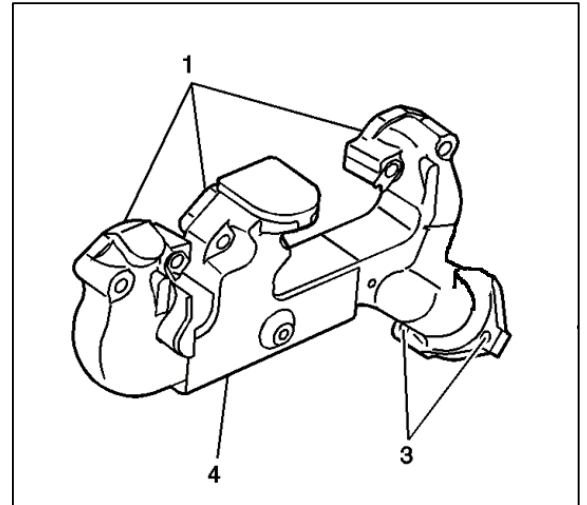
Tighten the oil pan baffle bolts to 12 N•m (106 lb in).

Exhaust Manifold Clean and Inspect

Caution: Refer to *Safety Glasses Caution in Cautions and Notices*.

1. Clean the exhaust manifolds in cleaning solvent.
2. Dry the components with compressed air.
3. Inspect the exhaust manifolds for the following:
 - Damage to the gasket sealing surfaces (1)
 - Damage to the threaded holes (3)
 - Restrictions within exhaust passages
 - Broken or damaged exhaust manifold heat shields (4) (if applicable)
 - Broken or damaged exhaust manifold
4. Measure the alignment or surface flatness of the exhaust manifold flanges using a straight edge and a feeler gauge. Refer to *Engine Mechanical Specifications*.

If the surface flatness is not within the specifications, the exhaust manifold is warped and must be replaced.



Water Pump Clean and Inspect

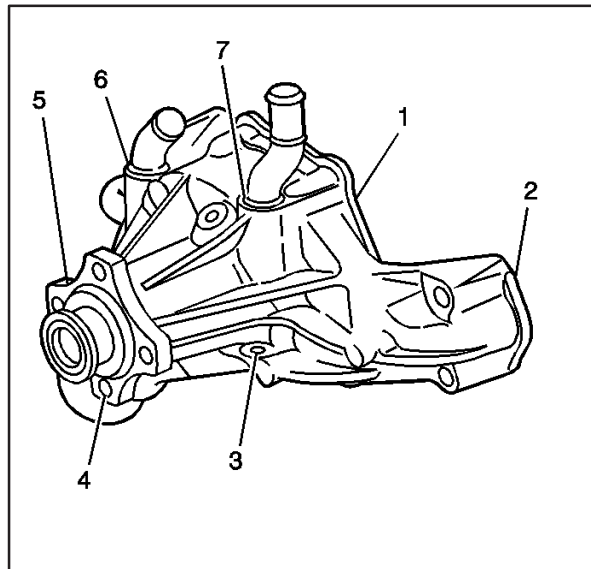
Caution: Refer to Safety Glasses

Caution in Cautions and Notices.

1. Remove all the old gasket material from the water pump sealing surfaces.
2. Clean all the dirt and any debris from the water pump.
3. Inspect the water pump for the following:
 - Leakage or damage to the housing cover or gasket (1)
 - Excessive scratches or gouging

To the gasket sealing surfaces (2)

- Leakage from the water pump vent hole (3)
A stain around the vent hole is acceptable. If leakage occurred (dripping) with the engine operating and the cooling system pressurized, then replace the water pump.
- Damaged bolt hole threads (4)
- Excessive side-to-side movement of the water pump shaft (5)
- Leakage around the water inlet pipe (6)
- Leakage around the heater hose pipe (7)
- Restrictions within the internal coolant passages



Thread Repair

General purpose thread repair kits are available commercially.

Caution: Refer to *Safety Glasses Caution in Cautions and Notices*.

Important: Refer to the thread repair kit manufacturer's instructions regarding the size of the drill and which tap to use.

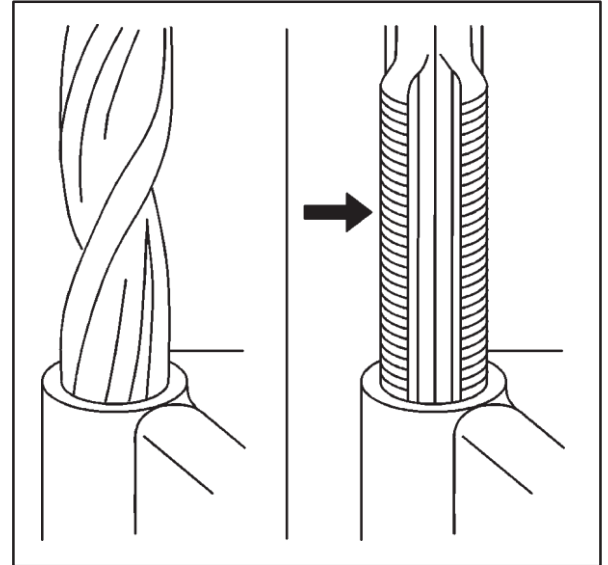
Always avoid any buildup of chips. Back out the tap every few turns and remove the chips.

Determine the size, the pitch and the depth of the damaged thread.

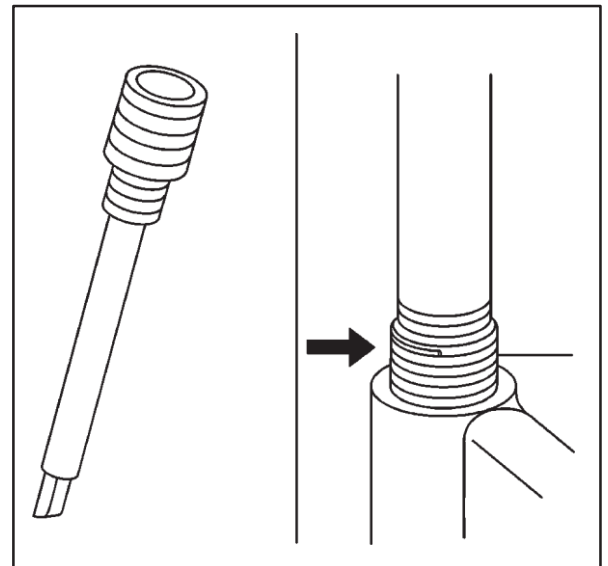
1. Adjust the stop collars on the cutting tool as needed. Tap the stop collars to the required depths.
2. Drill out the damaged thread.
3. Remove the chips.
4. Apply clean engine oil to the top thread.
5. Use the tap in order to cut new thread.
6. Clean the thread.
7. Screw the thread insert onto the mandrel of the thread insert installer. Engage the tang of the thread insert onto the end of the mandrel.

Important: The thread insert should be flush to 1 turn below the surface.

8. Lubricate the thread insert with clean engine oil (except when installing in aluminum) and install the thread insert.
9. If the tang of the thread insert does not break off when backing out the thread insert installer, break off the tang using a drift punch.



4962

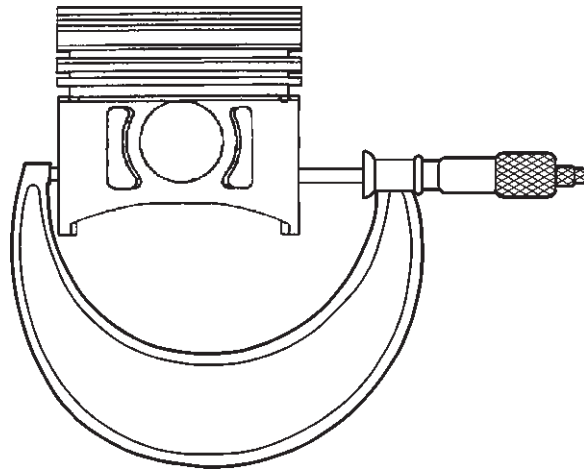


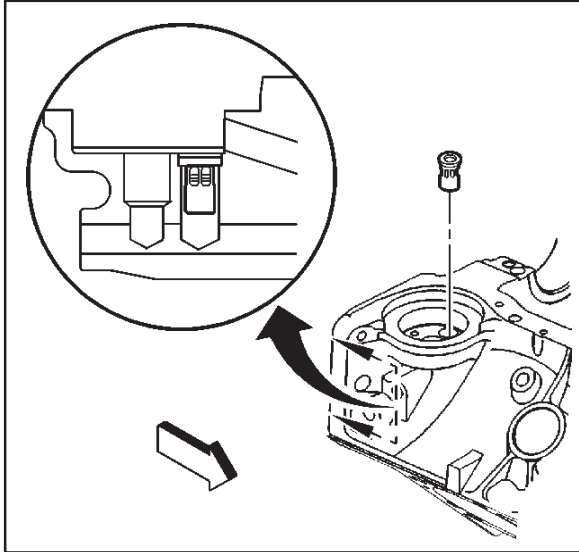
4963

Service Prior to Assembly

- Dirt will cause premature wear of the rebuilt engine. Clean all the components.
- Use the proper tools to measure the components when checking for excessive wear. Components not within the manufacturer's specification must be repaired or replaced.
- When the components are re-installed into an engine, return the components to the original location, position and direction.
- During assembly, lubricate all the moving parts with clean engine oil (unless otherwise specified). The engine oil will provide the initial lubrication when the engine is first started.

**This page
intentionally left
blank**





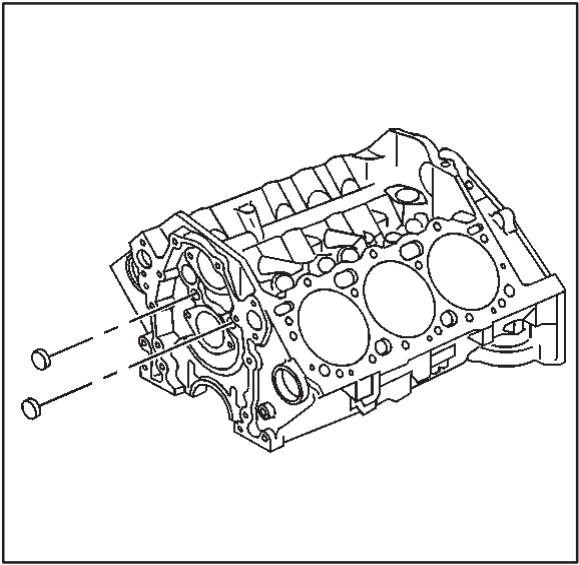
Engine Block Plug Installation

Tools Required

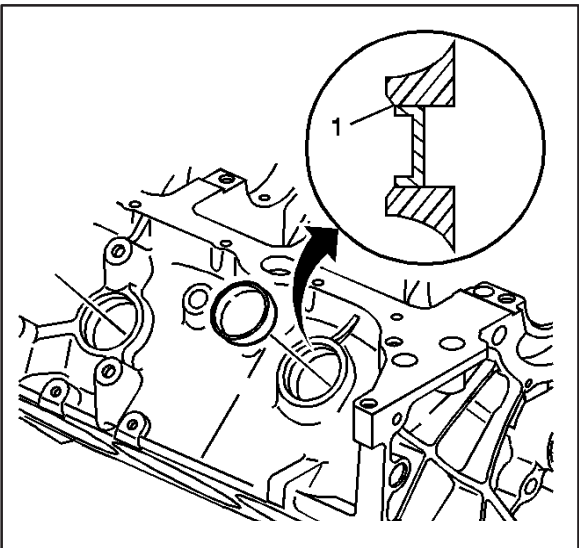
J 41712 Oil Pressure Switch Socket

Caution: Refer to Safety Glasses Caution in Cautions and Notices.

1. Install a NEW oil filter bypass valve.
 - Install the oil filter bypass valve into the oil gallery bore until slightly below flush with the surface of the engine block.
 - Using a pointed punch, stake the engine block area around the oil filter bypass valve.

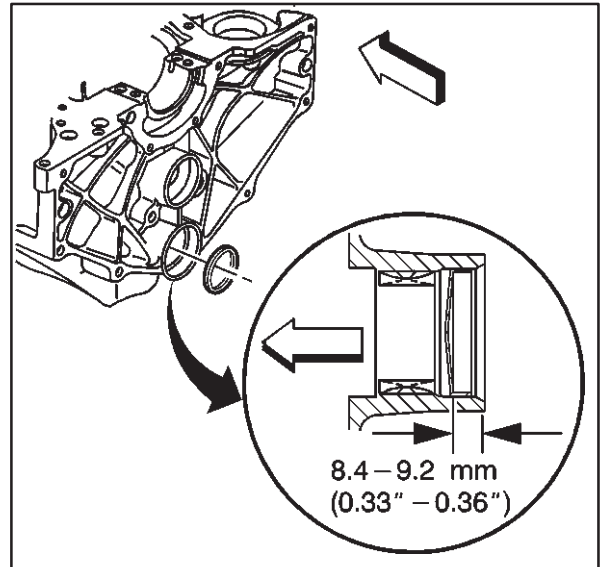


2. Apply Green Locktite or equivalent to the outside diameter of the NEW front engine oil gallery plugs.
3. Install the NEW front engine block oil gallery plugs. A properly installed front engine oil gallery plug must be installed slightly below flush with the front face of the engine block.



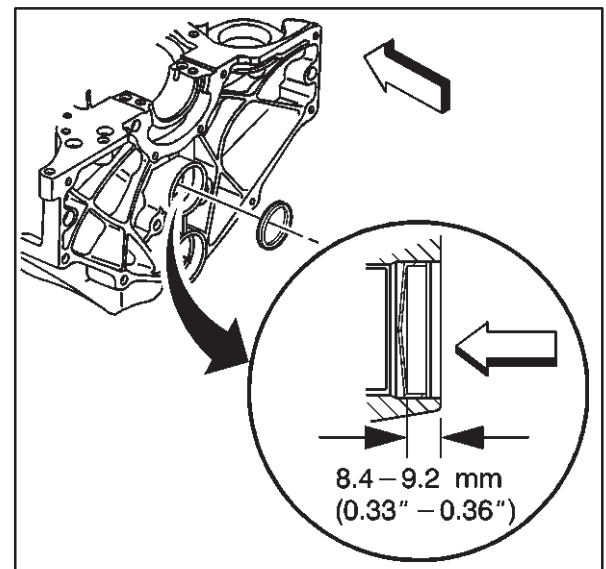
4. Apply Aviation Form-A-Gasket Liquid Sealant or equivalent to the outside diameter of the NEW engine block core hole plugs.
5. Install the NEW engine block core hole plugs. A properly installed engine block core hole plug must be installed flush with the bottom of the chamfer (1) of the engine block core hole.

6. Apply Green LockTite or equivalent to the outside diameter of the NEW expansion cup plug (balance rear bearing hole).
7. Install the NEW expansion cup plug (balance shaft rear bearing hole).



8. Apply Aviation Form-A-Gasket Liquid Sealant or equivalent to the outside diameter of the NEW expansion cup plug (camshaft rear bearing hole).

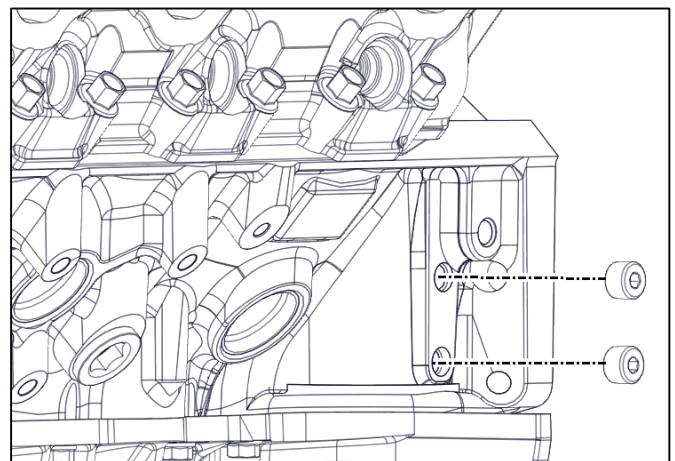
9. Install the NEW expansion cup plug (camshaft rear bearing hole).

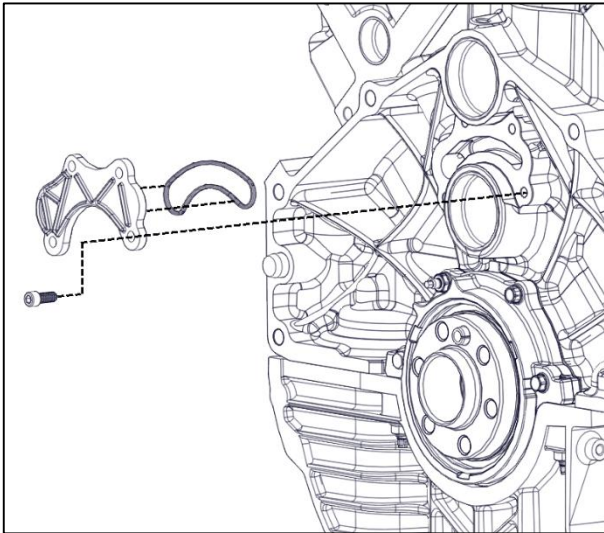


10. Apply PTFE Sealant or equivalent to the threads of the engine block left side oil gallery plug. Located above oil filter housing.

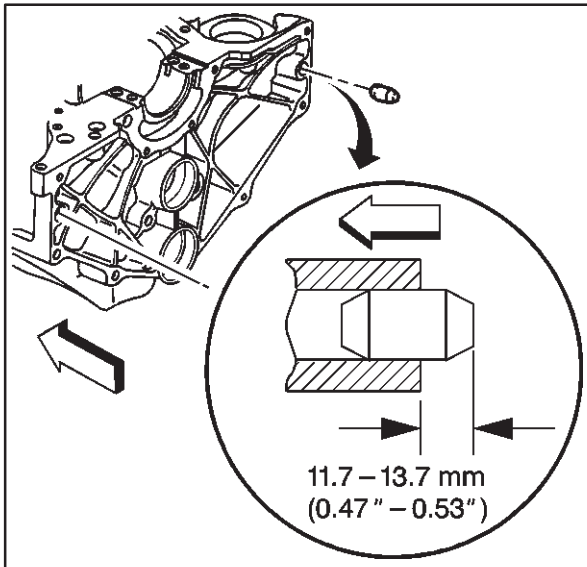
Tighten

Tighten the engine block left rear oil gallery plug to 150 in lbs Plus 3/4 turn.

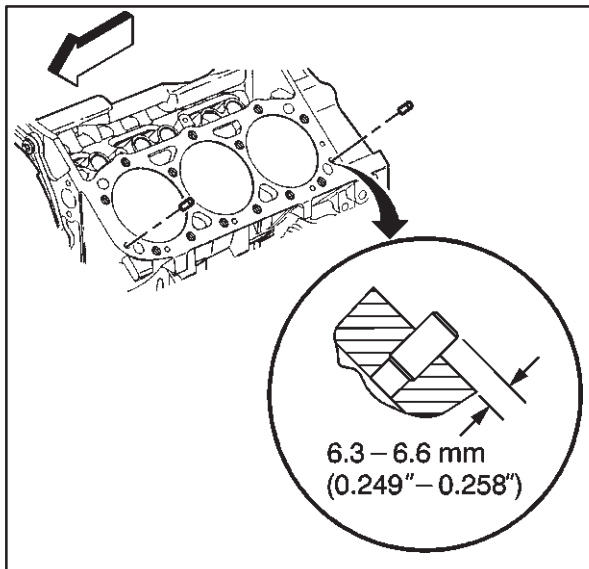




11. Tighten 4 rear crossover cover bolts to 96 in lbs. Ensure the O-ring is fully seated and does not move or get pinched during install.

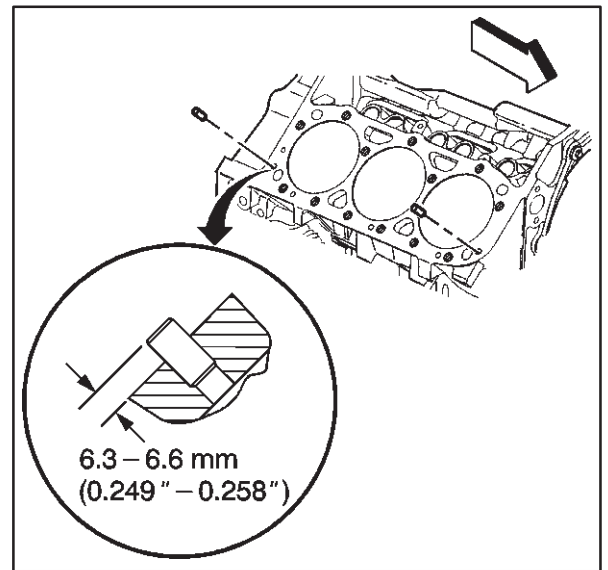


12. Install the dowel straight pins (if required). Ensure tapered end is facing outward.



13. Install the left side dowel pins (cylinder head locator).

14. Install the right side dowel pins (cylinder head locator).

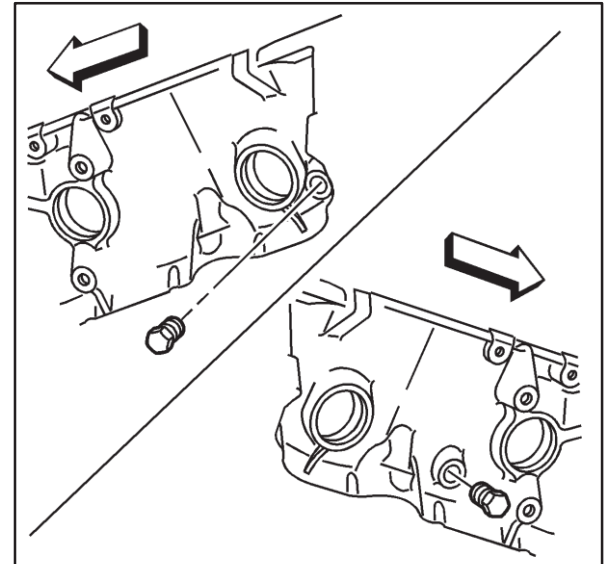


15. Apply PTFE Sealant or equivalent to the threads of the engine block coolant drain hole plugs.

16. Install the engine block coolant drain hole plugs.

Tighten

Tighten the engine block coolant drain hole plugs to 22 Ft. Lbs plus ½ turn.



17. If reusing the engine oil pressure sensor fitting, apply PTFE sealant or equivalent to the threads of the engine oil pressure sensor fitting.

Important: Do not loosen the engine oil pressure fitting after the initial torque has been obtained.

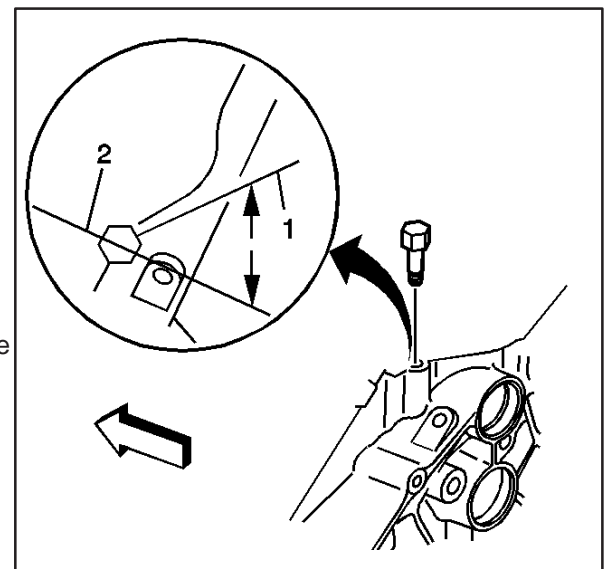
18. Install the engine oil pressure sensor fitting.

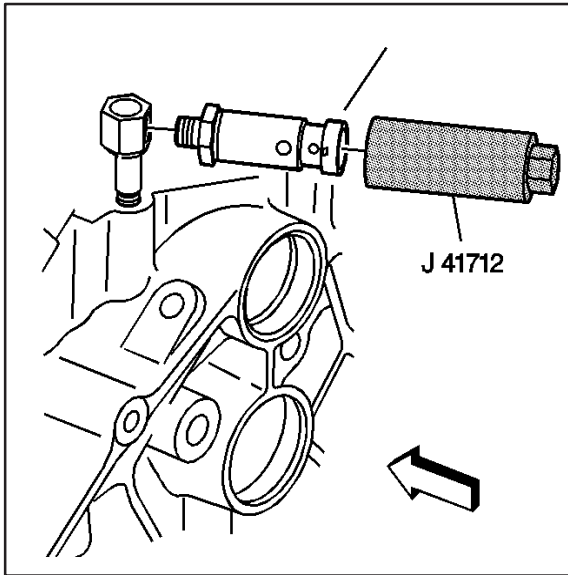
Tighten

Tighten the engine oil pressure sensor fitting to 15 N•m (11 lb ft.).

Important: Do not rotate the engine oil pressure fitting clockwise more than 359 degrees after the initial torque has been obtained.

19. Rotate the engine oil pressure sensor fitting clockwise to the proper position (1), 50 degrees from the centerline (2). Roughly the 4 O'clock Position.

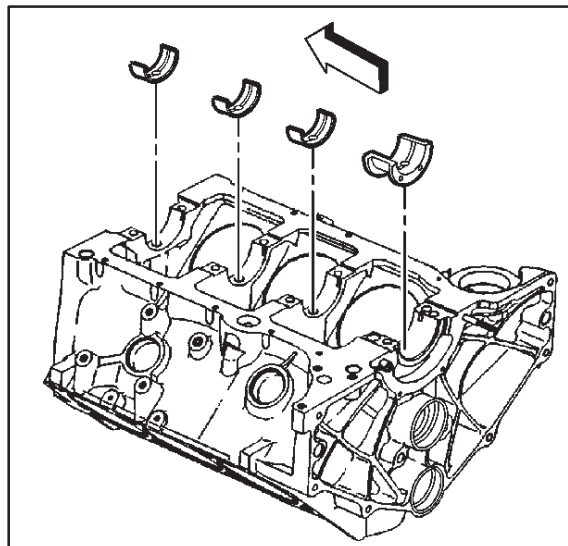




20. If reusing the engine oil pressure gauge sensor, apply PTFE sealant or equivalent to the threads of the engine oil pressure gauge sensor.
21. Install the engine oil pressure gauge sensor using the J 41712.

Tighten

Tighten the engine oil pressure gauge sensor to 30 N•m (22 lb ft.).



Crankshaft and Bearings Installation

Tools Required

J 36660 Electronic Torque Angle Meter

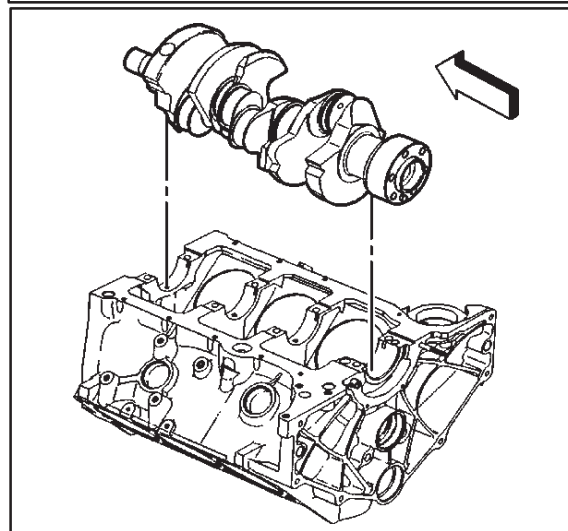
1. Install the crankshaft bearings into the engine block.

Align tang on the bearing to the keyway in the block. Ensure bearings are even across the top of the block.

2. Apply engine assembly lubricant on the main bearings.

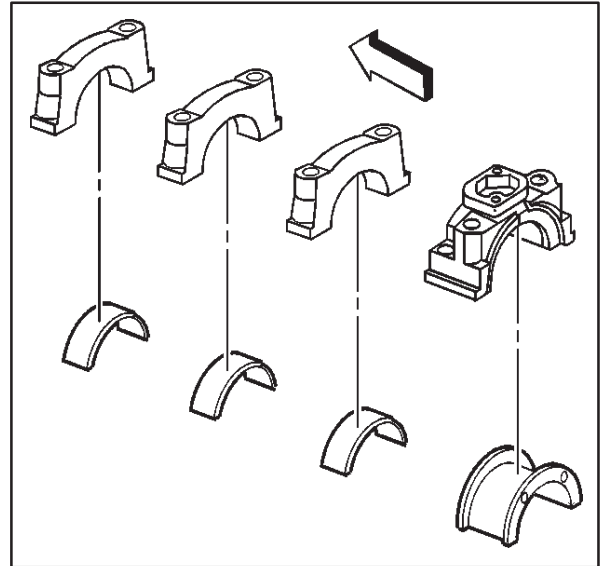
3. Apply clean engine oil to the crankshaft bearing journals.

4. Gently install the crankshaft into the crankshaft journals.



5. Install the crankshaft bearings into the crankshaft bearing caps. Align the tang on the bearing to the keyway in the main caps. Be sure the bearing is flat along the top of the main cap. Apply engine assembly lubricant to the bearings in the main cap bearings.

6. Apply clean engine oil to the crankshaft bearings.



7. Install the crankshaft bearing caps in the original position and with the arrow on the crankshaft bearing caps in the direction of the front of the engine block.

Notice: Refer to *Fastener Notice* in Cautions and Notices.

8. Install the crankshaft bearing cap bolts until snug.

9. Thrust the crankshaft rearward in order to set and align the crankshaft thrust bearings and the crankshaft bearing caps.

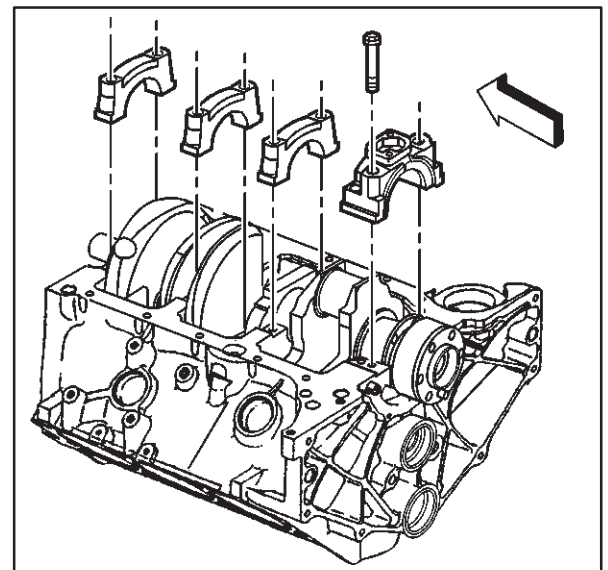
10. Thrust the crankshaft forward in order to align the rear faces of the crankshaft thrust bearings.

11. Tighten the crankshaft bearing cap bolts.

Tighten

Tighten the crankshaft bearing cap bolts on the first pass to 20 N•m (15 lb ft.).

Tighten the crankshaft bearing cap bolts on the final pass an additional 73 degrees using the J 36660.

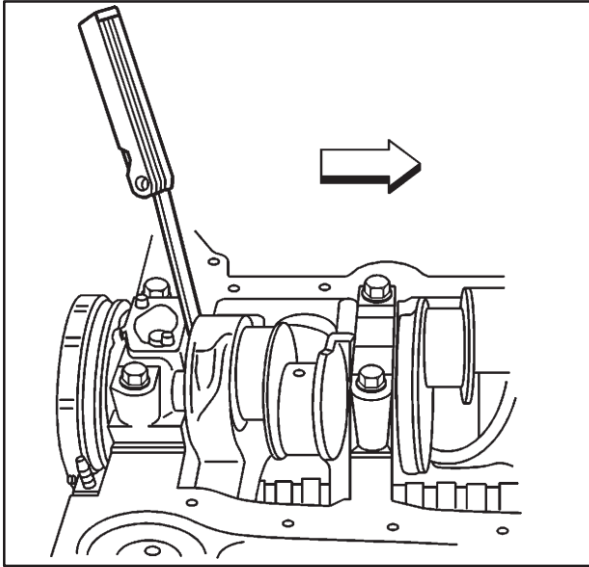


12. Measure the crankshaft end play.

Firmly thrust the crankshaft rearward, and then forward.

This will align the crankshaft rear bearing thrust surfaces.

With the crankshaft pushed forward, insert a feeler gauge between the crankshaft and the crankshaft rear bearing thrust surface to measure the clearance.



Specification

Crankshaft end play 0.05-0.20 mm (0.001-0.0089 in)

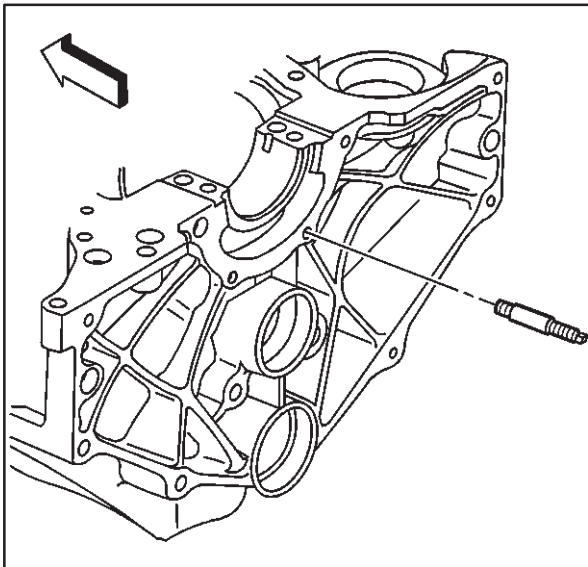
13. Rotate the crankshaft in order to check for binding.

A bent crankshaft or lack of proper crankshaft bearing clearance may cause binding.

14. If the crankshaft does not turn freely, loosen the crankshaft bearing cap bolts on 1 crankshaft bearing cap at a time in order to determine the location of the binding.

A lack of proper crankshaft bearing clearance may be caused by the following:

- Burrs on the crankshaft bearing cap
- Foreign material between the crankshaft bearing and the engine block
- Foreign material between the crankshaft bearing and the crankshaft bearing cap
- Damaged crankshaft bearing
- Improper size crankshaft bearing



Crankshaft Rear Oil Seal and Housing Installation

Tools Required

J 35621-B Rear Main Seal Installer

Notice: Refer to *Fastener Notices* in Cautions and Notices.

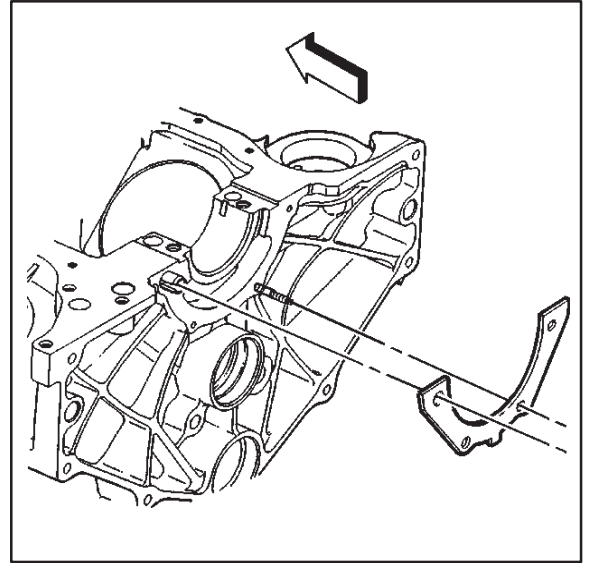
1. Install the crankshaft rear oil seal housing retainer stud.

Tighten

Tighten the crankshaft rear oil seal housing retainer stud to 6 N•m (53 lb in).

Important: Always use a NEW crankshaft rear oil seal housing gasket when installing the crankshaft rear oil seal housing.

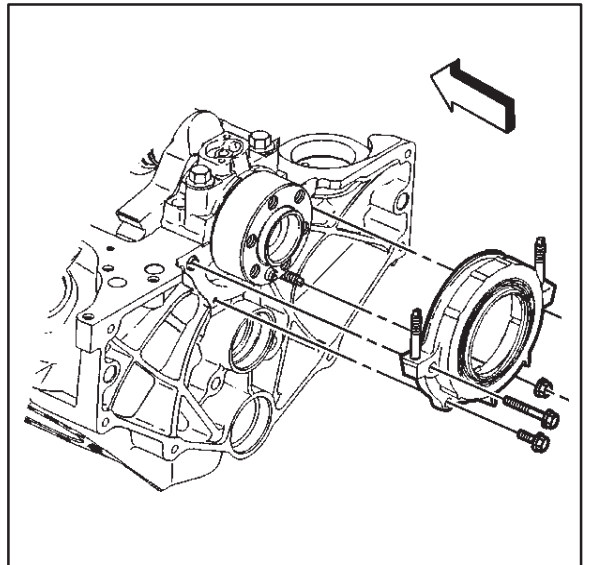
2. Install the NEW crankshaft rear oil seal housing gasket.



3. Install the crankshaft rear oil seal housing onto the crankshaft rear oil seal housing retainer stud.
4. Install the crankshaft rear oil seal housing nut and bolts.

Tighten

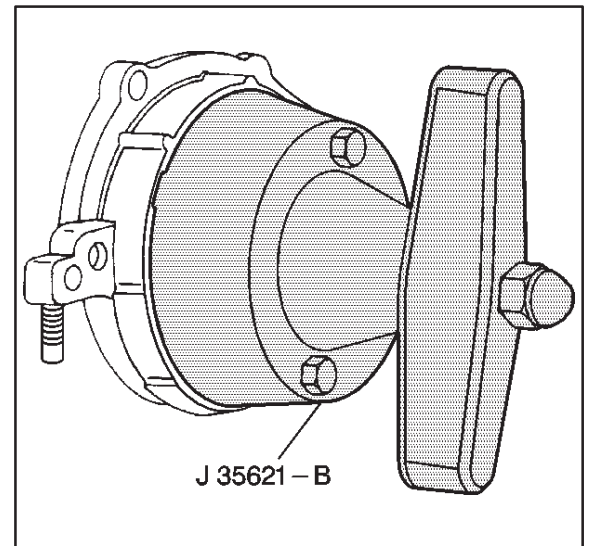
Tighten the crankshaft rear oil seal housing nut and bolts to 12 N•m (106 lb in).



5. Apply a small amount (2 to 3 drops) of clean engine oil to the bore of the crankshaft rear oil seal housing.
6. Apply a small amount (2 to 3 drops) of clean engine oil to the outside diameter of the engine flywheel pilot flange.
7. Apply a small amount (1 drop) of clean engine oil to the outside diameter of the flywheel locator pin.
8. Apply a small amount (2 to 3 drops) of clean engine oil to the crankshaft seal surface.
9. Inspect the J 35621-B flange for imperfections that may damage the crankshaft rear oil seal.

Minor imperfections may be removed with a fine grade emery cloth.

Important: DO NOT allow oil or any other lubricants to contact the seal lip of the crankshaft rear oil seal.



-
10. Remove the sleeve from the crankshaft rear oil seal.
 11. Apply a small amount (2 to 3 drops) of clean engine oil to the outside diameter of the crankshaft rear oil seal.
 12. Install the crankshaft rear oil seal onto the J 35621-B.
 13. Install the J 35621-B onto the rear of the crankshaft and hand tighten the tool bolts until snug.

Notice: Proper alignment of the crankshaft rear oil seal is critical. Install the crankshaft rear oil seal near to flush and square to the crankshaft rear oil seal housing. Failing to do so may cause the crankshaft rear oil seal or the crankshaft rear oil seal installation tool to fail.

14. Install the crankshaft rear oil seal onto the crankshaft and into the crankshaft rear oil seal housing.
 - 14.1. Turn the J 35621-B wing nut clockwise until the crankshaft rear oil seal is installed near to flush and square to the crankshaft rear oil seal housing.

Increased resistance will be felt when the crankshaft rear oil seal has reached the bottom of the crankshaft rear oil seal housing bore.
 - 14.2. Turn the J 35621-B wing nut counterclockwise to release the J 35621-B from the crankshaft rear oil seal.
15. Remove the J 35621-B from the crankshaft.
16. Wipe off any excess engine oil with a clean rag.

Piston, Connecting Rod and Bearing Installation

Piston

Selection Tools

Required

J 8087 Cylinder Bore Gauge

J 5239 Connecting Rod Bolt Guide Set

J 8037 Ring Compressor

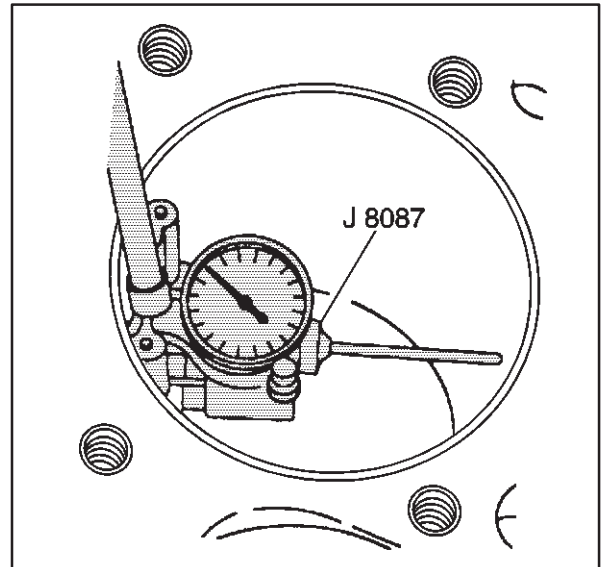
J 36660 Electronic Torque Angle Meter

Important: Measurements of all components should be taken with the components at normal room temperature.

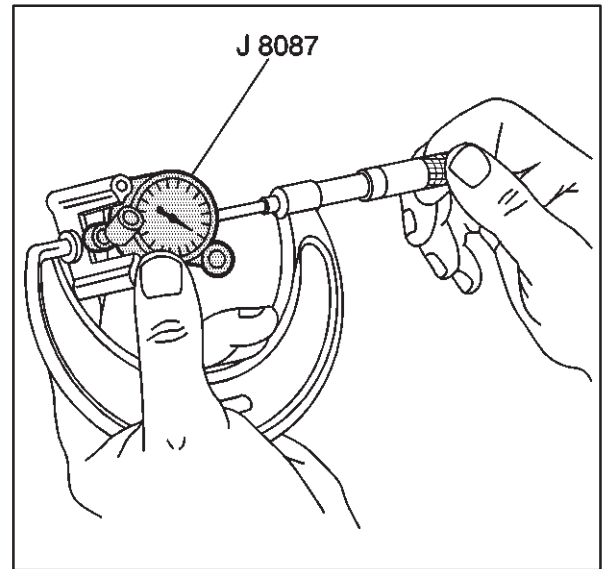
For proper piston fit, the engine block cylinder bores should not have excessive wear or taper.

A used piston and piston pin set may be reinstalled if, after cleaning and inspection, the piston and piston pin are within specifications.

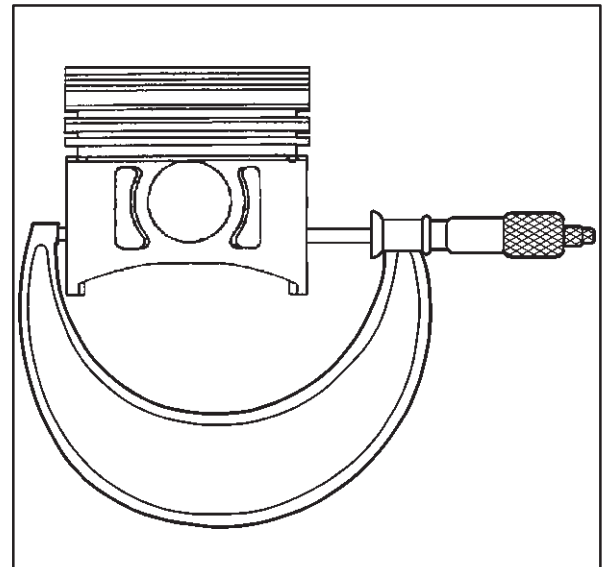
1. Use the *J 8087* in order to measure the cylinder bore diameter. Measure at a point 64 mm (2.5 in) from the top of the cylinder bore and 90 degrees to the crankshaft centerline.

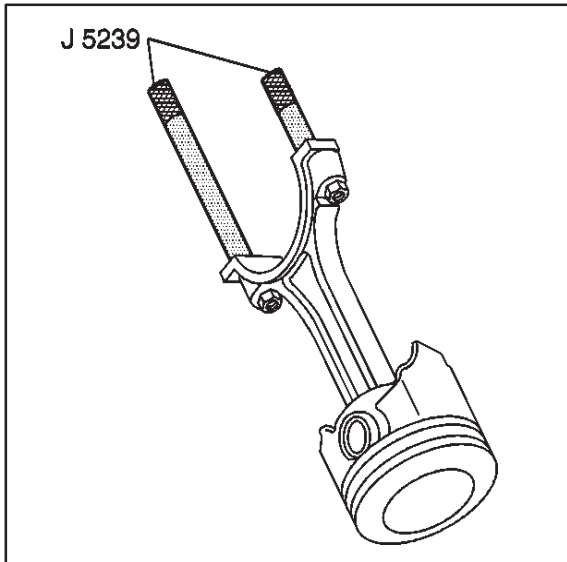


2. Measure the J 8087 with a micrometer and record the reading.



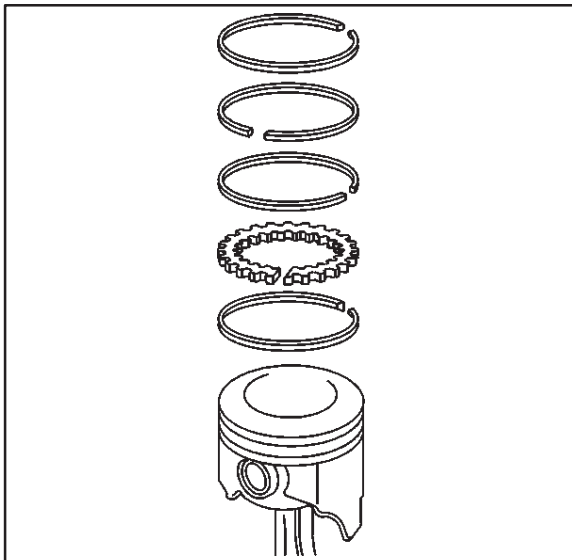
3. With a micrometer or caliper at a right angle to the piston pin bore, measure the piston 11 mm (0.433 in) from the bottom of the skirt.
4. Subtract the piston diameter from the cylinder bore diameter in order to determine piston-to-bore clearance. Refer to *Engine Mechanical Specifications*.
5. If the proper clearance cannot be obtained, then select another piston and measure the clearances.
If the proper fit cannot be obtained, the cylinder bore may require honing or boring.
6. When the piston-to-cylinder bore clearance is within specifications, permanently mark the top of the piston for installation into the proper cylinder.





Installation Procedure

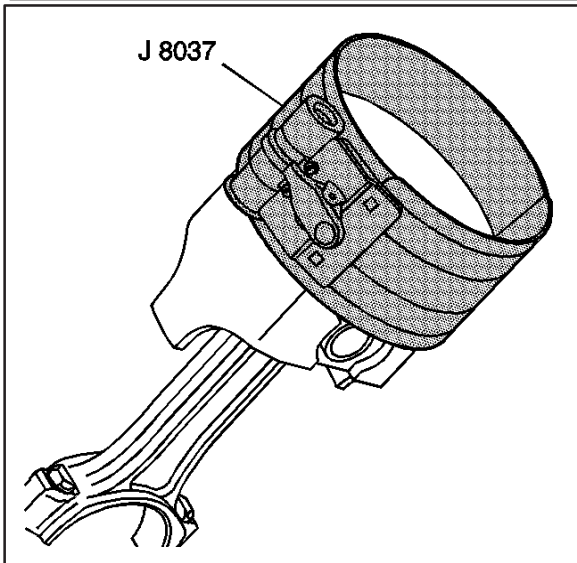
1. Apply Engine Assembly Lubricant to the following components:
 - The piston
 - The piston rings
 - The cylinder bore
 - The bearing surfaces
2. Install the J 5239 onto the connecting rod bolts.



3. With the piston facing upright install the piston rings in the following order.

Notice: Align rings on piston as shown in picture prior to installing piston assembly in block.

1. Lower oil control spacer ring
2. Oil control ring
3. Upper oil control spacer ring
4. Lower compression piston ring Ensure
5. Upper compression piston ring

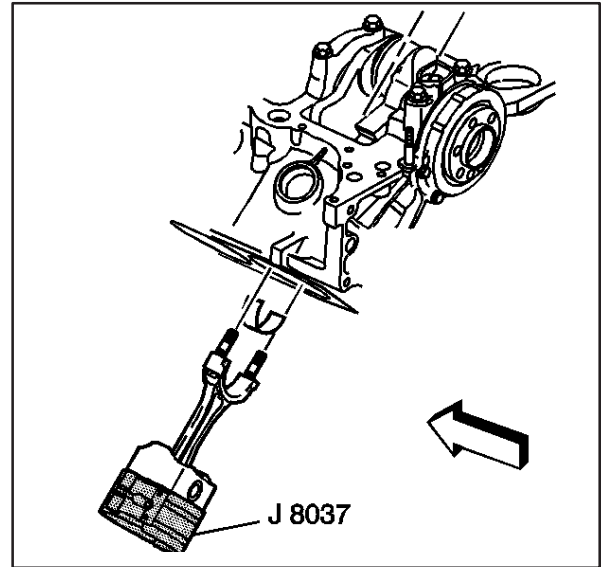


4. Install the J 8037 onto the piston and compress the piston rings.

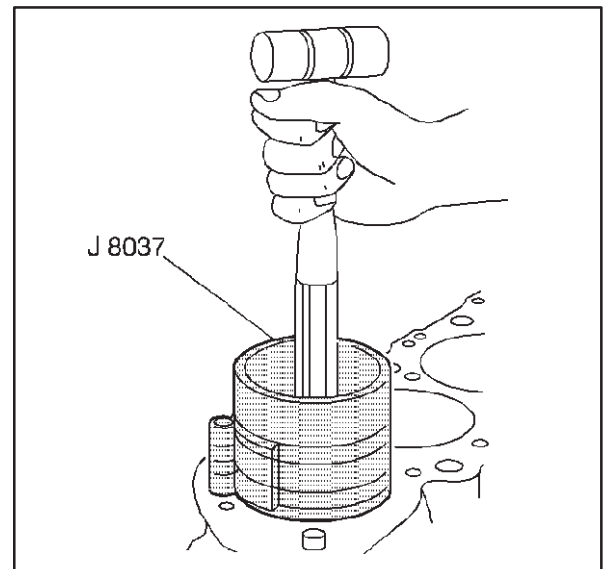
Important: The mark on the top of the piston must face the front of the engine block.

When assembled, the flanges on the connecting rod and connecting rod cap should face to the front of the engine block on the left bank, and to the rear of the engine block on the right bank.

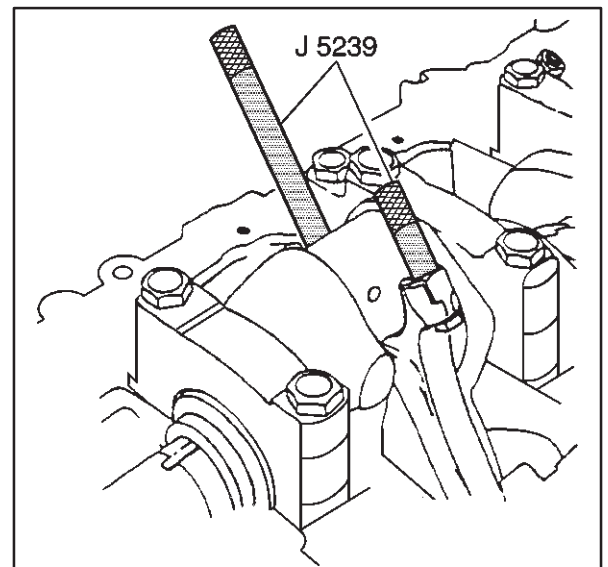
5. Apply a thin even coat of clean motor oil on piston skirt.
6. Install the piston and connecting rod assembly, and the J 8037 into the proper cylinder bore.

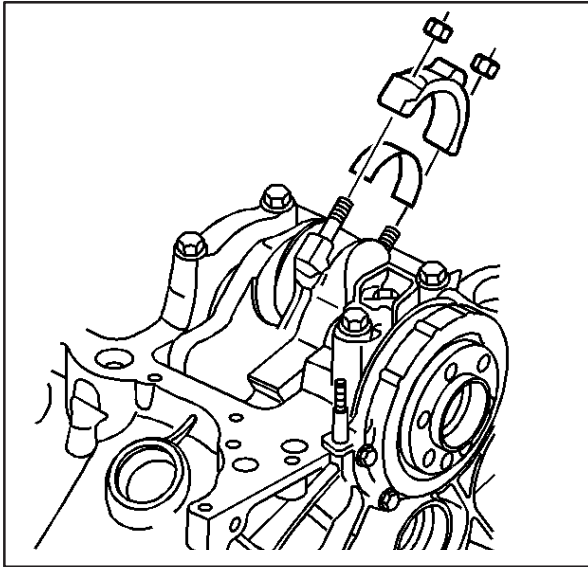


7. Use the J 8037 and the J 5239 and lightly tap the top of the piston with a wooden hammer handle.
Hold the J 8037 firmly against the engine block until all of the piston rings have entered the cylinder bore.
Use the J 5239 in order to guide the connecting rod onto the crankshaft journal.



8. Remove the J 5239





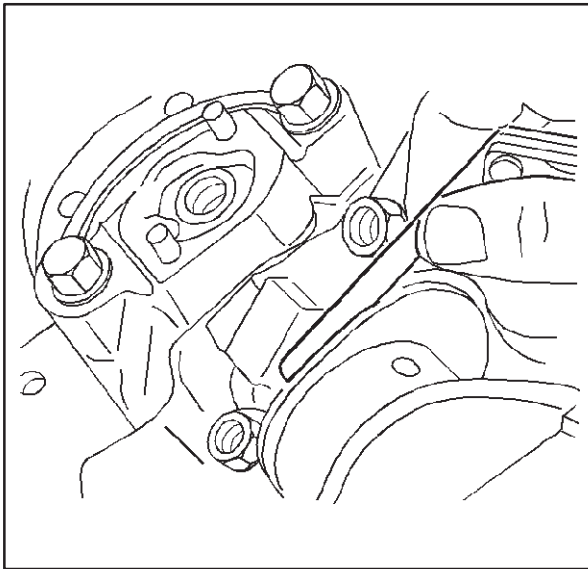
Notice: Refer to *Fastener Notice* in Cautions and Notices.

9. Install the connecting rod caps, bearings and nuts.

Tighten

Tighten the nuts evenly on the first pass to 27 N•m (20 lb ft.).

Use the J 36660 in order to tighten the nuts on the final pass an additional 70 degrees.



10. After the piston and connecting rod assemblies have been installed, then lightly tap each connecting rod assembly (parallel to the crankpin) in order to ensure that the connecting rods have side clearance.
11. Use a feeler gauge or a dial indicator to measure the connecting rod side clearance between the connecting rod caps. The connecting rod side clearance should be 0.15- 0.44 mm (0.006-0.017 in).

Camshaft Installation

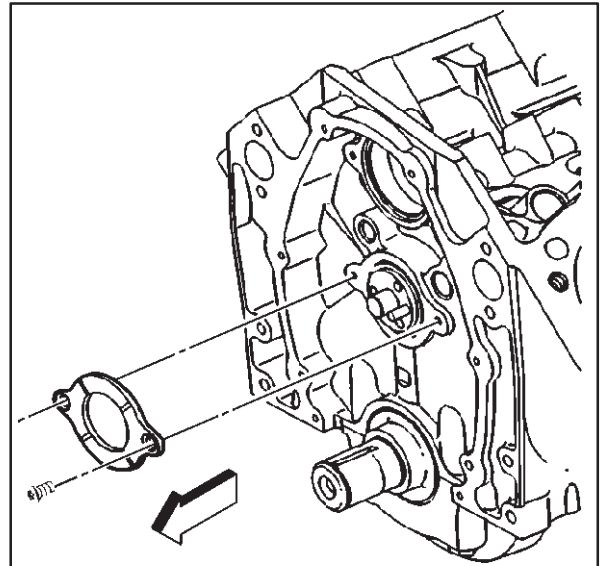
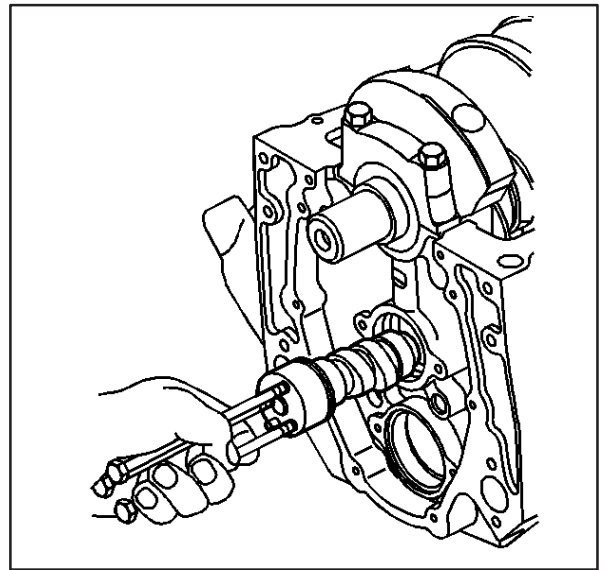
1. Apply clean engine oil, to the following components:
 - The engine camshaft lobes
 - The camshaft bearing journals
 - The camshaft bearingsUse Clevite Gear Lubricant or equivalent on oil pump gear
2. Install three 5/16-18 x 4.0 in. bolts into the engine camshaft front bolt holes.

Notice: All camshaft journals are the same diameter, so care must be used in removing or installing the camshaft to avoid damage to the camshaft bearings.

3. Use the bolts as a handle in order to install the engine camshaft.
4. Remove the 3 bolts from the front of the engine camshaft.

Notice: Refer to *Fastener Notice* in Cautions and Notices.

5. If reusing the fasteners, apply Blue Threadlock or equivalent to the threads of the camshaft retainer bolts. Apply Clevite Gear Lubricant or equivalent to camshaft retainer, where contact with the camshaft is made.
6. Install the camshaft retainer and bolts.
Tighten the camshaft retainer bolts to 12 N•m (106 lb in).



Balance Shaft Installation

Tools Required

J 8092 Universal Driver Handle

J 36660 Electronic Torque Angle Meter

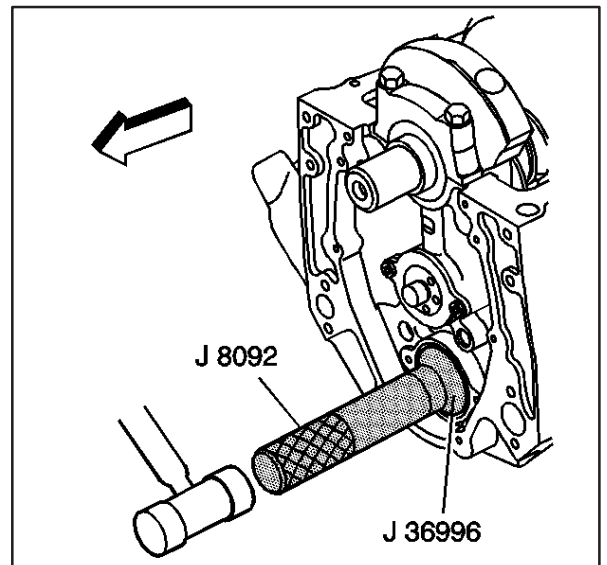
J 36996 Balance Shaft Installer

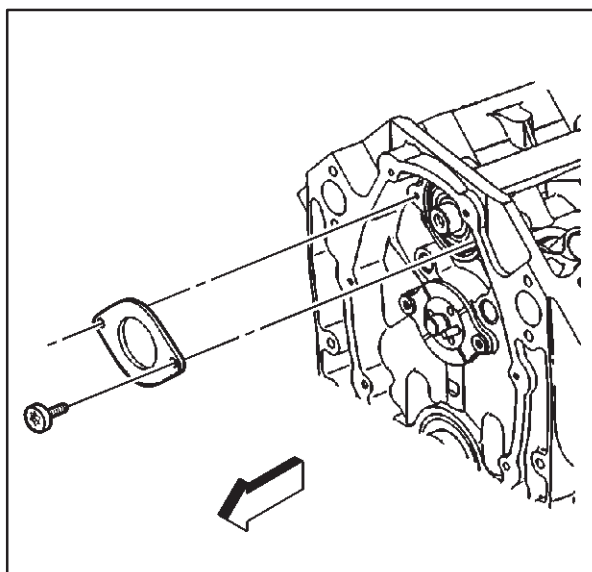
Important: The balance shaft and the balance shaft front bearing are serviced only as an assembly. Do not remove the balance shaft front bearing from the balance shaft.

1. Apply clean engine oil GM P/N 12345610 or equivalent to the balance shaft front bearing.

Caution: Refer to Safety Glasses Caution in Cautions and Notices.

2. Use the J 36996 and the J 8092 in order to install the balance shaft. Apply Clevite Gear Lubricant or equivalent to balance shaft retainer.



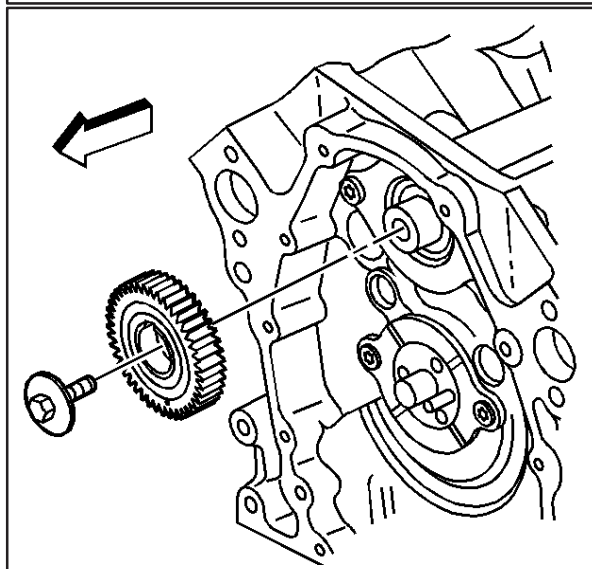


Notice: Refer to *Fastener Notice* in Cautions and Notices.

3. Apply Blue Locktite or Equivalent to balance shaft retainer bolts.
4. Install the balance shaft retainer and bolts.

Tighten

Tighten the balance shaft retainer bolts to 12 N•m (106 lb in).



Install the balance shaft driven gear onto the balance shaft.

5. If reusing the fastener, apply Blue threadlock or equivalent to the threads of the balance shaft driven gear bolt. Use BLUE Locktite
6. Install the balance shaft driven gear bolt.

- 6.1. Use a wrench to secure the balance shaft.

Place the wrench onto the balance shaft near to the balance shaft front bearing.

- 6.2. Install the balance shaft driven gear bolt.

Tighten

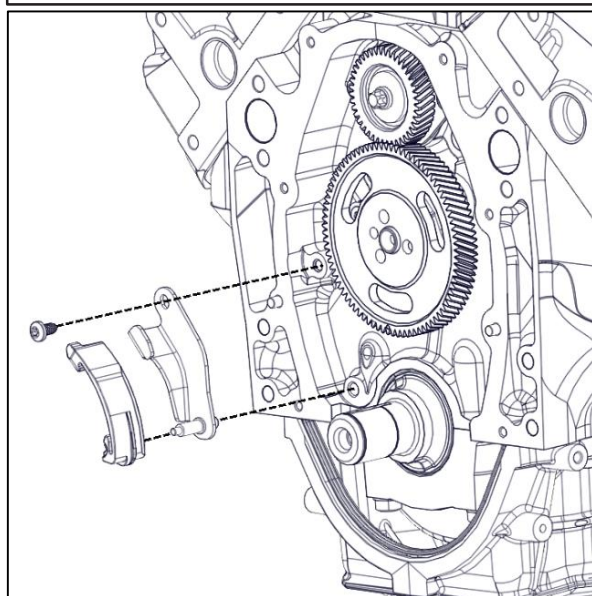
- 6.2.1. Tighten the balance shaft driven gear bolt on the first pass to 20 N•m (15 lb ft.).
- 6.2.2. Tighten the balance shaft driven gear bolt on the final pass using the J 36660 an additional 35 degrees.

7. Remove the wrench from the balance shaft.
8. Rotate the balance shaft by hand in order to ensure that there is clearance between the balance shaft and the valve lifter pushrod guide. If the balance shaft does not rotate freely, check to ensure that the retaining ring on the balance shaft front bearing is seated on the case.

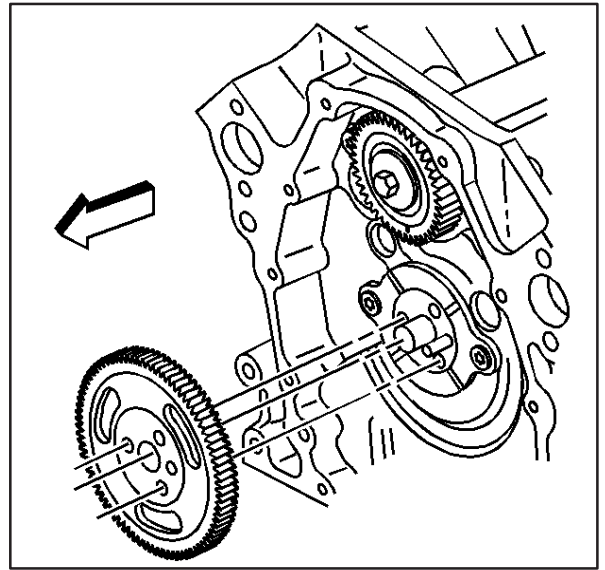
9. Install timing chain guide plate and timing chain guide.

Tighten

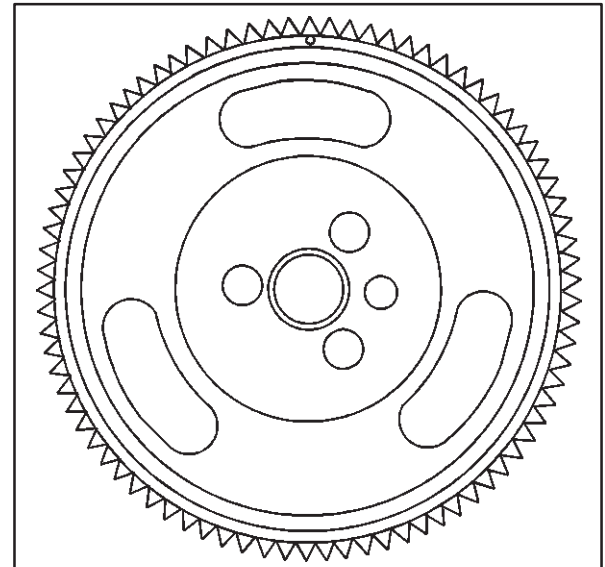
Tighten timing chain guide bolt to 106 in lb.



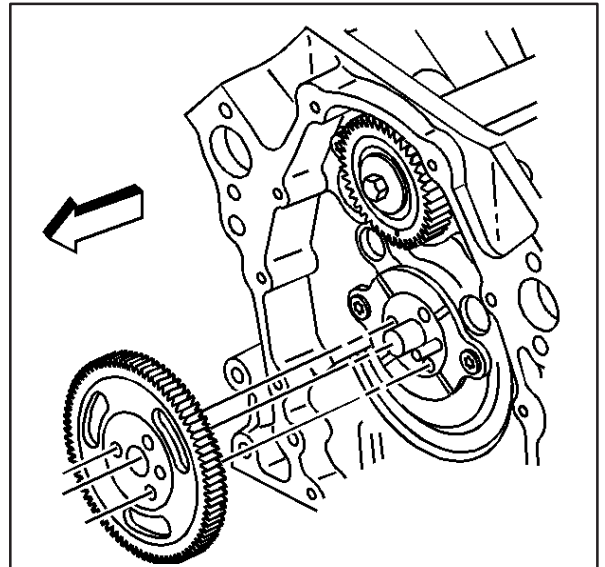
10. Install the balance shaft drive gear. DO NOT install the camshaft sprocket bolts at this time. Apply Clevite Gear Lubricant or equivalent to the Balance Shaft Drive Gear.

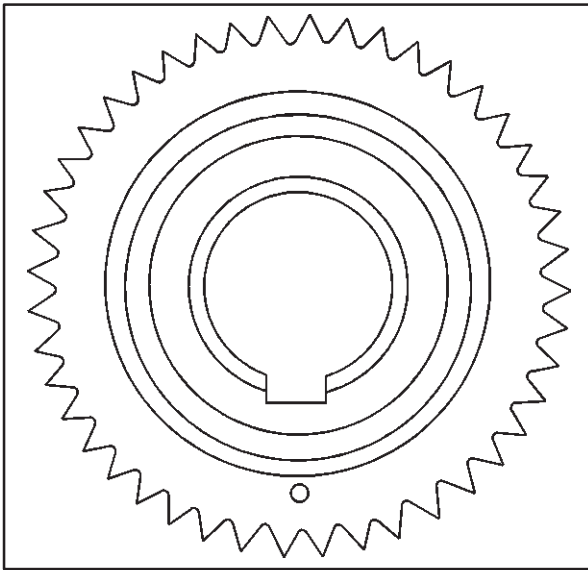


11. Rotate the engine camshaft so that the timing mark on the balance shaft drive gear is in the 12 o'clock position.

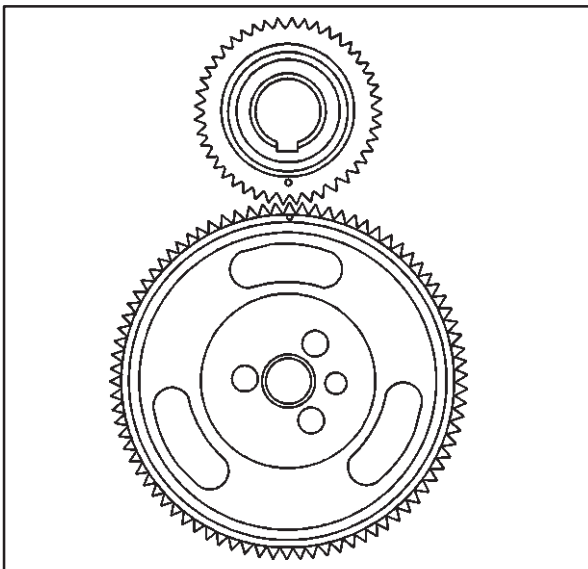


12. Remove the balance shaft drive gear.

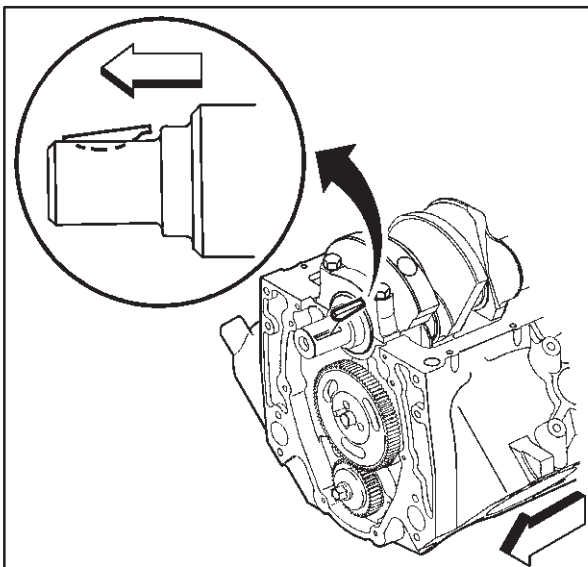




13. Rotate the balance shaft so that the timing mark on the balance shaft driven gear is in the 6 o'clock position.



14. Position the balance shaft drive gear onto the engine camshaft.
15. Look to ensure that the balance shaft drive gear and the balance shaft driven gear timing marks are aligned.



Timing Chain and Sprockets Installation

Tools Required

J 5590 Installer

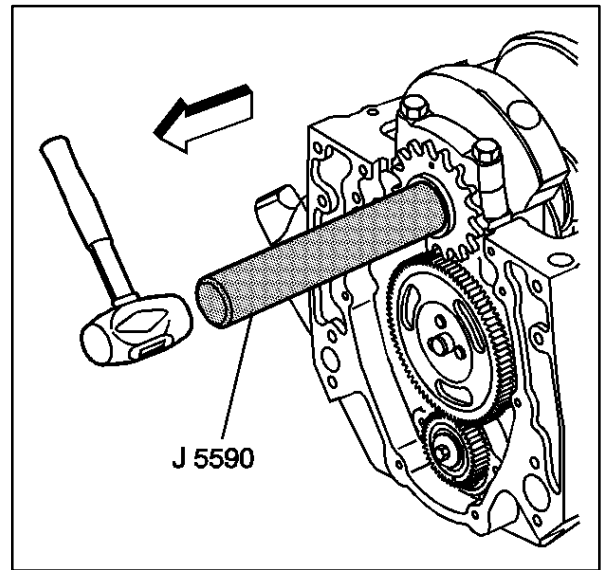
1. Install the crankshaft balancer key into the crankshaft keyway.

The crankshaft balancer key should be parallel to the crankshaft or with a slight incline.

- Align the keyway of the crankshaft sprocket with the crankshaft balancer key.

Caution: Refer to *Safety Glasses Caution in Cautions and Notices*.

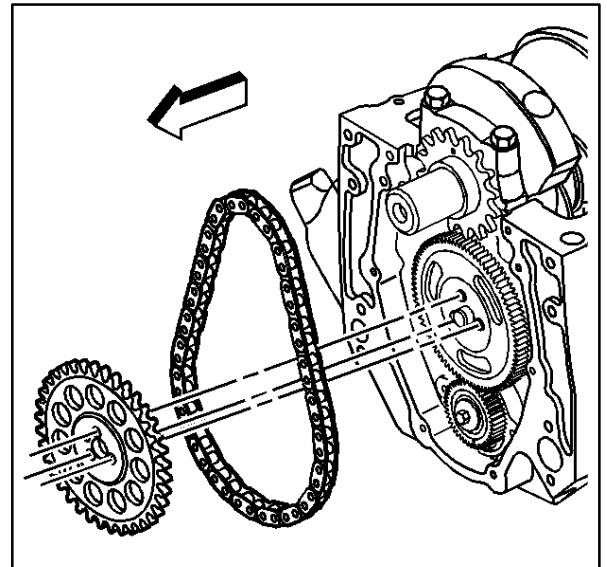
- Use the J 5590 in order to install the crankshaft sprocket.



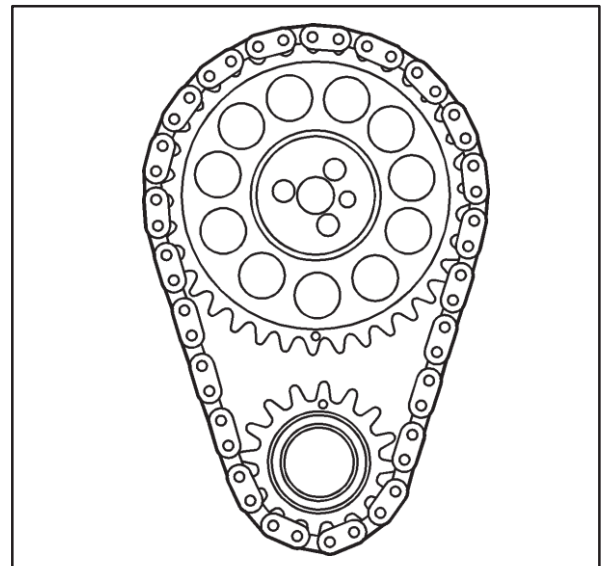
- Rotate the crankshaft until the crankshaft sprocket is at the 12 o'clock position.

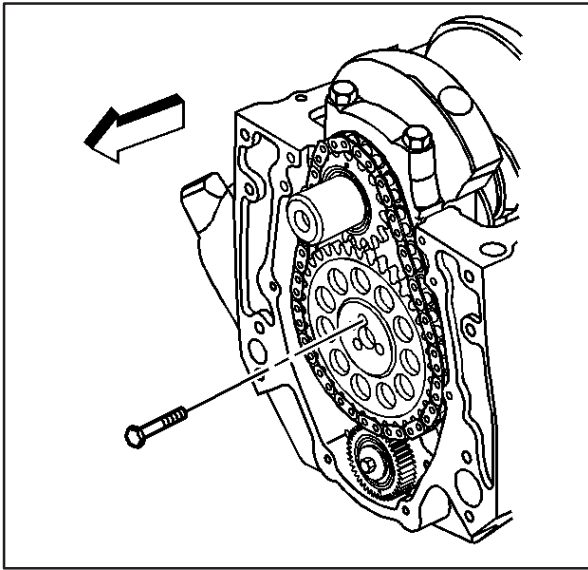
Important: Install the camshaft sprocket with the alignment mark at the 6 o'clock position.

- Install the camshaft sprocket and the camshaft timing chain.



- Look to ensure that the crankshaft sprocket is aligned at the 12 o'clock position and the camshaft sprocket is aligned at the 6 o'clock position.





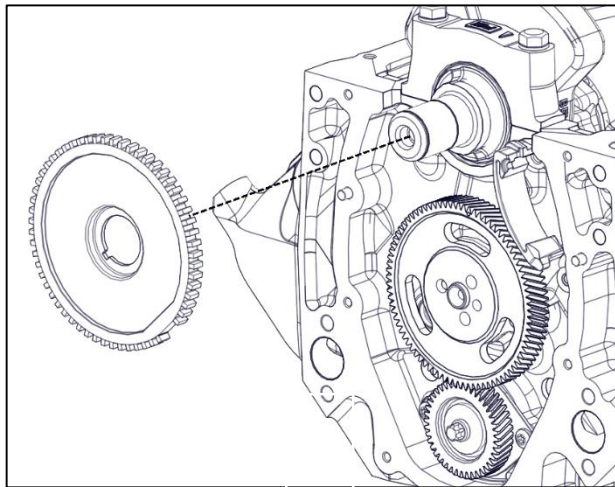
Notice: Refer to *Fastener Notice* in Cautions and Notices.

Important: Do not use a hammer to install the camshaft sprocket onto the camshaft. To do so may dislodge the expansion cup plug (camshaft rear bearing hole).

7. Install the camshaft sprocket bolts very loosely. Install timing chain tensioner.

Tighten

Tighten the camshaft sprocket bolts to 18 lb ft.

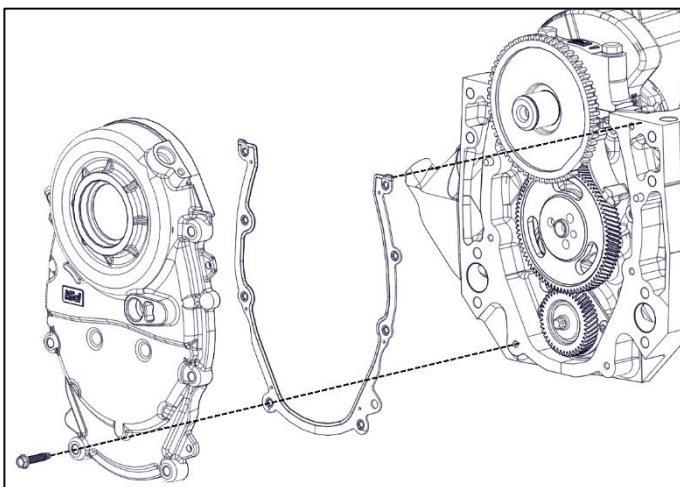


8. Install the crankshaft position sensor reluctor ring.

Align the keyway on the crankshaft position sensor reluctor ring with the crankshaft balancer key in the crankshaft.

Use the J 5590 in order to push the crankshaft position sensor reluctor ring onto the crankshaft until completely seated against the crankshaft sprocket.

Ensure the indent of the reluctor wheel is facing out from the engine



Engine Front Cover Installation

Important: Once the composite engine front cover is removed, DO NOT reinstall the engine front cover. Always install a NEW engine front cover.

1. Install the NEW engine front cover.

Notice: Refer to *Fasteners Notice* in Cautions and Notices.

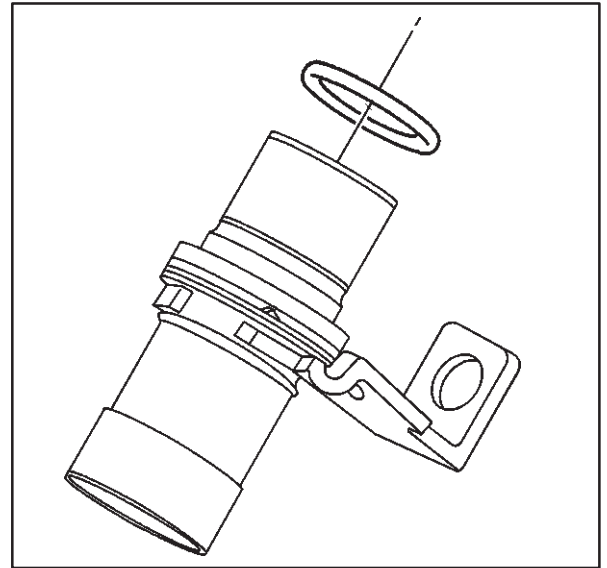
2. Install the engine front cover bolts.

Tighten

Tighten the engine front cover bolts to 12 N•m (106 lb in).
Use Blue Locktite on bolts.

Important: DONOT reuse the original crankshaft position sensor seal (O-ring). When installing the crankshaft position sensor, be sure the crankshaft position sensor is fully seated and held stationary in the engine front cover crankshaft position sensor bore. A crankshaft position sensor that is not completely seated will cock in the engine front cover and may result in erratic engine operation.

3. Lubricate the NEW crankshaft position sensor seal (O-ring) with clean engine oil.
4. Install the NEW crankshaft position sensor seal (O-ring) onto the crankshaft position sensor.



387759

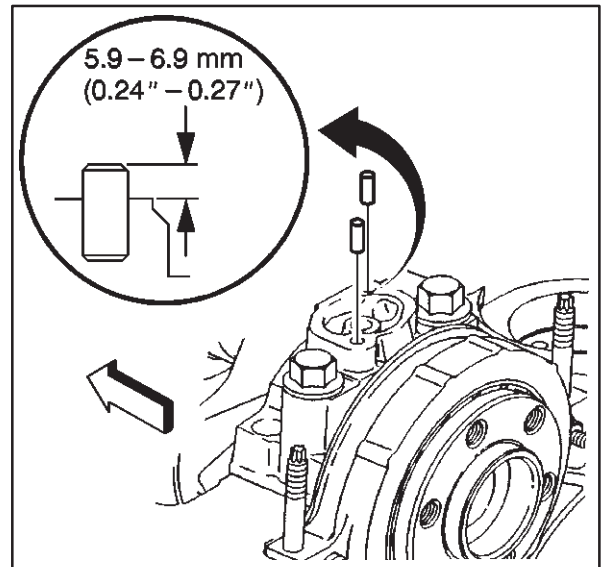
5. Install the crankshaft position sensor until fully seated into the engine front cover.
6. Install the crankshaft position sensor bolt.

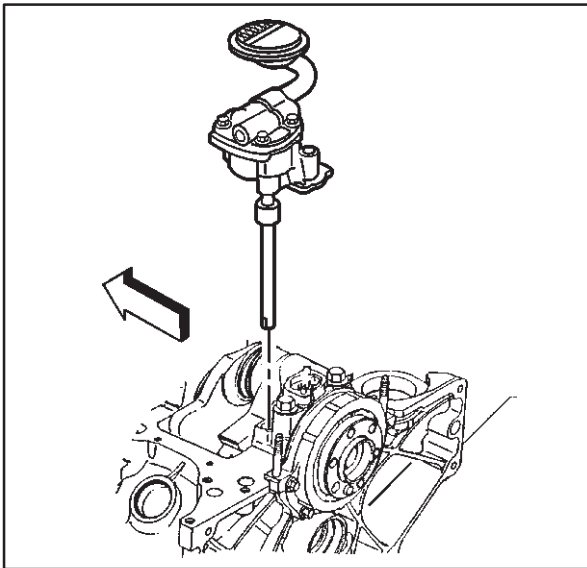
Tighten

Tighten the crankshaft position bolt to 106 lb in.

Oil Pump Installation

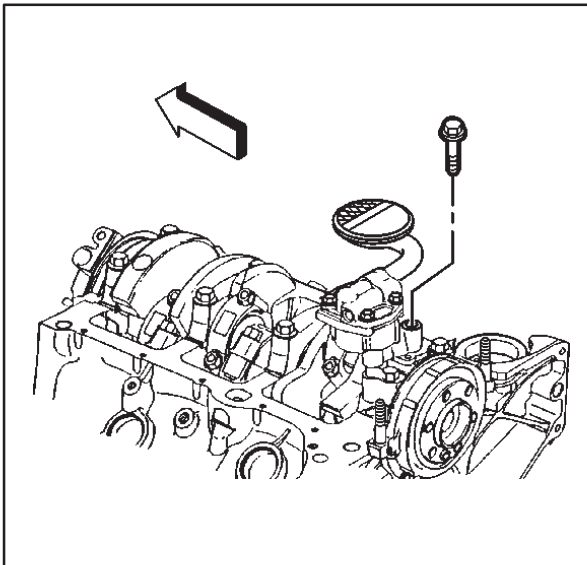
1. Inspect for properly installed pins (oil pump locator).





Important: DO not reuse the oil pump driveshaft retainer. During assembly, install a NEW oil pump driveshaft retainer.

2. Install the oil pump.
3. Position the oil pump onto the pins.

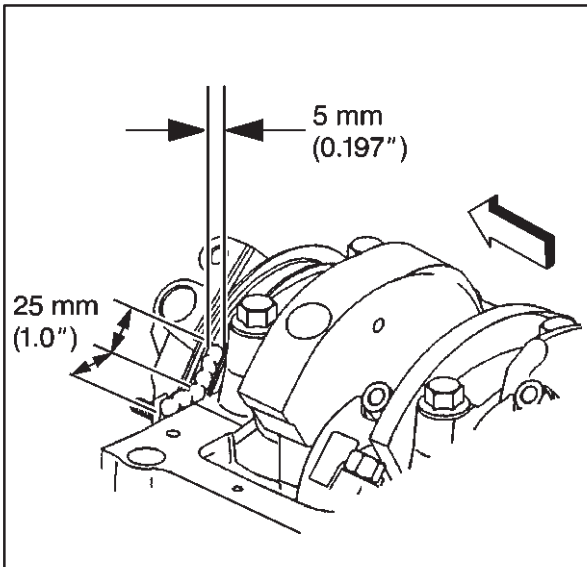


Notice: Refer to *Fasteners Notice* in Cautions and Notices.

4. Install the oil pump bolt attaching the oil pump to the rear crankshaft bearing cap.

Tighten

Tighten the oil pump bolt to 90 N•m (66 lb ft.). Apply Red Locktite



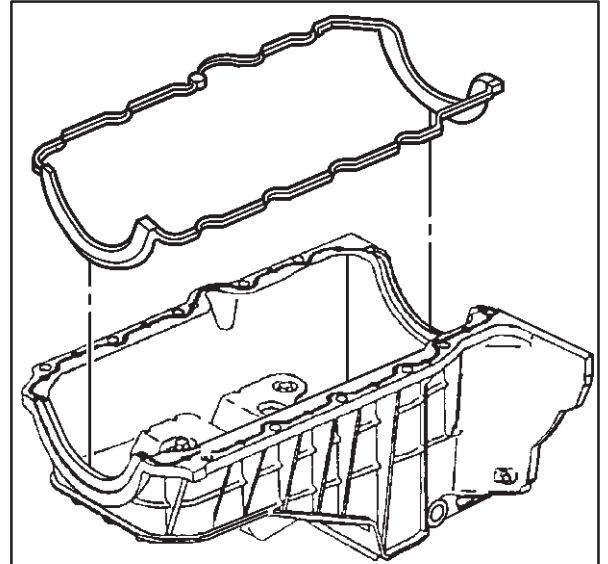
Oil Pan Installation

1. Apply a 5 mm (0.197 in) wide and 25 mm (1.0 in) long bead of Ultra Gray RTV or equivalent to both the right and left sides of the engine front cover to engine block junction at the oil pan sealing surfaces.

Important: Always install a NEW oil pan gasket.

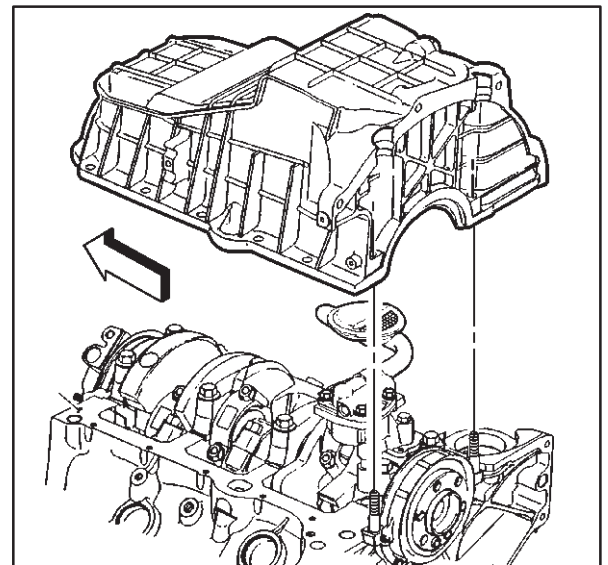
The oil pan gasket and oil pan must be installed and the fasteners tightened while the adhesive is still wet to the touch.

2. Install the NEW oil pan gasket into the groove in the oil pan.



Important: The oil pan alignment must always be flush or forward no more than 0.3 mm (0.011 in) from the rear face of the engine block.

3. Install the oil pan onto the engine block.
Press the oil pan gasket into the grooves of the engine front cover and crankshaft rear oil seal housing.

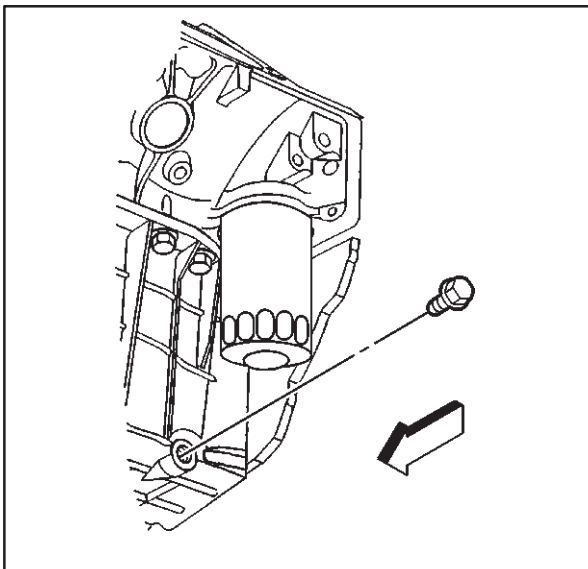
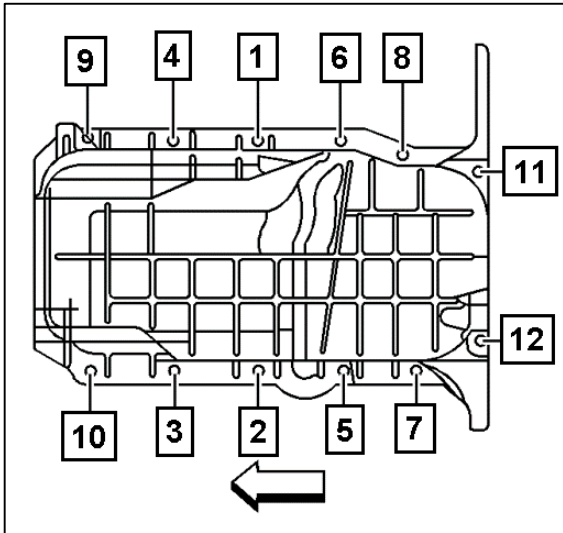


Notice: Refer to *Fastener Notice* in Cautions and Notices.

Tighten the oil pan bolts and nuts in sequence (1-12).

Tighten

Tighten the oil pan bolts to 25 N•m (18 lb ft.).



4. Install a NEW oil pan drain plug seal (O-ring) onto the oil pan drain plug.

5. Install the oil pan drain plug into the oil pan.

Tighten

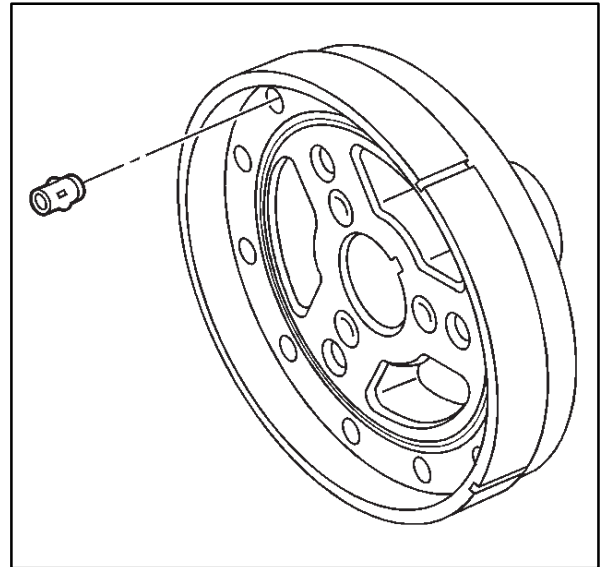
Tighten the oil pan drain plug to 21 lb ft.

Crankshaft Balancer Installation

Tools Required

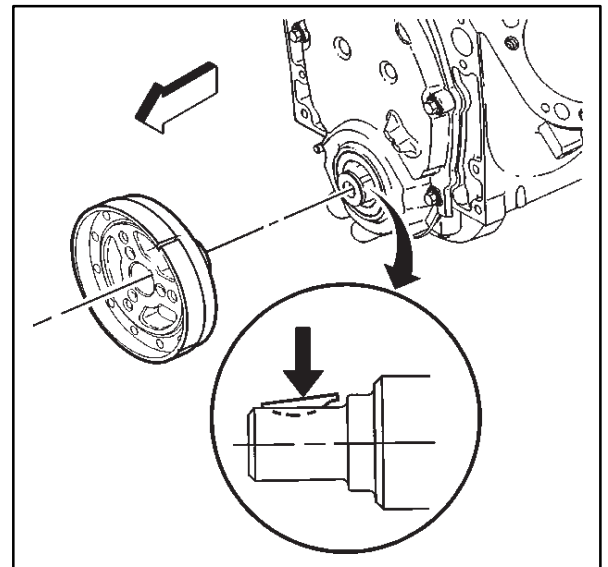
J 23523-F Balancer Remover and Installer

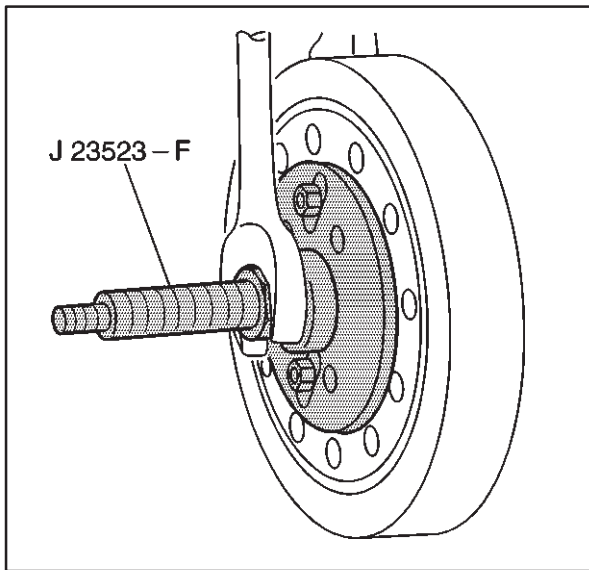
1. Look to ensure that the front groove pin (crankshaft balancer) is installed in the proper location (if applicable).



Notice: The inertial weight section of the crankshaft balancer is assembled to the hub with a rubber type material. The correct installation procedures (with the proper tool) must be followed or movement of the inertial weight section of the hub will destroy the tuning of the crankshaft balancer.

2. Apply a small amount of Ultra Gray RTV or equivalent onto the crankshaft balancer keyway in order to seal the crankshaft balancer keyway and crankshaft joint.
3. Apply a light amount of oil to crankshaft mating surface on balancer.
4. Align the keyway of the crankshaft balancer with the crankshaft balancer key.
5. Install the crankshaft balancer onto the end of the crankshaft.





6. Use the J 23523-F in order to press the crankshaft balancer onto the crankshaft.

6.1. Install the J 23523-F plate and bolts onto the front of the crankshaft balancer.

Tighten

Tighten the J 23523-F plate bolts to 25 N•m (18 lb ft.).

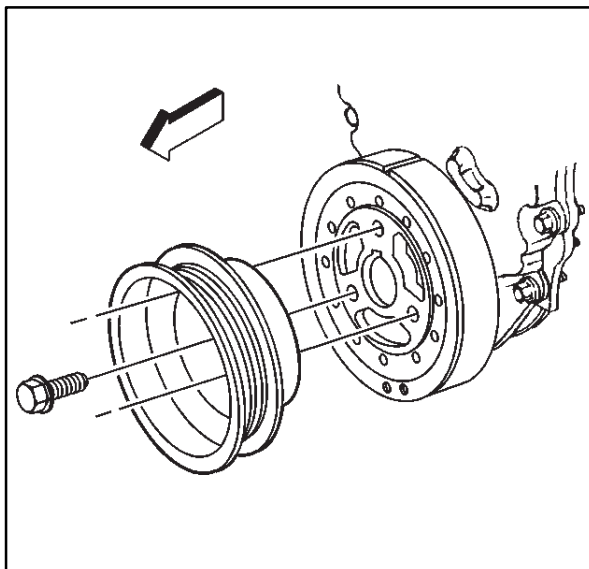
6.2. Install the J 23523-F screw into the end for the crankshaft.

6.3. Install the J 23523-F bearing, the washer and the nut onto the J 23523-F screw.

6.4. Rotate the J 23523-F nut clockwise until the crankshaft balancer hub is completely seated against the crankshaft position sensor reluctor ring.

7. Remove the J 23523-F.

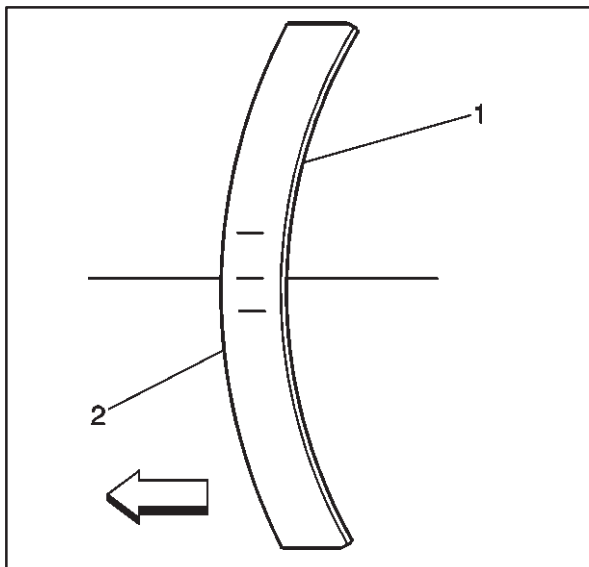
Notice: Refer to *Fastener Notice* in Cautions and Notices.



8. Install the crankshaft pulley and bolts.

Tighten

Tighten the crankshaft pulley bolts to 35 lb ft. with Blue Locktite

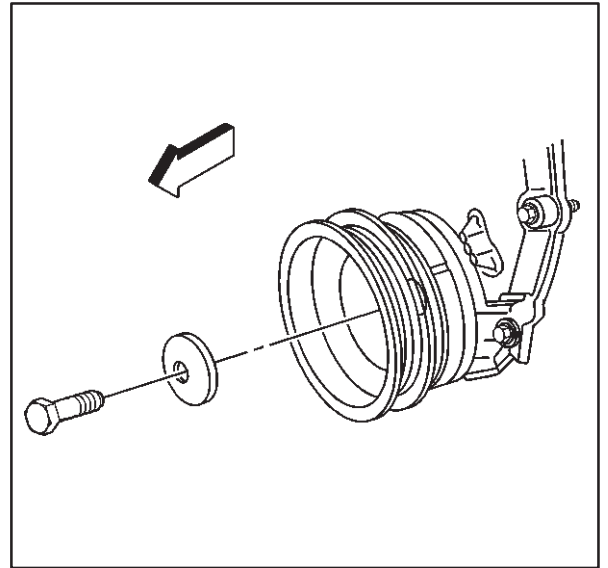


9. Ensure that the crown of the crankshaft balancer washer (2) is faced away from the engine.

10. Install the crankshaft balancer washer and the bolt.

Tighten

Tighten the crankshaft balancer bolt to 58 lb ft.

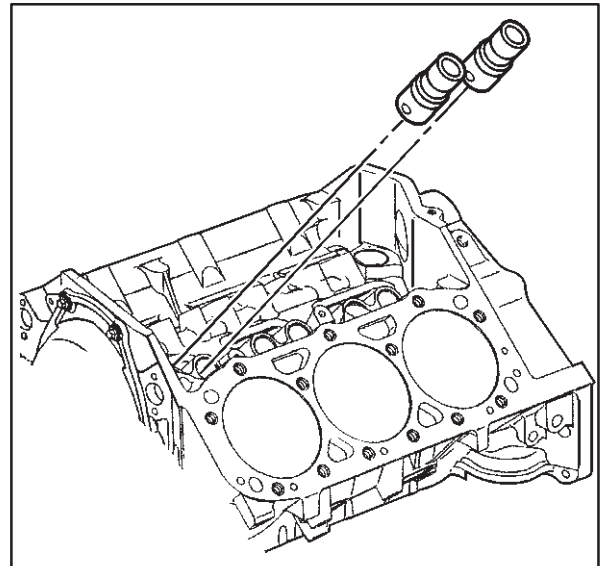


Valve Lifter Installation

1. Apply engine assembly lubricant or equivalent to the valve lifter rollers. Clean motor oil will also suffice.

Important: If reusing the valve lifters, install the valve lifters in the original positions.

2. Install the valve lifters.

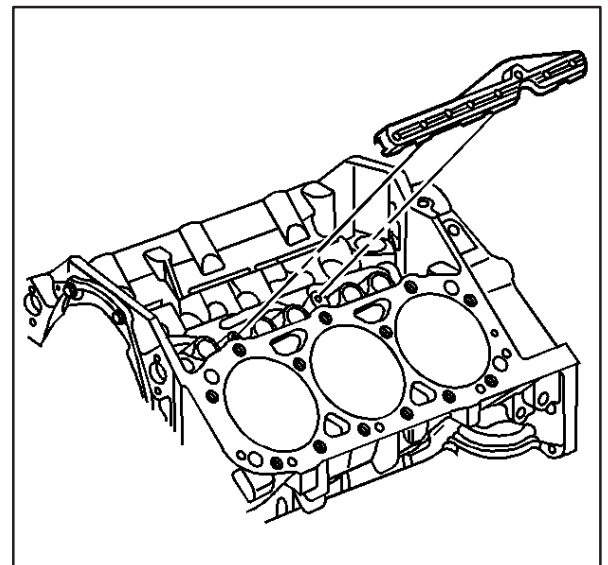


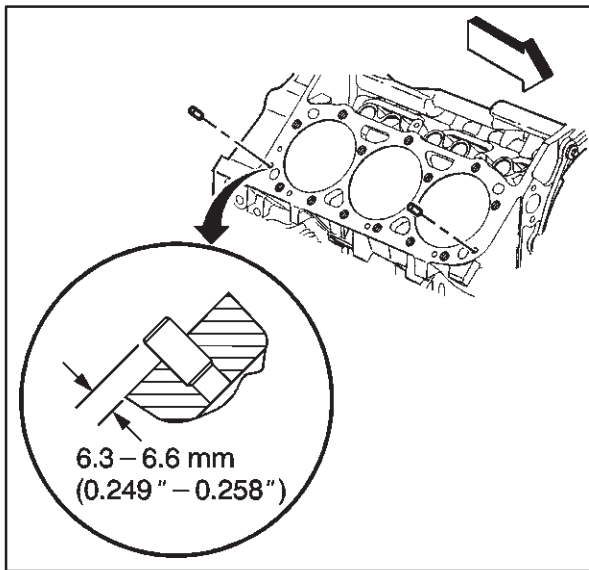
Notice: Refer to *Fastener Notice* in Cautions and Notices.

3. Install the valve lifter pushrod guides.

Tighten

Tighten the valve lifter pushrod guide bolts to 16 N•m (12 lb ft.).



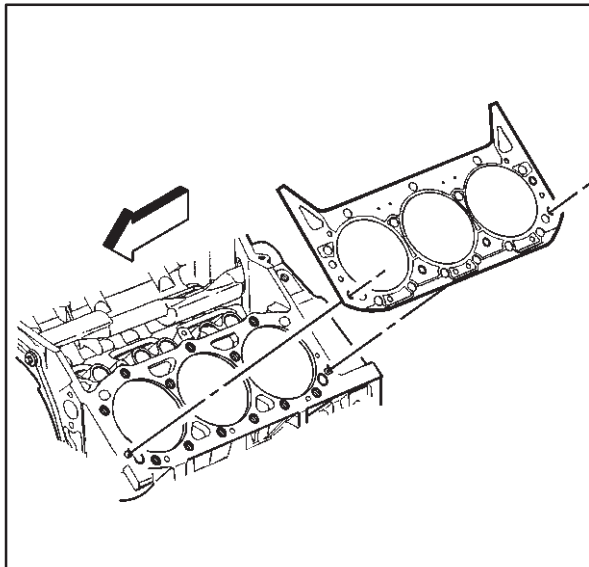


Cylinder Head Installation (Left)

Tools Required

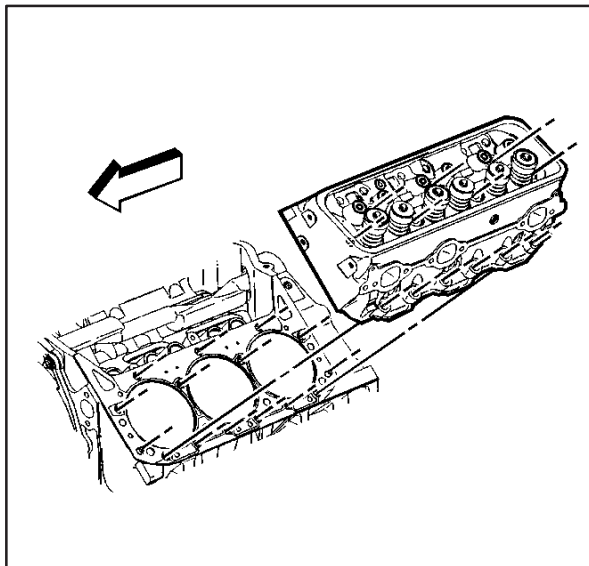
J 36660 Electronic Torque Angle Meter

1. Clean the cylinder head gasket surfaces on the engine block.
2. Inspect the dowel pins (cylinder head locators) for proper installation.
3. Clean the cylinder head gasket surfaces on the cylinder head.



Important: Do not use any type of sealer on the cylinder head gasket (unless specified).

4. Install the NEW cylinder head gasket in position over the dowel pins (cylinder head locators).



5. Install the cylinder head onto the engine block.
Guide the cylinder head carefully into place over the dowel pins and the cylinder head gasket.

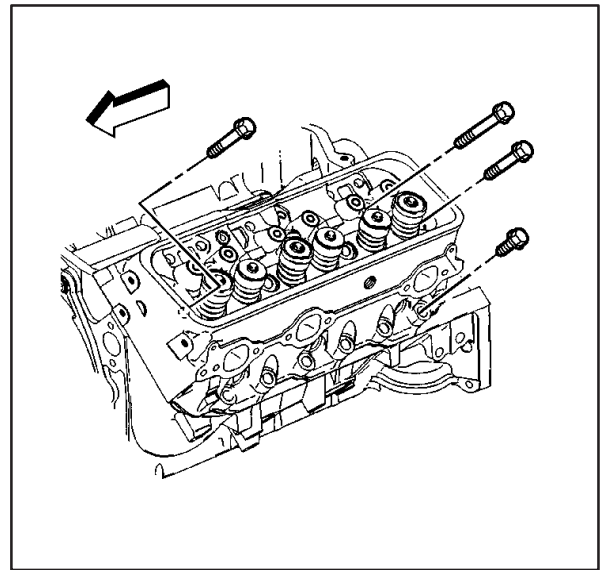
6. Apply PTFE sealant or equivalent to the threads of the cylinder head bolts.

Notice: Refer to *Fastener Notice* in Cautions and Notices.

7. Install the cylinder head bolts finger tight.

Note: Bolt number locations refer to torque sequence in steps 12 and 13.

8. Place the (5) long bolts into positions 1, 4,5,8,9.
9. Place the (2) medium bolts into positions 12 and 13.
10. Place the (6) short bolts into positions 2, 3,6,7,10,11.
11. Snug each bolt.

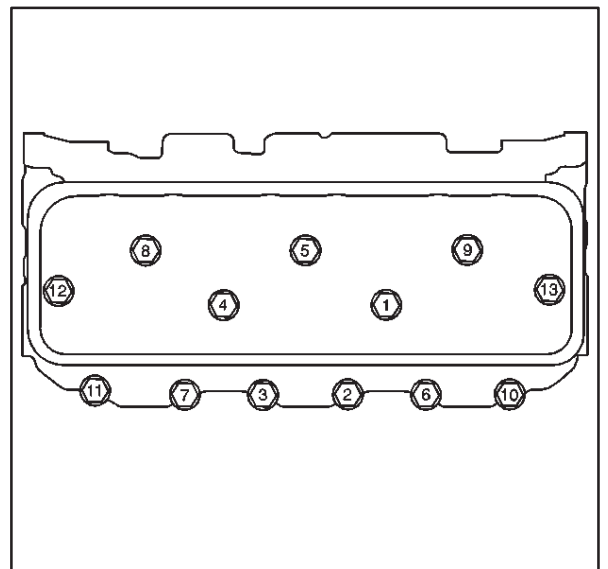


12. Tighten the cylinder head bolts in sequence on the first pass.

Tighten

Tighten the bolts in sequence on the first pass to 30 N•m (22 lb ft.).

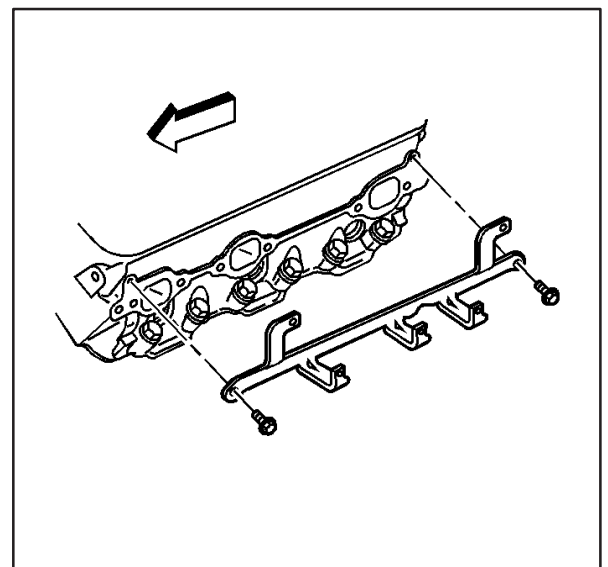
13. Use the J 36660 in order to tighten the cylinder head bolts in sequence on the final pass.
 - Tighten the long bolts (1,4,5,8 and 9) on the final pass in sequence to 75 degrees.
 - Tighten the medium bolts (12 and 13) on the final pass in sequence to 65 degrees.
 - Tighten the short bolts (2,3,6,7,10 and 11) on the final pass in sequence to 55 degrees.

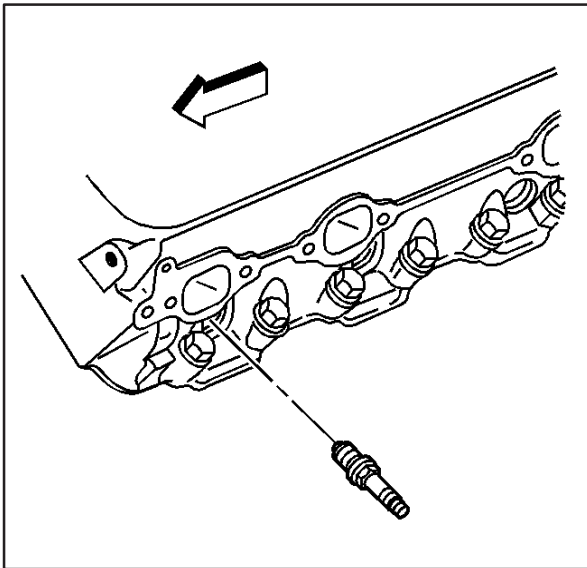


14. Install the spark plug wire support and bolts.

Tighten

Tighten the spark plug wire support bolts to 12 N•m (106 lb in).





15. Measure the NEW spark plugs for the proper gap.
Adjust the spark plug gap if necessary.

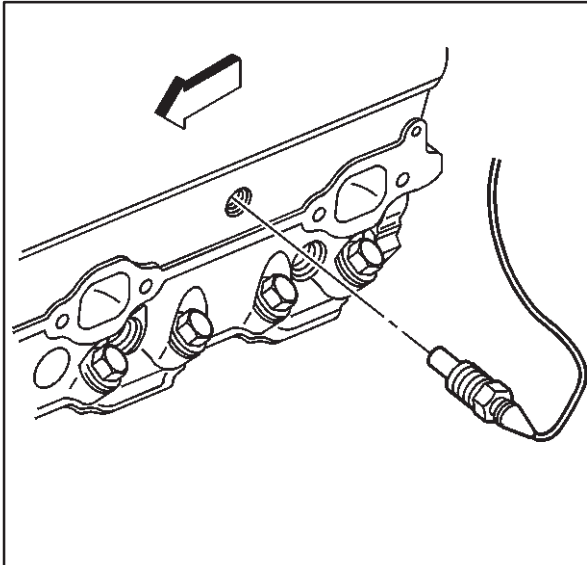
Specification

Spark plug gap to 0.030"

16. Install the spark plugs.

Tighten

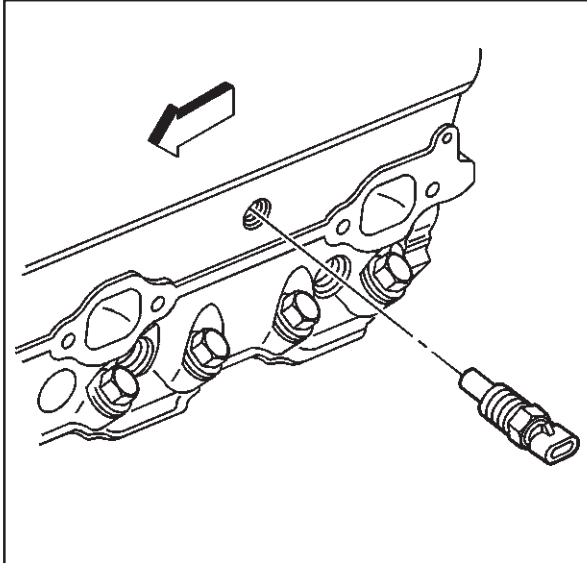
- Tighten the spark plugs for a USED cylinder head to 15 N•m (11 lb ft.)
- Tighten the spark plugs for the initial installation of a NEW cylinder head to 30 N•m (22 lb ft.).



17. If reusing the engine coolant temperature gauge sensor (if applicable), apply PTFE sealant or equivalent to the threads of the engine coolant temperature gauge sensor.
18. Install the engine coolant temperature gauge sensor (if applicable).

Tighten

Tighten the engine coolant temperature gauge sensor to 20 N•m (15 lb ft.).



19. If reusing the engine coolant temperature sensor (if applicable), apply PTFE sealant or equivalent to the threads of the engine coolant temperature sensor.
20. Install the engine coolant temperature sensor (if applicable).

Tighten

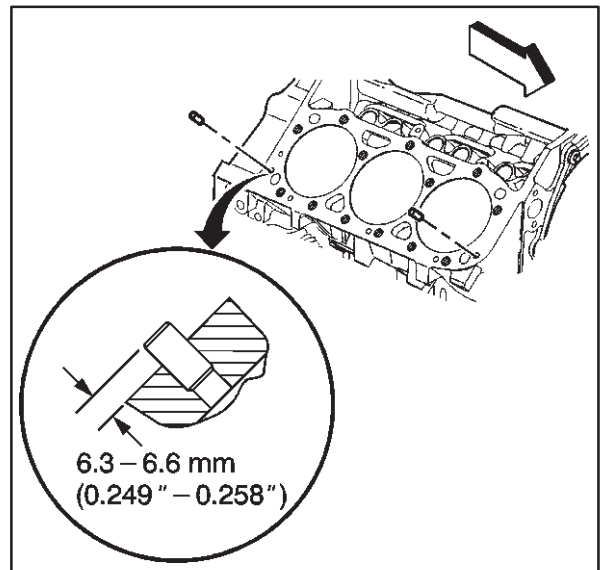
Tighten the engine coolant temperature sensor to 20 N•m (15 lb ft.).

Cylinder Head Installation (Right)

Tools Required

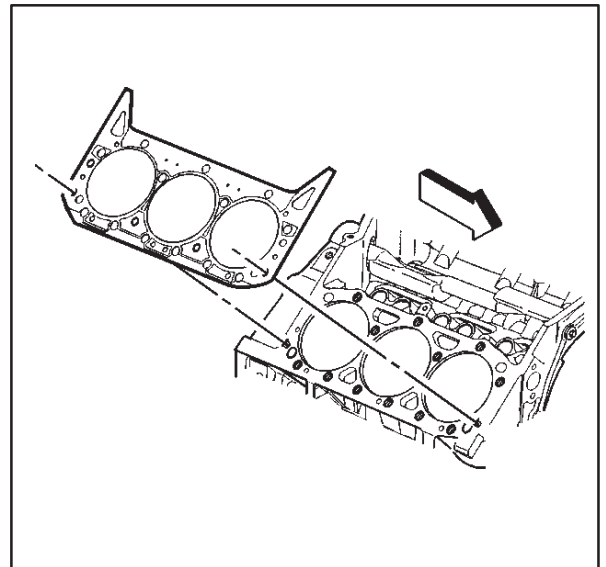
J 36660 Electronic Torque Angle Meter

1. Clean the cylinder head gasket surfaces on the engine block.
2. Inspect the dowel pins (cylinder head locators) for proper installation.
3. Clean the cylinder head gasket surfaces on the cylinder head.



Important: Do not use any type of sealer on the cylinder head gasket (unless specified).

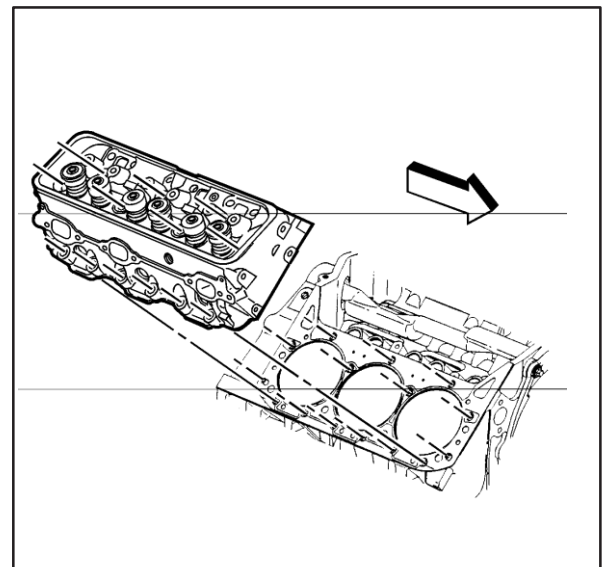
4. Install the NEW cylinder head gasket in position over the dowel pins (cylinder head locators).

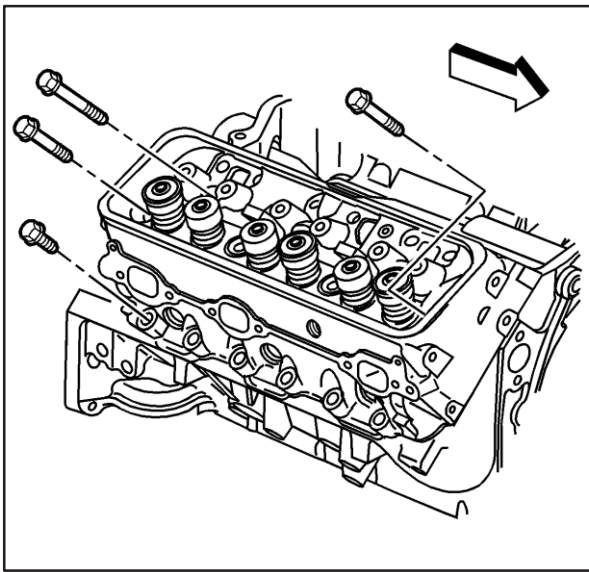


5. Install the cylinder head onto the engine block.
Guide the cylinder head carefully into place over the dowel pins and the cylinder head gasket.

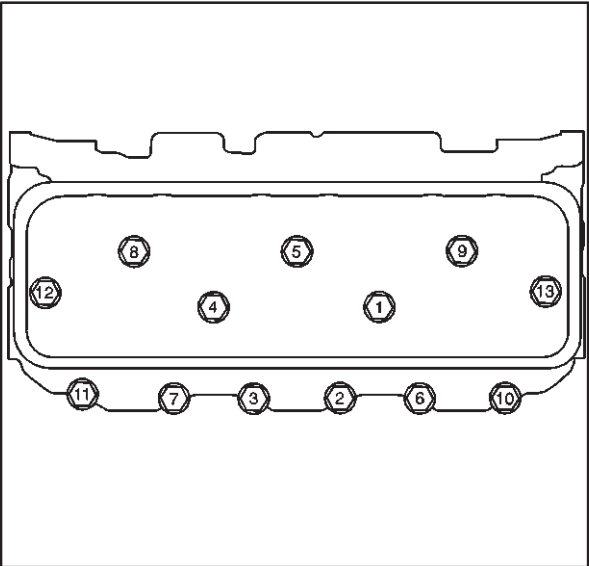
6. Apply PTFE sealant or equivalent to the threads of the cylinder head bolts.

Notice: Refer to *Fastener Notice* in Cautions and Notices.

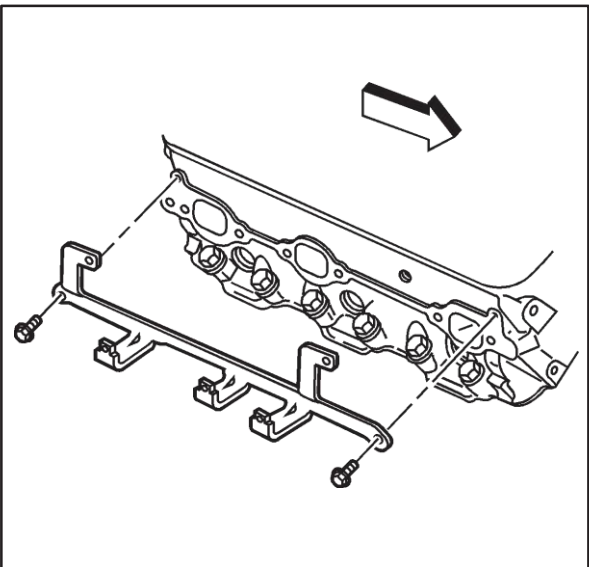




7. Place the (5) long bolts into positions 1, 4,5,8,9.
 8. Place the (2) medium bolts into positions 12 and 13.
 9. Place the (6) short bolts into positions 2, 3,6,7,10,11.
- Snug each bolt.



10. Tighten the cylinder head bolts in sequence on the first pass.
- Tighten**
Tighten the bolts in sequence on the first pass to 30 N•m (22 lb ft.).
11. Use the J 36660 in order to tighten the cylinder head bolts in sequence on the final pass.
 - Tighten the long bolts (1,4,5,8 and 9) on the final pass in sequence to 75 degrees.
 - Tighten the medium bolts (12 and 13) on the final pass in sequence to 65 degrees.
 - Tighten the short bolts (2,3,6,7,10 and 11) on the final pass in sequence to 55 degrees.



12. Install the spark plug wire support and bolts.
- Tighten**
Tighten the spark plug wire support bolts to 12 N•m (106 lb in).
13. Remove the front spark plug wire support bolt.
The front spark plug wire support bolt is used to fasten the oil level indicator tube, and will be installed within the oil level indicator tube installation procedure.

14. Measure the NEW spark plugs for the proper gap.
Adjust the spark plug gap if necessary.

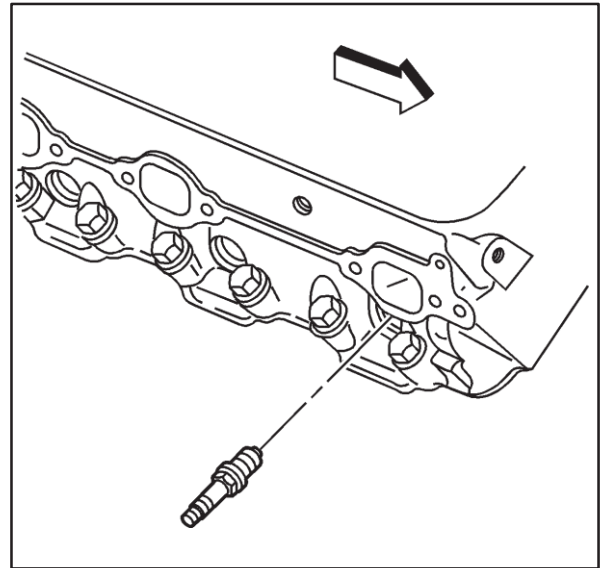
Specification

Spark plug gap to 0.030"

15. Install the spark plugs.

Tighten

- Tighten the spark plugs for a USED cylinder head to 15 N•m (11 lb ft.)
- Tighten the spark plugs for the initial installation of a NEW cylinder head to 30 N•m (22 lb ft.).



Valve Rocker Arm and Push Rod Installation

Important: Be sure to keep parts in order. Parts must be reinstalled into the original location and position.

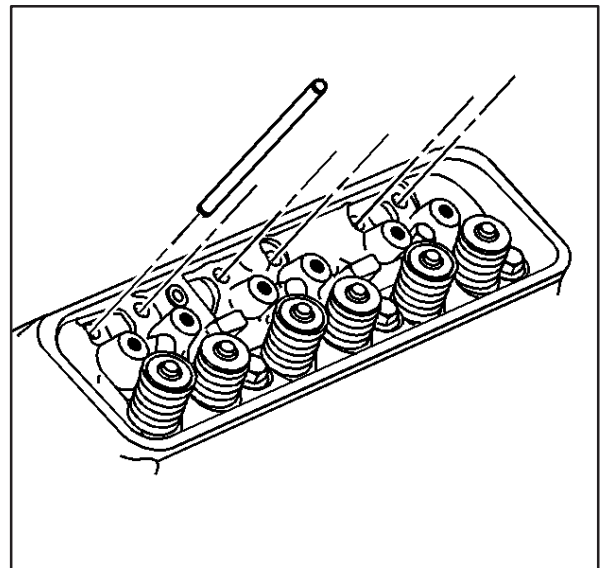
We put motor oil on push rods

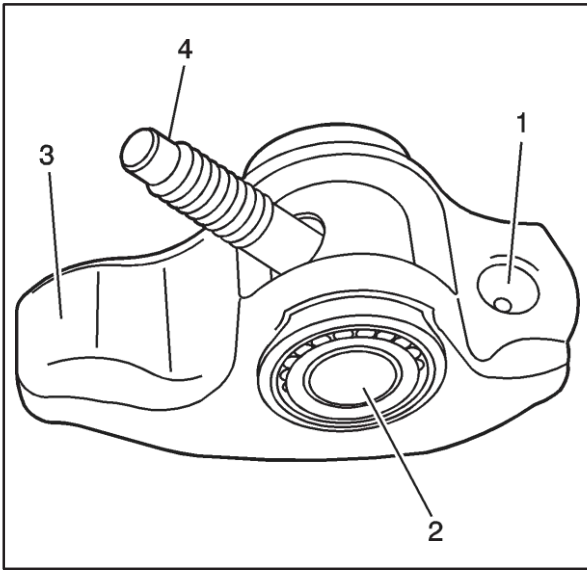
1. Install the valve pushrods.

Apply a light coat of engine assembly lube or motor oil to the ends of the pushrod.

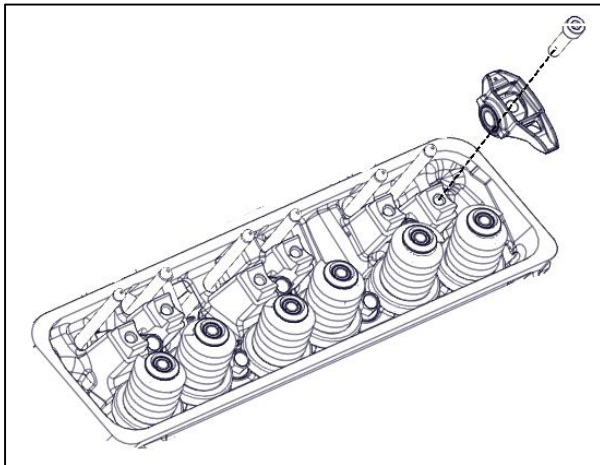
Intake and exhaust push rods are different

Intake marked with 7.271.080 Exhaust marked with 7.365.080





2. Apply engine assembly lube , or equivalent to the following valve rocker arm contact surfaces:
 - Valve pushrod socket (1)
 - Roller pivot (2)
 - Valve stem tip (3)
 - Rocker arm bolt



Notice: Refer to *Fastener Notice* in Cautions and Notices.

3. Install the valve rocker arm assemblies as follows:

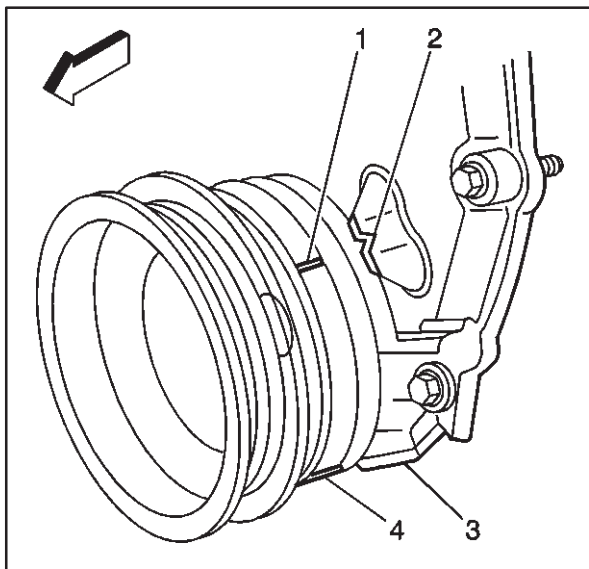
Turn the crank until cylinders 1 & 4 are at top dead center. This will position the lifter in the resting position. Torque the rocker bolts when the lifters are in this position only.

Continue turning crank to put cylinders 3 & 6 and then 5 & 2 at TDC for rocker bolt torquing.

Note: Intake and Exhaust rocker arms are different.

Tighten:

Torque each bolt to **30 ft./lbs.**



4. Rotate the crankshaft balancer to position the crankshaft balancer alignment mark (1) 57-63 degrees clockwise or counterclockwise from the engine front cover alignment tab (2).

Important: Once the valve rocker arm assemblies are installed and properly torqued, no additional valve lash adjustment is required.

5. Tighten the valve rocker arm bolts.

Tighten

Tighten the valve rocker arm bolts to 30 N•m (22 lb ft.).

Intake Manifold Installation

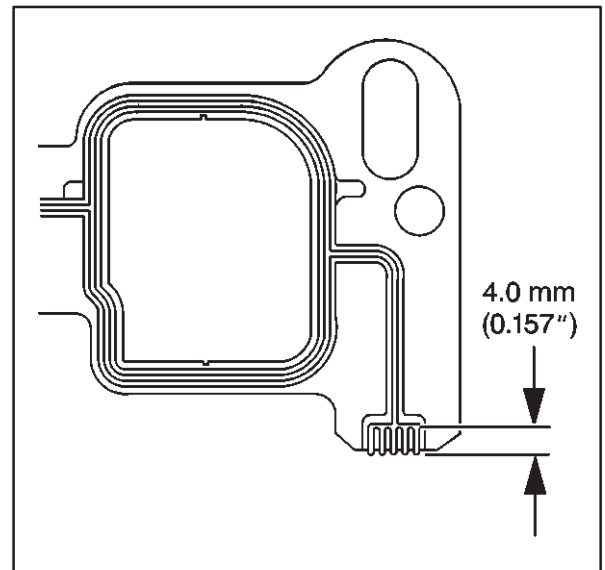
Notice: Applying excessive amounts of sealant may prohibit the intake manifold gaskets from sealing properly.

1. Apply a 4.0 mm (0.157 in) patch of Ultra Gray RTV or equivalent to the cylinder head side of the lower intake manifold gasket at each end.

Important: The lower intake manifold gasket must be installed while the adhesive is still wet to the touch.

2. Install the lower intake manifold gasket onto the cylinder head.

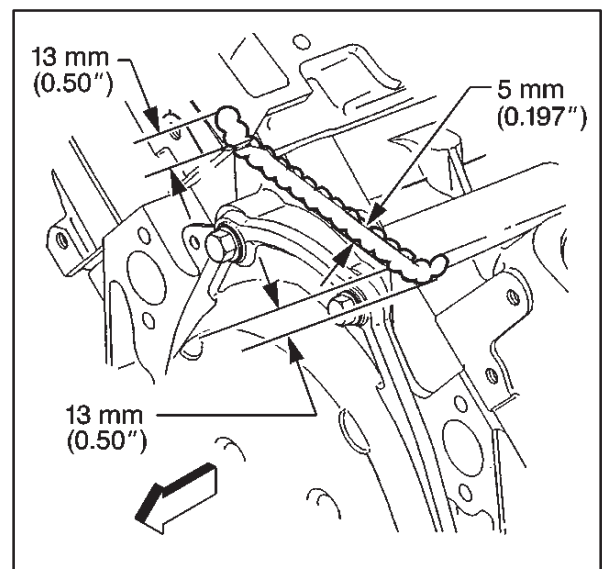
Use the gasket locator pins in order to properly seat the lower intake manifold gasket on the cylinder head.



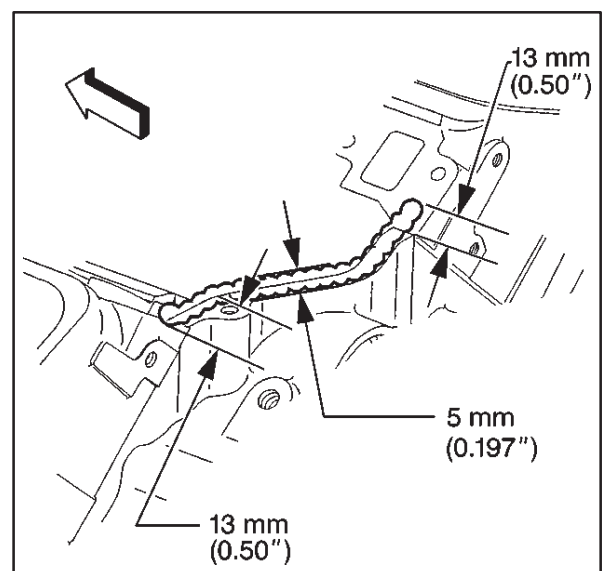
Notice: Care must be used to apply the correct amount of sealant onto the gaskets. Applying excessive amounts of sealant may prohibit the intake manifold gaskets from sealing properly.

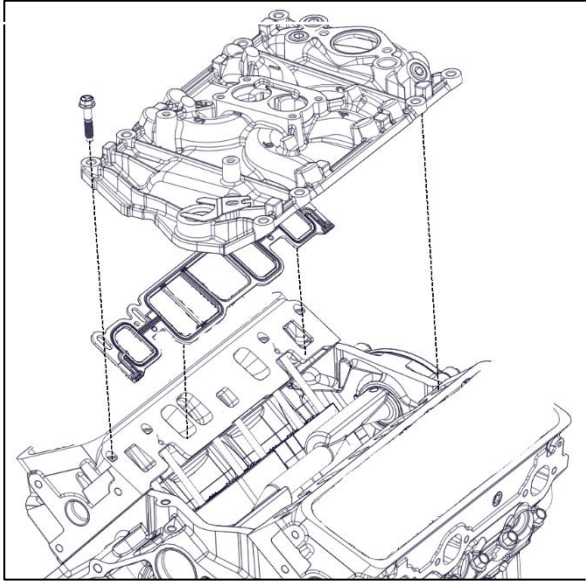
Important: The lower intake manifold must be installed and the fasteners tightened while the adhesive is still wet to the touch.

3. Apply a 5.0 mm (0.197 in) bead of Ultra Gray RTV or equivalent to the front top of the engine block.
Extend the adhesive bead 13 mm (0.50 in) onto each lower intake manifold gasket.



4. Apply a 5.0 mm (0.197 in) bead of Ultra Gray RTV or equivalent to the rear top of the engine block.
Extend the adhesive bead roughly 0.5 to 1 inch onto each lower intake manifold gasket.



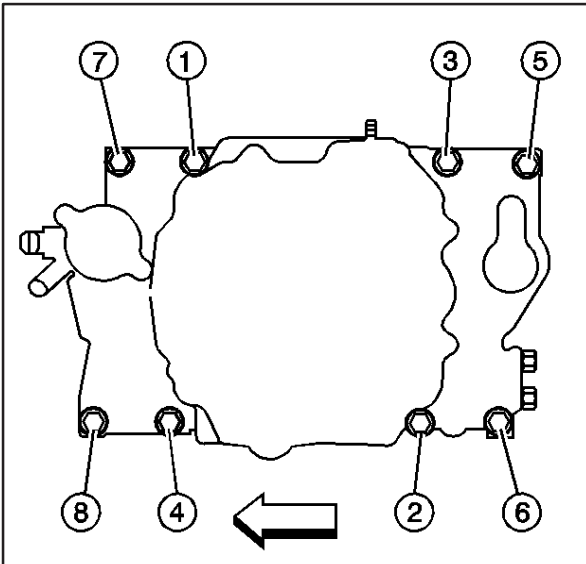


5. Install the lower intake manifold onto the engine block.

Notice: Refer to *Fastener Notice* in Cautions and Notices.

6. If reusing the fasteners, apply PTFE Sealant or equivalent to the threads of the lower intake manifold bolts.

7. Install the lower intake manifold bolts.



Notice: Proper lower intake manifold fastener tightening sequence and torque is critical. Always follow the tightening sequence, and torque the intake manifold bolts using the 3 step method. Failing to do so may distort the crankshaft bearing bore alignment and cause damage to the crankshaft bearings.

8. Tighten the lower intake manifold bolts.

Tighten

8.1. Tighten the bolts in sequence (1-8) on the first pass to 3 N•m (27 lb in).

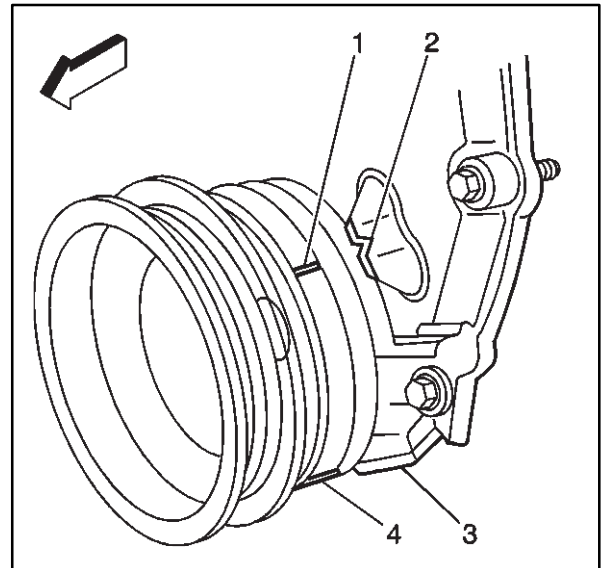
8.2. Tighten the bolts in sequence (1-8) on the first pass to 12 N•m (106 lb in).

8.3. Tighten the bolts in sequence (1-8) on the first pass to 15 N•m (132 in lb).

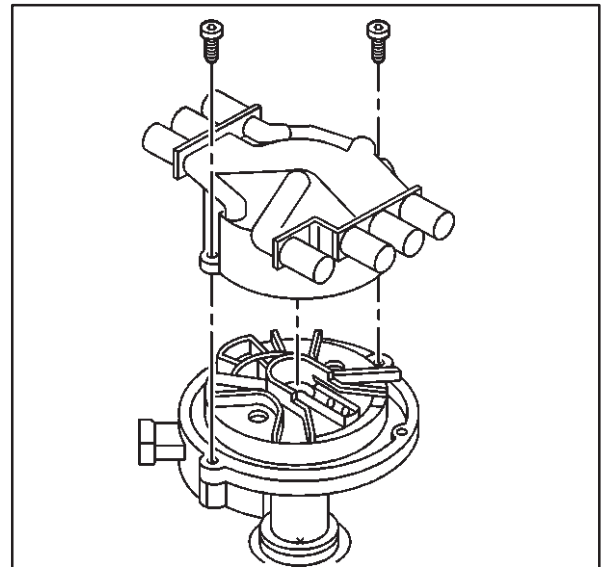
Distributor Installation

Important: The engine front cover has 2 alignment tabs and the crankshaft balancer has 2 alignment marks (spaced 90 degrees apart) which are used for positioning number 1 piston at Top Dead Center (TDC). With the piston on the compression stroke and at top dead center, the crankshaft balancer alignment mark (1) must align with the engine front cover tab (2) and the crankshaft balancer alignment mark (4) must align with the engine front cover tab (3).

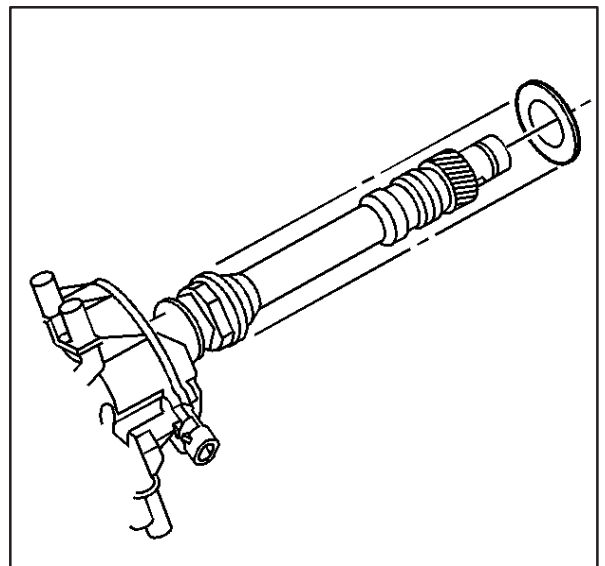
Rotate the crankshaft balancer clockwise until the alignment marks on the crankshaft balancer are aligned with the tabs on the engine front cover and the number 1 piston is at top dead center of the compression stroke.

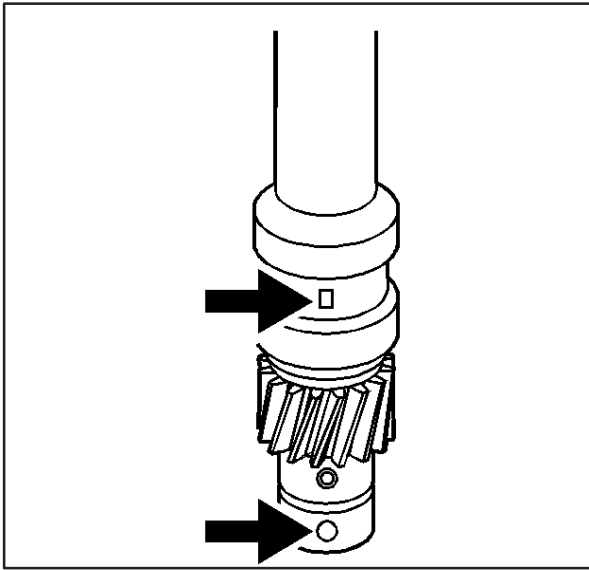


1. Remove the distributor cap bolts.
2. Remove the distributor cap.

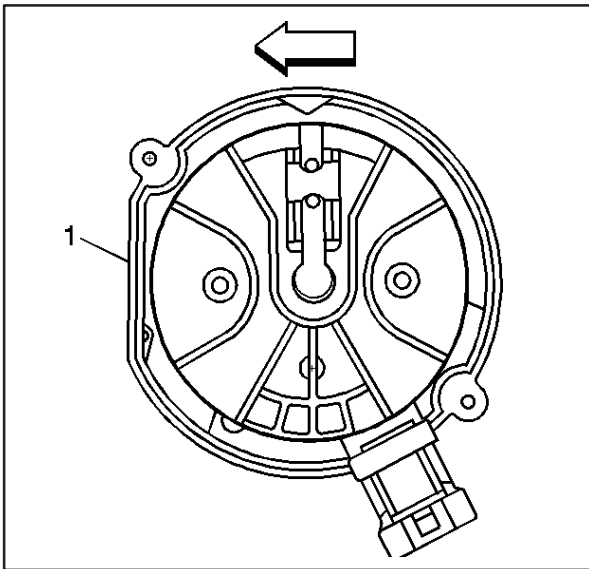


3. Install a NEW distributor gasket onto the distributor.

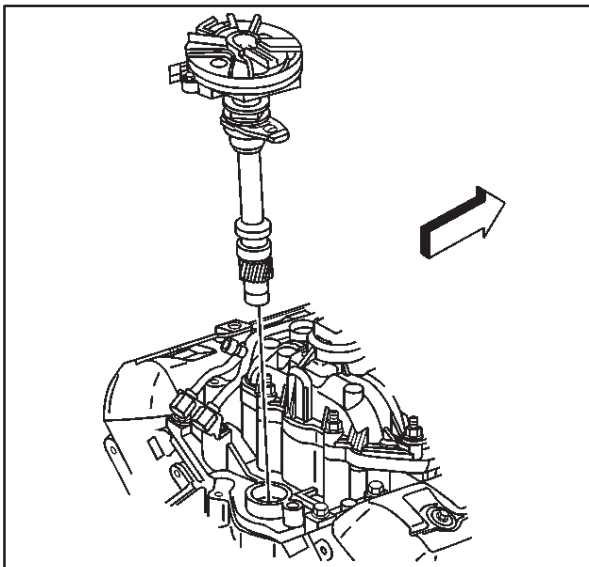




4. Align the indent hole on the driven gear with the paint mark on the distributor housing.
5. Ensure that the distributor rotor segment points to the cap hold area.



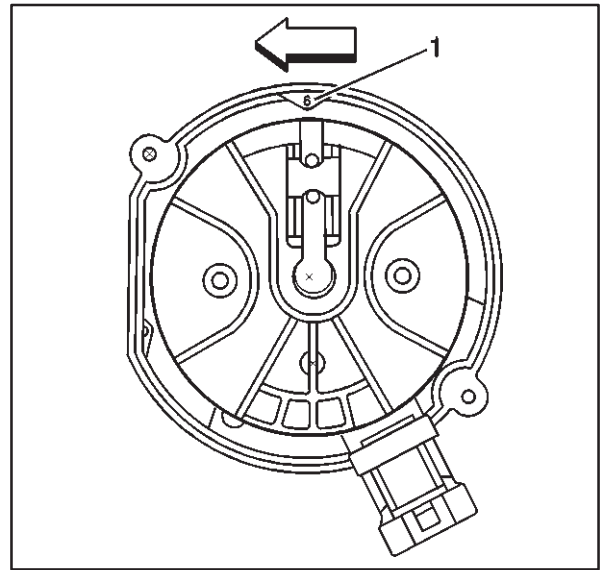
6. Align the slotted tang in the oil pump driveshaft with the distributor driveshaft.
Rotate the oil pump driveshaft with a screwdriver if necessary.
7. Align the flat (1) in the distributor housing toward the front of the engine.



8. Install the distributor and distributor clamp.
The flat in the distributor housing must point toward the front of the engine.

9. Once the distributor is fully seated, align the distributor rotor segment with the number 6 pointer (1) that is cast into the distributor base.

If the distributor rotor segment does not come with a few degrees of the number 6 pointer (1), the gear mesh between the distributor and camshaft may be off a tooth or more. Repeat the procedure again in order to achieve proper alignment.

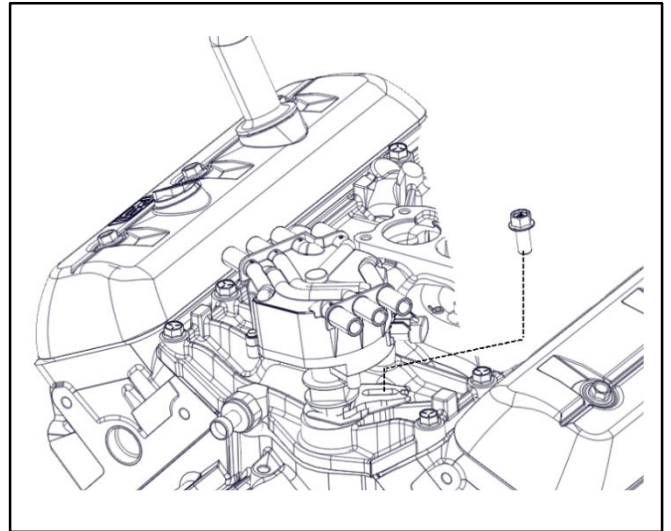


Notice: Refer to *Fastener Notice* in Cautions and Notices.

10. Install the distributor clamp bolt.

Tighten

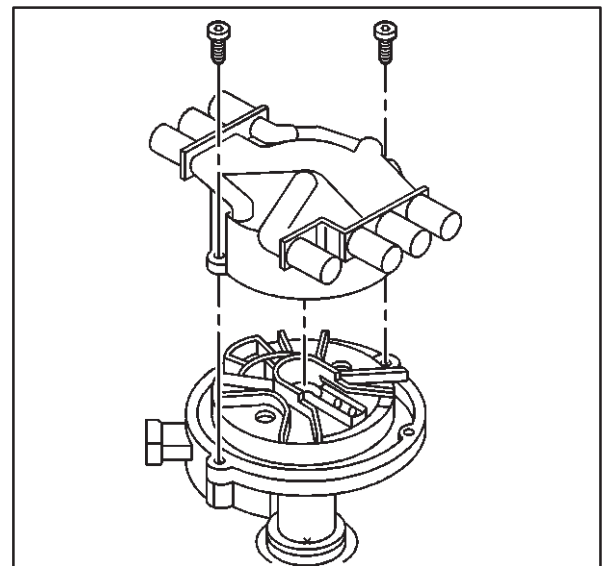
Tighten the distributor clamp bolt to 25 N·m (18 lb ft.).



11. Install the distributor cap and NEW distributor cap bolts.

Tighten

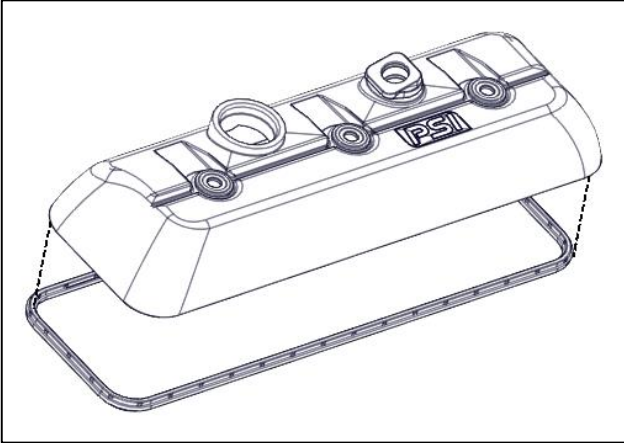
Tighten the distributor cap bolts to 2.4 N·m (21 lb in).



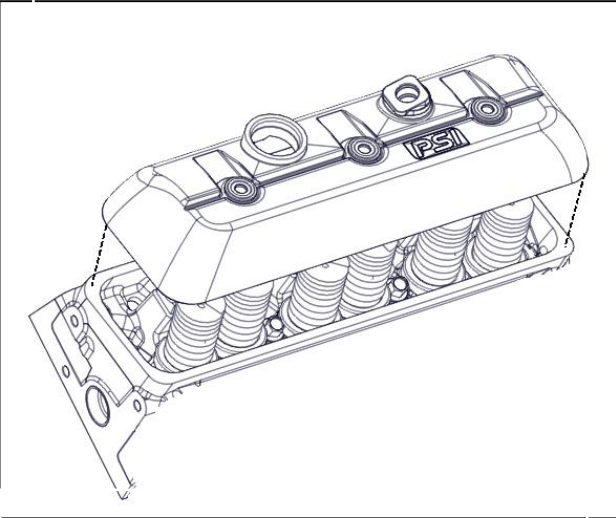
Valve Rocker Arm Cover Installation (Left)

Important: Do not reuse the valve rocker arm cover gasket or the valve rocker arm cover grommets.

1. Install the NEW valve rocker arm cover gasket into the groove of the valve rocker arm cover.
2. Install the NEW valve rocker arm cover bolt grommets into the valve rocker arm cover.



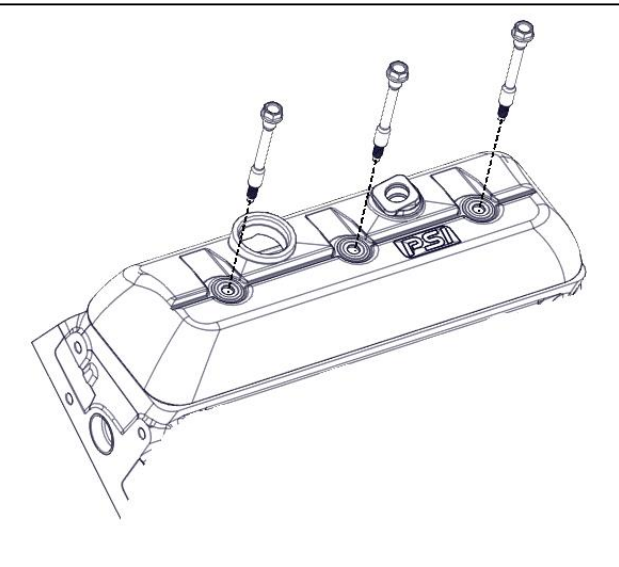
3. Install the valve rocker arm cover onto the cylinder head.



4. Install the valve rocker arm cover bolts.

Tighten

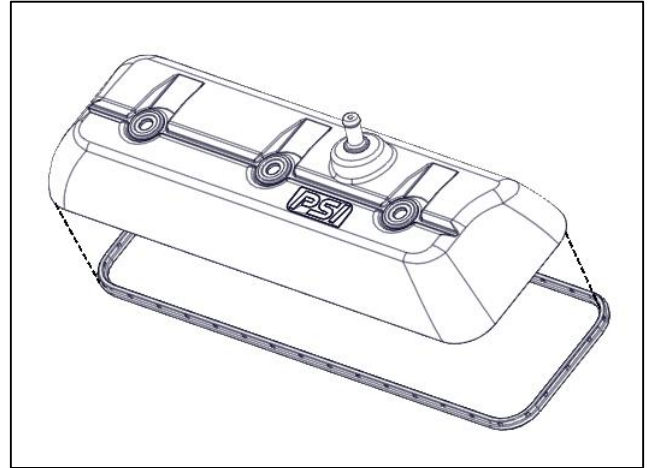
Tighten the valve rocker arm cover bolts to 12 N·m (106 lb in). Torque from the center out.



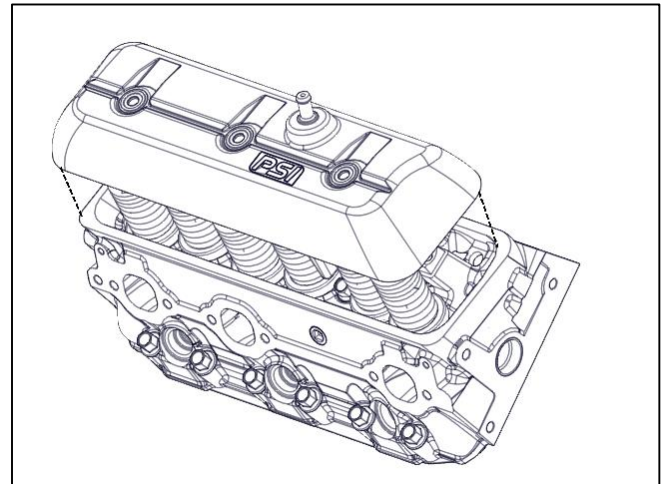
Valve Rocker Arm Cover Installation (Right)

Important: Do not reuse the valve rocker arm cover gasket or the valve rocker arm cover bolt grommets.

1. Install the NEW valve rocker arm cover gasket into the groove of the valve rocker arm cover.
2. Install the NEW valve rocker arm cover bolt grommets into the valve rocker arm cover.



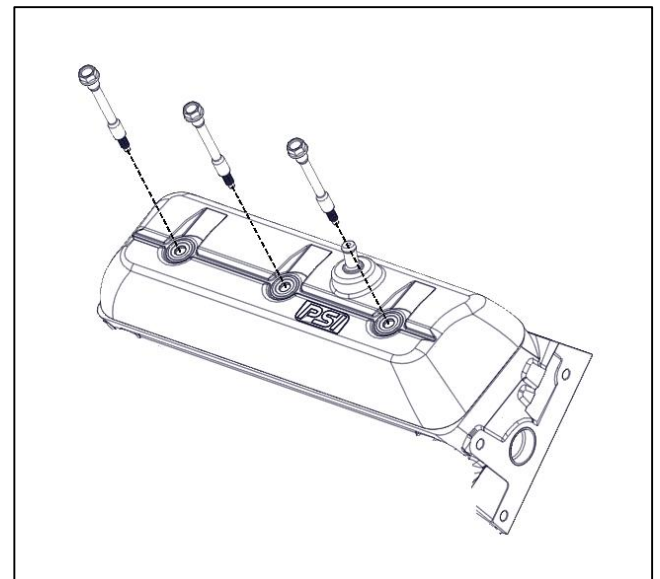
3. Install the valve rocker arm cover onto the cylinder head.



4. Install the valve rocker arm cover bolts.

Tighten

Tighten the valve rocker arm cover bolts to 12 N-m (106 lb in).
Torque from the center out.

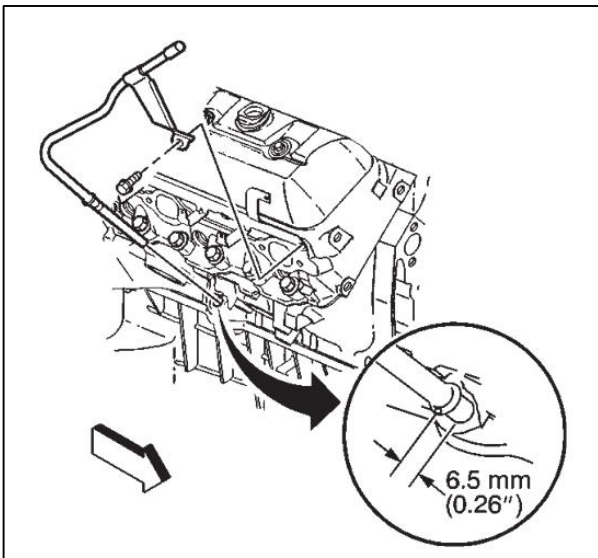


Notice: Refer to *Fastener Notice* in Cautions and Notices.

5. Install the valve rocker arm cover bolts.

Tighten

Tighten the valve rocker arm cover bolts to 12 N·m (106 lb in). Torque from the center out.



Oil Level Indicator and Tube Installation

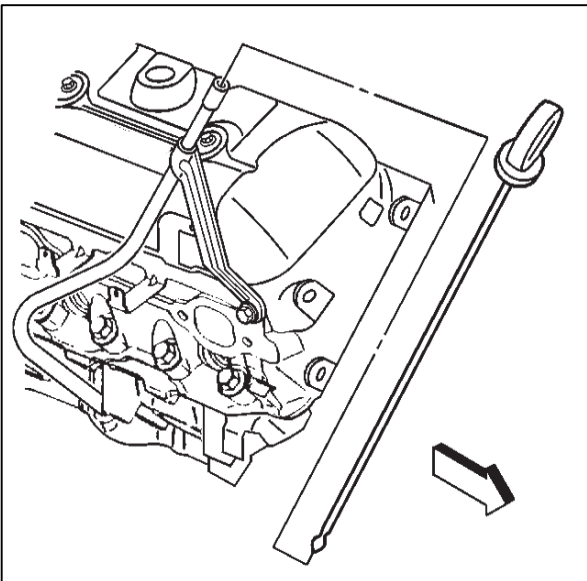
1. Apply PTFE sealant or equivalent around the oil level indicator tube 13 mm (0.50 in) below the tube bead.
2. Install the oil level indicator tube into the engine block. Rotate the oil level indicator tube into position.

Notice: Refer to *Fastener Notice* in Cautions and Notices.

3. Install the oil level indicator tube bolt.

Tighten

Tighten the oil level indicator tube bolt to 12 N·m (106 lb in).



4. Install the oil level indicator into the oil level indicator tube, if required.

Water Pump Installation

Tools Required

J 41240 Fan Clutch Remover and Installer

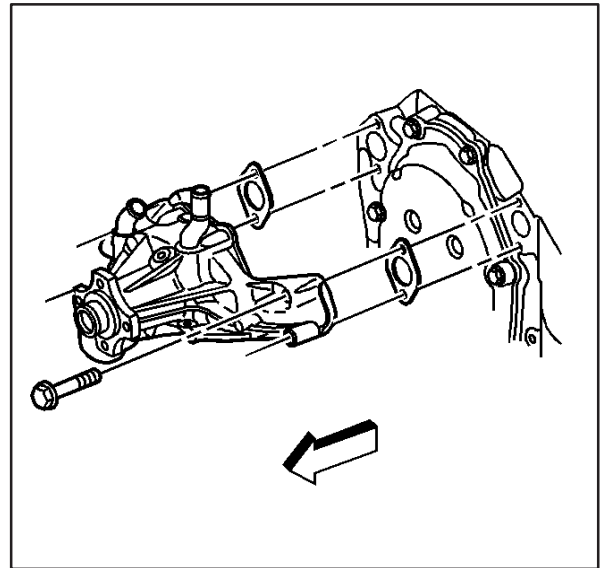
1. If reusing the fasteners, apply PTFE sealant or equivalent to the threads of the water pump bolts.
2. Install the water pump and the NEW water pump gaskets.

Notice: Refer to *Fastener Notice* in Cautions and Notices.

3. Install the water pump bolts.

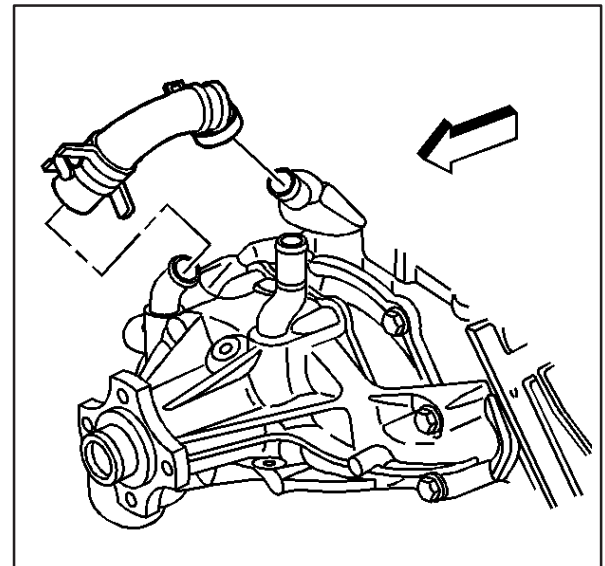
Tighten

Tighten the water pump bolts to 45 N·m (35 lb ft.).



Important: After final assembly, the water pump inlet hose clamp tangs (water pump end) must point forward and the upper tang should be level with the outside diameter of the water pump inlet hose.

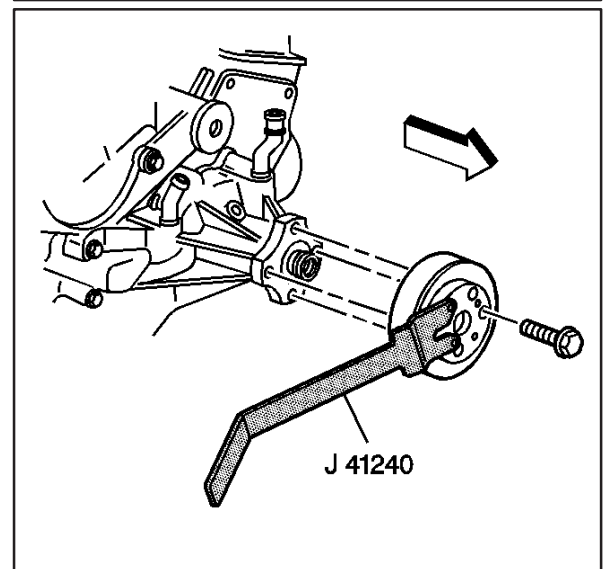
4. Install the water pump inlet hose and the water pump inlet hose clamps.



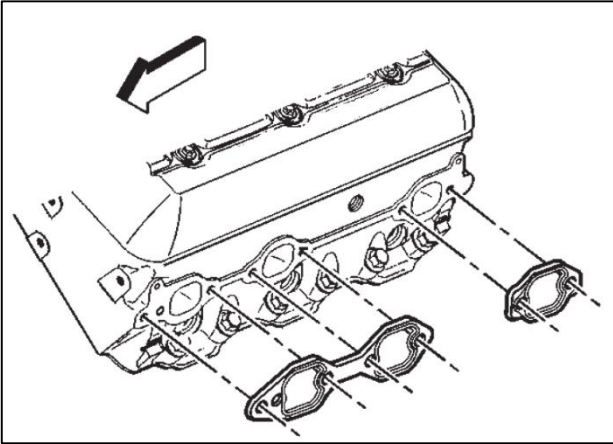
5. Install the fan and water pump pulley and bolts using the J 41240.

Tighten

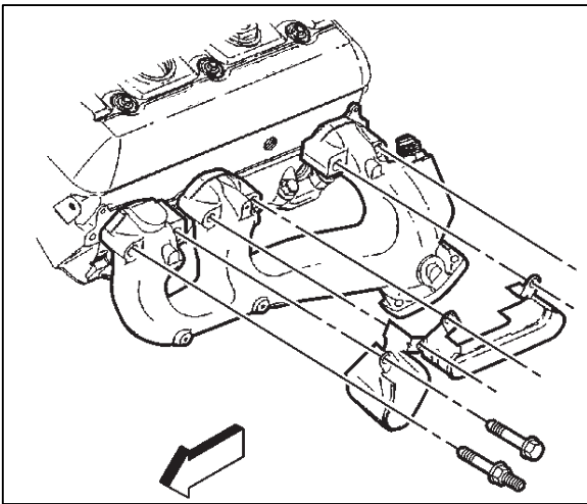
Tighten the fan and water pump pulley bolts to 35 lb ft.



Exhaust Manifold Installation (Left)



1. Install the NEW exhaust manifold gaskets.



2. Install the exhaust manifold.
3. Install the spark plug wire shields.

Notice: Refer to *Fastener Notice* in Cautions and Notices.

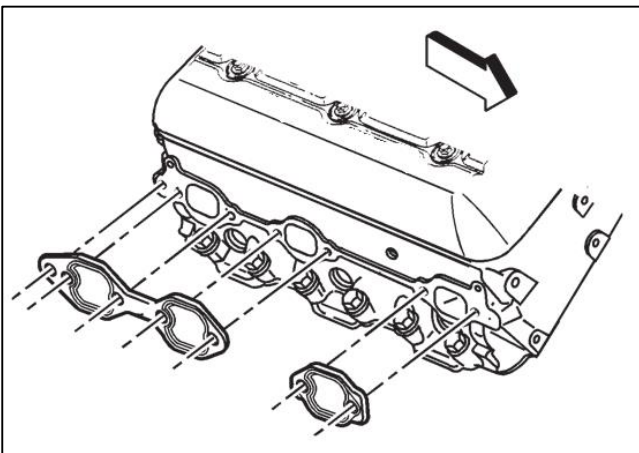
4. If reusing the fasteners, apply Blue Loctite or equivalent to the threads of the exhaust manifold bolts and stud.
5. Install the exhaust manifold bolts and stud.

Tighten

- 5.1. Tighten the exhaust manifold bolts and stud on the final pass to 35 lb ft.
6. Install the spark plug wires to the spark plug wire retainers.
7. Install the spark plug wires onto the spark plugs.

Exhaust Manifold Installation (Right)

1. Install the NEW exhaust manifold gaskets.



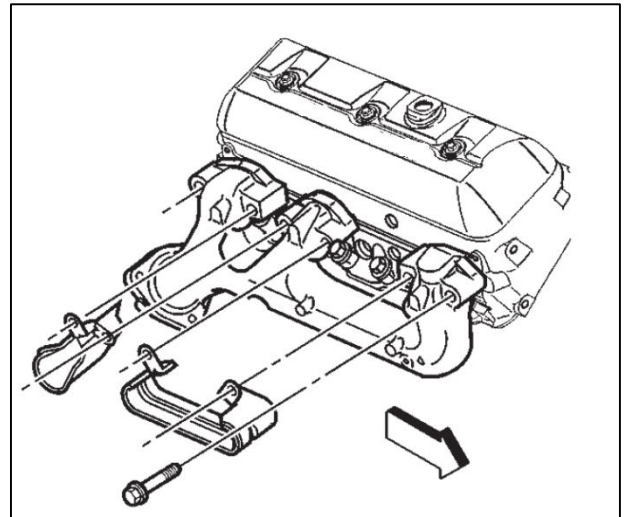
2. Install the exhaust manifold.
3. Install the spark plug wire shields.

Notice: Refer to *Fastener Notice* in Cautions and Notices.

4. If reusing the fasteners, apply Blue Loctite or equivalent to the threads of the exhaust manifold bolts and stud.
5. Install the exhaust manifold bolts and stud.

Tighten

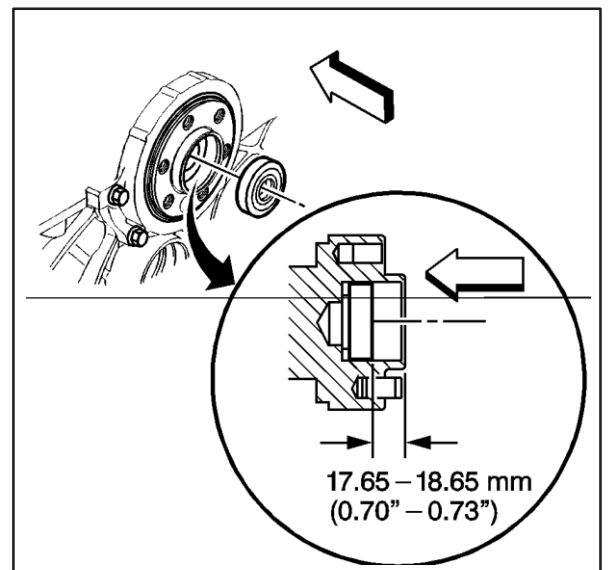
- 5.1. Tighten the exhaust manifold bolts and stud on the final pass to 35 lb ft.
6. Install the spark plug wires to the spark plug wire retainers.
7. Install the spark plug wires onto the spark plugs.



Clutch Pilot Bearing Installation

Caution: Refer to *Safety Glasses Caution in Cautions and Notices*.

1. Install the NEW clutch pilot bearing using a suitable clutch pilot bearing installation tool.
2. Measure to ensure the proper installation depth is obtained.

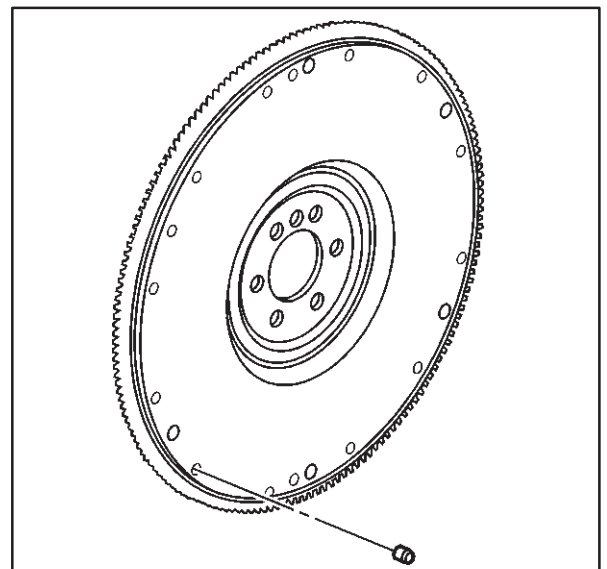


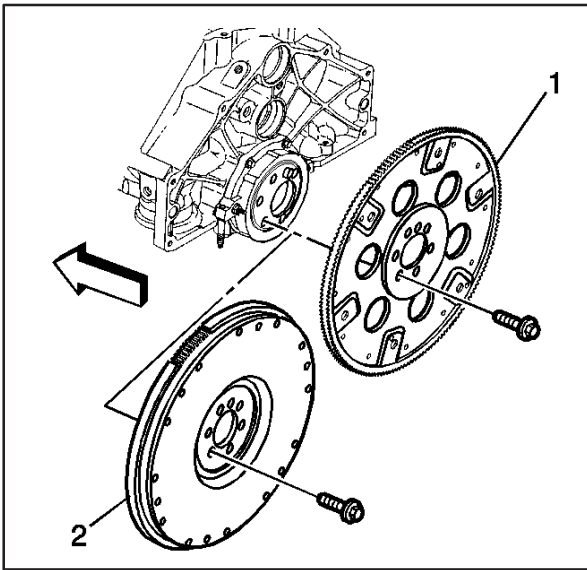
Engine Flywheel Installation

Important: If replacing the engine flywheel (manual transmission), note the position of the original flywheel weights (if applicable). Flywheel weights must be installed into the new engine flywheel in the same location as the old flywheel weights were in the old engine flywheel.

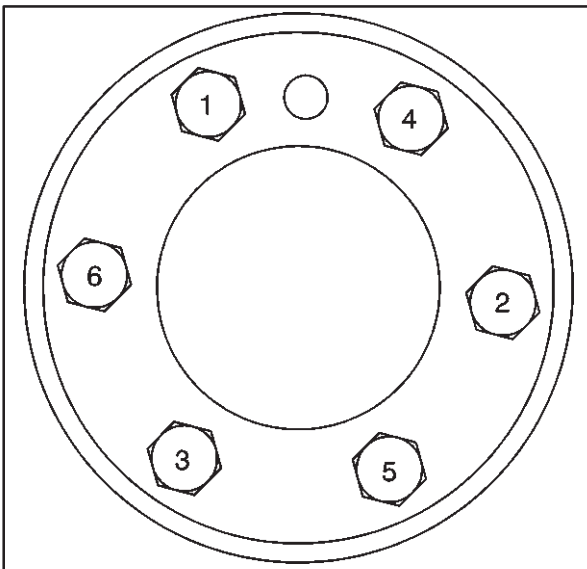
Note the position of the flywheel weights and install the NEW flywheel weights as required.

A properly installed flywheel weight will be flush or slightly below flush with the face of the engine flywheel.





1. Install the engine flywheel (1) or (2) to the crankshaft. Align the engine flywheel locator hole to the flywheel locator pin.



Notice: Refer to *Fastener Notice* in Cautions and Notices.

2. Install the engine flywheel bolts.

Tighten

Tighten the engine flywheel bolts in sequence (1-6) to 60 lb ft.

Engine Set-Up and Testing

After overhaul, the engine must be tested before it is installed in the vehicle. If a suitable test stand is not available, the following procedures can be used after the engine is installed in the vehicle.

1. Fill the crankcase with the proper quantity and grade of engine oil.
2. Add engine oil supplement GM P/N 1052367 or equivalent to the engine oil.

Notice: DO NOT use cooling system seal tabs (or similar compounds) unless otherwise instructed. The use of cooling system seal tabs (or similar compounds) may restrict coolant flow through the passages of the cooling system or the engine components. Restricted coolant flow may cause engine overheating and/or damage to the cooling system or the engine components/assembly.

3. Fill the cooling system with the proper quantity and grade of coolant.
4. With the ignition OFF or disconnected, crank the engine several times. Listen for any unusual noises or evidence that any of the parts are binding.
5. Start the engine and listen for unusual noises.
6. Check the vehicle oil pressure gauge or light and confirm that the engine has acceptable oil pressure.
If necessary, install an oil pressure gauge and measure the engine oil pressure.
7. Operate the engine at about 1,000 RPM until the engine has reached normal operating temperature.
8. Listen for improperly adjusted or sticking valves, sticking valve lifters or other unusual noises.
9. Inspect for oil and/or coolant leaks while the engine is operating.
10. Verify that the distributor is properly positioned.
11. Perform a final inspection for the proper engine oil and coolant levels.

Description and Operation

Engine Component Description

Balance Shaft

The cast iron balance shaft is mounted in the crankcase above and in-line with the camshaft. A camshaft gear drives the gear attached to the balance

shaft. The front end of the balance shaft is supported by a ball-type bearing. The rear end of the balance shaft uses a sleeve-type bearing.

Camshaft

The steel camshaft is supported by four bearings pressed into the engine block. The camshaft timing chain sprocket mounted to the front of the camshaft is driven by the crankshaft sprocket through a camshaft timing chain.

Crankshaft

The cast nodular iron crankshaft is supported by four crankshaft bearings. The number four crankshaft bearing at the rear of the engine is the end thrust bearing. The crankshaft bearings are retained by bearing caps that are machined with the engine block for proper alignment and clearances. The crankshaft position sensor reluctor ring has three lugs used for crankshaft timing and is constructed of powdered metal. The crankshaft position sensor reluctor ring has a slight interference fit onto the crankshaft and an internal keyway for correct positioning.

Cylinder Heads

The cast iron cylinder heads have one intake and one exhaust valve for each cylinder. A spark plug is located between the valves in the side of the cylinder head. The valve guides and seats are integral to the cylinder head. The 4.3L heavy duty applications have pressed in exhaust valve seats. The valve rocker arms are positioned on the valve rocker arm supports and retained by a bolt.

Engine Block

The cast iron engine block has six cylinders arranged in a V shape with three cylinders in each bank. Starting at the front side of the engine block, the cylinders in the left bank are numbered 1-3-5 and cylinders in the right bank are numbered 2-4-6 (when viewed from the rear). The firing order of the cylinders is 1-6-5-4-3-2. The cylinders are encircled by coolant jackets.

Exhaust Manifolds

The cast iron exhaust manifolds direct exhaust gases from the combustion chambers to the exhaust system. The left side exhaust manifold has a port for the EGR valve inlet pipe.

Valve Train

Motion is transmitted from the camshaft through the hydraulic roller valve lifters and the tubular valve

pushrods to the roller type valve rocker arms. The roller type valve rocker arm pivots on a needle type bearing in order to open the valve. The valve rocker arms for each bank of cylinders are mounted to a one piece valve rocker arm support. Each valve rocker arm is retained on the valve rocker arm support and the cylinder head by a bolt. The hydraulic valve lifters keep all the parts of the valve train in constant contact. Each hydraulic valve lifter acts as an automatic adjuster and maintains zero lash in the valve train. This eliminates the need for periodic valve adjustment.

Drive Belt System Description

The drive belt system consists of the following components:

- The drive belt
- The drive belt tensioner
- The drive belt idler pulley
- The crankshaft balancer pulley
- The accessory drive component mounting brackets
- The accessory drive components
 - The generator
 - The A/C compressor, if equipped
 - The engine cooling fan, if belt driven
 - The water pump, if belt driven

The drive belt system may use one belt or two belts. The drive belt is thin so that it can bend backwards and has several ribs to match the grooves in the pulleys. There also may be a V-belt style belt used to drive certain accessory drive components. The drive belts are made of different types of rubbers (chloroprene or EPDM) and have different layers or ply's containing either fiber cloth or cords for reinforcement.

Both sides of the drive belt may be used to drive the different accessory drive components. When the back side of the drive belt is used to drive a pulley, the pulley is smooth.

The drive belt is pulled by the crankshaft balancer pulley across the accessory drive component pulleys. The spring loaded drive belt tensioner keeps constant tension on the drive belt to prevent the drive belt from slipping. The drive belt tensioner arm will move when loads are applied to the drive belt by the accessory drive components and the crankshaft.

The drive belt system may have an idler pulley, which is used to add wrap to the adjacent pulleys. Some systems use an idler pulley in place of an accessory drive component when the vehicle is not equipped with the accessory.

New Product Information

The purpose of New Product Information is to highlight or indicate important product changes from the previous model year.

Changes may include one or more of the following items:

- A component comparison from the previous year
- Fastener changes
- Torque values and/or fastener tightening strategies
- Changed engine specifications
- New sealants and/or adhesives
- Disassembly and assembly procedure revisions
- Engine mechanical diagnostic procedure revisions
- New special tools required

Component Comparison

- Eliminated the oil filter adapter assembly
- Revised the water pump seal
- Revised the engine coolant thermostat
- New roller type timing chain and sprockets
- New roller pivot type valve rocker arm assemblies using a one piece valve rocker arm support to replace the ball pivot type valve rocker arm system
- Cylinder heads revised using dry holes for the valve rocker arm bolts

Torque Values and/or Fastener Tightening Strategies

- Cylinder head bolts, the crankshaft bearing cap bolts, the connecting rod bolts and balance shaft bolt apply a torque angle strategy.
In an on-vehicle situation where a torque angle meter may not fit into the vehicle packaging, a three step tightening process may be followed using a torque wrench.
- Certain fasteners should not be reused. Bolts, studs or other fasteners that must be replaced will be called out in the specific service procedures.

Changed Engine Specifications

Engine mechanical specifications are listed at the beginning of this manual.

New Sealants and/or Adhesives

No new sealants or adhesives have been added.

Disassembly and Assembly Procedure Revisions

- Valve rocker arm and pushrod
- Timing chain and sprockets
- Discard all used gaskets, seals or O-ring seals unless otherwise indicated
Gaskets, seals or O-ring seals that can be reused will be identified in the specific service procedure.

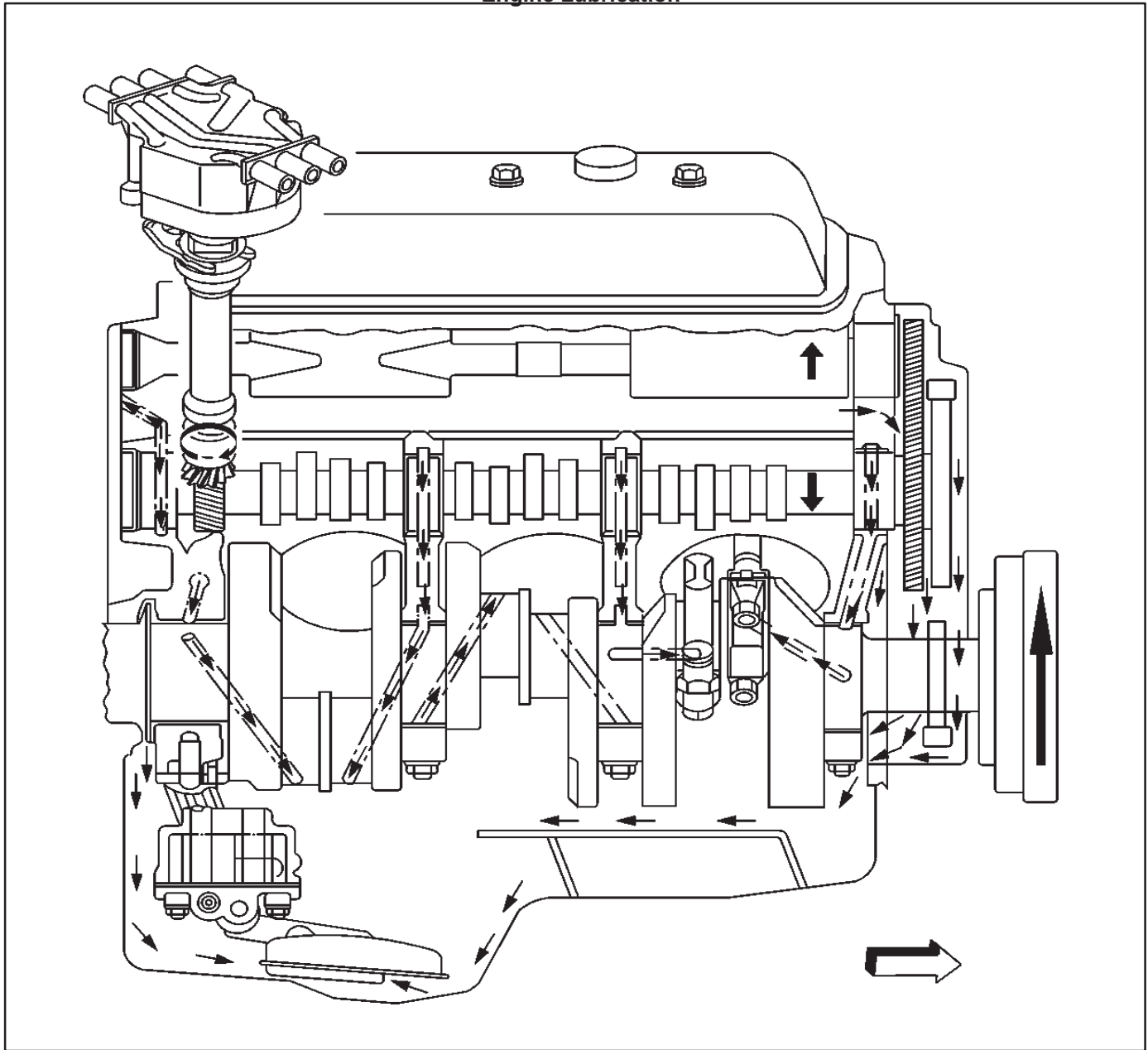
Engine Mechanical Diagnostic Procedure Revisions

- Valve Train diagnostic information is now provided in table form.
Potential or probable causes are supplied for each specific concern.
- Engine Noise diagnostic information is now provided in table form.
Potential or probable causes are supplied for each specific concern.

New Special Tools Required

No new special tools are required.

Engine Lubrication



Full pressure lubrication, through a full-flow oil filter is supplied by a gear-type oil pump. Oil is drawn up through the oil pump screen and passes through the pump to the oil filter. The oil filter is full-flow paper element unit with an anti-drain back valve. An oil filter bypass valve is used to ensure adequate oil supply, in the event the filter becomes plugged or develops excessive pressure drop. Filtered oil flows into the main gallery and then to the camshaft, the balance shaft, the rear bearing and the crankshaft bearings. The valve lifter oil gallery supplies oil to the valve lifters. Oil flows from the valve lifters through the hollow valve pushrods to the valve rocker arms. Oil drains back to the crankcase through the oil drain holes in the cylinder head. The camshaft timing chain is drip fed from the front camshaft bearing. The pistons and piston pins are lubricated by oil splash.

Cleanliness and Care

- Throughout this section, it should be understood that proper cleaning and protection of machined surfaces and friction areas is part of the repair procedure. This is considered standard shop practice even if not specifically stated.
- When any internal engine parts are serviced, care and cleanliness is important.
- When components are removed for service, the components should be marked, organized or retained in a specific order for re-assembly.
- At the time of installation, the components should be installed in the same location and with the same mating surface as when removed.
- An automobile engine is a combination of many machined, honed, polished and lapped surfaces with tolerances that are measured in millimeters or thousandths of an inch. The surfaces should be protected to avoid component damage.
- Apply a liberal amount of clean engine oil to friction areas during assembly.
- Proper lubrication will protect and lubricate friction areas during initial operation.

Replacing Engine Gaskets

Gasket Reuse and Applying Sealant

- Do not reuse any gasket unless specified.
- Gaskets that can be reused will be identified in the service procedure.
- Do not apply sealant to any gasket or sealing surface unless specified in the service procedure.

Separating Components

- Use a rubber mallet in order to separate the components.
- Bump the part sideways in order to loosen the components.
- Bumping of the component should be done at bends or reinforced areas of the component to prevent distortion of the components.

Cleaning Gasket Surfaces

- Use care to avoid gouging or scraping the sealing surfaces.
- Use a plastic or wood scraper in order to remove all the sealant from the components.
Do not use any other method or technique to remove the sealant or the gasket material from a part.
- Do not use abrasive pads, sand paper or power tools to clean the gasket surfaces.
 - These methods of cleaning can cause damage to

the component sealing surfaces.

- Abrasive pads also produce a fine grit that the oil filter cannot remove from the engine oil.
This fine grit is abrasive and can cause internal engine damage.

Assembling Components

- Assemble components using only the sealant (or equivalent) that is specified in the service procedure.
- Sealing surfaces must be clean and free of debris or oil.
- Specific components such as crankshaft oil seals or valve stem oil seals may require lubrication during assembly.
- Components requiring lubrication will be identified in the service procedure.
- Apply only the amount of sealant specified in the service procedure to a component.
- Do not allow the sealant to enter into any blind threaded holes, as the sealant may prevent the fastener from clamping properly or cause component damage when tightened.
- Tighten fasteners to the proper specifications. DO NOT over tighten the fasteners.

Use of RTV and Anaerobic Sealer

Sealant Types

Important: The correct sealant and amount of sealant must be used in the proper location to prevent oil leaks, coolant leaks or the loosening of the fasteners. DO NOT interchange the sealants. Use only the sealant (or equivalent) as specified in the service procedure.

The following 2 major types of sealant are commonly used in engines:

- Aerobic sealant [Room Temperature Vulcanizing (RTV)]
- Anaerobic sealant, which include the following:
 - Gasket eliminator
 - Pipe
 - Threadlock

Aerobic Type Room Temperature Vulcanizing (RTV) Sealant

Aerobic type Room Temperature Vulcanizing (RTV) sealant cures when exposed to air. This type of sealant is used where 2 components (such as the intake manifold and the engine block) are assembled together.

Use the following information when using RTV sealant:

- Do not use RTV sealant in areas where extreme temperatures are expected. These areas include:
 - The exhaust manifold
 - The head gasket
 - Any other surfaces where a different type of sealant is specified in the service procedure
- Always follow all the safety recommendations and the directions that are on the RTV sealant container.
- Use a plastic or wood scraper in order to remove all the RTV sealant from the components.

Important: Do not allow the RTV sealant to enter any blind threaded holes, as it may prevent the fasteners from clamping properly or cause damage when the fastener is tightened.

The surfaces to be sealed must be clean and dry.

- Use a RTV sealant bead size as specified in the service procedure.
- Apply the RTV sealant bead to the inside of any bolt hole areas.
- Assemble the components while the RTV sealant is still wet to the touch (within 3 minutes). Do not wait for the RTV sealant to skin over.
- Tighten the fasteners in sequence (if specified) and to the proper torque specifications. DO NOT over tighten the fasteners.
- The threaded surfaces must be clean and dry.
- Apply the threadlock sealant as specified on the threadlock sealant container.

Important: Fasteners that are partially torqued and then the threadlock sealant allowed to cure more than five minutes, may result in incorrect clamp load of assembled components.

Anaerobic Type Gasket Eliminator Sealant

Anaerobic type gasket eliminator sealant cures in the absence of air. This type of sealant is used where 2 rigid parts (such as castings) are assembled together. When 2 rigid parts are disassembled and no sealant or gasket is readily noticeable, then the 2 parts were probably assembled using an anaerobic type gasket eliminator sealant.

Use the following information when using gasket eliminator sealant:

- Always follow all the safety recommendations and directions that are on the gasket eliminator sealant container.
- Apply a continuous bead of gasket eliminator sealant to one flange.

The surfaces to be sealed must be clean and dry.

Important: Do not allow the gasket eliminator sealant to enter any blind threaded holes, as the gasket eliminator sealant may prevent the fasteners from clamping properly, seating properly or cause damage when the fastener is tightened.

Apply the gasket eliminator sealant evenly to get a uniform thickness of the gasket eliminator sealant on the sealing surface.

Important: Gasket eliminator sealed joint fasteners that are partially torqued and the gasket eliminator sealant allowed to cure more than 5 minutes, may result in incorrect shimming and sealing of the joint.

- Tighten the fasteners in sequence (if specified) and to the proper torque specifications. DO NOT over tighten the fasteners.
- After properly tightening the fasteners, remove the excess gasket eliminator sealant from the outside of the joint.

Anaerobic Type Threadlock Sealant

Anaerobic type threadlock sealant cures in the absence of air. This type of sealant is used for thread locking and sealing of bolts, fittings, nuts and studs. This type of sealant cures only when confined between 2 close fitting metal surfaces.

Use the following information when using threadlock sealant:

- Always follow all safety recommendations and directions that are on the threadlock sealant container.

the proper torque specification. DO NOT over tighten the fasteners.

Anaerobic Type Pipe Sealant

Anaerobic type pipe sealant cures in the absence of air and remains pliable when cured. This type of sealant is used where 2 parts are assembled together and require a leak proof joint.

Use the following information when using pipe sealant:

- Do not use pipe sealant in areas where extreme temperatures are expected. These areas include:
 - The exhaust manifold
 - The head gasket
 - Surfaces where a different sealant is specified
- Always follow all the safety recommendations and directions that are on the pipe sealant container.
- Their surfaces to be sealed must be clean and dry.
- Use a pipe sealant bead of the size or quantity as specified in the service procedure.

Important: Do not allow the pipe sealant to enter any of the blind threaded holes, as the pipe sealant may prevent the fastener from clamping properly, or cause component damage when the fastener is tightened.

- Apply the pipe sealant bead to the inside of any bolt hole areas.
- Apply a continuous bead of pipe sealant to 1 sealing surface.
- Tighten the fasteners in sequence (if specified) and to the proper torque specifications. DO NOT over tighten the fasteners.

Separating Parts

Important: Many internal engine components will

develop specific wear patterns on their friction surfaces.

When disassembling the engine, internal components MUST be separated, marked and organized in a way to ensure reinstallation to the original location and position.

Mark or identify the following components:

-
- Piston and the piston pin
 - Piston to the specific cylinder bore
 - Piston rings to the specific cylinder bore
 - Connecting rod to the crankshaft journal
 - Connecting rod to connecting rod cap
 - Crankshaft bearings and connecting rod bearings
 - Engine camshaft and valve lifters
 - Valve lifters, valve rocker arms and valve rocker arm supports
 - Valve to the valve guide
 - Valve spring to cylinder head location
 - Engine block bearing cap location and direction
 - Oil pump drive and driven gears

Tools and Equipment

Special tools are listed and illustrated throughout this section with a complete listing at the end of the section. The tools (or equivalents) are specially designed to

quickly and safely accomplish the operations for which the tools are intended. The use of special tools will also minimize possible damage to engine components. Some precision measuring tools are required for inspection of certain critical components. Torque wrenches and a torque angle meter are necessary for the proper tightening of various fasteners.

To properly service the engine assembly, the following items should be readily available:

- Approved eye protection and safety gloves
- A clean, well-lit, work area
- A suitable parts cleaning tank
- A compressed air supply
- Trays or storage containers to keep parts and fasteners organized
- An adequate set of hand tools
- Approved engine repair stand
- An approved engine lifting device that will adequately support the weight of the components

Special Tools and Equipment

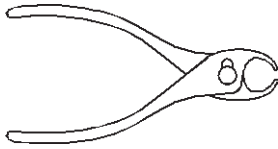
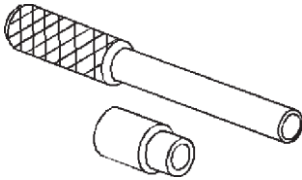
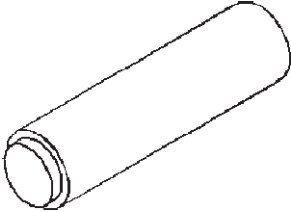
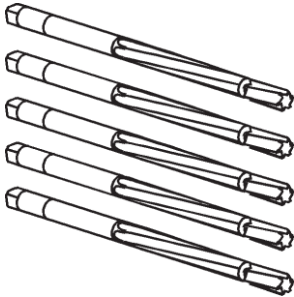
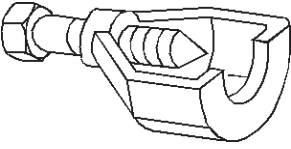
Illustration	Tool Number/Description
	J 3049-A Valve Lifter Remover
	J 5239 Connecting Rod Bolt Guide Set
	J 5590 Installer
	J 5830-02 Valve Guide Reamer Set
	J 5825-A Crankshaft Gear Remover

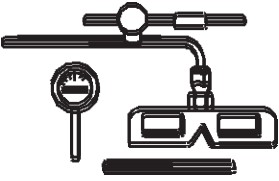
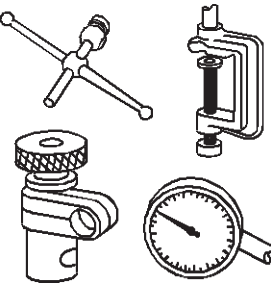
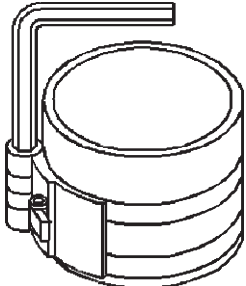
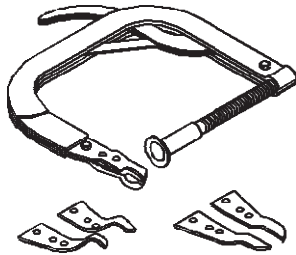
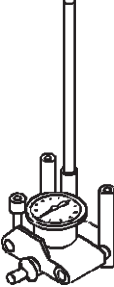
Illustration	Tool Number/Description
	J 7872 Magnetic Base Dial Indicator
	J 8001 Dial Indicator Set
	J 8037 Ring Compressor
	J 8062 Valve Spring Compressor
	J 8087 Cylinder Bore Gauge

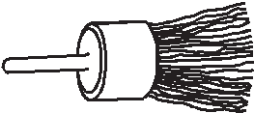
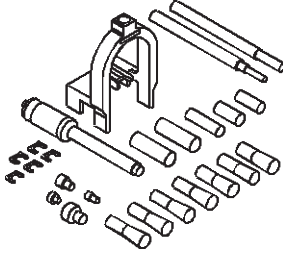

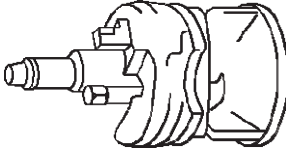
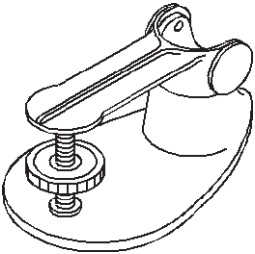
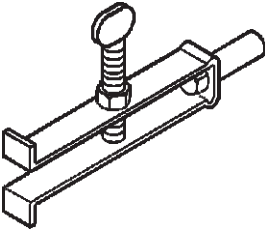

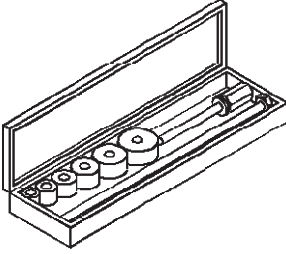
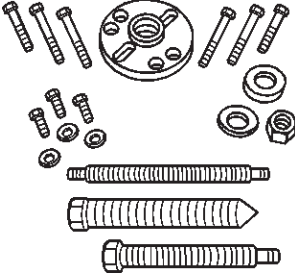
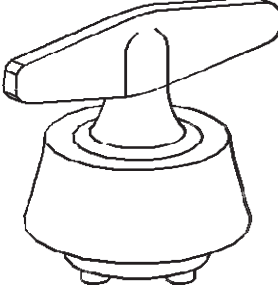
Illustration	Tool Number/Description	Illustration	Tool Number/Description
	<p>J 8089 Carbon Removing Brush</p>		<p>J 24086-C Piston Pin Remover/Installer</p>
	<p>J 8092 Universal Driver Handle</p>		<p>J 24270 Cylinder Bore Ridge Reamer</p>
	<p>J 9666 Valve Spring Tester</p>		<p>J 26941 Bushing/Bearing Remover</p>
	<p>J 21882 Oil Suction Pipe Installer</p>		<p>J 33049 Camshaft Bearing Service Kit</p>
	<p>J 23523-F Balancer Remover and Installer</p>		<p>J 35621-B Rear Main Seal Installer</p>

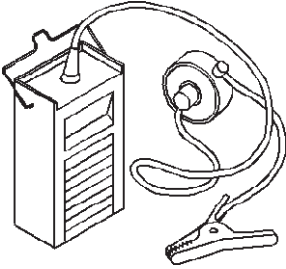
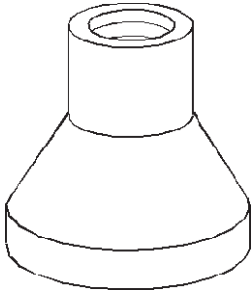
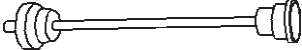
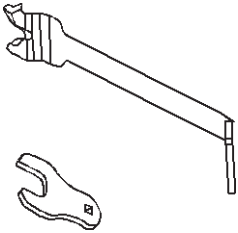
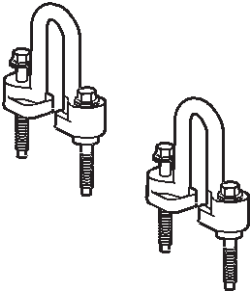
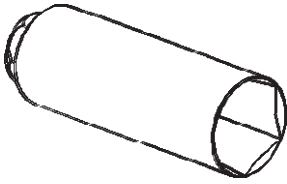
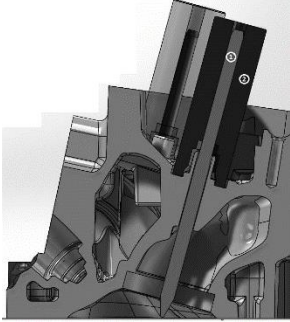
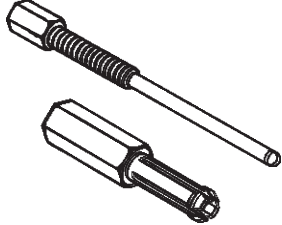

Illustration	Tool Number/Description
	<p>J 36660 Electronic Torque Angle Meter</p>
	<p>J 36996 Balance Shaft Installer</p>
	<p>J 38834 Balance Shaft Service Kit</p>
	<p>J 41240 Fan Clutch Remover and Installer</p>
	<p>J 41427 Engine Lift Bracket</p>

Illustration	Tool Number/Description
	<p>J 41712 Oil Pressure Switch Socket</p>
	<p>SK6970 Valve Stem Seal Installer (shown as item 1 & 2)</p>
	<p>J 43276 Clutch Pilot Bearing Remover</p>
	<p>J 43690 Rod Bearing Clearance Checking Tool</p>