

# OPERATION AND SERVICE

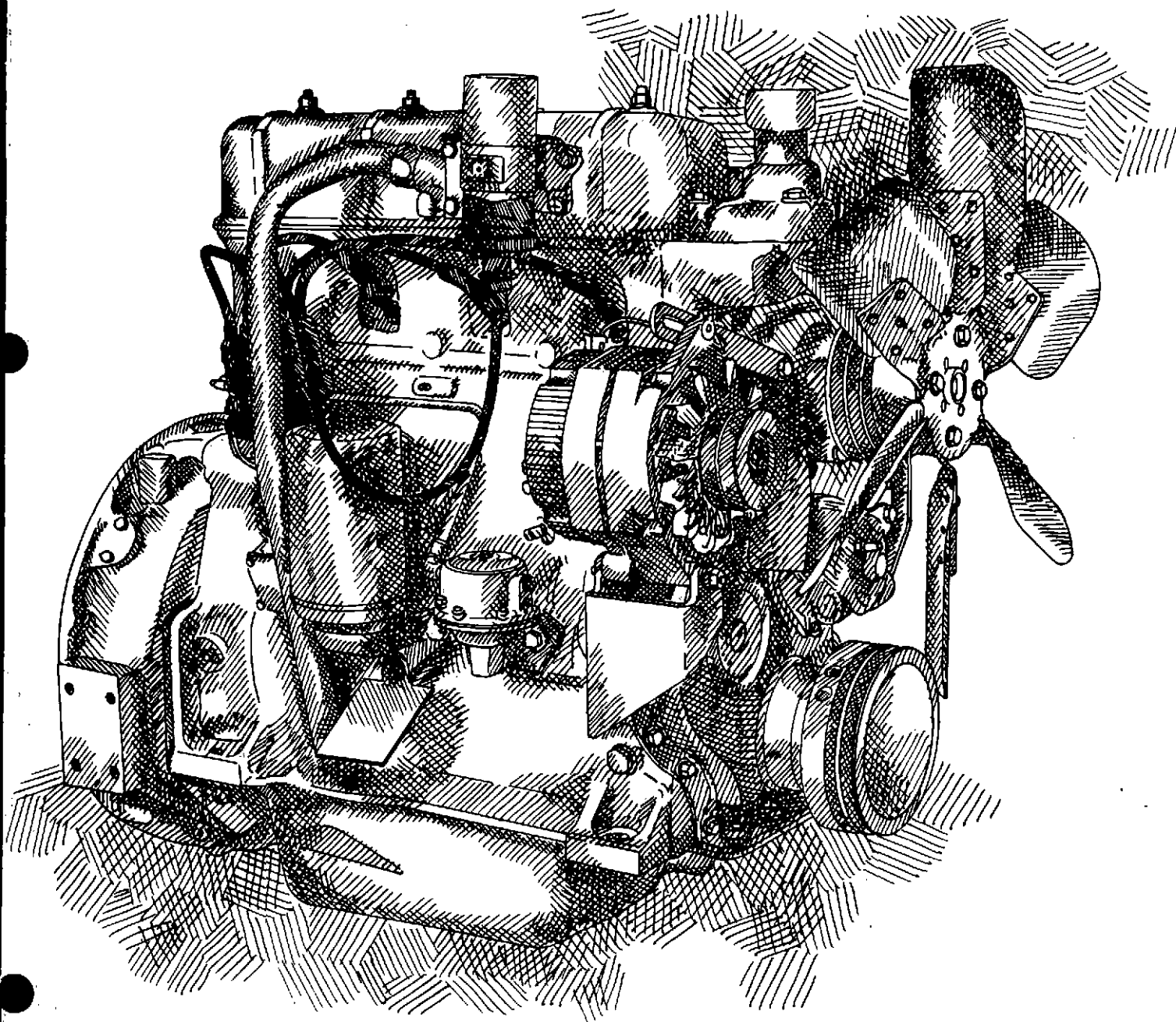

VR SERIES

**OPERATION  
AND  
SERVICE  
MANUAL**

**WAUKESHA VR SERIES  
GAS AND DIESEL ENGINES**

**VRD155**

**VRG155**

**VRD232**

**VRG232**

**VRG265**

**VRD283**

**VRG283**

**VRD310**

**VRG310**

**Waukesha**

**DRESSER**

## SAFETY PRECAUTIONS

### EXHAUST GASES

The exhaust products of an internal combustion engine are toxic and may cause injury or death if inhaled. All engine installations, especially those within a closed shelter or building, should be equipped and maintained with an exhaust discharge pipe so that exhaust gases are delivered into the outside air. A closed building or shelter must be adequately vented. A means of providing fresh air into a closed building or shelter is necessary.

### ENGINE FUELS

All internal combustion engine fuels are highly combustible and may ignite or explode. Fuels must be conducted to the engine with proper piping, free from leaks, and designed to resist breakage from vibration. When filling fuel tanks, never smoke or use open flame in the immediate area. Fuel tanks should be grounded to prevent buildup of static electricity.

### POSITIVE FUEL SHUT-OFF

All engine installations should be equipped with a means of positive fuel shut-off for emergency use when fuel is conducted to the engine from a remote source. Fuels under pressure such as natural gas or liquified petroleum gas, should be controlled by a positive shut-off valve, preferably automatic, other than those integral with the carburetor or gas pressure regulation equipment. It shall be the final responsibility of the engine owner to ensure that the installation is free from fuel or exhaust leakage, and such installation meets all applicable codes.

### GAS USED TO ENERGIZE STARTERS

Gas used to energize starters must be discharged away from the engine into a harmless area. Ignition connections and electrical equipment on engines exposed to potentially explosive ambient atmospheres should be specially equipped to eliminate spark hazard and it is the responsibility of the engine owner to specify or provide such connections and equipment.

### SAFETY GUARDS

Internal combustion engines must be properly provided with guards against hazards to persons or structures in close proximity to rotating or heated parts and it is the responsibility of the engine owner to specify or provide such protection.

### CRANKCASE ANTI-EXPLOSION VALVES

These valves must be kept in proper working condition to relieve crankcase pressure when regulations require their installation on engine crankcases.

### IGNITION SYSTEMS

Breakerless, magneto and battery ignition systems can cause electrical shocks. Avoid contacting these units or their wiring. The reaction from the shock could cause persons to fall or jerk their hands, thus striking other objects and injuries could occur.

### ENGINE SURGE TANK AND RADIATOR PRESSURE CAPS AND CONNECTIONS

Do not remove the pressure caps while the engine is operating or while coolant is hot. The cooling system is under pressure and severe burns could result from the hot coolant spewing out when cap is removed. Wait until engine and coolant have cooled down before removing radiator or surge tank caps. Always replace weak hoses, lines, and fittings.

### FUEL INJECTORS

Never allow an injector to spray against the skin. The fuel oil will penetrate the skin and may cause serious infection and injury.

## GENERATOR SETS

The voltage produced by generator sets is dangerous to personnel coming in contact with any part of the electrical system during operation. Severe, possibly fatal, shock may result. Make sure the generator set is grounded before operation. Be extremely careful when the unit or surrounding area is damp or wet.

When servicing any part of the electrical system or making any connections, make sure main power switch is OFF. Clean or service generator set only when engine is shut down.

In case of an accident from electrical shock, shut down the generator set at once. If it cannot be shut down, free the victim from the live conductor. Avoid direct contact with the victim. Use a dry board, dry rope, or any nonconducting implement to free the victim. If the victim is unconscious, apply artificial respiration and get medical help.

Do not operate the generator set with the ammeter circuit open. Voltage, dangerous to both equipment and personnel, can be generated in an open secondary circuit of a current transformer.

If the generator set is stopped by operation of safety devices, do not attempt to operate it until the cause has been eliminated.

When the generator set is shut down after operation, disconnect all line switches to all external power load and parallel circuits.

## ENGINE AND EQUIPMENT, REPAIR AND SERVICE

Always stop the engine before cleaning, servicing, or repairing the engine or driven equipment. Place all controls in off position to prevent accidental restarting. Before restarting, make sure that all tools and other material are removed from the engine and equipment.

Proper service and repair is important to the safe reliable operation of engines and related equipment. The procedures recommended by Waukesha in this manual are effective methods for performing service and repair operations. Some of these procedures require the use of specially designed tools. The special tools should be used when and as recommended. Anyone who uses a service, repair, or installation procedure not recommended by Waukesha must first satisfy themselves thoroughly that their safety will not be jeopardized by the service methods they select.

## HOUSEKEEPING

Good housekeeping results in a clean, safe work area. An orderly work area with clean walkways and neatly arranged tools and equipment is conducive to better work performance and morale, and is a major factor in accident prevention. Accidents resulting from poor housekeeping include tripping over loose objects on the floor, stairs, or platforms, slipping on greasy, oily, wet, or dirty floors, falling of poorly piled material, and cuts from sharp edges.

## ENGINE FAN BLADES

If a fan blade or fan drive shaft is bent or damaged in any way, it should be replaced. No attempt should be made to repair the damaged parts. Fan assemblies must remain in proper balance. When damaged, an unbalanced fan can fly apart during use and create an extremely dangerous condition.

## TURBOCHARGERS

Turbochargers are specifically designed for applicable engine horsepower and altitude ratings. Nozzle rings must not be changed without consulting the engine manufacturer since they limit turbocharger rpm. Excessive rpm may result in turbocharger failure with resultant personal safety hazards. Turbochargers operate at high temperatures. Therefore, all flammable material must be kept away from them. Engines must be shut down and at room temperature before working on turbochargers or burns will result.

## ENGINE STORAGE CHEMICALS

Nucle-Oil contains Petroleum Distillate. Harmful or fatal if swallowed. Avoid contact with skin. Vapor is harmful. Causes irritation of eyes, nose, throat and skin. Use only with adequate ventilation. Avoid prolonged or repeated breathing of vapor. Avoid contact with skin, eyes, and clothing. Do not take internally. Keep container closed and away from heat. Always read and observe the "CAUTION" labels on the containers. Do not destroy the labels on the containers.

Generally speaking, heating of preservative compounds is confined to 200°F. (93°C.) or less. These temperatures are easily reached by placing the preservative container in heated water. If this is done, the container must be vented or opened to reduce the danger of explosion. Direct heating presents a dangerous and unnecessary fire hazard.

#### FIRE PROTECTION

Locate fire extinguishers so that they are easily accessible if a fire starts. Carefully maintain records of extinguisher inspection and recharging to ensure the fire extinguishing capabilities when required. Consult your fire extinguisher supplier or insurance engineer for recommendations on the type, size, and quantity of fire extinguishers required for the engine installation. Select alternate routes of escape from any engine installation and post such routes in accordance with local and government requirements.

#### CLEANING SOLVENTS

Use approved cleaning solvents in a well ventilated area. Avoid breathing fumes. Keep away from open flames or sparks. Do not use gasoline or paint thinners or other highly volatile fluids for cleaning. Breathing carbon tetrachloride or carbon disulfide fumes can be fatal. Always read and observe the "CAUTION" labels on containers. Do not destroy the labels on the containers. Cleaning solvents can cause various types of skin irritations.

#### WELDING EQUIPMENT

If a welding gas cylinder is damaged by falling or being struck, it could burst with destructive force. Cylinders must be stored in accordance with manufacturer's specifications and applicable safety requirements.

When welding, brazing or cutting with acetylene, check valves should be installed between the regulators and hoses to prevent flashback into the regulators and supply tanks. Without these check valves, the flashback could cause the regulators and supply tanks to explode.

Oily and greasy materials must be kept away from oxygen valves, hoses, etc. Oxygen may combine with such materials and an explosive reaction could result.

Always wear protective eye shields when welding, cutting or watching a welding operation. Protective clothing and face shields must be worn. Do not weld or cut near combustible materials.

#### ELECTRIC POWER TOOLS

Be certain the electric tool is properly grounded. Wear proper eye protection. Do not work in wet or damp conditions. Be sure the tool is in good condition and safety guards are in position. An electric trouble light must also be grounded. Do not carry electric power tools by the cord. Do not yank the cord when removing from outlet; instead grasp the plug to remove it from outlet.

#### LEAD ACID BATTERIES

Always disconnect the battery ground connection from batteries before performing any work on the engine or equipment. This will prevent sparks or burns when accidentally shorting an electrical connection.

Never expose batteries to open flame or electric spark. Battery action generates hydrogen gas which is flammable and explosive. Don't allow battery fluid to contact skin, eyes, fabrics, or painted surfaces. Battery fluid is a sulfuric acid solution which could cause serious personal injury or property damage. Wear eye protection when working with batteries.

#### PRECAUTIONS WHEN USING BOOSTER BATTERIES AND CABLES

Do not attempt to jump start an engine having a frozen battery because the battery may rupture or explode. If a frozen battery is suspected, examine all fill vents on the battery. If ice can be seen, or if the electrolyte fluid cannot be seen, do not attempt to start with jumper cables.

Both charged and discharged batteries should be treated carefully when using jumper cables. The following procedures assist in reducing sparks and explosion hazards always present in both batteries when connecting charged batteries to discharged batteries.

Turn off all electrical loads. Remove vent caps and lay a damp cloth over open vent wells of each battery. The charged booster battery or batteries must have the same voltage capacity as the discharged battery or batteries.

The positive post is identified by a +, pos. and red color and is larger in diameter than the negative post.

The negative post is identified by a -, neg. and gray color.

#### Negative Grounded Battery or Batteries

First, connect one jumper cable from the positive post on charged battery or batteries to positive post on discharged battery or batteries. If more than one battery is connected in "series" or "series parallel" connect jumper cable to positive post that has cable leading to starting motor.

Second, connect other jumper cable from negative post on charged battery or batteries to a good ground on engine.

When removing jumper cables, always disconnect the ground jumper cable from the engine before disconnecting the other jumper cable.

#### Positive Grounded Battery or Batteries

Same procedure as for negative grounded battery or batteries, except the negative post will have the cable leading to the starting motor and the positive post will be grounded.

#### COMPRESSED AIR

Compressed air or gases should never be used to clean clothing or body of foreign materials. A highly compressed stream of air flowing through a very small opening can pierce the skin and cause severe and very painful injury. Never use your hand to check air, gas, or liquid flow rates. Do not engage in "horseplay" with air, gas, or liquid hoses. Observe all applicable regulations as related to compressed gases.

#### SODIUM FILLED VALVES

When handling sodium filled valves always wear approved safety goggles, a hat or cap, long sleeves, and gloves. If refacing sodium filled valves is required, do not exert undue force at the grinding wheel as this could crack the hollow valve stem and allow the sodium to escape.

Do not handle broken sodium filled valves with bare hands as the sodium or sodium residue can cause severe burns. Sodium burns on the skin are of the same nature as caustic burns. They must be washed with large volumes of cold water before being neutralized with vinegar. The affected parts should then be treated as a burn and medical attention sought.

If a broken valve should ignite, it may be extinguished by smothering in dry soda ash or dry sand. The smoke and fumes are irritating; adequate ventilation should be provided and inhalation or contact with the smoke and fumes avoided. Water, carbon dioxide in any form, or carbon tetrachloride should never be used on sodium fires since these materials react violently with hot sodium.

Broken sodium filled valves may be stored prior to disposal in moisture free clean oil or kerosene. Unserviceable sodium filled valves must be disposed of in accordance with local, state and/or federal regulations as applicable.

#### INTOXICANTS AND NARCOTICS

Workers under the influence of intoxicants and/or narcotics are unsafe workers and are a hazard to themselves and other employees.

#### SAFE DRESS

When around machinery, loose clothing, neckties, rings, wrist watches, bracelets, etc., should not be worn. Severe injuries have resulted from this all too common practice.

#### HAIR LENGTH

Long hair worn around rotating equipment is dangerous. Hair is charged with static electricity and can be drawn to a piece of rotating machinery like a magnet. Persons with long hair must wear complete head covering when around rotating machinery.

#### NOISE PROTECTION

Wear O.S.H.A. approved hearing protection devices when around excessive noise.

#### FOOT PROTECTION

Wear O.S.H.A. approved steel tip safety shoes.

#### HEAD PROTECTION

Wear O.S.H.A. approved safety helmets.

#### EYE PROTECTION

Wear O.S.H.A. approved eye shields, safety glasses, and sweat bands.

#### RESPIRATORY SYSTEM PROTECTION

Wear O.S.H.A. approved equipment when near dust and toxic fumes to protect the eyes and respiratory system. This type of equipment must be checked and maintained on a regular basis.

#### REFERENCES

For details on safety rules and regulations in the United States, contact your local Occupational Safety and Health Administration (O.S.H.A.).

The publication of these safety precautions is done for your information. The Waukesha Engine Division, Dresser Industries, Inc. does not, by the publication of these precautions, imply or in anyway represent that these published precautions are the sum of all dangers present near industrial engines. If you are operating industrial engines, it is your responsibility to insure that such operation is in full accordance with all applicable safety requirements and codes. All requirements of the United States Federal Occupational Safety and Health Administration Act must be met when Waukesha Engines are operated in areas that are under the jurisdiction of that United States Department. Engines operated in countries other than the United States of America must be installed, operated and serviced in accordance and compliance with any and all safety requirements of that country which may be applicable.

The logo consists of the word "Waukesha" in a bold, sans-serif font on the left, and the word "DRESSER" in a bold, sans-serif font inside an oval shape on the right.

## Waukesha Engine Division Dresser Industries, Inc.

### WARRANTY AND LIMITATION OF REMEDY AND LIABILITY

Effective September 1, 1976

A. Seller warrants only that its products and parts, when shipped, and its work (including start-up), when performed, will meet all applicable specifications and other specific product and work requirements, including those of performance, if any, of this agreement, and will be free from defects in material and workmanship. With respect to products, parts and work not manufactured or performed by Seller, Seller's only obligation shall be to assign to Buyer, to the extent possible, whatever warranty Seller receives from the Manufacturer. All claims for defective products or parts under this warranty must be made in writing immediately upon discovery and, in any event, within eighteen (18) months after shipment, but not to exceed twelve (12) months of service or 4000 operating hours after initial startup, whichever occurs first, and all claims for defective work must be made in writing immediately upon discovery and in any event within one (1) year of completion thereof by Seller. Defective items must be held for Seller's inspection and if requested by Seller returned to the original f.o.b. point, transportation prepaid. **THE FOREGOING IS EXPRESSLY IN LIEU OF ALL OTHER WARRANTIES WHATSOEVER, EXPRESS, IMPLIED AND STATUTORY INCLUDING WITHOUT LIMITATION THE IMPLIED WARRANTIES TO MERCHANTABILITY AND FITNESS.** It is understood that Seller's warranty shall not apply to products or parts, which in Seller's opinion, have been damaged as a result of overloading, overspeeding, overheating, inadequate maintenance, accident or improper installation or storage.

B. Upon Buyer's submission of a claim as provided above and its substantiation Seller shall at its option either (i) repair or replace its product, part or work at the business establishment of a Waukesha Distributor or other location authorized by Waukesha, during said Distributor's normal business hours. This Warranty does not include reimbursement of any costs for transporting the product or part to such establishment, or for removal or reinstallation of a product when necessary in connection with a Warranty repair, or (ii) refund an equitable portion of the purchase price. In no event shall Seller be liable for the cost of labor in connection with replacement or repair of defective parts when the engine or power unit has been in the possession of the using owner or rental operator for a period of six (6) months or longer.

C. **THE FOREGOING IS SELLER'S ONLY OBLIGATION AND BUYER'S EXCLUSIVE REMEDY FOR BREACH OF WARRANTY AND, EXCEPT FOR GROSS NEGLIGENCE WILLFUL MISCONDUCT AND REMEDIES PERMITTED UNDER THE PERFORMANCE, INSPECTION AND ACCEPTANCE AND THE PATENTS CLAUSES HEREOF, THE FOREGOING IS BUYER'S EXCLUSIVE REMEDY AGAINST SELLER FOR ALL CLAIMS ARISING HEREUNDER OR RELATING HERETO WHETHER SUCH CLAIMS ARE BASED ON BREACH OF CONTRACT, TORT (INCLUDING NEGLIGENCE AND STRICT LIABILITY) OR OTHER THEORIES; BUYER'S FAILURE TO SUBMIT A CLAIM AS PROVIDED ABOVE SHALL SPECIFICALLY WAIVE ALL CLAIMS FOR DAMAGES OR OTHER RELIEF, INCLUDING BUT NOT LIMITED TO CLAIMS BASED ON LATENT DEFECTS. IN NO EVENT SHALL BUYER BE ENTITLED TO INCIDENTAL OR CONSEQUENTIAL DAMAGES. ANY ACTION ARISING HEREUNDER OR RELATING HERETO WHETHER BASED ON BREACH OF CONTRACT, TORT (INCLUDING NEGLIGENCE AND STRICT LIABILITY) OF OTHER THEORIES, MUST BE COMMENCED WITHIN ONE (1) YEAR AFTER THE CAUSE OF ACTION ACCRUES OR IT SHALL BE BARRED.**

## Distributor Directory

## UNITED STATES

## ALABAMA

**BIRMINGHAM, 35233**  
Carlross Well Supply Company  
Branch Office  
2901 - 3rd Avenue, South  
Phone: (205) 324-0689  
Main Office - See Tennessee

## ALASKA

**ANCHORAGE, 99502**  
Waukesha-Alaska Corporation  
239 E. International Airport Road  
Phone: (907) 278-9651

## ARIZONA

**PHOENIX, 85005**  
Arizona Engine & Pump Co.  
P. O. Box 6159, Capital Station  
Phone: (602) 252-1731

**CASA GRANDE, 85222 - Branch Office**  
806 West Gila Bend Highway  
Phone: (602) 838-8731

## ARKANSAS

**FT. SMITH, 72901 - Branch Office**  
Waukesha-Pearce Industries, Inc.  
S. 32nd at Waco St.  
P. O. Box 6312  
Phone: (501) 646-4396

## CALIFORNIA

**EMERYVILLE, 94608**  
King-Knight Company  
8202 Christie Avenue  
Phone: (415) 658-9400

**COMPTON, 90221**  
Waukesha Engine Servicer, Inc.  
17803 S. Santa Fe Avenue  
Phone: (213) 774-5700

**BAKERSFIELD, 93301 - Branch Office**  
1221 - 33rd Street  
Phone: (805) 327-7571

**VENTURA, 93001 - Branch Office**  
1636 N. Ventura Avenue  
Phone: (805) 648-1865

**EMERYVILLE, 94608**  
Waukesha Engine Division  
(Western Regional Office)  
1900 Powell St., Suite 455  
Phone: (415) 653-1824

## COLORADO

**DENVER, 80239**  
PAMCO  
P. O. Box 39068  
10777 East 45th Avenue  
Phone: (303) 371-0330

## FLORIDA

**FORT LAUDERDALE, 33305**  
Melley Energy Systems, Inc.  
2501 N. E. 13th Avenue  
Phone: (805) 565-5567

**JACKSONVILLE, 32205**  
Gator Service & Supply, Inc.  
5213 Edgewood Ct.  
P. O. Box 37446  
Phone: (904) 783-1280

## GEORGIA

**ATLANTA, 30315**  
Southeastern Engine & Generator, Inc.  
1170 Sylvan Rd., S.W.  
Phone: (404) 752-5188, 752-9273

**DECATUR, 30035**  
Waukesha Engine Division  
(Southeastern Regional Office)  
4336 Covington Highway  
Suite 204C  
Phone: (404) 289-0960

## ILLINOIS

**VILLA PARK, 60181**  
Charles Equipment Company  
P. O. Box 368  
187 East North Avenue  
Phone: (312) 834-6000

**GRAYVILLE, 62844**  
Oil Field Motor Service, Inc.  
P. O. Box 98  
Phone: (618) 375-2151

## INDIANA

**INDIANAPOLIS, 46202**  
Eagle Machine Company, Inc.  
P. O. Box 88  
635 East Market Street  
Phone: (317) 637-2521

## IOWA

**WATERLOO, 50704**  
Lewis Motor Supply Inc.  
1801 Washington Street  
P. O. Box 328  
Phone: (319) 235-1481

## KANSAS

**KANSAS CITY, 66103**  
AAA Engine & Electric, Inc.  
700 Southwest Blvd.  
Phone: (913) 236-8971

**GREAT BEND, 67530**  
PAMCO - Branch Office  
714 Patton Road  
Phone: (316) 793-3553  
Main Office - See Colorado

**LIBERAL, 67901**  
PAMCO - Branch Office  
210 Country Estates Road  
Phone: (316) 824-5674  
Main Office - See Colorado

## KENTUCKY

**LOUISVILLE, 40203**  
Atlas Machine & Supply Inc.  
1328 West Jefferson  
Phone: (502) 584-7262

## LOUISIANA

**HARVEY, 70058**  
Reagan Equipment Company  
P. O. Drawer 628  
2230 Peters Road  
Phone: (504) 367-1870

**MORGAN CITY, 70380 - Branch Office**  
P. O. Drawer 2487  
Highway 90 East  
Phone: (504) 631-0321

**VADALIA, 71373 - Branch Office**  
P. O. Box 914  
Highway 84 West  
Phone: (318) 336-7181

**NEW IBERIA, 70660**  
Waukesha-Pearce Industries, Inc.  
Branch Office  
P. O. Box 938  
939 Jane Street  
Phone: (318) 369-3741  
Main Office - See Texas

**SHREVEPORT, 71107**  
Waukesha-Pearce Industries, Inc.  
Branch Office  
P. O. Box 7066  
1815 Barton Drive  
Phone: (318) 221-4075  
Main Office - See Texas

## MASSACHUSETTS

**ALLSTON, BOSTON, 02134**  
W. A. Kraft Corporation  
308 North Harvard Street  
Phone: (617) 782-0076

## MICHIGAN

**NOVI, 48050**  
Engine Supply  
P. O. Box 437  
44455 Grand River  
Phone: (313) 349-9330

**SOUTHFIELD, 48076**  
Waukesha Engine Division  
Dresser Industries, Inc.  
(Central Regional Office)  
29433 Southfield Rd., Suite 102  
Phone: (313) 557-2470

## MINNESOTA

**SOUTH ST. LOUIS PARK, 55428**  
Jeffco Power Systems  
2238 Florida Avenue S.  
Phone: (612) 546-5566

## MISSISSIPPI

**HEIDELBERG, 39439**  
Reagan Equipment Co. - Branch Office  
P. O. Box 285  
Highway 28 West  
Phone: (601) 787-2221  
Main Office - See Louisiana

**JACKSON, 39208**  
Reagan Equipment Co. - Branch Office  
P. O. Drawer 5700  
Highway 90 East  
Phone: (601) 939-4512  
Main Office - See Louisiana

## MISSOURI

**ST. LOUIS, 63118**  
Charles Equipment Company  
3100 Gravois Avenue  
Phone: (314) 771-4700

## NEW JERSEY

**CARLSTADT, 07072**  
W. A. Kraft Corporation - Branch Office  
485 Washington Avenue  
Phone: (201) 933-5151  
(212) 868-0135  
Main Office - See Massachusetts

**RIDGEWOOD, 07451**  
Waukesha Engine Division  
(Northeastern Regional Office)  
1156 East Ridgewood Avenue  
Phone: (201) 652-4808

## NEW MEXICO

**FARMINGTON, 87401**  
PAMCO - Branch Office  
P. O. Box 1558  
218 Airport Drive  
Phone: (505) 325-7529  
Main Office - See Colorado

**HOBBS, 89240**  
Waukesha-Pearce Industries, Inc.  
Branch Office  
P. O. Box 488  
2801 West Marland  
Phone: (505) 393-9135  
Main Office - See Texas

**NEW YORK**

SYRACUSE, 13202  
Power Plant Equipment Corp.  
929 S. Salina Street  
Phone: (315) 475-7251

LATHAM, 12110  
Power Plant Equipment Corp.  
6 Northway Lane  
Phone: (518) 783-1991

TONAWANDA, 14150  
Ronco Power Systems  
595 Sheridan Drive  
Phone: (716) 873-0760

**NORTH DAKOTA**

WILLISTON, 58801  
PAMCO - Branch Office  
P. O. Box 1147  
Highway 2 North  
Phone: (701) 572-6343  
Main Office - See Colorado

**OHIO**

YOUNGSTOWN, 44509  
Power Equipment, Inc.  
168 South Meridian Road  
Phone: (216) 792-1475

COLUMBUS, 43219 - Branch Office  
P. O. Box 19085  
889 N. 22nd Street  
Phone: (614) 253-2711

**OKLAHOMA**

WOODWARD, 73801  
Waukesha-Pearce Industries, Inc.  
Branch Office  
P. O. Box 1086  
Martin Road  
Phone: (405) 256-7421  
Main Office - See Texas

OKLAHOMA CITY, 73111  
Waukesha-Pearce Industries, Inc.  
Branch Office  
5800 N. Eastern Avenue  
P. O. Box 11196  
Phone: (405) 424-1468  
Main Office - See Texas

**OREGON**

PORTLAND, 97210  
I-D, Inc.  
P. O. Box 10124  
2355 N. W. Quimby Avenue  
Phone: (503) 226-7966

**PENNSYLVANIA**

PHILADELPHIA, 19134  
North American Engines Co., Inc.  
3219 "B" Street  
Phone: (215) 423-3700

PITTSBURGH, 15234  
P. C. McKenzie Company  
3561 Valley Drive  
Phone: (412) 833-2100

**SOUTH CAROLINA**

CHARLESTON, 29405  
Diesel Engineers, Inc.  
2025 Austin Avenue  
P. O. Box 4398  
Phone: (803) 554-5151

**TENNESSEE**

MEMPHIS, 38105  
Carloss Well Supply Company  
111 North Parkway Avenue  
Phone: (901) 526-1141

NASHVILLE, 37213 - Branch Office  
101 South First Street  
Phone: (615) 254-1669

**TEXAS**

HOUSTON, 77035  
Waukesha-Pearce Industries, Inc.  
P. O. Box 35068  
12320 South Main Street  
Phone: (713) 723-1050

ABILENE, 79604 - Branch Office  
P. O. Box 1962  
3542 S. Treadaway  
Phone: (815) 692-4045

CORPUS CHRISTI, 78408 - Branch Office  
P. O. Box 9267  
5226 Frontage Road I-37  
Phone: (512) 884-8275

IRVING, 75060 - Branch Office  
P. O. Box 365  
525 North Loop 12  
Phone: (214) 259-1581

KILGORE, 75662 - Branch Office  
P. O. Box 1185  
Industrial Blvd.  
Phone: (214) 984-2011

ODESSA, 79760 - Branch Office  
P. O. Box 3549  
1000 West 2nd Street  
Phone: (815) 332-9106

PAMPA, 79066 - Branch Office  
P. O. Box 1976  
201 N. Price Road  
Phone: (806) 669-3251

SAN ANTONIO, 78217 - Branch Office  
8602 N. New Braunfels  
Phone: (512) 824-7256

SAN JUAN, 78589 - Branch Office  
P. O. Box 246  
Phone: (512) 787-4231

WICHITA FALLS, 76307 - Branch Office  
P. O. Box 2185  
4725 Jackaboro Highway  
Phone: (817) 767-9234

HOUSTON, 77027  
Waukesha Engine Division  
(Mid-Continent Regional Office)  
1535 West Loop South  
410 Honeywell Building  
Phone: (713) 626-0255

**UTAH**

SALT LAKE CITY, 84115  
Diesel Electric Service & Supply  
P. O. Box 15858  
652 W. 17th Street, South  
Phone: (801) 972-1836

VERNAL, 84078  
PAMCO - Branch Office  
P. O. Box 400  
Highway 40 East  
Phone: (801) 789-3383  
Main Office - See Colorado

**VIRGINIA**

HERNDON, 22070  
North American Engines Co., Inc. Branch Office  
13835 Redskin Drive  
Phone: (703) 471-5481  
Main Office - See Pennsylvania

**WASHINGTON**

SEATTLE, 98107  
Kem Equipment, Inc.  
4301 Leary Way, N. W.  
Phone: (206) 784-2372

**WISCONSIN**

APPLETON, 54911  
Arthur G. Dietrich Co., Inc.  
641 Hickory Farm Lane  
Phone: (414) 731-6666

MILWAUKEE, 53217  
Arthur G. Dietrich Co., Inc.  
8035 N. Port Washington Road  
Phone: (414) 352-7452

WAUKESHA, 53186  
Waukesha Engine Division  
Main Office  
P. O. Box 379  
1000 West St. Paul Avenue  
Phone: (414) 547-3311

**WYOMING**

CASPER, 82801  
PAMCO - Branch Office  
P. O. Drawer 2795  
3400 West Yellowstone Road  
Phone: (307) 234-1548  
Main Office - See Colorado

**CANADA**

**ALBERTA**

EDMONTON 82 - T6E 4N6  
PAMCO, Ltd.  
P. O. Box 5798 Postal Station L  
8235 Wagner Road  
Phone: (403) 465-5371

CALGARY - T2C 1H9 - Branch Office  
8241 - 31st St., S. E.  
Phone: (403) 279-5561

REDCLIFFE - T1A 7N4 - Branch Office  
P. O. Box 1447  
No. 2 1001 Highway Avenue, N.  
Phone: (403) 464-3935

CALGARY X-T2P OM2  
Waukesha Engine Division  
(Western Canada Regional Office)  
Aquitaine Tower, Suite 540  
540 - 5th Avenue, S. W.  
Phone: (403) 266-8666

**BRITISH COLUMBIA**

NORTH VANCOUVER - V7P 1R4  
Farwest Diesel & Equipment, Ltd.  
1189 West 16th Street  
Phone: (604) 980-8394

**MANITOBA**

WINNIPEG R34 OX8  
Keewatin Electric & Diesels, Ltd.  
1040 Coulter Avenue  
Phone: (204) 772-0443

**NEW BRUNSWICK**

MONCTON - E1C 8N6  
Consolidated Engines & Machinery  
Co., Ltd. - Branch Office  
146 Albert Street  
P. O. Box 848  
Phone: (506) 854-0982  
Main Office - See Quebec

**NOVA SCOTIA**

HALIFAX  
Consolidated Engines & Machinery  
Co., Ltd. - Branch Office  
P. O. Box 1015, Suite 309  
The Trade Mart Building  
Scotia Square  
Phone: (902) 422-8421  
Main Office - See Quebec

**ONTARIO**

TORONTO 16 - M4A 2N3  
Atlas Polar Company, Ltd.  
60 Northline Road, P. O. Box 160  
Phone: (416) 751-7740

**QUEBEC**

MONTREAL H4T 1L7  
Consolidated Engines & Machinery  
Co., Ltd.  
8550 Delmeade Road  
Phone: (514) 342-9233

**SASKATCHEWAN**

PAMCO Ltd. (See Alberta)

**INTERNATIONAL**

**ARGENTINA**

TIPSA-Tecnica Industrial y Comercial Petrolera, S. C. A.  
Territory: Argentina  
Cordoba 1367, 3rd Floor  
Buenos Aires, Argentina  
Phone: 42 1367 Cable: TIPSA

Branch: San Martin 1002,  
Comodoro Rivadavia

**AUSTRALIA**

A. N. I. Perkins Division  
A. N. I. Australia Pty. Limited  
Territory: Australia  
16 Parramatta Road, P. O. Box 117  
Lidcombe, N. S. W., 2141, Australia  
Phone: 648-4088 Cable: PERKAUST  
SYDNEY

**AUSTRIA**

FILTOR  
Gross-und Kleinhandels-Grez. M. b. H.  
Territory: Austria  
Kaiser-Ebersdorferstrasse 254  
1110-Vienna, Austria  
Phone: (0222) 77 73 69

**BANGLADESH**

Dana Engineers, International  
Territory: Bangladesh  
67, Bangabandhu Avenue  
P. O. Box No. 914, Dacca-2  
Bangladesh  
Phone: 244028 Cable: DANARS-DACCA

**BELGIUM**

Waukesha Engine Division  
Dresser Europe S. A.  
(Brussels Regional Office)  
Boulevard Du Souverain 191-197 (B.3)  
B-1180 Brussels, Belgium  
Phone: 860, 20, 60 Cable: DRESSER CLARK

Werkhuizen Frans Stevens N. V.  
Territory: Belgium  
Slachthuislaan-21  
2000 Antwerp  
B-Belgium  
Phone: 031-36, 92, 02 TELEX: 33342  
(STEVEN B)

**BOLIVIA**

Oil Industry Supply & Service Company  
Territory: Bolivia  
Calle Buena No. 144 - Casilla 1268  
La Paz, Bolivia  
Phone: 23917 Cable: OISSCO

**COLOMBIA**

General Sales Corporation Ltda.  
Territory: Colombia - Marine Engines Only  
Air Mail Box 395  
Barranquilla, Colombia, S. A.  
Phone: 12-501 Cable: MAECO

Milchem Western Hemisphere, Inc.  
Territory: Colombia - Excluding Marine Engines  
Apartado Aereo 9313  
Bogota, D. E., Colombia  
Phone: 813704 Cable: MILCHEM

**ECUADOR**

Milchem Western Hemisphere, Inc.  
Territory: Ecuador  
Avenida de la Republica #20-50  
y 10 de Agosto, Casilla 41-43  
Quito, Ecuador  
Phone: 246-820, Cable: MILCHEM  
245-524

**EGYPT**

HCH Supply Co., Ltd.  
Territory: Arab Republic of Egypt  
110,26 July Street  
Zamalek, Cairo, Egypt  
Phone: 818721 TELEX: 2431HCH

**GREECE**

Gemco  
Stavropoulos-Leptourgos S. A.  
Territory: Greece  
24 Capodistriou St.  
Athens 208, Greece  
Phone: 21 364772 Cable: STAVROMOTORS

**GUYANA (British Guiana)**

Psaila Bros.  
Territory: Guyana  
P. O. Box 140  
Water & Holmes Streets  
Georgetown, Guyana  
Phone: 4170 Cable: PSAILA

**HONG KONG**

Gilman & Co. Ltd. Marine Department  
Territory: Hong Kong  
P. O. Box 56  
178 Gloucester Road  
Wanchai, Hong Kong  
Phone: 5-726386, 5-726387  
TELEX: 83667 GILMAN

**ICELAND**

Velasan, H. F.  
Territory: Iceland  
P. O. Box 1006  
Reykjavik, Iceland  
Cable: VELASAN

**INDIA**

AEICORP Private Limited  
Territory: India  
Mercantile Bldgs., 10,  
Lall Bazar Street  
Calcutta 700001, India  
Phone: 23-5120 and 23-0879  
Cable: EAGERNESS

Branch: Arun Chamber, Rm. 428 (4th Floor)  
Tardeo Rd., Bombay - 34  
Globe Agencies Chambers, HS-6,  
Kailash Colony Market, New Delhi 110048  
Central St., Hindpuri, Ranchi, Behar

**IRAN**

Shaya Co., Ltd.  
Territory: Iran  
Shaya Building, Argentine Square  
38, Alvand Street  
P. O. Box 155  
Tehran, Iran  
Phone: 685-261 to 685-265  
Cable: TEKMOSHAVER TEHRAN

**ITALY**

Eurodiesel-Milano S. R. L.  
Territory: Italy  
Via E. Cosenz 44  
Milano, Italy  
Phone: 3763450 Cable: EURODIESEL

**KUWAIT**

The Trading & Industrial Equipment Co.  
Territory: Kuwait, Iraq, & United Gulf Emirates  
P. O. Box Safat 2159  
Kuwait Town, State of Kuwait  
Phone: 819179/819188 Cable: SUCCESS -  
KUWAIT

Waukesha Engine Division  
Dresser Europe S. A.  
(Middle East Regional Office)  
P. O. Box Safat 2159  
Kuwait Town, State of Kuwait  
Phone: 819179/819188 Cable: SUCCESS -  
KUWAIT

**LEBANON**

S. Sadaka & Sons  
Territory: Lebanon, Syria, Jordan  
P. O. Box 4  
Zahle, Lebanon  
Phone: 82-00-31 TELEX: 21211

**LIBYA**

Sahara Oilfield Services Co. of Libya, Ltd.  
Territory: Libya  
Sc. Sidi Issa; P. O. Box 800  
Tripoli, Libya  
Phone: 34874/37773 Cable: SOS

**MALAYSIA**

Malayan Development Machinery SDN. BHD.  
Territory: Malaysia  
12/18 Jalan Kemajuan, Petaling Jaya  
P. O. Box 1033  
Kuala Lumpur, Selangor, Malaysia  
Phone: 51111/6 Cable: EARTHMOVE

**MAURITIUS & REUNION ISLANDS**

Robert Le Maire, Ltd.  
Territory: Mauritius & Reunion Islands  
26 Sir William Newtoe Street  
Port Louis, Mauritius  
Cable: ROBMER

**MEXICO**

Moto Equipos, S. A.  
Territory: Republic of Mexico (Excluding  
state of Sonora, state of Sinaloa up  
to and including Cabo Corrientes in  
the State of Jalisco for Marine  
Products Only)

Alemania 14  
Mexico 21, D. F., Mexico  
Phone: 549-32-65/66/67 Cable: MEOSA

Propulsion Industrial y Martne, S. A.  
Territory: State of Sonora, state of Sinaloa up  
to and including Cabo Corrientes in  
the State of Jalisco (Marine Engines  
Only)

A. Serdan y Calle 27-AP 74  
Guaymas, Sonora, Mexico  
Phone: 2-05-20

Waukesha Engine Division  
Dresser International, S. A.  
(Mexico/Central America/Caribbean Regional  
Offices)

Reforma 95-1101  
Mexico 1. D. F., Mexico  
Phone: 535-75-58,  
535-36-08 TELEX: 00177-2588

**MOROCCO**

Stanislas Jullien  
Territory: Morocco  
256 Boulevard Ba Hamad  
Casablanca, Morocco  
Cable: ORBI

**MOZAMBIQUE**  
(Portuguese East Africa)

Santos, Marques & Silva Ltda.  
Territory: Mozambique  
Rua da Electricidade 9 a 11  
Lourenco Marques, Mozambique  
Cable: ELECTRO

**NETHERLANDS**

Landre & Glunderman, N.V.  
Division Landre Ruhaak Motoren  
Territory: Netherlands (Industrial Gas and Diesel Products Only)  
P.O. Box 63  
Industrieweg, 30  
Vianen (Z.H.) 2620, The Netherlands  
Phone: 3473-3044 Cable: LANDREMAN

Branch: Rotterdam; Heugelo

Laan & Keoy Technische Handelmaatschappij BV  
Territory: The Netherlands (Marine Products Only)  
Zwinstraat 45  
Den Oever, Holland  
Phone: 02271-841

**NEW ZEALAND**

Motor Specialties Limited  
Territory: New Zealand  
80-86 Anzac Avenue, P.O. Box 3201  
Auckland 1, New Zealand  
Phone: 71-679 Cable: MOTOSPECS

**NICARAGUA**

Casa Comercial McGregor, S.A.  
Territory: Nicaragua  
3a. Calle S.E. No. 104; Aptdo. 448  
Managua, Nicaragua  
Phone: 2-1311 Cable: MCGREGOR

**NIGERIA**

Allied Oilfield Services, Ltd.  
Territory: Nigeria  
39, Norman Williams Street  
S.W. Ikoyi  
P.O. Box 7403  
Lagos, Nigeria  
Phone: 22863/27469/  
56068 Cable: OILTOOLS

**NORWAY**

Sverre Nilsen, Jr. A/S  
Territory: Norway  
Prinsengt, 3B  
P.O. Box 655/8 - Sentrum  
Oslo 1, Norway  
Phone: (02) 41 85 80 Cable: MOTORNILSEN

**PAKISTAN**

Brentford, Yusuf & Company Limited  
Territory: Pakistan  
'Canaan', 4-B, Lalazar  
P.O. Box No. 4327  
Karachi, Pakistan  
Phone: 230029 Cable: BRENTICO  
Branch: P.O. Box 85, The Mall, Lahore

**PORTUGAL**

Motodiesel Limitada  
Territory: Portugal  
Rua de Sao Paulo 246, 1.<sup>o</sup>  
Apartado 2053  
Lisbon, Portugal  
Phone: 32 39 38 Cable: MOTODIESEL

**PUERTO RICO & VIRGIN ISLANDS**

West India Machinery & Supply Company  
Territory: Puerto Rico and Virgin Islands  
Roosevelt Avenue at 26th Street  
G.P.O. Box 4308  
San Juan, Puerto Rico 00936  
Phone: 782 2850 Cable: WIMSCO

**SAUDI ARABIA**

Abdullah Ibrahim Alkhorayef  
Territory: Saudi Arabia  
P.O. Box 305  
Riyadh, Saudi Arabia  
Phone: 51479, Cable: AL-KHORAYEF  
51480

**SINGAPORE**

Avery-Laurence Equipment PTE, Ltd.  
Territory: Singapore, Indonesia, Brunei & Burma, Petroleum Products Only  
8th Floor, Cathay Building  
P.O. Box 190  
Singapore 9  
Phone: 324121 Cable: AVLAU  
Branch: 22nd Floor, Prince's Building  
G.P.O. Box 690, Hong Kong

Waukesha Engine Division  
Dresser Industries, Inc.  
(Singapore Regional Office)  
358 Orchard Rd.  
1st Floor, Lido Theatre Building  
Singapore 9  
Phone: 370-888  
Cable: WAUKASIA SINGAPORE

**SPAIN**

Iberdiesel/Navalux S.A.  
Territory: Spain, including Majorca, Ibiza, & Canary Islands  
Honduras, 4 1.<sup>o</sup>  
Madrid (16), Spain  
Phone: 457 56 62 TELEX: 42237 NAIB

**SUDAN**

The New Plant Equipment Company  
Territory: Sudan  
P.O. Box 2221, 865  
Khartoum, Sudan  
Phone: 77275 - 72565 Cable: PLECOY

**TAIWAN (Republic of China)**

William Hunt & Co. (Int'l.) Inc.  
Territory: Taiwan, Republic of China  
8th Floor, Lung-Men Building  
128 Chung Hsiao East Road, Sec. 4  
Taipei, Taiwan, Republic of China  
Phone: 721-9711/9713/9716 Cable: WILHUNT

**TRINIDAD & TOBAGO, B.W.I.**

Engineering Services & Supply Co., Ltd.  
Territory: Trinidad and Tobago  
Lady Hailes Avenue  
P.O. Box 104  
San Fernando, Trinidad  
Phone: 77355 Cable: ESSCOL

**TURKEY**

OBA Automotive & Mining Co. Ltd.  
Territory: Turkey  
Vali Dr. Resit Cad. 40/2  
Cankaya, Ankara, Turkey  
Phone: 27-10-28,  
27-79-52 TELEX: 42835

**UNITED ARAB EMIRATES**

The Trading & Industrial Equipment Co.  
P.O. Box 5291 Deira  
Dubai, United Arab Emirates  
Phone: 26255 Cable: TIECO-DUBAI

**UNITED KINGDOM**

Daegam Ltd.  
Applied Energy Systems  
Territory: United Kingdom, Northern and Republic of Ireland  
1 Whippendell Road  
Watford Herts WD1 7LZ, England  
Phone: Watford 42222 TELEX: 935926

**WEST GERMANY**

Industrie & Schiffstechnik  
Territory: West Germany  
2000 Hamburg-Schenefeld  
Osterbrooksweg, 21  
P.O. Box 1365  
West Germany  
Phone: 40 830 5041 Telex: 0212635

**VENEZUELA**

Bompel de Venezuela C.A.  
Territory: Venezuela  
Apartado 749  
Maracaibo, Venezuela  
Phone: 71163 Cable: USIVEN

Dresser International S.A.  
Waukesha Engine Division  
(South American Regional Office)  
Bompel de Venezuela, C.A.  
Edificio Acocias, Planta Baja Of. No. 7  
Avenida Rio Paragua, Complejo Prado Humboldt  
Prados Del Este, Caracas 108, Venezuela  
Phone: 978-03-68,  
978-21-46 TELEX: 395-232-67

**YUGOSLAVIA**

Stojan International  
Territory: Yugoslavia  
Trattnerhof 2, Postfach 12  
1014 Vienna, Austria  
Phone: 52 75 56 TELEX: 01-1675

# TABLE OF CONTENTS

Subject	Page	Subject	Page
SAFETY PRECAUTIONS .....	2	OPERATION .....	1-1
DISTRIBUTOR DIRECTORY .....	8	PREVENTIVE MAINTENANCE .....	2-1
TABLE OF CONTENTS/INDEX .....	12	TROUBLE SHOOTING .....	3-1
DISTRIBUTORS AND SERVICE .....	14	Systems Description	
INTRODUCTION .....	15	Trouble Shooting Chart	
ENGINE ILLUSTRATIONS .....	16	REPAIR AND REPLACEMENT .....	4-1
WARRANTY .....	7	Engine Construction	
		Repair Procedures	
		Fits and Clearances	
		INSTALLATION .....	5-1

## INDEX

Subject	Page	Subject	Page
Air Cleaners .....	2-9	Distributor Adjustments .....	2-12
Air Intake System Description .....	3-4	Dwell Angle; adjustment of .....	2-14
Air Intake System Installation		Electrical System Description .....	3-3
Recommendations .....	5-5	Energy Cell and Pintle Nozzle Service .....	2-19
Alignment .....	5-3	Engine Foundations .....	5-3
Alternator Servicing .....	2-15	Engine Performance Record .....	1-10
Alternator Pulley Removal and		Exercise of Standby Units .....	1-10
Installation Tool .....	2-17	Exhaust System Description .....	3-5
Angular Operating Limits .....	5-6	Exhaust System Installation Recommendations .....	5-5
Automatic Starting .....	5-3	Fits and Clearances .....	4-13
Basic Engine Data .....	4-12	Fuels .....	2-3
Before Starting Engine .....	1-3	Fuel Systems Description .....	3-5
Break-in Procedure .....	1-10	Fuel System Installation Recommendations .....	5-6
Camshaft Design .....	4-4	Gas Carburetor Adjustments .....	2-23
Checking Flywheel and Housing Run-Out and		Gas Carburetion Description .....	3-6
Crankshaft Endplay .....	5-7	Gasoline Carburetor Adjustments .....	2-22
Cleaning The Cooling System .....	2-11	Gasoline Carburetion Description .....	3-5
Cleaning And Inspection of Engine Parts .....	4-4	Governor Adjustments .....	2-23
Cold Weather Starting .....	1-10	Governing Systems Description .....	3-11
Compression Testing .....	2-25	Ignition Systems Description .....	3-8
Connecting Rod Design .....	4-4	Injector (Pencil) Description, Fuel .....	3-7
Cooling System Capacity .....	5-4	Injector (Pintle) Description, Fuel .....	3-8
Cooling System Description .....	3-4	Injection Pump Description .....	3-6
Cooling System Design .....	5-4	Injection Pump Maintenance .....	2-17
Cooling System Installation Recommendations .....	5-5	Injection Pump Operation .....	3-6
Cooling System Maintenance .....	2-10	Injector, Reinstalling Pencil Type .....	2-22
Crankcase Design .....	4-3	Injector Test, Fuel .....	2-18
Crankshaft Design .....	4-4		
Cylinder Head And Valve Design .....	4-3		
Cylinder Sleeve Design .....	4-3		

# INDEX (Cont.)

Subject	Page	Subject	Page
Lubrication Guide .....	2-4	Selecting Oil Viscosity .....	2-4
Lubricating Oils .....	2-4	Service Schedule and Procedures .....	2-6
Lubrication System Description .....	3-9	Space Requirements .....	5-3
Lubricating Oil System Installation Recommendations .....	5-6	Spark Plug Adjustments .....	2-14
Magneto Servicing .....	2-15	Starting Engine .....	1-6
Manifold Vacuum Test .....	2-25	Stationary Installations .....	5-3
Mounting .....	5-3	Stopping Engine .....	1-8
Oil Analysis .....	2-5	Storage, Basic Requirements .....	2-26
Oil Changes .....	2-5	Storage, Conventional .....	2-28
Oil Change Procedure .....	2-5	Storing Engines That Have Been In Service .....	2-29
Oil Consumption .....	2-4	Storing New Engines .....	2-28
Oil Filters .....	2-8	Storage, Nucle-Oil .....	2-27
Oil Pan Removal and Replacement .....	4-7	Storage of Fuel Injectors .....	2-30
Oil Pressures .....	3-10	Test Procedures For Engine Protection Devices .....	2-26
Oil Pump Inlet Screen .....	2-9	Thermostat Removal & Testing .....	2-11
Oil Pump Installation .....	4-6	Timing Data, Gas and Gasoline Engines .....	4-30
Operating Controls .....	3-3	Timing Data, Injection Pump .....	4-12
Operating Engine .....	1-7	Timing Gear Backlash .....	4-30
Operational Inspection .....	1-10	Timing Gear Bushing Clearances .....	4-30
Pencil Injector Adjustment .....	2-21	Timing Light, use of .....	2-14
Pintle Injector Spray Patterns .....	2-20	Timing The Magneto .....	2-15
Pistons and Rings, Installation of .....	4-6	Torque Recommendations .....	4-10
Preparing Engine For Operation After Storage .....	2-29	Torque Recommendations, General .....	4-9
Preparing Unit For Service .....	5-3	Torque Values, VR Diesel Engines .....	4-11
Preservation Equipment and Materials .....	2-29	Torque Values, VR Gas and Gasoline Engines .....	4-10
Preservative Oil .....	2-30	Trouble Check Chart for Operators .....	1-9
Protection of Engine and Parts .....	4-4	Trouble Shooting .....	3-3
Removal of Rust or Corrosion .....	4-6	Trouble Shooting Chart .....	3-13
Repair of Damaged Machined and Polished Surfaces .....	4-6	Valve Clearances .....	2-24
Repairing Damaged Threads .....	4-6	Valve Timing .....	4-30
		Vibration Damper Replacement .....	4-7
		Water Pump .....	
		Water Pump Pulley Installation .....	4-7
		Water Pump Seal Installation .....	4-7

## DISTRIBUTORS AND SERVICE

The Waukesha Engine Division, Dresser Industries, Inc., has established a system of reputable distributors with trained mechanics and full facilities for maintenance and rebuilding, and to carry an adequate parts stock in all areas of major engine population all over the world. Their sales engineers are available for installation consultation. If you cannot locate a Waukesha distributor in your area, contact the Waukesha Service Department, 1000 West St. Paul Avenue, Waukesha, Wisconsin 53186, or call (414) 547-3311.

Authorized distributors can respond to your service needs more quickly if the following procedures are observed:

1. Give engine model, serial number and specification number which are stamped on the nameplate attached to the crankcase. The serial number is also stamped on the crankcase at either the gear cover or flywheel housing end.
  2. When ordering parts, always furnish the complete description and part number, where known, of the parts wanted. Do not use the words "complete" or "sets" - state the quantity of each item required.
  3. Tell the distributor how and where to ship parts--state whether to ship by freight, express or parcel post--furnish shipping point and post office address. Without specific shipping instructions the distributor will use his own discretion and will not be responsible for any charges by doing so. Be sure to mark your name, address, and where you can be reached on any order for parts as well as on any correspondence.
  4. Terms on repair--to avoid delay, all repairs will be C.O.D. unless prior arrangements are made with the distributor.
- In situations which may fall within the parameter of the Waukesha standard warranty obligations, proceed as follows:
1. When placing a request for service, specifically state that the repair is believed to be within the terms of warranty (this may be indicated on the purchase order if desired). Produce documentation showing the date of start up or installation of the engine and the engine model, serial number and specification number.
  2. Once the service or repair is completed, pay for the service and/or parts in accordance with whatever terms were previously arranged, but indicate with the payment that a claim is pending under the provisions of warranty.
  3. Confirmation of the submission of a warranty claim can be requested from the Waukesha distributor handling the repair. This is usually done by a notation on the distributor's invoice to the end user.
  4. The Waukesha Distributor will notify you via letter or credit on an invoice of the decision of Waukesha as to the request for warranty on a particular repair.
  5. Any parts replaced in the repair which may be subject to warranty should be left with the distributor for proper handling.
  6. Any part replaced under warranty assumes the identity of the part which it replaces in regard to warranty. That is to say, if the engine is six months old the new part placed in that engine for a failed part is six months old in regard to any future warranty determination.

Remember - you own the best. If repairs are needed use only Genuine Waukesha Parts purchased from Authorized Waukesha Distributors.

## INTRODUCTION

Waukesha VR engines are intended for portable and stationary applications; such as material handling, portable water pumps, and generator sets. They are four stroke cycle, high speed, over-head valve engines, available in four and six cylinder in-line versions. These engines are capable of running on gasoline, natural gas, and diesel fuels.

The information in this manual has been written in an easy to read style and arranged in a time saving manner to provide technical information for Waukesha VR engines. The common construction features of these engines makes it convenient to operate and service any engine in the series through the use of this manual. Differences in procedures, due to fuel use or construction, will be pointed out as needed. Overhaul instructions are not included, except where certain special procedures are required. SPECIFICATIONS information, located in the REPAIR AND REPLACEMENT UNIT, will allow a competent mechanic to determine when parts are no longer usable.

All tabular data and recommendations contained in this manual represent the latest information available at the time of printing, and are of course subject to change.

Throughout this manual we have used symbols to stress important information. These symbols and their meanings are as follows:

- WARNING** ..... This symbol precedes information which, if disregarded, may result in injury or death of the user of the engine or to others.
- CAUTION** ..... This symbol precedes information which, if disregarded, may result in damage to the engine.
- NOTE** ..... This symbol precedes information which is vital to the operation or maintenance of the engine.

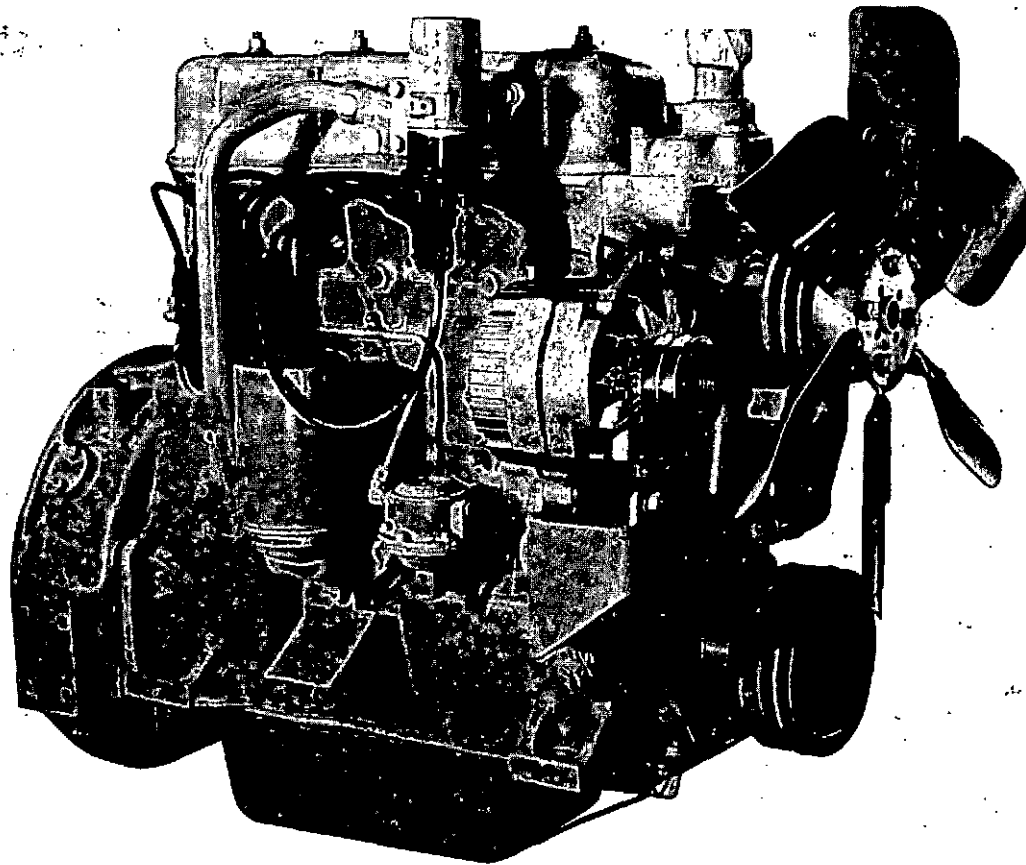

MH-001-174

VRG 155 GASOLINE ENGINE - RIGHT FRONT VIEW

ENGINE MODEL		VRG 155
Displacement	cu in. liters	155 2,54
Bore	inches mm	3 5/8" 92,0
Stroke	inches mm	3 3/4" 95,0
Speed Range	rpm	1200 - 2200
Maximum Continuous Horsepower	Gasoline Nat. Gas.	29 @ 2000 rpm 36 @ 2000 rpm
Normal Oil Pressure	psi	25-50 (avg.) @ 1500 rpm 12 (min) @ 800 rpm
Oil Temperature	oF oC	200 - 220 93,3 - 104,4
Normal Coolant Temperature	oF oC	180 - 200 82,2 - 93,3
Spark Plug Gap	Gasoline Nat. Gas	.025 in. .636 mm .020 in. .508 mm
Weight (Dry)	lbs. kg.	520 236

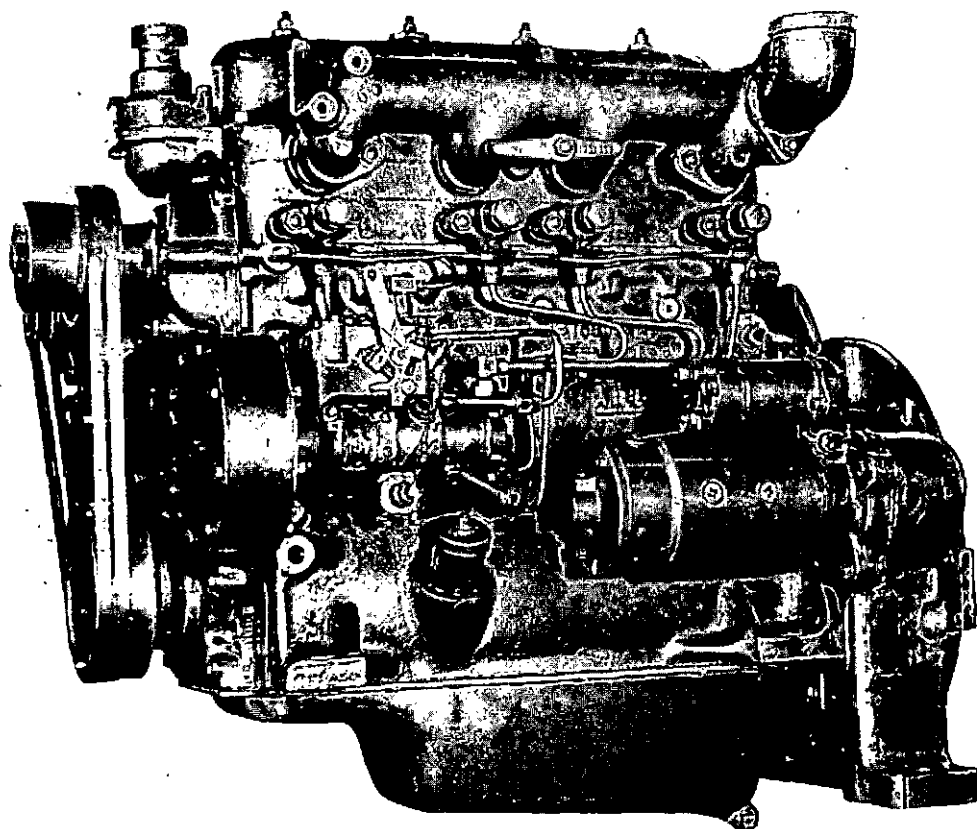

MH-001-171

VRD 155 DIESEL ENGINE - LEFT SIDE VIEW

ENGINE MODEL		VRD 155
Displacement	cu. in.	155
	liters	2,54
Bore	inches	3 5/8"
	mm	92,0
Stroke	inches	3 3/4"
	mm	95,0
Speed Range	rpm	1200 - 2200
Maximum Continuous Horsepower		36 @ 2000 rpm
Normal Oil Pressure		25-35 (avg.) @ 1500 rpm
		12 (min) @ 800 rpm
Oil Temperature	oF	200 - 220
	oC	93,3 - 104,4
Normal Coolant Temperature	oF	180 - 200
	oC	82,2 - 93,3
Weight (Dry)	lbs.	565
	kg.	257

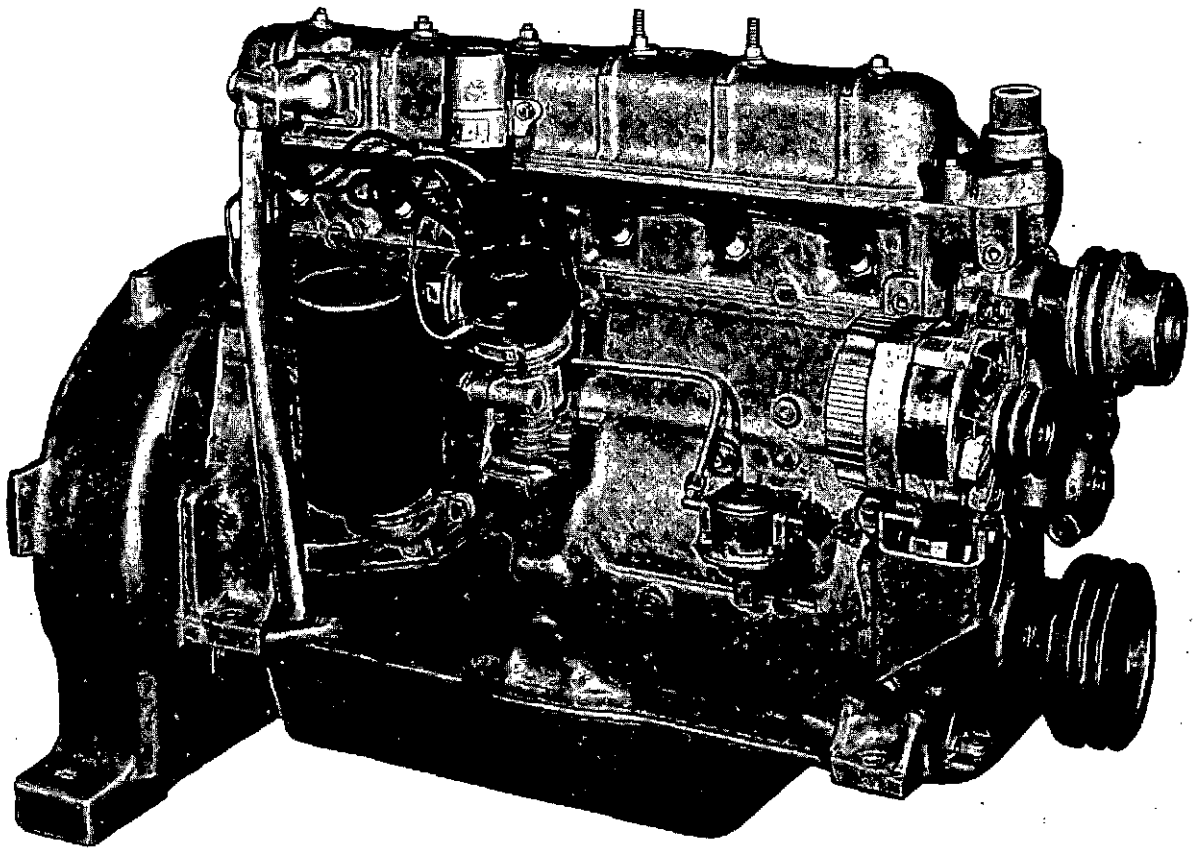

MH-001-3

VRG 232 GASOLINE ENGINE - RIGHT FRONT VIEW

ENGINE MODEL		VRG 232
Displacement	cu in. liters	232 3,8
Bore	inches mm	3 5/8" 92,0
Stroke	inches mm	3 3/4" 95,0
Speed Range	rpm	1200 - 2200
Maximum Continuous Horsepower	Gasoline Nat. Gas	53 @ 2000 rpm 46 @ 2000 rpm
Normal Oil Pressure	psi	25-50 (avg.) @ 1500 rpm 12 (min) @ 800 rpm
Oil Temperature	°F °C	200 - 220 93,3 - 104,4
Normal Coolant Temperature	°F °C	180 - 200 82,2 - 93,3
Spark Plug Gap	Gasoline Nat. Gas.	.025 in. .636 mm .020 in. .508 mm
Weight (Dry)	lbs. kg.	607 305

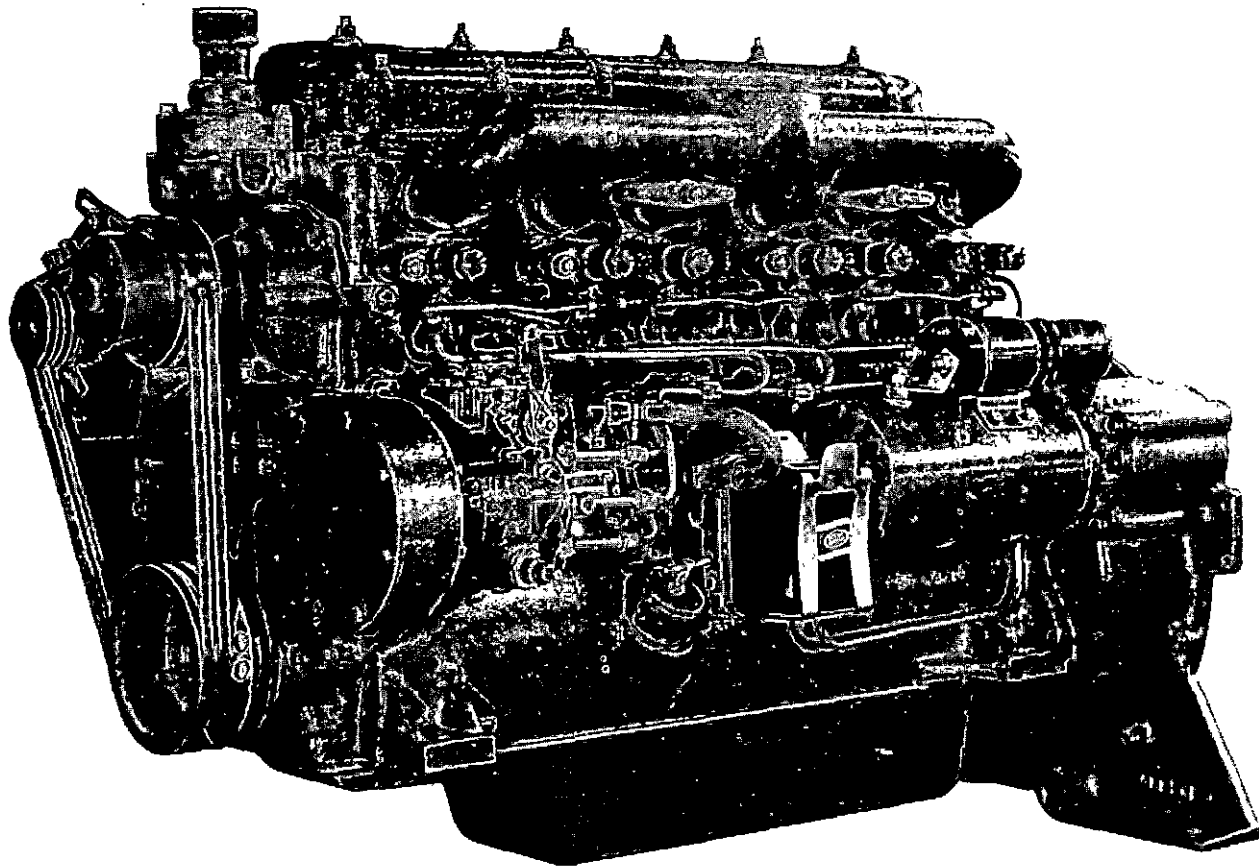

MH-001-173

VRD 232 DIESEL ENGINE - LEFT FRONT VIEW

ENGINE MODEL		VRD 232
Displacement	cu in. liters	232 3,8
Bore	inches mm	3 5/8" 92,0
Stroke	inches mm	3 3/4" 95,0
Speed Range	rpm	1200 - 2200
Maximum Continuous Horsepower		55 @ 2000 rpm
Normal Oil Pressure	psi	25-50 (avg.) @ 1500 rpm 12 (min) @ 800 rpm
Oil Temperature	°F °C	200 - 220 93,3 - 104,4
Normal Coolant Temperature	°F °C	180 - 200 82,2 - 93,3
Weight	lbs. kg.	870 395

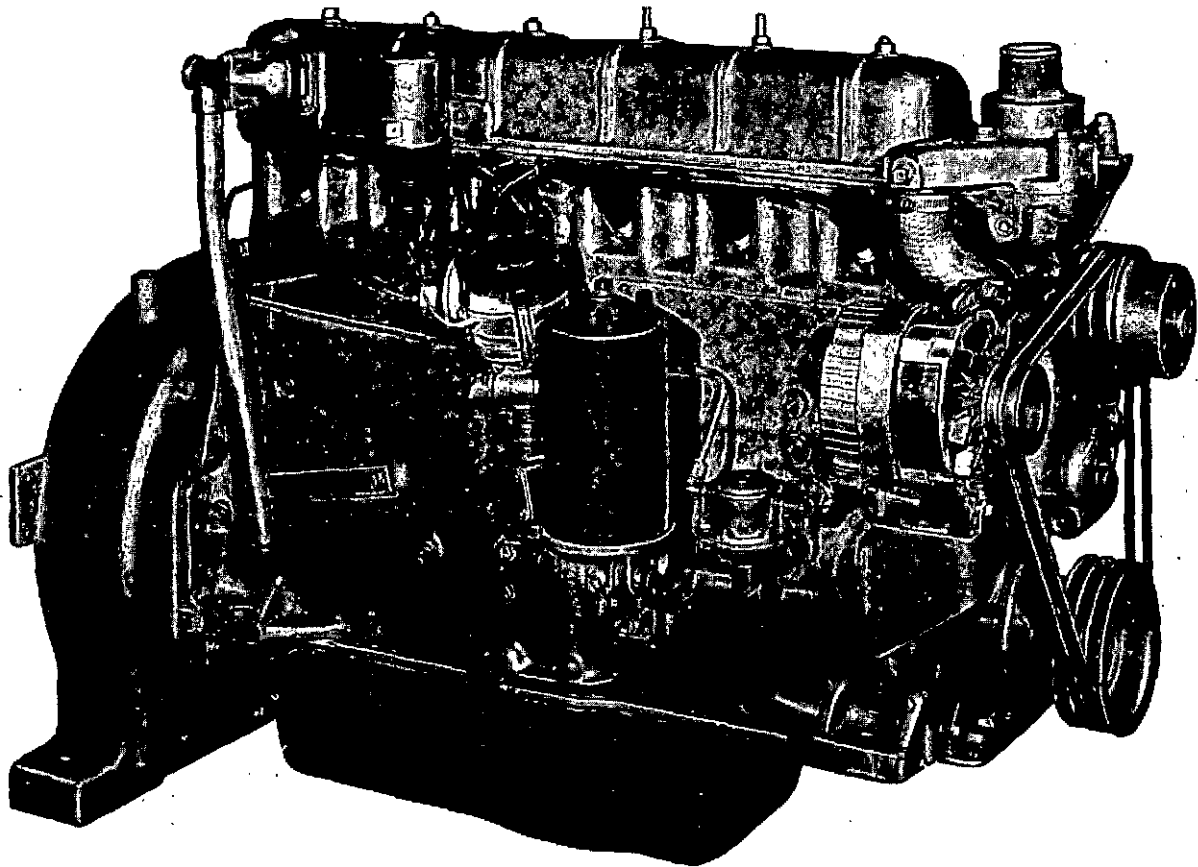

MH-001-7

VRG 265 GASOLINE ENGINE - RIGHT FRONT VIEW

ENGINE MODEL		VRG 265
Displacement	cu. in. liters	265 4,3
Bore	inches mm	3 3/4" 95,0
Stroke	inches mm	4" 102,0
Speed Range	rpm	1200 - 2200
Maximum Continuous Horsepower	Gasoline Nat. Gas	72 @ 2000 rpm 58 @ 2000 rpm
Normal Oil Pressure	psi	25-50 (avg.) @ 1500 rpm 12 (min) @ 800 rpm
Oil Temperature	oF oC	200 - 220 93,3 - 104,4
Normal Coolant Temperature	oF oC	170 - 190 76,6 - 87,7
Spark Plug Gap	Gasoline Nat. Gas	.025 in. .636 mm .020 in. .508 mm
Weight (Dry)	lbs. kg.	745 339

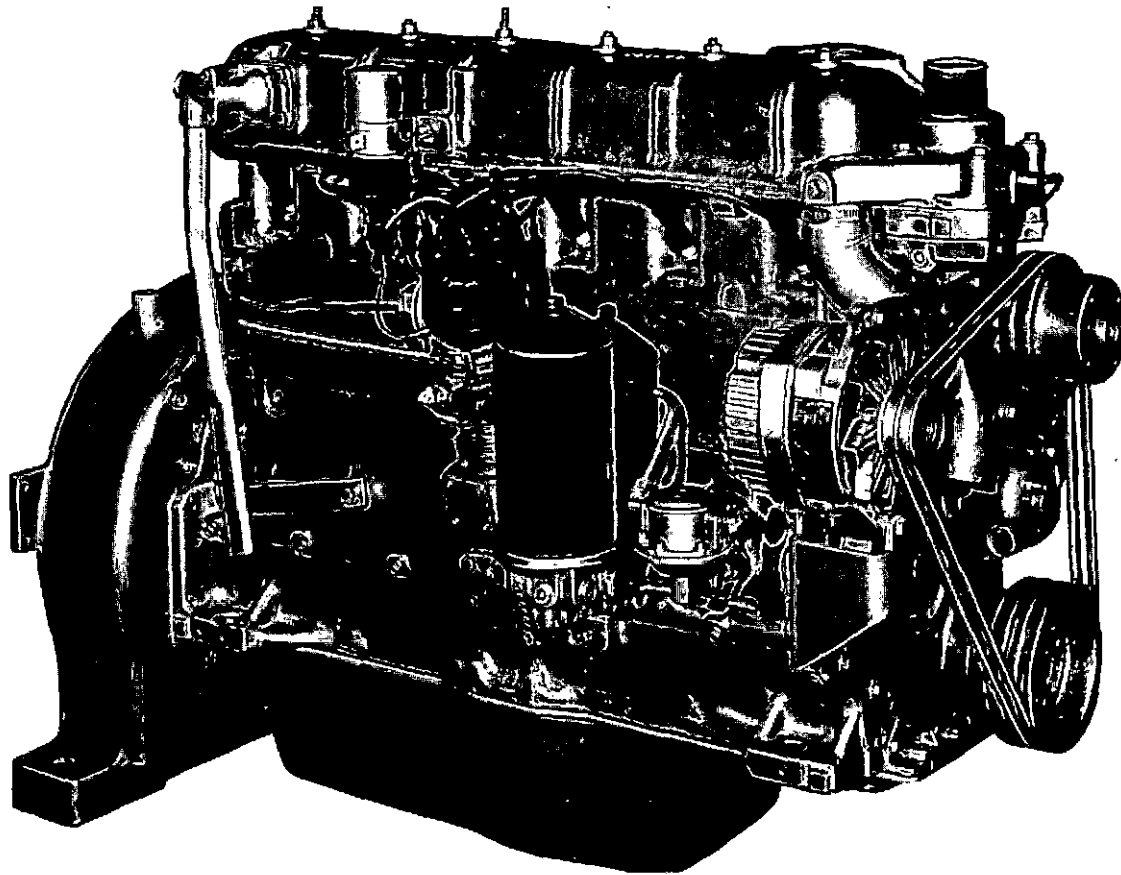

MH-001-2

VRG 283, VRG 310 GASOLINE ENGINE - RIGHT FRONT VIEW

ENGINE MODEL		VRG 283	VRG 310
Displacement	cu. in.	283	310
	liters	4,6	5,1
Bore	inches	3 7/8	3 7/8
	mm	98,0	98,0
Stroke	inches	4	4 3/8
	mm	102,0	111,0
Speed Range	rpm	1200 - 2400	1200 - 2400
Maximum Continuous Horsepower	Gasoline	83 @ 2000 rpm	91 @ 2000 rpm
	Nat. Gas	66 @ 2000 rpm	73 @ 2000 rpm
Normal Oil Pressure	psi	25-50 (avg.) @ 1500 rpm 12 (min) @ 800 rpm	25-50 (avg.) @ 1500 rpm 12 (min) @ 800 rpm
Oil Temperature	°F	200 - 220	200 - 220
	°C	93,3 - 104,4	93,3 - 104,4
Normal Coolant Temperature	°F	170 - 190	170 - 190
	°C	76,6 - 87,7	76,6 - 87,7
Spark Plug Gap	Gasoline	.025 in. .636 mm	.025 in. .636 mm
	Nat. Gas	.020 in. .508 mm	.020 in. .508 mm
Weight (Dry)	lbs.	825	840
	kg.	376	382

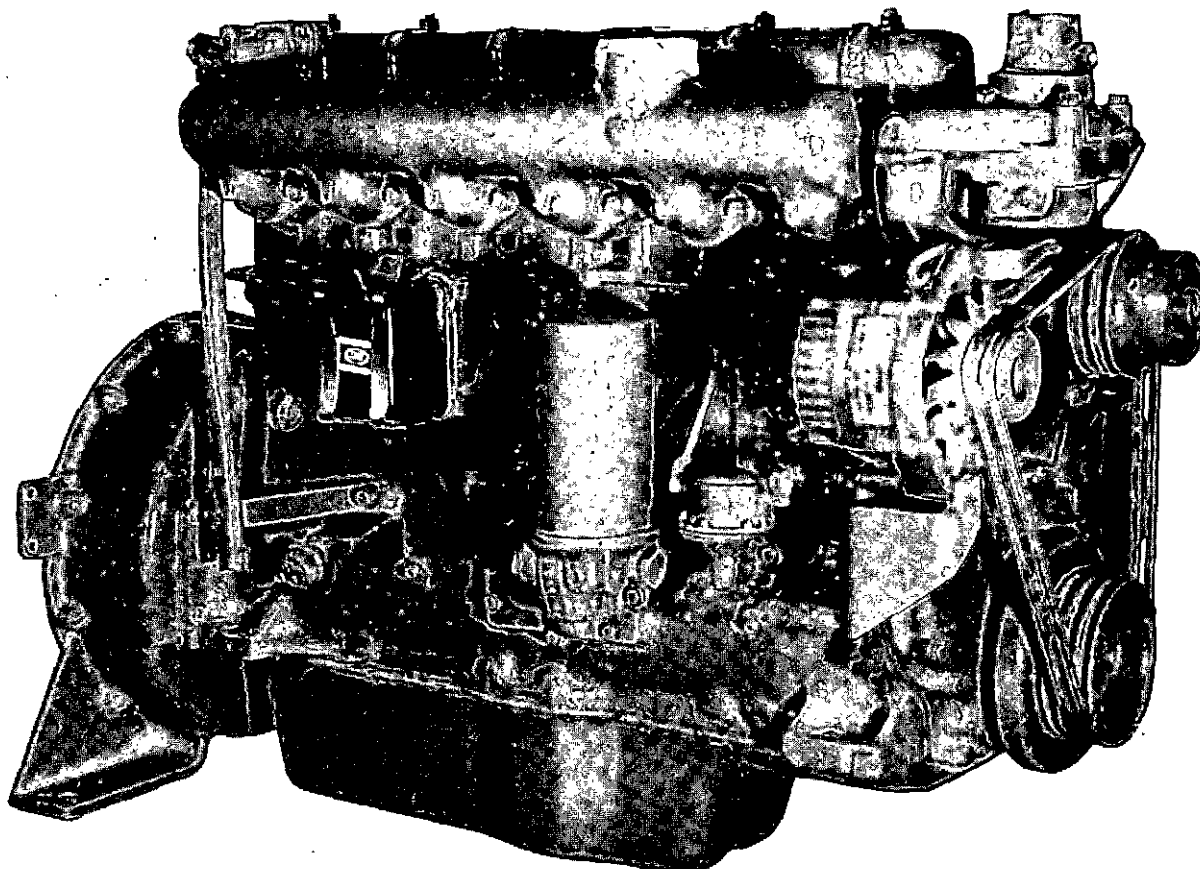

MH-001-175

VRD 283, VRD 310 DIESEL ENGINES - RIGHT FRONT VIEW

ENGINE MODEL		VRD 283	VRD 310
Displacement	cu. in. liters	283 4,6	310 5,1
Bore	inches mm	3 7/8 98,0	3 7/8" 98,0
Stroke	inches mm	4 102,0	4 3/8 111,0
Speed Range	rpm	1200 - 2200	1200 - 2400
Maximum Continuous Horsepower		61 @ 2000 rpm	79 @ 2000 rpm
Normal Oil Pressure	psi	30-50 (avg.) @ 1500 rpm 12 (min) @ 800 rpm	30-50 (avg.) @ 1500 rpm 12 (min) @ 800 rpm
Oil Temperature	oF oC	200 - 220 93,3 - 104,4	200 - 220 93,3 - 104,4
Normal Coolant Temperature	oF oC	170 - 190 76,6 - 87,7	170 - 190 76,6 - 87,7
Weight (Dry)	lbs. kg.	870 395	925 420

ENGINE REFERENCE POINTS

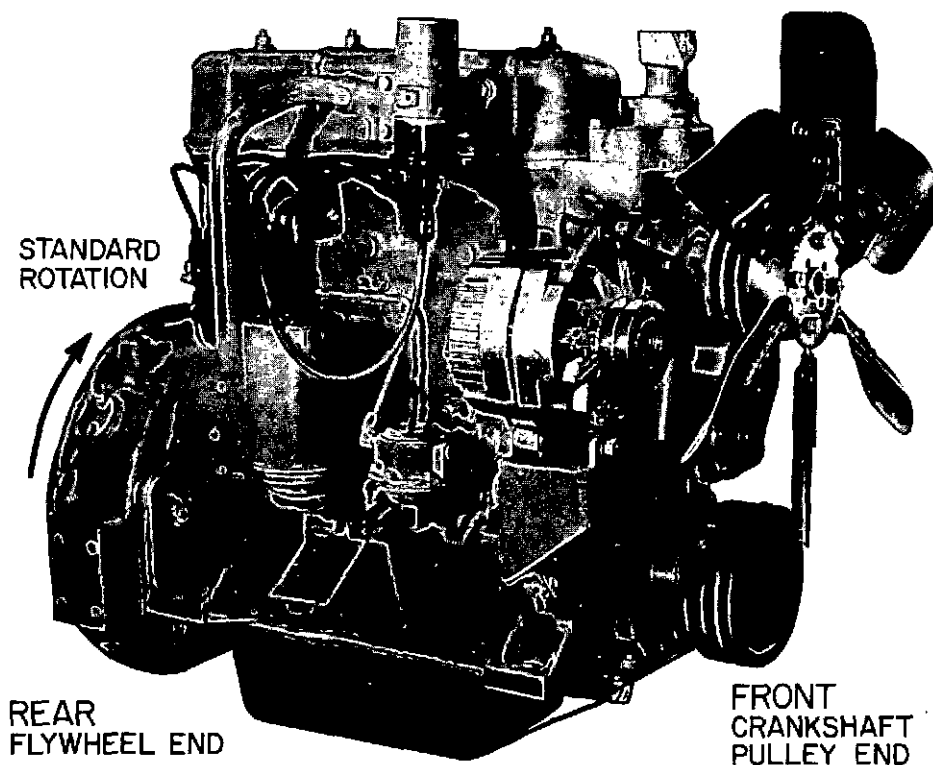

MH-001-174

FIRING ORDER

Six Cylinders - 1-5-3-6-2-4

Four Cylinders - 1-2-4-3

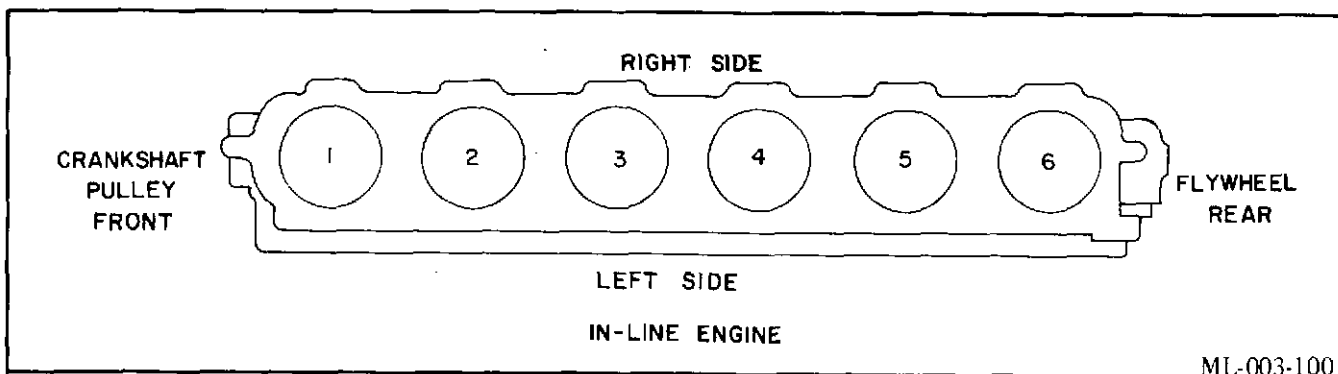

ML-003-100

MODEL, SERIAL, AND SPECIFICATION NUMBERS

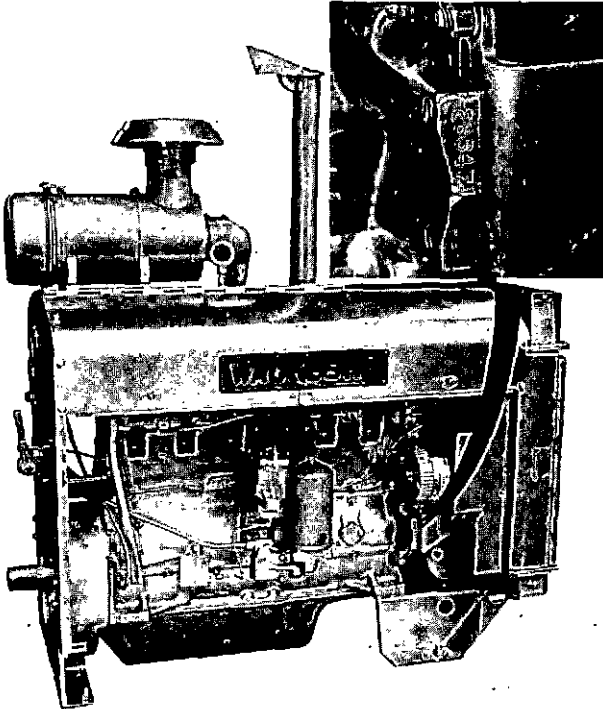

MH-001-172  
STAMPED SERIAL NUMBER LOCATION

MH-16-10

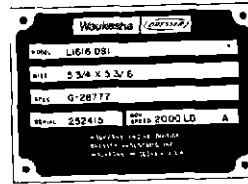

MH-16-11  
NAME PLATE LOCATION

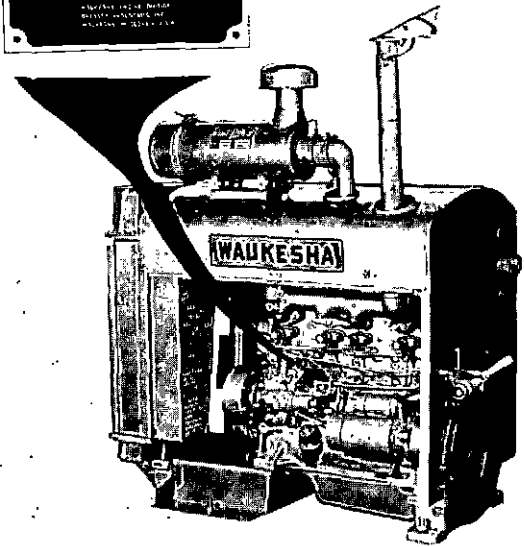

ML-16-9

UNDERSTANDING WAUKESHA MODEL DESIGNATIONS

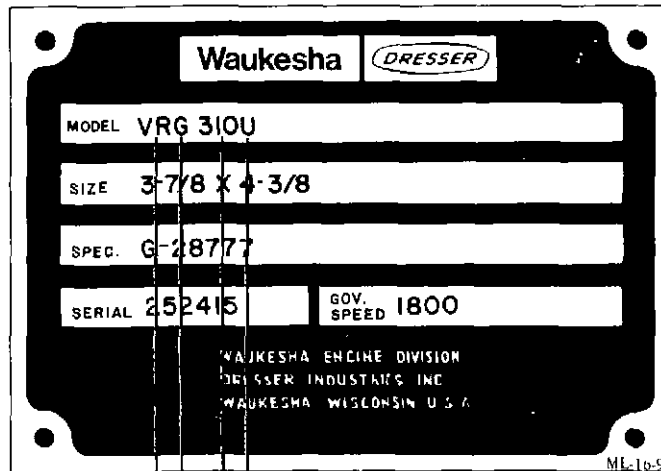

ENGINE SERIES \_\_\_\_\_

TYPE OF FUEL: G = GAS, D = DIESEL \_\_\_\_\_

DISPLACEMENT IN CUBIC INCHES \_\_\_\_\_

U = POWER UNIT \_\_\_\_\_

# OPERATION

BEFORE STARTING .....	1-3
STARTING .....	1-6
OPERATING .....	1-7
STOPPING .....	1-8
QUICK TROUBLE CHECK CHART FOR OPERATORS ....	1-9
COLD WEATHER STARTING .....	1-10
BREAK-IN PROCEDURE .....	1-10
EXERCISE OF STANDBY UNITS .....	1-10
ENGINE PERFORMANCE RECORD .....	1-10
OPERATIONAL INSPECTION .....	1-10

# PARTS ORDERING

GENUINE WAUKESHA PARTS ARE AVAILABLE WORLDWIDE AND MUST BE ORDERED THROUGH YOUR LOCAL WAUKESHA DISTRIBUTOR. FOR THE DISTRIBUTOR CLOSEST TO YOU, REFER TO THE DISTRIBUTOR LISTING IN THIS MANUAL.

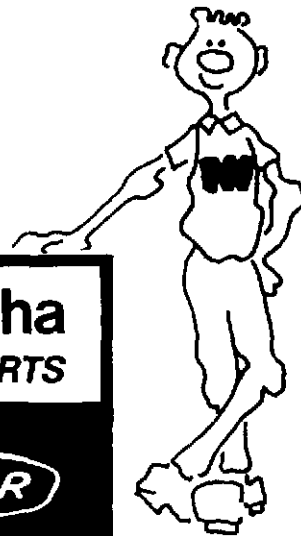

ML-1000-30

**BEFORE STARTING**

Be sure the main clutch, circuit breaker, or other power-transmission device is disengaged.

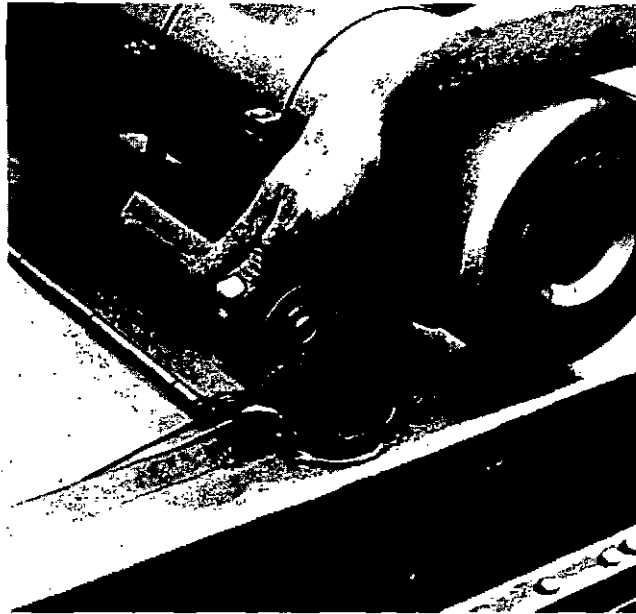

MH-200-53

Inspect drive belts (water pump, alternator, or other equipment). Examine for good condition and correct tension. If a cooling fan is used, be sure it is free to turn, properly lubricated, and the belt tension is correct.

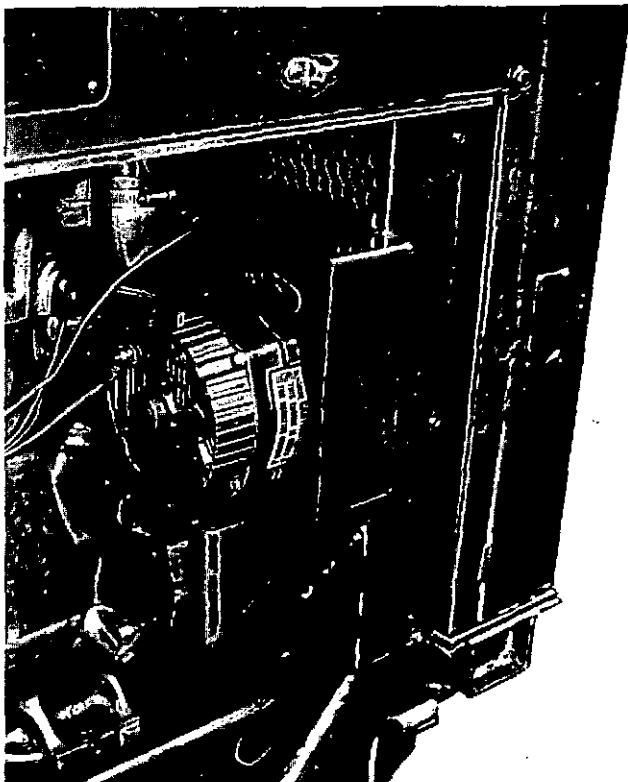

MH-201-2

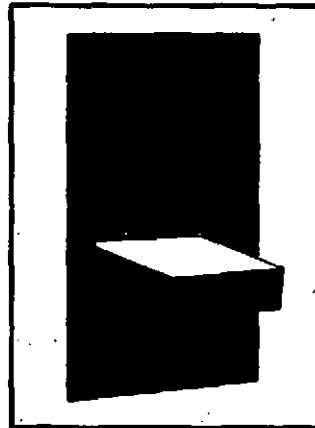

ML-500-49



MH-205-10

Trace through the external cooling system to make sure all control valves are properly opened and the drain cocks closed. Check the coolant level.



MH-200-54

Make certain all guards are secure on engine and driven equipment.

**BEFORE STARTING (Continued)**

Check the air restriction indicator, if engine is so equipped. Clean air filter element and dust cap if indicator shows red. Check oil bath type air cleaner daily.

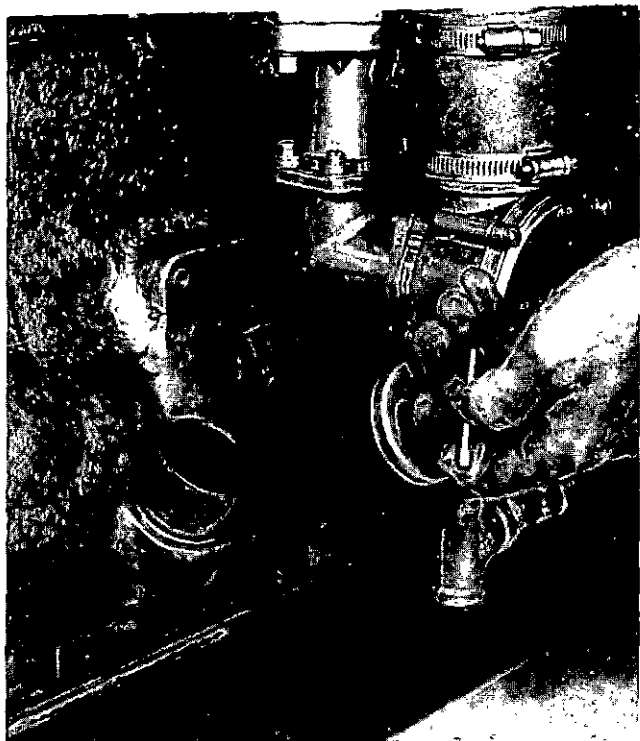

MH-03-4

If the engine has been standing idle for some time, bar it over by hand to be sure it is free.

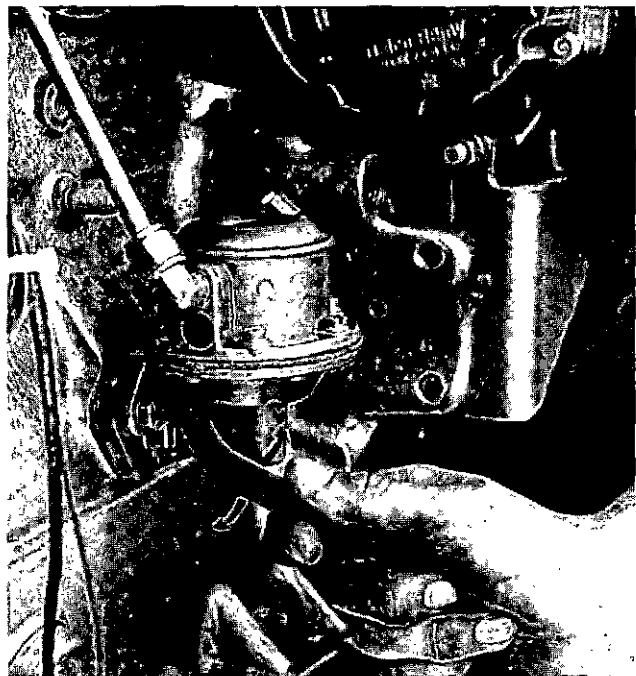

MH-19-8

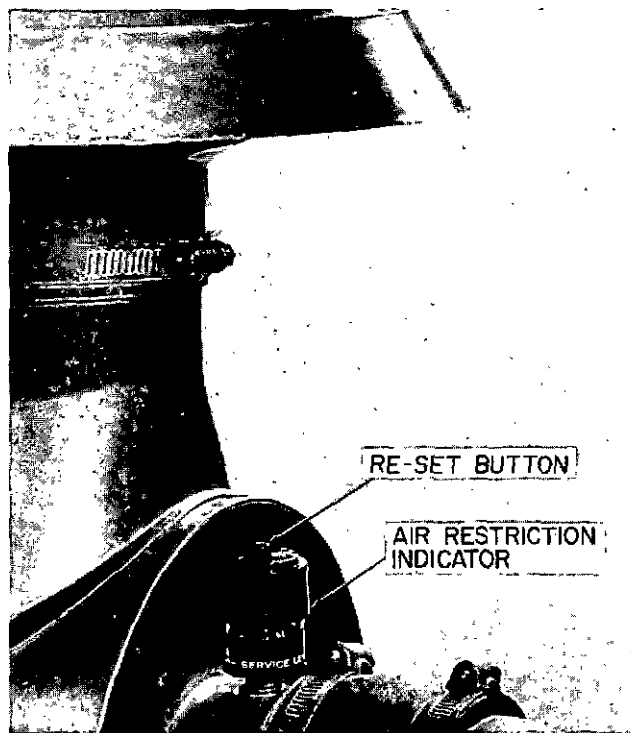

MH-208-32

Check the oil level as indicated on the dipstick prior to starting engine. Stop engine and recheck oil level after 5 to 10 minutes operation at low idle. Add oil as required to bring level to "full" mark.

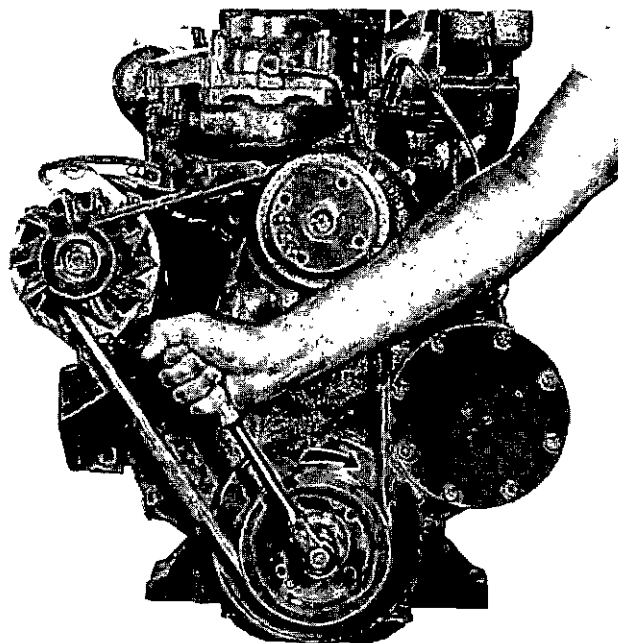

MH-11-68

Fill engine fuel tank and drain enough fuel from outlet sump trap to remove water or sediment accumulations. If diesel main fuel supply is gravity fed, allow a quantity of fuel to flow into a disposal bucket to clear up any air locks in the line and wash out scale and sediment. Use the hand primer to purge diesel fuel lines and filter units of air.

**BEFORE STARTING (Continued)**

Re-set the safety shutdown controls. Diesel and gasoline engines which utilize the oil pressure Murphy Swichgage must have the Swichgage re-set button depressed until the lockout latches. Depress the re-set button of the Murphy magnetic switch in the instrument panel (used only with diesels and distributor ignition engines which utilize Murphy Swichgages). Diesel and gasoline engines which utilize an overspeed switch (Synchro-Start) with a re-set button, must have the switch re-set before re-starting after an overspeed shutdown. Some Synchro-Start overspeed switches incorporate an automatic re-set and do not include a re-set button.

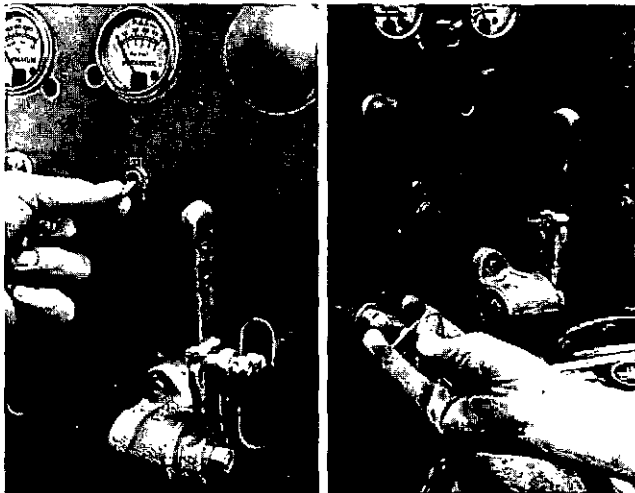

MH-202-10

MH-92-16

Position the choke control of gasoline engines as required for cold engine starting.

Be sure the fuel shutoff valve is opened prior to attempting to start the engine.

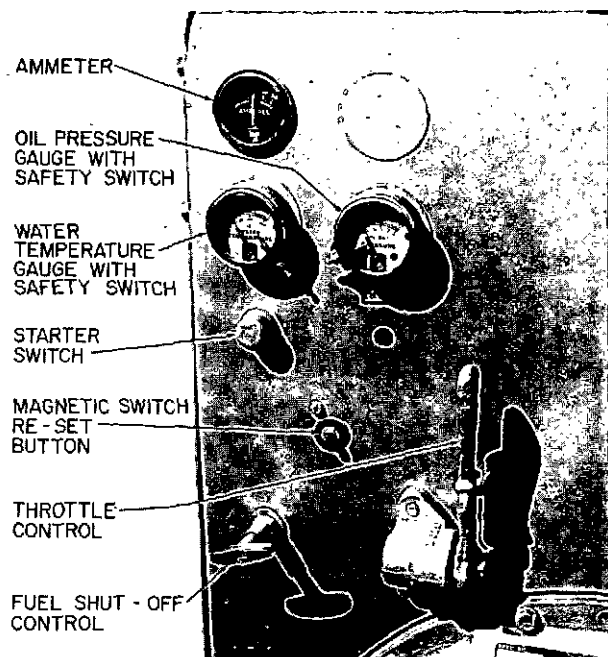

MH-215-4

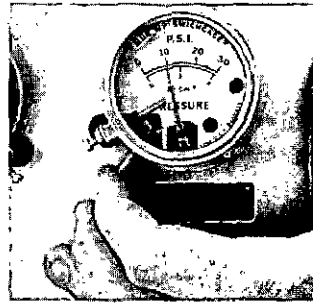

MH-202-11  
Push in gauge button until lockout engages.

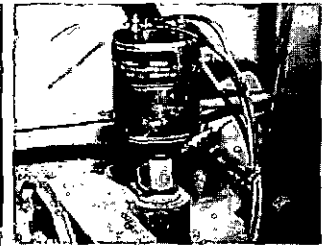

MH-233-1

Re-set overspeed switch (Synchro-Start) if engine shut down on overspeed.

Gasoline engines must have the ignition switch placed in the "ON" position.

Diesel engines must have the fuel shutoff control lever pushed towards the engine.

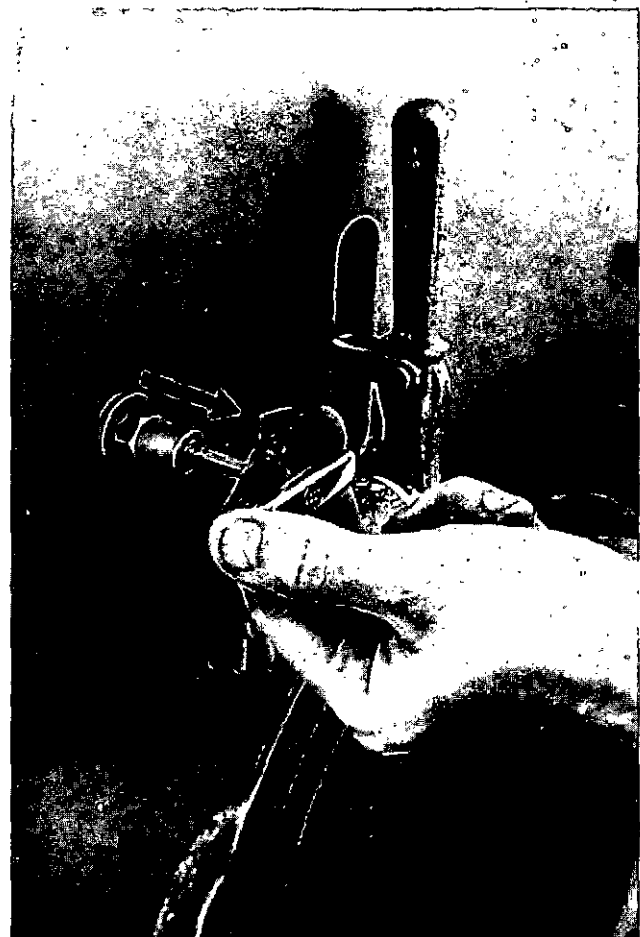

MH-215-6

Familiarize yourself with all engine controls before attempting to run engine.

### STARTING ENGINE

Place throttle control lever in "low speed" position.



MH-215-2

After engine starts, check for adequate oil pressure indications and place throttle control lever in medium idle speed position with no load for engine warm-up.

**CAUTION**

If adequate oil pressure is not indicated within 25 to 30 seconds, shut the engine down at once and correct the cause. Never operate without an adequate oil pressure indication in the hope that a faulty gauge or cold oil is responsible.



MH-92-16



MH-203-9

Actuate starter control to crank engine.

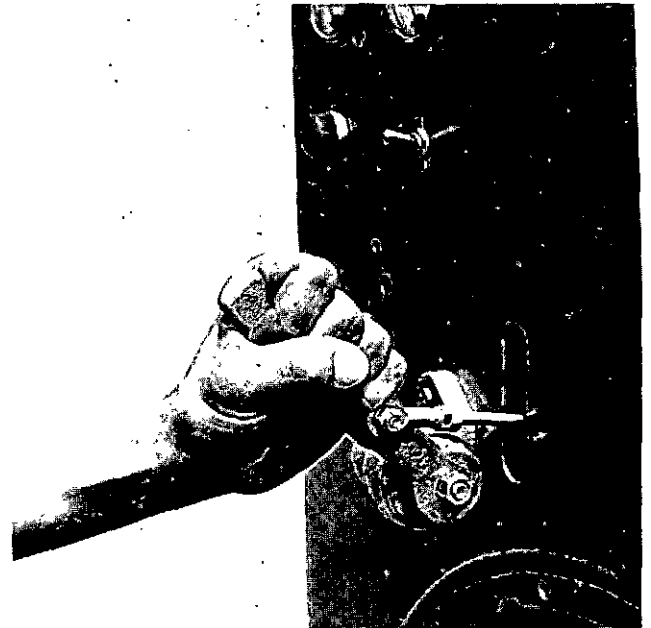

MH-203-11

Warm up engine until oil pressure stabilizes and coolant temperature reaches at least 100° - 120° F.

Place choke control of gasoline engines in "full-in" position.

Engine speed for applying load will vary depending upon engine application. Generally, load should be applied gradually with engine speed set high enough to carry the load.

**STARTING ENGINE (Continued)**

**NOTE**

Be sure white smoke in diesel engine exhaust has "cleaned-up" before applying maximum load. Experience and observation of exhaust for minimum smoking will enable operator to determine when diesel engine is warmed up. Use of partial load after start-up will shorten time required to warm-up engine.

**OPERATING**

There are a number of important things to check while the engine is running.

Learn and record the normal operating readings. Oil pressure 25-50 psi for 155, 232, 265, 283, and 310 gas engines and 25-35 psi for 155 and 232 diesel engines and 30-50 psi for 283 and 310 diesel engines. Water and oil temperature 160°F to 180°F. Changes from normal may be signs of developing trouble.

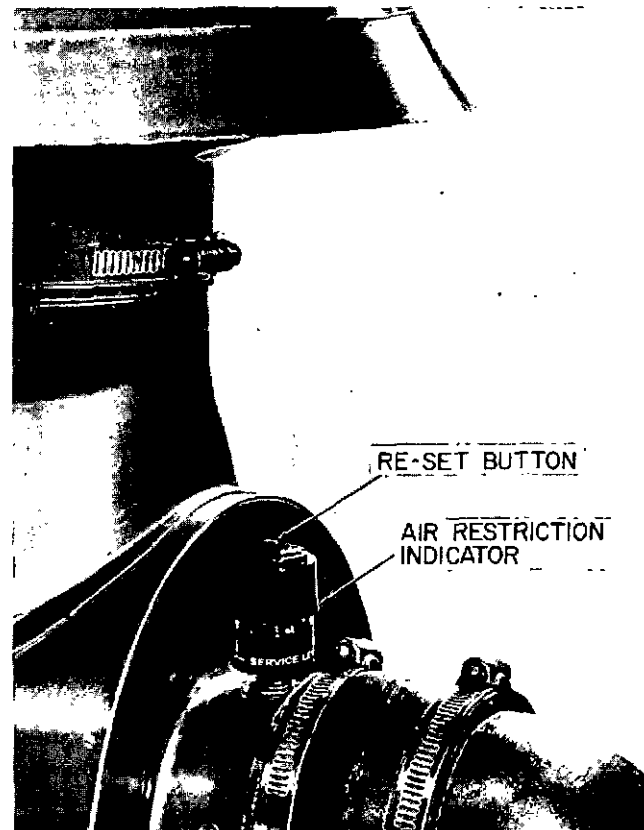

MH-208-32

Check general engine security such as air intake and exhaust connections, belt, guard bolts tight, etc.

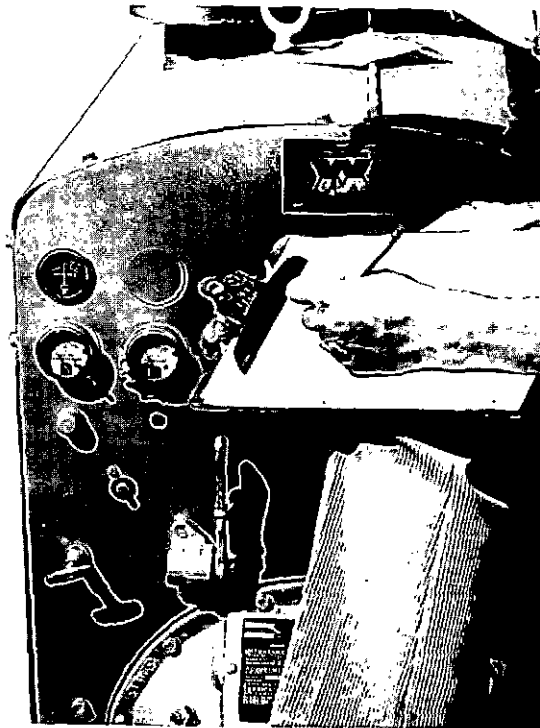

MH-215-5

Check the air intake restriction indicator, if engine is so equipped.

Listen to the engine. Certain problems, such as occasional misfiring, may first be noticeable in the engine sound.

Check for oil or coolant leaks.

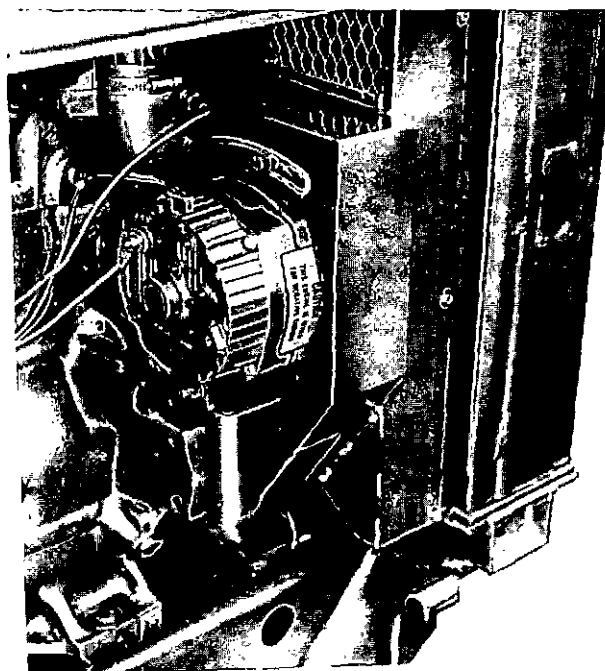

MH-201-2

**STOPPING**

Remove load by disengaging clutch control lever, opening main circuit breaker, etc.

Place throttle control lever in medium idle speed position, and allow engine to idle for a few minutes to reduce and normalize engine temperatures. It's advisable, if the engine has overheated due to either excessive load or through some malfunction of the cooling system, to operate the engine at idle speed for a few minutes to bring temperatures back to normal before stopping it.

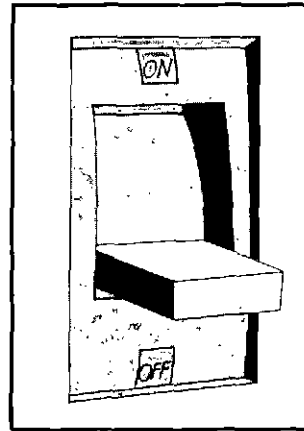

ML-500-49



MH-205-10

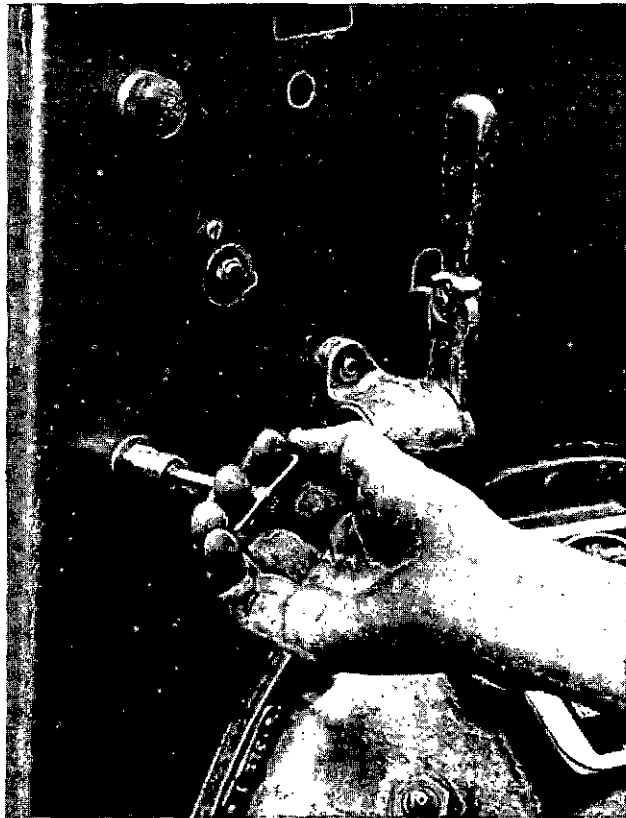

MH-92-15

Unless otherwise protected, the exhaust pipe should be capped upon shutting down the engine for long periods of time to prevent condensation, rain, or snow from getting into the engine if it is exposed to the elements. A pail or bucket inverted over the exhaust pipe will be sufficient.

Test the coolant solution for adequate anti-freeze to protect the engine from freezing during shutdown periods. The immediate and anticipated air temperature will govern the amount of anti-freeze needed.

Stop engine when it has cooled sufficiently. Depending upon the engine installation, it can be stopped in a number of ways.

Gas engines should normally be stopped by shutting off the fuel supply. Gasoline engines should be stopped by placing the ignition switch in OFF position.

Diesel engines should be stopped by pulling the fuel shut-off control lever away from the engine.

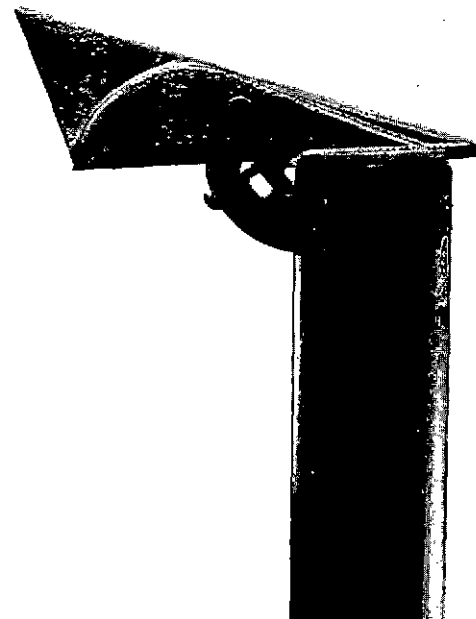

MH-217-2

doesn't start

slow start

low power

runs hot

new noises

QUICK TROUBLE CHECK CHART FOR OPERATORS

CHECK CONTROLS

follow starting steps, re-setting safety controls  
remote or automatic operation engines have special procedures.

CHECK FUEL

be sure fuel is getting to engine; check valves for open position, check possibility of water, rust, pipe scale: diesel - check supply lines for air lock and fuel filters for plugging

CHECKING COOLING SYSTEM

coolant level ok and system not air locked  
radiator not blocked (trash), shutter open, and fan operating  
raw water valves open to heat exchanger  
poor air circulation as a result of wind conditions or faulty installation

CHECK AIR INTAKE AND EXHAUST SYSTEMS FOR BLOCKS

air filter dirty, check air restriction indicator  
air intake or exhaust outlet capped

CHECK MECHANICAL THINGS

check throttle and governor control linkage for freedom from sticking and interference  
examine accessory drive belts for condition and tension  
if cranking speed seems low, check battery condition

CHECKING IGNITION ON GAS ENGINE

water on ignition parts and wires  
signs of corrosion at wire terminals or broken wires  
spark plugs poorly gapped or worn out

IF THESE CHECKS DO NOT SOLVE PROBLEM, REFER TO SERVICE MANUAL TROUBLE SHOOTING

**COLD WEATHER STARTING**

An engine jacket coolant heater, lubricating oil heater, and/or other approved starting aid should be utilized as required for cold weather starting.

**BREAK-IN PROCEDURE**

New or overhauled engines should receive a break-in run. **NOTE:** All new Class A diesel engines receive a break-in run before shipment from Waukesha Motor Company. This operation can be performed with the lube oil specified under LUBRICATING OILS. After warm-up of approximately 30 minutes, proceed with a load and unload cycle. Repeated loading (minimum of half load, maximum full load), with equal idle periods in 5 minute intervals for a period of two hours, results in rapid break-in and quick seating of piston rings. Never idle for more than 15 minutes during the break-in or for the first 100 hours of operation. **NOTE:** Stand-by generator engines should follow this procedure using a load bank.

**CAUTION**

If a break-in oil is used in this procedure, it must be removed from the engine within 100 hours to prevent damage to the engine.

**EXERCISE OF STAND-BY UNITS**

It is recommended that a generator set or other stand-by unit be exercised once each week. A record should be maintained of performance, incidental servicing, and output of both the engine and driven equipment.

Always operate the engine long enough to stabilize oil and water temperatures at the normal operating level expected under load. Do not operate under no load conditions for other than very brief periods. Loads of at least one-third up to the normal rated capacity are recommended. Ordinarily, an exercise run of one to one and one half hours will be needed to stabilize temperatures. If the engine cannot be loaded, it should not be exercised for more than 10 minutes each exercise period.

It is recognized that some types of driven equipment cannot be operated without fairly extensive procedures to "put them in line". Examples are hospital generators in some types of switching configurations; air-conditioning compressors which can only be loaded by changing over to chilled water from heating water circulation; and pumps which are not set up for waste discharge or recirculation. In such cases, weekly exercise periods may have to be reduced, where possible, to operational periods long enough only to prove the engine's ability to crank and start, or, checkout of starting circuitry and safety equipment with the starter disabled. In this event, special attention must be taken to

prevent internal corrosion, sticking and gumming of fuel controls, and deteriorated starting batteries. In all cases, arrangements should be made to run the engine and driven equipment under load at least every 90 days.

**ENGINE PERFORMANCE RECORD**

Engine operating information, recorded during regular inspections, is necessary to apply proper Preventive Maintenance schedules. Accurate records help control costs by avoiding unnecessary servicing, ensuring needed servicing, and provide "trend" information on the general engine condition. We recommend keeping a record of the following information, selecting items applying to your engine.

HOUR METER READING \_\_\_\_\_

TACHOMETER (RPM) \_\_\_\_\_

FUEL METER READING \_\_\_\_\_

ENGINE OIL PRESSURE \_\_\_\_\_

ENGINE OIL TEMP \_\_\_\_\_

COOLANT TEMPERATURE \_\_\_\_\_

GAS PRESSURE @ CARBURETOR  
INTAKE \_\_\_\_\_

MANIFOLD VACUUM \_\_\_\_\_

CRANKCASE PRESSURE pos/neg \_\_\_\_\_

UNUSUAL NOISE(S) VIBRATION \_\_\_\_\_

OIL LEAKS \_\_\_\_\_

COOLANT LEAKS \_\_\_\_\_

ALTERNATOR OUTPUT \_\_\_\_\_

**OPERATIONAL INSPECTION**

Examine fuel, water, and lubricant lines for signs of leaks, damage, or corrosion.

Inspect the coolant level and condition. Rust, foaming, or oil in the coolant shows need for cooling system servicing.

Air cleaners and breathers should be checked daily for cleanliness and tightness.

Examine engine foundation for condition of grout, tightness of hold down bolts, and general alignment of driven equipment.

# PREVENTIVE MAINTENANCE

FUELS .....	2-3
LUBRICATION GUIDE .....	2-4
LUBRICATING OILS .....	2-4
SELECTING OIL VISCOSITY .....	2-4
OIL CONSUMPTION .....	2-4
OIL CHANGES .....	2-5
OIL CHANGE PROCEDURE .....	2-5
OIL ANALYSIS .....	2-5
SERVICE SCHEDULE AND PROCEDURES .....	2-6
OIL AND COOLANT LEVEL .....	2-6
FUEL FILTER (Diesel Only) .....	2-6
AIR FILTERS .....	2-6
FAN BELTS .....	2-6
BATTERY .....	2-7
CRANKCASE BREATHER .....	2-7
DISTRIBUTOR (Gasoline Only) .....	2-7
FUEL STRAINERS (If Applicable) .....	2-7
SPARK PLUGS .....	2-7
OIL FILTERS .....	2-8
OIL PUMP INLET SCREEN .....	2-9
FUEL FILTER .....	2-9
AIR CLEANERS .....	2-9
COOLING SYSTEM MAINTENANCE .....	2-10
DISTRIBUTOR ADJUSTMENTS .....	2-12
SPARK PLUG ADJUSTMENTS .....	2-14
MAGNETO SERVICING .....	2-15
TIMING THE MAGNETO .....	2-15
ALTERNATOR SERVICING .....	2-15
ALTERNATOR PULLEY REMOVAL AND INSTALLATION TOOL .....	2-17
INJECTION PUMP MAINTENANCE .....	2-17
PENCIL INJECTOR ADJUSTMENT .....	2-21
GASOLINE CARBURETOR ADJUSTMENTS .....	2-22
GAS CARBURETOR ADJUSTMENTS .....	2-23
GOVERNOR ADJUSTMENTS .....	2-23
VALVE CLEARANCES .....	2-24
COMPRESSION TESTING .....	2-25
MANIFOLD VACUUM TESTING .....	2-25
TEST PROCEDURES FOR ENGINE PROTECTION DEVICES .....	2-26
ENGINE STORAGE .....	2-26
NUCLE-OIL STORAGE .....	2-27
CONVENTIONAL STORAGE .....	2-28
PRESERVATION EQUIPMENT AND MATERIALS .....	2-29
PREPARING ENGINE FOR OPERATION AFTER STORAGE .....	2-29
STORAGE OF FUEL INJECTORS .....	2-30
PRESERVATIVE OIL .....	2-30

# PARTS ORDERING

ANTICIPATE YOUR PARTS  
REQUIREMENTS:

- a) ORDER PARTS EARLY IN  
THE DAY.
- b) KEEP A SUPPLY OF NORMAL  
MAINTENANCE PARTS IN  
STOCK.
- c) OBTAIN A PARTS STOCKING  
RECOMMENDATION FROM  
YOUR DISTRIBUTOR.



ML-1000-28

**FUELS**

**NATURAL GAS** - Waukesha VR gas engines are designed to burn natural gas. Natural gas is normally considered as having an anti-knock (octane) rating equivalent to 120.

**GASOLINE** - It is important to use gasoline with an octane rating high enough to avoid serious detonation (knocking). 85 octane is suitable for VRG Series Engines, if the gasoline is of consistent good quality.

**DIESEL** - The VR diesel engines will operate on any good domestic commercial No. 2 Diesel fuel oil of 40 Cetane or above (see accompanying table). The fuel must be free from water, foreign material, and deterioration due to prolonged storage. Storage periods of one year should be considered maximum, after which fuel tanks should be drained, inspected, and fresh fuel provided. When fuel oil from sources other than the usual reputable refiners is con-

sidered, the Engineering Department of the Waukesha Engine Division should be consulted.

Jet "A" fuel is generally a satisfactory fuel for VR diesel engines from the standpoint of cetane rating and operational satisfaction with the following exceptions:

1. There may be Jet "A" from some refineries which does not meet our minimum cetane value of 40. In cases of doubt, a cetane rating should be obtained.
2. Jet "A" fuel may have a lighter specific gravity than No. 2 diesel fuel which averages around 0.83. If the Jet "A" is substantially lighter, engine maximum power will be reduced because of the lower BTU content per specific injected volume of fuel. This reduction will be in approximately the percentage by which the Jet "A" is lighter than No. 2 diesel fuel.

**PREVENTIVE MAINTENANCE**

**FUEL OIL SPECIFICATIONS**

Fuel Oil Physical Properties	Limits	ASTM Test Method
API Gravity	30 min.	D-287
Cetane Number	40 min. (Note 1)	D-613
Sulphur %	0.7 Max.	D-129
SU Viscosity-Sec @ 100°F.	30-50	D-88
Water and Sediment - %	0.1	D-96
Pour Point °F. Min.	10°F. Below Amb. Air	D-97
Conradson Carbon	0.25%	D-189
Ash % Max.	0.02	D-482
Alkali or Mineral Acid	Neutral	D-974
Distillation °F.		D-158
10% Min.	450	
50%	475 to 550	
90% Max.	675	
End Point Max.	725	
Cloud Point	Note 2	D-97

Note 1: For automatic starting units, a fuel with 50 cetane minimum is recommended.

Note 2: Cloud Point should not be more than 10°F. above Pour Point.

**LUBRICATION GUIDE**

Lubrication intervals listed in the Service Schedule and Procedures are for normal operation and should coincide with other preventive maintenance services; however, under unusual conditions, intervals should be changed if indicated by evidence of dirt, sludge or breakdown of lubricant.

The following precautions should be observed when lubricating the engine:

1. Keep all lubricants in closed containers and store them in a clean, dry place away from heat. Always protect the lubricants from dust, dirt or moisture. Keep lubrication equipment clean and ready for use at all times.
2. Before lubricating, wipe surrounding areas clean to prevent dirt or other foreign matter from entering the lubrication system. Use a cloth moistened with solvent to remove any old or hardened lubricants. After lubricating, remove any excess lubricant and wipe any spilled lubricant from parts not requiring lubrication.

**LUBRICATING OILS**

The performance of a lubricant, like that of any manufactured product, is the responsibility of the refiner and producer. Also, the engine operator, to a large degree, controls the oil's performance, for he is the one who must make decisions on oil changes, filter changes, loads, general maintenance, and operating conditions.

The Waukesha Engine Division does not recommend lubricating oils by brand name. A table of lubricating oils, and the performance grades for which their suppliers indicate these products are qualified, is available from the Engine Manufacturers Association, 111 East Wacker Drive, Chicago, Illinois - 60601. This publication is titled, "EMA Lubricating Oils Data Book for Heavy-Duty Automotive and Industrial Engines". All Waukesha VR engines are considered Class A, that is under 1000 cu. in. (163,9 dm<sup>3</sup>) displacement.

Oil is designated several ways; including the API, which is usually stamped on the container; the military, and the engine manufacturers.

For Class A engines operating on diesel fuel, Waukesha Engine Division recommends lubricating oils designated by the API as CD, by the military as MIL-L-45199B or MIL-L-2104C, and by the manufacturer as S-3.

For Class A engines operating on gasoline or gas, Waukesha Engine Division recommends lubricating oil designated by the API as CC, SD, or SE, and by the military as MIL-L-2104B or MIL-L-46152.

**SELECTING OIL VISCOSITY**

The correct lubricating oil viscosity (often referred to as "weight") must be determined with the engine operating under its normal loaded speed and temperature, using SAE 30 oil.

1. Start and load engine as described under "STARTING".
2. After oil and coolant temperatures no longer increase, note the temperature of the oil in the oil pan. Use a temperature gauge of known accuracy. Compare this temperature with the accompanying chart. The correct oil viscosity will be found in the right hand column.

Multi-viscosity oils (10W-30, for example) should be used only when cold starting conditions make it absolutely necessary. Oil change periods should not exceed 25 hours, because multi-viscosity oils may rapidly lose their highest viscosity rating in industrial service.

CLASS "A" ENGINES OIL TEMPERATURE METHOD	
Oil Pan Operating Temperatures	SAE Viscosity Numbers
210° - 250°F.	40
160° - 210°F.	30
130° - 160°F.	20

Engines operating with low oil temperatures (below 160° F (71°C)) can be expected to show excessive sludging and wear. Engines operating with high oil temperatures (above 230° F (110° C)) may experience lacquering and ring sticking due to oil oxidation. If, for any reason, oil temperatures cannot be corrected to the normal operating range, more frequent oil changes may help in extending engine life.

When the actual operating oil temperature is not known, an estimate of the SAE oil grade to use can be made by assuming the oil pan operating temperature of Class A engines will be 120 degrees above the air temperature in heavy-duty service. For example: At an air temperature of 70° F., estimated oil pan operating temperature would be 190° F. Use SAE 30 as indicated in the above table. NOTE: This is only an estimate, since the type of installation determines the amount of air circulation for cooling around the oil pan. Actual oil pan operating temperatures should be measured whenever possible.

**OIL CONSUMPTION**

Oil consumption should range from 0.0005 to 0.004 pounds per horsepower hour as determined by the following formula:

$$\text{LBS/HP-HR} = \frac{1.82 \times \text{quarts of oil used}}{\text{Operating HP} \times \text{total hours of operation}}$$

**OIL CHANGES**

The crankcase level should be checked prior to each day's engine operation and at the same time the condition of the oil as revealed on the bayonet gauge should be observed carefully. Replace oil at any time it is plainly diluted, broken down, thickened by sludge, or otherwise deteriorated. Remember that some modern oils cannot be judged on the basis of color alone because the additives are intended to hold carbon particles in suspension. The standard filters supplied will not remove these particles. The dark appearance of the oil is not necessarily an indication that the oil should be changed. Whenever oil is changed, the filters must be serviced. Oil performance will reflect engine load, temperature, fuel quality, atmospheric dirt, moisture and maintenance. Where oil performance problems arise or are anticipated, the oil supplier should be consulted. An oil change period of 100 hours of normal service can be used as a guide for Class A engines.

**OIL CHANGE PROCEDURE**

1. Remove crankcase oil drain plug, drain oil and securely replace plug.
2. Replace filter element.
3. Fill the crankcase with ten quarts of oil (only seven quarts for VRG and VRD 232 and five quarts for VRG and VRD 155).
4. Operate the engine for a few minutes in order to circulate oil through system.
5. Stop engine and check for additional oil requirement. Bring level to "full" mark.

Not all oils in every type of engine will give maximum service, therefore be careful to examine the oil after the first draining to determine whether it is standing up in service. Trial periods of ten hours are suggested and at the end of such periods make careful inspection of the oil depth gauge for sludging, frothing and emulsification. Such conditions call for more frequent changes or a different oil. In winter operation, low oil temperatures (below 160°F.) are particularly likely to cause sludge formation. Temperature-control devices - curtains, shutters, and so on - should be used if needed in order to hold the oil temperature around 180°F.

**OIL ANALYSIS**

The Waukesha Engine Division provides an inexpensive oil analysis program through its distributor organization. An oil analysis can reveal many potential problems. It is available for all types of closed lubrication systems—engines, compressors, transmissions, differentials, gear boxes and hydraulic systems. The test results are thorough, accurate, objective . . . and fast. You get results returned to you the same day they are received . . . and critical con-

ditions are reported by phone. Use the table below to determine the frequency at which oil samples should be taken.

**NOTE**

The ideal time to take an oil sample is just after shut-down at the time of oil and filter change.

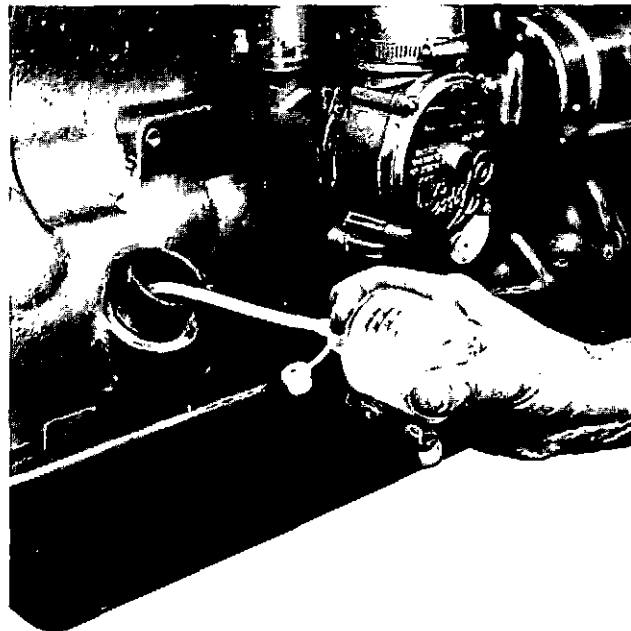

**PREVENTIVE MAINTENANCE**

MH-03-3

**SAMPLING RECOMMENDATIONS**

TYPE OF EQUIPMENT	SAMPLING FREQUENCY*
Natural Gas, LPG, Sewer Gas and Turbines	Every 700 - 850 Hours
Diesel Engines	Every 250 - 350 Hours
Gasoline Engines	Every 500 - 750 Hours
Compressors	Every 700 - 850 Hours
Transmissions, Differential and Gear Systems	Every 450 - 650 Hours
Hydraulic Systems	Every 750 - 900 Hours
Air Cooled Engines	Not Applicable

\*NOTE: These frequencies apply to oil samples only. Oil change frequencies are stated under "OIL CHANGES".

For more information on the Waukesha Oil Analysis Program see your nearest authorized Waukesha Distributor.

## SERVICE SCHEDULE AND PROCEDURES

### OIL AND COOLANT LEVEL

Check levels daily and fill as required. Change oil and filter every 100 hours.

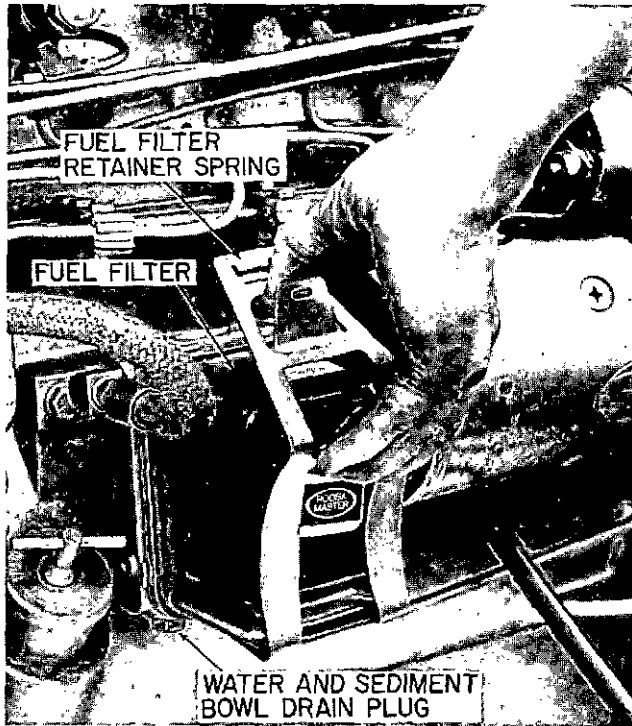

MH-54-7

### AIR FILTERS

Check restriction indicator daily and clean filter if indicator shows red.



MH-200-54

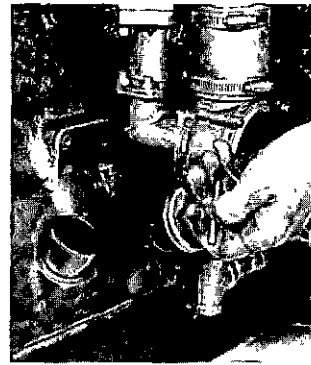

MH-03-4

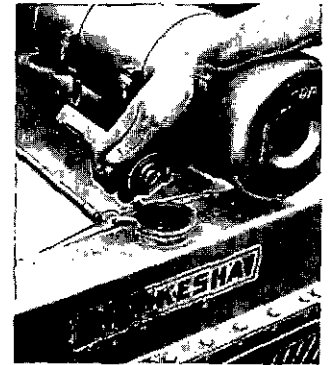

MH-200-53

### FUEL FILTER (Diesel Only)

Check sediment bowl daily for accumulation and drain if necessary. Replace element every 500 hours.

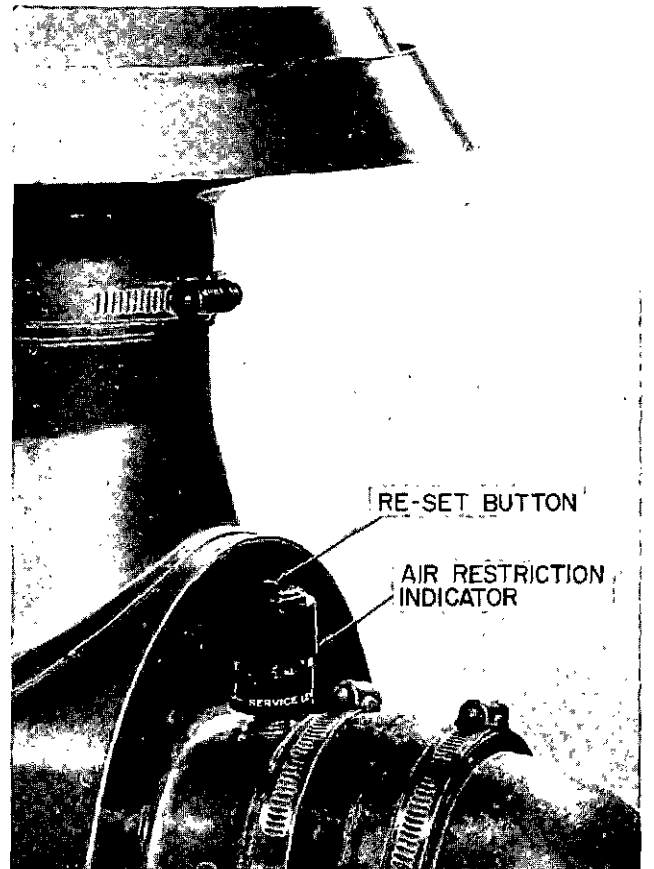

MH-208-32

### FAN BELTS

Check belts every 50 hours for proper tension and material condition. Make sure guards are secure.

### VALVE ADJUSTMENT

Adjust valve clearance every 500 hours.

**BATTERY**

Check electrolyte level every 50 hours and fill as required. Inspect terminals for corrosion periodically. A specific gravity of between 1.250 - 1.285 with all cells within 0.010 and 0.015 of each other indicates a well charged battery.

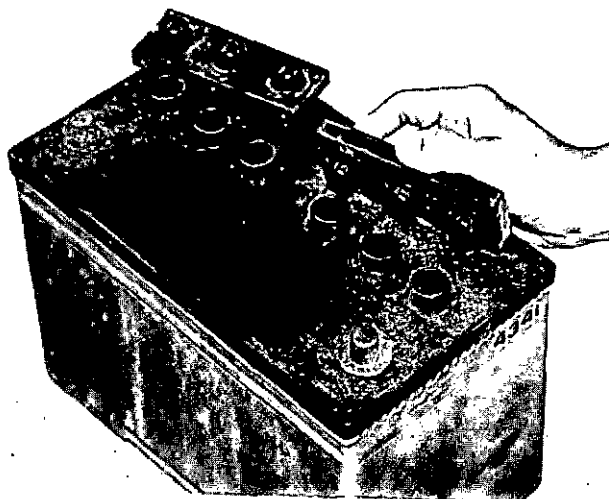

**GAS CARBURETOR**

Inspect diaphragm annually and replace if cracked or deteriorated.

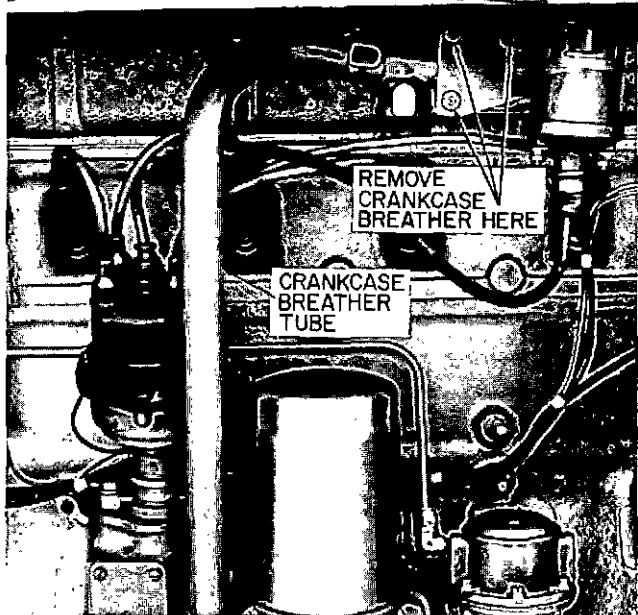

MH-70-17

**CRANKCASE BREATHER**

MH-236-1

Clean every 100 hours.

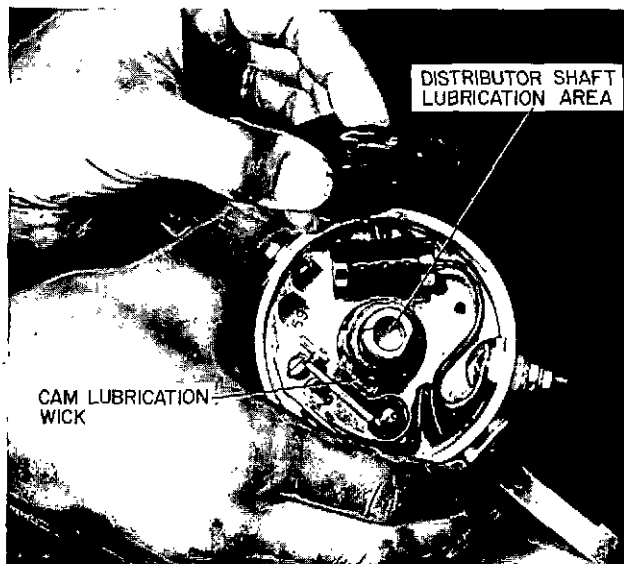

MH-22-65

**DISTRIBUTOR (Gasoline Only)**

Lubricate the cam lubrication wick every 500 hours (may be prelubricated). Lubricate shaft every 1000 hours.

**IGNITION POINTS**

Adjust point clearance every 500 hours. Replace points and condensor if necessary.

**POWER TAKE-OFF**

Lubricate at intervals according to instructions of manufacturer.

**FUEL STRAINERS (If Applicable)**

Disassemble, clean, and wash strainer elements at 150 hour intervals.

**SPARK PLUGS**

Inspect every 250 hours and replace every 500 hours.

Spark plug gap .025" Gasoline  
.020" Gas

Spark Plug Size 155 + 232 Models - 18 mm  
265, 283, + 310 Models - 14 mm

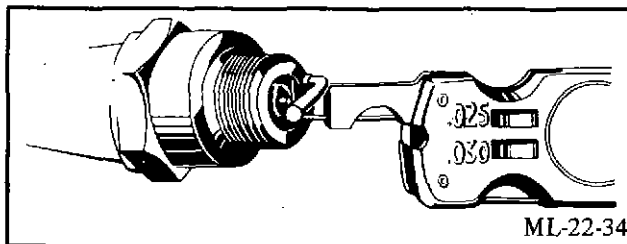

ML-22-34

PREVENTIVE MAINTENANCE

**OIL FILTERS**

Although some variations may appear in the oil filter installations used on the VR Series engines, the same general principles of maintenance apply to most of them. In all cases the manufacturer's recommendations accompanying the filter, or the instruction label applied to the side of the filter, should be followed carefully.

Full-flow filters are an integral part of the lubrication system. Never block off the filter, even temporarily, and run the engine. **ALL OIL GOING TO THE ENGINE MUST PASS THROUGH THE FILTER.** For this reason it is doubly important when changing oil that the element be changed and the filter parts thoroughly washed to prevent clogging or blocking of the oil flow to the engine. When a condition arises where neglect of the filters or an unusually rapid accumulation of sludge tends to bring about filter element clogging, the engine will not be starved of oil because of this condition, but it is very important to remember that the dirty oil that brought about the filter element clogging is now by-passing the filter and going through the engine itself, and may reduce engine life materially. All VR Series engines except VRG and VRD 155 and 232 engines are equipped with full-flow filters.

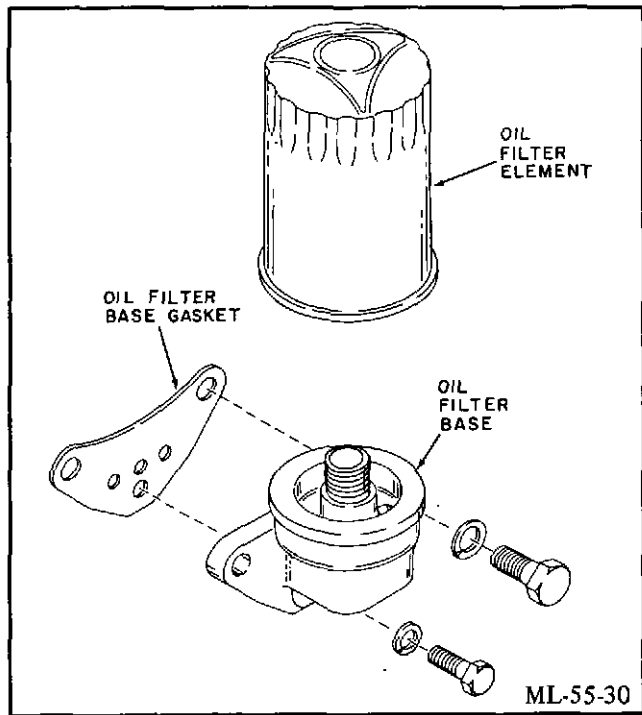

TYPICAL SHUNT TYPE OIL FILTER  
(155 AND 232 MODELS ONLY)

No particular difficulties are involved in replacing the element, although for the sake of cleanliness it is suggested that the filter be drained of the accumulation of sludge and oil before removing the element. About once a year it is good practice to remove the filter plugs and flush out the entire unit with mineral spirits, kerosene, benzol, or similar solvent. At the same time, the by-pass valve should be examined for freedom and proper operation. To ensure a clean job without leaks, it is important that the filter seal gasket be handled carefully and replaced at the same time as the element.

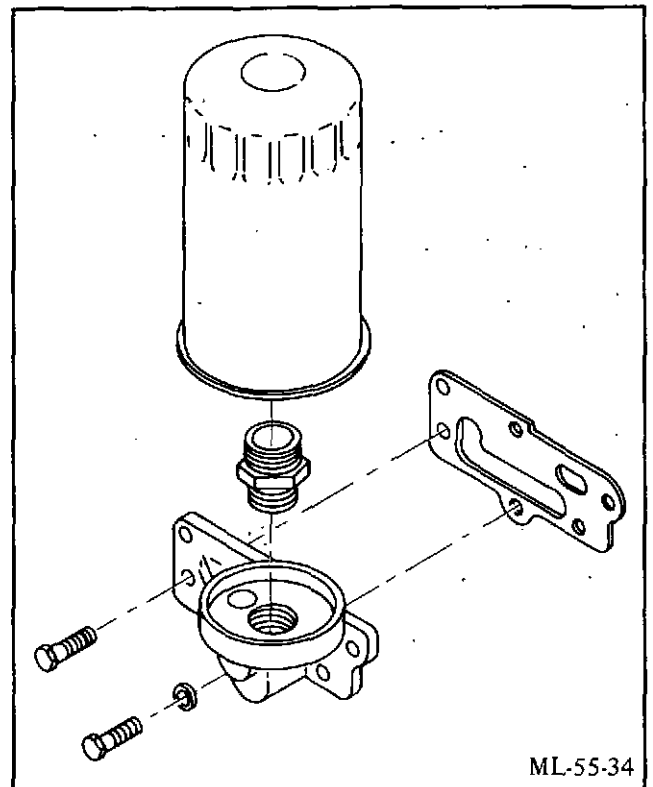

TYPICAL FULL-FLOW OIL FILTER  
(CURRENT 283 AND 310 MODELS ONLY)

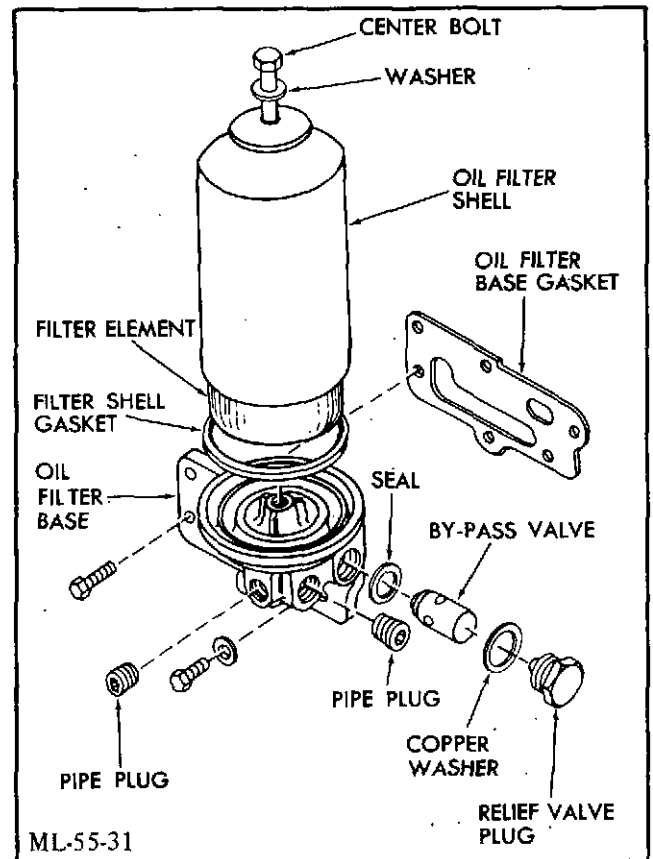

TYPICAL FULL FLOW OIL FILTER  
(PREVIOUS 283, 310 MODELS AND  
CURRENT 265 MODELS ONLY)

**OIL PUMP INLET SCREEN**

The inlet of the oil pump is protected by a wire screen designed to protect the pump and engine from the introduction of foreign material. If any indications of low or fluctuating oil pressure appear, it is recommended that the pump screen be very thoroughly washed in a solvent such as lacquer thinner or benzol.



CLEANING OIL PUMP INLET SCREEN MH-80-66

**FUEL FILTER**

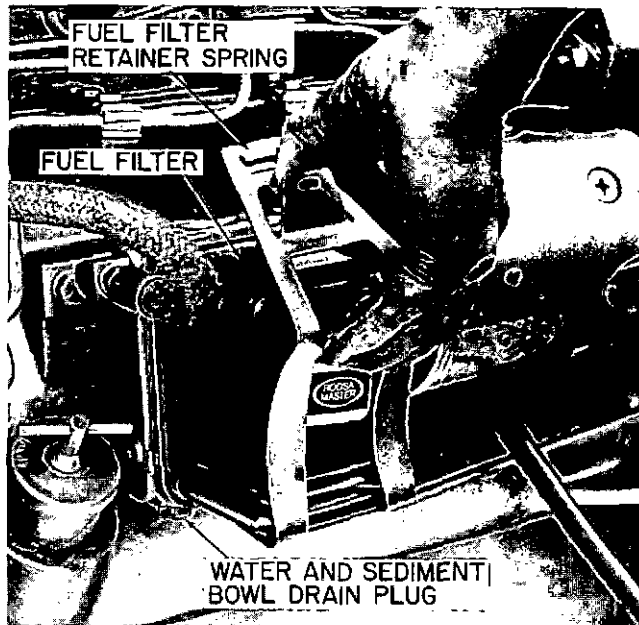

REMOVING FUEL FILTER MH-54-7

The element of the standard diesel engine fuel filter is removed by pressing inwards and towards engine block on upper tab of spring clip. Clip will unsnap when pulled and bowl and filter may be removed. Clean filter base with solvent not harmful to aluminum. Replacement is in reverse order. The fuel filter housing has a vent plug at the top and a water and sediment drain plug on the bottom.

**AIR CLEANERS**

Follow the directions attached to the cleaner if any are present. If no directions are visible, examine the cleaner to determine whether it is an oil bath type or not. Oil bath cleaners have an oil reservoir in which the dirt is trapped as a thick sludge. Wipe or wash out such accumulations and replenish the reservoir to the indicated level with clean engine oil. Oil in cleaner should be changed at each engine oil change. Both oil bath and screen type cleaners have a metal mesh or wool thru which the air passes. Ordinarily the unit containing this material should be washed clean in solvent, allowed to drain; then dipped in light oil and allowed to drain again at each cleaning.

A dry type air cleaner is usually supplied on VR Series engines. A pre-cleaner is built into each unit with the pre-cleaner dust collected in a dust cup on the end of the filter.

An air restriction indicator device mounted in the piping from the air filter serves as positive evidence when air filter service is necessary.

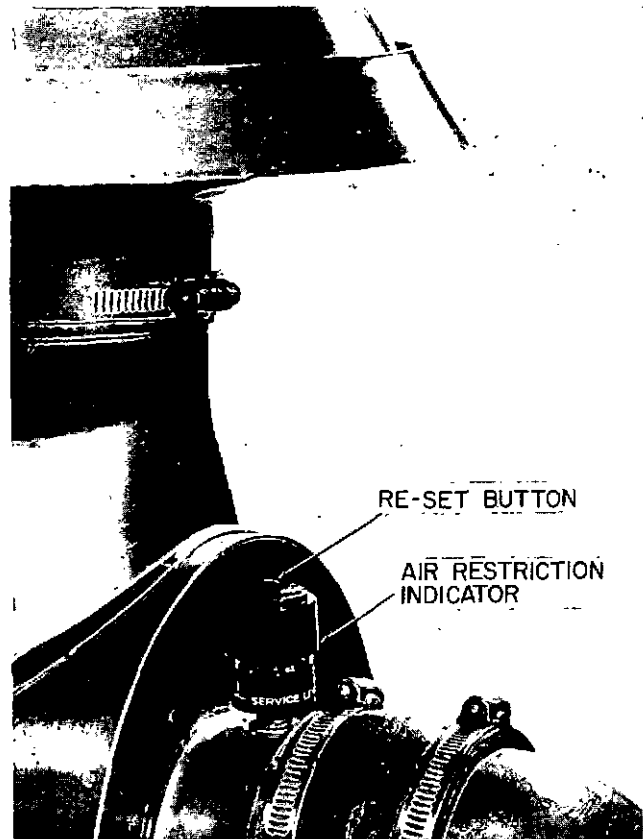

CHECKING AIR RESTRICTION INDICATOR MH-208-32

PREVENTIVE  
MAINTENANCE

**CAUTION**

Unless the signal is locked in view, indicating a clogged air cleaner, it will return to a normal setting upon engine shut-down. Normally the element is serviced long before the gauge indicates a need, but the operator is cautioned to check the gauge every day while the engine is running. After the element has been serviced the reset button on the restriction indicator should be depressed to re-set it.

When removing the dust cup of the filter element, use care to avoid spilling dust on the engine. In the case of the element, the dust cap may have to be positioned so as to catch any dirt which may be pulled out by the pre-cleaner fins.

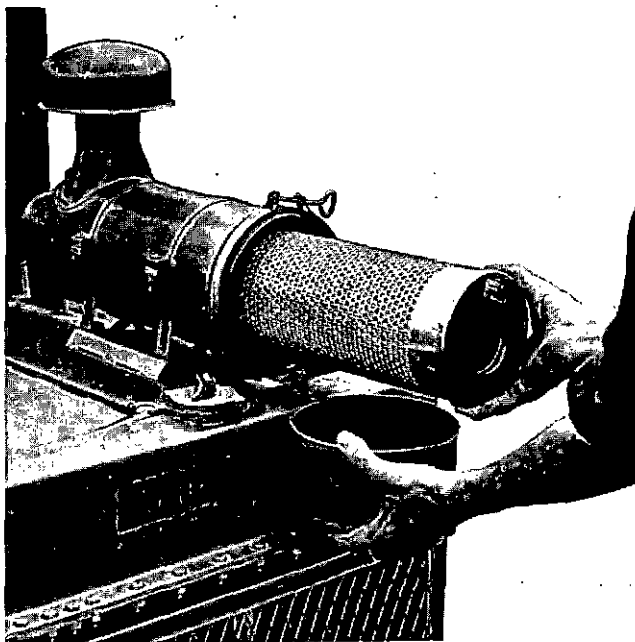

CLEANING AIR CLEANER  
 MH-208-33  
 MH-208-34

To clean the dry type elements, proceed as follows:

**CAUTION**

Do not rap, beat or drop element.

1. Compressed air cleaning. Direct air (max. 100 psi) inside element, moving nozzle up and down while rotating element.
2. Water wash cleaning. Soak element 10 minutes in luke-warm water and non-foaming detergent solution. Rinse with water (max. 40 psi) from inside of element until rinse water is clean. Air dry - don't use compressed air to dry.

Inspect after cleaning by placing a light inside the element. Replace element if it is ruptured, has pin holes or damaged gaskets. Always replace element after three cleanings or 6 months, whichever occurs first.

**COOLING SYSTEM MAINTENANCE**

The cooling system of the bare engine holds about 10 quarts of water without provision for radiators or other equipment. When adding antifreeze compounds on a percentage basis, remember to include the coolant volume of the radiator and other external parts of the cooling system. The following table may be used as a guide:

Ethylene Glycol "Prestone"	Radiator Glycerine (G.P.A.)	Freezing Points	
		oF.	oC
16%	37%	20	- 7
25%	55%	10	-12
33%	70%	0	-18
39%	81%	-10	-23
44%	92%	-20	-29
48%	100%	-30	-35

To prevent rust when using water alone, add one ounce of soluble oil for every gallon of coolant in the cooling system.

Never fill the cooling system with only water if the engine is to be exposed to subfreezing temperatures. This applies even when warm water is used because the water in the radiator and jacket passages cools rapidly and is likely to freeze before the engine can be started. If it is planned to leave the coolant in the engine at the next shutdown, then mix the proper proportion of antifreeze and water before filling the engine.

To drain cooling system, drain external components and remove drain plug from left rear side of engine.

Under normal conditions, the heat-sensitive thermostat in the water outlet will maintain temperatures within the desired limits of 170° to 180° Fahrenheit.

By way of caution, it must be remembered that if the engine is to be operated with the thermostat removed - and this is not recommended except in case of emergency - provision must be made to block off the by-pass passage or water will continue to recirculate without passing through the radiator or other external cooling system. Shutters or other means will be required to maintain the temperature at the desired level.

**Thermostat Removal and Testing**

Ordinarily, thermostats will seldom need replacement in the field. They should be checked from time to time, however, and are quickly accessible by removing the thermostat housing at the forward end of the cylinder head. The steps necessary to accomplish this are simply the removal of the water outlet connection hose, and the cap screws securing the housing. Thermostats damaged by corrosion or other causes are not repairable and must be replaced.



REMOVING THERMOSTAT

MH-21-21

Thermostats should be tested in hot water for proper opening. A bucket or other container should be filled with sufficient water to cover the thermostats and fitted with a good quality thermometer suspended in the water so that the sensitive bulb portion does not rest directly on the bucket bottom or side. A stove or torch is used to bring the water to a heat range of 170°F., while the thermostat is submerged in the water. Stir the water for even heating. As the temperature passes the 165° - 170° F. range, the thermostat should start to open and should be completely open when the temperature has risen to 185° - 190°F. VRG and VRD 155 and 232 thermostats start to open at about 180°F. and are fully open at 202°F. Lifting the thermostat into the colder temperature of the surrounding air should cause a pronounced closing action and the unit should close entirely within a short time. A large thermostat is used in order to ensure adequate reserve circulation for heavy operation and to pass large volumes of cooling water. Use care to seal the thermostat squarely and concentrically to avoid interference with the thermostatic action.

**Cleaning The Cooling System**

When clean, soft water is used as a coolant, and when the proper inhibitors or antifreeze solutions are used, radiator and cooling passage accumulations will not be excessive. About once each year, however, the engine will benefit if the cooling system is cleaned of sludge and sediment.

It is recognized that a number of excellent commercial cooling system cleaners are available. WAUKESHA ENGINE DIVISION SUGGESTS, HOWEVER, THAT AN OPERATOR CONSIDERING THE USE OF SUCH A CLEANER FIRST INVESTIGATE ITS POSSIBLE REACTION WITH THE COPPER AND BRONZE PARTS IN THE ENGINE. If such a cleaner is used, follow the manufacturer's recommendations carefully.

**Water Pump**

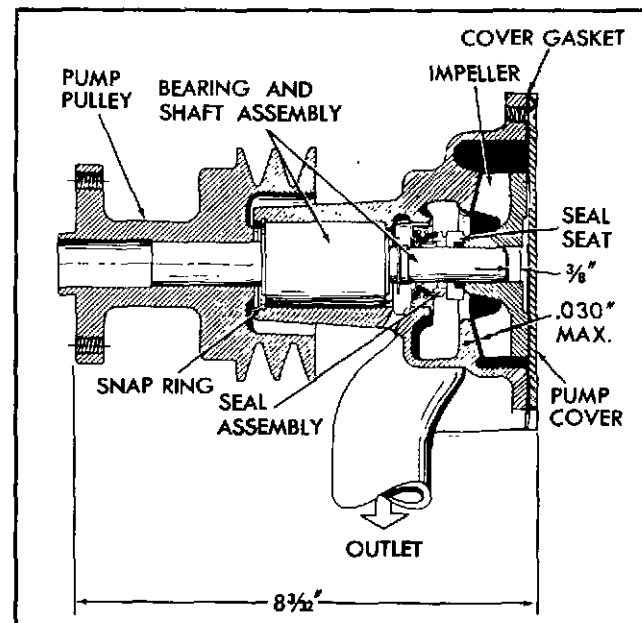

WATER PUMP - SECTIONAL VIEW

ML-60-108

PREVENTIVE MAINTENANCE

The belt driven water pump requires no special packing or attention during its service life. An internal seal, used in combination with a permanently lubricated integral ball bearing and pump shaft provides a durable, ruggedly constructed water pump.

For service purposes the entire shaft, bearing, and seal must be disassembled from the pump body and new parts installed. Since an arbor press is required for this purpose, field repairs are not recommended unless such equipment is readily available.

The sealing member of the pump consists of a smooth carbon washer riding against a polished surface.

### DISTRIBUTOR ADJUSTMENTS

Distributor point clearances may be adjusted with the distributor installed in the engine. In some cases, however, it will be found more convenient to loosen the cap screws holding the distributor clamps, disconnect the vacuum advance tube, (if applicable) and carefully lift the entire distributor from the engine for inspection and adjustment. This avoids working in cramped quarters and difficulties in trying to crank the engine over to bring the cam peak under the fiber bumper block.

Distributor points do not have to be absolutely free of pits and grey oxide for satisfactory performance. Excessive cratering and build-ups of sharp peaks, however, require

new breaker points. Slight point roughness may be cleaned up as much as is practical with a fine hone. Never use abrasive cloth or paper regardless of what the abrasive material is. A file is equally unsatisfactory with regard to continued point life, although improved performance may be obtained for a short while. If points are cleaned up with a fine hone, clean them with chlor-ethylene to remove the oily film which results from honing.

A feeler gauge is not an accurate method of setting points, particularly when there are some inequalities in the contact surfaces. If feeler gauge is used, caution should be taken to make sure gauge is clean and will not contaminate points.

An accurate method of setting points is the use of a dial indicator. Here, the gauge is solidly clamped to the distributor body in whatever manner is convenient. The gauge tip is brought to bear against the movable breaker point just behind the contact surface and the gauge is set to read zero with the fiber bumper on the flat of the cam and the points closed. By rotating the distributor cam with the starter, or with the fingers, if being bench adjusted, the exact point opening in thousandths is read on the dial indicator. This method will also reveal worn cams and distributor shafts that are loose in the bushings because the opening readings will be erratic. Clearances are adjusted in the conventional manner by turning the eccentric screw holding the fixed point. Do not forget to retighten the fixed point clamp screw after adjustment. A better method of measuring point opening is by the use of a dwell meter

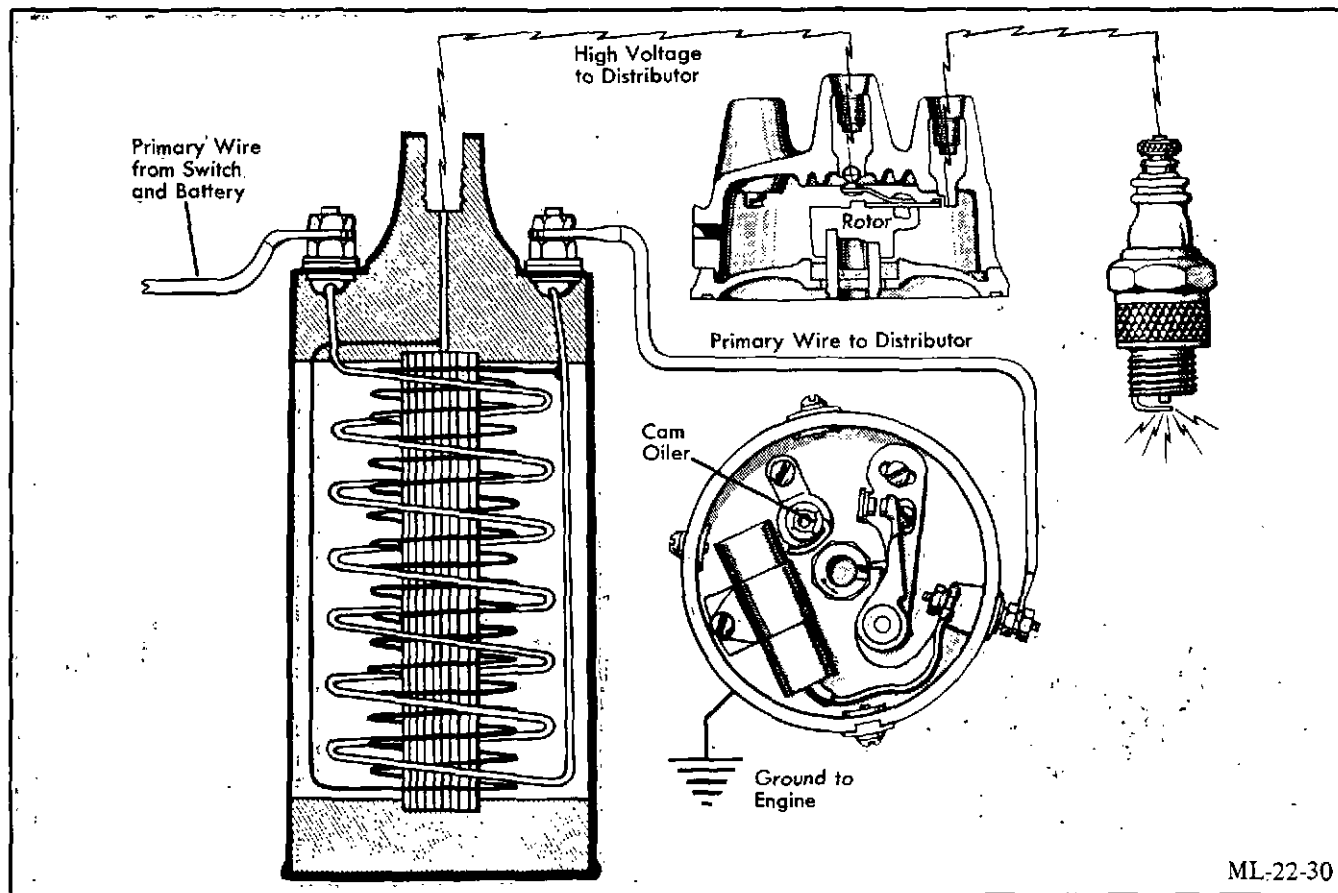

TYPICAL BATTERY IGNITION SYSTEM - SCHEMATIC

(see "Adjusting Dwell Angle" in this section).

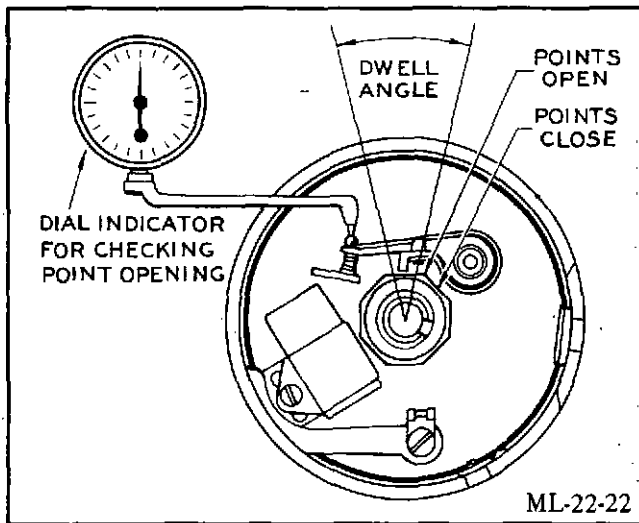

SETTING POINTS WITH DIAL INDICATOR

When the breaker point clearance is accurately adjusted, the engine should be turned to firing position on the compression stroke for No. 1 cylinder. This may be determined by aligning the distributor firing degree mark on the flywheel with the timing hole pointer in the flywheel housing. At the same time make sure that both valves on No. 1 cylinder are closed, or remove No. 1 spark plug and feel the compression with the thumb.

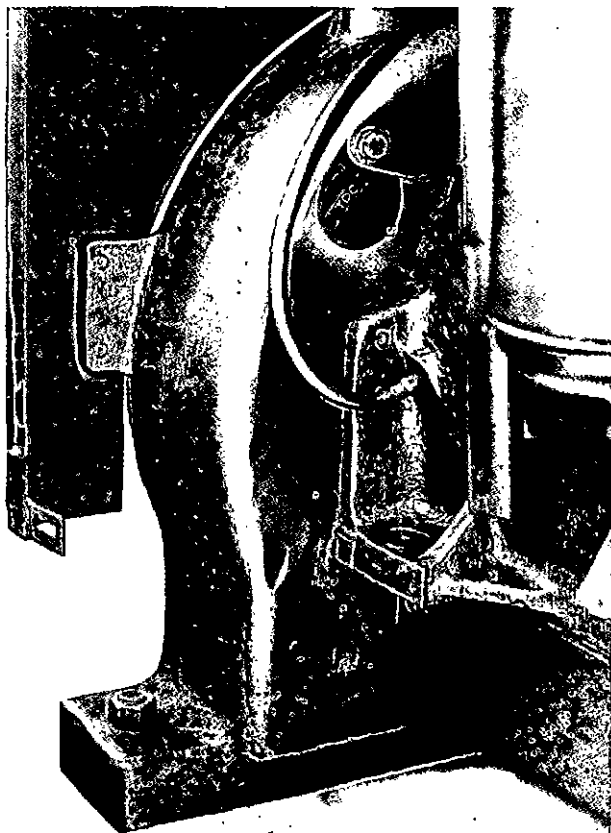

SETTING ENGINE AT TOP DEAD CENTER MH-14-19

Consult the Basic Engine Data Section of this manual or the timing plate attached to the engine for the correct timing degree.

If the distributor assembly was removed from the engine, turn the rotor to the same position it was in when removed. Insert the drive shaft carefully in the opening with the distributor body held approximately the same as it was when removed.

When the distributor drive strikes its mating member in the crankcase, it may be necessary to rotate the shaft slightly by turning the rotor back and forth until the proper alignment is felt and the distributor drops into position. Tighten the distributor clamp cap screws until they are snug but do not prevent rotating the distributor body.

The exact timing of the spark depends on the actual breaking of the electrical circuit by the points. Hence, checking for the apparent mechanical separation with feeler stock, cellophane, and so on is apt to be misleading. To assure accurate timing, make up a simple light circuit consisting of an automatic light bulb with soldered-on leads of a socket with lead wires attached. Clip or wedge one lead to the ungrounded side of the starting battery, and attach the other lead to the primary wire connection at the side of the distributor. Final timing should be done with the engine running, using a powered timing light (see "USING TIMING LIGHT" in this section).

With the above installation, if the bulb is lit the points are closed and the distributor should be shifted slightly to determine the point of opening where the light just goes out. The distributor clamps may now be tightened and the flywheel turned backwards about a quarter of a revolution and then brought forward towards the timing mark as before. The light should just go out as the timing mark on the flywheel aligns with the timing hold pointer in the flywheel housing.

Since the engine is set for No. 1 cylinder firing, install the distributor cap and start installing the spark plug wires with No. 1 in the hole to which the rotor points and working clockwise around the cap.

It is best to install a wire at the distributor, and then without installing any more follow up that wire and secure it to the proper spark plug in firing order. Take each in turn to avoid confusion.

Once the timing is properly set for the idle (no-speed) position, the centrifugal weight system of the distributor will automatically advance the spark as required by changes in engine speed. The mechanism involved is matched to each engine application by laboratory tests determining the best spark advance point over the entire speed range. Therefore, substitution of unmatched parts from other equipment will impair timing and engine performance. The advance curve for a distributor similar to that used on the VR Series engines is shown in the accompanying graph. Distributors on some VR Series engines also include a vacuum advance which (along with the centrifugal advance) advances the spark at part load operation to improve fuel economy.

PREVENTIVE  
MAINTENANCE

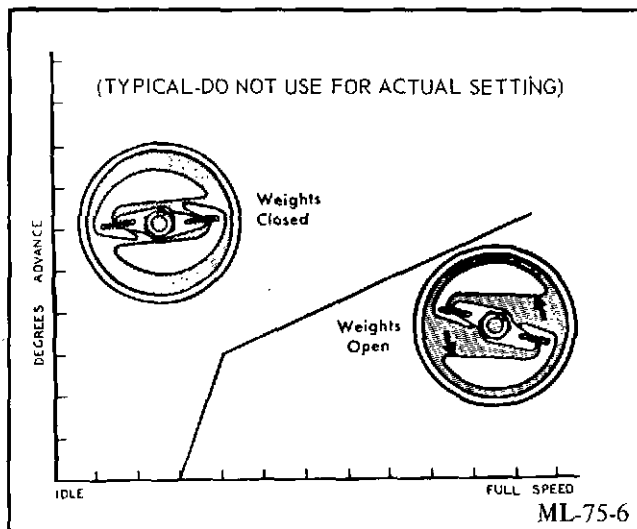

**CENTRIFUGAL ADVANCE CURVE**

The distributor requires lubrication of the shaft, advance mechanism, breaker cam, and breaker lever pivot. For shaft and advance mechanism lubrication add 20W oil to felt material in center of shaft under rotor (See Illustration).

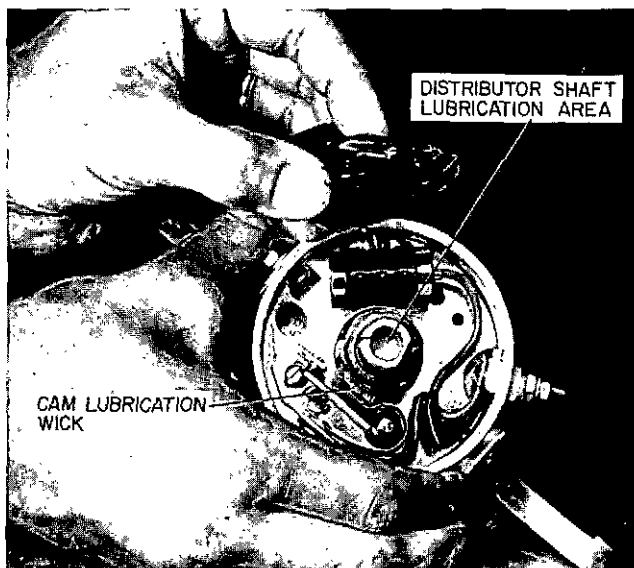

**DISTRIBUTOR OIL RESERVOIR LOCATION MH-22-65**

Every 500 hours put one drop of light engine oil on the breaker lever pivot, and a few drops on the felt wick under the rotor. Some distributor points come with prelubricated wicks.

The centrifugal advance mechanism can be checked for freeness by turning the breaker cam in the direction of rotation and then releasing it. The advance springs should return the cam to its original position without sticking.

**Adjusting Dwell Angle**

The dwell angle represents that period of time during which the distributor points are closed as the distributor cam rotates from the peak of one lobe thru the peak of the following lobe. As the point gap increases or decreases the

dwell angle will change proportionately. The proper distributor point gap will be represented by a specific dwell angle, as read on the dwell meter. This is accomplished while the engine is running at any speed, thereby giving a true representation of the adjustment. To check and adjust dwell angle, proceed as follows:

With the engine stopped:

1. Connect the dwell meter between the distributor primary lead, either at the distributor or at the coil, whichever is more convenient, and engine ground. Note polarity requirement.
2. Set the switches on the dwell meter to the settings per meter instructions.
3. Start the engine and read directly from the meter.
4. If the specified dwell angle is incorrect, stop the engine and adjust the point gap, repeat as required. Increasing the point gap will decrease the dwell angle, decreasing the point gap will increase the dwell angle (see "BASIC ENGINE DATA" in end of REPAIR AND REPLACEMENT for specific dwell angles.)

**Using Timing Light**

With the engine stopped:

1. Connect the timing light power leads to the battery (observing proper polarity).
2. Connect the timing light signal lead into the No. 1 spark plug lead, using supplied adaptor.
3. Loosen the bolts on the distributor housing retaining clamps just enough to allow the housing to be rotated.
4. Disconnect the vacuum advance tube (if applicable).
5. Start the engine and aim the timing light at the timing hole pointer in the flywheel housing. Be sure to aim directly towards the center. On some models a button on the timing light will have to be pushed to cause light to flash, on others the light will flash automatically. The correct firing degree mark on the timing tape should now appear under the reference pin, if not;
6. Rotate the distributor housing while observing the relationship of the specified timing mark and the reference pin. When they line up, the engine is properly timed.
7. Tighten the distributor clamp bolts, reconnect the vacuum advance tube, remove the timing leads and reconnect the spark plug lead.

**SPARK PLUG ADJUSTMENTS**

Misfiring or ragged operation may be due to faulty spark plugs caused by carbon accumulations and burning of the electrodes. They should be cleaned, inspected, and the gaps checked approximately every 250 hours of operation, or oftener if the engine idles for prolonged periods. After 500 hours, it is advisable to replace the entire set when any spark plug is defective.

Deposits on the electrodes and insulator may be removed by commercial abrasive cleaners. Scraping the insulator is not recommended since the resulting scratches increase the tendency of carbon deposits to form.

After the spark plug has been cleaned, adjust the gap with a round wire gauging tool to .025" (gasoline) or .020" (gaseous fuels) by bending the outer electrode. As the spark plugs will have a tendency to burn the electrodes and widen the gap, it is important that gap be checked whenever the plugs are removed from the engine. Missing at low speeds is very often due to a wide spark plug gap.

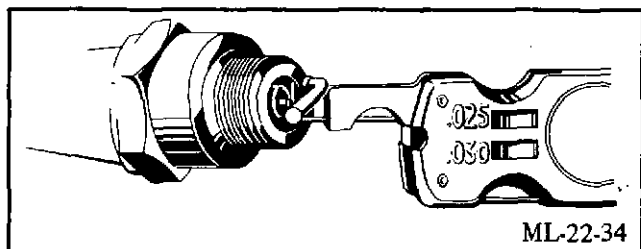

CHECKING SPARK PLUG GAP

Examine for cracked porcelain, leakage, burned electrodes, deposits on center insulator, correct gap, good washers, and clean threads and seating surface. Remember, a plug may appear satisfactory and still miss.

**NOTE**

When replacing spark plugs, use new gaskets. Proper seating of the gasket is necessary for sealing the combustion chamber and transferring heat from the plug.

**MAGNETO SERVICING**

Minor servicing of the magneto is confined to cleaning, replacement, and adjustment of the breaker points. Magneto point clearance is adjusted in the same manner as

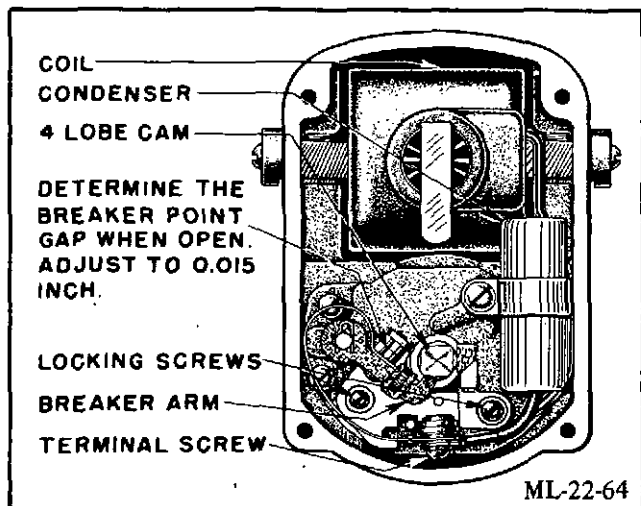

MAGNETO COVER REMOVED

distributor point clearance. More extensive repair and overhaul operations require specialized training and equipment and should be made only at authorized service agencies.

**TIMING THE MAGNETO**

The magneto timing procedure follows very closely the steps given for timing the distributor. The flywheel must be rotated until the proper timing mark aligns with the timing hole pointer in the flywheel housing and number one piston is coming up on compression stroke. This is the point at which firing occurs when the engine is running and the impulse coupling has disengaged.

When the impulse coupling is engaged, as it is when starting to time the magneto, it must be released or "snapped" in order not to incorporate its lag angle in the timing procedure. With the end cap cover removed, turn the magneto impulse coupling backwards as many turns as needed to align the rotor finger with the timing boss marked "6" inside the end cap. Reverse rotation automatically disengages the impulse unit. Connect the magneto to the magneto drive.

Final timing is done with the flange mounting screws snug. Connect a battery powered timing light to the spark plug lead of number one cylinder and check the timing with the engine running. If timing is not correct, tap the magneto by hand enough to rotate it on the mounting flange. With careful tapping, one direction or the other as required, exact timing is readily determined and the flange mounting screws must be tightened.

**ALTERNATOR SERVICING**

Alternator servicing within this manual is limited to testing the unit on the engine and replacing it if defective. To test the alternator proceed as follows:

**Continuity Testing**

1. With engine off, check drive belt for proper tension.
2. With ignition switch in the "ON" position (gas and gasoline engines only) and terminal wires connected, check current to each terminal with test light as shown in illustration. For diesel engines a jumper wire is required across terminals on oil pressure switch before making test at alternator terminals. If test light does not light at all terminals, check wires for good connections and frayed or broken wires. Test light will glow on terminal one, but this is normal due to resistance wire.

PREVENTIVE MAINTENANCE

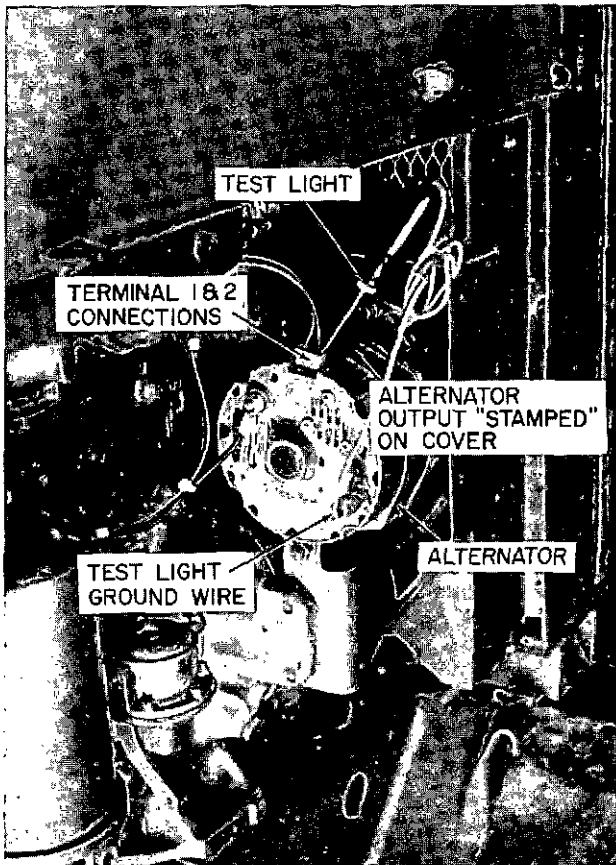

MH-28-12

TESTING ALTERNATOR WIRING

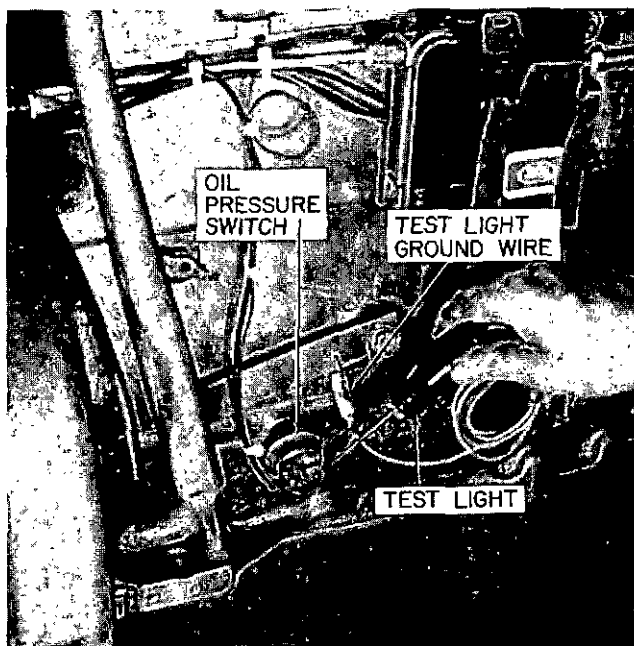

MH-202-9

CONTINUITY TEST FOR ALTERNATOR CIRCUIT  
(DIESEL ONLY)

NOTE

The wire connected to terminal one is a "resistance wire" and if replaced it must be matched with a wire of identical resistance.

- Using test light, check continuity at oil pressure switch (diesels only) on side of engine as shown in illustration. If test light does not light, inspect wiring for poor connections or damaged wire and repair as necessary.

Output Testing

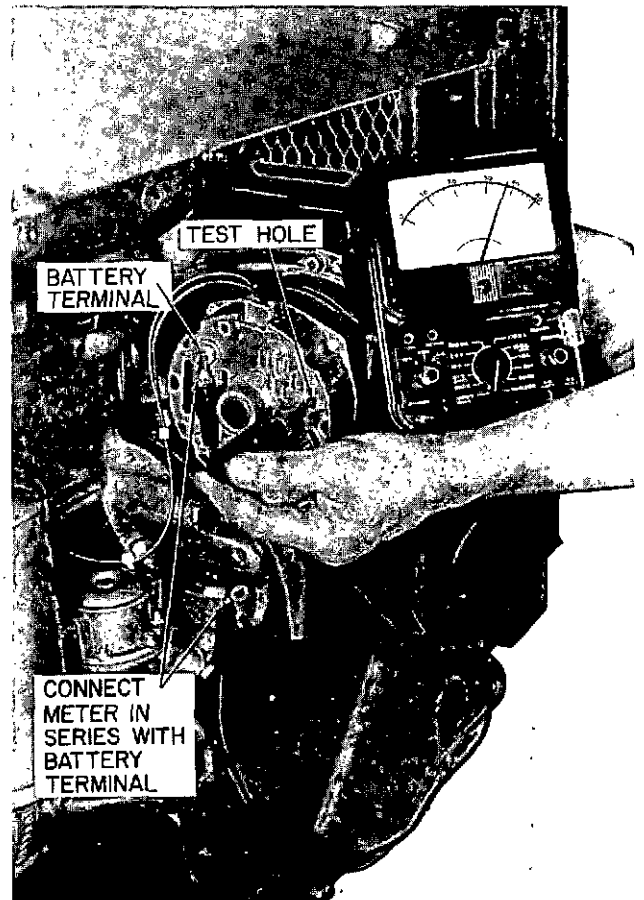

MH-28-11

TESTING ALTERNATOR OUTPUT

- Remove battery wire from alternator battery terminal and connect ammeter in series as shown in illustration. Run engine at 1000 - 12000 rpm. If ammeter reads low or no amperage, proceed to next step.
- With engine still running, insert screwdriver in test hole to ground tab - this by-passes the voltage regulator. The ammeter should read within 10% of rated output (stamped on alternator body). Replace if defective (See "ALTERNATOR PULLEY REMOVAL AND INSTALLATION TOOL" in this section).

**NOTE**

If alternator charges with tab grounded but does not charge when tab is not grounded it indicates a defective voltage regulator located inside alternator body. If alternator does not charge its maximum with tab grounded it indicates a defect in the alternator itself.

**ALTERNATOR PULLEY REMOVAL AND INSTALLATION TOOL**

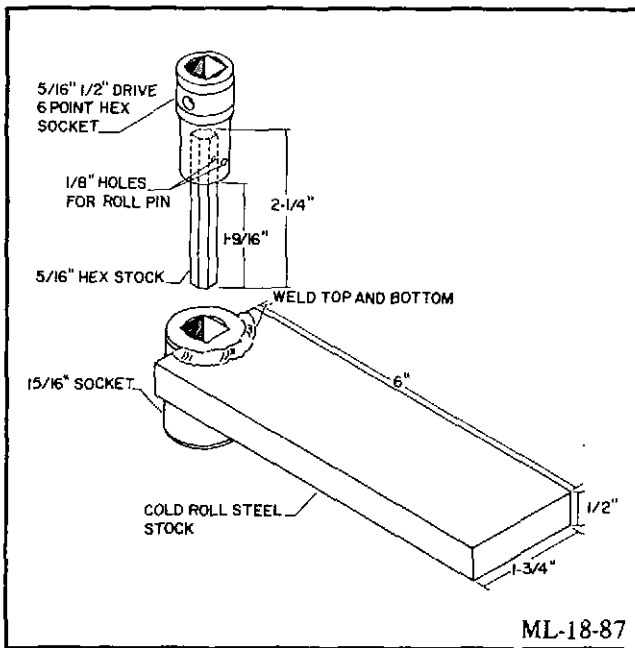

ALTERNATOR PULLEY NUT TIGHTENING TOOL



REMOVING ALTERNATOR PULLEY

MH-18-90

When replacing the alternator it is necessary to remove the alternator pulley and retain it for use on the replacement alternator. A special tool has been designed to perform this step and the materials and dimensions for making this tool are included in the illustration.

When installing or removing alternator pulley nut, place pulley nut holder in a vise and position alternator into nut holder as illustrated. Use the allen wrench attachment to loosen or tighten shaft to pulley nut. Pulley nut should be torqued to 60 lbs. ft.

**INJECTION PUMP MAINTENANCE**

Most pumps have the timing marks located as illustrated. Here, one mark is on the governor weight carrier and one on the cam, although not necessarily at the location shown. The mark might be on center, above center as shown, or possibly below center.

Removal or installation of the injection pump is considerably easier if the complete injection plumbing system is removed first. This is done by removing lines from injectors and pump and removing bracket bolt from engine block.

Clean all fittings before disconnecting them and plug or cap all openings after fittings are disconnected.

1. Disconnect throttle and shut-off linkage from pump. Remove nuts holding injection pump to gear housing. Slide pump off shaft towards rear of engine.
2. Installation is in reverse order.
3. When timing injection pump, place the No. 1 cylinder on compression stroke, using procedure outlined for valve adjustment, and position flywheel tape to specified degree number under the flywheel reference pin.
4. With the pump timing cover removed, use a clean, long blade screwdriver through the pump opening to turn the pump shaft until the mark on the cam ring and the mark on the weight carrier are aligned (refer to illustration). Slip the pump in place on the shaft and seat the drive. Grease the shaft and the shaft opening in the pump liberally with light grease. Be careful not to damage the lips of the seal when slipping the pump in place. A special tool, Roosa Master tool number 13371, is available to compress the drive shaft seals when installing the pump.
5. Pump should be rotated first in direction of rotation and then in opposite direction, within elongated mounting slots, to perfectly align timing marks, and to remove backlash.
6. Tighten pump retaining bolts.
7. Reconnect throttle and shut-off linkage.
8. Reinstall injection plumbing.

The limits of throttle travel are set by adjusting external screws for proper idling and high speed positions.

PREVENTIVE  
MAINTENANCE

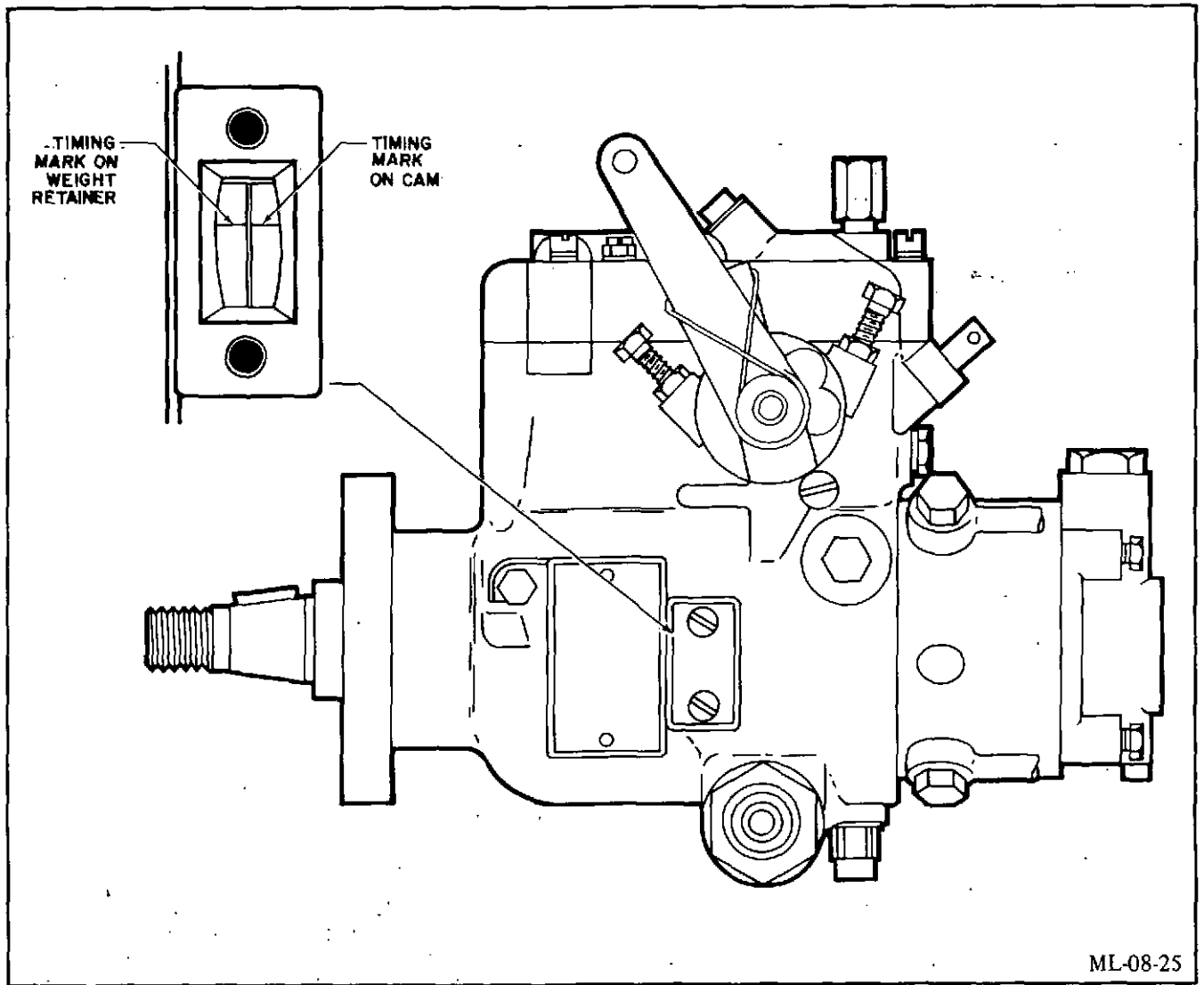

ML-08-25

INJECTION PUMP TIMING MARKS

**NOTE**

The fuel system must be bled when the injection pump is removed and reinstalled, and also whenever the fuel filter element is changed.

**Fuel Injector Test**

Unless proper service equipment is available, and the operator is skilled in its use, there is little actual repair work that can be accomplished on injectors.

If a nozzle is suspected of improper operation, it may be given a general test by allowing it to spray into the atmosphere while using a proper test stand.

Experience is the best indication of what may be considered a satisfactory spray pattern. Also an apparent chattering of the spray is normal and is easily recognized.

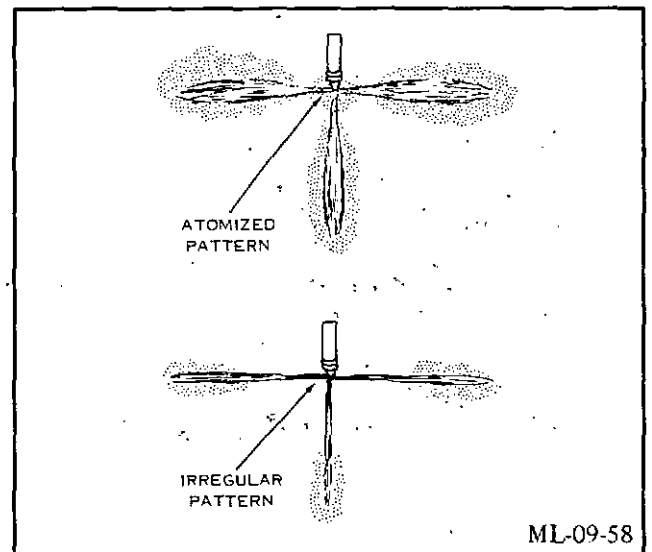

ML-09-58

ATOMIZED AND IRREGULAR PENCIL INJECTOR SPRAY PATTERNS

Certain other conditions, however, are definitely undesirable and will usually reduce engine performance substantially. These conditions are usually the result of valve damage or contamination and are characterized by dribbling, sprays of badly distorted patterns, and other self-evident troubles. The best remedy is replacement with another nozzle.

Sometimes, when the only real difficulty is carbon or gum interfering with the valve action, a thorough cleaning with a solvent such as "GUNK" will improve performance.

If the above operation does not improve the nozzle operation, a new injector is required.

**WARNING**

KEEP AWAY FROM INJECTION SPRAY. PENETRATING POWER OF DIESEL FUEL UNDER PRESSURE IS SUFFICIENT TO PUNCTURE SKIN AND CAUSE BLOOD POISONING.

**Energy Cell and Pintle Nozzle Service (VRD 155 and 232)**

Energy cells are made up of components shown in the accompanying illustration. They are located just below intake manifold on right side of cylinder head directly opposite their corresponding injector nozzles.

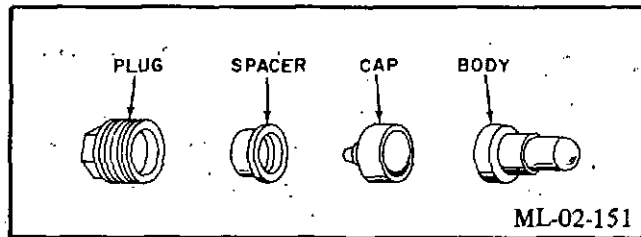

ENERGY CELL COMPONENTS

A stream of fuel injection spray is received by cells. Channels in cell body and cap turbulate the spray. Since cells have no cooling jackets, a high degree of heat is attained and fuel is ignited. Cells are angled slightly so that return flow from cells enters combustion chamber at an angle and aids in creating necessary swirl or turbulence required to thoroughly mix air and fuel for complete combustion of main spray in chamber.

Energy cells should be inspected for cleaning or replacement when fuel injectors are found to be faulty or when poor fuel combustion is evident.

It may be necessary to apply carbon solvent or scrape outer edge of cap with a soft metal scraper before removal is possible.

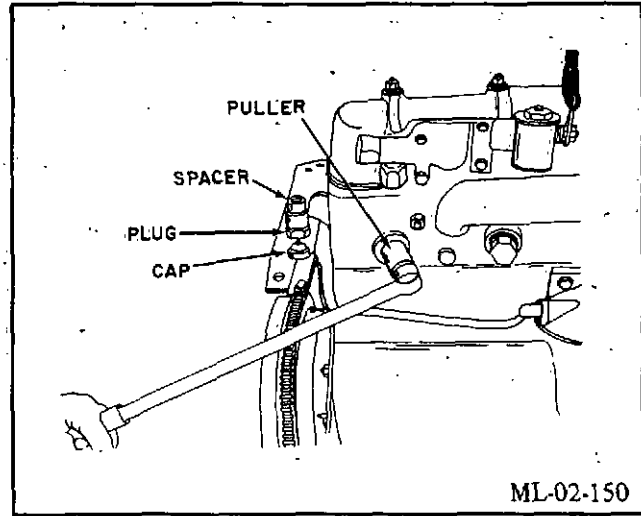

REMOVING ENERGY CELL BODY

Use a puller as illustrated to remove cell body. Use a soft metal wire or scraper if necessary to scrape carbon from cell body internal threads so that puller threads can be engaged.

After soaking cell parts in carbon solvent overnight, use brass scrapers and brushes to remove any remaining carbon deposits. Be sure body orifice opening is thoroughly clean. Lap cap and body sealing surfaces if necessary using a lapping compound and plate and a figure eight motion to assure a perfectly flat surface.

Rinse parts in clean diesel fuel and install energy cell by reversing removal procedure. Always replace energy cell in same cylinder it was removed from. Be sure cap is inserted flat against body surface before installing spacer and plug. Tighten plug to torque setting shown in specifications.

Nozzle service must be accomplished in a clean, dust free area. Cover injector openings and remove all traces of dirt, paint or carbon with diesel fuel and a brass wire brush.

Remove protection cap and gasket. Loosen spring retainer cap nut to release pressure on spring. If spring replacement is required, remove spring retaining cap nut and spring from holder body. Remove nozzle gasket and nozzle cap nut and remove valve body and valve from holder body. Examine valve body for carbon and whether valve lifts out freely. Soak valve and body in diesel fuel or a carbon solvent for valve removal (if necessary) and prior to inspection for bluing from overheating or other damage.

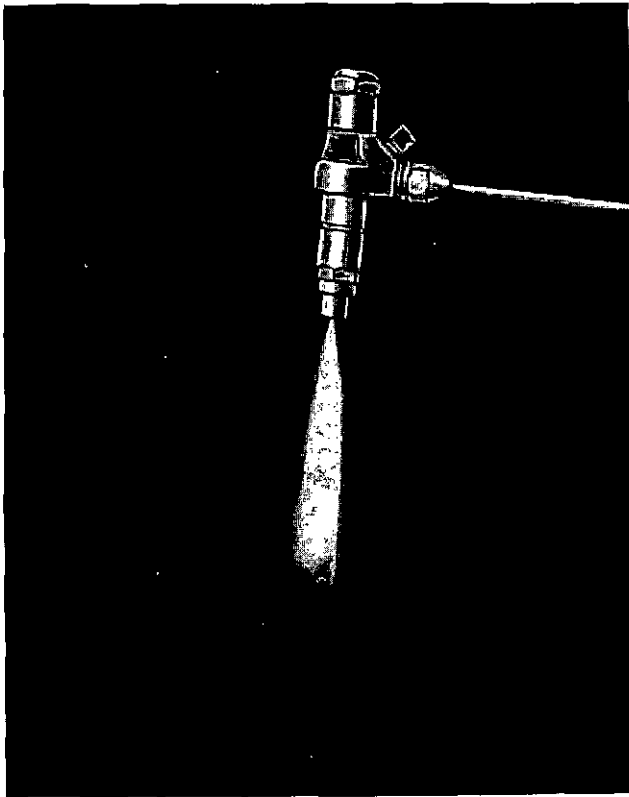

FULL-LOAD SPRAY PATTERN  
(PINTLE INJECTOR)

MH-09-39

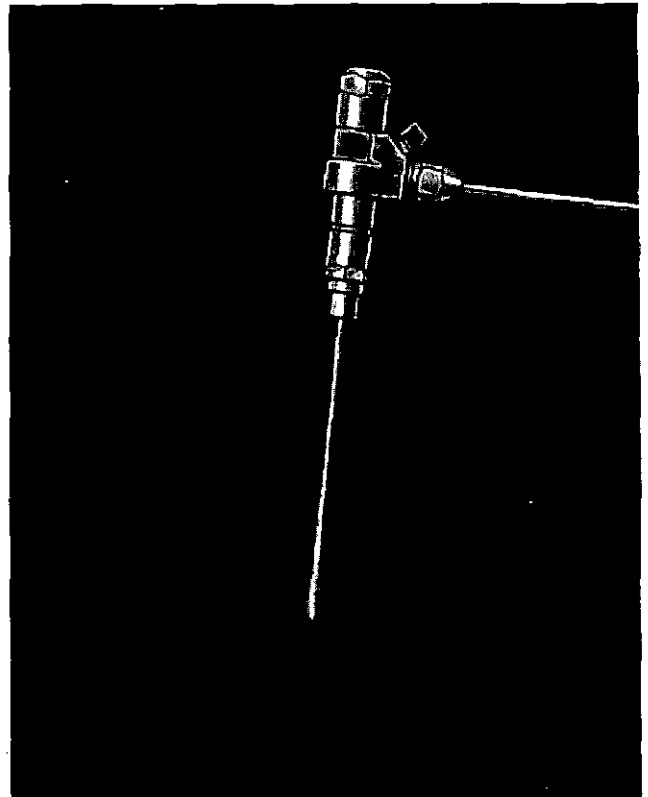

IDLE SPRAY PATTERN  
(PINTLE INJECTOR)

MH-09-39

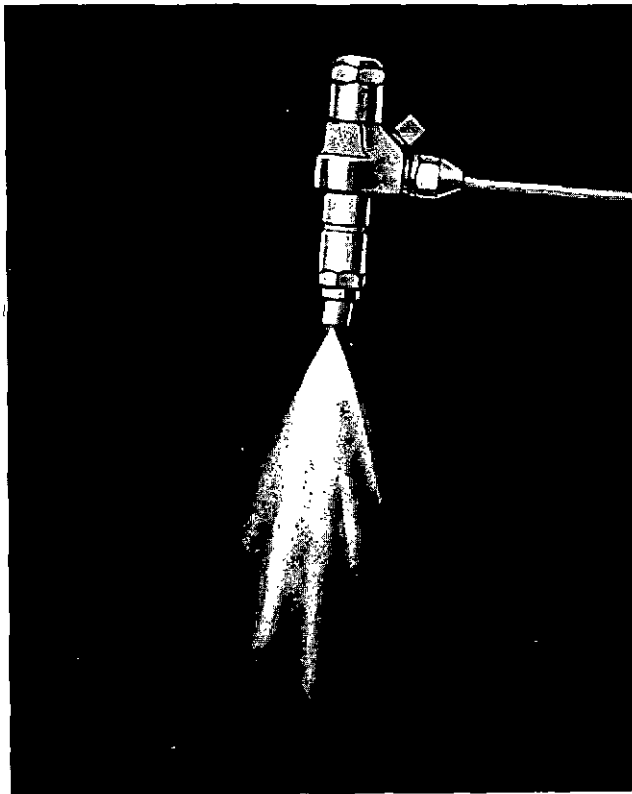

SPRAY RAGGED - UNSATISFACTORY  
(PINTLE INJECTOR)

MH-09-40

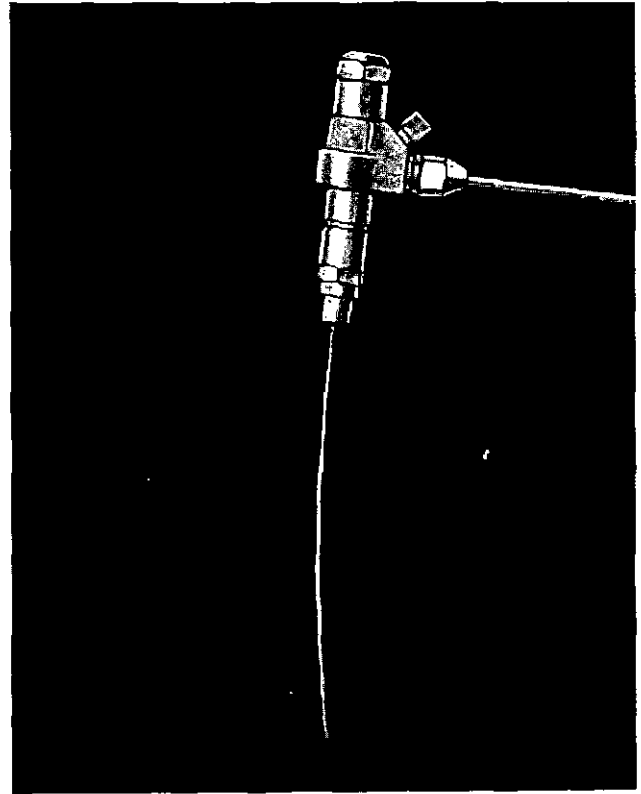

LEAKING NOZZEL VALVE, UNSATISFACTORY  
(PINTLE INJECTOR)

MH-09-40

Pressure surfaces should be lapped only as necessary using a lapping compound and plate. Surfaces should have a fine mirror finish when properly lapped.

Clean small feed channel bores with appropriate size drill or wire. Remove carbon and varnish from valve body seat by rotating and pressing seat scraper on seat. Seat may be polished with tallow and polishing stick.

Insert groove scraper in pressure chamber gallery in valve body, press against side of cavity and rotate to clean away carbon deposit. Use tallow and wooden polishing fixture to clean and polish valve.

Use cleaning stick dipped in tallow to clean valve body pintle orifice. Use diesel fuel or carbon solvent to clean away carbon from surface around orifice; do not scrape surface as serious damage may result.

Use a brass wire brush to clean pintle end of valve. Use a wooden or brass strip to dislodge hard carbon particles. Caution should be exercised to prevent scratching or burring of valve or valve pintle as serious damage may result.

Install valve in valve body while both are immersed in clean diesel fuel.

Make sure pressure surfaces between valve body and holder body are absolutely clean. Center valve body and valve in cap nut using centering sleeve and install valve and body in holder body. Sleeve fits over valve body and its tapered end centers within nozzle cap nut. Sleeve is easily removed after tightening cap nut on holder body.

Install spindle, spring, spring seat and spring retainer cap nut in holder body. Install spring adjusting screw and nut in spring retainer nut.

Install injector on tester, adjust opening pressure and test operation.

**PENCIL INJECTOR ADJUSTMENT**

**NOTE**

A good injector pressure test pump and gauge are needed to make the adjustment. If the proper equipment is not available, the injector should be adjusted by a properly equipped service station.

PREVENTIVE  
MAINTENANCE

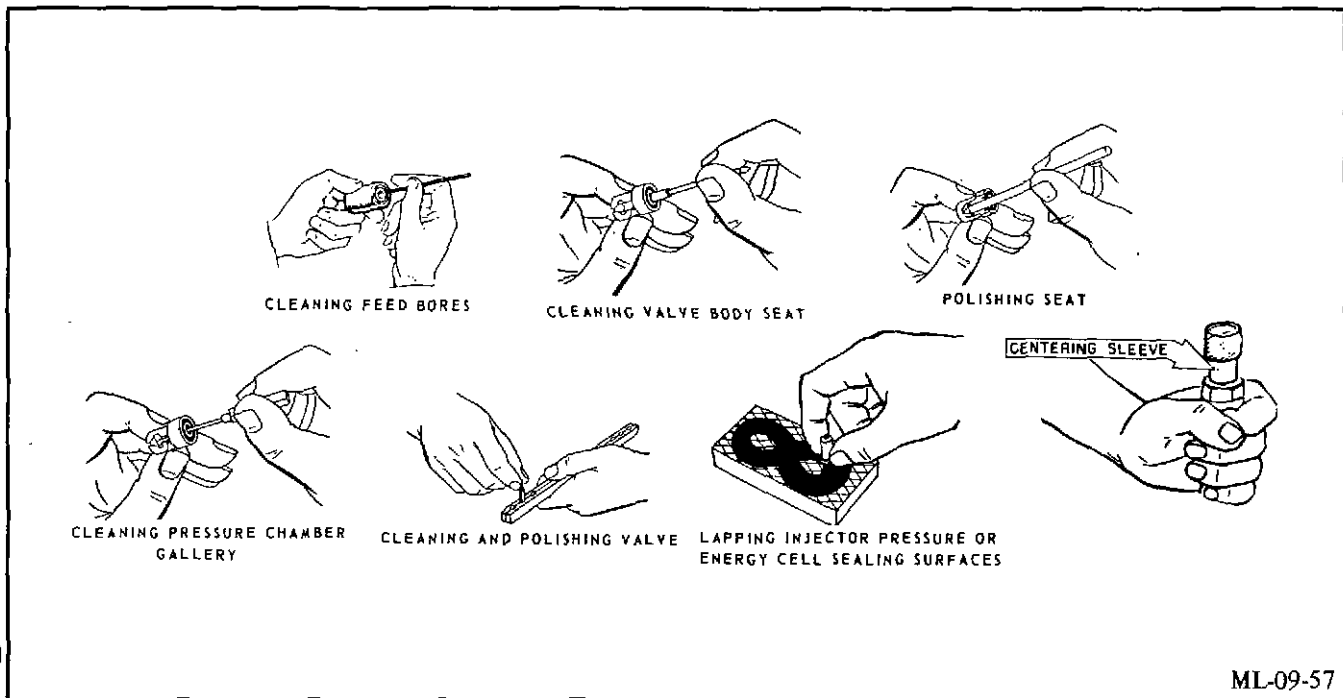

ML-09-57

**PINTLE INJECTOR NOZZLE CLEANING OPERATIONS**

To adjust opening pressure of pencil injectors proceed as follows:

1. Position injector in a holding device and loosen lock nuts (A) and (B). See Illustration.
2. Turn pressure adjusting nut (C) until injector opening pressure meets specification (see "BASIC ENGINE DATA" in end of REPAIR AND REPLACEMENT for proper pressure settings.)

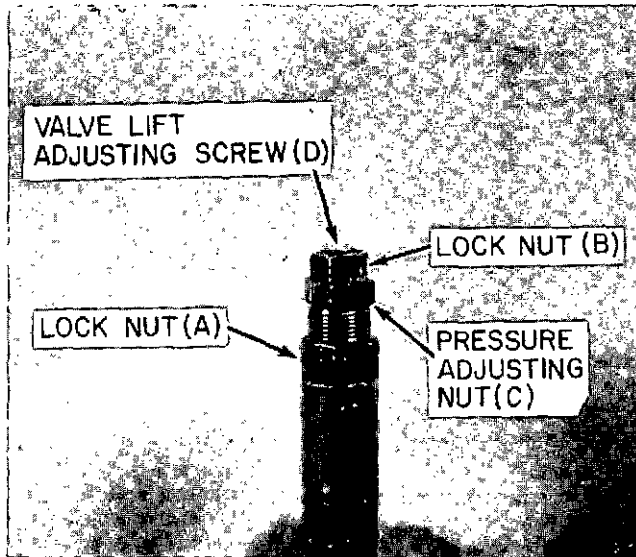

FUEL INJECTOR ADJUSTMENTS MH-09-54

3. Tighten lock nut (A) while holding pressure adjusting nut (C) steady.
4. Carefully turn valve lift adjusting screw (D) clockwise until it bottoms against valve. Then back out screw  $1/2$  turn  $\pm 1/8$  and tighten lock nut (B).

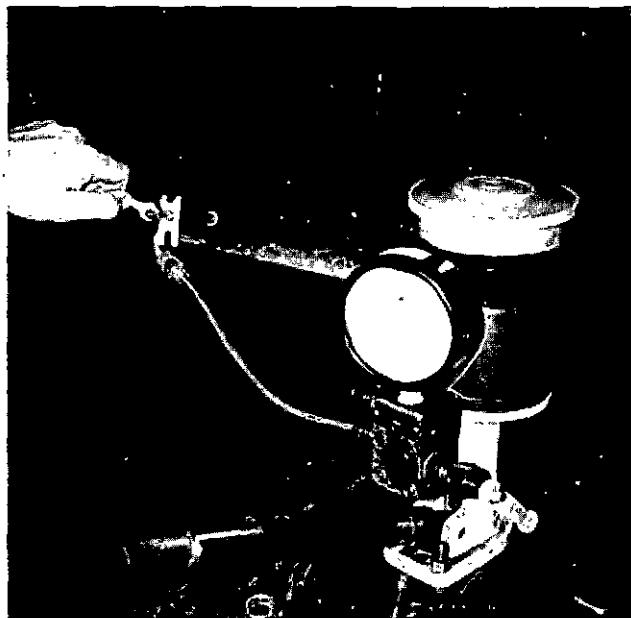

ADJUSTMENT OF PRESSURE ADJUSTING NUT MH-09-55

5. Test injector for correct opening pressure and readjust if necessary.

**WARNING**

KEEP AWAY FROM INJECTION SPRAY. PENETRATING POWER OF DIESEL FUEL UNDER PRESSURE IS SUFFICIENT TO PUNCTURE SKIN AND CAUSE BLOOD POISONING.

**REINSTALLING PENCIL INJECTORS**

Replace carbon stop seal before reinstalling injector in engine. Remove old seal by breaking with needle nose pliers. Use Roosa master tool (Part No. 16477) to install new seal. Check upper seal for possible damage, and replace if necessary.

**GASOLINE CARBURETOR ADJUSTMENTS**

**Idle Mixture Adjustments**

Warm up the engine and place the throttle control lever in the idle position. Turn the idle mixture adjusting screw in until the engine begins to lose speed; then turn the valve out until the engine again begins to slow down. Use one-eighth turns and allow sufficient time between each change for the engine to adjust itself to the new setting. Race the engine occasionally to about 1000 rpm to clear the combustion chambers of excess fuel. Continue this adjusting procedure until a maximum idle speed is determined.

**Idle Speed Adjustment**

Set the idle mixture before making the idle speed adjustment. With the throttle control lever in the idle position, check the tachometer and turn the adjusting screw in or out as required to obtain the desired low idle speed.

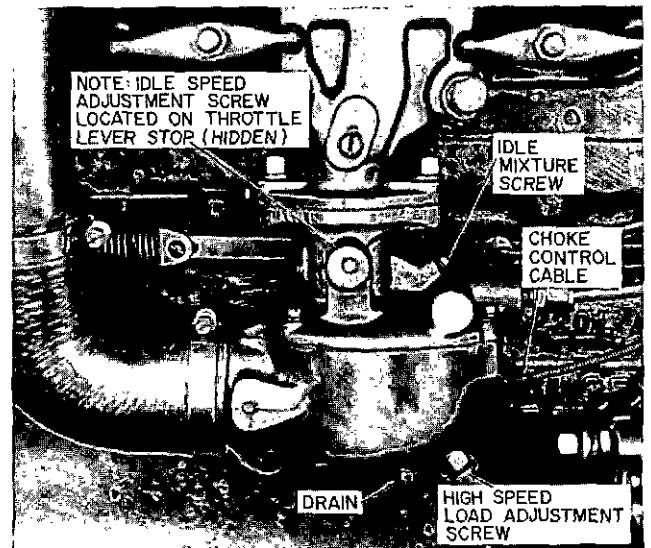

TYPICAL GASOLINE CARBURETOR MH-214-81

### High Speed Load Adjustment

Some models of the VR Series are supplied with a main jet adjustment. Turning the needle clockwise cuts off fuel making the medium and high speed mixtures leaner. The needle should be adjusted to give highest manifold vacuum (or highest R.P.M. on a tachometer) for a set-throttle position. Set the throttle to hold the engine speed just below the governed speed while making the main jet adjustment. If adjustment is set too lean, the engine will lack power and the fuel economy also will be poor. If set too rich, the engine will be sluggish and the fuel economy poor.

### GAS CARBURETOR ADJUSTMENTS

#### General

The normal arrangement for natural gas uses a field regulator to reduce pounds pressure to the final value of 5 inches water column (3 oz.) maximum. Excessive pressure will increase gas fuel consumption. This pressure will have its main effect on fuel economy.

For reasons of safety . . . ALL GAS INSTALLATIONS IN CLOSED AREAS OR BUILDINGS SHOULD HAVE A POSITIVE SHUT OFF VALVE TO PREVENT GAS LEAKAGE WHEN THE ENGINE IS AT REST.

With the Impco carburetor, VR Series engines use a 1" line pressure regulator with a 3/8" orifice. The regulator utilizes spring 1B6538 with 5 to 50 psi inlet line pressure and 5" H<sub>2</sub>O column outlet pressure to the carburetor for 1000 BTU LHV gas.

#### Load Adjustment

1. Set natural gas pressure with engine idling, by adjusting line pressure regulator, to 5" water column plus or minus 1/4 inch, for 1000 BTU LHV gas with idle mixture screw backed out 3 turns, and power fuel mixture turned to rich (R) position.
2. Full load gas pressure may drop as low as 3" water column at the carburetor gas inlet. Exact pressure at full load is immaterial as long as power mixture ad-

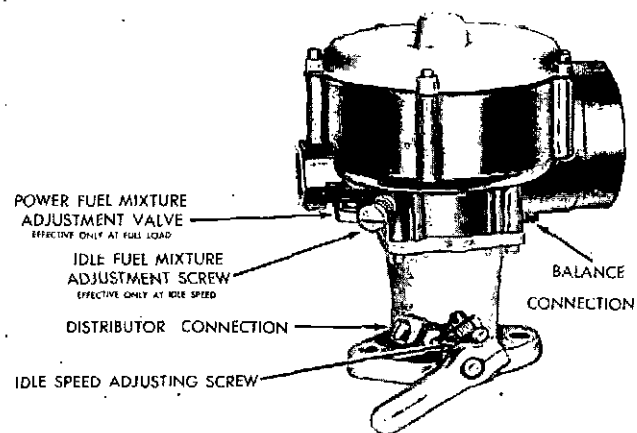

NATURAL GAS CARBURETOR

MH-214-6

justment is still effective (carburetor can be set over-rich).

3. With the engine warm and running full load at governed speed, adjust the power fuel mixture from rich (R) towards lean (L) slowly to obtain maximum vacuum. After maximum vacuum is obtained, adjust for slightly leaner mixture to decrease vacuum 1/2" of mercury. This setting will improve fuel economy. If application is such that transient load changes occur, such as a generator set, omit this adjustment to decrease vacuum. The power adjustment is not effective at a fast idle or light load.

#### Low Idle Adjustment

1. Reduce throttle speed setting to bring carburetor butterfly lever against low idle stop.
2. Adjust carburetor idle stop screw to obtain desired engine RPM.
3. Adjust carburetor idle fuel adjustment screw to obtain highest engine RPM.
4. Re-adjust idle stop screw to obtain desired engine RPM.

### GOVERNOR ADJUSTMENTS

#### Gasoline Engines

Should the governor and linkage have to be dismantled to permit access to the engine for other service work there are some basic requirements to be followed. Upon disassembly the parts of the governor and linkage must be carefully marked so they will be reassembled in exactly the same position. The length of the linkage must be carefully noted so that when the engine is stopped and the throttle lever in full speed position, the throttle valve stands just a trifle toward the closed position. Variation from the proper speed can be corrected by changing the tension of the regulating spring. Increasing the tension increases the maximum speed, and decreasing the tension decreases the max-

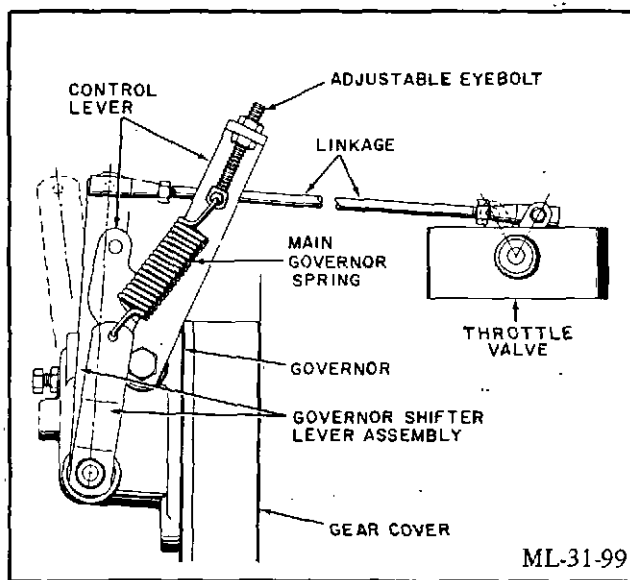

GOVERNOR, THROTTLE VALVE, AND LINKAGE

ML-31-99

PREVENTIVE MAINTENANCE

**WAUKESHA VR SERIES**

imum speed. To increase and decrease the tension on the VRG155 governor spring, disconnect the governor spring end assembly from the governor lever and turn it to change the number of working coils. (see illustration) Less working coils increases maximum speed and more working coils decreases maximum speed.

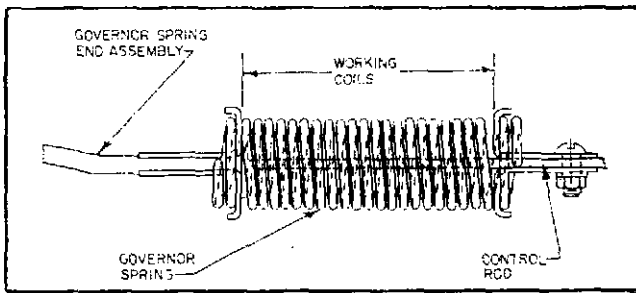

**VR155 GOVERNOR SPRING** ML-33-1

**VALVE CLEARANCES**

Accurate valve clearance settings materially prolong engine life and aid performance. In addition to impairing performance, excessive clearances are detrimental to cams and tappets. On the other hand, when clearances are too tight, timing is disturbed and the possibility of burned valves becomes much greater.

Valve clearances specified in the Basic Engine Data section of this manual and on the engine timing plate are for normal room temperatures . . . NOT FOR HOT ENGINES.

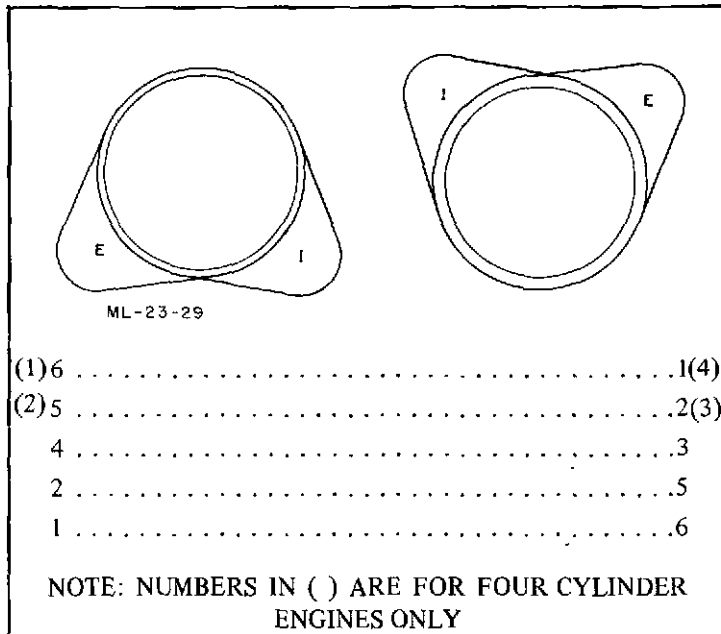

**CAMSHAFT RELATIONSHIP**

The prime consideration during valve adjustment is the accurate positioning of the camshaft in relation to the valve being adjusted. Valve clearance must be set only when the cam follower is on the base circle of the camshaft, that is to say, the cam follower must not be on any part of the camshaft lobe.

Referring to the illustration of cam lobe relationship notice that if the cam followers of number six cylinder are at the transition point, between closing exhaust and opening intake, the number one followers will be on the base circle and conversely when number one is at the transition point then number six is on the base circle. The same relationship holds true for all complimentary cylinders, as shown. When setting the valve clearance it is permissible to start at any cylinder as long as the complimentary cylinder is placed at that valve transition point. The least confusing method is to start at number one cylinder and then proceed in the firing order, which in this case is 1-5-3-6-2-4. The best way to determine this transition point is to slowly rotate the engine crankshaft until both push rods of the complimentary cylinder can be rotated by hand after the exhaust valve closes. In summary, put cylinder six in the valve transition position and set the intake and exhaust valve clearance on one. Put cylinder two in the valve transition position and set five and so on in the firing order till all valves are set to specified tolerance.

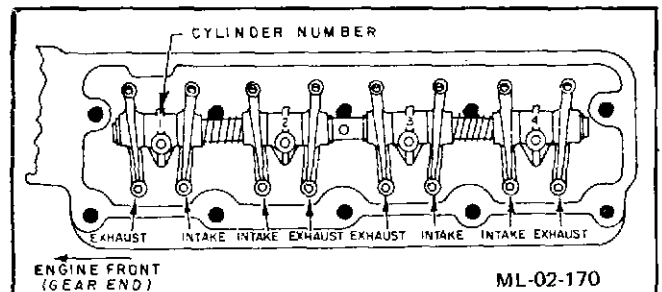

**VRG AND VRD155 SERIES**

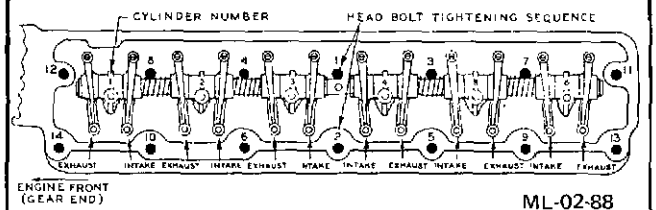

**VRG232, 265, 283, AND 310 SERIES  
VRD232 SERIES**

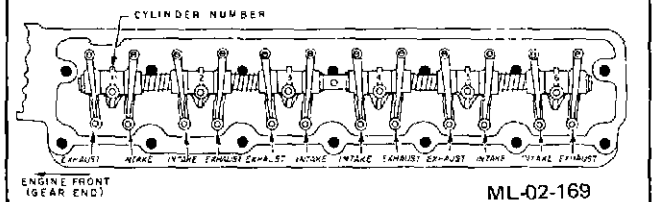

**VRD283 AND 310 SERIES**

**VR SERIES VALVE ARRANGEMENTS**

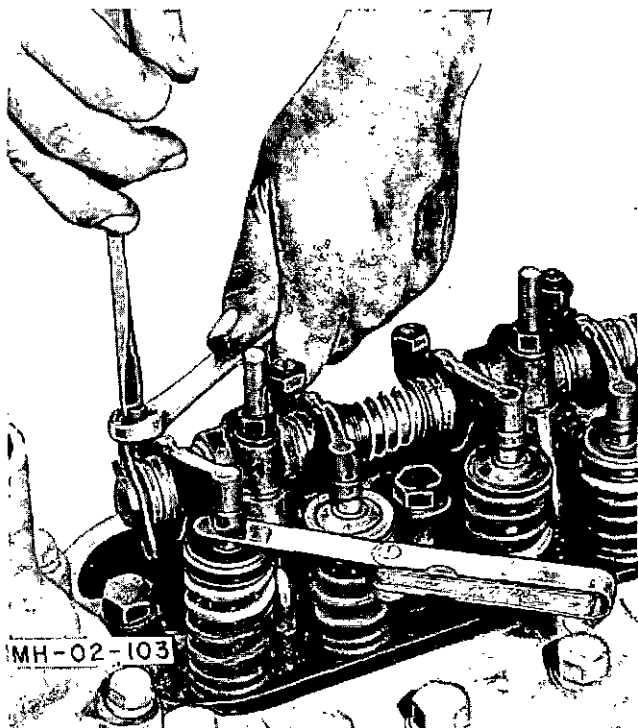

MH-02-103

ADJUSTING VALVE CLEARANCE

MH-02-103

**COMPRESSION TESTING**

To check the compression of the gas and gasoline engines, a standard automotive type compression tester with threaded adaptor can be used. For diesel engines with pintle injectors a special adapter (such as the MOTORITE ADAPTER Part No. 70-0256 made by Bacharach) is required to make a compression test. Diesel engine owners with pencil injectors should contact Bacharach for correct adapter part number.

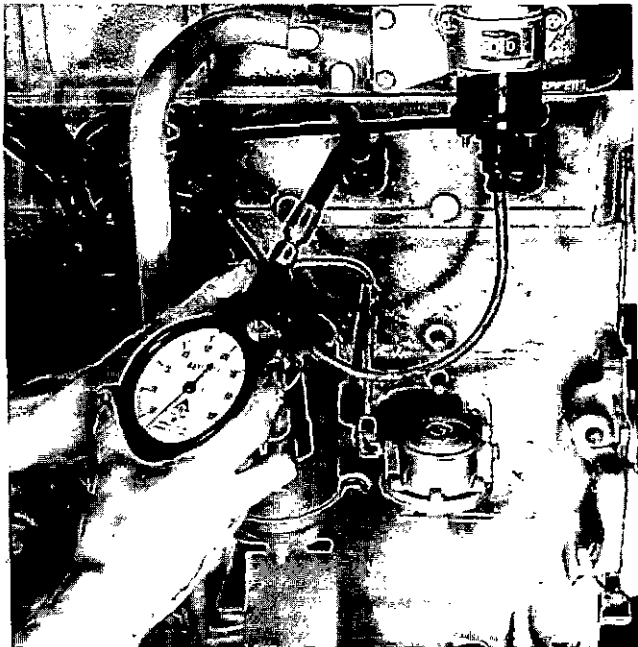

COMPRESSION TESTER

MH-18-91

Before checking compression, be sure the engine has been warmed up to operating temperature. Gas and gasoline engines must have the throttle held in open position and the ignition switch in off position. Diesel engines must have the fuel shutoff control in off position. Note the number of compression strokes needed to obtain the highest pressure reading. Repeat compression testing for each cylinder using the same number of compression strokes as used for the first cylinder tested.

Normal compression pressures at cranking speed are listed in REPAIR AND REPLACEMENT UNIT under "Basic Engine Data". Uneven compression or pressures lower than normal call for further checking. A need for valve regrinding, piston ring replacement, or other overhaul procedures may be required.

**MANIFOLD VACUUM TEST**

**Gas and Gasoline Engine**

Operate the engine until it is at normal operating temperature.

Connect vacuum gauge to the intake manifold and test with engine operating at idle speed, with no load condition (See tables below).

PREVENTIVE MAINTENANCE

GAUGE READINGS	ENGINE CONDITION
18 - 19 Inches at Idle Speed. (Approx.)	
HIGH AND STEADY	Good
LOW AND STEADY	Loss of power in all cylinders caused possibly by late ignition or valve timing, or loss of compression due to leakage around the rings.
VERY LOW	Manifold, carburetor or cylinder head gasket leak.
NEEDLE FLUCTUATES STEADILY AS SPEED INCREASES	A partial or complete loss of power in one or more cylinders caused by: a leaking valve, cylinder head or intake manifold gasket leak, a defect in the ignition system or a weak valve spring.
GRADUAL DROP IN READING AT ENGINE IDLE	Excessive back pressure in the exhaust system.
INTERMITTENT FLUCTUATION	An occasional loss of power possibly caused by a defect in the ignition system or a sticking valve.
SLOW FLUCTUATION OR DRIFTING OF THE NEEDLE	Improper idle mixture adjustment, or carburetor, spacer or intake manifold gasket leak.

**TEST PROCEDURES FOR ENGINE PROTECTION DEVICES**

**Low Oil Pressure (LOP) Test**

To test the low oil pressure Switchgage, install two needle valves, a 0-100 psi pressure gauge and piping as shown in the illustration. With the engine in operation, simulate a low oil pressure shutdown by closing the 1/4" needle valve in the oil pressure line to the Switchgage. This will trap oil pressure in the system. Then slowly open the 1/4" needle valve in the line to waste, observing the oil pressure indicated by the test gauge when the Switchgage is actuated. If necessary, adjust the Switchgage as required and repeat the test. After testing, immediately close the needle valve in the line to waste and open the needle valve in the oil pressure line to the Switchgage.

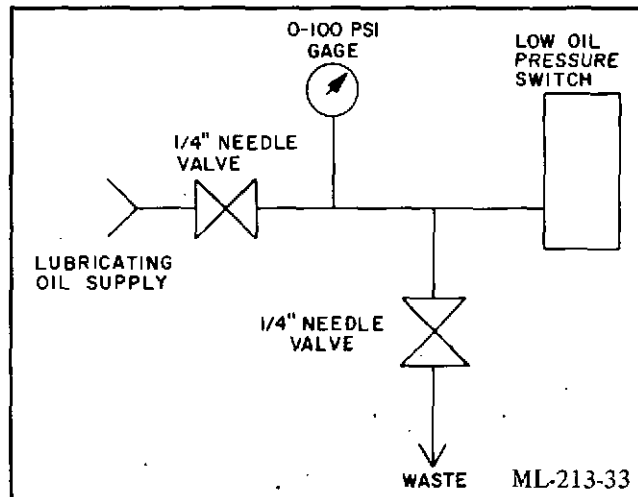

LOW OIL PRESSURE TEST PIPING ARRANGEMENT

**High Water Temperature (HWT) Test**

To assure high temperature shutdown, the temperature sensor bulb should be removed from the water manifold and immersed in hot water. Then the water should be heated until it boils. Allow sufficient time for the sensor to actuate the control.

**NOTE**

The preceding tests apply to the typical safety controls used on Waukesha engines. If engines contain special controls, test procedures may be obtained from Waukesha Engine Division Service Department.

**ENGINE STORAGE**

Preservation of engines and generators in storage involves several basic requirements. For new engines and generators, these are as follows:

1. Protection of machined metal surfaces, cylinders, valves, bearings, and so on, from the effects of both dampness and salt or other corrosive substances in the atmosphere.

2. Protection of openings into the engine against entrance of dirt, abrasive material, and foreign matter of all types.
  3. Protection of accessory equipment, including carburetors, gas regulators, magnetos, starters, generators, and fan belts against corrosion, dirt, moisture saturation and progressive deterioration.
  4. Protection of cooling system, intercoolers, and LPG vaporizers against freezing, rusting, or seizure or water pump seals.
  5. Protection of a general nature against the elements, rain, snow, and extremes of temperature.
  6. Protection of batteries by disconnecting and removing them to a slow charging station where they can be kept fully charged. If this is neglected, the plates may be damaged and ruined by becoming sulphated.
  7. Protection of the generator or alternator by covering all openings to prevent the entry of dust, moisture, dirt, and rodents. A heavy kraft paper will serve this purpose. Where these openings are in the form of screened or louvered guards or covered plates, the protective paper should be placed under these removable parts. If this is not possible a pressure sensitive tape can be used to hold the paper in position. Do not use masking tape -- it is not suitable for this type of service and will be very difficult to remove after extended use. Application of protective paper should be on both inside and outside of large, fixed, louvered surfaces. Large open areas should have a corrugated cardboard backing for the paper.
  8. Protect switchboards in the same manner as generators.
- In the case of engines previously operated, additional items must be considered.
9. Protection of interior engine parts, particularly bearings, cylinder walls, and valves against corrosion by the products of combustion combined with atmospheric moisture and corrosion by lubricating oil contaminants.
  10. Protection of fuel system units against gumming and the effects of stale fuel oil or gas residues.

The extent of the attention given to each of the foregoing points of possible damage, depends on the judgement of the person in charge of the equipment. Generally speaking, the following factors should be taken into consideration before deciding how much or how little preservation is required:

1. The period of time the equipment is likely to be inoperative.
2. The severity of the weather and atmospheric conditions at the point of storage. The problems of storing equipment in a tidewater warehouse, for example, differ greatly from storage problems in a location where the air is very dry and dusty.

NUCLE-OIL APPLICATION CHART

Upper Cylinder		Crankcase		Oil Bath Air Filter	Fuel Injection System*	Fuel Tank	Total Ounces
Ozs. of Nucle-Oil Per Cyl.	Ozs. of Nucle-Oil All Cyls.	Oil Cap. Qts.	Ozs. Nucle-Oil	Ozs. Nucle-Oil	Ozs. Nucle-Oil	Ozs. Nucle-Oil	Nucle-Oil Required
1/4	1-1/2	7 or 10	6-1/2	2	3	32	45

\*Introduce Nucle-Oil and fuel oil mixture (1 ounce Nucle-Oil to 1 pint of fuel oil) through fuel inlet line by hand priming or by cranking engine with starter.

- The accessibility of the equipment for periodic inspection and attention. An engine on a showroom floor that may be turned over occasionally and given periodic oiling requires less extensive treatment than engines crated and stocked in a warehouse.

**CAUTION**

VR Engines received from the factory are internally protected for up to six months. If storage period exceeds six months, the engine should receive additional storage preservatives. Engine stored outdoors or in a humid environment may require more frequent representation.

**NUCLE-OIL STORAGE**

Nucle-Oil, a product of the Daubert Chemical Company, is offered in one gallon cans through Waukesha Motor Company under Part No. 166709-A and offers a practical and economical solution to storage problem. This product is similar in appearance to a conventional lubricating oil of about SAE No. 10 viscosity. It contains volatile-corrosion-inhibiting chemicals which vaporize slowly and diffuse throughout any closed void such as the interior of an engine or gear housing. These chemicals form an invisible protective layer on the exposed surfaces even though the surfaces were not originally coated with the oil. Obviously, absolute sealing of an engine may not be 100% practical in the field but reasonable blockage of the escape paths for the vaporized chemicals is not difficult and ordinary storage times present no problem.

**WARNING**

Nucle-Oil contains Petroleum Distillate. Harmful or fatal if swallowed. Avoid contact with skin. Vapor is harmful. Causes irritation of eyes, nose, throat and skin. Use only with adequate ventilation. Avoid prolonged or repeated breathing of vapor. Avoid contact with skin, eyes, and clothing. Do not take internally. Keep container

closed and away from heat. In case of contact, immediately flush skin or eyes with plenty of water for at least 15 minutes; for eyes, get medical attention. Remove and wash clothing before reuse. If affected by exposure, move to fresh air. If swallowed, do not induce vomiting. Remove ingested material by gastric lavage with 2 to 4 quarts or liters of tap water or milk. Follow with fruit juice or vinegar to neutralize the alkali.

Equally important, the Nucle-Oil may simply be added to the existing crankcase oil in the amount of 2% without concern for future removal. Nucle-Oil will do an effective job if added to engine oil in normal clean condition. If high sulfur fuel or improper control of oil condition has left highly corrosive oil in the bearings and close contact surfaces, the protective vapors cannot be expected to force the oil from the bearing clearances and substitute a protective layer. Such engines should have an oil change and be run long enough to circulate the clean oil.

Nucle-Oil is not intended as an external surface coating protective measure since it would be about the same in effectiveness as coating the surface with conventional lubricating oil. Other excellent products are available for polished or machined surfaces and should be used when needed.

Although basic instructions for the use of Nucle-Oil are offered on each can label, the following material taken directly from our correspondence with Daubert Chemical is highly explanatory and should be read carefully.

Generally, Nucle-Oil is recommended for use in fuel tanks at the rate of 1 oz. Nucle-Oil per 20 gallons of air space plus enough additional Nucle-Oil to flush through the fuel lines.

The following procedure for preservation is suggested:

- Start with a cold engine (below 100° F) containing clean oil and filter elements.

PREVENTIVE  
MAINTENANCE

2. Add the required amounts of Nucle-Oil to the crankcase, oil bath type air filters, and fuel tanks.
3. Crank engine for 20 seconds, if possible, to help disperse Nucle-Oil, with fuel supply line picking up Nucle-Oil to protect injectors and injection pumps.
4. Add the required amounts of Nucle-Oil to each cylinder through the spark plug or injector openings and replace plugs or injectors. Apply to rocker area by light brushing or pouring. Replace rocker covers.
5. Store engine up to one year. If storing for more than one year, inspect and represerve annually, as necessary.

## CONVENTIONAL STORAGE

### Storing New Engines

Engines recently received from the factory and not intended to be used for an indefinite period may be stored successfully in the following manner. All VR Engines shipped by Waukesha Engine Division receive storage measures internally which prepare the engine for a storage period of up to 6 months, unless they are test run, operated for any reason, or have the external openings unsealed. Engines stored outdoors or in a humid environment may require more frequent represervation. Circumstances may compel omitting some steps and, on the other hand, special conditions may point to greater emphasis on other steps.

1. When engine is installed in an operable unit.
  - A. Mix an inhibitive type preservative oil with the engine lubricating oil in the proportions recommended by the manufacturer of the preservative oil, or, no mixing may be necessary. Operate engine until oil is hot. Cooling water used in this run should have inhibitor added in accordance to manufacturer's instructions.
  - B. Remove air cleaners of gas engines. With manually operated sprayer, squirt can, or other means, inject preservative oil of a type suited for this purpose into the air intake while the engine is running. Approximately one minute is ordinarily adequate. If possible, stop engine by "slugging" enough oil through intake to stall. Continue injecting oil until engine stops turning.

**CAUTION**

Never inject oil into the air intake of a diesel engine.

- C. Drain oil and water while hot. If extra protection is desired, the rocker arm covers may be removed and a quantity of preservative oil poured over the rocker arm and valve mechanisms.
- D. For diesel engines or for gas engines not stopped by "slugging", remove injectors or spark plugs and squirt or spray several teaspoons of pre-

servative oil into each combustion chamber. Coat injectors or spark plugs and reinstall.

- E. Remove distributor cap or magneto cover and apply small amount of petroleum jelly to polished surface of breaker cam. Where dampness in storage is expected, removal of magneto may be worthwhile.
- F. Refer to "STORAGE OF FUEL INJECTORS" for additional instructions for diesel engines.
- G. Wipe engine clean and dry. Apply wax type masking tape or like material to all openings such as intake openings in air cleaners, exhaust outlets, breathers, magneto vents, and open line fittings.
- H. Relieve tension on belts. This is important because continual tension on belts without the working action that occurs in normal operation causes deterioration of the rubber.
- I. Apply a coating of heavy preservative compound with brush to all exposed machined surfaces such as flywheels.

Engines treated in accordance with these instructions will normally be protected for one year or longer. Continual inspection, however, is the only way to determine if protection is adequate. If possible, crank the engine by hand for one or two turns about once a month. This helps prevent seizure of water pump seals. If this is done, however, it is usually best to add more preservative oil to each cylinder. Some types of preservative oil are not well suited to periodic engine rotation because they are scraped from the cylinder walls which are then unprotected. Other oils are not scraped away, and for this reason the operator should carefully investigate the characteristics of the oil used.

2. When engine is not operable.
  - A. Open drains as required to remove oil, water, and fuel.
  - B. Remove the injectors or spark plugs and pour or squirt about a teaspoon of preservative oil into each cylinder.
  - C. With hand or mechanically operated atomizing spray (do not use ordinary compressed air), inject preservative oil into each cylinder. Crank engine in normal direction about one-quarter turn and spray each cylinder again. Do this about eight times, or until engine has been turned through two complete revolutions. The purpose of this procedure is to bring each valve into an exposed position so the preservative oil will coat it.
  - D. Depending on the judgement of the operator as to the severity of storage conditions, open oil pan access doors, valve rocker covers, gear cover plates, and as many points as possible where oil may be sprayed, poured, or squirted over the interior parts. Replace all plugs and covers.

- E. Remaining steps may be the same as listed in "E" through "I" for an operable engine.

### Storing Engines That Have Been In Service

In the course of normal engine operation, residues of various combustion products such as lead and sulphur accumulate in the combustion area and in the lubricating oil. Portions of these residues combine with atmospheric moisture to form corrosive compounds of a destructive nature. The following treatment will help reduce damage from this source:

1. Engine in operable condition.
  - A. Run engine until original oil is hot. Drain.
  - B. If practical, run engine with a good flushing oil in crankcase and drain oil and water while still hot.
  - C. Refill crankcase with preservative oil, or with the proper grade of lube oil to which an inhibitive type preservative oil has been added in the proportion recommended.
  - D. Carry out previous instructions "D" through "I" as the circumstances indicate.
2. When engine is not operable.
  - A. Carry out instructions as for an inoperable new engine.
  - B. If the judgement of the operator and storage conditions warrant, the engine should be disassembled, thoroughly cleaned, and reassembled for treatment as a new engine. Ordinarily, this last procedure is unnecessary except in cases where fuels containing considerable sulphur have been used, or where extremely bad climatic conditions prevail.

### PRESERVATION EQUIPMENT AND MATERIALS

#### Sprays and Atomizers

In the foregoing instructions it is recognized that many times it is necessary to apply protective compound under difficult field conditions. Several simple tools may be used to atomize preservative oil and force it into the manifolds and combustion chambers. One of these is a manually operated atomizing gun used ordinarily to lubricate inaccessible points on car and truck chassis. Another is a hand operated pump type sprayer with a pointed discharge nozzle commonly used with insecticides. If desired, small oil pumps may be rigged with a motor drive to make a convenient spray unit of the mechanical pressure type. In almost all cases, the air available from shop compressor lines carries too much moisture to be safe for this purpose. Do not use high-pressure air from this source.

### Heating of Preservative Compounds

Many preservative compounds are most effective when heated before application. If possible engine should be warmed prior to applying preservatives. Heating reduces their viscosity so as to gain penetration into accessible areas. In addition, the hot compound reduces the moisture film at the metal surface and thus avoids trapping moisture under the preservative layer.

#### WARNING

Generally speaking, such heating is confined to 200° F (93° C), or less. These temperatures are easily reached by placing the preservative container in heated water. Direct heating presents a dangerous and unnecessary fire hazard.

### PREPARING ENGINE FOR OPERATION AFTER STORAGE

The steps needed to bring an engine into active service after storage in accordance with these instructions are about the same as those normally carried out on any new engine. These are inspection, checking for free rotation, adequate cooling water or antifreeze, ample lubricating oil of the correct type and viscosity, and proper adjustments.

In addition, accumulated dust and dirt should be wiped or washed from the exterior before removing the covers over the engine openings. Removal of installed protection should occur upon normal inspection of the engine, generator, and switchgear interiors prior to start-up. Partial removal may be necessary in the course of installation, but this should be kept at a minimum. Engines that have not been rotated for some time should be oiled through the injector or spark plug openings and cranked by hand or with the starting equipment before actually running. Any resistance to free cranking should be investigated; rust and corrosion can cause severe seizure that cannot be forced clear without engine damage.

#### CAUTION

All generators and switchgear which have been stored must be checked for insulation resistance with a "Megger" prior to being put into service. The megger used should produce 500 V.D.C. Disconnect voltage regulator, rotating diodes, suppressors and any other solid state devices which may be connected to the stator or rotor windings. The megger value should be: operating voltage ÷ 1000 + 1 (i.e., machine voltage of 480 V.A.C. ÷ 1000 = .480 + 1 = 1.480 megohms). If any circuit to ground measures less than calculated value, consult the Waukesha Motor Company Service Department for any corrective measures as may be necessary.

Never attempt to start an engine that has been stored without first cranking it over with the injectors or spark plugs out. Spurting oil, water or preservative compound from these openings indicates possible hydraulic lock if an attempt had been made to operate. Continue to crank engine with starter until liquid is no longer ejected from openings. Inspect intake passages and manifolds for thickened preservative oil. Oil accumulated in this condition may melt when the engine warms up and cause a runaway.

Specifications for Protective Materials	
Internal Surfaces, Cyls., Etc.	External Surfaces
U.S. Army Spec. 2-126 (Available as SAE 10 or SAE 30)	U.S. Army Spec. 2-121 (Waxy Coating)
Nucle Oil No. 120 Mil Spec. MIL-L-46002 Grade 2	Army Ordnance Spec. AXS 673 (Harder black coating)

**STORAGE OF FUEL INJECTORS**

**Storage**

Unless properly protected from corrosion and gumming, injectors, pumps and lines are subject to serious damage while idle for more than a few days' time. To protect against such damage when using conventional storage methods rather than Nucle-Oil storage, any of the preservative oils listed at the end of this section are recommended. Carry out the following instructions in the sequence given:

1. Disconnect main fuel supply line wherever convenient, carefully wipe it clean of dirt, and place in container filled with preservative oil.
2. Run engine until all of preservative oil has been taken into fuel system.

When preservative oil has been run through the injectors as in the foregoing instructions, they will ordinarily be protected for short periods of a week up to several months depending on climatic and storage conditions. Whenever dampness or long term storage up to a year seem likely, carry out the following operations after the above steps are completed:

1. Remove the injectors from the engine.
2. Install caps or tape over fuel line outlets and injector connection fittings. Seal injector openings in cylinder heads with plugs. Replace rocker arm covers.

3. Injectors should be serviced by a competent diesel repair station and hot wax sealed for storage.
4. Store injectors in clean, dry location.

**Operation After Storage**

If injectors were serviced as above, remove sealing wax and reinstall in engine.

If storage has been prolonged over a very long period, the preservative oil should be washed from the filters and lines by thoroughly purging with fuel oil with the fuel control in off position. Purge by operating hand priming pump.

**PRESERVATIVE OIL**

In addition to Nucle-Oil, the following preservative oils are of a type that has been found satisfactory for the protection of fuel injectors. Other equally good oils are probably available and omission of them from this listing does not necessarily mean they are not acceptable. In main, the properties making an oil suitable for preservative requirements are good aging stability; high resistance to gumming, oxidation and polymerization; low pour point and viscosity; freedom from acids, asphalts, reins, tars, and water.

SUPPLIER	PRESERVATIVE OIL
American Oil Company	Amoco Anti-Rust Oil 4-V
Gulf Oil Corporation	No rust Engine Oil Grade 1
Mobil Oil Company	Mobil Arma 522
Shell Oil Company	Donax T-6
Atlantic Richfield Co.	Dexron
Texaco, Inc.	No. 800 Regal Oil A (R O)

**NOTE**

Dexron automatic transmission fluid may be used if none of the above preservative oils are available.

# TROUBLE SHOOTING

TROUBLESHOOTING.....	3-3
OPERATING CONTROLS.....	3-3
ELECTRICAL SYSTEM.....	3-3
COOLING SYSTEM.....	3-4
AIR INTAKE SYSTEM.....	3-4
EXHAUST SYSTEM.....	3-5
FUEL SYSTEMS.....	3-5
IGNITION SYSTEMS.....	3-8
LUBRICATION SYSTEM.....	3-9
GOVERNING SYSTEMS.....	3-11
TROUBLESHOOTING CHART.....	3-13

TROUBLESHOOTING

# PARTS ORDERING

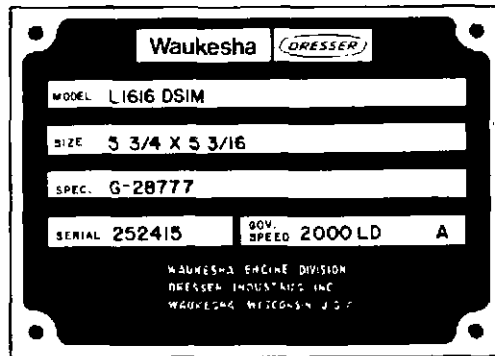

ALWAYS SPECIFY THE  
ENGINE MODEL DESIGNATION,  
SPECIFICATION NUMBER, AND  
SERIAL NUMBER, AS FOUND ON  
THE ENGINE NAMEPLATE.

ML-1000-29

**TROUBLE SHOOTING**

Good trouble shooting methods determine the cause of causes of unsatisfactory operation and point out the action needed to correct the problem. Knowledge of how engine systems work, together with the trouble-shooting chart in this unit and current indications from the engine instrument panel provide the best background for good trouble shooting.

**OPERATING CONTROLS**

Most VR Series engines are equipped with the following operating controls (See illustrations):

- a. Ammeter
- b. Water temperature gauge
- c. Oil pressure gauge
- d. Throttle
- e. Starter switch
- f. Ignition switch (gas and gasoline)
- g. Choke control (gasoline only)
- h. Fuel shut-off control (diesel)

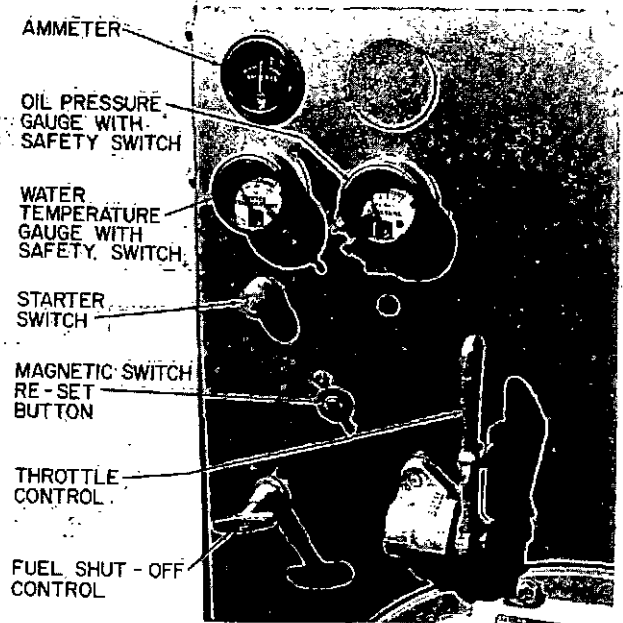

MH-215-4

TYPICAL DIESEL INSTRUMENT PANEL WITH SAFETY SWITCHES

**ELECTRICAL SYSTEM**

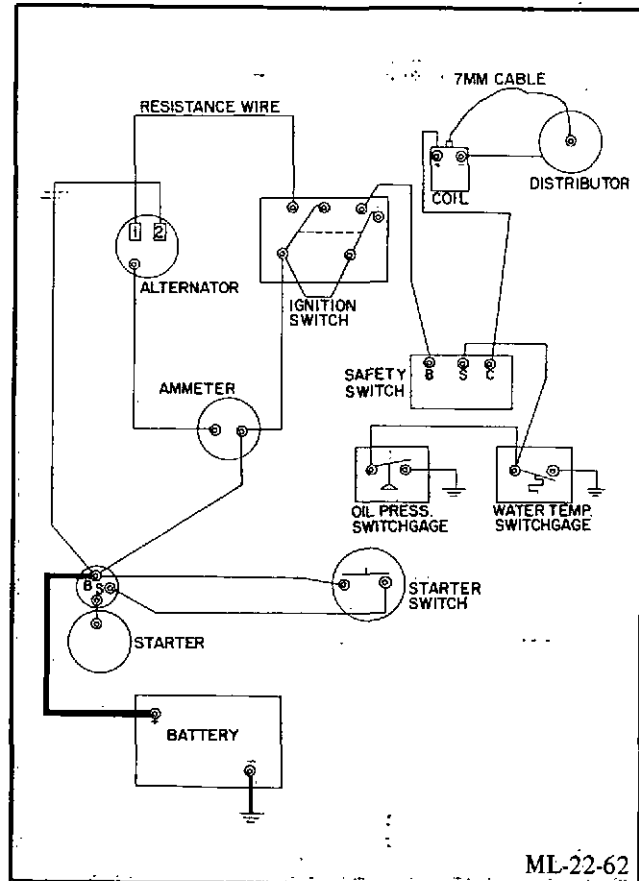

ML-22-62

TYPICAL VRG SERIES ELECTRICAL LAYOUT

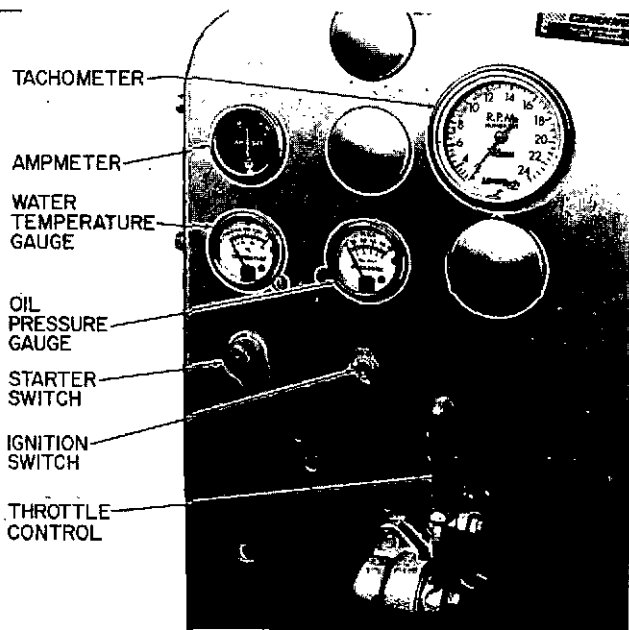

MH-215-3

TYPICAL GAS INSTRUMENT PANEL WITHOUT SAFETY SWITCHES

TROUBLESHOOTING

The engine electrical system consists of a battery, heavy-duty starter and alternator, regulating devices, switches, and circuits similar to automotive installations. Starting is accomplished by closing a circuit from battery to starter with the instrument panel switch that actuates the magnetic switch. Positive engagement of the pinion before cranking commences is accomplished by the starting motor solenoid. After cranking is completed and the engine starts, the alternator replenishes energy expended by the battery. Cut-outs and regulators control the alternator's output and protect the system from reverse currents and excessive charging rates.

The Waukesha Engine Division supplies engines with negatively-grounded electrical equipment only. This standardization of electrical system polarity is standard practice for most equipment manufacturers and thus increases compatibility between Waukesha supplied electrical equipment and that supplied by the equipment builder.

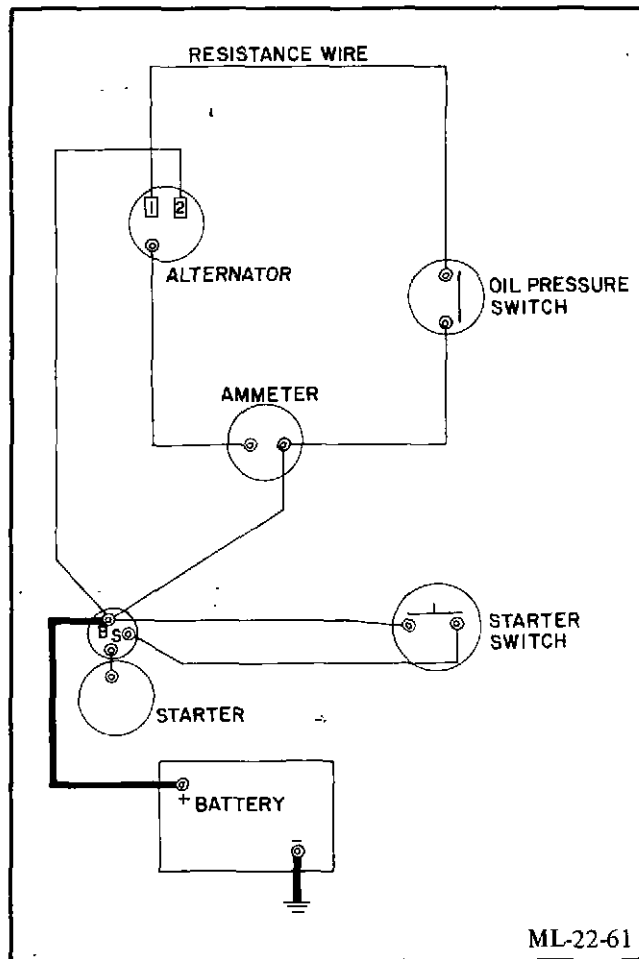

TYPICAL VRD SERIES ELECTRICAL LAYOUT

COOLING SYSTEM

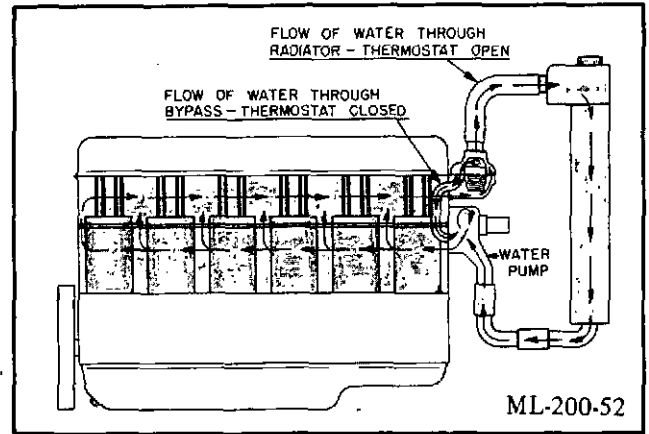

TYPICAL COOLING SYSTEM SCHEMATIC DIAGRAM

The cooling system used on the VR Series is of the pressure circulating type. The water enters the water pump inlet on the right side of the engine. The centrifugal pump pulls this supply of cool water through the pump body and into a passage leading directly into the engine cylinder jacket. The water enters the engine in the area of the cylinder sleeve lower ends. From here the water flow is directed about the cylinder sleeves in an even manner until it passes upward from the crankcase and into the cored passages in the cylinder heads. These passages are carefully designed to allow cooling water access to all areas around the valves. Water is collected from the cylinder head and enters a thermostat housing at the forward end. The thermostat controls the exit temperature of the water. Back pressure at the water outlet must not exceed 5 pounds per square inch.

AIR INTAKE SYSTEM

With the exception of adequate supplies of clean oil and water probably no other single service item contributes so much to engine life as a properly working air cleaner. This is particularly true under dusty and agricultural operating conditions, but surprising amounts of abrasive dirt are present in most atmospheres. When carried into the engine through the air inlet, such abrasives rapidly wear away cylinder walls, valve stems, bearings and other working parts.

Because the dust particles are so small, yet possess the ability to cause great damage, it is absolutely mandatory that air-inlet connections be kept in tight condition to avoid taking in unfiltered air.

Although various installations will have differences in air cleaner types and arrangements, it is important for the operator to realize that the common purpose of all air cleaners is to collect dirt and grit. Thus the cleaner itself must be cleaned as often as dirt accumulations start to build up. Sometimes this may be several times each day if conditions are especially bad.

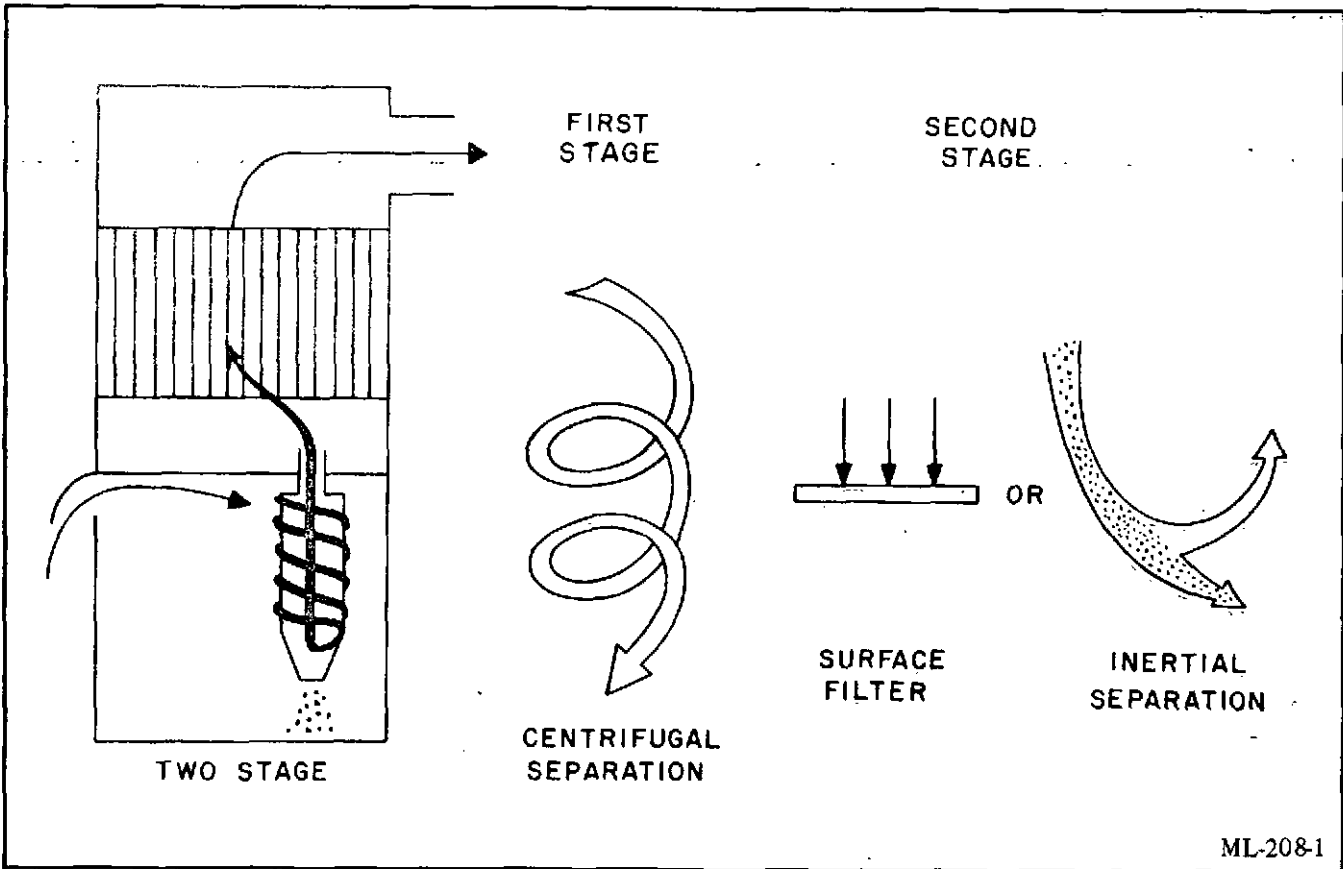

TWO STAGE AIR CLEANER

**EXHAUST SYSTEM**

Proper disposal of the exhaust of an engine is a very critical problem when you visualize its "breathing function". An engine consumes an incredible amount of air, and after combustion takes place, must push it out of the cylinders, manifolds and exhaust piping. Every provision possible must be made to minimize the restriction or back pressure on an exhaust system.

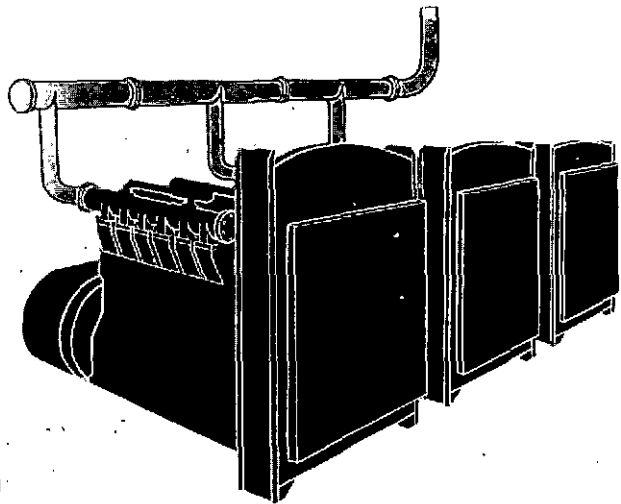

MH-88-1

MULTIPLE EXHAUST CONNECTIONS TO A COMMON HEADER ARE VERY POOR PRACTICES

Some of the adverse effects of excessive back pressure are:

1. Loss of power.
2. Poor fuel economy.
3. Excessive valve temperatures and premature wear.
4. Jacket water overheating.

The exhaust of an engine, particularly when running through long pipes, can accumulate quite a bit of condensed moisture. If allowed to run back through the piping into the engine after it is shut down, the obvious rusting and sticking of valves, rings, etc. and the possibility of a hydraulic "lock" become serious. Always provide a condensate trap and drain at some low point ahead of the engine manifolds.

**FUEL SYSTEMS**

**Gasoline Carburetion**

In the gasoline carburetor the functions of metering and vaporization of fuel are accomplished through a float valve and a series of jets and venturis according to the speed and load of the engine. This process is carried out in three phases; idling, part load, and full load, with each phase involving a particular combination of the carburetor system.

TROUBLESHOOTING

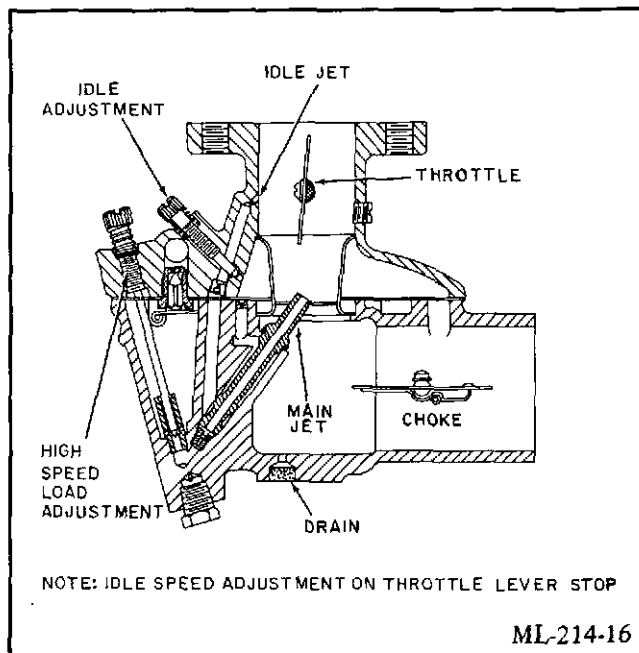

GASOLINE CARBURETOR - SECTIONAL VIEW

**Gas Carburetion**

The Impco carburetor is structurally quite simple, consisting of a main body with a conventional butterfly valve and a diaphragm operated gas metering valve. The amount of air going to the engine is measured by an air-flow measuring valve which rises in direct proportion to the air volume passing through. The gas metering valve is mechanically fixed to the air measuring valve and rises with it, thus opening the gas passage an amount proportionate to the air entering the engine. This establishes and holds a definite fuel/air ratio throughout the operating range.

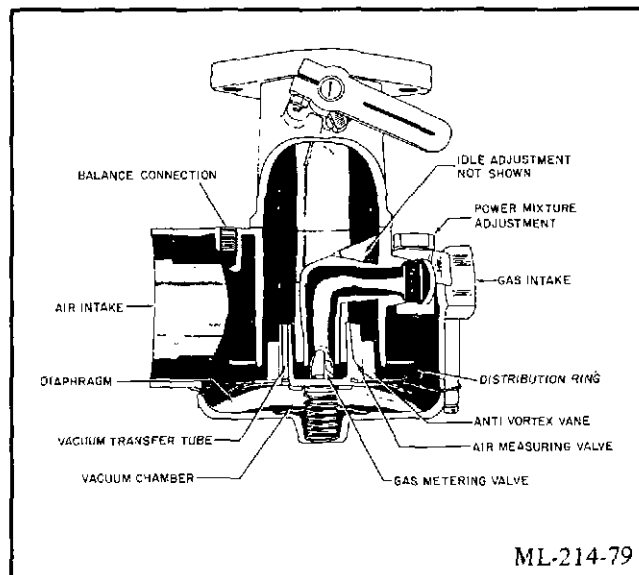

GAS CARBURETOR - SECTIONAL VIEW

**Diesel Injection Pump**

A diesel engine requires an evenly metered supply of fuel delivered to each cylinder at the correct time, pressure and quantity. The complete fuel injection system requires tight connections, good flow control and sufficient fuel filtering to ensure clean fuel. The heart of the system is the injection pump.

**Injection Pump Operation**

Fuel, under transfer pump pressure, is forced through the drilled passage in the hydraulic head into the annulus. It then flows around the annulus to the top of the sleeve and through a connecting passage to the metering valve. The rotary position of the metering valve, controlled by the governor, regulates the flow of fuel into the charging ring which incorporates the charging ports.

As the rotor revolves, its single charging hole registers with one of the charging ports in the hydraulic head and fuel, at transfer pump pressure, flows through the angled passage to the pumping cylinder.

At this point (charging) of the cycle, the rollers are in the "valley" or relieved part of the cam between lobes. The fuel is trapped in the cylinder for a very slight interval after charging is complete.

Further rotation of the rotor brings its discharge port into registry with an outlet port of the head at which point the rollers simultaneously contact the opposing cam lobes and the plungers are forced towards each other. The fuel trapped between the plungers is forced from the pump through one of the outlet ports to an injection line.

Lubrication of the pump is an inherent characteristic of the Roosa Master design. As fuel, at transfer pump pressure, reaches the charging ring, slots on the rotor shank allow fuel and any entrapped air to bleed to a reduced diameter on the shank. This fuel fills the pump housing cavity and acts as a coolant as well as a lubricant, since it is allowed to return to the supply tank via the oil return connection in the pump housing cover. This return line also permits any air entrained in the fuel or originally contained in the pump to be carried out.

**CHARGING CYCLE:** As the rotor revolves, the angled passage in the rotor registers with one of the charging ports in the charging ring. Fuel, at transfer pump pressure, then passes into the pumping cylinder, forcing the plungers apart a distance proportionate to the amount of fuel required for injection on the following stroke. Only at full load will the plungers move to the most outward position, controlled by the leaf spring setting (maximum fuel adjustment). This leaf spring is adjusted permanently for maximum fuel and any fuel adjustments should be made by using the smoke stop adjustment screw located on the rear of the pump (see illustration). Turning the screw "IN" reduces the maximum fuel use. Turning the adjusting screw "OUT" increases fuel use at full load.

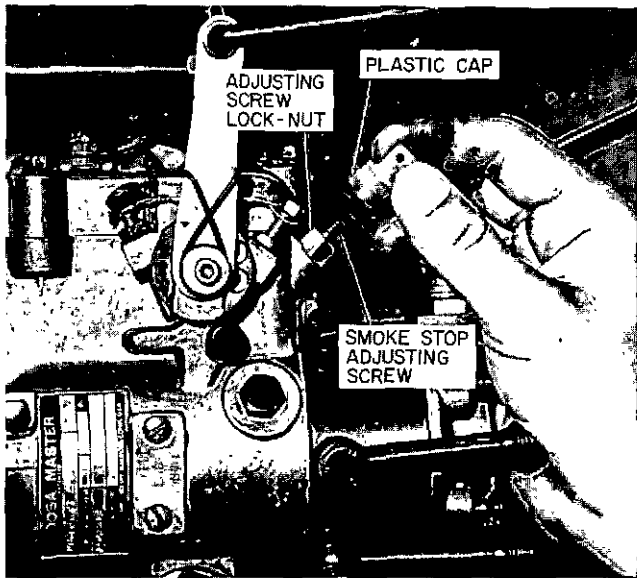

MH-08-119

SMOKE STOP ADJUSTING SCREW LOCATION

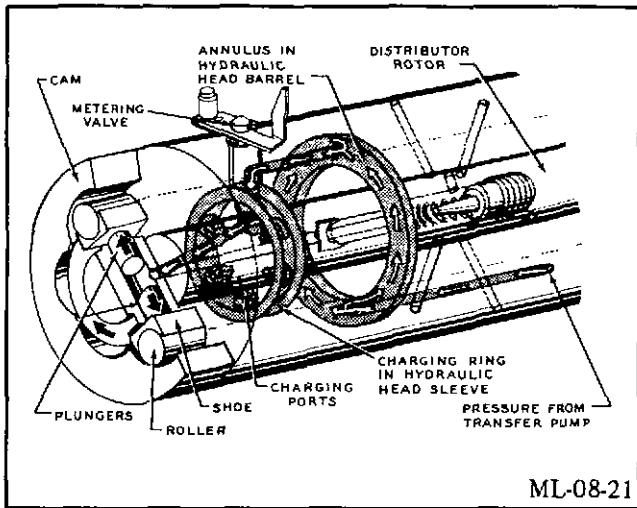

ML-08-21

CHARGE CYCLE SCHEMATIC

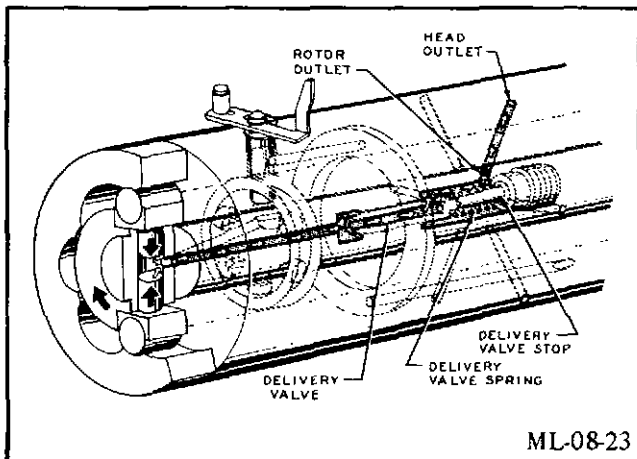

ML-08-23

DISCHARGE CYCLE SCHEMATIC

**DISCHARGE CYCLE:** As the rotor continues to revolve, the angled passage passes out of registry with the charging port. For a brief interval the fuel is trapped until the rotor outlet registers with one of the head outlets. As this registration takes place both rollers contact the rise of the cam lobes and are forced together. This is the discharge or injection stroke. The fuel trapped between the plungers is forced through the axial passage, through the delivery valve and out the rotor outlet.

**Fuel Injector (Pencil)**

The operation of the pencil injector, as used on VRD 283 and 310 engines is simple and positive. A metered quantity of fuel under high pressure from the injection pump flows through the inlet fitting of the injector around the injector valve. At the instant the pressure of the fuel against the valve exceeds the predetermined spring force - the valve is lifted off its seat allowing fuel under high pressure to flow through the four spray orifices to the combustion chamber.

The instant the fuel delivery ceases - the pressure against the valve is reduced and the control spring snaps the injector valve to its seat. This eliminates any possibility of dribbling or dripping after the metered amount of fuel has been delivered. During injection a small amount of fuel leaks through the closely controlled clearance at the guide, lubricating all the moving parts in the injector. This fuel then flows off through a leakoff boot at the top of the injector and returns to the fuel tank.

TROUBLESHOOTING

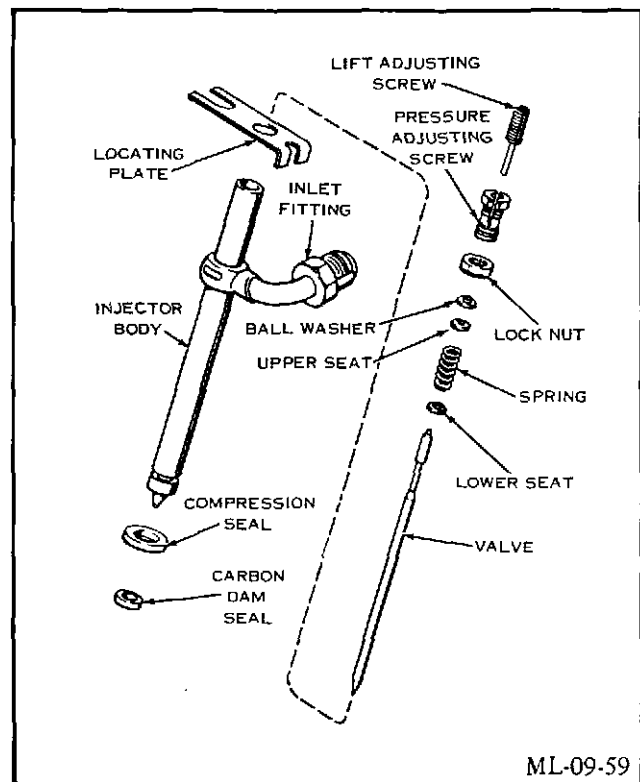

ML-09-59

TYPICAL PENCIL INJECTOR COMPONENTS

**Fuel Injector (Pintle)**

Pintle type nozzles are used on VRD 155 and 232 series engines. The nozzles are actually part of an injection system comprised of the injector on one side of the head and the energy cell directly in line with the nozzle on the other.

The injectors are operated hydraulically by the pressure of the fuel delivered from the injection pump. They utilize a spring-loaded valve and a seat located at the spray orifice to close off fuel at the end of injection. The Pintle or pin like protrusion projects into and cleans the spray orifice of carbon accumulation each time injection is ended thereby by appreciably increasing nozzle service life.

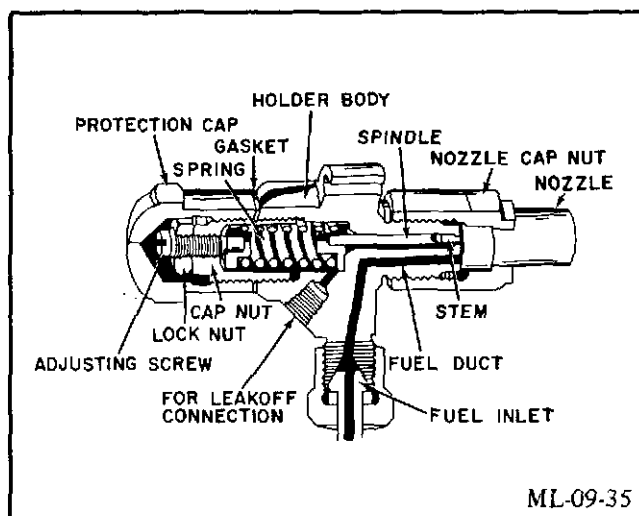

FUEL INJECTOR (PINTLE) CUT AWAY

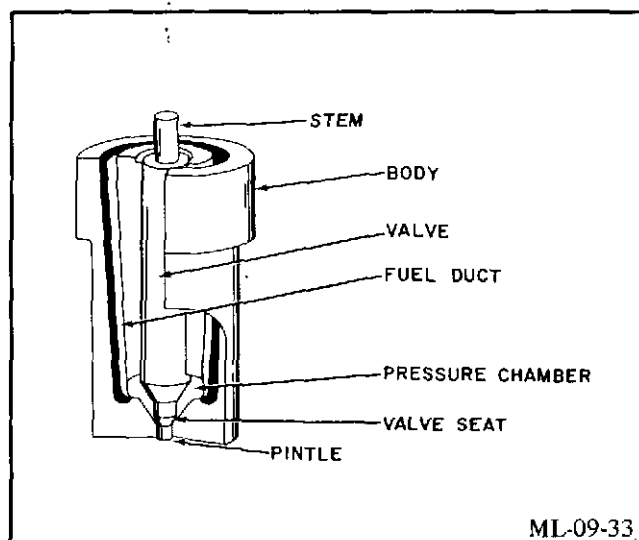

PINTLE NOZZLE CUTAWAY

Fuel is forced from injection pump through injection tubes to fuel inlet of nozzle holder body. Fuel then passes through fuel duct at high pressure to a pressure chamber

at base of valve. When fuel pressure equals opening pressure of spring controlled nozzle, fuel forces valve stem up against spindle which in turn bears against spring. This opens valve in nozzle and fuel is forced into engine combustion chamber. Spring closes valve immediately as momentary high injection pressure of fuel dissipates and ends. Opening pressure of valve may be varied by changing compression of spring with adjusting screw. Excess fuel which is not forced into combustion chamber returns to fuel tank through leakoff connection and drip line.

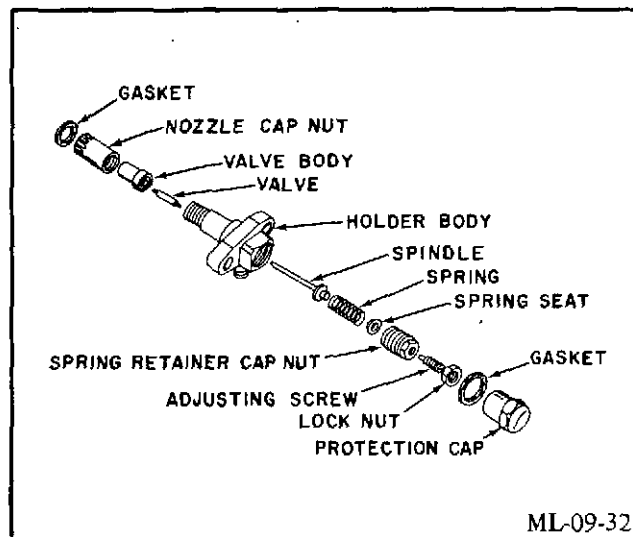

PINTLE INJECTOR DISASSEMBLED

**IGNITION SYSTEMS**

Smooth combustion requires positive ignition in the cylinders at finely defined intervals. VRG Series engines are equipped with either distributor or magneto ignition.

In both theory and service practice there is little difference between a magneto and a distributor. Whereas a distributor depends upon a generator and storage battery for its primary current, the magneto uses a primary current generated within itself by rotation of permanent magnets between the pole shoes.

Distributors are driven by a tang which is mated with a slot in the upper face of the oil pump drive gear. The magneto drive for the gear driven, vertically mounted magneto, is driven in the same manner.

Utilizing battery current and an ignition coil, the distributor functions in much the same way as a magneto. The retarded spark for starting is obtained by the centrifugal spark advance mechanism that automatically advances the spark as engine speed increases. The retarded spark for starting magneto ignition engines is obtained by use of an impulse coupling which disengages at operating speeds.

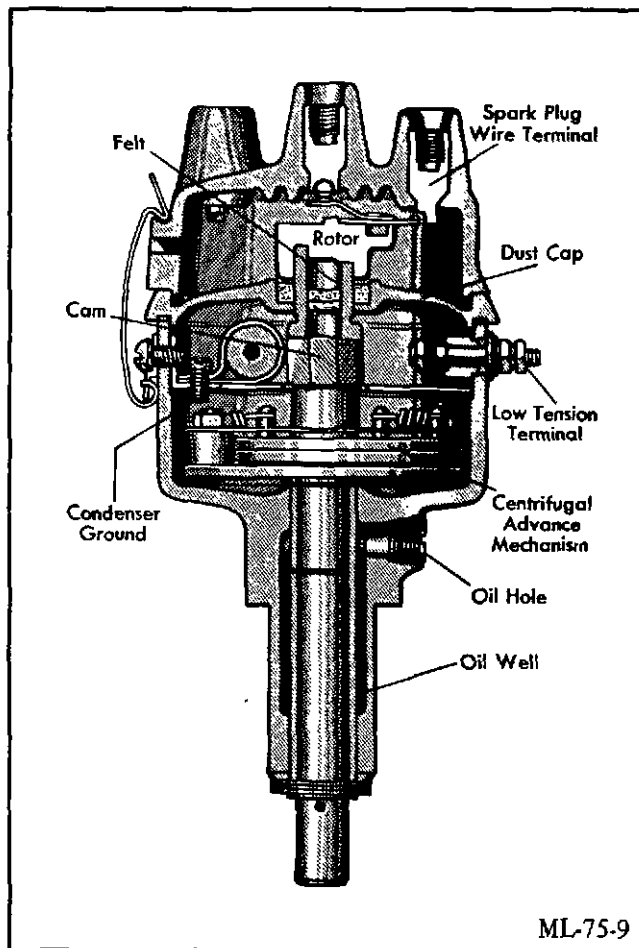

ML-75-9

TYPICAL IGNITION DISTRIBUTOR

**LUBRICATION SYSTEM**

All VR Series engines, except the VR 155 and VR 232 Gas and Diesel engines, have a gear type pump, full flow filter lubrication system. The 155 and 232 engines have a vane type pump and by-pass filtering.

The suction produced on the inlet side of the oil pump draws the oil into the floating inlet screen and conducts it to the oil pressure pump inlet. The oil is discharged under pressure at the top of the pump.

All the oil under pressure enters the full flow filter (except in the 155 and 232 Gas and Diesel engines), then passes through a passage in the crankcase directly into the main oil header which extends lengthwise along the right side of the engine. In case of excessive pressure build-up due to a clogged full flow oil filter element, a by-pass valve in the oil filter allows the oil to enter directly into the main oil header.

At the front of the gallery (gear-cover end) a pressure relief valve of the non-adjustable type controls the oil gallery pressure. Oil gallery pressure of current VRD and VRG 283 and 310 engines is controlled by the pressure relief valve in the oil pump. Drilled passages conduct the oil from the gallery to the main bearings and also to the rod bearings of all VR Series engines except the VR 155, 232, and

265 Gas engines and the VR 155 and 232 Diesel engines. Oil from the intermediate main bearing metering slots of these engines is conducted to a second gallery extending the length of the engine. This gallery has small jets located directly above the oil holes in the upper flanks of the connecting rod bearings when the connecting rods are in the proper position to receive lubrication. The outlets, or jets, meter the correct amount of oil into each of the rod bearings.

The piston pin bushings in the VR 155, 232, 265 Gas engines and the VR 155 and 232 Diesel engines are lubricated through an oiling hole in the top of the rod while the piston pin bushings of the other VR Series engines are lubricated through a drilled passage in the rod. The front and rear main bearing crankshaft journals include small pockets which index with the incoming oil passage and bridge across the journal to an outgoing oil passage. This happens for a brief portion of each revolution of the shaft.

Oil leaving the front main bearing through the passage system described above is conducted in part to a small jet just above the camshaft drive gear. This oil floods the meshing surfaces of the timing gears. This passage also connects to the governor gear lubrication passage of VR Series gasoline engines.

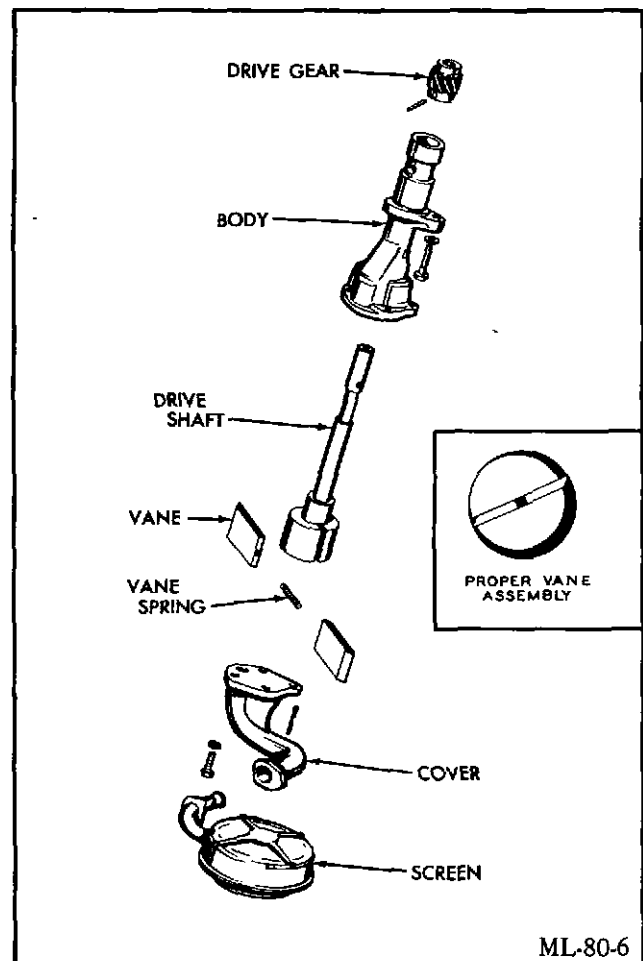

ML-80-6

TYPICAL VANE TYPE OIL PUMP

TROUBLESHOOTING

Oil leaving the outlet hole of the rear main bearing each time the pockets in the crank journal index, passes upward through drilled passages in the crankcase and cylinder head to a tube fitting on the head. From this fitting oil passes to the hollow rocker arm shaft and then to each valve in turn to provide controlled oiling of the valves and guides. Full pressure to the rocker arm shaft is provided on VRD 283 and 310 engines. Full pressure is also provided to the idler gear bushing of VR Series diesel engines.

After lubricating the rocker and valve mechanism the oil returns by gravity to the space around the push rods.

to the tappet compartment where it is collected in a large gallery located above the camshaft. Cam journals are lubricated directly from this oil gallery. Full pressure to the cam journals is provided on VRG and VRD283 and 310 engines.

**NOTE:**

Oil pressure readings should be taken at the oil gallery while engine is at governed speed. Oil temperature should be approximately 200°F.

**VR Series Oil Pressures (Average)**

ENGINE MODEL	HIGH IDLE (1500 rpm)	LOW IDLE (800 rpm)
VRG155	25-50	12 psi. min.
VRD155	25-35	12 psi. min.
VRG232	25-50	12 psi. min.
VRD232	25-35	12 psi. min.
VRG265	25-50	12 psi. min.
VRG283	25-50	12 psi. min.
VRD283	30-50	12 psi. min.
VRG310	25-50	12 psi. min.
VRD310	30-50	12 psi. min.

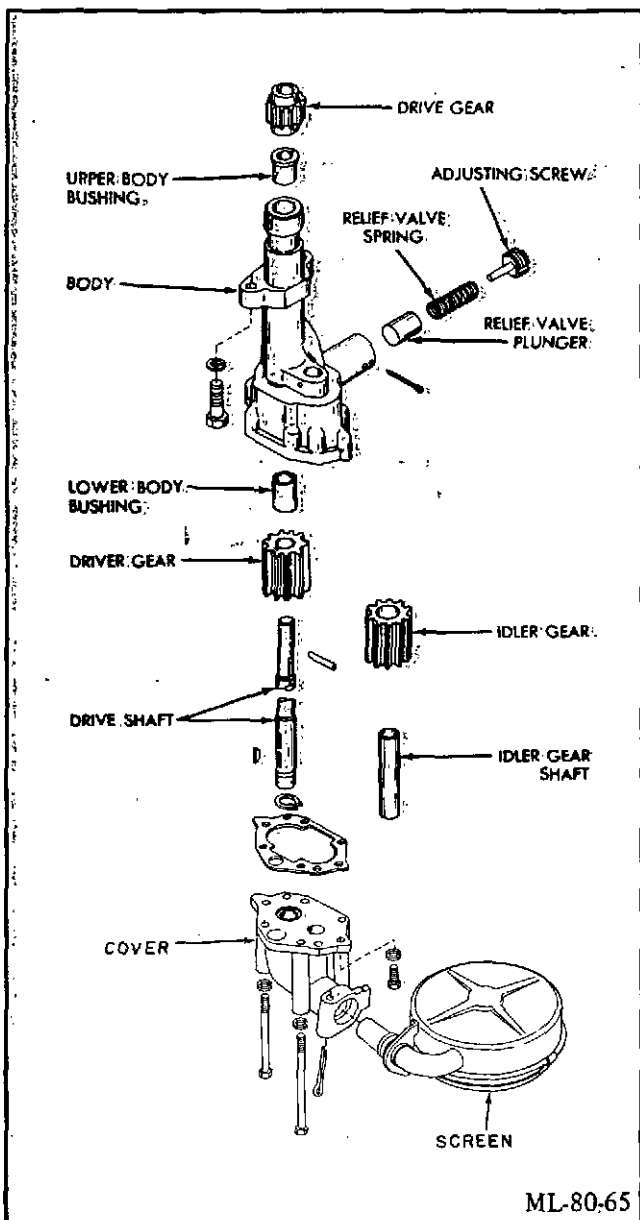

TYPICAL GEAR TYPE OIL PUMP

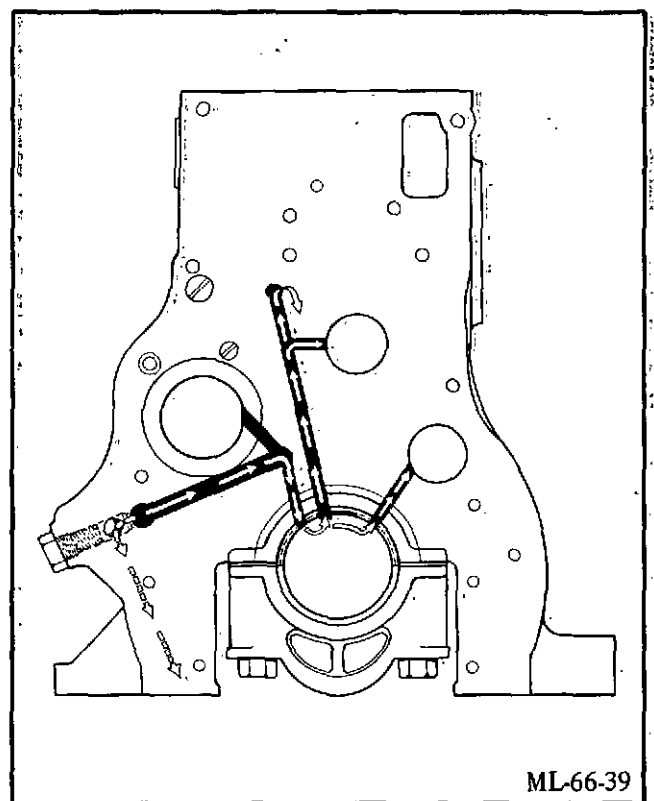

TYPICAL GEAR OILING - SCHEMATIC

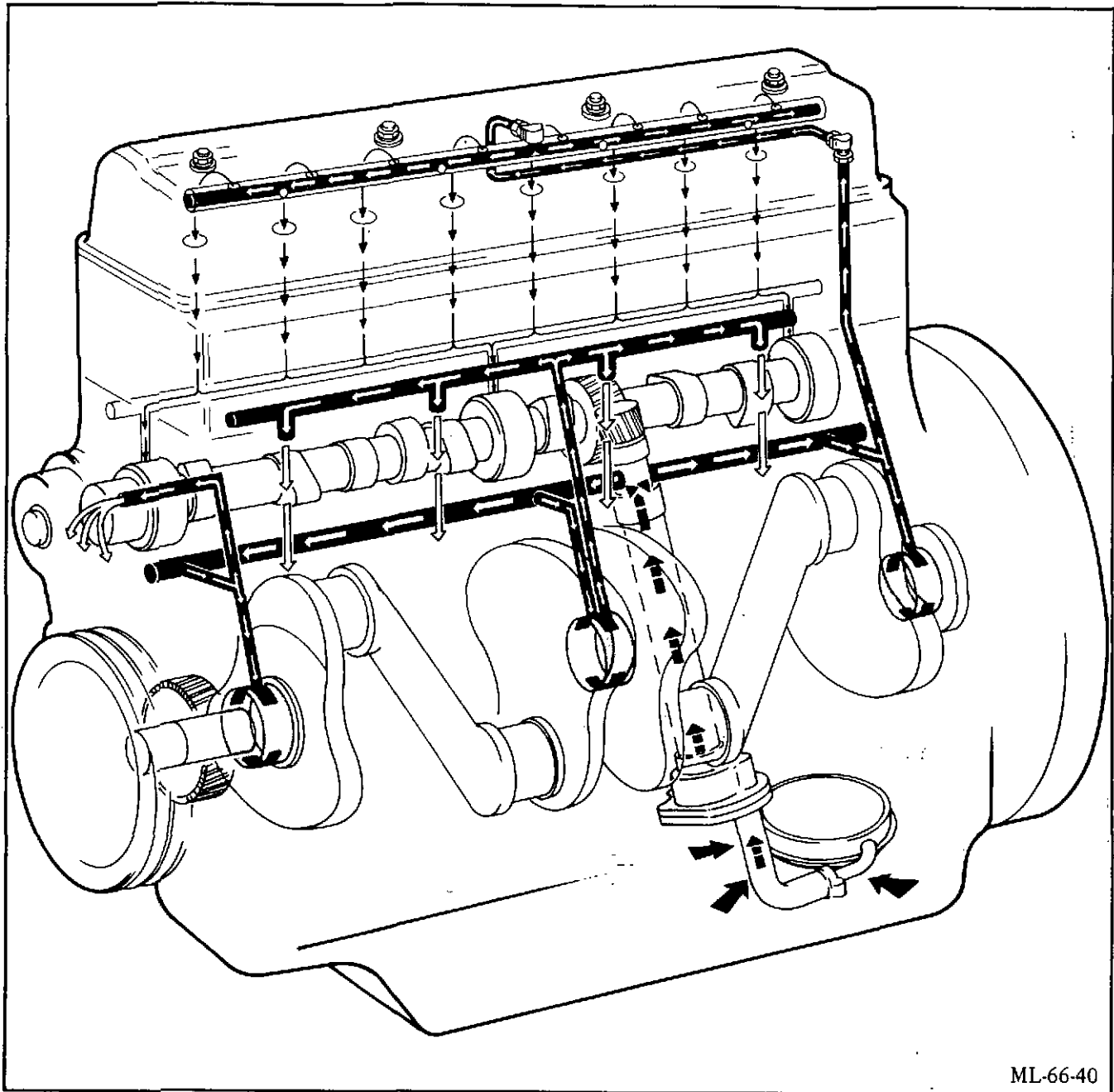

OIL SCHEMATIC - VRG 155

## GOVERNING SYSTEMS

### Injection Pump

In the centrifugal governor the movement of the flyweights against the governor thrust sleeve rotates the metering valve. This rotation varies the registry of the metering valve slot with the passage to the rotor, thus controlling the flow of fuel to the engine.

This type of governor derives its energy from the centrifugal action of the flyweights pivoting on their outer edge

of the retainer.

Centrifugal force tips them outward, moving the governor thrust sleeve against the governor arm, which pivots on the knife edge of the pivot shaft, and is connected through a simple positive linkage to the metering valve. The force on the governor arm caused by the centrifugal action of the flyweights is balanced by the compression type governor spring, which is manually controlled by the throttle shaft linkage in regulating engine speed. A light idle spring is provided for more sensitive regulation at the low speed range. The limits of throttle travel are set by adjusting screws for proper idling and high speed positions.

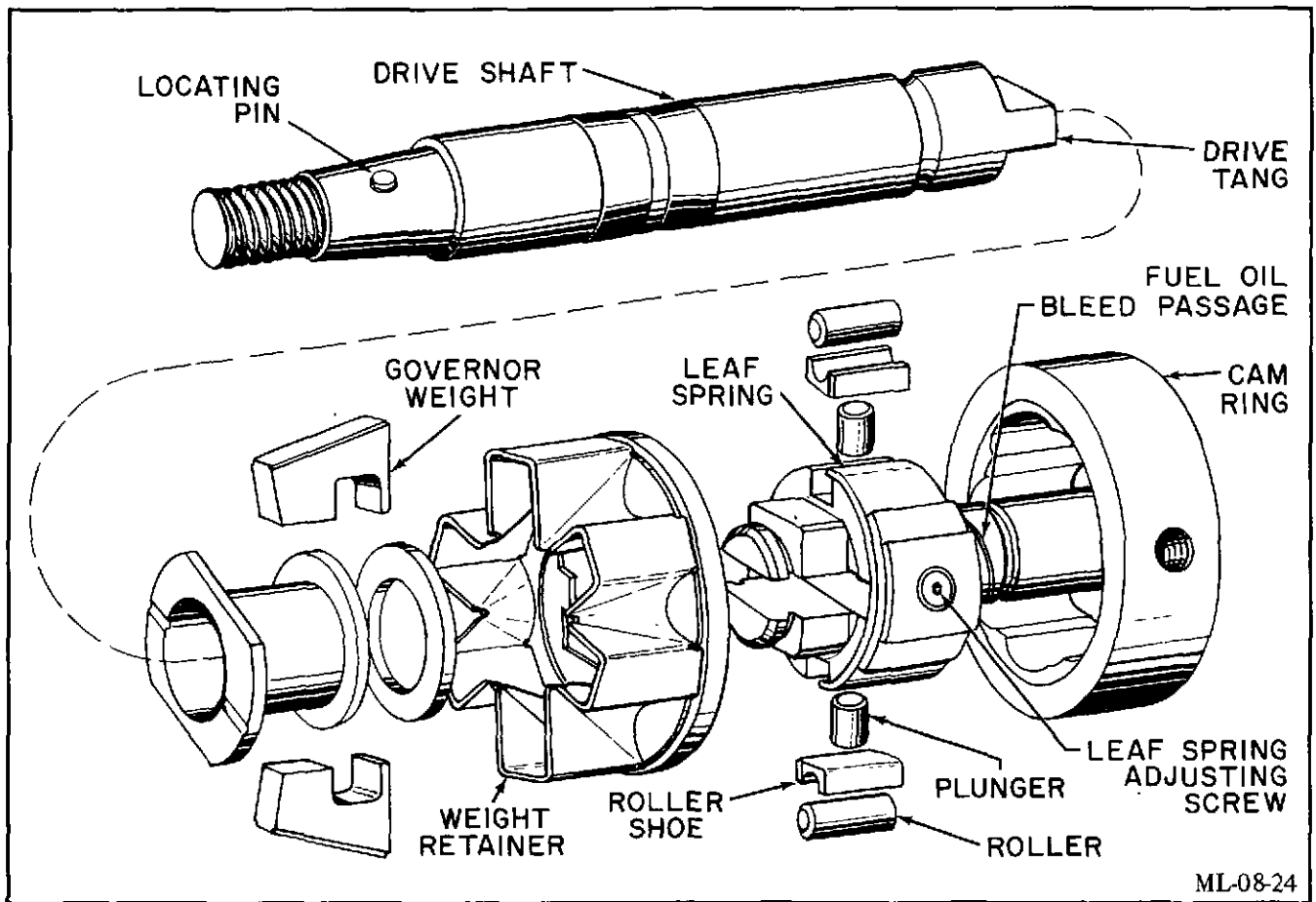

ROOSA PUMP GOVERNOR PARTS

**Mechanical Governors**

Mechanical governors used on VR gasoline engines are of the familiar centrifugal type with a variable speed "swinging spring" adaptation. Two weights, driven directly from the engine gear train, respond to variations in engine speed by moving inward or outward from the governor shaft. This movement is transmitted to the governor weight shifter lever through a pilot bearing sliding on the governor shaft. From the shifter lever the movement is carried to the throttle valve in the carburetor by a series of linkages. For example, as the engine tends to slow down under an applied load, the weights move inward due to the reduced centrifugal force. Through the linkage system, this weight movement causes the throttle valve to open and admit more fuel and air to the engine, thus restoring normal loaded speed.

The governor also acts as a protective device to prevent engine damage from overspeeding. Here, as the speed increases towards that speed established as the maximum, the weights move outward under the increased centrifugal force. This movement is opposed by the governor spring. When the force acting on the weights is balanced by the spring tension the governor linkage stabilizes. At this point the amounts of fuel and air entering the engine are held to those needed for the selected maximum speed and no more.

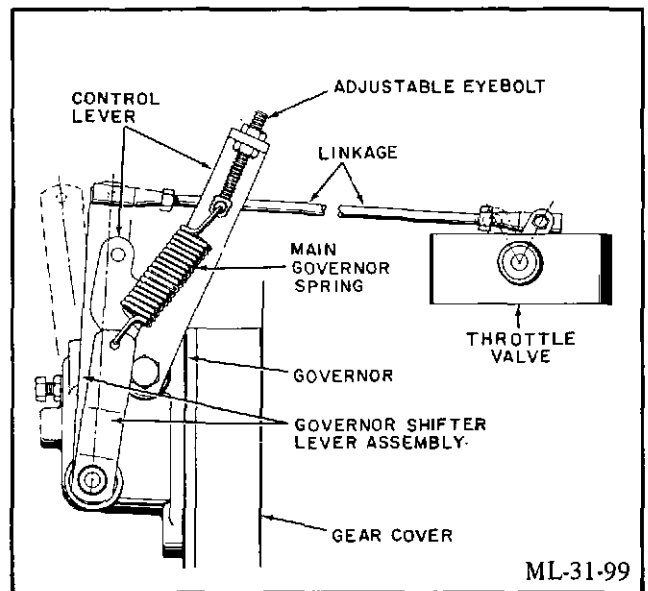

MECHANICAL GOVERNOR "SWINGING SPRING" TO BUTTERFLY VALVE AND LINKAGE

An adjustable eyebolt with locking nuts can also be used for closer regulation within the variable range.

**TROUBLE SHOOTING CHART**

SYMPTOM	PROBABLE CAUSE	REMEDY
<p>Crankshaft cannot be barred over.</p>	<p>Seized piston.</p> <p>Coolant or obstruction in cylinder:</p> <ul style="list-style-type: none"> <li>a. Cracked head.</li> <li>b. Cracked sleeve.</li> <li>c. Blown head gasket.</li> <li>d. Cracked crankcase.</li> </ul> <p>Bearings too tight:</p> <ul style="list-style-type: none"> <li>a. High spots on bearings.</li> <li>b. Improper torque.</li> <li>c. Main bearing caps installed out of location.</li> </ul> <p>Fuel in cylinder (diesels) from leaking injector.</p> <p>Load not disengaged from engine.</p>	<p><b>CAUTION: DO NOT ATTEMPT TO ROTATE CRANKSHAFT WITH STARTER.</b></p> <p>Replace piston assembly and possibly sleeve. Determine cause of seizure - insufficient ring gap, insufficient lubrication, inadequate cooling, overload.</p> <p><b>NOTE: REMOVE SPARK PLUGS OR INJECTORS TO VENT CYLINDERS OF ACCUMULATED COOLANT.</b></p> <ul style="list-style-type: none"> <li>a. Replace head.</li> <li>b. Replace sleeve.</li> <li>c. Replace head gasket.</li> <li>d. Replace crankcase.</li> </ul> <ul style="list-style-type: none"> <li>a. Replace bearings.</li> <li>b. Loosen bearing caps and re-torque.</li> <li>c. Check each bearing cap, place in proper location.</li> </ul> <p><b>NOTE: REMOVE INJECTORS TO VENT CYLINDERS OF ACCUMULATED FUEL.</b></p> <p>Replace or overhaul injector.</p> <p>Disengage load.</p>

**TROUBLESHOOTING**

TRUBLE SHOOTING CHART (Cont.)

SYMPTOM	PROBABLE CAUSE	REMEDY
<p>Engine will crank but will not start.</p>	<p>Ignition switch in OFF position or defective (gasoline engines).</p> <p>Insufficient cranking speed:</p> <ul style="list-style-type: none"> <li>a. Run-down battery or electric starter system malfunction.</li> <li>b. Lube oil viscosity too high.</li> </ul> <p>Mistimed or faulty ignition system (gasoline engines).</p> <p>Poor compression:</p> <ul style="list-style-type: none"> <li>a. Worn rings.</li> <li>b. Leaking valves.</li> <li>c. Leaking head gasket.</li> </ul> <p>Fuel shut-off control in off position (diesels).</p> <p>Fuel system inoperative:</p> <ul style="list-style-type: none"> <li>a. Air bound (diesels).</li> <li>b. Water in fuel.</li> <li>c. Insufficient fuel supply.</li> <li>d. Clogged fuel filters and strainers.</li> <li>e. Inoperative fuel supply pump.</li> <li>f. Improper timing of injection pump (diesels).</li> <li>g. Malfunctioning injectors.</li> <li>h. Ruptured line pressure regulator diaphragm (gas engines).</li> <li>i. Stiff carburetor diaphragm or worn air-gas valve assembly (gas engines).</li> </ul>	<p>Place switch in ON position - replace defective switch.</p> <ul style="list-style-type: none"> <li>a. Charge or replace battery; check starter system.</li> <li>b. Change to lower viscosity as recommended in PREVENTIVE MAINTENANCE.</li> </ul> <p>Re-time, repair or replace components as required.</p> <ul style="list-style-type: none"> <li>a. Renew rings.</li> <li>b. Recondition head and valves.</li> <li>c. Replace head gasket.</li> </ul> <p>Place fuel shut-off control in on position.</p> <ul style="list-style-type: none"> <li>a. Operate hand primer until air is expelled. Repair source of air entering into system.</li> <li>b. Drain water at strainers, filters, and fuel tank. Replace filter elements.</li> <li>c. Fill fuel tank (diesels and gasoline engines) - check gas pressure and carburetor adjustments (gas engines).</li> <li>d. Clean strainers and replace fuel filter elements.</li> <li>e. Rebuild or replace pump.</li> <li>f. Re-time injection pump.</li> <li>g. Repair or replace injectors.</li> <li>h. Replace diaphragm.</li> <li>i. Replace air-gas valve assembly.</li> </ul>

**TROUBLE SHOOTING CHART (Cont.)**

SYMPTOM	PROBABLE CAUSE	REMEDY
<p>Engine will crank but will not start (continued).</p>	<p>j. Bent line pressure regulator control rod (gas engines).</p> <p>Governor inoperative or binding control linkage:</p> <p>a. Linkage dirty.</p> <p>b. Linkage broken.</p> <p>c. Linkage pivot points.</p> <p>Poor compression:</p> <p>a. Worn rings.</p> <p>b. Leaking valves.</p> <p>c. Leaking head gaskets.</p> <p>Clogged intake air filter.</p> <p>Safety shut-down control not re-set.</p>	<p>j. Replace control rod.</p> <p>a. Clean.</p> <p>b. Repair linkage.</p> <p>c. Re-adjust or replace pivot point bearing surfaces.</p> <p>a. Renew rings.</p> <p>b. Recondition heads and valves.</p> <p>c. Replace head gaskets.</p> <p>Remove and clean.</p> <p>Re-set safety shut-down control.</p>
<p>Engine stops suddenly.</p>	<p>Fuel:</p> <p>a. Water in fuel.</p> <p>b. Air in fuel (diesels).</p> <p>c. Insufficient fuel supply.</p> <p>d. Clogged fuel strainers and filters.</p> <p>e. Loose fuel control linkage.</p> <p>f. Clogged fuel supply line.</p> <p>g. Fuel supply pump failure.</p> <p>Obstructed exhaust manifold.</p> <p>Faulty ignition system (gasoline engines).</p> <p>Clogged intake air filter.</p> <p>Engine overspeed causes safety control to shut down engine.</p> <p>Excessive load causes engine to stall.</p>	<p>a. Drain water at strainers, filters and fuel tank. Replace filter elements.</p> <p>b. Operate hand primer until air is expelled. Repair source of air entering into system.</p> <p>c. Fill tank (diesels and gasoline engines) - Check gas pressure (gas engines).</p> <p>d. Clean strainers and replace fuel filter elements.</p> <p>e. Readjust and tighten.</p> <p>f. Replace line.</p> <p>g. Repair or replace pump.</p> <p>Determine obstruction and remedy cause.</p> <p>Repair or replace components as required.</p> <p>Remove and clean.</p> <p>Determine and correct cause of overspeed.</p> <p>Determine and correct cause of overload.</p>

TROUBLESHOOTING

## TROUBLE SHOOTING CHART (Cont.)

SYMPTOM	PROBABLE CAUSE	REMEDY
<p>Engine stops suddenly (Continued).</p>	<p>Piston seizure:</p> <ul style="list-style-type: none"> <li>a. Insufficient ring gap (applicable only immediately after overhaul).</li> <li>b. Insufficient lubrication.</li> <li>c. Insufficient cooling.</li> </ul> <p>Seizure of bearings - main connecting rod, piston pin or camshaft.</p> <ul style="list-style-type: none"> <li>a. Lack of lubrication.</li> <li>b. Dirt in lube oil.</li> </ul> <p>Obstruction in cylinder.</p> <p>Low oil pressure causes safety control to shut down engine.</p> <p>High coolant temperature causes safety control to shut down engine.</p>	<ul style="list-style-type: none"> <li>a. Replace scored piston, sleeve and rings. Adjust ring gap.</li> <li>b. Replace scored piston, sleeve and rings. Clean oil passages and/or determine cause of lack of lubrication.</li> <li>c. Replace scored piston, sleeve and rings. Clean and/or fill cooling system.</li> </ul> <p>Replace bearings - clean up or replace crankshaft, camshaft, or piston pins as required.</p> <ul style="list-style-type: none"> <li>a. Check lube oil system - correct cause.</li> <li>b. Check lube oil filter.</li> </ul> <p>Replace all parts that failed.</p> <p>Inspect lubricating oil system and components - correct cause.</p> <p>Inspect cooling system and components - correct cause.</p>
<p>Engine power loss.</p>	<p>Low compression pressure:</p> <ul style="list-style-type: none"> <li>a. Leaking head gasket.</li> <li>b. Leaking exhaust; intake valves.</li> <li>c. Worn rings (excessive blow-by).</li> <li>d. Worn pistons/liner.</li> <li>e. Cracked piston.</li> <li>f. Cracked cylinder head.</li> <li>g. Misadjusted intake and exhaust valves (if recently overhauled).</li> </ul>	<ul style="list-style-type: none"> <li>a. Replace head gasket - inspect for warped cylinder head and/or crankcase - replace if necessary.</li> <li>b. Recondition head and valves.</li> <li>c. Replace rings.</li> <li>d. Replace as necessary.</li> <li>e. Replace.</li> <li>f. Replace.</li> <li>g. Adjust valves.</li> </ul>

**TROUBLE SHOOTING CHART (Cont.)**

SYMPTOM	PROBABLE CAUSE	REMEDY
<p>Engine power loss (continued).</p>	<p>Insufficient fuel:</p> <ul style="list-style-type: none"> <li>a. Dirty fuel filters or strainers.</li> <li>b. Cracked fuel lines/filters.</li> <li>c. Worn or improperly calibrated fuel injection pump (diesels).</li> <li>d. Worn fuel supply pump.</li> <li>e. Low gas pressure (gas engines).</li> <li>f. Clogged or improperly adjusted main carburetor jet (gasoline engines).</li> </ul> <p>Injectors malfunction (diesels):</p> <ul style="list-style-type: none"> <li>a. Clogged spray tip.</li> <li>b. Dirty.</li> </ul> <p>Excessive exhaust system back pressure.</p> <p>Dirty intake air filter.</p> <p>Ignition or injection system out-of-time.</p> <p>Air in fuel (diesels).</p> <p>Engine misfiring (gasoline engines):</p> <ul style="list-style-type: none"> <li>a. Incorrect carburetor or regulator adjustment.</li> <li>b. Faulty ignition system.</li> </ul>	<ul style="list-style-type: none"> <li>a. Clean strainer and replace fuel filter elements.</li> <li>b. Replace cracked line/filters.</li> <li>c. Overhaul, replace, or recalibrate.</li> <li>d. Overhaul or replace.</li> <li>e. Check gas fuel system.</li> <li>f. Clean or adjust.</li> </ul> <ul style="list-style-type: none"> <li>a. Overhaul injector, clean tip or replace.</li> <li>b. Overhaul and clean.</li> </ul> <p>Correct as required.</p> <p>Remove and clean.</p> <p>Re-time.</p> <p>Operate hand primer until air is expelled. Repair source of air entering system.</p> <ul style="list-style-type: none"> <li>a. Readjust.</li> <li>b. Repair or replace components as required.</li> </ul>

TROUBLESHOOTING

**TROUBLE SHOOTING CHART (Cont.)**

SYMPTOM	PROBABLE CAUSE	REMEDY
<p>Engine will not reach rated speed.</p>	<p>Injection or ignition not properly timed.</p> <p>Injection pump or carburetor improperly adjusted.</p> <p>Engine overloaded.</p> <p>One or more defective injectors (diesels).</p> <p>Tachometer inaccurate.</p> <p>Insufficient fuel supply.</p> <p>Governor misadjusted or faulty.</p> <p>Restricted air intake.</p>	<p>Re-time.</p> <p>Re-adjust.</p> <p>Determine and correct cause of overload.</p> <p>Replace or overhaul injectors.</p> <p>Calibrate or replace tachometer.</p> <p>Check fuel supply system.</p> <p>Readjust or repair.</p> <p>Correct cause.</p>
<p>Engine hunts or surges.</p>	<p>Misadjusted governor surge screw (gasoline engines).</p> <p>Governor linkage sticky or sloppy.</p> <p>Dirty governor.</p>	<p>Adjust.</p> <p>Remove all dirt and burrs from linkage. Realign and re-set.</p> <p>Clean or replace governor.</p>
<p>Low or fluctuating lubricating oil pressure.</p>	<p>Insufficient oil.</p> <p>Gauge inaccurate.</p> <p>Oil gauge line plugged or valve shut.</p> <p>Engine operated at angles in excess of maximum safe tilt angles.</p>	<p><b>CAUTION: SHUT DOWN ENGINE IMMEDIATELY.</b></p> <p>Add oil as required.</p> <p>Compare to master gauge - replace gauge.</p> <p>Renew gauge line/open valve.</p> <p>Operate within maximum safe tilt angles.</p>

## TROUBLE SHOOTING CHART (Cont.)

SYMPTOM	PROBABLE CAUSE	REMEDY
<p>Low or fluctuating lubricating oil pressure (continued).</p>	<p>Lubricating oil pressure regulating valve stuck in open position.</p> <p>Lube oil filter plugged.</p> <p>Worn lubricating oil pump.</p> <p>Worn bearings (connecting rod, main, and camshaft).</p> <p>Lubricating oil dilution.</p> <p>Cracked or leaking lubricating oil piping.</p> <p>Lubricating oil of low viscosity.</p> <p>Lubricating oil foaming.</p> <p>Clogged oil inlet screen.</p>	<p>Free valve.</p> <p>Change element. Clean filter.</p> <p>Repair or replace pump.</p> <p>Replace worn bearings.</p> <p>Change oil and filter element. Determine and correct source of dilution.</p> <p>Repair or replace piping.</p> <p>Change to higher viscosity oil, as recommended in PREVENTIVE MAINTENANCE.</p> <p>Use oil grade recommended in PREVENTIVE MAINTENANCE. Check for water leaks into oil.</p> <p>Remove and clean screen.</p>
<p>High lubricating oil pressure.</p>	<p>Gauge inaccurate.</p> <p>Lubricating oil temperature too low.</p> <p>Oil pressure regulating valve stuck in closed position.</p> <p>Lubricating oil of high viscosity.</p>	<p>Compare to master gauge - replace gauge.</p> <p>Raise temperature.</p> <p>Free valve.</p> <p>Change to lower viscosity oil as recommended in PREVENTIVE MAINTENANCE.</p>
<p>High fuel oil pressure (diesels).</p>	<p>Gauge inaccurate.</p> <p>Transfer pump regulating valve faulty.</p>	<p>Compare to master gauge - replace gauge.</p> <p>Repair or replace.</p>

**TROUBLE SHOOTING CHART (Cont.)**

SYMPTOM	PROBABLE CAUSE	REMEDY
<p>Low fuel oil pressure (diesels).</p>	<p>Gauge inaccurate.</p> <p>Transfer pump regulating valve faulty.</p> <p>Fuel filters and strainers clogged.</p> <p>Clogged or collapsed fuel supply line.</p> <p>Air leak on suction side of pump.</p> <p>Defective fuel supply pump.</p>	<p>Compare to master gauge - replace gauge.</p> <p>Repair or replace.</p> <p>Clean strainers and replace filter elements.</p> <p>Replace line.</p> <p>Locate and repair leak.</p> <p>Repair or replace pump.</p>
<p>Low cooling water temperature.</p>	<p>Gauge inaccurate.</p> <p>Inoperative thermostat.</p>	<p>Compare to master gauge/ replace gauge.</p> <p>Replace thermostat.</p>
<p>High cooling water temperature.</p>	<p>Gauge inaccurate.</p> <p>Cooling system is air bound.</p> <p>Low coolant level.</p> <p>Worn water pump.</p> <p>Frozen coolant.</p> <p>Engine overloaded.</p> <p>Poor coolant circulation.</p> <p>Blown head gasket.</p> <p>Insufficient circulation of air (radiator cooling).</p> <p>Cracked head.</p>	<p><b>NOTE: COOL ENGINE SLOWLY.</b></p> <p>Compare to master gauge/ replace gauge.</p> <p>Purge air from cooling system.</p> <p>Fill cooling system.</p> <p>Replace or overhaul pump.</p> <p>Completely thaw cooling system before re-starting engine.</p> <p>Determine and correct cause of overload.</p> <p>Check entire cooling system.</p> <p>Replace head gasket.</p> <p>Correct as required.</p> <p>Replace head.</p>

**TROUBLE SHOOTING CHART (Cont.)**

SYMPTOM	PROBABLE CAUSE	REMEDY
<p>High cooling water temperature (continued).</p>	<p>Cracked sleeve.</p> <p>Inoperative thermostat.</p> <p>Late ignition or injection timing.</p>	<p>Replace sleeve.</p> <p>Replace thermostat.</p> <p>Re-time.</p>
<p>High lubricating oil consumption.</p>	<p>Oil leaks in lubricating oil system.</p> <p>Improper viscosity.</p> <p>Leaking oil seal(s) - rear and/or front.</p> <p>Worn intake valve guides.</p> <p>Stuck/worn piston rings.</p> <p>One or more pistons with rings upside down (if recently overhauled).</p> <p>Excessive connecting rod bearing running clearance.</p>	<p>Find and repair leaks.</p> <p>Change to recommended viscosity for operating temperatures in PREVENTIVE MAINTENANCE.</p> <p>Change seal(s).</p> <p>Change head/renew guides, or valve stem seals.</p> <p>Renew rings.</p> <p>Remove piston - correct position of rings.</p> <p>Replace bearings.</p>
<p>Lubricating oil contaminated.</p>	<p>Lubricating oil diluted with diesel fuel:</p> <ul style="list-style-type: none"> <li>a. Injector(s) leaking.</li> <li>b. Injection pump shaft seals worn.</li> </ul> <p>Lubricating oil contaminated with water:</p> <ul style="list-style-type: none"> <li>a. Sleeve seals leaking or sleeve cracked.</li> <li>b. Cracked crankcase.</li> </ul>	<p>NOTE: CHANGE OIL.</p> <ul style="list-style-type: none"> <li>a. Replace or overhaul injector(s).</li> <li>b. Replace seals; check pilot tube for grooves in seal area.</li> </ul> <ul style="list-style-type: none"> <li>a. Replace sleeve and/or o-rings.</li> <li>b. Replace crankcase.</li> </ul>

**TROUBLESHOOTING**

**TROUBLE SHOOTING CHART (Cont.)**

SYMPTOM	PROBABLE CAUSE	REMEDY
Lubricating oil contaminated (continued).	Lubricating oil contaminated with dirt. a. Lube oil filter by-pass valve opening because element is plugged. b. Lube oil filter element punctured. c. Air intake filter punctured.	a. Replace element. b. Replace element. c. Replace air intake filter.
Excessive vibration.	Foundation bolts: a. Loose. b. Cracked.  Vibration dampener loose or failed (VRD310 only).  Unbalanced cylinders: a. One or more injectors inoperative (diesels). b. Misfiring ignition system (gasoline engines).  Crankshaft: a. Cracked. b. Main bearing bolts loose.  Loose flywheel.	NOTE: STOP ENGINE AT ONCE- INVESTIGATE CAUSE.  a. Torque. b. Replace bolts - torque all bolts.  Retorque bolts/replace dampener.  a. Replace all defective injectors. b. Repair or replace components as required.  a. Conduct a complete investigation of entire engine for damage. b. Determine reason for loosening, investigate the entire lower crank-case before torquing and subjecting engine to use.  Re-torque as required.
Blue - White exhaust (diesels).	Worn or stuck piston rings. Worn sleeves. Worn valve guides. Cracked piston.	Replace rings. Replace sleeves. Replace guides. Replace piston.

**TROUBLE SHOOTING CHART (Cont.)**

SYMPTOM	PROBABLE CAUSE	REMEDY
<p>Black Exhaust.</p>	<p>Insufficient intake air due to:</p> <p>Intake air filter clogged.</p> <p>Engine overloaded.</p> <p>Late injection or ignition timing.</p> <p>Inoperative injector (diesels).</p> <p>Low compression:</p> <p>a. Insufficient valve clearance.</p> <p>b. Burned valves.</p> <p>c. Worn/stuck rings and sleeves.</p> <p>Over-rich fuel/air mixture (gasoline engines).</p>	<p>Clean.</p> <p>Determine and correct cause of overload.</p> <p>Re-time.</p> <p>Replace or repair defective injector.</p> <p>a. Re-set valves.</p> <p>b. Replace or overhaul head.</p> <p>c. Overhaul.</p> <p>Readjust.</p>
<p>High lubricating oil temperature.</p>	<p>Gauge inaccurate.</p> <p>Engine overloaded.</p> <p>High cooling water temperature.</p> <p>Low lubricating oil pressure.</p>	<p>Compare to master gauge/replace gauge.</p> <p>Determine and correct cause of overload.</p> <p>See High Cooling Water Temperature causes.</p> <p>See Low Lubricating Oil Pressure causes.</p>
<p>Knocking or unusual noises.</p>	<p>Low octane fuel (gasoline engines) or low cetane fuel (diesels).</p> <p>Engine overload.</p>	<p>Adjust timing for gas fuel. Change to higher octane (gasoline) or cetane (diesel) fuel.</p> <p>Determine and correct cause of overload.</p>

**TROUBLESHOOTING**

## TROUBLE SHOOTING CHART (Cont.)

SYMPTOM	PROBABLE CAUSE	REMEDY
Knocking or unusual noises (continued).	<p>Overly advanced ignition or injection timing.</p> <p>Loose bearings (failed).</p> <p>Loose piston pins (failed).</p> <p>Damaged or excessively worn accessory drives.</p> <p>Excessive crankshaft end play.</p> <p>Excessive valve clearance.</p> <p>Sticking valves or rocker arms.</p> <p>Misfitted or excessively worn timing gears.</p>	<p>Re-time.</p> <p>Replace bearings.</p> <p>Replace piston pins and/or pin bushings as required.</p> <p>Repair or replace components as required.</p> <p>Replace main thrust bearing.</p> <p>Readjust valve clearance.</p> <p>Free up or replace.</p> <p>Replace.</p>
Excessive fuel consumption.	<p>Carburetors adjusted over-rich (gasoline engines).</p> <p>Excessively worn fuel injectors (diesels).</p> <p>Leaks in fuel system.</p> <p>Faulty ignition system (gasoline engines).</p> <p>Late ignition or injection timing.</p> <p>Engine overload.</p> <p>Poor compression.</p> <p>Improper matching of torque convertor to engine and load.</p>	<p>Readjust.</p> <p>Repair or replace.</p> <p>Repair as required.</p> <p>Repair or replace components as required.</p> <p>Re-time.</p> <p>Determine and correct cause of overload.</p> <p>Determine cause(s) and effect repair.</p> <p>Replace torque convertor.</p>

**TROUBLE SHOOTING CHART (Cont.)**

SYMPTOM	PROBABLE CAUSE	REMEDY
Excessive fuel consumption (continued).	Injection pump shaft seals worn and leak fuel oil into crankcase (diesels).  Injection pump improperly calibrated (diesels).	Replace seals; check pilot tube for grooves in seal area.  Recalibrate pump.
Low gas pressure (gas engines).	Incorrectly adjusted gas regulator.  Insufficient line pressure.  Incorrect orifice and/or spring in gas regulator.  Undersize gas regulator.  Undersize piping.  Gas regulator mounted too far from engine.	Readjust.  Increase line pressure.  Replace orifice and/or spring.  Replace with gas regulator of adequate size.  Replace with piping of adequate size.  Remount gas regulator as close to carburetor as possible.
High gas pressure (gas engines).	Incorrectly adjusted gas regulator.  Incorrect spring in gas regulator.  Excessive line pressure.	Readjust.  Replace spring.  Reduce line pressure.

**TROUBLESHOOTING**

# REPAIR & REPLACEMENT

CRANKCASE . . . . .	4-3
CYLINDER HEADS AND VALVES . . . . .	4-3
CYLINDER SLEEVES . . . . .	4-3
PISTONS . . . . .	4-4
CONNECTING RODS . . . . .	4-4
CRANKSHAFT . . . . .	4-4
CAMSHAFT . . . . .	4-4
PROTECTION OF ENGINE AND PARTS . . . . .	4-4
CLEANING AND INSPECTION OF ENGINE PARTS . . . . .	4-4
REPAIRING DAMAGED THREADS . . . . .	4-6
REPAIR OF DAMAGED MACHINED AND POLISHED SURFACES . . . . .	4-6
REMOVAL OF RUST OR CORROSION . . . . .	4-6
INSTALLATION OF PISTONS AND RINGS . . . . .	4-6
OIL PUMP INSTALLATION (GASOLINE ENGINES) . . . . .	4-6
WATER PUMP SEAL INSTALLATION . . . . .	4-7
WATER PUMP PULLEY INSTALLATION . . . . .	4-7
OIL PAN REMOVAL AND REPLACEMENT . . . . .	4-7
VIBRATION DAMPER REPLACEMENT . . . . .	4-7
REPLACING COOLING FAN . . . . .	4-8
INSTALLATION OF NEW VALVE LIFTERS ALONG WITH NEW CAMSHAFT . . . . .	4-8
GENERAL TORQUE RECOMMENDATIONS . . . . .	4-9
TORQUE RECOMMENDATIONS . . . . .	4-10
VR GAS AND GASOLINE TORQUE VALUES . . . . .	4-10
VR DIESEL TORQUE VALUES . . . . .	4-11
BASIC ENGINE DATA . . . . .	4-12
FITS AND CLEARANCES . . . . .	4-13 thru 4-30

REPAIR AND  
REPLACEMENT

# PARTS ORDERING

ALWAYS INCLUDE THE PART NUMBER, WHEN KNOWN, ALONG WITH THE DESCRIPTION OF THE PART, STATE THE QUANTITY OF THE PART YOU WISH TO ORDER. IF A SPECIAL PART IS NEEDED, THE ENGINE APPLICATION SHOULD ALSO BE STATED.

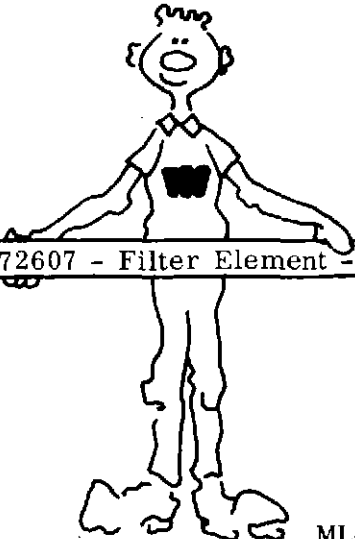

EXAMPLE: 172607 - Filter Element - (1) Ordered.

ML-1000-31

## CRANKCASE

The crankcase of the VR Series engines is a single piece iron casting incorporating three, four, or seven main-bearing supports and locations for four or six wet-type cylinder sleeves. The cooling water passages are formed between the side-wall structure of the crankcase casting and the cylinder sleeves. Thus, the sleeves are always in direct contact with the coolant. Since the cylinder sleeves are of the removable type, it is necessary to maintain a seal at the upper and lower sleeve-to-crankcase contact surfaces. This is done by the head gasket which seals the mating surfaces at the joint between the sleeve flange and the crankcase deck at the upper end, and by two rubber seal rings at the lower end of the sleeve.

The crankcase has three or four support locations for the camshaft journals. These support the camshaft at the front and rear and at one or two intermediate points. The front camshaft support of the VRD and VRG 155 and 232 and the VRG 265 engines has a pressed-in bushing. All four camshaft supports of the other VR Series engines have pressed-in bushings. Immediately above the camshaft lobes are locations for the mushroom type valve lifters.

At the rear end of the crankcase is a mounting surface for a flywheel housing and a lip type crankshaft oil seal cover. To ensure accurate mounting of the clutch or other drive unit in the flywheel housing, the rear surface of the engine is held to very close tolerances and the housing itself is machined true after the engine has been assembled. Whenever the power take-off, flywheel, or flywheel housing are removed, the run-out and eccentricity of the related parts should be checked and adjusted as required (see Installation section).

Faced mounting bosses and connections are provided at various points on the crankcase exterior for mounting accessories, lines, and other equipment selected by the engine operator. Crankcase ventilation is accomplished by a breather tube located in the valve cover.

## CYLINDER HEADS AND VALVES

The cast-iron cylinder head is designed and fabricated especially for the temperatures and pressures of industrial use. The cylinder head of VRG 283 and VRG 310 engines is of two piece construction. It is emphasized that this two piece head is factory assembled and is difficult to reassemble (see illustration). If it is necessary to disassemble this head, refer to service bulletin 7-1841 for detailed instructions.

Intake and exhaust valves are both of the poppet type with hardened tips and recesses for split-taper locks. Positive type valve rotators are used on the exhaust valves of all VRG Series engines and on the intake valves of VRD 155 and 232 engines to prevent prolonged exposure of any given area of the face to any hot spot that may have developed on the seat. All VR Series engines use intake valve stem seals, and VRD 283 and 310 engines also use exhaust valve stem seals.

The exhaust valves of all VRG Series engines and the in-

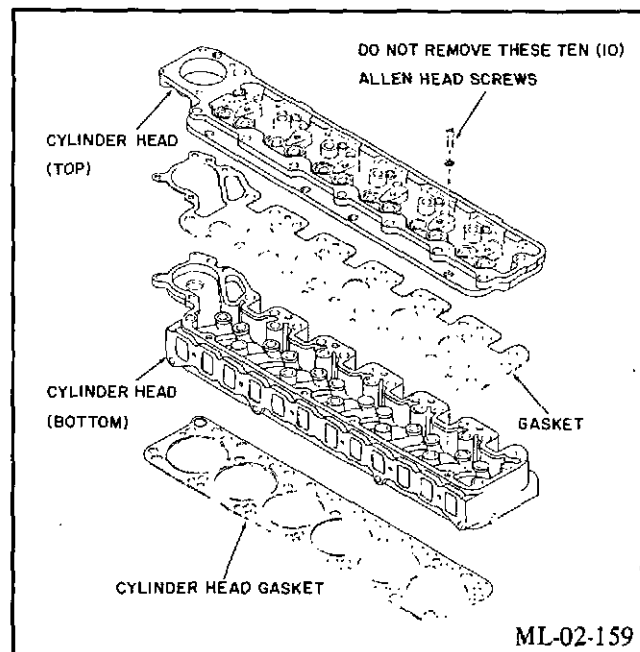

CYLINDER HEAD CONSTRUCTION  
(VRG283 AND 310 MODELS ONLY)

take valves of VRD 155 and 232 engines seat on hardened seat inserts in the cylinder heads. These inserts are shrunk and pressed into place. Intake and exhaust guides are pressed into place in the cylinder heads but may be pulled and replaced.

Valves and springs are retained by hardened washers stepped to center the springs and seating on split-taper locks.

Valve actuation is obtained through chilled and polished mushroom type valve lifters, riding directly on the camshaft. This motion is transmitted to rocker arms through tubular steel push rods equipped with hardened sockets at each end. Another socket seats in the valve lifter and receives the lower end push-rod tip.

The formed steel rocker arms pivot on a hardened hollow steel shaft. Rocker arm bushings are not replaceable. The rocker arms are curved to align with their respective intake or exhaust valve tips and to ensure long wear and accurate adjustment are hardened in the valve-tip contact area. Drilled openings along the shaft mate with passages in the rocker arms to permit lubrication of the entire overhead mechanism.

## CYLINDER SLEEVES

The wet-type cylinder sleeves are cast from iron and hardened for long wearing qualities and resistance to distortion. Each sleeve has a shoulder and flange at the upper end to locate it in the crankcase upper deck and prevent shifting and leakage when the cylinder head and gasket are secured above it. This flange, and the crankcase deck recess into which it fits, both have precision-finished mating surfaces to form a water seal in this area. The cylinder sleeve projects above the deck to insure a tight crush gasket joint. Whenever sleeves are installed, this should be checked. The lower end of the sleeve is tapered, and immediately above the taper are two grooves for the rubber seal rings. The top groove contains a red seal ring and the bottom groove a black seal ring.

## PISTONS

The aluminum alloy pistons are heavy-duty castings. The piston pins are of the full floating type and are retained in the piston by spring type clips. Two compression and one oil control ring are utilized on all pistons except VRG and VRD 155 and 232 pistons which use three compression and one oil control ring. Pistons for all VR Series engines, except VRG and VRD 155 and 232 engines, are marked with the word FRONT and an arrow, and must be installed with the arrow pointing towards the gear cover end of the engine.

## CONNECTING RODS

I-section connecting rods of the split-big-end type are used in the VR Series. The rods and caps are forged, heat-treated, and machined in one piece, then separated at the crank pin end to accommodate steel backed, precision-type bearings. Hard bronze bushings are a press fit in the piston-pin end and are burnished in place, then diamond bored for precise alignment. Connecting rods for all VR Series engines, except VRG and VRD 155 and 232 engines, are marked FRONT and should always be assembled with this mark towards the gear cover end of the engine. Model VRG and VRD 155 and 232 connecting rods are offset and must be replaced exactly as removed, with the pin ends farther apart than the journal ends for each pair of cylinders. Connecting rods are never bent for alignment purposes, neither at the factory nor in the field. Two heat-treated bolts with self-locking nuts or place type bolts retain the bearing caps in place. The upper and lower halves of connecting rod bearings are interchangeable.

## CRANKSHAFT

The crankshaft is precision ground from a heat-treated steel forging. The crankshaft has flame-hardened main-bearing journals which run in steel backed, alloy bearing shells. The upper and lower halves of the main bearings are interchangeable except for those in VRG and VRD 283 and 310 engines which are stamped "upper" and "lower". Connecting rod bearings are of similar construction for maximum serviceability.

The rear extremity of the shaft has an integral mounting flange for the flywheel. This flange is drilled and tapped for six flywheel mounting bolts. One bolt hole is offset 1/16 inch in order to ensure the installation of the flywheel in the proper relationship to the crankshaft. The front extension of the crankshaft provides a keyed mounting surface to support the crankshaft drive gear and fan pulley, which are press fitted and retained by a crank bolt.

## CAMSHAFT

The camshaft is a single casting, with ground cams and journals. Individual hardened cams actuate each of the valve

lifters. An integral worm gear drive drives the internal oil pump. The forward end of the camshaft is drilled and reamed and keyed for the retention of the cam-drive gear. Thrust and end play are absorbed by a spring loaded thrust button which rides against a thrust pad on the gear cover. Lubricating oil is supplied to each of the four journal areas. A steel backed babbitt bushing, pressed in the main crankcase, supports the camshaft at the front journal of VRG and VRD 155, 232, and the VRG265 engines, and at all four journals of all other VR Series engines.

## PROTECTION OF ENGINE AND PARTS

During all repair and replacement procedures, care should be exercised to prevent damage to parts in handling. All machined surfaces should be protected and kept separate from other parts. Parts that are easily damaged require particular care to prevent bending, denting, or breakage. All parts should be covered to protect them from dirt. This will also speed reassembly by reducing clean-up time at assembly.

When parts are removed, openings into the engine or liquid or air systems should be covered to prevent dirt or other foreign matter from entering the engine or the system involved.

## CLEANING AND INSPECTION OF ENGINE PARTS

Inspection of parts and assemblies can frequently be performed without removal or complete disassembly. Judgement should be exercised to avoid disassembly beyond that necessary to correct the fault and put the part or assembly in serviceable condition.

The following paragraphs describe cleaning procedures and, where applicable, name cleaning materials to be used if available. The different metals used in the engine and components require different techniques and materials, so a generalization of cleaning methods cannot readily be supplied.

### Carbon Removal

Carbon must be removed during maintenance operations from valves, pistons, and cylinder head.

Carbon can be removed from the hardened surfaces by softening the carbon with a suitable carbon remover. Never scrape parts with a metallic scraper.

Soften the carbon by soaking the parts in a carbon removing compound and then rinse in kerosene or hot water and remove softened carbon with a rag or soft brush.

### Castings

Clean inner and outer surfaces of castings and all areas subject to oil and grease with cleaning solvent.

Remove sludge and gum deposits with a stiff brush.

Blow out all tapped holes with compressed air and dry castings thoroughly, after cleaning, with compressed air.

### Oil Passages

Clean passages with wire brushes or probes to break up any sludge or gum deposits.

Wash passages by flushing with cleaning solvent and dry thoroughly with compressed air.

#### CAUTION

Do not use any material that will leave lint or other foreign particles when cleaning lube oil passages. Clogging or interference in passages may be caused by any foreign material. Such material would be worked into the bearings upon operating the engine.

### Oil Seals and Hoses

Clean seals and hoses with soap and water. Do not allow cleaning solvent to contact seals and hoses.

### Ball and Roller Bearings

#### CAUTION

Do not spin bearings with air.

Anti-friction bearings should receive special handling. As soon as a bearing is removed, cover it to keep out dirt and abrasives. Wash bearings in kerosene and inspect races and balls or rollers. Discard bearings if they are pitted, scored, or burned. If bearing is serviceable, coat it with light oil and wrap it in clean paper. Do not unwrap bearings until ready for installing.

Always use proper tool or fixture for pulling or pressing out bearings. Normally, it is unnecessary to remove bearings unless replacement is required.

When installing bearing against shoulder on shaft, be sure chamfered side is toward shoulder. When bearing is to be pressed in, lubricate mating surfaces prior to assembly.

### Oil Seals

Oil seals should not be removed unless absolutely necessary for gaining access to another item or unless they are to be replaced due to damage or wear. If it becomes necessary to cut through seal to remove it, care must be taken not to damage seating area around it.

Evidence of lubricant leakage around shaft or bearing is usually a sign of oil seal failure.

Oil seals that leak or are worn to a point where they may begin to leak must be replaced. An oil leak corrected in time will prevent overheated bearings resulting from loss of lubricant. Never use oil seals a second time; once removed, they must be discarded.

When possible, soak new rawhide seals in oil (120° - 125° F.) for one-half hour before installing. Install seal with wiping edge turned in direction recommended (towards area to

be sealed). Be careful not to cut leather seal as it is installed or when installing a shaft through the seal. Use shim stock if necessary to protect seal from shoulders or sharp edges during installation. Packing-type seals should always be renewed if contacting part is removed. Lubricant must be applied to lip of all shaft-type rubber seals before installation. This will prevent damage to seal during initial running until oil being sealed has contacted sealing face.

### Attaching Parts

Use screws of correct length. A screw which is too long may "bottom" before head is tight against part it is to hold. In addition, threads may be damaged when screw is removed. If a screw is too short, there will not be enough threads to hold part securely.

In addition to size variations, attaching parts may vary in material and heat treatment. Do not mix attaching parts.

Lock washers, cotter pins, or other locks should be used to lock each nut and cap screw when specified.

### Gears

Always use tools recommended (or equivalent) for removal and installation. Gears must be carefully inspected for damaged or worn teeth. Always align keyway in gear with keyway in shaft before installing. Lubricate mating surfaces of gear and shaft when pressing gear on shaft.

If crankshaft gear removal is necessary, use an appropriate heavy duty puller to remove it. Never apply heat to remove gear as this may damage crankshaft. Before installing new crankshaft gear, heat it in an oven or other even source of heat to maximum of 400°F. to facilitate installation. Do not use torch to heat gear.

#### WARNING

Use asbestos gloves when handling a hot gear.

Quickly place heated gear on crankshaft and hold it securely in place until gear cools and contracts on crankshaft. Gear may be carefully tapped into place with soft face hammer or driving tool if slight cocking or binding causes it to stick.

### Shims

Be sure to remove all shims where used. Keep shims together and identify them as to location. Keep shims clean and flat until they are reinstalled.

### Gaskets

Install gaskets where required and use new ones whenever possible. Never use cork or felt gaskets a second time. Be sure holes in gaskets correspond with lubricant passages in mating parts. If it is necessary to fabricate gaskets, select stock of proper type and thickness and be sure to cut sufficient holes in the right places. Blank or incorrectly installed gaskets can cause serious damage.

**Bushings**

Do not remove bushings unless inspection reveals damage or wear that exceeds specified clearance or if bushing is loose in its mating bore. Bushings should be pressed out whenever possible. When pressing or driving (in or out) apply pressure directly in line with bore. If bushing must be driven, use driver of largest possible diameter or bar with a smooth, flat end. Never drive bushings with a hammer. If bushing has an oil hole, be sure to line up hole in bushing with oil hole in part in which it is assembled.

**NOTE**

Service cam bushings should be installed when cam bushings need replacing. Service cam bushings are manufactured with dimensions to allow for proper bearing clearance and alignment without line reaming.

**Shafts**

If a shaft offers unexpected resistance to removal, check carefully to see that all nuts, keys and cap screws have been removed before using force. Also check possibility that another part is interfering which must be removed first. Clean rust preventive compound from all machined surfaces of new parts before installing. Shafts fitted to other parts with tapered splines are always very tight. If they are not tight when disassembled, inspect tapered splines and discard part if splines are worn. Before assembling shafts with tapered splines, be sure splines are clean, dry and free from burrs. Press mating parts together tightly.

**Flexible Hose Lines**

Fittings should be installed by threading the swivel nuts on by hand until they are finger tight. Hold the socket, on the hose behind the nut, with one wrench and tighten the swivel nut securely with another wrench. This method prevents twisting the hose and does not exert any strain on the hose. Correct installation prevents breaking of the hose plies or damaging the hose so that it may become separated or broken and leak under pressure.

**REPAIRING DAMAGED THREADS**

Damaged threads should be repaired by use of thread restorer or by chasing in lathe. Internal threads should be repaired using a tap of correct size. If threads cannot be satisfactorily repaired, install Heli-Coil or other standard insert or replace part.

**REPAIR OF DAMAGED MACHINED AND POLISHED SURFACES**

Smooth rough spots, scores, burrs, galling, and gouges from damaged machined and polished surfaces so that part will efficiently perform its normal function. Finish of repaired part is to approximate that of original finish. In performing any of these operations, critical dimensions must not be altered.

**REMOVAL OF RUST OR CORROSION**

Remove corrosion from all parts of material. To remove rust or corrosion, use brass wire brush, abrasive cloth, sand blast, vapor blast equipment, or rust remover except on highly polished surfaces. On these surfaces, buffing or use of crocus cloth is recommended.

**INSTALLATION OF PISTONS AND RINGS**

The type of oil ring used in VR Series diesel engines (except VRD 155 and 232 Models) must be installed with the spring towards the top of the piston as illustrated.

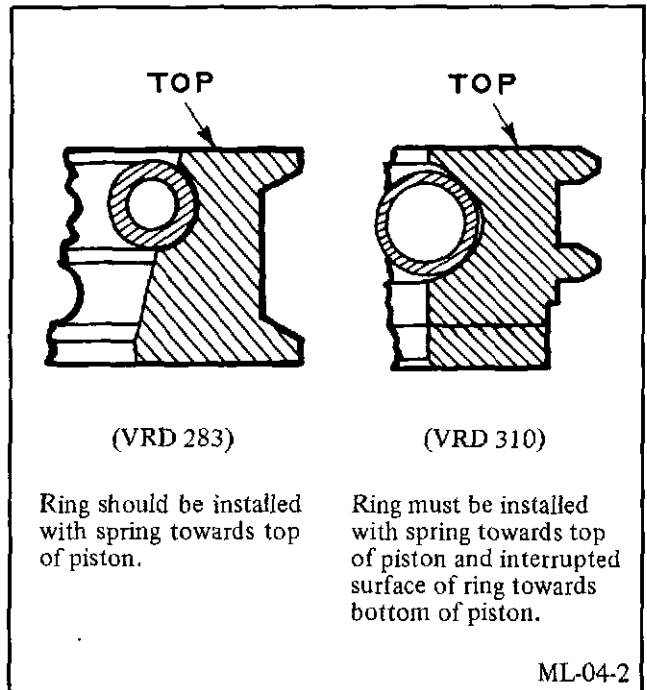

**PROPER INSTALLATION OF OFFSET SPRING OIL RING**

**CAUTION**

Do not expand rings more than is necessary to slip over the piston. Overexpansion of rings causes stress and may lead to early failure.

Compression rings of VR Series engines which are notched on the inner edge must be installed with the notch towards the top of the piston. Compression rings of VR Series engines which are notched on the outer edge must be installed with the notch towards the bottom of the piston.

All VR Series engine pistons (except VRG and VRD 155 and 232) are marked with an arrow and the word FRONT, and the pistons must be installed with the arrow pointing towards the front of the engine.

**OIL PUMP INSTALLATION (GASOLINE ENGINES)**

When the oil pump of VR Series gasoline engines is removed, it must be re-installed so the ignition drive keyway is positioned as illustrated, with the number one piston on compression stroke and the timing mark aligned.

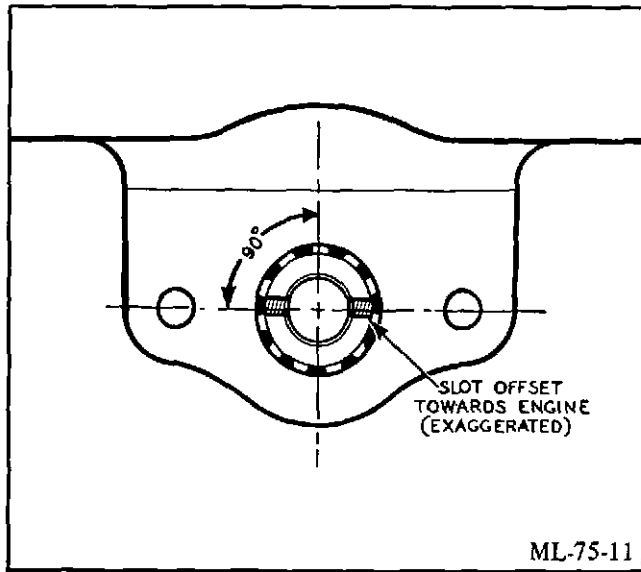

DISTRIBUTOR AND MAGNETO  
DRIVE KEYWAY

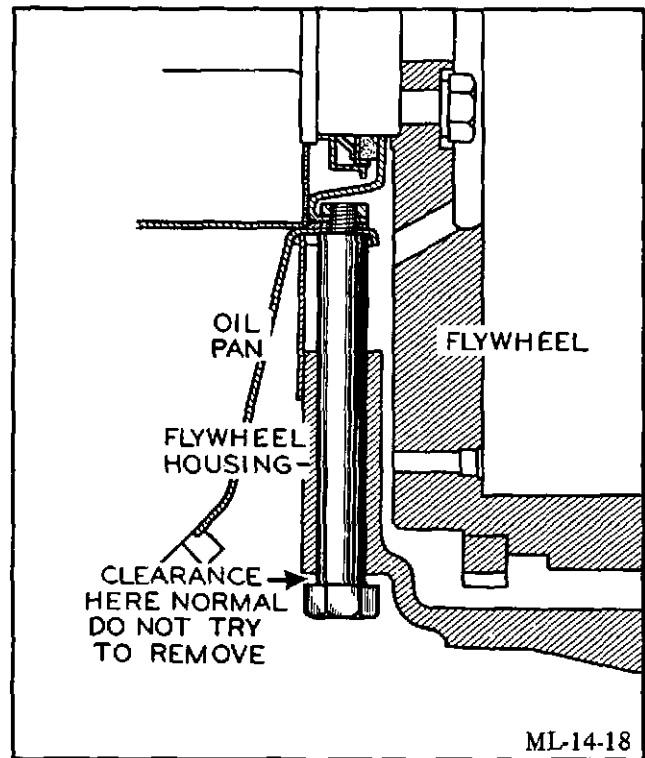

OIL PAN BOLT INSTALLATION

**WATER PUMP SEAL INSTALLATION**

When installing a new water pump seal, carefully wipe the carbon sealing surface and the mating ceramic surface with a soft cloth or absorbent paper to remove all traces of wax, grease, or oil. Use a small amount of solvent if necessary. To provide for initial lubrication of the seal, apply either a 1% soluble oil and water solution or ethylene glycol type antifreeze to both sealing faces.

**WATER PUMP PULLEY INSTALLATION**

When replacing water pump pulley it is necessary to apply locktite bearing mount to the water pump shaft before installing the old pulley. If a new pulley is used no locktite is required.

**OIL PAN REMOVAL AND REPLACEMENT**

The oil pans used on VR Series engines are held at the rear flange by two long, special bolts extending downward through the flywheel housing. This is necessary in order to provide adequate gasket pressure in this area and at the same time avoid placing the oil pan bolts in an inaccessible position. These long cap screws must be removed before removing the oil pan.

On reinstalling these cap screws it will be found that the heads do not seat on the flywheel housing. This is done to insure full pressure at the pan gasket. Attempting to seat the heads against the flywheel housing will strip the threads at the oil pan to rear oil seal joint.

**VIBRATION DAMPER REPLACEMENT**

The vibration dampers used on current VRD310 engines have radially aligned center punches on the inner and outer members. When the angular displacement between these marks equals or exceeds 1/4 inch, the damper has exceeded its useful life and should be replaced.

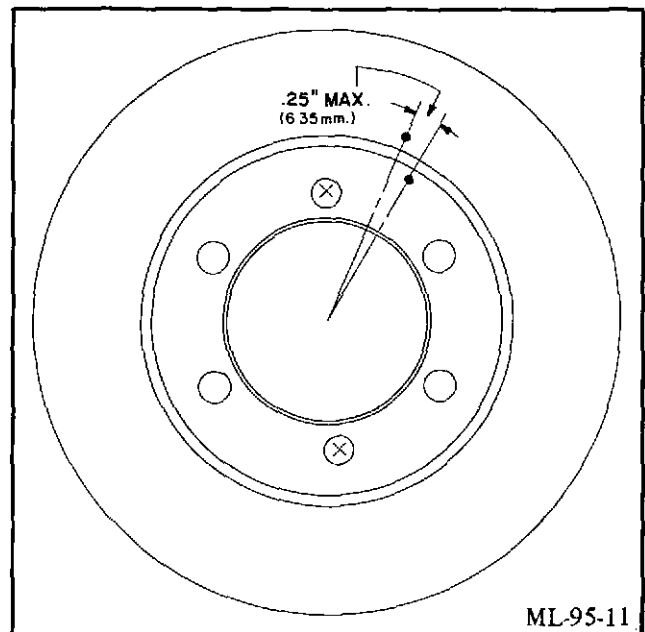

DETERMINING VIBRATION DAMPER  
REPLACEMENT

REPAIR AND  
REPLACEMENT

To replace the vibration damper, use the following procedure:

1. Remove cap screw securing crankshaft pulley to the crankshaft.
2. Using a pulling device remove crankshaft pulley from the crankshaft.
3. Remove four screws securing vibration damper to the crankshaft pulley. The two (2) dowels should remain in the crankshaft pulley.
4. Install new vibration damper on pulley and tighten bolts to 27 - 29 foot pounds (3.7 - 4.0 kgm).
5. Install pulley-damper assembly on the crankshaft and tighten crank bolt to 229 - 238 foot pounds (31.7 - 32.9 kgm).

#### REPLACING COOLING FAN

The VR Series engines are available with either a "pusher" or "suction" cooling fan. Special attention must be given to the fan blade spacer. Refer to your VR parts book for correct part numbers.

#### INSTALLATION OF NEW VALVE LIFTERS ALONG WITH NEW CAMSHAFT

When a new camshaft is installed to replace a failed or excessively worn camshaft, an entire set of new valve lifters must also be installed. The new camshaft will not be covered by warranty unless new lifters are also installed. Wear patterns on the old lifters and/or damaged old lifters can result in early failure of the new camshaft when new lifters are not installed.

**GENERAL TORQUE RECOMMENDATIONS**

The values specified below are to be used only in the absence of specified torquing instructions and are not to be construed as authority to change existing torque values. A tolerance of  $\pm 3\%$  is permissible on these values, which are for oiled threads.

HEAT TREATED MATERIAL SAE GRADE 5 & GRADE 8				
THREAD SIZE	NOTE: INCREASE VALUES 1/3 FOR DRY THREADS			
	GRADE 5 (3 radial dashes on bolt or cap screw head)		GRADE 8 (6 radial dashes on bolt or cap screw head)	
	U.S. Pounds-Feet	Metric Kgm	U.S. Pounds-Feet	Metric Kgm
1/4-20	6	0,8	9	1,2
1/4-28	7	0,9	11	1,5
5/16-18	13	1,8	18	2,5
5/16-24	15	2,1	21	2,9
3/8-16	24	3,3	34	4,7
3/8-24	27	3,7	38	5,3
7/16-14	38	5,3	54	7,5
7/16-20	42	5,8	60	8,7
1/2-13	58	7,9	82	11,3
1/2-20	65	8,9	90	12,4
9/16-12	84	11,7	120	16,6
9/16-18	93	12,9	132	18,3
5/8-11	115	15,7	165	22,8
5/8-18	130	17,9	185	25,6
3/4-10	205	28,4	290	40,1
3/4-16	230	31,8	320	44,3
7/8-9	305	42,2	455	62,9
7/8-14	335	46,3	515	71,2
1-8	455	62,9	695	96,1
1-14	510	70,5	785	108,6
1-1/8-7	610	84,4	990	136,9
1-1/8-12	685	94,7	1110	153,5
1-1/4-7	860	118,9	1400	193,6
1-1/4-12	955	132,1	1550	214,4
1-3/8-6	1130	156,3	1830	253,1
1-3/8-12	1290	178,4	2085	288,4
1-1/2-6	1500	207,5	2430	336,1
1-1/2-12	1690	233,7	2730	377,5
1-3/4-5	2370	327,8	3810	526,9
2-1/2	3550	490,9	5760	796,6

**REPAIR AND REPLACEMENT**

**TORQUE RECOMMENDATIONS**

The diagram illustrates a 6-cylinder engine head with the following details:

- Cylinder Numbers:** 1 through 6 are labeled across the top of the head.
- Head Bolt Tightening Sequence:** 14 numbered bolts are shown in a specific sequence around the head.
- Valve Locations:** Intake and Exhaust valves are labeled at the bottom of the head.
- Orientation:** The left side is labeled 'ENGINE FRONT (GEAR END)'.
- Firing Order:** 1-5-3-6-2-4

Cylinder heads should always be torqued in the proper sequence as illustrated. The first time through the torque sequence use 25 percent of the total torque value; each succeeding time through the torque sequence increase the torque setting by 25 percent of total torque value until final torque is reached. In order to be sure of proper torque, the torque sequence should again be repeated with the torque wrench set to the total torque value. Remember to retorque all replaced cylinder heads after running the engine either idle or after load testing.

TORQUING CYLINDER HEAD STUD NUTS. ILLUSTRATION ALSO SHOWS LOCATIONS OF INTAKE AND EXHAUST VALVES. THIS IS A TYPICAL 6 CYLINDER HEAD ONLY.

ML-02-88

**VR GAS AND GASOLINE TORQUE VALUES- FOOT POUNDS (Kgm)**

	VRG 155	VRG 232	VRG 265	VRG 283 AND 310
Cylinder Head Cap Screw (Solid)	112 - 117 15,5 - 16,2	92 - 100 12,7 - 13,8	112 - 117 15,6 - 16,2	129 - 133 17,9 - 18,5
Cylinder Head Cap Screw (Drilled)	96 - 100 13,3 - 13,8	92 - 100 12,7 - 13,8	96 - 100 13,3 - 13,8	129 - 133 17,9 - 18,5
Main Bearings	88 - 92 12,1 - 12,7	88 - 92 12,1 - 12,7	108 - 112 15,0 - 15,6	129 - 133 17,9 - 18,5
Connecting Rods	31 - 35 (Esna) 4,3 - 4,8	31 - 35 (Esna) 4,3 - 4,8	31 - 35 (Esna) 4,3 - 4,8	N/A
	44 - 46 (Marsden) 6,1 - 6,3	44 - 46 (Marsden) 6,1 - 6,3	44 - 46 (Marsden) 6,1 - 6,3	44 - 46 (Bolt) 6,1 - 6,3
Flywheel	67 - 69 9,2 - 9,5	67 - 69 9,2 - 9,5	67 - 69 9,2 - 9,5	67 - 69 9,2 - 9,5
Crank Bolt or Nut	75 - 85 10,4 - 11,8	75 - 85 10,4 - 11,8	75 - 85 10,4 - 11,8	75 - 85 10,4 - 11,8
Spark Plug	32 - 38 (Dry) 4,4 - 5,3	32 - 38 (Dry) 4,4 - 5,3	26 - 30 (Dry) 3,6 - 4,2	26 - 30 (Dry) 3,6 - 4,2
	24 - 28 (Oil) 3,3 - 3,9	24 - 28 (Oil) 3,3 - 3,9	20 - 23 (Oil) 2,7 - 3,2	20 - 23 (Oil) 2,7 - 3,2

## VR DIESEL TORQUE VALUES - FOOT POUNDS (Kgm)

	VRD 155	VRD 232	VRD 283	VRD 310
Cylinder Head	112 - 117 (Solid) 15,5 - 16,2	96-100 13,3-13,8	125-133 17,3 - 18,4	210 (Center 10) 29,1
	96 - 100 (Hollow) 13,3 - 13,8			133 (End 4) 18,5
Main Bearings	88 - 92 12,1 - 12,7	88 - 92 12,1 - 12,7	129 - 133 17,9 - 18,4	129 - 133 17,9 - 18,4
Connecting Rods	31 - 35 (Esna) 4,3 - 4,8	31 - 35 (Esna) 4,3 - 4,8	N/A	N/A
	44 - 46 (Marsden) 6,1 - 6,3	44 - 46 (Marsden) 6,1 - 6,3	44 - 46 (Bolt) 6,1 - 6,3	44 - 46 (Bolt) 6,1 - 6,3
Flywheel	67 - 69 9,2 - 9,5	67 - 69 9,2 - 9,5	67 - 69 9,2 - 9,5	67 - 69 9,2 - 9,5
Crank Bolt	75 - 85 10,4 - 11,8	75 - 85 10,4 - 11,8	75 - 85 10,4 - 11,8	229 - 238 31,7 - 32,9
Fuel Injector	12 - 17 1,7 - 2,4	12 - 17 1,7 - 2,4	10 - 11 1,4 - 1,5	10 - 11 1,4 - 1,5
Energy Cell	96 - 100 13,6 - 13,8	96 - 100 13,3 - 13,8	N/A	N/A
Injection Pump Lock Nut	35 - 40 4,8 - 5,5	35 - 40 4,8 - 5,5	35 - 40 4,8 - 5,5	35 - 40 4,8 - 5,5
Vibration Damper	N/A	N/A	N/A	27 - 29 3,7 - 4,0

\*NOTE: ALL TORQUE VALUES ARE BASED ON OILED THREADS UNLESS SPECIFIED AS DRY.

**BASIC ENGINE DATA**

	VRG 155 VRD 155	VRG 232 VRD 232	VRG 265	VRG 283 VRD 283	VRG 310 VRD 310
Number of Cylinders	4	6	6	6	6
Compression Ratio	8.0:1 (Gas) 16.5:1 (Diesel)	8.0:1 (Gas) 16.5:1 (Diesel)	8.5:1 (Gas) 16.7:1 (Diesel)	8.5:1 (Gas) 16.7:1 (Diesel)	8.5:1 (Gas) 16.0:1 (Diesel)
Firing Order	1-2-4-3	1-5-3-6-2-4	1-5-3-6-2-4	1-5-3-6-2-4	1-5-3-6-2-4
Number of Main Bearings	3	4	4	7	7
Engine Length	31 1/2" 800,1mm	42 1/4" 1073,2mm	44" 1117,6mm	44" 1117,6mm	44" 1117,6mm
Engine Width	17 - 1/2" 444,5 mm	20 - 1/4" 514 mm	20 - 1/4" 514 mm	20 - 1/4" 514 mm	20 - 1/4" 514 mm
Engine Height	21 - 1/2" 546,1 mm	37 1/2" 952 mm	39" 990 mm	39" 990 mm	39" 990 mm
Crankcase Capacity (Including Filter)	6 - 1/2 qts 7.4 liters	11 - 1/2 qts 13 liters	11 - 1/2 qts 13 liters	11 - 1/2 qts 13 liters	11 - 1/2 qts 13 liters
Cylinder Compression at Cranking Speed	170 - 195 psi (Gas) 11,95 - 13,7 kg/cm <sup>2</sup> 340 - 360 psi (Diesel) 23,9 - 25,3 kg/cm <sup>2</sup>	170 - 195 psi (Gas) 11,95 - 13,7 kg/cm <sup>2</sup> 340 - 360 psi (Diesel) 23,9 - 25,3 kg/cm <sup>2</sup>	185 - 205 psi (Gas) 13,0 - 14,4 kg/cm <sup>2</sup> N/A	185 - 205 psi (Gas) 13,0 - 14,4 kg/cm <sup>2</sup> 340 - 360 psi (Diesel) 23,9 - 25,3 kg/cm <sup>2</sup>	185 - 205 psi (Gas) 13,0 - 14,4 kg/cm <sup>2</sup> 340 - 360 psi (Diesel) 23,9 - 25,3 kg/cm <sup>2</sup>
Distributor Point Gap (Holly-except VRG155)	.021" - .023" 0,53mm-0,58mm (Delco-Remy)	.023 - .026" 9,58 - 0,66mm	.023 - .026" 0,58 - 0,66mm	.023 - .026" 0,58 - 0,66mm	.023 - .026" 0,58 - 0,66mm
(Mallory)	N/A	Approx. .022" 0,56mm	Approx. .022" 0,56 mm	Approx. .022" 0,56mm	Approx. .022" 0,56mm
Distributor Dwell Angle (Holly-except VRG155)	31° - 34° (Delco-Remy)	33 - 38°	33 - 38°	33 - 38°	33 - 38°
(Mallory)	N/A	32-36°	32-36°	32-36°	32-36°
Magneto Point Gap	N/A	.014 - .016" 0,36 - 0,40mm	.014 - .016" 0,36 - 0,40mm	.014 - .016" 0,36 - 0,40mm	.014 - .016" 0,36 - 0,40mm
Injection Pump Timing	4° BTDC	2° ATDC	4° BTDC	4° BTDC	4° BTDC
Valve Clearance Cold (Intake)	.011 - .013" 0,28 - 0,33mm	.011 - .013" 0,28 - 0,33mm	.019 - .021" 0,48 - 0,53mm	.019 - .021" (Gas)0,48 - 0,53 .029 - .031" (Diesel)0,74-0,79	.019 - .021" (Gas) 0,48 - 0,53 .029 - .031" (Diesel)0,74-0,79
Valve Clearance - Cold (Exhaust)	.019 - .021" 0,48 - 0,53mm	.019 - .021" 0,48 - 0,53mm	.029 - .031" 0,74 - 0,79 mm	.029 - .031" (Gas) 0,74 - 0,79 .029 - .031" (Diesel)0,74-0,79	.029 - .031" (Gas) 0,74 - 0,79 .029 - .031" (Diesel)0,74-0,79
Injector Nozzles Release Pressure	1975 psi (New) 138.8 kg per sq. centimeter	1975 psi (New) 138.8 kg per sq. centimeter	N/A	2800 psi (New) 224.9 kg per sq. centimeter	3200 psi (New) 224.9 kg per sq. centimeter
	1800 psi (Service) 126.5 kg per sq. centimeter	1800 psi (Service) 126.5 kg per sq. centimeter	N/A	2600 psi (Service) 210.9 kg per sq. centimeter	3000 psi (Service) 210.9 kg per sq. centimeter

NOTE: Additional Basic Engine Data is located in front of manual.

# FITS AND CLEARANCES

ILLUSTRATIONS FOUND IN THIS SECTION ARE FOR THE LOCATION OF MEASUREMENTS ONLY. THEY ARE NOT INTENDED TO BE ACCURATE REPRESENTATIONS OF THE PARTS INVOLVED.

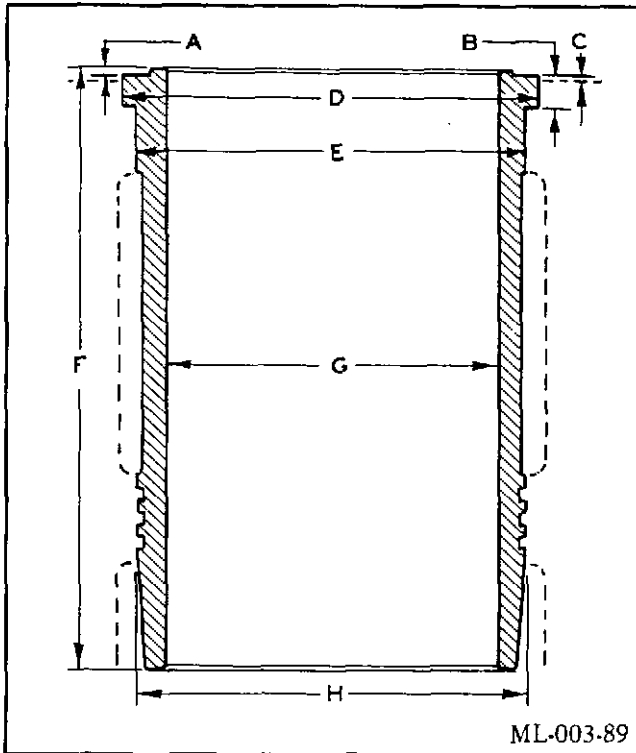

ML-003-89

TYPICAL CYLINDER SLEEVE

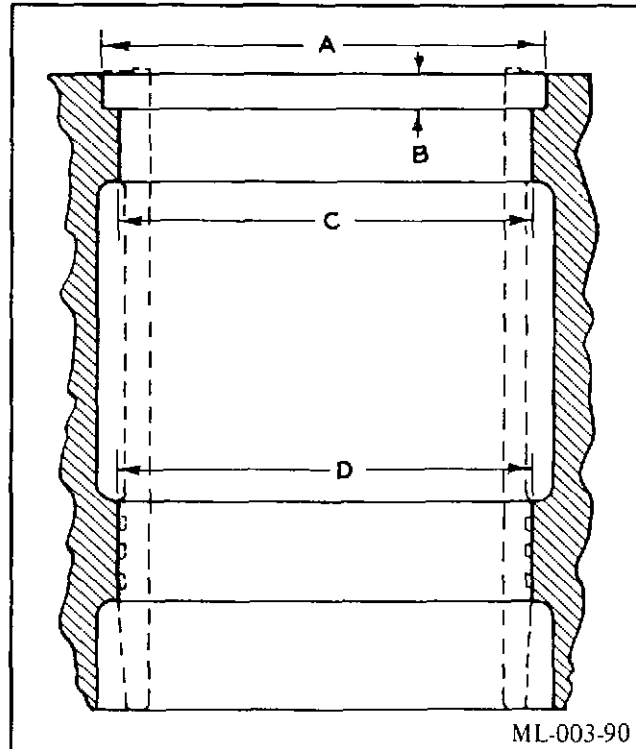

ML-003-90

TYPICAL SECTION THROUGH CRANKCASE

## VRG FITS AND CLEARANCES

	VRG 155	VRG 232	VRG 265	VRG 283/310
<b>CYLINDER SLEEVES</b>				
(A) Heat Dam Projection	--	--	--	.030 - .034 0,762 - 0,863
(B) Flange Height	.251 - .252 6,375 - 6,400	.251 - .252 6,375 - 6,400	.251 - .252 6,375 - 6,400	.251 - .252 6,375 - 6,400
(C) Sleeve Projection Above Crankcase	.001 - .004 0,025 - 0,101	.001 - .004 0,025 - 0,101	.001 - .004 0,025 - 0,101	.001 - .004 0,025 - 0,101
(D) Flange Diameter	4.3100 - 4.3085 109,474 - 109,423	4.3100 - 4.3085 109,474 - 109,423	4.5600 - 4.5585 115,824 - 115,773	4.5600 - 4.5585 115,824 - 115,773
(E) Sleeve Diameter Below Flange	4 - 3/32" 104 mm	4 - 3/32" 104 mm	4 - 11/32" 110 mm	4 - 11/32" 110 mm
(F) Sleeve Length Less Heat Dam	7 - 1/16" 179 mm	7 - 1/16" 179 mm	7 - 5/16" 186 mm	7 - 7/16" 189 mm
(G) Sleeve Bore Diameter ("B" size only)	3.6253 - 3.6257 92,082 - 92,092	3.6253 - 3.6257 92,082 - 92,092	3.7503 - 3.7507 95,257 - 95,267	3.8753 - 3.8757 98,432 - 98,442
(H) Sleeve Diameter Lower Seal Area	4.0290 - 4.0275 102,336 - 102,298	4.0290 - 4.0275 102,336 - 102,298	4.2790 - 4.2775 108,686 - 108,648	4.2800 - 4.2785 108,712 - 108,673
Sleeve Bore Maximum Out-of-Round	.002" 0,050 mm	.002" 0,050 mm	.002" 0,050 mm	.002" 0,050 mm
Sleeve Bore Maximum Taper	.002" 0,050 mm	.002" 0,050 mm	.002" 0,050 mm	.002" 0,050 mm
Sleeve Seal Area to Crankcase Clearance	.0045 - .002" 0,114 - 0,050 mm	.0045 - .002" 0,114 - 0,050 mm	.0045 - .002" 0,114 - 0,050 mm	.0035 - .001" 0,088 - 0,025 mm

REPAIR AND REPLACEMENT

## VRD FITS AND CLEARANCES

	VRD 155	VRD 232	VRD 283	VRD 310
<b>CYLINDER SLEEVES</b>				
(A) Heat Dam Projection	--	--	.030 - .034 0,762 - 0,863	.030 - .034 0,762 - 0,863
(B) Flange Height	.251 - .252 6,375 - 6,400	.251 - .252 6,375 - 6,400	.251 - .252 6,375 - 6,400	.251 - .252 6,375 - 6,400
(C) Sleeve Projection Above Crankcase	.001 - .004 0,025 - 0,101	.001 - .004 0,025 - 0,101	.001 - .004 0,025 - 0,101	.001 - .004 0,025 - 0,101
(D) Flange Diameter	4,3100 - 4,3085 109,474 - 109,423	4,3100 - 4,3085 109,474 - 109,423	4,5600 - 4,5585 115,824 - 115,773	4,5600 - 4,5585 115,824 - 115,773
(E) Sleeve Diameter Below Flange	4 - 3/32 104	4 - 3/32 104	4 - 11/32 110	4 - 11/32 110
(F) Sleeve Length Less Heat Dam	7 - 1/16 179	7 - 1/16 179	7 - 7/16 189	7 - 7/16 189
(G) Sleeve Bore Diameter ("B" size only)	3.6253 - 3.6257 92,082 - 92,092	3.6253 - 3.6257 92,082 - 92,092	3.8753 - 3.8757 98,432 - 98,442	3.8753 - 3.8757 98,432 - 98,442
(H) Sleeve Diameter Lower Seal Area	4.0290 - 4.0275 102,336 - 102,298	4.0290 - 4.0275 102,336 - 102,298	4.2800 - 4.2785 108,712 - 108,673	4.2800 - 4.2785 108,712 - 108,673
Sleeve Bore Maximum Out-of-Round	.002 0,050	.002 0,050	.002 0,050	.002 0,050
Sleeve Bore Maximum Taper	.002 0,050	.002 0,050	.002 0,050	.002 0,050
Sleeve Seal Area to Crankcase Clearance	.0045 - .002 0,114 - 0,050	.0045 - .002 0,114 - 0,050	.0035 - .001 0,088 - 0,025	.0035 - .001 0,088 - 0,025

## VRG FITS AND CLEARANCES

	VRG 155	VRG 232	VRG 265	VRG 283/310
<b>CRANKCASE</b>				
(A) Sleeve Counterbore Diameter	4.312 - 4.314 109,524 - 109,575	4.312 - 4.314 109,524 - 109,575	4.562 - 4.563 115,874 - 115,900	4.562 - 4.563 115,874 - 115,900
(B) Sleeve Counterbore Depth	.250 - .248 6,35 - 6,299	.250 - .248 6,35 - 6,299	.250 - .248 6,35 - 6,299	.250 - .248 6,35 - 6,299
(C) Crankcase Upper Bore	4.1255 - 4.1245 104,787 - 104,762	4.1255 - 4.1245 104,787 - 104,762	4.3755 - 4.3745 111,137 - 111,112	4.370 - 4.3800 110,998 - 111,252
(D) Crankcase Lower Bore	4.031 - 4.032 102,387 - 102,412	4.031 - 4.032 102,387 - 102,412	4.281 - 4.282 108,737 - 108,762	4.281 - 4.282 108,737 - 108,762
Crankcase Main Bearing Journal Bore	2.4210 - 2.4215 61,493 - 61,506	2.4210 - 2.4215 61,493 - 61,506	2.8175 - 2.8165 71,564 - 71,539	2.8175 - 2.8165 71,564 - 71,539
Crankcase Camshaft Bearing Bore (No. 1)	1.8745 - 1.8755 47,612 - 47,637	1.8745 - 1.8755 47,612 - 47,637	1.8745 - 1.8755 47,612 - 47,637	1.8745 - 1.8755 47,612 - 47,637
Crankcase Camshaft Bearing Bore (Nos. 2, 3, & 4)	1.7515 - 1.7520 44,488 - 44,500	1.7515 - 1.7520 44,488 - 44,500	1.7515 - 1.7520 44,488 - 44,500	1.8745 - 1.8755 47,612 - 47,637

VRD FITS AND CLEARANCES

	VRD 155	VRD 232	VRD 283	VRD 310
<b>CRANKCASE</b>				
(A) Sleeve Counterbore Diameter	4.312 - 4.314 109,524 - 109,575	4.312 - 4.314 109,524 - 109,575	4.562 - 4.563 115,874 - 115,900	4.562 - 4.563 115,874 - 115,900
(B) Sleeve Counterbore Depth	.250 - .248 6,350 - 6,299	.250 - .248 6,350 - 6,299	.250 - .248 6,350 - 6,299	.250 - .248 6,350 - 6,299
(C) Crankcase Upper Bore	4.1255 - 4.1245 104,787 - 104,762	4.1255 - 4.1245 104,787 - 104,762	4.370 - 4.3800 110,998 - 111,252	4.370 - 4.3800 110,998 - 111,252
(D) Crankcase Lower Bore	4.031 - 4.032 102,387 - 102,412	4.031 - 4.032 102,387 - 102,412	4.281 - 4.282 108,737 - 108,762	4.281 - 4.282 108,737 - 108,762
Crankcase Main Bearing Journal Bore	2.4210 - 2.4215 61,493 - 61,506	2.4210 - 2.4215 61,493 - 61,506	2.8175 - 2.8165 71,564 - 71,539	2.8175 - 2.8165 71,564 - 71,539
Crankcase Camshaft Bearing Bore (No. 1)	1.8745 - 1.8755 47,612 - 47,637	1.8745 - 1.8755 47,612 - 47,637	1.8745 - 1.8755 47,612 - 47,637	1.8745 - 1.8755 47,612 - 47,637
Crankcase Camshaft Bearing Bore (Nos. 2, 3, & 4)	1.7515 - 1.7520 44,488 - 44,500	1.7515 - 1.7520 44,488 - 44,500	1.8745 - 1.8755 47,612 - 47,637	1.8745 - 1.8755 47,612 - 47,637

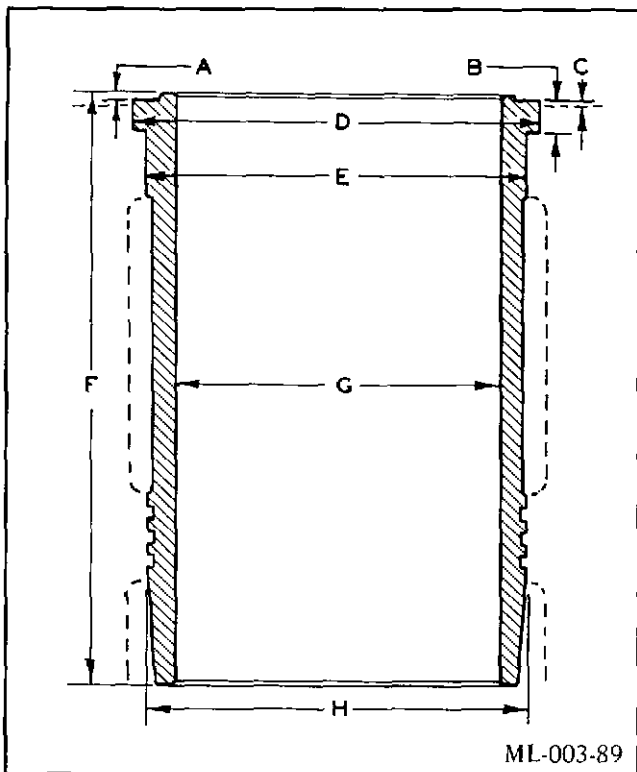

TYPICAL CYLINDER SLEEVE

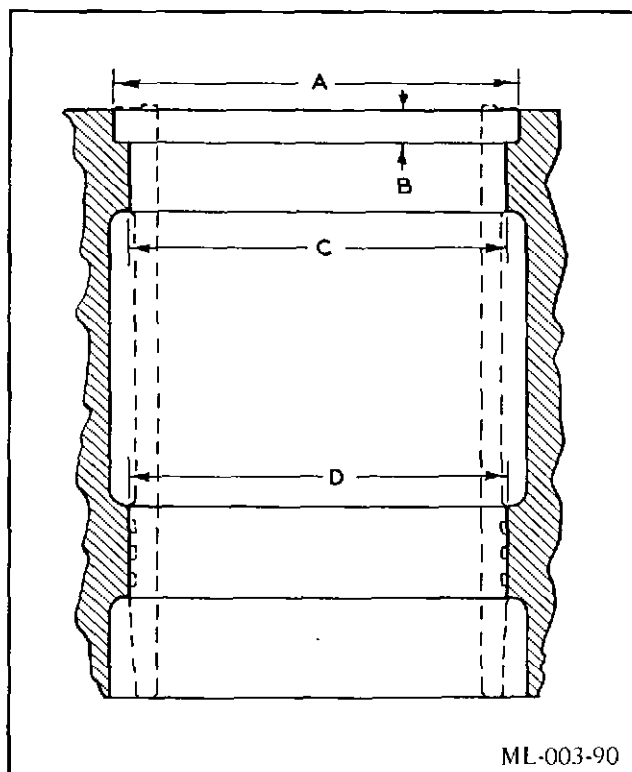

TYPICAL SECTION THROUGH CRANKCASE

REPAIR AND REPLACEMENT

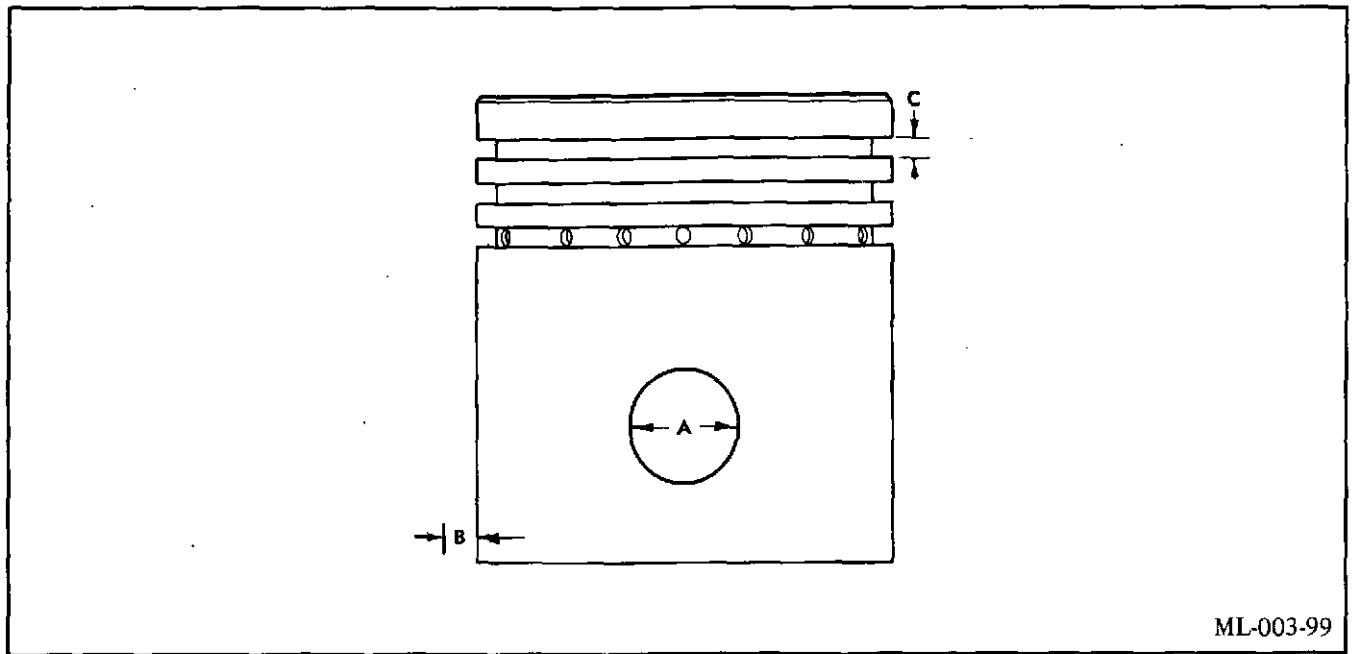

ML-003-99

TYPICAL PISTON

VRD FITS AND CLEARANCES

	VRD 155	VRD 232	VRD 283	VRD 310
<b>PISTON AND PIN</b>				
Piston Pin Diameter	1.2494 - 1.2496 31,734 - 31,739	1.2494 - 1.2496 31,734 - 31,739	1.2495 - 1.2497 31,737 - 31,742	1.2495 - 1.2497 31,737 - 31,742
Piston Skirt Diameter ("B" size only)	3.6229 - 3.6245 92,022 - 92,062	3.6229 - 3.6245 92,022 - 92,062	3.8713 - 3.8727 98,331 - 98,366	3.8703 - 3.8717 98,306 - 98,341
Piston Pin Fit (Room Temp.)	.0001 - .0006 0,002 - 0,015	.0001 - .0006 0,002 - 0,015	.0002 - .0007 0,005 - 0,017	.0002 - .0007 0,005 - 0,017
Weight Variation	737 ± 3 grams per piston	737 ± 3 grams per piston	1185 ± 5 grams per piston	1073 ± 5 grams per piston
(A) Piston Pin Hole Bore	1.2497 - 1.2500 31,742 - 31,750	1.2497 - 1.2500 31,742 - 31,750	1.2499 - 1.2502 31,747 - 31,755	1.2499 - 1.2502 31,747 - 31,755
(B) Piston Skirt to Sleeve Clearance	.0008 - .0028 0,020 - 0,071	.0008 - .0028 0,020 - 0,071	.0026 - .0044 0,066 - 0,111	.0036 - .0054 0,091 - 0,137
(C) Groove Width	-Top	.096 - .097 2,438 - 2,463	.096 - .097 2,438 - 2,463	.096 - .097 2,438 - 2,463
	-2nd	.096 - .095 2,438 - 2,413	.096 - .095 2,438 - 2,413	.0955 - .0965 2,425 - 2,451
	-3rd	.096 - .095 2,438 - 2,413	.096 - .095 2,438 - 2,413	.188 - .189 4,775 - 4,800
	-4th	.188 - .189 4,775 - 4,800	.188 - .189 4,775 - 4,800	--

**VRG FITS AND CLEARANCES**

	VRG 155	VRG 232	VRG 265	VRG 283/310
<b>PISTON AND PIN</b>				
Piston Pin Diameter	1.2494 - 1.2496 31,734 - 31,739	1.2494 - 1.2496 31,734 - 31,739	1.2495 - 1.2497 31,737 - 31,742	1.2495 - 1.2497 31,737 - 31,742
Piston Skirt Diameter ("B" size only)	3.6229 - 3.6245 92,022 - 92,062	3.6229 - 3.6245 92,022 - 92,062	3.7478 - 3.7482 95,194 - 95,204	3.8728 - 3.8732" (283) 3.8718 - 3.8732" (310) 98,344 - 98,379 mm
Piston Pin Fit (Room Temp.)	.0001 - .0006 0,002 - 0,015	.0001 - .0006 0,002 - 0,015	.0001 - .0005 0,002 - 0,012	.0002 - .0007 0,005 - 0,017
Weight Variation	737 ± 3 grams per piston	737 ± 3 grams per piston	828 ± 4 grams per piston	1113 ± 4 grams per piston
(A) Piston Pin Hole Bore	1.2497 - 1.2500 31,742 - 31,750	1.2497 - 1.2500 31,742 - 31,750	1.2497 - 1.2500 31,742 - 31,750	1.2499 - 1.2502 31,747 - 31,755
(B) Piston Skirt to Sleeve Clearance	.0008 - .0028 0,020 - 0,071	.0008 - .0028 0,020 - 0,071	.0021 - .0029 0,053 - 0,073	.0021 - .0029" (283) .0021 - .0039" (310) 0,053 - 0,099 mm
(C) Groove Width	-Top	.096 - .097 2,438 - 2,463	.096 - .097 2,438 - 2,463	.096 - .097 2,438 - 2,463
	-2nd	.096 - .095 2,438 - 2,413	.096 - .095 2,438 - 2,413	.0965 - .0955 2,451 - 2,425
	-3rd	.096 - .095 2,438 - 2,413	.096 - .095 2,438 - 2,413	.188 - .189 4,775 - 4,800
	-4th	.188 - .189 4,775 - 4,800	.188 - .189 4,775 - 4,800	-- --

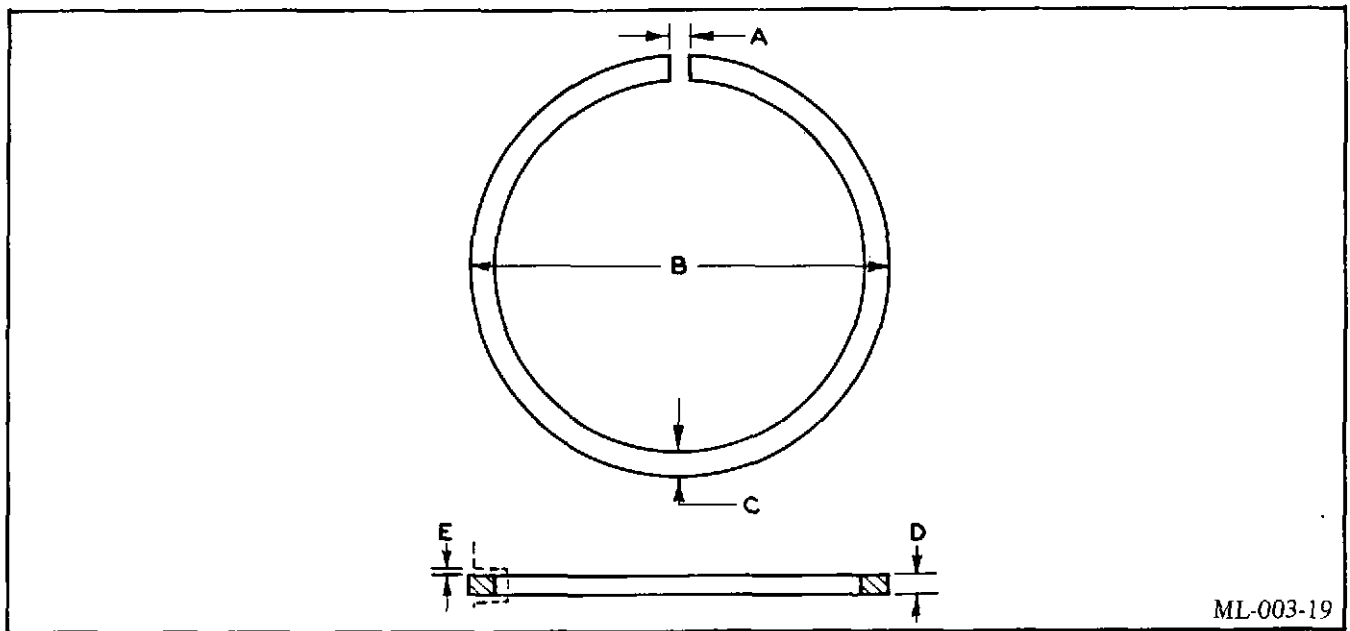

ML-003-19

TYPICAL PISTON RING

VRG FITS AND CLEARANCES

	VRG 155	VRG 232	VRG 265	VRG 283/310
<b>PISTON RINGS</b>				
(A) Ring Gap	-Top	.010 - .020 0,254 - 0,508	.010 - .020 0,254 - 0,508	.010 - .020 0,254 - 0,508
	- 2nd	.010 - .020 0,254 - 0,508	.010 - .020 0,254 - 0,508	.010 - .020 0,254 - 0,508
	-3rd	.010 - .020 0,254 - 0,508	.010 - .020 0,254 - 0,508	.015 - .055 0,381 - 1,397
	-4th	.010 - .018 0,254 - 0,457	.015 - .055 0,381 - 1,397	-
(B) Ring Gauge Diameter	-Top	3.625 @ 9.4# 92,075 @ 4,26 kg	3.625 @ 8.6# 92,075 @ 3,90 kg	3.750 @ 9.0# 95,25 @ 4,08 kg
	-2nd	3.625 @ 9.4# 92,075 @ 4,26 kg	3.625 @ 9.4# 92,075 @ 4,26 kg	3.750 @ 9.6# 92,25 @ 4,35 kg
	-3rd	3.625 @ 9.4# 92,075 @ 4,26 kg	3.625 @ 9.4# 92,075 @ 4,26 kg	3.750 @ 20# 95,25 @ 9,07 kg
	-4th	3.625 @ 8.6# 92,075 @ 4,26 kg	3.625 @ 21# 92,075 @ 9,52 kg	--
(C) Ring Wall	-Top	.181 - .171 4,597 - 4,343	.181 - .171 4,597 - 4,343	.187 - .177 4,749 - 4,495
	-2nd	.181 - .171 4,597 - 4,343	.181 - .171 4,597 - 4,343	.187 - .177 4,749 - 4,495
	-3rd	.181 - .171 4,597 - 4,343	.181 - .171 4,597 - 4,343	.156 - .150 3,962 - 3,81
	-4th	.159 - .149 4,039 - 3,785	.158 - .152 4,013 - 3,860	--
(D) Ring Width	-Top	.0935 - .0930 2,374 - 2,362	.0935 - .0930 2,374 - 2,362	.0935 - .0930 2,374 - 2,362
	-2nd	.0935 - .0930 2,374 - 2,362	.0935 - .0930 2,374 - 2,362	.0935 - .0925 2,374 - 2,349
	-3rd	.0935 - .0930 2,374 - 2,362	.0935 - .0930 2,374 - 2,362	.1825 - .1885 4,635 - 4,788
	-4th	.1865 - .1860 4,737 - 4,724	.1825 - .1885 4,635 - 4,788	--

**VRG FITS AND CLEARANCES (Continued)**

	VRG 155	VRG 232	VRG 265	VRG 283/310
<b>PISTON RINGS (Cont.)</b>				
(E) Side Clearance -Top	.0025 - .0040 0,063 - 0,101	.0025 - .0040 0,063 - 0,101	.0025 - .0040 0,063 - 0,101	.0025 - .004 0,063 - 0,101
-2nd	.0015 - .0030 0,038 - 0,076	.0015 - .0030 0,038 - 0,076	.0020 - .0035 0,050 - 0,088	.002 - .004 0,050 - 0,101
-3rd	.0015 - .0030 0,038 - 0,076	.0015 - .0030 0,038 - 0,076	.006 Max. 0,152	.006 Max. 0,152
-4th	.002 - .0025" 0,050 - 0,061mm	.006 Max. 0,152	--	--

**VRD FITS AND CLEARANCES**

	VRD 155	VRD 232	VRD 283	VRD 310
<b>PISTON RINGS</b>				
(A) Ring Gap -Top	.010 - .020 0,254 - 0,508	.010 - .020 0,254 - 0,508	.010 - .020 0,254 - 0,508	.010 - .020 0,254 - 0,508
-2nd	.010 - .020 0,254 - 0,508	.010 - .020 0,254 - 0,508	.010 - .020 0,254 - 0,508	.010 - .020 0,254 - 0,508
-3rd	.010 - .020 0,254 - 0,508	.010 - .020 0,254 - 0,508	.010 - .020 0,254 - 0,508	.010 - .020 0,254 - 0,508
-4th	.010 - .023 0,254 - 0,584	.015 - .055 0,381 - 1,397	--	--
(B) Ring Gauge Diameter -Top	3,625 @ 8.6# 92,075 @ 3,90 kg	3,625 @ 8.6# 92,075 @ 3,90 kg	3,875 @ 9.8# 98,42 @ 4,44 kg	3,875 @ 9.8# 98,42 @ 4,44 kg
-2nd	3,625 @ 9.4# 92,075 @ 4,26 kg	3,625 @ 9.4# 92,075 @ 4,26 kg	3,875 @ 9.4# 98,42 @ 4,26 kg	3,875 @ 11.1# 98,42 @ 5,03 kg
-3rd	3,625 @ 9.4# 92,075 @ 4,26 kg	3,625 @ 9.4# 92,075 @ 4,26 kg	3,875 @ 14.1# 98,42 @ 6,39 kg	3,875 @ 19# 98,42 @ 8,62 kg
-4th	3,625 @ 21# 92,075 @ 9,52 kg	3,625 @ 21# 92,075 @ 9,52 kg	--	--
(C) Ring Wall -Top	.181 - .171 4,597 - 4,343	.181 - .171 4,597 - 4,343	.194 - .184 4,927 - 4,673	.194 - .184 4,427 - 4,673
-2nd	.181 - .171 4,597 - 4,343	.181 - .171 4,597 - 4,343	.194 - .184 4,927 - 4,673	.171 - .181 4,343 - 4,597
-3rd	.181 - .171 4,597 - 4,343	.181 - .171 4,597 - 4,343	.135 - .145 3,429 - 3,683	.135 - .145 3,429 - 3,683
-4th	.158 - .152 4,013 - 3,860	.158 - .152 4,013 - 3,860	--	--
(D) Ring Width -Top	.0935 - .0930 2,374 - 2,362	.0935 - .0930 2,374 - 2,362	.0935 - .0930 2,374 - 2,362	.0935 - .0930 2,374 - 2,362
-2nd	.0935 - .0930 2,374 - 2,362	.0935 - .0930 2,374 - 2,362	.0935 - .0930 2,374 - 2,362	.0935 - .0925 2,374 - 2,349
-3rd	.0935 - .0930 2,374 - 2,362	.0935 - .0930 2,374 - 2,362	.1865 - .1860 4,737 - 4,724	.1870 - .1860 4,750 - 4,724
-4th	.1865 - .1860 4,737 - 4,724	.1825 - .1885 4,635 - 4,788	--	--
(E) Side Clearance -Top	.0025 - .0040 0,063 - 0,101	.0025 - .0040 0,063 - 0,101	.0025 - .0040 0,063 - 0,101	.0025 - .0040 0,063 - 0,101
-2nd	.0015 - .0030 0,038 - 0,076	.0015 - .0030 0,038 - 0,076	.0020 - .0035 0,050 - 0,088	.002 - .004 0,050 - 0,101
-3rd	.0015 - .0030 0,038 - 0,076	.0015 - .0030 0,038 - 0,076	.0015 - .0030 0,038 - 0,076	.001 - .003 0,025 - 0,076
-4th	.002 - .0025 0,051 - 0,061	.006 Max. 0,152	--	--

**REPAIR AND REPLACEMENT**

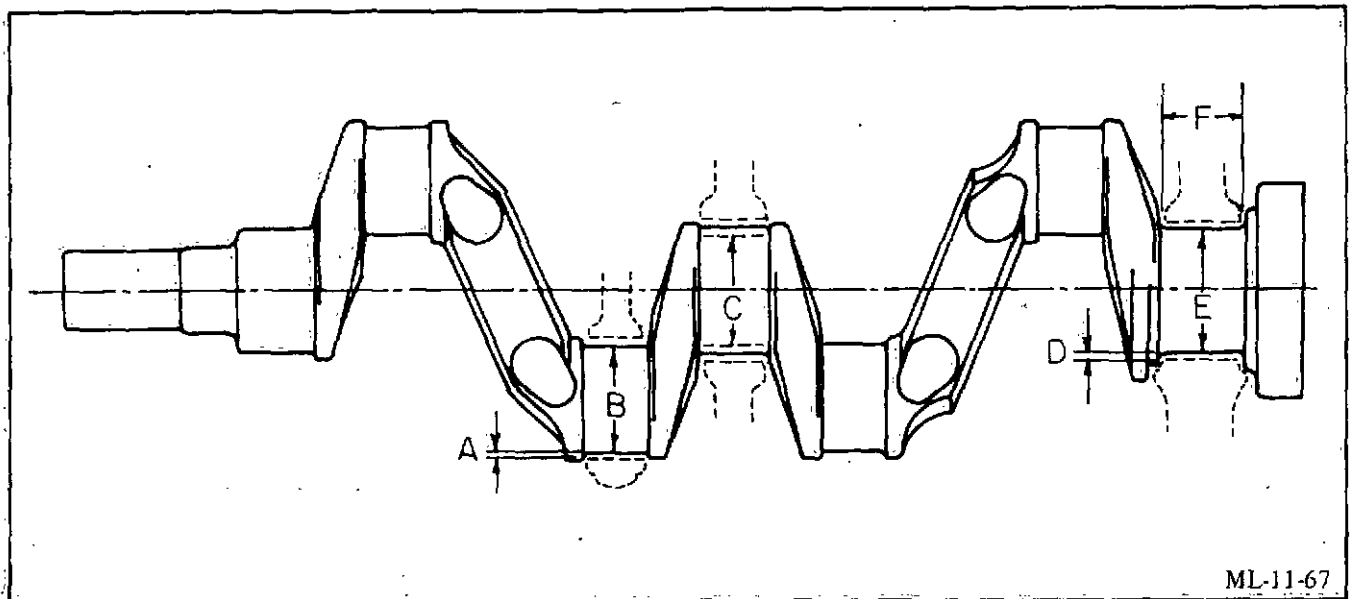

TYPICAL CRANKSHAFT

VRG FITS AND CLEARANCES

	VRG 155	VRG 232	VRG 265	VRG 283/310
<b>CRANKSHAFT</b>				
Crankshaft End Play	.0045 - .0085 0,114 - 0,215	.0045 - .0085 0,114 - 0,215	.0045 - .0085 0,114 - 0,215	.0045 - .0095 0,114 - 0,241
Thrust Bearing Thickness	1.621 - 1.623 41,173 - 41,224	1.621 - 1.623 41,173 - 41,224	1.746 - 1.748 44,348 - 44,399	1.495 - 1.498 37,973 - 38,049
(A) Connecting Rod Bearing Running Clearance	.0005 - .0025 0,012 - 0,063	.0005 - .0025 0,012 - 0,063	.0005 - .0025 0,012 - 0,063	.0005 - .0025 0,012 - 0,063
(B) Connecting Rod Bearing Journal Diameter	2.250 - 2.249 57,150 - 57,124	2.250 - 2.249 57,15 - 57,124	2.250 - 2.249 57,15 - 57,124	2.4375 - 2.4365 61,912 - 61,887
(C) Main Bearing Journal Maximum Undersize	.040 1,016	.040 1,016	.040 1,016	.040 1,016
(D) Main Bearing Running Clearance	.0002 - .0027 0,005 - 0,068	.0002 - .0027 0,005 - 0,068	.0005 - .0035 0,012 - 0,088	.0015 - .0045 0,038 - 0,114
(E) Main Bearing Journal Diameter	2.250 - 2.249 57,150 - 57,124	2.250 - 2.249 57,15 - 57,124	2.625 - 2.624 66,675 - 66,649	2.625 - 2.624 66,675 - 66,649
(F) Crankshaft Thrust Length (face to face)	1.6275 - 1.6295 41,338 - 41,389	1.6275 - 1.6295 41,338 - 41,389	1.7525 - 1.7545 44,513 - 44,564	1.5025 - 1.5045 38,163 - 38,214
Main and Rod Journal Maximum Out-of-Round	.001 0,025	.001 0,025	.001 0,025	.001 0,025
Main and Rod Journal Maximum Taper	.001 0,025	.001 0,025	.0006 0,015	.0006 0,015
Main Bearing Shell Thickness	.0854 - .0849 2,169 - 2,156	.0854 - .0849 2,169 - 2,156	.0955 - .0950 2,425 - 2,413	.0945 - .0950 2,400 - 2,413

VRD FITS AND CLEARANCES

	VRD 155	VRD 232	VRD 283	VRD 310
<b>CRANKSHAFT</b>				
Crankshaft End Play	.0045 - .0085 0,114 - 0,215	.0045 - .0085 0,114 - 0,215	.0045 - .0095 0,114 - 0,241	.0045 - .0095 0,114 - 0,241
Thrust Bearing Thickness	1.621 - 1.623 41,173 - 41,224	1.621 - 1.623 41,173 - 41,224	1.495 - 1.498 37,973 - 38,049	1.495 - 1.498 37,973 - 38,049
(A) Connecting Rod Bearing Running Clearance	.0005 - .0025 0,012 - 0,063	.0005 - .0025 0,012 - 0,063	.0005 - .0025 0,012 - 0,063	.0005 - .0025 0,012 - 0,063
(B) Connecting Rod Bearing Journal Diameter	2.250 - 2.249 57,150 - 57,124	2.250 - 2.249 57,15 - 57,124	2.4375 - 2.4365 61,912 - 61,887	2.4375 - 2.4365 61,912 - 61,887
(C) Main Bearing Journal Maximum Undersize	.040 1,016	.040 1,016	.040 1,016	.040 1,016
(D) Main Bearing Running Clearance	.0002 - .0027 0,005 - 0,068	.0002 - .0027 0,005 - 0,068	.0015 - .0045 0,038 - 0,114	.0015 - .0045 0,038 - 0,114
(E) Main Bearing Journal Diameter	2.250 - 2.249 57,150 - 57,124	2.250 - 2.249 57,15 - 57,124	2.625 - 2.624 66,675 - 66,649	2.625 - 2.624 66,675 - 66,649
(F) Crankshaft Thrust Length (face to face)	1.6275 - 1.6295 41,338 - 41,389	1.6275 - 1.6295 41,338 - 41,389	1.5025 - 1.5045 38,163 - 38,214	1.5025 - 1.5045 38,163 - 38,214
Main and Rod Journal Maximum Out-of-Round	.001 0,025	.001 0,025	.001 0,025	.001 0,025
Main and Rod Journal Maximum Taper	.001 0,025	.001 0,025	.0006 0,015	.0006 0,015
Main Bearing Shell Thickness	.0854 - .0849 2,169 - 2,156	.0854 - .0849 2,169 - 2,156	.0945 - .0950 2,400 - 2,413	.0945 - .0950 2,400 - 2,413

REPAIR AND REPLACEMENT

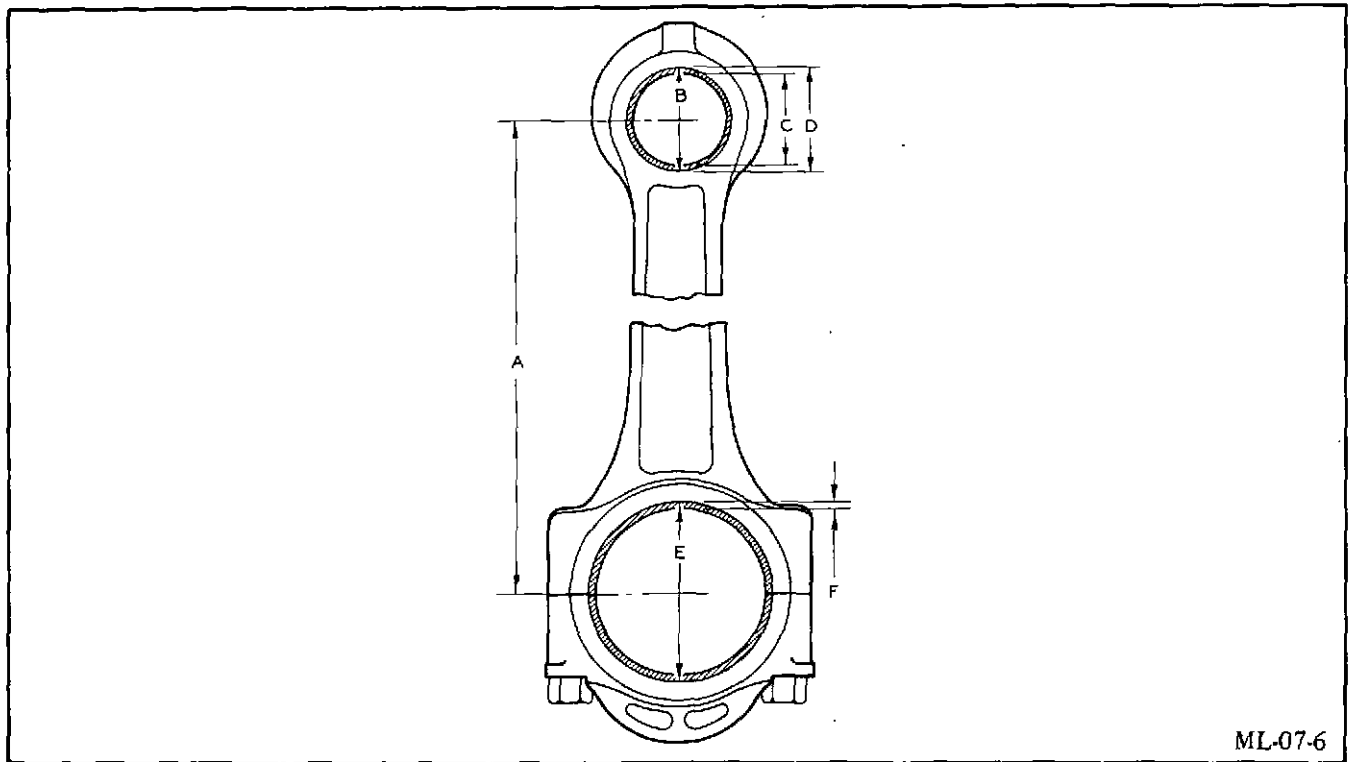

ML-07-6

TYPICAL CONNECTING ROD, BUSHING, AND BEARING

**VRG FITS AND CLEARANCES**

	VRG 155	VRG 232	VRG 265	VRG 283/310
<b>CONNECTING ROD, BUSHING AND BEARING</b>				
Weight Variation Per Set	.25 oz. (7 grams)	.25 oz. (7 grams)	.25 oz. (7 grams)	.25 oz. (7 grams)
(A) Rod Length Center-to-Center	6.750 - 6.749 171,450 - 171,426	6.750 - 6.749 171,450 - 171,426	6.747 - 6.750 171,373 - 171,450	6.750 - 6.749 171,450 - 171,426
(B) Small End Finish Size	1.312 - 1.313 33,324 - 33,350	1.312 - 1.313 33,324 - 33,350	1.312 - 1.313 33,324 - 33,350	1.312 - 1.313 33,324 - 33,350
(C) Bushing Bore Diameter	1.2501 - 1.2503 31,752 - 31,757	1.2501 - 1.2503 31,752 - 31,757	1.2501 - 1.2503 31,752 - 31,757	1.2501 - 1.2503 31,752 - 31,757
(D) Bushing Press In Rod	.0045 - .0070 0,114 - 0,177	.0045 - .0070 0,114 - 0,177	.0045 - .0070 0,114 - 0,177	.0045 - .0070 0,114 - 0,177
(E) Large End Finish Size	2.4205 - 2.4200 61,480 - 61,468	2.4205 - 2.4200 61,480 - 61,468	2.4205 - 2.4200 61,480 - 61,468	2.5885 - 2.589 65,748 - 65,760
(F) Bearing Wall Thickness	.0845 - .0850 2,146 - 2,159	.0845 - .0850 2,146 - 2,159	.0845 - .0850 2,146 - 2,159	.0750 - .0755 1,905 - 1,917
Bearing Running Clearance	.0005 - .0025 0,012 - 0,063	.0005 - .0025 0,012 - 0,063	.0005 - .0025 0,012 - 0,063	.0005 - .0025 0,012 - 0,063
Rod Side Clearance	.0075 - .0135 0,190 - 0,342	.0075 - .0135 0,190 - 0,342	.0075 - .0135 0,190 - 0,342	.0075 - .0135 0,190 - 0,342
Rod Large End Width	1.3655 - 1.3675 34,684 - 34,734	1.3655 - 1.3675 34,684 - 34,734	1.3655 - 1.3675 34,684 - 34,734	1.3655 - 1.3675 34,684 - 34,734

## VRD FITS AND CLEARANCES

	VRD 155	VRD 232	VRD 283	VRD 310
<b>CONNECTING ROD, BUSHING AND BEARING</b>				
Weight Variation Per Set	.25 oz. (7 grams)	.25 oz. (7 grams)	.25 oz. (7 grams)	.25 oz. (7 grams)
(A) Rod Length Center-to-Center	6.750 - 6.749 171,450 - 171,426	6.750 - 6.749 171,450 - 171,426	6.749 - 6.750 171,426 - 171,450	6.750 - 6.749 171,450 - 171,426
(B) Small End Finish Size	1.312 - 1.313 33,324 - 33,350	1.312 - 1.313 33,324 - 33,350	1.312 - 1.313 33,324 - 33,350	1.312 - 1.313 33,324 - 33,350
(C) Bushing Bore Diameter	1.2501 - 1.2503 31,752 - 31,757	1.2501 - 1.2503 31,752 - 31,757	1.2501 - 1.2503 31,752 - 31,757	1.2501 - 1.2503 31,752 - 31,757
(D) Bushing Press In Rod	.0045 - .0070 0,114 - 0,177	.0045 - .0070 0,114 - 0,177	.0045 - .0070 0,114 - 0,177	.0045 - .0070 0,114 - 0,177
(E) Large End Finish Size	2.4205 - 2.4200 61,480 - 61,468	2.4205 - 2.4200 61,480 - 61,468	2.5885 - 2.589 65,748 - 65,760	2.5885 - 2.589 65,748 - 65,760
(F) Bearing Wall Thickness	.0845 - .0850 2,146 - 2,159	.0845 - .0850 2,146 - 2,159	.0750 - .0755 1,905 - 1,917	.0750 - .0755 1,905 - 1,917
Bearing Running Clearance	.0005 - .0025 0,012 - 0,063	.0005 - .0025 0,012 - 0,063	.0005 - .0025 0,012 - 0,063	.0005 - .0025 0,012 - 0,063
Rod Side Clearance	.0075 - .0135 0,190 - 0,342	.0075 - .0135 0,190 - 0,342	.0075 - .0135 0,190 - 0,342	.0075 - .0135 0,190 - 0,342
Rod Large End Width	1.3655 - 1.3675 34,684 - 34,734	1.3655 - 1.3675 34,684 - 34,734	1.3655 - 1.3675 34,684 - 34,734	1.3655 - 1.3675 34,684 - 34,734

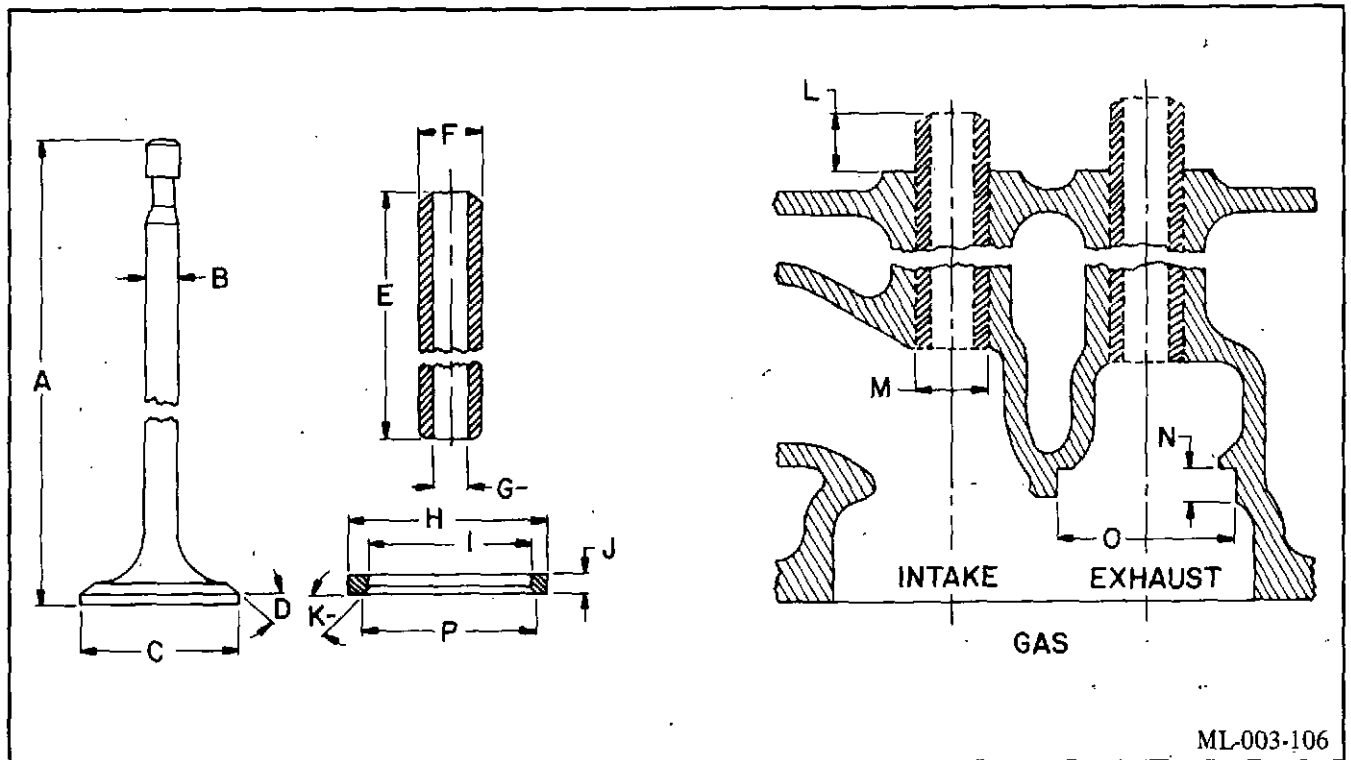

ML-003-106

TYPICAL VALVE TRAIN, VALVE PORT CLEARANCES  
GAS/GASOLINE ENGINES

VRG FITS AND CLEARANCES

	VRG 155	VRG 232	VRG 265	VRG-283/310
<b>VALVE TRAIN, VALVE PORT</b>				
(A) Valve Length (Intake)	4.984 126,594	5.047 128,193	5.406 - 5.396 137,312 - 137,058	5.418 - 5.408 137,617 - 137,363
Valve Length (Exhaust)	4.984 126,594	5.078 - 5.068 128,981 - 128,727	5.469 138,912	5.418 - 5.408 137,617 - 137,363
(B) Valve Stem Diameter (Intake)	.3730 - .3720 9,474 - 9,448	.3730 - .3720 9,474 - 9,448	.373 - .372 9,474 - 9,448	.373 - .372 9,474 - 9,448
Valve Stem Diameter (Exhaust)	.372 - .371 9,448 - 9,423	.372 - .371 9,448 - 9,423	.372 - .371 9,448 - 9,423	.372 - .371 9,448 - 9,423
Valve Lip Thickness (Intake)	.063 1,600	.063 1,600	.063 1,600	.063 1,600
Valve Lip Thickness (Exhaust)	.063 1,600	.063 1,600	.063 1,600	.063 1,600
Valve Face & Seat Run-out (Maximum)	.002 0,050	.002 0,050	.002 0,050	.002 0,050
(C) Valve Head Diameter (Intake)	1.449 - 1.459" 36,805 - 37,059mm	1.339 - 1.389 35,535 - 35,281	1.514 - 1.504 38,455 - 38,201	1.625 41,275
Valve Head Diameter (Exhaust)	1.389 - 1.399" 35,281 - 35,535mm	1.258 - 1.251 31,953 - 31,775	1.400 - 1.390 35,56 - 35,306	1.518 - 1.508 38,557 - 38,303
(D) Valve Face Angle (Intake)	44° 30' ± 15'	44° 30' ± 15'	44° 30' ± 15'	44° 30' ± 15'
Valve Face Angle (Exhaust)	44° 30' ± 15'	44° 30' ± 15'	44° 30' ± 15'	44° 30' ± 15'

VRG FITS AND CLEARANCES (Continued)

	VRG 155	VRG 232	VRG 265	VRG 283/310
<b>VALVE TRAIN, VALVE PORT (Cont.)</b>				
(E) Guide Length (Intake)	2.406 - 2.396 61,112 - 60,858	2.406 - 2.396 61,112 - 60,858	2.625 - 2.615 66,675 - 66,421	2.406 - 2.396 61,112 - 60,858
Guide Length (Exhaust)	2.303 - 2.323 58,496 - 59,004	2.500 - 2.490 63,500 - 63,246	2.625 - 2.615 66,675 - 66,421	2.625 - 2.615 66,675 - 66,421
(F) Guide Outside Diameter (Intake & Exhaust)	.6255 - .6260 15,887 - 15,900	.6255 - .626 15,887 - 15,900	.6255 - .626 15,887 - 15,900	.6255 - .626 15,887 - 15,900
(G) Guide Inside Diameter (Intake & Exhaust)	.375 - .374 9,525 - 9,500	.375 - .374 9,525 - 9,500	.375 - .374 9,525 - 9,500	.375 - .374 9,525 - 9,500
Guide to Stem Clearance (Intake)	.001 - .003 0,025 - 0,076	.001 - .003 0,025 - 0,076	.001 - .003 0,025 - 0,076	.001 - .003 0,025 - 0,076
Guide to Stem Clearance (Exhaust)	.002 - .004 0,050 - 0,101	.002 - .004 0,050 - 0,101	.002 - .004 0,050 - 0,101	.002 - .004 0,050 - 0,101
Exhaust Insert Seat Width	.080 - .090 2,032 - 2,286	.080 - .090 2,032 - 2,286	.080 - .090 2,032 - 2,286	.080 - .090 2,032 - 2,286
Intake Seat Width	.056 - .066 1,422 - 1,676	.056 - .066 1,422 - 1,676	.080 - .090 2,032 - 2,286	.062 1,574
(H) Exhaust Insert Outside Diameter	1.440 - 1.4395 36,576 - 36,563	1.440 - 1.4395 36,576 - 36,563	1.5020 - 1.5025 38,150 - 38,163	1.6275 - 1.6270 41,338 - 41,325
(I) Exhaust Insert Inside Diameter	1.255 - 1.245 31,877 - 31,623	1.130 - 1.120 28,702 - 28,448	1.270 - 1.260 32,258 - 32,004	1.390 - 1.385 35,306 - 35,179
(J) Exhaust Insert Depth	.250 - .248 6,350 - 6,299	.250 - .248 6,350 - 6,299	.2105 - .2055 5,346 - 5,219	.209 - .207 5,308 - 5,257
(K) Insert Seat Angle (Exhaust)	45°	45°	45°	45°
Seat Angle (Intake)	45°	45°	45°	45°
(L) Guide Extends Above Head (Intake)	.843 - .833 21,412 - 21,158	.843 - .833 21,412 - 21,158	.781 - .771 19,837 - 19,583	.843 - .833 21,412 - 21,158
Guide Extends Above Head (Exhaust)	.937 - .927 23,799 - 23,545	.937 - .927 23,799 - 23,545	.937 - .927 23,799 - 23,545	.937 - .927 23,799 - 23,545
(M) Guide Bore in Head	.624 - .625 15,849 - 15,875	.624 - .625 15,849 - 15,875	.624 - .625 15,849 - 15,875	.624 - .625 15,849 - 15,875
(N) Exhaust Insert Counterbore Depth	.260 - .263 6,604 - 6,680	.260 - .263 6,604 - 6,680	.217 - .219 5,512 - 5,563	.217 - .220 5,512 - 5,588
(O) Exhaust Insert Counterbore Diameter	1.500 - 1.499 38,100 - 38,075	1.4375 - 1.4365 36,512 - 36,487	1.500 - 1.499 38,100 - 38,075	1.624 - 1.625 41,250 - 41,275
(P) Exhaust Insert Seat O.D.	1.250 31,750	1.250 31,750	1.375 34,925	1.500 38,100
Intake Seat O.D.	1.315 33,401	1.343 34,112	1.500 38,100	1.593 40,462
Valve Spring Free Length (Intake)	2.562 ± .062" 65,074 ± 1,574mm	2.562 ± .062" 65,074 ± 1,574mm	2.562 ± .062" 65,074 ± 1,574mm	2.562 ± .062" 65,074 ± 1,574mm
Valve Spring Free Length (Exhaust)	2.440 ± .062" 61,976 ± 1,574mm	2.440 ± .062" 61,976 ± 1,574mm	2.440 ± .062" 61,976 ± 1,574mm	2.440 ± .062" 61,976 ± 1,574mm
Valve Closed Spring Length (Intake)	1.906 @ 59# 48,412 @ 26.7kg	1.906 @ 59# 48,412 @ 26.7kg	1.906 @ 59# 48,412 @ 26.7kg	1.906 @ 59# 48,412 @ 26.7kg
Valve Closed Spring Length (Exhaust)	1.750 @ 57# 44,450 @ 25.8kg	1.750 @ 57# 44,450 @ 25.8kg	1.750 @ 57# 44,450 @ 25.8kg	1.750 @ 57# 44,450 @ 25.8kg
Valve Open Spring Length (Intake)	1.506 @ 95# 38,252 @ 43.1kg	1.506 @ 95# 38,252 @ 43.1kg	1.506 @ 95# 38,252 @ 43.1kg	1.506 @ 95# 38,252 @ 43.1kg
Valve Open Spring Length (Exhaust)	1.350 @ 90# 34,290 @ 40.8kg	1.350 @ 90# 34,290 @ 40.8kg	1.350 @ 90# 34,290 @ 40.8kg	1.350 @ 90# 34,290 @ 40.8kg

REPAIR AND REPLACEMENT

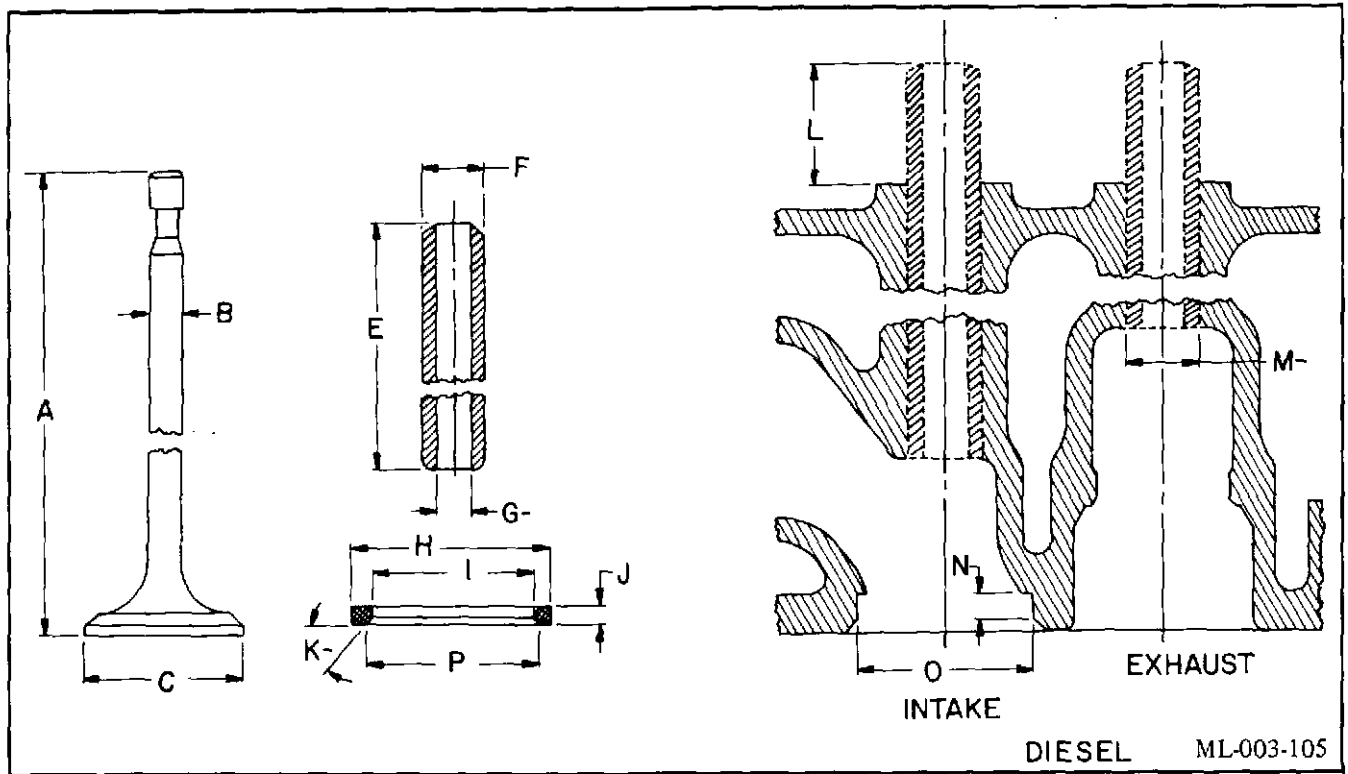

TYPICAL VALVE TRAIN, VALVE PORT CLEARANCES  
DIESEL ENGINES

VRD FITS AND CLEARANCES

	VRD 155	VRD 232	VRD 283	VRD 310
<b>VALVE TRAIN, VALVE PORT</b>				
(A) Valve Length (Intake)	5.953 - 5.943 151,206 - 150,952	5.953 - 5.943 151,206 - 150,952	6.812 - 6.802 173,024 - 172,770	6.812 - 6.802 173,024 - 172,770
Valve Length (Exhaust)	5.000 - 4.990 127,000 - 126,746	5.000 - 4.990 127,000 - 126,746	6.824 - 6.814 173,330 - 173,076	6.824 - 6.814 173,330 - 173,076
(B) Valve Stem Diameter (Intake)	.373 - .372 9,475 - 9,448	.373 - .372 9,474 - 9,448	.3725 - .3720 9,461 - 9,448	.3725 - .3720 9,461 - 9,448
Valve Stem Diameter (Exhaust)	.372 - .371 9,448 - 9,423	.372 - .371 9,448 - 9,423	.372 - .3715 9,448 - 9,436	.372 - .3715 9,448 - 9,436
Valve Lip Thickness (Intake)	.052 - .062 1,321 - 1,574	.052 - .062 1,321 - 1,574	.055 1,397	.055 1,397
Valve Lip Thickness (Exhaust)	.052 - .062 1,321 - 1,574	.052 - .062 1,321 - 1,574	.067 1,702	.067 1,702
Valve Face & Seat Run-out (Maximum)	.002 0,050	.002 0,050	.002 0,050	.002 0,050
(C) Valve Head Diameter (Intake)	1.447 - 1.437 36,753 - 36,499	1.447 - 1.437 36,753 - 36,499	1.640 - 1.630 41,656 - 41,402	1.718 - 1.708 43,637 - 43,383
Valve Head Diameter (Exhaust)	1.255 - 1.245 31,877 - 31,623	1.120 - 1.110 28,448 - 28,194	1.505 - 1.495 38,227 - 37,973	1.505 - 1.495 38,227 - 37,973
(D) Valve Face Angle (Intake)	44° 30' ± 15'	44° 30' ± 15'	29° 30' ± 15'	29° 30' ± 15'
Valve Face Angle (Exhaust)	44° 30' ± 15'	44° 30' ± 15'	44° 30' ± 15'	44° 30' ± 15'
(E) Guide Length (Intake)	3.187 - 3.177 80,949 - 80,695	3.187 - 3.177 80,949 - 80,695	3.500 - 3.490 88,900 - 88,646	3.500 - 3.490 88,900 - 88,646
Guide Length (Exhaust)	2.312 - 2.302 58,724 - 58,470	2.312 - 2.302 58,724 - 58,470	3.500 - 3.490 88,900 - 88,646	3.500 - 3.490 88,900 - 88,646

## VRD FITS AND CLEARANCES (Cont.)

	VRD 155	VRD 232	VRD 283	VRD 310
<b>VALVE TRAIN, VALVE PORT (Cont.)</b>				
(F) Guide Outside Diameter Intake & Exhaust	.6255 - .6260 15,887 - 15,900	.6255 - .626 15,887 - 15,900	.6255 - .626 15,887 - 15,900	.6255 - .626 15,887 - 15,900
(G) Guide Inside Diameter (Intake & Exhaust)	.375 - .374 9,525 - 9,500	.375 - .374 9,525 - 9,500	.374 - .373 9,500 - 9,474	.374 - .373 9,500 - 9,474
Guide to Stem Clearance (Intake)	.001 - .003 0,025 - 0,076	.001 - .003 0,025 - 0,076	.0005 - .002 0,012 - 0,050	.0005 - .002 0,012 - 0,050
Guide to Stem Clearance (Exhaust)	.002 - .004 0,050 - 0,101	.002 - .004 0,050 - 0,101	.001 - .0025 0,025 - 0,063	.001 - .0025 0,025 - 0,063
Intake Insert Seat Width	.062 1,574	.062 1,574	.091 2,311	.091 2,311
Exhaust Seat Width	.070 1,778	.070 1,778	.062 - .072 1,574 - 1,829	.062 - .072 1,574 - 1,829
(H) Intake Insert Outside Diameter	1.5650 - 1.5645 39,751 - 39,738	1.5650 - 1.5645 39,751 - 39,738	--	--
(I) Intake Insert Inside Diameter	1.315 - 1.309 33,401 - 33,248	1.315 - 1.309 33,401 - 33,248	--	--
(J) Intake Insert Depth	.2055 - .2105 5,219 - 5,346	.2055 - .2105 5,219 - 5,346	--	--
(K) Insert Seat Angle (Intake)	45°	45°	30°	30°
Seat Angle (Exhaust)	45°	45°	45°	45°
(L) Guide Extends Above Head (Intake)	.937 - .927 23,799 - 23,545	.937 - .927 23,799 - 23,545	.875 - .865 22,225 - 21,971	.875 - .865 22,225 - 21,971
Guide Extends Above Head (Exhaust)	1.137 - 1.177 28,879 - 29,896	.937 - .927 23,799 - 23,545	.875 - .865 22,225 - 21,971	.875 - .865 22,225 - 21,971
(M) Guide Bore In Head	.624 - .625 15,849 - 15,875	.624 - .625 15,849 - 15,875	.6245 - .625 15,862 - 15,875	.6245 - .625 15,862 - 15,875
(N) Intake Insert Counterbore Depth	.314 - .318 7,976 - 8,077	.314 - .318 7,976 - 8,077	--	--
(O) Intake Insert Counterbore Diameter	1.5615 - 1.5625 39,662 - 39,687	1.5615 - 1.5625 39,662 - 39,687	--	--
(P) Intake Insert Seat O.D.	1.406 35,712	1.406 35,712	1.546 39,268	1.609 40,869
Exhaust Seat O.D.	1.228 31,191	1.109 28,169	1.437 36,500	1.437 36,500
Valve Spring Free Length (Intake)	2.562 ± .062 65,074 ± 1,574	2.562 ± .062 65,074 ± 1,574	2.562 ± .062 65,074 ± 1,574	2.562 ± .062 65,074 ± 1,574
Valve Spring Free Length (Exhaust)	2.440 ± .062 61,976 ± 1,574	2.440 ± .062 61,976 ± 1,574	2.562 ± .062 65,074 ± 1,574	2.562 ± .062 65,074 ± 1,574
Valve Closed Spring Length (Intake)	1.906 @ 59# 48,412 @ 26.7 kg	1.906 @ 59# 48,412 @ 26.7 kg	1.906 @ 59# 48,412 @ 26.7 kg	1.906 @ 59# 48,412 @ 26.7 kg
Valve Closed Spring Length (Exhaust)	1.750 @ 57# 44,450 @ 25.8 kg	1.750 @ 57# 44,450 @ 25.8 kg	1.906 @ 59# 48,412 @ 26.7 kg	1.906 @ 59# 48,412 @ 26.7 kg
Valve Open Spring Length (Intake)	1.506 @ 95# 38,252 @ 43.1 kg	1.506 @ 95# 38,252 @ 43.1 kg	1.506 @ 95# 38,252 @ 43.1 kg	1.506 @ 95# 38,252 @ 43.1 kg
Valve Open Spring Length (Exhaust)	1.350 @ 90# 34,290 @ 40.8 kg	1.350 @ 90# 34,290 @ 40.8 kg	1.506 @ 95# 38,252 @ 43.1 kg	1.506 @ 95# 38,252 @ 43.1 kg

## VRG FITS AND CLEARANCES

	VRG 155	VRG 232	VRG 265	VRG 283/310
<b>CAMSHAFT</b>				
Camshaft Journal Diameter (No. 1)	1.749 - 1.750 44,425 - 44,450	1.749 - 1.750 44,425 - 44,450	1.749 - 1.750 44,425 - 44,450	1.749 - 1.750 44,425 - 44,450
Camshaft Journal Running Clearance	.0015 - .0035 0,038 - 0,088	.0015 - .0035 0,038 - 0,088	.0015 - .0035 0,038 - 0,088	.0015 - .0035 0,038 - 0,088
Camshaft Journal Diameter (Nos. 2, 3, & 4)	1.7495 - 1.7485 44,437 - 44,411	1.7495 - 1.7485 44,437 - 44,411	1.7495 - 1.7485 44,437 - 44,411	1.7495 - 1.7485 44,437 - 44,411
Camshaft End Play	SPRING AND BUTTON CONTROLLED			
Camshaft Bushing I.D.	1.7515 - 1.752 44,488 - 44,500	1.7515 - 1.752 44,488 - 44,500	1.7515 - 1.752 44,488 - 44,500	1.7515 - 1.752 44,488 - 44,500
Cam Lift Intake	.226 - .214 5,740 - 5,435	.226 - .214 5,740 - 5,435	.300 - .294 7,62 - 7,467	.300 - .294 7,62 - 7,467
Cam Lift Exhaust	.206 - .194 5,232 - 4,927	.206 - .194 5,232 - 4,927	.305 - .299 7,747 - 7,594	.305 - .299 7,747 - 7,594

	VRG 155	VRG 232	VRG 265	VRG 283/310
<b>OIL PUMP</b>				
Backlash Oil Pump Pressure Gears	--	--	.010 - .016 0,254 - 0,406	.010 - .016 0,254 - 0,406
Drive Shaft Bushing I.D. (Top)	.4955 - .4970 12,585 - 12,624	.4955 - .497 12,585 - 12,624	.4965 - .4955 12,611 - 12,585	.4965 - .4955 12,611 - 12,585
Drive Shaft Bushing I.D. (Bottom)	1.0005 - 1.0015 25,413 - 25,438	1.0005 - 1.0015 25,413 - 25,438	.6265 - .6260 15,913 - 15,900	.6265 - .6260 15,913 - 15,900
Drive Shaft Running Surface O.D. (Top)	.495 - .4945 12,573 - 12,560	.495 - .4945 12,573 - 12,560	.4945 - .494 12,560 - 12,547	.4945 - .494 12,560 - 12,547
Drive Shaft Running Surface O.D. (Bottom)	1.000 - .9995 25,400 - 25,387	1.000 - .9995 25,400 - 25,387	.6245 - .6240 15,862 - 15,850	.6245 - .6240 15,862 - 15,850
Idler Shaft O.D.	--	--	.622 - .6225 15,799 - 15,811	.622 - .6225 15,799 - 15,811
Idler Gear I.D.	--	--	.626 - .6265 15,900 - 15,913	.626 - .6265 15,900 - 15,913

	VRG 155	VRG 232	VRG 265	VRG 283/310
<b>ROCKER ARMS</b>				
Rocker Arm I.D.	.7445 - .7455 18,910 - 18,936	.7445 - .7455 18,910 - 18,936	.7445 - .7455 18,910 - 18,936	.7445 - .7455 18,910 - 18,936
Rocker Arm Shaft O.D.	.742 - .743 18,847 - 18,872	.742 - .743 18,847 - 18,872	.742 - .743 18,847 - 18,872	.742 - .743 18,847 - 18,872
Rocker Arm Running Clearance	.0015 - .0035 0,038 - 0,088	.0015 - .0035 0,038 - 0,088	.0015 - .0035 0,038 - 0,088	.0015 - .0035 0,038 - 0,088

	VRG 155	VRG 232	VRG 265	VRG 283/310
<b>FLYWHEEL HOUSING</b>				
Pilot Bearing Runout	.005" 0,127 mm	.005" 0,127 mm	.005" 0,127 mm	.005" 0,127 mm
Flywheel Face Runout	.008" 0,203 mm	.008" 0,203 mm	.008" 0,203 mm	.008" 0,203 mm
Flywheel Housing Bore Runout	.006" 0,152 mm	.008" 0,203 mm	.008" 0,203 mm	.008" 0,203 mm
Flywheel Housing Face Runout	.006" 0,152 mm	.008" 0,203 mm	.008" 0,203 mm	.008" 0,203 mm

**VRD FITS AND CLEARANCES**

	VRD 155	VRD 232	VRD 283	VRD 310
<b>CAMSHAFT</b>				
Camshaft Journal Diameter (No. 1)	1.749 - 1.750 44,425 - 44,450	1.749 - 1.750 44,425 - 44,450	1.7495 - 1.7485 44,437 - 44,411	1.7495 - 1.7485 44,437 - 44,411
Camshaft Journal Running Clearance	.0015 - .0035 0,038 - 0,088	.0015 - .0035 0,038 - 0,088	.002 - .0035 0,050 - 0,088	.002 - .0035 0,050 - 0,088
Camshaft Journal Diameter (Nos. 2, 3, & 4)	1.7495 - 1.7485 44,437 - 44,411	1.7495 - 1.7485 44,437 - 44,411	1.7495 - 1.7485 44,437 - 44,411	1.7495 - 1.7485 44,437 - 44,411
Camshaft End Play	SPRING AND BUTTON CONTROLLED			
Camshaft Bushing I.D.	1.7515 - 1.752 44,488 - 44,500	1.7515 - 1.752 44,488 - 44,500	1.7515 - 1.752 44,488 - 44,500	1.7515 - 1.752 44,488 - 44,500
Cam Lift Intake	.226 - .214 5,740 - 5,435	.226 - .214 5,740 - 5,435	.302 7,670	.302 7,670
Cam Lift Exhaust	.206 - .194 5,232 - 4,927	.206 - .194 5,232 - 4,927	.302 7,670	.302 7,670

	VRD 155	VRD 232	VRD 283	VRD 310
<b>OIL PUMP</b>				
Backlash Oil Pump Pressure Gears	--	--	.010 - .016 0,254 - 0,406	.010 - .016 0,254 - 0,406
Drive Shaft Bushing I.D. (Top)	.4955 - .497 12,585 - 12,624	.4955 - .497 12,585 - 12,624	.4965 - .4955 12,611 - 12,585	.4965 - .4955 12,611 - 12,585
Drive Shaft Bushing I.D. (Bottom)	1.0005 - 1.0015 25,413 - 25,438	1.0005 - 1.0015 25,413 - 25,438	.6265 - .6260 15,913 - 15,900	.6265 - .6260 15,913 - 15,900
Drive Shaft Running Surface O.D. (Top)	.495 - .4945 12,573 - 12,560	.495 - .4945 12,573 - 12,560	.4945 - .494 12,560 - 12,547	.4945 - .494 12,560 - 12,547
Drive Shaft Running Surface O.D. (Bottom)	1.000 - .9995 25,400 - 25,387	1.000 - .9995 25,400 - 25,387	.6245 - .6240 15,862 - 15,850	.6245 - .6240 15,862 - 15,850
Idler Shaft O.D.	--	--	.622 - .6225 15,799 - 15,811	.622 - .6225 15,799 - 15,811
Idler Gear I.D.	--	--	.626 - .6265 15,900 - 15,913	.626 - .6265 15,900 - 15,913

	VRD 155	VRD 232	VRD 283	VRD 310
<b>ROCKER ARMS</b>				
Rocker Arm I.D.	.7445 - .7455 18,910 - 18,936	.7445 - .7455 18,910 - 18,936	.7445 - .7455 18,910 - 18,936	.7445 - .7455 18,910 - 18,936
Rocker Arm Shaft O.D.	.742 - .743 18,847 - 18,872	.742 - .743 18,847 - 18,872	.7425 - .7435 18,859 - 18,885	.7425 - .7435 18,859 - 18,885
Rocker Arm Running Clearance	.0015 - .0035 0,038 - 0,088	.0015 - .0035 0,038 - 0,088	.001 - .003 0,025 - 0,076	.001 - .003 0,025 - 0,076

	VRD 155	VRD 232	VRD 283	VRD 310
<b>FLYWHEEL HOUSING</b>				
Pilot Bearing Runout	.005" (0,127mm)	.005" (0,127mm)	.005" (0,127mm)	.005" (0,127mm)
Flywheel Face Runout	.008" (0,203mm)	.008" (0,203mm)	.008" (0,203mm)	.008" (0,203mm)
Flywheel Housing Bore Runout	.006" (0,152 mm)	.008" (0,203 mm)	.008" (0,203 mm)	.008" (0,203 mm)
Flywheel Housing Face Runout	.006" (0,152mm)	.008" (0,203 mm)	.008" (0,203 mm)	.008" (0,203 mm)

**REPAIR AND REPLACEMENT**

**ENGINE TIMING DATA**

**VR Gas and Gasoline Ignition Timing**

	VRG 155	VRG 232	VRG 265/283	VRG 310
Distributor Timing (Gasoline)	TDC @ 450 RPM	TDC @ 450 RPM	TDC @ 450 RPM	TDC @ 450 RPM
Distributor Timing (Gas)	TDC @ 450 RPM	TDC @ 450 RPM	TDC @ 450 RPM	TDC @ 450 RPM
Magneto Timing (Gasoline)	N/A	20° BTDC @ 12 - 1500 RPM 24° BTDC @ 16 - 1800 RPM 26° BTDC @ 19 - 2200 RPM	20° BTDC @ 12 - 1500 RPM 24° BTDC @ 16 - 1800 RPM 26° BTDC @ 19 - 2200 RPM	20° BTDC @ 12 - 1500 RPM 24° BTDC @ 16 - 2200 RPM 26° BTDC @ 19 - 2400 RPM
Magneto Timing (Gas)	N/A	20° BTDC @ 12 - 1500 RPM 24° BTDC @ 16 - 1800 RPM 26° BTDC @ 19 - 2200 RPM	30° BTDC @ 12 - 1500 RPM 34° BTDC @ 16 - 1800 RPM 36° BTDC @ 19 - 2200 RPM	30° BTDC @ 12 - 1500 RPM 36° BTDC @ 16 - 2200 RPM 38° BTDC @ 22 - 2400 RPM

**Timing Gear Backlash**

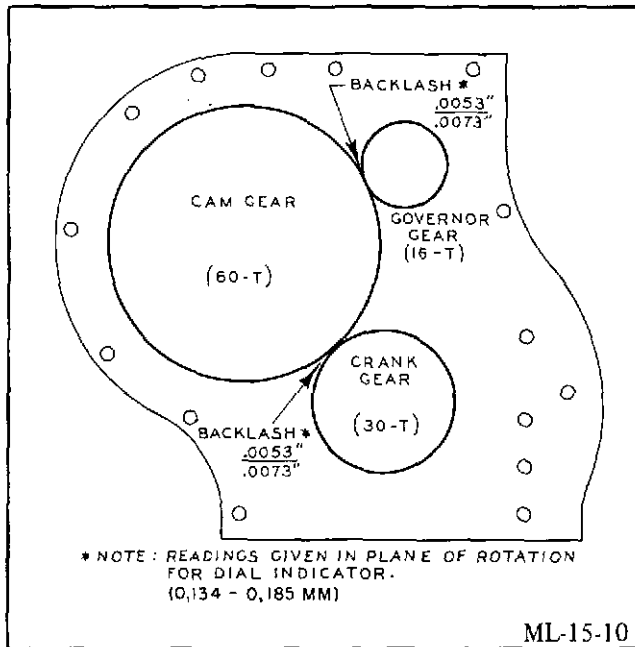

**TIMING GEAR BACKLASH DIAGRAM**

Note: Backlash stated for reading with a dial indicator. If feeler gauge is to be used, backlash will be .004 - .006" (0,101 - 0,152 mm).

**Valve Timing**

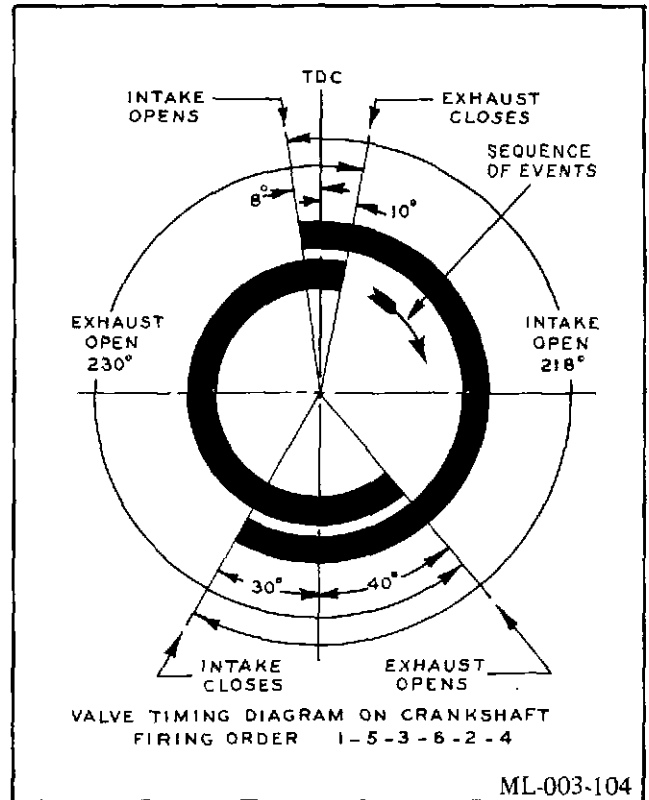

**TYPICAL VALVE TIMING DIAGRAM**

**Timing Gear Bushings**

	VRG Series		VRD Series
Governor Gear Bushing I.D.	1.0022 - 1.003 25,456 - 25,476	Idler Spindle Bushing I.D.	1.0015 - 1.002 25,438 - 25,451
Governor Gear Hub O.D.	.999 - .9995 25,375 - 25,387	Idler Spindle O.D.	1.000 - .999 25,400 - 25,375

# INSTALLATION

SCOPE .....	5-3
AUTOMATIC STARTING .....	5-3
SPACE REQUIREMENTS .....	5-3
STATIONARY INSTALLATIONS .....	5-3
PREPARING UNIT FOR SERVICE .....	5-3
COOLING SYSTEM .....	5-4
AIR INTAKE SYSTEM .....	5-5
EXHAUST SYSTEM .....	5-5
LUBRICATING OIL SYSTEM .....	5-6
CHECKING FLYWHEEL AND HOUSING RUN-OUT AND CRANKSHAFT ENDPLAY .....	5-7

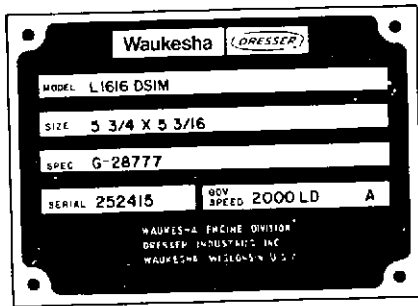

ALWAYS SPECIFY THE ENGINE MODEL DESIGNATION, SPECIFICATION NUMBER, AND SERIAL NUMBER, AS FOUND ON THE ENGINE NAMEPLATE.



GENUINE WAUKESHA PARTS ARE AVAILABLE WORLDWIDE AND MUST BE ORDERED THROUGH YOUR LOCAL WAUKESHA DISTRIBUTOR. FOR THE DISTRIBUTOR CLOSEST TO YOU, REFER TO THE DISTRIBUTOR LISTING IN THIS MANUAL.

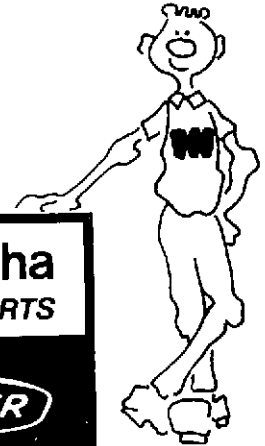

## PARTS ORDERING

ANTICIPATE YOUR PARTS REQUIREMENTS:

- a) ORDER PARTS EARLY IN THE DAY.
- b) KEEP A SUPPLY OF NORMAL MAINTENANCE PARTS IN STOCK.
- c) OBTAIN A PARTS STOCKING RECOMMENDATION FROM YOUR DISTRIBUTOR.

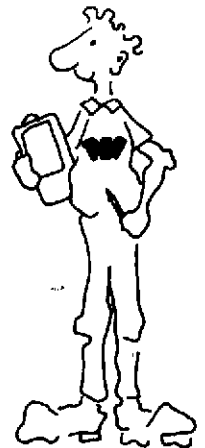

ALWAYS INCLUDE THE PART NUMBER, WHEN KNOWN, ALONG WITH THE DESCRIPTION OF THE PART, STATE THE QUANTITY OF THE PART YOU WISH TO ORDER. IF A SPECIAL PART IS NEEDED, THE ENGINE APPLICATION SHOULD ALSO BE STATED.

EXAMPLE: 172607 - Filter Element - (1) Ordered.

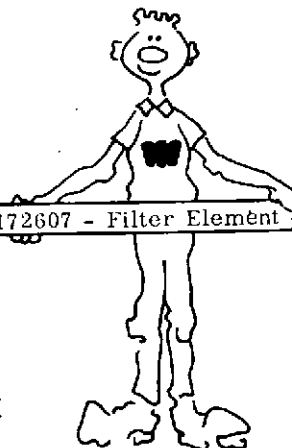

## SCOPE

These are general installation requirements. For more specific and detailed installation requirements, refer to the Waukesha Engine Division Installation Manual.

## AUTOMATIC STARTING

We recommend the inclusion of lube oil heaters and automatic prelube systems for installations of Waukesha engines which are subjected to unscheduled automatic starts and instantaneous loading.

## SPACE REQUIREMENTS

In order to ensure adequate access for engine installation, ventilation and in-service maintenance, engine location must be carefully considered.

The engines described in this manual require a minimum of 24 inches between engines or between engine and wall. End clearance required to remove camshaft is 36 inches. Sufficient overhead clearance is required to permit the use of a chain hoist for removal of heavy engine parts. The heaviest part of these engines is the crankcase which weighs approximately 270 lbs.

To prevent foreign objects from entering the engine, leave covers on all engine openings until ready to connect the openings during installation.

## STATIONARY INSTALLATIONS

### Engine Foundations

Nearly all stationary engine applications require a foundation or mounting base. This base serves to isolate the engine from the surrounding structure and absorb or inhibit vibration. A base provides a permanently accurate surface upon which the engine (and usually the driven equipment) may be mounted and aligned. To serve these purposes, the foundation must have a suitable size and mass, rest on an adequate soil or bearing surface, be provided with an accurately finished mounting surface for the engine, and be equipped with properly sized retaining bolts in the correct locations to secure the engine firmly in position.

### Mounting

No engine will perform properly if incorrectly installed and aligned. Any misalignment of mountings imposes stresses on engine structure with possible damage to flywheel housings, flywheels, crankshafts and thrustbearings. When making a new installation, a well-planned arrangement of the fuel, water, and exhaust systems is important. Because of the variety of power application, the VR Series engines will be found mounted in mobile and stationary applications. In all cases it is most important that proper mountings be selected for the specific application. If the engine and driven equipment have separate foundations, alignment is critical. To insure proper alignment inspect foundations for weld spatter, burrs, foreign matter or uneven surfaces. It is plainly a waste of time to attempt alignment if the foundation is not level and clean.

## Alignment

It is always desirable to have some shims under both engine and driven equipment so future alignment problems at time of rebuilding or replacement will not present a problem.

The nature of any shimming procedure is essentially "cut and try". Use easily cut steel or brass shim stock to make up trial shim pads. Remember the area of the shim pad must be large enough to support the weight of the engine when the bolts are tightened.

After the engine has been leveled and tightened down, the driven equipment can be aligned. In the case where the driven equipment is mounted permanently, the engine will have to be aligned relative to the driven equipment.

When engine and driven equipment are mounted on a common skid base, shims should be used under both units which will compensate for roughness and unevenness of the rolled or fabricated skid rails. This will also provide shims under drive and driven units for final alignment. Usually the heaviest machine is permanently mounted and the lightest aligned to the heaviest.

The correct aligning procedure may vary slightly with different types of drive equipment. Many manufacturers of driven equipment will specify the method used to align their equipment. In general, the object is the same; to make the driven shaft concentric with the driver shaft and to make the centerline of the driven shaft parallel with the centerline of the driver shaft.

If at all possible, final shims should be steel plates of such thickness that only the last few odd thousandths need be filled out with thinner shim stock. Always use shims of adequate width to permit the full base mounting area to bear on them. Do not shim just the outer edge of the engine base.

## PREPARING UNIT FOR SERVICE

Inspect all identification and data plates and comply with all servicing instructions. Compare data plates with information contained in invoices or packing slips to insure receipt of equipment as ordered.

Inspect entire engine for damage, loose connections, broken or sharply bent lines, and loose nuts or bolts. If tape or temporary coverings are torn or missing from engine openings, such as intake, exhaust, water or fuel, a thorough inspection is required to determine the possible presence of foreign objects in these openings.

The steps needed to bring an engine into active service are basically the same for a new engine or one that has been in storage. In addition to a very detailed visual inspection, check for free rotation. Any accumulated dust and dirt should be wiped or washed from the exterior before removing engine opening covers. Engines that have not been rotated for some time should be oiled through the spark plug or injector openings and cranked by hand before actual running. Any resistance to free cranking should be investigated; rust and corrosion can cause severe seizure that cannot be cleared without engine disassembly.

Never attempt to start a Diesel engine that has been stored without first inspecting intake passages and manifolds for thickened preservative oil. Then crank it over with the injectors out. Spurting oil, water or preservative compound from these openings indicates the possibility of a hydraulic lock. Continue to crank engine with starter until liquid is no longer ejected from openings.

Fill the crankcase with proper grade and viscosity oil to the full mark on the oil depth gauge. Fill oil bath air cleaners with engine oil to proper level as required.

If conditions permit, the cooling system should be filled with soft water. After the cooling system has been checked and any leaks have been repaired, drain a portion of the water and add an inhibitor or antifreeze as required. Soluble oil may be used as an inhibitor, one ounce oil per gallon of coolant.

Fill the fuel tank with appropriate fuel. The fuel supply should be checked for adequate flow as well as leaks. Diesel engine supply is considered adequate when there is a solid stream of fuel at the inlet to the injection pump. All air should be purged from the diesel fuel supply system. The diesel fuel system should be hand primed until the operator determines that fuel is delivered to the injection transfer pump. Ordinarily it is not necessary to purge the fuel lines between the injection pump and the injectors. If necessary, this can be done by loosening the injector lines at the injectors and cranking the engine until solid fuel is ejected during cranking.

Check connections for proper battery polarity. Pour the acid into the dry batteries and see that the battery plates are covered with solution. Connect the batteries and control wires. When a dry charge battery is used, the battery should be charged prior to use.

## COOLING SYSTEM

### Cooling System Design

Premature engine component failures and abnormal operating and maintenance conditions can often be traced to improper design or sizing of radiators or other coolers.

The Waukesha Engine Division will not be responsible for engine or component failure when the following cooling system design and application recommendations are not followed.

#### Recommendation for Specifying a Radiator or Other Cooler Design for Continuous Duty Operation.

1. Use 185° F. engine water outlet temperature. On compressor applications, use 180° F. engine water outlet temperature to agree with A.P.I. Standard 11K.
2. Base water flow and temperature rise across radiator core or cooler on jacket water pump curve.
3. Pressure drop through radiator core or cooler with full water flow at rated speed must not exceed 3 to 5 psi.

4. Allow 15% reserve for variations in application and environmental conditions, i.e., wind direction, dirt and debris. This is in addition to normal design fouling factors.
5. When possibility of using 50-50 solution of ethylene glycol exists, radiator core or cooler area should be sized 15% larger since there is a 15% reduction in heat transfer coefficient for ethylene glycol when compared with water.
6. Select radiator or cooler for highest ambient or sea water temperature that will be experienced in operation. For radiators, allowance must be made for air temperature rise across engine with blower fan, or in engine room if suction fan is used.
7. Radiators and surge tanks must have 7 psi pressure caps.
8. Provision must be made for de-aeration of coolant, such as divided top tank or separate surge tank.
9. Provision must be made for balance line connection to engine pump suction to prevent pump cavitation.
10. Adequate expansion volume for complete cooling system must be provided in radiator or separate surge tank.
11. Provisions must be made for connecting auxiliary pump to circulate water through oil cooler and/or intercooler where applicable.
12. Maximum back pressure, feeding into radiator or cooler, should not exceed 5 psi at 2000 RPM.
13. Maximum inlet head to jacket water pump is 20 feet of water.

#### Recommendation for Specifying a Radiator or Other Cooler Design for Intermittent or Standby Operation

Same as for Continuous Duty Operation, except:

1. Use 200° F. (instead of 185° F.) engine outlet temperature.
2. Allow 5% (instead of 15%) reserve for variations in application and environmental conditions.

#### Recommendation for Specifying a Radiator or Other Cooler Design for Torque Converter Application

When the engine cooler is used for cooling a torque converter in addition to the engine, the core or cooler surface should be at least 30% larger than the core required for the engine alone.

### Cooling System Capacity

To prevent rust when using water alone, either use a recommended corrosion preventive or inhibitor, or add one ounce of soluble oil for every gallon of coolant in the cooling system.

Ethylene Glycol	Radiator Glycerine (G.P.A.)	Freezing Points	
		oF.	oC.
16%	37%	20	-7
25%	55%	10	-12
33%	70%	0	-18
39%	81%	-10	-23
44%	92%	-20	-29
48%	100%	-30	-35

**Cooling System Installation Recommendations**

After the cooler installation is completed and prior to filling the cooling system, clean all dirt and welding spatter from low points in the system. Flush accessible sections of the piping and cooler to eliminate as much dirt as possible prior to operation of the engine.

After filling the system, check closely for leaks. Tighten all clamps and fittings prior to engine start-up to avoid loss of time at start-up.

The following installation suggestions are offered to improve cooling system performance and make future maintenance easier and less time consuming:

1. Mount all cooling system components such as water inlet connections, control valves, and raw water pumps with at least enough clearance to permit normal maintenance and removal and replacement of accessories at the front of the engine without major disruption of the cooling system.
2. Use suitable couplings so large portions of the piping and valves and raw water pump complex may be disconnected and moved aside as a unit for engine repair and maintenance. This avoids removal of individual pieces of pipe and "working backwards" to reach a given threaded connection.
3. Provide convenient drainage points to remove water from both fresh water and raw water systems.
4. Provide easily opened air vents to remove air blocks from cooling system piping and allow immediate priming of system.
5. Mount all belt driven water pumps so belts may be tightened easily while operating. Locate pump couplings and drive pulleys so packing can be removed and replaced without major disassembly or pump removal.
6. Keep the system clean!
7. Avoid electrolysis; use zinc anodes or other cathodes protection.

**AIR INTAKE SYSTEM**

Huge quantities of combustion air are required for all internal combustion engines. Combustion air requirements for VR Series engines may be obtained from your Waukesha sales engineer.

Certain factors must be considered to ensure an adequate clean supply of combustion air for internal combustion engines. These are as follows:

1. Combustion air required for engines installed in heated, air conditioned buildings may upset heating and ventilating calculations unless it is supplied via an external air intake.
2. If an external air intake is required, it must be suitably designed to supply intake air of the proper temperature range (high intake air temperature results in power loss while extremely cold intake air may hinder starting of automatic standby units), to prevent pick up of exhaust gas materials or exhaust from other industrial operations (such as foundry dust or paint spray), to prevent pick up of flammable vapors, and to prevent entry of rain and water.
3. All ducting, as well as air cleaner to manifold connections, must be airtight to avoid the intake of unfiltered air.
4. The restriction through the air intake system must be kept to a minimum. Restricted inlets, sharp or numerous bends and undersized ducting will all increase restriction unnecessarily.
5. Engine heat radiation will affect ambient air temperatures in building installations. Properly located intake and exhaust fans will be required when necessary to ventilate engine rooms.

**EXHAUST SYSTEM**

The huge quantities of combustion air consumed by internal combustion engines must be properly exhausted after combustion occurs. Therefore, every possible provision must be made to minimize restriction with resultant back pressure of an exhaust system.

Some of the adverse effects of excessive back pressure are loss of power, poor fuel economy, excessive valve temperatures and engine coolant overheating.

If exhaust back pressure is found to be excessive, check for undersized piping, undersized or inefficient silencer or muffler, or excessive bends or restrictions in the exhaust line. Correct any deficiencies.

Exhaust pipes must be adequately sized and supported. A condensate trap and drain must be provided at some low point ahead of the engine exhaust manifold. The back pressures caused by elbows and other pipe bends prohibit their use in a well designed exhaust system. Always use welded tube turns with a radius of four or five diameters. Multiple exhaust connections to a common header are not recommended, as this can result in erratic operation and damage.

Sometimes, pulsing effects can set up interferences in a single straight pipe, thus making it advantageous in every installation to locate the silencer as close to the engine as possible.

Attention must be given to adequate silencing of the engine, as unnecessary noise is objectionable and a public nuisance. Objectionable noise is unnecessary today with the available mufflers which can be used for silencing.

Before using any vent passage or chimney in an existing structure not specifically designed for service as an engine exhaust passage, it should be carefully checked for compliance with all fire and venting codes. It is extremely poor practice to discharge engine exhaust into a brick, tile, cement block, or structure of like material. The characteristics of the exhaust pulsations are very capable of causing severe structural damage.

Exhaust flow requirements for VR Series engines may be obtained from your Waukesha sales engineer.

**LUBRICATING OIL SYSTEM**

Lubricating oil specification recommendations are contained in the Preventive Maintenance Unit. The installation should include adequate provisions for draining lube oil.

**Angular Operating Limits**

Adherence to angular operating limits is very important to successful operation in many engine applications and users should be cautioned when job requirements are such that the engine can be tilted to extreme angles. (Refer to Service Bulletin 14-1629 for VR tilt angles). This sometimes occurs when machines have been modified for jobs different from their original purpose without proper consideration to the type of oil pan or oil pump used. In other cases the ramps or stockpiles on which the machine is working are too steep and the engine loses oil pickup each time the engine is tilted. Obviously, loss of oil pressure, even for brief periods, can have destructive results.

**Fuel System**

The fuel piping, if a remote fuel tank is used, must be adequately supported to prevent breakage from weight or vibration. A flexible section should be installed in the line, or lines, as close to the engine as possible. Back flush all diesel and gasoline fuel lines into an open container prior to final connection. This simple procedure will further eliminate the possibility of fuel contamination. Connections and couplings must be tight to eliminate leaks and air leakage into the fuel system.

Industrial engines may require a different piping arrangement to suit application peculiarities and performance demands. Generator sets, for example, are particularly sensitive to air and usually require a separate electrically or mechanically driven auxiliary supply pump to deliver fuel, at low pressure, to the unit day tank. This places a positive head of fuel at the transfer pump and virtually eliminates entrance of air to the system. (See accompanying illustrations).

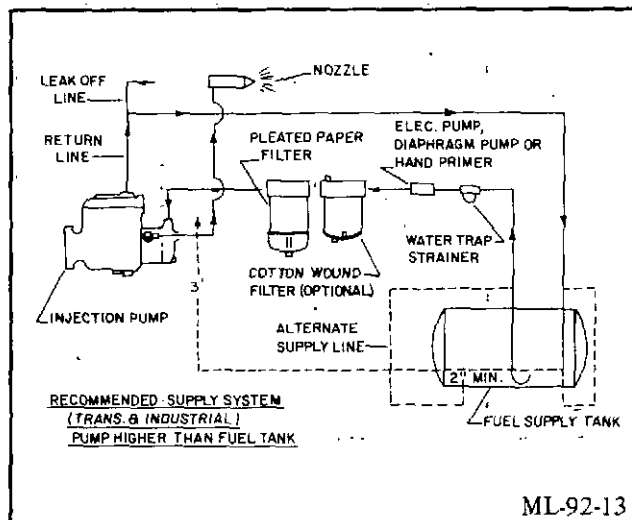

(FUEL SUPPLY PIPING DIAGRAM)

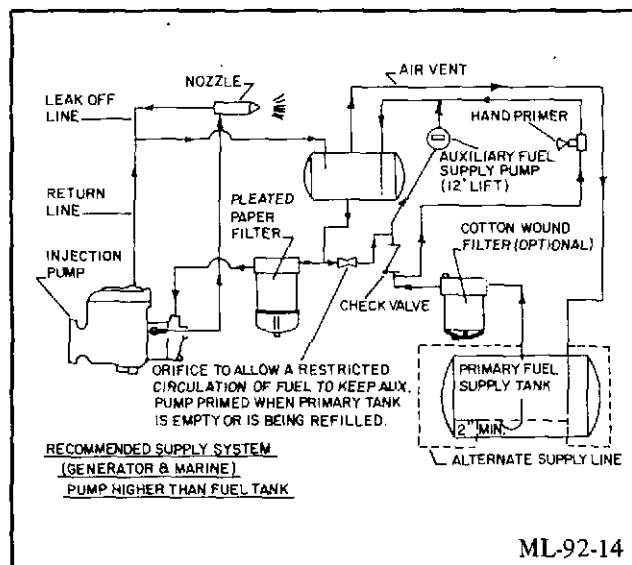

(FUEL SUPPLY PIPING DIAGRAM)

Proper selection of piping sizes, filter capacities and layout of the system must be made to prevent undue restriction which would affect pump and engine performance. Of equal importance, is the necessity for utmost cleanliness of fuel before and during handling. Admission of minute foreign particles, even in small quantities, will seriously wear the close clearances necessary to seal against internal hydraulic leakage.

Outside storage, as well as vehicle and unit tanks, should be guarded against entrance of dirt. They should have drains to remove water and settleings periodically, be adequately vented and kept as full as possible to prevent condensation. Attendant piping should not be galvanized. Rigid observance of fuel cleanliness standards from time of purchase to ultimate use will do much to assure trouble-free operation.

## CHECKING FLYWHEEL AND HOUSING RUN-OUT AND CRANKSHAFT ENDPLAY

Even with the best maintenance, an engine can encounter trouble if such things as proper mounting, alignment with other equipment, flywheel and housing runout and sufficient crankshaft endplay are disregarded in the initial installation or in subsequent relocations of the engine. Although flywheel and housing runout and crankshaft endplay are firmly established within limits at the factory, such things as rough handling or improper installation of power takeoffs or clutches may adversely affect these clearances and lead to serious engine damage. These items should be checked prior to operation.

A major factor in obtaining long service life from any engine and clutch or power takeoff assembly is the proper alignment of the flywheel housing, flywheel and pilot bearing bore. Distortion or lack of a common center on either of these parts will set up forces sure to be destructive to bearings, crankshaft, clutch, and the driven equipment. In addition, because of normal manufacturing tolerances, when an engine is installed in a mounting formerly occupied by another engine, it is not safe to assume that the drive shaft of the power takeoff will automatically line up with a coupling located for the previous engine. In such circumstances, either the engine mounts must be shimmed or adjusted, or the driven mechanism must be relocated and adjusted a few thousandths to bring the entire drive line from crankshaft bearings to driven shaft coupling into good alignment.

Make the following check for flywheel housing bore concentricity:

1. Support a dial indicator in the same general manner as shown and check the runout of the housing bore all the way around.

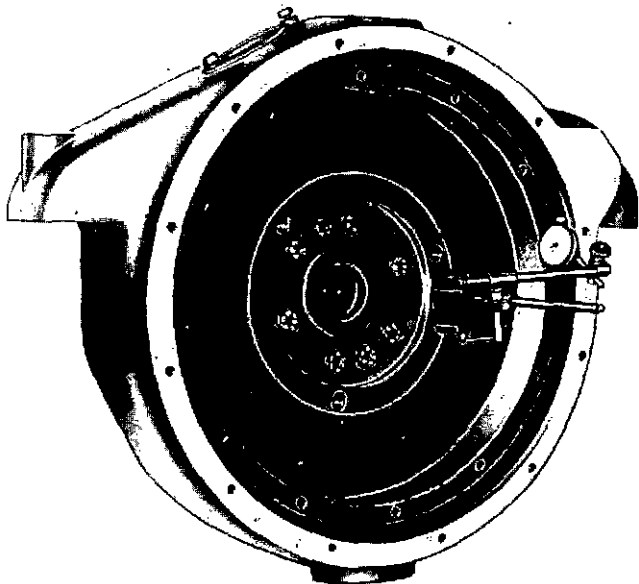

MH-13-4  
CHECKING HOUSING BORE RUN-OUT

2. If the flywheel housing is out of alignment, loosen all of the flywheel housing bolts and proceed as follows.

3. Use a small bar inserted in a bolt hole to correct misalignment until the runout does not exceed .008" (.006" for VRD and VRC155) total indicator reading.
4. Tighten bolts partially, working back and forth across the housing. Recheck bore concentricity with dial indicator.

Relocate the dial indicator as shown to indicate the flywheel housing face.

1. Housing face runout should not exceed .008" (.006" for VRD and VRC155) total indicator reading. If correction is required, it should be done with a cutting tool mounted on a radius arm and firmly attached to the flywheel. Thus, by rotating the crankshaft by means of a suitable drive, the cutting tool will dress the housing face into a plane in alignment with the crankshaft flange.
2. When making the above inspection, it is very important not to be misled by end movement of the crankshaft. To prevent this, use a pry bar to bring the shaft into full forward position at each point where the indicator reading is taken.

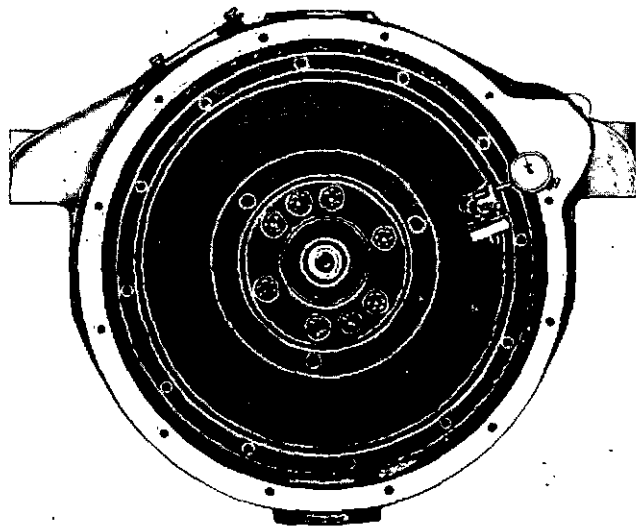

MH-13-3  
CHECKING HOUSING FACE RUN-OUT

Mount a dial indicator on the flywheel housing as shown and check the runout of the pilot bearing bore. Runout should not exceed .005" total indicator reading.

Remount the dial indicator as shown to measure the runout of the flywheel face. Again, it is emphasized that each reading must be taken with the crankshaft moved all the way forward to contact the thrust bearing. Unless rough handling has somehow distorted the wheel or crankshaft flange, maximum runout should not exceed .008" total indicator reading.

Measure crankshaft endplay with a dial indicator mounted on the crankcase. Use a small pinch bar to move the crankshaft fully forward. Set the indicator at zero and use the bar to thrust the shaft to fully rearward. Check endplay reading on dial indicator with the tolerance given in the Fits and Clearances section.

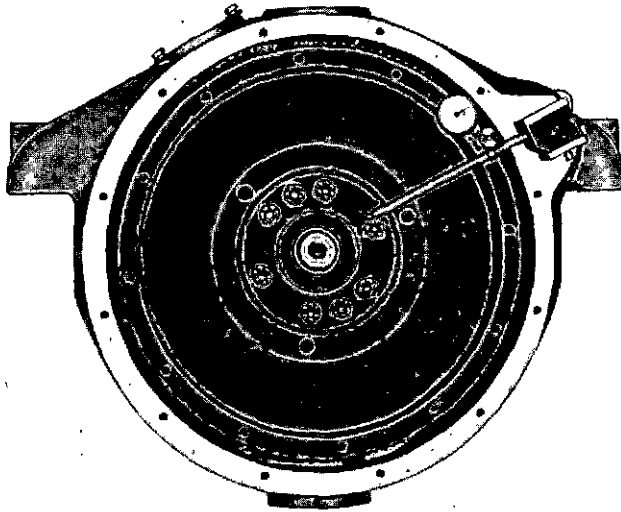

CHECKING FLYWHEEL FACE  
RUN-OUT

MH-13-2

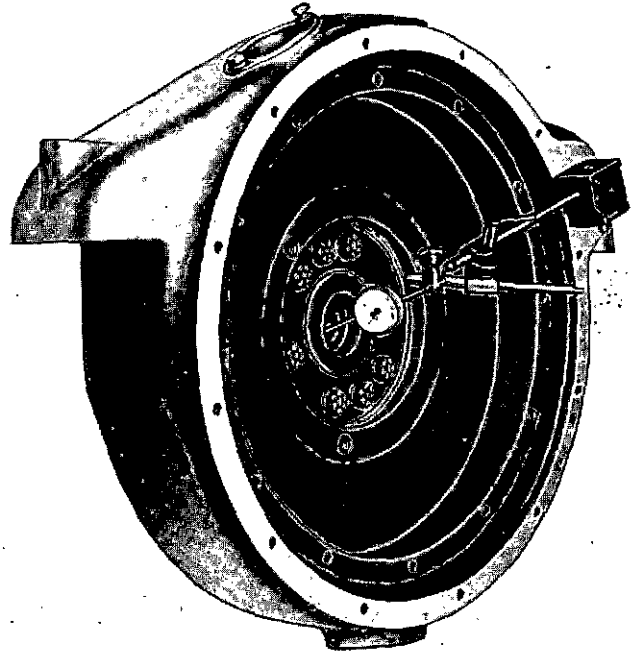

CHECKING PILOT BEARING  
BORE RUN-OUT

MH-13-1

**CAUTION**

The importance of correct crankshaft endplay cannot be overstressed. Operation of an engine having insufficient or excessive crankshaft endplay can result in serious damage. Insufficient clearance will prevent proper lubrication of the thrust surfaces, causing main bearings to overheat and lock on the shaft.

**Waukesha**

**DRESSER**