

WAUKESHA



MOTOR COMPANY

Service Manual

F-1861

570

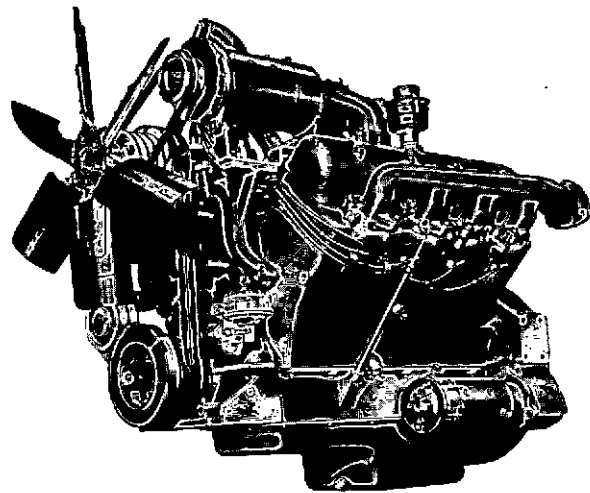

MODEL

884

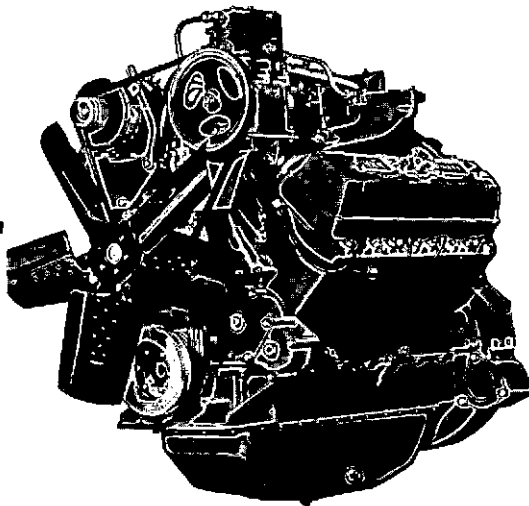

Engines

WAUKESHA MOTOR COMPANY

General Office and Factory

WAUKESHA, WISCONSIN, U. S. A.

Eastern Office: 1156 East Ridgewood Ave., Ridgewood, New Jersey 07451

Mid-Continent Office: 2815 East Skelly Drive, Tulsa, Okla. 74105

Pacific Coast Office: P.O. Box 1025, Downey, California 90240

Alaskan Office: 239 E. International Airport Road, Anchorage, Alaska 99502

Waukesha

TECHNICAL PUBLICATIONS ORDER FORM

PREVIOUS PRODUCTION ENGINES

MODEL	TYPE OF MANUAL	FORM	PRICE	QTY.
FC Gas	Operation and Maintenance	1715	30.00	
FC Gas	Parts	4977	30.00	
F11G/GSI	Operation and Maintenance	6236	30.00	
Engines built before July 1992	Repair and Overhaul	6237	50.00	
F11G/GSI	Parts	6235	30.00	
Engines built before July 1992	Parts - Spanish	6244	30.00	
F18DS/DSI	Parts	6233	30.00	
F1197D Series	Operation and Maintenance	1430	30.00	
F1197D Series	Parts	3974	30.00	
F1197DM - Marine	Operation and Maintenance	4082	30.00	
F1197GR	Parts	5111	30.00	
Marine Systems	Installation	5620	30.00	
F11905D Series (Clinton)	Operation and Maintenance	1613	30.00	
F11905D Series (Clinton)	Parts	4160	30.00	
F11905GR (Clinton)	Operation and Maintenance	1620	30.00	
F11905G (Clinton)	Parts	6224	30.00	
F2895D, F2896D, L5790D, L5792D	Parts	5939	30.00	
F3335D/DSI, L6670D/DSI	Operation and Maintenance Supplement (Must Use With 5579)	5579S	10.00	
F3335D/DSI, L6670D/DSI	Parts	105	30.00	
P8894DSI	Operation and Maintenance	1179	30.00	
P8894DSI	Parts	1181	30.00	
F2894D/DS Series	Operation and Maintenance	1523	30.00	
F2894D/DS Series	Parts	2841	30.00	
F2894G Series	Operation and Maintenance	1450	30.00	
F2894G Series	Parts	2589	30.00	
F3520G Series	Operation and Maintenance	1450	30.00	
F3520G Series	Parts	2812	30.00	
16 cyl. G/GSI	Operation - French	5108FR	20.00	
L6670D/DSI	Parts - French	105FR	30.00	
F554G Series	Operation and Maintenance	1476	30.00	
F554G Series	Parts	4877	30.00	

MODEL	TYPE OF MANUAL	FORM	PRICE	QTY.
F817 (Onan)	Parts	5200	30.00	
H24DS/DSI	Parts	6234	30.00	
H2475/6G (Clinton)	Operation and Maintenance	SA 642	30.00	
H2475G (Clinton)	Parts	SA 636	30.00	
H2476G (Clinton)	Parts	6225	30.00	
H570-H884 (Rolline)	Operation and Maintenance	1861	30.00	
H570G Series (Rolline)	Parts	2946	30.00	
H884G Series (Rolline)	Parts	2868	30.00	
H1077G/GSI Series (VC)	Parts	5341	30.00	
H1077G/D Series (VC)	Operation and Maintenance	5577	30.00	
H1077D Series (VC)	Parts	5392	30.00	
H540 GAS (Rolline)	Parts	1326	30.00	
ICK Gas	Operation and Maintenance	1585	30.00	
ICK Gas	Parts	4103	30.00	
K-67, K-75, V-80 (Climax)	Operation and Maintenance	SA410G	30.00	
V-80, V-85 (Climax)	Parts	SA570B	30.00	
V-122, V-125 (Climax)	Parts	SA 612	30.00	
L3711/12G (Clinton)	Operation and Maintenance	SA 642	30.00	
L3711G (Clinton)	Parts	SA 635	30.00	
L3712G (Clinton)	Parts	6226	30.00	
L5100D Series	Operation and Maintenance	1675	30.00	
L5100D Series	Parts	4533	30.00	
L5100GR Series	Operation and Maintenance	4642	30.00	
L5100GR Series	Parts	4213	30.00	
L5788D Series	Operation and Maintenance	1675	30.00	
L5788D Series	Parts	2458	30.00	
L5788G Series	Operation and Maintenance	4642	30.00	
L5788G Series	Parts	2457	30.00	
L7040G Series	Parts	3885	30.00	
L1616G/D (VC)	Operation and Maintenance	5577	30.00	
L1616G Series (VC)	Parts	5223	30.00	
L1616D Series (VC)	Parts	5316	30.00	
LRD Series	Operation and Maintenance	1523	30.00	
LRD Series	Parts	2841	30.00	
LRO, LRZ, NKR, VLROB	Operation and Maintenance	1843SP	30.00	

MODEL	TYPE OF MANUAL	FORM	PRICE	QTY.
LRO, LROR, LRZ Series	Operation and Maintenance	1450	30.00	
NKR Series	Operation and Maintenance	1620	30.00	
P2154G/D Series (VC)	Operation and Maintenance	5577	30.00	
P2154D Series (VC)	Parts	5562	30.00	
RR 180 Turbocharger	Operation and Maintenance	1184	30.00	
Service Data Handbook		128	30.00	
T-H8884G Series (Rolline)	Parts	2955	30.00	
VLRD Series	Operation and Maintenance	1675	30.00	
VLRD Series	Parts	2458	30.00	
VLRO Series	Operation and Maintenance	4642	30.00	
VLRO Series	Parts	2457	30.00	
VHP Series - Spanish	Operation and Maintenance	5579SP	30.00	
Waukesha Injection Pump	Parts & Overhaul	106	30.00	
130H (Hesselman)	Operation and Maintenance	908N	30.00	
135G Series	Operation and Maintenance	1654	30.00	
135G Series	Parts	5003	30.00	
135D Series	Operation and Maintenance	1645	30.00	
135D Series	Parts	2535	30.00	
140G Series	Operation and Maintenance	1476	30.00	
140G Series	Parts	4877	30.00	
140H & 145H Series	Operation and Maintenance	908N	30.00	
145G Series	Operation and Maintenance	1476	30.00	
145G Series	Parts	156	30.00	
148DK Series	Operation and Maintenance	1538	30.00	
148DK Series	Parts	1766	30.00	
General Gas	Operation and Maintenance	1131	30.00	
6B Series	Parts	1577	30.00	
6LRO Series	Parts	2589	30.00	
6LHZ Series	Parts	2812	30.00	
6M Series	Parts	1555	30.00	
6NKD Series	Operation and Maintenance	1613	30.00	
6NKD Series	Parts	4160	30.00	
6WAKD Series	Operation and Maintenance	1430	30.00	
6WAKD Series	Parts	3974	30.00	
6WAK-6WAKH	Parts	1593	30.00	
6WAKC GAS	Parts	3008	30.00	
6WAKR Series	Parts	2435	30.00	
8L-AT25/27GL	Parts	6257	30.00	

For **Previous Production** engines not shown on this form, please fill out the following:
Please type or print:

PREVIOUS PRODUCTIONS ENGINES (Archive manuals not shown on this form)

Engine Model: _____
 Operation and Maintenance: _____
 Parts: _____
 Quantity: _____

MICROFICHE	FORM	PRICE	QTY.
Microfiche Conversion w / tubs, covers, dividers, labels and index book. (REELS 1 THRU CURRENT RELEASE)	516	1,400.00	
Microfiche Conversion w / tubs, covers, dividers, labels and index book. (REELS 1 THRU 117 ONLY)	517	1,150.00	
Microfiche Conversion only (REELS 1 THRU 117)	518	1,100.00	
Microfiche single reels Reel # _____	519	20.00	
ENGINE SPECIFICATIONS - (List C or G-number)	FORM	PRICE	QTY.
Specification packs: ¹			
C# _____	520	90.00	
Specification packs: ²			
G# _____	521	180.00	

¹ = Computer printout of current database.
² = Non-electronic data/hand-pulled.

Note: For Current Production engine manuals, see Form 215A.

Please type or print: **Minimum Order... \$50.00**

Company: _____
 Address: _____
 Attn: _____
 Ship Via: _____
 Purchase Order No. _____

MAIL TO:

Waukesha Engine Division
 Dresser Industries, Inc.
 1000 W. St. Paul Avenue
 Waukesha, WI 53188-4999

ATTN: ADMINISTRATIVE SERVICES
 Telex: 26769 Rapiflex: 414-549-2703

The manufacturer reserves the right to change prices, specifications and design at any time without notice, and without incurring obligation. All prices quoted U.S. Dollars, F.O.B. Waukesha, Wisconsin unless otherwise indicated.

Waukesha



TECHNICAL PUBLICATIONS ORDER FORM

CURRENT PRODUCTION ENGINES

MODEL	TYPE OF MANUAL	FORM	PRICE	QTY.
AT SERIES				
12V-AT25/27GL	Operation and Maintenance 6th Edition	6240	30.00	
12V-AT25/27GL	Parts 2nd Edition	6245	30.00	
12V-AT25GL	Repair and Overhaul 1st Edition	6247	75.00	
8L-AT25/27GL	Operation and Maintenance 3rd Edition	6254	30.00	
8L-AT27GL	Parts 1st Edition	6269	30.00	
8L-AT25/27GL	Repair and Overhaul 1st Edition	6265	75.00	

VHP SERIES

F2895G, F3521G, L5108G, L5790G, L7042G, F2895D, F2896D, L5790D, L5792D	Operation and Maintenance 8th Edition	5579	30.00	
6, 12, 16 cyl. GL	Operation and Maintenance	6230	30.00	
5115GL	Operation and Maintenance 1st Edition	6266	30.00	
5115GL	Parts 1st Edition	6271	30.00	
6 cyl. G/GSI	Parts	5743D	30.00	
6 cyl. GL	Parts	6219	30.00	
12 cyl. G/GSI/GL	Parts	6246	30.00	
12 cyl. GL (Draw Thru)	Parts - Supplement	6220S	10.00	
5108, 5790, 7042G/GSI/GL	Repair & Overhaul 1st Edition	6248	100.00	
16 cyl. G/GSI	Operation and Maintenance	5108	30.00	
	Parts	1093A	30.00	
16 cyl. GL	Parts	6221	30.00	

MODEL	TYPE OF MANUAL	FORM	PRICE	QTY.
-------	----------------	------	-------	------

INTERMEDIATE SERIES

F817G	Operation and Maintenance	4192	30.00	
	Parts	156	30.00	
F1197G	Operation and Maintenance	1660B	30.00	
	Parts	4922	30.00	

VGF SERIES

F18G/GL/GLD, H24G/GL/GLD	Operation and Maintenance 2nd Edition	6238	30.00	
F18G/GL, H24G/GL	Repair and Overhaul	6243	50.00	
F18G/GL/GLD, H24G/GL/GLD	Parts	6252	30.00	
L36/P48GL/GLD	Operation and Maintenance 2nd Edition	6249	30.00	
L36/P48GL/GLD	Parts 2nd Edition	6260	30.00	

VSG SERIES

F11G/GSI/GSID	Operation and Maintenance 2nd Edition	6250	30.00	
F11G/GSI/GSID	Repair and Overhaul 1st Edition	6259	50.00	
F11G/GSI/GSID	Parts 2nd Edition	6251	30.00	

The manufacturer reserves the right to change prices, specifications and design at any time without notice, and without incurring obligation. All prices quoted U.S. Dollars, F.O.B. Waukesha, Wisconsin unless otherwise indicated.

SPECIAL PURPOSE MANUALS		FORM	PRICE	QTY
CUSTOM ENGINE CONTROL® IGNITION MODULE Installation, Operation and Maintenance – 2nd Edition		6253	30.00	
CUSTOM ENGINE CONTROL® AIR/FUEL MODULE Installation, Operation and Maintenance – 2nd Edition		6263	30.00	
CUSTOM ENGINE CONTROL® DETONATION SENSING MODULE (Does not include DSM software) Installation, Operation and Maintenance – 1st Edition		6268	30.00	
CUSTOM ENGINE CONTROL® TURBOCHARGER CONTROL MANAGEMENT SYSTEM (Does not include TCMS software) Installation, Operation and Maintenance – 1st Edition		6267	30.00	
WAUKESHA SERVICE REPAIR KITS – March 1996 ed.		6229	30.00	
SERVICE BULLETINS (2-Volume Set with Binders) Future updates upon request.		6241	100.00	
SERVICE BULLETIN BINDERS (2-Volume Set without tabs or bulletins).		6241B	50.00	
WAUKESHA FUEL SYSTEMS ADJUSTMENTS 2nd Edition		515	30.00	
WAUKESHA ENGINES INSTALLATION				
WAUKESHA ENGINES INSTALLATION (Binder Includes Chapters 1-8)		1091	50.00	
CHP 1 – Preparation For Mounting		1091-1	5.00	
CHP 2 – Mounting & Alignment		1091-2	5.00	
CHP 3 – Vibration, Couplings & Drives		1091-3	5.00	
CHP 4 – Cooling System		1091-4	5.00	
CHP 5 – Lube System		1091-5	5.00	
CHP 6 – Air Induction System		1091-6	5.00	
CHP 7 – Exhaust System		1091-7	5.00	
CHP 8 – Fuel System		1091-8	5.00	
BINDER FOR INSTALLATION CHAPTERS MOUNTING AND ALIGNMENT OF AT-GL ENGINES 2nd Edition		1091-B	15.00	
MOUNTING AND ALIGNMENT OF AT-GL ENGINES 2nd Edition		1214	5.00	
BINDERS		PART NO.	SIZE	PRICE
WAUKESHA 3-RING, SLANT D ORANGE BINDER		M774	1"	7.00
		M775	2"	8.00

Note: For Previous Production engine manuals, see Form 215B.

Orders for publications should not be included with engine or parts orders.

Waukesha

DRESSER

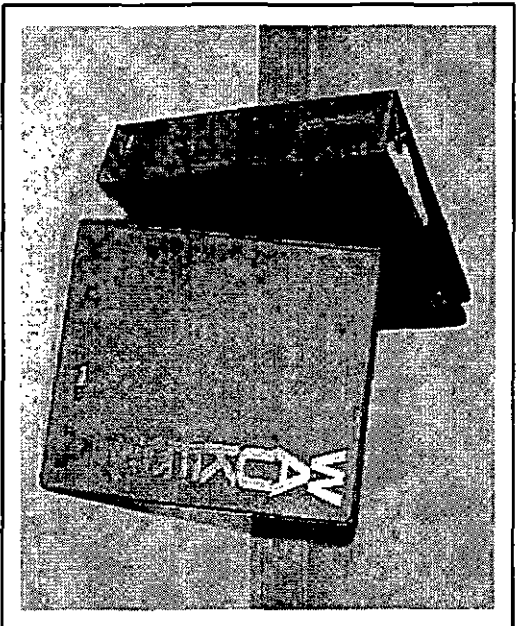

Waukesha Engine 3-Ring Slant D Orange Binder
(Now available in two sizes)

PLEASE TYPE OR PRINT:

Minimum Order . . \$50.00

PURCHASE ORDER NO:	
COMPANY:	
SHIPPING ADDRESS:	
CITY:	STATE:
ATTN:	ZIP:
SHIPPING INSTRUCTIONS:	

MAIL TO:

Waukesha Engine Division Dresser Industries, Inc. 1000 W. St. Paul Avenue Waukesha, WI 53188-4999	
ATTN: ADMINISTRATIVE SERVICES	
Telex: 28769	Fax: (414) 549-2703

The manufacturer reserves the right to change prices, specifications and design at any time without notice, and without incurring obligation. All prices quoted U.S. Dollars. F.O.B. Waukesha, Wisconsin unless otherwise indicated.

Service Manual

WAUKESHA

Models 570 and 884

GAS-GASOLINE ENGINES



Reg. U.S. Pat. Off.
F-1861

EDITION FOUR

WAUKESHA MOTOR COMPANY

W A U K E S H A , W I S C O N S I N , U . S . A .

Main Office

Waukesha, Wis. 53186

Factories

Waukesha, Wis. 53186
Clinton, Iowa 52732

Branch Offices

1156 East Ridgewood Ave.
Ridgewood, New Jersey 07451

2815 East Skelly Drive
Tulsa, Okla. 74105

P.O. Box 1025
Downey, California 90240

239 E. International Airport Road
Anchorage, Alaska 99502

SAFETY PRECAUTIONS

The exhaust products of an internal combustion engine are toxic and may cause injury to health or death if inhaled. All engine installations, especially those within a closed shelter, or building, should be equipped and maintained with an exhaust discharge pipe so that exhaust gases are delivered into the open air.

All internal combustion engine fuels are highly combustible and may explode under certain conditions. Fuels must be conducted to the engine with secure piping, free from leaks, properly designed to resist breakage from vibration.

All engine installations should be equipped with a means of positive fuel shutoff for emergency use when fuel is conducted to the engine from a remote source. In addition, fuels under pressure such as natural gas or liquified petroleum gas, should be controlled by a positive shutoff valve, preferably automatic, other than those integral with the carburetor or gas pressure regulation equipment. It shall be the final responsibility of the engine owner to ensure that the installation is free from fuel or exhaust leakage.

Gas used to energize starters must be discharged away from the engine into a harmless area. Ignition connections and electrical equipment on engines exposed to potentially explosive ambient atmospheres should be specially equipped to minimize spark hazard and it is the responsibility of the engine owner to specify or provide such connections and equipment.

Internal combustion engines must be properly provided with guards against hazard to persons or structures in close proximity to rotating or heated parts and it is the responsibility of the engine owner to specify or provide such protection.

Copyright 1961
WAUKESHA MOTOR CO.
Waukesha, Wis.

1.5M-12/71-Z.P.

Printed in U.S.A.

CONTENTS

Title	Page	Title	Page
DESCRIPTION		Distributor Timing	28
GENERAL	1	Advance Mechanism	29
ENGINE VARIATIONS	1	Checking Distributor System	
CRANKCASE	1	Spark Advance	30
CRANKCASE VENTILATION	2	Magnetos	30
CRANKSHAFT	2	Magneto Timing	30
MAIN BEARINGS	3	Checking Magneto System Spark	
CYLINDER HEADS	4	Advance	31
VALVE ROTATORS	4	FUELS	31
PISTONS	4	GASOLINE CARBURETORS	32
CONNECTING RODS	4	Carburetor Adjustments	32
CAMSHAFT	5	FUEL PUMP	33
GEAR COVER	6	GAS CARBURETORS	33
FLYWHEEL AND BELLHOUSING	6	ENSIGN TYPE "B" FUEL	
MANIFOLDS	7	REGULATOR	34
WATER PUMP	7	Operation	34
OIL PUMP	8	SUGGESTIONS FOR LOCATING	
OIL COOLER	9	TROUBLE ON GASEOUS FUEL	
IGNITION	9	ENGINES	35
Distributor Ignition	9	MODEL "B" FUEL REGULATOR	35
Magneto Ignition	10	IMPCO CARBURETORS	36
GOVERNOR	10	GENERAL IMPCO SERVICE	
LUBRICATION SYSTEM	14	INSTRUCTIONS	36
COOLING SYSTEM	15	Natural Gas	36
		Adjustment	36
		Thermac Pressure Reduction Valve	36
SERVICE		VALVE TIMING AND CLEARANCES	37
FUEL	18	Valve Rocker Arm Clearance	37
OIL CAPACITY	18	RESETTING GOVERNOR	37
PUMP INLET SCREEN	18	ENGINE STORAGE	38
OIL CHANGES	18	Protecting New Engines	38
SELECTING OIL VISCOSITY	18	Storing Engines That Have	
OPERATING TEMPERATURES	19	Been in Service	39
LUBRICATING OIL RECOM-		PRESERVATION EQUIPMENT	
MENDATIONS	19	AND MATERIALS	40
LOW TEMPERATURE OPERATION	19	Sprays and Atomizers	40
OIL CONSUMPTION	19	Heating Compounds	40
BREAK-IN	19	PREPARING ENGINE FOR	
LUBRICATION SERVICE GUIDE	20	OPERATION	40
OIL FILTERS	21	EXERCISE OF STANDBY UNITS	40
OIL COOLER	21		
OIL PRESSURE CONTROL	22	OVERHAUL AND REPAIR	
AIR CLEANERS	22	GENERAL	41
COOLING SYSTEM	23	DISASSEMBLY	41
Thermostat Removal	24	Vibration Damper and Fan Pulley	41
Thermostat Testing	24	Gear Cover	41
Draining the Cooling System	24	Flywheel	42
Cleaning the Cooling System	24	Cylinder Head	42
Commercial Cleaners	25	Cam Followers	42
Cooling Fans	25	Camshaft	42
Fan Belts	25	Crankshaft Gear	43
IGNITION SYSTEM MAINTENANCE	25	CRANKSHAFT OIL SEALS	44
Distributor	27		

CONTENTS

Title	Page	Title	Page
OVERHAUL AND REPAIR (Cont.)		CYLINDERS AND PISTONS	53
WATER PUMP REPAIR	44	Matching Replacement Pistons, Sleeves, and Pins	53
OIL PUMP REPAIR	44	Removing and Installing Sleeves	53
Disassembly of the Pump	45	Cylinder Head Gasket	54
Reassembly	46	Piston Fitting	54
VALVES AND MECHANISM - REPAIR	47	Reassembly of Pistons	56
Compression Checks	47	ALIGNING FLYWHEEL	
Valve Mechanism	48	HOUSING	57
Guides and Seats	48	ALIGNING FLYWHEEL	58
Reconditioning Valves	49	CLEARANCES AND LIMITS, MODEL	
Valve Grinding	49	570 SERIES	59
Hand Grinding	49	CLEARANCES AND LIMITS, MODEL	
Replacing Cylinder Head	49	884 SERIES	64
BEARING ADJUSTMENT	51	STANDARD WARRANTY	69
Side Clearances	52	DISTRIBUTORS AND SERVICE	70
Running Clearances	52		

LIST OF ILLUSTRATIONS

Left Side--Model H884	IV	Setting Distributor Points	27
Right Side--Model H884	V	Typical Centrifugal Advance	
Front Sectional--Model H570	VI	Curve	28
Side Sectional--Model T-H570	VII	Steps in Timing Ignition	29
Left Side--Model H570	VIII	Distributor Ignition Wiring	
Right Side--Model T-H570	IX	Diagram	29
Right Side--H570 Enclosed Unit	X	Magneto Ignition Wiring Diagram	30
Firing Order Chart	1	Typical Gasoline Carburetor	32
Crankcase, Exploded View	2	Gasoline Carburetor, Cross Section	33
Ventilation Connection	2	Natural Gas-LPG Fuel System	
Ventilation Regulator, Cross Section	2	Schematic	33
Crankshaft and Crankshaft Gear,		Ensign Type "B" Fuel Regulator	34
Exploded View	3	Typical Crankgear Puller	42
Main Bearings, Exploded View	3	Engine Timing Gear Marks	42
Cylinder Head, Exploded View	4	Removing Crankgear by Splitting	43
Connecting Rod and Piston, Exploded View	5	Camshaft End Play	43
Camshaft, Exploded View	5	Inserting Crankshaft Oil Seal	44
Gear Cover and Accessory Drive,		Water Pump Seal and Seat	44
Exploded View	6	Oil Pump Sectional View	45
Intake and Exhaust Manifold, Exploded		Drive Gear Removal	45
View	7	Drive Gear End Clearance	46
Water Pump, Exploded View	8	Pressing Roll Pin Into Shaft	46
H-884 Oil Pump, Exploded View	8	Pump Gear End Clearance	46
Oil Cooler	9	Idler Shaft End Clearance	47
Typical Ignition Distributor	9	Pump Gear Running Clearance	47
Flange Mounted Magneto	10	Valve Rotators	48
Mechanical Governor	10	Refacing Valves	49
Zenith Mechanical Governor, Cross		Pulling Seat Inserts	50
Section	11	Cylinder Head - Manifold Stud	
Woodward Hydraulic Governor	11	Tightening Sequence	50
570 Series Lubrication Diagram	12	Testing Bearing for Tightness	51
884 Series Lubrication Diagram	13	Tightening Main Bearing	
Water Outlet Manifold, Exploded View	14	Capscrews	51
Fan and Hub, Sectional View	15	Measuring Bearing Clearance	52
Fan and Hub Assembly, Exploded View	16	Checking Crankshaft Runout	52
Schematic of Typical Cooling Tower		Sleeve Puller in Use	54
Installation	16	Evening Up Rubber Rings, 570	54
Shell and Tube Heat-Exchanger Cooling	17	Checking Sleeve for Distortion	55
Typical Oil Filter	21	Measuring Piston Ring Gap	55
Oil Bath Air Cleaner	22	Piston Ring Side Clearance	56
Testing Thermostat Opening	23	Cam Ground Piston (Exaggerated)	56
Testing Thermostat Closing	24	Fitting Piston to Sleeve	57
Checking Fan Belt Tension	25	Correct Position of Piston in	
Cold Reduces Battery Power	25	Cylinder	57
Schematic of Typical Battery Ignition		Checking Housing Bore Runout	57
System	26	Checking Flywheel Runout	58

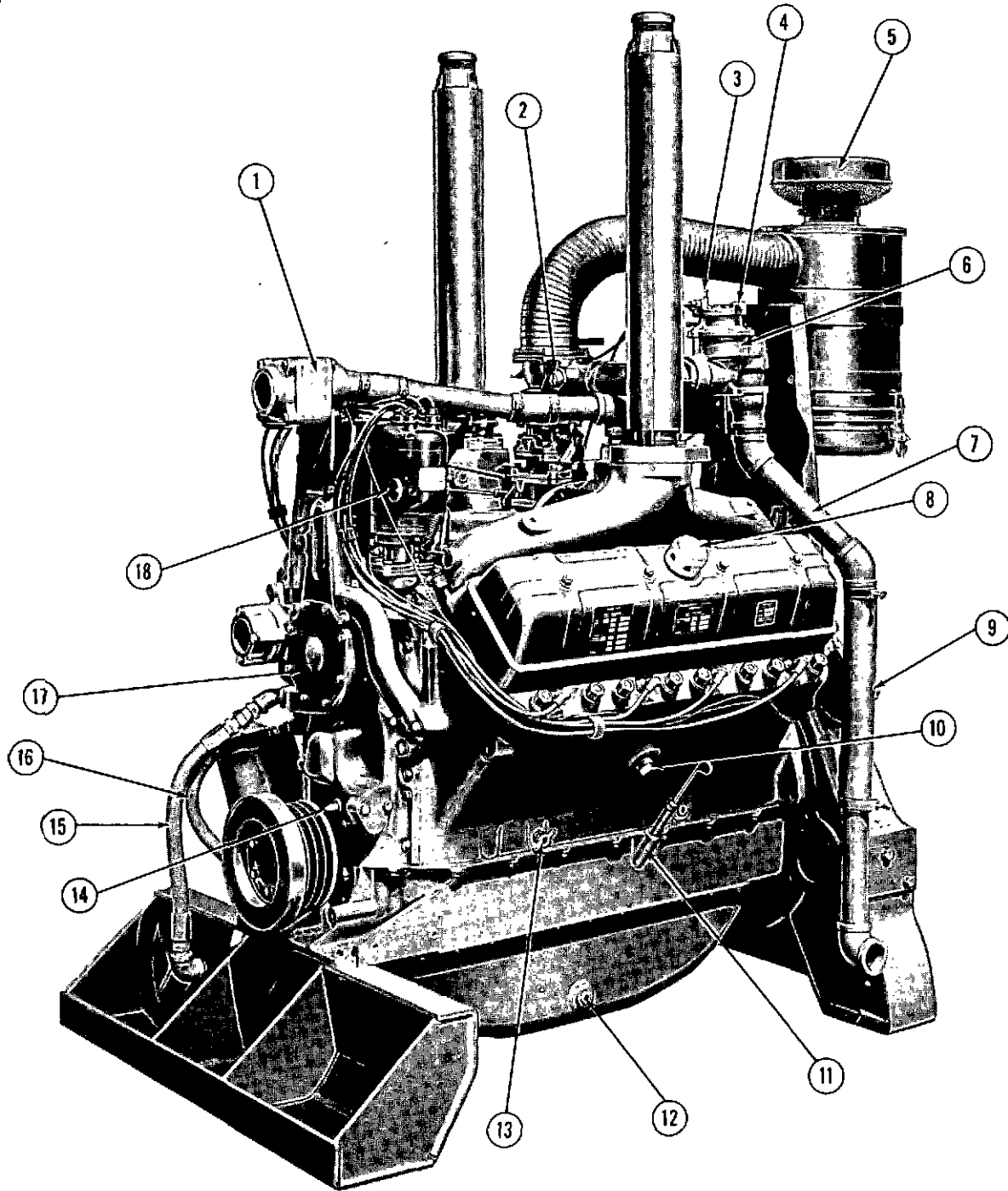

Left Side - Model H884

- | | |
|--------------------------------|---|
| 1. Thermostat Housing | 10. Crankcase Water Passage Plug |
| 2. Load Adjustment | 11. Oil Level Gauge |
| 3. Fuel Idle Adjustment | 12. Oil Pan Drain |
| 4. "B" Regulator Breather Vent | 13. Crankcase Water Drain |
| 5. Air Cleaner | 14. Engine Timing Pin |
| 6. Ensign "B" Regulator | 15. Water Line - Water Pump to Oil Cooler |
| 7. Gas Inlet Line | 16. Oil Line - Filters to Crankcase |
| 8. Breather and Filler Cap | 17. Water Pump Cover |
| 9. Safety Shut Down Switch | 18. Left Bank Magneto |

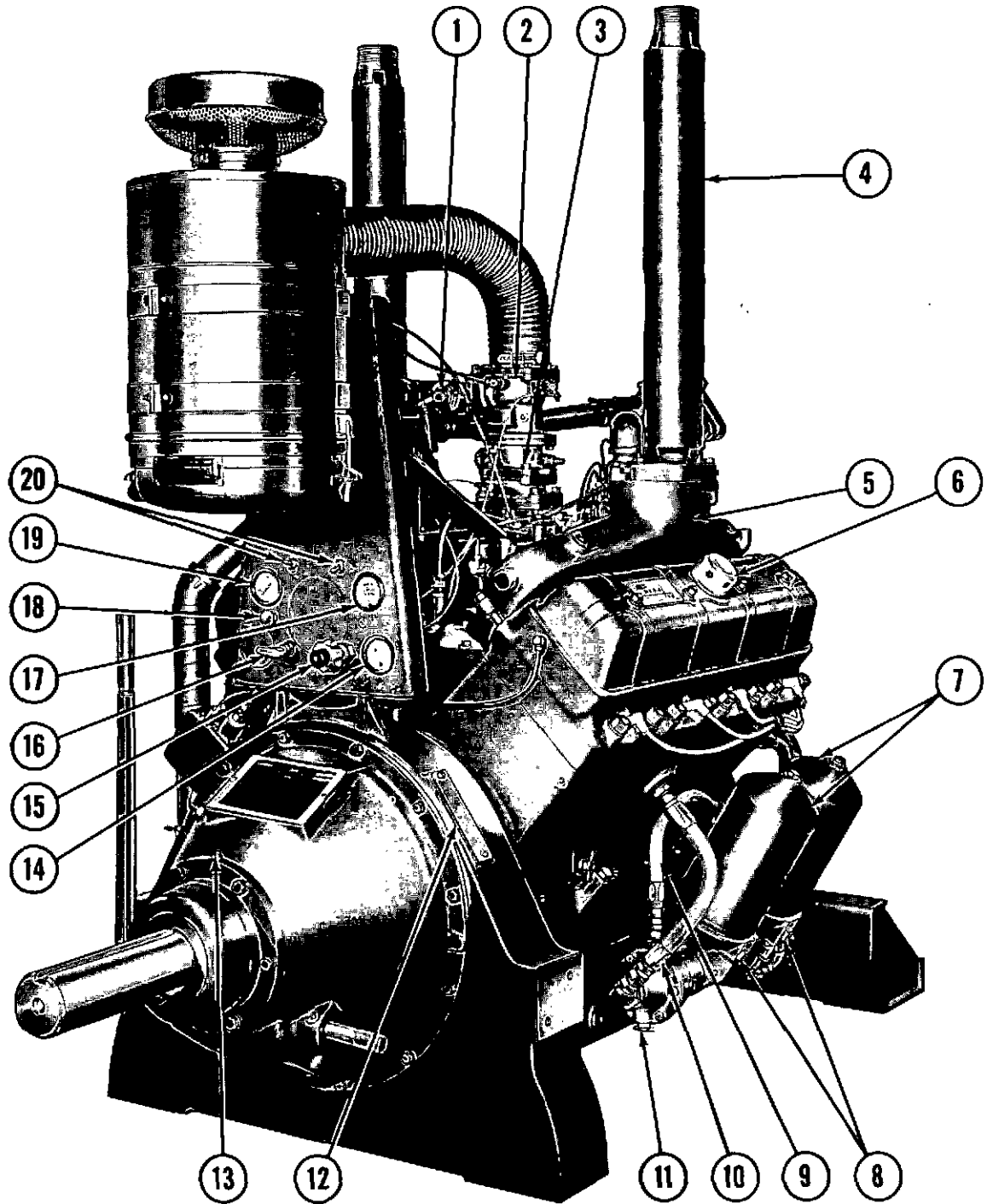

Right Side - Model H884

- | | |
|--------------------------------------|-----------------------------------|
| 1. Governor Slave Unit | 11. Oil Cooler Water Drain |
| 2. Gas Carburetor | 12. Timing Hole Cover |
| 3. Butterfly Valve Housing | 13. Power Take Off Grease Fitting |
| 4. Exhaust Pipe | 14. Oil Pressure Gauge |
| 5. Water Cooled Exhaust Manifold | 15. Governor Control Knob |
| 6. Breather and Filler Cap | 16. Throttle |
| 7. Dual "Full-Flow" Oil Filters | 17. Water Temperature Gauge |
| 8. Filter Base Oil Drain | 18. Choke |
| 9. Oil Line - Crankcase to Cooler | 19. Vacuum Gauge |
| 10. Water Line - Cooler to Crankcase | 20. Ignition Switches |

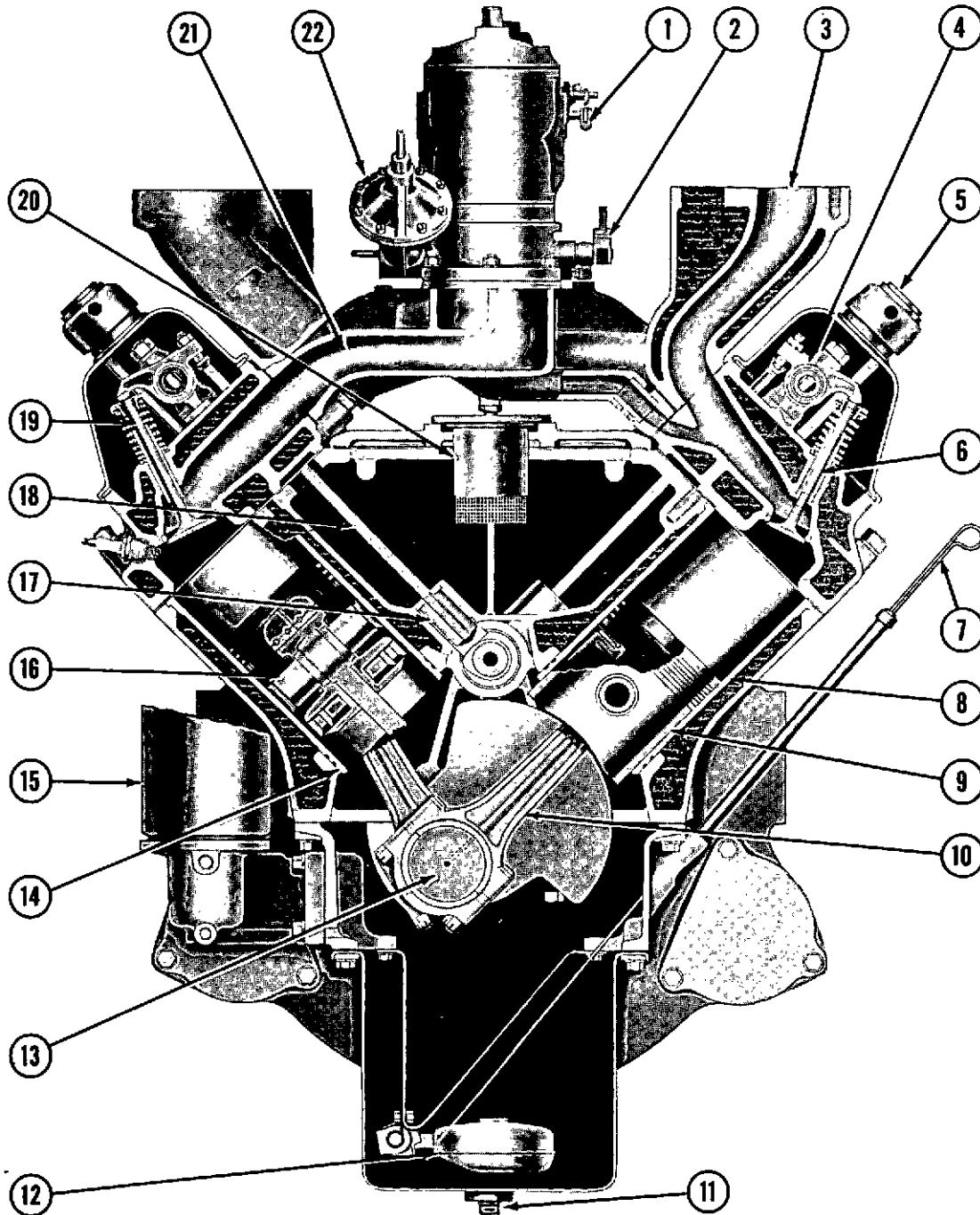

Front Sectional - Model H570

- | | |
|------------------------------|------------------------------|
| 1. Carburetor | 12. Oil Inlet Screen |
| 2. Throttle Shaft | 13. Crankshaft |
| 3. Water Cooled Exhaust Port | 14. Cylinder Sleeve "O" Ring |
| 4. Rocker Arm | 15. Oil Filter |
| 5. Breather and Filler Cap | 16. Piston Pin |
| 6. Exhaust Valve | 17. Cam Follower |
| 7. Oil Level Gauge | 18. Push Rod |
| 8. Cylinder Sleeve | 19. Intake Valve Spring |
| 9. Piston | 20. Oil Separator |
| 10. Connecting Rod | 21. Intake Manifold |
| 11. Oil Pan Drain | 22. Governor Slave Unit |

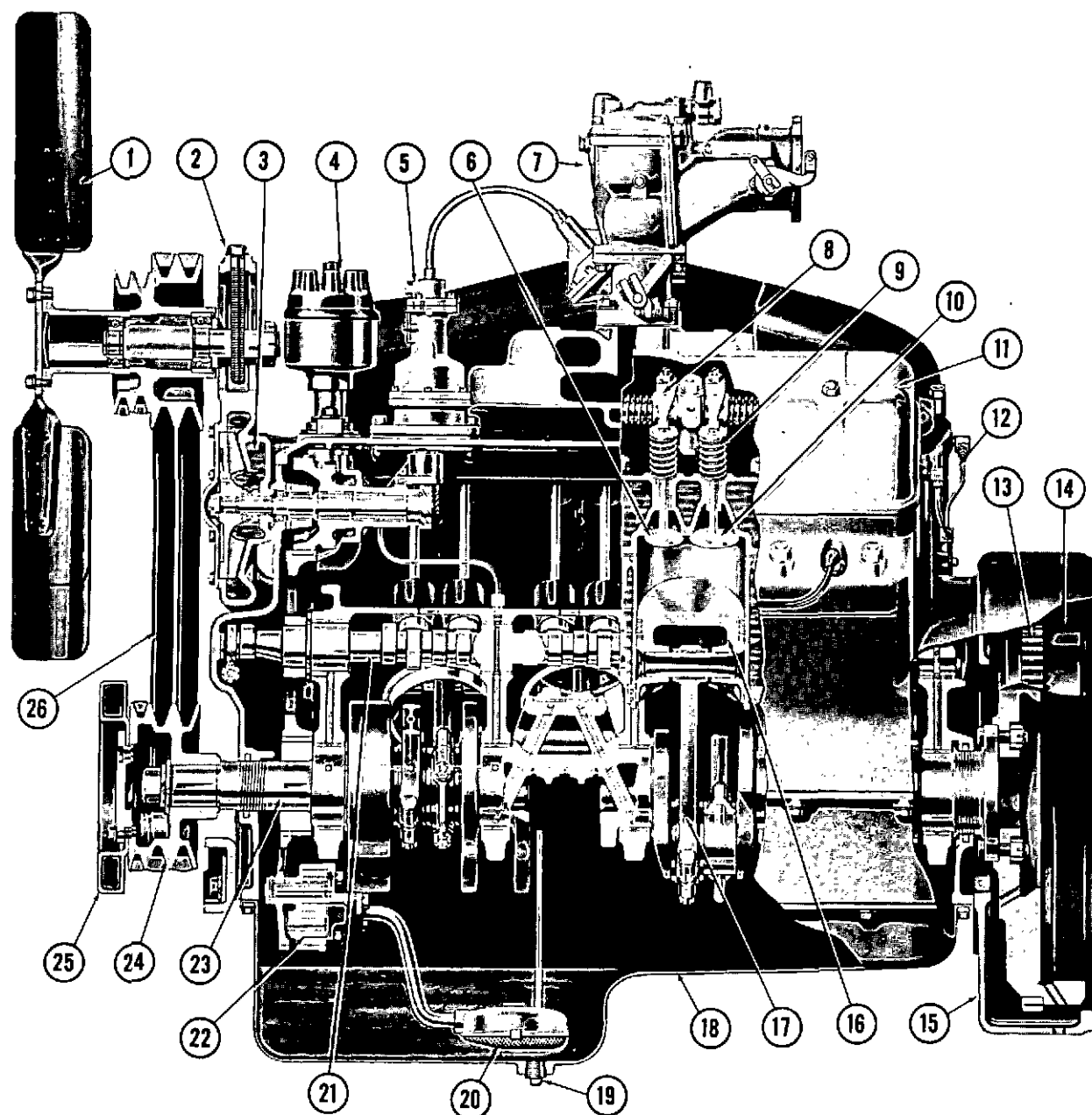

Side Sectional - Model TH570

- | | |
|-----------------------------|------------------------|
| 1. Fan Blade | 14. Flywheel |
| 2. Fan Belt Adjusting Screw | 15. Flywheel Housing |
| 3. Water Pump | 16. Piston |
| 4. Distributor | 17. Connecting Rod |
| 5. Governor Power Unit | 18. Oil Pan |
| 6. Exhaust Valve | 19. Oil Pan Drain Plug |
| 7. Carburetor | 20. Oil Inlet Screen |
| 8. Rocker Arms | 21. Camshaft |
| 9. Valve Spring | 22. Oil Pump |
| 10. Intake Valve | 23. Crankshaft |
| 11. Rocker Arm Cover | 24. Crankshaft Pulley |
| 12. Cylinder Head Oil Line | 25. Vibration Damper |
| 13. Ring Gear | 26. Fan Belts |

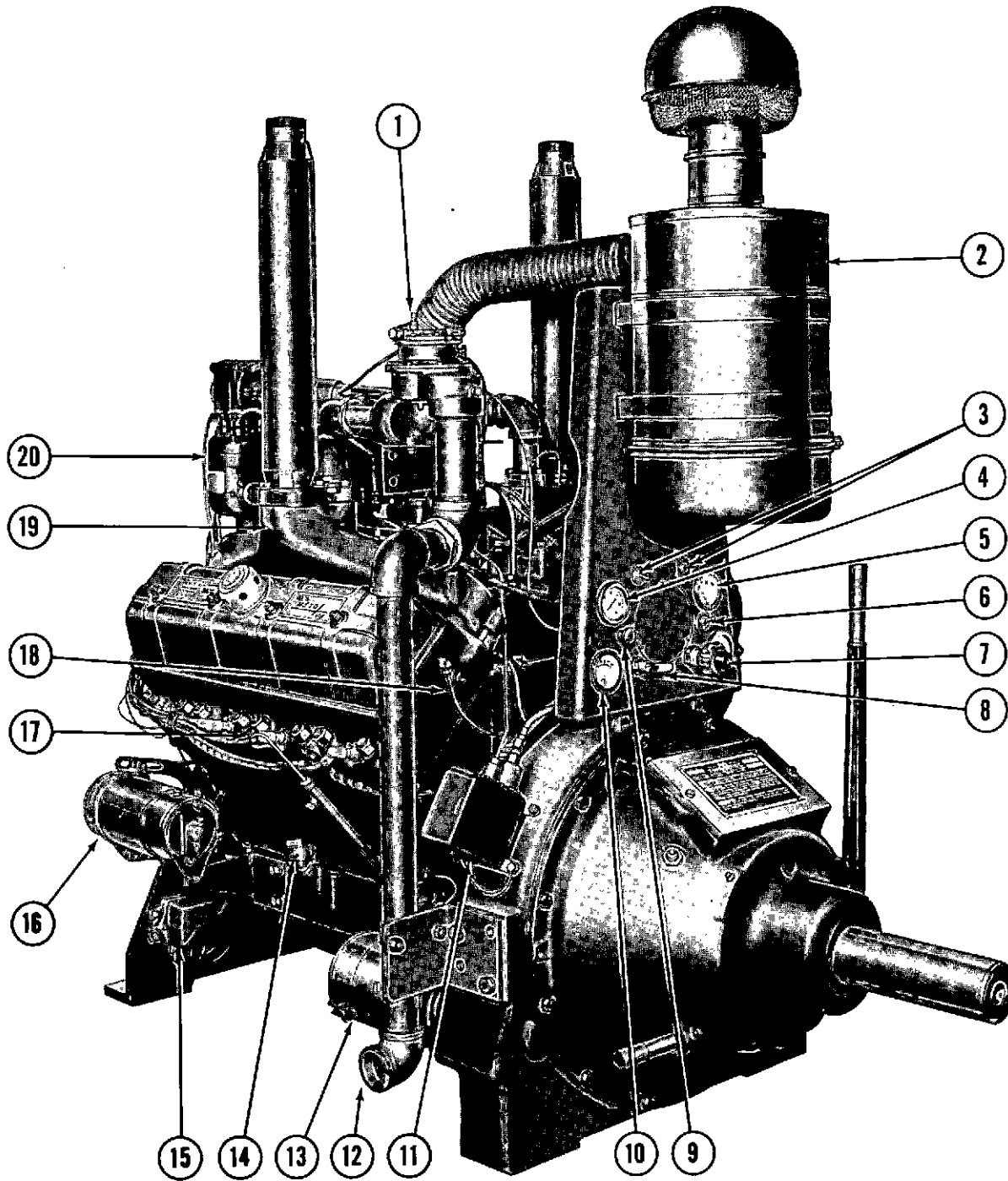

Left Side - Model H570

- | | |
|----------------------------|-----------------------------------|
| 1. Fuel Idle Adjustment | 11. Safety Shut Down Control |
| 2. Air Cleaner | 12. Gas Inlet Supply Line |
| 3. Ignition Switches | 13. Electric Starter |
| 4. Vacuum Gauge | 14. Crankcase Water Drain |
| 5. Water Temperature Gauge | 15. Voltage Regulator |
| 6. Starter Switch | 16. Generator |
| 7. Governor Control Knob | 17. Oil Level Gauge |
| 8. Throttle | 18. Cylinder Head Tube Line |
| 9. Choke | 19. Water Cooled Exhaust Manifold |
| 10. Ammeter | 20. Left Bank Magneto |

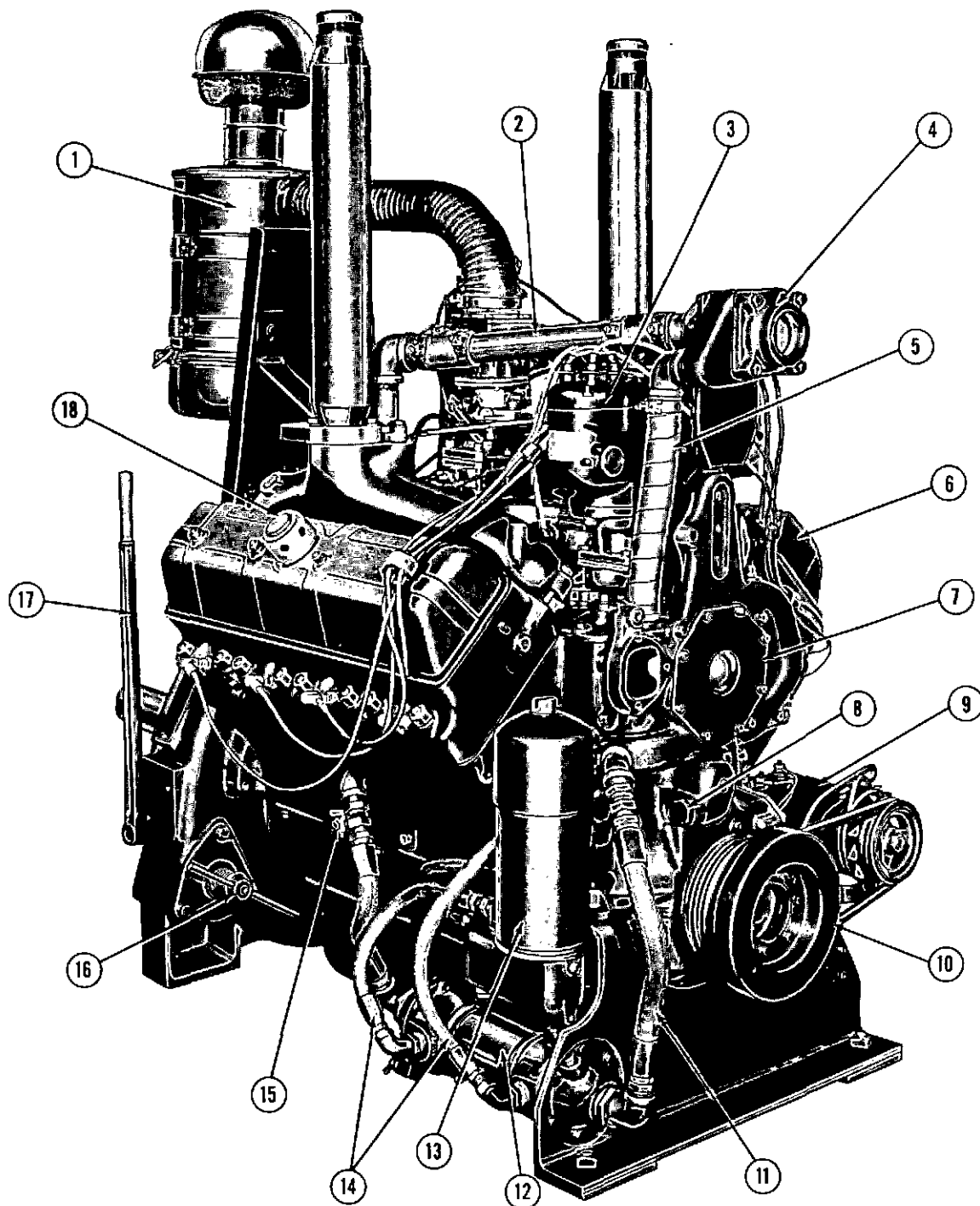

Right Side - Model H570

- | | |
|-------------------------------|---|
| 1. Air Cleaner | 10. Crankshaft Vibration Dampner |
| 2. Water Outlet Pipe | 11. Water Line - Pump to Oil Cooler |
| 3. Right Bank Magneto | 12. Oil Cooler |
| 4. Thermostat Housing | 13. Oil Filter |
| 5. Water By-Pass Line | 14. Oil Lines - Oil Cooler Inlet and Outlet |
| 6. Left Bank Rocker Arm Cover | 15. Crankcase Water Drain |
| 7. Water Pump Cover | 16. Barring Device |
| 8. Tachometer Drive Hole Plug | 17. Power Take Off Clutch Lever |
| 9. Generator | 18. Breather and Filler Cap |

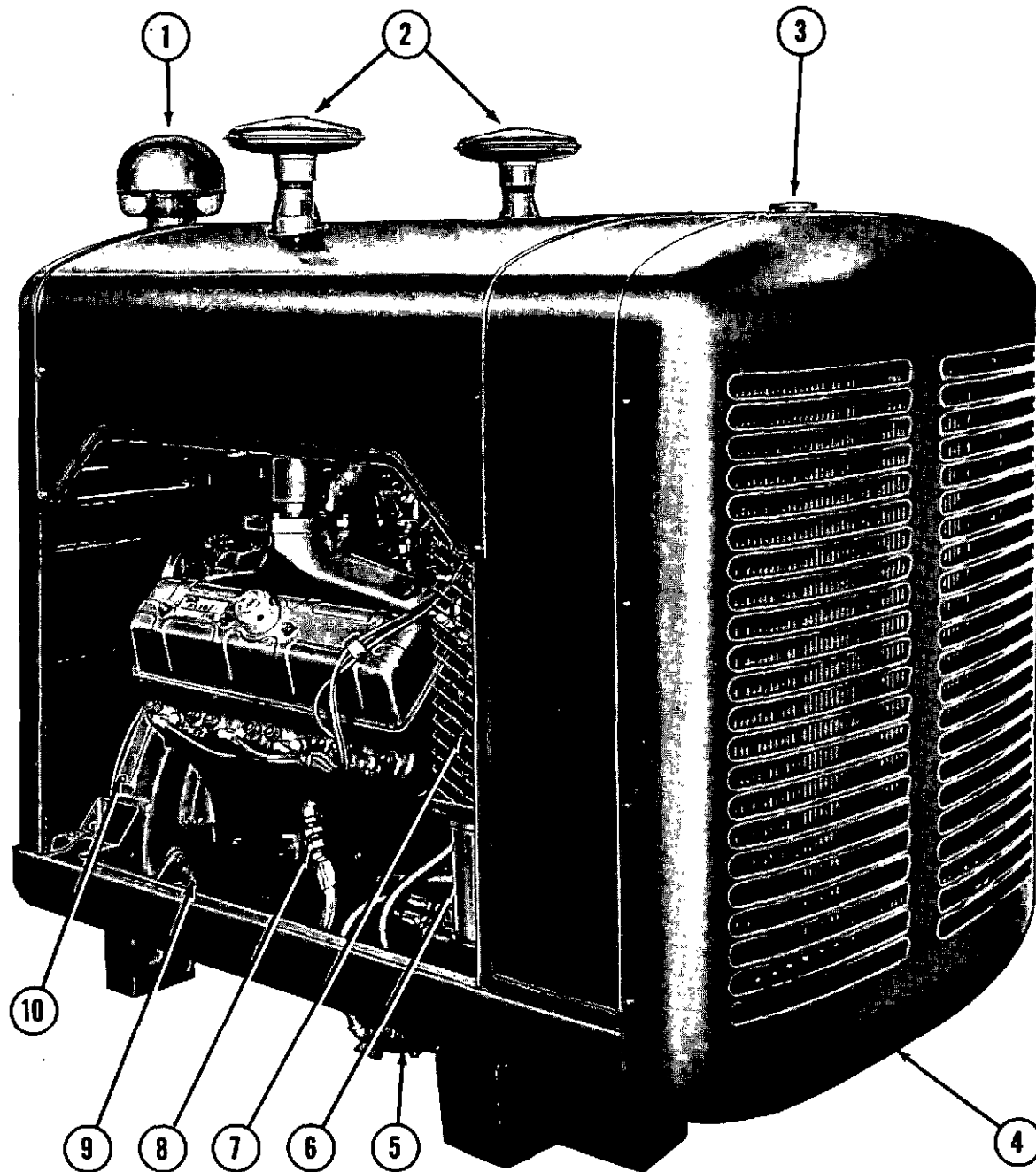

Right Side - Roiline H570 Enclosed Unit

- | | |
|--------------------------|--------------------------------|
| 1. Air Cleaner | 6. Oil Filter |
| 2. Mufflers | 7. Fan Blade Guard |
| 3. Radiator Pressure Cap | 8. Crankcase Water Drain |
| 4. Radiator Guard | 9. Barring Device |
| 5. Oil Cooler | 10. Flywheel Timing Hole Cover |

INTRODUCTION

The Waukesha Motor Company supplies this handbook as a guide for operating and servicing Waukesha Models 570 and 884 series engines. For the convenience of the user certain conventional and well-established maintenance practices have been omitted or included by brief mention only. In such instances, good judgment and common sense should be used as a basis for whatever mechanical operation is involved.

Occasionally, unusual or extreme circumstances may appear to justify some degree of variation from the recommended procedures. When this happens, it is urgently requested that the problem be submitted to the Service Department, Waukesha Motor Company, Waukesha, Wisconsin. When requesting information or ordering parts always be sure to include the engine model and serial number from the engine name plate. In addition, any special features of the installation, or conversions made by the owner, should be mentioned.

Where tabulated data is provided, the user should realize that clearances, part numbers, and so on, are sometimes changed over a period of time. Consult the manufacturer or his authorized representative if any doubt arises as to the suitability of a given part or clearance.

PRINCIPAL ENGINE DIMENSIONS

All Dimensions in Inches (Nominal)

	MODEL H570	MODEL T-H570	MODEL H884	MODEL T-H884
BORE AND STROKE	4-5/8x4-1/4	4-5/8x4-1/4	5-3/8x4-7/8	5-3/8x4-7/8
NUMBER CYLINDERS	8	8	8	8
DISPLACEMENT, Cubic In.	570	570	884	884
MAXIMUM HORSEPOWER (APPROXIMATE VALUES ONLY)	187-198 (2200 RPM)	238 (3000 RPM)	312 (2400 RPM)	360 (2600 RPM)
NUMBER MAIN BEARINGS	5	5	5	5
CRANKSHAFT, Thrust Taken	Center	Center	Center	Center
MAIN BEARINGS, Dia. and length	3-1/4x1-9/64	3-1/4x1-9/64	3-3/4x1-13/32	3-3/4x1-13/32
CONNECTING ROD BEARINGS Dia. and length	2-3/4x1-1/4	2-3/4x1-1/4	3-1/4x1-7/16	3-1/4x1-7/16
NUMBER CAMSHAFT BEARINGS	5	5	5	5
CAMSHAFT BEARING, Dia.	2	2	2-1/4	2-1/4
CON. ROD, Length Ctr. to Ctr.	8-9/16	8-9/16	9-3/4	9-3/4
PISTON PIN, Full Floating Dia. and length	1-3/8x4-1/8	1-3/8x4-1/8	1-1/2x4-9/16	1-1/2x4-9/16
PISTON RINGS, Comp., Top Chrome	3/32	3/32	3/32	3/32
PISTON RINGS, Comp., Taper Face	1/8	1/8	1/8	1/8
PISTON RINGS, Oil Control	1/4	1/4	1/4	1/4
TIMING GEARS, Face Width	1-1/4	1-1/4	1-1/4	1-1/4
LUBE OIL CAPACITY, Does not include filters and lines	9 qts.	9 qts.	20 qts.	16 qts. -Front sump 20 qts. -Center sump
FIRING ORDER FOR ALL MODELS		1-8-7-3-6-5-4-2		
COOLING SYSTEM CAPACITY	14 gals.		20 gals.	
SPARK PLUG GAP FOR ALL MODELS (14 mm) Champ. J-6 (.023-.028) - A. L. #AG-4 (.023-.028) - A. C. #C44XL (.023-.028)				
OIL PRESSURE	40 psi	40 psi	35-40 psi	35-40 psi
WEIGHTS (Dry)				
Bare Engine		1250 lbs.		1850 lbs.
Power Unit (Without Housing)	2175 lbs.		2850 lbs.	
Power Unit (With Housing)	2275 lbs.		3000 lbs.	

DESCRIPTION

GENERAL

Since this manual covers both the 570 and 884 models, the following method has been used to avoid confusion, and at the same time to prevent repetition when discussing parts that are essentially alike except for size. In all descriptions the 884 series will be considered the basic model. Minor differences between a 570 and 884 part will be mentioned where necessary. If no differences are mentioned, it is because the parts differ, for the most part, in size only. Where major differences exist for a given part between the two series, separate paragraphs will be used to describe each part. Where variations exist among engines in a given series, mention will usually be made in the text, and detailed information may be obtained by writing the Service Division, WAUKESHA MOTOR CO. Always include the engine serial number when writing. In most cases no attempt has been made to retrace the variations in design over years past. When rebuilding or servicing an engine, it is suggested that the latest changes and clearances be incorporated. Tabular data printed here represents the latest recommendations at time of printing.

For purposes of discussion, or correspondence, the following reference points have been established.

CYLINDER NUMBERING—Cylinders are numbered alternately between banks starting from the gear cover end of the engine, and continuing rearward. Thus, the right bank would consist of 2, 4, 6, and 8, and the left bank would be 1, 3, 5, and 7.

FRONT and REAR—Reference to such locations on the engine shall be interpreted as meaning from the gear-cover (front) and flywheel (rear) ends.

RIGHT and LEFT—Shall be interpreted as meaning from the right and left of a viewer standing at and facing the rear (flywheel) end of the engine.

Since many of the parts described contain complex oil or water passages, no mention has been made of these openings in most cases.

Lubrication and cooling are discussed under separate headings at the end of this section.

ENGINE VARIATIONS

Both the 570 and 884 models are produced in two different types. These types are . . . the industrial engine and the transportation engine. Also, there are a number of variations in ignition, manifolding, flywheels, fans, and so on, possible within the framework of a given series and type. For this reason, the description of the parts in both series must be somewhat generalized. All models may be converted to operate on either gasoline or gaseous fuels.

CRANKCASE

The crankcase is a rigid, compact 90° Vee block machined to receive the various component parts. Five main crankshaft bearings and five camshaft bearings rigidly supported, insure exact alignment of the crankshaft and camshaft.

The block is bored for the replaceable wet sleeve liners and drilled to provide oil passages from the camshaft bearings to the crankshaft bearings. A cover fits on the top of the crankcase to enclose the tappet chamber and support the distributor or magnetos, governor, and crankcase ventilator.

Replaceable liners eliminate the need for cylinder reboring, confining crankcase service to cleaning the oil passages and water jacket surfaces. This should be done whenever the engine is dismantled for overhaul.

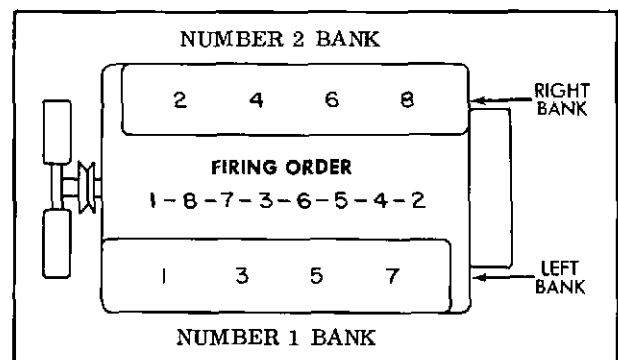

Firing Order Chart

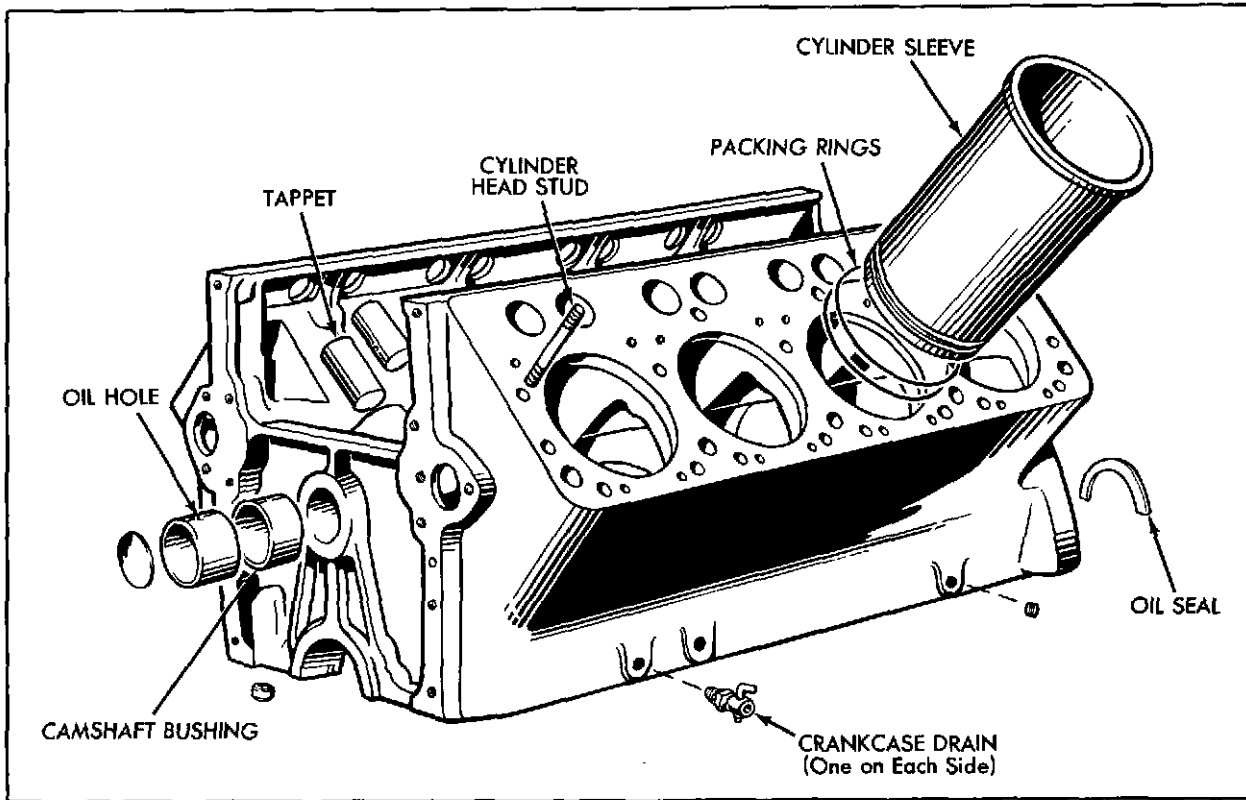

Crankcase, Exploded View

CRANKCASE VENTILATION

Crankcase ventilation is accomplished through either a check valve ventilation regulator or a breather line, continuously circulating fresh air through the crankcase. Fresh air is admitted at the breather caps located on the cylinder head covers, displacing harmful blow-by gases which are exhausted through an oil separator and ventilation connection into the intake manifold.

The crankcase ventilation regulator should be washed in varnish remover about every 250 hours or when the discharge of oil vapors from

the engine indicates increased pressure within the crankcase. Oil leaks may occur due to increased crankcase pressure, when the regulator is clogged.

CRANKSHAFT

The inherent balance of the V-8 engine crankshaft is used to full advantage by counterweighting. The counterweights on these engines are forged as integral parts of the crankshaft.

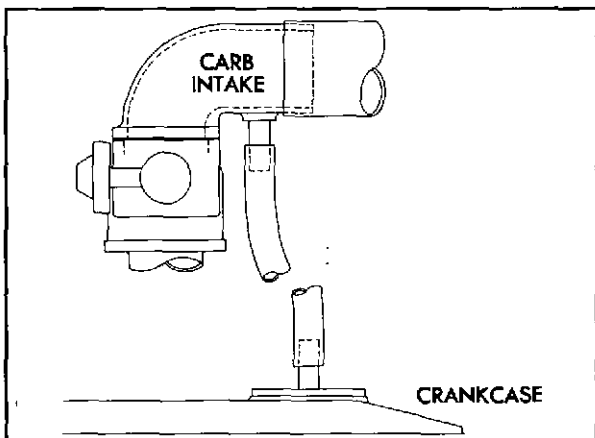

Ventilation Connection

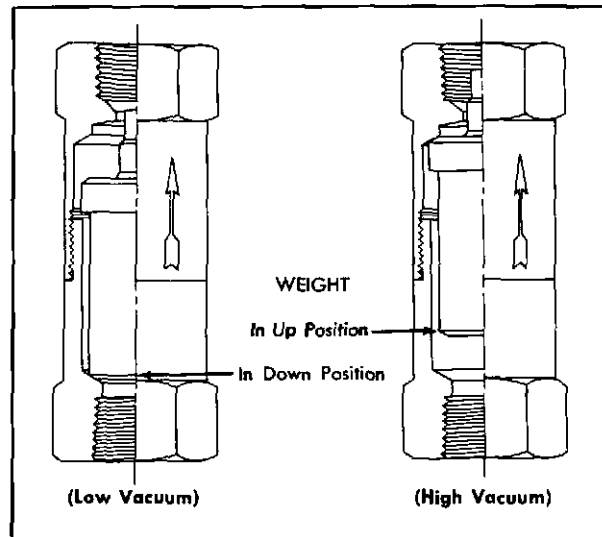

Ventilation Regulator, Cross Section

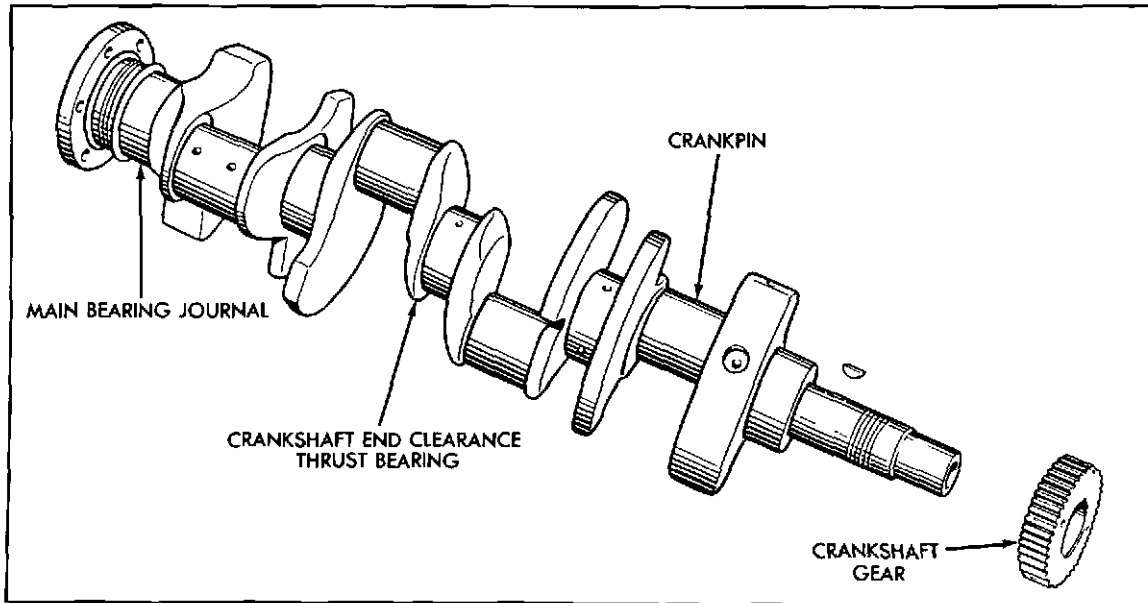

Crankshaft and Crankshaft Gear, Exploded View

Torsional vibration problems are materially reduced because of the short, stiff crankshaft design permitted by the V-8 cylinder arrangement.

Drilled holes from each main bearing journal to the adjacent half of the crankpins, carry oil from the main bearings to the connecting rod bearings.

Sealing around the crankshaft at both ends is provided by split felt rings held in place in recesses in both the crankcase and oil pan. Return oil grooves are cut into the crankshaft.

MAIN BEARINGS

Five main bearings support the crankshaft and provide easily replaceable bearing surfaces. The bearings are copper-lead, steel back, precision shells that require no fitting, scraping, or shimming upon installation. Upper and lower shells are interchangeable when new.

Tangs on the bearings and milled recesses in the bearing caps and crankcase prevent rotating or lateral movement. A hole in the top of the shell and a groove cut into the inner circumference of the bearing provides an oil

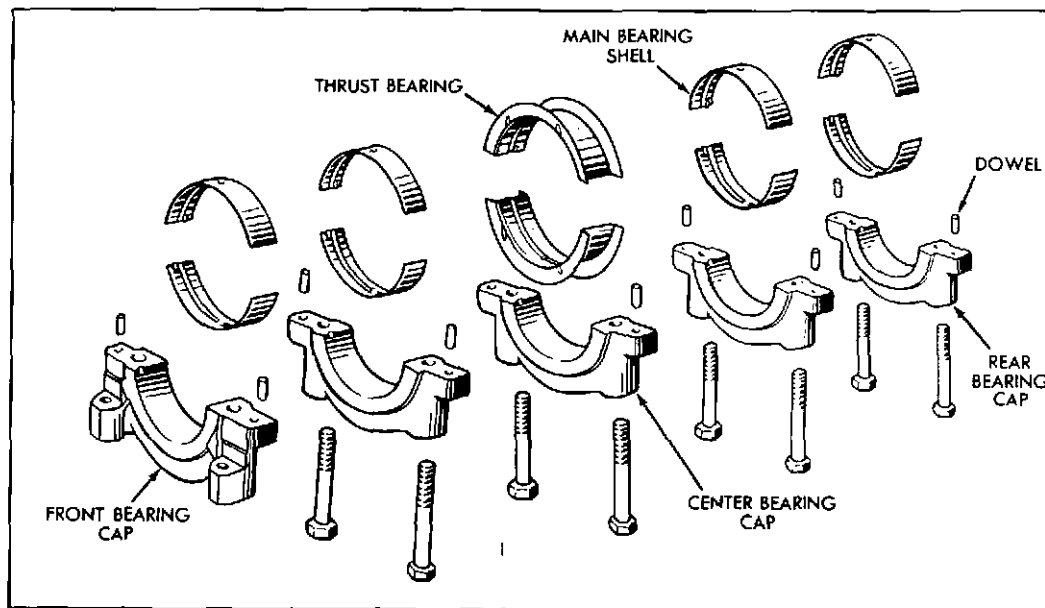

Main Bearings, Exploded View

passage from the crankcase to the crankshaft oil passages.

Oil pressure that becomes progressively lower over a period of several months is usually an indication of a clogged filter or of bearing wear to a point where running clearances are excessive. Continuous knocking from within the engine also points to excessive bearing wear.

CYLINDER HEADS

High-strength cast iron cylinder heads contain the valve mechanism and combustion chambers. The efficient combustion chamber design and ideal spark plug location make possible smooth, efficient, controlled combustion. To minimize power losses due to intake air restrictions, individual intake ports are cast in the head. These individual ports also aid in maintaining equal fuel distribution to all of the cylinders.

Parts and heads for each bank are interchangeable. The intake and exhaust valves seat in replaceable valve seat inserts.

VALVE ROTATORS

In some cases the rotator replaces the customary top valve spring washer. The valve rotators used on exhaust valves prevent prolonged exposure of any one sector of the valve face to any local hot spot that may develop on the seat. This results in lower and more uniform valve face operating temperatures. Valve rotation also provides a light wiping action between valve face and seat and between valve stem and guide to help prevent valve sticking and formation of combustion deposits.

Because all valve rotator parts are completely enclosed, they require no special lubrication or adjustment and are unaffected by sludge and varnish formation.

PISTONS

The light weight aluminum pistons are cam ground to compensate for piston expansion and to permit closer piston fit without danger of seizing. Each piston is provided with three compression rings and one oil control ring.

Pistons on present engine models have a steel groove insert above the top compression

ring and a chrome plated top ring. The steel insert for the top groove is part of the piston and does not have to be replaced when installing new rings.

All new pistons have a thin coating of tin plate to protect pistons and cylinder walls during the running in period.

CONNECTING RODS

Identical side-by-side connecting rods are used in the engine to reduce the number of different parts and to simplify servicing.

Connecting rod bearings are copper-lead precision shells. The upper and lower shells may be used interchangeably when new, but should be returned to their original position if used again.

Current production 884 series engines employ a special lock nut for the connecting rod cap to provide a more secure lock which will not loosen in service.

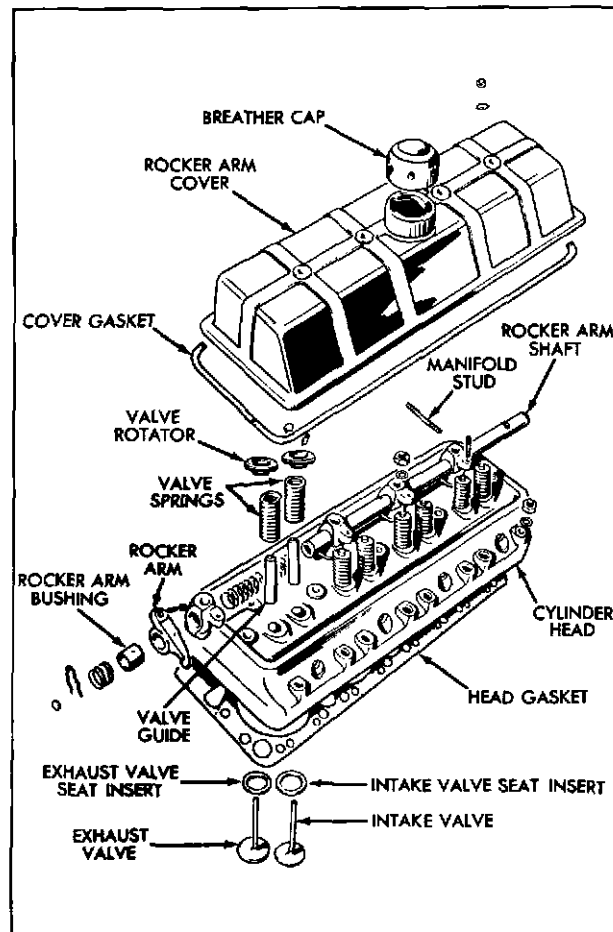

Cylinder Head, Exploded View

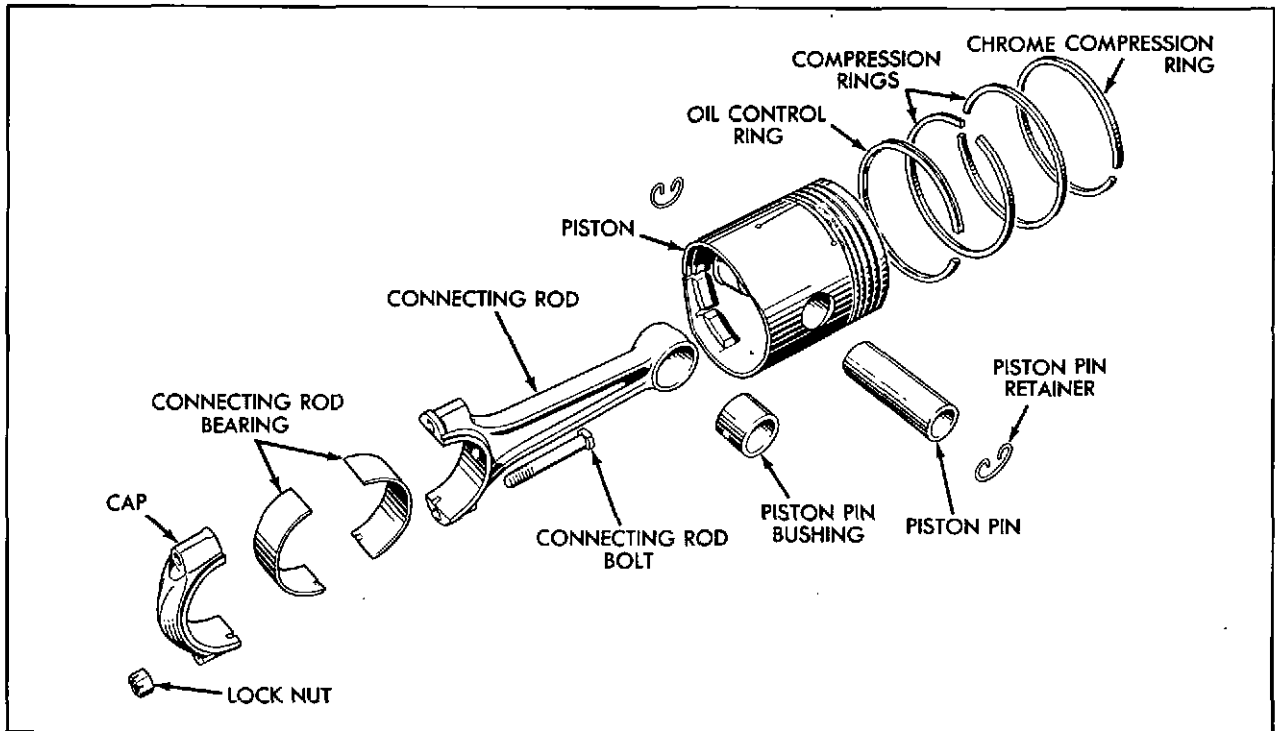

Connecting Rod and Piston, Exploded View

Current production engines have rifle drilled connecting rods which provide additional lubrication to the piston pin area.

sage is provided by an oil gallery in the crankcase.

CAMSHAFT

The single hollow camshaft is supported in five bearings which are pressed into the crankcase and line reamed. The hollow camshaft provides a passage for distributing the lubricating oil. The camshaft on current model TH570 engines is not rifle drilled, therefore oil pas-

Barrel type tappets operate in tappet bores for each bank directly over the camshaft to transmit the cam lift to the valve train. The barrel tappets can be replaced without removing the camshaft.

The water pump and accessory drive shaft is driven from the camshaft gear. A small gear on the front end of the camshaft is provided for a tachometer drive.

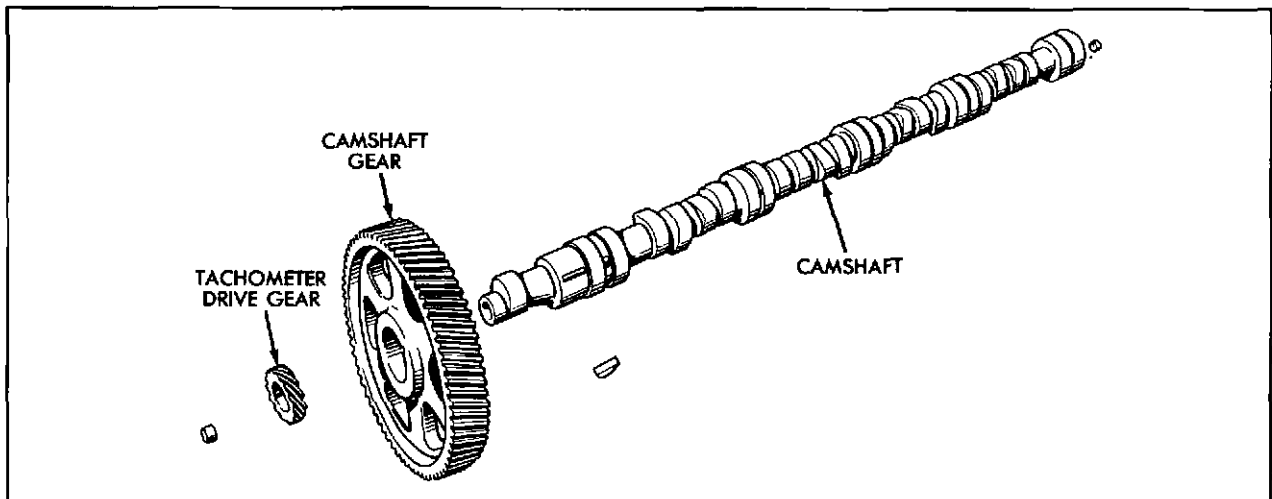

Camshaft, Exploded View

Camshaft thrust, on both 884 models and on the Industrial 570, is taken by a thrust button pressed into the inside face of the gear cover. On the Transportation 570, this thrust is taken just forward of the camshaft bearing front journal by a thrust plate which is secured to the crankcase by two special capscrews and lockwashers.

GEAR COVER

The gear cover houses crankshaft and camshaft gears, tachometer drive, accessory drive shaft, and the accessory drive housing mounted on the inside of the gear cover.

To maintain perfect gear alignment, the accessory drive shaft for the water pump, governor, and distributor or magnetos is rigidly supported in three bearings, and is pressure lubricated from the engine's lubrication system. Rotation of this shaft is effected by a gear drive from the camshaft. An oil seal on the water pump end of the shaft prevents leakage of oil from the bushing located in the gear cover.

FLYWHEEL AND BELLHOUSING

Optional flywheels are available according to the type of power take-off to be used. The flywheel is bolted to the crankshaft flange. Whenever the flywheel is taken off to remove the crankshaft, it should always be reassembled after the bellhousing has been mounted into its correct position.

The bellhousing encases the flywheel, and through a hole having a cover plate located on the top side, it is possible to see the flywheel timing marks or degree markings on timing tape. Because of inaccessibility of flywheel timing markings TH884 engines have a timing pin and D.C. timing notch on the crankshaft pulley.

Due to the nature of the bellhousing design and usage, no inspections or maintenance are required. However, it is extremely important to maintain exact centering of this part to align attaching parts with the crankshaft. Misalignment may cause serious damage to the engine from vibration.

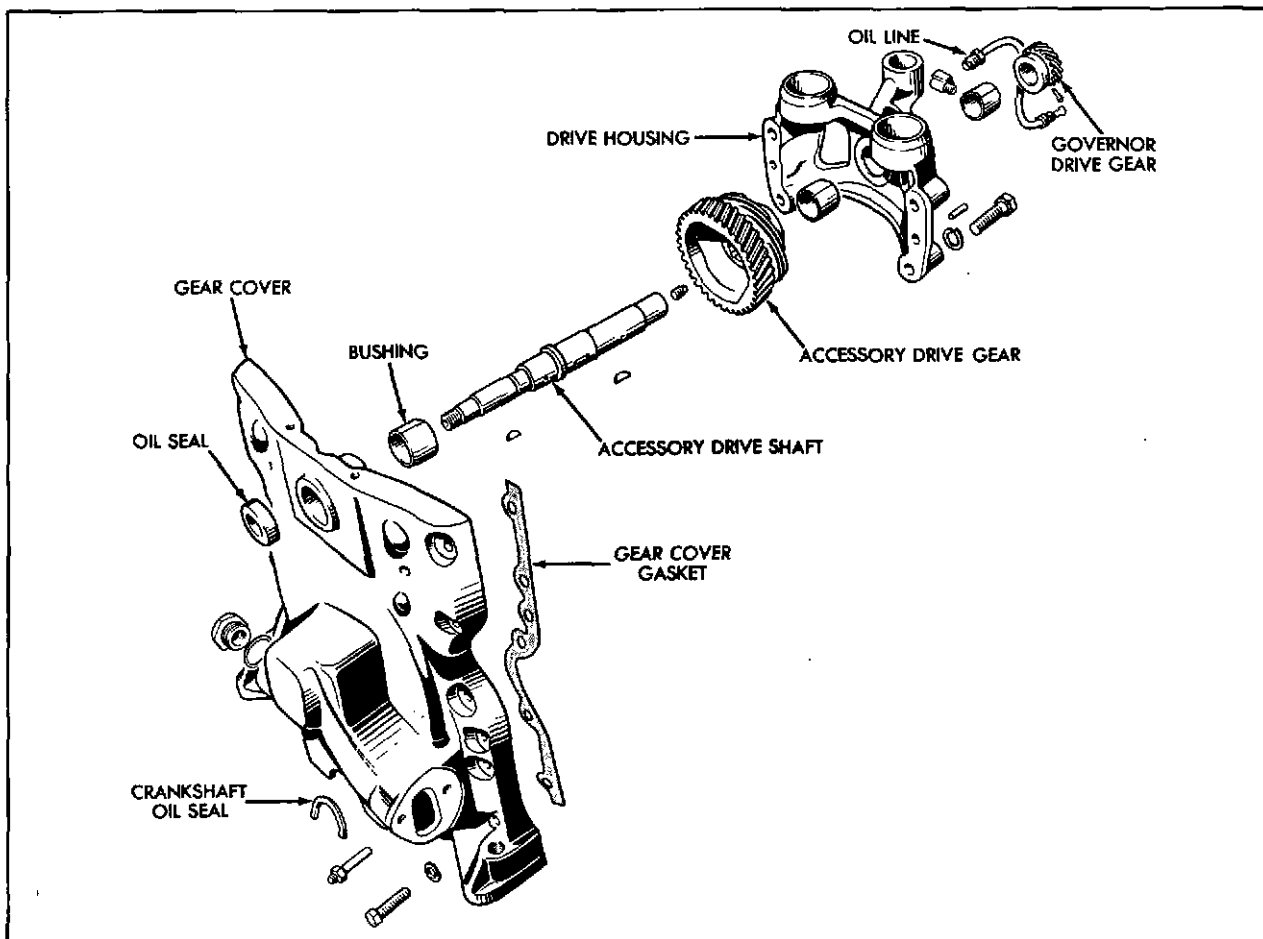

Gear Cover and Accessory Drive, Exploded View

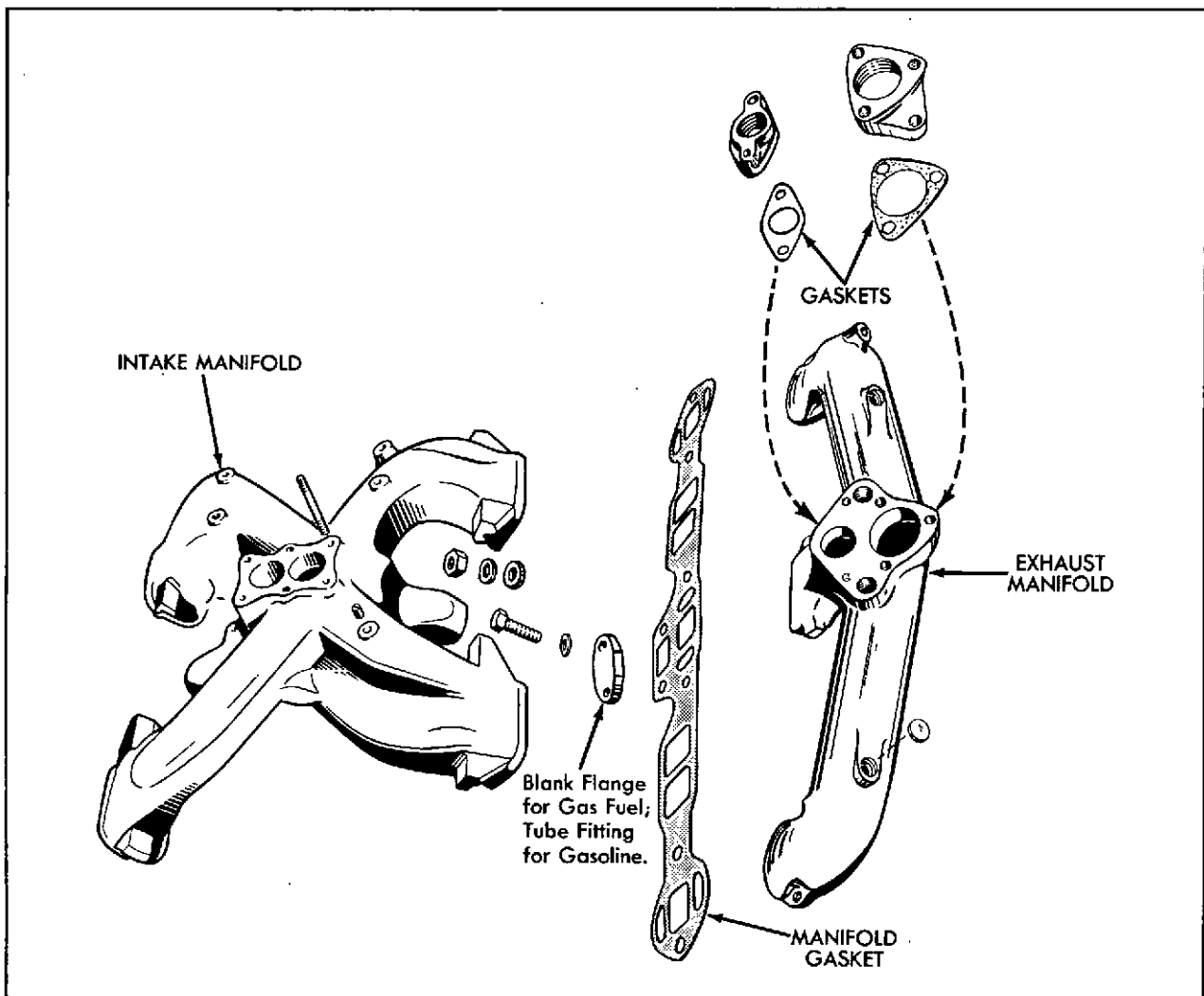

Intake and Exhaust Manifold, Exploded View

MANIFOLDS

Duplex gasoline carburetion and manifolding of the engine results in more equal distribution of fuel and air mixture to the cylinders. The carburetor divides incoming air from the air cleaner into two separate throttle passages and venturis. At the manifold flange, the two sections divide again into branches serving individual cylinders. Carburetion for gaseous fuels is effected with a single throttle passage and venturi, and two butterfly body sections.

When gasoline is used for fuel, connections from the cylinder heads admit hot exhaust gases to a jacket surrounding the intake manifold in order to supply the heat necessary for vaporizing the fuel. For gaseous fuels, this manifold heating is unnecessary, and a blank

flange is placed over the cylinder head exhaust gas openings.

A water cooled exhaust manifold collects exhaust gases from each cylinder head.

WATER PUMP

Ample coolant flow for the engine is provided by the water pump.

The pump circulates water from a common suction connection into each bank of the engine through individual discharge connections.

The pump drive shaft is lubricated under pressure from the main lubricating oil system of the engine. The pump impeller is mounted on the front end of the accessory drive shaft. An oil seal on the water pump end of the shaft

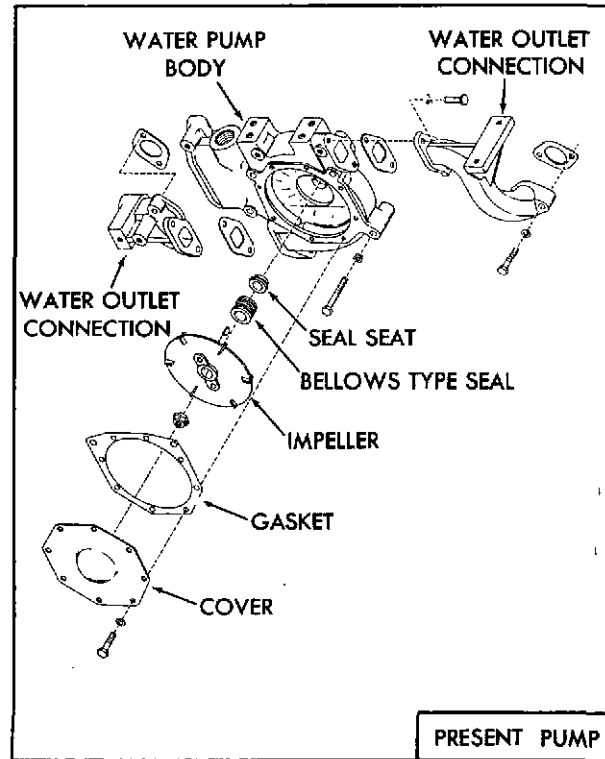
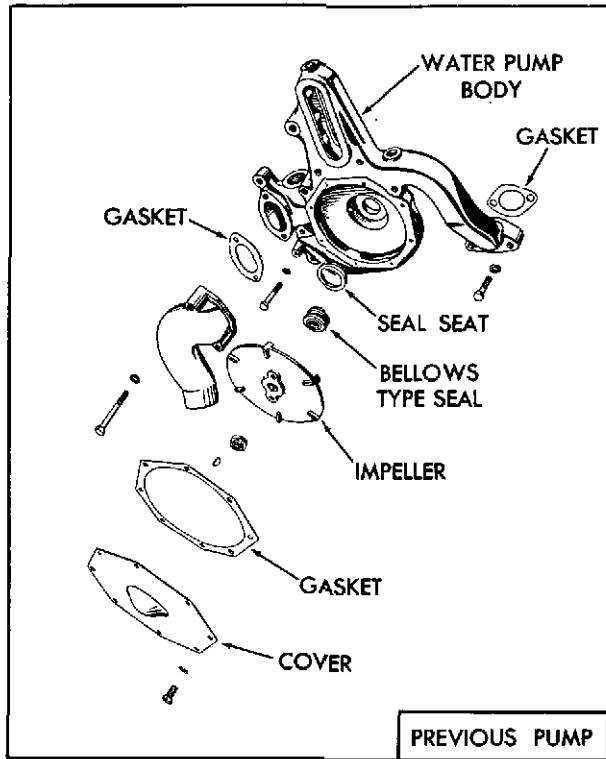

Water Pump, Exploded View

prevents leakage of oil from the bushing located in the gear cover.

OIL PUMP

The oil pump, driven by the crankshaft gear, draws oil through an automotive type floating suction screen so that the cleanest oil just

under the surface can be circulated regardless of the crankcase oil level. It is then discharged into a tube to the crankcase oil passage leading to the filter.

The positive displacement characteristics of the gear type pump require the use of a

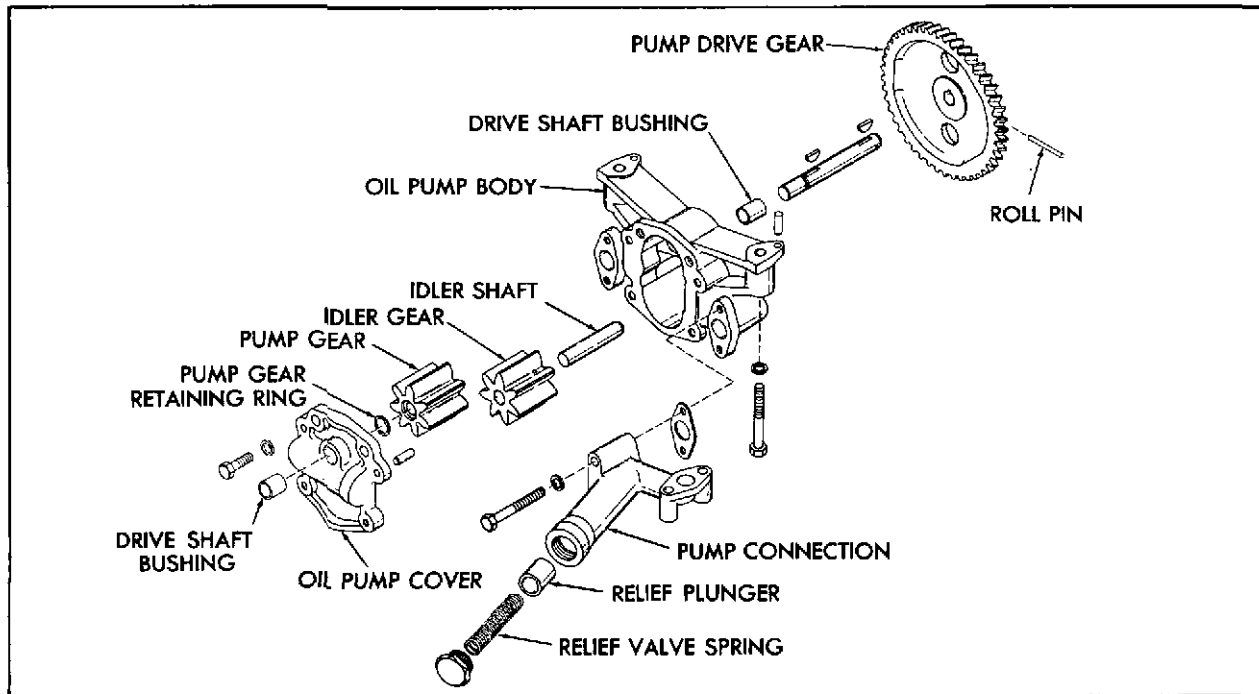

H-884 Oil Pump, Exploded View

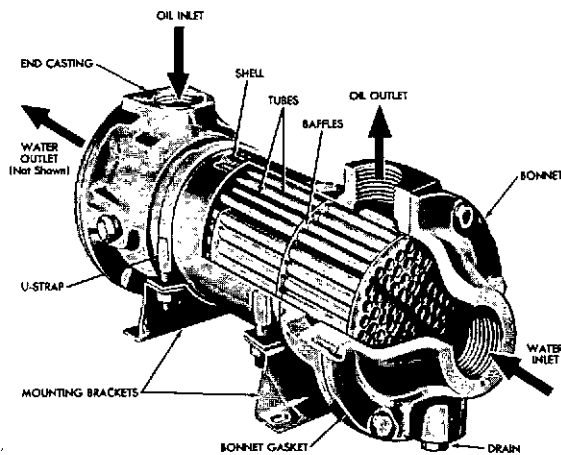

Oil Cooler

pressure regulating valve to bypass continually the excess oil pumped over that required to lubricate the engine.

The regulating valve, which is in an external pump connection, returns the excess oil to the sump, and maintains the correct oil pressure.

A combination pressure and scavenger oil pump is used on some transportation engines to assure full oil pressure to all bearings when the engine is operating at a tilt on a grade of 60 per cent longitudinally or 30 per cent side-wise. The combination pump is mounted on the front main bearing cap.

The special lower oil pan provided with this system has a large oil sump at the fan or front end and a smaller sump at the rear.

Oil is returned from the bearings to both the front and rear sumps. Oil returned to the rear sump is drawn back through the scavenger screen and connection by the scavenger or rear section of the oil pump and discharged to the front sump.

Both sections of the oil pump are driven by the external drive gear meshed to the crankshaft gear. The external drive gear is on the same shaft as the pressure pump gear. The shaft of the opposite pressure pump gear is also the drive shaft of the scavenger pump gear. The rear scavenger pump section has a separate idler shaft and gear.

OIL COOLER

The oil cooler, which is normally mounted on the front lower right side of the engine, assists

in maintaining proper oil temperatures and viscosity under all operating conditions. Oil entering the cooler flows around the tubes and baffles of the heat exchanger while water, which is diverted from the engine cooling system, flows through the tubes, absorbing or giving up heat to the oil as the conditions vary, thus resulting in relatively stable temperatures for both lubricating oil and cooling systems.

IGNITION

Ignition may be supplied by either a battery-coil-distributor system or by two vertically mounted 4 cylinder magnetos. Both systems have a retarded spark at cranking speeds for easy starting.

Distributor Ignition

The eight cylinder distributor employed is of the conventional type with centrifugal advance features. It is driven by a spiral gear mating with a similar gear on the accessory drive shaft.

Some military models use a 24 volt ignitor with the coil and distributor assembled in one housing to provide radio interference suppression and water-proofing.

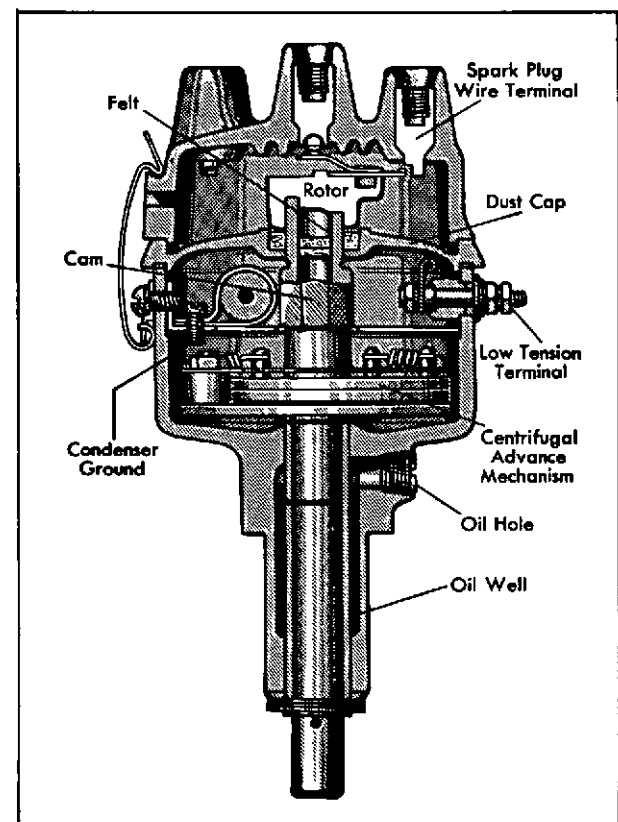

Typical Ignition Distributor

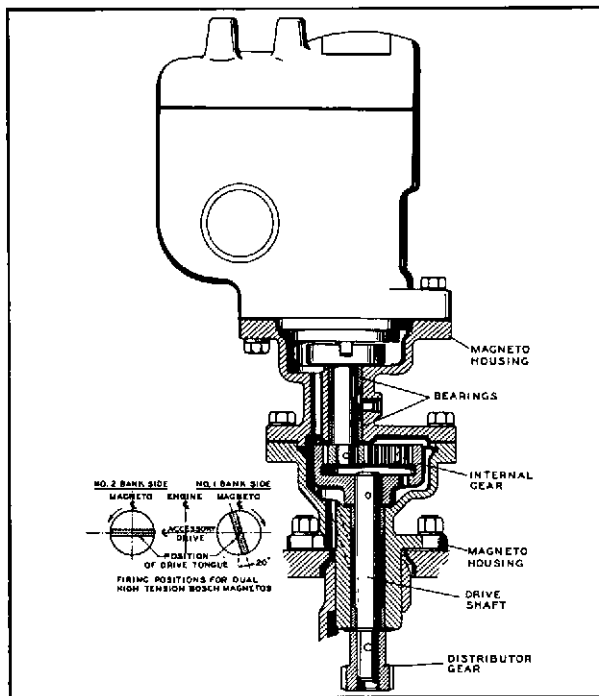

Flange Mounted Magneto

Magneto Ignition

Two vertically mounted magnetos are mounted on the crankcase cover and are driven by a gear on the accessory drive shaft. An impulse coupling built into each magneto retards the spark when the engine is being cranked. After the engine starts, the coupling becomes inoperative and the spark is advanced for normal operation. Though both magnetos are of similar design, they rotate in opposite directions and for this reason are NOT to be interchanged.

GOVERNOR

The governor is a device for maintaining desired engine speed by adjusting the throttle position to accommodate various loads imposed upon the engine.

The governors used on the 570 and 884 series engines are of the familiar centrifugal type. Weights, driven from the accessory drive shaft train, respond to variations in engine speed by moving inward or outward from the governor shaft. This movement is transmitted to the governor weight shifter lever through a pilot bearing sliding on the governor shaft. From the shifter lever the movement is carried to the butterfly valve between the intake manifold and the carburetor by a series of linkages. For example, as the engine tends to slow down under an applied load, the weights move inward due to the reduced centrifugal force. Through the

linkage system, this weight movement causes the butterfly valve to open and admit more fuel and air to the engine, thus restoring normal loaded speed.

The governor also acts as a protective device to prevent engine damage from overspeeding. Here, as the speed increases towards that speed established as the maximum, the weights move outward under the increased centrifugal force. This movement is opposed by the governor spring. When the force acting on the weights is balanced by the spring tension, the butterfly linkage stabilizes. At this point the amounts of fuel and air entering the engine are held to those needed for the selected maximum speed and no more.

From the above paragraph, it can be seen that the maximum speed of the engine is regulated by the tension of the spring. An increase in spring tension increases the maximum governed speed; a decrease in spring tension decreases the maximum governed speed.

Because overspeeding is apt to have such serious effects upon engine life, it is strongly recommended that the rated speed for any

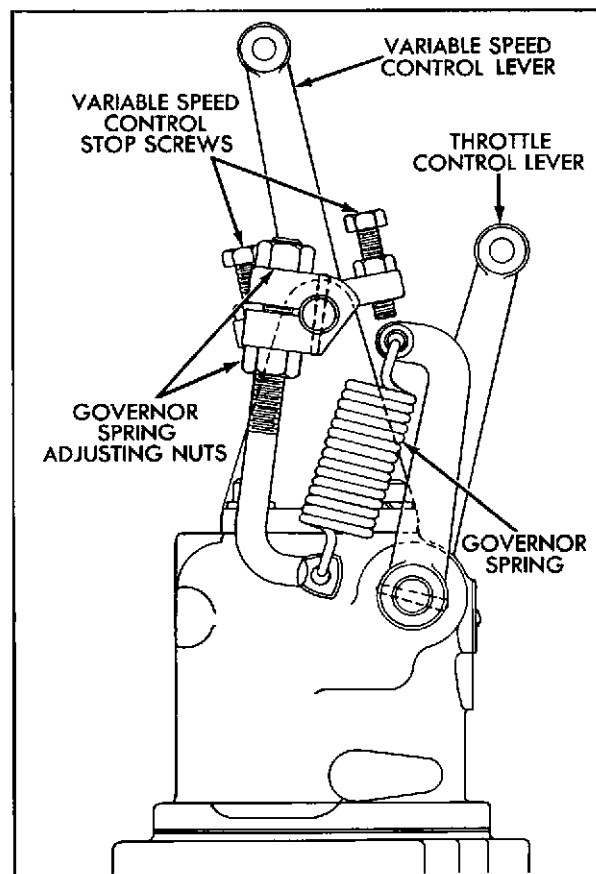

Mechanical Governor

particular engine not be exceeded. In cases where some advantage seems possible through increased speed, the Engineering Department of the WAUKESHA MOTOR COMPANY should be consulted before changes are made.

Also, since the speed of response to load, the desired speed drop under load, and so on, will differ depending on the engine application and circumstances, it is recommended that unusual governing requirements be worked out with the assistance of the Engineering Department of the WAUKESHA MOTOR COMPANY. Ordinarily, certain minor changes are all that are required to adapt the governor to its job.

These engines may be equipped with any of the following three governors:

1. A mechanical governor which has a moderate availability of force for operating the throttle.
2. The Zenith Mechanovac governor that uses the intake manifold vacuum to operate a booster to overcome frictional and velocity forces within the carburetor.

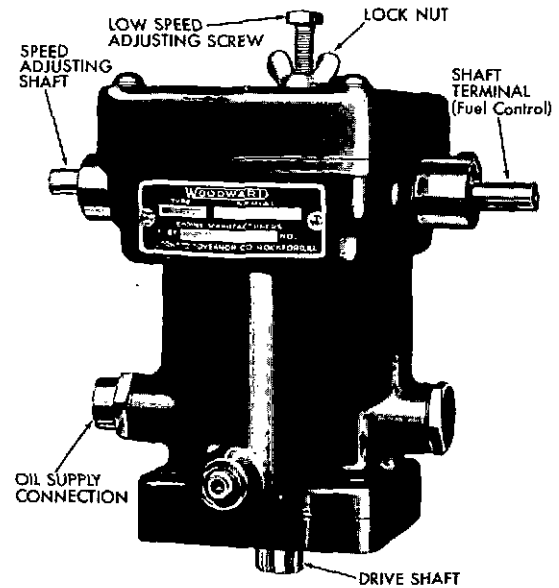

Woodward Hydraulic Governor

3. The Woodward SG hydraulic governor which is used to control speed regulation within a very small speed change.

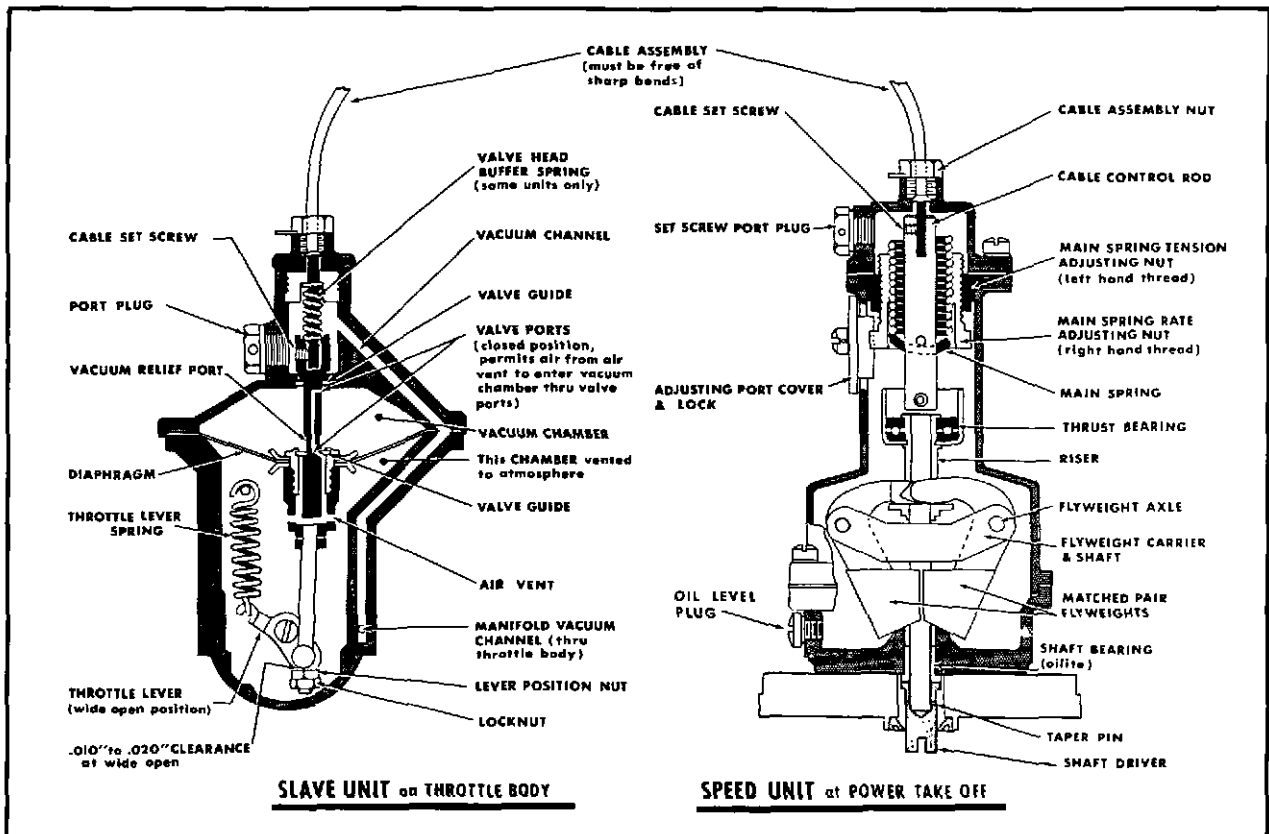

Zenith Mechanical Governor, Cross Section

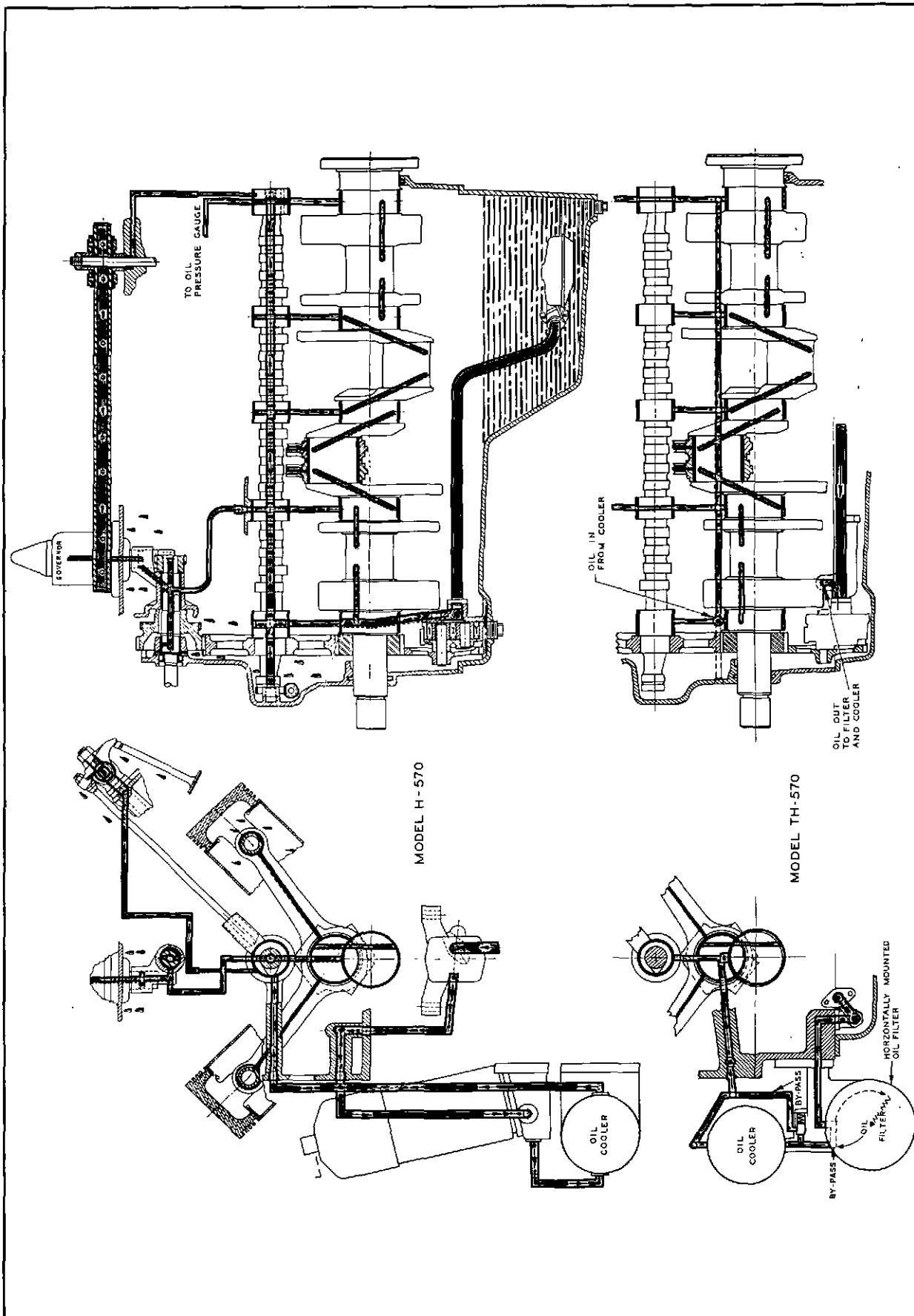

570 Series Lubrication Diagram

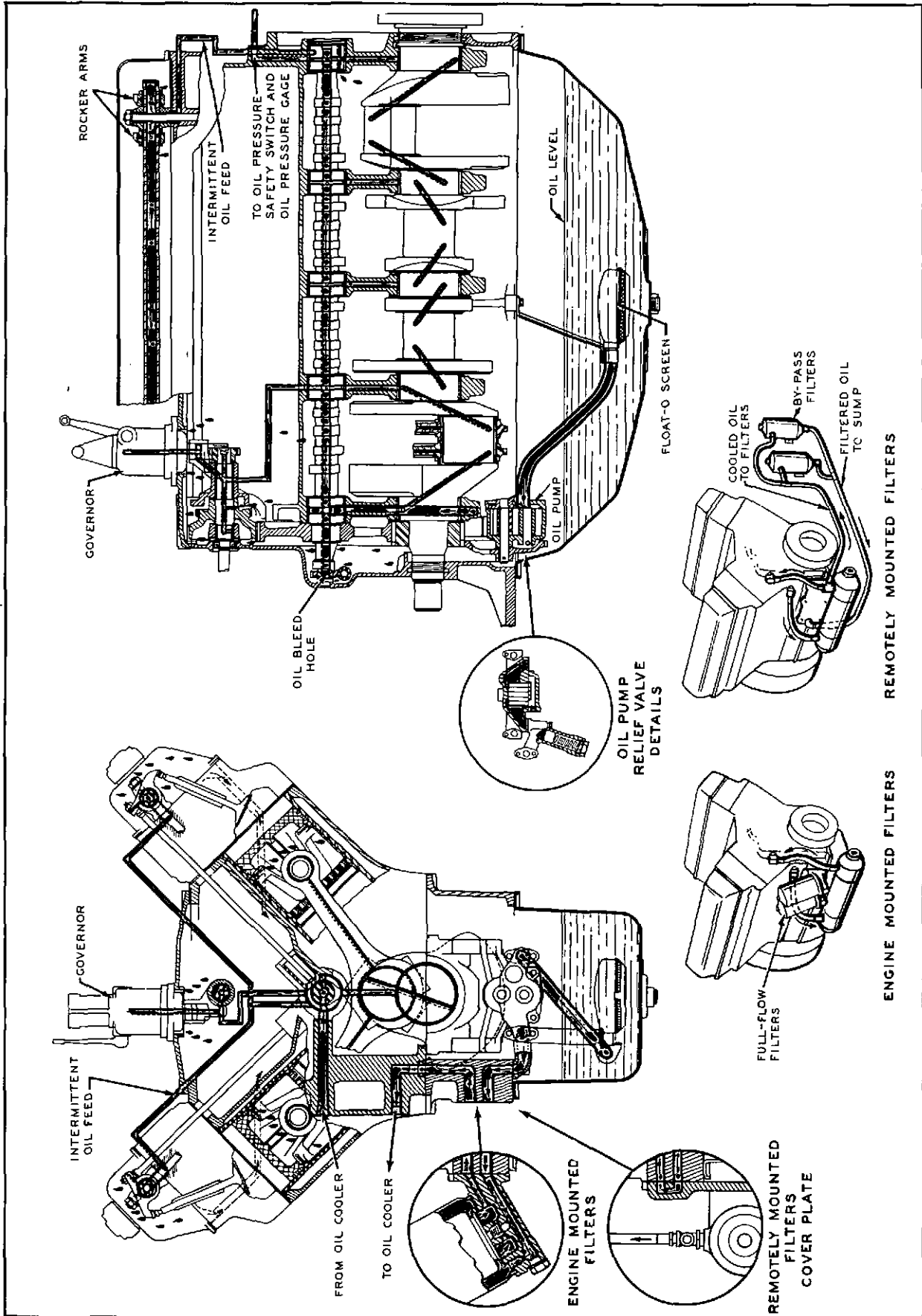

884 Series Lubrication Diagram

When utilizing a mechanical governor for variable governed speed applications, a flexible cable control from the instrument panel operates the governor speed control lever. Clockwise rotation of the control knob decreases engine speed, counterclockwise rotation increases engine speed and gives an accurate adjustment when the secondary lever located back of the knob is moved to locked position. With this secondary lever in unlocked position it is possible to pull the knob out for a quick increase in speed or to push it in for a decrease in speed.

LUBRICATION SYSTEM

Waukesha Models H570, TH570 and the H884 use a full flow lubricating system while the TH884 with remotely mounted filters uses a by-pass or full flow system. Single full flow type filters and throw-away elements are used on the H570 and TH570. Dual full flow filters are used on the H884 and remotely mounted by-pass or full flow filters on the TH884. While oil pans used on the H884 and TH884 generally have center

sump configuration, the H570 and TH570 has a sloping rear sump oil pan configuration.

Circulation of clean oil under pressure to all vital parts of the engine is accomplished by the floating oil pump suction screen, oil pump, oil filters, oil cooler and internal and external lubricating oil lines. No parts of the basic engine require greasing or oiling independently of the oil circulating system.

The oil pump, drawing the oil through a floating suction screen receives the cleanest oil from just under the oil surface regardless of the crankcase oil level.

As the lubrication systems vary from the point where oil is discharged from the pump until it enters the main oil gallery, this segment of the full-flow and by-pass systems will be discussed separately.

On the full-flow system, the oil discharged from the pump is directed through a tube to the upper oil pan passage leading to the engine mounted filters. After being filtered, the oil

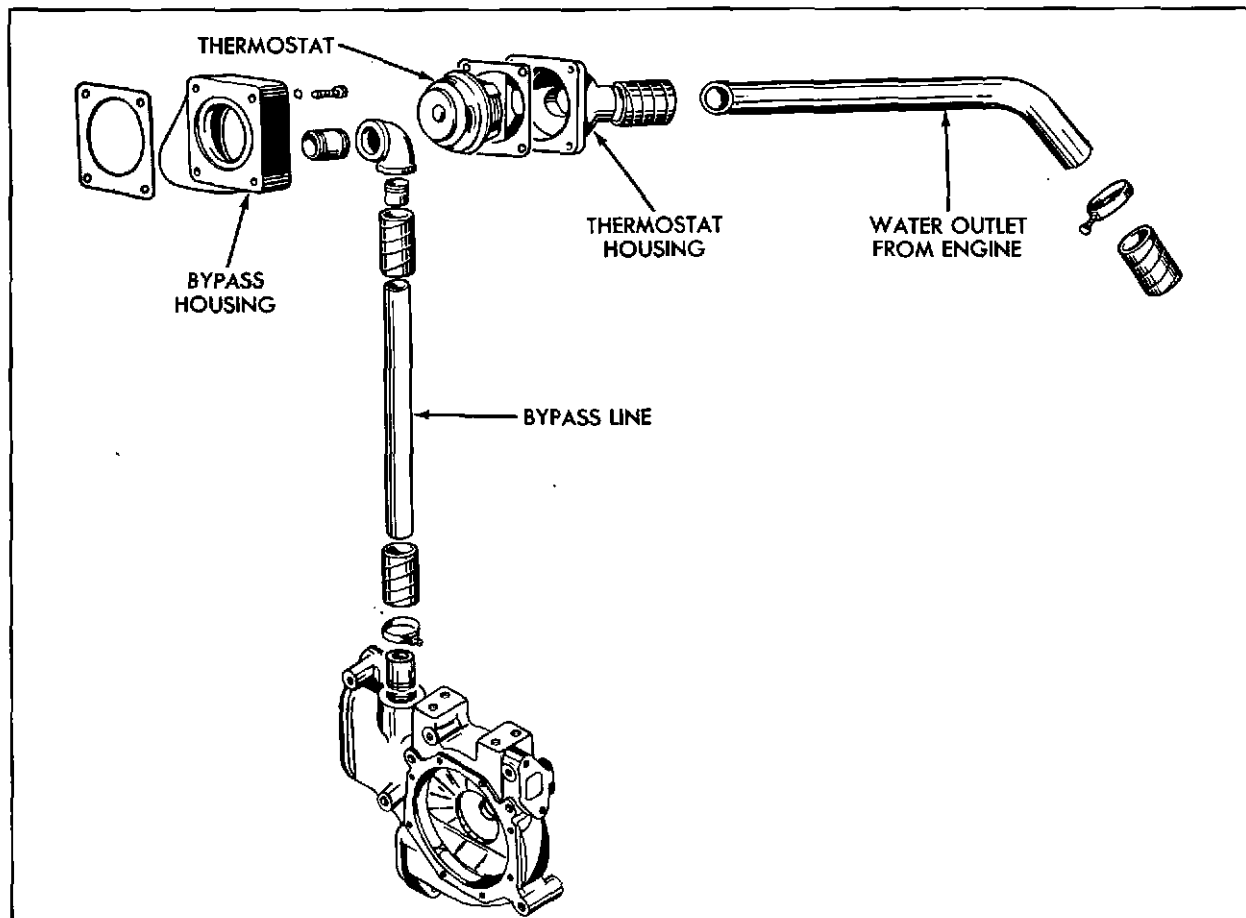

Water Outlet Manifold, Exploded View

flows to the oil cooler where lubricating and cooling system temperatures are stabilized. Relief valves are provided in both the oil filter base and oil cooler fittings which will by-pass oil in the event of filter or cooler clogging.

A grooved cover plate is used on the TH884 by-pass system. This plate redirects oil flow at the filter mounting pad back into the crankcase passage which leads to a flexible line to the oil cooler. Oil flow discharged from the oil cooler is diverted by a tee, which causes a portion of the oil to flow through a flexible line to the engine main oil gallery while the remaining portion of oil flows through another line to the remotely mounted by-pass type filters. Oil, after being filtered in this by-pass system, is returned through a flexible line to the engine oil sump, entering the engine at a tapped hole provided in the upper oil pan.

Oil, after being filtered and cooled, enters the main oil gallery and is directed to the front camshaft bearing support. On all models except the TH570, the hollow camshaft serves as the main lubricating oil gallery. The current TH570 camshaft is not rifle drilled as the main oil gallery is provided by a longitudinal oil passage in the crankcase block.

Holes in the camshaft bearings permit oil flow through holes in the crankcase that are drilled from each camshaft bearing down to the main bearings. At the main bearings, oil holes and grooves register with the drilled passages in the crankshaft. Connecting rod bearings are lubricated by oil transferred through these passages drilled from the main bearing to the crankpin. The connecting rods, which are currently rifle drilled, permit oil passage up through the length of the rods, thereby providing additional lubrication to the piston pin area.

A copper tube in the tappet chamber connects one of the camshaft bearings with the accessory drive housing. Oil flows through the tube into an annular space between accessory drive shaft bushings, and the remaining bearings.

Lubrication for the gear train is supplied by oil escaping around the shaft bearings.

Oil to the cylinder heads is supplied intermittently, when the radial passage in the rear camshaft bearing journal coincides with the hold drilled through the bearing support. A copper tube connects the cylinder heads with the camshaft bearing support hole.

Oil entering the heads is carried through a longitudinal passage in each head that crosses the over-size rocker arm shaft support stud holes. The oil is free to travel up the stud holes, into the rocker arm shaft, then out to the rocker arm bearings. A small drilled passage in the rocker arm supplies sufficient oil to lubricate the push rods, valve springs, and valve stems.

COOLING SYSTEM

The cooling systems used on the 570 and 884 engine are of the pressure circulating type and may employ a variety of external cooling devices such as radiators, cooling towers, heat exchangers, and so on.

The water pump discharges the coolant from the radiator or heat exchanger into each bank of the engine through individual discharge connections.

From the individual discharge connections, water passes around the cylinder liners and up through cored holes into the cylinder head. Here special attention is given to jacketing so as to avoid overheating of the valves and valve seats.

After cooling the cylinder head, valve seats and ports, and combustion chamber, the coolant flows into the water cooled exhaust manifold then out of the engine through the water outlet manifold.

To raise water jacket temperatures quickly when starting, and to maintain operating temperatures, a thermostat is located back of the top tank of the radiator where the water out-

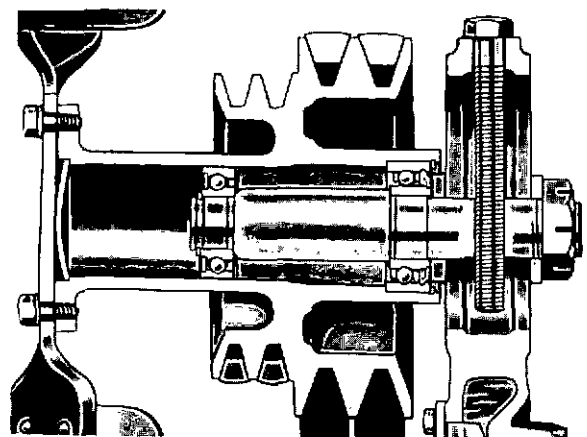

Fan and Hub, Sectional View

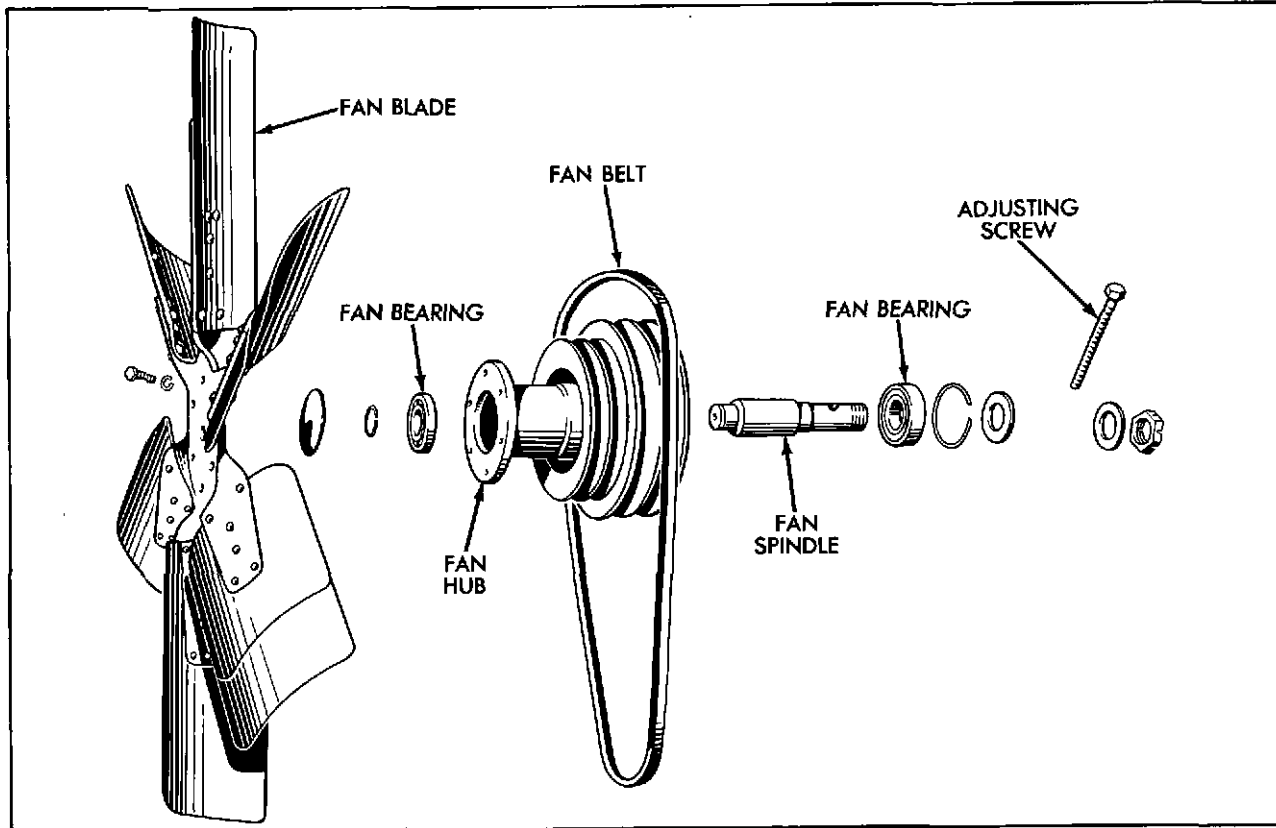

Fan and Hub Assembly, Exploded View

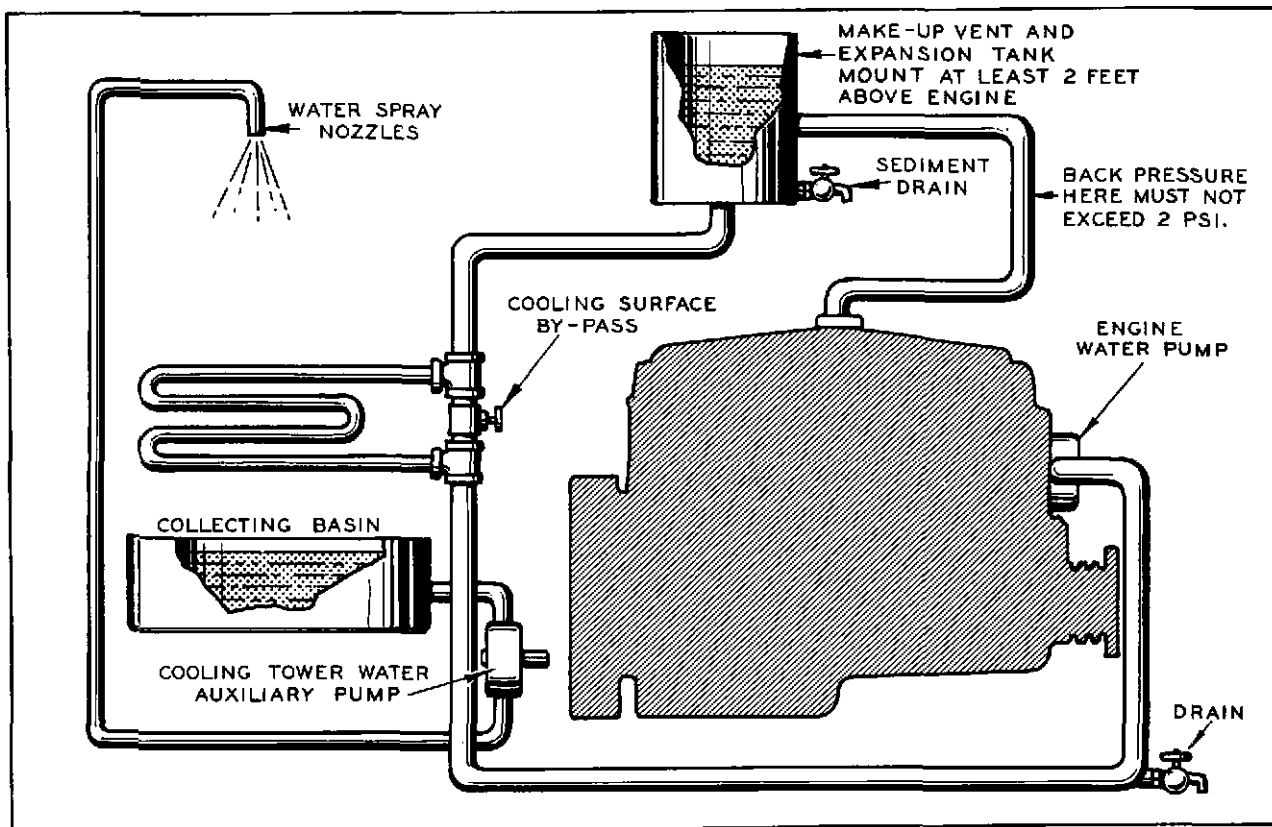

Schematic of Typical Cooling Tower Installation

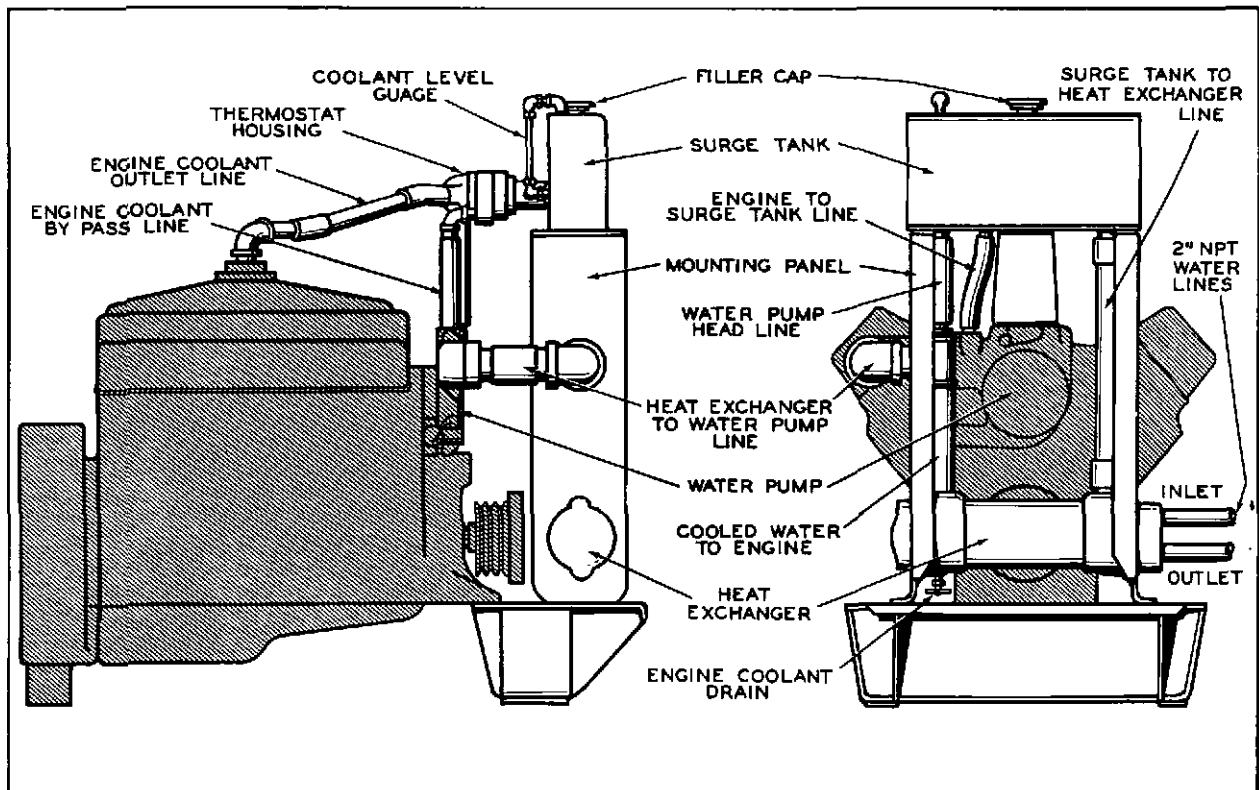

Shell and Tube Heat-Exchanger Cooling

lets from the two exhaust manifolds are joined into a single passage. When the engine is cold, the thermostat contracts, closing the radiator inlet passage and by-passing the water back into the pump suction. As the water temperature increases, to about 160° F, the thermostat expands and opens the external cooling system passage, diverting less water back into the pump suction. When a water temperature of about 182° F, is reached, the thermostat is fully expanded and all the water is cooled by the radiator or heat exchanger, the by-pass connection being closed. The thermostat and by-pass housing design is such that the thermostat is in contact with moving water as it is discharged from the engine.

The fan is driven by belts from the crankshaft pulley and rotates on a shaft supported by the fan bracket which is an integral part of the water pump. A jackscrew threaded into the stationary shaft and a large lock nut on the end of the shaft allow positive belt adjustments.

The heat exchanger type of cooling system consists of a tank for engine cooling water and nest of tubes to carry "raw" water from some outside source. Heat is transferred to the "raw" water as engine cooling water passes through the baffled heat exchanger tank. Raw water circulation is provided by a separate "high head" pump.

SERVICE

FUEL

It is very important to use fuel with an octane rating high enough to avoid serious detonation (knocking) in these high-output engines.

OIL CAPACITY

If filtering equipment, external lines, or other lubrication system components are added to the standard lubrication system, the oil requirements of such accessory equipment should be checked as follows:

1. Fill the crankcase with oil.
2. Operate the engine for a few minutes so as to circulate oil through the system.
3. Stop the engine and measure the additional oil required to bring the level to the "FULL" mark on the dipstick.
4. On future oil changes the entire amount of oil may be placed in the crankcase at once. However, if this extra oil is put in, and the external equipment requiring it is not completely drained of the old oil, then the engine will have an excessive oil supply which is undesirable. In addition, dirt and sludge from the old oil will contaminate the fresh oil.

PUMP INLET SCREEN

The inlet of the oil pump is protected by a screen designed to protect the pump and engine from the introduction of foreign material. If any indications of low or fluctuating oil pressure appear, it is recommended that the pump screen be very thoroughly washed in a solvent such as lacquer thinner or benzol.

OIL CHANGES

The crankcase level should be checked prior to each day's engine operation and at the same time the condition of the oil as revealed on the bayonet gauge should be observed carefully. Replace oil at any time it is plainly diluted, broken down, thickened by sludge, or otherwise deteriorated. Remember that some modern oils can't be judged on the basis of color alone because the additives are intended to hold

carbon particles in suspension. The standard filters supplied will not remove these particles. The dark appearance of the oil is not necessarily an indication that it should be changed. Oil performance will reflect engine load, temperature, fuel quality, atmospheric dirt, moisture and maintenance. Where oil performance problems arise or are anticipated, the oil supplier should be consulted. An oil change period of 100 hours of normal service can be used as a guide for Class A engines, unless monitoring by analysis indicates the suitability of a shorter or longer change period. One part of this analysis is monitoring the viscosity change, which should not exceed two SAE grades from the new oil. When extended drain periods are contemplated, the supplier's analysis, or that of a reputable laboratory, should determine the suitability of oil for further service. Whenever oil is changed, the filters must be serviced. Not all oils in every type of engine will give maximum service, therefore be careful to examine the oil after the first draining to determine whether it is standing up in service. Trial periods of 10 hours are suggested and at the end of such periods make careful inspections for sludging, frothing, and emulsification. Such conditions call for more frequent changes or a different oil. In winter operation, low oil temperatures (below 160°F.) are particularly likely to cause sludge formation. Temperature-control devices - curtains, shutters, and so on - should be used if needed in order to hold the oil temperature around 180°F.

SELECTING OIL VISCOSITY

All other things such as oil type and quality being equal, the principal factor in choosing the proper oil viscosity is the operating temperature of the oil in the crankcase. It is this temperature that establishes the running viscosity of the oil.

1. Make one or more check runs under actual operating conditions of speed and load. Use SAE 40 oil for this test. Note the temperature range of the oil in the crankcase by means of an accurate oil temperature gauge immersed in the oil.
2. Find the temperature range noted in the above test in the tabulation below. The proper oil viscosity for these operating conditions will be found directly to the

right. If different kinds of service cause the loads and operating conditions to vary, re-check the oil temperature as above and select an oil of lighter or heavier viscosity as required by the new conditions.

CLASS A ENGINES

OIL OPERATING TEMPERATURES	SAE VISCOSITY NUMBERS
210°-250°F.	40
160°-200°F.	30
130°-160°F.	20

When the actual operating oil temperature is not known, an estimate of the SAE oil grade to use can be made by assuming the oil temperature will be 120 degrees above the air temperature in heavy duty service. For example: At an air temperature of 80°F. estimated oil temperature would be 200°F. Use SAE 30 as indicated in the above table. Note: This is only an estimate, since the type of installation determines the amount of air circulation for cooling around the oil pan. Actual crankcase operating oil temperatures should be measured whenever possible.

Multi-viscosity oil should be used only where cold starting conditions make it absolutely necessary. Oil change periods should be reduced to 25 hours. At the present state of development, multi-viscosity oils are normally not recommended for use in heavy duty industrial engines. The viscosity improvers presently used may tend to deteriorate in continuous service; allowing the oil to revert to its original low viscosity base. In this state, the oil may not supply sufficient film strength and or oil pressure.

OPERATING TEMPERATURES

Engines operated with low oil temperatures below 160 deg. F. can be expected to show excessive sludging and wear. Engines operated with high oil temperatures above 230 deg. may experience lacquering and ring sticking. The undesirable effects of operating at abnormally low or high oil temperatures can be alleviated to some extent by the use of additive type oils.

LUBRICATING OIL RECOMMENDATIONS

The performance of a lubricant, like that of any manufactured product, is the responsibility of the refiner and producer. A tabulation of lubricant producers and marketers, together with the performance grades for which the producers have indicated their products are qualified, is

available from the Engine Manufacturers Association (EMA), 111 East Wacker Drive, Chicago, Illinois - 60601. This tabulation (EMA LO Form 1-12/70) is entitled "Lubricating Oils for Heavy Duty Automotive and Industrial Engines". The Waukesha Motor Company has made it a practice not to recommend oil by brand name.

NOTE

All Waukesha industrial engines are considered to be in heavy-duty service. They are classified "A" or "B" according to displacement: Class A, engines up to 1000 cubic inches and Class B, engines above 1000 cubic inches.

Oil is designated several ways; including the API, which is usually stamped on the container; the military, and the engine manufacturers. For Class A engines operating on gasoline or gas, Waukesha Motor Company recommends lubricating oil designated by the API as CC, SD or SE, and by the military as MIL-L-2104B or MIL-L-46152.

LOW TEMPERATURE OPERATION

At low temperatures an oil must be used which will provide proper lubrication when the engine is hot and working. If special heaters are needed to warm oil or coolant for starting, they should be used. Waukesha Motor Company will supply information on these devices upon request. Such heating systems permit the use of the recommended oil grades for the operating loads and temperatures involved.

OIL CONSUMPTION

Acceptable oil consumption should range from 0.0005 to 0.004 pounds per horsepower-hour. To figure use--

$$\text{LBS/HP-HR} = \frac{1.82 \times \text{quarts of oil used}}{\text{Operating HP} \times \text{total hours of operation}}$$

BREAK-IN

New or overhauled naturally aspirated or lightly loaded turbocharged engines should be "broken-in" to seat piston rings properly on a low additive type oil for the first 100 hours of operation. (NOTE: Stand-by engines should have a specific break-in cycle before being put into service). Never idle for more than 15 minutes. Load and unload procedure is best. Repeated loading with equal idle periods in 5-minute intervals for a period of one hour results in more rapid break-in of the engine.

LUBRICATION AND SERVICE GUIDE

ENGINE	Check oil level and condition daily. Change oil about every 100 hours of engine operation. Experience with the engine or periodical chemical analysis of the oil will indicate the best time for oil change under each particular engine application.
OIL PUMP INLET SCREEN	Low or fluctuating oil pressure may indicate oil pump inlet screen clogging. Remove and wash screen in solvent when necessary.
OIL FILTER	Change filter elements and clean filter base at each engine oil change. Use correct filter replacement element.
OIL COOLER	An increase in oil and water temperature may indicate restricted flow within oil cooler. Disassemble and clean cooler after first 300 to 500 hours of operation and thereafter as experience indicates.
AIR CLEANER	Service cleaners according to their attached instruction decal at least once daily and more often under severe operating conditions.
COOLING SYSTEM	Continued efficiency of the engine cooling system requires preventative maintenance and cleaning at least once yearly. A washing soda solution or a commercially available cooling system cleaner should be used as directed to remove sludge and sediment build up. Periodic addition of a soluble oil helps prevent rust formation within the system. The correct fan belt tension should be maintained and condition of belts checked frequently. Frayed, cracked or torn belts should be replaced only with matched sets of belts. Check fan hub monthly and add ball bearing grease (lithium soap type) if necessary to maintain 1/2 full level.
IGNITION SYSTEM	Distributor: Distributor shaft oil plug should be refilled with SAE 20 oil every 200 hours of operation. Magneto: Periodic authorized service station inspection and cleaning should be established with complete magneto reconditioning each 2500 hours of operation.
CRANKCASE VENTILATION REGULATOR	Wash in varnish remover about every 250 hours.
BREATHER CAPS AND CRANKCASE OIL SEPARATOR	Inspect each time oil is changed. Don't allow dirt to accumulate. Rinse in kerosene or some other non-volatile cleaning solution as required.
AIR STARTER	Check oil level weekly. Use SAE 30 (above 70°F), SAE 20 (30-70°F), SAE 10W (10-30°F), or No. 2 diesel oil (below 10°F). About every 3 months remove pipe plug from gearcase and lubricate with #2 cup grease (2 strokes of grease gun). Annually remove plugs from drive housing and saturate oil wicks with SAE 20 motor oil. If built-in lubricator adjustment is required, both adjusting screws are accessible through air inlet.

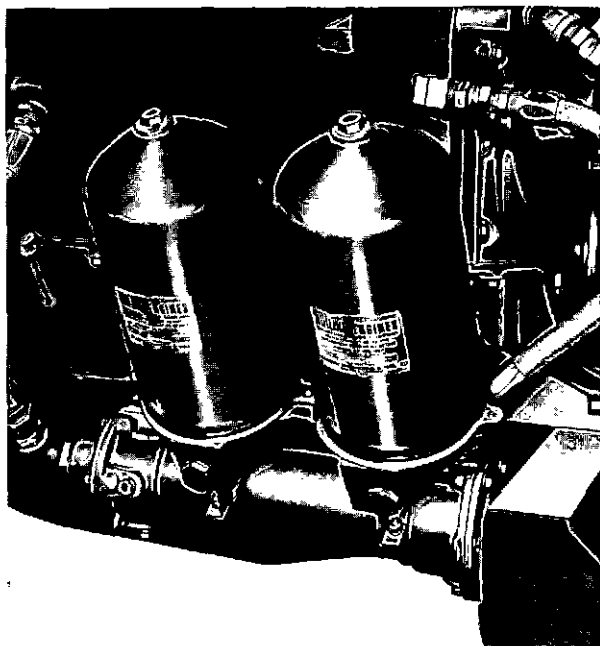

Typical Oil Filter

OIL FILTERS

A single element full-flow type oil filter is used on the H570 and TH570 series. The filter currently in use on the H570 is flange mounted in a vertical position to the upper oil pan, while the TH570 uses a full-flow filter which is mounted in a horizontal position immediately below the oil cooler. In the base of both filters, a relief valve is provided to prevent engine oil starvation in the event of filter element clogging. The relief valve would, under these conditions, cause the lubricating oils to by-pass the filter element.

Dual oil filters are used on most 884 engines. Earlier models used full-flow type filters, each filter having an inner and outer element with a metal separator located between the elements. Current H884 models have dual engine mounted full-flow filters, each filter having a single element. These elements are designed to be interchangeable with and replace the earlier inner-outer elements. The TH884 engines use remotely mounted oil filters, by-pass type or full-flow type.

Although some variations may appear in the oil-filter installations, the same general principles of maintenance apply to most of them.

In all cases the manufacturer's recommendations accompanying the filter, or the instruction label applied to the side of the filter should be followed carefully.

Where neglect of the filters or an unusually rapid accumulation of sludge tends to bring about filter clogging, a built in by-pass valve of the differential type opens to allow the oil a direct return to the engine without passing through the clogged filter elements. When this happens, the engine will not be starved of oil because of the filter condition, but it is very important to remember that the dirty oil that brought about the filter clogging is now passing through the engine itself and may reduce engine life materially.

Because of the above possibility, the recommendations made for filter change periods coincide with the recommendations for oil change. If the oil shows evidence of sludge formation or improper filter operation it should be changed and the filter element as well. Also, a check should be made to see that the oil and water temperatures are within the desired range of 170°-190° F.

If experience indicates the practicality of running the lubricating oil for maximum periods between changes, then the filters may be considered as satisfactory for this period of operation. In all cases, the filter elements should be changed at the time of oil change.

With each oil change: Service the full flow type filter on the 570 series by replacing the single element. If the now obsolete two element type filter is encountered when servicing the H884 dual oil filters, discard the separator and both inner and outer elements, replacing them with the specified single filter element. Service the full flow filters and the by-pass filters by replacing the elements at each oil change.

About once a year it is good practice to examine the by-pass valves for freedom and proper operation.

OIL COOLER

Maintenance of the oil cooler unit consists largely of periodic cleaning and inspection for clogging or corrosion. Improper or fluctuating oil pressure, or an undesirable increase in oil and water temperature may indicate the need for oil cooler service. Generally the cooler should be removed from the engine, disassembled, and cleaned after the first 300 to 500

hours of operation, and thereafter as the oil temperature indicates.

Disconnect all oil and water lines to the cooler, remove the U straps holding the cooler to the mounting brackets, and move cooler unit to bench for further disassembly. Remove capscrews holding both inlet and outlet bonnets and slide the tube and baffle bundle out of the shell. With unit disassembled, clean all rust and lime deposits that may have accumulated in the water passage area.

It is recommended that cleaning take place as quickly as possible after disassembly as exposure of the tube interiors to air contributes to a hardening action that makes cleaning more difficult. Several methods can be used to clean the cooler unit interior. Cleaning fluids suitable for sludge removal range from benzol, or coal-tar-naphtha, to more complex industrial washers and degreasers utilizing trichlorethylene, carbon tetrachloride or some of the excellent industrial detergents available. Personnel doing such cleaning should remember that most cleaning substances capable of removing oil varnish are also, to a greater or lesser degree, toxic and may be injurious to skin, eyes, and respiratory passages. Moreover, adequate ventilation and fire-protection measures are essential in most cases. Techniques for sludge removal will vary somewhat according to the equipment at hand. Generally, it is best to allow a soaking period during which the cooler core unit is submerged in the cleaner. When the cleaner has loosened the deposits, usually within about 15 minutes, a pressure pump should be used to force the cleaner back and forth through the core passages. This pumping should continue for several minutes. When all foreign material appears to be removed, drain and dry the core, then test it in a clean solvent solution for traces of deposits still remaining. Reassembly of the oil cooler unit is the reverse of disassembly. Observe normal precautions with the gaskets to prevent leaks and to ensure that no oil passage holes are blocked.

OIL PRESSURE CONTROL

Under all normal operating conditions, the high-capacity oil pump will maintain the oil pressure within the specified limits. A cold engine, or the addition of cold oil to the crankcase of a warm engine, will cause high oil pressure until the oil temperature stabilizes in the proper range. A warm engine will normally carry a low oil pressure at idle speeds and no alarm should be felt under these circumstances if it does not fall below 15 pounds. Moreover, the oil pressure gauge of an engine

started under cold conditions may fail to register pressure immediately because of congealed oil in the gauge line. If the pressure still fails to register after the engine has run for 25 to 30 seconds, the engine should be shut down and the cause of the lack of pressure determined and corrected.

Oil pressure fluctuations may sometimes be caused by erratic operation of the pressure relief valve. If this occurs, it is recommended that the pressure relief valve plug, plunger, and spring be removed. Check the pressure relief valve plunger for freedom of movement. Small particles of carbon or other material may have jammed the valve or clogged the vent passage behind the valve. In both cases, the plunger and the valve body passages should be cleaned thoroughly. If burring or nicking of the valve seat is found, it may be beneficial to polish the damaged surface carefully with a hone and crocus cloth dipped in fuel oil.

AIR CLEANERS

Although various types of engine installations will have differences in air-cleaner types and arrangements, it is important for the operator to appreciate that the common purpose of all air cleaners is to collect dirt and grit and so keep it out of the engine working parts. As a result, the cleaner units must themselves be cleaned, sometimes several times each day if operating conditions are particularly bad.

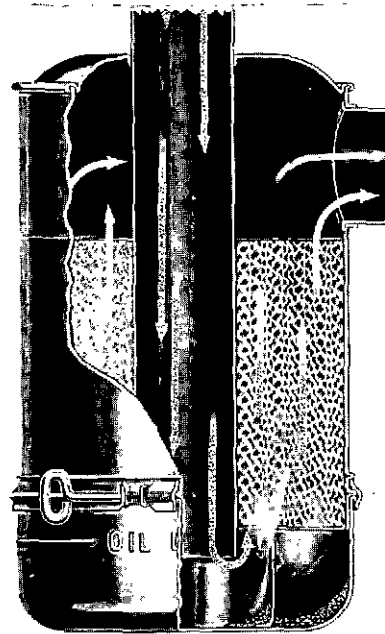

Oil Bath Air Cleaner

Glass jars, on those cleaners employing glass-jar pre-filters, should be emptied whenever they approach half-full. Do not oil the jar interiors. Most modern cleaners are of the so-called oil-bath type. In principle, the intake air passes over a pool of oil located at the bottom of the filter shell. Some of the dust particles are simply caught by the oil and settle at the bottom of the pool; other particles adhere to the oil vapor and droplets that leave the surface of the oil pool. The latter are prevented from entering the engine by a wire-screen element.

To clean filters of the oil-bath type, flush out the oil in the lower part whenever an obvious accumulation of sediment, or thickening of the oil, makes itself apparent. Scrape away any accumulation, then refill the unit with fresh, clean engine oil. A bead pressed in the metal indicates the proper oil level. The screen filter is easily washed out in gasoline or a similar solvent.

Because the dust particles are so small, yet possess the ability to cause great damage, it is absolutely imperative that air-inlet connections be kept in tight condition to avoid taking in unfiltered air.

The screen in dry type cleaners may become clogged with dust, lint, and other foreign material to the point of seriously reducing the engine's power if not attended frequently enough. The most effective method of removing this dirt is to wash the screen in solvent, blow clean

with an air hose, then dip in clean crankcase oil. Always direct the stream of air from the inside of the element outward to prevent clogging of inner layers of the screen.

Some of these cleaners are equipped with a pre-cleaner screen to prevent cotton lint, chaff and other foreign materials from entering the inner screen.

When cleaning the filter, the precleaner **MUST** be removed to clean the inner screen.

COOLING SYSTEM

The cooling system of the Model H570, using a standard radiator, holds 14 gallons of water. For H884 engines, this figure is 20 gallons. When adding anti-freeze compounds on a percentage basis, remember to include the coolant volume of any special radiator or external components of the cooling system. The following table may be used as a guide.

Pure Methyl Wood Alcohol	Denatured Wood Alcohol	Ethylene Glycol "Prestone"	Radiator Glycerine (G. P. A.)	Freezing Points	
				°F.	°C.
13%	17%	16%	37%	20	-7
20%	26%	25%	55%	10	-12
27%	34%	33%	70%	0	-18
32%	40%	39%	81%	-10	-23
37%	46%	44%	92%	-20	-29
40%	53%	48%	100%	-30	-35

To prevent rust when using straight alcohol and water solutions, and using water alone, add one ounce of soluble oil for every gallon of coolant in the cooling system.

Never fill an engine with straight water after it has been exposed to sub-freezing temperatures for any length of time. This applies even when warm water is used because the water in the radiator and jacket passages cools rapidly and is likely to freeze before the engine can be started. If it is planned to leave the coolant in the engine at the next shutdown, then mix the proper proportion of soluble oil, anti-freeze and water before filling the engine. If water alone is to be used, then be sure that enough water to fill the entire system is immediately available; start the engine; and add water quickly before overheating can occur. This last method requires, of course, that the water be drained immediately when the engine is shut down.

Periodic additions of anti-freeze will be required to compensate for evaporation. Use a

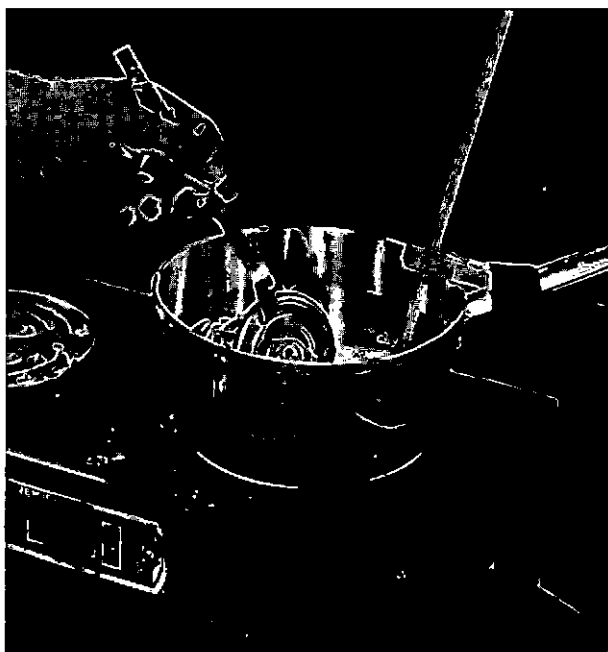

Testing Thermostat Opening

hydrometer type test gauge to ensure that the anti-freeze solution is maintained at its proper strength.

Under normal conditions, the heat-sensitive thermostat in the housing at the upper (inlet) radiator port will maintain temperatures within the desired limits.

By way of caution, it must be remembered that if the engine is to be operated with the thermostat removed—and this is not recommended except in case of emergency—provision must be made to block off the by-pass passage or else water will continue to recirculate without passing through the radiator or other external cooling system. Also, shutters or other means will be required to maintain the temperature at the desired level.

Thermostat Removal

Ordinarily, the thermostat will seldom need replacement in the field. It should be checked from time to time, however, and is quickly accessible by removing the thermostat housing at the upper port to the radiator. The steps necessary to accomplish this are simply the removal of the by-pass line hose, the radiator water inlet connection hose, and the cap screws securing the thermostat housing. A thermostat damaged by corrosion or other causes is not repairable and must be replaced.

Thermostat Testing

The thermostat should be tested in hot water for proper opening. A bucket or other container should be filled with sufficient water to cover the thermostat and fitted with a good quality thermometer suspended in the water so that the sensitive bulb portion does not rest directly on the bucket bottom or side. A stove or torch is used to bring the water to a heat range of 160° F. while the thermostat is submerged in the water. Stir the water for even heating. As the temperature passes the 157°-162° range, the thermostat should start to open and should be completely open when the temperature has risen to about 182°F. Lifting the thermostat into the colder temperature of the surrounding air should cause a pronounced closing action and the unit should close entirely within a short time. When replacing, use care to seat the thermostat squarely and concentrically to avoid interference with the thermostatic action.

Draining the Cooling System

Because the engine is designed with individual water jackets for each bank, it is equipped with a drain cock for each bank; therefore to

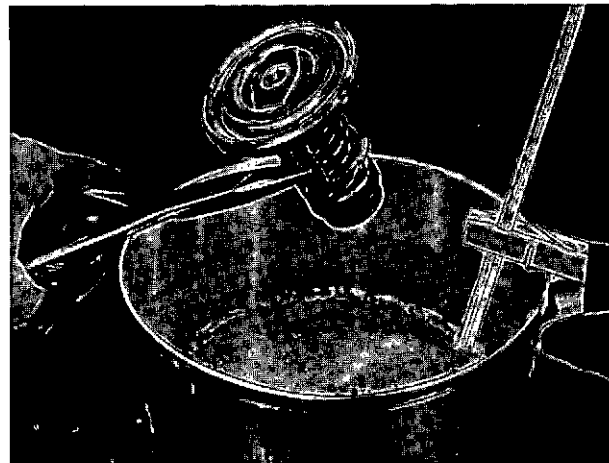

Testing Thermostat Closing

drain the coolant fully, both of these drain cocks must be opened.

The external portion of the cooling system must also be provided with a drain cock which has to be opened.

On engines burning LPG fuel, drain the water from the regulating unit also.

Open all drain cocks and inspect them to insure they are flowing freely.

Cleaning the Cooling System

When clean, soft water is used as a coolant, and when the proper inhibitors and anti-freeze solutions are used, radiator and cooling passage accumulations will not be excessive. About once each year, however, the engine will benefit if the cooling system is cleaned of sludge and sediment. A washing soda solution will ordinarily do this job satisfactorily.

To clean the cooling system . . .

1. Drain system and measure water volume.
2. Replace half of measured volume with fresh water.
3. Boil other half of volume and add washing soda until no more will dissolve.
4. Add hot soda solution to cooling system (fill up).
5. Operate engine normally for 24 hours.
6. Drain, flush, refill with clean water to which a soluble oil has been added in a proportion of 1 ounce per gallon of water.

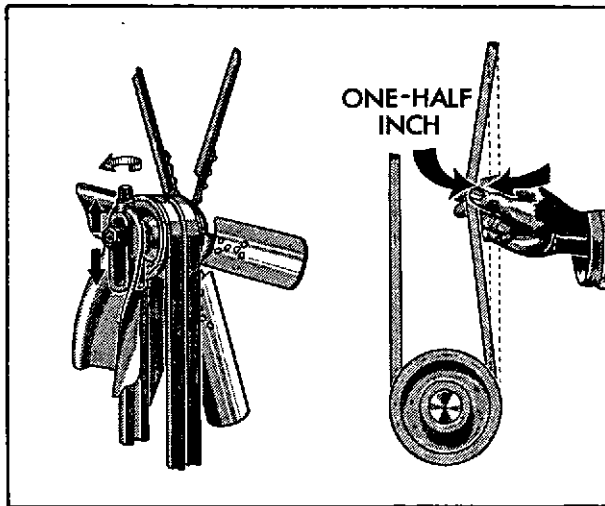

Checking Fan Belt Tension

Commercial Cleaners

It is recognized that a number of excellent commercial cooling system cleaners are available. The WAUKESHA MOTOR COMPANY suggests, however, that an operator considering the use of such a cleaner first investigate its possible reaction with the copper and bronze parts in the engine. If such a cleaner is used, follow the manufacturer's recommendations carefully.

Cooling Fans

About the only maintenance work encountered in connection with cooling fans will be the occasional straightening of a blade damaged in some manner and the replacement of fan belts. In the case of slightly bent blades, it is important to remember that inaccurate blade alignment can cause considerable roughness and vibration as well as inefficient cooling and bearing wear. Hence, bent blades should be brought into track, adjusted to the same angle as the other blades, and examined for security of the hub attachment and possible cracks in the spider area.

Fan Belts

Periodic replacement of fan belts is good insurance against damaged radiators and inopportune shut downs. Provision has been made to reduce the stretch between the fan pulley and the drive pulley on the engine and this adjustment should be used to install the belt. Attempting to force the belt over the pulley while it is under tension is almost certain to damage the belt.

To install new fan belts, (all should be replaced at the same time), follow the procedure below:

1. Loosen the fan-hub nut located behind the fan-support bracket.
2. Lower the fan-hub and pulley with the fan adjustment screw on top of the fan-support bracket until the belt tension is completely relieved and the old belts can be slipped free.
3. Slip the new belts over the pulley and take up on the adjusting screw until the belts show some tension but are not so tight as to prevent movement with the thumb and forefinger for about one-half an inch to either side.
4. Retighten the fan-hub retaining nut.

IGNITION SYSTEM MAINTENANCE

The 570-884 series engines may be equipped with either distributor or magneto ignition. For top engine performance, each unit of the ignition system must be in good condition and properly adjusted. Normal maintenance consists of replacing defective units at periods determined by experience with the type of service involved. Adjustment several times during the service life will extend the usefulness and help benefit engine life.

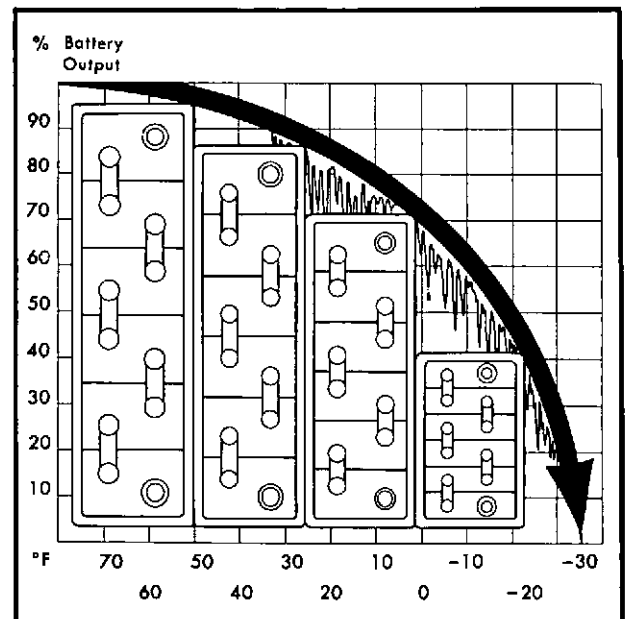

Cold Reduces Battery Power

The following tabulation will be found useful when checking through the ignition system. DO NOT SLIGHT MINOR POINTS, THEY ARE ALL IMPORTANT.

Spark Plugs

Check for correct heat range in plug manufacturer's chart. Examine for cracked porcelain, leakage, burned electrodes, deposits on center insulator, correct gap, good washers, and clean threads and seating surface. Remember, a plug may APPEAR satisfactory and still miss.

Lead Wires

Check for sound, unburned, insulation without cracks, breaks, or oil contamination. Terminals at each end should seat firmly on clean, uncorroded contacts.

Distributor Cap

Check for secure seating, clean exterior, and interior free from oil, grime, powdered metal, paint, or hairline cracks. Clean corrosion from terminal sockets.

Distributor Rotor

Check for cleanliness, firm seating, shiny center contact, arm contact not eroded short, nor striking cap contact lugs.

Breaker Points

Check for wear on fiber cam follower; secure mounting; tight, clean, well-insulated low-tension wire; correct spring breaker tension (19-23 ounces); point contacts meeting squarely and not excessively pitted; point gap .018 to .020 for distributors, .016 to .018 for magnetos.

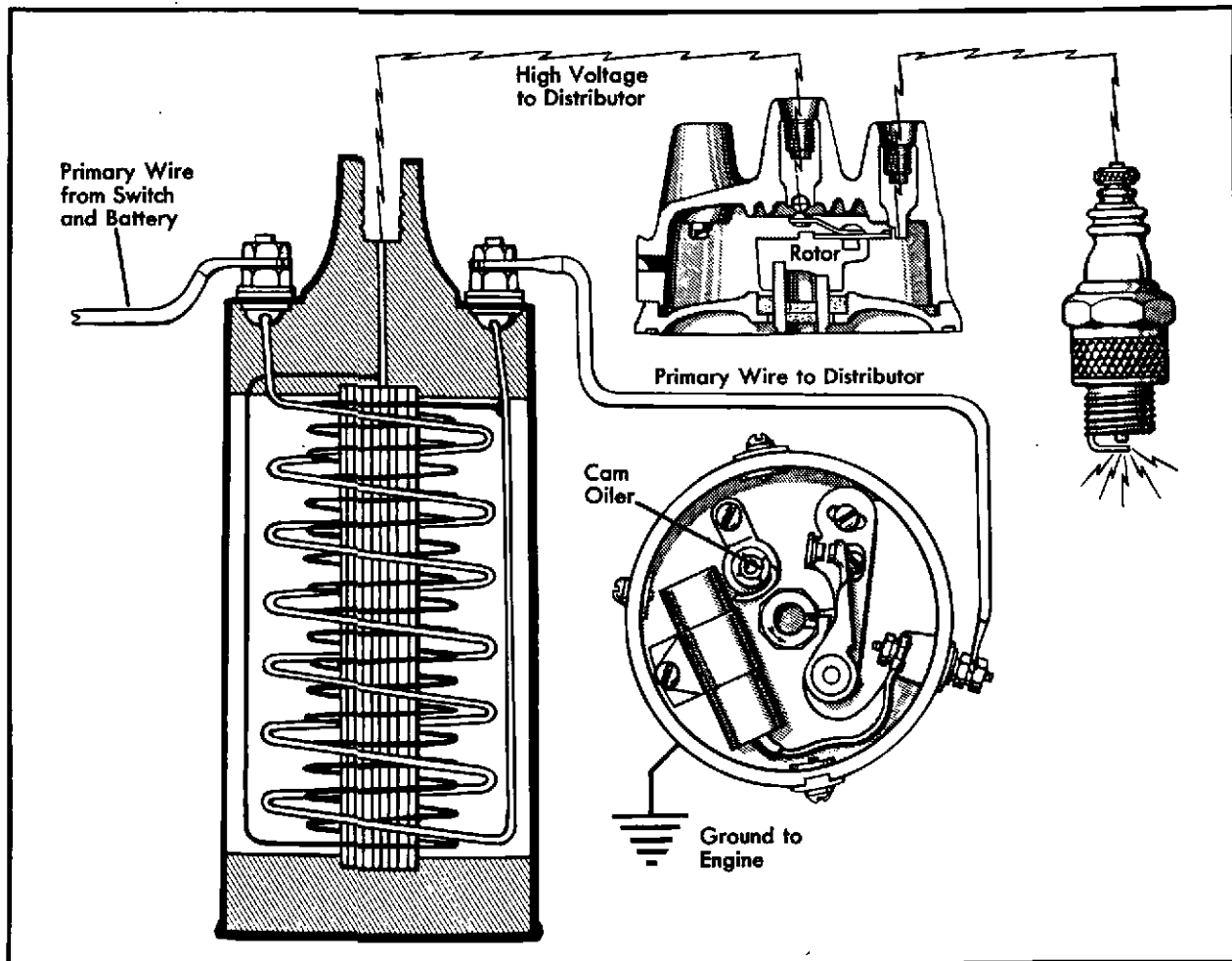

Schematic of Typical Battery Ignition System

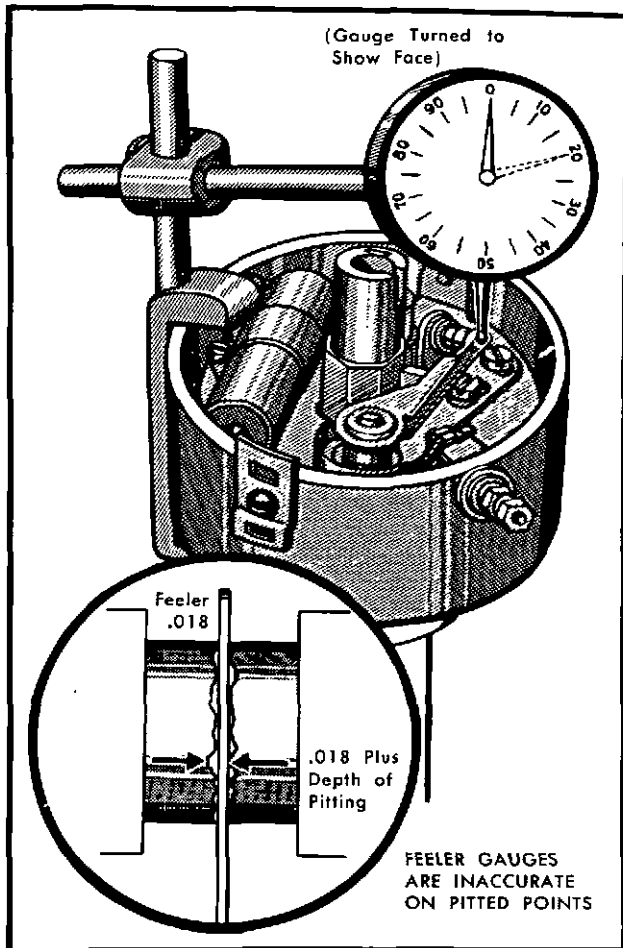

Setting Distributor Points

Condenser

Check for secure ground to breaker case, freedom from oil and grease, wire connection solid. Try new condenser if in doubt.

Breaker Housing

Check for interior cleanliness, freedom from oil and grease, free movement of centrifugal advance system without looseness or slack in parts.

Breaker Cam Wick

For magneto, lubricate with SAE 50 or 60 oil approximately every 500 hours of operation. For distributor, 3 to 4 drops of light engine oil every 200 hours. Do not over lubricate as excess oil is apt to cause contact points to burn.

Distributor Shaft

Refill at oil plug with SAE 20 engine oil every 200 hours; test manually at breaker cam for wobble from excessive bushing clearance.

Timing

Use simple light circuit across points to establish correct point opening with flywheel marks or correct degree on timing tape. Centrifugal advance compensates for higher speed timing. Present distributors are timed at TDC.

Coil

If a coil is suspected to be defective, test by replacing with one known to be good.

Distributor

The primary or low-tension circuit of an ignition distributor passes directly from the primary wire connection, through the breaker points, to the grounded body of the distributor. The condenser is connected across the breaker points. One side of the condenser is connected to the insulated primary wire connection; the other side is grounded to the distributor body. Each time the rotating cam in the center of the distributor permits the breaker points to close, the primary circuit is complete. Hence, the cam and breaker assembly is nothing more than a switch timed to pass primary current through the ignition coil eight times for every two revolutions of the engine crankshaft.

When the cam forces the breaker points apart, the primary current flow through the coil is interrupted. It is this abrupt interruption in primary current that induces the secondary current in the separate secondary winding of the coil. An explanation of the induction principle will be found in the publications of electrical equipment manufacturers. From the standpoint of engine maintenance, it is only necessary to be able to recognize when ignition units are in good condition, working properly, and accurately adjusted.

The high-voltage secondary current induced in the coil passes through another circuit of the distributor. Entering the distributor cap at the center lead, the current passes through the carbon button at the center of the cap interior and into the rotating distributor rotor.

The distributor rotor moving contact is held against the carbon button by spring pressure. The distributor rotor passes in turn each of the eight electrodes leading to the spark plugs. The positioning of the rotor tip opposite an electrode occurs at the same time the breaker points separate to cause a high voltage discharge through the secondary system. Consequently, this high-voltage current jumps from the rotor tip to the opposite electrode and into the lead going to the spark plug.

Since the mechanical arrangement of the engine requires a certain firing order, the wires leading to the spark plugs must be crossed to lead the successive sparks to the proper cylinder. For correct firing order, see the table of principal engine dimensions in the front of this manual. Since both the 570 and 884 have counterclockwise distributor rotation (viewed from above the cap) the wires are installed counterclockwise around the cap.

Distributor Timing

The steps in timing the distributor ignition system cannot be accomplished until the breaker points are accurately adjusted for clearance. Point clearances may be adjusted with the distributor installed in the engine. In some cases, however, it will be found much more convenient to remove the nuts holding the adjustment collar and carefully lift the entire distributor from the engine for inspection and adjustment. This avoids working in cramped quarters and difficulties in trying to crank the engine over to bring the cam peak under the fibre bumper block.

Distributor points do not have to be absolutely free of pits and grey oxide for satisfactory performance. Excessive cratering and build-ups of sharp peaks, however, require new breaker points. Slight point roughness may be cleaned up as much as is practical with a fine hone. Never use abrasive cloth or paper regardless of what the abrasive material is. A file is equally unsatisfactory with regard to continued point life, although improved performance may be obtained for a short while.

A feeler gauge is not an accurate method of setting points, particularly when there are some inequalities in the contact surfaces.

The simplest method, and the most accurate, is the use of a dial indicator. Here, the gauge is solidly clamped to the distributor body in whatever manner is convenient. The gauge tip is brought to bear against the movable breaker point just behind the contact surface and the

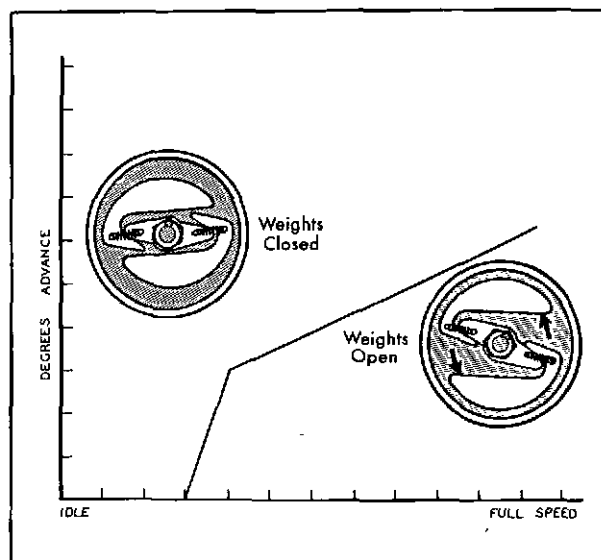

Typical Centrifugal Advance Curve

gauge is set to read zero with the fibre bumper on the flat of the cam and the points closed. Thus, by rotating the distributor cam, with the starter if the distributor is installed, or with the fingers if being bench adjusted, the exact point opening in thousandths is read on the dial indicator. This method will also reveal worn cams and distributor shafts that are loose in the bushings because the opening readings will be erratic. Clearances are adjusted in the conventional manner by turning the eccentric screw holding the fixed point. Do not forget to re-tighten the fixed point clamp screw after adjustment.

If the spark timing varies materially from the specified advance, some loss of power and possibly detonation are likely to result. For this reason it is advisable to check the timing whenever the engine is being given a tune up or when it is available for overhaul. The distributor must be retimed to the engine every time the points are removed or reset, and each time they are removed from the distributor.

To time the eight cylinder distributor:

1. Turn engine until cylinder No. 1 (see cylinder designation plate) is on Top Dead Center of its compression stroke. Continue rotating the engine until the notch on the crankshaft pulley is directly in line with the timing pin set in the gear cover. The notch in this position will indicate the proper timing location.

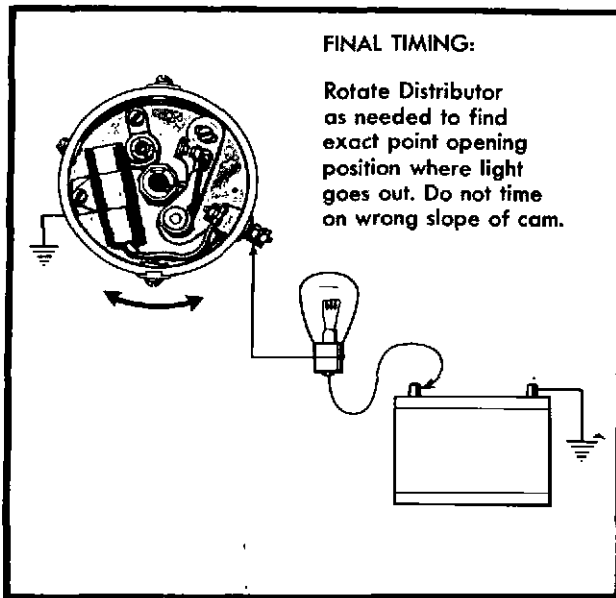

Steps in Timing Ignition

NOTE: A number of models of this engine have provisions for timing at the flywheel instead of the crankshaft pulley. On these engines rotate the flywheel until the proper timing degree or mark is in line with the timing pointer.

2. Insert the distributor so that the distributor cap clamps and primary lead are in convenient locations.
3. Remove distributor cap.
4. Place a piece of thin paper or cellophane between the breaker points, then turn the distributor body counterclockwise until the paper is released, just as the points begin to open.
5. Lock in this position.
6. Replace the cap and place ignition wire for cylinder No. 1 in cable outlet indicated in the wiring diagram.
7. Connect the remaining wires as shown in the wiring diagram.
8. Replace primary and secondary leads.

Advance Mechanism

Once the timing is properly set for the idle (no-speed) position, the centrifugal weight system of the distributor will automatically advance the spark as required by changes in engine speed. The mechanism involved is matched to each engine application by laboratory

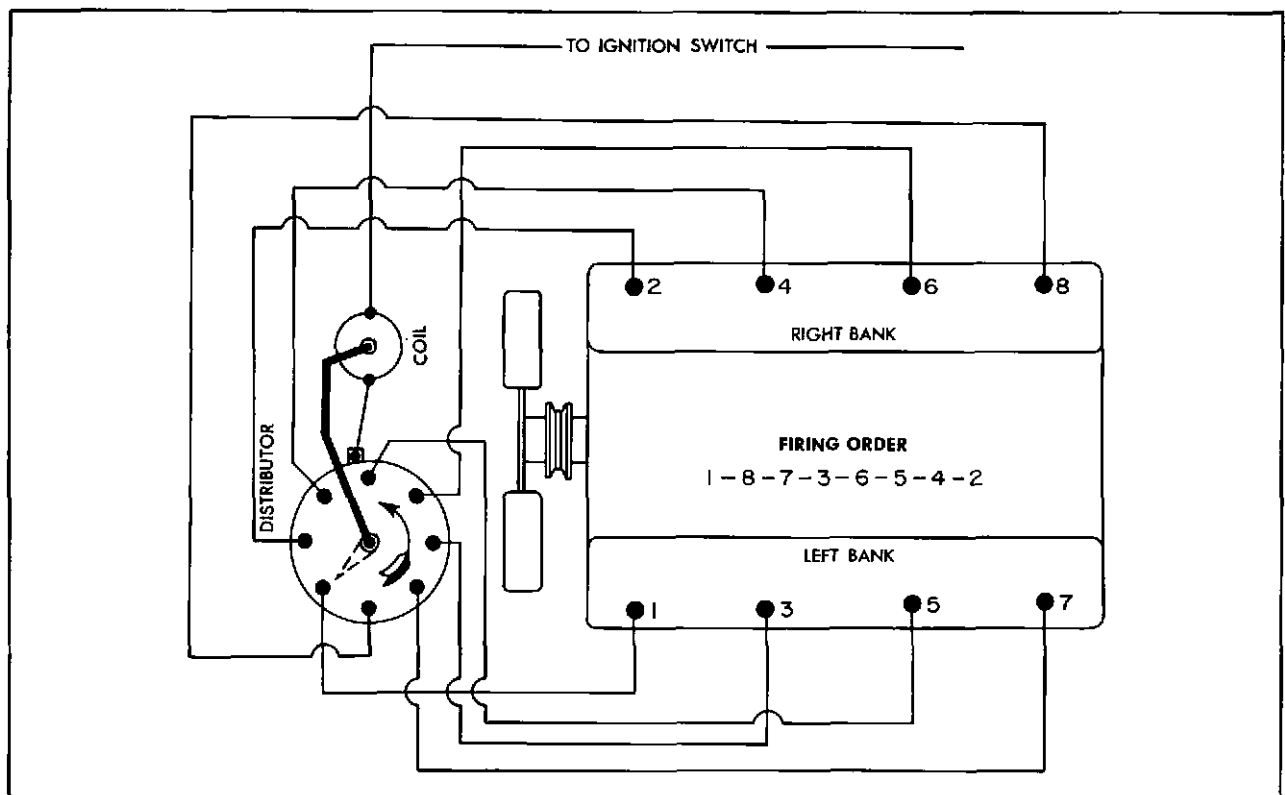

Distributor Ignition Wiring Diagram

tests determining the best spark advance point over the entire speed range. Therefore, substitution of unmatched parts from other equipment will impair timing and engine performance. The advance curve shown in the accompanying graph is merely a typical curve and not specific for these engines.

Checking Distributor System Spark Advance

For recommended spark advance data, consult the Clearance and Limits section of this manual or refer to the timing chart mounted on the engine.

1. On Model T-H884 with ignitor make chalk mark on crankshaft pulley 1-3/4 inches from the D.C. notch in the direction of engine rotation.

NOTE: On other engines with timing marks on flywheel make chalk mark at 30° mark.

2. Start the engine and connect timing light lead to No. 1 cylinder spark plug and observe running spark advance at crankshaft pulley or in timer opening in bellhousing. Spark advance may be altered by turning the distributor.

Magnetos

The vertically mounted magnetos feature simplified timing and spark setting. An impulse coupling built into the magneto retards

the spark when the engine is being cranked. After the engine starts, the coupling becomes inoperative and the spark is advanced to the optimum value for normal operation.

Minor servicing of magnetos is confined to cleaning, replacement, and adjustment of the breaker points. More extensive repair and overhaul operations require specialized training and equipment and should be made only at authorized service agencies.

In both theory and service practice there is little difference between a magneto and a distributor. Whereas a distributor depends upon a generator and storage battery for its primary current, the magneto uses a primary current generated within itself by rotation of permanent magnets between the pole shoes. Because of the movement of the permanent magnets and the periodic reversals of magnetic flux a magneto must be timed internally as well as with relation to the engine. To accomplish this internal timing requires an edge distance gage of a size specified for the magneto involved and for this reason a magneto that is properly adjusted at the factory or a service agency should not be upset by tampering with the breaker plate adjustment.

Magneto Timing

Check the timing whenever the engine is being given a tune-up or when it is available for overhaul. The magnetos must be retimed

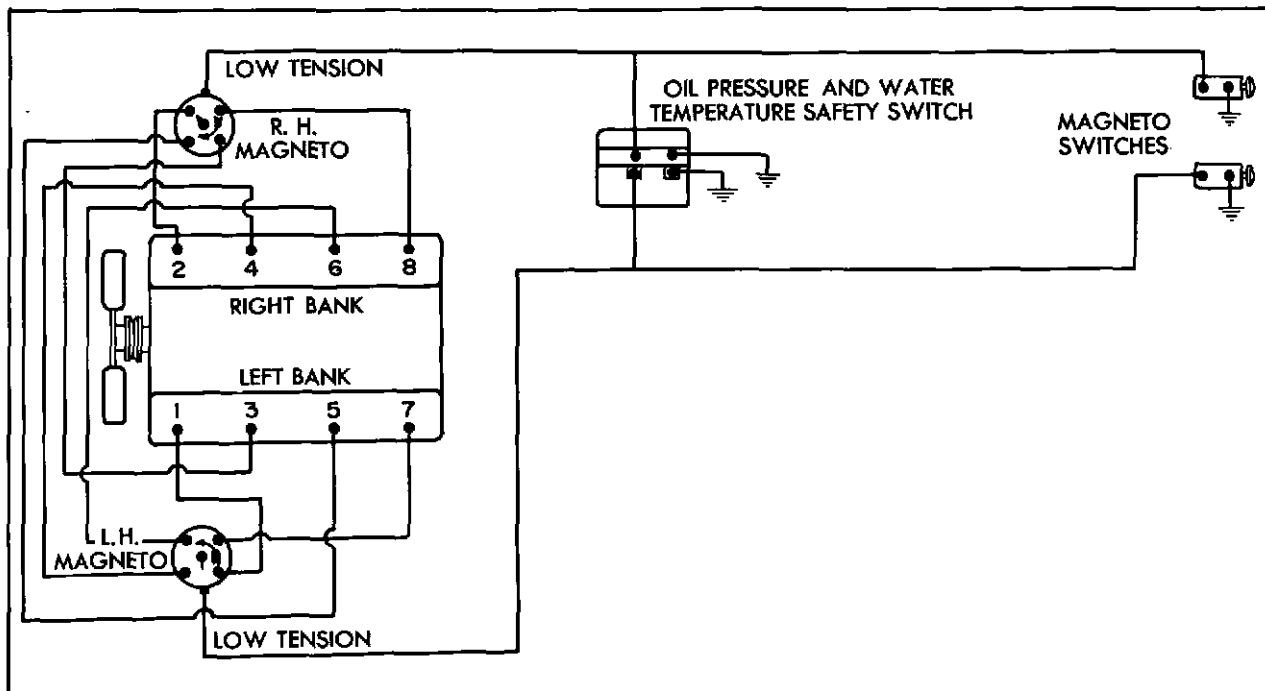

Magneto Ignition Wiring Diagram

to the engine whenever the points are removed or reset and whenever the magnetos are removed from the engine.

To time the right bank magneto:

1. Turn the engine over with engine barring mechanism until cylinder No. 2 is at Top Dead Center of its compression stroke (both intake and exhaust valves closed). Continue turning until D.C. in the RIGHT (No. 2) BANK markings on the flywheel appears under the timing pointer.
2. Insert a lead wire into tower No. 1 of right magneto. (See ignition diagram) Note: Magnetos are not interchangeable between banks; one is Right Hand rotation the other Left Hand rotation.
3. With the right magneto removed from the engine, turn the magneto drive shaft counterclockwise (viewing from drive end of magneto) until a spark occurs between ground and lead wire; at this point the impulse coupling 'snaps'. Hold this position.
4. Insert the right magneto into crankcase cover hole. Care should be taken to maintain proper relative position of both magnetos. It may be necessary to pull out the magneto and re-insert it so that there will be enough clearance between the main housings of both magnetos for turning.
5. Lock magneto with clamps and nuts in this position.

To time the left bank magneto:

1. Turn the engine over until cylinder No. 1 is at Top Dead Center of its compression stroke, (both intake and exhaust valves closed). Continue turning until D.C. mark in the LEFT (No. 1) BANK markings on the flywheel appears under the timing pointer.
2. Insert a lead wire into tower No. 1 of left magneto. Note: Magnetos are not interchangeable between banks because of different directions of rotation.
3. With the left magneto removed from the engine, turn the magneto drive shaft clockwise (viewing from drive end of magneto) until a spark occurs between ground and lead wire, the impulse coupling having snapped. (Hold this position.)
4. Insert the left magneto into the engine. Pull out and re-insert magneto if neces-

sary, to maintain proper relative position of both magnetos.

5. Connect remaining lead wires according to wiring diagram.

Checking Magneto System Spark Advance

1. Make chalk mark on flywheel in LEFT (No. 1) BANK markings corresponding to the number of degrees of spark advance required.
2. Disconnect No. 1 lead wire from the spark plug, attach the timing light lead to the end of the magneto wire (this cylinder will not be firing) and check spark timing with the engine running. Make sure speed is high enough so that impulse coupling is locked out.
3. Loosen the magneto mounting clamp and turn left magneto to obtain desired spark advance indicated on flywheel marking.
4. Repeat above procedure for right magneto; making chalk mark in RIGHT (No. 2) BANK series of markings, connecting timing light lead to No. 2 spark plug and adjusting magneto mounting to the required spark advance.
5. Both magnetos must be set to the same degree of spark advance.

FUELS

Fuels for internal combustion engines are composed principally of hydrogen and carbon in such proportions that in the presence of a suitable proportion of oxygen they will burn and liberate heat energy. This heat energy is transformed into mechanical energy. The heat value of a given fuel is a measure of the heat energy which can be liberated with perfect combustion, and is measured in BTU (British Thermal Units). One BTU is the heat required to raise the temperature of one pound of water one degree Fahrenheit. Therefore a thousand BTU, which is a common heat value assigned to natural gas, will raise the temperature of 1,000 pounds of water one degree Fahrenheit, or 100 lbs. of water ten degrees Fahrenheit. Most fuels used to power internal combustion engines are petroleum derivatives, and are classified as either gaseous or liquid by their physical properties. Gasoline is a liquid fuel that must be atomized (carbureted) before it can be burned in an internal combustion engine. Butane and propane are also liquid fuels when stored under pressure. At most atmospheric pressures and temperatures they become a gas.

Natural gas, as the name implies, is a gaseous fuel. Butane gas, and propane gas are often referred to as LPG, or liquified petroleum gas.

One of the most important characteristics from the engine builder's and engine user's standpoint is the anti-knock value (octane rating) of the fuel, although other physical properties are important from a practical standpoint. Volatility affects easy starting. Gum and carbon content will affect the valve and ring mechanism. Sulphur will affect some bearing materials.

Dealers in LPG control the volatility with the season so that any reputable brand will give satisfactory performance in Roiline gas engines. The octane rating, which is a measure of the anti-knock value, must be higher with high compression ratios, and may be lower with low compression ratios. Be sure to use a fuel that does not detonate under load in your engine. The proportion of propane to butane is very important. A minimum of 60% propane-40% butane is recommended for most applications. Do not take chances. Insist that your fuel supplier certify the fuel proportions.

An engine that is designed to operate on natural gas, butane or propane gas has gas type cylinder heads and cannot be operated on low octane gasoline. However, in an emergency, an engine with a gas type head can be operated on gasoline of 85 octane or better.

GASOLINE CARBURETORS

The 570 and 884 series engines have been built with a considerable variation in carburetor details to provide for specialized operating conditions. Therefore, carburetors should not be *interchanged or replaced indiscriminately*. Remember, a few thousandths of an inch in jet size can make the difference between normal engine operation and burned valves, ring sticking, poor economy, and so on. The carburetors are identified by stamped tags riveted to the top of the float bowl cover. When ordering replacement carburetors, always give all information on the tag plus the engine serial number and specification number.

Although the duplex gasoline carburetors used on these engines are of Zenith manufacture, a number of variations with respect to venturi and jet sizes, installation details, and so on, will be found.

Carburetor service consists largely of maintaining the fuel supply in a clean condition,

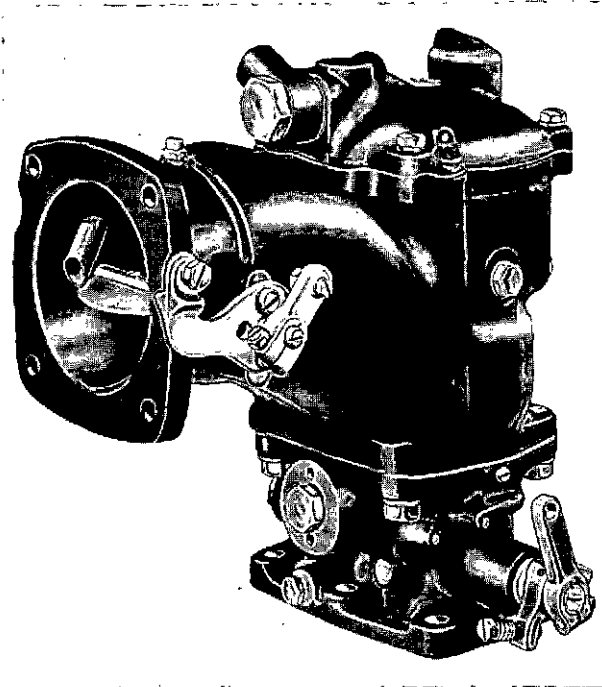

Typical Gasoline Carburetor

making proper adjustments at rare intervals, and leaving the carburetor alone when no specific attention is needed. More carburetors are ruined by tampering than by hard service.

When it becomes necessary to perform major cleaning and service operations, the carburetor manufacturer's special bulletin for the unit at hand should be followed without deviation.

Carburetor Adjustments

The throttle stop screw should be screwed in (clockwise) against the stop pin to hold the throttle *just slightly open*. Adjust the throttle stop screw to obtain the desired idling speed of the engine.

Adjust the idling adjusting screw to obtain smooth idling when engine has become thoroughly warmed up. Turn the idle adjusting needle screw clockwise towards the seat to restrict the flow of fuel-air mixture to the idle ports and make the mixture that enters the engine manifold leaner. Turn the idle adjusting needle counterclockwise away from the seat to permit a larger volume of the fuel-air mixture to reach the air stream, thus making the final mixture richer.

If it becomes necessary to turn the screw in to less than 1/2 turn off the seat to obtain good idling of the engine, it would indicate either an

air leak or a restriction in the flow of fuel for idling. Look for air leaks at the manifold flange; at carburetor throttle body to intake gasket, and at carburetor bowl to cover gasket, due to loosened assembly screws or damaged gaskets. A badly worn throttle shaft or worn vacuum piston will produce sufficient air leakage to affect the idling mixture.

Some models of these series are supplied with a main jet adjustment. The needle should be adjusted to give highest manifold vacuum (or highest R.P.M. on a tachometer) for a set-throttle position. If engine is equipped with speed governor, set the throttle to hold the engine speed just below the governed speed while adjusting the main jet adjustment. If adjustment is set too lean, the engine will lack power and the fuel economy also will be poor. If set too rich, the engine will be sluggish and the fuel economy poor.

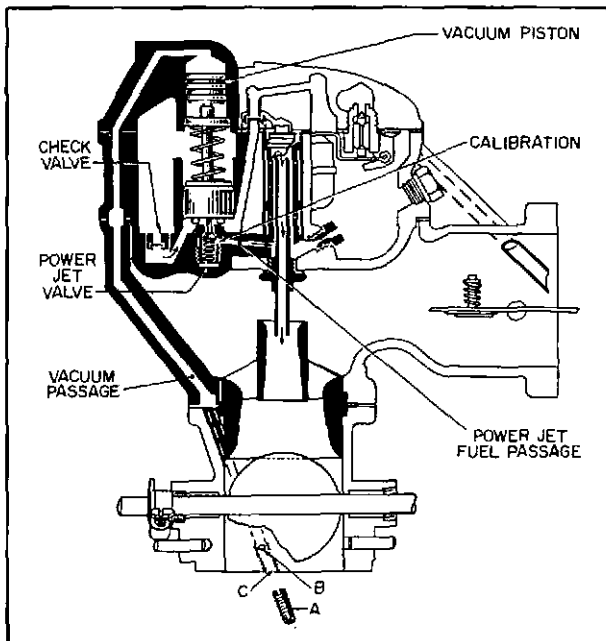

Gasoline Carburetor, Cross Section

Accelerating Power Jet

When a speed governor is used it is installed between the carburetor and the intake manifold. A vehicle so equipped is usually operated with the carburetor throttle held wide open relying on the governor throttle plate to regulate the speed. It is necessary in this case to use the suction in the intake manifold rather than the suction between the carburetor and the governor butterfly. Generally, in all applications where speed control is through the governor butterfly, the vacuum by-pass screw should be installed in the carburetor as shown.

The power jet system is so arranged that the passages to the vacuum cylinder can be bypassed around the governor butterfly thus using the suction in the intake manifold to control the power jet system under all operating conditions. This is accomplished by installing the vacuum passage by-pass screw (A) in the threaded end of the vacuum passage in the flange of the carburetor. The screw will shut off the short passage (B) from the vacuum passage into the throttle body bore but being hollow will leave the vertical vacuum passage (C) open to the face of the flange.

FUEL PUMP

To transfer fuel from the gasoline tank to the carburetor, the gasoline fuel system incorporates a fuel pump with fuel filter and priming lever, mounted on the gear cover and driven by an eccentric on the camshaft.

Fuel pump lines should be blown clean during overhaul with an air hose to assure a full flow of fuel. All fuel pump connections should be air-tight and checked occasionally for leaks.

GAS CARBURETORS

Both gas and gas-gasoline carburetors have only a single passage from their throttle valve, so a dual butterfly body is used to match the two top inlets in the intake manifold. A "Y" type connection is used between the single throat carburetor and duplex butterfly valve body.

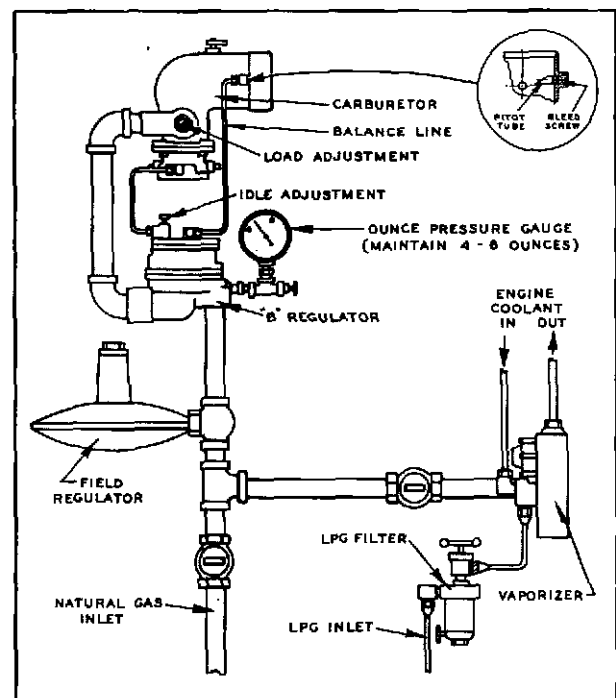

Natural Gas-LPG Fuel System Schematic

With gaseous fuel, a pressure regulator is used to meter the pressure of the incoming gas to the carburetor.

Because gaseous fuels do not require pre-heating in the manifold, the intake manifold passages are left cold.

When it becomes necessary to perform major cleaning and service operations, the carburetor manufacturer's special bulletin for the unit at hand should be followed without deviation.

When liquified petroleum gases (LPG) such as butane or propane are used, the fuel system will include a butane filter, butane regulating unit, either a gas or gas-gasoline carburetor and a heat exchanger to vaporize the fuel.

The butane regulating unit reduces the higher incoming fuel pressure to that required by the carburetor and converts LPG fuel from a liquid state under tank pressure into a dry gaseous fuel slightly below atmospheric pressure. This conversion is achieved by heating the fuel with hot water drawn from the engine cooling system.

CAUTION

Whenever the engine cooling system is drained to protect against freezing, the drain cock at the bottom of the butane convertor must also be turned wide open.

ENSIGN TYPE "B" FUEL REGULATOR

The Type "B" fuel regulator has the same general function with gas as the float bowl of a gasoline carburetor has with gasoline; it accurately regulates the supply of gas to the carburetor and it shuts off the supply of gas when engine demand has ceased.

The Type "B" fuel regulator is supplied in 1" and 2" sizes. The 1" size can be used with all sizes of carburetors from 1" to 2" inclusive and is available in several models each differing slightly in internal specifications, according to the B.T.U. value and pressure of the gas to be used. When the 1" fuel regulator is used with natural gas of 1100 B.T.U. at an inlet pressure of from 4 to 6 oz. (7 to 10" water column) it has sufficient capacity for 125 H.P. When used with Butane of 3000 B.T.U. and at an inlet pressure of from 3 to 8 pounds, it has capacity for 225 H.P.

The 2" fuel regulator is supplied in one model only for both natural gas and butane, and can be used with S.A.E. size carburetors from 2"

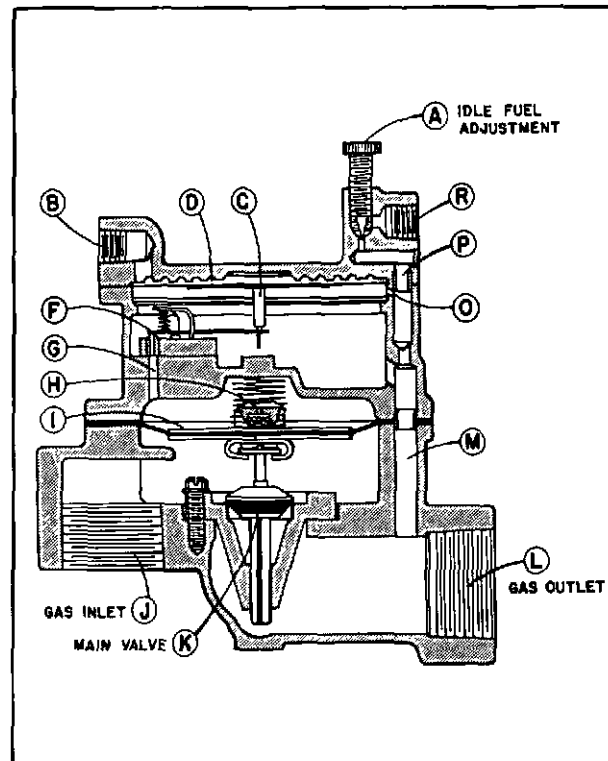

Ensign Type "B" Fuel Regulator

to 3-1/2". When used with natural gas of 1100 B.T.U. and at an inlet pressure of 4 to 6 oz. (7 to 10" water column) it has sufficient capacity for 325 H.P. When used with Butane, suitable pressure reducing equipment is necessary to obtain the required inlet pressure of 4 to 6 oz.

The fuel regulator operates as follows: (Refer to illustration above.)

Operation

With the engine at rest—the main valve "K" is closed and gas supply through the inlet "J" exerts a pressure below the lower diaphragm "I" and equally above "I" through orifice "H". Atmospheric pressure through the carburetor air intake is exerted on the upper side of the upper diaphragm "D" through opening "B" and on the under side of "D" through orifice "O", passage "M" and opening "L". "B" is connected to the carburetor air intake by a small tube known as the "balance tube connection." This connection compensates for increased air cleaner resistance, thereby maintaining a constant mixture in the carburetor.

When the engine is started, suction from the carburetor is applied to the regulator at "L" and communicated by way of passage "M" and

orifice "O" to the under side of diaphragm "D" which is pulled down. As diaphragm "D" moves down, push-rod "C" opens pilot valve "F". The reduction in pressure of gas over "I" bled through passage "G" by the opening at "F" permits "I" to lift and to open main valve "K" which in turn passes gas through to the carburetor.

Passage of gas through "K" into "L" relieves some suction on "D" by way of "M" and "O" thus partly closing "F" — allowing pressure to increase over "I" which in turn partly closes "K" to maintain pressure accurately at "L" of 3/16" water column below atmosphere. When the engine stops — suction ceases entirely, permitting "F" and "K" to close and completely shut off the supply of gas to the engine.

At idle engine speed the carburetor throttle is nearly closed and therefore little suction is applied at "L". The differential type regulator functions accurately at slow idle speed by means of a patented "idle fuel connection system". This system applies suction from the engine side of the carburetor throttle through the idle connection tube directly to the under side of upper diaphragm "D" by way of "R", "P" and "O" to operate the valve "K" as described above. Fuel for the engine at idle, is controlled therefore, by the idle fuel adjustment "A". Part of the idle fuel is supplied directly through the idle tube.

The fuel regulator should be protected from all foreign matter which might injure the regulator's valve seat.

SUGGESTIONS FOR LOCATING TROUBLE ON GASEOUS FUEL ENGINES

When Engine Fails to Start

No Fuel to Carburetor

Lines plugged.
Tank empty.
Fuel regulator main diaphragm broken thereby preventing valve opening. (Model "B" fuel regulator only.)
Check pressure at tank, on "B" regulator.

Too Much Fuel

Fuel regulator leaking.
Valve stuck open.
Starting adjustment set too rich.
Choke at fault causing wrong mixture.

When Engine Fails to Idle Properly

If the range of the idle adjustment screw will vary the mixture from too lean to too

rich without an improvement in the idling of the engine the trouble is outside the carburetion equipment.

Model "B" Fuel Regulator

If in adjusting the idle, the mixture is found to be too rich with idle screw closed tight it may be the regulator is leaking more gas than is required to idle the motor.

If in adjusting idle, the mixture is found to be too lean with the idle screw out several turns you will find one of the following:

1. Idle connections between regulator and carburetor leaking.
2. Idle connection plugged, such as: small hole in carburetor bore above throttle disc, small hole above brass plate in regulator bowl and adjusting screw seat.
3. Upper diaphragm too stiff.
4. Upper diaphragm ruptured.
5. Pilot valve pin low.
6. Balance tube (or vent, if used) plugged or badly restricted.

When Engine Fails to Operate Properly Under Load

Improper fuel adjustment.
Intake manifold too hot.
Fuel supply restricted or valve closed.
Fuel lines too hot.
Varying pressure in vaporizer due to high pressure regulator valve sticking, caused by using dirty fuel.
Regulator discharging in surges.
Liquid butane passing through fuel regulator and carburetor.
Balance tube plugged or badly restricted.
Diaphragm by-pass bleed, partially plugged. (On Model "B" fuel regulator.)

MODEL "B" FUEL REGULATOR

Fuel Regulator Leaks

Main valve or seat scored.
Pilot valve leaks.
Diaphragm by-pass bleed, plugged.
Lower diaphragm too stiff or too tight.

Main Valve Sticks Open

Guides and stem gummy.
Springs on top of main diaphragm broken.
Particles lodged between valve and seat.
Diaphragm by-pass bleed, plugged.
Diaphragm too stiff.

Butane Fuel Regulator Discharges in Surges

Pressure on vaporizer is excessive. May be helped by reducing pressure.

Discharging of high pressure regulator erratic because of sticky valve.

Four leaf springs on top of main diaphragm do not conform to dimension in manufacturer's data.

Balance tube connection in carburetor air intake plugged or too large.

Liquid Butane Passing Through Fuel Regulator and Carburetor

Water circulation through heater impaired.

1. Connections improperly made.
2. Water pump damaged. No thermostat.
3. Hot water connection too high on engine so as to allow it to be uncovered when cooling system loses water.
4. Heater and water passages become plugged due to dirt in water.
5. Heating coil leaks. Butane leaks into water space expelling water. Observed by butane vapor bubbling in radiator top tank.

IMPCO CARBURETORS

Impco carburetors are of the air valve type, designed to operate directly from an "ounce" regulator. No mechanical choke is provided for starting and none is necessary with this type of carburetor. Normal pressure to the carburetor is 5 inches water column for 1000 BTU natural gas. For natural gases of different heat values, slightly higher or lower pressures are required and readjustment is normally made in the field. LPG contains more heat units for a given volume than natural gas and for this reason the pressure at the carburetor inlet must be regulated at 1-1/2 inches water column negative. This pressure is non-adjustable and is controlled by the regulator. (Model "EB" with blue spring). Liquid fuel should be filtered before entering the vaporizer.

On natural gas, the Impco carburetor is somewhat less sensitive than other types to the effects of moderate air cleaner restriction and a balance line may not be needed. When operating on LPG, however, the results of air cleaner restriction may be quite significant and a balance line is important. Impco series 200D carburetors use a 7/16" ID balance line.

GENERAL IMPCO SERVICE INSTRUCTIONS

Natural Gas

The normal arrangement for natural gas uses a field regulator to reduce pounds pressure to

the final value of 5 inches water column (3 oz.) maximum. Excessive pressure will increase gas fuel consumption. This pressure will have its main effect on fuel economy.

For reasons of safety . . . ALL GASINSTALLATIONS IN CLOSED AREAS OR BUILDINGS SHOULD HAVE A POSTIVE SHUT OFF VALVE TO PREVENT GAS LEAKAGE WHEN THE ENGINE IS AT REST.

Adjustment

With the 1-1/2" line pressure regulator, the following orifice size and type of spring must be used to obtain required pressure to the carburetor.

Inlet Line Pressure	Orifice Size	Spring Color	Outlet Pressure to Carburetor
5 to 50 lbs.	3/4	Red	5" H ₂ O column

1. Set natural gas pressure at idle if Thermac reducing valve is used or with engine stopped (check at idle) if Thermac is not used, to 5" water column (3 oz.) for 1000 BTU gas with idle mixture screw backed out 2-1/2 turns.
2. Full load gas pressure may drop as low as 2" water column at the carburetor gas inlet. Exact pressure at full load is immaterial as long as power mixture adjustment is still effective.
3. If intake manifold vacuum is below 8" mercury with the engine running loaded at governed speed, adjust the power fuel mixture from rich towards lean slowly to obtain maximum vacuum at a fixed speed or until the governor throttle begins to open further. The power adjustment is not effective at a fast idle or light load. If with full load, the manifold vacuum is above 8" mercury, adjust the field regulator (instead of the power fuel mixture) to lower or raise the gas pressure to the carburetor to obtain a leaner or richer fuel mixture for maximum vacuum.

Thermac Pressure Reduction Valve

When pressure cannot be reduced at the line regulator to 5" W/C, or more pressure must be used to overcome line loss of pressure due to small pipe or long line, use a Thermac secondary pressure reduction valve at the carburetor. The line (primary) regulator may then be set as high as 14 ounces (25" W/C).

VALVE TIMING AND CLEARANCES

Accurate valve clearance settings materially prolong engine life and aid performance. In addition to impairing performance, excessive clearances are detrimental to cams and tappets as well as the rest of the valve mechanism. On the other hand, when clearances are too low, timing is again disturbed and the possibility of burned valves becomes much greater.

When checking clearances or timing, the rocker arms must be contacting the valve tips evenly and not be hollow. When the rocker arm to valve tip surfaces are worn hollow, it is impossible to make an accurate check with a feeler gauge. Never attempt to adjust valve clearances without loosening the adjusting screw lock nut and re-tightening it when completed.

It is very seldom necessary to check valve timing. The timing of the camshaft is established at the time of assembly. Since there are no couplings or other adjustment mechanisms to slip, there is no way in which the timing can be changed. Moreover, it is often difficult for a person inexperienced in this operation to check for proper timing with absolute accuracy even though the engine is correctly timed. This is because of the many factors such as gear backlash, manufacturing tolerances, cam wear, rocker arm wear, and personal judgement that vary.

Since improper valve timing may have very serious effects on engine performance and service life, and symptoms of low power, overheating, or similar troubles showing up after repair or overhaul procedures should be investigated and a valve timing check made to prevent damage to the engine.

Intake valve opening is TDC for Model 570 and 1° BTDC for Model 884.

Timing gear marks for engine valve timing are on the crankshaft and the camshaft gears.

Valve Rocker Arm Clearance

Before attempting to adjust the valve clearances, stop the engine and allow it to cool to normal room temperatures. Valve clearance cold settings are found on engine mounted valve clearance chart or in Clearance and Limits section.

1. Remove cylinder head cover, being careful not to damage the gasket between cover and cylinder head.
2. Lubricate valve stems with light engine oil to eliminate possibility of sticking.
3. Rotate the engine until the piston in No. 1 cylinder is at Top Dead Center on its compression stroke.

4. Loosen rocker arm lock nut and insert a feeler gauge between rocker arm and valve. Turn rocker arm screw until proper clearance is obtained.

5. Without further movement of screw tighten lock nut securely. Then recheck clearance with feeler gauge.

6. Follow firing order sequence and adjust clearances for the other rocker arms and valves in the same manner.

Whenever the rocker covers are removed, the valve and spring mechanism should be examined for evidence of inadequate lubrication due to sludging or plugged oil lines. Excessive sludge in the rocker arm area is an indication of too low oil operating temperatures, poor filtering action, or an oil that breaks down and is unsuited for the operation involved.

RESETTING GOVERNOR

If it should be necessary to dismantle the governor at any time for other adjustments — and it is only for that purpose that it should ever be necessary to disturb this mechanism — there are some basic requirements which should be observed. These requirements can all be met if the governor parts are carefully marked before they are removed so that they will be reassembled with the same adjustment and in the same places from which they were removed. Most important, make sure that the operating linkage and the adjusting nuts are accurately assembled exactly as before to prevent improper positioning of the butterfly valve. Also, be sure the lock nuts are in place and securely tightened to prevent change in the length of any of the linkage. Notice carefully, and mark, the position of the butterfly valve so that it goes back exactly as before. Close it, and with a pencil, mark the top side and the adjacent wall of the intake so that it is not re-assembled upside down, or backwards. If these precautions are followed, the governor should operate exactly as before when it is again put into service provided the tension of the governor spring and the length of the operating rods have not been changed. To secure the best operation, make sure that the length of the operating rod is adjusted so that the butterfly stands a trifle towards the closing position when the engine is stopped. Variation from the proper speed can be corrected by tension of the regulating spring. Increasing the tension increases the maximum speed, and decreasing the tension decreases the maximum speed.

ENGINE STORAGE

Preservation of engines in storage involves several basic requirements. For a completely new engine, these are as follows:

1. Protection of machined metal surfaces, cylinders, valves, bearings and so on, from the effects of both dampness and salt or other corrosive substances in the atmosphere.
2. Protection of openings into the engine against entrance of dirt, abrasive material, and foreign matter of all types.
3. Protection of accessory equipment, including fuel pump, carburetor, gas regulator, magnetos, starter, generator and fan belts against corrosion, dirt, moisture saturation and progressive deterioration.
4. Protection of cooling system against freezing, rusting or seizure of water pump seals.
5. Protection of a general nature against the elements, rain, snow, extremes of temperature, improper stacking and piling and objects that might scratch or batter the exterior, especially the radiator cores.

In the case of engines previously operated, several additional items must be considered.

6. Protection of interior engine parts, particularly bearings, cylinder walls, and valves against corrosion by the products of combustion combined with atmospheric moisture and corrosion by lubricating oil contaminants.
7. Protection of fuel system units against gumming and the effects of stale gasoline, oil and gas residues.

The extent of the attention given to each of the foregoing points of possible damage, depends on the judgment of the person in charge of the engine. Generally speaking, the following factors should be taken into account before deciding how much or how little preservation is required.

1. The period of time the engine is likely to be inoperative.
2. The severity of the weather and atmospheric conditions at the point of storage. The problems of storing an engine in a tidewater warehouse, for example, differ greatly from storage problems in a location where the air is very dry and dusty.

3. The accessibility of the engine for periodic inspection and attention. An engine on a show-room floor that may be turned over occasionally and given periodic oiling requires less extensive treatment than engines crated and stocked in a warehouse.

NOTE

For prolonged storage, the use of Nucle engine storage oil, W.M.Co. Part No. 166709-A, is recommended. Refer to Service Bulletin No. 1855.

Protecting New Engines

Engines recently received from the factory and not intended to be used for an indefinite period may be stored successfully in the following manner. As mentioned above, circumstances may compel omitting some steps and, on the other hand, special conditions may point to greater emphasis on other steps.

1. When engine is installed in an operable unit.
 - A. Mix an inhibitive type preservative oil with the engine lubricating oil in the proportions recommended by the manufacturer of the preservative oil, or, no mixing may be necessary. Operate engine until oil is thoroughly hot. Cooling water used in this run should have two to three per cent soluble oil added.
 - B. Remove air cleaner. With manually operated sprayer, squirt can, or other means, inject preservative oil of a type suited for this purpose into the air intake while the engine is running. Approximately one minute is ordinarily adequate. If possible, stop engine by "slugging" enough oil through intake to stall. Continue injecting oil until engine stops turning.
 - C. Drain oil and water while hot. If extra protection is desired the rocker arm covers may be removed and a quantity of preservative oil poured over the rocker arm and valve mechanism.
 - D. Remove spark plugs and squirt or spray several teaspoons of preservative oil into each combustion chamber. Coat plug threads with oil and re-install plugs.
 - E. Drain carburetor and fuel pump of gasoline if practicable. Be sure to

remove water from butane vaporizer if freezing is likely.

- F. Remove distributor cap or magneto covers and apply small amount of petroleum jelly to polished surface of breaker cam. Where dampness in storage is expected, removal of magnetos may be worthwhile.
- G. Wipe engine clean and dry. Apply wax type masking tape or like material to all openings such as intake openings in air cleaner, exhaust outlets, breathers, magneto vents and open line fittings.
- H. Relieve tension on fan belts and generator drive belts. This is important because continual tension on these parts without the working action that occurs in normal operation causes deterioration of the rubber.
- I. Apply a coating of heavy preservative compound with brush to all exposed machined surfaces such as flywheels, clutch shafts and like areas.

Engines treated in accordance with these instructions will normally be protected for six months or longer. Continual inspection, however, is the only way to determine if protection is adequate. If possible, crank the engine by hand for one or two turns about once a month. This helps prevent seizure of water pump seals. If this is done, however, it is usually best to add more preservative oil to each cylinder. Some types of preservative oil are not well suited to periodic engine rotation because they are scraped from the cylinder walls which are then unprotected. Other oils are not scraped away, and for this reason the operator should carefully investigate the characteristics of the oil used.

2. When engine is not operable.

- A. Open drains in oil pan, radiator, carburetor, butane vaporizer and fuel pump to remove oil, water and fuel.
- B. Remove spark plugs and pour or squirt about a teaspoon of preservative oil into each cylinder.
- C. With hand or mechanically operated atomizing spray (do not use ordinary compressed air) inject preservative oil into each cylinder. Crank engine in normal direction about one-quarter turn and spray each cylinder again.

Do this about eight times, or until engine has been turned through two complete revolutions. The purpose of this procedure is to bring each valve into an exposed position so the preservative oil will coat it.

- D. Depending on the judgment of the operator as to the severity of storage conditions, open as many points as possible . . . oil pan plug, valve rocker covers, tappet chamber cover, front gear cover and so on, where oil may be sprayed, poured or squirted over the interior parts. Replace all plugs and covers.
- E. Remaining steps may be the same as listed in "F" through "I" for an operable engine.

Storing Engines that Have Been in Service

In the course of normal engine operation residues of various combustion products such as lead and sulfur accumulate in the combustion area and in the lubricating oil. Portions of these residues combine with atmospheric moisture to form corrosive compounds of a destructive nature. Butane engines are probably less subject to this than others. The following treatment will help reduce damage from this source.

1. Engine in operable condition.

- A. Run engine until original oil is thoroughly hot. Drain.
- B. If practical, run engine with a good flushing oil in crankcase and drain while hot.
- C. Refill crankcase with preservative oil, or with the proper grade of lube oil to which an inhibitive type preservative oil has been added in the proportion recommended.
- D. Carry out previous instructions "B" through "I" as the circumstances indicate.

2. When engine is not operable.

- A. Carry out instructions as for an inoperable new engine.
- B. If in the judgment of the operator, storage conditions and the time period likely warrant it, the engine should be

disassembled, thoroughly cleaned and reassembled for treatment as a new engine. Ordinarily, this last procedure is unnecessary except in cases where fuels contain considerable sulfur, or where extremely bad climatic conditions prevail.

PRESERVATION EQUIPMENT AND MATERIALS

Sprays and Atomizers

In the foregoing instructions it is recognized that many times it is necessary to apply protective compound under difficult field conditions. Several simple tools may be used to atomize preservative oil and force it into the manifolds and combustion chambers. One of these is a manually operated gun used ordinarily to lubricate inaccessible points on car and truck chassis. Another is a hand operated pump type sprayer with a pointed discharge nozzle commonly used with insecticides. If desired, small oil pumps may be rigged with a motor drive to make a convenient spray unit of the mechanical pressure type. In almost all cases, the air available from shop compressor line carries too much moisture to be safe for this purpose. Do not use high-pressure air from this source.

Heating Compounds

Many preservative compounds are most effective when heated before application. Heating reduces their viscosity so as to gain penetration into inaccessible areas. In addition, the hot compound reduces the moisture film at the metal surface and thus avoids trapping moisture under the preservative layer.

Generally speaking, such heating is confined to 200° F., or less. These temperatures are easily reached by placing the preservative container in heated water. Direct heating presents a dangerous and unnecessary fire hazard.

PREPARING ENGINE FOR OPERATION

The steps needed to bring an engine into active service after storage in accordance with those instructions are about the same as those normally carried out on any new engine. These are inspection, checking for free rotation, adequate cooling water or anti-freeze, ample oil of the correct grade and proper adjustments. In addition, accumulated dust and dirt should be wiped or washed from the exterior before removing the covers over the engine openings. Engines that have not been rotated for some time should be oiled through the spark plug openings and cranked by hand or with the starter before actually running. Any resistance to free cranking should be investigated; rust and corrosion can cause severe seizure that cannot be forced clear without engine damage.

EXERCISE OF STANDBY UNITS

It is recommended that the generator set or other stand-by unit be exercised once each week. A record should be maintained of performance, incidental servicing, and output of both the engine and driven equipment.

Always run the engine long enough to stabilize oil and water temperatures at the normal operating level expected under load. Do not operate under no load conditions for other than very brief periods. Loads of at least one-third up to the normal rated capacity are recommended. Ordinarily, an exercise run of one to two hours will be needed to stabilize temperatures.

It is recognized that some types of driven equipment cannot be operated without fairly extensive procedures to "put them on the line." Examples are hospital generators in some types of switching configurations; air-conditioning compressors which can only be loaded by changing over to chilled water from heating water circulation; and pumps which are not set up for waste discharge or recirculation. In such cases, weekly exercise periods may have to be reduced, where possible, to operational periods long enough only to prove the engine's ability to crank and start, or, check out of starting circuitry and safety equipment with the starter disabled. In this event, special attention must be taken to prevent internal corrosion, sticking and gumming of fuel controls, and deteriorated starting batteries. In all cases, arrangements should be made to run the engine and driven equipment under load at least every 90 days.

Specifications for Protective Materials

Internal Surfaces, Cyls., Etc.	External Surfaces
U.S. Army Spec. 2-126 (Available as SAE 10 or SAE 30)	U.S. Army Spec. 2-121 (Waxy Coating)
Nucle-Oil #120 Mil. Spec. MIL-L-4600Z Grade 1	Army Ordnance Spec. AXS 673 (Harder black coating)

OVERHAUL AND REPAIR

GENERAL

The overhaul and adjustment of the 570 and 884 series engines, like any other mechanical operation on precision machinery is best accomplished by experienced personnel using equipment built for accurate work. On the other hand, assembly and disassembly present no unusual features requiring special tools or techniques. For this reason, no effort has been made to detail in this manual the steps that are self evident or well established mechanical practices. In those instances where a considerable number of these engines are being overhauled, the WAUKESHA MOTOR COMPANY will be glad to make suggestions on permanent type tooling such as pullers, jigs, and other fixtures.

There are a number of good practices that should be followed in overhauling any engine, some of these are listed below.

Do Not Mix or Confuse Engine Parts

Mark for position on disassembly; tag assemblies from different engines; stamp or otherwise identify parts reground to special sizes.

Do Not Mix Bolts, Capscrews, and Washers

Capscrews and like parts are of a length, material, and heat-treatment suited to the place they are used. Numerous instances have been reported where too long or too short a cap-screw has resulted in leakage or interference with internal parts. Washers of various materials and types are selected according to application. Standard soft steel washers, for example, when used to retain a bearing cap are known to have caused complete engine failures. Hardened washers are used at that particular point.

Inspect as Engine is Disassembled

Once engine parts have been disassembled and cleaned, many valuable indications of engine condition are lost. Materials found in the oil or on burned or carboned surfaces at disassembly often point to operating, service, or maintenance improvements of genuine value to the operator.

Protect Delicate Parts and Surfaces

Do not pile engine parts, ignition equipment, carburetors, and bearings, indiscriminately. Oil surfaces likely to rust. Tape surfaces subject to scratching or nicking during repair operations. Plug off passages likely to accumulate dust, abrasives, and machining chips. Some heavy-duty detergents and cleaning compounds will etch or corrode bearing materials and bushings. Test any cleaner before using it on good parts.

Clean Thoroughly

No engine is completely overhauled if it is not cleaned internally and externally to "new part" condition. Dirty parts can neither be inspected nor fitted; neither do they conduct heat properly nor allow top engine performance. Modern chemical cleaners easily remove all engine grime; but don't forget to remove the cleaners from oil passages and casting pockets when the job is completed.

Work Accurately

Use precision gauges where needed; follow tables of limits and tightening torque values for best performance.

DISASSEMBLY

Vibration Damper and Fan Pulley

The vibration damper is easily removed by taking out the capscrews holding it to the fan pulley. To remove the fan pulley from the crankshaft it is necessary to remove the fan pulley screw and washer.

The pulley screw may be replaced on the crankshaft if desired for turning the crankshaft during later operations.

Gear Cover

Ordinarily no service of the gear cover parts is necessary except for replacement of the crankshaft oil seal and the accessory drive shaft oil seal.

To disassemble the gear cover:

1. Remove water pump cover, water pump

- impeller, seal and seal seat.
- 2. Remove water pump body.
- 3. Remove manifolds, distributor or magnetos and governor. Also remove crankcase top cover.
- 4. Disconnect oil line from accessory drive housing.
- 5. Remove capscrews attaching upper oil pan to gear cover.
- 6. Remove gear cover.

When reassembling above parts in reverse order replace with new crankshaft oil seal and accessory drive shaft oil seal.

The accessory drive shaft oil seal may be removed without removing the gear cover by cutting it with a sharp chisel and hooking it straight out. When replacing this seal use a sleeve to drive it in the gear cover hole as far as it will go, being careful not to damage the seal.

Flywheel

Before loosening the flywheel retaining screws, make up a "dogleg" hoist eye to support the weight and permit swinging the wheel out without canting. Take up some of the weight on the hoist, remove the capscrews, and using

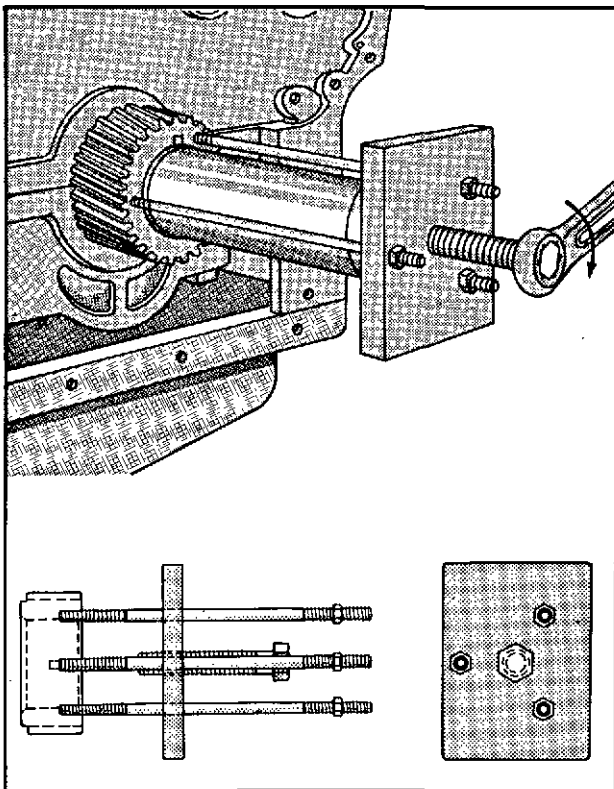

Typical Crankgear Puller

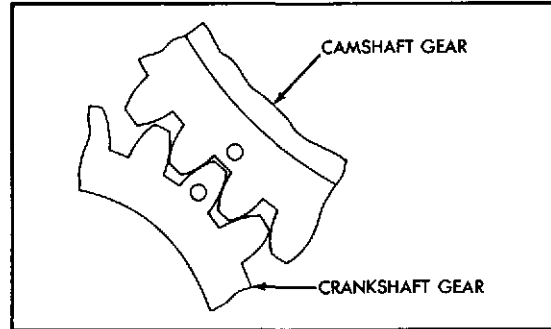

Engine Timing Gear Marks

suitable threaded pullers if necessary, pull the wheel free and swing it out of the housing. It is recommended that new bolts be used whenever a flywheel is re-installed.

Cylinder Head

To remove the cylinder heads:

- 1. Drain cooling system and remove manifolds, valve cover, and oil line.
- 2. Remove cylinder head stud nuts and rocker arm shaft assembly, and lift off the head.
- 3. Withdraw and tag the push rods.
- 4. Cover the exposed parts of the engine and place the head on a bench with block of wood in the combustion chamber to hold the valves closed when freeing.
- 5. Use a valve spring compressor to depress the spring until the split locking tapers can be removed.
- 6. Remove retainer washers, valve rotators, valve springs and finally the valves. Tag or locate them so that they may be reassembled in the same location.

Cam Followers

Cam followers may be lifted out after the cylinder head is removed without prior removal of the camshaft. Keep each cam follower in order as removed and re-install in the same place. When a worn or damaged cam follower is found, always inspect with particular care the cam lobe upon which it was operating.

Camshaft

Camshaft removal requires prior removal of the crankcase cover, the governor, the distributor or magnetos and drive assembly, and in the case of a fuel pump with the shoe riding directly on the camshaft this too must be removed.

Withdraw the camshaft from its bushings by

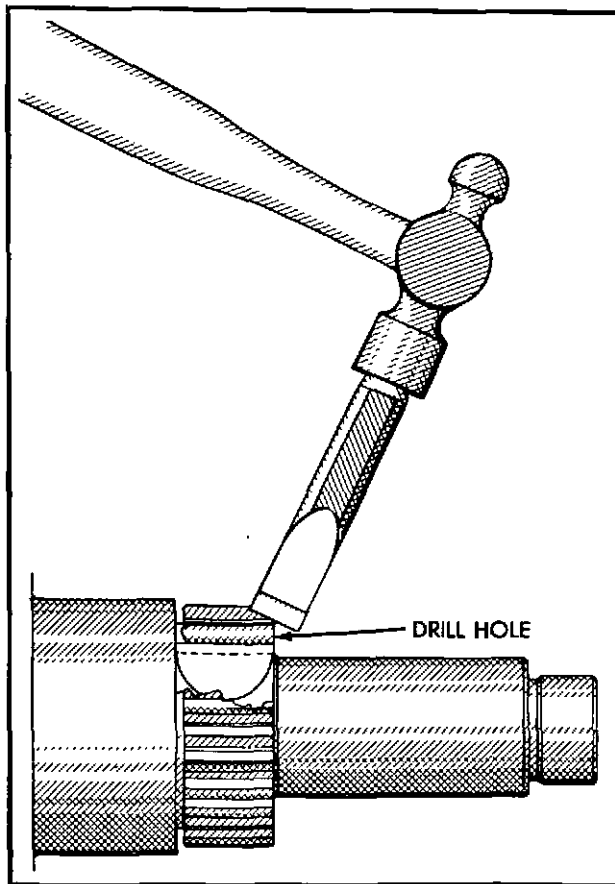

Removing Crankgear by Splitting

pulling gently and making sure that the lobes are not catching in the bushings or case. If the edges of the cam lobes are allowed to drag across the bushings, grooves and scratches may be formed that will impair lubrication and service life. Removal of the tachometer and camshaft gears from the camshaft requires an arbor press and a suitable support plate to hold the gears. Do not attempt to remove the gears by makeshift methods that may distort the shaft or gears.

Camshaft end thrust on all Models except the current TH570, is taken at the front of the camshaft by a thrust button which is a press fit in the gear cover. Excessive end play is adjusted by replacement of the thrust button. On the TH570 Models this thrust is taken by a thrust plate just forward of the front camshaft bearing journal. A new thrust plate, which is secured to the crankcase, is required to correct excessive end play of the TH570 camshaft. Camshaft end play tolerances are listed for each engine model in the "Clearance and Limits" section.

Crankshaft Gear

In those instances where replacement of the crankshaft gear is necessary, it is easiest to remove the gear with a puller having 7/16"-14

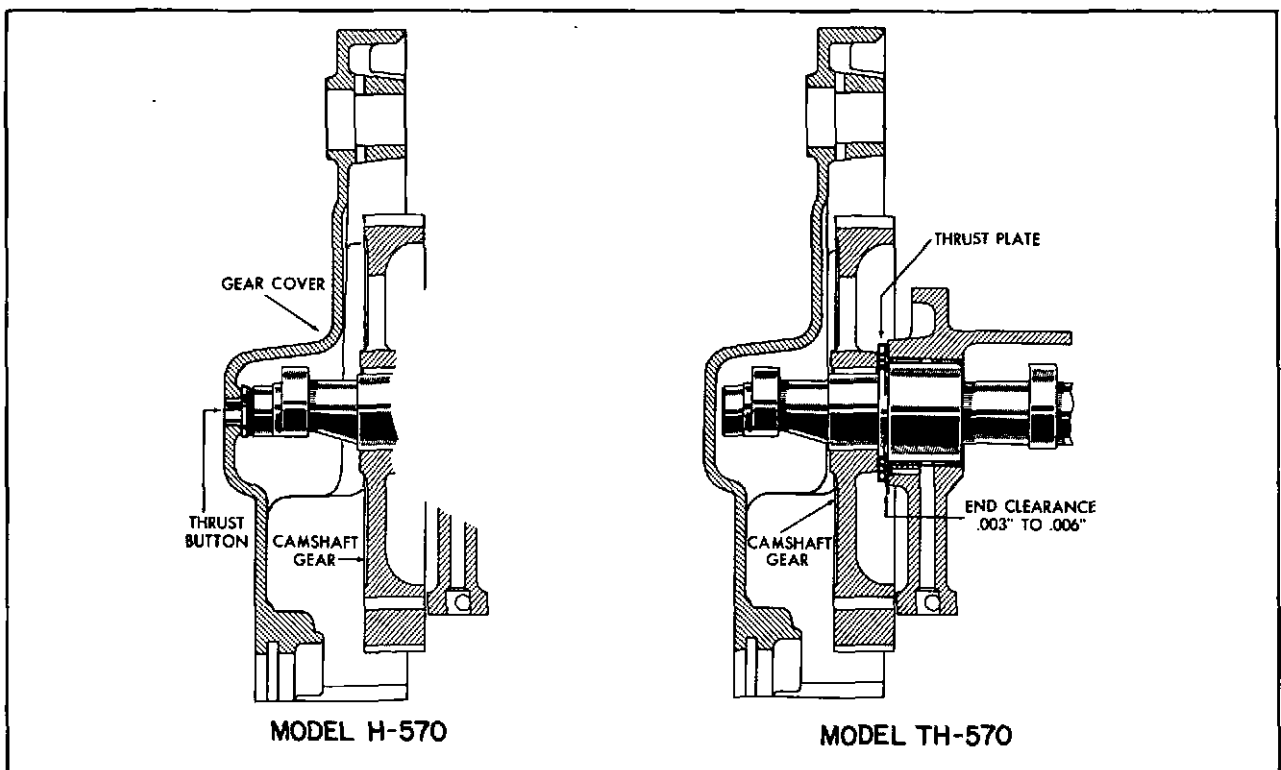

Camshaft End Play

threads similar to the one shown in the accompanying illustration, although the gear on the 570-884 engines has only two puller holes. If such a puller is not available, or if the gear has no puller holes it is necessary to split the gear as shown. First drill a hole of approximately 1/4-inch diameter lengthwise of the gear and between the keyway and the teeth. Thus, a variation in drill direction will result in nothing more than damage to the replaceable key. After drilling, a light blow with a cold chisel will spread the gear a few thousandths and permit removal.

Timing the crankshaft and camshaft after one or the other gear has been removed is an important consideration in servicing the engine. Timing marks are provided on both gears to insure correct meshing of the gears, as illustrated. Backlash originally provided for these gears is .006.

CRANKSHAFT OIL SEALS

Sealing around the crankshaft at both ends is provided by split felt rings held in place in recesses in both the crankcase and oil pan. Return oil grooves are cut into the crankshaft.

Insert the oil seal into the grooves provided in the crankcase, as illustrated, making certain no part of the oil seal projects above or below the groove edge. This is important to insure sealing. Do not trim the edges of the oil seals. Grooves for the oil seals are also provided in the upper oil pan. Coat the seals with graphite and oil after they have been installed. Then tighten oil pan to crankcase so that the ends of each felt half meet to form the proper seal.

WATER PUMP REPAIR

Leakage of water from between the water pump and gear cover may be due to a worn or defective sealing washer.

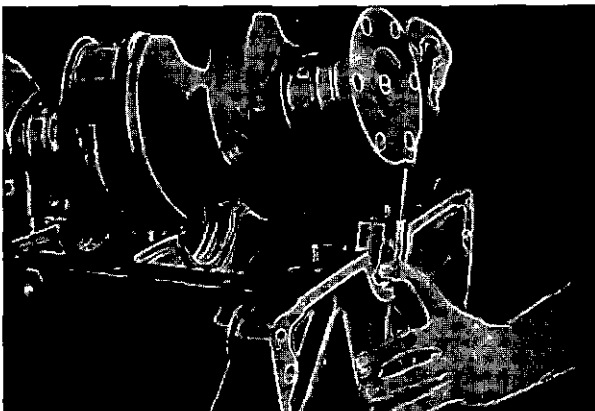

Inserting Crankshaft Oil Seal

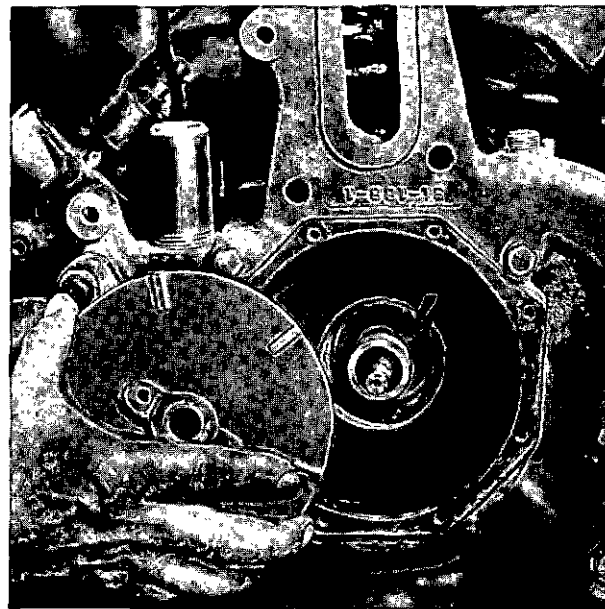

Water Pump Seal and Seat

Removal of the pump to accomplish this replacement is unnecessary.

To remove the water pump seal, first loosen and remove fan belts and remove water pump cover. Insert capscrews in the impeller and pull it off of the pump shaft. It may be necessary to remove rust and scale from the holes. Slide combination bellows and carbon seal washer off of the shaft. In all cases it is advisable to replace the seal and also the seal seat if necessary whenever disassembling the pump because of its insignificant cost and the likelihood of its being damaged during removal.

When replacing the water pump seal, carefully wipe the carbon sealing surface and its mating seat with a soft cloth or absorbent paper to remove all traces of wax, grease, or oil. Use a small amount of solvent if necessary. Do not lubricate or grease the seal mating surfaces.

While the cover and impeller are removed, check the gear cover and accessory drive housing bushing clearances by jiggling the shaft. Any noticeable play in the shaft indicates the need for replacing the bushings.

If rust and scale deposits have accumulated in the pump body, remove them and flush out the entire cooling system.

OIL PUMP REPAIR

Under normal operating conditions, service of the oil pump should become necessary only at engine overhaul time. However, severe

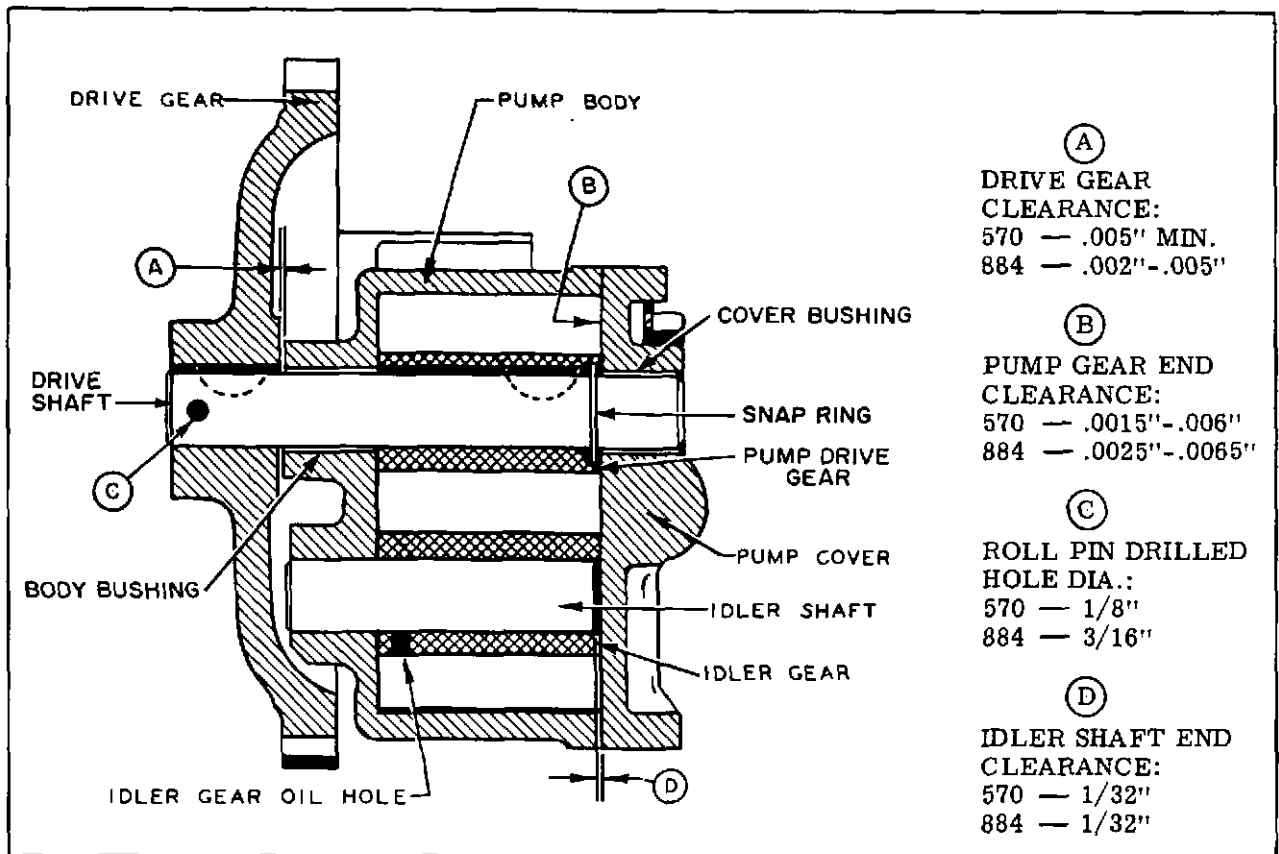

Oil Pump Sectional View

sludging may require occasional pump disassembly to keep oil passages clean. The oil pump should be completely disassembled, cleaned and inspected. Complete pump rebuilding kits including replacement bushings are available through the Roiline distributors.

Removal of the drive gear requires the usage of an arbor press and a piece of metal plate notched out to fit between the drive gear and the pump body. Before attempting

Several modifications have been incorporated in the current production Waukesha 570 and 884 oil pumps. The relief valve is now located in an external connection permitting improved oil flow within the pump body. The splined drive shaft formerly used has been discontinued in favor of a straight drive shaft which allows easier disassembly of the pump. Also, the new pump has provisions for doweling to the main bearing cap which eliminates pump drive gear misalignment.

Disassembly of the Pump

The first step in the disassembly of the pump is the removal of the pump cover. This is accomplished by removing the four cover to the pump body capscrews. A slight blow with a plastic or soft head hammer may be necessary to free the cover from the pump body dowels. Do not try to pry the cover. The idler pump gear is free on its shaft and should be removed immediately after the cover is taken off.

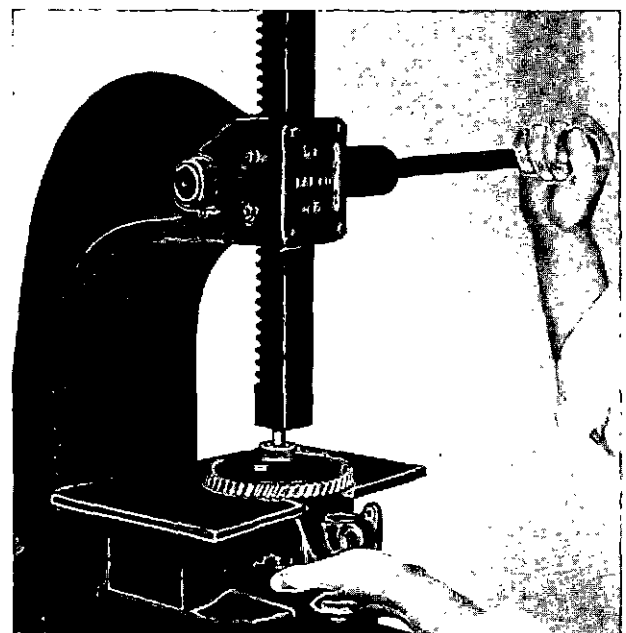

Drive Gear Removal

to remove the gear, drive the roll pin out of the gear hub and drive shaft. Next, place the plate on the arbor press base and position the pump with the drive gear resting on top of the plate so that the pump hangs freely, suspended by the gear. Using a short piece of 1/2 inch round stock, press the drive gear off of the pump drive shaft, make sure that the pump will not be damaged from dropping as the pump drive gear is pressed free.

Remove any burrs that may be present and press the drive shaft out of the pump body. Avoid dropping the shaft. The same pressing procedure is used if it is necessary to remove the idler shaft. The pump gear is removed from the drive shaft by first removing the snap ring, then pressing the shaft through the pump gear with the 1/2 inch round stock and the arbor press.

The arbor press and a plug can be used to both remove and install pump bushings. The pump and pump cover bushings both have the same inside and outside diameters. The plug can be made from a three inch long piece of 5/8 inch round stock, with a one inch section turned down to 17/32 inch diameter. Place the cover on the arbor press base and insert the small end of the plug into the bushing. Press the bushing out. The same procedure is used for removing the pump body bushing. New bushings should be used whenever the pump is disassembled. Waukesha replacement bushings which eliminate reaming are available.

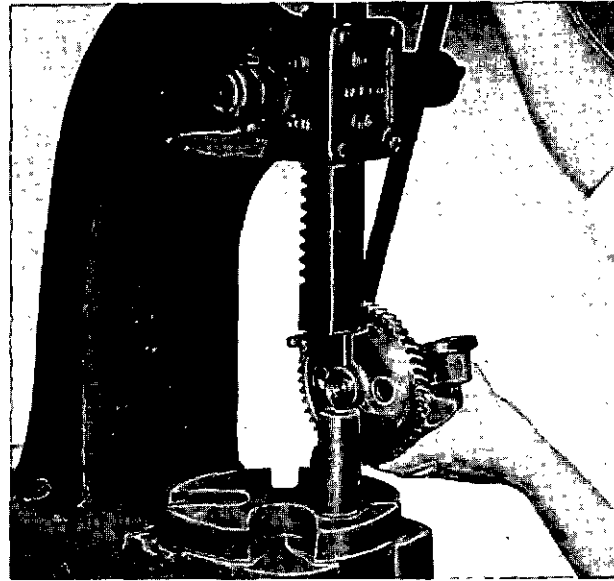

Pressing Roll Pin Into Shaft

Inspect the pump carefully for nicks, burrs, or signs of unusual wear. Worn or badly nicked parts should be replaced.

Reassembly

With the Woodruff key in the proper position, press the pump gear back on the drive shaft and lock in place with the snap ring. Insert drive shaft through pump body.

Check end clearance of the pump gear with feeler gauge and a straight edge ruler as shown in the illustration.

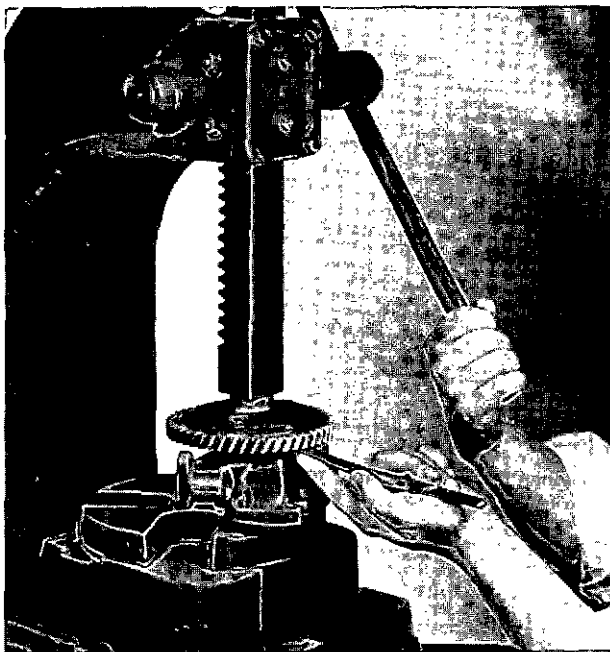

Drive Gear End Clearance

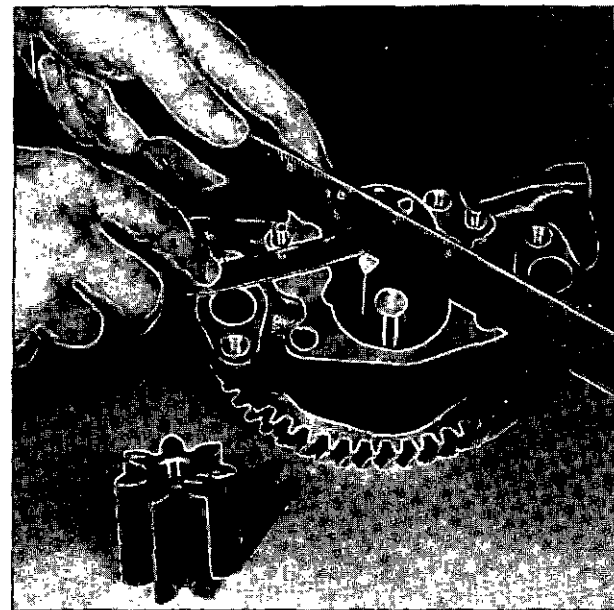

Pump Gear End Clearance



Idler Shaft End Clearance

Place the drive gear Woodruff key in position and press the drive gear on. Check clearance between pump and drive gear at this point. The clearance should be as stated on the sectional drawing. After proper clearance is obtained, press the roll pin through the drive gear hub and drive shaft. When replacement parts are used, drill a hole through the drive gear hub and shaft for the roll pin.

It is extremely important to install the idler pump gear with the oil holes toward drive gear end of pump. End clearance of idler pump gear must be $1/32$ inch.

Before replacing cover, the running clearance of the pump gears must be checked with feeler gauge as illustrated.

Before installing the completely reassembled pump in the engine, a test should be made for binding under normal pump operating temperatures. This test consists of placing the pump in oil heated to 250°F . Allow pump to remain in the heated oil for a few minutes before turning gears to test operating clearances and for evidences of binding.

VALVES AND MECHANISM—REPAIR

Valves require grinding at various intervals during the engine service life. These intervals cannot be specified exactly because a host of variable factors enter the picture, often without the engine operator's knowledge. Of these factors, the following have been found to a

greater or lesser degree to make for reduced valve life.

1. Fuels that break down to form deposits that impair seat contact and prevent heat conduction and valve cooling.
2. Deposits from either fuels or oils that accumulate on the valve stems and cause sticking and burning.
3. Oil not reaching rocker arms due to clogged lines or improper fittings.
4. Shutting down a hot engine without idling for a few minutes. Exhaust valves that happen to be off their seats when engine stops may warp so that burning occurs on restarting.
5. Improper valve clearances.
6. Lean mixtures due to improper carburetor or adjustment.
7. Pre-ignition due to wrong plugs, carbon deposits, excessive operating temperatures.

Compression Checks

A compression check is the best method of determining whether valves need grinding. The most significant thing is for the pressures on the individual cylinders to match with a fair degree of evenness. If it is felt that compression may be leaking past the piston rings,

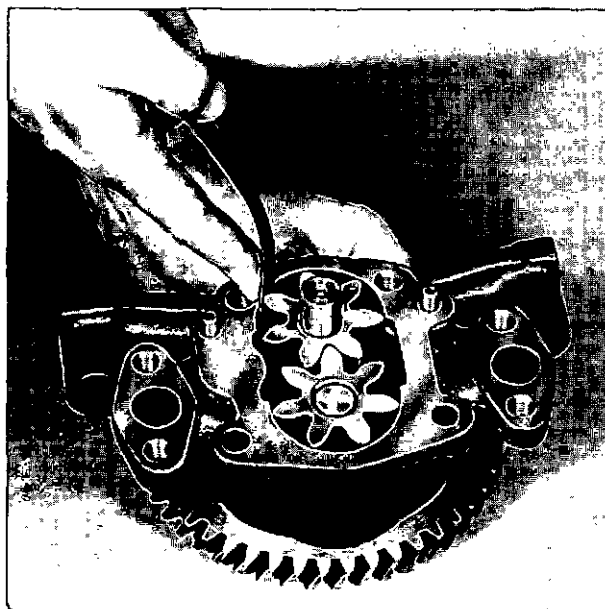

Pump Gear Running Clearance

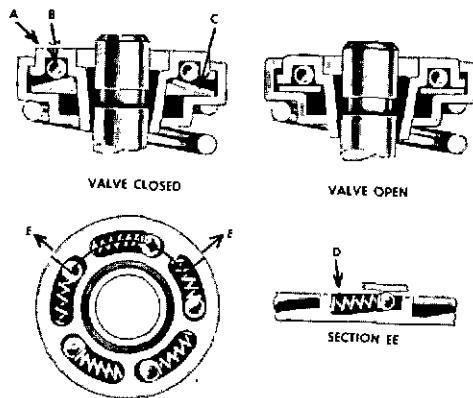

Valve Rotators

inject some heavy engine oil through the spark plug hole before making the test. This will seal the rings temporarily. In addition, a quick knowledge of valve condition may be gained by listening at the carburetor entrance (disconnect air cleaner) and the exhaust outlet while the engine is cranked over. Piston ring blow-by may be heard at the oil-filler opening as the pistons are slowly brought onto compression and the air allowed to seep past. If valves are leaking badly, the piston ring leakage may not be noticeable. Another indication of leaking valves is an unsteady vacuum reading, particularly at idle.

Valve Mechanism

When the push rods have been withdrawn they should be tagged or otherwise marked so that each rod may be replaced in its own tappet. Examine each rod to make sure it is straight, and that both upper and lower ends are in good condition. Replace—do not straighten—any that are bent.

The end of each valve stem is fitted with a shallow steel retainer that accommodates the end of the valve spring, and is held to the stem by a pair of split tapers. The locking tapers must be removed before the valve can be withdrawn. To release the lock from the recess in the spring retainer, it is only necessary to push the retainer or valve rotator down against the spring until the tapers fall away from the valve stem. Check the valve springs for cracks. Often they can be detected by rubbing chalk on the springs. The oil in a crack will stain a sharp line in the chalk. Weak or cocked springs should be discarded and new ones installed when re-assembling. Positive type rotators are used on the exhaust valves on these engines.

The valve rotator consists of a spring seating collar (A), a set of balls (B), spring

washer (C), ball-return spring (D) and retainer cap (E). As the valve starts to open the spring washer flexes, causing the balls to roll down the inclined races of the retainer cap. The reaction of the balls on the races causes the retainer to turn and through the friction grip of the valve tapers, the valve also rotates. As the valve closes, the balls are returned to their original position by the ball-return springs. The rotator is then set for the next valve cycle.

Because all valve rotator parts are completely enclosed, they require no special lubrication or adjustment and are unaffected by sludge and varnish formation. The approximate length of service of the valve rotators is about 4000 operating hours or 100,000 miles of operation and they may only be serviced by replacement.

Guides and Seats

Upon removing each valve examine it carefully. Remove all carbon and burned oil and check valve stem and its fit in guide. Excessive wear in either stem or guide will make it impossible to secure a tight seat by grinding unless valve or guide, and possibly both, are replaced. Special notice of exhaust valve guide and valve stem shoulder should be taken to make sure guide does not project into valve gas passage, and that the shoulder on the 570 series valve stem is sharp. This shoulder should be slightly below top of valve guide when valve is seated. Thus, any accumulation of carbon around guide and stem will be sheared off each time valve is lifted, and in this way prevent valve sticking.

Worn valve guides and valve seat inserts should be replaced with new ones. The guides are a pressed fit in the head casting. Service guides were previously supplied in a semi-finished form with adequate stock to permit finish reaming. Present service guides are specially machined to press in place and provide proper stem clearance without further machining. The valve seat in the head MUST be re-cut concentric with the new guide whenever new guides are installed. Check the Clearance and Limits section of this manual for the correct height guides should extend above the cylinder head. The valve seat inserts are a press fit, but require a further shrinking operation to anchor them in place.

To obtain the optimum service life from replaced inserts, the use of Waukesha inserts especially made for this job is strongly recommended. The steel and heat-treatment of these inserts has been developed by long service and laboratory experience for the very

best characteristics of heat resistance and expansion control to provide the correct shrink fit and maintain this fit under hard usage.

The accuracy of the machine method of valve grinding depends entirely upon the condition of the valve guide and the pilot mandrel's fit, both in the guide itself, and the hub of the grinder stone. It is vitally important, therefore, to make sure that the mandrel is a snug push fit in the valve guide, and will not wobble at the upper end. If it does have any upper-end movement the seat will not be ground true. Guides that are worn too much to give the mandrel solid support should be replaced before grinding is attempted. The maker's instructions for dressing the grinding wheel must be followed to secure smooth, accurate seats.

Reconditioning Valves

When refacing the valves, the maximum face runout in reference to the valve stems should not exceed .002 inch (total dial indicator readings), and only enough metal should be removed to produce a bright surface and a continuous margin as illustrated.

Severely burned valves should not be re-ground since the metal behind the burn has probably lost its original properties. Valves that are warped, pitted with damaged valve tips, have worn keeper grooves or a reduced diameter at the valve stem should also be discarded and replaced with new valves.

Valve Grinding

Modern valves are much harder than formerly so that a valve grinding machine is much quicker and more accurate than hand grinding. If machine grinding equipment for both valves and seats is not immediately at hand, it will often save time and money, as well as getting a better job if the head and valve assembly are sent to a local specialist. Even if hand grinding is employed, the valve stems and guides must be a good fit without wobble to insure a concentric seat and a tight valve.

Hand Grinding

Apply a good, medium grinding compound sparingly around the entire valve seat, slip a light lifting spring over the stem, lubricate the stem, and drop the valve into its original place in the cylinder head. The spring should just barely hold the valve off its seat. Place the grinding tool cup on the head of the valve to be ground, and press down until the valve is

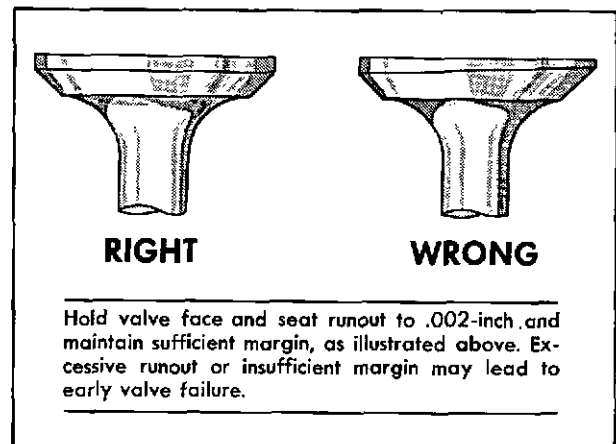

Refacing Valves

seated. Turn the valve a quarter turn, first in one direction then in the other. Do this three or four times. Release the pressure on the valve, and the little spring will lift it off its seat. Now turn the valve about 10 or 15 degrees to another position, and repeat the grinding. Do this until all the compound is rubbed off the valve seat. Withdraw the valve, and put on some fresh compound. Repeat the grinding operation.

Clean the valve and its seat occasionally to see how the grinding is progressing. When all pits and grooves have disappeared, clean the valve and valve seat, and place eight or ten equally spaced marks with a soft lead pencil on the seat. Then drop the valve in place, give it a quarter turn, and remove it. A perfect seat will be indicated if every pencil mark shows where the valve has rubbed it. If any pencil marks are left untouched, continue the grinding. When the grinding is completed, check the valve seat for concentricity with a dial indicator, then oil the valve stem, clean all traces of the grinding compound from the valve chamber and ports, and RE-ASSEMBLE EACH VALVE IN ITS OWN OPENING.

Replacing Cylinder Head

First, make sure that the oil leads drilled in the heads to feed the rocker arms, as well as the oil lines from the cylinder block, are clean to insure full oiling of the valve mechanism.

A torque wrench when used according to the table at the rear of this book will prevent overstraining studs, while insuring a tight joint.

Manifolds and cylinder heads are assembled together and require special attention to insure

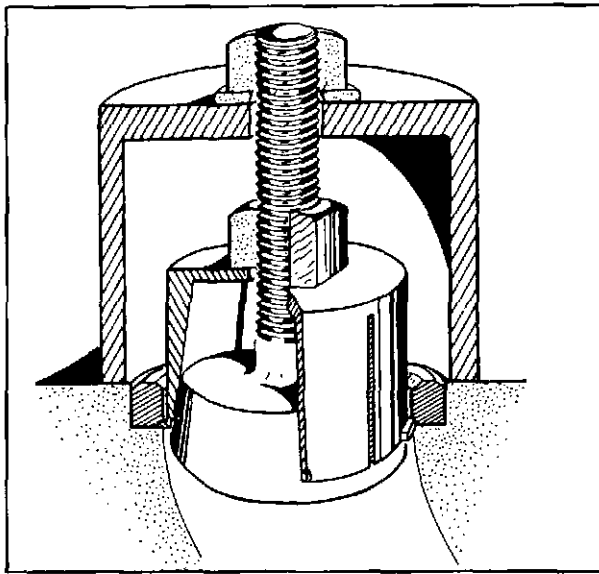

Pulling Seat Inserts

alignment and perfect contact of the mating flanges.

1. Replace valves, valve springs, and retaining washers or valve rotators. Block the valves closed and depress the springs to insert lock retainers.

2. Clean out the upper part of the cylinder liner while the head is removed and smooth

down the ring travel ridge. Be sure to clear the bore of all carbon particles and abrasive grit before replacing the head.

3. Place a new cylinder head gasket on the flange, replace the head, push rods and rocker arm shaft assembly, then tighten the cylinder head stud nuts finger tight.

4. With the cylinder head centered in the stud holes and the stud nuts tightened finger tight, place a new manifold gasket on each cylinder head manifold face. Replace the intake manifold between cylinder heads, and level it so that both sides have equal projections of gaskets above and below manifold flange.

5. Replace the exhaust manifolds, center them on the studs, and tighten the stud nuts and clamp nuts finger tight.

6. Tighten cylinder head nuts to approximately one third the final torque.

7. Tighten the manifold nuts to one third the final torque.

8. Tighten both manifold and cylinder head stud nuts to final torque according to the tightening sequence illustrated.

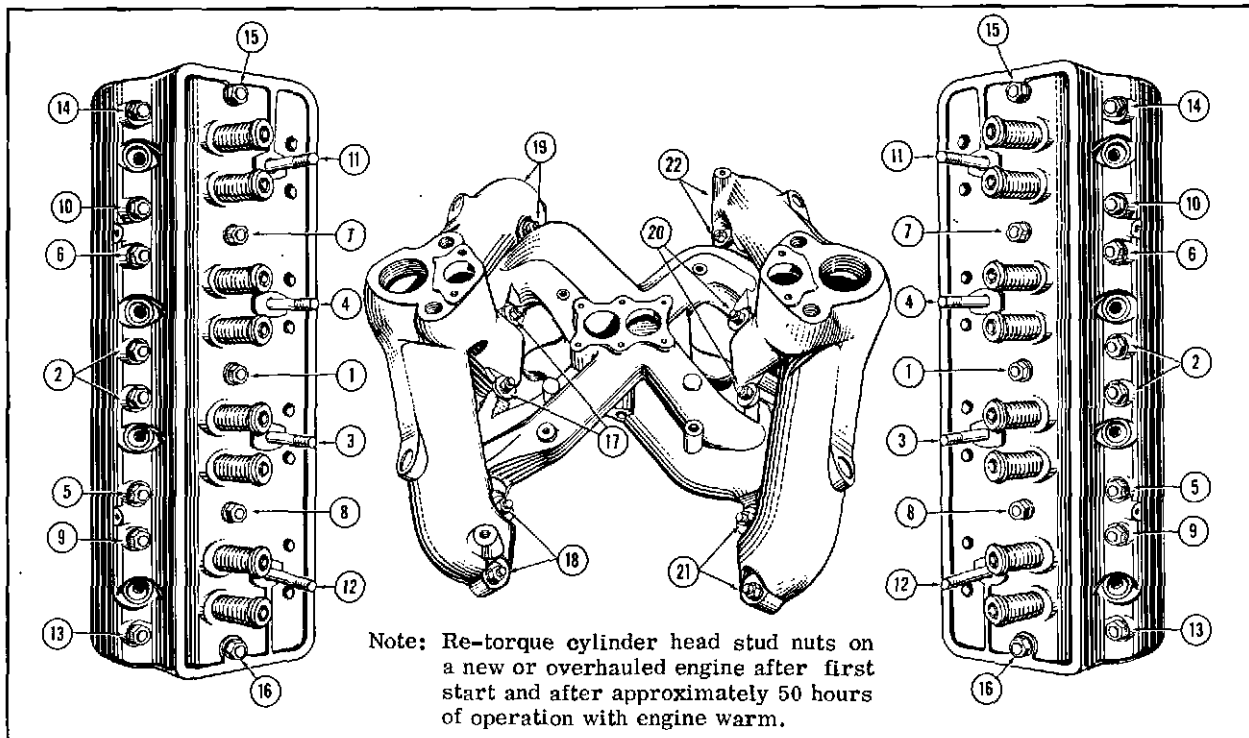

Note: Re-torque cylinder head stud nuts on a new or overhauled engine after first start and after approximately 50 hours of operation with engine warm.

Cylinder Head--Manifold Stud Tightening Sequence

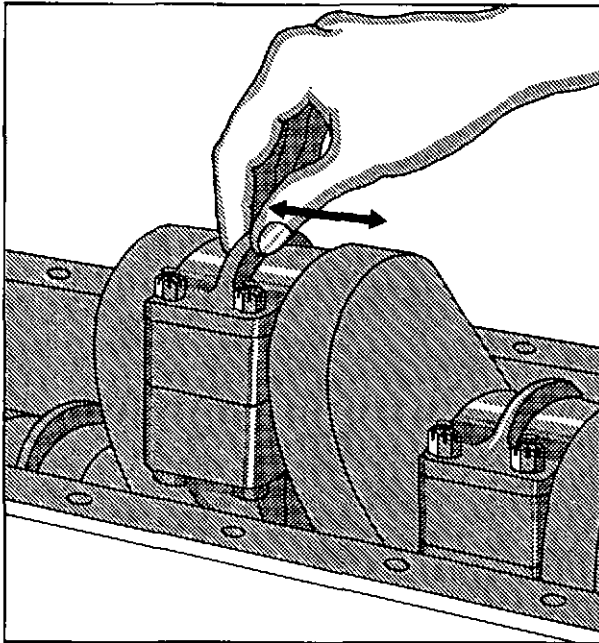

Testing Bearing for Tightness

9. Check the intake manifold alignment by sliding a thin feeler gauge around the flanges. To insure perfect sealing, the mating flange contact should be such that the feeler gauge cannot slide under the manifold.

10. Rotate the engine by hand to see that the push rods do not touch the cylinder head at any time. If this does happen, loosen and realign the head.

BEARING ADJUSTMENT

All main and connecting rod bearings in the 570 and 884 engines are of the steel-backed precision type. Because of the extremely close machining of this type bearing, no fitting, filing, scraping, boring, or other adjustment is required or permissible. Replacement must be in complete bearings units. Never replace only one half of a bearing. Service bearings are available in .010, .020, and .030 under size for use on reground crankshafts. Never attempt to adjust a bearing by filing, grinding, or lapping the bearing cap. The bearing seats are precision bored with the caps in place. Hence, any metal removed from either side forever prevents proper fitting of a connecting rod bearing in the rod, and in the case of a crankcase makes the entire case unsuited for further use.

Be sure that the bearings seat on absolutely clean surfaces and that the back of the bearing is wiped perfectly clean. The slightest bit of

dirt or carbon squeezed between the back of a bearing and its seat can cause rapid bearing failure due to a localized high spot.

Equally important in obtaining maximum bearing life is the correct tension on the bearing cap nuts or cap screws. Pull down on all nuts or screws evenly, going from one side of the bearing to the other. Apply final tension with a torque wrench using a slow steady pull and holding the wrench "on torque" for a few seconds when the proper value is reached. Desired torque values will be found in the table of limits at the end of this manual. Never back off on a bearing nut. It is preferable to go to a slightly higher tension if necessary. Previous over-torquing, or some other damage to the bolt or nut is sometimes encountered and will be felt by the torque "softening up" so that the nut or bolt can be turned without appreciable increase in wrench tension. Never allow a bolt or nut in this condition to remain in an engine.

Crankshaft end thrust is controlled by the center main bearing flanges and is established by the bearing dimension itself. Therefore, there is no necessity for adjustment of this at assembly. Excessive end play requires bearing replacement.

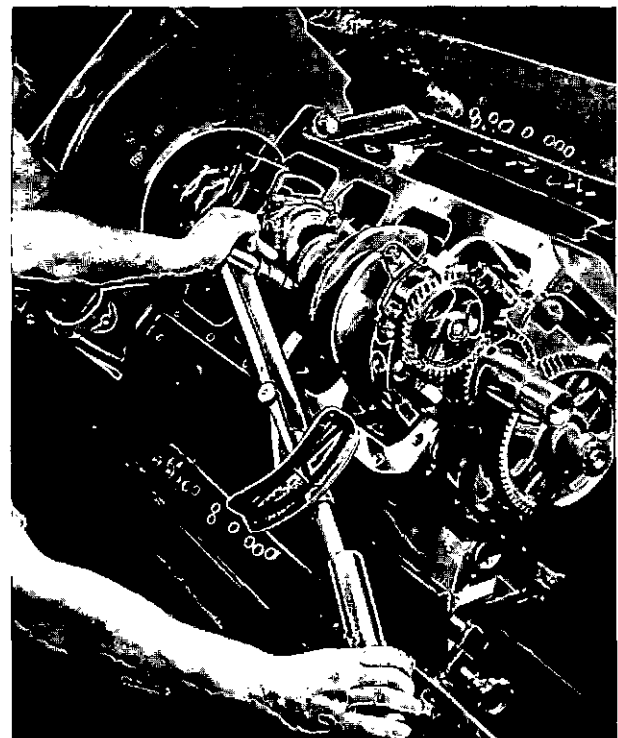

Tightening Main Bearing Capscrews

Side Clearances

Although less critical than the bearing running clearances, no bearing should be assembled without checking side clearance. This may be done by forcing the rod fully to one side or the other and inserting a feeler between the crankcheek and the bearing end. Shaft end play is measured with a feeler between the shaft and the center main bearing flange when the shaft is at full forward or rearward position. A dial indicator may also be used for this purpose. Consult the table of limits for the proper clearances.

Running Clearances

Even in the case of precision bearings, it is good mechanical practice to check running clearances when installing bearings. There are several methods of doing this, some of which are merely checks of whether ANY clearance exists and others that give an indication of HOW MUCH clearance is present. The familiar test of connecting rod bearing clearance consists of manually gripping the rod cap after the bearing bolts are tightened and attempting to move the bearing from side to side in the direction of end clearance. A well-fitted bearing is usually just loose enough to be "snapped" from side to side without actually feeling so

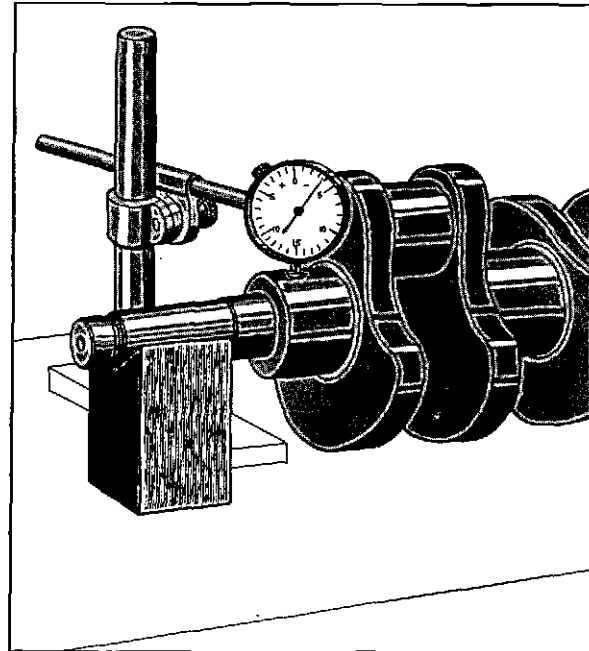

Checking Crankshaft Runout

loose as to push easily. Sometimes a slightly snug bearing will not move under finger pressure but will move readily under light blows from a soft-face hammer. This is usually considered as satisfactory providing the engine is given adequate break-in time. In the final analysis, this test is a matter of judgment and is not altogether suitable for general use.

A similar test on main bearings consists of tightening each bearing cap in turn and turning the shaft to detect binding. Again, the difference between tight and "about right" is a matter of judgment.

More accurate tests may be carried out with fuse wire or with a special crushing gauge material that squeezes between the shaft and the bearing to flatten into a measurable gauge.

It is emphasized that any unusual bending or run-out in a crankshaft makes it impossible to fit bearings accurately. For this reason, the time spent in making a run-out check at overhaul is well worth while. Also, magnetic inspection of the crankshaft and other stressed parts is recommended if the proper equipment is available.

DO NOT FORGET TO COAT ALL RUNNING SURFACES WITH CLEAN, FRESH ENGINE OIL WHEN INSTALLING NEW BEARINGS!

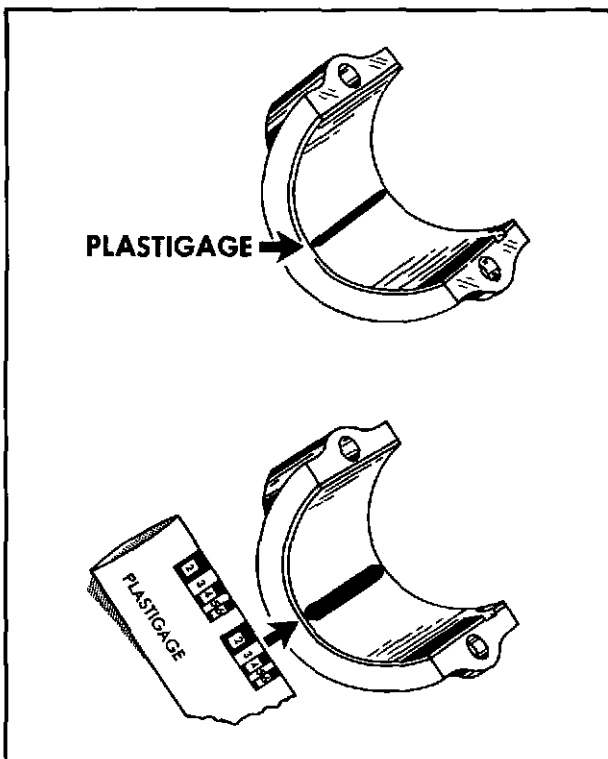

Measuring Bearing Clearance

CYLINDERS AND PISTONS

Matching Replacement Pistons, Sleeves, and Pins

The precision and skill with which pistons are re-fitted during overhaul is sure to have a very great effect on later engine performance.

Unusually loose pistons will soon show up as noisy, with excessive blow-by, high oil consumption and sluggish power characteristics. Overly tight pistons may be even more dangerous because of the possible severe damage to sleeves or cylinder walls and other running parts. Less well understood, but very definitely important, is the necessity for using pistons that match each other within specified weight limits. Off-balance conditions established by relatively slight variations in piston weight can bring about effects ranging from merely annoying vibrations to fatigue failure within a short time.

The vital point about the above details is that an overhaul job where they are ignored or improperly handled is often worse than no overhaul at all. It is not enough to use new pistons and sleeves assembled from open service parts stock. The pistons should all come within the specified weight range and the piston-to-sleeve clearances must fall within a selective fit tolerance as actually measured by a person skilled in this operation.

All of the above facts are borne out by the long experience of the Waukesha Motor Company both in production and in providing service parts. We therefore believe that the very best way to obtain properly matched and fitted pistons, sleeves and pins, is to order factory selected sets as complete units for a given job.

When ordering parts of the above type, the following points should be remembered:

1. Pistons, sleeves, and pins, ordered as separate items for stock cannot, of course, be fitted at the factory and will be selected at random. To ensure a sufficiently wide assortment of parts to select the correct fit on the above basis requires a large inventory. To use assemblies that have not been so fitted is an injustice to the engine.
2. Complete assemblies ordered as such, that is . . . all pistons and sleeves; pistons, sleeves, pins and retainers; or other combinations for a given engine, will be selected for both weight and clearances at the factory and will be equiv-

alent to new factory-production assemblies when properly installed. An extra charge is made for labor involved to make this service possible. We are sure your experience will prove this extra cost is more than justified.

3. Instances where a portion of a factory assembly, for example, one sleeve and piston; several pistons in an engine; and so on is replaced and is to run in conjunction with some of the original parts, it is good practice to order replacement pistons that will match the original weights. To do this, clean the original piston until the weight figure stamping becomes legible, or, if these markings are obscured, weigh the piston to the nearest quarter ounce without the pin or retainers. This may be done on a postal scale.

If the weight is not reported with the order, open stock parts must be supplied and consequently there is no assurance of a good match between old and new parts.

Removing and Installing Sleeves

Removal of the wet-type cylinder sleeve is a comparatively easy operation since the only substantial force required is that needed to loosen the lower rubber seal rings. A screw-jack type puller may be made up with a plate seating against the lower end of the sleeve and connected by a through bolt to a bridge-like structure at the top of crankcase. Once the rubber rings have been freed, the sleeve is readily lifted out. Rubber rings cannot be re-used.

There are several important points to note on installing the sleeves. First in importance is the use of seal rings that are fresh and elastic. Do not use aged and hardened rings since these will not compress evenly and sleeve distortion will result. Also, the ring seating surfaces must be clean and well lubricated with liquid soap. Do not use engine oil on rubber rings. After slipping the rings over the sleeve and into the grooves, run a pencil or like instrument around under the ring to distribute the rubber material around the sleeve more evenly.

Inspect all seating surfaces at the upper end of the sleeve and in the crankcase counterbore to ensure that no dirt will interfere with accurate seating.

After the rubber rings and surrounding area are well soaped, align the sleeve in the crank-

case and force it home with a smart, firm thrust of the hands. No hammering or driving is necessary or desirable.

When all sleeves are in place, check the sleeve bores for distortion that might have occurred due to inaccurate placement of the seal ring material. This must be done with a clamping load on the top of the sleeve and a dial indicator of the extension arm, three contact type. Practical limits for maximum out-of-round permissible are .001"-.0015". The clamping action may be obtained from any accurately built ring that simulates the cylinder head pressure and is retained by the head studs. If a considerable number of sleeves are to be replaced over a period of time, it may prove convenient to make up a clamping tool from a discarded cylinder head with openings cut out to allow the gauge to drop through into the cylinder.

It is not unusual when fitting this type of sleeve to find it necessary to withdraw the sleeve, re-soap and even up the rings, and re-install it several times before obtaining an out-of-round reading within the limits in the back of this manual. Uneven distribution of the rubber rings causes this trouble. Always make this check in the seal ring area.

In connection with the above check for out-of-round, it may be more convenient to make a gauging piston by re-grinding an oversize piston just to slide through the sleeve within

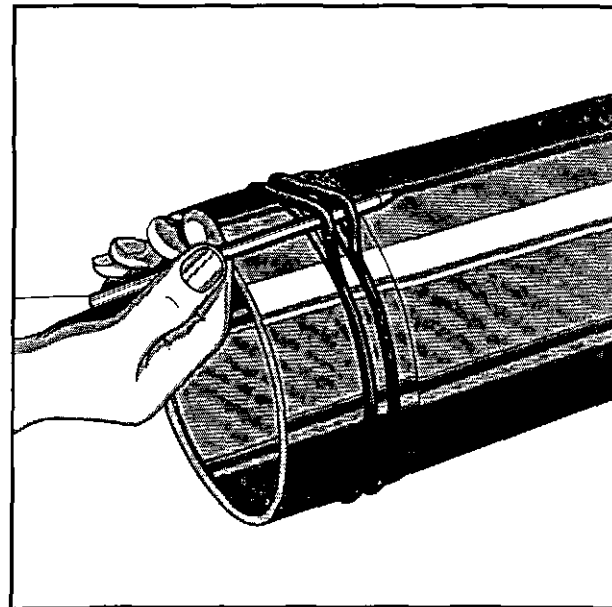

Evening Up Rubber Rings, 570

the proper tolerances. Such a gauge requires some skill and judgment in use since forcing it through a distorted sleeve will not correct the distortion and may cause score marks or scratches.

Cylinder Head Gasket

The operator is cautioned against using head gaskets other than those specified by the WAUKESHA MOTOR COMPANY. Cases have been reported where gaskets of somewhat harder material have overloaded the sleeve flange and started cracks in this area. By the same token, tighten cylinder hold down nuts to the correct torque value. A cylinder head gasket in obviously good condition may be re-used. It is poor economy, however, to risk engine damage and extra labor if the gasket is at all doubtful.

Piston Fitting

Proper fitting of pistons requires at least four different precision checks. These are: Ring gap, ring side clearance, pin clearance in boss, and piston skirt to sleeve clearance.

Ring gaps are easily checked with a feeler gauge. Slip a piston ring into the sleeve. Slide a piston into the sleeve above it. Push the piston up against the ring to square the ring with the bore. Move the piston out of the way and measure the gap in the ring with a feeler gauge. Those rings with gaps less than specified in the table of limits in the back of this

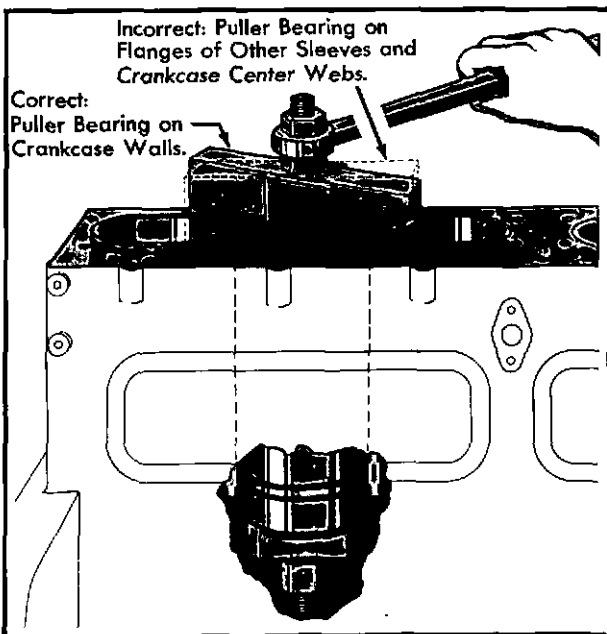

Sleeve Puller in Use

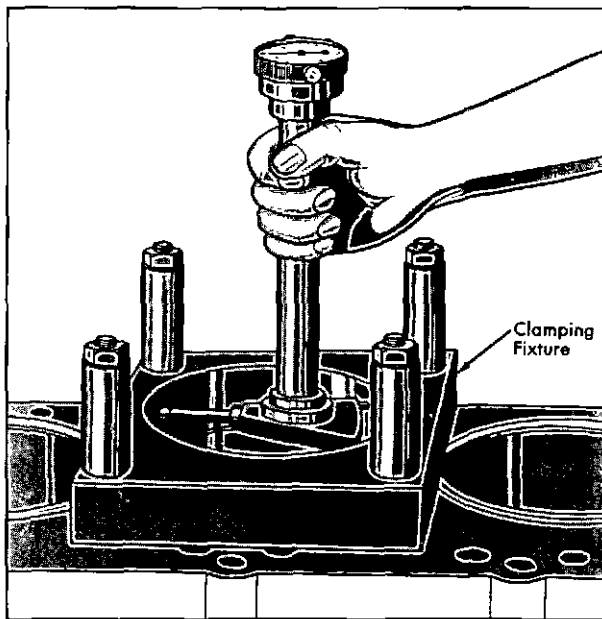

Checking Sleeve for Distortion

manual should be carefully dressed off with a flat cut file until the correct clearance is obtained. Contrary to popular impression, fairly wide ring gaps, near the top limit, are far less detrimental to engine performance than gaps which are too tight.

Piston ring side clearance must always be checked when fitting rings to pistons which have been in service. In this case, the object of the check is to spot any pistons in which the ring grooves may have worn excessively wide. A piston in this condition must be replaced. To check side clearance, select a piece of feeler stock of the maximum clearance specified in the table of limits. With the ring in place, insert the feeler if possible between the ring land and the ring held well back in the groove. If the feeler slides in at any point, it indicates the clearance is at or over allowable maximum. A snug fit of the feeler points to further consideration by the operator as to whether the piston warrants re-installation since the groove wear is at the top limit. On all pistons passing the above check, make an inspection for minimum clearance with a feeler of the minimum thickness specified in the table of limits. This feeler should slide freely all around the groove as the piston and ring are rotated.

Piston pin fitting is a job requiring great precision and pin and piston assemblies are normally sold in matched sets. The specified pin clearance will permit a hand "push" fit after the piston has been heated to about 165° F.

A pin that is loose enough to drop through the piston by its own weight, is ordinarily considered too loose. From the service standpoint, a fit of this variety, if not due to severely worn parts, will cause an engine to be somewhat noisy but will not necessarily impair performance or reduce engine life.

Piston to sleeve clearance is probably the most critical dimension in the entire piston fitting sequence. Pistons are not sold in semi-finished condition for these engines, and it is not recommended that a piston of given oversize be re-ground to a smaller oversize.

There are several reasons for this, including such factors as the nature of the equipment required, the necessity for specialized knowledge and skill, and the characteristics of cam-ground pistons. By cam-grinding, it is meant that the piston area below the rings is not round but slightly cam shaped or "oval". The long axis of the oval is located at 90° to the piston pin. Consequently, a micrometer measurement of the piston skirt diameter along the axis of the pin will be slightly less than a measurement taken across the thrust faces. The amount of "cam" for any piston is carefully worked out

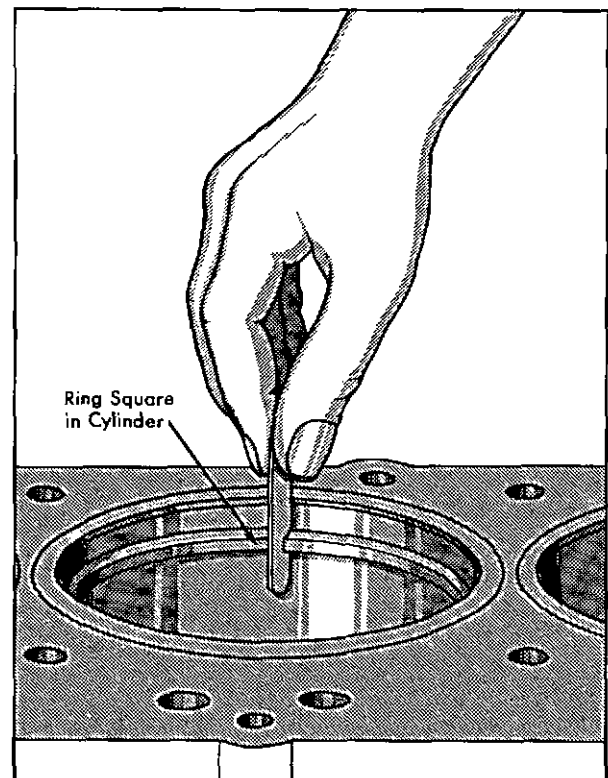

Measuring Piston Ring Gap

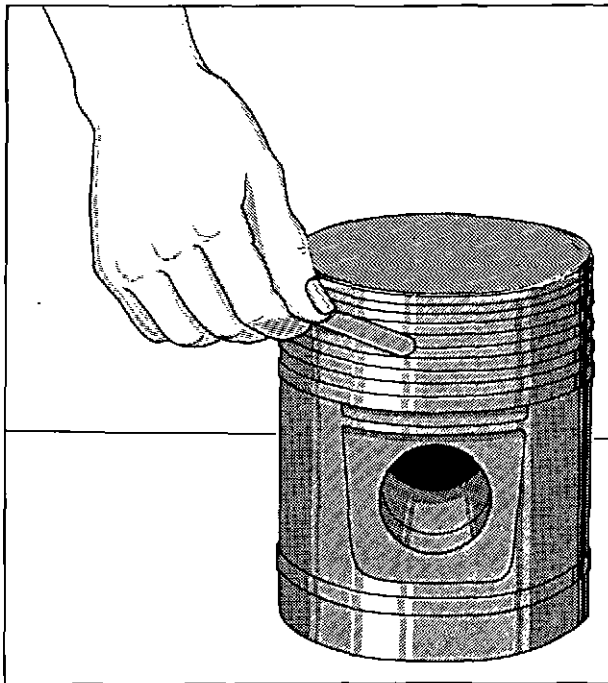

Piston Ring Side Clearance

to compensate for the metal mass, the engine temperature, and so on, that control piston expansion. Hence, the additional material at the piston pin bosses brings about an expansion that rounds out the piston under operating conditions.

Because of the foregoing facts, it is clear that piston skirt to sleeve clearance can only be taken on an axis 90° to the piston pin. That is, across the thrust faces. To take the clearance, select two pieces of $1/2$ "-wide feeler stock and totaling the desired skirt clearance. A single strip is not satisfactory because it is too stiff to conform to the curve of the sleeve bore and thus given an erroneous reading. Attach the feeler stock to an accurate spring scale as shown in the accompanying illustration. Invert the piston and support it with one hand while holding the feeler and spring scale in the other hand. Place the feeler stock in the sleeve and lower the piston into position in such a manner that the feeler stock is spaced 90° from the piston pin. Hold the piston and withdraw the feeler stock. If the correct clearance is present, the tension required to withdraw the feeler should read 4-8 pounds on the scale. Too low or too high a scale reading indicates too much or too little clearance.

When fitting a piston to a new or accurately re-sized sleeve, the sleeve inner diameter should be the same at top and bottom. Therefore, the clearance may be taken at either end.

In sleeves that have been worn, but not re-sized, some taper giving extra clearance at the top of the sleeve is likely. In such cases, the clearance must be checked at the bottom of the sleeve where the wear is least and the fit is closest. Remember, the skirt of the piston fits closer than the ring lands. Check skirt, not land, clearance.

Reassembly of Pistons

Install the piston rings with a piston ring expander, spreading the gap only enough to slide them in place. They should be installed in this order:

1. Oil control ring (slotted piston ring) in bottom groove with sharp edge at the bottom.
2. Compression rings (plain piston rings) in the middle two grooves with side stamped "TOP" facing up.
3. Compression ring (inside bevel ring) in the top groove, with side stamped "TOP" facing up.

To reassemble the piston and connecting rod, the piston must be heated to 165°F . Locate the piston arrow, when so marked, and connecting rod in their original relative position, then insert the piston pin with a "palm" push or a very light tap.

The connecting rod bearings are slightly off center in the connecting rod to allow for the crankshaft cheek fillet on the outer face, and to locate the bearing edge flush with the inner face.

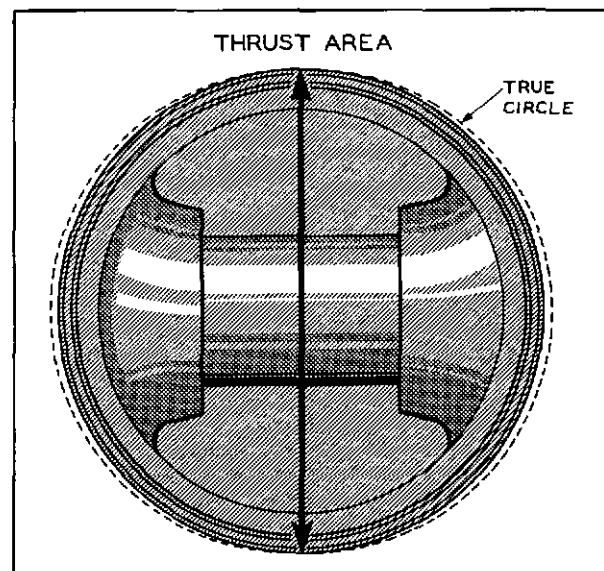

Cam Ground Piston (Exaggerated)

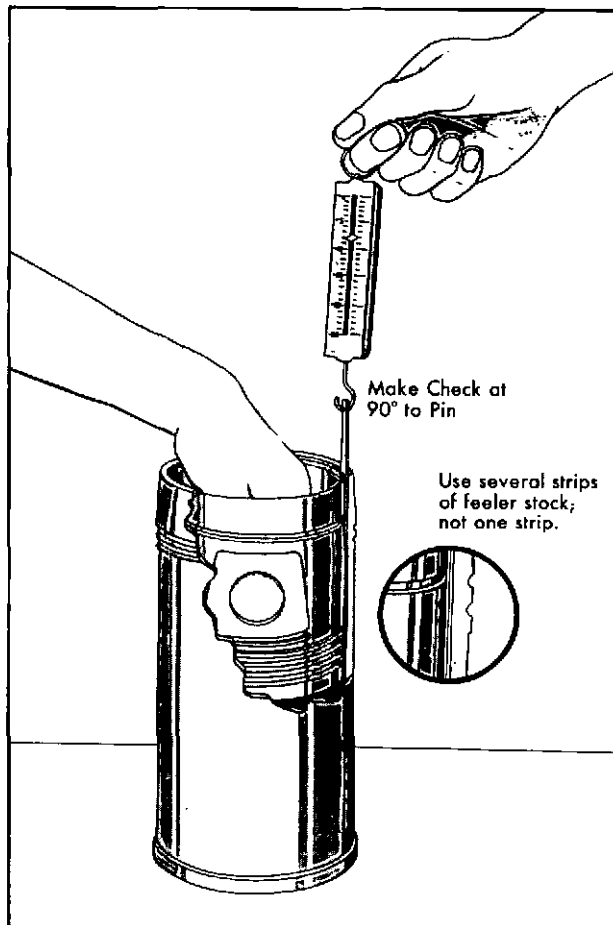

Fitting Piston to Sleeve

Coat the cylinder wall with clean engine oil. Insert the assembly with connecting rod facing in the proper direction and check to see that:

1. The side of the connecting rod with the least chamfer or radius faces the adjacent connecting rod.
2. Face arrow on flat head pistons when so marked, in direction of crankshaft rotation. Face dished head piston arrows toward inside of engine.

Guide the assembly into place using a piston ring compressor to pilot the rings into the bore.

The connecting rod bearings should be replaced with the backs clean and dry and bearing surfaces well lubricated with engine oil. Make sure that when the bearings are located in the connecting rod bearing recesses, both inner edges are flush with the inner connecting rod face. Then assemble the bearing caps so that the lower bearing shell coincides with the upper shell. Tighten the cap bolts alternately to the recommended torque.

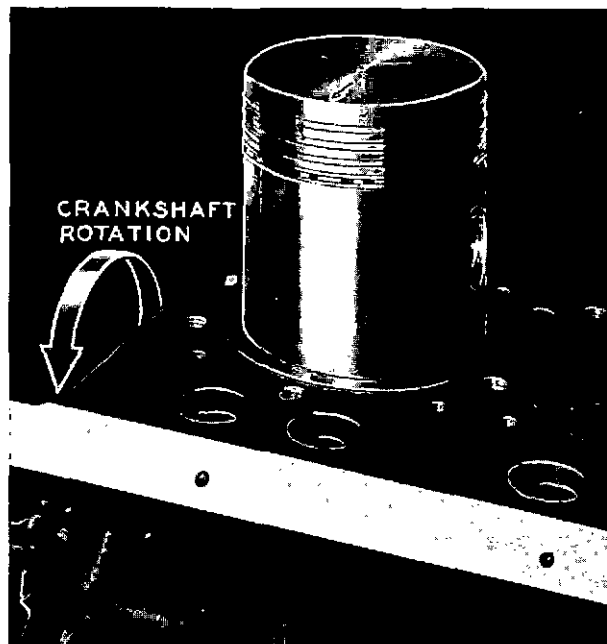

Correct Position of Piston in Cylinder

ALIGNING FLYWHEEL HOUSING

Whenever the flywheel or flywheel housing have been removed, or whenever a clutch assembly is installed, the run-out of both the flywheel and flywheel housing should be checked. These parts are carefully aligned at the factory and the housing face and bore are finish

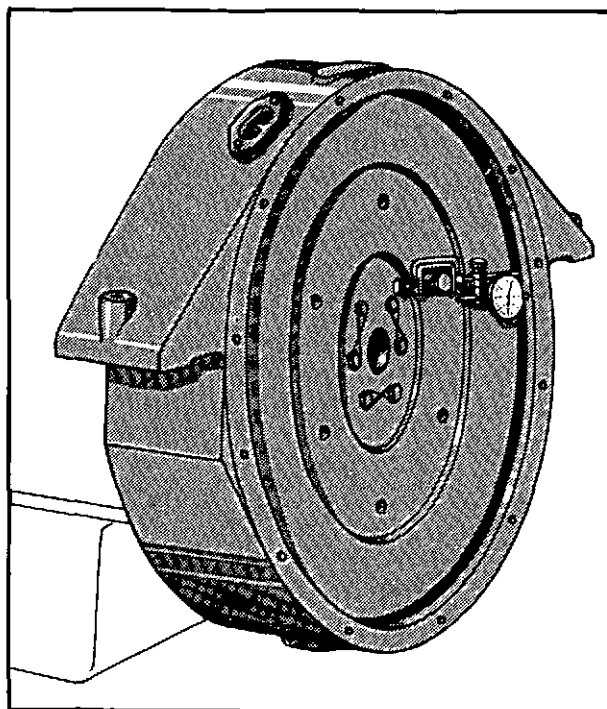

Checking Housing Bore Runout

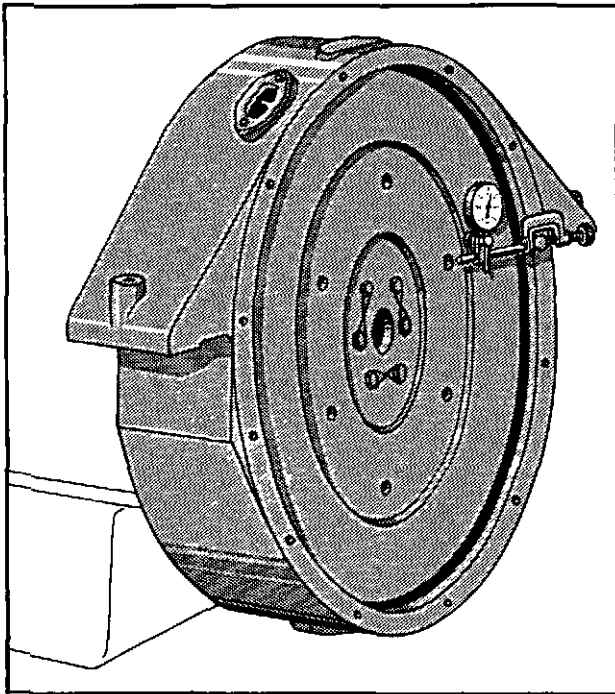

Checking Flywheel Runout

machined in place. Severe shocks and jars during shipment or transporting, however, may cause deflection to some degree. Moreover, it is well to check the fit of the pilot bearing bore and for lubrication of the pilot. For the sake of safety, always check the flywheel retaining cap screw torque at this time.

In order to be sure that grease is going to reach the pilot bearing when the clutch is in use, it is necessary to be sure that the grease channel through the clutch shaft is full of the proper grease at installation. By packing this

channel, the operator can eliminate doubt and overlubrication or, equally bad, no lubrication at all. In any case, the recommendations and instructions from the clutch manufacturer should be used.

Dowel pins are driven through the flywheel housing into the crankcase after it has been assembled and centered. These dowel pins must be replaced before the mounting cap-screws are tightened whenever the flywheel housing is being reassembled. If a new flywheel housing is to be installed, center it about the crankshaft centerline by mounting a dial indicating micrometer on the flywheel flange and shifting the flywheel housing so that the bore is centered within .010" total indicator reading. Then locate dowel pins to maintain this position.

ALIGNING FLYWHEEL

Because one of the stud holes on the crankshaft flange and one on the flywheel is slightly off-center, there is only one way the flywheel can be mounted. This mounting assures correct position of flywheel timing marks.

With the flywheel mounted and tightened, attach a dial indicating micrometer to the flywheel housing, as illustrated and check the flywheel "concentricity" which must not exceed .008" total indicator reading. Excessive "eccentricity" may be due to improper tightening or a dirty surface on the crankshaft flange or flywheel bore and may result in crankshaft bearing failure or the flywheel coming off.

The face deviation must not exceed .008".

PISTON

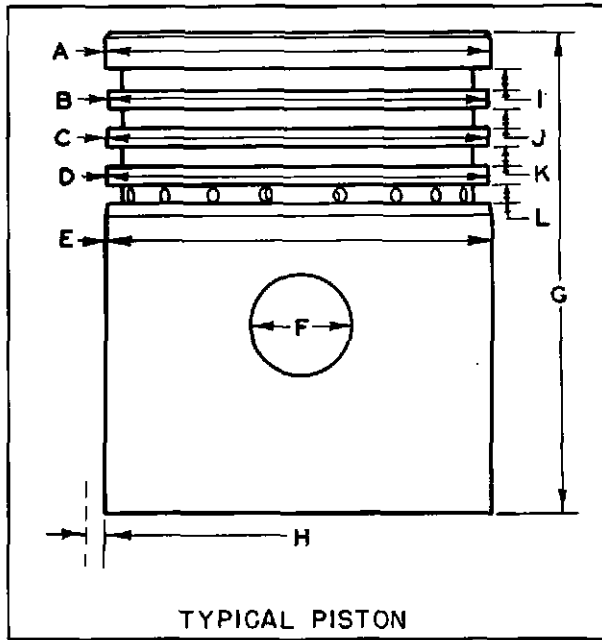

TYPICAL PISTON

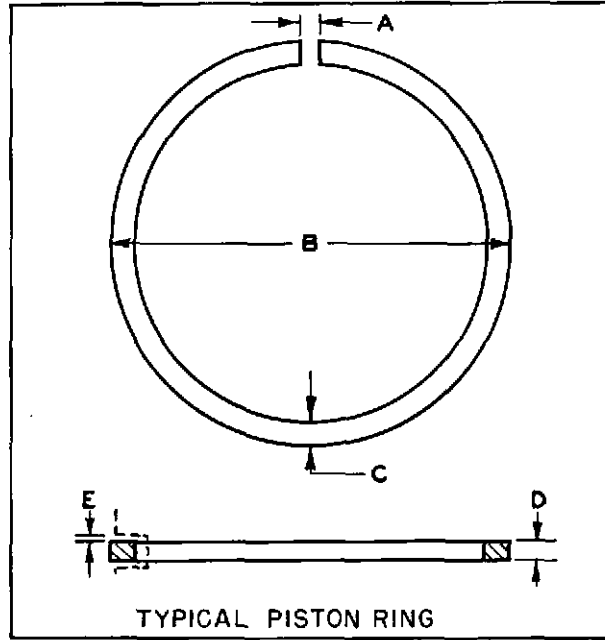

TYPICAL PISTON RING

Piston material	Aluminum alloy
Type	Cam ground
Pistons are removed from	Top of cylinders
Permissible weight variation (Piston & Pin)	1/2 ounce

PISTON LAND TO CYLINDER SLEEVE BORE CLEARANCE

	(Land dia.)	(Sleeve bore)	(Land to Bore Clearance)
(A) Top land	4.591"-4.595"	4.626"-4.627"	.031"-.036"
(B) 2nd land	4.591"-4.595"	4.626"-4.627"	.031"-.036"
(C) 3rd land	4.597"-4.601"	4.626"-4.627"	.026"-.029"
(D) 4th land	4.597"-4.601"	4.626"-4.627"	.026"-.029"
(E) Piston skirt diameter			4.6212"-4.6232"
(F) Piston pin hole diameter			1.3750"-1.3753"
(G) Piston length			5.240"-5.260"
(H) Piston skirt to sleeve clearance			.0028"-.0058"
			(GROOVE WIDTH)
(I)			.097"-.098"
(J)			.1265"-.1275"
(K)			.1265"-.1275"
(L)			.2510"-.2520"

PISTON RINGS

	Top ring	2nd ring	3rd ring	4th ring
Type				
(A) Ring gap	.013"-.025"	.013"-.025"	.013"-.025"	.013"-.025"
(B) Ring dia.	4.625"	4.625"	4.625"	4.625"
(C) Ring wall	.221"-.231"	.183"-.193"	.183"-.193"	.183"-.193"
(D) Ring width	.0925"-.0935"	.1230"-.1240"	.1230"-.1240"	.2480"-.2490"
(E) Side clearance	.0035"-.0055"	.0025"-.0045"	.0025"-.0045"	.002"-.004"

MAIN BEARINGS

Number Five
 Type Precision
 Material Copper lead, steel backed
 Undersize available010"-.020"-.030"
 Thrust bearing width 1.399"-1.401"
 Thrust bearing flange131"-.133"
 Adjustment Replacement-thrust brg.
 Bearing wall thickness1248"-.1253"
 Running clearance0014"-.0044"

CRANKSHAFT

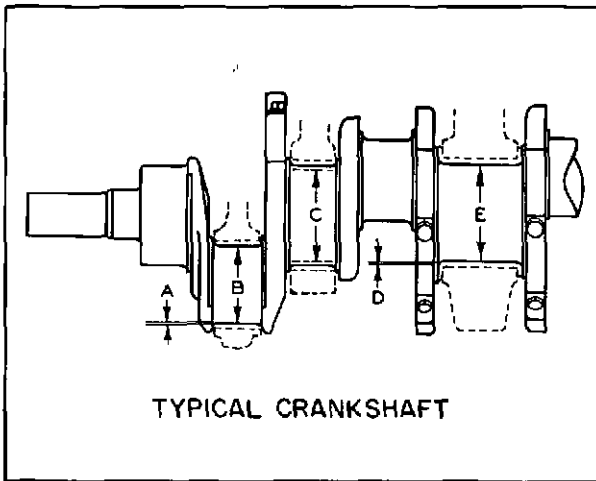

TYPICAL CRANKSHAFT

Crankshaft end play006"-.010"
 End play adjustment . . . Thrust bearing-replace
 (A) Connecting rod bearing running clearance0008"-.0034"
 (B) Connecting rod bearing journal diameter 2.7480"-2.7490"
 (C) Main bearing journal maximum undersize030"
 (D) Main bearing running clearance0014"-.0044"
 (E) Main bearing journal diameter 3.2490"-3.250"

OIL PUMP

Drive gear to body clearance005 Min.
 Pump gear to cover end clearance0015"-.006"
 Idler shaft end clearance03125
 Body bushing ream dia.5637"-.5642"
 Cover bushing ream dia.5623"-.5628"
 Pump gear running clearance0045"-.0065"

CONNECTING ROD, BUSHING AND BEARING

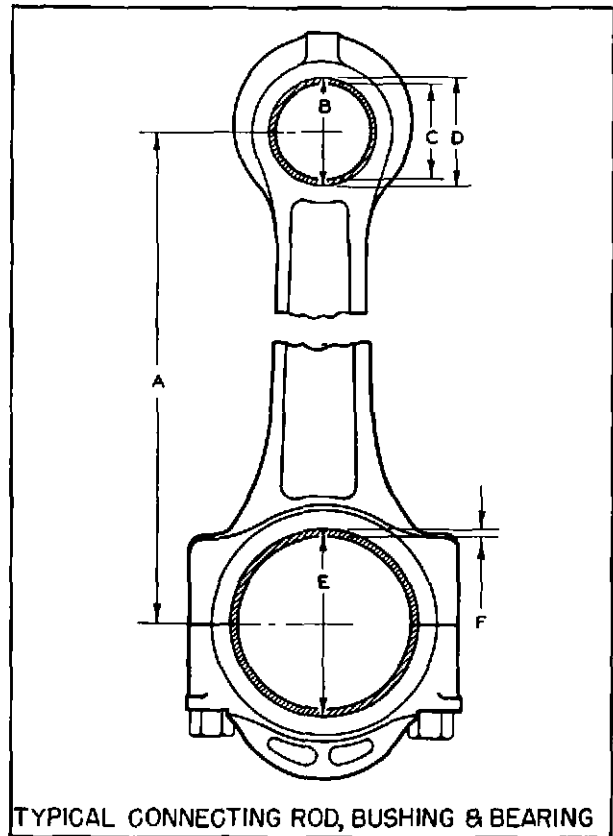

TYPICAL CONNECTING ROD, BUSHING & BEARING

Permissible weight variation 3/8 ounce
 Side play limit00525"-.00875"
 (A) Rod length, center to center 8.560"-8.564"
 (B) Rod small end finish size 1.5620"-1.5630"
 (C) Bushing bore 1.3753"-1.3756"
 (D) Bushing O.D. 1.566"-1.568"
 (E) Rod large end finish size 2.9004"-2.9010"
 (F) Bearing wall thickness0748"-.0753"
 Bearing running clearance0008-.0034
 Rod bearing material Precision, copper-lead, tri-metal

CAMSHAFT

Camshaft bushing bore 1.9995"-2.0005"
 Camshaft bushing journal dia. 1.997"-1.998"
 Camshaft running clearance in bushings0015"-.0035"
 Camshaft end play . . .003"-.006" TH570 with thrust plate
 Camshaft end play for H570 with thrust button003"-.019"
 Camshaft end play adjustment (H570) Thrust button-replace
 Camshaft end play adjustment (TH570) Thrust plate-replace

VALVE PORT CLEARANCES

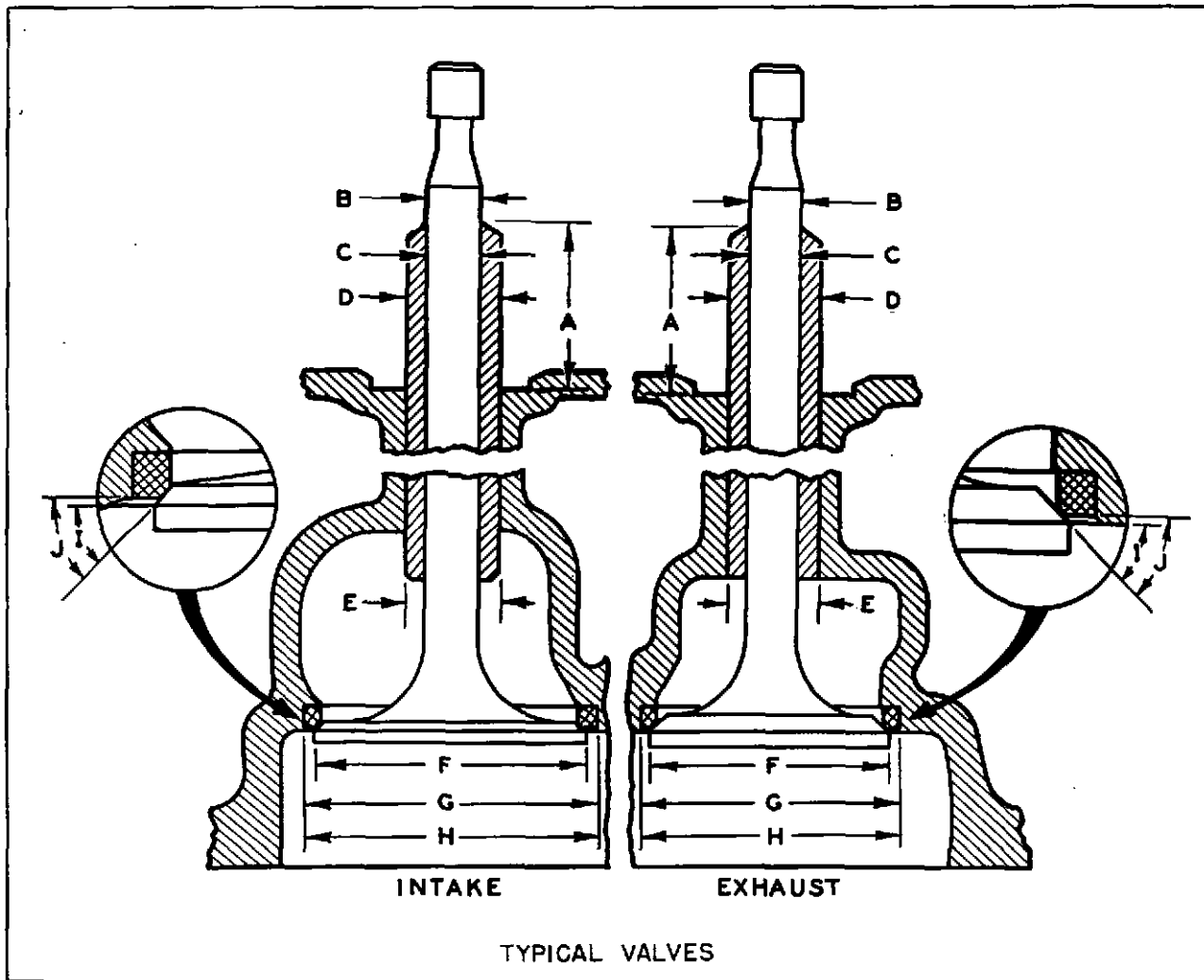

	INTAKE	EXHAUST
(A) Guide extends above block	1-3/32"	1-3/32"
(B) Valve stem dia.4345"- .4355"	.4345"- .4355"
(C) Guide I. D. (ream)4370"- .4380"	.4370"- .4380"
Clearance, stem to guide0015"- .0035"	.0015"- .0035"
(D) Guide O. D.7515"- .7521"	.7515"- .7521"
(E) Guide hole dia.7495"- .7505"	.7495"- .7505"
(F) Valve head dia.	1.995"- 2.005"	1.620"- 1.630"
(G) Insert O. D.	2.1285"-2.1295"	1.7525"-1.7535"
(H) Insert counterbore dia.	2.1240"-2.1250"	1.6495"-1.7505"
(I) Insert seat angle	45°	45°
(J) Valve seat angle	45°	45°

PISTON PINS

Pin diameter	1.3748"-1.3750"
Pin length	4.120"-4.125"
Piston pin fit0000" to .0005" loose

VALVE TIMING

TIMING	INTAKE	EXHAUST
Valve opens	TDC	46° BBDC
Valve closes	56° ABDC	10° ATDC

WAUKESHA MODELS 570 AND 884

VALVE CLEARANCE

(Adjust valves at normal room temperature)

**VALVE CLEARANCE
COLD SETTING**

INTAKE **.015-.017"**

EXHAUST **.020-.022"**

WAUKESHA MOTOR CO.
WAUKESHA, WISCONSIN
U.S.A.

H570

**VALVE CLEARANCE
COLD SETTING**

INTAKE **.015-.017"**

EXHAUST **.025-.027"**

WAUKESHA MOTOR CO.
WAUKESHA, WISCONSIN
U.S.A.

TH570

SPARK PLUG

Type of service	Normal duty	Heavy duty
Spark plug gap023"-.028"	.023"-.028"
Champion	J-6	J-6
AC spark plug	C44XL	C44XL
Auto-Lite	AG-4	AG-4
Spark plug size	14 mm	14 mm

SPARK ADVANCE RECOMMENDATIONS

DISTRIBUTOR IGNITION

COMPRESSION RATIO	FUEL	DISTRIBUTOR	DISTRIBUTOR TIMING
7.5 to 1	Gasoline	Delco Remy #1110616	5° BTDC
7.5 to 1	Gasoline	Delco Remy #1110629	TDC
7.5 to 1	Natural Gas	Delco Remy #1110629	10° BTDC
7.9 to 1 (TH570)	Gasoline	Delco Remy #1110629	7° ATDC
8.35 to 1	LPG	Delco Remy #1110622	2° BTDC
8.35 to 1	Natural Gas	Delco Remy #1110622	4° BTDC
8.35 to 1	Gasoline	Delco Remy #1110629	2° ATDC
8.35 to 1	LPG	Delco Remy #1110629	3° BTDC
8.35 to 1	Natural Gas	Delco Remy #1110629	6° BTDC
8.35 to 1	Gasoline	Delco Remy #1110616	3° BTDC
9.5 to 1	LPG	Delco Remy #1110629	2° ATDC
9.5 to 1	Natural Gas	Delco Remy #1110629	5° BTDC
10.0 to 1 (TH570)	Gasoline	Delco Remy #1110629	6° ATDC

MAGNETO IGNITION

COMPRESSION RATIO	FUEL	MAGNETO TIMING @ ENGINE RPM		
		1200-1600	1700-2000	2100-2400
7.5 to 1	Gasoline	18° BTDC	24° BTDC	30° BTDC
7.5 to 1	Natural Gas	35° BTDC	35° BTDC	40° BTDC
8.0 to 1	Natural Gas	30° BTDC	34° BTDC	38° BTDC
		1200-1800	2000-2200	2400-2600
8.35 to 1	Gasoline	18° BTDC	22° BTDC	25° BTDC
8.35 to 1	LPG	26° BTDC	29° BTDC	32° BTDC
8.35 to 1	Natural Gas	28° BTDC	31° BTDC	34° BTDC
9.5 to 1	LPG	21° BTDC	24° BTDC	24° BTDC
9.5 to 1	Natural Gas	28° BTDC	28° BTDC	32° BTDC

PISTON

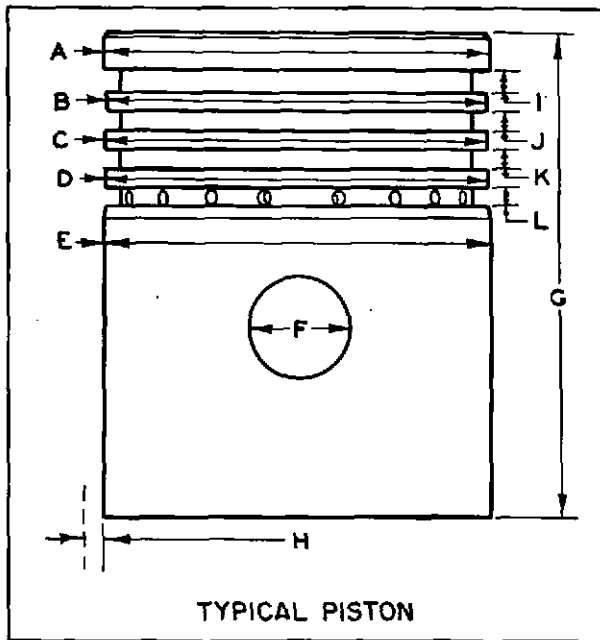

TYPICAL PISTON

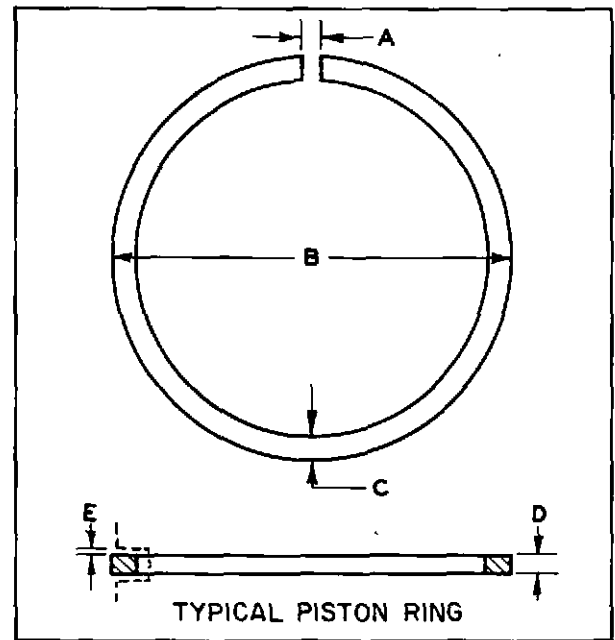

TYPICAL PISTON RING

Piston material	Aluminum alloy
Type	Cam ground
Pistons are removed from	Top of cylinders
Permissible weight variation (Piston & Pin).	1/2 ounce

PISTON LAND TO CYLINDER SLEEVE BORE CLEARANCE

	(Land dia.)	(Sleeve bore)	(Land to Bore Clearance)
(A) Top land	5.338"-5.342"	5.377"-5.378"	.035"-.040"
(B) 2nd land	5.338"-5.342"	5.377"-5.378"	.035"-.040"
(C) 3rd land	5.343"-5.347"	5.377"-5.378"	.030"-.035"
(D) 4th land	5.343"-5.347"	5.377"-5.378"	.030"-.035"
(E) Piston skirt diameter			5.3715"-5.3735"
(F) Piston pin hole diameter			1.4996"-1.4999"
(G) Piston length			6.0"
(H) Piston skirt to sleeve clearance0035"-.0065"

GROOVE WIDTH

(I)097"-.098"
(J)1265"-.1275"
(K)1265"-.1275"
(L)251"-.252"

PISTON RINGS

	Top ring	2nd ring	3rd ring	4th ring
Type	Compression, Plated	Compression	Compression	Oil Control
(A) Ring gap017"-.032"	.017"-.032"	.017"-.032"	.017"-.032"
(B) Ring dia.	5.375"	5.375"	5.375"	5.375"
(C) Ring wall208"-.218"	.195"-.205"	.195"-.205"	.208"-.218"
(D) Ring width0925"-.0935"	.1230"-.1240"	.1230"-.1240"	.2480"-.2490"
(E) Side clearance0035"-.0055"	.0025"-.0045"	.0025"-.0045"	.002"-.004"

WAUKESHA MODELS 570 AND 884

MAIN BEARINGS

Number	Five
Type	Precision
Material	Copper-lead, steel backed
Bearing wall1248"-.1253"
Thrust bearing width	1.649"-.1.651"
Thrust bearing flange131"-.133"
Adjustment	Precision-replace
Running clearance002"-.005"

CRANKSHAFT

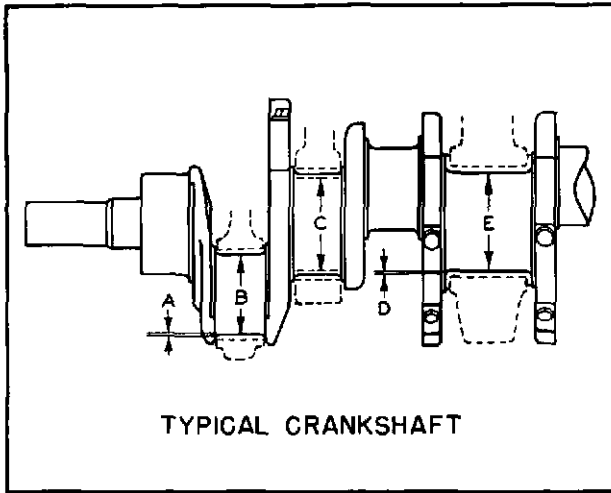

TYPICAL CRANKSHAFT

Crankshaft end play006"-.010"
End play adjustment	Main thrust bearing replacement
(A) Connecting rod bearing running clearance0019"-.0049"
(B) Connecting rod bearing journal diameter	3.2480"-.3.2490"
(C) Main bearing journal maximum undersize030"
(D) Main bearing running clearance002"-.005"
(E) Main bearing journal diameter	3.7480"-.3.7490"

OIL PUMP

Drive gear to pump body clearance002"-.005"
Pump gear end clearance0015"-.006"
Idler shaft end clearance	1/32"
Body bushing ream dia.5465"-.5485"
Cover bushing ream dia.5465"-.5485"
Pump gear end clearance0025"-.0065"
Pump gears to body clearance004"-.007"

CONNECTING ROD, BUSHING AND BEARING

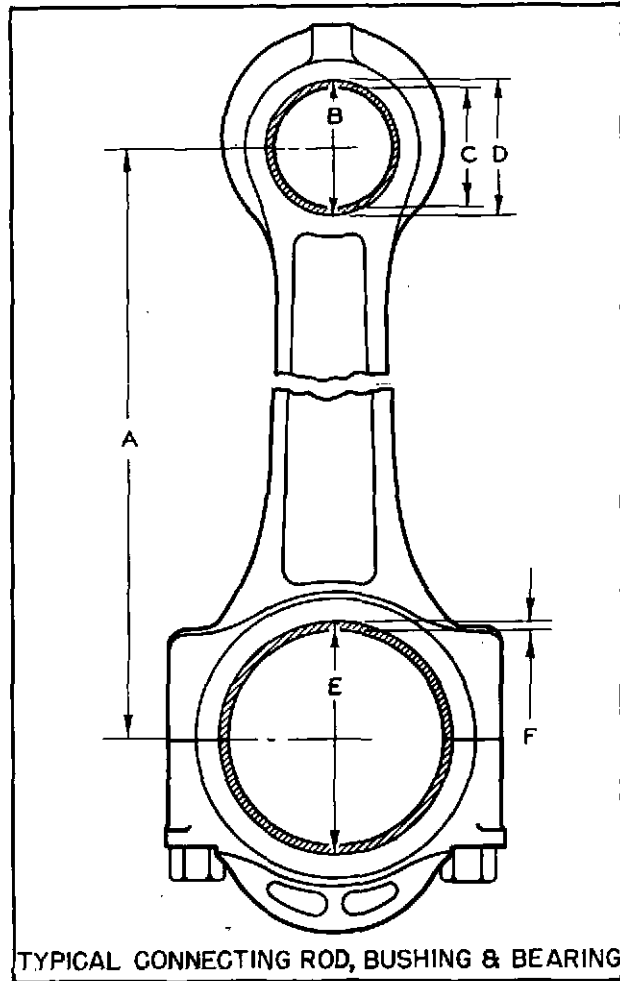

TYPICAL CONNECTING ROD, BUSHING & BEARING

Rod material	SAE 1040
Rods, permissible weight variation	3/8 ounce
Side play005"-.008"
(A) Rod length, center to center	9.748"-.9.752"
(B) Rod small end finish size	1.6870"-.1.6880"
(C) Bushing bore diameter	1.5002"-.1.5007"
(D) Bushing O. D.	1.691"-.1.693"
(E) Rod large end finish size	3.4415"-.3.4425"
(F) Bearing wall thickness0948"-.0.953"
Bearing running clearance0019"-.0049"
Rod bearing material	Copper lead, steel backed

CAMSHAFT

Camshaft bushing bore	2.2495"-.2.2505"
Camshaft bushing journal dia.	2.2470"-.2.2480"
Camshaft running clearance in bushings0015"-.0035"
Camshaft end play003"-.019"
Camshaft end play adjustment	Thrust button-replacement

VALVE PORT CLEARANCES

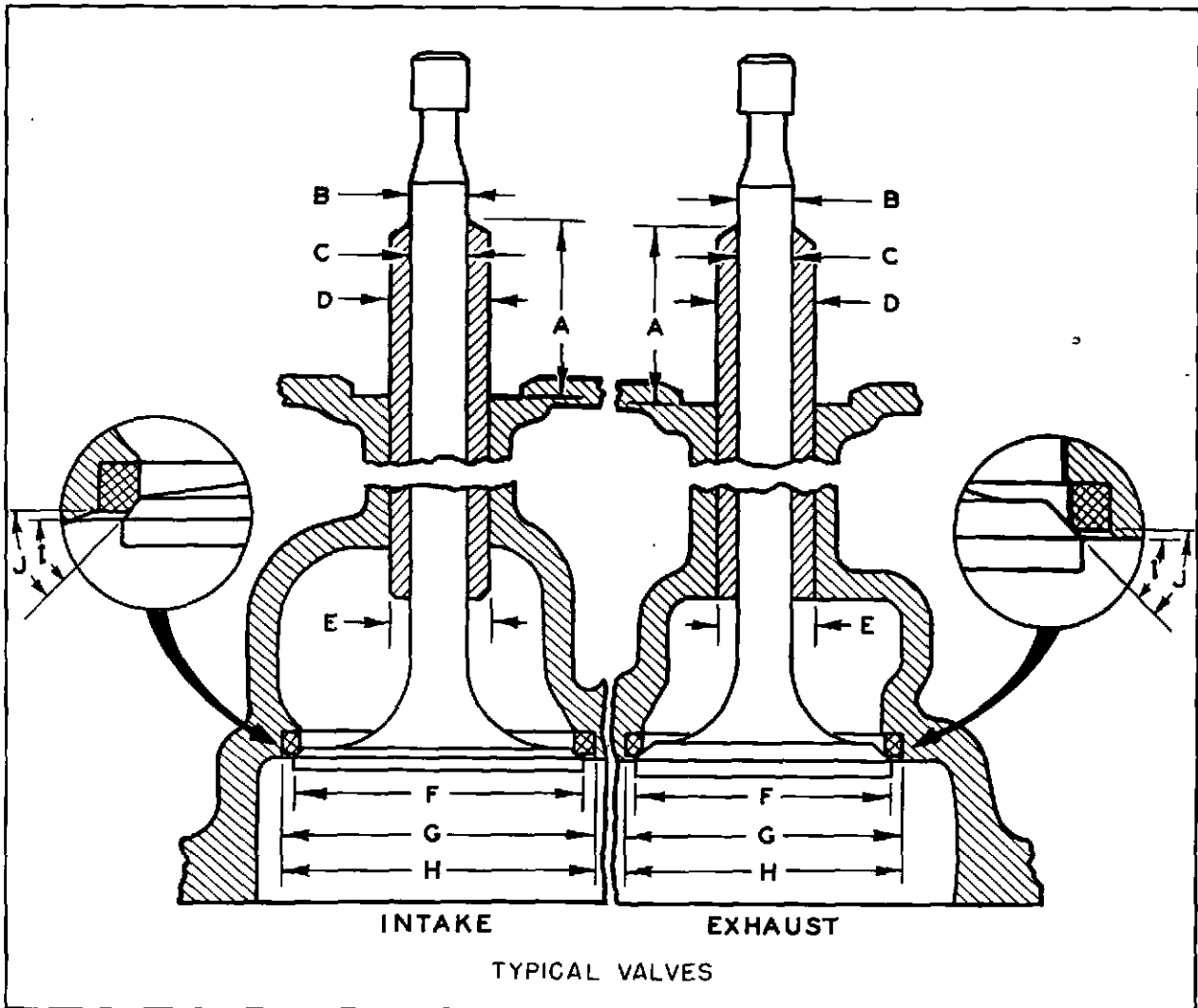

	INTAKE	EXHAUST
(A) Guide extends above block	1-3/8"	1-3/8"
(B) Valve stem dia.4345"-.4355"	.4335"-.4345"
(C) Guide I.D.4375"-.4385"	.4375"-.4385"
Clearance, stem to guide002"-.004"	.003"-.005"
(D) Guide O.D.7515"-.7521"	.7515"-.7521"
(E) Guide hole dia.7495"-.7505"	.7495"-.7505"
(F) Valve head dia.	2.253"-.2.263"	1.785"-.1.795"
(G) Insert O.D.	2.437"-.2.438"	1.9405"-.1.9415"
(H) Insert counterbore dia.	2.4335"-.2.4345"	1.937"-.1.938"
(I) Insert seat angle	45°	45°
(J) Valve seat angle	45°	45°
Insert seat width048"-.078"	.048"-.078"

PISTON PINS

Pin diameter	1.4994"-.1.4996"
Pin length	4.433"-.4.438"
Pin to rod bushing clearance0006"-.0013"
Piston pin fit.0000" to .0005" loose

VALVE TIMING

TIMING	INTAKE	EXHAUST
Valve opens	1° BTDC	37° BBDC
Valve closes	55° ABDC	19° ATDC

WAUKESHA MODELS 570 AND 884

VALVE CLEARANCE

(Adjust valves at normal room temperatures)

**VALVE CLEARANCE
COLD SETTING**

INTAKE **.015-.017"**

EXHAUST **.020-.022"**

WAUKESHA MOTOR CO.
WAUKESHA, WISCONSIN
U.S.A.

H884

**VALVE CLEARANCE
COLD SETTING**

INTAKE **.015-.017"**

EXHAUST **.020-.022"**

WAUKESHA MOTOR CO.
WAUKESHA, WISCONSIN
U.S.A.

TH884

SPARK PLUG

Type of service	Normal duty	Heavy duty
Spark plug gap . . .023"- .028"	. . .023"- .028"	
Champion J-6 J-6	
AC spark plug . . . C44XL C44XL	
Auto-Lite AG-4 AG-4	
Spark plug size . . .14 mm 14 mm	

SPARK ADVANCE RECOMMENDATIONS

DISTRIBUTOR IGNITION

Compression Ratio 7.6 to 1

FUEL	DISTRIBUTOR	DISTRIBUTOR TIMING
Gasoline	Delco Remy #1110616	4° BTDC
Gasoline-Natural gas	Delco Remy #1110629	3° BTDC
LPG	Delco Remy #1110629	2° BTDC
Natural gas	Delco Remy #1110629	8° BTDC
Gasoline	Delco Remy #1110629	2° ATDC
Gasoline (TH884)	Delco Remy #1111605	4° BTDC
Gasoline (TH884)	Delco Remy #1111643	4° BTDC
Gasoline (TH884)	Delco Remy #1111690	4° BTDC

Compression Ratio 9.0 to 1

FUEL	DISTRIBUTOR	DISTRIBUTOR TIMING
LPG	Delco Remy #1110629	1° ATDC
Natural Gas	Delco Remy #1110629	5° BTDC
Gasoline	Delco Remy #1110629	6° ATDC

MAGNETO IGNITION

Compression Ratio 7.6 to 1

FUEL	MAGNETO TIMING @ ENGINE RPM		
	1200-1600	1700-2000	2100-2400
Gasoline	16° BTDC	23° BTDC	28° BTDC
LPG	25° BTDC	27° BTDC	28° BTDC
Natural gas	31° BTDC	33° BTDC	35° BTDC

Compression Ratio 9.0 to 1

FUEL	MAGNETO TIMING @ ENGINE RPM		
	1200-1600	1700-2000	2100-2400
LPG	23° BTDC	25° BTDC	26° BTDC
Natural Gas	29° BTDC	31° BTDC	32° BTDC
Gasoline		(18° BTDC) (1800 rpm)	

WAUKESHA MOTOR COMPANY

STANDARD WARRANTY

(Effective May 1, 1971)

The Waukesha Motor Company (hereinafter called "Waukesha") warrants each new engine, power unit and part manufactured and sold by it (hereinafter collectively called "Products") to be free from defects in material and workmanship for a period which shall be the shorter of eighteen months from the date of shipment of the Product from the factory or twelve months from the commencement of the first use of the Product. Waukesha's sole obligation in the event of any such defect shall be to repair the Product at Waukesha's factories or through an authorized Waukesha Distributor, or, at Waukesha's option, to replace the Product, and, if such repair or replacement is requested prior to the expiration of six months from the date of first use (and within eighteen months of sale by Waukesha) of the Product, to bear the cost of labor required in connection with such repair or replacement.

No defect in material or workmanship shall be deemed to exist unless it is so determined by Waukesha upon inspection by Waukesha.

Waukesha's obligation pursuant to this Warranty shall be conditioned upon the return of the defective Product to Waukesha or an Authorized Waukesha Distributor, transportation to Waukesha or such Distributor, and return, prepaid.

Waukesha makes no warranty in respect to any product or trade accessory not manufactured by it, whether or not sold as a part of or with a Waukesha product. Such products and trade accessories are subject to the Warranties of their respective manufacturers.

The provisions of this Warranty do not apply to any Product which has been used for a purpose for which it is not designed, or which has been subject to misuse, negligence, alteration, or accident; nor does this Warranty cover normal maintenance service or engine tune up or the repair or replacement of parts when such repairs or replacements are made as part of normal maintenance service.

THIS WARRANTY IS THE ONLY WARRANTY APPLICABLE TO THE NEW WAUKESHA ENGINE AND IS EXPRESSLY IN LIEU OF ANY OTHER WARRANTIES, EXPRESSED OR IMPLIED, INCLUDING ANY IMPLIED WARRANTY OF MERCHANTABILITY OR FITNESS FOR A PARTICULAR PURPOSE. WAUKESHA'S SOLE RESPONSIBILITY SHALL BE FOR REPAIR OR REPLACEMENT PURSUANT TO THE ABOVE TERMS.

WAUKESHA SHALL IN NO EVENT BE LIABLE FOR CONSEQUENTIAL DAMAGES OR CONTINGENT LIABILITIES OF ANY KIND ARISING OUT OF THE FAILURE OF ANY ENGINE OR POWER UNIT OR PART TO OPERATE PROPERLY.

Waukesha Motor Company

DISTRIBUTORS AND SERVICE

The Waukesha Motor Company has established a system of distributors of unquestioned reputation with trained mechanics and full facilities for maintenance, rebuilding, and consultation, and to carry adequate parts stock in nearly every state of the Union and Canada as well as most Latin American and overseas countries. In addition, the Waukesha Motor Company owns and operates branch warehouses and servicing facilities in the Ridgewood, New Jersey; Tulsa, Oklahoma; Los Angeles, California; and Anchorage, Alaska areas, so that owners and operators are thus always within easy reach of a "Waukesha man".

Your service needs will be greatly facilitated whenever you have occasion to call upon either an Authorized Distributor, a Factory Branch, or the Factory Service Department if the following procedure is observed:

Give Engine Model Number Always specify size, model, and number of the engine, which is stamped on the nameplate attached to the fly-wheel housing. Be sure to give the number stamped after "SPEC" as "G20000", or whatever the number may be on the particular engine.

When Ordering parts Always furnish complete description and number, where known, of the part or parts wanted. Do not use the word "complete", state exactly each item that is wanted and do not designate the quantity by "sets"; mention how many parts are required.

Tell How to Ship and Where State whether to ship by freight, express or parcel post; furnish shipping point and post office address. Without specific shipping instructions the shipper will use his own discretion, and will not be responsible for any charges by so doing.

Mail Shipments Goods shipped by mail are entirely at customer's risk, unless cash or postage for insurance accompanies the order.

When shipping to Us Include a packing list, but mail the bill of lading or express receipt with a letter of advice. Do not enclose this letter with the shipment.

How to Mark Shipment to Us It is very important to have all shipments properly marked with the senders name and address, to insure prompt identification upon receipt. Always pre-pay the charges.

Terms on Repairs To avoid delay, all repairs will be sent C.O.D. unless cash accompanies the order. All prices quoted are f.o.b. Waukesha, Wisconsin.

How to Return Parts for Credit When returning parts for inspection and credit, (see Warranty, at back of this book), the engine number from which the parts were taken must be given and all transportation charges must be prepaid. Our receiving department is not authorized to accept "Collect" shipments.