

# TABLE OF CONTENTS

Section	Page
LIST OF ILLUSTRATIONS . . . . .	ii
LIST OF TABLES . . . . .	iv
<b>I GENERAL INFORMATION</b>	
1-1. General Description . . . . .	1-1
1-8. Specifications . . . . .	1-2
1-9. Safety Precautions . . . . .	1-3
<b>II OPERATION</b>	
2-1. New Equipment Service and Initial Starting . . . . .	2-1
2-2. Routine Starting . . . . .	2-2
2-3. Stopping . . . . .	2-2
2-4. Cold Weather Starting . . . . .	2-2
2-5. Operation . . . . .	2-2
2-6. High Altitude Operation . . . . .	2-3
2-7. Long-Term Storage . . . . .	2-3
<b>III LUBRICATION AND PREVENTIVE MAINTENANCE</b>	
3-1. Lubrication and Preventive Maintenance Schedule . . . . .	3-1
3-2. Air Cleaner . . . . .	3-1
3-3. Engine Oil and Filter . . . . .	3-1
3-4. Breather Cap . . . . .	3-3
3-5. Battery and Cables . . . . .	3-4
3-6. Valve Clearance Adjustment . . . . .	3-5
3-7. Compression Check . . . . .	3-5
3-8. Spark Plugs and Cables . . . . .	3-6
3-9. Distributor . . . . .	3-6
3-10. Magneto . . . . .	3-8
3-11. Carburetor . . . . .	3-9
3-12. Velocity Governor . . . . .	3-9
3-13. Mechanical Governor . . . . .	3-10
<b>IV TROUBLESHOOTING</b>	
4-1. General Information . . . . .	4-1
4-2. Troubleshooting Procedures . . . . .	4-1
<b>V ENGINE REPAIR AND OVERHAUL</b>	
5-1. General Information . . . . .	5-1
5-2. Engine Removal From Unit . . . . .	5-1
5-3. Lubrication System . . . . .	5-2
5-4. Oil Filter and Lines . . . . .	5-2
5-5. Oil Pan . . . . .	5-3
5-6. Oil Pump . . . . .	5-5
5-7. Cooling System . . . . .	5-7
5-8. Water Pump and Fan . . . . .	5-8
5-9. Thermostat . . . . .	5-10

## **TABLE OF CONTENTS (continued)**

Section		Page
5-10.	Fuel System . . . . .	5-11
5-11.	Fuel Pump . . . . .	5-11
5-12.	Fuel Filter . . . . .	5-12
5-13.	Carburetor . . . . .	5-13
5-14.	Mechanical Governor . . . . .	5-14
5-15.	Air Supply and Exhaust Systems . . . . .	5-15
5-16.	Air Cleaner . . . . .	5-15
5-17.	Intake Manifold . . . . .	5-17
5-18.	Exhaust Manifold . . . . .	5-17
5-19.	Electrical System . . . . .	5-18
5-20.	Starting Motor . . . . .	5-19
5-21.	Alternator and Regulator . . . . .	5-19
5-22.	Ignition System . . . . .	5-20
5-23.	Distributor and Ignition Coil . . . . .	5-21
5-24.	Magneto . . . . .	5-23
5-25.	Tachometer Drive . . . . .	5-24
5-26.	Rocker Arm Assembly . . . . .	5-25
5-27.	Cylinder Head . . . . .	5-27
5-28.	Valves . . . . .	5-30
5-29.	Flywheel . . . . .	5-32
5-30.	Bellhousing . . . . .	5-34
5-31.	Gear Housing and Cover . . . . .	5-35
5-32.	Camshaft . . . . .	5-38
5-33.	Pistons and Connecting Rods . . . . .	5-41
5-34.	Crankshaft and Main Bearings . . . . .	5-46
5-35.	Cylinder Block . . . . .	5-50
VI	TORQUE SPECIFICATIONS . . . . .	6-1
VII	FITS AND TOLERANCES . . . . .	7-1
	WARRANTY	

## **LIST OF ILLUSTRATIONS**

Figure	Title	Page
1-1.	Six-Cylinder Engine With Distributor Ignition, Right-Hand Side . . . . .	1-1
1-2.	Six-Cylinder Engine With Distributor Ignition, Left-Hand Side . . . . .	1-1
1-3.	Lubrication System . . . . .	2-4
3-1.	Checking Engine Oil Level . . . . .	3-1
3-2.	Valve Clearance Check and Adjustment . . . . .	3-5
3-3.	Spark Plug Cable Locations . . . . .	3-6
3-4.	Alternate Timing Locations . . . . .	3-8
3-5.	Standardized Timing Marks . . . . .	3-8
3-6.	Governor Adjustment Points . . . . .	3-11
5-1.	Engine Lubricating System External Connection Diagram . . . . .	5-2
5-2.	Typical Oil Filter and Lines, Exploded View . . . . .	5-3
5-3.	Typical Oil Pan and Adapters, Exploded View . . . . .	5-4
5-4.	Oil Pump, Exploded View . . . . .	5-5
5-5.	Oil Pump Drive Gear Installation Dimensions . . . . .	5-6

## LIST OF ILLUSTRATIONS (continued)

Figure	Title	Page
5-6.	Oil Pump Alignment at Installation . . . . .	5-6
5-7.	Oil Pressure Regulator Installation . . . . .	5-7
5-8.	Water Pump and Fan, Exploded View . . . . .	5-9
5-9.	Water Pump Impeller Installation Dimensions . . . . .	5-10
5-10.	Fuel System, Exploded View . . . . .	5-12
5-11.	Governor Gear Installation Dimension . . . . .	5-15
5-12.	Typical Air Intake System, Exploded View . . . . .	5-16
5-13.	Muffler and Exhaust Manifold, Exploded View . . . . .	5-17
5-14.	Electrical System and Ignition System Schematic Diagrams . . . . .	5-18
5-15.	Distributor Ignition System, Exploded View . . . . .	5-22
5-16.	Distributor Coupling Installation . . . . .	5-22
5-17.	Magneto Ignition System, Exploded View . . . . .	5-23
5-18.	Magneto Gear Installation . . . . .	5-24
5-19.	Rocker Arm, Cylinder Head, and Valve Assemblies, Exploded View . . . . .	5-26
5-20.	Rocker Arm Shaft Showing Spacer Positions for Engines Having Identically Sized Shaft Supports . . . . .	5-27
5-21.	Rocker Arm Shaft Showing Oil Hole Positions . . . . .	5-28
5-22.	Rocker Arm Shaft Support Installation for Engines Having Variable Sized Supports . . . . .	5-28
5-23.	Cylinder Head Nut Tightening Sequence and Torque Values . . . . .	5-29
5-24.	Valve Guide Installation . . . . .	5-30
5-25.	Valve Reseating Dimensions . . . . .	5-31
5-26.	Flywheel and Bellhousing Assembly, Exploded View . . . . .	5-33
5-27.	Indicating Flywheel Pilot Bore . . . . .	5-34
5-28.	Indicating Flywheel Face . . . . .	5-34
5-29.	Rear Cam Thrust Plate Plug . . . . .	5-35
5-30.	Gear Housing and Gears, Exploded View . . . . .	5-36
5-31.	Aligning Camshaft and Crankshaft Gear Timing Marks . . . . .	5-37
5-32.	Valve Tappet Positioned for Camshaft Removal . . . . .	5-38
5-33.	Thrust Plate Mounting Bolt Removal . . . . .	5-38
5-34.	Camshaft and Thrust Plate Removal . . . . .	5-38
5-35.	Cylinder Block, Exploded View . . . . .	5-40
5-36.	Measuring Camshaft End Play . . . . .	5-41
5-37.	Piston and Connecting Rod, Exploded View . . . . .	5-42
5-38.	Piston and Connecting Rod Removal . . . . .	5-42
5-39.	Piston Ring Shapes and Installation . . . . .	5-44
5-40.	Piston Installation . . . . .	5-44
5-41.	Checking Bearing Clearance . . . . .	5-45
5-42.	Crankshaft and Main Bearings . . . . .	5-46
5-43.	Upper Main Bearing Removal and Installation . . . . .	5-46
5-44.	Tightening Main Bearing Cap Bolts . . . . .	5-49
5-45.	Checking Crankshaft End Thrust . . . . .	5-49

---

## **LIST OF TABLES**

Table	Title	Page
1-1.	Specifications . . . . .	1-2
3-1.	Lubrication and Preventive Maintenance Schedule . . . . .	3-2
3-2.	Recommended Lubricating Oil Specifications . . . . .	3-3
3-3.	Crankcase Oil Capacities . . . . .	3-4
3-4.	Ignition Specifications . . . . .	3-7
4-1.	Troubleshooting Chart . . . . .	4-2
5-1.	Piston and Bore Sizes . . . . .	5-43
5-2.	Crankshaft Main and Connecting Rod Journal Dimensions . . . . .	5-48
5-3.	Main Bearing Cap Bolt Torques . . . . .	5-49
5-4.	Cylinder Bore Dimensions . . . . .	5-51
5-5.	Cylinder Stud Installation . . . . .	5-52
6-1.	Torque Specifications . . . . .	6-1

## SECTION I GENERAL INFORMATION

### 1-1. GENERAL DESCRIPTION.

1-2. This manual contains instructions for operation, maintenance, troubleshooting, and overhaul of White G-Series Gasoline Engines (figures 1-1 and 1-2), manufactured by White Engines, Inc., Canton, Ohio.

1-3. The G-Series gasoline engine includes four- and six-cylinder models. The engines are all overhead-valve, four-cycle, heavy-duty commercial types, incorporating either distributor or magneto ignition. Since the instructions are the same or very similar for all models, all are covered in this manual.

1-4. These engines are used in many different applications with different accessories. This manual is designed for service personnel who overhaul the engines and components supplied as part of the engine only. The instructions cover the essential operations necessary to disassemble, inspect, repair, assemble, and test the engine. Brief instructions for the operation and maintenance of the engines are also given.

1-5. All locations given as right-hand or left-hand refer to the observer's position when facing the flywheel or clutch. The camshaft, oil pump, fuel pump, and distributor or magneto may be mounted on either the right-hand or left-hand side of the engine block, depending on the application. The front of the engine is the timing gear end, regardless of the cylinder block position. The flywheel and clutch end is the rear of

the engine. When reference is made to No. 1 cylinder or front main bearing, it is always the one nearest the timing gears. Cylinders, connecting rods, and main bearing caps are numbered from the front or timing gear end and are stamped on the camshaft side of the engine.

### NOTE

All illustrations in this manual depict typical assemblies and installations, unless otherwise indicated. The pictured engine may not be exactly the same as your engine, but the same principles will apply. Engine illustrations apply to both four- and six-cylinder engines unless otherwise noted. Right-hand and left-hand camshaft installations are mirror images of each other.

1-6. Where necessary to refer to accessories and components not furnished with the White engine, information and comments given are general and may not apply to the specific accessory and application where used. If additional information about the various accessories is desired, a letter should be directed to the specific manufacturer.

1-7. Should you have a particular problem not covered in this book, we invite you to write to White Engines, Inc., Service Department, Canton, Ohio, U.S.A., whose experienced personnel will be pleased to assist you.

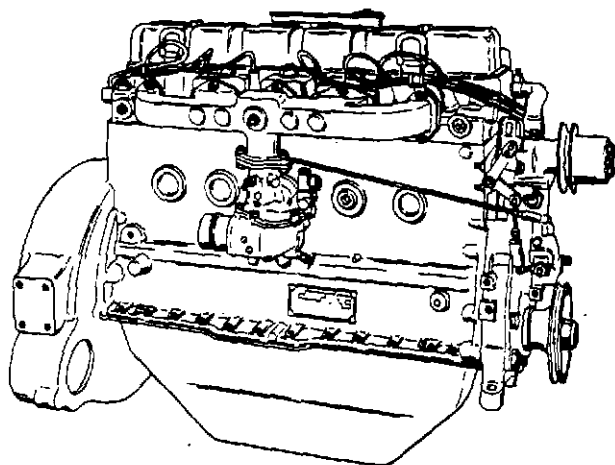

Figure 1-1. Six-Cylinder Engine With Distributor Ignition, Right-Hand Side

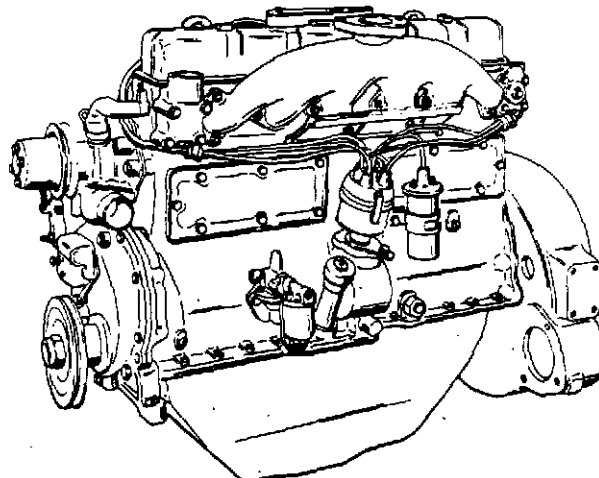

Figure 1-2. Six-Cylinder Engine With Distributor Ignition, Left-Hand Side

1-8. SPECIFICATIONS.

Specifications for the G-Series gasoline engines are given in table 1-1.

Table 1-1. Specifications

(Also see Fits and Tolerances, Section VII)

<u>Model</u>	<u>No. Cyl.</u>	<u>Bore and Stroke</u>	
G-2000 . . . . .	4	3-3/4 x 4-1/2 in.	
G-2300 . . . . .	4	4 x 4-1/2 in.	
G-3000 . . . . .	6	3-3/4 x 4-1/2 in.	
G-3400 . . . . .	6	4 x 4-1/2 in.	

MAIN BEARINGS			
	<u>Four Cylinder</u>	<u>Six Cylinder</u>	
Number of bearings . . . . .	5	7	
Bearing diameter (main) . . . . .	2-7/8 in. (73.0 mm)	2-7/8 in. (73.0 mm)	
Bearing length (front) . . . . .	1-1/32 in. (26.2 mm)	1-1/32 in. (26.2 mm)	
Bearing length (center) . . . . .	2-1/8 in. (54.0 mm)	2-1/8 in. (54.0 mm)	
Bearing length (rear) . . . . .	1-1/32 in. (26.2 mm)	1-1/32 in. (26.2 mm)	
Bearing length (intermediate) . . . . .	1-1/32 in. (26.2 mm)	1-1/32 in. (26.2 mm)	

CAMSHAFT BEARING			
	<u>Four Cylinder</u>	<u>Six Cylinder</u>	
Number of bearings . . . . .	4	4	
Bearing diameter . . . . .	2-1/16 in. (52.4 mm)	2-1/16 in. (52.4 mm)	
Bearing length (front) . . . . .	1-1/16 in. (27.0 mm)	1-1/16 in. (27.0 mm)	
Bearing length (intermediate) . . . . .	13/16 in. (20.6 mm)	13/16 in. (20.6 mm)	
Bearing length (rear) . . . . .	1-1/16 in. (27.0 mm)	1-1/16 in. (27.0 mm)	

CONNECTING ROD			
	<u>Four Cylinder</u>	<u>Six Cylinder</u>	
Bearing diameter . . . . .	2-3/8 in. (60.32 mm)	2-3/8 in. (60.32 mm)	
Bearing length . . . . .	1-11/64 in. (29.8 mm)	1-11/64 in. (29.8 mm)	
Rod length (C to C) . . . . .	8 in. (203.2 mm)	8 in. (203.2 mm)	

## GENERAL INFORMATION

Table 1-1. Specifications (Continued)

(Also see Fits and Tolerances, Section VII)

GENERAL DATA		
Cooling	Belt driven centrifugal pump	
Water pump - fan assembly	Mounted on front of cylinder block	
Method of suspension	3 or 4 Point	
Flywheel	For any standard clutch	
Serial number location	Stamped near top center of cylinder block, exhaust side	
Firing order		
Four cylinder	1-2-4-3	
Six cylinder	1-5-3-6-2-4	
Valve clearance		
Hot	0.015 inch	
Cold	0.016 to 0.017 inch	
BATTERY REQUIREMENTS (12 VOLT)		
	Four Cylinder	Six Cylinder
Cranking watts at 0°F	2400	2650
Plates per cell	11	13
Battery group (typical)		
B.C.I. system	24	24
SAE system	9 MJ3	9 MJ3
FUEL REQUIREMENTS		
Gasoline	Leaded, unleaded, low-lead; 85 octane rating, motor method	
L.P.G., Natural gas	Consult White Engines for requirements	

### 1-9. SAFETY PRECAUTIONS.

Observe all normal safety precautions during the operation, overhaul, and testing of the engine. These precautions include the following:

a. Do not operate the engine indoors without providing adequate measures to remove the exhaust gases from the enclosure. This can be done by piping exhaust gases to the outside. Exhaust gases contain carbon monoxide — a colorless, odorless, deadly poisonous gas.

b. Provide adequate ventilation when using cleaning solvents or other chemicals. Repeated or prolonged inhalation of solvent fumes can cause illness or death.

c. Use protective goggles, gloves, and other clothing when using solvents and chemicals. Prolonged or repeated exposure of the skin to chemicals can cause illness or death. If solvents are accidentally splashed onto the skin, wash the area immediately with soap and warm water.

d. Do not use gasoline or other highly flammable solutions for cleaning parts. When using Diesel fuel or kerosene, take care to avoid sparks or open flame in the cleaning area.

e. Do not use compressed air for blowing dirt from clothing or from the skin. Compressed air can enter body openings and cause severe injury or death.

f. Unless it is absolutely necessary to make adjustments while the engine is in operation, shut off the engine before performing any adjustments or other corrective actions.

g. Always disconnect the positive battery cable from the battery before removing the engine electrical components or leads.

h. Remove rings, ties, watches, identification bracelets, and other jewelry while working on the equipment.

## OPERATION

### SECTION II OPERATION

#### 2-1. NEW EQUIPMENT SERVICE AND INITIAL STARTING.

To start the engine for the first time or after a long period of shutdown, proceed as follows:

a. Perform a visual inspection of the engine to make sure there are no loose bolts, nuts, and screws.

#### CAUTION

Check that no loose bars, tools, and parts are lying in or on any part of the engine when starting. They could cause serious damage to the engine or bodily injury to nearby personnel.

b. Remove all plugs, caps, covers, and tape from all openings of the engine, fuel tank, and electrical equipment. Do not overlook the exhaust pipe and intake openings.

c. Check the entire electrical system to be sure there are no loose connections and all component parts are securely mounted. Refer to the installation wiring diagram, or see figure 5-14.

d. Check the lubrication of all accessories. Check the air cleaners to make sure they are not obstructed, and that they are clean and properly installed.

e. Fill the cooling system with clean water and rust inhibitor or, if the engine will be subjected to ambient air temperatures below freezing, use an antifreeze solution.

f. Remove any paper that was inserted between the pulleys and the belts to prevent belt sticking. Adjust fan belt tension by positioning the alternator so that the fan belts can be deflected approximately 3/4 inch per foot of belt span when thumb pressure is applied at midpoint of the belt. Tighten alternator mounting screws.

g. Drain all preservative oil from the fuel system. Open the drain on the bottom of the bowl of the fuel strainer (if provided) and allow all water and sediment in the bowl to drain. Close the fuel bowl drain, and check that the carburetor drain is closed. Check all fuel supply

lines from the fuel tank to the fuel pump to make sure the connections are tight and the lines are open with no obstructions or kinks.

h. Fill the fuel tank with gasoline having an octane rating of 85 minimum as measured by the motor method. Leaded or unleaded fuel can be used.

i. Drain the crankcase, replace the oil filter element, and fill to the FULL mark on the oil level bayonet gauge, using lubricating oil recommended in Table 3-2, Recommended Lubricating Oil Specifications. Add 1 quart of oil to compensate for the filter.

j. Tag and disconnect the spark plug wires and remove the spark plugs from the cylinder head. Squirt about a teaspoon of engine oil into each spark plug hole. Use the engine starter to turn the engine over until the oil pressure gauge on the instrument panel reads about 10 psi. This will ensure that the bearings and cylinder walls are adequately lubricated before a load is applied. If the engine is equipped with a mechanical fuel pump, this amount of cranking should also adequately prime the fuel system.

k. Reinstall the spark plugs and connect the spark plug cables. If there is any doubt about cable location, refer to figure 3-3 for instructions.

l. If the engine is equipped with a manual choke, pull out the choke control lever to close the choke. Open the throttle about half way.

#### NOTE

If the ambient air temperature is less than 32°F, refer to the cold weather starting instructions in paragraph 2-4.

#### CAUTION

Do not crank the engine for more than 15 seconds at a time. Allow the starting motor to cool for 1 minute between periods of cranking.

m. Turn the ignition switch ON. Operate the ignition switch or start switch to crank the engine. It should start almost at once. If the engine does not start after two or three attempts, refer to Section IV, Troubleshooting.

n. Once the engine has started, open the manual choke slightly until the engine runs smoothly. With an automatic choke, this function is performed by manifold vacuum. Continue to open the choke in small increments as the engine warms up. The choke should be fully open by the time the engine reaches normal operating temperature.

o. To ensure proper lubrication and extend engine life, allow the engine to run for several minutes before applying a load.

## 2-2. ROUTINE STARTING.

If the engine has been operating recently and components have not been removed or repaired since it last operated, proceed as follows:

- a. Check that there is an adequate fuel supply.
- b. Check the lubricating oil level in the engine with the oil level bayonet gauge. Be sure the oil level is above the ADD mark on the gauge.
- c. Check for proper level of coolant solution in the radiator.
- d. Inspect the installation to see that all is secure and in good order, and that no loose tools, bars, or parts are lying on the engine.

### NOTE

If the ambient temperature is less than 32°F, refer to paragraph 2-4 for cold weather starting instructions.

- e. Pull out the choke control lever to close the manual choke. An automatic choke closes itself. Open the throttle about one-fourth of the way.
- f. Turn the ignition switch to ON. Operate the ignition switch or start switch to crank the engine and start it.

### CAUTION

Do not crank the engine for more than 15 seconds at a time. Allow the starting motor to cool for 1 minute between cranking intervals.

g. When the engine starts, open the manual choke slightly until the engine runs smoothly. Continue to open the choke in small increments as the engine warms up. The choke should be

fully open by the time the engine reaches normal operating temperature. Opening of the automatic choke is controlled by an electric heating element and manifold vacuum.

## 2-3. STOPPING.

a. If the engine has been running hard, allow internal engine temperatures to equalize by idling the engine for several minutes. This will minimize the danger of warping or cracking the cylinder head or block.

b. Turn the ignition switch to OFF to stop the engine.

c. If the ambient temperature is below freezing, and no antifreeze solution is used, the complete cooling system must be drained. This includes the cylinder block, water pump, radiator, and all hoses.

d. If antifreeze solution is used, check the solution with a hydrometer to make sure it is the strength recommended to provide protection below the lowest expected temperature.

## 2-4. COLD WEATHER STARTING.

a. Check that the engine coolant has sufficient antifreeze to prevent freezing at the lowest temperature expected.

b. Refer to Table 3-2, Lubricating Oil Specifications, to select the correct grade of engine oil. An oil that is too heavy for the temperature will prevent the starting motor from cranking the engine at the required speed.

c. Keep the fuel tank filled to reduce the amount of moisture which condenses in the fuel tank. If water contamination of the fuel is suspected, treat the fuel with a commercial gas line antifreeze or gasoline dryer. Frequently drain water from the fuel pump fuel bowl, if equipped, and from the carburetor float bowl.

d. Check that the batteries are fully charged and that all electrical connections are clean and tight.

e. After starting, open the choke more slowly in cold weather. If the choke is opened too rapidly, the engine will stumble or hesitate when the throttle is opened.

## 2-5. OPERATION.

After the engine has started, make a thorough inspection of the engine unit to ensure that all

## OPERATION

parts are functioning properly. Proceed as follows:

a. Look at the oil pressure gauge. If insufficient pressure shows after the engine has run 10 or 12 seconds, shut down the engine and determine the trouble. With bearings in good condition and the proper grade of oil being used, normal pressure should be 40 to 60 psi at operating temperature (170°F) and full engine speed. If the oil is very cold or heavy, this pressure may be much higher. As the oil heats, the pressure will diminish.

b. Check the coolant temperature; if it exceeds 200°F, shut down the engine and determine the cause. Never operate the engine with the water at boiling temperature. This excessive heat on the cylinder walls will break down the oil film, causing rapid engine wear. Rapid coolant loss will also result due to steaming.

c. Check ammeter charging rate. The ammeter should indicate a charge immediately after starting and should drop to near zero as the battery becomes fully charged. If the ammeter does not indicate proper operation, stop the engine and thoroughly check the engine charging system.

d. Check the engine for smooth, quiet operation and for proper exhaust condition. A cold engine may run erratically because a cylinder or two is firing irregularly. As the engine begins to warm up, however, all cylinders should fire regularly.

e. If rough operation continues, refer to Section IV, Troubleshooting.

### 2-6. HIGH ALTITUDE OPERATION.

a. At altitudes above 3000 feet, lower atmospheric pressure reduces engine efficiency and upsets the calibration of the carburetor. Make sure that the engine is properly tuned to reduce power loss at high altitude.

b. For additional information on specific cases, write to White Engines, Inc., Service Department, Canton, Ohio, giving as much information as possible. For recommended modifications to the carburetor, contact the carburetor manufacturer.

### 2-7. LONG-TERM STORAGE.

If the engine is to be idle for a month or more, take special precautions as follows to prepare the engine so that rust will not form on the wearing surfaces or in the fuel system.

a. Engines which have been operating on leaded gasoline should be run on unleaded gasoline for at least 10 minutes in addition to the time it takes to run out the leaded gasoline in the fuel lines and carburetor.

b. Continue to operate the engine until it reaches normal operating temperature. Stop the engine and drain all oil from the oil pan. Replace the oil filter.

c. Refill the crankcase to the FULL mark on the bayonet gauge (figure 3-1) with a preservative lubricating oil meeting requirements of MIL-L-21260 (Gulf No-Rust Engine Oil, Grade No. 1 or 2; Shell Ensis MIL-L-21260, Code 66200 or Code 66202; or equivalent). Use SAE10 or SAE30, whichever viscosity is necessary to suit the climatic conditions.

#### NOTE

It is recommended that preservative oil be used when the end unit is to be shipped with lubricating oil in the engine.

d. Remove the spark plugs. Fill a pump-type oil can with the preservative oil specified above and squirt about a teaspoon of preservative oil into each cylinder. Reinstall the spark plugs.

#### CAUTION

Do not use too much oil. Excess oil in the cylinders can damage the engine when restarting.

e. Remove the cylinder head cover and side covers. Squirt or spray the pushrods, valve stems, tappets, and rocker arms thoroughly with preservative lubricating oil. Reinstall the covers, making sure the gaskets are in good condition.

f. If the engine cooling system has not been winterized and/or rust treated, it should be flushed thoroughly with a water-soluble oil or other rust inhibitor to prevent rust formation.

g. Disconnect the battery cables. Remove the batteries and store them, preferably where they can be recharged periodically since batteries tend to lose their charge when not in use.

h. Clean the entire engine exterior, except electrical system, with Diesel fuel oil or kerosene.

i. Release the fan belt(s) tension while the engine is in storage. Heavy paper strips inserted

between the pulleys and belt(s) will prevent belt sticking.

j. Cover ends of the exhaust pipe and air inlets with waterproof and vaporproof material so that moisture cannot reach the valve parts and cylinders. Store the engine where it will not be exposed to the elements, and preferably where it will be kept warm and dry. Moisture absorbing chemicals are available commercially for use when excessive dampness prevails in the storage area.

k. Coat unpainted exterior and interior surfaces of the air cleaner with preservative lubrication.

lating oil. If engines are stored with the clutch removed, coat the clutch contact surfaces, ring gear, and flywheel with oil. Rust-proof all accessories, such as air compressor and governor.

l. Periodically rotate the crankshaft while the engine is in storage. One-half turn every two weeks should suffice.

m. Periodically inspect the stored engine. Should there be any indication of rust or corrosion, take corrective steps at once to prevent damage to engine parts.

### 1-3. LUBRICATION SYSTEM.

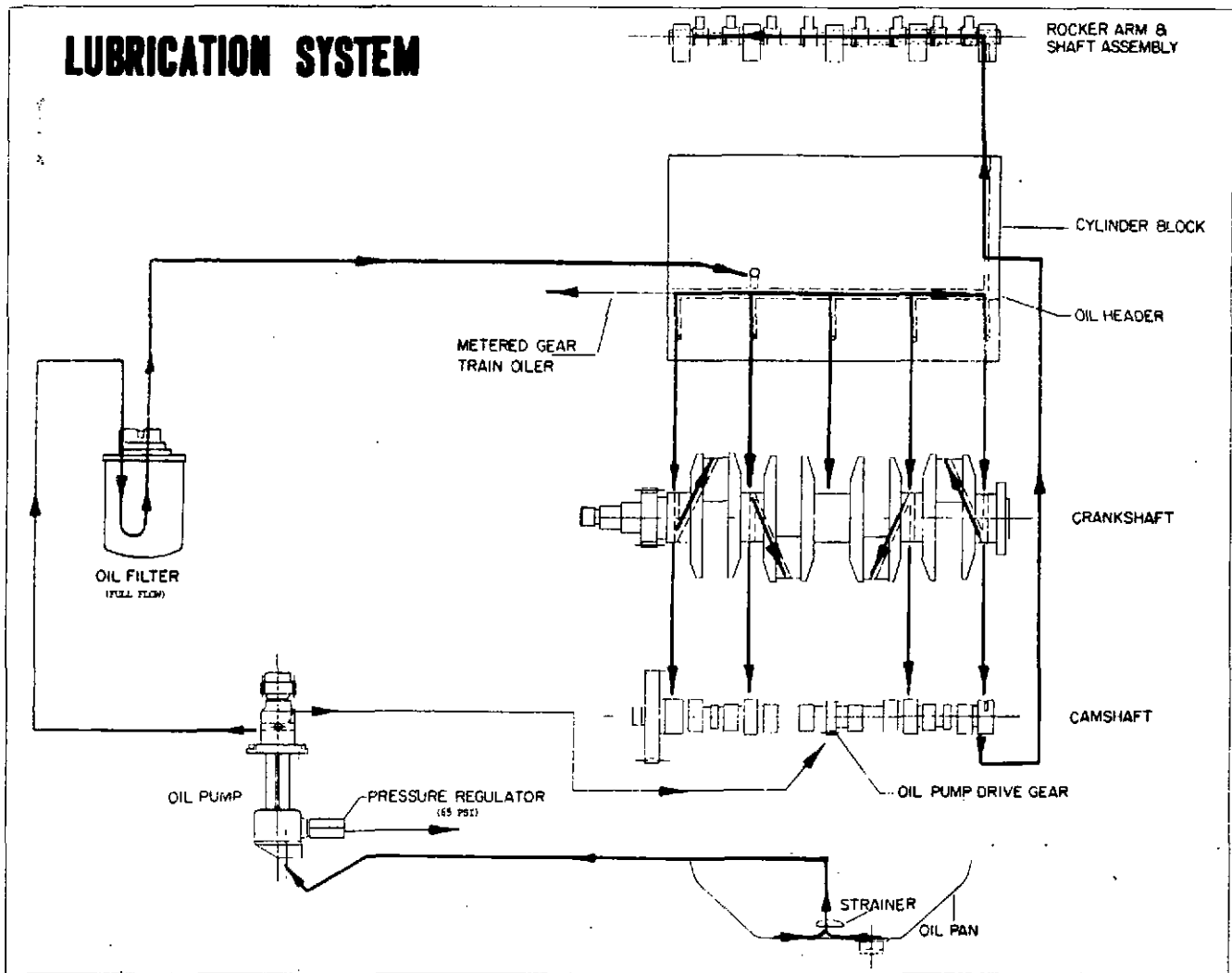

## SECTION III LUBRICATION AND PREVENTIVE MAINTENANCE

### 3-1. LUBRICATION AND PREVENTIVE MAINTENANCE SCHEDULE.

To obtain long life and maximum efficiency from your White gasoline engine, set up and follow a definite maintenance program. Table 3-1, Lubrication and Preventive Maintenance Schedule, provides a recommended maintenance schedule which may be altered for a specific application or to fit into the user's own preventive maintenance program.

The daily instructions pertain to routine starting of the engine and not to a new or reconditioned engine or one that has been in storage. For a new or stored engine, follow instructions given in paragraph 2-1, New Equipment Service and Initial Starting.

The time intervals of 50, 100, and 500 hours given in table 3-1 are actual operating hours of the engine. For engines used in road vehicles, the corresponding mileages — 1500, 3000, and 12,000 miles — are also given.

Table 3-1 indicates the items which must be serviced and the required interval of service. The remaining paragraphs in this section contain instructions for performing the indicated maintenance procedures, and normal and frequently performed checks and adjustments.

### 3-2. AIR CLEANER.

Several varieties of air cleaners are used on White engines. All are dry-type. Use the following as a guide for servicing air cleaners.

a. Under normal conditions, the dry-type air cleaners require servicing every 50 hours of operation. However, under extremely dusty conditions, the air cleaner must be cleaned daily. Remove the filter element from the air cleaner and clean by blowing compressed air through the element from the inside out. Do not apply air closer than 2 inches and do not use more than 50 psi pressure. Move the air jet up and down the filter, slowly rotating the element, until no more dust is removed. The element can be effectively cleaned only a few times, after which the element must be replaced.

b. Inspect all hoses, clamps, and connections between air cleaner and engine. Tighten loose clamps and replace damaged hoses promptly.

All connections between air cleaner and intake manifold must be air-tight.

### 3-3. ENGINE OIL AND FILTER.

a. Frequency of oil changes depends on the application of the engine and the type of operation. An extremely clean operation could go 150 hours while a dusty operation could require service in 50 hours or less. It is recommended that new or reconditioned engines be started with 50-hour oil change periods. Under normal operating conditions, the change interval can be gradually increased to 100 hours.

b. Drain the oil after the engine has been operating and while the oil is hot. Remove the drain plug from the oil pan and drain the oil into a suitable container. Select the proper grade of oil in accordance with table 3-2. Reinstall the oil drain plug and gasket and fill the crankcase to the FULL mark on the bayonet gauge. The engine oil capacities vary with the different sizes of oil pans available. Refer to Table 3-3, Crankcase Oil Capacities.

c. At every oil change, replace the oil filter.

1. If a full-flow, spin-on filter is used, remove and discard the old filter. Apply a thin coat of engine oil to the rubber gasket on the

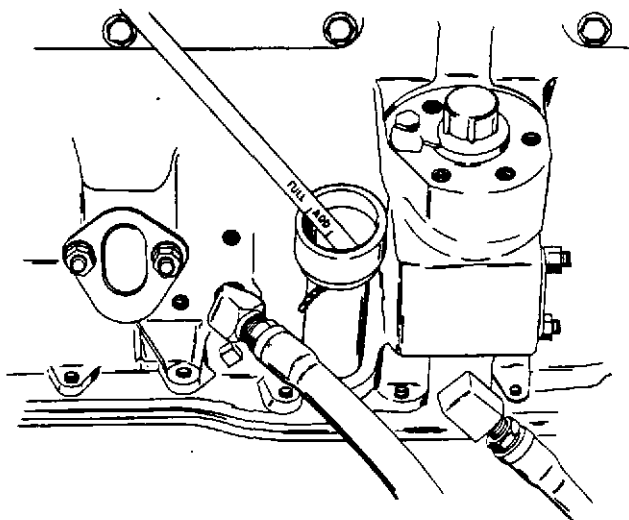

Figure 3-1. Checking Engine Oil Level

Table 3-1. Lubrication and Preventive Maintenance Schedule

Operation	Hours Miles	Time Interval				Remarks
		8 Daily	50 1500	100 3000	500 12,000	
Lubrication system Engine oil		*				Check level and refill (see table 3-2).
Oil filter				*	*	Change oil (para 3-3). Replace at every oil change (para 3-3c).
Cooling system Coolant		*				Check level daily.
Radiator			*			Remove dirt and debris from radiator fins; check for leaks.
Water pump						Inspect and lubricate at engine overhaul.
Hoses					*	Inspect for leaks, cracks, and deterioration.
Fuel system Fuel bowl			*			Clean fuel, water, and sediment from bowl (if equipped).
Carburetor					*	Adjust as required (para 3-11); service according to manufacturer's instructions.
Governor					*	Adjust as required (para 3-12 or 3-13); service according to manufacturer's instructions.
Fuel tank					*	Drain accumulated water and sediment from tank.
Air system Air cleaner		*	*			Service air cleaner (para 3-2); service daily in dusty conditions.
Crankcase breather			*			Clean breather cap (para 3-4).
Electrical system Starting motor				*		Lubricate with engine oil at oil cups (if equipped); service according to manufacturer's instructions.
Alternator				*	*	Adjust belt tension. Inspect for loose or broken wires and other damage; service according to manufacturer's instructions.
Battery			*		*	Check electrolyte level; refill with distilled or mineral-free water. Clean battery, cables, and terminals (para 3-5).

# LUBRICATION AND PREVENTIVE MAINTENANCE

Table 3-1. Lubrication and Preventive Maintenance Schedule (Continued)

Operation	Hours Miles	Time Interval				Remarks
		8 Daily	50 1500	100 3000	500 12,000	
Ignition system Distributor					*	Inspect, adjust, and set timing (para 3-9).
Magneto					*	Inspect, adjust, and set timing (para 3-10).
Spark plugs					*	Inspect and clean or replace spark plugs (para 3-8).
Miscellaneous General condition		*				Inspect for loose wires, leaking fuel or coolant lines, and loose mounting hardware.
Drive belts			*			Adjust belts to deflect 3/4 inch under thumb pressure midway between pulleys. Retighten new belts after 2 hours of operation.
Engine compression					*	Check compression (para 3-7).
Valve clearance					*	Check and adjust valve clearance (para 3-6).

\* Indicates that service or inspection is required.

new filter and screw it onto the adapter. Tighten the filter approximately one-half turn after the gasket contacts the adapter base.

2. If a filter with element is used, unscrew the bolt on the housing cap and remove the cap and gasket. Pull out and discard the old element, and wipe out the filter housing with a clean cloth. Install the new element in the housing. Install the gasket in the cover and secure the cover to the housing with the bolt provided. Check that the cover sits squarely on the housing.

3. Add one extra quart of oil when refilling the crankcase to compensate for the oil contained in the filter. Check for oil leaks after starting the engine.

### 3-4. BREATHER CAP.

a. Remove and clean the breather cap at every oil change. Clean the breather cap by immersing in Diesel fuel oil or solvent. Thoroughly drain all oil or solvent and use compressed air to blow out the cap. Reinstall the cap on the cylinder head cover.

Table 3-2. Recommended Lubricating Oil Specifications

Ambient Air Temperature	Viscosity Grade
-10°F to 30°F	10W
30°F to 60°F	20 - 20W
40°F and up	30
API classification . . . . . SD or SE	
NOTES:	
<p>1. Oil should meet MIL-L-2104B or MIL-L-45199A specifications. Engines may run on a good MIL-L-2104B oil, but the series 3 (MIL-L-45199A) oil gives longer service and increases engine life.</p> <p>2. For breaking in a new or reconditioned engine, use non-detergent oil. Drain after the first 40 hours (1500 miles) and refill with detergent oil.</p>	

Table 3-3. Crankcase Oil Capacities

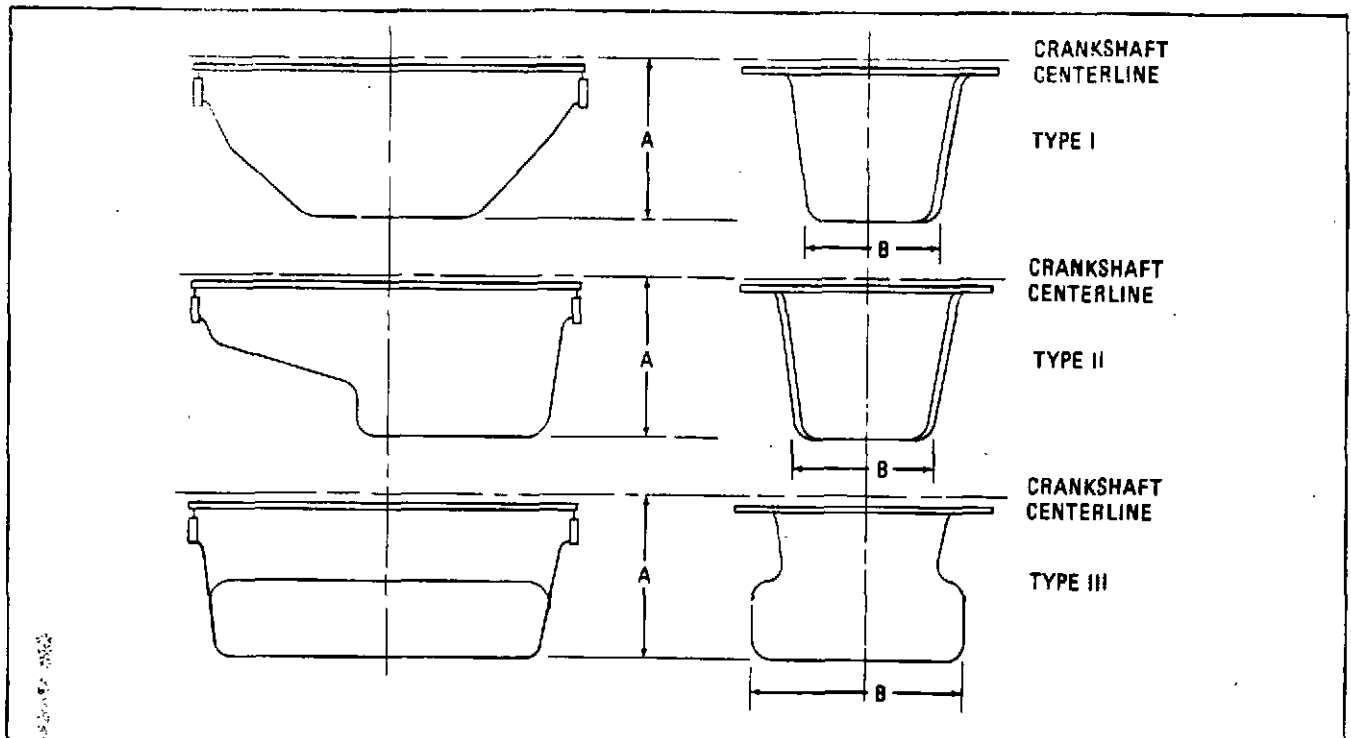

Engine Type	Oil Pan Type	Oil Pan Dimensions (Inches)		Crankcase Capacity (Quarts) (Not Including Oil Filter)
		A	B	
4 Cylinder	I	9	7-1/2	5-1/2
	III	10-7/8	12-1/4	8
6 Cylinder	I	10	7-3/16	7
	I	9	7-7/16	6
	I	12	8-7/16	8
	II	11	7-5/8	8
	III	12-5/8	11-7/8	7

b. If the engine installation contains a crankcase ventilation valve and hose connection to the intake manifold, remove the hoses and valve and clean with Diesel fuel oil or solvent. Blow through the hoses with compressed air to ensure that they are clear. Shake all solvent from the valve and allow it to dry thoroughly before installation. Connect the hoses to the manifold. Most valves have an arrow stamped or painted on the side; this arrow must point toward the manifold.

### 3-5. BATTERY AND CABLES.

a. Battery cable connections must be clean and tight to prevent excessive voltage drop across the connections. Current draw is high during

starting, and poor connections can prevent the battery from delivering the full voltage needed, resulting in reduced starting motor speed and hard starting.

b. Clean the battery posts and cable terminals regularly, as follows. Disconnect the cables and remove corrosion from posts and terminals with a wire brush. Flush the top of the battery and the battery hold-down clamps with a weak solution of baking soda in water. Do not allow any of the baking soda solution to enter the battery. Flush with clean water and allow to dry, then connect the cables.

c. If the battery cables must be replaced, choose the cable size as follows:

## LUBRICATION AND PREVENTIVE MAINTENANCE

1. If the combined length of the positive cable and ground cable is five feet or less, use SAE No. 0 stranded cable.

2. If the combined cable length is five to seven feet, use No. 00 stranded cable.

3. If the combined cable length is seven to nine feet, use No. 000 stranded cable.

d. When replacing a cable terminal, cut off the old terminal and strip back the insulation about an inch. Tin the cable end, then crimp the terminal onto the cable. Fill the terminal with solder to ensure a tight connection.

e. When replacing the battery or engine ground cable, use a wire brush or scraper to remove rust and paint to expose bare metal at the point of contact. When the engine installation frame is used as a ground, ensure that there are no riveted or bolted joints between the location of the battery ground cable and the location of the starting motor ground.

### NOTE

The following paragraphs comprise the services and adjustments recommended for engine tuneup. Perform the services in the order presented below.

### 3-6. VALVE CLEARANCE ADJUSTMENT.

a. Start the engine and allow it to warm to operating temperature.

b. Remove the cylinder head cover and gasket.

c. With the engine running at slow idle, check for 0.015 inch clearance between the rocker arm and end of the valve stem, using a feeler gauge as shown in figure 3-2

d. If the valve clearance is incorrect, adjust the setting of the adjusting screw to provide the required clearance. Refer to figure 3-2. When properly adjusted, there will be a slight drag on a 0.015 inch feeler gauge with the valve in the unoperated position.

### NOTE

After valve grinding or rocker arm or cylinder head removal, it is necessary to do a preliminary valve clearance adjustment with the engine shut down and using cold settings. Refer to paragraph 5-28 for instructions.

e. The adjusting screw is self-locking, therefore lock nuts are not required.

f. Repeat the procedure to adjust the remaining intake and exhaust valves. Adjust all valves to the same clearance.

g. Reinstall the cylinder head cover and gasket. Use a new gasket if the old one shows any signs of cracking or deterioration.

### 3-7. COMPRESSION CHECK.

Check the compression of the engine as follows:

a. Tag and disconnect all the spark plug wires. Disconnect the secondary cable from the ignition coil to the distributor. With a magneto ignition, disconnect the primary terminal at the side of the magneto.

b. Clean the area around the spark plugs to prevent the entry of dirt into the cylinders when the spark plugs are removed. Remove all the spark plugs.

c. Install a good quality compression pressure gauge into one of the spark plug holes in the cylinder head.

d. Block the throttle in the wide open position, then crank the engine with the starting motor and record the compression pressure. Remove the pressure gauge.

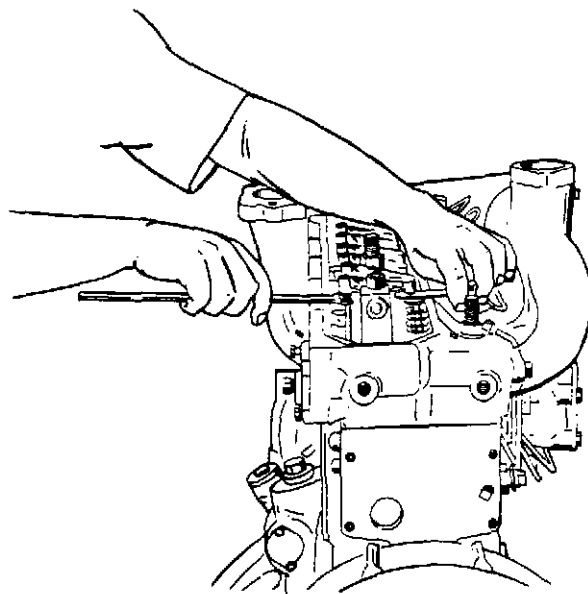

Figure 3-2. Valve Clearance Check and Adjustment

e. Repeat this procedure for the remaining cylinders.

f. If compression varies more than 25 percent among all cylinders, schedule the engine for valve grinding, piston ring replacement, or major overhaul as necessary.

g. Install the spark plugs as described in paragraph 3-8.

### 3-8. SPARK PLUGS AND CABLES.

a. Tag and disconnect the spark plug cables. Unscrew and remove the spark plugs from the cylinder head.

#### NOTE

It is normally safer and more economical to replace used spark plugs with new ones after the normal inspection interval has elapsed. However, old plugs can be reused, if desired, if the instructions below are followed.

b. Inspect the spark plugs for the following conditions:

1. Cracked insulator.
2. Worn, bent, or broken ground electrode.
3. Worn or bent center electrode.
4. Cracked or damaged ceramic cone around center electrode.
5. Stripped or damaged threads.

c. Plugs which are not damaged or excessively worn can be sandblasted to remove combustion deposits. Plugs cleaned in this manner can be reused if desired.

d. Bend the ground electrode to obtain the spark plug gap specified in Table 3-4, Ignition Specifications.

#### CAUTION

Overtightening the spark plugs can strip the threads tapped into the cylinder head. This defect can be corrected only by replacing the head.

e. Reinstall the spark plugs in the cylinder head and tighten them to 15 to 20 foot-pounds.

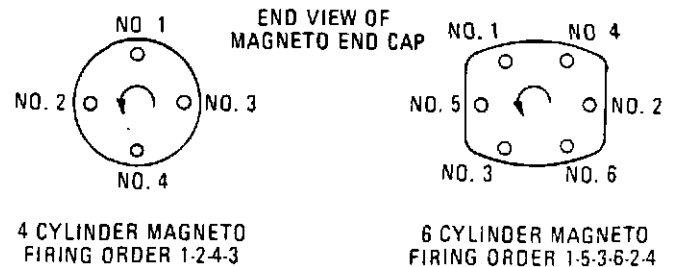
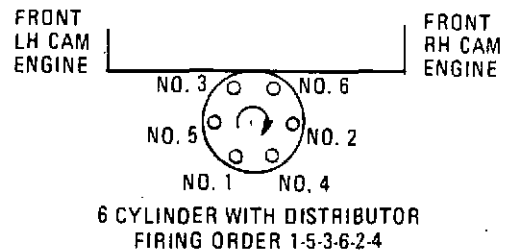
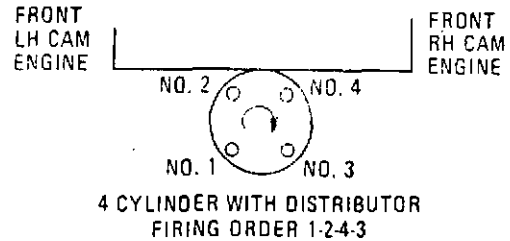

Figure 3-3. Spark Plug Cable Locations

f. Before connecting the spark plug cables, inspect each cable carefully for cracked or damaged insulation, loose terminals, rubbing wear, and other damage. Worn cables can cause hard starting, especially in damp weather. Replace cables that are worn or damaged.

g. Connect the spark plug cables from the distributor to the spark plugs. Refer to figure 3-3 for an illustration of spark plug cable locations. To help prevent cross-firing, avoid bundling the cables together in contact with each other. Route them to the spark plugs in groups of no more than three. The use of insulated cable brackets is also recommended.

### 3-9. DISTRIBUTOR.

Several different distributors are used with these engines. Locate the part number on the distributor and refer to Table 3-4, Ignition Specifications, for information.

a. Remove the distributor cap and inspect it for cracks, evidence of arcing, corroded terminals, and other defects. Replace defective cap.

## LUBRICATION AND PREVENTIVE MAINTENANCE

Table 3-4. Ignition Specifications  
ENGINES WITH SERIAL NUMBER 3320087 AND FOLLOWING

G-3400 and G-3000								
Fuel	Comp. Ratio	White Distributor Part Number	Purveyor Distributor Part Number	Timing		Spark Plug Gap	Breaker Points	
				Degrees	At RPM		Point Gap	Dwell Angle
Gasoline	7.5:1	40-2500608	Delco 1112491	22° BTDC	1800	.028 to .033	.022	31° to 34°
L.P.G.	7.5:1	40-2500608	Delco 1112491	22° BTDC	1800	.028 to .033	.022	31° to 34°
L.P.G.	10:1	40-2500608	Delco 1112491	16° BTDC	1800	.028 to .033	.022	31° to 34°
Nat. Gas	7.5:1	40-2500608	Delco 1112491	28° BTDC	1800	.028 to .033	.022	31° to 34°
Nat. Gas	10:1	40-2500608	Delco 1112491	22° BTDC	1800	.028 to .033	.022	31° to 34°
G-2300 and G-2000								
Gasoline	7.5:1	40-2500607	Delco 1112475	22° BTDC	1800	.028 to .033	.022	31° to 34°
L.P.G.	7.5:1	40-2500607	Delco 1112475	22° BTDC	1800	.028 to .033	.022	31° to 34°
L.P.G.	10:1	40-2500607	Delco 1112475	16° BTDC	1800	.028 to .033	.022	31° to 34°
Nat. Gas	7.5:1	40-2500607	Delco 1112475	28° BTDC	1800	.028 to .033	.022	31° to 34°
Nat. Gas	10:1	40-2500607	Delco 1112475	22° BTDC	1800	.028 to .033	.022	31° to 34°

NOTES: 1. See figure 3-5 for an illustration of standardized flywheel timing marks.

2. All timing specifications are for use with a fuel having a minimum octane rating of 85 (motor method).

3. Magneto timing for all gasoline engines is 25° BTDC at 1800 rpm.

4. If field conditions do not permit timing at the indicated speeds, time to 6° BTDC at the following idle speeds:

6-cylinder gasoline	500 rpm
4-cylinder gasoline	930 rpm (Delco distributor)
4-cylinder gasoline	700 rpm (Prestolite distributor)

5. For information on distributors not included in this table, or if engine operation is not satisfactory at the recommended settings, write to White Engines, Inc., Service Department, Canton, Ohio, giving as much information as possible.

b. Remove the distributor rotor and inspect the points for burning and pitting. The points can be filed and reused if desired, but it is generally advisable to replace the rotor, points, and condenser at each tuneup.

c. When installing new points, rotate the engine crankshaft by hand in the normal direction of its rotation until the rubbing block on the breaker arm rests on the high point of one of the distributor shaft lobes. Use a feeler gauge to set the breaker point gap specified for the distributor. Refer to Table 3-4, Ignition Specifications.

d. Use a dwell meter to read the distributor dwell angle to set reused breaker points, and to check the setting of new points. Connect the dwell meter to the engine according to the meter manufacturer's instructions. Crank the engine with the starter and adjust the breaker points to obtain the specified dwell (see Table 3-4, Ignition Specifications). Tighten the breaker point screws to secure the adjustment.

e. Reinstall the rotor and distributor cap. Refer to figure 3-3 and connect the spark plug cables. Connect the secondary lead from the ignition coil to the center tower of the distributor cap.

f. Connect a timing light to the No. 1 spark plug cable according to the manufacturer's instructions. If no timing specifications are provided with the engine installation, refer to table 3-4 and obtain the timing information specified for the distributor and fuel used.

g. Paint or chalk a line on the engine flywheel at the proper timing mark location. This will

make the timing mark more visible under the timing light. Start the engine and run it at the specified speed. Shine the timing light on the timing hole in the bellhousing, or on the edge of the bellhousing, as shown in figure 3-4. Read the timing by noting the mark on the flywheel which aligns with the mark on the bellhousing. Standardized timing marks for late model engines are shown in figure 3-5.

h. If the ignition timing must be adjusted, slightly loosen the cap screw on the distributor clamp or clamps. Rotate the distributor body slowly until the specified ignition timing is obtained. Tighten the cap screw to secure the adjustment, and recheck the timing.

i. Stop the engine and disconnect the timing light.

j. Refer to paragraph 5-23 for removal and installation of the distributor, and for timing it after engine overhaul.

### 3-10. MAGNETO.

Several different magnetos are used with these engines, and the tuneup information provided below is of a general nature. Obtain magneto specifications from the engine installation, or refer to the magneto manufacturer's literature.

a. To inspect the magneto end cap and breaker points, remove the cap screws and lock washers which secure the magneto end cap to the magneto body; remove the cap. Inspect the cap for cracks,

NOTE: FLYWHEEL ILLUSTRATED IS ON ENGINES WITH SERIAL NUMBER 3320087 AND FOLLOWING. MARKS APPEAR ON RIM OR FACE.

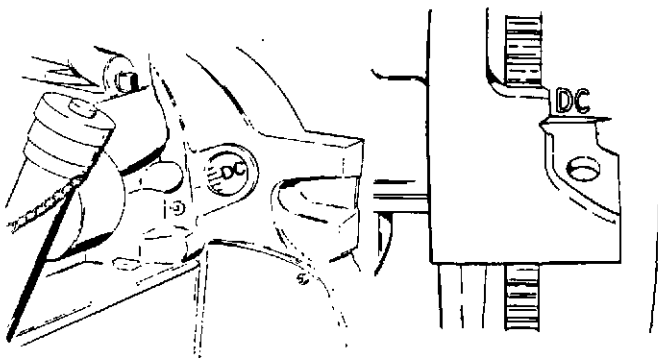

Figure 3-4. Alternate Timing Locations

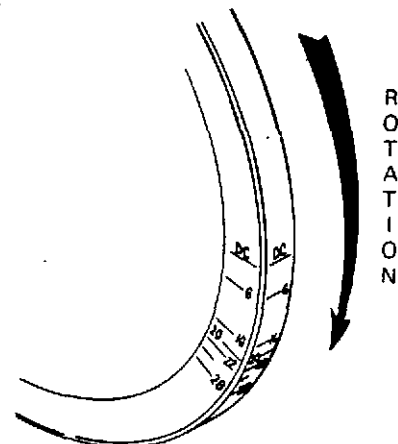

Figure 3-5. Standardized Timing Marks

## LUBRICATION AND PREVENTIVE MAINTENANCE

evidence of arcing, corroded terminals, and other defects. Replace a defective cap.

b. Remove the magneto rotor for access to the breaker points. Inspect the points for burning and pitting. The points can be filed and reused if desired, but it is generally advisable to replace the points and condenser at each tuneup.

c. Install the new points on the bearing support, but do not tighten the attaching screws. Rotate the engine crankshaft by hand in the normal direction of its rotation until the rubbing block on the breaker arm rests on the high point of the magneto cam. Use a feeler gauge to set the point gap to 0.020 inch.

d. Tighten the breaker point attaching screws and reinstall the rotor. Reinstall the magneto end cap and secure with the attaching screws. Connect the spark plug cables to the end cap as shown in the applicable illustration in figure 3-3.

e. Connect a timing light to the No. 1 spark plug cable according to the manufacturer's instructions. If no timing specifications are provided with the engine installation, refer to table 3-4.

f. Paint or chalk a line on the engine flywheel at the proper timing mark location. This will make the timing mark more visible under the timing light. Start the engine and run it at the specified speed. Shine the timing light on the timing hole in the bellhousing, or on the edge of the bellhousing, as shown in figure 3-4. Read the timing by noting the mark on the flywheel which aligns with the mark on the bellhousing. Standardized timing marks for late model engines are shown in figure 3-5.

g. If the timing must be adjusted, slightly loosen the two cap screws which secure the magneto to the gear housing. Rotate the magneto body slowly until the specified ignition timing is obtained. Tighten the cap screws and recheck the timing.

h. Stop the engine and disconnect the timing light.

i. Refer to paragraph 5-24 for removal and installation of the magneto, and for timing it after engine overhaul.

### 3-11. CARBURETOR.

Many different carburetors are used on these engines, including both updraft and downdraft

types. Refer to the engine installation or vehicle data plates for idle speed. Any other information not supplied with the installation can be obtained from the carburetor manufacturer. When requesting information, refer to the carburetor by manufacturer's name and model number.

a. If a variable speed mechanical governor is used on the engine installation, engine idle speed may be adjusted through the governor linkage. Refer to paragraph 3-13.

b. If a constant speed mechanical governor is used, or if the governor linkage operates a throttle plate within a valve box between the carburetor and intake manifold, disconnect the governor linkage until engine idle speed is adjusted.

c. If the engine is not equipped with a tachometer, connect a tachometer to the engine ignition system according to the instrument manufacturer's instructions.

d. Carburetor adjustment must be performed with the engine at normal operating temperature and the choke fully open. If an automatic choke is used, remove the air inlet hose and check that the choke is fully open before performing adjustments.

e. Idle speed and mixture, high speed, and power adjustments are commonly performed on industrial engines. Refer to the manufacturer's literature for further information.

f. After carburetor adjustments are performed, stop the engine and reconnect the governor linkage, if used. Refer to paragraph 3-12 or 3-13 for governor adjustments.

### 3-12. VELOCITY GOVERNOR.

The velocity governor, if used, is mounted between the carburetor and intake manifold. It controls the maximum engine speed to protect the engine and/or equipment from damage that could result from overspeed. Only one adjustment is required by the velocity governor. Adjust as follows:

#### WARNING

Do not increase maximum governed speed above that speed specified for the equipment. Excessive speed can cause engine or equipment damage and possibly result in bodily harm.

a. If the engine is not equipped with a tachometer, connect one to the engine ignition system as instructed by the instrument manufacturer.

b. Determine the maximum governed speed specification recommended by the manufacturer for the vehicle or equipment. Do not proceed without this specification.

c. If the engine is also equipped with a mechanical governor, disconnect or arrange to override it temporarily. Disengage the engine from the driven equipment if possible, or put the transmission in neutral.

d. Start the engine and allow it to reach operating temperature. Check that the choke is fully open.

e. Watch the tachometer and slowly move the throttle to the wide open position. The governor must act to limit engine speed to within  $\pm 25$  rpm of the specified maximum.

f. If the governed speed is not within limits, block the throttle in the wide open position and turn the adjustment screw on the governor approximately  $1/4$  turn. Watch the tachometer and note the new governed speed. Continue to turn the screw in  $1/4$ -turn increments to obtain the specified speed.

g. Unblock the throttle and return the engine to idle. Open the throttle again several times to recheck the adjustment. Allow the engine to idle for a few minutes, then stop the engine.

h. Disconnect the external tachometer, if used. Disconnect the mechanical governor linkage, if used, and adjust as described in paragraph 3-13.

### 3-13. MECHANICAL GOVERNOR.

Only one basic model mechanical governor is used with these White gasoline engines, but this model provides many variations in governing characteristics. The governor can be used either as the constant speed type, which is adjusted only through adjusting screws on the linkage, or as the variable speed type, in which the governed speed can be adjusted by a throttle control on the engine control panel. The governor is connected to the carburetor as shown in figure 3-6 for most variable speed applications. For constant speed use, the governor rod (1, figure 3-6) may be connected to a valve box mounted between the carburetor and intake manifold, instead of to the carburetor throttle shaft as shown. Some constant speed installations are not equipped with a bellcrank (8) and adjusting screws (5 and 7).

### NOTE

The adjustment points illustrated in figure 3-6 apply to all installations of Hoop Model GD505 governors used on White gasoline engines. The illustration shows a typical updraft carburetor installation. The configuration of some parts will change for use with a downdraft carburetor.

#### a. Preliminary Adjustments (all installations).

1. With the engine stopped and the throttle closed, check for  $1/32$  to  $1/16$  inch clearance between the lever on the carburetor or valve box and any throttle stop or speed adjustment screw. If this clearance is incorrect, loosen lock nuts (2, figure 3-6) and screw the rod (1) into or out of ball joints (3) to obtain this clearance. Tighten the lock nuts.

2. If the engine is not equipped with a tachometer, connect one to the engine ignition system according to the instrument manufacturer's instructions.

3. Start the engine and allow it to reach operating temperature. Check that the choke is fully opened, and that the carburetor is properly adjusted.

4. Perform the applicable speed adjustment described in subparagraph b, c, or d, below, then perform the sensitivity adjustment in subparagraph e, below.

#### b. Constant Speed (with bellcrank).

1. Perform the preliminary adjustments in subparagraph a, above.

2. Stop the engine. Loosen lock nuts (4 and 6, figure 3-6) and back out adjusting screws (5 and 7) several turns.

3. Start the engine again and note the governed speed on the tachometer.

### WARNING

Do not increase maximum governed speed above that speed specified for the equipment. Excessive speed can cause engine or equipment damage and possibly result in bodily harm.

4. Turn adjusting screw (5) clockwise to increase engine speed, or counterclockwise to

# LUBRICATION AND PREVENTIVE MAINTENANCE

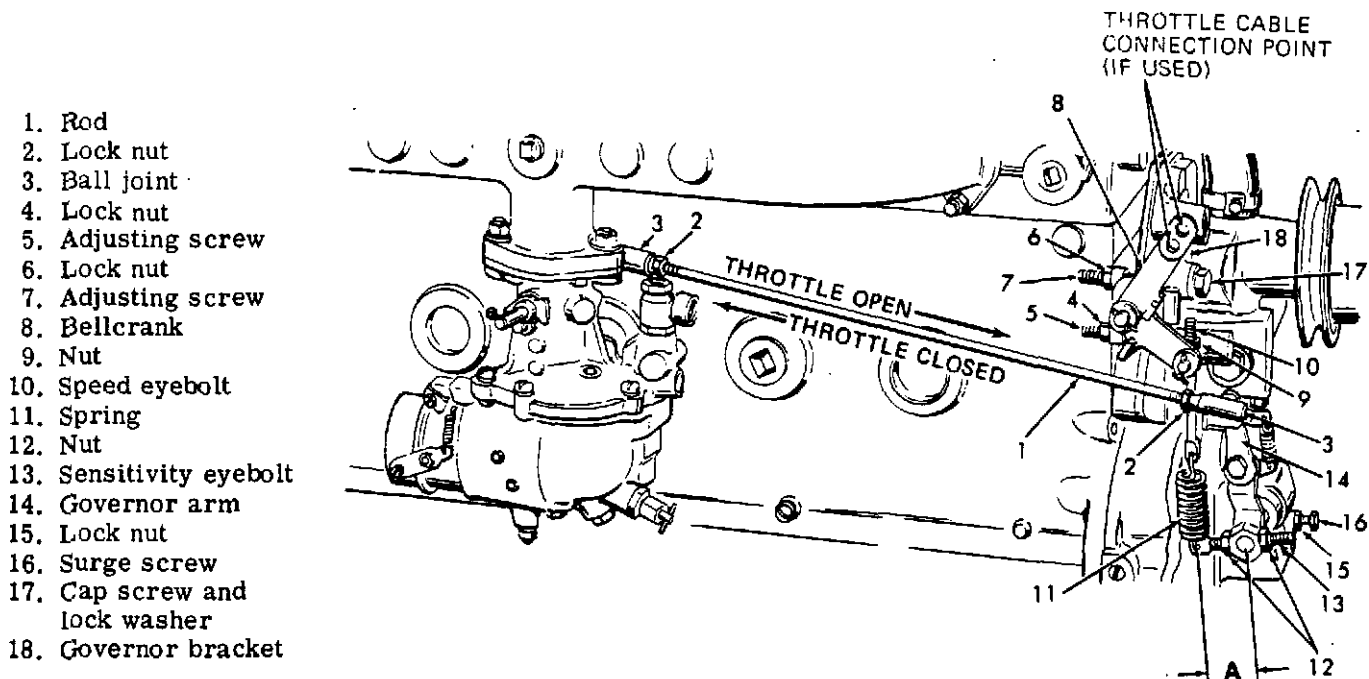

1. Rod
2. Lock nut
3. Ball joint
4. Lock nut
5. Adjusting screw
6. Lock nut
7. Adjusting screw
8. Bellcrank
9. Nut
10. Speed eyebolt
11. Spring
12. Nut
13. Sensitivity eyebolt
14. Governor arm
15. Lock nut
16. Surge screw
17. Cap screw and lock washer
18. Governor bracket

Figure 3-6. Governor Adjustment Points

decrease it. Turn the screw in 1/4-turn increments, and allow the engine speed to stabilize after each movement.

## WARNING

On some installations, the closeness of the fan, fan belts, and alternator drive belt make this adjustment hazardous when performed with the engine running. If these dangers exist, shut off the engine each time before attempting to make the governor adjustment.

5. If engine speed cannot be properly adjusted with adjusting screw (5), change the tension on spring (11). To do so, rotate nut (9) on speed eyebolt (10) clockwise to increase speed or counterclockwise to decrease speed. Repeat the adjustment in step 4.

6. When the speed has been adjusted with adjusting screw (5), turn in the second adjusting screw (7) until it is tight against the bellcrank (8). Tighten lock nuts (4 and 6) to secure the adjustment.

7. Perform the sensitivity adjustment in subparagraph e, below.

### c. Constant Speed (without bellcrank).

1. Perform the preliminary adjustments in subparagraph a, above.

2. With the engine running at governed speed, note engine speed on the tachometer.

## WARNING

Do not increase maximum governed speed above that speed specified for the equipment. Excessive speed can cause engine or equipment damage and possibly result in bodily harm.

3. Speed adjustment is performed by moving speed eyebolt (10, figure 3-6) up or down to change the tension on spring (11). Rotate nut (9) clockwise to increase speed or counterclockwise to decrease speed.

4. Perform the sensitivity adjustment in subparagraph e, below.

### d. Variable Speed (with throttle control connected to bellcrank).

1. Perform the preliminary adjustments in subparagraph a, above.

# WHITE ENGINES, INC.

2. Stop the engine. Loosen lock nuts (4 and 6, figure 4-3) and back out adjusting screws (5 and 7) all the way, so that the stops on the bellcrank (8) contact the governor bracket (18) instead of the adjusting screws.

3. Move the throttle control (on the control panel) to the lowest speed or THROTTLE CLOSED position. Turn nut (9) counterclockwise to allow speed eyebolt (10) to move down just enough to relieve all tension in spring (11).

4. Start the engine again. Slowly move the throttle control toward the THROTTLE OPEN position to increase engine speed.

## WARNING

Do not increase maximum governed speed above that speed specified for the equipment. Excessive speed can cause engine or equipment damage and possibly result in bodily harm.

5. Rotate screw (7) clockwise to stop movement of the throttle control to limit engine speed to the specified maximum. Tighten lock nut (6) to secure this adjustment.

6. Move the throttle control to the THROTTLE CLOSED position, and adjust idle speed, if necessary, by turning in adjusting screw (5). Tighten lock nut (4) to secure the adjustment.

7. At the idle position, there should be only enough tension on spring (11) to eliminate all slack in the linkage. Turn nut (9) to eliminate slack, if any.

8. Perform the sensitivity adjustment in subparagraph e.

e. Sensitivity Adjustment (all installations).

1. Perform the speed adjustments in subparagraph b, c, or d, above.

2. The effective length (A, figure 3-6) of sensitivity eyebolt (13) controls the governor's sensitivity to changes in speed. If the effective length is too short, the governor will cause the engine to surge; if it is too long, there will be an excessive difference between full-load and no-load engine speed.

3. With the engine running at full governed speed, loosen nuts (12). Loosen one nut while tightening the other to move sensitivity eyebolt (13) in or out of the governor arm (14) to increase or decrease effective length A of the eyebolt. Shorten the effective length until the engine begins to surge, then lengthen it until surging stops. Tighten nuts (12) to secure the adjustment.

4. Some governors are also provided with a surge screw (16) to dampen surging. If a surge screw is provided, shorten the effective length A of sensitivity eyebolt (13) just until surging begins. Loosen lock nut (15) and screw in surge screw (16) to dampen surging, then tighten lock nut (15) and nuts (12).

5. With a variable speed installation, return the throttle control to the closed position and check that the governor will allow the engine speed to return to idle. If it does not, back out surge screw (16) and repeat the adjustment in step 3.

6. Stop the engine and disconnect the tachometer, if connected only for testing.

# TROUBLESHOOTING

---

## **SECTION IV TROUBLESHOOTING**

### 4-1. GENERAL INFORMATION.

This troubleshooting section includes some of the most common problems that may be encountered during operation of a gasoline engine. Table 4-1, Troubleshooting Chart, lists symptoms, probable causes, and possible remedies. The chart refers to applicable paragraphs in the manual where possible remedial procedures will be found.

### 4-2. TROUBLESHOOTING PROCEDURES.

a. Note unusual operation and symptoms. Refer to table 4-1 to determine possible cause.

b. Always check the easiest and most obvious causes first to save time and trouble. Do not disassemble engine or components until all other possible causes and remedies for a specific problem have been examined.

c. After a mechanical failure has been corrected, locate and correct the cause of the trouble so that the failure will not reoccur.

Table 4-1. Troubleshooting Chart

Cause	Problem												Possible Remedy	
	Engine Will Not Start	Hard Starting	Engine Stops	Erratic Engine Performance	Black Exhaust Smoke	Blue Exhaust Smoke	White Exhaust Smoke	Low Power	Engine Overheating	Engine Overcooling	Engine Knocking	Low Oil Pressure		Bearing Failures
NOTE: Numbers in each column indicate sequence in which causes should be checked.														
Air cleaner dirty Air inlet restricted	11	4		1	1			1						Para. 3-2 and 5-16
Exhaust system restricted			6	13				13	10					Para. 5-18
Battery weak or discharged Battery cables worn or loose connections	5 4	2 3	5	5										
Low cylinder compression Foreign matter on pistons Worn or scored pistons, rings, etc.		11 16		11 17 18		5 7		11 16 17		7 8			11	Para. 3-7 Para. 5-33
Valves leaking or sticking Worn valve guides Valves incorrectly adjusted	14 13	15 14		16 15		8		15 14		6 5				Para. 5-28 Para. 3-5
Lube oil level too low Lube oil level too high Lube oil contaminated Wrong type of lube oil		1				1 3		3		1	1	1	1	Para. 3-6 Table 3-2
Oil pump inlet screen plugged Pressure regulator not functioning Rocker arm shaft upside down Oil header plug missing or loose Bearing failed - main, rod, camshaft				20		6		18		9	6 7 5 10	8 9 12		Para. 5-6 Para. 5-6 Para. 5-26 Para. 5-35 Para. 5-32, 5-33 and 5-34
Excessive angle operation Excessive thrust pressure on shafts	16	18	12			2					2 9	5 10		Para. 5-32 and 5-34
Fuel tank empty Fuel tank valve closed Fuel tank vent plugged Fuel pump worn or inoperative Fuel contamination Fuel incorrect for conditions Fuel filter dirty or plugged	2 3 12 6 7 8		1 2 3 10 6 7 8	1 2 3 6 7 8 9			4	10 4 5			2			Para. 5-11 Para. 5-12
Ignition switch in OFF Position Defective points, condenser, coil or spark plugs Ignition timing incorrect	1 9 10	10 9	7	4				8 7			3			Para. 5-23 or 5-24 Para. 3-9 or 3-10
Throttle linkage adjustment incorrect or sticking Carburetor choke closed Carburetor malfunction Air leak in intake system				12				9						Para. 3-11 and 3-13 Para. 5-13 Para. 5-15
Fan belt loose or slipping Radiator pins or tubes dirty or restricted Water system piped incorrectly Low coolant level Coolant in cylinders Inoperative thermostat Thermostat missing Internal coolant leak Wrong or defective radiator cap	15	17		19			3 1 2	3 4 1 5 2		1			4	Para. 5-8 Para. 5-8 Para. 5-9 Para. 5-9 Para. 5-27 and 5-35
Engine overloaded Engine overspeeded				3				8 9		4		6 7		Para. 3-12 or 3-13

# ENGINE REPAIR AND OVERHAUL

## SECTION V ENGINE REPAIR AND OVERHAUL

### 5-1. GENERAL INFORMATION.

This section includes brief descriptions of engine components and instructions for disassembly, repair and overhaul, and reassembly of the component parts of the White G-Series Engines.

Before removal or disassembly of a component or disassembly of the engine, inspect the overall condition and note all symptoms of faulty operation. This helps to determine causes of failure or faulty operation, and facilitates repair.

Provide a clean place to work, facilities for cleaning the engine and parts, and an engine overhaul stand.

Standard engine overhaul shop tools and resurfacing equipment are necessary. These tools save time and help ensure good workmanship.

Engine components and parts are overhauled in one of the following systems: Lubrication System, Cooling System, Fuel System, Air Supply and Exhaust Systems, Electrical System, Ignition System, and Engine. Instructions are given for removal, disassembly, repair or replacement, and reassembly of each component separately. Remove components and parts as required, and note any necessary precautions or special procedures.

### 5-2. ENGINE REMOVAL FROM UNIT.

Instructions given in this section are not for any specific engine application but serve as guides for a typical engine removal and disassembly procedure. Alter these procedures to suit a specific engine application.

#### a. Preparation for Removal.

1. Disconnect and remove electrical leads to the starting motor and distributor or magneto.
2. Remove the muffler and exhaust piping.
3. Remove the air cleaner and piping.
4. Drain the engine cooling system.
5. Remove side covers, top, rear covers, and associated parts of engine housing.

6. Remove the radiator, radiator supports, and cooling system hoses.

7. Disconnect the throttle and choke control linkages from the carburetor or governor.

8. Shut off fuel supply and disconnect fuel supply line from engine.

9. Disconnect and remove the engine instrument panel.

10. Remove the transmission, clutch, or power take-off.

#### b. Engine Removal.

1. Use a sling on the engine and support the weight of the engine with a hoist.

2. Remove the attaching hardware securing the engine to the front engine supports.

3. Remove the attaching hardware securing the engine to the rear engine supports.

4. Disconnect drive shaft or any other drive members secured to the engine.

5. Hoist the engine from the unit and rest the engine on blocks or mount it on an overhaul stand.

### CAUTION

Do not rest engine on the oil pan. Severe damage to the oil pan or engine can result.

#### c. Removal of Engine Accessories.

1. Remove the engine alternator.
2. Remove the engine starting motor.
3. Remove the carburetor.
4. Remove the distributor or magneto.
5. Remove clutch, torque converter, or other drive unit.

#### d. Installation of Engine.

Reinstall the engine by reversing the removal procedure.

### 5-3. LUBRICATION SYSTEM.

The engine lubrication system consists of an oil pump, oil filter, oil lines, and pressure regulator valve. An external connection diagram of the lubrication system is shown in figure 5-1.

The oil pump forces the oil under pressure through an oil filter to the main oil header in the cylinder block. This oil header is a drilled passage extending the length of the cylinder block on the side opposite the camshaft. The header is sealed with a plug at the rear of the block, but a metering plug at the front of the block allows oil from the header to drip onto the camshaft gear to lubricate it.

From the main header the oil is distributed, under controlled pressure, through drilled passages to all main bearings, camshaft bearings, and rocker arms. Oil for lubricating the connecting rod bearings is provided through drilled

passages in the crankshaft from the main bearings. The cylinder walls, piston pins, and valve tappets are lubricated by oil drain-back and by the mist of oil thrown from the various pressure-lubricated bearings. The gear train is lubricated by flow through the metering plug at the front of the cylinder block oil header.

External openings are provided for connection of an oil pressure gauge or accessories requiring pressure lubrication.

### 5-4. OIL FILTER AND LINES.

The engines use either a full-flow or shunt (bypass) type oil filter employing either a spin-on filter or a cartridge-type filter with replaceable element. Use the following as a guide, altering the instructions as necessary for the particular application. Note that all lines and fittings in a full-flow system must be no less than 3/8 inch id; all lines and fittings in a shunt (bypass) system must be no less than 1/4 inch id, as shown in figure 5-1.

#### a. Removal (Spin-on Filter).

1. Drain the oil from the crankcase.
2. Disconnect and remove the oil line assemblies (1 and 2, figure 5-2) from the oil filter and cylinder block.
3. Remove the oil filter (8) from the base assembly (16).
4. Remove the base assembly from the mounting bracket (17) by removing two each bolts (13), nuts (14), and lock washers (15).

#### b. Cleaning and Inspection.

1. Discard and replace the oil filter and gaskets.
2. Clean all remaining parts with cleaning solvent; dry thoroughly.
3. Inspect oil line assemblies for cracked, frayed, cut, or deteriorated hoses, worn or damaged threads. Replace damaged oil line assemblies.
4. Inspect the base assembly for cracks, clogged passages, damaged filter gasket seat, stripped threads, and other damage.
5. Remove and replace the stud (18) if damaged. Use Loctite at installation of stud. Replace a damaged base assembly.

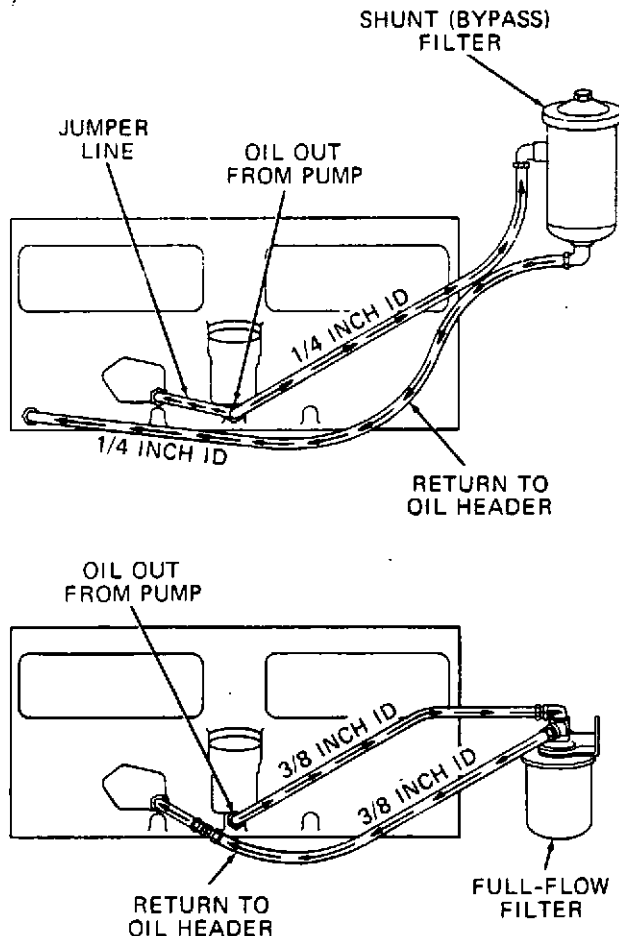
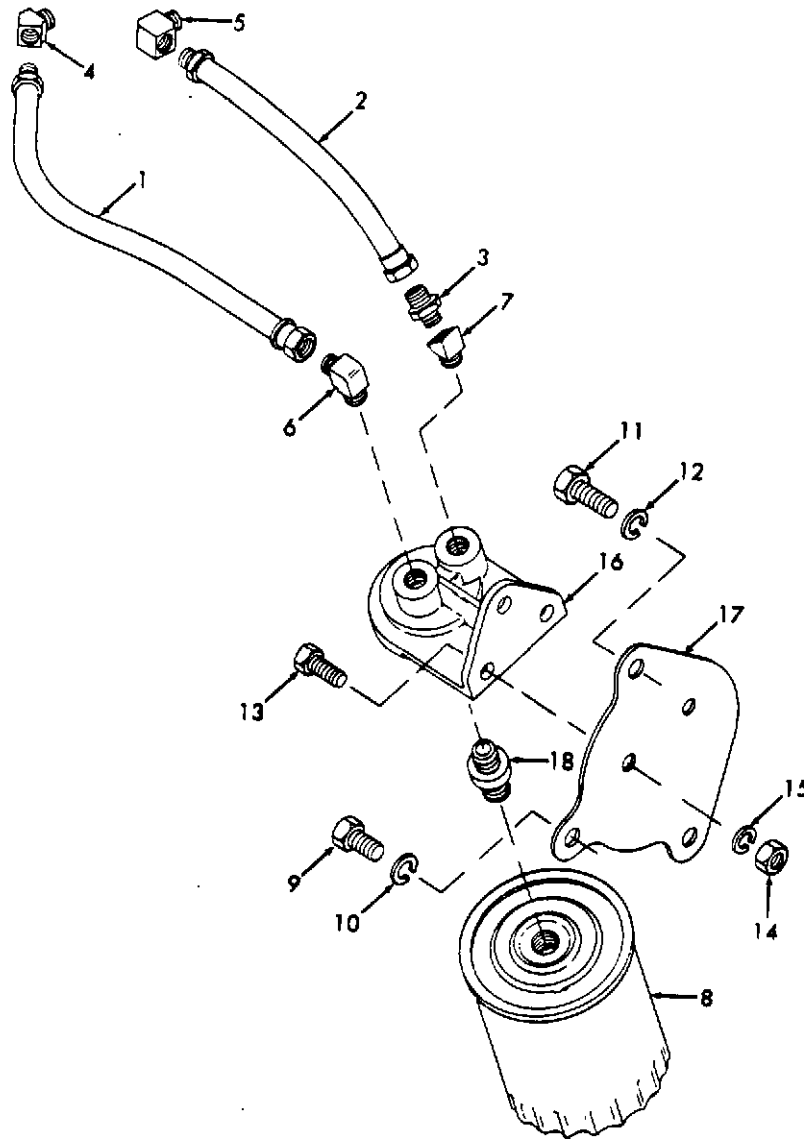

Figure 5-1. Engine Lubricating System External Connection Diagram



- |             |                 |                   |
|-------------|-----------------|-------------------|
| 1. Oil line | 7. Elbow        | 13. Bolt          |
| 2. Oil line | 8. Oil filter   | 14. Nut           |
| 3. Union    | 9. Bolt         | 15. Lock washer   |
| 4. Elbow    | 10. Lock washer | 16. Base assembly |
| 5. Elbow    | 11. Bolt        | 17. Bracket       |
| 6. Elbow    | 12. Lock washer | 18. Stud          |

Figure 5-2. Typical Oil Filter and Lines, Exploded View

**c. Installation (Spin-on Filter).**

1. Install the base assembly (16) on the mounting bracket (17) and secure with two each bolts (13), nuts (14), and lock washers (15).

2. Refer to figures 5-1 and 5-2 and connect the oil line assemblies. Note that a jumper line is used with a shunt-type filter.

3. Install new oil filter (8, figure 5-2).

**5-5. OIL PAN.**

The oil pan serves as an oil reservoir and also as a cover for the bottom of the crankcase.

**a. Removal.**

1. Remove the oil drain plug (1, figure 5-3) and gasket (2); drain the crankcase oil. If possible, drain the oil when the engine is at operating temperature.

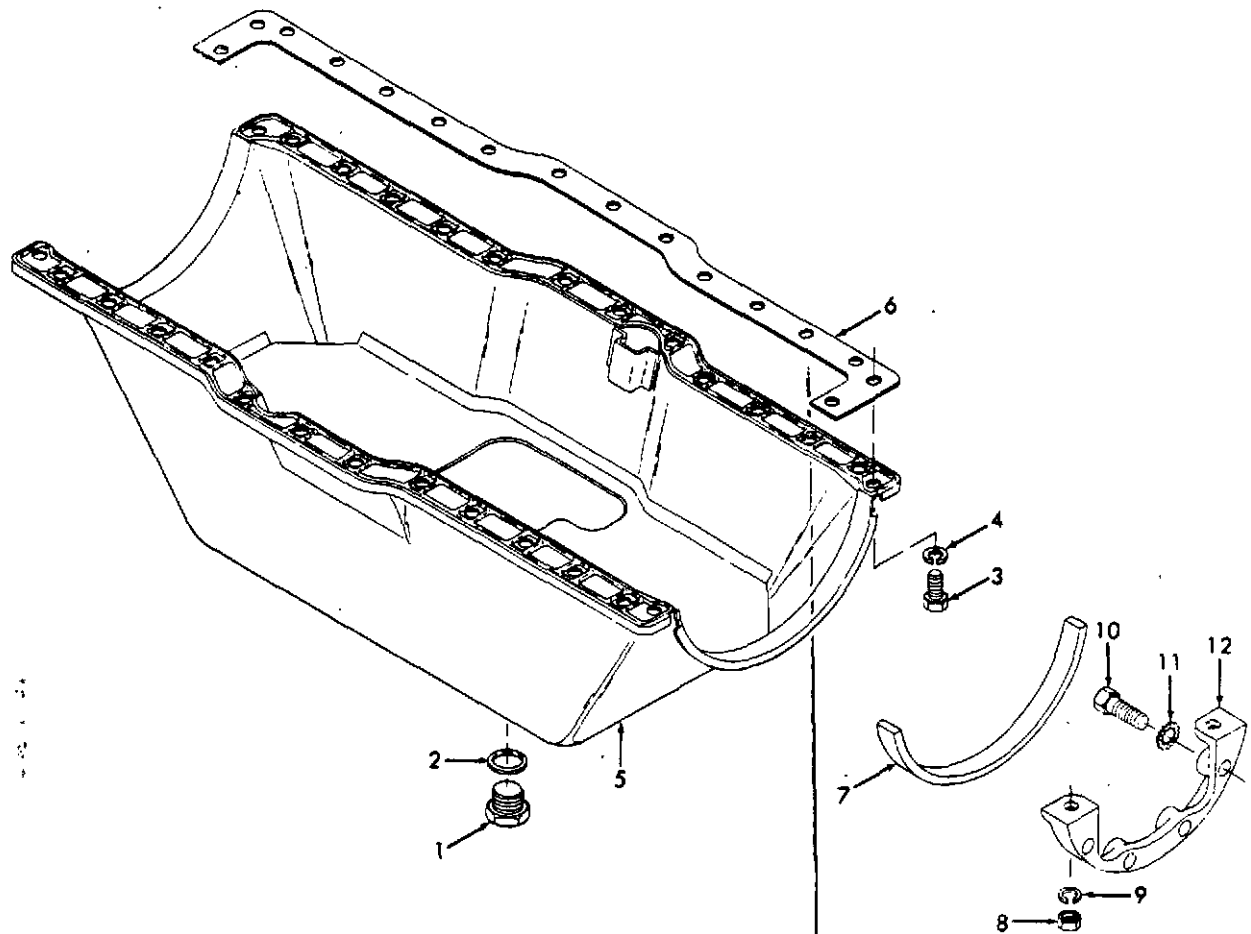

- |                |            |                 |
|----------------|------------|-----------------|
| 1. Drain plug  | 5. Oil pan | 9. Lock washer  |
| 2. Gasket      | 6. Gasket  | 10. Bolt        |
| 3. Bolt        | 7. Seal    | 11. Lock washer |
| 4. Lock washer | 8. Nut     | 12. Adapter     |

Figure 5-3. Typical Oil Pan and Adapters, Exploded View

2. If the starting motor is mounted below the oil pan level and will interfere with oil pan removal, disconnect the electrical leads and remove the starting motor from the bellhousing. Refer to paragraph 5-20.

3. Support the oil pan and remove the bolts (3, figure 5-3) and lock washers (4). Remove the oil pan (5) and gaskets (6).

4. Remove front and rear pan seals (7).

5. If the adapters (12) are cracked or damaged, remove the nuts (8), bolts (10), and lock washers (9 and 11) which secure the adapters to the cylinder block, and to the gear housing or bellhousing. Remove the adapters.

b. Cleaning and Inspection.

1. Discard all gaskets and seals. Make sure the gasket mounting surfaces on the oil pan, cylinder block, and oil pan adapters are clean and free from burrs.

2. Steam-clean pan and all mounting parts.

3. Inspect the oil pan for distortion, dents, and cracks. Check for signs of leakage. Repair small cracks in pan by welding. Do not weld finished surfaces.

4. Check threaded holes and bolts for damaged threads.

5. Repair a damaged oil pan plug hole by drilling it out and tapping for one size larger pipe plug.

## ENGINE REPAIR AND OVERHAUL

### c. Installation.

1. Before installing the oil pan, inspect the inside of the engine for loose nuts, screws, cotter pins, and lock wires; tighten or replace.

2. Remove all gasket particles from gasket mounting surface before applying new gasket. Cement the new oil pan side gaskets (6, figure 5-3) to the cylinder block using shellac, or equivalent.

3. If the adapters (12) were removed, install them on the cylinder block and secure with nuts (8) and lock washers (9). Before tightening the nuts, install the four bolts (10) and lock washers (11) which secure the adapters to the gear housing or bellhousing. Tighten the attaching nuts and bolts evenly to prevent cracking the adapters.

4. Remove protective coverings from oil pan adapter seals (7) and apply seals to adapters (12). Make sure both ends of the seal contact the pan gaskets (6) on each side. Seal surfaces on adapters must be free of oil and dirt.

5. Put the oil pan (5) in place and carefully start all the bolts (3). Be sure the lock washers (4) are on the bolts. Tighten all bolts evenly and progressively. This will allow the oil pan to center on the adapter blocks. Do not overtighten oil pan bolts.

6. Install the drain plug (1) and gasket (2).

7. Install the starting motor, if removed, and connect the electrical leads.

8. Refill with recommended oil to the correct level. Refer to table 3-2.

### 5-6. OIL PUMP.

The oil pump is mounted in the cylinder block with the lower end extending into the oil pan. The oil is drawn into the pump through a large screen which prevents coarse dirt from entering the pump. The pump requires no priming and is driven by a gear that engages a gear cut into the camshaft.

#### a. Removal and Disassembly.

1. Drain the oil from the crankcase and remove the oil pan. Refer to paragraph 5-5.

2. Remove the distributor, if used. Refer to paragraph 5-23.

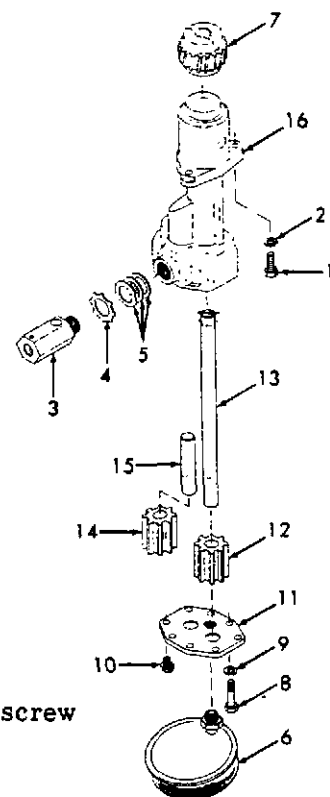

1. Bolt
2. Lock washer
3. Regulator
4. Lock washer
5. Shim
6. Strainer
7. Drive gear
8. Bolt
9. Washer
10. Assembled washer screw
11. Pump cover
12. Drive shaft gear
13. Drive shaft
14. Idler gear
15. Idler shaft
16. Body

Figure 5-4. Oil Pump, Exploded View

3. Remove the tachometer drive, if used. Refer to paragraph 5-25.

4. Turn the engine crankshaft as necessary to provide clearance for oil pump removal.

5. Remove the two attaching bolts (1, figure 5-4) and lock washers (2) from the pump flange and pull the oil pump from the engine.

#### NOTE

When the engine is equipped with a counterbalanced crankshaft, it is necessary to rotate the crankshaft and, at the same time, remove the oil pump with a spiral motion.

6. Bend up tangs on lock washer (4) and remove the regulator (3) and shims (5). Do not disassemble the regulator.

7. Remove the oil pump strainer (6) from the pump impeller cover by turning it counter-clockwise. Do not turn on the screen portion of the strainer.

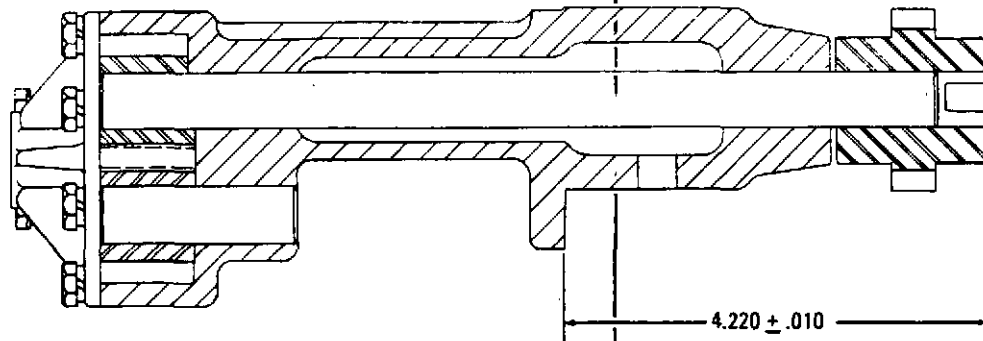

Figure 5-5. Oil Pump Drive Gear Installation Dimensions

8. Use a gear puller to remove drive gear (7) from shaft (13).

9. Remove the bolts (8), assembled washer screws (10), and washers (9) from the pump cover (11); remove the cover.

10. Remove the drive shaft gear (12) and shaft (13) as an assembly. Press the gear from the shaft if necessary.

11. Remove idler gear (14) from the idler shaft (15). On some older style oil pumps, the shaft can be removed manually from the pump body (16). On later pumps, the shaft is pressed into the pump body.

b. Cleaning and Inspection.

1. Clean all pump parts in cleaning solvent; dry with compressed air.

2. Inspect the oil pump strainer for clogged screen, holes, damaged threads, dents, or other

damage. Make sure the oil passage is clear and unobstructed. Replace a damaged or distorted strainer.

3. Inspect all gears for worn or broken teeth; replace if damaged.

4. Inspect all parts for burrs, pitting, rust, scoring, cracks, breaks, and damaged threads. Replace any damaged parts.

5. Replace idler shaft (15) if shaft has turned in pump body or is worn smaller than 0.6220-inch diameter at gear bearing area.

6. Replace drive shaft (13) if shaft has turned in gears or is worn smaller than 0.6220-inch diameter at bearing points.

7. Test piston in regulator body; replace regulator if piston binds.

c. Reassembly and Installation.

1. Press drive shaft gear (12) onto the drive shaft (13) so that the outside face of the gear and the end of the shaft are flush. Once removed, do not press old parts back together.

2. Insert the assembled shaft and gear into the pump body (16). Press the drive gear (7) onto the shaft. Replace gear that can be pressed onto the shaft with less than 35 pounds pressure. Press the gear onto the shaft to the dimensions shown in figure 5-5.

3. Install the idler shaft (15, figure 5-4), if removed, and install the idler gear (14).

4. Install the pump cover (11) and secure with bolts (8), assembled washer screws (10), and washers (9). Tighten the bolts progressively and evenly.

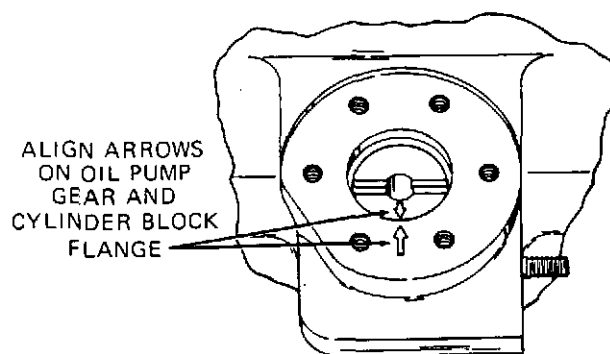

Figure 5-6. Oil Pump Alignment at Installation

## ENGINE REPAIR AND OVERHAUL

5. Install the assembled oil pump in the cylinder block so that the teeth on the drive gear mesh with the mating teeth cut into the camshaft. When properly installed, the arrow on the top of the drive gear must be aligned with the arrow stamped on the distributor mounting pad, as shown in figure 5-6. No alignment is necessary for magneto ignition.

6. Secure the pump with two bolts (1, figure 5-4) and lock washers (2). Tighten the bolts securely, but not excessively.

7. Install the oil pump strainer (6) on the pump cover by turning in clockwise. Do not apply force against the screen.

8. Install the 65 psi oil pressure regulator (3) with a new lock washer (4). The regulator, when mounted on the pump, must be turned so that the relief hole is aligned within  $30^\circ$  of horizontal (see figure 5-7). This position will prevent oil from spraying up into the cylinder bore, and will direct the spray toward the center of the engine and against the oil pan surface. If the oil pressure regulator is in an incorrect position when tightened, add shims (5, figure 5-4) until the proper alignment is achieved.

9. Install the oil pan (paragraph 5-5).

10. Install the tachometer drive, if used (paragraph 5-25).

11. Install and time the distributor, if used (paragraph 5-23).

12. Fill the crankcase to the proper level with the recommended grade of lubricating oil. See table 3-2.

### 5-7. COOLING SYSTEM.

A typical engine cooling system consists of a radiator, fan, water pump, thermostat, and coolant bypass. The coolant is drawn from the bottom of the radiator and into the water pump. The water pump forces the coolant into the coolant passages in the cylinder block, around the cylinders, through to the cylinder head coolant passages, through the thermostat, and into the top of the radiator. The radiator acts as a heat exchanger between the coolant and the surrounding air, so that the coolant is cooled as it passes through to the bottom of the radiator. The fan maintains a supply of cool air around the radiator tubes and fins.

During engine warmup, the thermostat remains closed and the coolant bypasses the radiator and returns directly to the water pump through the bypass tube. This accelerates the warmup time, since the coolant in the radiator is not heated until the engine is warm.

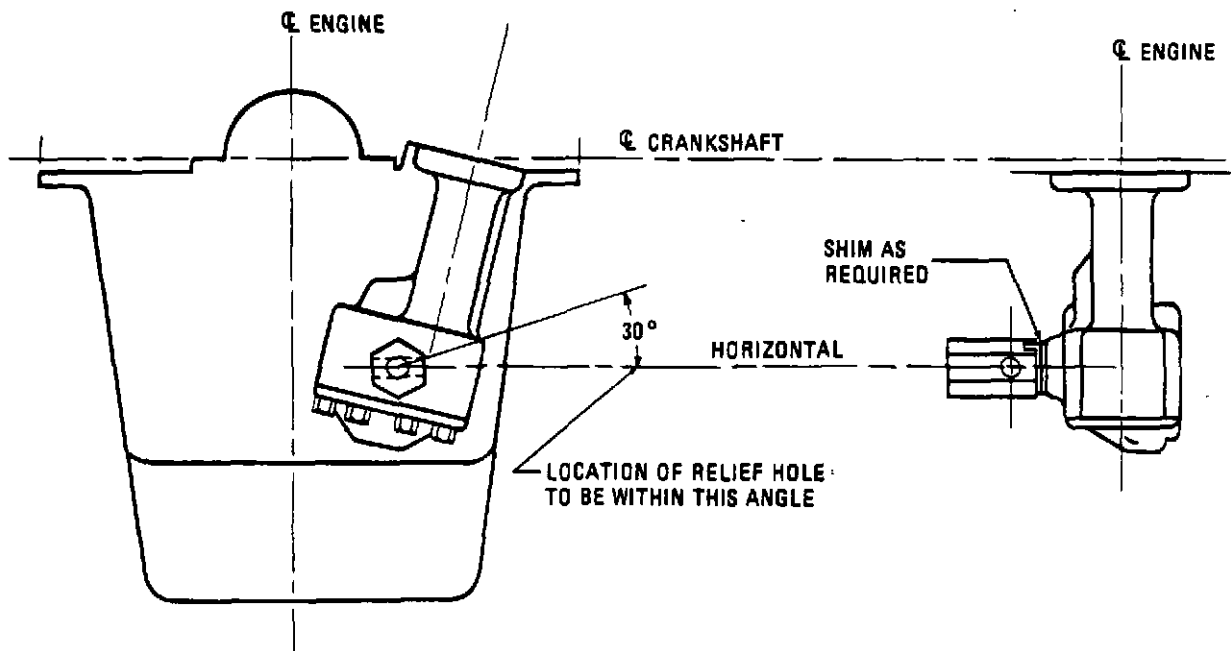

Figure 5-7. Oil Pressure Regulator Installation

## 5-8. WATER PUMP AND FAN.

The centrifugal-type water pump is driven from a crankshaft-mounted drive pulley through one or more V-belts. Various accessories mounted on the engine may be driven by these belts.

The cooling fan is mounted on the water pump driven pulley.

### a. Removal and Disassembly.

1. Drain the radiator and remove the radiator, hoses, and radiator support brackets.

2. Remove the fan (3, figure 5-8) by removing four bolts (1) and lock washers (2) securing fan to pulley (20).

3. Remove the fan belt(s) (4) by loosening the alternator attaching bolts and moving the alternator until the belt(s) can be removed.

4. Remove the bypass hose (7) and disconnect the water inlet hose (10) from the water pump.

5. Remove the three bolts (11) and lock washers (12) securing the assembled water pump and inlet pipe to the cylinder block, and remove the assembly from the engine. Remove water pump gasket (13).

6. Remove bolts (14 and 16) and lock washers (15 and 17) that secure the water inlet pipe (18) and gasket (19) to the pump body (30).

7. Disassemble the water pump by removing the pulley (20) from the adapter (22) or shaft.

8. Remove retaining ring (21) and use a puller to remove the pulley adapter (22) from the shaft. Remove retaining ring (23).

9. Remove cover plate (25) and gasket (26) by removing screws (24).

10. Place the front of the pump on a support in an arbor press and press the shaft and bearing assembly (27) out of the pump body (30) and impeller (28). The shaft and bearing assembly is one unit. Do not attempt to disassemble these parts.

11. Press the seal (29) out of the pump body.

### b. Cleaning and Inspection.

1. Discard gaskets and seals.

2. Wipe the fan blade with a cloth dampened with cleaning solvent. Clean all remaining parts except the shaft and bearing assembly with cleaning solvent; dry thoroughly.

### CAUTION

Do not immerse the shaft and bearing assembly in cleaning solvent. This may wash dirt into the bearings and contaminate the lubricant. The solvent cannot be removed entirely from the assembly after immersion.

3. Inspect the fan for cracks and for bent blades; replace if damaged.

### CAUTION

Do not attempt to straighten badly bent fan blades. Straightening blades may weaken them, resulting in failure during operation.

4. Inspect the fan pulley for cracks and distortion. Check the pulley groove(s) for rust and for rough spots. Clean up roughness or rust with fine emery cloth. Replace a worn or damaged pulley.

5. Inspect the fan belt(s) for cracks, deterioration, fraying, and wear. If more than one belt is used, replace as a matched set.

6. Inspect the bypass tube for cracks, dents, clogging, and other damage; replace a damaged bypass tube.

7. Inspect the pump shaft and bearing assembly for cracks, distortion, and signs of overheating. Check the bearings by rotating them on the shaft. If rough spots are detected, replace the shaft and bearing assembly using a service kit to ensure the required press between pulley and shaft.

8. If the bearings can be reused, check the seal surface of the shaft for a rough or grooved condition. If these conditions exist, a new shaft and bearing assembly must be installed.

9. Inspect the impeller for cracks, broken vanes, and wear. Replace a damaged impeller.

# ENGINE REPAIR AND OVERHAUL

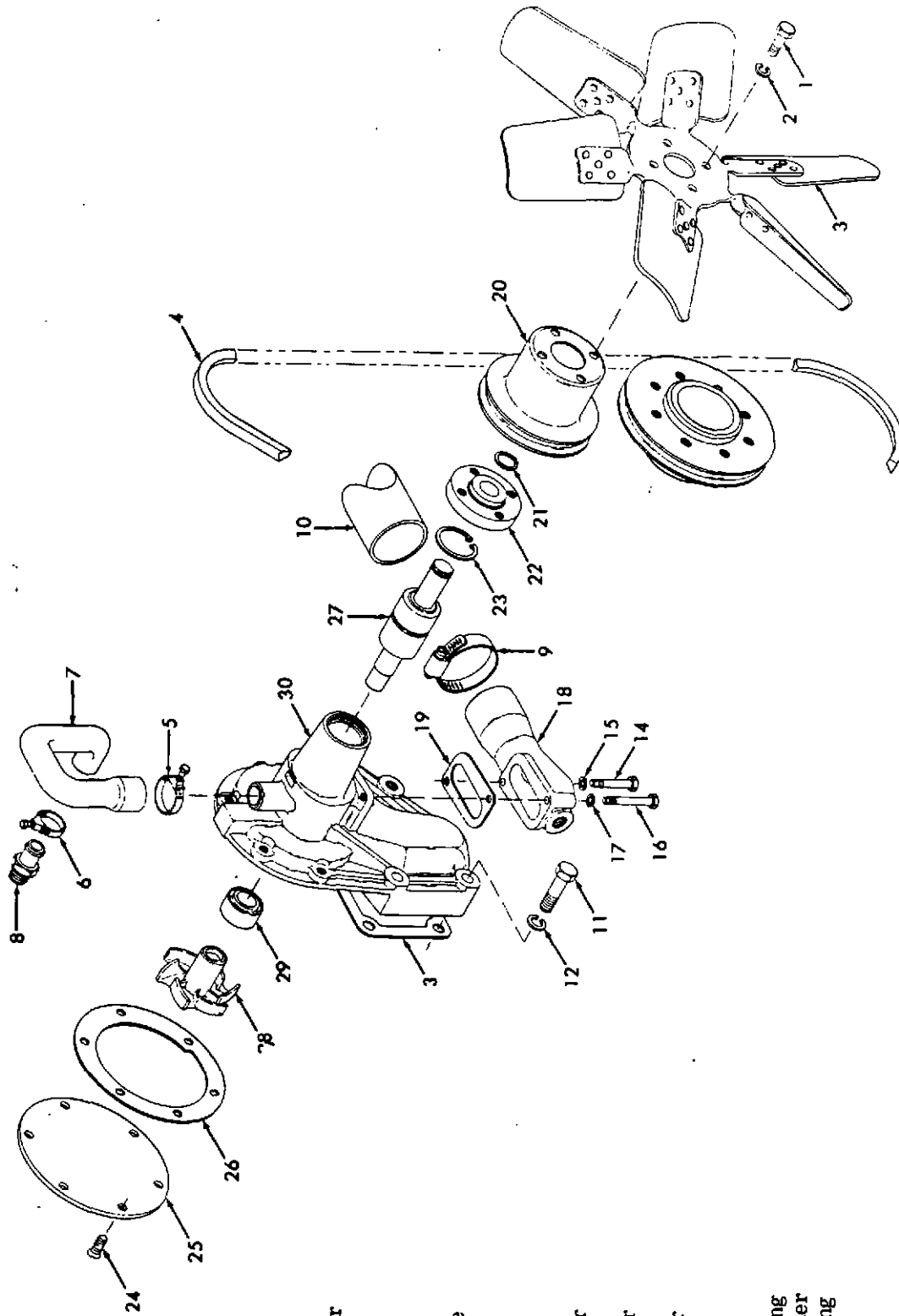

1. Bolt
2. Lock washer
3. Fan
4. V-belt
5. Hose clamp
6. Hose clamp
7. Bypass hose
8. Nipple
9. Hose clamp
10. Hose
11. Bolt
12. Lock washer
13. Bolt
14. Lock washer
15. Bolt
16. Lock washer
17. Inlet pipe
18. Gasket
19. Pulley
20. Retaining ring
21. Retaining ring
22. Pulley adapter
23. Retaining ring
24. Screw
25. Cover plate
26. Gasket
27. Shaft and bearing assembly
28. Impeller
29. Seal
30. Pump body

Figure 5-8. Water Pump and Fan, Exploded View

10. Inspect the pump body assembly and inlet pipe for cracks and for worn or damaged threads. Replace if damaged beyond repair.

c. Reassembly and Installation.

1. Press a new seal (29, figure 5-8) into the pump body (30). Press only on the outer flange of the seal to avoid damaging the seal.

2. Coat the seal surface of the shaft with grease and press the shaft and bearing assembly (27) into the body. Press only on the outer bearing race and not on the end of the shaft.

3. After installing retaining ring (23), support the pump shaft on the outer shaft end and press the impeller (28) onto the shaft. There must be 0.010-inch clearance between the impeller and a straight-edge placed across the rear face of the pump body. See figure 5-9.

4. Support the pump on the impeller end of the shaft and press the fan pulley adapter (22, figure 5-8) onto the shaft. Install the retaining ring (21).

5. Install a new cover gasket (26) and cover plate (25); and stake screws securely.

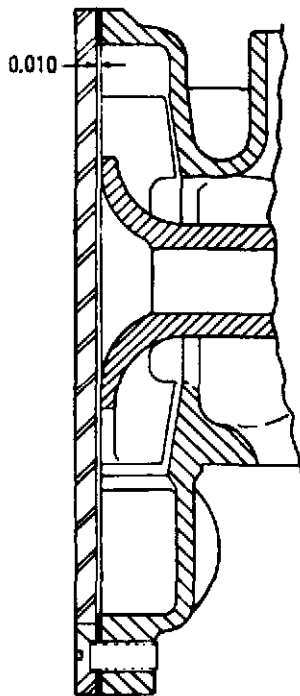

Figure 5-9. Water Pump Impeller Installation Dimensions

6. Install the pulley (20) on adapter (22) or shaft.

7. Use bolts (14 and 16) and lock washers (15 and 17) to mount water inlet pipe (18) and new gasket (19) to the water pump.

8. Install the assembled water pump and inlet pipe and gasket (13) on the engine; secure with bolts (11) and lock washers (12). Tighten the attaching bolts evenly and alternately to prevent possible damage.

9. Connect the water inlet hose (10) to the water pump and connect the bypass hose (7).

10. Install the fan belt(s) (4) but do not adjust belt tension at this time.

11. Install the fan (3) and secure the fan and pulley (20) to the adapter (22) with four bolts (1) and lock washers (2). Rotate the fan and check for binding or excessive resistance. If excessive resistance is felt, remove water pump and check for proper rotation of shaft and bearing assembly and for proper impeller clearance.

12. Adjust the fan belt tension by positioning the alternator in or out from the engine. Tighten the adjusting bolts. When properly tensioned, the belt deflects 3/4 inch with thumb pressure at a point midway between pulleys.

13. Install the radiator, hoses, and support brackets. Fill the radiator with clean water and rust inhibitor, or with a mixture of antifreeze and water.

5-9. THERMOSTAT.

The thermostat, located in the thermostat housing on side of the cylinder head, regulates coolant flow through the engine. It will not allow coolant from the engine to circulate through the radiator until the water in the engine reaches operating temperature. Instead, it bypasses water from the cylinder head through the bypass tube to the inlet side of water pump, where it is again circulated through the engine.

a. Removal.

1. Open the radiator drain cock and drain the radiator enough so that coolant will not flow from thermostat opening.

2. Loosen the hose clamp and disconnect the water return hose from the thermostat housing.

## ENGINE REPAIR AND OVERHAUL

3. Remove the thermostat housing (5, figure 5-19) and gasket (6) from the cylinder head by removing four bolts (1 and 3) and lock washers (2 and 4).

4. Remove the thermostat (7).

### b. Cleaning and Inspection.

1. Discard gasket (6).

2. Clean the exterior of all parts with a cloth dampened in cleaning solvent.

3. Inspect the thermostat housing for cracks, distortion, loose plug (8), and other damage; replace a damaged housing.

4. Inspect the thermostat for cracks, excessive scale, and other damage. Immerse the thermostat and a thermometer in a pan of water so that both are raised from the bottom of the container. Heat the water. Check that the thermostat starts to open at about 180°F, and is fully open at 200°F  $\pm 5^\circ$ . Replace a damaged or defective thermostat.

### c. Installation.

1. Install the thermostat (7) into the recess in the cylinder head so that the cone-shaped end points out.

2. Install the thermostat housing (5) and gasket (6) on the cylinder head; secure with four bolts (1 and 3) and lock washers (2 and 4).

3. Connect the water return hose and secure with a hose clamp.

4. Fill the radiator with required coolant. Make sure the drain is closed.

## 5-10. FUEL SYSTEM.

The engine fuel system consists of a fuel pump, fuel filter, fuel lines, and carburetor. The engine may also be equipped with either a velocity governor or a mechanical governor.

The fuel pump draws fuel from the fuel tank and pumps it through the filter to remove particles of dirt and moisture. Fuel is then forced to the carburetor, where it is metered, vaporized, and mixed with air for distribution to the cylinders.

The velocity governor, when used, is mounted between the carburetor throat and the intake manifold, where it can sense the speed of the

airflow through the carburetor. The velocity governor is designed to restrict the maximum speed of the airflow to limit the maximum speed of the engine.

A mechanical governor, when installed, senses engine speed through a drive gear in mesh with the camshaft gear in the gear housing. Flyweights on this gear change the rotary motion of the gear to longitudinal motion which operates through levers and linkage to close the carburetor throttle plates to control engine speed. Unlike the velocity governor, the mechanical governor can maintain the engine speed at a desired setting, instead of just limiting the maximum speed.

## 5-11. FUEL PUMP.

The fuel pump pumps fuel from the fuel tank to the carburetor. The mechanical fuel pump, when used, is a conventional diaphragm type. It is driven by an arm that contacts the fuel pump cam on the engine camshaft.

An electric fuel pump may be used in place of the mechanical pump. It is operated by current from the engine electrical system while the ignition switch is ON. Since electric fuel pumps are not usually supplied with the engine, only the mechanical pump is covered below.

### a. Removal.

1. Shut off fuel to the engine.

2. Disconnect and remove the fuel line from the fuel tank at the pump (5, figure 5-10). Remove the fuel line (1) from the pump to the carburetor (12).

3. Remove the fuel pump (5) and gasket (6) from cylinder block by removing two nuts (2), lock washers (3), and flat washers (4).

### b. Cleaning and Inspection.

1. Discard all gaskets.

2. Wipe the exterior of the fuel pump with a cloth dampened in cleaning solvent.

3. Clean all remaining parts in cleaning solvent; dry thoroughly. Blow air through the fuel lines and fittings to make sure they are clear and unobstructed.

4. Check the fuel pump rocker arm for free operation and excessive wear. Check for damaged threads.

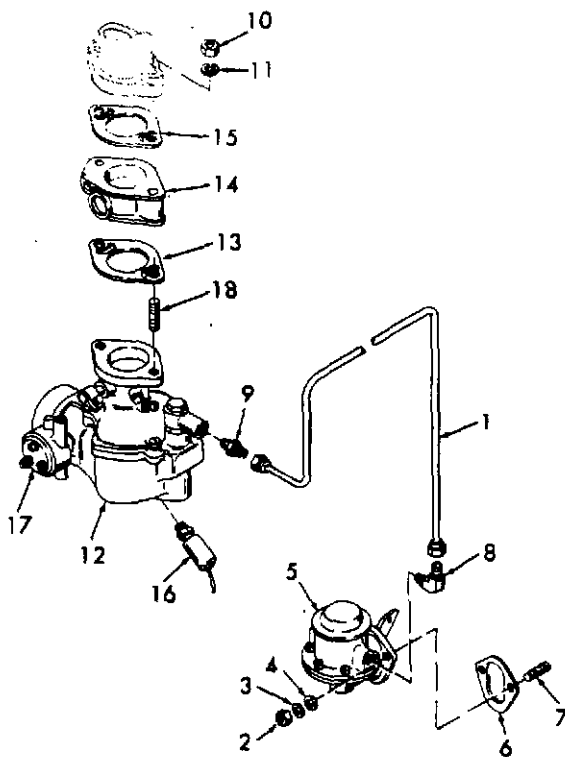

- |                |   |
|----------------|---|
| 1. Fuel line   | 11. Lock washer                               |
| 2. Nut         | 12. Carburetor                                |
| 3. Lock washer | 13. Gasket                                    |
| 4. Flat washer | 14. Valve box or velocity governor (optional) |
| 5. Fuel pump   | 15. Gasket                                    |
| 6. Gasket      | 16. Anti-dieseling solenoid (optional)        |
| 7. Stud        | 17. Automatic choke (optional)                |
| 8. Elbow       | 18. Stud                                      |
| 9. Connector   |   |
| 10. Nut        |   |

Figure 5-10. Fuel System, Exploded View

5. Inspect the fuel line for cracks, kinks, and other damage. Replace a damaged fuel line.

6. Inspect the fittings to make sure they are clear and check for damaged threads.

c. Installation.

1. Using new gasket (6), install the fuel pump (5) on the engine and secure with two nuts (2), lock washers (3), and flat washers (4).

2. Connect the fuel lines to the fuel pump and carburetor. Perform an on-engine test of the fuel pump; refer to following subparagraph d.

d. Testing.

The operation of the fuel pump can be tested on the engine by one of the following methods:

1. Install a tee in the fuel line between the pump and carburetor. Connect a pressure gauge to the tee. Start the engine and run it at approximately 1800 rpm. The gauge should register a pressure of 3 to 4-1/2 psi. Replace the fuel pump if pressure is less than 3 psi.

2. If no pressure gauge is available, test the fuel pump by disconnecting the fuel line at the carburetor. Crank the engine and check to see if fuel is being forcefully pumped from the fuel line. Replace pump if it is not operating properly.

5-12. FUEL FILTER.

The engine may be equipped with a fuel filter to remove solid particles and water from the fuel, preventing the contaminants from entering the carburetor to clog jets and passages. Filter use is optional, and filter type and installation vary with engine installation and application. Note the following:

a. A removable fuel bowl and filter, if used, may be mounted at the fuel pump outlet or elsewhere in the fuel system. To remove the bowl, loosen the knurled nut and swing aside the wire bail. Remove the bowl and gasket and discard the contaminated fuel. Remove and clean the filter element, then reinstall the element, bowl, and gasket. Swing the bail into place and check that the bowl seats squarely on the body. Tighten the knurled nut.

b. In-line filters cannot be cleaned. Remove the hose clamps which secure the fuel lines to the filter inlet and outlet, then remove and discard the filter. Install a new filter in the line with the arrow on the filter body toward the carburetor inlet, and tighten the hose clamps.

c. An electric fuel pump, if used, may contain a filter element. Unscrew the pump cover and remove the filter element. Clean the element in fuel oil or solvent and blow dry with compressed air. Reinstall the element and tighten the pump cover.

d. Some carburetors are provided with a bronze mesh filter in the carburetor inlet port. Disconnect the fuel line at the carburetor inlet. Unscrew the filter retainer and remove the element. The element can be cleaned with solvent, but replacement is recommended. Install the filter element and secure by tightening the filter retainer. Connect the fuel line.

# ENGINE REPAIR AND OVERHAUL

## 5-13. CARBURETOR.

The carburetor meters the fuel delivered to the engine and helps to vaporize the fuel and mix it with air so that it can burn readily in the combustion chambers. Metering of the fuel is accomplished by the float and inlet valve, and by calibrated jets and restriction orifices within the carburetor. The venturi within the carburetor throat creates an area of low pressure which helps to vaporize the fuel. Air mixes with the fuel vapors as they pass through the carburetor throat and into the intake manifold.

Several carburetor designs are in use on the engines covered in this manual, but the principles of operation are the same. Air flow can be upward through the carburetor (updraft) or downward into the manifold (downdraft), depending on the engine installation and carburetor model. The six-cylinder engine can be equipped with a two-barrel carburetor, which contains two throats to enable the carburetor to handle a larger volume of air and fuel at high efficiency.

The carburetor is equipped with either a manual or an automatic choke. The choke is closed during starting to restrict airflow into the carburetor, creating a richer fuel mixture required for engine operation until the engine warms up sufficiently to properly vaporize the fuel. The automatic choke, if used, performs the same function as a manual choke but is operated by an electric heating coil that slowly heats a bimetallic spring. A combination of manifold vacuum and the uncoiling action of the spring open the choke as required for smooth engine operation.

When specified, the carburetor can be equipped with an anti-dieseling solenoid. When the ignition switch is turned OFF, the solenoid is deenergized, closing the main jet orifice. This stops the flow of fuel to the engine to prevent dieseling caused by shutting down the engine with the throttle plates open.

A velocity governor or a valve box may be mounted between the carburetor and intake manifold. Refer to paragraph 3-12 for velocity governor adjustment instructions. The valve box, if used, operates with the mechanical governor. Refer to paragraph 5-14.

### a. Removal.

1. Shut off the fuel supply to the engine. Disconnect the fuel line (1, figure 5-10) to the carburetor inlet.

2. Disconnect the choke control cable, if used.

3. Tag and disconnect the wires to the anti-dieseling solenoid (16), if used, and the automatic choke (17), if used.

4. Disconnect the air inlet hose from the air cleaner to the carburetor inlet. Note the location of all other hoses and tubes and remove them from the carburetor.

5. Disconnect the throttle or accelerator linkage from the carburetor throttle lever. If the engine is equipped with a mechanical governor, disconnect the governor linkage at the ball joint on the carburetor throttle lever, or the lever on the valve box, if used.

6. Loosen the nuts (10) and lock washers (11) which secure the carburetor (12) to the intake manifold. Support an updraft carburetor, and remove the nuts and lock washers.

7. Pull off the carburetor and gasket (13). An updraft carburetor will fall free when the nuts are removed, and the velocity governor or valve box (14) and gasket (15), if used, will follow it.

### b. Cleaning and Inspection.

#### WARNING

Some carburetor cleaners are toxic and flammable. Take precautions to prevent inhalation of carburetor cleaner fumes and to prevent contact with the skin. Do not use carburetor cleaner in the presence of heat or flame.

#### CAUTION

Do not allow particles of dirt, old gasket material, or other foreign matter to enter the intake manifold. Once in the manifold, debris can enter the cylinders, causing damage to the pistons, rings, and cylinder walls.

1. Use a commercial carburetor cleaner to clean the carburetor and linkage, and the valve box, if used.

2. Move the carburetor to a clean work area and repair it according to the manufacturer's

instructions. When ordering parts, be sure to note the carburetor model, including dash number, stamped on the carburetor or identification tag.

3. Do not attempt to disassemble the velocity governor, if used. Wipe the outside of the governor and the governor throat with a cloth dampened with carburetor cleaner, but do not allow the solvent to enter the spring chamber.

4. Remove all traces of old gaskets from the mating surfaces of the carburetor, intake manifold, and velocity governor or valve box.

5. Inspect fuel lines, fittings, and carburetor attaching hardware for stripped threads and other damage. Replace defective parts.

#### c. Installation.

Installation of the carburetor is the reverse of removal. Refer to figure 5-10 and note the following:

1. The velocity governor, if used, must be installed with the longer side of the throttle plate toward the carburetor. If an airflow arrow is provided on the governor body, it must point toward the intake manifold.

2. Use new gaskets. Tighten the attaching nuts evenly and alternately to avoid warping or cracking the carburetor casting. Do not over-tighten the nuts.

3. Reconnect all hoses, tubes, wires, and controls. Start the engine and allow it to reach operating temperature, then refer to paragraph 3-11 for carburetor adjustment instructions.

### 5-14. MECHANICAL GOVERNOR.

The mechanical governor is used primarily to maintain the selected engine speed under varying loads. The governor assembly is mounted on the gear housing cover, and has a gear which is in mesh with the camshaft gear to sense engine speed. Flyweights on the governor shaft move outward as engine speed increases. The weights exert a thrust which is transferred through levers to open or close the carburetor throttle plate to regulate engine speed.

When used as a constant speed governor, the governor maintains engine speed at a preset value. A throttle cable is used only to override the governor to return the engine to idle; when the throttle is released, the engine returns to full governed speed within the power limits of the engine. This governed speed is adjusted with stop screws.

When used as a variable speed governor, a throttle control connected to a bellcrank allows the operator to adjust the governed speed from the control panel. Once the speed is selected, the governor will maintain the engine speed under varying loads, within the power limits of the engine, until the throttle control is moved again.

#### a. Adjustment.

Adjust the governor as described in paragraph 3-13.

#### b. Removal.

1. Disconnect the throttle linkage, if used, at the governor bellcrank (8, figure 3-6). Disconnect the governor connecting rod (1) at the governor arm and carburetor, or valve box, if used. Remove the rod.

2. Loosen the nut (9) to release tension on the spring (11), and disconnect the spring from the eyebolts (10 and 13). Remove the speed eyebolt (10) from the bellcrank (8). Disassemble the bellcrank as required. In some constant speed applications, the bellcrank (8), adjusting screws (5 and 7), and bracket (18) may be replaced by a governor spring bracket, which provides mounting for speed eyebolt (10).

3. Remove the cap screws (1, figure 5-30) and lock washers (2) securing the governor (3) to the gear housing cover (18).

#### NOTE

The governor gear thrust washer (5) is not secured to the governor shaft. Remove the governor carefully to avoid dropping the thrust washer into the gear housing.

4. Carefully pull out the assembled governor (3), gear (6), and thrust washer (5) from the gear housing, and remove the gasket (4). Pull off the thrust washer.

5. If the governor gear is worn or damaged and requires replacement, measure the distance from the face of the gear to the mating surface of the governor housing (dimension A, figure 5-11). Record this dimension for use when reinstalling the governor gear.

#### NOTE

Different timing gear sets and governor gears are used on distributor ignition engines than on magneto ignition engines.

## ENGINE REPAIR AND OVERHAUL

Distributor ignition engines use a combination having a 25-tooth crankshaft and a 50-tooth camshaft gear, with a 17-tooth governor drive gear. Magneto ignition engines use a combination having a 24-tooth crankshaft gear and a 48-tooth camshaft gear with a 16-tooth governor drive gear.

6. When installed, the end of the governor shaft rides in a replaceable bushing (27, figure 5-30) pressed into the gear housing. If the bushing is scored or worn, screw a pipe tap into it and pull it from the bore in the gear housing.

### c. Cleaning and Inspection.

1. Clean all parts by immersing in diesel fuel oil or cleaning solvent. Clean threaded parts with a wire brush. Allow all parts to dry thoroughly before reassembly.

2. Inspect the governor housing for cracks and other damage. Check that the weights move freely, but without excessive play. Replace the governor if the housing is damaged, or if any parts are worn or damaged. No repair of the governor assembly is recommended.

3. Inspect the springs for distortion and damage; replace if defective.

### d. Installation.

1. If the bushing (27, figure 5-30) was removed, press a new bushing into the bore in the gear housing until it is flush with the back surface of the housing.

2. If a new gear is being installed, press it onto the governor shaft to the dimension measured at removal. See figure 5-11.

3. Lubricate the governor assembly with engine oil and slide the thrust washer (5, figure 5-30) onto the end of the governor shaft. Install the assembled governor and gear in the gear housing cover, using a new gasket (4). Secure the governor with two cap screws (1) and lock washers (2).

4. Assemble the remaining parts of the governor linkage as shown in figure 3-6.

5. Refer to paragraph 3-13 and adjust the governor linkage.

## 5-15. AIR SUPPLY AND EXHAUST SYSTEMS.

The intake air first passes through an air cleaning system, which removes all foreign

NOTE: MEASURE AND RECORD DIMENSION "A" BEFORE REMOVING GOVERNOR GEAR

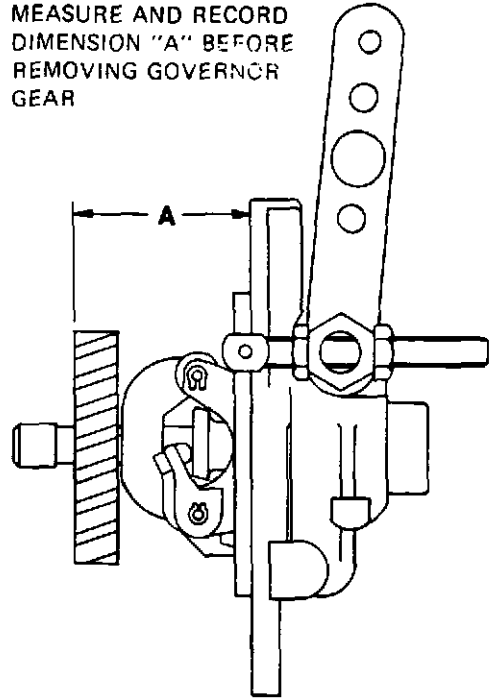

Figure 5-11. Governor Gear Installation Dimension

matter, dust, and grit which would otherwise enter the engine and cause excessive wear. This is accomplished by a dry-type air cleaner which filters the air through a porous paper element.

From the air cleaner, the air passes into the carburetor, where it is mixed with the vaporized fuel. The air-fuel mixture passes into the intake manifold and is distributed to the cylinders for combustion.

After combustion occurs in the cylinders, the hot exhaust gases are forced out of the cylinders and pass into the exhaust manifold. From the manifold, the gases are directed to a muffler to reduce the noise level, then to the atmosphere.

The crankcase ventilation system vents crankcase gases into the intake manifold. A hose connects the breather cap on the cylinder head cover to the air cleaner to filter the crankcase gases. When the engine is running, piston blow-by and oil vapors pass through the air cleaner and carburetor, to be burned in the combustion chambers along with the fuel-air mixture.

## 5-16. AIR CLEANER.

It is important to perform extensive inspections of the air cleaner system from time to time. Figure 5-12 illustrates a typical air intake system. Check particularly for the following:

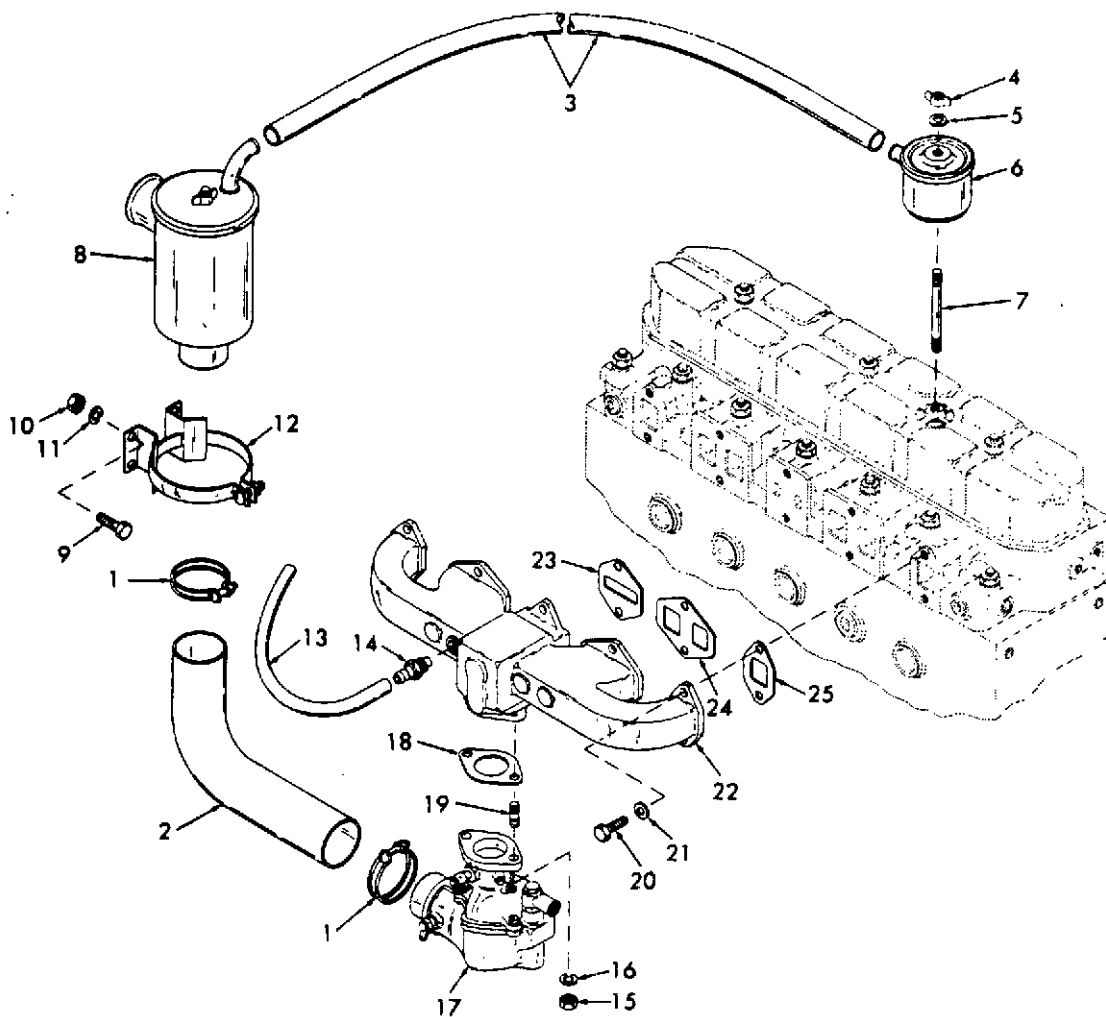

- |                  |                                  |                     |
|------------------|----------------------------------|---------------------|
| 1. Hose clamp    | 10. Nut                          | 18. Gasket          |
| 2. Hose          | 11. Lock washer                  | 19. Stud            |
| 3. Breather hose | 12. Bracket                      | 20. Cap screw       |
| 4. Wing nut      | 13. Ventilation hose (optional)  | 21. Washer          |
| 5. Washer        | 14. Ventilation valve (optional) | 22. Intake manifold |
| 6. Breather cap  | 15. Nut                          | 23. Gasket          |
| 7. Stud          | 16. Lock washer                  | 24. Gasket          |
| 8. Air cleaner   | 17. Carburetor                   | 25. Gasket          |
| 9. Cap screw     |                                  |                     |

Figure 5-12. Typical Air Intake System, Exploded View

a. Check carefully for leaks which could allow unfiltered air to enter the engine. Make sure all gaskets are in good condition and that all tubes, hoses, and pipes are free from cracks, holes, and faulty connections.

b. Check the element of dry-type air cleaners for cracks, holes, clogging, and defective sealing surfaces. If the element is damaged, or if it has been cleaned more than six times, the element must be replaced.

c. Check the air cleaner-to-manifold hoses. Accumulations of dust and dirt in the interior of the hoses indicate inefficient air cleaner operation. Determine and correct the reason for the faulty operation.

d. Check the air cleaner mounting to make sure it is secure. A loosely mounted air cleaner may shake loose the interconnecting lines to the engine.

# ENGINE REPAIR AND OVERHAUL

## 5-17. INTAKE MANIFOLD.

The intake manifold distributes the fuel-air mixture from the carburetor to the cylinders. When the engine is at operating temperature, the heat from the manifold assists in the vaporization of the fuel.

### a. Removal.

1. Disconnect the ventilation hose (13, figure 5-12), if used, from the manifold (22).

2. Remove the carburetor (paragraph 5-13).

3. Remove the cap screws (20) and washers (21) securing the intake manifold (22) to the cylinder head. Pull off the manifold and gaskets (23, 24, and 25).

### b. Cleaning and Inspection.

1. Discard all gaskets.

2. Clean the manifold with cleaning solvent. Make sure all gasket mounting surfaces are clean. Dust and dirt in the interior of the manifold indicate poor air cleaner operation. Correct the cause at reassembly.

3. Inspect the intake manifold for cracks, distortion, damaged threads, and other damage. Replace a damaged manifold.

4. Replace damaged manifold mounting studs or intake pipe mounting studs.

### c. Installation.

Always use new gaskets (23, 24, and 25, figure 5-12) when assembling the manifold (22) to the engine. Secure with cap screws (20) and washers (21). Tighten all cap screws lightly at first; then, starting at the center of the manifold, work outward, tightening the cap screws in progressive steps to 20 foot-pounds torque.

## 5-18. EXHAUST MANIFOLD.

The exhaust manifold conducts the hot exhaust gases from the cylinders and out of the engine. In some applications, an exhaust pipe and muffler are mounted on the manifold.

### a. Removal.

1. Remove the muffler (1, figure 5-13) from the adapter (3). Remove any muffler adapters (3) and gaskets (4) by removing attaching nuts (2) from manifold studs (13).

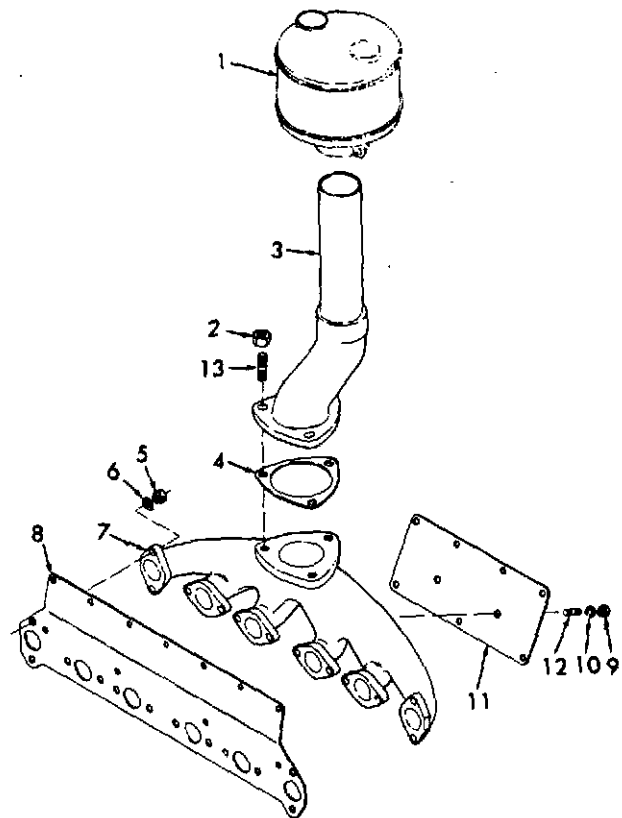

- |                     |                             |
|---------------------|-----------------------------|
| 1. Muffler          | 8. Gasket                   |
| 2. Nut              | 9. Nut                      |
| 3. Adapter          | 10. Lock washer             |
| 4. Gasket           | 11. Distributor heat shield |
| 5. Nut              | 12. Stud                    |
| 6. Washer           | 13. Stud                    |
| 7. Exhaust manifold |                             |

Figure 5-13. Muffler and Exhaust Manifold, Exploded View

2. Remove the exhaust manifold (7) and gaskets (8) from the engine by removing nuts (5) and washers (6).

3. Remove the nuts (9) and lock washers (10) which secure the distributor heat shield (11) to the exhaust manifold; remove heat shield.

4. Remove the studs (12 and 13) if they are stripped or damaged.

### b. Cleaning and Inspection.

1. Discard all gaskets.

2. Clean the exhaust manifold and related parts with a wire brush.

3. Inspect the exhaust manifold for cracks, distortion, severe rust, and damaged threads.

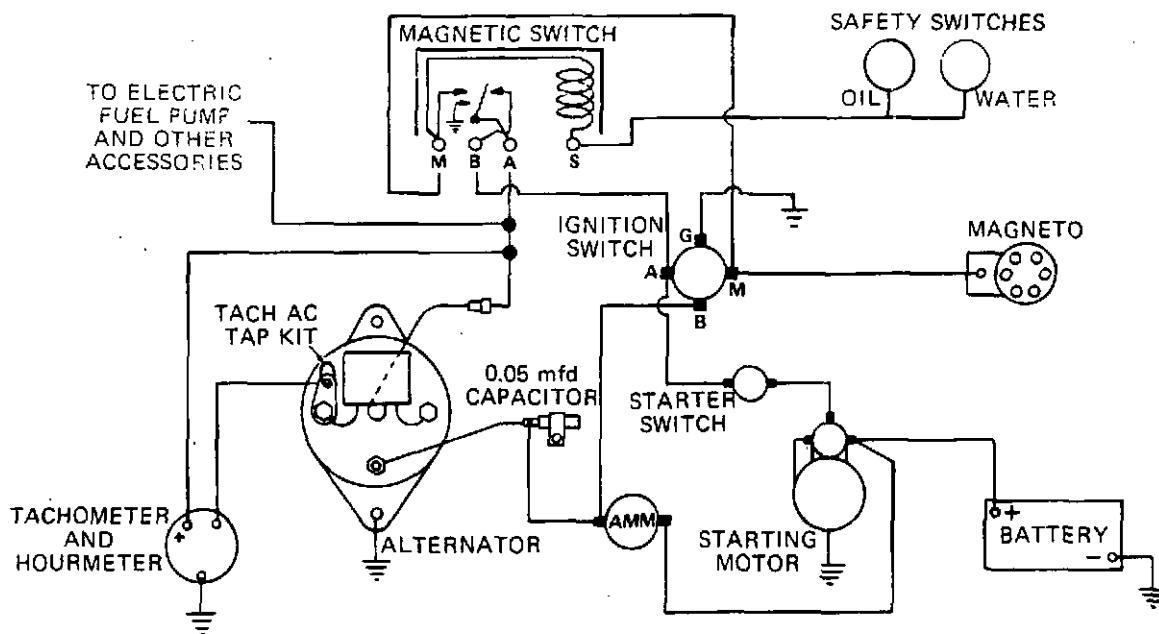

TYPICAL GASOLINE ENGINE WITH MAGNETO IGNITION AND SAFETY SWITCHES

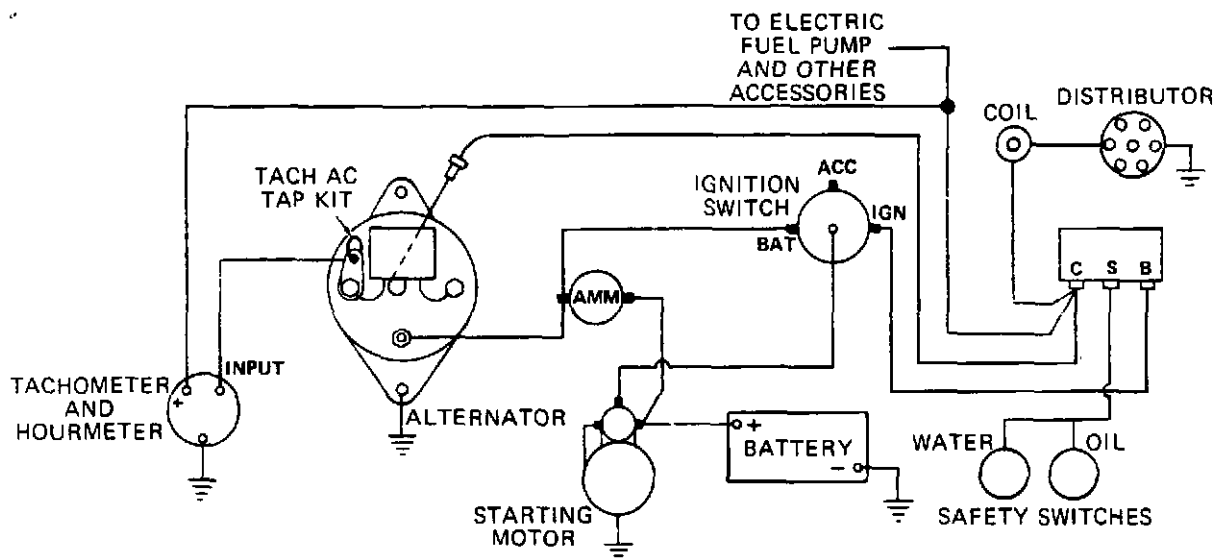

TYPICAL GASOLINE ENGINE WITH DISTRIBUTOR IGNITION AND SAFETY SWITCHES

Figure 5-14. Electrical System and Ignition System Schematic Diagrams

4. Inspect the remaining parts for cracks, distortion, corrosion, damaged threads and other damage; replace damaged parts.

c. Installation.

Always use new exhaust gaskets (8) at installation. Tighten the nuts to 20 foot-pounds torque. Start the tightening sequence at the center of the manifold and work outward, tightening the nuts in progressive steps.

5-19. ELECTRICAL SYSTEM.

The engine electrical system supplies power to the starting motor, ignition system, and electrical accessories. During cranking, this power is obtained from one or more storage batteries; while the engine is running, the alternator generates electricity to recharge the battery and maintain the operation of the ignition system and engine accessories. Typical schematics illustrating the interconnection of the components of

## ENGINE REPAIR AND OVERHAUL

the electrical system with the ignition system are shown in figure 5-14.

The starting motor cranks the engine when either the ignition switch or starter switch supplies power to energize the starter solenoid. When energized, this solenoid causes engagement of the starter pinion with the flywheel ring gear and completes the circuit to energize the starter motor and crank the engine.

The alternator provides charging current for the battery and operating current for the ignition system and electrical components while the engine is running. A voltage regulator is provided to maintain alternator output voltage within preset limits. This regulator can be integral with the alternator, or mounted separately. An ammeter on the instrument panel monitors alternator output.

When required, the electrical system can include a magnetic ignition switch in addition to the usual key-operated ignition switch on the instrument panel. This switch incorporates a solenoid controlled by one or more safety switches. These safety switches stop the engine if engine oil pressure is too low or if coolant temperature is too high. An electric tachometer, or tachometer and hourmeter, can be connected through an AC tap on the alternator to sense engine speed. The electrical system also supplies power to an electric fuel pump, if used, and to other electrical accessories.

### 5-20. STARTING MOTOR.

The starting motor cranks the engine when the switch closes the circuit between the storage battery and the starter. Refer to manufacturer's service manual for repair and testing of the starting motor.

Some starting motor models have oil cups and require periodic lubrication as indicated in Section III. If no oil cups are provided, the starting motor requires lubrication only at overhaul.

If the starting motor fails to crank the engine, or cranks erratically, or if it fails to crank with sufficient speed to start the engine, check for poor cable connections, damaged leads, or worn brushes. Replace brushes if worn to less than half their original length. Clean and tighten cable and wire connections. If the starting motor still fails to operate properly, take it to an authorized service center.

### a. Removal.

#### WARNING

Before disconnecting leads to any electrical accessory, disconnect and tape the positive battery cable to deenergize the electrical system.

1. Disconnect and tag the electrical leads to the starting motor solenoid. Tape electrical lead ends to prevent shorting.

2. Remove the three nuts and lock washers securing the starting motor to the bellhousing.

### b. Cleaning.

To clean the starting motor, wipe the exterior with a cloth dampened in cleaning solvent; dry thoroughly.

### c. Installation.

1. Align the three holes on the starting motor mounting flange with the studs on the bellhousing.

2. Secure the starting motor with nuts and lock washers.

3. Connect the electrical leads to the starting motor solenoid.

4. Check starter operation. The starter drive must engage the ring gear smoothly and quietly, and the starting motor must crank the engine smoothly, without excessive noise, and with enough speed to start the engine.

### 5-21. ALTERNATOR AND REGULATOR.

The alternator and voltage regulator, whether integral or separate, operate together to maintain the required charge on the battery. The ammeter provides a good check of alternator output and regulator control. If the alternator charges at a higher rate immediately after starting and then slowly tapers off to a near-zero charging rate, the alternator is functioning properly.

Faulty operation may be due to high resistance wiring connections, broken wires, faulty ground connection, or worn brushes. Replace brushes if they are worn to less than half their original length.

Some alternator models require periodic lubrication as indicated in Section III. This is essential to the proper operation of the alternator. A noisy alternator is usually a sign of bearing failure.

If the alternator fails to maintain sufficient output, take it to an authorized service center for repairs.

a. Removal.

1. Disconnect and tag electrical leads from the alternator.

2. Loosen the hinge bolt in the mounting bracket and loosen the bolt in the alternator adjusting arm. Remove the belts from the alternator pulley.

3. Support the alternator and remove the hinge bolt. Remove the alternator mounting bolt from adjusting arm; remove the alternator from the engine.

4. Remove the pulley and alternator fan by removing nut and lock washer from alternator shaft.

b. Cleaning and Inspection.

1. Wipe the exterior of the alternator with a cloth dampened in cleaning solvent. Be careful not to allow solvent to enter the alternator.

2. Clean all remaining parts with cleaning solvent; dry thoroughly.

3. Inspect all parts for cracks, distortion, damaged threads, or other damage. Replace any damaged parts.

c. Installation.

1. Mount the fan and pulley on the alternator shaft and secure with a nut and lock washer.

2. Install alternator and secure with hinge bolt and adjusting arm bolt, but do not tighten. Place belt(s) on alternator pulley and adjust belt tension. The belt(s) tension is correct when thumb pressure midway between pulleys deflects the belt(s) 3/4 inch. Tighten bolts.

3. Connect electrical leads to alternator.

## 5-22. IGNITION SYSTEM.

The ignition system supplies a high-voltage electrical charge to the spark plugs to ignite the

fuel-air mixture in the combustion chambers. This spark must be accurately timed to the motion of the crankshaft and valves so that the spark occurs at precisely the right instant for maximum power. White engines are provided with either a distributor or magneto ignition system. The difference between a distributor type and magneto type system is that, in a distributor type system, the power to generate the ignition spark is derived from the engine electrical system through use of an ignition coil. In the magneto system, the power is generated by a rotating magnet and an electrical coil in the magneto.

The distributor shaft is rotated by the oil pump shaft, which is gear-driven by the engine camshaft. A cam and breaker point set within the distributor starts and stops the flow of current from the electrical system through the primary circuit in the ignition coil. When the flow of current stops, a high voltage current is induced in the ignition coil secondary circuits. This current flows to the center tower of the distributor cap, and the distributor rotor distributes it to the correct spark plug.

The magneto can be used in place of the distributor and ignition coil. It is driven by a gear which is in mesh with the camshaft gear in the gear housing, and contains a small generator to supply current to an integral ignition coil. As occurs in a distributor, cam-operated breaker points within the magneto open to stop the flow of current in the ignition coil primary circuit, inducing high voltage current in the secondary windings. A rotor within the magneto distributes this current to the correct spark plug.

The spark plugs are mounted in the cylinder head with their electrodes projecting into the combustion chamber. High voltage current from the distributor or magneto flows through the insulated center electrode of each spark plug and jumps the gap between the center and ground electrodes. This creates a spark which ignites the fuel-air mixture in the combustion chamber.

Refer to figure 5-14 for schematic diagrams of typical distributor and magneto ignition systems. Note that with a distributor ignition, the ignition switch controls the flow of current from the electrical system to the distributor breaker points and ignition coil. With magneto ignition, no current from the engine electrical system is required. When the ignition switch is ON, one circuit of a double-pole ignition switch is open to ground to enable the magneto breaker points to control the current flow in the magneto primary circuit.

## ENGINE REPAIR AND OVERHAUL

### 5-23. DISTRIBUTOR AND IGNITION COIL.

The distributor performs two distinct functions simultaneously to provide a spark at the spark plugs to ignite the fuel-air mixture. A cam on the distributor shaft opens and closes a set of breaker points to control the flow of current to the primary circuit of the ignition coil. The distributor rotor and cap distribute secondary current from the ignition coil secondary circuits to the correct spark plug as required.

The distributor must be timed to the crankshaft and camshaft to ensure that the spark is produced in the correct cylinder at precisely the correct time. Fine timing adjustments are made by rotating the distributor body with respect to the distributor shaft. Mechanical spark advance is provided to advance or retard the timing to coincide with engine speed.

#### a. Adjustment and Timing.

1. Refer to paragraph 3-9 for adjustment and timing procedures, except for timing at installation, which is provided below.

2. Spark plug cable locations are illustrated in figure 3-3.

#### b. Removal.

1. Disconnect the primary wire and ignition cable (1, figure 5-15) from the distributor to the ignition coil. Tag and disconnect the spark plug cables (2).

2. Remove the No. 1 spark plug. With your thumb or finger over the spark plug hole, rotate the crankshaft in the normal direction of its rotation until the No. 1 piston is on the compression stroke, as indicated by air being expelled from the cylinder. Continue to rotate the crankshaft until the top dead center (TDC) mark on the flywheel aligns with the timing mark on the bellhousing (see figure 3-4).

3. Remove the distributor cap and note carefully the position of the distributor rotor. It should point approximately to the position of the No. 1 spark plug cable indicated in figure 3-3.

4. Remove the cap screws (4, figure 5-15) and lock washers (5) which secure the clamps (6) to the cylinder block. Remove the clamps and pull the distributor (7) from the cylinder block.

5. Remove the O-ring (8) and spacer (9) from the distributor body.

6. If the coupling (11) is worn or damaged, drive out the pin (10) and remove the coupling.

7. If the ignition coil (14) is defective, disconnect the wires and remove the screws (12) and washers (13) which secure the ignition coil to the bracket (16). Remove the coil from the bracket.

#### c. Cleaning and Inspection.

1. Wipe the outside of the distributor with a cloth dampened with Diesel fuel oil or solvent, but do not immerse the distributor in the fluid. Use filtered compressed air to dry the distributor and to blow out loose dust and dirt.

2. Inspect the distributor for a cracked body, excessively worn shaft bushings, and loose or damaged breaker plate.

3. Inspect the insulation at the top of the ignition coil for cracks and chips and for signs of arcing. Replace the coil if it is defective.

4. If the engine is equipped with a distributor heat shield, check that it is not cracked or damaged, and that it is securely mounted to the exhaust manifold. Refer to paragraph 5-18.

#### d. Installation.

1. If the ignition coil was removed, reinstall the ignition coil (14, figure 5-15) and bracket (16) on the cylinder block.

2. To reinstall the coupling (11), rotate the distributor shaft until the rotor points to the No. 1 cylinder firing position (figure 3-3). Install the coupling on the shaft with the coupling offset positioned as shown in figure 5-16, and press it onto the shaft to the length shown. If a new coupling is being installed on an old distributor drill a hole for the pin (10, figure 5-15), using the partially factory pre-drilled hole for a guide. Use a No. 30 (0.1285 inch diameter) drill. If the old coupling is being installed on a new distributor shaft, position the coupling on the shaft as shown in figure 5-16 and use a No. 30 drill to drill through the shaft, using the old hole in the coupling as a guide. Install the pin (10, figure 5-15).

3. Install the spacer (9) on the distributor body. Coat the O-ring (8) with light grease and install it on the distributor.

4. Install the rotor on the distributor shaft. Refer to figure 3-3 and rotate the distributor shaft until the rotor points in the approximate location of the No. 1 spark plug cable.

1. Ignition cable
2. Spark plug cable
3. Spark plug
4. Cap screw
5. Lock washer
6. Clamp
7. Distributor
8. O-ring
9. Spacer
10. Pin
11. Coupling
12. Cap screw
13. Washer
14. Ignition coil
15. Cap screw
16. Bracket
17. Spacer
18. Nut
19. Lock washer
20. Adapter
21. Shaft and gear
22. Gasket

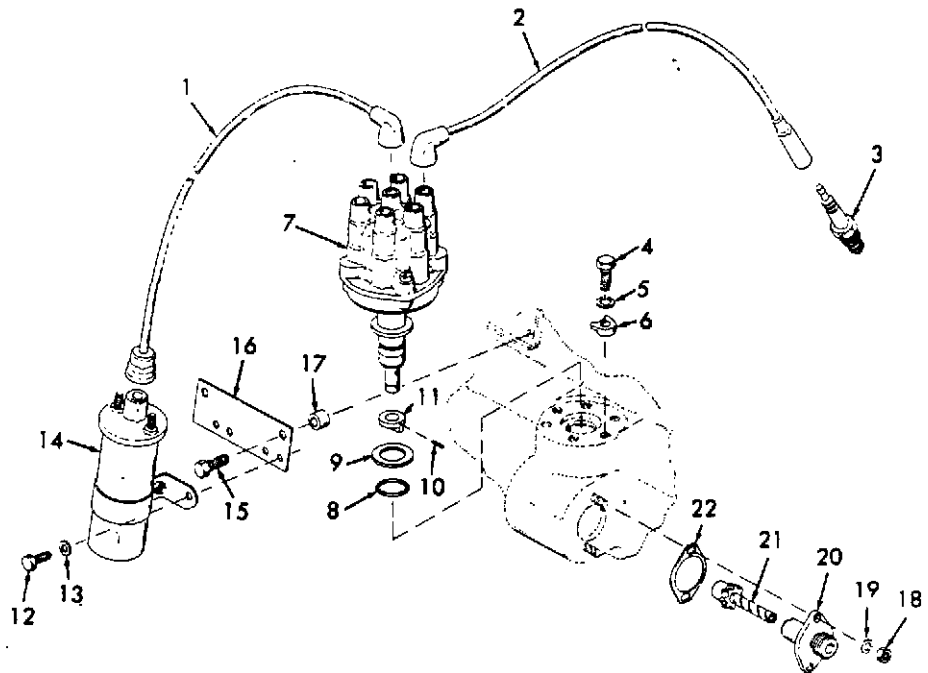

Figure 5-15. Distributor Ignition System, Exploded View

5. Check that the arrows stamped on the oil pump shaft and distributor mounting flange are aligned as shown in figure 5-6. With the distributor coupling positioned at No. 1 spark plug cable location as shown in figure 3-3, install the distributor in the cylinder block bore.

6. Rotate the rotor slightly until the coupling tang engages the notch in the oil pump drive shaft, and push the distributor firmly into the block bore. Install the two clamps (6, figure 5-15), cap screws (4), and lock washers (5), but do not tighten the screws fully.

7. Check that the engine is at top dead center (TDC) for the No. 1 cylinder. Refer to subparagraph b.2., above, for instructions.

8. Rotate the distributor body slightly to position the rubbing block on the breaker arm on the highest point of the nearest cam lobe. Use a feeler gauge to set the point gap to  $0.020 \pm 0.001$  inch.

9. Rotate the distributor body clockwise to bring the breaker arm to the low part of the cam.

10. Rotate the distributor body counter-clockwise until the breaker arm rubbing block is just starting up the cam lobe. Continue to rotate very slightly until there is a 0.002 inch gap between the breaker points. Tighten the cap screws (4) on the clamps (6) to secure this preliminary adjustment.

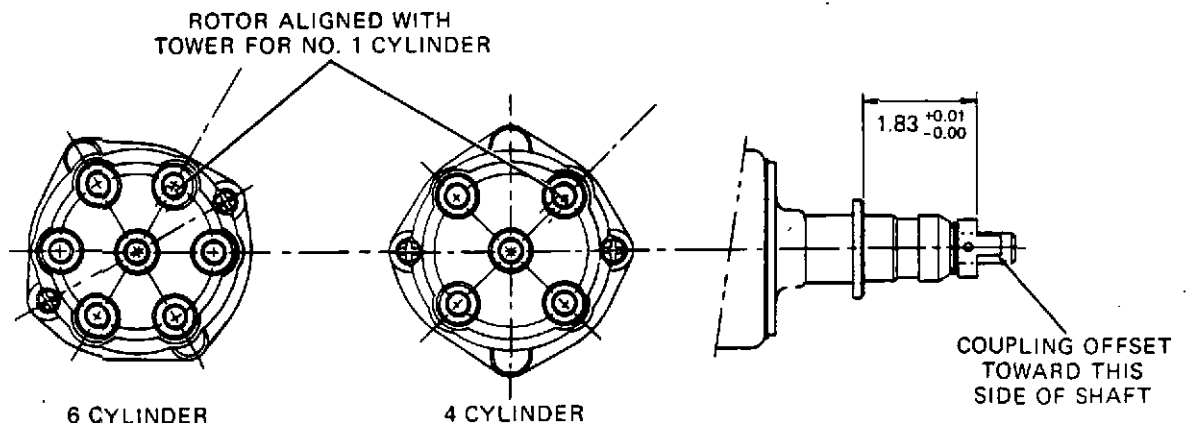

Figure 5-16. Distributor Coupling Installation

## ENGINE REPAIR AND OVERHAUL

1. Spark plug cable
2. Spark plug
3. Nut
4. Lock washer
5. Stud
6. Cap screw
7. Cover
8. Gasket
9. Nut
10. Lock washer
11. Flat washer
12. Magneto
13. Gasket
14. Adapter
15. Gasket
16. Cotter pin
17. Nut
18. Gear
19. Stud
20. Stud

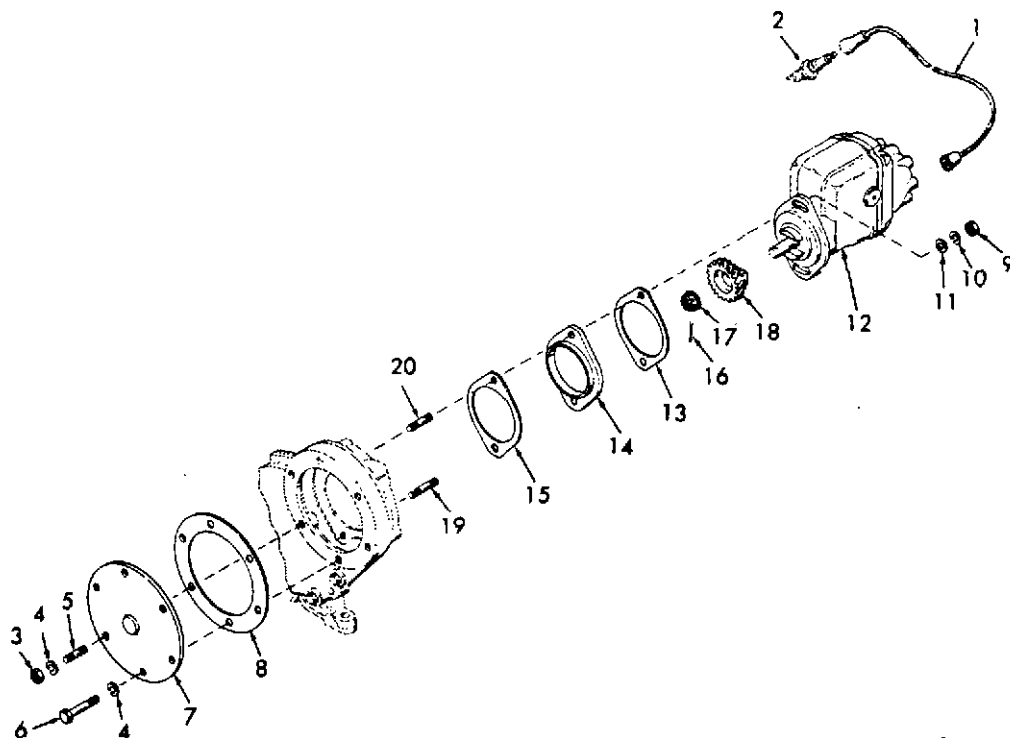

Figure 5-17. Magneto Ignition System, Exploded View

11. If possible, recheck the ignition timing as described in paragraph 3-9.

### 5-24. MAGNETO.

A magneto contains its own means of generating ignition current, and does not require any power connections to it. A cam on the magneto shaft opens and closes a set of breaker points to control the flow of current through the integral ignition coil. A distributor rotor and cap distribute high-voltage current from the coil to the correct spark plug as required.

The magneto must be timed to the crankshaft and camshaft to ensure that the spark is produced in the correct cylinder at the required time. The timing is adjusted by aligning timing marks on the magneto and camshaft gear, and then rotating the magneto body with respect to the shaft. Mechanical spark advance is provided to advance or retard the timing during engine operation.

#### a. Adjustment and Timing.

1. Refer to paragraph 3-10 for adjustment and timing procedures, except for timing at installation, which is provided below.

2. Spark plug cable locations are illustrated in figure 3-3.

#### b. Removal.

1. Tag and disconnect the spark plug cables. Disconnect the primary lead to the ignition switch.

2. Remove the nuts (3, figure 5-17), cap screws (6), and lock washers (4) which secure the cover (7) to the gear housing cover. Remove the cover and gasket (8).

3. Rotate the engine crankshaft by hand in the normal direction of its rotation until the timing marks on the camshaft gear and magneto gear are aligned. This will facilitate installation of the magneto.

4. Remove the nuts (9), lock washers (10), and flat washers (11) which secure the magneto (12) to the gear housing. Pull the magneto straight back, and remove the gasket (13), adapter (14), and gasket (15).

5. If the magneto gear (18) is worn or damaged, remove the cotter pin (16) which retains the nut (17). Unscrew and remove the nut while holding the gear, and pull off the gear from the magneto shaft.

6. If studs (5, 19, and 20) are bent, stripped, or damaged, remove them from the gear housing cover and gear housing.

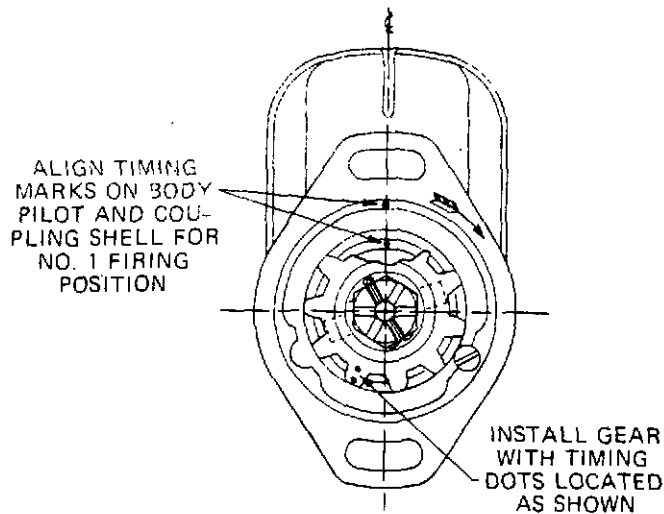

Figure 5-18. Magneto Gear Installation

c. Cleaning and Inspection.

1. Wipe the magneto with a clean cloth dampened with kerosene or solvent, but do not allow fluid to enter the magneto. Clean all other parts by immersing in solvent, using a wire brush if necessary to remove accumulations of dirt and grease.

2. Remove all traces of old gaskets from the magneto, adapter, cover, and gear housing, using a gasket scraper or knife.

3. Refer to paragraph 3-10 for replacement and adjustment of the magneto breaker points. Other magneto repairs should be performed by a fully equipped ignition shop.

4. Inspect the adapter and cover for cracks, distortion, and other damage. Inspect attaching hardware for stripped threads and other damage; replace defective parts.

d. Installation and Timing.

1. Rotate the coupling shell to align the timing marks on the coupling shell and magneto body pilot, as shown in figure 5-18. Install the magneto gear (18, figure 5-17) with the timing dots on the gear positioned as shown. Secure the gear with the nut (17), and retain the nut with a cotter pin (16).

2. If they were removed, install the studs (5, 19, and 20) in the gear housing cover and the gear housing.

3. Check that the crankshaft is at No. 1 cylinder top dead center (TDC). If it was not set previously, remove the No. 1 spark plug and place your thumb or finger over the spark plug

hole. Rotate the engine crankshaft in the normal direction of its rotation until the No. 1 piston is on the compression stroke as indicated by air being expelled from the cylinder. Continue to rotate the crankshaft until the TDC mark on the flywheel aligns with the timing mark on the bell-housing (see figure 3-4).

4. Install the adapter (14, figure 5-17) and gaskets (13 and 15) on the gear housing.

5. Position the assembled magneto and gear on the gear housing, making sure that the timing marks on the magneto gear align with the timing marks on the camshaft gear.

6. Secure the magneto and adapter to the gear housing with two nuts (9), lock washers (10) and flat washers (11). Do not overtighten the nuts.

7. Position the cover (7) and gasket (8) on the gear cover, and secure the cover (7) with nuts (3), cap screws (6), and lock washers (4).

8. Refer to figure 3-3 to connect the spark plug cables. Connect the primary wire to the magneto terminal. If this wire is not connected, it will not be possible to stop the engine with the ignition switch.

9. Time the magneto to the engine as described in paragraph 3-10.

5-25. TACHOMETER DRIVE.

The engine may be equipped with provision for a mechanical tachometer driven off the oil pump shaft. The tachometer drive mechanism is mounted in the distributor mounting boss in the side of the cylinder block, and is rotated through a gear which is in mesh with the oil pump drive gear. If the engine is not equipped with a tachometer drive, the opening in the cylinder block is sealed with a cover (46, figure 5-35).

The engine may be equipped with an electrical tachometer connected to the engine electrical system. Refer to paragraph 5-19 for further information.

a. To remove the tachometer drive, disconnect the tachometer cable from the adapter (20, figure 5-15). Unscrew and remove the nuts (18) and lock washers (19) which secure the adapter (20) to the cylinder block. Remove the adapter and gasket (22) and pull out the assembled shaft and gear (21).

b. Clean all parts with kerosene or solvent. Replace defective parts.

## ENGINE REPAIR AND OVERHAUL

c. Insert the shaft and gear (21) into the adapter (20), and install the adapter and gasket (22) in the side of the cylinder block. Secure with two lock washers (19) and nuts (18).

### 5-26. ROCKER ARM ASSEMBLY.

The rocker arm assembly is mounted on top of the cylinder head to operate the intake and exhaust valves. The rocker arms are pivoted on the rocker arm shaft by the camshaft-operated pushrods which engage one end of the rocker arms. As the rocker arms raise at one end, the opposite end pushes down on the ends of the valve stems to open the valves. In this manner, the valves control the intake and exhaust cycles of the engine. The rocker arms are pressure lubricated through an axial passage in the rocker arm shaft. When disassembling earlier model rocker arm assemblies, take care to identify the positions of the shaft supports to facilitate reassembly. On later model rocker arm assemblies, shaft supports are identical and require no differentiation. Spacer washers are used on the shaft to space the rocker arms.

#### a. Removal and Disassembly.

1. Remove the cylinder head cover (12, figure 5-19) and gasket (13) by removing the nuts (9) and washers (10 and 11) securing it to the cylinder head (31).

2. Remove the nuts (15) and washers (16) that secure the rocker arm assembly to the cylinder head. On six-cylinder engines, the rocker arm shaft is in two sections. When removing rocker arms from six-cylinder engines, it is suggested that a wire be used between the front and rear rocker arms to hold the two shaft assemblies together and to prevent accidental disassembly of the rocker arms. Carefully lift the complete assembly from the cylinder head.

3. Disassemble the rocker arm assembly by removing the retaining rings (17) from the shaft ends. Slide the shaft supports (18), rocker arms (19), spacing springs (20), and spacers (21 and 22) from the rocker arm shaft (23). Earlier engines used several sizes of shaft supports. Facilitate reassembly by marking the order and position of the shaft supports as removed.

#### b. Cleaning and Inspection.

1. Clean all parts with cleaning solvent and dry thoroughly with compressed air. Make sure all gasket material is removed from sealing edge of cylinder head cover.

2. Blow out the rocker arm lubricating passages with compressed air.

3. Check the rocker arms for cracks and surface imperfections by magnetic inspection.

4. Check the spacer springs for damaged ends and misaligned coils. A 10-pound load on the spring should compress it to 1 inch. Replace a damaged or weak spring.

5. Check the ball end of the rocker arm adjusting screw (25) and the rocker arm. Replace the screw if flat on bottom or if there is evidence of scratching or wearing. If rocker arm contact surfaces are worn or damaged, replace with new rocker arm.

6. Check for damaged threads on all adjusting screws and rocker arms. The adjusting screws are self-locking and must take a minimum of 3 foot-pounds torque to turn into the rocker arms. Replace any loose-fitting adjusting screws.

7. Check the rocker arms for worn shaft bore diameter. The maximum allowable diameter is 0.8665 inch. Discard worn rocker arms if damaged or worn beyond this limit.

8. Check rocker arm shaft for wear or scoring. If shaft has shoulders or ridges due to rocker arm action on shaft, replace with new shaft. The rocker arm shaft diameter should not be worn to less than 0.8560 inch.

9. Inspect the cylinder head cover for cracks, dents, and distorted sealing area. Discard and replace if damaged. Make sure the breather cap is clean and in good condition and that it fits securely on the cylinder head cover.

#### c. Reassembly and Installation.

The rocker arms are lubricated by oil which is forced through a hollow cylinder head stud into the rocker arm shaft. Oil is forced out through small holes in the rocker arms, over the valve stems and pushrods. For proper lubrication it is imperative that the rocker arm and shaft be correctly assembled and installed on the engine. To reassemble and install the rocker arm assembly, proceed as follows:

1. Coat the rocker arm shaft (23) lightly with clean lubricating oil. Slide the shaft supports (18), rocker arms (19), spacing springs (20), and spacers (21 and 22) onto the rocker arm shaft. Install the spacers on the shaft of engine models that use them, as indicated in figure 5-20. On the four-cylinder engines, make

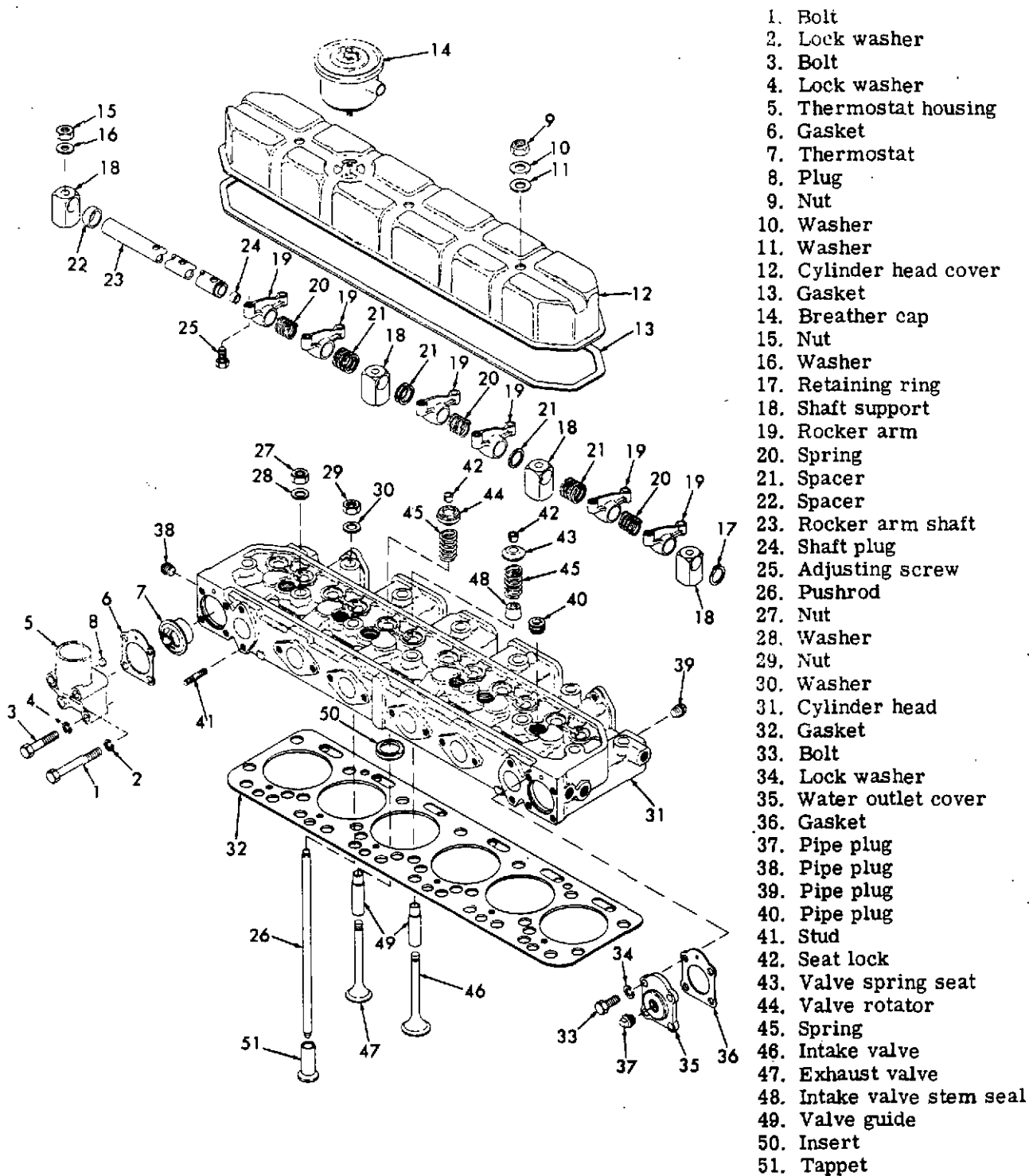

Figure 5-19. Rocker Arm, Cylinder Head, and Valve Assemblies, Exploded View

## ENGINE REPAIR AND OVERHAUL

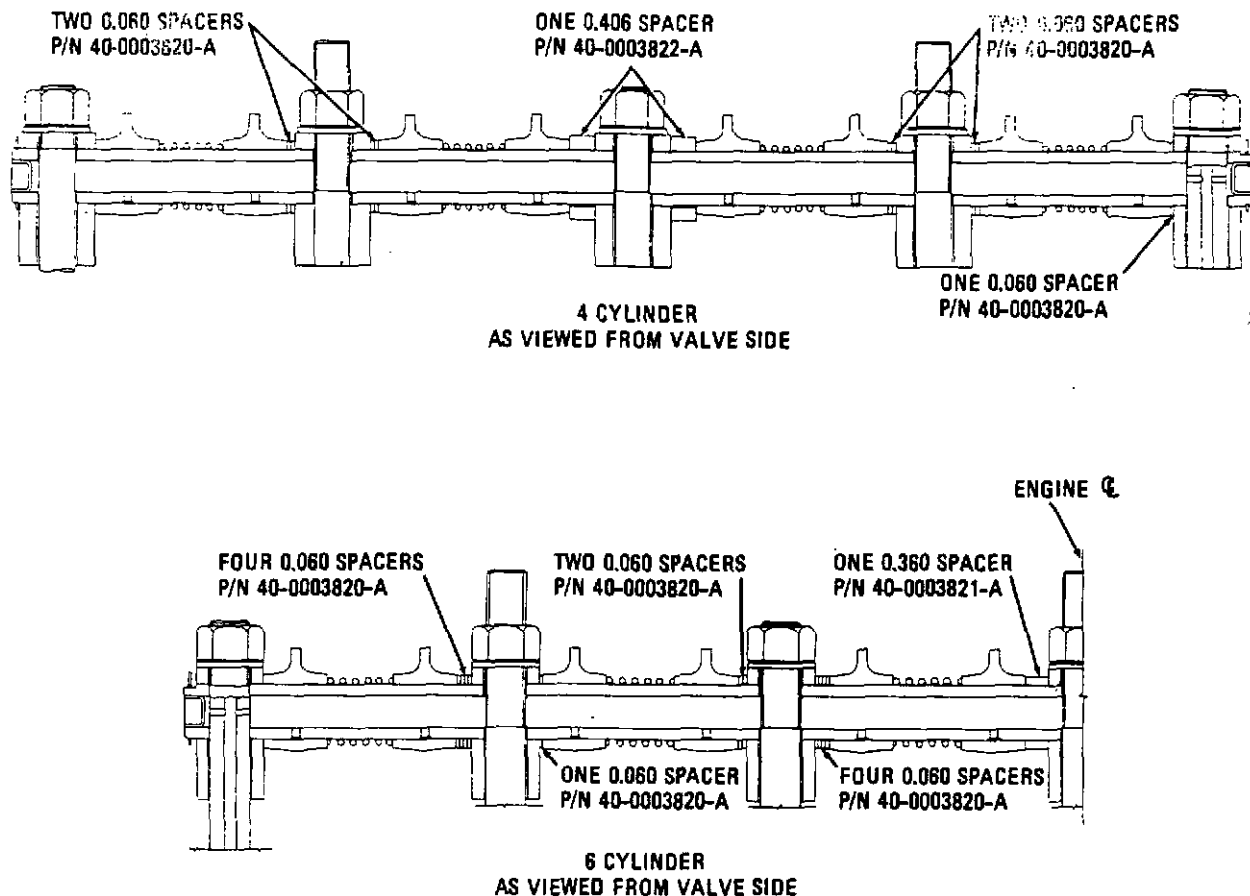

Figure 5-20. Rocker Arm Shaft Showing Spacer Positions for Engines Having Identically Sized Shaft Supports

certain that the oil holes in the shaft face downward and toward the camshaft side of the engine, as shown in figure 5-21. On older type G-Series engines, there are two oil holes for each rocker arm and they must face downward as shown in figure 5-21. Newer type rocker arms shown on figure 5-20 have only one mounting hole which must be assembled downward. On older G-Series engines, the shaft supports (18, figure 5-19) vary in size and mounting hole location and must be assembled exactly as shown in figure 5-22. Install the retaining rings (17, figure 5-19) on each end of the rocker arm shaft.

2. Before installing the rocker arm assembly on the cylinder head, check that rocker arms are properly installed and that they move freely on the shaft. It will aid installation of the six-cylinder engine rocker arm assembly if a wire is used to hold the shaft together as in removal.

3. Install the rocker arm assembly over the cylinder head stud extensions and seat it firmly

on the cylinder head. Make certain the rocker arm adjusting screws (25, figure 5-19) are positioned over the pushrods (26). Secure the rocker arm assembly to the cylinder head with nuts (15) and washers (16).

4. Adjust the valve clearance; refer to paragraph 5-28f.

5. Start the engine and warm up to operating temperature. With the engine idling slowly, readjust the valve clearance; refer to paragraph 5-28f.

6. Install the cylinder head cover (12) and new gasket (13) and secure to cylinder head with nuts (9) and washers (10 and 11).

7. Install breather cap on the cylinder head cover.

### 5-27. CYLINDER HEAD.

The cylinder head is a one-piece casting which mounts the valves and rocker arms and provides

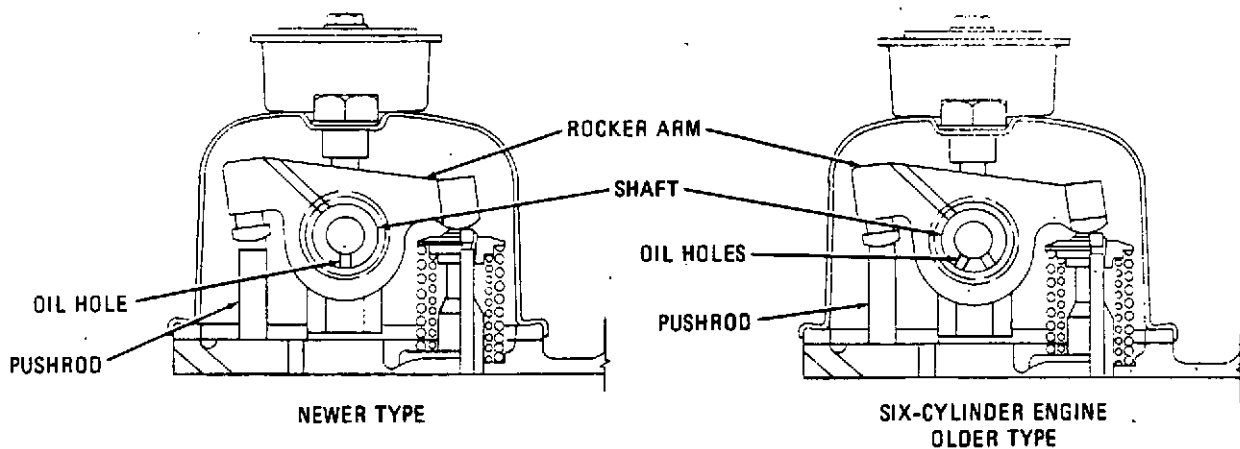

Figure 5-21. Rocker Arm Shaft Showing Oil Hole Positions

inlet and outlet passage to and from the valves. The valve seats are formed as part of the casting. The valve guides are removable. The cylinder head contains cored passages for water flow to promote cooling of the head.

a. Removal.

1. Drain the radiator and remove the thermostat housing, hoses, and the bypass hose (paragraphs 5-8 and 5-9). Disconnect the coolant temperature gauge thermocouple from the cylinder head.

2. Remove the spark plugs and cables (paragraph 3-8).

3. Remove the exhaust manifold (paragraph 5-18).

4. Remove the intake manifold (paragraph 5-17).

5. Remove the cylinder head cover and rocker arm assembly (paragraph 5-26).

6. Lift out the pushrods (26, figure 5-19).

7. Remove the cylinder head nuts (27 and 29) and washers (28 and 30); lift the cylinder head (31) and gasket (32) from the engine. It may be necessary to tap the head lightly with a soft hammer to loosen it. Do not pry on the contact surfaces.

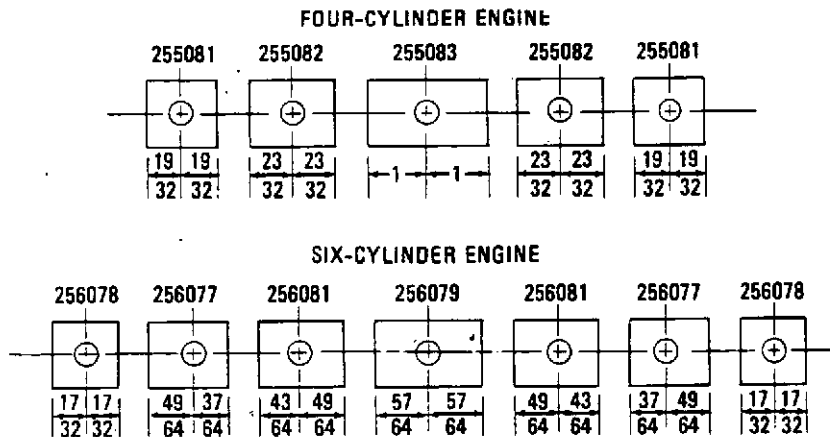

Figure 5-22. Rocker Arm Shaft Support Installation for Engines Having Variable Sized Supports

## ENGINE REPAIR AND OVERHAUL

8. Remove the water outlet cover (35) and gasket (36) by removing four bolts (33) and lock washers (34).

9. Disassemble the cylinder head by removing the valve assemblies (paragraph 5-28).

10. Do not remove stud (41) or plugs (38, 39, and 40) unless they are damaged and require replacement.

### b. Cleaning and Inspection.

1. Before cleaning the cylinder head, inspect the cylinder head gasket and cylinder head for indications of gasket failure and leaking. If cylinder head gasket failure is apparent, make a thorough check of contributing factors. Detonation (caused by improper ignition timing) will cause a shock load in the combustion chamber which will damage cylinder head gaskets and, if allowed to continue, may destroy the piston pins and piston rings. Fuel with an octane rating too low may also contribute to detonation. Cooling solutions which are contaminated by corrosive combustion gases leaking into the cooling system are very detrimental to the internal parts of the entire cooling system.

2. Remove all carbon from combustion areas using a scraper and wire brush.

3. Clean the cylinder head thoroughly with a solvent or degreasing solution and dry thoroughly with dry, compressed air.

4. Make sure that gasket contact surfaces on the head and block are clean, smooth, and flat. Rework contact surfaces to ensure that they are free of erosion, pits, burrs, scratches, or blemishes.

5. Check out-of-flatness with straight edge and feeler gauge; maximum allowable is 0.005 inch on width or length. Out-of-flatness should vary gradually and uniformly from end to end and side to side. Resurface the cylinder head if necessary, only enough to bring flatness within the 0.005 inch maximum.

6. Check for free water flow through the cylinder head. If restriction is evident, remove plugs, and clean water jackets of salt, lime, or sludge by submerging cylinder head into a tank of heated cleaning solution. Circulate the cleaning solution. When clean, remove cylinder head from tank and dry with compressed air.

7. Water-test the cylinder head for cracks and leaks. Check for cracks in the valve port areas using magnetic particle inspection.

8. Check for loose valve seat inserts, if used, by lightly tapping head near inserts. If valve seat insert is loose enough to bounce, remove and replace insert.

9. Inspect all other parts for cracks, distortion, damaged threads, and other damage. Replace any damaged parts.

### c. Reassembly and Installation.

1. Before reassembling the cylinder head, regrind or service the valves as necessary. Refer to paragraph 5-28 for valve servicing and installation.

2. Make sure the cylinder block contact surface is clean of carbon deposits. Install a new cylinder head gasket on the cylinder block. The gasket must be assembled with the bead (rolled edge around the combustion chamber) down. For sealing, use any good cylinder head gasket cement.

3. Install water outlet cover (35, figure 5-19) and gasket (36) on cylinder head and secure with bolts (33) and lock washers (34).

4. Install the valve assemblies into the cylinder head; refer to paragraph 5-28.

5. Place the cylinder head assembly on the block. Be careful not to damage contact surfaces or the cylinder head studs.

6. Install the cylinder head nuts (27 and 29) and washers (28 and 30). Tighten evenly, working from the center of the head outward. Refer to figure 5-23 for tightening sequence, torque, and procedure for tightening cylinder head to cylinder block. Tighten all nuts first to 75 foot-pounds torque in the sequence indicated, then to 125 foot-pounds torque, then to the final torque indicated in figure 5-23.

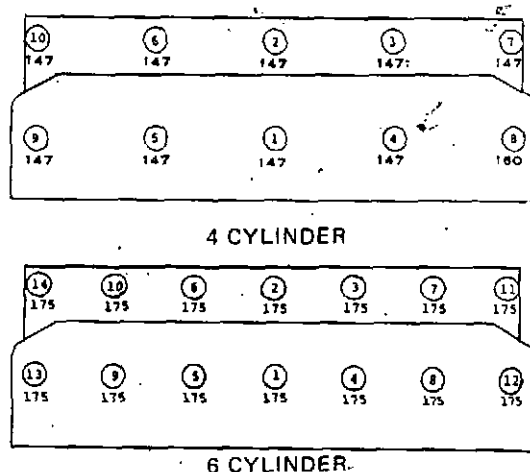

Figure 5-23. Cylinder Head Nut Tightening Sequence and Torque Values

## CAUTION

The cylinder head nuts must be retightened and the valve clearance reset after 1 hour of service.

7. Install the valve pushrods (26, figure 5-19).
8. Install the rocker arm assembly (paragraph 5-26).
9. Install the air cleaner and intake manifold (paragraphs 5-16 and 5-17).
10. Install the exhaust manifold and exhaust pipe (paragraph 5-18).
11. Install the spark plugs and cables (paragraph 3-8).
12. Install coolant temperature gauge thermocouple in the cylinder head.
13. Install the thermostat and housing and the radiator hoses (paragraph 5-9). Fill the cooling system with clean water or antifreeze.

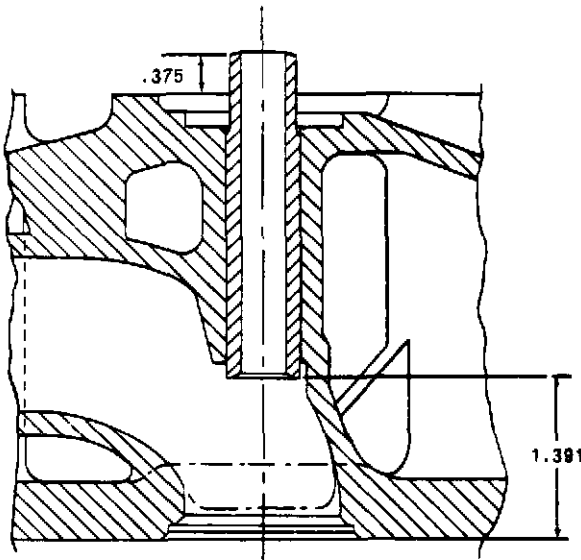

Figure 5-24. Valve Guide Installation

## 5-28. VALVES.

The intake and exhaust valves operate in valve guides pressed into the cylinder head. They are held to their seats by springs which are secured to the valves by spring seats and valve locks. The valves are operated by conventional-type tappets with hollow pushrods running from the tappets to the rocker arms.

Some engines are equipped with valve rotators, which control the motion of the exhaust valves during the lift cycle. The natural vibrations of the valve train and the flow of gases around the valve heads cause the valves to rotate slowly, a small fraction of a revolution each lift cycle. This equalizes wear and provides a wiping action to keep sealing surfaces clean.

### a. Removal.

1. Remove the cylinder head (paragraph 5-27).
2. With a clamp-type valve spring compressor, compress the valve springs (45, figure 5-19) and remove valve spring seat locks (42).
3. Remove the valve springs (45), seats (43), and valve rotators (44); lift out the valves (46 and 47). Place valves in order in a rack, with holes numbered for both intake and exhaust valves so that the valves can be installed in their respective places at reassembly.
4. Remove the intake valve stem seals (48) from the valve guides.

### b. Cleaning and Inspection.

1. Discard all seals and gaskets.
2. Clean all carbon from the cylinder head, piston heads, valve seats, and valves, using suitable scraping or buffing tools.
3. Clean the valve guides. Remove lacquer or other deposits by running a valve cleaner or wire brush through the guides. Inspect the valve guides for excessive wear. The exhaust valve guides will usually show the most wear. The maximum allowable bore diameter of the intake valve guides is 0.3780 inch. The maximum allowable bore diameter of the exhaust valve guides is 0.3790 inch. Refer to Section VII, Fits and Tolerances.
4. Inspect the valve seats. If they are pitted or if new valve guides will be installed, the seats must be refinished.

## ENGINE REPAIR AND OVERHAUL

5. Inspect the valves carefully. If the stems are bent or badly worn or if the valves are deeply pitted, the valves must be replaced by new ones. Valves that are only slightly pitted can be used by refacing them on a valve grinder. Intake valves must have an accurately finished 45-degree face angle and exhaust valves a 45-degree face angle.

### c. Repair and Replacement.

1. If the valve guides are excessively worn and require replacing, it must be done before any refinishing is done on the valve seats. This will ensure that the seat being finished is square with respect to the new guide. To drive out the guides, use a drift with a 5/8-inch diameter and a 3/8-inch diameter pilot. Drive in the new guides so that the dimension from the lower edge of the valve guide to the gasket face of the cylinder head is 1.391 inches. See figure 5-24. After the new guides are driven in, ream the inside diameter to correct any squeezing in or any distortion. Ream the exhaust valve guides to 0.3745 to 0.3750 inch. Ream the intake valve guide to 0.3745 to 0.3750 inch.

2. If the valve seats are pitted or if new valve guides have been installed, the seats must be refinished. The intake valve seats are finished on a 45-degree angle and the exhaust valve seats are finished on a 45-degree angle. Use a vibrating angle grinder-type reseating tool with a 3/8-inch diameter pilot. Lightly lubricate and install the pilot into the valve guide bore. Lower the grinder head over the pilot shank until the stone just clears the valve seat. Turn on the power and gently allow the stone to contact the valve seat. Very little pressure other than the weight of the stone should be used. Grind the seat sufficiently to remove shoulders and pits, and to provide an even, smooth surface. Do not grind any deeper than necessary. The finished valve seat should contact the approximate center of the valve face. Refer to figure 5-25.

### d. Seating Valves.

If the valves and seats are not deeply pitted or shouldered or have been refaced, grind or lap each valve to its seat as follows:

1. Lubricate the valve stem and apply a thin coating of good quality, medium coarse grinding compound on the valve face.

2. Take a light coil spring with enough tension to just hold the valve off the seat and insert it over the valve stem. Insert the valve in the valve guide.

3. Use a power lapping tool to rotate the valve back and forth a few times, pressing firmly on the grinding tool. (Avoid using a grinding tool with a continuous circular motion that will cut grooves in the valves or seat.) Release the pressure on the tool and allow the spring to lift the valve from its seat. Rotate the valve 15 or 20 degrees and repeat the grinding process. Periodically wipe off valve and seat and inspect the seating progress. Reapply another thin coating of compound and continue grinding until inspection shows the surfaces are in contact.

4. Wipe off all heavy compound, apply a thin coating of fine compound, and continue the grinding.

5. When the surfaces show a bright, silver-like band of uniform width on both the valve and seat, clean off all traces of the compound.

6. Test each valve for a tight fit as follows: Make 10 or 12 pencil marks, equally spaced, across the valve seat. Firmly rotate the valve in the seat for a part of a turn and again lift out the valve to observe if all the pencil marks are rubbed out on the contact surface. If not, regrind until this test shows a gas-tight mating of the valve and seat.

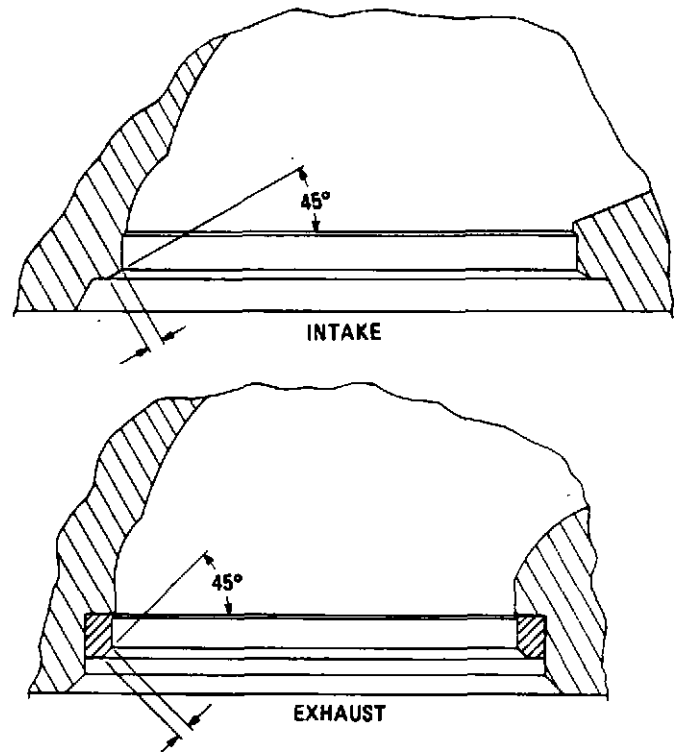

Figure 5-25. Valve Reseating Dimensions

#### NOTE

It is imperative that the valves be assembled in the same seats to which they were ground.

#### e. Reassembly and Installation.

#### NOTE

Make certain that the valves are reinstalled in the same position from which they were removed.

1. Thoroughly clean all traces of grinding compound from the valves, stems, and guides. Lubricate the valve stems with a few drops of engine oil and insert the valves in the same holes from which they were removed.

2. Insert the intake valve stem seals (48, figure 5-19) over the ends on the intake valves (46) and secure firmly on the exposed ends of the valve guides (49).

3. Install the valve springs (45), spring seats (43), and exhaust valve rotators (44) on the valve stems. Using a valve spring compressor, compress the valve springs and install the valve seat locks (42).

4. Turn the head on the exhaust manifold side and pour solvent in the intake openings. If solvent seeps out around any valve, remove that valve and regrind it. Repeat the test, pouring solvent in the exhaust opening. If any exhaust valve leaks, regrind it.

5. When assured of gas-tight valve seating, install the assembled cylinder head on the engine. Refer to paragraph 5-27.

6. Install the rocker arm assembly (paragraph 5-26).

7. Adjust the valve clearance; refer to following subparagraph f.

8. Fill the cooling system with recommended coolant. Start the engine and warm to operating temperatures.

9. With the engine idling slowly, readjust the valve clearance to the correct operating clearance. Refer to following subparagraph f.

10. Install the cylinder head cover (12, figure 5-19) and new gasket (13). Secure to cylinder head cover with nuts (9) and washers (10 and 11).

#### f. Adjusting Valve Clearance.

Adjust valve stem-to-rocker arm clearance whenever the cylinder head has been removed from the cylinder block. Proceed as follows to adjust valve clearance:

1. Rotate the crankshaft by hand or with the starting motor until both intake and exhaust valves of No. 1 cylinder are fully closed. The valves will be fully closed when the No. 1 cylinder is at top dead center; refer to figures 3-4 and 3-5. For a cold engine, use a 0.016- or 0.017-inch feeler gauge inserted between the rocker arm and the valve stem and adjust the adjusting screw until it just touches the pushrod. See figure 3-2. There should be a slight pull when removing the feeler gauge.

2. Adjust the remaining valve clearances in similar manner. Rotate the crankshaft in the direction of normal rotation and adjust the valves in the cylinder firing order. The firing orders for the four- and six-cylinder engines are 1-2-4-3 and 1-5-3-6-2-4.

3. After all the valves have been adjusted, install the cylinder head cover and gasket. Start the engine and allow it to warm up to operating temperature. When it is warm, let the engine run for one hour, under load if possible, then shut it down and retorque the cylinder head nuts as shown in figure 5-23.

4. Start the engine and adjust the valve clearance to 0.015 inch while the engine is running at slow idle. Refer to paragraph 3-6.

#### 5-29. FLYWHEEL.

Flywheels used on this series of engines are usually made of cast iron and may be machined to accommodate different types and sizes of clutches, generators, and a variety of types of couplings. The flywheel also provides indications for timing the engine. All flywheels have a line marked DC (dead center) that can be viewed through a hole in the bellhousing; see figure 3-4. From this line are graduations designating degrees of crankshaft travel; see figure 3-5.

#### a. Removal.

1. Disconnect and remove the power take-off, torque converter, transmission, or clutch, whichever is used.

2. Remove the starting motor (paragraph 5-20).

## ENGINE REPAIR AND OVERHAUL

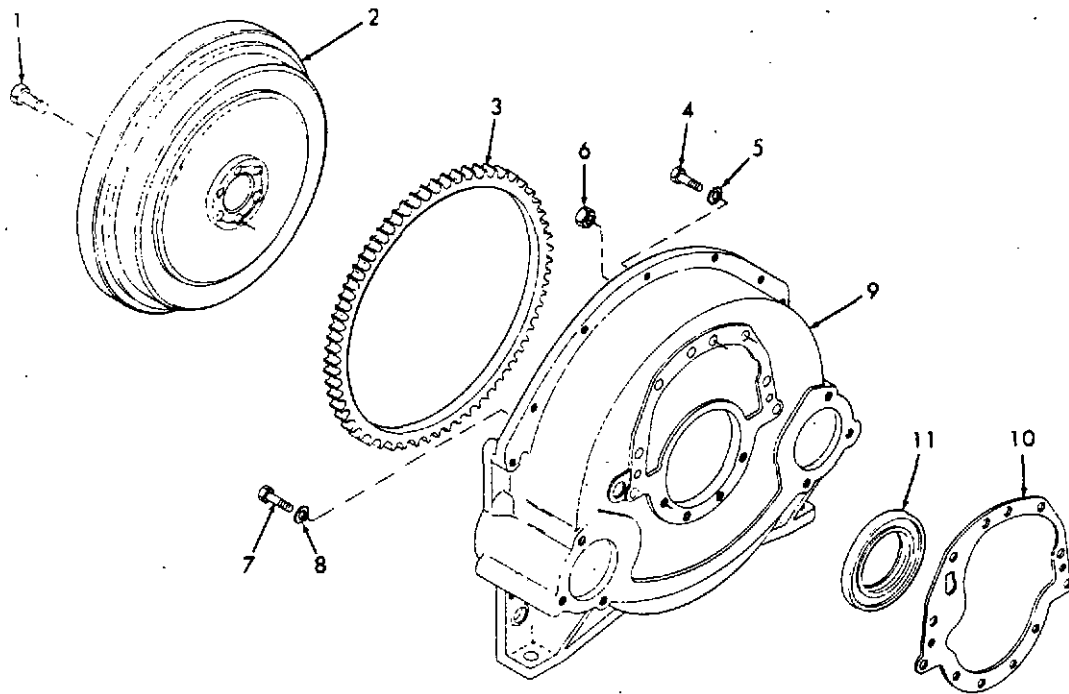

- |              |                |                |
|--------------|----------------|----------------|
| 1. Bolt      | 5. Lock washer | 9. Bellhousing |
| 2. Flywheel  | 6. Nut         | 10. Gasket     |
| 3. Ring gear | 7. Bolt        | 11. Oil seal   |
| 4. Bolt      | 8. Lock washer |                |

Figure 5-26. Flywheel and Bellhousing Assembly, Exploded View

3. Remove the six flywheel bolts (1, figure 5-26).

4. Using a pry bar, pull the flywheel (2) from the crankshaft.

5. Do not attempt to remove the ring gear (3) from the flywheel unless it is damaged and must be replaced.

### b. Cleaning, Inspection, and Replacement.

1. Clean the flywheel and attaching parts with cleaning solvent; dry thoroughly with compressed air.

2. Inspect the flywheel ring gear for broken or cracked teeth. If damage is evident and replacement is necessary, drive gear from flywheel with a blunt chisel.

3. Inspect the flywheel for distortion, cracks, or other damage or wear. Replace a damaged flywheel.

4. To install a new ring gear, heat it in an oven or with a heating torch to approximately

600°F (315.6°C). Do not overheat. Place heated ring gear on flywheel and quickly drive onto flywheel until gear is firmly seated.

### c. Installation.

1. Install the flywheel on the crankshaft. Note that one of the six bolts is off center so that the flywheel can only be installed in one position. This ensures proper location of the flywheel on the crankshaft for timing purposes. Draw the flywheel onto the crankshaft by tightening the six bolts alternately and evenly. Torque the bolts to 80 foot-pounds.

2. Attach the indicator, as shown in figure 5-27, to check the concentricity of the pilot bore. This should not exceed 0.005 inch total indicator reading.

3. Attach the indicator as shown in figure 5-28 to check the face of the flywheel. Runout should not exceed 0.008 inch total indicator reading. If runout is excessive, remove the flywheel and check for dirt or foreign matter between the flywheel and mounting seat on the crankshaft. Reinstall and recheck.

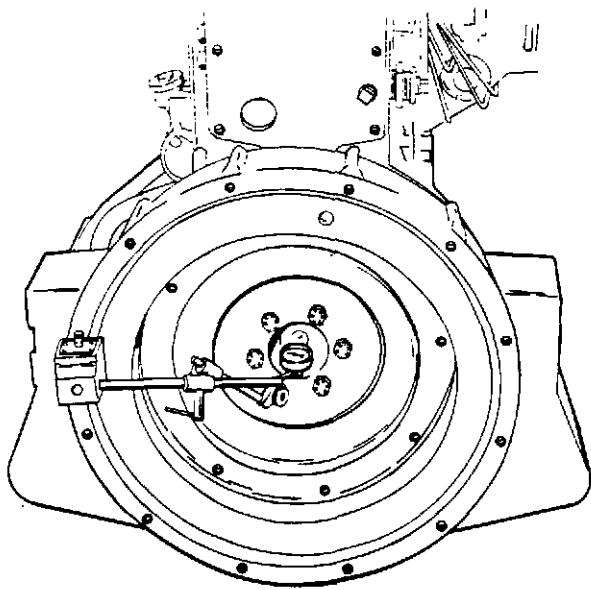

Figure 5-27. Indicating Flywheel Pilot Bore

4. Install the lock wires (if used).

5. Install the clutch and transmission or power take-off, as removed.

### 5-30. BELLHOUSING.

The bellhousing is a casting which covers the rear end of the cylinder block and oil pan. There are many types of housings used. One may be a plate-type housing; another type may form a complete housing for the flywheel and clutch, to which the transmission, torque converter, or other drive mechanism is attached. The bellhousing usually forms the rear engine support.

#### a. Removal.

1. Drain the crankcase oil.
2. Remove the clutch or power take-off mechanism.
3. Remove the flywheel (paragraph 5-29).
4. Remove starting motor (paragraph 5-20).
5. Disconnect the oil lines and remove oil filter (paragraph 5-4).
6. Remove the oil pan (paragraph 5-5).
7. If the engine is being serviced in the unit, place suitable supports under the rear of the crankcase to support the engine.
8. Remove the rear engine support bolts.

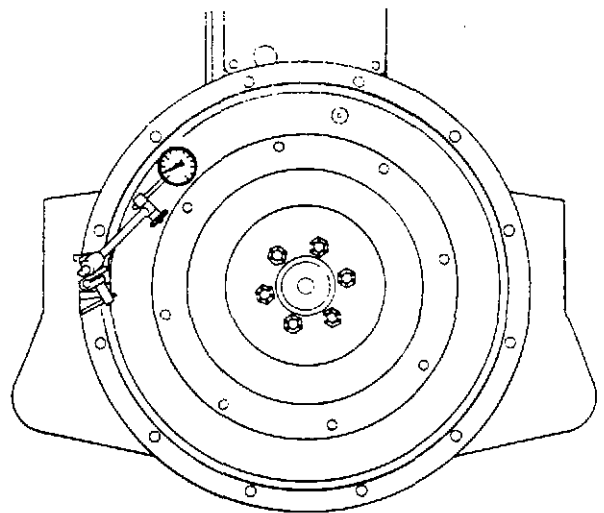

Figure 5-28. Indicating Flywheel Face

9. Remove the four bolts (10, figure 5-3) securing the oil pan adapter (12) to the bellhousing. The adapter need not be removed from the cylinder block; the two nuts (8) will hold the adapter in place until the bellhousing is re-installed.

10. Remove the bellhousing attaching bolts (4 and 7, figure 5-26), stud nuts (6), and lock washers (5 and 8).

11. Pull the bellhousing away from the engine. It may be necessary to tap the housing with a soft hammer to loosen it from the dowels or from gasket (10) sticking to the block. Remove and discard the gasket.

12. Remove and discard rear oil seal (11).

#### b. Cleaning, Inspection, and Repair.

1. Clean the parts with cleaning solvent; dry thoroughly. Make sure all old gasket material is removed from the parts.

2. Inspect the bellhousing for cracks, distortion, and other damage; replace a damaged bellhousing.

3. Check that bellhousing dowel pins in the block are tight and in good condition.

#### c. Installation.

1. Install a new oil seal (11, figure 5-26) in the bellhousing, using a small amount of sealing compound in the bore before pressing in the seal. If new seal is pre-coated, sealing compound is not required. Cement a new gasket (10) to the

## ENGINE REPAIR AND OVERHAUL

bellhousing, allowing the cement to dry sufficiently to prevent the gasket from slipping at installation.

2. Clean and polish the oil seal surface of the crankshaft to remove nicks or scratches. Use crocus cloth or very fine polishing cloth.

3. Apply a thin coat of oil soap to the seal and to the seal surface of the crankshaft. If seal is already oil treated, additional lubricant is not required; however, take care to keep the seal surface clean during reassembly.

4. Check the rear of the cylinder block to make sure that the top hole for the thrust plate attaching screw is plugged with a setscrew. See figure 5-29.

### CAUTION

This hole runs to an oil passage in the cylinder block. It must be plugged before installation of the bellhousing or a severe oil leak will result.

5. Carefully place the bellhousing on the cylinder block so that the seal is not damaged as it engages the crankshaft. Align so that the dowels properly enter their respective holes. Seat the bellhousing (9, figure 5-26) on the cylinder block and install the bolts (4 and 7), nuts (6), and lock washers (5 and 8), but do not tighten.

6. Secure the adapter (12, figure 5-3) to the bellhousing with four bolts (10) and lock washers (11). Tighten the bellhousing bolts and nuts evenly and securely.

7. Install the oil pan (paragraph 5-5), using new gaskets if necessary.

8. Install the starting motor and connect the electrical leads (paragraph 5-20).

9. Install the oil filter and connect the oil lines (paragraph 5-4).

10. Install the rear engine support bolts and remove the jack or block from under the crankcase.

11. Install the flywheel (paragraph 5-29).

12. Check concentricity of bellhousing in relation to flywheel (figures 5-27 and 5-28).

13. Install the clutch or power take-off mechanism.

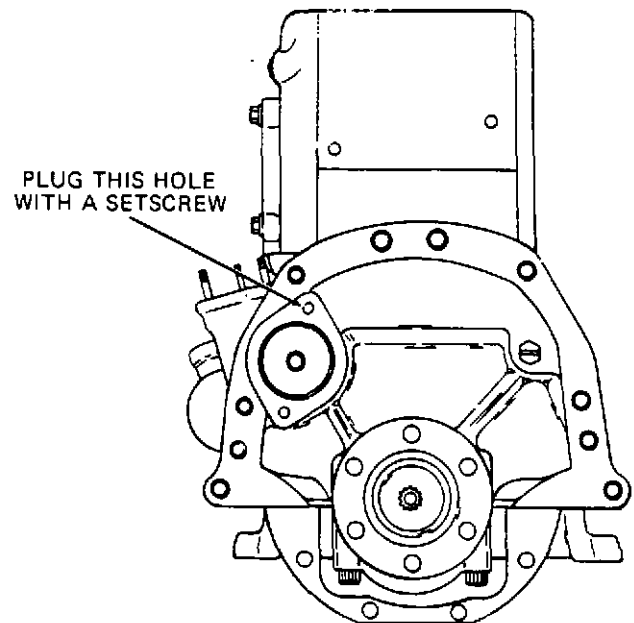

Figure 5-29. Rear Cam Thrust Plate Plug

14. Fill the crankcase to the proper level with the correct grade of lubricating oil. Refer to Table 3-2, Recommended Lubricating Oil Specifications.

### 5-31. GEAR HOUSING AND COVER.

The gear housing and cover are mounted on the front of the cylinder block to cover the timing gears, and to provide mounting for the mechanical governor, if used. If the engine is equipped with a magneto, a larger gear housing and cover are used and the magneto is mounted on the rear face of the gear housing. The front crankshaft oil seal is mounted in the cover, and the cover can be removed for inspection of the gears or replacement of the oil seal without removing the gear housing.

#### a. Removal.

1. Remove the radiator, hoses, and radiator supports from the engine.

2. Remove the fan and drive belt to provide access to the gear housing cover (paragraph 5-8). Remove any other drive belts.

3. Remove the mechanical governor, if used (paragraph 5-14).

4. Remove the nut (7, figure 5-30) and lock washer (8) which secure the pulley (10) and hub (11) to the crankshaft. Pull off the washer (9) and separate the pulley (10) from the hub (11).

Remove the hub with a gear puller and remove the key from the crankshaft keyway.

5. Remove the nut (13), cap screws (15 and 17), and lock washers (14 and 16) which secure the gear housing cover (18) to the gear housing (25) and the cylinder block. Pull off the gear housing cover and gasket (19). If the oil seal (20) is worn or damaged, press it out from the cover bore.

6. If the gear housing must be removed from the cylinder block, proceed as follows:

(a) If the engine is equipped with a magneto, disconnect the spark plug cables and remove the magneto (paragraph 5-24).

(b) Drain the oil from the engine and remove the oil pan (paragraph 5-5).

(c) Remove the four bolts (10, figure 5-3) securing the oil pan adapter (12) to the gear housing. The adapter need not be removed from the cylinder block; the two nuts (8) will hold the adapter in place until the gear housing is reinstalled.

(d) Remove the camshaft nut (21, figure 5-30). To keep the shaft from turning, insert a brass bar between crankshaft gear and camshaft gear. Using a standard foot-type puller inserted in holes in gear, pull the camshaft gear (22) from the camshaft.

(e) Remove the cap screws (23) and lock washers (24) securing the gear housing (25) to the front of the cylinder block. Pull off the housing and remove the gasket (26).

7. Discard and replace all gaskets and seals.

#### b. Cleaning, Inspection, and Repair.

1. Clean the gear cover, housing, and attaching parts with cleaning solvent. Dry thoroughly. Make sure all old gasket material is removed from the gasket surfaces.

2. Inspect the gear cover and gear housing for cracks, distortion, and other damage. Replace either if damaged.

3. Check that gear housing dowel pins and studs in the cylinder block are tight and that the

1. Cap screw
2. Lock washer
3. Governor
4. Gasket
5. Thrust washer
6. Governor gear
7. Nut
8. Lock washer
9. Washer
10. Pulley
11. Pulley hub
12. Roll pin
13. Nut
14. Lock washer
15. Cap screw
16. Lock washer
17. Cap screw
18. Gear housing cover
19. Gasket
20. Oil seal
21. Nut
22. Camshaft gear
23. Cap screw
24. Lock washer
25. Gear housing
26. Gasket
27. Bushing
28. Dowel pin

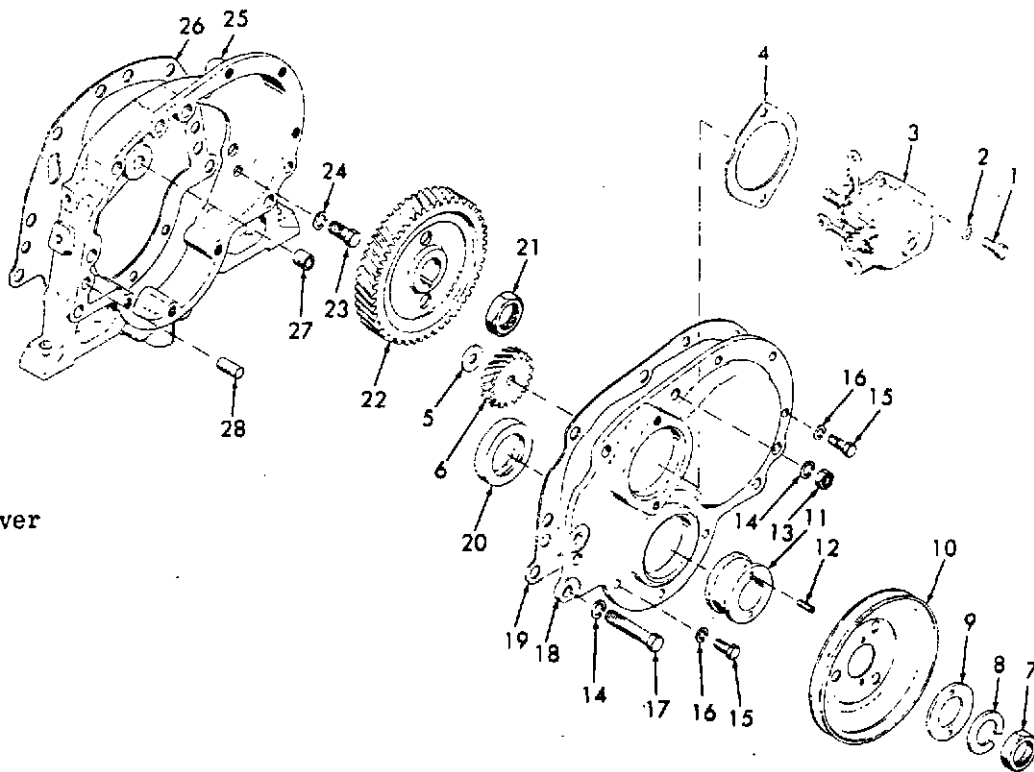

Figure 5-30. Gear Housing and Gears, Exploded View

## ENGINE REPAIR AND OVERHAUL

stud threads are in good condition. Replace any damaged parts.

4. Inspect the camshaft gear, crankshaft gear, and governor gear (if used) for chipped, cracked, worn, or broken teeth. Replace worn or damaged gears.

### NOTE

Different timing gear sets and governor gears are used on distributor ignition engines than on magneto ignition engines. Distributor ignition engines use a combination having a 25-tooth crankshaft gear and a 50-tooth camshaft gear, with a 17-tooth governor drive gear. Magneto ignition engines use a combination having a 24-tooth crankshaft gear and a 48-tooth camshaft gear, with a 16-tooth governor drive gear.

5. Clean and polish the oil seal surfaces of the crankshaft to remove any nicks or scratches which could damage the seal. Use an oil stone or very fine emery cloth and polish with crocus cloth.

6. Inspect the governor shaft bushing (27, figure 5-30) for scoring and wear. If it must be replaced, screw a pipe tap into the bushing and pull it from the bore in the gear housing. Press in a new bushing until it is flush with the surface of the housing.

7. Inspect the governor, if used, as described in paragraph 5-14.

### c. Installation.

1. If the gear housing was removed, install as follows:

(a) Cement a new gasket (26, figure 5-30) to the gear housing (25). Allow the cement to set enough to prevent the gasket from slipping at installation.

(b) Install the gear housing on the cylinder block and secure with cap screws (23) and lock washers (24). Do not fully tighten the screws.

(c) Secure the gear housing to the front oil pan adapter (12, figure 5-3) with four bolts (10) and lock washers (11). Tighten the gear housing bolts and nuts evenly and securely.

(d) Install the oil pan (paragraph 5-5).

(e) Install the alternator bracket screws and lock washers (paragraph 5-21).

POSITION OF GOVERNOR  
GEAR (IF USED) WHEN  
COVER IS INSTALLED

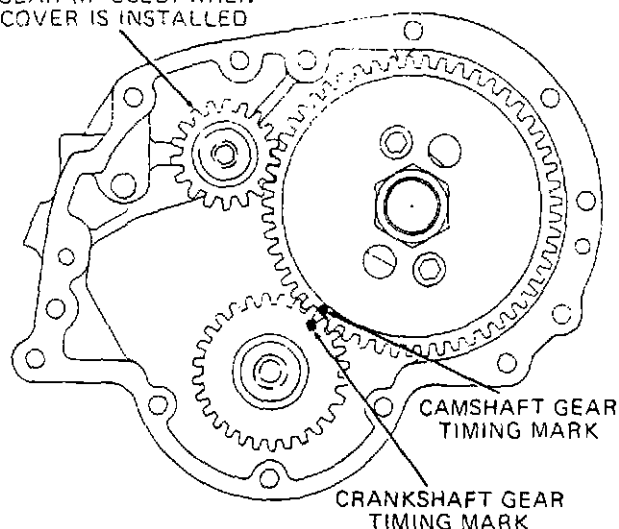

Figure 5-31. Aligning Camshaft and Crankshaft Gear Timing Marks

(f) Install the camshaft gear (22, figure 5-30) on the camshaft, aligning the timing mark with timing mark on the crankshaft gear (see figure 5-31). Insert a brass bar between the camshaft and crankshaft gears. Pull down and secure the gear with the camshaft nut (21, figure 5-30). Tighten the nut to 125 to 135 foot-pounds torque.

(g) Install and time the magneto, if used, and connect the spark plug cables (paragraph 5-24).

2. Install a new oil seal (20, figure 5-30) in the gear housing cover (18), using a small amount of sealing compound in the bore before pressing in the seal. If new seal is pre-coated, sealing compound is not required. Cement a new gasket (19) to the gear housing cover.

3. Apply a thin coat of oil soap to the seal and to the seal surface of the crankshaft. If seal is already oil treated, additional lubricant is not required; however, take care to keep the seal surface clean during reassembly.

4. Use a seal slip, if available, to protect the oil seal lips when installing the gear housing cover. If a seal slip is not available, carefully slide the gear housing cover over the end of the crankshaft to prevent damage to the seal lips. Secure the cover with nut (13), cap screws (15 and 17), and lock washers (14 and 16).

5. Install the key in the crankshaft keyway. Start the pulley hub (11) onto the end of the crankshaft and carefully drive it on. Install the pulley (10), washer (9), and lock washer (8) on the

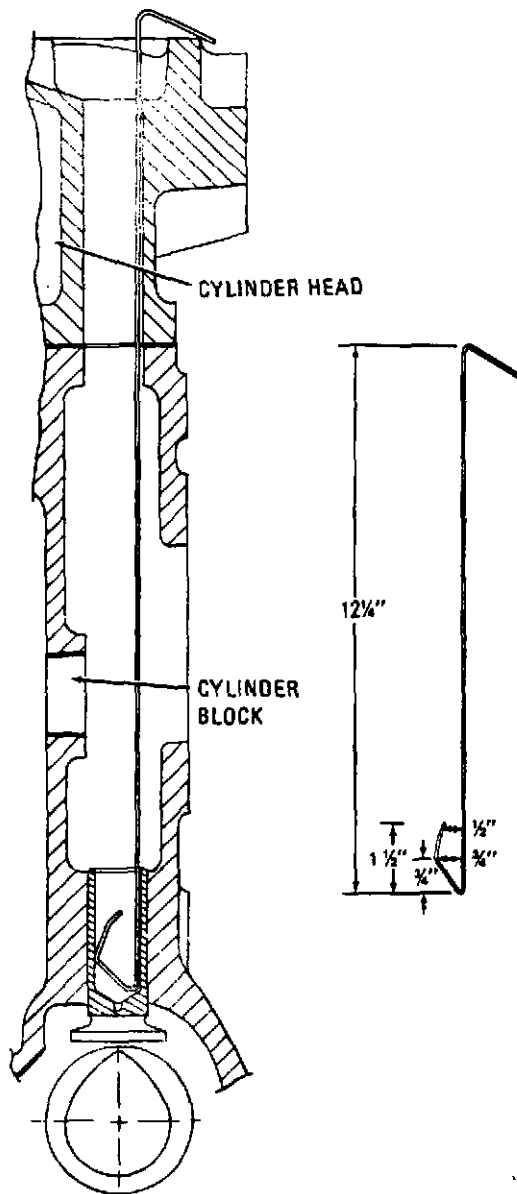

Figure 5-32. Valve Tappet Positioned for Camshaft Removal

crankshaft. Secure by installing the nut (7); torque it to 125 foot-pounds.

6. Install the mechanical governor, if used (paragraph 5-14).

7. Install the fan and belt (paragraph 5-8).

8. Install the radiator, hoses, and radiator supports.

9. Fill the crankcase to the proper level with the correct grade of lubricating oil. Refer to table 3-2.

10. Start the engine and check for oil, water, and fuel leaks.

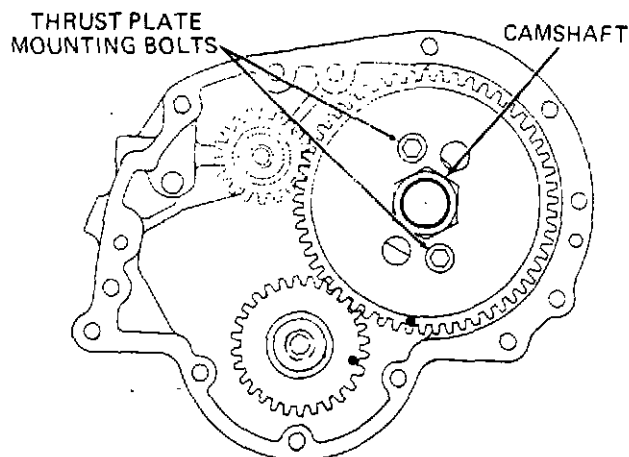

Figure 5-33. Thrust Plate Mounting Bolt Removal

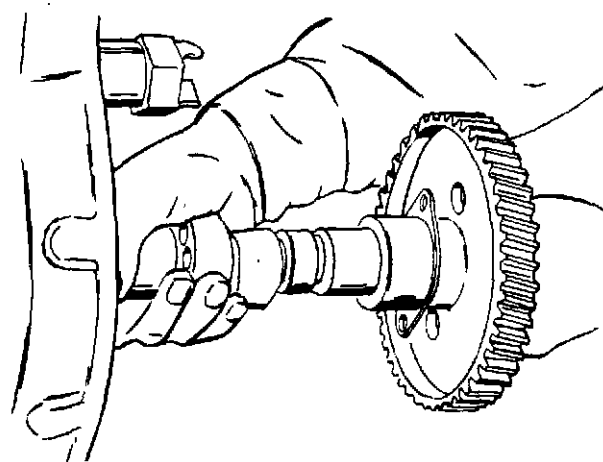

Figure 5-34. Camshaft and Thrust Plate Removal

## 5-32. CAMSHAFT.

The camshaft is supported on large diameter, pressure-lubricated, removable bearings in the cylinder block, and is driven by the camshaft gear which meshes with the crankshaft gear. In some installations, the camshaft can be removed without removing the engine from the unit.

### a. Removal.

1. Drain the radiator and remove the radiator, hoses, and radiator support bracket.

2. Drain the lubricating oil from the crankcase and remove the oil pan (paragraph 5-5).

3. Remove the distributor (paragraph 5-23) or magneto (paragraph 5-24).

4. Remove the oil pump (paragraph 5-6).

## ENGINE REPAIR AND OVERHAUL

5. Remove the fan and belt(s) for easier access to the gear cover and gears (paragraph 5-8).

6. Remove the gear housing cover (paragraph 5-31).

7. Remove the mechanical fuel pump, if used (paragraph 5-11).

8. Remove the cylinder head cover and rocker arm assembly (paragraph 5-26).

9. After removing the rocker arm assembly, remove the pushrods (26, figure 5-19) from the cylinder block.

10. If the engine is being serviced while in the unit, the valve tappets (51) must be held in the raised position in order to remove the camshaft. Make a holder, as illustrated in figure 5-32, by bending a wire to form a spring-acting hook on one end. Insert the holder into the hollow part of the tappet to lift it away from the camshaft. Bend the holder over the edge of the pushrod hole in the cylinder head so that the tappet will remain in this position. Repeat this procedure for each of the remaining tappets. With the engine out of the unit, set the engine on the bellhousing or upside down (support the engine with suitable blocks so that the cylinder head studs will clear), push the tappets to the raised position, and remove the camshaft.

11. With the tappets in the raised position, rotate the engine crankshaft until the two holes in the camshaft gear expose the thrust plate mounting bolts, as shown in figure 5-33.

12. Remove the thrust plate mounting bolt and washer assembly (2, figure 5-35) and pull the camshaft out of the cylinder block as shown in figure 5-34.

13. Remove the camshaft bearings (6, 7, and 8, figure 5-35). If they cannot be withdrawn by hand, drive out the camshaft bearings with a brass drift. If difficulties are encountered removing the rear camshaft bearing, it may be necessary to remove the bellhousing.

14. If it is necessary to remove the camshaft gear (22, figure 5-30) from the camshaft, remove the nut (21), place the shaft in an arbor press and, with suitable supports under the gear, press the shaft out of the gear. Remove woodruff key (4, figure 5-35) from camshaft and remove the camshaft thrust plate (3).

15. After the camshaft has been removed from the engine, the valve tappets (51, figure 5-19) can be removed from the underside of the block.

### b. Cleaning and Inspection.

1. Clean the parts with cleaning solvent.

2. Inspect the camshaft for scored or worn cams and bearing surfaces, damaged oil pump gear, threads, or keyway, or worn thrust surfaces. Replace camshaft if it has scuffed, scored, or cracked valve cams. Replace camshaft if any bearing journal diameter is worn to less than 2.051 inches.

3. Inspect the bearings for cracks, scored faces, and scored or worn bores. Replace worn or damaged bearings. The maximum allowable clearance between camshaft journal and bearing bore is 0.006 inch.

4. Inspect the thrust plate for worn or scored thrust surfaces and distortion.

5. Inspect the camshaft gear for worn, cracked, or broken teeth, and for a worn keyway. Replace a damaged gear.

### NOTE

Different timing gear sets are used on distributor ignition engines than on magneto ignition engines. Distributor ignition engines use a combination having a 25-tooth crankshaft gear and a 50-tooth camshaft gear. Magneto ignition engines use a combination having a 24-tooth crankshaft gear and a 48-tooth camshaft gear.

6. Check the valve tappets for wear and replace any that exceed 0.005-inch clearance in the cylinder block bore.

### c. Installation.

1. Install the front, rear, and intermediate camshaft bearings (6, 7, and 8, figure 5-35) in the cylinder block. Replacement camshaft bearings are precision cut and no line reaming is required. When installing, make sure the oil holes in the bearings are aligned with the oil holes in the drilled passageways in the cylinder block. Tap bearings into place with a bearing driver.

2. Insert the valve tappets (51, figure 5-19) into their respective holes in the cylinder block. Use the holding wires to keep the tappets in the raised position during camshaft installation, as shown in figure 5-32.

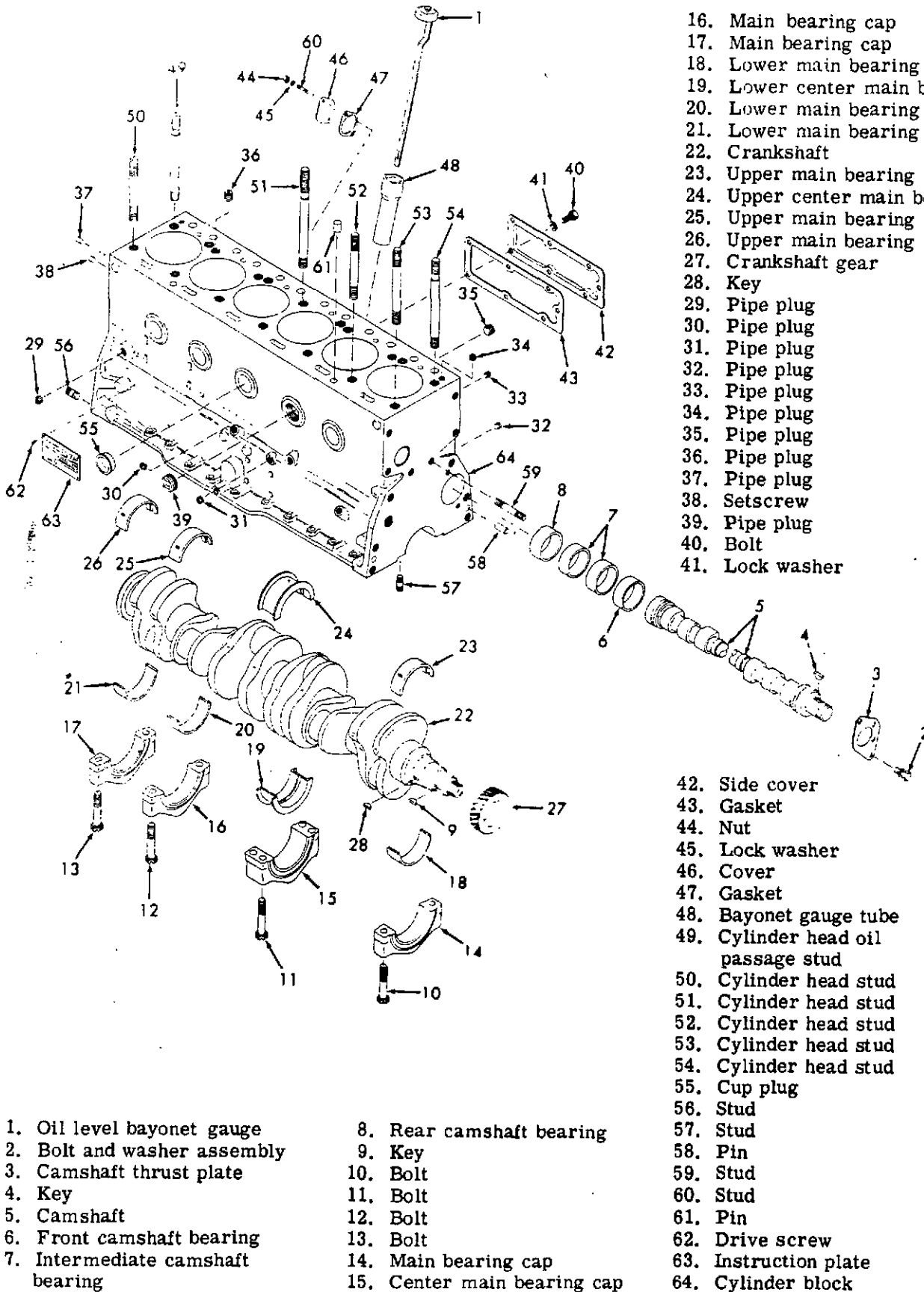

- 1. Oil level bayonet gauge
- 2. Bolt and washer assembly
- 3. Camshaft thrust plate
- 4. Key
- 5. Camshaft
- 6. Front camshaft bearing
- 7. Intermediate camshaft bearing

- 8. Rear camshaft bearing
- 9. Key
- 10. Bolt
- 11. Bolt
- 12. Bolt
- 13. Bolt
- 14. Main bearing cap
- 15. Center main bearing cap

- 16. Main bearing cap
- 17. Main bearing cap
- 18. Lower main bearing
- 19. Lower center main bearing
- 20. Lower main bearing
- 21. Lower main bearing
- 22. Crankshaft
- 23. Upper main bearing
- 24. Upper center main bearing
- 25. Upper main bearing
- 26. Upper main bearing
- 27. Crankshaft gear
- 28. Key
- 29. Pipe plug
- 30. Pipe plug
- 31. Pipe plug
- 32. Pipe plug
- 33. Pipe plug
- 34. Pipe plug
- 35. Pipe plug
- 36. Pipe plug
- 37. Pipe plug
- 38. Setscrew
- 39. Pipe plug
- 40. Bolt
- 41. Lock washer

- 42. Side cover
- 43. Gasket
- 44. Nut
- 45. Lock washer
- 46. Cover
- 47. Gasket
- 48. Bayonet gauge tube
- 49. Cylinder head oil passage stud
- 50. Cylinder head stud
- 51. Cylinder head stud
- 52. Cylinder head stud
- 53. Cylinder head stud
- 54. Cylinder head stud
- 55. Cup plug
- 56. Stud
- 57. Stud
- 58. Pin
- 59. Stud
- 60. Stud
- 61. Pin
- 62. Drive screw
- 63. Instruction plate
- 64. Cylinder block

Figure 5-35. Cylinder Block, Exploded View

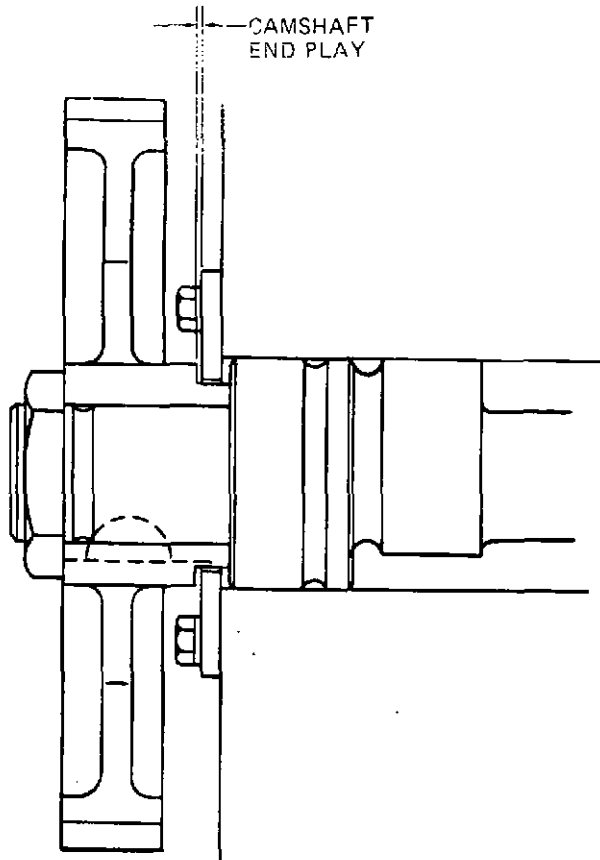

Figure 5-36. Measuring Camshaft End Play

3. If the camshaft gear was removed from the camshaft, place the thrust plate (3, figure 5-35) on the camshaft (5) and press the gear onto the camshaft with woodruff key (4) in place. Secure with nut (21, figure 5-30). Make certain all tappets are in the raised position. Carefully insert the assembled camshaft into the cylinder block, aligning the timing marks on the camshaft gear with the timing marks on the crankshaft gear to ensure correct timing of the valves (see figure 5-31).

4. Secure the thrust plate to the cylinder block with two bolt and washer assemblies (2, figure 5-35). Check the camshaft end play. Normal end play is 0.005 to 0.008 inch and shall not exceed 0.012 inch. If the end play is not within limits, the thrust plate or camshaft gear, or both, are excessively worn and must be replaced. Check the backlash of the camshaft gear to the crankshaft gear. The backlash must be 0.0015 to 0.0025 inch.

5. Remove the wire holders, allowing the valve tappets to fall into position on the camshaft.

6. Place the pushrods (26, figure 5-19) into their proper places in the cylinder head.

7. Install the rocker arm assembly and cylinder head cover (paragraph 5-26).

8. Install the gear housing cover (paragraph 5-31).

9. Install the fan and belt(s) (paragraph 5-8).

10. Install the oil pump (paragraph 5-6).

11. Install and time the distributor (paragraph 5-23) or magneto (paragraph 5-24).

12. Install the radiator, hoses, and radiator support brackets.

13. Install oil pan (paragraph 5-5c) and fill the crankcase to the proper level with the recommended grade of lubricating oil. Refer to table 3-2.

14. Install the mechanical fuel pump, if used (paragraph 5-11).

15. Adjust the valve clearance (paragraph 5-28f).

## 5-33. PISTONS AND CONNECTING RODS.

The pistons are the solid type, having no saw slots or splits in the skirt. Piston ring sets consist of compression rings and oil regulating rings. The piston pin is the full floating type, able to rotate in the piston as well as in the connecting rod bushing. The connecting rods are heavy alloy steel forgings with precision-type bearings for the crankshaft and bronze bushings for the piston pins.

### a. Removal and Disassembly.

1. Drain the radiator and disconnect the hoses.

2. Remove the thermostat housing and thermostat and remove the water pump bypass hose from the water pump. Also disconnect the water temperature gauge thermocouple.

3. Remove the carburetor from the manifold. Refer to paragraph 5-13.

4. Disconnect the exhaust pipe from the manifold.

5. Disconnect the spark plug cables.

6. Remove the cylinder head cover, rocker arm assembly, and pushrods (paragraph 5-26).

7. Remove the cylinder head assembly (manifolds may be removed with the head). (Refer to paragraph 5-27.)

8. Remove the distributor, if used (paragraph 5-23).

9. Remove the oil pan (paragraph 5-5) and oil pump (paragraph 5-6).

10. Carefully scrape the carbon deposits from the top of each cylinder bore so that the pistons can be removed without damage to the rings. On cylinder bores with excessive wear, it may be necessary to use a ridge reamer.

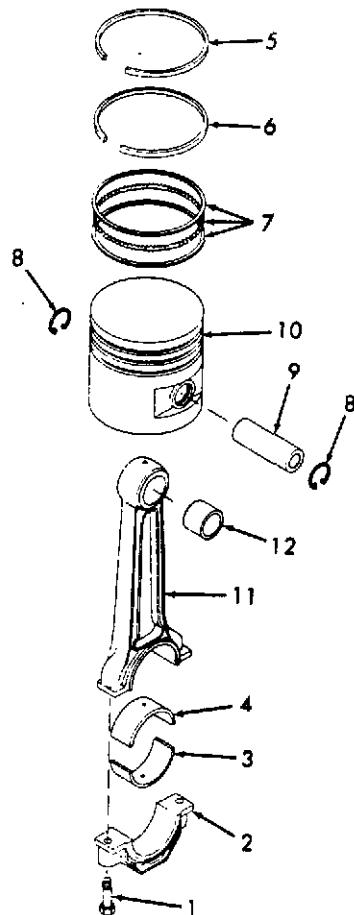

- |                       |                        |
|-----------------------|------------------------|
| 1. Cap bolt           | 7. Piston ring         |
| 2. Connecting rod cap | 8. Retaining ring      |
| 3. Lower bearing      | 9. Piston pin          |
| 4. Upper bearing      | 10. Piston             |
| 5. Piston ring        | 11. Connecting rod     |
| 6. Piston ring        | 12. Piston pin bushing |

Figure 5-37. Piston and Connecting Rod, Exploded View

11. Crank the engine so that the No. 1 piston connecting rod caps can be removed. Remove the cap bolts (1, figure 5-37), connecting rod cap (2), and lower bearing (3). Be sure to keep the connecting rod, cap, and bearings for each piston together. Do not mix parts. Rotate the crankshaft until the piston is at the top of its stroke, and use a block of wood or hammer handle to carefully push the assembled piston and rod out through the top of the cylinder block. See figure 5-38. After the connecting rod (11, figure 5-37) and piston (10) are removed from the cylinder block, reassemble the connecting rod cap (2) and lower bearing (3) to the connecting rod.

12. Remove the remaining pistons and connecting rod assemblies in a similar manner. Rotate the crankshaft as necessary to provide easy access to each connecting rod cap.

13. Secure the connecting rod in a vise equipped with soft jaws and remove the piston rings (5, 6, and 7) with a piston ring expander tool.

14. To disconnect the connecting rods from the pistons, remove the piston pin retaining rings (8) and push the pin (9) out of the piston (10) and piston pin bushing (12).

#### b. Cleaning and Inspection.

1. Clean the parts with cleaning solvent. If this does not remove the carbon deposits,

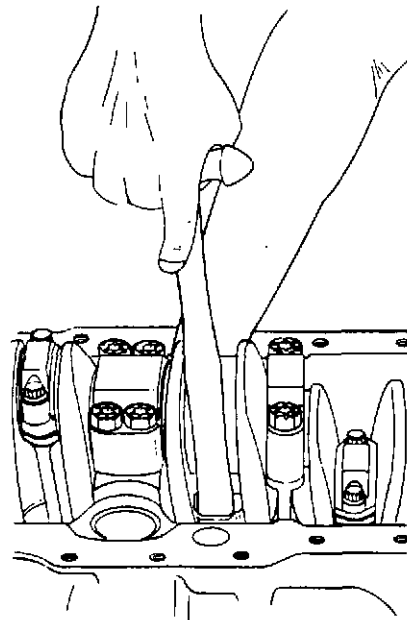

Figure 5-38. Piston and Connecting Rod Removal

## ENGINE REPAIR AND OVERHAUL

use a chemical carbon solvent that will not attack the aluminum pistons or the bronze piston pin bushings.

2. Clean the compression ring grooves of the piston. This can be done with a broken compression ring that has been ground to a bevel edge.

3. Using a standard aligning fixture, check the connecting rod for distortion and misalignment. Check the connecting rods, caps, and bolts for cracks with magnetic particle test. Discard and replace parts if cracks are detected.

4. Inspect the connecting rod bearings for scoring, chipping, flaking, pits, cracks, and signs of overheating. Bright spots on back of bearings indicate shifting and are cause for replacement.

5. Check the piston pin bushing for scoring or wear. Replace bushing if bore is scored or if worn to more than 1.2523 inches. Press worn bushing from connecting rod and press in new one.

6. Inspect the piston pin for wear or scoring. Replace pin if worn to less than 1.2478-inch diameter. Maximum allowable pin clearance in piston is 0.0005 inch and in connecting rod is 0.0012 inch.

7. Inspect the pistons for damaged ring grooves, scoring, or cracks. Remove light scor-

ing with fine emery cloth. Replace piston if damaged beyond repair.

### c. Reassembly and Installation.

#### NOTE

All parts should be at room temperature to ensure proper dimensional tolerances during piston and ring fitting.

1. Check the fit of the piston without rings in the cylinder bore with a feeler 0.002 x 1/2 (Bohn Piston) or 0.005 x 1/2 (Zollner Piston) between the piston and bore. Use a spring scale to determine the force required to withdraw the feeler stock. A newly honed bore with a new piston should require between 5 and 8 pounds pull. A used piston in a honed bore must require a minimum of 5 pounds of pull. If any binding occurs, remove the piston and examine the piston and cylinder wall for burrs. Remove burrs with a fine hone (a flat one is preferable) before proceeding with the clearance check.

2. If piston clearance is excessive, measure the bore diameter and refer to table 5-1 to select a new piston. Piston sizes are indicated by the letter A, B, C, D, or E stamped on the top of the piston. Within the limits of the size variations available, a slightly larger piston can be fitted to a worn cylinder bore to obtain the correct clearance.

Table 5-1. Piston and Bore Sizes

Letter	3-3/4 Inch Bore		4 Inch Bore	
	Piston Diameter	Bore Diameter	Piston Diameter	Bore Diameter
A	<u>3.7479</u> 3.7483	<u>3.7492</u> 3.7498	<u>3.9974</u> 3.9978	<u>3.9987</u> 3.9991
B	<u>3.7484</u> 3.7488	<u>3.7497</u> 3.7501	<u>3.9979</u> 3.9983	<u>3.9992</u> 3.9996
C	<u>3.7489</u> 3.7493	<u>3.7502</u> 3.7506	<u>3.9984</u> 3.9988	<u>3.9997</u> 4.0001
D	<u>3.7494</u> 3.7498	<u>3.7507</u> 3.7511	<u>3.9989</u> 3.9993	<u>4.0002</u> 4.0006
E	<u>3.7499</u> 3.7503	<u>3.7512</u> 3.7516	<u>3.9994</u> 3.9998	<u>4.0007</u> 4.0011

NOTE: Select piston to obtain 0.0009 to 0.0017 inch clearance (all engines).

3. All new piston rings must be installed whenever a piston is removed, regardless of whether a new or used piston is installed.

4. Insert one ring at a time inside of the cylinder bore, far enough down to be within the normal area of the ring travel. Use a piston to push down the ring to be sure it is parallel with the top of the cylinder bore. Measure the ring gap with a feeler gauge. All ring gaps shall be 0.010 to 0.020 inch.

5. Check the ring clearance in the piston ring grooves. See Fits and Tolerances in Section VII.

6. Install each piston on its connecting rod by placing the upper end of the connecting rod between the piston pin bosses and in line with the piston pin holes. Then, slide the piston pin (9, figure 5-37) in place. To facilitate assembly, heat the piston in boiling water for a few minutes, but do not heat the piston pin. Install the pin retaining rings (8).

7. Install the piston rings (5, 6, and 7) on the piston as follows:

(a) Install the rings on the piston with an expander tool. To avoid breaking or overstressing the rings, do not spread them any more than necessary to slip them over the piston.

(b) When installing the piston rings, stagger the positions of the ring gaps around the piston to minimize compression loss. No two ring gaps may be in line.

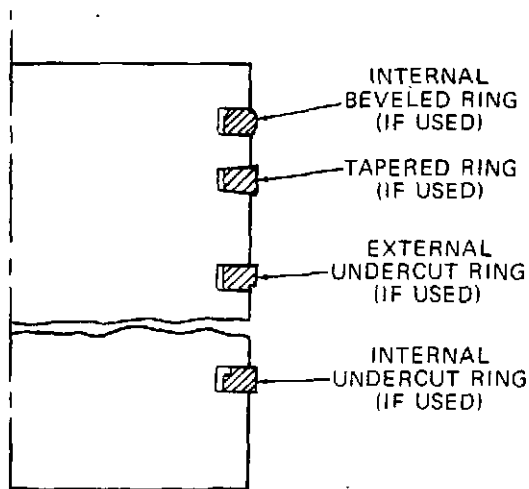

NOTE: PISTON RINGS ARE NOT NECESSARILY INSTALLED IN THE ORDER SHOWN

Figure 5-39. Piston Ring Shapes and Installation

(c) When installing piston rings with undercut grooves, note the following instructions:

(1) On all piston rings that have a bevel or chamfer on the inside diameter of the ring, place the bevel toward the top of the piston. See figure 5-39.

(2) On all piston rings that have the groove on the outside diameter of the ring, place the undercut or groove toward the bottom of the piston. See figure 5-39.

(3) On all piston rings that have the groove cut on the inside diameter of the ring, place the undercut or groove toward the top of the piston. See figure 5-39.

8. Inspect the crankshaft for any rough or scored marks that might damage the connecting rod bearing. If any rough marks are found, polish the shaft with an oil stone, very fine emery cloth, or crocus cloth. Clean the shaft thoroughly after polishing.

#### NOTE

The cylinder number is stamped on the connecting rods and caps on the camshaft side and to the front of the engine.

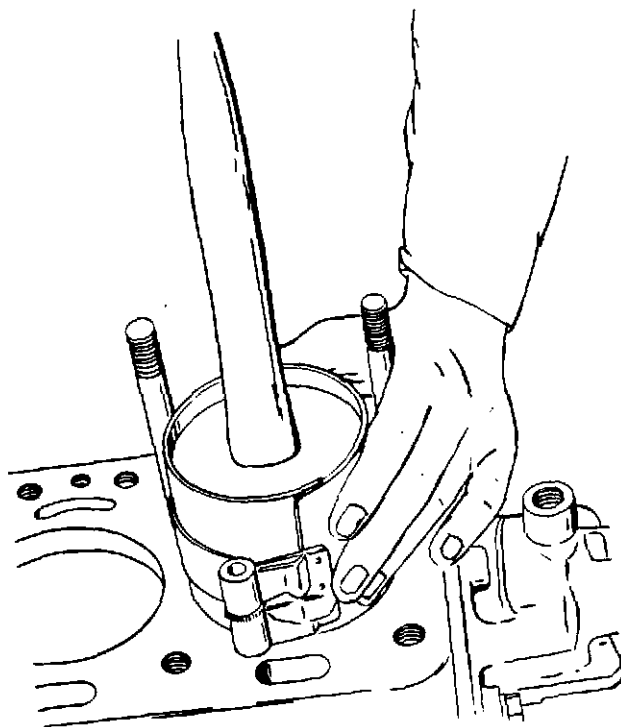

Figure 5-40. Piston Installation

## ENGINE REPAIR AND OVERHAUL

9. Select the proper assembled piston and connecting rod for the first cylinder bore and turn the crankshaft so that the connecting rod journal for that cylinder is in the lowered position. Apply a coat of lubricating oil to the cylinder bores, pistons, rings, piston pin, and crankshaft journal.

10. Use a ring compressor to compress the piston rings to facilitate installation of the assembled piston and rod. Remove the connecting rod bearing cap, wipe the bearings clean, and insert the piston from the top of the cylinder block. Use a hammer handle or block of wood against the top of the piston to push the piston into the cylinder bore. See figure 5-40. Make certain that the connecting rod is in line with the crankshaft journal and that the bearing is properly positioned in the connecting rod.

11. Install the bearings and connect the connecting rod to the crankshaft as follows:

(a) To check crankshaft journal-to-bearing shell clearance, place a piece of plastic gauge material the full width of the lower bearing (3) about 1/4 inch off center (see figure 5-41). Rotate the crankshaft about 30° from bottom dead center and install the connecting rod cap. Tighten the connecting rod cap bolts to 70 foot-pounds torque. Make sure the rod cap cylinder identification number is toward the camshaft side of the engine facing the front of the engine.

(b) Remove the connecting rod cap. The flattened plastic gauge material will be found adhering to either the lower bearing or the crankshaft. Compare the width of the flattened plastic gauge material at its widest point with the graduations on the package, as shown in figure 5-41. The required clearance for new parts is 0.001 to 0.003 inch. With used parts, the maximum allowable clearance is 0.005 inch.

(c) If the clearance is within required limits, remove the gauge material, lubricate the bearings with engine oil, and reinstall the connecting rod bearings and cap (2, figure 5-37). Tighten the bolts (1) to 68 to 72 foot-pounds torque. Check the connecting rod side clearance; it should be 0.005 to 0.012 inch with a maximum clearance of 0.020 inch.

12. Install the remaining piston and connecting rod assemblies in a similar manner. Be sure that the cylinder numbers in the rods and caps are on the camshaft side facing the front of the engine.

13. Install the oil pump (paragraph 5-6).

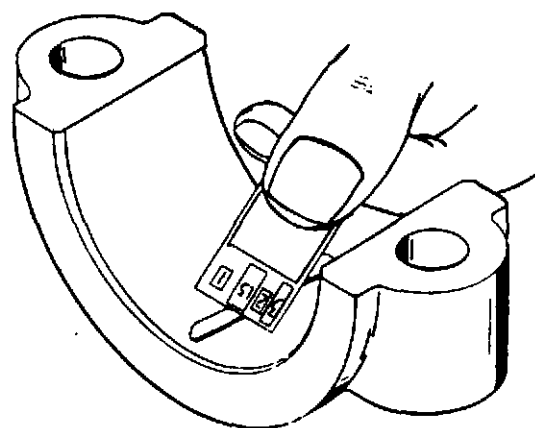
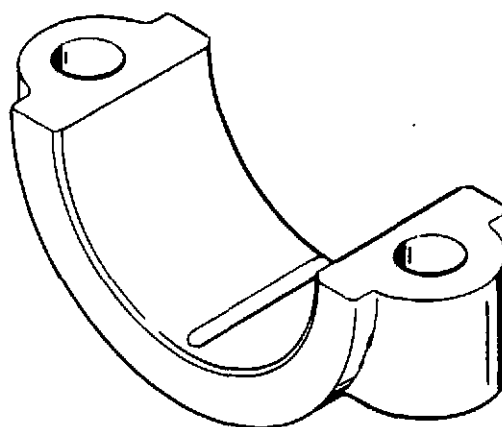

Figure 5-41. Checking Bearing Clearance

14. Inspect the top of the cylinder block and pistons. Make sure no foreign matter is present; install the cylinder head gasket.

15. Install the cylinder head (paragraph 5-27).

16. Insert the valve pushrods and install the rocker arm assembly (paragraph 5-26).

17. Install the cylinder head cover, using a new gasket. Install the nuts and washers.

18. Install the thermostat, thermostat housing, and water pump bypass hose; connect the water temperature gauge thermocouple.

19. Install the carburetor (paragraph 5-13) and fuel pump (paragraph 5-11).

20. Install and time the distributor (paragraph 5-23).

21. Connect the exhaust pipe to the manifold.

22. Connect the radiator hoses and fill the radiator with clean water or antifreeze.

23. Install the oil pan, using new gaskets, and fill the crankcase with the proper grade of lubricating oil (paragraph 5-5).

24. Adjust the valve clearance (paragraph 5-28f).

#### 5-34. CRANKSHAFT AND MAIN BEARINGS.

The crankshaft is a machined forging with surface-hardened bearing journals. The shaft has passages drilled to carry oil, under pressure, to the connecting rod bearings. Normally, it is not necessary to remove the crankshaft gear from the crankshaft.

The use of seven main bearings in the six-cylinder engine and five in the four-cylinder engine permits a main bearing to be placed on each side of each connecting rod bearing (see figure 5-42). This construction helps to eliminate vibration at high speeds. The main bearings are removable, precision, shell-type bearings. The upper shell of each bearing is not interchangeable with the lower shell. No shims are used. These precision-type shells are completely finished before being put in place and no line reaming or scraping is required.

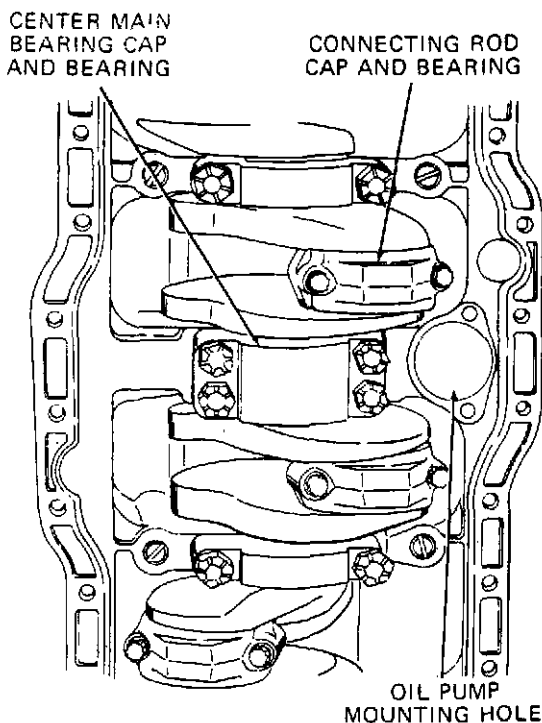

Figure 5-42. Crankshaft and Main Bearings

#### a. Removal.

Removal of the crankshaft is greatly facilitated if the engine is mounted on an engine overhaul stand with the cylinder head, pistons, and connecting rods removed. However, it may not be necessary to remove the engine from the unit to replace only the main bearings. To remove the main bearings only, proceed as indicated in steps 4 through 8 below. To remove the crankshaft and main bearings, the following minimum disassembly is required.

1. Drain the radiator and remove the radiator, hoses, and radiator support bracket.

2. Disconnect and remove the carburetor from the intake manifold (figure 5-12) and disconnect the muffler and exhaust pipe from the exhaust manifold.

3. Remove the fan and belt(s) for easier access to the gear cover and gears (paragraph 5-8) and remove the fan drive pulley and gear housing cover (paragraphs 5-8 and 5-31).

4. Remove the distributor (paragraph 5-23) or magneto (paragraph 5-24).

5. Drain the crankcase and remove the oil pan (paragraph 5-5).

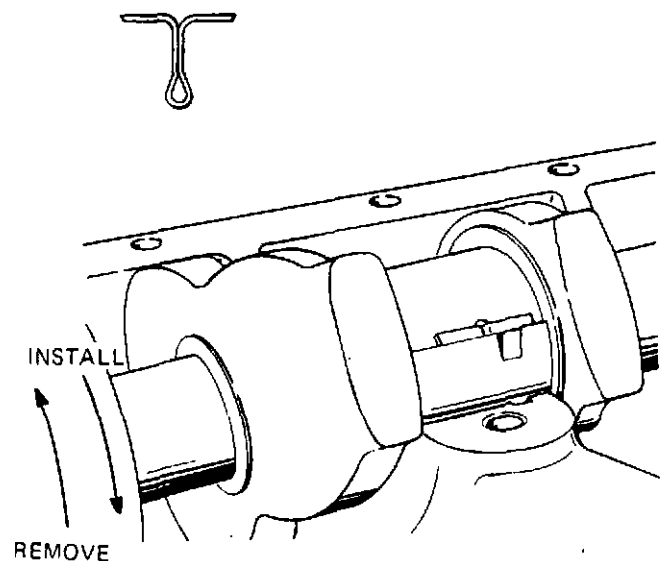

Figure 5-43. Upper Main Bearing Removal and Installation

## ENGINE REPAIR AND OVERHAUL

6. Remove the oil pump (paragraph 5-6). If a tachometer drive is used, it must be removed before the oil pump can be removed.

7. Remove the front and rear oil pan adapters (paragraphs 5-30 and 5-31).

8. Remove the main bearing caps (14, 15, 16, and 17, figure 5-35) by removing the bolts (10, 11, 12, and 13). Remove the main bearing caps and lower main bearings (18, 19, 20, and 21), one cylinder at a time. Keep each bearing matched with its bearing cap. It may be necessary to use a small pry bar to remove the main bearing caps from the cylinder block. Be careful not to score or mar the crankshaft journals.

9. To remove the upper main bearings (23, 24, 25, and 26, figure 5-35) without removing the crankshaft, insert a small tee-shaped pin in the crankshaft oil hole. Rotate the crankshaft (22) counterclockwise so that the pin will push the upper main bearing out, as shown in figure 5-43. If the crankshaft is to be removed, remove the upper bearings after removing the crankshaft.

10. Remove the connecting rod bearing caps and bearings (paragraph 5-33).

11. With the engine inverted on an overhaul stand, use a rope sling and a hoist to remove the crankshaft (22, figure 5-35) from the cylinder block (64). Take care to prevent scoring of the crankshaft journals.

12. Remove the upper main bearings (23, 24, 25, and 26) from the cylinder block.

### b. Cleaning and Inspection.

1. Discard used gaskets and seals.

2. Clean all parts with cleaning solvent; dry with filtered compressed air.

3. Clean the oil passages in the crankshaft with a small tube brush.

4. Inspect the crankshaft gear for cracked or worn gear teeth. If gear removal is necessary, properly support the crankshaft and gear in an arbor press and remove the gear (27, figure 5-35) from the crankshaft. Remove the woodruff key (28). If the gear must be replaced and an arbor press is not available, use a 1/4-inch drill centered midway between the edge of the keyway and the base of the gear teeth and drill through the gear parallel with the keyway. Spread the gear with a chisel and pull from the shaft. Be careful not to drill into the crankshaft.

### NOTE

Different timing gear sets are used on distributor ignition engines than on magneto ignition engines. Distributor ignition engines use a combination having a 25-tooth crankshaft gear and a 50-tooth camshaft gear. Magneto ignition engines use a combination having a 24-tooth crankshaft gear and a 48-tooth camshaft gear.

5. Inspect the bearing caps for cracks and distortion. Replace if damaged.

6. Inspect the main bearings for scoring, chipping, flaking, pits, and signs of overheating. Bright spots on back of bearings indicate shifting and are cause for replacement. Replace all main bearings if one or more is damaged and requires replacement.

7. Inspect the crankshaft for cracks, scored journals, and misalignment. Replace if damaged beyond repair. Perform detailed inspection of the crankshaft as follows:

(a) Check the surfaces of the crankshaft for cracks. There are several methods of determining the presence of minute cracks not visible to the eye. These inspection methods include magnetic particle, fluorescent magnetic particle, and fluorescent penetrant. Check for circumferential fillet cracks at the critical areas, and 45° cracks (45° with axis of the shaft) starting from either the critical fillet locations or the crankshaft holes. Cracks of this nature require replacement of the shaft.

(b) Inspect the keyways for cracks or wear; replace the shaft if necessary.

(c) If the crankshaft is worn so that the maximum journal-to-bearing clearance (with new bearings) exceeds 0.007 inch, or the maximum taper is 0.0015 inch, or the out-of-round is 0.002 inch, the crankshaft must be reground to 0.010, 0.020, 0.030, 0.040, or 0.060 inch undersize. Proceed as follows:

### NOTE

The crankshafts of engines used in air compressor applications may be surface hardened by the Tufftriding process. Regrinding of the journals of these crankshafts requires that the crankshaft be Tufftrided again before installation.

(1) Prior to grinding a crankshaft, check carefully for cracks which start at an oil

Table 5-2. Crankshaft Main and Connecting Rod Journal Dimensions

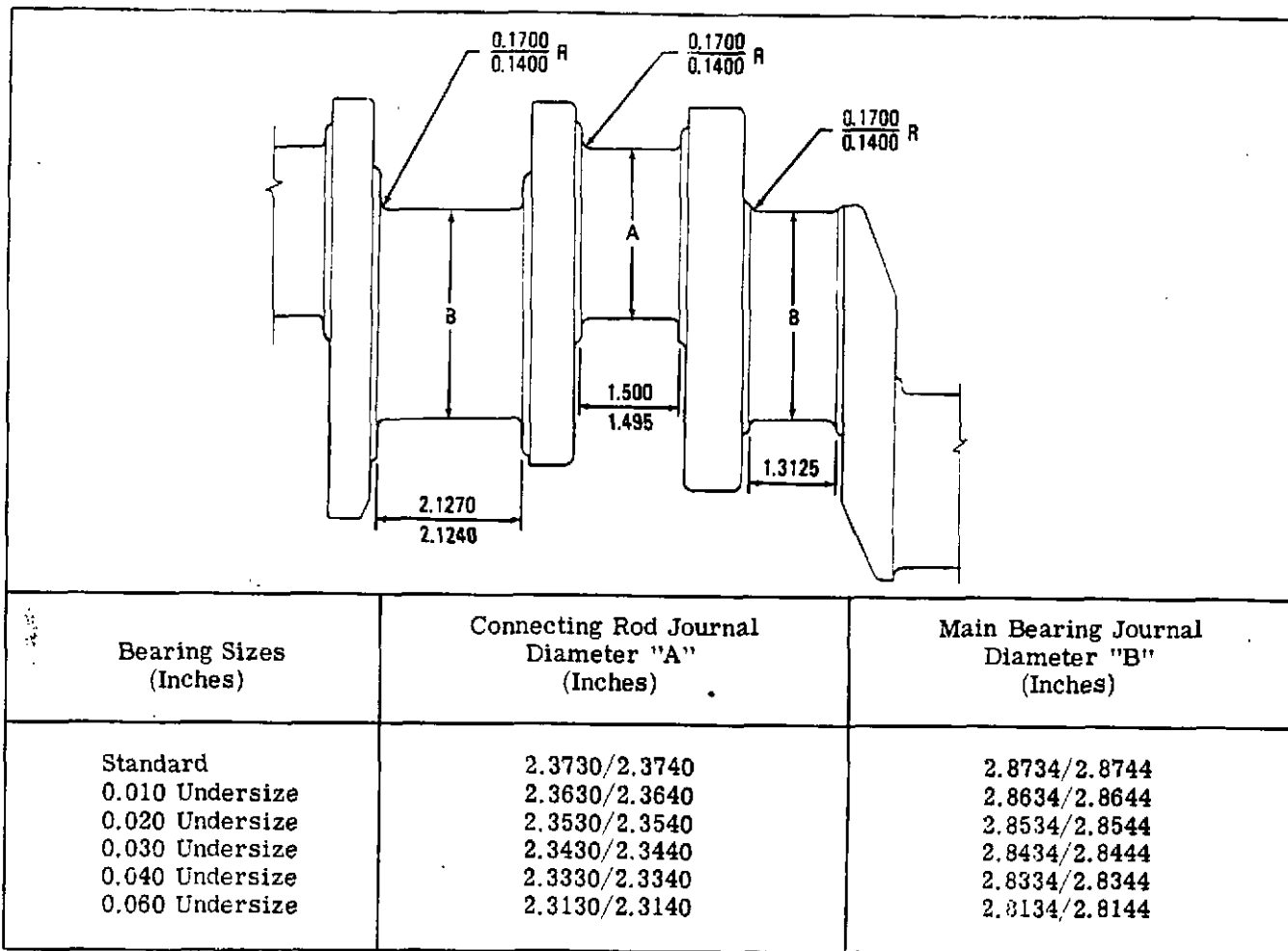

hole and follow the journal surface at an angle of 45° to the axis. Any crankshafts with such cracks must be rejected, as these cracks indicate torsional fatigue. Grinding of the shaft will increase the stress at the cracks causing eventual failure.

(2) Measure the crankshaft journals, and compare these measurements to the diameters required for various undersize bearings shown in table 5-2. These measurements will determine the size to which the crankshaft journals must be reground.

(3) If one or more main or connecting rod journals require grinding, then all main or all connecting rod journals must be ground to the same required size.

(4) When regrinding crankshafts, all journal fillets must have a 0.140- to 0.170-inch radius between the crank cheek and the crank journal, and must not have any sharp grind marks. The fillet must blend smoothly into the journal and cheek, and must be free of scratches.

(5) After all of the regrinding operations have been completed, perform another magnetic particle inspection of the crankshaft to determine whether grinding cracks have originated due either to insufficient cooling or crowding of the grinding wheel. Finally, demagnetize the crankshaft.

(6) Wash and clean the crankshaft with solvent, and blow dry with air. Blow out the oil passages to make sure they are clear.

#### c. Reassembly and Installation.

1. Install the crankshaft gear (27, figure 5-35) onto the crankshaft (22). Use an arbor press, if available, to press the gear on the shaft. Make sure the woodruff key (28) is in place. If an arbor press is not available, the following method may be used:

(a) Insert the woodruff key (28) in the crankshaft.

## ENGINE REPAIR AND OVERHAUL

Table 5-3. Main Bearing Cap Bolt Torques

	T-Stamped Caps (Foot-Pounds)	Plain Caps (Foot-Pounds)
9/16-inch bolts for front, rear, and intermediate caps	130	80
1/2-inch bolts for center main bearing cap	100	80

(b) Lay the gear on a sheet of asbestos or other fireproof material and, with a torch, heat the gear evenly on both sides until the gear turns a pale straw yellow. (If the gear is clean and untarnished, this color will indicate it is heated to approximately 450°F.)

(c) Assemble the hot gear on the crankshaft and quickly drive the gear into the correct position. A piece of 2-inch diameter pipe may be used as a driver.

(d) Allow the gear and shaft to cool.

2. Install the upper main bearings (23, 24, 25, and 26) in the cylinder block. The upper bearings are the bearings with two holes and an oil groove. The bearings must be installed in the same positions from which they were removed.

### NOTE

The upper main bearings can be installed with the crankshaft in place. Install a small tee-shaped pin into the crankshaft oil hole. After starting the bearing into place, rotate the crankshaft clockwise to seat it on the cylinder block, as shown in figure 5-43.

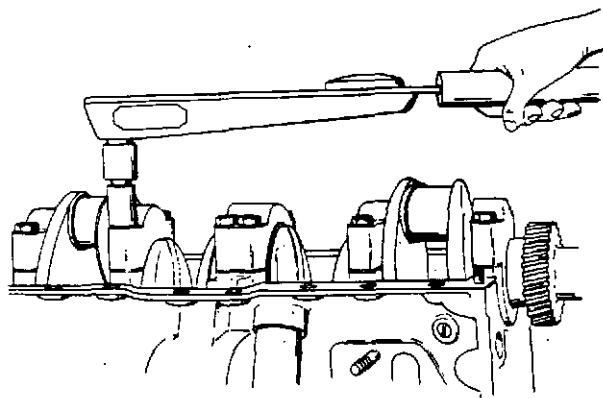

Figure 5-44. Tightening Main Bearing Cap Bolts

3. Apply clean engine oil to all of the crankshaft journals and bearings and, using a sling and hoist, carefully set the crankshaft in place so that the timing marks on the crankshaft gear and the camshaft gear align as shown in figure 5-31.

4. With the lower main bearings (18, 19, 20, and 21, figure 5-35) installed in the bearing caps (14, 15, 16, and 17) from which they were removed, install the caps in their original positions on the cylinder block. The caps are marked with the journal number in which they are used. The center main bearing cap is secured with four 1/2-inch diameter bolts. The remaining bearing caps are secured with two 9/16-inch diameter bolts each. Draw the bolts up snug, then rap the caps sharply with a soft hammer to seat them properly. Check the original center main bearing cap for a T stamped on the side opposite the cylinder number to determine the required torque value. Tighten the bearing cap bolts to the torque specified in table 5-3. Refer to figure 5-44. Start with the center cap and work alternately toward both ends of the block. If the

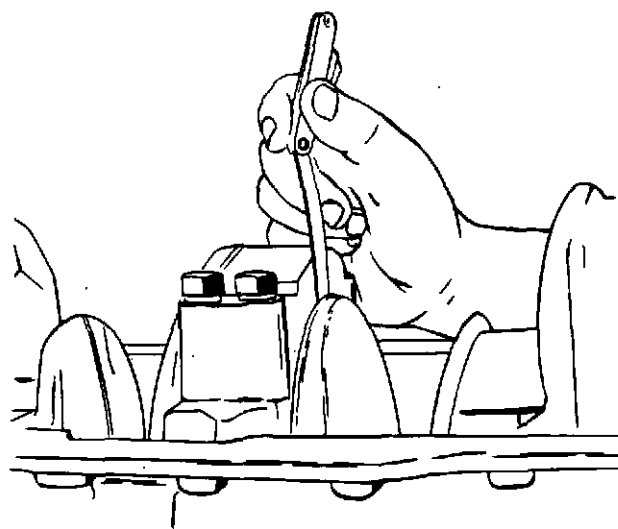

Figure 5-45. Checking Crankshaft End Thrust

bearings have been installed properly, the crankshaft will turn freely with all main bearing caps drawn down to the specified torque.

5. After installing crankshaft with new bearings and center thrust bearing, check the crankshaft end thrust. Insert different dimension feeler gauges until one just fits between the center thrust bearing and the crankshaft as shown in figure 5-45. This dimension must be between 0.005 and 0.010 inch for new bearings, and the maximum allowable clearance of 0.015 inch. Insufficient clearance can be the result of a misaligned main bearing, or a burr or dirt on the inner face of the thrust bearing flange. Disassemble, clean, and reassemble as necessary. If clearance is still insufficient, polish the thrust bearing flanges on a flat surface with crocus cloth to obtain the proper clearance.

6. Position the connecting rods so that they engage the journals of the crankshaft. Apply a coat of engine oil to the bearing shells to ensure proper lubrication. Install the connecting rod bearings and bearing caps (paragraph 5-33).

7. Install the front and rear oil pan adapters (paragraphs 5-30 and 5-31).

8. Install the oil pump (paragraph 5-6); install the tachometer drive, if used (paragraph 5-25).

9. Install and time the distributor (paragraph 5-23) or magneto (paragraph 5-24).

10. Place a new seal in gear housing cover and install cover. Install the fan drive pulley (paragraphs 5-8 and 5-31).

11. Install the fan and belt(s) (paragraph 5-8).

12. Install muffler and exhaust pipe on the exhaust manifold and install the carburetor on the intake manifold (figure 5-12).

13. Install the oil pan, using new gaskets. Fill the crankcase with the proper grade of lubricating oil. See table 3-2.

14. Install the radiator, hoses, and support brackets. Fill with water or antifreeze.

#### 5-35. CYLINDER BLOCK.

The cylinders are machined into the cast iron cylinder block. For uniform cooling, water jackets are carried the full length of the cylinders.

The cylinder block has an oil header running the length of the block. From this header, various passages carry oil to the main bearings, camshaft bearings, and rocker arms.

#### a. Removal and Disassembly.

1. Remove the engine and mount it on an overhaul stand as directed in paragraph 5-2.

2. Remove the carburetor (paragraph 5-13).

3. Remove the intake and exhaust manifolds (paragraphs 5-17 and 5-18).

4. Remove the mechanical fuel pump, if used (paragraph 5-11).

5. Remove the spark plugs and cables.

6. Remove the distributor (paragraph 5-23) or magneto (paragraph 5-24).

7. Remove the water pump and fan assembly (paragraph 5-8).

8. Remove the cylinder head (paragraph 5-27).

9. Remove the flywheel (paragraph 5-29).

10. Remove the oil filters and lines (paragraph 5-4).

11. Remove the oil pan (paragraph 5-5).

12. Remove the bellhousing (paragraph 5-30).

13. Remove the mechanical governor, if used (paragraph 5-14).

14. Remove the gear housing (paragraph 5-31).

15. Remove the tachometer drive, if used (paragraph 5-25).

16. Remove the oil pump (paragraph 5-6).

17. Remove the camshaft (paragraph 5-32).

18. Remove the pistons and connecting rods (paragraph 5-33).

19. Remove the crankshaft and main bearings (paragraph 5-34).

20. Remove the bolts (40, figure 5-35) and lock washers (41) attaching the side cover (42) and gasket (43) to the engine; remove the side cover and gasket.

## ENGINE REPAIR AND OVERHAUL

Table 5-4. Cylinder Bore Dimensions

Cylinder Bore Diameter	Manufacturing Diameter		Maximum Allowable Diameter
	Minimum	Maximum	
3-3/4 inch bore	3.749	3.751	3.756
0.020 over-size	3.769	3.771	3.776
0.040 over-size	3.789	3.791	3.796
4 inch bore	3.999	4.001	4.006
0.020 over-size	4.019	4.021	4.026
0.040 over-size	4.039	4.041	4.046

21. Remove the oil level bayonet gauge tube (48) from the cylinder block (64).

22. Refer to figure 5-35 and remove oil passage pipe plugs (30 thru 34, and 37) from the block. Do not remove the expansion plugs (55) in the core openings, unless they show signs of leaking.

23. Do not remove the various studs and dowel pins from the block unless they are damaged and require replacement.

**b. Cleaning and Inspection.**

1. Clean block by submerging in tank of heated cleaning solvent. Circulate the solvent to increase cleaning effectiveness.

**NOTE**

If additional machining is to be performed, clean oil passage and reinstall plugs after all machining is completed.

2. Clean oil passages by running a wire brush through them.

3. Check the cylinder block for cracks by using dye penetrants according to manufacturer's instructions. Replace a damaged block.

4. Check for excessive cylinder bore wear by determining the diameter of the wear area and comparing this with the original cylinder bore diameter. Gauge at intervals of approximately 45 degrees. Refer to table 5-4 for standard bore dimensions. Maximum allowable wear is 0.005 inch.

**NOTE**

If wear appears to be unusually excessive, check for original cylinder bore

diameter by gauging the diameter of the cylinder below the piston ring wear area. The cylinder may already have been re-bored for over-sized pistons.

5. The out-of-round must not exceed 0.003 inch or the taper must not be more than 0.002 inch in each bore. Irregularities in the cylinder bore (out-of-round and taper) may result in galling and seizing of new pistons.

6. If the cylinder bores are worn excessively, they can be re-bored for 0.020 and 0.040 oversize pistons and piston rings. Use a good commercial boring unit and follow the manufacturer's instructions. After boring, check the bore finish to be sure it is smooth.

7. Hone the cylinders and ridge ream, if necessary. After honing the cylinders, visually check the honed surface of each cylinder bore. There must not be any low spot with an area larger than a half dollar. Recheck the cylinder tolerance as described above.

8. Check the top of the block for flatness with an accurate straightedge and a feeler gauge. The top surface must not vary more than 0.005 inch on width or length. Out-of-flatness should vary gradually and uniformly from end to end and side to side. If it is necessary to machine the top surface of the block to correct for the above conditions, do not remove more than 0.005 inch of metal. The dimension from the center-line of the crankshaft to the top of the block must not be less than 13.12 inches.

9. Remove and replace any damaged or broken cylinder head studs (49 thru 54). With studs removed, inspect the tapped stud holes in the block and, if the threads are damaged, use a tap (same size as hole) to clean up the threads or retap larger and install a helical thread insert. Add Loctite in hole and install new studs

Table 5-5. Cylinder Stud Installation

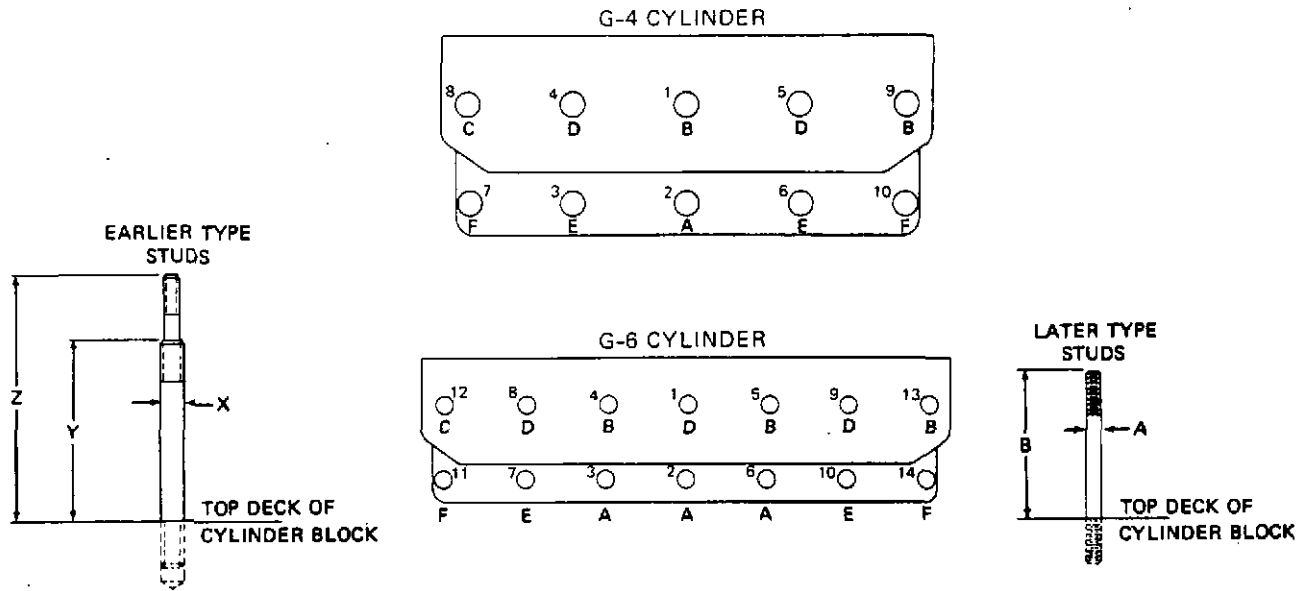

EARLIER TYPE STUDS				
Stud Identification	4 Cylinder		6 Cylinder	
	X-Diameter	Height	X-Diameter	Height
A	0.562	Y 4.625	0.562	Y 4.625
B	0.562	Y 4.625 Z 6.250	0.625	Y 4.688
C - Oil supply	0.625	Y 4.625 Z 6.250	0.625	Y 4.625
D - Cover	0.562	Y 4.625 Z 6.250	0.625	Y 4.625
E - Lift	0.562	Y 5.500	0.625	Y 5.375
F	0.562	Y 3.375	0.625	Y 3.375
LATER TYPE STUDS				
Stud Identification	4 Cylinder		6 Cylinder	
	A-Diameter	B-Height	A-Diameter	B-Height
A	0.562	4.620	0.625	4.688
B	0.562	6.650	0.625	6.625
C - Oil supply	0.625	6.620	0.625	6.625
D - Cover	0.562	7.430	0.625	7.435
E - Lift	0.562	5.750	0.625	5.560
F	0.562	3.375	0.625	3.375

## ENGINE REPAIR AND OVERHAUL

in the cylinder block to the dimensions indicated in table 5-5. Install the end oil passage studs so that the oil holes are within a 40-degree angle with the center line of the rocker arm shaft, as shown in figure 5-21.

10. Check the main bearing bores as follows:

(a) Install the main bearing caps in their original positions. Draw the bolts up snugly, and rap the bearing cap sharply with a soft hammer to ensure proper seating. Tighten the bolts to the torques given in table 5-3.

### NOTE

It is imperative that the main bearing caps are reinstalled in their original positions to maintain the main bearing bore alignment. The caps are marked with the number of the journal in which they are used.

(b) Measure the main bearing bores. The bearing bores must be 3.0665 to 3.0670 inches. If the bores do not fall within these limits, discard the cylinder block.

(c) Check the main bearing bores for alignment. Misalignment may be caused by a broken crankshaft, excessive heat, or other severe damage. Check bearing bore alignment. If a crankshaft having standard size journals, new standard size main bearing shells installed and lubricated, and the bearing caps properly tightened, can be rotated freely by hand, the bores are properly aligned. If a main bearing bore is out of alignment, the block must be line-bored or scraped. After boring, all bores must be within the 3.0665- to 3.0670-inch limits.

11. Check the camshaft bearing bores. The internal diameter of bearing bores must be 2.1870 to 2.1889 inches. If the bores do not fall within these limits, replace the cylinder block.

12. Check the plugs in the vertical oil passages in the corners of the block to be sure they are flush with or below the top surface of the block.

13. Check all of the machined accessory mounting pads for flatness, nicks, and burrs. Remove nicks and burrs with a fine file.

14. Check the remaining studs and dowel pins in the block for damaged threads, distortion, cracks, or other damage. Replace any damaged parts.

15. Check all the threaded holes in the cylinder block. Make sure they are clean and the threads are in good condition. Clean up damaged threads in the tapped holes with a same-size tap or retap larger and install helical thread inserts, if necessary.

16. Inspect the covers (42 and 46, figure 5-35) and bayonet gauge tube for cracks, dents, distortion, and other damage. Replace any damaged parts.

### c. Reassembly and Installation.

1. Reinstall any studs, dowel pins, or expansion plugs (55, figure 5-35) that have been removed.

2. Reinstall pipe plugs (30 thru 34, and 37) in open oil passages. Make sure the lower camshaft thrust flange mounting hole is plugged with setscrew (38) as shown in figure 5-29. This is the rear end opening of the oil passage for the rocker arms and must be plugged to prevent oil leakage.

3. Install the oil level bayonet gauge tube (48, figure 5-35) in the cylinder block (64).

4. Install the cover (46) and gasket (47); secure with nuts (44) and lock washers (45).

5. Install the side cover plate (42) and gasket (43); secure with bolts (40) and lock washers (41).

6. Install the crankshaft and main bearings (paragraph 5-34).

7. Install the pistons and connecting rods (paragraph 5-33).

8. Install the camshaft (paragraph 5-32).

9. Install the oil pump (paragraph 5-6).

10. Install the tachometer drive, if used (paragraph 5-25).

11. Install the gear housing (paragraph 5-31).

12. Install the mechanical governor, if used (paragraph 5-14).

13. Install the bellhousing (paragraph 5-30).

14. Install the oil pan (paragraph 5-5).

15. Install the oil filters and lines (paragraph 5-4).

- 
16. Install the flywheel (paragraph 5-29).
  17. Install the cylinder head (paragraph 5-27).
  18. Install the thermostat and housing (paragraph 5-9).
  19. Install the water pump and fan assembly (paragraph 5-8).
  20. Install and time the distributor (paragraph 5-23) or magneto (paragraph 5-24).
  21. Install the spark plugs and cables. Refer to figure 3-3.
  22. Install the mechanical fuel pump if used (paragraph 5-11).
  23. Install the intake and exhaust manifolds (paragraphs 5-17 and 5-18).

24. Install the carburetor (paragraph 5-13).
25. Reassemble the engine accessories and install the engine in the power unit by reversing the procedure given in paragraph 5-2.
26. After overhaul, make the following adjustments:
  - (a) Adjust valve clearance (paragraph 3-6).
  - (b) Time the distributor or magneto (paragraph 3-9 or 3-10).
  - (c) Adjust idle speed (paragraph 3-11).
  - (d) Adjust maximum governed speed (paragraph 3-12 or 3-13).

# TORQUE SPECIFICATIONS

## SECTION VI TORQUE SPECIFICATIONS

Table 6-1 lists the torque specifications which must be used during engine reassembly. Follow these values to ensure proper fits, tolerances, and alignment of the reassembled engine.

Table 6-1. Torque Specifications

	Torque (Foot-Pounds)			Torque (Foot-Pounds)	
	4 Cylinder	6 Cylinder		4 Cylinder	6 Cylinder
Main bearing cap bolts			Intake manifold cap screws	20	20
Front	130	130			
Intermediate	130	130	Fuel pump attaching nut	15	15
Center	100	100	Vibration damper-to-pulley nut	35	35
Rear	130	130			
Older block without "T" on cap	80	80	Water pump attaching bolt	24	24
All connecting rod bolts	70	70	Oil pan attaching bolt	20	20
Camshaft gear nut	130	130	Gear housing attaching cap screws	40	40
Crankshaft pulley	125	125	Gear housing cover attaching cap screws and nut	15	15
Flywheel-to-crankshaft bolt	80	80	Thermostat housing bolt	15	15
Flywheel housing nuts	40	40	Cam thrust plate bolt	9	9
Grade 5 bolts	75	75	Oil pan adapter-to-housing bolt	15	15
Oil pump attaching bolt	25	25	PTO adapter ring bolt	35	35
Cylinder head					
9/16" stud nut	147				
5/8" stud nut	160	175			
Exhaust manifold nut	20	20			

# FITS AND TOLERANCES

## SECTION VII FITS AND TOLERANCES

Model G-Series: 4 and 6 Cylinder	Mfg. Tolerances		Clearance		Maximum Allowable Wear
	Minimum	Maximum	Minimum	Maximum	
<b>CYLINDER BLOCK</b>					
Cylinder bore diameter					
3-3/4" bore	3.7492	3.7516			0.0050
4" bore	3.9987	4.0012			0.0050
Cylinder bore out of round		0.0005			0.0030
Cylinder bore taper		0.0005			0.0020
Main bearing bore - less bearings	3.0665	3.0670			
Camshaft bearing bore - less bearings	2.186	2.1865			
Oil pump bore	2.0000	2.0005			
Valve tappet bore	0.7496	0.7505			
<b>CRANKSHAFT</b>					
Main bearing journal diameter	2.8734	2.8744			0.0030
Main bearing journal out of round		0.0005			0.0020
Main bearing journal taper		0.0003			0.0015
Main bearing run-out at center		0.0020			0.0030
Connecting rod journal diameter	2.3730	2.3740			0.0020
Connecting rod journal out of round		0.0005			0.0020
Connecting rod journal taper		0.0003			0.0015
Fillet radii	0.1400	0.1700			
Crankshaft main bearing clearance			0.0009	0.0034	
Crankshaft thrust clearance			0.0050	0.0100	
Seal surface diameter - rear	4.3100	4.3150			0.0150
Seal surface diameter - front	1.8740	1.8750			0.0150
<b>CONNECTING ROD</b>					
Length - c/l to c/l	7.9980	8.0020			
Bearing bore - less bearings	2.5260	2.5270			
Bearing to crankshaft clearance			0.0010	0.0030	
Connecting rod side clearance			0.0050	0.0120	
Piston pin bushing bore - less bearings	1.3745	1.3755			
Piston pin bushing bore	1.2503	1.2506			0.0015
<b>CAMSHAFT</b>					
Bearing journal diameter - all	2.0530	2.0540			0.0020
Lobe diameter - base to tip	1.7200	1.7250			0.0100
Journal run-out in vee blocks		0.0010			0.0040
Bearing clearance			0.001	0.003	
End thrust			0.0050	0.0080	0.0040
Backlash - camshaft to crank gear			0.0015	0.0025	
<b>PISTON</b>					
Clearance in cylinder bore - all	(With newly honed bores and new pistons)				
	5 lb.	8 lb.	(Pull on 1/2 x .002 ribbon Bohn) (1/2 x .005 Zollner)		
Piston pin bore	1.2500	1.2502			0.0010
Width of ring groove - top	0.0970	0.0980			0.0080
Width of ring groove - 2nd	0.126	0.127			0.0050
Width of ring groove - oil control	0.1880	0.189			0.0050

Model G-Series: 4 and 6 Cylinder	Mfg. Tolerances		Clearance		Maximum Allowable Wear
	Minimum	Maximum	Minimum	Maximum	
PISTON PIN Length 3-3/4" diameter piston Length 4" diameter piston Diameter Clearance in piston Clearance in connecting rod	3.025 3.025 1.2498	3.035 3.035 1.2500	0.0001 0.0003	0.0004 0.0008	0.0020
PISTON RING Clearance in groove - top Clearance in groove - 2nd Clearance in groove - oil control Gap	0.0035 0.0040 0.0015 0.0100	0.0050 0.0060 0.0030 0.0200			
INTAKE VALVE Head diameter Stem diameter Stem to guide clearance Stem to rocker arm clearance - hot Seat diameter in head Seat width in head Valve protrusion above cylinder head deck Valve seat angle	1.6825 0.3725  1.618  0.0875 45°	1.6925 0.3732  1.630 7/64  0.1035	0.0015 0.015	0.0020	0.0025  1/8
EXHAUST VALVE Head diameter Stem diameter Stem to guide clearance Stem to rocker arm clearance - hot Seat diameter in head Seat width in head Valve protrusion above cylinder head deck Valve seat angle	1.4950 0.3725  1.431  0.0875 45°	1.5050 0.3732  1.443 7/64  0.1035	0.0015 0.015	0.0020	0.0025  1/8
VALVE GUIDE Length Outside diameter Bore diameter Intake - ream Exhaust - ream Depth below cylinder head deck Intake Exhaust	2.724 0.6265  0.3745 0.3745  1.386 1.386	2.744 0.6270  0.3750 0.3750  1.396 1.396			0.0030 0.0030
TAPPET, VALVE LIFTER Body diameter Overall length Clearance in bore (block)	0.7485 2.2450	0.7490 2.2550	0.0005	0.0015	0.0030
VALVE SPRINGS - INTAKE AND EXHAUST Free length Total coils Diameter wire Outside diameter Test load at 1.4920 inches lbs. Test load at 1.0820 inches lbs.	1.702 6 0.172 1.286 45 130	1.722   1.3020 51 144			

## FITS AND TOLERANCES

Model G-Series: 4 and 6 Cylinder	Mfg. Tolerances		Clearance		Maximum Allowable Wear
	Minimum	Maximum	Minimum	Maximum	
<b>VALVE SPRING - INTAKE AND EXHAUST</b> NOTE: This spring is used on some engines and is not interchangeable Free length Total coils Diameter wire Outside diameter Test load at 1.5225 inches lbs. Test load at 1.1725 inches lbs.	1.8630	1.9030			
<b>OIL PUMP BODY</b> Shaft bore diameter Main Idler Pump gear bore diameter Pump gear bore depth	0.6255	0.6265			0.0030
<b>SHAFTS - OIL PUMP</b> Length Main Idler Diameter Main Idler Shaft clearance in body Drive shaft Idler shaft	9.2400	9.2500			0.0020
<b>GEARS - OIL PUMP</b> Outside diameter - both Length - both Clearance in body bore End clearance to body Backlash drive gear to camshaft	1.4975	1.4985			0.0020
<b>FLYWHEEL</b> Clutch face run out at 6 in. radius Pilot bore eccentricity		0.0080			
<b>FLYWHEEL HOUSING</b> Clutch attaching face deviation Clutch housing bore eccentricity		0.0080			
<b>ROCKER ARM MECHANISM</b> Rocker shaft length 4 cylinder 6 cylinder Rocker shaft diameter Rocker arm bore diameter Rocker arm clearance on shaft	19.4900	19.5100			0.0030
<b>GOVERNOR</b> Shaft diameter in bushing Shaft diameter - end Gear backlash	0.4365	0.4370			

100-100000

100-100000

100-100000