

OPERATION MANUAL

ENGINE SERIES

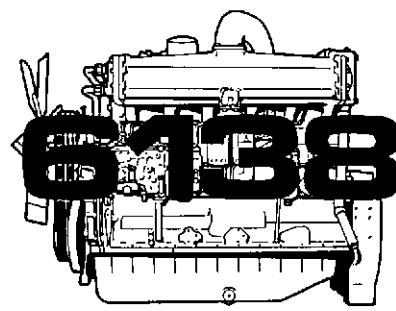
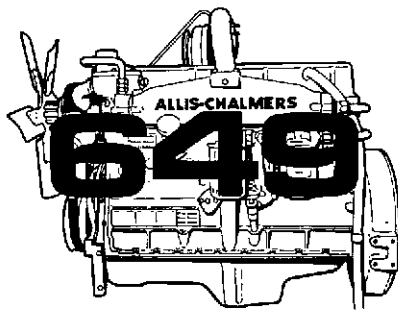
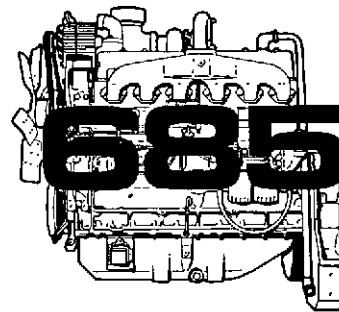
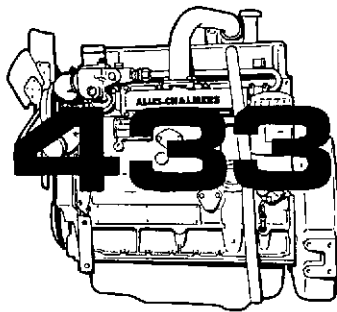
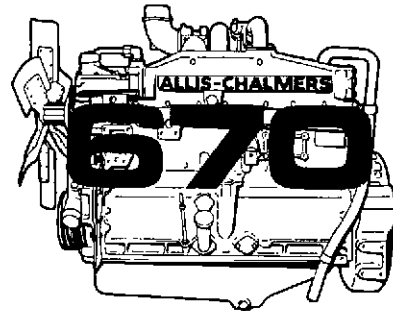

ENGINE DIVISION
HARVEY, ILLINOIS
60426, USA

Form: TM-5078
Part No: 4036346
Printed in USA

FOREWORD

THIS MANUAL IS PROVIDED TO GIVE THE OPERATOR ESSENTIAL INFORMATION REGARDING PROPER OPERATION AND MAINTENANCE OF ALLIS-CHALMERS DIESEL ENGINES AND AUXILIARY EQUIPMENT.

THE MANUAL CONTAINS INFORMATION AND INSTRUCTIONS ON PROPER OPERATION. TO KEEP THE UNIT OPERATING AT ITS MAXIMUM EFFICIENCY, THE MANUAL SHOULD BE READ, BY THE OPERATOR AND BY THOSE RESPONSIBLE FOR THE MAINTENANCE OF THE UNIT.

AN IMPORTANT ITEM IN PROLONGING THE LIFE OF THE UNIT IS TO KEEP DIRT AND OTHER FOREIGN PARTICLES AWAY FROM ITS VITAL PARTS. ALLIS-CHALMERS HAS TAKEN PRECAUTIONS IN THE DESIGN OF THE EQUIPMENT TO SAFEGUARD AGAINST DIRT AND OTHER FOREIGN MATERIALS FROM REACHING THE WORKING PARTS UNDER NORMAL OPERATING CONDITIONS. THE OPERATOR MUST ALSO TAKE PRECAUTIONS TO ASSURE THAT THE OIL, WATER, AND FUEL ARE ALWAYS KEPT CLEAN, AND THAT AIR FOR COMBUSTION IS ALWAYS FILTERED. THIS CAN BE ACCOMPLISHED BY THE PROPER STORAGE AND HANDLING OF FUEL AND LUBRICATING OIL SPECIFICATIONS AND CHANGE INTERVALS, FUEL SPECIFICATIONS, MAINTENANCE OF FILTERS, AIR CLEANER SERVICING, AND PROPER CARE OF THE COOLING SYSTEM.

TO ASSURE THE BEST RESULTS AND MAINTAIN THE HIGH QUALITY OF THE EQUIPMENT, IT IS IMPORTANT THAT ALLIS-CHALMERS PARTS ARE ALWAYS USED WHEN NEW PARTS ARE REQUIRED. IMPORTANT: ALWAYS FURNISH MODEL AND ENGINE SERIAL NUMBER WHEN ORDERING PARTS.

MANY OWNERS OF ALLIS-CHALMERS EQUIPMENT RELY UPON THE SERVICE DEPARTMENT OF OUR DEALERS FOR ALL WORK OTHER THAN ROUTINE MAINTENANCE AND ADJUSTMENT. THIS PRACTICE IS ENCOURAGED AS OUR DEALERS ARE KEPT WELL INFORMED BY THE FACTORY REGARDING THE MOST UP-TO-DATE METHODS OF SERVICING ALLIS-CHALMERS EQUIPMENT AND ARE EQUIPPED TO RENDER THE MOST COMPETENT SERVICE.

AVOID ACCIDENTS

MOST ACCIDENTS, WHETHER THEY OCCUR IN INDUSTRY, ON THE FARM, AT HOME OR ON THE HIGHWAY, ARE CAUSED BY THE FAILURE OF SOME INDIVIDUAL TO FOLLOW SIMPLE AND FUNDAMENTAL SAFETY RULES OR PRECAUTIONS. FOR THIS REASON MOST ACCIDENTS CAN BE PREVENTED BY RECOGNIZING THE REAL CAUSE AND DOING SOMETHING ABOUT IT BEFORE THE ACCIDENT OCCURS.

REGARDLESS OF THE CARE USED IN THE DESIGN AND CONSTRUCTION OF ANY TYPE OF EQUIPMENT THERE ARE MANY CONDITIONS THAT CANNOT BE COMPLETELY SAFEGUARDED AGAINST WITHOUT INTERFERING WITH REASONABLE ACCESSIBILITY AND EFFICIENT OPERATION.

IT IS THE RESPONSIBILITY OF USERS TO PROVIDE AND INSTALL GUARDS OR SAFETY DEVICES WHICH MAY BE REQUIRED BY RECOGNIZED SAFETY STANDARDS OR BY THE OCCUPATIONAL SAFETY AND HEALTH ACT OF 1970 AND ITS SUBSEQUENT PROVISIONS.

A careful operator is the best insurance against an accident. The complete observance of one simple rule would prevent many thousand serious injuries each year. That rule is:

Never attempt to clean, oil or adjust a machine while it is in motion.

SAFETY PRECAUTIONS



This symbol is used to call your attention to safety precautions that should be followed by the operator, maintenance and service personnel to avoid accidents. When you see this symbol-heed its warning-become alert-your safety is involved. Many hours of lost time and much suffering is caused by the failure to practice simple safety rules.

It is too late to remember what should have been done after the accident has happened.

OPERATION

1. Read this manual carefully to acquaint yourself with the engine. Operating unfamiliar equipment can cause accidents.
2. Do not wear rings, wrist watches, jewelry, loose or hanging apparel, such as ties, torn clothing, scarves, unbuttoned, or unzipped jackets that can catch on moving parts. Do wear proper safety equipment as authorized for the job. Examples: hard hats, safety shoes, heavy gloves, ear protectors, and safety glasses or goggles.
3. Long hair should be tied up short to prevent it from becoming entangled in moving parts.
4. Engine should be operated only by those who are responsible and delegated to do so.
5. Quick access to a FIRST AID KIT should be provided at all times to treat minor cuts and scratches.
6. It is recommended that a FIRE EXTINGUISHER be provided at an easy to get to location.
7. Keep engine exhaust system and exhaust manifolds clear of combustible material. Equip machine with screens and guards when working under conditions of flying combustible material.
8. Do not run the engine in closed area without proper ventilation to remove deadly exhaust gases.
9. Starting fluid is flammable. Follow the recommendations outlined in this manual and those marked on the containers. Store containers in cool, well-ventilated place secure from unauthorized personnel. Do not puncture or burn containers. Follow the recommendations of the manufacturer for storage and disposal.
10. Never use starter fluid near lighted smoking materials or open flame or sparks due to the flammability of the fluid.
11. Do not place head, body, limbs, feet, fingers, or hands near a rotating fan or belt. Be especially alert around a pusher fan.
12. Keep the operator's area clean and free of obstructions.
13. Always shift transmission to neutral, stop engine, set brake and remove start key before permitting anyone to inspect, lubricate adjust or repair any part of the engine or its attachments, unless otherwise specifically recommended in this manual.
14. Be sure that the gear shift lever is in neutral before starting the engine.
15. Be sure that everyone is clear of the machine before starting the engine and mechanism.
16. Use extreme caution when removing the radiator cap. Loosen very slowly and avoid pressurized steam that might be in the radiator. Allow engine to cool before removing cap.
17. Electric storage batteries give off highly inflammable hydrogen gas. To prevent possible explosion, never allow lighted smoking material, an open flame or electrical sparks near

SAFETY PRECAUTIONS (CONTINUED)

the battery. Do not lay tools or other conductive materials on the battery where they may cause short circuits and sparks.

18. Fluid in electric storage batteries contains sulfuric acid which can cause severe burns. Avoid all contact of fluid with eyes, skin or clothing. If contact does occur, flush off immediately with large amounts of water. Get prompt medical attention.
19. Always stop engine when refueling. Always place the fuel nozzle against the side of the filler opening before starting and during fuel flow, to reduce the chance of a static electricity spark. Keep contact until after fuel flow is shut off. Do not smoke or have open flame in the refueling area.
20. Always be sure that all shields, guards, and access covers are in place when engine is in operation.
21. Never attempt to check or adjust fan belts when engine is running.
22. Always permit parts that contain hot fluid to cool to a safe temperature before handling or disconnecting.

MAINTENANCE AND SERVICE

1. Follow all safety precautions listed above and those listed below.
2. Shop or field service platforms and ladders used to maintain or service engine should be constructed and maintained according to OSHA requirements.
3. Disconnect batteries and TAG all controls according to OSHA requirements to warn that work is in progress.
4. Never use gasoline or diesel fuel or other flammable fluid for cleaning parts. Use authorized commercial, non-flammable, non-toxic solvents.
5. When using compressed air for cleaning parts use safety glasses with side shields or goggles. Limit the pressure to 30 psi (207 kPa) according to OSHA requirements.
6. Lift and handle all heavy parts with a lifting device of proper capacity. Be sure parts are supported by proper slings and hooks. Use lifting eyes if provided. Watch out for people in the vicinity.
7. Never align holes with finger or hands. Use the proper aligning tool.

8. Remove sharp edges and burrs from reworked parts.
9. Do not use an open flame as a light source to look for leaks or for inspection anywhere on the machine.
10. Be sure all mechanics tools are in good condition. Do not use tools with mushroomed heads. Always wear safety glasses with side shields.
11. Handle all parts with extreme care. Keep hands and fingers from between parts. Wear authorized protective equipment such as safety glasses, heavy gloves, safety shoes.
12. Do not adjust engine fuel pump when the machine is in motion.
13. Never lubricate engine while in operation.
14. Avoid running engine with open unprotected air inlets. If such running is unavoidable for service reasons, place protective screens over all inlet openings before servicing engine.
15. Disconnect batteries before working on electrical system.
16. Be sure to connect the booster cables to the proper terminals (+ to +) and (- to -) at both ends. Avoid shorting clamps.
17. BATTERY GAS IS HIGHLY FLAMMABLE. Leave battery box open to improve ventilation when charging batteries. Never check charge by placing metal objects across the posts. Keep sparks or open flame away from batteries. Do not smoke near battery to guard against the possibility of an accidental explosion.
18. Do not charge batteries in a closed area. Provide proper ventilation to guard against an accidental explosion from an accumulation of gases given off in the charging process.
19. Fluid escaping under pressure from a very small hole can almost be invisible and can have sufficient force to penetrate the skin. Use a piece of cardboard or wood to search for suspected pressure leaks. DO NOT USE HANDS. If injured by escaping fluid, see a doctor at once. Serious infection or reaction can develop if proper medical treatment is not administered immediately.
20. Shut off engine and be sure all pressure in system has been relieved before removing panels, housing covers, and caps.
21. When making pressure checks use the correct gauge for expected pressure.

TABLE OF CONTENTS

<u>TOPIC</u>	<u>TITLE</u>	<u>PAGE</u>
1	ENGINE DESCRIPTION	1
2	ENGINE SPECIFICATIONS	2
3	PREPARATION OF ENGINE FOR OPERATION	12
4	LUBRICATION - FUEL - COOLANT RECOMMENDATION	13
5	OPERATING CONTROLS AND INSTRUMENTS	16
6	OPERATING INSTRUCTIONS	18
7	MAINTENANCE AND SERVICE SCHEDULE	21
8	TROUBLESHOOTING	25
9	COOLING SYSTEM	27
10	FUEL SYSTEM	38
11	LUBRICATING SYSTEM	47
12	ENGINE ELECTRICAL SYSTEM	53
13	INTAKE AND EXHAUST SYSTEM	61
14	COLD WEATHER STARTING AIDS	68
15	SAFETY CONTROLS	70
16	ENGINE ACCESSORIES	74

THE METRIC SYSTEM OF MEASUREMENT

Today's rapid communication and transportation between the nations of the world has resulted in the use of more of each other's products and services. This has caused a trend among the nations to adapt a standardization of units for use in both scientific and technical fields.

The customary United States (English) units and some metric units are being replaced with those of a modernized metric system known as the International System of Units which is officially abbreviated SI in all languages.

The SI or modernized metric system consists of the following basic units:

BASIC UNITS

Quantity	Unit	Symbol
length	metre	m
mass	kilogram	kg
time	second	s
electrical current	ampere	A
*thermodynamic temperature	kelvin	K
luminous intensity	candela	cd
amount of substance	mole	mol

*For nonscientific temperature, use degree Celsius (°C)

Because Allis-Chalmers' products are used worldwide and the adaptation of the SI metric system by all nations is getting nearer, both English and metric system of units appear in this manual.

To assist those not completely familiar with the metric system, the following nomenclature and tables will be of assistance.

METRIC CUSTOMARY UNIT EQUIVALENTS

METRIC CUSTOMARY UNIT EQUIVALENTS

Multiply: by: to get: Multiply: by: to get:

LINEAR

inches	X 25.4	= millimetres (mm)	X 0.03937	= inches
feet	X 0.3048	= metres (m)	X 3.281	= feet
yards	X 0.9144	= metres (m)	X 1.0936	= yards
miles	X 1.6093	= kilometres (km)	X 0.6214	= miles
inches	X 2.54	= centimetres (cm)	X 0.3937	= inches
microinches	X 0.0254	= micrometres (µm)	X 39.37	= microinches

AREA

inches ²	X 645.16	= millimetres ² (mm ²)	X 0.00155	= inches ²
inches ²	X 6.4516	= centimetres ² (cm ²)	X 0.155	= inches ²
feet ²	X 0.0929	= metres ² (m ²)	X 10.764	= feet ²
yards ²	X 0.8361	= metres ² (m ²)	X 1.196	= yards ²
acres	X 0.4047	= hectares (ha)	X 2.471	= acres

VOLUME

inches ³	X 16.387	= millimetres ³ (mm ³)	X 0.000061	= inches ³
inches ³	X 16.387	= centimetres ³ (cm ³)	X 0.06102	= inches ³
inches ³	X 0.01639	= litres (l)	X 61.024	= inches ³
quarts	X 0.94635	= litres (l)	X 1.0567	= quarts
gallons	X 3.7854	= litres (l)	X 0.2642	= gallons
feet ³	X 28.317	= litres (l)	X 0.03531	= feet ³
feet ³	X 0.02832	= metres ³ (m ³)	X 35.315	= feet ³
fluid oz	X 29.57	= millilitres (ml)	X 0.03381	= fluid oz
yards ³	X 0.7646	= metres ³ (m ³)	X 1.3080	= yards ³
teaspoons	X 4.929	= millilitres (ml)	X 0.2029	= teaspoons
cups	X 0.2366	= litres (l)	X 4.227	= cups

MASS

ounces (av)	X 28.35	= grams (g)	X 0.03527	= ounces (av)
pounds (av)	X 0.4536	= kilograms (kg)	X 2.2046	= pounds (av)
tons (2000 lb)	X 907.18	= kilograms (kg)	X 0.001102	= tons (2000 lb)
tons (2000 lb)	X 0.90718	= metric tons (t)	X 1.1023	= tons (2000 lb)
tons (long) (2240 lb)	X 1016.05	= kilograms (kg)	X 0.000984	= tons (long) (2240 lb)

FORCE

dynes — f (av)	X 0.228	= newtons (N)	X 3.597	= ounces — f (av)
pounds — f (av)	X 4.448	= newtons (N)	X 0.2248	= pounds — f (av)
kilograms — f	X 9.807	= newtons (N)	X 0.10197	= kilograms — f

Multiply: by: to get: Multiply: by: to get:

ENERGY OR WORK

(watt-second = joule = newton-metre)

foot-pounds	X 1.3558	= joules (J)	X 0.7376	= foot-pounds
calories	X 4.187	= joules (J)	X 0.2388	= calories
Btu	X 1055	= joules (J)	X 0.000948	= Btu
watt-hours	X 3600	= joules (J)	X 0.0002778	= watt-hours
kilowatt-hrs	X 3.600	= megajoules (MJ)	X 0.2778	= kilowatt-hrs

PRESSURE OR STRESS

(newton/sq metre = pascal)

inches Hg (60°F)	X 3.377	= kilopascals (kPa)	X 0.2961	= inches Hg
pounds/sq in	X 6.895	= kilopascals (kPa)	X 0.145	= pounds/sq in
inches H ₂ O (60°F)	X 0.2488	= kilopascals (kPa)	X 4.0193	= inches H ₂ O
bars	X 100	= kilopascals (kPa)	X 0.01	= bars
pounds/sq ft	X 47.88	= pascals (Pa)	X 0.02088	= pounds/sq ft

POWER

horsepower	X 0.746	= kilowatts (kW)	X 1.34	= horsepower
ft-lbf/min	X 0.0226	= watts (W)	X 44.25	= ft-lbf/min

TORQUE

pound-inches	X 0.11298	= newton-metres (N·m)	X 8.851	= pound-inches
pound-feet	X 1.3558	= newton-metres (N·m)	X 0.7376	= pound-feet

VELOCITY

miles/hour	X 1.6093	= kilometres/hour (km/h)	X 0.6214	= miles/hour
feet/sec	X 0.3048	= metres/sec (m/s)	X 3.281	= feet/sec
kilometres/hr	X 0.27778	= metres/sec (m/s)	X 3.600	= kilometres/hr
miles/hour	X 0.4470	= metres/sec (m/s)	X 2.237	= miles/hour

COMMON METRIC PREFIXES

mega (M) = 1 000 000 or 10 ⁶	deci (d) = 0.1 or 10 ⁻¹
kilo (k) = 1 000 or 10 ³	centi (c) = 0.01 or 10 ⁻²
hecto (h) = 100 or 10 ²	milli (m) = 0.001 or 10 ⁻³
deka (da) = 10 or 10 ¹	micro (µ) = 0.000 001 or 10 ⁻⁶

TEMPERATURE

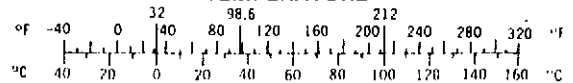

°Celsius 0.556 (°F - 32)

°F (1.8°C) + 32

QUICK REFERENCES CONVERSIONS (APPROXIMATE VALUES)

- One (1) Fahrenheit Degree: approximately equals .55 Centigrade Degree
- One (1) gallon: approximately equals 3.75 litres
- One (1) PSI: approximately equals 7 kilopascals
- One (1) in-lb of torque: approximately equals 0.11 Nm
- One (1) ft-lb of torque: approximately equals 1.35 Nm

DECIMAL AND METRIC EQUIVALENTS OF FRACTIONS OF AN INCH

INCHES		MILLI-METERS	INCHES		MILLI-METERS
FRACTIONS	DECIMALS		FRACTIONS	DECIMALS	
1/64	.015625	.40	33/64	.515625	13.10
1/32	.03125	.79	17/32	.53125	13.49
3/64	.046875	1.19	35/64	.546875	13.89
1/16	.0625	1.59	9/16	.5625	14.29
5/64	.078125	1.98	37/64	.578125	14.68
3/32	.09375	2.38	19/32	.59375	15.08
7/64	.109375	2.78	39/64	.609375	15.48
1/8	.125	3.18	5/8	.625	15.88
9/64	.140625	3.57	41/64	.640625	16.27
5/32	.15625	3.97	21/32	.65625	16.67
11/64	.171875	4.37	43/64	.671875	17.07
3/16	.1875	4.76	11/16	.6875	17.46
13/64	.203125	5.16	45/64	.703125	17.86
7/32	.21875	5.56	23/32	.71875	18.26
15/64	.234375	5.95	47/64	.734375	18.65
1/4	.250	6.35	3/4	.750	19.05
17/64	.265625	6.75	49/64	.765625	19.45
9/32	.28125	7.14	25/32	.78125	19.84
19/64	.296875	7.54	51/64	.796875	20.24
5/16	.3125	7.94	13/16	.8125	20.64
21/64	.328125	8.33	53/64	.828125	21.03
11/32	.34375	8.73	27/32	.84375	21.43
23/64	.359375	9.13	55/64	.859375	21.83
3/8	.375	9.53	7/8	.875	22.23
25/64	.390625	9.92	57/64	.890625	22.62
13/32	.40625	10.32	29/32	.90625	23.02
27/64	.421875	10.72	59/64	.921875	23.42
7/16	.4375	11.11	15/16	.9375	23.81
29/64	.453125	11.51	61/64	.953125	24.21
15/32	.46875	11.91	31/32	.96875	24.61
31/64	.484375	12.30	63/64	.984375	25.00
1/2	.500	12.70	1	1.000	25.40

INDEX

OPERATION MANUAL

<u>TOPIC</u>	<u>TITLE</u>	<u>PAGE</u>
1.	ENGINE DESCRIPTION.....	1
	A. GENERAL	
	B. ENGINE NAMEPLATE	
2.	ENGINE SPECIFICATIONS.....	2
	A. SERIES 433 ENGINES	
	B. SERIES 649 ENGINES	
	C. SERIES 670 ENGINES	
	D. SERIES 685 ENGINES	
	E. SERIES 6138 ENGINES	
3.	PREPARATION OF ENGINE FOR OPERATION.....	12
	A. SAFETY PRECAUTIONS	
	B. PROCEDURE	
4.	LUBRICATION - FUEL - COOLANT RECOMMENDATION.....	13
	A. GENERAL	
	B. ENGINE LUBRICATING OIL	
	C. GREASE RECOMMENDATION	
	D. FUEL RECOMMENDATION	
	E. COOLANT RECOMMENDATION	
5.	OPERATING CONTROLS AND INSTRUMENTS.....	16
	A. OPERATING CONTROLS	
	B. INSTRUMENTS	
6.	OPERATING INSTRUCTIONS.....	18
	A. OPERATING PRECAUTIONS	
	B. STARTING AND STOPPING	
	C. CHECKS DURING OPERATION	
	D. COLD WEATHER OPERATION	
	E. EXERCISE OF ENGINE ON STAND BY SERVICE	
	F. ENGINE STORAGE	
7.	MAINTENANCE AND SERVICE SCHEDULE.....	21
	A. GENERAL	
	B. LUBRICATION AND MAINTENANCE GUIDE	
8.	TROUBLESHOOTING.....	25
	A. GENERAL	
	B. WHEN TROUBLE OCCURS	
	C. TROUBLESHOOTING GUIDE	
9.	COOLING SYSTEM.....	27
	A. GENERAL DESCRIPTION	
	B. RADIATOR AND FAN SYSTEM	
	C. HEAT EXCHANGER AND EXPANSION TANK SYSTEM	
	D. GENERAL MAINTENANCE -- COOLANT	
	E. DRAINING COOLING SYSTEM	
	F. FILLING COOLING SYSTEM	
	G. CLEANING COOLING SYSTEM	
	H. THERMOSTATS	
	I. ENGINE OIL COOLER	
	J. BELTS -- REPLACEMENT OR ADJUSTMENT	
	K. FAN HUB LUBRICATION -- SERIES 685 AND 6138 ENGINES	
	L. COOLING SYSTEM CONDITIONER (FILTER)	
	M. TORQUE CONVERTER COOLER	
	N. COOLANT HEATERS	
	O. COOLING SYSTEM -- MAINTENANCE SCHEDULE	

<u>TOPIC</u>	<u>TITLE</u>	<u>PAGE</u>
10.	FUEL SYSTEM	38
	A. GENERAL DESCRIPTION	
	B. FUEL FILTER AND FUEL/WATER SEPARATOR	
	C. ELECTRIC FUEL TRANSFER PUMP	
	D. PRIMING FUEL SYSTEM	
	E. FUEL INJECTION PUMP/GOVERNOR	
	F. FUEL INJECTION NOZZLE HOLDER ASSEMBLY	
	G. CHECKING FUEL SYSTEM	
	H. FUEL SYSTEM MAINTENANCE SCHEDULE	
11.	LUBRICATION SYSTEM	47
	A. GENERAL	
	B. FULL FLOW OIL FILTER — STANDARD	
	C. OPTIONAL BYPASS OIL FILTER	
	D. DRAINING, CHANGING FILTER AND FILLING LUBRICATING SYTEM	
	E. ENGINE OIL COOLER	
	F. OIL PRESSURE REGULATOR VALVE	
	G. LUBRICATING SYSTEM MAINTENANCE SCHEDULE	
12.	ENGINE ELECTRICAL SYSTEM	53
	A. GENERAL	
	B. ELECTRICAL SYSTEM WARRANTY AND ADJUSTMENT	
	C. BATTERY	
	D. STARTING MOTOR	
	E. ALTERNATOR/GENERATOR WITH VOLTAGE REGULATOR (ALL TYPES)	
	F. ALTERNATORS WITH VOLTAGE REGULATOR — SERIES 433, 649, AND 670 ENGINES	
	G. ALTERNATORS WITH EXTERNAL MOUNTED VOLTAGE REGULATOR — SERIES 685 AND 6138 ENGINES	
	H. ALTERNATORS WITH INTERNAL REGULATORS — SERIES 685 AND 6138 ENGINES	
	I. DC GENERATOR WITH SEPARATELY MOUNTED VOLTAGE REGULATOR — SERIES 685 AND 6138 ENGINES	
	J. DRIVE BELT ADJUSTMENT	
13.	INTAKE AND EXHAUST SYSTEMS	61
	A. GENERAL	
	B. AIR CLEANERS	
	C. TURBOCHARGER	
	D. INTAKE AND EXHAUST SYSTEM MAINTENANCE SCHEDULE	
14.	COLD WEATHER STARTING AIDS	68
	A. GENERAL	
	B. HANDLING PRECAUTIONS	
	C. FUEL CYLINDER INSTALLATION	
	D. OPERATION OF DISCHARGER	
	E. MAINTENANCE	
	F. TROUBLESHOOTING	
15.	SAFETY CONTROLS	70
	A. GENERAL	
	B. OIL PRESSURE SWITCH-GAUGE	
	C. COOLANT TEMPERATURE SWITCH-GAUGE	
	D. STARTING AND STOPPING WITH SAFETY CONTROLS	
	E. AUTOMATIC SAFETY ENGINE SHUTDOWN	
	F. GAUGE CIRCUIT TROUBLESHOOTING CHECKS	
	G. WARNING HORN & WARNING HORN RELAY	
16.	ENGINE ACCESSORIES	74
	A. AIR COMPRESSOR	
	B. POWER TAKE-OFF CLUTCH	

TOPIC 1 ENGINE DESCRIPTION

A. GENERAL

Engine models covered in this manual are turbocharged, 4-cycle, water-cooled, overhead valve, compression-ignition type diesels with vertical, in-line cylinders and piston cooling jets.

The basic engine, engine assemblies, and power units are engineered with equipment necessary for usual installation requirements. All units can be modified for a variety of optional equipment.

Data regarding the operation and maintenance of equipment and accessories not originally supplied by Allis-Chalmers is the responsibility of the firm that assembles the accessories to the engine.

B. ENGINE NAMEPLATE

All engines shipped from Allis-Chalmers are equipped with a combination nameplate and optional equipment plate (Fig. 1). The engine serial number and engine catalog number are stamped in the nameplate section; remainder of plate is used to list catalog number of various optional equipment groups as specified on factory order with specific factory shipping order number.

To assure prompt and complete shipment of replacement parts, always supply information on engine nameplate with repair part number and name. Order all parts from your Allis-Chalmers dealer.

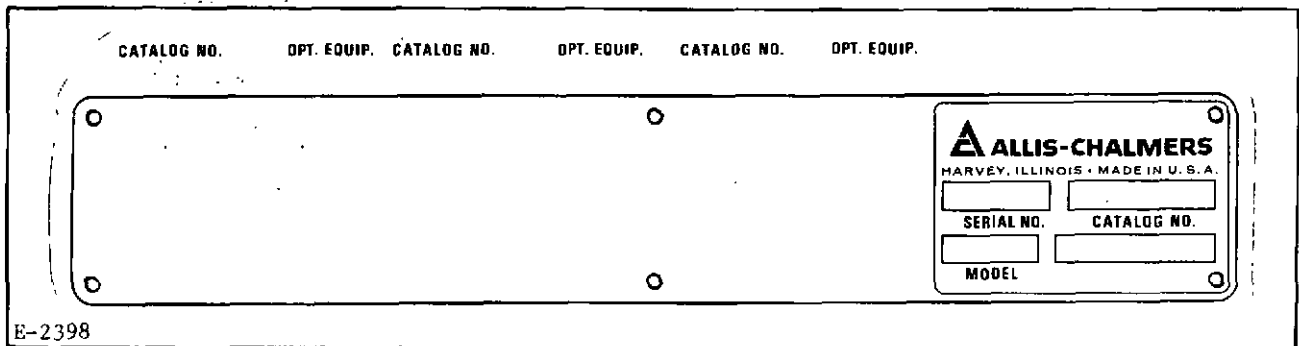

Figure 1. Combination Engine Name Plate and Optional Equipment Plate

TOPIC 2 ENGINE SPECIFICATIONS

Allis-Chalmers reserves the right to make changes in the following specifications and add improvements at any time without notice or obligations.

A. SERIES 433 SPECIFICATIONS

1. ENGINE (BASIC)

	ENGLISH	METRIC
Model Number-Turbocharged Engine	433T	433T
Model Number-Turbocharged and Intercooled Engine	433I	433I
Type	4 Cycle	4 Cycle
Number of Cylinders	4	4
Firing Order	1-3-4-2	1-3-4-2
Bore	3.87 in.	98.0 mm
Stroke	4.25 in.	108.0 mm
Displacement	200 cu. in.	3.3 lt.
Crankshaft Rotation (viewed from fan end of engine)	Clockwise	Clockwise
Number of Main Bearings	5	5
Compression Ratio (nominal)	14.1:1	14.1:1
Compression Pressure at Sea Level, 600 rpm, Hot	400 psi	2758 kPa
Maximum Permissible Exhaust Restriction	2 in. Hg.	6.75 kPa

2. COOLING SYSTEM

Water Pump, Centrifugal Type	Belt Driven	Belt Driven
Stabilized Coolant Temperature (minimum)	180°F	82°C
Radiator and Expansion Tank Cap (pressurized)	7 psi	48 kPa
Nominal Capacities		
Basic Engine with Dry Exhaust Manifold	*8 qt.	*7.6 lt.
Basic Engine with Dry Exhaust Manifold and Intercooler	*9 qt.	*8.5 lt.

*Note: To obtain capacity of cooling system for particular application, add basic engine capacity to capacity of applicable optional cooling system equipment listed below.

Optional Cooling System Equipment:

Radiator and Hoses-used with basic engine having dry exhaust manifold	13.7 qt.	14.0 lt.
---	----------	----------

3. LUBRICATION SYSTEM

Circulating Pressure Type System	Full Flow	Full Flow
Oil Pump	Gear Type	Gear Type
Pressure Control	Regulating Valve	Regulating Valve
Standard Oil Filters	Full Flow Type	Full Flow Type
Supplemental Oil Filter (optional)	Bypass Type	Bypass Type
Oil Pressure - Hot:		
Full Load Speed Oil Pressure Range	30 to 50 psi	207 to 345 kPa
Idle Speed, 600-700 rpm	15 psi minimum	103 kPa minimum

Angle of Operation:

Standard Oil Pan	30°	30°
Optional Oil Pan	45°	45°

Nominal Oil Capacities:

Filter and Oil Change Quantity:

Standard Oil Pan and Full-Flow Filters	**11 qt.	**10.4 lt.
Optional Oil Pan and Full-Flow Filters	**14 qt.	**13.2 lt.
Optional Bypass Filter	4 qt.	3.8 lt.

**If engine is equipped with optional bypass type oil filter, add capacity of filter to oil pan and full flow oil change capacities listed above.

4. FUEL INJECTION SYSTEM

Nozzle Holder Assembly:

Nozzle, Spring Loaded Type	Four Hole Orifice	Four Hole Orifice
----------------------------------	-------------------	-------------------

A. SERIES 433 SPECIFICATIONS—CONTINUED

	ENGLISH	METRIC
Fuel Injection Pump:		
Power Unit:		
Manufacture	Roosa Master Distributor	Roosa Master Distributor
Pump Type		
Generator Drive Engine:		
Manufacture	Roosa Master Distributor	Roosa Master Distributor
Pump Type		
Pump Speed Ratio to Crankshaft.....	0.5:1.0	0.5:1.0
Fuel Pump Timing to Engine-Static:		
Roosa-Master Injection Pump as follows:		
Power Unit-433T & 433I-1600 to 2400 rpm	18° BTDC	18° BTDC
Generator Drive-433T & 433I-1500 & 1800 rpm.....	18° BTDC	18° BTDC
 5. GOVERNOR		
Governor Regulation:		
Standard Mechanical Type:		
Power Units	7-10%	7-10%
Generator Drive	3.5%-5%	3.5%-5%
Speed Settings:		
Idle-Power Units	750 rpm	750 rpm
Full Load-Power Units	1600-2400 rpm	1600-2400 rpm
Idle-Generator Drive Engines	1400 rpm	1400 rpm
Full Load-Generator Drive Engines.....	1500 and 1800 rpm	1500 and 1800 rpm
 6. VALVE DATE		
Valve Lash Adjustment:		
Intake Valve Clearance-Hot	0.015 in.	0.38 mm
Exhaust Valve Clearance-Hot	0.015 in.	0.38 mm
 7. ELECTRICAL SYSTEM		
Standard:		
Starter	12V.	12V.
Alternator	12V., 61 Amp	12V., 61 Amp
Ground Polarity	Negative (-)	Negative (-)

B. SERIES 649 SPECIFICATIONS

1. ENGINE (BASIC)

Model Number-Turbocharged Engine
 Model Number-Turbocharged and Intercooled Engine
 Type
 Number of Cylinders
 Firing Order
 Bore
 Stroke
 Displacement
 Crankshaft Rotation (viewed from fan end of engine) ...
 Number of Main Bearings
 Compression Ratio (nominal):
 649T and 649I
 649I (First type with piston 4008107)
 Compression Pressure at Sea Level, 600 rpm, Hot:
 649T and 649I
 649I (First type with piston 4008107)
 Maximum Permissible Exhaust Restriction

ENGLISH

METRIC

649T
 649I
 4 Cycle
 6
 1-5-3-6-2-4
 3.87 in.
 4.25 in.
 301 cu. in.
 Clockwise
 7
 15.1:1
 14.1:1
 445 psi
 400 psi
 2 in. Hg.
 649T
 649I
 4 Cycle
 6
 1-5-3-6-2-4
 98.0 mm
 108.0 mm
 4.9 lt.
 Clockwise
 7
 15.1:1
 14.1:1
 3068 kPa
 2758 kPa
 6.75 kPa

2. COOLING SYSTEM

Water Pump, Centrifugal Type.....
 Stabilized Coolant Temperature (minimum).....
 Radiator and Expansion Tank Cap (pressurized).....
 Nominal Capacities:
 Basic Engine with Dry Exhaust Manifold
 *NOTE: To obtain total capacity of cooling system
 for particular application, add basic engine capac-
 ity to capacity of applicable optional cooling sys-
 tem equipment listed below.
 Optional Cooling System Equipment:
 Radiator and Hoses-used with basic engine having dry
 exhaust manifold:
 649T
 649I
 Radiator for High Ambient:
 649T
 649I

Belt Driven
 180°F
 7 psi
 *13 qt.
 12.5 qt.
 13.0 qt.
 21.0 qt.
 16.0 qt.
 Belt Driven
 82°C
 48 kPa
 *12.3 lt.
 11.8 lt.
 12.3 lt.
 19.9 lt.
 15.1 lt.

3. LUBRICATION SYSTEM

Circulating Pressure Type System
 Oil Pump
 Pressure Control
 Standard Oil Filters
 Supplemental Oil Filter (optional)
 Oil Pressure-Hot:
 Full Load Speed Oil Pressure Range
 Idle Speed, 600-700 rpm.....
 Angle of Operation:
 Standard Oil Pan
 Optional Oil Pan.....
 Nominal Oil Capacities:
 Filter and Oil Change Quantity:
 Standard Oil Pan Full-Flow Filters
 Optional Oil Pan and Full-Flow Filters
 Optional Bypass Filter.....
 **If engine is equipped with optional bypass type oil
 filter, add capacity of filter to oil pan and full flow
 oil change capacities listed above.

Full Flow
 Gear Type
 Regulating Valve
 Full Flow Type
 Bypass Type
 30 to 50 psi
 10 psi minimum
 Full Flow
 Gear Type
 Regulating Valve
 Full Flow Type
 Bypass Type
 207 to 345 kPa
 69 kPa
 minimum
 30°
 45°
 **17 qt.
 **17 qt.
 4 qt.
 **16.1 lt.
 **16.1 lt.
 3.8 lt.

4. FUEL INJECTION SYSTEM

Nozzle Holder Assembly:
 Nozzle, Spring Loaded Type.....

Four Hole
 Orifice
 Four Hole
 Orifice

B. 649 SPECIFICATIONS—CONTINUED

	ENGLISH	METRIC
Fuel Injection Pump:		
Power Unit:		
Manufacture	Roosa Master Distributor	Roosa Master Distributor
Pump Type		
Generator Drive Engine:		
Manufacture	Roosa Master Distributor	Roosa Master Distributor
Pump Type		
Pump Speed Ratio to Crankshaft	0.5:1.0	0.5:1.0
Fuel Pump Timing to Engine-Static:		
Roosa-Master Injection Pump as follows:		
Power Unit-1600 to 2400 rpm:		
649T	18° BTDC	18° BTDC
649I (Except Group 4008093 & 4008659)	20° BTDC	20° BTDC
649I with 2600 rpm Gov. Speed Setting		
Group 4008093 & 4008659	18° BTDC	18° BTDC
Generator Drive-649T & 649I-1500 & 1800 rpm	18° BTDC	18° BTDC
 5. GOVERNOR		
Governor Regulation:		
Power Units	7-10%	7-10%
Generator Drive	3.5-5%	3.5-5%
Speed Settings:		
Idle-Power Units	750 rpm	750 rpm
Full Load-Power Units	1600-2600 rpm	1600-2600 rpm
Idle-Generator Drive Engines	1400 rpm	1400 rpm
Full Load-Generator Drive Engines	1500 and 1800 rpm	1500 and 1800 rpm
 6. VALVE DATA		
Valve Lash Adjustment:		
Intake Valve Clearance-Hot	0.015 in.	0.38 mm
Exhaust Valve Clearance-Hot	0.015 in.	0.38 mm
 7. ELECTRICAL SYSTEM		
Standard:		
Starter	12V.	12V.
Alternator	12 V., 61 Amp	12V., 61 Amp
Ground Polarity	Negative (-)	Negative (-)

C. SERIES 670 SPECIFICATIONS

1. ENGINE (BASIC)

	ENGLISH	METRIC
Model Number-Turbocharged Engine	670T	670T
Model Number-Turbocharged and Intercooled Engine	670I	670I
Type	4 Cycle	4 Cycle
Number of Cylinders	6	6
Firing Order	1-5-3-6-2-4	1-5-3-6-2-4
Bore	4.25 in.	108.0 mm
Stroke	5.00 in.	127.0 mm
Displacement	426 cu. in.	7.0 lt.
Crankshaft Rotation (viewed from fan end of engine) ...	Clockwise	Clockwise
Number of Main Bearings	7	7
Compression Ratio (nominal)	15.8:1	15.8:1
Compression Pressure at Seal Level, 600 rpm, Hot ...	500 psi ± 15 psi	500 psi ± 15 psi
Maximum Permissible Exhaust Restriction	2 in. Hg.	6.75 kPa

2. COOLING SYSTEM

Water Pump, Centrifugal Type	Belt Driven	Belt Driven
Stabilized Coolant Temperature (minimum)	180°F	82°C
Radiator and Expansion Tank Cap (pressurized)	7 psi	48 kPa
Nominal Capacities		
Basic Engine with Dry Exhaust Manifold	*15.5 qt.	*14.7 lt.
Basic Engine with Dry Exhaust Manifold and Inter-cooler	*16.5 qt.	*15.6 lt.
*NOTE: To obtain total capacity of cooling system for particular application, add basic engine capacity to capacity of applicable optional cooling system equipment listed below.		
Optional Cooling System Equipment:		
Radiator and Hoses-used with basic engine having dry exhaust manifold	23.8 qt.	22.5 lt.
Radiator for High Ambient	28.4 qt.	26.9 lt.
Water Cooled Exhaust Manifold	6.0 qt.	5.7 lt.
Heat Exchanger and Expansion Tank	18.0 qt.	17.0 lt.
Torque Converter Fluid Cooler	2.5 qt.	2.4 lt.

3. LUBRICATION SYSTEM

Circulating Pressure Type System	Full Flow Gear Type	Full Flow Gear Type
Oil Pump	Regulating Valve	Regulating Valve
Pressure Control	Full Flow Type	Full Flow Type
Standard Oil Filters	Bypass Type	Bypass Type
Supplemental Oil Filter (optional)		
Oil Pressure-Hot:		
Full Load Speed Oil Pressure Range	30 to 50 psi	207 to 345 kPa
Idle Speed, 600-700 rpm	10 psi minimum	69 kPa minimum
Angle of Operation:		
Standard Oil Pan	30°	30°
Optional Oil Pan	40°	40°
Nominal Oil Capacities:		
Filter and Oil Change Quantity:		
Standard Oil Pan and Full-Flow Filters	**25 qt.	**23.7 lt.
Optional Oil Pan and Full-Flow Filters	**25 qt.	**23.7 lt.
Optional Bypass Filter	6 qt.	5.7 lt.
**If engine is equipped with optional bypass type oil filter, add capacity of filter to oil pan and full flow oil change capacities listed above.		

4. FUEL INJECTION SYSTEM

Nozzle Holder Assembly:		
Nozzle, Spring Loaded Type	Four Hole Orifice	Four Hole Orifice

C. SERIES 670 SPECIFICATIONS--CONTINUED

	ENGLISH	METRIC
Fuel Injection Pump:		
Power Unit:		
Manufacture	Roosa Master or American Bosch Distributor	Roosa Master or American Bosch Distributor
Pump Type		
Generator Drive Engine:		
Manufacture	Roosa Master	Roosa Master
Pump Type	Distributor	Distributor
Pump Speed Ratio to Crankshaft:		
Roosa Master	0.5:1.0	0.5:1.0
American Bosch	1.0:1.0	1.0:1.0
Fuel Pump Timing to Engine-Static:		
American Bosch-Industrial & Power Units	19° BTDC	19° BTDC
Roosa-Master Injection Pump as follows:		
Power Units:		
Model 670T-1400 to 2400 rpm	16° BTDC	16° BTDC
Model 670I-1400 to 2400 rpm	18° BTDC	18° BTDC
Generator Drive-670T-1500 & 1800 rpm	18° BTDC	18° BTDC
Optional, 1-5% Regulator Governor	30° BTDC	30° BTDC
5. GOVERNOR		
Governor Regulation:		
Standard Mechanical Type:		
Power Units	8-12%	8-12%
Generator Drive	3-5%	3-5%
Speed Settings:		
Idle-Power Units	700-750 rpm	700-750 rpm
Full Load-Power Units	1600-2400 rpm	1600-2400 rpm
Idle-Generator Drive Engines	1400 rpm	1400 rpm
Full Load-Generator Drive Engines	1500 and 1800 rpm	1500 and 1800 rpm
6. VALVE DATA		
Valve Lash Adjustment:		
Intake Valve Clearance-Hot	0.015 in.	0.38 mm
Exhaust Valve Clearance-Hot	0.015 in.	0.38 mm
7. ELECTRICAL SYSTEM		
Standard:		
Starter	12V.	12V.
Alternator	12V., 61 Amp	12V., 61 Amp
Ground Polarity	Negative (-)	Negative (-)
Optional:		
Starter	24V.	24V.
Alternator	24V., 40 Amp	24V., 40 Amp
Ground Polarity	Negative (-)	Negative (-)

D. SERIES 685 SPECIFICATIONS

1. ENGINE (BASIC)

Model Number-Turbocharged Engine
 Model Number-Turbocharged and Intercooled Engine
 Type
 Number of Cylinders
 Firing Order
 Bore
 Stroke
 Displacement
 Crankshaft Rotation (viewed from fan end of engine)
 Number of Main Bearings
 Compression Ratio (nominal)

Compression Pressure at Sea Level, 600 rpm, Hot.....
 Maximum Permissible Exhaust Restriction

2. COOLING SYSTEM

Water Pump, Centrifugal Type.....
 Stabilized Coolant Temperature (minimum).....
 Radiator and Expansion Tank Cap (pressurized).....
 Nominal Capacities:

Basic Engine with Dry Exhaust Manifold - 685I
 - 685T

*NOTE: To obtain total capacity of cooling system for particular application, add basic engine capacity to capacity of applicable optional cooling system equipment listed below:

Optional Cooling System Equipment:
 Radiator and Hoses-used with basic engine having dry exhaust manifold - 685I
 - 685T
 Water Cooled Exhaust Manifold.....
 Heat Exchanger and Expansion Tank.....
 Torque Converter (Fluid) Lube Oil Cooler

3. LUBRICATION SYSTEM

Circulating Pressure Type System
 Oil Pump
 Pressure Control
 Standard Oil Filters
 Supplemental Oil Filter (optional)

Oil Pressure-Hot:
 Full Load Speed Oil Pressure Range
 Idle Speed, 600-700 rpm.....

Angle of Operation:
 Standard Oil Pan
 Optional Oil Pan

Nominal Oil Capacities:
 Filter and Oil Change Quantity:
 Standard Oil Pan and Full-Flow Filters.....
 Optional Oil Pan and Full-Flow Filters

Optional Bypass Filter:
 Spin-On Type - 685I
 Replaceable Element Type - 685T

**If engine is equipped with optional bypass type oil filter, add capacity of filter to oil pan and full flow oil change capacities listed above.

4. FUEL INJECTION SYSTEM

Nozzle Holder Assembly:
 Nozzle, Spring Loaded Type.....

	ENGLISH	METRIC
	685T	685T
	685I	685I
	4 Cycle	4 Cycle
	6	6
	1-5-3-6-2-4	1-5-3-6-2-4
	4.44 in.	113.0 mm
	5.56 in.	141.0 mm
	516 cu. in.	8.5 lt.
	Clockwise	Clockwise
	7	7
	16.2:1	16.2:1
	445 psi ± 15 psi	3068 kPa ± 103
	2 in. Hg.	6.75 kPa
	Belt Driven	Belt Driven
	180°F	82°C
	7 psi	48 kPa
	*6.5 gal.	*24.6 lt.
	*5.5 gal.	*20.8 lt.
	*7.0 gal.	*26.5 lt.
	*5.5 gal.	*20.8 lt.
	1.5 gal.	5.7 lt.
	6 gal.	22.7 lt.
	1.5 qt.	5.7 lt.
	Full Flow Gear Type	Full Flow Gear Type
	Regulating Valve	Regulating Valve
	Full Flow Type	Full Flow Type
	Bypass Type	Bypass Type
	30 to 50 psi	207 to 345 kPa
	10 psi minimum	69 kPa minimum
	30°	30°
	45°	45°
	**32 qt.	**30.3 lt.
	**32 qt.	**30.3 lt.
	3 qt.	2.9 lt.
	14 qt.	13.3 lt.
	Four Hole Orifice	Four Hole Orifice

D. SERIES 685 SPECIFICATIONS--CONTINUED

	ENGLISH	METRIC
Fuel Injection Pump:		
Power Unit - 685T and all applications 685I		
Manufacture	Robert Bosch	Robert Bosch
Pump Type	Multiple Plunger	Multiple Plunger
Generator Drive Engine - 685T		
Manufacture	Roosa Master	Roosa Master
Pump Type	Distributor	Distributor
Pump Speed Ratio to Crankshaft	0.5:1.0	0.5:1.0
Fuel Pump Timing to Engine-Static:		
Roosa-Master Injection Pump as follows:		
Generator Drive-1500 & 1800 rpm - 685T	24° BTDC	24° BTDC
Optional, 1-5% Regulation Governor	36° BTDC	36° BTDC
Robert Bosch Injection Pump as follows:		
Generator Drive and Power Units - 685I	31° BTDC	31° BTDC
Industrial and Power Units - 685T	34° BTDC	34° BTDC
5. GOVERNOR		
Governor Regulation:		
Standard Mechanical Type:		
Power Units	7-12%	7-12%
Generator Drive	3-5%	3-5%
Optional-Hydraulic - Roosa-Master	1-5%	1-5%
Speed Settings:		
Idle-Power Units	500-600 rpm	500-600 rpm
Full Load-Power Units	1600-2200 rpm	1600-2200 rpm
Idle-Generator Drive Engines	1400 rpm	1400 rpm
Full Load-Generator Drive Engines	1500 and 1800 rpm	1500 and 1800 rpm
6. VALVE DATA		
Valve Lash Adjustment:		
Intake Valve Clearance-Hot	0.018 in.	0.46 mm
Exhaust Valve Clearance-Hot	0.018 in.	0.46 mm
7. ELECTRICAL SYSTEM		
Standard:		
Starter	24V.	24V.
Alternator	24V., 45 Amp	24V., 45 Amp
Ground Polarity	Negative (-)	Negative (-)

E. SERIES 6138 SPECIFICATIONS

1. ENGINE (BASIC)

Model Number-Turbocharged Engine
 Model Number-Turbocharged and Intercooled Engine.....
 Type.....
 Number of Cylinders.....
 Firing Order.....
 Bore.....
 Stroke.....
 Displacement.....
 Crankshaft Rotation (viewed from fan end of engine) ...
 Number of Main Bearings.....
 Compression Ratio (nominal).....
 Compression Pressure at Sea Level, 600 rpm, Hot.....
 Maximum Permissible Exhaust Restriction.....





ENGLISH	METRIC
6138LT-6138T	6138LT-6138T
6138I	6138I
4 Cycle	4 Cycle
6	6
1-5-3-6-2-4	1-5-3-6-2-4
5.25 in.	133.0 mm
6.50 in.	165.0 mm.
844 cu. in.	13.8 lt.
Clockwise	Clockwise
7	7
15.1:1	15.1:1
500 psi ± 15 psi	3447 kPa±103 kPa
2 in. Hg.	6.75 kPa
2. COOLING SYSTEM	
Water Pump, Centrifugal Type.....	Belt Driven
Stabilized Coolant Temperature (minimum).....	180°F
Radiator and Expansion Tank Cap (pressurized).....	7 psi
Nominal Capacities:	
Basic Engine with Dry Exhaust Manifold.....	*8 gal.
Basic Engine with Dry Exhaust Manifold and Inter-cooler.....	*9 gal.
*NOTE: To obtain total capacity of cooling system for particular application, add basic engine capacity to capacity of applicable optional cooling system equipment listed below:	
Optional Cooling System Equipment:	
Radiator and Hoses-used with basic engine having dry exhaust manifold.....	8.5 gal.
Radiator and Hoses-used with basic engine having dry exhaust manifold and intercooler.....	10 gal.
Water Cooled Exhaust Manifold.....	2 gal.
Heat Exchanger and Expansion Tank.....	6 gal.
Torque Converter Fluid Cooler.....	2 gal.
3. LUBRICATION SYSTEM	
Circulating Pressure Type System.....	Full Flow
Oil Pump.....	Gear Type
Pressure Control.....	Regulating Valve
Standard Oil Filters.....	Full Flow Type
Supplemental Oil Filter (optional).....	Bypass Type
Oil Pressure-Hot:	
Full Load Speed Oil Pressure Range.....	30 to 50 psi
Idle Speed, 600-700 rpm.....	10 psi minimum
Angle of Operation:	
Standard Oil Pan.....	30°
Optional Oil Pan.....	45°
Nominal Oil Capacities:	
Filter and Oil Change Quantity:	
Standard Oil Pan and Full-Flow Filters.....	**45 qt.
Optional Oil Pan and Full-Flow Filters.....	**47 qt.
Optional Bypass Filter.....	14 qt.
**If engine is equipped with optional bypass type oil filter, add capacity of filter to oil pan and full flow oil change capacities listed above.	
4. FUEL INJECTION SYSTEM	
Nozzle Holder Assembly:	
Nozzle, Spring Loaded Type.....	Four Hole Orifice

E. SERIES 6138 SPECIFICATIONS--CONTINUED

	ENGLISH	METRIC
Fuel Injection Pump:		
Manufacture	Robert Bosch	Robert Bosch
Pump Type-Multi Plunger	In-line	In-line
Pump Speed Ratio to Crankshaft	0.5:1.0	0.5:1.0
Fuel Pump Timing to Engine-Static:		
Generator Drive - 1200/1500/1800 rpm	34° BTDC	34° BTDC
Industrial & Power Unit Applications:		
1200 rpm	30° BTDC	30° BTDC
1400 rpm	32° BTDC	32° BTDC
1500 rpm	34° BTDC	34° BTDC
1600 rpm	34° BTDC	34° BTDC
1800 rpm	37° BTDC	37° BTDC
2000 rpm	37° BTDC	37° BTDC
2100 rpm	37° BTDC	37° BTDC
 5. GOVERNOR		
Governor Regulation:		
Standard Mechanical Type:		
Power Units	10%	10%
Generator Drive	3-5%	3-5%
Optional-Hydraulic Woodward Type SG	3-5%	3-5%
Optional-Hydraulic Woodward Type PSG	1-5%	1-5%
Speed Settings:		
Idle-Power Units	500-600 rpm	500-600 rpm
Full Load-Power Units	1600-2100 rpm	1600-2100 rpm
Idle-Generator Drive Engines	1400 rpm	1400 rpm
Full Load-Generator Drive Engines	1500 and 1800 rpm	1500 and 1800 rpm
 6. VALVE DATA:		
Valve Lash Adjustment:		
Intake Valve Clearance-Hot	0.015 in.	0.38 mm
Exhaust Valve Clearance-Hot	0.020 in.	0.51 mm
 7. ELECTRICAL SYSTEM		
Standard:		
Starter	24V.	24V.
Alternator	24V., 45 Amp	24V., 45 Amp
Ground Polarity	Negative (-)	Negative (-)

TOPIC 3 PREPARATION OF ENGINE FOR OPERATION

A. SAFETY PRECAUTIONS

-  When locating engines in closed area, pipe all exhaust fumes outside. Breathing of exhaust fumes may be fatal.
-  When servicing batteries, do not smoke or use an open flame. Batteries generate an explosive gas during charging. Have ample ventilation when charging battery.
-  When filling fuel tank, always provide metal-to-metal contact between container and fuel tank to prevent spark generation. Do not smoke or use an open flame in vicinity.
-  Always use a lifting device of more than adequate capacity when lifting or moving engine.

B. PROCEDURE

Upon receipt, thoroughly inspect the engine for damage or parts shortage. Have the carrier make notation on freight bill and notify transit agent at once if any problems arise.

Install engine in clear open area so that it will be accessible for inspection and service.

Foundation must be ample in size and strength to assume accurate alignment with the equipment to which it will furnish power.

Before starting engine, operator should fully understand use and function of all controls and instruments. See Topic 5., Operating Controls.

After installation and before starting, perform these important operations.

1. Remove all tape and shipping caps used to seal engine.
2. Check radiator for damage and for proper cooling capacity of engine. Remove any foreign matter that has collected in radiator that may obstruct air flow past fins and through air passages.
3. If cooling system drain plugs have been removed and wired to engine, install them properly. Fill system with coolant (See Topic 9).
4. Open inlet and outlet valves to coolant conditioners.
5. Check air cleaner for tightness and proper installation of filler element.
6. If an oil bath type air cleaner is employed fill oil cup with grade of oil and to level specified on instruction plate of cleaner.
7. Engines are shipped without lubricating oil (dry) or with lubricant (wet) depending upon specifications on the purchase order.

If delivered dry, add oil to pan, check level with side of dipstick marked ADD, FULL and STOPPED.
If delivered wet, check oil level as above.

Engines shipped wet have CD (Service DS-Series 3), SAE 20 or 10W30 weight lubricating oil. Maintain oil level with any good quality CD (Service DS) oil. At first regular oil change, drain factory oil and fill with proper classification and SAE weight oil for prevailing atmospheric temperatures, (See Topic 4), Lubricant Recommendations.
8. Check all engine drive belts for correct tension (See Topic 9).
9. Connect battery to electrical system (Topic 12).
10. Fill fuel tank with recommended fuel (Topic 4).
11. If necessary, connect fuel supply line from tank to inlet of fuel system. Connect over-flow return line to top of fuel tank. Open fuel shut-off line. Prime system.
12. Bar engine over by hand to make sure it turns freely.
13. If unit has power take-off clutch, check adjustment of operating lever, (Topic 16, Engine Accessories).
14. Check intake and exhaust systems. Make sure they are unobstructed by foreign matter. Exhaust piping must be adequately supported, should have no sharp bend or crimps and be as short as possible.
15. With engine stop control in the STOP position and the load disconnected from the engine, crank the engine with the starter for 30 seconds to assure initial lubrication of the turbocharger. Do not operate starter for more than 30 seconds without pausing for at least two minutes before again using the starter.

TOPIC 4 LUBRICANT-FUEL-COOLANT RECOMMENDATIONS

SAFETY PRECAUTIONS

! **WARNING:** To prevent injury, always turn the key switch or stop control to the "OFF" position before cleaning, repairing, or servicing the engine.

! **WARNING:** No unauthorized person must be allowed to service or maintain this machine. Study the Operation and Maintenance manuals before starting, operating, maintaining, fueling, or servicing this machine.

! **DANGER:** Extinguish all smoking materials, or open flames, before checking and filling tanks, changing filters and before opening sediment drain due to the presence of flammable fluid.

! **WARNING:** Never service or adjust with the engine running except as called for in the Operation and Maintenance Instruction Manual or Service Manuals to keep from being caught in moving parts or by a moving machine.

! **WARNING:** Never use gasoline or other toxic or flammable fluids to clean parts.

! **WARNING:** Do not place head, body, limbs, feet, fingers or hands near a rotating fan or belt. Be especially alert around a pusher fan.

! **WARNING:** Study this manual through before starting, operating, maintaining, fueling or servicing this machine.

A. GENERAL

It is important to be selective in the lubricating oils, grease, and coolants used in the operation of your Allis-Chalmers engine. By following these recommendations, you can be assured of most efficient and longest trouble-free engine life.

B. ENGINE LUBRICATING OIL

1. General

For all turbocharged engines, in all

applications, the general recommendation is to use oils meeting the American Petroleum Institute (API) Classification CD and Military Specification MIL-L-45199B. This also applies to naturally aspirated (non-turbocharged) engines that are operating under severe application or when the fuel sulphur content exceeds 0.5%. In most normal duty applications of the non-turbocharged engines, an API classification CC, MIL-L-2104B, oil can be used.

SAE 30 or 15W40 viscosity oil is the lubricant weight around which Allis-Chalmers diesels have been designed. Use of SAE 30 or 15W40 weight will, in most cases, provide optimum performance life and lube oil control at normal operating speeds.

When crankcase temperatures are below 32°F (0°C), during engine starting, lighter viscosity oils can be used for easier starting without damage from marginal lubrication. Freezing cold is the only reason to use less than SAE 30 or 15W40 weight oil in Allis-Chalmers engines.

Crankcase Temperature When Starting Engine	Weight (Viscosity)
0°F & Below (-18°C)	SAE 10W or SAE 10W30
0°F to 32°F (-18°C to 0°C)	SAE 20/20W or SAE 15W40
32°F to 95°F (0°C to 35°C)	SAE 30 or SAE 15W40
Above 95°F (35°C)	SAE 40 or SAE 15W40

2. Multi Viscosity Lube Oils

Any multi viscosity lubricating oil conforming with API classification CD and Military Specification MIL-L-45199B test requirements is approved for use in Allis-Chalmers diesel engines.

3. Synthetic Lube Oils

Any synthetic or partially synthetic oil conforming with API classification CD and Military Specification MIL-L-45199B test requirements is approved.

Mixing grades of lubricating oils in Allis-Chalmers diesels is not recommended.

4. Oil & Filter Change Period

In general, it is recommended to renew the oil and standard engine mounted full flow type oil filters after each 100

hours of operation. This period is based on use of high quality oils, fuels with less than .5% sulphur, average engine loads, and operating conditions. If engine has approved optional by-pass filter, renew the oil, full flow filters, and bypass filter elements every 250 hours.

Under severe operating conditions, with engine in poor operating condition, or when using high sulphur fuels, lubricating oils deteriorate at a faster rate. Because of this, oil change periods can vary.

5. Lubricating Oil Testing

After recommended oil change interval has been reached, actual tests of the oil should be made at intervals of 10 and 20 hours. These tests will determine condition of oil and indicate if change periods should be lengthened or shortened. Your lubricant supplier provides this testing service, usually on a gratis basis.

6. High Ash Lubricating Oils

Allis-Chalmers diesel engines will operate equally well on either high ash or low ash CD lubricants. Our tests, however, show that under severe service (extended operation under full throttle, high ambient temperatures, etc.) oils having an ash level of at least 1.5% will usually out-perform oils of lower ash contents.

C. GREASE RECOMMENDATIONS

1. General

Use a ball and roller bearing lubricant that has a minimum melting point of 300°F (149°C). It must be water-proof, and have a viscosity that assures easy handling in a hand operated pressure gun at prevailing ambient temperatures.

D. FUEL OIL RECOMMENDATIONS

1. General

Allis-Chalmers diesel engines will perform as well or better than other diesels of comparable size, using any grade of fuel oil. However, if superior performance under all conditions is required, experience has shown that the best suited for these engines closely approximates the specifications listed below:

FUEL OIL SPECIFICATION GUIDE	
Gravity, API	30-40
Cetane Number	40 min
Viscosity, Kinematic Centistokes	1.4.5.8
@ 100°F (38°C)	
Flash Point	100°F (38°C)
	or legal
Pour Point 10°F (-12°C)	Below
	Ambient Temperature
Distillation Temp 90%	Max
Point 640°F (338°C)	
Ash % by Weight	0.01 Max
Water & Sediment % by Volume	0.10 Max
Sulphur Content % by Weight	0.5 Max
Carbon Residue on 10%	0.35 Max
Ramsbottom	
Copper Strip Corrosion	No. 3 Max

This specification is within the American Society for Testing Materials (ASTM) specification for No. 1 and No. 2 fuels. The American Society for Testing Materials has established fuel oil specifications and testing methods to which the petroleum industry conforms very closely. Diesel engine manufacturers have, over the years, come to rely on the ASTM specifications as a standard of the industry and a simple means for the engine owner to identify and purchase fuel oil.

In general, Allis-Chalmers engines have been designed to take advantage of the higher energy content of No. 2 diesel fuels.

Fuels not meeting complete specifications will require shortening of filter renewal and inspection intervals to obtain a reasonable useful life from injection equipment.

NOTE: When handling or storing fuel oil, always practice all caution to keep fuel supply and system free from dirt and moisture.

E. COOLANT RECOMMENDATIONS

1. General

Engine operating in areas where ambient temperature is always above freezing must be kept full of an all-seasons coolant system fluid. Use as recommended by the manufacturer. Clean, soft water can also be used. This water must be as free as possible of scale forming minerals and have an inhibitor added to it. The inhibitor will contain a rust preventative and lubricant to lubricate the coolant seals in the water pump. Follow instructions printed on inhibitor container.

Do not use household-type softened water (because its pH factor is too low acidity). Distilled or clean rain water is preferred.

In freezing areas, use a permanent type anti-freeze solution to protect against damage from freezing. After addition of either water or anti-freeze to cooling system, test the new solution when it

has become thoroughly mixed.

Never use anti-freeze solution that is harmful to aluminum.

Always refer to protection charts furnished by anti-freeze manufacturer for information regarding quantity required for lowest anticipated temperatures.

TOPIC 5 OPERATING CONTROLS AND INSTRUMENTS

SAFETY PRECAUTIONS

WARNING: This engine and its attachments are to be operated only by a qualified operator.

WARNING: No unauthorized person must be allowed to service or maintain this machine. Study the Operation and Maintenance manuals before starting, operating, maintaining, fueling, or servicing this machine.

imum engine performance and life. Regardless of control panel configuration or location, operator must be completely familiar with function of each engine control and instrument provided for engine operation.

A. OPERATING CONTROLS

A variety of controls and instruments are available to assist operator in realizing op-

1. Key Switch

The key switch or toggle switch (Fig. 1, Item 10) energizes the electric solenoid valve or fuel injection pump shut off solenoid circuit.

2. Starter Button

This button (3) energizes the cranking motor.

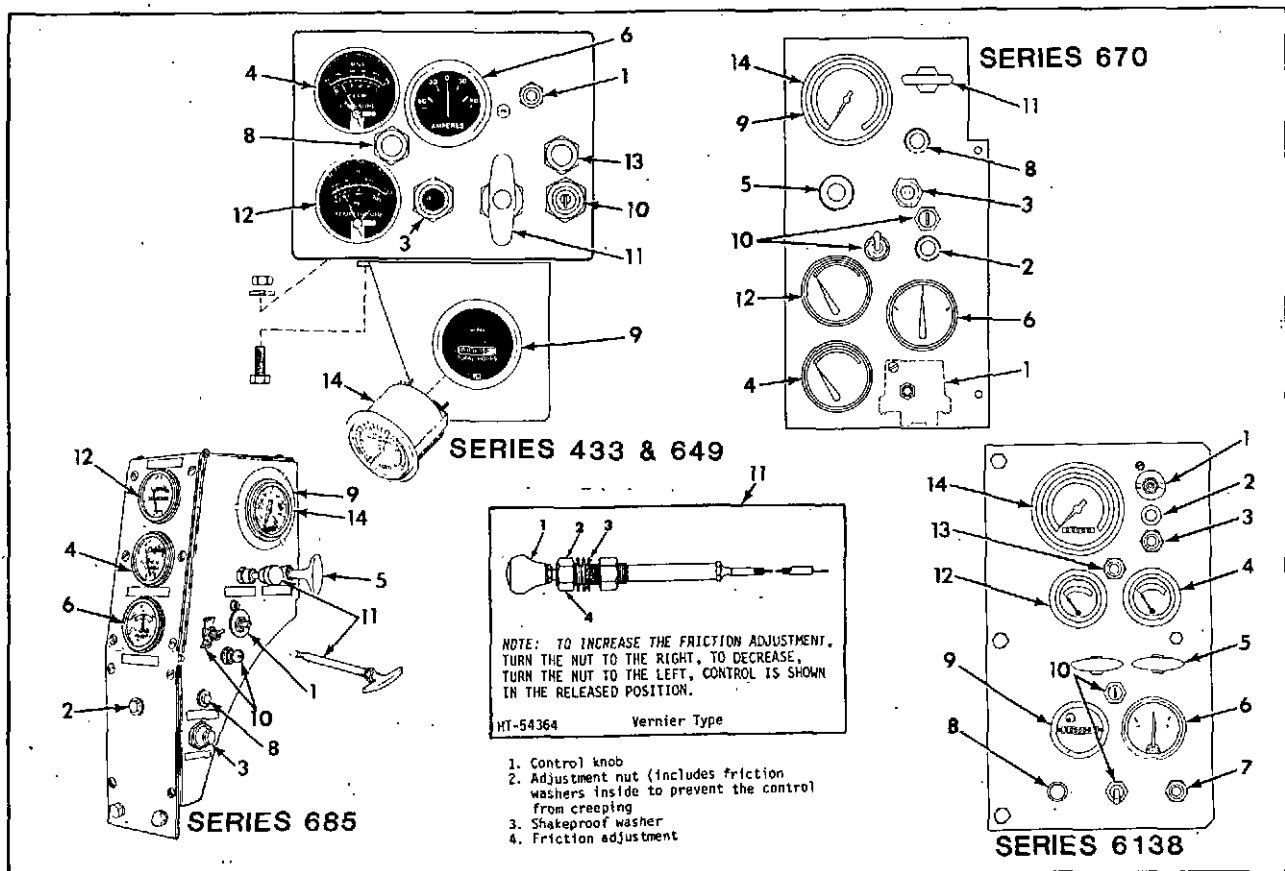

- | | |
|--|--|
| <ul style="list-style-type: none"> 1. Reset button-safety control magnetic switch 2. Bypass button-safety switch-gauges (if applicable) 3. Starter button 4. Oil pressure gauge or low oil pressure safety switch-gauge 5. Stop control-mechanical type 6. Ammeter 7. Stop button-electric fuel shutoff | <ul style="list-style-type: none"> 8. Starting aid push button or pull control 9. Electric tachometer/hourmeter 10. Safety control off-on toggle switch or key switch 11. Speed control - throttle 12. Water temperature gauge or high temperature safety switch-gauge 13. Air heater switch 14. Tachometer or combination tachometer and hourmeter |
|--|--|

Figure 1. Operating Controls and Instruments

3. Throttle (Speed Control)

A turn-to-lock control (11) actuates the governor speed control lever. Engine speed is varied by pulling out the control handle. Control is locked in desired position by turning handle either clockwise or counterclockwise. It is released by turning back to mid-position.

4. Stop Control

To stop engine, control (5) must be pulled full out. To start engine, control must be pushed in completely.

5. Air Heater Switch (if applicable)

This switch (13) energizes the air heater element.

6. Clutch Operating Lever

The clutch operating lever actuates the clutch mechanism to connect and disconnect engine load. See Topic 16, Accessories.

7. Safety Controls

If engine is equipped with safety shut off controls (4 and 12), a bypass switch (2), and an on-off switch (10), refer to Topic 15, Safety Controls.

Allis-Chalmers recommends application of safety controls in the majority of engine installations.

B. INSTRUMENTS

1. Oil Pressure Gauge

This gauge (4) continually indicates pressure at which lubricating oil is circulating through the engine.

2. Ammeter

The ammeter (6) indicates the current flow (charging output) of the battery charging alternator.

3. Water Temperature Gauge

The coolant temperature gauge (12) shows temperature of fluid being circulated through the cooling system.

4. Tachometer

An indicator (14) of engine speed shown in revolutions per minute (rpm).

5. Hourmeter

The hourmeter (14) registers elapsed hours of engine operation.

6. Combination Tachometer & Hourmeter (electronic type)

This hourmeter records the number of hours the unit was in service regardless of operating speed. No lubrication of unit required.

7. Combination Tachometer & Hourmeter (mechanical type)

This combination is applied primarily in 1800 rpm engine operation. If operation is at other than 1800 rpm, refer to table.

<u>Governed RPM</u>	<u>Divisor</u>
1500	.8333
1600	.888
1800	1.000
2000	1.111
2200	1.222
2400	1.333

Lubricate-tachometer angle adaptor each 600 hours with grease conforming to MIL-G-10924 or equivalent. Do not over grease.

TOPIC 6 OPERATING INSTRUCTIONS

SAFETY PRECAUTIONS

 **WARNING:** Study this manual through before starting, operating, maintaining, fueling or servicing this machine.

 **WARNING:** This engine and its attachments are to be operated only by a qualified operator.

 **WARNING:** If engine is to be started indoors, insure proper ventilation to remove deadly exhaust gases.

 **WARNING:** Warn all people who may be servicing or working around machine before starting engine.

 **DANGER:** Do not use starting fluid with electric air heater. Explosion and personal injury could result.

 **WARNING:** Starting fluid is flammable. Do not puncture or burn containers. Follow precautions printed on containers for storage and disposal.

A. OPERATING PRECAUTIONS

1. Be sure air filter element is installed.
2. Be sure fuel filters are tight on their header.
3. Be sure engine and accessories are clean.
4. Always allow engine to warm up at reduced speed and without load.
5. Do not allow engine to idle for prolonged period except in cold weather below 0°F (-18°C).
6. Refuel at end of daily operation to keep condensation at a minimum.
7. When starting: Never crank starting motor longer than 30 seconds without a pause of 2 minutes for cooling.
8. When using option ether starting aid, remove and tape electrical lead from air heater and solenoid switch to prevent possible explosion.

B. STARTING & STOPPING

The engine starting procedure depends upon whether it is equipped with standard controls and instruments, or cold weather start-

ing aids and safety shut down equipment.

When controls are furnished by the Original Equipment Manufacturer (OEM), follow their instructions for stopping, starting, and operating the engine and their equipment.

The following instructions supplement OEM instructions and is to be followed when instruments and controls are furnished by Allis-Chalmers.

Before starting a new engine, prepare it for operation as in Topic 3.

1. Starting Procedure-Without Starting Aid

- a. Disconnect or remove load from engine.
- b. Place all controls in START/RUN position.
- c. Move speed control to full throttle position.
- d. Turn key to ON position.
- e. Press and hold starter button. Release when engine will run without aid of starter. Do not hold starter button down longer than 30 seconds without 2 minutes to cool.
- f. Allow engine to warm up at half throttle.
- g. Within seconds after starting engine, oil pressure should exceed 10 psi (60kPa) minimum. If oil does not meet this minimum limit, stop engine, locate and correct the cause. After engine has reached operating temperature, oil pressure should be within range of 30 to 55 psi (207 to 370kPa) at full load rpm.

2. Starting Procedure-With Air Heater

- a. Disconnect or remove load from engine.
- b. Place engine stop controls in START/RUN position, if mechanical type.
- c. Move speed control to full throttle position.
- d. Turn key switch to ON position.
- e. Press and hold air heater switch for 45 seconds.
- f. Press and hold starter switch while still holding air heater switch in ON position (30 seconds maximum). When engine starts, release both switches. If engine does not run on all cylinders immediately, after

starting, again press air heater for short period (30 seconds maximum) until combustion occurs in all cylinders.

- g. Allow engine to warm up at half throttle before applying load.

3. Starting Procedure-Using Optional Ether

Starting Aid

There are two types of starting aids, one is a mechanically operated type, the other electrically operated. Refer to Topic 14-Cold Weather Starting Aids.

Start engine as follows:

- a. Disconnect or remove load from engine.
- b. Crank engine with stop control in OFF position for 5 seconds
- c. Place stop control or switch in START/RUN position.
- d. Move speed control to full throttle position.
- e. Crank engine for 2 or 3 seconds and inject one shot of starting fluid while cranking. One shot of starting fluid is:
 - 1. Mechanical types: Pull and hold starting aid control for 3 to 5 seconds.
 - 2. Electrical types: Press button and hold for 3 to 5 seconds.
- f. When engine first fires, repeat shots of starting fluid at rate only to keep engine from stalling.
- g. If engine stalls, repeat steps e and f.
- h. After engine is running smoothly, allow to warm up to normal operating temperature at fast idle before applying load.

4. Stopping the Engine.



CAUTION: Always allow engine to run at fast idle speed without load for at least 5 minutes before stopping. This allows engine to cool gradually and uniformly.

- a. Move the stop control to STOP position.
- b. Cover exhaust pipe to prevent rain from coming into engine.

C. CHECKS DURING OPERATION

- 1. Observe general performance of engine

while running.

- 2. Listen for unusual noises.
- 3. Make frequent checks of instruments.

D. COLD WEATHER OPERATION

- 1. Keep battery in full charged condition and all other electrical equipment in optimum condition.
- 2. Use permanent type anti-freeze solution to protect against damage by freezing. Refer to Topic 4.
- 3. At end of each daily operation, drain condensed water from fuel tank and water separator.
- 4. If operating in arctic temperatures, consult your Allis-Chalmers dealer for information about special cold weather equipment.

E. EXERCISE OF ENGINE ON STAND BY SERVICE

A diesel engine on stand by service that is relied upon to perform under stress conditions, should be exercised at least every 30 days.

Exercise period should be of duration to allow engine to reach normal operating temperature while carrying at least 50% of normal load.

When engine is under conditions of extreme temperatures, humidity, dust, sand, etc., it may be necessary to shorten intervals between exercise periods to as often as weekly.

To exercise engine:

- 1. Before starting, check lubricating oil and coolant levels. Make complete visual check of unit.
- 2. Start engine and run 15 minutes with speed control at half position.
- 3. Run engine at full speed with whatever load is available, up to full load, for the time needed to obtain two consecutive temperature readings of 160°F (71°C) minimum at 15 minute intervals. Continue engine operation for 30 minutes. Check and correct all coolant or oil leaks.

If no load or a light load is used in exercise period, cover radiator to hasten warm up. Never cover radiator on an unattended engine.

- 4. Run engine at half speed with no load for 5 minutes to allow combustion chamber to cool evenly.

5. Stop engine

If accumulated hours of operation during exercise periods do not total 100 hours within a 6 month period, it is recommended that lube filters and lubricating oil be changed regardless. If in a 12-month period engine hours do not total 600, it is recommended to replace fuel filter.

F. ENGINE STORAGE

1. General

An engine stored for an extended period of time must be protected from corrosion and deterioration. The following preventative measure should be adhered to promptly after the engine is shut down. Store the engine in an enclosed moisture free building that is heated during the winter months. If a building is not available, cover the engine with a waterproof tarpaulin or a durable plastic cover that is tied securely to the engine.

An engine prepared for storage in one of the following manners can be returned to service at any time and within a minimum amount of time.

2. 30 Days or Less Storage Period

For protection during a temporary period (30 days or less), perform the following instructions.

- a. Drain engine oil pan. Fill oil pan with new lubricating oil of normal classification and SAE weight (refer to Topic 4).
- b. Service the air cleaner.
- c. Drain water and sediment from fuel tank, fuel filter and water separator.
- d. If temperatures below 32°F (0°C) are expected, add a permanent type antifreeze to the cooling system.
- e. Clean exterior of engine and dry it thoroughly.
- f. Service battery and cables. Make certain battery is at full charge.

g. In the event the engine is to be stored outside and uncovered, it is recommended the following steps be taken to guard against excessive rusting of the crankshaft pulley grooves, due to moisture being trapped between the bottom of the pulley and the belts. This could result in increased belt wear when the engine resumes its normal day to day usage and can be more serious when cog type belts are used.

- (1) With the engine stopped, paint the exposed portion of the crankshaft pulley with a fast drying paint, spray painting is acceptable.
- (2) After the paint is thoroughly dry, bar the engine over part way and again paint the exposed portion of the pulley.
- (3) Continue this procedure until all grooves of the crankshaft pulley are painted a full 360°.

h. Use a durable water and vaporproof material and seal all engine openings.

i. Store engine inside of a building or cover it with a waterproof material that is tied to the engine.

3. More Than 30 Days Storage Period

Engine removed from operation for an extended period (more than 30 days and not to exceed 6 months) must be prepared for storage as follows:

- a. Service the air cleaner.
- b. Check interior of radiator. Remove any foreign matter that has collected around and between the radiator fins.
- c. Drain and flush the cooling system. If rust or scale is observed during the flushing operation, clean the system with a commercial cleaner following the manufacturers instructions.

NOTE: Close the coolant filter inlet and outlet shutoff valves before cleaning system. Do not allow a commercial cleaner to circulate through the coolant filter.

- d. Unscrew and remove coolant filter. Install new filter according to the instruction printed on it.

NOTE: Leave filter inlet and outlet valves closed during the storage period.

- e. Fill cooling system with clean water and add a good commercial soluble oil type rust inhibitor. However, if temperatures below 32°F (0°C) are expected, add a permanent type antifreeze to the cooling system instead.
- f. Start engine and operate it with sufficient speed and load to enable the coolant to reach minimum temperature. At this point the thermostat will open and the coolant will circulate through the entire system. Continue to operate engine for one hour.
- g. Stop engine. Remove drain plug and drain lubricating oil from pan. Remove lubricating oil filters and install new filters.
- h. Install drain plug and fill oil pan to the FULL mark on the dipstick with any commercial rust preventive CD oil. Operate engine for 10 minutes and add oil to bring oil level up to the FULL mark on the dipstick.
- i. Drain water and sediment from fuel water separator. Install new fuel filters and prime the fuel system. Then drain the fuel tank.
- j. If fuel injection nozzles have not been serviced recently, check spray pattern and opening pressure of the nozzle holder assemblies, clean and adjust if necessary. This precaution will assure the nozzle holder assemblies are ready for operation when the engine is put back into service.

- k. Disconnect the fuel tank to injection pump fuel supply line and the fuel return line at the fuel tank. Using two clean containers, fill one with regular fuel and fill the other with a fuel oil containing a rust preventative such as The Texas Company "564 Rust Proofing Oil" or an equivalent.
- l. Start engine using the container with the regular fuel oil. After engine is running smoothly, switch the second container to the fuel supply line. Continue to operate engine until the rust preventative fuel oil is observed at outlet of the overflow line; then stop the engine.
- m. Connect fuel supply line and return line to fuel tank.
- n. Clean exterior of engine and dry it thoroughly.
- o. In the event the engine is to be stored outside and uncovered, it is recommended to guard against excessive rusting of the crankshaft pulley grooves, due to moisture being trapped between the bottom of the pulley and the belts. This could result in increased belt wear when the engine again resumes its normal day to day usage, and can be more serious when cog type belts are used. Paint the crankshaft pulley as detailed under step g. in preceding subparagraph 2.
- p. Use a durable water and vaporproof material and seal all engine openings.
- q. Disconnect battery from engine. Clean battery and battery cables. Add distilled water to bring electrolyte up to proper level. Charge battery to make certain it is fully charged. Store battery in a cool, dry location shielded from direct sunlight and away from heat duct outlets. Do not stack a battery on top of another. Check electrolyte level and specific gravity every 30 days. Add distil-

led water and charge battery to maintain it in full operational condition.

- r. Store engine inside of a building or cover it with a waterproof material that is tied securely to the engine.

NOTE: The engine should be tagged to indicate the date it was processed for storage and the duration of the storage period. Also, when returning engine to operation, it must be processed for operation according to the instructions in paragraph 5, titled, Returning Engine to Service.

4. More Than 6 Months Storage Period

Any engine removed from operation for a period of more than 6 months must be prepared for storage as detailed in the preceding subparagraph 3. Then after every 6 months of storage, perform the following:

- a. Check fuel tank for condensation and drain if necessary.
- b. Check fuel filter and water separator for condensation, drain if necessary.
- c. Fill supply tank with a sufficient amount of rust preventive fuel oil such as The Texas Company "564 Rust Proofing Oil" or an equivalent in order to exercise engine.

NOTE: Do not allow engine to run out of fuel during the exercise period.

- d. Check radiator coolant level and add coolant if necessary.
- e. Loosen but do not remove oil pan drain plug to drain any moisture that may have been collected. When oil free of moisture appears, tighten oil pan drain plug.
- f. Remove material that was used to seal engine openings.
- g. Connect the storage battery observing correct polarity.

CAUTION: If engine is operated inside of a building pipe the exhaust gases to the outside.

- h. Start engine and run 15 minutes at 1/2 speed.

- i. Run engine at full speed with whatever load is available up to full load for a period of time that is required to obtain two consecutive water temperature readings at a minimum temperature of 160°F (71°C) that are the same when taken at a 15 minute interval. Then continue to operate engine for 30 minutes. Check and correct any coolant or oil leaks.

If no load or very light load must be used during exercise period, it is recommended that radiator be covered on an attended engine to hasten the warm-up period.

- j. Run engine at 1/2 speed with no-load for 5 minutes before stopping to reduce combustion chamber temperatures to a minimum.

- k. Stop the engine.

- l. Disconnect the storage battery and store it as detailed in the preceding subparagraph 3.

- m. Drain the fuel tank.

- n. Use a durable water and vaporproof material and seal all engine openings.

- o. Again store engine inside of a building or cover it with a waterproof material that is tied securely to the engine.

5. Returning Engine To Service

After an engine has been in storage for a period up to 6 months and before returning it to service, perform the following:

- a. Check the fuel tank for condensation and drain if necessary.

- b. Drain condensation from fuel filter and water separator, if necessary.

- c. Fill fuel supply tank with specified fuel. Prime the fuel system.

- d. Remove oil pan drain plug and drain rust preventive lubricating oil.
- e. Install drain plug and fill oil pan with proper classification and SAE weight of lube oil to proper level.
- f. Open coolant filter inlet and outlet shutoff valves.

NOTE: If a soluble oil type inhibitor was added to the cooling system before engine was stored, drain and flush the cooling system before opening the coolant filter inlet and outlet shut-off valves.

- g. Check radiator coolant level and add coolant if necessary.
- h. Check condition of drive belts. Adjust or replace if necessary.
- i. Remove material that was used to seal engine openings.
- j. Connect the storage battery observing correct polarity.

TOPIC 7 MAINTENANCE AND SERVICE SCHEDULE

SAFETY PRECAUTIONS

 **WARNING:** Always disconnect the battery before cleaning, repairing or servicing the engine.

 **WARNING:** No unauthorized person must be allowed to service or maintain this machine. Study the Operation and Maintenance manuals before starting, operating, maintaining, fueling, or servicing this machine.

 **WARNING:** Study this manual through before starting, operating, maintaining, fueling or servicing this machine.

 **DANGER:** Extinguish all smoking materials, or open flames, before checking and filling tanks, changing filters and before opening sediment drain due to the presence of flammable fluid.

 **WARNING:** Never service or adjust with the engine running except as called for in the Operation and Maintenance Instruction Manual or Service Manuals to keep from being caught in moving parts or by a moving machine.

 **WARNING:** Never use gasoline or other toxic or flammable fluids to clean parts.

 **WARNING:** Do not use your hands to search for pressure leaks. Fluid escaping under pressure can penetrate skin.

 **Warning:** Keep hands away from nozzle tip when popping a nozzle. The finely atomized fuel is ejected with sufficient force to penetrate the skin and cause blood poisoning. Also wear safety glasses with side shields or goggles when popping a nozzle.

 **WARNING:** Do not check or adjust belts when engine is running.

 **DANGER:** Fluid under pressure. Do not remove radiator cap until pressure has been relieved as coolant may boil over and cause personal injury.

 **DANGER:** Flammable Vapors Extinguish all smoking material and open flames before checking and filling batteries. Do not check battery by sparking.

 **WARNING:** Wear safety glasses with side shields or goggles when using compressed air for cleaning to reduce the danger of personal injury from flying particles. Limit the pressure to 30 psi (207 kPa) according to OSHA requirements.

 **DANGER:** Do not use matches, lighters, or torches for a light source when inspecting or repairing engine due to presence of flammable fluids.

A. GENERAL

Your Allis-Chalmers engine, like all mechanical devices, requires attention to keep it operating at peak efficiency and to prevent the development of trouble.

Most engine wear is caused by the entry of foreign elements-water, dust, grime, etc.-into the various engine systems. Therefore, it is wise to keep your engine as clean as possible. Make sure all fittings, caps, filters and level plugs, plus the surrounding surfaces, are wiped clean before any servicing is begun. For proper servicing, a schedule must be determined and followed and an engine history maintained.

*Note: The environment and load conditions to which your engine is subjected, can considerably lengthen or shorten the intervals between major service needs such as valve reconditioning, piston ring replacement, or complete overhaul. Observation of crankcase breathing, exhaust sound and color, lubricating oil consumption, engine power, and the sound of the engine in operation by a qualified diesel mechanic will determine the need for reconditioning.

The following suggested maintenance and service schedule is based on experience in normal operation. For details on any of the individual items of service, consult the Topic Number referral for detailed description of

the service functions.

The maintenance interval is the same for maintenance Phases 1,2,3, and 4. See follow-

ing tabulation. Where the time interval varies between the engine series, within a maintenance phase, adhere to the time interval listed for the particular engine series.

MAINTENANCE PHASE	MAINTENANCE INTERVAL	ENGINE SERIES				
		433	649	670	685	6138
Phase 1	Daily-Each 8 Hrs.	X	X	X	X	X
Phase 2	100 Hours	X	X	X	X	X
Phase 3	250 Hours	X	X	X	X	X
Phase 4	600 Hours	X	X	X	X	X
Phase 5	1000 Hours				X	X
	1200 Hours	X	X			
	1300 Hours			X		
Phase 6	2250 Hours	X	X			
	2600 Hours			X		
	3000 Hours				X	
	4000 Hours					X
Phase 7	4500 Hours	X	X			
	5200 Hours			X		
	6000 Hours				X	
	8000 Hours					X

B. LUBRICATION AND MAINTENANCE GUIDE

Regular checks should be made at the intervals shown (hours or months). Generally the hours shown are for prime power units...the months for stand by units.

PHASE 1 DAILY—ALL ENGINE SERIES (or when stand by unit is exercised).

	Topic	Paragraph
1. Before starting engine:		
a. Visually inspect all belts and hoses for deterioration. Check total engine for signs of fuel lubricant, coolant, air, and exhaust leaks or damage.		
b. Check and correct coolant level	9	F
c. Check oil level with side of dipstick marked STOPPED.	11	A
d. Drain water from fuel tank, fuel filters, and/or fuel/water separator (if applicable).	10	B
e. Check air cleaner service indicator and replace filter element if red indicator is visible.	13	B
f. Empty and clean dust cup and baffle in air cleaner.	13	B
g. Drain moisture from air compressor reservoir.	16	A
h. Grease power take-off clutch throw-out collar.	16	B
2. While starting engine:		
a. Check and correct starter performance.	12	D
b. Check and correct oil pressure.	11	A
c. Check alternator charging rate.	12	E, F, G, H, I
3. After engine reaches operating temperature:		
a. Check engine oil level at idling speed. Maintain between ADD, and FULL marks on dipstick, RUNNING side.	11	A

PHASE 1 DAILY—ALL ENGINE SERIES—CONTINUED

	Topic	Paragraph
b. Observe:		
(1) Coolant temperature	9	H
(2) Lube oil pressure	11	A
(3) Idle/full load speed		
(4) Air cleaner and service indicator.	13	B
c. Check and correct for engine knocks or unusual noises.		
d. Check/correct air compressor operation and reservoir pressure.	16	A

PHASE 2 — EACH 100 HOURS/6 MONTHS—ALL ENGINE SERIES

1. Check/correct radiator for cleanliness and restriction of air through fins.	9	G
2. Make initial replacement of coolant filter.	9	L
3. Change engine lubricating oil—see Phase 3.	11	
4. Renew full flow type engine oil filter—see Phase 3.	11	
5. Check liquid level in battery.	12	C
6. Check and repair any coolant, fuel, oil, air and exhaust leaks.	9,10,11,16	
7. Lubricate throttle/stop control swivels (lube oil).		
8. Check/correct air compressor for: belt alignment and adjustment, (where applicable) mounting, air lines and coolant lines for leaks; cleanliness.	16	A
9. Grease power take-off clutch shaft, pilot bearings, and operating lever shaft.	16	B
10. Check clutch adjustment.	16	B

PHASE 3 — EACH 250 HOURS/6 MONTHS—ALL ENGINE SERIES

If engine is equipped with optional bypass type engine oil filter, oil renewal and filter replacement is extended to 250 hours.

1. Renew engine oil.
2. Replace full flow lube oil filters.
3. Replace bypass lube oil filter.

PHASE 4 — EACH 600 HOURS/12 MONTHS—ALL ENGINE SERIES

1. Replace all fuel filters	10	H
2. Replace coolant filter.	9	L
3. Check/clean engine breather tubes.	11	A
4. Check/clean or replace air compressor governor filter.	16	A
5. Grease adaptor for mechanical type tachometer.	5	B













	Topic	Paragraph
6. Check belt tension and condition of alternator, water pump, and air compressor drives.	12,16	
7. Renew (500 hours) shaft bearing lubricating oil of heavy duty power take-off clutch.	16	B
<u>PHASE 5</u> - EACH 1000 HOURS/24 MONTHS—ENGINE SERIES 685 AND 6138		
EACH 1200 HOURS/24 MONTHS—ENGINE SERIES 433 AND 649		
EACH 1300 HOURS/24 MONTHS—ENGINE SERIES 670		
1. Inspect/correct injection nozzle holder and spray pattern.	10	F
2. Check specific gravity (charge) of battery fluid.	12	B
3. Inspect, clean, and tighten all electrical connections.	12	
4. Visually inspect all fasteners on exhaust intake system and tighten.	13	D
5. Inspect and clean nozzle hole in the starting aid, discharge valves, and springs in air compressor discharge.	14	E
6. Check/correct air compressor discharge valves and springs for excessive carbon.	16	A
7. Check/tighten engine mounting fasteners.		
8. Grease overspeed governor.		
<u>PHASE 6</u> - EACH 2250 HOURS—ENGINE SERIES 433 AND 649		
EACH 2600 HOURS—ENGINE SERIES 670		
EACH 3000 HOURS—ENGINE SERIES 685		
EACH 4000 HOURS—ENGINE SERIES 6138		
1. Recondition nozzle holder assemblies.	10	F
*2. Check valve lash adjustment. If necessary, recondition exhaust valves and seats.		
3. Check/correct turbocharger for dirt and carbon.	13	D
*4. Check/correct cylinder sleeve bores for excessive wear.		
5. Check/correct/clean complete exterior of engine and radiator.		
<u>PHASE 7</u> - EACH 4500 HOURS—ENGINE SERIES 433 AND 649		
EACH 5200 HOURS—ENGINE SERIES 670		
EACH 6000 HOURS—ENGINE SERIES 685		
EACH 8000 HOURS—ENGINE SERIES 6138		
*1. Make major inspection of complete engine and replace all parts showing excessive wear.		

It is suggested that any maintenance function not fully described in this manual be handled only by a factory trained mechanic or your Allis-Chalmers dealer.

*See note at beginning of this topic.

TOPIC 8 TROUBLESHOOTING

SAFETY PRECAUTIONS

-  **WARNING:** No unauthorized person must be allowed to service or maintain this machine. Study the Operation and Maintenance manuals before starting, operating, maintaining, fueling, or servicing this machine.
-  **WARNING:** Always disconnect the battery before cleaning, repairing or servicing the engine.
-  **DANGER:** Extinguish all smoking materials, or open flames before checking and filling fuel tanks, changing filters and before opening sediment drain due to the presence of flammable fluid.
-  **WARNING:** Never use gasoline or other toxic or flammable fluids to clean parts.
-  **DANGER:** Fluid under pressure. Do not remove radiator cap until pressure has been relieved as coolant may boil over and cause personal injury.
-  **WARNING:** Do not place head, body, limbs, feet, fingers or hands near a rotating fan or belt. Be especially alert around a pusher fan.
-  **WARNING:** If engine is to be started indoors, insure proper ventilation to remove deadly exhaust gases.
-  **WARNING:** Keep hands away from nozzle tip when popping a nozzle. The finely atomized fuel is ejected with sufficient force to penetrate the skin and cause blood poisoning. Also wear safety glasses with side shields or goggles when popping a nozzle.
-  **WARNING:** Do not check or adjust belts when engine is running.
-  **DANGER:** Fluid under pressure. Do not remove radiator cap until pressure has been relieved as coolant may boil over and cause personal injury.
-  **DANGER:** Flammable vapors. Extinguish all smoking materials and open flames before checking and filling batteries. Do not check battery by sparking.
-  **WARNING:** Wear safety glasses with side shields or goggles when using compressed air for cleaning to reduce the danger of personal injury from flying particles. Limit the pressure to 30 psi (207 kPa) according to OSHA requirements.
-  **WARNING:** Do not use your hands to search for pressure leaks. Fluid escaping under pressure can penetrate skin.

A. GENERAL

Over 90% of the troubles that occur in engine operation are avoidable if those responsible adhere to an adequate program of lubrication, inspection and maintenance. It has been proven that the time and expense of such programs, as spelled out in this manual, is a fraction of that incurred when poor maintenance results in major malfunction or complete engine breakdown.

When signs of trouble are detected and remedied immediately, more expensive and time consuming repairs can be avoided.

The following troubleshooting chart includes some of the problems an operator may encounter during the service life of an Allis-Chalmers diesel engine. The chart itself will assist you in making an organized study of the problem and a planned method of procedure for investigation and correction of the difficulty.

To use the troubleshooting chart, find the complaint at top and then follow down that column to the colored dot or dots. Reference to left of dot indicates the possible cause.

B. WHEN TROUBLE OCCURS

Corrective and effective troubleshooting of the engine is a common sense process. It is ways best to first review what repairs have previously been made and determine how they could contribute to present condition.

Secondly, check and recheck the obvious simple things that can go wrong—fuel supply, loose belts or fittings, dirty filters, leaking gaskets.

Thirdly, check another time to be absolutely sure that disassembly is necessary.

Last, once trouble has been spotted, be sure to identify the reason for creating of this fault and correct same.

C. TROUBLESHOOTING GUIDE

See following page for guide.

TOPIC 9 COOLING SYSTEM

A. GENERAL DESCRIPTION

Maintenance of a favorable heat level is important for proper engine operation. Your engine efficiency and life will be reduced if block heat is consistently too low or too high. It is the function of the cooling system to keep the engine within a designed temperature range. On intercooled engines, the system is extended to cool the turbocharged air prior to entrance into the cylinder.

B. RADIATOR AND FAN SYSTEM

Most common system of engine temperature control is the radiator and fan combination. Other major components include a coolant pump, inlet and outlet piping, water cooled exhaust manifold, thermostat, oil cooler, coolant filter, temperature gauge, and immersion heater, (see Fig. 1).

Coolant is drawn from bottom of radiator through pump into pipe leading to engine

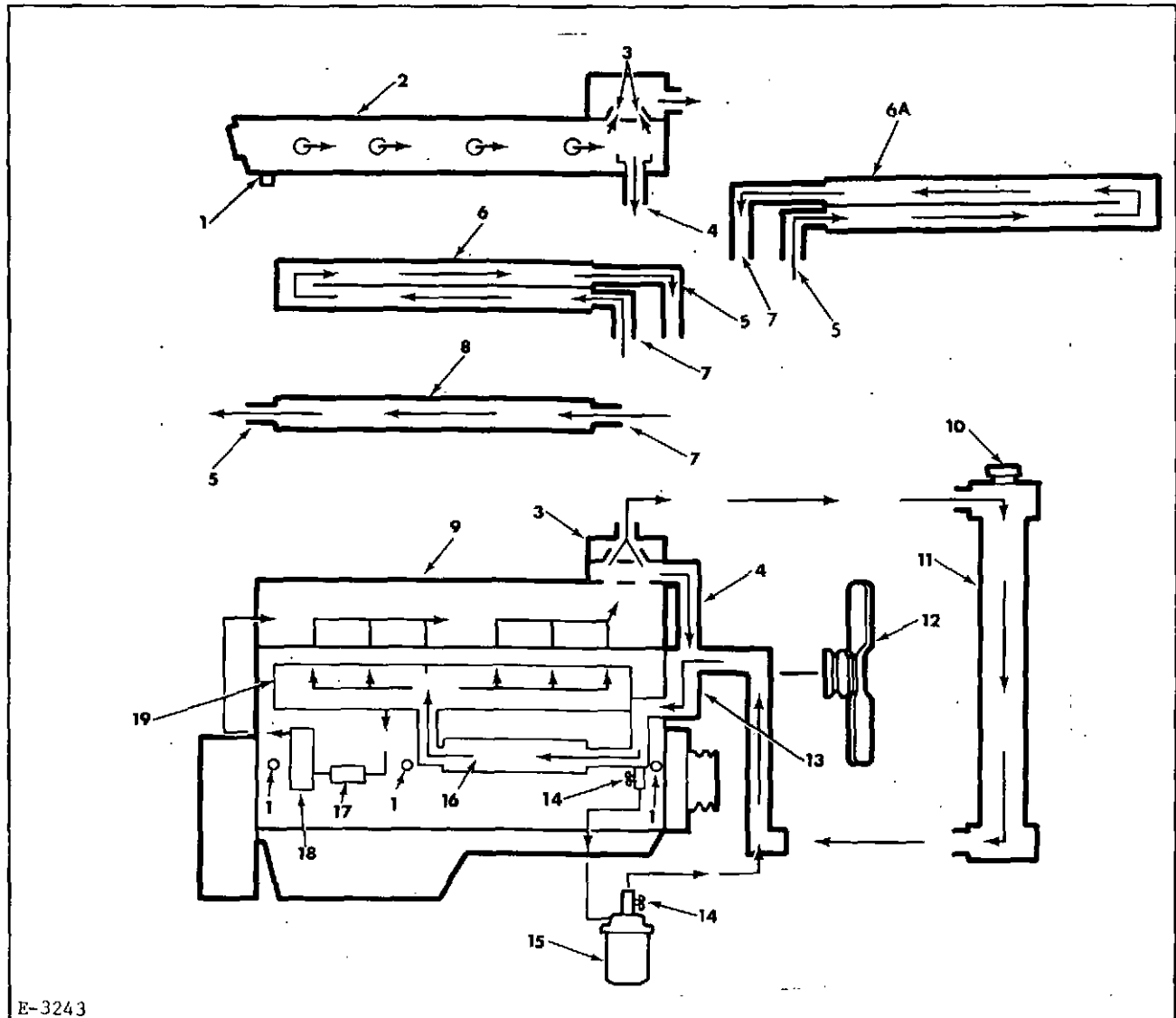

E-3243

- | | | |
|--|-------------------------------|---|
| 1. Drain cock | 7. Intercooler inlet | 15. Coolant filter |
| 2. Water cooled exhaust manifold | 8. Intercooler model 649I | 16. Oil cooler |
| 3. Thermostat/s | 9. Cylinder head | 17. Immersion heater thermostat (tank style) option |
| 4. Bypass tube | 10. Pressure cap-7psi (48kPa) | 18. Immersion heater (tank style) optional |
| 5. Intercooler outlet | 11. Radiator | 19. Coolant inlet manifold |
| 6. Intercooler-models 433I, 670I & 6138I | 12. Fan | |
| 6A. Intercooler-model 685I | 13. Coolant pump | |
| | 14. Shutoff cock | |

Figure 1. Cooling System Schematic Diagram - Radiator and Fan Type Cooling System - Typical

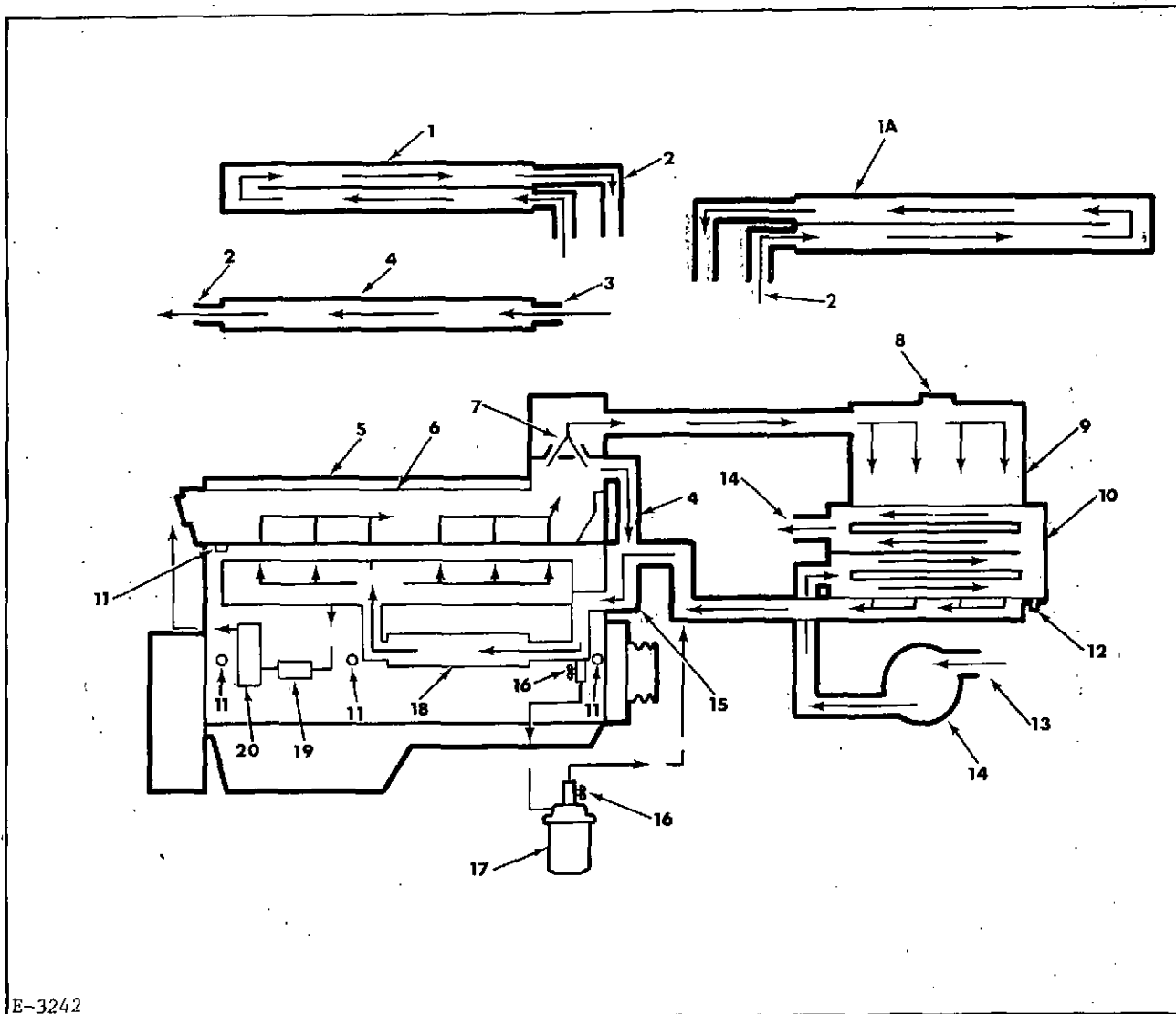

E-3242

- | | | |
|------------------------------------|------------------------------|--|
| 1. Intercooler-models 670I & 6138I | 8. Pressure cap-7psi (48kPa) | 16. Shutoff cock |
| 1A. Intercooler-model 685I | 9. Expansion tank | 17. Coolant filter |
| 2. Intercooler outlet | 10. Heat exchanger | 18. Oil cooler |
| 3. Intercooler inlet | 11. Drain cock or location | 19. Immersion heater thermostat-option |
| 4. Intercooler model 649I | 12. Tube bundle drain cock | 20. Immersion heater optional |
| 5. Cylinder head | 13. Raw water pump | |
| 6. Water cooled exhaust manifold | 14. Raw water outlet | |
| 7. Thermostat/s | 15. Coolant pump | |

Figure 2. Cooling System Schematic Diagram - Heat Exchanger and Expansion Tank Type Cooling System - Typical

oil cooler. From there coolant flows into side of engine block where it circulates around cylinder sleeves, into cylinder head, to thermostat and to top of radiator. On intercooled engines, a share of the coolant is also directed from pump through the intercooler assembly in the intake manifold to precool the air prior to combustion, see Fig. 1, Items 6 or 8.

The thermostat is the control element regulating flow of coolant. It remains closed until engine heat raises to 180°F (82°C) and is full open at 200°F (93°C).

The cooling system is pressurized by a 7 psi (48 kPa) pressure cap. By pressurizing, boiling point of water is raised 3°F per psi (0.25°C per kPa). Hence, water coolant will not boil until 233°F (111°C) is reached.

Operating your engine in this temperature range is not harmful. Some temperature gauges are not accurate and may indicate higher than actual temperature thus leading operator to falsely believe engine is running too hot--a condition always associated with loss of coolant. When in doubt, check level in radiator or expansion tank.

A double-acting valve in radiator pressure cap releases pressure caused by expansion of heated coolant. It also allows air to enter when cooling contraction occurs. Thus it is necessary to keep cap turned on tightly at all times.

 **WARNING:** Do not remove pressure cap when temperature is 212°F (100°C) or above. Coolant will flash boil and may splash on person removing cap.

C. HEAT EXCHANGER AND EXPANSION TANK SYSTEM

The heat exchanger and expansion tank perform the same function as radiator and fan (See Fig. 2). The tank is reservoir for engine coolant. As coolant is heated and expands, it enters tank located slightly above highest point in system. Tank filler cap is pressurized type (7 psi)(48 kPa). The coolant is drawn from the bottom of the tank to the inlet side of the water pump. From there, coolant follows same path as in Radiator and Fan System.

Customer supplied raw water pump circulates cool raw water through inside of heat exchanger tubes. Heat in engine coolant is dissipated to raw water.

D. GENERAL MAINTENANCE -- COOLANT

When coolant filter/conditioner is specified, rust, scale, and corrosion are reduced thus extending engine life.

Engines operating in areas where ambient temperature remains above freezing, must be kept full of an all-seasons coolant system fluid as recommended, or clean soft water. Do not use household type softened water because of low pH factor (acidity), distilled water or clean rain water is preferred.

For engine operating in sub-freezing temperatures, a permanent type anti-freeze must be used to protect against freeze damage. After any addition of water to anti-freeze compound, test solution after mixing to assure complete protection. Do not use anti-freeze solution harmful to aluminum. Refer to instructions furnished by anti-freeze manufacturer for quantity required for lowest ambient temperature protection.

E. DRAINING COOLING SYSTEM

 **DANGER:** Fluid under pressure. Do not remove radiator cap until pressure has been relieved as coolant may boil over and cause personal injury.

1. Engines installed in portable equipment must be level to assure complete drainage.

2. Disconnect power source of immersion heater element.
3. If radiator-cooled (Fig. 1), remove radiator cap, open radiator drain cock, cylinder block drain cock/plug, cooler drain cocks and vent cocks/plugs (at high point on engine).
4. If engine has heat exchanger (Fig. 2) shut off raw water source and open tube bundle drain cock. Remove expansion tank cap and open vent cocks/plugs. Open engine drain cocks.
5. Leave coolant filter shut off valves open (Fig. 1, Item 14). Remove spin-on type filter (17) and replace with new filter after draining.

F. FILLING COOLING SYSTEM

 **WARNING:** Improper filling technique may result in permanent engine component damage. Proper filling and venting is necessary.

1. Check to assure vent cocks/plugs are open (at high point on engine).
2. Close all drain cocks/plugs that were open to drain system.
3. Pour coolant into radiator or expansion tank until it flows from vent provisions.
4. When coolant flows (free of air) without bubbles, close vent cocks/plugs and continue filling until coolant level is approximately 1-1/2 in. (38 mm) below bottom of filler neck or fill heat exchanger system tank to approximately 2/3 full. Install filler cap.
5. Operate engine until thermostat opens.
6. Remove filler cap to check level of coolant and add if necessary. Install filler cap.

G. CLEANING COOLING SYSTEM

1. Clean system when inspection reveals accumulation of rust or scale, before anti-freeze is added, and after anti-freeze is drained.
2. If coolant filter has been properly maintained cleaning of system should not be necessary.
3. Before putting cleaning solvent in radiator, close coolant filter inlet and shut off valves (Fig. 1, Item 14).
4. Commercial solvents are available for cooling system cleaning. Use according to manufacturers instructions. Never mix anti-freeze compounds or inhibitors with any cleaning or flushing compounds.
5. After cleaning and flushing, open filter

shutoff valves (Fig. 1, Item 14), install new filter and fill system to proper level. Inspect system for leaks and correct.

6. If radiator tubes are closed, reverse flush as follows:
 - a. Disconnect upper and lower radiator hoses.
 - b. Connect pressure water hose to lower hose.
 - c. Plug upper connection and remove radiator cap.
 - d. Force water through radiator. Foreign material will flow out top with overflow water. Never use more than 6 psi (41 kPa) pressure when flushing. Excess pressure can rupture radiator.
7. Radiator must be kept free of debris and other obstructions. Clean with air blast carrying a nontoxic, nonflammable grease solvent. With sucker-type fan, direct cleaning spray at rear (far side) of radiator. If blower-type fan, direct cleaning spray at front of radiator. Keep engine covered during cleaning.

CAUTION: Provide adequate ventilation to avoid toxic effects of spray. Do not clean with gasoline, fuel oil, or kerosene.

WARNING: Wear safety glasses with side shields or goggles when using compressed air for cleaning to reduce the danger of personal injury from flying particles. Limit the pressure to 30 psi (207 kPa) according to OSHA requirements.

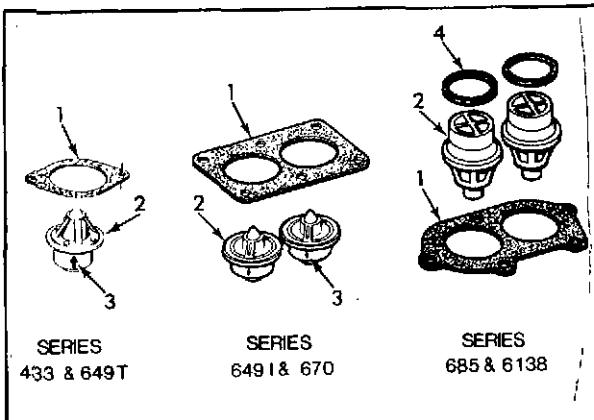

1. Gasket
2. Thermostat/s
3. Installation directional arrow.
4. Seals-located in thermostat cover

Figure 3. Thermostats

H. THERMOSTATS

1. Description

The thermostat (Fig. 3) is the control element that regulates flow of coolant. It remains closed when engine is cold and does not begin to open until coolant temperature raises to 180°F (82°C). It is fully open at 200°F (93°C). When closed, coolant is directed from engine through bypass tube to inlet side of water pump. Thus you get even and rapid temperature increase of all engine parts during warm-up.

2. Maintaining normal coolant operating temperatures depends upon a properly functioning thermostat. If engine runs cool or overheats, remove and test thermostat.

3. Removing Thermostat With Engine Cooled.

- a. Drain cooling system.
- b. If applicable, remove coolant bypass tube or hose.
- c. Remove cap screws and lockwashers that secure water outlet flange to thermostat housing.
- d. Raise flange with hose intact.
- e. Remove gasket with thermostat.
- f. Clean, inspect, test, and replace thermostat.

4. Replacing Thermostat

- a. Install thermostat(s) in clean housing with arrow pointing up (Series 433, 649, and 670 engines) making sure thermostats are properly set in their respective counterbores.
- b. Position new gasket as indicted in Figure 3.
- c. Position outlet flange on housing and secure with lockwashers and cap-screws.

I. ENGINE OIL COOLER

1. Description:

The engine oil cooler consists of corrosion resistant tubes, water inlet and outlet headers. Coolant circulates through tubes surrounded by engine oil. Engine oil under pressure circulates oil through tank, around coolant tubes. Oil heat is dissipated through to coolant.

2. If proper engine oil maintenance is followed, oil cooler will function ef-

fectively. Otherwise impurities will deposit in cooler and restrict oil flow around tubes. Restricted oil flow is indicated by a drop in oil pressure. To correct, oil cooler must be removed and cleaned or replaced.

3. Removal of engine oil cooler and cleaning is a service operation. It is best handled by a factory trained mechanic or your Allis-Chalmers dealer.

J. BELTS—REPLACEMENT OR ADJUSTMENT

⚠ **WARNING:** Do not place head, body, limbs, feet, fingers or hands near a rotating fan or belt. Be especially alert around a pusher fan.

⚠ **WARNING:** To prevent injury, always turn the key switch or stop control to the "OFF" position before cleaning, repairing, or servicing the engine.

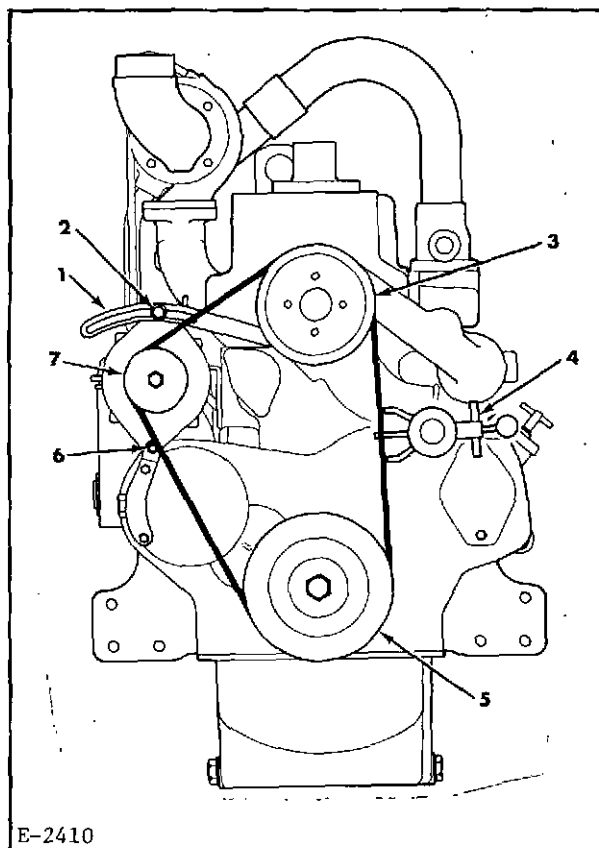

E-2410

1. Adjusting brace
2. Retaining capscrew
3. Water pump pulley
4. Belt tension gauge
5. Crankshaft pulley
6. Mounting bolt or capscrew
7. Alternator pulley

Figure 4. Belt Adjustment—Series 433, 649 and 670

⚠ **WARNING:** Do not check or adjust belts when engine is running.

1. General

The alternator, water pump, fan and optional air compressor are driven by a single belt, a pair of belts, or set of 3 belts, depending upon the engine series.

Replace belts if damaged, badly worn, or soaked with oil or grease.

Where sets of 2 or 3 belts are used, if only one of the belts needs replacement, it is imperative that all of the belts be replaced to obtain satisfactory belt life.

2. Belt Adjustment and Replacement

a. Belt Tension

Proper belt tension assures maximum service life of bearings, pulleys and belts. Correct adjustment of belt tension requires use of a belt tension gauge reading in pounds of tension. A suggested gauge for use is manufactured by Borrough Tool and Equipment Corp., 2429 N. Burdick St., Kalamazoo, MI. 49007. A different tension gauge is required for each V-Belt width. Chart below shows proper gauge and tension for various belt widths. The term, "used", in chart, denotes used belt that has been loosened to permit component change then retensioned. On "new" belts it was previously recommended to tension new belt for run-in period then retension. Today when installing new belt it is initially tensioned at specified "New Belt" value. After running, the belt will stretch and loosen to lower "used belt" value. Never tension a "Used Belt" to "New Belt" tension.

On multiple belt engines it is necessary to check tension only on belt closest to engine or inside belt. This is normally the tightest belt since it is closest to supporting bearings.

Always position tension gauge at center of span between most distant pulleys. If cog type belt is checked, place gauge finger on top of cog.

If tension gauge is not available, belt tension can be checked by hand. Belts of 1/2 inch (12.70 mm) width are properly adjusted when they can be depressed 3/16 inch (4.76 mm) to 1/2 inch (19.05 mm). 11/16 3/4 and 7/8 inch (17.46, 19.05, and 22.23 mm) width belts to between 1/2 to 3/4 inch (12.70 to 19.05 mm).

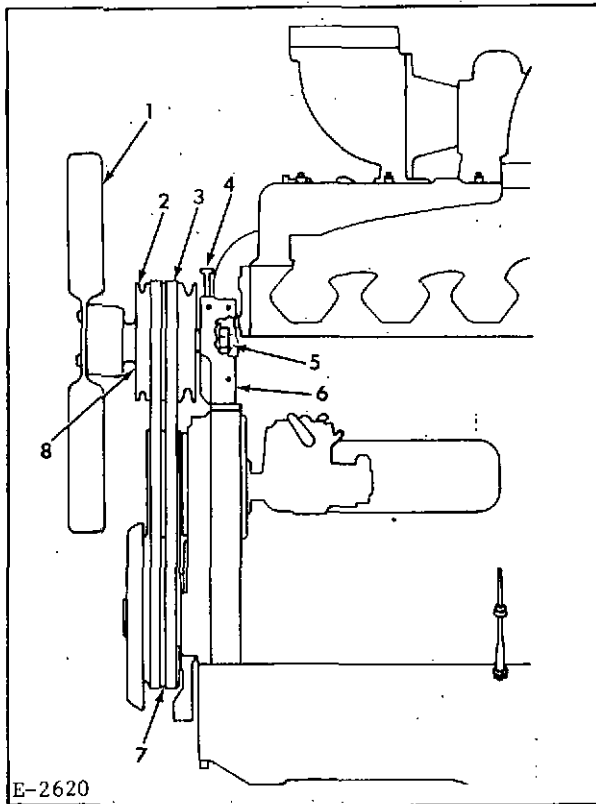

- | | |
|--------------------|---------------------------|
| 1. Fan | 5. Locknut |
| 2. Fan hub | 6. Bracket |
| 3. Belts | 7. Crankshaft pulley |
| 4. Adjusting screw | 8. Fan hub grease fitting |

Figure 5. Belt Adjustment-Series 685 Engines

3. Belt Replacement and Adjustments

a. Series 433, 649 and 670 Engines

- (1) Stop engine, remove belt guard.
- (2) Loosen alternator adjusting brace capscrew (Fig. 4, Item 2) and mounting bolt or capscrew (6).
- (3) Install new belt (s) in pulley grooves. Move alternator away from engine until specified belt tension is achieved. Tighten brace capscrew (2) and mounting bolt or capscrew (6).
- (4) Reinstall belt guard.

b. Series 685 Engines

- (1) With engine stopped, remove belt guards.
- (2) Remove battery charging alternator drive belt.
- (3) Loosen locknut at rear of the fan hub spindle (shaft) (Fig. 5, Item 5) so spindle can be moved in slot of the fan hub mounting bracket (6).
- (4) Lower the hub by turning the adjustment screw (4) counterclockwise.
- (5) Remove and inspect both old belts.

BELT TENSION CHART				
Belt Width	1/2 inch (12.70 mm)	11/16 inch (17.46 mm)	3/4 inch (19.05 mm)	7/8 inch (22.23 mm)
Borroughs Gage Model Number	33-73F	*33-74	33-74	33-72C
POUNDS OF TENSION				
Single Belt New	107-114 (49-52 Kg)	123-130 (56-59 Kg)	143-150 (65-68 Kg)	143-150 (65-68 Kg)
Single Belt Used	90-95 (41-43 Kg)	102-107 (46-49 Kg)	118-124 (54-56 Kg)	118-124 (54-56 Kg)
Dual Belt New	107-114 (49-52 Kg)	120-127 (54-58 Kg)	120-127 (54-58 Kg)	120-127 (54-58 Kg)
Dual Belt Used	90-95 (41-43 Kg)	102-107 (46-49 Kg)	118-124 (54-56 Kg)	118-124 (54-56 Kg)
Triple Belt New	107-114 (49-52 Kg)	120-127 (54-58 Kg)	120-127 (54-58 Kg)	120-127 (54-58 Kg)
Triple Belt Used	90-95 (41-43 Kg)	102-107 (46-49 Kg)	118-124 (54-56 Kg)	118-124 (54-56 Kg)

*NOTE: When ordering gauge 33-74, specify calibration for 11/16 inch (17.46 mm) belt width.

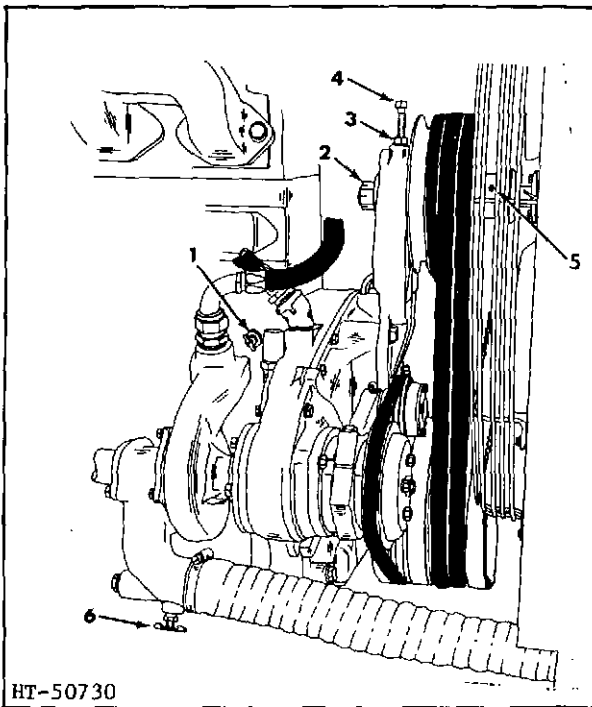

HT-50730

- | | |
|------------------|------------------------|
| 1. Drain cock | 4. Adjusting capscrew |
| 2. Retaining nut | 5. Fan hub grease plug |
| 3. Locknut | 6. Drain cock |

Figure 6. Fan Hub, Drive Belts, and Drain Cocks-Series 6138 Engines

Replace both belts if either is defective.

- (6) Position new belts on pulley grooves.
- (7) Raise the hub by turning adjustment screw (4) clockwise and adjust proper tension.
- (8) Tighten the spindle locknut securely.
- (9) Install battery charging generator drive belt. Adjust belt to specified tension.

c. Series 6138 Engines

- (1) Loosen the spindle clamp retaining nut (Fig. 6, Item 2) and loosen locknut (3) securing adjusting capscrew (4).
- (2) Turn capscrew (4) until enough slack is obtained to facilitate removal of the fan belts. Remove belts.
- (3) Inspect belts and replace belts if necessary. Inspect pulleys.
- (4) Position belts on fan hub and crankshaft pulley.

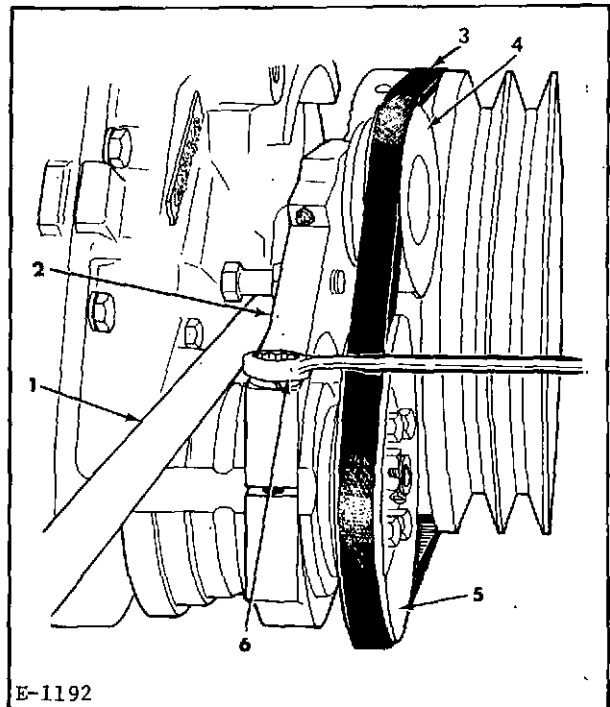

E-1192

- | | |
|---------------------------------------|--------------------------------|
| 1. Bar | 4. Belt tightener idler pulley |
| 2. Water pump belt tightener assembly | 5. Water pump pulley |
| 3. Water pump drive belt | 6. Clamping bolt |

Figure 7. Adjusting Water Pump Drive Belt-Series 6138 Engines

- (5) Turn adjusting capscrew (4) until belts are to the specified belt tension.

- (6) Tighten locknut (3) and spindle retaining nut (2).

**d. Series 6138 Engines
Water Pump Drive Belt**

- (1) Remove fan belts. Refer to preceding paragraph, titled, Fan Drive Belts.
- (2) Loosen water pump belt tightener assembly clamping bolt (Fig. 7, Item 6). Force assembly downward. Remove Belt.
- (3) Inspect belt. Replace if necessary.
- (4) Install belt in grooves of crankshaft pulley, water pump pulley, and belt tightener idler pulley.
- (5) Adjust tightener up or down until the specified belt tension is obtained.
- (6) Securely tighten the clamping capscrew to a torque of 35 lb. ft. (47Nm).

K. FAN HUB LUBRICATION--
SERIES 685 AND 6138 ENGINES

! WARNING: To prevent injury, always turn the key switch or stop control to the "OFF" position before cleaning, repairing, or servicing the engine.

! WARNING: Do not place head, body, limbs, feet, fingers or hands near a rotating fan or belt. Be especially alert around a pusher fan.

1. General

Some bearings in fan hub assemblies must be lubricated at prescribed intervals with pressure gun lubricant. Do not overgrease fan hub bearings.

2. Series 685 Engines

At 600 hour intervals, apply 1 or 2 shots of grease with low pressure, hand operated grease gun in either of the two fittings. (Fig. 5, Item 8).

3. Series 6138 Engines

At 600 hour intervals, remove pipe plug (Fig. 6, Item 5) from fan hub, install grease fitting, pump 1 or 2 shots of grease into hub. Remove fitting and reinstall pipe plug.

L. COOLING SYSTEM CONDITIONER
(FILTER)

1. General

The cooling system conditioner extends engine life. It contains an all purpose element suitable for use with water and all types of permanent and non-permanent anti-freezes except Dowtherm.

2. The Coolant Conditioner (Fig. 8)

- a. Removes dirt, sludge, and other foreign material by mechanical filtration.
- b. Prevents precipitation of scale on system surfaces by ion exchange of water softening.
- c. Protects against corrosion activity in the engine by chemicals present in the element.
- d. Controls electrolysis by use of a sacrificial plate.
- e. Decreases the natural tendency towards rust formation and chemical deterioration of cooling system metal surfaces.

3. Maintenance

When an element is changed from one type to another, you must drain and flush cooling system. Never use soluble oil or other coolant conditioners if system is equipped with coolant filter. Before adding leak stoppers to coolant, shut off inlet and outlet valves to water conditioner. Change initial coolant conditioner element after first 100 hours of operation and thereafter, each 600* hours.

4. Changing the Element

- a. Clean base and surrounding area.

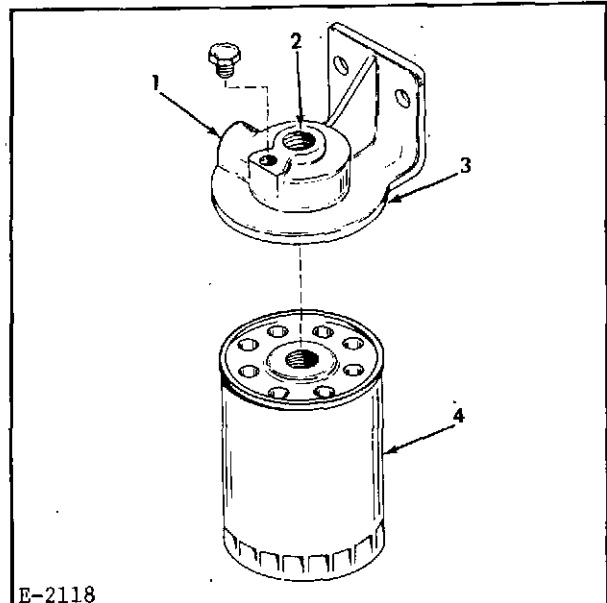

- | | |
|-----------|-------------------|
| 1. Inlet | 3. Header |
| 2. Outlet | 4. Spin-on filter |

Figure 8. Coolant Filter-Spin-On Type

- b. Close both coolant conditioner inlet and outlet valves.
- c. Remove exhausted spin-on element.
- d. Lubricate gasket with thin film of oil.
- e. Install new element until gasket contacts base of mounting housing.
- f. Hand tighten 1/2 turn.
- g. Open inlet and outlet valves.
- h. Operate engine and check for leaks.

M. TORQUE CONVERTER COOLER

1. General

The torque converter cooler (optional equipment) maintains the temperature of

the converter fluid within safe operating range.

Engine coolant, after leaving the lube oil cooler, passes through the inside of the converter cooler tubes and flows from there to the engine block.

2. Maintenance

It is absolutely necessary that cooler be kept clean to provide for proper oil cooling.

Torque converter cooler maintenance is a service operation.

N. COOLANT HEATERS

1. General

There are two types of immersion coolant heaters, none thermostatically controlled (Fig. 9) and thermostatically controlled (Figs. 10 and 11). Both preheat engine coolant for ease of starting. Both operate on 120 volt a.c. current.

Coolant heaters do not eliminate need for anti-freeze.

CAUTION: As a safety factor, install switch between immersion heater and power source to de-energize unit whenever engine is being worked on or coolant is drained.

a. Non-Thermostatically Controlled Heater

For best results, allow 8 hour heating time.

Heating element (Fig. 9, Item 2) is positioned in engine coolant and connected to energy source by electric cord.

Periodically, disconnect electrical source, drain cooling system, remove and clean heating element.

b. Thermostatically Controlled Coolant Heater

All immersion heaters operate on thermosiphon principal of heating coolant and circulating it through cooling system. The pulsating valve (Fig. 10, Item 4) assists this circulation. The safety thermostat (1) prevents damage from overheating. A temperature control thermostat activates heating element when coolant temperature is 7° to 15°F (4° to 8°C) or more below setting on dial--

usually 80° to 140°F (27° to 60°C). Element is automatically deactivated when pre-set dial setting is reached.

Before applying current to immersion heater be sure that the radiator is full and all air has been bled from the cooling system, all hose connections are secure, antifreeze solution is not too strong, coolant is not frozen.

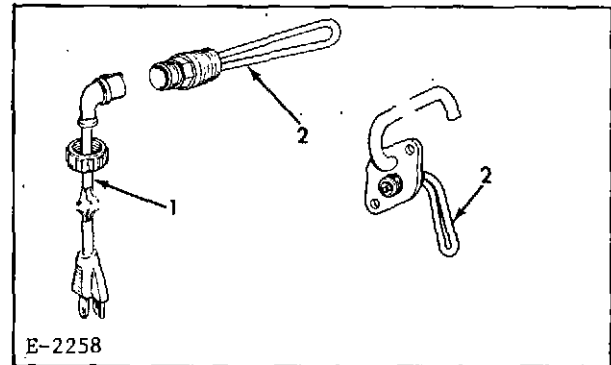

1. Heater cord 2. Element

Figure 9. Immersion Heater

2. Maintenance

At least once a year or every 2,000 hours disassemble the immersion heater to inspect and clean all scale and foreign matter from the components. See Service Manual for disassembly and cleaning instructions.

3. Troubleshooting

a. If heater has been operating and fails, check the following:

- (1) Current supply to heater.
- (2) Water level in radiator.
- (3) Coolant. It may be frozen or in mush condition.
- (4) Air in system.
- (5) Sediment in system that may have clogged lower inlet.

b. If temperature control thermostat or heater element is suspect (Fig. 11).

- (1) Remove temperature control thermostat cover. Using 120 volt test lamp across terminals #2 and #4 of thermostat, lamp will light if thermostat is energized.
- (2) Increase temperature dial to highest setting to close contacts. Test with lamp across terminals #1 and #4. Lamp will light if thermostat is operating correctly.

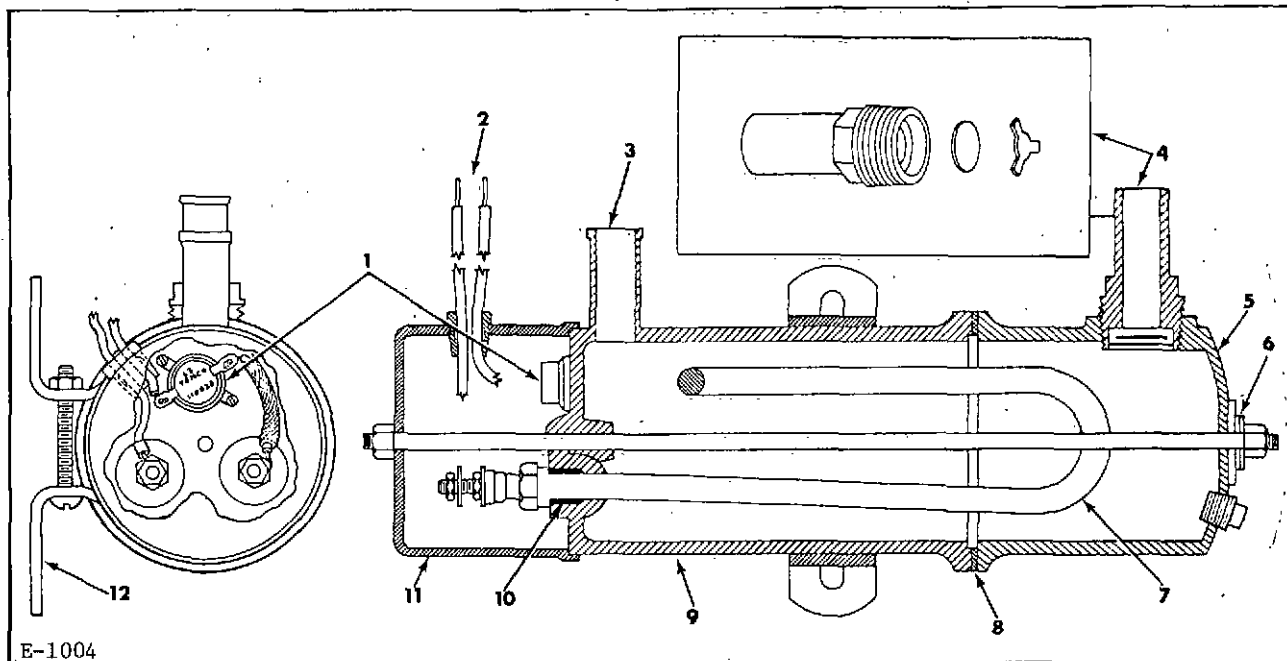

- | | | |
|--------------------------------------|-------------------|-----------------------------|
| 1. Safety Thermostat | 5. Bottom casting | 9. Top Casting |
| 2. To temperature control thermostat | 6. Lead washer | 10. Silicone rubbering seal |
| 3. Coolant outlet | 7. Element | 11. Terminal cover |
| 4. Pulsating valve and coolant inlet | 8. Gasket | 12. Bracket |

Figure 10. Immersion Heater

(3) Remove terminal cover (Fig. 10, Item 11) from heater unit. Place test lamp leads across element terminals. If lamp lights and top outlet hose is cold, element must be replaced. If lamp remains dark, place test lamp leads against element terminal where lead from safety control thermostat is connected and against the safety thermostat terminal where lead from control thermostat is soldered. If lamp lights either the safety thermostat and element terminal requires replacement. Move test lamp leads and place against both terminals of safety thermostat. If lamp does not light, safety thermostat must be replaced. If lamp does light the short lead between safety thermostat and element must be replaced.

(4) Return thermostat temperature dial to normal setting. Replace cover.

c. If coolant circulation is blocked by air lock or obstruction, thermostat will trip out. After heater has cooled, thermostat will reset automatically. If reason for overheating is not corrected, engine block will remain cold even though heater is going on and off.

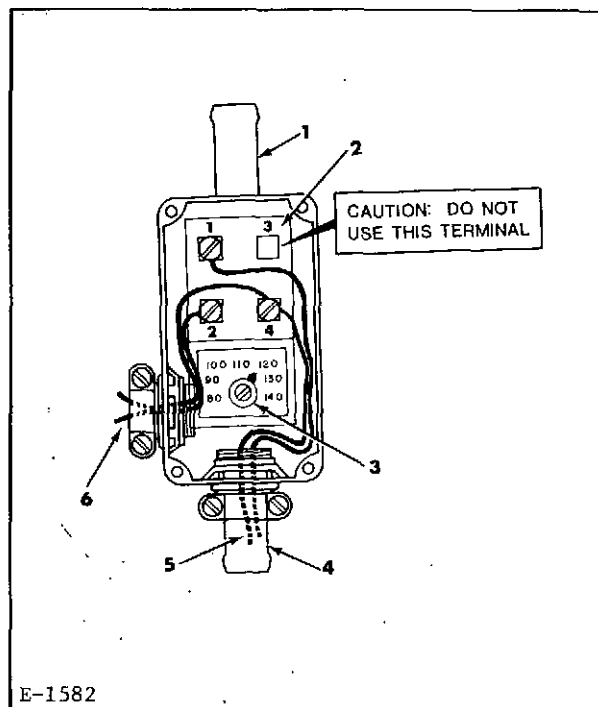

- | |
|------------------------|
| 1. Coolant inlet |
| 2. Terminal block |
| 3. Temperature dial |
| 4. Coolant outlet |
| 5. To immersion heater |
| 6. To AC source |

Figure 11. Temperature Control Thermostat

O. COOLING SYSTEM—
MAINTENANCE SCHEDULE

1. Phase 1, Maintenance—Daily—Before Operation

- a. Inspect belts and hose for deterioration.
- b. Check coolant level, if necessary, fill radiator to within 1.5 in (38 mm) below bottom of filler neck.
- c. Check coolant temperature.

2. Phase 4, Maintenance-Each 6 Months

- a. Check/correct radiator for external

cleanliness and restriction of air through fins.

- b. Replace coolant filter.

- c. Lubricate fan hub pulley—Series 685 and 6138 only.

3. Seasonal

- a. Clean cooling system.

- b. Check and replace hose when necessary.

- c. Replace coolant with new.

- d. Check and clean coolant heater.

TOPIC 10 FUEL SYSTEM

SAFETY PRECAUTIONS

WARNING: No unauthorized person must be allowed to service or maintain this machine. Study the Operation and Maintenance manuals before starting, operating, maintaining, fueling, or servicing this machine.

DANGER: Extinguish all smoking materials, or open flames, before checking and filling tanks, changing filters and before opening sediment drain due to the presence of flammable fluid.

WARNING: To prevent injury, always turn the key switch or stop control to the "OFF" position before cleaning, repairing, or servicing the engine.

DANGER: Do not use matches, lighters, or torches for a light source when inspecting or repairing engine due to presence of flammable fluids.

WARNING: Never use gasoline or other toxic or flammable fluids to clean parts.

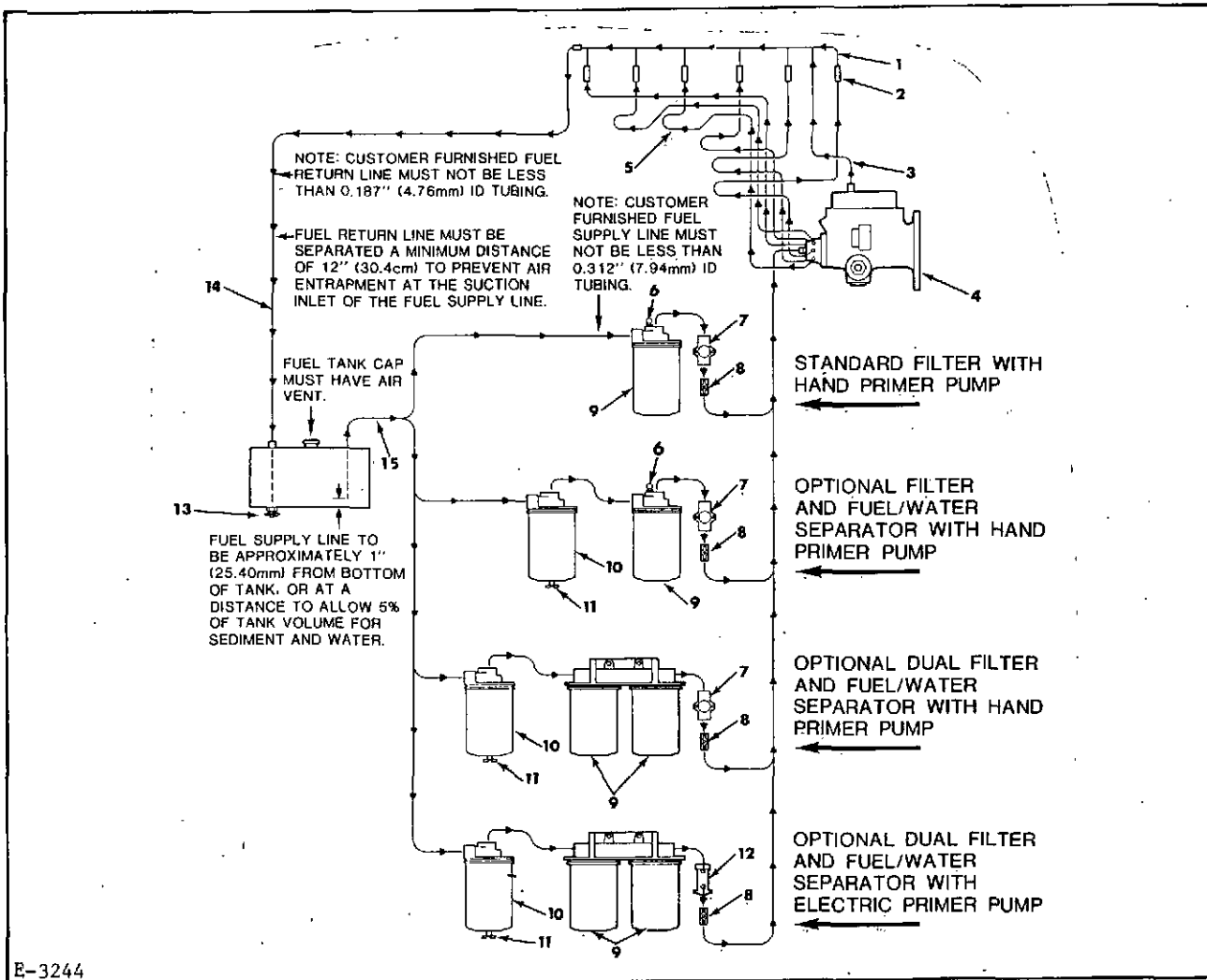

E-3244

- | | | | |
|---------------------------|---------------------|------------------------|----------------------|
| 1. Drip manifold | 5. Injection lines | 9. Fuel filter/s | 13. Drain cock |
| 2. Nozzle holder assembly | 6. Vent | 10. Water separator | 14. Fuel return line |
| 3. Fuel return line | 7. Hand primer pump | 11. Drain cock | 15. Fuel supply line |
| 4. Fuel injection pump | 8. Vent | 12. Electric fuel pump | |

Figure 1. Fuel System Schematic Diagram-Series 433 and 649 Engines with Distributor Type Fuel Injection Pumps

A. GENERAL DESCRIPTION

The fuel systems, (Figs. 1, 2, and 3) consists of a fuel tank, a fuel and water separator, throwaway-type filter(s), hand primer pump, fuel injection pump, fuel injection pump, fuel injection nozzle-holder assemblies. Fuel is drawn from the tank through fuel/water separator and filter(s) and primer pump or electric fuel pump to the transfer pump which is integral with the fuel injection pump. Transfer pump forces fuel to cam-actuated plungers which force the fuel under high pressure through fuel lines to fuel injection nozzles from which

fuel enters combustion chambers in four, fine cone-shaped sprays.

The system operates at low pressure to the transfer pump. High pressure system begins in the injection pump and continues through the injection nozzle.

The transfer pump delivers more fuel than is required to the sump of injection pump. A fuel return line conveys surplus fuel back to fuel tank.

There is fuel seepage between the surfaces of each fuel injection nozzle valve and its

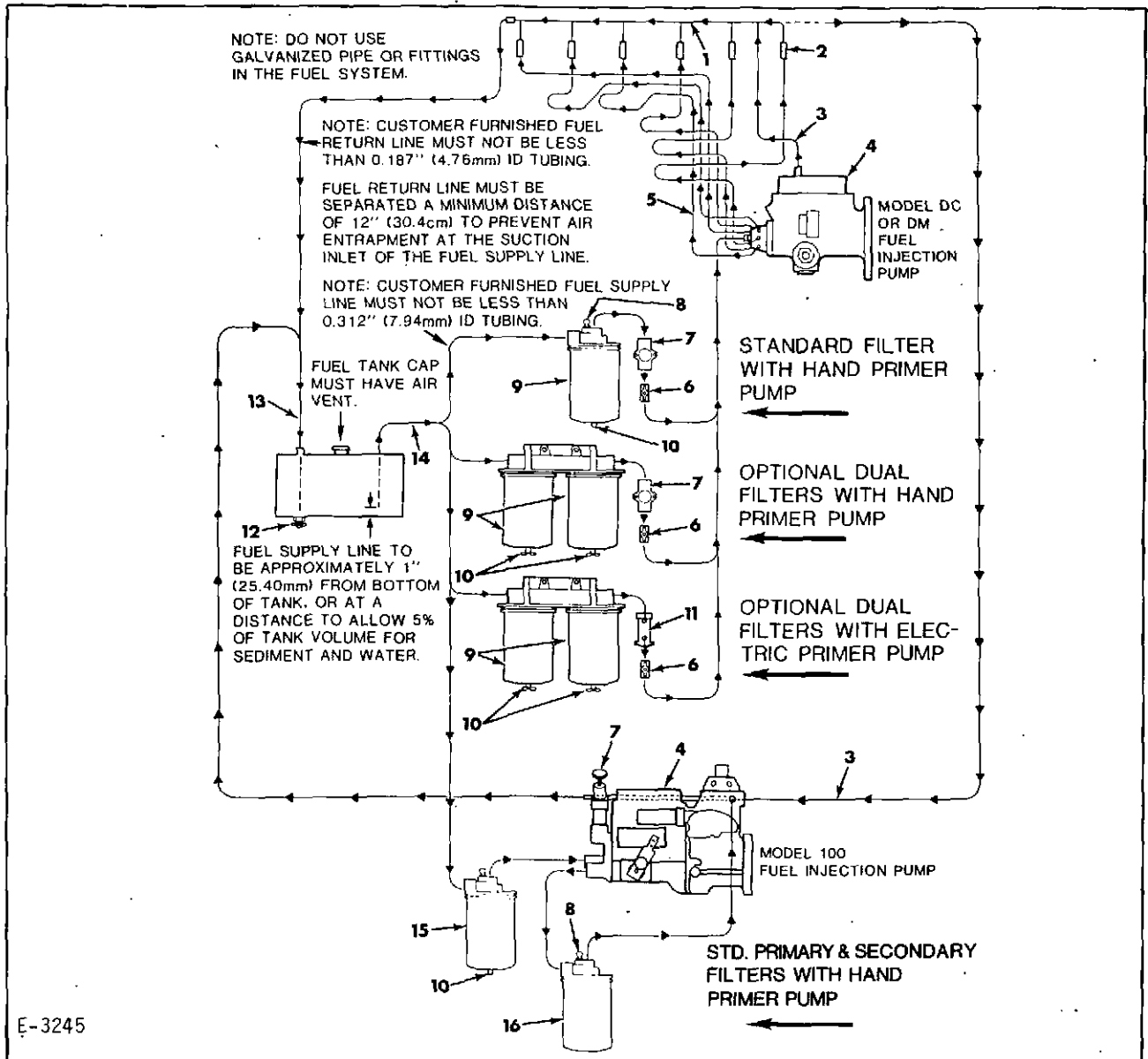

- | | | | |
|---------------------------|---------------------|---------------------------|---|
| 1. Drip manifold | 5. Injection lines | 9. Filter/water separator | 13. Fuel return line |
| 2. Nozzle holder assembly | 6. Vent cock | 10. Drain cock-filter | 14. Fuel supply line |
| 3. Fuel return line | 7. Hand primer pump | 11. Electric fuel pump | 15. Primary Filter/W.S. |
| 4. Fuel injection pump | 8. Vent | 12. Drain cock-tank | 16. Secondary filter
(High Pressure) |

Figure 2. Fuel System Schematic Diagram-Series 670 Engines with Distributor Type Fuel Injection Pumps

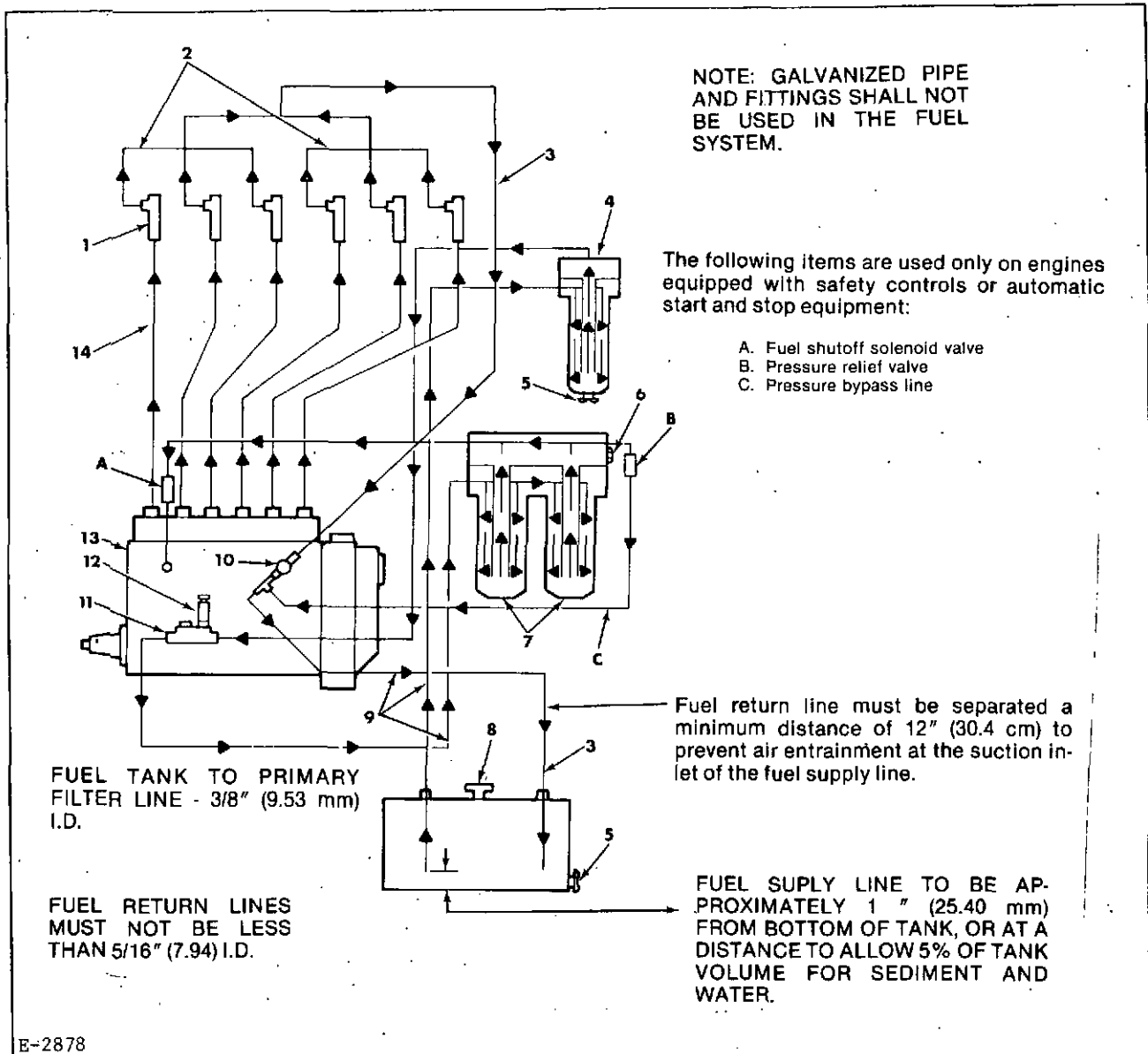

- | | | |
|--|--------------------------------|---------------------------|
| 1. Nozzle holder assembly | 5. Drain cock | 10. Pressure relief valve |
| 2. Drip manifolds | 6. Vent plug | 11. Transfer pump |
| 3. Fuel return lines | 7. Secondary filters | 12. Hand primer pump |
| 4. Primary filter with water separator | 8. Fuel tank cap (vented type) | 13. Fuel injection pump |
| | 9. Fuel supply lines | 14. Injection lines |

Figure 3. Fuel System Schematic Diagrams-Series 685 and 6138 Engines with In-line Multiple Plunger Fuel Injection Pumps

body. This is necessary for lubrication. The leaked fuel accumulates around the spindle and into the spring compartment of the type I nozzle holder. In the type II nozzle, the leaked fuel accumulates in the pressure adjusting spring compartment. The fuel is returned through fuel drip manifold and fuel return line to the fuel tank. A regulating valve in transfer pump end of distributor type pump or in the gallery of the multiple plunger type injection pump allows larger share of fuel to be by-passed back to tank. Fuel by-passed increases with engine speed. Special care must be taken in the storage of fuel, transfer to fuel tank, and keep-

ing fuel tank full to prevent condensation. Foreign matter and water in system will damage injection pump and nozzles. The standard fuel filter(s) will clean the fuel. When contamination is a serious problem, additional fuel filtering components are available as options. Persons responsible for engine operation and maintenance must follow these basic recommendations:

1. Use fuel meeting specifications outlined in Topic 4.
2. Store and handle fuel with care in

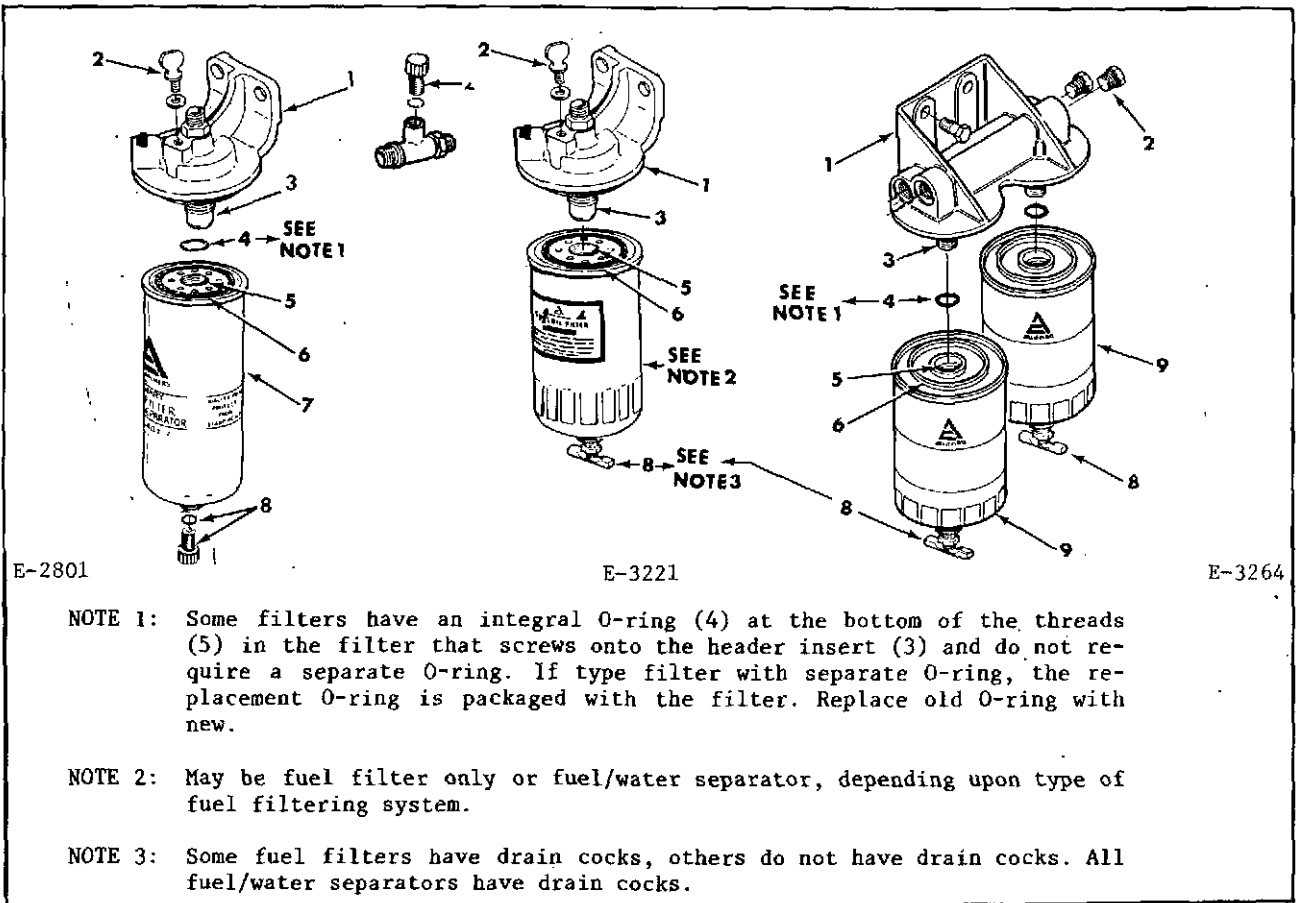

E-2801

E-3221

E-3264

NOTE 1: Some filters have an integral O-ring (4) at the bottom of the threads (5) in the filter that screws onto the header insert (3) and do not require a separate O-ring. If type filter with separate O-ring, the replacement O-ring is packaged with the filter. Replace old O-ring with new.

NOTE 2: May be fuel filter only or fuel/water separator, depending upon type of fuel filtering system.

NOTE 3: Some fuel filters have drain cocks, others do not have drain cocks. All fuel/water separators have drain cocks.

- | | | |
|-------------------------|------------|--------------------------------|
| 1. Filter header (base) | 4. O-ring | 7. Filter/water separator |
| 2. Vent screw or plug | 5. Threads | 8. Drain cock or plug & o-ring |
| 3. Threaded insert | 6. Gasket | 9. Filter |

Figure 4. Fuel Filters and Fuel/Water Separators

clean conditions.

3. Maintain fuel oil filter(s).
4. Remove injection nozzles at prescribed intervals, adjust opening pressure, check spray pattern.
5. Drain water from fuel/water separator, fuel filter with drain cocks, and tank daily.
6. Check injection pump timing.
7. Keep all components securely tightened on engine (specified torque).
8. Clean all parts and surrounding area with a nontoxic and nonflammable solvent before removing any part. Cover all openings immediately.

B. FUEL FILTER AND FUEL/WATER SEPARATOR

! DANGER: Extinguish all smoking materials, or open flames before checking and filling fuel

tanks, changing filters and before opening sediment drain due to the presence of flammable fluid.



WARNING: Never use gasoline or other toxic or flammable fluids to clean parts.

Filters and fuel/water separators are of the spin-on-disposable, throw-away type. The fuel systems for the various engine series consist of a fuel filter only, a fuel/water separator and filter(s) or optional heavy duty filter systems with addition filters and electric fuel pump.

Replace elements at 600 hours or 12 months whichever occurs first, (more often when operating conditions warrant) or when filter become clogged. Clogged filters are usually indicated by irregular engine performance.

In warm weather, open the vent screw or plug and the drain cocks of each filter and drain before starting the daily operations. In cold weather, when there is the possibility that

the condensed water will freeze, drain the contaminants shortly after the end of daily operations. Allow the filter to drain until the fuel runs clean.

A hand primer is connected into the system and is used to purge air from system after new filters are installed or after other service repairs.

All fuel supply and return line fittings at the filter header have straight threads and require O-rings to prevent leakage. Always inspect O-rings before replacement.

1. Filter or Fuel/Water Separator Renewal
 - a. Remove dirt from around filters.
 - b. Close fuel tank shut off valve if fuel level is above level of fuel filter.
 - c. Remove filter(s) from base.
 - d. Inspect and clean base.
 - e. Apply a light coating of lubricating oil to the filter gasket. Screw new filter by hand into position until gasket contacts base of filter head. Using hand pressure, tighten filter 1/2 to 3/4 of a turn more. CAUTION: Do not use any tools to tighten filter. Always use an Allis-Chalmers replacement filter.
 - f. Open fuel tank shut off valve.
 - g. Prime fuel system. See paragraph D.

NOTE: Some filters have an integral gasket or O-ring at the bottom of the threads that screw onto the header inserts (fig. 4, Item 3) and others have a separate O-ring (4). If separate type, it is packaged with new filter and the old O-ring must be removed from the insert (3) and the new one installed.

2. Heavy Duty Fuel Filters and Water Separator

Heavy duty fuel filters are standard on larger engines--Series 685 and 6138--and are suggested for use on smaller engines operating in a dirty area. They are similar to lighter duty units except two filters are mounted on a common header and work in parallel. Usually the water separator is mounted separately and ahead of fuel filters (Fig. 1). Function and servicing of heavy duty filter arrangement is the same as for standard explained above.

C. ELECTRIC FUEL TRANSFER PUMPS



WARNING: To prevent the possibility of bodily injury, always disconnect the battery-to-ground cable before cleaning, repairing, disconnecting or connecting any of the electrical cables.

1. General

Transfer pumps are needed to draw fuel through heavy duty fuel filtering system and when fuel tank is below engine. There are two types commonly used (Fig. 5).

Type 1 is of solid state electronic control circuitry and is non-serviceable.

Type 2, the interrupter type, has a filter in the bottom end. Replace filter once a year.

2. Wiring

The pump is internally grounded so mounting surfaces must be clean and free from paint, rust, or oil. All wiring from starter solenoid to switches and pump should be 12 gauge (2.06 mm) stranded type.

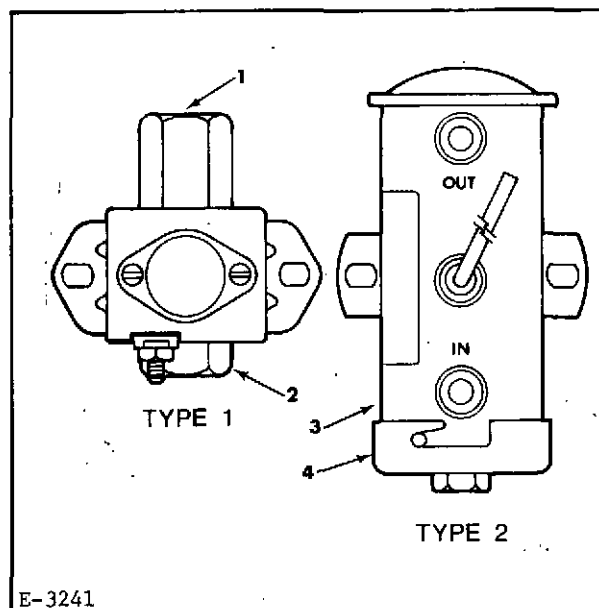

- | | |
|-----------|--------------------|
| 1. Inlet | 3. Filter location |
| 2. Outlet | 4. Cover |

Figure 5. Electric Fuel Pumps

3. Maintenance

Disassembly of type two electric fuel transfer pump for yearly maintenance is a service operation. It is best handled by a factory trained mechanic at your Allis-Chalmers dealer.

D. PRIMING FUEL SYSTEM

Procedures vary for standard and optional heavy duty filters.

1. Priming Low Pressure Fuel System-- Standard Filters

- a. Check fuel level in tank and open shut off valve.
- b. Make certain all plugs, vent cocks and line fittings on suction side of fuel transfer pump are tight.
- c. Open vent cock or plug (Fig. 1, Item 8), (Fig 2, Item 6) or (Fig. 3, Item 6).
- d. Loosen locking screw on hand primer pump (Figs. 1 and 2) and move clamp to one side or unlock the primer pump plunger (Fig. 3) by turning it counterclockwise several turns.
- e. Move primer plunger back and forth in pumping motion to fill filter with fuel and expel air.
- f. When flow of fuel around vent is bubble free, tighten securely.
- g. Reposition primer pump clamp and retighten locking screw.

2. Priming Low Pressure Fuel System With Heavy Duty Filters.

 **WARNING:** Clean up all spilled fuel to prevent a potential fire hazard and other unsafe or slippery conditions.

All larger engines have heavy duty filters; on Series 433, 649, and 670 engines they are optional.

- a. Follow steps a, b, and c covering standard filter arrangements.
- b. Disconnect load from engine.
- c. With vent cock open, turn key on instrument panel to ON thus energizing electric fuel pump.
- d. Operate pump until fuel free of air bubbles appears at vent cock. Tighten vent cock and turn key to OFF position.

3. Priming High Pressure Fuel System

This part of the system is usually self-priming since any trapped air in injection pump is usually forced out through the injection nozzle. If, however, engine has run out of fuel, been shut down for an extended period, or has had fuel injection lines removed, it may be necessary to prime as follows:

- a. Loosen fuel injection line connecting nut attaching each line to corres-

ponding nozzle holder.

- b. Place speed control in high speed position and stop control in RUN position.
- c. Energize starting motor. Do not operate starting motor for more than 30 seconds at a time without pause of two minutes to permit starter to cool.
- d. When fuel flows from end of all high pressure fuel injection lines, stop starting motor. Connect lines to nozzle holders and tighten connection nuts.



WARNING: Clean up all spilled fuel to prevent a potential fire hazard and other unsafe or slippery conditions.

4. Servicing Priming Pumps

This is a service function best handled by a factory trained mechanic or your Allis-Chalmers dealer.

E. FUEL INJECTION PUMP/GOVERNOR

Purpose of the injection pump is to accurately meter and deliver fuel under high pressure to injection nozzles at a specific timing to correspond with engine firing cycle and within required injection period. The injection pumps are of two types, the distributor type and the in-line type.

1. Roosa Master Injection Pump

This distributor type fuel injection pump incorporates inlet metering and opposed plunger actuated by an internal cam ring and automatic advance device. The pump is self-lubricating except for the drive shaft ball bearing which is splash-lubricated by engine oil.

A mechanical-centrifugal type integral governor controls fuel delivery and therefore engine speed. The governor is driven directly off the pump drive shaft without gearing. Shaft rotation is clockwise.

The transfer pump is of the positive displacement vane type and is located under the end cap opposite the rotor. The end cap also houses a fuel inlet strainer and pump regulator:

The electric solenoid mechanism within the fuel pump opens or closes the metering valve to permit or stop the flow of fuel to the system. De-energizing the solenoid shuts off all fuel and stops engine since mechanism is the energized-to-run type (open when energized).

2. American Bosch Injection Pump

This injection pump, as used on the 670 Engine Series, is a single plunger design of the constant stroke, distributing plunger, sleeve control type. It is flange mounted and driven through a gear on

the pump camshaft at engine speed (1:1 ratio).

The fuel supply pump draws fuel from the tank, through a primary filter and pumps the fuel through a final (secondary) filter to the hydraulic head. Fuel pressure in the head area is controlled by a regulating valve in the supply pump. An orifice tee limits the amount of fuel returned to the tank.

3. Robert Bosch Injection Pump

This injection pump is an in-line multiple plunger type with constant stroke. It is gear driven in clockwise direction. Fuel delivery is varied by a control rack which when moved, rotates the control sleeve on each plunger thus metering the fuel pumped to the nozzle-holder assemblies.

A fuel transfer pump is mounted on the sides of the Bosch injection pump. Its function is to draw fuel from the tank through the fuel/water separator and force it through the fuel filters into the injection pump. It, and the mechanical type governor are lubricated by oil supply line connected into engine lube system.

4. Fuel Injection Pump/Governor Adjustments

All engines before leaving the factory, are equipped with carefully calibrated injection pumps and governors which have been adjusted to a factory approved setting.

No lubrication or regularly scheduled service, other than operational checks, are required on the governor assembly. If engine speed is irregular, check fuel system and all other engine adjustments before having a factory trained mechanic change governor setting.

It is not recommended to make adjustments in field. Injection pump should be removed and turned over to your qualified Allis-Chalmers dealer for checking and adjustment.

NOTE: Pump failures due to unauthorized tampering with seals, the maximum fuel adjustment setting, or the control-lever high speed stop screw can violate the warranty of the engine.

F. FUEL INJECTION NOZZLE HOLDER ASSEMBLY



WARNING: Keep hands away from nozzle tip when popping a nozzle. The finely atomized fuel is ejected with sufficient force to penetrate the skin and cause blood poisoning. Also wear safety glasses with side shields or goggles when popping a nozzle.



WARNING: To prevent injury, always turn the key switch or stop control to the "OFF" position before cleaning, repairing, or servicing the engine.



WARNING: Never use gasoline or other toxic or flammable fluids to clean parts.



WARNING: Do not use your hands to search for pressure leaks. Fluid escaping under pressure can penetrate skin.

1. General

Each engine cylinder is provided with a multi-hole nozzle with a differential needle, hydraulically lifted fuel injection nozzle holder assembly (Fig. 6). The function of each is to direct a pre-metered quantity of fuel from the injection pump into the corresponding engine combustion chamber in a highly atomized pre-determined spray pattern.

Each nozzle assembly consists of the nozzle holder assembly and the nozzle assembly. The holder positions the nozzle in the cylinder head and provides a means of conducting fuel from injection pump to the nozzle.

The type II nozzle holder assembly has a holder body (9), spacer (8), part of shim kit on 670 series unit, pressure adjusting shims (7), adjusting spring (6), spring seat (5), spacer assembly (valve stop, includes 2 dowel pins) (4), nozzle assembly (3), nut (2), and gasket (10) used on 670 series engines. Washer (11), and dust shield (12) are not components of the assembly.

The type I nozzle holder assembly has a steel body (10), two locating dowels (11) (except series 6138 engines), spindle (8), spindle spring (7), wear washer (6), (except series 6138 engines) pressure adjusting screw (2), adjusting locknut (3), protection cap (4) and gaskets (5) (series 6138 engines only) nozzle retaining nut (15), and an O-ring (9) located in an internal groove of body spring compartment (except series 6138 engines).

Nozzle assembly (14) consists of nozzle assembly gasket (16), needle valve (12), and nozzle body (13), in which are 4 spray orifices set 90° apart. The nozzle valve is actuated hydraulically by fuel delivered under pressure by injection pump. Nozzle is positioned on holder by two dowels (except Series 6138 engines), so that the 4 spray orifices are in a plane parallel to face of piston and nozzle fuel duct matches holder fuel duct.

Fuel enters holder inlet passage, flows

through holder fuel duct into nozzle fuel duct and pressure chamber above nozzle valve by spindle/spring, the nozzle valve lifts off seat and fuel is forced through orifices in the nozzle body end and into the corresponding engine combustion chamber. The nozzle valve is returned to its seat by spindle/spring pressure when fuel injection pump has ceased to deliver pressurized fuel into nozzle holder. The combined assemblies are self-lubricating.

Dust shields (17), are placed on each nozzle holder of all engines (except Series 6138) to prevent moisture and foreign matter from entering nozzle holder bore in cylinder head.

2. Maintenance

At the hours of operation recommended in Phase 5 of the maintenance schedule (Topic 7), the fuel injection nozzles should be removed, cleaned, tested, and adjusted if necessary. This is a service function best handled by a factory trained mechanic at your Allis-Chalmers dealer.

G. CHECKING FUEL SYSTEM



WARNING: Never service or adjust with the engine running except as called for in the Operation and Maintenance Instruction Manual or Service Manuals to keep from being caught in moving parts or by a moving machine.



WARNING: Do not use your hands to search for pressure leaks. Fluid escaping under pressure can penetrate skin.

Missing or uneven running of the engine, excessive vibration, stalling when idling, and loss of power are indications of insufficient fuel supply to the engine. Before making any checks, be sure there is an ample supply of clean fuel in tank and that fuel shut off valve is open.

1. Check for Admission of Air Into Fuel System

Distributor Type Fuel Injection Pump

Remove fuel return line from fitting, (Fig. 1 and 2, Item 3) in injection pump cover. Insert length of hose into container partially filled with fuel oil. Run engine at about 1000 RPM and observe end of hose in container for bubbles. Excessive bubbling or foaming indicates air being drawn into system. Correct by tightening any loose low pressure fuel oil connections and filter connections.

Multi-Plunger In-line Pump

Loosen the vent screw in the filter header (Fig. 3, Item 5). Crank the engine with the starter. If fuel containing bubbles is observed flowing from the vent screw, air is being drawn into the system on the suction side of the fuel supply pump. Correct this situation by tightening any loose connections between the supply pump

and fuel tank. Check all lines and fittings for tightness.

2. Check for Clogged Fuel Filter and Clogged or Collapsed Fuel Lines

Any restriction in fuel lines will cause loss of power, stalling, and rough operation. A possible solution is to remove fuel filter, blow out all low pressure lines with filtered compressed air, and install a new filter. Any stoppage should be purged from the affected line, or if crimped, replaced. Further checking is best done by a factory trained mechanic with vacuum gauges.

To check high pressure lines between fuel injection pump and nozzles, start engine and loosen each line nut, one at a time at each nozzle holder. If no fuel is observed at loosened nut, line may be clogged, crimped, or cracked. It must be replaced.



WARNING: Clean up all spilled fuel to prevent a potential fire hazard and other unsafe or slippery conditions.

3. Checks for Inoperative Fuel Injection Nozzles or Injection Pump

This is a service function best handled by a trained mechanic at your Allis-Chalmers dealer.

H. FUEL SYSTEM MAINTENANCE SCHEDULE

Phase 1 Maintenance—Daily

1. Inspect all lines and connections for leaks, crimps, or damage and correct.
2. Check fuel level in tank.
3. Drain any water from fuel filters, fuel/water separators, and fuel tank.
4. Check fuel filters.
5. Be sure to add only clean fuel as specified.

Phase 4 Maintenance—Each 600 Hours/12 Months

1. Renew all fuel oil filters.

Phase 5 Maintenance—

- Each 1000 Hours/24 Months
Series 685 and 6138 Engines
- Each 1200 Hours/24 Months
Series 433 and 649 Engines
- Each 1300 Hours/24 Months
Series 670 Engines

1. Remove, clean, test, and adjust fuel injection nozzles to specified opening pressure.

Phase 6 Maintenance—

- Each 2250 Hours
Series 433 and 649 Engines
- Each 2600 Hours
Series 670 Engines
- Each 3000 Hours
Series 685 Engines
- Each 4000 Hours
Series 6138 Engines

1. Remove and recondition fuel injection nozzles.

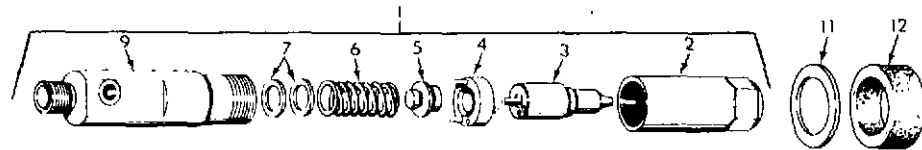

STYLE 'E'
NOZZLE HOLDER ASSEMBLY - Series 433 and 649 Engines
Type II - Lower Spring Type

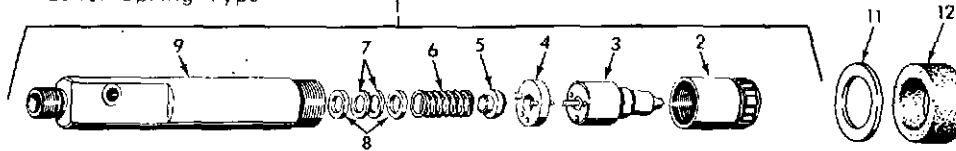

STYLE 'K'
NOZZLE HOLDER ASSEMBLY - Series 433 and 649 Engines
Type II - Lower Spring Type

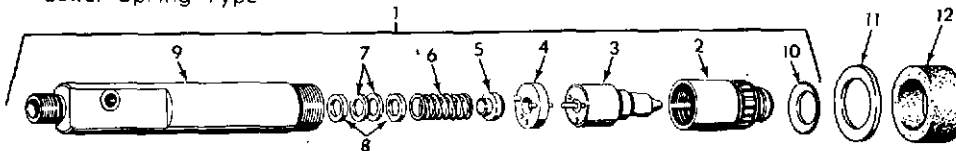

STYLE 'K'
NOZZLE HOLDER ASSEMBLY - Series 670 Engines
Type II - Lower Spring Type

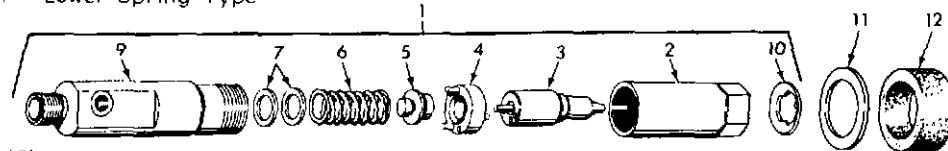

STYLE 'E'
NOZZLE-HOLDER ASSEMBLY - Series 685 Engines
Type II - Lower Spring Type

- | | |
|-------------------------------------|--|
| 1. Nozzle holder assembly - Type II | 8. Spacer (.062" shim, Style 'K' Units) |
| 2. Nozzle retaining nut | 9. Holder (steel body) |
| 3. Nozzle assembly | 10. Gasket - component of item 1 and/or 3 for series 670 & 685 engines |
| 4. Spacer assembly (valve stop) | 11. Washer (used on application) |
| 5. Spring seat | 12. Dust shield (used on application) |
| 6. Spring (pressure) | |
| 7. Shims (pressure adjusting) | |

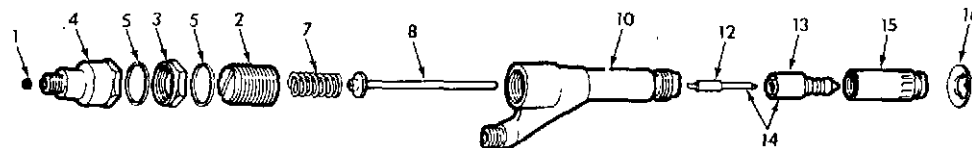

NOZZLE HOLDER ASSEMBLY - Series 6138 Engines
Type I - Upper Spring Type

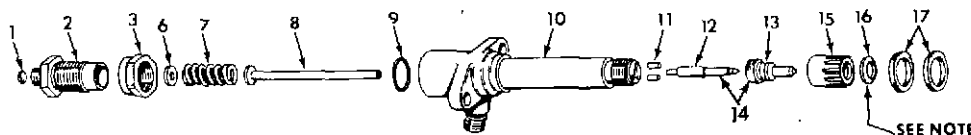

NOTE: Item 16, Nozzle Gasket, not used on Series 433 and 649 Engines

NOZZLE HOLDER ASSEMBLY - Series 433, 649, 670 and 685T Engines
Type I - Upper Spring Type

- | | |
|-----------------------------|--------------------------|
| 1. Felt filter | 10. Holder body |
| 2. Pressure adjusting screw | 11. Locating dowels |
| 3. Locknut | 12. Nozzle valve |
| 4. Protection cap | 13. Nozzle body |
| 5. Gasket | 14. Nozzle assembly |
| 6. Wear washer | 15. Nozzle retaining nut |
| 7. Spring | 16. Nozzle gasket |
| 8. Spindle | 17. Dust shield |
| 9. O-ring | |

E-3569

Figure 6. Nozzle Holder Assemblies

**NOZZLE HOLDER ASSEMBLIES
SPECIFICATIONS**

**STYLE 'K'
TYPE II - LOWER SPRING TYPE**

Engine Series	Part Number	Nozzle Orifice Size		Nozzle Opening Pressure		Nozzle Retaining Nut Torque	
		English	Metric	English	Metric	English	Metric
433T & 433I	4063270	0.0130 in.	0.33mm	3900-4050psi	26890-27920 kPa	32 lb-ft	44Nm
649T & 649I	4063270	0.0130 in.	0.33mm	3900-4050psi	26890-27920 kPa	32 lb-ft	44Nm
670T & 670I Std.	4036654	0.0122 in.	0.31mm	3950-4100psi	27230-28270 kPa	32 lb-ft	44Nm
670I-200HP&Above	4036652	0.0142 in.	0.36mm	4200-4350psi	28960-29990 kPa	32 lb-ft	44Nm

**STYLE 'E'
TYPE II - LOWER SPRING TYPE**

433T & 433I	4063266	0.0126 in.	0.32mm	3842-4016psi	26500-27690 kPa	44 lb-ft	60Nm
649T & 649I	4063266	0.0126 in.	0.32mm	3842-4016psi	26500-27690 kPa	44 lb-ft	60Nm
685T	4322945	0.0146 in.	0.37mm	3800-3900psi	26200-26890 kPa	44 lb-ft	60Nm
685I	4322412	0.0157 in.	0.40mm	3800-3900psi	26200-26890 kPa	44 lb-ft	60Nm

TYPE I - UPPER SPRING TYPE

Engine Series	Part Number	Nozzle Orifice Size		Nozzle Opening Pressure		Nozzle Retaining Nut Torque		Locknut and Capnut Torque	
		English	Metric	English	Metric	English	Metric	English	Metric
433T & 433I	4007787	0.013 in.	0.34mm	3800-3850psi	26200-26545 kPa	55 lb-ft	75Nm	55 lb-ft	75Nm
649T & 649I	4007787	0.013 in.	0.34mm	3800-3850psi	26200-26545 kPa	55 lb-ft	75Nm	55 lb-ft	75Nm
670T Gen. Drive	4035780	0.0138 in.	0.35mm	3800-3850psi	26200-26545 kPa	55 lb-ft	75Nm	55 lb-ft	75Nm
670T & 670I Power Unit Standard	4036042	0.0126 in.	0.32mm	3800-3850psi	26200-26545 kPa	55 lb-ft	75Nm	55 lb-ft	75Nm
670I-200HP&Above	4035511	0.0148 in.	0.375mm	3800-3850psi	26200-26545 kPa	55 lb-ft	75Nm	55 lb-ft	75Nm
685T	4320642	0.0148 in.	0.375mm	3800-3850psi	26200-26545 kPa	55 lb-ft	75Nm	55 lb-ft	75Nm
6138LT, T & I	4396705	0.0187 in.	0.475mm	4125 ± 25psi	28441 ± 172 kPa	55 lb-ft	75Nm	75 lb-ft	102Nm

IF AN OPENING PRESSURE LOSS OF 15% BELOW MINIMUM IS OBSERVED THE ASSEMBLY SHOULD BE RE-ADJUSTED TO ORIGINAL SPECIFICATIONS. EXAMPLE 4200-(4200) (.15) = 3570

A REDUCTION OF UP TO 10% IN OPENING PRESSURE CAN BE EXPECTED SHORTLY AFTER ASSEMBLY IS PLACED IN SERVICE AND WILL NOT ADVERSELY AFFECT ENGINE PERFORMANCE. NEW ASSEMBLIES WILL LOSE OPENING PRESSURE MORE RAPIDLY THAN USED ASSEMBLIES. NEVER ADJUST OPENING PRESSURE ABOVE THE SPECIFICATIONS TO OFFSET THE INITIAL BREAK-IN PRESSURE LOSS. TO DO SO CAN CAUSE A SPRING TO BREAK, RESULTING IN POSSIBLE ENGINE DAMAGE.

NOZZLE HOLD-DOWN CAPSCREW TORQUE 180 LB. INCH (20.34 Nm)

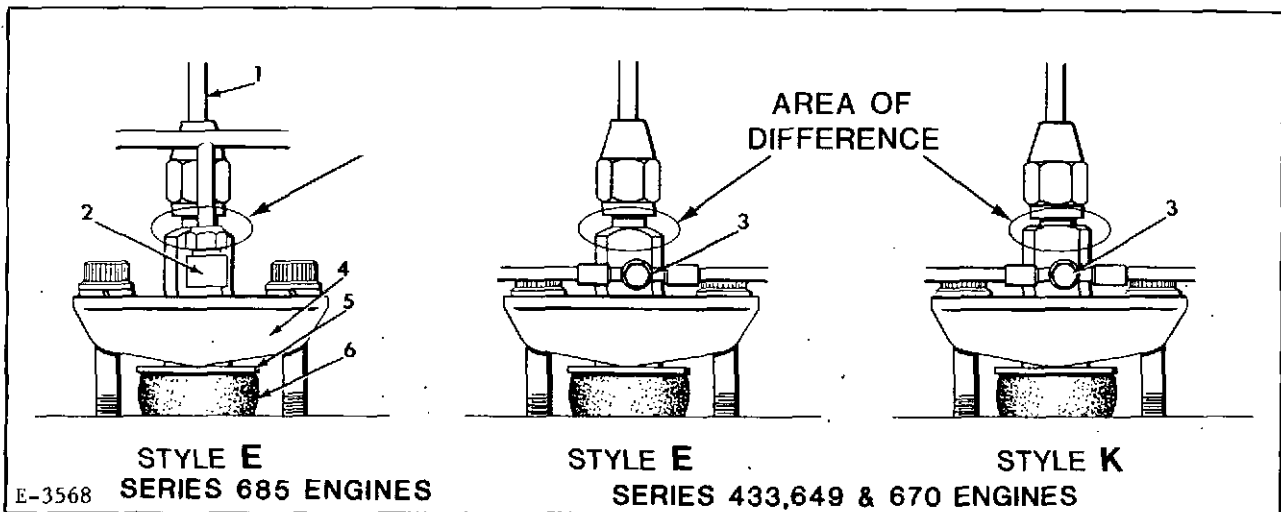

- | | |
|---|-----------------------|
| 1. Fuel inlet | 4. Flange - hold-down |
| 2. Elbow, adjustable (drip return manifold) | 5. Washer - hold-down |
| 3. Banjo fitting (return manifold) | 6. Dust shield |

Figure 9. External View of the Type II - Lower Spring Type Assemblies

TOPIC 11 LUBRICATION SYSTEM

A. GENERAL

WARNING: To prevent injury, always turn the key switch or stop control to the "OFF" position before cleaning, repairing, or servicing the engine.

Your engine is pressure lubricated to keep all internal parts moving freely and within a designed temperature range. From the oil pan reservoir, oil is pumped by the oil pump driving gear in mesh with the crankshaft gear. The Allis-Chalmers oil pan design will permit operation at angles up to 30°. Optional design will permit higher slant operation.

At full load speed and engine in normal condition, oil pressure should range between 30 and 55 psi (207 and 379 kPa).

Engine oil keeps the pistons cool by directional jets in the upper main bearing support of cylinder block or top of connecting rods. These jets direct a flow of oil onto the bottom side of the piston domes. The oil is provided to jets through passage holes connected to annular oil groove in main bearing.

Volume of engine oil available for cooling and lubrication must be maintained. Oil level can be checked when engine is running or stopped. Engine needs to be level before checking oil level.

Oil level gauge (dipstick) (Fig. 1) is stamped with two different oil levels. One side is stamped IDLING with ADD and FULL marks, the other side is stamped STOPPED with ADD and FULL marks. Engine should be stopped at least five minutes to allow oil to drain in to pan before checking level. If level of oil is low, add lubrication oil to bring level up to FULL mark. Use only lubricating oil as specified in Topic 4, Lubricant Recommendations.

System includes an engine breather tube to vent inside of engine to atmosphere. If tube becomes clogged, vapors build up in engine and pressure will force oil past crankcase seals, dipstick, cylinder head, cover gasket, etc.

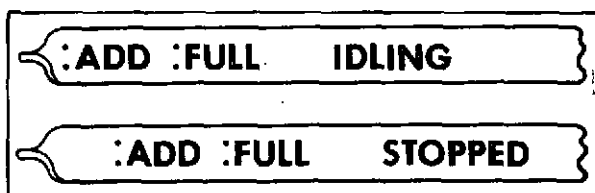
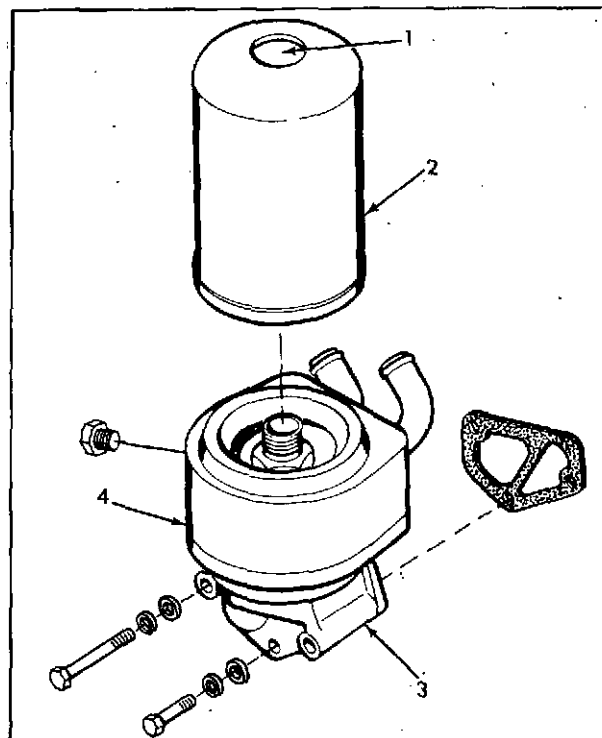

Figure 1. Oil Level Gauge (Dipstick)



1. Bypass valve-integral with filter
2. Lube oil filter
3. Filter base
4. Oil cooler

Figure 2. Standard Full Flow Oil Filter-Series 433 Engines

B. FULL-FLOW OIL FILTER--STANDARD

Maintenance of clean oil in the lubricating system is mandatory. The full flow filters (Figs. 2 through 6) are of two designs, the throwaway type and the replaceable element type.

All filters have bypass valve built into them, either in the filter itself or the filter header. If filters become blocked or should oil become too thick in cool weather, the spring loaded bypass valve permits unfiltered oil to flow directly to the main gallery.

C. OPTIONAL BYPASS OIL FILTER

The remote-mounted bypass oil filter (Figs. 7, 8 and 9) will assist the full flow filters to remove impurities that cause sludge, acid and varnish to form and to help extend lubrication change period. Only after laboratory analysis of oil should new change period be established.

Where supplied unmounted, mount the bypass filter on an engine support close to engine. Capacity of the bypass filter must be added to regular quantity of oil needed for change.

The filter capacities, when factory supplied, are as follows:

- Series 433 Engines—
Filter Capacity 4 qts. (3.78 lts.)
- Series 649 Engines—
Filter Capacity 4 qts. (3.78 lts.)
- Series 670 Engines—
Filter Capacity 6 qts. (6.62 lts.)
- Series 685 Engines— Spin-On Type
Single Can Filter Capacity 3 qts.
(2.9 lts.)
- Series 685 Engines—Replaceable Element
Type
Filter Capacity 14 qts. (13.25 lts.)
- Series 6138 Engines—
Filter Capacity 14 qts. (13.25 lts.)

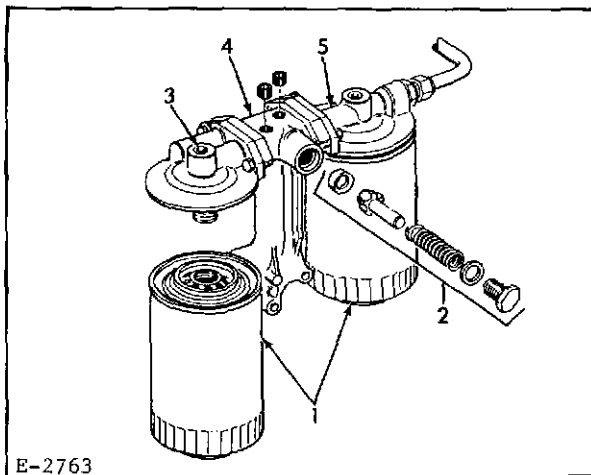

E-2763

- 1. Lube oil filter
- 2. Bypass valve
- 3. Left header
- 4. Manifold
- 5. Right header

Figure 3. Standard Full Flow Oil Filters
Series 649 Engines

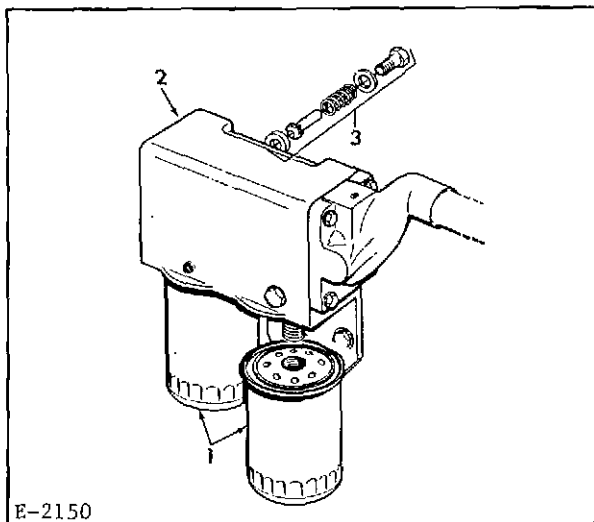

E-2150

- 1. Lube oil filters
- 2. Oil cooler housing
- 3. Bypass valve

Figure 4. Standard Full Flow Oil Filters
Series 670 Engines

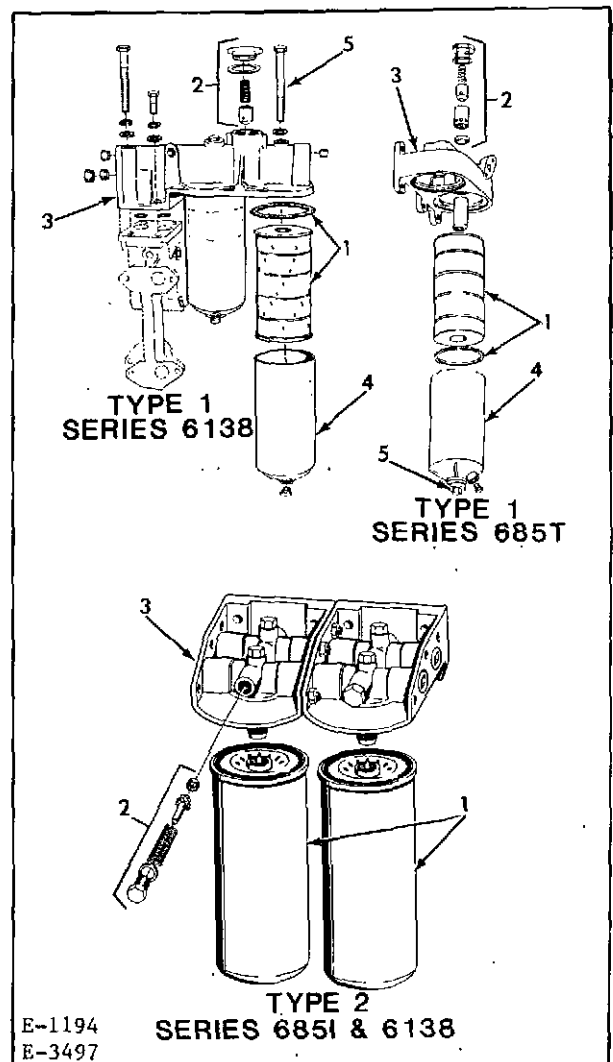

E-1194
E-3497

- 1. Filter/element
- 2. Bypass valve
- 3. Filter header
- 4. Filter body w/drain
- 5. Center bolt & gasket

Figure 5. Series 685 & 6138 Engines
For Engines with Dry Exhaust Manifolds

D. DRAINING, CHANGING FILTER AND FILLING LUBRICATING SYSTEM

At regular intervals lubricant must be changed and new filters installed. Periods are recommended in Topic 4, Lubricant Fuel—Coolant Recommendations.

1. Always operate engine until coolant is at minimum operating temperature. Remove plug from oil pan and let all oil drain out.
2. Thoroughly clean all filters and surrounding areas.
3. Removing and Replacing Filters (Full Flow)
 - a. Throw-away Spin-on Type Filters (Figs. 2, 3, 4, 5 and 6)

- (1) Unscrew filters from base assemblies and discard.
- (2) Apply light coat of engine oil to gasket on both new filters and screw in by hand until gasket contacts surface of base assembly. Continue to tighten at least 1/2 turn with hand pressure only. Never use tools to tighten full flow oil filters. To be sure, always use Allis-Chalmers replacement filters.

b. Replaceable Element Type Filters (Figs. 5 and 6).

- (1) The filters are similar in construction except for the configuration of the filter headers and location of the center bolts.
- (2) Thoroughly clean filter header, filter bodies, and surrounding area. Remove drain plugs from bodies and allow filters to drain.

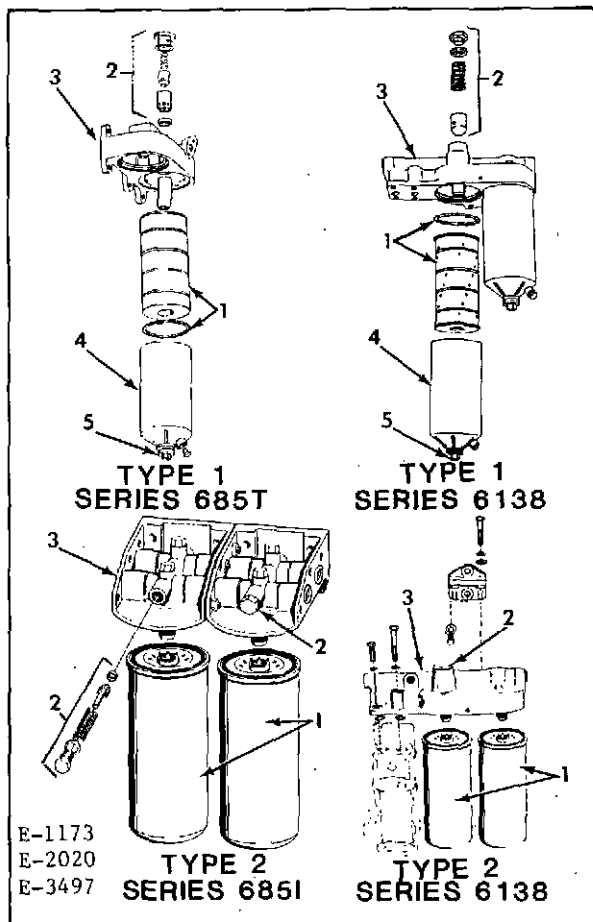

1. Filter/element
2. Bypass valve
3. Filter header
4. Filter body w/drain
5. Center bolt & gasket

Figure 6. Series 685 & 6138 Engines
For Engines with Water Cooled
Exhaust Manifolds

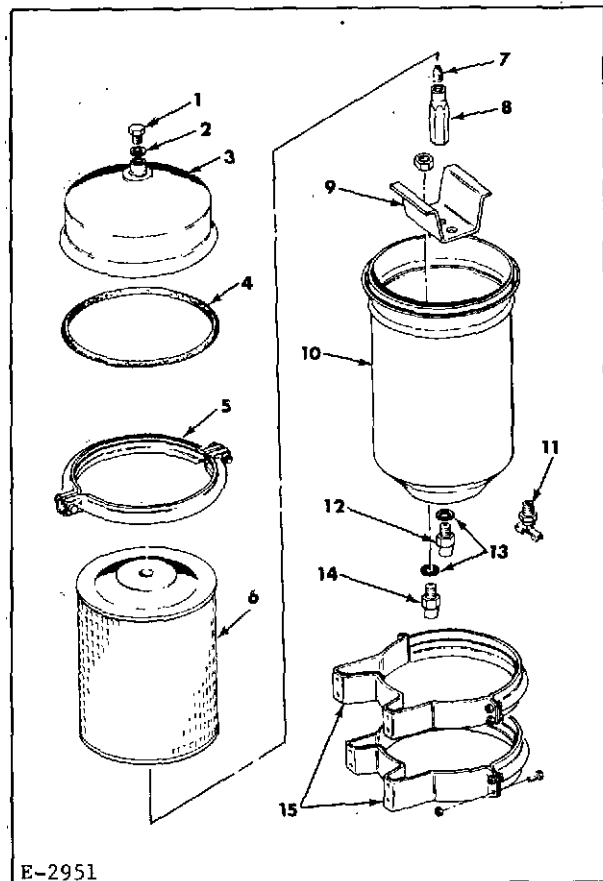

1. Vent plug
2. Sealing washer
3. Cover
4. Cover gasket
5. Cover clamp
6. Element
7. Plug orifice
8. Outlet post
9. Element support
10. Filter housing
11. Drain cock
12. Inlet check valve
13. Sealing washers
14. Outlet check valve
15. Brackets

Figure 7. Optional Bypass Filter-Typical of Series 433, 649, and 670 Engines



WARNING: Never use gasoline or other toxic or flammable fluids to clean parts.

- (3) Remove centerbolts, filter bodies, and filter elements from filter header as an assembly.
- (4) Remove and discard body gaskets.
- (5) Remove and inspect filter element. If clogged, do not try to clean. Discard old element.
- (6) Thoroughly wash and dry the filter body. Install new element.
- (7) Reinstall entire assembly, using new gaskets. Tighten centerbolts to 45 or 50 lb-ft. (61 to 80 Nm). Reinstall drain plugs.

4. Removing Optional Bypass Type Filter Element (Figs. 7 and 8).

a. Loosen vent plug or cover and open drain cock, allow filter to drain. Remove cover clamp and lift cover from housing. Take off cover gasket.

b. Remove element:

(1) Figure 7 type filter by unscrewing element (6) (counterclockwise) from outlet post (8) and lift from housing.

(2) Figure 8 type filter by unscrewing (counterclockwise) support assembly (4) from center tube and lift from housing.

c. Clean interior of housing and tighten drain cock.

d. Element kit includes new cover gasket. Install this gasket in lip of filter housing or cover.

e. Install element:

(1) Figure 7 type filter-insert element and turn clockwise until firmly seated.

(2) Figure 8 type filter-insert element in housing. Install support assembly (4) and tighten securely.

f. Install cover clamp and tighten securely.

g. Tighten vent plug and drain cock.

h. Figure 9 - spin-on type. To replace (install to header) oil gasket with lubricant, screw on until gasket contacts base (header), then tighten one (1) additional turn. Prepare engine for start and check for leaks.

5. Install engine oil pan drain plug and fill pan to full mark on oil level dipstick with specified quantity of oil. On engines with bypass filter, add additional oil to accommodate the filter. See Paragraph C, above, for filter capacities.

6. Crank engine 15 seconds, but do not start, to assure complete filling of all filters and to pump oil to all engine components.

7. Start engine. After five minutes, with engine running, check filters for leaks and proper installation.

8. Stop engine. Allow oil to drain into oil pan and check oil level with dipstick. Add more oil if necessary.

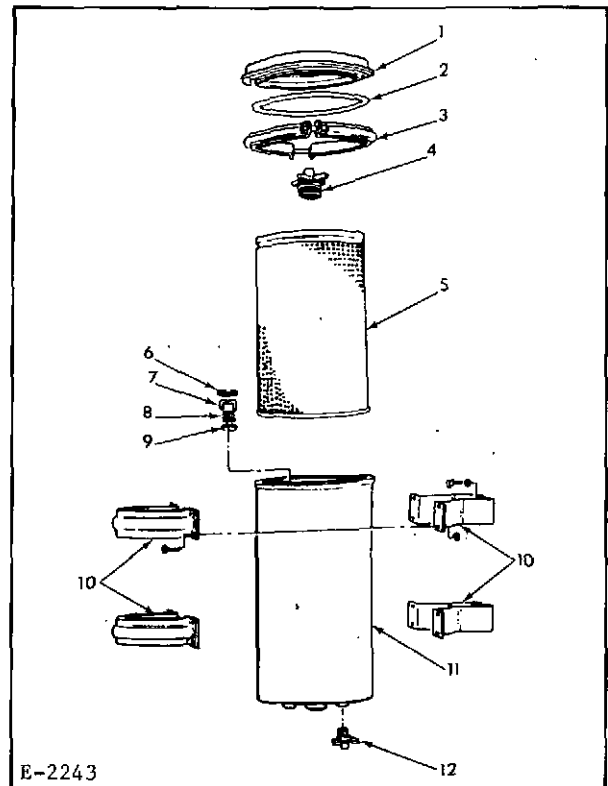

- | | |
|---------------------|----------------|
| 1. Cover | 7. Cage |
| 2. Cover gasket | 8. Spring |
| 3. Cover clamp | 9. Disc |
| 4. Support assembly | 10. Brackets |
| 5. Element | 11. Shell |
| 6. Ring | 12. Drain cock |

Figure 8. Optional Bypass Filter
Series 685 and 6138 Engines

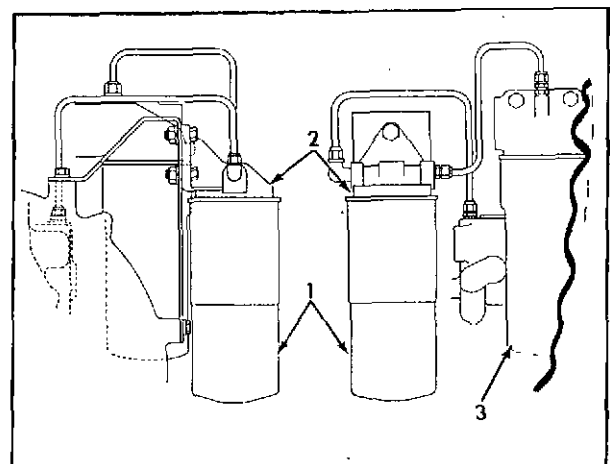

- | | |
|-------------------|--------------------|
| 1. Filter/element | 3. Full flow units |
| 2. Header | model 685I |

Figure 9. Spin-On Type
Bypass Lube Oil Filter - 1st use Model 685I
Unit may be factory installed or also
available for remote mounting

E. ENGINE OIL COOLER

This unit is discussed in detail as part of the cooling system. See Topic 9.

F. OIL PRESSURE REGULATOR VALVE

The lubricating oil pressure regulating valve located in the side of the cylinder block maintains stabilized oil pressure within lube system. When pressure exceeds valve setting, valve piston is forced open and oil is bypassed directly into pan.

Keeping lubricating system free from sludge and foreign matter will prevent valve malfunction. If valve sticks open, a sharp drop in engine oil pressure will occur. A sharp rise indicates a valve that does not open.

To service oil pressure regulator (recommended at Phase 7 Maintenance Schedule) consult service manual.

G. LUBRICATING SYSTEM MAINTENANCE SCHEDULE

Lubricating oil must be of best quality and of proper SAE weight for prevailing ambient temperature (refer to Topic 4). Keep oil free of water and abrasives by proper handling and storage.



CAUTION: Continued exposure of the skin with used motor oil may be harmful. Thoroughly wash the oil off your skin with soap and water as soon as possible after exposure.

1. Check oil level in pan.
2. Add oil if necessary.
3. Inspect engine for evidence of oil leaks and repair if necessary.

Phase 2 Maintenance-Each 100 Hours

1. Replace engine lubricating oil.
2. Replace full flow oil filters.

If engine is equipped with optional bypass filter, see Phase 3 Maintenance below.

Phase 3 Maintenance-Each 250 Hours

1. Replace engine lubricating oil.
2. Replace full flow filters.
3. Replace optional bypass filter element.

Phase 4 Maintenance-Each 600 Hours

1. Remove breather tube. Clean with solvent and blow out with compressed air.

Phase 7 Maintenance

1. Service oil pressure regulator.

TOPIC 12 ENGINE ELECTRICAL SYSTEM

A. GENERAL

WARNING: To prevent the possibility of bodily injury, always disconnect the battery-to-ground cable before cleaning, repairing, disconnecting or connecting any of the electrical cables.

A conventional electrical system (Figs. 1 and 2) included the starter, the alternator or generator, voltage regulator, and a wet cell-type storage battery. Systems with alternators have a negative ground. Systems with generators can have either negative or positive grounds depending upon owner requirements.

NOTE: The electrical components are supplied by either the OEM or Allis-Chalmers. The data following is for equipment assembled on engine by Allis-Chalmers.

The battery is the storage plant for the electrical energy and must be kept fully charged. Energy drained from the battery is replaced by the alternator. Too much power output will usually burn out the alternator or damage the battery. To prevent this, a voltage regulator is connected into the circuit.

IMPORTANT: When any work is performed on the electrical system, disconnect the battery ground to prevent short circuit.

B. ELECTRICAL SYSTEM WARRANTY AND ADJUSTMENT

Manufacturing suppliers of the battery, starter, alternator, and regulator are responsible for same during warranty period. Any claim must be directed to them, not Allis-Chalmers. Each item has its own nameplate for identification. Manufacturers of such equipment have local dealers who can make reasonable adjustments or replacements.

C. BATTERY

WARNING: Batteries contain sulfuric acid. Shield your eyes when working near the battery to protect against possible spilling of the acid solution. In case of acid contact with skin, eyes or clothing, flush immediately with water for a minimum of fifteen minutes. Get medical attention immediately.

WARNING: Be sure to connect booster cables to the proper terminals: + to + and - to -, at both ends. Avoid shorting

cable clamps.

DANGER: Flammable vapors. Extinguish all smoking materials and open flames before checking and filling batteries. Do not check battery by sparking.

1. If liquid level is low, add distilled water to bring level in each cell up to bottom of filler hole. Do not overfill. **CAUTION:** In freezing weather, never fill battery after operation. Water will not mix with acid and may freeze. Always fill battery before putting engine into operation.
2. Always be sure filler plugs are tight and plug vents are open.
3. Check external condition of battery and cables. Keep clean by scrubbing with soda solution and brush. After foaming stops, flush with clean water. Be sure plugs are tight when cleaning battery. After cleaning, apply thin coat of vaseline to posts and cable terminals.
4. Regularly check charge or specific gravity of battery fluid with hydrometer. Follow instructions on instrument carefully and correct for temperature of fluid being tested.
5. In cold weather, keep batteries fully charged because an uncharged battery will freeze at 18°F (-8°C). A half charged battery will freeze at -31°F (-36°C).

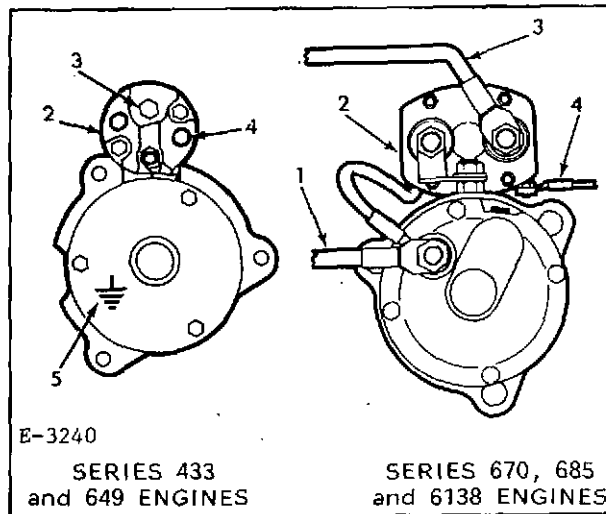

1. Cable (ground)
2. Starter solenoid
3. Cable (to positive post of battery)
4. To starter switch
5. Self-grounded

Figure 1. Starter

D. STARTING MOTOR

1. General

Heavy duty type, 12 or 24 volt, with over-running clutch, the starting motors supplied are simple and positive in action (Fig. 1). A solenoid switch for closing the starting circuit is an integral part of the unit. A shift lever in the drive housing is linked to the solenoid switch so that lever operation not only closes circuit between battery and starter, it also shifts starter motor drive pinion into mesh with flywheel ring gear. When energized, it cranks the engine. After engine starts, and shift lever is released, the gears are disengaged and de-energized starter motor stops. Do not operate cranking motor continuously for more than 30 seconds without pausing for at least two minutes. Longer application will cause overheating and motor failure.

2. Removal and Installation

This is a service function best handled by a qualified mechanic or your Allis-Chalmers dealer.

3. Maintenance

- a. During start up, note motor action. Pinion gear should mesh with ring gear. After engine starts and motor switch opens, starter motor should stop operation.
- b. If starter motor cranks slowly or not at all, check battery charge, defective battery cables, poor connections, defective motor, or low temperature.
- c. Normal periodic checks include investigation of battery condition, cable and connections, starting motor, solenoid switch, motor mounting.
- d. Starter motor bearings are lubricated only at time of disassembly or repair. This is a service function as is replacement of brushes or commutator cleaning.

E. ALTERNATOR/GENERATOR WITH VOLTAGE REGULATOR (ALL TYPES)

1. General

All Allis-Chalmers engines require electrical power for operation and control. Each uses an alternator or generator driven by the engine to provide an electrical power source and a voltage regulator to monitor the flow of current back into the electrical system to recharge the storage battery.

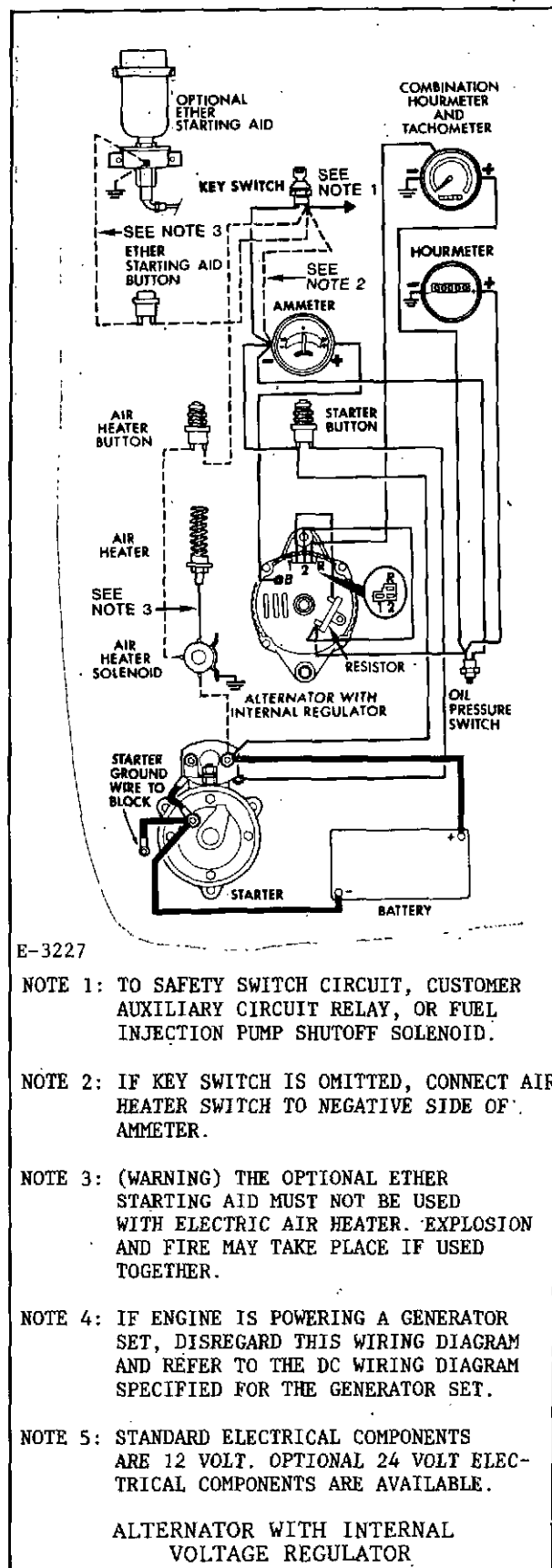

Figure 2. Alternator with Internal Regulator Wiring Diagram (Negative Ground System) - Series 433, 649 and 670 Engines

With an alternator as the power source the regulator can be integral with the alternator or mounted as a separate unit.

The regulator function in the charging circuit is to limit alternator or generator voltage to a pre-set value by controlling the alternator/generator field current. The voltage limitation is determined by the regulator adjustment. Once set, the voltage remains practically constant because regulator is unaffected by length of service, temperature or alternator/generator output.

IMPORTANT: Ground polarity of regulator and ground polarity of the battery must be the same. Do not attempt to polarize the alternator. Do not ground alternator output terminal. Never operate regulator and alternator without battery in circuit. Never short between regulator terminals and ground.

2. Maintenance

Only inspection of the alternator or generator for loose bolts, loose drive pulley or loose belt drive is usually necessary. After these have been checked and unit still runs noisily, remove unit from engine and return to manufacturer for service or replacement unit.

Voltage regulator also requires minimum maintenance. If voltage fluctuates indicating dirty contacts, they should be cleaned. Before cleaning, make sure voltage fluctuation is not due to loose connections. Use strip of No. 400 silicon carbide paper, folded over. Pull back and forth between contact points. After cleaning, wash with trichloroethane or alcohol to remove residue. Repeat process if necessary. Contacts are of soft material and must never be cleaned with a file.

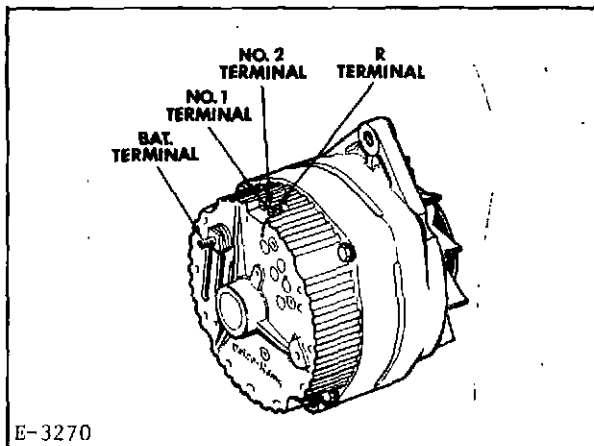

E-3270

Figure 3. Alternator with Internal Volt Regulator-Series 433, 645, and 670 Engines

If voltage regulator develops additional trouble, it must be replaced as an assembly.

F. ALTERNATOR WITH INTERNAL REGULATOR SERIES 433, 649 AND 670 ENGINES

1. General (Figs. 2 and 3)

This configuration has a regulator of solid state type and is enclosed in a solid mold mounted along with the brush holder assembly on the slip ring end of alternator. Six rectifier diodes change AC voltage to DC which appears at BAT (battery) terminal of alternator. Rotor runs on ball bearings with grease re-

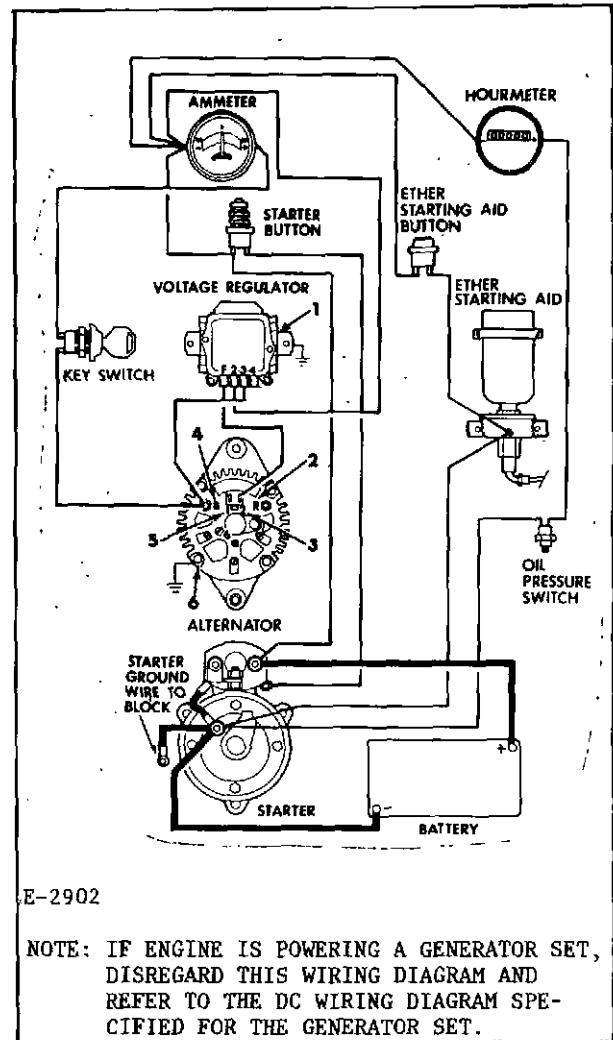

E-2902

NOTE: IF ENGINE IS POWERING A GENERATOR SET, DISREGARD THIS WIRING DIAGRAM AND REFER TO THE DC WIRING DIAGRAM SPECIFIED FOR THE GENERATOR SET.

1. Ground wire
2. Relay terminal CAUTION: Do not ground relay terminal
3. Field terminal (2)
4. Indicator light terminal (1)
5. Battery terminal
6. Ground terminal

Figure 4. Alternators with two Unit Type Regulator-(Negative Ground System) Wiring Diagram-Series 685 and 6138 Engines

serve to eliminate need for periodic lubrication.

2. Maintenance

Service should be limited to general instructions, paragraph E-2. No regulator maintenance is required. Can be removed as a complete element only.

G. ALTERNATOR WITH EXTERNAL MOUNTED VOLTAGE REGULATOR SERIES 685 AND 6138 ENGINES

1. General (Figs. 4, 5 and 6)

Construction of this alternator is similar to preceding paragraph (F) but is used with a two unit separately mounted voltage regulator.

The regulator has 4 slip connection type terminals. A projection on connector body serves to latch assembly together and prevent disconnection by lifting slightly on latch.

IMPORTANT: Do not polarize alternator after installation or at any other time.

2. Maintenance

Service is limited to instructions in paragraph E-2.

H. ALTERNATORS WITH INTERNAL REGULATORS SERIES 685 AND 6138 ENGINES

1. General (Figs. 7, 8; 9, 10 and 11)

Alternator with internal voltage regulators used with this engine series are of two types:

- a. One type, (Fig. 8) contains solid state regulator mounted inside slip ring end frame. Regulator voltage setting can be adjusted. Two brushes carry current through the two slip rings to field coil on rotor. Rectifier bridge connected to stator windings contain six diodes and electrically changes the stator a.c. voltages which appear at output terminal. Field current is supplied through a diode trio also connected to the stator windings.
- b. The other type alternator (Fig. 9) is a self-rectifying, brushless unit with built-in voltage regulator. Regulator voltage setting can be adjusted. Only moveable part in assembly is the rotor.

Both types of alternators require only one wire to connect the charging system to the battery, along

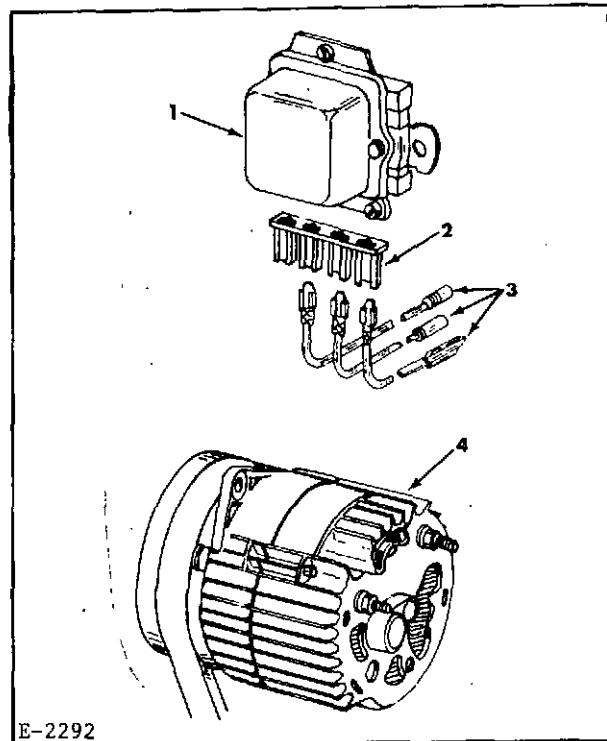

E-2292

- | | |
|--------------|---------------|
| 1. Regulator | 3. Leads |
| 2. Connector | 4. Alternator |

Figure 5. Alternator with Two Unit Regulator-Series 685 and 6138 Engines

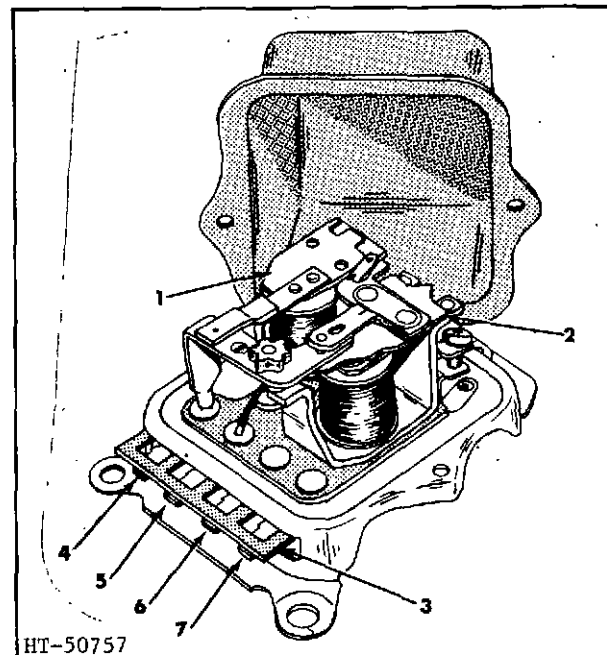

HT-50757

- | | |
|---------------------------|-------------------|
| 1. Field relay unit | 5. No. 2 terminal |
| 2. Voltage regulator unit | 6. No. 3 terminal |
| 3. Latch | 7. No. 4 terminal |
| 4. F terminal | |

Figure 6. Two Unit Voltage Regulator-Series 685 and 6138 Engines

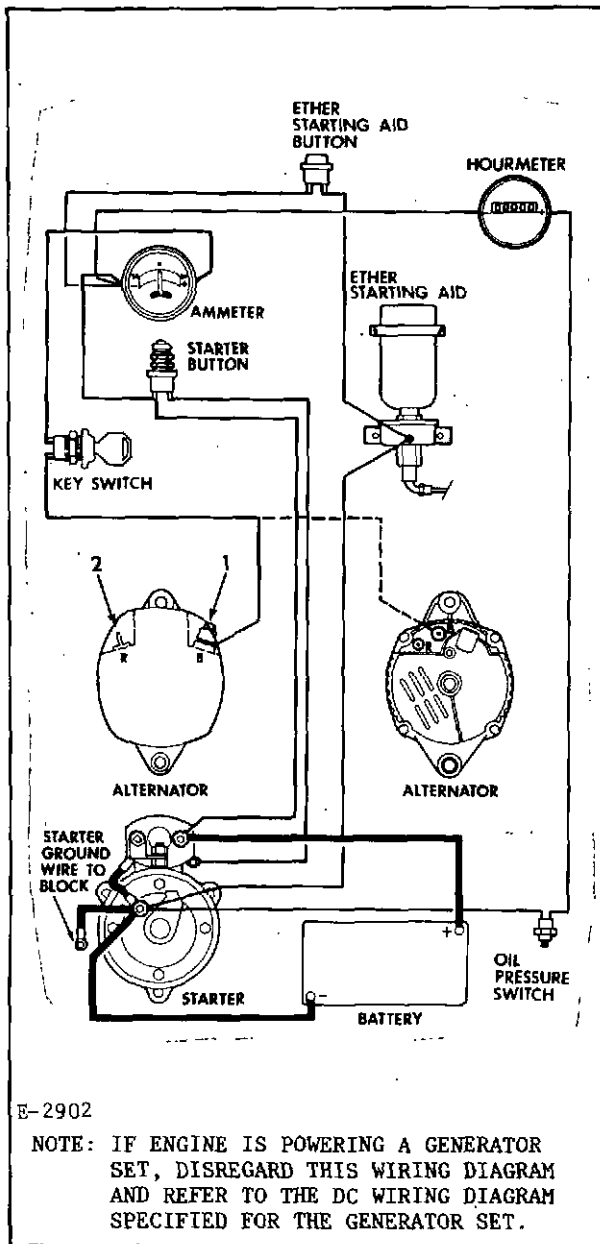

1. Output terminal
2. Relay "R" terminal CAUTION: Do not ground relay terminal

Figure 7. Alternators with Internal Regulator- (Negative Ground Systems) Wiring Diagram-Series 685 and 6138 Engines

with adequate ground return. Both have extra large grease reservoirs with adequate lubricant supply. No periodic maintenance is required.

Do not polarize alternator after installation or at any other time.

2. Alternator/Voltage Regulator Adjustment

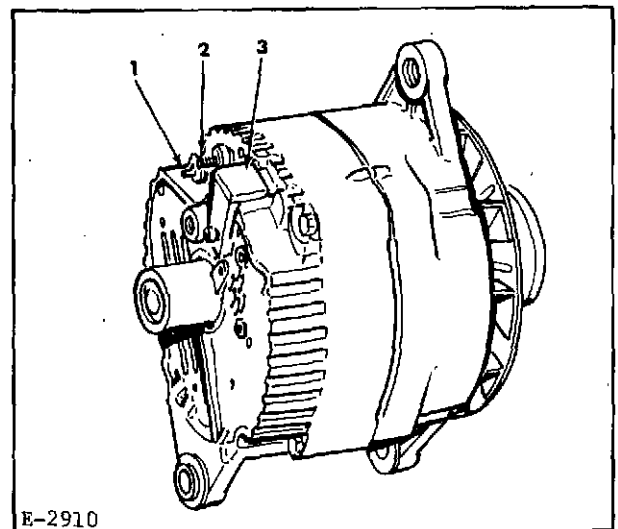

1. "R" terminal
2. "BAT" terminal
3. Voltage adjustment cap

Figure 8. Alternator Integral Voltage Regulator (Brush Type) Series 685 and 6138 Engines

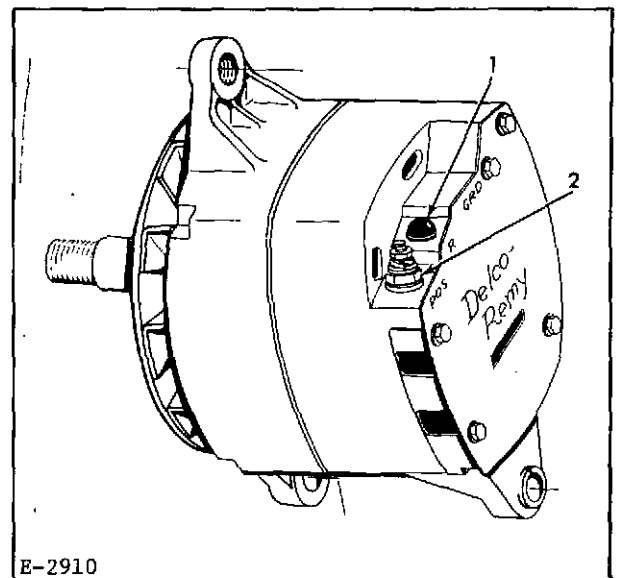

1. "R" terminal
2. "BAT" terminal

Figure 9. Alternator Integral Voltage Regulator (Brushless Type) Series 685 and 6138 Engines

a. Integral Regulator Brush Type.

Setting can be adjusted externally by repositioning the voltage adjustment cap in slip ring end frame (Fig. 10).

"LO" position is lowest voltage regular

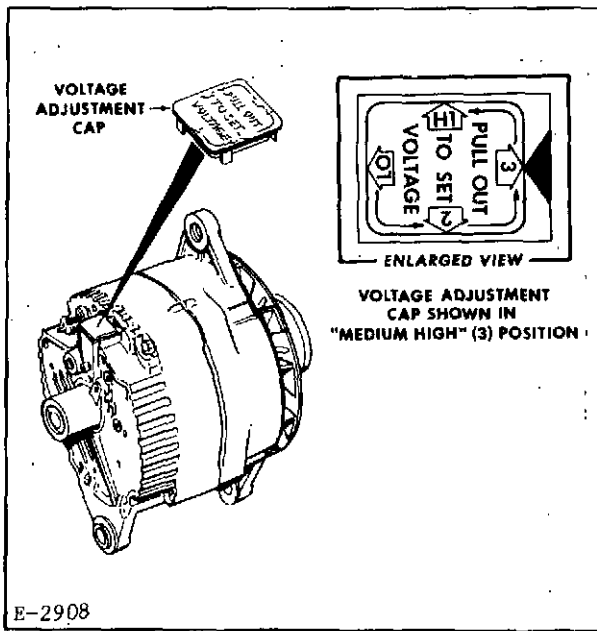

Figure 10. Alternator/Voltage Adjustment
(Brush Type)-Series 685 Engines

setting, "2" position is medium low, "3" position is medium high, and "HI" position is highest voltage regulator setting.

Make adjustment by removing voltage adjusting cap and rotating in 90° increments. Then reinsert cap in connector body.

b. Integral Regulator Brushless Type

Regulator setting can be adjusted externally (Fig. 11).

Remove pipe plug from alternator. Turn adjusting screw one or two notches clockwise to raise voltage setting for undercharged battery. Replace pipe plug.

After making adjustment change, check for an improved battery condition over a service period of reasonable length, such as a week.

3. Maintenance

Service should be limited to instructions in paragraph E-2.

1. DC GENERATOR WITH SEPARATELY MOUNTED VOLTAGE REGULATOR SERIES 685 AND 6138 ENGINES

1. General (Figs. 12, 13 and 14).

The d.c. generator is of brush type design. The voltage regulator (Figs. 13 and 14) is an electromagnetic relay of the vibrating type. It has a cutout relay which connects and disconnects

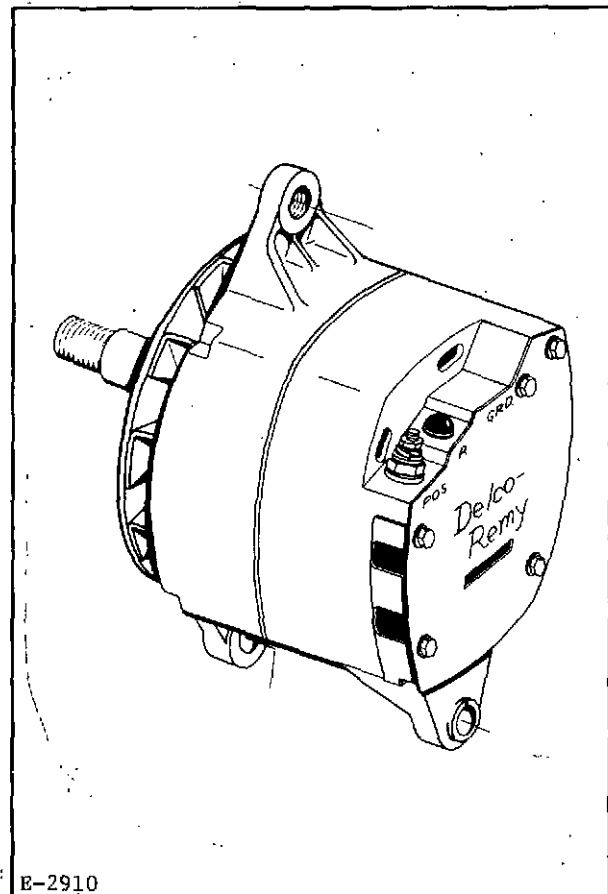

Figure 11. Alternator/Voltage Adjustment
(Brushless Type)-Series 685 and 6138 Engines

battery, a voltage regulator to prevent battery overcharge and high voltage, and a current regulator to protect generator of alternator from overloads.

NOTE: Whenever generator has been removed or regulator leads have been disconnected and reconnected, generator MUST be polarized before engine is started to prevent severe regulator damage.

2. Polarizing the generator (Fig. 13).

Using short jumper lead, momentarily touch the jumper from BAT to GEN terminal of the regulator. A solid contact is required. A flash or arc will be noticed when arc is removed.



CAUTION: Do not test or operate generator on an open circuit. If it should be necessary to operate generator without being connected to the batteries, it should be short circuited. Disconnect the lead connected to the GEN terminal of regulator and connect to any convenient ground to accomplish the short circuit.

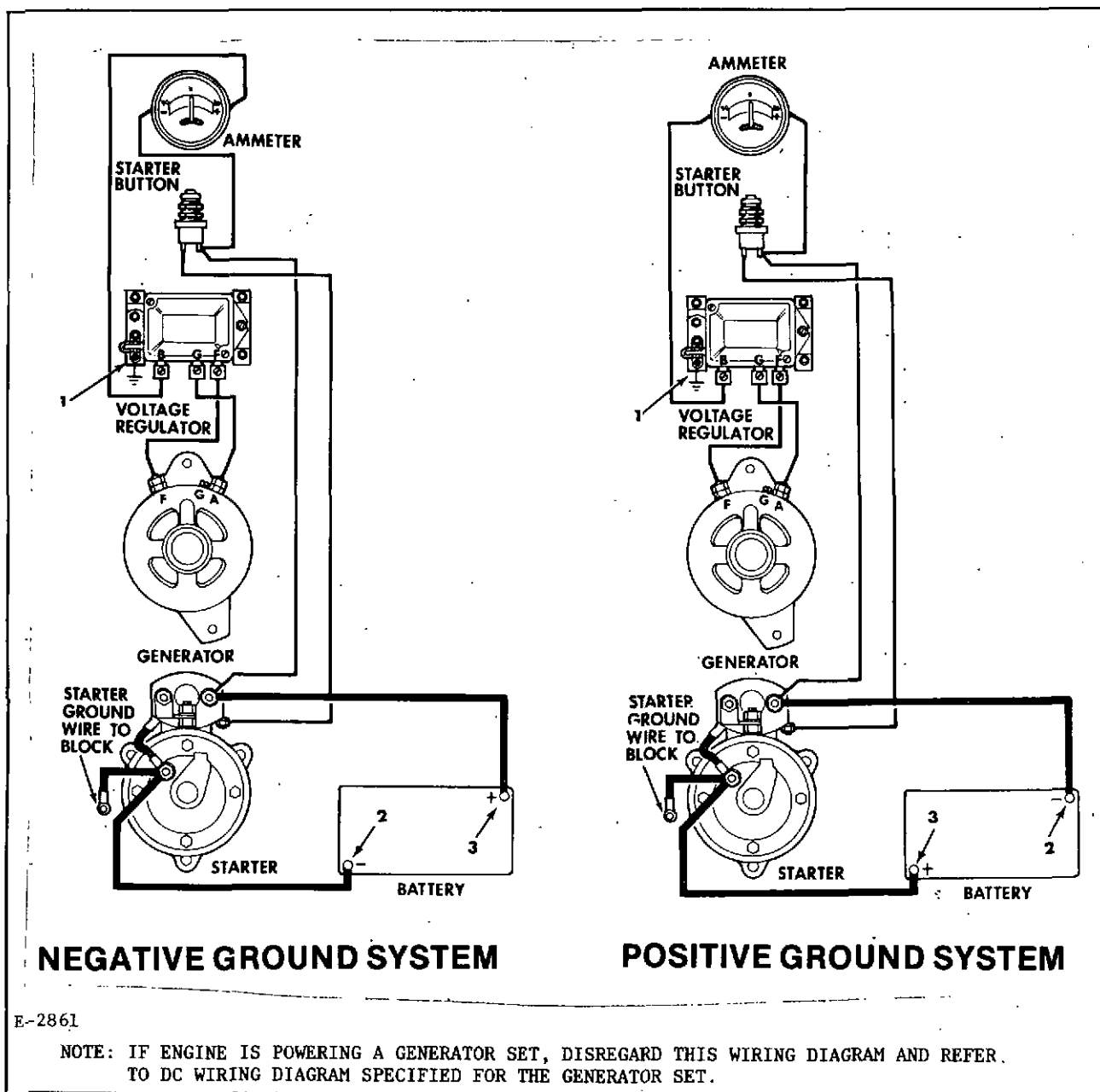

NEGATIVE GROUND SYSTEM

POSITIVE GROUND SYSTEM

E-2861

NOTE: IF ENGINE IS POWERING A GENERATOR SET, DISREGARD THIS WIRING DIAGRAM AND REFER. TO DC WIRING DIAGRAM SPECIFIED FOR THE GENERATOR SET.

- 1. Ground wire
- 2. Negative terminal
- 3. Positive terminal

Figure 12. DC Generator with Voltage Regulator Wiring Diagram (Negative and Positive Ground System) Series 685 and 6138 Engines

3. Generator Maintenance

Periodically, the communicator should be inspected and cleaned. If necessary clean only with #00 sandpaper, never use emery cloth. Also inspect brushes for wear. If sandpaper is used, wipe clean with a dry cloth.

Should communicator be rough, out-of-round, or have high mica it must be turned down by an authorized mechanic or your Allis-Chalmers dealer.

If generator has oil cups, lubricate with 3 to 5 drops of engine oil at each engine oil renewal interval.

4. Regulator Maintenance

Do not attempt service on regulator due to fluctuating voltage until after checking for loose connections or high resistance elsewhere in the system.

Cleaning of regulator contacts is the only maintenance suggested. A sooty or discolored appearance of contacts is normal after a short operational period. However, if voltage fluctuates, as evidenced by unsteady volt-meter indication, contacts may have excessive resistance or be sticking thus requiring cleaning and possible readjustment (Fig. 14).

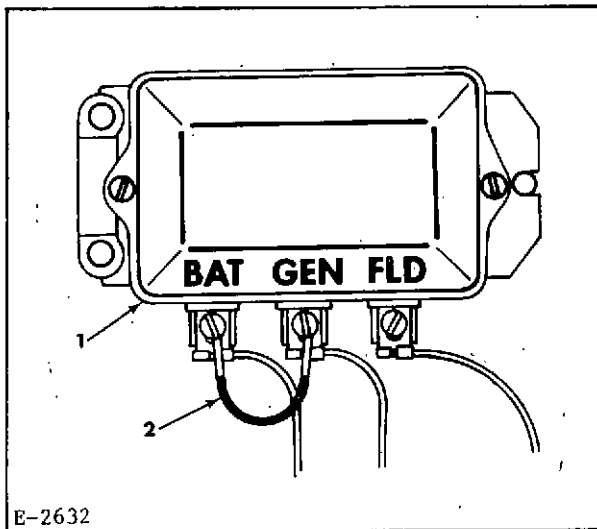

1. General regulator 2. Jumper lead

Figure 13. Polarizing Circuit Diagram
(DC Generator ONLY)-SERIES
685 AND 6138 ENGINES

NOTE: Never use emery cloth or sandpaper to clean contact points. This will change the gap between contacts and will have to be re-adjusted to the correct gap.

Using a spoon or riffle file, clean the large flat point located on the armature of the voltage regulator (4) and a similar flat point on the upper contact support of current regulator (2). The second point will require the most attention. All oxides must be removed and pure metal exposed. On regulators which have the flat contact point on armature, loosen upper bracket mounting screws (8) so that bracket can be tilted to one side for cleaning. On regulators with the flat contact on upper contact bracket, bracket must be removed for cleaning of points.

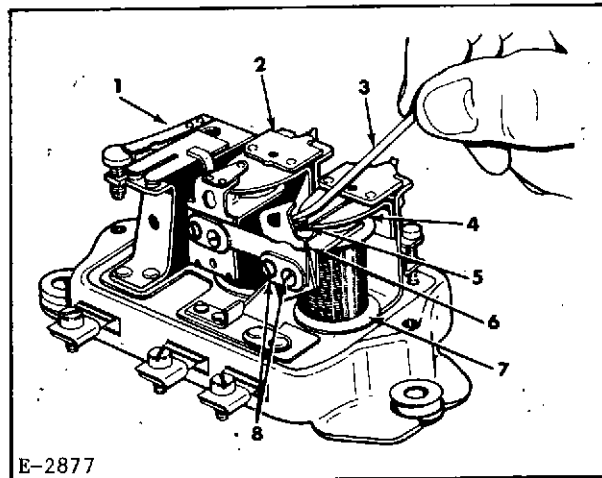

1. Cutout relay
 2. Current regulator
 3. Spoon or riffle file
 4. Armature
 5. Large flat point
 6. Contact mounting bracket
 7. Voltage regulator
 8. Mounting bracket screws

Figure 14. Cleaning Voltage Regulator Contact
Points-DC generator)-Series 685
and 6138 Engines

The small soft-alloy contact points on upper contact support bracket of voltage regulator and the point on the armature of current regulator, do not oxidize. They may be cleaned using crocus cloth or a fine abrasive material. After cleaning any contact points be sure to wash thoroughly with clean trichloroethane to remove any foreign material remaining on contact surfaces.

J. DRIVE BELT ADJUSTMENT

See Cooling System, Topic 9, Paragraph J.

TOPIC 13 INTAKE AND EXHAUST SYSTEMS

SAFETY PRECAUTIONS

⚠ **WARNING:** No unauthorized person must be allowed to service or maintain this machine. Study the Operation and Maintenance manuals before starting, operating, maintaining, fueling, or servicing this machine.

⚠ **WARNING:** Wear safety glasses with side shields or goggles when using compressed air for cleaning to reduce the danger of personal injury from flying particles. Limit the pressure to 30 psi (207 kPa) according to OSHA requirements.

⚠ **WARNING:** Never use gasoline or other toxic or flammable fluids to clean parts.

⚠ **WARNING:** To prevent injury, always turn the key switch or stop control to the "OFF" position before cleaning, repairing, or servicing the engine.

⚠ **WARNING:** Study this manual through before starting, operating, maintaining, fueling or servicing this machine.

A. GENERAL

The intake and exhaust systems consist of these components that convey clean air to engine cylinders and exhaust gases to atmosphere. The intake side includes an air cleaner, compressor side of the turbocharger, intake manifold, and intake valves. The exhaust side has exhaust valves, exhaust manifold, turbine side of the turbocharger, muffler, and exhaust piping extensions.

It is important that an ample supply of fresh air be provided to the combustion chambers. Insufficient air will limit the amount of fuel engine can burn and lead to power loss, excessive smoke, high fuel consumption and perhaps, engine failure.

At the same time, restriction of the exhaust system will cause back pressure with poor engine performance and shortened engine life. Measurement of exhaust pressure will indicate whether or not capacity of system is adequate. This can be performed best by a factory trained mechanic or your Allis-Chalmers dealer.

In general, your exhaust and intake system should include no sharp angles in any piping and have a minimum of turns. Pipe size must

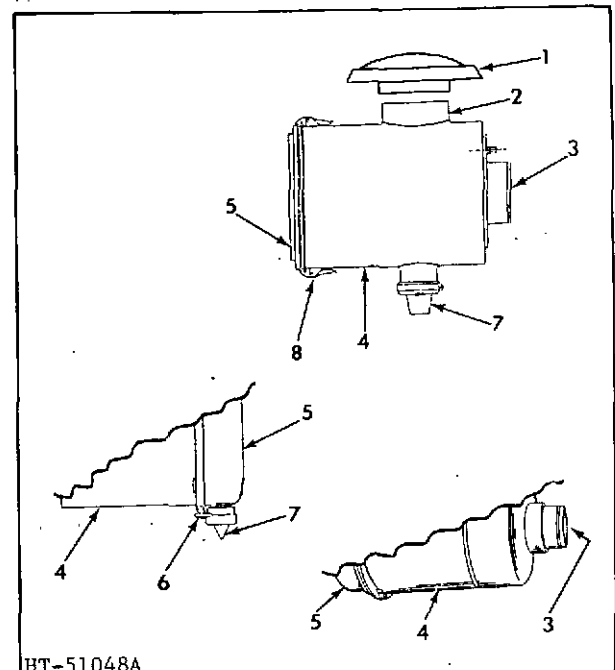

HT-51048A

- | | |
|---------------|---------------------|
| 1. Stack cap | 5. Dust cup/cover |
| 2. Air inlet | 6. Clamp ay. |
| 3. Air outlet | 7. Vacuator |
| 4. Body | 8. Latch (Integral) |

Figure 1. Dry - Air Cleaner
(Single Element)

never be less than diameter of exhaust outlet opening. The system must be kept clear of any obstruction at all times.

B. AIR CLEANERS (Optional Equipment)

The air cleaner is employed to remove dust and dirt from air to be used by the engine. Engine life depends largely on efficiency of air cleaner. Rapid wear of cylinder sleeves, pistons, and rings will result from inadequate air filtration.

Regardless of type of filter applied, frequency of element removal, and servicing is dependent upon amount and type of dust and foreign material in the air close to engine. You can never over service the air filter.

Air cleaners as supplied on Allis-Chalmers engines are normally by selection of normal duty versus heavy duty. When specified, units may also include a moisture and dust unloader valve, commonly called vacuator.

1. Dry - Re-Cleanable Type

The air cleaner (Figs. 1 thru 5) is mounted horizontally with stack in vertical position. The unit is composed of a stack cap, air inlet, single or dual elements, baffle and dust cap, clamp assembly, air outlet and vacuator where specified.

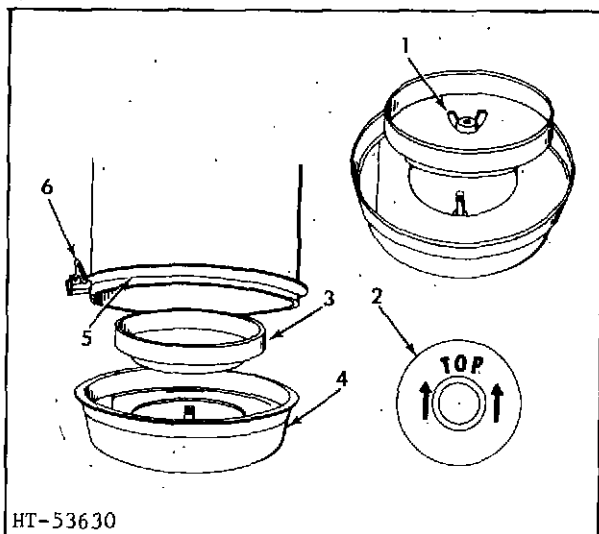

- | | |
|--------------------|-------------------|
| 1. Wing nut | 4. Dust cup |
| 2. Dust cup bottom | 5. Cup gasket |
| 3. Baffle | 6. Clamp assembly |

Figure 2. Baffle and Dust Cup Details

Inspect air cleaner body periodically for dents, cracks, etc. Also check for damaged gaskets, hoses, loose hose clamps, and leaks that may allow air to enter engine without first passing through filter element. Correct any such condition immediately or replace faulty parts.

Inspect dust cap daily or prior to operation. Never allow dust level to build up to less than 1 inch (25.4 mm) from slot in dust cap baffle.

a. Cleaning Air Filter Cup

- (1) Clean exterior of air cleaner (Fig. 1) and surrounding area.
- (2) Loosen clamp assembly (Item 6) and remove dust cup (Fig. 2, Item 4).
- (3) Loosen wing nut (Fig. 2, Item 1) and remove baffle from dust cup.
- (4) Empty dirt from cup. Clean cup and baffle.
- (5) Remove foreign material from around filter element.
- (6) Assemble baffle to dust cup. Tighten wing nut.
- (7) Position dust cup as marked with arrows and word TOP up (Fig. 2) on air cleaner body and tighten clamp assembly securely.

b. Replacing Filter Element

Clean or replace filter element when

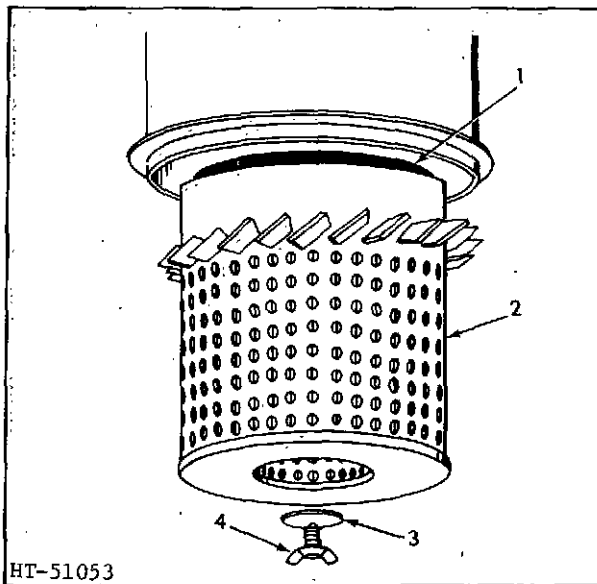

- | | |
|-------------------|------------------|
| 1. Element gasket | 3. Gasket washer |
| 2. Filter element | 4. Wing screw |

Figure 3. Removing Filter Element

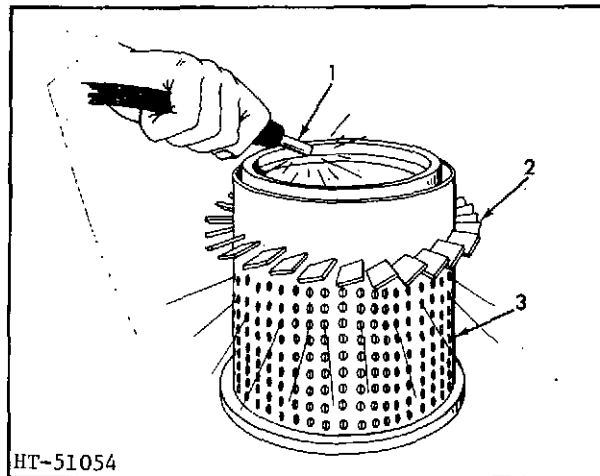

- | | |
|----------------------|-------------------|
| 1. Nozzle | 3. Filter element |
| 2. Pre-cleaning fins | |

Figure 4. Cleaning Filter Element

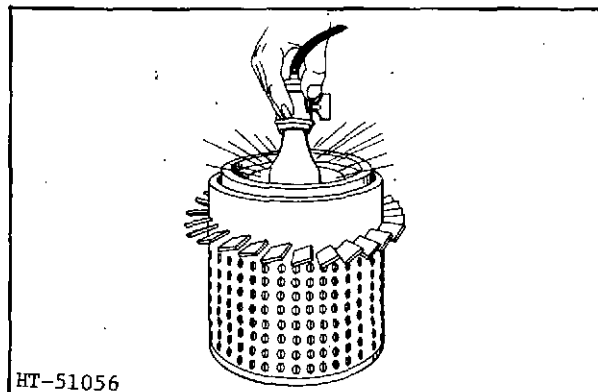
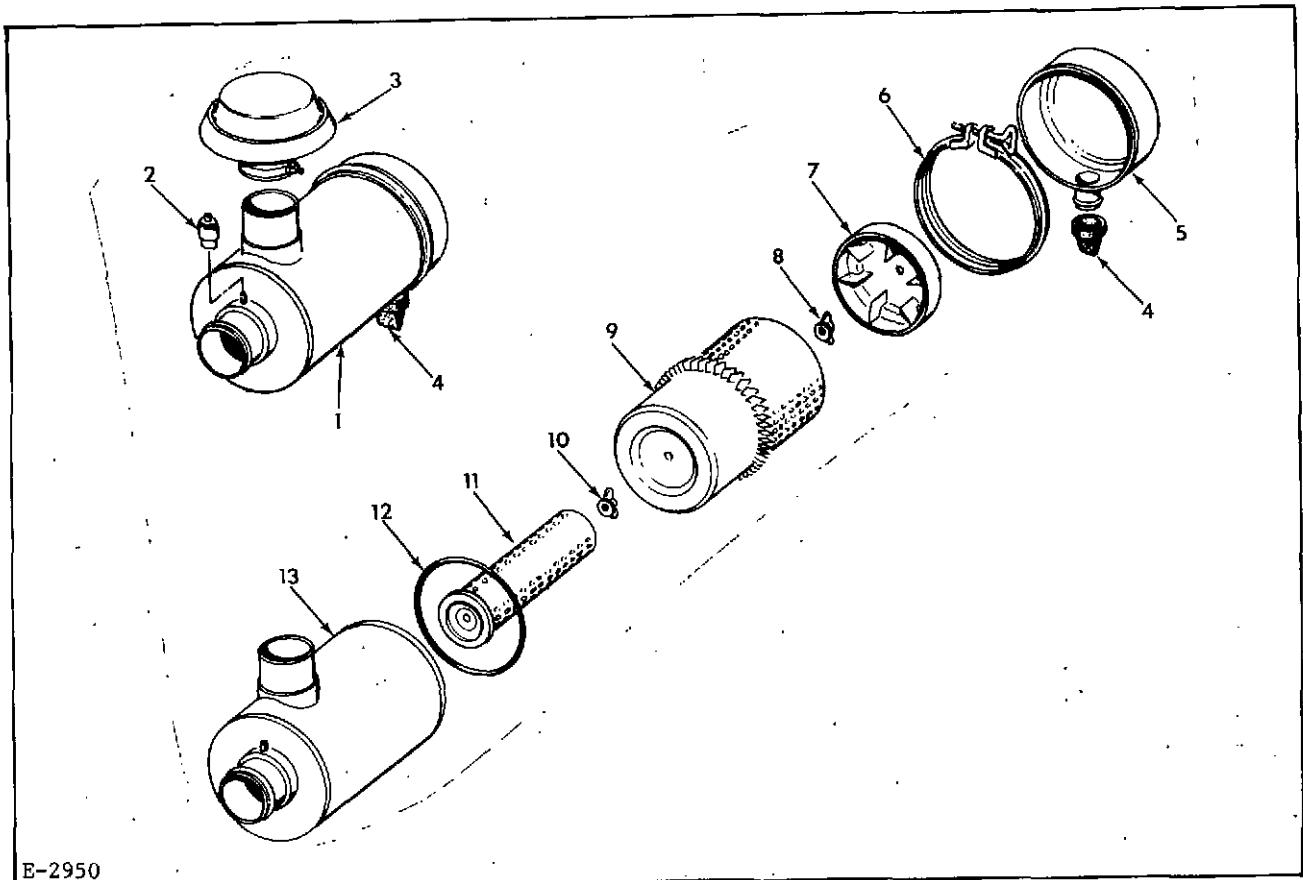

Figure 5. Inspecting Filter Element



- | | | |
|-----------------------------------|-------------------|----------------------------------|
| 1. Air cleaner assembly | 6. Clamp assembly | 11. Inner element (safety) |
| 2. Service indicator | 7. Baffle | 12. O-Ring/Gasket (if specified) |
| 3. Inlet cap | 8. Wing nut | 13. Housing Body |
| 4. Vacuator (dust unloader valve) | 9. Outer element | |
| 5. Dust cup | 10. Wing nut | |

Figure 6. Dry Air Cleaner (Two Element Type)

red signal covers exposed section of window on air filter indicator (Fig. 8).

- (1) Remove dust cup.
- (2) Remove wing screw (Fig. 3, Item 4) and gasket washer (3). Remove filter element (2).
- (3) Inspect element gasket (1) for damage.
- (4) Install new or clean element.
- (5) Inspect cup gasket and replace if damaged.
- (6) Reinstall dust cup assembly with top up.
- (7) Reset service indicator by pressing reset button on top of indicator.

The filter element can be cleaned by dry cleaning or washed for

additional service life.

c. Cleaning Filter Element

- (1) Pre-cleaning fins on filter element are not removable.
- (2) Direct jet of clean air up and down pleats on clean air side of element, (Fig. 4). Maintain reasonable distance between nozzle and element. Air pressure at nozzle must not exceed 100 psi (689 kPa).
- (3) If element is oily and soot laden, wash with filter cleaner available at your Allis-Chalmers dealer. Mix 2 ounces (56.7 g) of cleaner with small amount of cool water. Add warm (70°F to 100°F) (21° to 38°C) water until volume equals one gallon (3.79 lts). The warmer the solution, the better it will clean. Immerse element and soak for 15 minutes. Remove and rinse with clear running tap water. Air

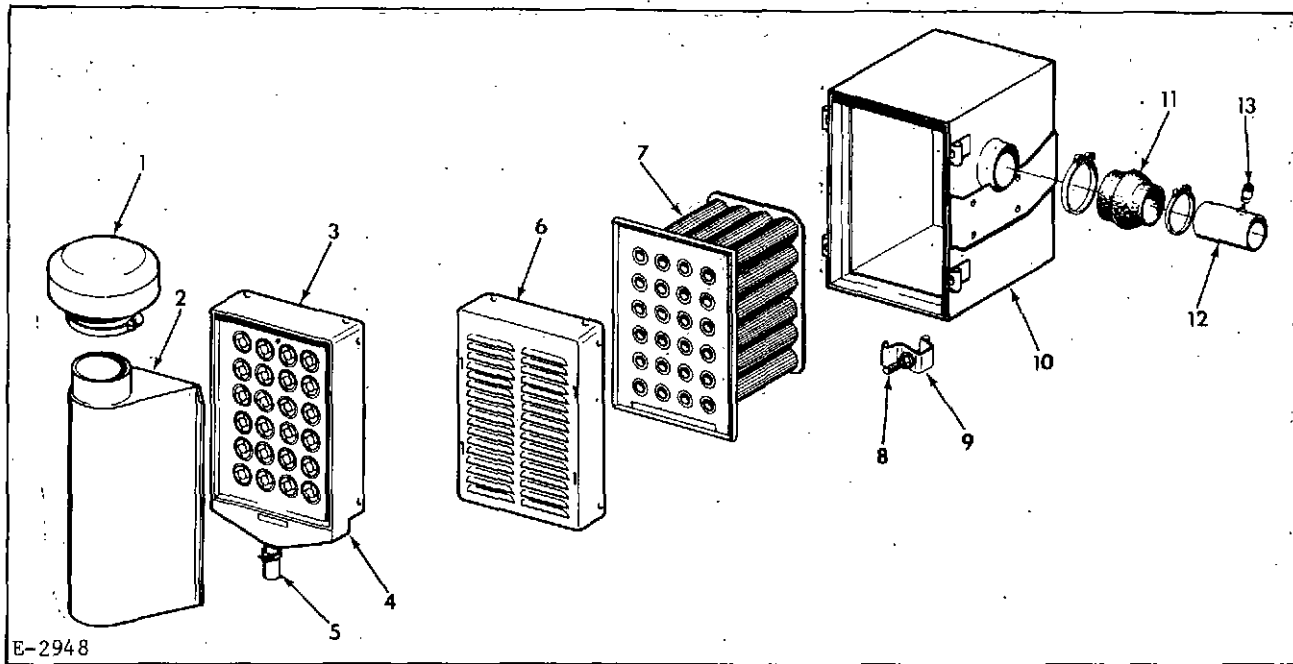

- | | | |
|-------------------------|-----------------------|-----------------------|
| 1. Rain cap | 6. Moisture separator | 11. Reducer adaptor |
| 2. Vertical air inlet | 7. Cartridge | 12. Tube |
| 3. Pre-cleaner panel | 8. Fastener | 13. Service indicator |
| 4. Dust bin | 9. Clamp | |
| 5. Dust discharge valve | 10. Housing | |

Figure 7. Dry Air Cleaner - Tube Type Cartridge

dry thoroughly. Do not heat to dry. A fan or air draft can be used to speed drying.

- (4) Inspect element for damage after dry cleaning or washing by placing a bright light inside element (Fig. 5). Any thin rupture, spot, or pin hole renders filter unfit for further use.

Never clean filter more than 6 times.

2. Dry - Air Cleaner (Two Element Type)

For minimum maintenance and extra protection, this air cleaner features two elements plus automatic dust and moisture elimination from dust cup through an unloader valve.

For service of the two element type (Fig. 6):

- Service outer element and dust cup as in preceding paragraph.
- Never clean inner element. Replacement after each third outer replacement or if service indicator signal indicates a clogged filter after a new or cleaned outer element has been installed.
- To remove inner element, first remove outer element.

- Unscrew wing nut (10) and pull inner element from housing.

- Clean interior of housing and check housing to dust cup gasket for condition and proper seat.

- Install new inner element and tighten with wing nut.

- Replace outer element and dust cup with unloader valve in down position.

- Check to be sure lips of unloader valve are directed outward and clear of debris.

- Reset service indicator. Start and run engine at high speed idle. Indicator red signal should not be in sight denoting a clean air cleaner.

3. Air Cleaner - Tube Type Cartridge

The air cleaner (Fig. 7) consists of a housing, cartridge, moisture separator, or optional pre-cleaner with self-cleaning dust bin and vertical air inlet with rain cap. Dust is ejected automatically from pre-cleaner through flexible discharger valve (5). Unit also has service indicator (Fig. 8).

Periodic external inspection should be made for dents, cracks, damaged hoses, or gaskets, loose clamps or any leaking that would allow air to enter engine without passing through cleaner. Any damage must be corrected immediately.

Under normal conditions, the pre-cleaner (3) is self-cleaned. Under extreme adverse conditions, it may require cleaning by steam, washing, or blowing clean air back through the front of the cyclonic tubes and dust bin.

Do not clean cartridge (7). Experience shows attempts by washing, shaking, or compressed air result in undetected damage.

The moisture eliminator (6) can be cleaned as is the pre-cleaner (3). Make certain all foreign matter and moisture is drained through holes in the bottom.

a. Replacing air cleaner cartridge:

- (1) If applicable, loosen clamp fasteners (8 & 9) in housing (10), remove vertical air inlet adaptor and rain cap (1 & 2).
- (2) Remove moisture separator (6) or pre-cleaner (3) depending on specifications of the unit.
- (3) Insert fingers into cartridge openings and loosen all four corners of cartridge, one at a time, by pulling straight out at each corner. After breaking seal, remove cartridge (7) by pulling straight out and slightly up so it clears sealing frame. Discard cartridge.

Do not clean dirty element. Inspect for soot or oil. If soot is inside tubes, check for leaks in engine exhaust system. If oily film is present, check for fumes escaping from breather tube. Correct these conditions before new element is installed.

- (4) Remove all foreign matter from inside total air cleaner unit and dust discharge valve.
- (5) Inspect new cartridge for shipping damage prior to installation.
- (6) Install new cartridge into housing. Avoid hitting cartridge tubes against sealing flange. Firmly press all edges and corners of cartridge against sealing flange with fingers to effect positive seal. Do not pound cen-

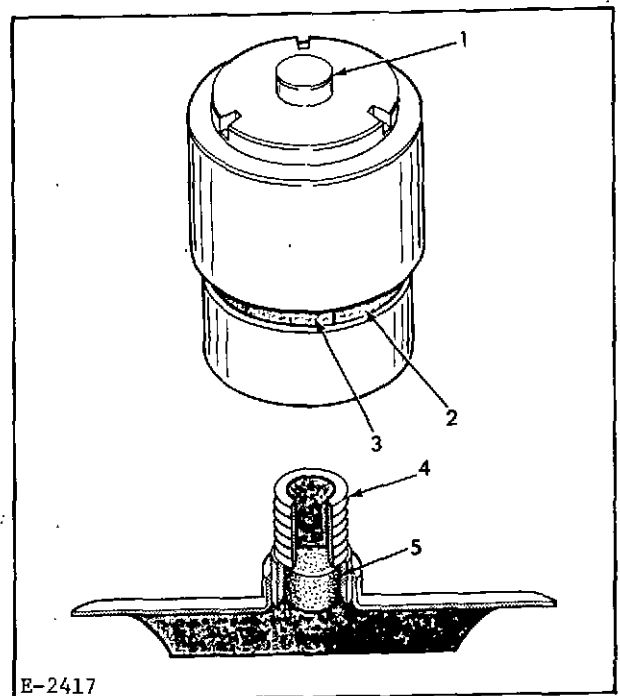

- | | |
|----------------------|-----------------------------------|
| 1. Reset button | 4. Connector with sintered filter |
| 2. Red signal window | 5. Sintered filter |

Figure 8. Air Filter Service Indicator

ter of cartridge under any circumstances.

- (7) Tighten fasteners finger tight. Then, turn fastener 1.5 turns with tool. Tighten in sequence to assure uniform seating procedure.

Should later inspection of fasteners indicate that they are at less than specified torque, probable cause is a slight set in plastic face of element. This does not necessarily impair the seal. Do not retighten unless very loose because preset seal could be broken.

- (8) Make certain all connections are tight. Reset service indicator (Fig. 8) by pressing reset button (1).

4. Air Filter Service Indicator

This gauge provides the engine operator with a visual signal indicating the need for filter service or element replacement. It is factory set.

As pressure flow in the air duct following the filter decreases, the red signal of the indicator gradually moves up in the window (Fig. 8, Item 3). When fully exposed, it locks in position denoting need for air cleaner service or filter

element replacement. After servicing, reset signal by pressing reset button (1) on top of service indicator.

If seals in indicator should rupture; filter in connector (4) will temporarily prevent dust from entering systems. Entire service indicator should then be replaced.

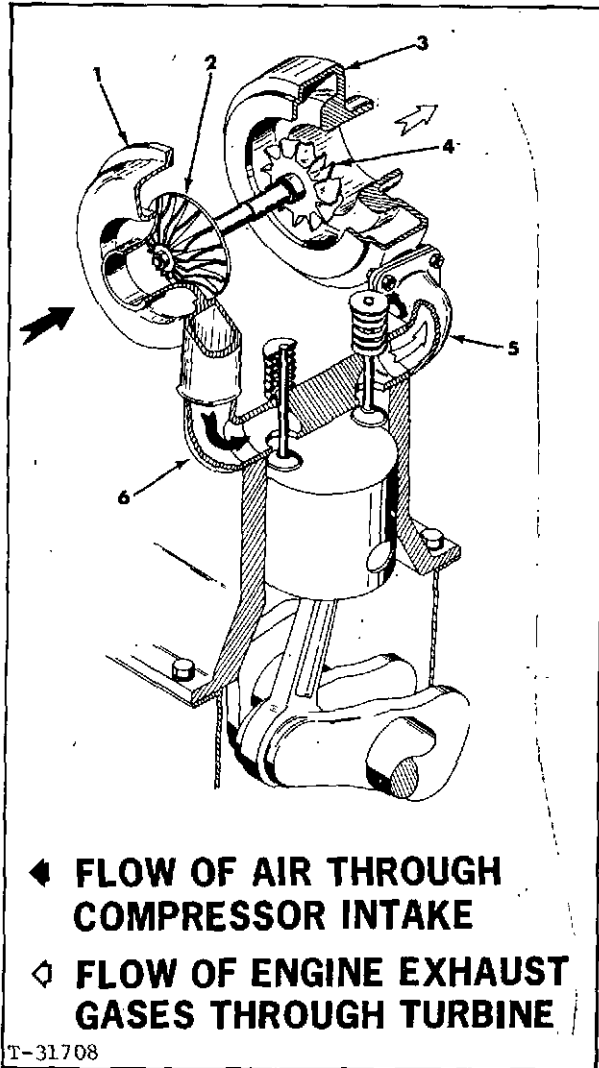

1. Compression housing
2. Impeller
3. Turbine housing
4. Turbine wheel
5. Exhaust manifold
6. Intake manifold

Figure 9. Turbocharger Operation Diagram

C. TURBOCHARGER

The power of an internal combustion engine is governed in part by the volume of air entering the combustion chamber. Most engines

are naturally aspirated and rely on atmospheric pressure to move fresh air through filters and manifold to inlet valves. The turbocharger is used to increase power output by increasing air supply to cylinders. It is a highly efficient, rugged, and simply designed exhaust driven blower incorporating a single stage radial inflow turbine wheel mounted on a common shaft with a single stage centrifugal compressor impeller. The rotating parts are precision balanced and rotate in the center housing. A turbine housing, and a compressor housing are mounted on each side of the center housing (Fig. 9).

1. Operation

During engine operation, filtered air enters turbocharger at center of compressor housing and is forced under pressure to the intake manifold and from there through inlet valves.

After combustion, the exhaust gases collect in the manifold and flow to turbine side of turbocharger. These hot, expanded gases move rapidly through turbine housing causing turbine wheel to spin. The turbine wheel drives the compressor wheel through a common single shaft.

The turbocharger responds directly to engine loads. During heavy load/lugging, increased flow of exhaust gases turns turbine wheel faster causing compressor impeller to turn faster and supply more air to intake manifold. Conversely, with light engine load, flow of gases decrease and less fresh air is pumped into intake manifold. Lubrication and cooling of the turbocharger shaft is critical. Filtered engine oil does this job by circulation through bearing housing at normal oil pump pressure.

IMPORTANT: Never operate engine with air inlet or exhaust elbow removed from turbocharger. Clothing or foreign matter can be drawn into compressor inlet. Discharged carbon particles and hot gases exiting from turbine outlet can cause personal injury.

2. Effect of Altitude on Turbocharged Engines

Each thousand feet (304.8 mm) of altitude rise will cause a 1% decrease of horsepower output. After pre-determined altitude is reached, the engine must be derated and maximum fuel setting reduced. This is a service function handled best by a factory trained mechanic or your Allis-Chalmers dealer.

3. Turbocharger Maintenance

There are no specific maintenance procedures required for the turbocharger.

Its successful, trouble-free operation is dependent upon the air intake filtering system, and the engine lubrication system. Therefore, it is most important to make sure of maintenance in these two areas. Continuous inspection and monitoring is necessary.

CAUTION: If engine has been in storage for several months or more, it is recommended that 3 to 4 ounces (85 to 113 g) of lubricant be placed in oil inlet of center housing. Also fill oil inlet line with oil. Do this before operating engine.

The exhaust system should be rigidly mounted and free from leaks due to ruptured gaskets, cracks, or loose connections.

D. INTAKE AND EXHAUST SYSTEM MAINTENANCE SCHEDULE

Phase 1: Maintenance-Daily

1. Inspect complete system for any external damage such as dents, leaks, loose fittings and correct.
2. Empty and clean dust cup and baffle in air cleaner.
3. Check air cleaner service indicator and change filter element if necessary.
4. If air cleaner has no service indicator, inspect filter on regular schedule.

Phase 6: Maintenance

1. Conduct a major inspection of turbo-charger by an experienced mechanic or your Allis-Chalmers dealer.

TOPIC 14 COLD WEATHER STARTING AIDS

SAFETY PRECAUTIONS

- !** DANGER: Do not use starting fluid with electric air heater. Explosion and personal injury could result.
- !** WARNING: Starting fluid is flammable. Do not puncture or burn containers. Follow precautions printed on containers for storage and disposal.
- !** DANGER: Do not use matches, lighters, or torches for a light source when inspecting or repairing engine due to presence of flammable fluids.
- !** DANGER: Flammable Vapors-Extinguish all smoking material and open flames before checking and filling batteries. Do not check battery by sparking.
- !** WARNING: To prevent injury, always turn the key switch or stop control to the "OFF" position before cleaning, repairing, or servicing the engine.

A. GENERAL

Two types of cold weather starting aids are available as options. One is manually operated, the other is electrically operated. Both use a very volatile fluid stored under pressure in a can or tank.

The discharger or control is mounted on or near the engine control panel. The spray nozzle is connected to the discharge by a length of nylon tubing. It is positioned so that sprayed starting fluid is distributed proportionally to all cylinders.

- !** DANGER: Starting fluid is extremely flammable. Store away from heat, sparks, or open flame. Avoid contact of fluid with skin and do not breathe fumes. Observe precautions printed on container.

IMPORTANT: Be sure tubing is supported so it does not contact surfaces or areas where it may be damaged by mechanical action or vibration.

B. HANDLING PRECAUTIONS

1. Do not heat fuel cylinders.
2. When discharge is being tested or inspected and is not installed in engine, do not discharge spray into confined area or near an open flame.

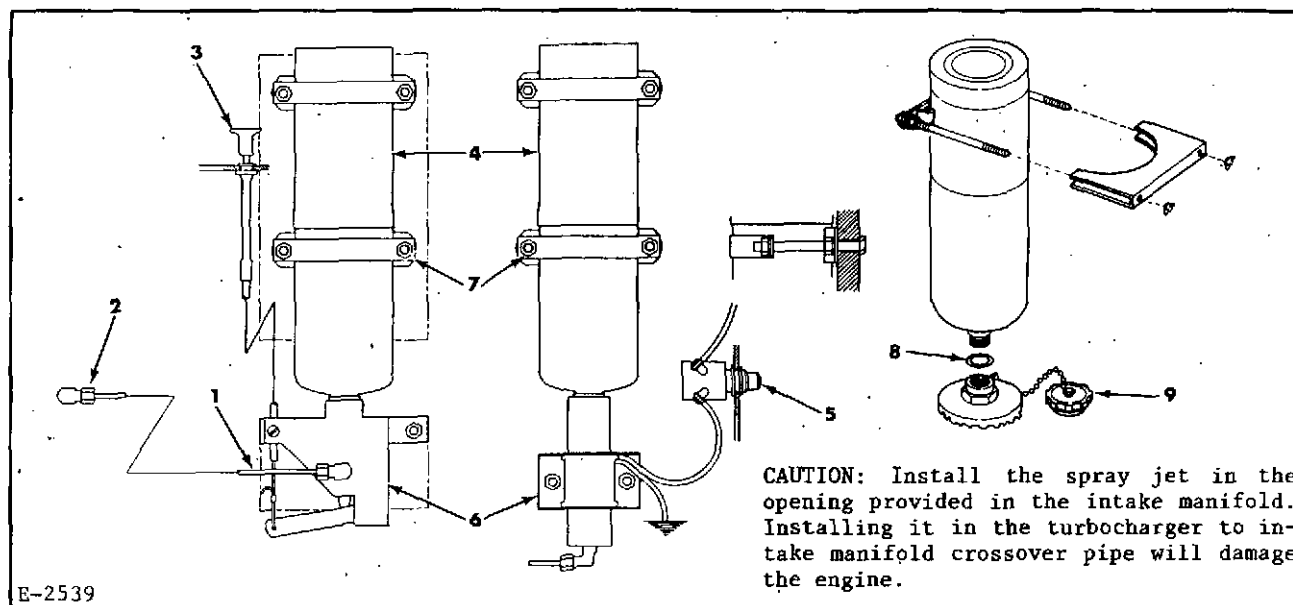

- | | | |
|-------------------------|-----------------------------|-------------------|
| 1. Discharge tube | 4. Fuel cylinder | 7. Mounting clamp |
| 2. Spray fitting | 5. Electric push button | 8. O-ring |
| 3. Manual control lever | 6. Discharge valve assembly | 9. Cap |

Figure 1. Cold Weather Starting Aid

3. Ether component of starting fluid is toxic. Avoid breathing of fumes.
4. Never puncture or incinerate cylinder.
5. When fuel cylinder (Fig. 1, Item 4) is removed from discharger valve assembly (6), always keep top of valve assembly covered with provided plastic cap (9) attached to chain to prevent entrance of foreign matter into valve assembly.
6. If the starting aid is removed from engine, first disconnect the tube from spray fitting. Then, remove spray fitting from air intake system and replace with a pipe plug.

C. FUEL CYLINDER INSTALLATION

1. Remove plastic cap from top of discharge valve assembly.
2. Place O-ring (furnished) in metering chamber well.
3. Install fuel cylinder by placing in position to engage threads. Screw hand tight. Secure cylinder with clamp. Follow instructions on cylinder.

D. OPERATION OF DISCHARGER

See Topic 6, paragraph B.

E. MAINTENANCE

The ether starting aid is of rugged construction and ordinarily does not require servicing. Should assembly sustain major damage, remove and replace complete unit.

1. When replacing empty fuel cylinder, wipe dirt from around valve inlet and follow instructions in preceding paragraph C.
2. Periodically remove fuel cylinder and lubricate the valve.
3. Periodically check all connections for leaks, all mounting bolts and clamps for tightness.
4. Periodically test for proper functioning by disconnecting the spray fitting from engine air inlet system. The side of fitting is marked (chisel mark) to indicate location of spray orifices. Replace the fitting with location mark in same position.
5. Reassemble spray fitting tube.
6. Actuate system. A fine, mist-like spray should be emitted from the orifice in spray fitting.

F. TROUBLESHOOTING

If inoperable conditions exist, perform the following:

1. Check fuel cylinder for hand tightness and check fuel supply. An empty cylinder weighs 17 ounces (0.48 kg), a full cylinder weighs 37 ounces (1.05 kg). Make sure fuel cylinder is tight. If empty, replace.
2. If system is still not functioning, replace entire assembly.

TOPIC 15 SAFETY CONTROLS

SAFETY PRECAUTIONS

⚠ WARNING: To prevent the possibility of bodily injury, always disconnect the battery-to-ground cable before cleaning, repairing, disconnecting or connecting any of the electrical cables.

⚠ WARNING: Never use gasoline or other toxic or flammable fluids to clean parts.

A. GENERAL

Optional engine safety controls (Fig. 1) automatically stop the engine when oil pressure drops below safe operating pressure or coolant rises above a safe preset limit. Thus these controls protect engine from damage. To meet owners requirements, various combinations of safety components are available including an oil pressure safety switch gauge, water temperature safety-switch gauge, and electric fuel shut off valve.

The safety-switch gauges are wired to energize the electric fuel shut off solenoid which is of the "energized to run" (open) type.

B. OIL PRESSURE SWITCH-GAUGE

1. Operation

The oil pressure switch gauge is a combination oil pressure gauge and safety switch. The visible pointer in dial indicates engine oil pressure. The gauge

is connected by a tube directly to the engine oil gallery. If pressure drops below 10 to 15 psi (64 to 103 kPa) lowest safe operating range, the pointer moves to the low pressure range of the switch-gauge. At this point, the contact in the switch-gauge opens and the electric fuel shut off solenoid is de-energized. In turn, the shut off arm spring in the Roosa Master injection pump forces the metering valve to the no-fuel position and stops the engine. On engines with Robert Bosch injection pumps, the fuel shut off solenoid valve stops engine when all fuel in the injection pump is expended.

Once engine has stopped, the switch-gauge contact will remain open until engine oil pressure exceeds 20 psi (138 kPa).

NOTE: To start engine magnetic switch reset button must be held IN until engine starts and oil pressure exceeds 20 psi (138 kPa). At this pressure, the normally open contact in the switch-gauge closes to complete circuit to fuel solenoid.

2. Adjustment

The switch-gauge is factory adjusted to shut down engine when oil pressure drops below 10 to 15 psi (64 to 103 kPa). This setting can be changed to compensate for change in operating pressure. The setting change is best done by a factory trained mechanic or your Allis-Chalmers dealer.

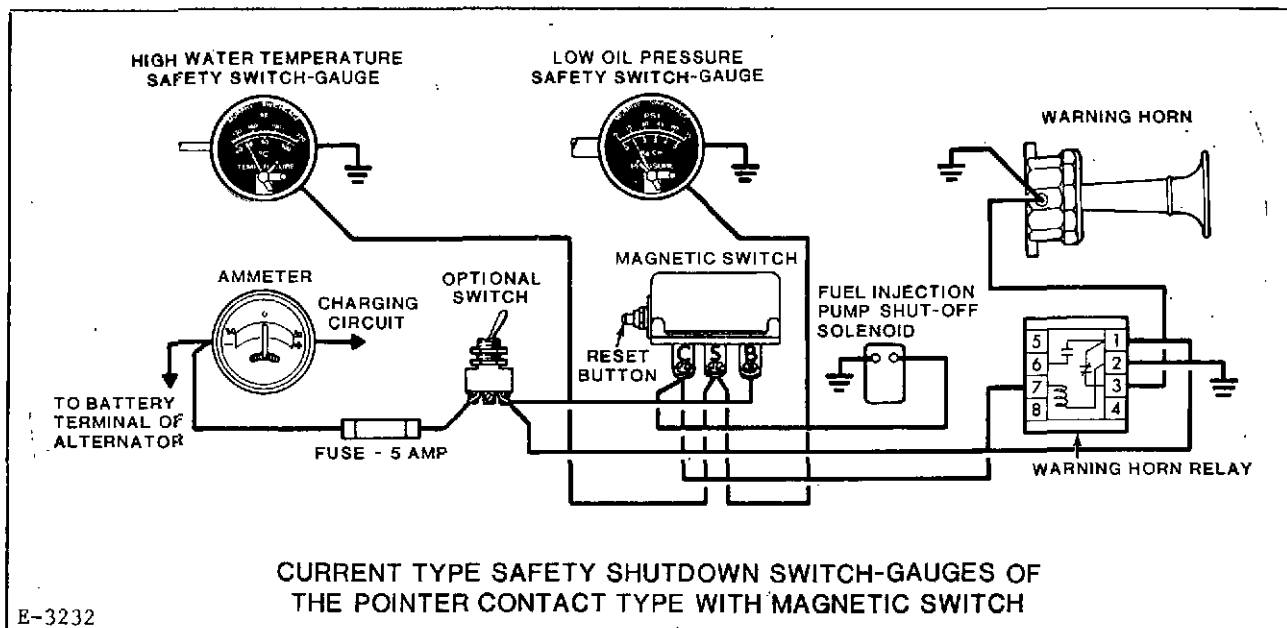

E-3232

Figure 1. Safety Controls-Schematic Wiring Diagram

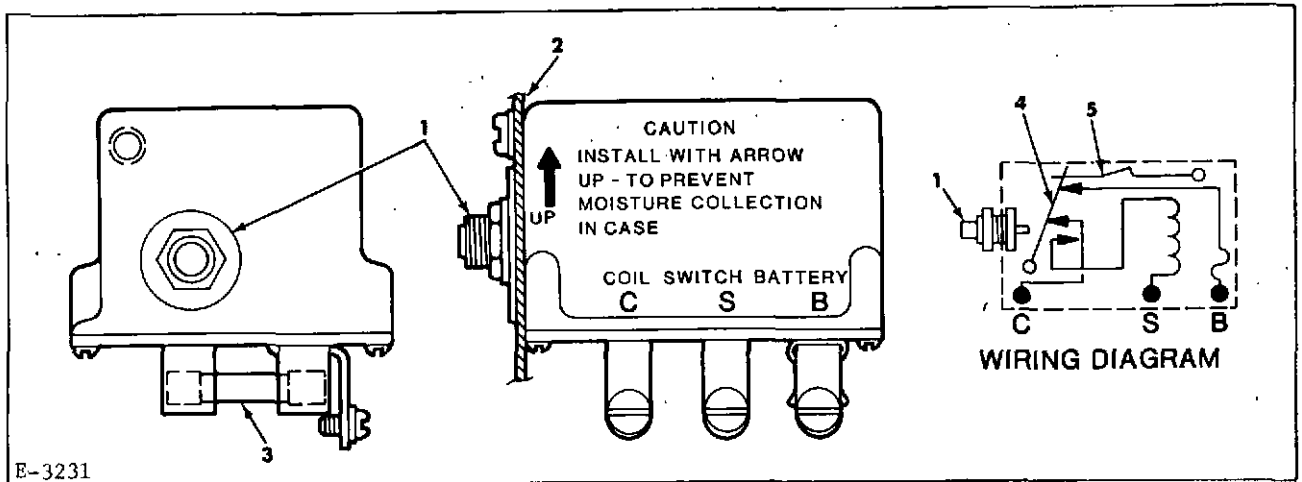

1. Reset button
2. Panel

3. Fuse (BUS SFE-14)
4. Armature

5. Armature latch

Figure 2. Magnetic Switch-Used with Current and First Type Safety Switch-Gauges

C. COOLANT TEMPERATURE SWITCH-GAUGE

1. Operation

This gauge is a combination coolant temperature indicator and safety switch. The gauge is connected directly into the engine cooling system at rear of thermostat housing by a heat bulb and capillary tube. If coolant temperature rises excessively, pointer in dial moves to high temperature range. At this point, the normally closed contact in the switch-gauge opens to de-energize the electric fuel shut off solenoid and the engine stops when fuel in injection pump is exhausted. While pointer remains in high range, it is impossible to start engine. Coolant must drop to safe range before contact in the switch-gauge will close.

2. Adjustment

Coolant temperature switch-gauge is factory adjusted to shut off engine when temperature reaches 205° to 210°F (96° to 99°C). This setting can be changed to compensate for altitude variation that effect boiling effect boiling point of water. Setting change should be done by a qualified mechanic or your Allis-Chalmers dealer.

D. STARTING AND STOPPING WITH SAFETY CONTROLS

1. Starting

a. Disconnect all load from engine.

b. Place stop control (if applicable) or key switch to ON position.

c. Place throttle in full load position.

d. Where applicable, press air heater switch as in paragraph B, Topic 6, Operating Instructions.

e. Press starter button and magnetic switch reset button (Fig. 2) simultaneously and hold until engine starts- No longer than 30 seconds on the starter switch. It is necessary to hold magnetic switch button until oil pressure reaches 20 psi (138 kPa).

f. Once engine is firing on most cylinders, move throttle to fast idle and allow engine to warm up before applying load.

g. Within a few seconds after starting engine, oil pressure should exceed 10 psi (69 kPa). If it does not, stop engine, locate and correct cause. After warm up, the oil pressure should be between 30 to 50 psi (207 to 379 kPa) at full load.

2. Stopping

a. Move throttle slowly to slow idle and disengage load.

b. Return idle to fast and allow engine to run at least 5 minutes to cool gradually.

c. Position stop control (switch if applicable) to OFF position.

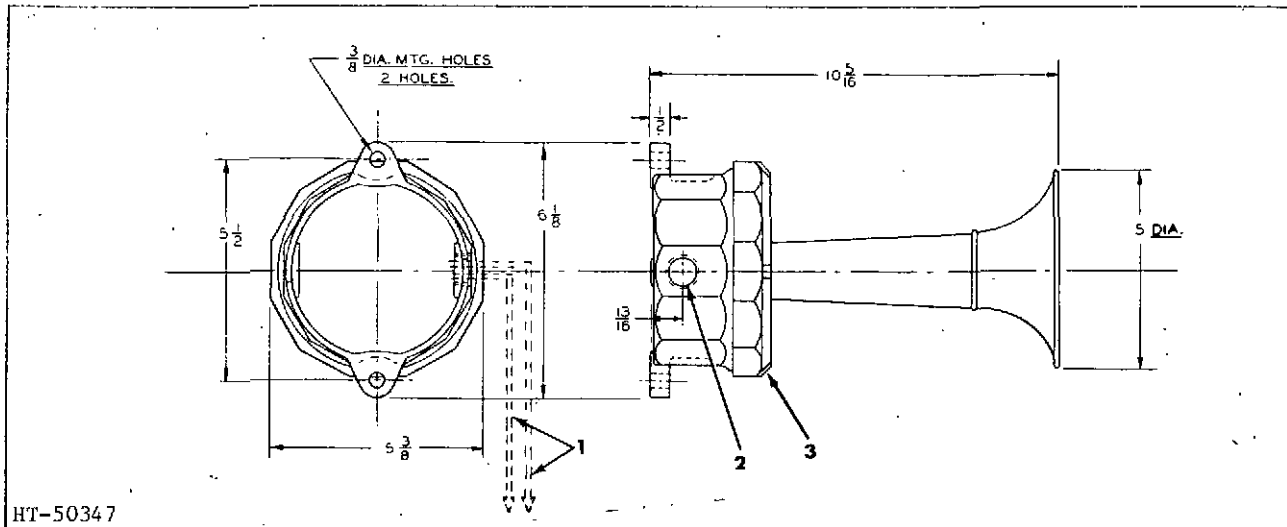

HT-50347

1. Number 12 size wire (furnished by customer)
2. 1/2 std. pipe tap for conduit, this side only
3. Trumpet to base retaining nut

Figure 3. Warning Horn

d. Cover exhaust pipes to prevent rain from entering engine.

E. AUTOMATIC SAFETY ENGINE SHUTDOWN

1. High Coolant Temperature

If high temperature should activate the water temperature switch-gauge and shut down engine, it is impossible to restart engine until coolant temperature is lowered to safe level and switch-gauge closes.

2. Low Oil Pressure

If shut down is due to low engine oil pressure, locate source of trouble and make repairs before attempting to restart unit.

F. GAUGE CIRCUIT TROUBLESHOOTING CHECKS

If fuel and electrical systems and the oil and coolant levels have been checked, and engine is still not normal:

1. Check entire control panel for loose electrical fittings, tube connections, and/or gum varnish and dirt deposits in damper unit on back of switch-gauge.
2. Any further testing should be handled by a qualified mechanic or your Allis-Chalmers dealer.

G. WARNING HORN & WARNING HORN RELAY

1. Warning Horn

A 12 or 24 volt DC warning horn is em-

ployed to give audible signal in conjunction with engine shut down due to high coolant temperature, low engine oil pressure, and/or excessive speed.

The horn (Fig. 3) is shipped unmounted to enable owner to mount in convenient location less than 100 feet (30.48m) from engine.

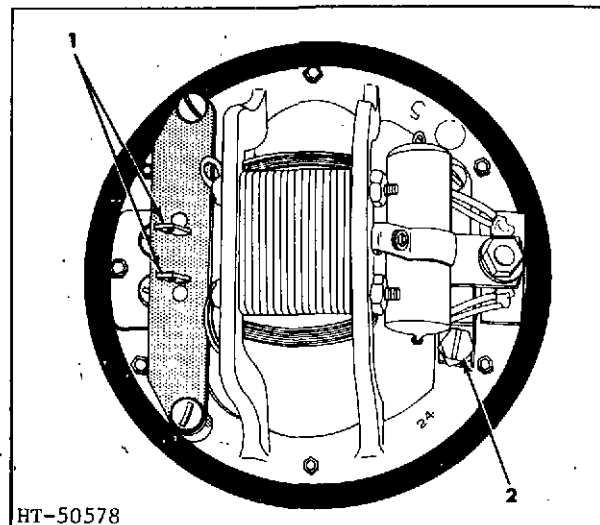

HT-50578

1. Prong type connector
2. Sound adjusting screw

Figure 4. Warning Horn Adjusting

For easy mounting, remove horn and vibrator coil assembly from base (Fig. 3) by loosening large retaining nut until it is free from base. Pull horn straight out to disengage prong-type (Fig. 4) convenient location. Reinstall by reversing procedure. The horn sound is ad-

justable. Change if necessary by turning sound adjusting screw (Fig. 4).

2. Warning Horn Relay

Before engine is started, those with a safety control off-on toggle switch must have it placed in ON position. The horn will sound until the by-pass button is pressed IN and the warning horn relay is energized thus causing the contacts to open the circuit to the horn. When engine starts, the operator releases by-

pass button. By this time, engine oil pressure should exceed 20 psi (138 kPa) and the low oil pressure safety control contacts have closed, the warning horn relay remains energized, and its contacts are held open.

Upon engine safety shut down, contacts in safety controls open, the warning horn relay is de-energized and its circuit closed—completing the electrical circuit to the horn. It will sound until safety control off-on toggle switch is placed in off position.

TOPIC 16 ENGINE ACCESSORIES

SAFETY PRECAUTIONS

⚠ WARNING: To prevent injury, always turn the key switch or stop control to the "OFF" position before cleaning, repairing, or servicing the engine.

⚠ WARNING: No unauthorized person must be allowed to service or maintain this machine. Study the Operation and Maintenance manuals before starting, operating, maintaining, fueling, or servicing this machine.

⚠ WARNING: Do not check or adjust belts when engine is running.

A. AIR COMPRESSOR

The air compressors available as optional equipment are single stage, reciprocating piston type with capacities of either 7.5 cu. ft./min. (3.4 cu. m/sec.) or 12 cu. ft./min. (5.7 cu. m/sec.). All compressors are

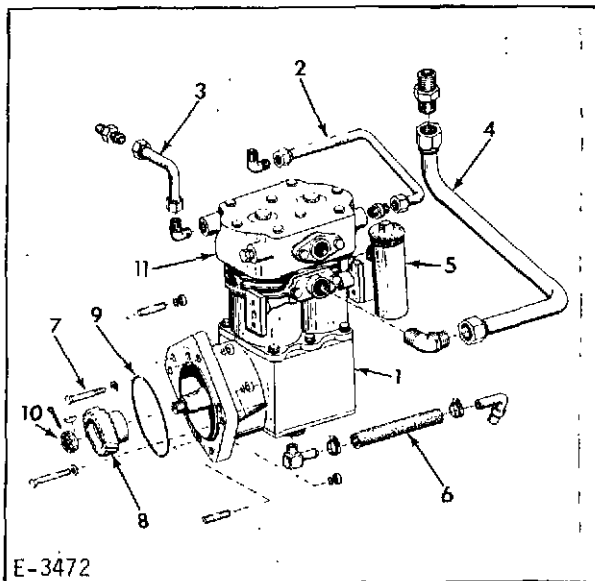

1. Compressor assembly
2. Coolant supply
3. Coolant return to engine
4. Air to compressor
5. Governor
6. Oil drain
7. Capscrews and lockwashers
8. Drive gear
9. O-ring
10. Gear retaining nut and cotter pin
11. Drain plug - coolant

Figure 1. Air Compressor
Gear Driven For 433, 649 and 670
Series Engines
(Piping is typical)

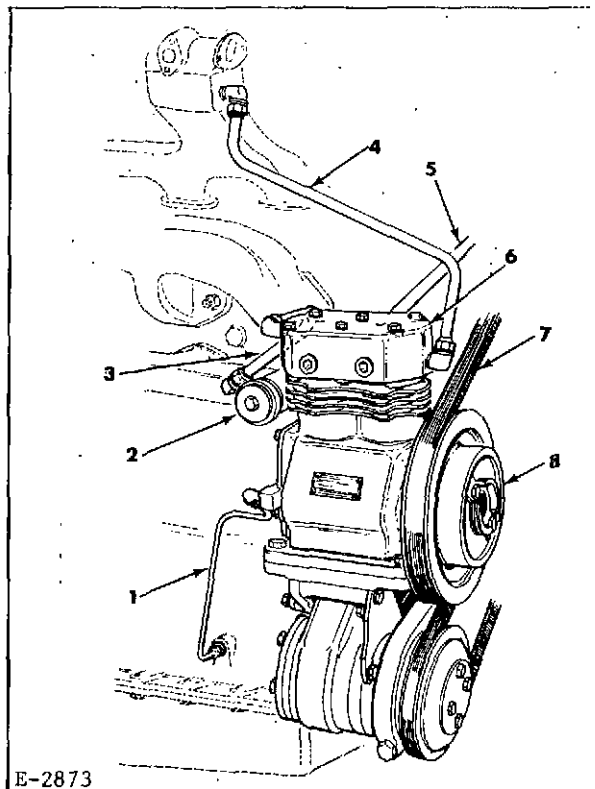

1. Lubricating oil hose/tube
2. Governor
3. Coolant inlet hose/tube
4. Coolant outlet hose/tube
5. Air inlet tube
6. Air compressor cylinder head
7. Air compressor drive belt
8. Adjustable pitch pulley

Figure 2. Air Compressors
685 and 6138 Series Engines
(Piping is typical)

2 cylinder in line. The compressors used on the 433, 649 and 670 series engine are located on the left side of the engine and are driven off of the camshaft gear. The compressors used on the 685 and 6138 series engine are belt driven and normally mounted on the right hand side of the engine.

Compressor is lubricated by a continuous flow of oil from engine main oil gallery through external oil line. Excess oil spills down and drains directly back to engine through the hollow mounting bracket or drain lines.

Inlet air is obtained through tube connecting inlet part of compressor to engine air inlet manifold. Thus air is cleansed by engine air filter.

The current compressor is cooled in two ways. The head is cooled by the engine's

cooling system. The block is air cooled by external fins. Coolant piping is such that compressor head is drained when engine coolant is drained. On the first type compressors, a drain cock is provided and must be drained separately to prevent freezing.

The compressor runs continuously while engine is running. Actual compression of air is controlled by a governor (Fig. 3). It starts and stops compression by loading or unloading when reservoir (air storage tank) pressure reaches preset limits. The governor is spring actuated.

Air reservoir must be supplied by customer.

1. Compressor drive belt is properly adjusted when it can be pressed inward 1/2 inch (12.7 mm) at half-way point. To adjust:

- a. Remove capscrew attaching lock plate to pulley front section and remove lockplate (Fig. 4).
- b. Hold pulley rear section stationary and turn pulley front section clockwise to tighten; counterclockwise to loosen.
- c. When correct belt tension is obtained, turn pulley front section as necessary to align nearest capscrew holes with notches in pulley hub.
- d. Install lockplate in position on hub. Secure to pulley front section with capscrews.

2. Belt Replacement

- a. Remove capscrews, lockwashers, and locking plate securing front half of pulley.
- b. Remove front half of pulley by turning counterclockwise. Slip off the old belt.
- c. Position new belt in fan pulley and rear half of compressor pulley.
- d. Install front half of pulley.
- e. Adjust front half of pulley for tension as in paragraph c and d above.

3. Air Compressor Maintenance

Phase 1 Maintenance-Daily

- a. Drain moisture from air reservoir (storage tank) before start of operation.

Phase 2 Maintenance-Each 100 Hours/ 6 Months

- a. Check drive belt alignment.
- b. Check tightness of mounting bolts.

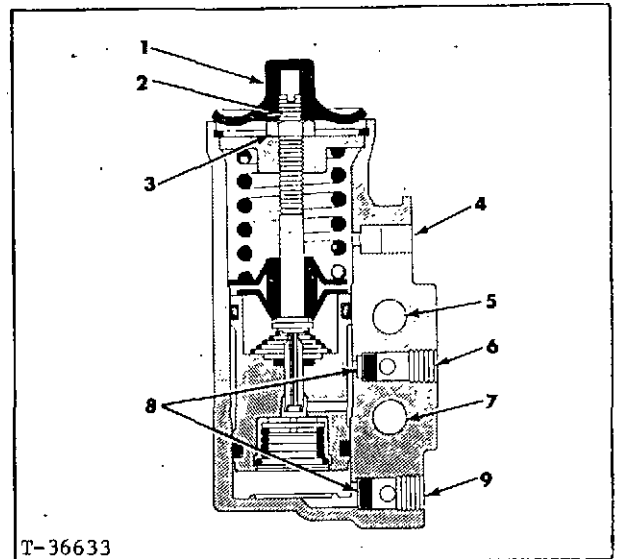

- | | |
|----------------------------|-------------------|
| 1. Cover | 6. Unloader port |
| 2. Adjusting screw | 7. Mounting hole |
| 3. Adjusting screw locknut | 8. Filters |
| 4. Mounting hole | 9. Reservoir port |

Figure 3. Air Compressor Governor

- c. Check for clean supply of air. All connections must be secure and not leaking.
- d. Check oil and coolant lines for leaks or damage.
- e. Make certain compressor fins are clean and not clogged.

Phase 3 Maintenance — Each 600 Hours/12 Months

- a. Clean governor air filters in place by using small brush and small amount of trichloroethylene solution.

NOTE: Filters should be cleaned in place. Do not remove unless they are damaged. They may be removed and replaced with new ones by installing new filters using end of pencil to seat them in governor body.

Phase 4 Maintenance—Each 1,000 Hours

- a. Remove compressor head and discharge head fitting. Inspect discharge ports and line for carbon deposits. If excessive, clean or replace.
- b. Remove and clean external lubricating oil line.
- c. Remove compressor from mounting.

Clean interior of hollow base and oil return hole.

When leakage in air system is not excessive, failure of compressor to deliver adequate air pressure usually denotes efficiency loss due to wear. Another sign of wear is presence of

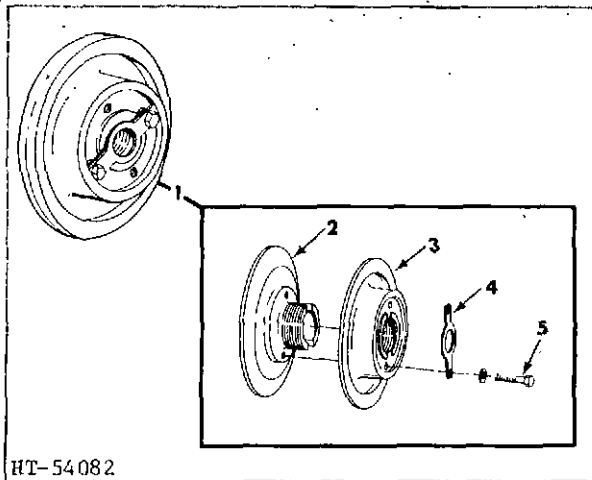

1. Adjustable pulley assembly
2. Stationary pulley half
3. Adjustable pulley half
4. Pulley lockplate
5. Capscrew

Figure 4. Adjustable Pulley Assembly

excessive oil in water bled from air in reservoir tank. In either case, compressor should be replaced or rebuilt.

B. POWER TAKE-OFF CLUTCH

The clutches (Figs. 5 and 6) are either standard or heavy duty having single, double, or triple dry type clutch plates with an over-center engaging action. A shifting collar and bearing mechanism, carried on power take-off shaft, is operated by clutch lever to engage or disengage the clutch. A threaded adjusting yoke provides means to maintain adjustment to compensate for clutch wear.

Clutch should engage with a definite over-center "snap" and require an appreciable push on operating lever for engagement. If "snap" is not evident, or clutch slips under load, adjust clutch immediately.

If clutch is heavy duty type (Fig. 6), when engine is first put into operation make certain the oil for the shaft bearings is to the proper level. Check with dipstick gauge located in the bearing carrier.

Always refer to instructions in clutch adjustment access cover.

1. Power Take-off Clutch Adjustment (Fig. 7)

- a. Shut engine off/down and remove access cover and gasket.
- b. Disengage clutch. Turn clutch shaft until adjusting lock pin may be reached through opening in housing.
- c. Pull adjusting lock pin out and turn

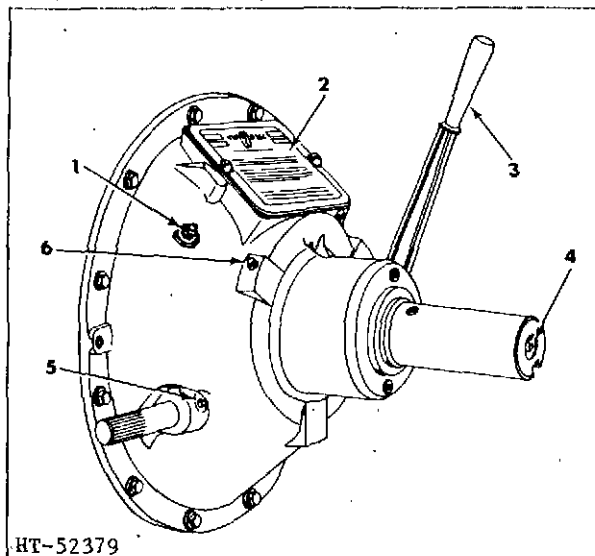

1. Throw-out collar lube fitting
2. Clutch access cover
3. Clutch operating lever
4. Pilot bearing lube fitting
5. Operating lever shaft lube fitting
6. Shaft bearing lube fitting

Figure 5. Power Take-off Clutch

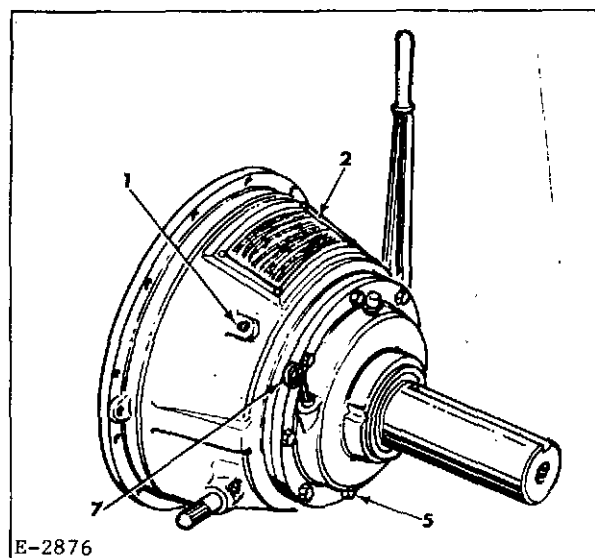

1. Throw-out collar lube fitting
2. Clutch access cover
3. Clutch operating lever
4. Pilot bearing lube fitting
5. Drain plug
6. Operating lever shaft lube fitting
7. Oil level gauge

Figure 6. Power Take-off Clutch-Heavy Duty Type with Oil Lubricating Shaft Bearings

adjusting yoke clockwise to tighten, opposite to loosen, as necessary. Moving two or three notches is usually sufficient.

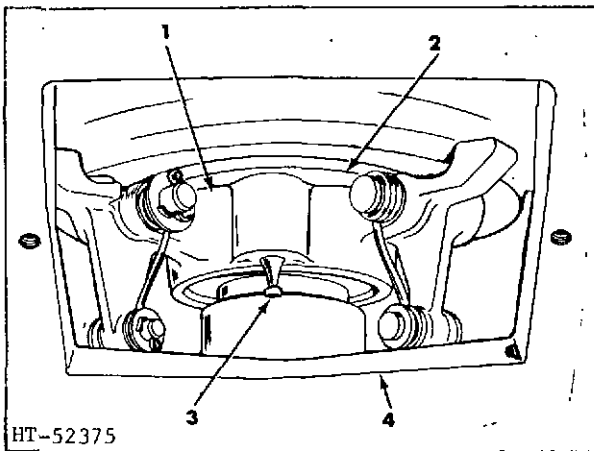

1. Adjusting yoke
2. Clutch back plate
3. Clutch adjusting lock pin
4. Power take-off housing

Figure 7. Clutch Adjustment

d. Lock adjusting yokes in place by inserting adjusting lock pin into nearest notch in clutch back plate. Clutch should engage with definite over center snap.

e. Replace access cover and gasket.

2. Maintenance

Phase 1—Maintenance Daily

a. Lubricate throw-out collar through fitting on tapered parts of housing.

(Fig. 4 and 5, Item 1) Refer to topic 4 for grease recommendations.

Phase 2 — Maintenance — Each 100 Hours/ 6 Months

- a. Lubricate the pilot bearings, through the fitting in clutch shaft. Sealed-for-life pilot bearing should not be lubricated. Damage to engine thrust bearing could result from trapped grease pressure. Clutch shaft is not normally drilled. If drilled, a plug(s) should be installed to prevent inadvertent greasing.
- b. Lubricate shaft bearings through fitting on housing hub.
- c. Lubricate operating lever shaft.
- d. Check clutch adjustment. If clutch slips under load or has no over center snap, adjust immediately.

Phase 4 — Maintenance — Heavy Duty Clutch (Fig. 6) Each 500 Hours

- a. Change oil that lubricates tapered roller bearing. The drain and filler plugs are located in the bearing carrier.

Use a good grade of SAE 30 engine oil with an APE classification of SD or CA (formerly MS or DG) or better.

The information contained herein is general in nature and is not intended for specific application purposes. Allis-Chalmers reserves the right to make changes in specifications shown herein, add improvements, or discontinue manufacture at any time without notice or obligation.