

**OPERATING AND  
MAINTENANCE  
MANUAL**

**MODELS**

**16000 H, 16000 MARK II**

**17000 MARK II**

**21000 MARK II**

**25000 MARK II**

**GENERATOR DRIVE  
ENGINES**

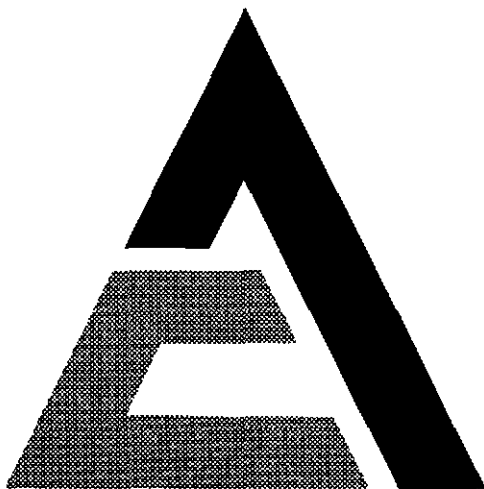

**ALLIS-CHALMERS**

**ENGINE DIVISION  
HARVEY, ILLINOIS 60426, USA**

**Printed in USA  
(6-75)**

**Form: TM-5069-1  
Part No. 4395614**

**OPERATING AND  
MAINTENANCE  
MANUAL**

**MODELS**

**16000 H, 16000 MARK II**

**17000 MARK II**

**21000 MARK II**

**25000 MARK II**

**GENERATOR DRIVE  
ENGINES**

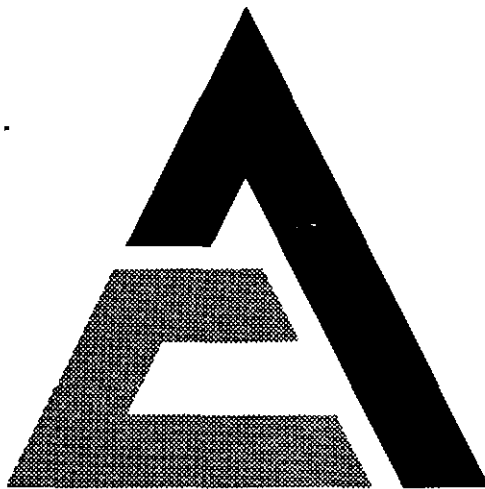

**ALLIS-CHALMERS**

**ENGINE DIVISION  
HARVEY, ILLINOIS 60426, USA**

**Printed in USA  
(6-75)**

**Form: TM-5069-1  
Part No. 4395614**

## **AVOID ACCIDENTS**

**MOST ACCIDENTS, WHETHER THEY OCCUR IN INDUSTRY, ON THE FARM, AT HOME OR ON THE HIGHWAY, ARE CAUSED BY THE FAILURE OF SOME INDIVIDUAL TO FOLLOW SIMPLE AND FUNDAMENTAL SAFETY RULES OR PRECAUTIONS. FOR THIS REASON MOST ACCIDENTS CAN BE PREVENTED BY RECOGNIZING THE REAL CAUSE AND DOING SOMETHING ABOUT IT BEFORE THE ACCIDENT OCCURS.**

**REGARDLESS OF THE CARE USED IN THE DESIGN AND CONSTRUCTION OF ANY TYPE OF EQUIPMENT THERE ARE MANY CONDITIONS THAT CANNOT BE COMPLETELY SAFEGUARDED AGAINST WITHOUT INTERFERING WITH REASONABLE ACCESSIBILITY AND EFFICIENT OPERATION.**

**IT IS THE RESPONSIBILITY OF USERS TO PROVIDE AND INSTALL GUARDS OR SAFETY DEVICES WHICH MAY BE REQUIRED BY RECOGNIZED SAFETY STANDARDS OR BY THE OCCUPATIONAL SAFETY AND HEALTH ACT OF 1970 AND ITS SUBSEQUENT PROVISIONS.**

**A careful operator is the best insurance against an accident. The complete observance of one simple rule would prevent many thousand serious injuries each year. That rule is:**

**Never attempt to clean, oil or adjust a machine while it is in motion.**

## FOREWORD

This manual is provided to give the operator essential information regarding proper operation and maintenance of Allis-Chalmers diesel engine and auxiliary equipment.

The manual contains information and instructions on proper operation. To keep the unit operating at its maximum efficiency, the manual should be read by the operator and by those responsible for the maintenance of the unit.

An important item in prolonging the life of the unit is to keep dirt and other foreign particles away from its vital parts. Allis-Chalmers has taken precautions in the design of the equipment to safeguard against dirt and other foreign materials from reaching the working parts under normal operating conditions. The operator must also take precautions to assure that the oil, water, and fuel are always kept clean, and that air for combustion is always filtered. This can be accomplished by the proper storage and handling of fuel and lubricating oils and by following Allis-Chalmers recommendations in regard to lubricating oil specifications and change intervals, fuel specifications, maintenance of filters, air cleaner servicing, and proper care of the cooling system.

To assure the best results and maintain the high quality of the equipment, it is important that Allis-Chalmers parts are always used when new parts are required. **IMPORTANT: ALWAYS FURNISH MODEL AND ENGINE SERIAL NUMBER WHEN ORDERING PARTS.**

Many owners of Allis-Chalmers equipment rely upon the Service Department of our Dealers for all work other than routine maintenance and adjustment. This practice is encouraged as our Dealers are kept well informed by the factory regarding the most up-to-date methods of servicing Allis-Chalmers equipment and are equipped to render the most competent service.

# THE METRIC SYSTEM OF MEASUREMENT

Today's rapid communication and transportation between the nations of the world has resulted in the use of more of each other's products and services. This has caused a trend among the nations to adapt a standardization of units for use in both scientific and technical fields.

The customary United States (English) units and some metric units are being replaced with those of a modernized metric system known as the International System of Units which is officially abbreviated SI in all languages.

The SI or modernized metric system consists of six basic units:

- Meter for length
- Kilogram for mass
- Second for time
- Ampere for electric current
- Kelvin for temperature
- Candela for luminous intensity

Because Allis-Chalmers' products are used worldwide and the adaptation of the SI metric system by all nations is getting nearer, both English and metric system of units appear in this manual.

To assist those not completely familiar with the metric system, the following nomenclature and tables will be of assistance.

## A. GENERAL NOMENCLATURE USAGE

	METRIC	ENGLISH
Length	millimeter (mm)	inch (in)
Pressure	kilonewton/meter <sup>2</sup> (kN/m <sup>2</sup> )	pounds per square inch (PSI)
Force	newton (N)	pound (lb)
Mass	kilogram (kg)	pound (lb)
Time	second (s)	second (s)
Volume (liquid)	liter (l)	gallon (gal)
Temperature	kelvin (K)	degrees fahrenheit (° F)
Torque	newton-meter (Nm)	pound foot (lb-ft)
Power	kilowatt (kw)	horsepower (hp)
Frequency	hertz (Hz)	cycles per second (cps)

## B. CONVERSIONS FACTORS

TO CONVERT	TO OBTAIN	MULTIPLY BY
Cubic Feet (cu ft)	Cubic Centimeters (cu cm)	28320
Cubic Inches (cu in)	Cubic Centimeters (cu cm)	16.39
Degree Centigrade (° C)	Kelvin (K)	° C + 273.15
Degree Fahrenheit (° F)	Kelvin (K)	(° F - 32) 5/9 + 273.15
Feet (ft)	Meter (m)	0.3048
Gallon (gal)	Liter (l)	3.785
Inch (in)	Millimeter (mm)	25.40
Inches of Mercury (in of Hg)	Newton per square meter (N/m <sup>2</sup> )	3376.85
Inches of Water (in of H <sub>2</sub> O)	Newton per square meter (N/m <sup>2</sup> )	248.84
Mile (mi)	Meter (m)	1609.344
Miles per Hour (mi/hr)	Kilometer per hour (km/hr)	1.6093
Ounces (oz)	Grams (g)	28.349
Ounces (oz)	Liter (l)	0.02957
Pound (lb)	Kilogram (kg)	0.4536
Pounds per square inch (PSI)	Kilonewton per square meter (kN/m <sup>2</sup> )	6.894757
Pounds per inch (lb in) (torque)	Newtons per meter (Nm)	0.1129848
Pounds per foot (lb ft. (torque)	Newtons per meter (Nm)	1.355818
Quart (qt)	Liter (l)	0.9463
Yard (yd)	Meter (m)	0.9144

**C. QUICK REFERENCES CONVERSIONS (APPROXIMATE VALUES)**

- One (1) Fahrenheit Degree: approximately equals .55 Centigrade Degree
- One (1) gallon: approximately equals 3 - 3/4 liters
- One (1) PSI: approximately equals 7 kN/m<sup>2</sup>
- One (1) in-lb of torque: approximately equals 0.11 Nm
- One (1) ft-lb of torque: approximately equals 1.35 Nm

**D. DECIMAL AND METRIC EQUIVALENTS OF FRACTIONS OF AN INCH**

INCHES		MILLI-METERS	INCHES		MILLI-METERS
FRACTIONS	DECIMALS		FRACTIONS	DECIMALS	
1/64	.015625	.40	33/64	.515625	13.10
1/32	.03125	.79	17/32	.53125	13.49
3/64	.046875	1.19	35/64	.546875	13.89
1/16	.0625	1.59	9/16	.5625	14.29
5/64	.078125	1.98	37/64	.578125	14.68
3/32	.09375	2.38	19/32	.59375	15.08
7/64	.109375	2.78	39/64	.609375	15.48
1/8	.125	3.18	5/8	.625	15.88
9/64	.140625	3.57	41/64	.640625	16.27
5/32	.15625	3.97	21/32	.65625	16.67
11/64	.171875	4.37	43/64	.671875	17.07
3/16	.1875	4.76	11/16	.6875	17.46
13/64	.203125	5.16	45/64	.703125	17.86
7/32	.21875	5.56	23/32	.71875	18.26
15/64	.234375	5.95	47/64	.734375	18.65
1/4	.250	6.35	3/4	.750	19.05
17/64	.265625	6.75	49/64	.765625	19.45
9/32	.28125	7.14	25/32	.78125	19.84
19/64	.296875	7.54	51/64	.796875	20.24
5/16	.3125	7.94	13/16	.8125	20.64
21/64	.328125	8.33	53/64	.828125	21.03
11/32	.34375	8.73	27/32	.84375	21.43
23/64	.359375	9.13	55/64	.859375	21.83
3/8	.375	9.53	7/8	.875	22.23
25/64	.390625	9.92	57/64	.890625	22.62
13/32	.40625	10.32	29/32	.90625	23.02
27/64	.421875	10.72	59/64	.921875	23.42
7/16	.4375	11.11	15/16	.9375	23.81
29/64	.453125	11.51	61/64	.953125	24.21
15/32	.46875	11.91	31/32	.96875	24.61
31/64	.484375	12.30	63/64	.984375	25.00
1/2	.500	12.70	1	1.000	25.40

# Engine Division Warranty

ALLIS-CHALMERS CORPORATION (the Company) warrants new engines and diesel electric systems sold by it to be merchantable and free of defects in workmanship and material at the time of shipment from the Company's factory. THERE ARE NO WARRANTIES WHICH EXTEND BEYOND THOSE EXPRESSED HEREIN.

The Company will repair or replace, at its option and subject to the following provisions, any part of its new engines and diesel electric systems that fails to conform to this warranty, provided that such part is returned to the Company's factory or to the Company's dealer authorized to handle engines or diesel electric systems, transportation charges prepaid, within the following periods:

**(1) 2 YEARS OR 100,000 MILES OR 3600 HOURS OF OPERATION**, whichever first occurs, from the date of delivery to the first user of

- (a) Engines used for on-highway vehicles and marine pleasure boat applications, and
- (b) Stand-by diesel electric systems.

As to such products, the Company will supply all required parts free of charge. In addition, the Company will bear all reasonable warranty labor costs during the 2 year period, as follows:

- 100% in the case of parts subjected to no more than 50,000 miles or 1800 hours of operation, whichever first occurs; thereafter,
- 75% in the case of parts subjected to no more than 75,000 miles or 2700 hours of operation, whichever first occurs; and thereafter,
- 50% in the case of parts subjected to no more than 100,000 miles or 3600 hours of operation, whichever first occurs.

**(2) 1 YEAR OR 3600 HOURS OF OPERATION**, whichever first occurs, from the date of delivery to the first user of

- (a) Engines used for off-highway, construction, industrial and marine commercial work-boat applications, and
- (b) Continuous duty diesel electric systems.

As to such products, the Company will supply all required parts free of charge. In addition, the Company will bear all reasonable warranty labor costs during the 1 year period as follows:

- 100% in the case of parts subjected to no more than 1800 hours of operation; thereafter
- 75% in the case of parts subjected to no more than 2700 hours of operation; and thereafter,
- 50% in the case of parts subjected to no more than 3600 hours of operation.

**(3) 3 YEARS OR 300,000 MILES OR 10,800 HOURS OF OPERATION**, whichever first occurs, from the date of delivery to the first user of

- (a) Crankshafts in new engines, and
- (b) Engine blocks for new engines.

As to such parts, the Company will supply all required parts free of charge during the first 2 years or 200,000 miles or 7200 hours of operation, whichever first occurs, from the date of delivery to the first user, and thereafter the company will bear one-half of the cost of such parts, during the remainder of the warranty period. In addition, the Company will bear reasonable warranty labor costs, as follows:

100% during the first 2 years or 100,000 miles or 3600 hours of operation, whichever first occurs from date of delivery to the first user, in the case of crankshafts and blocks in engines used for on-highway vehicles and marine pleasure boat applications and stand-by diesel electric systems.

100% during the first year or 3600 hours of operation, whichever first occurs from date of delivery to the first user, in the case of crankshafts and blocks in engines used for off-highway, construction, industrial, marine commercial work-boat applications and continuous duty diesel electric systems.

The Company will not be obligated to bear labor costs for removing or installing engines at any time during the warranty periods set forth herein.

No warranty of any kind is made or shall be imposed upon the Company with respect to (1) new engines or diesel electric systems which have been subject to operation in excess of recommended capacities, misuse, negligence or accident, or have been altered or repaired in any manner not authorized by the Company, or (2) accessory items not manufactured by the Company as such items are separately warranted by their respective manufacturers.

THE COMPANY'S LIABILITY, WHETHER IN CONTRACT OR IN TORT ARISING OUT OF WARRANTIES, OR REPRESENTATIONS, INSTRUCTIONS, OR DEFECTS FROM ANY CAUSE, SHALL BE LIMITED EXCLUSIVELY TO REPAIRING OR REPLACING PARTS UNDER THE CONDITIONS AS AFORESAID. IN NO EVENT SHALL THE COMPANY BE LIABLE FOR INCIDENTAL, INDIRECT, SPECIAL OR CONSEQUENTIAL DAMAGES.

# TABLE OF CONTENTS

TOPIC	TITLE	
1	GENERAL DESCRIPTION . . . . .	1.1
2	SPECIFICATIONS . . . . .	1.2
3	PREPARATION OF ENGINE FOR OPERATION. . . . .	1.3
4	OPERATING CONTROLS AND INSTRUMENTS . . . . .	1.4
5	OPERATING INSTRUCTIONS . . . . .	1.5
6	LUBRICATION RECOMMENDATIONS. . . . .	1.6
7	FUEL OIL RECOMMENDATIONS . . . . .	1.7
8	LUBRICATION AND MAINTENANCE SCHEDULE, AND MAINTENANCE TOOLS. . . . .	1.8
9	TROUBLESHOOTING. . . . .	1.9
10	FITS AND TOLERANCES; BOLT, CAPSCREW AND NUT TORQUE WRENCH SPECIFICATIONS; STUD GAUGE HEIGHTS . . . . .	1.10
11	COOLING SYSTEM . . . . .	1.11
12	FUEL SYSTEM. . . . .	1.12
13	LUBRICATION SYSTEM . . . . .	1.13
14	ELECTRICAL SYSTEM. . . . .	1.14
15	VALVE ADJUSTMENT AND CYLINDER HEAD . . . . .	1.15
16	INTAKE AND EXHAUST SYSTEMS . . . . .	1.16
17	AIR CLEANER. . . . .	1.17
18	TURBOCHARGER . . . . .	1.18
19	SAFETY CONTROLS . . . . .	1.19
20	COLD WEATHER STARTING AIDS . . . . .	1.20

# OPERATING AND MAINTENANCE INSTRUCTIONS

TOPIC	TITLE	
1	GENERAL DESCRIPTION. . . . .	1.1
	A. GENERAL	
	B. PRINCIPLES OF OPERATION	
	C. ENGINE STROKE SEQUENCE	
2	SPECIFICATIONS . . . . .	1.2
	A. ENGINE (BASIC)	
	B. COOLING SYSTEM	
	C. LUBRICATING SYSTEM	
	D. FUEL INJECTION SYSTEM	
	E. VALVE DATA	
	F. ELECTRICAL SYSTEM	
3	PREPARATION OF ENGINE FOR OPERATOR . . . . .	1.3
	A. SAFETY PRECAUTIONS	
	B. PROCEDURE	
4	OPERATING CONTROLS AND INSTRUMENTS . . . . .	1.4
	A. GENERAL	
5	OPERATING INSTRUCTIONS . . . . .	1.5
	A. GENERAL	
	B. OPERATING PRECAUTIONS	
	C. STARTING AND STOPPING ENGINE	
	D. DURING OPERATION CHECKS	
	E. COLD WEATHER OPERATION	
	F. HOT WEATHER OPERATION	
	G. EXERCISE OF ENGINE ON STANDBY SERVICE	
	H. ENGINE STORAGE	
6	LUBRICATION RECOMMENDATIONS. . . . .	1.6
	A. ENGINE LUBRICATING OIL	
	B. GREASE	
7	FUEL OIL RECOMMENDATIONS . . . . .	1.7
	A. GENERAL	
	B. FUEL OIL CHARACTERISTICS	
	C. HANDLING AND STORAGE OF FUEL OIL	
8	LUBRICATION AND MAINTENANCE SCHEDULE, AND MAINTENANCE TOOLS . . . . .	1.8
	A. GENERAL	
	B. LUBRICATION AND MAINTENANCE GUIDE	
	C. MAINTENANCE TOOLS	
9	TROUBLESHOOTING. . . . .	1.9
	A. GENERAL	
	B. ENGINE	
	C. STARTING SYSTEM	
	D. FUEL SYSTEM	
	E. AIR INTAKE SYSTEM	
	F. COOLING SYSTEM	
	G. LUBRICATING SYSTEM	
	H. ELECTRICAL SYSTEM	
	I. INSTRUMENTS	
	J. LOCATING CYLINDER CUTOUT	
	K. MAKING COMPRESSION TEST	

TOPIC	TITLE	
10	FITS AND TOLERANCES: BOLT, CAPSCREW, AND NUT TORQUE WRENCH SPECIFICATIONS: STUD GAUGE HEIGHTS. . . . .	1.10
	A. FITS AND TOLERANCES	
	B. BOLT, CAPSCREW, AND NUT TORQUE WRENCH SPECIFICATIONS	
11	COOLING SYSTEM . . . . .	1.11
	A. GENERAL	
	B. GENERAL MAINTENANCE	
	C. DRAINING OF COOLING SYSTEM	
	D. FILLING OF COOLING SYSTEM	
	E. CLEANING OF COOLING SYSTEM	
	F. ENGINE OIL COOLER	
	G. THERMOSTATS	
	H. FAN HUB AND WATER PUMP BELT TIGHTENER ASSEMBLY IDLER PULLEY LUBRICATION	
	I. FAN-WATER PUMP BELT REPLACEMENT AND ADJUSTMENT	
	J. IMMERSION HEATER AND THERMOSTAT	
	K. COOLING SYSTEM CONDITIONER	
12	FUEL SYSTEM. . . . .	1.12
	A. GENERAL	
	B. FUEL FILTERS-SPIN-ON TYPE	
	C. FUEL FILTERS-REPLACEABLE ELEMENT TYPE	
	D. PRIMING THE FUEL SYSTEM	
	E. FUEL INJECTION PUMP	
	F. FUEL SUPPLY (TRANSFER) PUMP	
	G. CHECKING THE FUEL SYSTEM	
	H. GOVERNOR AND GOVERNOR DRIVE	
	I. GOVERNOR TROUBLESHOOTING	
	J. HYDRAULIC GOVERNOR OIL RESERVOIR	
	K. FUEL SOLENOID SHUTOFF VALVE	
	L. FUEL INJECTION NOZZLE HOLDER ASSEMBLY	
	M. REMOVING CARBON FROM FUEL INJECTION NOZZLE-HOLDER SLEEVES IN CYLINDER HEADS	
	N. FLOW TIMING THE FUEL INJECTION PUMP	
	O. OPTIONAL GEAR TYPE FUEL OIL TRANSFER PUMP	
13	LUBRICATION SYTEM. . . . .	1.13
	A. GENERAL	
	B. GENERAL MAINTENANCE	
	C. FULL-FLOW OIL FILTERS (STANDARD)	
	D. BYPASS OIL FILTER (OPTIONAL)	
	E. DRAINING AND FILLING OIL SYSTEM	
	F. ENGINE OIL COOLER	
	G. LUBRICATION SYSTEM MAINTENANCE	
14	ELECTRICAL SYSTEM. . . . .	1.14
	A. GENERAL	
	B. WARRANTY AND ADJUSTMENT	
	C. BATTERY	
	D. ELECTRIC STARTING MOTOR	
	E. DC GENERATORS AND VOLTAGE REGULATORS	
	F. ALTERNATORS AND VOLTAGE REGULATORS	
	G. DRIVE BELT ADJUSTMENT	
15	VALVE ADJUSTMENT AND CYLINDER HEAD . . . . .	1.15
	A. VALVE ADJUSTMENT	
	B. CYLINDER HEAD REINSTALLATION	
16	INTAKE AND EXHAUST SYSTEM. . . . .	1.16
	A. DESCRIPTION	
	B. MEASURING EXHAUST SYSTEM BACK-PRESSURE	
	C. MANIFOLD MAINTENANCE	

TOPIC	TITLE	
17	AIR CLEANER. . . . .	1.17
	A. GENERAL	
	B. MAINTENANCE	
	C. SERVICE	
	D. AIR FILTER SERVICE INDICATOR	
18	TURBOCHARGER . . . . .	1.18
	A. GENERAL	
	B. OPERATION	
	C. MAINTENANCE	
	D. EFFECT OF ALTITUDE ON TURBOCHARGED ENGINES	
19	SAFETY CONTROLS. . . . .	1.19
	A. GENERAL	
20	COLD WEATHER STARTING AID. . . . .	1.20
	A. GENERAL	
	B. ELECTRICALLY OPERATED TYPE	
	C. MANUALLY OPERATED TYPE	

## TOPIC 1. GENERAL DESCRIPTION

### A. GENERAL

All these engine models are four cycle, water cooled, compression-ignition, overhead valve, open combustion chamber, direct injection, "full diesel" engines. Models 16000H and 16000MKII are naturally aspirated (nonturbocharged), and models 17000MKII, 21000MKII, and 25000MKII are turbocharged. The pistons of Models 21000MKII and 25000MKII are cooled by oil jets located in the main oil gallery.

Model 25000MKII is equipped with an intercooler in the intake manifold to cool the air from the turbocharger before it enters the cylinders. To cool the air engine coolant is circulated through the tube arrangement of the intercooler and the intake air is circulated around the outside of the tubes and fins. The cooling of the air allows more oxygen and fuel to be utilized in the combustion cycle and hence higher horsepower.

The basic engine, engine assemblies, and power units have been engineered with equipment necessary for usual installation requirements. All units can be modified for various applications by addition of optional equipment.

The furnishing of pertinent data regarding the operation and maintenance of equipment and accessories not originally supplied by Allis-Chalmers is the responsibility of the company that assembles the accessories to the engine.

Engines shipped from Allis-Chalmers are equipped with a combination name plate and optional equipment plate. The engine serial number and engine catalog number are stamped in the name plate section, the remainder of the plate is used to list the catalog numbers of the various optional equipment groups as specified on the original factory order, together with the specific factory shipping order number.

NOTE: To obtain shipment promptly when ordering repair parts, always give the information on the engine name plate, and the repair part number and name. Order parts from the dealer covering the local territory.

### B. PRINCIPLES OF OPERATION

The engines utilize two intake valves and two exhaust valves per cylinder. Each valve is provided with a valve rotator and all valve springs are equipped with damper springs.

Fuel is supplied to the cylinder by a constant stroke, cam-actuated, multi-plunger fuel injection pump. The pump delivers accurately metered quantities of fuel, under high pressure, through fuel injection nozzles, into the cylinders at a definite timing in relation to the engine firing cycle. The fuel is ignited by heat generated by compression of air in the cylinders.

A combustion chamber is located in the head of each piston, and fuel injection nozzles are mounted in the cylinder head directly above each combustion chamber. The shape of the combustion chamber, angle of fuel injection, and contour of cored air passages in the cylinder heads, causes extreme turbulence of the air within the cylinders. This results in the fuel and air being thoroughly mixed for complete combustion.

The engines are full pressure lubricated by a gear type oil pump driven by the crankshaft gear.

Cooling is accomplished by the coolant being forced through the engine jackets by a centrifugal type pump. The coolant from the engine jackets is cooled while passing through either a radiator or heat exchanger.

A turbocharger is used to obtain greater power output over that of the naturally aspirated model engine by increasing the supply of air to the cylinders. The turbocharger is essentially a rugged yet highly efficient exhaust driven blower.

### C. ENGINE STROKE SEQUENCE

In a 4-cycle diesel engine, a power stroke is made by each piston every two complete revolutions of the crankshaft. Sequence of strokes is intake, compression, power, and exhaust.

CATALOG NO.	OPT. EQUIP.	CATALOG NO.	OPT. EQUIP.	CATALOG NO.	OPT. EQUIP.

**ALLIS-CHALMERS**  
HARVEY ILLINOIS MADE IN U.S.A.

SERIAL NO.	CATALOG NO.
MODEL	

Combination Engine Name Plate and Optional Equipment Plate.

16000H 16000MKII 17000MKII  
21000MKII 25000MKII

Revision 1

1.1  
Page 1

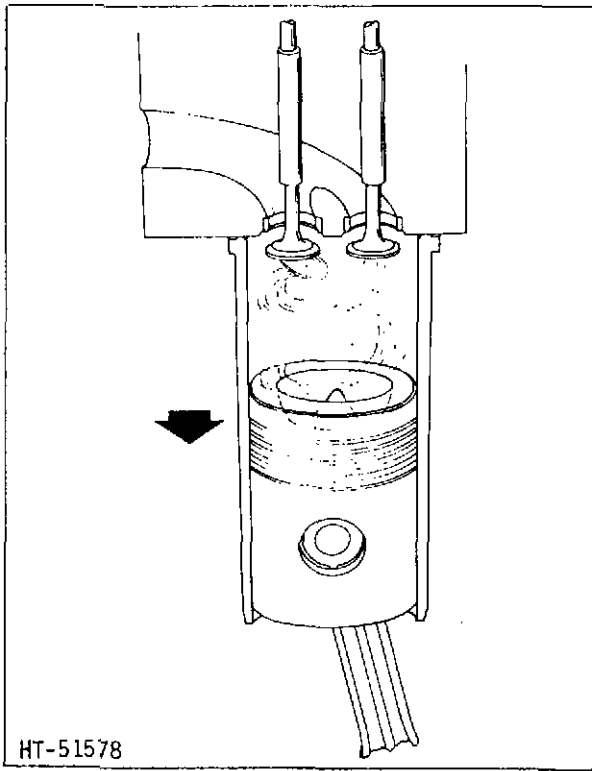

HT-51578

Figure 1. Intake Stroke

## 1. Intake Stroke

As the piston moves downward on the first, or intake stroke, air enters the cylinder through the air intake manifold and intake valve, which starts to open a few degrees before the piston reaches top dead center. The intake charge, consisting of air only, rushes into the cylinder and is given a swirling motion by directional ports in the cylinder head.

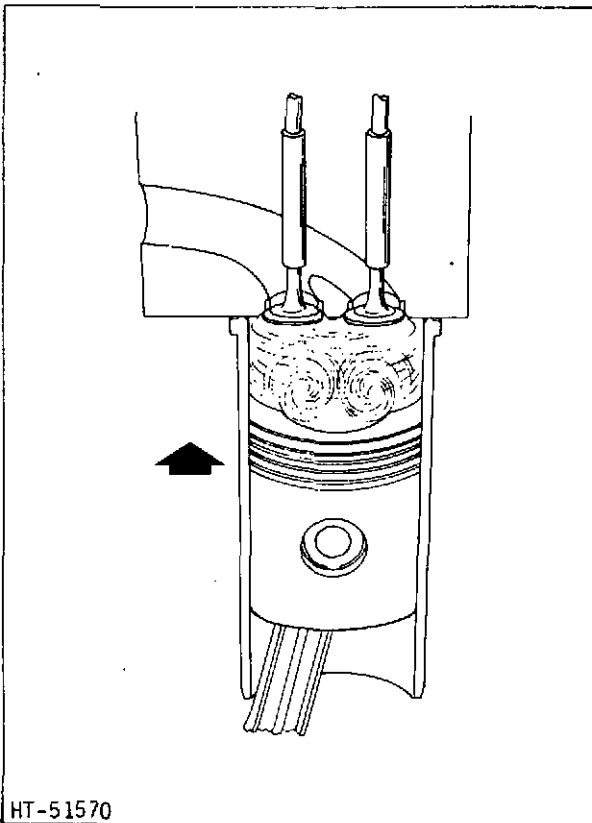

HT-51570

Figure 2. Compression Stroke

## 2. Compression Stroke

Shortly after the piston starts to move upward on the second, or compression stroke, the intake valve closes. The swirling motion of air admitted on the intake stroke is intensified during the compression stroke and its temperature is raised to approximately 1000°F (811 K). The contoured piston top compresses and simultaneously forces the air toward its center, giving it an additional rolling motion and greater velocity. At the proper instant during the compression stroke, a metered quantity of fuel is injected into the combustion chamber in a four-jet pattern under extremely high pressure. When the finely atomized fuel has mixed thoroughly with the turbulent air it is ignited by heat of the compressed air and immediately starts to burn.

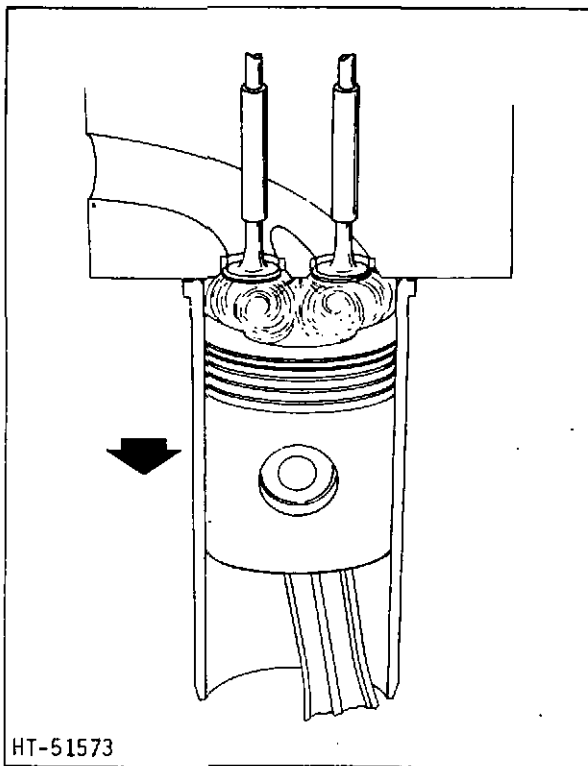

Figure 3. Power Stroke

### 3. Power Stroke

Because the fuel and air is thoroughly mixed in the cylinder, it burns smoothly and evenly. As the burning gases expand they force the piston downward on its third, or power stroke. Near bottom of the power stroke the exhaust valve starts to open.

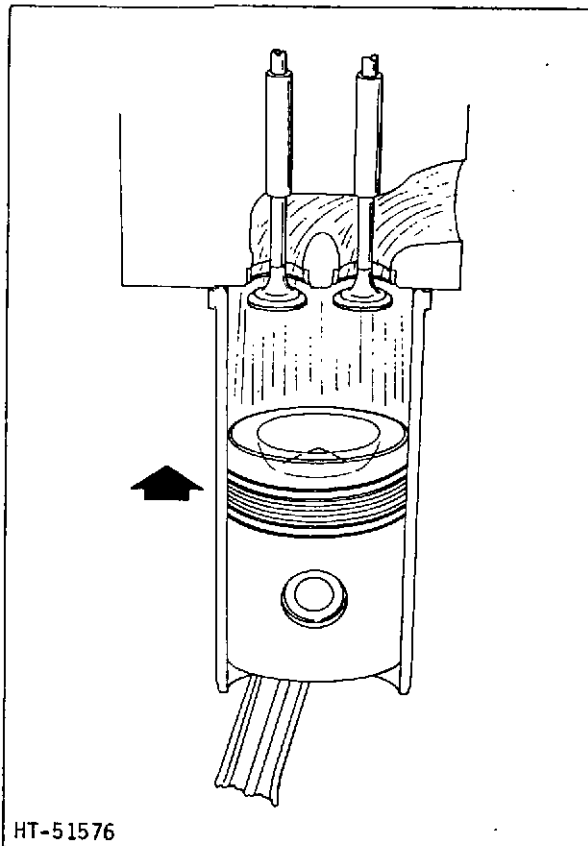

Figure 4. Exhaust Stroke

### 4. Exhaust Stroke

As the piston moves upward on the fourth, or exhaust stroke, the exhaust valve opens and burned gases are forced out of the cylinder by the upward travel of the piston. Shortly before the piston reaches top dead center, the intake valve starts to open to admit a fresh charge of air to the cylinder. A few degrees after the piston reaches top dead center, the exhaust valve closes completely, denoting the end of one cycle and beginning of the next.

## TOPIC 2. SPECIFICATIONS

Allis-Chalmers reserves the right to make changes in the following specifications and to add improvements at any time without notice or obligation.

	ENGLISH	METRIC
<b>A. ENGINE (BASIC)</b>		
Model 16000H and 16000MKII .....	Naturally Aspirated	Naturally Aspirated
Model 17000MKII, 21000MKII, and 25000MKII.....	Turbocharged	Turbocharged
Type.....	4 cycle	4 cycle
Number of Cylinders.....	6	6
Firing Order.....	1-5-3-6-2-4	1-5-3-6-2-4
Bore.....	5.25 in	133.35 mm
Stroke.....	6.50 in	165.10 mm
Displacement.....	844 cu in	13833 cm <sup>3</sup>
Crankshaft Rotation (viewed from fan end).....	Clockwise	Clockwise
Number of Main Bearings.....	7	7
Compression Ratio (Nominal).....	15.1:1	15.1:1
Compression Pressure at Sea Level, 600 rpm, Hot.....	500 psi ± 15 psi 30 psi max	3447 kN/m <sup>2</sup> ± 103 kN/m <sup>2</sup> 207 kN/m <sup>2</sup>
Pressure Differential Between Cylinders.....		
Maximum Permissible Exhaust Restriction Naturally Aspirated.....	3 in Hg	10131 N/m <sup>2</sup>
Turbocharged.....	2 in Hg	6754 N/m <sup>2</sup>
<b>B. COOLING SYSTEM</b>		
Water Pump, Centrifugal Type.....	Belt Driven	Belt Driven
Stablized Coolant Temperature (minimum).....	180° F	355 K
Thermostat (fully open).....	200° F	366 K
Nominal Coolant Capacities:		
1. Basic Engine with Dry Exhaust Manifold		
16000H 16000MKII 17000MKII 21000MKII ...	8 gal*	30.28 lts*
25000MKII .....	9 gal*	34.07 lts*
*NOTE: To obtain total capacity of cooling system for particular engine model, add basic engine capacity to capacity of the applicable optional cooling system equipment listed below.		
2. Optional Cooling System Equipment		
Radiator and Hoses for:		
16000H 16000MKII 17000MKII 21000MKII....	8.5 gal	31.17 lts
25000MKII.....	10.0 gal	37.85 lts
Water Cooled Exhaust Manifold.....	2.0 gal	7.57 lts
Expansion Tank with Tube Bundle and Piping.....	6.0 gal	22.71 lts
Expansion Tank with Piping, without Tube Bundle.....	7.0 gal	26.50 lts
Radiator, Pressurized.....	7 psi	48 kN/m <sup>2</sup>
<b>C. LUBRICATION SYSTEM</b>		
Circulating Pressure Type System.....	Full Flow	Full Flow
Oil Pump.....	Gear Type	Gear Type
Oil Pressure Range, Hot, Full Throttle.....	30 to 55 psi	207 to 379 kN/m <sup>2</sup>
Oil Filter Type.....	Full Flow	Full Flow
Pressure Regulation Governed by.....	Regulation Valve	Regulation Valve
Oil Pump Speed Ratio to Crankshaft.....	1.33:1	1.33:1
Oil Capacity - Filter and Oil Change:		
Std. Oil Pan - Aluminum (Current) .....	45 qts	42.58 lts
Std. Oil Pan - Iron (Early) .....	31 qts	29.34 lts
<b>D. FUEL INJECTION SYSTEM</b>		
Nozzle Holder Assembly:		
Manufacturer.....	Allis-Chalmers	Allis-Chalmers
Nozzle, Spring Loaded Type.....	Four Hole Orifices	Four Hole Orifices
Nozzle Orifice Size.....	0.0187 in	0.475 mm
Nozzle Opening Pressure.....	4100 psi	28268 kN/m <sup>2</sup>

	ENGLISH	METRIC
Fuel Injection Pump:		
Pump Type, Engine Lubricated.....	Multiple Plunger	Multiple Plunger
Pump Speed Ratio to Crankshaft.....	.5:1	.5:1
Fuel Pump Timing to Engine (Static):		
1200 rpm.....	28° BTDC	28° BTDC
1500 rpm.....	32° BTDC	32° BTDC
1600 rpm.....	32° BTDC	32° BTDC
1800 rpm.....	34° BTDC	34° BTDC
2000 rpm.....	34° BTDC	34° BTDC
2100 rpm.....	34° BTDC	34° BTDC
Governor		
Woodward SG Standard.....	Hydraulic	Hydraulic
Woodward PSG Optional.....	Hydraulic	Hydraulic
Regulation:		
SG Type.....	3 to 5%	3 to 5%
PSG Type.....	Near 0 to 5%	Near 0 to 15%
Speed Setting 60 Hz Operation:		
Full Load.....	1800 rpm	1800 rpm
High Idle - No Load.....	1854 to 1890 rpm	1854 to 1890 rpm
Low Idle.....	1400 rpm	1400 rpm
Speed Setting 50 Hz Operation:		
Full Load.....	1500 rpm	1500 rpm
High Idle - No Load.....	1545 to 1575 rpm	1545 to 1575 rpm
Low Idle.....	1400 rpm	1400 rpm
E. VALVE DATA		
Valve Lash Adjustment:		
Intake Valve Clearance (Hot).....	0.015 in	0.38 mm
Exhaust Valve Clearance (Hot).....	0.020 in	0.51 mm
Valve Timing:		
Exhaust Valves w/Tappet Clearance of.....	0.023 in	0.58 mm
Opens BBDC.....	53°	53°
Closes ABDC.....	23°	23°
Duration.....	256°	256°
Intake Valve w/Tappet Clearance of.....	0.023 in	0.58 mm
Opens BTDC.....	28°	28°
Closes ABDC.....	48°	48°
Duration.....	256°	256°
Overlap.....	51°	51°
CAUTION: Tappets must be set with 0.023 in (0.58 mm) clearance to obtain proper valve opening and closing in degrees tabulated for the camshaft. Do not confuse this setting with valve lash adjustment data.		
F. ELECTRICAL SYSTEM		
Starter.....	24 Volt	24 Volt
Alternator, Negative Ground.....	24 Volt, 30 Amp.	24 Volt, 30 Amp.
Alternator, Negative Ground.....	24 Volt, 32 Amp.	24 Volt, 32 Amp.
Alternator, Negative Ground.....	24 Volt, 45 Amp.	24 Volt, 45 Amp.
Generator, Positive Ground.....	24 Volt, 10 Amp.	24 Volt, 10 Amp.
Generator, Positive Ground.....	24 Volt, 18 Amp.	24 Volt, 18 Amp.
Generator, Negative Ground.....	24 Volt, 10 Amp.	24 Volt, 10 Amp.

## TOPIC 3. PREPARATION OF ENGINE FOR OPERATION

### A. SAFETY PRECAUTIONS

1. When operating the engine in a closed area, pipe exhaust fumes outside. Continued breathing of exhaust fumes may be fatal.
2. When servicing batteries, do not smoke or use an open flame in the vicinity. Batteries generate explosive gas during charging. Make sure there is adequate ventilation when charging batteries.
3. When filling fuel tank, always provide metal-to-metal contact between the container and fuel tank. This will prevent a spark from being generated as fuel flows over the metallic surfaces.
4. When filling fuel tank, do not smoke or use an open flame in the vicinity.
5. Always use a lifting device of more than adequate capacity when lifting or moving the engine.

### B. PROCEDURE

Use extreme care when unpacking the unit to avoid damage to engine parts and accessories.

For your protection, make a thorough inspection of the engine immediately upon delivery. In case of damage or shortage, have the carrier make a notation on the freight bill, and notify the transit agent at once.

Install the engine in a clean, well-ventilated area where it will be accessible for inspection, maintenance, and repair. The foundation must be of ample size and strength to support the unit and assure its accurate alignment with equipment to which it will furnish power.

Before starting the engine, the operator should fully understand the use and function of the operating controls and instruments.

After the engine is installed and before starting it, perform the operations listed below.

1. Remove all tape and shipping caps used to seal the engine openings.
2. Check the radiator for damage and for proper cooling capacity. Remove any foreign material that has collected on the radiator which would obstruct the flow of air past the fins and through the air passages.
3. If the cooling system drain plugs have been removed and wired to the engine, install them properly. Fill the system with coolant (refer to Topic 11).

4. Open the inlet and outlet valves to the coolant system conditioner (refer to Topic 11).
5. Make certain all air cleaner connections are tight and the filter element is installed.
6. If an oil bath type air cleaner is applied to the engine, fill the oil cup with grade of oil and to level specified by the instruction plate on the air cleaner.
7. Engines are shipped from the factory without lubricating oil (dry) or with lubricating oil (wet) depending upon whether or not oil is specified on the engine purchase order.

If engine is ordered without oil, add oil to the oil pan following the procedure in TOPIC 13, LUBRICATION SYSTEM using a quality oil of the classification specified in TOPIC 6, LUBRICATION RECOMMENDATION.

If engine is ordered with oil in the oil pan, check oil level with the side of the dipstick stamped ADD, FULL, and STOPPED before initial start of engine.

NOTE: Engine shipped wet have CD (Service DS-Series 3), SAE 20 weight lubricating oil. Maintain proper oil pan level with any good quality CD (Service DS) oil. The factory oil is compatible with any CD (Service DS) oil supplied by any major oil company. At the first regular oil change period, drain factory oil and fill with proper classification and SAE weight of oil for the prevailing atmospheric temperature. (Refer to Topic 6).

8. Check the engine drive belts for correct adjustment. The deflection should be .25 in (6.35 mm) to .50 in (12.70 mm) at midpoint on the belts. Refer to Topic 11.
9. Connect the storage batteries to the electrical system. Refer to Topic 2, Paragraph F. for ground polarity.
10. Fill the fuel tank with the recommended fuel. Refer to Topic 7.
11. If applicable, connect the fuel supply line from the fuel tank to the inlet of the fuel system. Connect the overflow line to the top of the fuel tank. Open the fuel tank shutoff valve and prime the fuel system. Refer to Topic 12.

- Bar the engine over by hand to make certain it turns freely.

**CAUTION:** Any muffler installations or exhaust pipe extensions from the exhaust outlet must be adequately supported and flexibly connected to eliminate any possibility of strain on either the manifold or the turbocharger outlet. Total restriction for the exhaust system must not exceed the specified number of inches of mercury listed in Topic 2, Paragraph A, with the engine running under full load, full speed conditions. Refer to Topic 16 for procedure to check the restriction in the exhaust system.

- Check the engine intake and exhaust systems to make certain they are unobstructed by foreign material. The exhaust line should not be restricted by sharp bends/crimps, but should be kept as short as possible and installed with a minimum number of elbows.

### C. FRONT SUPPORT BRACKET

To provide 3 point mounting for the engine, a front support bracket (Fig 2) is secured to a trunnion on the timing gear cover. The other 2 mounting points are the pads with threaded holes on each side of the flywheel housing.

If the front support bracket is removed from the engine to facilitate the installation of the engine, note the number of shimming washers removed from each side. When assembling the cap to the mounting bracket, install the same amount of shimming washers to each side as where removed. Tighten the flanged screw to 95-105 lb-ft (129-143 Nm) torque.

The liners are made from a nylon like material and it is essential that the front support bracket is a tight fit on the trunnion to avoid "beating out" the liners. If the liners are replaced after a period of operation, they must be installed as follows:

- Clean grooves of cap and mounting bracket and install liners.
- If type 1 support bracket (Fig 2) install flanged capscrew (5) and if type 2 support bracket, (Fig 3) install capscrew (1) and lockwasher (2) and tighten by alternating from one screw to the other until a torque of 50 lb-ft (68 Nm) is obtained.
- Measure the gap between the cap and mounting bracket and determine the amount of shimming washers required for each side. If measurement is between shim thickness add full shim.

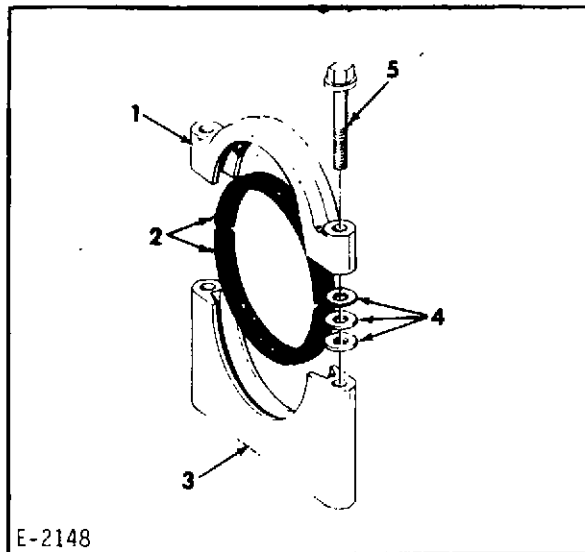

- |                     |                     |
|---------------------|---------------------|
| 1. Cap              | 4. Shimming washers |
| 2. Liners           | 5. Flanged screws   |
| 3. Mounting bracket |                     |

Figure 2. Engine Front Support Bracket (Type 1)

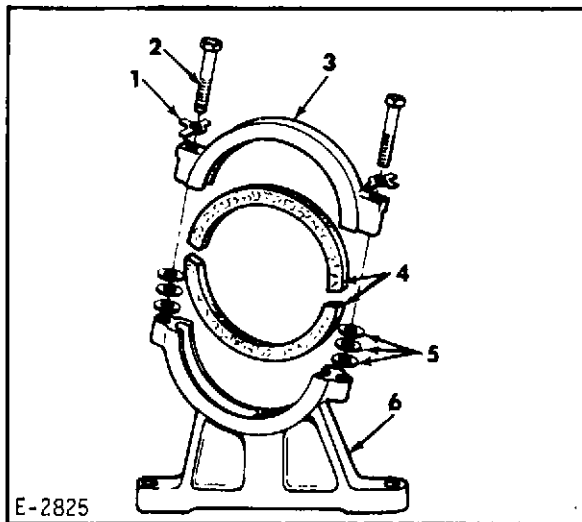

- |                   |            |
|-------------------|------------|
| 1. Locking washer | 4. Liners  |
| 2. Capscrew       | 5. Shims   |
| 3. Cap            | 6. Bracket |

Figure 3. Engine Front Support Bracket (Type 2)

- Remove capscrews and install shimming washer to equal the gap.

**NOTE:** Shimming washers are .031" (.792 mm) thick and must be evenly distributed on both sides of bracket.

- Reinstall capscrews and torque to 95-105 lb-ft (129-143 Nm).

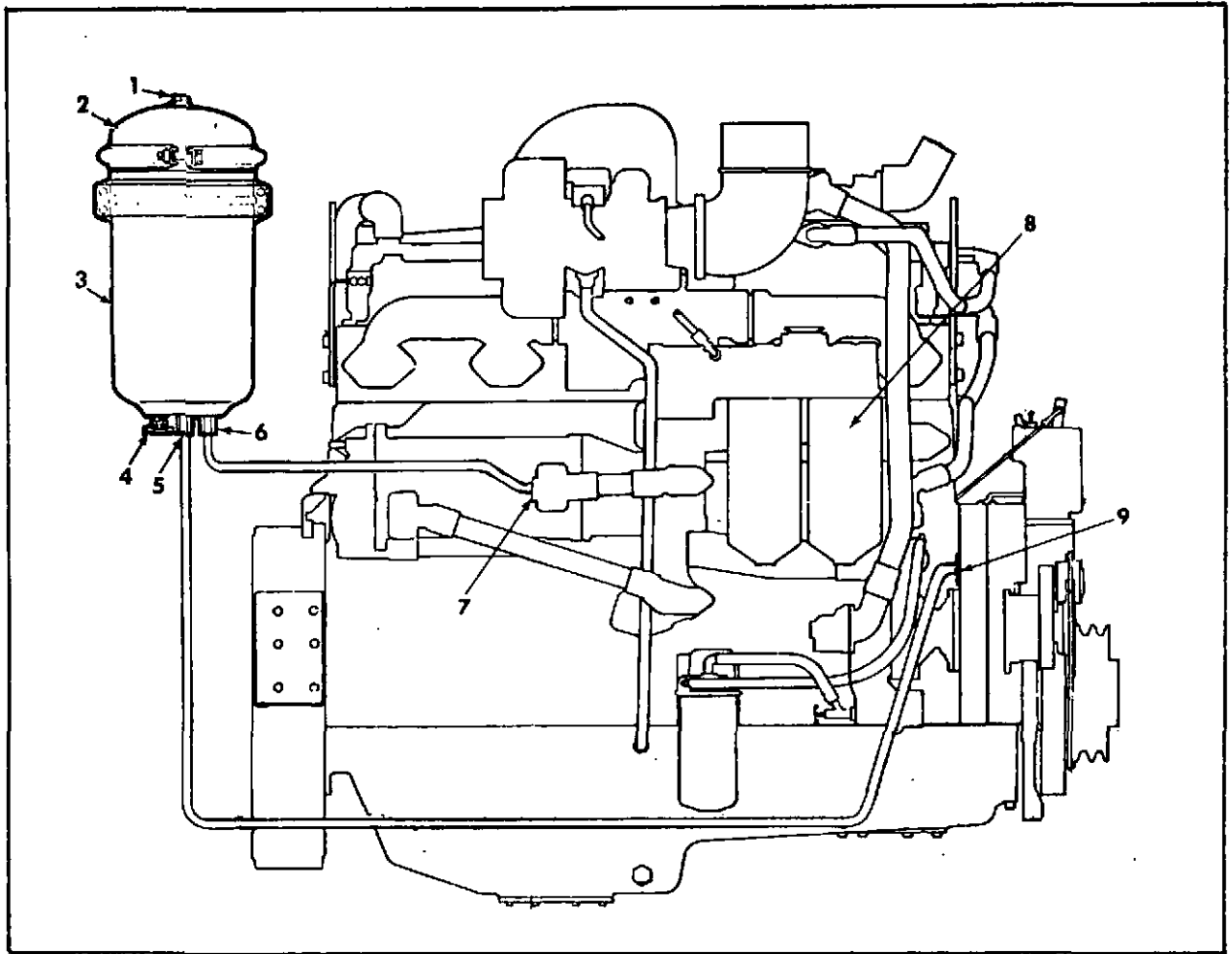

- |                           |   |  |
|---------------------------|---|--|
| 1. Vent                   | 5. Outlet - 1/2" pipe thread            | 9. Drain hole location at rear of timing gear housing - 3/8" pipe thread |
| 2. Cover                  | 6. Inlet - 1/2" pipe thread             |  |
| 3. Bypass type oil filter | 7. Engine oil outlet - 3/8" pipe thread |  |
| 4. Drain cock             | 8. Full flow oil filters (standard)     |  |

Figure 1. Optional Bypass Type Oil Filter Piping Connections

#### D. BYPASS TYPE OIL FILTER

##### 1. Installation Instructions

Mount the filter on a rigidly constructed support and position it in a location as near as possible to the oil supply and drain openings on the right side of the engine (Fig 1).

Select oil supply and drain hose size based on the length required:

No. 6 hose for lengths under 10 ft  
(3048.0 mm)

No. 8 hose for lengths over 10 ft  
(3048.0 mm)

Adequately support hoses and give consideration to routing hoses away from exhaust manifolds and moving parts.

Refer to Paragraph D of Topic 13 for details of how to service filter.

## TOPIC 4. OPERATING CONTROLS AND INSTRUMENTS

### A. GENERAL

Various controls and instruments are supplied by the generator set manufacture to assist the operator to monitor and operate the equip-

ment and the engine. The operator must become familiar with the function of the controls and instruments provided for operating the unit. Refer to the generator set operating and maintenance manual for this information.

## TOPIC 5. OPERATING INSTRUCTIONS

### A. GENERAL

Before initial startup of the diesel engine complete the procedures detailed in Topic 3, PREPARATION OF ENGINE FOR OPERATION. Refer to your OWNERS MANUAL for instructions on operating the unit.

### B. OPERATING PRECAUTIONS

1. Do not operate the engine without having the air cleaner filter element installed.
2. Always allow the engine to warm up at reduced speed without load.
3. Keep the engine and accessories clean; inspect the engine while cleaning.
4. If the engine overheats due to lack of coolant, replenish slowly while engine is running.
5. Do not allow the engine to idle for prolonged periods except in cold weather below 0°F (255 K).
6. Refuel at the end of daily operation to keep condensation to a minimum.
7. In extreme cold weather optional ether starting aids or immersion heaters are available.

CAUTION: To prevent damage to the starting motor, do not crank engine for more than 30 seconds without a pause of 2 minutes to allow it to cool.

### C. STARTING AND STOPPING ENGINE

Refer to the generator set operating and maintenance manual for procedure to start and stop the engine.

If engine is equipped with an optional equipment ether starting aid (manually operated generator sets only), refer to TOPIC 20, titled Cold Weather Starting Aid, for procedure to start engine.

### D. DURING OPERATION CHECKS

1. Observe general condition of unit while it is running.
2. Look for loose bolts, leaks, and overheated assemblies.
3. Listen for unusual noise.
4. Stop engine and make necessary repairs and adjustments.

### E. COLD WEATHER OPERATION

1. Make certain battery is fully charged and all other electrical equipment is in optimum operating condition.
2. Use a permanent type antifreeze solution to protect engine from damage by freezing. Refer to instructions on Protection Charts furnished by antifreeze manufacturer for quantity of antifreeze required for lowest anticipated temperature.
3. Provide radiator cover if thermostat proves inadequate to maintain normal coolant operating temperature.

CAUTION: Do not leave engine running unattended while radiator is covered. Overheating and damage may result.

4. At end of daily operation, drain water from fuel tank.
5. When the ambient temperature is -20°F (244 K) or lower, warming the engine and battery is recommended in order to obtain satisfactory starting and to prevent engine damage. Consult your dealer for information regarding availability of special cold weather equipment. Immersion heater kits and ether base fluid starting aid kits are available.

### F. HOT WEATHER OPERATION

1. Keep cooling system filled with clean water that is low in chemical impurities.
2. Make certain that fins and passages of radiator are free of foreign material.
3. Keep external surface of engine clean.

### G. EXERCISE OF ENGINE ON STANDBY SERVICE

NOTE: It is recommended that standby Diesel Electric Systems be equipped with an optional rectifier type battery charger.

Under optimum conditions, a diesel engine on standby service should be exercised at least every 30 days. However, under environmental conditions including extreme temperatures, humidity, dust, sand, etc., it may be found necessary to shorten the interval between exercise periods to as often as weekly.

Exercise periods should be long enough to enable the engine to attain normal operating temperature while carrying, if possible, at least 50 percent of its normal load. To exercise engine proceed as follows:

1. Before starting engine check lubricating oil and coolant levels. Make complete visual inspection of unit to be sure that it is in operating condition.
2. Start engine and run 5 minutes with no load.
3. Run engine at rated speed with whatever load is available up to full load, for the period of time required to obtain two consecutive water temperature readings of 160°F (344 K) minimum, taken at 15 minute intervals. Continue to operate engine for 40 minutes. Check and correct any coolant or oil leaks.

CAUTION: If no load or a very light load must be used during exercise period cover the radiator to hasten the warmup period, but do not leave the unit unattended. Overheating and damage may result.

4. Run engine with no load for 5 minutes to allow combustion chamber temperature to decrease gradually to a minimum.
5. Stop engine.

NOTE: If the accumulated hours of operation during the above exercise periods is less than 100 hours (recommended lube, filter, and lubricating oil change periods) during the 6 months period, it is recommended that the lubricating oil and filter be changed every 6 months or sooner. If the accumulated hours of operation during the exercise periods is less than 500 hours (recommended fuel filter change period) during the 12 months period, it is recommended that the fuel filter element be replaced at the end of the 12 months period.

## H. ENGINE STORAGE

### 1. General

An engine stored for an extended period of time must be protected from corrosion and deterioration. The following preventive measures should be adhered to promptly after the engine is shut down. Store the engine in an enclosed moisture-free building that is heated

during the winter months. If a building is not available, cover the engine with a waterproof tarpaulin or a durable plastic cover that is tied securely to the engine.

An engine prepared for storage in one of the following manners can be returned to service at any time and within a minimum amount of time.

### 2. 30 Days Or Less Storage Period

For protection during a temporary period (30 days or less), follow the instructions indicated below:

- a. Drain engine oil pan. Fill oil pan with new lubricating oil of proper classification and SAE weight.
- b. Service the air cleaner.
- c. Drain water and sediment from fuel filters and fuel tank.
- d. If a temperature below 32°F (273 K) is expected, add a permanent type antifreeze to the cooling system.
- e. Clean exterior of engine and dry it thoroughly.
- f. Service battery and cables. Make certain battery is at full charge.
- g. Use a durable water and vaporproof material and seal all engine openings.
- h. Store engine inside of a building or cover it with a waterproof material that is tied securely to the engine.

### 3. More Than 30 Days Storage Period

Engines removed from operation for an extended period (more than 30 days and not to exceed 6 months) must be prepared for storage as follows:

- a. Service the air cleaner.
- b. Check exterior of radiator. Remove any foreign matter that has collected around and between the radiator fins.
- c. Drain and flush the cooling system. If rust or scale is observed during the flushing operation, clean the system with a commercial cleaner following the manufacturers instructions.

NOTE: Close the coolant filter inlet and outlet shutoff valves before cleaning system. Do not allow a commercial cleaner to circulate through the coolant filter.

- d. Renew coolant filter element or spin-on-can type filter. Refer to Topic 11 for procedure.
- e. Fill cooling system with clean water and add a good commercial soluble oil type rust inhibitor. However, if a temperature below 32°F (273 K) is expected, add a permanent type anti-freeze to the cooling system instead.
- f. Start engine and operate it with sufficient speed and load to enable the coolant temperature to reach 180° to 185°F (355 to 358 K). At this point the thermostats will open and the coolant will circulate through the entire system. Continue to operate engine for one hour.
- g. Stop engine. Remove drain plug and drain lubricating oil from pan. Remove lubricating oil filter elements and install new filter elements.
- h. Install drain plug and fill oil pan to the full mark on the dipstick with any commercial rust preventive oil (SAE 30) meeting Military Specification MIL-L-21260. Operate engine for 10 minutes and add oil to bring oil level up to the FULL mark on the dipstick.
- i. Drain water and sediment from fuel system. Install new fuel filter/elements and prime the fuel system. Then drain the fuel tank.
- j. If fuel injection nozzles have not been serviced recently, check spray pattern and opening pressure of the nozzle holder assemblies; clean and adjust if necessary. This precaution will assure the nozzle holder assemblies are ready for operation when the engine is put back into service.
- k. Disconnect the fuel tank to primary fuel filter supply line and the fuel return line at the fuel tank. Using two clean containers, fill one with regular fuel oil and fill the other with a fuel oil containing a rust preventative such as The Texas Company "564 Rust Proofing Oil" or an equivalent.
- l. Start engine using the container with the regular fuel oil. After engine is running smoothly, switch the fuel supply line to the second container. Continue to operate engine until the rust preventive fuel oil is observed at outlet of the overflow line; then stop the engine.
- m. Connect fuel supply line and return line to fuel tank.
- n. Clean exterior of engine and dry it thoroughly.
- o. In the event the engine is to be stored outside and uncovered, it is recommended the following steps be taken to guard against excessive rusting of the crankshaft pulley grooves, due to moisture being trapped between the bottom of the pulley and the belts. This could result in increased belt wear when the engine again resumes its normal day to day usage and can be more serious when cog type belts are used.
  - (1) With the engine stopped, paint the exposed portion of the crankshaft with a fast drying paint; spray painting is acceptable.
  - (2) After the paint is thoroughly dry, bar the engine over part way and again paint the exposed portion of the pulley.
  - (3) Continue this procedure until all grooves of the crankshaft pulley are painted a full 360°.
- p. Use a durable water and vaporproof material and seal all engine openings.
- q. Disconnect battery from engine. Clean battery and battery cables. Add distilled water to bring electrolyte up to the proper level. Charge battery to make certain it is fully charged. Store battery in a cool, dry location shielded from direct sunlight and away from heat duct outlets. Do not stack a battery on top of another. Check electrolyte level and specific gravity every 30 days. Add distilled water and charge battery to maintain it in full operational condition.
- r. Store engine inside of a building or cover it with a waterproof material that is tied securely to the engine.

NOTE: The engine should be tagged indicating a certain storage manner has been performed. It should also be noted on the tag the importance of performing detailed

NOTE (cont): procedure before returning engine to service.

#### 4. More Than 6 Months Storage Period

An engine removed from operation for an extended period of more than 6 months must be prepared for storage as detailed in the preceding Subparagraph 3. Then after every 6 months of storage, perform the following:

- a. Check fuel tank for condensation and drain if necessary.
- b. Drain water from fuel filters.
- c. Fill supply tank with a sufficient amount of rust preventive fuel oil such as The Texas Company "564 Rust Proofing Oil" or an equivalent in order to exercise engine.

CAUTION: Do not allow engine to run out of fuel during exercise period.

- d. Check radiator or expansion tank coolant level and add coolant if necessary.
- e. Loosen but do not remove oil pan drain plug to drain any moisture that may have collected. When oil free of moisture appears, tighten oil pan drain plug.
- f. Remove material that was used to seal engine openings.
- g. Connect the storage battery observing correct polarity.

CAUTION: If engine is operated inside of a building, pipe the exhaust gases to the outside.

- h. Start engine and run 15 minutes at 1/2 speed.
- i. Run engine at full speed with whatever load is available up to full load for a period of time that is required to obtain two consecutive water temperature readings (minimum 160°F (344 K) that are the same when taken at a 15 minute interval. Then continue to operate engine for 30 minutes. Check and correct any coolant or oil leaks.

If no load or very light load must be used during exercise period, it is recommended the radiator (if appli-

cable) be covered on an attended engine to hasten the warm-up period.

- j. Run engine at 1/2 speed with no-load for 5 minutes before stopping to reduce combustion chamber temperatures to a minimum.
- k. Stop the engine.
- l. Disconnect the storage battery and store it as detailed in the preceding Subparagraph 3.
- m. Drain the fuel tank.
- n. Use a durable water and vaporproof material and seal all engine openings.
- o. Again store engine inside of a building or cover it with a waterproof material that is tied securely to the engine.

#### 5. Returning Engine To Service

After an engine has been in storage for an extended period up to 6 months and before returning it to service, perform the following:

- a. Check fuel tank for condensation and drain if necessary.
- b. Drain water from fuel filters.
- c. Fill fuel supply tank with specified fuel. Prime the fuel system.
- d. Remove oil pan drain plug and drain rust preventive lubricating oil.
- e. Install drain plug and fill oil pan with proper classification and SAE weight of lube oil to proper level.
- f. Open coolant filter inlet and outlet shutoff valves.

NOTE: If a soluble oil type rust inhibitor was added to the cooling system before engine was stored, drain and flush the cooling system before opening the coolant filter inlet and outlet shutoff valves.

- g. Check radiator or expansion tank coolant level and add coolant if necessary.
- h. Check condition of drive belts. Adjust or replace if necessary.

i. Remove material that was used to seal engine openings.

j. Connect the storage battery observing correct polarity.

## TOPIC 6. LUBRICATION RECOMMENDATIONS

### A. ENGINE LUBRICATING OIL

The general recommendation is to use CD lubricating oil in all turbocharged engines in all applications. This also applies to naturally aspirated (non-turbocharged) engines that are operating under severe applications or when the fuel sulphur content exceeds 0.5%. In most normal duty applications of non-turbocharged engines a CC grade oil can be used.

NOTE: API classification CD was formerly DS, Series 3 (MIL-L-45199B) and CC was DM (MIL-L-2140B/45199)

Allis-Chalmers diesel engines are designed for optimum performance, life and lubricating oil control, at normal operating speeds, loads and temperature, with SAE 30 viscosity lubricating oil.

Lighter viscosity oils are required for satisfactory engine starting, without damage from marginal lubrication, when crankcase temperatures during engine starting are below 32° F. This is the only reason for the use of lubricating oils lighter than SAE 30 in Allis-Chalmers engines.

Crankcase Temperature When Starting Engine	Weight (Viscosity)
0° F and below (255 K)	SAE 10W
0° F to 32° F (255 to 273 K)	SAE 20/20W
32° F to 90° (273 to 308 K)	SAE 30
Above 95° F (308 K)	SAE 40

The use of multigrade lubricating oils in Allis-Chalmers diesel engines is not recommended.

**OIL AND FILTER CHANGE PERIOD** - The general recommendation is to renew the oil and standard engine mounted full flow type oil filters every 100 hours of operation. If the engine is equipped with an optional Model 750-C Luber-Finer bypass type filter, renew the oil, full flow filters and bypass filter element every 250 hours. This change period is based on the use of high quality oils, fuels with less than .5% sulphur, and average engine loads not exceeding the continuous rating with engines in good adjustment and operating with coolant and lubricating oil temperatures between 170° F (350 K) to 200° F (336 K).

Variations from these considered normal operating conditions must be compensated for by more frequent oil change and/or filter change periods. Our recommendations for oil change periods are further based on what experience has shown to be conservative and safe hours of operation between oil changes.

The quality and type of the oils and additive compounds used, and the additive quantity in various brands of lubricating oils affect their performance level. Under severe operating conditions, with engines in poor mechanical condition or when using high sulphur fuels, lubricating oils will deteriorate at a faster rate. For these reasons oil change periods can vary.

After the recommended oil change interval has been reached, actual tests of the lubricating oil at intervals of 10 to 20 hours should be made. As a result of these tests the oil condition can be determined, which may either allow extending or necessitate shortening of oil and oil filter change periods. Most major lubricant suppliers provide this oil testing service on a gratis basis. We recommend that our customers take advantage of this service, not only for the protection of the engines but also to realize maximum safe usage from the lubricating oil.

Most manufacturers of lubricants recognize the importance of the quality required for use in Allis-Chalmers engines and are cooperating fully to assure the use of only those oils which fulfill these requirements. The oil distributor and oil manufacturer are to be held responsible for the results obtained from their products. Acquire your lubricants from manufacturers and suppliers with unquestioned integrity, supplying known and tested products. Do not jeopardize your engine with inferior lubricating oils.

Field experience has shown that Allis-Chalmers diesel engines, in the majority of applications and under most service conditions, will perform equally well on either high ash or low ash CD lubricating oils. Our laboratory tests, however, have shown that under severe duty conditions (extended operation under full throttle conditions, high ambient temperatures, etc.) an oil having a sulfated ash level of at least 1.5% will usually outperform an oil having a lower ash level. Where a choice in lubricating oils is practical and economical, a high ash oil should therefore be selected for such applications.

Optimum oil life and also optimum engine life can be realized if the following items are given proper consideration.

1. Use of quality fuels meeting our published specifications.
2. Use of Allis-Chalmers replacement filters.
3. Adequate turbocharger and combustion chamber cooling by running engine at a fast idle for 5 minutes before shutdown.

## TOPIC 7. FUEL OIL RECOMMENDATIONS

### A. GENERAL

Using any given grade of fuel oil, Allis-Chalmers engines perform as well as, or better than other diesel engines of comparable size and rating. However, from the standpoints of fuel economy and availability, as well as engine performance, maintenance and environmental control requirements, experience has shown that the fuel best suited for these engines closely approximates the fuel oil specification listed below.

This specification is within the American Society for Testing Materials (ASTM) specification for No. 1 and No. 2 fuels. The American Society for Testing Materials has established fuel oil specifications and testing methods to which the petroleum industry conforms very closely. Diesel engine manufacturers have, over the years, come to rely on the ASTM specifications as a standard of the industry and a simple means for the engine owner to identify and purchase fuel oil.

#### Fuel Oil Specification:

Gravity, API Degrees.....	30-40
Cetane Number.....	40 Min
Viscosity, Kinematic, Centistokes @ 100°F (311 K).....	1.4-5.8
Flash Point.....	100°F (311 K) or Legal
Pour Point 10°F (6 K).....	Below Ambient Temp
Distillation Temp 90% Point 640°F (611 K) Max	
Ash % by Weight.....	0.02 Max
Water and Sediment % by Volume.....	0.10 Max
Sulfur Content % by Weight.....	0.5 Max
Carbon Residue on 10% Ramsbottom....	0.35 Max
Copper Strip Corrosion.....	No. 3 Max

These specifications are offered as a guide to help the diesel engine owner/operator make a satisfactory selection from the most available stocks of fuel oil. Such factors as climate, economy, and availability of fuel may at times necessitate the use of fuel with certain specifications which are outside those listed in the table.

In general the design of the Allis-Chalmers engines has been developed to take advantage of the higher energy content and generally lower cost of the No. 2 diesel fuels.

Using fuel oils that do not meet the complete specification will require shortening the filter renewal and inspection intervals to obtain a reasonable useful life from the injection equipment.

### B. FUEL OIL CHARACTERISTICS

It is not within the scope of this topic to set down all diesel fuel characteristics and the details of all testing methods, but on occasion it is necessary that the engine operator, and particularly, the person responsible for buying diesel fuel, have a working knowledge of the subject.

#### 1. API Gravity

The API gravity rating is an index of the fuel's density or weight per unit volume. In addition, it affords an indication of the viscosity, distillation characteristics and heating value of a fuel. Since fuel is purchased on a volume basis, gravity is used when setting up purchasing specs and in delivery inspections. Low API (heavier) fuels are desirable because they contain more BTU's per gallon but if they are too heavy, combustion may be incomplete.

Data extracted from a typical table based on degrees API at 60°F (289 K) is listed in the table at the bottom of this page (Figure 1).

#### 2. Cetane Number

The cetane number indicates the ignition quality of fuel oil, a critical factor in both ease of starting and smooth operation of a diesel engine. The higher the cetane number, the higher the ignition quality of the fuel.

#### 3. Viscosity

The viscosity rating of fuel oil is a measure of its resistance to flow due to the friction that exists within the oil itself. It must have the proper body or viscosity to work properly in the fuel

Degrees API At 60°F (289 K)	Specific Gravity At 60°F (289 K)	Pounds Per Gallon At 60°F	Kilogram Per Liter At 289 K	Gallons Per Pound At 60°F	Liter Per Kilogram At 289 K	BTU Per Pound	Kilogram Joule Per Liter	BTU Per Gallon	Kilogram Joule Per Liter
30	.8762	7.296	.876	.1371	1.1413	19,420	45 171	141,800	39 522
35	.8498	7.076	.850	.1413	1.1767	19,590	45 566	138,800	38 686
40	.8251	6.870	.825	.1456	1.2120	19,750	45 938	135,800	37 850

4. Large storage tanks should be equipped with covered manholes, and small tanks should be provided with ports and removable covers in order to facilitate tank cleaning.
5. Fuel fill pipe should extend above ground level and be equipped with a watertight, dustproof cap or cover.
6. Tanks should be vented to a safe area to allow normal "breathing" caused by expansion and contraction of the fuel and air.
7. *The fuel outlet line should be connected to the tank either at the end opposite the sediment collection point or at a point that is well above the area of maximum accumulation.*
8. Fuel lines should be of aluminum or steel wherever possible. Copper accelerates deterioration of fuel and induces sludge and gel formation.
9. All fuel handling equipment, such as funnels, hand pumps, and dipsticks, should be kept clean at all times and covered when not in use.
10. Do not open fuel containers or transfer fuel from drums to tanks in areas exposed to blowing dust and dirt. Also, do not use cotton waste material or linty rags to wipe containers, funnels, hand pumps, dipsticks, etc.
11. All fuel oils deteriorate at different rates depending upon such factors as the original source of the crude oil, the extent of refining and blending it has undergone, the degree of contamination introduced during storage, and age of the fuel oil.
  - a. Do not use tanks of larger capacity than necessary. The maximum recommended storage period for current type diesel fuels composed of blends of straight run distillates and catalytically cracked stocks is 6 months to one year. The user is inviting clogged filters and fuel injection difficulties if fuel is used that has been stored for longer periods. When longer storage periods are anticipated, a stabilizing additive should be specified when the fuel is ordered. Regardless of storage time, a full tank is preferable to one that is only partially filled.
  - b. Fuel instability is related in some degree to its sulfur content. Sulfur promotes the formation of corrosive compounds that are very destructive to metals in the fuel storage and fuel injection system.
  - c. Do not continually add new fuel to old fuel in storage without occasionally draining and disposing of all fuel remaining in the tank. The chemical change already started in the old fuel accelerates deterioration of the new fuel.

## TOPIC 8. LUBRICATION AND MAINTENANCE SCHEDULE, AND MAINTENANCE TOOLS

### A. GENERAL

Maintenance includes those functions and activities that will keep the engine in peak operating condition and prevent unnecessary trouble from developing.

Lubrication is an essential part of the maintenance program controlling to a great extent the useful life of the engine. It is important that the instructions regarding the types of lubricant (Topic 6) be closely followed. The lubrication intervals given in the schedule are based on normal engine operation, using the recommended oil and filters. This maintenance schedule is designed to be used as a guide until adequate data has been acquired to establish a schedule to fit a specific operation. Actual tests of the lubricant should be made to increase or decrease the interval as the actual condition of the oil may dictate.

In addition to lubrication, the schedule specifies other maintenance functions that must be performed at prescribed intervals. These intervals are based on normal operation, alter the intervals length to suit your particular operating conditions.

Thoroughly clean all lubrication fittings, caps, filter and level plugs, and the surrounding surfaces before servicing the engine. Prevent dirt or other contaminants from entering the lubricants and coolants.

For detailed information regarding the lubrication, inspection or service procedure of any given components, refer to the applicable topic in this manual.

NOTE: The environment and load conditions to which engines are subjected can considerably lengthen or shorten the intervals they will efficiently operate between valve reconditioning, piston ring replacement, and complete overhaul. Observation of crankcase breathing, exhaust sound and color, lubrication oil consumption, engine power, and the sound of the engine in operation by a qualified diesel mechanic will determine the need of reconditioning.

### B. LUBRICATION AND MAINTENANCE GUIDE

Checks must be made at the intervals shown (hours or months) whichever occurs first.

Generally the hours listed in the following guide are for prime power units and the months for standby units.

16000H 16000MKII 17000MKII  
21000MKII 25000MKII

1. Daily/Each 8 Hours/At Time Standby Unit is Exercised	Reference	
	Topic	Paragraph
<b>Description</b>		
<b>a. Before Starting Engine</b>		
(1) Visually inspect belts and hoses for deterioration and engine accessories for signs of fuel, lubricant, coolant, air or exhaust leaks. Make corrections as required.		
(2) Check/correct coolant level.	11	D
(3) Check oil level with side of dipstick marked STOPPED to assure safe level for starting engine.	13	F
(4) Drain water from fuel tank, supply pump sediment bowl, and fuel filters as required	12	A,B
(5) Check air cleaner restriction indicator. Replace air cleaner element if red indicator is visible.	17	C
(6) Check/correct air cleaner to turbo loose clamps or deteriorated hoses.	18	C
<b>b. Start Engine</b>		
(1) Check/correct starter performance	14	D
(2) Check/correct oil pressure	13	A
(3) Check/correct alternator charging rate.	14	E
<b>c. After Engine Reaches Operating Temperature</b>		
(1) Check engine oil level at low speed. Maintain between running high and low marks on dipstick.	13	B
(2) Observe the following for Normal operation:		
(a) Coolant temperature	11	G
(b) Lube oil pressure	13	A,F
(c) Full load speed	12	G
(d) Air cleaner service indicator	17	C
(3) Check/correct for knocks or other unusual noises.	9	B

2. Each 100 Hours/6 Months		
Description	Reference	
	Topic	Para-graph
a. Check/correct radiator for external cleanliness and restriction of air through fins.	11	E
b. Grease water pump belt tightener idler pulley.	11	H
c. Make initial replacement of coolant filter.	11	K
d. Change engine lubricating oil.	13	E
e. Renew lubricating fullflow oil filter.	13	C
f. Check/correct liquid level of battery cells.	14	C
g. If applicable, lubricate the battery charging generator with engine oil.	14	E
h. Check/correct leaks: (1) Lube oil (4) Air (2) Fuel (5) Exhaust (3) Coolant		
i. Using engine oil lubricate governor/throttle/stop control swivels.		

\*NOTE:

Each 250 Hours		
Description	Reference	
	Topic	Para-graph
If engine is equipped with an optional bypass type oil filter in addition to the standard full flow filters, renew the lubricating oil, full flow filters, bypass filter element each 250 hours.		
a. Change engine lubricating oil	13	E
b. Renew full flow oil filters	13	C
c. Renew bypass oil filter	13	D

3. Each 600 Hours/12 Months		
Description	Reference	
	Topic	Para-graph
a. Renew fuel filter.	12	B
b. Grease fan drive pulley hub bearings.	11	H
c. Check tension and condition of fan, water pump, and alternator drive belts.	11	I
d. Clean immersion heater.	11	J
e. Renew coolant filter.	11	K
f. Check/clean engine breather tube	13	F
g. Check/correct turbocharger for loose mounting nuts and piping.	18	C

4. Each 1000 Hours/24 Months		
Description	Reference	
	Topic	Para-graph
a. Inspect/check nozzle-holder opening pressure and nozzle spray pattern.	12	K
b. Check specific gravity of battery fluid.	14	C
c. Inspect/clean/tighten electrical connections: (1) Battery (3) Alternator (2) Starter (4) Regulator.	14	C,D D,E
d. Check/tighten exhaust and intake manifold fasteners.	16	C
e. Check/tighten engine mounting fasteners.		

5. Each 4000 Hours		
Description	Reference	
	Topic	Para-graph
a. Recondition nozzle-holder assemblies.	12	K
* b. Recondition intake and exhaust valves and seats.		Service Manual
* c. Check/correct cylinder sleeve bores for excessive wear.		Service Manual
d. Check/correct turbocharger: (1) Wheels for dirt and carbon (2) Bearing clearance (3) Shaft endplay.	18	C
e. Renew grease in governor speed control motor gear housing.	12	H
f. Clean exterior of engine and radiator		

6. Each 8000 Hours		
Description	Reference	
	Topic	Para-graph
* a. Make major inspection of engine. Repair or replace parts with excessive wear.		Service Manual

\*See NOTE in Paragraph A of this Topic.

C. MAINTENANCE TOOLS

TOOL MANUFACTURERS

The following tool listing has been prepared to assist service and maintenance personnel in the selection of tools (other than standard hand or shop tools) to accomplish the various maintenance operations described and illustrated in this manual.

The tools are illustrated in the Topic and Figure as indicated in the following tabulation.

The tools must be ordered directly from the tool manufacturer.

(BI) Bacharach Instrument Company  
Division of American Bosch ARMA Corp.  
200 North Braddock Avenue  
Pittsburgh, Pennsylvania 15208

(KM) Service Tool Division  
Kent-Moore Corporation  
28635 Mound Road  
Warren, Michigan 48092

(SO) Snap-On Tools Corporation  
2905 60th Street  
Kenosha, Wisconsin 53140

Topic	Figure No.	Manufacturer's	Tool Number and Description
9	1	(KM)	J-6692 Compression Gauge Assembly
9	1	(KM)	J-7850-02 Compression Gauge Adaptor
12	43	(KM)	J-6765 Fuel Injection Tube Nut Wrench
12	44	(BI)	65-030D Nozzle Tester Set (Only)
12	44	(BI)	65-481 Connector Set (used with Nozzle Tester)
12	44	(BI)	65-317 Plastic Cup (Spray Collector)
	*	(BI)	65-808 Carrying Case for Nozzle Tester
12	46	(KM)	J-4298-1 Pin Vise
12	46	(KM)	J-22537 Nozzle Hole Cleaning Wire
12	47	(KM)	J-21762 Injection Nozzle Sleeve Cleaner
15	*	(SO)	IMFD-242 Flank Drive Type, 3/4" (19.05mm) Drive, 3/4" (19.05mm) 12 Point Opening Socket (use on both the 5/8" (15.875mm) and 3/4" (19.05mm) 12 point head capcrew)
15	4	(KM)	J-21314 Cylinder Head Guide Studs (4 required)
15	4	(KM)	J-7891-2 Guide Stud Removal Wrench (use with above)
15	6	(KM)	J-7856 Rocker Arm Shaft Bracket Retaining Nut Wrench

\*Not Illustrated

## TOPIC 9. TROUBLESHOOTING

PARAGRAPH	TITLE	PAGE
A	GENERAL.....	1
B	ENGINE.....	1
C	STARTING SYSTEM.....	4
D	FUEL SYSTEM.....	5
E	AIR INTAKE SYSTEM.....	5
F	COOLING SYSTEM.....	6
G	LUBRICATING SYSTEM.....	6
H	ELECTRICAL SYSTEM.....	8
I	INSTRUMENTS.....	8
J	LOCATING CYLINDER CUTOUT.....	8
K	MAKING COMPRESSION TEST.....	8

### A. GENERAL

It has been proved that over 90% of the troubles that occur in engine operation are avoided when those responsible for maintenance adhere to an adequate program of lubrication, inspection, and maintenance. The time and expense involved in such programs is only a fraction of that incurred when poor maintenance practice results in a major malfunction or breakdown.

In most cases, when a trouble is detected and remedied immediately, a more expensive, time-consuming repair will be avoided. The following list of troubles, causes, and remedies is given to aid the operator in locating and correcting mechanical and electrical troubles as quickly as possible. For detailed inspection and service procedures for any given component, refer to that section or topic pertaining to the part, assembly, or system.

### B. ENGINE

TROUBLE	POSSIBLE CAUSES	REMEDY
Engine will not crank.	<ol style="list-style-type: none"> <li>1. Batteries weak.</li> <li>2. Starting system faulty.</li> <li>3. Engine is locked or seized.</li> <li>4. Hydro-static lock.</li> </ol>	<ol style="list-style-type: none"> <li>1. Check specific gravity.</li> <li>2. Refer to Paragraph C.</li> <li>3. This can be due to extended idle or storage periods, or to improper preparation of the engine for storage, in which case the parts may be rusted or corroded and seized. Broken piston rings, gears, etc., may also cause locking. Repair or replace defective parts.</li> <li>4. Check for rain water having entered an uncovered exhaust pipe, leaking cylinder head gasket and cracked block or cylinder head. Repair or replace defective parts.</li> </ol>
Engine will not start.	<ol style="list-style-type: none"> <li>1. Slow cranking speed.</li> <li>2. Engine controls out of adjustment.</li> </ol>	<ol style="list-style-type: none"> <li>1. Specific gravity of battery too low. Charge battery. Starter not delivering maximum torque. Repair or replace defective parts. Use cold weather starting aids if applicable.</li> <li>2. Check all engine control linkages for proper adjustment.</li> </ol>

TROUBLE	POSSIBLE CAUSES	REMEDY
Engine will not start (cont.).	3. Insufficient supply of fuel to fuel injection nozzles. 4. Fuel injection nozzles not operating properly. 5. Fuel injection pump improperly timed.	3. Refer to paragraph D. 4. Test and repair or replace nozzles. 5. Time fuel injection pump.
Engine hard to start.	1. Batteries weak. 2. Insufficient fuel in fuel tank. 3. Incorrect grade of fuel. 4. Clogged fuel filters. 5. Fuel injection nozzles not operating properly. 6. Fuel supply pump not operating properly. 7. Air in fuel system. 8. Insufficient air supply to cylinders. 9. Fuel injection pump improperly timed. 10. Valve lash incorrect. 11. Piston rings or cylinder sleeves worn. 12. Valves warped or pitted.	1. Recharge or replace batteries. 2. Check fuel level in tank. Fill with specified fuel if necessary. 3. Drain fuel system. Fill the tank with the specified fuel. 4. Replace filter elements. 5. Test and repair or replace nozzles. 6. Test and repair or replace fuel supply pump. 7. Refer to Paragraph D. 8. Refer to Paragraph E. 9. Time fuel injection pump. 10. Adjust valve lash. 11. Replace affected parts. 12. Recondition or replace valves and/or valve guides.
Engine stops frequently.	1. Idling speed too low. 2. Restricted fuel supply.	1. Adjust low idling speed. 2. Check fuel system.
Engine stops unexpectedly.	1. Out of fuel. 2. Restricted fuel supply. 3. Broken or loose fuel lines. 4. Fuel supply pump or fuel injection pump inoperative.	1. Fill fuel tank with specified fuel and prime the fuel system. 2. Check fuel system. 3. Correct or replace affected parts. 4. Replace inoperative parts.
Engine overheats.	1. Cooling system faulty.	1. Refer to Paragraph F.

TROUBLE	POSSIBLE CAUSES	REMEDY
Engine overheats (cont.).	<ul style="list-style-type: none"> <li>2. Radiator core coolant passages clogged.</li> <li>3. Radiator air passages clogged.</li> <li>4. Fan drive belts loose.</li> <li>5. Thermostats inoperative.</li> <li>6. Engine oil cooler clogged.</li> <li>7. Improper engine lubrication.</li> <li>8. Water pump malfunctioning.</li> <li>9. Fuel injection pump improperly timed.</li> </ul>	<ul style="list-style-type: none"> <li>2. Clean and flush radiator.</li> <li>3. Remove debris from radiator core.</li> <li>4. Adjust fan drive belts to proper tension.</li> <li>5. Test the thermostats for proper operation; replace if necessary.</li> <li>6. Clean or replace the oil cooler core.</li> <li>7. Refer to Paragraph G.</li> <li>8. Repair or replace the water pump.</li> <li>9. Time fuel injection pump.</li> </ul>
Engine shows loss of power.	<ul style="list-style-type: none"> <li>1. Insufficient supply of air to cylinders.</li> <li>2. Insufficient supply of fuel to fuel injection nozzles.</li> <li>3. Governor not operating properly.</li> <li>4. Air in fuel system.</li> <li>5. Clogged fuel filters.</li> <li>6. Improper valve lash.</li> <li>7. Fuel injection pump improperly timed.</li> <li>8. Inoperative fuel injection pump or fuel injection nozzles.</li> <li>9. Cylinder cutting out.</li> <li>10. Loss of compression.</li> </ul>	<ul style="list-style-type: none"> <li>1. Refer to Paragraph E.</li> <li>2. Refer to Paragraph D.</li> <li>3. Inspect and adjust governor.</li> <li>4. Refer to Paragraph D.</li> <li>5. Change filter elements.</li> <li>6. Adjust valve lash.</li> <li>7. Time fuel injection pump.</li> <li>8. Repair or replace affected parts.</li> <li>9. Refer to Paragraph J.</li> <li>10. Refer to Paragraph K.</li> </ul>
Engine runs unevenly with excessive vibration.	<ul style="list-style-type: none"> <li>1. Governor not operating properly.</li> <li>2. Fuel supply erratic or insufficient.</li> <li>3. Engine operating temperature too low.</li> <li>4. Fuel injection pump malfunctions.</li> <li>5. Valves in bad condition.</li> </ul>	<ul style="list-style-type: none"> <li>1. Adjust governor and linkage.</li> <li>2. Refer to Paragraph D.</li> <li>3. Refer to Paragraph F.</li> <li>4. Check fuel injection pump.</li> <li>5. Recondition valves.</li> </ul>

TROUBLE	POSSIBLE CAUSE	REMEDY
Engine runs unevenly with excessive vibration (cont.).	6. Cylinder "cutting-out". 7. Fuel injection nozzle malfunctions.	6. Correct cause. 7. Repair nozzle.
Engine emits black smoke from exhaust.	1. Air system clogged. 2. Governor torque cam or stop plate incorrectly adjusted. 3. Improper fuel. 4. Lack of good fuel injection spray pattern.	1. Check engine air intake system. 2. Correct the adjustment. 3. Drain fuel system and refill with specified fuel. 4. Clean and adjust nozzles.
Engine emits bluish-white smoke from exhaust.	1. Engine operating temperature too low. 2. Fuel injection nozzle valve stuck in open position. 3. Low compression. 4. Early fuel injection pump timing.	1. Check thermostat. 2. Test and adjust nozzles. 3. Make compression test and necessary repairs. 4. Test and adjust.
Engine detonates or knocks.	1. Fuel pump improperly timed. 2. Loose bearings. 3. Loose piston. 4. Loose flywheel. 5. Improperly adjusted valve(s). 6. Foreign material in cylinder(s).	1. Check and adjust. 2. Replace bearings. 3. Inspect piston assembly. Replace parts required. 4. Check tightness of flywheel bolts and dowel. Tighten/replace parts required. 5. Check and adjust. 6. Clean and make necessary repairs.
<p>CAUTION: If a hard metallic knock indicates detonation in one or more cylinder, the engine must be stopped immediately to prevent serious damage due to the excessive pressure accompanying the detonation.</p>		

### C. STARTING SYSTEM

Starter will not crank engine.	1. Batteries weak. 2. Cables and/or connections loose or corroded. 3. Starter switch inoperative.	1. Check batteries. 2. Tighten all loose connections and clean corrosion from all terminals. 3. Replace switch.
--------------------------------	---	---

TROUBLE	POSSIBLE CAUSES	REMEDY
Starter will not crank engine (cont.).	4. Starter brushes worn or not contacting properly. 5. Starter brush springs weak. 6. Starter commutator dirty or worn. 7. Starter armature shaft bushings worn (armature drags on fields). 8. Starter armature burned out.	4. Install new brushes or fit brushes to conform to contour of commutator. 5. Check brush spring tension; replace springs if necessary. 6. Polish commutator, machine commutator and under-cut mica if necessary. 7. Replace worn bushings and related items. 8. Replace armature.
Starter pinion will not engage with flywheel ring gear.	1. Grease and/or dirt in starter drive mechanism. 2. Broken or excessively worn parts.	1. Disassemble and clean the drive assembly. 2. Replace broken or worn parts.

#### D. FUEL SYSTEM

Insufficient fuel supply to fuel injection nozzles.	1. No fuel in fuel tank. 2. Inoperative fuel supply pump. 3. Fuel injection nozzle valve binding in valve body. 4. Fuel lines and/or fuel filters clogged. 5. Fuel injection pump malfunctioning. 6. Fuel injection nozzles improperly adjusted.	1. Fill fuel tank with specified fuel. Prime fuel system. 2. Repair or replace supply pump. 3. Replace valve assembly in nozzle holder body. 4. Clean fuel lines, replace fuel filter elements. 5. Replace fuel injection pump. 6. Adjust fuel injection nozzles.
Air in fuel system.	1. Loose fuel line fitting or leak in fuel line on suction side of fuel supply pump. 2. Damaged gasket on first stage fuel filter.	1. Tighten loose fitting or replace damaged line. 2. Replace gasket.

#### E. AIR INTAKE SYSTEM

Insufficient air supply to cylinders.	1. Air cleaner clogged. 2. Foreign material lodged in turbocharger impeller or turbine. 3. Excessive dirt buildup in compressor or turbocharger.	1. Replace air filter element. 2. Disassemble and clean. 3. Thoroughly clean compressor assembly.
---------------------------------------	--	---

TROUBLE	POSSIBLE CAUSES	REMEDY
Insufficient air supply to cylinders (cont.).	4. Excessive dirt buildup in compressor in short period of time. 5. Leaks in engine intake and/or exhaust manifolds reducing turbocharger efficiency. 6. Turbocharger rotating assembly bearing seized.	4. Clean compressor assembly, and service air intake system for leaks. 5. Tighten loose manifold retaining capscrews. Replace manifold gaskets. 6. Overhaul turbocharger.
Rapid wear on engine parts.	1. Dirt admitted with intake air. 2. Dirty lubricating oil. 3. Improper fuel.	1. Inspect air cleaner body, pipe, connecting hoses, gaskets, etc., thoroughly for cracks or openings which would allow air to enter engine without passing through air cleaner. Make necessary repairs. 2. Change engine oil and the lubricating oil filter elements at the intervals recommended. Keep oil clean when filling engine. 3. Use the proper fuel. It is important that the fuel be within the specified limits for ash, carbon, sulfur, etc. to prevent excessive wear on engine parts.

F. COOLING SYSTEM

Engine operating temperature too high, even with ample coolant in system.	1. Temperature gauge inoperative. 2. Radiator air passages restricted. 3. Thermostats inoperative. 4. Loose or broken fan drive belts. 5. Lime deposits in coolant passages of radiator, cylinder heads and/or cylinder block. 6. Coolant passages in oil cooler restricted. 7. Water pump inoperative. 8. Engine pulling excessive load. 9. Engine speed set too high.	1. Check gauge. Replace if necessary. 2. Clean exterior of radiator. 3. Replace thermostats. 4. Adjust or replace fan drive belts. 5. Thoroughly clean affected parts. 6. Remove and clean oil cooler core. 7. Repair or replace water pump. 8. Reduce load. 9. Adjust speed to within specified rpm limits.
Engine operating temperature too high due to loss of coolant.	1. External leaks. 2. Ruptured oil cooler core (oil in coolant).	1. Repair affected parts. 2. Replace oil cooler core.

TROUBLE	POSSIBLE CAUSES	REMEDY
Engine operating temperature too high due to loss of coolant (cont.).	3. Engine cylinder head gaskets leaking. 4. Engine cylinder heads cracked. 5. Engine cylinder block cracked.	3. Replace gaskets and torque cylinder head capscrews to specified torque. 4. Replace cylinder head. 5. Replace cylinder block.
Engine operating temperature too low	1. Thermostats stuck in open position. 2. Operating in extremely cold weather.	1. Replace thermostats. 2. Provide covers for radiator and engine side openings.

G. LUBRICATING SYSTEM

No lubricating oil pressure.	1. Insufficient oil. 2. Oil pressure gauge inoperative. 3. Lubricating oil pump screen clogged. 4. Lubricating oil pump inoperative. 5. Oil lines loose or broken inside engine.	1. Fill oil pan to proper level. 2. Replace gauge. 3. Remove and clean the screen. 4. Repair or replace oil pump. 5. Repair or replace affected parts.
Low lubricating oil pressure with proper oil level in oil pan	1. Oil pressure gauge inaccurate. 2. Oil pressure relief valve or regulator valve stuck in open position. 3. Oil lines loose or broken. 4. Improper lubricant. 5. Main and/or connecting rod bearings worn. 6. Camshaft bearings worn. 7. Lubricating oil pump worn.	1. Check gauge. Replace if necessary. 2. Clean, repair, or replace affected parts. 3. Repair or replace affected items. 4. Fill oil pan with specified lubricant. 5. Replace bearings. 6. Replace bearings. 7. Repair or replace oil pump.
Excessive lubricating oil pressure	1. Oil pressure gauge inaccurate. 2. Oil pressure regulating valve improperly adjusted. 3. Improper lubricant.	1. Check gauge. Replace if necessary. 2. Adjust valve to obtain proper pressure. 3. Fill oil pan with specified lubricant.

TROUBLE	POSSIBLE CAUSES	REMEDY
Overheating of lubricating oil	<ol style="list-style-type: none"> <li>1. Insufficient oil.</li> <li>2. Improper lubricant.</li> <li>3. Engine oil cooler clogged.</li> </ol>	<ol style="list-style-type: none"> <li>1. Fill oil pan to proper level.</li> <li>2. Fill oil pan with specified lubricant.</li> <li>3. Clean or replace the oil cooler.</li> </ol>
Excessive oil consumption	<ol style="list-style-type: none"> <li>1. External oil leakage (gaskets, etc.).</li> <li>2. Engine oil seals worn or damaged.</li> <li>3. Lubricating oil too light.</li> <li>4. Pistons, rings, and/or cylinder sleeves worn.</li> <li>5. Oil control rings stuck in piston ring grooves.</li> <li>6. Valve guides worn.</li> </ol>	<ol style="list-style-type: none"> <li>1. Correct all external leaks.</li> <li>2. Replace oil seals.</li> <li>3. Fill oil pan with specified lubricant.</li> <li>4. Replace affected parts.</li> <li>5. Clean ring grooves and replace rings.</li> <li>6. Replace valve guides. Check related parts.</li> </ol>
Rapid wear on engine parts.	<ol style="list-style-type: none"> <li>1. Lubricating oil contaminated.</li> <li>2. Improper engine lubricating oil being used.</li> <li>3. Dirt admitted with intake air.</li> </ol>	<ol style="list-style-type: none"> <li>1. Fill system with clean engine oil. Replace engine oil filters.</li> <li>2. Fill system with engine lubricating oil of proper specifications.</li> <li>3. Inspect air cleaner body, pipe connecting hoses, gaskets, etc., thoroughly for cracks or openings which would allow air to enter engine without passing through air cleaner. Make necessary repairs.</li> </ol>

#### H. ELECTRICAL SYSTEM

No output from alternator.	<ol style="list-style-type: none"> <li>1. Drive belt loose or broken.</li> <li>2. Regulator inoperative.</li> <li>3. Alternator/generator inoperative.</li> </ol>	<ol style="list-style-type: none"> <li>1. Adjust or replace drive belt.</li> <li>2. Remove regulator for repair or replacement.</li> <li>3. Remove unit for repairs or replacement.</li> </ol>
Alternator output low and/or unsteady	<ol style="list-style-type: none"> <li>1. Drive belt improperly adjusted.</li> <li>2. Regulator operating improperly.</li> <li>3. Brush spring tension too low.</li> <li>4. Alternator/generator circuit components damaged.</li> </ol>	<ol style="list-style-type: none"> <li>1. Adjust drive belt.</li> <li>2. Remove regulator for repair or replacement.</li> <li>3. Replace brush springs.</li> <li>4. Remove alternator/generator for repair or replacement.</li> </ol>

TROUBLE	POSSIBLE CAUSES	REMEDY
Batteries will not hold charge.	1. Loose terminals or connections. 2. Short in electrical system. 3. Short circuit in battery. 4. Electrolyte level low (regulator output excessive or battery case cracked). 5. Regulator inoperative.	1. Tighten affected parts. 2. Correct short. 3. Remove and repair or replace battery. 4. Reduce charging rate. Remove and repair or replace battery. 5. Remove regulator for repair or replacement.

#### I. INSTRUMENTS

If any of the instruments/gauges fail to register proper readings while engine is in operation, the system/circuit to which the instrument applies should be thoroughly checked/tested. If failure of the instrument is suspected, test by installing a new tested instrument. Replace any inoperative instrument.

#### J. LOCATING CYLINDER CUTOUT

**CAUTION:** The tests in Paragraph J and K require the engine to be operated at speeds below 1400 rpm. If the engine is powering a generator set, the main generator voltage regulator must be disconnected from the system to protect it from damage at the lower speed.

Locate "missing" cylinders by following the procedure indicated below.

Run engine at low idle speed and cutout each fuel injection nozzle, one at a time by loosening the fuel injection lines at their connectors in the lower cylinder head covers.

A decrease in engine speed with line nut loosened indicates nozzle for that cylinder is functioning properly. If engine speed does not decrease, nozzle is malfunctioning and must be replaced.

#### K. MAKING COMPRESSION TEST

Loss of compression may be due to leaking valves, worn piston rings, or cylinder sleeves. Using a suitable compression tester, check and record the compression of each cylinder.

Compression pressure of a normal engine at normal operating temperature firing on five cylinders at 600 rpm and at sea level con-

ditions is 500 psi (3447 kN/m<sup>2</sup>).

When checking the compression pressure, the altitude at which the engine is located must be taken into consideration for an accurate evaluation of the test, because the density of air decreases as altitude increases. For each 1000 feet (304.8 meters) of altitude above sea level the specified sea level figure of 500 psi (3447 kN/m<sup>2</sup>) must be de-rated by 3%.

It is common practice to consider a differential of 30 psi (207 kN/m<sup>2</sup>) between one or more cylinders as an indication of possible trouble. This is not always true. Pressure readings taken at 600 rpm are not always representative of what is happening within the engine at 1800 or 2000 rpm, under load. If a spread between cylinders of 30 psi (207 kN/m<sup>2</sup>) or more at 600 rpm is noted and there is no evidence of excessive oil consumption, intake or exhaust valve blow-by into the manifolds, or loss of engine power, it is safe to continue to operate the engine. However, if any of the above conditions exist or if a difference of 50 psi (345 kN/m<sup>2</sup>) or more is noted between cylinders, the cylinder heads should be removed and a detailed inspection made of cylinder heads, valves, pistons, rings, and cylinder sleeves, and necessary repairs should be made to eliminate cause of the low compression pressure.

To check compression pressure, proceed as follows:

1. Start the engine and warm up to a minimum temperature of 160°F (344 K).
2. Stop the engine.
3. Remove cylinder head covers.

**NOTE:** To prevent spill of fuel inside the engine, install a flexible fuel jumper line between the fuel injection

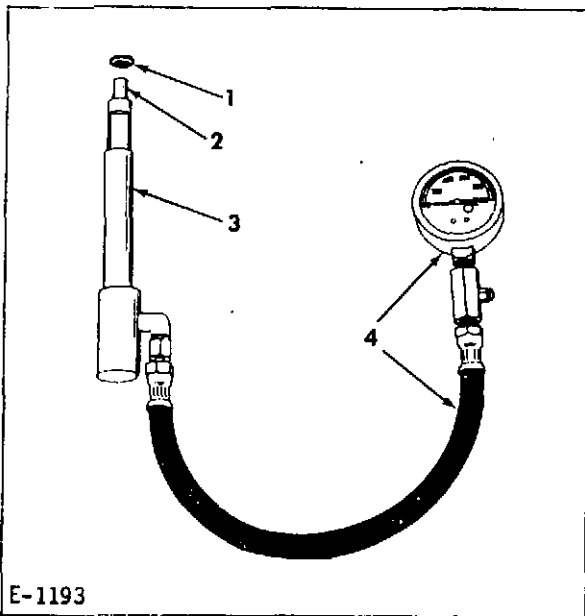

E-1193

1. Nozzle gasket
2. Tip
3. Adaptor
4. Compression gauge assembly

Figure 1. Tools for Checking Compression

NOTE:(cont.): line connector and the fuel return for the cylinder under test so the fuel from the open fuel injection line will be pumped directly to the fuel return line when the engine is running.

4. Start with the number 1 cylinder when checking the compression. Remove the fuel injection nozzle and install the compression tester adaptor in the same manner as the fuel injection nozzle was installed. Install the compression tester hose and gauge assembly (Figure 2).

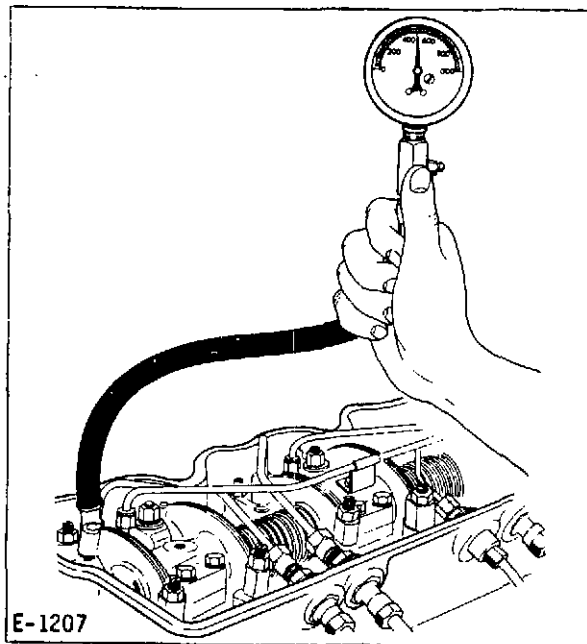

E-1207

Figure 2. Checking Compression Pressure

CAUTION: If the nozzle-holder assemblies, have the long sac type nozzles (Topic 12) the tip of the compression gauge adaptor (Figure 1, Item 2) must be machined to shorten its length to 1/8" (3.17 mm) from 5/8" (15.87 mm). This will prevent damage to the long sac nozzle insert in the lower end of the bore in the cylinder head for the nozzle-holder assemblies.

5. Start the engine, run at approximately 600 rpm and take several readings on gauge.

NOTE: Do not check compression by cranking engine with starter.

6. Remove the tester assembly, install nozzle holder, connect fuel injection line and fuel return line.
7. Repeat the operation on each remaining cylinder.

**TOPIC 10. FITS AND TOLERANCES; BOLT, CAPSCREW, AND NUT TORQUE  
WRENCH SPECIFICATIONS; STUD GAUGE HEIGHTS**

PARAGRAPH	TITLE	PAGE
A	FITS AND TOLERANCES.....	1
	1. Cylinder Sleeve.....	1
	2. Cylinder Block.....	2
	3. Piston.....	2
	4. Piston Pin.....	2
	5. Piston Rings.....	3
	6. Crankshaft.....	3
	7. Main Bearings.....	3
	8. Connecting Rod Bearings.....	3
	9. Connecting Rods.....	4
	10. Exhaust Valve.....	4
	11. Exhaust and Intake Valve Spring.....	4
	12. Exhaust Valve Seat Insert.....	4
	13. Exhaust Valve Guide.....	5
	14. Intake Valve.....	5
	15. Intake Valve Guide.....	5
	16. Intake Valve Seat Insert.....	5
	17. Exhaust and Intake Valve Bridge.....	6
	18. Rocker Arm Shaft.....	6
	19. Rocker Arm.....	6
	20. Camshaft.....	6
	21. Valve Lifter and Valve Lifter Bracket.....	6
	22. Timing Gear Train Backlash Between Mating Gears....	6
	23. Lubricating Oil Pressure Pump - Current Type .....	6
	24. Lubricating Oil Pressure Pump - First Type .....	7
	25. Water Pump .....	7
	26. Fan Hub .....	7
	27. Accessory Drive .....	8
	28. Idler Assembly Water Pump .....	8
B	BOLT, CAPSCREW, AND NUT TORQUE WRENCH SPECIFICATIONS ..	9
	1. Specific Application Torque Values .....	9
	2. Standard Torque Values .....	10
	3. Stud Gauge Heights .....	11

A. FITS AND TOLERANCES

DESCRIPTION

1. Cylinder Sleeve
  - a. Type.....
  - b. I.D.....
  - c. O.D. of sleeve at machined area below flange.
  - d. O.D. of cylinder sleeve at packing ring locations.....
  - e. O.D. of sleeve flange.....
  - f. Cylinder block-to-sleeve clearance - sleeve lower O.D.....
  - g. Cylinder block-to-sleeve clearance at machined area below flange.....
  - h. Cylinder block-to-sleeve clearance at sleeve flange.....

SIZE OF NEW PARTS	
INCHES	MILLIMETERS
Replaceable Wet	Replaceable Wet
5.251 - 5.2525	133.37 - 133.41
5.871 - 5.873	149.12 - 149.17
5.778 - 5.780	146.76 - 146.81
6.217 - 6.221	157.91 - 158.01
.001 - .005	0.02 - 0.12
.001 - .005	0.02 - 0.12
.008 - .017	0.20 - 0.43

1600OH 1600MKII 1700MKII  
2100MKII 2500MKII

DESCRIPTION

SIZE OF NEW PARTS

DESCRIPTION	SIZE OF NEW PARTS	
	INCHES	MILLIMETERS
i. Clearance between bottom piston skirt (right angle to piston pin hole) and cylinder sleeve.....	.006 - .0085	0.15 - 0.22
j. Fire wall height above cylinder sleeve flange.....	.037 - .040	0.93 - 1.01
k. Cylinder sleeve flange thickness.....	.464 - .465	11.78 - 11.81
l. Projection of cylinder sleeve flange above cylinder block with sleeve installed.....	.002 - .005	0.05 - 0.12
m. Flange height adjusting shims available.....	.005, .010, .015 and .020	0.12 / 0.25 / 0.38 - 0.50
n. Allowable cylinder wall taper.....	.0015	0.03
o. Allowable out-of-round when installed.....	.0015	0.03
2. Cylinder block		
a. Counterbore diameter in cylinder block for cylinder sleeve flange.....	6.229 - 6.234	158.21 - 158.34
b. Depth of counterbore for cylinder sleeve....	.460 - .462	11.68 - 11.73
c. Bore in cylinder block for cylinder sleeve - Top.....	5.874 - 5.876	149.19 - 149.25
d. Bore in cylinder block for cylinder sleeve - Bottom.....	5.781 - 5.783	146.83 - 146.88
e. Bore in cylinder block for camshaft bearings	2.747 - 2.748	69.77 - 69.79
f. Main bearing bore in cylinder block (less bearing, cap in place, and capscrews tightened to specified torque).....	4.3743 - 4.3750	111.10 - 111.12
3. Piston		
NOTE: Combustion chamber is in piston.		
a. Combustion chamber I.D.....	3.557 - 3.561	90.34 - 90.44
b. Combustion chamber depth.....	.881 - .885	22.37 - 22.47
c. Compression pressure (Minimum) at sea level, 600 rpm, (hot), pressure differential between cylinders in an engine not to exceed 30 psi (207 kN/m <sup>2</sup> ).....	500 psi.	3447 kN/m <sup>2</sup>
d. Material.....	Aluminum Alloy	Aluminum Alloy
e. Length.....	7.0	177.80
f. Diameter of bottom of skirt measured at right angle to piston pin.....	5.243 - 5.244	133.17 - 133.19
g. Bore for piston pin (cold):		
(1) Bore for current piston pin .....	2.2518 - 2.2522	57.20 - 57.21
(2) Bore for early piston pin .....	2.0018 - 2.0022	50.84 - 50.86
h. Measurement from center of piston pin bore to top of piston .....	4.251 - 4.255	107.97 - 108.07
i. Piston skirt-to-sleeve clearance at skirt bottom, right angle to piston pin .....	.007 - .009	0.17 - 0.22
4. Piston Pin		
a. Type .....	Full Floating	Full Floating
b. Length:		
(1) Current piston pin .....	4.237 - 4.247	107.62 - 107.87
(2) Early piston pin .....	4.365 - 4.375	110.87 - 111.12
c. Diameter:		
(1) Current piston pin .....	2.2515 - 2.2517	57.18 - 57.19
(2) Early piston pin .....	2.0015 - 2.0017	50.83 - 50.84
d. Fit of pin at room temperature .....	.0001 - .0007 Loose	0.00 - 0.018 Loose
e. I.D. of connecting rod bushing after reaming:		
(1) Current bushing .....	2.2527 - 2.2533	57.22 - 57.23
(2) Early bushing .....	2.0027 - 2.0033	50.86 - 50.88
f. Piston pin-to-connecting rod bushing clearance .....	.0010 - .0018	0.02 - 0.04

DESCRIPTION

SIZE OF NEW PARTS		
	INCHES	MILLIMETERS
5. Piston Rings		
a. Location of rings-above piston pin		
b. Gap between ends		
Top compression ring.....	.015 min - .041 max	0.53 min - 1.04 max
2nd compression ring.....	.015 min - .041 max	0.53 min - 1.04 max
3rd compression ring.....	.013 min - .043 max	0.48 min - 1.09 max
4th, oil control - ventilated w/spring.	.012 min - .040 max	0.46 min - 1.02 max
c. Clearance of rings in grooves		
Top compression ring.....	.0040 - .0070	0.10 - 0.17
2nd compression ring.....	.0025 - .0045	0.06 - 0.11
3rd compression ring.....	.0025 - .0050	0.06 - 0.12
4th, oil control - ventilated w/spring.	.0015 - .0035	0.03 - 0.08
6. Crankshaft		
a. Journal diameter for connecting rods.....	3.3715 - 3.3730	85.63 - 85.67
b. Journal diameter for main bearings.....	3.9945 - 3.9960	101.46 - 101.49
c. Width between connecting rod journal cheeks.....	2.1235 - 2.1265	53.93 - 53.98
d. Width of main bearing journals		
Front.....	2.933 - 2.943	74.50 - 74.75
Intermediate.....	2.057 - 2.067	51.24 - 52.50
Center.....	3.250 - 3.252	82.55 - 82.60
Rear.....	2.669 - 2.673	67.79 - 67.89
e. Separate type thrust flanges - Available in standard size and.....	.005, .010, .015 oversize	0.12 / 0.25 / 0.38 oversize
f. Crankshaft end clearance.....	.007 - .015	0.17 - 0.38
g. Crankshaft journals may be ground.....	.010, .020, .030, .040	0.25 / 0.50 / 0.76 / 1.01
h. Fit of crankshaft front gear on crankshaft	.0005 - .0025 tight	0.01 - 0.06 tight
7. Main Bearings		
a. Number used.....	7	7
b. Type.....	Replaceable Precision	Replaceable Precision
c. Main bearing-to-crankshaft journal vertical clearance.....	.0021 - .0053	0.05 - 0.13
d. I.D. of front, intermediate, center, and rear bearings (bearings installed and caps tightened to specified torque).....	3.9981 - 3.9998	101.55 - 101.59
e. Diameter of crankshaft main bearing journals.....	3.9945 - 3.9960	101.46 - 101.49
f. Length of front and rear bearings.....	1.995 - 2.005	50.67 - 50.92
g. Length of center bearing.....	2.746 - 2.756	69.74 - 70.00
h. Length of intermediate bearing.....	1.495 - 1.505	37.97 - 38.22
i. Undersize bearings available for service...	.010, .020, .030, .040	0.25 / 0.50 / 0.76 / 1.01
j. Separate type thrust flanges - Available in standard and oversize.....	.005, .010, .015 oversize	0.12 / 0.25 / 0.38 oversize
k. Standard wall thickness.....	.1876 - .1881	4.76 - 4.77
8. Connecting Rod Bearings		
a. Type.....	Replaceable Precision	Replaceable Precision
b. I.D. of bearing.....	3.3756 - 3.3771	85.74 - 85.77
c. Diameter of crankshaft connecting rod journal.....	3.3715 - 3.3730	85.63 - 85.67
d. Connecting rod bearing-to-crankshaft journal, vertical clearance (bearings installed and caps tightened to specified torque).....	.0026 - .0056	0.06 - 0.14

DESCRIPTION	SIZE OF NEW PARTS	
	INCHES	MILLIMETERS
e. Length.....	1.675 - 1.685	42.54 - 42.79
f. Undersize bearings available for service....	.010, .020, .030, .040	0.25 / 0.50 / 0.76 / 1.01
g. Standard wall thickness.....	.12395 - .12445	3.14 - 3.15
9. Connecting Rods		
a. Type.....	Balanced Forging	Balanced Forging
b. Connecting rod length (center-to-center)....	11.998 - 12.002	304.74 - 304.85
c. I.D. of connecting rod bushing (finished bore).....	2.0027 - 2.0033	50.86 - 50.88
d. O.D. of connecting rod bushing.....	2.2525 - 2.2545	57.21 - 57.26
e. Bearing bore (less bearing, cap in place, and nuts tightened to specified torque)....	3.6245 - 3.6250	92.06 - 92.07
f. Connecting rod width at lower end.....	2.1175 - 2.1195	53.78 - 53.83
g. End play at crankshaft end.....	.004 - .009	0.10 - 0.22
h. Piston pin bushing length in connecting rod.	1.865 - 1.885	47.37 - 47.87
i. Piston pin-to-connecting rod bushing clearance.....	.0010 - .0018	0.02 - 0.04
j. Bore in connecting rod for piston pin bushing.....	2.249 - 2.250	57.12 - 57.15
10. Exhaust Valve (Two per cylinder)(With ROTOCOIL)		
a. Lift at valve (with .020" lash) (0.50 mm)...	.5236	13.29
b. Lift at cam.....	.360	9.14
c. Lash (cold).....	.025	0.064
d. Lash (engine coolant at normal operating temperature).....	.020	0.50
e. Head diameter.....	1.605 - 1.615	40.76 - 41.02
f. Length overall.....	7.3645	187.05
g. Stem diameter.....	.3715 - .3720	9.43 - 9.44
h. Minimum clearance between valve surface and bottom deck of cylinder head.....	.064 min	1.62 min
i. Face angle.....	30°	30°
11. Exhaust and Intake Valve Spring		
a. Free length		
(1) Spring only.....	2-5/8	66.67
(2) Spring w/damper.....	2-5/8	66.67
b. Length - valve closed		
(1) Spring only.....	2.200	55.88
(2) Spring w/damper.....	2.200	55.88
c. Length - valve open		
(1) Spring only.....	1.656	42.06
(2) Spring w/damper.....	1.656	42.06
d. Spring load at 2.200" (55.88 mm)		
(1) Spring only.....	46 - 54 lb	20.86 - 24.49 kg
(2) Spring w/damper.....	50 - 63 lb	22.67 - 28.57 kg
e. Spring load at 1.656" (42.06 mm)		
(1) Spring only.....	123 - 133 lb	55.79 - 60.32 kg
(2) Spring w/damper.....	136 - 150 lb	61.68 - 68.04 kg
NOTE: Install new spring when old spring is 5% below the low limit or 5% above the high limit.		
12. Exhaust Valve Seat Insert		
a. Seat angle.....	30°	30°
b. Seat width.....	3/32	2.38
c. Insert O.D. (not installed).....	1.6445 - 1.6450	41.77 - 41.78
d. Bore in cylinder head for insert.....	1.6415 - 1.6425	41.69 - 41.71
e. Fit in cylinder head.....	.0020 - .0035	0.05 - 0.08
f. Run-out (total indicator reading).....	.002	0.05
g. Oversize insert.....	.005 over standard	0.127 over standard

DESCRIPTION	SIZE OF NEW PARTS	
	INCHES	MILLIMETERS
13. Exhaust Valve Guide		
a. Length.....	3-7/8	98.42
b. I.D. - ream in field.....	*.374	*9.49
c. Valve stem-to-guide clearance - after reaming.....	.002 - .0025	0.05 - 0.06
d. Guide stand-out above flat surface of counterbore in cylinder head.....	1.271 - 1.296	32.28 - 32.91
*NOTE: Exhaust guides installed in new production and new factory service heads do not require reaming in the field. They are factory bearingized to .3742" - .3747" I.D. (9.50 mm - 9.51 mm) and checked with a .3732" (9.48 mm), GO gauge and a .3742" (9.50 mm) NO-GO gauge, 4" (101.60 mm) long. Exhaust guides installed in heads in the field must be reamed after installation.		
14. Intake Valve (Two per cylinder) (Valve rotation obtained with ROTOCOIL)		
a. Lift at valve (with .015" lash) (0.38 mm)...	.5286	13.42
b. Lift at cam.....	.360	9.14
c. Lash (cold).....	.020	0.51
d. Lash (engine coolant at normal operating temperature).....	.015	0.38
e. Head diameter.....	1.619 - 1.629	41.12 - 41.37
f. Length overall.....	7.3645	187.05
g. Stem diameter.....	.3715 - .3720	9.43 - 9.44
h. Minimum clearance between valve surface and bottom deck of cylinder head.....	.064	1.62
i. Face angle.....	30°	30°
15. Intake Valve Guide		
a. Length.....	3-7/8	98.42
b. I.D. ream after assembly - ream in field....	*.373	*9.47
c. Valve stem-to-guide clearance - after reaming.....	.001 - .0015	0.02 - 0.03
d. Guide stand-out above flat surface of counterbore in cylinder head.....	.721 - .736	18.31 - 18.69
*NOTE: Intake guides installed in new production and new factory service heads do not require reaming in the field. They are factory bearingized to .3735" - .3740" I.D. (9.49 mm - 9.50 mm) and checked with a .3725" (9.46 mm) GO gauge and a .3735" (9.49 mm) NO-GO gauge, 4" (101.60 mm) long. Intake guides installed in heads in the field must be reamed after installation.		
16. Intake Valve Seat Insert		
a. Seat angle.....	30°	30°
b. Seat width.....	1/16	1.58
c. Insert O.D. (not installed).....	1.6445 - 1.6455	41.77 - 41.79
d. Bore in cylinder head for insert.....	1.6415 - 1.6425	41.69 - 41.71
e. Fit in cylinder head.....	.0020 - .0040	0.05 - 0.10
f. Run-out (total indicator reading).....	.002 TIR	0.05 TIR
g. Oversize insert.....	.005 over standard	0.12 over standard

DESCRIPTION	SIZE OF NEW PARTS	
	INCHES	MILLIMETERS
17. Exhaust and Intake Valve Bridge		
a. Bore in bridge for guide pin.....	.4995 - .5000	12.68 - 12.70
b. Bridge-to-guide pin clearance.....	.002 - .003	0.05 - 0.07
c. Guide pin length.....	3-5/16	84.13
d. Guide pin O.D.....	.4970 - .4975	12.62 - 12.63
e. Guide pin gauge height above cylinder head machined surface.....	2	50.80
f. Bore in head for bridge guide pin.....	.4945 - .4960	12.56 - 12.59
18. Rocker Arm Shaft		
a. Length.....	17	431.80
b. O.D.....	1.249 - 1.250	31.72 - 31.75
19. Rocker Arm		
a. Bore in rocker arm for bushing.....	1.311 - 1.312	33.29 - 33.32
b. Rocker arm bushing finished bore (burnished).....	1.2510 - 1.2515	31.77 - 31.78
c. Fit of rocker arm bushing in rocker arm bore.....	.004 - .0065 tight	0.10 - 0.16 tight
d. Rocker arm shaft-to-bushing clearance.....	.001 - .0025	0.02 - 0.06
e. Rocker arm ratio.....	1.51:1	1.51:1
f. Size of orifice in rocker arm shaft (located in Nos. 3 and 4 rocker arm bracket positions)	3/32	2.38
20. Camshaft		
a. Number of bearings used.....	4	4
b. I.D. of installed camshaft bearings.....	2.498 - 2.501	63.44 - 63.52
c. O.D. of camshaft journals.....	2.494 - 2.495	63.34 - 63.37
d. Camshaft bearing-to-journal running clearance.....	.003 - .007	0.07 - 0.17
e. O.D. of camshaft bearings.....	2.750 - 2.751	69.85 - 69.87
f. Bore in block for camshaft bearings.....	2.747 - 2.748	69.77 - 69.79
g. Fit of camshaft bearing in bore of cylinder block.....	.002 - .004 tight	0.05 - 0.10 tight
h. Camshaft front and rear bearing length.....	1-7/8	47.62
i. Camshaft intermediate bearing length.....	1-3/8	34.92
j. Camshaft end play.....	.003 - .009	0.07 - 0.22
k. Thrust plate thickness.....	.329 - .331	8.35 - 8.40
l. Fit of camshaft gear on camshaft.....	.0025 - .0043 tight	0.06 - 0.10 tight
21. Valve Lifter and Valve Lifter Bracket		
a. Bore in valve lifter bracket for lifter.....	.7505 - .7515	19.06 - 19.08
b. O.D. of valve lifter.....	.7465 - .7470	18.96 - 18.97
c. Fit of valve lifter in bore of valve lifter bracket.....	.0035 - .0050	0.08 - 0.12
22. Timing Gear Train Backlash Between Mating Gears		
a. Oil pump driving gear to crankshaft gear.....	.006 - .014	0.15 - 0.35
b. Camshaft gear to crankshaft gear.....	.003 - .011	0.07 - 0.27
c. Accessory drive gear to camshaft gear.....	.003 - .013	0.07 - 0.33
23. Lubricating Oil Pressure Pump - Current Type		
a. Radial clearance - gear-to-pump body .....	.002 - .0045	.05 - .11
b. End clearance - gear-to-pump body with gasket in place .....	.004 - .009	10 - .23
c. I.D. of bore in body for gears .....	2.5754 - 2.5784	65.42 - 65.49
d. O.D. of gears .....	2.5694 - 2.5714	65.26 - 65.31
e. Thickness of gears .....	1.180 - 1.181	29.97 - 30.00
f. Gasket thickness (compressed) .....	.005 - .006	.13 - .15
g. I.D. of bore in body and cover for shafts ...	.873 - .875	22.17 - 22.22

DESCRIPTION	SIZE OF NEW PARTS	
	INCHES	MILLIMETERS
h. O.D. of shafts .....	.8715 - .872	22.14 - 22.15
i. Clearance - shafts to bore in body and cover .....	.001 - .0035	.03 - .09
j. I.D. of bore in gears and drive gear .....	.8695 - .8705	22.08 - 22.11
k. Fit of gears to shafts .....	.001 - .0025 tight	.03 - .06 tight
l. I.D. of bore in pump drive gear .....	.8695 - .8705	22.08 - 22.11
m. Fit of pump drive gear to shaft .....	.001 - .0025 tight	.03 - .06 tight
n. Clearance between side of drive gear and body-gear even with end of shaft .....	.004 - .061	.10 - 1.55
24. Lubricating Oil Pressure Pump - First Type		
a. Running clearance between pump driving gear and pump cover.....	.010 - .029	0.25 - 0.73
b. Gear-to-pump body radial clearance.....	.00225 - .00325	0.05 - 0.08
c. Pump gear side clearance.....	.005 - .007	0.12 - 0.17
d. I.D. of gear shaft bushings (finished bore)...	.7495 - .7505	19.03 - 19.06
e. O.D. of pump gear shafts.....	.7475 - .7480	18.98 - 18.99
f. Pump gear shaft-to-bushing clearance.....	.0015 - .0030	0.03 - 0.07
25. Water Pump		
a. Front bearing		
Bearing bore (I.D. for shaft).....	1.1807 - 1.1811	29.98 - 29.99
Shaft diameter (for bearing).....	1.1814 - 1.1819	30.00 - 30.02
Fit - shaft to bearing.....	.0003 - .0012	0.00 - 0.03
	tight	tight
Bearing O.D.....	2.8341 - 2.8346	71.98 - 71.99
Bore in water pump body (for bearing)....	2.8341 - 2.8351	71.98 - 72.01
Fit - bearing O.D. to body.....	.0010 loose -	0.02 loose -
	.0005 tight	0.01 tight
b. Rear bearing		
Bearing bore (I.D. for shaft).....	.9839 - .9843	24.96 - 24.97
Shaft diameter (for bearing).....	.9845 - .9850	24.98 - 25.01
Fit - shaft to bearing.....	.0002 - .0011	0.00 - 0.02
	tight	tight
Bore in water pump body (for bearing)....	2.0467 - 2.0477	51.98 - 52.01
O.D. of bearing.....	2.0467 - 2.0472	51.98 - 51.99
Fit - bearing O.D. to body.....	.0010 loose -	0.02 loose -
	.0005 tight	0.01 tight
c. Hub- water pump drive - bore.....	1.1250 - 1.1260	28.57 - 28.60
Shaft diameter (for hub).....	1.1255 - 1.1260	28.58 - 28.60
Fit - bore (hub to shaft).....	.0005 loose -	0.01 loose -
	.0010 tight	0.02 tight
26. Fan Hub		
a. Front bearing		
Bearing bore (I.D. for shaft).....	1.1807 - 1.1811	29.98 - 29.99
Shaft diameter.....	1.1803 - 1.1808	29.97 - 29.99
Fit - shaft to bearing.....	.0008 loose -	0.02 loose -
	.0001 tight	0.00 tight
Bearing O.D.....	2.4404 - 2.4409	61.98 - 61.99
Bore in hub (for bearing).....	2.4403 - 2.4413	61.98 - 62.00
Fit - bearing to hub.....	.0009 loose -	0.02 loose -
	.0006 tight	0.01 tight
b. Rear bearing		
Bearing bore (I.D. for shaft).....	1.3775 - 1.3780	34.98 - 35.00
Shaft diameter.....	1.3771 - 1.3776	34.97 - 34.99
Fit - shaft to bearing.....	.0009 loose -	0.02 loose -
	.0001 tight	0.00 tight
Bearing O.D.....	2.8341 - 2.8346	71.98 - 71.99
Bore in hub (for bearing).....	2.8340 - 2.8350	71.98 - 72.00
Fit - bearing to hub.....	.0009 loose -	0.02 loose -
	.0006 tight	0.01 tight

DESCRIPTION	SIZE OF NEW PARTS	
	INCHES	MILLIMETERS
27. Accessory Drive		
a. Accessory drive housing		
O.D. of upper and lower shafts for housing bushings.....	1.2470 - 1.2480	31.67 - 31.69
O.D. of bushing.....	1.4385 - 1.4390	36.53 - 36.55
Bore in housing for bushing.....	1.4370 - 1.4375	36.49 - 36.51
I.D. of bushing installed.....	1.2495 - 1.2507	31.73 - 31.76
Fit - bushing to bore in housing.....	.001 - .0025 tight	0.02 - 0.06 tight
Upper and lower shaft-to-bushing clearance	.0015 - .0037	0.03 - 0.09
b. Accessory drive cover		
O.D. of lower shaft for cover bushing.....	.9990 - 1.0000	25.37 - 25.40
O.D. of bushing.....	1.2510 - 1.2515	31.77 - 31.78
Bore in cover for bushing.....	1.2495 - 1.2500	31.73 - 31.75
I.D. of bushing installed.....	1.0015 - 1.0027	25.43 - 25.46
Fit - bushing to bore in cover.....	.001 - .002 tight	0.02 - 0.05 tight
Lower shaft-to-cover bushing clearance.....	.0015 - .0037	0.03 - 0.09
c. Drive gear		
O. D. of shaft for drive gear.....	1.2505 - 1.2515	31.76 - 31.78
Bore in drive gear for shaft.....	1.2495 - 1.2500	31.73 - 31.75
Fit - shaft-to-gear.....	.0005 - .0020 tight	0.01 - 0.05 tight
d. Gear - upper shaft		
O.D. of shaft for upper shaft gear.....	.7500 - .7505	19.05 - 19.06
Bore in gear for upper shaft.....	.7495 - .7500	19.03 - 19.05
Fit - shaft-to-gear.....	.0000 - .001 tight	0.00 - 0.02 tight
e. Gear - lower shaft		
O.D. of shaft for lower shaft gear.....	1.2505 - 1.2515	31.76 - 31.78
Bore in gear for lower shaft.....	1.2495 - 1.2500	31.73 - 31.75
Fit - shaft-to-gear.....	.0005 - .0020 tight	0.01 - 0.05 tight
f. End play - upper and lower shafts.....	.001 - .008	0.05 - 0.12
28. Idler Assembly Water Pump		
a. Bearing bore (I.D. for shaft).....	.9839 - .9843	24.99 - 25.00
b. Shaft diameter.....	.9836 - .9840	24.98 - 24.99
Fit - shaft-to-bearing.....	.0001 - .0007	0.00 - 0.01
c. Bearing O.D.....	2.0467 - 2.0472	51.98 - 51.99
Fit - bearing-to-pulley.....	.0005 loose - .0006 tight	0.01 loose - 0.01 tight

NOTE: REFER TO FOLLOWING TABULATIONS FOR SPECIFIC APPLICATION TORQUE VALUES AND STANDARD TORQUE VALUES.

B. BOLT, CAPSCREW, AND NUT TORQUE WRENCH SPECIFICATIONS

1. Specific Application Torque Values

The torque values tabulated below have been calculated for specific applications. SAE standard torque values must not be used where those listed in this table apply.

NOTE: Torque values are in pound-feet and all torque values in this table are calculated for threads lubricated with engine oil.

ITEM	APPLICATION	SIZE AND THREAD	ENGLISH TORQUE LB-FT	METRIC TORQUE Nm
Capscrew	Cylinder Head Mounting (12 point head)...	5/8-11 x 6	185	251
Capscrew	Cylinder Head Mounting (12 point head)...	5/8-11 x 7	185	251
Capscrew	Cylinder Head Mounting (12 point head, reduced shank).....	3/4-10 x 7-1/4	390	529
Capscrew	Main Bearing Cap, Front, Intermediate and Rear: Current engines - 12 point head Early engines - hexhead with hardened steel washers	7/8-9 x 6-7/16 7/8-9 x 6-7/16	400 370-380	542 502-515
Capscrew	Main Bearing, Center: Current engines - 12 point head Early engines - hexhead with hardened steel washer	5/8-11 x 5-15/16 5/8-11 x 5-15-16	185 160-170	251 217-231
Capscrew	Front Support Bracket.....	1/2-13 x 2-1/2	95-105	129-143
Capscrew	Crankshaft Pulley (ductile iron without keyway) .....	3/4-10 x 7-1/4	325	441
Capscrew	Flywheel Mounting (socket head).....	5/8-18 x 1-15/64	200	271
Capscrew	Piston Cooling Jet.....	5/8-18 x 1-3/16	35	47
Capscrew	Exhaust Manifold Mounting.....	1/2-13 x 1-1/2	85	115
Bolt	Lubricating Oil Filter Center Bolt.....	1/2-13 x 4-3/4	45-50	61-68
Bolt	Cylinder Head Cover Extension Bolt.....	3/8-16 x 5-1/8	38-42	52-57
Bolt	Connecting Rod (12 point or socket head).	5/8-18 x 3-3/4	245	332
Nut	Connecting Rod.....	5/8-18	190-200	258-271
Nut	Nozzle Holder Clamp.....	3/8-24	43-48	58-65
Nut	Fuel Injection Line.....	9/16-18	20-25	27-34
Nut	Fuel Injection Pump Delivery Valve Holder (Robert Bosch).....	Special	50-55	68-75
Nut	Fuel Injection Pump Delivery Valve Holder (cadmium plated)(American Bosch)..	Special	60-65	81-88
Nut	Oil Pressure Regulating Screw Locknut....	3/4-16	125-135	170-183
Nut	Turbocharger To Manifold Mounting.....	3/8-16 stainless	18-21	24-28
Nut	Air Cleaner-Pre-cleaner and Moisture Eliminator Mounting Clamp.....	5/16-18	*72	8
Capscrew	Oil Pan Mounting (12 point head)	1/2-13 x 1	68-73	92-99
Capscrew	Oil Pan Mounting (12 point head)	1/2-13 x 1-1/2	68-73	92-99

\* 1b-inch

2. Standard Torque Values

six marks, 60° apart. (See figures in table below.)

The heads of capscrews used in Allis-Chalmers engines bear grade marks conforming to standards specified by the Society of Automotive Engineers (SAE). The three grades of capscrews used are identified as follows: Grade 2, no marks; Grade 5, three marks, 120° apart; Grade 8,

CAUTION: The standard torque values tabulated above are for use when specific torque data is not available. Do not use these values in place of those specified elsewhere in this manual:

a. Grade 2 Capscrews 

Capscrew Size	Grade 2			
	NC		NF	
	English lb-ft	Metric Nm	English lb-ft	Metric Nm
1/4	5-7	7-9	6-8	8-11
5/16	11-13	15-18	13-15	18-20
3/8	18-21	24-28	19-22	26-30
7/16	30-33	41-45	32-35	43-47
1/2	45-50	61-68	45-50	61-68
9/16	60-65	81-88	60-65	81-88
5/8	75-85	102-115	75-85	102-115
3/4	125-135	170-183	125-135	170-183
7/8	105-115	143-156	105-115	143-156
1	155-165	211-224	140-150	190-204

b. Grade 5 Capscrews 

Capscrew Size	Grade 5			
	NC		NF	
	English lb-ft	Metric Nm	English lb-ft	Metric Nm
1/4	9-11	12-15	11-13	15-18
5/16	18-20	24-27	21-23	28-31
3/8	28-33	38-45	30-35	41-47
7/16	44-49	60-66	50-55	68-75
1/2	68-73	92-99	68-73	92-99
9/16	95-105	129-143	95-105	129-143
5/8	125-135	170-183	125-135	170-183
3/4	210-230	285-312	210-230	285-312
7/8	290-310	393-421	290-310	393-421
1	420-450	569-610	380-410	515-556

c. Grade 8 Capscrews



Capscrew Size	Grade 8			
	NC		NF	
	English lb-ft	Metric Nm	English lb-ft	Metric Nm
Inches (")				
1/4	12-14	16-19	14-16	19-22
5/16	25-27	34-37	28-30	38-41
3/8	41-46	56-62	43-48	58-65
7/16	69-74	94-100	72-77	98-104
1/2	95-105	129-143	95-105	129-143
9/16	130-140	177-190	130-140	177-190
5/8	170-190	231-258	170-190	231-258
3/4	290-310	393-421	290-310	393-421
7/8	450-500	610-678	450-500	610-678
1	670-700	908-949	600-630	813-854

3. Stud Gauge Heights

Stud Description	Stud Size					Gauge Height		Driving Torque*	
	Dia	Thread		Length		in.	mm	lb-ft	Nm
		Stud End	Nut End	in.	mm				
Nozzle Clamp to Cylinder Head	Stud 1/2 Nut 3/8	13	24	5.328	135.33	4.656	118.27	22-71	30-96
Turbocharger Mounting to Exhaust Manifold	3/8	16	16	1.875	47.63	1.250	31.75	10-35	14-47
Water Pump to Timing Gear Housing	3/8	16	24	1.875	47.63	1.375	34.93	10-35	14-47

\*Torque values in this table are calculated for threads lubricated with engine oil.

## TOPIC II. COOLING SYSTEM

### A. GENERAL

Depending upon the optional cooling system components selected for a particular engine application proper temperature of engine cool-

ant is maintained by a radiator and fan combination, or by a heat exchanger and expansion tank. The most commonly used system is the radiator and fan combination (Figure 1). If the heat exchanger and expansion tank cooling

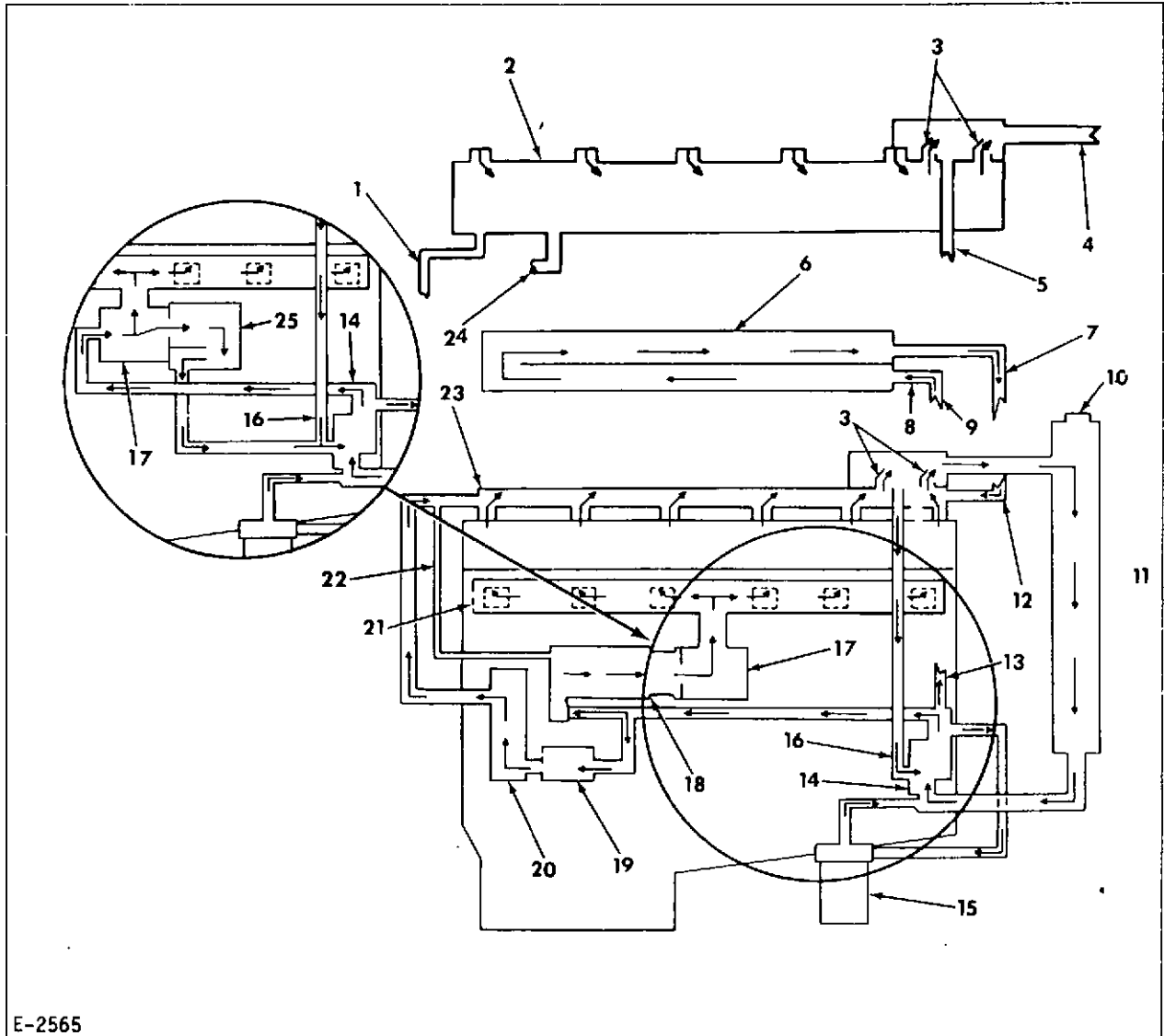

E-2565

- |   |   |   |
|---|---|---|
| 1. Bleed tube                                   | 9. From pressure side of water pump (25000MKII) | 18. Oil cooler (16000MKII, 17000MKII, 21000MKII, and 25000MKII) |
| 2. Water cooled exhaust manifold                | 10. Pressure cap (7 psi) (48kN/m <sup>2</sup> ) | 19. Immersion heater thermostat                                 |
| 3. Thermostats                                  | 11. Radiator                                    | 20. Immersion heater  |
| 4. To radiator                                  | 12. From intercooler outlet (25000MKII)         | 21. Water inlet manifold  |
| 5. Bypass tube to suction side of water pump    | 13. To intercooler inlet (25000MKII)            | 22. Bleed tube  |
| 6. Intake manifold and inter-cooler (25000MKII) | 14. Water pump                                  | 23. Water outlet manifold                                       |
| 7. Intercooler outlet (25000MKII)               | 15. Coolant filter                              | 24. From immersion heater                                       |
| 8. Intercooler inlet (25000MKII)                | 16. Bypass tube                                 | 25. Oil cooler (16000H)   |
|   | 17. Water manifold                              |   |

Figure 1. Cooling System Schematic Diagram

16000H 16000MKII 17000MKII  
21000MKII 25000MKII

1.11  
Page 1



Proper maintenance of the cooling system is important. Engine temperature must be brought up to and maintained within satisfactory range for efficient operation, and engine must be kept from overheating in order to prevent damage to valves, pistons, and bearings.

On radiator cooled applications (Figure 1), coolant is drawn from the bottom of the radiator and conveyed to the inlet side of the water pump. The coolant then passes through the water pump-to-oil cooler tube and then through the oil cooler. The coolant is then directed into the water inlet manifold and into the cylinder block. A small portion of the coolant passes through the bleed tube that is connected between the oil cooler and the rear of the water outlet manifold or the rear of the water cooled exhaust manifold, if so equipped. Once the coolant reaches the water inlet manifold, it is circulated through coolant passages within the engine. The coolant is discharged from the cylinder heads into the water outlet manifold and passes through the thermostat housing and radiator upper hose to the top tank of the radiator. As coolant passes from top to bottom of the radiator, the radiator dissipates heat to the air drawn or pushed through the radiator core by the cooling fan.

Coolant is forced to the inlet of the 25000 MKII intercooler through a hose connected to the outlet side of the water pump. The coolant flows through the intercooler and returns to the engine by a hose connected to the water outlet manifold.

On heat exchanger and expansion tank cooled applications (Figure 2) the coolant is drawn from the bottom of the expansion tank and conveyed to the inlet side of the water pump. The coolant then passes through the water pump-to-oil cooler tube and then through the oil cooler. The coolant is then directed into the water manifold and inlet manifold and into the cylinder block. A small portion of the coolant passes through the bleed tube that is connected between the oil cooler and the rear of the water cooled exhaust manifold. Once the coolant reaches the water inlet manifold, it is circulated through coolant passages within the engine. The coolant is discharged from the cylinder heads into the water outlet manifold and passes through the thermostat housing into a hose connected to the top of the expansion tank. As the coolant flows around the outside of the heat exchanger tubes, heat dissipates to the raw water flowing through the inside of the heat exchanger tubes.

Coolant is forced to the inlet of the 25000 MKII intercooler through a hose connected to the outlet side of the water pump. The coolant flows through the intercooler and returns to the engine by a hose connected to the water outlet manifold.

**WARNING: DO NOT REMOVE PRESSURE CAP WHEN COOLANT TEMPERATURE EXCEEDS 200°F (366 K). THE SUDDEN RELEASE OF PRESSURE MAY CAUSE THE COOLANT TO BOIL. HOT COOLANT OR STEAM ESCAPING FROM THE SYSTEM MAY CAUSE INJURY.**

The cooling system is pressurized by a 7 psi (48 kN/m<sup>2</sup>) pressure cap. By pressurizing the system the normal boiling point of 212°F (373 K) of clean water at sea level is raised approximately 3°F per psi (0.24 K per kN/m<sup>2</sup>). Consequently, coolant in the system at sea level will not boil until a temperature of 212°F (373 K), plus 21°F (12 K), or a total of 233°F (385 K) is reached. Temperatures above this figure will cause loss of coolant and result in engine overheating. Altitude affects the point at which coolant will boil, that is, the higher the altitude, the sooner (lower temperature) the coolant will boil. To estimate coolant boiling point at various altitudes above sea level, deduct 1-1/2°F per 1000 ft (0.83 K per 304.8 m) altitude, from 233°F (385 K), the boiling point established with a 7 psi (48 kN/m<sup>2</sup>) pressure cap at sea level.

**IMPORTANT:** The engine thermostats begin to open at 180°F (355 K) and are fully open at 200°F (366 K). Operating the engine in this temperature range is not harmful. However, some temperature gauges are not always exactly accurate and may indicate a higher than actual temperature. This can lead the operator to believe the engine is overheating when actually it is operating normally.

Overheating is always associated with loss of coolant. In the event of any doubt, the coolant level in the radiator should be checked. Use care when opening fill cap.

A double-acting valve in the pressure cap relieves air pressure caused by expansion of heated coolant, and allows atmospheric pressure to enter when cooling contraction occurs. Because this is a pressure-type cooling system, it is necessary to keep the cap turned on tightly at all times to prevent loss of pressure.

#### B. GENERAL MAINTENANCE

A coolant filter is provided that extends engine life by establishing and maintaining a rust, scale, and corrosion free cooling system. Refer to Paragraph K.

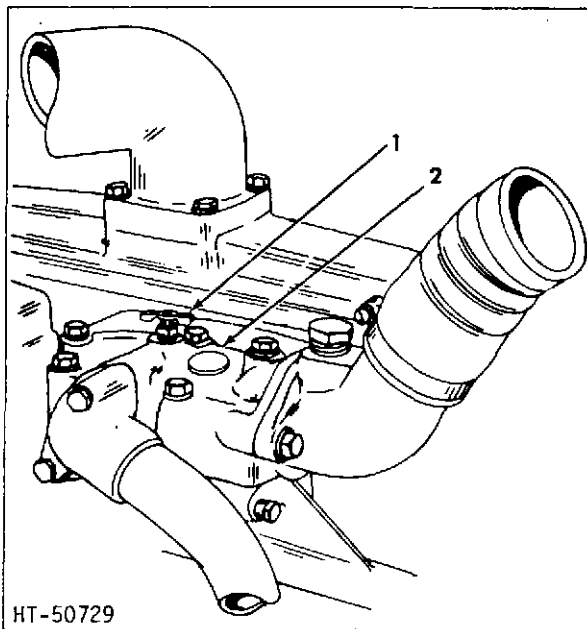

1. Vent cock
2. Thermostat housing

Figure 3. Venting Cooling System

When operating the engine in areas where the ambient temperature is above freezing, keep the cooling system filled with clean water that is low in chemical impurities.

In winter weather, or when operating in areas where the ambient temperature drops below freezing, drain and flush the cooling system and refill it with a permanent type antifreeze solution. Refer to the instruction or protection charts furnished by the manufacturer of the antifreeze to determine the amount of antifreeze required.

**CAUTION:** Do not use antifreeze solutions that are harmful to aluminum.

Keep the radiator air passages free of any foreign material that may restrict the flow of air through the radiator.

**CAUTION:** It is absolutely necessary that that the oil cooler be kept clean to provide for proper oil cooling.

If salt water is used in the heat exchanger to cool the fresh water, inspect the zinc pencil each 100 hours of operation. Replace zinc pencil if it is over 50% disintegrated. The square head zinc pencil is located in the expansion tank inlet bonnet (Figure 6).

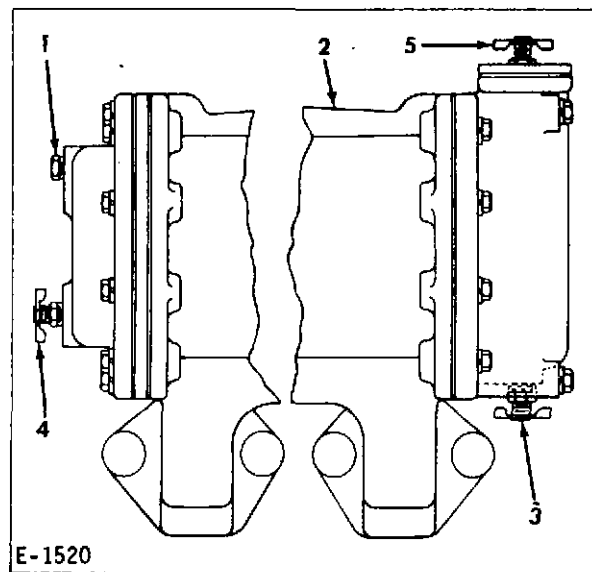

1. Plug
2. Intake manifold
3. Rear drain cock
4. Front drain cock
5. Vent cock

Figure 4. Location of Intercooler Drain Cocks

**CAUTION:** Keep cylinder head capscrews, water pump mounting capscrews, hose clamps and fitting connections tight. Correct all leaks as soon as they become evident. Inspect hoses carefully and replace them if they have deteriorated.

The engine operates most efficiently when coolant temperature is 180°F (355 K) minimum. Operation with low coolant temperature will result in incomplete fuel combustion, higher fuel consumption with less power, and formation of harmful deposits in the engine. A properly functioning thermostat is required to maintain normal coolant temperature. If the coolant temperature is consistently below minimum operating temperature, the thermostat should be removed, checked for proper operation, and replaced if necessary.

#### C. DRAINING OF COOLING SYSTEM

**CAUTION:** If engine is equipped with an immersion heater, disconnect power source from immersion heater thermostat.

1. If engine is installed in portable

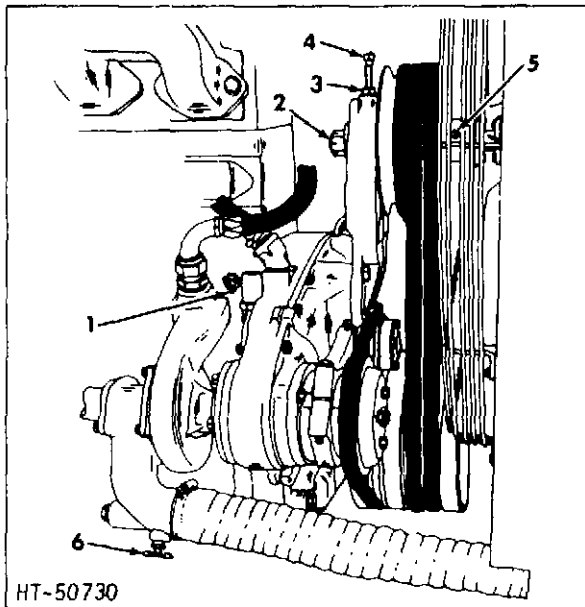

1. Drain cock
2. Retaining nut
3. Locknut
4. Adjusting capscrew
5. Fan hub grease plug
6. Drain cock

Figure 5. Fan Hub, Drive Belts, and Drain Cocks

type equipment, make certain it is in a level position to assure complete draining.

2. Remove radiator or expansion tank cap.
3. Open vent cock located in top of thermostat housing (Figure 3).
4. If applicable, open drain cocks at each end of intercooler and intake manifold assembly (Figure 4).

**CAUTION:** Because of capillary action, coolant may not completely drain from tubes of intercooler. To assure complete drainage, remove plug from intercooler front end cover and blow into it or tap end covers with a padded or rubber hammer.

5. Open drain cock located at forward right side of cylinder block (Figure 5).
6. Open drain cock at water pump inlet (Figure 5).
7. Open drain cock located in bottom of radiator.
8. Remove coolant filter (Fig 15) or drain plug from filter housing (Fig 16).

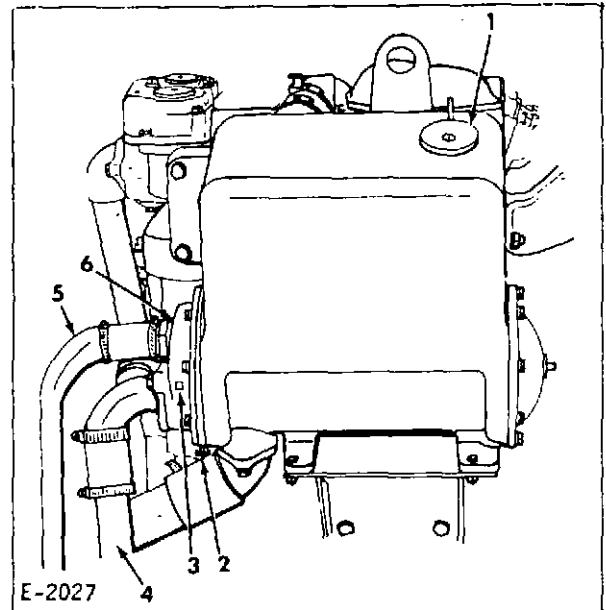

1. Filler cap (7 psi)
2. Drain plug
3. Zinc pencil
4. Raw water inlet
5. Raw water outlet
6. Tube bundle location - heat exchanger

Figure 6. Location of Expansion Tank Drain Plug

(Figure 14).

9. If applicable, open drain cock at lower front of water cooled exhaust manifold.
10. Open vent cock in bonnet at rear of oil cooler (model 16000H only).
11. If applicable, remove drain plug located near water inlet of expansion tank (Figure 6).
12. If applicable, loosen raw water pump cover retaining screws. Jar cover loose and allow water to drain from pump.
13. If applicable, disconnect inlet hose from immersion heater thermostat to allow immersion heater and thermostat to drain.

**CAUTION:** When draining the cooling system in freezing weather, make certain the coolant flows freely from all drains and the system drains completely.

#### D. FILLING OF COOLING SYSTEM

1. Close all drain cocks that were opened and install all drain plugs that were

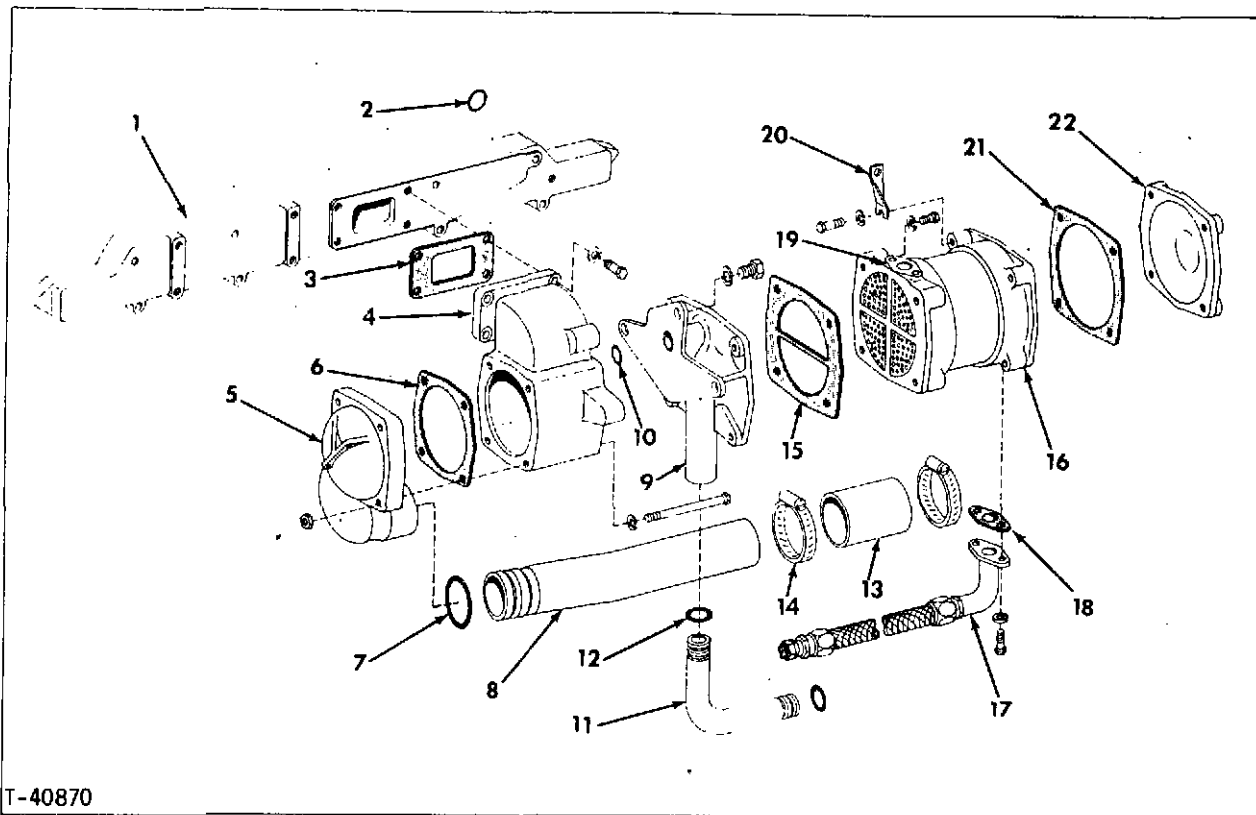

- |                           |                              |                    |
|---------------------------|------------------------------|--------------------|
| 1. Water inlet manifold   | 8. Bonnet tube               | 15. Gasket         |
| 2. O-ring                 | 9. Bonnet (inlet and outlet) | 16. Exchanger      |
| 3. Gasket                 | 10. O-ring                   | 17. Oil inlet hose |
| 4. Water and oil manifold | 11. Cooler tube              | 18. Gasket         |
| 5. Bonnet                 | 12. O-ring                   | 19. Oil outlet     |
| 6. Gasket                 | 13. Hose                     | 20. Bracket        |
| 7. O-ring                 | 14. Clamp                    | 21. Gasket         |
|                           |                              | 22. Bonnet         |

Figure 7. Lube Oil Cooler and Components - Model 16000H

removed to drain the cooling system (refer to preceding Paragraph C of this Topic).

2. If applicable, tighten raw water pump cover retaining screws and/or connect inlet hose to immersion heater thermostat.
3. Check to assure vent cock in top of thermostat housing is open.
4. Pour coolant into radiator until it flows from vent cock.
5. Close vent cock and continue filling until coolant level is approximately 1-1/2" (38 mm) below bottom of filler neck.
6. Open the vent cock at top rear of inter-cooler. Vent the air and check the level of the coolant.

7. Install filler cap.

NOTE: Connect power source to immersion heater thermostat.

#### E. CLEANING OF THE COOLING SYSTEM

1. Clean the cooling system at the beginning of cold weather before antifreeze is added, and again after antifreeze is drained for warm weather operation. Also, if the coolant system conditioner filter is changed from one type to another.
2. If the coolant filter has been properly maintained, cleaning of the system should not be necessary. However, the coolant filters effectiveness is only as good as the maintenance it receives. If inspection reveals coolant to be

brown and rusty color, drain, flush, and refill the cooling system; replace the coolant filter element.

**CAUTION:** Close coolant filter inlet and outlet shutoff valves before adding a cleaning compound to the cooling system. Never mix antifreeze compounds or inhibitors with any cleaning, neutralizing, or flushing compounds.

3. Many good solvents are on the market for cleaning of cooling system; use according to instructions.
4. If radiator tubes become clogged, reverse flush radiator as follows:
  - a. Disconnect upper and lower radiator hoses.
  - b. Connect a pressure water hose to lower connections with a suitable adaptor.
  - c. Plug upper connection and remove radiator cap.
  - d. Force water through radiator. Foreign material will flow out through top of radiator with the water.

**CAUTION:** Do not use more than 5 or 6 psi (35 to 41 kN/m<sup>2</sup>) pressure when flushing. Excessive pressure may rupture radiator.

5. Keep radiator air passages free of debris and other obstructions. Clean exterior with an air blast carrying a grease solvent. If engine is equipped with sucker type fan, direct cleaning spray at rear (fan side) of radiator. For engines having a blower type fan, direct spray at front of radiator.

**WARNING:** PROVIDE ADEQUATE VENTILATION TO AVOID POSSIBLE TOXIC EFFECTS OF THE CLEANING SPRAY. NEVER USE GASOLINE, FUEL OIL, OR KEROSENE.

6. After cooling system has been cleaned and flushed, open coolant filter shutoff valves. Refill and inspect system for coolant leaks. Correct all leaks found to avoid foaming, corrosion, and loss of solution.

## F. ENGINE OIL COOLER

### 1. General

The engine oil cooler is located on the right side of the engine and consists of a corrosion resistant core and jacket. The model 16000H engine oil cooler (Figure 7, Item 16) is mounted to the front of the coolant and oil manifold (4) and the models 16000MKII, 17000MKII, 21000MKII, and 25000MKII oil cooler (Figure 9, Item 4) is mounted to the rear of the water and oil manifold (8).

Coolant is circulated through the cooling tubes and engine oil around the tubes. The coolant absorbs heat from the oil, thereby controlling the oil temperature.

**CAUTION:** It is important that the oil cooler be kept clean and free of deposits in order to maintain proper cooling.

If the recommended maintenance and lube oil renewal are not performed at the indicated interval, deposits may form in the oil cooler and restrict the flow of oil or coolant. Restriction of the flow of oil is usually indicated by a drop in oil pressure and a rise in oil temperature.

### 2. Oil Cooler Removal and Installation - Model 16000H

#### a. Removal and Disassembly

- (1) Drain the cooling system.
- (2) Remove capscrews and lockwashers securing bypass tube (Figure 8, Item 2) to thermostat cover.
- (3) Loosen clamp (3) on hose (4) end of bypass tube and remove bypass tube.
- (4) Remove capscrews and lockwashers securing bypass tube elbow (5) to pump cover (8); force oil cooler tube (Figure 7, Item 11) and bypass elbow down and remove them as an assembly. Remove the gasket (7).
- (5) Loosen clamps (Figure 7, Item 14) securing bonnet tube hose (13); force hose onto bonnet tube (8).
- (6) Remove capscrews and lockwashers securing oil inlet (17) and outlet (19) hoses to oil cooler; remove inlet and outlet hoses from oil cooler (16).

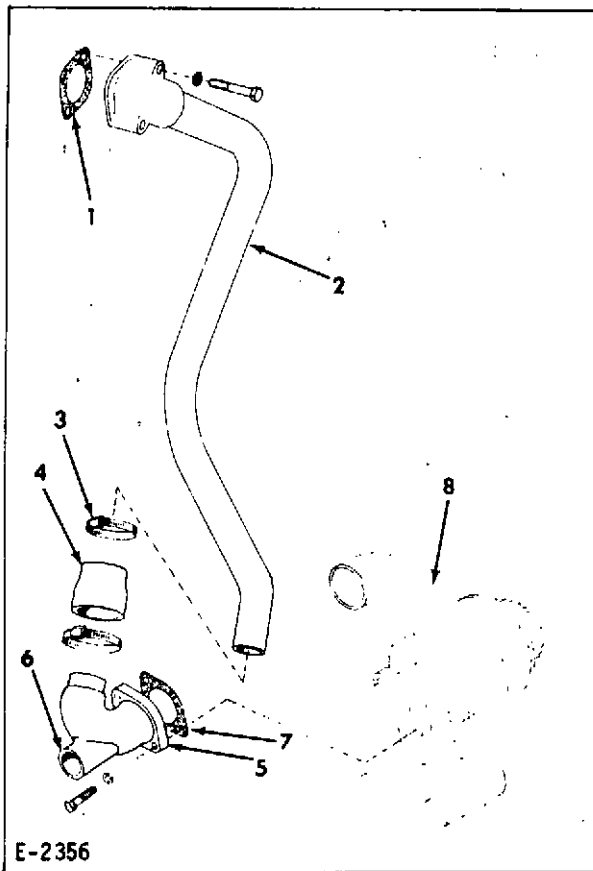

1. Gasket
2. Bypass tube
3. Clamp
4. Hose
5. Bypass elbow
6. Inlet for cooler tube
7. Gasket
8. Water pump cover

Figure 8. Coolant Bypass Tube - Model 16000H

- (7) Remove capscrew and lockwashers securing oil cooler support bracket (20) to water inlet manifold (1).
- (8) Remove the capscrews and lockwashers securing the inlet and outlet lube oil cooler bonnet (9) to the water and oil manifold assembly (4). Remove the oil cooler.
- (9) Remove the capscrews and lockwashers securing the inlet and outlet lube oil cooler bonnet (9) to the oil cooler. Remove the bonnet gasket (15) and o-ring (10).
- (10) Remove the capscrews and lockwashers securing the oil cooler end bonnet (22) to the oil cooler. Remove the bonnet and gasket (21).

#### b. Assembly and Installation

- (1) Prior to installation of oil cooler, it should be cleaned and tested. Refer to procedure in following Paragraph 4 for cleaning and Paragraph 5 for testing.
  - (2) Using new gaskets and O-rings, assemble the oil cooler and install it on the engine by reversing the removal and disassembly procedure.
  - (3) Close all coolant drain cocks and fill cooling system with coolant.
  - (4) Operate engine and check all connections for oil and coolants leaks.
  - (5) Stop engine and bring oil level up to the full mark on the dipstick.
3. Oil Cooler Removal and Installation  
Models 16000MKII, 17000MKII, 21000MKII and 25000MKII

#### a. Removal

- (1) Drain the cooling system.
- (2) Remove the oil drain plug from the bottom of the oil cooler (Figure 9, Item 4) and drain oil from the cooler.

CAUTION: Do not allow oil to drain onto starter.

- (3) Remove the coolant vent line(1) from the rear of the cooler and water outlet manifold.
- (4) Remove oil inlet and outlet tubes (13) and elbows (11) as assemblies from the water and oil manifold (8). Remove elbow-to-oil cooler and elbow-to-water manifold O-rings (14 and 12) from the elbows.
- (5) Loosen the clamps at the hose (9) connecting the water pump outlet and water pump-to-cooler bonnet tube (5).
- (6) Remove the support (16) from between the flywheel housing and oil cooler bonnet (2).
- (7) Remove the capscrews and lockwashers securing the oil cooler (4) to the oil cooler adaptor (7).
- (8) Pull the cooler toward rear of

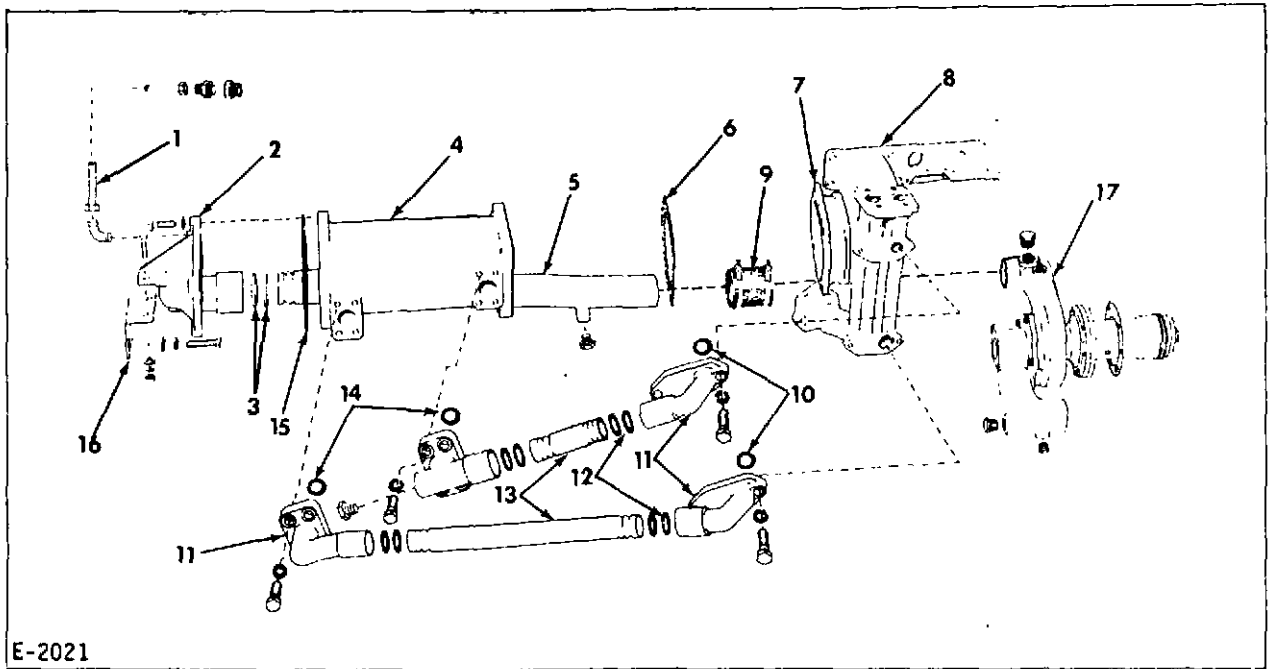

E-2021

- |                              |                    |
|------------------------------|--------------------|
| 1. Vent line                 | 9. Hose and clamps |
| 2. Bonnet                    | 10. O-rings        |
| 3. O-rings                   | 11. Elbows         |
| 4. Oil cooler                | 12. O-rings        |
| 5. Water pump-to-bonnet tube | 13. Oil tubes      |
| 6. Gasket                    | 14. O-rings        |
| 7. Adaptor                   | 15. Gasket         |
| 8. Water and oil manifold    | 16. Support        |
|                              | 17. Water pump     |

Figure 9. Lube Oil Cooler and Components - Model 1600MKII, 17000MKII, 21000MKII, and 25000MKII

engine to disconnect water pump-to-oil cooler tube (5) from water pump outlet. Remove the oil cooler from the engine.

- (9) Remove the water pump-to-cooler tube from the bonnet (2). Remove O-rings (3) from tube.
- (10) Remove the bonnet from the oil cooler.
- (11) Remove all particles of gaskets from mounting surfaces.
- (12) Clean and inspect oil cooler and components.

#### b. Assembly and Installation

- (1) Prior to installation of the oil cooler it should be cleaned and tested. Refer to procedure in following Paragraph 4 for cleaning and Paragraph 5 for testing.
- (2) Using new gaskets and O-rings,

assemble the oil cooler and install it on the engine by reversing the removal and disassembly procedure.

- (3) Install oil drain plug in oil cooler.
- (4) Close all coolant drain cocks and fill cooling system with coolant.
- (5) Operate engine and check all connections for oil and coolant leaks.
- (6) Stop engine and bring oil level up to the full mark on the dipstick.

#### 4. Engine Oil Cooler Cleaning

Thorough cleaning of the oil cooler may require use of special solvents. Several solvents for this purpose are available and must be used according to manufacturer's instructions. Some of the solvents are:

Excello Floor Cleaning Compound  
Turco Cleaning Compound  
No. 70 Stripper

Mixture of 3 parts Oakite No. 7 and  
5 parts fuel oil  
Bendix Cleaning Compound

To use the last-named solvent, merely submerge oil cooler into the solution for a sufficient length of time to allow chemical action of the solvent to dissolve or loosen sludge or other foreign matter. Flush oil cooler thoroughly with live steam or spirits after cleaning, regardless of type of cleaner used.

NOTE: If oil cooler core is badly clogged, a new oil cooler core must be installed.

### 5. Engine Oil Cooler Testing

Before testing the oil cooler, it must be cleaned thoroughly and inspected. To test the oil cooler, proceed as follows:

- a. Make up two suitable improvised plates, one with a drilled and

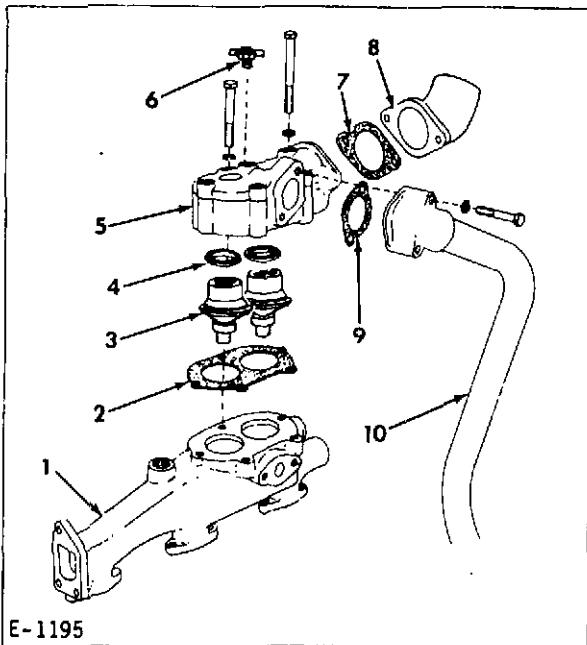

E-1195

1. Front water outlet manifold
2. Gasket
3. Thermostats
4. Seals
5. Thermostat cover
6. Vent cock
7. Gasket
8. Water outlet elbow
9. Gasket
10. Water bypass tube

Figure 10. Thermostats -  
Dry Type Exhaust

tapped hole to accept an air hose fitting, and secure them with gaskets, capscrews, and lockwashers to cover the oil inlet and outlet openings in the side of the oil cooler.

- b. Attach an air hose to the drilled and tapped plate; submerge the oil cooler in hot water for a sufficient length of time until the oil cooler is up to approximately 150°F (339 K) temperature. Test for leaks with air pressure of 200 psi (1379 kN/m<sup>2</sup>) or as near to that pressure as possible.
- c. Air bubbles observed at either open end of the oil cooler indicates that the cooler core has a puncture or may be defective in another way. If the cooling core is faulty, the oil cooler must be replaced. If repair of the shell is necessary, the repair should be made by a reputable radiator repair shop.

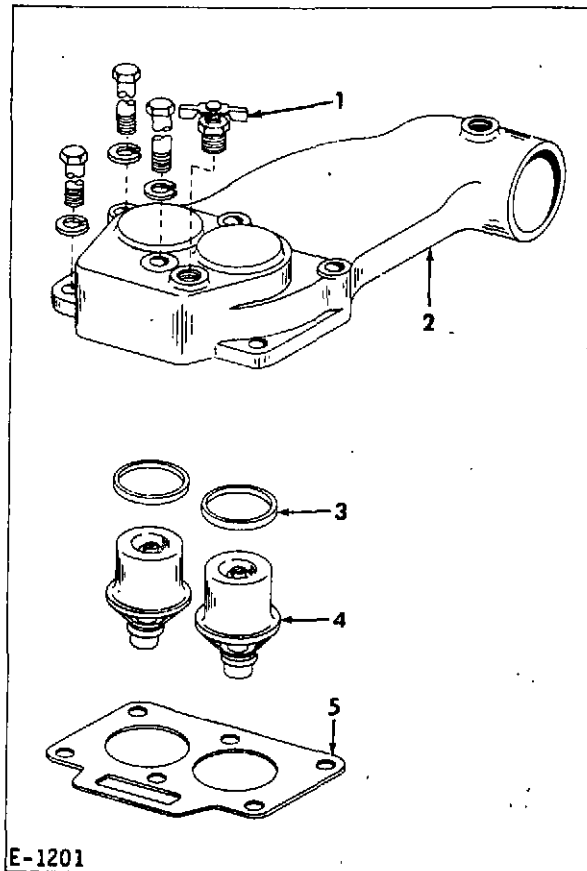

E-1201

1. Vent cock
2. Thermostat cover
3. Seal
4. Thermostat
5. Gasket

Figure 11. Thermostats - Water Cooled Type  
Exhaust Manifold

## G. THERMOSTATS

The bypass type thermostats remain closed and only allow the coolant to circulate within the engine itself until minimum operating temperature is reached. This provides for rapid and even temperature increase of all engine parts during the warm-up period. When desired temperature is reached, the thermostats open and allow the coolant to circulate through both the engine and radiator.

Operation of the engine with coolant temperature below 180°F (355 K) will result in incomplete fuel combustion, higher fuel consumption with less power, and cause harmful deposits to form within the engine. Maintenance of normal coolant operating temperature depends on properly functioning thermostats. If the engine overheats or does not reach and maintain a minimum 180°F (355 K), remove and test the thermostats.

### 1. Thermostat Removal

- a. Drain cooling system (refer to preceding Paragraph C).
- b. Remove capscrews from upper end of water bypass tube (Figure 10, Item 10) and free it from thermostat cover (5). Remove the capscrews from the outlet elbow (8) and remove the elbow gasket (7).
- c. Remove the thermostat cover (5) from the water manifold (1). Remove the thermostats (3) and gasket (2) from their positions on the manifold.
- d. Clean and inspect the cover (5). Examine the seals (4) in the cover. Replace the gaskets (2, 7 and 9). Replace seals, if necessary.

NOTE: To remove the seals, pry them from their seats in the thermostat housing cover. Install new seals using a suitable driver. The open side of the seal must be positioned toward the top of the thermostat housing cover.

### 2. Thermostat Testing

- a. Suspend thermostat in a container of clean water. Thermostat must be completely immersed but not touching bottom or side of container.
- b. Heat water gradually and stir so heat is evenly distributed.

CAUTION: Check temperature of water with a reliable thermometer. Do not overheat.

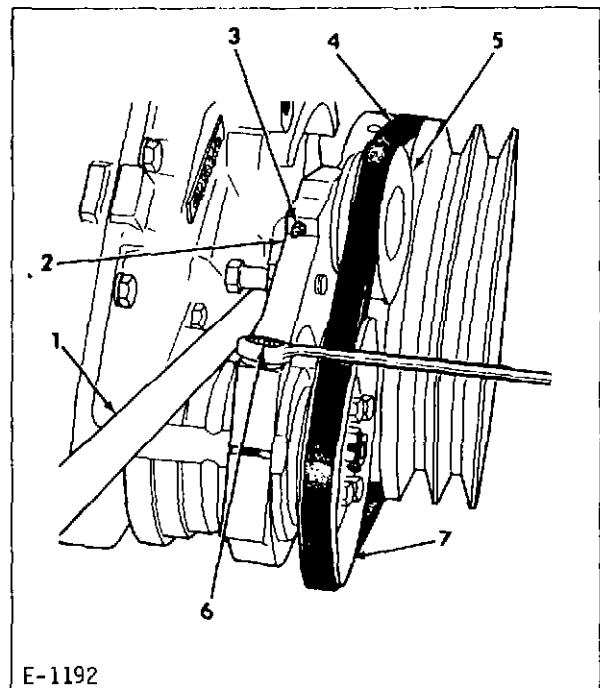

1. Bar
2. Water pump belt tightener assembly
3. Grease fitting (16000H only)
4. Water pump drive belt
5. Belt tightener idler pulley
6. Clamping capscrew
7. Water pump pulley

Figure 12. Adjusting Water Pump Drive Belt

- c. Observe thermostat as temperature of the water increases. If the thermostat is functioning properly, it should begin to open at 180°F (355 K) and be fully open at 200°F (366 K). The amount of travel between the closed and open positions of the thermostat should be 5/16" to 11/32" (7.94 to 8.73 mm).
  - d. Thermostats are not adjustable. If they do not operate within the above limits they must be replaced.
- ### 3. Thermostat Installation

- a. Place a gasket in position on the manifold and install the thermostats.
- b. Position the thermostat cover on the manifold and secure with capscrews and lockwashers.
- c. Place water outlet elbow and gasket in position at the front of the thermostat cover and secure with capscrews and lockwashers. Using a new gasket, position the top of the water bypass tube on the thermostat cover and secure with capscrews and

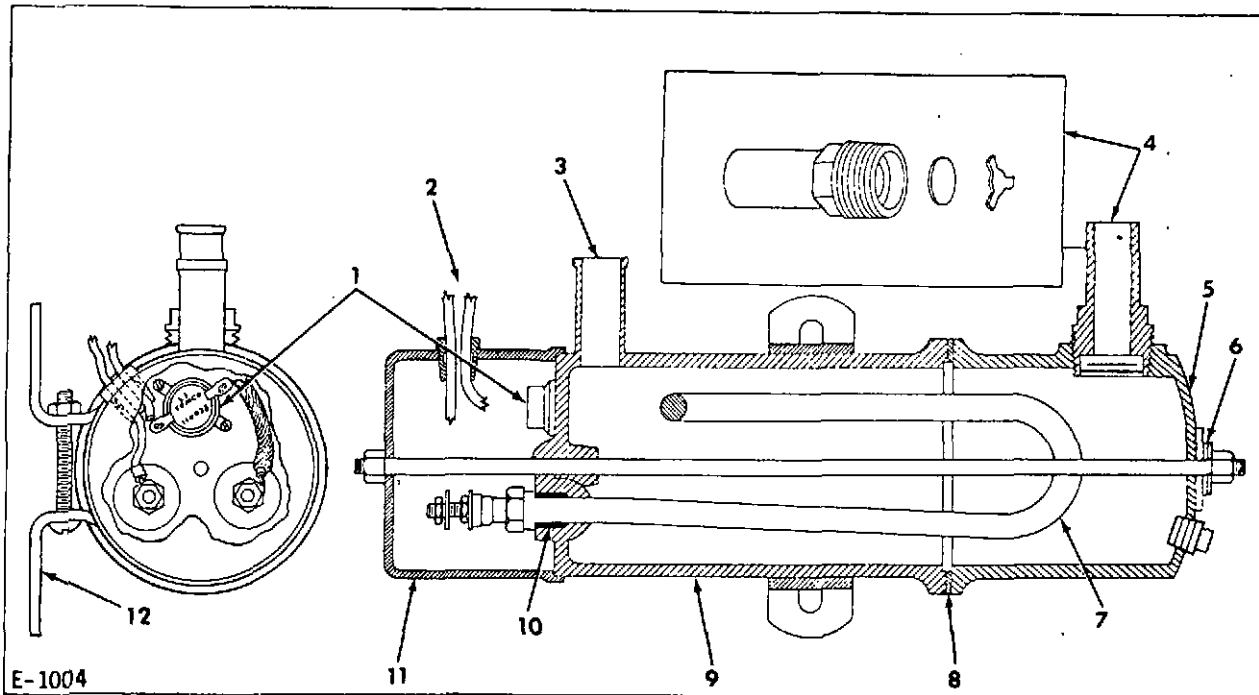

- |                                      |                   |                          |
|--------------------------------------|-------------------|--------------------------|
| 1. Safety thermostat                 | 5. Bottom casting | 9. Top casting           |
| 2. To temperature control thermostat | 6. Lead washer    | 10. Silicone rubber seal |
| 3. Coolant outlet                    | 7. Element        | 11. Terminal cover       |
| 4. Pulsating valve and coolant inlet | 8. Gasket         | 12. Bracket              |

Figure 13. Immersion Heater

lockwashers.

- d. Fill the cooling system (refer to preceding Paragraph D).

#### H. FAN HUB AND WATER PUMP BELT TIGHTENER ASSEMBLY IDLER PULLEY LUBRICATION

The bearings in the fan hub must be lubricated at the prescribed intervals with a pressure gun lubricant.

##### 1. Fan Hub

Each 600 hours of operation remove pipe plug from fan hub, install grease fitting, and pump 1 or 2 shots of grease into hub. Remove grease fitting (Figure 5, Item 5) and install pipe plug.

**CAUTION:** Do not overgrease fan hub bearings.

##### 2. Water Pump Tightener Idler Pulley

###### a. Model 16000H

Each 100 hours of operation pump 1 shot of grease into the fitting (Figure 12, Item 3) for the belt

tightener idler pulley.

- b. Models 16000MKII, 17000MKII, 21000MKII and 25000MKII

The sealed type bearing in the water pump belt tightener idler pulley is prelubricated and does not require lubrication until at time of overhaul. At time of engine overhaul, the bearing should be inspected and replaced if there is any indication of roughness, wear, or end play.

#### I. FAN-WATER PUMP BELT REPLACEMENT AND ADJUSTMENT

It is important that fan and water pump drive belts be inspected frequently to make certain no oil or grease has accumulated on it, and that proper belt tension is maintained. Replace badly worn, burned, oil/grease soaked belts.

##### 1. Fan Belts

The fan driving belts furnished are a matched pair of identical length. If only one belt replacement is required, both belts MUST be replaced.

###### a. Loosen the spindle clamping

16000H 16000MKII 17000MKII  
16000H 21000MKII 25000MKII

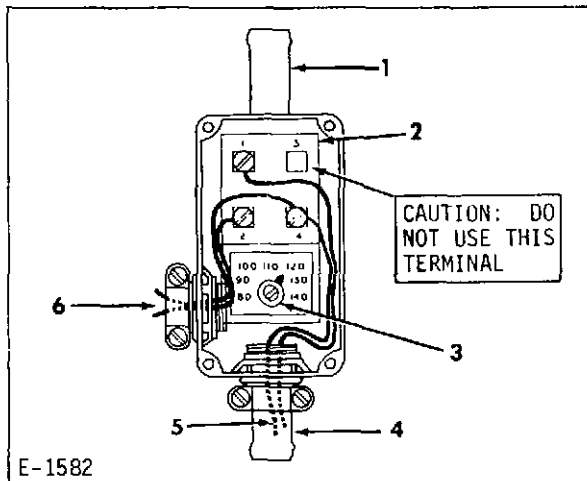

1. Coolant inlet
2. Terminal block
3. Temperature dial
4. Coolant outlet
5. To immersion heater
6. To AC source

Figure 14. Temperature Control Thermostat

retaining nut (Figure 5, Item 2) at rear of fan hub mounting bracket and loosen locknut (3) securing adjusting capscrew (4) that protrudes through the fan hub spindle.

- b. Turn capscrew (4) until enough slack is obtained to facilitate removal of the fan belts, then remove belts.
- c. Inspect belts for slickness, oil soak, wear, tears, cracks, and overstretching. Replace belts if necessary. Inspect pulleys.
- d. Position belts on fan hub and crankshaft pulley.
- e. Turn adjusting capscrew until belts can be pressed inward  $3/4$ " to 1" (19.05 to 25.40 mm) at a point half-way between fan hub and crankshaft pulley.
- f. Tighten locknut and spindle retaining nut.

## 2. Water Pump Drive Belt

- a. Remove fan belts (refer to preceding Subparagraph 1).
- b. Loosen water pump belt tightener assembly clamping capscrew (Figure 10, Item 9). Force assembly downward and remove belt.
- c. Inspect belt. Replace if necessary.

- d. Install belt in grooves of crankshaft pulley, water pump pulley, and belt tightener idler pulley.
- e. Adjust tightener up or down until belt can be pressed inward  $1/2$ " (12.70 mm) at a point half-way between the water pump and crankshaft pulleys.
- f. Securely tighten the clamping capscrew to a torque of 35 lb ft (47 Nm).

## J. IMMERSION HEATER AND THERMOSTAT

### 1. General (Figures 13 and 14)

The immersion heater operates on the thermosiphon principle of heating the coolant and circulating it through the cooling system. A pulsating valve located in the water inlet of the heater bottom casting assists the circulation. A safety thermostat located on the top casting is connected into the wiring circuit to prevent damage from overheating. Operating current for the immersion heater must be 120 volt, 60 Hertz, single-phase alternating current and connected by the contractor.

The temperature control thermostat is designed to control the temperature of the coolant. It contains a single-pole, double-throw control of which only one set of contacts are utilized. The control is quick to respond to temperature changes because of the low mass bimetal actuator which assures accurate temperature regulation. The thermostat is equipped with a positive snap action switch to assure a long life of trouble-free service. If thermostat becomes faulty, it must be replaced as an assembly.

The temperature control thermostat is suspended by the coolant hoses and hose clamps. With the thermostat in position, the coolant passing through the thermostat must reach the temperature set on the dial (80° to 140°F) (300 to 333 K) before the unit will automatically shut off. When the coolant passing through the thermostat cools down 7° to 15°F (4 to 8 K) below the setting on the dial, the thermostat automatically comes back on and the coolant is being heated again.

**CAUTION:** The heater does not eliminate the need for antifreeze.

### 2. Operating And Maintenance

- a. Before applying current to the heater for the first time, be sure:

- (1) The air has been bled from the cooling system.
- (2) The radiator is full.
- (3) All hose connections are tight.
- b. If the cylinder block remains cold, and both the inlet and outlet hoses to the immersion heater are hot, it indicates lack of circulation caused by:
  - (1) Trapped air preventing siphoning action.
  - (2) Water too low in radiator.
  - (3) Antifreeze solution too strong.
  - (4) Frozen coolant.
- c. When the heater is operating properly, the lower inlet hose will be warm.
- d. If the radiator gets warm before the engine block has warmed a faulty engine thermostat may be the cause.
- e. At least once a year or every 2000 hours of operation, whichever occurs first, disassemble the immersion heater unit in order to inspect and clean all scale and foreign matter from the components.

Corrosion, sludge, and scale affect the efficient operation of the immersion heater:

- (1) Corrosion is caused by the mineral content in the water.
- (2) Sludge is caused by impurities in the cooling system.
- (3) Scale is caused by the combination of heat and impurities in the cooling system.

CAUTION: Never use a glycol solution stronger than the mixtures recommended for each particular brand.

NOTE: As a convenience and safety factor, it is recommended a switch be provided between the thermostat and the power source to de-energize the immersion heater and thermostat whenever the coolant is drained from the engine cooling system, or when personnel are working around the engine.

### 3. Troubleshooting

a. If the heater has been working satisfactorily for a length of time and then fails, the following items should be checked:

- (1) Electric wiring. Make sure current is supplied to the heater.
- (2) Water level in the radiator. Level may be too low.
- (3) Condition of coolant. Coolant may have been frozen or in a mushy condition when current was furnished to the heater.
- (4) Air in system. Cooling system may have been drained, refilled, but not vented.
- (5) Sediment in the system. A layer of sediment in the bottom of the heater may have clogged the lower inlet.

b. If temperature control thermostat or heater element is suspected of being inoperative, perform the following checks:

- (1) Remove temperature control thermostat cover. Place the leads of a 120 volt test lamp across #2 and #4 terminals of thermostat. Test lamp will light up if circuit to thermostat is energized.
- (2) Increase temperature dial to its highest setting so thermostat contacts close. Place test lamp leads across #1 and #4 thermostat terminals. If test lamp lights up, thermostat is operating properly to energize the heater circuit.
- (3) Remove terminal cover from heater top casting. Place test lamp leads across element terminals. If test lamp lights up and top outlet hose is cold, the element must be replaced. If test lamp does not light up, place test lamp leads against element terminal where the lead from the safety control thermostat is connected and against the safety thermostat terminal where the lead from the control thermostat is soldered. If test lamp lights up, the safety thermostat or the short lead between the safety thermostat and the element terminal requires replacement. Move the test lamp lead that was against the safety thermostat terminal and place it against the other terminal of the safety thermostat. If test lamp does not

light up, the safety thermostat must be replaced. If test lamp does light up, the short lead between the safety thermostat and the element terminal must be replaced.

(4) Return thermostat temperature dial to its normal setting.

c. If circulation is prevented by an air lock or other obstruction, the thermostat will trip out. After the heater has cooled, the thermostat will reset automatically. However, if the reason for overheating is not corrected, the engine block will remain cold even though the heater is hot

#### 4. Immersion Heater And Thermostat Removal

**CAUTION:** Disconnect power source from immersion heater thermostat.

- a. Drain the cooling system.
- b. Remove cover from temperature control thermostat (Figure 12).
- c. Tag and disconnect all electrical leads from thermostat to facilitate removal of it. Remove leads and clamps from thermostat.
- d. Loosen hose clamps, remove thermostat inlet and outlet connections from hoses, and remove control thermostat.
- e. Loosen hose clamps and remove hoses from immersion heater outlet and inlet connections.
- f. Remove nuts, lockwashers, washers, and capscrews that secure immersion heater to mounting bracket and remove immersion heater.
- g. Remove water inlet and outlet tube assemblies.

#### 5. Immersion Heater Disassembly And Assembly

- a. Remove nut from top of heater and remove terminal cover (Figure 13, Item 11) from top casting (9).
- b. Remove screws that secure snap-acting type safety thermostat (1) to top casting. Remove electrical leads from heater element terminals. If safety thermostat is to be replaced, disconnect electrical leads from it. Solder end of leads to new safety thermostat terminals.

c. Remove nut, washer, and lead seal washer (6) from bottom of heater and remove bottom casting (5) and gasket (8). Do not pry the two castings apart. If necessary, break gasket seal by tapping heater sharply on the edge of a wooden block.

d. Unscrew and remove coolant inlet valve assembly (4) from bottom casting (5). If pulsating valve does not operate freely in the coolant inlet it must be replaced as an assembly.

e. Remove nuts, washers, porcelain sleeves, rubber washers, and compression nuts from ends of element (7). Twist element a little bit at the lower end to loosen it and remove it from the top casting.

f. Remove element seals (10) from top casting with a sharp pointed tool such as an ice pick. Be careful not to damage the threads.

g. Insert new silicone rubber seals into top casting and also start compression nuts in slightly but do not tighten them.

h. Insert element through seals and compression nuts until the steel sheath of the element ends is showing above the compression nuts. Then tighten the compression nuts firmly.

i. Use a new gasket and lead seal washer and complete the assembly of the immersion heater by a direct reversal of the disassembly procedure.

#### 6. Inspection

a. Inspect immersion heater components and thermostat for corrosion, sludge and scale. If necessary, clean with trichloroethylene and a wire brush.

**WARNING:** TRICHLOROETHANE SOLVENT IS TOXIC AND VERY VOLATILE. USE ONLY IN A WELL VENTILATED ROOM OR AREA. DO NOT INHALE FUMES FOR AN EXTENDED LENGTH OF TIME. DO NOT USE CLEANING SOLUTIONS THAT ARE HARMFUL TO ALUMINUM.

b. Inspect hoses for deterioration or damage. Replace if necessary.

#### 7. Immersion Heater And Thermostat Installation

a. Install immersion heater and thermostat by a direct reversal of the

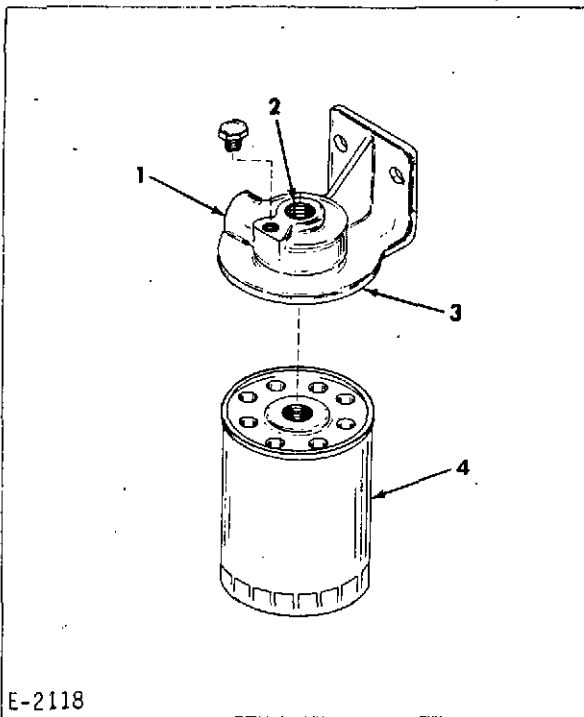

E-2118

- |           |                   |
|-----------|-------------------|
| 1. Inlet  | 3. Header         |
| 2. Outlet | 4. Spin-on filter |

Figure 15. Coolant Filter-Spin-on Type

removal procedure as detailed under preceding Subparagraph 4.

- b. Connect power source to immersion heater thermostat, and repeat procedure in Subparagraph 2, before applying current to the heater.

#### K. COOLING SYSTEM CONDITIONER

##### 1. General

The cooling system conditioner filter is of two types, the current spin-on type (Figure 15) and the former replaceable element type (Figure 16).

Both types of filters function in the same manner, to extend engine life by establishing and maintaining a rust, scale, and corrosion free cooling system. The filter header or housing must make a good ground with the engine for the cooling system conditioner to operate properly.

The piping connecting the filter into the engine cooling system is fitted with coolant inlet and outlet shutoff valves. The valves are closed when an engine is shipped from the factory and must be opened after it is installed in a unit. Also, the valves are closed when renewing a filter or element to prevent the

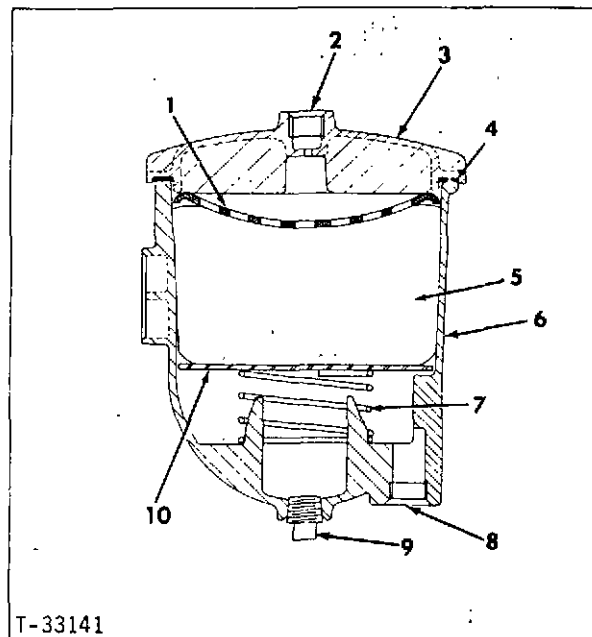

T-33141

- |                |                                    |
|----------------|------------------------------------|
| 1. Upper plate | 6. Body                            |
| 2. Outlet      | 7. Spring                          |
| 3. Cover       | 8. Inlet                           |
| 4. Gasket      | 9. Drain plug                      |
| 5. Element     | 10. Lower corrosion resistor plate |

Figure 16. Coolant Filter - Replaceable Element Type

loss of engine coolant.

The type of water conditioner filter or element in a new engine is an all purpose type and can be used with plain water and all types of permanent and non-permanent antifreezes, with the exception of Dowtherm 209. Refer to Parts Manual for the element to be used with Dowtherm 209.

**CAUTION:** Whenever element is changed from one type element to the other, it is necessary to drain and flush the cooling system.

The coolant conditioner performs the following functions:

- a. By mechanical filtration, it removes suspended foreign material which may be circulating through the cooling system.
- b. It prevents precipitation of water hardness scale on all cooling system surfaces by the ion exchange method of water softening.
- c. The chemicals present in the water conditioner element protect against

corrosion activity in the engine.

- d. Electrolytic control is accomplished by the use of a sacrificial plate.
- e. The natural tendency toward rust formation and chemical deterioration of cooling system metal surfaces is reduced by the effective buffering agents contained in the element.

CAUTION: Do not use soluble oil or other conditioners in the cooling system of an engine equipped with a coolant filter. If a leak stopper is added to the coolant, do not allow it to circulate through the water conditioner. Shut-off valves are provided in inlet and outlet lines for isolating the water conditioner from remainder of cooling system.

## 2. Maintenance

The all-purpose type element or filter should be replaced each 600 to 800 hours. The chromate-type element or filter used with Dowtherm 209 antifreeze should be replaced each 300 to 500 hours. Maintain the coolant conditioner as follows:

NOTE: Whenever all the liquid in the cooling system is replaced with new coolant, the first filter must be replaced after 100 hours of operation.

### a. Spin-on Type Filter (Figure 15)

- (1) Thoroughly clean base and surrounding area.
- (2) Close coolant inlet and outlet shut-off valves.
- (3) Remove exhausted spin-on element and discard.
- (4) Lubricate gasket with a thin film of oil.
- (5) Install element until gasket contacts base of mounting housing.
- (6) Hand tighten 1/2 turn more.
- (7) Open inlet and outlet shutoff valves.
- (8) Operate engine and check for leaks.

### b. Replaceable Element Filter (Figure 16)

- (1) Thoroughly clean the filter body and surrounding area. Close the

inlet and outlet shutoff valves.

- (2) Remove drain plug from the bottom of filter body and allow coolant to drain.
- (3) Remove capscrews attaching filter cover to filter body; remove cover and gasket.
- (4) Lift the upper plate and filter element out of the filter body.
- (5) Discard the filter element and cover gasket.
- (6) Remove the lower corrosion resistor plate and spring from the filter body.
- (7) Clean sump area in filter body.
- (8) Install the spring and a new lower corrosion resistor plate (included in filter element service kit).
- (9) Install a new filter element in the filter body.
- (10) Install a new upper plate in filter body.
- (11) Install a new cover gasket. Then, install the filter cover and secure it with attaching capscrews.
- (12) Replace the drain plug and open the inlet and outlet shutoff valves.
- (13) Operate engine and check for leaks.

## 3. Removal and Installation

- a. Close coolant conditioner inlet and outlet shutoff valves.
- b. Remove outlet hose between top conditioner mounting base and thermostat housing.
- c. Remove inlet hose between side of conditioner mounting base and cylinder block.
- d. Remove lockwashers, washers and capscrews that secure coolant conditioner to the cylinder block and remove mounting base.
- e. Remove hose fittings from inlet and outlet of coolant conditioner.
- f. Inspect coolant conditioner hoses for deterioration or damage. Replace if necessary.
- g. Install hose fittings in coolant conditioner inlet and outlet

openings.

- h. Install coolant conditioner and secure with capscrews, washers, and lock-washers.

NOTE: Make certain conditioner header or body makes a clean, tight, metal-to-metal contact with the engine, otherwise connect a ground wire between them.

- i. Install hoses on fittings and tighten hose securely.
- j. Install new coolant conditioner element.
- k. Open coolant conditioner inlet and outlet shutoff valves.
- l. Check coolant level; add coolant if necessary.
- m. Operate engine and check for leaks.

## TOPIC 12. FUEL SYSTEM

### A. GENERAL

The engine fuel system consists of two fuel pressure systems; the low pressure system, and the high pressure system.

The low pressure system consist of the fuel supply pump, fuel supply lines, fuel return lines, and relief valves. Three arrangements of fuel filters (Figs 1, 2, and 5A) have been applied to these engines. The function of the low pressure system is to convey fuel from the tank through the fuel filters and deliver clean fuel to the fuel sump of the injection pump.

Once the injection pump fuel sump is full the excess fuel builds up pressure, opens the fuel pressure relief valve, and returns the fuel to the fuel tank.

There is a certain amount of fuel seepage between the lapped surfaces of each fuel injection nozzle valve and its body, which is necessary for lubrication. This leakage of fuel accumulates around the spindle and in the spring compartment of each fuel injection nozzle holder and is returned through the fuel drip manifold to the fuel return line, extending to the fuel tank.

Before the cleaned fuel from the filters enters the injection pump, it passes through a normally closed (energized to run) fuel shutoff solenoid valve which is connected into the fuel inlet of the injection pump gallery.

When the engine stop switch is placed in the STOP position, the fuel shutoff solenoid valve is de-energized, stopping the flow of fuel to the fuel injection pump. The engine speed decreases due to lack of fuel. This causes the oil supply to the governor to be reduced which allows the return spring at the rear of the pump to move the rack to the STOP position.

Generally, it takes approximately 10 seconds for the engine to stop. During this time interval the fuel supply pump continues to operate and imposes a pressure on the fuel solenoid shutoff valve. If starting is initiated during the shutdown interval, the fuel solenoid shutoff valve will not open due to the pressure. Normally, the pressure will leak off in 1 to 2 minutes after the engine is stopped and no difficulty will be encountered when again starting the engine.

To eliminate the pressure at the fuel solenoid shutoff valve, a pressure relief valve and bypass line are installed between the clean fuel outlet of the filter and the fuel return line at a tee connected to the outlet

of the fuel pressure relief valve located at the sump of the injection pump. The bypass line and relief valve functions to relieve the pressure at the fuel shutoff solenoid valve.

If the arrangement of the low pressure system components should locate the fuel tank in the system where it would create a suction head in excess of 36 inches (914 mm), an optional gear type fuel transfer pump is recommended. For details of this fuel transfer pump refer to following Paragraph 0.

In the high pressure system, the fuel injection pump picks up fuel from the sump, meters and forces the fuel, under extremely high pressure, to the fuel injection nozzles. The nozzles spray the fuel into the engine combustion chambers. The fuel injection lines are seamless steel tubing and each line is the same length. These lines being of equal length assures proper timing and the proper amount of fuel to each injection nozzle.

The accessory drive is mounted on the rear of the timing gear housing on the left side of the engine and its main function is to drive the fuel injection pump. However, on some engine applications a generator drive pulley is driven from the front end of the accessory drive upper shaft. On other engine applications a hydraulic pump drive pulley is driven from the front end of the accessory drive upper shaft, and in some applications an optional high-lift fuel transfer pump is driven at the rear of the accessory drive.

If necessary precautions are not taken in the storage of fuel, in the transfer of fuel to the fuel tank, and in keeping the fuel tank full to prevent condensation, foreign matter and water will enter the fuel system and damage fuel injection pump and fuel injection nozzles. The fuel filters are installed in the fuel system to clean the fuel before it enters the fuel injection pump.

It is essential that personnel responsible for the care and operation of the engine adhere to the following maintenance recommendations:

1. Use only fuel meeting the recommended specifications.
2. Store and handle fuel with utmost care to prevent water and foreign matter from entering the fuel system.
3. Properly maintain fuel oil filters.
4. Remove injection nozzle holder assemblies at the prescribed intervals; adjust

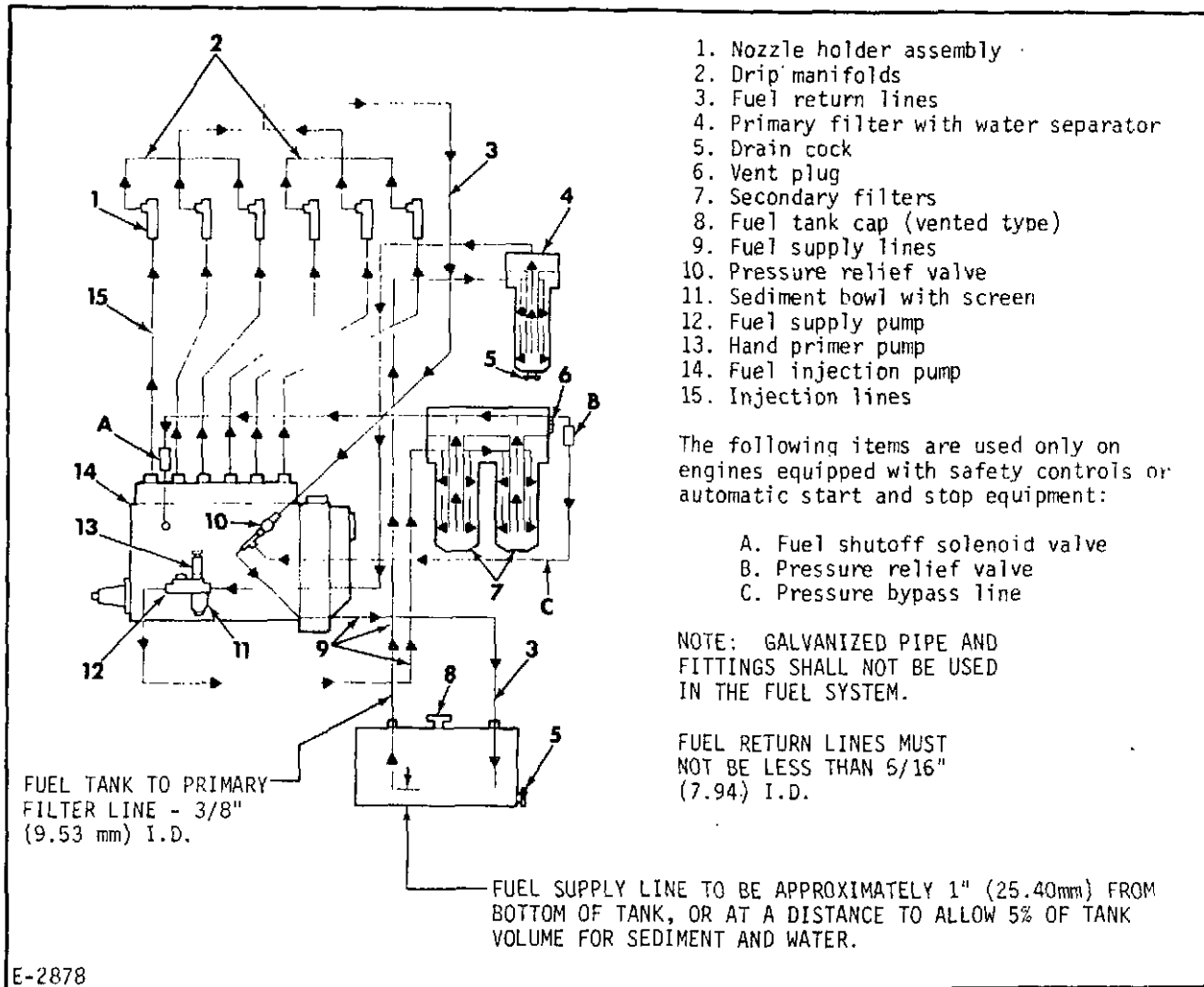

Figure 1. Fuel System Schematic Diagram - Current Type Spin-On Type Filters

the opening pressure and check the spray pattern.

5. Daily inspect the fuel supply pump filter glass bowl for water and sediment. If necessary, clean bowl and screen.
6. Periodically check injection pump timing.
7. Keep all fuel line connections, filters, injection pump and injection nozzle assemblies tightened securely (specified torque) to the engine.
8. Before removing any part of the fuel injection system from the engine be sure to wash the part with cleaning solvent, also the surrounding area to prevent the entrance of abrasives into the system. Cover all openings immediately.

B. FUEL FILTERS - SPIN-ON TYPE

1. General

The spin-on throw-away type filters are of two arrangements (Figs 1 and 2). The filters are screwed onto headers (Figs 4 and 5) and an o-ring which is replaced each time a filter is renewed and an integral gasket prevent fuel from leaking to the outside.

In some applications the supply pump on the side of the injection pump has a glass bowl in which is contained a filter screen.

2. Current Arrangement of Spin-On Type Filters

The current type filtering system (Fig 1)

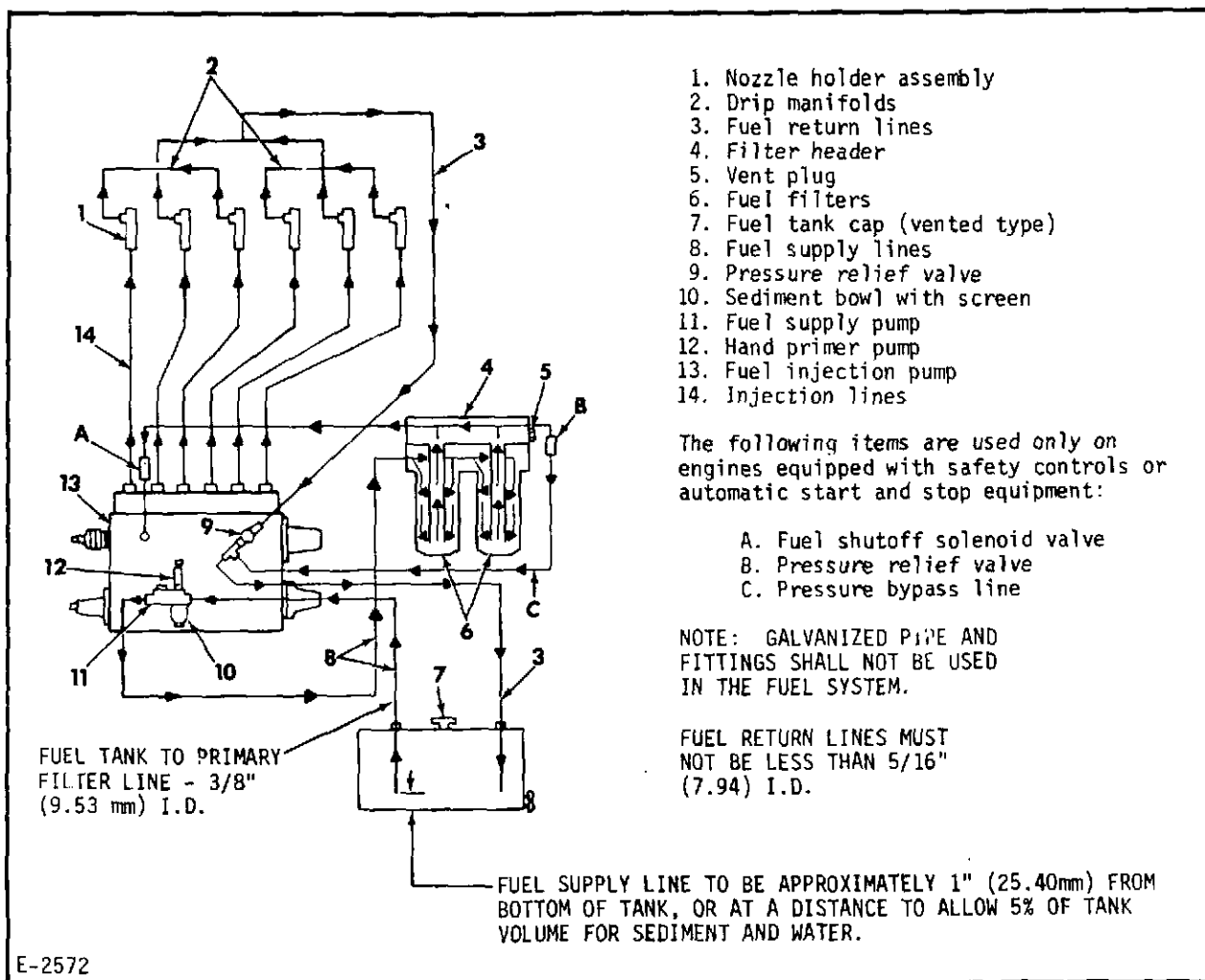

Figure 2. Fuel System Schematic Diagram - Early Type Spin-On Type Filters

consist of a primary fuel filter/water separator (Fig 4) which collects dirt and sediment from the fuel and prevents it from entering the fuel supply pump. A drain cock is located in the bottom of the primary filter allowing water and contaminants to be drained from the filter. Any dirt or sediment passing through the primary filter and the fuel supply pump is collected in the dual secondary filters (Fig 5).

Fuel from the fuel tank enters the primary filter passing around the outside and through the filter medium. Filtered fuel from the primary filter passes through the supply pump to the dual secondary fuel filters. The fuel enters both filters at the same time, passing around the outside and through the filter medium. Cleaned fuel from the center of each filter is forced into a common passage in the filter head and passes through a tube assembly connected to the fuel inlet of the injection pump.

### 3. Early Arrangement of Spin-On Type Filters

The early spin-on type filter arrangement (Fig 2) is similar to the current type except it did not have the primary fuel filter/water separator (Fig 4) in the system.

Fuel is drawn from the fuel tank by the supply pump and forced through the dual fuel filters and into the sump of the injection pump. The dual fuel filters function in an identical manner as those in the current arrangement.

### 4. Filter Maintenance

#### a. General (Figs 1, 2, 3, 4, and 5)

In warm weather, open the drain cock in the bottom of the primary fuel filter/water separator before starting the daily operations. In cold weather, when there is the possibility that the condensed water will

freeze, drain the contaminants shortly after the end of daily operations. Allow the filter to drain until the fuel runs clean.

Replace the filters and o-rings at 600 hours or 12 months whichever occurs first, (more often when operating conditions warrant) or when filter become clogged. Clogged filters are usually indicated by irregular engine performance.

#### b. Fuel Supply Pump Filter

If applicable, daily inspect the glass bowl (Fig 3 Item 9) of the fuel supply pump. If necessary empty sediment from the bowl and clean the bowl and screen (7) as follows:

- (1) Unscrew bowl clamp nut and swing clamp to one side.
- (2) Remove bowl, filter screen, and spring.
- (3) The bowl gasket will remain in the supply pump body. Remove it for inspection and if it is damaged, replace it.
- (4) Wash bowl and filter screen in fuel oil. Direct a blast of dry, low pressure air through the screen.
- (5) Install filter screen and spring, making certain screen is properly seated in supply pump body.
- (6) Install glass bowl and position clamp in bottom of bowl. Tighten clamp nut securely.

#### c. Fuel Filters

- (1) Clean all dirt from around the filter, filter head, and surrounding area.
- (2) Primary filter (Fig 1 Item 4: Loosen the vent screw and open the drain cock, allow the filter to drain completely.
- (3) Unscrew and remove filter and o-ring from filter head. Discard filter and o-ring.
- (4) Clean dirt and sediment from the filter annular groove in the filter head.
- (5) Position new o-ring from filter replacement kit on threaded insert in filter head. Apply a light coating of lubricating oil to the filter gasket. Screw new filter by hand into position until gasket contacts

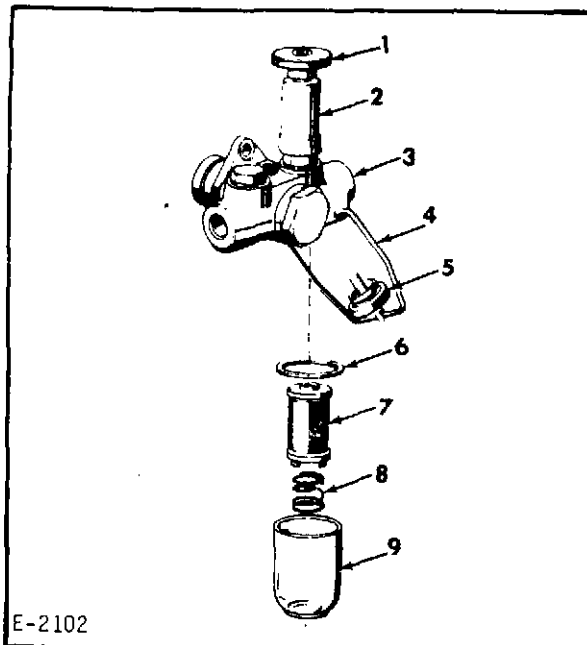

- |                     |                  |
|---------------------|------------------|
| 1. Plunger          | 6. Gasket        |
| 2. Primer pump      | 7. Filter screen |
| 3. Fuel supply pump | 8. Spring        |
| 4. Clamp            | 9. Glass bowl    |
| 5. Clamp nut        |                  |

Figure 3. Fuel Supply Pump with Hand Primary and Filter

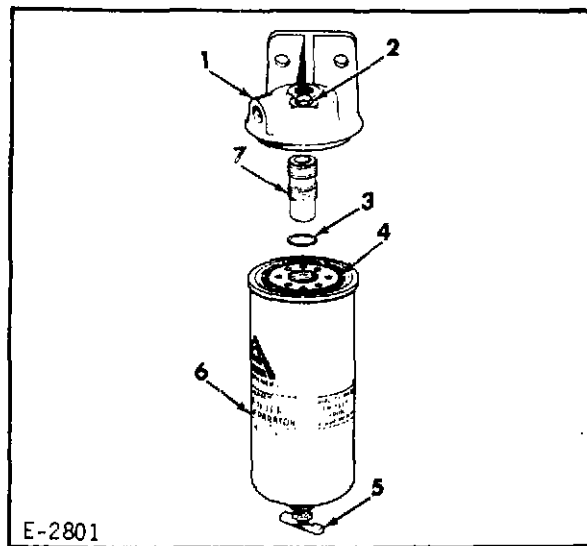

- |                  |                    |
|------------------|--------------------|
| 1. Filter header | 5. Drain cock      |
| 2. Vent screw    | 6. Filter          |
| 3. O-ring        | 7. Threaded insert |
| 4. Gasket        |                    |

Figure 4. Primary Fuel Filter and Water Separator

base of filter head head. Using hand pressure, tighten filter 1/2 to 3/4 of a turn more.

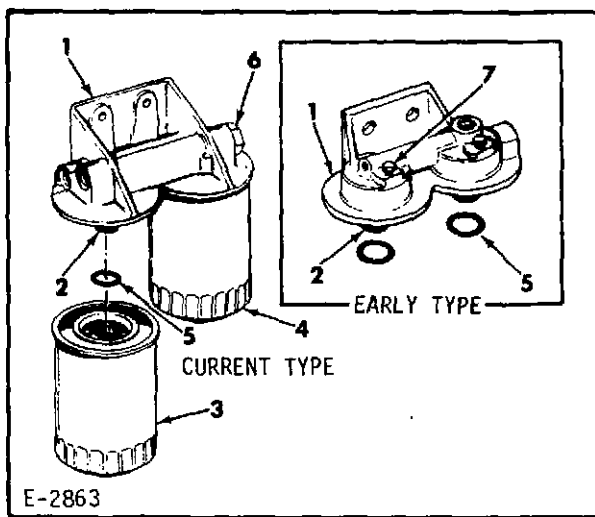

1. Filter head
2. Threaded insert
3. Fuel filter
4. Gasket
5. O-ring
6. Filter head vent plugs (current type)
7. Filter vent (early type)

Figure 5. Secondary Dual Fuel Filters

**CAUTION:** Do not use any tools to tighten filter. Do not use sealing compounds or lubricants. Always use an Allis-Chalmers replacement filter.

- (6) If applicable, open tank shutoff valve.
- (7) Close primary filter drain cock and tighten the vent screw.
- (8) Prime fuel system (refer to Paragraph D).

#### C. FUEL FILTERS - REPLACEABLE ELEMENT TYPE

##### 1. General (Figs 5A and 6)

The first stage and second stage fuel filters each contain a replaceable element. Dirt and sediment are collected by the first stage filter and prevented from entering the fuel supply pump. Any dirt or sediment passing through the first stage filter and the fuel supply pump is collected in the second stage filter. A drain cock is located in the bottom of each filter to allow the operator to drain the contaminants from the filter.

##### 2. Maintenance

- a. In warm weather, open the drain

1600H 1600MKII 1700MKII  
21000MKII 25000MKII

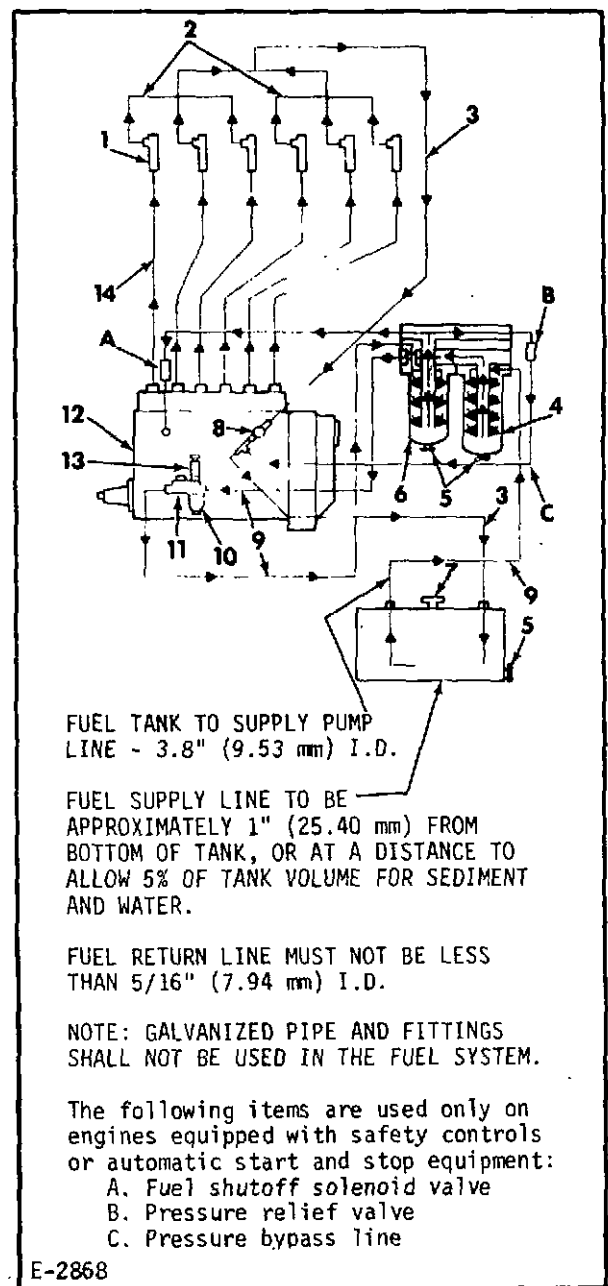

1. Nozzle holder assembly
2. Drip manifolds
3. Fuel return lines
4. Primary filter
5. Drain cocks
6. Secondary filters
7. Fuel tank cap (vented type)
8. Pressure relief valve
9. Fuel supply lines
10. Sediment bowl w/screen
11. Fuel supply pump
12. Hand primer pump
13. Fuel injection pump
14. Injection lines

Figure 5A. Fuel System Schematic Diagram  
Replaceable Element Type Filters

Revision 1

1.12  
Page 5

cock in the bottom of each filter before starting the daily operations. In cold weather, when there is the possibility that the condensed water will freeze, drain the contaminants shortly after the end of daily operations. Allow the filter to drain until the fuel runs clean.

- b. Replace elements and shell gaskets at 600 hours or 12 months whichever occurs first, (more often when operating conditions warrant) or when filter become clogged. Clogged filters are usually indicated by irregular engine performance.

### 3. First Stage Fuel Filter Element Replacement

- a. Clean all dirt from around the filter head and shell.
- b. Loosen the vent screw and open the drain cock. Allow the shell to drain completely.
- c. Loosen the retaining nut in the filter head until it is free from the shell centerbolt. Remove the filter shell from the filter head.
- d. Remove and discard the element and the shell gasket. Thoroughly wash and dry the filter shell interior.
- e. Install a new filter element and push it down firmly so that the upturned edge of the seat plate, attached to the bottom of the shell centerbolt, is firmly impressed into the bottom of the filter element.
- f. Install a new shell gasket in position in the lip of the shell. Hold the shell under the filter head and engage the threads of the retaining nut with the centerbolt. Tighten the nut securely.

**CAUTION:** Do not overtighten the retaining nut.

- g. Close the drain cock and tighten the vent screw.
- h. Prime the fuel system (refer to following Paragraph D).

### 4. Second Stage Fuel Filter Element Replacement

- a. Clean all dirt from around the filter head and filter shell.
- b. Loosen the vent screw and open the drain cock. Allow the filter to drain completely.
- c. Loosen the retaining nut in the filter head until it is free of the centerbolt. Remove the shell from the filter head.
- d. Remove and discard the filter element. Remove the centering guide, the element seating plate gasket, and metal washer from the shell centerbolt. Discard the seating plate gasket, metal washer, and shell gasket.

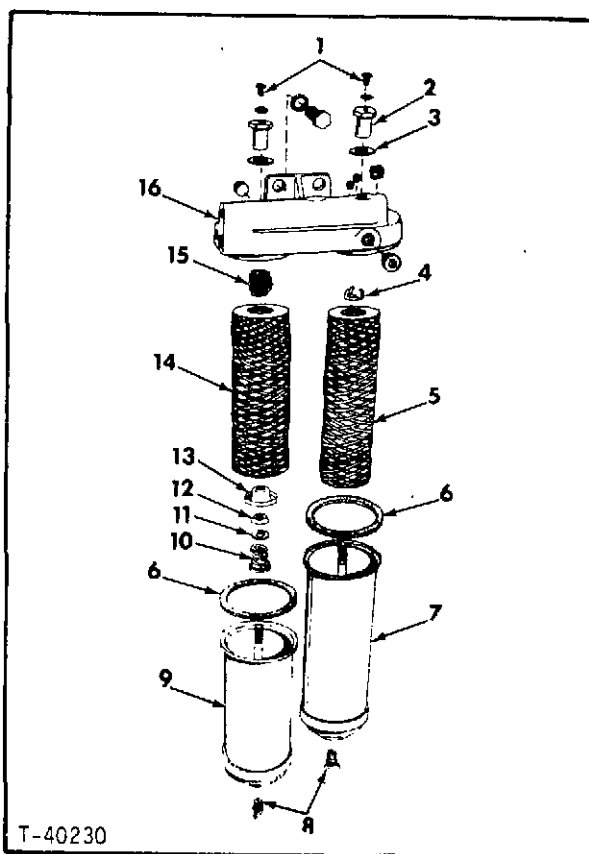

1. Vent screw
2. Hex retaining nut
3. Retaining nut gasket
4. Centering guide
5. First stage filter element
6. Shell gasket
7. First stage filter shell
8. Drain cock
9. Second stage filter shell
10. Spring
11. Metal washer
12. Seat plate gasket
13. Seating plate (seat plate)
14. Second stage filter element
15. Centering guide
16. Filter head

Figure 6. Fuel Filter Details

- e. Thoroughly wash and dry the filter shell interior.
- f. Place the element spring, large end down, in position on the shell centerbolt. Install a new metal washer over the centerbolt and down onto the element spring.
- g. Install a new seating plate gasket in position in the element seating plate. Then install the element seating plate in position on the shell centerbolt. Install the

seating plate so that the gasket contacts the metal washer.

- h. Install the centering guide in position near the top of the shell centerbolt and install a new filter element in the filter shell. Place a new shell gasket in position in the lip of the filter shell.
- i. Hold the filter shell under the head. Install the retaining nut and gasket. Tighten the nut securely without overtightening.
- j. Close the drain cock.
- k. Prime the fuel system (refer to following Paragraph D).
- l. With the engine running, check for fuel leaks around both fuel filters. Correct any leaks that are found.

#### D. PRIMING THE FUEL SYSTEM

When the filters or filter elements are replaced it is necessary to vent the air from them. If the engine ran out of fuel, it is necessary to vent the air from the filters and fuel gallery of the fuel injection pump. This hastens engine starting and eliminates excessive use of the starter to crank the engine, thus activating the fuel supply pump to force the air out of the low pressure system.

NOTE: If the engine is equipped with the optional gear type fuel supply pump (Fig 49) which replaces the standard fuel supply pump and hand primer (Fig 1), follow the procedure in Paragraph O, to prime the low pressure system.

The procedure to prime the low pressure system with standard duty and heavy duty filters with standard fuel supply pump is as follows:

1. Priming Low Pressure System with Standard Duty Filters
  - a. If engine ran out of fuel, fill fuel tank.
  - b. If filter is current type (Fig 3) loosen one of the plugs in the end of the filter head.
  - c. If filter is early type (Fig 4) make certain vent screw nearest fuel inlet is tight. Loosen the other vent screw.

- d. Unlock the plunger of the primer pump (Fig 1) by turning it counterclockwise several turns. Move the primer pump plunger up and down in a pumping motion to fill the filters with fuel and to expel the air from the filters.
- e. When fuel free of air bubbles appears at the filter vent, tighten the vent screw securely, while continuing to operate hand primer plunger.
- f. Continue to operate the primer pump plunger to expel the air from the fuel gallery of the injection pump.
- g. If the low pressure system has been properly primed, the hand primer will have a "solid" feel. If the primer has a "spongy" feel, an air leak in the fuel lines on the suction side of the fuel transfer pump is indicated. Correct the malfunction and prime the system again.

CAUTION: Make certain the hand primer pump plunger is at the bottom of its stroke and locked in position before attempting to start the engine.

- h. Refer to following Subparagraph 3 and prime the high pressure system.

#### 2. Priming Low Pressure System with Heavy Duty Filters

- a. If engine ran out of fuel, fill fuel tank.

NOTE: Make certain that the vent screw for the first stage filter (Fig 6) is tight. If it is loose, air will be drawn into the filters when the hand primer is actuated.

- b. Loosen the second stage fuel filter vent screw.
- c. Unlock the plunger of the primer pump (Fig 1) by turning it counterclockwise several turns. Move the primer pump plunger up and down in a pumping motion to fill the filters with fuel and to expel the air from the filters.
- d. When fuel free of air bubbles appears at the filter vent, tighten the vent screw securely, while continuing to operate hand primer plunger.

- e. Continue to operate the primer pump plunger to expel the air from the fuel gallery of the injection pump.
- f. If the low pressure system has been properly primed, the hand primer will have a "solid" feel. If the primer has a "spongy" feel, an air leak in the fuel lines on the suction side of the fuel transfer pump is indicated. Correct the malfunction and prime the system again.

CAUTION: Make certain the hand primer pump plunger is at the bottom of its stroke and locked in position before attempting to start the engine.

- g. Refer to following Subparagraph 3 and prime the high pressure system.

### 3. Priming High Pressure System

The high pressure fuel system is usually self-priming due to the fact that any air trapped by the fuel injection pump plungers is forced out through the fuel injection nozzles and into the engine combustion chambers. However, in the event the fuel lines have been removed, the engine has run out of fuel, or the engine has not been operated for some time, priming of the high pressure system may be necessary to facilitate engine starting.

Prime the high pressure fuel system as follows:

- a. Loosen connector nut attaching the upper end of each fuel injection line to its corresponding fuel line connector in the rocker cover housing.
- b. Place the engine speed control in the high speed position.
- c. Crank engine with the starter until fuel flows from ends of all fuel injection lines. Tighten fuel line connector nuts.

CAUTION: Do not use starting motor continuously for more than 30 seconds. After 30 seconds of use, pause two minutes to allow it to cool.

### E. FUEL INJECTION PUMP

No lubrication of the injection pump and hydraulic governor is required. They are engine lubricated.

### 1. Fuel Injection Pump Removal

Before removing the pump from the engine, make certain the FPI mark (Fig 7 Item 2) on the pump coupling hub (1) is aligned with the timing pointer (26) attached to the pump. This will position the Number 1 piston on its compression stroke and facilitate pump installation.

- a. Disconnect the governor linkage (3) and ball joint (8) from the injection pump rack (6).
- b. Disconnect the tape the leads (12) of the fuel shutoff valve solenoid (14).
- c. Shut off the fuel supply.
- d. Disconnect the fuel inlet (13) shutoff solenoid valve (14) tubes and the fuel return (19) lines. Disconnect lube oil supply (15) and drain (20) tubes.
- e. Remove fuel injection lines (16).
- f. Remove capscrews, lockwashers and washers, (Fig 9 Item 9) which secure the injection pump drive coupling flange (5) to the hub clamp (8).
- g. Remove capscrews and lockwashers (Fig 7 Item 25) that secure the injection pump to the support bracket (22).
- h. The injection pump support bracket is of two types and the pump is removed from them as follows:

#### (1) Current Type Pump Support Bracket

The current injection pump support bracket (Fig 7 Item 22) is slotted (23) at the 2 outside pump mounting capscrew (25) locations. The dowels (24) in the bottom of the pump fit into these slots so that it can slide when forced toward the rear of the support bracket. This allows the pilot (Fig 10 Item 2) on the hub clamp (1) to disengage the pilot bore in the flange (4) and the pump can be lifted from the support bracket.

#### (2) Early Type Pump Support Bracket

Early or first type pump support bracket does not have the slots and the dowels are located in the support bracket. To remove the pump from the support bracket it is necessary to remove the capscrew and lockwasher (Fig 9 Item 10) which secures the

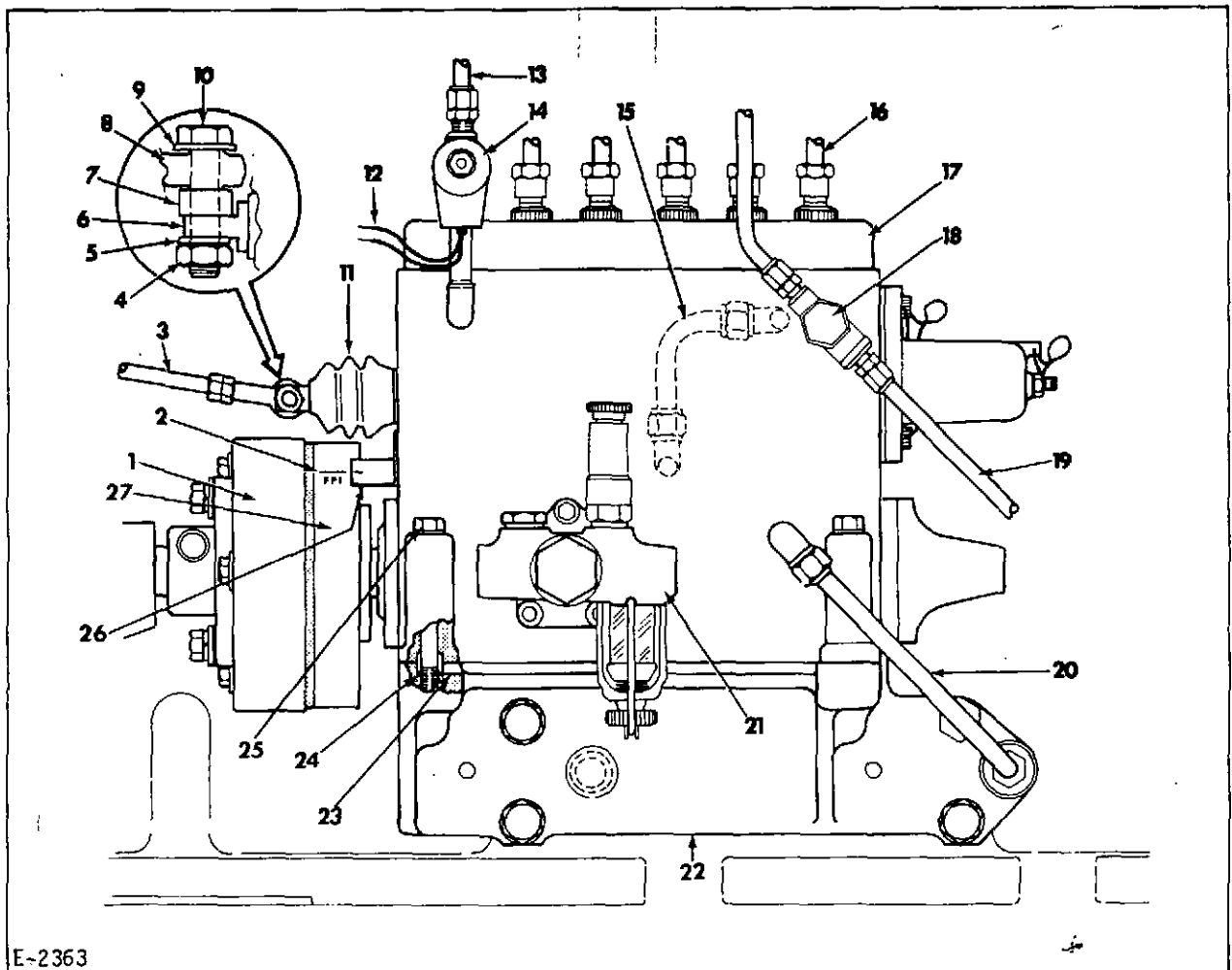

E-2363

- |                                 |                                |
|---------------------------------|--------------------------------|
| 1. Injection pump coupling      | 15. Lube oil supply tube       |
| 2. FPI timing mark              | 16. Fuel injection line        |
| 3. Governor linkage             | 17. Fuel injection pump        |
| 4. Nut                          | 18. Fuel pressure relief valve |
| 5. Lockwasher                   | 19. Fuel return tube           |
| 6. Injection pump rack          | 20. Lube oil return tube       |
| 7. Spacer                       | 21. Fuel supply pump           |
| 8. Balljoint                    | 22. Pump support bracket       |
| 9. Plain washer                 | 23. Slot                       |
| 10. Capscrew                    | 24. Dowel                      |
| 11. Bellows                     | 25. Mounting capscrew          |
| 12. Leads                       | 26. Timing pointer             |
| 13. Fuel inlet tube             | 27. Coupling hub               |
| 14. Fuel shutoff solenoid valve |                                |

Figure 7. Fuel Injection Pump and Coupling

hub clamp (8) to the shaft of the accessory drive assembly. This allows the hub clamp to be forced toward the front of the engine to disengage the pilot of the hub clamp from the pilot bore in the flange so that the pump could be lifted from the dowels in the support bracket.

2. Fuel Injection Pump Installation and Timing (Figs 7, 8, 9 and 10)

The timing pointer is located in the flywheel housing (Fig 8).

- a. If the engine was not rotated from its position since the injection

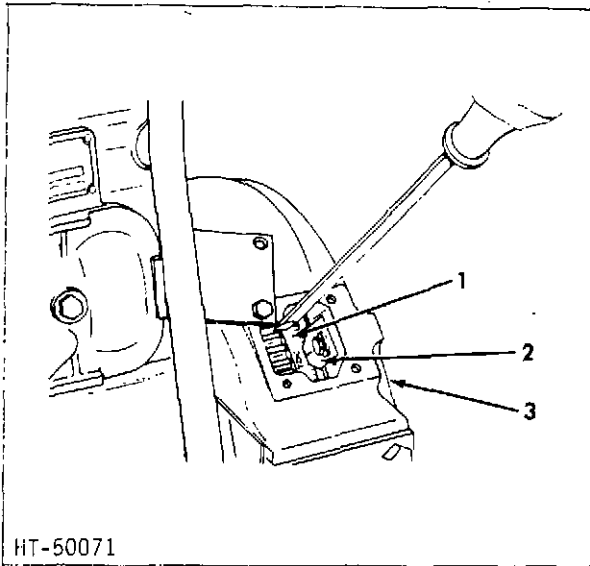

1. Flywheel timing marks (stamped on flywheel)
2. Pointer
3. Flywheel housing

Figure 8. Location of Rear End Timing Pointer

pump was removed as indicated in Subparagraph 1, the engine is properly positioned for installation of the injection pump. If the engine has been rotated or overhauled, make certain the Number 1 piston is on its compression stroke before installing the injection pump on the engine.

To make certain that the Number 1 piston (the piston nearest the fan) is on the compression stroke, remove the cylinder head covers so that the valve action can be observed. Hand rotate the flywheel until the Number 6 cylinder exhaust valves are nearly closed and the Number 6 cylinder intake valves are just starting to open.

- b. Remove the timing hole cover from the flywheel housing. Rotate the crankshaft in the normal direction of rotation, using a heavy screw driver to pry against the gear teeth of the flywheel, until the timing pointer is aligned with the correct number of degrees BTDC at which the fuel injection begins for the specified engine rpm and with the No. 1 piston near the top of the compression stroke.

To be certain that all of the slack is out of the engine timing gears and the fuel pump drive, never

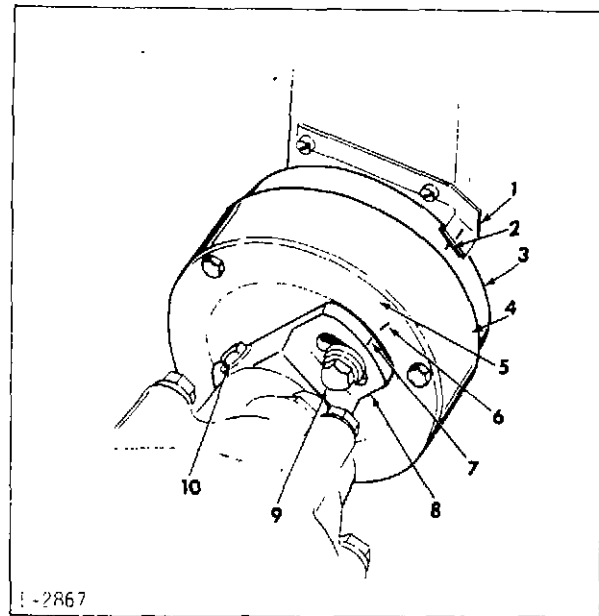

1. Pump timing pointer
2. FPI timing mark
3. Hub
4. Cover
5. Flange
6. Flange alignment mark
7. Hub clamp reference mark
8. Hub clamp
9. Hub clamp retaining capscrew
10. Hub clamping capscrew

Figure 9. Location of Injection Pump Timing Mark (FPI)

rotate the flywheel backward to line up the pointer and the timing mark. If the correct degree mark is passed, back up several inches and then approach the correct mark in the direction of normal rotation.

- c. If coupling (Fig 10) was removed from the injection pump, assemble it to the pump as follows:
  - (1) Position key in injection pump camshaft keyway.
  - (2) Position hub (7) on pump camshaft. Install lockwasher and nut. Tighten nut to 85-90 lb-ft (115-122 Nm) torque.
  - (3) Current couplings have a dust shield (8). Install in groove of hub (7) with peak side of shield to front of engine.
  - (4) Position the 2 insert rings (6) in the flange (4).
  - (5) Assemble flange to hub with rubber

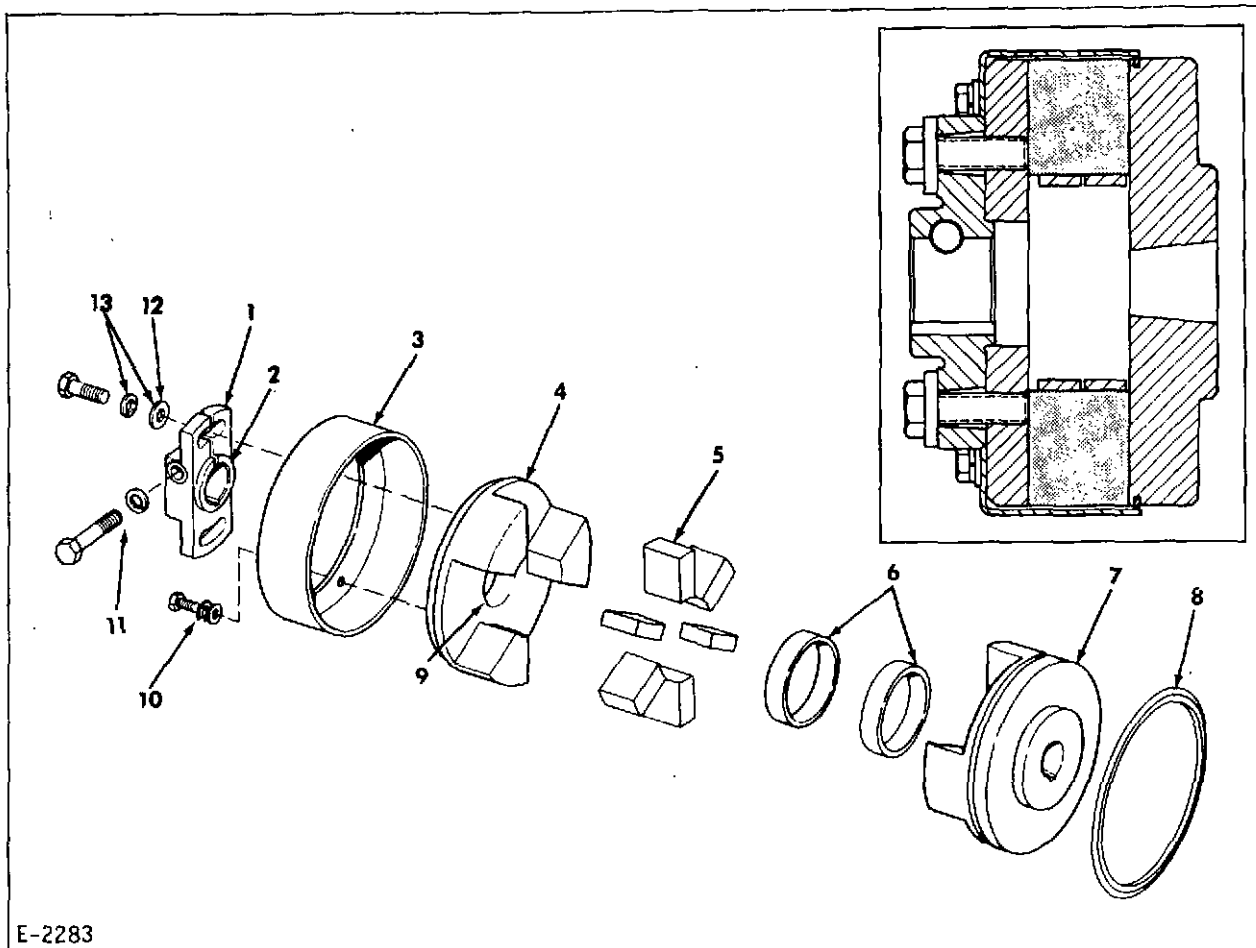

- |                            |   |   |
|----------------------------|---|---|
| 1. Hub clamp               | 6. Insert rings                         | 10. Capscrew, plainwasher and lockwashers                       |
| 2. Pilot                   | 7. Hub                                  | 11. Capscrew and lockwasher                                     |
| 3. Cover                   | 8. Dust shield (current type couplings) | 12. 3/16" (4.76 mm) thick plain washer (current type couplings) |
| 4. Flange                  | 9. Pilot bore                           | 13. Lockwasher and plainwasher (early type couplings)           |
| 5. Rubber inserts (spider) |   |   |

Figure 10. Injection Pump Coupling - Early and Current Types

inserts (5) separating the flange and hub fingers, and the flange alignment mark (Fig 9, Item 6) in alignment with FPI mark (2) on the hub (3).

(6) Work cover (Fig 10, Item 3) over the rubber inserts and secure to flange with lockwashers and capscrews.

d. Position the FPI mark (Fig 7 Item 2) hub (27), opposite the pointer (26) on the injection pump.

e. Install the injection pump and coupling as an assembly following the procedure listed below:

(1) Current Type Pump Support Bracket

(a) Position pump (Fig 7 Item 17) with

its dowels (24) in the slots (23) of the support bracket (22).

(b) Slide the pump toward the front of engine until the pilot (Fig 10 Item 2) of the hub clamp (1) engages the pilot bore (9) of coupling flange (4).

(c) Install pump mounting capscrews (Fig 7 Item 25) with lockwashers and plain washers. Tighten to 18-23 lb-ft (24-31 Nm) torque.

(d) Install capscrews (Fig 9 Item 9) with 3/16" (4.76 mm) thick plain washer which retains the hub clamp (8) to the flange (5). Make certain FPI mark on coupling is aligned with pump pointer. Tighten capscrews

(9) to 45 lb-ft (61 Nm) torque on current couplings with dust shield.

(e) Check tightness of coupling hub clamp retaining capscrew (10). The specified torque is 45 lb-ft (61 Nm).

(2) Early Type Pump Support Bracket

(a) Install the injection pump and coupling as an assembly on the pump support bracket by holding the pump assembly at a slight angle and positioning the bore in the coupling flange on the pilot of the hub clamp and lowering the pump onto the dowels.

(b) Install the capscrews and lockwashers that secure the injection pump to the support bracket and tighten to 18-23 lb-ft (24-31 Nm) torque.

(c) Install the capscrews, lockwashers, and plain washers that secure the hub clamp to the coupling flange but do not tighten at this time.

(d) Force the hub clamp toward the injection pump and install the clamping capscrew and lockwashers and tighten to 30 lb-ft (41 Nm) torque (First type coupling without dust shield).

(e) Align the FPI mark on the coupling flange with the pointer on the injection pump.

(f) Tighten the capscrews that secure the hub clamp to the coupling flange to a torque of 29 lb-ft (39 Nm).

f. Install lube oil supply and drain tube assemblies.

g. Install fuel supply and return tube assemblies.

h. Install high pressure injection lines.

i. Connect the governor linkage to injection pump rack. For proper alignment, the spacer (Fig 7 Item 7) must be between the rack and ball joint and on the engine side.

j. Connect leads of fuel shutoff valve solenoid.

k. Install timing hole cover on flywheel housing.

l. Prime the fuel system. Refer to Paragraph D.

### 3. Fuel Injection Pump Adjustments

Most Allis-Chalmers dealers are equipped with fuel injection pump calibrating and test stands and with the special tools required to test, adjust, and repair this assembly. Therefore, if at any time the fuel injection pump requires repairs or adjustment, the assembly should be removed and taken to your Allis-Chalmers dealer. It is important the dealer be furnished with the pump serial number to facilitate repair.

#### F. FUEL SUPPLY (TRANSFER) PUMP

The fuel transfer pump (Fig 11) is mounted directly on the fuel injection pump. The purpose of the pump is to supply fuel under low pressure, to the fuel sump of the injection pump

Periodically the fuel transfer pump should be removed and inspected. Disconnect the fuel lines from the fuel transfer pump. Remove the nuts, lockwashers, and plain washers attaching the transfer pump to the fuel injection pump and remove the transfer pump and hand primer (if engine is so equipped) as an assembly. Connect a piece of tubing to the fitting on the inlet side of the pump and place the free end of the tubing in a container of clean diesel fuel.

Work the tappet assembly in and out, by hand, until fuel flows from outlet side of the transfer pump. If a solid flow of fuel does not emerge from the outlet opening, weak valve springs and/or worn or damaged valves or valve seats are indicated. Disassemble the transfer pump and inspect the various components. If the valve seats are damaged in any way, the transfer pump must be replaced as a unit.

#### G. CHECKING THE FUEL SYSTEM

The fuel system should be checked if the engine runs rough, misses, stalls when idling, or seems to lack power. These symptoms are indicative of an inadequate fuel supply.

Before performing any of the following checks, make certain that there is an ample supply of clean fuel in the fuel tank and that the fuel tank shutoff valve is open.

##### 1. Check for Admission of Air into the System

Loosen the vent screw in the filter head. Crank the engine with the starter. If fuel containing bubbles is observed flowing from the vent screw, air is being drawn into the system on the suction side of the fuel supply pump. Correct this

situation by tightening any loose connections between the supply pump (primary fuel filter of heavy duty type filter), and fuel tank check all line fittings for tightness.

NOTE: If little or no fuel flows from around the loosened vent screw, check for clogged filters. Refer to Step 2 below.

2. Check for Clogged Fuel Filters and Clogged or Collapsed Fuel Lines

Loosen vent screw in the top of standard filter head (Fig 3 and 4) or secondary filter (Fig 6) of heavy duty type filter. Crank the engine with starter. If a full flow of fuel cannot be observed from around the loosened vent screw, it is likely that a fuel line is clogged or collapsed, or that the filters are clogged.

3. Check for Inoperative Fuel Supply Pump or Fuel Pressure Relief Valve

The fuel supply pump should deliver more fuel to the fuel gallery of the fuel injection pump than is required for engine operation. The fuel pressure relief valve, connected in the fuel return passage of the fuel injection pump, controls the maximum fuel pressure within the fuel gallery. The relief valve is set to open between 16 and 18 psi (110 and 124 kN/m<sup>2</sup>), with the engine at operating temperature and running at high idle no load.

H. GOVERNOR AND GOVERNOR DRIVE

1. General

Two types of hydraulic governors are installed on generator drive engines. The type SG governor (3-1/2 to 5% regulation) is standard and the type PSG governor (1 to 5% regulation) is optional.

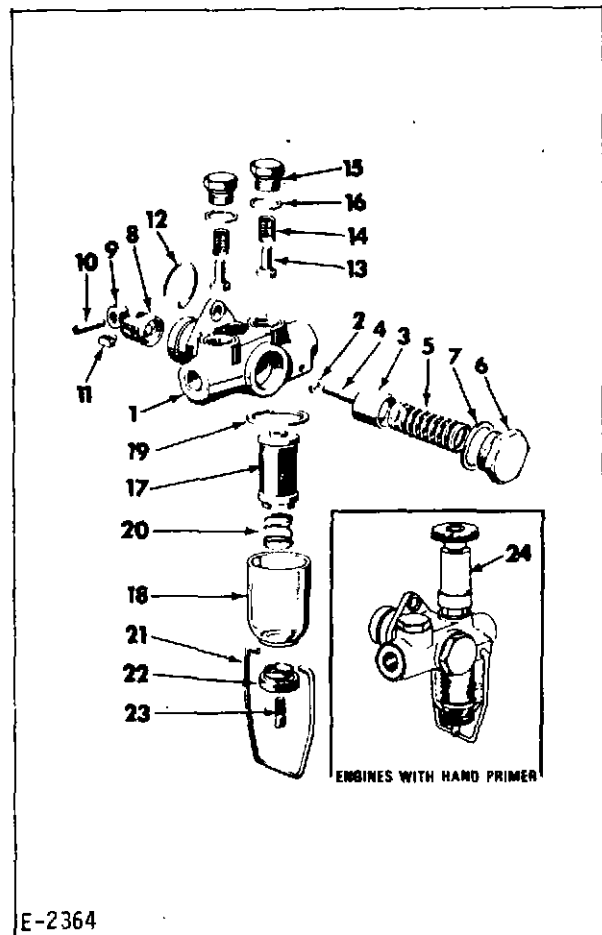

E-2364

- |                     |                   |
|---------------------|-------------------|
| 1. Pump housing     | 13. Valve         |
| 2. O-ring           | 14. Valve spring  |
| 3. Pump plunger     | 15. Screw plug    |
| 4. Pressure spindle | 16. Gasket        |
| 5. Spring           | 17. Filter        |
| 6. Retaining screw  | 18. Sediment bowl |
| 7. Gasket           | 19. Gasket        |
| 8. Roller tappet    | 20. Spring        |
| 9. Roller           | 21. Clip          |
| 10. Roller pin      | 22. Clamping nut  |
| 11. Sliding block   | 23. Stud          |
| 12. Snap ring       | 24. Hand primer   |

Figure 11. Fuel Transfer (Supply) Pump

Both types of hydraulic governors are driven by a drive assembly located at the front of the engine. Engine oil, used as a control medium, is supplied to the governors by a tube assembly connected

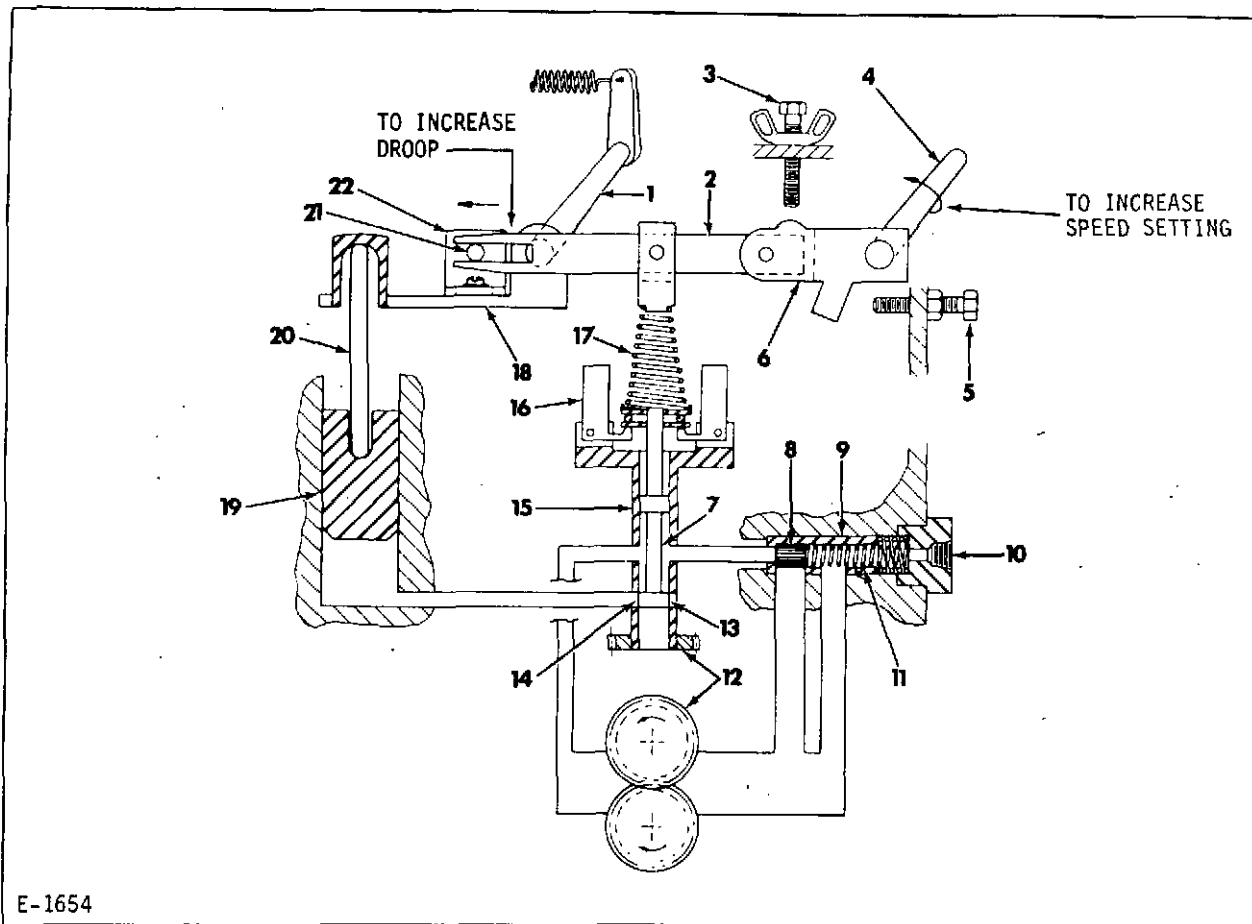

E-1654

- |                          |                                |                           |
|--------------------------|--------------------------------|---------------------------|
| 1. Terminal shaft        | 8. Relief valve plunger        | 16. Ballarm               |
| 2. Floating lever        | 9. Relief valve plunger sleeve | 17. Speeder spring        |
| 3. Low speed stop screw  | 10. Oil inlet                  | 18. Terminal lever        |
| 4. Speed adjusting shaft | 11. Relief valve spring        | 19. Power piston          |
| 5. High speed stop screw | 12. Governor pump gears        | 20. Power piston pin      |
| 6. Speed adjusting lever | 13. Control land               | 21. Speed droop lever pin |
| 7. Pilot valve plunger   | 14. Control port               | 22. Speed droop bracket   |
|                          | 15. Ballhead bushing           |                           |

Figure 12. Type SG Governor Schematic

to the engine oil gallery. Oil drains from the bottom of the governor, through the drive assembly and returns to the oil pan.

The governors can be equipped with either a 24 V dc or 120 V ac speed control motor. The motor is a split field, series wound, reversible type. Its function is to enable the operator to match the alternator frequency with that of other units before synchronizing, and to change the load distribution after synchronizing. The motor is controlled with a toggle switch mounted in the control panel or remote mounted. Also, the motor is equipped with a speed adjusting knob with friction clutch assembly to manually adjust the engine speed.

This manual contains instructions pertaining to: the hydraulic governors, the governor drive assembly, the governor-to-fuel injection pump linkage, and the maximum fuel stop at the rear of the injection pump.

2. Operation-Type SG Governor (3-1/2 to 5% Regulation)
  - a. General (Fig 12)

The type SG governor is a hydraulic speed droop type governor. The design of the governor is such that the governor controls the fuel input to the engine at all times, up to full load. By controlling the fuel input, the gov-

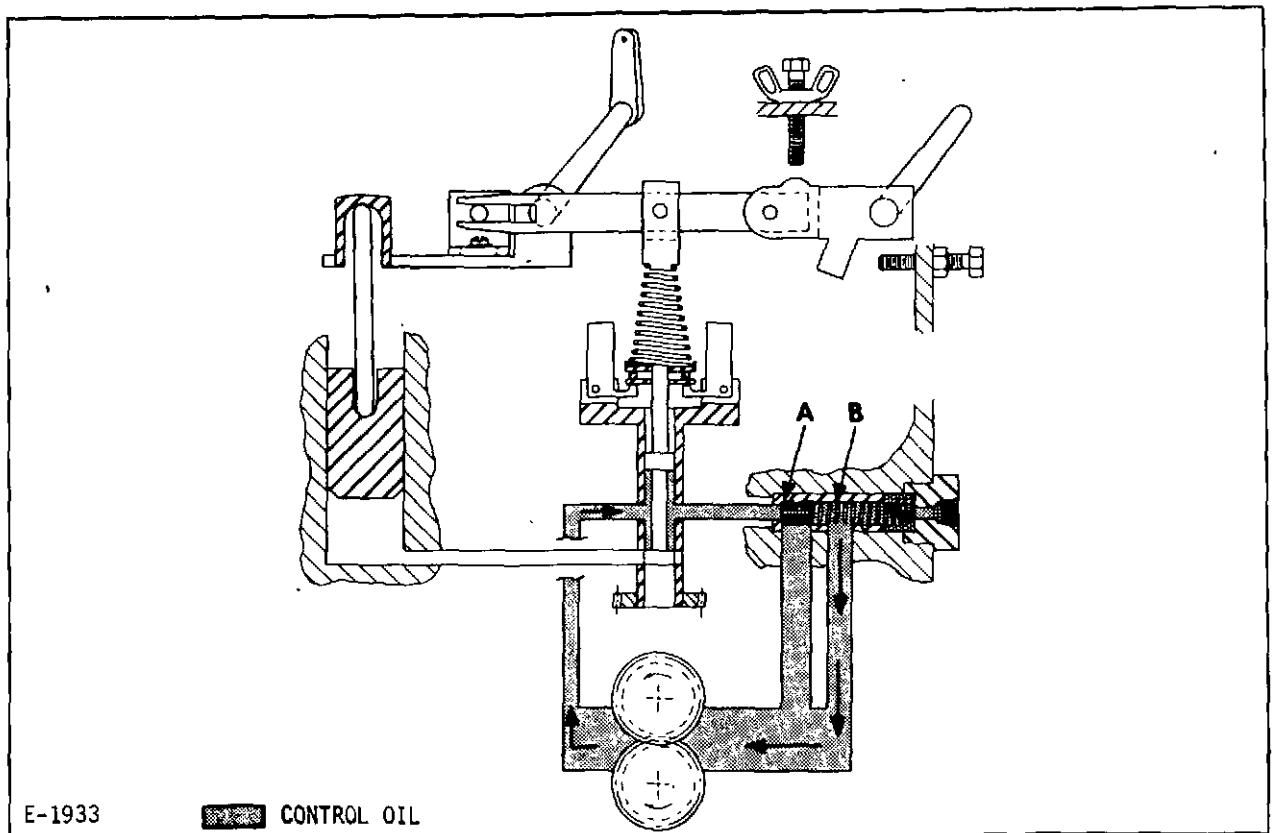

Figure 13. Initial Start Conditions - SG Governor

ernor regulates the engine speed and provides stability, within the limits of regulation.

The schematic arrangement of governor components is shown in Figure 12. Engine oil, used as the control medium, is supplied to the governor by a tube assembly from the engine oil gallery. The oil enters the governor at the oil inlet (10) and relief valve (8,9, and 11) and flows down to the cavity on the suction side of the governor pump (12).

b. Initial Start (Fig 13) (Numbers in parentheses refer to Figure 12)

As the engine is started, the ballarms (16) begin to swing out and compress the speeder spring (17). Oil from the engine gallery enters the governor through the oil inlet (10) and is circulated by the governor pump gears (12). The oil continues to flow into the governor until the engine speed exceeds the preset limit, or until the pressure at point A exceeds the relief spring (11) pressure. When the pressure at A exceeds the spring pressure, the relief valve plunger (8) is forced to point B and closes the oil inlet. The ballarms will continue to swing out un-

til engine reaches predetermined speed at which the governor begins to control the engine speed.

c. Static Conditions (Fig 14) (Numbers in parentheses refer to Figure 12)

When the engine is running at the predetermined speed, the centrifugal force of the ballarms (16) is balanced by the speeder spring (17) pressure and the pilot valve plunger (7) is centered. Because the oil is not needed for governing, the pressure builds up at point A and forces the relief plunger (8) to point B and causes the oil inlet (10) to close. The oil is then recirculated within the governor by the pump gears (12).

d. Fuel Increase Conditions (Fig 13)(Numbers in parentheses refer to Figure 10)

As the engine speed decreases, the governor will move to the fuel increase condition to compensate for the decrease in engine speed. The decreasing engine speed will cause the ballarms (16) to rotate at a slower speed. Thus, the centrifugal force is reduced and the speeder spring (17) force will exceed the force produced by the ballarms. The spring force will force the pilot valve



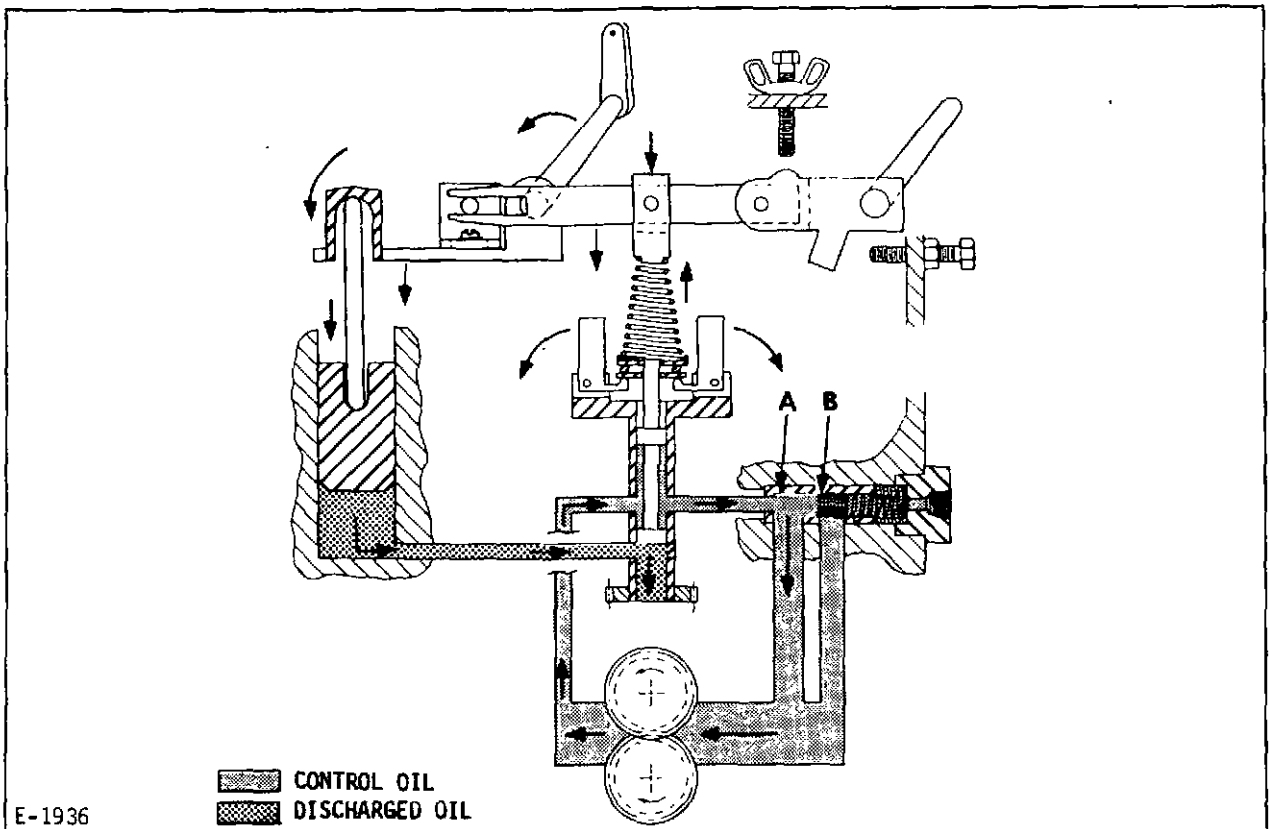

E-1936

Figure 16. Fuel Decrease Conditions - SG Governor

plunger (7) down and allow oil to flow into the cavity beneath the power piston (19).

As the oil flows into the cavity beneath the power piston, the pressure is reduced and the relief valve plunger moves to point A, allowing the oil inlet to open and supply make-up oil to the system. As the system fills, the pressure builds up and forces the power piston (19) up, and forces the oil inlet to close.

The increased pressure beneath the power piston forces the piston up. As the piston moves up, the power piston pin (20) forces the terminal lever (18) to rotate upward. The rotating lever causes the terminal shaft (1) to rotate in the increase fuel direction.

The speed droop bracket (22) to which the speed droop pin (21) is attached, is secured to the terminal lever (18). As the terminal lever rotates, the speed droop pin, fitted into a slot in the floating lever (2), raises the floating lever and thereby reduces the tension on the speeder spring (17). The reduced tension permits the speeder spring to decompress and pull the pilot valve plunger (7) to the static condition.

With the pilot valve plunger in the static condition, the oil supply to the base of the power piston (19) is cut off and further movement of the piston is stopped. When the pilot valve plunger is in the static condition, the forces produced by the ballarms (16) and the speeder spring (17) are balanced and the governor returns to the static condition (refer to Subparagraph c).

e. Fuel Decrease Condition (Fig 16) (Numbers in parentheses refer to Figure 10)

When the engine speed exceeds the predetermined speed the governor acts to reduce the fuel flow to the engine. The increasing engine speed causes the ballarms (16) to rotate at a faster speed. Thus, the centrifugal force is increased and will exceed the force produced by the speeder spring (17). As the speeder spring is further compressed, the pilot valve plunger (7) is pulled up and opens the port (14) in the ballarm bushing (15) to allow oil to flow from the cavity beneath the power piston (19).

The oil flowing from the cavity will reduce the tension on the speeder spring (17) and allow the floating lever (2),

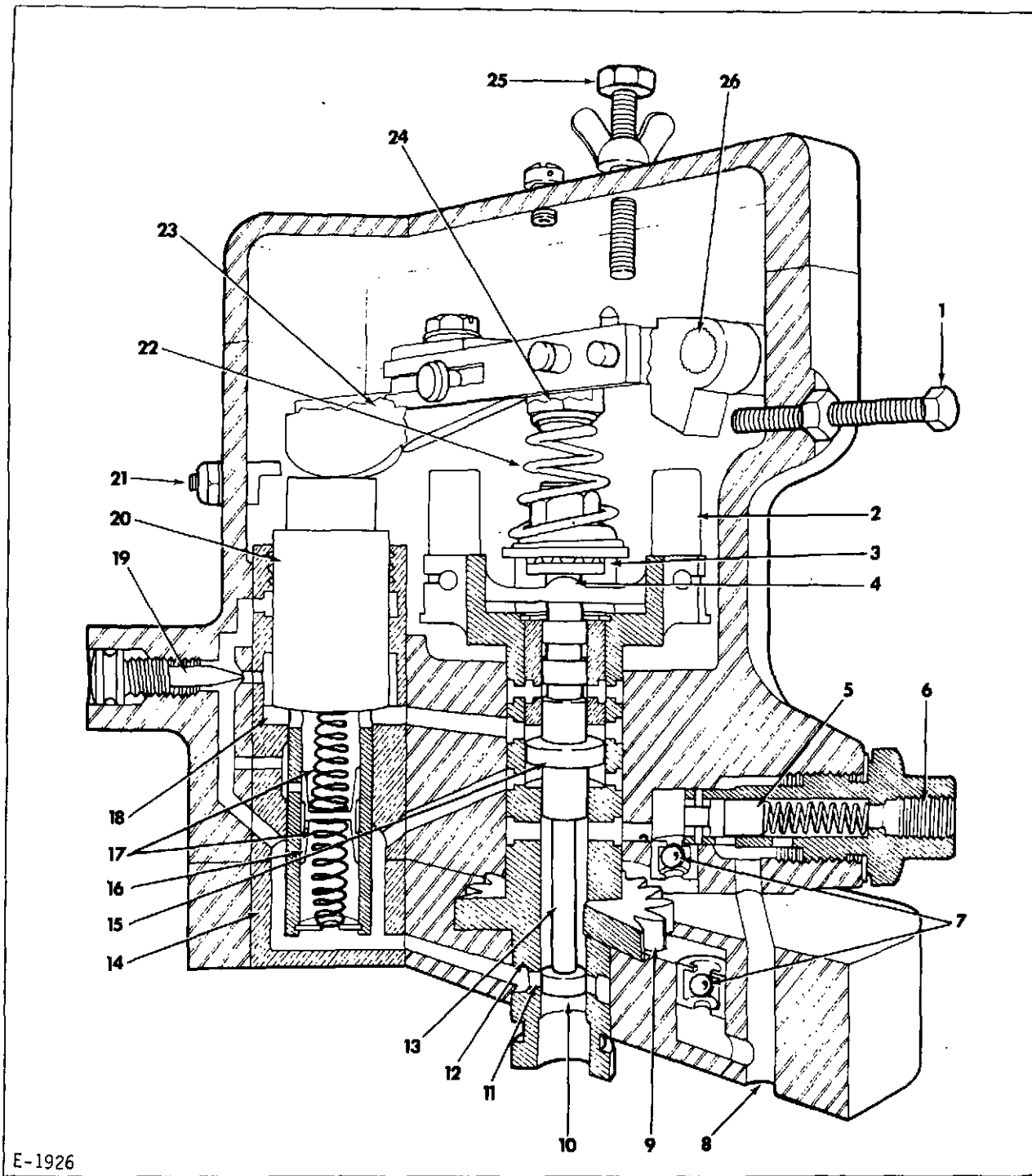

E-1926

- |  |                         |                               |
|--|-------------------------|-------------------------------|
| 1. High speed adjustment stop            | 9. Oil pump             | 18. Upper annulus             |
| 2. Flyweights                            | 10. Control land        | 19. Needle valve              |
| 3. Thrust bearing                        | 11. Regulating port     | 20. Power piston              |
| 4. Flyweight toe                         | 12. Pilot valve bushing | 21. Power piston stop screw   |
| 5. Relief valve                          | 13. Pilot valve plunger | 22. Speeder spring            |
| 6. Oil supply inlet from engine          | 14. Power cylinder      | 23. Terminal lever            |
| 7. Check valves                          | 15. Compensating land   | 24. Spring fork               |
| 8. Optional oil supply inlet from engine | 16. Buffer piston       | 25. Low speed adjustment stop |
|  | 17. Buffer springs      | 26. Speed adjusting shaft     |

Figure 17. Type PSG Governor Schematic

speed droop pin (21), speed droop bracket (22), terminal lever (18), power piston pin (20), and power piston (19) to drop and achieve a balance between the centrifugal force of the ballarms and the tension on the speeder spring to balance. When the forces are balanced the pilot valve plunger (7) will return to the static position and return the governor to the static condition (refer to Subparagraph c).

During the time that the pilot valve plunger (7) is up, the oil pressure in the system causes the relief valve plunger to move to point B and block the oil inlet (10). The oil within the system is recirculated by the governor pump gears (12).

#### f. Speed Change Adjustment

The amount of speed change for a given terminal shaft (Fig 12, Item 1) rotation depends on the setting of the speed droop pin (21). To increase the speed change, move the speed droop pin away from the ballhead. To decrease the speed change, move the speed droop pin toward the ballhead. Refer to following Subparagraph 8 for procedure to adjust the speed droop.

### 3. Operation-Type PSG Governor (1 to 5% Regulation) (Fig 17)

The PSG governor is a hydraulic speed governor with buffer type compensation. It is normally isochronous, that is, if the engine is not overloaded it maintains the same speed regardless of load, except momentarily at the time load change occurs.

The schematic arrangement of the governor components is shown in Figure 17. Oil is supplied to the governor oil inlet (6) by a tube assembly connected to the engine oil gallery.

This oil is supplied to the governor oil pump (9) where its pressure is boosted to 175 (1206 kN/m<sup>2</sup>) psi above inlet pressure. Four check valves (7), two of which are shown, are used to permit rotation of the governor in either direction. Relief valve (5) discharge is back to the oil supply, so unused oil is recirculated within the governor.

The governor oil under pressure is carried through ducts to the pilot valve (13), which is a three-way spool valve arranged to connect the area below the governor power piston (20) to the pressure oil supply upon an overspeed signal or to discharge upon overspeed. The governor flyweights (2) are carried on pivot pins in the rotating bushing which forms both the

outer member of the valve and the drive shaft. The flyweights (2) act upon a thrust bearing (3) attached to the pilot valve plunger (13) and their centrifugal force is translated to axial force at the flyweight toes (4) and opposed by the speeder spring (22). Speed spring compression, and therefore, the speed at which the governor must run in order that the flyweight force will balance that of the spring, is adjusted by the position of the speed control lever attached to the speed adjusting shaft (26).

The isochronous feature of this governor is provided through the use of a compensating system which establishes temporary speed droop stability and then dissipates this droop so that engine speed is constant under steady state conditions regardless of load. This compensating system consists of a buffer piston (16) floating between two springs (17) to establish a pressure differential as oil flows to or from a section of the power cylinder (14) together with a compensating land (15) on the pilot valve plunger (13) across which this differential pressure is applied, and a needle valve (19) through which the pressure difference is dissipated.

Upon a reduction in engine speed from its set value, the speeder spring (22) force overcomes the reduced centrifugal force of the flyweights (2) and the pilot valve plunger (13) moves downward in its bore. This movement uncovers the port (11) at the lower end of the plunger, permitting oil under pressure to enter the passage leading to the power cylinder (14). The power piston (20) has two concentric areas, both of which are exposed to the control oil metered by the pilot valve, the lower smaller diameter being acted upon directly, and the upper annulus (18) being connected through the bore in the power piston in which the buffer piston (16) is carried. Flow of the oil into the power cylinder forces the power piston up against the return spring (not shown in diagram) and some of the oil displaces the buffer piston to force oil into the upper annulus. This flow into the upper annulus establishes a pressure differential across the buffer piston, which is transmitted to the spaces above and below the compensating land (15) on the pilot valve plunger. The higher pressure on the lower side of this land acts in the direction to supplement the flyweight force, causing the closure of the pilot valve before the original speed has been regained. As oil leaks across the needle valve (19), this false speed signal is dissipated and the buffer piston returns in its bore with engine speed returning to normal.

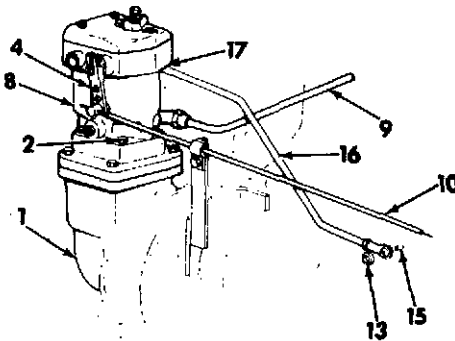
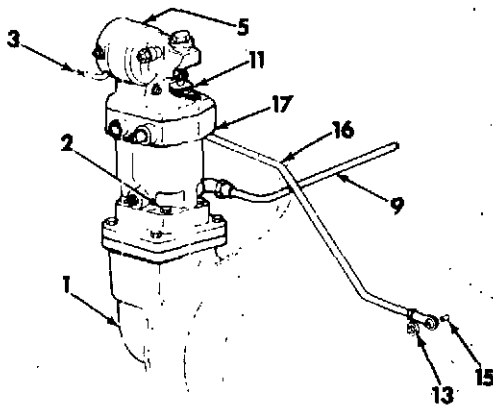

**CURRENT TYPE GOVERNOR TO INJECTION PUMP LINKAGE**

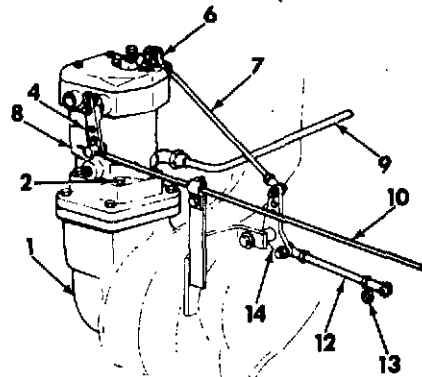
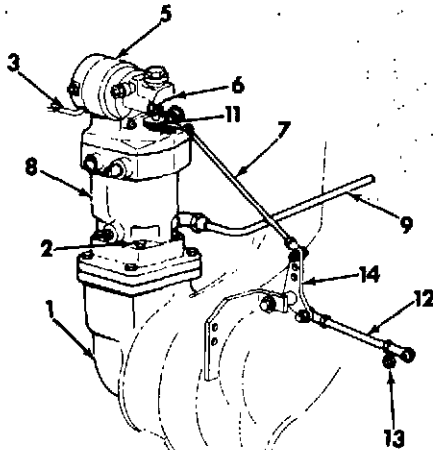

**FIRST TYPE GOVERNOR TO INJECTION PUMP LINKAGE**

E-2993

- |                                  |                                  |                            |
|----------------------------------|----------------------------------|----------------------------|
| 1. Governor drive assembly       | 7. Rod assembly                  | 12. Rod assembly           |
| 2. Capscrew - governor retaining | 8. Hydraulic governor            | 13. Spacer                 |
| 3. Electrical leads              | 9. Oil supply line               | 14. Bellcrank assembly     |
| 4. Governor speed control lever  | 10. Throttle control             | 15. Sleeve - balljoint     |
| 5. Speed control motor           | 11. Manual speed adjustment knob | 16. Link                   |
| 6. Lever - terminal shaft        |                                  | 17. Lever - terminal shaft |

Figure 18. Hydraulic Governors with and without Speed Control Motor

**4. Governor and Governor Drive Assembly Removal and Installation - Governor Drive Disassembly and Assembly**

The hydraulic governor is driven by bevel gears of the drive assembly located on the injection pump side of the timing gear housing cover. The assembly is lubricated by oil returning to the oil pan from the hydraulic governor. Gear tooth contact and backlash are established by

shim packs composed of 0.003" (0.08 mm) brass laminations. An opening is provided on the side of the drive housing through which drive gear backlash is checked at time of assembly.

**a. Removal of Governor Drive Assembly**

Refer to Figure 18

- (1) Disconnect and tag electrical leads

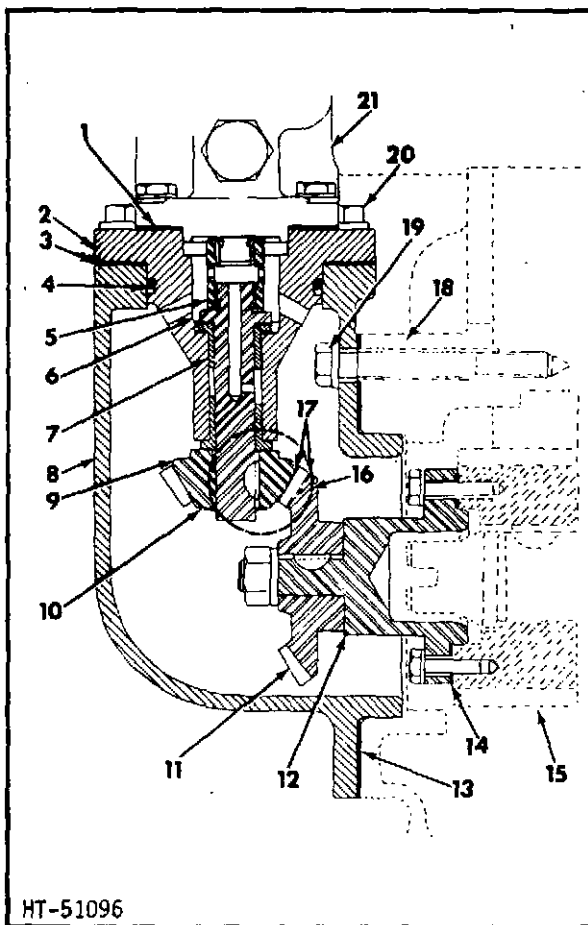

- |                        |                                |
|------------------------|--------------------------------|
| 1. Gasket              | 13. Gasket                     |
| 2. Adaptor             | 14. Shim pack                  |
| 3. Shim pack           | 15. Accessory drive gear       |
| 4. O-ring              | 16. 1-1/2" (37.1 mm) pipe plug |
| 5. Splined sleeve      | 17. Gear tooth contact         |
| 6. Splined shaft       | 18. Timing gear housing cover  |
| 7. Flange type bushing | 19. Capscrew                   |
| 8. Housing             | 20. Capscrew                   |
| 9. Pinion gear         | 21. Governor                   |
| 10. Snap ring          |                                |
| 11. Drive gear         |                                |
| 12. Drive shaft        |                                |

Figure 19. Governor Drive Assembly Details

(3) from speed control motor (5), if applicable.

(2) Disconnect rod assembly (7) or link (16) from hydraulic governor (6) lever. If applicable, remove throttle (10) from speed control lever (4).

(3) Disconnect oil supply line (9) from the governor.

NOTE: If governor is equipped with the current type oil reservoir (Fig 36) remove oil tube (10) between the governor drive housing and oil outlet solenoid valve (8).

(4) Remove capscrews (2) securing the hydraulic governor base flange to the drive assembly.

Refer to Figure 19.

(5) Remove hydraulic governor (21) from the governor drive, being careful not to drop splined drive sleeve (5) which connects the governor to the splined governor drive shaft (6). Remove gasket (1) from governor.

(6) Remove capscrews and lockwashers (20) securing governor adaptor assembly (2) to drive housing (8). Remove adaptor assembly from the governor drive housing.

(7) Remove shim pack (3) and o-ring (4) from drive adaptor (2).

(8) Note that the governor drive assembly housing is secured to the timing gear housing cover with 5 capscrews and lockwashers. Two of the capscrews are 7/16"-16 x 1" (25.4 mm) and three are 3/8"-16 x 3" (76.2 mm). Remove all 5 capscrews.

NOTE: Capscrew (19) 3" (76.2 mm) long must be removed through the large opening in the top of the governor drive housing (8).

(9) Remove governor drive housing (8) from the timing gear housing cover. Remove gasket (13) from the drive assembly housing.

NOTE: Be sure to remove all particles of the gasket from the governor drive housing (8) and timing gear housing cover (18).

(10) Remove nut and lockwasher securing the governor drive gear (11) to drive shaft (12).

(11) Remove capscrews and lockwashers securing drive shaft (12) to the accessory drive assembly drive gear (15).

(12) Remove shim pack (14) from the governor drive shaft (12).

b. Disassembly, Inspection, and Assembly of

Governor Adaptor Assembly (Component of the governor drive assembly)

Refer to Figure 20.

The governor adaptor assembly contains two flanged bushings (3) in which splined shaft (4) rotates. At the bottom of the shaft, pinion gear (2) is retained by an interference fit, Woodruff key (6) and snap ring (1). The bushings are replaceable and after being pressed into the adaptor must be reamed to 0.563" - 0.564" (14.30-14.33 mm) diameter. The outside diameter of the splined shaft is 0.561"-0.5615" (14.25-14.26 mm) giving a shaft-to-bushing clearance of 0.0015"-0.003" (0.04-0.08 mm). End play between the gear and lower bushing flange is 0.003"-0.005" (0.08-0.13 mm).

To disassemble, inspect, and reassemble the governor adaptor assembly:

- (1) Remove snap ring (1) from bottom of splined shaft (4).
- (2) Press pinion gear (2) from splined shaft and remove Woodruff key (6). Remove shaft from governor adaptor.
- (3) Inspect pinion gear and replace if excessive wear or pitting is evident.

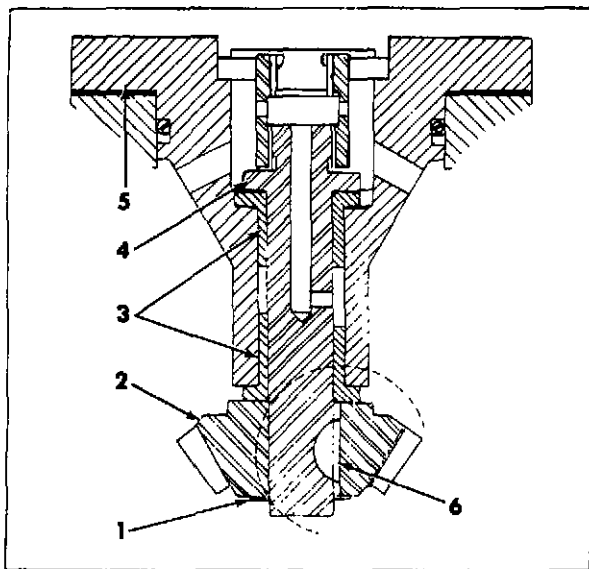

1. Snap ring
2. Governor pinion gear
3. Bushings
4. Splined shaft
5. Governor adaptor
6. Woodruff key

Figure 20. Governor Adaptor Assembly Details

Inspect splined shaft (4) and bushing (3) for wear.

- (4) Specified clearance between splined shaft and bushings is 0.0015"-0.003" (0.04-0.08 mm). Replace shaft/bushings to maintain specified clearance.
- (5) Assemble governor adaptor in reverse order of Steps (1) through (5) above.

NOTE: When pressing pinion gear onto the splined shaft, allow 0.003" (0.08 mm) end play between top of gear and lower bushing flange.

c. Assembly and Installation of the Governor Drive Assembly.

- (1) Fabricate the gauge shown in Figure 22. This gauge is designed to properly position the drive gear on the drive shaft. If the gauge is not used, the

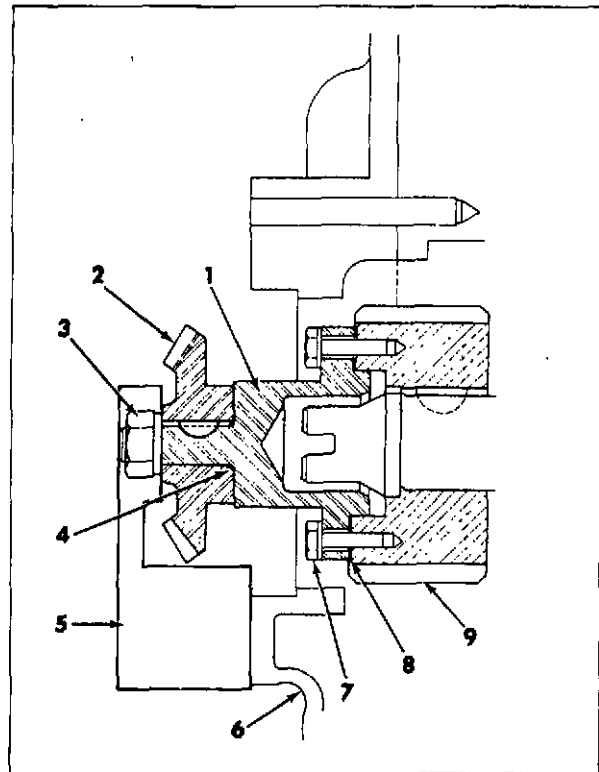

1. Drive shaft
2. Drive gear
3. Nut and lockwasher
4. Chamfer
5. Gauge
6. Timing gear housing cover
7. Capscrew and lockwasher
8. Shim pack
9. Accessory drive assembly drive gear

Figure 21. Positioning Drive Gear

trial and error method of establishing the backlash must be resorted to.

Refer to Figure 21.

- (2) Position the shim pack (8) on the drive shaft (1) and secure it to the accessory drive assembly drive gear (9) with capscrews and lockwashers (7). Tighten the 1/4"-20 x 7/8" (22.23 mm), Grade 5, capscrews to 9-11 lb-ft (12-15 Nm) torque.

NOTE: If grade 2 capscrews are found to be securing the drive shaft to the accessory drive assembly drive gear, replace them with Grade 5 capscrews.

- (3) Inspect the drive gear (2), making certain the chamfer (4) at the rear of the bore does not prevent the back of the gear from contacting the shoulder of the drive shaft (1). If necessary, increase the chamfer so that the gear will make good contact with the drive shaft shoulder.
- (4) Position the drive gear (2) on the drive shaft (1). Install the lockwasher and tighten the retaining nut to 30-33 lb-ft (41-45 Nm) to seat the gear on the shaft.
- (5) Remove the nut and lockwasher (3) from the drive shaft (1). Position the gauge (5) as indicated, holding it against the hub of the drive gear.
- (6) Using a feeler gauge, determine the clearance between the gauge and the timing gear housing cover (6). Record the clearance dimension. If

there is no clearance between the gauge and the cover, hold the gauge against the timing gear housing, measure and record the clearance between the gauge and gear hub.

- (7) Remove the drive gear (2), drive shaft (1), and shim pack (8) from the accessory drive assembly drive gear (9).
- (8) If clearance was measured between the gauge and the timing gear housing, remove laminations from the shim pack equivalent to the recorded clearance. Conversely, if a clearance was measured between the gauge and the gear hub, add laminations to the shim pack equivalent to the recorded clearance.

NOTE: Each shim pack lamination is .003" (0.08 mm) thick. If the clearance falls between lamination dimension, favor the "loose" side of the adjustment.

- (9) Position the shim pack (8) on the drive shaft (1) and secure the shaft to the accessory drive assembly drive gear with lockwashers and capscrews (7). Tighten the capscrews to 9-11 lb-ft (12-15 Nm) torque.
- (10) Position the Woodruff key in the drive shaft. Place the drive gear on the drive shaft and secure it with the lockwasher and retaining nut. Tighten the nut to 30-33 lb-ft (41-45 Nm) torque.

Refer to Figure 19.

- (11) Position gasket (13) on the governor

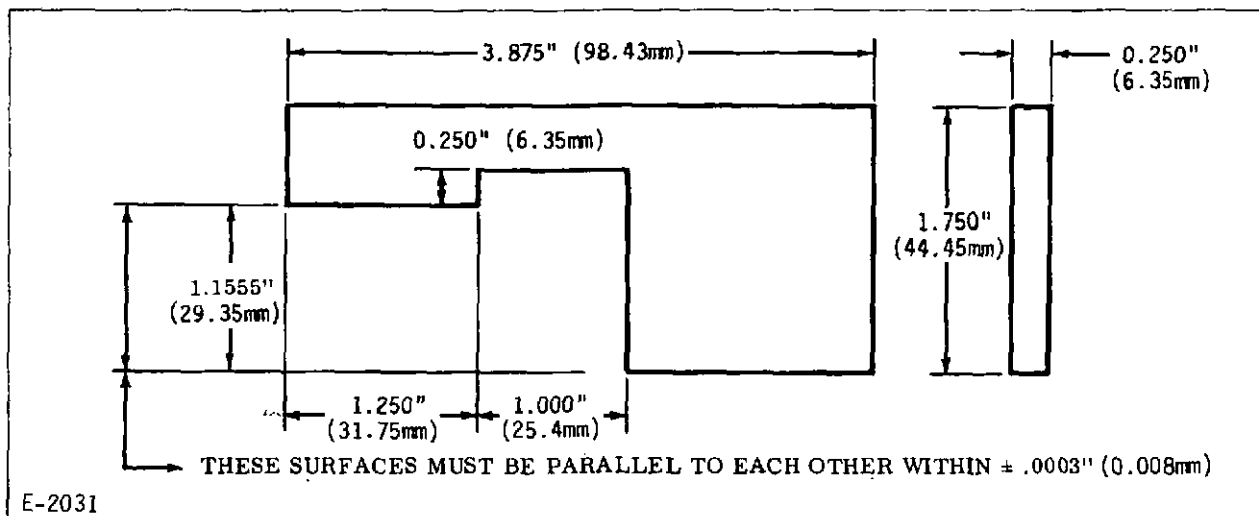

Figure 22. Gauge - Drive Gear Locating

drive housing (8). Insert the lower end of the drive housing into the opening of the timing gear cover. Secure with capscrews and lockwashers. Tighten the 7/16" (11.11 mm) capscrews to 44-49 lb-ft (60-66 Nm) torque; tighten the 3/8" (9.53 mm) capscrews to 28-33 lb-ft (38-45 Nm) torque.

NOTE: Capscrew (19) 3" (76.2 mm) long must be installed through the large upper opening of the drive housing.

- (12) Place the o-ring (4) in the groove of the governor adaptor assembly (2).
- (13) Position the shim pack (3) under the flange of the governor adaptor assembly and insert the assembly into the governor drive housing. Secure with capscrews (20) and lockwashers. Tighten the capscrews to 18-21 lb-ft (24-28 Nm) torque.
- (14) Remove the 1-1/2" (37.1 mm) pipe plug (16) from the side of the governor drive housing to gain access for checking backlash.
- (15) Check the backlash of the pinion gear (9) and governor drive gear (11) at 90° intervals. Remove or add laminations from the shim pack (3) to obtain a backlash of .003"-.005" (0.08-0.12 mm). Shim laminations are .003" (0.08 mm) thick.
- (16) If the gauge was not used to position drive gear, check the tooth contact between the pinion gear (9) and the drive gear (11) by inserting finger through the 1-1/2" pipe plug hole (17) in the side of the drive housing (8) and feeling the beveled surfaces (17) on the back of the gears. The two surfaces must be in the same plane (even) to obtain proper tooth contact. If the surfaces are not even, the drive gear has been improperly positioned on the drive shaft, and it is necessary to remove the governor adaptor (2) and the drive housing (8) and reposition the drive gear (11).

CAUTION: Incorrect backlash or improper tooth contact will result in rapid gear failure.

- (17) Place splined sleeve (5) on the splined shaft (6) in the governor adaptor assembly (2).

CAUTION: Ensure the gasket does not block off the drain holes in the bottom of the governor housing. The splined drive shaft of the governor must freely slip into the splined sleeve (5) and the governor must drop into the drive assembly without force.

- (19) Position the hydraulic governor on the adaptor assembly and secure it with capscrews and lockwashers. Tighten the capscrews to 11-13 lb-ft (15-18 Nm) torque.

Refer to Figure 18.

- (20) Connect the oil supply line (9) to the hydraulic governor. Install pipe plug (16).

NOTE: If governor is equipped with a current type oil reservoir (Fig 36), install oil tube (10) between the governor drive housing and the oil outlet solenoid (8).

- (21) Connect the rod assembly (7) to the governor lever (6).
- (22) If the hydraulic governor is equipped with a speed control motor (5), connect the electrical leads (3). If the unit is not so equipped, connect the throttle control (10) to the speed control lever (4) of the governor.

## 5. Governor Linkage and Fuel Injection Pump Rack Bellows

Refer to Figure 23.

Linkage between governor (2) and injection pump (21) is of two types. The first type consists of a bellcrank (12) and two rod assemblies (8 and 15). The second type (current) consists of a single link assembly (27).

### a. Governor Linkage - Second Type (Current)

Lever assembly (28) is attached to the governor terminal shaft (3). The link assembly consists of the link (27), two right-hand thread balljoints (29) and locknuts (7 and 16). The balljoint at the pump rack end of the link must have a sleeve (26) in the balljoint to reduce the hole size to 0.250" (6.35 mm) which is the diameter of the capscrew that retains the balljoint to the pump rack (24).

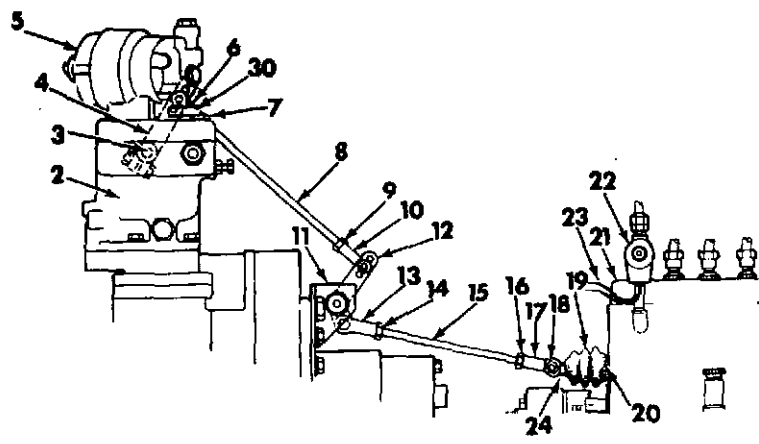

FIRST TYPE GOVERNOR TO INJECTION PUMP LINKAGE

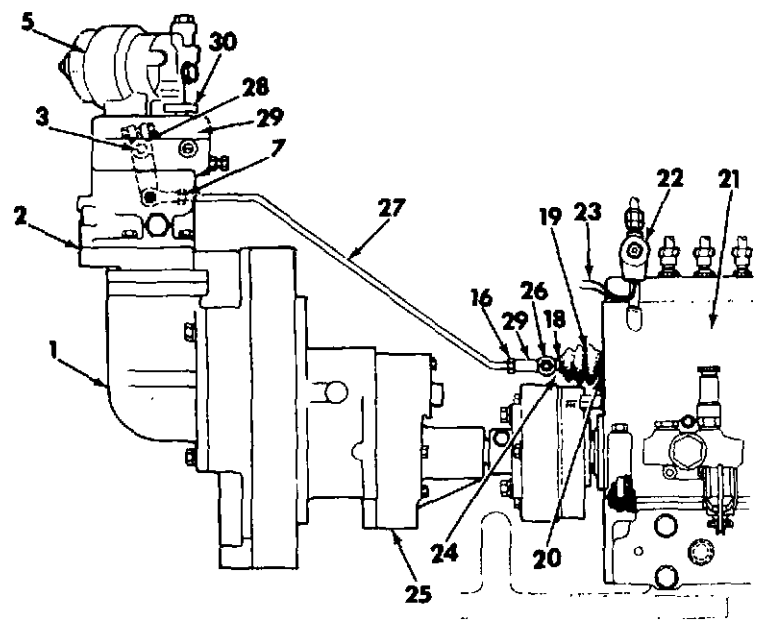

CURRENT TYPE GOVERNOR TO INJECTION PUMP LINKAGE

E-3025

- |   |   |
|---|---|
| <ul style="list-style-type: none"> <li>1. Governor drive</li> <li>2. Hydraulic governor</li> <li>3. Terminal shaft</li> <li>4. Lever assembly</li> <li>5. Speed control motor</li> <li>6. Rod end</li> <li>7. Locknut</li> <li>8. Rod</li> <li>9. Locknut</li> <li>10. Rod end</li> <li>11. Linkage support assembly</li> <li>12. Bellcrank</li> <li>13. Rod end</li> <li>14. Locknut</li> <li>15. Rod</li> </ul> | <ul style="list-style-type: none"> <li>16. Locknut</li> <li>17. Rod end</li> <li>18. Nut, lockwasher, rack, spacer, plain washer, and capscrew</li> <li>19. Bellows</li> <li>20. O-ring to retain bellows</li> <li>21. Injection pump - Robert Bosch</li> <li>22. Fuel shutoff solenoid valve</li> <li>23. Leads</li> <li>24. Rack</li> <li>25. Accessory drive assembly</li> <li>26. Sleeve for balljoint</li> <li>27. Link - governor to pump rack</li> <li>28. Lever - terminal shaft</li> <li>29. Balljoint</li> <li>30. Manual speed control adjustment</li> </ul> |
|---|---|

Figure 23. Robert Bosch Injection Pump Linkage and Rack Bellows

NOTE: In event it is necessary to remove the balljoints (29) from the link (27) record the center-to-center dimension between the holes in the balljoints.

If a new terminal shaft lever (28), link (27) and balljoints (29) are being assembled to the governor and pump rack proceed as follows:

- (1) Assemble the link with balljoints to the terminal shaft lever. The governor end balljoint is positioned on the cutout side of the lever and this side of lever is toward the governor.
- (2) Place a screw driver in the slot in the end of the terminal shaft (3) and turn it all the way toward the front of the engine (clockwise) as viewed from the slot end of the shaft. This is the governor shutdown position.
- (3) Place the lever and link on the terminal shaft (3) in a downward position and inclined 50-10° toward the injection pump. Make certain the terminal shaft remains in the shutdown position.
- (4) The rack (24) of the injection pump is held in the no fuel position (fail-safe) by the rack return spring (Fig 25 Item 5) when the pump is in a static state and not connected to the governor.
- (5) With the pump in this position adjust the length of the link assembly until the lower balljoint is aligned with the hole in the rack.
- (6) With the balljoint on the engine side of the rack, locate the space between them and secure in place with cap-screw, plain washer, lockwasher, and nut.

NOTE: Make certain the sleeve is in the balljoint.

- (7) Tighten the balljoint locknuts. Make certain the balljoint move freely.
- (8) No further adjustment is required.

#### b. Governor Linkage - First Type (Early)

Lever assembly (4) is attached to governor terminal shaft (3). Rod assembly (8) connects lever assembly (4) and bellcrank (12). This bellcrank type

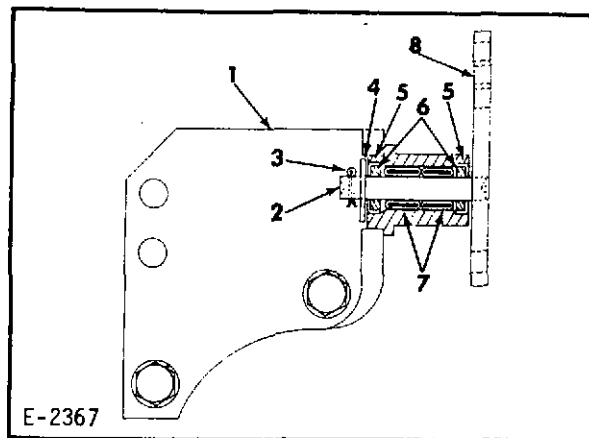

1. Linkage support
2. Shaft, bellcrank
3. Cotter key
4. Plain washer
5. Cup, felt washer
6. Felt washer
7. Needle bearings
8. Lever, bellcrank

Figure 24. Support Linkage Assemble and Bellcrank Details

lever pivots in the linkage support assembly (11), which contains 2 needle bearings and has felt oil seal at both ends. Rod assembly (15) connects the bell crank to the fuel injection pump rack.

Control rods (8) and (15) have right-hand threads at one end, and left-hand threads at the other end, to permit adjustment of proper center-to-center dimension. Rod end bearings should be lubricated with engine oil at intervals of 100 hours of operation.

#### Removal and Disassembly of Linkages (Fig 23)

##### (1) Rod Assemblies

- (a) Remove rod assemblies, (8 and 15) by removing nuts, lockwashers, and cap-screws securing rod ends (Items 6, 10, 13, and 17) to lever (4), bellcrank (12), and rack (24).

NOTE: In event it is necessary to remove rod ends from the rods, record the center-to-center dimensions of both rods to facilitate reassembly. Also, for reference in reassembly, note the hole in bellcrank (12) and lever assembly (4) used for mounting of rod assembly (8).

**CAUTION:** Note that the ends of rods (8) and (15) toward the fuel injection pump have left-hand threads and the ends away from the pump have right-hand threads.

c. Linkage Support and Bellcrank-First Type Linkage (Fig 24).

- (1) Remove linkage support (1) and bellcrank (8) by removing capscrews and lockwashers securing linkage support and bellcrank to the accessory drive housing.
- (2) Remove cotter key (3) and plain washer (4) from bellcrank shaft (2), and withdraw it from support (1).
- (3) Inspect needle bearings (7) and shaft of bellcrank (2). Renew bearings if there is evidence of roughness or binding of needles. Renew bellcrank if shaft is rough or scored.
- (4) To remove needle bearings (7), pry felt washer cups (5) from bores in linkage support (1). Remove felt washers (6) and needle bearings from the support.
- (5) Reassemble the linkage support and bellcrank following reverse order of disassembly.

**NOTE:** Prior to installing bellcrank into the linkage support, lubricate needle bearings with a general purpose grease.

- (6) If rod ends were removed from the rods, reassemble and adjust ends to obtain dimensions previously recorded in preceding Step b(1) (See following Subparagraph 7 for final adjustment of governor linkage).

d. Fuel Injection Pump Rack Bellows (Fig 23).

- (1) The purpose of the bellows (19) is to keep foreign matter from collecting on the rack (24) and causing the rack bushing in the front of the pump to wear.
- (2) The front opening of the bellows is a tight fit on the rack and the rear opening is retained on the rack bushing by an o-ring (20).
- (3) Replace the bellow if it is cracked or shows signs of deterioration.

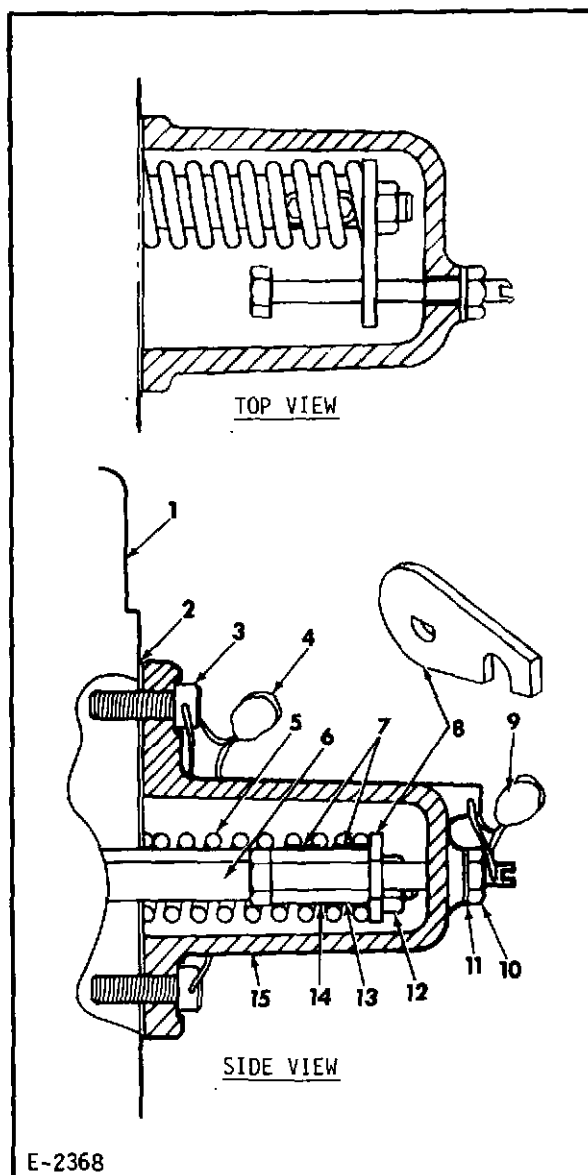

1. Injection pump
2. Gasket
3. Socket headed screws
4. Seal
5. Return spring
6. Rack - injection pump
7. Flat headed hexagon socket screws
8. Smoke stop plate
9. Seal
10. Nut
11. Seal washer
12. Locknut
13. Smoke stop plate adaptor
14. Smoke stop adjusting screw
15. Cover

Figure 25. Injection Pump Rack Return Spring and Smoke Stop

## 6. Smoke Stop Assembly and Rack Return Spring

### a. General (Fig 25)

The end of the rack (6) at the rear of the injection pump (1) is enclosed with a cover (15). The cover is attached to the injection pump with a gasket (2) and secured in place with hex head screws (3) and seal (4).

The rack is fitted with a return spring (5) which is retained on the rack by the smoke stop plate adaptor (13), smoke stop plate (8), and locknut (12). The spring forces the rack to the low speed position when the hydraulic governor is deactivated. This is a fail-safe feature. In the event of governor failure, engine speed is decreased to the low speed setting.

The smoke stop adjusting screw (14) is located in the end of the cover (15). The head of the screw contacts the smoke stop plate (8) which is secured to the smoke stop plate adaptor is secured to the rack by 2 flat headed hexagon socket screws (7). The smoke adjusting screw is retained in the cover by a seal washer (11) and nut (10). After final adjustment, the screw is locked in position with the nut and sealed (9).

When properly adjusted, the smoke stop adjusting screw limits the injection pump rack movement toward the increase fuel position and causes the injection pump to deliver the specified maximum fuel. This is accomplished by positioning the smoke stop adjusting screw head so that it contacts the smoke stop plate and limits the movement of the rack to the specified maximum fuel delivery.

**CAUTION:** Do not exceed specified maximum fuel delivery. Damage to the engine and turbocharger will result.

Should it be necessary to replace a damaged fuel injection pump, remove fuel pump cover but do not disturb position of the smoke stop adjusting screw. Assemble cover to the replacement fuel injection pump using a new pump-to-cover gasket (1). It is recommended that the injection pump be placed on a fuel injection pump test stand and maximum fuel delivery adjusted to the full load engine rpm specified for the individual engine application.

**NOTE:** The maximum fuel delivery specification can be obtained from the local Allis-Chalmers dealer.

### b. Removal and Disassembly

- (1) Cut and remove seal wire (4) from upper and lower socket head screws (3) securing the cover (15) to the injection pump (1).
- (2) By tilting cover, the head of smoke stop adjusting screw (14) will disengage from the smoke stop plate (8).
- (3) Should it be necessary to remove the smoke stop adjusting screw, proceed as follows:
  - (a) Measure and record distance from the smoke stop adjusting screw head to the machined mounting surface of the cover (15).
  - (b) Cut and remove seal wire (9).
  - (c) Remove smoke stop adjusting screw nut (10) and seal washer (11).
  - (d) Remove smoke stop adjusting screw from cover.
- (4) Remove locknut (12) securing smoke stop plate (8) to end of smoke stop plate adaptor (13). Remove the adaptor.
- (5) Remove return spring (14) from rack.
- (6) Remove the flat headed hexagon socket screws (7) securing the smoke stop adaptor to the injection pump rack. Remove the adaptor from the rack.

### c. Reassembly and Installation

- (1) Position the chamfered edge of the smoke stop plate adaptor in the corner of the injection pump rack and secure in position with the flat headed screws.

**NOTE:** Before installing spring, it should be inspected. Examine coils for cracks or other deterioration. The free length of the spring is 2-11/16 (68.20 mm). It should have a specified load of 16 lb (7.26 kg) when compressed to 2" (50.80 mm) and require 35 lb (15.87 kg) to close the coils at 1-3/16" (30.15 mm) length.

- (2) Position return spring on rack.

- (3) Position smoke stop plate on the adaptor with the open end of the slot to the bottom. Secure in position with locknut.
- (4) Turn the smoke stop adjusting screw into the cover to the distance recorded in Step b (3) above. Position seal washer on the screw and turn nut onto screw. Tighten nut securely.
- (5) Cement gasket to cover. Tilt the rear end of the cover upward and position the smoke stop adjusting screw so that it is in the slot of the smoke stop plate with its head between the plate and rear of the injection pump.
- (6) Secure the cover to the pump with the socket headed screws and tighten securely. Install seal wire in head of screws.
- (7) After the specified maximum fuel delivery has been adjusted with the pump on an injection pump test stand, install the seal through the holes in the smoke stop adjusting screw and cover.

## 7. Final Adjustments and Speed Settings

### a. General

Final adjustment of the governor and linkage is made after all components of the system have been installed on the engine. Prior to making adjustments, check to ensure the following conditions exist: the fuel injection pump is properly timed to the engine, the fuel injection nozzle holder assemblies are in good condition and properly adjusted, the intake and exhaust valves are properly adjusted, and the fuel filters and air cleaner are clean and in good condition. If the rack cover at the rear fuel injection pump was removed, make certain the smoke stop adjusting screw has been adjusted to the specified maximum fuel delivery with the pump on an injection pump test stand.

**CAUTION:** If a new governor or one that has had the low speed adjustment changed since the original factory setting is installed on the engine, a preliminary adjustment should be made to assure the engine does not operate below 1400 rpm when first started, otherwise the diodes in the voltage regulator will be destroyed.

### b. Terminal Shaft Lever Installation (Fig 26)

#### (1) Governors without Speed Control Motor

Regardless of the type of governor (SG or PSG) or the type of linkage, it is necessary to make a preliminary low speed adjustment by positioning the low speed stop screw (Fig 26 Item 13) so that there is a 1/2" (12.70 mm) distance between the top of the center portion of the wingnut and the underside of the head of the stop screw.

Place a screwdriver in the slot in the end of terminal shaft (Fig 26 Item 5) and turn it all the way toward the front of the engine (clockwise, as viewed from the terminal shaft side of the governor). This is the governor no fuel position. Install the terminal shaft lever as follows:

#### (a) Current Governor to Pump Linkage (Fig 26)

Install terminal shaft lever (3) on terminal shaft with the lower end of lever inclined 5°-10° toward rear of engine. Secure lever in position.

#### (b) First Type Governor to Pump Linkage (Fig 26)

Install terminal shaft lever (3) so the lever is inclined approximately 20° toward the rear (flywheel end) of the engine. Secure the lever in this position.

#### (2) Governors with Speed Control Motors

In governors with speed control motors, the speed control shaft (Fig 30 Item 4) is spring loaded in order for it to remain in contact with the motor controlled speed adjusting screw (Fig 31 Item 6).

Prior to installing the terminal shaft lever (Fig 23 Item 3) on the terminal shaft (5), turn the manual speed control adjustment (15) out of the governor cover several turns or until a lesser turning effort is felt. Then, turn the manual speed adjustment into cover to the point where a greater turning effort is felt.

#### (a) Current Governor to Pump Linkage

With the terminal shaft positioned

as indicated and the speed control motor speed adjustment adjusted as indicated above, position the terminal shaft lever on the terminal shaft in a downward position and inclined 5°-10° toward the injection pump and install link as indicated in the preceding Paragraph 5.

The procedure for installing the terminal shaft lever is the same, regardless if the governor does or does not have a speed control motor.

(b) First Type Governor to Pump Linkage (Fig 26)

Install the terminal shaft lever (3) on the terminal shaft (5) in the straight up position. Turn the manual

speed control (15) into the cover until lever is inclined approximately 20° toward the rear (flywheel end) of the engine. Secure the lever in this position.

Adjust control rods as follows:

NOTE: Control rods (7) and (9) have right-hand threads at one end and left-hand at the other like a turnbuckle which permits the adjustment of the center-to-center dimension by twisting the rod while the rod assembly is attached to the levers at each end.

(1) To adjust the length of rod assembly (7), rod assembly (9) must be removed from bellcrank (8). Adjust the length

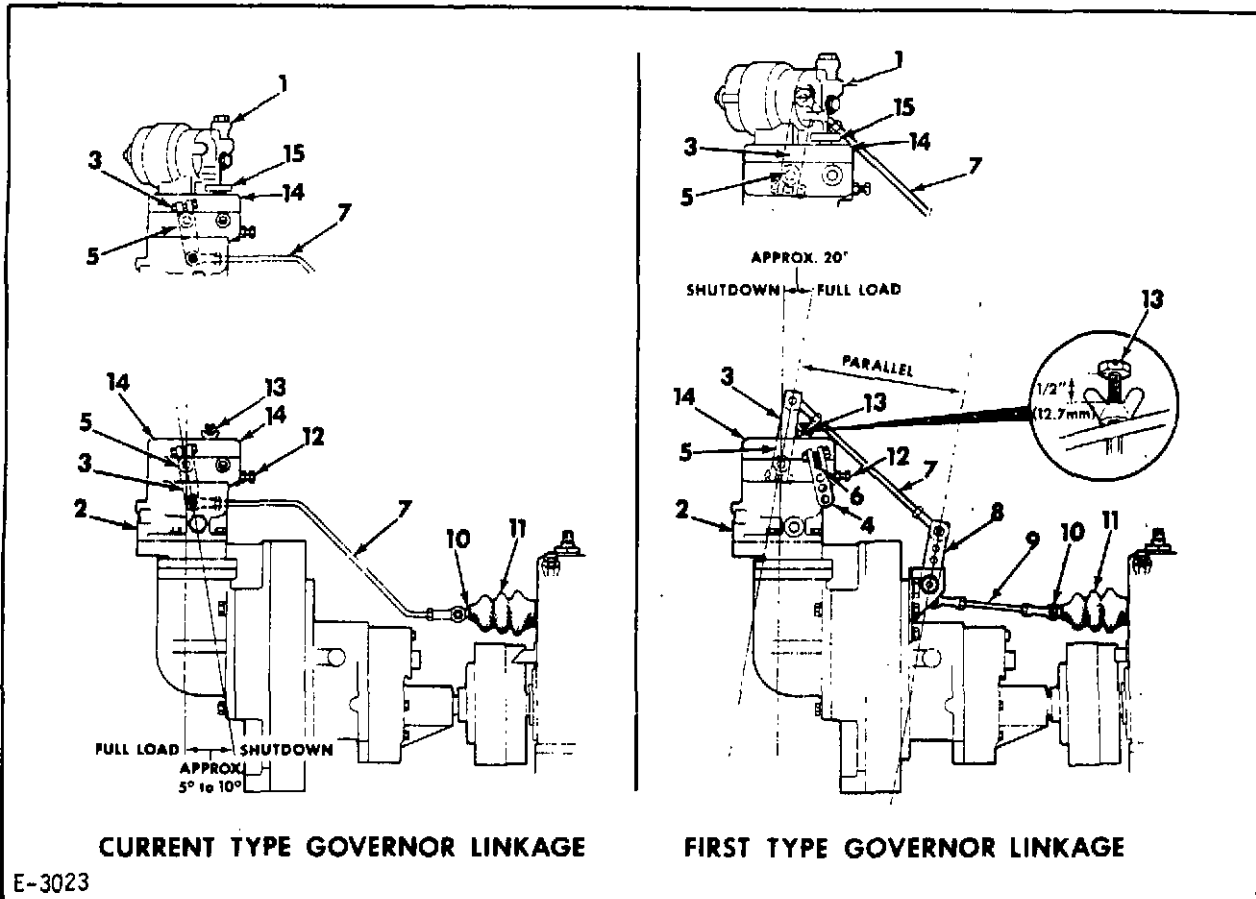

- 1. Governor with speed control motor
- 2. Governor without speed control motor
- 3. Terminal shaft lever
- 4. Speed control lever
- 5. Terminal shaft
- 6. Speed adjusting shaft
- 7. Link/rod assembly

- 8. Bell crank
- 9. Rod assembly
- 10. Fuel injection pump rack
- 11. Bellows
- 12. High speed stop screw
- 13. Low speed stop screw
- 14. Governor cover
- 15. Manual speed control adjustment

Figure 26. Final Adjustments

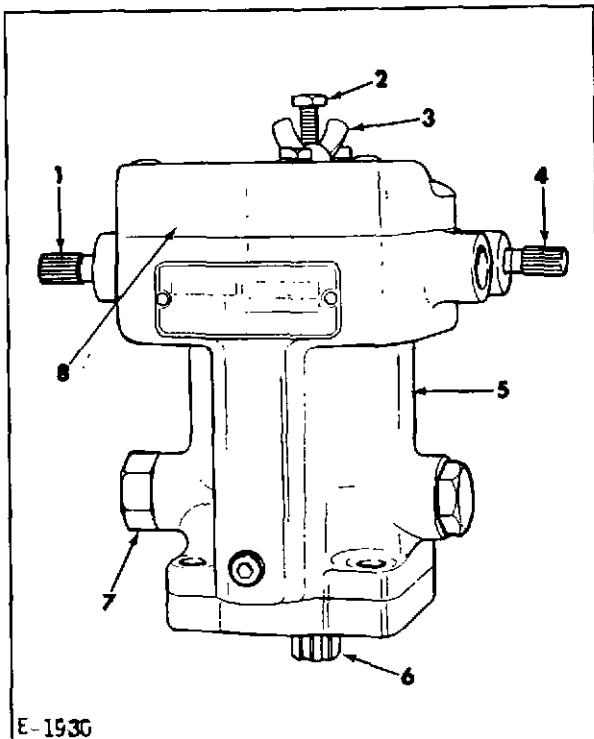

1. Terminal shaft (fuel control)
2. Low speed stop adjusting screw
3. Lock nut
4. Speed adjusting shaft
5. High speed stop screw (at rear of governor)
6. Drive shaft
7. Oil supply connection
8. Cover

Figure 27. Type SG Hydraulic Governor

of the rod assembly (7) between the terminal shaft lever (3) and the bellcrank (8) so the upper arm of the bellcrank is approximately parallel with the terminal shaft lever when the lever is in the no fuel position (fully toward the front of the engine). Tighten rod end locknuts.

**NOTE:** The usual locations for the rod ends of rod assembly (7) are the middle hole of terminal shaft lever (3) and the top hole of bellcrank (8) or the original locations recorded when the rod assembly was removed from the levers.

- (2) Make certain the return spring in the smoke stop cover at the rear of the injection pump moves the rack to the no fuel position (toward rear of engine) and that the rack does not bind in any manner.
- (3) Loosen the locknuts on the end of rod

assembly (9). Install one end of the rod assembly on the lower arm of the bellcrank (8) and the other end on the fuel injection pump rack (10).

- (4) Secure the locknuts on the rod ends.
- (5) Check all linkage ball joints for excessive friction; realign where necessary.
- (6) Start the engine and adjust the low speed stop screw (governor without speed control motor) or the speed control motor manual adjustment for 1400 rpm (minimum). Allow the engine to warm up.
- (7) Stop the engine. Connect the throttle (Fig 18, Item 10) to the governor speed control lever (4), or connect the speed control motor electrical leads (3) to the toggle switch on the control panel.

**WARNING: MAKE CERTAIN ELECTRICAL CIRCUIT IS DE-ENERGIZED BEFORE MAKING CONNECTION.**

- (8) Start the engine. Temporarily adjust the high idle, no load speed to 1400 rpm for 50 Hz operation or 1700 rpm for 60 Hz operation.

**NOTE:** If the governor is a type PSG governor (Fig 28), open the compensating needle valve (9) two or three turns and allow the engine to hunt or surge for about one-half minute to bleed the trapped air from the governor oil passages. Gradually close the needle valve until the hunting just stops. Closing the needle valve too far will make the governor slow to return to normal speed after load changes. Test the governor action by manually disturbing the engine speed. The engine should return promptly to the original steady speed with only a small overshoot.

If the governor is a type SG governor and the engine surges during warm up, stop the engine, remove the governor cover (Fig 29, Item 3) or the cover and speed control motor (2) as an assembly, and adjust the speed droop bracket toward the maximum droop position (6). Reinstall the cover and speed control motor.

#### d. Speed Range

The speed range, from low speed rpm to high idle, no-load rpm, is established by adjusting the low speed stop screw Item 2, Figures 27 and 28, and the high speed stop screw Item 5, Figures 27 and

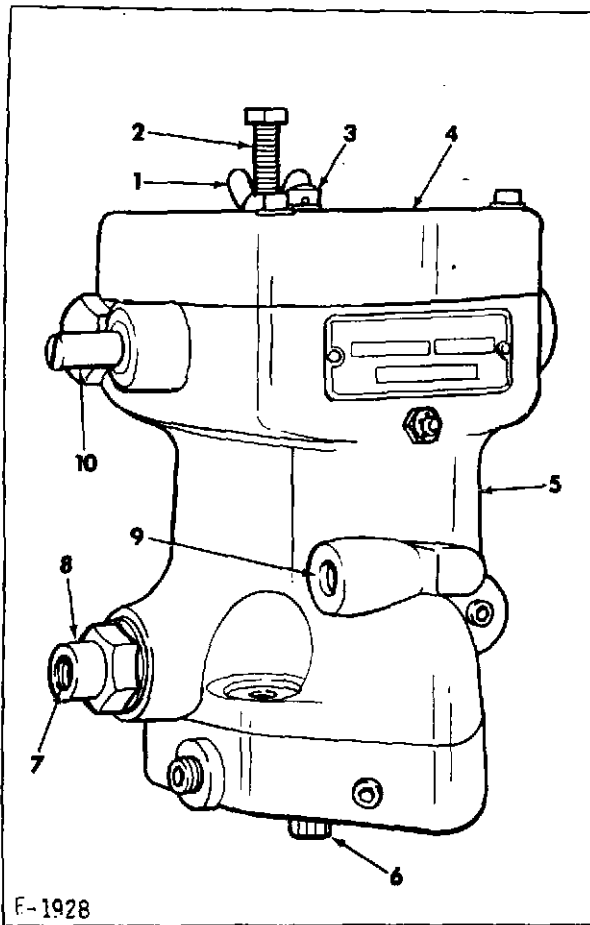

1. Locknut
2. Low speed setting stop screw
3. Vent screw - keep holes open
4. Cover
5. High speed stop screw (at rear of governor)
6. Drive shaft
7. Oil supply connection
8. Relief valve
9. Compensating needle valve
10. Terminal shaft

Figure 28. Type PSG Hydraulic Governor

28. The high speed stop screw is located at the rear of the governor body.

**CAUTION:** Operating the engine below 1400 rpm will destroy the diodes in the voltage regulator.

- (1) Adjust the low speed stop screw to achieve a low speed of 1400 rpm, and adjust the high speed stop screw to achieve the high idle, no-load speed of 1545-1575 rpm; 51.5-52.5 Hz (50 Hz operation) or 1854-1890 rpm, 61.8-63.0 Hz (60 Hz operation).

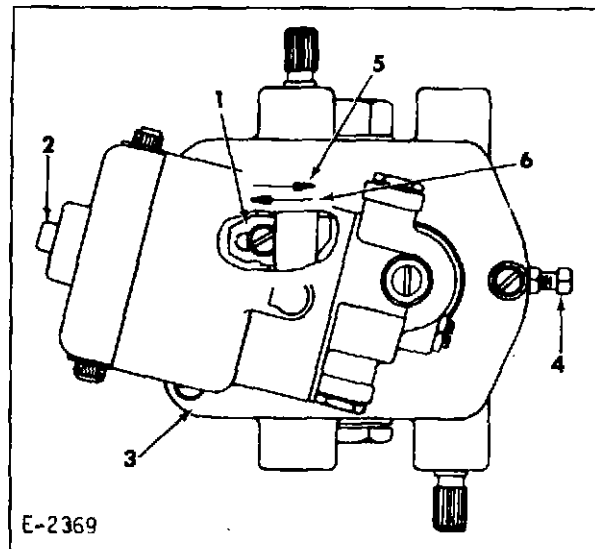

1. Speed droop bracket and locking screw
2. Speed control motor (optional)
3. Cover (in place)
4. High speed stop screw
5. Direction for decreasing (minimum) speed droop
6. Direction for increasing (maximum) speed droop

Figure 29. Speed Droop Adjustment (Type SG Governor)

- (2) Allow the engine to operate for 20-30 minutes after the minimum operating temperature is reached. This assures that the components of the governor and engine have reached normal operating temperature.
- (3) Using a stroboscopic type tachometer, or a direct reading frequency meter, check the high idle, no-load speed. Apply the full load (or as near full load as possible) and again check the engine speed. If the engine speed drops below or stays above 1500 rpm (50 Hz operation) or 1800 rpm (60 Hz operation) when the engine is fully loaded, the governor speed droop must be adjusted. Refer to Subparagraph 8 for the speed droop adjustment.

**NOTE:** The standard original factory installed governor is adjusted to a speed droop differential of 3-1/2% from high idle, no-load rpm to full load rpm.

All speed droop adjustment must be made after the engine has been warmed up and operated for another 20-30 minutes. This assures that all components of the governor and engine have reached their normal operating temperature.

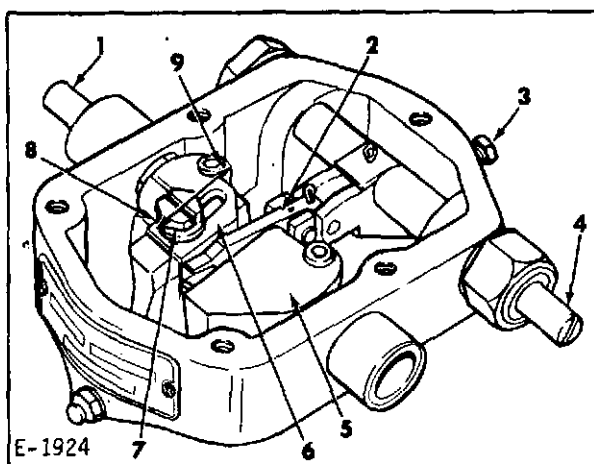

- |                                  |                                  |
|----------------------------------|----------------------------------|
| 1. Terminal shaft                | 5. Terminal lever                |
| 2. Speed droop lever             | 6. Speed droop adjusting bracket |
| 3. High speed setting stop screw | 7. Hex head screw                |
| 4. Speed adjusting shaft         | 8. Maximum droop                 |
|                                  | 9. Minimum droop shaft           |

Figure 30. Speed Droop Adjustment (Type PSG Governor)

#### 8. Speed Droop Adjustment (Figs 29 and 30)

When the engine is at operating temperature, adjust the droop bracket and pin as much towards minimum as possible while maintaining steady speed. Move the engine fuel linkage to cause a temporary engine speed increase. If the engine returns to the original steady speed, the adjustment is satisfactory for most single engine installations. If the engine speed does not settle out, increase droop slightly (small increment of 1/16" movement of bracket) and test again. After each adjustment of the droop bracket it will be necessary to make a slight adjustment of the full load rpm. Continue to increase the droop until the operation is satisfactory.

#### 9. Speed Control Motor

##### a. Motor Bearing Lubrication

Under normal, intermittent operation, the motor bearings should be lubricated - through the oil cup provided - every six months with Gulfcrest A, Stanoil No. 18, or equivalent. Apply a few drops to each oil cup.

##### b. Gear Lubrication

The speed reduction gear housing (Fig 32, Item 6) of a new motor is filled with sufficient lubricant to last for a one to two year period. When lubri-

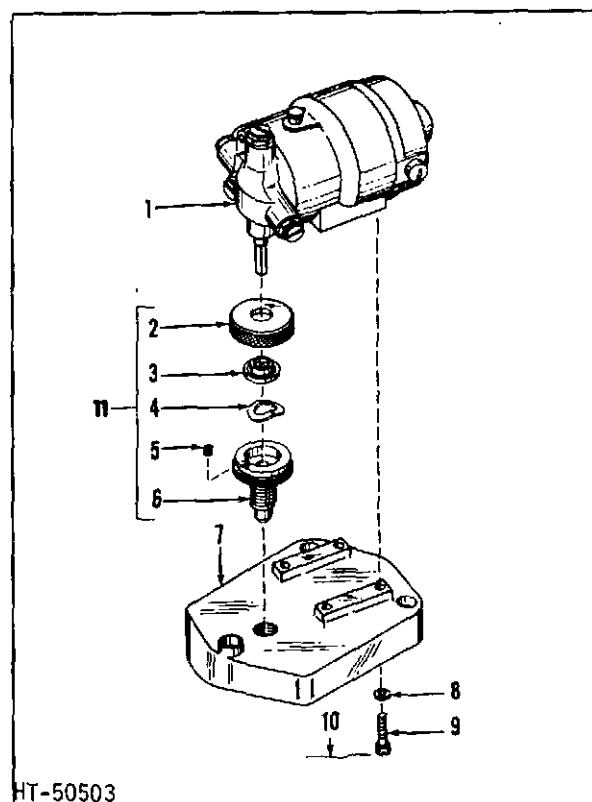

- |                          |                             |
|--------------------------|-----------------------------|
| 1. Speed control motor   | 7. Governor cover           |
| 2. Friction cover        | 8. Copper washer            |
| 3. Friction disc         | 9. Securing screw           |
| 4. Friction spring       | 10. Lockwire                |
| 5. Set screw             | 11. Manual speed adjustment |
| 6. Speed adjusting screw |                             |

Figure 31. Speed Control Motor and Governor Cover

cating, clean out the old grease and refill the gear housing 3/4 full of one of the following greases, or their equivalents, depending upon the service in which the unit is used:

Temperature at Location of Motor	Recommended Lubricant (or Equivalent)
-65° F to +32° F (219 K to 273 K)	Bodine - LG2 Beacon - 325
+32° F to +212° F (273 K to 373 K)	D.A. Stuart - H.M.P. Hodson - #2-1000
Above +212° F (373 K)	Dow-Corning - #44 (put directly on gears)

##### c. Friction Coupling Adjustment

A friction coupling (Fig 31, Items 2 through 6) is incorporated in the cover (7) assemblies to permit overtravel of the motor with no resulting damage.

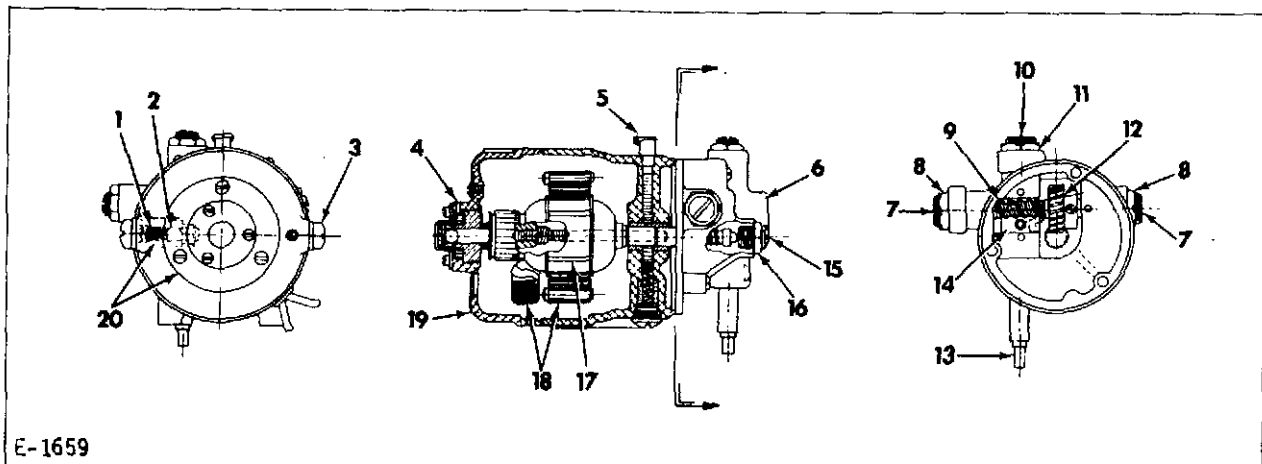

E-1659

- |                           |                   |                                 |
|---------------------------|-------------------|---------------------------------|
| 1. Brush spring           | 8. Locknut        | 15. Screw                       |
| 2. Brush                  | 9. Worm shaft     | 16. Locknut                     |
| 3. Brush holder cap screw | 10. Screw         | 17. Armature and shaft assembly |
| 4. Oil hole               | 11. Locknut       | 18. Field frame assembly        |
| 5. Oil cup                | 12. Bakelite gear | 19. Front end shield            |
| 6. Gear housing assembly  | 13. Output shaft  | 20. Brush holder                |
| 7. Adjusting screw        | 14. Gear          |                                 |

Figure 32. Speed Control Motor

This coupling should be adjusted to slip at 4-1/2 in-lb (0.50 Nm) of torque and then be locked in place with the set screw (5).

The motor must be mounted in such a manner as to center the shaft in the coupling. Full travel of the shaft in each direction should produce no bind.

#### d. Shaft End Play Adjustments

Adjustments are not necessary unless one of the locknuts securing the adjusting screws should loosen, changing the factory adjustments. In this case there are three adjustments possible with the gear housing (Fig 32, Item 6) removed.

##### (1) Output Shaft

Loosen locknut (11) and turn screw (10) in until it is hand tight, then back it off one quarter turn and tighten the locknut while holding the adjusting screw stationary. Rotate the bakelite gear (12), to make sure it turns freely. Check the output shaft (13) for end play by pulling it in the lengthwise direction while holding the gear housing firmly. When adjusted properly, the output shaft should show no visible movement.

##### (2) Worm Shaft

Loosen locknuts (8) on both sides of

worm shaft (9) and turn adjusting screws (7) to center the worm shaft with the output shaft (13). Check visually to determine proper alignment of the two gears. The worm adjusting screws should be positioned so each protrudes equally from its locknut when hand-tight. After hand tightening, the worm adjusting screws should be loosened just enough so that the bakelite gear (12) turns freely and there is no side play in the worm shaft (9).

##### (3) Armature Shaft

With gear housing (6) reassembled on the motor, hold motor firmly and shake it in a length wise direction. If a faint clicking sound is heard inside the motor, then an adjustment should be made. With locknut (16) loosened, turn screw (15) in just enough to take play out of the armature and shaft assembly (17). Adjust screw so that the clicking sound is absent, then back screw up a few degrees. Check by shaking motor again. If clicking sound is there again, adjust screw forward approximately one-half the number of degrees it was reversed and tighten the locknut while holding the adjusting screw stationary. Check again, and with the absence of the clicking sound, this should be the approximate adjustment.

**IMPORTANT: Do not bind armature.**

## I. GOVERNOR TROUBLESHOOTING

### 1. General

It is impossible to anticipate every kind of trouble that will be encountered in the field.

This manual covers the most common troubles experienced. Poor regulation may be due to faulty governor performance, or due to the governor attempting to correct for faulty operation of auxiliary equipment. If auxiliary equipment is used, the effect of this equipment on the overall control required of the governor must be considered.

### 2. Speed Droop Adjustment

Although the governor may appear to be operating satisfactorily because the engine runs at constant speed (without load) the governor still may not be correctly adjusted. High over-speeds and low underspeeds after load changes are some of the results of incorrect speed droop adjustments. See preceding Sub-paragraph 8 for speed droop adjustment.

### 3. Analysis and Correction of Governing Troubles

The following chart may be used to determine the probable causes of faulty governor operation and to correct these troubles.

Definitions of a few terms used in the chart are as follows:

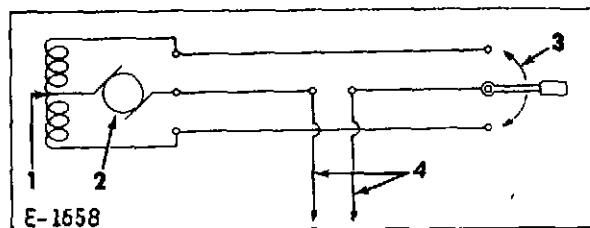

- 1. Field
- 2. Armature
- 3. Switch
- 4. To line

Figure 33. Wiring Diagram for Synchronizing Motor

#### a. Hunt

A rhythmic variation of speed which can be eliminated by blocking the fuel supply manually but which will reappear when returned to governor control.

#### b. Surge

A rhythmic variation of speed always of large magnitude which can be eliminated by blocking the fuel supply manually and which will not reappear when returned to governor control unless the speed adjustment or the load changes.

#### c. Jiggle

A high frequency vibration of the governor terminal shaft or engine linkage. Do not confuse with normal regulating action of the governor.

## GOVERNOR TROUBLESHOOTING

TROUBLE	POSSIBLE CAUSE	REMEDY
Engine hunts or surges.	<ol style="list-style-type: none"> <li>1. Speed droop adjustment incorrect.</li> <li>2. Dirty oil in governor.</li> <li>3. Foamy oil supplied to governor.</li> <li>4. Insufficient oil supply.</li> <li>5. Lost motion in engine linkage or fuel pump.</li> <li>6. Binding in engine linkage or fuel pumps.</li> <li>7. Governor worn or not correctly adjusted.</li> </ol>	<ol style="list-style-type: none"> <li>1. Increase speed droop.</li> <li>2. Clean governor, change engine oil if necessary.</li> <li>3. Drain engine oil. Refill with specified lubricant.</li> <li>4. Clean oil supply line.</li> <li>5. Repair linkage and pump.</li> <li>6. Repair and realign linkage and pump.</li> <li>7. Repair and/or adjust governor.</li> </ol>

GOVERNOR TROUBLESHOOTING (Continued)

TROUBLE	POSSIBLE CAUSE	REMEDY
Engine hunts or surges (Cont)	<p>8. Low oil pressure.</p> <p>9. Engine misfiring.</p> <p>10. Loss of compression.</p> <p>11. Main alternator voltage regulator not operating properly.</p>	<p>8. Governor oil pump gear clearance incorrect. Use .005" (0.013) gasket between case and base. No gasket used if base has rubber seal ring. Lap base and case surfaces flat. Relief valve plunger may be sticking. Excessive end play of drive shaft.</p> <p>9. Locate "missing" cylinder as follows: Run engine at low speed and cut out each fuel injection nozzle in turn by loosening the fuel injection line nut attaching line to fuel injection pump. A decrease in engine speed with line nut loosened indicates nozzle for that cylinder is functioning properly. If engine speed does not decrease, nozzle is malfunctioning and must be replaced.</p> <p>10. This may be due to leaking valves or to worn piston rings or cylinder sleeves. Use a suitable compression tester and check each cylinder.</p> <p>11. Adjust or repair voltage regulator.</p>
Fuel pump rack does not open quickly when cranking engine.	Low oil pressure	Governor oil pump gear clearance incorrect. Use .005" (0.013 mm) gasket between case and base. No gasket used if base has rubber seal ring. Lap base and case surfaces flat. Relief valve plunger may be sticking. Excessive end play of drive shaft.
Terminal shaft or rod and engine linkage jiggles.	<p>1. Rough governor drive assembly.</p> <p>2. Speed droop at critical setting.</p> <p>3. Governor base not bolted down evenly.</p>	<p>1. Check alignment of gears. Inspect for rough gear teeth. Check backlash of gears.</p> <p>2. Reduce droop to eliminate critical setting, if possible. Load division will be affected if this is done. Re-adjust droop on units affected.</p> <p>3. Loosen bolts, realign, and secure.</p>
Load does not divide properly on interconnected engines.	<p>1. Speed droop adjustment incorrect.</p> <p>2. Speed droop adjustment vibrating out of position.</p>	<p>1. Readjust droop to divide load properly. Increase droop to resist picking up (or dropping off) load. Reduce droop to increase picking up (or dropping off) load.</p> <p>2. Readjust droop and tighten screw securely.</p>

GOVERNOR TROUBLESHOOTING (Continued)

TROUBLE	POSSIBLE CAUSE	REMEDY
	<p>NOTE: Speed droop is not essential in a DC electrical system. The equivalent of speed droop in a DC system is obtained by changing the compounding of the generators at the bus between generators. An under compounded generator is equivalent to a speed droop governor. Governors with speed droop adjustment are commonly used for DC service since the droop adjustment may be used to correct for errors or inequalities of generator compounding.</p> <p>3. Slippage in hydraulic or electric couplings if used.</p>	<p>3. Adjust couplings.</p>
<p>Engine is slow to respond to a speed change or a load change.</p>	<p>1. Governor is not sensitive in measuring speed change.</p> <p>2. Governor may be intentionally designed to protect engine from overloading during a load change.</p> <p>3. Low oil pressure.</p> <p>4. Engine may be overloaded.</p> <p>5. Restricted fuel supply.</p>	<p>1. Repair and adjust governor.</p> <p>2. No field correction.</p> <p>3. Governor oil pump gear clearance incorrect. Use .005" (0.013 mm) gasket between case and base. No gasket used if base has rubber seal ring. Lap base and case surfaces flat. Relief valve plunger may be sticking. Excessive end play of drive shaft.</p> <p>4. Reduce load.</p> <p>5. Clean out fuel supply line and filters.</p>
<p>Engine will not pick up rated full load.</p>	<p>1. Fuel rack will not open far enough.</p> <p>2. Restricted fuel supply.</p> <p>3. Main alternator voltage regulator not functioning.</p> <p>4. Engine misfiring.</p> <p>5. Slipping clutch (if used) between engine and driven load.</p> <p>6. Speed adjustment of the governor is restricted.</p>	<p>1. Adjust engine to governor fuel linkage. Adjust load limiting device or fuel pump stops.</p> <p>2. Clean out fuel supply line and filters.</p> <p>3. Readjust or repair.</p> <p>4. Check fuel injection pump timing and nozzle opening pressure and make necessary repairs or adjustments.</p> <p>5. Foaming oil or low oil level in hydraulic clutch.</p> <p>6. Check maximum speed limit adjustment. Inspect speed adjusting linkage for interference.</p>

GOVERNOR TROUBLESHOOTING (Continued)

TROUBLE	POSSIBLE CAUSE	REMEDY
Governor oil overflows.	1. Drain holes plugged.  2. Insufficient drain capacity below governor.	1. Clean governor. The governor to engine gasket may be restricting the two drain holes at the governor pilot.  2. Engine to governor drive shaft (coupling, shaft, gear, etc.) not assembled properly. Drain holes in engine plugged up.

J. HYDRAULIC GOVERNOR OIL RESERVOIR

1. General

For faster starting and stopping of engines equipped with hydraulic governors, an oil reservoir is available as an option to supplement the governing system (refer to Fig 35 and 36).

When the engine stop switch is placed in the STOP position, the fuel shutoff solenoid valve is de-energized, stopping the flow of fuel to the fuel injection pump. The normal stopping of an engine equipped with a hydraulic governor, but without the oil reservoir, generally takes approximately 10 seconds. While the engine is slowing to a stop, the oil supply to the hydraulic governor decreases and the rack return spring (Fig 25) at the rear of the fuel injection pump moves the pump rack and governor linkage to the STOP position.

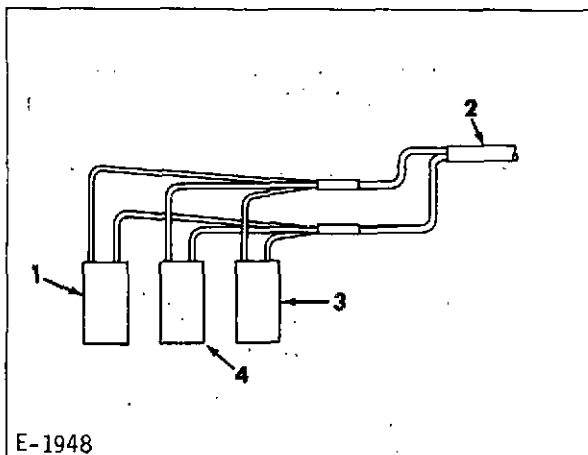

1. Outlet solenoid valve (normally open)
2. Wiring harness
3. Fuel solenoid shutoff valve (normally closed)
4. Inlet solenoid valve (normally closed)

Figure 34. Wiring Diagram

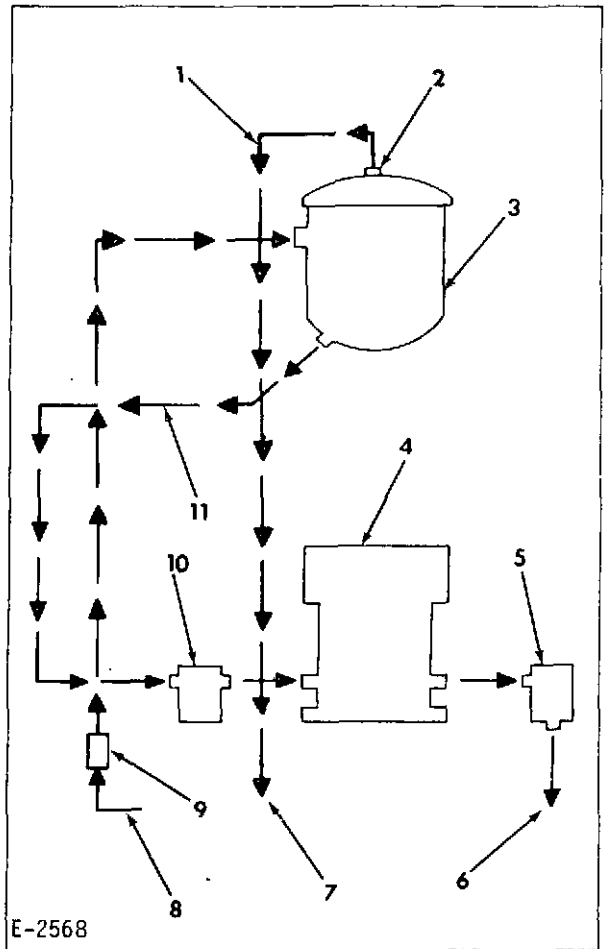

1. Vent tube (current units)
2. Orifice 0.0156" (0.397 mm)
3. Oil reservoir
4. Hydraulic governor
5. Oil outlet solenoid valve
6. Oil return to oil pan
7. Oil and air return to oil pan
8. Oil supply from engine oil gallery
9. Check valve (current units)
10. Oil inlet solenoid
11. Oil supply to governor

Figure 35. Oil Flow Schematic

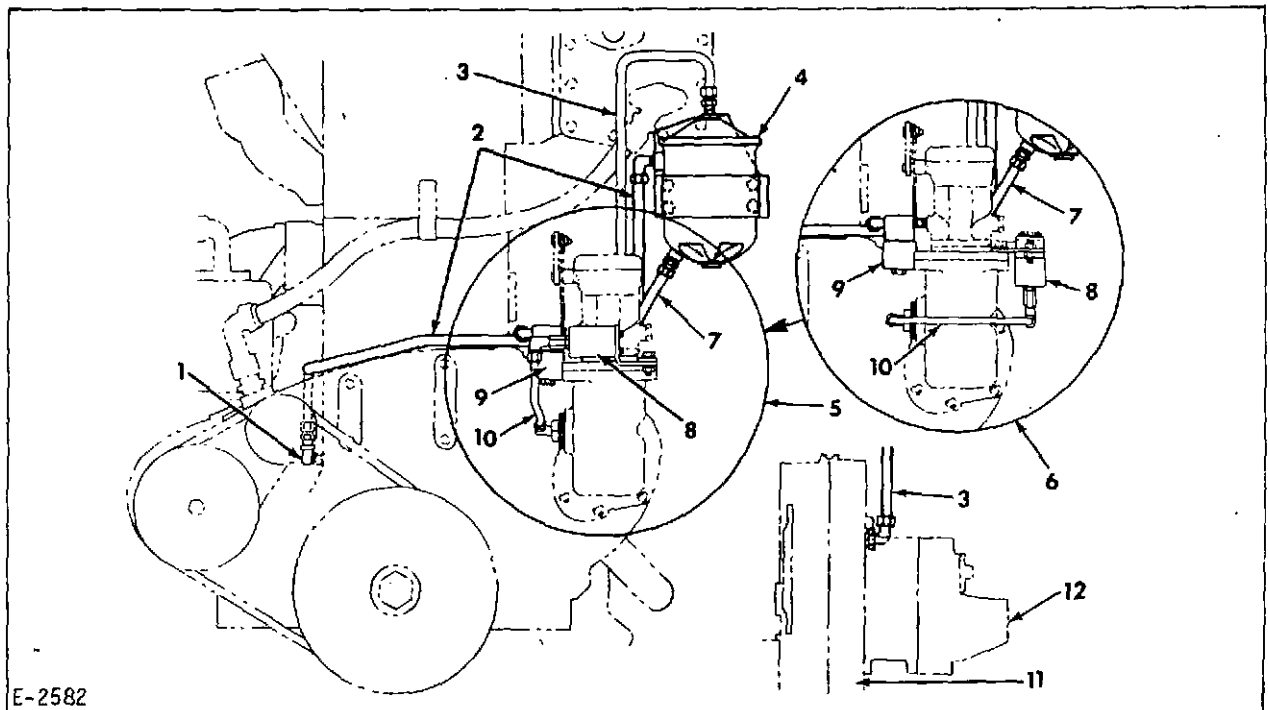

E-2582

- |   |  |
|---|--|
| 1. Check valve                                | 7. Tube - reservoir to oil inlet solenoid      |
| 2. Tube-engine oil gallery to reservoir       | 8. Oil outlet solenoid valve                   |
| 3. Vent tube-reservoir to timing gear housing | 9. Oil inlet solenoid valve                    |
| 4. Oil reservoir                              | 10. Tube - oil return from oil outlet solenoid |
| 5. SG Type Governor arrangement               | 11. Timing gear housing                        |
| 6. PSG Type Governor arrangement              | 12. Accessory drive assembly                   |

Figure 36. Oil Reservoir Installation (Current Type)

The purpose of the hydraulic governor oil reservoir with its two fuel solenoid valves is to make possible the quick starting and stopping of the engine. Quick starting is accomplished by making available to the hydraulic governor an immediate supply of oil which is contained in the oil reservoir thus eliminating the time required by the engine oil pump to supply the necessary quantity of oil to the governor while the engine is being cranked.

Quick stopping is accomplished by dumping the oil from the hydraulic governor, thus permitting the rack return spring at the rear of the fuel injection pump to immediately move the rack to the STOP position.

After engines with the early type oil reservoir (Fig 37) were stopped, the oil would drain from the oil supply tube (2) and fill with air. When the engine was started, the incoming oil would force the air into the reservoir and aeriate the oil. This and the air trapped in the dome of the reservoir

cause an erratic governor for a short period of time until the air passed through the system.

To eliminate the air, the current type oil reservoir (Fig 36) has a check valve (1) added to the inlet of the oil supply tube (2) to the reservoir (4). The valve prevents the draining of the oil from the tube. The top of the reservoir center bolt has had a 0.0156" (0.40 mm) orifice drilled through it and is drilled and tapped for a 0.125"-27 pipe thread to accept a vent line extending to the rear of the timing gear housing.

The hydraulic governor inlet solenoid valve (9) (normally closed) and the hydraulic governor outlet solenoid (8) (normally open) are wired in parallel with the fuel shutoff solenoid in the fuel inlet line to the pump. When the engine is started, the solenoids are energized and the inlet solenoid is open and the outlet solenoid is closed and an immediate supply of oil is available to the governor which overcomes

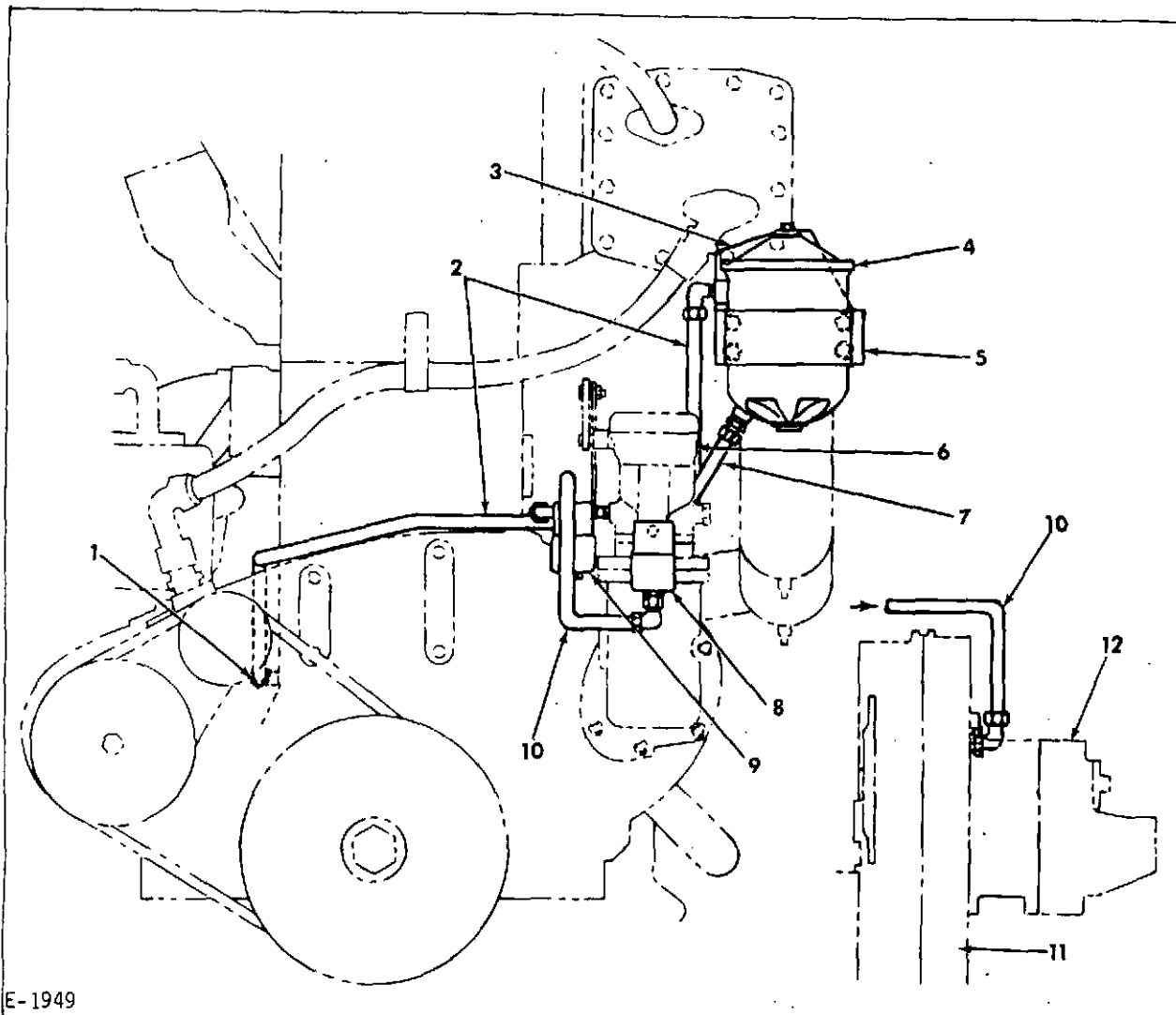

E-1949

- |   |   |
|---|---|
| <ul style="list-style-type: none"> <li>1. Engine oil gallery</li> <li>2. Tube - engine oil gallery to reservoir</li> <li>3. Oil reservoir mounting bracket</li> <li>4. Oil reservoir</li> <li>5. Oil reservoir mounting strap</li> <li>6. Hydraulic governor</li> </ul> | <ul style="list-style-type: none"> <li>7. Tube - reservoir to oil inlet solenoid</li> <li>8. Oil outlet solenoid valve</li> <li>9. Oil inlet solenoid valve</li> <li>10. Tube - oil return from oil outlet solenoid valve</li> <li>11. Timing gear housing</li> <li>12. Accessory drive assembly</li> </ul> |
|---|---|

Figure 37. Oil Reservoir Installation (Early Type)

the tension of the rack return spring, therefore immediately putting the fuel injection pump rack in the run position.

When the hydraulic governor solenoid valves are de-energized by placing the stop switch in the STOP position or by any of the safety shutdown devices, the inlet solenoid is closed and prevents the oil from draining from the oil reservoir thus making the oil supply available for the next starting of the engine. The outlet solenoid opens,

dumping the oil from the governor, and the rack return spring at the rear of the injection pump immediately moves the pump rack to the no-fuel position thereby stopping the engine.

## 2. Maintenance

### a. Reservoir

At periodic intervals inspect the oil line fittings and reservoir cover for leaks (Figs 36 and 37).

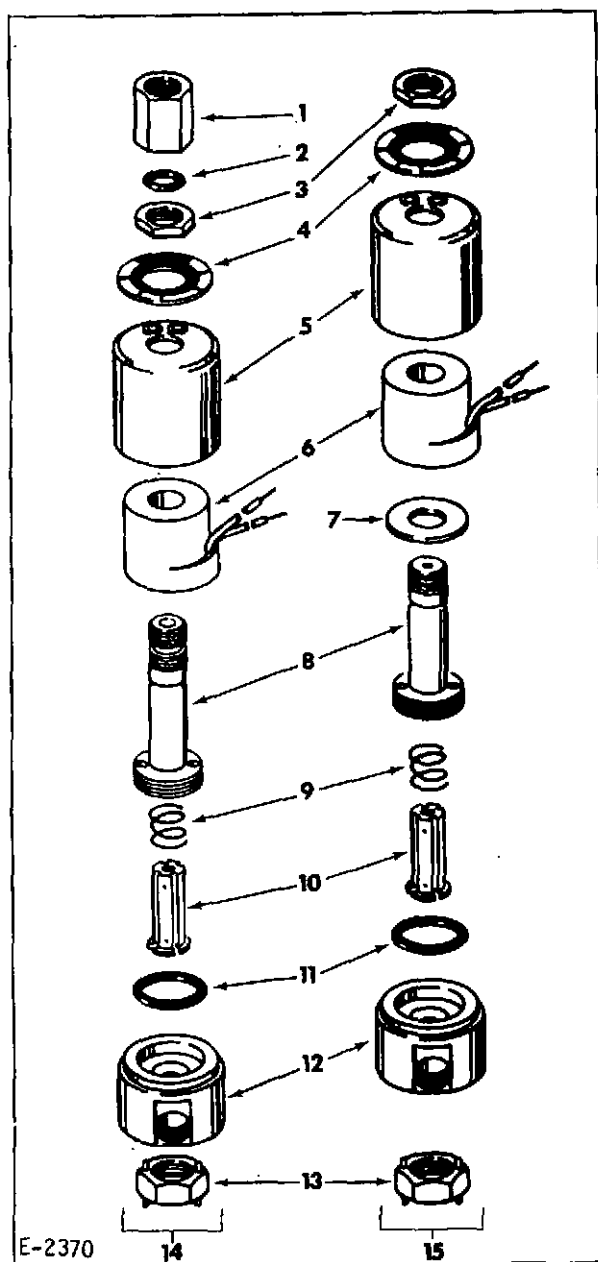

E-2370

1. Sleeve adaptor
2. Seal
3. Housing nut
4. Name plate
5. Housing
6. Coil
7. Insulating washer
8. Sleeve adaptor
9. Plunger spring
10. Plunger
11. Seal
12. Body
13. Spanner wrench
14. Oil outlet solenoid
15. Oil inlet solenoid

Figure 38. Lubricating Oil Solenoid Valves

16000H 16000MKII 17000MKII  
21000MKII 25000MKII

Eliminate any leaks at the oil line fittings by tightening only enough to stop the leak. Tighten the reservoir center bolt to 25 to 30 lb-ft (34 to 41 Nm) to stop leaks at cover.

#### b. Solenoids

The inlet opening in the solenoid is marked "P" and the outlet opening is marked "A".

Check the solenoid valves for proper operation by energizing them and listening for the sound of the valve opening or closing. Absence of the click indicates a faulty operating solenoid valve. Check for open-circuited or grounded coil, broken lead wires or connectors, burned out coil, or low voltage to the solenoid.

If it is suspected the plunger (Fig 38, Item 10) is sticking in the sleeve adaptor (8) disassemble, clean, and assemble using the solenoid manufacturer's spanner wrench (13).

#### K. FUEL SOLENOID SHUTOFF VALVE

##### 1. General (Figs 39 and 40)

The fuel shutoff valve is of brass construction and designed for installation in the fuel supply line at its entrance into the fuel injection pump.

NOTE: The valve must be installed according to the arrow or flow marking on the valve body.

The fuel valve is provided with a coil designed for continuous duty service. When the solenoid is energized for a long period the solenoid becomes hot and can be touched only for an instant. This is a safe operating temperature. Any excessive heating will be indicated by the smoke and odor of burning coil insulation.

The fuel shutoff valve is normally closed and when the solenoid is energized the valve opens, allowing fuel to enter the fuel injection pump.

While the engine is in operation the valve can be de-energized by the safety device or devices, due to overheated coolant and/or engine overspeed and/or low lubricating oil pressure. When de-energized, the valve is closed and stops the flow of fuel to the injection pump.

##### 2. Maintenance

It is not necessary to remove the valve

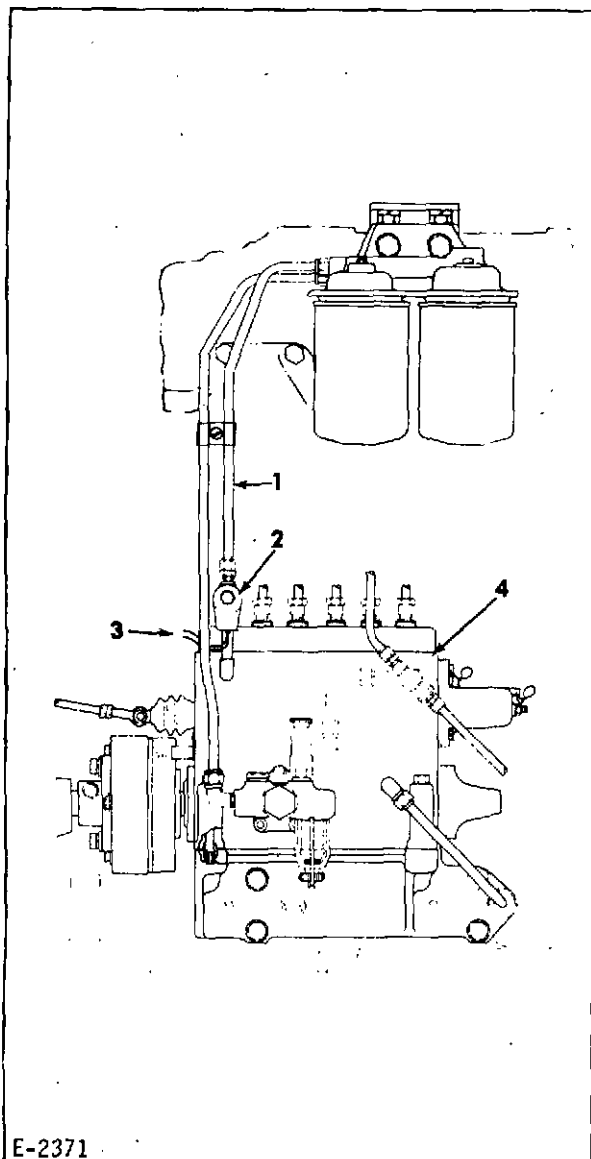

1. Fuel supply tube
2. Fuel solenoid valve
3. Solenoid valve leads
4. Fuel injection pump

Figure 39. Fuel Solenoid Shutoff Valve

from the fuel pump for repairs. Before working on the valve, shut off the engine and close the shutoff valve on the fuel tank if the tank or the fuel level in the tank is above the level of the fuel solenoid shutoff valve.

A periodic cleaning of the solenoid valve is recommended. The time between cleanings will vary, depending upon the type of operating conditions. Sluggish solenoid valve operation or excessive leakage will indicate that cleaning is required.

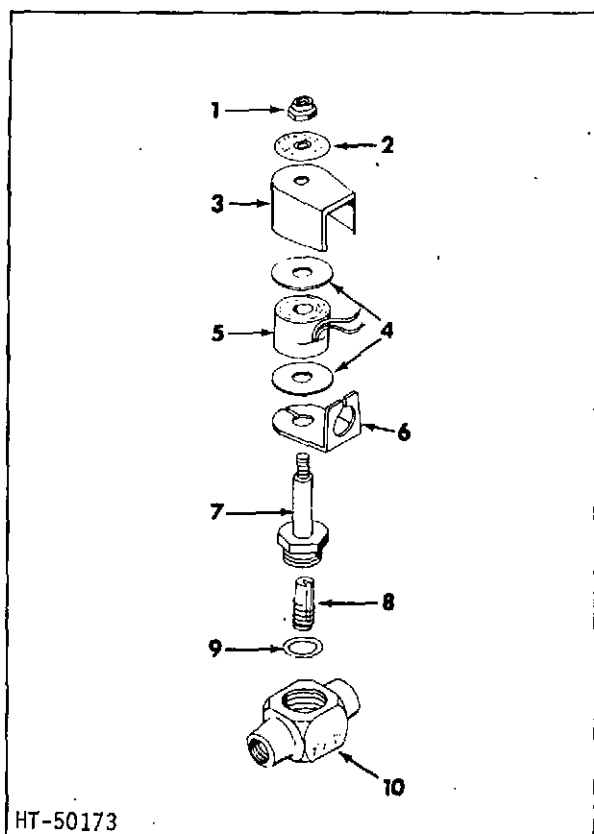

1. Cap nut
2. Nameplate
3. Housing assy.
4. Insulating washers (omitted when molded coil is used)
5. Coil
6. Housing base plate
7. Solenoid base assy.
8. Core spring assy.
9. Solenoid base gasket
10. Valve body

Figure 40. Fuel Solenoid Valve Details

a. Improper Operation

- (1) Faulty Control Circuit. Check the electrical system by energizing the solenoid. A metallic click signifies the solenoid is operating. Absence of the click indicates loss of power. Check for open-circuited or grounded coil, broken lead wires or defective lead connectors.
- (2) Burned Out Coil. Check for open-circuited coil. Replace if necessary.
- (3) High or Low Voltage. Check voltage across the coil leads with a voltmeter. Voltage must be between 85% and 110% of nameplate rating.
- (4) Incorrect Pressure. Check valve pressure. Pressure to valve must be within the range specified on the nameplate.

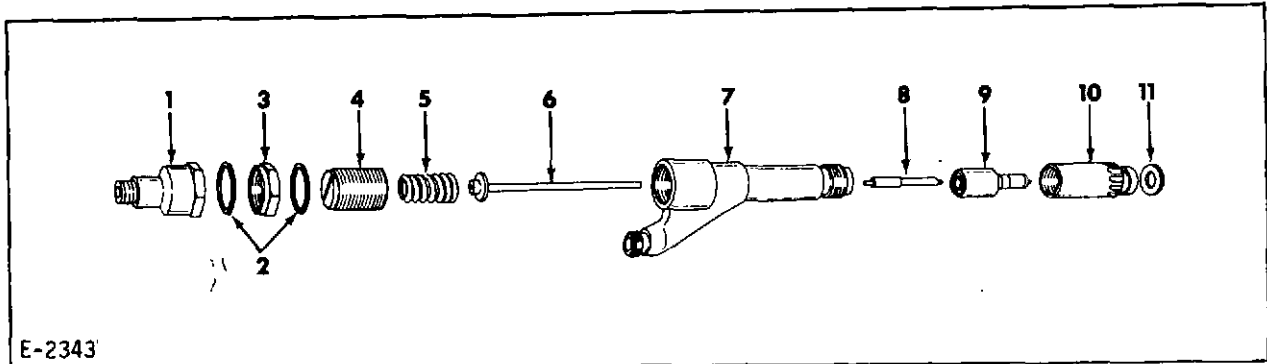

E-2343

- |                                     |                             |                          |
|-------------------------------------|-----------------------------|--------------------------|
| 1. Protection cap                   | 4. Pressure adjusting screw | 8. Nozzle valve          |
| 2. Gasket                           | 5. Spindle spring           | 9. Nozzle valve body     |
| 3. Pressure adjusting screw locknut | 6. Spindle                  | 10. Nozzle retaining nut |
|                                     | 7. Holder body              | 11. Nozzle holder gasket |

Figure 41. Fuel Injection Nozzle-Holder Assembly

- (5) Excessive Leakage. Disassemble valve and clean all parts. Replace any parts that are worn or damaged.

b. Disassembly and Reassembly

**CAUTION:** Remove valve seat, located in valve body, only when absolutely necessary.

With engine shut off, disconnect the coil lead wires from the engine wiring; remove tube assembly and remove the base assembly (with solenoid intact). The internal parts are then accessible as shown in Figure 40. However, if a new valve seat is assembled, use pipe compound on the threads and remove the excess. Tighten to 75 lb-ft (102 Nm) torque. Reassemble the valve in reverse order of the disassembly.

L. FUEL INJECTION NOZZLE HOLDER ASSEMBLY

1. General

**IMPORTANT:** The fuel injection nozzle-holder assemblies may be equipped with either a standard sac or long sac nozzle assembly, refer to Figure 41. The nozzles are not interchangeable in the same cylinder head. Long sac nozzles require a cylinder head with a smaller bore for the nozzle tip and they should never be used to replace the standard sac nozzles unless the cylinder head is also replaced or reworked.

The standard and long sac nozzle-holder assemblies (Fig 42) are identical except for the length of the sac and the location of the seat in the nozzle valve body;

therefore, all the following information applies to either nozzle-holder assembly.

Each cylinder of the engine is provided with a multi-hole, differential needle, hydraulically-lifted fuel injection nozzle-holder assembly. The function of each fuel injection nozzle-holder is to direct the metered quantity of fuel, received from the fuel injection pump, into the corresponding combustion chamber of the engine in a highly atomized, pre-determined spray pattern and in such a manner as to produce the most efficient engine performance. Each fuel injection nozzle-holder (Fig 41) consists of two assemblies; the holder assembly and nozzle assembly. The holder assembly is used to hold the nozzle in its correct position in the cylinder head and to provide a means of conducting fuel, received from the fuel injection pump, to the nozzle. The holder assembly consists of a holder body (7), spindle (6), spindle spring (5), pressure adjusting screw (4), adjusting screw locknut (3), protection cap (1), and a nozzle retaining nut (10).

Both the standard and long sac nozzles consist of a nozzle valve (9), and a nozzle valve body (10) in which is located four equally spaced spray orifices .475 mm (.0187") in diameter.

2. Fuel Injection Nozzle-Holder Operation

The metered quantity of fuel under pressure, delivered by the fuel injection pump, enters the fuel inlet passage of the nozzle-holder, passes through the holder fuel duct into the nozzle fuel duct via the annular groove in the nozzle body, and then into the pressure chamber above the nozzle valve seat. At the in-

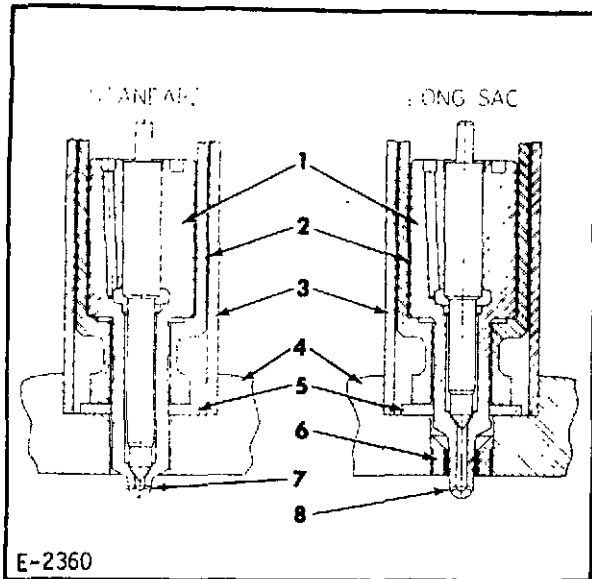

- |                         |              |
|-------------------------|--------------|
| 1. Nozzle assembly      | 5. Gasket    |
| 2. Nozzle retaining nut | 6. Insert    |
| 3. Nozzle-holder sleeve | 7. Short sac |
| 4. Cylinder head        | 8. Long sac  |

Figure 42. Standard and Long Sac Fuel Injection Nozzle Assemblies

stant the pressure of the fuel in the pressure chamber exceeds the pressure exerted on the spindle and the nozzle valve is lifted off its seat and the fuel is forced through the orifices in the end of the valve body and into the corresponding combustion chamber of the engine. The nozzle valve is returned to its seat by the pressure exerted by the spindle spring as soon as the fuel injection pump has ceased to deliver fuel to the nozzle-holder.

### 3. Maintenance

After approximately 4000 hours of normal service, the fuel injection nozzles should be removed, cleaned, tested, and the nozzle must be adjusted to an opening pressure of 4100-4150 psi (28 268-28 613 kN/m<sup>2</sup>).

### 4. Fuel Injection Nozzle-Holder Removal

- Thoroughly clean the valve rocker covers and the surrounding area.
- Remove the valve rocker cover capscrews, capscrew sealing washers, and rocker covers.
- Disconnect and remove the fuel return manifold.
- Using a fuel injection tube nut wrench (Fig 43), loosen the injection tube nuts from the top of the fuel injection nozzles.

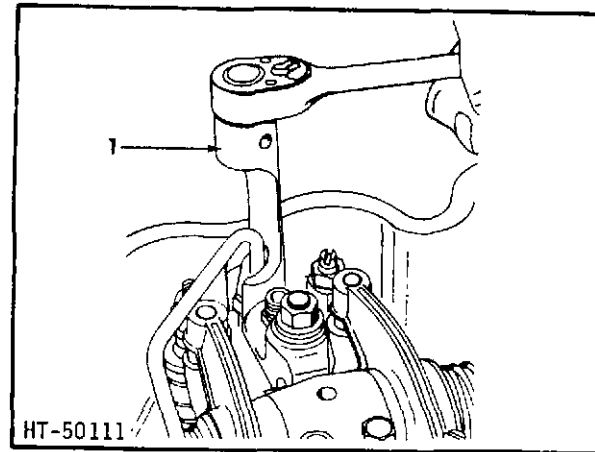

- Injection tube nut wrench

Figure 43. Removing Fuel Injection Tube

- Loosen the fuel injection tube nuts from the fuel line connectors.

**CAUTION:** Do not bend the lines during the removal. Cover all openings immediately to prevent the entrance of dirt or other foreign material.

- Free the injection nozzle end of the tubes and remove the tubes from the engine.
- Remove the nut and washer that secure the nozzle holder clamps, and remove the clamps.
- Using a small pry bar, pry upward on the nozzle protection cap. Pull the nozzles from the cylinders.

**CAUTION:** Do not permit the nozzle tip to contact a hard object or surface which could result in damage to the tip.

- Cover the openings in the cylinder heads to prevent the entrance of dirt.

### 5. Testing and Adjusting the Fuel Injection Nozzle-Holder

To test and properly adjust the fuel injection nozzles, use a nozzle tester similar to the one illustrated in Figure 44.

**WARNING:** KEEP HANDS CLEAR OF THE NOZZLE TIP WHEN TESTING; THE FINELY ATOMIZED FUEL IS EJECTED WITH SUFFICIENT FORCE TO PENETRATE THE SKIN AND CAUSE BLOOD POISONING!

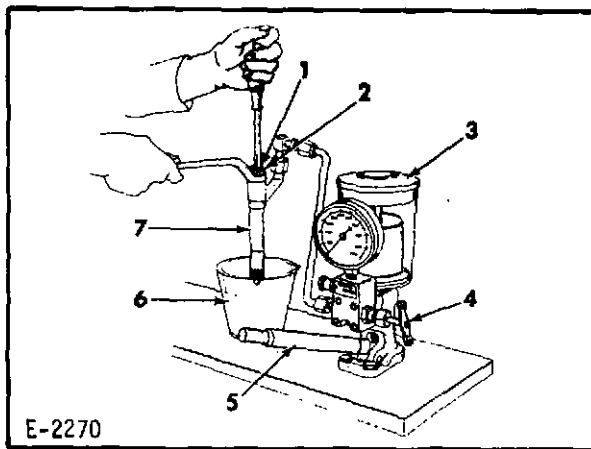

1. Pressure adjusting screw
2. Adjusting screw locknut
3. Nozzle tester
4. Valve handle
5. Tester handle
6. Spray collector
7. Nozzle-holder assembly

Figure 44. Adjusting Nozzle Opening Pressure

Test and adjust each nozzle as follows:

- a. Secure the base of the nozzle tester to a work bench.
- b. Open the nozzle tester valve. Loosen the filler cap to prevent an air lock from forming. Operate the tester handle until fuel flows from the tester fuel line. Close the valve.
- c. Connect the fuel injection nozzle to be tested to the tester. Place the spray collector under the valve end of the nozzle under test.
- d. Open nozzle tester valve. Operate tester handle and observe tester pressure gauge. Nozzle under test should "pop" at 4100-4150 psi (28 268-28 613 kN/m<sup>2</sup>).
- e. Refer to Figure 41 and adjust the fuel injection nozzle to pop at the specified pressure as follows:
- f. Remove the protection cap from the upper end of the fuel injection nozzle and loosen the adjusting screw locknut.
- g. Operate tester handle and turn adjusting screw until the proper popping pressure is obtained. Turn the adjusting screw in to increase the popping pressure; turn the screw out to decrease the popping pressure. When

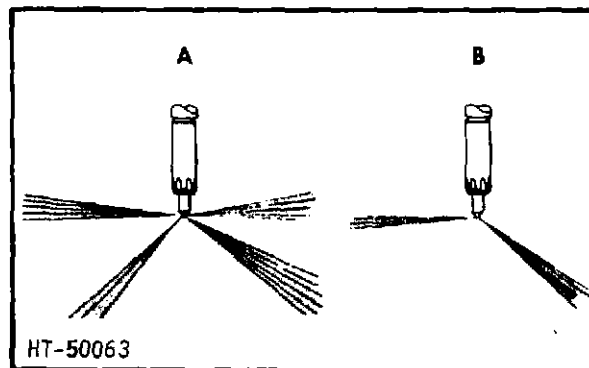

- A. Acceptable spray pattern
- B. Non-acceptable spray pattern

Figure 45. Nozzle Spray Patterns

the proper pressure is obtained, prevent the adjusting screw from turning and tighten adjusting screw locknut to 75 lb-ft (102 Nm).

- h. Dry the tip of the fuel injection nozzle. Test for leakage by operating the tester handle until the pressure gauge indicates approximately 3900 psi (26 889 kN/m<sup>2</sup>) (200 psi (1379 kN/m<sup>2</sup>) below the popping pressure). Observe the tip of the nozzle for indications of leakage. If no leakage is observed, the nozzle valve is properly seated. If leakage is observed, relieve the pressure by loosening one of the line nuts and remove the valve and valve body for cleaning and inspection.
- i. If the fuel injection nozzle proved satisfactory when subjected to the leakage test, operate the tester handle at a speed of approximately 100 strokes per minute and observe the spray pattern.

**WARNING: KEEP HANDS CLEAR OF THE NOZZLE TIP WHEN TESTING; THE FINELY ATOMIZED FUEL IS EJECTED WITH SUFFICIENT FORCE TO PENETRATE THE SKIN AND CAUSE BLOOD POISONING!**

- j. The nozzle tip has four equally spaced holes. The size and spacing of these holes determines the spray pattern. The spray pattern is considered proper when fuel is being discharged evenly through all four holes (Fig 45). If the spray pattern is not acceptable, remove the nozzle and clean the orifices with the cleaning wire (Fig 46).

- k. Install the nozzle holder protection

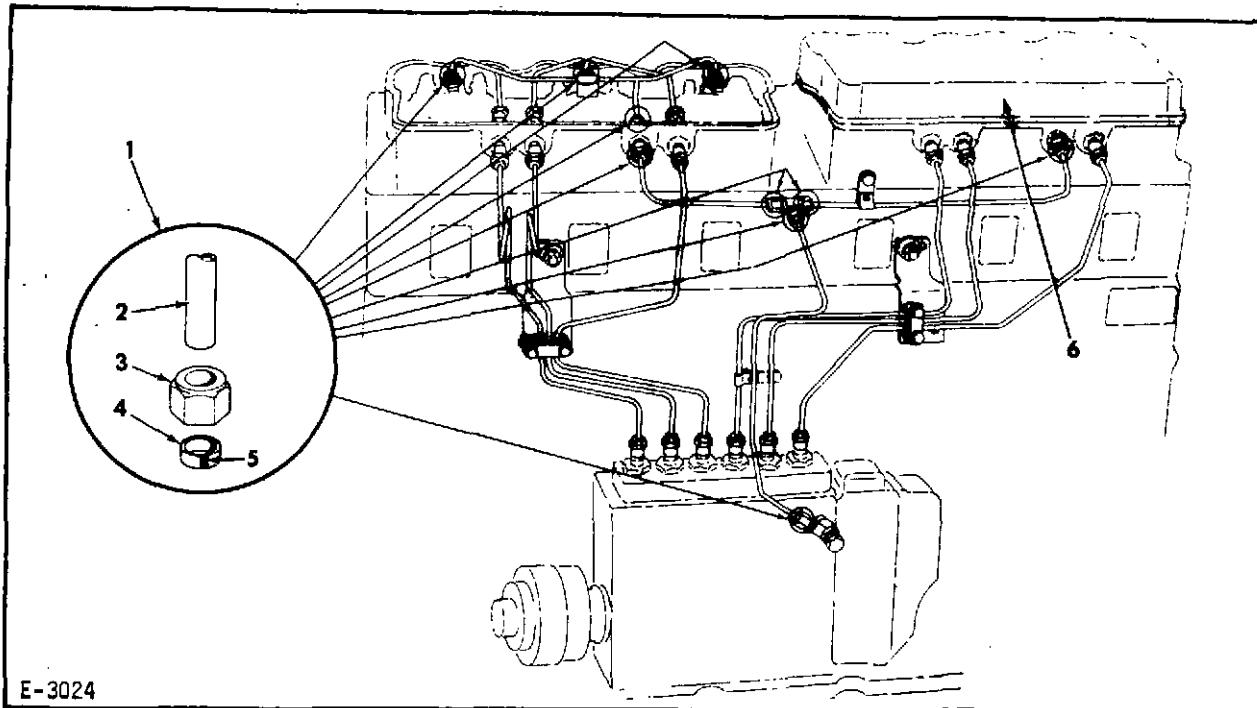

- E-3024
- |  |   |   |
|--|---|---|
| <p>1. Locations of high temperature type sealing sleeves</p> <p>2. Fuel return manifold</p> <p>3. Tube nut</p> | <p>4. Tube sealing sleeve</p> <p>5. Red strip denotes high temperature material in sealing sleeve</p> | <p>6. Internal tube sealing sleeve locations same as front head</p> |
|--|---|---|

Figure 45A. Location of High Temperature Sealing Sleeves

cap and tighten it to 75 lb-ft (102 Nm).

6. Cleaning and Inspection of Fuel Injection Nozzle-Holder Assembly

Should a fuel injection nozzle holder assembly require tear down for cleaning and inspection, it is recommended that the assembly be returned to your Allis-Chalmers dealer, who has the facilities and proper equipment to perform this service.

7. Installation of Fuel Injection Nozzle-Holder Assembly

- a. Remove and discard the nozzle holder gasket. Thoroughly clean the inside of the nozzle holder sleeves before installing the nozzle holder. Make sure that no small particles of carbon are present in the sleeve. Such particles may prevent the nozzle holder gasket from seating properly, thereby permitting "blow-by" from the cylinder.

- b. Place a new nozzle-holder gasket in position on the nozzle-holder with convex (rounded) face toward the nozzle retaining nut. Carefully insert the nozzle holder into the injection nozzle sleeve in the cylinder head.

**CAUTION:** The sealing sleeves (Fig 45A) of the fuel return manifolds and tubes are made of a material to be used in location where high temperatures exists. This sealing sleeve is identified by a red stripe. Experience indicates the sealing sleeve is damaged when the line nut is backed off. Replace these sealing sleeves each time the line nuts are loosened or removed, especially those on the internal connections of the fuel return manifold which would dilute the engine oil if they leaked fuel oil into the crankcase.

- c. Install the nozzle holder clamp and the washer and nut for each nozzle. Do not tighten. Install the fuel injection tubes, inserting one end of the tubes into the injection line connectors, and then inserting the other end into the injection nozzle holders. Start the injection tube nuts but do not tighten them. Install the fuel return

**NOTE:** When the cylinder head has been removed, it is advisable to use a carbon removing tool (Fig 47) to clean carbon deposits from the sleeves before reinstalling the cylinder head. Refer to following Paragraph M.

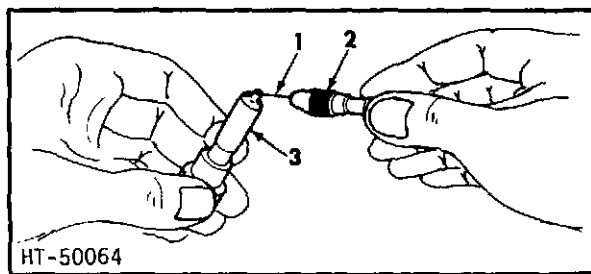

1. Cleaning wire
2. Pin vise
3. Valve body

Figure 46. Cleaning Nozzle Orifices

manifold.

- d. Tighten the nozzle holder clamp nuts to a torque of 45 lb-ft (61 Nm). Tighten the injection tube nuts and the fuel return manifold nuts.
- e. Start the engine. Inspect the fuel injection tubes and the return manifold for leaks. Correct any leaks discovered.
- f. Inspect the rocker cover gaskets, replace if necessary. Install the valve rocker covers. Install the rocker cover sealing washers and capscrews.

#### M. REMOVING CARBON FROM FUEL INJECTION NOZZLE-HOLDER SLEEVES IN CYLINDER HEADS

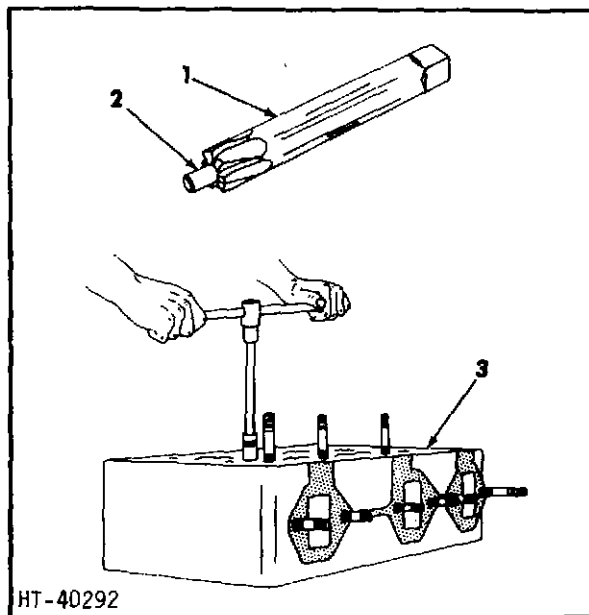

1. Fuel injection nozzle sleeve carbon removing tool
2. Pilot
3. Cylinder head

Figure 47. Removing Carbon from Fuel Injection Nozzle Sleeve

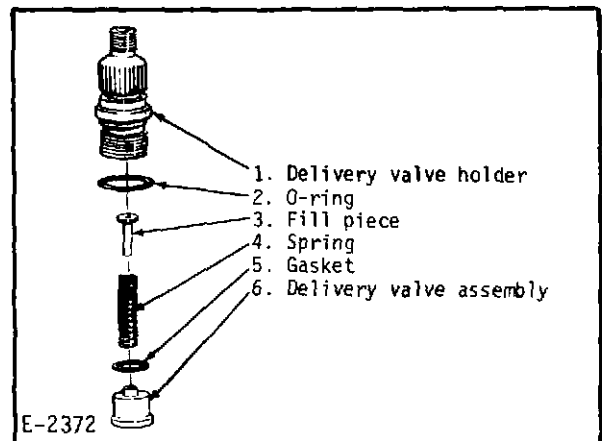

Figure 48. Delivery Valve Components

**CAUTION:** Under no circumstances should an engine be operated with a leaking or "blow-by" nozzle holder. These conditions will allow heat build up and cause distortion of the nozzle holder, resulting in serious damage.

If the cylinder head has been removed from the engine, it is advisable to remove carbon deposits from the nozzle sleeves before reinstallation. Use a tool similar to the one illustrated in Figure 47. Clean the holes in the cylinder head for the tips of the nozzles with a wire rifle type cleaning brush.

**IMPORTANT:** The carbon removing tool can be used on cylinder heads equipped with long sac nozzle assemblies and inserts (Fig 42) if the pilot at the end of the tool is removed. The pilot is a pressed fit in the tool and may be pulled out.

#### N. FLOW TIMING THE FUEL INJECTION PUMP

##### 1. General

The flow method is used to obtain precise timing of the fuel injection pump to the engine as compared to the usual method of aligning timing pointers with timing marks.

The objective of this method is to position the number 1 pump plunger so that it precisely closes off the intake port of the barrel. It is at this point that the commencement of injection occurs.

The flow method of timing consists of removing the delivery valve, subjecting the fuel gallery of the injection pump to fuel oil pressure, and rotating the pump camshaft to locate the fuel shut off point of the number 1 pump plunger. However, prior to flow timing the pump, the following must be checked:

- a. The injection pump must be securely mounted.
- b. A new delivery valve holder o-ring (Fig 48, Item 2) and copper gasket (5) must be available. These items can be used only one time and must be replaced if an adequate seal is to be maintained in the pump.
- c. A properly functioning hand primer pump or another suitable means of applying pressure to the fuel oil in the pump gallery must be available.

## 2. Procedure

The following procedure is to be used when using the flow timing method.

- a. Position the engine crankshaft so that the flywheel is at the specified timing degree mark when the number 1 piston is on the compression stroke.
- b. Remove the screws securing the top cover of the injection pump and raise the cover up around the injection lines as far as possible. Clean all external surfaces of the injection pump, including lines, delivery valve holders, and exposed side of pump.
- c. Temporarily return the top cover to its original position and remove the number 1 cylinder nozzle holder injection line.
- d. Remove the delivery valve holder (1) from the injection pump. Be sure to remove all pieces of the destroyed delivery valve holder o-ring (2).
- e. Remove the fill piece (3), spring (4), delivery valve gasket (5), and delivery valve assembly (6) from the top of the barrel and plunger assembly. The delivery valve gasket may remain within the delivery valve holder when it is removed from the injection pump.
- f. Remove the fluted delivery valve from the delivery valve body and reinstall the delivery valve body, old gasket, and delivery valve holder. Tighten delivery valve holder securely. Care must be taken when handling the delivery valve as its surfaces are mated with the valve body.
- g. Loosen the capscrews (Fig 9, Item 9) securing the injection pump coupling hub clamp (8) to the coupling flange; place the stop lever in the run position; place the speed control lever in the high speed position; then turn the injection pump coupling clockwise several degrees. Direction of rotation is determined by viewing from the pump drive end.
- h. While operating the hand primer pump, rotate the injection pump camshaft counterclockwise in very small increments. As the number 1 plunger in the injection pump starts to close off the fuel intake port of the barrel, the volume of fuel flowing from the delivery valve holder will be reduced.  
  
Continue turning the pump camshaft counterclockwise until the fuel stops flowing. At the time when the fuel stops flowing, there will be a bulge of fuel on top of the delivery valve holder. Wipe off this bulge of fuel while continuing to operate the primer pump. If the bulge of fuel appears again, it indicates the fuel inlet port in the barrel is not completely closed. A very slight rotation of the pump camshaft will now cause the plunger to close the inlet port. When the inlet port is completely closed, the bulge of fuel will not appear and the fuel will remain level with the top of the delivery valve holder. At this point the FPI (Fuel Pump Injection) mark on the pump coupling will align with the pointer on the injection pump, indicating proper timing of the pump to the engine.
- i. Repeat step h several times to assure the number 1 plunger of the injection pump is properly positioned to close off the inlet port when the pump timing marks are aligned.
- j. Securely tighten the hub clamp to injection pump coupling flange retaining capscrews. To be positive the injection pump is properly timed to the engine, bar it over two revolutions in the direction of engine rotation. On the second of the two revolutions the number 1 piston will again be on the compression stroke. When the crankshaft reaches approximately 40 degrees BTDC start operating the primer pump. Fuel should flow from the delivery valve holder. Continue to turn the crankshaft until it reaches the specified timing degree mark on the flywheel. At this point fuel should stop flowing from the delivery valve holder. If fuel continues to flow with the crankshaft at the specified timing degree mark, the injection pump is not properly timed to the engine and steps g and h must be repeated.
- k. After the injection pump is properly timed to the engine, remove the delivery valve holder, copper gasket, and delivery valve body from the injection pump. Wash all components in fuel oil before reassembly in the injection pump. Start the reassembly by

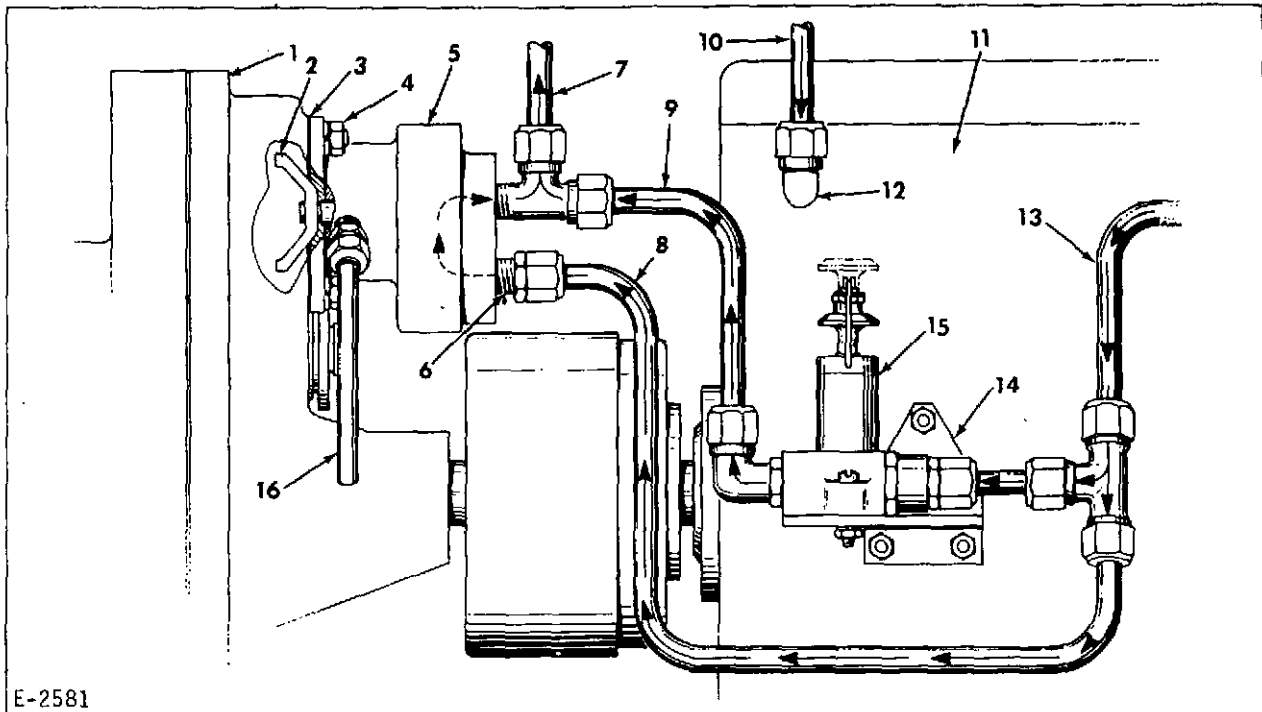

E-2581

- |                             |                             |                             |
|-----------------------------|-----------------------------|-----------------------------|
| 1. Accessory drive assembly | 7. Tube - to fuel filter    | 12. Restrictor elbow 0.093" |
| 2. Coupling fork            | 8. Tube - from fuel tank    | (2.39 mm)                   |
| 3. Gasket                   | 9. Tube - from hand primer  | 13. Tube - from fuel tank   |
| 4. Nut and lockwasher       | 10. Tube - from fuel filter | 14. Bracket and cover       |
| 5. Fuel transfer pump       | 11. Injection pump          | 15. Hand primer pump        |
| 6. Connector                |                             | 16. Drain tube              |

Figure 49. Optional Gear Type Fuel Oil Transfer Pump

placing the delivery valve into the delivery valve body and positioning this assembly on top of the plunger and barrel assembly.

Next place a new copper gasket on top of the delivery valve assembly, and insert the fill piece into the spring and position this assembly on top of the delivery valve assembly with the piece to the top. Lubricate the new O-ring and position it on the delivery valve holder. Screw the delivery valve holder into the injection pump and tighten to 50-65 lb-ft (68-75 Nm) torque. Secure the top cover to the injection pump with the retaining screws, connect the high pressure injection line to the delivery valve holder and tighten the line nut securely.

The pump and engine have now been accurately timed together by use of the flow timing method.

#### 0. OPTIONAL GEAR TYPE FUEL OIL TRANSFER PUMP

##### 1. General

The standard fuel supply and hand primer pump located on side of the injection pump has a maximum lift of 3 ft (91 cm). If the fuel must be lifted a greater distance, it is necessary to replace it with an optional equipment gear type fuel oil transfer pump, which has a maximum lift of 20 ft (610 cm) and a hand primer pump which due to its construction also acts like a check valve allowing the fuel to only flow in one direction.

The fuel is drawn from the fuel tank by the transfer pump (Fig 49, Item 5) and forced through the fuel filters (standard filters Figure 3 only) and to the fuel sump of the injection pump.

NOTE: The elbow (Figure 49, Item 12) at the fuel inlet of the injection pump is

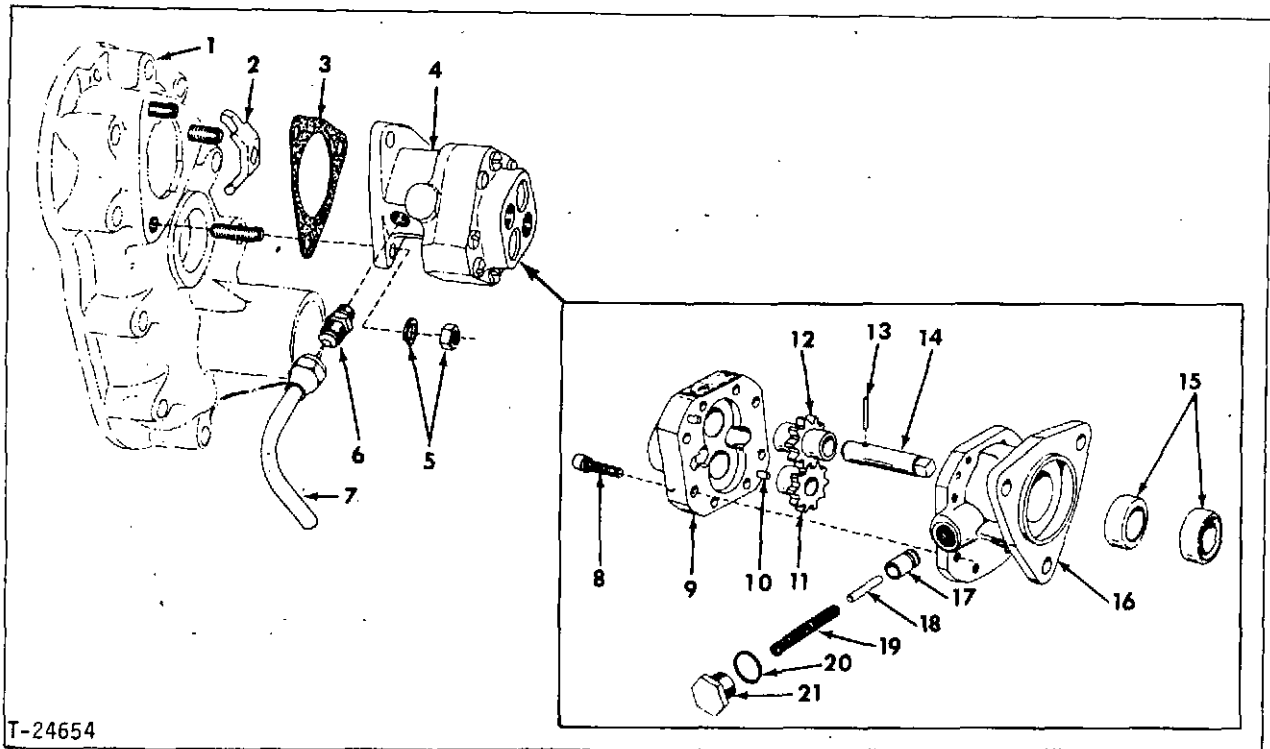

T-24654

- |                             |                  |                             |
|-----------------------------|------------------|-----------------------------|
| 1. Accessory drive assembly | 8. Bolt          | 15. Shaft seals             |
| 2. Coupling fork            | 9. Housing       | 16. Stator                  |
| 3. Gasket                   | 10. Dowel        | 17. Pressure relief plunger |
| 4. Fuel oil transfer pump   | 11. Driven gear  | 18. Spring guide            |
| 5. Nut and lockwasher       | 12. Driving gear | 19. Spring                  |
| 6. Connector                | 13. Pin          | 20. Gasket                  |
| 7. Drain tube               | 14. Shaft        | 21. Plug                    |

Figure 50. Gear Type Fuel Oil Transfer Pump Mounting and Details

NOTE (cont): fitted with a restrictor having a 0.093" (2.39 mm) orifice.

The fuel transfer pump is driven at 2 times engine speed by a coupling fork (Fig 50, Item 2) which fits into slots of the upper gear of the accessory drive assembly (1).

The transfer pump is provided with a spring loaded, plunger-type pressure relief valve (17 thru 21). The pressure relief valve bypasses fuel back to the inlet side of the transfer pump when the outlet pressure exceeds 47 to 60 psi (324 to 414 kN/m<sup>2</sup>). This valve normally does not open since its purpose is to relieve excessive pressure in case clogging occurs in the fuel filter or fuel lines.

The area between the shaft seals (15) in the stator (16) is connected to a drain tube (7). This tube is known as a "tell tale tube" and excessive fuel leaking from it indicates the seals are leaking.

The seals, shaft, gears, and relief valve parts are the only serviceable items. The pump stator and housing are not serviceable and if worn or damaged they must be replaced with a new pump assembly.

## 2. Removal Of Fuel Transfer Pump

If it becomes necessary to repair or replace the pump, it may be removed as follows:

- a. Disconnect fuel lines (Fig 49, Items 7, 8, and 9) from the pump.
- b. Remove the nuts and lockwashers (Fig 50, Item 5) attaching the pump to the accessory drive assembly (1) and remove the pump and fork as an assembly.
- c. Remove fork (2) from pump.
- d. Remove gasket (3) from pump.

### 3. Disassembly Of Fuel Transfer Pump

The pressure relief valve assembly may be removed from the pump stator, without disassembly of the other parts of the pump, by removing the pressure relief spring plug (21) and jarring the valve parts from the stator (16).

If the relief valve only is to be inspected, no further disassembly is necessary. If the pump is to be disassembled proceed as follows:

- a. Remove the screws attaching the pump housing to the stator and install capscrews 1/4" NC x 3" (76.2 mm) long, so that the heads of the capscrews extend out from the pump housing.
- b. Holding the pump assembly in the hand, tap the heads of the capscrews with a soft hammer, separating the stator (16) and housing (9).

CAUTION: Do not pry the stator and housing apart.

- c. Remove the pump driven gear (11).
- d. Remove the pump shaft (14) and driving gear (12) from the stator (16), using care to prevent damage to the pump shaft seals (15).
- f. If it is necessary to remove the shaft seals, drive or press the seals out of the stator.

### 4. Inspection Of Fuel Supply Pump Parts

- a. Wash all the parts in clean fuel or solvent and inspect them carefully. New shaft seals should be installed when the pump is reassembled.
- b. Inspect the pump gears. If the gears are slightly worn on the involute surfaces, they should be replaced. If the pump is operated until an appreciable amount of wear is noticeable, the delivery capacity of the pump will be affected. The shear pin (13) holding the driving gear to the pump shaft (14) must be tight. Replace any worn or damaged parts.
- c. Check the fit of the gear hubs in the bores of the stator and housing. If the stator and housing are worn or scored, the entire pump must be replaced.
- d. Inspect the surfaces inside the stator and housing contacted by the gear

faces. If the surfaces show excessive wear or are scored, the entire pump must be replaced.

- e. Check the pressure relief valve plunger (17). If the plunger does not form a tight seal on its seat in the stator, lap the plunger and seat using fine grind lapping compound. A piece of wood about the size of a pencil may be used as a holder for the lapping. Use only a small amount of compound so that only the seat of the plunger and the seat in the stator is lapped. Thoroughly wash all the lapping compound and foreign material off the plunger and out of the stator after lapping. It is recommended that a new plunger spring be used when the valve is reassembled.

### 5. Assembly Of Fuel Transfer Pump

- a. Install a pump shaft seal in the stator, with the sealing lip of the seal directed toward the pump housing end of the stator. Install the other shaft seal in the stator with the sealing lip of the seal directed toward the mounting flange end of the stator.
- b. Lubricate the pump driving gear shaft and seals and install the pump shaft (with driving gear pinned in place) in the stator. Push the shaft through the seals using care not to damage the sealing lips.
- c. Install the driven gear in place in the housing. Lubricate the gears with light engine oil.
- d. Coat the mating machined surfaces of the stator and the pump housing with a commercial non-hardening sealing compound.

CAUTION: Do not allow any sealing compound inside the pump. Place the pump housing in position on the stator, turn the pump shaft to mesh the gear teeth, and push the parts together. Install the attaching screws with lockwashers and tighten securely.

- e. Turn the pump shaft and test it for bind. The shaft should turn smoothly, with a slight drag, but should not bind or have tight spots.
- f. Lubricate and install the pressure relief valve parts, making certain that the parts are installed in their proper sequence.

## 6. Installation Of Fuel Supply Transfer Pump

Install the pump on the accessory drive assembly by reversing the removal procedure, making certain that the gasket used between the pump and the accessory drive is in good condition. Be sure the coupling fork used to couple the pump driving gear shaft to the drive assembly gear is in good condition and properly installed.

## 7. Hand Primer Pump

The main function of the hand primer pump is to force air from the fuel system which enters when the engine runs out of fuel, the fuel filters are renewed, or from servicing the injection pump.

### a. Disassembly

- (1) Unscrew the clamp screw (Fig 51 Item 13) and swing clamp wire off plunger (11).
- (2) Spread clamp wire (12) ends to disengage from body (1). Remove plunger (11), guide (9), and piston seal (8), and retaining cap (10) as an assembly.
- (3) Place body (1) in a soft-jaw vise and remove nut (6), seal ring (5), valve seal (4), upper valve (7), spring (3), second valve (7), and valve gasket.

NOTE: Hand primer pumps of early manufacture had paper gaskets instead of current type valve gasket (2) and the valve seal (4). If the valve nut is reusable, replace it using paper gasket.

### b. Inspection

- (1) Examine valve gaskets for tears and replace as needed. Check piston seal (8) on bottom of plunger (11) for damage, and replace if necessary. Check for foreign matter in valves (7) and body (1).
- (2) If rubber plunger guide (9) is worn, cut it for removal from plunger (11).

### c. Assembly

- (1) Position retaining cap (10) on plunger (11). Using clean grease to lubricate, slip plunger guide (9) onto plunger with the chamfered side down. Position piston seal (8) on end of plunger.

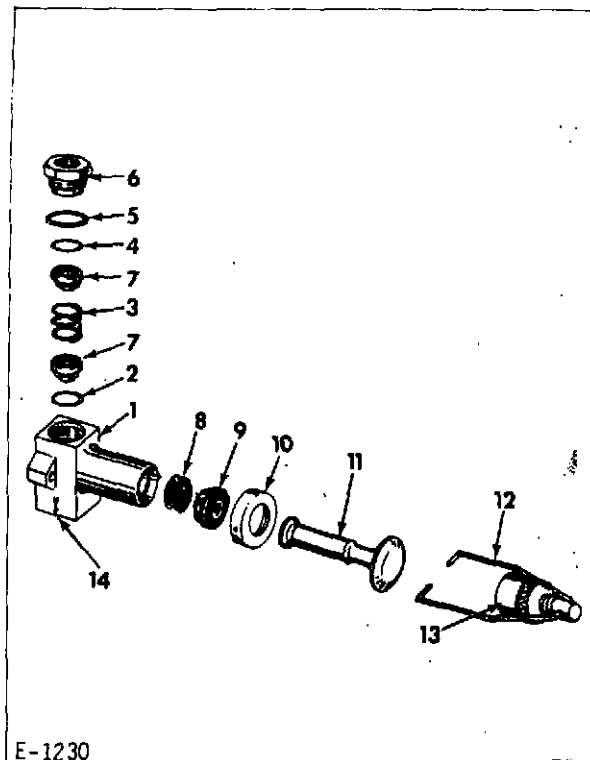

E-1230

- |                        |                            |
|------------------------|----------------------------|
| 1. Body                | 8. Piston seal             |
| 2. Valve gasket        | 9. Plunger guide           |
| 3. Spring              | 10. Retaining cap          |
| 4. Valve nut seal      | 11. Plunger                |
| 5. Valve nut seal ring | 12. Clamp                  |
| 6. Valve nut           | 13. Clamp screw            |
| 7. Valve               | 14. Direction of fuel flow |

Figure 51. Hand Primer Pump

- (2) Assemble lower valve gasket (2) in pump body (1). The two valves (7) are identical; place one of them in the body followed by the valve spring (3) and the second valve. Make certain the valves are positioned in the direction of the arrow (14) on the side of the pump body.
- (3) Assemble valve nut seal (4) valve nut seal ring (5), and valve nut (6). Tighten nut securely.
- (4) Assemble plunger with piston seal, and plunger guide in pump body.
- (5) Align holes in plunger retaining cap with holes in body. Spread clamp wire ends and insert them in cap and body.
- (6) Position clamp over plunger and tighten clamp screw.

## 8. Priming Fuel System

It is necessary to prime the fuel system to force the air from it whenever new fuel filters are installed or the engine runs out of fuel.

The design of the hand primer pump (Fig 49, Item 15) includes a check valve feature at its inlet which prevents fuel from returning to the tank when it is subjected to the force of the primer plunger.

### a. Priming Low Pressure System

- (1) If engine ran out of fuel, fill fuel tank. If fuel tank is equipped with a fuel shutoff valve, make certain it is in the open position.
- (2) Loosen the connector nut and the injection pump end of the filter to injection pump tube (10).
- (3) Loosen locking screw on top of hand primer pump plunger and move clamp to one side.
- (4) Move primer plunger back and forth in a pumping motion to fill the filter with fuel and expel the air.
- (5) When flow of fuel around loosend tube is free of air bubbles, tighten the tube connector nut.
- (6) Position primer pump plunger clamp and retighten locking screw.

### b. Priming High Pressure System

The high pressure fuel system is usually self-priming due to the fact that any air trapped by the fuel injection pump plungers is forced out through the fuel injection nozzles and into the engine combustion chambers. However, in the event the fuel lines have been removed, the engine has run out of fuel, or the engine has not been operated for some time, priming of the high pressure system may be necessary to facilitate engine starting.

Priming the high pressure fuel system as follows:

- (1) Loosen connector nut attaching the upper end of each fuel injection line to its corresponding fuel line connector in the rocker cover housing.
- (2) Place the engine speed control in the high speed position.
- (3) Crank engine with the starter until fuel flows from ends of all fuel injection lines. Tighten fuel line connector nuts.

**CAUTION:** Do not use starting motor continuously for more than 30 seconds. After 30 seconds of use, pause two minutes to allow it to cool.

## TOPIC 13. LUBRICATION SYSTEM

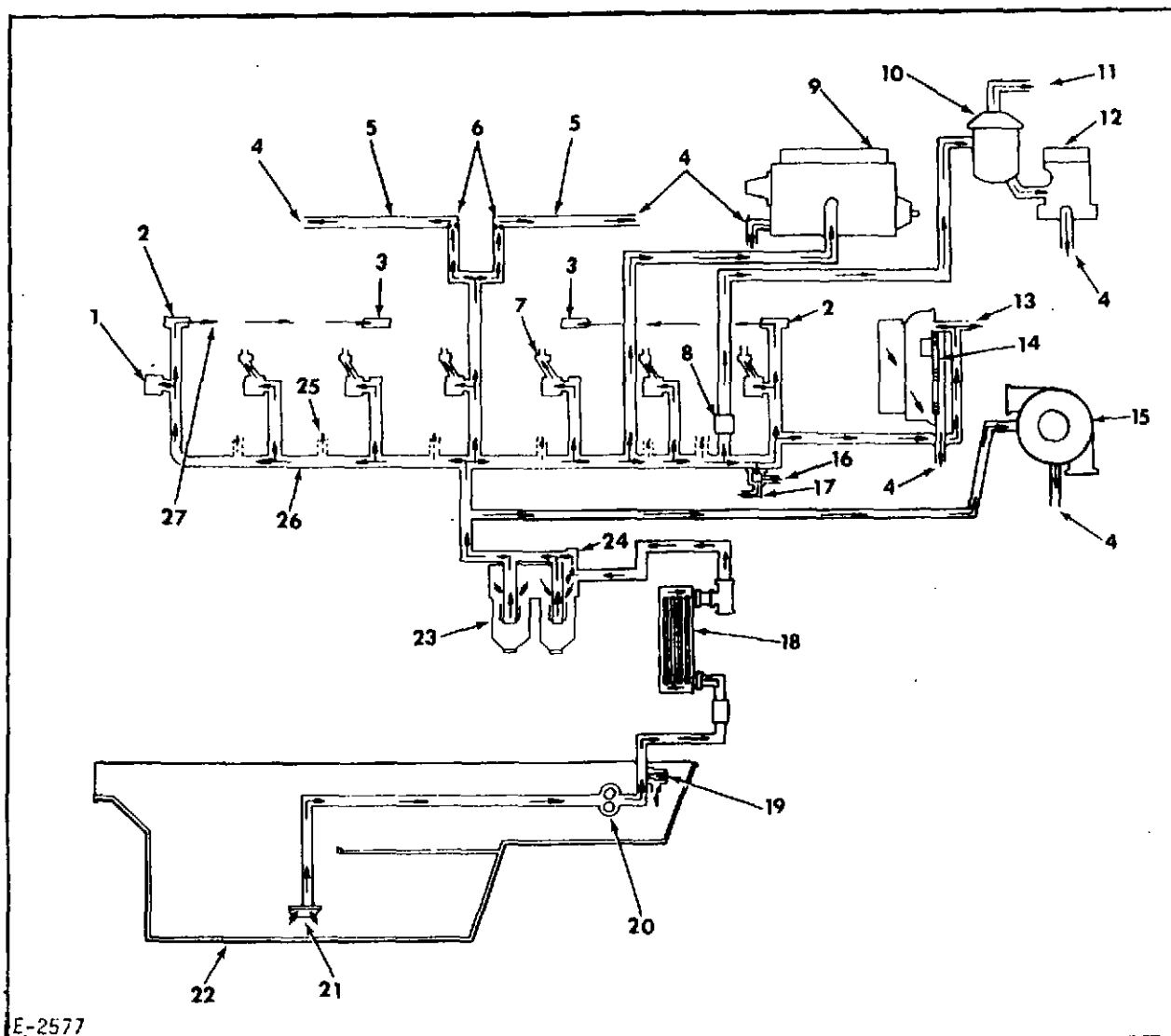

E-2577

- |   |  |
|---|--|
| 1. Main bearings  | 15. Turbocharger   |
| 2. Front and rear camshaft bearings   | 16. Oil restrictor hole (oil bleeds to timing gear housing)  |
| 3. Intermediate camshaft bearings   | 17. Oil pressure regulating valve                            |
| 4. Returns to oil pan   | 18. Engine oil cooler  |
| 5. Rocker arm shaft   | 19. Oil pump pressure relief valve                           |
| 6. Orifice in rocker arm shafts (located at numbers 3 and 4 rocker arm bracket positions) | 20. Oil pressure pump  |
| 7. Connecting rod bearings to piston pins   | 21. Suction screen   |
| 8. Check valve-line to oil reservoir  | 22. Oil pan  |
| 9. Fuel injection pump  | 23. Oil filter (full flow)                                   |
| 10. Hydraulic governor oil reservoir (optional)   | 24. Oil filter by-pass valve                                 |
| 11. Vent line-to gear housing   | 25. Piston cooling oil jets (21000 MK II & 25000 MK II only) |
| 12. Hydraulic governor  | 26. Main oil gallery   |
| 13. Drilled elbow (oil spray to timing gears)   | 27. Oil passage in camshaft                                  |
| 14. Accessory drive gears   |  |

Figure 1. Lubricating System Schematic Diagram.

16000H 16000MKII 17000MKII  
21000MKII 25000MKII

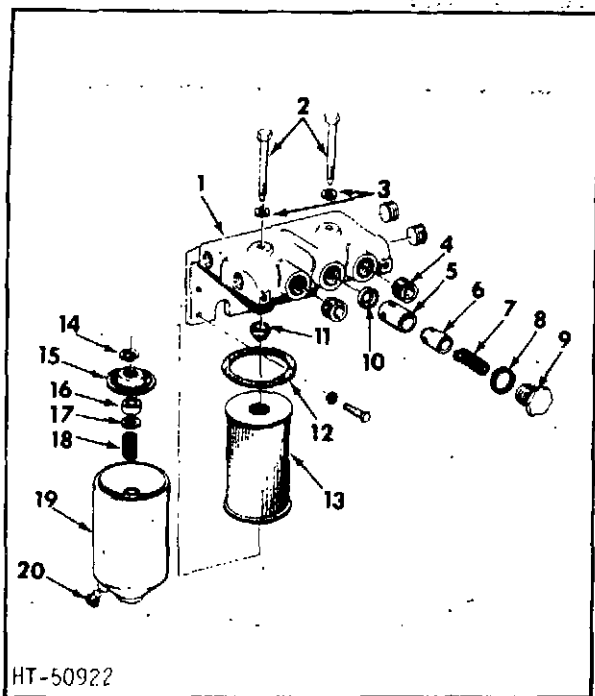

HT-50922

- |                  |                         |
|------------------|-------------------------|
| 1. Filter header | 11. Guide element       |
| 2. Center bolt   | 12. Gasket              |
| 3. Washer        | 13. Filter element      |
| 4. Plug          | 14. Snap ring           |
| 5. Sleeve        | 15. Element adaptor     |
| 6. Piston        | 16. Element seal        |
| 7. Spring        | 17. Element seal washer |
| 8. Gasket        | 18. Element spring      |
| 9. Cap           | 19. Filter body         |
| 10. Seat         | 20. Drain plug          |

Figure 2. Lube Oil Filter Details  
(Model 16000H Only)

#### A. GENERAL

The engine is pressure lubricated throughout by gear-type lubrication pump (Fig 1.). The pump is driven by its driving gear in mesh with the front crankshaft gear.

With the engine running at full throttle and at normal operating temperature, the engine oil pressure should range between 30 and 55 psi (207 and 379 kN/m<sup>2</sup>).

In addition to lubricating the moving parts of the engine, the pistons of Models 21000MKII and 25000MKII are cooled by a stream of oil directed at their undersides by jets in the main oil gallery.

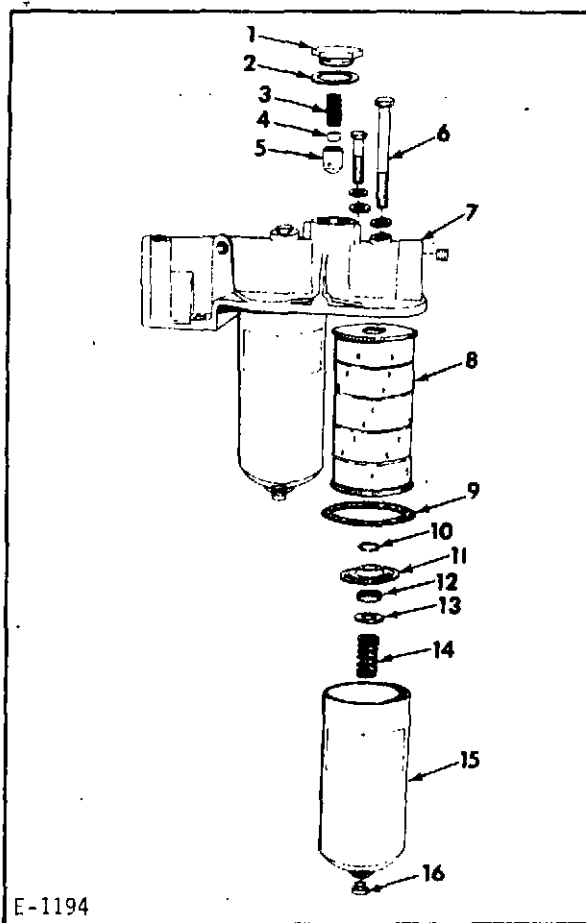

E-1194

- |                        |                         |
|------------------------|-------------------------|
| 1. Bypass valve cap    | 9. Body gasket          |
| 2. Gasket              | 10. Snap ring           |
| 3. Spring              | 11. Element adaptor     |
| 4. Spacer (Early Type) | 12. Element seal        |
| 5. Piston              | 13. Element seal washer |
| 6. Center bolt         | 14. Element spring      |
| 7. Filter header       | 15. Filter body         |
| 8. Filter element      | 16. Drain plug          |

Figure 3. Lube Oil Filter Details  
(For Engines With Dry Exhaust Manifolds)

#### B. GENERAL MAINTENANCE

The level of lubricating oil in the oil pan should be checked prior to the start of each period of engine operation. Add the specified lubricant, as necessary to raise the oil level to the FULL mark on the oil level gauge (dipstick). Refer to following subparagraph 4 in Paragraph F, covering the various types of dipsticks applied to these engines.

Once the engine has been started, check the reading on the oil pressure gauge. Shortly after starting, the gauge should indicate a pressure within the prescribed limits.

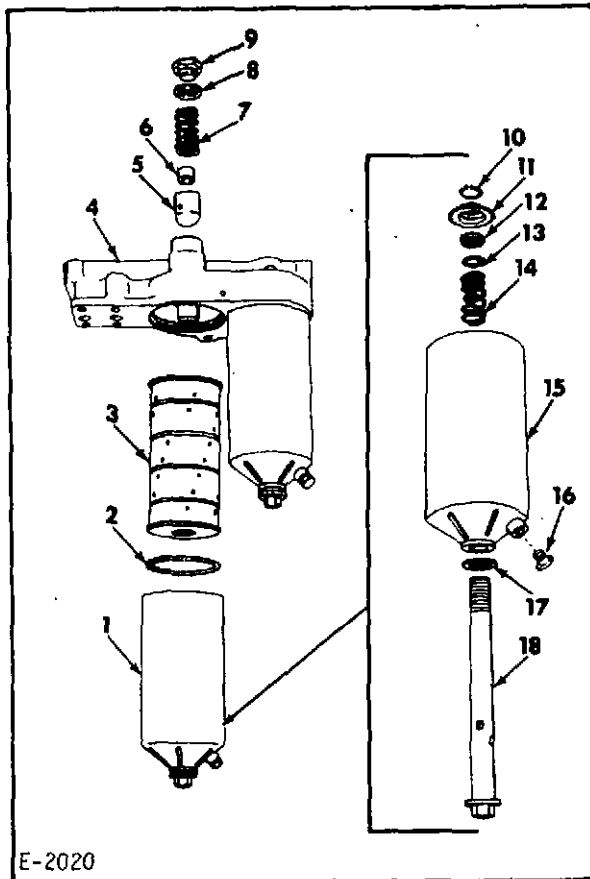

E-2020

- |                        |                         |
|------------------------|-------------------------|
| 1. Filter body         | 10. Snap ring           |
| 2. Body gasket         | 11. Element adaptor     |
| 3. Filter element      | 12. Element seal        |
| 4. Filter header       | 13. Element seal washer |
| 5. Piston              | 14. Element spring      |
| 6. Spacer (Early Type) | 15. Filter body         |
| 7. Spring              | 16. Drain plug          |
| 8. Gasket              | 17. Center bolt gasket  |
| 9. Bypass valve cap    | 18. Center bolt         |

Figure 4. Lube Oil Filter Details  
(For Engine With Water Cooled  
Exhaust Manifold)

**CAUTION:** If the oil pressure gauge does not indicate the specified minimum pressure after a few seconds of operation, stop the engine immediately.

After starting a turbocharged engine, it is extremely important that it be allowed to operate at a fast idle speed for 3 to 5 minutes without load. Permitting the engine to operate at this speed assures free circulation of lubricant through the turbocharger bearings and engine. Allowing the turbocharger to operate at high speed without sufficient lubrication can result in turbocharger bearing failure within 30 seconds.

16000H 16000MKII 17000MKII  
21000MKII 25000MKII

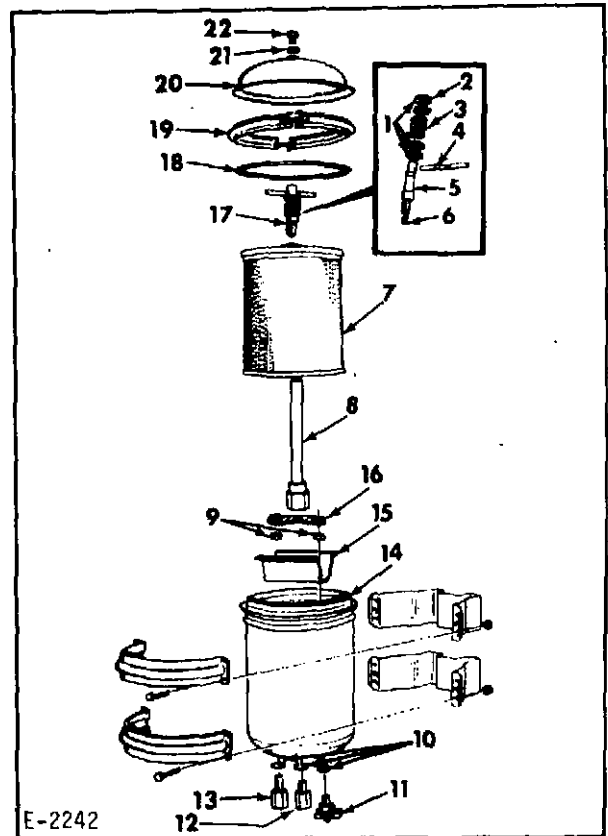

E-2242

- |                 |                           |
|-----------------|---------------------------|
| 1. Washers      | 12. Valve, check (outlet) |
| 2. Spring       | 13. Valve, check (inlet)  |
| 3. Seal         | 14. Housing               |
| 4. Handle       | 15. Support               |
| 5. Stud         | 16. Retainer              |
| 6. Orifice plug | 17. T-handle              |
| 7. Element      | 18. Gasket (O-ring)       |
| 8. Center tube  | 19. Cover clamp           |
| 9. Nuts         | 20. Cover                 |
| 10. Gaskets     | 21. Washer                |
| 11. Cock, drain | 22. Plug, vent            |

Figure 5. By-Pass Oil Filter

It is equally important to allow the engine to operate at half throttle speed without load for 3 to 5 minutes before it is shut down. Permitting the engine to operate at this speed assures an even cooling of the components and allows the turbocharger speed to be minimal when the supply of lubricant is cut off.

Maintenance personnel should familiarize themselves with the recommended lubrication and filter change periods and grades of lubricant specified in Topic 6 and Topic 8.

#### C. FULL-FLOW OIL FILTERS (STANDARD)

##### 1. General

The engine lubricating oil filters (Figures 2, 3, and 4) are similar in

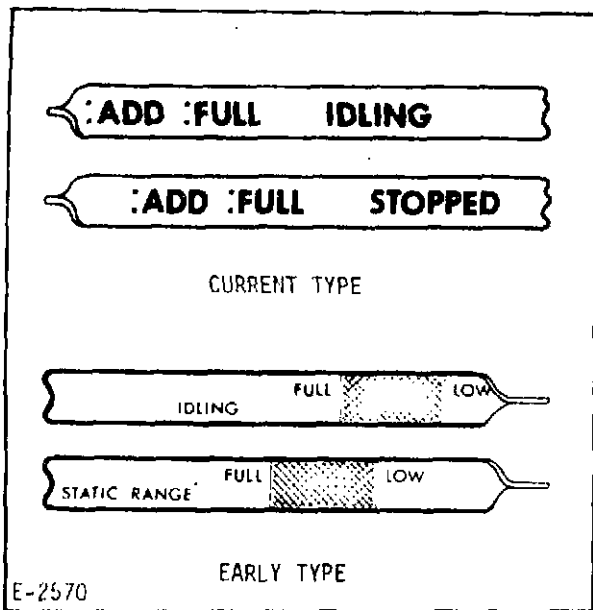

Figure 6. Oil Level Gauge (Dipstick)

construction except for the configuration of the filter headers, location of the center bolts, and the location of the filter assemblies on the engines.

The filters are of the full-flow type and contain replaceable elements. A drain plug in each filter body permits draining of the filters when replacing the elements. New elements must be installed each time the oil pan lubricant is changed.

A bypass valve in the filter header permits unfiltered oil to bypass the filter element and go directly to the main gallery if element becomes clogged, or if oil becomes too thick in cold weather to circulate freely through the element.

## 2. Maintenance

- a. Thoroughly clean the filter header, the filter bodies, and the surrounding area. Remove the drain plugs from the bodies and allow the filters to drain.
- b. Inspect the oil which has been drained. Allow the foreign matter to settle, pour off the oil, and examine the sediment, (if any).
- c. Remove the centerbolts, filter bodies, and filter elements from the filter header as an assembly.
- d. Remove and discard the body gaskets.
- e. Remove and inspect the filter ele-

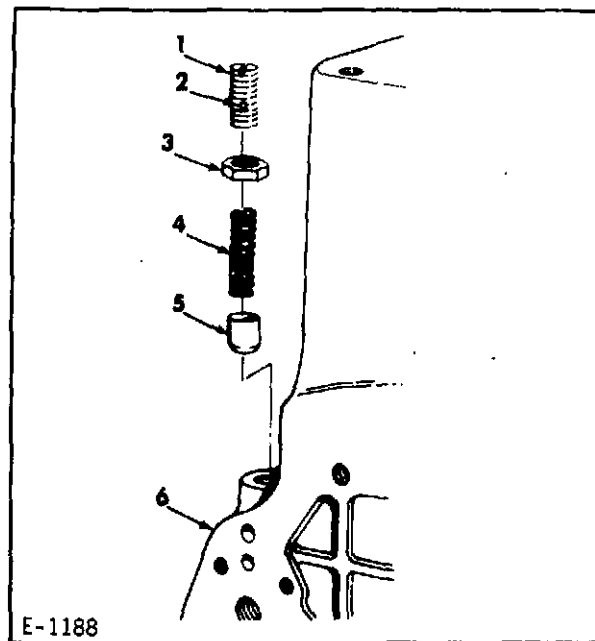

E-1188

- |                    |                   |
|--------------------|-------------------|
| 1. Adjusting screw | 4. Spring         |
| 2. Nylon pellet    | 5. Piston         |
| 3. Jam nut         | 6. Cylinder block |

Figure 7. Oil Pressure Regulating Valve Details

ment. The presence of metal particles indicates the possibility of a faulty lubrication system and/or component malfunction. After the inspection, discard the element. Correct any malfunctions.

- f. Thoroughly wash and dry the filter body. Install a new element.
- g. Reinstall the entire assembly, using new gaskets. Tighten the centerbolts to 45 to 50 lb-ft (61 to 68 Nm). Reinstall the drain plugs.

## D. BYPASS OIL FILTER (OPTIONAL)

### 1. General

The optional bypass type oil filter must be used with turbocharged engines to supplement the standard full flow oil filters.

When the filter is applied to the engine, 14 qts (13.25 lts) and the quantity of oil in the oil supply and drain hoses must be added to the engine oil renewal quantity.

### 2. Maintenance

The filter element must be changed at each lubrication change period. Refer

to Fig 5 and replace the element as follows:

- a. Clean the filter cover and surrounding area. Loosen the drain cock in the bottom of the filter housing and allow filter to drain. Remove the cover clamp ring and lift the cover from filter housing. Do not damage the gasket.
- b. Unscrew and remove the T-handle hold-down from the center-tube. Remove the filter element from the housing by lifting with pull-out bail; discard element.
- c. Clean the interior of housing and tighten drain cock.
- d. To assure leak-proof sealing, examine center-tube seat at each end of new filter element to see that seats are clean and in good condition. Insert the new element in the filter housing and press down firmly.
- e. Be certain the hole in the orifice plug, located in the T-handle hold-down, is open. Install hold-down and tighten securely.
- f. Install cover gasket and place the cover in position on filter housing. Install cover clamp ring and tighten securely.
- g. Fill engine crankcase with specified lubricant.
- h. Be sure engine shut-off control is in the STOP position; crank engine with starter for 15 seconds to assure filling filters and complete engine lubrication before engine is started. Start engine and operate it at 1/4 speed for about 5 minutes.
- i. Stop the engine and check oil level; add oil as necessary to raise oil to FULL mark on dipstick.
- j. Observe filter for leakage; correct any leaks.

#### E. DRAINING AND FILLING OIL SYSTEM

1. Before draining the system, operate the engine until the normal operating temperature is reached. Stop the engine.
2. Remove the drain plug from the oil pan and allow the oil to drain. Allow any foreign matter to settle, pour off the oil and examine the sediment, if any.
3. Reinstall the drain plug and fill the

system with the specified grade and type of lubricant. Fill to the FULL mark on the side of the dipstick stamped STATIC or STOPPED.

4. Crank the engine, without starting, for 15 seconds. This will assure that the filters are filled and that lubricant has been pumped to the engine components before the engine is started.
5. Start the engine and allow it to run for approximately 5 minutes.
6. Stop the engine, allow several minutes for the oil to drain back to the sump, and recheck the oil level. Add lubricant as required.
7. Inspect the lubricating system for leaks.

#### F. ENGINE OIL COOLER

The engine oil cooler is located on the right side of the engine and consists of a corrosion resistant core and jacket. Coolant is circulated through the cooling core tubes and engine lubricating oil is circulated around the tubes. The coolant absorbs heat from the oil, thereby controlling the oil temperature.

**CAUTION:** It is important that the oil cooler be kept clean and free of deposits in order to maintain proper cooling.

If recommended maintenance and lubrication is not performed at the indicated interval, deposits may form in the oil cooler and restrict the flow of oil or coolant. Restriction of the flow of oil is usually indicated by a drop in oil pressure and a rise in oil temperature. Refer to Topic 11, Paragraph F, for instructions covering the cleaning of the oil cooler.

#### G. LUBRICATION SYSTEM MAINTENANCE

Proper maintenance of the lubrication system requires adherence to the following:

##### 1. Lubricating Oil

Lubricating oil must be of the best quality available and be of a proper SAE weight for prevailing ambient temperature. (Refer to Topic 6). Keep oil free of water and abrasives by proper handling and storage.

##### 2. Daily Check

Before each period of operation, check oil level in the oil pan. If necessary, add oil to bring level to FULL mark on

the level gauge. Inspect engine for evidence of oil leaks and make necessary repairs.

### 3. Cooling System Temperature

It is important that the cooling system temperature be maintained at a minimum of 180° F (356 K) so that the lubricating oil will be fluid enough for proper filtering. A low cooling system temperature will result in a low lubricating oil temperature. Thus, proper filtering cannot be achieved. Improper filtering will result in rapid engine wear.

### 4. Oil Level Gauge (Dipstick)

The oil level must be maintained between the FULL and ADD or LOW markings. A check of the level should be made prior to each period of operation.

Both sides of the dipstick are stamped with FULL and LOW marks. The side stamped STOPPED or STATIC must be used for checking the oil level with the engine stopped. The side stamped IDLING is used to check oil level when the engine is operating at idle speed to full load speed.

A seal in the oil level gauge cap prevents oil from leaking to the outside of the engine and prevents foreign matter from entering. The dipstick should be kept tight in its holder. Inspect the seal each time the engine oil level is checked.

### 5. Engine Breather Tube

The engine breather tube vents the interior of the engine to the atmosphere, thus preventing a pressure buildup in the crankcase, gear train, and valve compartment. The venting also eliminates harmful vapors from the interior of the engine. A clogged breather will cause a pressure buildup which will force oil past the crankcase seals, cover gaskets, and other seals.

At oil change, remove the breather tube and wash it in cleaning solvent. Blow out the tube with compressed air and reinstall it on the engine.

### 6. Oil Pressure Regulating Valve

The oil pressure regulating valve (Figure 7) is located at the right front corner of the cylinder block. The valve maintains stabilized oil pressure within the lubricating system. When the oil

pressure exceeds the valve setting, the valve piston is forced off of the valve seat and the oil is bypassed directly from the cylinder block to the oil pan.

Keeping the lubrication free of sludge and foreign matter will help prevent a valve malfunction. If, for some reason, the valve sticks in the open position, a sharp drop in the engine oil pressure will occur. A sharp rise in oil pressure is indicative of a valve that does not open.

NOTE: A gasket is not required between the regulating valve screw jam nut and the cylinder block because a nylon pellet is located in the side of the adjusting screw to prevent oil leakage past the threads.

Remove, clean, and inspect the valve after every 8000 hours of normal operation. Proceed as follows:

- a. Thoroughly clean the area surrounding the pressure regulating valve.
- b. Loosen the jam nut.
- c. Noting the number of turns required for removal, remove the adjusting screw.
- d. Withdraw the spring and piston.
- e. Wash the valve parts in a suitable cleaning solvent. Inspect the parts for wear and damage. Replace faulty or worn parts.
- f. Thoroughly clean the valve bore in the cylinder block. Inspect the valve seat. Lubricate the valve piston with clean engine oil and reinstall the regulating valve components. Turn the valve screw into the cylinder block the same number of turns required for removal.
- g. Start the engine and allow it to reach operating temperature. Adjust the pressure regulator valve adjusting screw to obtain an oil pressure of 40 to 50 psi (276 to 345 kN/m<sup>2</sup>) at high idle speed. Tighten the jam nut.

## TOPIC 14. ENGINE ELECTRICAL SYSTEM

### A. GENERAL

The engine electrical system includes the starting motor, battery charging generator or alternator, voltage regulator, and storage battery (customer supplied).

Basic components of the charging system include the battery, generator or alternator, and voltage regulator. The battery is the storage plant for electrical energy and must be kept fully charged. The generator or alternator functions to recharge the battery. Excessive current flow can burn out the generator or alternator and damage the battery to the extent that it cannot hold a charge. A voltage regulator is connected into the circuit to prevent such damage.

The cranking circuit is composed of an electrical starting motor, a storage battery, and a starter switch. When current flows through the starter solenoid, the starter drive pinion is shifted into mesh with the flywheel ring gear, and main contacts in the solenoid close, connecting the battery directly to the starting motor that turns the engine. When the engine starts and the starter switch is released, the solenoid contacts open, automatically disengaging the drive pinion.

NOTE: For specific ratings and polarity of the generator or alternator and voltage regulator refer to SPECIFICATIONS, Topic 2, Paragraph F.

### B. WARRANTY AND ADJUSTMENT

Manufacturers of the battery, starting motor, generator or alternator, and regulator are responsible for this equipment during the warranty period. Any claim for replacement or repair of these items must be presented to the equipment manufacturer, not to Allis-Chalmers. Suppliers of such equipment are represented in nearly all cities by distributors or dealers who are authorized to make reasonable adjustments or replacements. Always give the serial number of the engine and the date on which it was delivered when presenting a claim of this nature.

### C. BATTERY

If liquid level of battery is low, add distilled water to bring level of each cell to bottom of filler hole. Be sure filler plugs are tight and plug vents are open.

CAUTION: Never fill battery after operation in below freezing weather because water will not mix with acid and may freeze. Always fill battery before putting engine into service.

Periodically check external condition of battery and connecting cables. Keep battery clean and secured. If battery is dirty, clean with soda solution and brush. Filler plugs should be tight to prevent any solution from entering cells. After foaming stops, flush surface with clean water and apply a thin coat of petroleum jelly to posts and cable terminals.

Maintain battery in a fully charged condition. Check charge condition or specific gravity with a hydrometer with electrolyte temperature corrected to 80°F (300 K). Add .004 for every 10° above 80°F (5.55 K above 300 K); subtract .004 for every 10° below 80°F (5.55 K below 300 K).

<u>Hydrometer Indication</u>	<u>Charge Condition</u>
1.110 to 1.135.....	Completely discharged
1.170 to 1.200.....	One-fourth charged
1.205 to 1.230.....	One-half charged
1.235 to 1.260.....	Three-fourths charged
1.265 to 1.290.....	Fully charged

CAUTION: The ground polarity of the generator or alternator and the battery must be the same before connecting. Make sure all grounding points have a metallic contact. When connecting either a trickle or fast type charger to the battery, it is imperative that correct polarity be observed. That is, connect the positive lead of the charger to the positive battery post and the negative lead to the negative battery post. Observe the same polarity rule when connecting booster batteries. When any work is performed on the electrical charging system, disconnect the battery to prevent short circuits.

### D. ELECTRIC STARTING MOTOR

#### 1. General

The starting motor is a heavy duty, 24 volt overrunning clutch type unit. A solenoid switch, which is an integral part of the starting motor, is connected by linkage and a shift lever to a clutch in the starting motor nose housing.

Closing of the starter switch completes the electrical circuit between storage battery and solenoid. The solenoid shifts the starter pinion gear into mesh with the engine flywheel ring gear and holds it in mesh during engine cranking.

**CAUTION:** Do not operate starting motor continuously for more than 30 seconds without pausing to allow it to cool for at least 2 minutes. Failure to observe this rule can result in overheating and failure of the motor.

**2. Removal And Installation**

- a. Tag and disconnect battery cables and electrical lead wires from starting motor.
- b. Remove capscrews and lockwashers that attach starting motor to flywheel housing. Remove starting motor and adaptor.
- c. Install starting motor on engine by a direct reversal of the removal procedure. Connect cables and wires to it.

**3. Maintenance**

- a. During startup, note starting motor action. The pinion gear should mesh promptly with the flywheel ring gear and spin the engine. After engine starts and motor switch opens, the starting motor should stop operating.
- b. If starting motor cranks engine slowly or not at all, check the equipment. Failure to crank is normally caused by low battery charge, defective battery cables, poor connections in starting motor to battery circuit, defective starting motor, low temperatures, or various conditions in the engine.
- c. Periodically check condition of battery, battery cables and connections, starting motor, solenoid switch, commutator, brushes, lead connections, and mounting.
- d. Starting motor bearings are lubricated only when unit is disassembled for inspection or repair.
- e. Brushes must make good contact with the commutator. Minimum tension of brushes is 80 ounces (2.27 kg).
- f. Check length of brushes. Original brush length is 1/2" (12.70 mm).

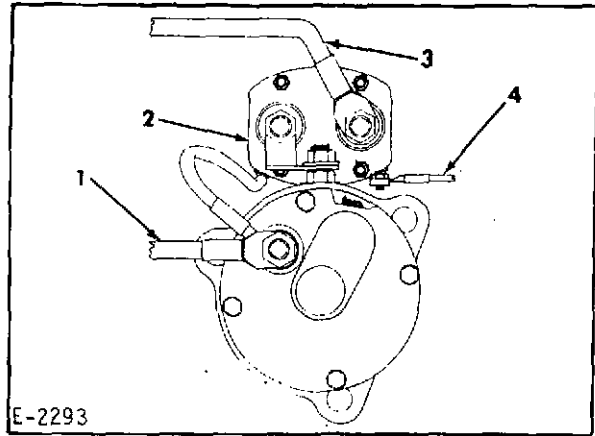

- 1. Cable (ground)
- 2. Starter solenoid
- 3. Cable (to battery)
- 4. To starter switch

Figure 1. Starter

**NOTE:** CABLE TABULATION LISTS THE MAXIMUM ALLOWABLE LENGTH OF CABLE USED FOR 24 OR 32 VOLT SYSTEMS. LENGTH INCLUDES DISTANCE FROM BATTERY TO GROUND, AND BATTERY TO STARTER TERMINAL.

STARTING CABLE TABULATION 24 AND 32 VOLT SYSTEMS			
CABLE MAXIMUM LENGTH		CABLE SIZE	
INCH	CENTIMETER (CM)	AWG	MM
188	477	#0	0.835
237	602	#00	0.865
300	762	#000	1.179
380	965	#0000 or two #0	1.326

They should be replaced if wear has decreased their length to 5/16" (7.94 mm) or less.

- g. If commutator is dirty, clean with #00 sandpaper.

**CAUTION:** Do not clean commutator with emery cloth. Emery is a conductor and can cause electrical shorts.

**4. Starting System Checks**

If starting motor cranks engine slowly, check the following:

- a. Test for excessive resistance in starting circuit. Resistance can be

16000H 16000MKII 17000MKII  
21000MKII 25000MKII

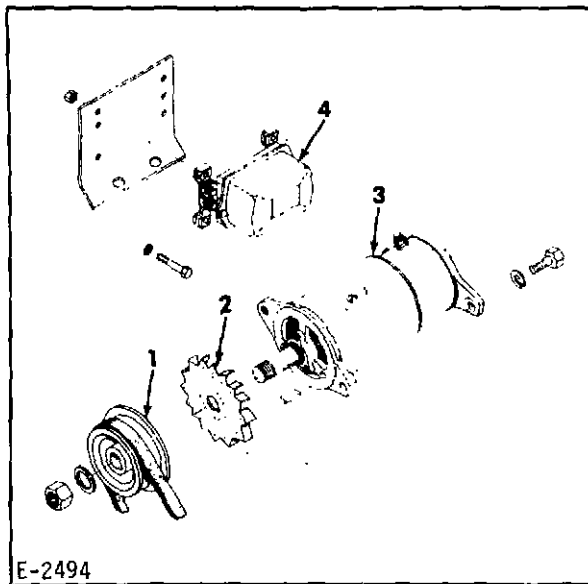

- |           |                      |
|-----------|----------------------|
| 1. Pulley | 3. DC generator      |
| 2. Fan    | 4. Voltage regulator |

Figure 2. DC Generator and Voltage Regulator

checked by using a voltmeter to measure the voltage drop between the various terminals in the circuit. Readings should never show a drop of more than 0.2 volt.

- b. Check for low or discharged battery.
- c. Check engine for tight bearings, pistons, heavy oil, etc., which imposes heavy loads on the starting motor.
- d. Check starting motor for bent armature, defective bearings or worn brushes.

If starting motor will not crank the engine, check the following:

- a. Check for completely discharged battery.
- b. Check for open starting circuit - starter switch, open wiring, defective solenoid switch.
- c. Check starting motor. Disassemble and repair as required.
- d. Check drive mechanism.
- e. Check flywheel ring gear - teeth may be broken out.

#### E. DC GENERATORS AND VOLTAGE REGULATORS

The generating system (Fig 2) restores to the battery the current withdrawn during cranking.

16000H 16000MKII 17000MKII  
21000MKII 25000MKII

The system also carries the connected electrical load up to the capacity of the generator when the generator is operating at a speed to produce maximum output.

The voltage regulator is an electromagnetic relay of the vibrating type. It consists of three units (1) a cutout relay which connects and disconnects battery, (2) a voltage regulator which prevents battery overcharge and high voltage, and (3) a current regulator to protect generator or alternator from overloads.

#### 1. Generator And Regulator Removal

- a. Remove the capscrew and lockwasher attaching the generator to the generator adjusting brace. Remove the drive belt. Disconnect generator lead wires.
- b. Remove the capscrews and lockwashers attaching the generator to the generator mounting bracket and remove the generator.

**CAUTION:** Whenever a dc generator has been removed or disconnected, it must be polarized.

- c. Disconnect generator regulator wires; identify the wires to facilitate installation.
- d. Remove generator regulator attaching capscrews, nuts, and lockwashers.
- e. Remove the generator regulator.

#### 2. Generator Maintenance

- a. Periodically the commutator should be inspected and cleaned, if necessary. Clean only with #00 sandpaper, never use emery cloth. Also inspect the brushes.
- b. If commutator is rough, out-of-round, or has high mica, it must be turned down in a lathe and the mica undercut. If necessary to turn down commutator, make cut no deeper than necessary. The mica should be undercut 1/32" (0.031 mm).

**CAUTION:** Make certain cut is not made on commutator riser bars because solder will be removed, thereby weakening the coil connection at this section.

- c. If generator is equipped with oil cups, lubricate with 3 to 5 drops of engine oil at each engine lubricating oil renewal interval.

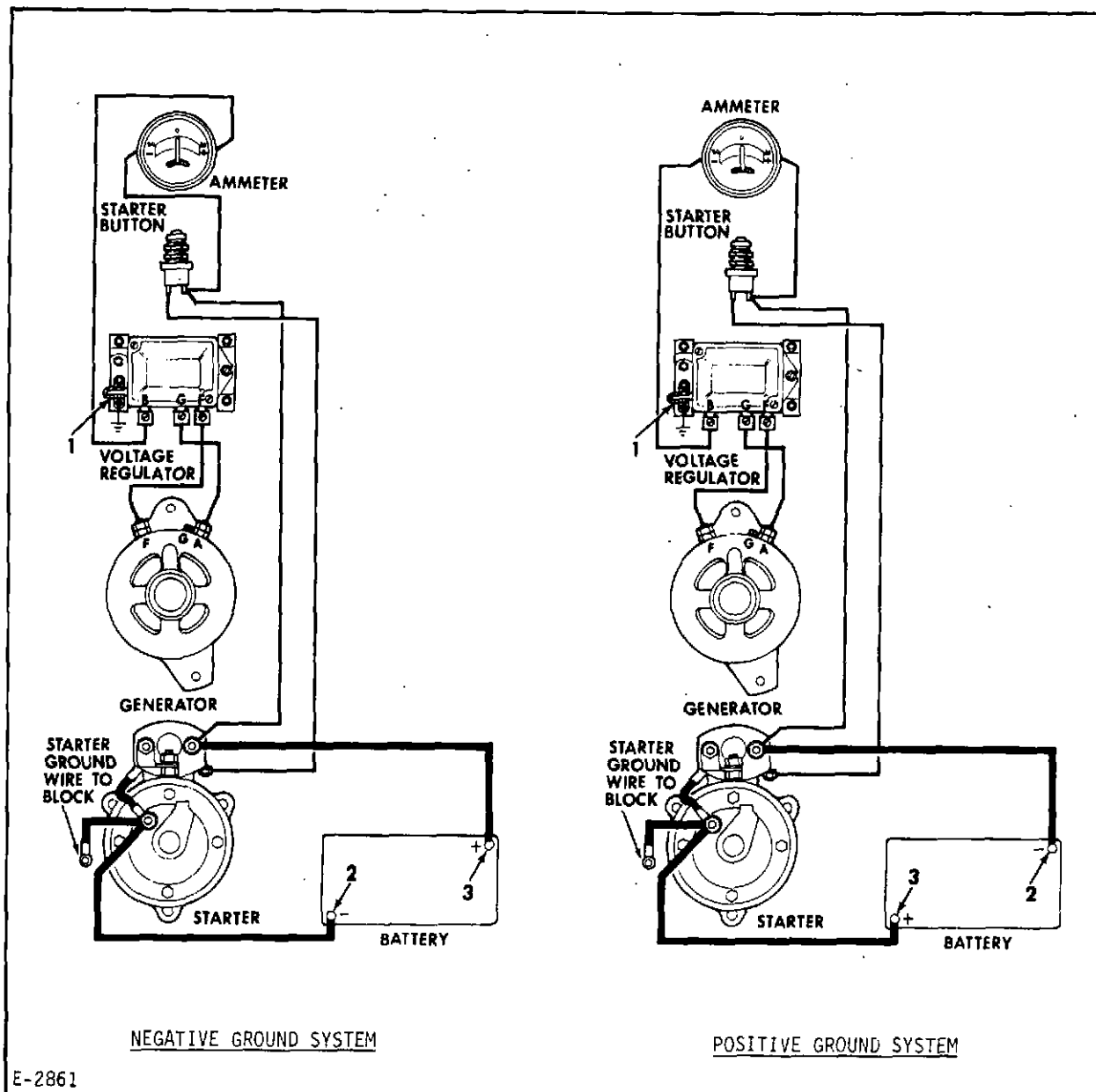

1. Ground wire 2. Negative terminal 3. Positive terminal

NOTE: If engine is powering a generator set, disregard this wiring diagram and refer to the DC wiring diagram furnished with the generator set.

Figure 3. DC Generator with Voltage Regulator.

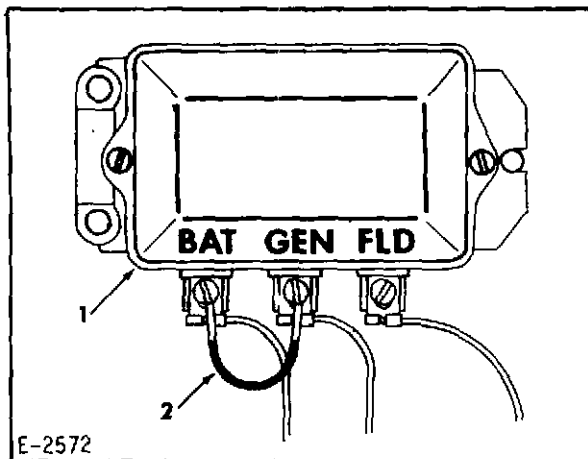

1. Generator regulator
2. Jumper lead

Figure 4. Polarizing Circuit Diagram  
(DC Generator ONLY)

**NOTE:** Whenever the generator has been removed or the regulator leads have been disconnected and reconnected, the generator **MUST** be polarized before engine is started to prevent severe regulator damage.

d. Polarize the generator as follows (Fig 4):

- (1) Insulate generator brushes from the armature by placing cardboard between brushes and armature.
- (2) Using a short jumper lead, momentarily touch the jumper from the BAT to the GEN terminal of the regulator. A solid contact between jumper lead and terminal is required, and a flash or arc will be noted when lead is removed.
- (3) Remove the cardboard from under the brushes.

**CAUTION:** Do not test or operate the generator on an open circuit. If it should become necessary to operate the generator without it being connected to the batteries, it should be short circuited; disconnect the lead connected to the GEN terminal of the regulator and connect to any convenient ground to accomplish the short circuit.

### 3. Generator And Regulator Installation

a. Installation procedure is the reverse

16000H 16000MKII 17000MKII  
21000MKII 25000MKII

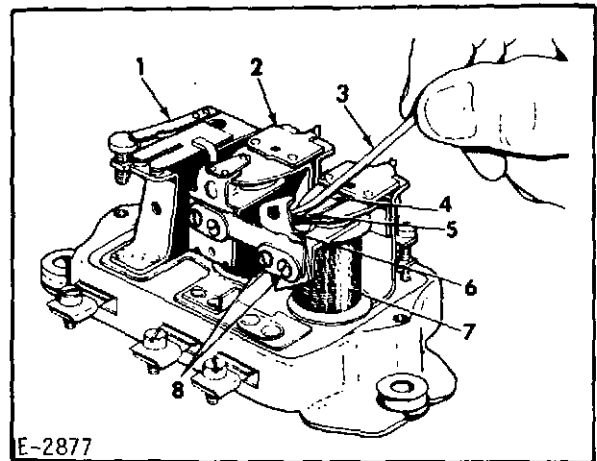

1. Cutout relay
2. Current regulator
3. Spoon or riffle file
4. Armature
5. Large flat point
6. Contact mounting bracket
7. Voltage regulator
8. Mounting bracket screws

Figure 5. Cleaning Contact Points

of removal.

- b. Adjust drive belt to proper tension. See procedure in Paragraph G this topic.

### 4. Regulator Maintenance

Do not clean voltage regulator contacts unless performance indicates cleaning is necessary. A sooty or discolored appearance of contacts is normal after a relatively short period of operation and is not an indication that cleaning is necessary. However, if the voltage fluctuates, as evidenced by an unsteady voltmeter indication, contacts may have excessive resistance or by sticking and therefore, should be cleaned, and possibly readjusted.

**CAUTION:** Before cleaning, make sure fluctuating voltage is not caused by loose connections or high resistance elsewhere in the system.

The large flat point located on the armature of the voltage regulator should be cleaned with a spoon or riffle file (Fig 5). A similar flat point is located on the upper contact support of the current regulator of negative grounded regulator unit. This contact point will usually require the most attention. It is not necessary to have a flat surface on this contact point but all oxides should be removed with a riffle file

so that pure metal is exposed and should be followed by a thorough wash with clear carbon tetrachloride. On regulators which have the flat contact point on the armature, loosen the upper contact bracket mounting screws so that the bracket can be tilted to one side. On regulators which have the flat contact on the upper contact bracket, the bracket must be removed for cleaning the points.

The small soft-alloy contact point, located on the upper contact support bracket of the voltage regulator and on the armature of the current regulator for the negative grounded regulators, does not oxidize. This contact point may be cleaned with crocus cloth or fine abrasive material followed by a thorough wash with clear trichloroethane to remove any foreign material remaining on the contact surface.

Remove all oxides from the contact points but note that it is not necessary to remove any cavity that may have developed.

**CAUTION:** Never use emery cloth or sandpaper to clean the contacts points.

## F. ALTERNATORS AND VOLTAGE REGULATORS

### 1. General

The alternators with their respective regulators are of two types and configurations. The alternators are similar in construction, however the regulators are different. One uses a two unit type regulator and the other a transistor type.

The two unit type regulator utilizes the alternator shown in Figure 6 and is connected into the engine electrical system according to wiring diagram Figure 8.

The transistor type regulator utilizes the alternator shown in Figure 7 and is connected into the electrical system according to wiring diagram Figure 11.

**NOTE:** If engines are driving generator sets, follow the schematic wiring diagrams furnished with the units.

**NOTE:** For specific ratings and polarity of the alternators and regulators, refer to SPECIFICATIONS, Topic 2, Paragraph F.

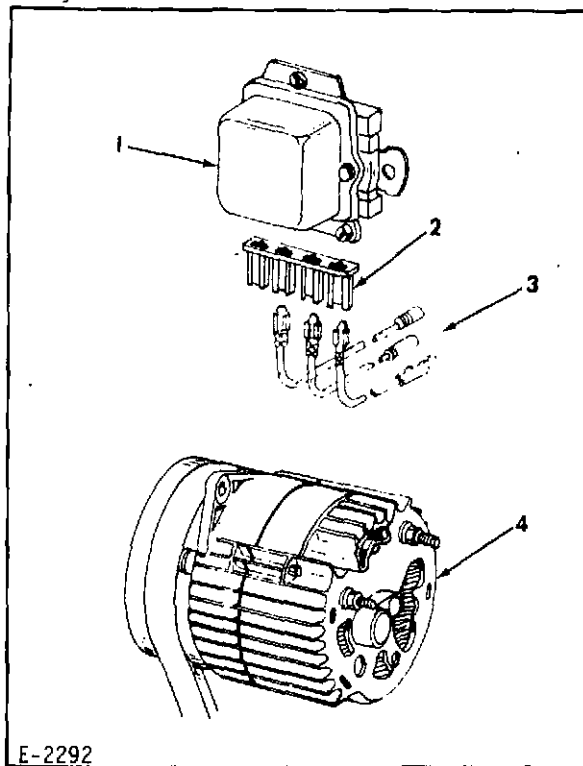

- |              |               |
|--------------|---------------|
| 1. Regulator | 3. Leads      |
| 2. Connector | 4. Alternator |

Figure 6. Alternator with Two Unit Regulator

### 2. Alternators

**CAUTION:** The ground polarity of these alternators and the ground polarity of the battery must be the same before making connections. Instant damage to the wiring and diodes will result if the alternator is connected to the battery with ground polarities not matched.

To prevent accidental grounding a lead and damaging the diodes when removing and installing an alternator or regulator, always remove the ground cable from the battery.

#### a. Description

These alternators are designed and constructed to provide long periods of reliable service. The alternators feature two brush assemblies and two slip rings. A constant tension spring holds each brush in contact with the slip ring. The rotor of the alternator shown in Figure 7 is supported at the front and rear with ball bearings.

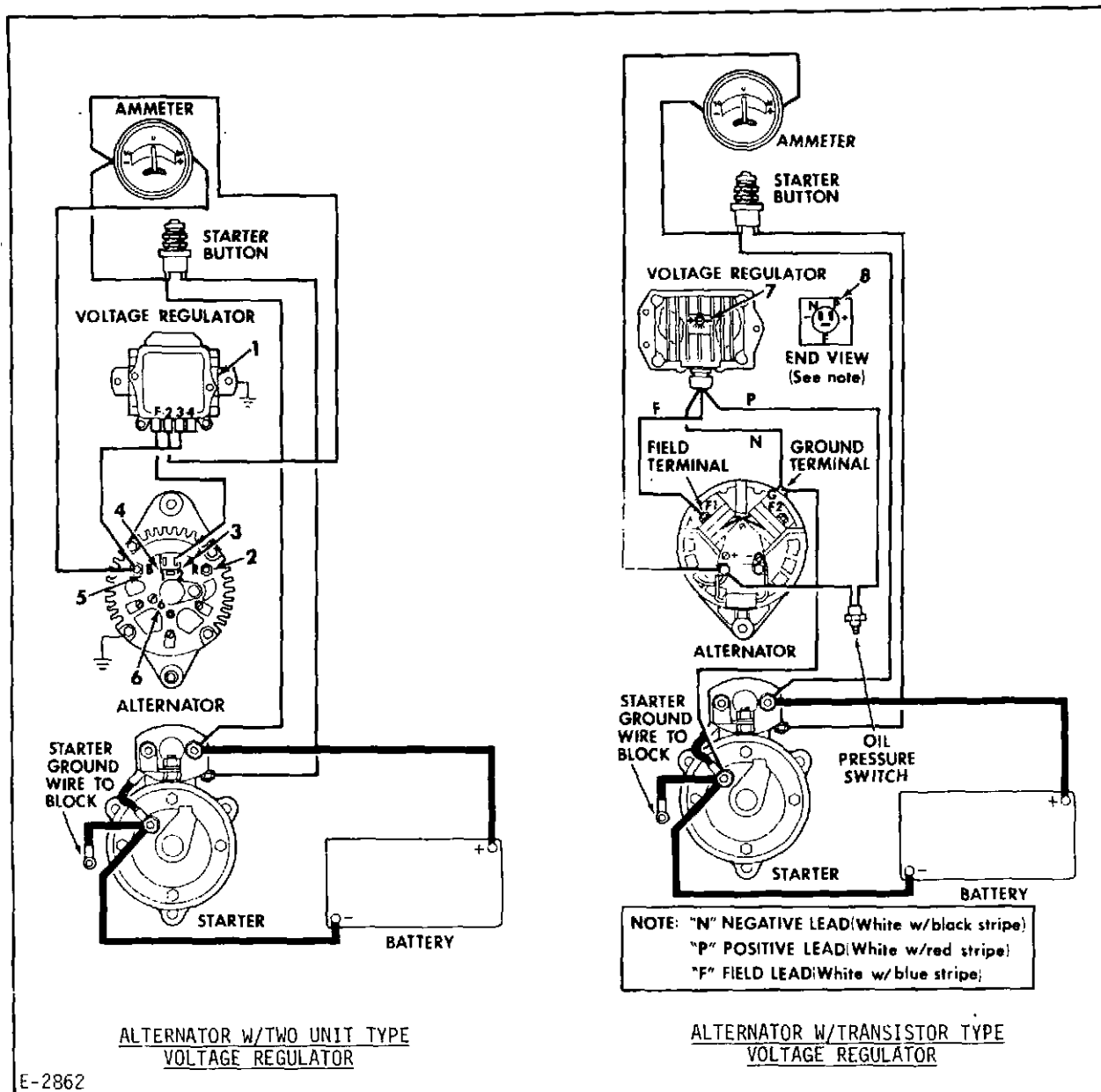

E-2862

1. Ground wire
2. Relay terminal  
CAUTION: Do not ground relay terminal
3. Field terminal (2)

4. Indicator light terminal (1)
5. Battery terminal
6. Ground terminal
7. Voltage adjust cover plug
8. Connection details

**NOTE:** If engine is powering a generator set, disregard this wiring diagram and refer to the DC wiring diagram furnished with the generator set.

Figure 7. Alternators with two Unit Type Regulator and Transistor Type Regulator Wiring Diagrams ( Negative Ground Systems )

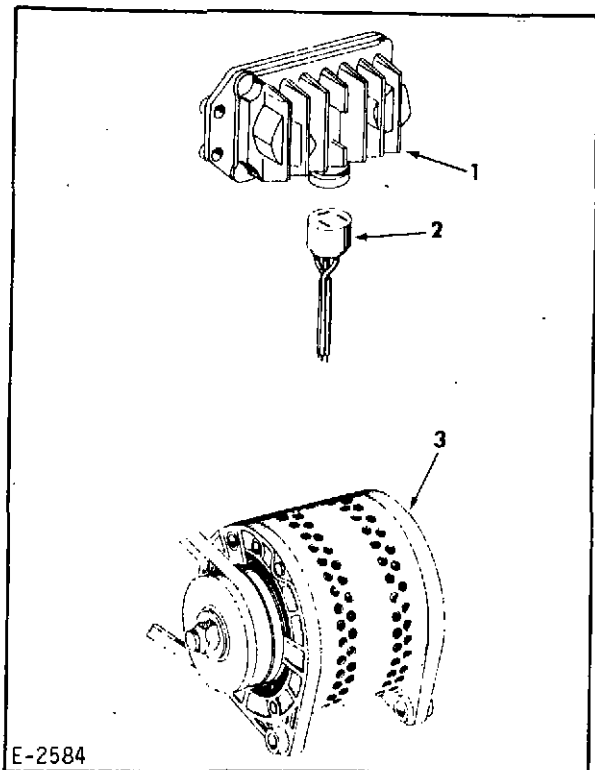

E-2584

1. Regulator
2. Connector
3. Alternator

Figure 7. Alternator with Transistor Type Regulator

The rotor of the alternator shown in Figure 6 is supported with a ball bearing at the front and a roller bearing at the rear. Six rectifier diodes are located at the slip ring end of the alternators and change the a.c. to d.c. voltage which appears at the BAT (battery) terminal of the alternators.

b. Removal and Installation

Remove ground cable from battery.

Remove electrical leads from alternator terminals.

Remove capscrew, lockwasher, and flat washer securing adjusting brace to alternator.

Loosen capscrews securing the alternator end frames to the mounting bar.

Force alternator toward the engine and remove the drive belt.

Remove alternator by supporting it and removing the capscrews and washers that secure it to the mounting bar.

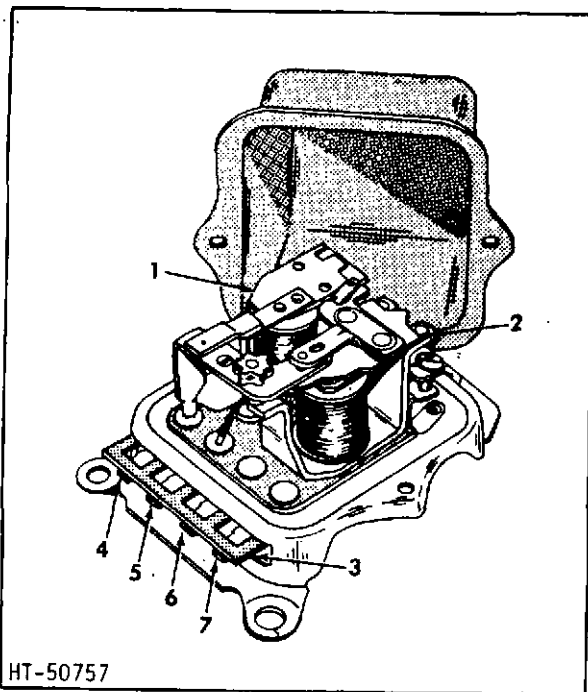

HT-50757

1. Field relay unit
2. Voltage regulator unit
3. Latch
4. F terminal
5. No. 2 terminal
6. No. 3 terminal
7. No. 4 terminal

Figure 9. Two Unit Voltage Regulator

Install the alternator in reverse order of the removal procedure.

Adjust drive belt to proper tension. See procedure in Paragraph G this topic.

**IMPORTANT: DO NOT POLARIZE ALTERNATOR AFTER INSTALLATION OR AT ANY OTHER TIME.**

c. Maintenance

Periodic maintenance is limited to inspection for loose mounting bolts, a loose drive pulley, or a loose drive belt.

If the alternator is noisy, it may be caused by any of the above mentioned defects, plus worn or dirty bearings, a defective diode or a grounded or shorted stator.

If after tightening the mounting bolts and/or adjusting the drive belt, the alternator is still noisy, it must be removed from the engine and disassembled for further checks.

Check the drive belt for alignment, tension, and wear. Alternator belt

16000H 16000MKII 17000MKII  
21000MKII 25000MKII

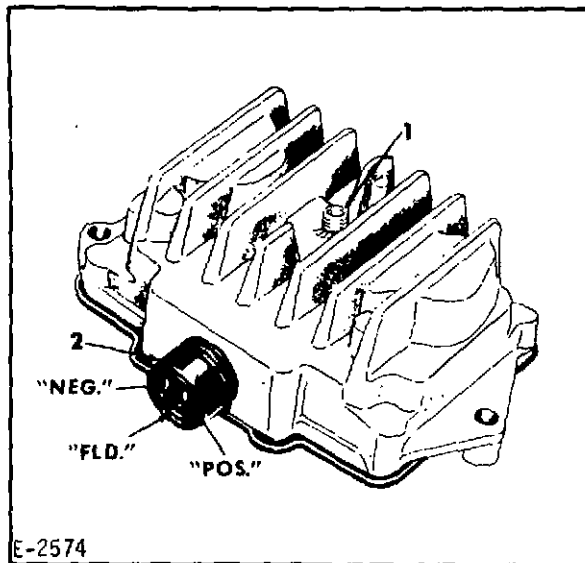

1. Plug (remove to adjust voltage setting)
2. Terminal

Figure 10. Regulator - Transistor Type

tension is a bit more critical than with a d.c. generator. Check for loose drive pulley. Specified pulley retaining nut torque is 40-60 lb-ft (54-81 Nm).

Inspect the terminals for corrosion and loose connections. Check wiring for frayed insulation.

If slip rings are rough or out of round, the alternator must be disassembled so the slip rings can be trued in a lathe to a .002" (.005 mm) maximum indicator reading. Remove only enough material to make rings smooth and round. Finish with 400 grain or finer polishing cloth and blow all dust away.

The grease reservoir provides an adequate supply of lubricant for long periods of operation. When alternator is disassembled for overhaul or repair, inspect bearings and replace if necessary. Fill the grease reservoir in each end frame with Delco-Remy (their Part No. 1948791) to one-half full.

**CAUTION:** Do not overfill reservoirs because this will cause the bearings to overheat.

When alternator is disassembled, inspect brushes and brush springs.

16000H 16000MKII 17000MKII  
21000MKII 25000MKII

Compare brushes from alternator with new brushes and replace if necessary. Inspect brush springs for evidence of damage or corrosion. If there is any doubt as to the condition of the springs, they should be replaced.

### 3. Voltage Regulator

#### a. Two Unit Type Regulator

##### (1) General

The two unit type voltage regulator (Fig 9) consists of a voltage regulator unit and field relay unit. The voltage regulator unit operates to limit alternator voltage to a pre-set value, whereas the field relay unit connects the alternator field winding and regulator winding directly to the battery.

The regulator has 4 slip connection type terminals. A projection on the connector body serves to latch the assembly together and prevent disconnections due to vibration. The assembly can be disconnected by lifting slightly on the latch.

**CAUTION:** Polarities of the regulator, alternator, and battery must be the same. Instant damage will result if polarities are mismatched. Do not short across or ground regulator terminals. Do not operate without a battery.

##### (2) Removal and Installation

Remove battery ground cable.

Lift connector latch and withdraw the connector from the regulator.

Remove attaching capscrews, nuts, and lockwashers and remove regulator.

Install voltage regulator in reverse order of removal.

##### (3) Maintenance

Do not clean voltage regulator contacts unless performance indicates cleaning is necessary. A sooty or discolored appearance of contacts is normal after a relatively short period of operation and is not an indication that cleaning is necessary. However, if the voltage fluctuates, as evidenced by an unsteady voltmeter indication, contacts may have excessive resistance or be sticking and therefore, should be cleaned.

**CAUTION:** Before cleaning, make sure fluctuating voltage is not caused by loose connections or high resistance elsewhere in the system.

Contacts of the voltage regulator unit are made of soft material and must not be cleaned with a file. A strip of No. 400 silicon carbide paper, or equivalent, folded over and then pulled back and forth between the contacts is recommended as a satisfactory method of cleaning. After cleaning, wash contacts with trichloroethane or alcohol to remove any residue. If voltage control has not improved, repeat cleaning and washing process.

Clean field relay contacts with a thin, fine-cut, flat file. Never use emery cloth or sandpaper. Remove only sufficient material to clean.

#### b. Transistor Type Regulator

##### (1) General

The transistor type voltage regulator (Fig 10) is an assembly composed principally of transistors, diodes, capacitors, and resistors. These components form a completely static electrical unit containing no moving parts.

The function of the regulator in the charging circuit is to limit the generator voltage to a pre-set value by controlling the generator field current.

The voltage at which the generator is limited is determined by the regulator adjustment. Once adjusted, the generator voltage remains practically unchanged, since the regulator is relatively unaffected by such factors as length of service, changes in temperature or by changes in generator output and speed.

##### (2) Removal and Installation

Remove battery ground cable.

Mark regulator and lead wires for subsequent identification. Disconnect lead wires.

Remove attaching capscrews, nuts, and lockwashers and remove regulator.

Install voltage regulator in reverse order of removal.

##### (3) Maintenance

To adjust voltage setting, remove plug and turn slotted adjusting button inside regulator (Fig 9). For an undercharged battery, raise voltage setting by turning adjusting button one notch in a clockwise direction. To lower voltage setting, turn button one notch in a counterclockwise direction. Check for improved battery condition after a reasonable period of operation.

If the regulator cannot be adjusted to a significant value, replace the regulator.

**NOTE:** If repeated regulator failures are experienced, but no defects are found; a shorted, grounded, or open generator field winding, or grounded leads of an intermittent nature should be suspected.

#### G. DRIVE BELT ADJUSTMENT

Belt is properly adjusted when it can be pressed inward 3/16" to 1/2" (4.76 to 12.70 mm) at a point half-way between the generator or alternator pulley and the fan pulley. About 24 hours of operation is required to properly seat a new belt.

To adjust belt tension, loosen adjusting brace capscrews necessary to move generator or alternator inward or outward to obtain proper belt tension, and tighten capscrews.

## TOPIC 15. VALVE ADJUSTMENT AND CYLINDER HEAD

### A. VALVE ADJUSTMENT

#### 1. General

The correct clearance (valve lash) between the rocker arms (Figure 1) and the intake and exhaust valve bridges is very important because of the high compression developed within the cylinders. Insufficient valve clearance can cause the loss of compression, engine misfiring, and eventual burning of the valves and valve seats. Excessive clearance will result in faulty engine operation, valve lifter noise, and rapid wear of the valve lifting mechanism.

#### 2. Specification

With the engine coolant temperature at a minimum of 160° F (344 K), the intake valve clearance should be .015" (.38 mm) and the exhaust valve clearance is .020" (.51 mm).

**CAUTION:** If the valve operating mechanism has been affected by maintenance, set the valve clearances with the engine cold. Set the intake valve clearance to .020" (.51 mm) and the exhaust valve clearance to .025" (.64 mm). Start the engine and allow it to reach normal operating temperature. Reset the intake valve clearance to .015" (.38 mm) and the exhaust valve clearance to .020" (.51 mm).

#### 3. Procedure

The valve lash must be adjusted when the piston is near top dead center on the compression stroke and the intake and exhaust valves are closed. The relationship between the pistons is such that when the number 1 piston is moving upward on the compression stroke, the number 6 piston is moving upward on the exhaust stroke. The relationship is same between the number 2 piston and the number 5 piston, and between the number 3 piston and the number 4 piston. This relationship makes it possible to determine when a piston nears top dead center on the compression stroke by observing the valves associated with the related cylinder. For example, when the number 1 piston nears top dead center on the compression stroke, the exhaust valves for the number 6 cylinder are nearly closed and the intake valves are beginning to open.

To adjust the valves, proceed as follows:

- Operate the engine until normal operating temperature is reached.
- Thoroughly clean the valve rocker covers and the surrounding area.
- Remove the valve rocker cover cap-screws, rocker cover sealing washers, and the rocker covers.

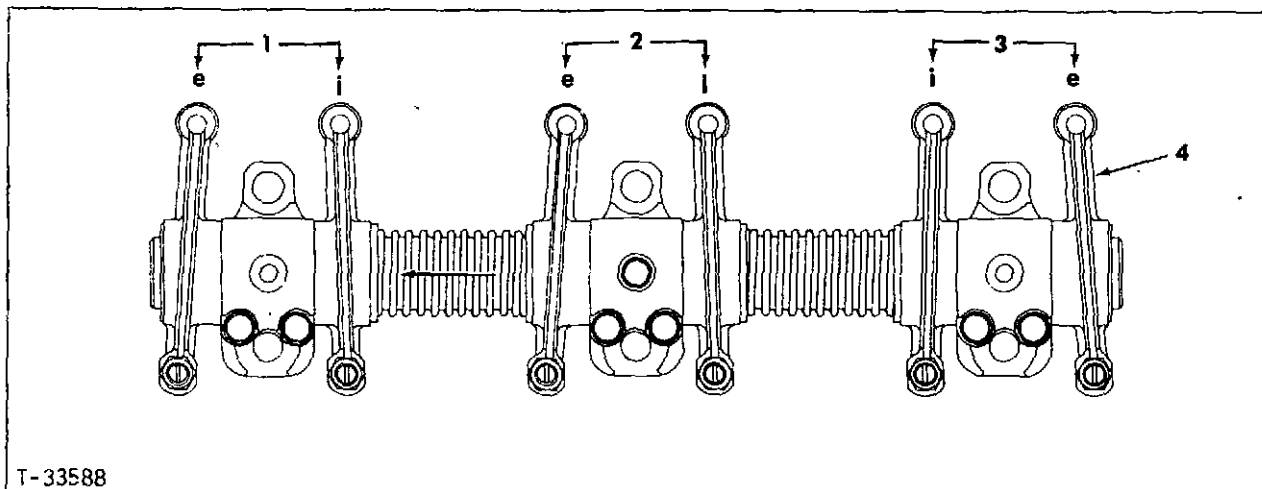

T-33588

- No. 1 Cylinder  
e. Exhaust valves  
i. Intake valves

- No. 2 cylinder  
e. Exhaust valves  
i. Intake valves

- No. 3 cylinder  
i. Intake valves  
e. Exhaust valves
- Rocker arm

Figure 1. Rocker Arms and Valve Location  
(Front Head Shown - Rear Head Identical)

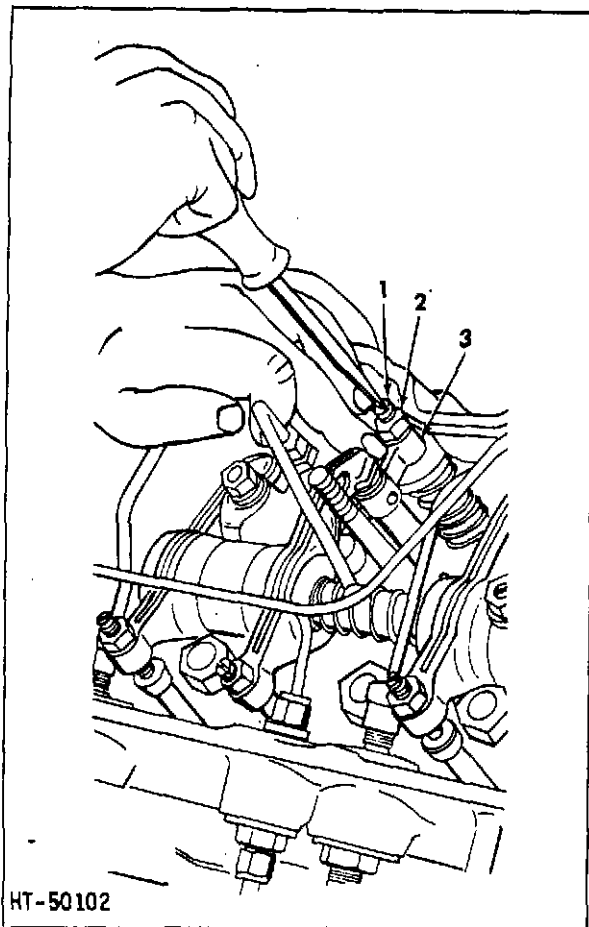

1. Bridge adjusting screw
2. Locknut
3. Valve bridge

Figure 2. Adjusting Valve Bridge

- d. Crank the engine until the intake valves for the number 6 cylinder begin to open.
- e. Loosen the locknut on the number 1 valve cylinder bridge adjusting screw. Back off the adjusting screw approximately one turn. (Refer to Figure 2)
- f. Press down firmly on the center of the bridge and turn the adjusting screw until it makes contact with the valve stem. Hold the screw stationary and tighten the lock nut.
- g. Loosen the rocker arm adjusting screw locknut (Figure 3) and adjust the clearance between the rocker arm and valve bridge by turning the adjusting screw. The proper clearance for the intake valves is .015" (.38 mm). The proper clearance for the exhaust valves is .020" (.51 mm)

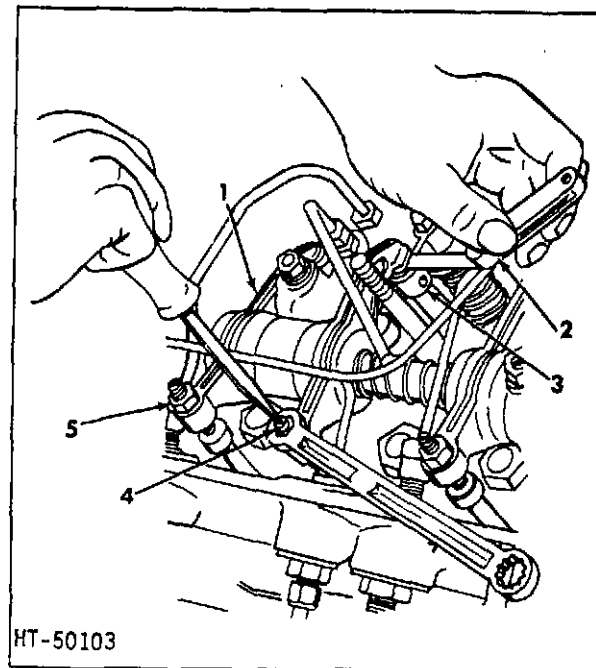

1. Rocker arm
2. Feeler gauge
3. Valve bridge
4. Rocker arm adjusting screw
5. Locknut

Figure 3. Adjusting Valve Lash

- h. Hold the adjusting screw stationary and tighten the locknut. Recheck the clearances to make certain they did not change.
- i. Refer to the table below and adjust the valve bridge and rocker arm clearance for remaining cylinders. Repeat the steps above, substituting appropriate cylinder number in steps d and e.

When the Exhaust Valves Are Nearly Closed and the Intake Valves Start to Open for Cylinder:	Adjust Valves for Cylinder:
Number 6	Number 1
Number 2	Number 5
Number 4	Number 3
Number 1	Number 6
Number 5	Number 2
Number 3	Number 4

#### B. CYLINDER HEAD REINSTALLATION

##### 1. General

New cylinder head gaskets must be used

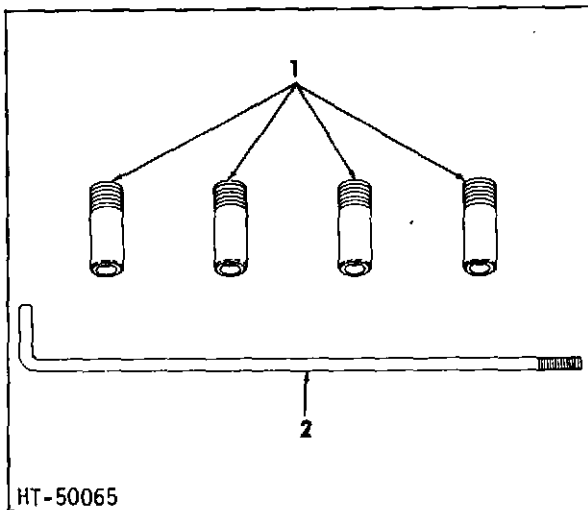

1. Guide studs
2. Stud removal wrench

Figure 4. Cylinder Head Guide Studs and Stud Removal Wrench

when reinstalling the cylinder heads. Install the gaskets and fire rings following the detailed instructions enclosed with each set of service head gaskets. Make certain the head gaskets are installed so that the side stamped TOP faces up.

## 2. Procedure

- a. Screw the guide studs (Figure 4) into capscrew holes as indicated in Figure 5, Item 3. Tighten finger tight.
- b. Install new cylinder head gaskets according to the directions enclosed with the service head gasket set.
- c. Check to make certain no foreign matter has entered the cylinders.
- d. Dip the head retaining capscrews into clean engine oil and allow them to drain.

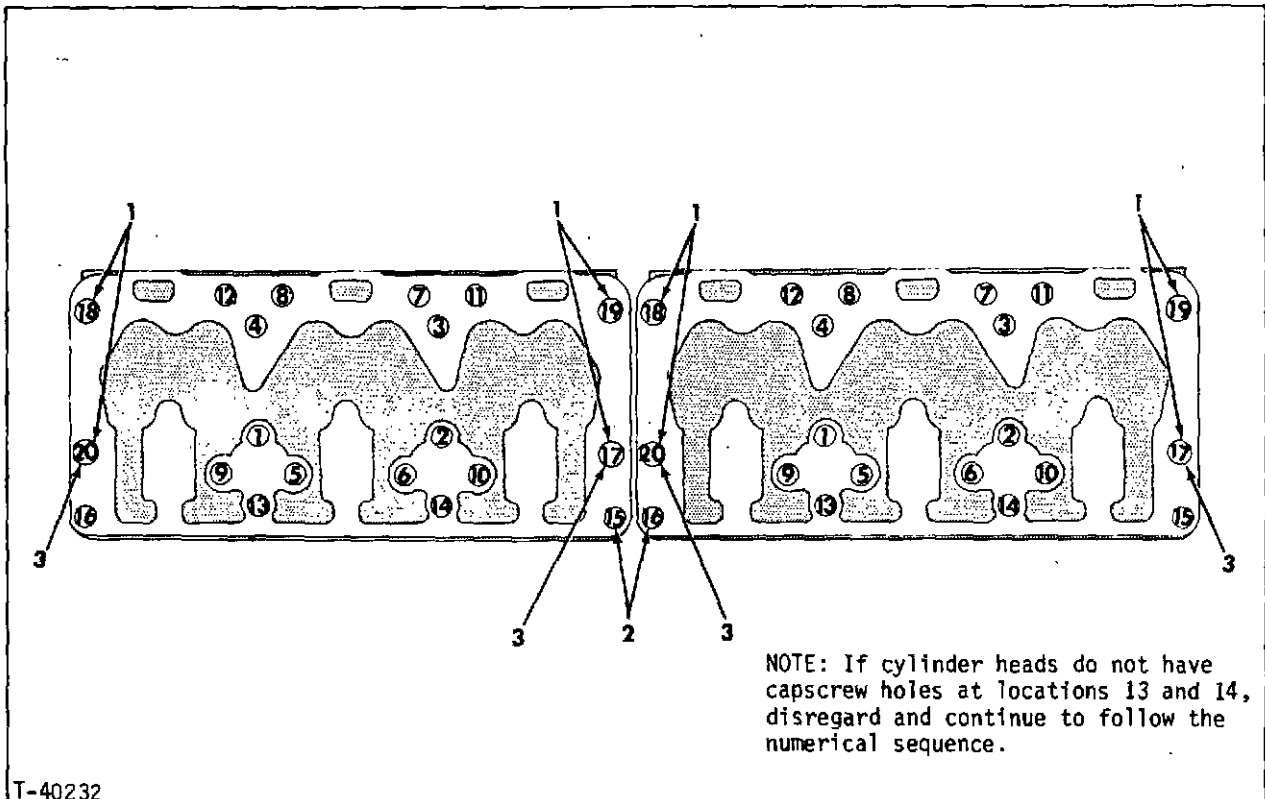

T-40232

1. 3/4" (19.05 mm) diameter by 7-1/4" (178.44 mm) long capscrews
2. 5/8" (15.88 mm) diameter by 6" (152.40 mm) long capscrews  
All other capscrew locations require 5/8" (15.88 mm) diameter by 7" (177.80 mm) long capscrews.
3. Guide stud location

Figure 5. Cylinder Head Capscrew Location and Torquing Sequence

- e. Position the cylinder heads on the block. Check the capscrew holes for foreign matter. Refer to Figure 5 and insert the capscrews into the proper holes. Tighten the capscrews finger tight.
- f. Remove the guide studs. The thread on the removal wrench (Figure 4) is LEFT HANDED, and by continuing to turn the wrench to the left, the guide studs will turn out of the block and can be withdrawn.
- g. Insert the remaining capscrews into the holes from which the guide studs were removed.
- h. Align the two cylinder head manifold mounting surfaces with a straight-edge.
- i. Tighten the capscrews in numerical sequence, to one-half of the specified torque. Refer to Topic 10, Sub-paragraph B for the specified torque.
- j. Tighten the capscrews, in numerical sequence, to full specified torque.
- k. Retighten to full specified torque.
- l. Set the valve lash to the cold setting:
  - Intake valves .020 (.51mm)
  - Exhaust valves .025 (.64mm)
 Refer to Paragraph A for procedure.
- m. Start the engine and run it until coolant reaches a minimum of 160°F (344 K).
- n. Retighten the head capscrews, in nu-

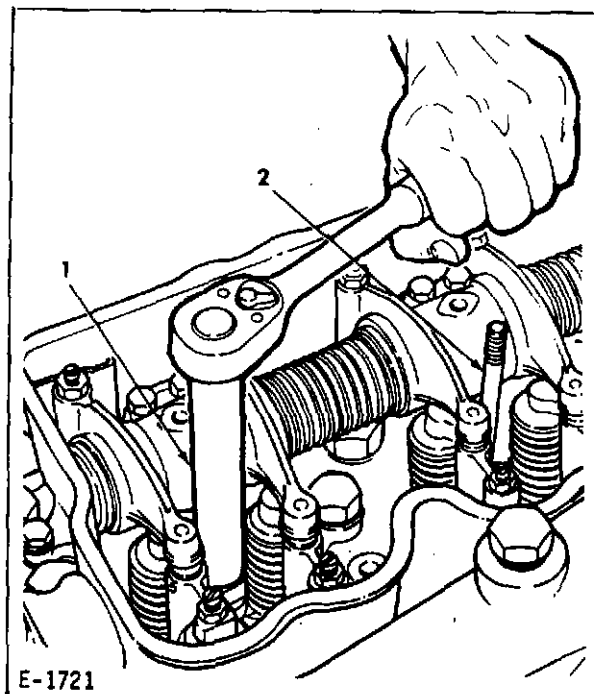

1. Rocker shaft bracket retaining nut wrench
2. Rocker shaft bracket stud

Figure 6. Removing Rocker Arm Shaft Bracket Retaining Nut

- merical sequence, to the full specified torque.
- o. Readjust the valve lash to the HOT setting:
  - Intake valves .015" (.38mm)
  - Exhaust valves .020" (.51mm)
- p. Retorque nozzle-holder assembly hold-down clamp nut to 45 lb-ft (61 Nm).

## TOPIC 16. INTAKE AND EXHAUST SYSTEMS

### A. DESCRIPTION

The intake and exhaust system consists of those components that convey filtered air to the engine cylinders and convey exhaust gases from the engine.

**CAUTION:** Never operate the engine with the air cleaner or exhaust pipe removed.

The intake system consists of the air cleaner, intake manifold, and intake valves. The exhaust system consists of the exhaust valves, exhaust manifold, muffler, and exhaust piping extensions. If the engine is equipped with a turbocharger, the compressor side of the turbocharger is part of the intake system and the turbine side is part of the exhaust system.

Various types of manifolds are applied to the engines and they differ as to the air intake opening locations and exhaust outlet openings. The different openings are provided to meet specific installation requirements of the engines. Manifolds requiring replacement should always be replaced with the same type unless the engine is to be prepared for a different application.

It is important that an ample supply of fresh clean air be provided to the combustion chambers. Insufficient air will limit the amount of fuel the engine can burn and will lead to loss of power, excessive exhaust smoke, and high fuel consumption, and eventual engine failure.

In warm weather, sufficient heat is generated by compression of the air within the cylinders to ignite the fuel and start the engine within a very short cranking period. However, in cold weather the "drag" caused by cold oil between the pistons and cylinder walls and in the bearings reduces the cranking speed of the engine. A large part of the heat generated by compression of the air is absorbed by the cold pistons and cylinder walls. This heat loss and the reduced cranking speed may reduce the temperature of the air in cylinders to a point too low to ignite the fuel and the starting of the engine must be assisted by the use of optional equipment cold weather starting aids. These aids consist of a pressurized cylinder containing a highly volatile fluid that is injected into the intake manifold while the engine is being cranked or an immersion heater which maintains the coolant temperature between 90°F (305 K) and 120°F (322 K) with the engine stopped.

If there is any question as to whether or not the engine has excessive exhaust back-pressure, check the back-pressure with a mercury

manometer as shown in Fig. 1.

**CAUTION:** Muffler installations or exhaust pipe extensions must be adequately supported and flexibly connected to eliminate any possibility of strain on the exhaust manifold or turbocharger outlets.

### B. MEASURING EXHAUST SYSTEM BACK-PRESSURE

Total restriction of the entire exhaust system of a naturally aspirated engine at the exhaust outlet with engine under full speed, full load conditions, must not exceed 3 inches (0.09 kg/cm<sup>2</sup>) mercury back-pressure. Total restriction of the entire exhaust system of a turbocharged engine must not exceed 2 inches (0.06 kg/cm<sup>2</sup>) mercury back-pressure.

Most manifolds on naturally aspirated engine are provided with a .25" (6.35 mm) pipe threaded hole in the side of the exhaust outlet to facilitate manometer installation. If necessary, drill and tap a .25" (6.35 mm) pipe threaded hole in side of manifold near the exhaust outlet opening. On turbocharged engines, the manometer is connected to the exhaust elbow. (See Figure 1.) To connect manometer to exhaust manifold, screw a .25" x .125" (6.35 x 3.175 mm) reducer bushing into hole in side of manifold.

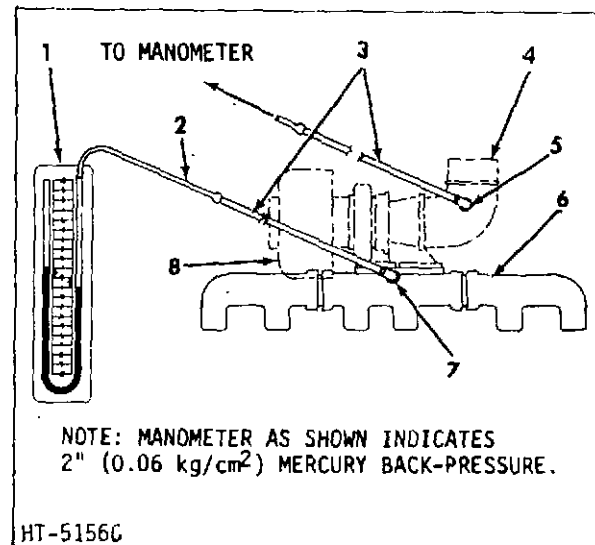

1. U-tube manometer
2. Rubber tubing
3. Copper tubing
4. Exhaust elbow for naturally aspirated engines
5. Location of fitting for turbocharged engines
6. Exhaust manifold
7. Location of fitting for naturally aspirated engines
8. Turbocharger

Figure 1. Checking Exhaust Back-Pressure

Fitting must be flush with inside and perpendicular to manifold to avoid false readings. Fasten about 3 feet (914 mm) of .25" (6.35 mm) OD copper tubing to fitting in manifold. From other end of copper tubing connect a length of rubber tubing to one side of the manometer.

It should be noted in the illustration, Figure 1, that the manometer scale is graduated in inches both above and below the 0 mark, and each inch is divided into tenths. When manometer is set up for use, sufficient mercury must be put in the U-shaped tube so height in both columns aligns with 0 line on the scale.

Take exhaust back-pressure readings when engine is developing its maximum horsepower and rpm. When reading manometer, add height of liquid in both columns to obtain final figure. For example, if liquid is 1" (0.03 kg/cm<sup>2</sup>) high in left column and 1" (0.03 kg/cm<sup>2</sup>) low in right column, the manometer indicates 2" (0.06 kg/cm<sup>2</sup>) mercury back-pressure.

NOTE: If mercury is 1" (0.03 kg/cm<sup>2</sup>) high in right column and 1" (0.03 kg/cm<sup>2</sup>) low in left column, the manometer indicates 2" (0.06 kg/cm<sup>2</sup>) mercury vacuum, rather than pressure. A 1" (0.03 kg/cm<sup>2</sup>) mercury indication is equivalent to 0.491 psi (3.38 kN/m<sup>2</sup>), 2" (0.06 kg/cm<sup>2</sup>) of mercury is equal to 2 x 0.491 (3.38 kN/m<sup>2</sup>) or 0.982 psi (6.76 kN/m<sup>2</sup>). If a manometer is not available, an accurate pressure gauge can be used.

Excessive back-pressure will result in poor engine performance and shortened engine life. Measurement of exhaust pressure will indicate whether or not capacity of exhaust system is adequate. If back-pressure reading is higher than the specified figure, one or more of the following factors is the cause:

1. Sharp right angles or excessive bends in exhaust piping. All angles and bends must be gentle sweeping curves. Piping should have as few angles/bends as possible.
2. Exhaust piping diameter too small. Pipe size must never be less than diameter of exhaust outlet opening. As piping length increases, so should the diameter.
3. Foreign material causing restrictions in muffler or piping.
4. Inadequate muffler capacity.

#### C. MANIFOLD MAINTENANCE

1. Use new gaskets when reinstalling manifolds.
2. Periodically check all manifold mounting capscrews for tightness after engine is hot. Tighten manifold mounting capscrews to specified torque, starting at the center and working alternately toward each end. Tighten intake manifold mounting capscrews to 68-73 lb-ft (92-99 Nm) torque and exhaust manifold mounting capscrews to 85 lb-ft (115 Nm).
3. At time of overhaul, check manifold for carbon deposits. Clean and remove obstructions found within the manifold.
4. If manifold is cracked, repair or replace as necessary.
5. If mounting surfaces of one section are warped and will not seal, it must be replaced or remachined. If material is machined from one section, a like amount must be removed from the other 2 sections.

## TOPIC 17. AIR CLEANER

### A. GENERAL

The purpose of the air cleaner is to remove dust and other foreign matter from the air used by the engine. The amount of servicing required and frequency of element change is completely dependent upon the abrasives (dirt) in the air surrounding the engine.

A filter service indicator provides the most accurate and convenient means of determining when the filter cartridge should be changed. If a service indicator is not utilized, a cartridge renewal period should be determined by daily inspection of the air cleaner under actual operating conditions, until the period can be established.

The heavy duty dry type air cleaner consists of a housing (Fig 1 Item 4), cartridge (8), and moisture eliminator (11) or (12). Moisture is removed from the air by it striking the screening in the moisture eliminator and draining from the bottom of it. The air is cleaned while passing through the pleated paper sides of the cartridge tubes. Cleaned air leaves the housing and passes on to the engines.

The extra heavy duty dry type air cleaner consists of a housing (Fig 1 Item 4), cartridge (8), pre-cleaner (9), aspirator (15), and its piping, and rain cap (16). Automatic self-cleaning of the pre-cleaner is achieved by the use of an aspirator in the exhaust system. Air

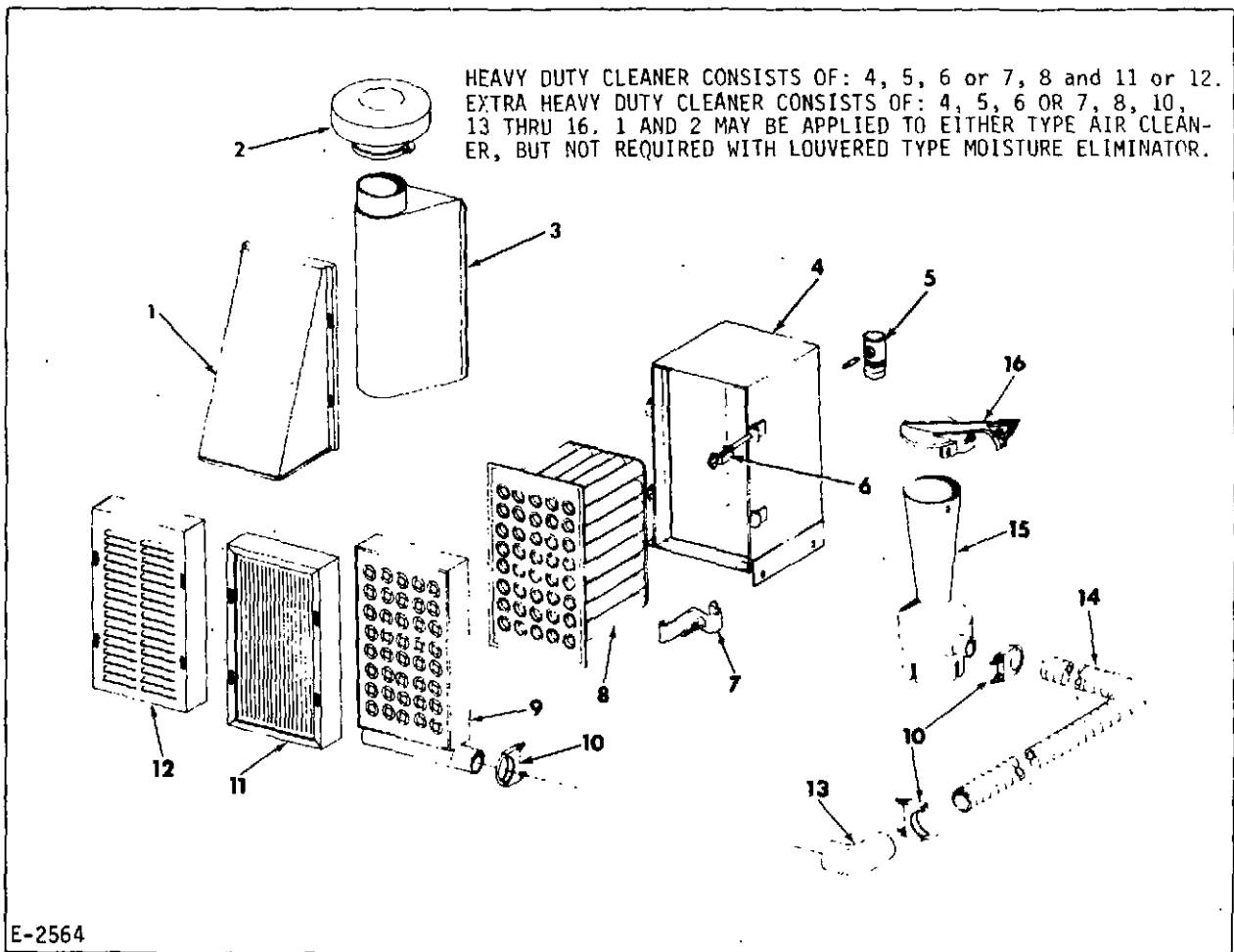

E-2564

- |                   |                       |                                       |                   |
|-------------------|-----------------------|---------------------------------------|-------------------|
| 1. Rain guard     | 5. Service indicator  | 10. Clamp                             | 13. Elbow         |
| 2. Stack cap      | 6. Wingnut type clamp | 11. First type moisture eliminator    | 14. Flexible hose |
| 3. Vertical inlet | 7. Nut type clamp     | 12. Louvered type moisture eliminator | 15. Aspirator     |
| 4. Housing        | 8. Cartridge          | 16. Rain cap                          |                   |
|                   | 9. Pre-cleaner        |                                       |                   |

Figure 1. FARR Dry Type Air Cleaners

enters the precleaner and is spun to remove moisture and 90% of the dust particles. The separated moisture and dust falls into the dust bin and are drawn out through the aspirator. Precleaned air then enters the filter cartridge for second-stage cleaning. The aspirator is connected to the precleaner panel by means of a flexible metal hose. The rain cap (16) prevents moisture from entering the exhaust system when the engine is stopped.

**CAUTION:** Do not under any circumstances cover up the precleaner face.

## B. MAINTENANCE

Periodic inspection of air cleaner body for dents, cracks, etc., should be made. Also check for damaged hoses, loose hose clamps, damaged gaskets, or any kind of leak that allows air to enter engine without first passing through the air cleaner. If any of the above conditions exist immediate corrective action must be taken.

Do not clean the cartridge. Experience has shown that attempting to clean a dirty cartridge by washing, shaking, or compressed air, frequently results in damage to it. Internal damage caused by cleaning often is too minute to be seen, or may develop after re-installation.

Under normal conditions the precleaner is self-cleaning, however, under extreme conditions the precleaner may require cleaning. It may be cleaned by steam cleaning, washing, or by blowing air through the front and back of the cyclonic tubes and dust bin.

If necessary, the moisture eliminator can be cleaned in a similar manner as the pre-cleaner, making certain all foreign matter and cleaning solutions are drained out through the holes in the bottom of it.

The fasteners of the clamps which secure the cartridge, precleaner, or moisture eliminator to the housing are of 2 types. The first type (Fig 1 Item 6) uses a wingnut, whereas the second type (7) uses a flanged hex nut.

Replace cartridge and clean air cleaner housing when red signal is visible in window of service indicator (Fig 2). Refer to following the paragraphs to service air cleaner and the procedure to replace cartridge.

## C. SERVICE

Replace cartridge and service air cleaner as follows:

1. Loosen wing/nuts (Fig 1 Item 6 or 7) and clamps and remove moisture eliminator, (11 or 12) or precleaner (9) after

removing its flexible hose (14) from elbow (13).

2. Insert fingers into cartridge (8) openings and loosen all four corners of the cartridge one at a time by pulling straight out at each corner. After seal has been broken, remove cartridge by pulling it straight out and slightly up so cartridge clears the sealing frame. Discard dirty cartridge.

**NOTE:** Do not clean or reuse dirty cartridge. Inspect dirty cartridge for soot or oil. If there is soot inside the tubes, check for leaks in the engine exhaust system or exhaust from other equipment. If the cartridge appears to have an oily film, check for fumes escaping from the breather tube. Correct any of these conditions, if necessary, before a new cartridge is installed.

3. Inspect inside of housing (4) and remove all foreign material.

**CAUTION:** Inspect new cartridge for shipping damage before installation.

4. Install new cartridge into housing. Avoid hitting the cartridge tubes against the sealing flange of the housing. Firmly press all edges and corners of the cartridge against the sealing flange with your fingers to effect a positive air seal.

**CAUTION:** Do not pound in the center of the cartridge to effect a seal.

5. If necessary, clean moisture eliminator or precleaner.
6. If heavy duty type air cleaner, install moisture eliminator (11 or 12) with drain holes to bottom. If the air cleaner is the extra heavy duty type, install the precleaner (9) with dust bin to the bottom.
7. Tighten the moisture eliminator and precleaner clamp fasteners in a diagonal sequence. If wingnut type (6), tighten finger tight and 1 1/2 to 2 additional turns with pliers or wrench. If hex nut type (7) tighten to 72 lb-in (8 Nm).

**NOTE:** If, at a later date, inspection of the wing/nuts indicates that they are at less than specified torque, this is due to a slight set in the plastic face

NOTE. (Cont): of the cartridge and does not impair the seal between the cartridge and the housing. Retightening of the wing/nuts is not recommended, unless they are loose, as this may break the seal which has been formed.

8. If extra heavy duty type air cleaner, install flexible hose (14) over end of precleaner elbow (13) and tighten clamp (10). Inspect flexible hose and clamps. Make certain all connections, including aspirator (15), are air tight.
9. Reset service indicator by pressing reset button on top of indicator (Fig 2).

CAUTION: The only allowable modification that can be made to the aspirator is the addition of an exhaust pipe extension to the large end of the cone. A maximum of 4 feet (122 cm) of straight exhaust pipe of at least the same diameter as the large end of the cone may be added. When an exhaust extension longer than 4 feet (122 cm) is required, resizing of the aspirator is necessary. The size and the shape of the cone of the aspirator must never be modified in service. If the aspirator system must be modified from its original configuration, or if extensions longer than 4 feet (122 cm) are required, consult your Allis-Chalmers dealer to assist in its design and modification.

#### D. AIR FILTER SERVICE INDICATOR

Purpose of the service indicator (Fig 2), which is factory set, is to provide a visual signal when the air cleaner is in need of maintenance. The operator can ascertain the degree of filter contamination by observing the indicator during periods of actual engine operation.

Dirt trapped by the air cleaner gradually reduces volume of air flow through the filter and increases the air cleaner-to-engine pressure drop. As pressure flow decreases, the red signal of the filter indicator gradually moves in the window and when fully exposed is locked in position. At this time the air cleaner should be maintained or the ele-

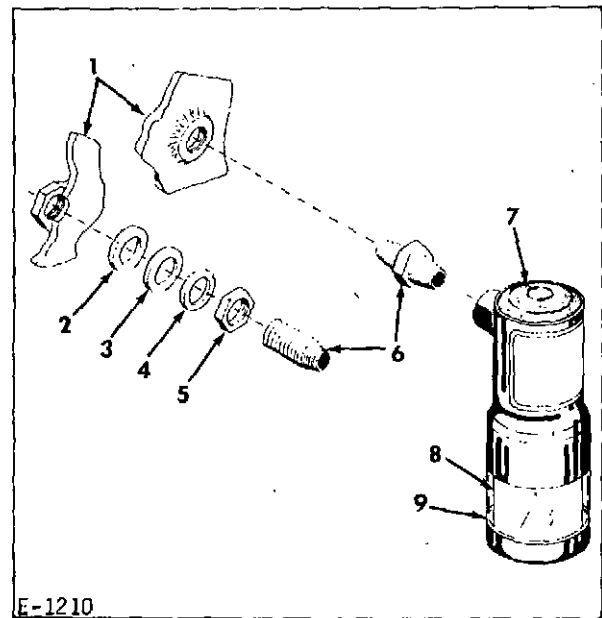

E-1210

1. Air cleaner housing
2. Fiber washer
3. Washer
4. Lockwasher
5. Jam nut
6. Connector with sintered filter
7. Press to reset
8. Red signal
9. Window

Figure 2. Air Filter Service and Connector Filters

ment replaced or cleaned. Reset signal by pressing reset button located on top of the service indicator.

The indicator is connected to the connector (6) on the outlet side of the air cleaner. If seals in the indicator rupture, the filter in the connector will prevent dust and other foreign material from entering the engine. If seals are damaged, the service indicator must be replaced. If the connector filter becomes clogged with foreign material that passes through a defective service indicator, remove the tube assembly and service indicator. Clean the filter within the connector with a cleaning solvent and dry with compressed air. Air pressure should be directed through the filter in reverse of normal air flow.



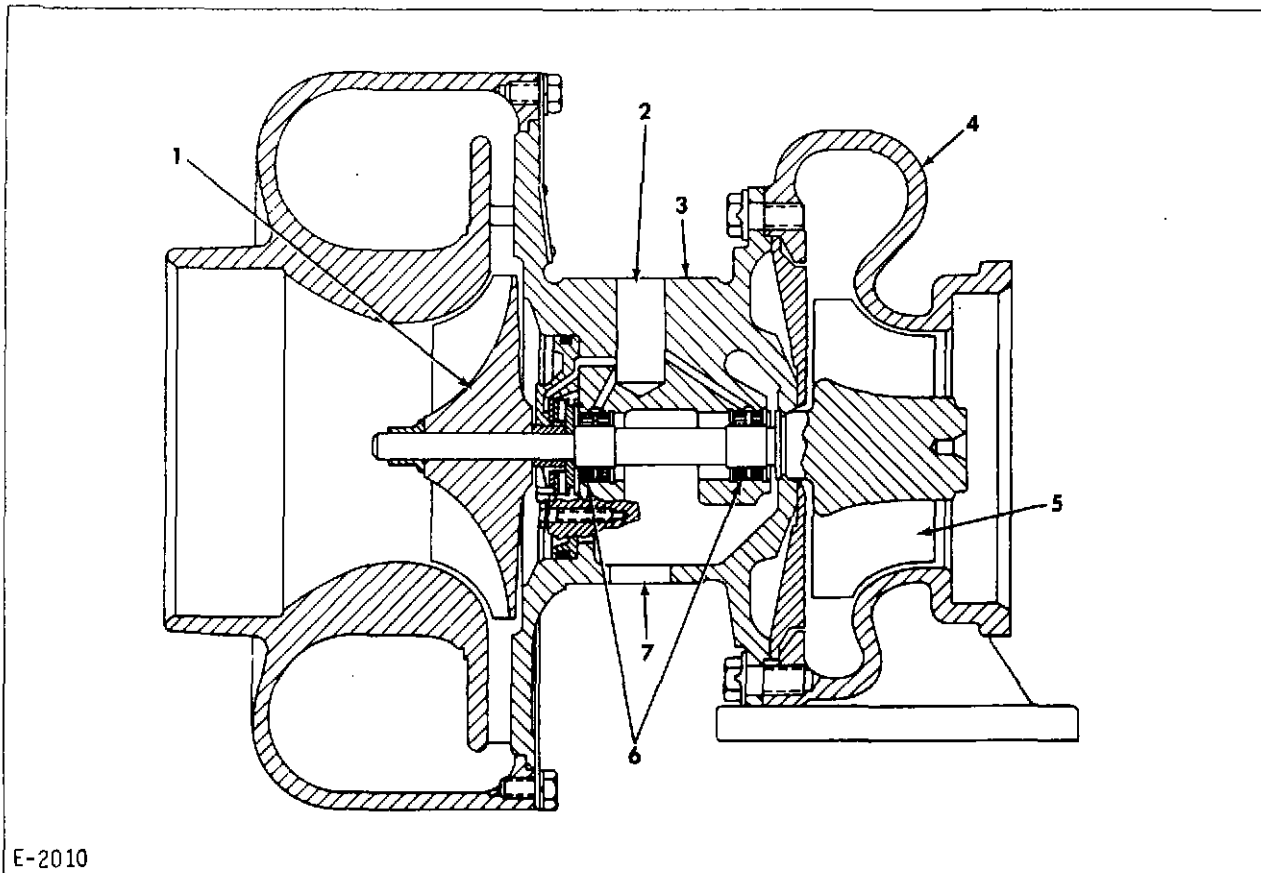

- |                            |  |
|----------------------------|--|
| 1. Compressor impeller     | 5. Turbine impeller and shaft assembly |
| 2. Oil inlet               | 6. Impeller shaft bearings             |
| 3. Center housing assembly | 7. Oil outlet                          |
| 4. Turbine housing         |  |

Figure 2. Turbocharger (Engine Models 21000 MKII, 25000 MKII - Dry Type Exhaust Manifolds)  
(Engine Models 17000 MKII, 21000 MKII, 25000 MKII - Water Cooled Exhaust Manifolds)

the air intake manifold. The turbocharger responds to the engine demands by reacting to the flow of expanding exhaust gases. As the power output of the engine increases, the energy contained within the flow of exhaust gases increases proportionately. As the power requirement is reduced, such as when the engine load is reduced or when the engine speed is lowered, the energy contained within the flow of exhaust gases decreases and the speed at which the rotating assembly turns decreases proportionately.

The turbocharger is pressure lubricated with filtered engine oil supplied through an external line extending from the oil filter to the oil inlet on the center housing. The oil is directed through internal passages to the impeller shaft bearings, thrust ring, thrust bearing, and thrust plate. A return line, extending from the oil outlet of the turbocharger to the oil pan, returns lubricant directly to the oil pan.

**WARNING: NEVER OPERATE THE ENGINE WITH THE AIR INLET PIPING OF EXHAUST ELBOW REMOVED FROM THE TURBOCHARGER. FOREIGN OBJECTS DRAWN INTO THE COMPRESSOR INLET WILL RESULT IN DAMAGE TO THE COMPRESSOR WHEEL AND MAY ENTER THE CYLINDERS. HOT GASES AND DISCHARGED CARBON PARTICLES FLOWING FROM THE TURBINE OUTLET CAN CAUSE PERSONAL INJURY.**

### C. MAINTENANCE

#### 1. Inspections and Checks

Each time the engine lubricating oil and filter elements are replaced, or any other routine maintenance operation is performed, inspect the following:

- a. Air Cleaner and Intake System

Restriction in the air intake system will cause malfunction of the turbocharger as well as the engine. The restriction (vacuum) should never exceed 30 inches of water (7465 N/m<sup>2</sup>) at the turbocharger air inlet at engine full speed and full load.

- (1) Inspect the hose connections, air cleaner-to-turbocharger inlet tubing, and gaskets for air leaks. Check for loose clamps.
- (2) Inspect for restrictions due to dented tubing or collapsed hoses.

#### b. Lubrication System

The engine lubricating oil and filter elements must be replaced at specified intervals to assure a clean supply of oil. Loss of engine oil pressure can quickly damage or destroy a turbocharger. Minimum oil flow to the turbocharger with engine running is 10 psi (69 kN/m<sup>2</sup>) with oil temperature of 180°F (355 K).

**CAUTION:** If an engine has been in storage for several months without being operated, it is recommended that the oil inlet connection at the turbocharger be removed and 3 to 4 ounces (85 to 113 g) of lubricant be placed in the oil inlet of the center housing. Also, fill oil inlet line with oil. Perform the above BEFORE operating engine.

Inspect the oil inlet lines, drain lines, and fittings for leakage, clogging, or other damage.

#### c. Exhaust System

The total restriction of the exhaust system must not exceed 2 inches (6754 N/m<sup>2</sup>) of mercury back pressure at the turbocharger turbine housing exhaust outlet at engine full speed and full load. Excessive back pressure will reduce turbine speed and subject the turbine to excessive temperatures.

- (1) Inspect for exhaust leaks due to damaged gaskets, cracks in exhaust manifold, loose manifold mounting, or loose turbocharger-to-manifold mounting.
- (2) Observe engine exhaust. Excessive smoke may indicate a restricted air cleaner or air intake pipe, over-fueling, or faulty turbocharger operation. Check air filter service

indicator.

#### d. Fuel Injection Pump

**CAUTION:** Under no circumstances should the factory maximum fuel delivery specification for the injection pump be exceeded in order to increase power. The resulting turbocharger and engine damage will be costly and off-set any benefits that might have been derived from increasing engine power.

#### e. Engine Breather System

A clogged engine breather tube will cause a pressure build-up in the engine. This pressure will prevent the oil from draining down the oil return line and will force oil out of the turbocharger and into the engine air intake system.

Check the engine breather tube to make certain it is not clogged.

#### f. Operating Checks

Operate the engine at approximately rated output and listen for unusual turbocharger noises. (Do not confuse the whine heard during run-down with one which indicates an impeller shaft bearing failure during operation.)

Other unusual noises can result from improper clearance between the turbine impeller and the turbine housing. If such noises are heard, the turbocharger assembly must be removed, disassembled, and inspected.

## 2. Major Inspection

After each 4000 hours of normal service (or depending on operating conditions), visually inspect for an accumulation of dirt on the compressor impeller vanes and on the diffuser of the compressor housing.

If the coating of dirt on the impeller is light and even, cleaning is not necessary. If the coating of dirt is uneven, excessive, or approaching the appearance of a layer which may flake off, cleaning is necessary. An uneven build-up of dirt will disturb the balance of the rotating assembly and lead to failure of the turbocharger.

**CAUTION:** A poor cleaning job which leaves deposits on the compressor impeller is as destructive as an uneven layer of dirt.

An excessive build-up of dirt on the diffuser will result in a loss of turbocharger efficiency and is indicated by an excessive amount of black exhaust smoke.

Normally, a slight build-up of carbon deposits will not affect turbine operation.

#### D. EFFECT OF ALTITUDE ON TURBOCHARGED ENGINES

**CAUTION:** To prevent damage to the engine from excessive exhaust temperatures and turbocharger overspeeding when operating at altitudes above sea level, it is necessary to consider a reduction in the maximum fuel setting of the fuel injection pump. The necessity or amount of derating is dependent upon several interrelated factors.

Altitude affects a turbocharged engine in the amount of an approximate 1% decrease in horsepower per 1000 feet (304.8 meters) of altitude until an altitude is reached at which the engine must be derated and the maximum fuel setting of the fuel injection pump reduced for one of the following reasons:

1. In a continuous type operation the turbocharger must not exceed the rpm indicated below:  
Model 17000MKII - 109,500 rpm  
Model 21000MKII - 75,500 rpm  
Model 25000MKII - 75,500 rpm
2. In an intermittent type operation the turbocharger must not exceed the rpm indicated below:  
Model 17000MKII - 117,500 rpm  
Model 21000MKII - 82,600 rpm  
Model 25000MKII - 82,600 rpm
3. Maximum allowable exhaust temperature is 1300°F (978 K).
4. Turbocharger cavitation (surging) cannot be tolerated.

An engine operating under conditions of continuous type loading must be derated more than an engine operating under conditions of intermittent loading where loading intervals are of a time duration that does not allow stabilization of manifold temperatures and pressures, even though both may be set to deliver the same amount of horsepower. Likewise, an engine delivering near maximum horsepower must be derated more than a similar engine set to deliver a conservative amount of horsepower.

At governed speeds the exhaust temperature increases at the rate of approximately 20°F per 1000 ft (11 K per 304.8 m) altitude. However, when the engine is lugged down to 1400 to 1500 rpm the temperature may increase at a rate of 35°F per 1000 ft (19 K per 304.8 m) altitude.

The maximum ambient temperature expected must be considered when making adjustments to control exhaust temperatures. For example, a 10°F (6 K) change in ambient temperature will affect a Model 21000MKII non-intercooled engine exhaust temperatures from approximately 20°F (11 K) at governed speed to as much as 35°F (19 K) when lugged down to 1400 or 1500 rpm. The Model 25000MKII intercooled engine is affected only approximately one-half this amount.

Engines equipped with the specified turbocharger will exceed the 1300°F (978 K) maximum allowable exhaust temperature before the maximum allowable speed of the turbocharger is reached. Therefore, as a practical field approach, safe control of turbocharger speed and exhaust temperature during altitude operation can be maintained by reducing the fuel injection pump flow thereby limiting the exhaust temperature so that it does not exceed 1300°F (978 K).

**NOTE:** The exhaust temperature must be taken before it enters the turbocharger. The turbocharger mounting flange of the dry type exhaust manifold or the turbocharger-to-water cooled exhaust manifold adaptor are provided with a 1/4" pipe plug for installing thermocouples of temperature indicators.

## TOPIC 19. SAFETY CONTROLS

### A. GENERAL

The purpose of the optional engine safety controls is to automatically stop the engine or audibly warn the operator to stop the engine, thereby protecting it from damage if oil pressure drops below safe operating pressure, if

the coolant temperature rises above a safe preset limit, or if the engine should overspeed.

For information covering these safety devices, refer to the owner's manual covering the equipment being driven by the engine.

## TOPIC 20. COLD WEATHER STARTING AIDS

### A. GENERAL

**CAUTION:** Too much starting fluid injected into an engine can produce any or all of the following harmful conditions; premature detonation, with resulting undue pressures on pistons, rings, and crankshaft; "ether wash" which reduces or eliminates the oil film on the cylinder walls causing scoring or premature engine failure; and accumulations of excess ether in the intake system which can cause disastrous effects when the ether is sucked into the engine after it is running.

Two types of cold weather starting aids are available as optional equipment to assist engine starting in extreme cold weather. The first, is an electrically operated type and the second is a manually operated type.

The discharger or control is mounted on or near the engine control panel where it is accessible to the operator during startup. The spray nozzle is connected to the discharge by a length of nylon tubing. The position of the nozzle in the air intake system is such that discharged starting fluid is distributed proportionally to all engine cylinders.

### B. ELECTRICALLY OPERATED TYPE (Figure 1)

**CAUTION:** Starting fluid containers are under pressure and extremely flammable. Keep away from heat, sparks, or open flame. Avoid contact with the skin and avoid breathing of fumes. Observe the precautions printed on the containers.

#### 1. Description

Injection of the starting fluid into the engine air intake system is accomplished by the electrically controlled discharger valve assembly. When the push button on the control is pressed, the discharger valve is energized to open the valve to receive a measured quantity of starting fluid. The valve then closes and discharges the starting fluid into the intake manifold.

**CAUTION:** When the fuel cylinder is removed from the discharger valve assembly, always keep top of valve assembly covered with the plastic cap that is

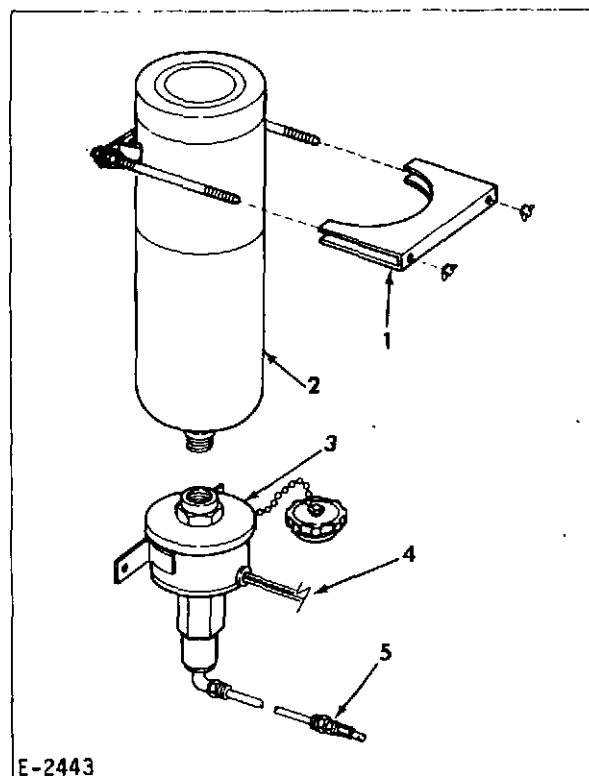

E-2443

1. Mounting clamp assembly
2. Fuel cylinder
3. Discharger valve assembly
4. Source wires to push button
5. Spray fitting

Figure 1. Cold Weather Starting Aid (Electric Type)

**CAUTION (Cont):** attached to the chain provided with the assembly to prevent entrance of foreign material into the discharger valve assembly. If it is ever decided to remove the starting aid assembly and operate the engine without it in the air intake system, first disconnect the tube from the spray fitting. Then remove the spray fitting and replace it with a pipe plug.

#### 2. Handling Precautions

- a. Do not heat fuel cylinders.
- b. Starting fluid contained in the cylinders is volatile and highly flammable. When discharger is being tested or inspected and is not installed on engine, do not discharge spray in a confined area or near an open flame.
- c. The ether component of the starting

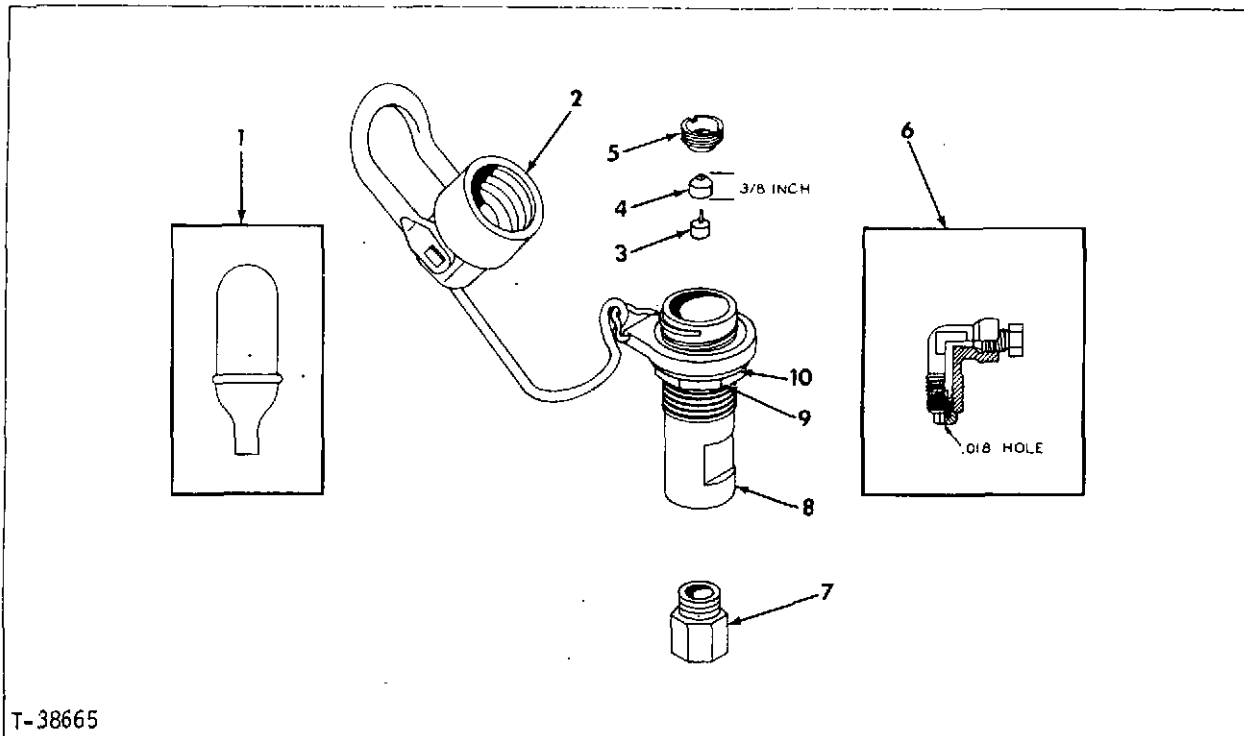

T-38665

- |                            |                    |
|----------------------------|--------------------|
| 1. Bulb assembly (SP-5C-5) | 6. Spray nozzle    |
| 2. Cap                     | 7. Screen assembly |
| 3. Piercing Pin            | 8. Body            |
| 4. Neck washer (rubber)    | 9. Nut             |
| 5. Retaining ring          | 10. Washer         |

Figure 2. Ether Discharger

fluid is toxic. Avoid prolonged breathing of fumes.

- d. Do not puncture or incinerate cylinder.

### 3. Operation of Discharger

- a. Remove plastic cap from top of discharger valve assembly. Install fuel cylinder by placing it in position to engage threads and screw in hand tight. Then secure cylinder with clamp. Refer to instructions printed on cylinder.
- b. Place speed control in the run position.
- c. Push starting aid button on engine control panel for 1 second and release to fill the measured chamber in the valve assembly.
- d. Wait 2 seconds and press starter button on engine control panel.
- e. If temperature of 0°F (255 K) or below, repeat steps c and d.

- f. If engine does not start immediately, repeat steps c, d, and e.

### 3. Maintenance

The ether starting aid assembly is ruggedly constructed and ordinarily does not require servicing. If the assembly sustains major damage, remove and replace the complete unit.

- a. When replacing empty fuel cylinder, wipe dirt from around valve inlet and follow instructions in Step a of preceding Paragraph 3, Operation of Discharger. Use care in wiping dirt from entering valve.
- b. Periodically remove fuel cylinder and lubricate the valve.

**WARNING: CONTENTS OF FUEL CYLINDER ARE TOXIC AND EXTREMELY FLAMMABLE, DO NOT DISCHARGE IN A CONFINED AREA OR NEAR AND OPEN FLAME.**

- c. Periodically check all connections

for leaks. Correct any leaks found.

- d. Check mounting bolts and clamp for tightness.
- e. Periodically test unit for proper functioning by disconnecting the spray fitting from air inlet system. The side of the fitting is marked (chisel mark) to indicate the location of the spray orifices. Note location mark when removing the fitting. Install the fitting with location mark on the same position.
- f. Reassemble spray fitting to tube.
- g. Actuate system.
- h. A fine mist-like spray should be emitted from the orifice in the spray fitting.

#### 4. Troubleshooting

If an inoperable condition exists, perform the following:

- a. Check fuel cylinder for hand tightness and check fuel supply. An empty fuel cylinder weighs 17 ounces (0.45 kg); a full fuel cylinder weighs 37 ounces (1.05 kg). Make certain fuel cylinder is tight, if empty, replace it.
- b. If system is still not functioning, replace entire unit.

### C. MANUALLY OPERATED TYPE (Figure 2)

#### 1. Description

This cold weather starting aid is a Chevron pressure primer system that meets requirements of Specification MIL-P-16912 and Federal Specification F-P-00666 (GSA-FSS) for cold starting aids. It is approved by the U.S. Coast Guard for use on board vessels subject to the Dangerous Cargo Regulations.

The discharger assembly is located on the engine control panel where it is accessible to the operator during start-up. The spray nozzle is installed in such a position that the discharged priming fuel is distributed proportionally to all engine cylinders. The spray nozzle is installed to a 1/4" NPT hole in the inlet elbow that is located between the intake manifold and turbocharger. A length of 1/8" (3.18 mm) copper tubing connects the discharger assembly to the spray nozzle.

Injection of priming fuel into the

engine air intake system is accomplished by inserting a pressure primer bulb into the cam-actuated discharger that is designed to pierce the bulb sealing cap. The released priming fuel is directed through connecting tubing to the spray nozzle in the engine air intake flange or elbow.

The cold weather starting aid has the following features:

- a. The discharger is rugged, easy to operate, and requires minimum maintenance. It is adaptable to most engine installations and can be actuated from the operators position at the control panel.
  - b. The steel pressure primer bulbs are impervious to water and dirt, and are not affected by atmospheric conditions. Because the bulbs will not deteriorate during storage, they may be purchased in quantities to meet requirements of various operations. Bulbs are packaged 10 in a cardboard box and 50 boxes in a master carton (total 500 bulbs). These may be procured through any local division of the California Oil Company.
  - c. Priming fuel is a combination of gaseous and liquid components found most effective for engine starting. Its extremely low auto-ignition temperature, wide range of flammability, and high volatility at low temperatures, together with delivery in atomized form, makes it a very effective cold weather starting aid.
  - d. Because the priming fuel is under pressure, it does not require a pump to force it into the air intake system.
  - e. Bulbs are sealed with welded closures. Their all metal construction excludes water/dust and eliminates the fire hazard normally associated with handling of flammable materials.
- #### 2. Handling Precautions and Operation of Discharger
- a. Do not heat bulbs. Although they will withstand temperatures of 600°F (588.71 K), they should not be subjected to heat unnecessarily.
  - b. When the discharger is being tested or inspected and is not installed on the engine, the bulbs should not be discharged in confined areas or near an open flame.

**CAUTION:** Fluid contained in the bulb is similar to ether and is toxic. Do not breathe fumes.

- c. A plugged discharger, tube or spray nozzle can cause starting fluid to be thrown onto the operator when the discharger cap is removed after discharging a bulb. To check operation of the system, refer to Paragraph 3 of this Topic.
- d. Operation of discharger:
  - (1) The engine speed control must be in the run position.
  - (2) Unscrew pressure primer discharger cap. Insert steel primer bulb, neck down, and screw down cap.
  - (3) After starting motor has brought the engine up to cranking speed, discharge the pressure primer bulb by pushing or pulling the discharger actuating lever up and over (180° swing).
  - (4) When bulb in discharger has had sufficient time to empty (approximately 15 seconds), place actuating lever back in its original position, unscrew discharger cap, remove empty bulb, and insert another bulb in the discharger for subsequent use.

**NOTE:** When using the cold weather starting aid on an engine equipped with a hydraulic starter (which consequently has a short cranking period), it may be necessary to discharge a bulb into the engine prior to engaging the starter.

### 3. Maintenance

No special tools are required for disassembling the pressure primer discharger. Use a screwdriver with a 1/2" (12.70 mm) wide blade to unscrew the retaining ring from the body of the discharger for re-

placing the rubber neck washer and piercing pin. Use an 8" adjustable wrench to disassemble all other removable parts.

A detachable fine screen assembly is installed in the lower body of the discharger to prevent foreign material from clogging the spray nozzle in the air intake system. This assembly should be removed and the screen cleaned each time the rubber neck washer is replaced or if the nozzle becomes clogged. The nozzle hole is approximately (.018") (0.46 mm) and requires cleaning from time to time.

If the equipment has been in storage or has not been used for several months, the system must be checked for proper operation. Disassemble and inspect the system as follows:

- a. Disconnect tubing and elbow from bottom of discharger.
- b. Remove nut and washer and detach discharger from control panel.
- c. Remove screen assembly and wash screen.
- d. Remove retaining ring, neck washer, and piercing pin.
- e. Inspect pin for sharpness. If pin is not sharp, replace it.
- f. Check small hole through the pin to see that it is clean.
- g. Inspect rubber neck washer. Washer should not be distorted and must have a free length measurement of approximately 3/8" (9.53 mm) as depicted in Figure 2 otherwise replace it.
- h. Assemble the discharger and recheck operation prior to installing it on the engine.

**CAUTION:** Do not expel fluid in confined area. Vapor is toxic and flammable.

ALL TECHNICAL PUBLICATIONS MUST BE ORDERED FROM AN ALLIS-CHALMERS DEALER

**IMPORTANT**

Always furnish the following information (available from the engine nameplate secured to side of the engine) when ordering manuals for a specific unit.

ENGINE MODEL

ENGINE CATALOG NUMBER

ENGINE SERIAL NUMBER

A-C ORDER NUMBER

**MANUAL FOR  
CURRENT PRODUCTION UNITS**

Model	Parts	Operating & Maintenance
<b>Industrial Engines and Power Units</b>		
G-262	TPL-512-B	TM-5016-A
D-175	TPL-489-C	TM-5018-A
D-262	TPL-454-E	TM-5018-A
2800 & 2900 MK II	TPL-4111-2	TM-5067-2
3500 MK II	TPL-4108-2	TM-5071-2
11000	TPL-4112-2	TM-5070-2
16000 H, 16000 MKII, 17000 MKII,		
21000 MKII, 25000 MKII	TPL-4110-2	TM-5069-2
61000 & 65000	TPL-4109-A	TM-5064-A
<b>Diesel Electric Systems</b>		
NOTE: Diesel Electric Systems operating and maintenance (TM) manuals (-3) include a TM-5063, main alternator and voltage regulator manual.		
DES-90	TPL-4108-3	**TM-5071-3
DES-125	TPL-4112-3	**TM-5070-3
DES-175/200/220/250	TPL-4110-3	**TM-5069-3
DES-500/550	TPL-4109	**TM-5064-A
DES-Service Handbook		
<b>Marine Engines</b>		
25000 MKII	TPL-4110-4	TM-5001-A
<b>Diesel Generator Drive Units</b>		
D-262	TPL-454-E	TM-5018-A
2800 & 2900 MKI	TPL-4111-1	TM-5072-1
3500 MKII	TPL-4108-1	TM-5071-1
11000	TPL-4112-1	TM-5070-1
16000 H, 16000 MKII, 17000 MKII,		
21000 MKII, 25000 MKII	TPL-4110-1	TM-5069-1
61000 & 65000	TPL-4109	TM-5064
<b>Service (Overhaul) Manuals</b>		
G-262 (Gasoline and Natural Gas Engines)		TM-5003
D-175 & D-262		TM-5049
2800 & 2900		TM-5028
3500		TM-5066
11000		TM-5034
16000 H, 21000 H, & 25000		TM-5006
16000 MKII, 17000 MKII, 21000 MKII, & 25000 MKII		TM*
Service Labor Guide		TM-5026
<b>Fuel Systems</b>		
Roosa Master Fuel Injection Pump	TPL-4059	TM-5023
Amer. Bosch APE Type Fuel Injection Pump	*	TM-5035
Robert Bosch Fuel Injection Pump	TPL-4097-B	TM-5058-A
Simms Fuel Injection Pump	TPL-4106	TM-5061
Fuel Injection Nozzle Assemblies	***	TM-5055-A
<b>Special Application Manuals</b>		
Turbocharger TO-4 Series (Airesearch)	***	TM-5057-A
Turbocharger T-1817, T-1818, T-1819, & T-1852		TM-5074
Engine Service Bulletins		
Historical Bulletins		*
Current Bulletins		*
Automotive Bulletins		*

\*When ordering literature not assigned a number order by description.   \*\*Not Available

\*\*Includes: Operating & Maintenance of Voltage Regulator & Main Alternators

NOTE: When manuals are required for units not listed above, refer to Technical Publications Index, TM-5056.

The information contained herein is general in nature and is not intended for specific application purposes. Allis-Chalmers reserves the right to make changes in specifications shown herein, add improvements, or discontinue manufacture at any time without notice or obligation.

The information contained herein is general in nature and is not intended for specific application purposes. Allis-Chalmers reserves the right to make changes in specifications shown herein, add improvements, or discontinue manufacture at any time without notice or obligation.