

# OPERATION MANUAL

---

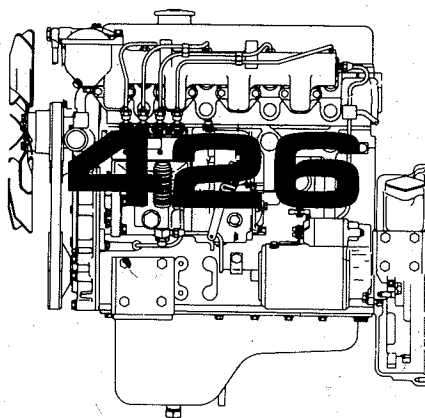
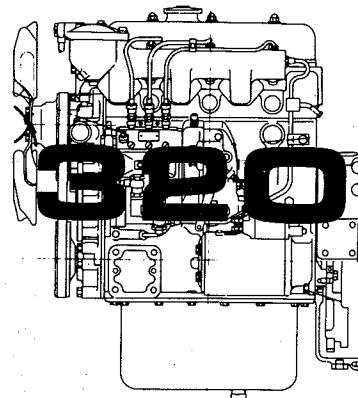
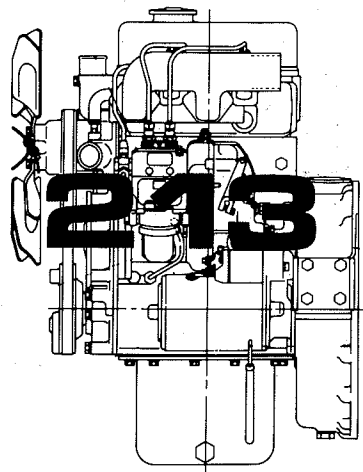

**ENGINE DIVISION  
HARVEY, ILLINOIS  
60426, USA**

**Form: TM-5080  
Part No: 4530692  
Printed in USA (1 - 81)**

# SAFETY PRECAUTIONS (CONTINUED)

the battery. Do not lay tools or other conductive materials on the battery where they may cause short circuits and sparks.

18. Fluid in electric storage batteries contains sulfuric acid which can cause severe burns. Avoid all contact of fluid with eyes, skin or clothing. If contact does occur, flush off immediately with large amounts of water. Get prompt medical attention.
19. Always stop engine when refueling. Always place the fuel nozzle against the side of the filler opening before starting and during fuel flow, to reduce the chance of a static electricity spark. Keep contact until after fuel flow is shut off. Do not smoke or have open flame in the refueling area.
20. Always be sure that all shields, guards, and access covers are in place when engine is in operation.
21. Never attempt to check or adjust fan belts when engine is running.
22. Always permit parts that contain hot fluid to cool to a safe temperature before handling or disconnecting.

## MAINTENANCE AND SERVICE

1. Follow all safety precautions listed above and those listed below.
2. Shop or field service platforms and ladders used to maintain or service engine should be constructed and maintained according to OSHA requirements.
3. Disconnect batteries and TAG all controls according to OSHA requirements to warn that work is in progress.
4. Never use gasoline or diesel fuel or other flammable fluid for cleaning parts. Use authorized commercial, non-flammable, non-toxic solvents.
5. When using compressed air for cleaning parts use safety glasses with side shields or goggles. Limit the pressure to 30 psi (207 kPa) according to OSHA requirements.
6. Lift and handle all heavy parts with a lifting device of proper capacity. Be sure parts are supported by proper slings and hooks. Use lifting eyes if provided. Watch out for people in the vicinity.
7. Never align holes with finger or hands. Use the proper aligning tool.

8. Remove sharp edges and burrs from reworked parts.
9. Do not use an open flame as a light source to look for leaks or for inspection anywhere on the machine.
10. Be sure all mechanics tools are in good condition. Do not use tools with mushroomed heads. Always wear safety glasses with side shields.
11. Handle all parts with extreme care. Keep hands and fingers from between parts. Wear authorized protective equipment such as safety glasses, heavy gloves, safety shoes.
12. Do not adjust engine fuel pump when the machine is in motion.
13. Never lubricate engine while in operation.
14. Avoid running engine with open unprotected air inlets. If such running is unavoidable for service reasons, place protective screens over all inlet openings before servicing engine.
15. Disconnect batteries before working on electrical system.
16. Be sure to connect the booster cables to the proper terminals (+ to +) and (- to -) at both ends. Avoid shorting clamps.
17. BATTERY GAS IS HIGHLY FLAMMABLE. Leave battery box open to improve ventilation when charging batteries. Never check charge by placing metal objects across the posts. Keep sparks or open flame away from batteries. Do not smoke near battery to guard against the possibility of an accidental explosion.
18. Do not charge batteries in a closed area. Provide proper ventilation to guard against an accidental explosion from an accumulation of gases given off in the charging process.
19. Fluid escaping under pressure from a very small hole can almost be invisible and can have sufficient force to penetrate the skin. Use a piece of cardboard or wood to search for suspected pressure leaks. DO NOT USE HANDS. If injured by escaping fluid, see a doctor at once. Serious infection or reaction can develop if proper medical treatment is not administered immediately.
20. Shut off engine and be sure all pressure in system has been relieved before removing panels, housing covers, and caps.
21. When making pressure checks use the correct gauge for expected pressure.

# TABLE OF CONTENTS

<u>TOPIC</u>	<u>TITLE</u>	<u>PAGE</u>
1	ENGINE DESCRIPTION .....	1
2.	ENGINE SPECIFICATIONS .....	2
3.	PREPARATION OF ENGINE FOR OPERATION .....	4
4.	LUBRICATION - FUEL - COOLANT RECOMMENDATION .....	5
5.	OPERATING CONTROLS AND INSTRUMENTS .....	7
6.	OPERATING INSTRUCTION .....	9
7.	MAINTENANCE AND SERVICE SCHEDULE .....	12
8.	TROUBLESHOOTING .....	17
9.	COOLING SYSTEM .....	25
10.	FUEL SYSTEM .....	29
11.	LUBRICATION SYSTEM .....	34
12.	ENGINE ELECTRICAL SYSTEM .....	37
13.	INTAKE AND EXHAUST SYSTEM .....	40
14.	COLD WEATHER STARTING AIDS .....	44
15.	SAFETY CONTROLS .....	45
16.	ENGINE ACCESSORIES .....	49

# Engine Division Warranty

ALLIS-CHALMERS CORPORATION (the Company) warrants new engines and diesel electric systems sold by it to be merchantable and free of defects in workmanship and material at the time of shipment from the Company's factory. THERE ARE NO WARRANTIES WHICH EXTEND BEYOND THOSE EXPRESSED HEREIN.

The Company will repair or replace, at its option and subject to the following provisions, any part of its new engines and diesel electric systems that fails to conform to this warranty, provided that such part is returned to the Company's factory or to the Company's dealer authorized to handle engines or diesel electric systems, transportation charges prepaid, within the following periods.

- 
- (1) 2 YEARS OR 3600 HOURS OF OPERATION, whichever first occurs, from the date of delivery to the first user of
- (a) Engines used for marine pleasure boat applications, and
  - (b) Stand-by diesel electric systems.

As to such products the Company will supply all required parts free of charge. In addition, the Company will bear all reasonable warranty labor costs during the 2 year period, as follows:

100% in the case of parts subjected to no more than 1800 hours of operation, whichever first occurs; thereafter,  
75% in the case of parts subjected to no more than 2700 hours of operation, whichever first occurs; and thereafter,  
50% in the case of parts subjected to no more than 3600 hours of operation, whichever first occurs.

- (2) 1 YEAR OR 3600 HOURS OF OPERATION, whichever first occurs, from the date of delivery to the first user of
- (a) Engines used for construction, industrial and marine commercial work-boat applications, and
  - (b) Continuous duty diesel electric systems.

As to such products, the Company will supply all required parts free of charge. In addition, the Company will bear all reasonable warranty labor costs during the 1 year period as follows:

100% in the case of parts subjected to no more than 1800 hours of operation; thereafter  
75% in the case of parts subjected to no more than 2700 hours of operation; and thereafter,  
50% in the case of parts subjected to no more than 3600 hours of operation.

- (3) 3 YEARS OR 10,800 HOURS OF OPERATION, whichever first occurs, from the date of delivery to the first user of
- (a) Crankshafts in new engines, and
  - (b) Engine blocks for new engines.

As to such parts, the Company will supply all required parts free of charge during the first 2 years or 7200 hours of operation, whichever first occurs, from the date of delivery to the first user, and thereafter the Company will bear one-half of the cost of such parts, during the remainder of the warranty period. In addition, the Company will bear reasonable warranty labor costs, as follows:

100% during the first 2 years or 3600 hours of operation, whichever first occurs from date of delivery to the first user, in the case of crankshafts and blocks in engines used for marine pleasure boat applications and stand-by diesel electric systems.

100% during the first year or 3600 hours of operation, whichever first occurs from date of delivery to the first user, in the case of crankshafts and blocks in engines used for construction, industrial, marine commercial work-boat applications and continuous duty diesel electric systems.

The Company will not be obligated to bear labor costs for removing or installing engines at any time during the warranty periods set forth herein.

No warranty of any kind is made or shall be imposed upon the Company with respect to (1) new engines or diesel electric systems which have been subject to operation in excess of recommended capacities, misuse, negligence or accident, or have been altered or repaired in any manner not authorized by the Company, or (2) accessory items not manufactured by the Company as such items are separately warranted by their respective manufacturers.

THE COMPANY'S LIABILITY, WHETHER IN CONTRACT OR IN TORT ARISING OUT OF WARRANTIES, OR REPRESENTATIONS, INSTRUCTIONS, OR DEFECTS FROM ANY CAUSE, SHALL BE LIMITED EXCLUSIVELY TO REPAIRING OR REPLACING PARTS UNDER THE CONDITIONS AS AFORESAID. IN NO EVENT SHALL THE COMPANY BE LIABLE FOR INCIDENTAL, INDIRECT, SPECIAL OR CONSEQUENTIAL DAMAGES.

# THE METRIC SYSTEM OF MEASUREMENT

Today's rapid communication and transportation between the nations of the world has resulted in the use of more of each other's products and services. This has caused a trend among the nations to adapt a standardization of units for use in both scientific and technical fields.

The customary United States (English) units and some metric units are being replaced with those of a modernized metric system known as the International System of Units which is officially abbreviated SI in all languages.

The SI or modernized metric system consists of the following basic units:

## BASIC UNITS

Quantity	Unit	Symbol
length	metre	m
mass	kilogram	kg
time	second	s
electrical current	ampere	A
*thermodynamic temperature	kelvin	K
luminous intensity	candela	cd
amount of substance	mole	mol

\* For nonscientific temperature, use degree Celsius (°C)

Because Allis-Chalmers' products are used worldwide and the adaptation of the SI metric system by all nations is getting nearer, both English and metric system of units appear in this manual.

To assist those not completely familiar with the metric system, the following nomenclature and tables will be of assistance.

## METRIC CUSTOMARY UNIT EQUIVALENTS

Multiply: by: to get: Multiply: by: to get:

### LINEAR

inches	X 25.4	= millimetres (mm)	X 0.03937	= inches
feet	X 0.3048	= metres (m)	X 3.281	= feet
yards	X 0.9144	= metres (m)	X 1.0936	= yards
miles	X 1.6093	= kilometres (km)	X 0.6214	= miles
inches	X 2.54	= centimetres (cm)	X 0.3937	= inches
microinches	X 0.0254	= micrometres (µm)	X 39.37	= microinches

### AREA

inches <sup>2</sup>	X 645.16	= millimetres <sup>2</sup> (mm <sup>2</sup> )	X 0.00155	= inches <sup>2</sup>
inches <sup>2</sup>	X 6.4516	= centimetres <sup>2</sup> (cm <sup>2</sup> )	X 0.155	= inches <sup>2</sup>
feet <sup>2</sup>	X 0.0929	= metres <sup>2</sup> (m <sup>2</sup> )	X 10.764	= feet <sup>2</sup>
yards <sup>2</sup>	X 0.8361	= metres <sup>2</sup> (m <sup>2</sup> )	X 1.196	= yards <sup>2</sup>
acres	X 0.4047	= hectometres <sup>2</sup> (hm <sup>2</sup> )	X 2.471	= acres

[hectares (ha)]

### VOLUME

inches <sup>3</sup>	X 16387	= millimetres <sup>3</sup> (mm <sup>3</sup> )	X 0.000061	= inches <sup>3</sup>
inches <sup>3</sup>	X 16.387	= centimetres <sup>3</sup> (cm <sup>3</sup> )	X 0.06102	= inches <sup>3</sup>
inches <sup>3</sup>	X 0.01639	= litres (l)	X 61.024	= inches <sup>3</sup>
quarts	X 0.94635	= litres (l)	X 1.0567	= quarts
gallons	X 3.7854	= litres (l)	X 0.2642	= gallons
feet <sup>3</sup>	X 28.317	= litres (l)	X 0.03531	= feet <sup>3</sup>
feet <sup>3</sup>	X 0.02832	= metres <sup>3</sup> (m <sup>3</sup> )	X 35.315	= feet <sup>3</sup>
fluid oz	X 29.57	= millilitres (ml)	X 0.03381	= fluid oz
yards <sup>3</sup>	X 0.7646	= metres <sup>3</sup> (m <sup>3</sup> )	X 1.3080	= yards <sup>3</sup>
teaspoons	X 4.929	= millilitres (ml)	X 0.2029	= teaspoons
cups	X 0.2366	= litres (l)	X 4.227	= cups

### MASS

ounces (av)	X 28.35	= grams (g)	X 0.03527	= ounces (av)
pounds (av)	X 0.4536	= kilograms (kg)	X 2.2046	= pounds (av)
tons (2000 lb)	X 907.18	= kilograms (kg)	X 0.001102	= tons (2000 lb)
tons (2000 lb)	X 0.90718	= metric tons (t)	X 1.1023	= tons (2000 lb)
tons (long) (2240 lb)	X 1016.05	= kilograms (kg)	X 0.000984	= tons (long) (2240 lb)

### FORCE

ounces — f (av)	X 0.278	= newtons (N)	X 3.597	= ounces — f (av)
pounds — f (av)	X 4.448	= newtons (N)	X 0.2248	= pounds — f (av)
kilograms — f	X 9.807	= newtons (N)	X 0.10197	= kilograms — f

## METRIC CUSTOMARY UNIT EQUIVALENTS

Multiply: by: to get: Multiply: by: to get:

### ENERGY OR WORK

(watt-second = joule = newton-metre)

foot-pounds	X 1.3558	= joules (J)	X 0.7376	= foot-pounds
calories	X 4.187	= joules (J)	X 0.2388	= calories
Btu	X 1055	= joules (J)	X 0.000948	= Btu
watt-hours	X 3600	= joules (J)	X 0.0002778	= watt-hours
kilowatt-hrs	X 3.600	= megajoules (MJ)	X 0.2778	= kilowatt-hrs

### PRESSURE OR STRESS

(newton/sq metre = pascal)

inches Hg (60°F)	X 3.377	= kilopascals (kPa)	X 0.2961	= inches Hg
pounds/sq in	X 6.895	= kilopascals (kPa)	X 0.145	= pounds/sq in
inches H <sub>2</sub> O (60°F)	X 0.2488	= kilopascals (kPa)	X 4.0193	= inches H <sub>2</sub> O
bars	X 100	= kilopascals (kPa)	X 0.01	= bars
pounds/sq ft	X 47.88	= pascals (Pa)	X 0.02088	= pounds/sq ft

### POWER

horsepower	X 0.746	= kilowatts (kW)	X 1.34	= horsepower
ft-lbf/min	X 0.0226	= watts (W)	X 44.25	= ft-lbf/min

### TORQUE

pound-inches	X 0.11298	= newton-metres (N·m)	X 8.851	= pound-inches
pound-feet	X 1.3558	= newton-metres (N·m)	X 0.7376	= pound-feet

### VELOCITY

miles/hour	X 1.6093	= kilometres/hour (km/h)	X 0.6214	= miles/hour
feet/sec	X 0.3048	= metres/sec (m/s)	X 3.281	= feet/sec
kilometres/hr	X 0.27778	= metres/sec (m/s)	X 3.600	= kilometres/hr
miles/hour	X 0.4470	= metres/sec (m/s)	X 2.237	= miles/hour

### COMMON METRIC PREFIXES

mega (M) = 1 000 000 or 10 <sup>6</sup>	deci (d) = 0.1	or 10 <sup>-1</sup>
kilo (k) = 1 000 or 10 <sup>3</sup>	centi (c) = 0.01	or 10 <sup>-2</sup>
hecto (h) = 100 or 10 <sup>2</sup>	milli (m) = 0.001	or 10 <sup>-3</sup>
deka (da) = 10 or 10 <sup>1</sup>	micro (µ) = 0.000 001 or 10 <sup>-6</sup>	

### TEMPERATURE

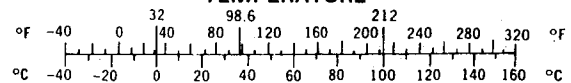

°Celsius 0.556 (°F — 32) °F (1.8°C) + 32

**QUICK REFERENCES CONVERSIONS (APPROXIMATE VALUES)**

- One (1) Fahrenheit Degree: approximately equals .55 Centigrade Degree
- One (1) gallon: approximately equals 3.75 litres
- One (1) PSI: approximately equals 7 kilopascals
- One (1) in-lb of torque: approximately equals 0.11 Nm
- One (1) ft-lb of torque: approximately equals 1.35 Nm

**DECIMAL AND METRIC EQUIVALENTS OF FRACTIONS OF AN INCH**

INCHES		MILLI-METERS	INCHES		MILLI-METERS
FRACTIONS	DECIMALS		FRACTIONS	DECIMALS	
1/64	.015625	.40	33/64	.515625	13.10
1/32	.03125	.79	17/32	.53125	13.49
3/64	.046875	1.19	35/64	.546875	13.89
1/16	.0625	1.59	9/16	.5625	14.29
5/64	.078125	1.98	37/64	.578125	14.68
3/32	.09375	2.38	19/32	.59375	15.08
7/64	.109375	2.78	39/64	.609375	15.48
1/8	.125	3.18	5/8	.625	15.88
9/64	.140625	3.57	41/64	.640625	16.27
5/32	.15625	3.97	21/32	.65625	16.67
11/64	.171875	4.37	43/64	.671875	17.07
3/16	.1875	4.76	11/16	.6875	17.46
13/64	.203125	5.16	45/64	.703125	17.86
7/32	.21875	5.56	23/32	.71875	18.26
15/64	.234375	5.95	47/64	.734375	18.65
1/4	.250	6.35	3/4	.750	19.05
17/64	.265625	6.75	49/64	.765625	19.45
9/32	.28125	7.14	25/32	.78125	19.84
19/64	.296875	7.54	51/64	.796875	20.24
5/16	.3125	7.94	13/16	.8125	20.64
21/64	.328125	8.33	53/64	.828125	21.03
11/32	.34375	8.73	27/32	.84375	21.43
23/64	.359375	9.13	55/64	.859375	21.83
3/8	.375	9.53	7/8	.875	22.23
25/64	.390625	9.92	57/64	.890625	22.62
13/32	.40625	10.32	29/32	.90625	23.02
27/64	.421875	10.72	59/64	.921875	23.42
7/16	.4375	11.11	15/16	.9375	23.81
29/64	.453125	11.51	61/64	.953125	24.21
15/32	.46875	11.91	31/32	.96875	24.61
31/64	.484375	12.30	63/64	.984375	25.00
1/2	.500	12.70	1	1.000	25.40

# INDEX

## OPERATION MANUAL

<u>TOPIC</u>	<u>TITLE</u>	<u>PAGE</u>
1.	ENGINE DESCRIPTION .....	1
	A. GENERAL	
	B. ENGINE NAMEPLATE	
2.	ENGINE SPECIFICATIONS .....	2
3.	PREPARATION OF ENGINE FOR OPERATION .....	4
	A. SAFETY PRECAUTIONS	
	B. PROCEDURE	
4.	LUBRICATION - FUEL - COOLANT RECOMMENDATIONS .....	5
	A. GENERAL	
	B. ENGINE LUBRICATING OIL	
	C. GREASE RECOMMENDATIONS	
	D. FUEL RECOMMENDATIONS	
	E. COOLANT RECOMMENDATIONS	
5.	OPERATING CONTROLS AND INSTRUMENTS .....	7
	A. OPERATING CONTROLS	
	B. INSTRUMENTS	
6.	OPERATING INSTRUCTIONS .....	9
	A. OPERATING PRECAUTIONS	
	B. STARTING AND STOPPING	
	C. CHECKS DURING OPERATION	
	D. COLD WEATHER OPERATION	
	E. EXERCISE OF ENGINE ON STANDBY SERVICE	
	F. STORAGE	
7.	MAINTENANCE AND SERVICE SCHEDULE .....	12
	A. GENERAL	
	B. PERIODICAL SERVICING SCHEDULE	
	C. SPECIAL ENGINE SERVICE TOOLS	
8.	TROUBLESHOOTING .....	17
	A. GENERAL	
	B. WHEN TROUBLE OCCURS	
	C. TROUBLESHOOTING GUIDE	
9.	COOLING SYSTEM .....	25
	A. GENERAL DESCRIPTION	
	B. RADIATOR AND FAN SYSTEM	
	C. GENERAL MAINTENANCE—COOLANT	
	D. DRAINING COOLING SYSTEM	
	E. FILLING COOLING SYSTEM	
	F. CLEANING COOLING SYSTEM	
	G. THERMOSTAT	
	H. ENGINE OIL COOLER	
	I. BELTS— REPLACEMENT OR ADJUSTMENT	
	J. COOLING SYSTEM MAINTENANCE SCHEDULE	
10.	FUEL SYSTEM .....	29
	A. GENERAL DESCRIPTION	
	B. FUEL FILTER	
	C. PRIMING FUEL SYSTEM	
	D. FUEL INJECTION PUMP/GOVERNOR	
	E. FUEL INJECTION NOZZLE HOLDER ASSEMBLY	
	F. CHECKING FUEL SYSTEM	
	G. FUEL SYSTEM MAINTENANCE SCHEDULE	

<u>TOPIC</u>	<u>TITLE</u>	<u>PAGE</u>
11.	LUBRICATION SYSTEM .....	34
	A. GENERAL	
	B. FULL FLOW OIL FILTER—STANDARD	
	C. DRAINING, CHANGING FILTER AND FILLING LUBRICATING SYSTEM	
	D. ENGINE OIL COOLER	
	E. OIL PRESSURE REGULATOR VALVE	
	F. LUBRICATING SYSTEM MAINTENANCE SCHEDULE	
12.	ENGINE ELECTRICAL SYSTEM .....	37
	A. GENERAL	
	B. ELECTRICAL SYSTEM WARRANTY AND ADJUSTMENT	
	C. BATTERY	
	D. STARTING MOTOR	
	E. ALTERNATOR WITH EXTERNAL VOLTAGE REGULATOR	
	F. DRIVE BELT ADJUSTMENT	
	G. ELECTRICAL SYSTEM MAINTENANCE SCHEDULE	
13.	INTAKE AND EXHAUST SYSTEMS .....	40
	A. GENERAL	
	B. AIR CLEANER	
	C. CHECK AND ADJUST VALVE CLEARANCE PROCEDURE	
	D. CHECK/ADJUST VALVE CLEARANCE SCHEDULE	
	E. INTAKE AND EXHAUST SYSTEM MAINTENANCE SCHEDULE	
14.	COLD WEATHER STARTING AIDS .....	44
	A. GENERAL	
	B. OPERATION OF GLOW PLUGS	
	C. MAINTENANCE	
15.	SAFETY CONTROLS .....	45
	A. GENERAL	
	B. MAGNETIC SWITCH	
	C. OVERSPEED SWITCH	
	D. GAUGE CIRCUIT TROUBLESHOOTING CHECKS	
	E. STARTING AND STOPPING PROCEDURE WITH SAFETY CONTROLS	
16.	ENGINE ACCESSORIES .....	49
	A. POWER TAKE-OFF CLUTCH	
	B. POWER TAKE-OFF CLUTCH ADJUSTMENT	
	C. MAINTENANCE	

# TOPIC 1 ENGINE DESCRIPTION

## A. GENERAL

Engine models covered in this manual are 4-cycle, water-cooled, overhead valve, swirl type combustion chamber, compression-ignition type diesels with vertical, in-line cylinders.

The basic engine, engine assemblies, and power units are engineered with equipment necessary for usual installation requirements. All units can be modified for a variety of optional equipment.

Data regarding the operation and maintenance of equipment and accessories not originally supplied by Allis-Chalmers is the responsibility of firm that assembles the accessories to engine.

NOTE: Engines are manufactured to metric dimensions and all hardware is metric threaded

allowing for various pitches. For proper servicing, metric tools are required.

## B. ENGINE NAME PLATE

All engines are equipped with a name plate and optional equipment plate. The name plate is located on the left side of the cylinder block and contains the engine model number, engine catalog number, and engine serial number. The optional equipment plate is located on the left side of the cylinder head cover. The catalog numbers of the various optional equipment groups as applied to the unit by the Allis-Chalmers dealer are indicated on this plate.

NOTE: To assure prompt and complete shipment of replacement parts, always supply information on engine name plate with repair part number and name. Order all parts from your local Allis-Chalmers dealer.

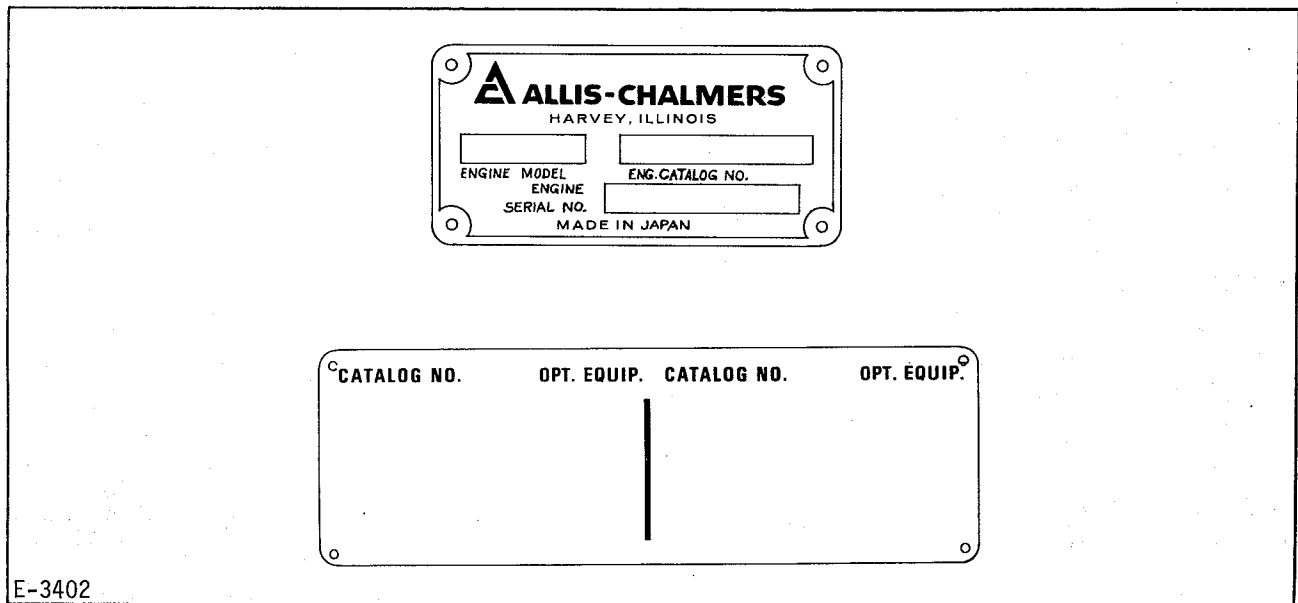

Figure 1. Engine Name Plate and Optional Equipment Plate

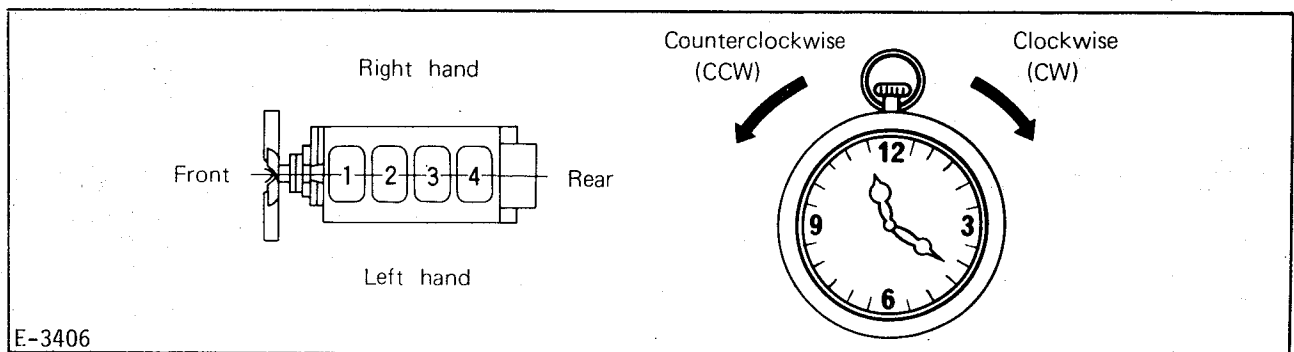

Figure 2. Engine Rotation

# TOPIC 2 ENGINE SPECIFICATIONS

Allis-Chalmers reserves the right to make changes in the following specifications and to add improvements at any time without notice or obligation.

ITEMS	MODELS		
	213	320	426
<b>1. ENGINE (BASIC)</b>			
Aspiration	Natural	Natural	Natural
Type	4-Cycle	4-Cycle	4-Cycle
Number of Cylinders	2	3	4
Bore	94mm (3.701 in)	94mm (3.701 in)	94mm (3.701 in)
Stroke	94mm (3.701 in)	94mm (3.701 in)	94mm (3.701 in)
Firing Order	1-2	1-3-2	1-3-4-2
Combustion chamber type	Swirl Type	Swirl Type	Swirl Type
Piston Displacement	1.3 lt (79.5 cu in)	2.0 lt (121 cu in)	2.61 lt (159.0 cu in)
Crankshaft Rotation	Clockwise from fan end of engine	Clockwise from fan end of engine	Clockwise from fan end of engine
Number of main bearings	3	4	5
Compression ratio-nominal	18:1	18:1	18:1
Compression pressure at sea level, 240 rpm, hot	28 kg/cm (400 psi)	28 kg/cm (400 psi)	28 kg/cm (400 psi)
Maximum permissible exhaust restriction	6.8 kPa (3 in Hg)	6.8 kPa (3 in Hg)	6.8 kPa (3 in Hg)
<b>2. COOLING SYSTEM</b>			
Water pump, centrifugal type	Belt driven	Belt driven	Belt driven
Water pump lubrication	Engine oil	Engine oil	Engine oil
Stabilized coolant temperature	82°C (180°C)	82°C (180°F)	82°C (180°F)
Radiator cap-pressurized	48 kPa (7 psi)	48 kPa (7 psi)	48 kPa (7 psi)
Nominal coolant capacities: Engine only Radiator and hoses- 41° (105°F) Ambient	3.0 lt (0.8 gal) 5.7 lt (1.5 gal)	4.0 lt (1.1 gal) 6.8 lt (1.8 gal)	4.6 lt (1.2 gal) 6.8 lt (1.8 gal)
<b>3. LUBRICATION SYSTEM</b>			
Type system	Full pressure	Full pressure	Full pressure
Oil pump type	Trochoid	Trochoid	Trochoid
Pressure regulation	Regulating valve	Regulating valve	Regulating valve
Oil filter type-spin-on	Full flow	Full flow	Full flow
Oil pan capacity	4 lt (1.05 gal)	6 lt (1.6 gal)	7 lt (1.85 gal)
Oil pressure hot:			
Oil pressure at 3000 rpm	400 kPa (57 psi)	400 kPa (57 psi)	400 kPa (57 psi)
Idle speed-600 to 700 rpm (minimum)	117 kPa (17 psi)	117 kPa (17 psi)	117 kPa (17 psi)
Oil pan-angle of operation	30°	30°	30°
Oil-Cooler above 2500 rpm	Required	Required	Required
<b>4. FUEL INJECTION SYSTEM</b>			
Fuel pump manufacture	Nippondenso	Nippondenso	Nippondenso
Fuel pump lubrication	Engine oil	Engine oil	Engine oil
Fuel filter type	Replaceable paper element	Replaceable paper element	Replaceable paper element
Fuel feed pump type	Plunger	Plunger	Plunger
Fuel injection nozzles	Throttle type	Throttle type	Throttle type
Injection pressure	11763 kPa (1706 psi)	11763 kPa (1706 psi)	11763 kPa (1706 psi)

ITEMS	MODELS		
Fuel pump timing to engine —static: All speeds w/speed advance 1500/2400 rpm without speed advance Above 2400 rpm without speed advance	213	320	426
	18° BTDC 24° BTDC	18° BTDC 24° BTDC	18° BTDC 24° BTDC
	27° BTDC	27° BTDC	27° BTDC
5. GOVERNOR TYPE	Mechanical centrifugal	Mechanical centrifugal	Mechanical centrifugal
Governor regulation: Power units Generator drive	7-12% 3-5%	7-12% 3-5%	7-12% 3-5%
6. VALVE DATA			
Valve lash adjustment, intake and exhaust cold	0.25mm (0.010 in)	0.25mm (0.010 in)	0.25mm (0.010 in)
7. ELECTRICAL			
Polarity	Negative	Negative	Negative
Starter	12 Volt	12 Volt	12 Volt
Alternator	12 Volt, 35 amp	12 Volt, 35 amp	12 Volt, 35 amp

### 8. Specific Bolt and Nut Torque

kg-m (lb-ft)

Secured part or component	Tightening torque
Cylinder head bolts	12 ± 0.5 (86.8 ± 3.6)
Main bearing cap bolts	10.4 ± 0.5 (75.2 ± 3.6)
Connecting rod bearing cap bolts	8.5 ± 0.5 (61.5 ± 3.6)
Flywheel bolts	8.5 ± 0.5 (61.5 ± 3.6)
Camshaft thrust plate bolts	1.8 ± 0.5 (13.0 ± 3.6)
Front plate bolts	1.8 ± 0.5 (13.0 ± 3.6)
Timing gear case bolts	1.0 ± 0.5 (7.2 ± 3.6)
Crank pulley bolts	40 ± 0.5 (289.3 ± 3.6)
Camshaft gear bolt	3.5 ± 0.5 (25.3 ± 3.6)
Idler thrust plate bolts	3.5 ± 0.5 (25.3 ± 3.6)
Rear oil seal bolts	0.4 (2.9)
Oil pan bolts	0.7 (5.1)
Oil case bolts	0.7 (5.1)
Oil pan drain plug	10.0 ± 0.5 (72.3 ± 3.6)
Oil pump fixing connector	5.5 ± 0.5 (39.8 ± 3.6)
Oil filter center bolt	2.3 ± 0.5 (16.6 ± 3.6)
Nozzle holder retaining nuts	5.0 ± 0.5 (36.2 ± 3.6)
Injection pump delivery valve holders	3.0 ± 0.5 (21.7 ± 3.6)
Flywheel housing bolts	3.5 ± 0.5 (25.3 ± 3.6)

### 9. General Bolt and Nut Torque Specifications

Screw thread		Tightening torque			
Diameter mm inch	Metric Pitch	With spring washer		Without spring washer	
		kg-m	lb-ft	kg-m	lb-ft
8 (0.203)	1.0	1.8	13	2.2	16
	1.25	1.8	13	2.1	15
10 (0.254)	1.25	3.6	26	4.2	30
	1.5	3.4	25	4.0	29
12 (0.304)	1.25	6.5	47	7.6	55
	1.75	6.0	43	7.1	51
14 (0.356)	1.5	10.4	75	12.2	88
	2.0	9.8	71	11.5	83
16 (0.406)	1.5	15.8	114	18.6	135
	2.0	15.0	108	17.6	127
18 (0.457)	1.5	22.9	166	26.9	195
	2.5	20.7	150	24.4	176

# TOPIC 3 PREPARATION OF ENGINE FOR OPERATION

## A. SAFETY PRECAUTIONS

 When locating engines in closed area, pipe all exhaust fumes outside. Breathing of exhaust fumes may be fatal.

 When servicing batteries, do not smoke or use an open flame. Batteries generate an explosive gas during charging. Have ample ventilation when charging battery.

 When filling fuel tank, always provide metal-to-metal contact between container and fuel tank to prevent spark generation. Do not smoke or use an open flame in vicinity.

 Always use a lifting device of more than adequate capacity when lifting or moving engine.

## B. PROCEDURE

Upon receipt, thoroughly inspect the engine for damage or parts shortage. Have the carrier make notation on freight bill and notify transit agent at once if any problems arise.

Install engine in clear open area so that it will be accessible for inspection and service.

Foundation must be ample in size and strength to assure accurate alignment with the equipment to which it will furnish power.

Before starting engine, operator should fully understand use and function of all controls and instruments.

See Topic 5, Operating Controls.

After installation and before starting, perform these important operations:

1. Remove all tape and shipping caps used to seal engine.
2. Check radiator for damage and for proper cooling capacity of engine. Remove any foreign matter that has collected in radiator that may obstruct air flow past fins and through air passages.
3. If cooling system drain plugs have been removed and wired to engine, install them properly. Fill system with coolant. (See Topic 9)
4. Check air cleaner for tightness and proper installation of filter element.
5. Engines are shipped without lubricating oil. Fill oil pan with specified lubricating oil until oil level is even with full mark on the oil level gauge. (See Topic 4 for specified lubricant)
6. Check all engine drive belts for correct tension. (See Topic 9)
7. Connect battery to electrical system. (See Topic 12)
8. Fill fuel tank with recommended fuel. (See Topic 4)
9. If necessary, connect fuel supply line from tank to inlet of fuel system.
10. Bar engine over by hand to make sure it turns freely.
11. If unit has power take-off clutch, check adjustment of operating lever. (See Topic 16, Engine Accessories)
12. Check intake and exhaust systems. Make sure they are unobstructed by foreign matter. Exhaust piping must be adequately supported, should have no sharp bends or crimps, and be as short as possible.

# TOPIC 4 LUBRICANT-FUEL-COOLANT RECOMMENDATIONS

## SAFETY PRECAUTIONS

 **WARNING:** To prevent injury, always turn the key switch or stop control to the "OFF" position before cleaning, repairing, or servicing the engine.

 **WARNING:** No unauthorized person must be allowed to service or maintain this machine. Study the Operation and Maintenance Manuals before starting, operating, maintaining, fueling, or servicing this machine.

 **DANGER:** Extinguish all smoking materials, or open flames, before checking and filling tanks, changing filters and before opening sediment drain due to the presence of flammable fluid.

 **WARNING:** Never service or adjust with the engine running except as called for in the Operation and Maintenance Instruction Manual or Service Manuals to keep from being caught in moving parts or by a moving machine.

 **WARNING:** Never use gasoline or other toxic or flammable fluids to clean parts.

 **WARNING:** Do not place head, body, limbs, feet, fingers or hands near a rotating fan or belt. Be especially alert around a pusher fan.

 **WARNING:** Study this manual through before starting, operating, maintaining, fueling or servicing this machine.

### A. GENERAL

It is important to be selective in the lubricating oils, grease, and coolants used in the operation of your Allis-Chalmers engine. By following these recommendations, you can be assured of most efficient and longest trouble-free engine life.

### B. ENGINE LUBRICATING OIL

#### 1. General

The general recommendation is to use oils meeting the American Petroleum Institute (API) classification CD and Military

Specification MIL-L-45199B. This also applies to naturally aspirated (non-turbocharged) engines that are operating under severe application or when the fuel sulphur content exceeds 0.5%. In most normal duty applications of the non-turbocharged engines, an API classification CC, MIL-L-2104B, oil can be used.

SAE 30 or 15W40 viscosity oil is the lubricant weight around which Allis-Chalmers diesels have been designed. Use of SAE 30 or 15W40 weight will, in most cases, provide optimum performance life and lube oil control at normal operating speeds.

When crankcase temperatures are below 32°F (0°C), during engine starting, lighter viscosity oils can be used for easier starting without damage from marginal lubrication. Freezing cold is the only reason to use less than SAE 30 or 15W40 weight oil in Allis-Chalmers engines.

Crankcase Temperature When Starting Engine	Weight (Viscosity)
0°F & Below (-18°C)	SAE 10W or SAE 10W30
0°F to 32°F ..... (-18°C to 0°C)	SAE 20/20W or SAE 15W40
32°F to 95°F ..... (0°C to 35°C)	SAE 30W or SAE 15W40
Above 95°F (35°C) ...	SAE 40W or SAE 15W40

#### 2. Multi Viscosity Lube Oils

Any multi-viscosity lubricating oil conforming with API classification CD and Military Specification MIL-L-45199B test requirements is approved for use in Allis-Chalmers diesel engines.

#### 3. Synthetic Lube Oils

Any synthetic or partially synthetic oil conforming with API classification CD and Military Specification MIL-L-45199-B test requirements is approved.

Mixing grades of lubricating oils in Allis-Chalmers diesels is not recommended.

#### 4. Oil and Filter Change Period

In general, it is recommended to renew the oil and standard engine mounted full flow type oil filter after each 100 hours of operation. This period is based on use of high quality oils, fuels with less than .5% sulphur, average engine loads, and operating conditions.

Under severe operating conditions, with engine in poor operating condition, or when using high sulphur fuels, lubricating oils deteriorate at a faster rate. Because of this, oil change periods can vary.

#### 5. Lubricating Oil Testing

After recommended oil change interval has been reached, actual tests of the oil should be made at intervals of 10 and 20 hours. These tests will determine condition of oil and indicate if change periods should be lengthened or shortened. Your lubricant supplier provides this testing service, usually on a gratis basis.

#### 6. High Ash Lubricating Oils

Allis-Chalmers diesel engines will operate equally well on either high ash or low ash CD lubricants. Our tests, however, show that under severe service (extended operation under full throttle, high ambient temperatures, etc.) oils having an ash level of at least 1.5% will usually out-perform oils of lower ash contents.

### C. GREASE RECOMMENDATIONS

#### 1. General

Use a ball and roller bearing lubricant that has a minimum melting point of 300°F (149°C). It must be water-proof, and have a viscosity that assures easy handling in a hand operated pressure gun at prevailing ambient temperatures.

### D. FUEL OIL RECOMMENDATIONS

#### 1. General

Allis-Chalmers diesel engines will perform as well or better than other diesels of comparable size, using any grade of fuel oil. However, if superior performance under all conditions is required, experience has shown that the fuel best suited for these engines closely approximates the specifications listed.

This specification is within the American Society for Testing Materials (ASTM) specification for No. 1 and No. 2 fuels. The American Society for Testing Materials has established fuel oil specifications and testing methods to which the petroleum industry conforms very closely. Diesel engine manufacturers have, over the years, come to rely on the ASTM specifications as a standard of the industry and a simple means for the engine owner to identify and purchase fuel oil.

### FUEL OIL SPECIFICATION GUIDE

Gravity API .....	30-40
Cetane Number .....	40 Min
Viscosity, Kinematic Centistokes ..	1.4 - 5.8 @ 100°F (38°C)
Flash Point .....	100°F (38°C) or Legal
Pour Point 10°F (-12°C) .....	Below Ambient Temperature
Distillation Temp 90% .....	Max Point 640°F (338°C)
Ash % by Weight .....	0.02 Max
Water & Sediment % by Volume .....	0.10 Max
Sulphur Content % by Weight .....	0.5 Max
Carbon Residue on 10% .....	0.35 Max Ramsbottom
Copper Strip Corrosion .....	No. 3 Max

In general, Allis-Chalmers engines have been designed to take advantage of the higher energy content of No. 2 diesel fuels.

Fuels not meeting complete specifications will require shortening of filter renewal and inspection intervals to obtain a reasonable useful life from injection equipment.

NOTE: When handling or storing fuel oil, always practice all caution to keep fuel supply and system free from dirt and moisture.

### E. COOLANT RECOMMENDATIONS

#### 1. General

Engine operating in areas where ambient temperature is always above freezing must be kept full of an all-seasons coolant system fluid. Use as recommended by the manufacturer. Clean, soft water can also be used. This water must be as free as possible of scale forming minerals and have an inhibitor added to it. The inhibitor will contain a rust preventative and lubricant to lubricate the coolant seals in the water pump. Follow instructions printed on inhibitor container.

Do not use household-type softened water because its pH factor is too low (acidity). Distilled or clean rain water is preferred.

In freezing areas, use a permanent type anti-freeze solution to protect against damage from freezing. After addition of either water or anti-freeze to cooling system, test the new solution when it has become thoroughly mixed.

Never use anti-freeze solution that is harmful to aluminum.

Always refer to protection charts furnished by anti-freeze manufacturer for information regarding quantity required for lowest anticipated temperatures.

# TOPIC 5 OPERATING CONTROLS AND INSTRUMENTS

## SAFETY PRECAUTIONS

**WARNING:** This engine and its attachments are to be operated only by a qualified operator.

**WARNING:** No unauthorized person must be allowed to service or maintain this machine. Study the Operation and Maintenance manuals before starting, operating, maintaining, fueling, or servicing this machine.

## A. OPERATING CONTROLS

A variety of controls and instruments are available to assist operator in realizing optimum engine performance and life. Regardless of control panel configuration or location, operator must be completely familiar with function of each engine control and instrument provided for engine operation.

### 1. Key Switch

The key switch (5) energizes the fuel solenoid circuit. The oil pressure switch (3-6 psi Not Shown) closes the circuit to the alternator.

### 2. Starter Button

This button (10) energizes the starting motor.

### 3. Throttle (Speed Control)

A turn-to-lock control (7) actuates the governor speed control lever. Engine speed is varied by pulling out the control handle. Control is locked in desired position by turning handle either clockwise or counterclockwise. It is released by turning back to mid-position.

### 4. Electric Stop Control

To stop engine, control button (9) must be pushed in.

### 5. Glow Plug Switch (Air Heater)

This switch (4) energizes the glow plug elements.

### 6. Clutch Operating Lever

The clutch operating lever actuates the clutch mechanism to connect and disconnect engine load. (See Topic 16, Accessories)

### 7. Safety Controls with Magnetic Switch, Overspeed Switch, and Fuel Valve (Refer to Topic 15)

If engine is equipped with safety shut-off controls (2 and 6), a magnetic bypass switch and an overspeed governor, refer to Topic 15, Safety Controls. Allis-Chalmers recommends application of safety controls in the majority of engine installations.

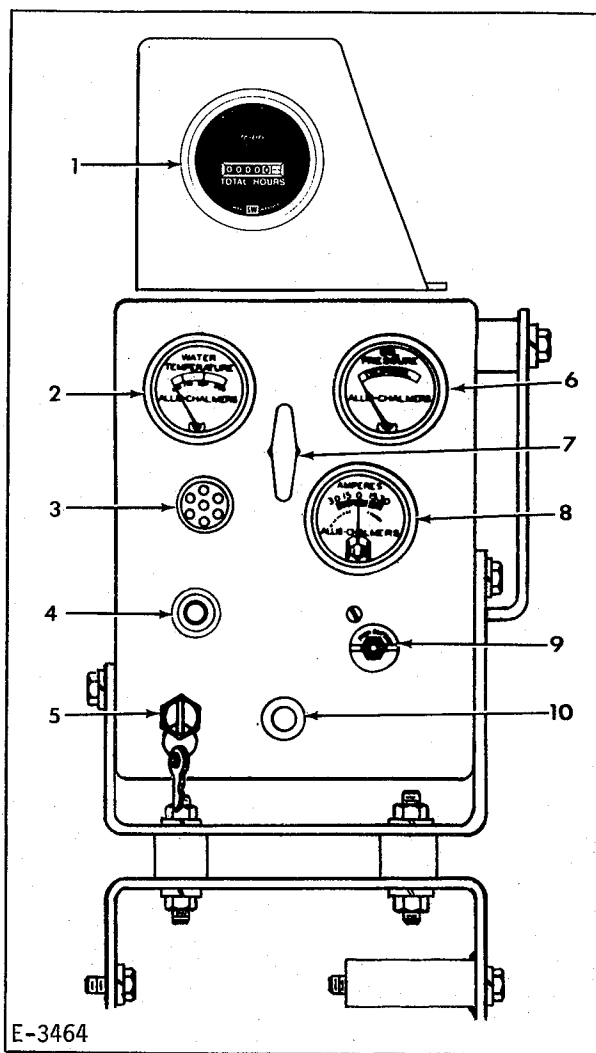

Figure 1. Operating Controls and Instruments

## B. INSTRUMENTS

### 1. Oil Pressure Gauge

This gauge (6) continually indicates pressure at which lubricating oil is circulating through the engine.

2. Ammeter

The ammeter (8) indicates the current flow (charging output) of the alternator.

3. Water Temperature Gauge

The coolant temperature gauge (2) shows temperature of fluid being circulated through the cooling system.

4. Tachometer

An indicator (1) of engine speed shown in revolutions per minute (rpm).

5. Electric Hourmeter

The hourmeter (1) registers elapsed hours of engine operation.

6. Glow Plug Indicator

An indicator (3) shows that glow plugs are at operating temperature.

7. Combination Tachometer & Hourmeter (mechanical type)

This combination is applied primarily in 1800 rpm engine operation. If operation is at other than 1800 rpm, refer to table.

Governed RPM	Divisor
1500	.8333
1600	.888
1800	1.000
2000	1.111
2200	1.222
2400	2.333
2500	1.388
3000	1.666
3200	1.777
3600	2.00

Lubricate tachometer angle adaptor each 600 hours with grease conforming to MIL-G-10924 or equivalent. Do not overgrease.

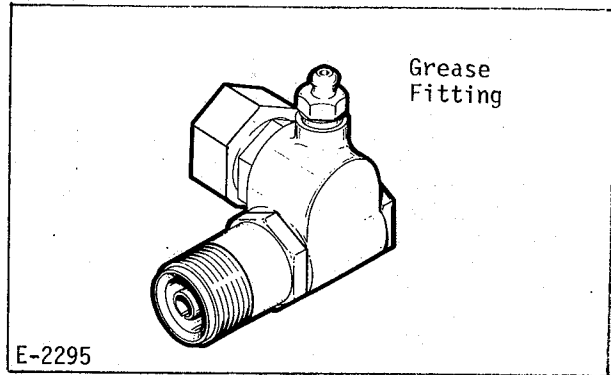

Figure 2. Angle Adaptor Drive Assembly









Figure 3. Schematic Wiring Diagram (Less Safety Controls)

NOTE: Refer to Topic 15 for safety controls.

# TOPIC 6 OPERATING INSTRUCTIONS

## SAFETY PRECAUTIONS

-  **WARNING:** Study this manual through before starting, operating, maintaining, fueling or servicing this machine.
-  **WARNING:** This engine and its attachments are to be operated only by a qualified operator.
-  **WARNING:** If engine is to be started indoors, insure proper ventilation to remove deadly exhaust gases.
-  **WARNING:** Warn all people who may be servicing or working around machine before starting engine.
-  **DANGER:** Do not use starting fluid with electric air heater. Explosion and personal injury could result.
-  **WARNING:** Starting fluid is flammable. Do not puncture or burn containers. Follow precautions printed on containers for storage and disposal.

## A. OPERATING PRECAUTIONS

1. Be sure air filter element is installed.
2. Be sure fuel filter case is tight to filter cover.
3. Be sure engine and accessories are clean.
4. Always allow engine to warm up at reduced speed and without load.
5. Do not allow engine to idle for prolonged period except in cold weather below -18°C (0°F).
6. Refuel at end of daily operation to keep condensation at a minimum.
7. When starting: Never crank starting motor longer than 30 seconds without pause of 2 minutes for cooling.

## B. STARTING AND STOPPING

The engine starting procedure depends upon whether it is equipped with standard controls and instruments or safety shutdown equipment.

When controls are furnished by the Original Equipment Manufacturer (OEM), follow their instructions for stopping, starting, and operating the engine and their equipment.

The following instructions supplement OEM instructions and are to be followed when instruments and controls are furnished by Allis-Chalmers.

Before starting a new engine, prepare it for operation as in Topic 3.

### 1. Starting Procedure

- a. Disconnect or remove load from engine.
- b. Place engine stop controls in START/RUN position.
- c. Move speed control to half throttle position.
- d. Turn key switch to ON position.
- e. Press and hold air heater button. Release when air heater indicator element glows. Limit the preheating time to 15 seconds. In extremely cold weather up to 30 seconds of preheating is permissible.
- f. Press and hold starter button. Release button when engine starts. If engine does not run on all cylinders immediately, again press air heater button for short period (30 seconds maximum) until combustion occurs in all cylinders.
- g. With engine running, move speed control to fast idle and allow engine to warm up before applying load.
- h. Within seconds after starting engine, oil pressure should exceed 97kPa (14 psi) minimum. If oil does not meet this minimum limit, stop engine, locate and correct the cause. After engine has reached operating temperature, oil pressure should be within range of 276 to 370kPa (40 to 55 psi) at full load rpm.

### 2. Stopping the Engine

**CAUTION:** Always allow engine to run at fast idle speed without load for at least 5 minutes before stopping. This allows engine to cool gradually and uniformly.

- a. Move the stop control to the STOP position.
- b. Cover exhaust pipe to prevent rain from coming into engine.

## C. CHECKS DURING OPERATION

1. Observe general performance of engine while running.

2. Listen for unusual noises.
3. Make frequent checks of instruments.
4. Look for unusual vibration.

#### D. COLD WEATHER OPERATION

1. Keep battery in full charged condition and all other electrical equipment in optimum condition.
2. Use permanent type anti-freeze solution to protect against damage by freezing. Refer to Topic 4.
3. At end of each daily operation, drain condensed water from fuel tank and fuel filter.
4. If operating in arctic temperatures, consult your Allis-Chalmers dealer for information about special cold weather equipment.

#### E. EXERCISE OF ENGINE ON STANDBY SERVICE

A diesel engine on stand by service that is relied upon to perform under stress conditions, should be exercised at least every 30 days.

Exercise period should be of duration to allow engine to reach normal operating temperature while carrying at least 50% of normal load.

When engine is under conditions of extreme temperatures, humidity, dust, sand, etc., it may be necessary to shorten intervals between exercise periods to as often as weekly.

To exercise engine:

1. Before starting, check lubricating oil and coolant levels. Make complete visual check of unit.
2. Start engine and run 15 minutes with speed control at half position.
3. Run engine at full speed with load (up to full load) for the time needed to obtain two consecutive temperature readings of 71°C (160°F) minimum at 15 minute intervals. Continue engine operation for 30 minutes. Check and correct all coolant or oil leaks.

If no load or a light load is used in exercise period, cover radiator to hasten warm up. Never cover radiator on unattended engine.

4. Run engine at half speed with no load for 5 minutes to allow combustion chamber to cool evenly.

5. Stop engine

If accumulated hours of operation during exercise periods do not total 100 hours within a 6 month period, it is recommended that lube filter and lubricating oil be changed regardless. If in a 12 month period engine hours do not total 600, it is recommended to replace fuel filter.

#### F. STORAGE

##### 1. Preparation

- a. Drain the oil pan completely, fill with a rust-preventive SAE 30 weight oil (meeting the requirements of the Military Specifications MIL-L-21260) and run the engine for 5 to 10 minutes in idling condition.
- b. To preserve the fuel system, run the engine with a corrosion inhibited fuel oil conforming to grade 1 of Military Specification MIL-46002 or MIL-L-23310A. After running the engine with this fuel, drain the fuel tank and fuel system.
- c. Drain the cooling system completely.
- d. Using a grease gun, relubricate each grease-lubricated part.
- e. Block all openings with oil cloths to prevent entry of moisture and dust. The openings to be blocked are the air cleaner, exhaust pipe, air breathers, and air-intake pipe.
- f. Protect the alternator and starter motor by covering up the terminal connections with wide fabric-type adhesive tape, and closing their openings with cloth tape, polyethylene tape or sheets.

NOTE: Do not use vinyl sheets for these sealing purposes.

- g. Slacken the "V" belts and leave them in loose state.
- h. Cover the entire engine unit with an awning sheet.

NOTE: Do not use a vinyl sheet for unit cover.

NOTE: Attach a caution tag to a suitable place on the engine, the sheet or tag should read "Rust-preventive oil in the engine. Before placing the engine in service, drain the engine oil pan and refill it with the regular engine oil."

## 2. Care of the Battery in Storage

Have the electrolyte raised slightly higher than usual by adding distilled water and recharge the battery fully before taking it down for storage. After removal, clean the terminals and terminal posts, and place the battery in a dry, cool place. During storage, recharge the battery at a rate of once a month.

## 3. Before Placing the Engine in Service After a Long Storage

a. Remove the protective coverings and tapings.

b. Replace the rust-preventive engine oil with regular lube oil; fill up the fuel system and cooling system. Bleed air out of the fuel oil circuits.

c. Carry out the steps of walk-around checks and check the various items to be sure that the engine is ready for starting. (See Topic 3)

d. Crank the engine for 15 seconds with the fuel lever left in STOP position. While the engine is being cranked, oil the valve mechanism. Repeat this cranking two more times, checking to be sure that the lube oil pressure comes up on each cranking. Having thus lubricated the valve mechanism, start up the engine in the usual manner.

e. Run the engine in idling condition for 10 minutes to warm it up properly, and then engage the clutch to take up load.

# TOPIC 7 MAINTENANCE AND SERVICE SCHEDULE

## SAFETY PRECAUTIONS



**WARNING:** Always disconnect the battery before cleaning, repairing or servicing the engine.



**WARNING:** No unauthorized person must be allowed to service or maintain this machine. Study the Operation and Maintenance manuals before starting, operating, maintaining, fueling, or servicing this machine.



**WARNING:** Study this manual through before starting, operating, maintaining, fueling or servicing this machine.



**DANGER:** Extinguish all smoking materials, or open flames, before checking and filling tanks, changing filters and before opening sediment drain due to the presence of flammable fluid.



**WARNING:** Never service or adjust with the engine running except as called for in the Operation and Maintenance Instruction Manual or Service Manuals to keep from being caught in moving parts or by a moving machine.



**WARNING:** Never use gasoline or other toxic or flammable fluids to clean parts.



**WARNING:** Do not use your hands to search for pressure leaks. Fluid escaping under pressure can penetrate skin.



**WARNING:** Keep hands away from nozzle tip when popping a nozzle. The finely atomized fuel is ejected with sufficient force to penetrate the skin and cause blood poisoning. Also wear safety glasses with side shields or goggles when popping a nozzle.



**WARNING:** Do not check or adjust belts when engine is running.



**DANGER:** Fluid under pressure. Do not remove radiator cap until pressure has been relieved as coolant may boil over and cause personal injury.



**DANGER:** Flammable vapors. Extinguish all smoking material and open flames before checking and filling batteries. Do not check battery by sparking.



**WARNING:** Wear safety glasses with side shields or goggles when using compressed air for cleaning to reduce the danger of personal injury from flying particles. Limit the pressure to 30 psi (207 kPa) according to OSHA requirements.



**DANGER:** Do not use matches, lighters, or torches for a light source when inspecting or repairing engine due to presence of flammable fluids.

### A. GENERAL

Your Allis-Chalmers engine, like all mechanical devices, requires attention to keep it operating at peak efficiency and to prevent the development of trouble.

Most engine wear is caused by the entry of foreign elements - water, dust, grime, etc. into the various engine systems. Therefore, it is wise to keep your engine as clean as possible. Make sure all fittings, caps, filters and level plugs, plus the surrounding surfaces, are wiped clean before any servicing is done. For proper servicing, a schedule must be determined and followed and an engine history maintained.

**Note:** The environment and load conditions to which your engine is subjected, can considerably lengthen or shorten the intervals between major service needs such as valve reconditioning, piston ring replacement, or complete overhaul. Observation of crankcase breathing, exhaust sound and color, lubricating oil consumption, engine power, and the sound of the engine in operation by a qualified diesel mechanic will determine the need for reconditioning.

The following suggested maintenance and service schedule is based on experience in normal operation. For details on any of the individual items of service, consult the Topic Number referral for detailed description of the service functions.

Some servicing jobs are simple while the others are not. Those jobs not covered in the following periodical servicing schedule

charts are of a complicated or difficult kind and should be assigned to your local dealer service shop.

**B. PERIODICAL SERVICING SCHEDULE**

Regular checks should be made at the intervals shown (hours or months). Generally the hours shown are for prime power units...the months for stand-by units.

**PHASE 1 DAILY—EACH 8 HOURS**

	Topic	Paragraph
1. Before Starting Engine:		
a. Visually inspect all belts and hoses for deterioration. Check total engine for signs of fuel, lubricant, coolant, air, and exhaust leaks or damage.		
b. Check and correct coolant level.	9	E
c. Check oil level.	11	A
d. Drain water from fuel tank and fuel filter.	10	A
e. Check air cleaner service indicator and replace filter element if red indicator is visible.	13	B
f. Empty and clean dust cup and baffle in air cleaner.	13	B
g. Check electrical connections for tightness.	12	D
h. Grease power take-off clutch throw-out collar.	16	C
2. While Starting Engine:		
a. Check and correct starter performance.	12	D
b. Check and correct oil pressure.	11	F
c. Check alternator charging rate.	2	Item 7
3. After engine reaches operating temperature:		
a. Observe:		
(1) Coolant temperature	9	B
(2) Lube oil pressure	11	F
(3) Idle/full load speed		
(4) Air cleaner service indicator	13	B
b. Check and correct for engine knocks, unusual noises or vibrations.		

**PHASE 2—EACH 100 HOURS/6 MONTHS**

1. Check/correct radiator for cleanliness and restriction of air through fins.	9	F
2. Change engine lubricating oil.	11	C
3. Renew full flow type engine oil filter.	11	C
4. Check liquid level in battery.	12	C
5. Check and repair any coolant, fuel, oil, air, and exhaust leaks.	9,10,11,16	

PHASE 2—EACH 100 HOURS/6MONTHS—CONTINUED

	Topic	Paragraph
6. Lubricate throttle/stop control swivels (lube oil).		
7. Grease power take-off clutch shaft and operating level shaft.	16	C
8. Check clutch adjustment	16	B

PHASE 3—EACH 600 HOURS/12 MONTHS

1. Check belt tension and condition of alternator/water pump belt.	9	I
2. Check/clean engine breather tubes.	11	F
3. Grease adaptor for mechanical type tachometer.	5	B
4. Replace fuel filter.	10	B

PHASE 4—EACH 1000 HOURS/24 MONTHS

1. Inspect/correct injection nozzle holder and spray pattern.	10	E
2. Check specific gravity (charge) of battery fluid.	12	C
3. Inspect, clean, and tighten all electrical connections.	12	G
4. Check/correct all fasteners around the engine.		
5. Grease overspeed governor adaptor.	5	B
6. Renew engine coolant.		
*7. Check/correct valve lash adjustment after initial setting.	13	C

PHASE 5—EACH 2000 HOURS

1. Recondition fuel injection nozzles.
- \*2. Check/correct intake/exhaust valves and seats.
- \*3. Check/correct cylinder sleeve bores for excessive wear.
4. Check/correct/clean complete exterior of engine and radiator.





PHASE 6—3000 HOURS

- \*1. Make major inspection of complete engine and replace all parts showing excessive wear.

\*See note at beginning of this topic.

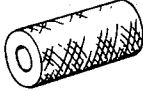
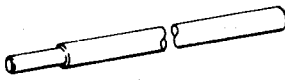
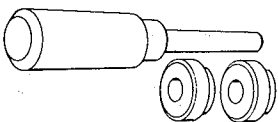
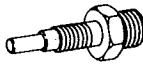
It is suggested that any maintenance function not fully described in this manual be handled only by a factory-trained mechanic or your Allis-Chalmers dealer.

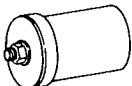
**C. SPECIAL ENGINE SERVICE TOOLS**

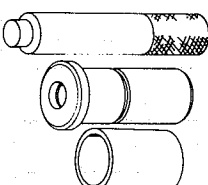
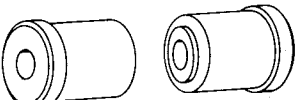
ILLUSTRATION	TOOL NO.	DESCRIPTION
(NOT ILLUSTRATED)	<b>ACTP-2089</b>	ENGINE TOOL KIT FOR 213, 320, AND 426 DIESEL ENGINES. KIT CONSISTS OF ONE EACH OF THE FOLLOWING TOOLS:
	<b>ACTP-2089-1</b>	VALVE GUIDE INSTALLER.
	<b>ACTP-2089-2</b>	VALVE GUIDE REMOVER.
	<b>ACTP-2089-3</b>	VALVE SEAT INSTALLING AND CALKING TOOL.
	<b>ACTP-2089-4</b>	COMPRESSION TEST ADAPTER.
	<b>ACTP-2089-5</b>	RING COMPRESSOR.
	<b>ACTP-2089-6</b>	IDLER SHAFT PULLER.
	<b>ACTP-2089-7</b>	CYLINDER SLEEVE INSTALLER.
	<b>ACTP-2089-8</b>	IDLER BUSHING REMOVER AND INSTALLER.
	<b>ACTP-2089-9</b>	CAM BUSHING ADAPTERS.

These tools must be ordered directly from the tool manufacturer:

Owatonna Tool Company  
P.O. Box 314  
Owatonna, Minnesota 55060  
(507) 451-0514



# TOPIC 8 TROUBLESHOOTING

## SAFETY PRECAUTIONS



**WARNING:** No unauthorized person must be allowed to service or maintain this machine. Study the Operation and Maintenance manuals before starting, operating, maintaining, fueling, or servicing this machine.



**WARNING:** Always disconnect the battery before cleaning, repairing, or servicing the engine.



**DANGER:** Extinguish all smoking materials, or open flames before checking and filling fuel tanks, changing filters and before opening sediment drain due to the presence of flammable fluid.



**WARNING:** Never use gasoline or other toxic or flammable fluids to clean parts.



**DANGER:** Fluid under pressure. Do not remove radiator cap until pressure has been relieved as coolant may boil over and cause personal injury.



**WARNING:** Do not place head, body, limbs, feet, fingers or hands near a rotating fan or belt. Be especially alert around a pusher fan.



**WARNING:** If engine is to be started indoors, insure proper ventilation to remove deadly exhaust gases.



**WARNING:** Keep hands away from nozzle tip when popping a nozzle. The finely atomized fuel is ejected with sufficient force to penetrate the skin and cause blood poisoning. Also wear safety glasses with side shields or goggles when popping a nozzle.



**WARNING:** Do not check or adjust belts when engine is running.



**DANGER:** Fluid under pressure. Do not remove radiator cap until pressure has been relieved as coolant may boil over and cause personal injury.



**DANGER:** Flammable vapors. Extinguish all smoking materials and open flames before checking and filling batteries. Do not check battery by sparking.



**WARNING:** Wear safety glasses with side shields or goggles when using compressed air for cleaning to reduce the danger of personal injury from flying particles. Limit the pressure to 30 psi (207 kPa) according to OSHA requirements.



**WARNING:** Do not use your hands to search for pressure leaks. Fluid escaping under pressure can penetrate skin.

### A. GENERAL

Over 90% of the troubles that occur in engine operation are avoidable if those responsible adhere to an adequate program of lubrication, inspection and maintenance. It has been proven that the time and expense of such programs, as spelled out in this manual, is a fraction of that incurred when poor maintenance results in major malfunction or complete engine breakdown.

When signs of trouble are detected and remedied immediately, more expensive and time consuming repairs can be avoided.

The following troubleshooting chart includes some of the problems an operator may encounter during the service life of an Allis-Chalmers diesel engine. The chart itself will assist you in making an organized study of the problem and a planned method of procedure for investigation and correction of the difficulty.

To use the troubleshooting chart, find the complaint at top and then follow down that

column to the circle or circles. Reference to left of the circle indicates the possible cause and to the right, the remedy.

### B. WHEN TROUBLE OCCURS

Corrective and effective troubleshooting of the engine is a common sense process. It is always best to first review what repairs have previously been made and determine how they could contribute to present condition.

Secondly, check and recheck the obvious simple things that can go wrong—fuel supply, loose belts or fittings, dirty filters, leaking gaskets.

Thirdly, check another time to be absolutely sure that disassembly is necessary.

Last, once trouble has been spotted, be sure to identify the reason for creating of this fault and correct same.

### C. TROUBLESHOOTING GUIDE

See following charts for guide.

## TROUBLESHOOTING CHART 1

Complaint  Possible cause		Engine will not start						Preheater plugs do not glow red Preheater plugs glow red too early		Engine lacks power			Abnormal exhaust smoke		Engine knocks excessively Engine is noisy Engine runs rough When idling When operating		Engine hunts			
		Engine turns over but does not start			Starter does not turn over sufficiently to crank engine	Engine does not turn				A little exhaust smoke	Too much whitish exhaust smoke	Too much black exhaust smoke	When operating							
		No exhaust smoke	A little exhaust smoke			Engine can be cranked manually	Engine cannot be cranked manually						When idling	Whitish exhaust smoke			Black exhaust smoke			
			Too much exhaust smoke																	
Fuel system	Insufficient fuel supply to injection pump																			
	Greater variance of injection quantity																			
	Defective injection pump seals																			
	Insufficient injection quantity																			
	Excessive injection quantity																			
	Improper fuel spray from injection nozzles																			
	Excessive fuel return from injection nozzles																			
	Injection timing too advanced																			
	Injection timing too retarded																			
	Defective auto timer																			
	Defective governor control spring																			
	Maladjusted governor damper spring																			
	Engine speed too low																			
	Failure of engine to stop properly																			
	Poor grade of fuel oil																			
Fuel viscosity too high																				
Lubrication system	Poor grade of oil																			
	Oil viscosity too high																			
	Oil viscosity too low																			
	Low oil pressure																			
	Excessive oil leakage																			
	Pumping up of oil																			
	Clogged oil filter																			
	Defective oil bypass alarm or lamp																			
	Defective oil indicator switch or lamp																			
Air system	Insufficient air																			
	Poor compression																			
	Low pressure at high atmospheric temperature (or altitude)																			



Complaint Possible cause		Engine will not start								Engine lacks power			Abnormal exhaust smoke				Engine hunts			
		Engine turns over but does not start			Starter does not turn over sufficiently to crank engine.	Engine does not turn		Preheater plugs do not glow red	Preheater plugs glow red too early	A little exhaust smoke	Too much whitish exhaust smoke	Too much black exhaust smoke	When operating		Engine knocks excessively	Engine is noisy	Engine runs rough	When idling	When operating	
		No exhaust smoke	A little exhaust smoke	Too much exhaust smoke		Engine can be cranked manually	Engine cannot be cranked manually						Whitish exhaust smoke	Black exhaust smoke						
Cooling system	Engine is too cold.	-	-	o	o	-	-	-	-	-	-	o	-	o	-	-	-	-	-	
	Radiator dissipates heat excessively	-	-	-	-	-	-	-	-	-	o	-	o	-	-	-	-	-	-	
	Insufficient coolant	-	-	-	-	-	-	-	-	-	o	-	o	-	-	-	-	-	-	
	Failure of radiator to dissipate heat properly	-	-	-	-	-	-	-	-	-	o	-	o	-	-	-	-	-	-	
	Water leak through cylinder head gasket	-	-	-	-	-	-	-	-	o	-	-	o	-	-	-	-	-	-	
Cracks in crankcase water jacket	-	-	-	-	-	-	-	-	-	-	-	-	-	-	-	-	-	-	-	
Electrical equipment	Defective starter switch	-	-	-	-	o	-	-	-	-	-	-	-	-	-	-	-	-	-	
	Defective starter magnetic switch	-	-	-	-	o	-	-	-	-	-	-	-	-	-	-	-	-	-	
	Defective starter	-	-	-	o	o	-	-	-	-	-	-	-	-	-	-	-	-	-	
	Defective starter free wheel	-	-	-	o	o	-	-	-	-	-	-	-	-	-	-	-	-	-	
	Defective flywheel ring gear and pinion	-	-	-	o	o	-	-	-	-	-	-	-	-	-	-	-	-	-	
	Battery voltage drop	-	-	o	o	o	-	-	-	-	-	-	-	-	-	-	-	-	-	
	Open circuit in heater plugs or pilot lamp	-	-	o	o	-	-	o	-	-	-	-	-	-	-	-	-	-	-	
	Short circuit in heater plugs	-	-	o	o	-	-	o	-	-	-	-	-	-	-	-	-	-	-	
	Defective alternator	-	-	-	-	-	-	-	-	-	-	-	-	-	-	-	-	-	-	-
	Defective alternator relay	-	-	-	-	-	-	-	-	-	-	-	-	-	-	-	-	-	-	-
Improper wiring	-	-	o	o	o	-	-	o	-	-	-	-	-	-	-	-	-	-	-	
Main moving parts	Jammed moving parts	-	-	-	o	-	-	-	-	-	-	-	-	-	-	-	-	-	-	
	Worn cylinders, pistons or piston rings	-	-	o	-	-	-	-	-	-	o	-	o	-	-	-	-	-	-	
	Sticking piston rings	-	-	o	-	-	-	-	-	-	o	-	o	-	-	-	-	-	-	
	Excessive main bearing clearance	-	-	-	-	-	-	-	-	-	-	-	-	-	-	o	-	-	-	
	Loose connecting rod cap bolts	-	-	-	-	-	-	-	-	-	-	-	-	-	-	o	-	-	-	
	Interference between valve and piston	-	-	-	-	-	-	-	-	o	-	-	-	-	-	o	-	-	-	
	Broken valve springs	-	-	o	-	-	-	-	-	o	-	-	-	-	-	o	-	-	-	
	Excessive valve clearance	-	-	-	-	-	-	-	-	-	o	-	-	-	-	o	-	-	-	
	Foreign substances in cylinders	-	-	-	-	-	-	-	-	o	-	-	-	-	-	o	-	-	-	
	Excessive gear backlash	-	-	-	-	-	-	-	-	-	-	-	-	-	-	o	-	-	-	

Engine vibrates excessively	Engine stalls	Poor response for deceleration	Engine does not pick up speed	Engine operates at high speeds but fails to stop	Engine turns in reverse direction	Excessive fuel consumption	Excessive oil consumption	Oil is diluted by fuel	Water in oil	Excessive blow-by	Defective lubrication system			Abnormal water temperature rise		Defective alternator		Remedy	
											When engine stops, warning lamp does not come on	Warning lamp comes on at low-speed operation	Warning lamp comes on at high-speed operation	Water temperature too high (Engine overheats)	Water temperature too low	Indicator lamp does not come on when engine stops	Indicator lamp comes on at high-speed operation		
-	-	-	-	-	-	-	-	-	-	-	-	-	-	-	-	-	-	-	Heat oil pan from bottom side at starting. After starting, warm up engine thoroughly.
-	-	-	-	-	-	-	-	-	-	-	-	-	-	-	-	-	-	-	•
-	-	-	-	-	-	-	-	-	-	-	-	-	-	-	-	-	-	-	•
-	-	-	-	-	-	-	-	-	-	-	-	-	-	-	-	-	-	-	•
-	-	-	-	-	-	-	-	-	-	-	-	-	-	-	-	-	-	-	Retighten and replace gasket if necessary.
-	-	-	-	-	-	-	-	-	-	-	-	-	-	-	-	-	-	-	Replace crankcase.
-	-	-	-	-	-	-	-	-	-	-	-	-	-	-	-	-	-	-	Check for connections and repair. Replace if necessary.
-	-	-	-	-	-	-	-	-	-	-	-	-	-	-	-	-	-	-	Repair or replace if necessary.
-	-	-	-	-	-	-	-	-	-	-	-	-	-	-	-	-	-	-	Repair or replace.
-	-	-	-	-	-	-	-	-	-	-	-	-	-	-	-	-	-	-	Repair or replace motor if necessary.
-	-	-	-	-	-	-	-	-	-	-	-	-	-	-	-	-	-	-	Repair or replace ring gear. Replace pinion.
-	-	-	-	-	-	-	-	-	-	-	-	-	-	-	-	-	-	-	Recharge or replace battery. If necessary heat it.
-	-	-	-	-	-	-	-	-	-	-	-	-	-	-	-	-	-	-	Replace.
-	-	-	-	-	-	-	-	-	-	-	-	-	-	-	-	-	-	-	Replace copper packings and if necessary heater plugs.
-	-	-	-	-	-	-	-	-	-	-	-	-	-	-	-	-	-	-	Replace alternator if necessary.
-	-	-	-	-	-	-	-	-	-	-	-	-	-	-	-	-	-	-	Adjust or replace.
-	-	-	-	-	-	-	-	-	-	-	-	-	-	-	-	-	-	-	Connect wires properly.
-	-	-	-	-	-	-	-	-	-	-	-	-	-	-	-	-	-	-	•
-	-	-	-	-	-	-	-	-	-	-	-	-	-	-	-	-	-	-	Repair or replace.
-	-	-	-	-	-	-	-	-	-	-	-	-	-	-	-	-	-	-	Repair or replace.
-	-	-	-	-	-	-	-	-	-	-	-	-	-	-	-	-	-	-	Check and replace bearing(s) with undersize one(s) if necessary.
-	-	-	-	-	-	-	-	-	-	-	-	-	-	-	-	-	-	-	Retighten.
-	-	-	-	-	-	-	-	-	-	-	-	-	-	-	-	-	-	-	Re-time timing gear train or adjust valve sinkage properly.
-	-	-	-	-	-	-	-	-	-	-	-	-	-	-	-	-	-	-	Replace.
-	-	-	-	-	-	-	-	-	-	-	-	-	-	-	-	-	-	-	Adjust valve clearance to 0.25 mm (0.0098 in.).
-	-	-	-	-	-	-	-	-	-	-	-	-	-	-	-	-	-	-	Repair.
-	-	-	-	-	-	-	-	-	-	-	-	-	-	-	-	-	-	-	Replace gears or idler bushing.

• FOR DETAILED INFORMATION REFER TO CHART 2

TROUBLESHOOTING CHART 2

Trouble	Possible Cause	Remedy
<p>Poor fuel supply to fuel injection pump</p>	<p>Closed fuel tank supply cock                      No fuel in tank                      Clogged fuel lines                      Air in fuel system                      Clogged fuel feed pump inlet strainer                      Defective fuel feed pump                      Leaky fuel lines or connections                      Clogged fuel filter                      Air in fuel system</p>	<p>Open the cock                      Fill fuel tank                      Repair or clean fuel pipes with air                      Retighten connections or replace fuel pipes                      Remove and clean strainer                      Repair                      Retighten connections                      Dissassemble and clean filter                      Bleed air out of fuel system</p>
<p>Greater variance of injection quantity</p>	<p>Jammed plungers                      Jammed tappets                      Worn plungers                      Worn tappet cams                      Worn bearings                      Worn or broken plunger springs                      Loose plunger pinions                      Defective delivery valves                      Worn or broken delivery valve springs</p>	<p>Replace plungers                      Replace tappets                      Replace plungers                      Replace tappet cams                      Replace bearings                      Replace plunger springs                      Reinstall properly by matching marks                      Replace valves                      Replace valve spring</p>
<p>Insufficient injection quantity</p>	<p>Governor stop lever link is binding                      Control rack is sticky                      Jammed plungers                      Jammed tappets                      Worn plungers                      Worn tappet cams                      Worn bearings                      Loose plunger pinions                      Improper full-load setting of governor</p>	<p>Straighten link, placing lever in neutral position                      Relubricate or repair                      Replace plungers                      Replace tappets                      Replace plungers                      Replace tappet cams                      Replace bearings                      Reinstall properly by matching marks                      Adjust governor setting on bench</p>
<p>Excessive injection quantity</p>	<p>Stop lever jammed in "increase" position                      Improper full-load setting of governor                      Loose plunger pinions</p>	<p>Repair lever link, placing lever in neutral position                      Adjust governor setting on bench                      Reinstall properly by matching marks</p>

(CHART 2 CONTINUED)

Trouble	Possible Cause	Remedy
Improper fuel spray from injection nozzles	Sticking needle valve in one or more nozzles	Repair and replace nozzles if necessary
	Damaged nozzle tip seats	Repair and replace seats if necessary
	Worn or broken nozzle springs	Replace nozzle springs
	Too low an injection pressure	Adjust pressure to $120 \pm 5 \text{ kg/cm}^2$ ( $1706 \pm 7.1 \text{ psi}$ ) on nozzle tester by inserting shim(s).
Injection timing too advanced	Carbon deposited on packings at nozzle tips	Remove carbon
	Improper installation of fuel injection pump	Re-time properly by tilting injection pump away from engine
Injection timing too retarded	Incorrect installation of timing gears	Re-time timing gear train
	Improper installation of fuel injection pump	Re-time properly by tilting injection pump toward engine
	Incorrect meshing of timing gears	Re-time timing gear train
Poor grade of fuel oil	Worn cams, tappets or bearing in fuel injection pump	Replace
	Water in fuel	Use good quality fuel
Low oil pressure	Use good quality fuel	Use good quality fuel
	Lack of oil in oil pan	Add oil to prescribed level
	Air in oil strainer	Replace damaged pipes or packings Retighten loose connections if any
	Defective oil pump	Repair
	Clogged fuel lines	Clean
	Defective oil pressure regulating valve	Repair and replace if necessary
	Clogged oil filter	Change element and oil
Leak in lubricating system	Repair	
Pumping up of oil	Excessive oil in oil pan	Drain oil to lower oil level
	Worn cylinders, pistons or piston rings	Repair and replace parts if necessary
	Sticking piston rings	Repair and replace damaged rings if necessary
	Worn valve guides	Replace valve guides
Insufficient air	Prolonged operation under no load	Overhaul engine if oil-laden gases are exhausted
	Clogged air cleaner (Paper element type)	Clean and replace element if necessary
	Clogged air cleaner (Oil bath type)	Wash interior
	Clogged intake manifold	Check and clean

## (CHART 2 CONTINUED)

Trouble	Possible Cause	Remedy
Poor compression	Defective valve seats Sticking valve stems Failure of rocker arms to lift valves Worn cylinders, pistons or piston rings Sticking piston rings Exhaust gases leak through cylinder head gasket Worn or broken valve springs Insufficient torque of starting motor (at starting)	Repair Repair and replace valve stems if necessary Adjust valve clearance to 0.25mm (0.0098 in.) Repair and replace parts if necessary Replace damaged rings Retighten and replace gasket if necessary Replace springs Replace parts
Insufficient coolant	Insufficient coolant Overheating Water leaks from unit seal of water pump Crack in crankcase water jacket Water leaks from other parts	Add water to prescribed level Replace seal Replace crankcase Check and repair
Failure of radiator to dissipate heat properly	Air in cooling system Rust and scale deposited in radiator Dust and dirt around radiator Slippage of fan belt Inoperative thermostat (kept closed)	Bleed air by loosening air bleed plug, drain plug, or hose clamp Flush Flush Adjust belt tension Replace
Radiator dissipates heat excessively	Extremely low atmospheric temperature Uncovered radiator Inoperative thermostat (kept open)	Cover radiator Replace
Jammed moving parts	Sticking cylinders, pistons or piston rings Sticking main bearings and crankpin bearings Sticking cam bushing and idler bushing	Repair and replace if necessary Repair and replace if necessary Repair and replace if necessary

# TOPIC 9 COOLING SYSTEM

## A. GENERAL DESCRIPTION

Maintenance of a favorable heat level is important for proper engine operation. Your engine efficiency and life will be reduced if block heat is consistently too low or too high. It is the function of the cooling system to keep the engine within a designed temperature range.

## B. RADIATOR AND FAN SYSTEM

The engine can be supplied with a radiator and fan combination for temperature control. Other major components include a coolant pump, inlet and outlet piping, thermostat, coolant, temperature gauge, and oil cooler.

Coolant is drawn from bottom of radiator through oil cooler into piping leading to water pump. From there coolant flows into side of engine block where it circulates around cylinder sleeves, into cylinder head, to thermostat and to top of radiator.

The thermostat is the control element regulating flow of coolant. It remains closed until engine heat raises to 76°C (170°F) and is full open at 90°C (195°F). The cooling system is pressurized. By pressurizing, boiling point of water is raised 0.25° per

kPa (3°F per psi). Hence, water coolant will not boil until a higher temperature is reached. Operating your engine in this higher temperature range is not harmful. Some temperature gauges are not accurate and may indicate higher than actual temperature thus leading operator to falsely believe engine is running too hot—a condition always associated with loss of coolant. When in doubt, check level in radiator or expansion tank.

A double-acting valve in radiator pressure cap releases pressure caused by expansion of heated coolant. It allows air to enter when cooling contraction occurs. Thus it is necessary to keep cap turned on tightly at all times.



**WARNING:** Do not remove pressure cap when temperature is 212°F (100°C) or above. Coolant will flash boil and may splash on person removing cap.

## C. GENERAL MAINTENANCE - COOLANT

Engines operating in areas where ambient temperature remains above freezing, must be kept full of an all-seasons coolant system fluid as recommended, or clean soft water.

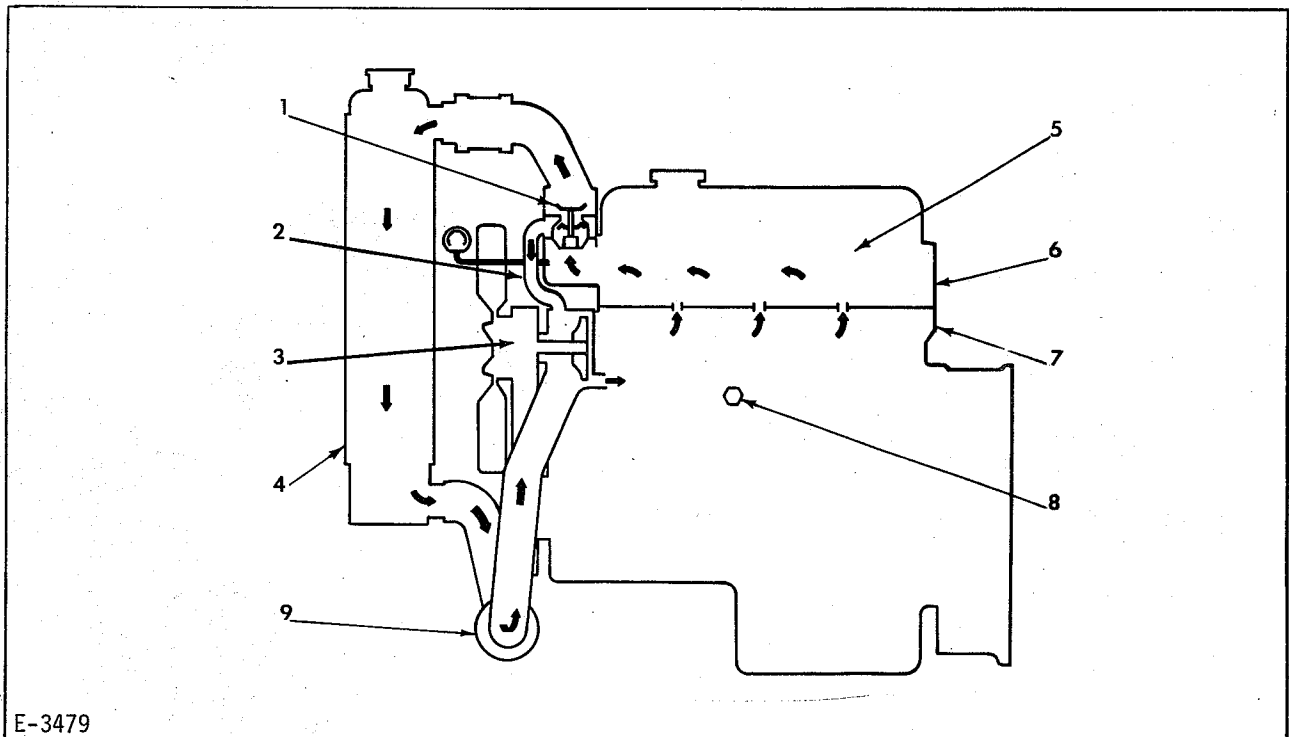

- |                |                  |                          |
|----------------|------------------|--------------------------|
| 1. Thermostat  | 4. Radiator      | 7. Crankcase             |
| 2. Bypass hose | 5. Water jacket  | 8. Drain plug            |
| 3. Water pump  | 6. Cylinder head | 9. Oil cooler if applied |

Figure 1. Cooling System Schematic Diagram

Do not use household type softened water because of low pH factor (acidity), distilled water or clean rain water is preferred.

For engines operating in sub-freezing temperatures, a permanent type anti-freeze must be used to protect against freeze damage. After any addition of water to anti-freeze compound, test solution after mixing to assure complete protection. Do not use anti-freeze solution harmful to aluminum. Refer to instructions furnished by anti-freeze manufacturer for quantity required for lowest ambient temperature protection.

#### D. DRAINING COOLING SYSTEM

**⚠ DANGER:** Fluid under pressure. Do not remove radiator cap until pressure has been relieved as coolant may boil over and cause personal injury.

1. Engines installed in portable equipment must be level to assure complete drainage.
2. Remove radiator cap, open radiator drain cock, and cylinder block drain plug.

#### E. FILLING COOLING SYSTEM

1. Close all drain cocks that were open to drain system.
2. Fill system to approximately 38.10mm (1.5 inch) below filler neck with clean, soft water or anti-freeze solution. Replace filler cap.

**⚠ WARNING:** Never service or adjust with the engine running except as called for in the Operation and Maintenance Instruction Manual or Service Manuals to keep from being caught in moving parts or by a moving machine.

3. Operate engine at normal temperature to vent air from system.
4. Check level of coolant and add if necessary.

#### F. CLEANING COOLING SYSTEM

1. Clean system when inspection reveals accumulation of rust or scale, before anti-freeze is added, and after anti-freeze is drained.
2. Drain cooling system as stated in Paragraph D.
3. Commercial solvents are available for cooling system cleaning. Never mix anti-freeze compounds or inhibitors with

any cleaning or flushing components.

4. After cleaning and flushing, fill system to proper level. Inspect system for leaks and correct.
5. If radiator tubes are closed, reverse flush as follows:
  - a. Disconnect upper and lower radiator hoses from engine.
  - b. Connect pressure water hose to lower hose.
  - c. Plug upper connection and remove radiator cap.
  - d. Force water through radiator. Foreign material will flow out top with overflow water. Never use more than 6 psi (4 kPa) pressure when flushing. Excess pressure can rupture radiator.
6. Radiator must be kept free of debris and other obstructions. Clean with air blast carrying a nontoxic, nonflammable grease solvent. With sucker-type fan, direct cleaning spray at rear (far side) of radiator. If blower-type fan, direct cleaning spray at front of radiator. Keep engine covered during cleaning.

**⚠ CAUTION:** Provide adequate ventilation to avoid toxic effects of spray. Do not clean with gasoline, fuel oil, or kerosene.

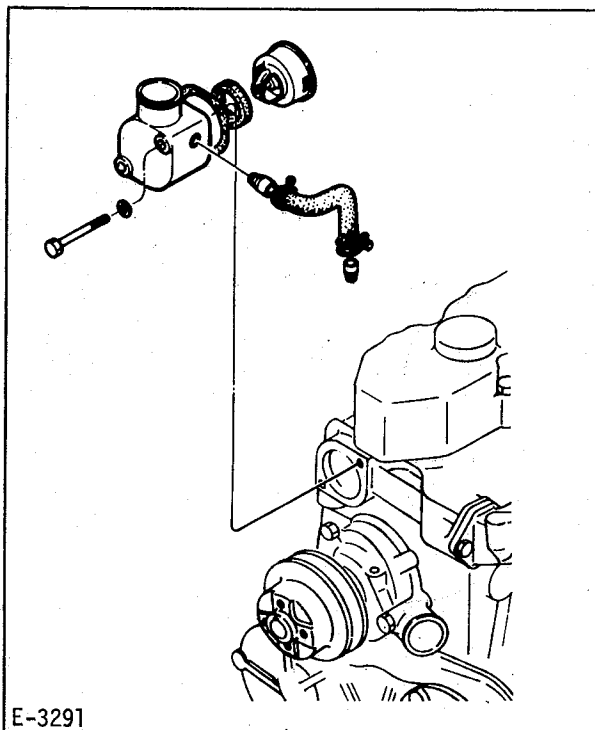

Figure 2. Thermostat and Thermostat Case



**WARNING:** Wear safety glasses with side shields or goggles when using compressed air for cleaning to reduce the danger of personal injury from flying particles. Limit the pressure to 30 psi (107 kPa) according to OSHA requirements.

### G. THERMOSTAT

#### 1. Description

The thermostat is the control element that regulates flow of coolant. It remains closed when engine is cold and does not begin to open until coolant temperature raises to 76°C (120°F). It is fully open at 90°C (185°F). When closed, coolant is directed from engine through bypass tube to inlet side of water pump. Thus you get even and rapid temperature increase of all engine parts during warmup.

2. Maintaining normal coolant operating temperatures depends upon a properly functioning thermostat. If engine runs cool or overheats, remove and test thermostat.

#### 3. Removing Thermostat

- a. Drain cooling system.
- b. Remove coolant bypass hose.
- c. Remove capscrews and lockwashers that secure thermostat housing to cylinder head.
- d. Raise housing with hose intact.
- e. Remove gasket with thermostat.
- f. Clean, inspect, test, and replace thermostat.

### H. ENGINE OIL COOLER

#### 1. Description

The engine oil cooler consists of corrosion resistant tubes, water inlet and outlet headers. Coolant circulates through tubes surrounded by engine oil. Engine oil under pressure circulates oil through tank, around coolant tubes. Oil heat is dissipated through to coolant.

2. If proper engine oil maintenance is followed, oil cooler will function effectively. Otherwise impurities will deposit in cooler and restrict oil flow around tubes. Restricted oil flow is indicated by a drop in oil pressure. To correct, oil cooler must be removed and cleaned or replaced.

3. Removal of engine oil cooler and cleaning is a service operation. It is best handled by a factory-trained mechanic or your Allis-Chalmers dealer.

### I. BELTS - REPLACEMENT OR ADJUSTMENT



**WARNING:** Do not place head, body, limbs, feet, fingers or hands near a rotating fan or belt. Be especially alert around a pusher fan.



**WARNING:** To prevent injury, always turn the key switch or stop control to the "OFF" position before cleaning, repairing, or servicing the engine.



**WARNING:** Do not check or adjust belts when engine is running.

#### 1. General

The alternator, water pump, and fan are driven by a single belt. Replace belt if damaged, badly worn, or soaked with oil or grease.

#### 2. Belt Adjustment and Replacement

##### a. Belt Tension

Proper belt tension assures maximum service life of bearings, pulleys, and belts. Correct adjustment of belt tension requires use of a belt tension gauge reading in pounds of tension. A suggested gauge for use is manufactured by Borrough Tool and Equipment Corp., 2429 N. Burdick St., Kalamazoo, MI 49007. A different tension gauge is required for each V-Belt width. Chart below shows proper gauge and tension for various belt widths. The term, "used", in chart, denotes used belt that has been loosened to permit component

BELT TENSION CHART		
Belt Width	1/2 inch (12.70mm)	11/16 inch (17.46mm)
Borroughs Gage Model Number	33-73F	*33-74
POUNDS OF TENSION		
Single Belt New	107-114 (49-52 Kg)	123-130 (56-59 Kg)
Single Belt Used	90-95 (41-43 Kg)	102-107 (46-49 Kg)

\*NOTE: When ordering gauge 33-74, specify calibration for 11/16 inch (17.46mm) belt width.

change then retensioned. On "new" belts it was previously recommended to tension new belt for run-in period then retension. Today when installing new belt it is initially tensioned at specified "New Belt" value. After running, the belt will stretch and loosen to lower "used belt" value. Never tension a "Used Belt" to "New Belt" tension.

Always position tension gauge at center of span between most distant pulleys, i. e. cog-type belt is checked, place gauge finger on top of cog.

If tension gauge is not available, belt tension can be checked by hand.

On these series engines nominal belt deflection is 19.05mm (1/2 inch).

3. Belt Replacement and Adjustments
  - a. Stop engine, remove belt guard.
  - b. Loosen alternator adjusting brace capscrew and alternator mounting capscrew.
  - c. Install new belt in pulley groove. Move alternator away from engine until specified belt tension is achieved. Tighten brace capscrew and mounting capscrew.
  - d. Reinstall belt guard

## J. COOLING SYSTEM MAINTENANCE SCHEDULE

1. Before Starting Engine
  - a. Inspect belt and hoses for deterioration and leaks.
  - b. Check coolant level, if necessary, fill radiator to within 38mm (1.5 inch) below bottom of filler neck.
2. After Engine Reaches Operating Temperature
  - a. Check coolant temperature and possible leaks.
3. Each 100 Hours/6 Months
  - a. Check/correct radiator for cleanliness and restriction of air through fins.
4. Each 600 Hours/12 Months
  - a. Check belt tension.
5. Seasonal
  - a. Clean cooling system.
  - b. Check and replace belts and hoses when necessary.
  - c. Replace coolant with new.

# TOPIC 10 FUEL SYSTEM

## SAFETY PRECAUTIONS

**!** WARNING: No unauthorized person must be allowed to service or maintain this machine. Study the Operation and Maintenance Manuals before starting, operating, maintaining, fueling, or servicing this machine.

**!** DANGER: Extinguish all smoking materials, or open flames, before checking and filling tanks, changing filters and before opening sediment drain due to the presence of flammable fluid.

**!** WARNING: To prevent injury, always turn the key switch or stop control to the "OFF" position before cleaning, repairing, or servicing the engine.

**!** DANGER: Do not use matches, lighters, or torches for a light source when inspecting or repairing engine due to presence of flammable fluids.

**!** WARNING: Never use gasoline or other toxic or flammable fluids to clean parts.

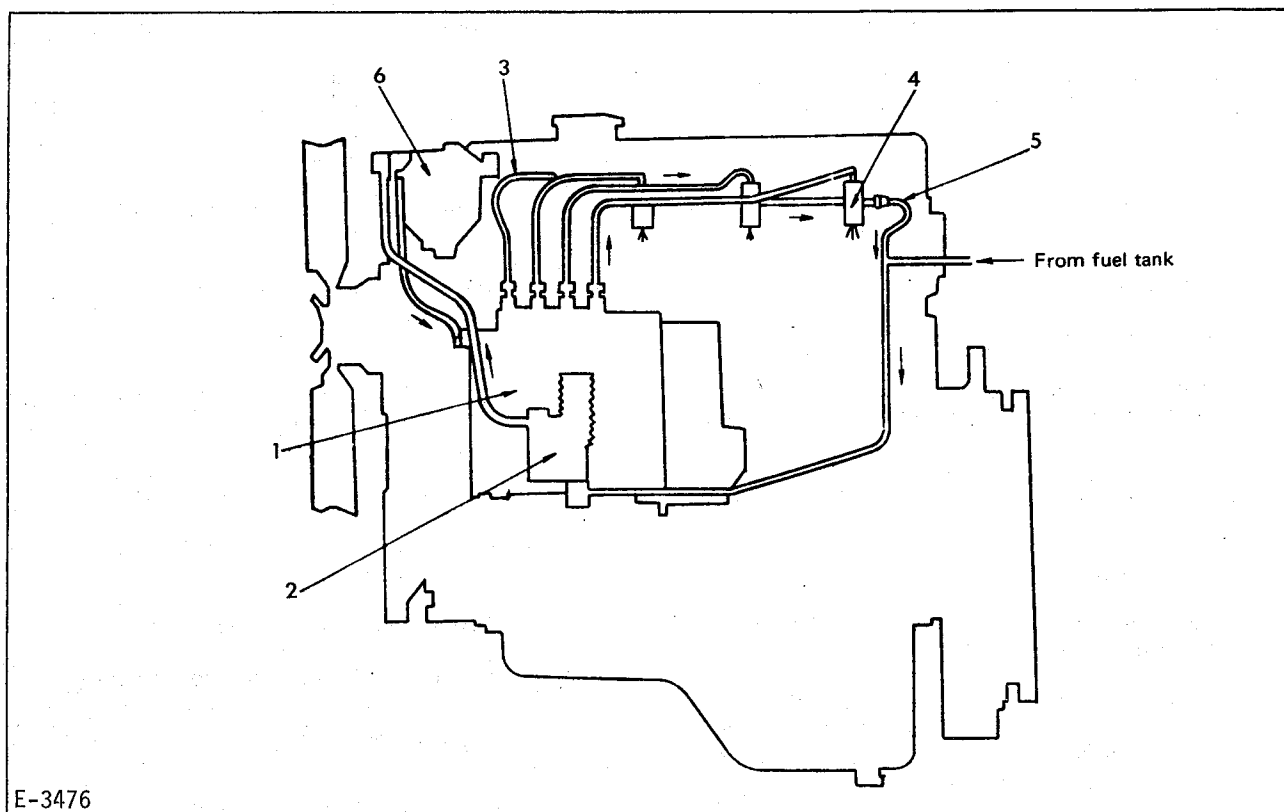

E-3476

- |                                     |                     |                |
|-------------------------------------|---------------------|----------------|
| 1. Fuel injection pump              | 3. Injection lines  | 5. Fuel return |
| 2. Fuel transfer pump w/hand primer | 4. Injection nozzle | 6. Fuel filter |

Figure 1. Fuel System Schematic Diagram

### A. GENERAL DESCRIPTION

The fuel system consists of a fuel tank, a filter with replaceable element and water/sediment drain, hand primer pump, fuel transfer pump, fuel injection pump, and fuel injection nozzle-holder assemblies. Fuel is drawn from the tank through the hand primer pump to fuel filter to the transfer pump which is integral with the fuel injection

pump. Transfer pump forces fuel to cam actuated pluggers which force the fuel under high pressure through fuel lines to fuel injection nozzles from which fuel enters combustion chambers in one fine cone-shaped spray.

The system operates at low pressure to the transfer pump. High pressure system begins in the injection pump and continues through

the injection nozzle. The transfer pump delivers more fuel than is required to the sump of injection pump. A fuel return line conveys surplus fuel back to fuel system. There is fuel seepage between the surfaces of each fuel injection nozzle valve and its body. This is necessary for lubrication. The leaked fuel accumulates around pressure pin and in spring compartment of each nozzle holder and is returned through fuel drip manifold and fuel return line to the fuel system. A regulating valve in the gallery of the multiple plunger type injection pump allows larger share of fuel to be bypassed back to system. Fuel bypassed increases with engine speed.

Special care must be taken in the storage of fuel, transfer to fuel tank, and keeping fuel tank full to prevent condensation. Foreign matter and water in system will damage injection pump and nozzles. The fuel filter will clean the fuel.

Persons responsible for engine operation and maintenance must follow these basic recommendations:

1. Use fuel meeting specifications outlined in Topic 4.
2. Store and handle fuel with care in clean conditions.
3. Maintain fuel oil filter.
4. Remove injection nozzles at prescribed intervals, adjust opening pressure, check spray pattern.
5. Drain water from fuel filter and tank daily.
6. Check injection pump timing.
7. Keep all components securely tightened on engine (specified torque).
8. Clean all parts and surrounding area with a nontoxic and nonflammable solvent before removing any part. Cover all openings immediately.

## B. FUEL FILTER



**DANGER:** Extinguish all smoking materials, or open flames before checking and filling fuel tanks, changing filters and before opening sediment drain due to the presence of flammable fluid.



**WARNING:** Never use gasoline or other toxic or flammable fluids to clean parts.

The fuel filter is of the replaceable element type.

Replace elements at 600 hours or 12 months whichever occurs first, (more often when operating conditions warrant) or when filter becomes clogged. A clogged filter is usually indicated by irregular engine performance. The fuel filter is fitted with a drain plug. In warm weather, open the drain plug before starting the daily operations. In cold weather, when there is the possibility that the condensed water will freeze, drain the contaminants shortly after the end of daily operations. Allow the filter to drain until the fuel runs clean.

A hand primer is connected into the system and is used to purge air from system after new filter is installed or after other service repairs.

### 1. Filter Renewal

- a. Remove dirt from around filter.
- b. Close fuel tank shut-off valve if fuel level is above level of fuel filter.
- c. Drain fuel from filter.
- d. Remove filter case from filter cover by removing lower center bolt.
- e. Remove filter from case.
- f. Inspect and clean base.
- g. Place new filter in filter case. Always use an Allis-Chalmers replacement filter.
- h. Replace gasket in filter cover.
- i. Mount filter case to filter cover. Install center bolt.
- j. Open fuel tank shut-off valve.
- k. Prime fuel system to remove air.

## C. PRIMING FUEL SYSTEM

### 1. Priming Low Pressure Fuel System

- a. Check fuel level in tank and open shut-off valve.
- b. Make certain all plugs and line fittings on suction sides of fuel transfer pump are tight.
- c. Loosen air vent plug on filter cover.
- d. Unlock handle of primer pump plunger by turning it counterclockwise several turns.
- e. Move primer plunger in pumping motion to fill filter with fuel and expel air.

- f. When flow of fuel around vent is bubble free, tighten vent plug.
2. Priming High Pressure Fuel System
- a. Remove air vent plugs from fuel injection pump housing.
- b. Move primer plunger in pumping motion to fill fuel injection pump with fuel and expel air.
- c. When flow of fuel around vents is bubble free, lock the primer pump plunger by turning it clockwise while depressing it.
- d. Tighten air vent plugs. This sequence is necessary to allow the feed pump to return to its relaxed state.

NOTE: Complete air bleeding operation by locking the priming pump handle before tightening the last vent plug.

NOTE: Have a sufficient amount of wiping rags to wipe off the fuel spilled out of each vent plug hole.

#### D. FUEL INJECTION PUMP/GOVERNOR

Purpose of the injection pump is to accurately meter and deliver fuel under high pressure to injection nozzles at a specific timing to correspond with engine firing cycle and within required injection period. The injection pump is of the in-line type (Nippondeso).

##### 1. Nippondenso Fuel Injection Pump

This injection pump is in-line multiple plunger type with constant stroke. It is gear driven in clockwise direction. Fuel delivery is varied by a control rack which when moved, rotates the control sleeve on each plunger thus metering the fuel injected to the nozzle-holder assemblies.

A fuel transfer pump is mounted on the side of the injection pump. Its function is to draw fuel from the tank through the fuel filter and into the injection pump. It and the mechanical type governor are lubricated by oil supply line connected into engine lube system.

##### 2. Fuel Injection Pump/Governor Adjustments

All engines before leaving the factory, are equipped with carefully calibrated injection pumps and governors which have been adjusted to a factory approved power setting.

No lubrication or regularly scheduled

service, other than operational checks, are required on the governor assembly. If engine speed is irregular, check fuel system and all other engine adjustments before having a factory trained mechanic change governor setting.

It is not recommended to make adjustments in field. Injection pump should be removed and turned over to your qualified Allis-Chalmers dealer for checking and adjustment.

NOTE: Unit failures due to unauthorized tampering with seals, the maximum fuel adjustment setting, or the control-level high speed stop screw, can violate the warranty of the engine.

#### E. FUEL INJECTION NOZZLE-HOLDER ASSEMBLY



WARNING: Keep hands away from nozzle tip when popping a nozzle. The finely atomized fuel is ejected with sufficient force to penetrate the skin and cause blood poisoning. Also wear safety glasses with side shields or goggles when popping a nozzle.



WARNING: To prevent injury, always turn the key switch or stop control to the "OFF" position before cleaning, repairing, or servicing the engine.



WARNING: Never use gasoline or other toxic or flammable fluids to clean parts.



WARNING: Do not use your hands to search for pressure leaks. Fluid escaping under pressure can penetrate skin.

##### 1. General

Each engine cylinder is provided with a single hole differential needle, hydraulically lifted fuel injection nozzle holder assembly. The function of each is to direct a pre-metered quantity of fuel from the injection pump into the corresponding engine combustion chamber in a highly atomized pre-determined spray pattern.

Each nozzle assembly consists of the nozzle-holder assembly and the nozzle assembly. The holder positions the nozzle in the cylinder head and provides a means of conducting fuel from injection pump to the nozzle.

The holder has a steel body, hold down nut, gasket, adjusting washer, pressure spring, pressure pin, distance piece, and retaining nut.

The nozzle assembly consists of a needle valve and nozzle body in which is the centered injection hole. The nozzle valve is actuated hydraulically by fuel delivered under pressure by injection pump.

Fuel enters holder inlet passage, flows through holder fuel duct into nozzle fuel duct pressure chamber above nozzle valve. The nozzle valve lifts off seat and fuel is forced through orifice in the nozzle body end and into the corresponding engine combustion chamber. The nozzle valve is returned to its seat by spring pressure when fuel injection pump has ceased to deliver pressurized fuel into nozzle holder. The combined assemblies are self-lubricating.

A copper nozzle gasket is located in nozzle holder bore in cylinder head for a combustion seal.

## 2. Maintenance

At 1000 hours/24 months, the fuel injection nozzles should be removed, cleaned, tested, and adjusted if necessary. This is a service function best handled by a factory trained mechanic at your Allis-Chalmers dealer.

## F. CHECKING FUEL SYSTEM

**⚠ WARNING:** Never service or adjust with the engine running except as called for in the Operation and Maintenance Instruction Manual or Service Manuals to keep from being caught in moving parts or by a moving machine.

**⚠ WARNING:** Do not use your hands to search for pressure leaks. Fluid escaping under pressure can penetrate skin.

Missing or uneven running of the engine, excessive vibration, stalling when idling, and loss of power are indications of insufficient fuel supply to the engine. Before making any checks, be sure there is an ample supply of clean fuel in tank and that fuel shut-off valve is open.

### 1. Check for Admission of Air Into Fuel System

Loosen the vent screw in the filter cover. Crank the engine with the starter. If fuel containing bubbles is observed flowing from the vent screw, air is being drawn into the system on the suction side of the fuel supply pump. Correct this situation by tightening any loose connections between the supply pump and fuel tank. Check all lines

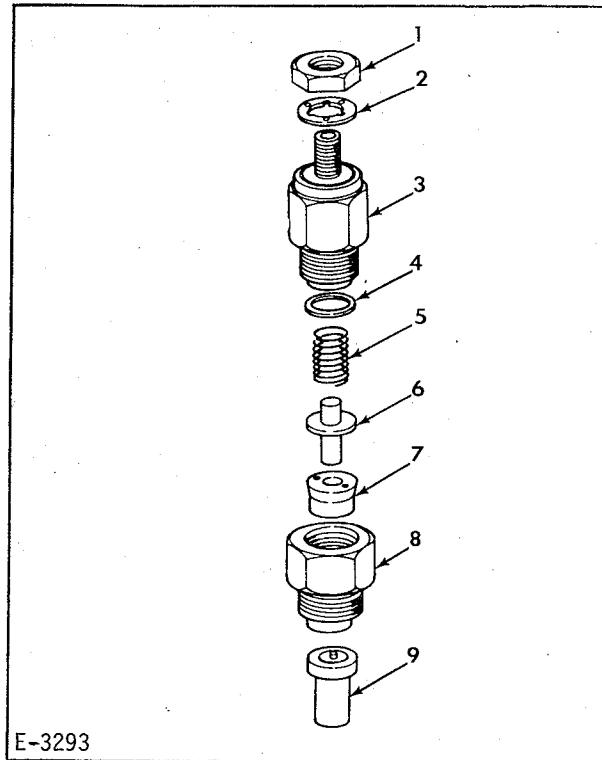

- |                    |                   |
|--------------------|-------------------|
| 1. Nut             | 6. Pressure pin   |
| 2. Gasket          | 7. Distance piece |
| 3. Body            | 8. Retaining nut  |
| 4. Washer          | 9. Nozzle tip     |
| 5. Pressure spring |                   |

Figure 2. Nozzle-Holder Assembly

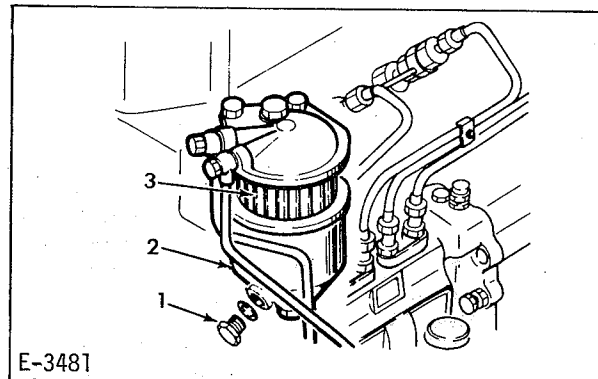

1. Drain
2. Filter case
3. Element

Figure 3. Fuel Filter

and fittings for tightness.

### 2. Check for Clogged Fuel Filter and Clogged or Collapsed Fuel Lines

Any restriction in fuel lines will cause loss of power, stalling, and rough operation. A possible solution is to remove fuel filter, blow out all low pressure lines with filtered compressed air, and install a new filter. Any stoppage should be purged from the affected line, or if

crimped, replaced. Further checking is best done by a factory trained mechanic with vacuum gauges.

To check high pressure lines between fuel injection pump and nozzles, start engine and loosen each line nut, one at a time at each nozzle-holder. If no fuel is observed at loosened nut, line may be clogged, crimped, or cracked. It must be replaced.

3. Checks for Inoperative Fuel Injection Nozzles or Injection Pump

This is a service function best handled by a trained mechanic at your Allis-Chalmers dealer.

G. FUEL SYSTEM MAINTENANCE SCHEDULE

1. Daily

- a. Inspect all lines and connections for

leaks, crimps, or damage and correct.

- b. Check fuel level in tank, drain water.

- c. Drain any water from fuel filter.

- d. Be sure to add only clean fuel as specified.

2. Each 600 Hours/12 Months

- a. Replace fuel oil filter.

3. Each 1000 Hours/24 Months

- a. Remove, clean, test, and adjust fuel injection nozzles to specified opening pressure.

4. Each 2000 Hours

- a. Remove and recondition fuel injection nozzles.



3. Remove filter by unscrewing filter from base assembly and discard.
4. Apply light coat of engine oil to gasket on new filter and screw in by hand until gasket contacts surface of base assembly. Continue to tighten at least 1/2 turn with hand pressure only. Never use tools to tighten full flow oil filters. To be sure, always use Allis-Chalmers replacement filters.
5. Install engine oil pan drain and oil filter base plugs and fill pan to full mark on oil level dipstick with specified quantity of oil.
6. Crank engine 15 seconds, but do not start to assure complete filling of all filters and to pump oil to all engine components.
7. Start engine. After five minutes, with engine running, check filters for leaks and proper installation.
8. Stop engine and allow oil to drain into oil pan and check oil level with dipstick. Add more oil if necessary.

#### D. ENGINE OIL COOLER

This unit is discussed in more detail as part of the Cooling System, Topic 9.

NOTE: Models 320 or 426—In engines equipped with an oil cooler, the passageway in the header (bracket) from the filter to the cylinder block (main oil gallery) is plugged, thus routing lube oil to the cooler and finally to the cylinder block. In engines NOT equipped with an oil cooler, the filter header is NOT plugged and allows oil to enter directly into the main oil gallery.

#### E. OIL PRESSURE REGULATOR VALVE

The lubricating oil pressure regulating valve located in the bottom of the oil filter base assembly maintains stabilized oil pressure within lube system. When pressure exceeds valve setting, valve piston is forced open and oil is bypassed directly into pan.

Keeping lubricating system free from sludge and matter will prevent valve malfunction. If valve sticks open, a sharp drop in engine oil pressure will occur. A sharp rise indicates a valve that does not open. To service oil pressure regulator (recommended at 3000 hours) consult service manual.

#### F. LUBRICATING SYSTEM

Lubricating oil must be of best quality and of proper SAE weight for prevailing ambient temperature (refer to Topic 4). Keep oil free of water and abrasives by proper handling and storage.

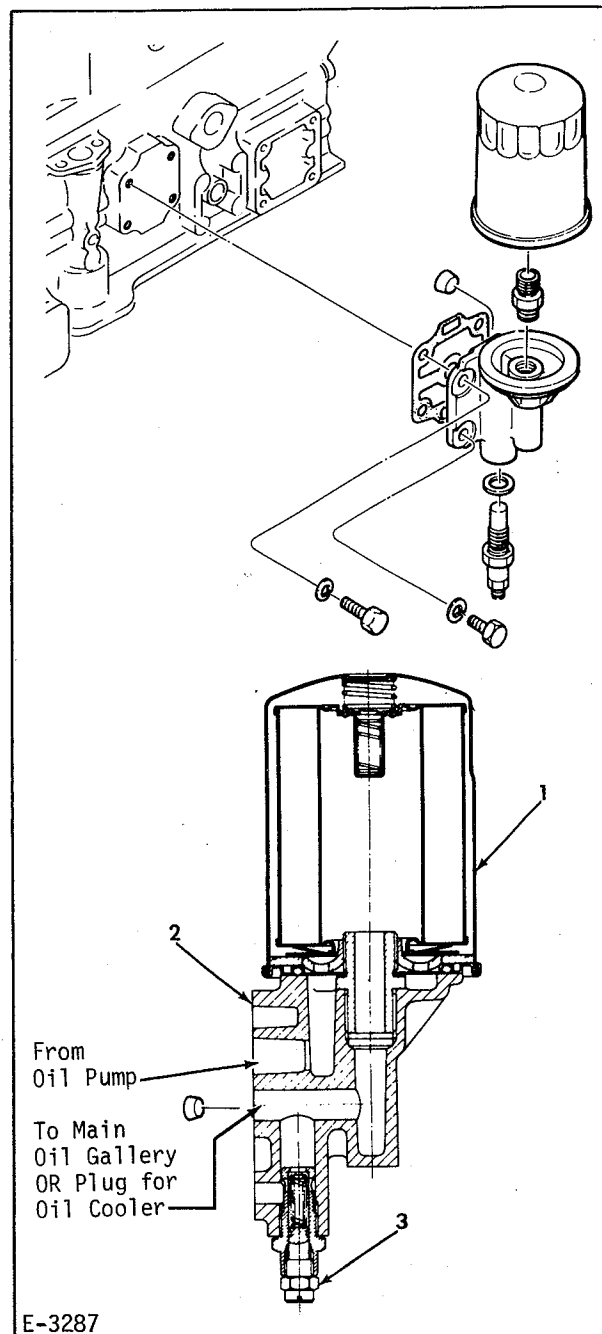

1. Filter element
2. Bracket (header)
3. Valve, Regulating

Figure 5. Lube Oil Filter

1. Daily
  - a. Check oil level in pan.
  - b. Add oil if necessary.
  - c. If oil level is higher, fuel or water has leaked into the pan. Operation of engine will cause damage. This problem is best handled by a factory trained mechanic or your Allis-Chalmers dealer.

- d. Inspect engine for evidence of oil leaks and repair if necessary.
- 2. While starting engine
  - a. Check oil pressure.
- 3. After engine reaches operating temperature
  - a. Check oil pressure.
- 4. Each 100 Hours/6Months
  - a. Replace engine lubricating oil.
  - b. Replace full flow oil filter.
- 5. Each 600 Hours/12 Months
  - a. Remove breather tube. Clean with solvent and blow out with compressed air.
- 6. Each 3000 Hours
  - a. Service oil pressure regulator.

# TOPIC 12 ENGINE ELECTRICAL SYSTEM

## A. GENERAL



**WARNING:** To prevent the possibility of bodily injury, always disconnect the battery-to-ground cable before cleaning, repairing, disconnecting or connecting any of the electrical cables.

A conventional electrical system includes the starter, alternator, voltage regulator, and a wet cell-type storage battery. This system, with alternator, has a negative ground.

**NOTE:** The electrical components are supplied by either the OEM or Allis-Chalmers. The data following is for equipment assembled on engine by Allis-Chalmers.

The battery is the storage plant for the electrical energy and must be kept fully charged. Energy drained from the battery is replaced by the alternator. Too much power output will usually burn out the alternator or damage the battery. To prevent this, a voltage regulator is connected into the circuit.

## B. ELECTRICAL SYSTEM WARRANTY AND ADJUSTMENT

Manufacturing suppliers of the battery, starter, alternator, and regulator are responsible for same during warranty period. Any claim must be directed to them, not Allis-Chalmers. Each item has its own name plate for identification. Manufacturers of such equipment have local dealers who can make reasonable adjustments or replacements.

## C. BATTERY



**WARNING:** Batteries contain sulfuric acid. Shield your eyes when working near the battery to protect against possible spilling of the acid solution. In case of acid contact with skin, eyes or clothing, flush immediately with water for a minimum of fifteen minutes. Get medical attention immediately.



**WARNING:** Be sure to connect booster cables to the proper terminals: + to + and - to -, at both ends. Avoid shorting cable clamps.



**DANGER:** Flammable vapors. Extinguish all smoking materials and open flames before checking and filling batteries. Do not check battery by sparking.

1. If liquid level is low, add distilled water to bring level in each cell up to bottom of filler hole. Do not overfill.

**CAUTION:** In freezing weather, never fill battery after operation. Water will not mix with acid and may freeze. Always fill battery before putting engine into operation.

2. Always be sure filler plugs are tight and plug vents are open.
3. Check external condition of battery and cables. Keep clean by scrubbing with soda solution and brush. After foaming stops, flush with clean water. Be sure plugs are tight when cleaning battery. After cleaning, apply thin coat of vaseline to posts and cable terminals.
4. Regularly check charge of specific gravity of battery fluid with hydrometer. Follow instructions on instrument carefully and correct for temperature of fluid being tested.
5. In cold weather, keep batteries fully charged because an uncharged battery will freeze at  $-8^{\circ}\text{C}$  ( $18^{\circ}\text{F}$ ). A half charged battery will freeze at  $-36^{\circ}\text{C}$  ( $-31^{\circ}\text{F}$ ).

## D. STARTING MOTOR

### 1. General

Heavy duty type, 12 volt, with over-running clutch, the starting motor supplied is simple and positive in action. A solenoid switch for closing the starting circuit is an integral part of the unit. A shift lever in the drive housing is linked to the solenoid switch so that lever operation not only closes circuit between battery and starter, it also shifts starter motor drive pinion into mesh with fly-wheel ring gear. When energized, it cranks the engine. After engine starts, and shift lever is released, the gears are disengaged and de-energized starter motor stops. Do not operate cranking motor continuously for more than 30 seconds without pausing for at least two minutes. Longer application will cause overheating and motor failure.

### 2. Removal and Installation

This is a service function best handled by a qualified mechanic or your Allis-Chalmers dealer.

### 3. Maintenance

- a. During start up, note motor action. Pinion gear should mesh with ring

gear. After engine starts and motor switch opens, motor should stop operation.

- b. If starter motor cranks slowly or not at all, check battery charge, defective battery cables, poor connections, defective motor, or low temperature.
- c. Normal periodic checks include investigation of battery condition, cable and connections, starting motor, solenoid switch and motor mounting.
- d. Starter motor bearings are lubricated only at time of disassembly or repair. This is a service function as is replacement of brushes or commutator cleaning.

#### E. ALTERNATOR WITH EXTERNAL VOLTAGE REGULATOR

##### 1. General

All Allis-Chalmers engines require electrical power for operation and control. These use an alternator driven by the engine to provide an electrical power source and a voltage regulator to monitor the flow of current back into the electrical system to recharge the storage battery.

With the alternator as the power source the regulator is mounted as a separate unit.

The regulator function in the charging circuit is to limit alternator voltage to a pre-set value by controlling the alternator field current. The voltage limitation is determined by the regulator adjustment. Once set, the voltage remains practically constant because regulator is unaffected by length of service, temperature or alternator output.

The alternator has three independent three-phase armature coils in the stator, with a rotor core and coil assembly including stainless steel slip rings, and a rectifier with six silicon diodes. The six rectifier diodes change A-C voltage to DC which appears at BAT (Battery) terminal of alternator. Rotor runs on ball bearings with grease reserve to eliminate need for periodic lubrication.

The voltage regulator is a two-element separately mounted unit assembly including a core, voltage coil, angle, armature, low-speed contact, and high speed contact.

**IMPORTANT:** Ground polarity of regulator and ground polarity of the battery must be the

same. Do not attempt to polarize the alternator output terminal. Never operate regulator and alternator without battery in circuit. Never short between regulator terminals and ground.

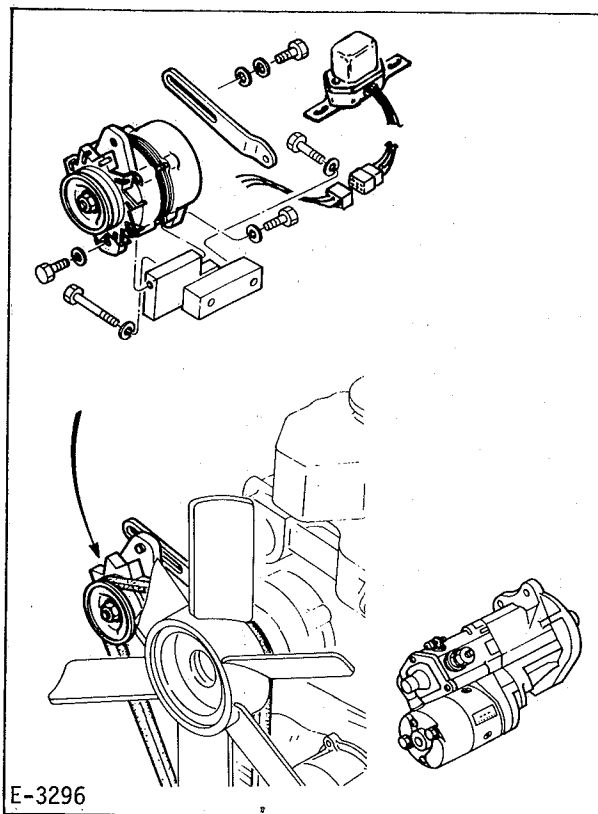

Figure 1. Alternator and Starter

NOTE: Refer to Topics 5 and 15 for wiring schematics.

##### 2. Maintenance

Only inspection of the alternator for loose bolts, loose drive pulley or loose belt drive is usually necessary. After these have been checked and unit still runs noisily, remove unit from engine and return to manufacturer for service or replacement unit.

Voltage regulator also requires minimum maintenance. If voltage fluctuates indicating dirty contacts, they should be cleaned. Before cleaning, make sure voltage fluctuation is not due to loose connections. Use strip of No. 400 silicone carbide paper, folded over. Pull back and forth between contact points. After cleaning, wash with trichloroethane or alcohol to remove residue. Repeat process if necessary. Contacts are of soft material and must never be cleaned with a file.

If voltage regulator develops additional trouble, it must be replaced as an assembly.

## F. DRIVE BELT ADJUSTMENT

See Cooling System, Topic 9, Paragraph 1.

## G. ELECTRICAL SYSTEM MAINTENANCE SCHEDULE

### 1. Before starting engine

- a. Inspect alternator/water pump belt.
- b. Check electrical connections for tightness.

### 2. While starting engine

- a. Check/correct starter performance.

- b. Check alternator charging rate.

### 3. Each 100 Hours/6 Months

- a. Check liquid level in battery.

### 4. Each 600 Hours/12 Months

- a. Check belt tension and condition of alternator/water pump belt.

### 5. Each 1000 Hours/24 Months

- a. Check specific gravity (charge) of battery fluid.
- b. Inspect, clean, and tighten all electrical connections.

# TOPIC 13 INTAKE AND EXHAUST SYSTEMS

## SAFETY PRECAUTIONS

**!** **WARNING:** No unauthorized person must be allowed to service or maintain this machine. Study the Operation and Maintenance Manuals before starting, operating, maintaining, fueling, or servicing this machine.

**!** **WARNING:** Wear safety glasses with side shields or goggles when using compressed air for cleaning to reduce the danger of personal injury from flying particles. Limit the pressure to 30 psi (207 kPa) according to OSHA requirements.

**!** **WARNING:** Never use gasoline or other toxic or flammable fluids to clean parts.

**!** **WARNING:** To prevent injury, always turn the key switch or stop control to the "OFF" position before cleaning, repairing, or servicing the engine.

**!** **WARNING:** Study this manual through before starting, operating, maintaining, fueling or servicing this machine.

## A. GENERAL

The intake and exhaust systems consist of these components that convey clean air to engine cylinders and exhaust gases to atmosphere. The intake side includes an air cleaner, intake manifold, and intake valves. The exhaust side has exhaust valves, exhaust manifold, muffler, and exhaust piping extensions.

It is important that an ample supply of fresh air be provided to the combustion chambers. Insufficient air will limit the amount of fuel engine can burn and lead to power loss, excessive smoke, high fuel consumption and perhaps, engine failure.

At the same time, restriction of the exhaust system will cause back pressure with poor engine performance and shortened engine life. Measurement of exhaust pressure will indicate whether or not capacity of system is adequate. This can be performed best by a factory trained mechanic or your Allis-Chalmers dealer.

In general, your exhaust and intake system should include no sharp angles in any piping and have a minimum of turns. Pipe size must

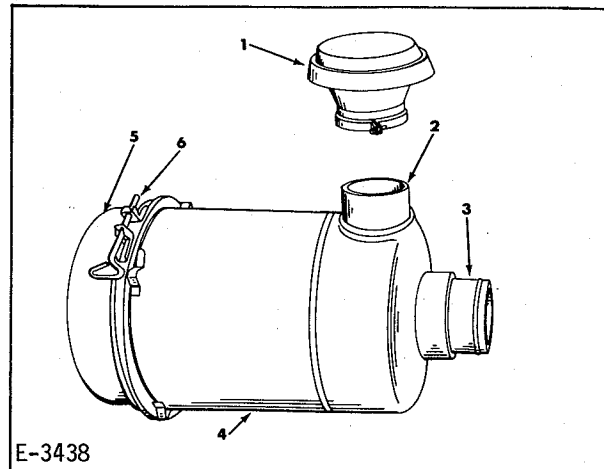

- |               |                   |
|---------------|-------------------|
| 1. Stack cap  | 4. Body           |
| 2. Air inlet  | 5. Dust cup       |
| 3. Air outlet | 6. Clamp assembly |

Figure 1. Donaldson-Single Element Type Air Cleaner

never be less than diameter of exhaust outlet opening. The system must be kept clear of any obstruction at all times.

The altitude will have an effect on the engine performance. Each 304.8m (1000 Feet) of altitude rise will cause a 1% decrease of horsepower output. After predetermined altitude is reached, the engine must be derated and maximum fuel setting reduced. This is a service function handled best by a factory trained mechanic or your Allis-Chalmers dealer.

The intake and exhaust system should be rigidly mounted and free from leaks due to ruptured gaskets, cracks, or loose connections.

## B. AIR CLEANER

The air cleaner is employed to remove dust and dirt from air to be used by the engine. Engine life depends largely on efficiency of air cleaner. Rapid wear of cylinder sleeves, pistons, and rings will result from inadequate air filtration.

Regardless of type of filter applied, frequency of element removal and servicing is dependent upon amount and type of dust and foreign material in the air close to engine. You can never over service the air filter.

Air cleaner supplied on these Allis-Chalmers engines is the Donaldson Single Element Type.

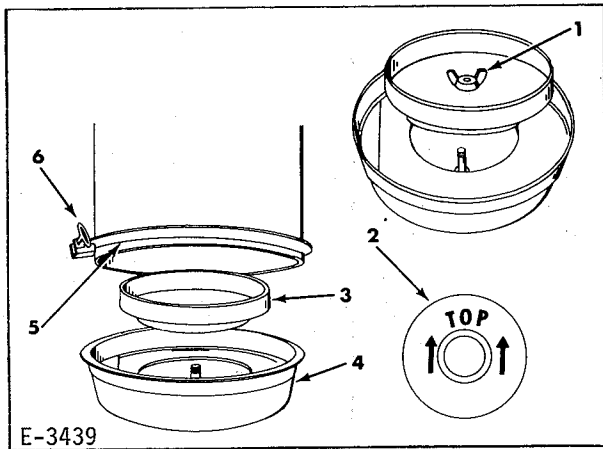

- |                    |                   |
|--------------------|-------------------|
| 1. Wing nut        | 4. Dust cup       |
| 2. Dust cup bottom | 5. Cup gasket     |
| 3. Baffle          | 6. Clamp assembly |

Figure 2. Baffle and Dust Cup Details

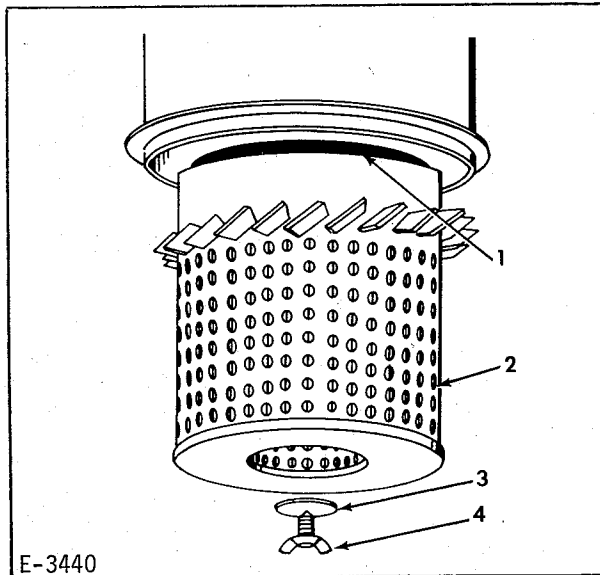

- |                   |                  |
|-------------------|------------------|
| 1. Element gasket | 3. Gasket washer |
| 2. Filter element | 4. Wing screw    |

Figure 3. Removing Filter Element

#### 1. Donaldson Air Cleaner-Single Element Type

The Donaldson air cleaner is mounted horizontally with stack in vertical position. The unit is composed of a stack cap, air inlet, single element, baffle and dust cap, clamp assembly and air outlet.

Inspect air cleaner body periodically for dents, cracks, etc. Also check for damaged gaskets, hoses, loose hose clamps, and leaks that may allow air to enter engine without first passing through filter element. Correct any such condition immediately or replace faulty parts.

Inspect dust cap daily or prior to op-

eration. Never allow dust level to build up to less than 1 inch (25.4mm) from slot in dust cap baffle.

#### a. Cleaning Air Filter Cup

- (1) Clean exterior of air cleaner (Fig. 1) and surrounding area.
- (2) Loosen clamp assembly (Item 6) and remove dust cup (Fig. 2, Item 4).
- (3) Loosen wing nut (Fig. 2, Item 1) and remove baffle from dust cup.
- (4) Empty dirt from cup. Clean cup and baffle.
- (5) Remove foreign material from around filter element.
- (6) Assemble baffle to dust cup. Tighten wing nut.
- (7) Position dust cup as marked with arrows and word TOP up (Fig. 2) on air cleaner body and tighten clamp assembly securely.

#### b. Replacing Filter Element

Clean or replace filter element when red signal covers exposed section of window on air filter indicator (Fig. 6)

- (1) Remove dust cup.
- (2) Remove wing screw (Fig. 3, Item 4) and gasket washer (3). Remove filter element (2).
- (3) Inspect element gasket (1) for damage.
- (4) Install new or clean element.
- (5) Inspect cup gasket and replace if damaged.
- (6) Reinstall dust cup assembly with top up.
- (7) Reset service indicator by pressing reset button on top of indicator.

The filter element can be cleaned by dry cleaning or washed for additional service life.

#### c. Cleaning Filter Element

- (1) Pre-cleaning fins on filter elements are not removable.
- (2) Direct jet of clean air up and down pleats on clean air side of element, (Fig. 4). Maintain reasonable distance between nozzle

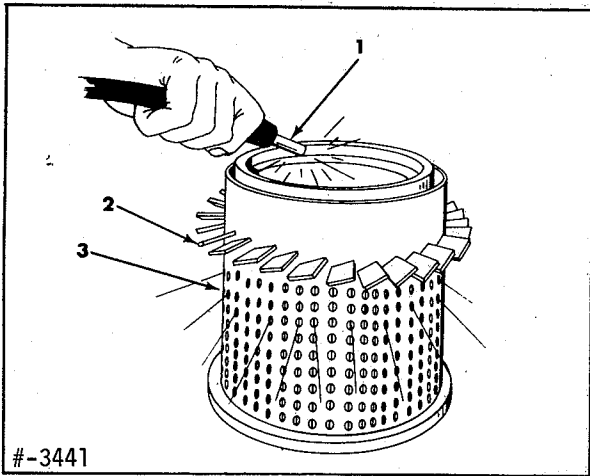

1. Nozzle
2. Pre-cleaning fins
3. Filter element

Figure 4. Dry Cleaning Filter Element

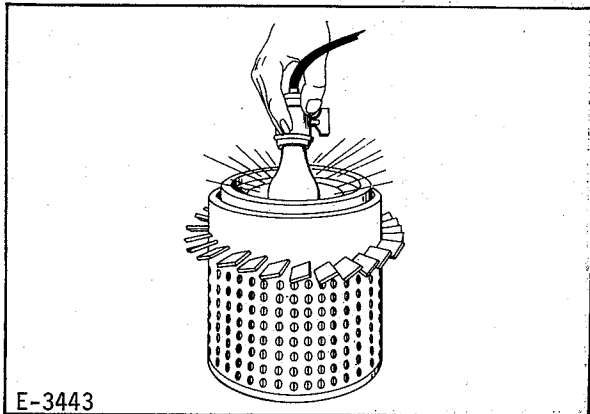
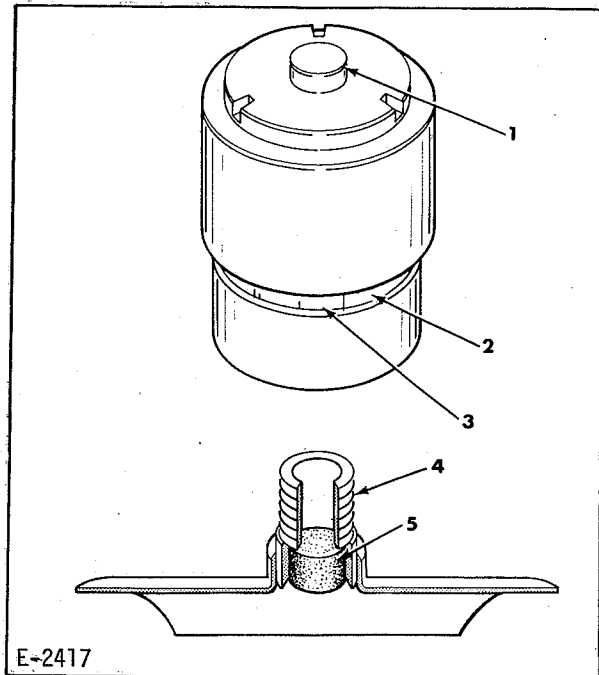

Figure 5. Inspecting Filter Element

and element, air pressure at nozzle must not exceed 689 kPa (100 psi.).

- (3) If element is oil and soot laden, wash with filter cleaner available at your Allis-Chalmers dealer. Mix 56.7 grams (2 oz.) of cleaner with small amount of cool water. Add warm water (21° to 38°C) (70° to 100°F) until volume equals 3.79 litres (1 gallon). The warmer the solution, the better it will clean. Immerse element and soak for 15 minutes. Remove and rinse with clear running tap water. Air dry thoroughly. Do not heat to dry. A fan or air draft can be used to speed drying.
- (4) Inspect element for damage after dry cleaning or washing by placing a bright light inside element (Fig. 5). Any thin rupture, spot, or pin hole renders filter unfit for further use. Never clean filter more than 6 times.



1. Reset button
2. Red signal
3. Window
4. Connector with sintered filter
5. Sintered filter

Figure 6. Air Filter Service Indicator

#### d. Air Filter Service Indicator

This gauge provides the engine operator with a visual signal indicating the need for filter service or element replacement. It is factory set.

As pressure flow in the air duct following the filter decreases, the red signal of the indicator gradually moves up in the window (Fig. 6, Item 3). When fully exposed, it locks in position denoting need for air cleaner service or filter element replacement. After servicing, reset signal by pressing reset button (1) on top of service indicator.

If seals in indicator should rupture, filter in connector (4) will temporarily prevent dust from entering systems. Entire service indicator should be replaced.

#### C. CHECK AND ADJUST VALVE CLEARANCE

When the engine is cold, check the clearance between the valve stem and rocker on each cylinder. The clearance is .010 inch (0.25mm) and is available with the piston at its top dead center (TDC) on compression stroke. This position of the piston can be found by referring to the timing mark on crank pulley.

### 1. Engine Model 426 (4-Cylinder)

- a. Turn the crankshaft until the intake valve rocker on No. 4 cylinder begins to go down, with its exhaust valve rocker remaining up.
- b. At that point, match the engraved line on the crank pulley to the timing mark on the gear case. The piston in No. 1 cylinder is now at TDC on compression stroke. Check and adjust clearance at:

No. 1 cylinder-intake and exhaust valves  
No. 2 cylinder-intake valve  
No. 3 cylinder-exhaust valve

- c. Turn the crankshaft by exactly 360° or one complete rotation. At this point, the piston in No. 4 cylinder is at TDC on compression stroke. Check and adjust clearance at:

No. 2 cylinder-exhaust valve  
No. 3 cylinder-intake valve  
No. 4 cylinder-intake and exhaust valves

- d. To check/adjust the clearance, use a .010 inch (0.25mm) thickness gauge. The gauge should be between valve stem and rocker arm.
- e. To adjust the clearance, loosen locknut and turn adjusting screw.
- f. After setting the clearance, tighten the locknut while holding the screw steadily. Recheck the clearance after tightening the nut.

### 2. Engine Model 320 (3-Cylinder)

- a. When the piston in No. 1 cylinder is at TDC on its compression stroke, check and adjust clearance at:

No. 1 cylinder-intake and exhaust valves

- b. Turn engine 240° or 2/3 revolution. At this point, check and adjust clearance at:

No. 3 cylinder-intake and exhaust valves

- c. From this position, turn engine another 240° or 2/3 revolution. At this point, check and adjust clearance at:

No. 2 cylinder-intake and exhaust valves

- d. Follow steps d, e, and f of 426 Engine description.

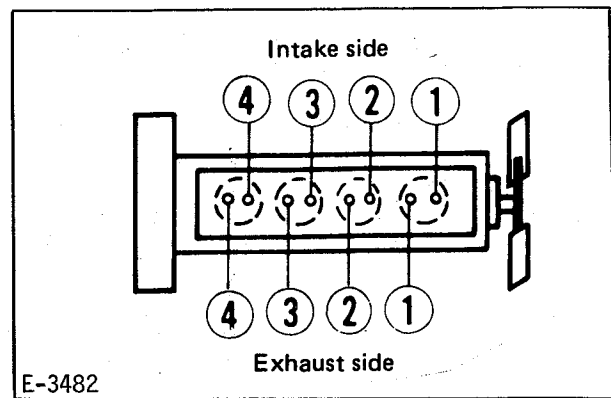

Figure 7. Valve numbering guide  
(4-Cylinder)

### 3. Engine Model 213 (2-Cylinder)

- a. When the piston in No. 1 cylinder is at TDC on its compression stroke, check and adjust clearance at:

No. 1 cylinder-intake and exhaust valves

- b. Turn engine 180° or 1/2 revolution. At this point, check and adjust clearance at:

No. 2 cylinder-intake and exhaust valves

- c. Follow steps d, e, and f of 426 engine description.

### D. CHECK/ADJUST VALVE CLEARANCE SCHEDULE

#### 1. Initial Setting

- a. Under 2500 rpm all models 500 hours.
- b. Over 2500 rpm all models 200 hours.

#### 2. 1000 Hours/24 Months

- a. All models all rpm.





### E. INTAKE AND EXHAUST SYSTEM MAINTENANCE SCHEDULE

#### 1. Daily

- a. Inspect complete system for any external damage such as dents, leaks, loose fittings, and correct.
- b. Empty and clean dust cup and baffle in air cleaner.
- c. Check air cleaner service indicator and change filter element if necessary.

# TOPIC 14 COLD WEATHER STARTING AIDS

## SAFETY PRECAUTIONS

-  **DANGER:** Do not use starting fluid with electric air heater. Explosion and personal injury could result.
-  **WARNING:** Starting fluid is flammable. Do not puncture or burn containers. Follow precautions printed on containers for storage and disposal.
-  **DANGER:** Do not use matches, lighters, or torches for a light source when inspecting or repairing engine due to presence of flammable fluids.
-  **DANGER:** Flammable vapors. Extinguish all smoking material and open flames before checking and filling batteries. Do not check battery by sparking.
-  **WARNING:** To prevent injury, always turn the key switch or stop control to the "OFF" position before cleaning, repairing, or servicing the engine.

## A. GENERAL

Each engine is equipped with a preheating glow plug for each cylinder. Glow plugs are electrically operated by a pushbutton switch located on control panel. A glow plug indicator is also located on control panel to indicate operation.

## B. OPERATION OF GLOW PLUGS

See Topic 6, paragraph B.

The glow plugs are for 12 volt operation. The current draw of each plug, 1 per cylinder, is 8.3 amp at 10.5 volts.

## C. MAINTENANCE

The glow plug air heating system does not require regular servicing. Should an assembly not function, remove and replace complete plug.

Periodically inspect, clean, and tighten all electrical connections.

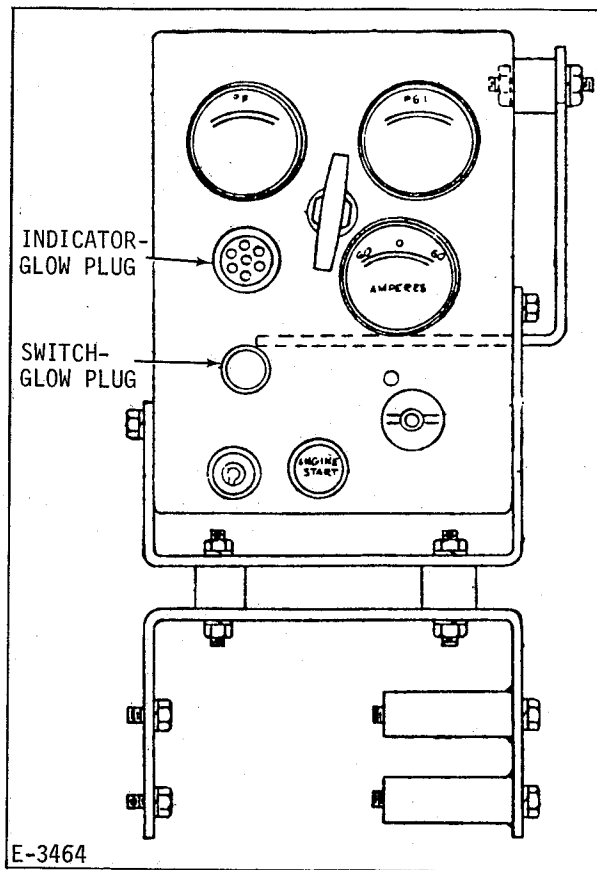

Figure 1. Air Heater Indicator and Switch

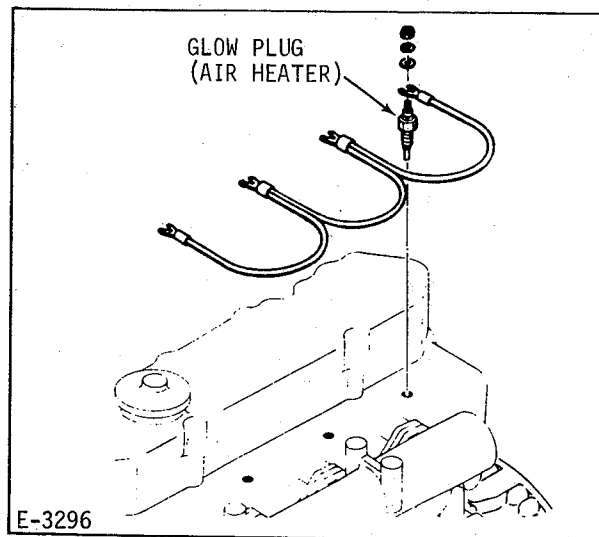

Figure 2. Air Heater

# TOPIC 15 SAFETY CONTROLS

## SAFETY PRECAUTIONS



**WARNING:** To prevent the possibility of bodily injury, always disconnect the battery-to-ground cable before cleaning, repairing, disconnecting or connecting any of the electrical cables.



**WARNING:** Never use gasoline or other toxic or flammable fluids to clean parts.

### A. GENERAL

The purpose of the optional engine safety controls is to automatically stop the engine, thereby protecting it from damage if oil pressure drops below safe operating pressure, if coolant temperature rises above a safe, pre-set limit, or if engine should overspeed.

The safety switch-gauges (Fig. 2) are wired to energize the electric fuel shut-off solenoid. The fuel shut-off solenoid valve is of the "energize to run" type.

The low oil pressure and high water temperature switch-gauges are the contact pointer type and operate in conjunction with a magnetic switch (Fig. 1).

### B. MAGNETIC SWITCH

#### 1. Purpose and Operation

A magnetic switch (circuit breaker) (Fig. 1) is wired into the circuit of the safety controls. Its purpose is to stop the engine by opening the circuit to the electric fuel shut-off solenoid which returns the injection pump shut-off lever to the "STOP" position whenever the overspeed contacts are tripped, the

pointer of either the oil pressure or water temperature switch-gauge makes contact with gauge adjusting screw. This action momentarily energizes the coil in the magnetic switch and pulls the armature latch down to release the armature, opening the circuit to the fuel shut-off solenoid, stopping the engine, and opening the circuit between the magnetic switch and the battery to prevent battery discharge.

The reset button (Fig 1, Item 1) magnetic switch must be pressed in to latch the armature in the running position to complete the circuit to the electric fuel shut-off before the engine can be started.

### C. OVERSPEED SWITCH

Two (2) trip speeds are available. The 2150 engine rpm trip speed overspeed switch (Fig. 4) is driven by the engine source 1/2 to 1 engine speed ratio with 1:1 angle adaptor at each end of cable. The 4300 engine rpm trip speed overspeed switch is the same except a 1/2 to 1 ratio angle adaptor is connected at the overspeed switch. This arrangement permits the use of the same overspeed (governor) switch for both the 1500/1800 rpm and 3000/3600 rpm generator drive speeds.

In the event the engine should overspeed and exceed safe limits, the overspeed switch shutdown contacts are tripped and open the circuit to the electric fuel shut-off solenoid, thus stopping the engine before damage is incurred.

**NOTE:** Contacts will remain in the tripped position until reset manually by depressing the reset button on top of the overspeed switch. The overspeed switch reset button must be reset first and then the magnetic switch reset button pushed in; otherwise, the magnetic switch will not stay reset.

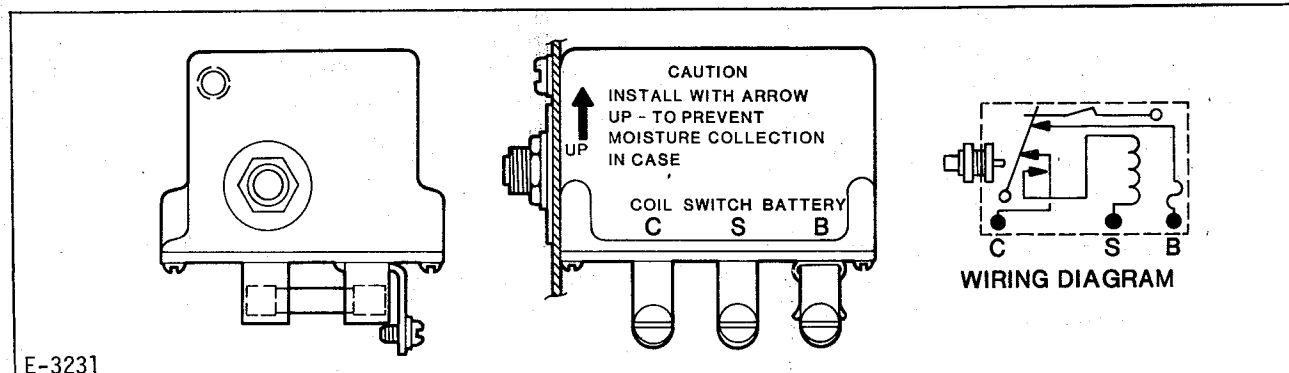

E-3231

1. Reset button  
2. Panel

3. Fuse (BUS SFE-14)  
4. Armature

5. Armature latch

Figure 1. Magnetic Switch



#### D. GAUGE CIRCUIT TROUBLE SHOOTING CHECKS

If fuel and electrical systems and the oil coolant levels have been checked, and engine is still not normal:

1. Check entire control panel for loose electrical fittings, tube connections, and/or gum varnish and dirt deposits in damper unit on back of switch-gauge.
2. Any further testing should be handled by a qualified mechanic or your Allis-Chalmers dealer.

#### E. STARTING AND STOPPING PROCEDURE WITH SAFETY CONTROLS

Following is procedure for starting and stopping an engine equipped with safety controls having a magnetic switch in the circuit:

1. Normal Starting (See Topic 3 Before Starting)
  - a. Make certain load is disconnected from engine.
  - b. Move speed control to half throttle position.
  - c. Place the key switch in the "ON" position.
  - d. Press the starter button and the magnetic switch reset button simultaneously and hold them until the oil pressure exceeds 138 kPa (20 psi) and the engine starts.

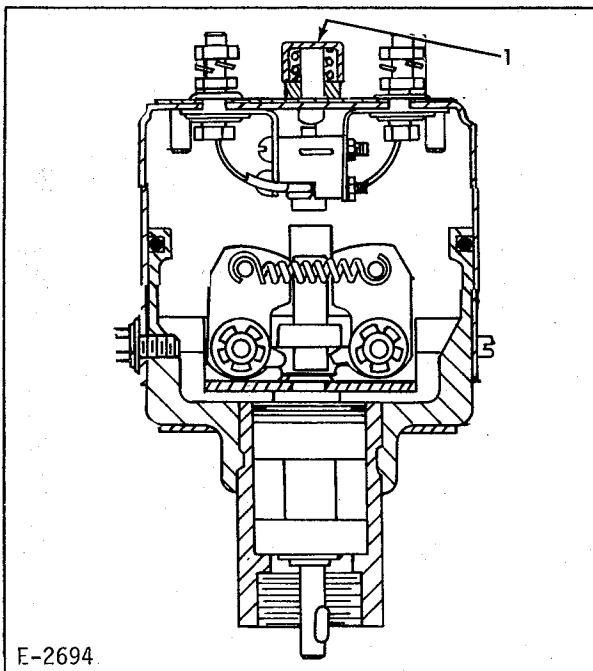

Figure 4. Overspeed Switch

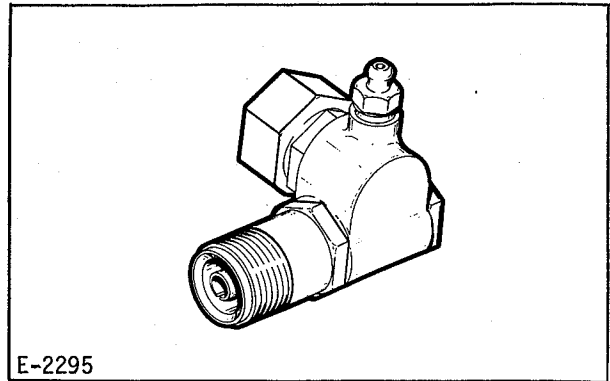
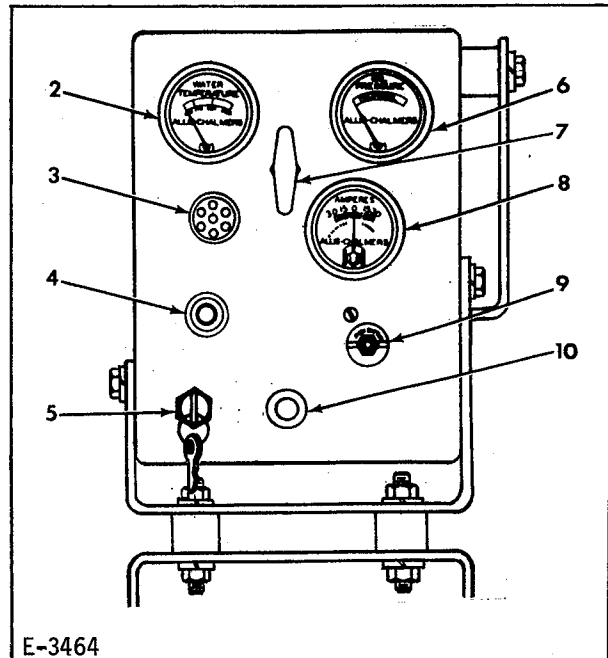

Figure 5. Angle Adaptor Drive Assembly



2. Water temperature switch-gauge
3. Glow plug indicator light
4. Glow plug switch
5. Key switch
6. Oil pressure switch-gauge
7. Throttle (speed control)
8. Ammeter
9. Stop button-electric fuel shut-off
10. Starter button

Figure 6. Panel with Safety Switches

NOTE: The starting motor must never be used continuously for more than 30 seconds at any one time without a pause of two minutes until it cools.

- e. As soon as engine starts, move speed control to "FAST IDLE" speed and allow engine to warm up.

#### 2. Normal Stopping

- a. Move speed control knob slowly to "LOW IDLE" speed and disengage load from engine.

NOTE: Run engine for at least five (5) minutes at "FAST IDLE" so it can cool gradually and uniformly.

b. Turn key switch to "OFF" position.

3. Automatic Safety Engine Shutdown

a. High Coolant Temperature

- (1) If shutdown is due to high coolant temperature, the contacts in the water temperature safety switch-gauge react to de-energize the fuel shut-off solenoid. The engine cannot be started until the temperature is lowered to the safe operating range.
- (2) Locate source of trouble causing overheating and make necessary repairs.
- (3) Fill system with coolant and start engine in the normal manner. See

Paragraph 1 (above), Normal Starting.

b. Low Oil Pressure

- (1) If shutdown is due to low oil pressure, locate source of trouble and make necessary repairs.
- (2) Make certain oil pan is filled to proper level or cause of lost oil pressure is eliminated. Start engine in normal manner. See Paragraph 1 (above), Normal Starting.

c. Overspeed Switch

- (1) If engine is shut down due to engine overspeed, locate and eliminate the source of trouble.
- (2) Press inward on overspeed switch reset button (Fig. 4, Item 1) and start engine in normal manner. See Paragraph 1 (above), Normal Starting.

# TOPIC 16 ENGINE ACCESSORIES

## SAFETY PRECAUTIONS

**⚠** **WARNING:** To prevent injury, always turn the key switch or stop control to the "OFF" position before cleaning, repairing, or servicing the engine.

**⚠** **WARNING:** No unauthorized person must be allowed to service or maintain this machine. Study the Operation and Maintenance Manuals before starting, operating, maintaining, fueling, or servicing this machine.

**⚠** **WARNING:** Do not check or adjust belts when engine is running.

## A. POWER TAKE-OFF CLUTCH

The clutch is a single dry plate type with an over-center engaging action. A shifting collar and bearing mechanism, carried on power take-off shaft, is operated by clutch lever to engage or disengage the clutch. A threaded adjusting yoke provides means to maintain adjustment to compensate for clutch wear.

Clutch should engage with a definite over-center "snap" and require an appreciable push on operating level for engagement. If "snap" is not evident, or clutch slips under load, adjust clutch immediately.

Always refer to instructions on clutch adjustment access cover.

## B. POWER TAKE-OFF CLUTCH ADJUSTMENT

1. Remove access cover and gasket.
2. Disengage clutch. Turn clutch shaft until adjusting lock pin may be reached through opening in housing.
3. Pull adjusting lock pin out and turn adjusting yoke clockwise to tighten, opposite to loosen, as necessary. Moving two or three notches is usually sufficient.
4. Lock adjusting yokes in place by inserting adjusting lock pin into nearest notch in clutch back plate. Clutch should engage with definite over-center snap.
5. Replace access cover and gasket.

## C. MAINTENANCE

1. Daily
  - a. Lubricate throw-out collar through fitting on tapered parts of housing.

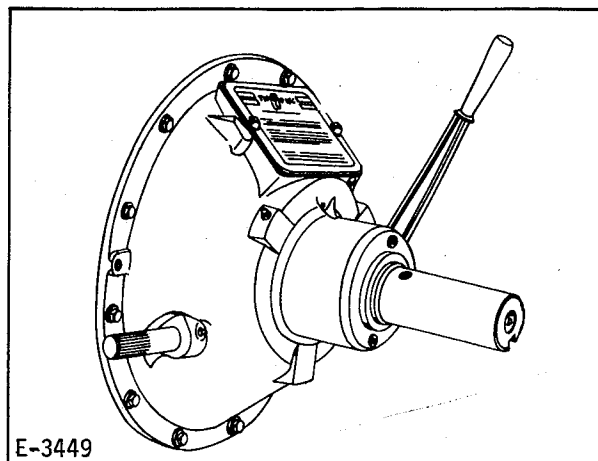
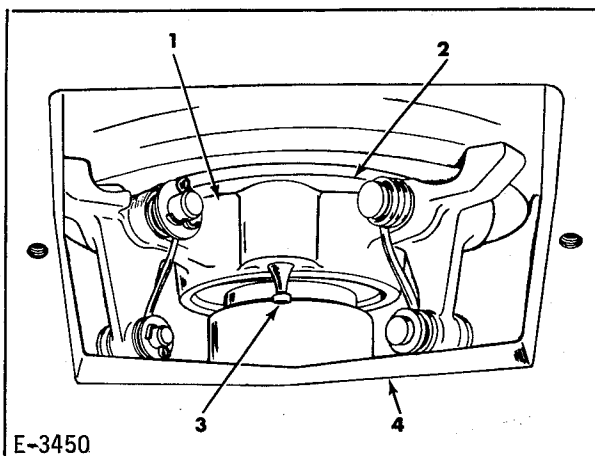

Figure 1. Power Take-off Clutch  
(With Sealed-for-Life Pilot Bearing)



1. Adjusting yoke
2. Clutch back plate
3. Clutch adjusting lock pin
4. Power take-off shaft

Figure 2. Clutch Adjustment

Refer to Topic 4 for grease recommendations.

2. Each 100 Hours/6 Months
  - a. Lubricate the pilot bearings through the fitting in clutch shaft. Sealed-for-life pilot bearing should not be lubricated. Damage to engine thrust bearing could result from trapped grease pressure. Clutch shaft is not normally drilled. If drilled, a plug(s) should be installed to prevent inadvertent greasing.
  - b. Lubricate shaft bearings through fitting on housing hub.
  - c. Lubricate operating lever shaft.
  - d. Check clutch adjustment. If clutch slips under load or has no over-center snap, adjust immediately.



The information contained herein is general in nature and is not intended for specific application purposes. Allis-Chalmers reserves the right to make changes in specifications shown herein, add improvements, or discontinue manufacture at any time without notice or obligation.

