

# Briggs & Stratton OPERATING AND MAINTENANCE INSTRUCTIONS

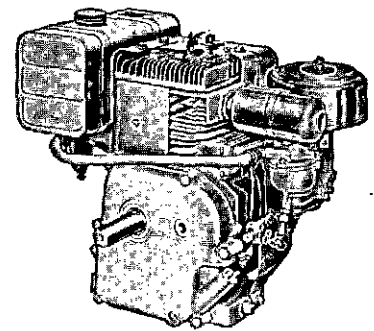

## MODELS 170400 to 170457 190400 to 190497

### IN THE INTEREST OF SAFETY, DO NOT RUN ENGINE AT EXCESSIVE SPEEDS

Operating an engine at excessive speeds increases the hazard of personal injury. **DO NOT TAMPER WITH PARTS WHICH MAY INCREASE THE GOVERNED SPEED.**

For rotary lawnmower safety, USA Standard Safety Specifications for Power Lawn Mowers specify a maximum blade tip speed of 19,000 feet per minute, primarily to reduce the hazard from thrown objects.

Rotary lawnmower manufacturers select the governed top speed of the engine based on the length and design of the cutter blade and design of other mower parts.

All rotary lawnmowers should be checked for conformance to the USA Standard Safety Specifications for Power Lawn Mowers on blade tip speed, if the engine is repaired or replaced, or if mower parts are changed.

Dirt and grass clippings, or other debris, in cooling fins or governor parts can affect engine speed. See cleaning instructions in Section 3.

### CAUTION

TO PREVENT ACCIDENTAL STARTING always remove the spark plug before working on the engine or equipment driven by the engine or remove cable from spark plug and insert terminal in V-notch in cylinder head cover.

**DO NOT RUN THE ENGINE IN AN ENCLOSED AREA.** Exhaust gases contain carbon monoxide, an odorless and deadly poison. **DO NOT FILL GASOLINE TANK WHILE ENGINE IS RUNNING.** Spilling gasoline on a hot engine may cause a fire or explosion.

## Section 1 BEFORE STARTING

READ THE OPERATING INSTRUCTIONS OF THE EQUIPMENT THIS ENGINE POWERS

- ① **FILL SUMP WITH OIL** — Use a high quality detergent oil classified "For Service SC, SD, SE or MS". Nothing should be added to the recommended oil.

**Summer**  
(Above 40° F.)  
Use SAE 30

If not available,  
Use SAE 10W-30  
or  
SAE 10W-40

**Winter**  
(Under 40° F.)  
Use SAE 5W-20 or SAE 5W-30

If not available,  
Use SAE 10W or SAE 10W-30

Below 0° F.,  
Use SAE 10W or SAE 10W-30  
Diluted 10% with Kerosene

**DIRECTIONS:** Place the engine level. **FILL THE OIL SUMP TO OVERFLOWING** or to the **FULL** mark on dipstick. Pour slowly. Capacity 2-3/4 pints.

**EXTENDED OIL FILL (Optional).** Remove cap and dipstick and fill to full mark on dipstick. When checking oil level push dipstick assembly firmly but slowly until cap bottoms on tube. **Do not overfill.** Dipstick assembly must be pushed fully into tube at all times when engine is operating.

- ② **FILL FUEL TANK** — Use clean, fresh, lead-free or leaded "regular" grade automotive gasoline. **Fill tank completely!**

**DO NOT MIX OIL WITH GASOLINE.**

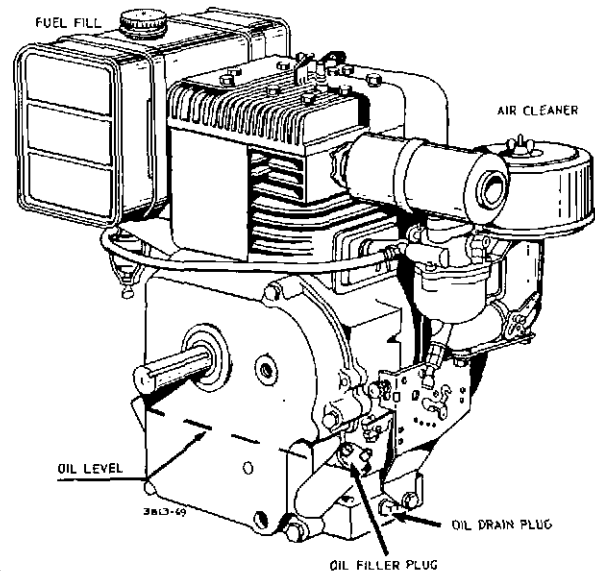

**1 BE SURE THE STOP SWITCH IS AWAY FROM SPARK PLUG**

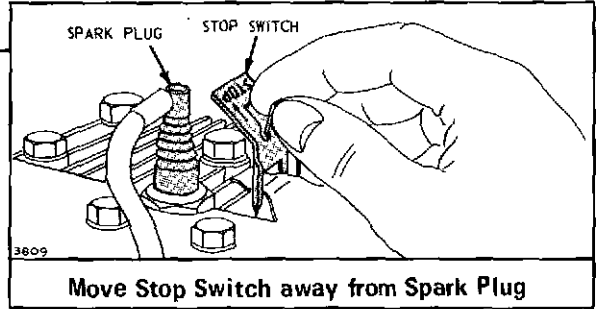

**2 OPEN FUEL VALVE**

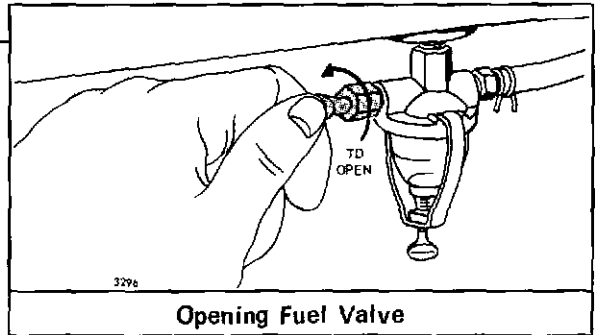

**3 CHOKE THE CARBURETOR**

**a. Manual Type**

Move lever in direction of arrow to fully closed choke position. Set governor control in normal operating position.

**b. Choke-A-Matic**

Move lever to "Full Choke" or "Start" position.

**Note:** This should fully close choke on carburetor. If it does not, remote control must be re-adjusted. See "Choke-A-Matic Carburetor" Adjustments, Section 4.

**Note:** A warm engine requires less choking than a cold engine.

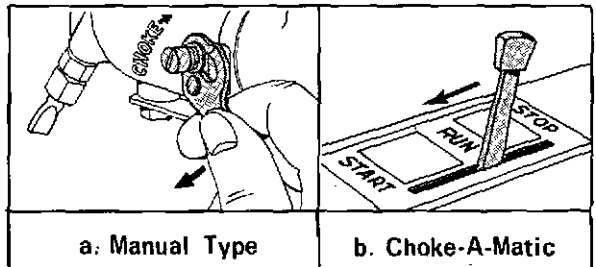

**4 START ENGINE**

**a. Rewind Starter** Grasp starter grip as illustrated and pull out cord two to three feet. Repeat if necessary with choke opened slightly. When engine starts open choke gradually.

**b. Rope Starter** Wind the starter rope around the pulley in direction shown by arrow. Pull the rope with a quick full arm stroke. Repeat if necessary with choke opened slightly. When engine starts open choke gradually.

**c. Electric Starter** Press starter button on powered equipment. When engine starts open choke gradually.

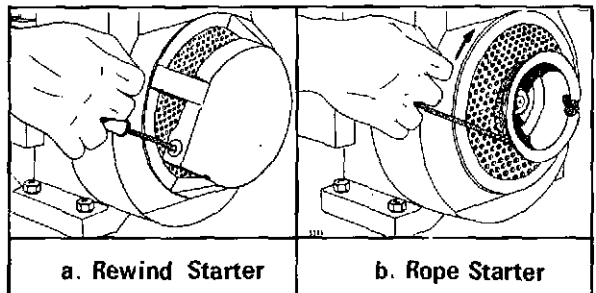

**CAUTION:** The 110 volt electric starter is equipped with a three prong plug for your safety. If a longer extension cord is used it should also have three-prong and three hole plugs. If the outlet or receptacle is the two-hole type, an adapter must be used. To get the proper grounding, fasten the ground lead on the adapter to something electrically grounded, such as the metal box on the end of a grounded metal conduit.

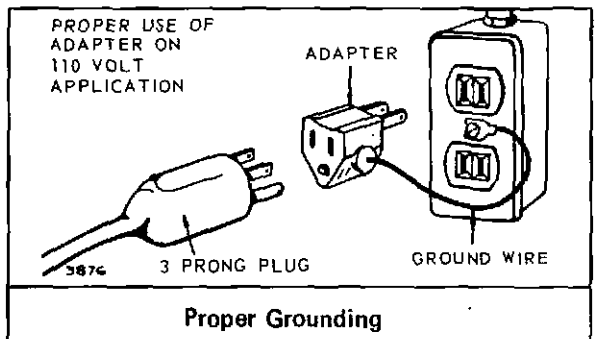

## Section 4 ADJUSTMENTS (cont'd)

### CHOKE-A-MATIC CARBURETOR CONTROL ADJUSTMENTS

Proper choke and stop switch operation is dependent upon proper adjustment of remote control on the powered equipment.

#### To Check Operation of Choke-A-Matic Controls:

- Remove air cleaner.
- Move remote control lever to "Choke" position. The carburetor choke should be closed.
- Move remote control to "Stop" position. Lever should make good contact with stop switch.

#### To Adjust:

Place remote control lever on equipment in FAST (high speed) position. Loosen control casing clamp screw "B". Move control casing "A" and wire until lever "D" touches choke operating link at "C". Tighten casing clamp screw "B". Replace air cleaner.

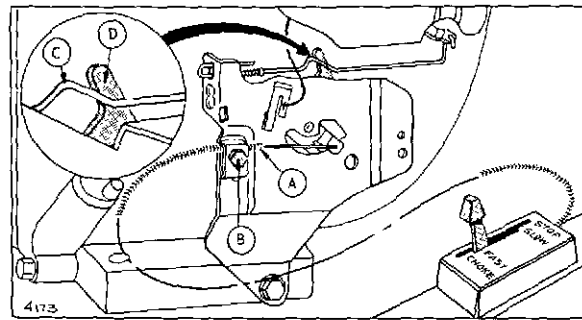

### SPEED CONTROL ADJUSTMENTS

The recommended operating speed range is 1800 to 3600 RPM. The standard speed setting (no load) is 3600 RPM. Idle speed is 1750 RPM.

Refer to illustration. Select the control on your engine. To increase engine speed move control in direction shown by arrow.

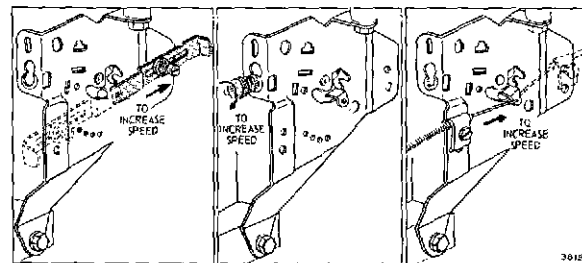

## Section 5 GENERAL INFORMATION

**ENGINE DESIGN** – Your engine is 4 cycle, single cylinder and L-head. It is air cooled.

	MODEL SERIES 170400 to 170457	MODEL SERIES 190400 to 190497
Bore	3"	3"
Stroke	2-3/8"	2-3/4"
Displacement	16.79 cu. in.	19.44 cu. in.
Horsepower	7.0 H.P. max. @ 3600 RPM	8.0 H.P. max. @ 3600 RPM
Torque (Ft. Lbs.)	11.0 max. @ 2600 RPM	12.7 max. @ 2500 RPM

The horsepower ratings listed above are established in accordance with the Society of Automotive Engineers Test Code-J607. For practical operation, the horsepower loading should not exceed 85% of these ratings. Engine power will decrease 3½% for each 1,000 feet above sea level and 1% for each 10° above 60° F.

#### TUNE-UP SPECIFICATIONS

	A.C.	Autolite	Champion
Spark Plug Type	CS-45	A7N	CJ-8
Short Plug	GC-46	A71	J-8
Long Plug			
Spark Plug Gap			.030"
Ignition Point Gap			.020"
Intake Valve Clearance			.005"-.007"
Exhaust Valve Clearance			.009"-.011"

#### STORAGE INSTRUCTIONS

Engines to be stored over 30 days should be completely drained of fuel to prevent gum deposits forming on essential carburetor parts, fuel filter, fuel lines and tank.

- Drain fuel tank completely and clean fuel filter. (See Section 3).
- Operate engine until gasoline in carburetor is completely consumed.
- While engine is still warm, drain oil from crankcase. Refill with fresh oil.
- Remove spark plug, pour one ounce (2 or 3 tablespoons) of SAE-30 oil into cylinder and crank slowly to distribute oil. Replace spark plug.
- Clean dirt and chaff from cylinder head fins and blower housing. (See Section 3).

**Dry Element Type**

To clean — tap element (top or bottom) on flat surface or wash in non-sudsing detergent and flush from inside until water is clear. After washing, air dry thoroughly before using. DO NOT OIL.

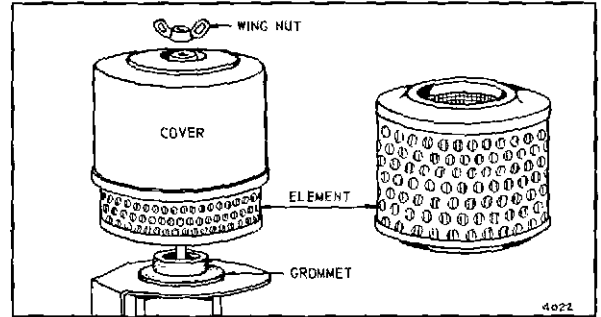

- 5 **CLEAN COOLING SYSTEM** — Grass or chaff may clog cooling system after prolonged service in cutting tall dry grasses or hay. Continued operation with a clogged cooling system causes severe overheating and possible engine damage. Remove blower housing and clean regularly.

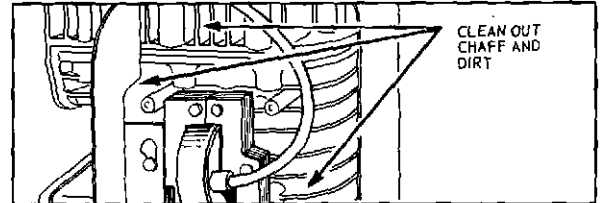

- 6 **SPARK PLUG** — Clean and reset gap at .030" every 100 hours of operation.

**CAUTION:** Blast cleaning of spark plugs in machines that use abrasive grit is not recommended. Spark plugs should be cleaned by scraping or wire brushing and washing with a commercial solvent or gasoline.

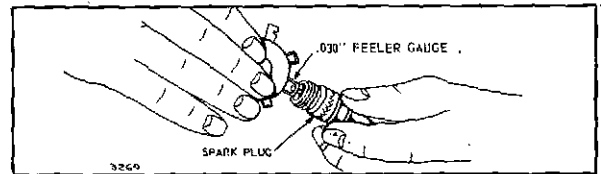

**CLEAN COMBUSTION CHAMBER** every 100-300 hours of operation. The use of regular automotive fuels and constant speed and load operation, often result in a gradual build-up of tetraethyl lead deposits in the combustion chamber. Remove cylinder head. Scrape and wire brush the lead and carbon deposits from cylinder head, top of piston and around valves. Use a soft brush or compressed air to remove loose deposits.

Reassemble cylinder head, gasket, cover and turn down screws finger tight. Use the three longer screws around the exhaust valve. Using a socket wrench with a 6" handle, turn all screws an additional 1/4 turn (150-175 torque). **BE SURE TO TIGHTEN** head mounting screws in a staggered sequence.

**CARBURETOR ADJUSTMENTS**

Minor carburetor adjustment may be required to compensate for differences in fuel, temperature, altitude and load.

**To Adjust Carburetor** Turn needle valve clockwise until it just closes. **Caution:** Valve may be damaged by turning it in too far.

Now open needle valve 1-1/8 turns counterclockwise. Close idle valve in same manner and open 1-1/8 turns. This initial adjustment will permit the engine to be started and warmed up prior to final adjustment.

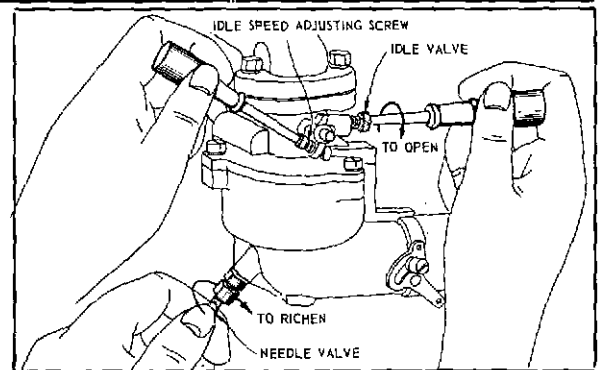

**Final Adjustment:** Turn needle valve in until engine misses (lean mixture) then turn it out past smooth operating point until engine runs unevenly (rich mixture); Now turn needle valve to the mid-point between rich and lean so the engine runs smoothly. Hold throttle at idle position and set idle speed adjusting screw until fast idle is obtained (1750 RPM). Hold throttle in idle position and turn idle valve in (lean) and out (rich) until engine idles smoothly. Then reset idle speed adjusting screw so that engine idles at 1750 RPM. Release throttle — engine should accelerate without hesitation or sputtering. If engine does not accelerate properly, the carburetor should be re-adjusted to a slightly richer mixture.

Section  
2

# STARTING (cont'd)

**SPECIAL LOW TEMPERATURE STARTING PROCEDURE** 1. Turn needle valve on carburetor 1/8 turn counterclockwise from normal summer adjustment. **Note:** If fuel drips out of carburetor while trying to start engine, the engine is over choked. Pull starter several times or push starter button with choke open. 2. Be sure to use the proper weight of oil for the air temperature expected. 3. Disconnect all external loads. Any V-belt drives must be removed or loosened so that the belts are standing still for satisfactory operation below freezing. Starter, motor and battery are designed to start the engine only. 4. Keep battery and engine warm if possible. If it is not possible to keep the entire unit warm, there is a big advantage in keeping the battery warm until it is required for starting. A warm battery has much more starting capacity than a cold battery.

5 **STOP ENGINE**

- a. **Manual Choke** – Push the stop switch against end of spark plug.
- b. **Choke-A-Matic** – Move control lever to "Stop" position.

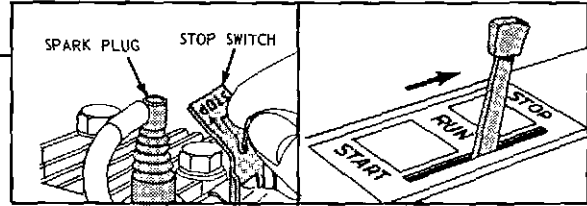

Section  
3

# MAINTENANCE

1 **CHECK OIL LEVEL** regularly – after each 5 hours of operation. **BE SURE OIL LEVEL IS MAINTAINED.**

2 **CHANGE OIL** after first 5 hours of operation. Thereafter change oil every 25 hours of operation. Remove oil drain plug and drain oil while engine is warm. Replace drain plug. Remove oil filler plug or cap and refill with new oil of proper grade. Replace oil filler plug or cap.

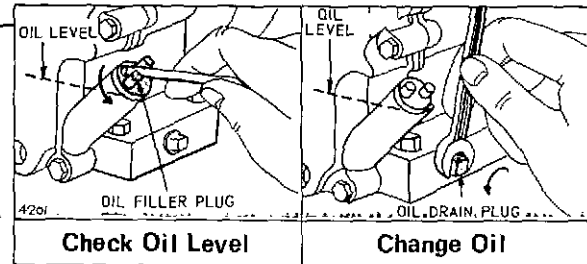

Check Oil Level

Change Oil

3 **CHANGE OIL (GEAR REDUCTION optional)** by removing oil level plug. Remove drain plug in bottom of gear case cover and drain oil every 100 hours of operation. To refill, remove oil check plug and oil filler plug and pour oil (same grade as used in crankcase) into filler hole until it runs out level check hole. Replace both plugs. Oil filler plug has a vent hole and must be installed on top of gear case cover.

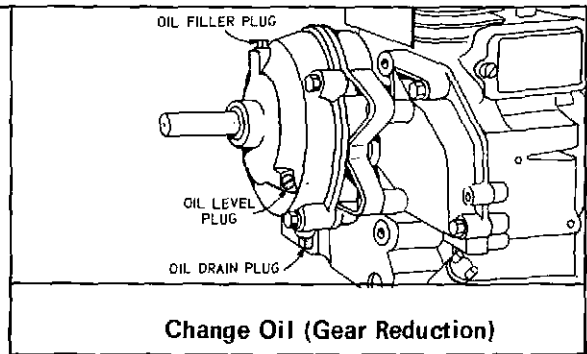

Change Oil (Gear Reduction)

4 **SERVICE AIR CLEANER REGULARLY** – Clean element every 25 hours – more often under dirty conditions.

**"Oil-Foam"® Type**

1. Remove wing nut and cover.
2. Lift off foam element from base.
3. Push down foam element as shown, and pull out air cleaner cup.
4. A – Wash foam element in kerosene or liquid detergent and water to remove dirt.  
 B – Wrap foam in cloth and squeeze dry.  
 C – Saturate foam in engine oil. Squeeze to remove excess oil.  
 D – Put air cleaner cup inside element. **Be sure sealing lip is over end of cup (top and bottom).**
5. Reassemble parts as shown. Screw wing nut down tight.

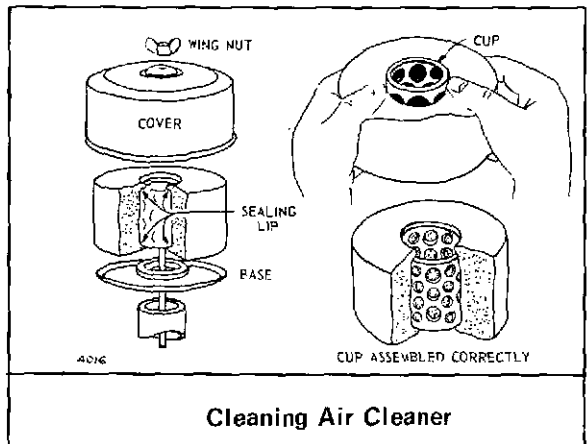

Cleaning Air Cleaner

**Section  
6**

**SERVICE & REPAIR INFORMATION**

If service or repair is needed, contact an Authorized Briggs & Stratton Service Center. To serve you promptly and efficiently, the Service Center will need the model, type and code number on your engine. (See Section 7).

Each Authorized Service Center carries a stock of original Briggs & Stratton repair parts and is equipped with special service tools. Trained mechanics assure expert repair service on all Briggs & Stratton engines.

Your nearest service center is listed in the "Yellow Pages" under "Engines, Gasoline" or "Gasoline Engines". He is one of over 15,000 service centers available to serve you.



FOR REPAIRS AND SERVICE CONTACT THE DEALER DISPLAYING THIS SIGN



**Section  
7**

**WARRANTY**

SAVE THIS SECTION FOR YOUR RECORD

**BRIGGS & STRATTON ENGINE WARRANTY**

For ONE YEAR from purchase date, Briggs & Stratton Corp. will replace for the original purchaser, FREE OF CHARGE, any part, or parts, found upon examination by any Factory Authorized Service Center, or by the Factory at Milwaukee, Wisconsin, to be DEFECTIVE IN MATERIAL AND/OR WORKMANSHIP.

All transportation charges on parts submitted for replacement under this Warranty must be borne by purchaser.

*There is no other Warranty express or implied. Briggs & Stratton Corp. shall in no event be liable for consequential damages.*

BRIGGS & STRATTON CORP.

*V. R. Shiely*  
V. R. SHIELY - PRESIDENT

NOTE: The Briggs & Stratton Engine Warranty does not cover breakage of parts or damage to parts due to abuse or failure to follow the recommended maintenance procedures. The warranty also excludes any accessories, controls or equipment which are not manufactured by Briggs & Stratton Corporation.

If warranty service is needed contact your nearest Authorized Service Center. For Prompt Attention your center will need to know the engine model, type and code number, the trouble experienced and the total number of hours the engine has run. If you differ with the decision of a Service Center on a warranty claim, ask the Service Center to submit all supporting facts to the Factory for review. If the Factory decides that your claim is justified, you will be fully reimbursed for those items accepted as defective.

FILL IN THE REQUIRED INFORMATION FOR YOUR RECORD:  
(See Decal on Blower Housing for Model, Type and Code Number)

Engine Model No. \_\_\_\_\_ Type No. \_\_\_\_\_ Code No. \_\_\_\_\_  
 Dealer Purchased From \_\_\_\_\_ Date \_\_\_\_\_  
 Type of Equipment \_\_\_\_\_  
 Name or Trademark of Equipment Manufacturer \_\_\_\_\_

BRIGGS & STRATTON ENGINES ARE MADE UNDER ONE OR MORE OF THE FOLLOWING PATENTS:

2,669,922	2,796,453	3,114,851	3,149,618	3,194,224	3,252,449	DESIGN
2,693,789.	2,999,491	3,118,433	3,165,094	3,236,937	3,276,439	D-191,806 D-196,017 D-197,175 D-213,476
2,693,791	2,999,562	3,144,097	3,168,936	3,242,741	3,378,099	OTHER PATENTS PENDING
					3,415,237	