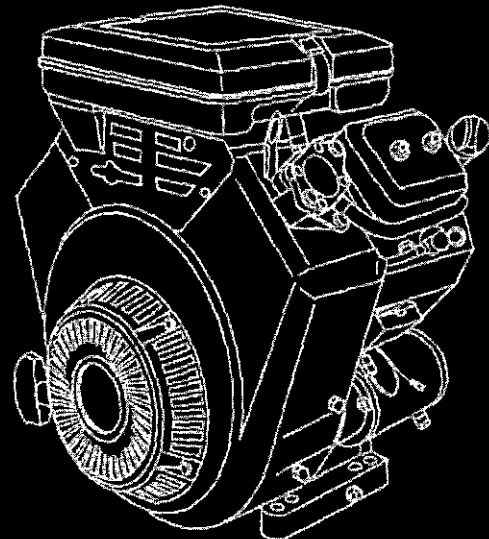
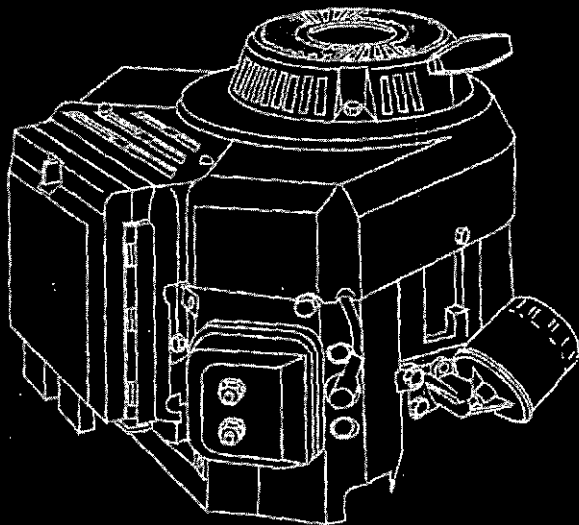
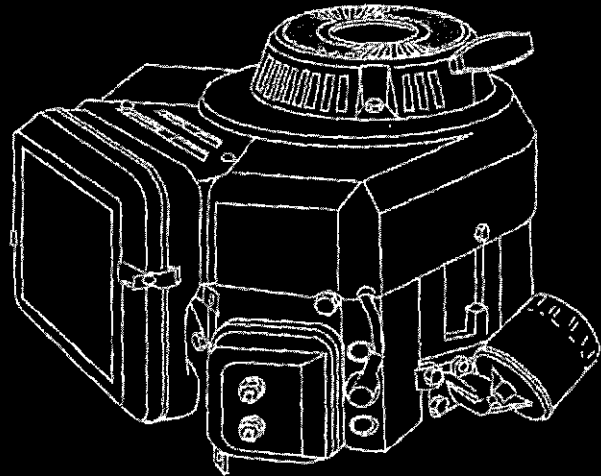
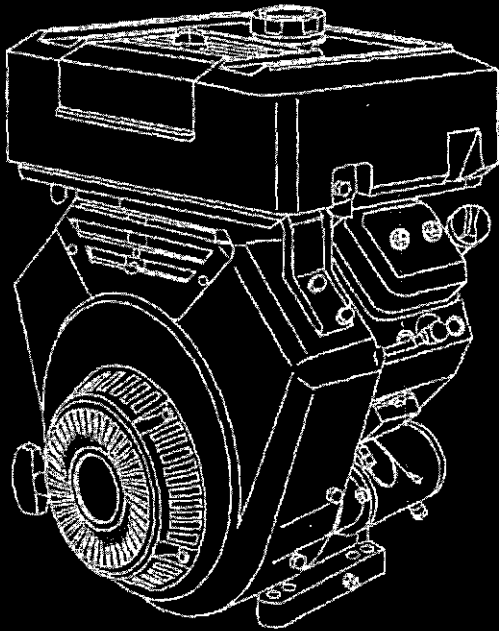




**VANGUARD**

# *Repair Manual*

*For 4-Cycle V-Twin Cylinder OHV Engines*



## COMMON SPECIFICATIONS FOR OHV-TWIN CYLINDER ENGINE MODELS

1. Spark plug gap: .76 mm (0.30")
2. Crankshaft end play: .08-.40 mm (.003"-.015")
3. Top governed speed: See Briggs & Stratton Service Engine Sales Manual MS-4052 or MS-6225.

Standard Bore Size Model 290000 & 303000	Standard Bore Size Model 350000 & 351000	Idle Speed* RPM	Armature Air Gap	Intake & Exhaust Valve Clearance (Cold)	Valve Guide Reject Size
68.0-68.025 mm (2.677"-2.678")	72.0-72.025 mm (2.835"-2.836")	1750 1100	.20-.30 mm (.008"-.012")	.10-.15 mm (.004"-.006")	6.05 mm (.238")

\*Governed Idle            1750 RPM Spring #805453 (red)  
                                   1100 RPM Spring #805454 (white)

### CYLINDER RESIZING

Resize if .076 mm (.003") or more wear. Resize if out of round .038 mm (.0015") or more. Resize .25 mm (.010"), .51 mm (.020"), .76 mm (.030") over Standard Bore.

### TORQUE SPECIFICATIONS

Flywheel	Cylinder Head	Connecting Rod	Crankcase Cover
175 Nm (125 ft. lbs.)	19 Nm (165 in. lbs.)	13 Nm (115 in. lbs.)	17 Nm (150 in. lbs.)

Crankshaft Reject Sizes			Main Bearing Reject Sizes	
Mag. Journal	Crankpin	PTO Journal	Mag Bearing	PTO Bearing Plain Bearing
29.94 mm (1.179")	36.95 mm (1.455")	34.92 mm (1.375")	30.08 mm (1.1845")	35.07 mm (1.381")

### PISTON RING REJECT SIZE

Comp. Rings	Oil Ring
.76 mm (.030")	.76 mm (.030")

### MISCELLANEOUS TORQUE SPECIFICATIONS

Governor Lever Lock Nut: 8 Nm (70 in. lbs.)  
 Spark Plugs: 22.5 Nm (200 in. lbs.)  
 Starter Mounting Screws: 16 Nm (140 in. lbs.), Electric Start Models  
 Intake Manifold Screws: 16 Nm (140 in. lbs.)

# INDEX

	SECTION	PAGE
Air Cleaner		
Servicing .....	3	1, 2
Alternators		
Identification .....	7C	1-3
AC Only .....	7C	5
DC Only .....	7C	6
Dual Circuit .....	7C	7, 8
Regulated 5 or 9 Amp .....	7C	9, 10
Regulated 10 & 16 Amp .....	7C	10-12
Regulator/Rectifier With Charge Indicator .....	7C	12-14
Test Equipment .....	7C	4, 5
Tri-Circuit .....	7C	8, 9
Troubleshooting .....	7C	4
Armature		
Air Gap .....	2	5
Installation .....	2	4, 5
Removal .....	2	2
Battery		
Cable .....	7B	14
Information .....	7B	13
Recommendation .....	7B	14
Bearings		
Checking .....	11	3, 5
Installation .....	11	4, 5
Removal .....	11	3, 4
Breather		
Checking .....	8	3
Installation .....	8	4
Removal .....	8	3
Cam Gear		
Checking .....	10	2
Installation .....	10	3
Removal .....	10	1
Carburetor		
Adjustment		
Models 290000-350000 .....	3	43-46
Models 351400-351700 .....	3	46-48
Anti-Afterfire System .....	3	48, 49
Assemble		
Models 290700-303700 .....	3	10-13
Models 290400-303400 .....	3	32-34
Model 350700 .....	3	16-18
Model 350400 .....	3	38-40
Models 351400-351700 .....	3	21-23
Disassemble		
Models 290700-303700 .....	3	7-10
Models 290400-303400 .....	3	29-32
Model 350700 .....	3	13-16
Model 350400 .....	3	35-38
Models 351400-351700 .....	3	18-21
Operation .....	3	3-5
Removal .....	3	5-7, 26-29
Replace Float Needle Seat .....	3	15, 16, 36, 38
Testing Solenoid .....	3	49
Carburetor Linkage - Controls .....	4	

## INDEX (Continued)

	SECTION	PAGE
Coils (see Armature)		
Check-Up .....	1	7-9
Connecting Rod		
Checking .....	9	2
Installation .....	9	3, 4
Controls, Governor & Carburetor Linkage .....	4	
Crankshaft		
Checking .....	10	1, 2
End Play .....	10	4
Installation .....	10	3
Removal .....	10	1
Cylinder Balance Test .....	1	7
Cylinder Head		
Installation .....	6	6, 7
Removal .....	6	1-3
Cylinder		
Bearings .....	11	3-5
Resizing Bore .....	11	1, 2
Dipsticks .....	8	2
Engine Model System .....	1	10
Engine Specifications .....	Preface	
Extended Oil Fill .....	8	2
Exhaust System		
Inspection .....	12	1
Installation .....	12	1
Flywheel		
Installation .....	2	4
Removal .....	2	2, 3
Fuel Filter .....	3	50
Fuel Recommendations .....	3	1
Fuel Pump .....	3	50
General Information .....	1	1 to 9
Governor		
Adjustment .....	5	3
Bushing .....	5	2
Control Adjustments .....	5	4-9
Governed Idle .....	5	6, 9
Mechanical .....	5	1
Throttle Restrictor Adjustment OR .....	5	6, 9
Throttle Restrictor Adjustment .....	3	46, 48
Secondary Governor Spring .....	5	7, 8
Ground Terminal (Testing) .....	2	6, 7
Ground Wire Harness (Testing) .....	2	6, 7
Mufflers		
General Information .....	12	1
Oil Drain .....	8	1
Oil Fill .....	8	1
Oil Filter .....	8	1
Oil Pump .....	8	4-6
Oil Pressure Switch .....	8	8
Oil Recommendations .....	1	3
Remove Combustion Chamber Deposits .....	6	4

## INDEX (Continued)

	SECTION	PAGE
Oil Seal Installation .....	11	4, 5
Overhaul Procedure .....	1	5, 6
Piston Pin .....	9	2
Piston Rings .....	9	2
Assembling .....	9	3
Checking .....	9	2
Removal .....	9	1
Piston		
Assembling .....	9	3
Checking .....	9	2
Removing .....	9	1
Pressure Lube .....	8	4-6
Remote Control		
Adjustment .....	4	1, 2
Wire Travel .....	4	1
Spark Plugs .....	2	2
Starter, Electric		
Assemble Starter - Nylon Pinion Gear .....	7B	8
Assemble Starter - Steel Pinion Gear .....	7B	8, 9
Assemble Starter Drive - Nylon Pinion Gear .....	7B	5
Assemble Starter Drive - Steel Pinion Gear .....	7B	6
Disassemble Starter - Both Styles .....	7B	6, 7
Disassemble Starter Drive - Nylon Pinion Gear .....	7B	5
Disassemble Starter Drive - Steel Pinion Gear .....	7B	5
Identification .....	7B	1
Replace Brushes - Both Styles .....	7B	7
Test Equipment .....	7B	2
Testing .....	7B	4
Troubleshooting .....	7B	3
Starter Rewind .....	7A	
Identification .....	7A	1
Installation - Both Styles .....	7A	7
Rope Installation - Removal - Both Styles .....	7A	2, 3
Spring Installation - Removal - Current Style .....	7A	3-5
Spring Installation - Removal - Early Style .....	7A	5-8
Starter Solenoid (Testing) .....	7B	11
Stop Switch - Rotary Key Switch (Testing) OR .....	2	8
Stop Switch - Rotary Key Switch (Testing) .....	7B	10, 11
Stop Switch - Rocker Type (Testing) .....	2	7
Tools .....	13	
Torque Tables .....	Preface	
Tune-Up Procedure .....	1	4
Valves		
Adjust Clearances .....	6	8
Guides .....	6	4, 5
Installation .....	6	6
Push Rods .....	6	7
Refacing .....	6	5
Rocker Arms .....	6	5, 6
Removal .....	6	4
Seals .....	6	5

## INDEX OF TABLES

	TABLE NO.	SECTION	PAGE
Alternator Identification .....	1	7C	1
Cam Bearing Reject Sizes .....	4	11	5
Cam Gear Reject Sizes .....	3	10	3
Connecting Rod Reject Sizes .....	2	9	3
Crankshaft Reject Sizes .....	1	10	2
Crankshaft Grinding Dimensions .....	2	10	2
Cylinder Bore Standard Sizes .....	1	11	1
Diode Failure Diagnosis .....	1	2	6
Flywheel Identification .....	2	7C	3
Generator RPM .....	1	5	8
Magneto Bearing Reject Size .....	2	11	3
PTO Bearing Reject Size .....	3	11	5
Piston Pin & Piston Pin Bore Reject Size .....	3	9	3
Ring Gap Reject Size .....	1	9	2

# Section 1

## GENERAL INFORMATION

Briggs & Stratton OHV twin cylinder engines are of the same basic 4-stroke cycle design used in automobiles, aircraft, trucks and tractors. As the name indicates, there are four strokes to one complete power cycle, Fig. 1.

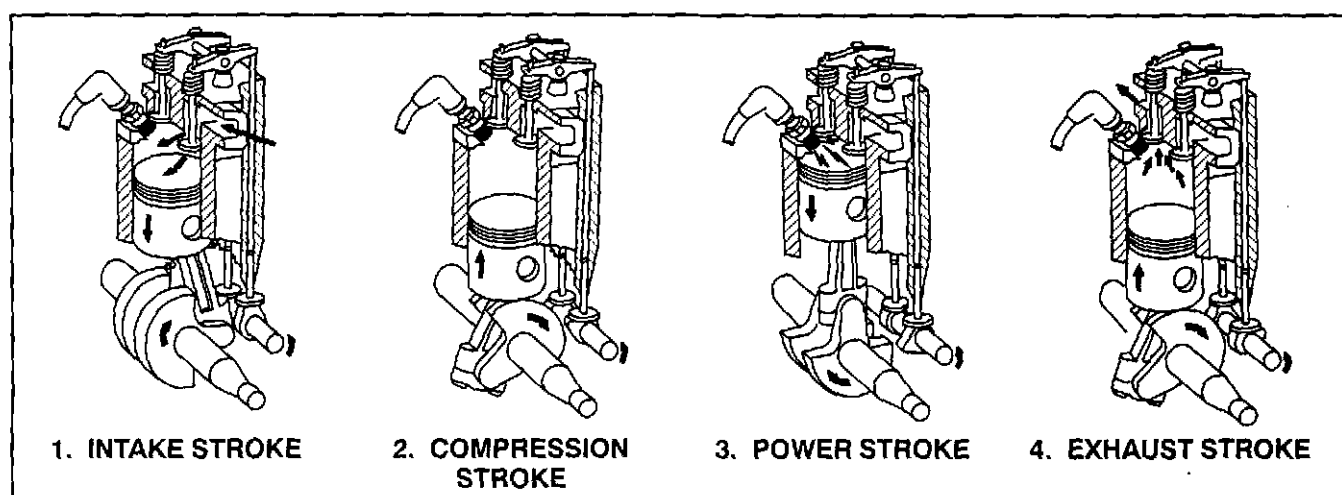


Fig. 1 - The 4-Stroke Cycle

**1. INTAKE STROKE:**

As the piston moves down, a vacuum occurs in the cylinder. The intake valve has been opened by the intake cam lobe. Atmospheric pressure pushes the air/fuel mixture through the open intake valve into the cylinder above the piston. At the bottom of the stroke the intake valve closes. The exhaust valve stays closed.

**2. COMPRESSION STROKE:**

As the piston moves up with both valves closed, the air/fuel mixture becomes highly compressed in the space left between the top of the piston and the cylinder head.

**3. POWER STROKE:**

Just before the compression stroke ends, the magneto produces a high voltage arc across the spark plug gap igniting the air/fuel mixture. The rapidly burning mixture expands producing very high pressure, pushing the piston downward.

**4. EXHAUST STROKE:**

As the piston begins to go up, the exhaust cam lobe opens the exhaust valve and the piston pushes out the burned gases. The exhaust valve closes near the top of the stroke, completing the cycle and the intake stroke begins again.

### IMPORTANT

Fill the crankcase with proper oil before starting engine. See that oil level is maintained at the proper level.

# GENERAL INFORMATION

1

## IN THE INTEREST OF SAFETY



THIS SAFETY ALERT SYMBOL INDICATES THAT THIS MESSAGE INVOLVES PERSONAL SAFETY. SIGNAL WORDS DANGER, WARNING AND CAUTION INDICATE HAZARD DEGREE. DEATH, PERSONAL INJURY AND/OR PROPERTY DAMAGE MAY OCCUR UNLESS INSTRUCTIONS ARE FOLLOWED CAREFULLY.



### WARNING: DO NOT

1. DO NOT run engine in an enclosed area. Exhaust gases contain carbon monoxide, an odorless and deadly poison.
2. DO NOT place hands or feet near moving or rotating parts.
3. DO NOT store, spill, or use gasoline near an open flame, or devices such as a stove, furnace, or water heater which use a pilot light or devices which can create a spark.
4. DO NOT refuel indoors where area is not well ventilated. Outdoor refueling is preferred.
5. DO NOT fill fuel tank while engine is running. Allow engine to cool for 2 minutes before refueling. Store fuel in approved safety containers.
6. DO NOT remove fuel tank cap while engine is running.
7. DO NOT operate engine when smell of gasoline is present or other explosive conditions exist.
8. DO NOT operate engine if gasoline is spilled. Move machine away from the spill and avoid creating any ignition until the gasoline has evaporated and dissipated.
9. DO NOT transport engine with fuel in tank.
10. DO NOT smoke when filling fuel tank.
11. DO NOT choke carburetor to stop engine. Whenever possible, gradually reduce engine speed before stopping.
12. DO NOT run engine at excessive speeds. This may result in injury.
13. DO NOT tamper with governor springs, governor links or other parts which may increase the governed engine speed.
14. DO NOT tamper with the engine speed selected by the original equipment manufacturer.
15. DO NOT check for spark with spark plugs or spark plug wires removed. Use an approved tester.
16. DO NOT crank engine with spark plug removed. The fuel mixture exits the spark plug hole and can be ignited outside the engine by the loose spark plug or spark plug wire. If engine is flooded, place throttle in "FAST" position and crank until engine starts.
17. DO NOT strike flywheel with a hard object or metal tool as this may cause flywheel to shatter in operation. Use proper tools to service engine.
18. DO NOT operate engine with a damaged muffler or without muffler. Inspect periodically and

replace, if necessary. If engine is equipped with muffler deflector(s), inspect periodically and replace, if necessary, with correct deflector(s).

19. DO NOT operate engine with an accumulation of grass, leaves, dirt or other combustible material in the muffler area.
20. DO NOT use this engine on any forest covered, brush covered, or grass covered unimproved land unless a spark arrester is installed on the muffler. The arrester must be maintained in effective working order by the operator. In the State of California the above is required by law (Section 4442 of the California Public Resources Code). Other states may have similar laws. Federal laws apply on federal lands.
21. DO NOT touch hot muffler(s), cylinder(s), or fins because contact may cause burns.
22. DO NOT run engine with air cleaner or air cleaner cover removed.



### WARNING: DO

1. ALWAYS DO remove the wire from the spark plug when servicing the engine or equipment TO PREVENT ACCIDENTAL STARTING. Disconnect the negative wire from the battery terminal if equipped with a 12 volt starting system.
2. DO wear eye protection when operating or repairing equipment.
3. DO keep cylinder fins and governor parts free of grass and other debris which can affect engine speed.
4. DO pull starter cord slowly until resistance is felt (if equipped). Then pull cord rapidly to avoid kickback and prevent hand or arm injury.
5. DO examine muffler(s) periodically to be sure it is functioning effectively. A worn or leaking muffler(s) should be repaired or replaced as necessary.
6. DO use fresh gasoline. Stale fuel can gum carburetor and cause leakage.
7. DO check fuel lines and fittings frequently for cracks or leaks. Replace if necessary.

**NOTE:** Use Original Briggs & Stratton Service Replacement Parts when servicing your engine. Briggs & Stratton Authorized Service Centers carry a stock of such parts. The use of Briggs & Stratton parts preserves the original design of your engine. Imitation replacement parts may not fit or function as original Briggs & Stratton parts and can expose the operator to potential personal injury. Contact any Briggs & Stratton Authorized Service Center for Original Briggs & Stratton Replacement Parts.

## FUEL AND OIL RECOMMENDATIONS

### Gasoline

We recommend the use of clean, fresh, lead-free gasoline, AND THE USE OF BRIGGS & STRATTON GASOLINE ADDITIVE, PART #5041. Leaded gasoline may be used if it is commercially available, and if lead-free is not available. A minimum of 85 octane is recommended. The use of lead-free gasoline results in fewer combustion deposits and longer valve life.

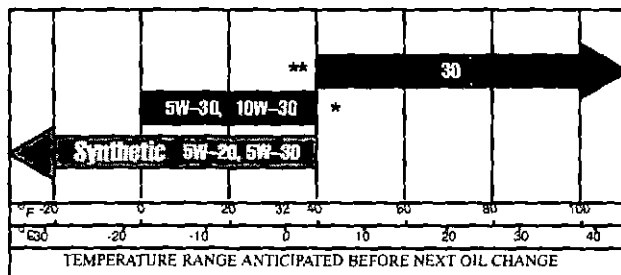
NOTE: Some fuels, called oxygenated or reformulated gasolines, are gasolines blended with alcohols or ethers. Excessive amounts of these blends can damage the fuel system or cause performance problems. Do not use gasoline which contains Methanol. If any undesirable operating symptoms occur, use gasoline with a lower percentage of alcohol or ether.

We also recommend gasoline be purchased in small quantities, not more than a 30 day supply. FRESH gasoline minimizes gum deposits, and also will ensure fuel volatility tailored for the season in which the engine will be operated.

### Oil Recommendations

We recommend the use of a high quality detergent oil classified "For Service SE, SF, or SG" such as Briggs & Stratton 30 weight oil part #100005 or #100028. Detergent oils keep the engine cleaner and retard the formation of gum and varnish deposits. No special additives should be used with recommended oils.

#### RECOMMENDED SAE VISCOSITY GRADES 4-Cycle Vanguard (Overhead Valve) Gasoline Engines



\* Air cooled engines run hotter than automotive engines. Use of multi-viscosity oils (10W-30, etc.) above 4° C (40° F) will result in high oil consumption and possible engine damage. Check oil level more frequently if using these types of oils.

\*\* SAE 30 oil, if used below 4° C (40° F), will result in hard starting and possible engine bore damage due to inadequate lubrication.

CHANGE OIL after first 8 hours of operation. Thereafter, change oil every 50 hours of operation, under normal operating conditions. Change engine oil every 25 hours of operation if the engine is operated under heavy load, or in high ambient temperature.

During normal operation, small particles of metal from the cylinder walls, pistons, bearings and combustion deposits will gradually contaminate the oil. Dust particles from the air also contaminate the oil. If oil is not changed regularly, these foreign particles can cause increased friction and an abrasive action which shortens the life of the engine. Fresh oil also assists in cooling. Old oil gradually becomes thick and loses its cooling ability as well as its lubricating qualities.

CHANGE OIL FILTER every 100 hours. Before installing new filter, lightly oil filter gasket with fresh clean engine oil. Screw filter on by hand until gasket contacts filter adapter. Tighten 1/2-3/4 turn farther. Start and run engine at idle for 30 seconds and stop engine. Recheck oil level and add if required. Restart engine and check for oil leaks.

### Clean Cooling System

Grass particles, chaff or dirt can clog the air cooling system, especially after prolonged service in cutting dry grass or very dirty air. Continued operation with a clogged cooling system can cause severe overheating and possible engine damage. Figure 2 shows the blower housing removed and areas to be cleaned. This should be a regular maintenance operation, performed yearly or every 100 hours, whichever comes first.

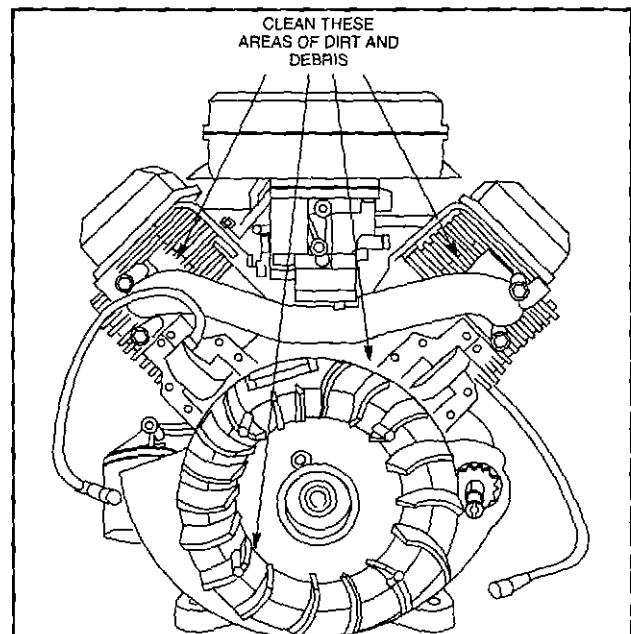


Fig. 2

# GENERAL INFORMATION

1

## TUNE-UP PROCEDURE

A "Tune-Up," see the steps listed below, would normally be performed on relatively new engines brought in for minor difficulties. By performing these steps you will either be sure that the engine is functioning properly or will know what major repairs should be made.

The steps are also covered in the Overhaul Procedure and will normally be performed as a part of the complete overhaul.

STEP  
NO.

1.	Remove and ground spark plug wires.
2.	Remove air cleaner cartridge, check for proper servicing. Check gaskets, pre-cleaner and cartridge for damage.
3.	Check oil level and drain oil. Remove oil filter.
4.	Remove blower housing, inspect rewind assembly, when so equipped.
5.	Clean cooling fins and entire engine.
6.	Check governor, linkage and springs for damage, wear, also check adjustment.
7.	Remove intake manifold and carburetor, disassemble carburetor and inspect for wear or damage. Wash in solvent. Replace gaskets and parts as necessary. Reinstall carburetor on manifold. Set initial adjustment.
8.	Remove spark plugs and clean or replace. Remove flywheel. Check flywheel key. Check for oil seal leakage, both flywheel and PTO sides.
9.	Check coils. Inspect all wires for breaks and/or damaged insulation. Be sure ground wires do not touch flywheel. Check ground wire and stop switch connection.

STEP  
NO.

10.	Install flywheel and set air gap. Check for spark with tool #19368, tester.
11.	Remove cylinder heads. Remove carbon. Check gaskets. Inspect valves for seating.
12.	Reinstall cylinder heads using new gaskets. Tighten to specified torque. Adjust valve clearance. Set spark plug gaps.
13.	Reinstall intake manifold using new gaskets.
14.	Reinstall blower housing.
15.	Install new oil filter. Replace oil and fuel.
16.	Adjust equipment control and cables, if used, for correct operation.
17.	Service air cleaner pre-cleaner and cartridge, or replace.
18.	Check muffler for restrictions or damage.
19.	Start engine and bring up to operating temperature. Then, adjust carburetor mixture and engine top speed.

# GENERAL INFORMATION

## Overhaul Procedure

### OVERHAUL PROCEDURE

The Overhaul Procedure which follows is intended to help you to become accustomed to a systematic method of repairing Briggs & Stratton OHV engines. Naturally these steps could be rearranged in different order but efficiency is obtained when the repair operations are performed in the same sequence every time. The exact procedure will vary according to the engine model being repaired.

The Overhaul Procedure can also be used as an index. For information on how to perform most operations listed, refer to the section number shown. Be careful to locate the instructions covering the specific model being repaired.

SEC.	DISASSEMBLE
8	Drain oil - Remove oil filter
2	Spark plugs. Clean or replace
3	Air cleaner assembly Fuel tank and bracket assembly (if equipped) Fuel pump and bracket (if equipped)
2	Rotating screen (if equipped) Blower housing
7	Rewind starter (if equipped)
12	Exhaust manifold, muffler(s)
3	Intake manifold and carburetor
3	Check throttle shaft and bushings for wear
3	Disassemble carburetor
2	Check armature air gap, Remove armatures
2	Flywheel
7	Electric starter
8	Breather

SEC.	DISASSEMBLE (cont'd.)
5	Governor control bracket
6	Check valve clearances
6	Cylinder shields Rocker arms. Push rods. Cylinder heads
6	Valves, springs and seals Inspect and check guides and seats
10	Check crankshaft end play Remove burrs from crankshaft extension
10	Crankcase cover - Inspect and check bearings, Remove oil seal
10	Cam gear and tappets - Inspect governor
9	Connecting rods and pistons
10	Crankshaft - Inspect and check
11	Cylinder - check cylinder bores and bearings, Remove oil seal
9	Disassemble and check connecting rods, pistons, piston pins and rings
8	Disassemble and check oil pump

# GENERAL INFORMATION

## Overhaul Procedure

1

### SEC. REPAIRS

	Clean parts
11	Resize cylinder bore to next oversize
11	Replace main bearing
11	Replace all oil seals
6	Replace valve guides - intake or exhaust
6	Reface valves and seats and lap
2	Replace armatures
3	Repair carburetor
7	Replace rewind starter spring and rope (if so equipped)

### SEC. REASSEMBLE

10	Crankshaft
9	Pistons, piston pins, rings and connecting rods
10	Tappets, cam gear
5	Mechanical governor
8	Oil pump
10	Crankcase cover - check end play
7B	Electric starter (12 V)
2	Flywheel and starter pulley (if equipped)
2	Armatures - adjust air gap
2	Check spark
6	Valves, seals, springs and retainers
6	Cylinder heads, pushrods, rocker arms and cylinder shields
6	Adjust valve clearance
8	Valve covers, breather and valley cover

### SEC. REASSEMBLE

4	Linkage and governor controls
3	Carburetor and intake manifold
5	Check and adjust mechanical governor
2	Blower housing
3	Fuel pump and bracket (if equipped), fuel tank and bracket (if equipped)
3	Clean and assemble air cleaner
12	Exhaust manifold, mufflers
2	Spark plugs
8	Fill crankcase with oil, Fill with gas Start engine
3	Adjust carburetor
5	Adjust governor controls to obtain correct engine speed (remote controls)
6	Retorque cylinder head screws
	Spray paint engine and apply decals

# GENERAL INFORMATION

## Check-Up

### Check-Up

Most complaints concerning engine operation can be classified as one or a combination of the following:

1. Will not start
2. Hard starting
3. Lack of power
4. Runs rough
5. Vibration
6. Overheating
7. High oil consumption

NOTE: What appears to be an engine malfunction may be a fault of the powered equipment rather than the engine. If equipment is suspect, see Equipment Affecting Engine Operation.

### Cylinder Balance Test

If the engine is hard starting, runs rough, misses or lacks power, perform a cylinder balance test to determine whether both cylinders are operating to their full potential.

### Tools Required

1. Tachometer, Tool #19200
2. Two #19368 Ignition Testers.
3. Screw driver with insulated handle.

With engine running at top no load speed, note spark at ignition testers. If the spark is equal at both testers, the problem is not ignition related. A spark miss will be readily apparent. See Section 2. Now note RPM of engine. Ground out one cylinder with screw driver by contacting alligator clip on tester and a good ground on engine. Note RPM loss. Remove screw driver and allow engine to clear itself. Then ground out the other spark plug and note the RPM loss. If the difference between the two cylinders is less than 75 RPM, the amount of work the two cylinders are doing should be considered equal.

If the RPM loss is less than 75 RPM between cylinders and the engine runs poorly, the problem is common to both cylinders.

### Things Which Effect Both Cylinders

1. Carburetion
2. Crankcase vacuum
3. Ignition timing - Magnatron® Ignition
  - a. A partially sheared flywheel key will effect ignition timing.

If the difference between the two cylinders is greater than 75 RPM this indicates that the cylinder with the least RPM loss is the weakest of the two cylinders. Look to that cylinder for a problem. See Example.

### Example:

Engine RPM - Both Cylinders = 3400 RPM

Engine RPM - #1 Cylinder Grounded = 3300 RPM

Engine RPM - #2 Cylinder Grounded = 3100 RPM

Conclusion: #1 cylinder is weakest of the two cylinders.

### Things Which Affect One Cylinder

1. Spark plug
  - a. A fouled spark plug may indicate that carburetor is out of adjustment.
2. Leak in spark plug wire
3. Head gasket
4. Intake manifold
  - a. A leak at either end of the intake manifold will only effect one cylinder, not both.
5. Valves
6. Rings
7. Piston
8. Cylinder

The cylinder balance test will also detect a cylinder that is not functioning. When grounding out one cylinder there will be no RPM loss. When the other cylinder is grounded out the engine will stop.

NOTE: A twin cylinder engine will run adequately on one cylinder as long as the power required for the application does not exceed the power produced by the one cylinder.

If the engine will not start and the cause of malfunction is not readily apparent, perform a check of the ignition system, carburetion system and compression. This check-up, performed in a systematic manner, can usually be done in a matter of minutes. It is the quickest and surest method of determining the cause of failure. This check-up will point out possible cause of future failures, which can be corrected at the time. The basic check-up procedure is the same for all engine models, while any variation, by model, will be shown under the subject heading.

# GENERAL INFORMATION

## Check-Up

1

### Check Ignition (With Engine Starter)



**WARNING:** BE SURE THERE IS NO FUEL OR FUEL VAPOR PRESENT, WHICH MIGHT BE IGNITED BY THE SPARK AND CAUSE A FIRE OR EXPLOSION.

Attach a #19368 tester to each spark plug lead and ground the other end of the testers to the engine block. With spark plugs installed, spin the flywheel with the engine starter. If spark jumps the 4.2 mm (.166") tester gaps, you can assume the ignition system is performing satisfactorily. See Section 2 for additional information.

**NOTE:** If engine runs but misses during operation, a quick check to determine if ignition is or is not at fault can be made by inserting the #19368 testers between the ignition cable and the spark plugs. A spark miss will be readily seen with the engine running. See Section 2.

If spark does not occur look for -

1. Improperly operating interlock system
2. Shorted equipment stop switch wire
3. Two closed diodes in ground wire harness (current style) or ground terminal (early style)
4. Incorrect armature air gap
5. Armature failure

### Check Carburetion

Before making a carburetion check, be sure the fuel tank has an ample supply of fresh, clean gasoline. Be sure that the shutoff valve, if equipped, is open and fuel flows freely through the fuel line before starting engine. Inspect and adjust the idle needle valve. Check to see that the choke closes completely. If engine will not start, remove and inspect the spark plugs. If plugs are wet, look for -

1. Overchoking
2. Excessively rich fuel mixture
3. Water in fuel
4. Float needle valve stuck open
5. Plugged air cleaner

If plug is dry, look for -

1. Leaking carburetor mounting gaskets
2. Gummy or dirty carburetor, fuel line or tank
3. Float needle valve stuck shut
4. Inoperative fuel pump
5. Inoperative anti-afterfire solenoid.

A simple check to determine if the fuel is getting to the combustion chamber through the carburetor is to remove either spark plug and pour a small quantity of gasoline through the spark plug hole. Replace the plug. If the engine fires a few times and then stops, look for the same conditions as for a dry plug.

### Check Compression

See Section 6, page 1, for proper procedure.

If compression is poor, look for -

1. Loose spark plug(s)
2. Loose cylinder head bolts
3. Blown head gasket(s)
4. Burned valves, valve seats and/or loose valve seats
5. Insufficient tappet clearance
6. Warped cylinder head(s)
7. Warped valve stems
8. Worn bore and/or rings
9. Broken connecting rods

# GENERAL INFORMATION

## Check-Up

1

### Equipment Affecting Engine Operation

Frequently, what appears to be a problem with engine operation, such as hard starting, vibration, etc., may be the fault of the equipment powered rather than the engine itself. Since many varied types of equipment are powered by Briggs & Stratton engines, it is not possible to list all of the various conditions that may exist. Listed are the most common effects of equipment problems, and what to look for as the most common cause.

### Hard Starting, or Will Not Start

1. Loose belt - a loose belt like a loose blade can cause a backlash effect, which will counteract engine cranking effort.
2. Starting under load - see if the unit is disengaged when engine is started; or if engaged, does not have a heavy parasitic load.
3. Check remote control assembly for proper adjustment.
4. Check interlock system for shorted wires, loose or corroded connections, or defective modules or switches.

### Engine Won't Stop

1. Check equipment ignition stop switch.
2. Check for loose or disconnected equipment stop switch wire.

3. Check ground wire harness (current style) or ground terminal (early style) on engine.

a. See Section 2 for test procedure.

### Vibration

1. Cutter blade or other rotating part bent or out of balance - remove and balance.
2. Mounting bolts loose - tighten.
3. Loose belt - tighten.

### Power Loss

1. Bind or drag in unit - if possible, disengage engine and operate unit manually to feel for any binding action.
2. Grass cuttings build-up under deck.
3. No lubrication in transmission or gear box.
4. Excessive drive belt tension may cause excess bearing wear or seizure.

### Noise

1. Cutter blade coupling or pulley - an oversize or worn coupling can result in knocking, usually under acceleration. Check for fit, or tightness.
2. No lubricant in transmission or gear box.
3. Worn drive belts.

# GENERAL INFORMATION

1

## BRIGGS & STRATTON NUMERICAL NUMBER SYSTEM

All Briggs & Stratton engines have a unique numerical designation system. Each engine is identified by a Model, Type and Code number. Example:

Model	Type	Code
303447	0125 01	95052115

This chart explains the numerical model designation system. It is possible to determine most of the important mechanical features of the engine by merely knowing the model number. Here is how it works.

CUBIC INCH DISPLACEMENT	FIRST DIGIT AFTER DISPLACEMENT	SECOND DIGIT AFTER DISPLACEMENT	THIRD DIGIT AFTER DISPLACEMENT	FOURTH DIGIT AFTER DISPLACEMENT
	BASIC DESIGN SERIES	CRANKSHAFT, CARBURETOR, GOVERNOR	PTO BEARING, REDUCTION GEAR, AUXILIARY DRIVE, LUBRICATION	TYPE OF STARTER
6	0	0 - Horizontal Shaft	0 - Plain Bearing/DU Non-Flange Mount	0 - Without Starter
8	1	Diaphragm Carburetor		1 - Rope Starter
9	2	Pneumatic Governor	1 - Plain Bearing Flange Mounting	2 - Rewind Starter
10	3	1 - Horizontal Shaft	2 - Sleeve Bearing Flange Mounting Splash Lube	3 - Electric Starter Only 120 Volt Gear Drive
11	4	Vacu-Jet Carburetor		4 - Electric Starter/Generator 12 Volt Belt Drive
12	5	Pneumatic Governor	3 - Ball Bearing Flange Mounting Splash Lube	5 - Electric Starter Only 12 Volt Gear Drive
13	6	2 - Horizontal Shaft	4 - Ball Bearing Flange Mounting Pressure Lubrication on Horizontal Shaft	6 - Alternator Only
16	7	Pulsa-Jet Carburetor	5 - Plain Bearing Gear Reduction (6 to 1) CW Rotation Flange Mounting	7 - Electric Starter 12 Volt Gear Drive With Alternator
17	8	Pneumatic or Mechanical Governor	6 - Plain Bearing Gear Reduction (6 to 1) CCW Rotation	8 - Vertical Pull Starter or Side Pull Starter
18	9	3 - Horizontal Shaft	7 - Plain Bearing Pressure Lubrication on Vertical Shaft	
19	A to Z	Flo-Jet Carburetor	8 - Plain Bearing Auxiliary Drive (PTO) Perpendicular to Crankshaft	
22		Pneumatic Governor	9 - Plain Bearing Auxiliary Drive Parallel to Crankshaft	
23		4 - Horizontal Shaft		
24		Flo-Jet Carburetor		
25		Mechanical Governor		
26		5 - Vertical Shaft		
28		Vacu-Jet Carburetor		
29		Pneumatic or Mechanical Governor		
30		6 - Vertical Shaft		
32		7 - Vertical Shaft		
35		Flo-Jet Carburetor		
40		Pneumatic or Mechanical Governor		
42		8 - Vertical Shaft		
		Flo-Jet Carburetor		
		Mechanical Governor		
		9 - Vertical Shaft		
		Pulsa-Jet Carburetor		
		Pneumatic or Mechanical Governor		

The type number identifies certain unique features such as the crankshaft or governor spring used on an engine.

The code number identifies the assembly date of the engine. In some instances it is necessary to know the code number as well as the model and type number when performing adjustments, repairs or ordering replacement parts for an engine. Here is how it works.

Example: 93052115

- |   |  |
|---|--|
| A. The first two digits, 95, indicate the calendar year, 1995.  | C. The third two digits, 21, indicate the calendar month day.                  |
| B. The second two digits, 05, indicate the calendar month, May. | D. The last two digits, 15, indicate the assembly line or manufacturing plant. |

## Section 2 IGNITION

Briggs & Stratton OHV-Twin engines use MAGNETRON® ignition: an ignition armature with a self-contained transistor module (no moving parts). Two MAGNETRON® ignition armatures are used, with a flywheel containing a permanent magnet.

### Check Ignition (With Engine Starter)

**WARNING:** BE SURE THERE IS NO FUEL OR FUEL VAPOR PRESENT, WHICH MIGHT BE IGNITED BY THE SPARK AND CAUSE A FIRE OR EXPLOSION.

NOTE: Magnetron® ignition system requires a minimum of 350 RPM to produce spark.

With spark plugs installed, attach Tool #19368 tester to each spark plug lead and ground the other end of the tester as shown in Fig. 1. Spin the flywheel rapidly with engine starter. If spark jumps the 4.2 mm (.166") tester gaps, you may assume the ignition system is functioning satisfactorily.

**WARNING:** ON MAGNETRON® EQUIPPED ENGINES, SPARK CAN STILL OCCUR WITH A SHEARED FLYWHEEL KEY. A SEVERE SHOCK OR KICKBACK HAZARD MAY EXIST.

### Current Style

NOTE: Engines equipped with Magnetron® ignition system will still display spark at tester with a partially or fully sheared flywheel key. A partially sheared flywheel key will affect ignition timing and engine performance.

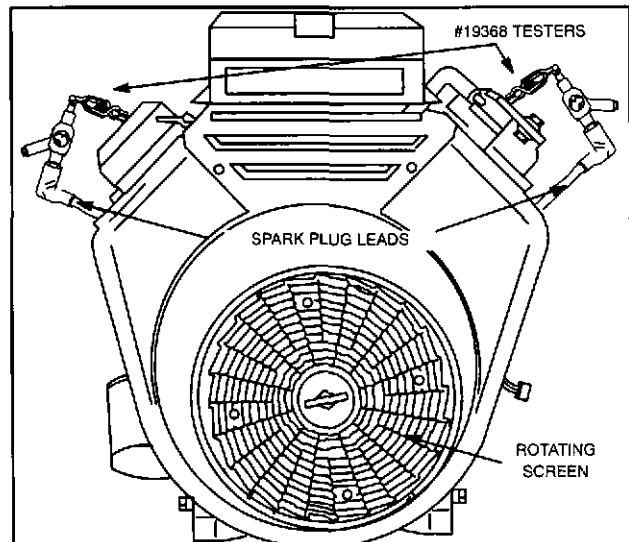


Fig. 1 - Checking for Spark

### Check Ignition (Engine Running)

If engine runs but misses during operation, a quick check to determine if ignition is or is not at fault can be made by installing Tool #19368 tester between the spark plug lead and each spark plug, Fig. 2. A spark miss will be readily apparent when the engine is running. If spark is good but engine misses, check for a fouled spark plug.

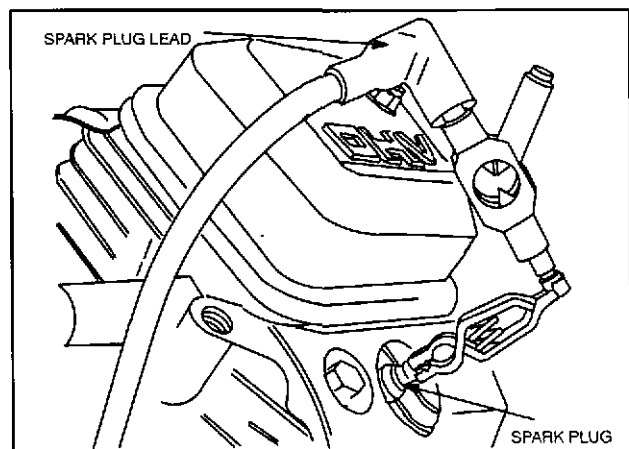


Fig. 2 - Running Check

# IGNITION

## Remove Flywheel

### Check Ignition (Fouled Plug or Other Causes)

2

To check for a fouled spark plug or a non-functioning cylinder, attach Tool #19368 tester between the spark plug lead and each spark plug. With engine running at top no load speed, ground one spark plug, Fig. 3. The engine should continue to run on the other cylinder. Repeat this test with the other cylinder. If the engine will not continue to run when making this test, the cylinder that is NOT grounded is not functioning and/or the spark plug is fouled. Install a new spark plug before proceeding. If miss continues, problem may be carburetion or compression. See Check Carburetion, Check Compression, Section 1. Also see Cylinder Balance Test, Section 1.

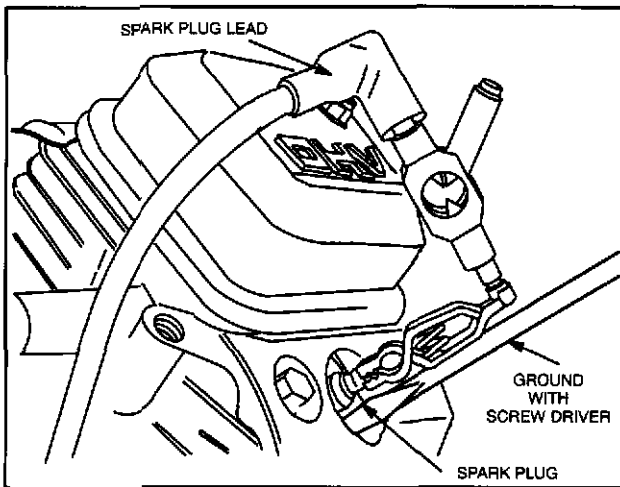


Fig. 3 - Checking For Fouled Plugs

### Spark Plugs

Spark plugs recommended by Briggs & Stratton for OHV Twin engines are:

Spark Plug Type	Champion	B&S Part No.
Resistor Plug	RC12YC	491055
Resistor Plug	RC14YC	496018

### Replace Spark Plugs

Replace spark plugs every 100 hours of operation or every season, whichever occurs first. Replace spark plugs if electrodes are burned away, or the porcelain is cracked. Set spark plug gap at .76 mm (.030") for all models, Fig. 4. Torque spark plugs to 20 Nm (180 in. lbs.).

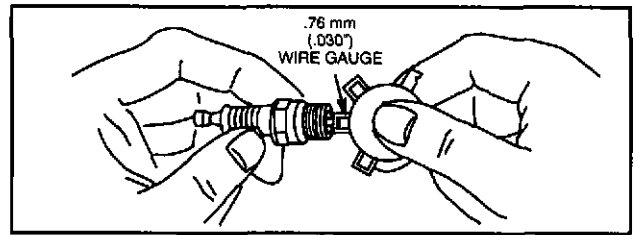


Fig. 4 - Checking Plug Gap

**NOTE:** Do not blast clean spark plugs. Spark plugs should be cleaned by scraping or hand wire brushing and washing in a commercial solvent.

### Removing Armature

The flywheel does not need to be removed to service MAGNETRON® ignition except to check keyways and flywheel key. If damaged, replace parts. Remove armature screws and lift off armature(s). Disconnect stop switch wire(s).

**⚠ DO NOT STRIKE FLYWHEEL WITH A HARD OBJECT OR A METAL TOOL AS THIS MAY CAUSE FLYWHEEL TO SHATTER IN OPERATION. ALWAYS USE APPROVED FLYWHEEL REMOVAL TOOLS.**

### Remove Flywheel Nut Engine Models 290000-303000

Remove rotating screen, if equipped. Remove blower housing.

Place flywheel strap wrench, Tool #19372 around outer rim of flywheel, Fig. 5. Insert 1/2" breaker bar into drive end of strap wrench and wind clockwise to remove slack in strap. While holding breaker bar, loosen flywheel nut using 30 mm socket and wrench.

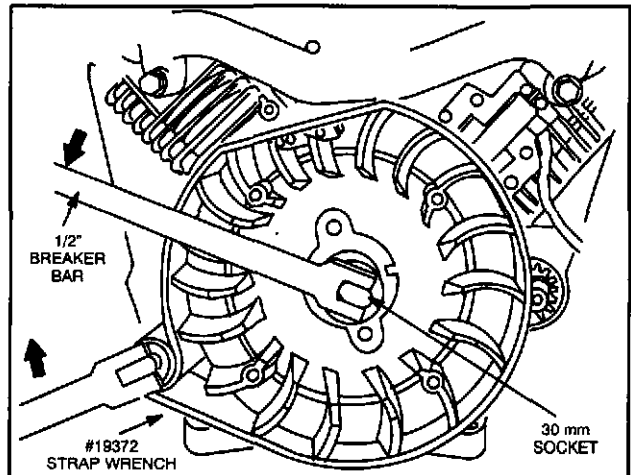


Fig. 5 - Remove Flywheel Nut  
Engine Models 290000 & 303000

# IGNITION

## Remove Flywheel

### Remove Flywheel Nut - Engine Models 350000

Remove rotating screen, if equipped. Remove blower housing.

NOTE: Do not remove the fan retainer and fan.

Place flywheel holder, Tool #19321 on fan retainer with lugs of flywheel holder engaging slots on the fan retainer. While holding flywheel holder, use a 30 mm socket and wrench and loosen starter hub screw (if equipped). Remove screw and starter hub, Fig. 6 (if equipped). Then, remove flywheel nut, Fig. 7.

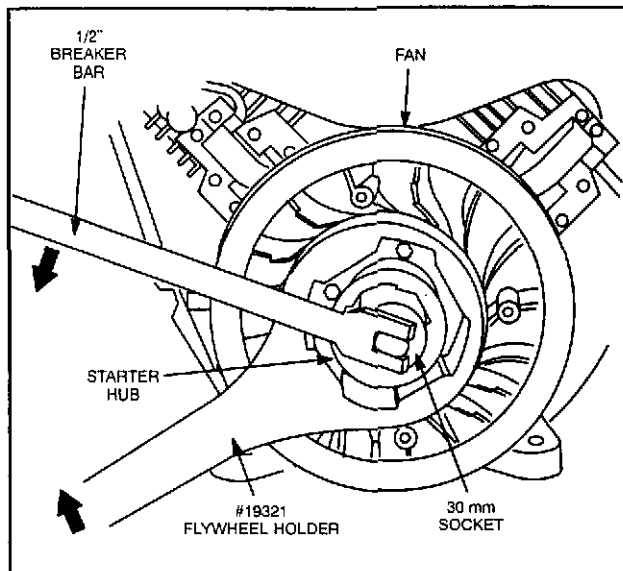


Fig. 6 - Remove Starter Hub

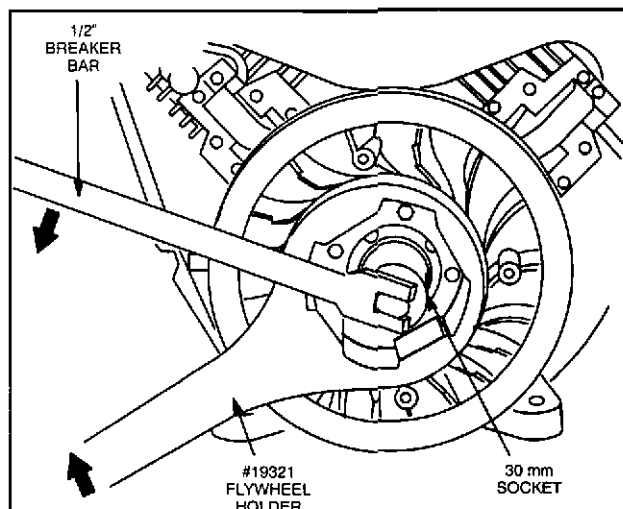


Fig. 7 - Remove Flywheel Nut

### Remove Flywheel - All Models

Reinstall flywheel nut, Part #805021, to protect crankshaft threads. Turn nut down flush with top of threads. Install flywheel puller, Tool #19203, turning puller screws into flywheel puller holes evenly. Tighten puller screws equally until flywheel loosens, Fig. 8.

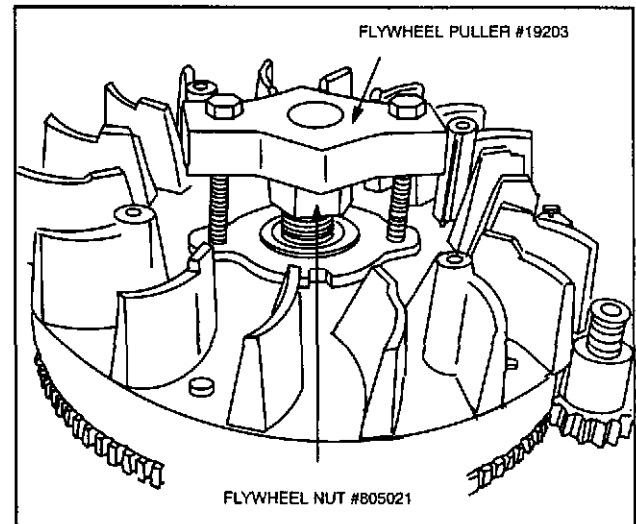


Fig. 8 - Pulling Flywheel

### Inspect Flywheel Key and Keyways, Flywheel and Crankshaft

Flywheel should be inspected for cracks, broken flywheel fins, burrs on taper or keyway and distortion of keyway. Also check taper of crankshaft for burrs, rust or other damage. Replace crankshaft, if damaged.

# IGNITION

## Torque Flywheel

### Install Flywheel - All Models

**!** CLEAN FLYWHEEL TAPER AND CRANK-SHAFT TAPER REMOVING ALL OIL, DIRT OR GREASE.

Insert flywheel key into crankshaft. Align keyway in flywheel with flywheel key and slide flywheel onto crankshaft.

### Torque Flywheel Nut - Engine Models 290000 & 303000

Install starter hub, when used, washer and flywheel nut. Place flywheel strap wrench, Tool #19372 around outer rim of flywheel. Insert 1/2" breaker bar into drive end of strap wrench and wind counterclockwise to remove slack in strap, Fig. 9. While holding breaker bar, torque flywheel nut to 175 Nm (125 ft. lbs).

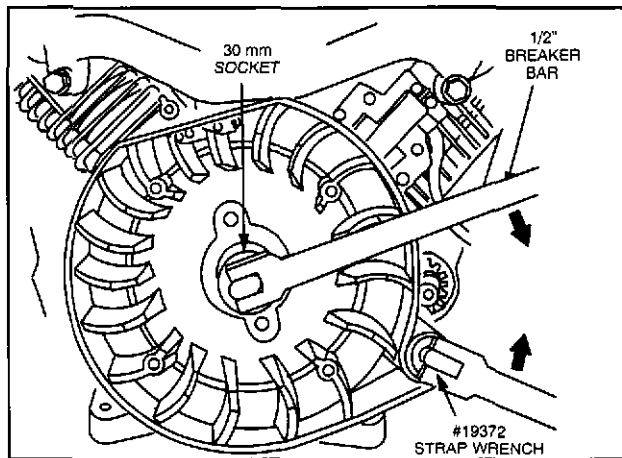


Fig. 9 - Torquing Flywheel Nut  
Engine Models 290000 & 303000

### Torque Flywheel Nut - Engine Models 350000

Install washer and flywheel nut. Place flywheel holder, Tool #19321 on fan retainer with lugs of flywheel holder engaging the slots of the fan retainer. Torque flywheel nut to 175 Nm (125 ft. lbs), Fig. 10.

Install starter hub and screw, if equipped, Fig. 11. Torque screw to 48 Nm (35 ft. lbs.).

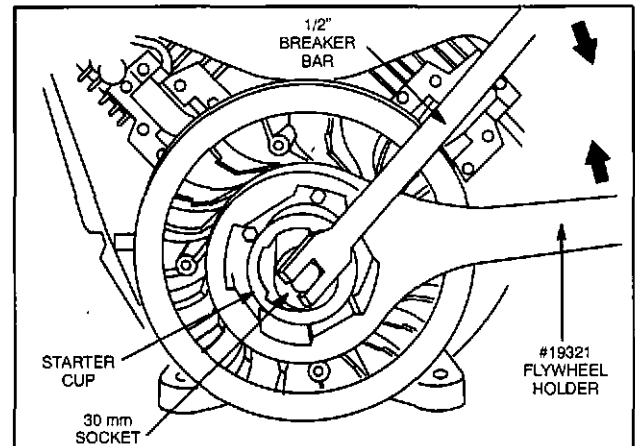


Fig. 10 - Torquing Flywheel Nut

### Remove Fan - Engine Model 350000

The fan and retainer do not need to be removed unless fan or retainer is damaged or warped.

If engine is equipped with starter hub, hold flywheel with Tool #19321 and remove starter hub screw with 30 mm socket and wrench. Remove two fan retainer screws and fan, Fig. 11.

### Install Fan - Engine Model 350000

Place fan on flywheel and align recess in flywheel with boss on back of fan. Install fan retainer, aligning cut out in retainer with cut out area in fan and install two screws, Fig. 11. Torque screws to 17 Nm (150 in. lbs).

Install starter hub and screw if equipped. Use flywheel holder, Tool # 19321 and torque screw to 48 Nm (35 ft. lbs.).

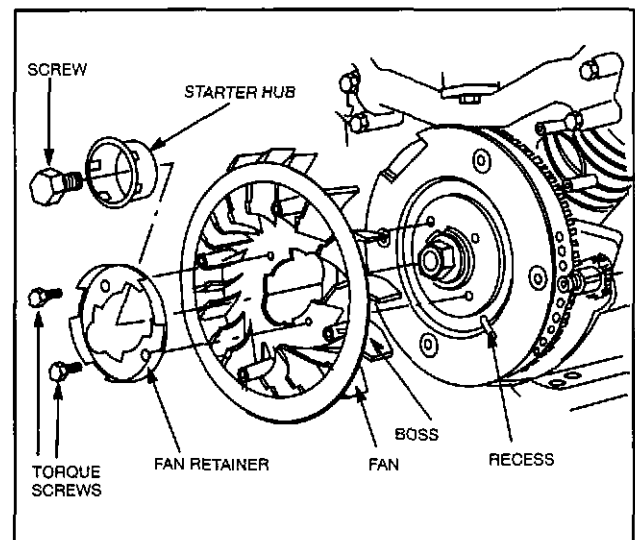


Fig. 11 - Installing Fan Retainer

# IGNITION

## Install Armatures

### Install Armatures

Turn flywheel so magnet is away from armature. Install ground wire onto tab terminal on armature. Make sure wires are routed over armature mounting posts and away from flywheel.

Install armature on engine as shown in Fig. 12. Mounting holes in armature are slotted. Push armature away from flywheel as far as possible and tighten one screw to hold armature in place. Repeat for second armature.

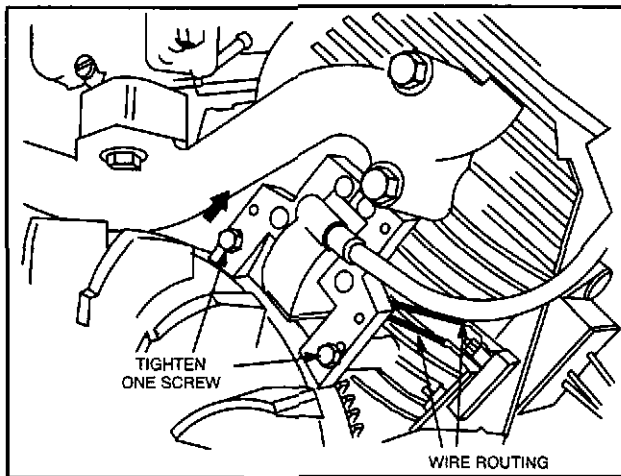


Fig. 12 - Installing Armature

### Adjust Armature Air Gap

Rotate flywheel until magnet is under armature laminations. Place thickness gauge, .20 mm (.008") - .30 mm (.012") between magnet and armature laminations, Fig. 13. Loosen mounting screw so magnet will pull armature down against thickness gauge. Tighten both mounting screws securely. Rotate flywheel to remove thickness gauge. Repeat for second armature.

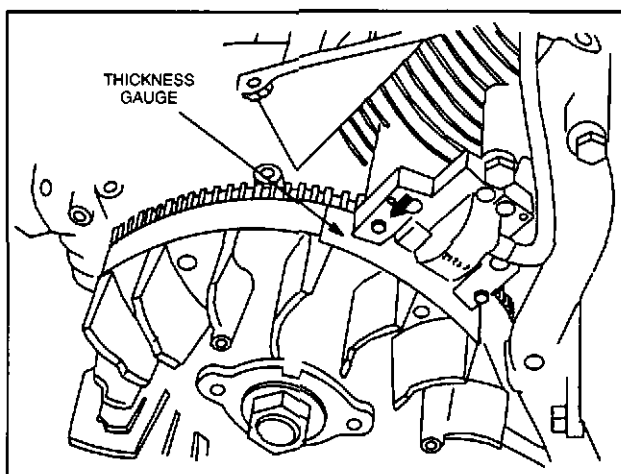


Fig. 13 - Adjusting Air Gap

### Ground Wire Harness And Ground Terminal

Two different style ground wires and ground terminals are used.

### Current Style

The current style system uses a ground wire harness, containing diodes, with an insulated stop terminal mounted on the #1 cylinder shield. The ground wire harness has a lead and brass colored spade terminal for each armature and a right angled ground spade terminal, Fig. 14. The right angle ground spade terminal attaches to the insulated stop terminal.

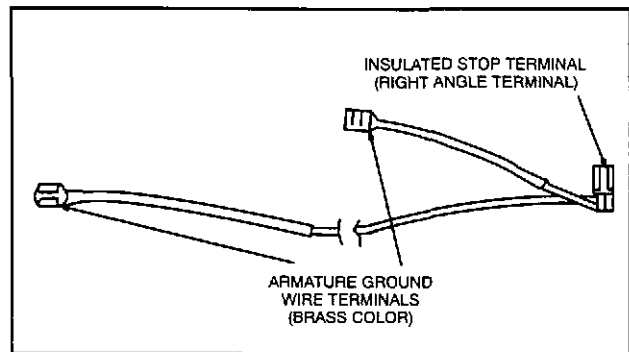


Fig. 14 - Ground Wire Harness - Current Style

The ground wire harness used with the rocker stop switch has two ground spade terminals; a right angle ground spade terminal that attaches to the insulated stop terminal and a large insulated spade terminal, Fig. 15. The larger insulated spade terminal attaches to the rocker stop switch.

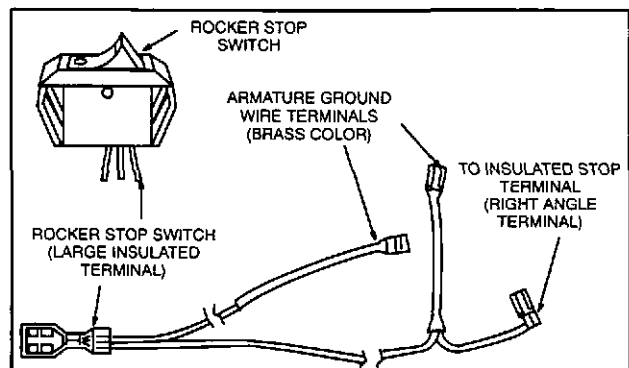


Fig. 15 - Ground Wire Harness - Used With Rocker Stop Switch

# IGNITION

## Testing Ground Wire

2

### Early Style

The early style system consists of a ground terminal, containing diodes. The ground terminal has a tab terminal for each armature ground wire, and a tab terminal for the equipment stop switch wire Fig. 16. The ground terminal is located on the #1 cylinder shield near the starter motor.

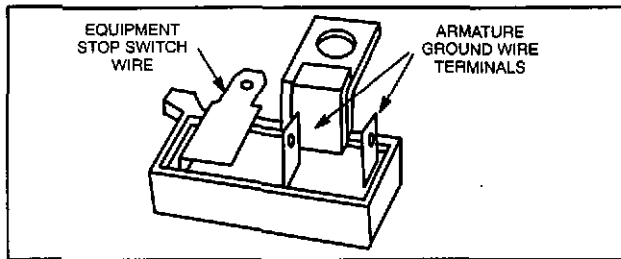
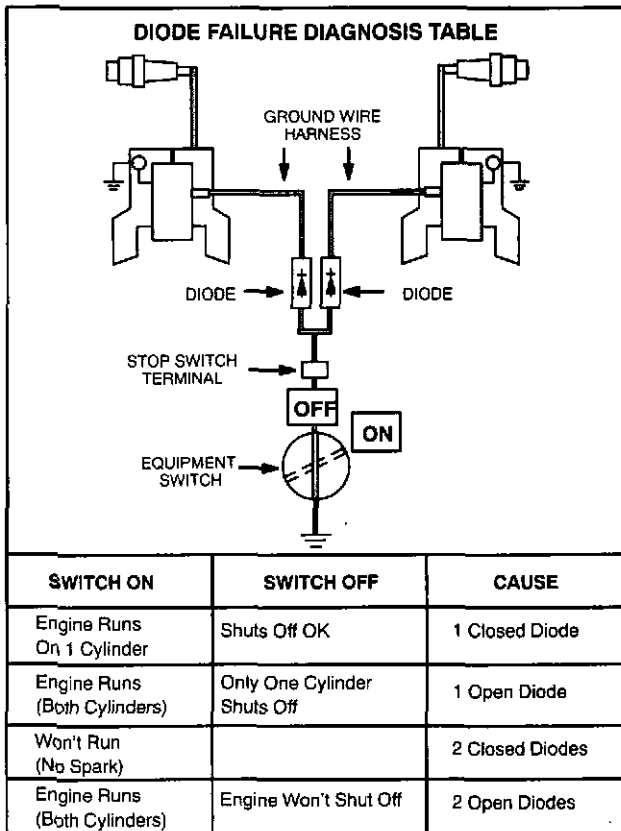


Fig. 16 - Ground Terminal - Early Style

The ground wire harness (current style) and ground terminal (early style) contain two diodes. If a diode fails "open," the cylinder with the open diode will continue to run when the equipment key switch is turned off. If a diode fails "short," the cylinder with the shorted diode will not run (no spark). See Table 1 below.

TABLE 1



### Test Ground Wire Harness And Ground Terminal

The following equipment is recommended to test the ground wire harness and ground terminal.

#### Digital Multimeter - Tool #19357 or #19390

The Digital Multimeter is available from your Briggs & Stratton source of supply. Order as Tool #19357 or #19390. The meter may be used to test diodes and measure Volts, Ohms, or Amperes, Fig. 17.

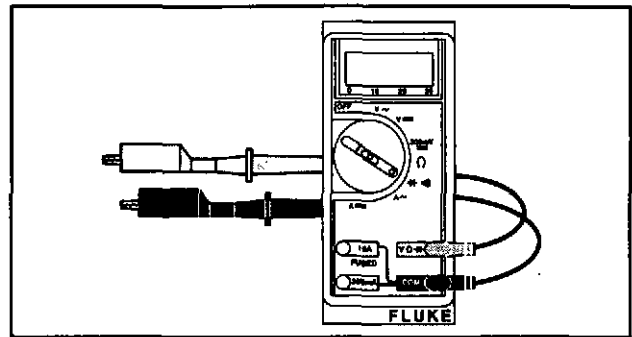


Fig. 17 - Digital Multimeter - Tool #19357 or #19390

### Testing Ground Wire Harness And Ground Terminal

The following test will be made with the meter in the "Diode Test Position"  $\rightarrow \Omega \rightarrow$ .

In the Diode Test position, the meter will display the forward voltage drop across the diode(s). If the voltage drop is less than 0.7 volts, the meter will "Beep" once as well as display the voltage drop. A continuous tone indicates continuity (shorted diode) An incomplete circuit (open diode) will be displayed as "OL."

- Insert RED test lead into  $\vee \Omega \rightarrow$  receptacle in meter.
- Insert BLACK test lead into COM receptacle in meter.
- Rotate selector to  $\rightarrow \Omega \rightarrow$  (Diode Test) position.
- Attach RED test lead clip to terminal "A" (stop switch wire terminal), Fig. 18, current style or Fig. 19, early style. Leave attached for remainder of test.
- Touch BLACK test lead probe to terminal "B."
  - If meter "Beeps" once, diode is OK.
  - If meter makes a continuous tone, diode is defective (shorted). Replace ground harness or ground terminal.
  - If meter displays "OL," diode is defective (open). Replace ground harness or ground terminal.
- Now repeat test for terminal "C." Results must be the same.

# IGNITION

## Testing Ground Wire

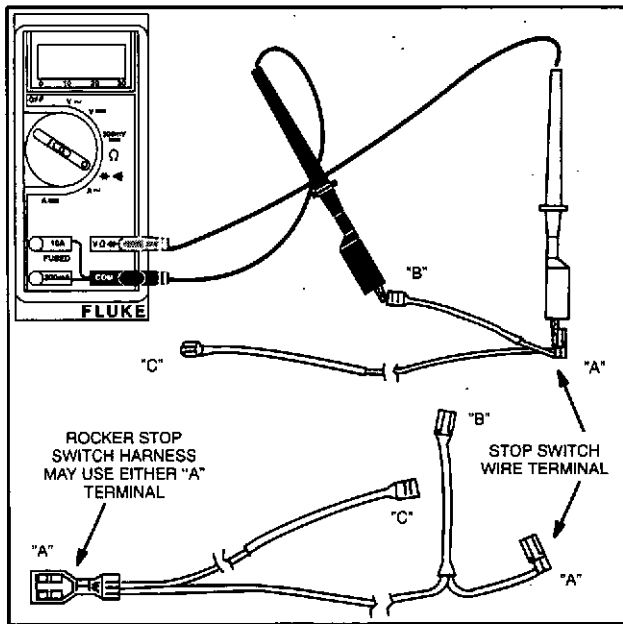


Fig. 18 - Testing Ground Wire Harness - Current Style

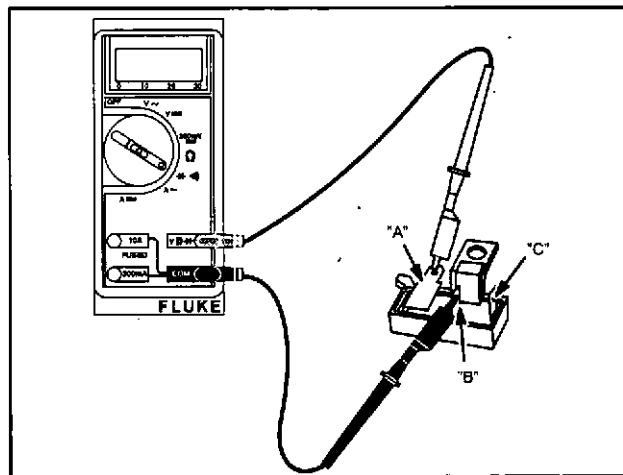


Fig. 19 - Testing Ground Terminal - Early Style

### Testing Rocker Stop Switch

The rocker stop switch can be checked for continuity using the digital multimeter, Tool #19357 or #19390.

NOTE: If rocker stop switch is mounted in carburetor cover, it will be necessary to remove cover to access terminals on switch.

The following test will be made with the meter in the "Diode Test Position"  $\rightarrow \rightarrow \rightarrow$ .

When meter test leads are attached to switch terminals, and switch is in "STOP" position, a continuous tone  $\rightarrow \rightarrow \rightarrow$  indicates continuity, With switch in "RUN" position, no tone indicates no continuity (incomplete circuit). An incomplete circuit will be displayed as "OL."

1. Disconnect stop switch wire from spade terminal on stop switch. Leave ground lead attached to stop switch. Move switch to "STOP" ("O") position.
2. Insert red test lead into  $\rightarrow \rightarrow \rightarrow$  receptacle in meter.
3. Insert black test lead into **COM** receptacle in meter.
4. Rotate selector to  $\rightarrow \rightarrow \rightarrow$  position.
5. Attach either meter test lead to spade terminal. Attach other lead to switch mounting surface or a good ground Fig. 20.
  - a. Meter should make a continuous tone.
6. Now, move switch to "RUN" ("I") position.
  - a. Meter should display "OL."

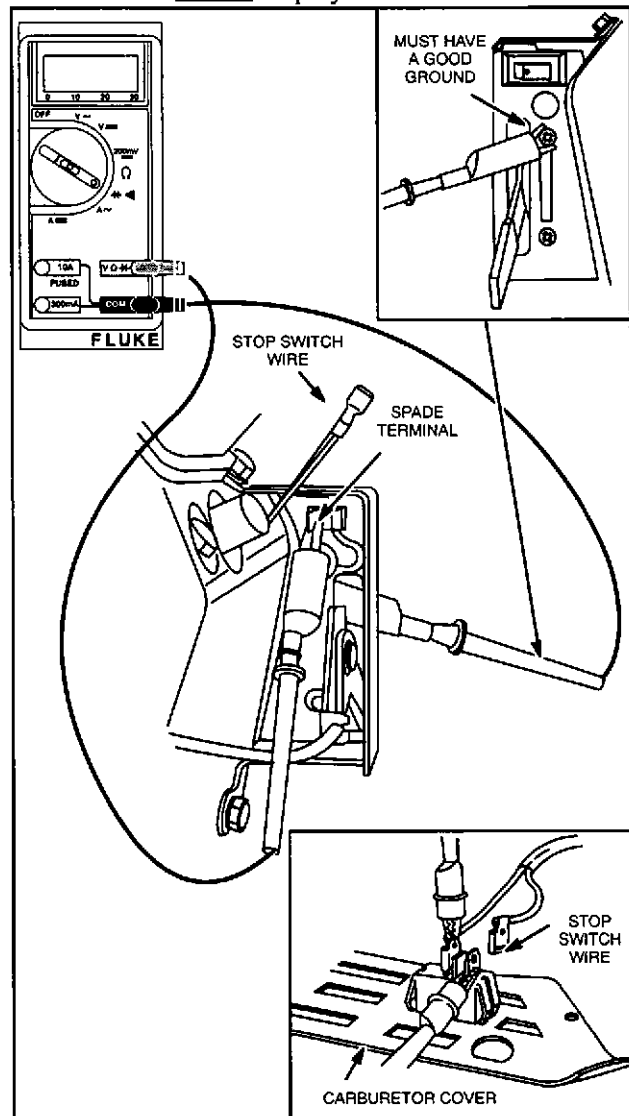


Fig. 20 - Testing Rocker Stop Switch

# IGNITION

## Testing Stop Switch

2

### Testing Rotary Key Switch – Used With Starter Panel Kit

The rotary key switch can be checked for continuity using the digital multimeter, Tool #19357 or #19390.

Remove carburetor cover with keyswitch. Disconnect wiring harness from keyswitch.

With meter selector switch in  $\rightarrow \Omega$  position, and test leads attached to switch terminals, a continuous tone  $\rightarrow \Omega$  indicates continuity (complete circuit). No tone indicates no continuity (incomplete circuit). An incomplete circuit will be displayed as “OL.”

1. Insert red test lead into  $\vee \Omega \rightarrow$  receptacle in meter.
2. Insert black test lead into **COM** receptacle in meter.
3. Rotate meter selector to  $\rightarrow \Omega$  position.
4. Meter must indicate continuity between terminals with keyswitch in position shown. See number sequence of terminals shown in Fig. 21.

**NOTE:** Terminal 1 grounded internally to keyswitch case. Meter must also indicate continuity between terminal 1 and keyswitch case in “OFF” position.

When testing “RUN” and “START” terminals, meter should show continuity between terminals, with key switch in position shown.

**NOTE:** The #2 and #5 terminals should show continuity in both the “RUN” and “START” position.

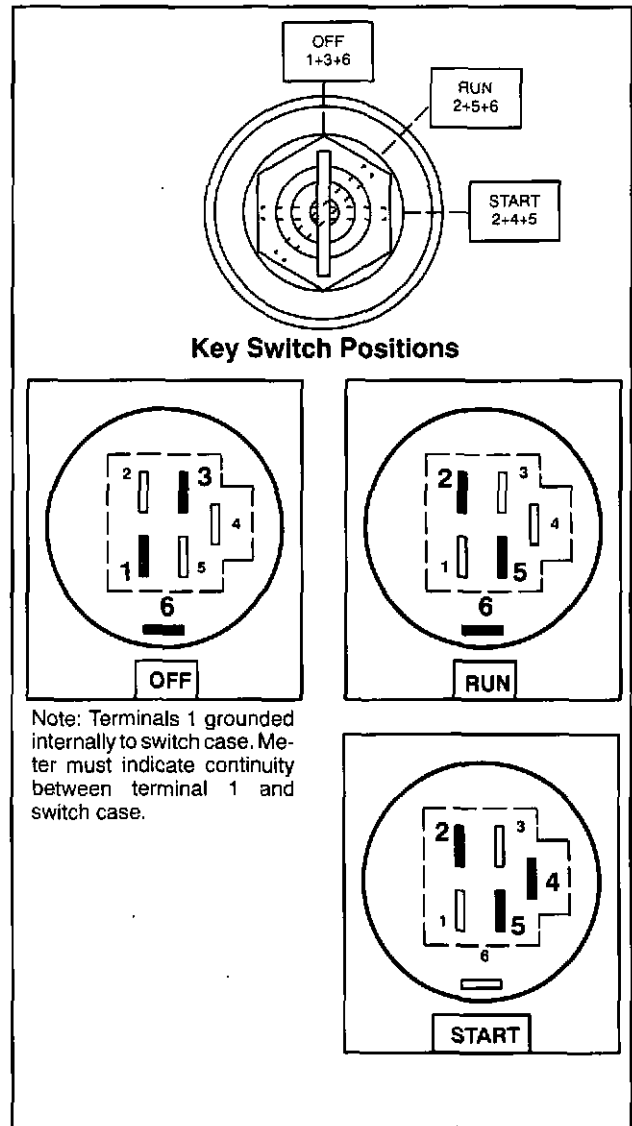


Fig. 21 – Testing Keyswitch

Switch Position	Continuity
1. OFF	1+3+6
2. RUN	2+5+6
3. START	2+4+5

# Section 3

## CARBURETION

### Air Cleaners



**WARNING:** NEVER OPERATE ENGINE WITH AIR CLEANER ASSEMBLY OR AIR CLEANER CARTRIDGE REMOVED. FIRE MAY RESULT.

A properly serviced air cleaner protects internal parts of the engine from dirt and dust particles in the air. If air cleaner instructions are not carefully followed, dirt and dust which should be collected in the cleaner, will be drawn into the engine. These particles are highly abrasive and will cause the piston rings and cylinder bore to wear quickly. As the rings and cylinder bore become worn, these abrasive particles enter the crankcase and contaminate the oil, forming an abrasive mixture which will cause wear on all of the internal moving parts.

The air cleaner on every engine brought in for a check up or repair should be examined and serviced. If the air cleaner shows signs of neglect, show it to the customer before cleaning. Instruct the customer on proper care, to assure long engine life.

**NOTE:** Replace air cleaner gaskets and mounting gaskets that are worn or damaged, to prevent dirt and dust entering engine due to improper sealing. Replace bent air cleaner mounting bracket.

### Service Dual Element Air Cleaners

Remove and service foam pre-cleaner every 25 hours or every season, whichever occurs first, Fig. 1, Fig. 2 or Fig. 3. Service cartridge every 100 hours or every season, whichever occurs first.

**NOTE:** Service air cleaner more often under dusty conditions.

### To Service Pre-Cleaner - Round Dual Element

1. Remove cover assembly, Fig. 1, or Fig. 2.
  - a. Slide foam pre-cleaner off cartridge.
  - b. Wash it in liquid detergent and water.
  - c. Squeeze it dry in a clean cloth .
  - d. Saturate it in engine oil. Wrap it in clean absorbent cloth and squeeze to remove excess oil.
  - e. Reinstall pre-cleaner over cartridge.
  - f. Reinstall air cleaner cover.

### To Service Cartridge - Round Dual Element

1. Remove knob and cover plate, Fig. 1 or Fig. 2.
  - a. Remove cartridge and clean by tapping gently on a flat surface. If very dirty, replace.

**NOTE:** DO NOT use petroleum solvents, such as kerosene, to clean paper cartridge. They may cause cartridge to deteriorate. DO NOT oil paper cartridge. DO NOT use pressurized air to clean or dry paper cartridge.

- b. Reinstall cartridge, cover plate, knob and pre-cleaner.
2. Reinstall air cleaner cover, Fig. 1 or Fig. 2.

# CARBURETION

## Air Cleaner

3

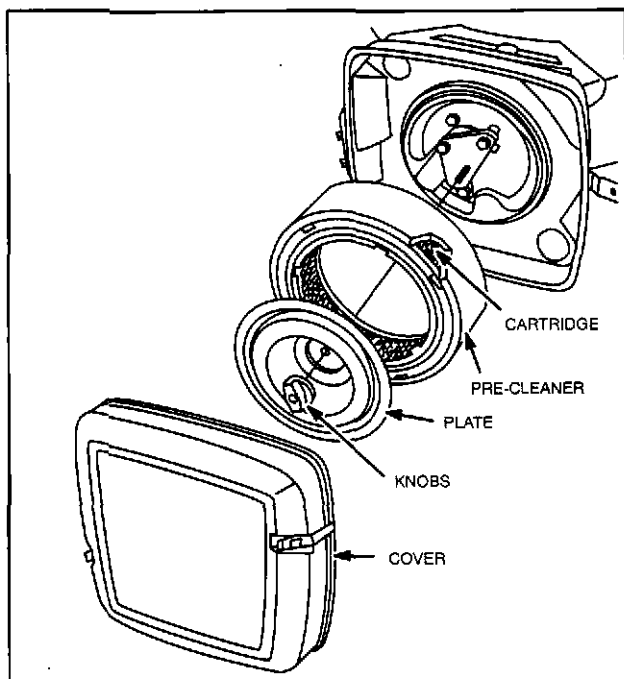


Fig. 1 - Round Dual Element Air Cleaner

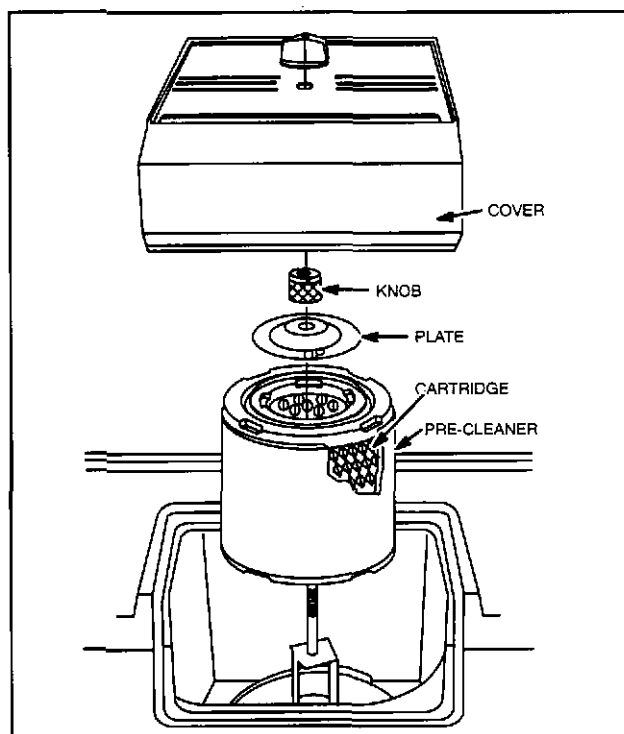


Fig. 2 - Round Dual Element Air Cleaner  
(With Optional Fuel Tank)

### To Service Pre-Cleaner - Square Dual Element

1. Remove cover assembly, Fig. 3.
  - a. Remove cartridge and pre-cleaner from cover.

- b. Wash pre-cleaner in liquid detergent and water.
- c. Squeeze it dry in a clean cloth .
- d. Saturate it in engine oil. Wrap it in clean absorbent cloth and squeeze to remove excess oil.
- e. Install pre-cleaner in cover with foam toward cover. (Nylon screen toward paper element.)
- f. Install paper cartridge in cover with tabs on cartridge in slots of cover, Fig. 3.
- g. Reinstall cover assembly on air cleaner body.

### To Service Cartridge - Square Dual Element

1. Remove cover assembly, Fig. 3.
    - a. Remove cartridge from cover.
    - b. *Clean by tapping gently on flat surface. If very dirty, replace.*

NOTE: DO NOT use petroleum solvents, such as kerosene, to clean paper cartridge. They may cause cartridge to deteriorate. DO NOT oil paper cartridge. DO NOT use pressurized air to clean or dry paper cartridge.

  - c. Reinstall paper cartridge in cover with tabs on cartridge in slots on cover, Fig. 3.
2. Reinstall cover assembly on air cleaner body.

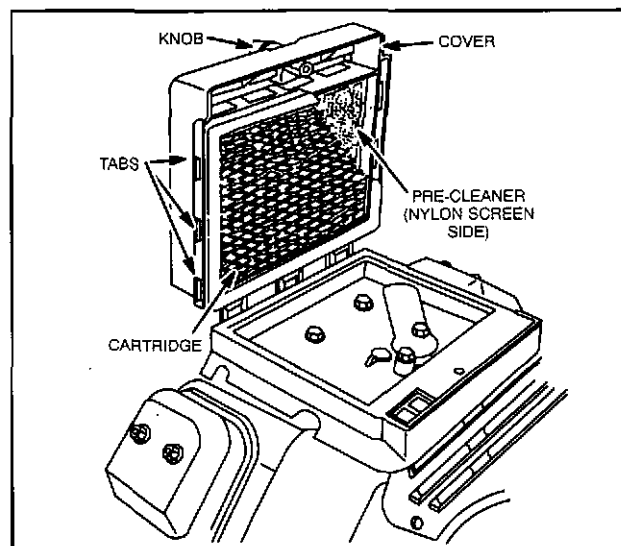


Fig. 3 - Square Dual Element Air Cleaner

# CARBURETION Operation

## Operation of Carburetor

Two types of carburetors are used on the Vanguard OHV V-Twin engines:

1. One-piece Flo-Jet side-draft on Model Series 290700, 294700, 303700 and 350700.
2. Two-piece Flo-Jet down-draft on Model Series 290400, 303400, 350400, 351400 and 351700. Both types use similar systems of operation. The side-draft carburetor is used in the following illustrations to show system operation.

## Float System Operation

Fuel is delivered from the fuel tank and delivered to the carburetor by gravity or a fuel pump. Fuel enters through the inlet nipple, past the inlet needle valve and begins filling the carburetor bowl, Fig. 4.

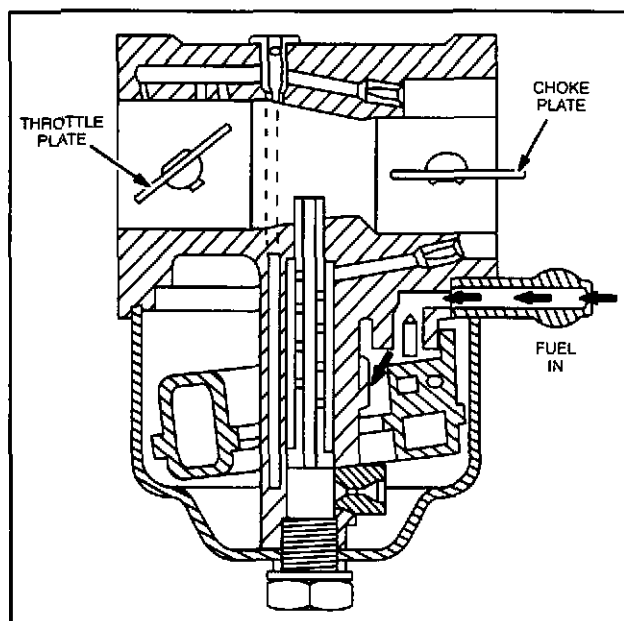


Fig. 4 - Fuel Inlet (Typical)

As the bowl fills, the float rises, raising the inlet needle toward the inlet seat. When the inlet needle closes, fuel flow into the bowl stops, Fig. 5. Fuel remains at this level until engine operation begins to draw fuel from the bowl. As the fuel level drops, the float moves down causing the inlet needle to move away from the inlet seat. Fuel flows into the bowl to maintain a supply for engine operation.

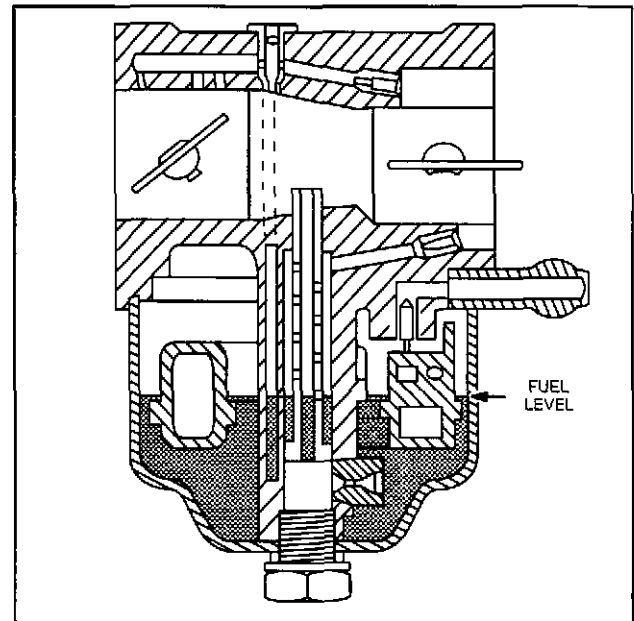


Fig. 5 - Normal Fuel Level (Typical)

The air space above the fuel in the bowl is vented to the atmosphere. This vent allows air to move into and out of the bowl area as the fuel level changes.

## Idle System Operation

When the engine is idling, the fuel flows as follows:

1. As the piston moves down in the cylinder when the intake valve is open, a partial vacuum forms between the throttle valve and the top of the piston. Atmospheric pressure in the carburetor bowl pushes fuel through the fixed high speed jet, Fig. 6 and up the idle passage. Atmospheric pressure also pushes air into the throat of the carburetor.

# CARBURETION

## Operation

3

2. Atmospheric pressure also enters through the idle air jet, Fig. 6.
3. The fuel being pushed up the idle passage enters the center of the idle speed jet and mixes with air from the idle air jet.
4. This air/fuel mixture then is pushed to the primary idle port and out into the carburetor throat. There it mixes with air flowing through the throat and is carried into the cylinders, Fig. 6.

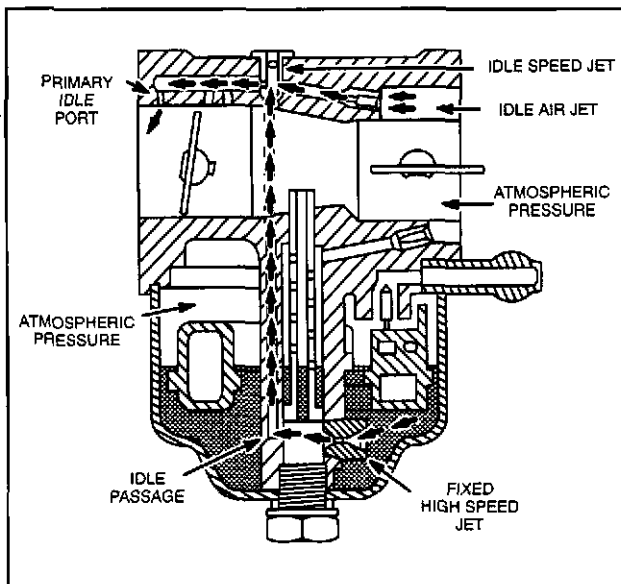


Fig. 6 - Idle System Operation (Typical)

### Part Throttle Operation

As the throttle valve opens and the air/fuel mixture flow increases from the primary and secondary idle ports, engine speed increases, Fig. 7.

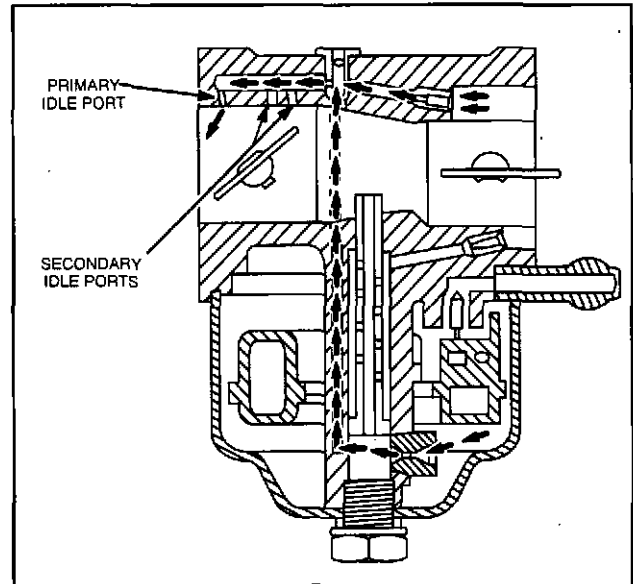


Fig. 7 - Part Throttle Operation (Typical)

### High Speed System Operation

When the engine is running with the speed control in the "FAST" position, the fuel flows as follows:

1. As the intake valve opens, a partial vacuum forms in the carburetor throat, Fig. 8.
2. Atmospheric pressure pushes air through the venturi causing a drop in pressure at the venturi throat, Fig. 8.
3. Atmospheric pressure also pushes fuel through the fixed high speed jet and up the inside of the main pickup tube.
4. Atmospheric pressure pushes air through the main air jet to the outside of the main pickup tube, Fig. 8.
5. This air then enters through the main pickup tube bleed holes and mixes with the fuel coming up the inside of main pickup tube, Fig. 8.
6. This air/fuel mixture is pushed up and out of the main pickup tube into the incoming air at the venturi and into the engine through the intake valve.
7. The throttle valve controls the amount of air/fuel mixture entering the engine, as the governor responds to changing loads.

# CARBURETION

## Remove Carburetor – Vertical Crankshaft Models

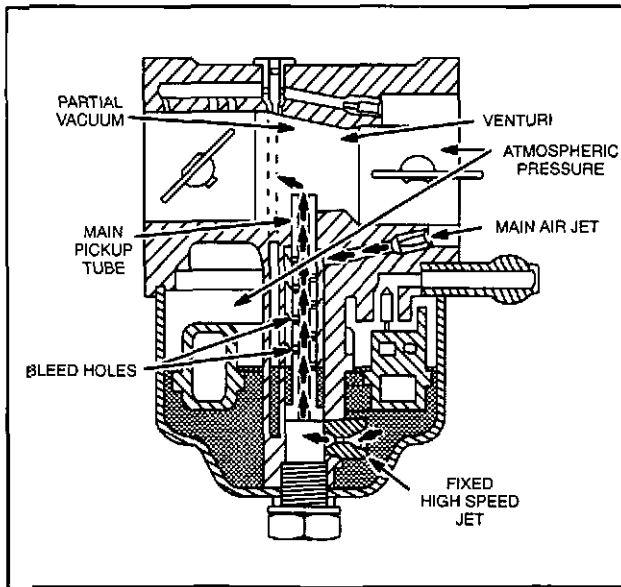


Fig. 8 - High Speed Operation (Typical)

### Choke System Operation

When starting a cold engine, the choke valve is closed and the following events occur:

1. As the intake valve opens, a partial vacuum forms in the carburetor behind the choke valve, Fig. 9.
2. Atmospheric pressure acts on the idle system through an air bleed hole in the choke valve and fuel flows as described in "IDLE SYSTEM OPERATION."
3. Atmospheric pressure acts on the high speed system as described in "HIGH SPEED SYSTEM OPERATION."

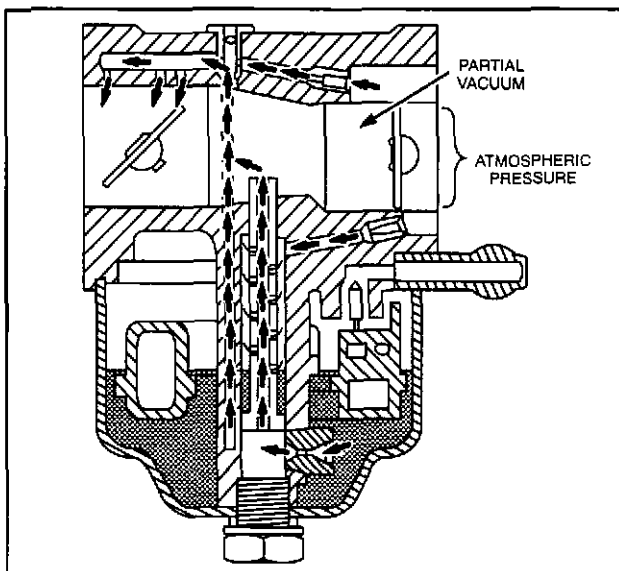


Fig. 9 - Choke Operation (Typical)

### Remove Carburetor – Vertical Crankshaft Models 290700-350700

**All models:** If engine is equipped with anti-afterfire solenoid, it is recommended that the blower housing be removed so that solenoid wire can be properly routed during reassembly. Disconnect anti-afterfire solenoid wire from equipment switch wire.

**Current style:** Remove air cleaner cover, cartridge and pre-cleaner. Remove three screws and breather deflector. Then remove two carburetor mounting nuts, Fig. 10. Remove air cleaner base and breather tube.

**Early style:** Remove air cleaner cover. Remove four screws, Fig. 11. Remove air cleaner base and breather tube. Then, remove carburetor mounting screws.

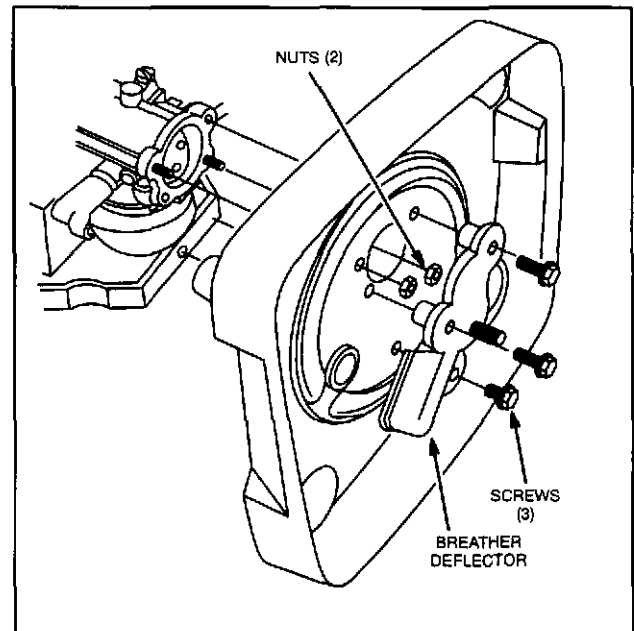


Fig. 10 - Remove Air Cleaner Base (Current Style)

# CARBURETION

## Remove Carburetor - Vertical Crankshaft Models

3

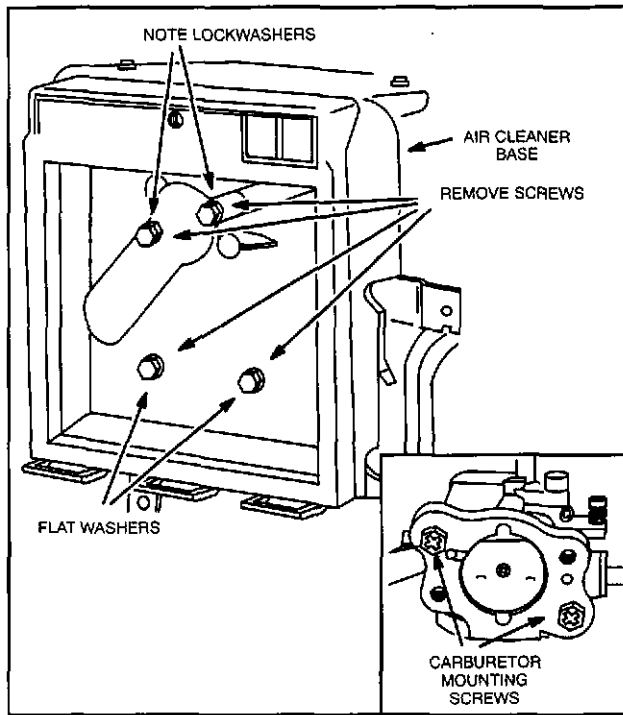


Fig. 11 - Remove Air Cleaner Base (Early Style)

Remove two screws and choke control bracket, Fig. 12. Disconnect choke link from carburetor.

NOTE: If engine is equipped with anti-afterfire solenoid, air cleaner bracket must be removed before removing carburetor, Fig. 12.

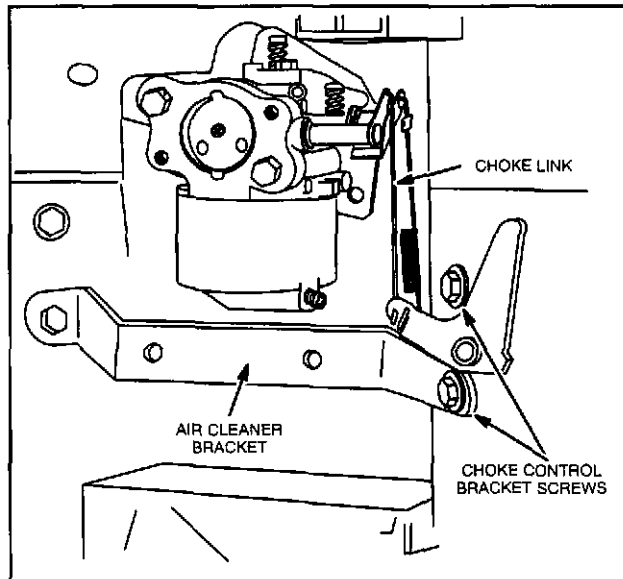


Fig. 12 - Removing Choke Control Bracket

Remove fuel line clamp and fuel line from carburetor. Unhook governor link spring from throttle lever.

Disconnect governor link, Fig. 13. Remove carburetor, gaskets and spacer.

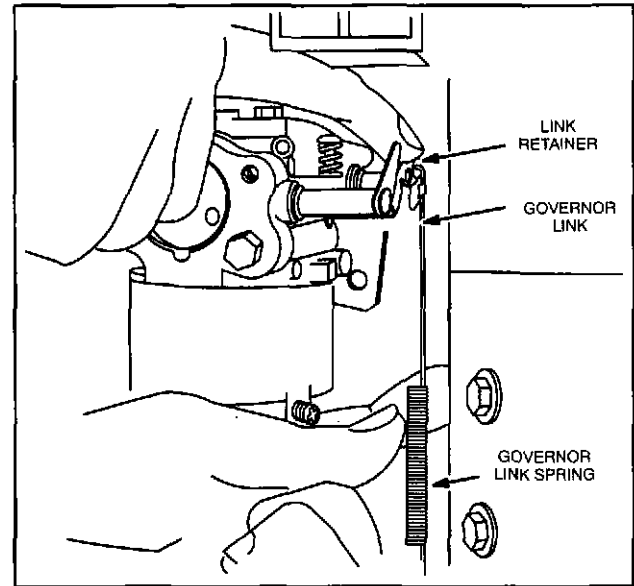


Fig. 13 - Removing Carburetor

### Remove Carburetor Vertical Crankshaft Model 351700

The blower housing must be removed so that anti-afterfire solenoid wire can be properly routed during reassembly.

Remove air cleaner cover, cartridge and pre-cleaner. Remove two nuts and three screws and breather deflector, Fig. 14. Remove breather tube at breather and remove air cleaner base.

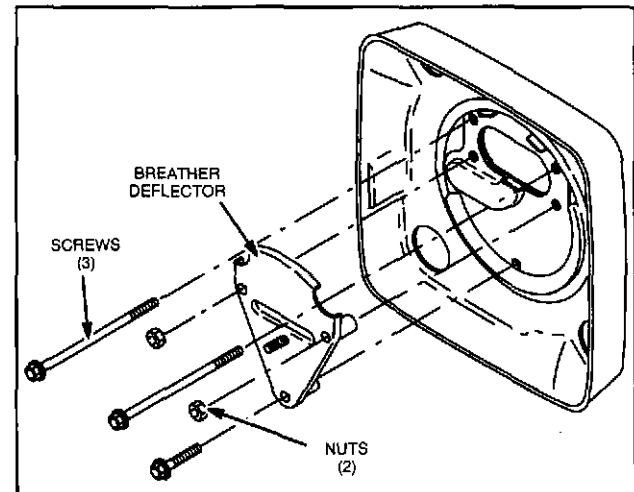
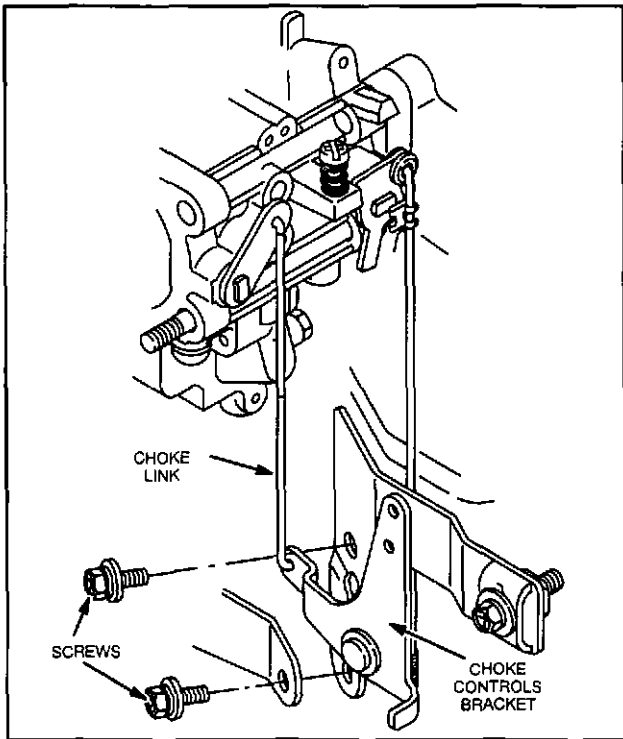


Fig. 14 - Remove Air Cleaner Base Model 351700

# CARBURETION

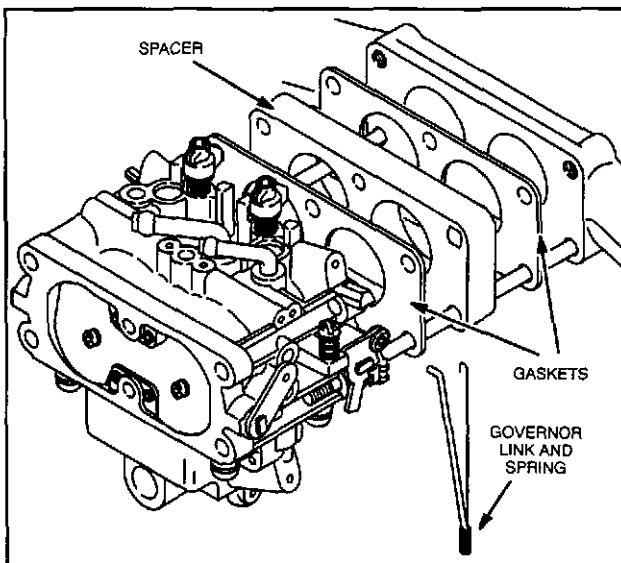
## Disassemble Carburetor Models 290700-303700

Remove two screws and choke control bracket, Fig. 15. Disconnect choke link from carburetor.



**Fig. 15 - Removing Choke Control Bracket**

Remove fuel line clamp and fuel line from carburetor. Unhook governor link spring from throttle lever. Disconnect governor link, Fig. 16. Note routing of solenoid wire. Remove carburetor with solenoid, gaskets and spacer.

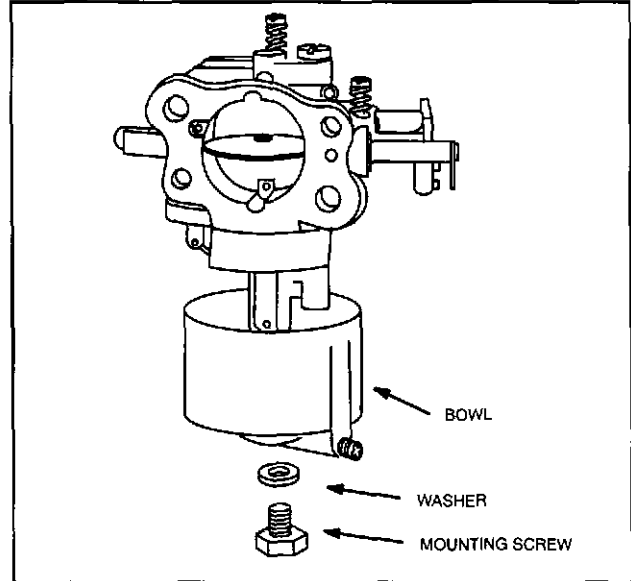


**Fig. 16 - Removing Carburetor**

See pages 19-24 for carburetor disassembly and reassembly procedure.

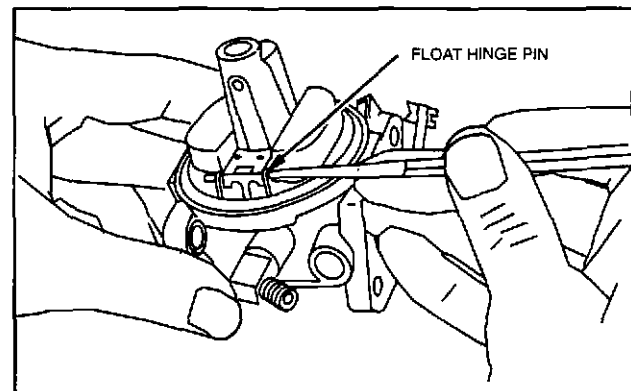
### Disassemble Carburetor - Engine Models 290700, 294700, 303700

Remove anti-afterfire solenoid, if equipped, or bowl mounting screw, washer and bowl, Fig. 17.



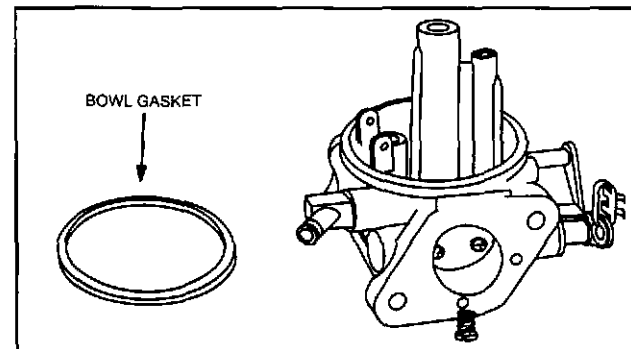
**Fig. 17 - Removing Bowl**

With a small punch, drive the float hinge pin out of float hinge, Fig. 18. Remove float and fuel inlet valve assembly.



**Fig. 18 - Removing Float Hinge Pin**

Remove carburetor bowl gasket, Fig. 19.



**Fig. 19 - Removing Bowl Gasket**

# CARBURETION

## Disassemble Carburetor Models 290700-303700

Remove fixed main jet using screwdriver Tool #19062, Fig. 20. NOTE: Special high altitude jets are available. Consult the Illustrated Parts List for the correct number.

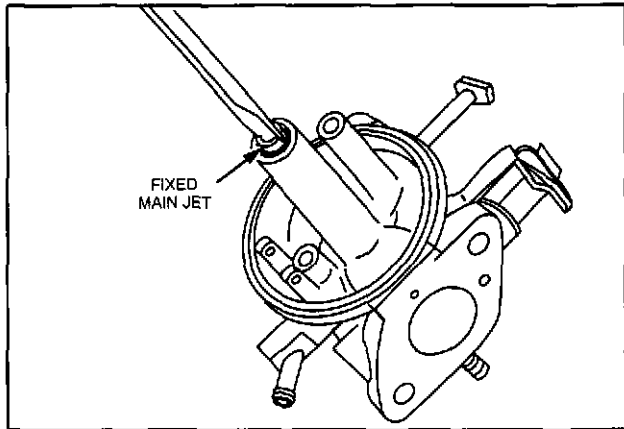


Fig. 20 - Removing High Speed Jet

When the fixed main jet has been removed, the high speed nozzle can be removed, Fig. 21. Reach into carburetor throat with a flat blade screw driver and push down on end of nozzle.

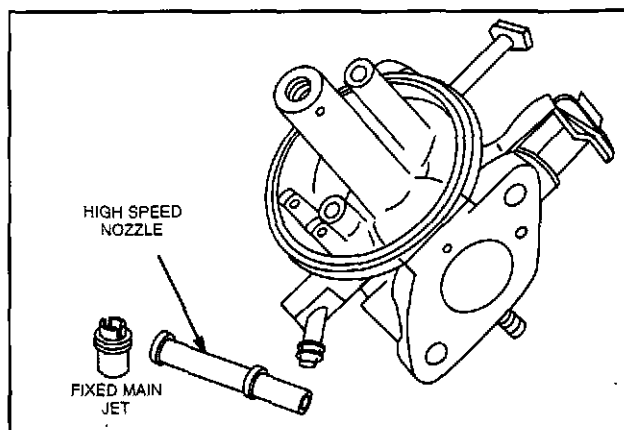


Fig. 21 - Removing High Speed Nozzle

Remove idle jet plug and idle jet, Fig. 22.

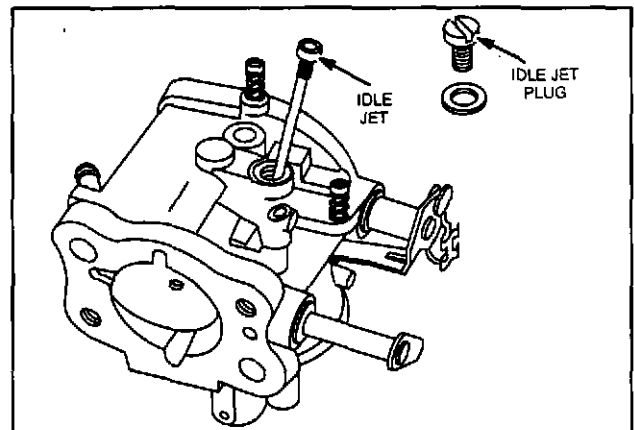


Fig. 22 - Removing Idle Jet

If idle mixture valve is equipped with adjustment limiter cap, use a pliers to remove it before removing idle mixture valve, Fig. 23.

Remove idle mixture valve, Fig. 23.

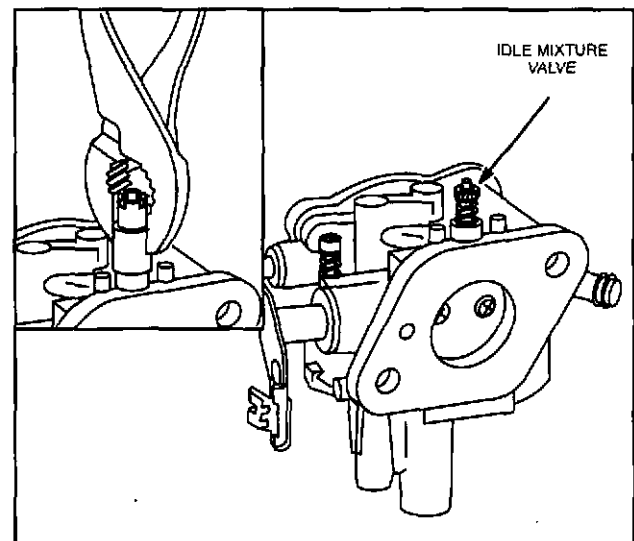
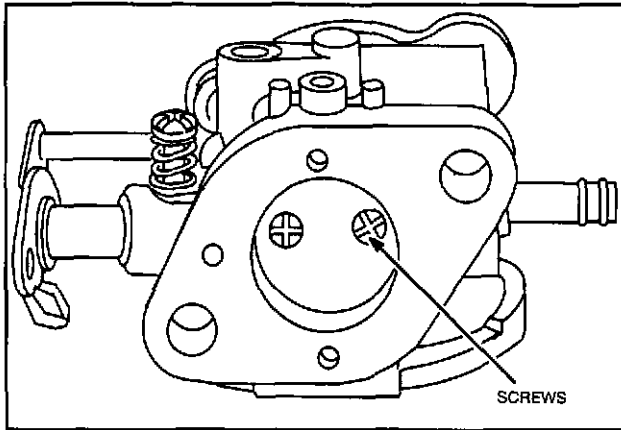


Fig. 23 - Removing Idle Mixture Valve

# CARBURETION

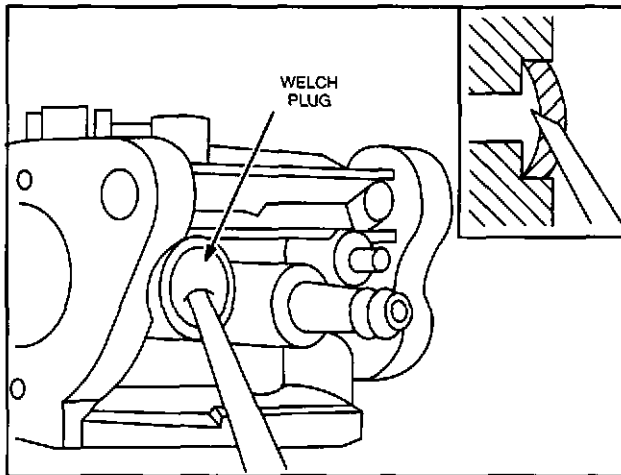
## Disassemble Carburetor Models 290700-303700

Remove two screws holding throttle valve to throttle shaft and remove throttle valve, Fig. 24.



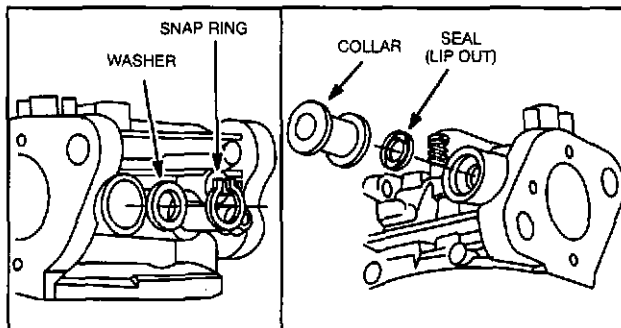
**Fig. 24 - Removing Throttle Valve Screws**

To remove throttle shaft it is necessary to first remove welch plug from side of carburetor. Use a punch as shown, Fig. 25.



**Fig. 25 - Removing Welch Plug**

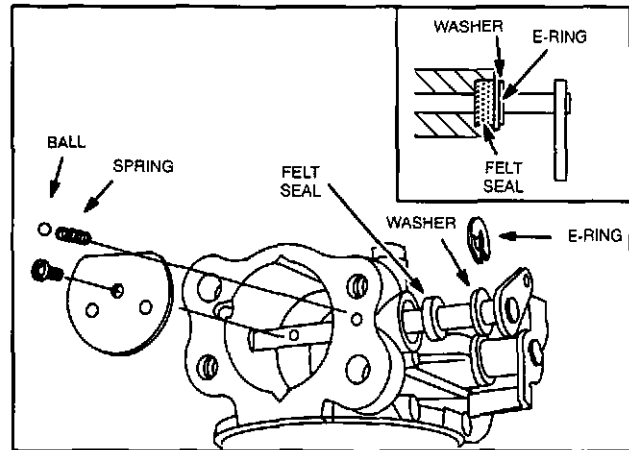
Remove external snap ring and throttle shaft washer. Remove throttle shaft, throttle shaft collar and throttle shaft seal, Fig. 26.



**Fig. 26 - Removing Throttle Shaft**

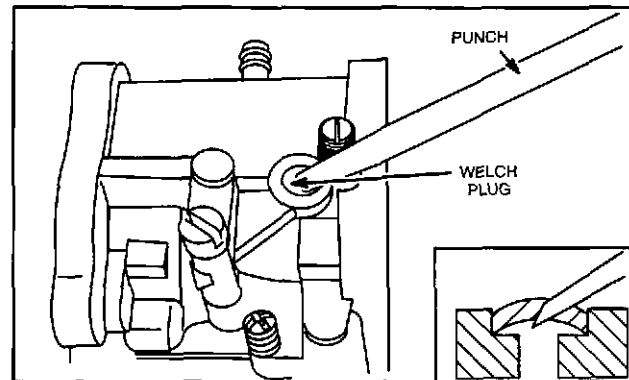
**NOTE:** The choke shaft has a ball and spring that keeps tension on the choke shaft. Use care when removing choke shaft.

Remove choke valve screw and choke valve. Remove "E" ring, then remove choke shaft, washer and felt seal, Fig. 27.



**Fig. 27 - Removing Choke Shaft**

Remove small welch plug from top of carburetor body, Fig. 28.



**Fig. 28 - Removing Welch Plug**

This completes the carburetor disassembly procedure.

### Clean Fuel System

Gummy or dirty fuel tanks and carburetors should be cleaned in a carburetor cleaner such as Bendix Carburetor Cleaner or equivalent. **DO NOT** soak rubber, neoprene or plastic parts in cleaner.

### Inspect Carburetor

Check all moving parts for wear, nicks and burrs. Replace, if worn or damaged. Check float for leaks or damage. Replace, if damaged or leaking. Check all mating surfaces for nicks, burrs, foreign material, or cracks. Replace all damaged parts.

# CARBURETION

## Assemble Carburetor Models 290700-303700

### Check Throttle And Choke Shaft and Bushings for Wear

Wear between throttle shaft and bushing should not exceed .25 mm (.010"). Check wear by placing carburetor on a flat surface, as shown in Fig. 29. Measure the distance between the throttle lever and flat surface with a feeler gauge while moving shaft up and down, Fig. 29.

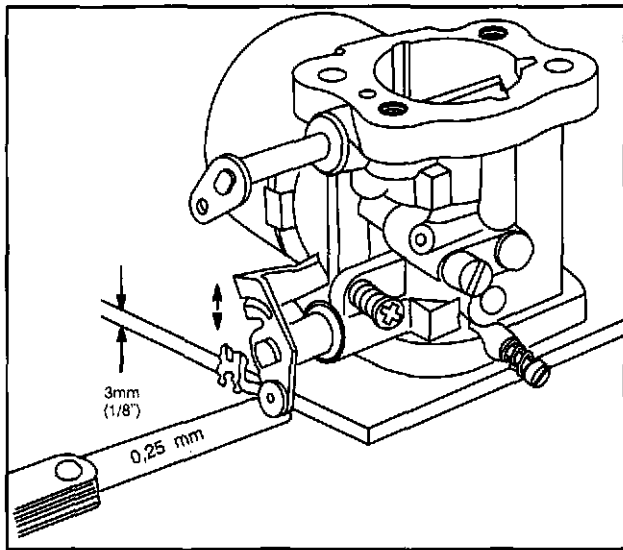


Fig. 29 - Checking Throttle Wear

If the difference is greater than .25 mm (.010"), this indicates that the throttle shaft and/or bushings are worn. Wear on the throttle shaft can be checked by comparing the worn and unworn portions of the shaft, Fig. 30.

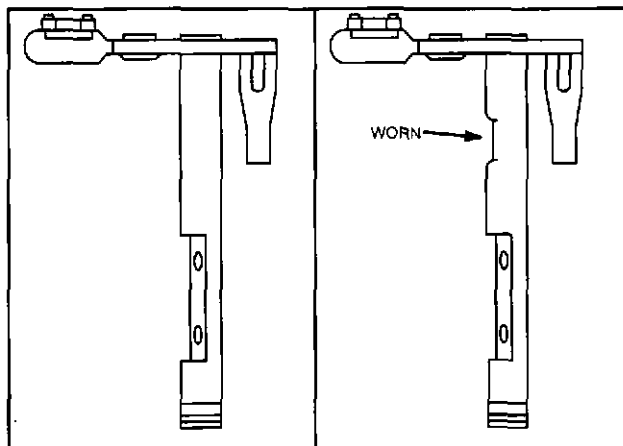


Fig. 30 - Checking Throttle Shaft Wear

Choke shaft and bushings are checked in the same manner.

Throttle and choke shaft are replaceable. If throttle and/or choke shaft bushings are worn, replace carburetor.

### Assemble Carburetor - Engine Models 290700, 294700, 303700

When assembling carburetor, use new seals and gaskets.

Install new secondary idle port welch plug. Use a round punch and tap in plug until it is flat, Fig. 31. Use a sealant such as Permatex® #2 or nail polish on outside diameter of plug to prevent air leaks.

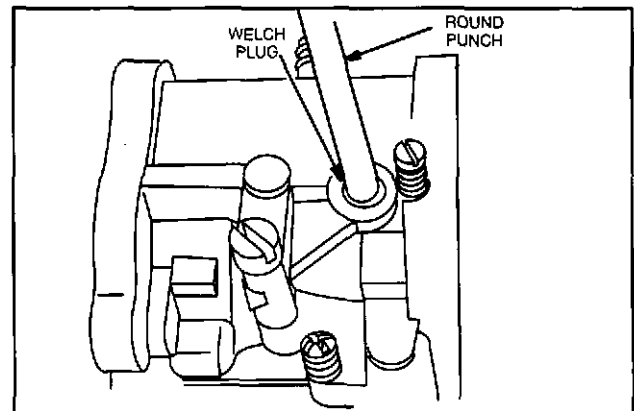


Fig. 31 - Installing Welch Plug

Install throttle shaft seal with sealing lip out. Slide collar over throttle shaft and insert throttle shaft through carburetor body, Fig. 32. Place washer over end of throttle shaft and install new snap ring, Fig. 32.

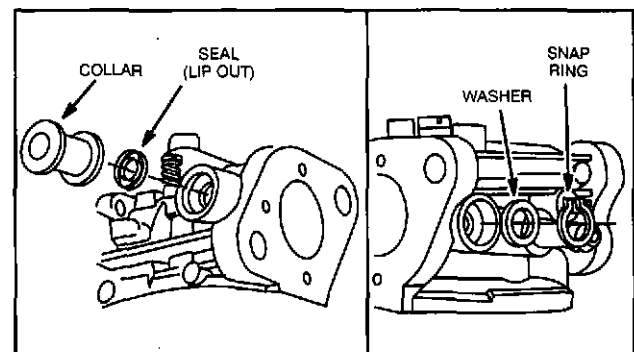
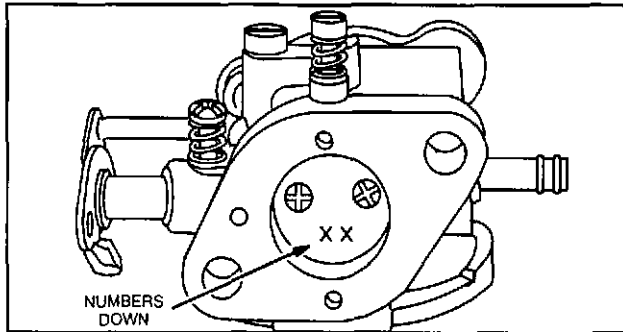


Fig. 32 - Installing Welch Plug

# CARBURETION

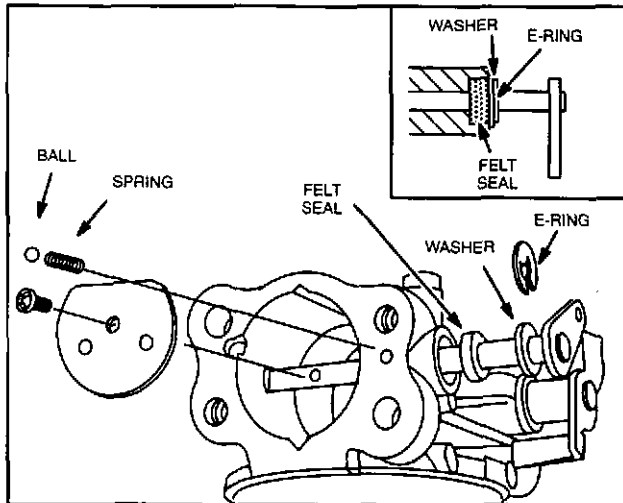
## Assemble Carburetor Models 290700-303700

Install throttle valve on shaft with numbers down, Fig. 33. With throttle valve in closed position, tighten screws securely. Then install new welch plug in side of carburetor body. Use a round punch and tap in plug until it is flat. Use a sealant on outside diameter of plug to prevent air leaks.



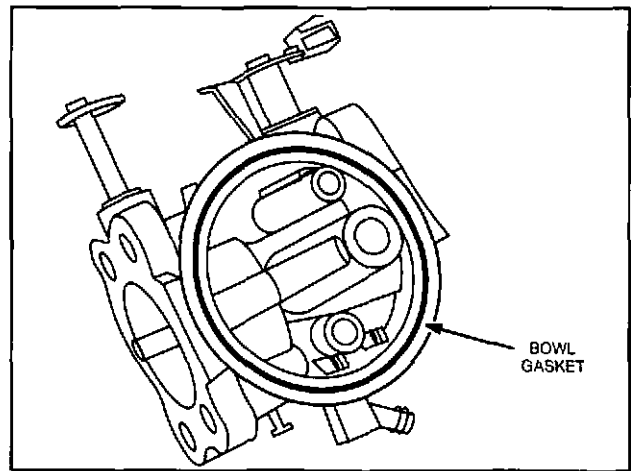
**Fig. 33 - Installing Throttle Valve**

Install new "E" ring, washer and felt seal onto choke shaft. Insert spring and check ball in to spring pocket. Push choke shaft into hole until ball engages groove in choke shaft, Fig. 34. Place choke valve onto flat on choke shaft with flat edge of choke valve up and dimples down. With choke valve in closed position, install and tighten screw securely.



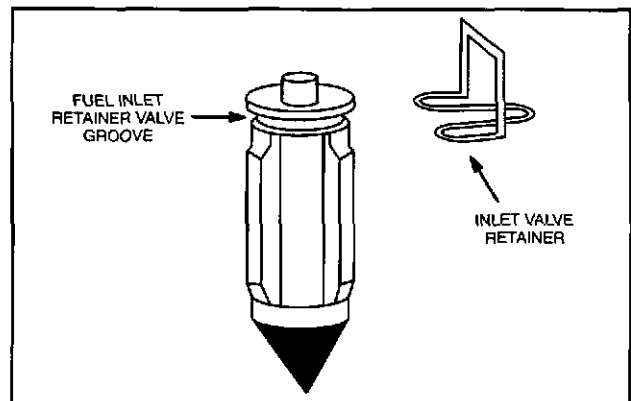
**Fig. 34 - Installing Choke Valve**

Install carburetor bowl gasket in carburetor body groove, Fig. 35. Make sure gasket does not twist or kink.



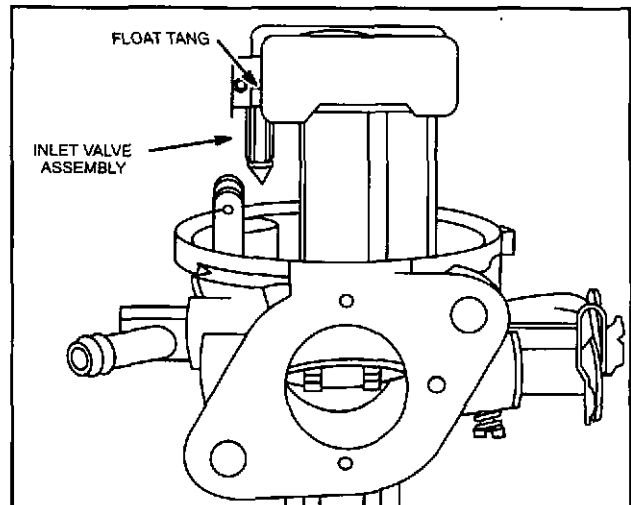
**Fig. 35 - Installing Bowl Gasket**

Install fuel inlet valve retainer in fuel inlet valve groove, Fig. 36.



**Fig. 36 - Installing Inlet Valve Retainer**

Slide fuel inlet valve assembly onto float tang and place assembly in carburetor, Fig. 37.



**Fig. 37 - Installing Float Assembly**

# CARBURETION

## Assemble Carburetor Models 290700-303700

Install float hinge pin into place as shown, Fig. 38.

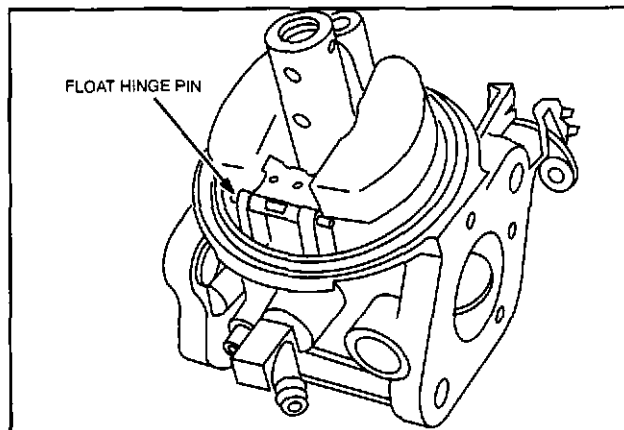


Fig. 38 - Installing Float Hinge Pin

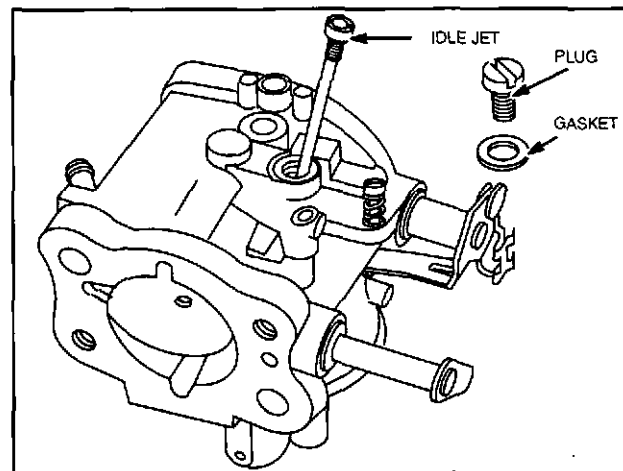


Fig. 40 - Installing Idle Jet and Plug

Hold carburetor in a vertical position, with float hinge up, as shown in Fig. 39. The float should be parallel with carburetor bowl mounting surface. If not, bend tang Fig. 39. DO NOT press on float to adjust.

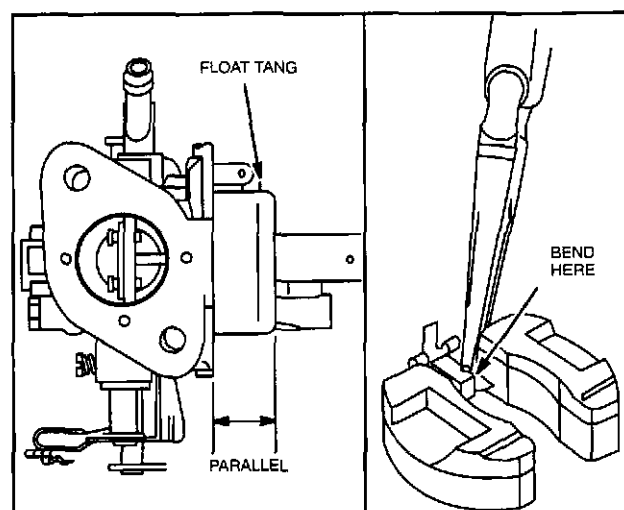


Fig. 39 - Adjusting Float

Install idle mixture valve and spring, Fig. 41. DO NOT tighten valve.

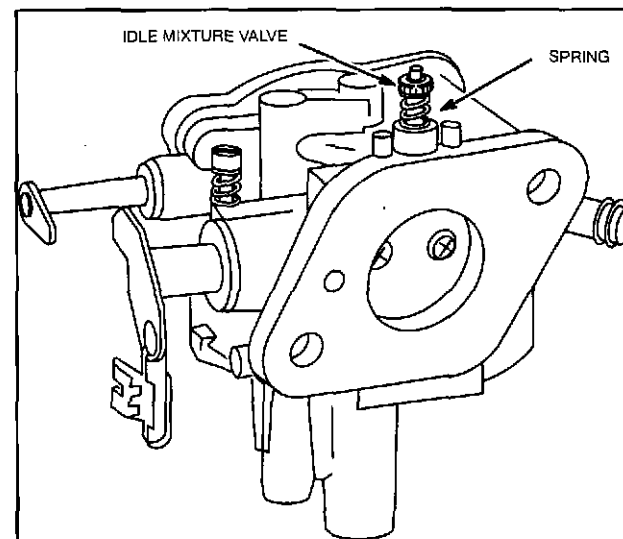


Fig. 41- Installing Idle Mixture Valve

Install idle jet, plug and gasket Fig. 40. Tighten plug securely.

# CARBURETION

## Disassemble Carburetor Model 350700

Install high speed nozzle and fixed main jet using screwdriver Tool #19062, Fig. 42.

Note: Special high altitude jets are available. Consult the Illustrated Parts List for the correct part number.

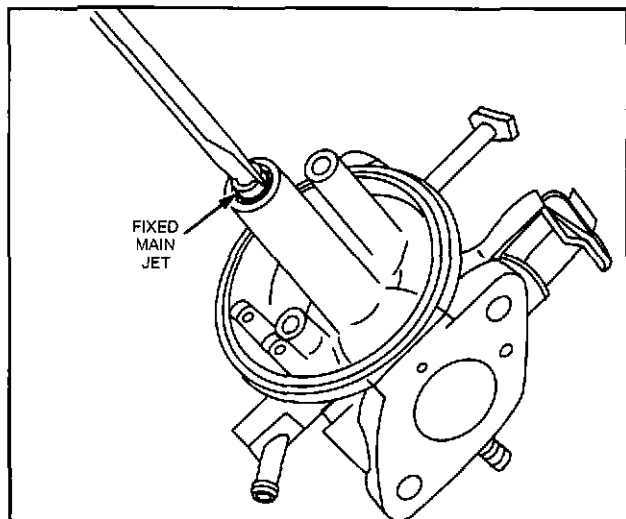


Fig. 42 - Installing High Speed Nozzle and Jet

Install bowl, washer and screw or anti-afterfire solenoid, if equipped. Position bowl drain as shown, Fig. 43. Torque screw or solenoid to 5 Nm (45 in. lbs.).

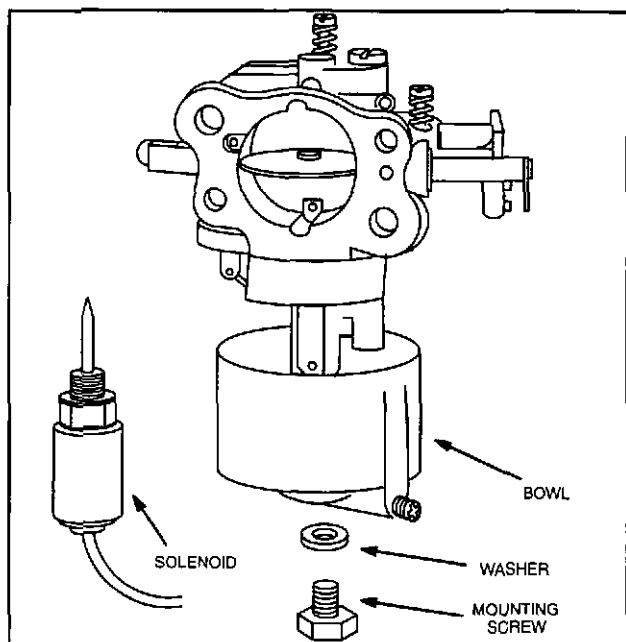


Fig. 43 - Installing Bowl

### Disassemble Carburetor - Engine Model 350700

Remove anti-afterfire solenoid or bowl screw, washer and bowl, Fig. 44.

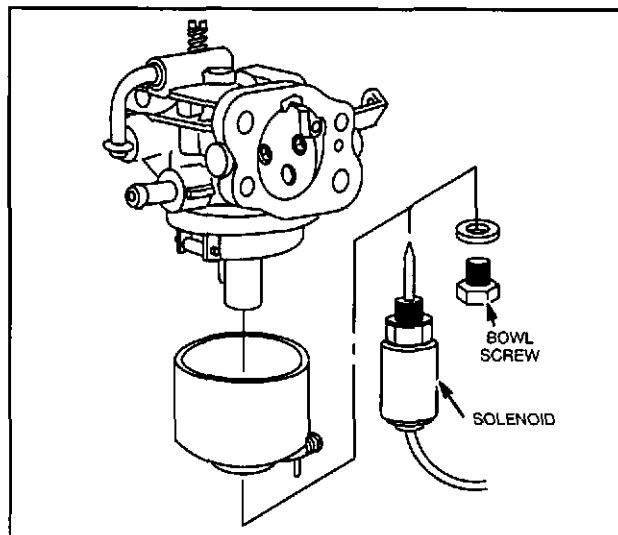


Fig. 44 - Removing Bowl

Remove fixed main jet using screwdriver Tool #19061 Fig. 45.

NOTE: Float hinge pin is swaged on one end. Drive hinge pin out from side opposite swage.

With a small punch, drive the float hinge pin out of float hinge, Fig. 45. Remove float and fuel inlet valve assembly.

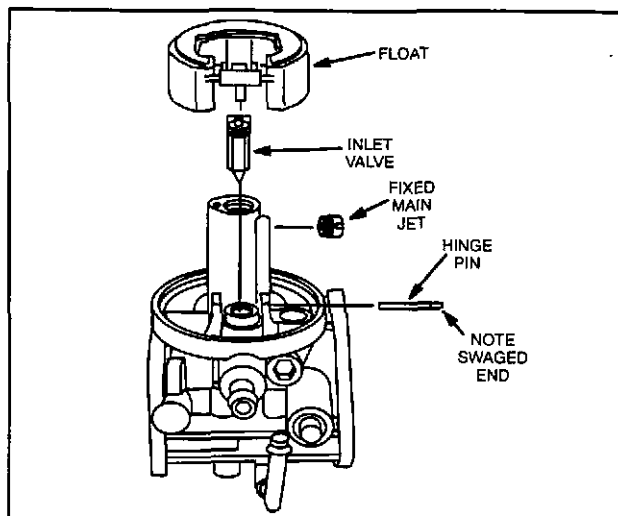


Fig. 45 - Removing Float and Fixed Main Jet

# CARBURETION

## Disassemble Carburetor Model 350700

Remove carburetor bowl gasket, Fig. 46.

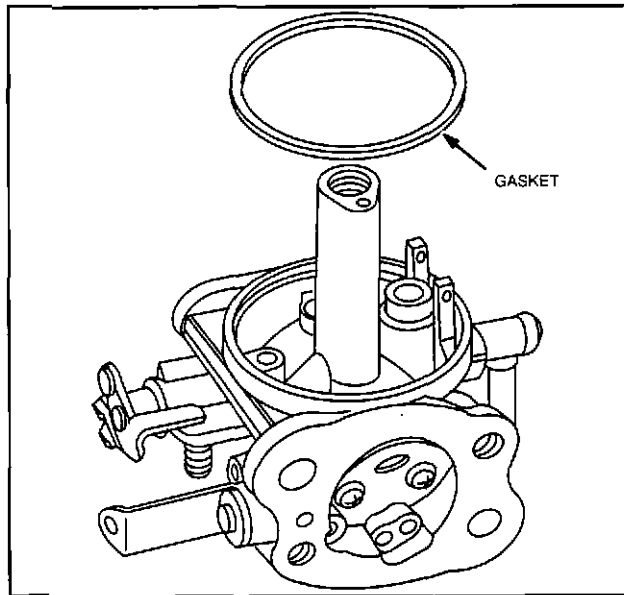


Fig. 46 - Removing Bowl Gasket

Remove high speed nozzle using screwdriver Tool #19062, Fig. 47.

Note: If carburetor is equipped with solenoid, remove solenoid seat, then remove high speed nozzle, Fig. 47.

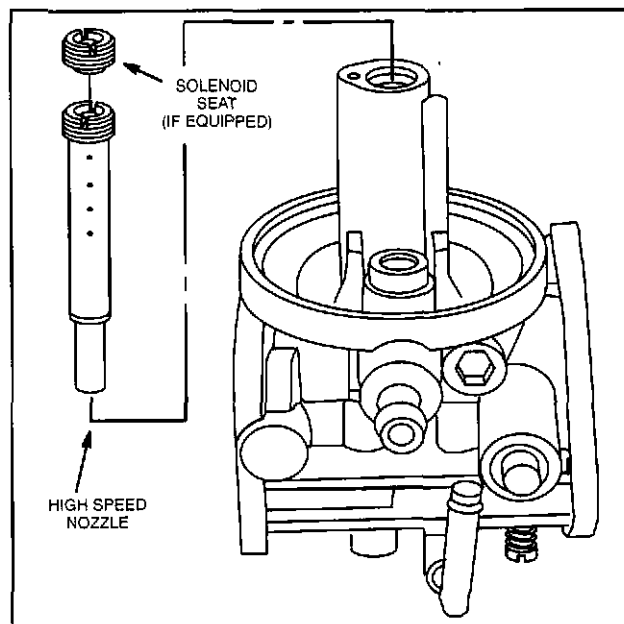


Fig. 47 - Removing Nozzle

If idle mixture valve is equipped with adjustment limiter cap, use a pliers to remove it before removing idle mixture valve, Fig. 48.

Remove idle mixture valve and spring. Remove idle jet, Fig. 48.

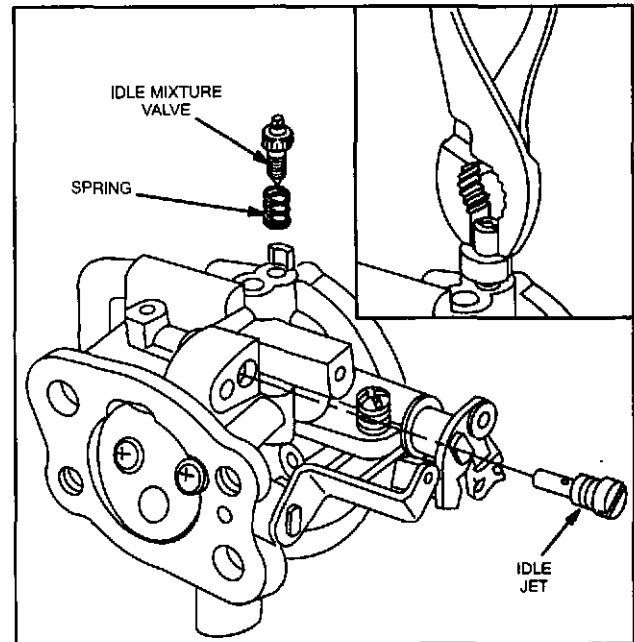


Fig. 48 - Removing Idle Mixture Valve and Idle Jet

Remove two screws holding throttle valve to throttle shaft and remove throttle valve, Fig. 49. Remove throttle shaft retainer, then remove throttle shaft with spacer and foam seals. Remove throttle shaft seals from carburetor.

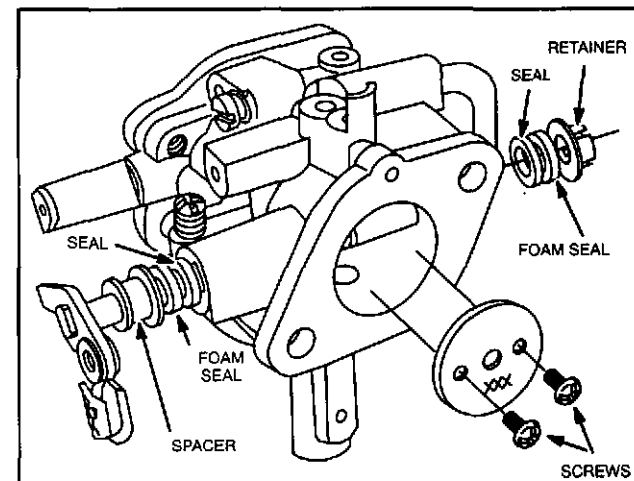


Fig. 49 - Removing Throttle Shaft

# CARBURETION

## Disassemble Carburetor Model 350700

NOTE: The choke shaft has a ball and spring that keeps tension on the choke shaft. Use care when removing choke shaft.

Remove two screws holding choke valve to choke shaft and remove choke valve, Fig. 50. Remove choke shaft and washer. Remove choke shaft seal.

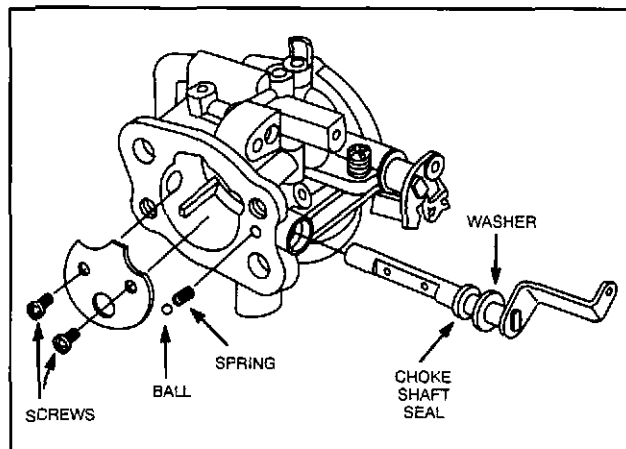


Fig. 50 - Removing Choke Shaft

### Remove Fuel Inlet Body And Seat

The fuel inlet body must be removed before the inlet seat can be removed.

To remove fuel inlet body, use self-threading screw #93029 from flywheel puller, Tool #19165. Thread screw into seat body 3-4 turns. Then, remove the screw, Fig. 51.

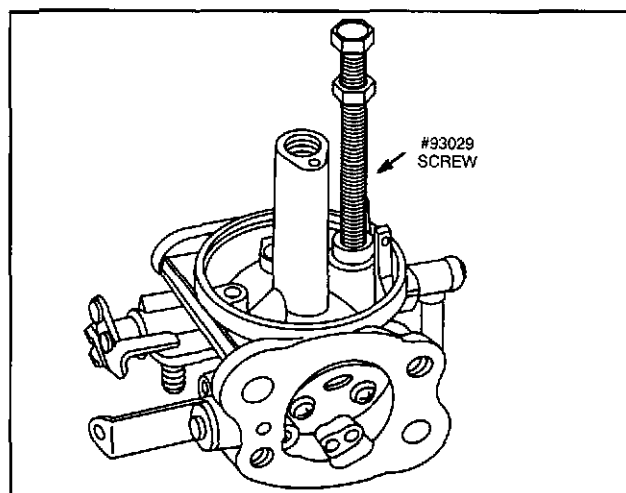


Fig. 51 - Thread Valve Seat Body

Install 1/4" x 20 nut #92278 and washer #224061 from 19332 Tool Kit onto screw. Place a 1/4" drive 9 mm (3/8") socket over seat body. Install screw, washer and nut. Thread nut down on washer. Continue turning until seat body is removed, Fig. 52.

The fuel inlet seat may now be removed.

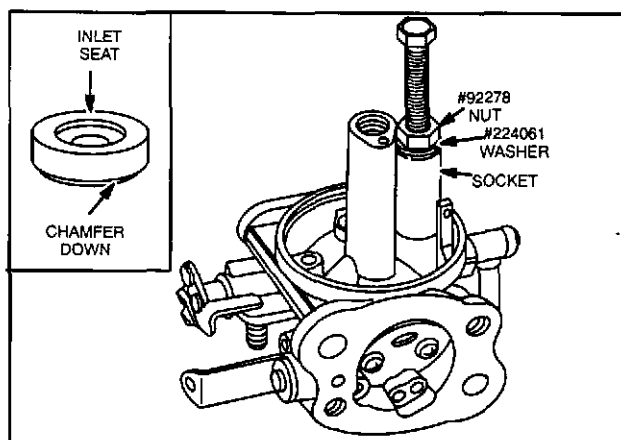


Fig. 52 - Remove Seat Body

This completes the carburetor disassembly procedure.

### Clean Fuel System

Gummy or dirty fuel tanks and carburetors should be cleaned in a carburetor cleaner such as Bendix Carburetor Cleaner or equivalent. DO NOT soak rubber, neoprene or plastic parts in cleaner.

### Inspect Carburetor

Check all moving parts for wear, nicks and burrs. Replace, if worn or damaged. Check float for leaks or damage. Replace, if damaged or leaking. Check all mating surfaces for nicks, burrs, foreign material, or cracks. Replace all damaged parts.

### Check Throttle And Choke Shaft And Bushings For Wear

Wear between throttle shaft and bushing should not exceed .25 mm (.010"). Check wear by placing carburetor on a flat surface, as shown in Fig. 53. Measure the distance between the throttle lever and flat surface with a feeler gauge while moving shaft up and down, Fig. 53.

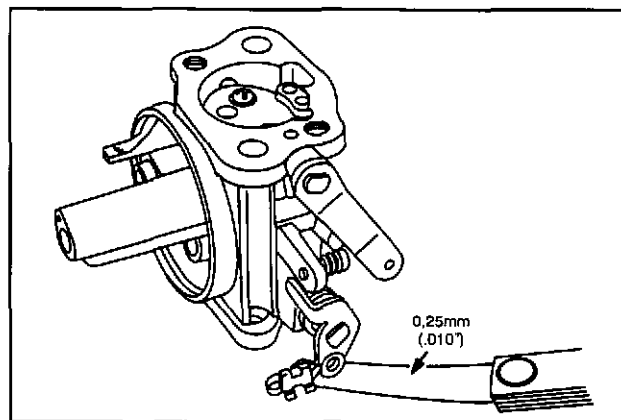


Fig. 53 - Checking Throttle Wear

# CARBURETION

## Assemble Carburetor Model 350700

If the difference is greater than .25 mm (.010"), this indicates that the throttle shaft and/or bushings are worn. Wear on the throttle shaft can be checked by comparing the worn and unworn portions of the shaft, Fig. 54.

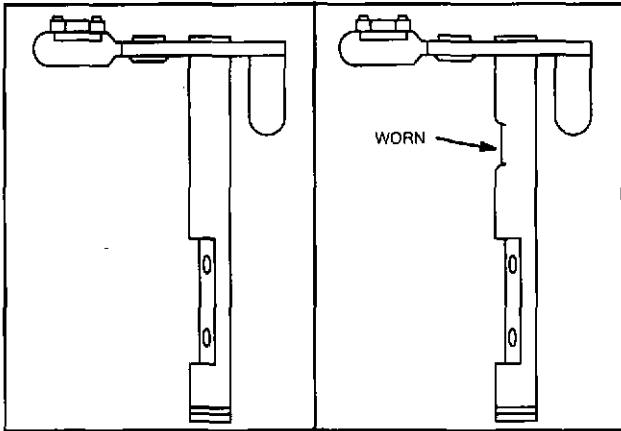


Fig. 54 - Checking Throttle Shaft Wear

Choke shaft and bushings are checked in the same manner.

Throttle and choke shaft are replaceable. If throttle and/or choke shaft bushings are worn, replace carburetor.

### Install Fuel Inlet Seat And Body

Insert new inlet seat in to carburetor. Install with chamfered end down. Make sure seat is installed as far as it will go. Press in new body until it bottoms using knock out pin, Tool #19135, Fig. 55.

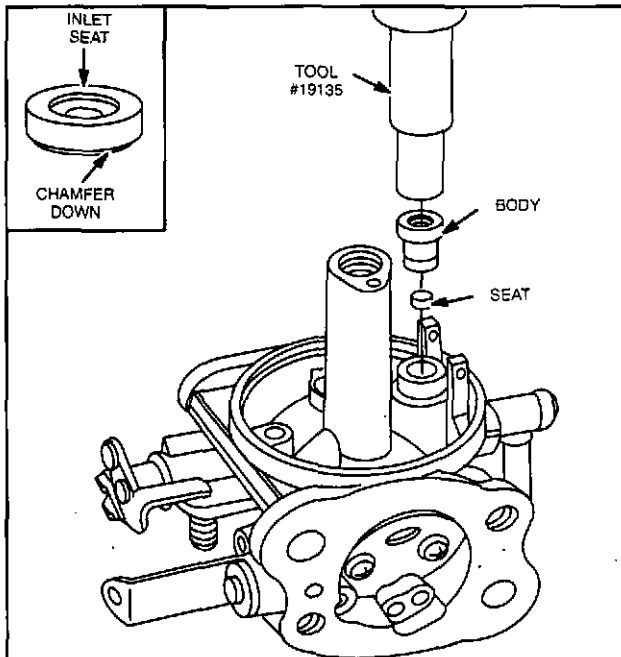


Fig. 55 - Installing Inlet Seat and Body

### Assemble Carburetor - Engine Model 350700

When assembling carburetor, use new seals and gaskets.

Install new throttle shaft seals with sealing lips out. Slide spacer and foam seal over throttle shaft and insert throttle shaft through carburetor body, Fig. 56. Install foam seal, then, slide retainer over end of throttle shaft until it snaps into position. Install throttle valve on shaft with numbers down. Tighten screws securely.

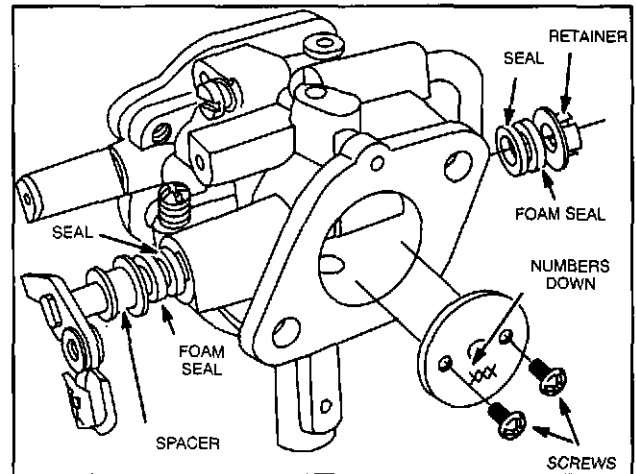


Fig. 56 - Installing Throttle Shaft

Install new choke shaft seal with sealing lip out. Assemble washer onto choke shaft. Insert spring and check ball in to spring pocket and compress spring and ball with a small round punch. Push choke shaft into hole until ball engages groove in choke shaft, Fig. 57. Place choke valve onto flat on choke shaft with number facing out and hole down. Install and tighten screws securely.

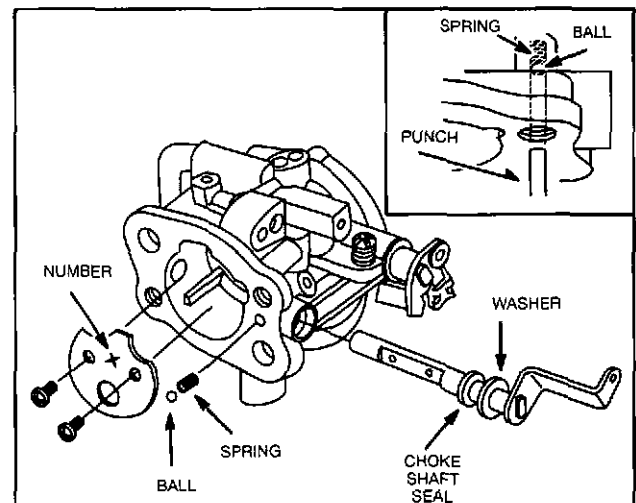


Fig. 57 - Installing Choke Shaft

# CARBURETION

## Assemble Carburetor Model 350700

Install carburetor bowl gasket in carburetor body groove, Fig. 58. Make sure gasket does not twist or kink.

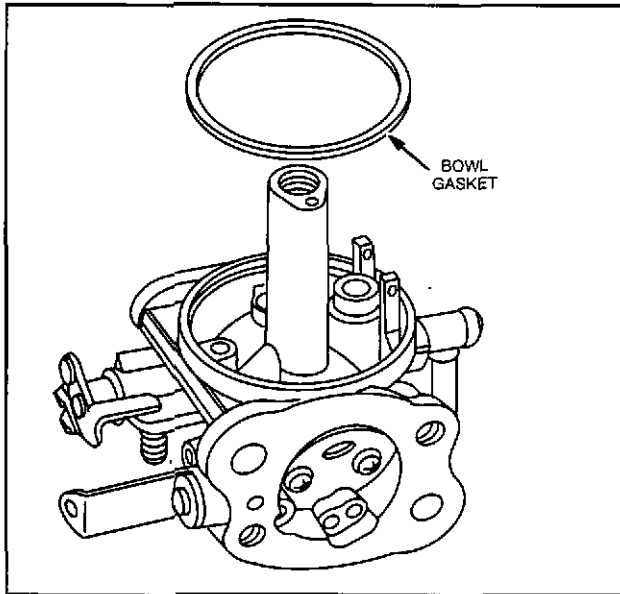


Fig. 58 - Installing Bowl Gasket

Install inlet valve retainer into groove in inlet valve. Assemble inlet valve assembly to float and install float assembly, Fig. 59. Install float hinge pin with swaged end out.

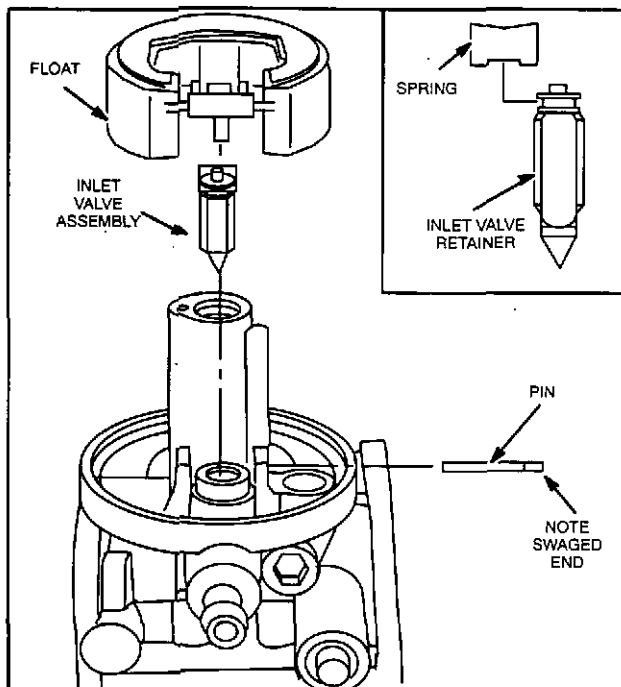


Fig. 59 - Installing Float Assembly

Install idle jet, Fig. 60. Then, install idle mixture valve and spring. DO NOT tighten idle mixture valve.

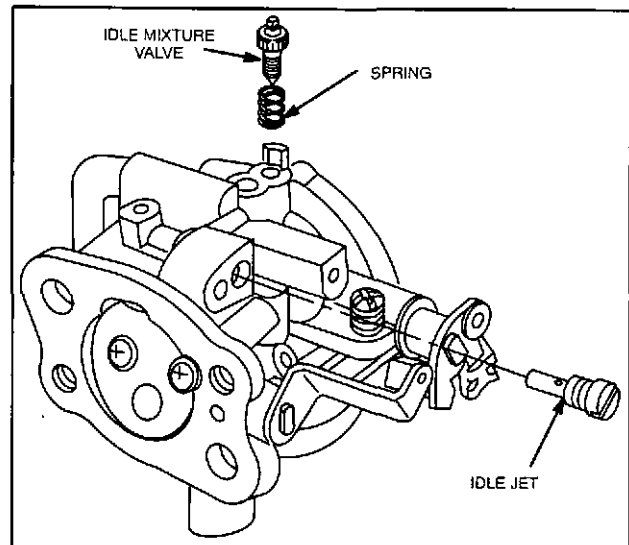


Fig. 60 - Installing Idle Jet and Idle Mixture Valve

Install high speed nozzle using screwdriver Tool #19062, Fig. 61. If carburetor is equipped with anti-afterfire solenoid, install solenoid seat. Then, install fixed main jet using screwdriver Tool #19061, Fig. 61.

Note: Special high altitude jets are available. Consult the Illustrated Parts List for the correct part number.

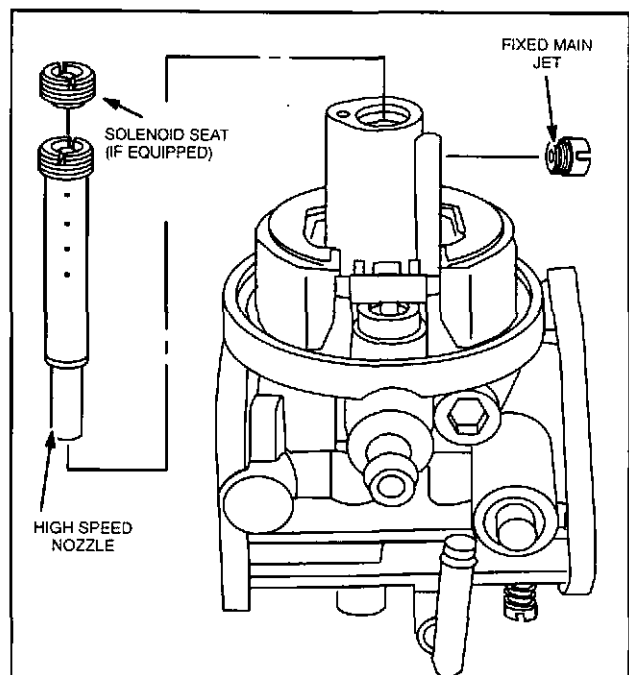


Fig. 61 - Installing High Speed Nozzle and Fixed Main Jet

# CARBURETION

## Disassemble Models 351700 and 351400

3

Assemble bowl to carburetor in position shown and install bowl screw or solenoid, Fig. 62. Torque screw or solenoid to 5 Nm (45 in. lbs.).

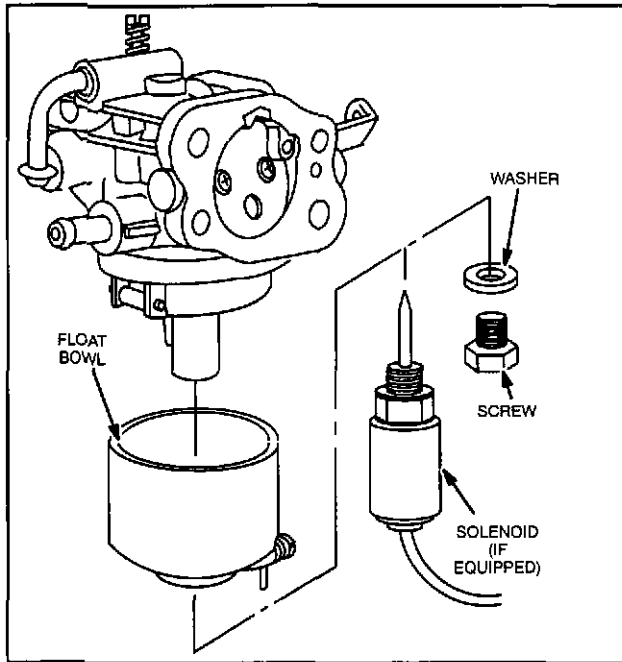


Fig. 62 - Installing Float Bowl

### Disassemble Carburetor - Engine Models 351700 And 351400

**IMPORTANT:** The carburetors used on the vertical crankshaft Model 351700 and horizontal crankshaft Model 351400 are similar enough that carburetor disassembly and reassembly procedures can be considered the same. The only significant differences in the carburetors are the location of the idle mixture screws and the fixed main jet orifice sizes.

Remove anti-afterfire solenoid with washer. Remove fixed main jet plugs with washers, Fig. 63.

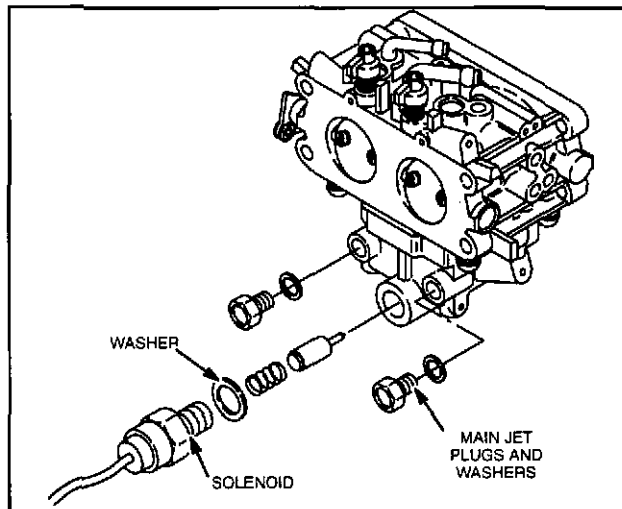


Fig. 63 - Removing Solenoid and Plugs

Remove fixed main jets, Fig. 64.

Note: Carburetor is equipped with a different size fixed main jet for each cylinder. The carburetor is marked "L" (#1 cylinder) and "R" (#2 cylinder). The carburetor is marked in two areas: The carburetor upper body near the choke valve and the lower body near the main jet plugs. See Fig. 64.

#### Fixed Main Jet Sizes - Model 351700:

"L", or #1 cylinder is equipped with #98 main jet. "R", or #2 cylinder is equipped with #100 main jet.

#### Fixed Main Jet Sizes - Model 351400:

"L", or #1 cylinder is equipped with #94 main jet. "R", or #2 cylinder is equipped with #98 main jet.

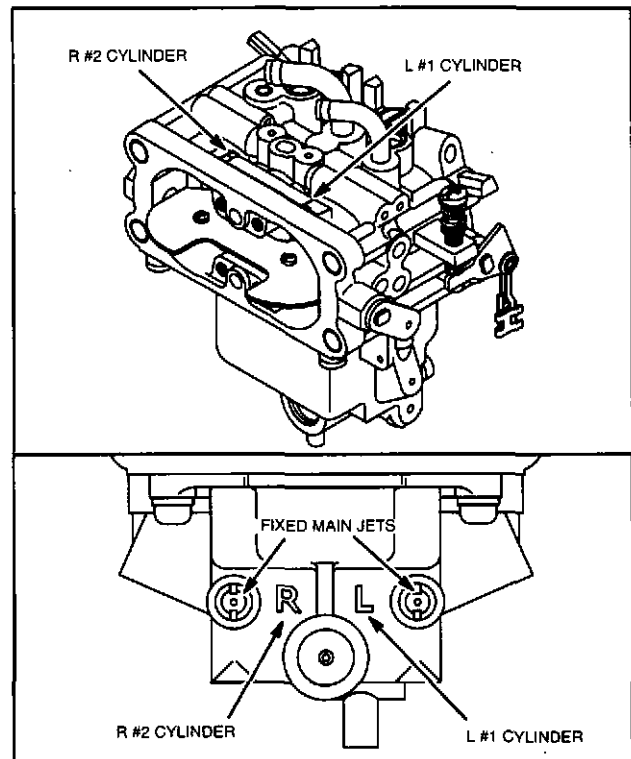


Fig. 64 - Removing Fixed Main Jets

# CARBURETION

## Disassemble Models 351700 and 351400

Remove carburetor lower body screws and lift lower body straight away from upper body, Fig. 65. Discard gasket.

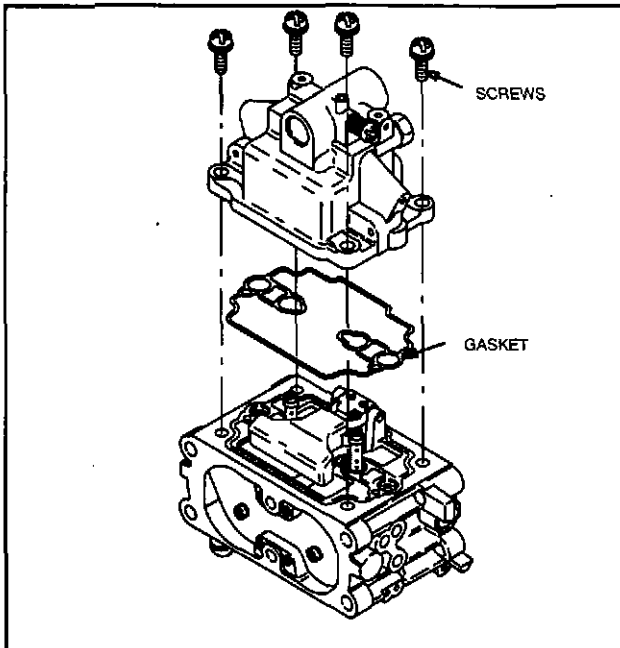


Fig. 65 - Removing Carburetor Lower Body

With a small punch drive out float hinge pin from side opposite throttle lever. Remove float and fuel inlet valve assembly, Fig. 67.

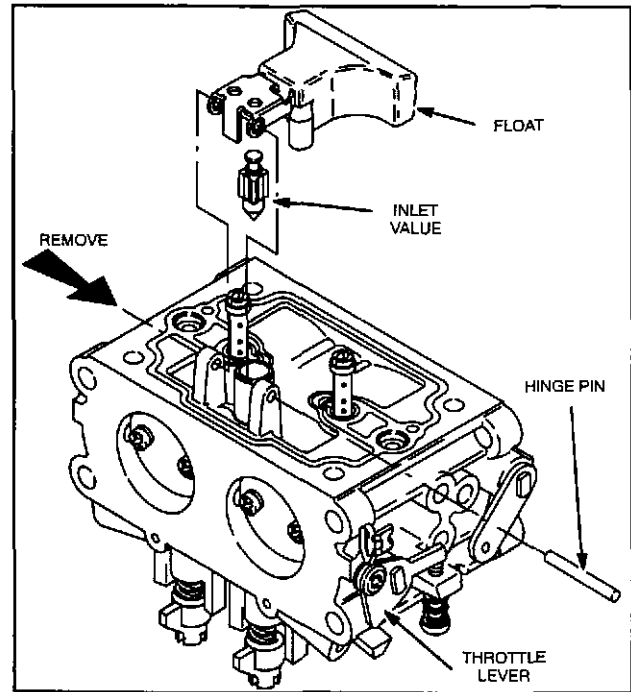


Fig. 67 - Removing Float and Inlet Valve

Remove idle jets, Fig. 66. Remove float bowl drain screw and spring.

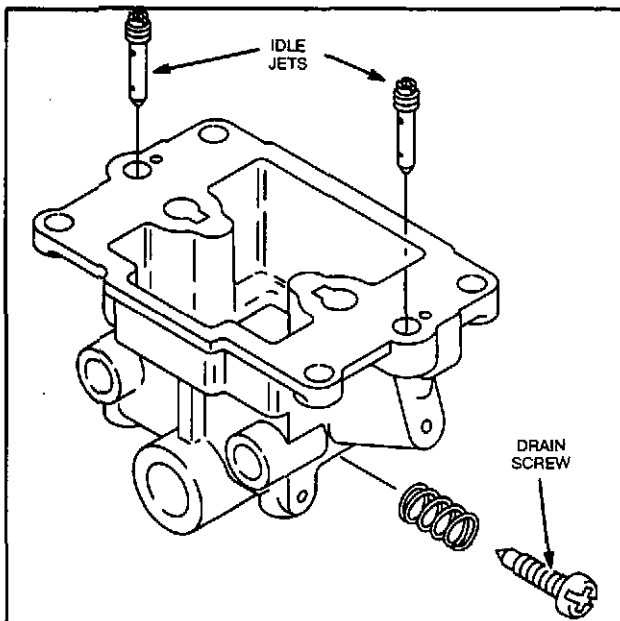


Fig. 66 - Removing Idle Jets

If idle mixture valves are equipped with adjustment limiter caps, use a pliers to remove them before removing idle mixture valves.

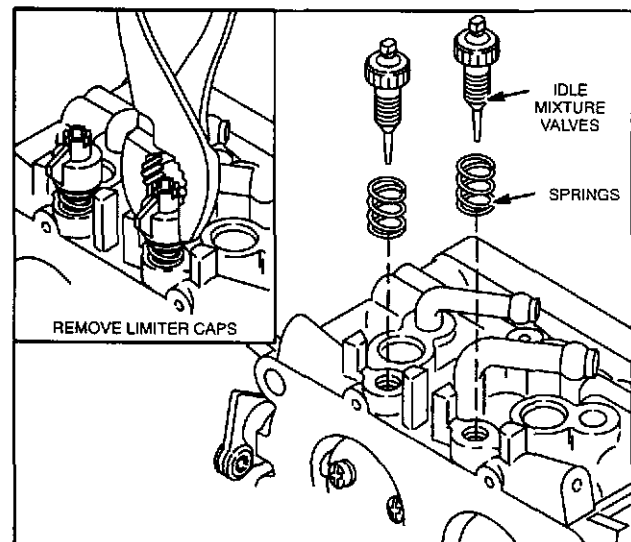


Fig. 68 - Removing Idle Mixture Valves

# CARBURETION

## Disassemble Models 351700 and 351400

Mark throttle valves so that they may be returned to their original position. Then remove screws and throttle valves. Remove throttle shaft with spacer and seal, Fig. 69.

3

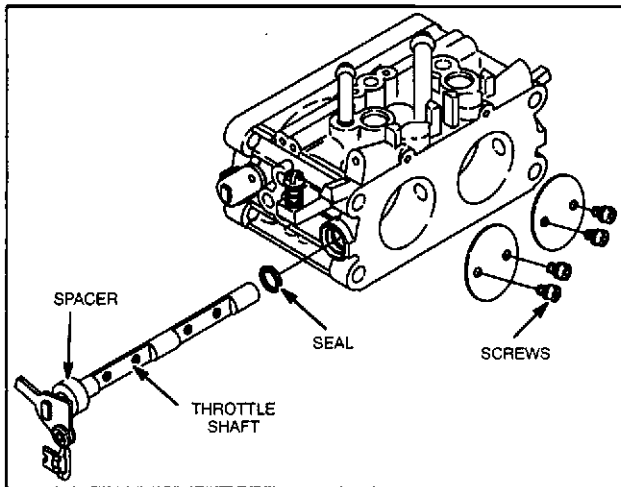


Fig. 69 - Removing Throttle Shaft

Mark choke valve so it may be returned to its original position. Then remove screws and choke valve. Remove choke shaft and seal.

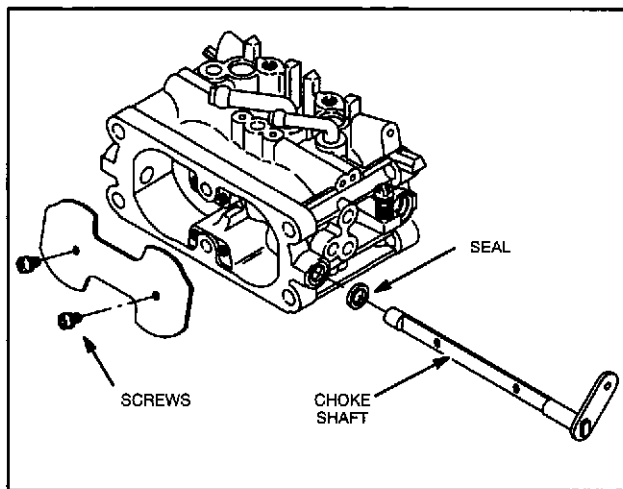


Fig. 70 - Removing Choke Shaft

This completes the carburetor disassembly procedure.

### Clean Fuel System

Gummy or dirty fuel tanks and carburetors should be cleaned in a carburetor cleaner such as Bendix Carburetor Cleaner or equivalent. DO NOT soak rubber, neoprene or plastic parts in cleaner.

### Inspect Carburetor

Check all moving parts for wear, nicks and burrs. Replace, if worn or damaged. Check float for leaks or damage. Replace, if damaged or leaking. Check all mating surfaces for nicks, burrs, foreign material, or cracks. Replace all damaged parts.

### Check Throttle And Choke Shaft And Bushings For Wear

Wear between throttle shaft and bushing should not exceed .25 mm (.010"). Check wear by placing carburetor on 6 mm (1/4") raised flat surface, as shown in Fig. 71. Measure the distance between the throttle lever and flat surface with a feeler gauge while moving shaft up and down, Fig. 71.

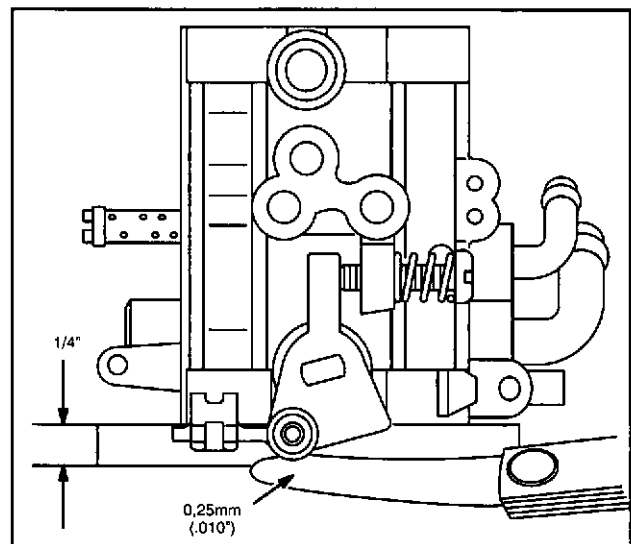


Fig. 71 - Checking Throttle Wear

# CARBURETION

## Assemble Models 351700 and 351400

If the difference is greater than .25 mm (.010"), this indicates that the throttle shaft and/or bushings are worn. Wear on the throttle shaft can be checked by comparing the worn and unworn portions of the shaft, Fig. 72.

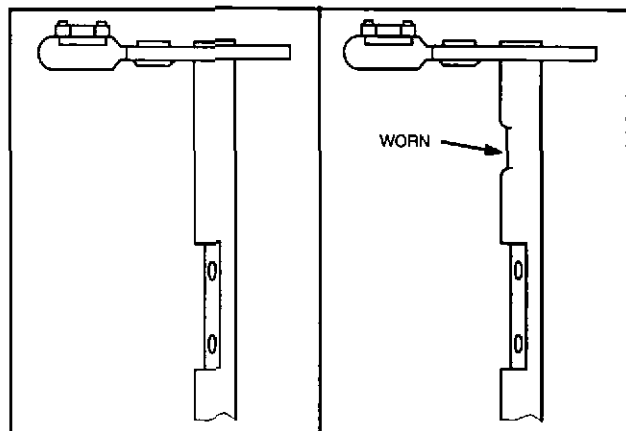


Fig. 72 - Checking Throttle Shaft Wear

Choke shaft and bushings are checked in the same manner.

Throttle and choke shaft are replaceable. If throttle and/or choke shaft bushings are worn, replace carburetor.

### Assemble Carburetor - Engine Models 351700 And 351400

When assembling carburetor, use new seals and gaskets.

Install new throttle shaft seal with sealing lip out. Assemble spacer to throttle shaft and insert throttle shaft into carburetor body. Assemble previously marked throttle valves in position and install screws, Fig. 73. Tighten screws securely.

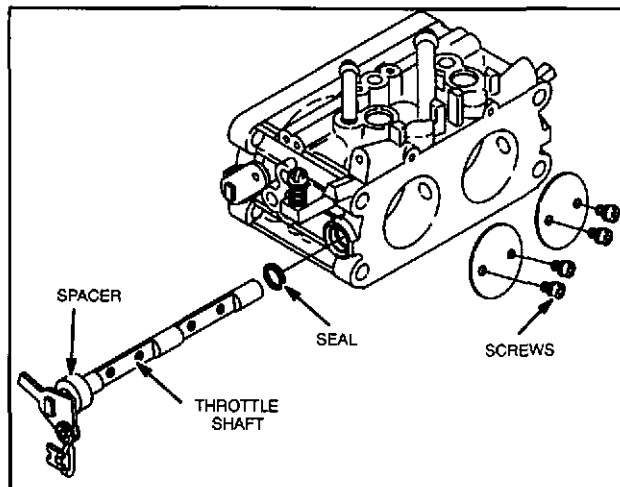


Fig. 73 - Installing Throttle Shaft

Install new choke shaft seal with sealing lip out. Insert choke shaft into carburetor body. Assemble previously marked choke valve in position and install screws, Fig. 74. Tighten screws securely.

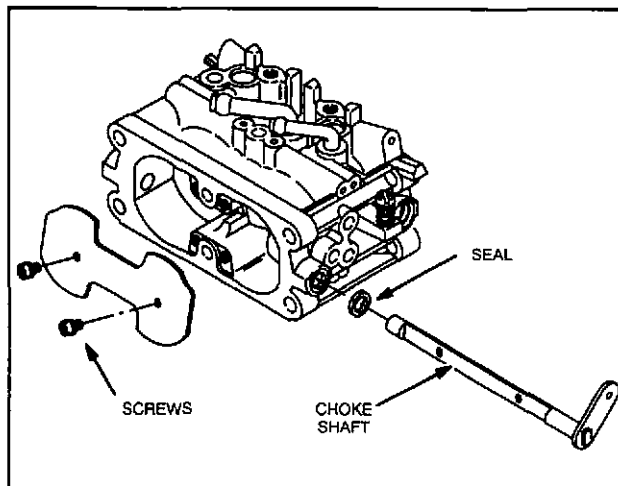


Fig. 74 - Installing Choke Shaft

3

# CARBURETION

## Assemble Models 351700 and 351400

Assemble inlet valve to float and install float assembly, Fig. 75. Install float hinge pin from throttle lever side.

**IMPORTANT:** Be sure float hinge pin is flush with float support or hinge pin will interfere with lower body.

3

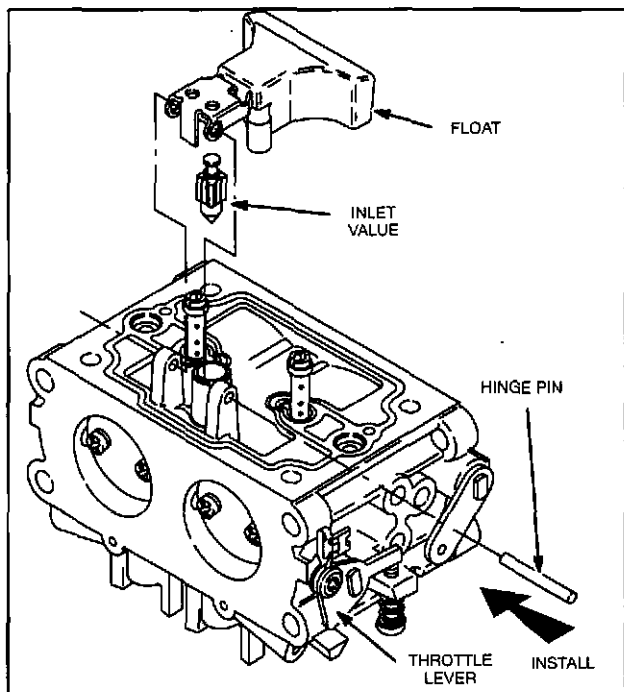


Fig. 75 - Installing Float Assembly

Install idle mixture valves with springs, Fig. 76. **DO NOT** tighten idle mixture valves.

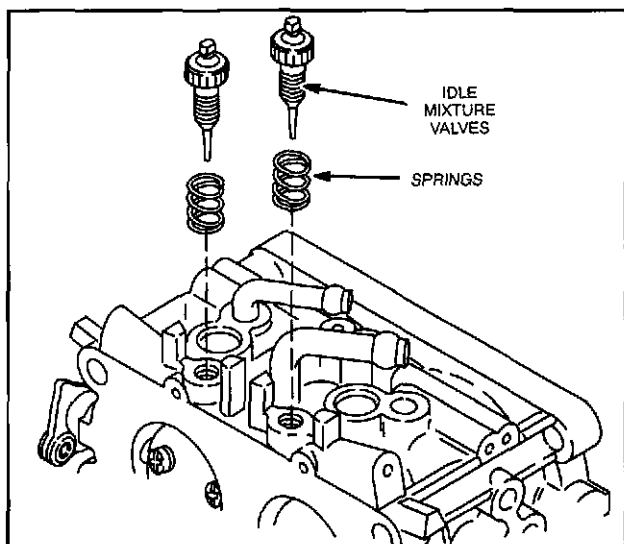


Fig. 76 - Installing Idle Mixture Valves

Install idle jets, Fig. 77. Install fuel bowl drain screw and spring.

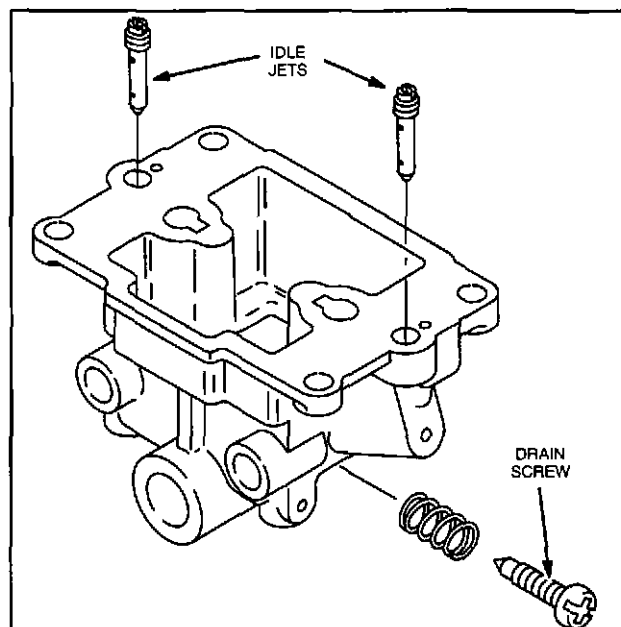


Fig. 77 - Installing Idle Jets

Install fixed main jets, Fig. 78.

### Model 351700:

Install #98 jet in left side ("L").

Install #100 jet in right side ("R").

### Model 351400:

Install #94 jet in left side ("L").

Install #98 jet in right side ("R").

Install main jet plugs and washers.

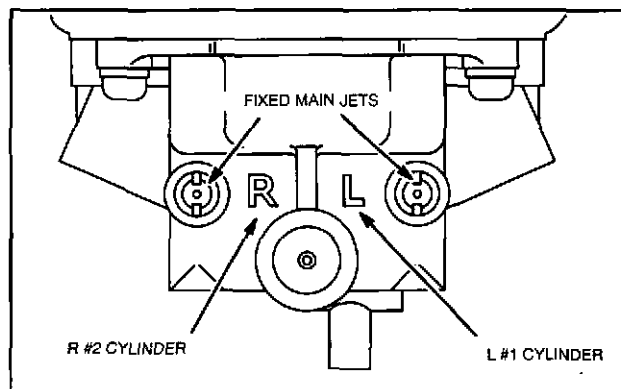


Fig. 78 - Installing Fixed Main Jets

# CARBURETION

## Assemble Models 351700 and 351400

Install gasket in groove in carburetor upper body, Fig. 79. Make sure gasket does not twist or kink.

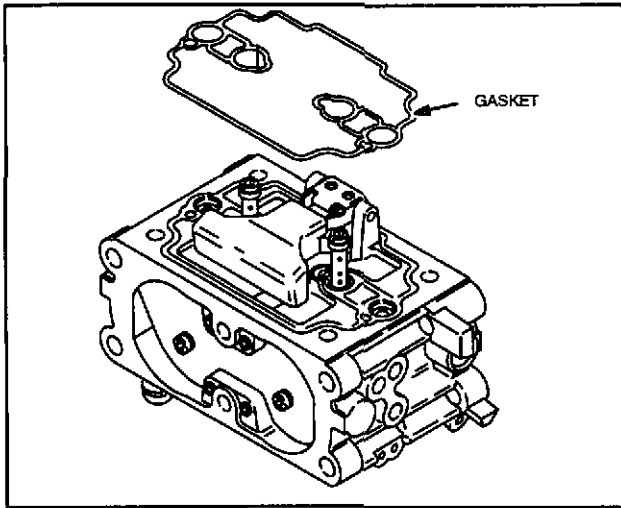


Fig. 79 - Installing Gasket

Assemble lower body with main jet plugs facing throttle shaft side of carburetor. Make sure gasket remains in position, Fig. 80. Tighten screws securely.

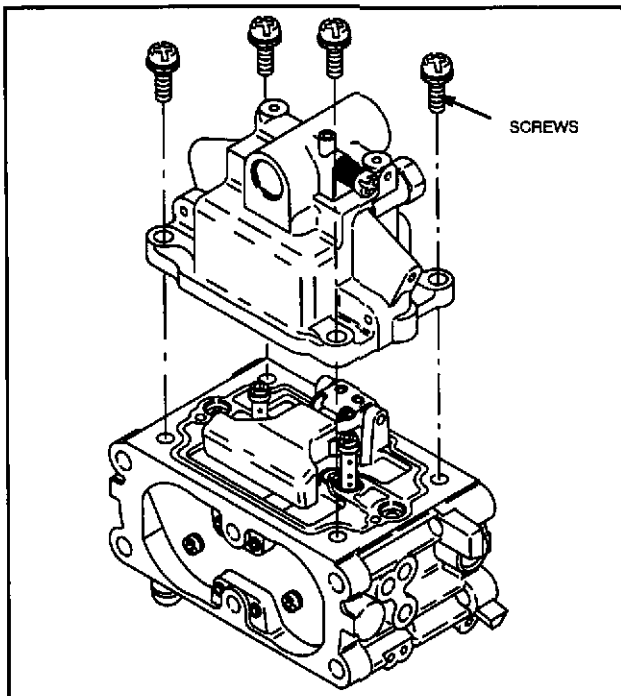


Fig. 80 - Installing Lower Body

Install anti-afterfire solenoid with washer. Torque to 10 Nm (90 in. lbs.).

This completes the carburetor assembly procedure.

See carburetor installation procedure for engine model 351700 on page 25.

See carburetor installation procedure for engine model 351400 on page 43.

### Install Carburetor - Vertical Crankshaft Models 290700-350700

**Current style:** Assemble gaskets and spacer to manifold as shown in Fig. 81A. Make sure that locating pin on carburetor spacer fits in recess in manifold. Assemble carburetor onto mounting studs.

**Early style:** Insert carburetor mounting screws through carburetor, gasket, spacer and gasket, and assemble to manifold. Fig. 81B. Make sure that locating pin on carburetor spacer fits in recess in manifold. Install carburetor on intake manifold and torque screws to 7 Nm (65 in. lb.).

**NOTE:** If carburetor is equipped with anti-afterfire solenoid, route wire under intake manifold and through hole in #1 cylinder shield at this time.

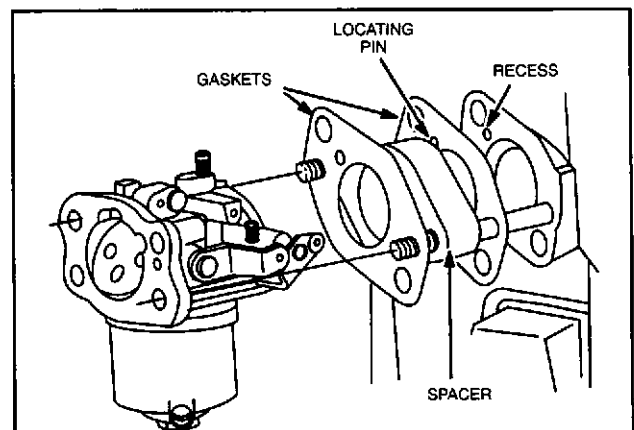


Fig. 81A - Installing Carburetor (Current Style)

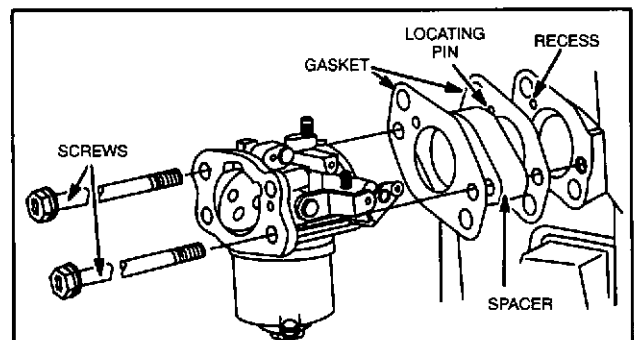


Fig. 81B - Installing Carburetor (Early Style)

# CARBURETION

## Install Carburetor Vertical Crankshaft Models

**All models:** Connect governor link to throttle lever and snap retainer over link, Fig. 82. Then, install governor link spring in loop on link retainer.

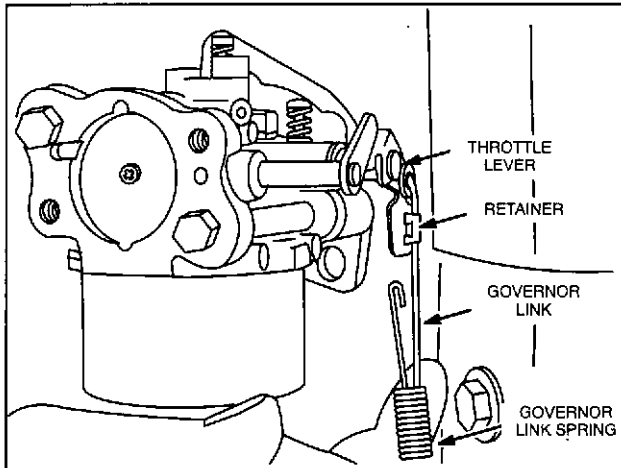


Fig. 82 - Connecting Governor Link

Install air cleaner bracket, if removed. Install choke link on choke lever on carburetor. Connect link to choke control lever and install choke control bracket, Fig. 83. Torque screws to 7 Nm (65 in. lbs.). Install fuel line and fuel line clamp.

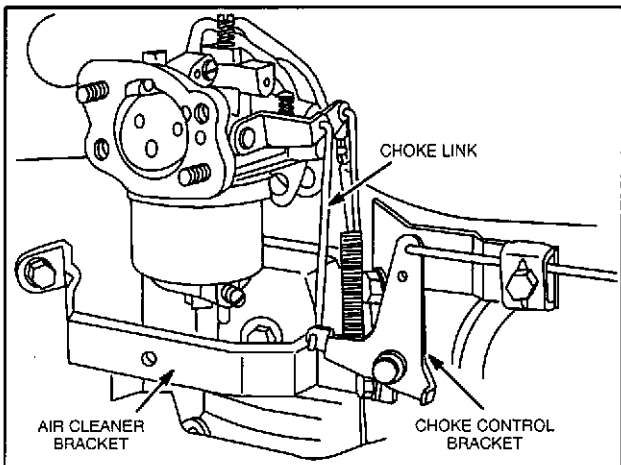


Fig. 83 - Installing Choke Control

Install blower housing at this time, if removed. Re-install fuel line and clamp.

Install air cleaner base as described below.



**STATIC GOVERNOR ADJUSTMENT MUST BE MADE WHENEVER CARBURETOR AND, OR MANIFOLD HAS BEEN REMOVED FROM ENGINE. FAILURE TO MAKE STATIC ADJUSTMENTS FIRST COULD RESULT IN ENGINE OVERSPEEDING WHICH MAY RESULT IN ENGINE OR EQUIPMENT DAMAGE CAUSING PERSONAL INJURY AND/OR PROPERTY DAMAGE. SEE SECTION 5.**

### Install Air Cleaner Base - Vertical Crankshaft Models 290700-350700

**Current style:** Place air cleaner base gasket onto carburetor mounting studs. Guide breather tube onto nipple on breather and install air cleaner base on carburetor mounting studs. Install carburetor mounting nuts, Fig. 84. Do not tighten nuts at this time. Now, install breather deflector and three screws. Torque nuts and screws to 7 Nm (65 in. lbs.). Make sure air inlet tube is installed correctly in air cleaner base.

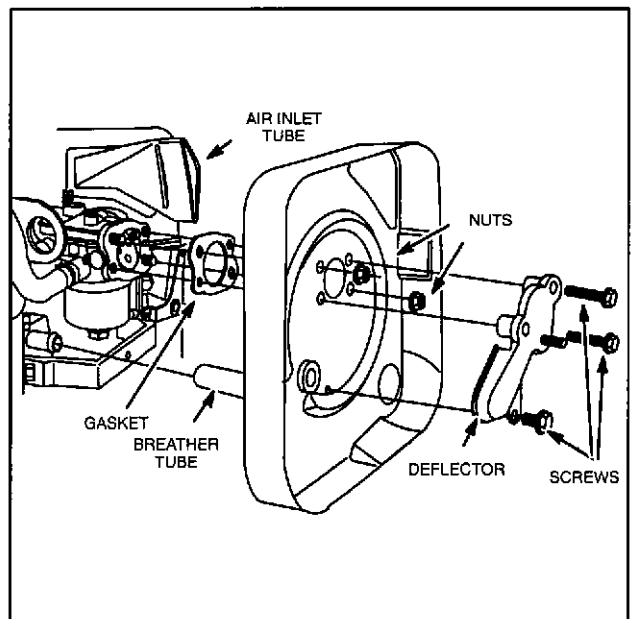


Fig. 84 - Installing Base (Current Style)

## Install Carburetor Vertical Crankshaft Models

**Early style:** Insert air cleaner base to carburetor mounting screws through breather deflector and base and place base to carburetor gasket on screws, Fig. 85. Guide breather tube onto nipple on breather and install mounting screws in carburetor. Do not tighten screws at this time. Now, install two air cleaner bracket screws. Torque all four screws to 7 Nm (65 in. lbs.). Make sure air inlet tube is installed correctly in air cleaner base.

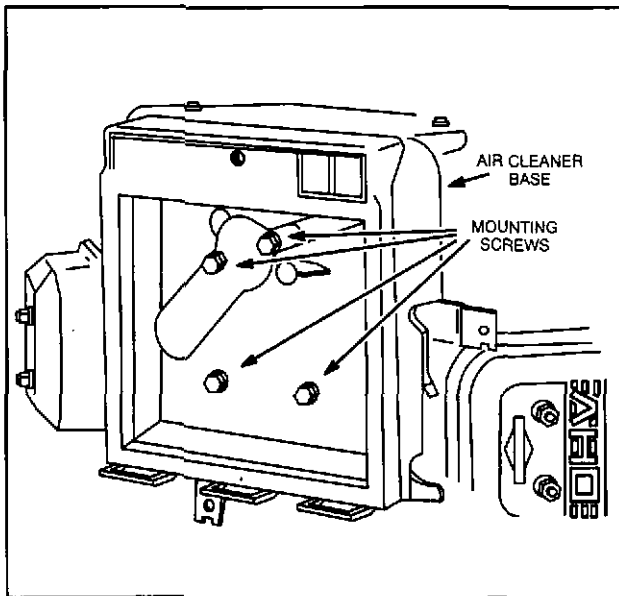


Fig. 85 - Installing Base (Early Style)

**NOTE:** All models: Be sure breather tube is not kinked. Be sure breather tube is installed onto nipple as far as it will go.

Install air cleaner cartridge, pre-cleaner and cover as described in "Service Air Cleaner."

See pages 44-47 for carburetor adjustment procedure.

### Install Carburetor Vertical Crankshaft Model 351700

Assemble gaskets and spacer to intake manifold as shown in Fig. 86. Assemble carburetor onto mounting studs and route solenoid wire through wire tie on manifold and through hole in #1 cylinder shield, Fig. 86.

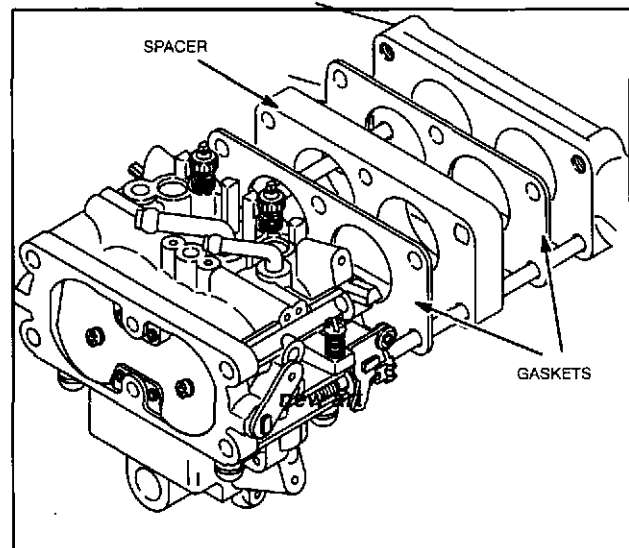


Fig. 86 - Installing Carburetor

Connect governor link to throttle lever and snap retainer over link, Fig. 87. Then install governor link spring in loop on retainer.

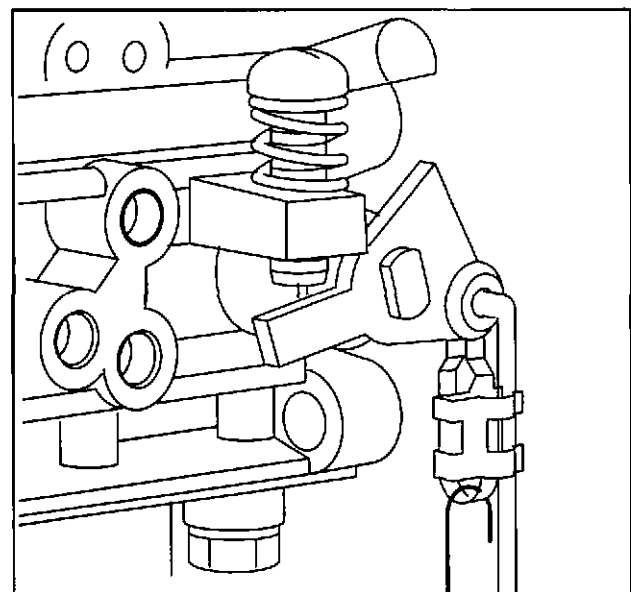


Fig. 87 - Connecting Governor Link

# CARBURETION

## Install Carburetor Vertical Crankshaft Models

Connect choke link to choke lever and install choke control bracket, Fig. 88. Torque screws to 7 Nm (65 in. lbs.).

3

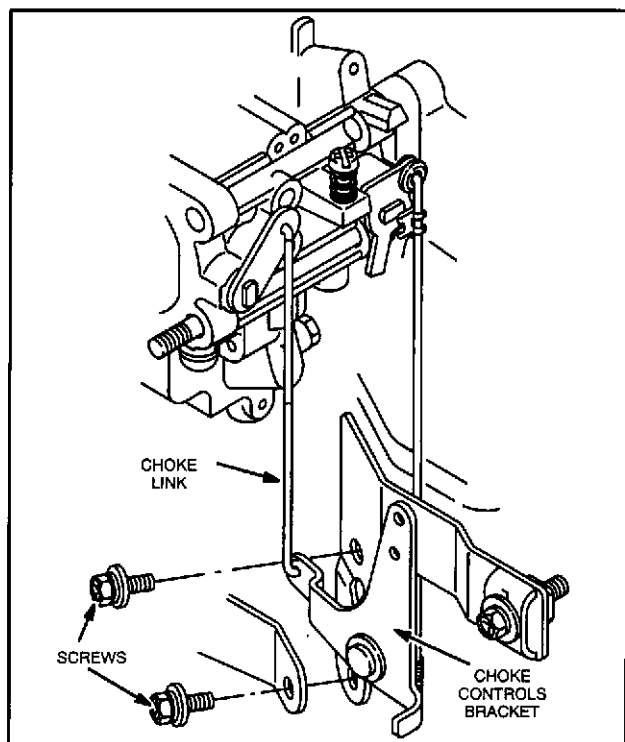


Fig. 88 - Installing Choke Control

Install blower housing and rotating screen. Install fuel pump and bracket and connect fuel line to carburetor. Rotate fuel line clamp so that it will not interfere with carburetor cover. DO NOT install carburetor cover at this time.

Install air cleaner base as described below.



**STATIC GOVERNOR ADJUSTMENT MUST BE MADE WHENEVER CARBURETOR AND, OR MANIFOLD HAS BEEN REMOVED FROM ENGINE. FAILURE TO MAKE STATIC ADJUSTMENTS FIRST COULD RESULT IN ENGINE OVERSPEEDING WHICH MAY RESULT IN ENGINE OR EQUIPMENT DAMAGE CAUSING PERSONAL INJURY AND/OR PROPERTY DAMAGE. SEE SECTION 5.**

### Install Air Cleaner Base - Vertical Crankshaft Model 351700

Install new air cleaner mounting gasket with adhesive side toward air cleaner base. Guide breather tube onto nipple on breather and install air cleaner base on carburetor mounting studs. Install carburetor shield. Install nuts and screws finger tight, Fig. 89. Then, torque to 7 Nm (65 in. lbs.). Make sure air inlet tube is installed correctly in air cleaner base.

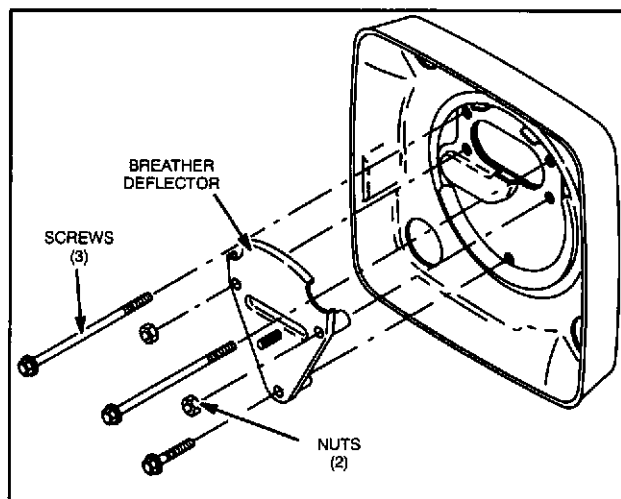


Fig. 89 - Installing Air Cleaner Base

**NOTE:** Be sure breather tube is not kinked. Be sure breather tube is installed onto nipple as far as it will go.

Install air cleaner cartridge, pre-cleaner and cover as described in "Service Air Cleaner."

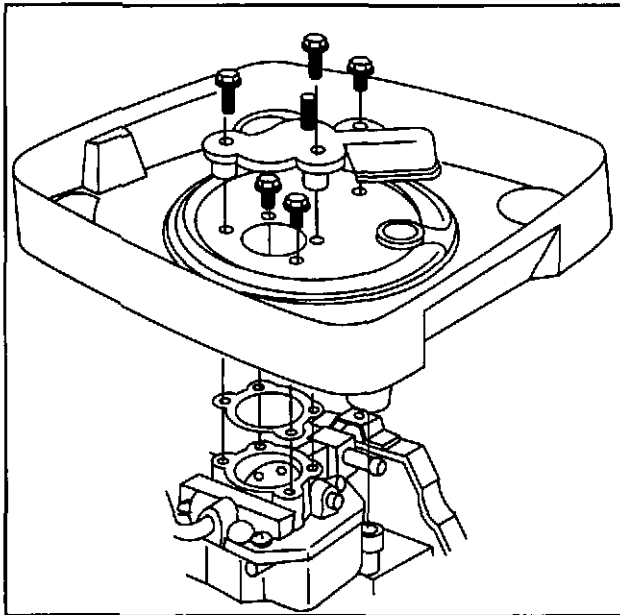
**See pages 46-48 for carburetor adjustment procedure.**

### Remove Carburetor And Intake Manifold - Horizontal Crankshaft Models 290400 - 350400

**Current style:** Remove air cleaner cover and cartridge with pre-cleaner. Remove five screws holding air cleaner base, Fig. 90.

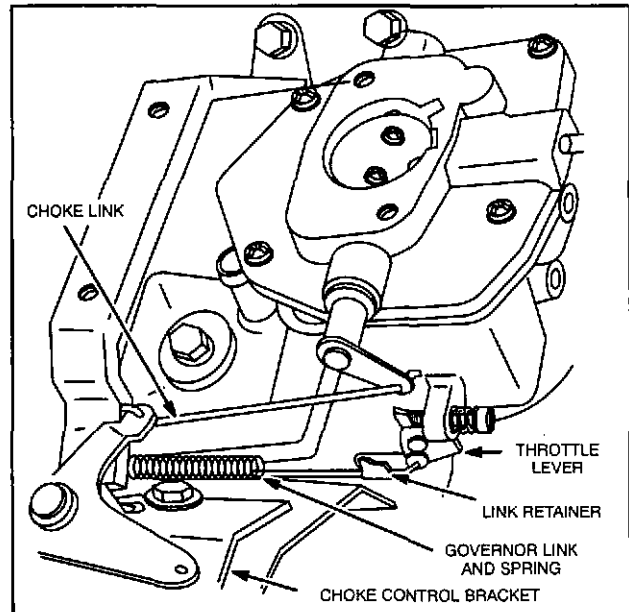
**Early style:** Remove air cleaner cover. Remove four screws holding air cleaner base, Fig. 91.

## Remove Carburetor – Horizontal Crankshaft Models

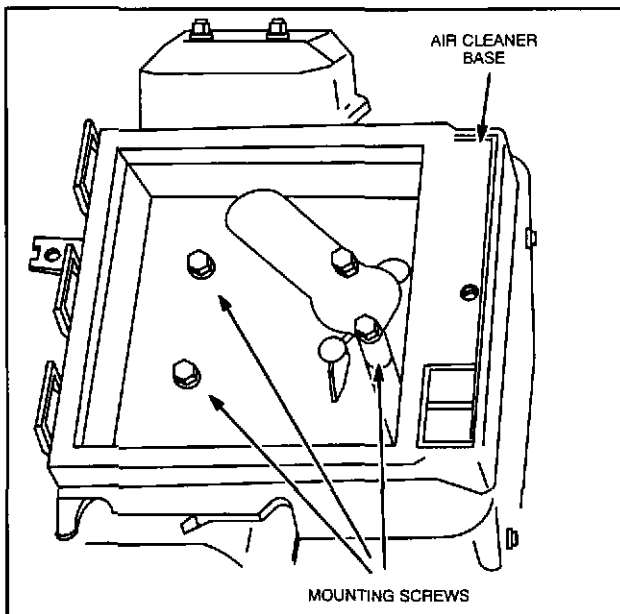


**Fig. 90 Removing Air Cleaner Base – (Current Style)**

Unhook governor link spring from throttle lever, Fig. 92. Then disconnect governor link.

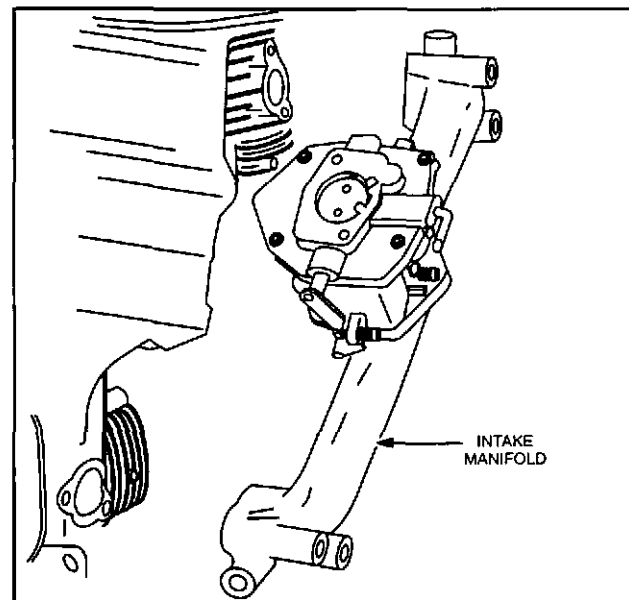


**Fig. 92 – Removing Linkage**



**Fig. 91 – Removing Air Cleaner Base – (Early Style)**

Remove four screws holding manifold to cylinders and remove carburetor and manifold assembly from engine, Fig. 93.



**Fig. 93 – Removing Carburetor and Manifold**

If engine is equipped with anti-afterfire solenoid, disconnect solenoid wire from equipment switch wire.

Remove blower housing from engine. Remove two screws from choke control bracket. Disconnect choke link from carburetor, Fig. 92. Remove fuel line clamp and fuel line from carburetor.

# CARBURETION

## Remove Carburetor Horizontal Crankshaft Models

Remove two screws holding carburetor to manifold and remove carburetor, spacer block and gaskets, Fig. 94.

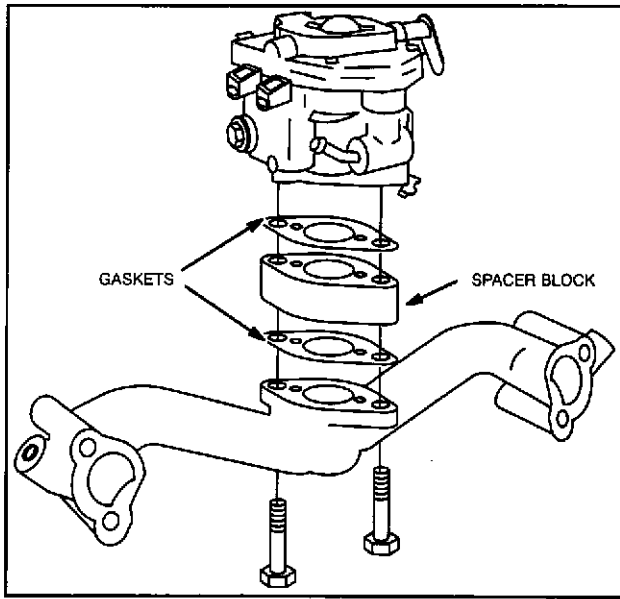


Fig. 94 - Removing Carburetor

See pages 29 - 34 for carburetor disassembly and assembly procedure for Engine Models 290400 - 303400.

### Remove Carburetor - Horizontal Crankshaft Model 351400

The blower housing must be removed so that anti-afterfire solenoid wire can be properly routed during reassembly.

Remove air cleaner cover, cartridge and pre-cleaner. Remove five screws and breather deflector, Fig. 95. Disconnect breather tube at air cleaner base and remove air cleaner base.

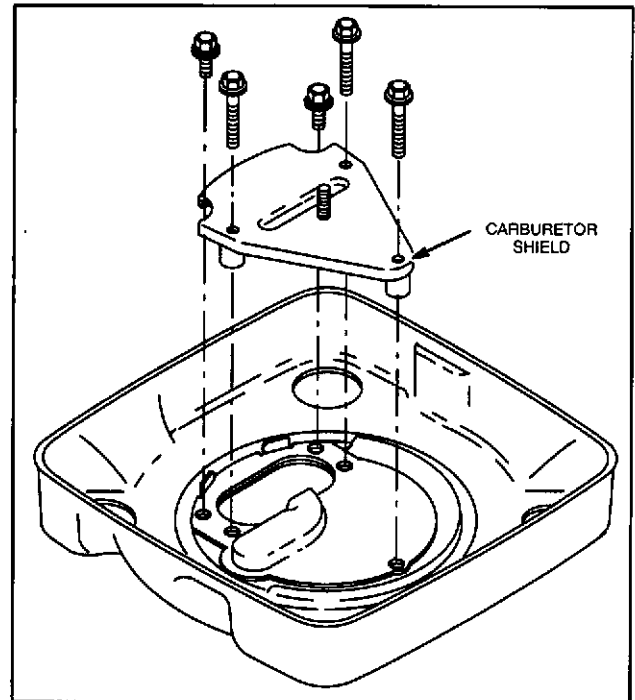


Fig. 95 - Remove Air Cleaner Base Model 351400

Disconnect fuel line at carburetor. Remove anti-afterfire solenoid ground wire. Remove choke control bracket and disconnect link, Fig. 96.

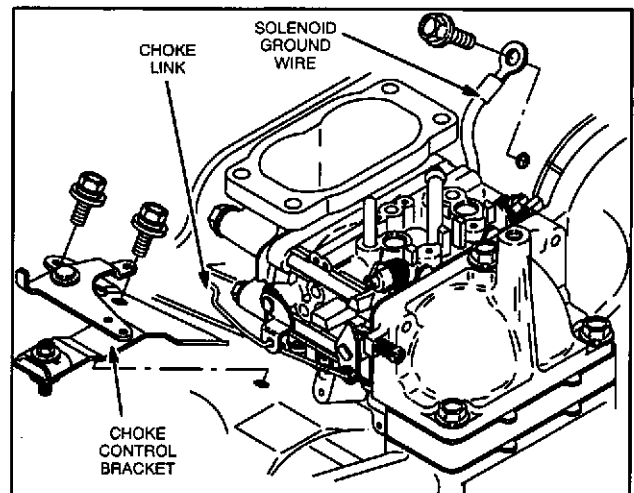


Fig. 96 - Removing Choke Control

# CARBURETION

## Remove Carburetor Horizontal Crankshaft Models

Unhook governor link spring from throttle lever and disconnect governor link, Fig. 97.

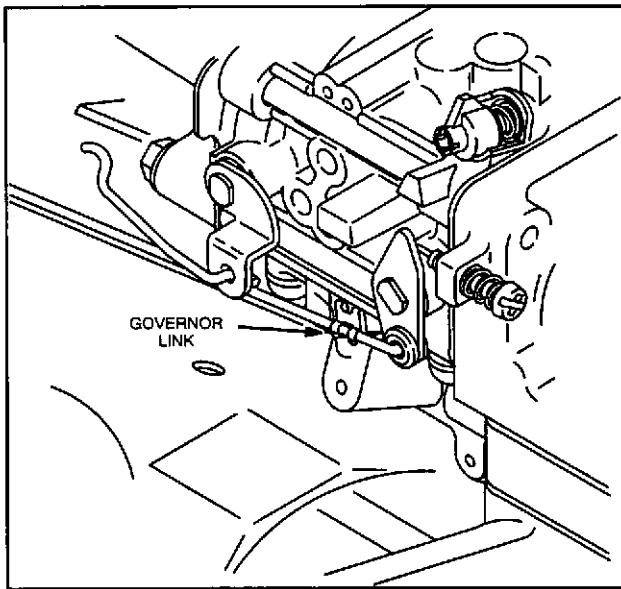


Fig. 97 - Removing Governor Link

Remove air cleaner elbow support screw. Remove 3 intake elbow screws and carburetor assembly, Fig. 98. Note routing of solenoid wires. Remove carburetor spacer and gaskets.

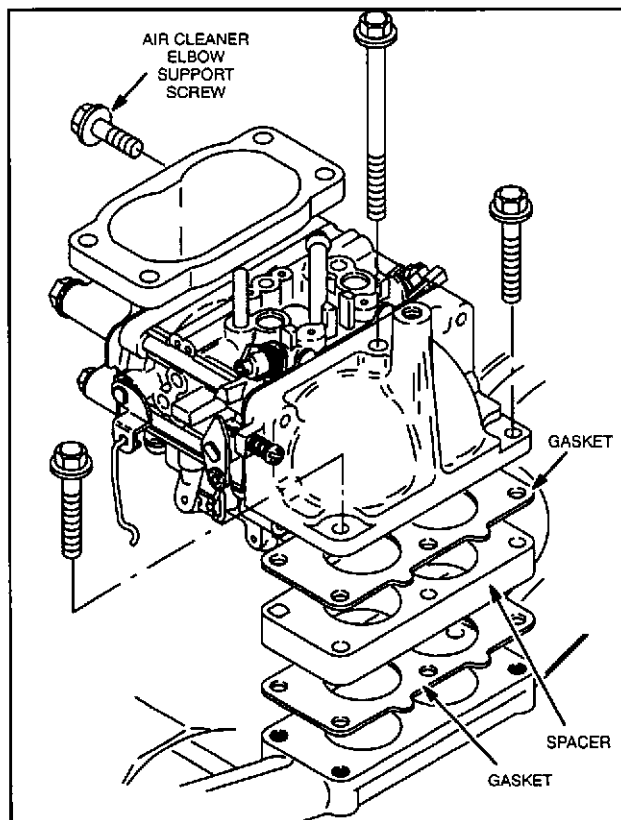


Fig. 98 - Removing Carburetor Assembly

Remove two nuts and two screws and separate air cleaner elbow and intake elbow from carburetor, Fig. 99.

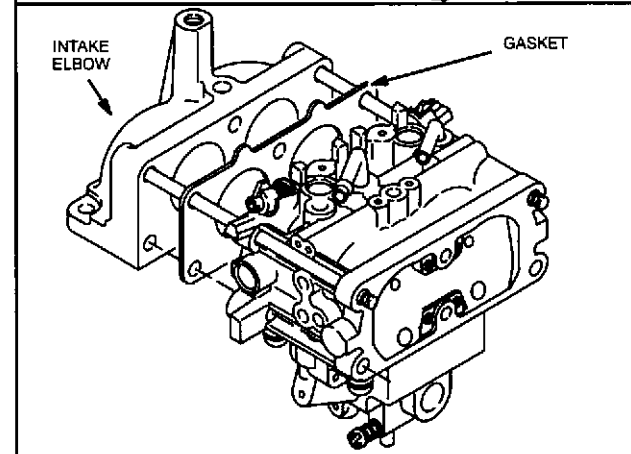
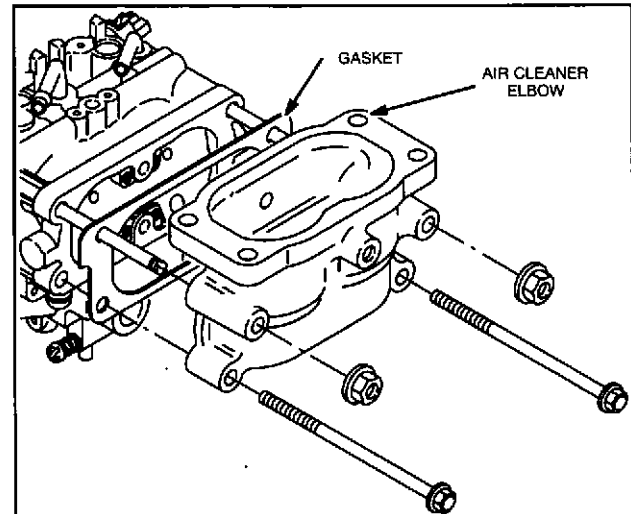


Fig. 99 - Removing Air Cleaner and Intake Elbow

See pages 18-21 for carburetor disassembly and assembly procedure for Engine Model 351400.

### Disassemble Carburetor - Engine Models 290400, 294400 And 303400

Remove four screws holding upper body to lower carburetor body. Separate upper body from lower body, Fig. 100. Do not damage emulsion tube in upper body.

33

# CARBURETION

## Disassemble Carburetor Models 290400-303400

3

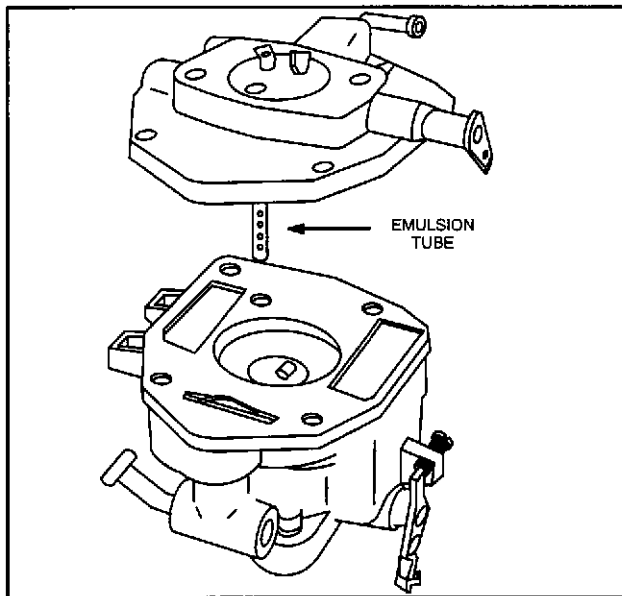


Fig. 100 - Removing Upper Body

Remove gasket. Lift float hinge with inlet valve and float assembly from lower body, Fig. 101.

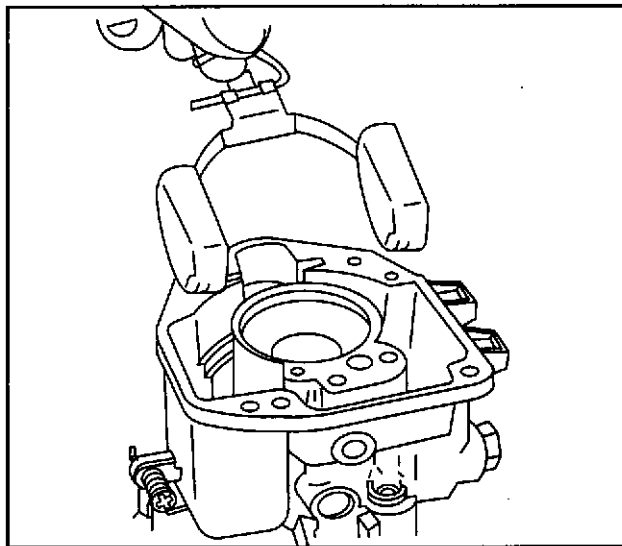


Fig. 101 - Removing Float

If idle mixture valve is equipped with adjustment limiter cap, use a pliers to remove it before removing idle mixture valve, Fig. 102.

Remove idle mixture valve and spring. Remove anti-afterfire solenoid, if equipped, or plug and washer. Then remove fixed main jet using screwdriver, Tool #19062, Fig. 102.

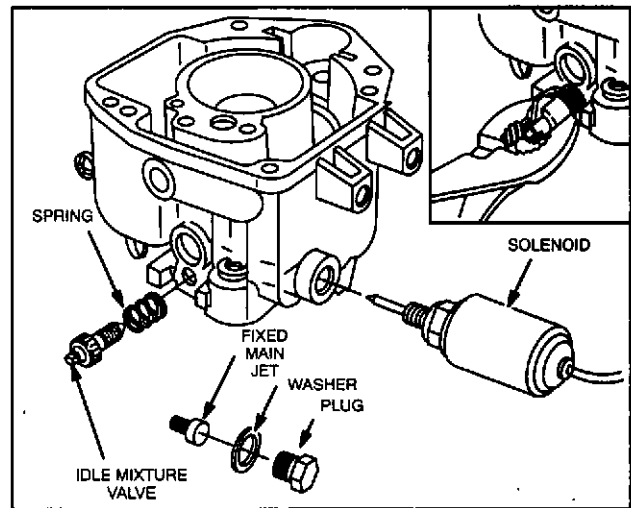


Fig. 102 - Removing Valve and Jet

Remove idle jet, Fig. 103.

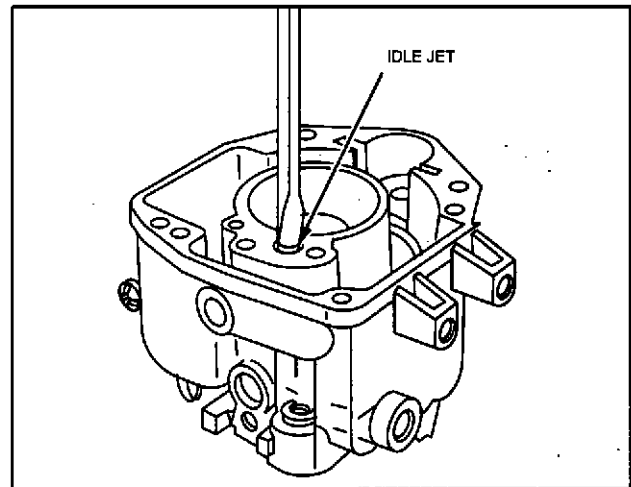


Fig. 103 - Removing Idle Jet

Remove throttle valve screw and throttle valve, Fig. 104. Then remove throttle shaft and spacer. Remove throttle shaft seal.

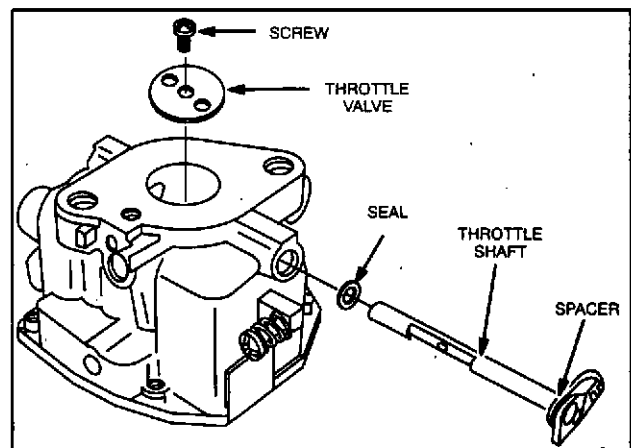


Fig. 104 - Removing Throttle Valve and Shaft

# CARBURETION

## Disassemble Carburetor Models 290400-303400

Support upper body on a vise or wood block so that emulsion tube will not be damaged. Remove choke valve screws, valve, choke shaft and spacer bushing, Fig. 105. Remove choke shaft seal.

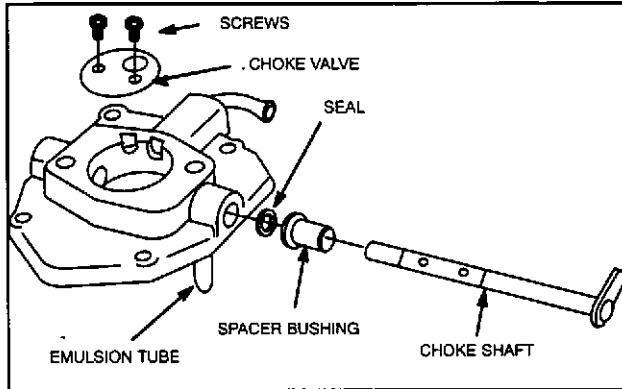


Fig. 105 - Removing Choke Shaft

Remove idle port welch plug with a punch as shown in Fig. 106.

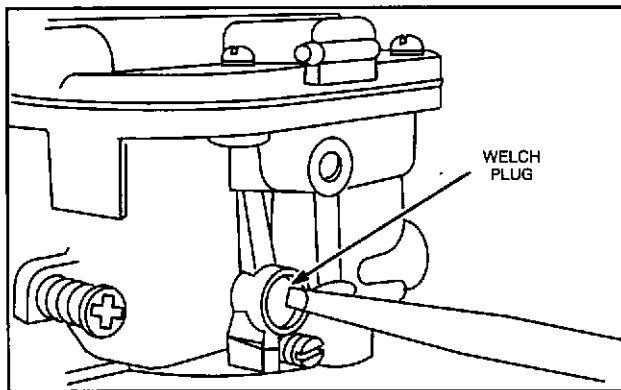


Fig. 106 - Removing Welch Plug

This completes the carburetor disassembly procedure.

### Clean Fuel System

Gummy or dirty fuel tanks and carburetors should be cleaned in a carburetor cleaner such as Bendix Carburetor Cleaner or equivalent. DO NOT soak rubber, neoprene or plastic parts in cleaner.

### Inspect Carburetor

Check all moving parts for wear, nicks and burrs. Replace, if worn or damaged. Check float for leaks or damage. Replace, if damaged or leaking. Check all mating surfaces for nicks, burrs, foreign material, or cracks. Replace all damaged parts.

### Check Throttle And Choke Shaft And Bushings For Wear

Wear between throttle shaft and bushing should not exceed .25 mm (.010"). Check wear by placing carburetor on a flat surface, as shown in Fig. 107. Measure the distance between the throttle lever and flat surface with a feeler gauge while moving shaft up and down, Fig. 107.

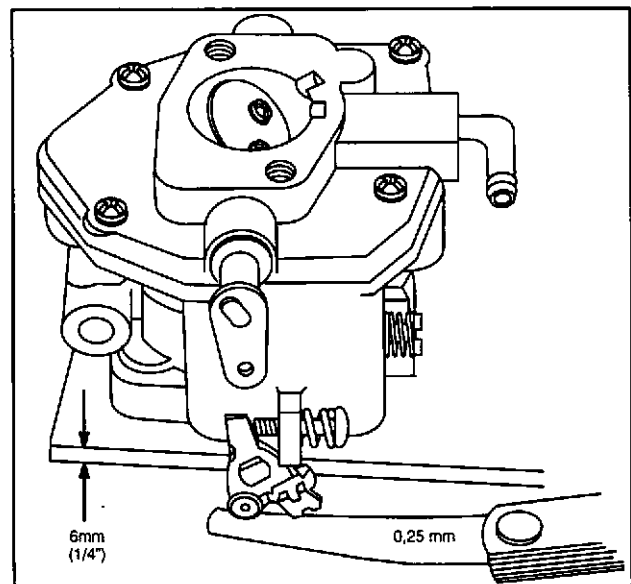


Fig. 107 - Checking Throttle Wear

# CARBURETION

## Assemble Carburetor Models 290400-303400

If the difference is greater than .25 mm (.010"), this indicates that the throttle shaft and/or bushings are worn. Wear on the throttle shaft can be checked by comparing the worn and unworn portions of the shaft, Fig. 108.

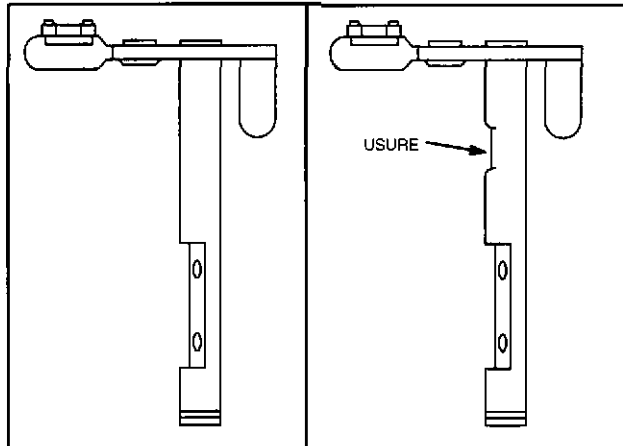


Fig. 108 - Checking Throttle Shaft Wear

Choke shaft and bushings are checked in the same manner.

Throttle and choke shaft are replaceable. If throttle and/or choke shaft bushings are worn, replace carburetor.

### Assemble Carburetor - Engine Models 290400, 294400 And 303400

When assembling carburetor, use new seals and gaskets.

Install new idle port welch plug. Use a round punch and tap in plug until it is flat, Fig. 109. Use a sealant such as Permatex® #2 or nail polish on outside diameter of plug to prevent air leaks.

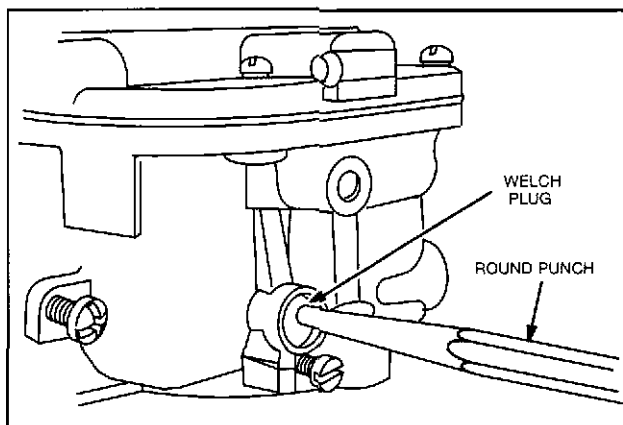


Fig. 109 - Installing Welch Plug

Install new choke shaft seal with sealing lip in. Slide choke shaft and bushing into upper body. Lay choke valve on flat of shaft with air hole positioned toward bowl vent nipple. Install screws and tighten securely, Fig. 110. Check for freedom of movement.

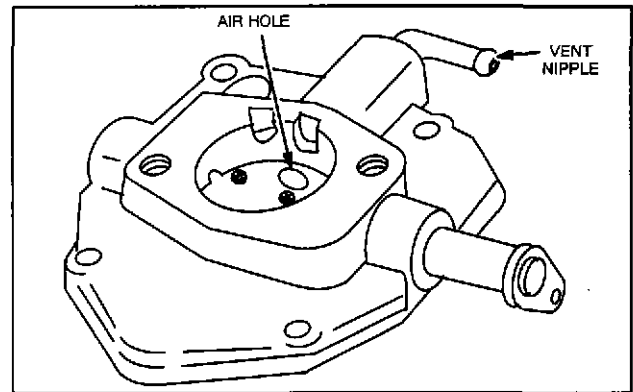


Fig. 110 - Installing Choke Valve

Install throttle shaft seal with sealing lip in. Insert throttle shaft with spacer into lower carburetor body. Position throttle valve on flat of shaft so that two outer holes are covered by shaft and the chamfered edges of the valve are against sides of carburetor throat when valve is closed, Fig. 111. Install and tighten screw securely.

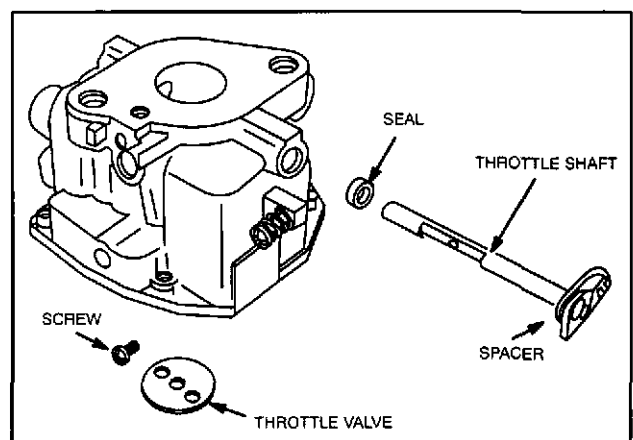
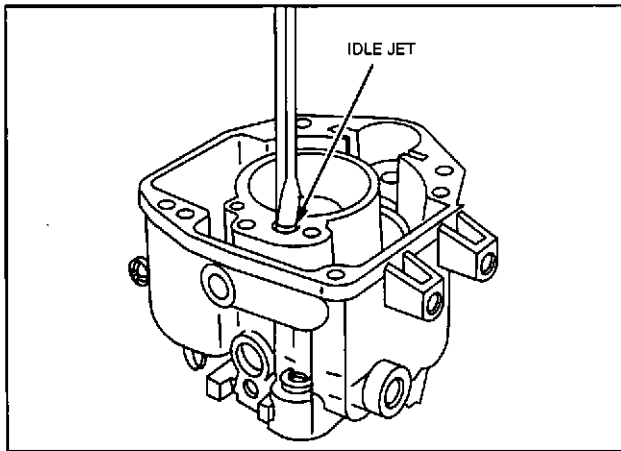


Fig. 111 - Installing Throttle Valve

# CARBURETION

## Assemble Carburetor Models 290400-303400

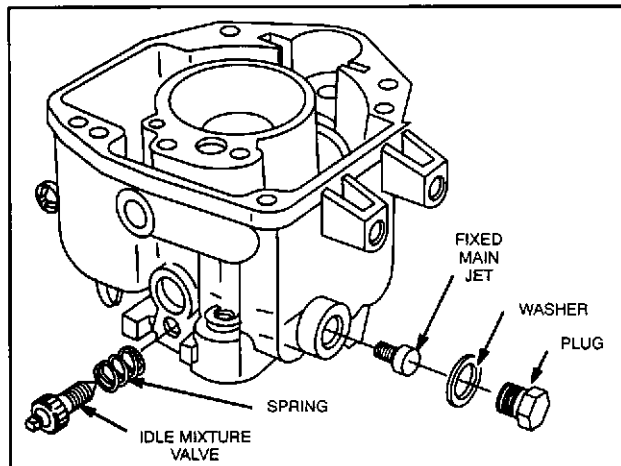
Install idle jet and tighten securely, Fig. 112.



**Fig. 112 - Installing Idle Jet**

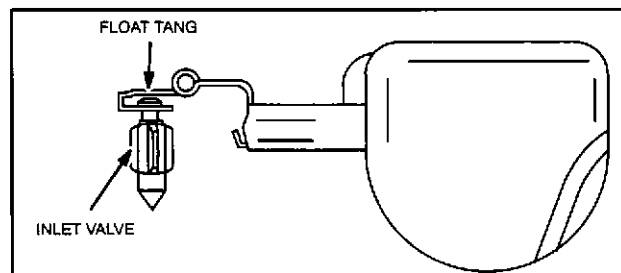
Install fixed main jet using screwdriver, Tool #19062. Install washer and plug or anti-afterfire solenoid, if equipped. Torque solenoid to 5 Nm (45 in. lbs.). Install idle mixture valve and spring. **DO NOT** tighten idle mixture valve against its seat, Fig. 113.

Note: Special high altitude jets are available. Consult the Illustrated Parts List for the correct part number.

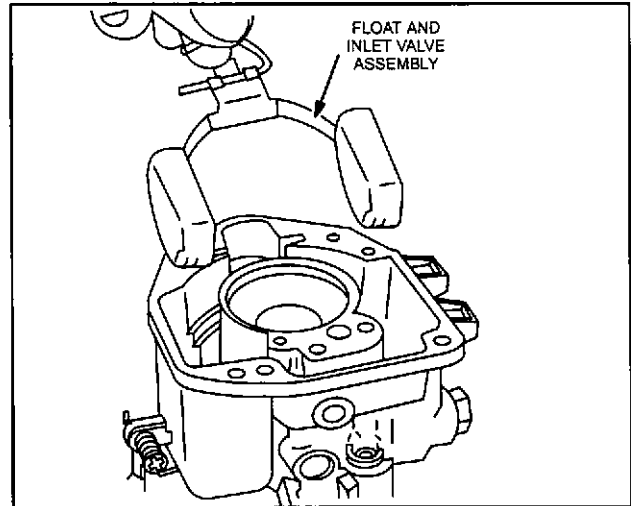


**Fig. 113 - Installing Valve and Jet**

Slide inlet valve into slot of float tang, Fig. 114, and install valve and float assembly into lower carburetor body, Fig. 115.



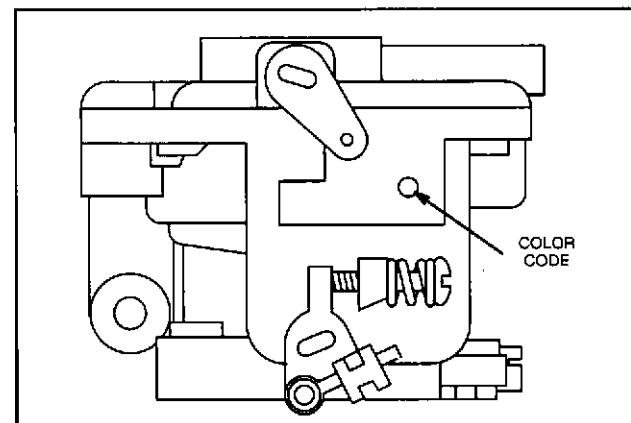
**Fig. 114 - Inlet Valve and Float**



**Fig. 115 - Installing Float**

The fuel inlet seat orifice size and inlet valve are different, depending upon the type of fuel delivery system used. The inlet seat is not replaceable. Therefore, different carburetor bodies are required.

A color code system is used to identify the carburetor by engine model and fuel delivery system. The color code is located on the side of the carburetor as shown in Fig. 116. Then see chart below.



**Fig. 116 - Carburetor Identification**

Engine Model	Fuel System	Color Code
290400	Gravity	Yellow
290400	Pump	White
294400	Gravity	Blue
294400	Pump	None
303400	Gravity	Blue
303400	Pump	None

# CARBURETION

## Assemble Carburetor Models 290400-303400

The float height setting on engine models 290400, 294400 and 303400 depends upon the type of fuel delivery system used. A fuel pump system requires a different float height setting than a gravity feed system.

3

The procedure for checking the float height setting is unique. Hold the carburetor in one hand and place the index finger on the float hinge pin. While holding the float hinge pin down, turn the carburetor to a position **past** vertical as shown in Fig. 117. This allows the weight of the float to close the inlet valve in a natural fashion. The float height measurement, "C" is taken at point "B," which is the top flat area of the float just before the radius. See chart for dimensions.

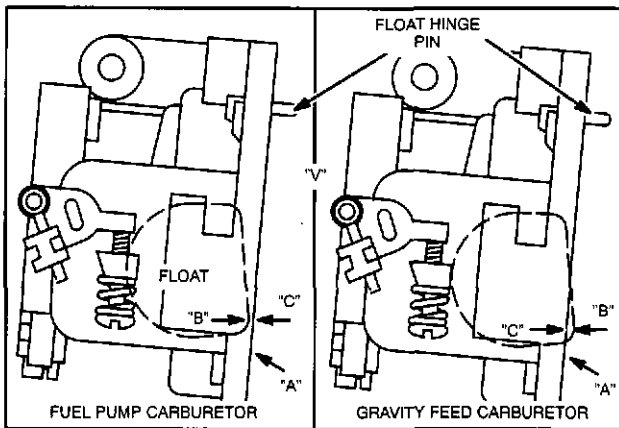


Fig. 117 - Measuring Float Height

- V - Represents Vertical Line
- A - Machined Surface Of Carburetor
- B - Top Of Float (Before Radius)
- C - Dimension From A to B (Float Height)

### C - Float Height

Fuel Pump	Gravity Feed
1.6 mm (1/16") (Below "A")	2.4 mm (3/32") (Above "A")

To adjust float level, hold float arm at "A" with needle nose pliers and carefully bend tang in direction shown, Fig. 118. **Do not** collapse hooked end of float tang.

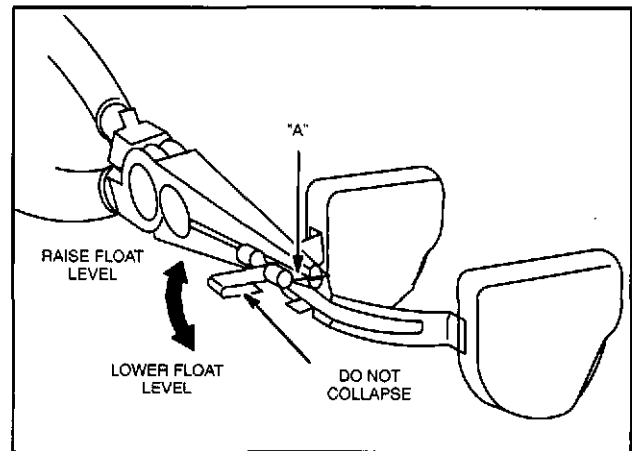


Fig. 118 - Adjusting Float Level

Place new gasket on lower carburetor body. Make sure holes in body line up with holes in gasket. Install upper carburetor body on lower body. Tighten screws securely, Fig. 119.

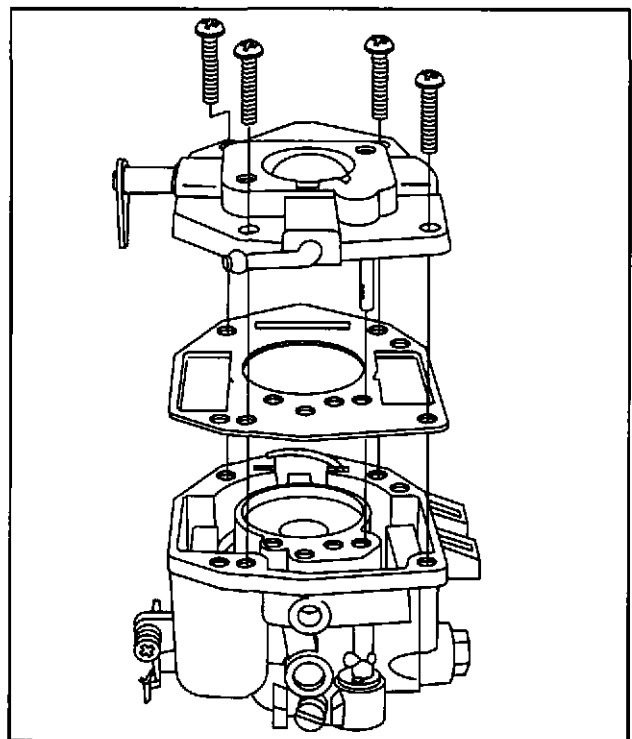


Fig. 119 - Installing Upper Body

See carburetor and manifold installation procedure on pages 40 and 41.

# CARBURETION

## Disassemble Carburetor Model 350400

### Carburetor Identification - Engine Model 350400

Two different carburetor bodies are used, depending upon the type of fuel delivery system; gravity or fuel pump. In addition to a change in jetting, the end of the discharge nozzle is machined at a different angle. The discharge nozzle is an integral part of the carburetor body. Therefore, different bodies are required.

The fixed main jet used with a fuel pump system is numbered 110. The fixed main jet used with a gravity system is numbered 117.5.

The carburetor bodies may be identified by looking down the carburetor throat and comparing the end of the discharge nozzle in relation to the choke shaft, Fig. 120. On a fuel pump carburetor the end of the nozzle is at approximately a 20 degree angle to the choke shaft. On a gravity feed carburetor the end of the nozzle is approximately parallel to the choke shaft.

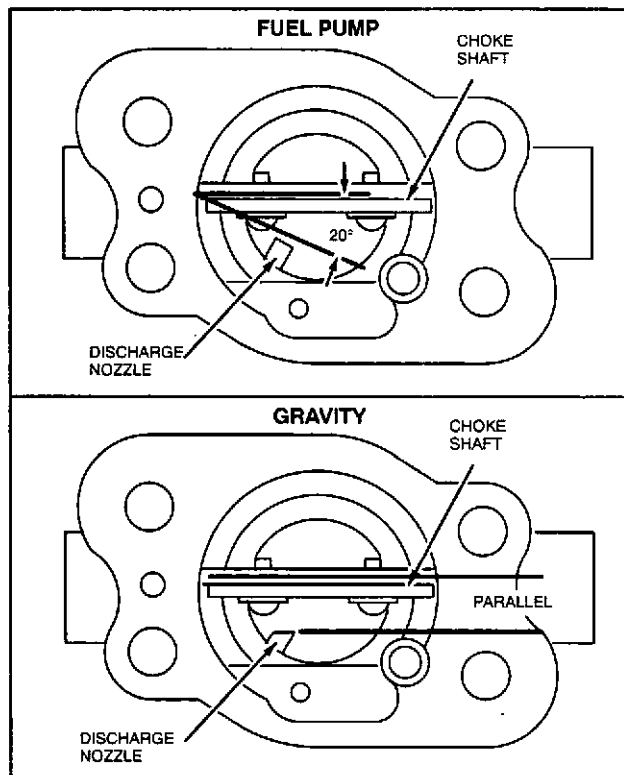


Fig. 120 -Carburetor Identification

### Disassemble Carburetor - Engine Model 350400

Remove idle jet. Remove four screws holding upper body to lower carburetor body. Separate upper body from lower body, Fig. 121.

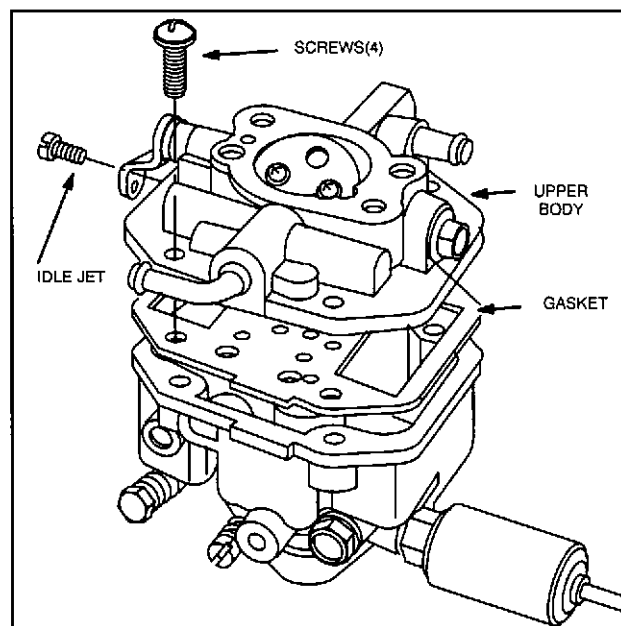


Fig. 121 - Removing Upper Body

With a small punch, drive the float hinge pin out of float hinge, Fig. 122. Remove float and fuel inlet valve assembly.

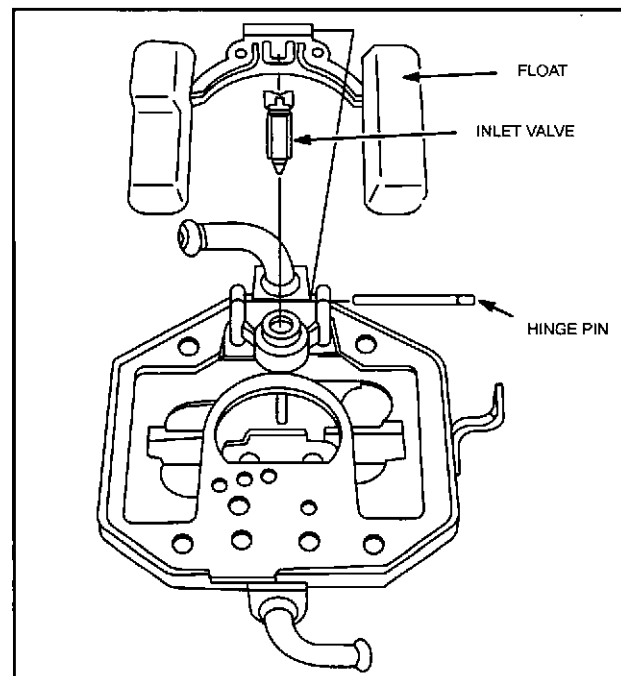
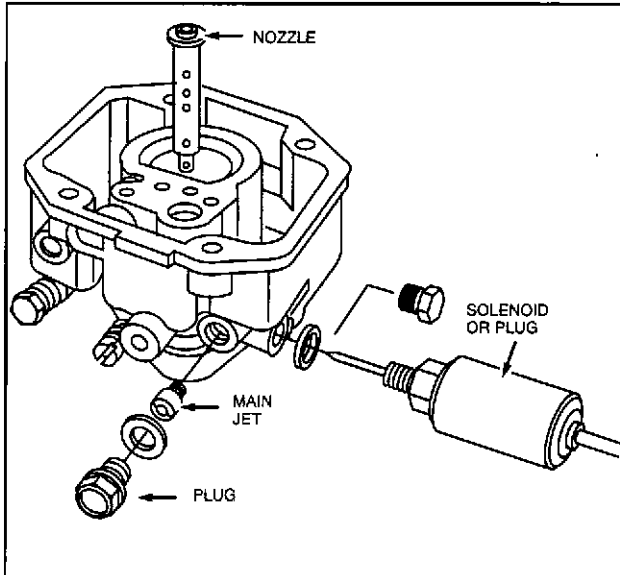


Fig. 122 - Removing Float Hinge Pin

# CARBURETION

## Disassemble Carburetor Model 350400

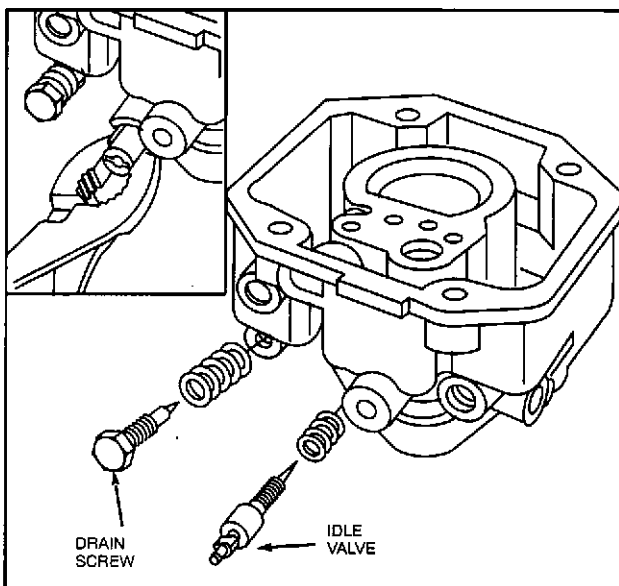
Remove anti-afterfire solenoid or plug. Remove fixed jet plug and washer, Fig. 123. Remove fixed main jet with jet screwdriver, Tool #19062. Remove fuel delivery nozzle.



**Fig. 123 - Removing Solenoid and High Speed Jet**

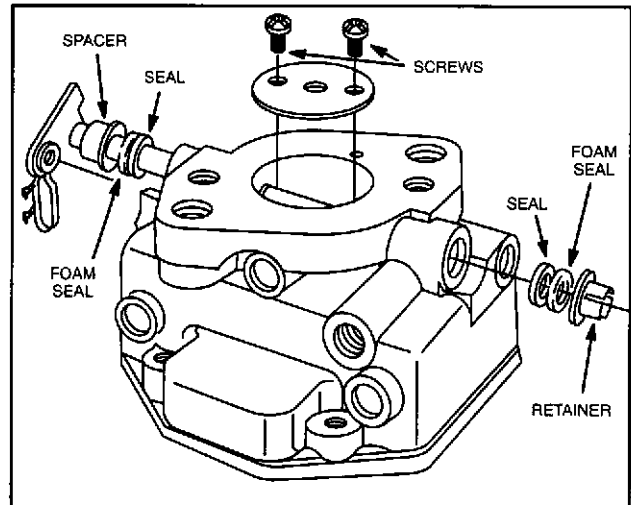
If idle mixture valve is equipped with adjustment limiter cap, use a pliers to remove it before removing idle mixture valve, Fig. 124.

Remove idle mixture valve and spring. Remove fuel bowl drain screw and spring, Fig. 124.



**Fig. 124 - Removing Idle Mixture Valve and Drain Screw**

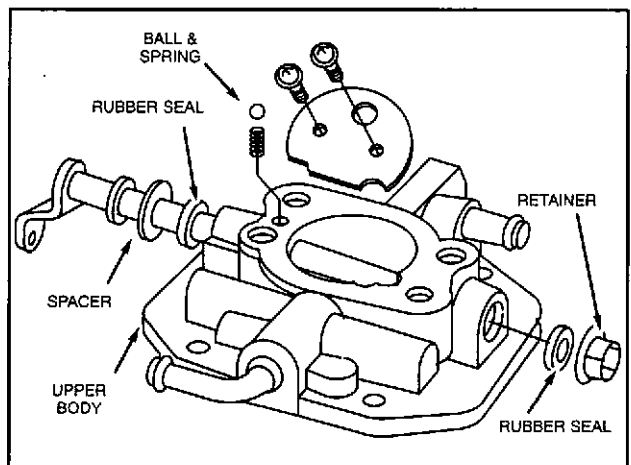
Pry throttle shaft retainer from end of shaft, Fig. 125. Remove two screws and throttle valve. Remove throttle shaft with spacer and foam seals. Then remove throttle shaft seals.



**Fig. 125 - Removing Throttle Shaft**

NOTE: The choke shaft has a ball and spring that keeps tension on the choke shaft. Use care when removing choke shaft.

Place an identification mark on choke valve so that choke valve can be reassembled in same position. Pry choke shaft retainer from end of shaft, Fig. 126. Remove two screws and choke valve. Remove choke shaft, and spacer. Then, remove rubber seals.



**Fig. 126 - Removing Choke Shaft**

### Remove Fuel Inlet Body And Seat

Use self-threading screw #93029 from flywheel puller, Tool #19165. Thread screw into seat body 3-4 turns. Then, remove the screw, Fig. 127.

# CARBURETION

## Disassemble Carburetor Model 350400

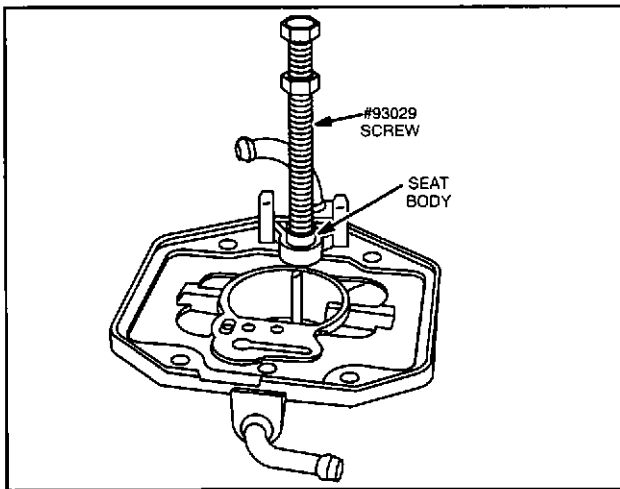


Fig. 127 - Thread Valve Seat Body

Install 1/4"x 20 nut #92278 and washer #224061 from 19332 Tool Kit onto screw. Place a 1/4" drive 3/8" socket over seat body. Install screw, washer and nut. Thread nut down on washer. Continue turning until seat body is removed, Fig. 128. Then remove inlet seat.

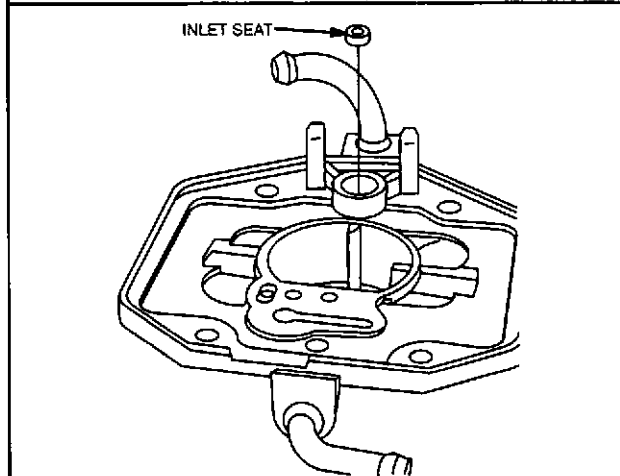
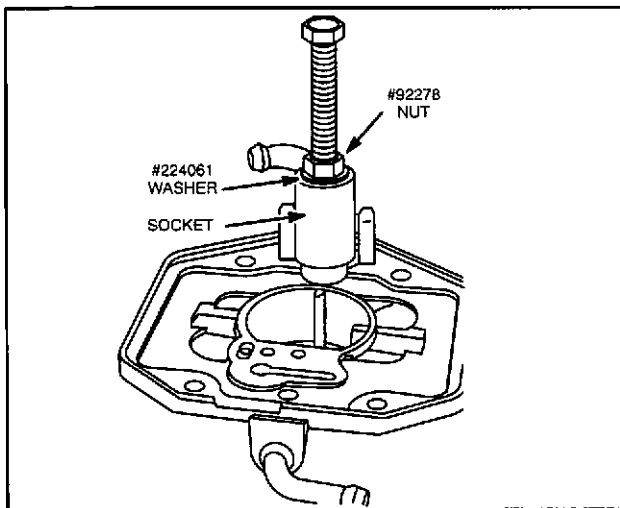


Fig. 128 - Remove Seat Body

This completes the carburetor disassembly procedure.

### Clean Fuel System

Gummy or dirty fuel tanks and carburetors should be cleaned in a carburetor cleaner such as Bendix Carburetor Cleaner or equivalent. DO NOT soak rubber, neoprene or plastic parts in cleaner.

### Inspect Carburetor

Check all moving parts for wear, nicks and burrs. Replace, if worn or damaged. Check float for leaks or damage. Replace, if damaged or leaking. Check all mating surfaces for nicks, burrs, foreign material, or cracks. Replace all damaged parts.

### Check Throttle And Choke Shaft And Bushings For Wear

Wear between throttle shaft and bushing should not exceed .25 mm (.010"). Check wear by placing carburetor on a flat surface, as shown in Fig. 129. Measure the distance between the throttle lever and flat surface with a feeler gauge while moving shaft up and down, Fig. 129.

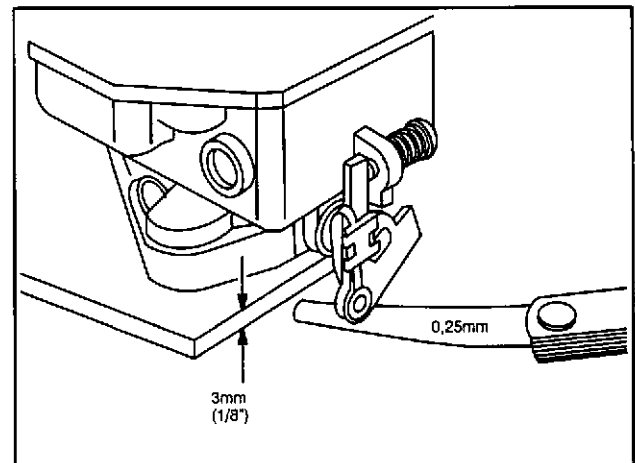


Fig. 129 - Checking Throttle Wear

# CARBURETION

## Assemble Carburetor Model 350400

If the difference is greater than .25 mm (.010"), this indicates that the throttle shaft and/or bushings are worn. Wear on the throttle shaft can be checked by comparing the worn and unworn portions of the shaft, Fig. 130.

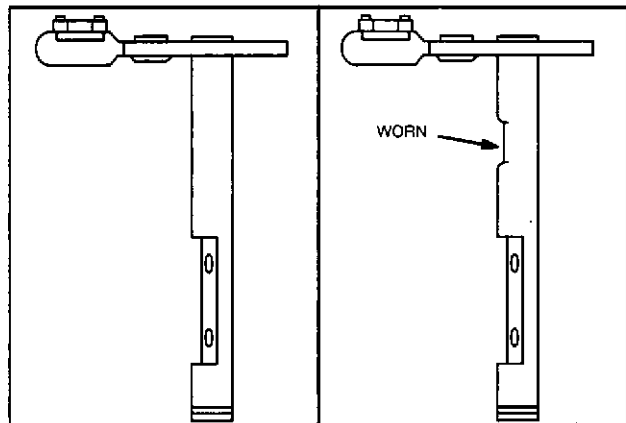


Fig. 130 - Checking Throttle Shaft Wear

Choke shaft and bushings are checked in the same manner.

Throttle and choke shaft are replaceable. If throttle and/or choke shaft bushings are worn, replace carburetor.

### Install Fuel Inlet Seat And Body

Insert new inlet seat in to carburetor. Install with chamfered end down. Make sure seat is in as far as it will go. Press in new body until it bottoms using knock out pin, Tool #19135, Fig. 131.

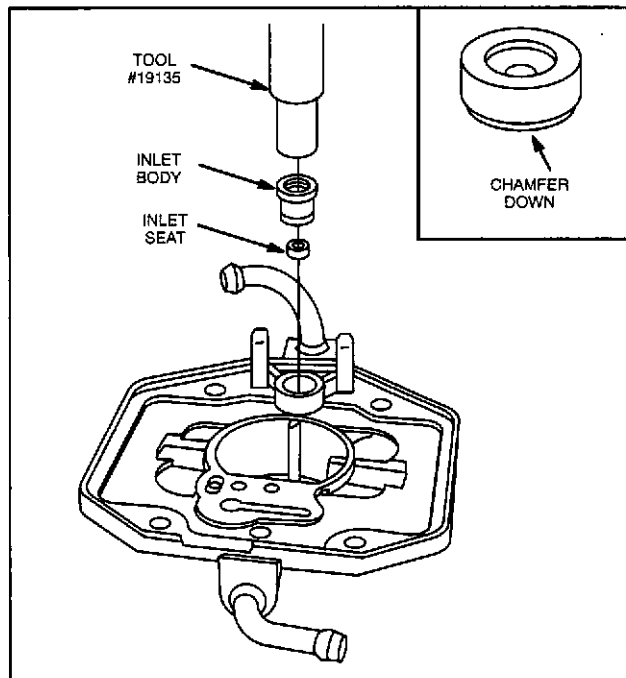


Fig. 131 - Installing Inlet Seat and Body

### Assemble Carburetor - Engine Model 350400

When assembling carburetor, use new seals and gaskets.

Install new throttle shaft seals with sealing lips out. Slide spacer and foam seal over throttle shaft and insert throttle shaft through carburetor body, Fig. 132. Install foam seal, then, slide retainer over end of throttle shaft until it snaps into position.

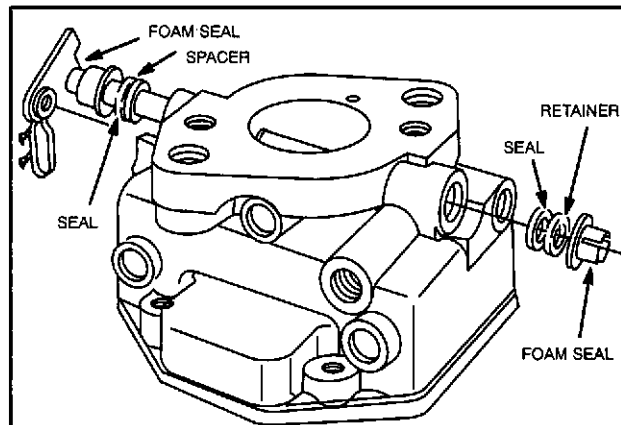


Fig. 132 - Installing Throttle Shaft

Install throttle valve on shaft with numbers down and facing away from idle mixture valve screw hole, Fig. 133. Tighten screws securely.

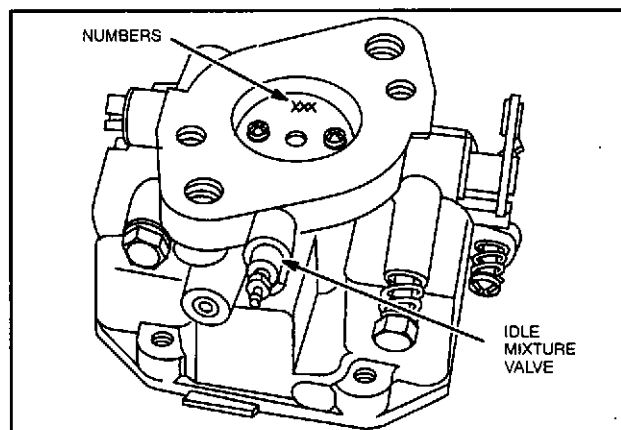


Fig. 133 - Installing Throttle Valve

# CARBURETION

## Assemble Carburetor Model 350400

Install choke shaft seals with sealing lips out. Assemble spacer to choke shaft. Insert spring and check ball in to spring pocket. Use a 4.75 mm (3/16") drill and insert through choke shaft bushings from side opposite check ball and spring. Push drill bit through until ball and spring start to compress. Now, carefully push choke shaft into bushing against drill bit. Continue pushing until ball engages groove in choke shaft, Fig. 134.

Slide retainer over end of choke shaft until it snaps into position. Place choke valve onto flat on choke shaft with identification mark out. Install and tighten screws securely.

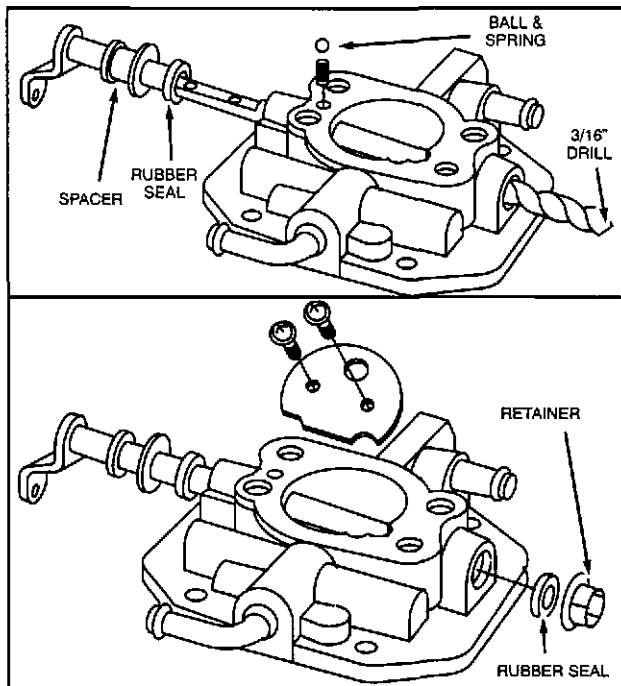


Fig. 134 - Installing Choke Shaft

Install fixed main speed jet using screwdriver, Tool #19062, Fig. 135. Install washer and plug. Install fuel delivery nozzle.

NOTE: Fixed main jets are numbered for the type of fuel delivery system used. Install #110 jet if engine is equipped with a fuel pump. Install #117.5 jet if engine is equipped with a gravity fuel tank.

NOTE: Special high altitude jets are available. Consult the Illustrated Parts List for the correct part number.

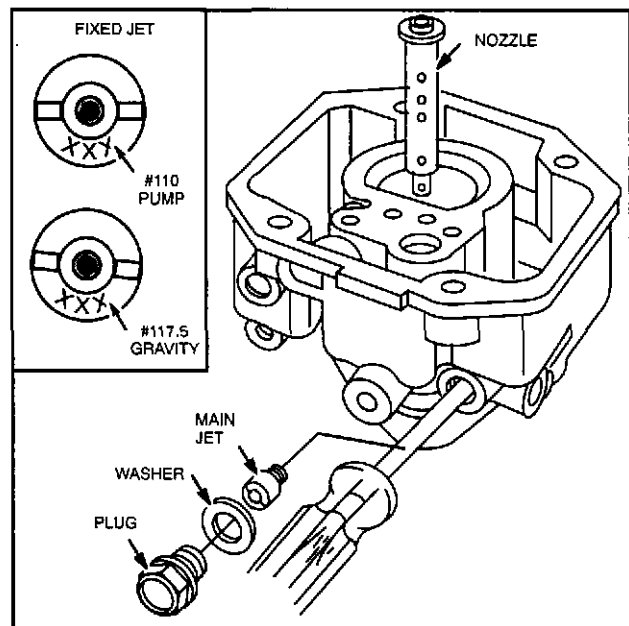


Fig. 135 - Installing High Speed Jet and Nozzle

Install idle mixture valve and spring, Fig. 136. DO NOT tighten idle mixture valve against its seat.

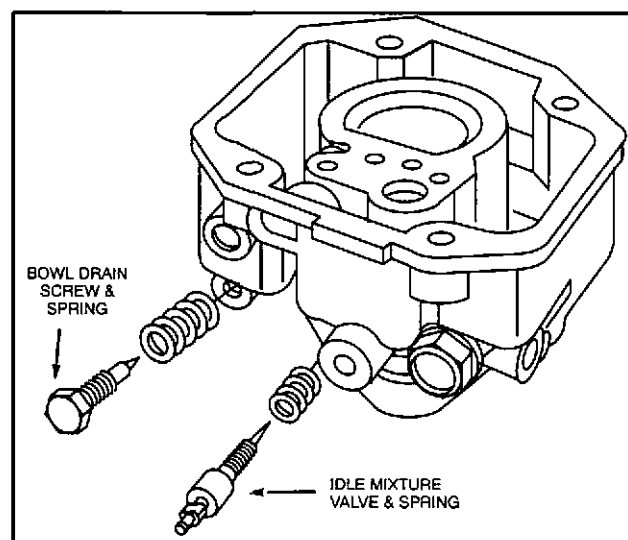
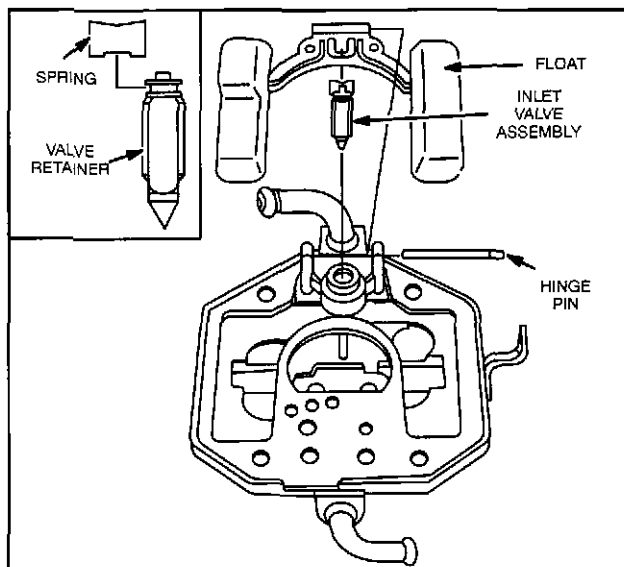


Fig. 136 - Installing Idle Mixture Valve and Drain Screw

# CARBURETION

## Install Carburetor - Horizontal Crankshaft Models

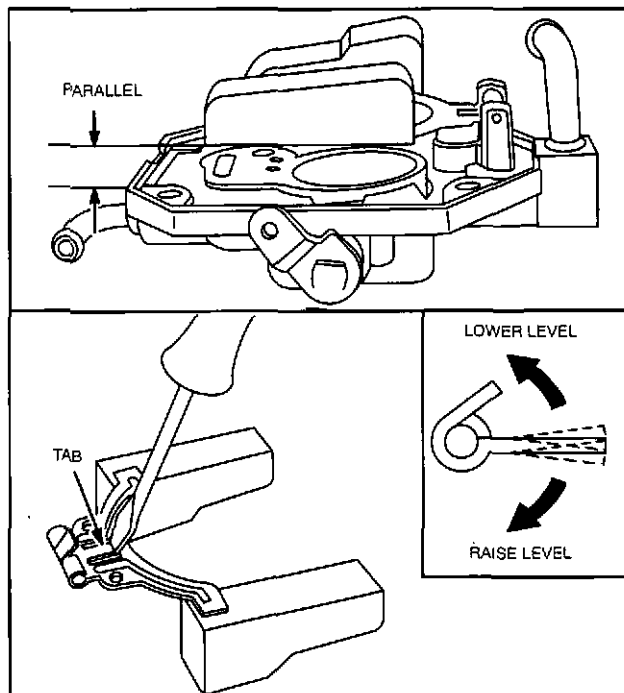
Insert inlet valve retainer into groove in inlet valve, Fig. 137. Then, slide retainer and inlet valve over tang on float.



**Fig. 137 - Inlet Valve and Float**

Install valve and float assembly in upper body. Install float hinge pin.

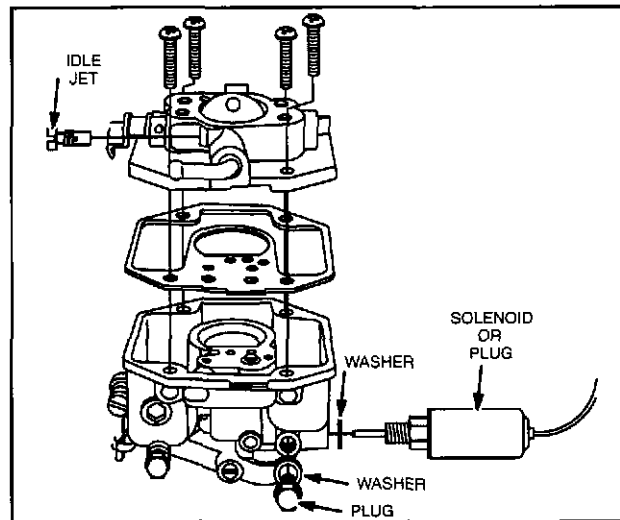
Hold carburetor upper body upside-down as shown in Fig. 138. The float should be parallel with carburetor bowl mounting surface. If not, use a small screw driver and bend tang as shown. DO NOT press on float to adjust.



**Fig. 138 - Adjusting Float**

Place new gasket on lower carburetor body. Make sure holes in body line up with holes in gasket. Install upper

carburetor body on lower body. Tighten screws securely, Fig. 139. Install idle jet.



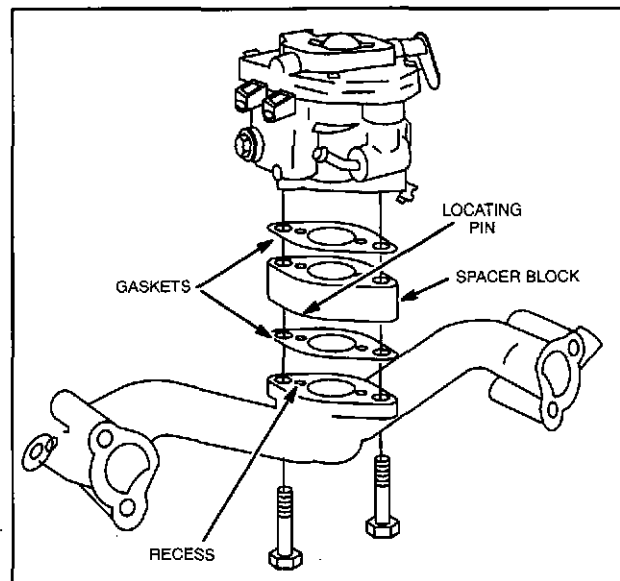
**Fig. 139 - Installing Upper Body**

Install washer and anti-afterfire solenoid or plug (if equipped). Torque to 5 Nm (45 in. lbs.).

Install carburetor and intake manifold as described below.

### Install Carburetor And Intake Manifold - Horizontal Crankshaft Models 290400 - 350400

Assemble gasket, spacer, gasket and carburetor to intake manifold and install mounting screws. Make sure that locating pin on carburetor spacer fits in recess in manifold, Fig. 140. Torque screws to 7 Nm (65 in. lbs.).



**Fig. 140 - Assembling Carburetor to Manifold**

# CARBURETION

## Install Carburetor - Horizontal Crankshaft Models

Install carburetor and manifold assembly to cylinder heads, Fig. 141. Torque screws to 16 Nm (140 in. lbs.).

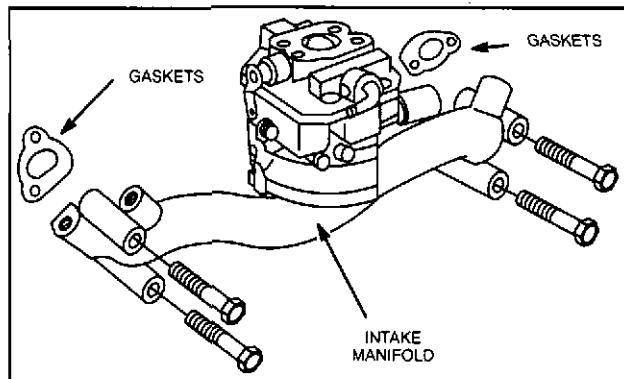


Fig. 141 - Installing Manifold

Insert governor link into hole in throttle lever. Clip retainer onto governor link. Hook governor link spring in loop on link retainer. Connect choke link to carburetor and choke control lever. Install choke control bracket, Fig. 142. Torque screws to 7 Nm (65 in. lbs.). Install fuel line and fuel line clamp.

**NOTE:** If carburetor is equipped with anti-afterfire solenoid, route wire under intake manifold and through hole in #1 cylinder shield at this time.

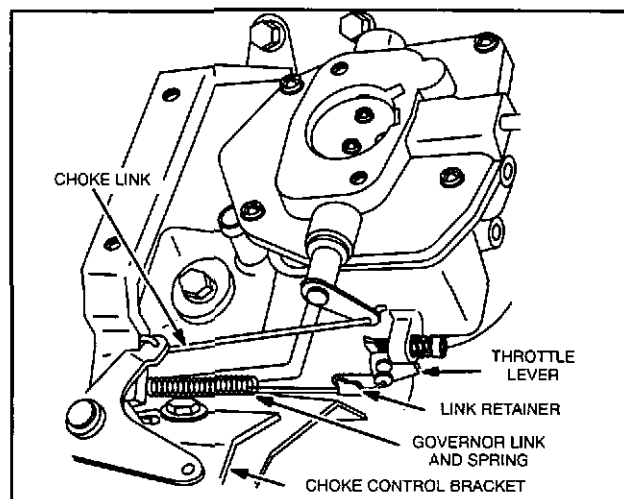


Fig. 142 - Installing Linkage

Install blower housing on engine. Install air cleaner base and air cleaner assembly as described below.

**⚠** **STATIC GOVERNOR ADJUSTMENT MUST BE MADE WHENEVER CARBURETOR AND, OR MANIFOLD HAS BEEN REMOVED FROM ENGINE. FAILURE TO MAKE STATIC ADJUSTMENTS FIRST COULD RESULT IN ENGINE OVERSPEEDING WHICH MAY RESULT IN ENGINE OR EQUIPMENT DAMAGE CAUSING PERSONAL INJURY AND/ OR PROPERTY DAMAGE. SEE SECTION 5.**

### Install Air Cleaner Base - Horizontal Crankshaft Models 290400 - 350400

**Current style:** Place air cleaner base gasket onto carburetor. Guide breather tube onto nipple on breather and install air cleaner base on carburetor and support bracket. Install two air cleaner base screws, Fig. 143. Do not tighten screws at this time. Now, install breather deflector and three screws. Torque screws to 7 Nm (65 in. lbs.). Make sure air inlet tube is installed correctly in air cleaner base.

**Early style:** Place air cleaner base gasket onto carburetor. Guide breather tube onto nipple on breather and install air cleaner base on carburetor and support bracket. Insert two screws through breather deflector and install mounting screws in carburetor. Do not tighten screws at this time. Now, install two air cleaner bracket screws, Fig. 144. Torque all four screws to 7 Nm (65 in. lbs.). Make sure air inlet tube is installed correctly in air cleaner base.

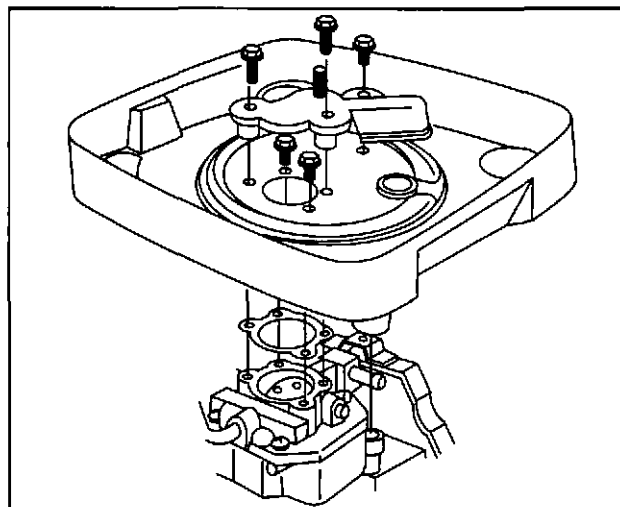
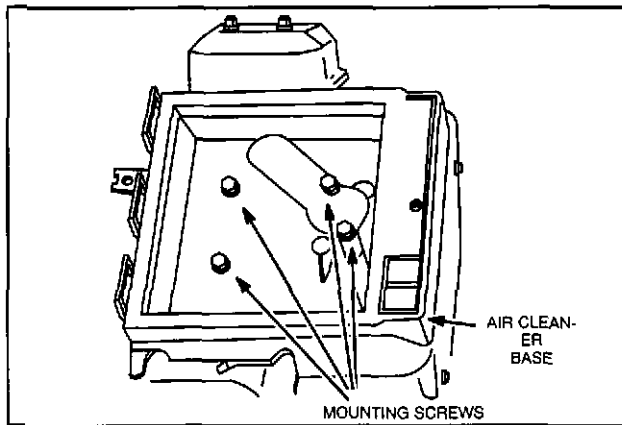


Fig. 143 - Installing Air Cleaner Base (Current Style)

# CARBURETION

## Install Carburetor - Horizontal Crankshaft Models

3



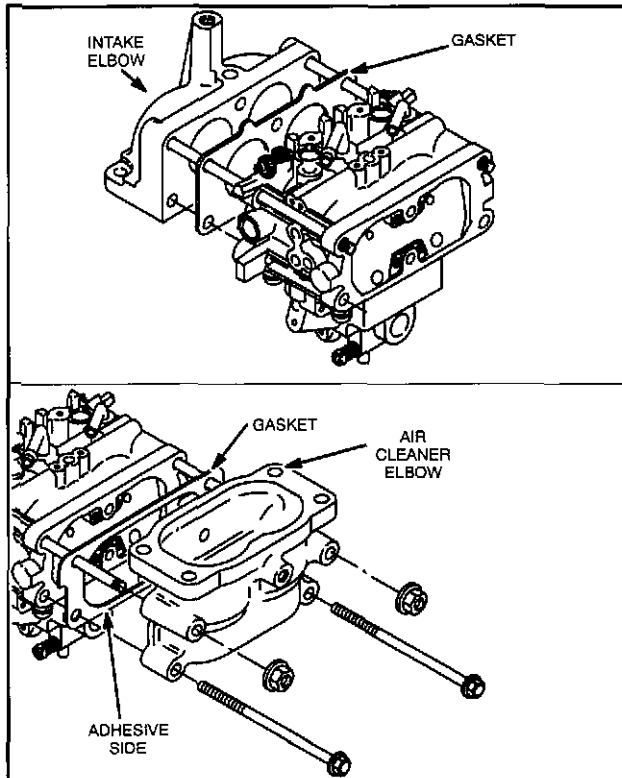
**Fig. 144 - Installing Air Cleaner Base (Early Style)**

Install air cleaner cartridge, pre-cleaner (when so equipped) and cover as described in "Service Air Cleaner."

See pages 43-46 for carburetor adjustment procedure.

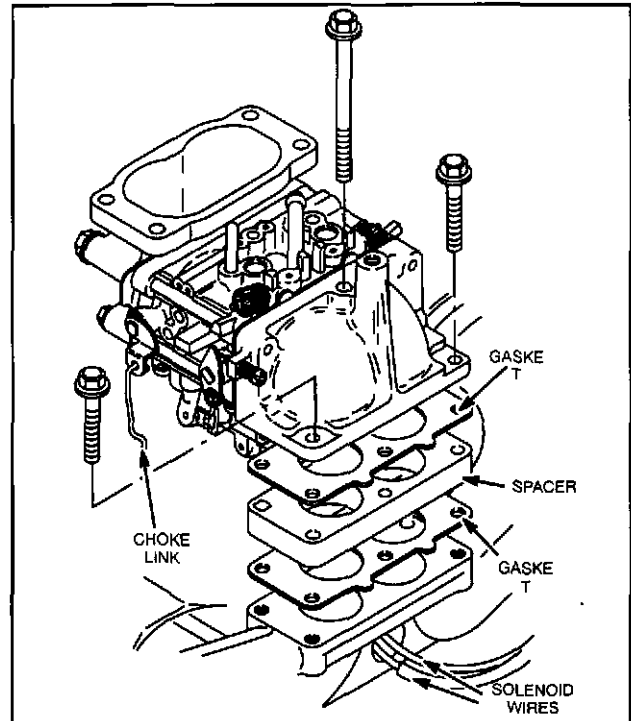
### Install Carburetor Horizontal Crankshaft Model 351400

Assemble intake elbow and air cleaner elbow to carburetor with new gaskets, Fig. 145. Install air cleaner elbow gasket with adhesive side toward air cleaner elbow and arrow up. Torque nuts and screws to 7 Nm (65 in. lbs.).



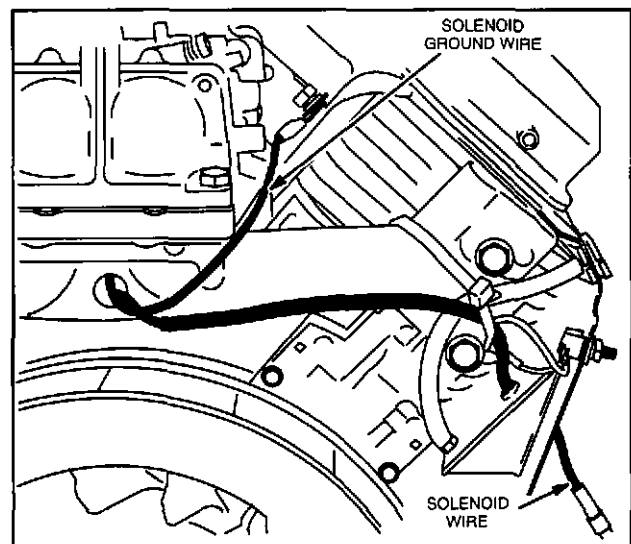
**Fig. 145 - Assemble Intake and Air Cleaner Elbow**

Assemble choke link to choke lever. Assemble carburetor, gasket, spacer and gasket to intake manifold. Route both solenoid wires through hole in intake manifold. Fig. 146 Torque three screws to 7 Nm (65 in. lbs.).



**Fig. 146 - Assembling Carburetor to Manifold**

Install solenoid ground wire as shown, Fig. 147. Torque screw to 7 Nm (65 in. lbs.). Route long solenoid wire under wire tie on manifold, then through hole in #1 cylinder shield.



**Fig. 147 - Route Solenoid Wires**

# CARBURETION

## Carburetor Adjustment – Models 290000–350000

Insert governor link into hole in throttle lever. Clip retainer onto governor link. Hook governor link spring in loop on link retainer. Connect choke link to choke control lever and install choke control bracket, Fig. 148. Torque screws to 7 Nm (65 in. lbs.).

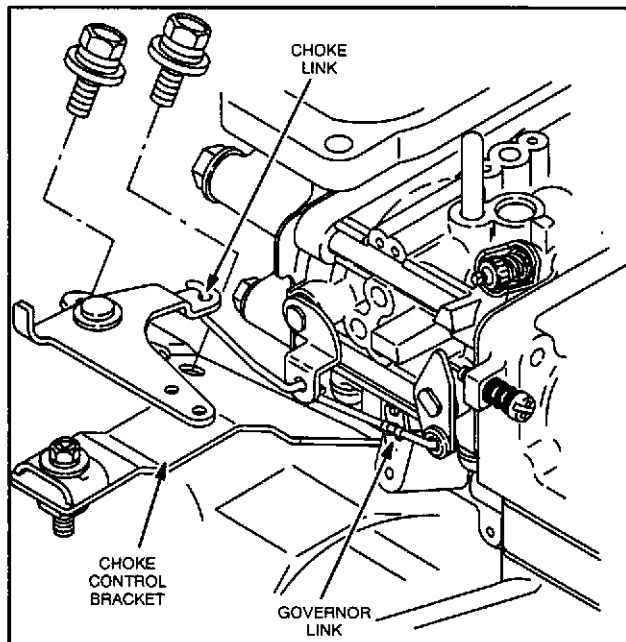


Fig. 148 - Installing Linkage

Install air cleaner elbow support screw and torque to 7 Nm (65 in. lbs.).

Install blower housing, rotating screen and fuel pump assembly. Install fuel line at carburetor. Rotate fuel line clamp tabs horizontally to prevent interference with air cleaner base.



**STATIC GOVERNOR ADJUSTMENT MUST BE MADE WHENEVER CARBURETOR AND, OR MANIFOLD HAS BEEN REMOVED FROM ENGINE. FAILURE TO MAKE STATIC ADJUSTMENTS FIRST COULD RESULT IN ENGINE OVERSPEEDING WHICH MAY RESULT IN ENGINE OR EQUIPMENT DAMAGE CAUSING PERSONAL INJURY AND/ OR PROPERTY DAMAGE. SEE SECTION 5.**

### Install Air Cleaner Base Horizontal Crankshaft Model 351400

Install new air cleaner mounting gasket with adhesive side toward air cleaner base. Connect breather tube to air cleaner base and assemble air cleaner base to air cleaner elbow. Install carburetor shield and five screws finger tight, Fig. 149. Then torque screws to 7 Nm (65 in. lbs.). Make sure air inlet tube is installed correctly in air cleaner base.

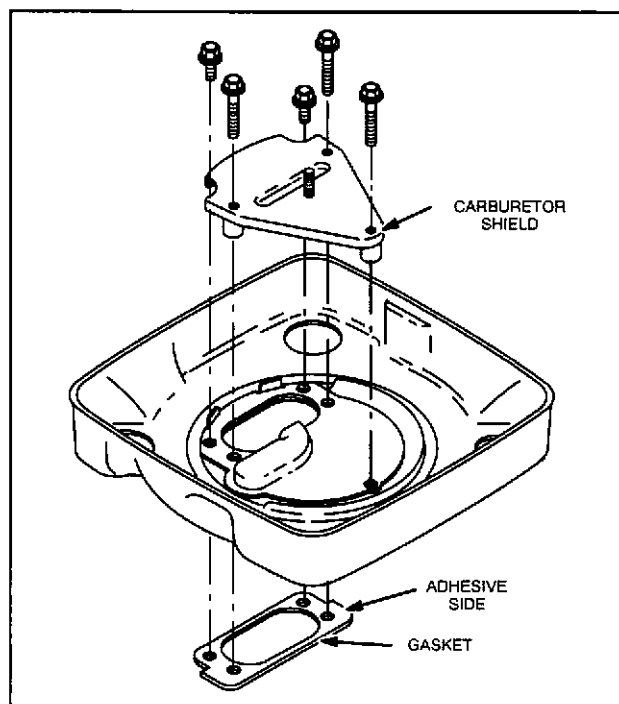


Fig. 149 - Installing Air Cleaner Base

Install air cleaner cartridge, pre-cleaner and cover as described in "Service Air Cleaner."

**See pages 46–48 for carburetor adjustment procedure.**

### Initial Adjustment – Engine Models 290000–350000

THE OHV TWIN CYLINDER ENGINE CARBURETOR FUEL MIXTURE ADJUSTMENT PROCEDURE IS UNIQUE. PERFORM ADJUSTMENTS EXACTLY IN THE SEQUENCE SHOWN.

# CARBURETION

## Carburetor Adjustment - Models 290000-350000

Turn idle mixture valve clockwise until it just seats. **DO NOT FORCE.** Turn valve counter-clockwise 1-1/4 turns. Fig. 150 and Fig. 151. This setting will permit engine to start. Final adjustment will be made with engine running.

3

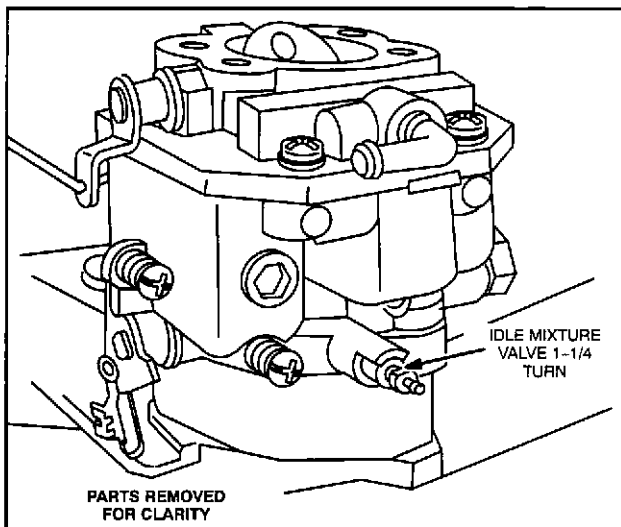


Fig. 150 - Horizontal Crankshaft Models

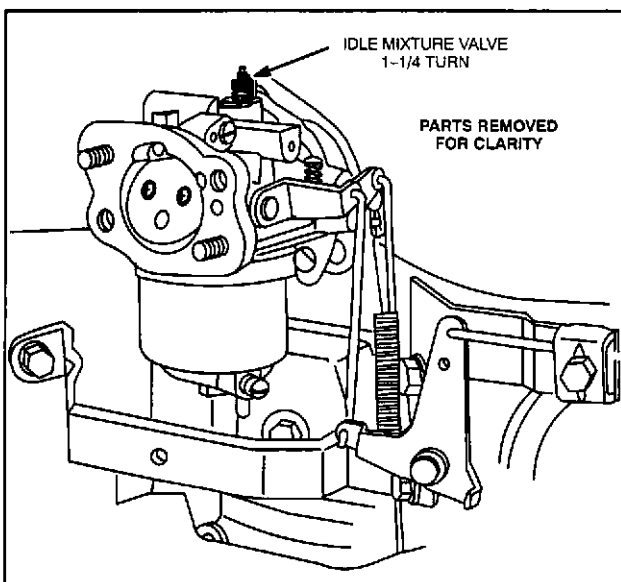


Fig. 151 - Vertical Crankshaft Models

NOTE: If engine is equipped with a secondary governor spring as shown in Fig. 152, check governor lever adjustment procedure before starting engine. See Adjust Secondary Governor Spring, Section 5.

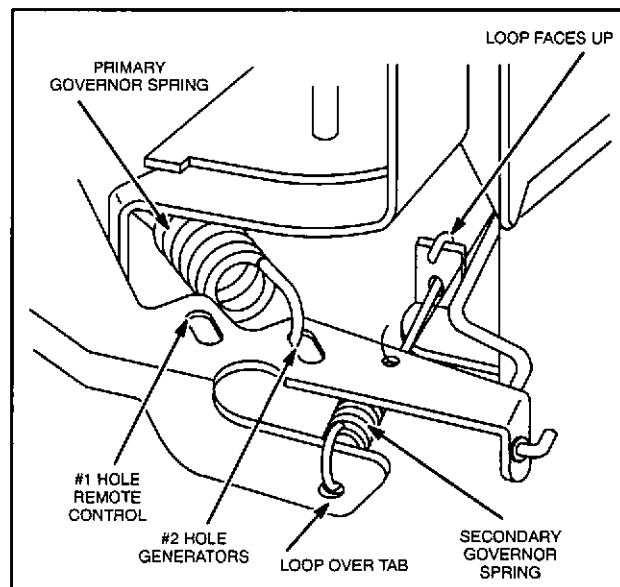


Fig. 152 - Secondary Governor Spring

### Final Adjustment - Engine Models 290000-350000

ALL CARBURETOR ADJUSTMENTS WITH ENGINE RUNNING MUST BE MADE WITH THE AIR CLEANER INSTALLED AS DONE AT THE FACTORY.

The following tools are required when making carburetor adjustments.

1. An accurate tachometer, such as Tool #19200 or #19389.
2. Tang bender, Tool #19352.

The tachometer and tang bender can be ordered through your Briggs & Stratton Source of Supply.

Start engine and run it for approximately 5 minutes to allow engine to reach operating temperature.

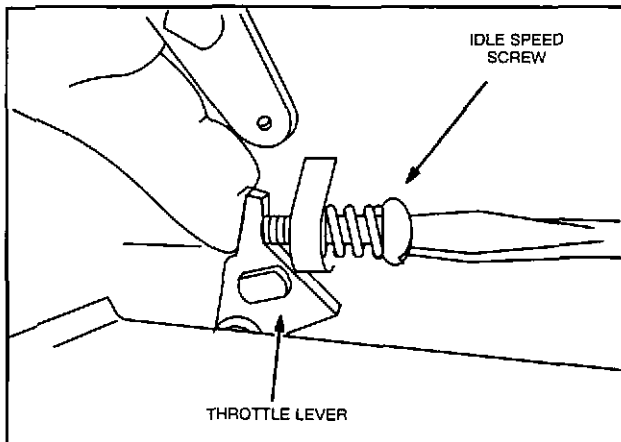
3. Move control lever on equipment to SLOW position.
4. Hold throttle lever against idle speed screw and temporarily adjust idle (Fig. 153) to RPM shown below.

1400 RPM - Governed idle spring Part #805453 (red).

1100 RPM - Governed idle spring Part #805454 (white).

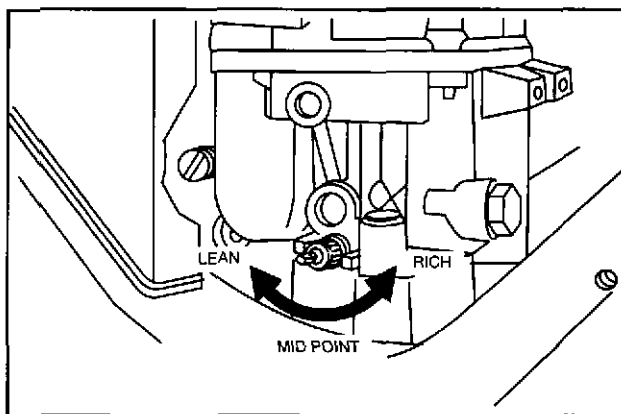
# CARBURETION

## Carburetor Adjustment – Models 290000–350000



**Fig. 153 - Adjusting Idle Speed**

5. Turn idle mixture valve slowly clockwise until engine speed just starts to slow (lean mixture).
6. Then turn idle mixture valve counterclockwise until engine speed just starts to slow (rich mixture).
7. Turn valve to mid point between rich and lean, Fig. 154.



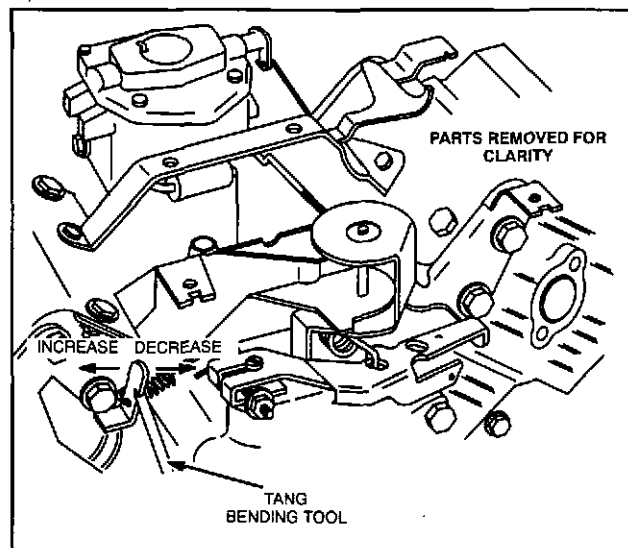
**Fig. 154 - Adjusting Idle Mixture**

8. Hold throttle lever against idle speed adjustment screw and readjust idle to RPM shown below:
  - 1200 RPM – Governed idle spring Part #805453 (red).
  - 900 RPM – Governed idle spring Part #805454 (white).
9. Release throttle lever. Note RPM.

If necessary, use tang bending Tool, #19352, and bend governed idle tang, (Fig. 155) to obtain RPM shown:

1750 RPM – Governed idle spring Part #805453 (red).

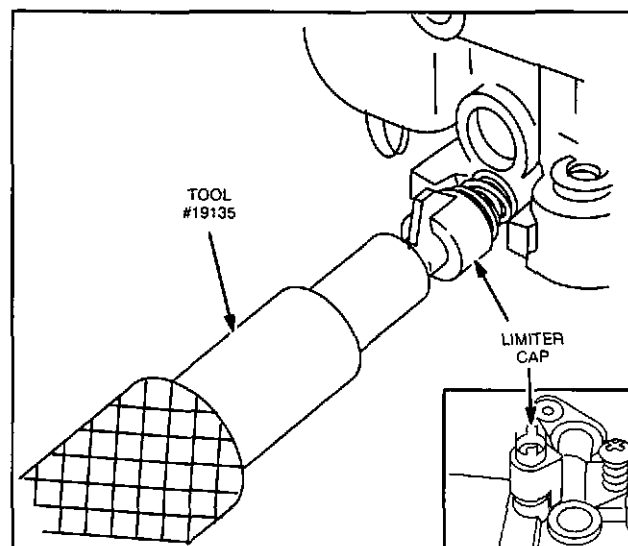
10. 1100 RPM – Governed idle spring Part #805454 (white).



**Fig. 155 - Adjusting Governed Idle**

11. IF CARBURETOR IS EQUIPPED WITH AN IDLE MIXTURE LIMITER CAP, INSTALL AT THIS TIME.

- a. Position limiter cap so that stop(s) on limiter cap are at mid point between stop(s) on carburetor body. Press limiter into position using knock out pin, Tool #19135 as shown in, Fig. 156.



**Fig. 156 - Installing Limiter Cap**

# CARBURETION

## Carburetor Adjustment – Models 351400–351700

12. With equipment control lever in SLOW position and engine running at governed idle RPM, use tang bender, Tool #19352, and bend throttle restrictor tang so that tang just contacts governor lever. Fig. 157.

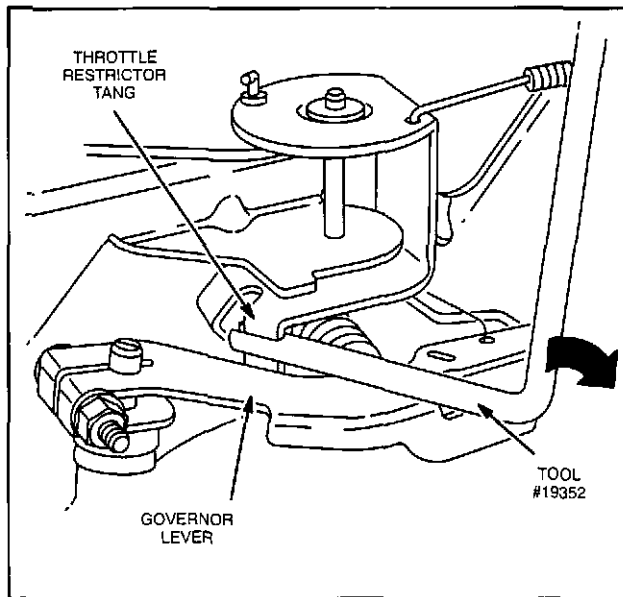


Fig. 157 – Adjusting Throttle Restrictor Tang

13. Move equipment control to FAST position. Engine should accelerate smoothly.
- a. Readjust idle mixture valve 1/8 turn richer if necessary.

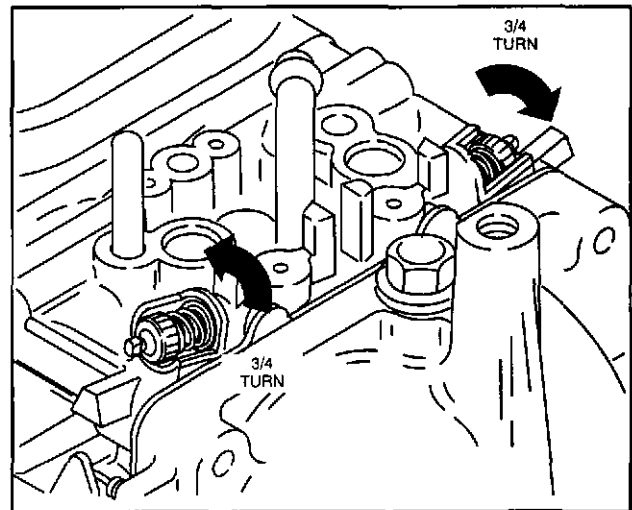


Fig. 158 – Horizontal Crankshaft Models

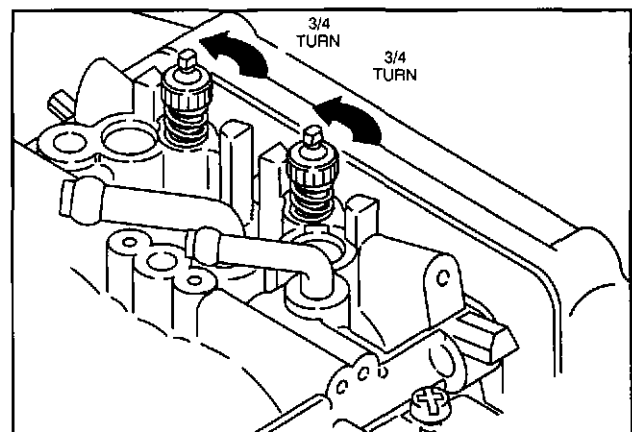


Fig. 159 – Vertical Crankshaft Models

### Initial Adjustment – Engine Models 351400–351700

THE OHV TWIN CYLINDER ENGINE CARBURETOR FUEL MIXTURE ADJUSTMENT PROCEDURE IS UNIQUE. PERFORM ADJUSTMENTS EXACTLY IN THE SEQUENCE SHOWN.

Turn idle mixture valve for #1 cylinder clockwise until it just seats. DO NOT FORCE. Then turn valve counter-clockwise 3/4 turn. Fig. 158 and Fig. 159. Repeat for #2 cylinder.

This setting will permit engine to start. Final adjustment will be made with engine running.

### Final Adjustment – Engine Models 351400–351700

ALL CARBURETOR ADJUSTMENTS WITH ENGINE RUNNING MUST BE MADE WITH THE AIR CLEANER INSTALLED AS DONE AT THE FACTORY.

IMPORTANT: IDLE MIXTURE ADJUSTMENT MUST BE PERFORMED WITH THE ENGINE RUNNING AT 1200 RPM.

The following tools are required when making carburetor adjustments.

1. An accurate tachometer, such as Tool #19200 or #19389.

# CARBURETION

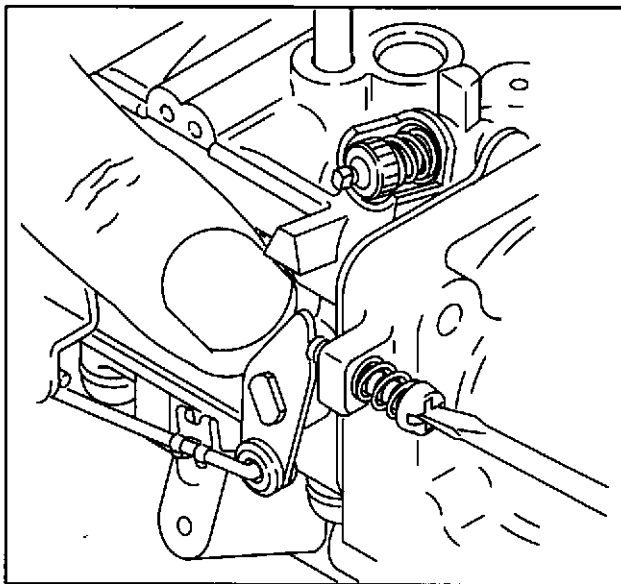
## Carburetor Adjustment – Models 351400–351700

2. Tang bender, Tool #19352.

The tachometer and tang bender can be ordered through your Briggs & Stratton Source of Supply.

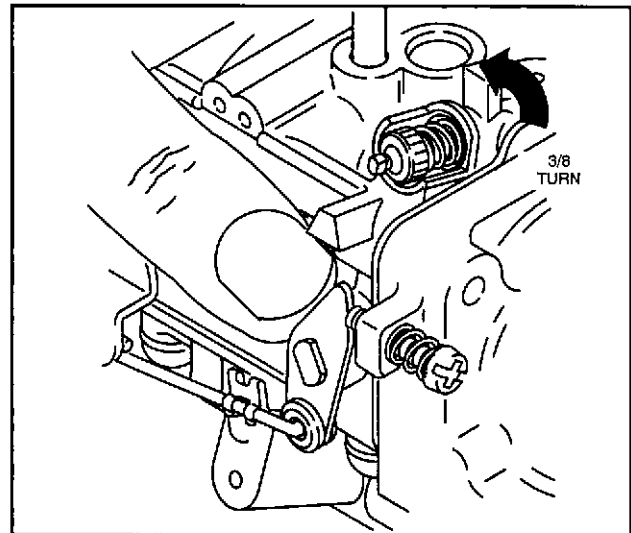
Start engine and run it for approximately 5 minutes to allow engine to reach operating temperature.

3. Move control lever on equipment to SLOW position.
4. Hold throttle lever against idle speed screw and temporarily adjust idle (Fig. 160) to **1200 RPM**.



**Fig. 160 – Adjusting Idle Speed**

5. While holding throttle lever, **SLOWLY** turn idle mixture valve for #1 cylinder clockwise until engine speed just starts to slow (lean mixture).
6. Then turn idle mixture valve counterclockwise 3/8 turn, Fig. 161.



**Fig. 161 – Adjusting Idle Mixture**

**NOTE:** It may be necessary to readjust idle speed screw to 1200 RPM before proceeding.

7. Adjust idle mixture valve for #2 cylinder as described in steps 5 and 6.
8. Now, readjust idle speed screw to RPM shown below, if necessary.

1200 RPM – Governed idle spring Part #805453 (red).

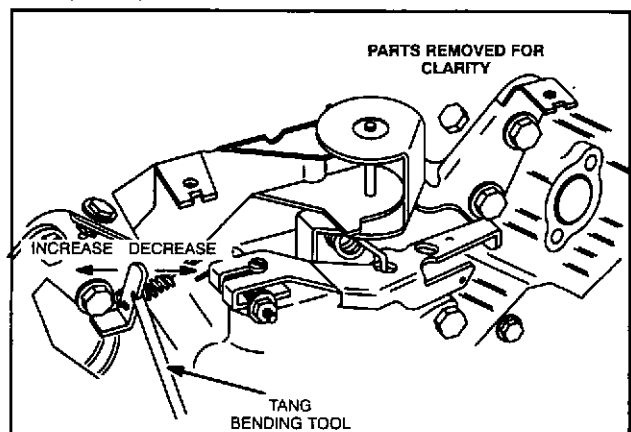
900 RPM – Governed idle spring Part #805454 (white).

9. Release throttle lever. Note RPM.

If necessary, use tang bending Tool, #19352, and bend governed idle tang, (Fig. 162) to obtain RPM shown:

1750 RPM – Governed idle spring Part #805453 (red).

10. 1100 RPM – Governed idle spring Part #805454 (white).



**Fig. 162 – Adjusting Governed Idle**

# CARBURETION

## Anti-Afterfire - Operation

3

### 11. IF CARBURETOR IS EQUIPPED WITH AN IDLE MIXTURE LIMITER CAPS, INSTALL AT THIS TIME.

- a. Position limiter cap so that stop on limiter cap is at mid point between stops on carburetor body. Press limiter into position using knock out pin, Tool #19135 as shown in, Fig. 163. Repeat for other idle mixture valve.

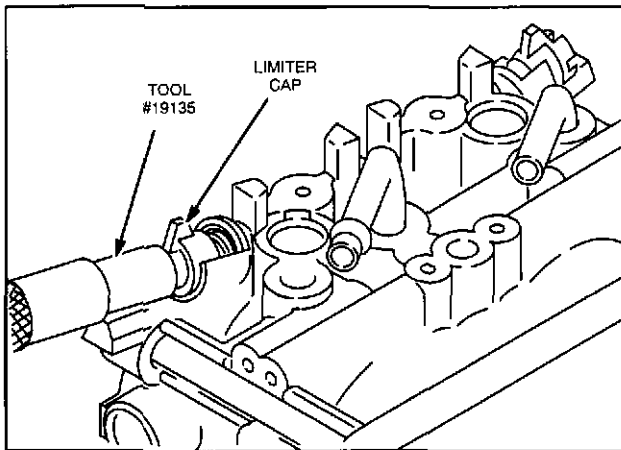


Fig. 163 - Installing Limiter Cap

- 12. With equipment control lever in SLOW position and engine running at governed idle RPM, use tang bender, Tool #19352, and bend throttle restrictor tang so that tang just contacts governor lever. Fig. 157.

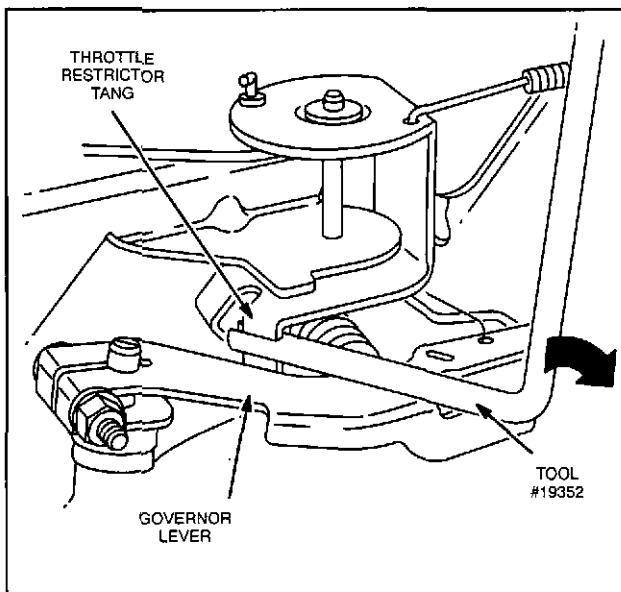


Fig. 164 - Adjusting Throttle Restrictor Tang

- 13. Move equipment control to FAST position. Engine should accelerate smoothly.
  - a. Readjust idle mixture valve 1/8 turn richer if necessary.

### Anti-Afterfire System (Operation)

Some models are equipped with an optional Anti-Afterfire system, Fig. 165 and Fig. 166. The system contains a solenoid valve assembly controlled by the equipment ignition switch.

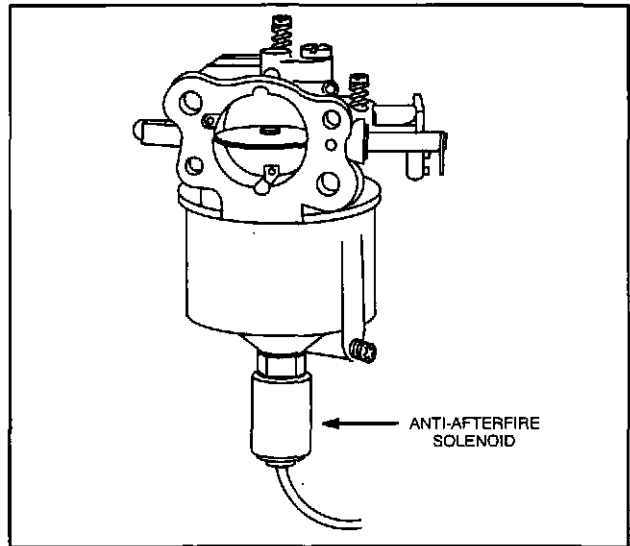


Fig. 165 - Vertical Crankshaft

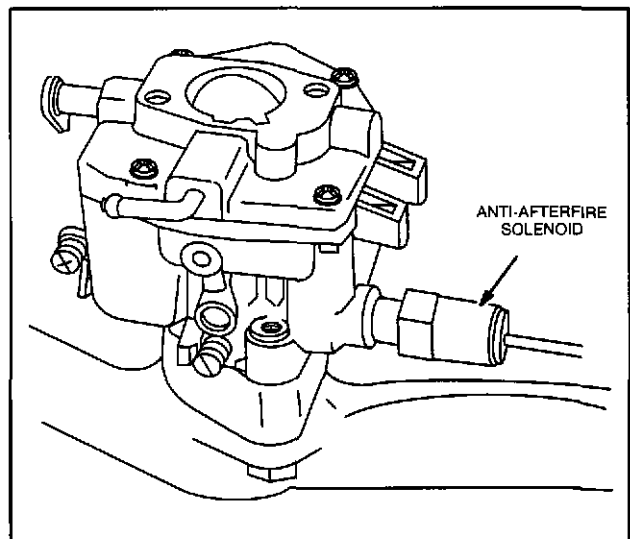


Fig. 166 - Horizontal Crankshaft

# CARBURETION

## Anti-Afterfire - Testing

3

When the equipment switch is in the "Off" position, the solenoid valve plunger closes, stopping fuel flow through the fixed main jet, Fig. 167. When the switch is in the "On" and "Start" position, the solenoid valve opens, moving the plunger away from the fixed main jet allowing normal fuel flow, Fig. 168.

**NOTE:** Anti-afterfire solenoid requires a minimum of 9 volts DC to function.

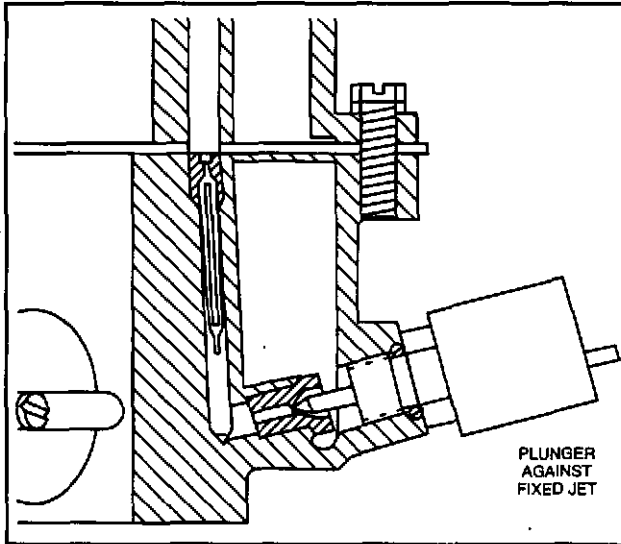


Fig. 167 - Solenoid Valve Closed (Typical)

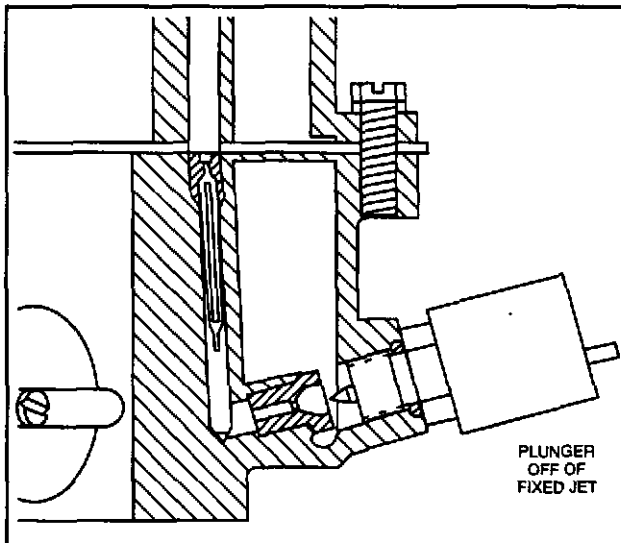


Fig. 168 - Solenoid Valve Open (Typical)

### Test Solenoid Operation (On Engine)

Solenoid is operating properly if a click is heard when equipment ignition switch is turned "On" and "Off."

If solenoid does not click, the problem may be in equipment wiring. Disconnect wire from solenoid. Place either terminal of a 9 volt transistor battery on the solenoid connector and other terminal on body of solenoid. If solenoid now clicks, the problem is in the equipment wiring, or ignition switch.

If battery voltage drops below 9 volts when cranking engine or while engine is running, solenoid will not function.

### Test Solenoid Operation (On Bench)

With solenoid removed from carburetor, touch either terminal of a 9 volt transistor battery to the solenoid connector and other terminal on body of solenoid. Plunger should retract freely. When battery is removed, plunger should return freely. Replace solenoid if plunger sticks or doesn't move.

**NOTE:** Engine Model 350400: When bench testing solenoid, tip must be retracted manually approximately 0.8 mm (.030") before solenoid will energize. With 9 volt transistor battery applied to solenoid, apply finger pressure to tip of solenoid.

**NOTE:** If solenoid is not working (defective solenoid, defective ignition switch or broken solenoid wire), the engine will not start or run.

### Fuel Pump Description

The fuel pump, mounted on the blower housing near the No. 1 cylinder valve cover, allows remote fuel tank installations. The fuel pump will prime at 30.5 cm (12") maximum lift. Fuel pump pressure is 0.1 kg cm<sup>2</sup> (1.5 psi). The pump is operated by pulsating crankcase vacuum from the engine. The vacuum pulse line is installed on the No. 1 cylinder valve cover, Fig. 169.

Some engines are manufactured without a fuel pump where a remote fuel pump is required. The remote fuel pump is supplied by the equipment manufacturer.

**FUEL PUMP PRESSURE MUST NOT EXCEED 0.1 kg cm<sup>2</sup> (1.5 PSI).**

# CARBURETION

## Fuel Pump / Fuel Filter

**NOTE:** Excessive fuel pump pressure may result in an over rich carburetor mixture and ultimately cylinder scoring and or, other engine damage, resulting from crankcase oil dilution from gasoline.

Replace fuel lines and vacuum pulse line if stiff and brittle.

Note: An air leak at the fuel pump pulse line hose connections will result in improper fuel flow.

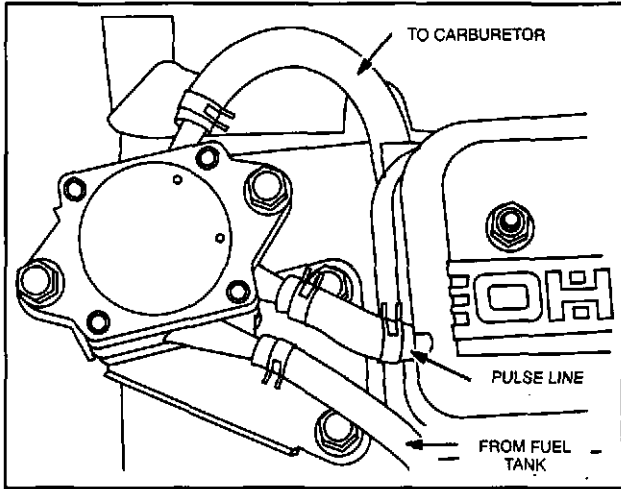


Fig. 169 - Fuel Pump

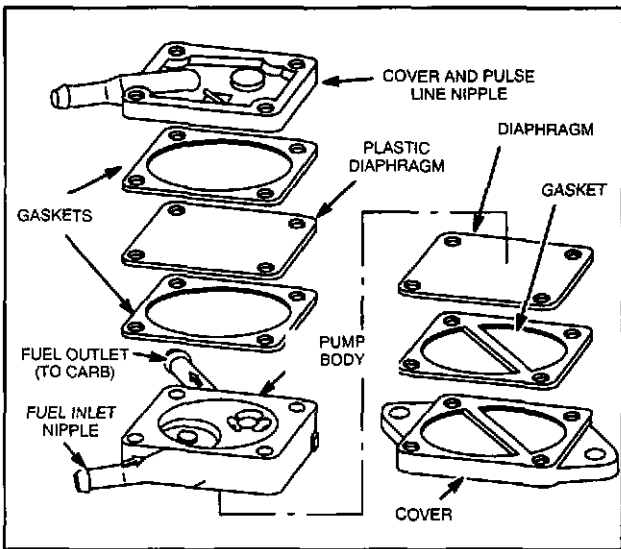


Fig. 170 - Exploded View

Note: Fuel pump is available as an assembly only.

### Inline Fuel Filter Service

Replace inline fuel filter yearly or every 100 hours, whichever occurs first. Replace filter if dirt or water are present.

Inline fuel filter, Part #493629 is used on engines equipped with fuel pump, Fig. 171. We recommend

that filter Part #493629 be added to engines not so equipped.

Inline fuel filter, Part #298090 is used on engines equipped with optional fuel tank, Fig. 171.

**NOTE:** Inline fuel filter, Part #298090 can be installed without regard to marking on filter (In, Out). However, if filter is removed, install with flow in same direction as removed. If in doubt, use new filter.

Inline fuel filter, Part #493629 has an arrow to indicate fuel flow direction. Always install filter with arrow towards carburetor.

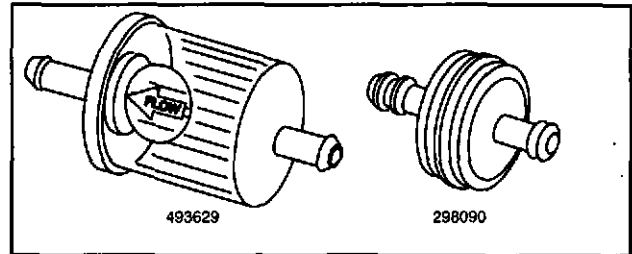


Fig. 171 - Fuel Filters

### Inspect Fuel Tank

Inspect fuel tank for cracks or leaks. Inspect fuel filter for dirt, debris or gum deposits. Replace fuel tank if it leaks.

### Fuel Shut-Off Valve

Engines equipped with optional fuel tank are equipped with a fuel shut-off valve which allows fuel flow to the carburetor to be stopped. The carburetor can then be drained for short term storage or removed for servicing.

Inspect valve for ease of operation and leakage. Replace if operation is difficult or valve will not shut off fuel flow or leaks externally.

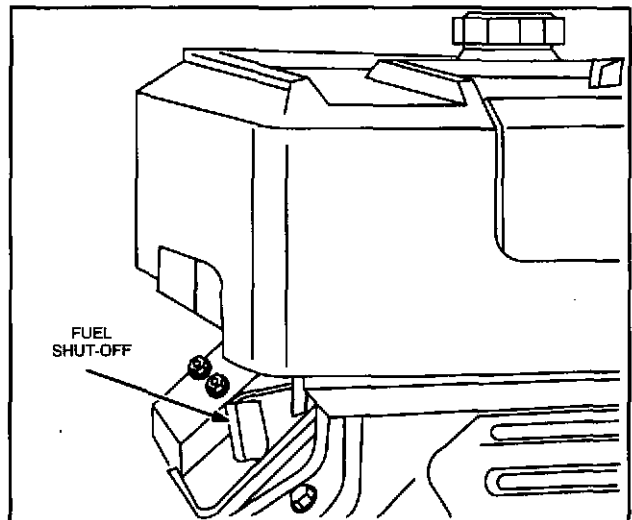


Fig. 172 - Fuel Tank

# Section 4

## GOV. CONTROLS & CARB. LINKAGE

### General Information

OHV Twin engines may be equipped for remote control, manual friction or fixed speed adjustable governor controls.

### Manual Friction And Remote Governor Controls (Speed Regulation)

Manual friction (mounted on engine) and remote governor controls (supplied by equipment manufacturer) control engine speed by increasing or decreasing tension on governor spring(s) to obtain desired engine speed, Fig. 1 and Fig. 2. Both controls will provide governor control at all positions.

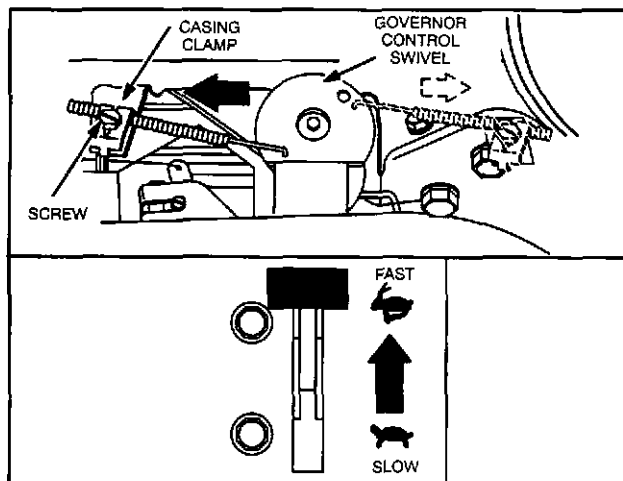


Fig. 1 - Remote Control Adjustment

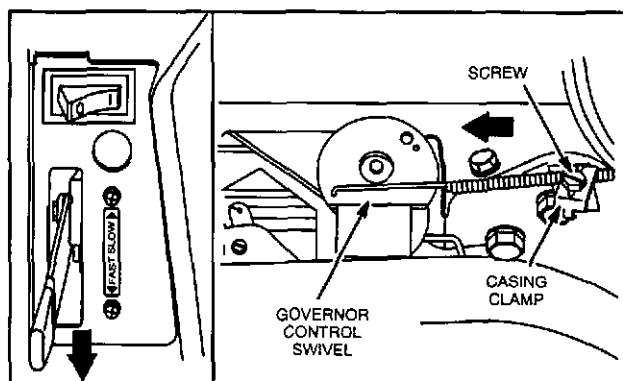


Fig. 2 - Manual Friction Control

### Manual Friction And Remote Governor Controls (Governed Idle)

OHV Twin cylinder engines equipped for manual friction or remote control have a governed idle system. A throttle restrictor permits the engine to maintain engine speed when a load is applied with the equipment control in the SLOW position.

### Manual Friction And Remote Control Adjustment

In order to make proper remote control adjustments, the travel of the remote control wire must be not less than 35 mm (1-3/8") with controls mounted in equipment, Fig. 3.

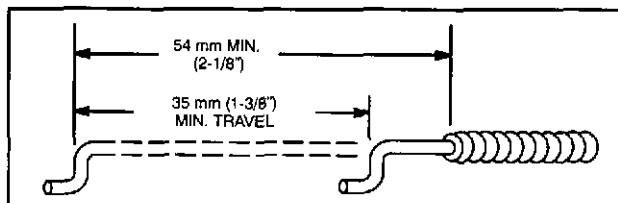


Fig. 3 - Control Wire Travel

### Manual Friction And Remote Control Wire Travel

NOTE: Manual friction and remote control adjustment procedure is identical.

1. Loosen control casing clamp at governor control bracket, Fig. 1 or Fig. 2.
2. Move speed control lever to "FAST" position.
3. Move control casing and wire in direction shown by arrow until governor control swivel is at end of travel;
4. Tighten casing clamp screw.

# GOV. CONTROLS & CARB. LINKAGE

## Choke Control Adjustment

Place choke control lever on equipment in "CHOKE" position. Loosen control casing clamp screw. Move control casing and wire until choke is completely closed. Tighten casing clamp screw, Fig. 4.

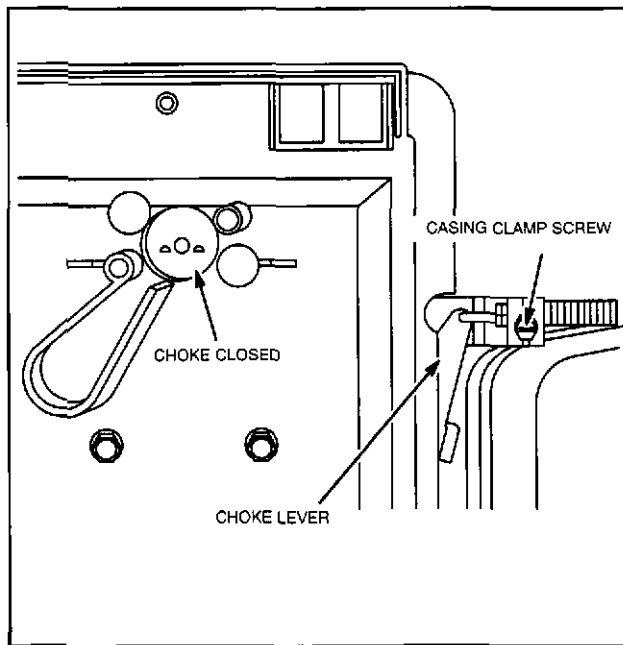


Fig. 4 - Adjusting Choke

## Governor And Carburetor Linkages

The following figures show governor and carburetor linkages, Fig. 5, Fig. 6, Fig. 7, Fig. 8 and Fig. 9.

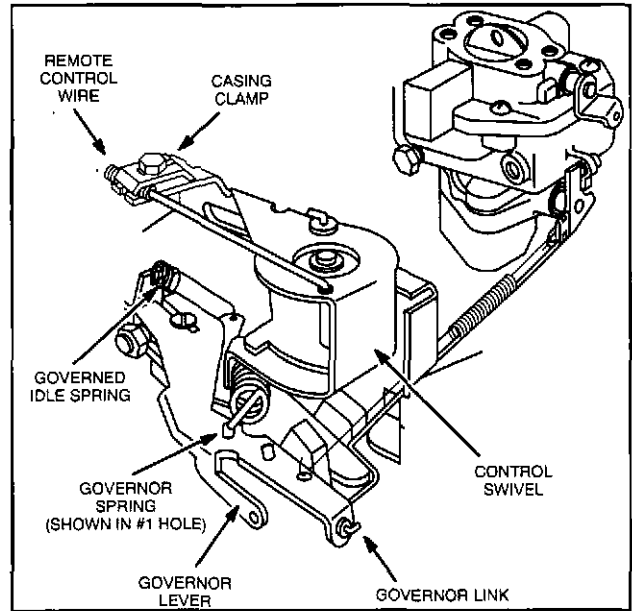


Fig. 5 - Remote Control

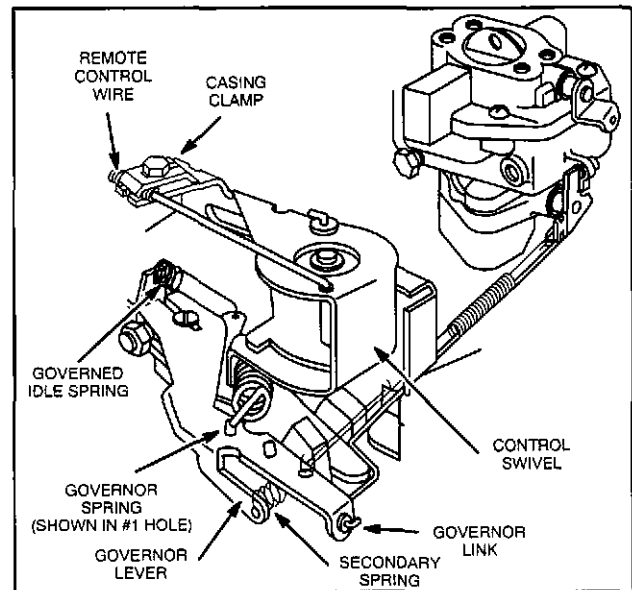


Fig. 6 - Remote Control With Secondary Governor Spring

## Governor Adjustments

Refer to Section 5 for specific procedures for governor adjustments.

# GOV. CONTROLS & CARB. LINKAGE

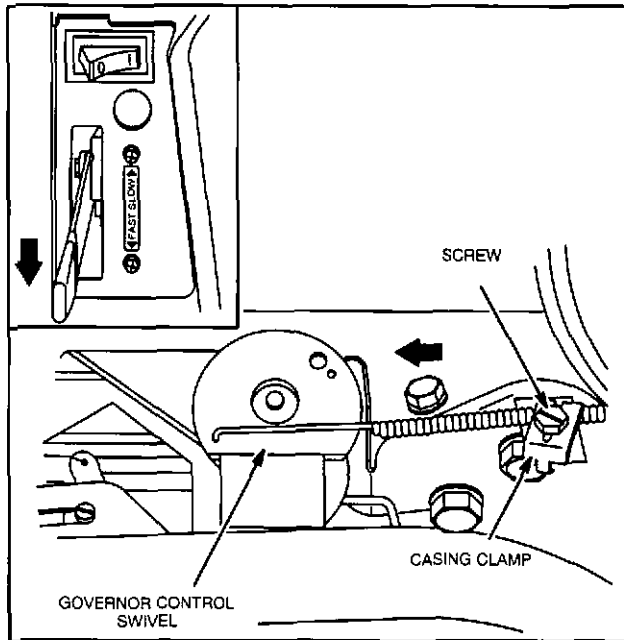


Fig. 7 - Manual Friction Control

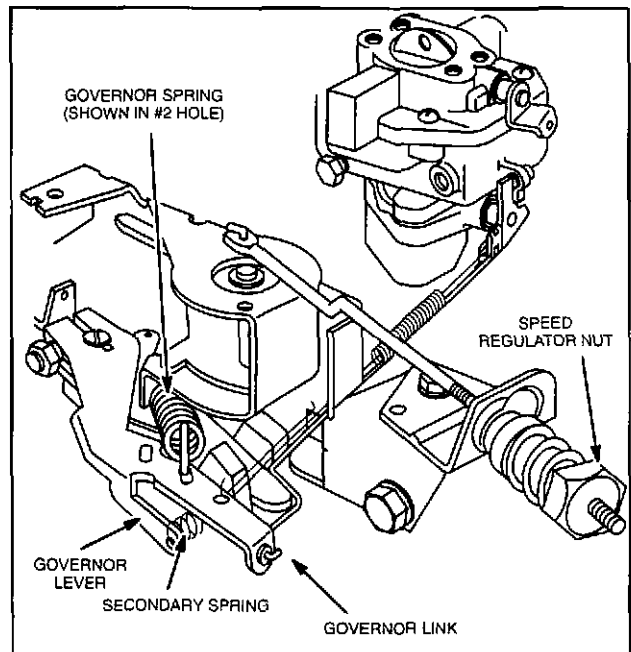


Fig. 9 - Fixed Speed, Adjustable With Secondary Governor Spring

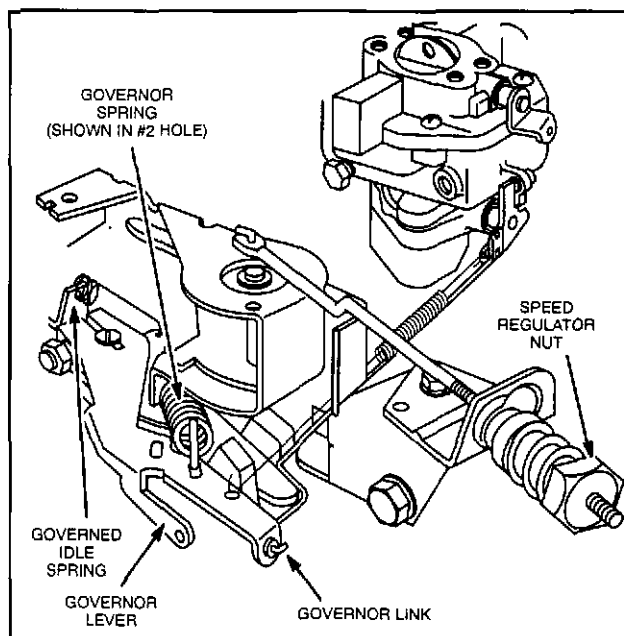


Fig. 8 - Fixed Speed, Adjustable

# Section 5 GOVERNORS

THE PURPOSE OF THE GOVERNOR IS TO MAINTAIN, WITHIN CERTAIN LIMITS, A DESIRED ENGINE SPEED, EVEN THOUGH LOADS MAY VARY.

## Mechanical Governor

The governor spring tends to pull the throttle open. The force of the counterweights, which are operated by centrifugal force, tends to close the throttle. The engine speed at which these two forces balance is called the governed speed. The governed speed can be varied by changing governor spring tension and hole location, Fig. 1.

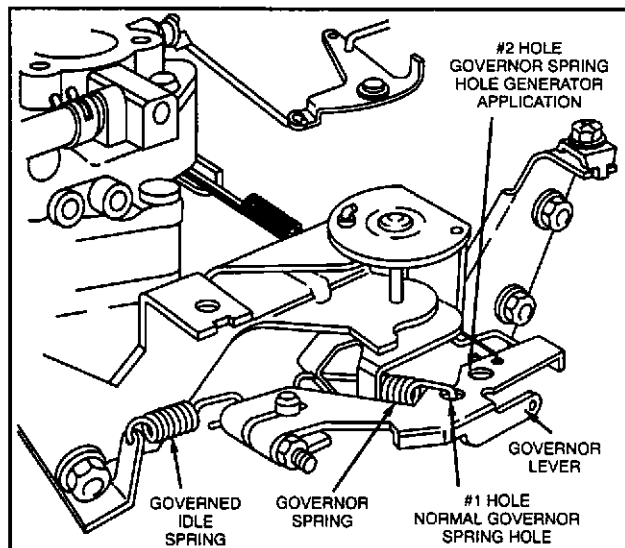


Fig. 1 - Governor Spring Positions

To comply with specific top governed speed limits, Briggs & Stratton supplies manufacturers with engines having an adjustable top speed limit, which is set to equipment manufacturers' specifications.

The top speed limit will allow no more than the desired top governed speed, when the engine is operated on a rigid test stand at our own factory. However, the design of the equipment used can affect engine speeds;

therefore, the top governed speed should be checked with a tachometer when the engine is operating on a completely assembled unit. The equipment should be operated at no load when making these checks. If a governor spring must be replaced, consult the appropriate Illustrated Parts List. Choose the proper governor springs by engine type number.

**CAUTION:** AFTER A NEW GOVERNOR SPRING IS INSTALLED, CHECK ENGINE TOP GOVERNED SPEED WITH AN ACCURATE TACHOMETER.

## Remove Governor Lever

The governor is located on the cam gear shaft. Drain oil from engine before beginning disassembly, Section 8 (Fig. 1 or 2). Loosen governor lever nut and remove governor lever. Disconnect governor springs, governor link and governor link spring, Fig. 2.

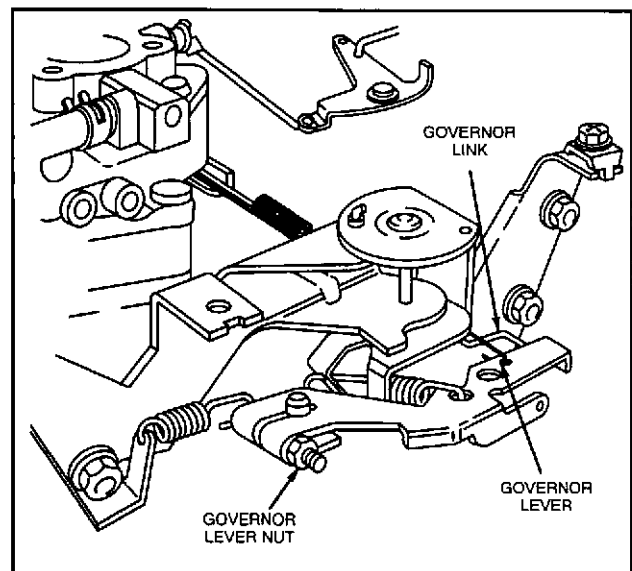


Fig. 2 - Removing Governor Lever

Remove rust, nicks and burrs from crankshaft PTO. Remove crankcase cover screws. Tap on side of cover to remove.

# GOVERNORS

## Remove & Inspect

### Inspect Governor

Governor slider must move freely on PTO journal of cam gear. Governor weights must move freely on hinge pins. Make sure hinge pins are not loose, Fig. 3. Replace governor if hinge pins are loose or governor slider does not move freely on journal.

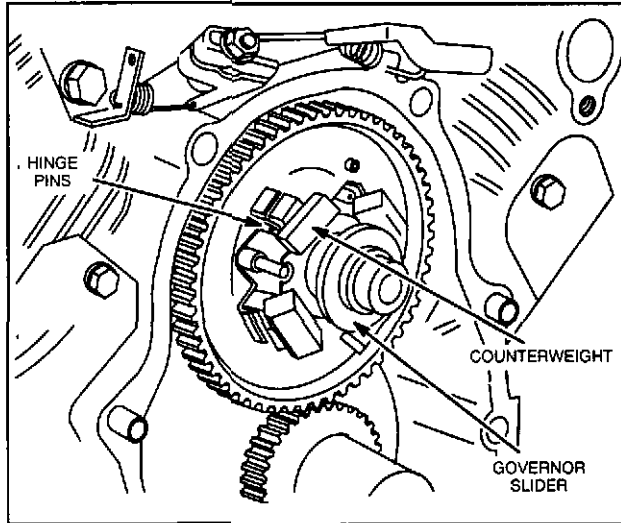


Fig. 3 - Governor Assembly

### Remove Governor Shaft

Remove cotter pin from upper end of shaft. Slide shaft downward and out of upper and lower bushings, Fig. 4. Remove shaft seal and discard. Remove any burrs around cotter pin hole in governor shaft.

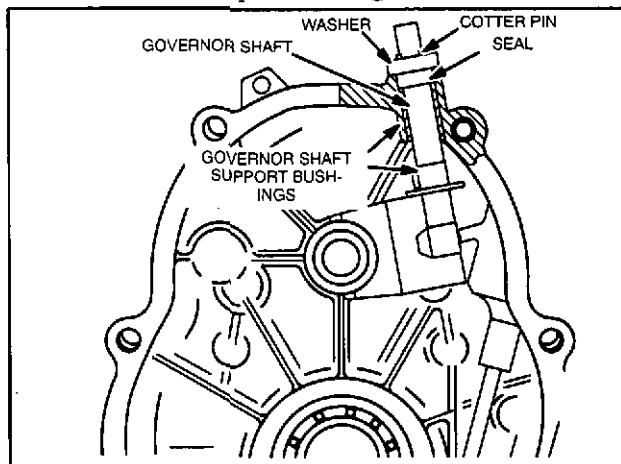


Fig. 4 - Governor Shaft Assembly

### Inspect Governor Shaft Bearings

Check bushings for burrs or foreign material. Replace bushings if worn out of round. The upper bushing can be removed using a 9.5 mm (3/8") rod to drive bearing downward into cover. Lower bushing is a slip fit. Replace the upper bushing using Tool #19204, Bushing Driver, to press in new bushing, Fig. 5. If lower bearing is worn in crankcase cover, crankcase cover must be replaced.

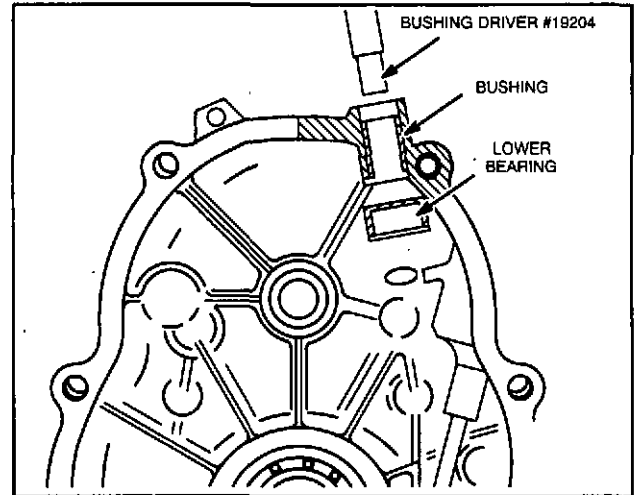


Fig. 5 - Replacing Upper Bearing

### Install Governor Shaft

Place lower bushing on governor shaft and slide shaft up through lower bearing and upper bushing. Install new shaft seal, then install plastic washer and cotter pin.



**WARNING:** MAKE SURE GOVERNOR SHAFT IS IN PROPER POSITION BEFORE INSTALLING CRANKCASE COVER, Fig. 6. IF GOVERNOR SHAFT IS NOT IN PROPER POSITION DURING ASSEMBLY, PROPER GOVERNOR ADJUSTMENTS CANNOT BE MADE AND ENGINE OVERSPEEDING COULD OCCUR. ENGINE DAMAGE, PERSONAL INJURY AND/OR PROPERTY DAMAGE ARE POSSIBLE.

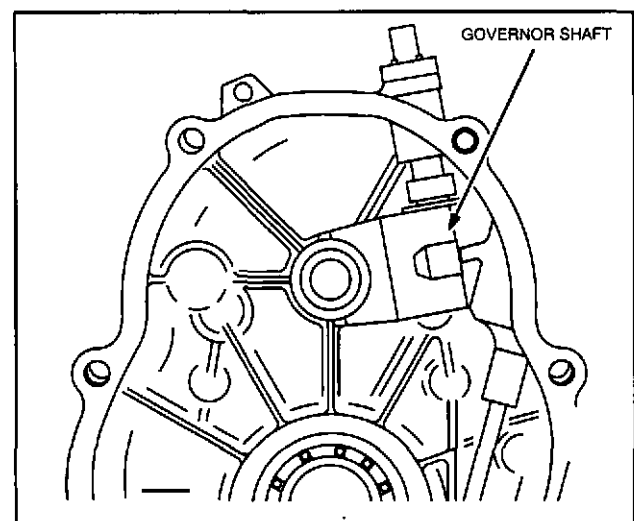


Fig. 6 - Governor Shaft Position

# GOVERNORS

## Install & Adjust

### Install Governor

Install governor slider onto shaft making sure that slot on slider fits over locating pin on cam gear, Fig. 7. Be sure the weights are in the proper location so that they will be able to move freely without binding.

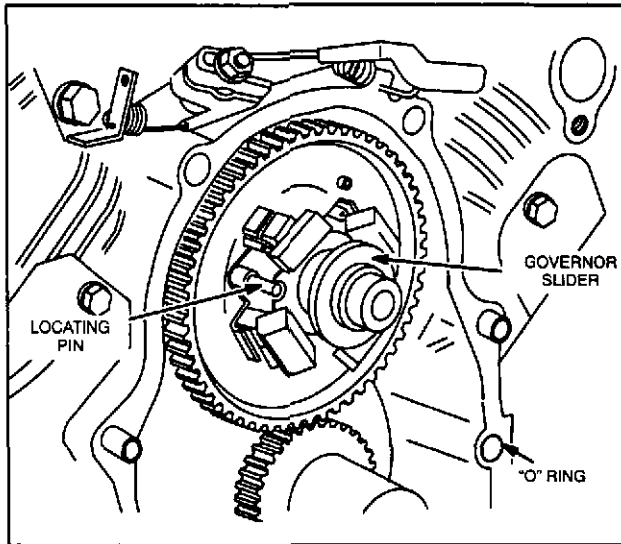


Fig. 7 - Governor

### Install Crankcase Cover

Place new cover gasket on crankcase. Rotate governor shaft clockwise to end of travel, Fig. 6. Insert Tool #19334, yellow seal protector, through seal. Slide cover onto crankshaft. No force should be used. NOTE: Be sure "O" ring is installed in cylinder, Fig. 7. Torque cover bolts in sequence shown to 17 Nm (150 in. lbs.), Fig. 8.

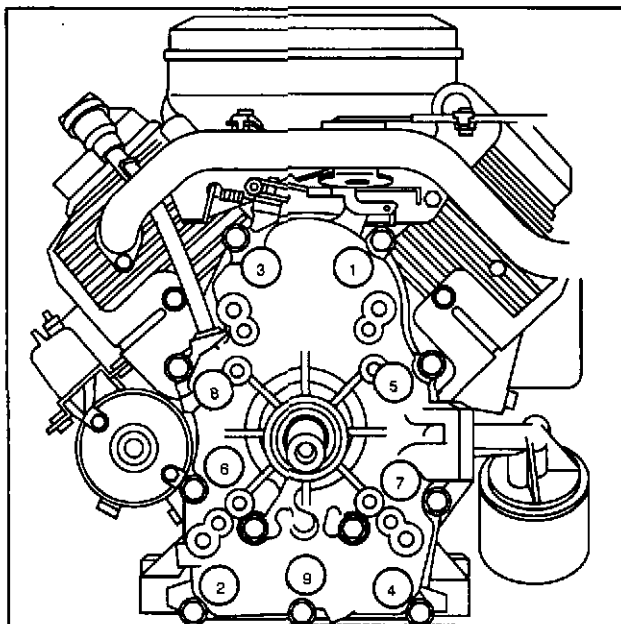


Fig. 8 - Torque Bolts

### Adjust Governor, Static (Before Running Engine)

**WARNING:** BEFORE STARTING OR RUNNING ENGINE, STATIC ADJUSTMENT OF THE GOVERNOR MUST BE MADE. FAILURE TO MAKE STATIC ADJUSTMENTS FIRST COULD RESULT IN ENGINE OVERSPEEDING WHICH MAY RESULT IN ENGINE OR EQUIPMENT DAMAGE CAUSING PERSONAL INJURY AND/OR PROPERTY DAMAGE.

All linkage must be installed to make adjustment. Loosen governor lever bolt and nut. Push on governor lever until throttle is wide open. **Do not bend governor link or distort governor lever.** Hold lever in this position and rotate governor shaft counterclockwise as far as it will go. Hold lever and shaft in position and torque governor lever bolt and nut to 8 Nm (70 in. lbs.), Fig. 9.

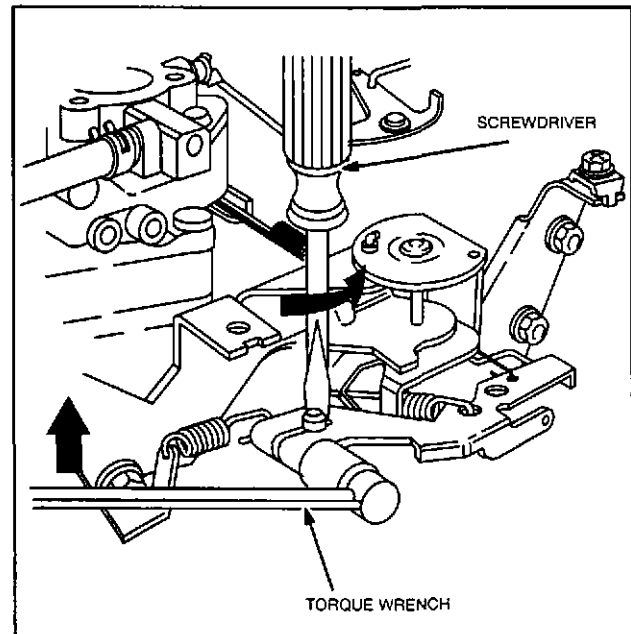


Fig. 9 - Static Governor Adjustment

# GOVERNORS

## Controls-Adjust

### Control Adjustments

Proper choke and speed control operation is dependent upon proper adjustment of manual friction or remote controls.

Move control lever to "CHOKE" position. The carburetor choke should be closed.

### To Adjust Choke - Remote Controls

Place control lever on equipment in "CHOKE" position. Loosen casing clamp screw. Move casing and wire until choke is completely closed. Tighten casing clamp screw, Fig. 10.

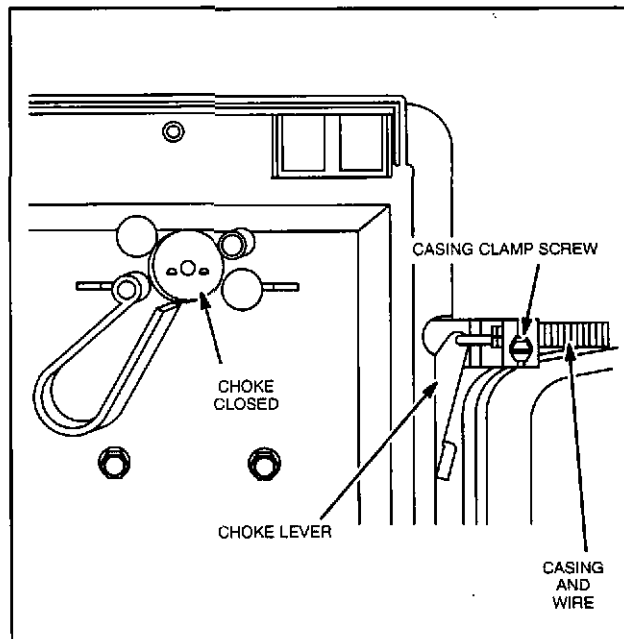


Fig. 10 - Choke Control Adjustment

### To Adjust Manual Friction or Remote Speed Control

Engine speed is controlled by the speed control lever. Move control lever to FAST position. Swivel on control bracket should be against stop. To adjust, loosen casing clamp screw. Move casing and wire in direction shown by arrow until swivel contacts stop, Fig. 11 or Fig. 12. Retighten casing clamp screw.

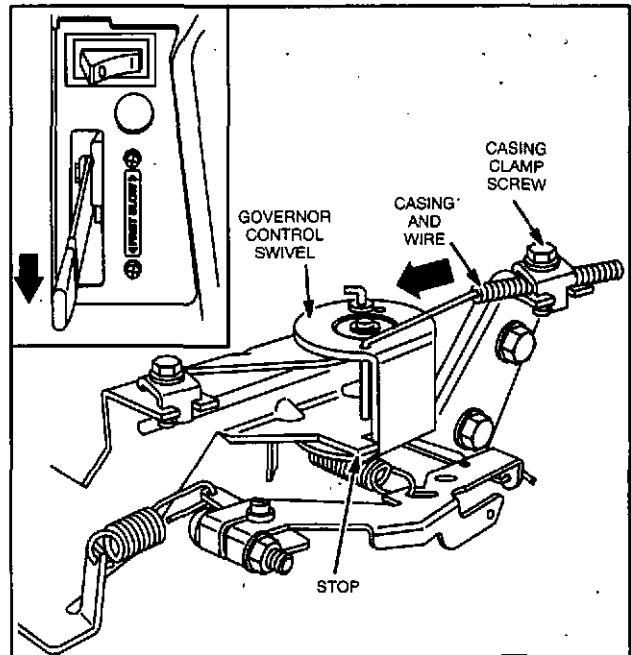


Fig. 11 - Manual Friction Control Adjustment

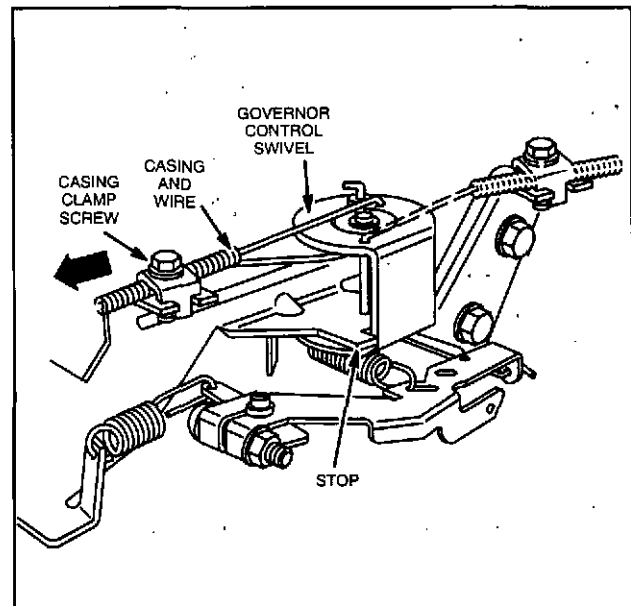


Fig. 12 - Remote Control Adjustment

# GOVERNORS Control-Adjust

## Adjust Governor, Manual Friction And Remote Speed Controls (Engine Running)

NOTE: Carburetor mixture adjustments must be made before adjusting governed idle, throttle restrictor and top no load RPM.

The following tools are required when making governor adjustments.

1. An accurate tachometer, such as Tool #19200 or #19389.
2. Tang bender, Tool #19352.

The tachometer and tang bender can be ordered through your Briggs & Stratton source of supply.

3. Move control lever to "SLOW" position. With an accurate tachometer and tang bender, Tool #19352, bend governed idle tang, (Fig. 13), to obtain RPM shown below:

1750 RPM - Governed idle spring Part #805453 (red).

1100 RPM - Governed idle spring Part #805454 (white).

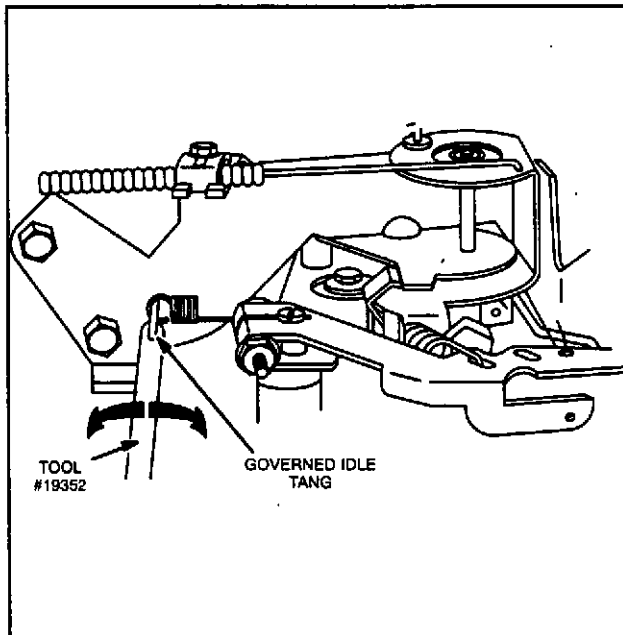


Fig. 13 - Adjusting Governed Idle

4. With equipment control lever in SLOW position and engine running at governed idle RPM, use

tang bender, Tool #19352, and bend throttle restrictor tang so that tang just contacts governor lever, Fig. 14.

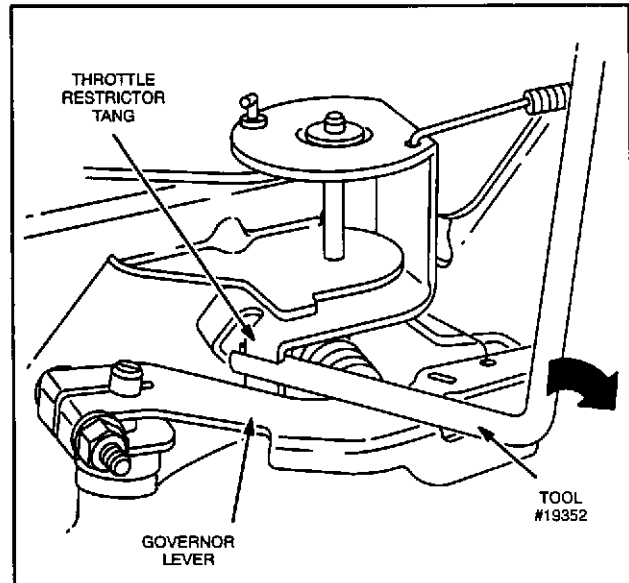


Fig. 14 - Adjusting Throttle Restrictor Tang

5. Refer to Service Engine Sales Microfiche, MS-6225 or the Service Engine Sales Manual, MS-4052, for Top No Load RPM by engine Model and Type Number.
6. Move control throttle lever to "FAST" position and check engine RPM with Tool #19200 or equivalent. Bend tang with Tool #19352 to obtain desired Top No Load RPM, Fig. 15.

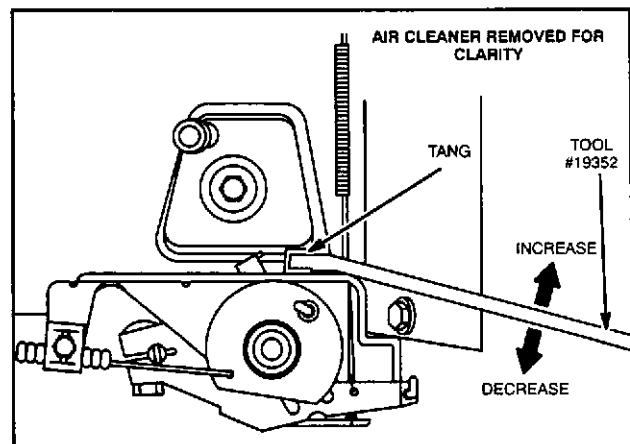


Fig. 15 - Adjusting Top No-Load Speed

# GOVERNORS

## Control-Adjust

### Adjust Governor Fixed Speed Adjustable (Engine Running)

NOTE: Carburetor mixture adjustments must be made before adjusting governed idle, throttle restrictor and top no load RPM.

The following tools are required when making governor adjustments.

1. An accurate tachometer, such as Tool #19200 or #19389.
2. Tang bender, Tool #19352.

The tachometer and tang bender can be ordered through your Briggs & Stratton source of supply.

1. Turn fixed speed adjustable control nut counter-clockwise until control swivel contacts slow speed stop. With an accurate tachometer and tang bender, bend governed idle tang (Fig. 16) to obtain RPM shown below:

1750 RPM – Governed idle spring Part #805453 (red).

1100 RPM – Governed idle spring Part #805454 (white).

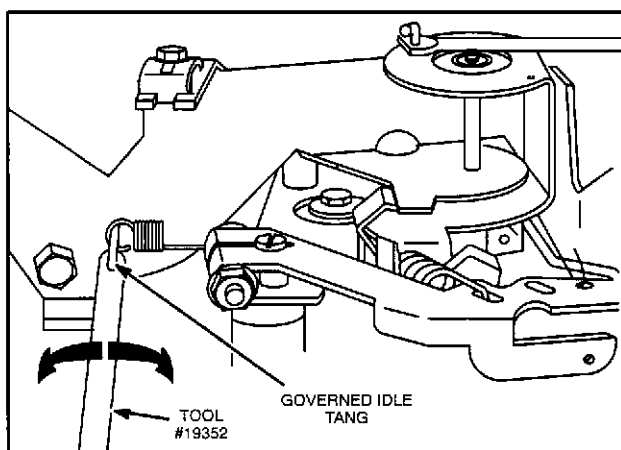


Fig. 16 - Adjusting Governed Idle

2. With engine running at governed idle RPM, use tang bender, Tool #19352, and bend throttle restrictor tang so that tang just contacts governor lever, Fig. 17.

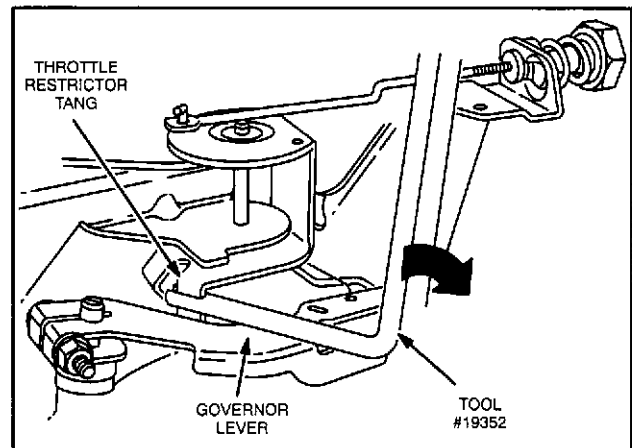


Fig. 17 - Adjusting Throttle Restrictor Tang

3. Refer to Service Engine Sales Microfiche, MS-6225 or Service Engine Sales Manual, MS-4052 for Top No Load RPM by engine Model and Type Number.
4. While checking engine RPM with tachometer, turn fixed speed adjustable control nut clockwise until desired Top No Load RPM is obtained, Fig. 18.

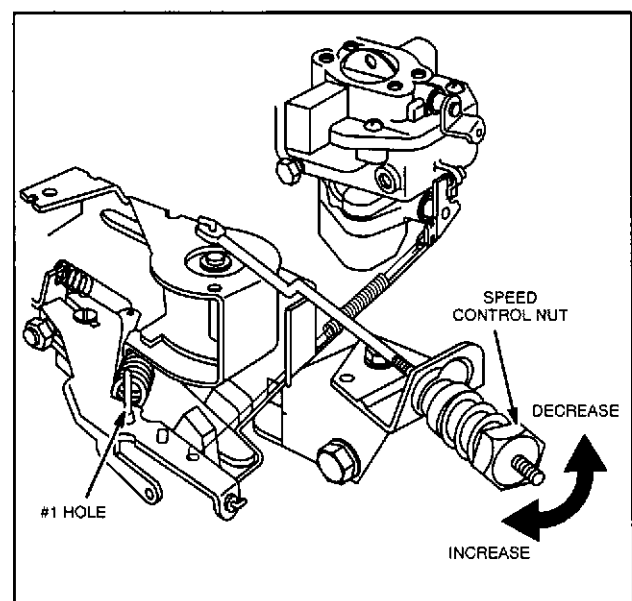


Fig. 18 - Governor Adjustment, Fixed Speed

# GOVERNORS Control-Adjust

## Adjust Governor Fixed Speed Adjustable – Generators

No governed idle spring is used with this system. No throttle restrictor adjustment is necessary. The primary governor spring is installed in #2 hole on governor lever. A secondary governor spring is installed as shown in Fig. 19.

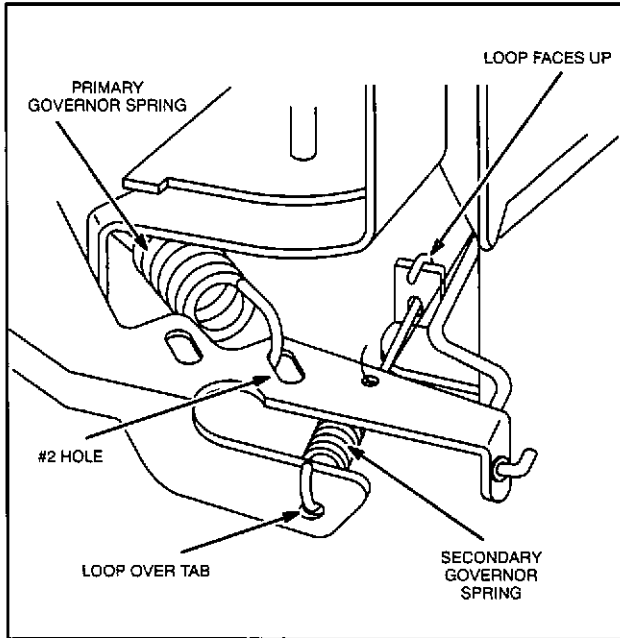


Fig. 19 – Governor Springs, Generator

NOTE: Carburetor mixture adjustments must be made before adjusting governed idle, throttle restrictor and top no load RPM.

## Adjust Secondary Governor Spring

NOTE: Secondary governor spring must be adjusted before the engine is started. Perform adjustment in the sequence shown.

The secondary governor spring adjustment is made with the engine not running.

1. Disengage the adjustable fixed speed control nut.
2. Loosen and remove fixed speed adjustable control nut, spring and retainer. Then, rotate governor control swivel counterclockwise to end of travel.
3. Install adjustment gauge, Tool #19385, with notch over end of governor lever and flat end of tool

against governor control bracket as shown in Fig. 20.

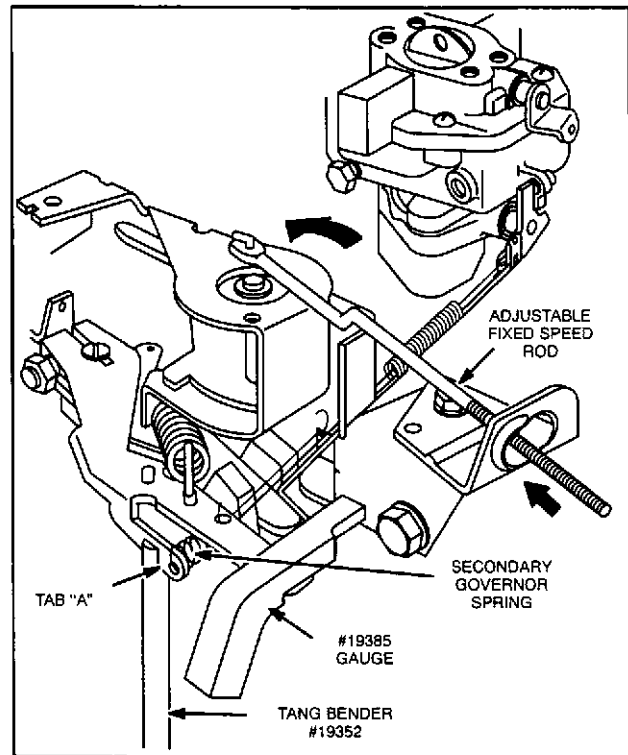


Fig. 20 – Adjusting Secondary Spring

4. Holding gauge in position, bend tab "A" so that all slack is removed from secondary governor spring between its two anchor points, Fig. 20. DO NOT STRETCH SPRING.
5. Remove adjustment gauge.

## Adjust Governor Fixed Speed Adjustable – Generators (Engine Running)

NOTE: Carburetor mixture adjustments must be made before adjusting top no load RPM.

The following tools are required when making governor adjustments.

1. An accurate tachometer, such as Tool #19200 or #19389.
2. Tang bender, Tool #19352.

The tachometer and tang bender can be ordered through your Briggs & Stratton source of supply.

# GOVERNORS

## Control-Adjust

1. With engine running, pull control rod out until swivel is against stop and hold in this position, Fig. 21. Using tang bender, Tool #19352, adjust to **Top No Load RPM**, for the type of generator listed in Table 1. Then, re-install fixed speed adjustable control nut, spring and retainer. Turn nut clockwise until threads on control rod are visible from end of nut.

TABLE NO. 1

Generator Type	Top-No-Load RPM	Regulated No-Load RPM
3600 RPM 60 Cycle	4250 RPM	3750 RPM
3000 RPM 50 Cycle	3600 RPM	3150 RPM

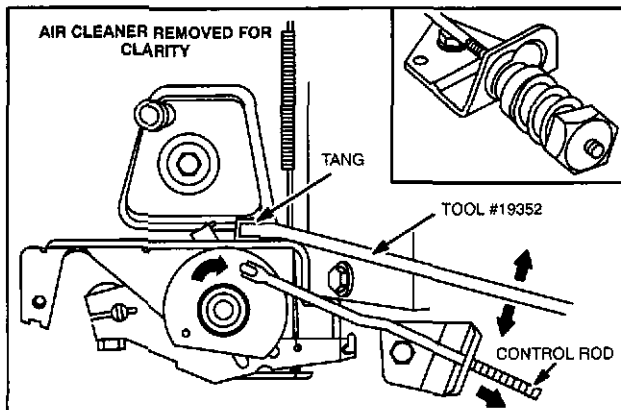


Fig. 21 - Adjusting Top No Load Speed

2. Now, engage the fixed speed adjustable control nut and adjust to **Regulated No Load RPM** for the type of generator listed in Table 1. Turn nut clockwise to increase speed. Turn nut counter-clockwise to decrease speed, Fig. 22.

Note: Final adjustment should be made with with generator loaded to rated capacity or manufacturers specifications.

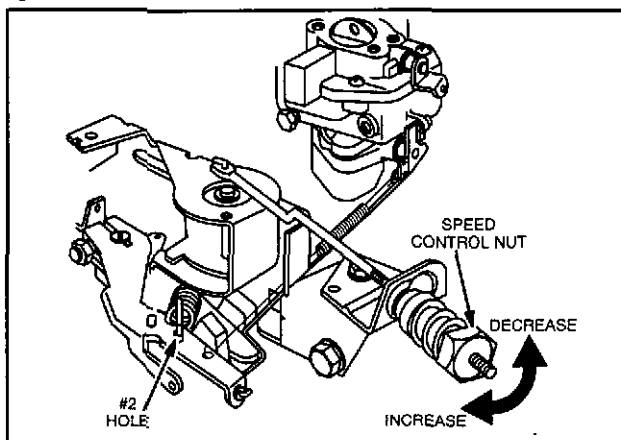


Fig. 22 - Adjusting Top No Load Speed

## Adjust Governor, Remote Speed Control Engines Equipped With Secondary Governor Spring

Some OHV-Twin engines with remote speed control are equipped with a secondary governor spring. The primary governor spring is installed in #1 hole on governor lever.

NOTE: Secondary governor spring must be adjusted before the engine is started. Perform adjustment in the sequence shown.

## Adjust Secondary Governor Spring

1. With equipment control in SLOW position, install adjustment gauge, Tool #19385, with notch over end of governor lever and flat end of tool against governor control bracket as shown in Fig. 23.

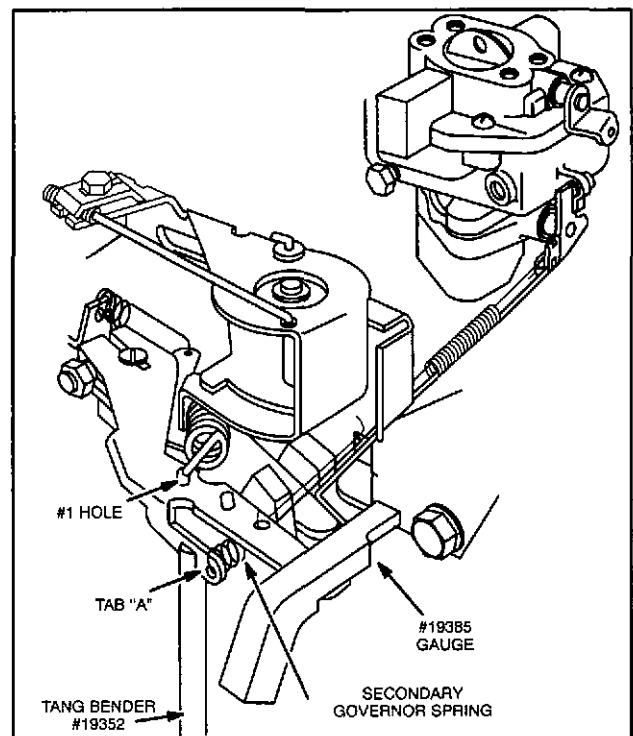


Fig. 23 - Adjusting Secondary Spring

2. Holding gauge in position, bend tab "A" so that all slack is removed from secondary governor spring between its two anchor points, Fig. 23. DO NOT STRETCH SPRING.
3. Remove adjustment gauge.

# GOVERNORS Control-Adjust

## Adjust Governor, Remote Speed Control Engines Equipped With Secondary Governor Spring (Engine Running)

NOTE: Carburetor mixture adjustments must be made before adjusting governed idle, throttle restrictor and top no load RPM.

The following tools are required when making governor adjustments.

1. An accurate tachometer, such as Tool #19200.
2. Tang bender, Tool #19352.

The tachometer and tang bender can be ordered through your Briggs & Stratton source of supply.

1. Move control lever to "SLOW" position. With an accurate tachometer and tang bender, Tool #19352, bend governed idle tang, (Fig. 24), to obtain RPM shown below:

1750 RPM - Governed idle spring Part #805453 (red).

1100 RPM - Governed idle spring Part #805454 (white).

NOTE: Engine Model 303447 Type 0411-01: Adjust governed idle to 1350 RPM  $\pm$  50 RPM.

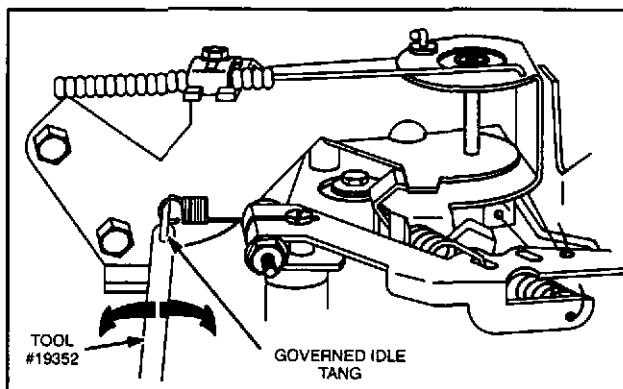


Fig. 24 - Adjusting Governed Idle

2. With equipment control lever in SLOW position and engine running at governed idle RPM, use tang bender, Tool #19352, and bend throttle restrictor tang so that tang just contacts governor lever. Fig. 25.

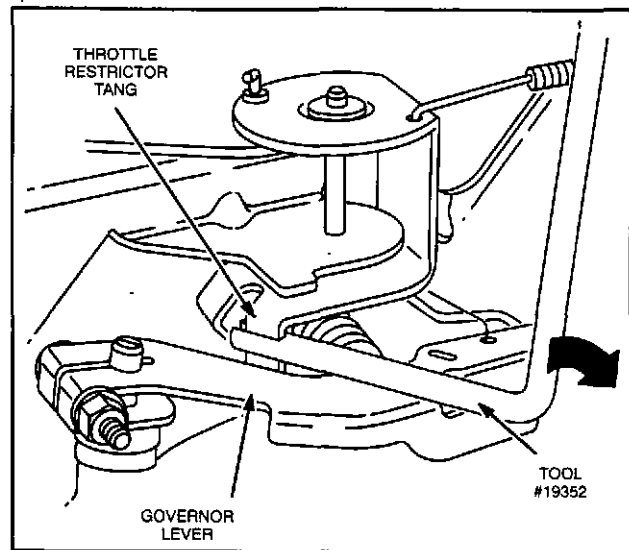


Fig. 25 - Adjusting Throttle Restrictor Tang

3. Refer to Service Engine Sales Microfiche, MS-6225 or the Service Engine Sales Manual, MS-4052, for Top No Load RPM by engine Model and Type Number.
4. Move control throttle lever to "FAST" position and check engine RPM with Tool #19200 or equivalent. Bend tang with Tool #19352 to obtain desired Top No Load RPM, Fig. 26.

NOTE: Engine Model 303447 Type 0411-01: Set Top No Load to 2900 RPM  $\pm$  50 RPM.

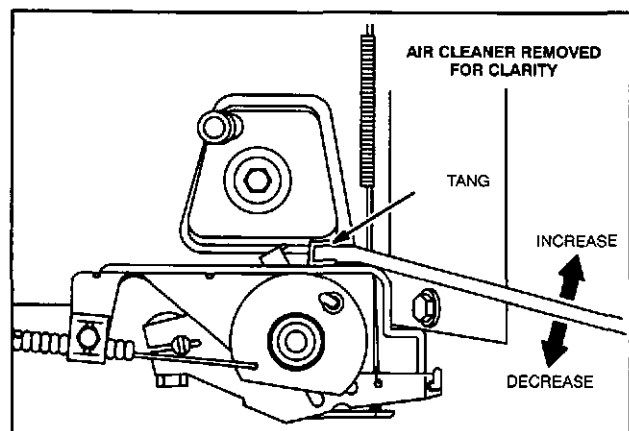


Fig. 26 - Adjusting Top No Load Speed

# Section 6 COMPRESSION

Briggs & Stratton does not publish any compression pressures, as it is extremely difficult to obtain an accurate reading without special equipment.

It has been determined through testing, a simple and accurate indication of compression can be made as follows:

Remove both spark plugs and insert a compression gauge into either cylinder (one cylinder at a time). Turn engine over with engine starter until there is no further increase in pressure. Record this reading. Repeat procedure on other cylinder and record that reading. The difference between both cylinders should not exceed 25%. More than 25% indicates loss of compression in the cylinder with lower pressure. See example.

### Example:

	Cyl. #1	Cyl. #2	Diff.	% Diff.
Eng. #1	4.5 Kgcm(2) (65 PSI)	3.9 Kgcm(2) (60 PSI)	0.3 Kgcm(2) (5 PSI)	7.6%
Eng. #2	5.1 Kgcm(2) (75 PSI)	3.8 Kgcm(2) (55 PSI)	1.4 Kgcm(2) (20 PSI)	26.7%

**LOSS OF COMPRESSION WILL USUALLY BE THE RESULT OF THE FOLLOWING:**

1. Blown or leaking head gasket.
2. Valves sticking or not seating properly.
3. Piston rings not sealing, which would also cause the engine to consume an excessive amount of oil.

Combustion chamber deposits should be removed every 500 hours of use or whenever the cylinder head is removed. To aid identification of cylinders and cylinder heads, numbers are cast on the cylinder facing the flywheel side of the engine, Fig. 1, and on the cylinder heads, Fig. 1A.

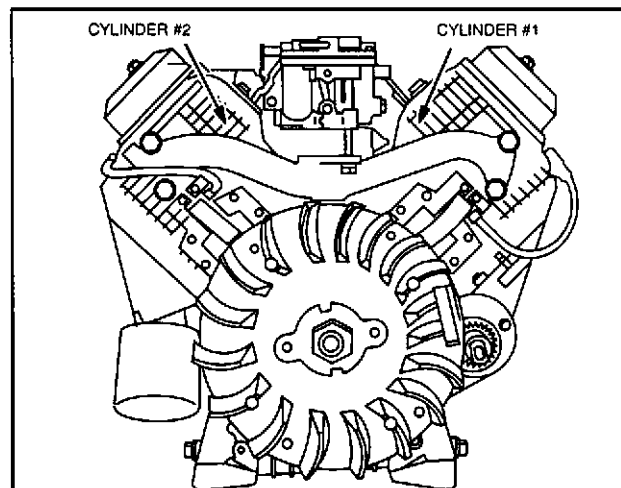


Fig. 1 - Cylinder Number Location

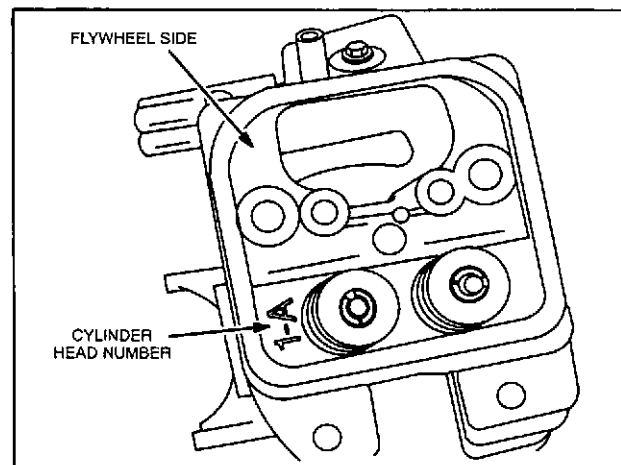


Fig. 1A - Cylinder Head Number Location

### Remove Cylinder Heads

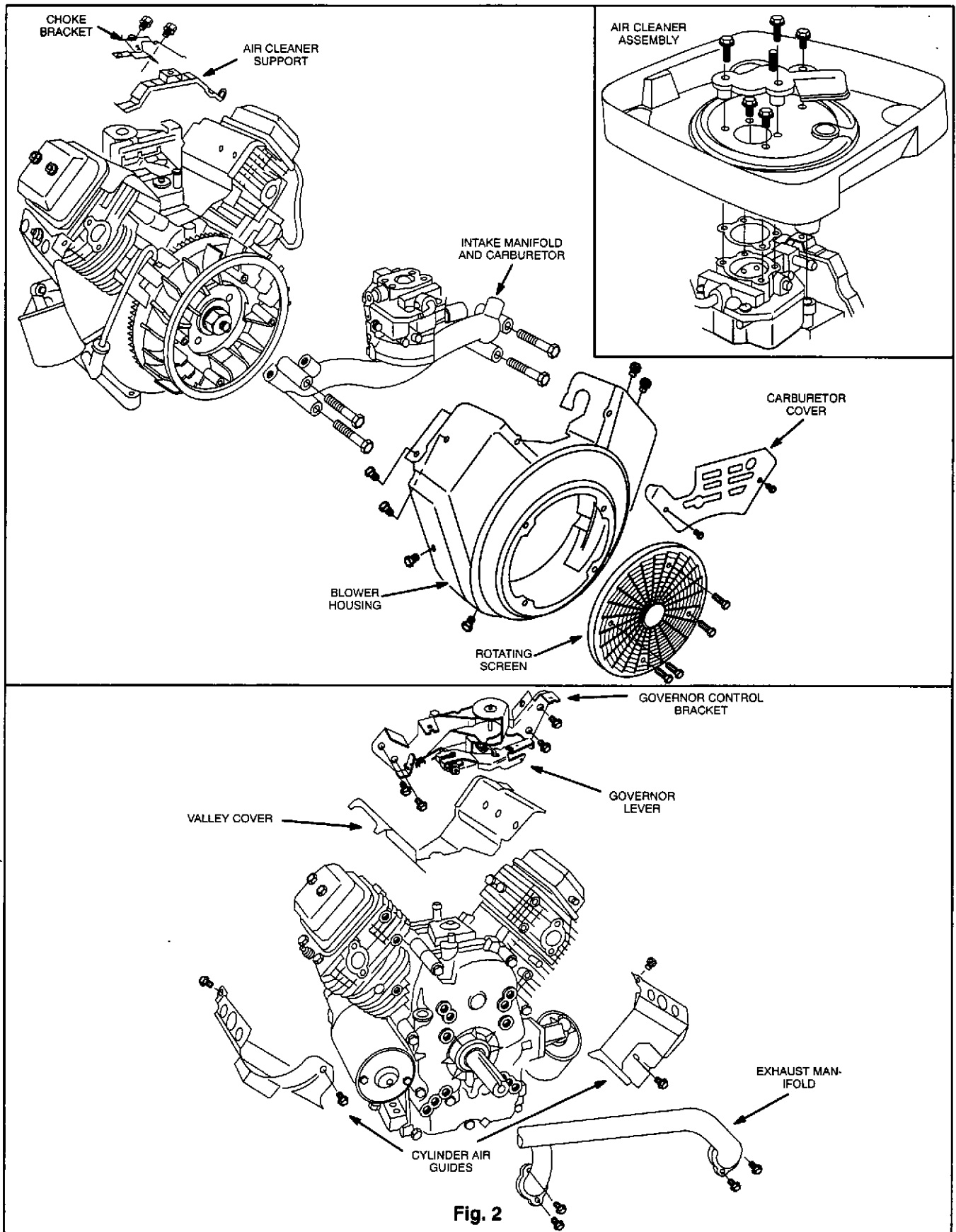
IT IS RECOMMENDED THAT ALL PARTS BE MARKED WHEN DISASSEMBLING CYLINDER HEADS TO PREVENT INTERCHANGING.

Disconnect spark plug leads and remove spark plugs. Air cleaner assembly and support, choke bracket, blower housing, intake manifold and carburetor, valley cover, exhaust manifold, governor control bracket and linkage and cylinder air guides must be removed before cylinder heads can be removed, Fig. 2.

# COMPRESSION

## Cylinder Head Removal

6



# COMPRESSION Disassemble Cylinder Head

## Remove Rocker Arm Shaft

Remove two nuts and seals from valve cover. Remove valve cover and gasket, Fig. 3.

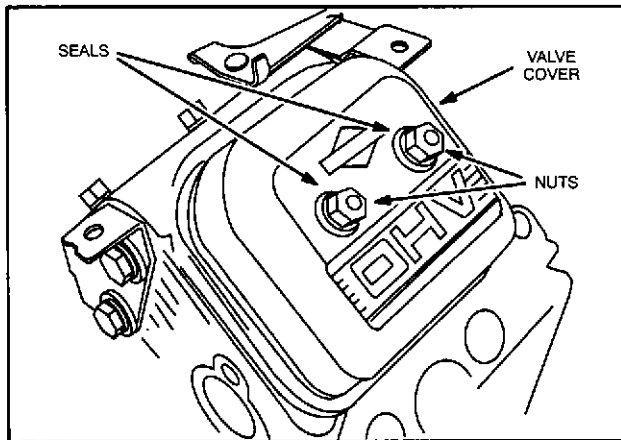


Fig. 3 - Removing Valve Cover

To release spring pressure from rocker arms, rock the arm against spring pressure and allow push rod to drop out of the rocker arm socket. Push rod will move out of position, releasing valve spring pressure, Fig. 4.

NOTE: EXHAUST VALVE PUSH RODS ARE ALUMINUM. MARK PUSH RODS FOR IDENTIFICATION WITH TAPE OR TAGS TO PREVENT INTERCHANGING.

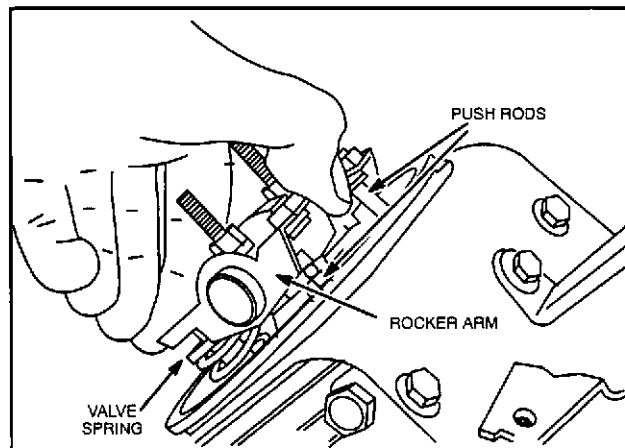


Fig. 4 - Releasing Spring Pressure

NOTE: Two different style rocker arms have been used. Engines manufactured after code date 93103100 are equipped with cast aluminum rocker arms. Engines manufactured before code date 93110100 were equipped with stamped steel rocker arms. See Fig. 5.

The valve springs are different, depending upon the type of rocker arm used. The valve springs used with the cast aluminum rocker arms are color coded PURPLE and must only be used with cast aluminum rocker arms. The valve springs used with the stamped steel rocker arms are NOT color coded and must only

be used with stamped steel rocker arms. DO NOT INTERCHANGE VALVE SPRINGS.

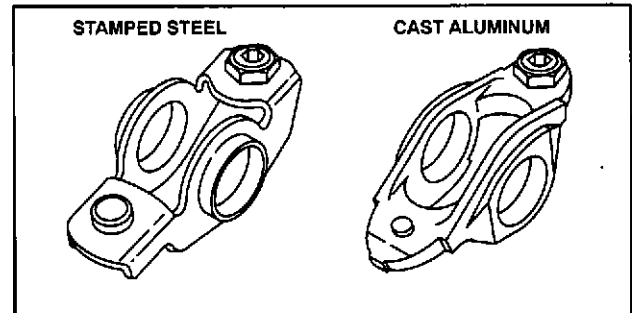


Fig. 5 - Rocker Arm Identification

Remove two rocker studs. Then, remove shaft, rocker arms and rocker arm supports, Fig. 6 and Fig. 7. Lift out push rods.

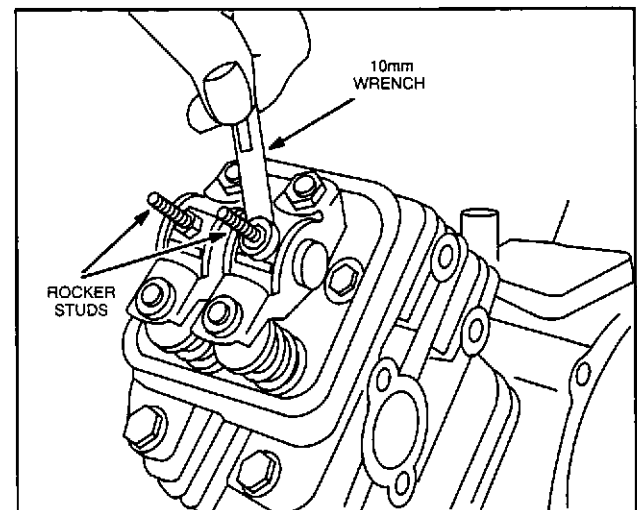


Fig. 6 - Removing Rocker Studs

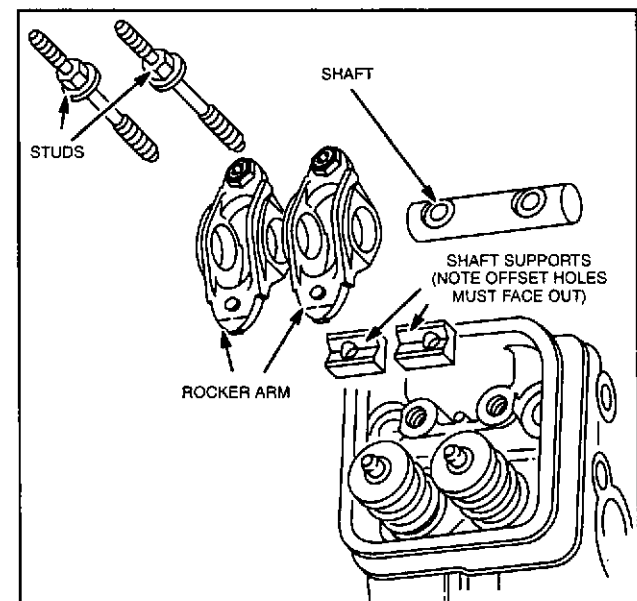


Fig. 7 - Removing Rocker Assembly

# COMPRESSION

## Disassemble Cylinder Head

### Remove Cylinder Head

Remove four cylinder head screws, Fig. 8. Remove two sealing washers.

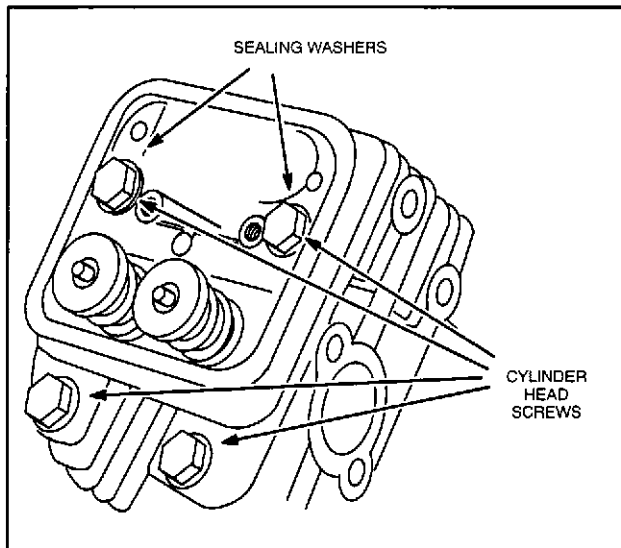


Fig. 8 - Removing Cylinder Head Bolts

Remove cylinder head, and gasket, Fig. 9.

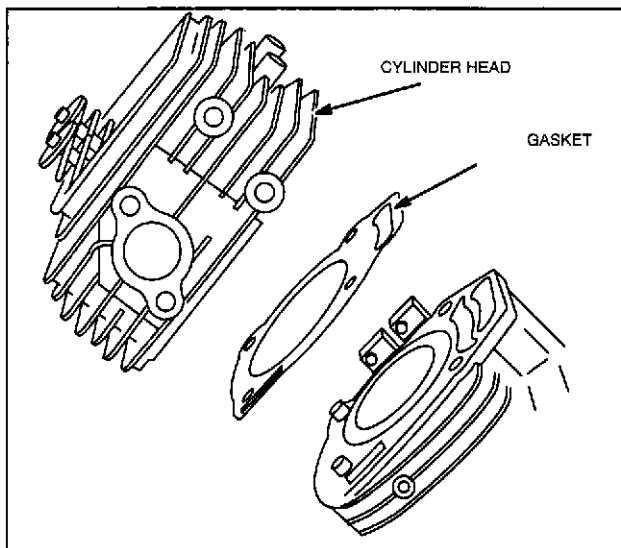


Fig. 9 - Removing Cylinder Head

### Remove Combustion Chamber Deposits

Remove combustion chamber deposits from combustion chamber and around valves using a soft, hand wire brush or scraper. With piston at Top Dead Center, remove combustion chamber deposits from top of piston. Use care to prevent combustion chamber deposits from entering push rod or oil return cavity in cylinder.

Take care not to damage cylinder, top of piston, cylinder head and cylinder head gasket surfaces.

**NOTE:** Remove only the combustion chamber deposits. It is not necessary to remove the discoloration marks on the piston, valves and cylinder head. These marks are normal and will not affect engine operation.

Remove the loose deposits from around the top ring land area using compressed air or a soft bristle brush.

**WARNING:** To prevent eye injury always wear eye protection when using compressed air.

Inspect cylinder head for broken fins or cracks. Repeat procedure for other cylinder head and cylinder.

### Remove Valves

Place cylinder head on workbench with support to hold valves in place. A shop cloth or short section of starter rope placed in the combustion chamber will hold the valves in place when compressing the valve springs.

Reinstall rocker studs into cylinder head. Do not tighten. Slip end of Valve Spring Compressor, Tool # 19347, under stud and over valve spring. Press down on tool handle to compress valve spring and remove split retainers, Fig. 10. Release pressure and remove retaining washer and spring. Remove rocker studs.

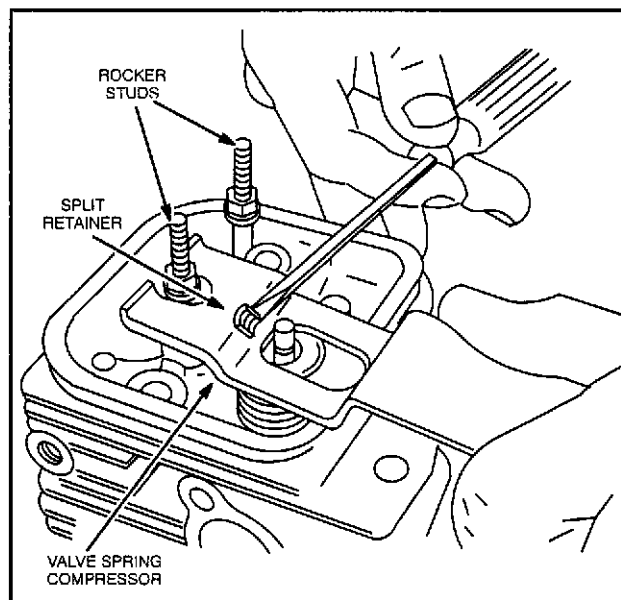


Fig. 10 - Removing Retainers

# COMPRESSION Valves & Guides

## Remove Valve Stem Seals

Always replace valve stem seals whenever valves are removed for servicing.

To remove valve stem seals, grasp seal with pliers and pull up on seal while turning, Fig. 11.

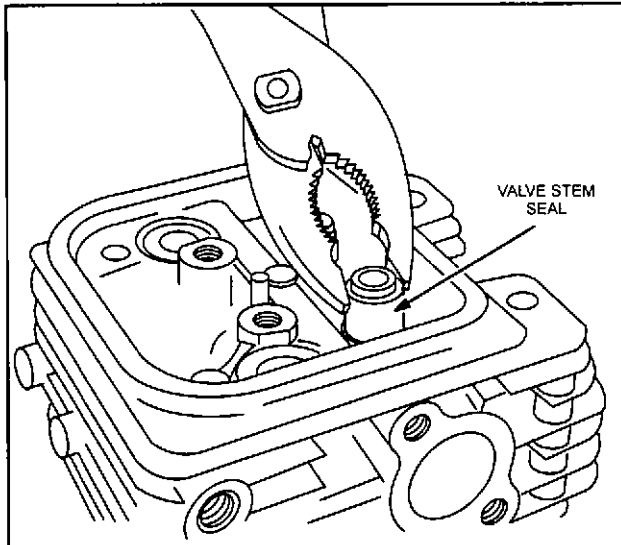


Fig. 11 - Removing Seals

## Reface Valves And Seats

Faces on valves may be resurfaced with a valve grinder to 45°. Valve seats can be reconditioned using Valve Seat Cutter, Tool #19343. Valves and seats should then be lapped with Valve Lapping Tool #19258 and Valve Lapping Compound, Tool #94150 to remove grinding marks and assure a good seal between valve and seat. Thoroughly clean lapping compound from valve seat and valve face.

Valve seat width should be 1.6 mm (1/16") to not less than 1.2 mm (3/64"), Fig. 11. If seat is wider, it may be narrowed using Valve Seat Cutter, Tool #19343. Use 30° side of cutter to narrow the seats. If the valve is badly burned, it should be replaced. Replace valve if margin is .4 mm (1/64") or less, after refacing, Fig. 12. If seat is badly burned or damaged, replace cylinder head. Valve seats are not replaceable.

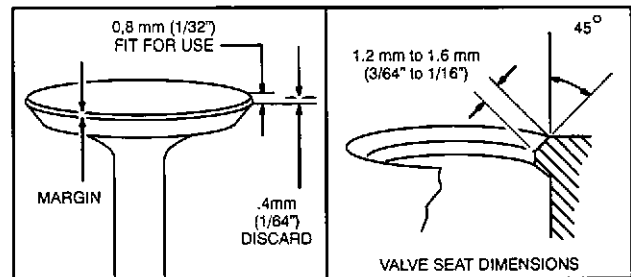


Fig. 12 - Valve and Seat Dimensions

## Inspect Valve Springs

Replace broken or worn valve springs.

## Inspect Valve Guides

If flat end of plug gauge, Tool # 19382, can be inserted into the valve guide 1/4" or more, the guide must be replaced. If plug gauge is not available, refer to Table No. 1 for reject dimension.

Table No. 1  
Valve Guide Reject Dimension

Intake and Exhaust  
6.05 mm  
(.238")

## Remove Valve Guides

Use Tool #19367, Bushing Driver, to remove valve guide. Support cylinder head and press out valve guide, Fig. 13.

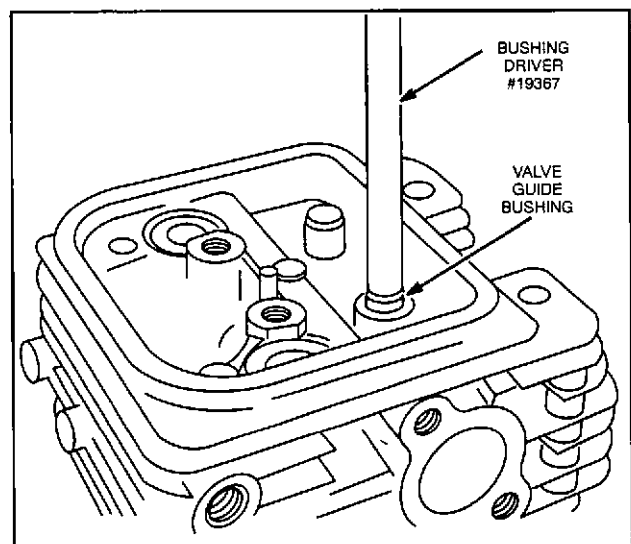


Fig. 13 - Removing Valve Guide

# COMPRESSION Cylinder Head Assembly

## Install Valve Guides

Place new valve guide, on Bushing Driver, Tool #19367. Valve guide can be installed either way. Press in valve guide to dimension shown in Fig. 14, 7 mm (9/32").

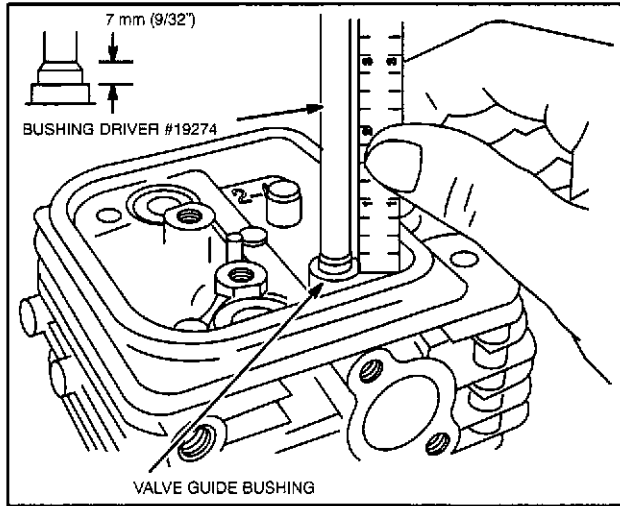


Fig. 14 - Installing Valve Guide

Use Finish Reamer, Tool #19346, and Reamer Pilot Guide, Tool #19345, to finish ream valve guide, Fig. 15. Use oil, Stanisol® or kerosene to lubricate reamer. Ream through entire guide. Keep turning reamer clockwise when removing reamer. Flush out all chips.

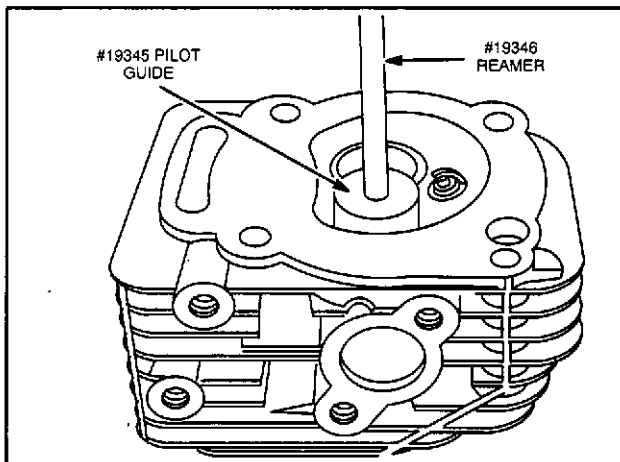


Fig. 15 - Reaming Valve Guide

## Install Valve Stem Seals And Valves

Install new seals over valve guides. Press down on seal until it bottoms.

Valve stems must be free of foreign material and burrs or sticking will occur and valve stem seals will be damaged. Be sure valve guides are free of foreign materials and burrs. Lightly coat valve stems with Valve Guide Lubricant, #93963 and insert valves into valve guides.

NOTE: Be sure Valve Guide Lubricant, #93963 is not on valve face, seat or end of valve stem.

Place cylinder head on workbench with support to hold valves in place. A shop cloth or short section of starter rope placed in the combustion chamber will hold the valves in place when compressing the valve springs.

Install springs and valve spring retainers over valve stems. Temporarily install rocker studs in cylinder head. With Valve Spring Compressor, Tool #19347, compress spring and install split retainers, Fig. 16. Repeat procedure for other valves. Remove rocker studs.

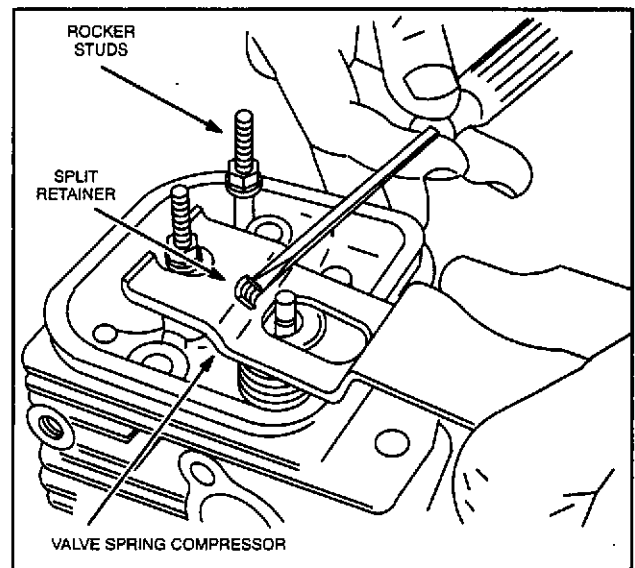


Fig. 16 - Installing Valve Retainers

## Install Cylinder Heads

Place new gasket and cylinder head on cylinder. Some engine models are equipped with cylinder head alignment sleeves located in the cylinder, Fig. 17.

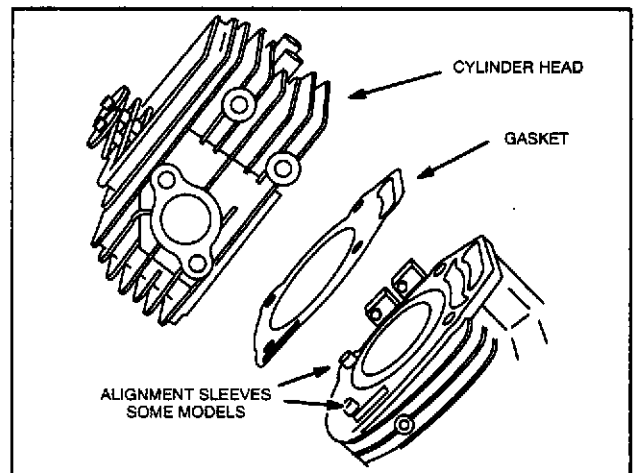


Fig. 17 - Installing Cylinder Head

# COMPRESSION Cylinder Head Assembly

Apply #93963 Lubricant, to screw threads and install four cylinder head screws and two sealing washers, Fig. 16. **DO NOT USE SEALER OF ANY KIND ON GASKETS.** Tighten four screws down evenly by hand. Then, using Torque Wrench, Tool #19197 or equivalent, torque cylinder head screws in sequence shown, Fig. 18, to 19 Nm (165 in. lbs.).

**NOTE:** Do not tighten one screw down completely before the others, as it may cause a warped cylinder head.

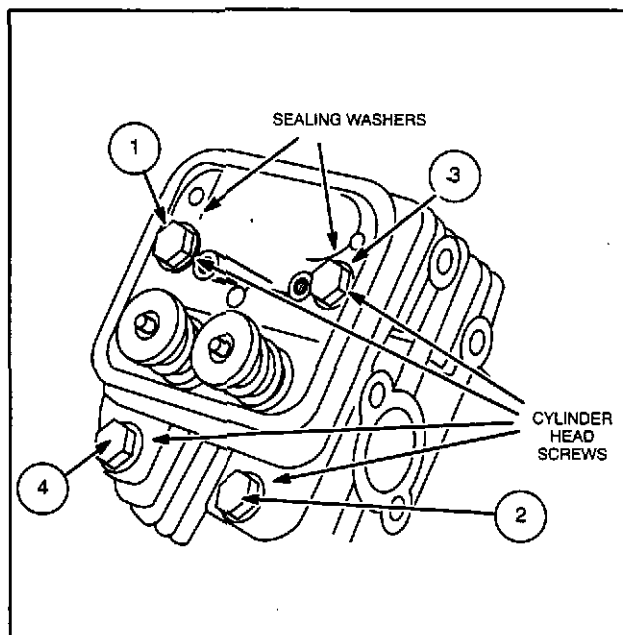


Fig. 18 - Installing Cylinder Head Bolts

## Install Push Rods

**NOTE:** EXHAUST VALVE PUSH RODS ARE ALUMINUM. DO NOT interchange with intake push rods. Exhaust valve push rods are a dull gray color. If in doubt, a magnet may be used to identify push rods.

Insert push rods into recess in tappets.

## Install Rocker Arms

**NOTE:** Rocker shaft support holes are offset. Install with holes facing ends of rocker shaft, Fig. 19. Assemble rocker arms, shaft, supports and studs and install on cylinder head, Fig. 19. Torque studs to 16 Nm (140 in. lbs.), Fig. 20.

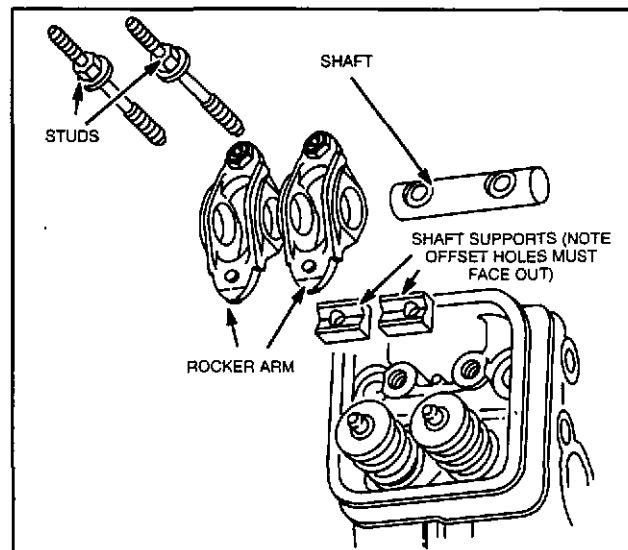


Fig. 19 - Assembling Rocker Arms

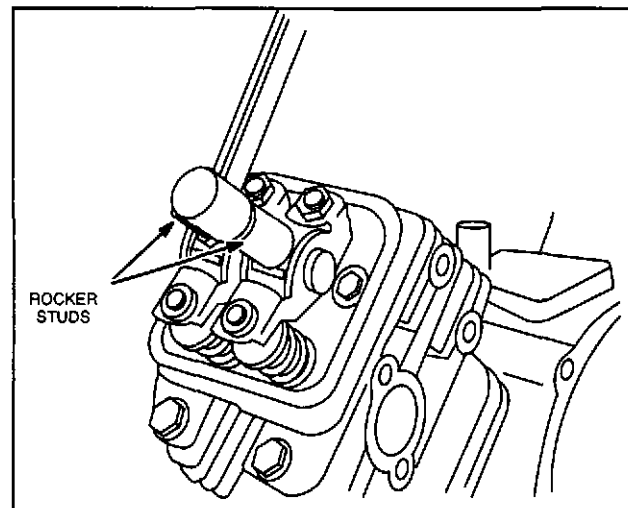


Fig. 20 - Installing Rocker Studs

Compress valve spring with rocker arm and insert push rod into rocker arm socket, Fig. 21. Be sure push rods remain seated in recess in tappets.

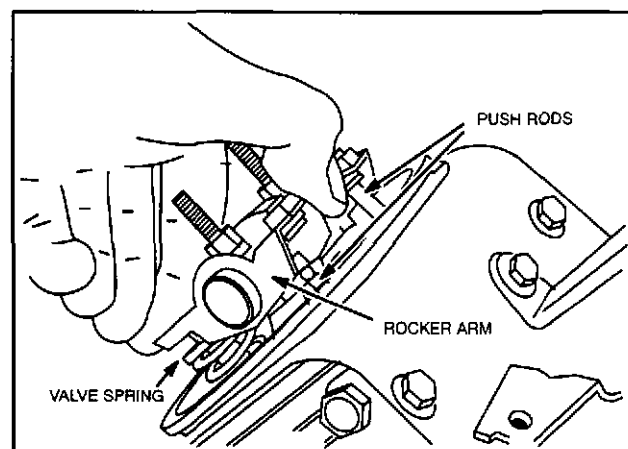


Fig. 21 - Insert Push Rods

# COMPRESSION

## Adjust Valve Clearance

### Adjust Valve Clearance

NOTE: Correct position of crankshaft is necessary to eliminate interference by the compression release mechanism on the cam gear when adjusting valve clearance.

Turn crankshaft until piston in cylinder you are checking is at Top Dead Center, on the compression stroke (both valves closed). Using a screwdriver or similar object inserted through spark plug hole and touching the top of the piston, continue turning crankshaft clockwise until piston has moved 6.35 mm (1/4") past Top Dead Center.

Check valve clearance with feeler gauge between valve stem and rocker arm. Valve clearance is .10-.16 mm (.004"-.006") for intake and exhaust. Adjust as necessary, Fig. 22. Tighten locknut while holding adjusting screw. Torque lock nut to 7 Nm (60 in. lbs.). Recheck clearance. Readjust if required.

Rotate crankshaft several turns to check for proper operation.

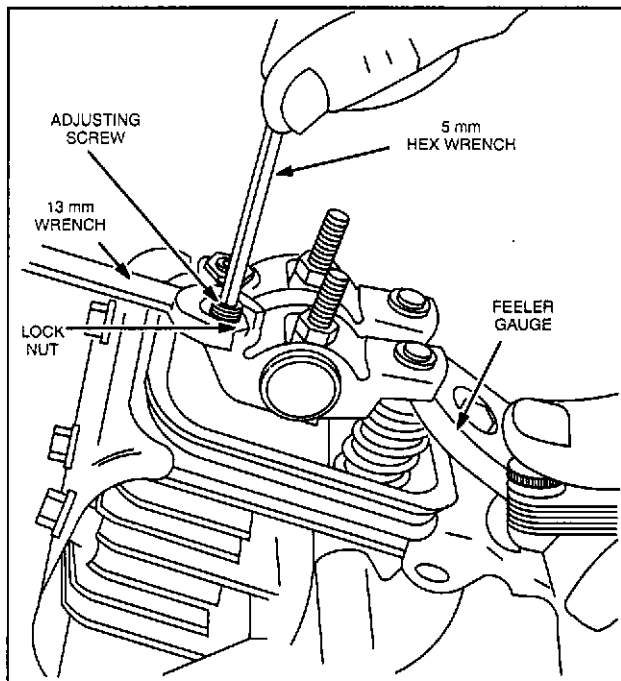


Fig. 22 - Adjusting Valve Clearance

### Install Valve Cover

Install gasket and valve cover. Place seal washers and nuts on studs, Fig. 23. Torque nuts to 3 Nm (25 in. lbs.).

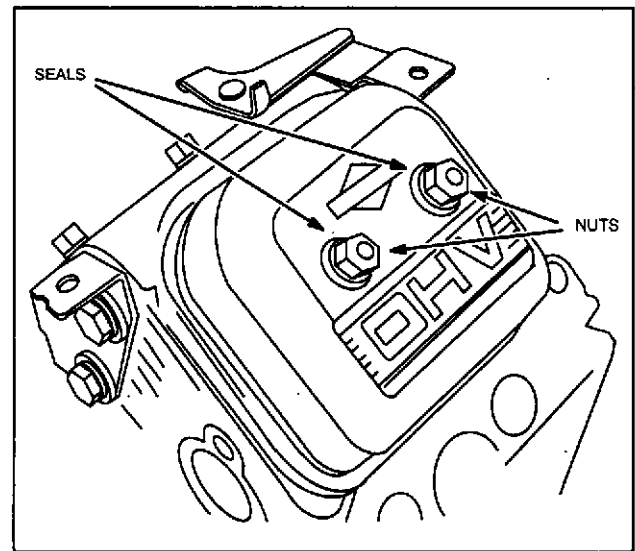


Fig. 23 - Installing Valve Cover

Install intake and exhaust manifold, governor control bracket, cylinder air guides, valley cover, blower housing and air cleaner assembly. Install and torque spark plugs to 20 Nm (180 in. lbs.). Install spark plug leads.

# Section 7A

## REWIND STARTERS

### Starter Identification

Two different rewind starters are used on V-Twin engines. The current style starter along with the starter cup are not interchangeable with the early style starter and cup. Also, the rewind starter components are not interchangeable. Fig. 1 shows how to identify the current style rewind starter from the the early style.

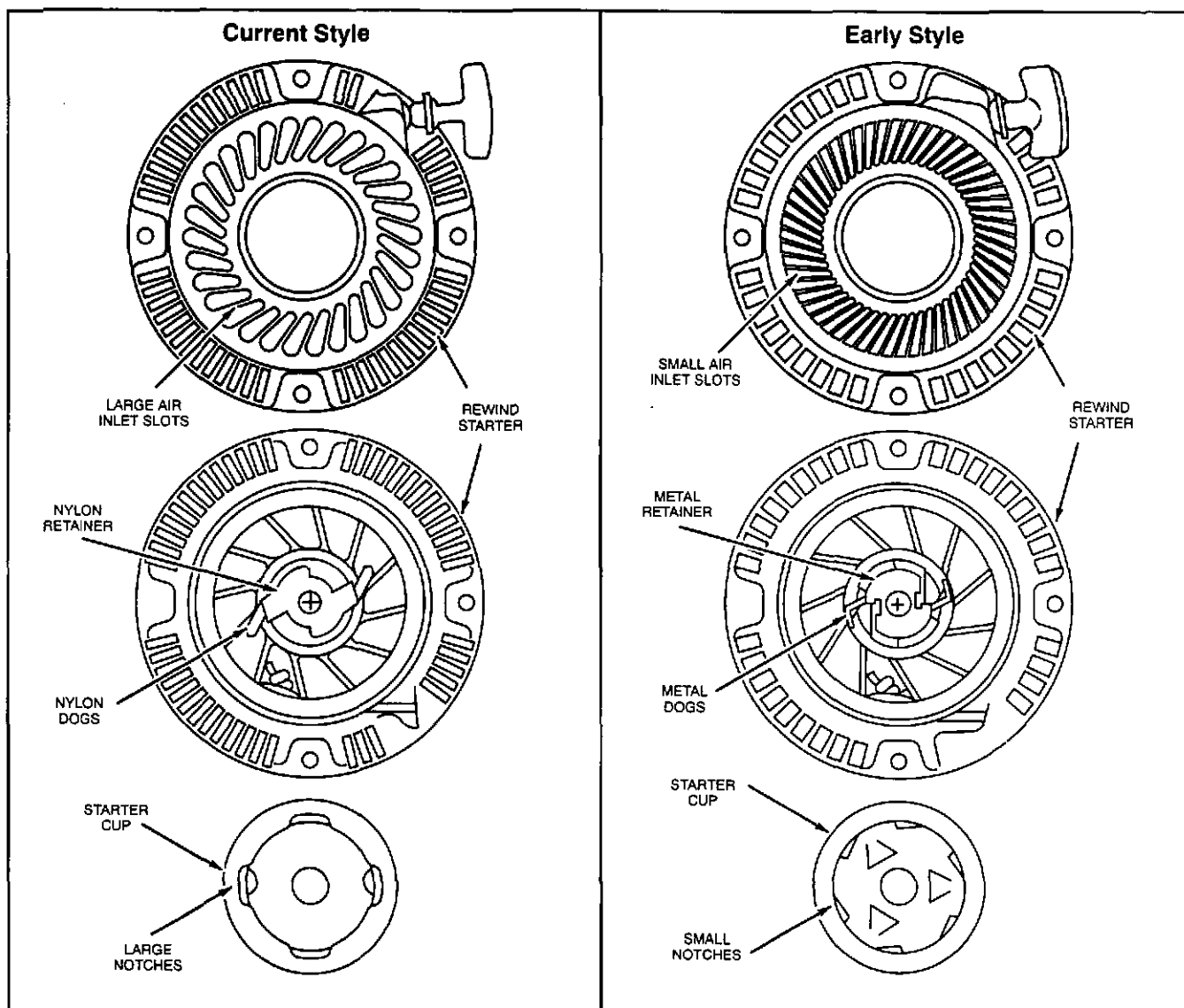


Fig. 1 - Starter Identification

# REWIND STARTERS

## Disassemble

### Remove Starter - Both Styles

Remove four screws holding rewind starter and remove starter, Fig. 2.

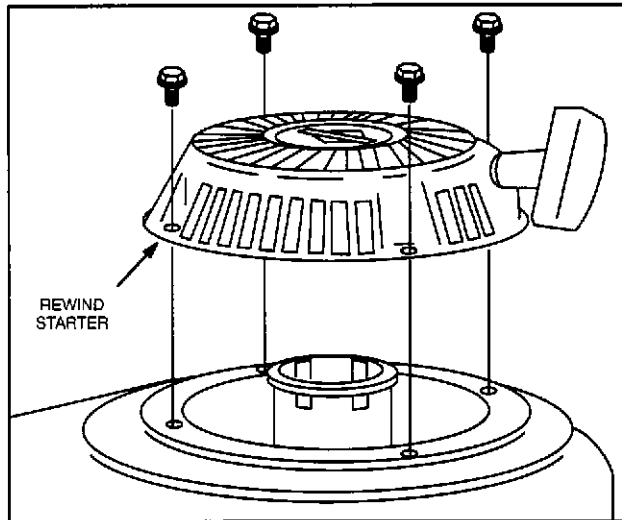


Fig. 2 - Remove Rewind Starter

waste cloth, using caution, while it is still hot, to prevent swelling and unraveling.

NOTE: WHEN INSTALLING A NEW ROPE, CHECK PARTS LIST TO BE SURE CORRECT LENGTH ROPE IS USED. THE SERVICE REPLACEMENT ROPE IS CUT TO LENGTH AS REQUIRED.

Current Style Starter	200 cm (80")
Early Style Starter	178 cm (70")

### Install Rope - Both Styles

Tie a figure eight knot at one end of the rope, Fig. 4.

NOTE: The current style rewind requires a different procedure for winding the spring than the early style.

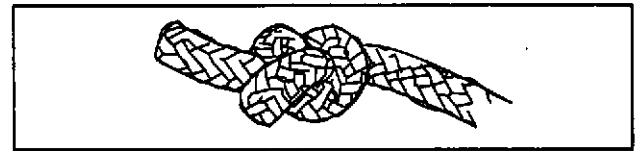


Fig. 4 - Tie Knot

### Remove Rope - Both Styles

Pull rope out part way and tie a temporary knot. Remove rope insert from rope handle, and pull knot out of rope insert. Untie knot and remove insert and handle from rope, Fig. 3.

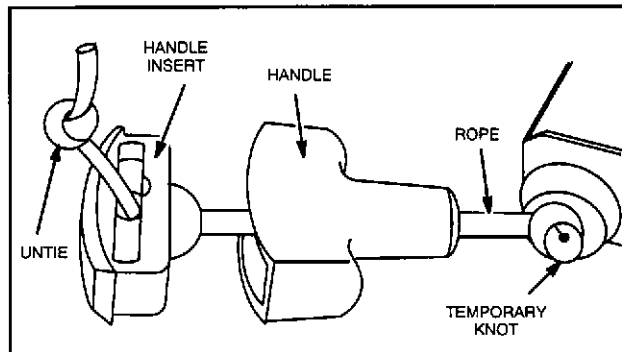


Fig. 3 - Removing Handle and Insert from Rope

Pull rope out as far as it will go. While holding rewind pulley, grasp knot with a pair of needle nose pliers and pull rope out of pulley.

Slowly release spring tension on pulley until pulley stops turning.

### Inspect Rope - Both Styles

Inspect rope for fraying or broken strands. Replace if frayed or broken strands are found. If reusing old rope, burn each end of rope with an open flame. Wipe with

### Winding Spring - Current Style

Turn pulley **COUNTERCLOCKWISE SIX (6) complete turns**. Then rotate pulley clockwise until rope hole in pulley is in line with starter housing eyelet. Hold pulley in this position, Fig. 5.

### Winding Spring - Early Style

Turn pulley **COUNTERCLOCKWISE** until spring is **WOUND TIGHT**. Then rotate pulley clockwise until rope hole in pulley is in line with starter housing eyelet. Hold pulley in this position, Fig. 5.

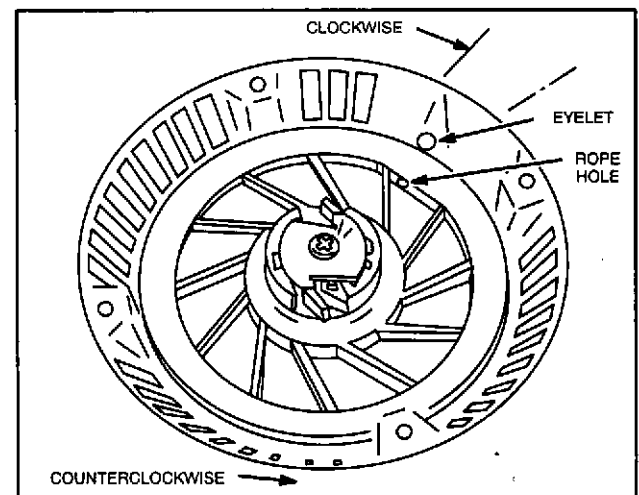


Fig. 5 - Winding Spring

# REWIND STARTERS

## Disassemble

### Insert Rope - Both Styles

Insert other end of rope through knot cavity and rope hole in pulley. Thread end of rope through eyelet and pull rope until knot is fully seated, Fig. 6.

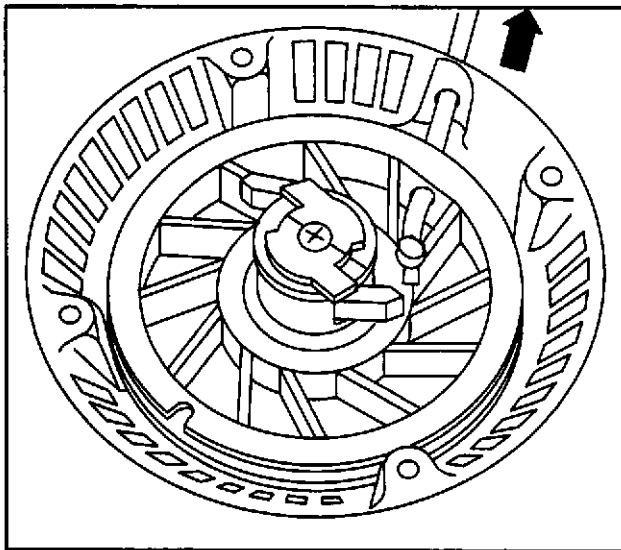


Fig. 6 - Insert Rope

While still holding pulley, tie a temporary knot part way out on rope. Let pulley and spring slowly rewind pulling rope into temporary knot. Insert rope through starter rope handle and starter rope insert, Fig. 7. Tie knot on end of rope, Fig. 4. Pull knot into rope insert and pull insert into rope handle. Untie temporary knot and slowly let rope rewind into starter. Operate starter to check for smooth operation. See last page for starter installation.

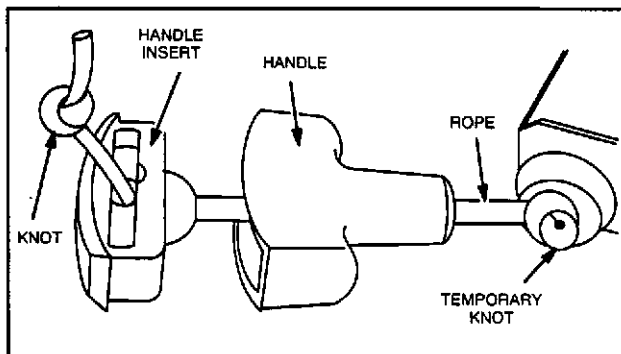


Fig. 7 - Assembling Rope and Handle

### REPLACE STARTER SPRING CURRENT STYLE STARTER



**WARNING:** The starter spring is still under tension when the rope has been removed and the pulley has no spring tension against it. Wear eye protection to prevent eye injury while disassembling and reassembling starter pulley and spring.

First, remove rope as described in "Remove Rope."

### Remove Pulley And Spring - Current Style

Remove shoulder screw and retainer. Fig. 8. Lift out dogs and dog springs. Rotate pulley until pulley feels free. Carefully lift out pulley with spring, Fig. 9.

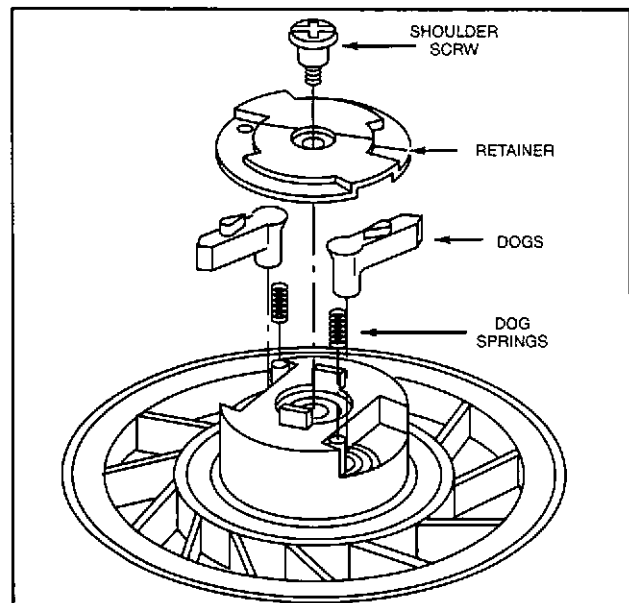


Fig. 8 - Removing Retainer - Current Style

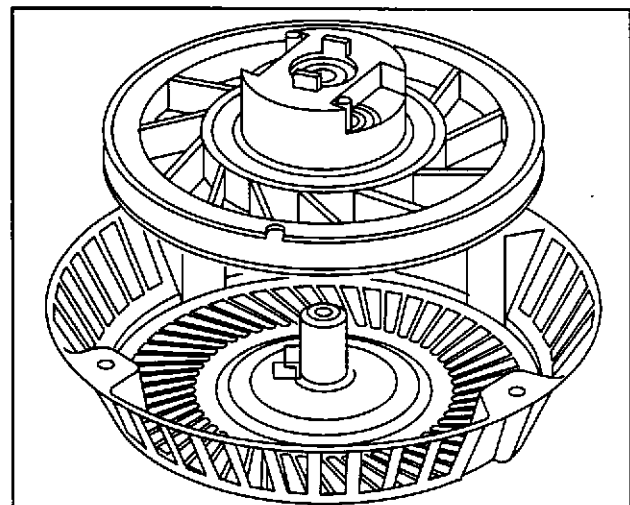


Fig. 9 - Removing Pulley - Current Style

# REWIND STARTERS

## Install

With a needle nose pliers, grasp outside of spring through spring notch in pulley. Firmly grip spring and slowly lift from pulley. While still gripping spring with pliers, slowly relieve spring tension, Fig. 10.

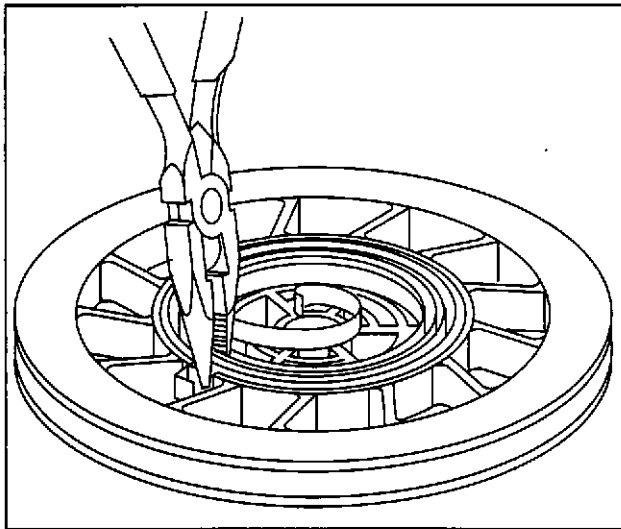


Fig. 10 - Removing Spring

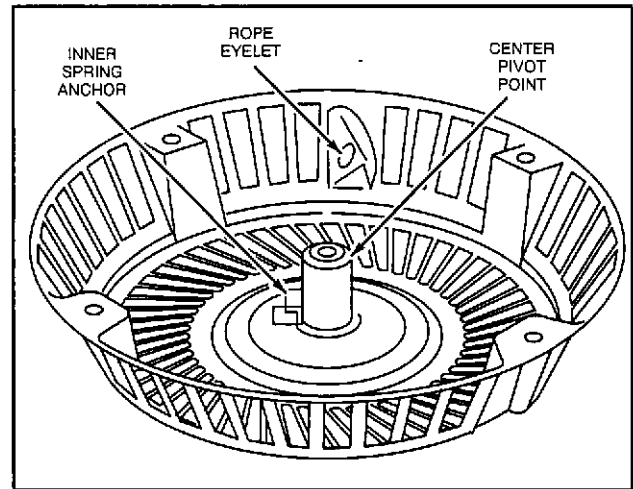


Fig. 12 - Inspecting Starter Housing

### Install Spring In Pulley

Service replacement springs are held in a retainer.

Position hook in spring over spring notch in pulley. Push spring down into pulley, Fig. 13. Make sure spring is fully seated in pulley.

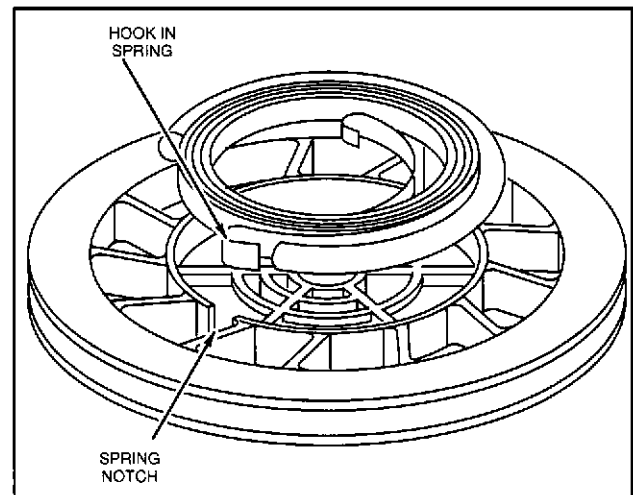


Fig. 13 - Installing Spring

### Inspect Spring, Starter Housing And Pulley

Inspect pulley for wear, cracks, rough edges or burrs in pulley groove and wear on center hole, Fig. 11. Replace pulley if damaged or worn.

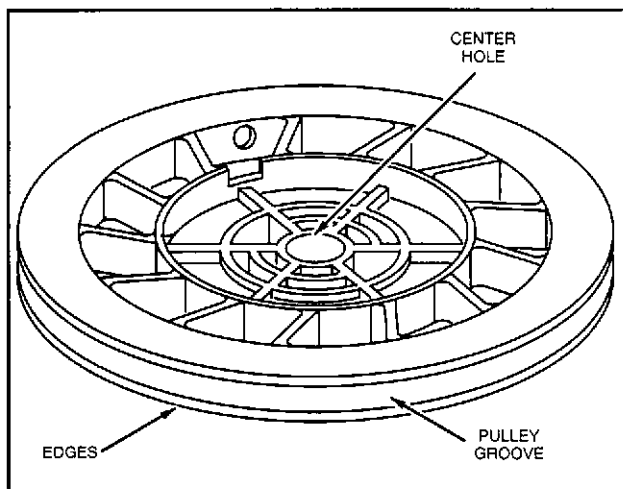


Fig. 11 - Inspecting Pulley

Inspect starter housing for wear or sharp edges at rope eyelet, center pivot post, and inner spring anchor tab, Fig. 12. Replace if worn or damaged.

### Assemble Pulley To Housing

Lay starter housing on work bench. Assemble starter pulley to center pivot post in housing, Fig. 14. Rotate pulley counter clockwise until slight resistance is felt, indicating that spring is engaged in spring tab in housing, Fig. 15.

# REWIND STARTERS Assembly

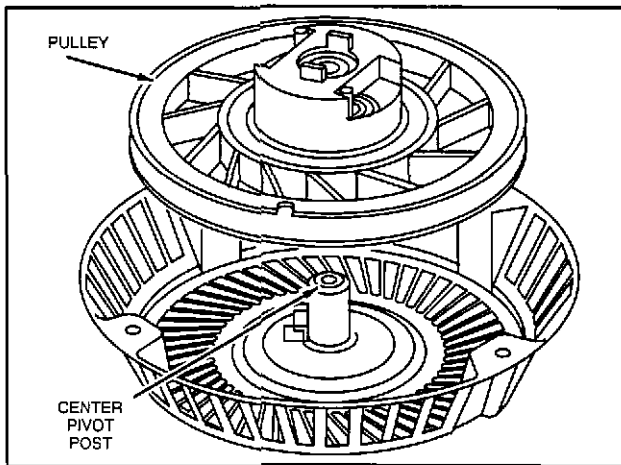


Fig. 14 - Installing Pulley

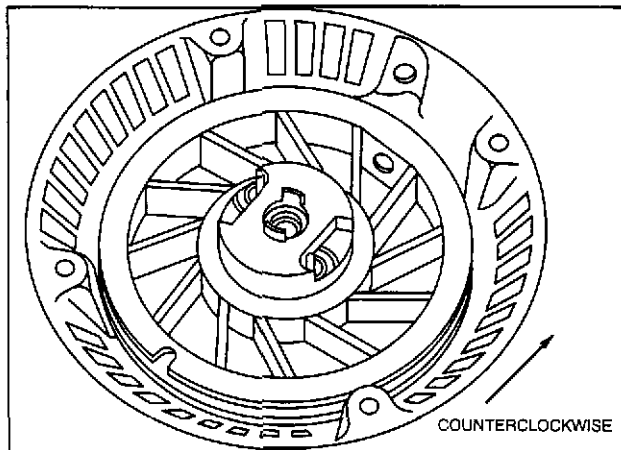


Fig. 15 - Engaging Spring

## Install Dogs, Dog Springs, And Retainer Assembly

Position springs over posts in pulley, then install dogs  
Fig. 16.

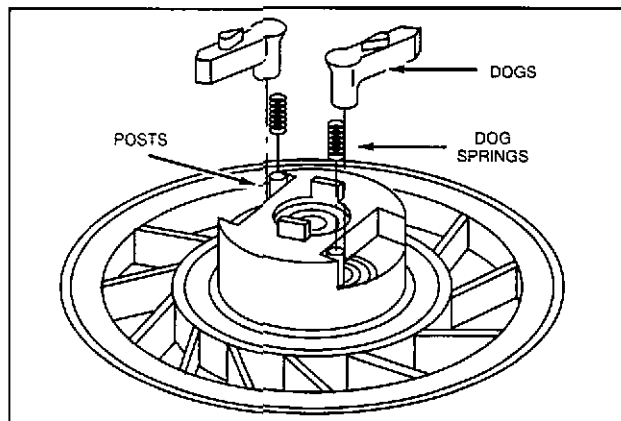


Fig. 16 - Installing Dog Springs and Dogs

Install retainer making sure that slots in retainer  
engage tabs on pulley, Fig. 17. Hold retainer down,

compressing dog springs and install retainer screw.  
Torque screw to 8 Nm (70 in. lbs).

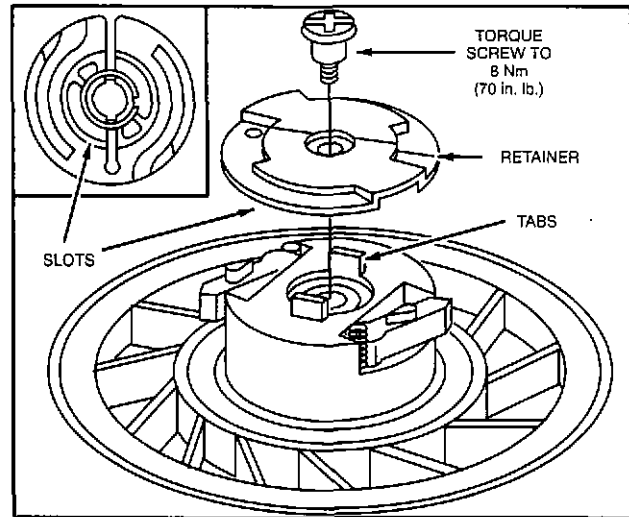


Fig. 17 - Installing Retainer and Screw

Complete assembly of starter as described in "Install  
Rope".

## REPLACE STARTER SPRING EARLY STYLE STARTER



**WARNING:** The starter spring is still under  
tension when the rope has been removed and  
the pulley has no spring tension against it. Wear  
eye protection to prevent eye injury while  
disassembling and reassembling starter pulley  
and spring.

## Remove Pulley And Spring

First, remove rope as described in "Remove Rope."

Remove shoulder screw, small washer, retainer, brake  
spring and large washer, Fig. 18.

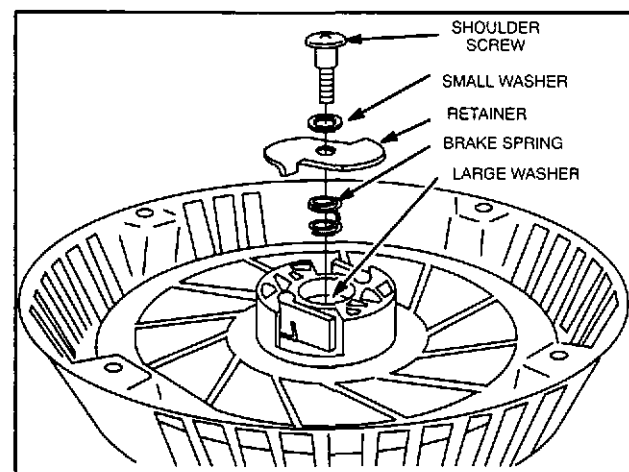


Fig. 18 - Removing Retainer

7A

# REWIND STARTERS

## Assembly

Lift out dogs and dog springs. Rotate pulley until pulley feels free. Carefully lift out pulley, Fig. 19.

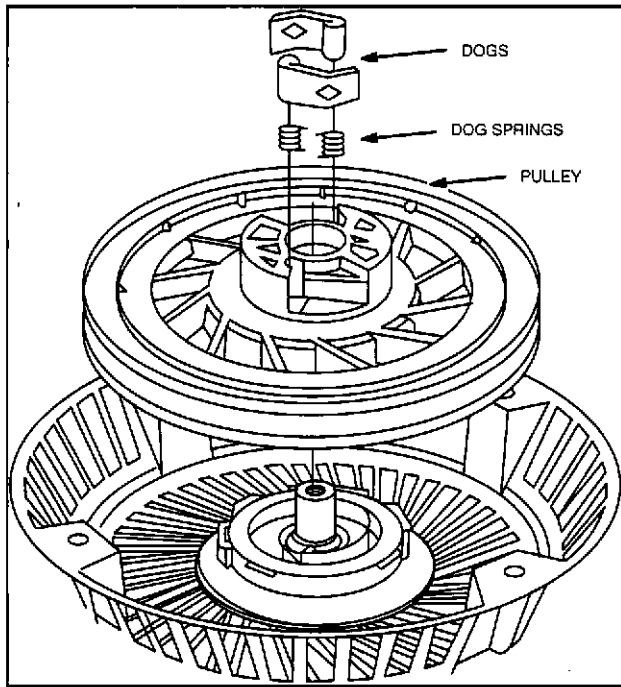


Fig. 19 - Removing Dogs, Dog Springs, and Pulley

### Inspect Spring, Starter Housing, And Pulley

Inspect pulley for cracks, rough edges or burrs in pulley groove, wear on spring cup lugs, and wear on center hole, Fig. 21. Replace pulley if damaged or worn.

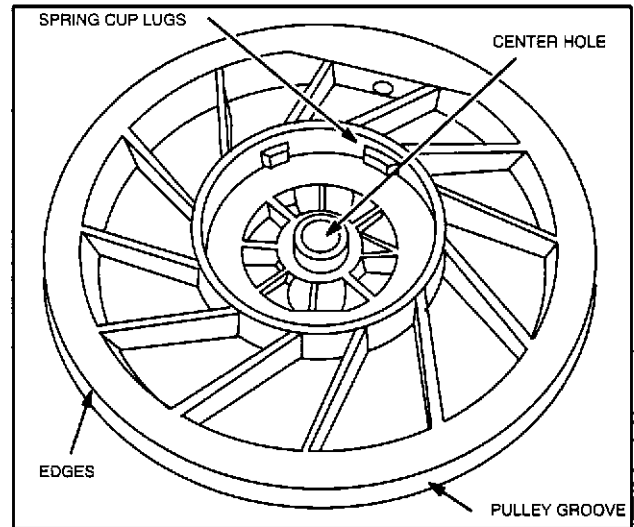


Fig. 21 - Inspecting Pulley

The starter spring and cup will normally remain as an assembly in starter housing. Remove spring and cup assembly from starter housing, Fig. 20.

**CAUTION:** Spring and cup are serviced as an assembly. DO NOT ATTEMPT TO REMOVE SPRING FROM CUP.

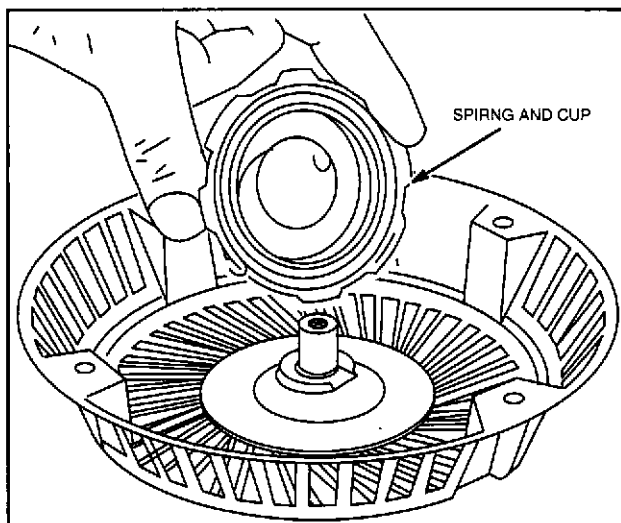


Fig. 20 - Removing Spring and Cup Assembly

Inspect starter housing for wear and sharp edges at rope eyelet, center pivot post, and at inner spring anchor, Fig. 22. Replace if worn or damaged.

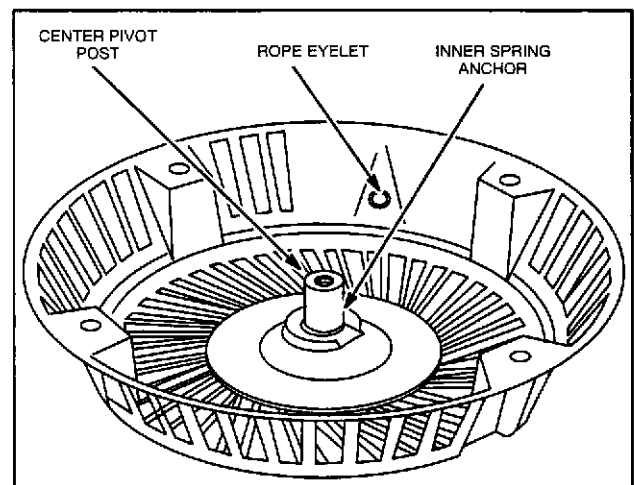


Fig. 22 - Inspecting Starter Housing

# REWIND STARTERS Assembly

## Install Spring And Cup Assembly, Pulley In Starter Housing

Place spring and cup assembly in pulley with outer end of spring tab between two wide lugs in pulley and spring cup projections next to the two wide lugs, Fig. 23.

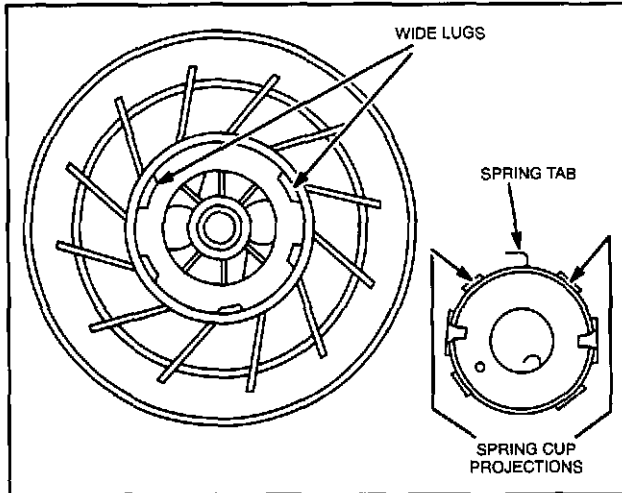


Fig. 23 - Locating Spring Cup In Pulley

Note location of inner spring tab and location of inner spring anchor at center post of starter housing. Lower starter housing onto pulley and spring assembly, Fig. 24.

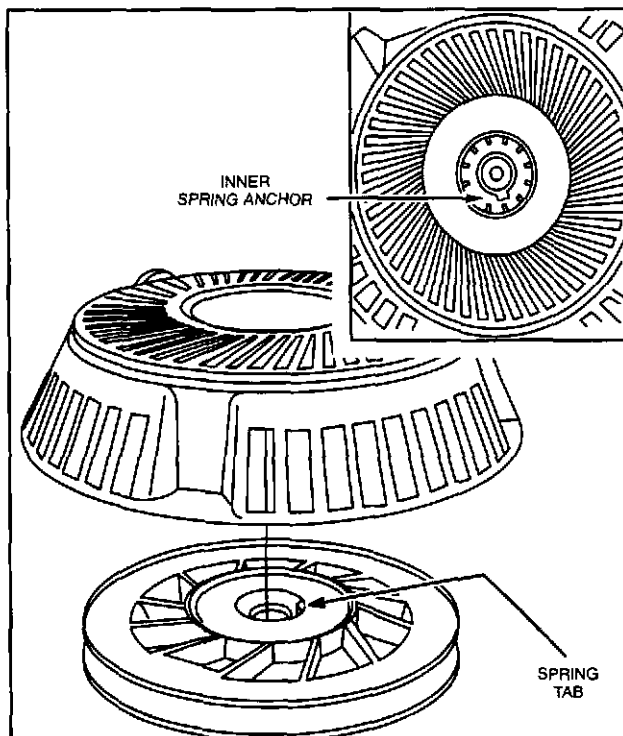


Fig. 24 - Installing Pulley

Invert assembly, rotate pulley counterclockwise until inner spring tab engages spring anchor, Fig. 25.

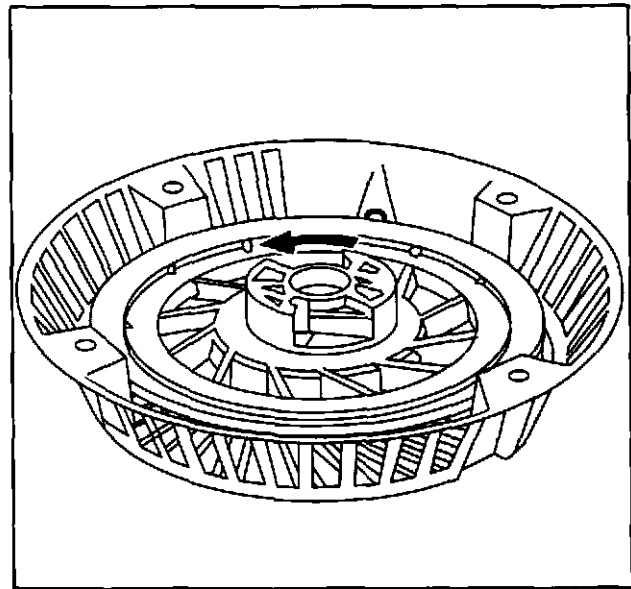


Fig. 25 - Engaging Spring

## Install Dogs, Dog Springs, And Retainer Assembly

Install dogs and dog springs in pulley, Fig. 26.

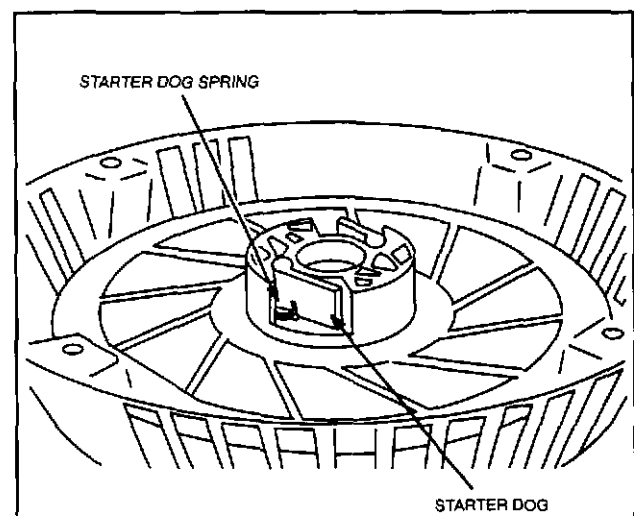


Fig. 26 - Installing Dogs and Dog Springs

# REWIND STARTERS Assembly

Place large washer, brake spring and retainer on pulley. Place small washer on shoulder screw and install screw and washer in center pivot post, Fig. 27.

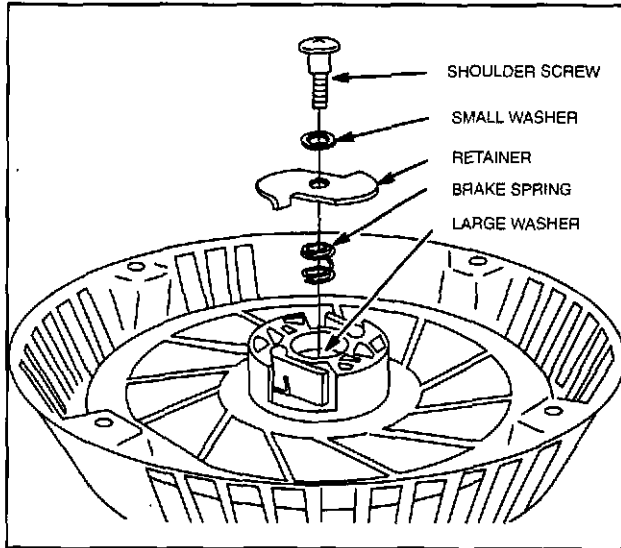


Fig. 27 - Installing Retainer

Position tabs of retainer inside dogs, Fig. 28, and torque retainer screw to 8 Nm (70 in. lbs.).

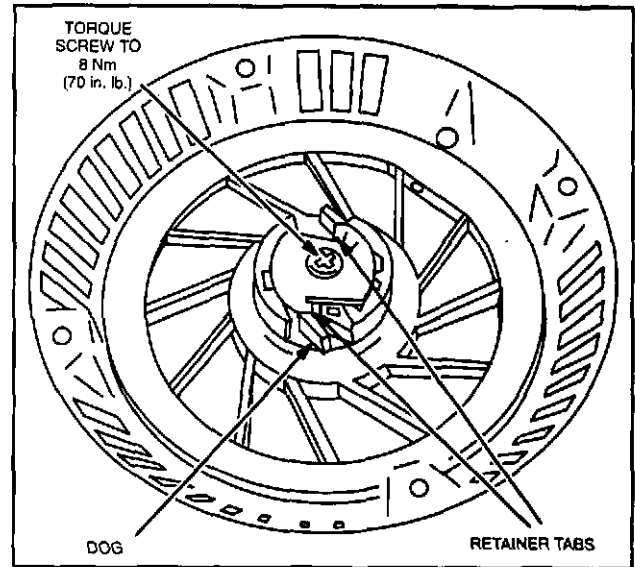


Fig. 28 - Positioning Retainer

Complete assembly of starter as described in "Install Rope".

## Install Rewind Starter

Install rewind starter on blower housing and install screws finger tight. Pull rope to engage dogs in starter cup. While holding rope, tighten screws to 7 Nm (60 in. lbs.)

# Section 7B

## ELECTRIC STARTERS

### Description

The starter motor uses a gear type engagement method, similar to an automobile starter. When the starter motor is activated, the pinion gear engages a ring gear attached to the engine flywheel and cranks the engine.

See Fig. 1 and Fig. 2 for location of starter motor.

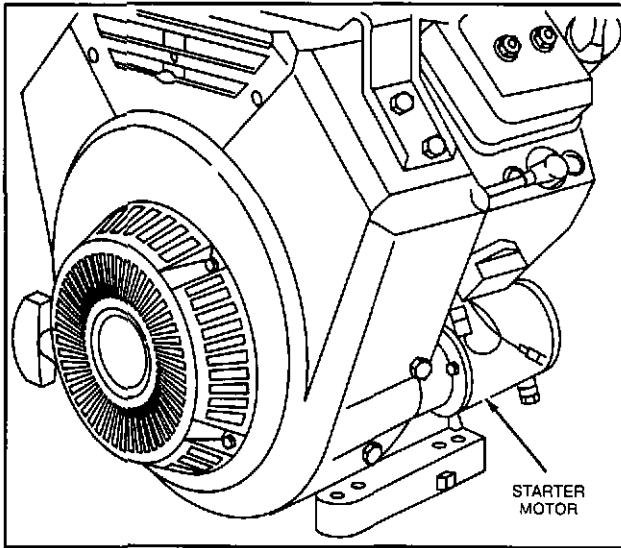


Fig. 1 - Horizontal Crankshaft Models

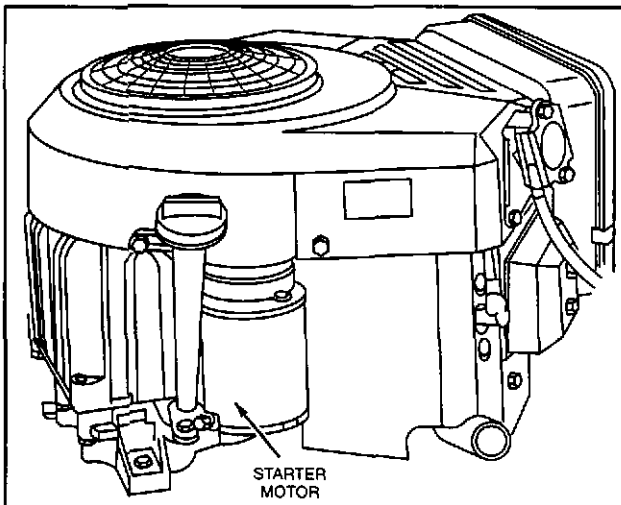


Fig. 2 - Vertical Crankshaft Models

Two style starter motors are used on V-twin engines.

The starter motor shown in Fig. 3 has a nylon type pinion gear and is used only on flywheels equipped with an aluminum ring gear. The flywheel ring gear is replaceable. See page 10.

The starter motor shown in Fig. 4 has a steel pinion gear and is used only with flywheels equipped with a steel ring gear. The flywheel ring gear is NOT replaceable.

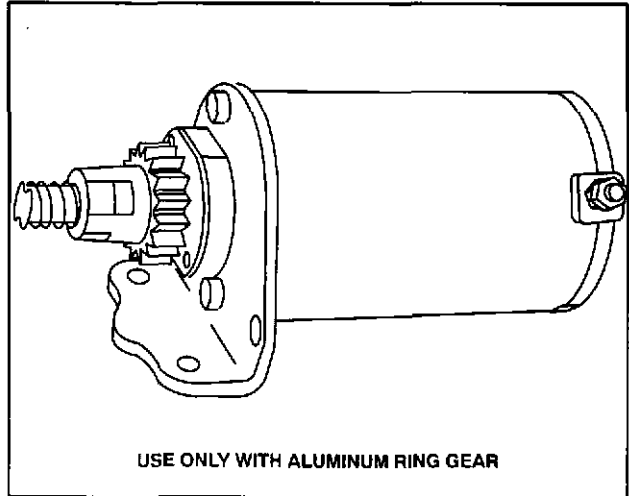


Fig. 3 - Nylon Pinion Starter Motor

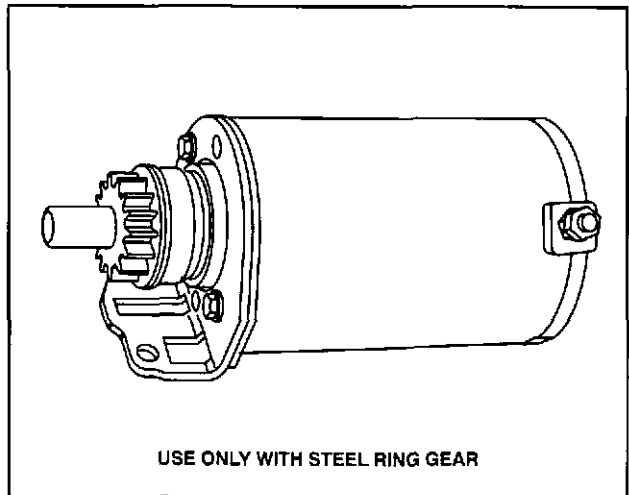


Fig. 4 - Steel Pinion Starter Motor

7B

# STARTERS

## Troubleshooting Starter

### Equipment To Test Starter Motors

The following is a list of equipment recommended to test and repair starter motors.

#### Digital Multimeter

The Digital Multimeter is available from your Briggs & Stratton source of supply. Order as Tool #19357 or #19390. The meter may be used to read volts, ohms, amperes and test diodes (rectifiers) when test leads are inserted in the appropriate receptacle, Fig. 5.

The Digital Multimeter will withstand DC input of 10-20 Amps for up to 30 seconds. When checking current draw of 12 volt starter motors, the DC Shunt, Tool #19359, is required.

NOTE: The Digital Multimeter is equipped with two fuses to prevent damage to the meter in the event that the input limits are exceeded. If the meter displays a reading of 0.00 when testing DC output, check fuses in meter. Refer to FLUKE Operators Manual for procedure for checking fuses. Replacement fuses are available from an electrical supply house.

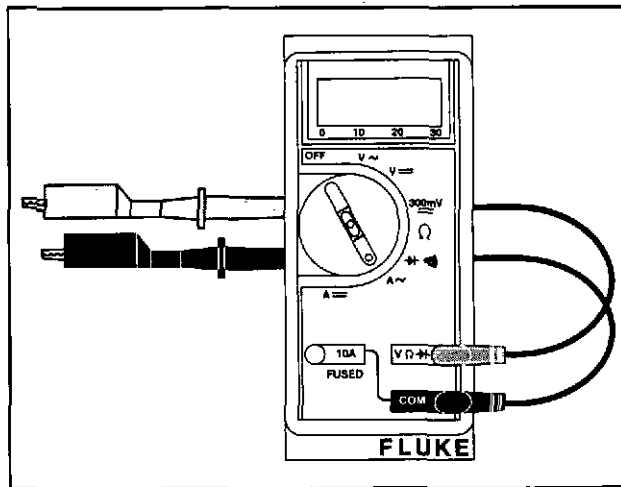


Fig. 5 - Digital Multimeter

#### DC Shunt

Use with Digital Multimeter. The DC Shunt is required when checking starter motor current draw on 12 volt starter motors. Order as Tool #19359, Fig. 6.

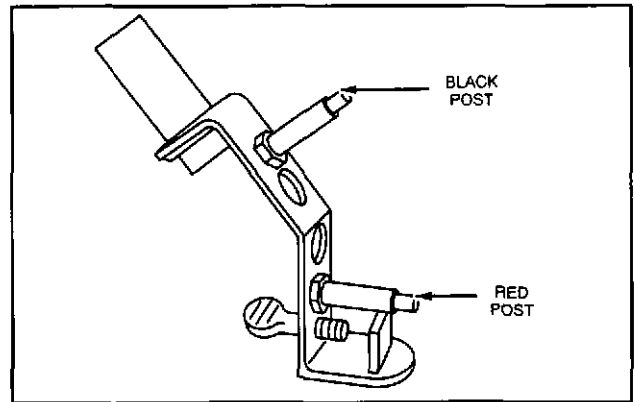


Fig. 6 - DC Shunt - Tool No. 19359

A tachometer is available from your Briggs & Stratton source of supply. Order as Tool #19200. The tachometer measures from 800 to 50,000 revolutions per minute (RPM), Fig. 7.

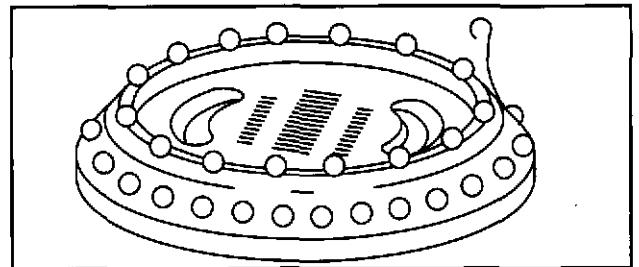


Fig. 7 - Tachometer

A starter motor test bracket may be made as shown in Fig. 8.

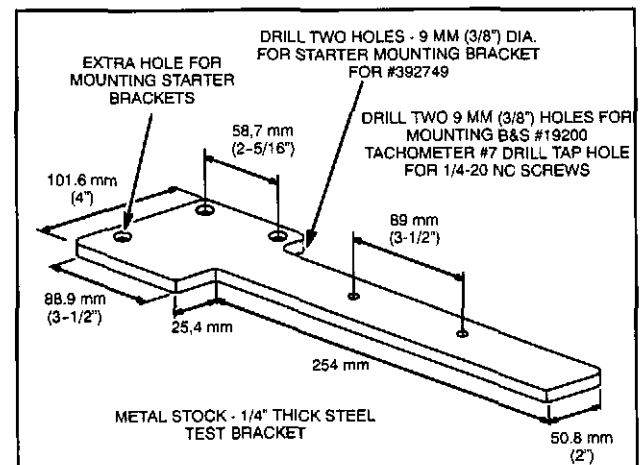


Fig. 8 - Starter Motor Test Bracket


# STARTERS

## Troubleshooting Starter

A growler or armature tester is available from an Automobile Diagnostic service supplier. A known good 12 volt battery is required.

### Troubleshooting 12 Volt Starter Systems

NOTE: If a starting problem is encountered, the engine itself should be thoroughly checked to eliminate it as the cause of starting difficulty. It is a good practice to check the engine for freedom of rotation by removing the spark plugs and turning the crankshaft over slowly by hand, to be sure it rotates freely.

 **WARNING: DO NOT ROTATE ENGINE WITH ELECTRIC STARTER OR REWIND STARTER WITH SPARK PLUGS REMOVED. ARCING AT THE SPARK PLUG ENDS MAY IGNITE THE GASOLINE VAPOR EXITING THE SPARK PLUG HOLE.**

#### 1. Engine Cranks Slowly -

- a. Additional load affecting performance (see note above).
- b. Discharged battery.
- c. Faulty electrical connection (battery circuit).
- d. Discharged battery (see alternators).
- e. Dirty or worn starter motor commutator, bearing, weak magnets, etc.
- f. Worn brushes or weak brush spring.
- g. Wrong oil viscosity for temperature expected.
- h. Battery leads too long or wire too small.
- i. Battery too small.

#### 2. Engine Will Not Crank -

- a. Faulty safety interlocks.
- b. Discharged or defective battery.
- c. Faulty electrical connections.
- d. Faulty starter motor switch (open circuit).
- e. Open circuit in starter motor.

f. Brushes sticking, etc.

g. Faulty solenoid.

#### 3. Starter Motor Spins; But Does Not Crank Engine -

- a. Sticking pinion gear due to dirt.
- b. Damaged pinion or ring gear.
- c. Battery faulty or damaged.
- d. Incorrect rotation due to reversed motor polarity - all motors rotate counterclockwise viewed from pinion gear.

#### 4. Starter Motor Spins; Will Not Stop -

- a. Defective starter switch.

### Removing Starter Motor

It is recommended that the starter motor be removed from the engine when testing starter motor performance. Remove starter shield. Remove two starter motor mounting screws using universal socket, Tool #19353.

### Checking the Starter Motor Performance

A performance test of the 12 volt DC starter motor may be made in the following manner.

### Equipment Needed

See page 2 for a starter mounting test bracket that can be made.

**IMPORTANT:** DO NOT clamp motor housing in a vise or strike with a steel hammer. Starter motors contain two ceramic magnets which can be broken or cracked if the motor housing is hit, deformed or dented.

Digital Multimeter, Tool #19357 or #19390 and DC Shunt, Tool #19359.

A tachometer capable of reading 10,000 RPM.

A 12 volt battery fully charged.

# STARTERS

## Troubleshooting Starter

### Testing Starter Motor With Digital Multimeter and DC Shunt

1. The DC Shunt **MUST** be installed on the **negative (-)** battery terminal as shown in Fig. 9.
2. Insert RED test lead into  $\nabla\Omega\rightarrow$  receptacle in meter and connect to RED post terminal on shunt.
3. Insert BLACK test lead into COM receptacle in meter and connect to BLACK post terminal on shunt.
4. Rotate selector to 300mV  $\rightarrow$  position.

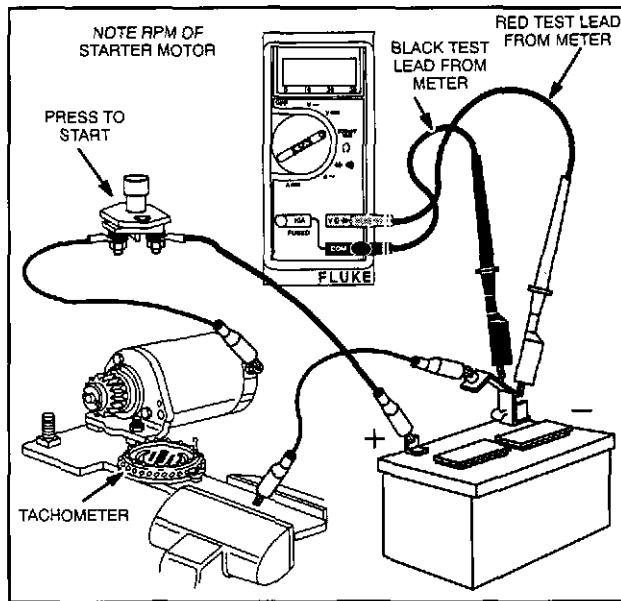


Fig. 9 - Testing 12 Volt Starter Motor Digital Multimeter & DC Shunt

5. Activate the starter motor and note reading on meter and tachometer (RPM).
6. Identify the type starter motor by the type of pinion gear and refer to specifications below. A starter motor in good condition will be within specifications listed.

#### STARTER MOTOR SPECIFICATIONS

Pinion Type	Minimum Motor RPM	Maximum Amperes
Nylon	6500	35
Steel	7000	24

If 12 volt starter motor does not perform satisfactorily, see Conditions Affecting Starter Motor Performance.

### Conditions Affecting Starter Motor Performance

1. A binding or seizing condition in the starter motor bearings.

2. A shorted, open or grounded armature.
  - a. Shorted, armature (wire insulation worn and wires touching one another). Will be indicated by low or no RPM.
  - b. Open armature (wire broken) will be indicated by low or no RPM and excessive current draw.
  - c. Grounded armature (wire insulation worn and wire touching armature lamination or shaft). Will be indicated by excessive current draw or no RPM.
3. A defective starter motor switch.
4. Weakened magnets.
5. Starter drive dirty or binding.

### Checking Starter Motor Drive - Both Types

When the starter motor is activated, the pinion gear should engage the flywheel ring gear and crank the engine. If the starter motor drive does not react properly, inspect the helix and pinion gear for freedom of operation.

If any sticking occurs, this must be corrected. Proper operation of starter is dependent on the pinion freely moving on the helix. Nylon pinion shown in Fig. 10. Steel pinion shown in Fig. 11.

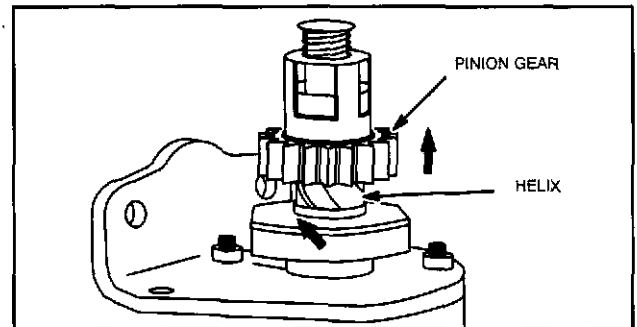


Fig. 10 - Checking Starter Motor Drive Nylon Pinion

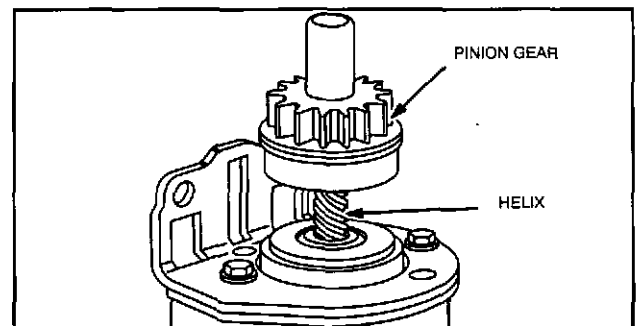


Fig. 11 - Checking Starter Motor Drive Steel Pinion

7B

# STARTERS

## Disassemble Starter Drive

### Disassemble Starter Motor Drive - Nylon Pinion

Place starter drive retainer on support block, Fig. 12, and drive out roll pin with a hammer and 4 mm (5/32") pin punch to remove starter drive retainer.

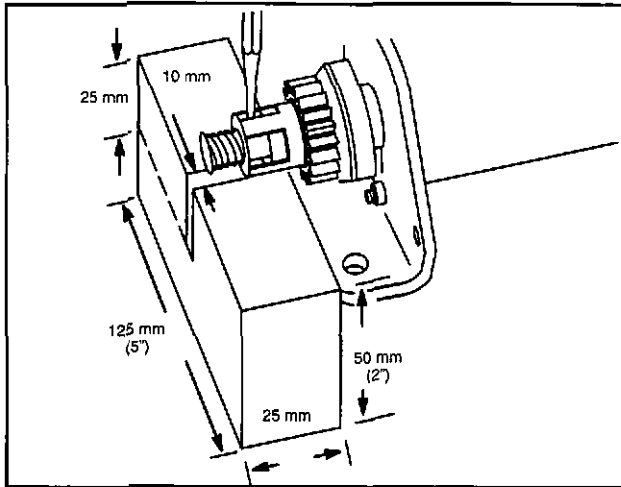


Fig. 12 - Disassembling Starter Drive

### Inspect Starter Drive - Nylon Pinion

The pinion gear should be inspected for damaged teeth. Pinion gear must move freely on helix. The parts may be washed in a solvent such as Stanisol® or Varsol®.

The starter drive assembly is available from your Briggs & Stratton source of supply if required.

NOTE: Do not oil or grease helix or starter gear. Refer to Fig. 13 for proper location of parts.

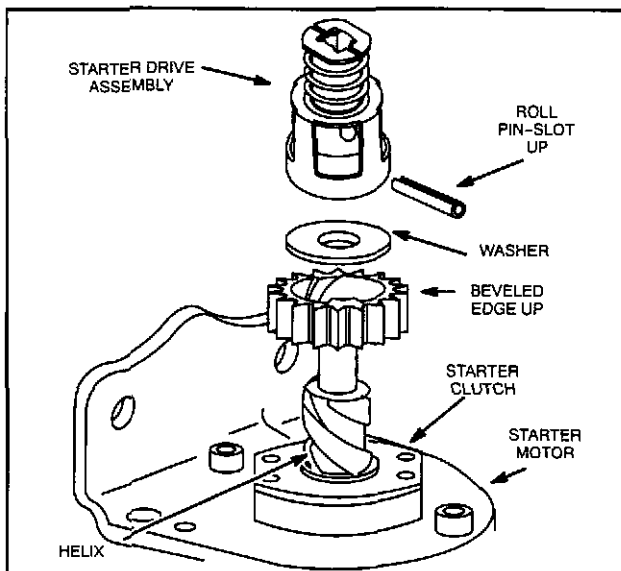


Fig. 13 - Starter Drive

### Assemble Starter Drive - Nylon Pinion

Place starter clutch on armature shaft and rotate clutch until it drops into place. Install pinion gear with beveled edges of pinion gear teeth away from motor. Place thrust washer and starter gear return on armature shaft. Press or drive NEW roll pin through retainer slot and hole in armature shaft. Roll pin should be centered in armature shaft within .8 mm (1/32").

### Disassemble Starter Motor Drive - Steel Pinion

Grasp end of rubber dust cover and pull to remove. Push down on upper spring retainer to expose retaining ring on shaft. Use a small screw driver and pry off retaining ring, Fig. 14. Remove upper spring retainer, spring, lower spring retainer, pinion gear and clutch.

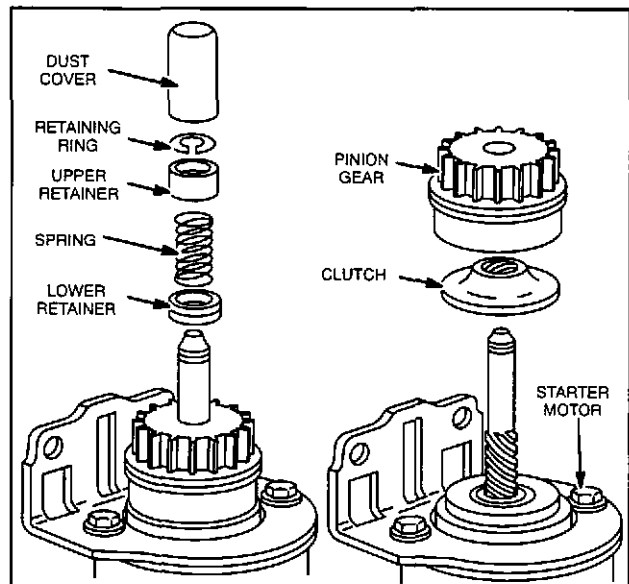


Fig. 14 - Disassembling Starter Drive

### Inspect Starter Drive - Steel Pinion

The pinion gear should be inspected for damaged teeth. Rubber bottom of pinion is part of clutch. Check for wear or damage. Check clutch for wear.

NOTE: If clutch rubber inside of pinion gear is worn or damaged, pinion gear will slip when starter is engaged.

The starter drive assembly is available from your Briggs & Stratton source of supply if required.

7B

# STARTERS

## Disassemble Starter

### Assemble Starter Drive - Steel Pinion

Lubricate helix with a light coat of grease. Assemble clutch and pinion gear to shaft. Assemble lower spring retainer with OPEN END UP. Install spring. Install upper spring retainer with OPEN END UP. Compress spring and install new retaining ring on shaft, Fig. 15.

NOTE: Always install NEW retaining ring.

Use a pliers and compress retaining ring to ensure that it is seated properly in groove in shaft. Pull up on upper spring retainer until retaining ring snaps into groove in upper spring retainer.

Install rubber dust cover. Push dust cover down until it snaps into groove in lower spring retainer, Fig. 15.

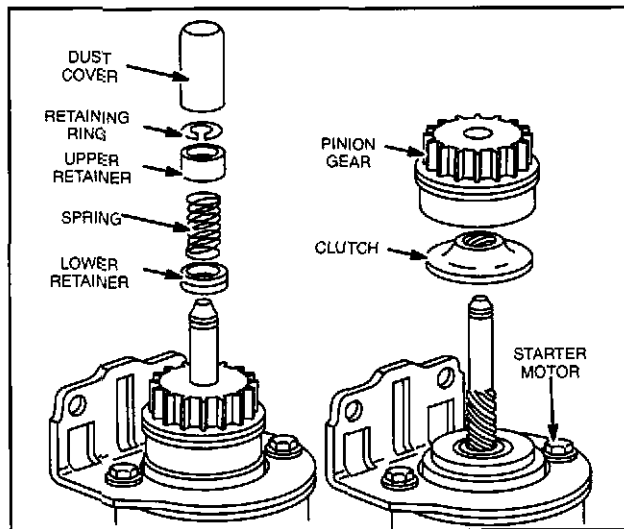


Fig. 15 - Assembling Starter Drive

### Disassemble Starter Motor - Both Styles

**IMPORTANT:** DO NOT clamp motor housing in a vise or strike with steel hammer. Starter motors contain two ceramic magnets which can be broken or cracked if the motor housing is hit, deformed, dented or dropped.

The disassembly and inspection procedure of the two style starter motors is similar. Where a procedure or specification is different, those differences will be shown.

See Fig. 16 or Fig. 17 for exploded view of two style starter motors. To aid in reassembly, scribe a mark on drive end cap and starter housing for alignment purposes. Remove thru bolts.

Drive end cap assembly can now be removed. Inspect bushing for wear or damage. Replace drive end cap if worn or damaged.

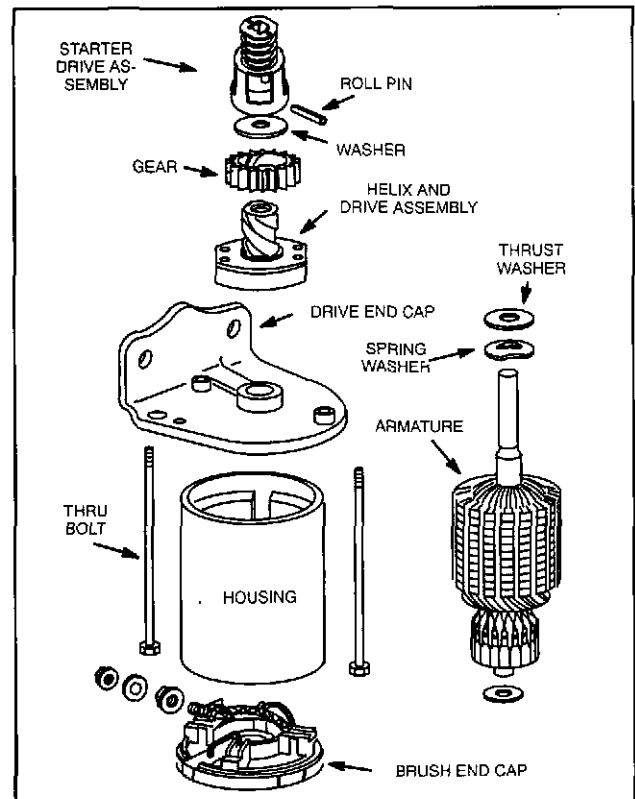


Fig. 16 - Exploded View - Starter Motor With Nylon Pinion

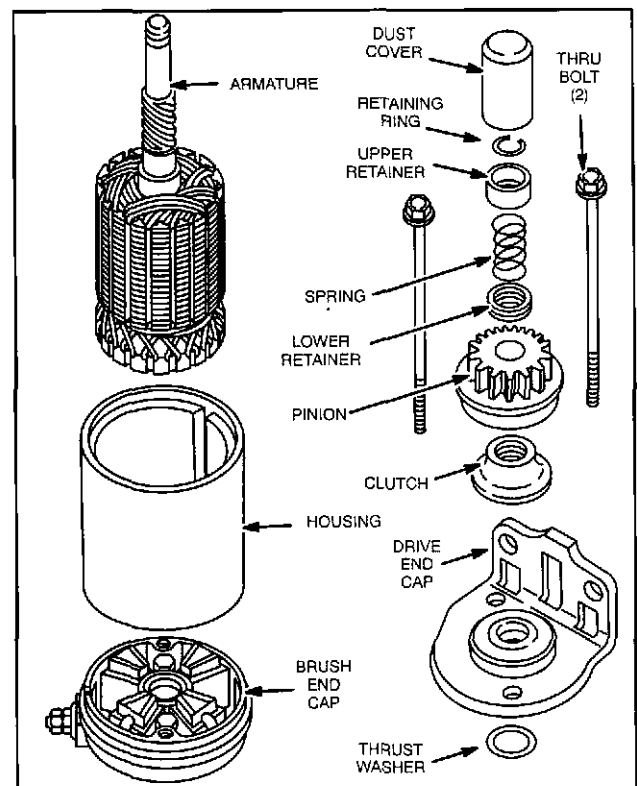


Fig. 17 - Exploded View - Starter Motor With Steel Pinion

# STARTERS

## Replace Brushes

Hold the armature and commutator end cap against a work surface while sliding housing off the armature. NOTE: This allows the armature to remain in the end cap for inspection of brush to commutator contact, Fig. 18.

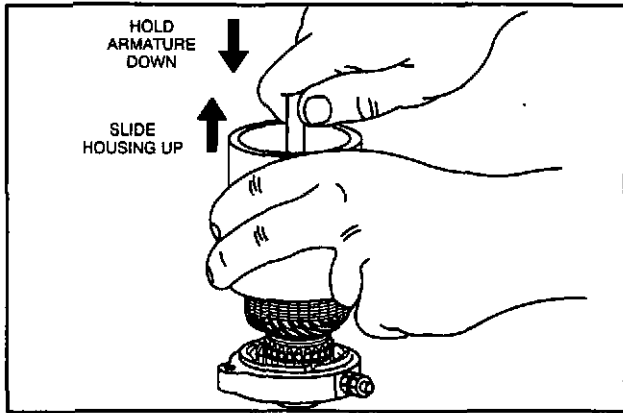


Fig. 18 - Removing Motor Housing

Remove armature from commutator end cap. Clean all dirt or corrosion accumulations from the armature, end cap, motor support, etc. The bearings, housing and armature should not be soaked in a cleaning solution. The armature commutator may be cleaned with a fine sand paper. Do not use emery cloth, as emery will become embedded in the commutator causing rapid brush wear.

If the commutator is like the style shown in Fig. 16, it may be machined with the use of a diamond cutting tool to no less than 31.24 mm (1.23") outside diameter.

Slots between commutator bars should be cleaned as shown in Fig. 19 after cleaning or machining.

If the commutator is like the style shown in Fig. 17, it may not be machined.

If it is suspected that the armature, magnets or motor housing are defective, a new part should be tried in the motor. If proper testing equipment is available, check the suspected armature to determine if it is defective (opens, shorts or grounds).

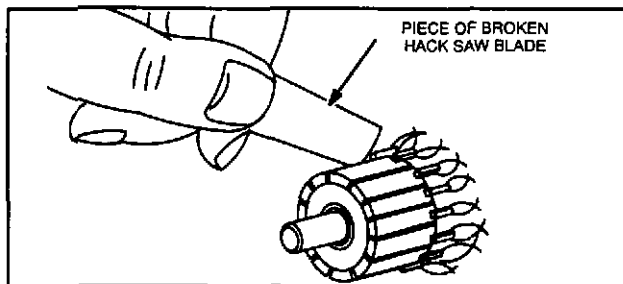


Fig. 19 - Cleaning Commutator-Typical

The brushes should be checked for proper seating, weak brush springs, dirt, oil or corrosion. Brush spring

pressure should be strong enough to ensure good brush contact with armature. If brushes are worn as shown in Fig. 20, replace. Check to be sure brushes are not sticking in their holders.

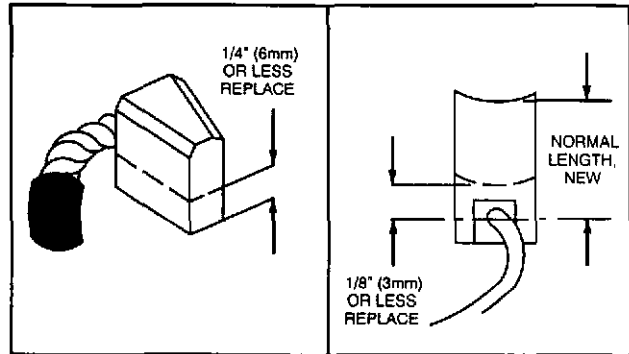


Fig. 20 - Checking Brushes

### Replace Brushes

Two different style brush end caps are used. Refer to Fig. 21, and Fig. 22 for correct location of brushes and brush leads.

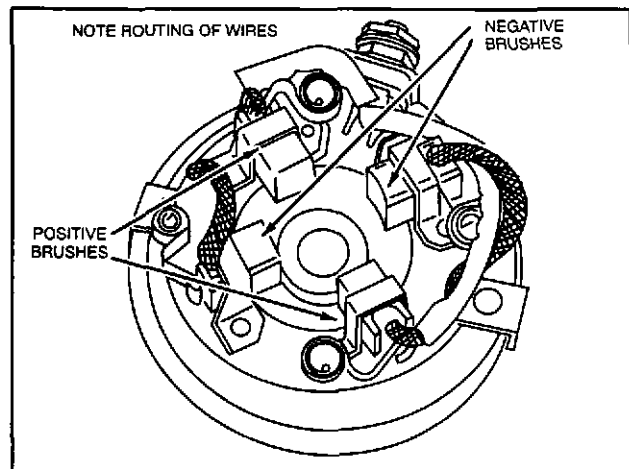


Fig. 21 - Location of Brushes

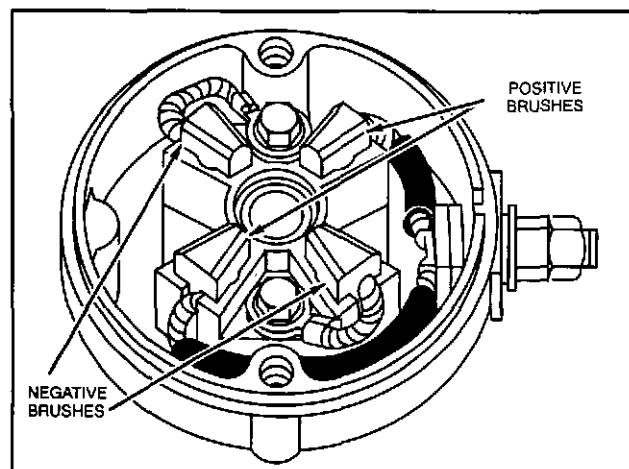


Fig. 22 - Location of Brushes

7B

# STARTERS

## Assemble Starter

### Assemble Starter - Nylon Pinion Style

When all parts have been inspected, lightly lubricate bearings in both end caps with #20 oil.

Install armature onto brush end cap. Place brush in holder. Position brush spring over tab as shown in Fig. 23. While holding spring on tab, use a screwdriver and bend spring counterclockwise and position over end of brush, Fig. 23. Then push spring down firmly over tab. Repeat for other brushes.

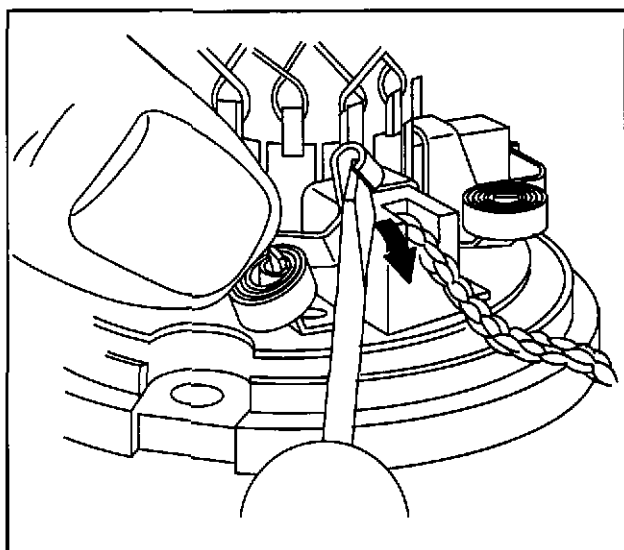


Fig. 23 - Installing Brushes

The starter housing has a large notch which indexes over the insulated terminal, Fig. 24. While pushing down on armature and brush end cap, slide starter housing down until large notch indexes. Care should be used to prevent damage to magnets in the starter housing.

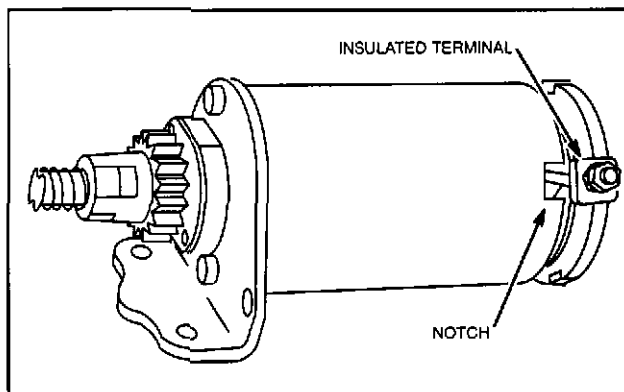


Fig. 24 - Assemble Brush End Cap

### Install Drive End Cap

Place spring washer and spacer washer on armature, Fig. 25. Slide drive end cap down armature shaft until mark on drive end cap lines up with mark on starter housing.

Install thru bolts and torque to 50 in. lbs.

Turn armature to check for binding. Correct any binding, if found.

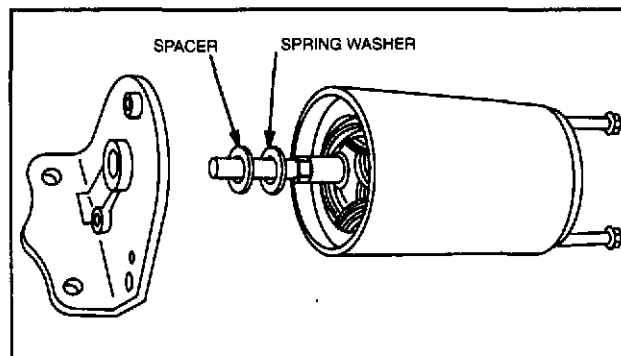


Fig. 25 - Installing Drive End Cap

### Assemble Starter - Steel Pinion Style

When all parts have been inspected, lightly lubricate bearings in both end caps with #20 oil.

It is recommended that a brush retainer be used to hold brushes in place while assembling armature to end cap. See Fig. 26 for dimensions to make a sheet metal brush retaining tool.

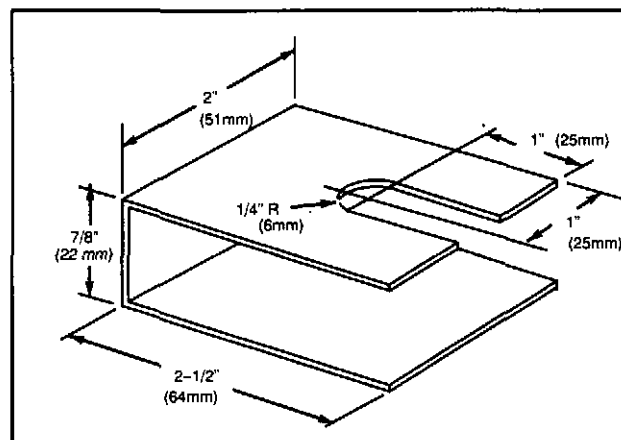


Fig. 26 - Brush Retainer Tool

# STARTERS

## Assemble Starter

Install brushes in position shown in Fig. 28. Install brushes with beveled edge up.

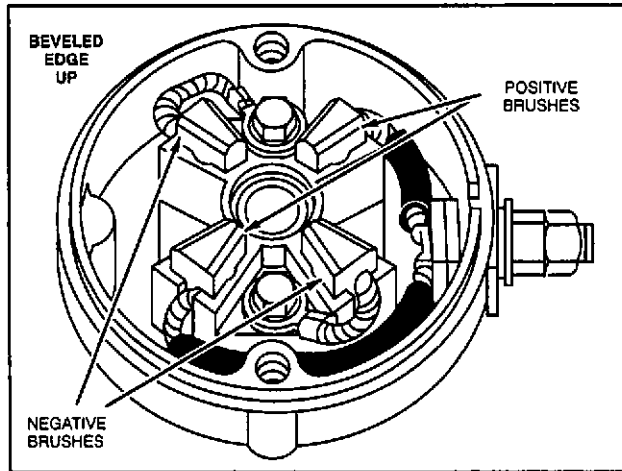


Fig. 27 - Installing Brushes

With brushes retained in their respective holders, assemble armature onto end cap.

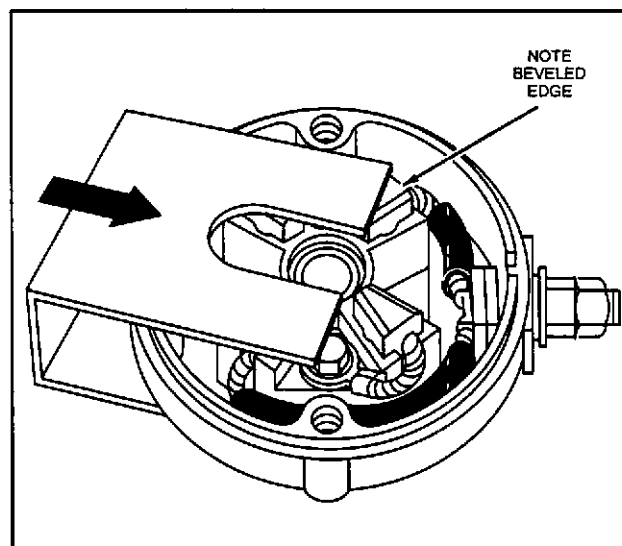


Fig. 28 - Installing Brushes

While pushing down on armature and brush end cap, slide starter housing down onto end cap, aligning notch in housing with notch in end cap, Fig. 29. Care should be used to prevent damage to magnets in the starter housing.

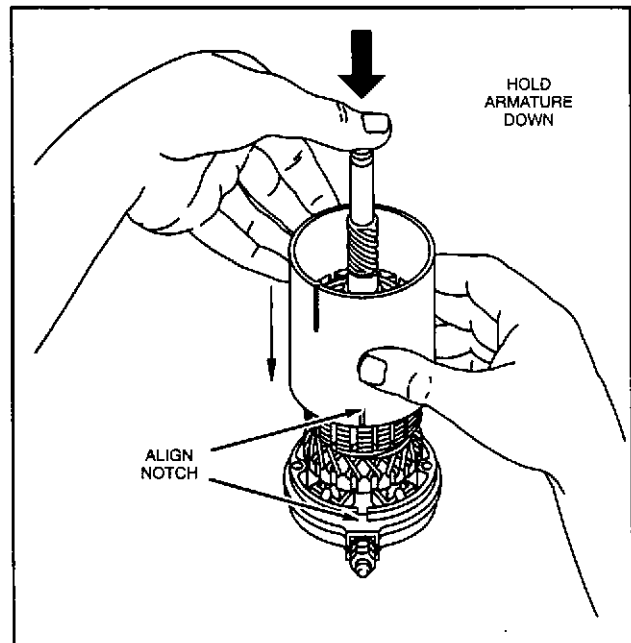


Fig. 29 - Assembling Starter Motor

### Install Drive End Cap

Install drive end cap aligning mark on cap with mark on starter housing, Fig. 30.

Install thru bolts and torque to 5.7 Nm (50 in. lbs.).

Turn armature to check for binding. Correct any binding, if found.

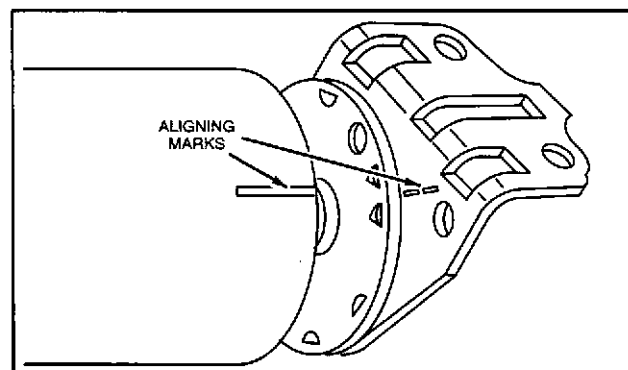


Fig. 30 - Installing Drive End Cap

### Install Starter Motor - Both Styles

Install starter motor on engine using universal socket, Tool #19353. Torque screws to 15.8 Nm (140 in. lbs.). Install starter motor shield.

# STARTERS

## Testing Key Switch

### Replacing Ring Gear

To replace a worn or damaged flywheel ring gear, proceed as follows.

Mark the center of the rivets holding the ring gear to flywheel, with a center punch. Drill out the rivets using a 4.7 mm (3/16") drill. Remove ring gear and clean mounting surface.

Attach new gear to flywheel using four screws and lock nuts provided with gear, Fig. 31. Tighten nuts and screws securely.

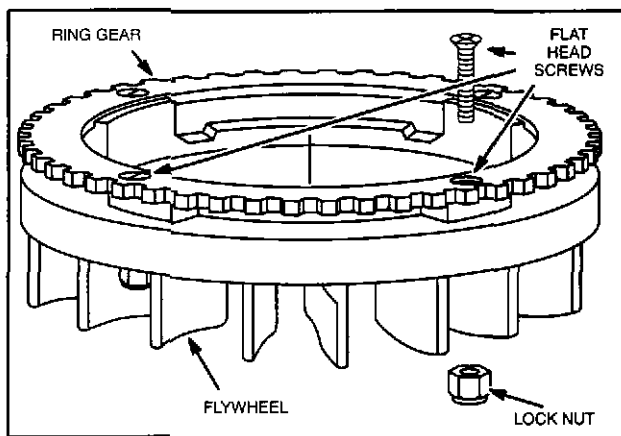


Fig. 31 - Replacing Ring Gear

### Electric Starter Panel Kit With Rotary Key Switch And Solenoid

Some V-Twin engines are equipped with a rotary key switch panel and solenoid. See wiring diagram on page 12.

### Testing Rotary Key Switch - Used With Starter Panel Kit

The rotary key switch can be checked for continuity using the digital multimeter, Tool #19357 or #19390.

Remove carburetor cover with keyswitch. Disconnect wiring harness from keyswitch.

With meter selector switch in  $\rightarrow \Omega \rightarrow$  position, and test leads attached to switch terminals, a continuous tone  $\rightarrow \Omega \rightarrow$  indicates continuity (complete circuit). No tone indicates no continuity (incomplete circuit). An incomplete circuit will be displayed as "OL."

1. Insert red test lead into  $\vee \Omega \rightarrow$  receptacle in meter.
2. Insert black test lead into **COM** receptacle in meter.
3. Rotate meter selector to  $\rightarrow \Omega \rightarrow$  position.
4. Meter must indicate continuity between terminals with keyswitch in position shown. See number sequence of terminals shown in Fig. 21.

NOTE: Terminals 1, 3 and 6 are grounded to keyswitch case. Meter must also indicate continuity between terminals and keyswitch case in "OFF" position.

When testing "RUN" and "START" terminals, meter should show continuity between terminals, with key switch in position shown.

NOTE: The #2 and #5 terminals should show continuity in both the "RUN" and "START" position.

# STARTERS

## Testing Solenoid

Switch Position	Continuity
1. OFF	1+3+6
2. RUN	2+5+6
3. START	2+4+5

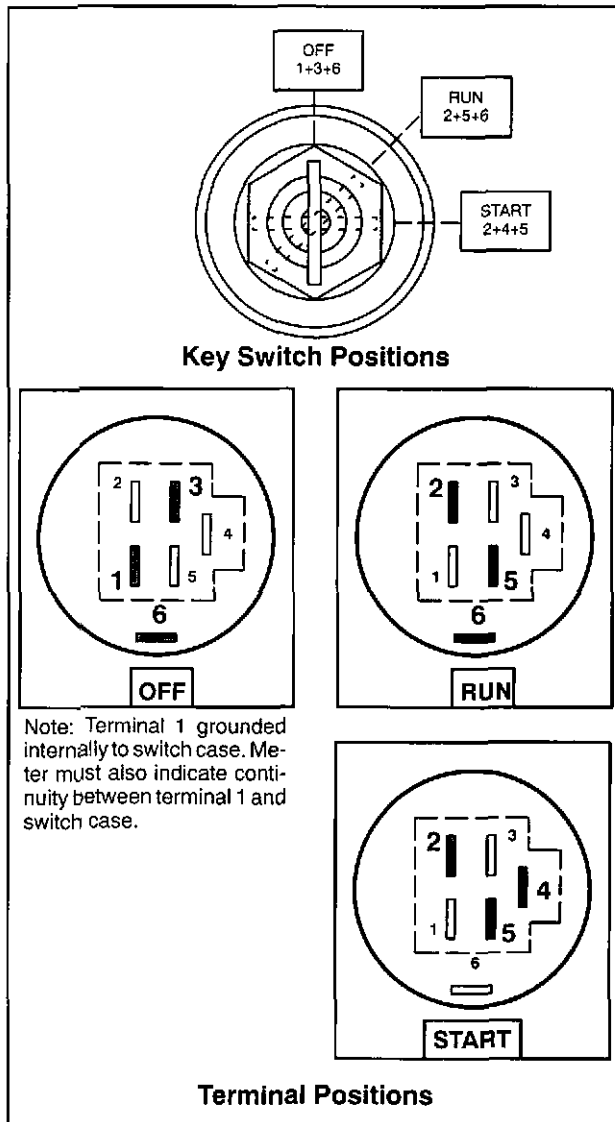


Fig. 32 - Testing Keyswitch

### Testing Starter Solenoid

The solenoid is a normally open, electrically activated switch. With the keyswitch in the "START" position, the switch closes, allowing battery current to flow to the starter motor and crank the engine.

The solenoid may be tested while mounted on engine.

A jumper test lead is required for this test.

Remove positive battery cable from battery. Then remove battery cable from stud terminal on solenoid.

Disconnect yellow wire from tab terminal on solenoid.

Keyswitch must be in "OFF" position.

1. Insert red test lead into  $V\Omega$  receptacle in meter.
2. Insert black test lead into **COM** receptacle in meter.
3. Rotate meter selector to  $\Omega$  position.
4. Attach one meter test lead to each stud terminal on solenoid, Fig. 33.
5. Attach one end of jumper lead to positive terminal on battery.
6. Touch jumper wire to tab terminal on solenoid.
  - a. An audible "Click" should be heard as the solenoid switch "closes".
  - b. Meter should make a continuous tone (continuity).

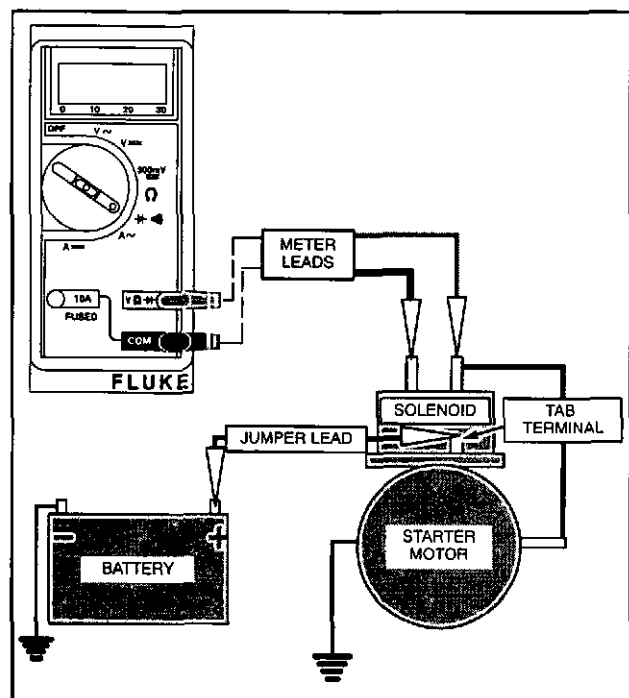
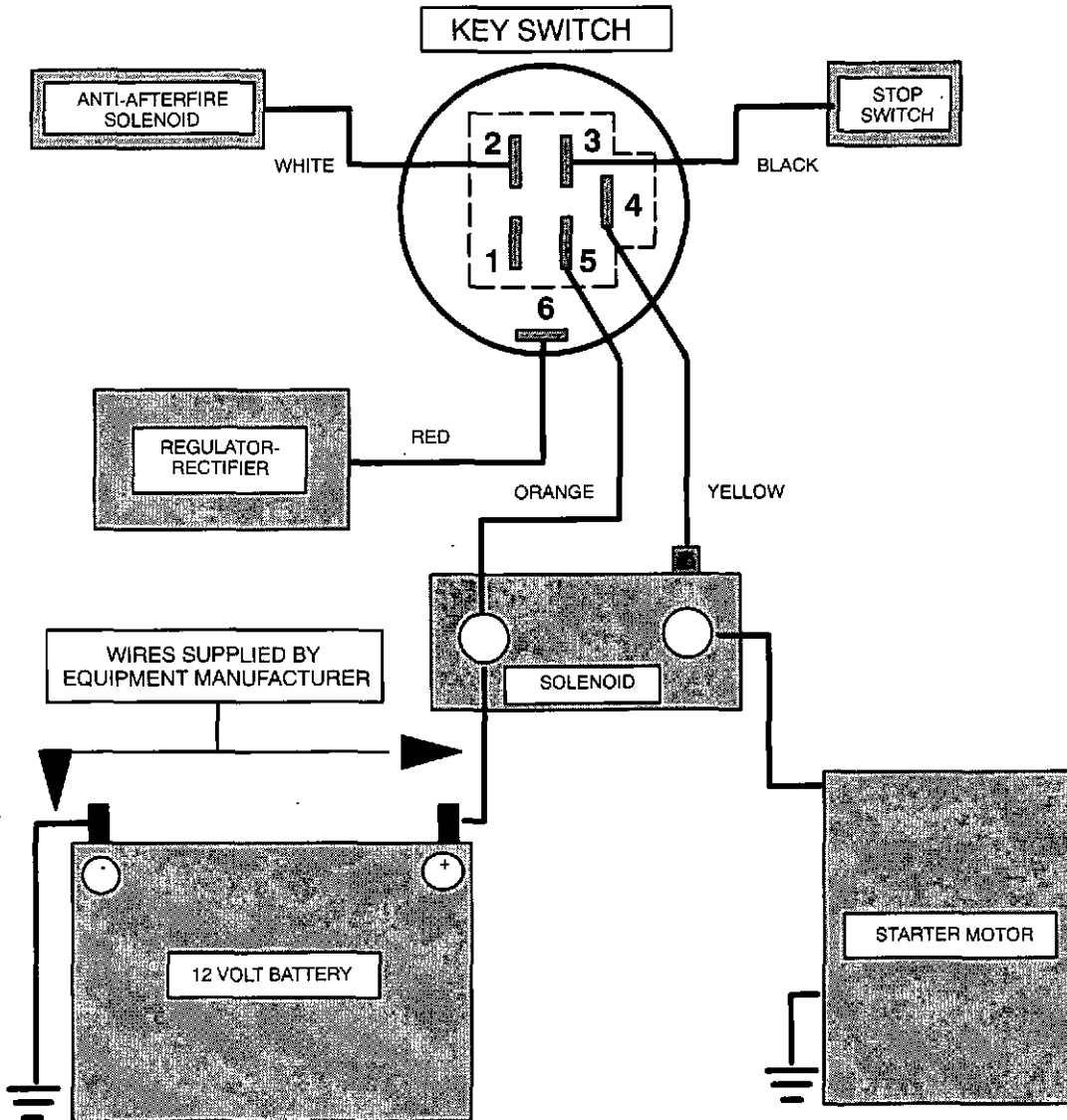


Fig. 33 - Testing Solenoid

# SOLENOID Testing

**Wiring Diagram For Starter Panel & Key Switch For V-Twin Engines**

Terminal No.	Wire Color	Function
1	Not Used	
2	White	To Carburetor Solenoid (when used)
3	Black	To Stop Switch Terminal On Engine
4	Yellow	To Solenoid (tab terminal)
5	Orange	To Battery (battery terminal on solenoid)
6	Red	To Regulator/Rectifier



Switch Position	Continuity
1. OFF	1+3+6
2. RUN	2+5+6
3. START	2+4+5

7B

## Battery Information

The battery used to operate starter motors on Briggs & Stratton OHV-Twin engines is 12 volt, lead acid, wet cell type. This type is available as a wet charge or dry charge battery. The wet charged maintenance-free battery is filled with electrolyte and sealed at the time of manufacture. The level of electrolyte cannot be checked.

The dry charge battery is manufactured with fully charged plates. Electrolyte must be added at the time that the battery is placed in service. Before activating a dry charge battery, read and follow the manufacturer's recommended procedure.

**WARNING:** WEAR EYE PROTECTION WHEN SERVICING THE BATTERY. AVOID SKIN CONTACT. IF CONTACT DOES OCCUR, FLUSH WITH COLD WATER AND CONSULT A PHYSICIAN.

**CAUTION:** BEFORE SERVICING BATTERY, DISCONNECT NEGATIVE (-) BATTERY CABLE FIRST, THEN POSITIVE (+) CABLE SECOND.

**WARNING:** BATTERIES PRODUCE HYDROGEN, AN EXPLOSIVE GAS. DO NOT STORE OR CHARGE A BATTERY NEAR AN OPEN FLAME OR DEVICES WHICH UTILIZE A PILOT LIGHT OR CAN CREATE A SPARK.

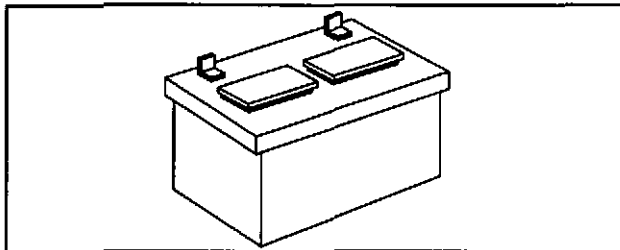


Fig. 34 - Typical Dry Charge Battery

### Installation:

1. Before installing battery, connect all equipment to be operated.
2. Place battery in holder with flat base. Tighten holder down evenly until snug. DO NOT overtighten.
3. Connect positive terminal to positive post FIRST to prevent sparks from accidental grounding. Tighten connectors securely.
4. Connect negative terminal to negative battery terminal. Tighten connectors securely.

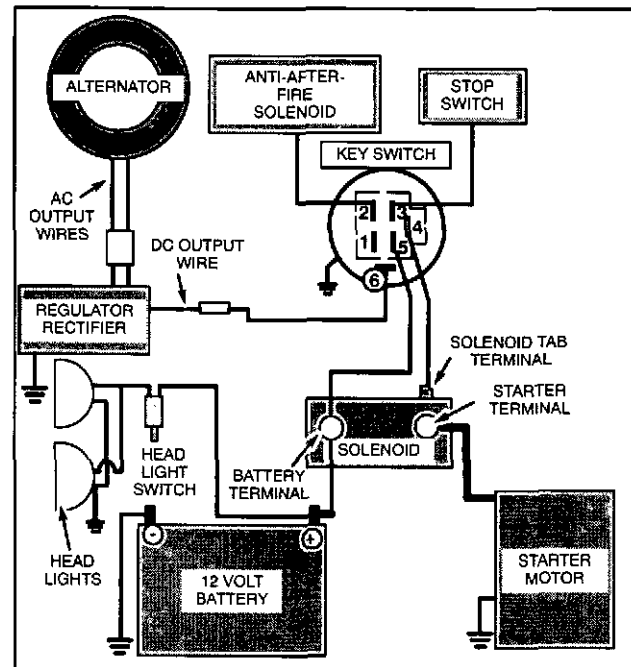


Fig. 35 - Typical 12 V Wiring Diagram

### Checking Battery

1. Physical check - clean if necessary.
  - a. Corrosion
  - b. Dirt
  - c. Terminal and clamps (secure - good condition)
2. Bring battery to full charge.

**WARNING:** DO NOT EXCEED CHARGE RATE OF 1/10 AMPERE FOR EVERY AMPERE OF BATTERY RATING. CONSULT BATTERY MANUFACTURER FOR MAXIMUM CHARGE RECOMMENDATIONS.

- a. Use a taper charge (automatically reduces charge rate).
  - b. Fill battery cells with distilled water or tap water after charging (for batteries that have been in service).
3. NOTE: If battery gets "Hot" to the touch or is spitting acid (gassing) excessively, unplug charger periodically.
  4. With battery fully charged, check specific gravity readings of each cell with a Battery Hydrometer and record readings (Fig. 36). All readings should be above 1.250 (compensating for temperature). If specific gravity readings varied .50 or if all cells read less than 1.225, replace battery.

# STARTERS

## Battery

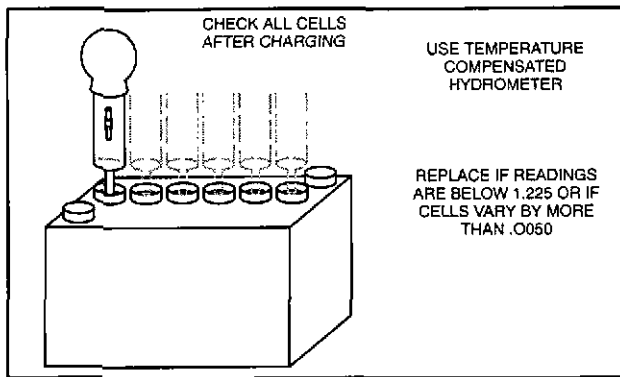


Fig. 36 - Checking 12 V Battery Cells (Lead Acid, Wet Cell, Dry Charge)

### Testing Battery

Use Digital Multimeter, Tool #19357 or #19390

Set meter to read DC Volts.

Attach RED meter test clip to positive (+) battery terminal. Attach BLACK meter test lead to negative (-) battery terminal. With ignition switch "OFF," press starter button. If ignition switch and starter switch are the same switch, disconnect wires from spark plugs and ground ignition using two Ignition Testers, Tool #19368. Turn switch to "START." Meter should

display 9 volts or more while cranking engine. If less than 9 volts, replace battery.



**CAUTION: DO NOT CRANK STARTER MOTOR FOR MORE THAN 15 SECONDS WITHOUT ALLOWING STARTER MOTOR TO COOL AT LEAST 2 MINUTES.**

### Battery Recommendations

These battery size recommendations are based on minimum temperature expected and correct weight of oil being used. See Section 8.

30 Amp. Hr.  $-6^{\circ}\text{C}$  ( $+20^{\circ}\text{F}$ ) or higher

40 Amp. Hr.  $-20^{\circ}\text{C}$  ( $-5^{\circ}\text{F}$ ) or higher

50 Amp. Hr.  $-26^{\circ}\text{C}$  ( $-15^{\circ}\text{F}$ ) or higher

### Battery Cable Recommendations

These cable sizes are based on total length of cable from battery positive post to starter switch or solenoid, and to starter plus ground return to battery negative post.

#6 AWG - 1.2 m (4 ft.) or less

#5 AWG - 1.5 m (5 ft.) or less

#4 AWG - 1.8 m (6 ft.) or less

# Section 7C ALTERNATORS

The alternator systems installed on Briggs & Stratton OHV-Twin Cylinder Engines can easily be identified by the color of the stator output wires and the connector.

Table No. 1 provides a means of identifying the various alternator systems. Note: All output figures are rated at 3600 RPM.

**TABLE NO. 1**

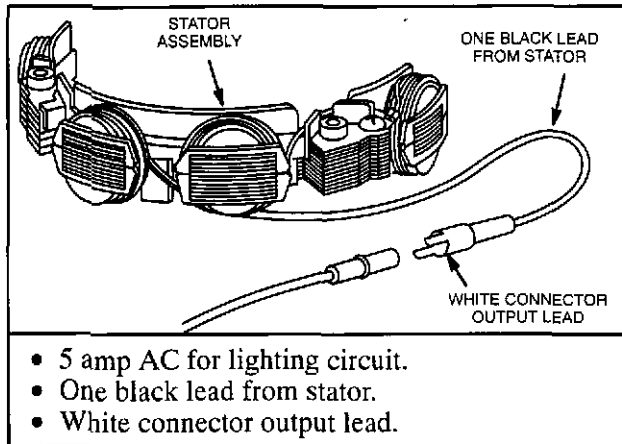
Fig.	Alternator Type	Stator Output Wire(s) Color	Connector Color	Alternator Output (at 3600 RPM)	Test Page
1	AC Only	Black	White	5 Amps AC (Lights) Unregulated	5
2	DC Only	Red	Red	2 - 4 Amps + DC (Charging) Unregulated	6
3	Dual Circuit	Red Black	White	2 - 4 Amps + DC (Charging) Unregulated 5 Amps AC (Lights) Unregulated	6
4	Tri-Circuit	Black	Green	5 Amps + DC (Charging) 5 Amps - DC (Lights)	8
5	Regulated 5 Amp	Black	Green	* 1-5 Amps + DC (Charging) Regulated	9
5	Regulated 9 Amp	Black	Green	* 1-9 Amps + DC (Charging) Regulated	9
6	Regulated 10 Amp	2-Black	Yellow	* 1-10 Amps + DC (Charging) Regulated	10
6	Regulated 16 Amp	2-Black	Yellow	* 1-16 Amps + DC (Charging) Regulated	10

\* Alternator output is determined by flywheel alternator magnet size.

7C

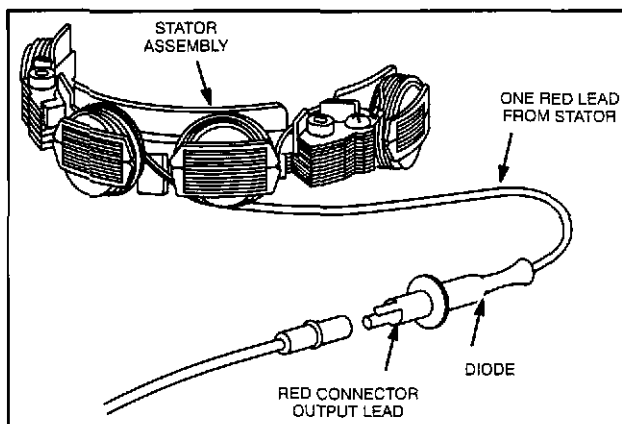
# ALTERNATORS

## Alternator Identification



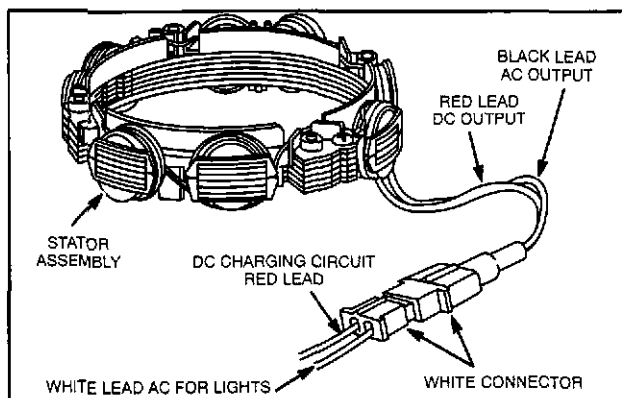
- 5 amp AC for lighting circuit.
- One black lead from stator.
- White connector output lead.

**Fig. 1 - AC Only Stator**



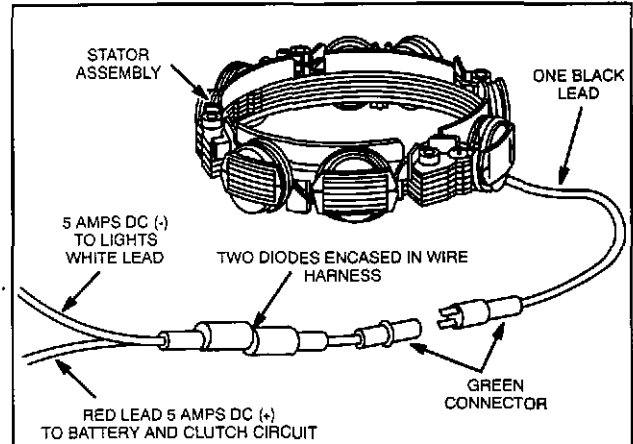
- 3 amp DC unregulated for charging battery.
- One red lead from stator.
- Diode encased at connector.
- Red connector output lead.

**Fig. 2 - DC Only Stator**



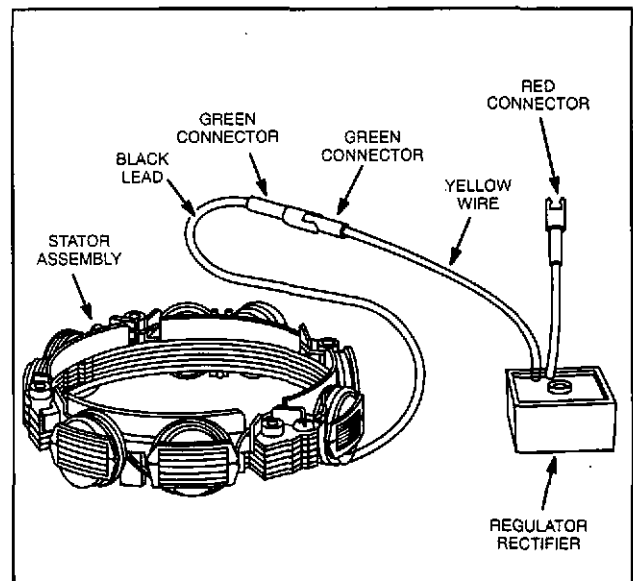
- 3 amp DC unregulated for charging battery (ONE red lead from stator).
- 5 amp AC for lighting circuit (ONE black lead from stator).
- Diode encased at connector.
- White connector with two pin terminals.

**Fig. 3 - Dual Circuit Stator**



- 10 amp AC.
- One black lead from stator.
- Green connector.
- Two diodes encased in wire harness.
- Red and white output leads.

**Fig. 4 - Tri-Circuit Stator**

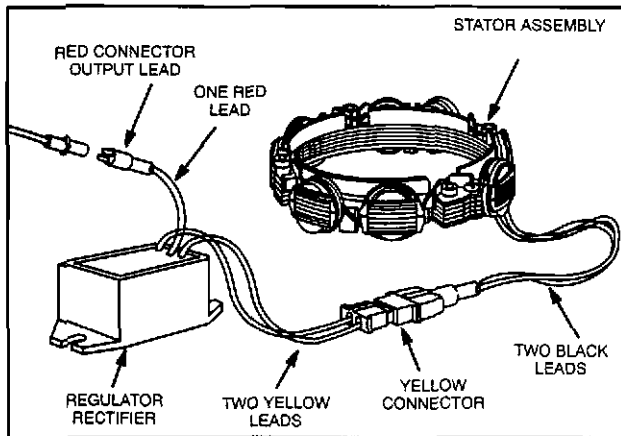


- 5 or 9 amp DC regulated for charging battery.
- Alternator output (5 or 9 amp) is determined by flywheel alternator magnet size.
- Uses same stator as Tri-Circuit system.
- One black lead from stator.
- Green connector.

**Fig. 5 - 5 or 9 amp Regulated Stator**

# ALTERNATORS

## Flywheel Identification



- 10 or 16 amp DC regulated for charging battery.
- Two black leads from stator.
- Yellow connector with two pin terminals.
- Two yellow leads to regulator-rectifier.
- One red lead from regulator-rectifier to red connector output lead.
- 10 and 16 amp system use the same stator, color coding and regulator-rectifier.
- Alternator output is determined by the flywheel alternator magnet size.

Fig. 6 - 10 or 16 amp Regulated Stator

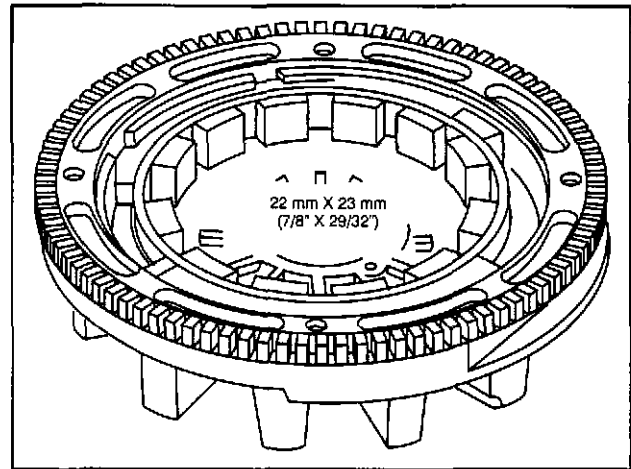


Fig. 8 - Large Magnet

### Flywheel Identification

OHV-Twin Cylinder Flywheels have a single ring of magnets which provide the magnetic field for the various alternator systems. There are two (2) sizes of flywheel magnets. The size of the magnet determines the alternator output Fig. 7 and Fig. 8.

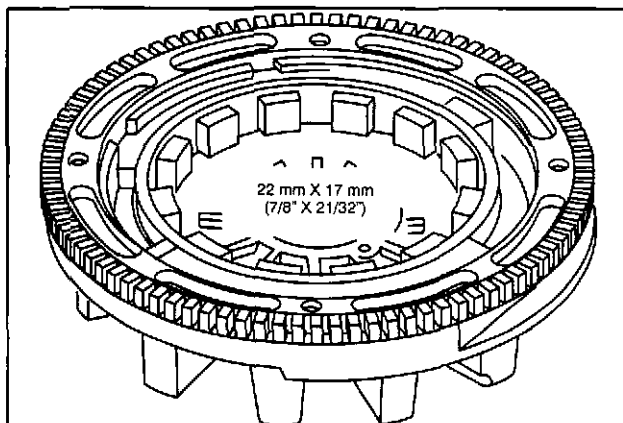


Fig. 7 - Small Magnet

Table 2 identifies the magnet size to be used with a specific alternator system.

TABLE NO. 2

Alternator	Small Magnet	Large Magnet
AC Only	•	
DC Only	•	
Dual Circuit	•	
Tri-Circuit	•	
Regulated 5 AMP	•	
Regulated 9 AMP		•
Regulated 10 AMP	•	
Regulated 16 AMP		•

NOTE: Large magnet flywheels cannot be used with the AC only, DC only, Dual Circuit and Tri-Circuit alternator systems.

# ALTERNATORS

## Troubleshooting

The following list is provided to aid you in diagnosing problems with alternator systems.

### ALTERNATOR SYSTEMS – TROUBLESHOOTING

COMPLAINT	POSSIBLE CAUSES
"Battery not charging"	<ul style="list-style-type: none"> <li>• Engine RPM too low.</li> <li>• Inline fuse "blown" (if equipped).</li> <li>• Defective battery.</li> <li>• Loose, pinched, or corroded battery ground leads.</li> <li>• Loose, pinched, or corroded battery charge leads.</li> <li>• Open, shorted, or grounded wires between output connector and battery.</li> <li>• Defective diode (open or shorted).</li> <li>• Defective or improperly grounded regulator-rectifier.</li> <li>• Diode installed incorrectly (reversed).</li> <li>• Damaged battery (shorted battery cells).</li> <li>• Excessive current draw from accessories.</li> <li>• Low magnetic flux or damaged alternator magnets.</li> </ul>
"Battery in state of overcharge"	<ul style="list-style-type: none"> <li>• Severe battery vibration (missing or broken tie-down straps).</li> <li>• Battery rate of charge not matched to alternator output.</li> <li>• Damaged battery (shorted battery cells).</li> <li>• Defective regulator.</li> <li>• One OHM resistor shorted or grounded (Tri-Circuit system only).</li> </ul>
"Headlamps not working"	<ul style="list-style-type: none"> <li>• Inline fuse "blown" (if equipped).</li> <li>• Defective headlamps.</li> <li>• Loose or corroded wires.</li> <li>• Open, shorted or grounded wires between output connector and headlamps.</li> <li>• Light switch defective.</li> <li>• Defective diode Tri-Circuit system (open or shorted - white output lead side).</li> <li>• Low magnetic flux or damaged alternator magnets.</li> </ul>
"Electric clutch not working" (Tri-Circuit Alternator)	<ul style="list-style-type: none"> <li>• Inline fuse "blown" (if equipped).</li> <li>• Loose or corroded wires.</li> <li>• Open, shorted or grounded wires between output connector and electric clutch.</li> <li>• Defective diode (open or shorted-red output lead side).</li> <li>• NOTE: Battery will also not charge.</li> <li>• Defective electric clutch switch.</li> <li>• Open, shorted or grounded clutch circuit.</li> <li>• Low magnetic flux or damaged alternator magnets.</li> </ul>

7C

#### Equipment To Test Alternators

The following equipment is recommended to test and repair alternators.

#### Digital Multimeter

The Digital Multimeter is available from your Briggs & Stratton source of supply. Order as Tool #19357 or

#19390. The meter may be used to read volts, ohms or amperes, and test diodes, when leads are inserted in the appropriate receptacle, Fig. 9.

The Digital Multimeter will withstand DC input of 10-20 amps for up to 30 seconds. When checking DC output on 16 amp regulated system, use the DC shunt, Tool #19359, to avoid blowing fuse in meter, Fig. 10.

# ALTERNATORS Testing

NOTE: The Digital Multimeter is equipped with two fuses to prevent damage to the meter in the event that the input limits are exceeded. If the meter displays a reading of 0.00 when testing DC output (  $A \text{---}$  ), check fuses in meter. Refer to FLUKE Operators Manual for procedure for checking fuses. Replacement Fuses are available from an electrical supply house.

## Testing Alternator Output

When checking alternators, make the tests in the following sequence.

1. Test alternator output.
2. Test diode(s) or regulator, rectifier (if equipped).

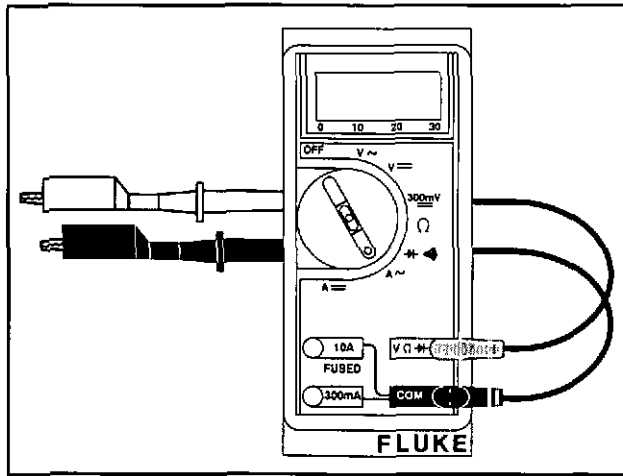


Fig. 9 - Digital Multimeter

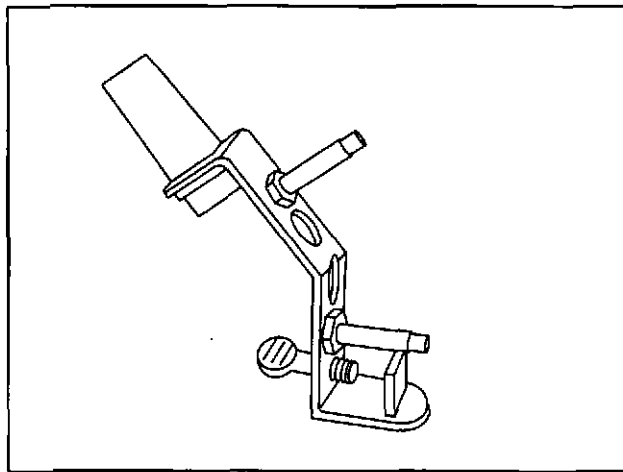


Fig. 10 - DC Shunt - Tool No. 19359

NOTE: Before testing the alternator's output (volts, amps), first use an accurate tachometer and temporarily adjust the engine speed to the RPM specified in the test instructions.



**CAUTION:** Upon completion of the alternator output test, always readjust the engine RPM to its correct Top No Load Governed Speed as found in the Service Engine Sales Manual Microfiche MS-6225 or the Service Sales Manual, MS-4052.

## AC Only Alternator

The AC alternator provides current for headlights only. Current for the lights is available as long as the engine is running. The output depends upon engine speed. 12 volt lights with a total rating of 60 to 100 watts may be used. With lights rated at 70 watts, the voltage rises from 8 volts at 2400 RPM to 12 volts at 3600 RPM, so the brightness of the light changes with the engine speed.

## Test AC Output

1. Insert RED test lead into  $V\Omega\sim$  receptacle in meter.
2. Insert BLACK test lead into COM receptacle in meter.
3. Rotate selector to  $V\sim$  (AC volts) position.
4. Attach RED test lead clip to AC output terminal, Fig. 11.

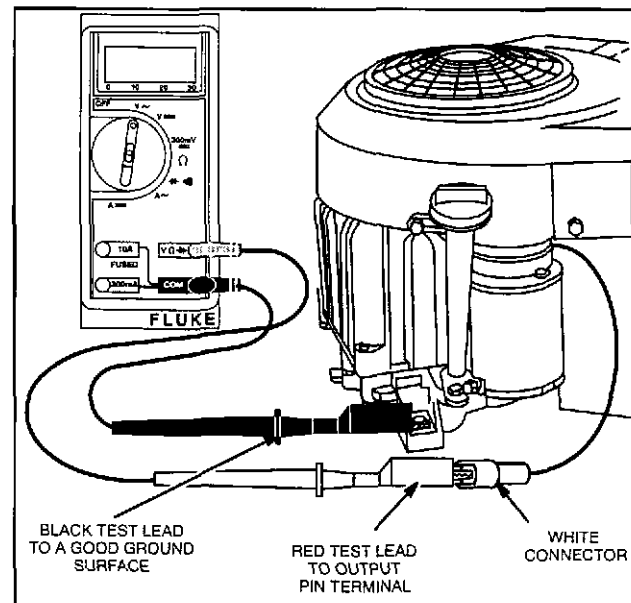


Fig. 11 - Testing AC Output

5. Attach BLACK test lead clip to engine ground.
6. With engine running at 3600 RPM, AC output should be no less than 14 volts.
7. If no or low output is found, replace the stator.

# ALTERNATORS

## Testing

### DC Only Alternator

The DC alternator provides DC current for charging a 12 volt battery. The current from the alternator is unregulated and is rated at 3 amps. The output rises from 2 amps at 2400 RPM, to 3 amps at 3600 RPM.

Recommended battery sizes range from 30 ampere hour for warm temperature service to 50 ampere hour in coldest service.

WHEN CHECKING ALTERNATOR COMPONENTS, MAKE THE TEST IN THE FOLLOWING SEQUENCE:

### Test Alternator Output

1. Insert RED test lead into 10 A receptacle in meter.
2. Insert BLACK test lead into COM receptacle in meter.
3. Rotate selector to  $A \overline{=}$  (DC amps) position.
4. Attach RED test lead clip to DC output terminal, Fig. 12.
5. Attach BLACK test lead clip to positive (+) battery terminal.
6. With engine running at 3600 RPM, output should be between 2-4 amps DC.
  - a. Output will vary with battery voltage. If battery voltage is at its maximum, output will be approximately 2 amps.
7. If no or low output is found, test diode.

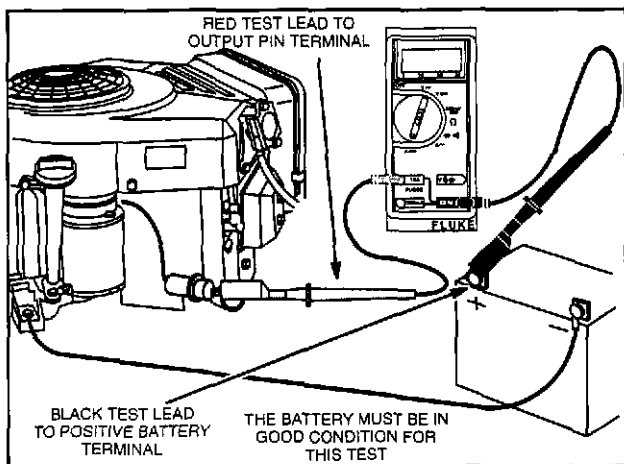


Fig. 12 - Testing DC Output

### Test Diode

In the Diode Test position, the meter will display the forward voltage drop across the diode(s). If the voltage

drop is less than 0.7 volts, the meter will "Beep" once as well as display the voltage drop. A continuous tone indicates continuity (shorted diode). An incomplete circuit (open diode) will be displayed as "OL."

1. Insert RED test lead into  $V \Omega \overline{+}$  receptacle in meter.
2. Insert BLACK test lead into COM receptacle in meter.
3. Rotate selector to  $\overline{+} \overline{=}$  (Diode Test) position.
4. Attach RED test lead clip to point "A" and BLACK test lead clip to point "B," Fig. 13. (It may be necessary to pierce wire with a pin as shown.)
  - a. If meter "Beeps" once, diode is OK.
  - b. If meter makes a continuous tone, diode is defective (shorted). Replace diode.
  - c. If meter displays "OL," proceed to step 5.
5. Reverse test leads.
  - a. If meter "Beeps" once, diode is installed backwards. Replace diode.
  - b. If meter still displays "OL," diode is defective (open). Replace diode.
6. If diode tests OK, check stator for bare wires or other obvious defects. If grounded leads are not visible, replace the stator.

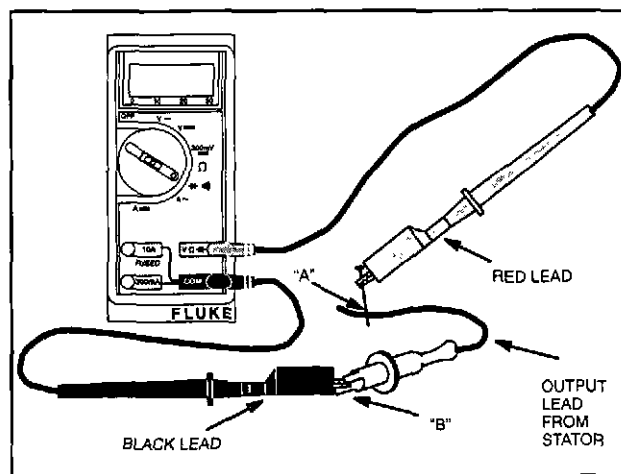


Fig. 13 - Testing Diode

NOTE: Service replacement diode harnesses are available. Use Resin Core solder when installing new harness. Use shrink tubing or tape all connections. DO NOT USE CRIMP CONNECTORS.

# ALTERNATORS Testing

## Dual Circuit Alternator

Dual circuit alternators use a single polarized plug with two pins. One pin is for charging the battery and the second is for the AC light circuit.

The dual circuit alternator provides DC current for battery charging and an independent AC circuit for headlights. The battery is not used for lights, so lights are available even if battery is disconnected or removed.

Current for lights is available as long as the engine is running. The output depends upon engine speed, so brightness of the lights changes with engine speed. 12 volt lights with a total rating of 60 to 100 watts may be used. With lights rated at 70 watts, the voltage rises from 8 volts at 2400 RPM to 12 volts at 3600 RPM.

The current from the DC side of the alternator is unregulated and is rated at 3 amps. The output rises from 2 amps at 2400 RPM to 3 amps at 3600 RPM.

## Test Alternator Output

1. Insert RED test lead into 10 A receptacle in meter.
2. Insert BLACK test lead into COM receptacle in meter.
3. Rotate selector to **A ---** (DC amps) position.
4. Attach RED test lead clip to DC output pin in connector, Fig. 14.

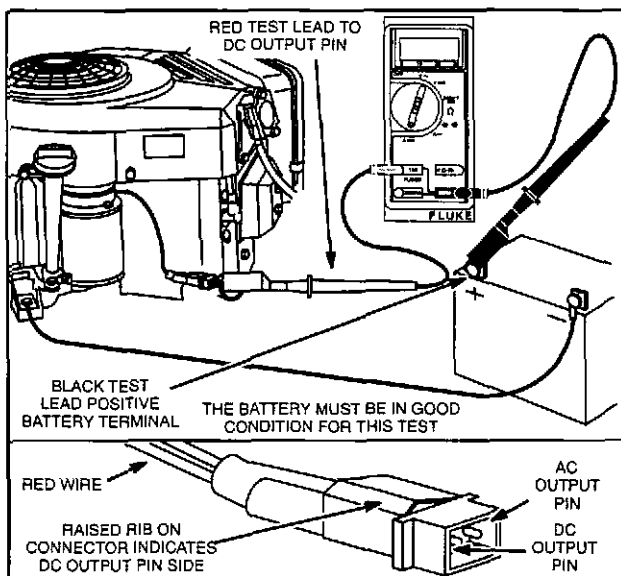


Fig. 14 - Testing DC Output

5. Attach BLACK test lead clip to positive (+) battery terminal.
6. With engine running at 3600 RPM output should be between 2-4 amps DC.

- a. Output will vary with battery voltage. If battery voltage is at its maximum, output will be approximately 2 amps.

7. If no output or low output is found, test diode.

## Diode Test

In the Diode Test position, the meter will display the forward voltage drop across the diode(s). If the voltage drop is less than 0.7 volts, the meter will "Beep" once as well as display the voltage drop. A continuous tone indicates continuity (shorted diode) An incomplete circuit (open diode) will be displayed as "OL."

1. Insert RED test lead into **VΩ\*** receptacle in meter.
2. Insert BLACK test lead into COM receptacle in meter.
3. Rotate selector to **\* -|||** (Diode Test) position.
4. Attach RED test lead clip to point "A" and BLACK test lead clip to point "B," Fig. 15. (It may be necessary to pierce wire with a pin as shown.)
  - a. If meter "Beeps" once, diode is OK.
  - b. If meter makes a continuous tone, diode is defective (shorted). Replace diode.
  - c. If meter displays "OL," proceed to step 5.
5. Reverse test leads.
  - a. If meter "Beeps" once, diode is installed backwards. Replace diode.
  - b. If meter still displays "OL," diode is defective (open). Replace diode.
6. If diode tests OK, check stator for bare wires or other obvious defects. If grounded leads are not visible, replace the stator.

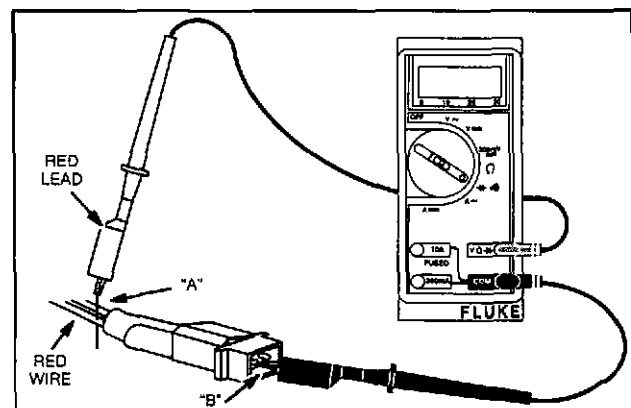


Fig. 15 - Testing Diode

# ALTERNATORS

## Testing

NOTE: Service replacement diode harnesses are available. Use Resin Core solder when installing new harness. Use shrink tubing or tape all connections. DO NOT USE CRIMP CONNECTORS.

### AC Output Test

1. Insert RED test lead into  $V\Omega$  receptacle in meter.
2. Insert BLACK test lead into COM receptacle in meter.
3. Rotate selector to  $V\sim$  (AC volts) position.
4. Attach RED test lead clip to AC output terminal, Fig. 16.

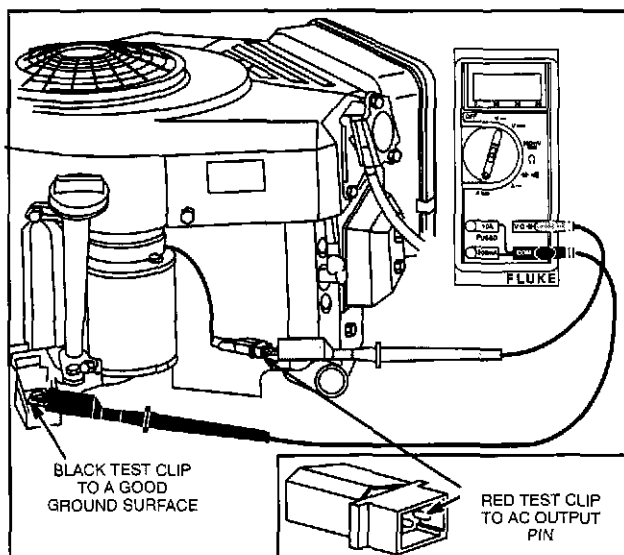


Fig. 16 - Testing AC Output

5. Attach BLACK test lead clip to engine ground.
6. With engine running at 3600 RPM output should be no less than 14 volts AC.
7. If no output or low output is found, replace stator.

### Tri-Circuit Alternator

The tri-circuit alternator provides alternating current through a single output lead and connector to a wiring harness containing two diodes.

One diode rectifies the AC current to 5 amps negative (-) DC for lights. The second diode rectifies the AC current to 5 amps positive (+) DC for battery charging and external loads, such as an electric clutch.

NOTE: Some equipment manufacturers supply the diodes as an integral part of the equipment wiring harness.

Some equipment manufacturers use a 1 OHM 20 WATT resistor placed in series with (+) DC charging lead, limiting the charging current to approximately 3 amps when the clutch is not engaged. When the clutch is engaged the resistor is bypassed allowing full output to the battery and clutch.

NOTE: The 1 OHM 20 WATT resistor is supplied by the equipment manufacturer.

The battery is not used for the lights, so lights are available even if the battery is disconnected or removed. Current for the lights is available as long as the engine is running. The output depends upon engine RPM, so the brightness of the lights changes with engine speed.

### Test Alternator Output

1. Insert RED test lead into  $V\Omega$  receptacle in meter.
2. Insert BLACK test lead into COM receptacle in meter.
3. Rotate selector to  $V\sim$  (AC volts) position.
4. Attach RED test lead clip to output terminal, Fig. 17.

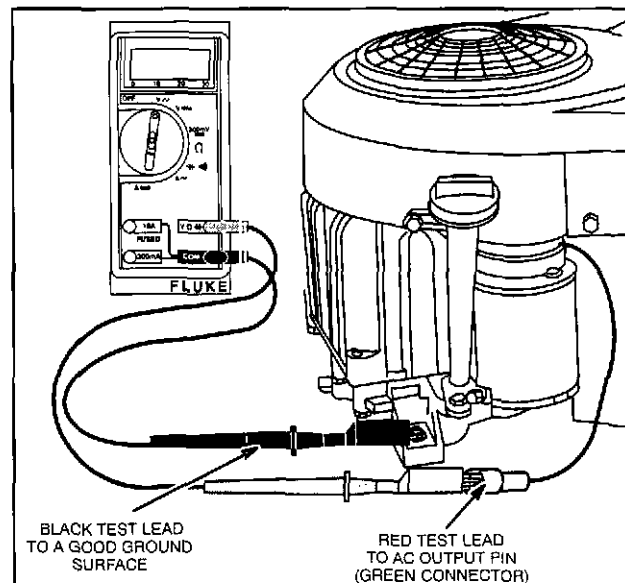


Fig. 17 - Testing Alternator Output

5. Attach BLACK test lead clip to engine ground.
6. With engine running at 3600 RPM, output should be no less than 28 volts AC.
7. If no output or low output is found, replace stator.
8. If alternator output is good, test diodes located in wiring harness.

### Diode Test

NOTE: One diode is for the charging circuit and the other diode is for the lighting circuit.

# ALTERNATORS Testing

In the Diode Test position, the meter will display the forward voltage drop across the diode(s). If the voltage drop is less than 0.7 volts, the meter will "Beep" once as well as display the voltage drop. A continuous tone indicates continuity (shorted diode) An incomplete circuit (open diode) will be displayed as "OL."

## Charging Circuit (Red Wire)

1. Insert RED test lead into  $V\Omega\rightarrow$  receptacle in meter.
2. Insert BLACK test lead into COM receptacle in meter.
3. Rotate selector to  $\rightarrow \rightarrow$  (Diode Test) position.
4. Attach BLACK test lead clip to point "A," (red wire) Fig. 18. (It may be necessary to pierce wire with a pin as shown.)
5. Insert RED test lead probe into harness connector.
  - a. If meter "Beeps" once, diode is OK.
  - b. If meter makes a continuous tone, diode is defective (shorted). Replace harness.
  - c. If meter displays "OL," proceed to step 6.
6. Reverse test leads.
  - a. If meter "Beeps" once, diode is installed backwards. Replace harness.
  - b. If meter still displays "OL," diode is defective (open). Replace harness.

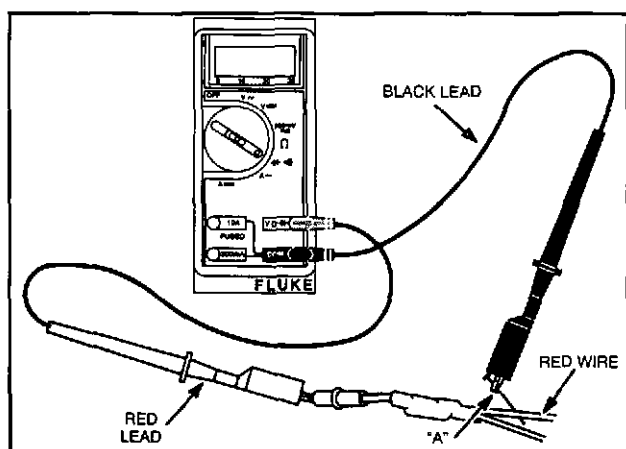


Fig. 18 - Diode Testing - Charging Circuit

## Lighting Circuit (White Wire)

1. Insert RED test lead into  $V\Omega\rightarrow$  receptacle in meter.
2. Insert BLACK test lead into COM receptacle in meter.
3. Rotate selector to  $\rightarrow \rightarrow$  (Diode Test) position.

4. Attach RED test lead clip to point "A,"(white wire) Fig. 19. (It may be necessary to pierce wire with a pin as shown.)
5. Insert BLACK test lead probe into harness connector.
  - a. If meter "Beeps" once, diode is OK.
  - b. If meter makes a continuous tone, diode is defective (shorted). Replace harness.
  - c. If meter displays "OL," proceed to step 6.
6. Reverse test leads.
  - a. If meter "Beeps" once, diode is installed backwards. Replace harness.
  - b. If meter still displays "OL," diode is defective (open). Replace harness.

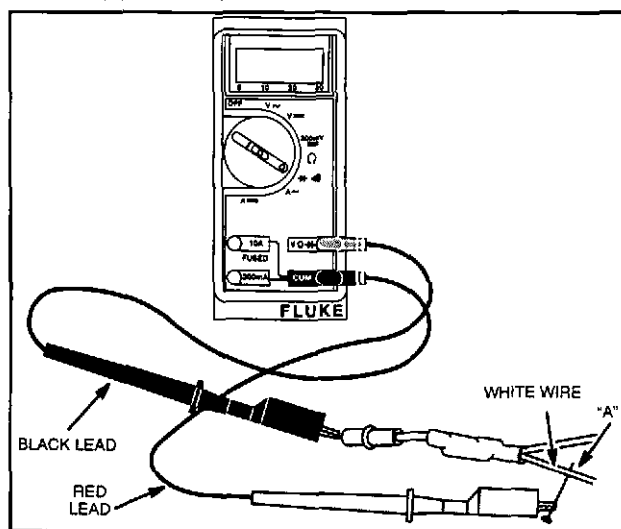


Fig. 19 - Diode Testing - Lighting Circuit

NOTE: Service replacement diode harnesses are available.

## 5 & 9 amp Regulated Alternator

The 5 & 9 amp regulated alternator systems provide AC current through a single lead to the regulator-rectifier. The regulator-rectifier converts the AC current to DC and regulates current to the battery. The charging rate will vary with engine RPM and temperature.

Alternator output (5 or 9 amp) is determined by the flywheel alternator magnet size. The stator and regulator-rectifier are the same for the 5 and 9 amp system.

The 5 & 9 amp regulated system and the Tri-Circuit system use the same stator.

WHEN CHECKING ALTERNATOR COMPONENTS, MAKE TESTS IN THE FOLLOWING SEQUENCE:

# ALTERNATORS

## Testing

### Testing Alternator Output

Temporarily, disconnect stator wire harness from regulator-rectifier.

1. Insert RED test lead into  $V\Omega$  receptacle in meter.
2. Insert BLACK test lead into COM receptacle in meter.
3. Rotate selector to  $V^-$  (AC volts) position.
4. Attach RED test lead clip to output terminal, Fig. 20.

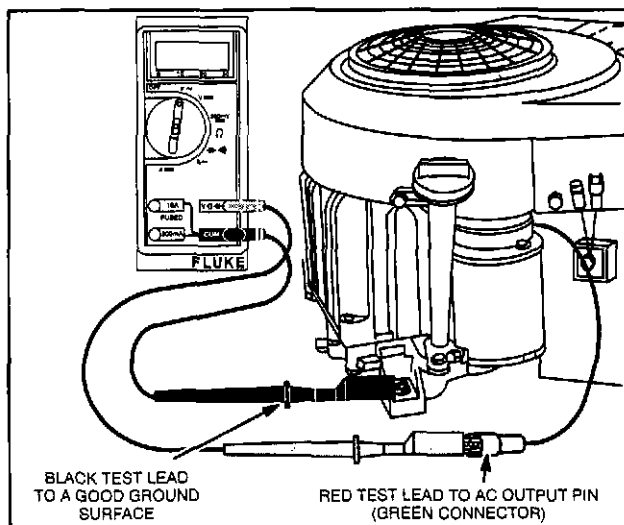


Fig. 20 - Testing AC Output

5. Attach BLACK test lead clip to engine ground.
6. With the engine running at 3600 RPM, AC output should be no less than:

**28 Volts AC - 5 amp System**  
**40 Volts AC - 9 amp System**

7. If no or low output is found, replace the stator.

### Testing Regulator-Rectifier

NOTE: Regulator-rectifier will not function unless it is grounded to engine. Make sure the regulator-rectifier is securely mounted to engine.

When testing regulator-rectifier for amperage output, a 12 volt battery with a minimum charge of 5 volts is required. There will be no charging output if battery voltage is below 5 volts.

NOTE: Connect test leads before starting engine. Be sure connections are secure. If a test lead vibrates loose while engine is running, the regulator-rectifier may be damaged.

1. Insert RED test lead into 10 A receptacle in meter.

2. Insert BLACK test lead into COM receptacle in meter.
3. Rotate selector to  $A$  (DC amps) position.
4. Attach RED test lead clip to red DC output terminal on regulator-rectifier, Fig. 21.

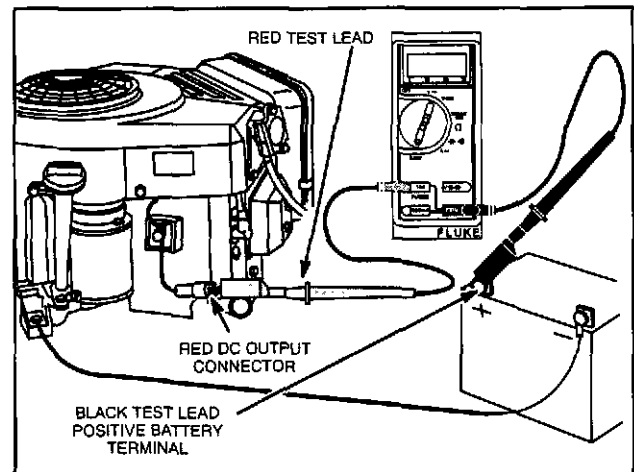


Fig. 21 - Testing Regulator-Rectifier

5. Attach BLACK test lead clip to positive (+) battery terminal.
6. With the engine running at 3600 RPM. The output should be:

**\* 3 - 5 Amps - 5 amp System**  
**\* 3 - 9 Amps - 9 amp System**

\* Depending upon battery voltage. For example, if the battery voltage was below 11 volts, the output reading would be 5 or 9 amps, depending upon the alternator system being tested. If battery voltage is at its maximum, the amperage will be less.

7. If no or low output is found, be sure that regulator-rectifier is grounded properly and all connections are clean and secure. If there is still no or low output, replace the regulator-rectifier.

### 10 & 16 amp Regulated Alternator

The 10 or 16 amp regulated alternator system provides AC current through two output leads to the regulator-rectifier. The regulator-rectifier converts the AC current to DC, and regulates the current to the battery. The charging rate will vary with engine RPM and temperature.

Alternator output (10 or 16 amp) is determined by flywheel alternator magnet size. Therefore, stator and regulator-rectifier are the same for the 10 and 16 amp system.

WHEN CHECKING THE ALTERNATOR COMPONENTS, MAKE THE TESTS IN THE FOLLOWING SEQUENCE:

# ALTERNATORS Testing

## Test Alternator Output

1. Insert RED test lead into  $V\Omega\ast$  receptacle in meter.
2. Insert BLACK test lead into COM receptacle in meter.
3. Rotate selector to  $V^-$  (AC volts) position.
4. Insert RED and BLACK test lead probes into output terminals in yellow connector, as shown in Fig. 22. (Meter test clip leads may be attached to either terminal.)

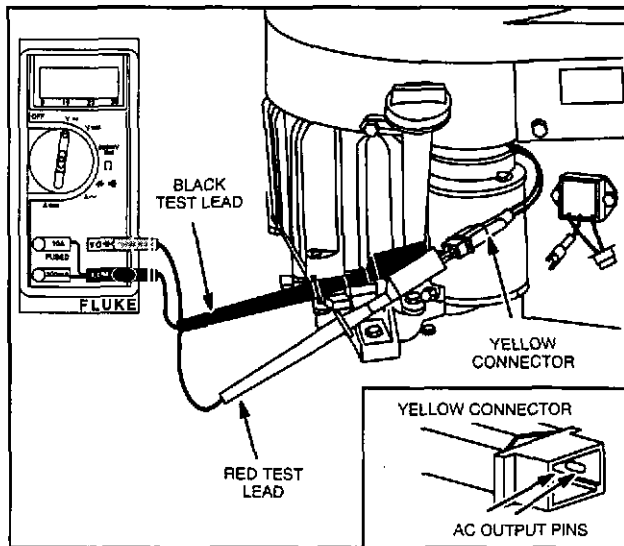


Fig. 22 - Testing AC Output

5. With the engine running at 3600 RPM output should be no less than:

**20 Volts - 10 amp System**  
**\*30 Volts - 16 amp System**

\*If alternator output test indicates a 16 amp system, see special instructions for testing regulator-rectifier.

6. If no or low output is found, check for bare wires or any other obvious defects. If "shorted" leads are not visible, replace the stator.

## Test Regulator-Rectifier All Systems

NOTE: The Digital Multimeter will withstand DC input of 10-20 amps for up to 30 seconds. When checking DC output on 16 amp regulated system, use DC Shunt, Tool #19359, to avoid blowing fuse in meter. See special instructions for installation procedure on 16 amp system.

NOTE: Regulator-rectifier will not function unless it is grounded to engine. Make sure the regulator-rectifier is securely mounted to engine.

When testing regulator-rectifier for amperage output, a 12 volt battery with a minimum charge of 5 volts is required. There will be no charging output if battery voltage is below 5 volts.

NOTE: Connect test leads before starting engine. Be sure connections are secure. If a test lead vibrates loose while engine is running, the regulator-rectifier may be damaged.

## Testing Regulator-Rectifier 10 amp System

1. Insert RED test lead into 10 A receptacle in meter.
2. Insert BLACK test lead into COM receptacle in meter.
3. Rotate selector to  $A \text{ ---}$  (DC amp) position.
4. Attach RED test lead clip to red DC output terminal on regulator-rectifier, Fig. 23.

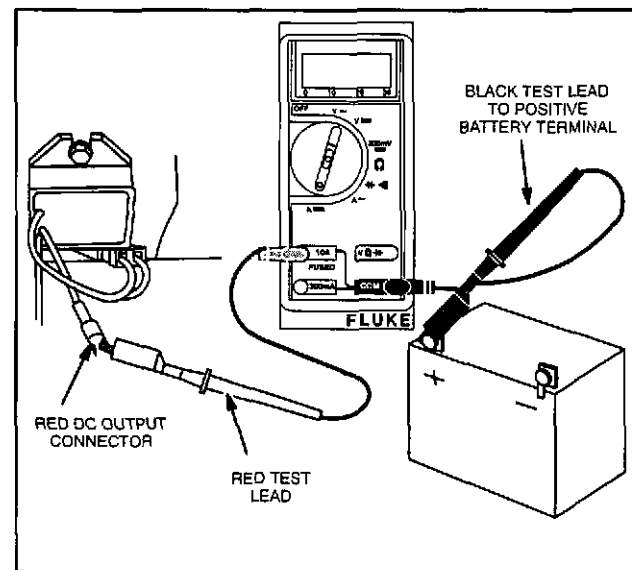


Fig. 23 - Testing Regulator-Rectifier

5. Attach BLACK test lead clip to positive (+) battery terminal.
6. With the engine running at 3600 RPM. The output should be:

**\* 3 - 10 Amps - 10 amp System**

\*Depending upon battery voltage. For example, if the battery voltage was below 11 volts, the output reading would be 10 amps. If battery voltage is at its maximum, the amperage will be less.

7. If no or low output is found, be sure that regulator-rectifier is grounded properly and all connections are clean and secure. If there is still no or low output, replace the regulator-rectifier.

# ALTERNATORS

## Testing

### Testing Regulator-Rectifier 16 amp System

To avoid blowing fuse in meter when testing DC output of 16 amp system the DC Shunt, Tool #19359 is required.

The DC Shunt **must** be installed on the **negative (-)** terminal of the battery, Fig. 24. All connections must be clean and tight for correct amperage readings.

1. Install shunt on negative battery terminal.
2. Insert RED test lead into  $V\Omega$  receptacle in meter and connect to RED post terminal on shunt, Fig. 24.
3. Insert BLACK test lead into COM receptacle in meter and connect to BLACK post terminal on shunt.
4. Rotate selector to  $300mV$  position.

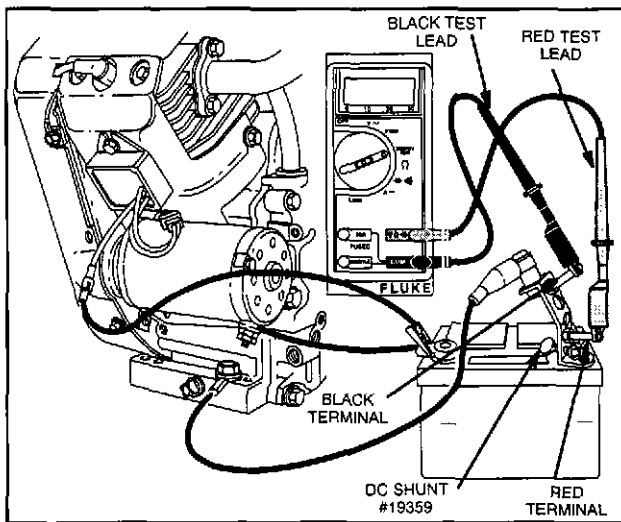


Fig. 24 - Testing Regulator-Rectifier 16 Amp System With DC Shunt

5. With the engine running at 3600 RPM, the output should be:

**\* 3 - 16 Amps - 16 amp System**

\* Depending upon battery voltage. For example, if the battery voltage was below 11 volts, the output reading would be 16 amps. If battery voltage is at its maximum, the amperage will be less.

6. If no or low output is found, be sure that regulator-rectifier is grounded properly and all connections are clean and secure. If there is still no or low output, replace the regulator-rectifier.

### 493219 Regulator-Rectifier With Charge Indicator

Regulator-rectifier Part #493219, Fig. 25, is used by some equipment manufacturers that have a charging indicator light instead of an ammeter. In addition to the red DC output wire, the regulator-rectifier is equipped with a blue wire which is used to activate a charging indicator light when battery voltage is below 12 volts.

The charging indicator light should light when the key switch is in the ON position; engine not running. With engine running, the charging indicator light should go out, indicating that the charging circuit is operating, providing that battery voltage is above 12 volts.

The charge indicator light and all wiring is supplied by the equipment manufacturer. See typical wiring diagram, page 13.

DC charging output values and test procedures are the same as those listed for the 10 amp or 16 amp system.

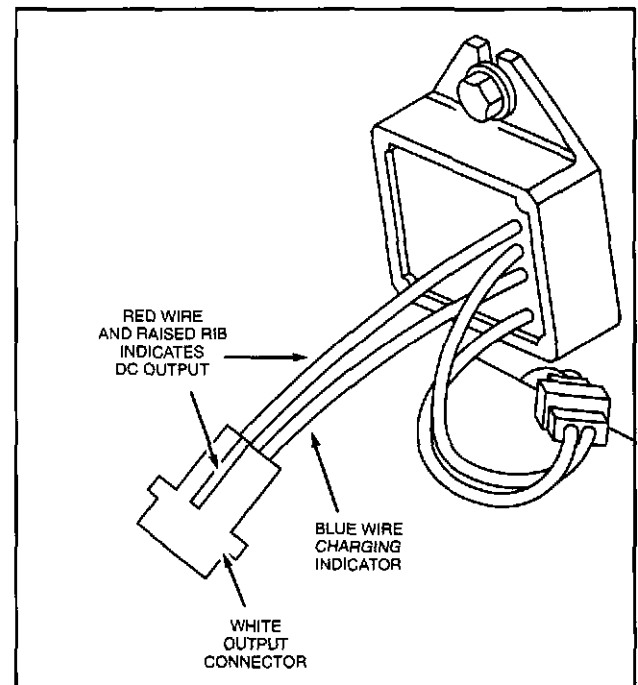
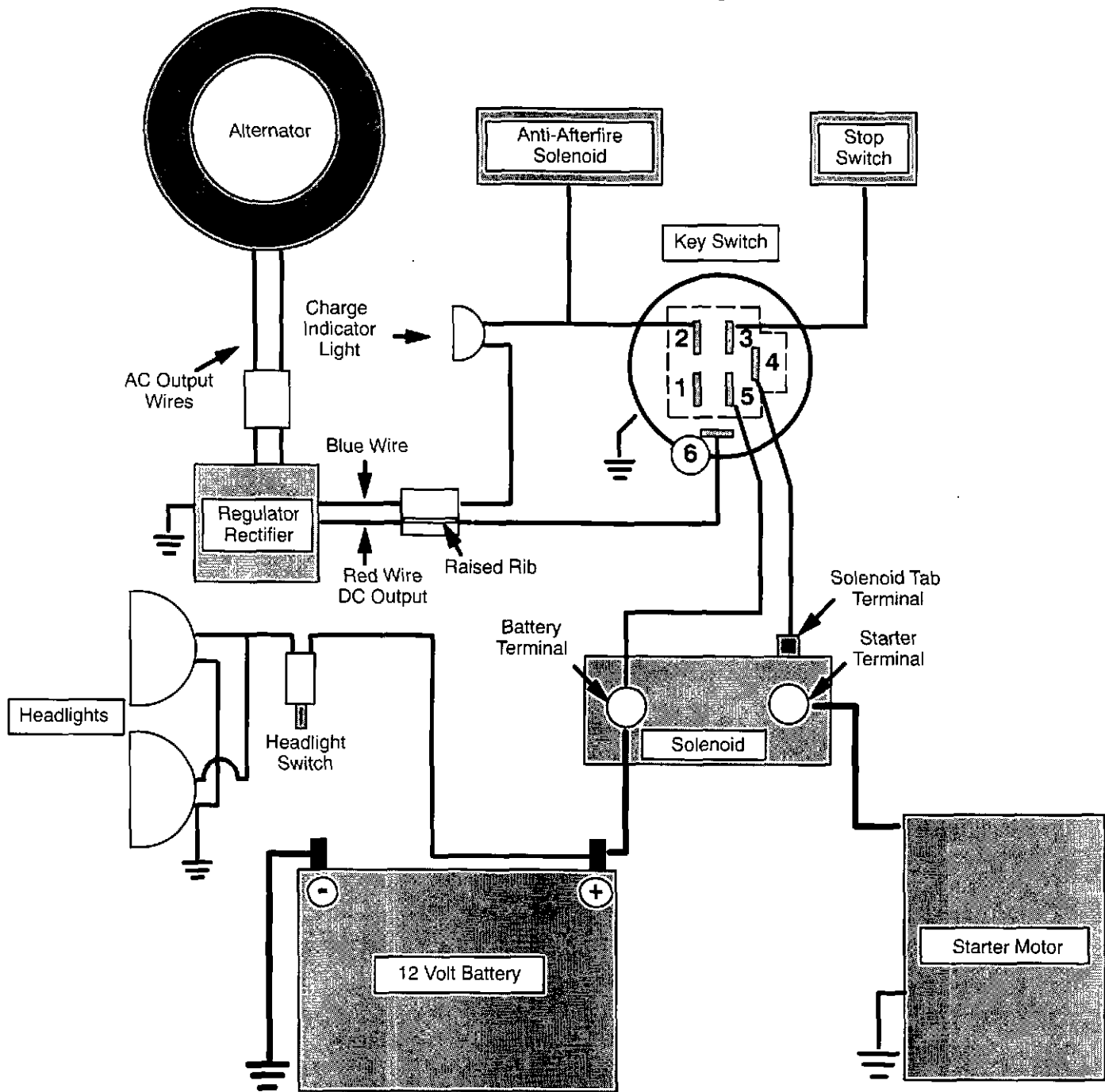


Fig. 25 - 493219 Regulator/ Rectifier

## Typical 16 Amp Regulated Alternator Wiring Diagram - 6 Pole Switch With Charge Indicator Light



7C

### Key Switch Test

Switch Position	Continuity
1. OFF	*1 + 3 + 6
2. RUN	2+5 + 6
3. START	2 + 4+5

\* Terminal 1 Grounded Internally  
To Key Switch Case

Terminal No.	Function
1	To Ground (used only with insulated panel)
2	To Carburetor Solenoid.
3	To Stop Switch Terminal On Engine
4	To Solenoid (tab terminal)
5	To Battery (battery terminal on solenoid)
6	To Alternator (DC Output)

# ALTERNATORS

## Testing

### Testing Charge Indicator

It is important that the test procedure be done in a systematic manner to identify whether the problem is related to the regulator/rectifier or the charging indicator wiring system. Follow test procedure in the sequence listed.

A known good battery is required for this test.

**BEFORE TESTING THE CHARGING INDICATOR SYSTEM, TEST THE ALTERNATOR AND REGULATOR/RECTIFIER FOR CORRECT OUTPUT.**

NOTE: Output values are the same as the 10 amp and 16 amp system.

**Symptom: Charge Indicator Light Will Not Light - Key Switch On - Engine Not Running**

A jumper wire is required for this test.

Make sure key switch is in OFF position before connecting jumper wire.

**IMPORTANT:** Before disconnecting output harness from connector, mark or identify the charging indicator wire in the output harness. If jumper wire contacts charging output wire during test, while key switch is in ON position, wiring harness may be damaged.

1. Disconnect output harness at white connector.
2. Attach one end of jumper wire to a good ground.
3. Attach other end of jumper wire to charge indicator terminal in harness connector, Fig. 26.
  - a. Turn keyswitch to ON position.
  - b. If bulb lights, charge indicator wiring system is OK. Replace regulator/rectifier.
  - c. If bulb does not light, replace bulb.
  - d. If new bulb does not light, the problem must be a broken wire (open circuit) in charging indicator circuit. Refer to typical wiring diagram, page 13.

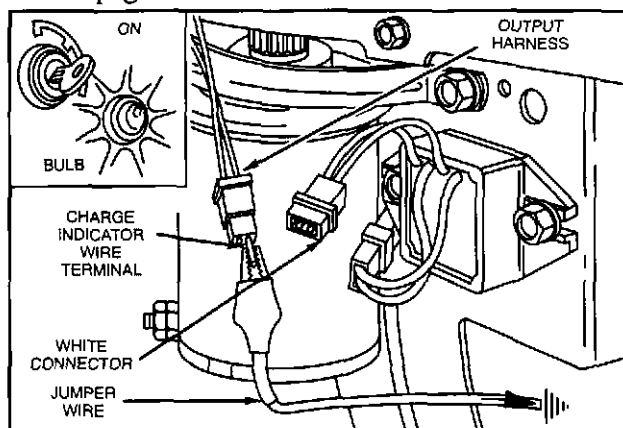


Fig. 26 - Testing Charge Indicator

**Symptom: Charge Indicator Light Stays On - Engine Running**

NOTE: Indicator light will remain on if battery voltage is below 12 volts.

1. Check indicator light wiring.
  - a. If wiring is grounded, light will remain on when engine is running.
  - b. If wiring is OK, replace regulator/rectifier.

### Batteries

The battery is of the 12 volt, lead acid, wet cell type. This type is available as a maintenance free or a dry charged battery.

The maintenance-free battery is filled with electrolyte at the time of manufacture. The level of electrolyte cannot be checked, Fig. 27.

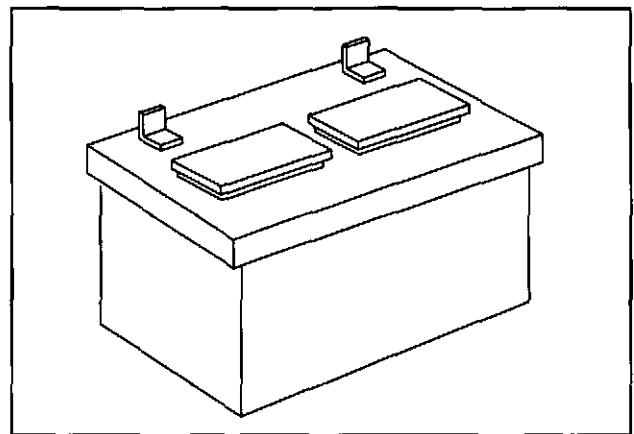


Fig. 27 - Typical Wet Charge Battery

The dry charged battery is manufactured with fully charged plates. Electrolyte must be added at the time that the battery is placed in service. Before activating a dry charged battery, read and follow the manufacturer's recommended procedure.

Recommended battery sizes range from a minimum 30 ampere hour for warm temperature service to 50 ampere hour in coldest service.



**WARNING: BATTERIES PRODUCE HYDROGEN, AN EXPLOSIVE GAS. DO NOT store, charge or use a battery near an open flame or devices which utilize a pilot light or can create a spark.**

# ALTERNATORS Installation

## Installation

1. Before installing battery, connect all equipment to be operated. Fig. 28.
2. Place battery in holder with a flat base. Tighten hold downs evenly until snug. DO NOT overtighten.
3. Connect positive terminal to positive post FIRST to prevent sparks from accidental grounding. Tighten connectors securely.
4. Connect negative terminal to negative battery terminal. Tighten connectors securely.

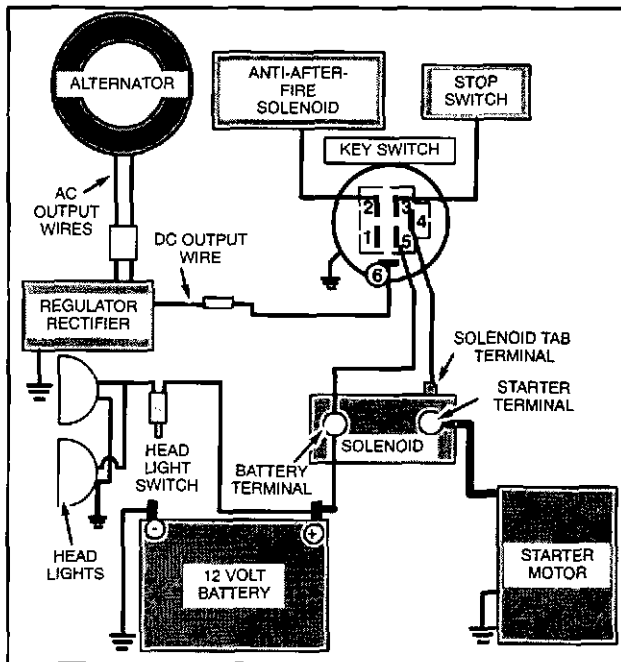


Fig. 28 - Typical 12 V Wiring Diagram

## Checking Battery

1. Physical check - clean if necessary.
  - a. Corrosion
  - b. Dirt

- c. Terminal and clamps  
(secure - good conditions)
2. Bring battery to full charge.

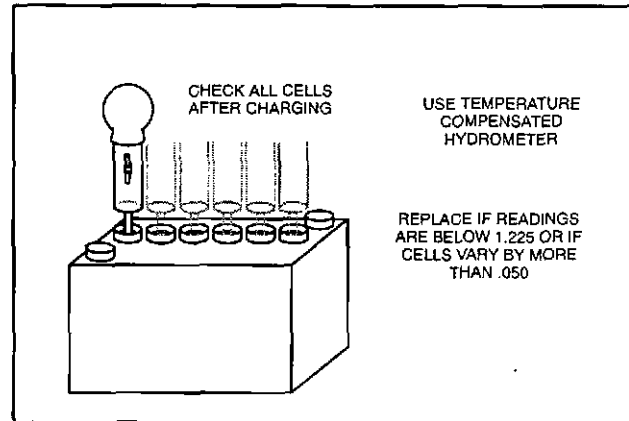


Fig. 29 - Checking 12 V Battery Cells  
(Lead Acid, Wet Cell, With Fill Caps)



**WARNING:** DO NOT EXCEED CHARGE RATE OF 1/10 AMPERE FOR EVERY AMPERE OF BATTERY RATING. Consult battery manufacturer for charging recommendations.

- a. Use a taper charger (automatically reduces charge rate).
  - b. Fill battery cells with distilled water or tap water (unless maintenance free type) after charging (for batteries that have been in service). NOTE: If battery gets "hot" to the touch or is spitting acid (gassing) excessively, unplug charger periodically.
3. With battery fully charged, check specific gravity readings (unless maintenance free type) of each cell with a Battery Hydrometer and record readings (Fig. 29).

All readings should be above 1.250 (compensating for temperature). If specific gravity readings varied .050 or if ALL cells read less than 1.225, replace battery.

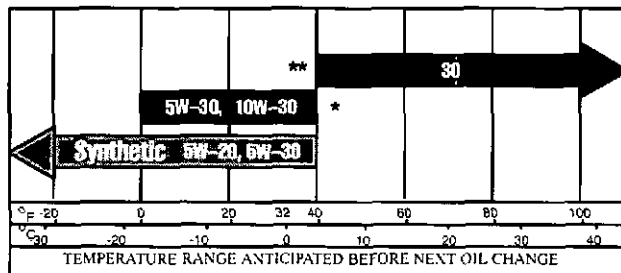
# Section 8 LUBRICATION

Oil has four purposes. It cools, cleans, seals and lubricates. Briggs & Stratton OHV V-Twin engines are lubricated with a gear-driven oil pump.

## Oil Recommendations

We recommend the use of a high quality detergent oil classified "For Service SE, SF, or SG" such as Briggs & Stratton 30 weight oil part #100005 or #100028. Detergent oils keep the engine cleaner and retard the formation of gum and varnish deposits. No special additives should be used with recommended oils.

### RECOMMENDED SAE VISCOSITY GRADES 4-Cycle Vanguard™ (Overhead Valve) Gasoline Engines



\* Air cooled engines run hotter than automotive engines. Use of multi-viscosity oils (10W-30, etc.) above 40° F (4° C) will result in high oil consumption and possible engine damage. Check oil level more frequently if using these types of oils.

\*\* SAE 30 oil, if used below 40° F (4° C), will result in hard starting and possible engine bore damage due to inadequate lubrication.

## Change Oil

The crankcase capacity of OHV V-Twin cylinder engines is approximately:

**1.65 liters (3-1/2 Pints) with filter**

**1.42 liters (3 Pints) without filter**

**IMPORTANT: DO NOT OVERFILL.** Check and maintain oil level regularly. Change oil after first eight (8) hours of operation.

Thereafter, change oil every fifty (50) hours of operation. Change oil more often if engine is operated in dirty or dusty conditions or if engine is operated under heavy loads or in high ambient air temperatures.

Remove oil drain plug and drain oil while engine is still warm, Fig. 1 and Fig. 2. Replace drain plug.

Remove dipstick and refill slowly with new oil of proper service classification and viscosity grade. Refill to full mark on dipstick. When checking oil level, dipstick must be screwed all the way in for accurate readings. Start and run engine to check for oil leaks.

## Change Oil Filter

Replace oil filter every 100 hours. Before installing new filter, lightly oil filter gasket with fresh clean engine oil. Screw filter on by hand until gasket contacts filter adapter. Tighten 1/2 to 3/4 turn more, Fig. 1 and Fig. 2.

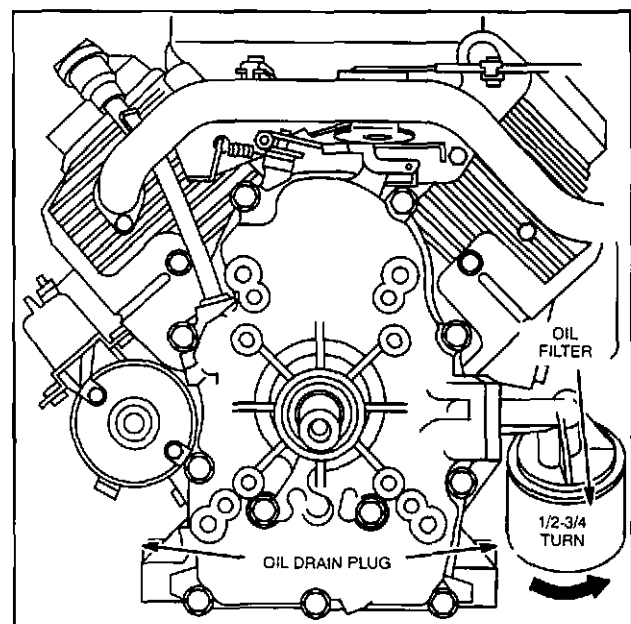


Fig. 1 - Horizontal Crankshaft Engine

# LUBRICATION

## General

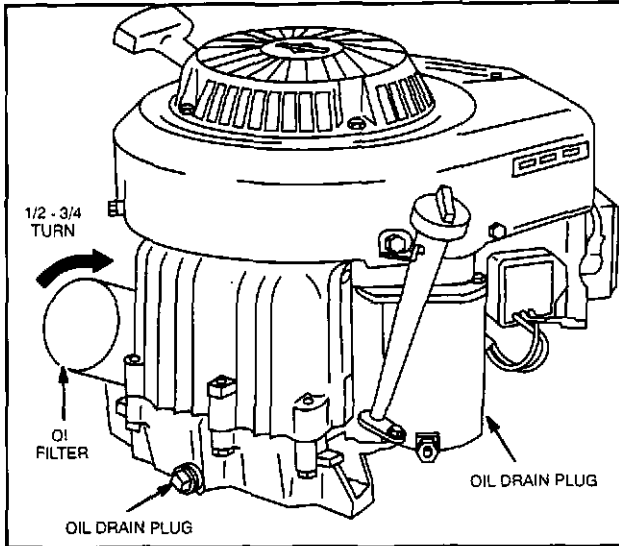


Fig. 2 - Vertical Crankshaft Engine

### Extended Oil Fill And Dipsticks

Horizontal crankshaft OHV V-Twin engines use an extended oil fill tube with locating bracket and screw-in dipstick. The oil fill tube is pressed into a rubber grommet in the cylinder block. To hold and locate the oil fill tube, a bracket is welded to the tube, Fig. 3.

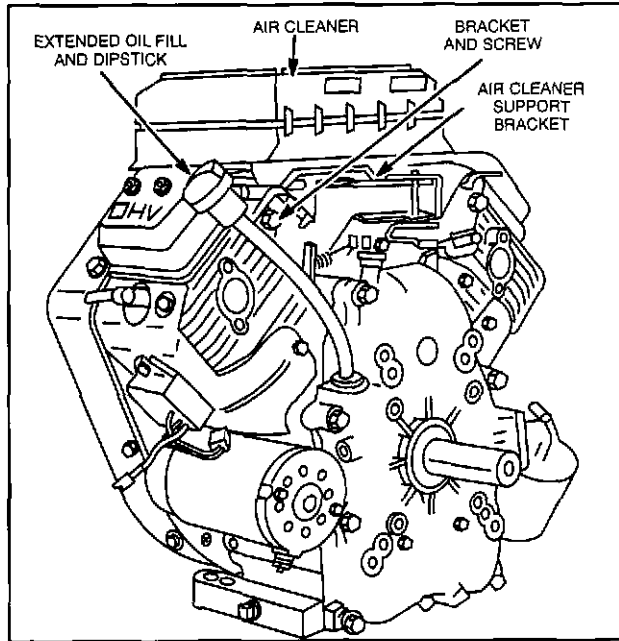


Fig. 3 - Horizontal Crankshaft

Some horizontal crankshaft OHV V-Twin engines are equipped with an optional valve cover oil fill, Fig. 4.

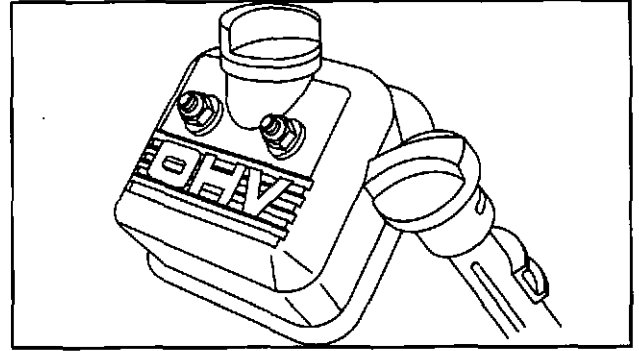


Fig. 4 - Optional Oil Fill Valve Cover

Vertical crankshaft OHV V-Twin engines use a plastic extended oil fill tube and screw-in dipstick and cap assembly. When installing the oil fill tube, make sure "O" ring is in place, then push down firmly on tube until it seats firmly in crankcase cover. Install screws, Fig. 5.

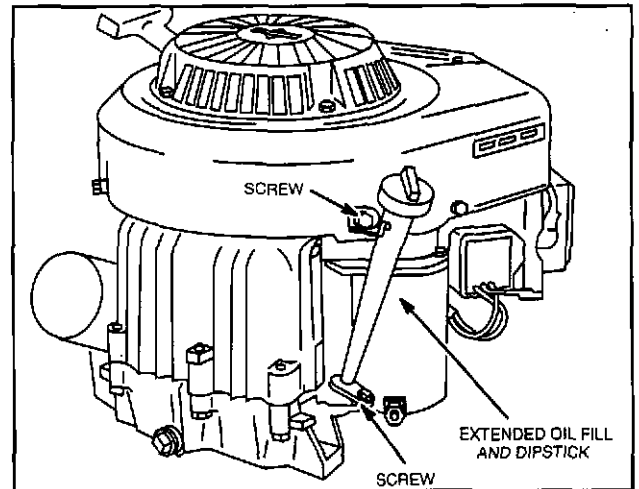


Fig. 5 - Vertical Crankshaft

A LEAK AT THE SEAL BETWEEN THE TUBE AND CRANKCASE COVER, OR AT THE SEAL AT THE UPPER END OF THE DIPSTICK, CAN RESULT IN A LOSS OF CRANKCASE VACUUM AND A DISCHARGE OF OIL OR SMOKE THROUGH THE MUFFLER.

Caution owners or operators not to overfill crankcase with oil when using the extended oil fill and dipstick. Always fill to full mark on dipstick. The dipstick is marked "DO NOT OVERFILL." Overfilling crankcase can cause a smoking or overheating condition because of oil foaming.

### Breathers

The engine utilizes a breather valve to control and maintain a vacuum in the crankcase. The breather valve closes on the up stroke of the piston and opens on the down stroke of the piston to maintain a vacuum in the crankcase. This vacuum prevents oil leakage past piston rings, valve guides, oil seals, governor shaft and gaskets.

# LUBRICATION Breathers

Two styles of breathers are used on Briggs & Stratton OHV V-Twin Engines. The current style breather uses a reed valve to maintain crankcase vacuum, Fig. 6A. Early style breathers contain a fiber disc type valve, Fig. 6B. The breather mounting screw for the current style and early style breather is NOT interchangeable.

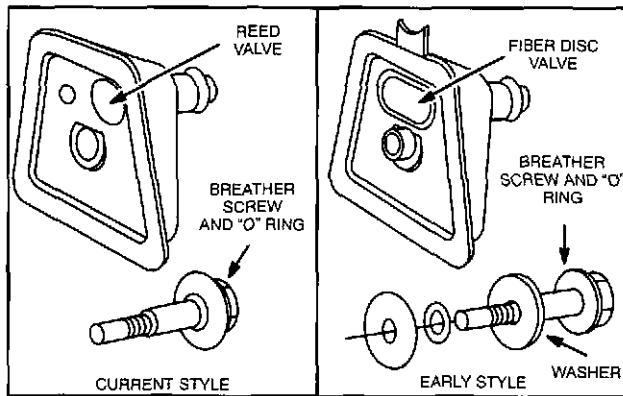


Fig. 6A

Fig. 6B

## Remove Breather Valve Assembly

Before breather valve assembly can be removed for inspection, the air cleaner assembly and support bracket must be removed, Fig. 3. Then remove breather, Fig. 7.

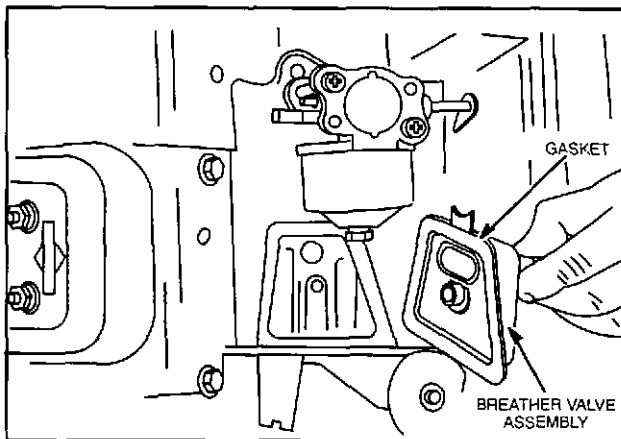


Fig. 7 - Removing Breather

## Checking Breather - Current Style

The reed valve is spring loaded and must make a complete seal around the vent hole in breather body, Fig. 8. Check to see that reed valve is not deformed. **DO NOT USE FORCE ON REED VALVE.**

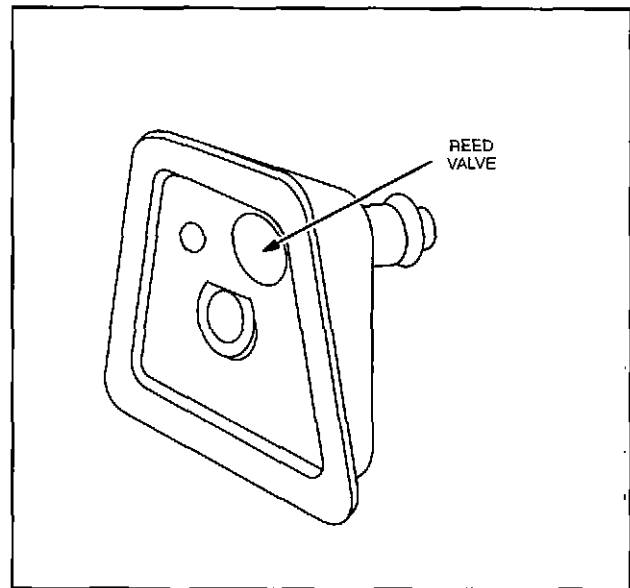


Fig. 8 - Checking Breather - Current Style

## Checking Breather - Early Style

If the fiber disc valve is stuck or binding, the breather cannot function properly and must be replaced. A 1.14 mm (.045") wire gauge should not enter the spacer between the fiber disc valve and body. (A spark plug wire gauge may be used.) **DO NOT FORCE GAUGE.** Check as shown in Fig. 9. **NOTE:** The fiber disc valve is held in place by an internal bracket which will be distorted if pressure is applied to the fiber disc valve. Therefore, do not force when checking with wire gauge.

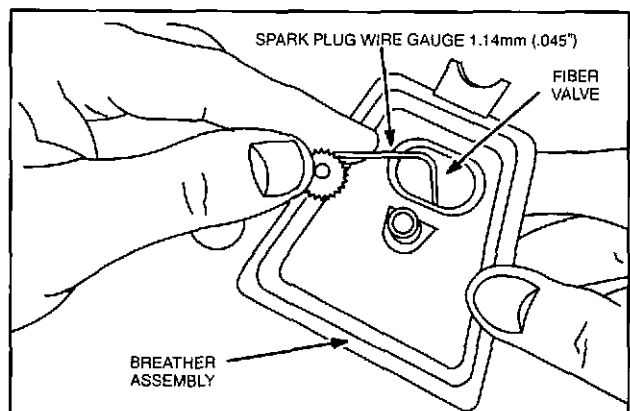


Fig. 9 - Checking Breather - Early Style

# LUBRICATION

## Breathers

### Install Breather

When installing breather, make sure breather gasket is located properly, Fig. 10.

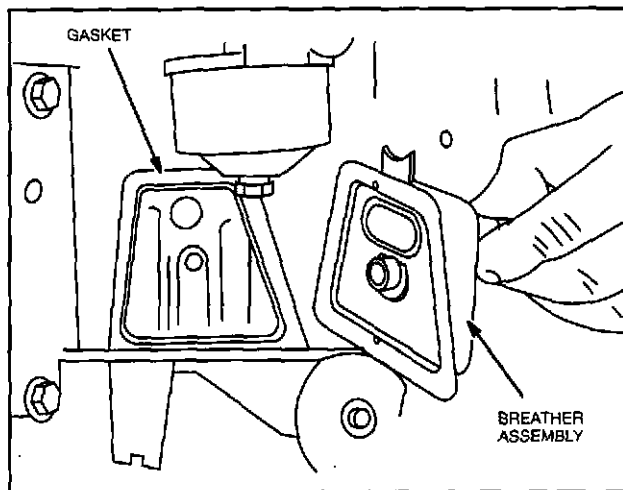


Fig. 10 - Gasket Location

Place breather on gasket. On current style breather, slip large O-ring onto mounting screw and install screw, Fig. 11. Torque screw to 3 Nm (30 in. lbs.).

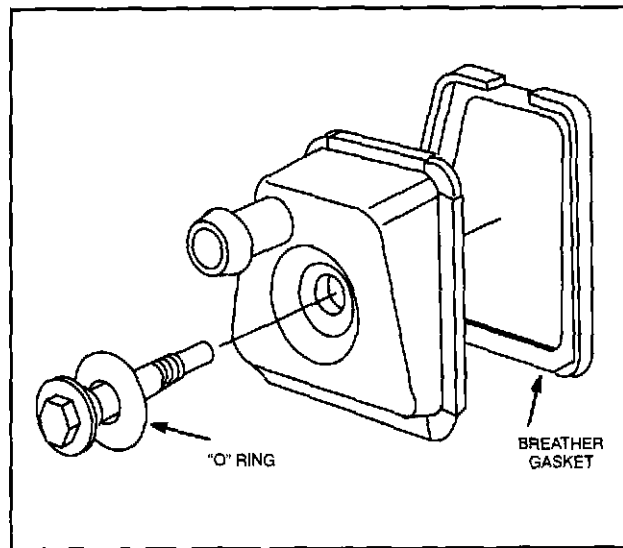


Fig. 11 - Install Breather - Current Style

On early style breather, position large O-ring on cover. Then, slide washer and small O-ring on mounting screw and install screw, Fig. 12. Torque screw to 3 Nm (30 in. lbs.).

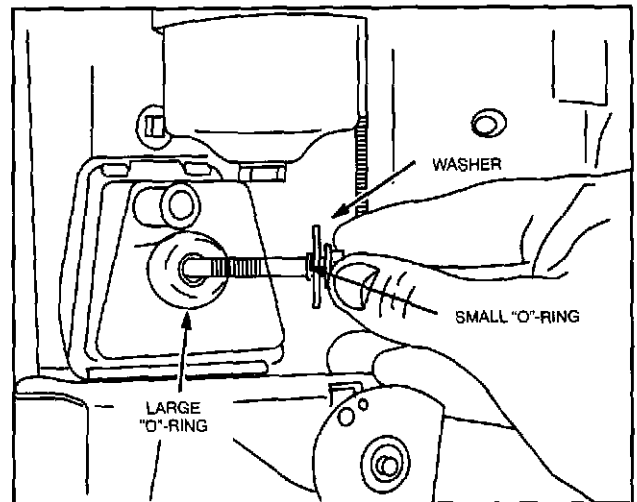


Fig. 12 - Install Breather - Early Style

### Inspect Breather Tube

The breather is vented through the air cleaner to prevent dirt from entering the crankcase. Check breather tube for cracks, holes or hardening, Fig. 13. Replace if damaged.

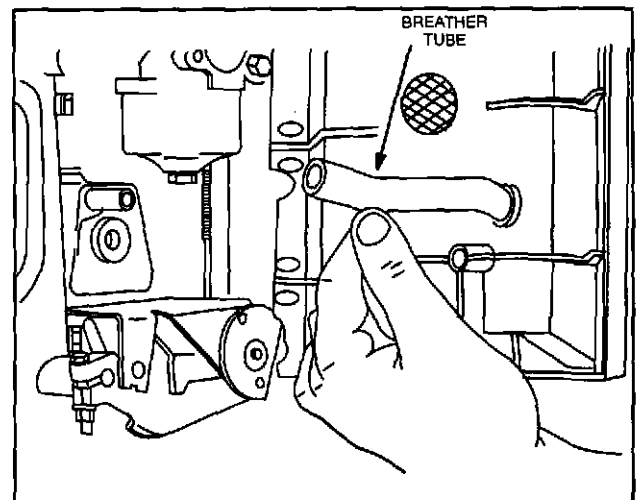


Fig. 13 - Inspect Breather Tube

### Pressure Lube

Briggs & Stratton OHV V-Twin engines are equipped with a full pressure lubrication system with an oil filter.

Oil filters are available through your Briggs & Stratton source of supply. Order Part #491056.

**NOTE:** A shorter oil filter (6.4 cm, 2-1/2") is available for restricted access applications. Order Part #492932.

The gear driven oil pump, Fig. 14 supplies lubrication to all bearing journals at 10-50 PSI.

**NOTE:** Engine oil pressure will vary with oil viscosity, ambient air temperature differences, operating temperatures and engine load. Follow the oil recommendation on page 1 of this section.

# LUBRICATION Pressure Lube

The oil pump draws oil through a screened pick up in the engine base and pumps the oil through the oil filter. The filtered oil flows through oil galleries (passages) in the crankcase cover and cylinder where it is distributed to the main bearings and cam gear bearing.

A pressure relief valve located in the oil pump housing limits the maximum oil pressure in the system.

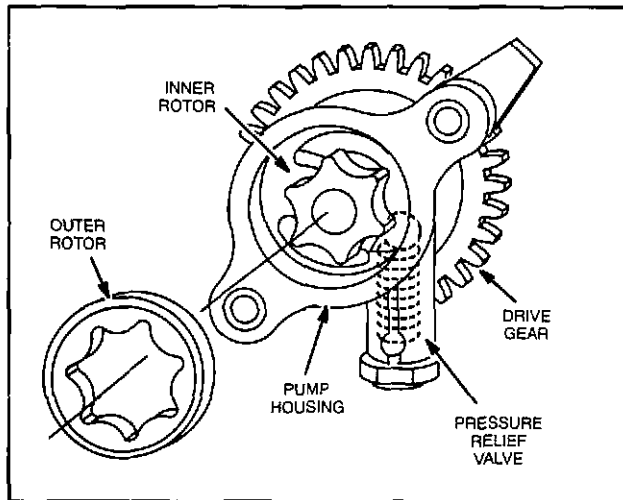


Fig. 14 - Oil Pump

An oil gallery in the crankshaft supplies oil from the magneto bearing to the crankpin, lubricating the connecting rods, Fig. 15, Fig. 16.

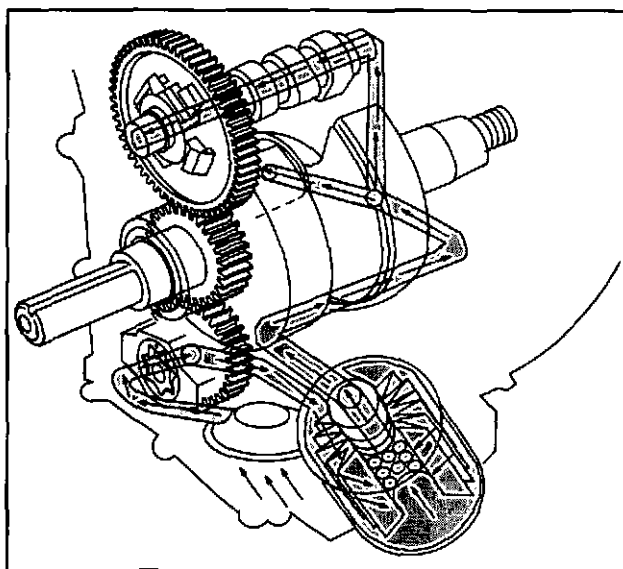


Fig. 15 - Full Pressure Lubrication System - Horizontal Crankshaft

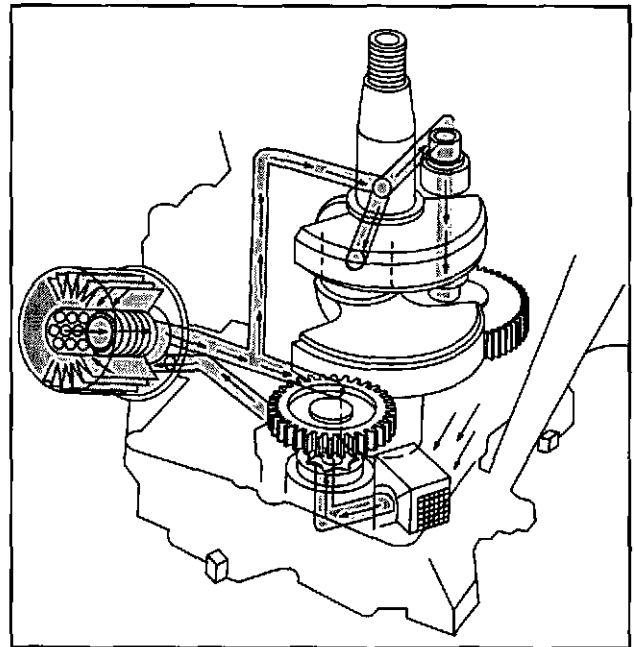


Fig. 16 - Full Pressure Lubrication System - Vertical Crankshaft

## Remove Oil Pump - All Models

The oil pump is attached to the inside of the crankcase cover. Remove oil fill and dipstick assembly. Remove crankcase cover. Remove two screws attaching oil pump assembly to crankcase cover, Fig. 17. Outer rotor of pump can be removed for inspection and cleaning. With pump removed, oil pick-up screen may be removed for cleaning (vertical crankshaft models). No further disassembly is required for vertical crankshaft models.

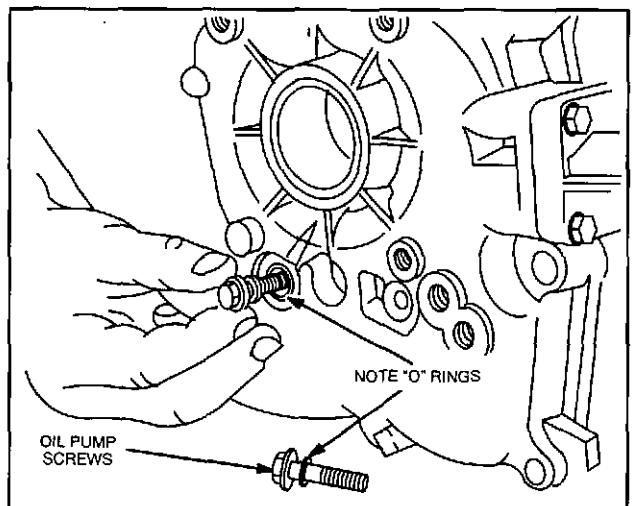


Fig. 17 - Removing Pump

# LUBRICATION

## Oil Pump

### Disassemble Oil Pump - Horizontal Crankshaft Models

Remove oil pump gear baffle or windage plate, if equipped, Fig. 18. Remove oil pick-up tube and screen assembly, Fig. 19.

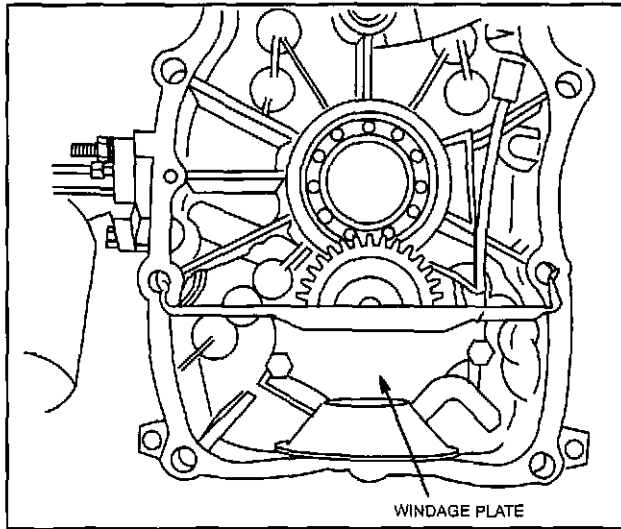


Fig. 18 - Removing Windage Plate

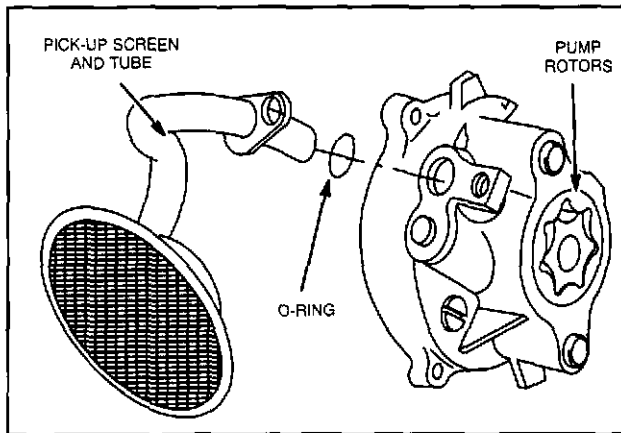


Fig. 19 - Removing Pick-Up Horizontal Shaft

### Inspect Oil Pump

Inspect pump drive gear for obvious wear or chipped teeth. Inspect pump rotors, housing and crankcase cover for scoring or wear. If any of these conditions are found, replace the oil pump assembly.

### Assemble Oil Pump

Lubricate outer rotor with oil and install in pump with dimples aligned, Fig. 20.

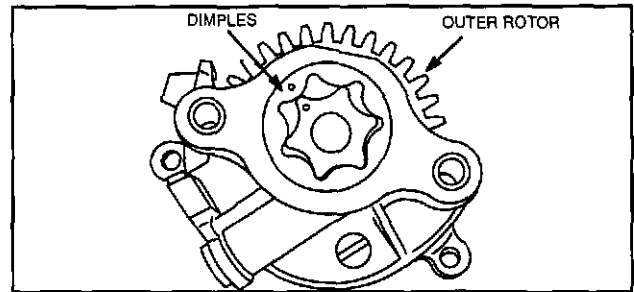


Fig. 20 - Installing Rotor

Horizontal crankshaft models: Install oil pick-up tube and screen assembly with new O-ring on pump. Torque screw to 7 Nm (65 in. lbs.). Attach oil pump to crankcase cover, Fig. 21. Be sure to install new "O" rings on pump mounting screws. Torque screws to 7 Nm (65 in. lbs.). Install oil pump gear baffle or windage plate, if equipped. Torque screws to 7 Nm (65 in. lbs.).

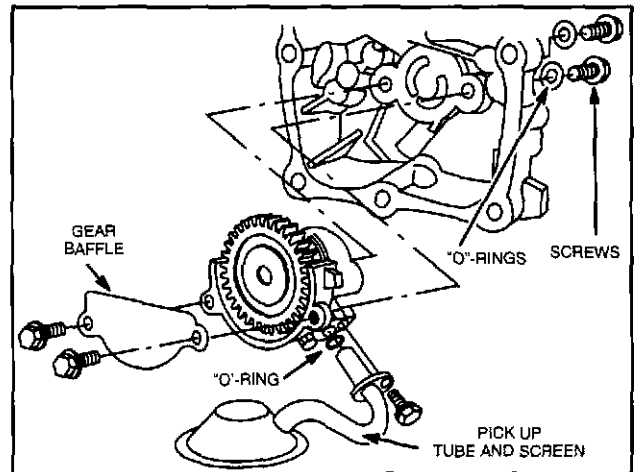


Fig. 21 - Installing Oil Pump - Horizontal Shaft

Vertical crankshaft models: Slip oil pick-up screen into slots in crankcase cover. Then, install oil pump, Fig. 22. NOTE: Boss on oil pump body holds pick-up screen in proper position. Be sure to install new "O" rings on pump mounting screws. Torque screws to 7 Nm (65 in. lbs.).

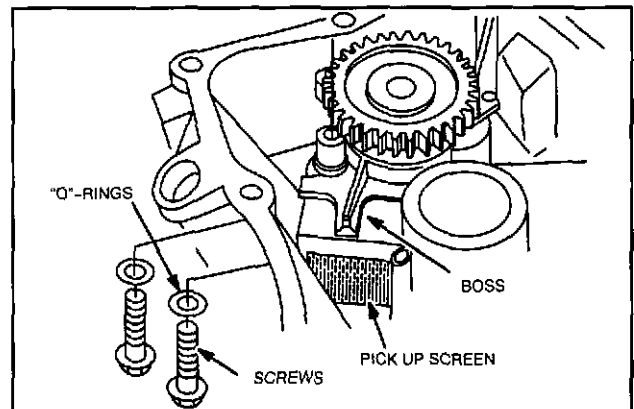


Fig. 22 - Installing Oil Pump - Vertical Shaft

### Install Crankcase Cover

Place new cover gasket on crankcase. NOTE: Be sure "O" ring is installed in cylinder, Fig. 23. Rotate governor shaft clockwise as far as it will go, Fig. 24. To protect the oil seal while assembling crankcase cover, insert yellow seal protector from seal protector kit #19356 into oil seal and slide cover onto crankshaft. No force should be used. Remove seal protector and torque cover bolts in sequence shown to 17 Nm (150 in. lbs.), Fig. 25.

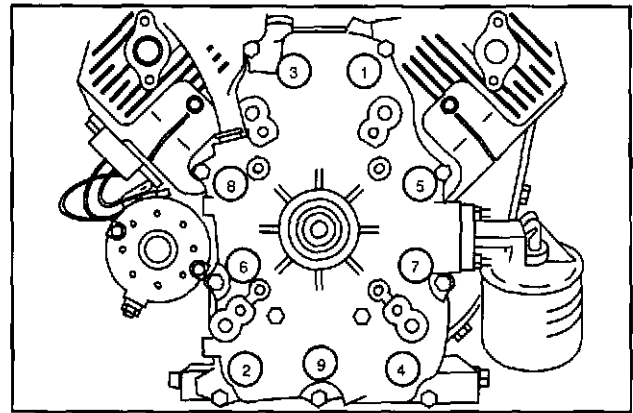


Fig. 25 - Torque Bolts

Install oil filter adapter or optional remote filter adapter to crankcase cover (if removed), Fig. 26. Torque screws to 7 Nm (65 in. lbs.).

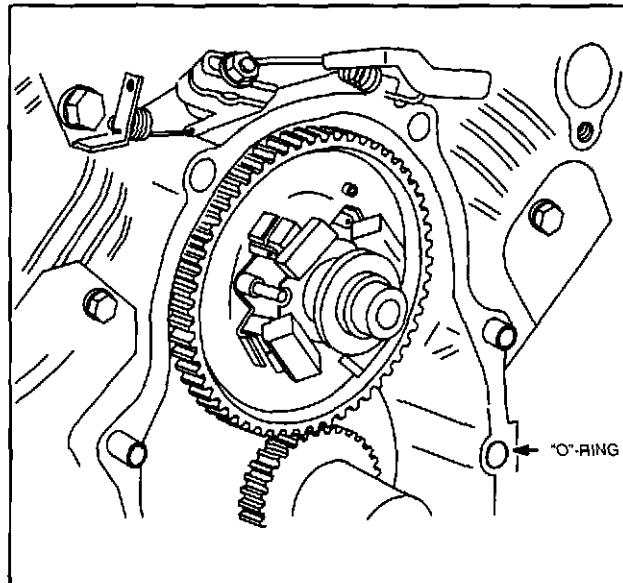


Fig. 23 - "O"-Ring

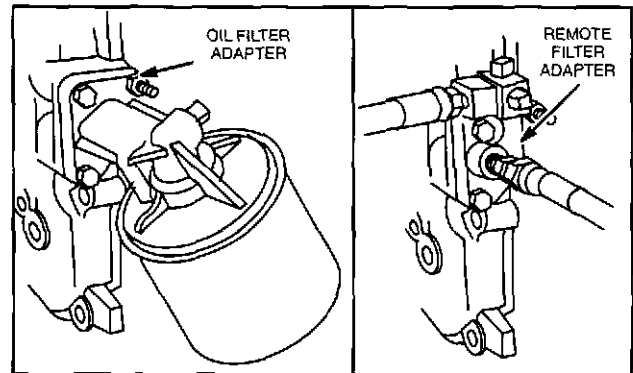


Fig. 26 - Installing Oil Filter Adapter

NOTE: The oil pump is virtually trouble free and requires very little service.

The following chart can be used as a troubleshooting guide for diagnosing the pressure lube system.

#### LOW OIL PRESSURE

- Low Engine RPM
- Low Oil Level
- Incorrect Viscosity or Diluted Oil
- Incorrect Oil Filter
- Defective Oil Pressure Gauge
- Broken Pressure Relief Spring
- Missing Pressure Relief Ball
- Worn Bearings
- Damaged or Defective Oil Pump

#### HIGH OIL PRESSURE

- Incorrect Viscosity Oil
- Defective Oil Pressure Gauge
- Plugged Oil Galleries

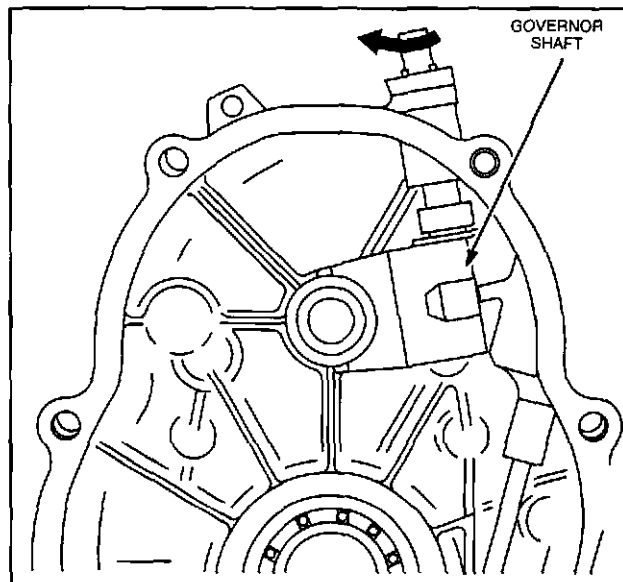


Fig. 24 - Governor Shaft Position

# LUBRICATION

## Pressure Switch

### Low Oil Pressure Switch (Optional)

A 1/8" NPTF plug in the oil filter adapter can be removed to install an optional oil pressure switch. When the oil pressure drops below approximately 5 psi, the switch may be used to activate a warning device and/or stop the engine, Fig. 27. The warning device and all wiring is supplied by the equipment manufacturer.

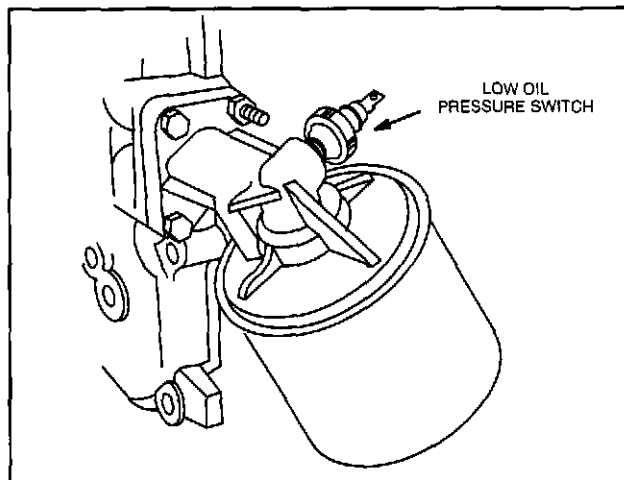


Fig. 27 - Low Oil Pressure Switch and Filter

### Testing Pressure Switch

Use Digital Multimeter, Tool #19357 or #19390. Set meter to test for continuity.

Remove pressure switch for testing. Connect one continuity tester lead to the switch terminal and the other tester lead to the metal body of the switch. The tester *should* indicate continuity when no pressure is applied to the switch. The switch should open (no continuity) when approximately  $.32 \text{ kg/cm}^2$  (4.5 PSI) is applied. Replace the switch if test results are not to specification.

# Section 9

## PISTON - RINGS - RODS

It is recommended that new piston rings be installed whenever the engine is disassembled for major servicing or overhaul, providing that cylinder bores are within specification.

Measure cylinder bores before checking pistons and rings. See Section 11. If cylinder bore(s) require re-sizing it will not be necessary to check pistons and rings since a new oversized piston assembly will be used.

If the cylinder bore is more than .08 mm (.003") oversize, or .04 mm (.0015") out of round, it must be resized.

### Remove Piston And Connecting Rod

When servicing pistons, rings, piston pins or rods, it is recommended practice that each rod, piston, piston pin and ring set be kept as a set for the cylinder from which it was removed. Mark each set before removing from the engine.

Remove any carbon or ridge at the top of the cylinder bore. This will prevent breaking the rings when removing the piston and connecting rod from the engine. Remove the connecting rod cap. Then push the piston and connecting rod out through the top of the cylinder.

### Remove Connecting Rod

To remove connecting rod from piston, remove piston pin locks with screwdriver, Fig. 1. Piston pin is a push fit in piston and rod. Deposits may build up on piston pin and require the piston pin to be pressed out.

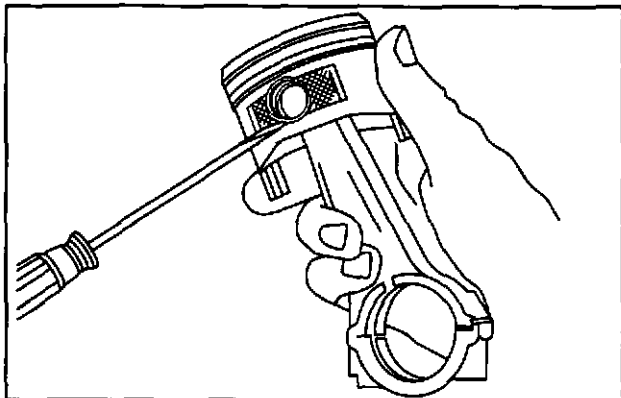


Fig. 1 - Removing Rod

### Remove Rings

Remove top and center compression rings using ring expander, Tool #19340, Fig. 2.

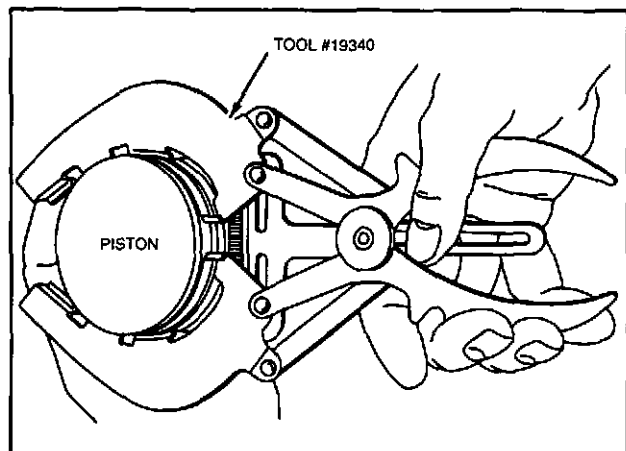


Fig. 2 - Removing Compression Rings

Spiral top oil control ring from oil ring groove into center compression ring groove. Repeat into top compression ring groove, and then off piston. Repeat for bottom oil control ring. Then remove expander, Fig. 3.

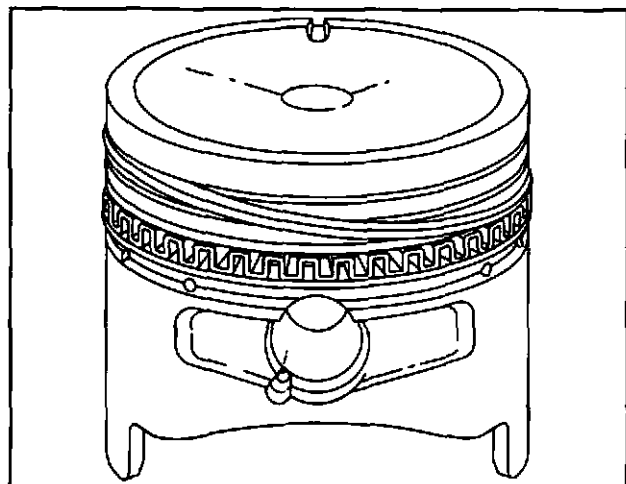


Fig. 3 - Removing Oil Ring

# CHECKING

## Check Piston

If the cylinder is to be resized, there is no reason to check the piston, since a new oversized piston assembly will be used.

If, however, the cylinder is not to be resized and the piston shows no signs of wear or scoring, the piston should be checked.

To do so, clean carbon from top two ring grooves. Place a NEW ring in each groove, Fig. 4. If a .10 mm (.004") or larger feeler gauge for the compression rings or a .20 mm (.008") or larger feeler gauge for the oil ring can be inserted, the ring groove is worn and the piston should be replaced.

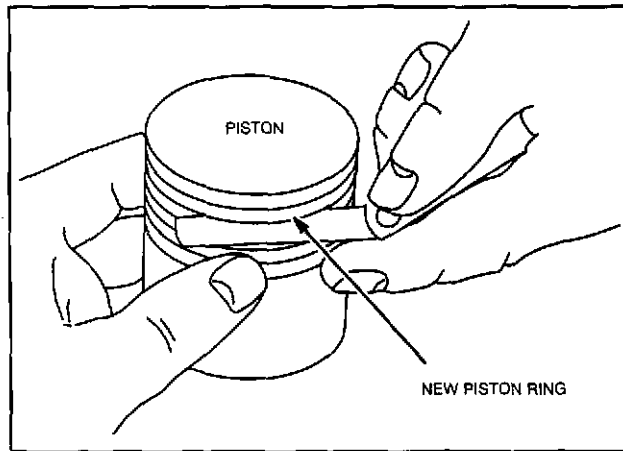


Fig. 4 - Checking Ring Grooves

## Check Rings

To check ring end gap, first clean all carbon from the end of the rings. Insert old rings one at a time approximately 25 mm (1") down into a cylinder bore.

Check end gap with feeler gauge, Fig. 5. If ring gap is greater than shown in Table No. 1, the ring is worn and should be rejected.

A worn ring will usually show scratches caused by abrasives and/or have a shiny appearance. Also, the top and bottom edges of the ring may be extremely sharp. Never reuse worn piston rings.

NOTE: If new piston rings are going to be installed in a cylinder that is within specification, the cylinder bore should be reconditioned, using a rigid hone with

finishing stones, to restore the proper cross hatch angle in the cylinder bores. The proper cylinder cross hatch ensures proper lubrication and piston ring rotation. See Section 11, *Cylinder Finish (Cross Hatch)*, for procedure for applying cross hatch to cylinder bore.

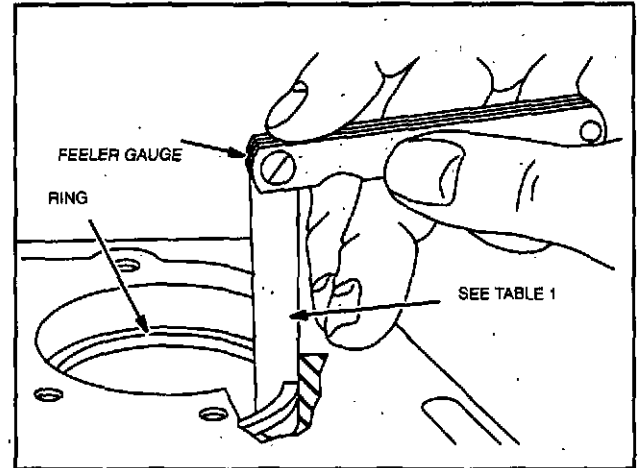


Fig. 5 - Checking Ring End Gap

TABLE NO. 1

Ring End Gap Rejection Size	
Compression Ring	Oil Ring
.80 mm (.030")	.80 mm (.030")

## Check Connecting Rod

If the crankpin bearing in the connecting rod is scored, the rod must be replaced. Reject sizes of crankpin bearing and piston pin bearing (Fig. 6) are shown in Table No. 2. Replace connecting rod if worn.

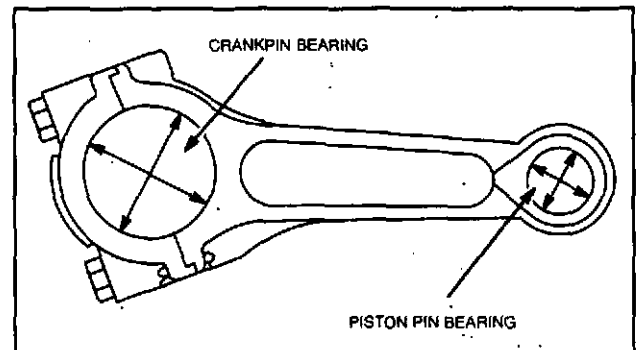


Fig. 6 - Checking Rod Bearings

# ASSEMBLE & INSTALL

**TABLE NO. 2**

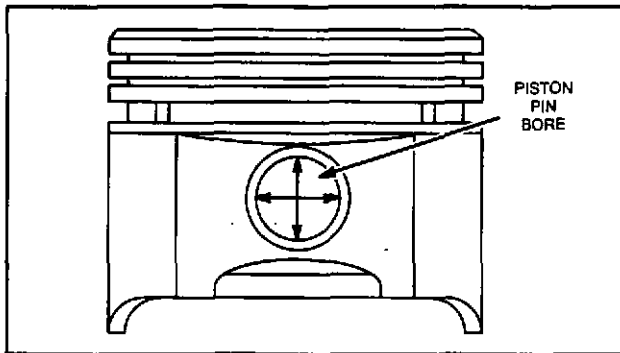
Connecting Rod Reject Size	
Crankpin Bearing	Piston Pin Bearing
37.12 mm (1.4615")	17.10 mm (.6735")

NOTE: .020" undersize connecting rods are available for use on a re-ground crankpin journal. See Section 10, Table 2 for crankshaft grinding dimensions. Complete instructions are included with the undersize connecting rods. See Illustrated Parts List for correct part number for undersize connecting rods.

## Checking Piston Pin And Piston Pin Bore

Reject sizes for piston pin and piston pin bore (Fig. 7) are shown in Table No. 3.

NOTE: If piston pin is worn .01 mm (.0005") out of round or below reject size shown in Table No. 3, it must be replaced.



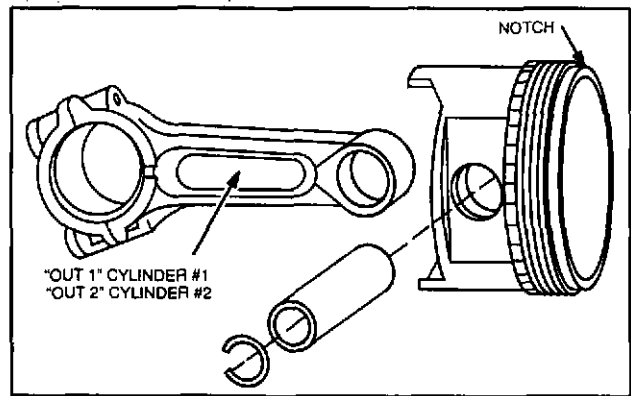
**Fig. 7 - Checking Piston Pin Bore**

**TABLE NO. 3**

Piston Pin & Piston Pin Bore Reject Size	
Piston Pin	Piston Pin Bore
17.06 mm (.6718")	17.10 mm (.6735")

## Assemble Piston And Connecting Rod

The piston pin is a slip fit in both piston and connecting rod. Use a thin nose pliers or screwdriver and install a piston pin lock in groove on one side of piston. Refer to Fig. 8 to determine correct location of rod in relation to notch on piston. Insert piston pin from opposite side of piston until pin stops against piston pin lock. Then install other piston pin lock. Be sure both locks are seated in grooves.



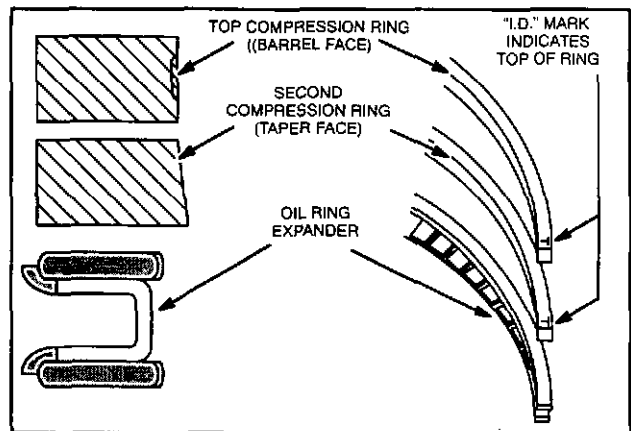
**Fig. 8 - Piston - Connecting Rod Assembly**

## Assemble Rings To Piston

The correct piston ring positions are shown in Fig. 9. The oil ring is installed with the expander between the two oil control rings. The top and second compression rings are installed with "I.D." mark toward top of piston.

Install expander first. Spiral bottom oil control ring into top ring groove, then into second ring groove and into position below expander. Repeat procedure for top oil control ring.

Using ring expander, Tool #19340, install center compression ring then, top compression ring as shown in Fig. 9.



**Fig. 9 - Piston Ring Installation**

## Install Piston And Rod Assembly

Oil piston rings, piston skirt, and compress rings with Ring Compressor Tool #19070, Fig. 10. Place piston and ring compressor upside down on bench and push down until head of piston and edge of ring compressor are even. Tighten ring compressor until rings are fully compressed. Then loosen ring compressor very slightly so that compressor can be rotated on piston skirt while holding connecting rod, Fig. 11.

# ASSEMBLE & INSTALL

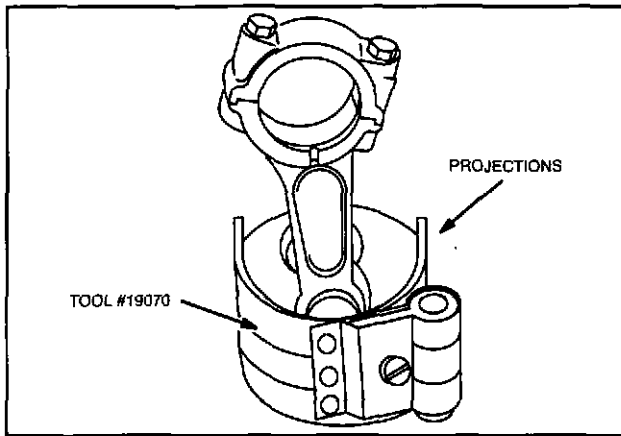


Fig. 10 - Compressing Rings

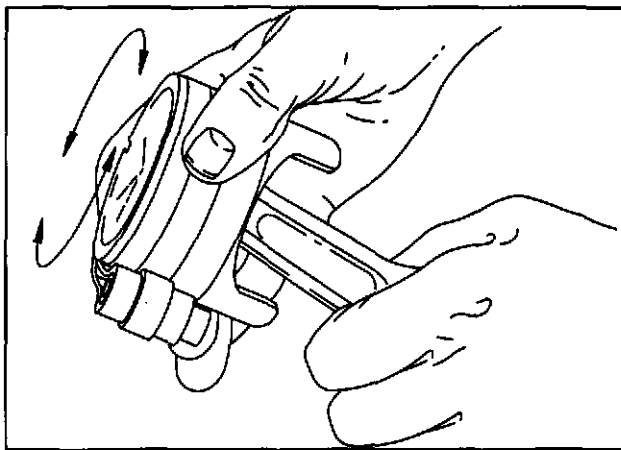


Fig. 11

9

**NOTE:** Briggs & Stratton OHV-Twin engines use pistons with offset piston pin bores. When the notch on piston is facing toward the flywheel side of engine, the words "OUT-1" on the side of the connecting rod for cylinder No. 1 and "OUT-2" on the side of the connecting rod for cylinder No. 2 should face toward the P.T.O. side of the crankcase, Fig. 12.

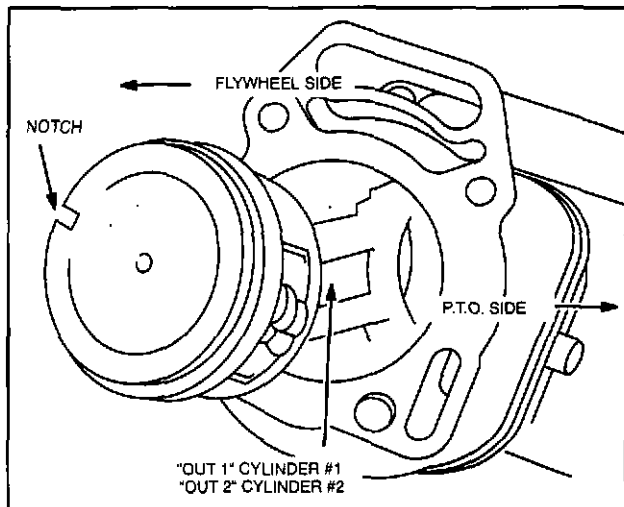


Fig. 12 - Piston Position

Thoroughly clean and then oil cylinder bore. Rotate crankshaft until crankpin journal is at bottom of stroke. This permits complete entry of compressed rings, piston and rod assembly, when pushed into cylinder, Fig. 13. If other piston and rod assembly was removed, repeat procedure for that cylinder.

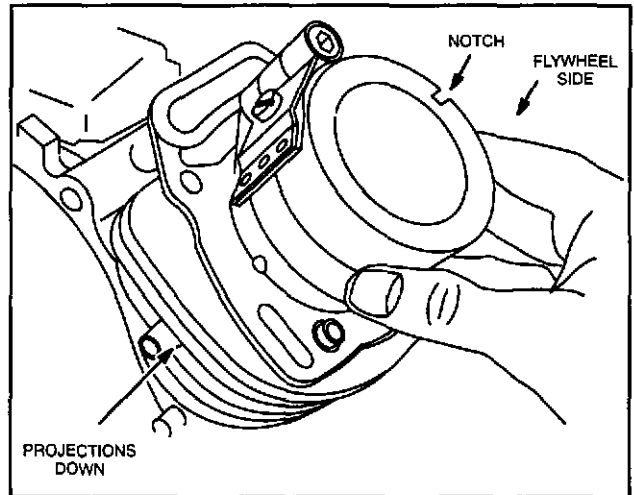


Fig. 13 - Installing Piston Assembly

Clean and oil crankshaft crankpin. Pull connecting rod against crankpin and install rod cap with match marks aligned, Fig. 14. Install connecting rod screws.

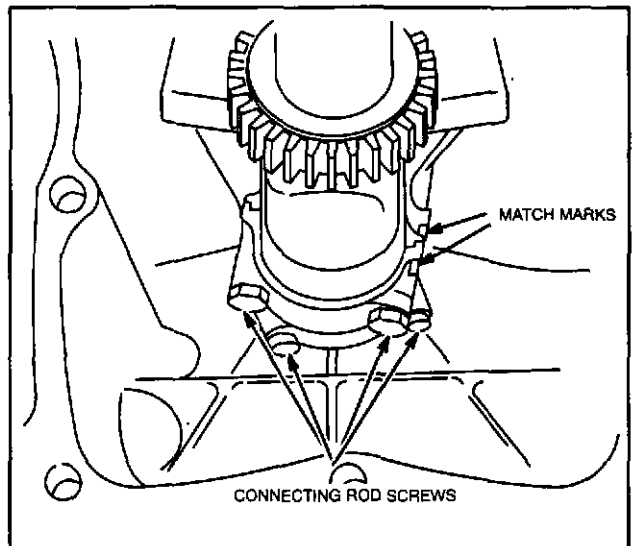


Fig. 14 - Match Marks

Torque connecting rod screws, using Torque Wrench, Tool #19197, to 13 Nm (115 in. lbs.), Fig. 14. Rotate crankshaft two (2) revolutions to check for binding. Rod should also be free to slide sideways on crankpin.

**NOTE: FAILURE TO USE A TORQUE WRENCH CAN RESULT IN LOOSE CONNECTING RODS CAUSING BREAKAGE, OR TIGHT CONNECTING RODS CAUSING SCORING.**

# Section 10

## CRANKSHAFT & CAM GEARS

### Remove Cam Gear

Before crankcase cover is removed, it is recommended that any rust, paint or burrs be removed from power take off end of crankshaft. This will eliminate or reduce chances of damaging the oil seal or crankcase cover bearing.

Remove governor lever and disconnect governor link and springs. Remove governor control bracket. Remove oil fill tube and dipstick assembly.

Remove exhaust manifold, intake manifold and cylinder heads. See Section 6.

**NOTE:** If crankshaft is not going to be removed, it is not necessary to remove cylinder heads. Compress valve springs and then remove push rods. Exhaust push rods are aluminum. DO NOT MIX. When reinstalling push rods, be sure push rods are seated in tappet recesses.

Remove crankcase cover. If crankcase cover sticks, tap lightly with soft hammer on alternate sides near dowel pins, Fig. 1.

**NOTE:** DO NOT REMOVE DOWEL PINS.

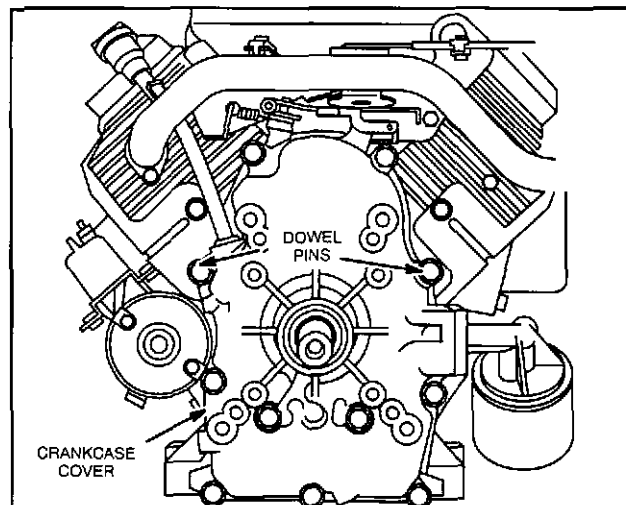


Fig. 1 - Removing Crankcase Cover

Tip engine over onto flywheel side of crankcase. Support engine to prevent end of crankshaft from resting on workbench. Rotate crankshaft until timing marks are aligned. With cam gear in this position, the valve tappets will remain clear of cam lobes. Lift out cam gear and governor assembly, Fig. 2.

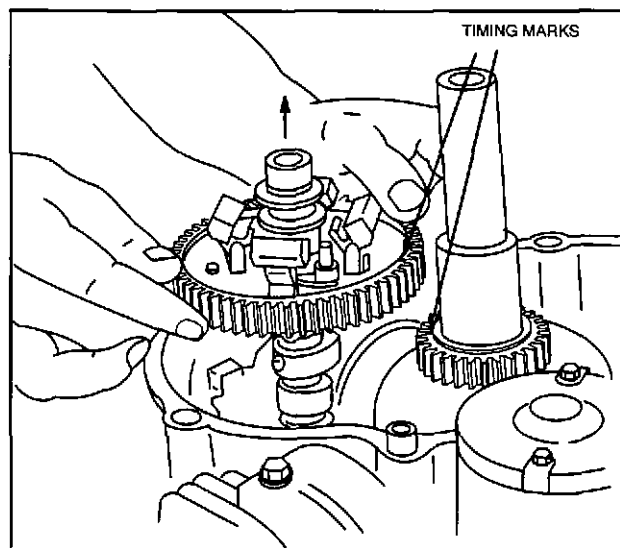


Fig. 2 - Removing Cam Gear

### Remove Crankshaft

Before crankshaft can be removed, it is necessary to remove flywheel, cylinder heads and piston and connecting rod assemblies first.

Follow disassembly procedure as listed in Remove Cam Gear.

Mark the connecting rods and caps to prevent interchanging when reassembling. Remove piston and connecting rod assemblies. See Section 9. Remove crankshaft from crankcase.

# CRANKSHAFTS & CAM GEARS

## Install

### Inspect Crankshaft

Table No. 1 shows the reject sizes of the various wear points on the crankshaft. Replace crankshaft if worn or if journals are scored. Keyways should be checked to be sure they are not worn or spread. Remove burrs from keyway edges to prevent damaging the bearing or oil seal. Check oil galleries for blockage or obstructions. Fig. 3 shows the various points to be checked on the crankshaft.

TABLE NO. 1

Crankshaft Reject Sizes			
All Models	PTO Journal	Mag. Journal	Crankshaft Crankpin
	34.92 mm (1.375")	29.94 mm (1.179")	36.95 mm (1.455")

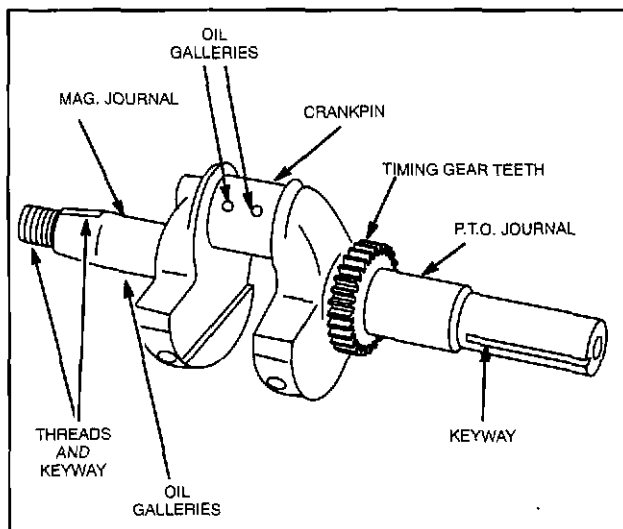
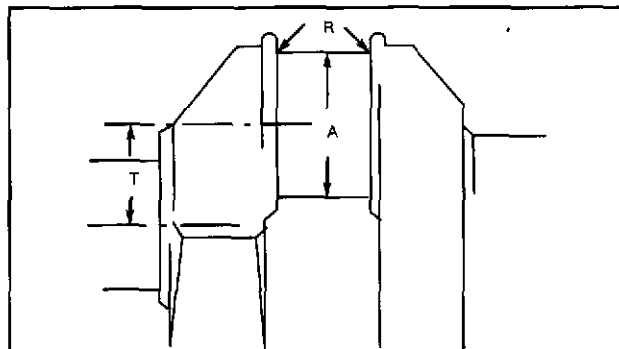


Fig. 3 - Crankshaft Check Points

Check timing gear teeth for chipped or cracked teeth. Engines manufactured after 91062300 have a replaceable timing gear. Check key and keyway for wear. Engines manufactured before 91062400 do not have a replaceable timing gear. If timing gear is damaged, replace crankshaft.

NOTE: .020" undersize connecting rods are available for use on a re-ground crankpin journal. See Table 2 for crankshaft grinding dimensions. Complete instructions are included with the undersize connecting rods. See Illustrated Parts List for correct part number for undersize connecting rods.

TABLE NO. 2



Crankshaft Grinding Dimensions		
Dim. A	R	Dim T
36.46/36.48 mm	2.4/2.5 mm	32.96/33.03 mm
1.4357/1.4362	.095/100	1.2977/1.3007

### Checking Cam Gear

Inspect gear teeth, lobes and journals for wear and nicks, Fig. 4. Cam gear journal and lobe reject sizes are shown in Table No. 3.

Governor slider must move freely on PTO journal of cam gear. Flyweight must pivot freely. Make sure flyweight spring is not stretched. Governor weights must move freely on hinge pins. Make sure hinge pins are not loose.

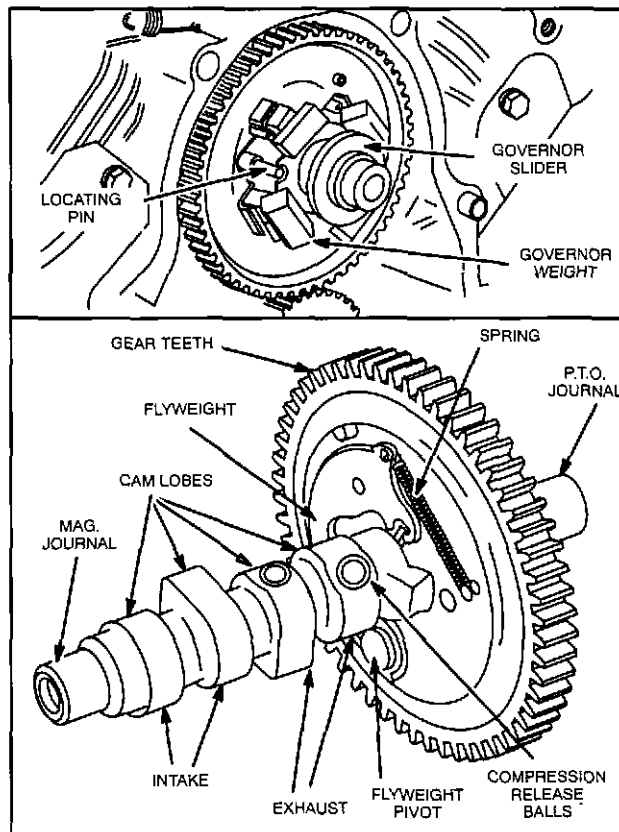


Fig. 4 - Cam Gear Check Points

# CRANKSHAFTS & CAM GEARS

## Install

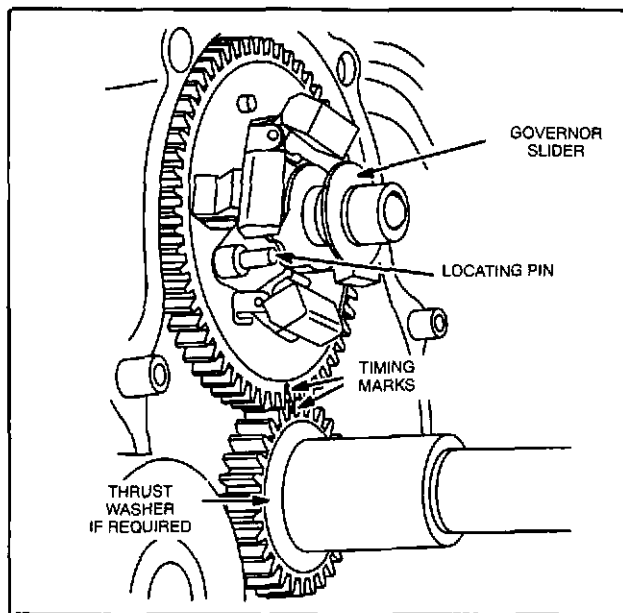
**TABLE NO. 3**

Cam Gear Reject Size			
Cam Gear			
All Models	PTO Journal	Mag. Journal	Cam Lobes
	19.92 mm (.7845")	15.93 mm (.6273")	30.25 mm (1.191")

### Install Crankshaft And Cam Gear

Support both ends of crankshaft and install in cylinder. Install thrust washer on crankshaft, if used, Fig. 5. Then, install pistons and assemble connecting rods to crankshaft. See Section 9.

Install intake and exhaust tappets. Rotate crankshaft until timing mark is toward cam gear side of engine. Then install cam gear, making sure tappets clear cam lobes. Timing marks must align, Fig. 5.

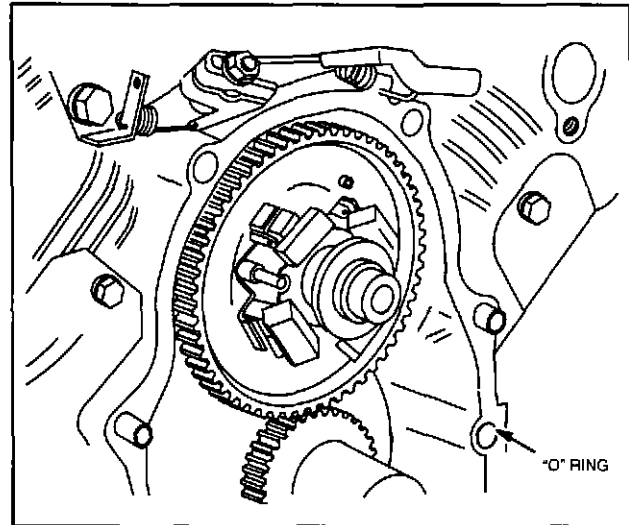


**Fig. 5 - Installing Crankshaft And Cam gear**

Assemble governor slider onto PTO journal on cam gear making sure that slot on slider fits over locating pin on cam gear, Fig. 5. Be sure the weights are in the proper location so that they will be able to move freely without binding. Tip engine to position crankshaft horizontally.

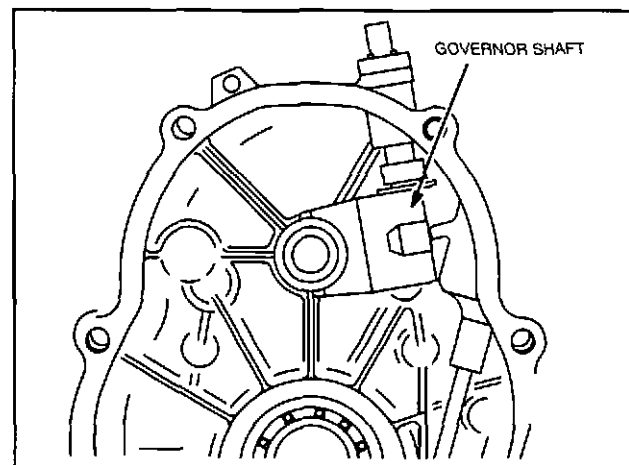
### Install Crankcase Cover

Place new crankcase cover gasket on crankcase. NOTE: Be sure "O" ring is installed in cylinder, Fig. 6.



**Fig. 6 - "O" Ring**

Rotate governor shaft clockwise as far as it will go, Fig. 7.



**Fig. 7 - Governor Shaft Position**

# CRANKSHAFTS & CAM GEARS

## Install

To protect the oil seal while assembling crankcase cover, insert yellow seal protector from seal protector kit #19356 into oil seal and slide cover onto crankshaft. No force should be used. Remove seal protector and torque cover bolts in sequence shown to 17 Nm (150 in. lbs.), Fig. 8.

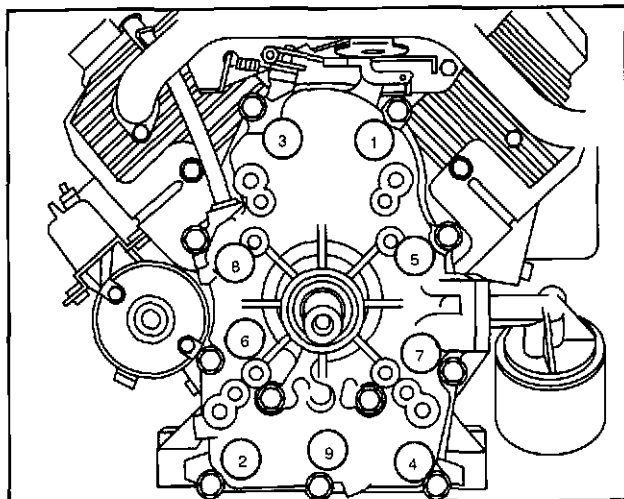


Fig. 8 - Torque Bolts

### Crankshaft End Play

Crankshaft end play for all models is .08 mm to .40 mm (.003" to .015"). Crankshaft end play may be adjusted by adding or removing a thrust washer. Thrust washer kit, part #807625, contains three shims with the following thicknesses; 1.0 mm (.039"), 1.25 mm (.049") and 1.5 mm (.059"). The thrust washer is installed on the PTO side of the crankshaft next to timing gear. See Fig. 5.

Install cylinder heads. See Section 6.

Install flywheel. See Section 2.

Install intake manifold and carburetor assembly. See Section 3.

Install governor lever and governor springs. Install oil fill tube and dipstick assembly. Perform static governor adjustment. See Section 5.

# Section 11

## CYLINDERS & BEARINGS

Always inspect cylinder after engine has been disassembled. Visual inspection will show if there are any cracks, stripped bolt holes, broken fins or if the cylinder walls are damaged. Use a telescoping gauge, Tool #19198, and dial caliper, Tool #19199 or an inside micrometer to determine the size of the cylinder bore. Measure at right angles, see Fig. 1. Table No. 1 lists the standard cylinder bore sizes.

If the cylinder bore is more than .08 mm (.003") oversize, or .04 mm (.0015") out of round, it must be resized, or replaced.

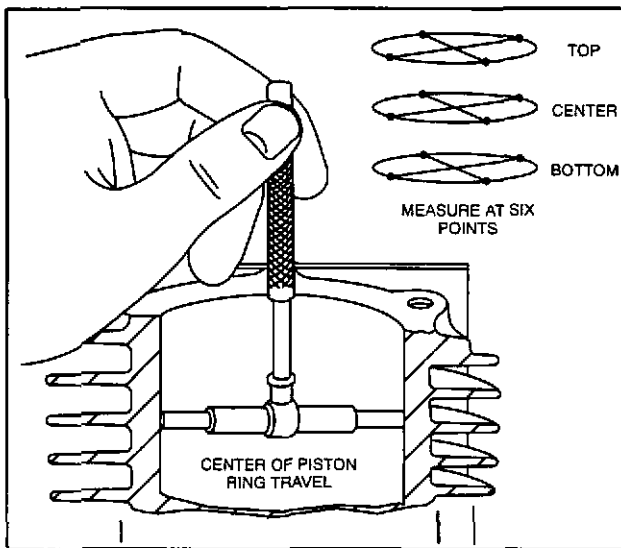


Fig. 1 - Checking Cylinder Bore

TABLE NO. 1

Engine Model	Standard Bore Size	
	Min.	Max.
290000-303000	68.0 mm (2.677")	68.025 mm (2.678")
350000	72.0 mm (2.835")	72.025 mm (2.836")

NOTE: If cylinder bores are within specification and show no signs of scoring or other damage, new piston

rings may be installed providing the cylinder bores are reconditioned using a rigid hone with finishing stones, to restore the proper cross hatch angle in the cylinder bores. The proper cylinder cross hatch ensures proper lubrication and piston ring rotation.

Refer to Page 2, "Cylinder Finish" (Cross Hatch) for correct procedure for installing cross hatch.

### Resizing

ALWAYS RESIZE TO EXACTLY .25 mm (.010") OR .51 mm (.020") OR .76 mm (.030") OVER STANDARD SIZE AS SHOWN IN TABLE NO. 1. IF THIS IS DONE ACCURATELY, THE SERVICE OVERSIZE RINGS AND PISTONS WILL FIT PERFECTLY AND PROPER CLEARANCES WILL BE MAINTAINED.

Cylinders can be quickly resized with a good hone such as Briggs & Stratton Tool #19205. Contact your Briggs & Stratton source of supply. Use the stones and lubrication recommended by the hone manufacturers to produce the correct cylinder cross hatch.

NOTE: Automatic transmission fluid is an acceptable honing oil. Another acceptable honing oil can be made by mixing 4 parts No. 30 weight oil with 1 part kerosene.

If a boring bar is used, a hone must be used after the boring operation to produce the proper cylinder cross hatch.

Honing is done with a variable speed 1/2", portable drill and a honing fixture. See page 6 for dimensions to make your own honing fixture.

### To Set Up For Honing

Check cylinder bores at top and bottom for burrs. Remove burrs. Cylinder head and crankcase cover surfaces must be free of burrs and gasket material.

# CYLINDERS

## Resizing & Cleaning

### Resizing Bore

Use four crankcase cover mounting screws and fasten cylinder to a honing fixture, Fig. 2 .

Clamp honing fixture and cylinder securely in a vise at a convenient work height. Place hone drive shaft in chuck of portable drill and tighten.

Cut a wood block and place inside cylinder to prevent hone from extending further than 19 mm to 25 mm (3/4" to 1") below cylinder bore.

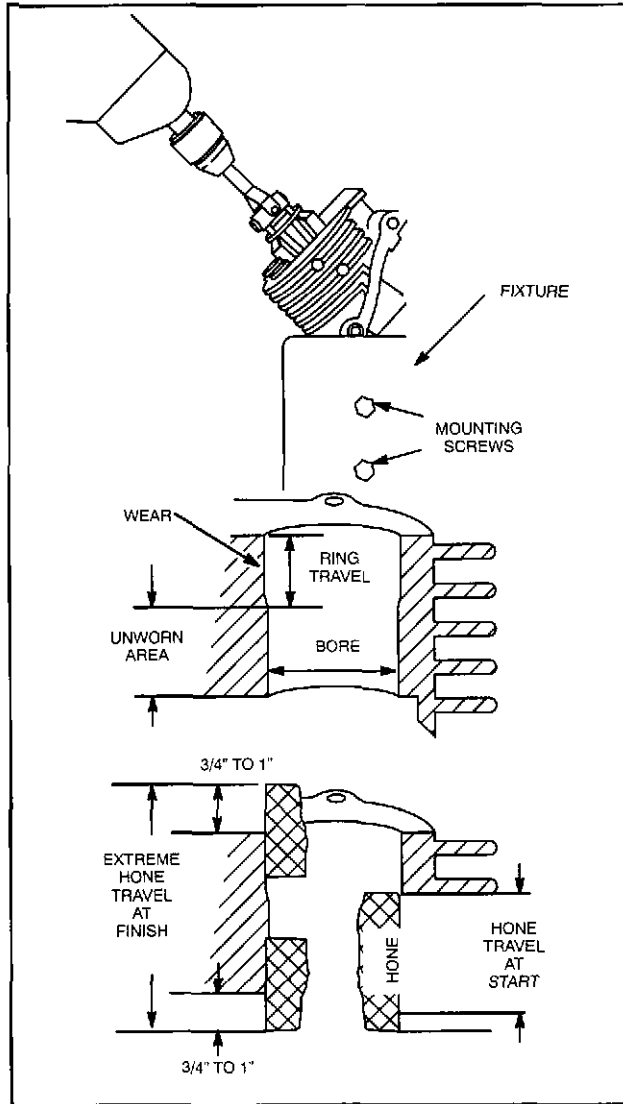


Fig. 2 - Honing Cylinders

### To Hone Cylinder

Place hone in middle of cylinder bore. Tighten adjusting knob with finger until stones fit snugly against cylinder wall. **DO NOT FORCE.**

Connect drive shaft to hone. Be sure that cylinder and hone are centered and aligned with drive shaft and drill spindle. Lubricate hone as recommended by hone

manufacturer. The recommended drill speed is 300 to 700 RPM MAXIMUM and 40-60 strokes per minute. Because cylinder bores normally wear only in the area of ring travel, the cylinder bore will be round above and below ring travel, Fig. 2. Start drill and, as hone spins, move it up and down at the bottom of the cylinder bore. Gradually increase the length of the strokes until hone travels full length of cylinder bore, and no more than 3/4" to 1" above cylinder bore, Fig. 2. Lubricate hone frequently to prevent build up on stones.

As cutting tension decreases, stop hone and tighten adjusting knob following hone manufacturer's recommendations. Check cylinder bore frequently using Telescoping Gauge, Tool #19198, and Dial Caliper, Tool #19199 or equivalent. **ALWAYS HONE .25 mm, (.010") OR .51 mm (.020") OR .76 mm (.030") OVER THE STANDARD DIMENSIONS GIVEN IN TABLE NO. 1. IF THIS IS DONE ACCURATELY, THE PROPER CLEARANCES WILL BE MAINTAINED.**

### Cylinder Finish (Cross Hatch)

The finishing stones are used after the cylinder bore has been resized to within .0015" of the desired size or when reconditioning a cylinder bore. The finishing stones will produce the correct cross hatch necessary for proper lubrication and piston ring rotation. The correct cross hatch angle is approximately 45 degrees, Fig. 3.

It is recommended that the cylinder bores be reconditioned to restore the cross hatch when new piston rings are to be installed in a cylinder that is within specification. Be careful not to hone oversize or it will be necessary to resize the cylinder.

NOTE: To produce the proper cross hatch finish use a drill speed of approximately 200 RPM and 40-60 strokes per minute. Lubricate hone liberally to prevent build up on finishing stones.

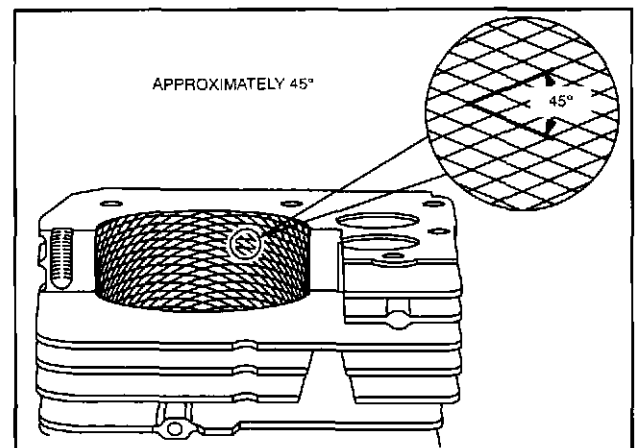


Fig. 3 - Crosshatch

# CYLINDERS Bearings

## Cleaning

IT IS MOST IMPORTANT THAT THE ENTIRE CYLINDER AND CRANKCASE BE THOROUGHLY CLEANED AFTER HONING. FIRST WASH THE CYLINDER AND CRANKCASE CAREFULLY IN A SOLVENT SUCH AS KEROSENE OR COMMERCIAL SOLVENT. THEN THOROUGHLY WASH CYLINDER AND CRANKCASE USING A STIFF BRUSH WITH SOAP AND HOT WATER. RINSE THOROUGHLY WITH HOT RUNNING WATER. REPEAT WASHING AND RINSING UNTIL ALL TRACES OF HONING GRIT ARE GONE.

HONING GRIT IS HIGHLY ABRASIVE AND WILL CAUSE RAPID WEAR TO ALL OF THE INTERNAL COMPONENTS OF THE ENGINE UNLESS IT IS COMPLETELY REMOVED.

NOTE: When cylinder and crankcase have been thoroughly cleaned, use a clean white rag or napkin and wipe the cylinder bore. If honing grit is present it will appear as a gray residue on rag. If any honing grit is evident, re-wash and rinse entire cylinder and crankcase and check again. When there is no trace of honing grit on rag, the cylinder is properly cleaned. Then oil cylinder bore to prevent rusting

## Check Magneto Bearing

Main bearing should be replaced if scored or if Plug Gauge, Tool #19380, enters bearing. Try gauge at several locations in bearing, Fig. 4. If plug gauge is not available, refer to Table No. 2 for reject dimension.

TABLE NO. 2

Magneto Bearing Reject Size
30.08 mm (1.1845")

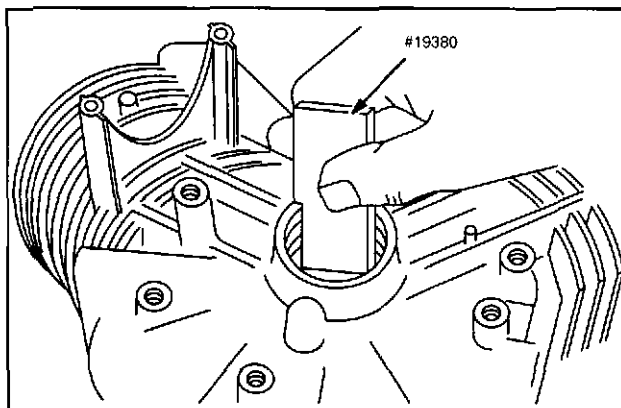


Fig. 4 - Checking Bearing

## Remove Magneto Bearing

Remove oil seal. The magneto bearing has a roll pin installed in the oil gallery to prevent the bearing from turning. Use a 4.8mm (3/16") punch to drive roll pin into oil gallery, Fig. 5.

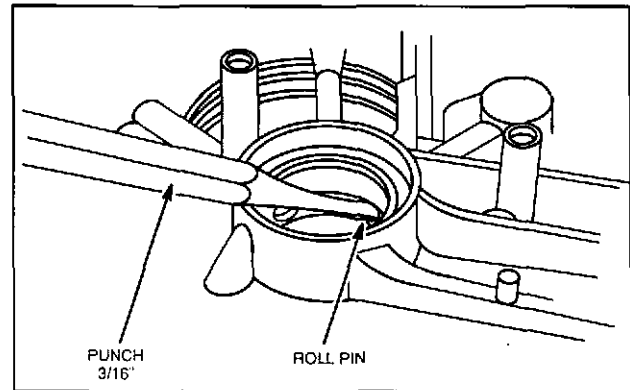


Fig. 5 - Driving Locating Pin

Place cylinder on Cylinder Support, Tool #19227. Insert Bushing Driver, Tool #19349 into bushing and press bushing out of crankcase, Fig. 6.

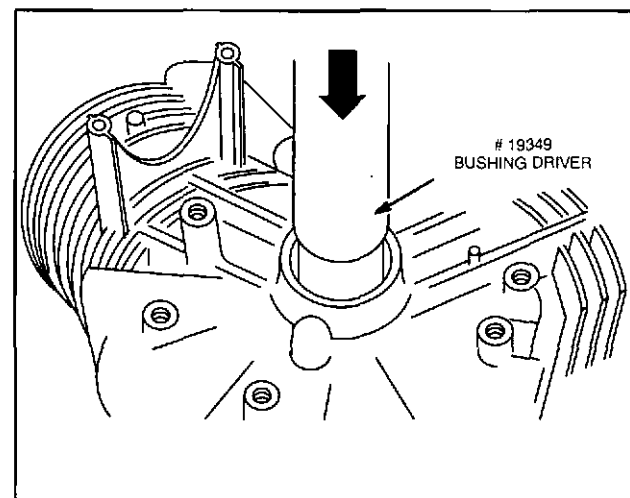


Fig. 6 - Removing/Installing Bushing

## Install Magneto Bearing

Place cylinder on Cylinder Support, Tool #19227. Position new bushing against counterbored bearing in crankcase and carefully align oil holes in bushing with oil gallery holes in bearing, Fig. 7. Press in new bushing with Bushing Driver, Tool #19349, Fig. 6.

NOTE: Be sure oil holes in bushing are aligned with oil gallery holes in bearing.

# CYLINDERS

## Bearings

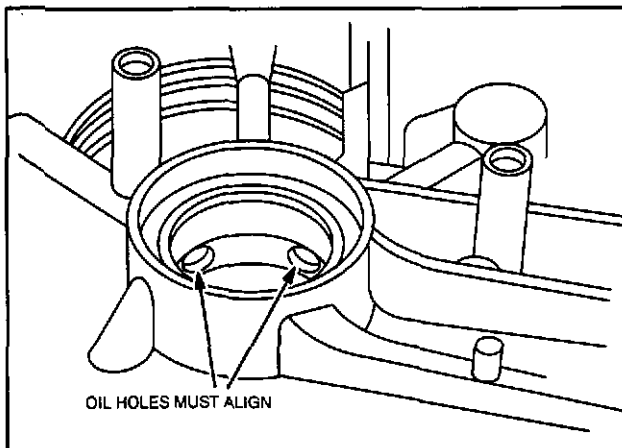


Fig. 7 - Align Oil Holes

Grind off the taper, approximately 3mm (1/8"), from one end of new roll pin as shown, Fig. 8. Quench pin in water periodically to prevent loss of temper. Remove all burrs and clean thoroughly.

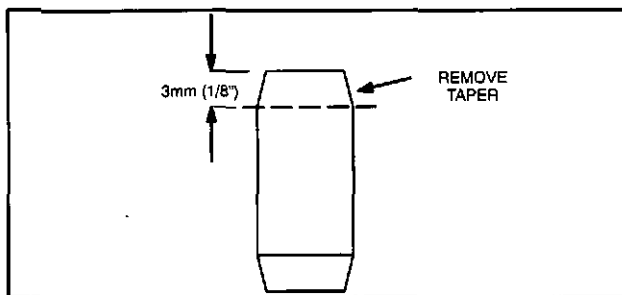


Fig. 8 - Grinding Roll Pin

Place tapered end of new roll pin in oil hole in bearing. Use Tool #19344, Roll Pin Driver, to install new roll pin, Fig. 9. Drive in new roll pin until tool bottoms. Install new oil seal. Use Cylinder Support, Tool #19227, and press in new oil seal until it is flush with cylinder.

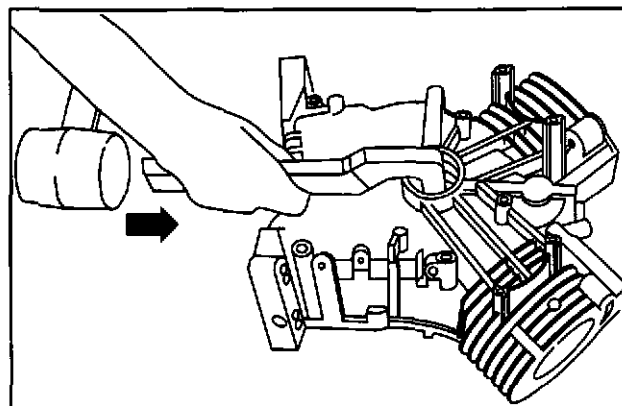


Fig. 9 - Installing Roll Pin

### Remove PTO Ball Bearing

Remove oil pump, see Section 8. Remove oil seal. Support crankcase cover on arbor press and using Bushing Driver, Tool #19226, press out bearing toward inside of the cover.

### Install PTO Ball Bearing

Lubricate outside surface of bearing and place on inside of cover. Using an arbor press and flat steel plate, press in bearing until flush with surface of cover, Fig. 10. Install new oil seal using Cylinder Support, Tool #19227. Press in seal until it is flush with mounting surface.

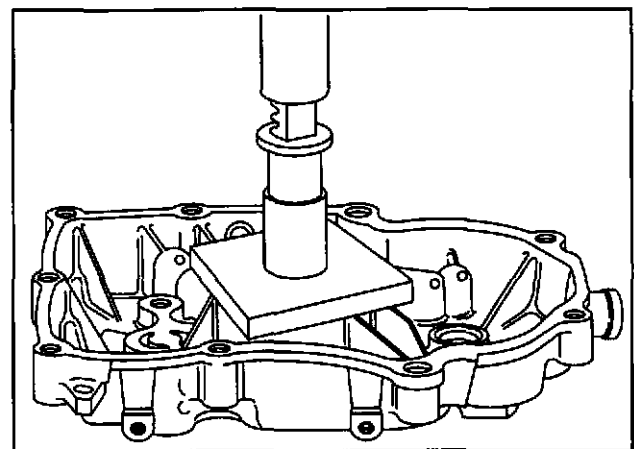


Fig. 10 - Installing Ball Bearing

### Plain PTO Main Bearings

Crankcase cover must be replaced if PTO bearing is scored or if Plug Gauge, Tool #19380, enters bearing. Try gauge at several locations in bearing, Fig. 11. If plug gauge is not available, refer to Table No. 3 for reject dimension.

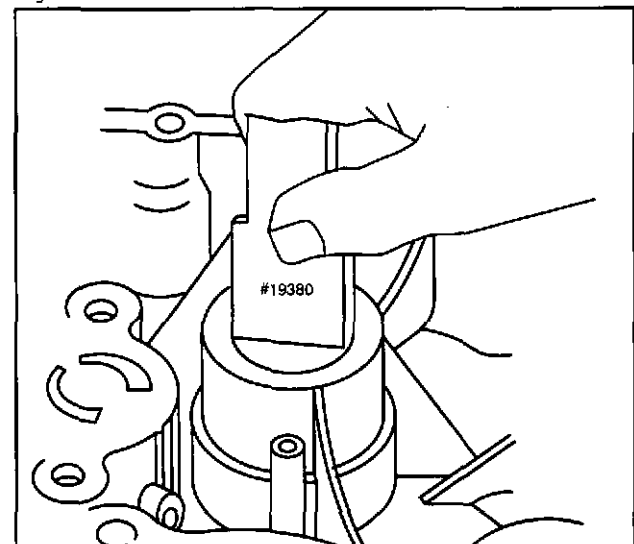


Fig. 11 - Checking PTO Bearing

# CYLINDERS Bearings

**TABLE NO. 3**

<b>PTO Main Bearing Reject Size</b>
35.07 mm (1.381")

When installing new PTO oil seal, use 47.6 mm (1-7/8") side of Cylinder Support, Tool #19227. Press in seal until it is 1.5 mm (1/16") below mounting surface.

### Checking Cam Gear Bearings

Use Plug Gauge, Tool #19384, to check cam bearing, magneto side. Use Plug Gauge, Tool #19386, to check cam bearing, PTO side. Plug gauge should not enter bearing. If plug gauges are not available, see Table No.

4 for reject size. If cam bearings are worn, cylinder or crankcase cover must be replaced.

**TABLE NO. 4**

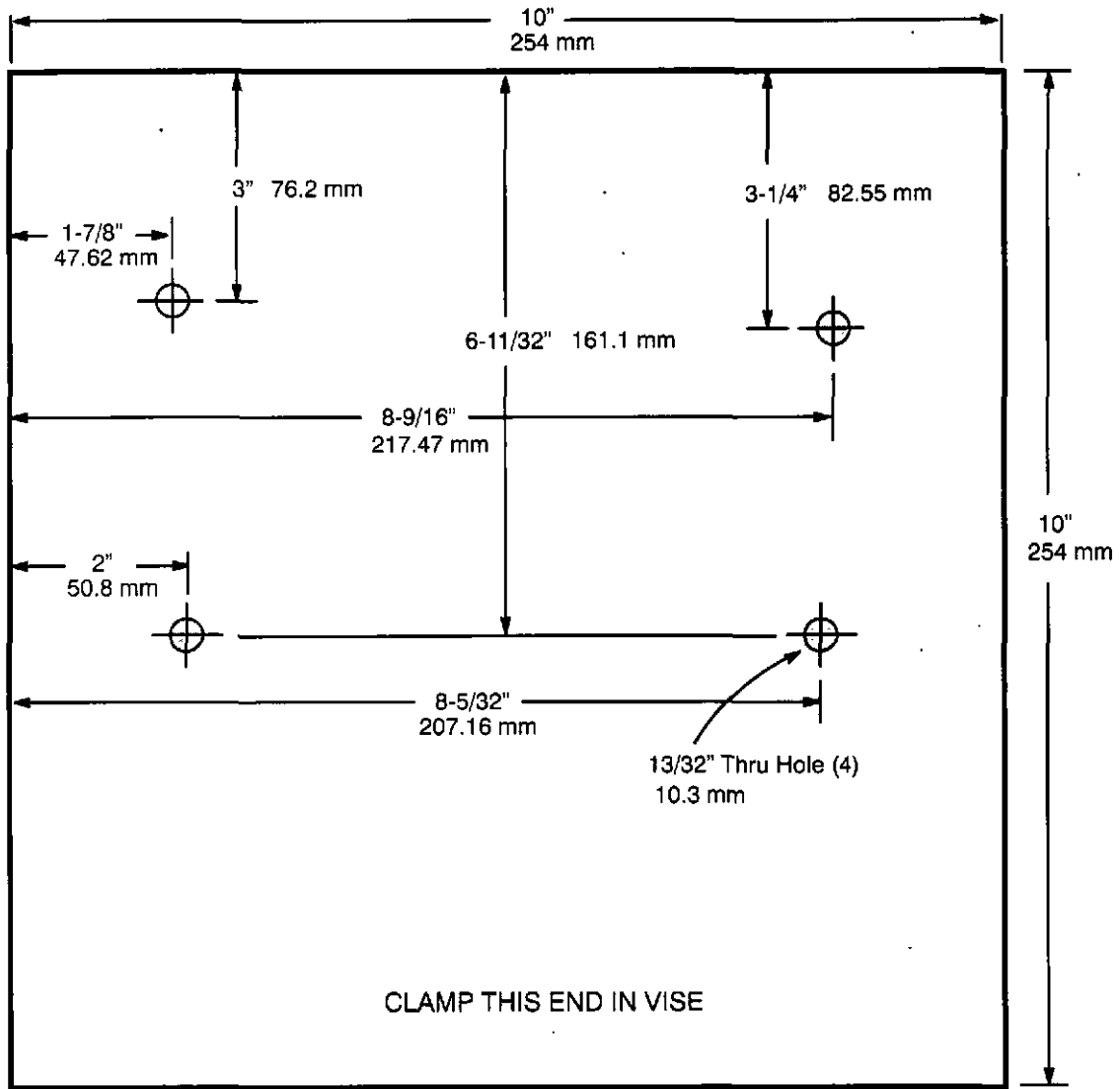
<b>Cam Bearing Reject Size</b>		
	<b>Magneto Bearing</b>	<b>PTO Bearing</b>
<b>All Models</b>	16.08 mm (.633")	20.04 mm (.789")

### Oil Seals

Always install new oil seals whenever engine is disassembled for major servicing or when repairing bearings. Always use the correct seal protector to prevent damaging oil seal.

# CYLINDERS Bearings

## Honing Fixture



Material - Wood 2" x 10" x 10" long  
(50.8 mm x 254 mm x 254 mm Long)

### Cylinder Mounting Hardware

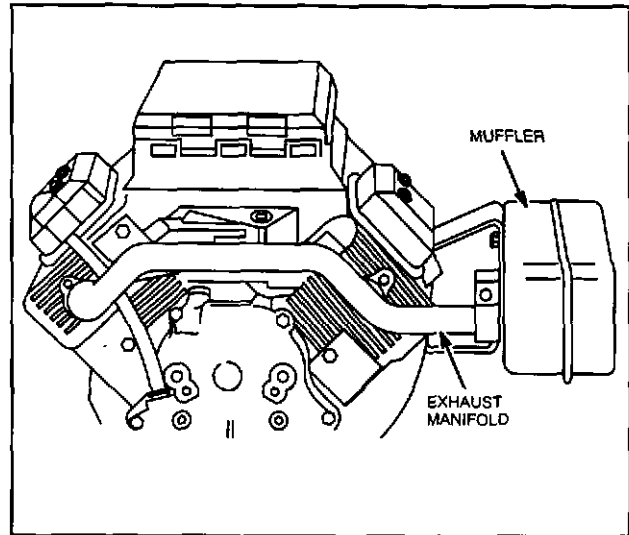
Fasteners Required: 4 Crankcase Cover Screws  
4 Flat Washers 3/8" (9.5 mm) I.D.

# Section 12

## MUFFLERS

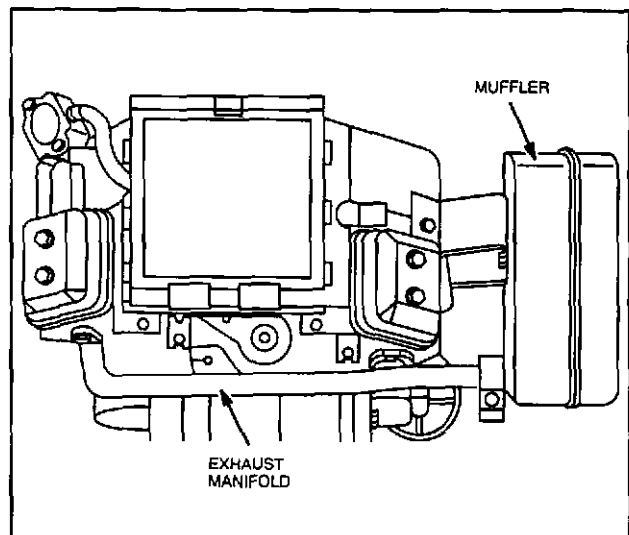
### Muffler

To meet various application requirements of Original Equipment Manufacturers, some OHV-Twin cylinder engines are shipped without mufflers. NOTE: Some exhaust manifolds and mufflers are installed by the Original Equipment Manufacturer using their mounting brackets. Remove and lift off muffler assembly. NOTE: If exhaust pipes and exhaust nipples appear to be frozen, use penetrating oil to loosen.



### Inspect Exhaust System

Check exhaust manifold, muffler mounting bracket and/or muffler adapters for cracked welds or breakage. Check muffler(s) for split seams, loose internal parts or cracked welds. Replace any damaged parts with new Original Equipment Parts.

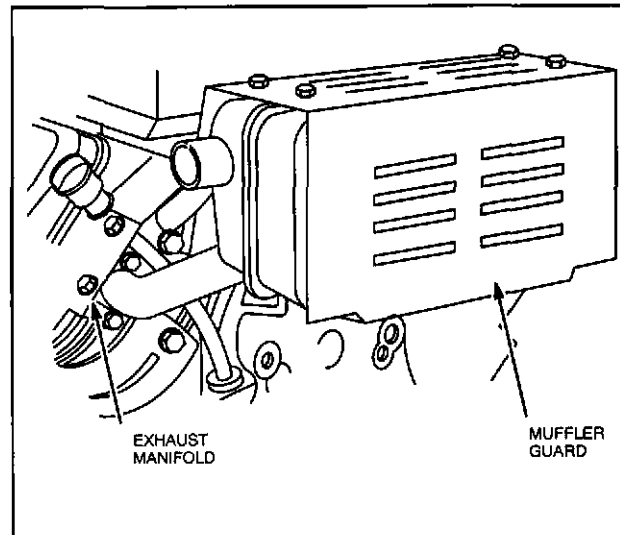
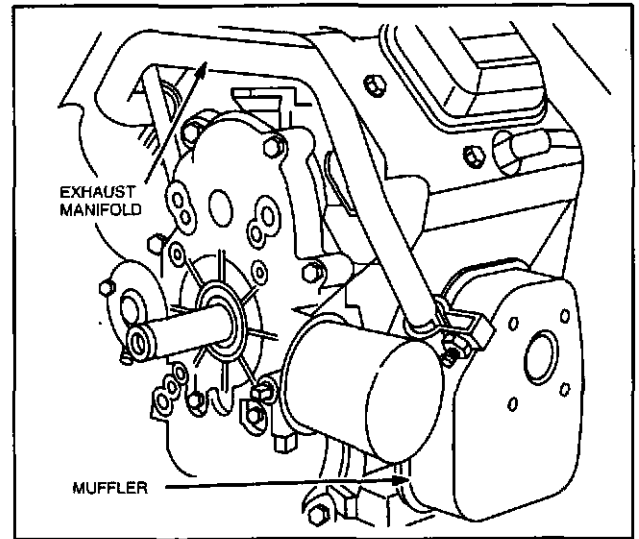
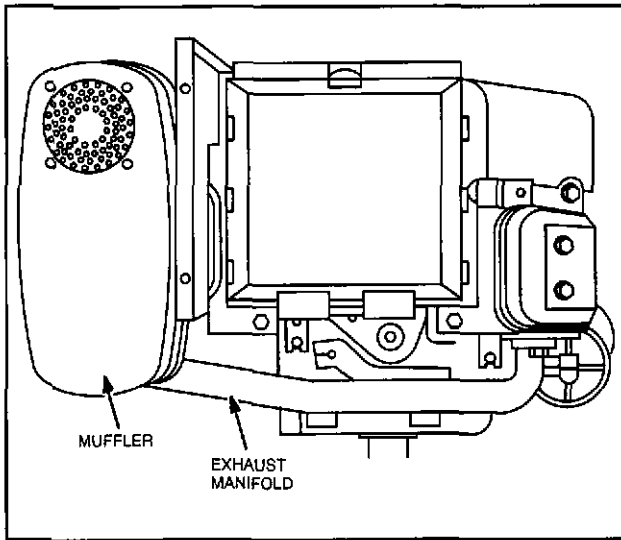


### General Information

Use Anti Seize Valve Lubricant, Tool #93963 on all exhaust system threads to prevent galling of threads and permit easier disassembly, should it be required. Always use new exhaust manifold gaskets. Torque exhaust manifold screws to 17 Nm (150 in. lbs.).

# MUFFLERS

## Muffler Variations

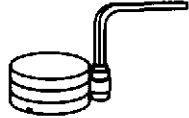

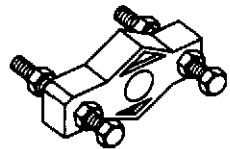
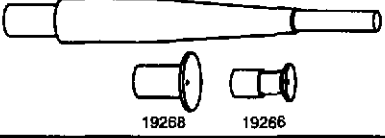
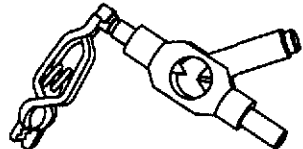



# Section 13

## TOOLS


It is assumed that Briggs & Stratton Authorized Service Centers have common hand tools to repair engines.

All Briggs & Stratton Authorized Service Centers are required to have Tool Kit #19300. Tools listed below are used on OHV twin cylinder engines and are part of Tool Kit #19300.

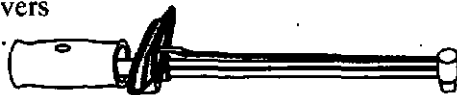
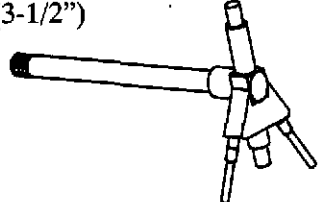
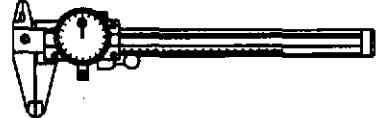


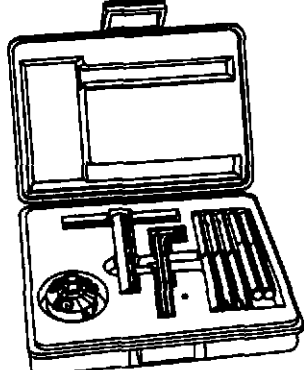
DESCRIPTION	TOOL NO.	USE
RING COMPRESSOR	19070	Install Piston and Rings 
TACHOMETER	19200	Set correct idle and Top No Load RPM 
FLYWHEEL PULLER	19203	Remove Flywheel 
VALVE LAPPER	19258	Lap Valve Face to Valve Seat Face 
IGNITION TESTER	19368	Check for Ignition Spark 
VALVE GUIDE LUBRICANT (Anti-Seize Compound)	93963	Lubricate valve stems and valve guides, spark plug threads, muffler bolts and cylinder head bolts 

# TOOLS

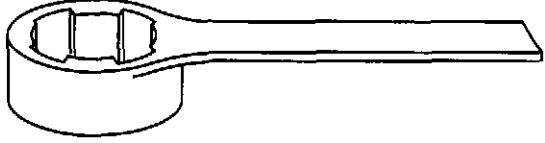
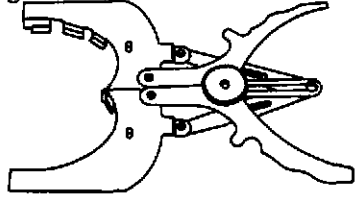
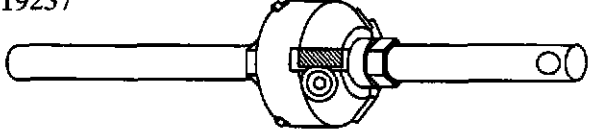
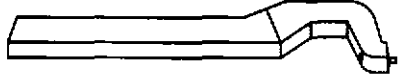


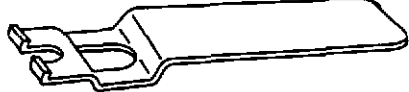

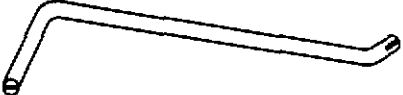
## BRIGGS & STRATTON REPAIR TOOLS (cont'd.)

DESCRIPTION	TOOL NO.	USE
CLOVER® VALVE LAPPING COMPOUND	94150	Lapping Valves 

The following special tools are required for Briggs & Stratton Authorized Service Centers, in addition to Tool Kit #19300 .

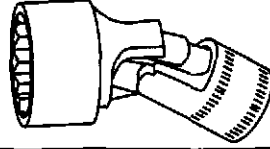
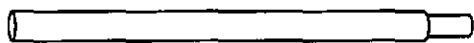
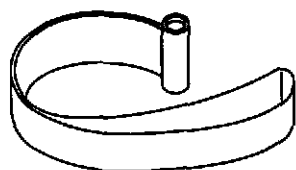
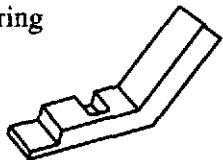
DESCRIPTION	TOOL NO.	USE
TORQUE WRENCH	19393	Accurately torque Connecting Rods, Cylinder Heads, Sumps, Crankcase Covers Range 0 to 300 in. lbs. 
GAUGE, TELESCOPING	19404	Measure Cylinder bores for wear Range 51 mm (2") to 89 mm (3-1/2") 
DIAL CALIPER	19199	Measure engine wear Range 0" to 6" Accurate to .001" 
BEARING DRIVER	19226	Remove Ball Bearing - Horizontal Crankshaft Models 
CYLINDER SUPPORT	19227	Remove And Install Magneto Main Bearing, Install Oil Seals 
VALVE SEAT CUTTER KIT	19237	Restore Valve Seats 30 and 45 Seat Angles 

BRIGGS & STRATTON REPAIR TOOLS (cont'd.)



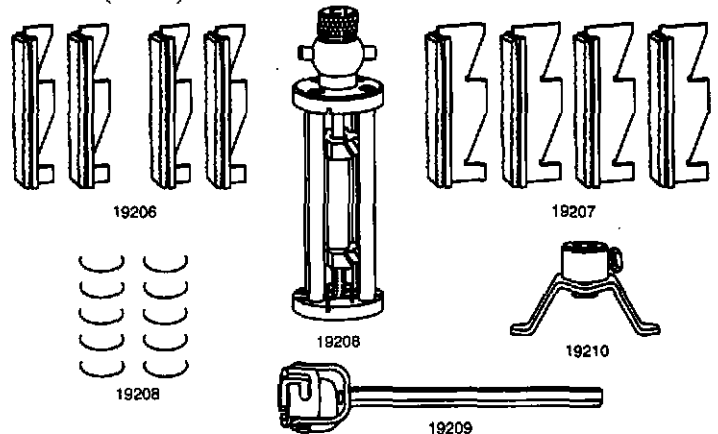
DESCRIPTION	TOOL NO.	USE
FLYWHEEL HOLDER	19321	For Engine Model 350000 Flywheels 
RING EXPANDER	19340	Remove and Install Piston Rings 
VALVE SEAT CUTTER	19343	Use with 19237 
ROLL PIN DRIVER	19344	Install Roll Pin in Magneto Main Bearing 
REAMER PILOT GUIDE	19345	Use with 19346 
VALVE GUIDE REAMER	19346	Ream Valve Guides 
VALVE SPRING COMPRESSOR	19347	Remove and Install Valve Springs 
BEARING DRIVER	19349	Replace Magneto Main Bearing 
TANG BENDER	19352	Adjust Governor Tangs for Top No Load RPM and Governed Idle 

# TOOLS

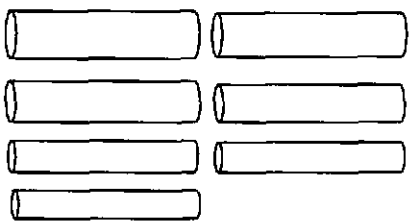
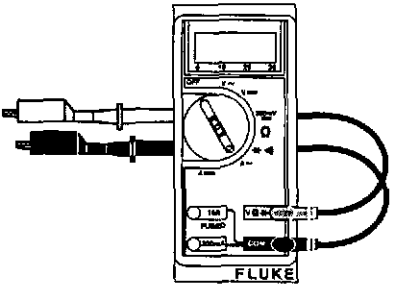
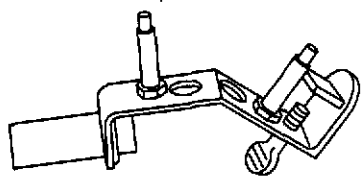
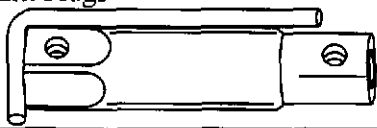
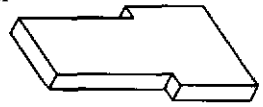

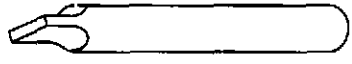
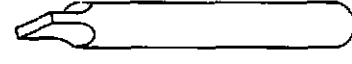
## BRIGGS & STRATTON REPAIR TOOLS (cont'd.)

DESCRIPTION	TOOL NO.	USE
UNIVERSAL SOCKET	19353	13mm, 12 point, 1/4" Drive. For Removing Electric Starter Mounting Screws 
BUSHING DRIVER	19367	Remove and Install Valve Guides 
FLYWHEEL STRAP WRENCH	19372	Hold Flywheel While Removing and Torquing Flywheel Nut 
ADJUSTMENT GAUGE	19385	Adjust Secondary Governor Spring 

The following tools, while not required, are recommended for complete engine repair.

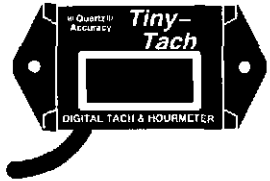

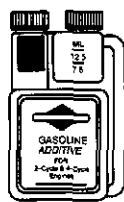
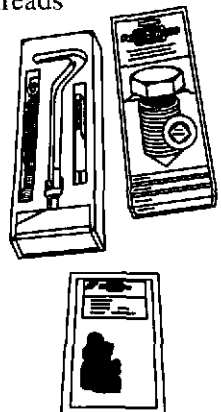

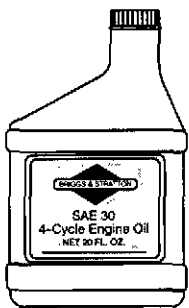
DESCRIPTION	TOOL NO.	USE
SCREWDRIVER	19061	Remove carburetor jets 
SCREWDRIVER	19062	Remove carburetor jets 
HONE SET	19205	Resize Cylinder Bores to .25 mm (.010"), .51 mm (.020"), .76 mm (.030") Oversize 

## BRIGGS & STRATTON REPAIR TOOLS (cont'd.)



DESCRIPTION	PART NO.	USE
SEAL PROTECTOR KIT	19356	Protects oil seals when installing crankshafts and crankcase covers 
DIGITAL MULTIMETER	19357 or 19390	Measure electrical equipment AC Volts, 0 to 750 DC Volts, 0 to 1000 Ohms, 0 to 320,000,000 AC & DC Amps, 0 to 10 Continuous 0 to 20 for 30 Seconds Audible Diode Test Audible Continuity Test Auto Ranging 
DC SHUNT	19359	Use with Digital Multimeter for measuring current draw of 12 volt electric starter motors and out put of 16 Amp regulated alternators 
SPARK PLUG WRENCH	19374	Remove 5/8" Hex Head Spark Plugs 
PLUG GAUGE	19380	Check Main Bearings For Wear 
PLUG GAUGE	19382	Check Valve Guides For Wear 
PLUG GAUGE	19384	Check Cam Gear Bearing For Wear (Mag. Side) 
PLUG GAUGE	19386	Check Cam Gear Bearing For Wear (PTO Side) 

# TOOLS

## BRIGGS & STRATTON REPAIR TOOLS (cont'd.)

DESCRIPTION	PART NO.	USE
DIGITAL TACHOMETER & HOURMETER	19389	Meter displays RPM while engine is running. When engine is stopped, meter displays elapsed time. 
HEAVY DUTY TOWELS	100000	
GASOLINE ADDITIVE	100001	Prevents Gum & Varnish Stabilizes Fuel for Storage 
FIX-A-THREAD KITS	100010 100011 100012 100013	For Repairing Damaged and Stripped Threads Thread Repair Kit M5x.8 Thread Repair Kit M6x1 Thread Repair Kit M8x1.25 Thread Repair Kit 14mm Spark Plug - 3/4" 
THREAD INSERT REFILLS	100017 100018 100019 100021	M5x.8 Refill M6x1 Refill M8x1.25 Refill 14mm Spark Plug Refill - 3/4" 
30 WEIGHT	100005	SAE 30 Weight Oil (20 oz.) 

BRIGGS & STRATTON REPAIR TOOLS (cont'd.)

DESCRIPTION	PART NO.	USE
GASOLINE TESTER	100023	Use To Determine The Alcohol Contents In Gasoline 
PAINT, 13 oz. SPRAY CAN PAINT, 13 oz. SPRAY CAN	271403 271675	Satin Black American Red 



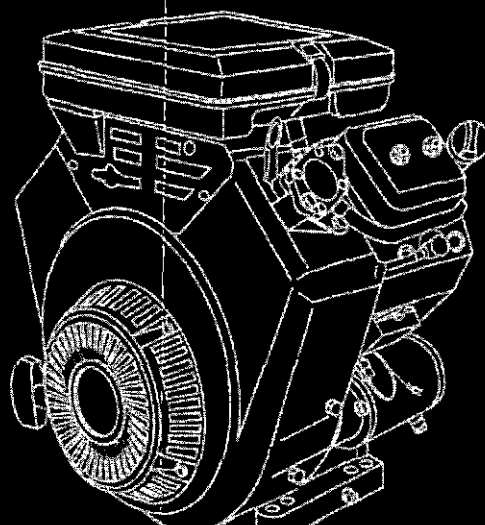
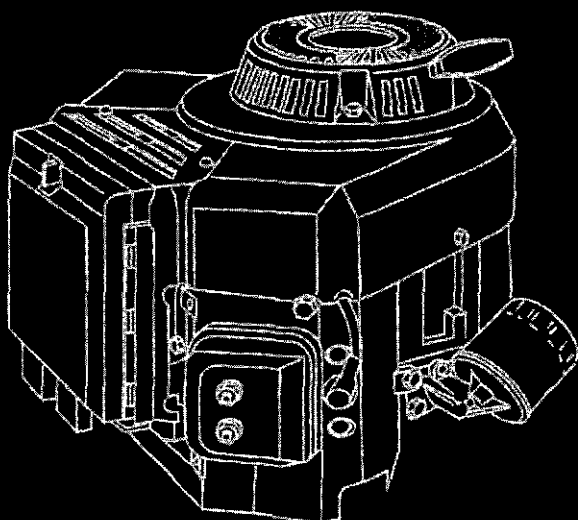
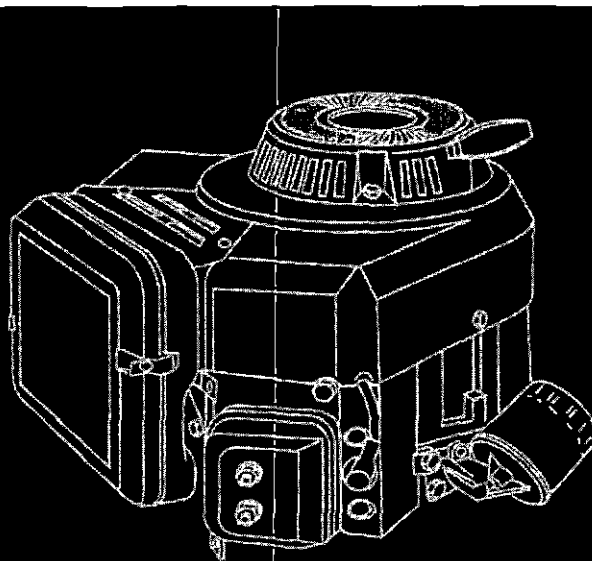
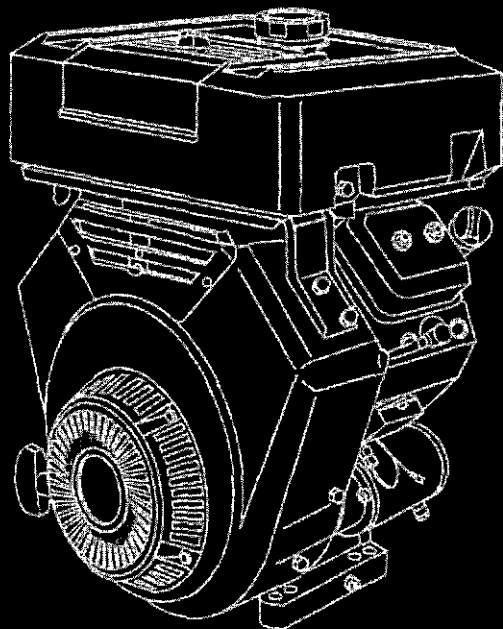
*For Repair Manuals for other  
Briggs & Stratton Engines, order:*

*270962—Single Cylinder 4-Cycle Engines*

*271172—Twin Cylinder "L" Head Engines*

*272147—Vanguard Single Cylinder OHV  
Engines*

*800100—2-Cycle Single Cylinder Engines*



**BRIGGS & STRATTON CORPORATION**  
Milwaukee, WI 53201  
Part No. 272144 -1/95 Printed in U.S.A.